

MAY 1976  
\$1.50

# 73

AMATEUR RADIO

**SPECIAL  
ANTENNA  
ISSUE**

PLUS



**COMPUTER  
SECTION**

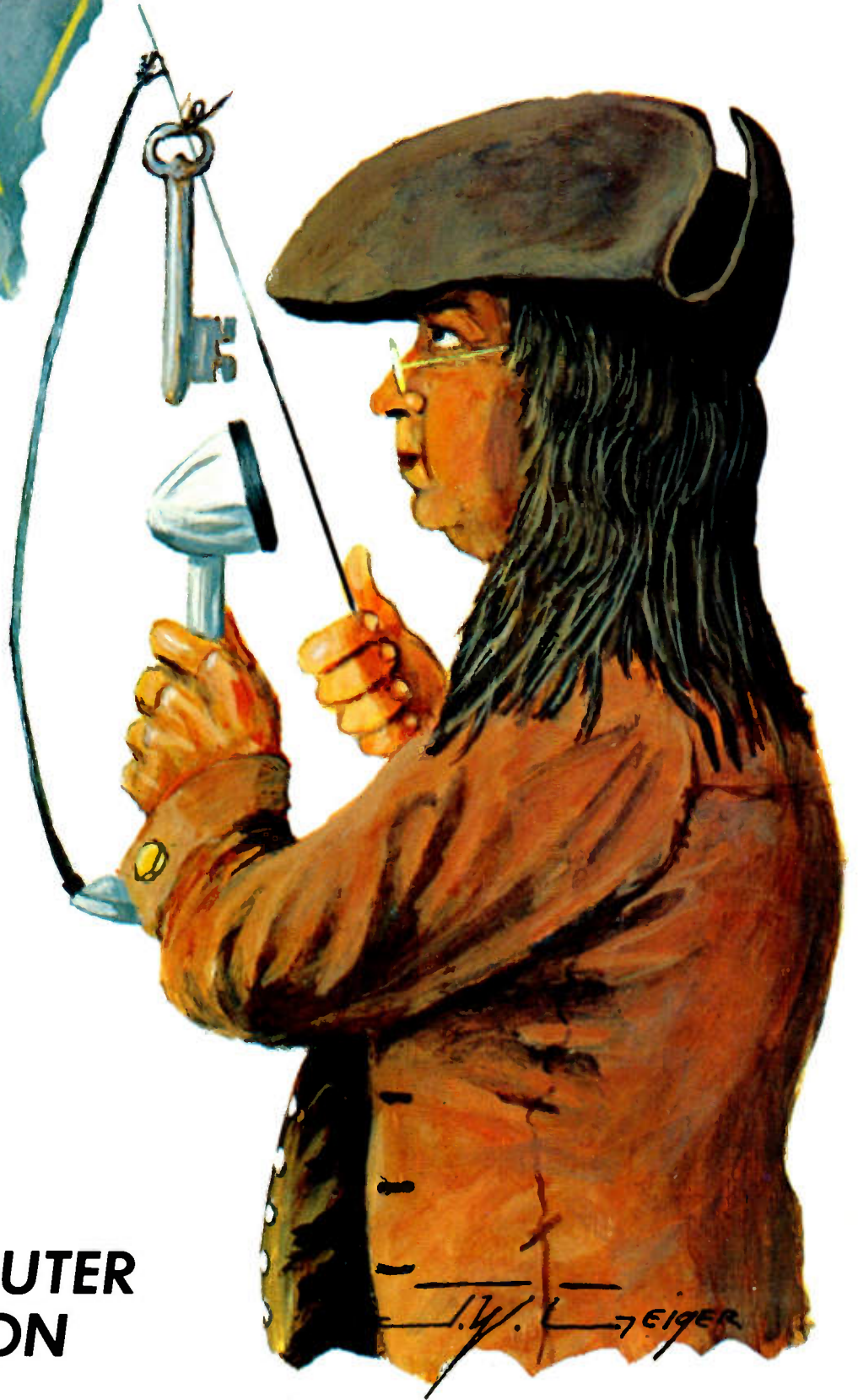

think of yourself as an  
**antenna expert!**  
 —you select your components!

**1** Get optimum performance band for band. Choose from medium or high power resonators for your favorite bands.

**2** Fold over, 360° swivel mast for quick band change or easy garaging. Select from two versions, fender/deck or bumper mount location.

**3** Stainless steel ball mount, 180° adjustable, commercial duty for superior mechanical and electrical performance.

**4** Get exceptional reports, broadest bandwidth, lowest SWR. Use with any convenient length 50 ohm coax. Matching devices not required.

**5** For convenience, use the Hustler stainless steel resonator spring, and special design quick disconnect.

...and you'll mobile with the experts' foremost choice...



Get fixed station reports from your mobile—operate 6-10-15-20-40-75 or 80 meters with the experts and join the vast majority using Hustler for nearly two decades.



Model SSM-2 Ball Mount



Model BM-1 Bumper Mount



Model QD-1 Quick Disconnect



Model RSS-2 Resonator Spring



Model L-14-240 MII Spec 50 Ohm Feedline



Model MO-1 For Deck or Fender Mount Location



Model MO-2 For Bumper Mount Location



Super Resonators RM(S) 2 KW PEP Greatest Coverage



Standard Resonators RM 400 Watts PEP

"the home of originals"



Available from all distributors who recognize the best.

**new-tronics corporation**

15800 Commerce Park Drive  
 Brookpark, Ohio 44142  
 (216) 267-3150

HUSTLER ANTENNA PRODUCTS—for sixteen years—original designs—created and manufactured by American ingenuity, labor and materials—used by communicators throughout the world.

Hustler designs are patented under one or more of the following assigned to New-Tronics Corporation 3287732, 3513472, 3419869, 3873985, 3327311, 3599214, 3582951.



Miniature Drawn Box



INTERLOCKING TYPE



JIFFY BOX

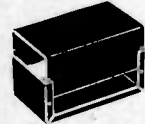

FLANGE LOCKING TYPE



Slide Cover Box

# LMB

Exclusive specialization in original precision engineered box chassis, chassis, cabinets, panels.

A size, type and shape for every application. LMB box chassis are designed and built by engineers.

*The Better Box for Better Results IN*

**ELECTRONICS  
TELEVISION  
COMMUNICATION  
DEFENSE  
INDUSTRY**

**RADIO  
AVIATION  
AUTOMOTIVE  
GOV'T AGENCIES  
HOBBY**

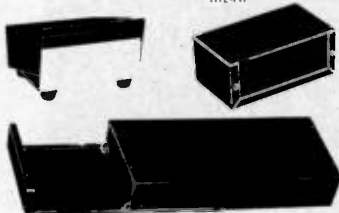

## STRICTLY FOR PERFORMANCE

### RINGO RANGER

**BASE  
STATION  
HAM  
ANTENNA**  
4.5° - 6.0° dB  
GAIN

ARX-2, 137-160 MHz  
ARX-220, 220-225 MHz  
ARX-450, 435-450 MHz

\* Reference 1/2 wave dipole  
\*\* Reference 1/4 wave whip used as gain standard by many manufacturers.

... designed by  
professionals  
to professional  
standards!

... smart in looks, practical in design, light in weight, exclusive in matching and phasing system, the ultimate in "capture area" ... we call RINGO RANGER, "Mr. Prof" This offers hams a superior omni-directional base station antenna with a very low angle of radiation for higher gain and extended coverage. Easily mast or tower mounted. In stock worldwide with your distributor.



## There's a unit of DRAKE gear just right for any ham...

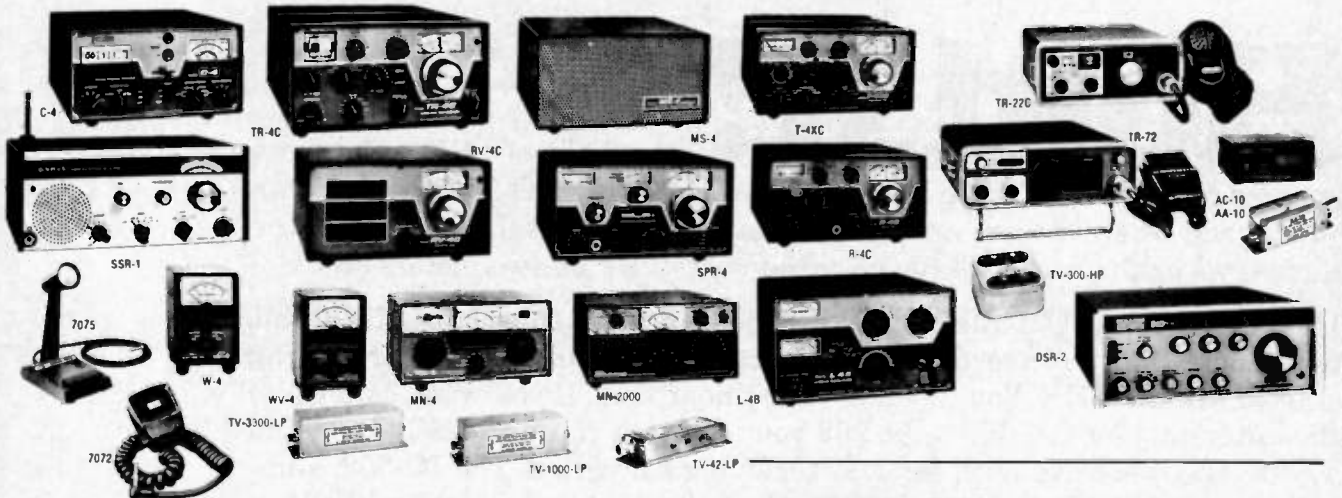

### COMPLETE LINE OF ASTATIC MIKES

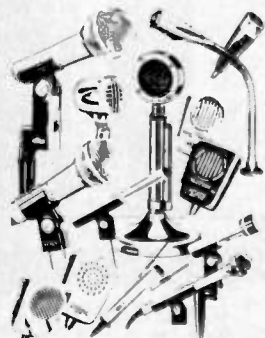

## Mosley ANTENNAS

TRAP MASTER 33...10, 15 & 20 Meters

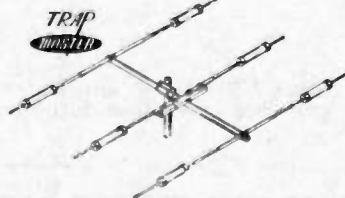

Complete Mosley  
Line of Antennas

## HF FIXED STATION FOUR BAND VERTICAL ANTENNA

Covers 10 - 15 - 20 - 40 Meters  
Only Hustler Gives One Setting for  
Whole Band Coverage

### MODEL 4-BTV

- Lowest SWR—PLUS.
- Bandwidth at its broadest! SWR 1.6 to 1 or better at band edges.
- Hustler exclusive trap covers "Spritz" extruded to other-wise unattainable close tolerances assuring accurate and permanent trap resonance.
- Solid one inch fiberglass trap forms for optimum electrical and mechanical stability.
- Extra heavy duty aluminum mounting bracket with low loss — high strength insulators. Mounting hardware included.
- All sections 1 1/2" heavy wall, high strength aluminum.
- Stainless steel clamps permitting adjustment without damage to the aluminum tubing.
- Guaranteed to be easiest assembly of any multi band vertical.
- Antenna has 3/8" 24 stud at top to accept RM-75 or RM-75-S Hustler resonator for 75 meter operation when desired.
- Top loading on 75 meters for broader bandwidth and higher radiation efficiency!
- Feed with any length 50 ohm coax.
- Power capability — full legal limit on SSB or CW.
- Mounting: Ground mount with or without radials, or roof mount with radials. Length: 21'5" Weight: 15 lbs.

MODEL 4-BTV

\$79.95

AMATEUR RADIO IS OUR BUSINESS

68 N. York Rd., Willow Grove PA 19090  
Phone: (215) 659-5900

CALL OR WRITE FOR BEST DEAL



# "HAM" BUERGER



# Hold it!

Take hold of SSB with these two low cost twins. ICOM'S new portable IC-202 and IC-502 put it within your reach wherever you are. You can take it with you to the hill top, the highways, or the beach. Three portable watts PEP on two meters or six!

**Hello, DX!** The ICOM quality and excellent receiver characteristics of this pair make bulky converters and low band rigs unnecessary for getting started in SSB-VHF. You just add your linear amp, if you wish, connect to the antenna, and DX! With the **202** you may talk through OSCAR VI and VII! Even transceive with an "up" receiving converter! The **IC-502**, similarly, makes use of six meters in ways that you would have always liked but could never have before. In fact, there are so many things to try, it's like opening a new band.

Take hold of Single Side Band. Take hold of some excitement. Take two.

#### IC-202

2 Meter SSB • 3 Watts PEP • True IF Noise Blanker  
Switched Dial Lights • Internal Batteries • 200KHz  
VXO Tuning • 144.0, 144.2 + 2 More! • RIT!

#### IC-502

6 Meter SSB • 3 Watts PEP • True IF Noise Blanker  
Switched Dial Lights • Internal Batteries • 800KHz  
VFO • RIT!

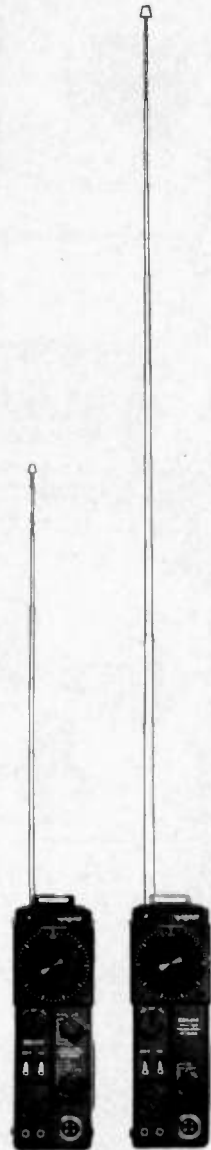

VHF/UHF AMATEUR AND MARINE COMMUNICATION EQUIPMENT

Distributed by:



# ICOM

**ICOM WEST, INC.**  
Suite 3  
13256 Northrup Way  
Bellevue, Wash. 98005  
(206) 747-9020

**ICOM EAST, INC.**  
Suite 307  
3331 Towerwood Drive  
Dallas, Texas 75234  
(214) 620-2780





#187 MAY 1976

The Magnificent Sevens Microhelix .....16  
 An Allband Inverted Vee .....22  
 Squaring the Conical .....24  
 Secret Antennas for Cliff Dwellers .....26  
 The Novice Inverted Vee .....30  
 Closed Loop Antenna Tuning .....32  
 The 75-80m Broadbander .....34  
 The Magic of a Matchmaker .....38  
 How to Coax Your Antenna .....40  
 40m DXing — City Style .....42  
 The Secret 2m Mobile Antenna .....44  
 An Inverted Vee for 160/80m .....46  
 The Dipole Dangler .....48  
 Amateur Weather Satellite Reception .....52  
 Scan Your HR212 .....66  
 Computer Languages — Simplified .....70  
 A Very Cheap I/O — the Model 15 .....77  
 Code Converter Using PROMs .....84  
 A Nifty Cassette-Computer System .....88  
 Is Digital All That New? .....94  
 The Ins and Outs of TTL .....96  
 Build a CW Memory .....102  
 AM is not Dead — It Never Existed at All .....110  
 Is Extraterrestrial Communication Possible? .....114  
 5/8 Wave Power for Your HT .....118  
 Strobing: Gone in a flash ... only to return .....120  
 It Happened to Me .....132  
 555 Timer Sweep Circuit for SSTV .....134  
 Tech Manuals .....140  
 RF and Mod Monitor .....142  
 A Failure to Communicate .....143

4 Never Say Die  
 6 Letters  
 11 Looking West  
 13 Contests  
 64 Oscar Orbits  
 64 Ham Help  
 69 I/O Editorial  
 116 Ancient Aviator  
 124 New Products  
 126 Briefs  
 148 Docket 20686  
 148 Hamburglar  
 160 Reader Service  
 160 Propagation

COVER: Oils on masonite, by Jerry W. Geiger, Delafield WI.

### NOTICE TO READERS

**IT IS A CRIMINAL VIOLATION OF FEDERAL LAW AND OF THE LAW OF MANY STATES TO USE ANY INSTRUMENT, DEVICE, OR SCHEME TO OBTAIN ANY TELEPHONE SERVICE WITHOUT PAYMENT OF THE LAWFUL CHARGES THEREFOR. IT MAY ALSO BE A CRIME TO PROVIDE INFORMATION THAT IS USEFUL FOR SUCH PURPOSE UNDER CERTAIN CIRCUMSTANCES TO ANY PERSON, INCLUDING THE INFORMATION APPEARING IN THE ARTICLE BEGINNING AT PAGE 67 OF THE JUNE 1975 ISSUE OF THIS MAGAZINE.**

**WE HAVE BEEN NOTIFIED BY THE BELL SYSTEM THAT SUCH VIOLATIONS ARE VIGOROUSLY INVESTIGATED AND PROSECUTED. ACCORDINGLY, YOU ARE URGED TO DESTROY ANY DEVICES YOU MAY HAVE WHICH VIOLATE ANY OF THESE LAWS, INCLUDING ANY DEVICES BASED IN ANY WAY ON THE MATERIAL APPEARING BEGINNING AT PAGE 67 OF THE JUNE 1975 ISSUE OF THIS MAGAZINE.**

**THIS STATEMENT IS BEING PUBLISHED BY ORDER OF THE SUPERIOR COURT OF THE STATE OF CALIFORNIA WITH THE CONSENT OF THE PUBLISHER OF THIS MAGAZINE.**

*73 Magazine (where the action is) is published monthly by 73, Inc., Peterborough NH 03458 (a good place to live). Subscription rates are a ridiculously low \$10 for one year worldwide, \$17 for two years, and \$17.76 for three years (the buy of the year?). Second class postage paid at Peterborough NH 03458 and at additional mailing offices. Phone: 603-924-3873 (hey, don't call much after 4:30 pm EST, okay?). Microfilm edition — University Microfilms, Ann Arbor MI 48106. Tapes — Science for the Blind, 332 Rock Hill Rd, Bala Cynwyd PA 19004. Entire contents copyright 1976 by 73, Inc. INCLUDE OLD ADDRESS AND ZIP CODE WITH ADDRESS CHANGE NOTIFICATION.*



# 73 staff

**EDITOR/PUBLISHER**  
Wayne Green W2NSD/1

**GENERAL MANAGER**  
Biff Mahoney

**MANAGING EDITOR**  
John C. Burnett

**ASSISTANT EDITOR**  
Susan G. Philbrick

**ASSOCIATE EDITORS**  
Alex Barvicks WB4RVH  
Fred R. Goldstein WA1WDS

**PRODUCTION MANAGER**  
Lynn Panclera-Fraser

**ART DEPARTMENT**  
Nancy Estle  
Peri Mahoney  
Michael Murphy  
Bob Sawyer

**PRINTER**  
Brent Lawler

**PHOTOGRAPHY**  
Bill Heydolph

**TYPESETTING**  
Barbara J. Lattl

**ADVERTISING**  
Bill Edwards WB6BED/1  
Nancy Cluff

**COMPTROLLER**  
Knud E. M. Keller KV4GG/1

**CIRCULATION**  
Barbara Block  
Susan Chandler  
Frances Dillon  
Dorothy Gibson  
Florence Goldman  
Pearl Lahey  
Marge McCarthy  
Judy Waterman

**MARKETING**  
Sherry Smythe

**INVENTORY CONTROL**  
Kim Johansson  
Marshall Raymond

**PLANT MAINTENANCE**  
Bill Barry

**ASSOCIATES**  
Robert Baker WA1SCX  
E. H. Barnett WB0IIX  
Schley Cox WB9LHO  
Tom DiBiase WBBKZD  
Terry Fox WB4JFI  
W. Sanger Green  
Dave Ingram K4TWJ  
Joe Kasser G3CZC  
Bill Pasternak WA6ITF  
John Schuttz W2EEY/K3EZ  
Waller Scott KBDIZ  
Peter A. Stark K2OAW  
Bill Turner WA0ABI

**DRAFTING**  
Bill Morello  
Lynn Malo  
T. M. Graham Jr. W8FKW



NEVER SAY DIE

# ...de W2NSD/1

EDITORIAL BY WAYNE GREEN

### MISSING ADVERTISERS

Many readers have been writing in to ask about specific manufacturers whose ads have not been running in 73. Since 73 has more ads than any other ham magazine ... and since the 73 policy is to refuse ads to unreliable firms ... firms which are advertising in other ham magazines even though the publishers know they are unreliable ... readers ask, to make sure, whether such and such a firm has been refused ads in 73.

Several readers have asked about Eimac recently. Eimac advertises in the other three ham magazines, but not in 73. As far as we know the reason for this is that Eimac is trying to put pressure on 73 to run non-controversial editorials. No one in the industry is going to force 73 to run or not to run anything, including editorials, and we at 73 think that this attempt to use economic power to influence the press is a serious matter. Read the editorials in the other ham magazines and decide for yourself how successful Eimac has been ... not a controversy in a carload.

We at 73 think that thought-provoking controversy is healthy for amateur radio ... and we know with a certainty that it is healthy for 73. 73 is published for the readers and will continue to be responsive to the readers, not manufacturers who try to buy what they think should be in the magazines. Ads should be run for the purpose of selling products, not for forcing the manufacturer's views on the editor.

Eimac is big enough and independent enough of the ham market so they can do very well with or without ham magazine advertising. This puts them in a good position to throw weight around ... weight which few magazine publishers can afford to ignore.

About the only difference to the average 73 reader is that each issue of the magazine is just a few pages thinner ... perhaps there is one less article as a result of the Eimac boycott.

Another missing advertiser, of late, has been EBC. We at 73 felt that the EBC rig did not meet the published specs and held up further ads until the situation was cleared up. Recent reports are that EBC had cleared up the problems with the rig so as soon as this can be verified by a test of a new

rig with all the latest mods, EBC may be back in 73 again.

Missing ads like that are expensive both for 73 and for the advertiser, so ads are not held up frivolously.

### MORE HAMFESTS?

If local hamfests were better promoted to bring in CBers and other prospective hams instead of just being geared for the entertainment of those already licensed, we might be able to bootstrap more chaps into our interesting hobby.

Hamfests can be run for a profit, you know. Those interested in finding out details on how to make big money out of hamfests should get in touch

with Leonard Norman ... an ex-ham (the FCC took away his ticket) ... who has been running 'em for years in Las Vegas. Write to him at his convention headquarters in Boulder City, Nevada or, if there is any problem, get his Boulder City office address from *Ham Radio Magazine* in Greenville NH ... they are very close to Norman.

Commercialism can go too far, of course, so you have to be careful about this. If you charge for manufacturer booth space, for admission, for technical talks, dinners, cocktail parties, and everything, you may find interest dropping. You may be able to get away with having a manufacturer pay for a cocktail party ... and then

*Continued on page 100*

### HINT OF THINGS TO COME?

*Is this a new CB magazine? Thanks to Marc Leavey WA3AJR for spotting this "new" QST cover.*

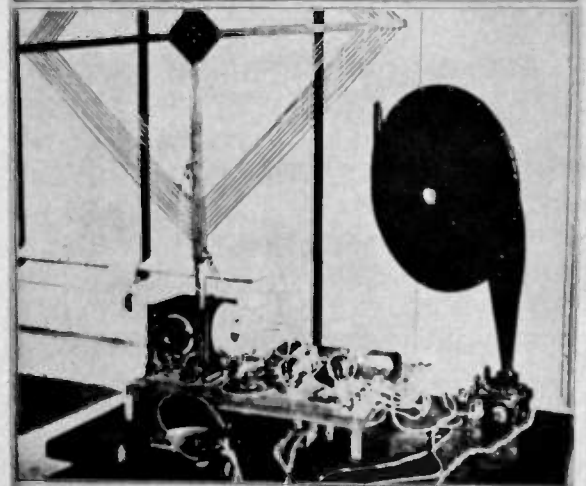

The Armstrong Super-Regenerator—This Issue

AUGUST '22

20¢



**either way is the  
right way**

**...they're both  
KENWOOD**



## the TR-2200A

*Kenwood's high performance portable 2-meter FM transceiver... completely transistorized, rugged and compact.*

12 channel capacity. Built in telescoping antenna can be easily replaced, or stored in carrying case. Connector for external antenna also. External 12 VDC or internal ni-cad batteries, complete with 120 VAC battery charger. 146-148 MHz frequency coverage. 12 channels, 6 supplied. Battery saving "light off" position. Hi-Lo power switch (2 watts - 400 mW). Sensitivity: 0.5 uV or less/26 dB S+N/N. Built-in speaker. Size: 5-3/8" x 2-5/16" x 7-1/8", 3-3/4 lbs. Complete with Dynamic mike, O-T-S carrying case, all cables, speaker/headphone plug and 10 Ni-Cad batteries. Amateur net... \$229.00.



## the TR-7200A

*Kenwood's superb 2-meter FM mobile transceiver. Designed to withstand the most severe punishment while providing consistently excellent performance.*

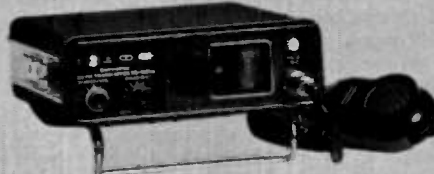

Packed with features like the PRIORITY function... Put your favorite crystals in channel 7, and the

7200A automatically returns to that frequency when it senses activity there. 146-148 MHz coverage, 22 channels, 6 supplied. Completely solid state. Voltage required: 13.8 VDC. Antenna impedance: 50 ohms. Frequency adjusting trimmers on every crystal. RF output power: 10 watts (or 1 watt at low power). Adjustable frequency deviation (factory set at  $\pm 5$  kHz). Automatic VSWR protection. Receiver sensitivity less than .5 uV for 27 dB. Selectivity: 12 kHz/-6 dB and 24 kHz/-70 dB. Size: 7-1/16" W x 2-3/8" H x 9-7/16" D, 5-1/2 lbs.

Complete with dynamic mike, DC power cord, mobile mount, mike hanger, auxiliary connector and external speaker plug. Amateur net... \$249.00.

The perfect companion to the TR-7200A is the PS-5 AC/DC power supply. Together they provide an efficient and handsome base station. The PS-5 is complete with a digital clock and automatic time control feature built in. Amateur net... \$79.00.

TRIO-KENWOOD COMMUNICATIONS INC.  
116 EAST ALONDRA/GARDENA, CA 90248

 **KENWOOD**  
...pacesetter in amateur radio

ou goons don't ever proofr  
loasy man scripts from bab  
bunch of trocks preening on  
you ignored my comments in  
I insist that you print ev

## ROCKY MOUNTAIN HIGHS

Aspen was a blast — all that we expected and then some! We all regretted leaving there, that's for sure. I skied solidly for six days, starting Sunday, January 11, on the four 11,000-foot mountains — Aspen, Aspen Highlands, Buttermilk and Snowmass — and found them all superb. Aspen village is located at the foot of Aspen Mountain and Aspen Highlands, and Snowmass was about 12 miles away.

Chuck WA1KPS, Wayne W2NSD, and Pete WB9FLW from Illinois took lessons on Buttermilk most of the week and I skied with Eric WA1HON from Lincoln, Mass. We did our damndest to ski everywhere, but were lucky just to hit every lift on the mountain for one ride during the day. That's how many lifts there were and how big the mountains were! Most of the trails were very wide, sweeping down the mountainsides. Sugarloaf in Maine has, in my opinion, the only trails in the Northeast at all comparable and it's less than half the size of, say, Snowmass. The weather was clear almost every day we were there, with the exception of Monday when we had snow flurries. The scenery was simply majestic with snowcovered mountains and valleys visible in every direction. The temperature during the day ran from 15 or 20 degrees to about 30 to 40 degrees by the end of the week. Because of the altitudes

(Aspen village is 8000 feet — almost 2000 feet higher than New England's Mount Washington), we'd get winded easily; I came up puffing just from bending down to buckle my boots.

We all carried 2 meter FM walkies and had fun chatting together on "52 direct" between mountains while riding up on the chair lifts. No repeaters yet in Aspen — wait until *next* time! Chuck brought along an Atlas SSB transceiver and Dentron tuner and we had a batch of 75m QSOs using an end-fed "long wire" hung on the hotel balcony one dark night.

Our hotel was very nice as expected — very convenient, located between the two chair lifts at the foot of Aspen Mountain, about a block from the nearest lift and a block from the bus stop from where the free bus shuttles ran to all the other mountains. After skiing each day, we jumped into the hotel's heated pool for awhile. Boy, that hot water was great for the aching muscles after 6-7 hours of skiing! Fun to float on your back and look up at the stars or snowflakes, whatever. Then, into the sauna to sweat for a bit in its 230 degree temperature. We all got together for supper every night, which was a "peak" experience of the day, since, although the town has a population of 7000 to 8000, it has 80 restaurants and nightclubs and we went to a different gourmet restaurant each night. Supper would last a couple of hours, then maybe we'd look in on a nightspot briefly, and off to bed.

The restaurant prices were a bit high — as was everything else in town — usually supper cost around 15 bucks apiece. But the food and service were superb.

We did encounter several unpleasant situations, unfortunately. We had a beautiful flight out to Denver from Boston on Saturday, January 10th. Chuck, Eric and I met Wayne W2NSD, fresh in from the SAROC hamfest, at the Denver airport. That's where our troubles began. Seems that the little airline which was to fly us the 200 miles out to Aspen had sold at least two tickets for every available seat. Things were totally screwed up when we arrived with a lot of people standing around getting unhappier by the moment and the airline people acting unpleasant about the whole thing. Wayne finally managed to get on a plane and leave for Aspen, but not the rest of us. After we'd been there about 4 hours, we said the hell with it, cancelled our tickets, had a heckuva time reclaiming our bags and skis, rented a car and set out about 7 pm to drive to Aspen, in spite of warnings about icy roads and snow-blocked mountain passes. Fortunately, the weather was fine, and with good moonlight, the visibility was excellent. Immediately west of Denver, which is 5000 feet, you climb into the mountains and we drove over a couple of 11,000-foot passes, a fantastic drive. Passed the Loveland ski area, the top of which seems to be above timberline, then through Vail which is a mass of condominiums tucked in a narrow, deep valley, and some other big ski areas I don't remember the names of. Finally, about midnight, we left the main highway west, and drove the last 40 miles or so south to Aspen, arriving about 1 am. We finally found the hotel after plowing through masses of party-goers (that's Aspen *every* night!) and off to bed. Up early and off to Buttermilk for a super first day of skiing in foot-deep powder and balmy weather. When we returned to the hotel, Chuck and Wayne's room had been robbed: tape recorder, still and movie cameras, airline tickets, and a 2m walkie — in all about \$2000 worth. Three days later, Pete WB9FLW from Illinois, who had joined our group, had his room robbed. There were several other thefts from our hotel during the week. Chuck caught a bad cold and was unable to ski for the last two days. On a few occasions, we were

overcharged for meals, but our sharp eyes caught the errors.

It was a great vacation and my skiing here in New England can now be described as only second-best. You can't believe how much fun it is to run those big beautiful trails out there — even the moguls are bigger — can you visualize Cannon Mountain's Zoomer or Polly's Folly trails half to three-quarters of a mile long or even steeper? Or skiing a trail even longer without seeing one mogul? Or being scared stiff while riding a chair lift up an 11000-foot high narrow ridge — just wide enough for chair lift and ski trail underneath and looking down sheer cliffs on either side? I was in terror on that one, located at the top of Aspen Highlands. Rode it a second time to see if I was still scared — I was . . . Or the beauty of the snow plume blowing off the 14,000 footer up the valley between Buttermilk and the Highlands. Or the memory of stopping high up on Aspen (Ajax) Mountain late in the afternoon and looking down at the village a couple of thousand feet below. Or the sheer fun of running the open snow fields near the summit of Snowmass, called the "Big Burn," due to a fire which cleared most of the trees from the area years ago. Still an occasional tree there to dodge in the half-mile wide ski "trail." One can get spoiled fast with this kind of a mountain.

So, inevitably, it all came to an end. On the 17th, we caught the shuttle bus to the airport near the foot of Buttermilk, packed into the little twin-engined Otter aircraft — big enough for 19 passengers, and climbed out over the Aspen valley en route to Denver, about an hour away. No cabin pressurization — my fingers turned blue, Wayne appeared to be slumped over up forward. Scenery below was superb. Then, big DC-10 Airbus to Boston — 2 seats wide on either side plus 4 seats in the middle. Landed a little after 6 local time and found it bitter cold and windy in Boston. Home about 8, vacation over. I'd like to give some credit where it is due — first to Wayne and Chuck for the whole idea last summer, to Rocky Mountain Airways who provided us the inspiration to drive from Denver to Aspen (I wonder whatever happened to the 47 anxious folks ahead of us in the Rocky Mountain queue at Denver), to the Continental Inn at Aspen where the accommodations were excellent, but had unsolicited room service (the burglars), and to amateur radio itself which got me going on the best vacation imaginable for this ham skier.

Sandy Cole W1PVF/1  
Concord MA

## HI YOURSELF

Just received your new 73 format. I don't like it. Looks like mid-winter Sears sale catalog. Hi.

Jack Kulish K7YNY  
Stanford MT





## WHAT SERVICE!

I would like to tell you how pleased I am with one of your advertisers. I mailed two separate orders at different times to James Electronics. Both orders were mailed on Sunday and received back in my mail box the following Saturday. What service! Also I received 100% of what was ordered. No back orders, no substitutions, and no oversights. You can't believe how easy this makes building a project. Others are still waiting to receive their B/Os or missent parts.

Harry R. Clement  
Des Moines IA

I recently placed orders with three of the advertisers in the pages of 73: S. D. Sales, James Electronics, and A P Products, Inc.

All three of the orders were received complete, exactly as ordered, within 10 days of my mailing of the orders!!! This is fantastic!!! S. D. Sales even included a free package of LEDs, which is unheard of when dealing with the large suppliers.

I'm sure I am not alone in saying THANK YOU to you and the advertising staff of 73 for making it possible for these relatively small companies to become known to your readers. I think that it is unfortunate for amateur radio that the January 1976 issue of *OST* contained only one advertisement from a small parts supplier which, incidentally, was not one of the three listed above.

Please continue with your work at 73 in the same vein as you have been. We may not always agree with your viewpoint, but at least you do make your readers aware that there occasionally can be justifiable, sensible and rational alternatives to the ARRL position on various matters. Thanks for the originality of 73!

Louis A. Hodges W9LMI  
Chester IL

*Thanks, Louis — I do like to hear about good experiences with advertisers. I also want to hear immediately about any bad experiences with our or other magazine advertisers. I have been known to raise hell over things like that. 73 loses a lot of money every month by refusing to accept ads from firms running ads in QST, HR and CQ... I need to know who the good guys are and who the bad guys are... and I want to know when they change their spots. Re my editorials... I get a big laugh out of a few manufacturers who won't advertise in 73 because they think this will force me to run QST-type editorials... that's dumb. I write my stuff to get the juices running and whether I believe what I write or not is irrelevant. I want readers to think and have some fun. Oh, a few get up tight... but you know, oddly enough, I get virtually no letters to the editor which I could use instead of my editorials to get readers thinking... pity, for I'd rather be out skiing than writing.*

*Without controversial ideas, 73 would be just like the other ham magazines... and you wouldn't want that — Wayne.*

## KEEPING PACE

K8YYP's request for heart pacer information reminded me that others having or contemplating a pacer installation might benefit from a cassette tape made by VE7QQ, another pacer recipient.

Sadly, Ken VE7QQ died from other causes. However, I will make a copy of his interesting recording, at cost, for those interested.

Yes, I contacted K8YYP.

Gene Brizendine W4ATE  
Huntsville AL

## EXCEPTIONAL OAKLAND

In light of recent editorial comments about repeater operations, we feel that certain points should be brought to light. In our area, we have a repeater (of which we are both control ops) which *does* provide a source of intelligent discussion and which *does* provide first rate emergency service. We are speaking of WR2ABN (10/70) in Oakland, N.J.

We have both had the privilege to monitor and to participate in serious discussions of music (both classical and jazz), astronomy, astrology, religion and philosophy on this repeater in the evening hours, and have found these discussions most stimulating.

Likewise, the Oakland 10/70 machine regularly handles more emergency traffic in a week than any of the repeaters listed in that other magazine do in a month, a fact which we intend to publicize further. In addition, in every instance of bad driving conditions in the metro North Jersey/New York City area which has occurred in the past year, WR2ABN has been used almost continually throughout the period as a clearing house for road and weather information, with formal net control and monitoring of the National Weather Service reports and local police channels to provide greater assistance. Travelers in and through our area know that, if they should need assistance or encounter an emergency during the normal operating hours of the repeater, they need only put out a call for help and someone will come right back to them.

In contrast, local Citizens Band is almost impossible as far as transmitting a readable message through the din is concerned. The total discourtesy and lack of concern for any sort of operating standards is the rule here on CB. In much monitoring, we and others have yet to hear an emergency report on CB in this area, even on Channel 9, because that too is usually clogged with multiple QSOs all interfering with one another.

In short, we do not really wish to

disagree with your premises entirely, although we have both encountered other machines elsewhere which are also most helpful, but rather to point out that, in our area, WR2ABN is an exception to the sentiments expressed in recent issues.

Page E. Taylor K2QAR  
Butler NJ  
Russell J. Edmunds WB2BJH  
Kinnelon NJ

## QUICK AND CHEAP

Suggestions from a pre-Novice — Include projects on a regular basis that can be constructed cheaply and would help a Novice to get on the air. Examples: T-R switches, CW transmitters and receivers, quick and cheap antennas, etc.

If we are to attract new people to amateur radio we need attractive projects that can be built quickly, from readily available parts, and give the builder an immediate sense of participation in radio. Construction projects for Novices are all too often built and designed by amateurs with years of "junk box" materials and experience at hand. Novices, on the other hand, have no used parts, no familiar sources of supply, and little or no schematic and construction experience.

The 5 band transmitter on pg. 125 of the Nov/Dec issue is a typical example. This transmitter is just what I'm looking for. However, the article does not include a complete parts list, has no wiring diagram that shows component placement, and makes no attempt to teach a Novice. The project could have included construction details, theory, suggestions for coupling with a receiver/antenna (T-R switch), and a single source that sold all parts.

The scope project on pg. 74 is much more complete, as it includes many of the details mentioned for a Novice project. Yet this project is written for far more advanced hams. Quick and cheap projects seem to get short and sweet space in magazines these days, yet if a beginner can't get started, he will move on to another field of interest — one that will gratify his needs and interest.

William Cook  
Alpena MI

## ROCKING HAM

I want to tell you how much that 13+ wpm code tape has really helped me. Believe me, I've only spent a total of less than 7 hours, and my speed is up to about 15 wpm!

I am 20 years old (soon to be 21). I took my Novice test in Nov. 1974 and got the license in Jan. 1975. Then 3 months later I was out of work for 3½ weeks because my place of work had to close for remodeling. So I "boned up" on the theory (even though I knew some radio theory) and the code. Then in April, 1975 (note the 3 months later!), I took the General and

Advanced on the same day and passed! I also used your tape at school in spite of the other kids giving me that weird look.

I also plan to go for my Extra class soon. I also agree that if you want that ham ticket, *earn it!* Don't sit around lazily and hope someone else will give it to you!

I now work 2 meters as well as HF, and would you know? These guys on 2 meters are beautiful and I love them! I've received a lot of help from them too, which I dearly appreciate!

I'm also planning to get up a rock group and call it "Larry WA4MJQ, And His Ancient of Days." Who knows? This may indirectly expose amateur radio to the public.

After reading some articles in 73, I also want to note that I've also had trouble with Trigger Electronics. However, I did get my money back through the intervention of the Postal Inspection Service.

I really like your magazine!

Larry S. Lawhorn WA4MJQ  
Richmond VA

## COMPUTERE(A)SE?

Keep the microcomputer articles coming...

Robert Brubaker K3UPK  
Lebanon PA

Thank you for stimulating our interest in computers.

What we need now is articles which tell us for what purpose we may use a computer.

What will a computer do for us in the home, the workshop, and the ham shack?

Tell us. It will help us to know the applications, and that would in turn be good for the industry.

Harry D. Minshew W6ZOW  
Hemet CA

*Right! Well, I can think of a lot of things I want to do with a computer, such as get a list of the times and antenna bearings for accessing Oscar 7... playing Star Trek, Twenty-One, Lunar Landing and many other games... keeping an index and list of all the recipes I like... an index to all of the ham articles of possible interest to me such as RTTY, SSTV, uP, FM... an index to my record and tape collections... a list of all the repeaters in the world... a list of all the DX stations I've contacted and the details about them, QSLs... my checking account... generation of SSTV pictures and art... generation of art on my color TV set... RTTY generation and contacts over the air using Baudot, ASCII or Morse Code... accessing other computers via Oscar 7... mailing list for some clubs I belong to... editing letters and articles which said computer then can print out... key word sorting RTTY short wave news broadcasts for anything concerning amateur radio... checking for any calls via any repeaters within range automatically...*

things like that. With two or three terminals most computers can do several tasks at once ... okay?  
— Wayne.

I will not forgive you for bringing a new interest into my life, just when I had decided that I had more than enough projects to keep me busy. A friend of mine, Dave K5WNV/7, has an Altair 8800 with 16K memory, CRT terminal and TTY I/O. Friday he brought home from Albuquerque one of their floppy disk units. Since I don't want to get in that deep and his unit is idle a good deal of the time, we have started a ham radio-computer project. We live 25 miles apart and he is going to send me the video output from his I/O port on 439.25 MHz and I am going to access the machine with an ASCII keyboard modulating a 147 MHz FM transmitter. At least that's the plan. We've applied to the FCC to use ASCII on two meters. Enough for now — I'll get Dave to write it up when we are up and running.

Rod Hallen WA7NEV  
Tombstone AZ

Sure like the new format, but am wondering about all the highly technical computer and digital articles you feature. I'm an Extra and schooled as an E.E., but this stuff is so far beyond me — only thing I understand is the title. I'm certainly for progress, but it seems many of these articles are way beyond the normal reader you may have. I take all four ham pubs — and like yours the best — but honestly it's leaving a good part of us in a cloud of dust. Respectfully submitted,

Lon C. Brickley W4AFS  
Pompano Beach FL

If you live in the metropolitan New Orleans area and are interested in computers, you are invited to join our group. Whether your interest is hardware, software, applications, or just general interest, we welcome your input. For further details please write or call me.

Emile Alline, Jr. WA5WUJ  
1119 Pennsylvania Ave.  
Slidell LA 70458  
504-641-2360

P.S. Keep up the good work — especially in translating "computerese."

### ENTERPRISE

Just finished building the Starfleet Communicator (February, 1976). Nice toy; the girls love it! However, I did have some trouble getting the little unit going, and so offer the following suggestions to those who have built, or will build, this device.

First off, use only a fresh, heavy-duty 9 volt battery when checking out the unit. Secondly, the voltage on pin 5 of IC1 (7493) should be fairly close to 5 volts. When I first tried the unit, the voltage on this pin was less than 4.5 volts, and the communicator

would not function. The problem could have been due simply to the characteristics of the various devices I used. The LEDs were from James Electronics (Model XC526), while the UJT was one contained in a package of 4 which was purchased at Radio Shack (Part Number 276111). Regardless, I lowered the 100 Ohm resistor in the 5 volt supply line to about 50 Ohms so as to obtain the proper operating voltage.

At this point, it was necessary to lower the 82 Ohm resistor in the gating line (pin 11 of IC1) to 39 Ohms, and to bypass pin 14 of IC1 with 0.3 uF (for noise suppression) before the unit would function.

Some other hints ... I built my unit in the case of an old transistor radio. This provided the case, a speaker, and a battery compartment all in one step. Further, not wanting to bother with the flip-up top, I simply mounted an SPST switch on the side of the case which is used to activate the communicator. Finally, I used ElectroCraft Model 35-414 push-button switches (miniature, momentary switches) for S2 and S3.

As I said, the unit is working and the girls love it (ages 6 and 7). Further, I learned quite a bit in the process of building it. Hopefully, with the above info, others will have an easier time getting their communicators going.

Ted Cohen W4UMF  
Alexandria VA

P.S. James Electronics is fantastic!!! Ordered some parts by mail on Saturday, and had them by noon, the following Wednesday!

### YL 73 73!

Recently Jim Ricks W9TO, inventor of the world-famous keyer, sent his young lady to pick up his auto tags. Completely by chance, his new plates read: YL 73 73!

Gene Brizendine W4ATE  
Huntsville AL

### BAD APPEARANCE

I recently learned a valuable lesson about automobile security. While parked in a hotel lot in Milwaukee, my car was broken into, and my broadcast radio, along with a good part of the dash, was stolen. This was not a tape machine, and an examination of nearby cars turned up several with better, more easily removable units. However, my car did have the bottom half of an HF antenna on the bumper. The police seemed to think that the thief was looking for CB units, and being unable to see through the frosted windows, broke in, and then took what was there. I guess the moral is avoid even the appearance of a rig in the car.

Alan P. Biddle WB9SQB  
Madison WI

### TYPING

I really enjoy your magazine. I'm planning to get my Novice license pretty soon. Do you think you could have a few how-to-do-it articles for the guy who is not too experienced. Thanks. So much for my typing.

Tom Rosicka  
Springfield OH

### THE QUEST FOR THE HOLY PR

Please eyeball the enclosed PR spot I landed in my local newspaper. I'm proud of it and you should be too, because WA4BDW's story in the Jan. 73 inspired its beginnings. You know this guy had a lot of nerve with his item #2, "Land a feature story in a local newspaper;" bit. But since the CBers get it done now and then I thought what the hell. So I wrote Bob Iverson (author of article enclosed) a letter and invited him over to the house to see what I had going. I baited the invite with things like Oscar, ATV and the like, and used the basic premise (per FCC R&R) that hams are around to provide emergency communications and enhance international goodwill. Note how that got in the first paragraph.

This story appeared on Sunday, Jan 18th in the Danville *Commercial News*, which is owned by a big outfit called the Gannett News Service. The local paper circulates better than 75,000 with Danville, Illinois the hometown of about 41,000 people.

You might be interested in knowing that I took about an hour to prepare for the reporter's interview by painstakingly bookmarking articles (especially ones with photos) from 73 and QST to back up everything in the story. My presentation took about 25 minutes, including questions from Iverson and the photo. It was topped off with a short QSO with WN4BSL in Owensboro, Ky. for effect. I might add that my presentation was very general and not at all technical, touching on a variety of things which I thought non-hamming, non-technical readers might like. Again, the basic premise was to make aware the existence of us in the event of a large scale disaster. Detente is in too, so hence the goodwill.

A local ham whom I've never met called to tell me that the story created a lot of interest on the 2 meter net and congratulations were offered on behalf of himself and all the locals. A very nice gesture, I thought, since this guy is a General and is into slow scan in a big way, which would have been nice for the mug shot.

At my place of full-time work, I was treated as somewhat of a man-of-the-hour and greeted by a programmer on the staff with "Who the hell do you know at the paper?" No one. At my place of part-time work, country FM station WIAI, the manager was very pleased and intended to send the owner of the station and the building

a copy of it. He lives out of town, in fact out of the county. This, despite the fact that WIAI is not mentioned in the article. I jock there on weekends, just in case you ever buzz around here, Wayne. 50,000 Watts 99.1 and good country music. What more could you want???

Anyway, that's my effort toward PR, and you and WA4BDW should be congratulated for the inspiration. But most of all, Bob Iverson of the *Commercial News* should be honored for his excellent writing and comprehension. After all, the reporters have to write these things and they really decide how well it's going to go over.

You know, I've read many articles telling us we need PR, but nothing about *how* to PR. Maybe you could help by telling us how to prepare feature article presentations, or HOW to set up booths at local CB jamborees or HOW to give demonstrations for school science classes. Some of us don't know how to organize our time or talk or any damn thing. I made my presentation without any idea how it would turn out. Lucked out I guess.

Well, so much for all this. Hope you enjoyed the clipping and thanks for listening. Also like the new mag format. It's about time.

Ted Osborn WN9PIQ  
Danville IL

P.S. Also, tell Mary she did a fine job with my Reader Service requests for this month.

### INFLATION

In reference to the January 76 issue of 73 Magazine. The article "County Hunting" by W2SDU quotes the price of Directory of Post Offices available from Government Printing Office under stock No. 3900-00242 at \$4.25.

Have just received the copy I ordered and find the correct price is now \$5.05 — the price quoted now being obsolete.

Earl Stacy K7BD  
Selah WA

### IN ENGLISH, PLEASE

In reference to your article "Stereo — A New Type of CW Filter," in the March issue, it doesn't take much imagination for RTTYers like myself to stick the Mark and Space scope monitoring audio outputs of the teletype converter into an inexpensive "hi-fi" stereo amplifier and tune for equal left and right separation of the FSK signal. Using stereo headphones gives you a pretty broad left-to-right audio "picture" of the signal so that centering the FSK around the crossover point is fast and very accurate. Note that QSBing of the Mark and Space frequencies does not effect the tuning sense you have as you bring the signal into proper position. This simple method of tuning FSK gives you a great sense of security, because

Continued on page 74



# KLM HF, VHF, UHF antennas penetrate the pile-ups!

KLM ... big, broad, super-performance line of beam antennas with the same "take charge" Big Stick leverage from forty meters to sevenfy centimeters! Covers the whole band.\* Cleaner patterns and lower VSWR are attributable to sophisticated designs featuring multiple driven elements, optimized between-element spacings and KLM's custom insulators.

Every KLM antenna ... HF through UHF ... is a carefully crafted product, engineered for maximum mechanical strength consistent with low weight ... is corrosive- resistive with stainless steel hardware and 6063-T832 aluminum ... uses high strength, low-loss insulation materials and castings.

Don't be second best in HF or VHF contests, Oscar, Moon bounce, tropo ... **penetrate the pileups with KLM antennas!**

\*KLM Model 432-16-LB covers 430-434 MHz only.

## KLM 70 CENTIMETER ANTENNAS

The fine series of UHF antennas consists of 6, 14 and 27 element high gain, broad coverage antennas (6 and 14 element types are rear mountable). All antennas (except the 432-16-LB) cover 420-450 MHz without need for tuning.

These are ideal, maximum gain antennas for point-to-point or repeater control applications. An available long boom 12' model, optimized at 432 ± 2MHz, is particularly desirable for EME and DX communications. Eight of these beams, using KLM high efficiency couplers are comparable to a 128 element, extended, expanded collinear array.

A typical antenna: (KLM-420-470-14)  
Elements: 14  
Gain: 11.5db (dipole reference)  
Beam width: 18 degrees @ 3db pts.  
Diameters: Boom: 1" (25.4mm)  
Elements 3/4"D (9.5mm)

## KLM 20 METER MONOBANDER

Do you operate both phone and CW and so are forced to compromise with higher VSWR on one or the other mode? Not with this KLM 20 meter monobander! Multiple driven elements and other KLM design exclusives, give broad-band action, low VSWR over 13.9 to 14.4MHz. F/B (and sides) ratio is excellent, gain is exceptionally high. (9.75 dipole reference). Impedance is 200 ohms balanced (matched w/KLM's 4:1 4KW p.e.p. balun (optionally available). Assembly is simple and fast.

Other KLM beams for 40, 15 and 10 meters feature dual driven elements for high gain, F/B ratio and low VSWR over both phone and CW band sections. Also, a 7 element log periodic w/26' turning radius, 30' boom (3", 76 mm) D that gives continuous coverage, 10-30MHz! Makes an excellent NO TRAP, 20-15-10 meter beam with gains equivalent to long boom, 3 element Yagi. Matches 50 ohm line w/4KW p.e.p. balun (supplied).

5 full size elements: Boom: 42', 3" (76mm)D.  
Turning radius: 28' Wgt: 65 lbs. (29.4KG)

## KLM 2 METER ANTENNAS

The antennas in this series will beat all comers! Individually, these antennas are doing a tremendous job where high gain, F/B ratio and low VSWR are important ... in VHF DX contests for example. Many are stacking them for moon bounce and tropo work using available KLM baluns and couplers. Included in the series are antennas with 7, 8, 9, 11, 12, 14 and 16 elements, all providing broad coverage. 143.5 to 148.5MHz (without tuning) plus exceptionally high gain.

A typical antenna: (KLM-144-148-14)  
Elements: 14  
Gain: 14.2db (dipole reference)  
Beam width: 18 degrees @ 3db pts.  
Boom: 208" (5283mm). Wgt.: 9 lbs (4 KG)

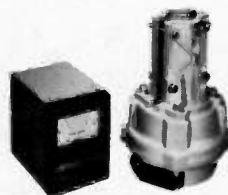

## NEW AZIMUTH ROTATOR

Ideal for most HF tribanders and VHF arrays. Medium duty w/electrical brake/limit switches. 1 minute/360 degrees. Rugged ... weatherproof. Attractive direction indicator.

## NEW ELEVATION ROTATOR

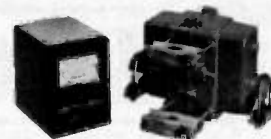

Use for OSCAR 6-7, Moonbounce, etc. Medium duty w/electrical brake/limit switches. 1 min./180 degrees. Rugged ... weatherproof. Attractive direction indicator.

At your dealers. Write for descriptive catalog.

# KLM electronics

17025 Laurel Road, Morgan Hill CA 95037 (408) 226-1780, (408) 779-7363



# the little surprise

The IC-22A has caused some pretty big surprises since it first started making waves in VHF-FM. Veteran operators have been delightfully surprised by its sophisticated styling and ease of operation; FM beginners, by its versatility, large number of possible channels, and its great value as a starter unit for FM transceiving; and all owners, by its unexcelled high quality construction and low maintenance problem record, ICOM traditions. The competition was in for a big surprise as it raced past everything in its field to become the most popular two meter crystal controlled radio on the market. Surprise. Surprise.

But the IC-22A's best surprise is the little surprise, its price. surprise. The little radio with all the big surprises is also the best FM transceiver value available. Engineered for versatility and sophistication: priced within the reach of the most modest beginner. Whether the IC-22A is your first FM or your last, you're in for a little surprise.



SEMICONDUCTORS	22
TRANSISTORS	4
FET	3
IC	16
DIODES	
FREQUENCY RANGE	146-148MHz
CHANNELS	22
MODULATION	Phase, F3
VOLTAGE	13.8 (15%)
SIZE	58x156x2305 (dim in MM)
WEIGHT	1.7 kilos

POWER OUTPUT  
BANDWIDTH (TRANSMITTED)  
MICROPHONE  
SENSITIVITY

INTERMEDIATE FREQUENCIES

MODULATION ACCEPTANCE  
RECEIVER BANDWIDTH

AUDIO POWER

HI 10 Watts, LO 1 Watt  
15KHz with 5KHz deviation  
DYNAMIC 500 Ohms.  
.4 microvolts for 20DB quieting  
.3 microvolts for 12DB SINAD  
10.7MHz First I.F.  
455KHz Second I.F.  
7KHz peak dev. freq. less than 3KHz  
+/- 13KHz more than -6DB  
+/- 23KHz more than -60DB  
1 Watt into 8 Ohms

VHF/UHF AMATEUR AND MARINE COMMUNICATION EQUIPMENT

Distributed by:



**ICOM WEST, INC.**  
Suite 3  
13256 Northrup Way  
Bellevue, Wash. 98005  
(206) 747-9020

**ICOM EAST, INC.**  
Suite 307  
3331 Towerwood Drive  
Dallas, Texas 75234  
(214) 620-2780

# Looking West

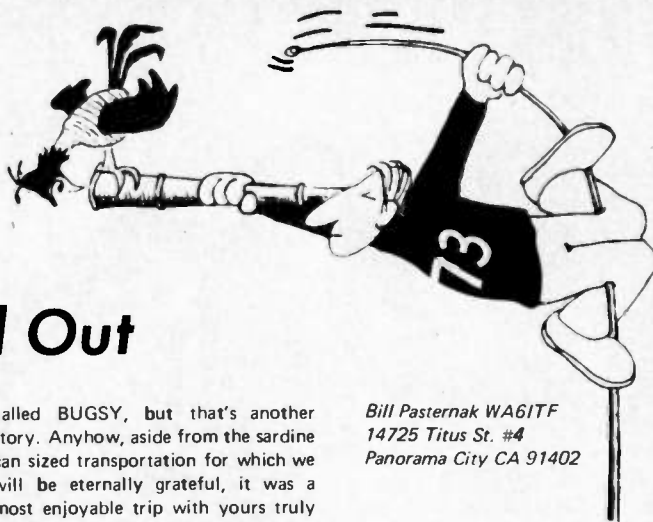

## A Dark Horse Will Out

Ever have a run of luck when nothing goes right? You know, when it seems like the gods have things stacked up against you. That's just the way 1976 began. Actually, it began in early December when some low creature decided that he needed my Icom IC-2F (serial #4893 if you happen to run across it) more than I did and went to the trouble of purloining said radio from under the dash of our '63 Cadillac. I said trouble, since it not being my nature to trust mounting brackets and such, I had drilled three holes through the top case cover and mounted the radio directly to the dash in as inconspicuous a spot as I could find. I guess the spot was just not inconspicuous enough and scratch one IC-2F.

On New Year's Eve I remember telling Sharon that '76 would be better than '75; it had to be. Was old ITF ever wrong! On New Year's Day afternoon, the oil pump in our '71 Torino let go and took the engine with it. Oh, the idiot light did come on ... after the car had chugged and grinded its way to a stop. My thanks to the many amateurs from both WR6ABB and WR6ABE that came to our aid and got us down to sea level from atop Muholland Drive, and a special thanks to George WA6MQM who is currently hard at work putting all the pieces together once more.

This morning, though, was the clincher. Though on its last legs, the old Cad was still running and I had to renew my driver's license. The Department of Motor Vehicles office is about a mile from here, so bright and early this am, I drove over and obtained my renewal. I was going to make a stop at one of my parts suppliers when I noted some steam from under the hood. Well, this car has had a water leak since I bought it, but it is always wise to check. Being almost at my house, I drove there and parked. Lucky I did, since it seems that the water pump and the radiator had given up at about the same time. Have you any idea what it's like to be sans wheels in Los Angeles? You cannot even get to the corner unless you have a car, and here I sit in our living room — the auto score, 2 down, 0 to go! Oh well! If '75 was bad, so far '76 could be classified as a disaster!

The Torino going down for repair came at the wrong time — just a week prior to SAROC. We had about given up hope of getting there when Rick WA6VSK offered us a lift across the Mojave to the fun city of Las Vegas. Three people and all the necessary luggage packed tightly into the confines of Rick's '72 VW bug. Reminds me a bit of a trip cross country in '70 with Lou K2VMR in his VW lovingly

called BUGSY, but that's another story. Anyhow, aside from the sardine can sized transportation for which we will be eternally grateful, it was a most enjoyable trip with yours truly playing pilot. It should be noted that this area is enjoying (and I use that term loosely due to the fire hazard now present) a very warm and dry winter season. In fact as I write this, it is Feb. 2, the temperature is almost 80 degrees and kids are out swimming in the apartment house pool. While slightly cooler, the weather across the desert and in Las Vegas was similar. Beautiful.

Since I described SAROC last year in some detail, I will not bore you again with the same story. Suffice it to say that SAROC is unlike any other amateur radio convention in that the city of Las Vegas rather than the convention itself is the top attraction. Las Vegas is a world in itself and one of my favorite vacation spots. I really think that Vegas should adopt the motto "Have Fun and Enjoy" since that's what the city is really all about. Even the "losers" often smile.

Our first stop upon arriving at the Sahara was of course the registration desk where we found out that our pre-paid reservations for that hotel had been transferred to the Thunderbird since the Sahara was full up. I was set to "blow a gut" when I

Bill Pasternak WA6ITF  
14725 Titus St. #4  
Panorama City CA 91402

remembered that the Mt. Wilson Repeater Association was to be hosting a "Hospitality Suite." A quick call on Rick's HT brought forth the melodious tones of Bill Orenstein KH6IAF/7. Bill advised me to "cool my head" and come up to room 4022, better known as the "Mt. Wilson Repeater Association Friendship Suite." This was the "Dark Horse" of which I spoke in the column header. While the theme of most hospitality suites at conventions is one of "party-party," this one was different. It was kept low key — a place to get away from the festivities and regroup one's head. You were greeted by the state flag of Hawaii as you walked through the door, with soft music mostly of Hawaiian origin playing in the background. It was just a tranquil spot in the middle of the confusion that is any convention.

The room was made possible through the cooperative efforts of the MWRA, Worldradio News and Midnite Radio. If one must single out individuals who were responsible for the overwhelming success of this



Capt. Dick McKay K6VEP (left) and Gary Wood WA6DTX (right) enjoy lunch with John Johnston K3BNS, head of the FCC's Amateur and Citizens Division.



Wayne and Sherry visit with Lon and Sybil Albright of SANDRA in SAROC FM Hospitality Suite.





Bill Orenstein KH6IAF/7 (left) and John Marin WA2IEU show Wayne WR6ALD/7 in MWRA Hospitality Suite.



Squeak's "drinkie-talkie" — never saw that option in a Motorola catalog!

special kind of convention hospitality center, there are two people that then deserve special mention. First, Bill Orenstein KH6IAF, this time /7, for conceiving the idea, doing the legwork and giving up just about all his time at SAROC to play host. However, all this work would have been for naught if it were not for the fine cooperation given the MWRA and Bill by the Sahara itself. This cooperation came in the form of Mr. Billy Snyder, Executive Host and Assistant to the President of the Hotel Sahara. Working together, the MWRA and the Sahara had one of the nicest "let's get away from the convention for a while" spots to be found. Heck, it was the only such spot aside from our room at the hotel. Yes, we finally did get one by the way, though we had to wait a while. I guess patience will out.

Now, as if all the above were not enough, there was more. The MWRA is a user support organization for the Mt. Wilson based WR6ABE repeater. Being one of the busiest repeaters in the nation, it was conceivable that a goodly number of its members would be attending SAROC. For this reason, it was decided that a portable repeater might just be in order. John Barreiro WA6HQL made available a modified Heathkit HW202 which was further modified, converted and completed as a repeater by Kirk Nemzer WB6EGR. It was set up "split-site" with the receiver and its antenna on the top floor of the hotel and the transmit site on the balcony of the MWRA hospitality room. How does one go about tying the two ends together so that a system such as this can function? The MWRA electronics crew made use of the "house" phone system, of course. Now the frosting on the cake. It is always good to have an ID of some type on a repeater and a special events repeater such as this naturally requires a special ID. Again thanks to Bill KH6IAF/7, the voice of Mr. Jerry Lewis could be heard on 146.40

stating, "Fooled ya! This is not WR6ABE Los Angeles; this is WR6ALD/7 at the Sahara Hotel, Las Vegas, just the other side of the Colorado River thingie. Ha hahhhh." To read it is not to hear it, and one must have heard it to have really appreciated it. A lot of us did. Thanks, Jerry.

This was not the only portable system to show up. The Palisades ARC of Culver City was there as usual with its portable .01/.61 system, that thanks to Neil McKie WA6KLA, performed at its high level of efficiency. One must remember that PARC was in the forefront of supplying their membership with portable systems of this sort for occasions such as this. Someone else brought a .93/.33 system, I understand, but that never really went into full time operation.

UHF was well represented, with a number of remote owners bringing their goodies along for use by their people. One system, a full-blown remote, came in all the way from New Jersey along with its owners John Marin WA2IEU and his brother Tom WA2IKB. But, this year it was the MWRA that really stole the show when it came to both hospitality and portable repeaters, and for this "Looking West" must give them the "Hats Off Salute" this year. They deserve it.

Surprises, you bet your sweet bippie. I guess that the biggest one to yours truly was the guy who walked into the FM Hospitality Suite Friday evening. None other than 73's very own Mr. Green himself. I was just standing there talking with someone when it was suggested by someone else that I turn around. Surprise! More like shock. Wayne, why don't you warn me when you are going to pull these surprise visits!

Anyhow, not long thereafter, in walks Bill KH6IAF and in short order, Wayne finds himself shanghaied up to the 40th floor to view the MWRA

suite and the WR6ALD/7 repeater. As you can see from the photo, I get the feeling that our "leader" was somewhat impressed. Unfortunately, it was to be a brief visit that we would have that evening, but in the time we had to talk I was able to catch up with what has been happening back East. Wayne was the smarter of the two; after our get-together he went "73s" for the evening. Me, I was up most of the night talking with this one and that one. How I ever made it to the FM forum and the FCC forum the next day I will never know. Thank heavens that someone developed the cassette tape recorder.

At this point I should really get into a discussion of what Johnny Johnston talked about at the FCC forum, and until about 48 hours ago that would have been exactly what I would have done. However, something very important has transpired within the last two days that deserves very special attention now. Therefore, we will continue with our coverage of SAROC and the FCC forum held there next month. Right now it is again "Giving Credit Where Credit is Due" time, and it is with a heck of a lot of pride that "Looking West" salutes the accomplishments of a great many Southern California amateurs who have spent the last few days working hand in hand with the Guatemalan Consul General to Los Angeles in relief efforts to that earthquake-ravaged nation.

For time reference, this portion of "LW" is being written on the morning of February 9; it is exactly a week since I began to write this and the blue skies and warm temperatures of a week ago have since been replaced by an unending torrent of rain. Winter — the winter we have waited for has finally arrived. It's 1:11 am and about an hour ago I finally returned home from Los Angeles International Airport where I had spent the last 8 or 10 hours. As a writer it is strange to find

yourself a part of your own story, but in this case it is what happened. I had gone to LAX to photograph and report on a rather unique and highly successful communication effort and within minutes found myself taking an active part in what was happening.

Problem: How do you get communication in and out of a country that has had most of its communication with the rest of the world severed by natural disaster? I guess you know the answer, since the answer is what we, the amateur radio community, are all about. Such was the situation in regard to Guatemala. Less than a week ago, that nation suffered a major earthquake that according to the latest network newscasts has taken 15,000 lives and effectively cut Guatemala off from the rest of the world save amateur radio. Though a number of area amateurs had been providing communication to Guatemala for the past few days, there had been no organized effort set up. The local consulate had been swamped with requests by local citizens as to the whereabouts of friends and relatives in Guatemala and the load was increasing as hours wore on. It was obvious that some fully organized effort was needed, one that would insure that a maximum number of health and welfare requests were handled while at the same time taking some of the load off the local consulate so that they could work on other important relief efforts. Such was the problem that Doug K4SWJ/6 posed to me on the telephone some 48 hours ago. Doug, like myself, is a member of the Palisades Amateur Radio Club of Culver City, and both of us felt that it was a definite obligation for PARC to take an active role in this project on a large scale basis. Saturday morning, February 7th, Doug called PARC President Dan Deckert WA6FQC and plans were formulated. The local

Continued on page 138

# CONTESTS

Editor:  
Robert Baker WA1SCX  
34 White Pine Drive  
Littleton MA 01460

## CORRECTION

The Delta QSO Party will be held September 25-27 — not April 24-25, as listed in our April issue.

## COMMON MARKET CONTEST

CW

Saturday, April 3  
0600 to 2400 GMT  
Phone

Sunday, April 4  
0600 to 2400 GMT

Use appropriate mode on all amateur bands, 80 to 10 meters. Please keep the lower 10 kHz of the CW bands and the upper 25 kHz of phone bands free according to IARU recommendations. Entry classes consist of: single operator — all band, low band (80 and 40), high band (20, 15 and 10); multi-operator — single transmitter, all band only.

### EXCHANGE:

RS(T) and QSO number starting from 001.

### SCORING:

Common Market stations score 1 point for QSOs with other Common Market stations and 5 points for QSOs with others: multiply total QSO points by the number of DXCC countries on each band. Non-Common Market stations score 5 points for each Common Market QSO and 1 point for any other QSOs; multiply total QSO points by the number of Common Market countries worked on each band.

### AWARDS:

Certificates to the highest scoring station in each country, in each entry class, on each mode. Trophies awarded to the highest scoring single operator in the Common Market on each mode and to the highest scoring single operator outside of the Common Market on each mode.

### LOGS:

All entries must be mailed no later than April 30th to: Jacky Luyten, Ave. Max 134 b1, 1040 Brussels, BELGIUM. Please use the common log form style and do not forget a summary sheet.

Common Market Countries: Belgium, Denmark, France, W. Germany, Great Britain, Ireland, Italy, Luxemburg, Netherlands.

## TRIPLE LETTER QSO PARTY

Starts: 1700 GMT Saturday,  
April 24  
Ends: 2000 GMT Sunday,  
April 25

The contest is sponsored by the University of Missouri-Rolla ARC, W0EEE and is open to all amateurs. Any contact between amateurs is valid on any band 160 to 2 meters, using any mode. No repeater QSOs or cross-mode contacts will be allowed. Each station may be worked once per

band per mode.

### FREQUENCIES:

3950, 7215, 14290, 21375, 28600.  
CW — 45 kHz up from band edge.

### EXCHANGE:

RS(T) and consecutive QSO number.

### SCORING:

Each QSO counts for one point, with one extra point added for each repeated letter in the suffix of the station worked call. An extra point is also added for 2 letter suffix calls. (Examples: WB4GOP = 1 pt, WA7UMU = 2 pts, W0EEE = 3 pts, W0GS = 2 pts.) Total score is the total QSO points times the number of states, countries and provinces on each band, times the total number of triple letter stations on each band. Example scoring: 500 QSO pts x 67 (states, countries and provinces) x 24 triple letter stations = 814,000 pts total.

### ENTRIES:

Send logs along with the usual data and declaration before May 20th to: Ward Silver WB0GQP, 590 Fieldstone, Ballwin MO 63011.

## GEORGIA QSO PARTY

Starts: 2000 GMT, Saturday,  
May 8  
Ends: 0200 GMT, Monday  
May 10

The 15th annual Georgia QSO Party is sponsored by the Columbus Amateur Radio Club. There are no time or power restrictions and contacts may be made once on phone and once on CW on each band with each station.

### FREQUENCIES:

CW — 1810, 3590, 7060, 14060, 21060, 28060. SSB — 3900, 3975, 7245, 14290, 21360, 28600. Novices — 3718, 7125, 21110, 28110. Try 160m at 0300 GMT, try 10m on the hour, and 15m on the half hour during daylight hours.

### EXCHANGE:

QSO Number, RS(T), and QTH — county for GA stations; state, province, or country for others. GA to GA contacts are permitted.

### SCORING:

Each completed QSO counts 2 points. GA stations multiply total QSO points by number of different states and Canadian provinces worked. DX stations may be worked by GA stations for QSO points only; they do not count as multipliers. Out-of-state stations will use the number of GA counties (max. 159) worked for their multiplier.

### AWARDS:

Certificates to the highest scoring station in each state, province, country, and GA county. Also to the highest scoring GA and non-GA Novice. Second and third place awards will be made in sections where addi-

tional recognition warrants. A plaque will be presented to the single operator and multi-operator GA stations submitting the highest score in each category. Plaques will also be awarded to the highest scoring out-of-state entry and to the highest scoring GA portable and mobile stations operating outside their home county.

### LOGS & ENTRIES:

Your logs should show: date and time in GMT, station worked, exchange sent and received, band used, type emission, and multipliers claimed. Check lists will be appreciated. Include a signed declaration that all contest rules and operating regulations were observed and mail your entry to CARC, c/o John T. Laney K4BA1, Post Office Box 421, Columbus GA 31902. Entries should be postmarked no later than June 7, 1976. Please include a large SASE for a copy of the results.

## VERMONT QSO PARTY

Starts: 2100 GMT Saturday,  
May 8  
Ends: 0100 GMT Monday,  
May 10

The 1976 Vermont QSO Party is sponsored by the Central Vermont Amateur Radio Club in Montpelier VT. The same station may be worked

once on each band and mode. Mobile stations may be worked in each new county (consider each new county they enter as a new station).

### FREQUENCIES:

Try CW on odd hours and phone on even hours (GMT). 3560, 7060, 14060, 21060, 28160, 50260, 144-144.5, 3909, 7265, 14290, 21375, 28600, 50360, 145.8, 3932, 7290, 14325.

### EXCHANGE:

QSO number, RS(T), and county for VT stations, or ARRL section for others.

### SCORING:

VT stations score one point per contact and multiply by the number of ARRL sections and countries worked. All others score 3 points per VT station worked and multiply total by the number of VT counties worked on each band. Maximum of 14 counties per band.

### AWARDS:

Trophies will be awarded to the highest scoring station outside of VT and to the highest scoring single operator station in VT. In addition, certificates will be awarded to the highest scoring station in each ARRL section and country with a minimum of 3 different QSOs. Certificates also will go to the 2nd, 3rd and 4th highest

# CALENDAR

Apr 24 - 25	Triple Letter QSO Party
May 1 - 2*	MASS Bicentennial QSO Party
May 1 - 2*	Helvetia 22 Contest (H22)
May 8 - 10	Georgia QSO Party
May 8 - 10*	BARC Contest — CW
May 8 - 10	Vermont QSO Party
May 14 - 16	YL International SSBers QSO Party
May 15	World Telecommunications Day Contest — Phone
May 15 - 17	Michigan QSO Party
May 22	World Telecommunications Day Contest — CW
May 22 - 23	Wisconsin State QSO Party
June 4 - 7	IARS/CHC/FHC/HTH QSO Party
June 12 - 13	ARRL VHF QSO Party
June 12 - 13	RSGB National Field Day
June 12 - 14	West Virginia QSO Party
June 26 - 27	ARRL Field Day
July 3 - 4	QRP — Summer — Contest
July 3	ARRL Straight Key Night
July 17 - 19	CW County Hunters Contest
July 24 - 25	ARRL Bicentennial Celebration
Aug 14 - 15	European DX Contest — CW
Sept 4 - 5	ARRL VHF QSO Party
Sept 11 - 12	European DX Contest — Phone
Oct 8 - 10	CD Party — Phone
Oct 9 - 10	RSGB 21/28 MHz Contest — Phone
Oct 16 - 17	RSGB 7 MHz Contest — CW
Oct 16 - 18	CD Party — CW
Oct 30 - 31	CQ Worldwide DX Contest — Phone

\* = described in last issue

scoring stations in VT. A special certificate will be awarded multi-operator and mobile stations operating in VT. QSO Party contacts can be credited toward the Worked

Vermont (W-VT) Award issued to stations working 13 out of VT's 14 counties.

**LOGS:**  
In order to be eligible for awards, logs

or facsimiles together with an SASE must be mailed no later than June 15th to: Peter Kragh W1AYK, 170 Summit Avenue, Ramsey NJ 07446. *All band/mode activity is urgently needed from the counties of Bennington, Caledonia, Essex, Grand Isle and Orleans. Anyone interested in portable or mobile operation is asked to contact W1AYK or the CVARC.*

Party, teams requesting to be recorded may do so through system controls during daily operation. No team assignments may be made after the party begins.

**YL/OM team** — Each team consists of one YL SSB member and one OM SSB member who are related: husband/wife, father/daughter, etc. Operation must be from the same QTH, using the same rig with his/her own call.

**LOGS:**  
All logs must show date and time in GMT, RS(T), SSBer number, partner's call, mode and period of rest time. Each entry must operate a minimum of 6 hours with a minimum of 6 hours rest period for each 24 hours of contest period. Logs should be post-marked on or before June 30th and be received on or before July 15th. Send logs to: Lyle Coleman W7EOI, 412 - 19th Street SW, Great Falls MT 59404.

*For free QSO Party entry form (no logs), send an SASE to: Robert Baker WA1SCX, 34 White Pine Dr., Littleton MA 01460.*

**MICHIGAN QSO PARTY**  
Starts: 1800 GMT Saturday,  
May 15  
Ends: 0200 GMT Monday,  
May 17

The QSO Party will be sponsored by the Oak Park Amateur Radio Club. Phone and CW are separate contests, but a station may enter logs for both modes. MICH stations may work MICH counties for multipliers. A station may be contacted once per band on each mode. Portable or mobile stations may be counted as new contacts when they change counties.

**FREQUENCIES:**  
CW — 1810, 3540, 3725, 7035, 7123, 14035, 21035, 21125, 28035, 28125. 1600 - 1900 GMT try phone: 1815, 3905, 7280, 14280, 21380, 28580. Try 15 meters on the hour and 10 meters on the half hour. On VHF, try: 50.125 and 145.025.

**EXCHANGE:**  
RS(T), QSO #, QTH — county for MICH stations, state or country for others.

**SCORING:**  
**MULTIPLIERS ARE COUNTED ONLY ONCE.** MICH stations score one point per QSO times the total number of states, countries, and MICH counties worked. Non-MICH stations score QSO points as: 1 point for each W/KWA/WB8 MICH QSO, 5 points for each WN8 and special events station QSO. Total score is sum QSO points times the number of MICH counties worked (83 max.). VHF only entries score same as above except multipliers per VHF band are added together for total multipliers.

**AWARDS:**  
Only single operator stations qualify. Trophies will be awarded to MICH stations for: high CW, high phone, high aggregate club score. Plaques will go to high Novice, high VHF only entry. Certificates to high CW and phone in each MICH county. For non-MICH stations, trophies for high

# RESULTS

## RESULTS OF THE 1975 CW COUNTY HUNTERS CONTEST

High score — fixed	WB4OGW	433,048 points (new record)
High score — portable	WA0KXJ/6	220,869
High score — mobile	WA5KQD/m	438,658 (new record)
Composite mobile score	K0DEQ	292,358

There were a total of 301 counties activated by portable/mobile stations during the contest, while the total number of counties worked by contest stations was 613. The highest number of different counties worked by any single entry was 407 counties (WB4OGW). The winners in each state and category are as follows:

STATE	CALL	SCORE (pts)	
CONN	WA1KMP	48,723	fixed
ME	W1APU	4,750	fixed
MASS	W1AQE	65,860	fixed
VT	K11IK	21,930	fixed
NJ	WA2DFC	47,125	fixed
	K3NVC	16,720	portable
NY	W2MEI	204,428	fixed
MD/DC	W3HQU	192,375	fixed
PA	W3ARK	150,960	fixed
	W3ZUH	8,601	mobile
FLA	WB4OGW	433,048	fixed
	W4OZF	19,313	mobile
GA	WB4QGN	355,616	fixed
KY	W4KFB	10,296	fixed
NC	K4ENL	89,240	fixed
	W4OMW	2,600	portable
SC	W4MCQ	11,766	mobile
TENN	WB4CQC	8,662	fixed
	WB4WHE	2,904	portable
VA	W4KMW	2,640	fixed
MISS	W5RUB	68,425	fixed
TEX	W5RPJ	22,620	fixed
	WA5KQD	438,658	mobile
CAL	W6CLM	7,068	fixed
	WA0KXJ	220,869	portable
	W6OKX	5,974	mobile
IDAHO	W7GHT	122,286	fixed
MONT	W7JYW	14,784	mobile
ORE	WA7GOO	108,624	fixed
	WA7GOO	6,600	mobile
UTAH	W7ZC	24,072	fixed
WYOM	WA0NZA	4,032	mobile
MICH	WC8CAL	15,554	fixed
	W8KPK	2,142	portable
	W8CXS	37,833	mobile
OHIO	K8QWY	161,460	fixed
	W8RYP	24,030	mobile
WVA	W4UM	4,056	portable
ILL	W9AXT	11,004	fixed
IND	K9UKM	140,750	portable
	WA9WIF	5,610	mobile
WISC	W9PJT	117,700	fixed
	K9DAF	53,428	portable
	WB9ONA	16,737	mobile
COLO	WB0JGT	7,866	fixed
IOWA	W0II	10,560	fixed
	K0DEQ	78,522	mobile
KANS	K0DEQ	17,995	mobile
MO	K0LIR	40,584	fixed
	W0QWS	24,297	mobile
NEBR	W0QNP	1,998	fixed
	WB9DED	27,951	portable
	K0DEQ	29,631	mobile
SDAK	K0DEQ	1,652	mobile
Nova Scotia	VE1AHG	17,765	fixed

## YL INTERNATIONAL SSBers QSO PARTY

Starts: 1901 GMT Friday,  
May 14

Ends: 1900 GMT Sunday,  
May 16

All bands will be used on CW and phone and the same station may be contacted on different bands for contact points but not for country multiplier. Use country multiplier only one time. The QSO Party is in three categories: DX/WK teams, YL/OM teams, single operator. Non-members are welcome to participate and QSO party logs will be accepted for SSBers awards in lieu of QSLs.

### EXCHANGE:

Name, RS(T), SSBers number (send no number if non-member), country, state, partner's call (if no partner leave blank).

### FREQUENCIES:

CW: 3565, 7085, 14070, 21070. Phone: 3873, 7273, 14333, 21373, 28673.

Some European stations cannot work in the US phone band on 80 or 40 meters; when calling them please announce that you will tune around 3775 or 7090.

### SCORING:

Contact with SSBer member on same continent = 2 pts phone, 4 pts CW. Contact with SSBer member on different continent = 4 pts phone, 8 pts CW. Non-member contacts = 1 point phone, 2 pts CW. Multipliers are number of different DXCC countries (must be YL-SSB members), US states, DX/WK teams, and YL/OM teams regardless of bands. Final score is total QSO points times total multiplier.

### AWARDS:

Plaques will be awarded to the highest individual score, DX/WK teams, and YL/OM teams, as well as to the highest score single operator. Certificates to first and second place in country and state. No certificate to plaque winners.

### CATEGORIES:

**DX/WK team** — Each team consists of a DX and W/K SSB member. The team score is the sum of both partners. Score will be determined when both logs are received. If only one log is received it will be scored as a single operator entry. All stations entering the DX/WK team category should immediately send a request to W7EOI. You may choose your own partner or, if you have no choice, W7EOI will assign one to you as requests are received. All requests must be in writing (for records) except DX stations who may make their requests through system controls. One week preceding the QSO



CW and phone. Certificates for high CW and phone in each state and country. Members of the Michigan Week QSO Party Committee are not eligible for individual awards.

**ENTRIES:**

A summary sheet is requested showing the scoring and other pertinent information, name and address in BLOCK LETTERS, and a signed declaration that all rules and regulations have been observed. MICH stations include name of club for combined club score. Party contacts do not count toward the Michigan Achievement Award unless one fact about MICH is communicated. Decisions of the Contest Committee are final. Results will be final on July 31, 1976 and will be mailed to all entries. Mailing deadline is June 18th and should be addressed to: Mark Shaw WA8EDC, 3810 Woodman, Troy MI 48084.

**WORLD TELECOMMUNICATIONS DAY CONTEST**

Phone

Starts: 0000 GMT Saturday, May 15

Ends: 2400 GMT Saturday, May 15  
CW

Starts: 0000 GMT Saturday, May 22

Ends: 2400 GMT Saturday, May 22

This is the seventh running of this annual contest sponsored by the Brazilian Ministry of Communications and is open to all amateurs. Categories include: single operator multi-band, or fixed/maritime mobile stations operating from ITT Zones 76 to 90. Use all amateur bands from 160 to 10 meters. Contacts with the same station are allowed on different bands, but ITU zones are valid only once as a multiplier regardless of bands.

**EXCHANGE:**

RS(T) plus ITU zone number. (Please remember that the ITU zone numbers are different from those shown on the ARRL and CQ maps and charts.)

**QSO POINTS:**

Contacts with stations in the same country = 0 points. Contacts with stations in different country same ITU zone = 1 on 10 to 40 meters, 2 on 80 and 160 meters. In another ITU zone, same continent: 10 to 20 meters = 2 points, 40 meters = 3 points, 80 and 160 meters = 4 points. Another ITU zone, another continent: 10 to 20 meters = 3 points, 40 meters = 5 points, 80 and 160 meters = 6 points.

**SCORING:**

Final score equals sum of QSO points times total number of different ITU zones. ITU zones only count once regardless of bands.

**LOGS:**

Use separate logs for each mode. Logs should indicate in this order: GMT time, worked station, message sent/rcvd, band, continent, zone (and multipliers), QSO points. Logs should be postmarked before June 30th and sent to: Ministerio das Comunicacoes, Dentel, Brasilia, D. F. Brazil.

**AWARDS:**

The sum of points earned by the top five contestants of each country on each mode will be used as "Country Points" to determine the winner of the ITU trophy. A winner country for three consecutive years or five inter-spaced years will keep the ITU trophy permanently. Gold, silver and bronze medals will be awarded to the three top world scorers on each mode. Diplomas will go to the three top scorers in each country, on each mode. Countries with a high number of logs will be granted diplomas to the first three in each call area.

Clubs and associations will be included in a special multi-operator multi-band category and will not be counted for country points. A silver plate will be awarded to the top world winners on each mode. Diplomas will be awarded to the three top winners in each country on each mode. Logs must be signed by all participants from each club or association.

**WISCONSIN STATE QSO PARTY**

Starts: 0000 GMT Saturday, May 22

Ends: 2400 GMT Sunday, May 23

This is the annual QSO Party sponsored by the Neenah-Menasha Amateur Club. Phone and CW are considered separate bands. The same station may be worked on each band and mode. Wisconsin stations may work other Wisconsin stations for QSO and multiplier credit.

**FREQUENCIES:**

1810, 3550, 3735, 3900, 7050, 7135, 7235, 14050, 14280, 21050, 21135, 21300, 28050, 28600, 50-50.5, 144-146.

**EXCHANGE:**

RS(T) and QTH - Wisconsin stations will send their county for QTH, others send ARRL section or country.

**SCORING:**

US and VE contacts count one point while DX contacts count 3 points for Wisc stations. All others score one point per Wisc contact. Wisc stations are to multiply the total QSO points by the number of ARRL sections contacted (74 max.); KP4, KH6, KL7 and KZ5 count both as 3 point QSOs and as section multipliers. All non-Wisc stations should multiply the number of Wisc QSOs by the number of Wisc counties worked (72 max.).

**AWARDS:**

Certificates will be awarded to the high scoring fixed, portable, mobile, Novice, and VHF stations in Wisc as well as each ARRL section and each DX country.

**ENTRIES:**

A summary sheet and station log are requested. Indicate each multiplier the first time worked. Logs must be received no later than June 15 (DX logs by July 1). All entries should be addressed to: Neenah-Menasha Amateur Radio Club, Inc., Mark Michel W9PJT, 700 Kinzie Court, Menasha WI 54952.

**MICHIGAN ACHIEVEMENT AWARD**

The Governor of Mich will award Achievement Certificates to hams who take an active part in telling the world of Michigan's unlimited resources, opportunities, and advantages. Certificates are awarded on the following basis:

1. A MICH ham submits log information and names (addresses if possible) of 15 or more contacts made to out-of-state or DX hams with information regarding MICH.

2. An out-of-state ham, including Canada, submits log information and names (addresses if possible) of at least 5 MICH hams who relate facts to him about MICH.

3. A foreign ham, excluding any resident of Canada, submits the call letters and name/address plus log information for at least one MICH ham who told him about MICH.

Only QSOs made during MICH Week, May 15 - 22, will be considered valid. All applications for certificates must be postmarked by July 1, 1976 and mailed to Governor William Milliken, Lansing MI 48902.

**OVER FORTY NOVICE CLUB**

Did you know that there is now an "Over Forty Novice Club" for Novices over 40 years of age? If you know of any Novices who meet the requirements please pass the word on to them. If you qualify yourself, you are welcome in the club.

An HONORARY Membership is also available to hams of General Class and above (any age) who have contacted at least 10 Novices since January 1, 1976, and can supply a list of calls and dates of contact.

You will receive a handsome certificate (suitable for framing) and a membership card for your wallet by sending \$2.00, plus 25¢ for mailing and handling, to: O.F.N.C., P.O. Box 622, Carson City NV 89701.

The reason for the club is to offer camaraderie to those Novices trying for their General in the age group of 40 and over. Further, to encourage the more experienced hams to contact Novices and help them to improve by benefiting from their extensive experience. Last but not least, to maybe give a little incentive to those of our age group who are considering joining the rewarding hobby of amateur radio.

**WEEKLY PROPAGATION**

A free weekly propagation forecast is offered by the Telecommunication Service Center. Anyone interested in receiving the forecasts should submit their name and address to: US Dept. of Commerce, Office of Telecommunications Center, Boulder CO 80302. Ask to have your name added to their weekly mailing list. The reports include a propagation forecast of conditions for the next seven days, a summary of conditions and solar activity for the preceding seven days, a 12 month running average prediction of sunspot numbers, and semi-monthly revised ionospheric predictions.

In addition, the latest six hour forecasts may be obtained at any time by phoning 303-499-8129. The recording is updated every 6 hours, seven days a week. Also included in the recording are the latest 3 hour index of geomagnetic activity and the most recent value of the solar flux reported from Ottawa, Ontario.

**RESULTS**

**RESULTS OF THE 1975 DELAWARE QSO PARTY**

Highest scoring DEL station was K3YHR with 16,064 points. Highest scoring station outside DEL was WN1UYU with 325 points.

**DELAWARE Stations...**

County	Call	Total Score
New Castle	K3YHR	16,064
	K3HBP	11,078
	WA3DUM	330
Keny	WA3UUN	3,192
	K3QBD	544
	W3ZNF	160
Sussex	WN3WIY/3	108

**Out of DEL Stations...**

State/prov/country	Call	Total Score
Vermont	WN1UYU	325
Connecticut	W1TEE	225
New Jersey	WA2VYA	30
Pennsylvania	WA3KFT	5
Kentucky	WB4AJA	5
Michigan	WB8TNC	45
JAPAN	JA2HLX	25

# The Magnificent Sevens Microhelix

7 feet, 7MHz

**T**he matching of a low band antenna of reasonable performance to either the high impedance of the Novice wallet or the much less than a quarter wavelength size of a city lot is a problem which not only faced me when my ticket arrived, but

also can crop up on field day or in portable operations. When you only have room for a ten meter antenna and most Novice activity is on 40 and 80 meters, obviously you need a little of that spirit you sometimes hear from an old timer when he recalls the days when a rig was improved by rebuilding, rather than giving up two months pay for another brand or later model.

Clearly, for a single band antenna, the frequency range of interest is quite narrow, covering 500 kHz at most and extending only 50 kHz (if only the Novice portion of the band is tuned). It is well known that an antenna whose size is a small fraction of a wavelength can provide an output equivalent to the full sized version, provided it is properly matched and losses are kept low. As the size of an antenna is reduced, a reactive component of the driving point impedance appears, and must be cancelled by one of opposite sign to leave the purely resistive radiation resistance term. A further complication is that as the antenna is made smaller and smaller the reactive cancellation becomes more and more frequency-dependent, requiring a "tuning" of the antenna as its operating frequency is changed.

Another undesirable side effect of the reduction in size

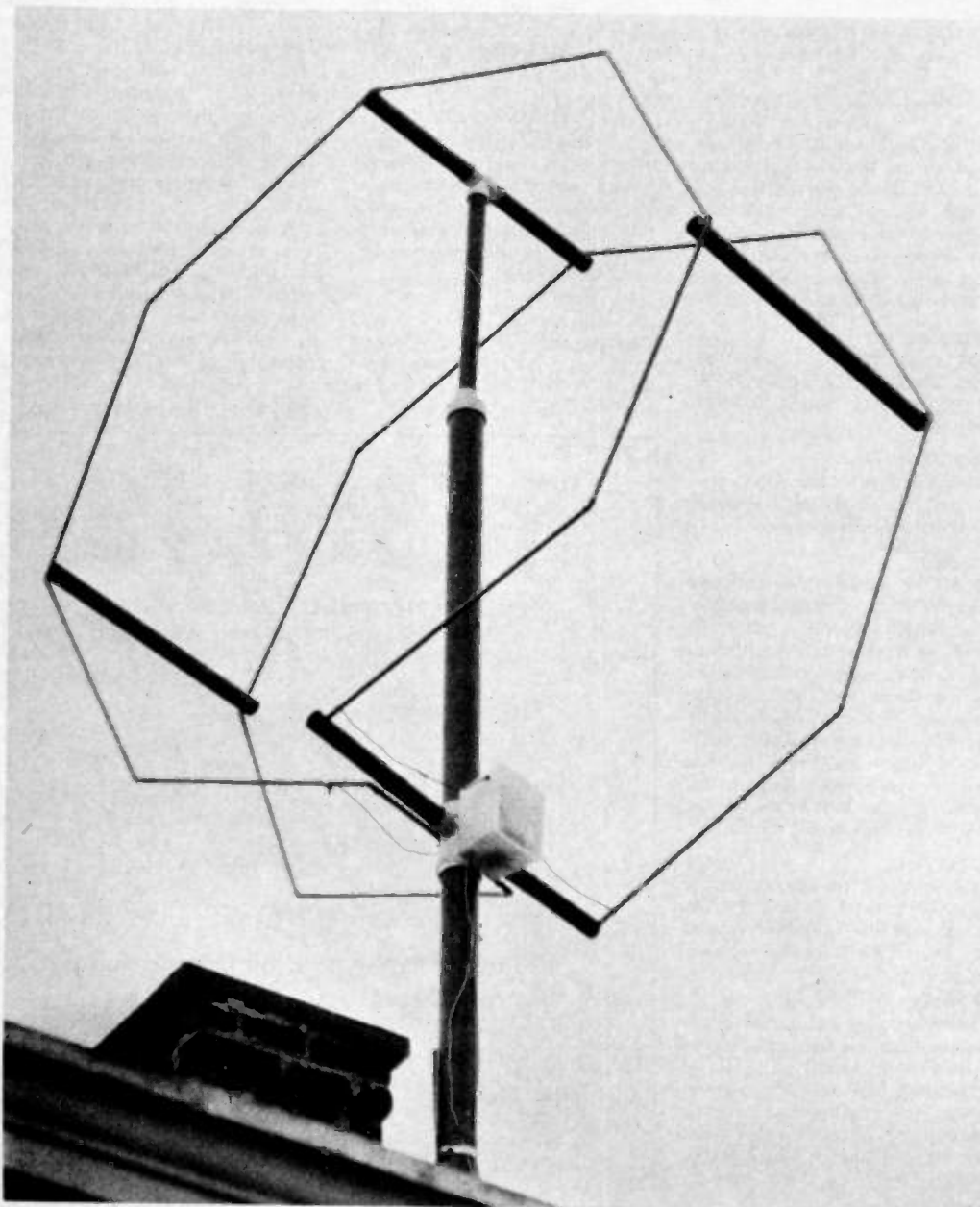

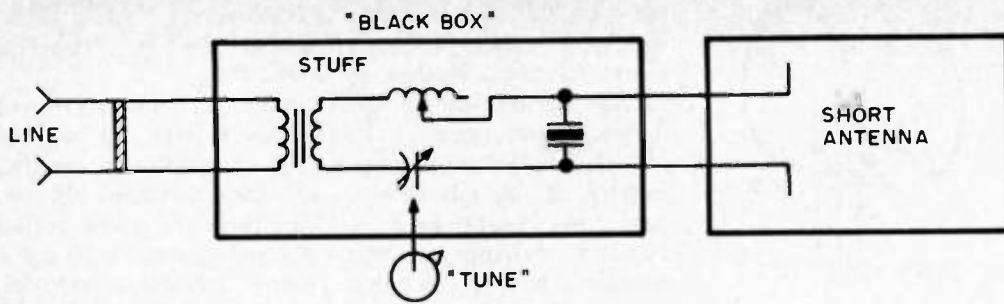

Fig. 1. The "nub."

is a reduction in the value of the radiation resistance, so that, even when the reactive components of the driving point impedance are eliminated, a transformer of some kind is required to raise the resistive portion from a value (in some cases) as low as a fraction of an Ohm to something suitable for matching a transmission line of reasonable dimensions.

Thus, the conceptual nub of our problem is a black box providing the matching functions necessary to make our small antenna have an output equivalent to a large one, i.e., to convert the undesirable output characteristics to those required to match the feed line. I found much pooping of tuned small antennas among amateurs, because of the high losses found in most standard matching networks (although W2FMI has done much work with this approach and has reported excellent results in many *QST* articles). It seems to me, however, that many of these problems have arisen because attempts were made to actually build a "black box" full of coils, caps and stuff, rather than to allow the black box to remain simply a concept, which is then used as a starting point for thinking.

Let us do some thinking about losses. Losses in the antenna itself increase as the size of the antenna is reduced and it becomes more and more reactive. This is because increased reactance results in larger and larger currents

flowing on the antenna, causing it to act more as a heater than an antenna. The answer is to make our antenna out of some low resistance material like silver and, further, to increase the surface area where the currents are flowing as much as possible, since heating is an  $I^2R$  effect and a small reduction in current density makes for a relatively large drop in losses. Hence, wire is out! Large diameter low resistance pipe is *in*. For experimenting, I chose easily soldered copper tubing in a relatively inexpensive and lightweight  $\frac{1}{2}$ " size.

As an aside, I would mention that I once saw an article for the construction of a small low frequency antenna from steel exhaust pipe. This is the worst possible choice, since it is heavy, hard to work with, relatively resistive, and throws in, as a bonus, magnetic losses not found in non-magnetic metals. If your shack is heli-arc equipped, one inch or so diameter aluminum tubing would probably

result in a much lighter antenna.

Our small antenna problem is now reduced to determining the configuration into which our pipes will be soldered, so that the antenna will become its own impedance matching network. Since it is usually much easier to step an impedance down (rather than up) without a transformer, we can ask, "Are there any short antennas with resistive terminal impedances larger than standard coax?" An inspection of short dipoles, loaded whips, etc., is discouraging, but wait! Again it's J. D. Kraus to the rescue. In his classic *Antennas* textbook we find that the small helix can have this property.

An examination of a typical impedance plot for a helical antenna, as given in Kraus and sketched in Fig. 2, shows that when the circumference is on the order of a wavelength, the terminal impedance is mostly resistive and loops around a value

suitable for matching a standard coaxial line for a wide range of frequencies (producing the well-known broadband matching characteristics). In this size the helix radiates along its axis and hence is called an "axial mode" of propagation. As we go lower in frequency or build smaller and smaller antennas, these loops suddenly become very large and now pass quite quickly through the purely resistive points. Moreover, the antenna now radiates perpendicular to (i.e., "normal to") the axis of the helix and is thus termed the "normal mode" of propagation. For normal mode operation we are usually talking about maximum dimensions of less than one-half wave. In conclusion, it is seen that the normal mode helix has two useful operating points where the reactive impedance is zero: one where the resistive value is low (which would give rise to a matching problem equivalent to that of a short dipole), and also a high resistance operating point with a value much greater than standard coax (that can easily be matched by a tap down arrangement so that the antenna can, in effect, act as its own matching transformer).

Now that you know where on the impedance plot you wish to operate, the trick is to put that point at the frequency at which you wish to operate. Since an alteration

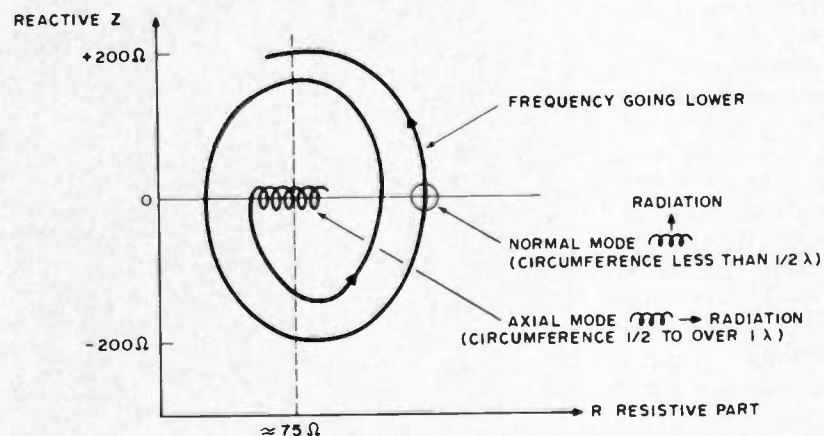

Fig. 2. Helix terminal impedance.



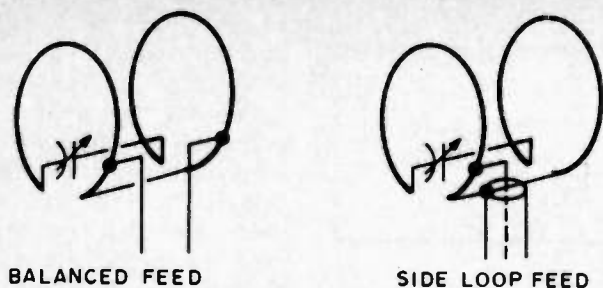

Fig. 3. Feedpoints.

of the scale of the antenna is more or less out, I chose an end-loading capacitor ( $\approx 40$  pF) between the two loop ends to electrically alter the antenna's apparent length. This has the disadvantage of putting your tuning element at the high voltage point of your antenna, but does result in a small C variation (thereby resulting in a wide tuning range, which, with careful construction, does not arc over at Novice power levels). Other tuning methods are possible, including warping the antenna to alter its size (which would probably be a superior method if high power operation were a goal).

I am not going to be too specific on the actual construction details, since this project is basically a junk box el cheapo affair. Each loop is made by the mathematical operation of dividing four  $\frac{1}{2}$ "D 10 ft. copper tubes into four 30 inch pieces each, and using standard  $45^\circ$  pipe fittings to solder up 2 octagons, about 2 meters across. They are not completely joined, however. One connection is left unmade, where the two loops are joined crosswise by a short piece of tube and two  $90^\circ$  elbows to make a 20" separation between the joined ends of the loops. The other ends are stretched out to 39" when mounted and the tuning capacitor is connected between them. The whole works is supported on a mast and crossmembers made of ABS plastic sewer pipe. I have found that the availability of sewer pipe and fitting varies

considerably from time to time and from store to store, so I leave it to you to resonate the bins at your local plumbing supply to get a combination that will work. Metal supports and towers will tend to soak up your power, so try to keep them away — but if you use much pipe as a mast, probably 6" ABS would be better than the 4" I used. I have survived 60-70 mph winds on 4" but as you can see in the photo my mast section is very short. As a finishing touch, the copper can be cleaned and sprayed with clear plastic to protect it from corrosion.

Finally, I would just like to say a few words about the tuning capacitor. I would suggest a plate spacing of at least  $\frac{1}{4}$  inch. This may seem large, but remember that it is located at a high voltage

point on the antenna and I had some trouble with arc-overs in damp weather. A vacuum variable would be the optimum, but tends to be rather expensive (even surplus). If you only wish to tune the Novice band, a tuning motor is not necessary, but I predict that if you don't take time to install one, later you will wish you had (especially since I've noticed a slight shift of tuning point with the weather). I used a plastic refrigerator box to protect the capacitor and motor from the weather, and silicon bathtub seal is great for waterproofing the lid. In choosing a motor you will doubtless find as I did that you really need one much slower than you would think. My  $\frac{1}{2}$  rpm still seems rather fast. **BE SURE THAT BOTH THE STATOR AND ROTOR OF THE CAP ARE ISOLATED FROM GROUND (MOTOR).** I used plastic for the mounts and a ceramic shaft insulator.

Optimum feed is a balanced connection at symmetrical points on each loop (as shown in Fig. 3) with a balun if coax is used, but my loop feed to one side also seems to work with coax and is cheaper. Good low loss

connections are also important in this feed network as well.

Now that our basic plan of attack is laid out we can begin to examine the specifics of helical antennas. We note that there are several critical dimensions suitable for variations in experimenting, including the turn diameter, the pitch of each turn, and the number of turns. Helical antennas can be built with or without ground planes, but since the ground plane is just a device used to eliminate the construction of the other side or "image" of an antenna, and since it has been my experience that a ground plane really has to be large and relatively conductive to be effective, it seems to me that unless you have a copper roof it is far easier to just build the image structure than to construct a huge ground plane to save a few feet of pipe. There is a relationship between circumference and pitch which results in circular polarization and is given in Kraus as

$$C_\lambda = 2S_\lambda,$$

where  $C_\lambda$  and  $S_\lambda$  are the respective circumference and pitch in fractions of a wave-

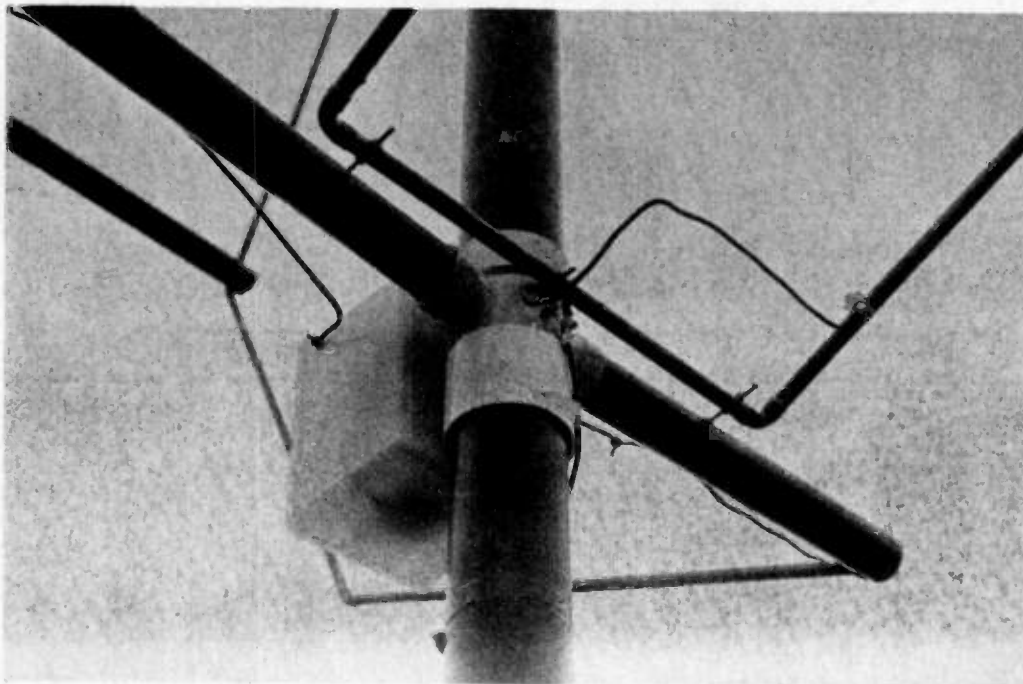

length (but I see no special advantage in insuring circular polarization for amateur use).

The final choice of circumference, pitch, and number of turns now becomes a matter of experimentation and the antenna "arts." As a rule of thumb, it probably pays to make the diameter as large as the mechanics of mounting it allow and, for simplicity, I chose  $n$  equal to one (i.e., one turn on each side). The pitch can go from zero to any reasonable value, and it is interesting to note that in this light the mysterious DDDR antenna would appear to be nothing more than a normal mode helix of pitch zero with a ground plane. The pitch on my final antenna version was determined experimentally and was used only because it seemed to work the best, rather than because of some long-winded theoretical justification. I used small  $\frac{1}{4}$ " copper tubing for my feed connections.

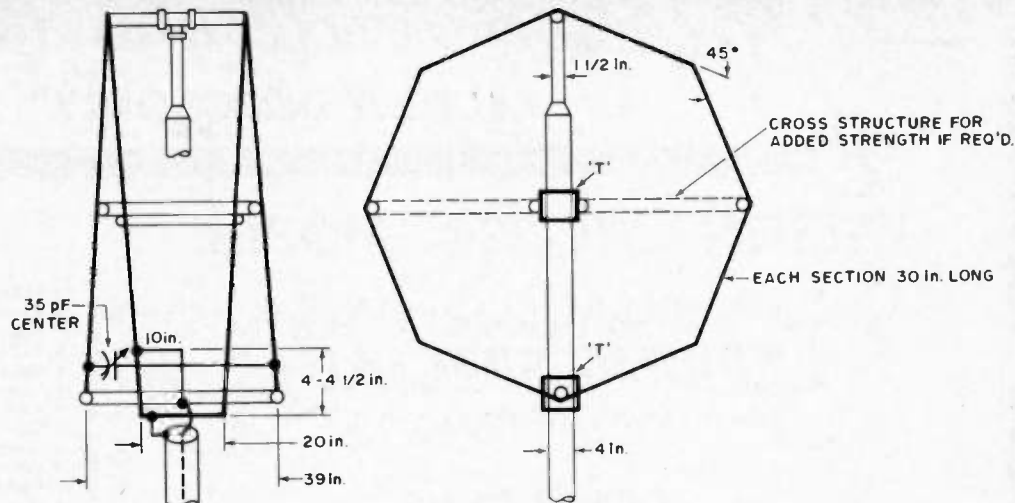

Fig. 4. Forty meter normal mode helix.

The antenna pattern is directional, having a figure 8 dipole pattern when mounted with the helix axis horizontal and a low angle omnidirectional radiation when mounted with the helix axis vertical. For all around use with both high and low angle radiation, the horizontal mounting is best, while for DX a vertical axis mounting

with the antenna  $\frac{1}{4}$  wave above the ground should give optimum results.

The swr of the antenna should be less than 2 over the entire Novice band and should be phenomenally close to 1 at the frequency to which the antenna is tuned — if your matching tap is properly located.

I have compared this antenna to a wire dipole and found it to be only a little over one dB down. Here in the city, however, the big problem is not signal but noise, and the helix clearly had less noise pickup than the dipole. Weak signals that were nearly obscured by noise with the dipole were easily copyable with the helix. ■

W6YGN  
HANK HENNES

WB6DAP  
FRED K. SCHMIDT

# WB6DAP

SMITTY'S RADIO, 221 E. NEWBURGH AVE.,  
AZUSA, CALIFORNIA, PHONE: 213-334-9817

ALL AMATEUR RADIOS — MARINE AND STEREOS  
AUTHORIZED YAESU DEALER

LICENSED TECH. ON HAND  
FOR ALL WARRANTY WORK  
W6YGN — HANK

CALL FOR FREE BOOK AND PRICE LIST OR WRITE.

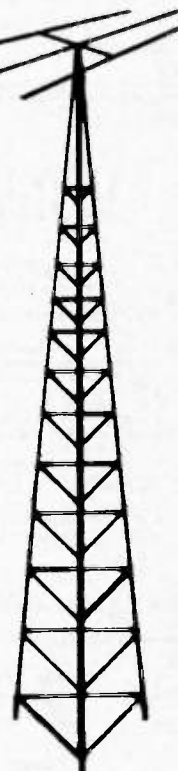

# Wilson Electronics Corp.

"FACTORY DIRECT ONLY"



## WILSON "WE-224" MOBILE

**SPRING SPECIAL**

**\$209<sup>95</sup>**

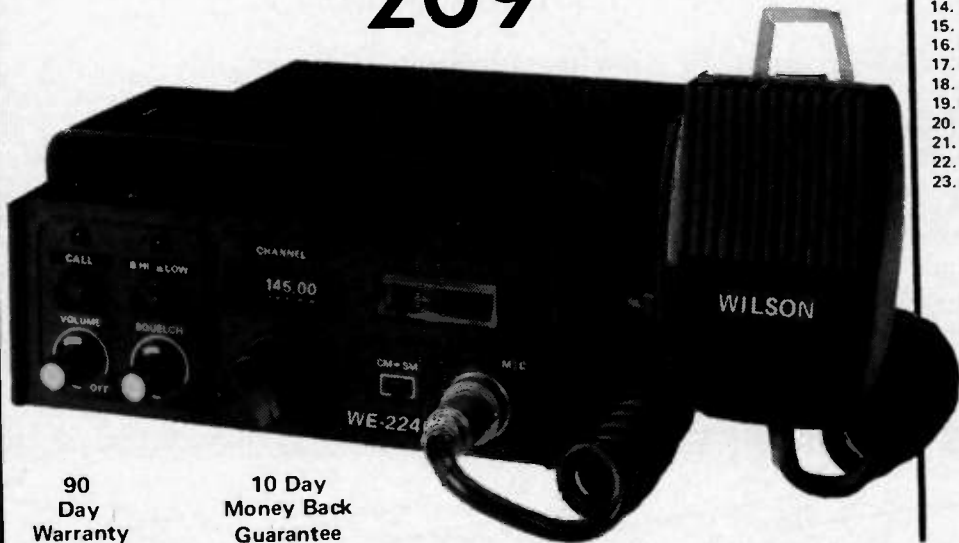

### FEATURES

1. 24 Channel Operation
2. One priority Channel
3. Selectable 1 or 10 Watts Out
4. 10.7 Monolithic Filter Installed
5. 455 KHz Ceramic Filter
6. Numerical Read-out on each Channel
7. Built-in Adjustable "Tone-Burst" Generator
8. Front Panel Tone Burst Control
9. Accepts Wilson 1402 & 1405SM Xtals
10. Individual Trimmer Capacitors for both TX/RX
11. Mosfet Front End
12. Helical Resonator
13. High VSWR Protection Circuit
14. Reverse Polarity Protection Circuit
15. NBFM - 15 KHz Channel Separation
16. External Speaker Jack
17. Built-in Speaker
18. Dynamic Microphone Included
19. Mobile Mounting Bracket Included
20. Frequency Range 144-148 MHz
21. 6 1/2" W x 2 1/2" H x 9 1/2" D
22. Weight: 5 1/2 lbs.
23. Power Requirements:
  - Source: 13.5 VDC ± 10%
  - Receive: 45A
  - Transmit: 2.6A (10W), .7A (1W)

### SPECIAL INCLUDES:

- A. WILSON "WE-224"
- B. MOBILE MIKE
- C. MOUNTING BRACKET
- D. 146.52/52 SIMPLEX CRYSTALS
- E. TWO PAIR TX/RX CRYSTALS OF YOUR CHOICE.  
(Common Repeater Frequency only)

90 Day Warranty

10 Day Money Back Guarantee

## SPRING Special on Wilson Hand Held 220 and 450

### 2202 SM

FREQUENCY RANGE 220 - 225 MHz

- 6 Channel Operation
- Individual Trimmers on all TX/RX Crystals
- All Crystals Plug In
- 12 KHz Ceramic Filter
- 10.7 and 455 KC IF
- .3 Microvolt Sensitivity for 20 Db Quieting
- Weight: 1 lb. 14 oz. less Battery
- Battery Indicator
- Size: 8 7/8 x 1 3/4 x 2 7/8
- Switchable 1 & 2.5 Watts Output
- 12 VDC
- Current Drain: RX 14 MA TX 500 MA
- Microswitch Mike Button
- Unbreakable Lexan® Case

USES SAME ACCESSORIES AS 1405

INTRODUCTION SPECIAL

**\$239<sup>95</sup>**

INCLUDES

1. 2202 SM
2. Flex Antenna
3. 223.50 Simplex Installed



### 4502 SM

FREQUENCY RANGE 420 - 450 MHz

- 6 Channel Operation
- Individual Trimmers on all TX/RX Crystals
- All Crystals Plug In
- 12 KHz Ceramic Filter
- 10.7 and 455 KC IF
- .3 Microvolt Sensitivity for 20 Db Quieting
- Weight: 1 lb. 14 oz. less Battery
- Battery Indicator
- Size: 8 7/8 x 1 3/4 x 2 7/8
- Switchable 1 & 1.8 Watts Output
- 12 VDC
- Current Drain: RX 14 MA TX 500 MA
- Microswitch Mike Button
- Unbreakable Lexan® Case

USES SAME ACCESSORIES AS 1405

INTRODUCTION SPECIAL

**\$279<sup>95</sup>**

INCLUDES

1. 4502 SM
2. Flex Antenna
3. 446.00 Simplex Installed

## HAND HELD ACCESSORY SPECIALS

NOTE: ACCESSORY SPECIAL PRICE AVAILABLE ONLY AT TIME OF RADIO PURCHASE

DESCRIPTION	SPECIAL PRICE
BC1 - BATTERY CHARGER	\$29.95
BP - NI-CAO BATTERY PACK	10.95
LC1 - 1402 LEATHER CASE	8.50
LC2 - LEATHER CASE FOR 1405, 2202, 4502	8.50
SM2 - SPEAKER MIKE FOR 1402 AND 1405	24.95
TE1 - SUB-AUDIBLE TONE ENCODER INSTALLED	34.95
TTP - TOUCH TONE PAD INSTALLED (With Purchase)	49.95
XF1 - 10.7 MONOLITHIC IF XTAL FILTER INST.	8.95
CRYSTALS: TX OR RX (Common Freq. Only)	3.00



BC - 1 BATTERY CHARGER



# Wilson Electronics Corp.

FACTORY DIRECT ONLY

**SPRING SPECIAL**

1402SM  
HAND HELD  
2.5 WATT  
TRANSCIVER  
144-148 MHz

**\$164<sup>95</sup>**

1405SM  
HAND HELD  
5 WATT  
TRANSCIVER  
144-148 MHz

**\$239<sup>95</sup>**

## FEATURES

### 1402 SM

- 6 Channel Operation
- Individual Trimmers on all TX/RX Crystals
- All Crystals Plug In.
- 12 KHz Ceramic Filter
- 10.7 IF and 455 KC IF
- .3 Microvolt Sensitivity for 20 dB Quieting
- Weight: 1 lb. 14 oz. less Battery
- S-Meter/Battery Indicator
- Size: 8 7/8 x 1 7/8 x 2 7/8
- 2.5 Watts Minimum Output @ 12 VDC
- Current Drain RX 14 MA TX 500 MA
- Microswitch Mike Button

### 1405 SM

- 6 Channel Operation
- Individual Trimmers on all TX/RX Crystals
- All Crystals Plug In
- 12 KHz Ceramic Filter
- 10.7 and 455 KC IF
- .3 Microvolt Sensitivity for 20 dB Quieting
- Weight: 1 lb. 14 oz. less Battery
- Battery Indicator
- Size: 8 7/8 x 1 3/4 x 2 7/8
- Switchable 1 & 5 Watts Minimum Output @ 12 VDC
- Current Drain: RX 14 MA TX 400 MA (1w) 900 MA (5W)
- Microswitch Mike Button
- Unbreakable Lexan® Case



Optional  
Touch-Tone Pad  
Shown

Can be Modified  
for  
MARS or CAP



10 Day  
Money Back  
Guarantee

90  
Day  
Warranty

**SPECIAL  
ON EACH  
RADIO  
INCLUDES:**

Flex Antenna  
52/52 Simplex Xtal

TO: WILSON ELECTRONICS CORP., 4288 S. POLARIS AVE., LAS VEGAS, NEVADA 89103  
(702) 739-1931

## SPRING SPECIAL DIRECT SALE ORDER BLANK

\_\_\_\_ 2202 SM @ \$239.95. \_\_\_\_ 4502 SM @ \$269.95. \_\_\_\_ WE-224 @ \$199.95 \_\_\_\_ 1402 SM @ \$164.95. \_\_\_\_ 1405 SM @ \$239.95.  
Accessory Special Prices Available Only at Time of Radio Purchase.

\_\_\_\_ BC1 @ \$29.95. \_\_\_\_ BP @ \$10.50. \_\_\_\_ LC1 @ \$8.50. \_\_\_\_ LC2 @ \$8.50.

\_\_\_\_ SM2 @ \$24.95. \_\_\_\_ TE1 @ \$34.95. (SPECIFY FREQUENCY \_\_\_\_\_)

\_\_\_\_ TTP @ \$49.95. \_\_\_\_ XF1 @ \$8.95. \_\_\_\_ TX or RX XTALS @ \$3.00 ea. \_\_\_\_ INSTALL XTALS @ \$7.50/Radio.

EQUIP TRANSCIVER AS FOLLOWS: XTALS A. \_\_\_\_\_ B. \_\_\_\_\_

C. \_\_\_\_\_ D. \_\_\_\_\_ E. \_\_\_\_\_ F. \_\_\_\_\_

ENCLOSED IS \_\_\_\_\_  CHECK  MONEY ORDER  MC  BAC

CARD # \_\_\_\_\_ EXPIRATION DATE \_\_\_\_\_

NAME \_\_\_\_\_

ADDRESS \_\_\_\_\_

CITY \_\_\_\_\_ STATE \_\_\_\_\_ ZIP \_\_\_\_\_

SIGNATURE \_\_\_\_\_

SHIPPING & HANDLING PREPAID FOR SPRING SPECIAL

VALID ONLY APRIL 1 THRU 30, 1976

NEVADA RESIDENTS ADD SALES TAX

Eugene G. Preston WA5FGC  
906 Cedar Glen  
Austin TX 78745

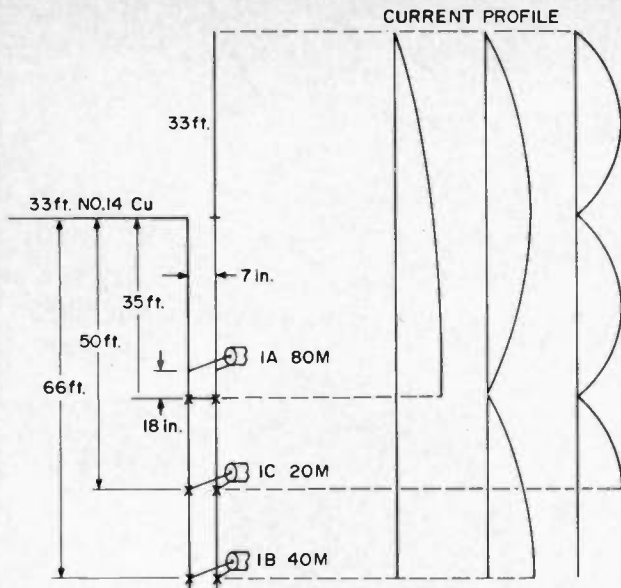

Fig. 1. First allband antenna.

# An Allband Inverted Vee

An allband antenna system has usually meant an antenna farm. The original objective in this case was to have just one antenna, without loading coils or traps, that would fit in the restricted space at this QTH, yet be able to operate efficiently on all the high frequency ham bands. The task did not appear to be easy.

Several antenna systems described in the *ARRL Antenna Book* were successfully used during the last three years, but each had some problem that would finally be cause for rejection. The main problems encountered were rf burns from touching the rig while operating, arcing, coil overheating, the need to slightly retune the transmatch after QSY, and poorer signal reports when compared with an ordinary dipole. The

decision was made that the antenna system should incorporate the following characteristics:

1. A single section of 50 Ohm coax from the transmitter to some remote point helps minimize rf problems in the shack, especially if the coax is buried for several feet.
2. A single section of open wire transmission line would be used as a matching element. The only adjustable connections to this line were to be a jumper or shorting element and the coax itself. Series switches, shunt matching stubs, and shunt variable capacitors were ruled out.
3. The antenna was to be a single inverted vee. The open wire line would feed the inverted vee in the center to maintain an almost balanced

radiating system.

Two antenna systems were developed and tested. Figs. 1 and 2 are schematic representations of the two systems, showing dimensions of the elements and the coax tap location for operation on different ham bands. Figs. 3 and 4 show swr curves associated with Figs. 1 and 2, respectively. The center frequency of all these curves can be easily shifted by relocating the coax tap point.

There are three different ways the open wire line can be used. The first matching technique is shown in Fig. 1A. Short dipoles can be easily resonated by positioning the jumper at the maximum current point on the line. The coax feed point for 50 Ohms will be a short distance from the jumper if the current in the line is large.

This method simply makes the line look like an auto-transformer. A perfect match can be obtained for a specific frequency, but the antenna has an undesirably high Q.

The second matching technique is shown in Figs. 1B and 1C. This is the best and most interesting matching technique. The 650 Ohm open wire line has an almost magical ability to match an inverted vee of any length if the inverted vee is not too short at the lowest desired frequency. Equations for half wave and quarter wave matching are well known for cases where the antenna is a half wave or full wave inverted vee, respectively. What is not so well known is that the line will also match any other antenna length provided the length of one leg of the inverted vee and the length of the line sum up to an odd multiple of a quarter wavelength. This fact, which was discovered by experiment, is the basis for the success of this unique matching system. From a reactive standpoint the length of the antenna is no longer of significance since a line length can always be found to compensate for the antenna reactance.

The third matching technique is shown in Figs. 2A and 2B. The coax feed point is put further down the line than the maximum line current location. This increases the resistance to 50 Ohms but also introduces series inductive reactance. A variable capacitor is introduced in series with the coax and line to tune out the inductive reactance. In Fig. 2B a shunt capacitor makes a voltage divider if the resistance is greater than 50 Ohms. Notice the highly useful double resonance condition produced by this circuit as shown by the swr curve in Fig. 4B.

Construction of this

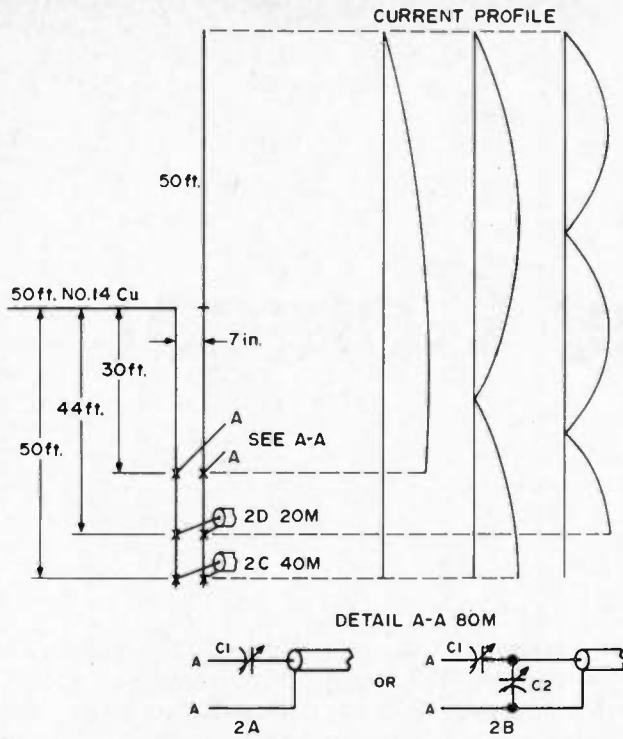

Fig. 2. Second allband antenna. Note: A jumper placed  $\frac{1}{4}\lambda$  down the line may improve the swr on 20, 15 and 10 meters.

antenna system is simple since tuning is done after all elements have been erected or installed. The inverted vee is a 100 foot roll of number 14 copper wire that was cut into two 50 foot sections. The open wire line was made from another 100 foot roll of number 14 copper wire. The tower used for center support was constructed from three 18 foot, 2 x 4 sections of wood and has a height of 30 feet when raised. The open wire line is brought down the tower using TV type standoff insulators for support and spacing. They are screwed directly into the wood to provide six to seven inches spacing between the open wire conductors. The number of supports should be minimized to reduce losses from leakage currents. Also, the TV type supports will need additional insulation if arcing is observed. A one inch length of RG/8 insulation slipped into the TV spacer with the number 14 wire run in the center of the insulation has worked well for me, even in rainy weather. Since the

open wire line is longer than 30 feet, it is continued along the side of the house with the same construction techniques just described.

Several months' operation on the air providing signal strength comparisons with other hams and the ability to be heard in pileups was convincing evidence that this system performs as well as a farm of dipoles. Although the antenna shown in Fig. 2 tunes broadly on 80 meters, the shorter antenna in Fig. 1 produced comparable reports. The Fig. 1 antenna would be ideal for the Novice who wants to operate on 80, 40 and 15 meters with a single 40 meter dipole but is restricted to a narrow frequency range or has insufficient property for a full 80 meter dipole. The antennas and their matching systems described in this article have eliminated the transmatch, reduced rf in the shack, reduced antenna losses, reduced antenna costs, and increased the frequencies available from a single inverted vee antenna. ■

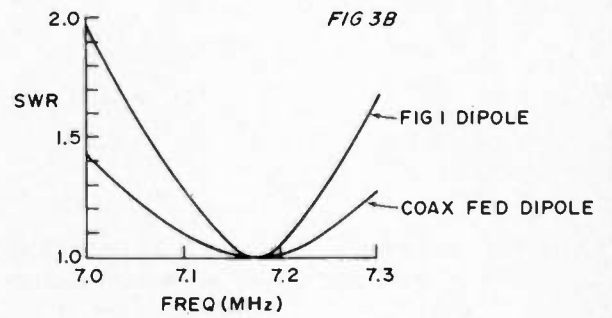
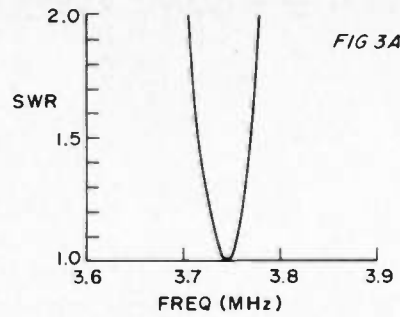

Fig. 3. Swr curves for Fig. 1.

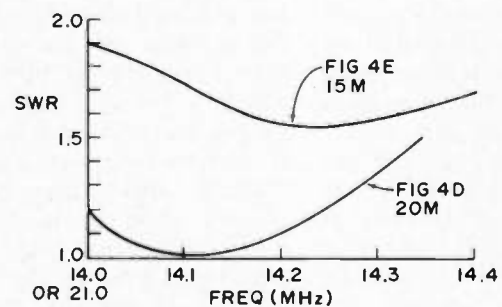
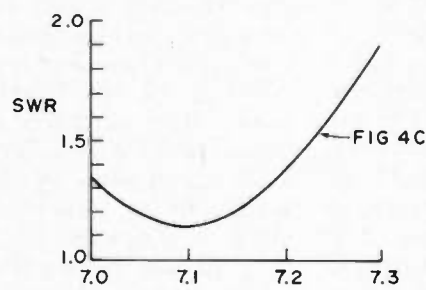
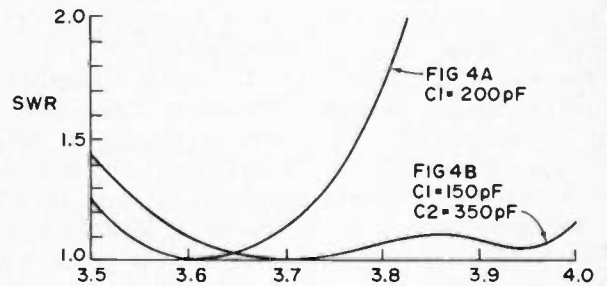

Fig. 4. Swr curves for Fig. 2.



# Squaring the Conical

If you don't mind having an antenna in your yard which looks a bit like a piece of modern art, the conical monopole has some extremely interesting advantages. The form described here can be constructed inexpensively from TV masting and lots of wire. It is extremely rugged and storm-proof since, as will be seen later, it is practically the equivalent of having a 30' high TV mast guyed by about 200 small guy wires!

The conical monopole as such is not a new form of antenna. It has been widely used on VHF and sometimes on the HF bands, formed in its usual circular shape as shown in Fig. 1. It is a vertically polarized antenna and offers extremely broad bandwidth while maintaining a low swr. In a sense, it is similar to the wide-band disccone antenna, although it does not have the large "top-hat" element required of the disccone. The antenna functions over a broad frequency range because the circumference of the cone-shaped monopole becomes resonant at different frequencies as determined by the extent of the circumference variation from top to bottom of the monopole. Within the frequency range for which the

antenna is constructed, therefore, it is continuously in resonance rather than just being resonant in certain distinct bands. A typical frequency range spread for such an antenna is about 4:1 although this will vary a bit depending upon the exact design used.

The design presented in this article covers basically from 80 through 20 meters. However, it will show good performance up to about 19 MHz or so. So, if the 18 MHz band ever becomes a reality in the distant future, the antenna would, in fact, continuously cover 5 amateur bands (80, 40 and 20 plus the proposed 12 and 18 MHz bands). The antenna is fed directly with 52 Ohm coaxial cable and requires no additional tuning devices. A simple loading coil can be switched in at the base of the antenna to extend its range to 160 meters, if desired, and it should show very creditable performance on this band — especially if a reasonable ground radial system is used. If one has the real estate available, more than one antenna could be used to form a directional array by proper phasing of the current fed to each antenna. Since the spacing of the antennas would be fixed physically but

vary electrically on the different bands, this would mean, however, that the phasing lines between antennas would have to be changed on each band.

The basic conical antenna as shown in Fig. 1 would seem to present some almost impossible constructional aspects on the lower frequency bands if the classic

formula dimensions of the antenna were maintained. For instance, for basic 80-20 meter coverage the overall height has to be 32 feet. This dimension is not impossible, of course, but the upper and lower rings of the monopole have to be about 6 and 18 feet in diameter, respectively. Constructing an 18 diameter ring of lightweight tubing is

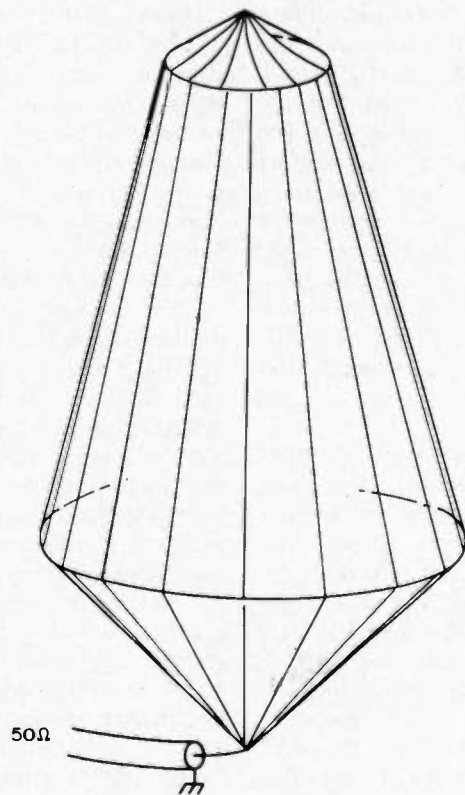

Fig. 1. Basic disccone monopole antenna is frequency independent over about a 4:1 frequency range.

hardly a simple matter for the average amateur.

The circular form of the antenna is important if absolutely omnidirectional radiation characteristics are to be achieved. But, only a slight deviation from this characteristic will result if the antenna is made square in shape instead of perfectly circular. The radiation from the corners of the antenna will suffer a bit (perhaps 3-5 dB down), but it should not be difficult for any amateur to orient the antenna with the aid of a great circle map centered on his QTH such that these points fall into areas which are of minor preference. The other advantages of this form of antenna should far outweigh this disadvantage.

A "squared-off" conical monopole for 80-20 meters is shown in skeleton form in Fig. 2. Not every wire is shown for the sake of clarity. The total mast height above the base insulating section is

30 feet and may consist simply of telescoping TV mast sections. The height from ground to the insulating section may be 2-3 feet. The upper square is located about 2 feet from the top of the mast. Each side of this square is 6 feet long. The square can be constructed from metallic tubing, but a better choice is probably PVC plumbing type tubing using the right angle fittings easily available for this type of tubing to form the square. Holes are drilled through the tubing for each wire element and a fixing wire placed around the entry and exit points of each wire to keep the overall square in place. At the top of the mast, each wire element is secured to a ring which metallically connects it to the mast.

At the base of the antenna, four approximately 6 foot tall guy posts are installed spaced 16 feet apart and centered around the central mast. The lower ring of Fig. 1 is simulated by an *insulated* wire ring running

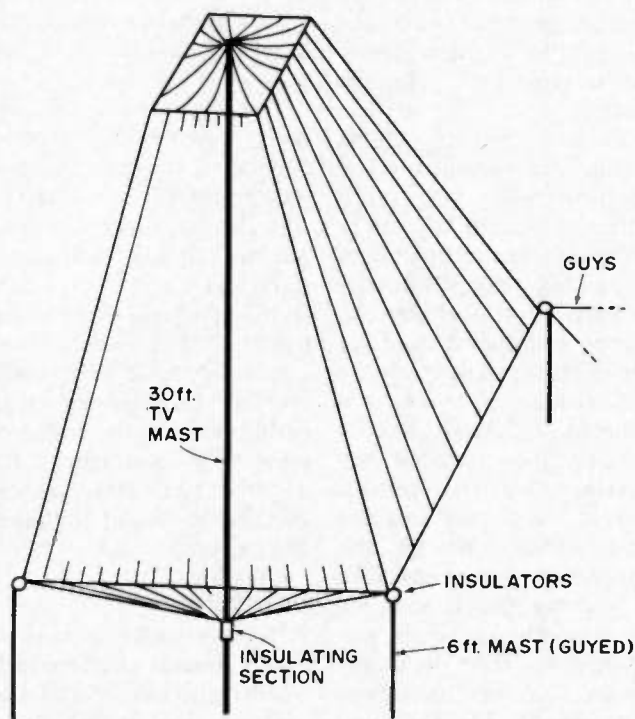

Fig. 2. Squared form of antenna form shown in Fig. 1. Distance between 6 foot masts is 16 feet. Other dimensions are discussed in text.

---

The conical monopole is a vertically polarized antenna that offers extremely broad bandwidth while maintaining a low swr . . .

---

around between the four guy posts. This wire should be particularly taut, and it may be advisable to guy each guy post in two directions, depending upon the type of soil encountered. Each wire element from the top of the antenna is run through the upper square, then to the lower wire ring (where it is soldered or clamped to the wire ring), and then to a collector ring just above the insulating section on the central mast. The spacing between the wires as they reach the lower wire ring should be about 3 inches. Belden copper-bronze antenna wire is particularly suitable, but any good antenna wire of the copper-bronze or copperweld variety will more than adequately suffice.

The center conductor of the coaxial feed line should be connected to the wire collector ring above the insulating section on the central mast. The shield is connected to the mast support pipe going into the ground. Although this type of antenna is less dependent upon ground radials than the usual type of single element vertical antenna, ground radials will improve its performance. But, again because of its unique design, the antenna does not require ground radials of the usual length as single element quarter-wave vertical antennas. A group of 10-12 radials, each being 16-17 feet long, will suffice for normal operation, although numerous experiments have shown that a greater number of radials will

improve the low angle radiation characteristics for DX purposes. Experiments have also shown that ground radial extension in the direction of desired DX performance will considerably improve performance in that direction. For instance, say one does have room to bury 16-17 foot radials all around the antenna but one's particular DX interest is South America. By making the radials pointing in the South American direction as long as possible (34 feet to infinity), considerable improvement in low angle DX radiation in that direction will occur. A rough estimate is that radials one wavelength long in the desired direction result in a 3 dB gain at the low vertical angles useful for DX purposes.

The squared conical monopole is certainly not the overall answer to HF antenna problems, but it does offer reasonably omnidirectional coverage and coverage of the main HF bands usable during the present sunspot cycle. Since the swr to the antenna also remains less than 2:1 over its design range, it also serves as an excellent antenna companion to the various solid state transceivers on the market which have broadband transmitter output circuits (non-tunable). These circuits demand for maximum power output that the antenna transmission line they work into presents a very uniform low swr pattern on each of the bands involved if the "instant" bandswitch advantage of these rigs is to be a realistic operating convenience. ■

# Secret Antennas for Cliff Dwellers

J. Craig Caston WA6PXY  
5403 Newcastle Avenue #20  
Encino CA 91316

**T**here have been countless articles published about the various antennas that can be adapted for those of us who live in the wonderful world of "urbanville." Whether it has been for convenience or necessity, many amateurs today find themselves living in an apartment, a small city lot, or the popular condominium. Admittedly, this kind of living has its advantages. But one of the greatest disadvantages for radio amateurs, however, is how and where are you going to erect an effective antenna?

After moving from a house into an apartment, I found myself confronted with this problem. I learned, sometimes the hard way, what can and cannot be done. This article will present various configurations involving what

*Fig. 1. One way to avoid publicity is shown here. If possible, wire small enough not to be seen, but strung low, will do a good job.*

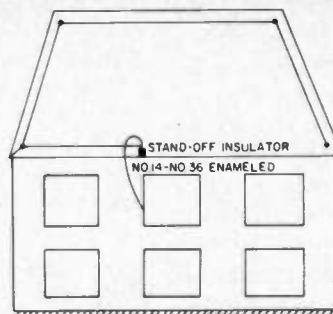

I believe is a functional all-band antenna system that anybody can use successfully, which is something that most other articles discussing antennas for urban dwellers seem to ignore.

To start, let's be honest about one always overlooked fact: the utilization of an indoor antenna. Forget it. Unless your dwelling is built of wood, it is a totally futile effort. Modern buildings are made of concrete and steel, all components that love to block rf. You may occasionally hear and work somebody with an indoor antenna, but that kind of situation is truly like working into a dummy load!

Even hanging something outside a convenient window opening will not really suffice, especially if you're looking out to an apartment canyon like I do. Remember, antennas, to work effectively, have to be installed clear and free of nearby objects.

Second, if you are planning to move into a building that requires permission for an outside antenna, and that includes most of us, just ask the manager about the possibility of erecting one. It took me three months to obtain permission to erect a simple vertical, but my persistence paid off. If the building's manager has misgivings over such an arrangement, explain to the person carefully what you plan to do. In fact, a

little persuasion on your part might turn into a blessing in disguise.

But even if you are not plagued with space or permission problems, and need just an effective antenna for 80 or 160 meters, then I have the antenna for you. What I am talking about is the end-fed, random length antenna — an antenna that is easy to construct, and yet so effective.

In terms of cost and simplicity, the end-fed is hard to beat. However, the only time anybody sees the end-fed configuration nowadays is usually around the Field Day site.

The limitations of my home brew vertical led me to try the end-fed, random length idea. A single strand of #24 enameled wire was hung out my window, led up the roof, and strung over a pole to the other end of the building, all 200 feet of it. When completed, I had an all-band, end-fed, inverted-vee type random length antenna, minus the transmatch, for \$1.29! A real winner in these peculiar times of inflation and recession.

## Description

A true end-fed random length antenna can be several wavelengths long.<sup>1</sup> It is not necessary that it be cut to resonate for any frequency; therefore, any convenient length will suffice.

As a rule of thumb, you



should not make the length of the wire shorter than one-half wavelength at the lowest frequency planned to be used. This means that for 80 meters the antenna should be approximately 125 feet long. For 40, 66 feet. However, one source states that an end-fed can be utilized effectively down to one-quarter its lowest frequency and still work well.<sup>2</sup>

This may sound like a contradiction to the random length idea, but in relation to all other frequencies the wire will look, you might say, randomly long.

### Installations

Before erecting the end-fed antenna you should first plan the site in which it is to be strung. Doing so will facilitate the actual erection of the antenna, especially if it is to be done in a secretive way. By viewing the roof and designing a mental picture of how you want to place the wire, you can easily rearrange the antenna in your mind, thus avoiding any erection problems later on.

The best method is to have the wire attached to a pole on the roof, the higher the pole the better. But, if for any reason the antenna cannot be strung on the roof, attachment to an adjacent building or down to an open field will do just as well. That's the beauty of the antenna — its versatility.

I've already mentioned that getting at least part of the antenna in the clear is probably the most important consideration. This fact cannot be overemphasized, because the efficiency of the whole system depends upon the antenna's being in the open somewhere along its length. Figs. 1 and 2 give a couple of ideas on how this could be accomplished.

It is suggested that solid enameled wire be used for the antenna element. Enameled wire is cheap, convenient, and it is easy to handle — you just

wind it off the roll. Moreover, enameled wire can be strung, if necessary, without the use of insulators because of its protective coating. To avoid unwanted publicity, #34 or #36 wire is a good choice. Your decision on the right size will depend, again, on your own situation.

Widely different wire sizes will have a negligible effect on performance. It has been proven that wire as small as #36 can work well and handle high power levels just as easily as #12 or #14. How far you can go in power on a thin wire antenna, without damaging it, however, will have to be determined experimentally.

Where needed, insulators can be made of anything that insulates. For deceptive purposes clear plastic or plexiglas cut to suit your needs will do. Also small diameter vinyl, fishing line, or plastic tubing is a good choice to consider since it can be tied to support structures easily.

An effective way to lead the antenna up to the roof, if you use that configuration, is with stand-off insulators (see photo). Again, the proper choice and placement of insulators will depend upon your needs.

One of the nice things about the end-fed antenna is

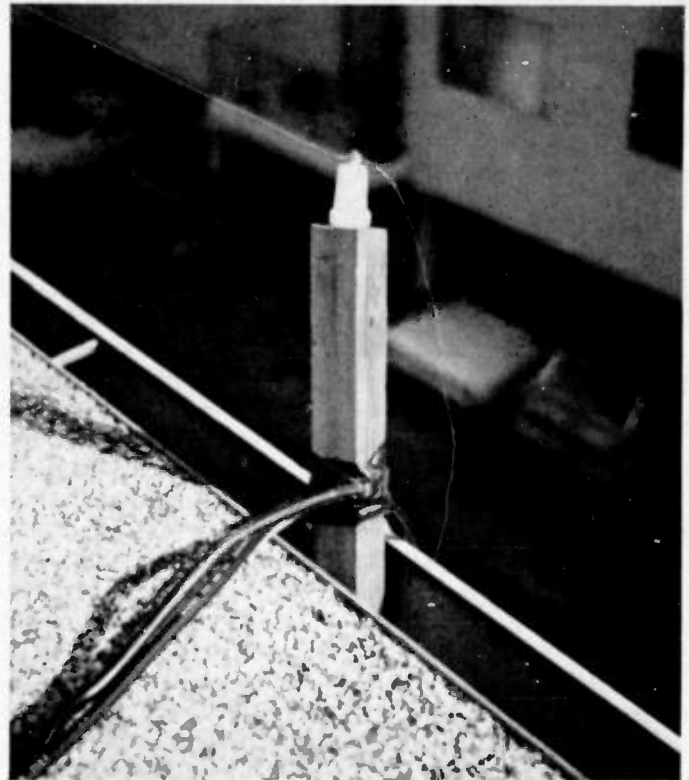

*An insulator on top of a piece of wood stuck into the rain gutter is one convenient way to lead the antenna up to the roof.*

that it requires no lead in. One end of the antenna, as the name properly says, is fed the power. However, because different impedances will be presented at the feedpoint of the antenna, depending on which band you operate, a tuner will be required.

simple coil and capacitor arrangement is all that's needed (Fig. 4). If you want to spend the money, a commercial unit will do nicely. But constructing a tuner yourself can be achieved without too much difficulty or expense. On power levels up to around 200 Watts, a broadcast band variable out of an old receiver and an

### Tuner Considerations

As you probably know, a

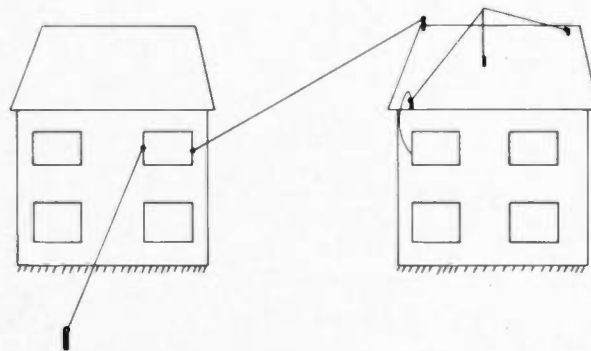

*Fig. 2. Here are three ways an end-fed can be used around a building. Note that in all three examples, the wire is reasonably clear of objects somewhere along its length.*

inductor of about 30 uH will do the job.

A check into a parts catalog will list a number of coils and capacitors that can fit your own needs. My tuner uses an E. F. Johnson roller inductor #229-203. This coil works beautifully. If you can pick one up, it is suggested you do so. Unfortunately, it has been reported that this inductor is no longer in production. A little searching, however, might produce one at a moderate cost.

C1 is a Johnson type E transmitting capacitor #154-10. It's rated about 350 pF at 3 kV. These components were chosen with the thought of using higher power in the future.

Installation of L1 and C1 into an enclosed chassis is necessary for proper shielding. The photo should give a good idea of component layout and assembly.

As an added bonus, I found that my tuner knocked out all remaining TVI, something that apartment hams are keenly aware of since interferences into just one building's TV system could easily disturb the viewing enjoyment of many people.

#### Inside the Shack

Because of the tuner, a

good ground system is needed. An effective ground will help prevent useless rf currents from flowing around the shack. If a decent ground is not used, the operator will face problems in achieving a minimum swr from his unit. In addition, his equipment will develop a condition of "biting" when he touches it.

Finding a satisfactory ground is a difficult problem for apartment dwellers. This is because the most obvious ground systems may not be readily available, especially if your apartment is several stories above terra firma.

One way to "ground" the tuner is to use a counterpoise or artificial ground. This is a wire one-quarter wave long of whatever band you use placed conveniently around the shack. The only drawback to this idea, however, is that to be effective at least one wire must be installed for each band. I have one counterpoise in use now. It's cut for 40 meters even though I frequent 80 as well. Therefore, it's possible that you might be able to get by using just one counterpoise for two bands.

Another way to help eliminate stray rf currents is to try to terminate the antenna wire at a current

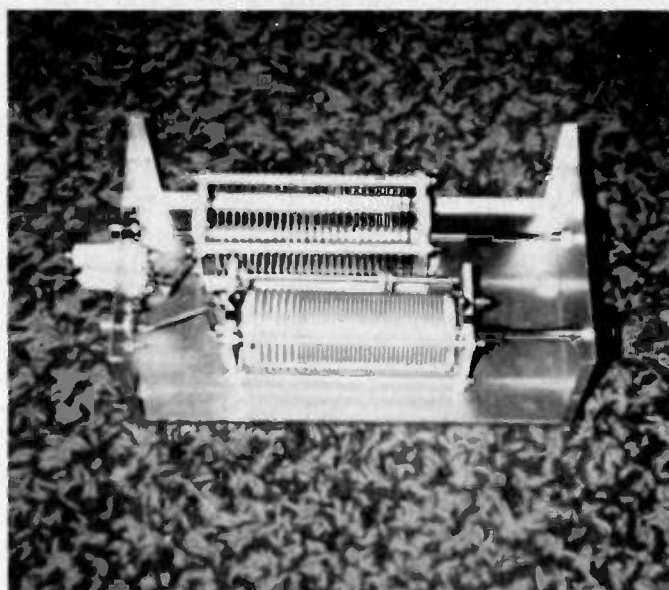

A look at the home brew transmatch. Note the standoff insulators, and the placement of L1 and C1 in the spacious chassis.

loop. This involves using a length or antenna cut for your favorite band at least one-quarter wave long or multiples thereof.<sup>3</sup> This minimizes the amount of rf introduced into the shack. Doing this is not imperative, but it might aid in stopping a hot rig.

If you can connect the tuner with a short piece of wire to some grounded water pipes or something of similar nature, then you're in good shape. In addition to the counterpoise, I have a wire running from the shack and

connected to the pipes in my bathroom shower. Quite surprisingly, this eliminated most of my ground problems.

Those wishing additional information can find an excellent article on tuners in the December, 1974 *QST* by DJ2LR/W2<sup>4</sup>, or consult *The Radio Amateur's Handbook*.

#### Conclusion

The performance of the end-fed system at my QTH has been very gratifying. DX on 40 and 80 meters has been easier to hear, while signal reports with only 200 Watts of power have been excellent from stateside stations.

It's hoped this primer will guide the amateur in making the right decisions involving the end-fed concept which fit his own individual and unique situation, while at the same time giving the amateur plagued with space and permission problems a chance to enjoy his or her hobby with a minimum of difficulty. ■

#### References

- <sup>1</sup> *The ARRL Antenna Book*, 13th Edition, ARRL, Newington CT, 1974, p. 178.
- <sup>2</sup> *Ibid.*, p. 178.
- <sup>3</sup> *Ibid.*, p. 179.
- <sup>4</sup> Ulrich L. Rohde, "Some Ideas on Antenna Couplers," *QST*, December, 1974, pp. 48-52.

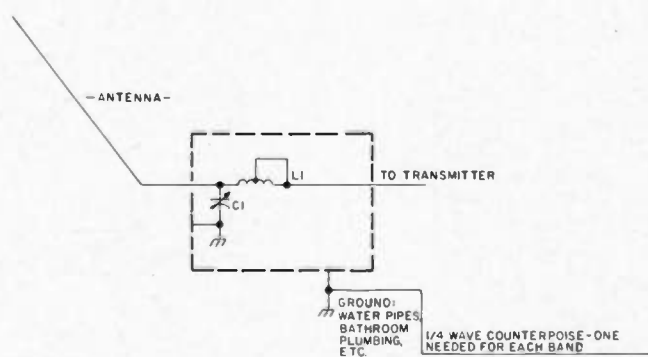

Fig. 3. C1 — 350 pF single gang variable capacitor; L1 — 20-30 uH inductor (E. F. Johnson #229-203 roller inductor suggested).

# Now...more than ever--- the TEMPO line means solid value

## Tempo VHF/ONE

the "ONE" you've been waiting for

No need to wait any longer – this is it! Whether you are already on 2-meter and want something better or you're just thinking of getting into it, the VHF/ONE is the way to go.

- Full 2-meter band coverage (144 to 148 MHz for transmit and receive. • Full phase lock synthesized (PLL) so no channel crystals are required. • Compact and lightweight – 9.5" long x 7" wide x 2.25" high. Weight – About 4.5 lbs. • Provisions for an accessory SSB adaptor. • 5-digit LED receive frequency display. • 5 KHz frequency selection for FM operation. • Automatic repeater split – selectable up or down for normal or reverse operation. • Microphone, power cord and mounting bracket included. • Two built-in programmable channels. • All solid state. • 10 watts output. • Super selectivity with a crystal filter at the first IF and E type ceramic filter at the second IF. • 800 Selectable receive frequencies. • Accessory 9-pin socket. • \$495.00

### TEMPO SSB/ONE

SSB adapter for the Tempo VHF/One

- Selectable upper or lower sideband. • Plugs directly into the VHF/One with no modification. • Noise blanker built-in. • RIT and VXO for full frequency coverage. • \$225.00



### TEMPO/fmh

So much for so little! 2 watt VHF/FM hand held 6 Channel capability, solid state, 12 VDC. 144-148 MHz (any two MHz), includes 2 pair of crystals, built-in charging terminals for ni-cad cells, S-meter, battery level meter, telescoping whip antenna, internal speaker & microphone.

FMH MC for Marine & Commercial service also available.

\$199.00



### TEMPO/CL 146A

...a VHF/FM mobile transceiver for the 2 meter amateur band. It is compact, ruggedly built and completely solid state. One channel supplied plus two channels of your choice FREE

144 to 148 MHz coverage • Multifrequency spread of 2 MHz • 12 channel possible • Metering of output and receive • Internal speaker, dynamic microphone, mounting bracket and power cord supplied. A Tempo "best buy" at \$239.00.

### TEMPO CL 220

As new as tomorrow! The superb CL-220 embodies the same general specifications as the CL-146A, but operates in the frequency range of 220-225 MHz (any two MHz without retuning). At \$299.00 it is undoubtedly the best value available today.



**TEMPO 100AL10** | SOLID STATE VHF LINEAR AMPLIFIER. 144-148 MHz. Power output of 100 watts (nom) with only 10 watts (nom) in. Reliable and compact.

### TEMPO 6N2

The Tempo 6N2 meets the demand for a high power six meter and two meter power amplifier. Using a pair of Eimac 8874 tubes it provides 2000 watts PEP input on SSB and 1000 watts input on CW and FM. Completely self-contained in one small desk mount cabinet with internal solid state power supply, built-in blower and RF relative power indicator.

\$795.00

The Tempo 2002.. 2 meters only \$695.00  
The Tempo 2006.. 6 meters only \$695.00

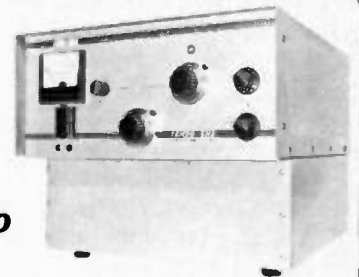

### TEMPO VHF/UHF AMPLIFIERS

Solid state power amplifiers for use in most land mobile applications. Increase the range, clarity, reliability and speed of two-way communications.

VHF (135 to 175 MHz)				UHF (400 to 512 MHz)			
Drive Power	Output	Model No.	Price	Drive Power	Output	Model No.	Price
2W	130W	130A02	\$199	2W	70W	70002	\$270
10W	130W	130A10	\$179	10W	70W	70D10	\$250
30W	130W	130A30	\$189	30W	70 V	70D30	\$210
2W	80W	80A02	\$169	2W	40 V	40D02	\$180
10W	80W	80A10	\$149	10W	40W	40D10	\$145
30W	80W	80A30	\$159	2W	10W	10002	\$125

FCC Type accepted models also available.

Most of the above products are available at dealers throughout the U.S.

# Henry Radio

11240 W. Olympic Blvd., Los Angeles, Calif. 90064 213/477-6701  
931 N. Euclid, Anaheim, Calif. 92801 714/772-9200  
Butler, Missouri 64730 816/679-3127

Prices subject to change without notice.





One of the most popular antennas is the so-called "inverted V," which is actually a dipole with the legs drooping at approximately a 45° angle on each side of a single support. The single support is the secret of its appeal, because almost everyone can find something to support this type of antenna, as in Fig. 1, where it is supported on a TV mast pulled up with a pulley. This way it can easily be lowered for tuning. However, even if not on a pulley, it's quite an easy antenna to tune, because the legs are so close to the ground.

The ideal inverted V antenna would have the included angle (a) 90°, and the legs in the same plane as the tower. It would be a little better if the top was supported about 3' away from the metal tower, to keep the tower out of the field of the antenna. See Fig. 3.

However, the antenna will work well — even in the most unusual configurations. See Fig. 2. For example, my available yard for antennas is 74' x 70', which is no way close to the ideal required space for an 80 meter V. I have two towers, 48 feet apart. Figs. 4 and 5 show the slope and separation of my antennas.

These antennas have an important amount of vertical polarization, as when angle "a" is less than 90°, the vertical polarization predominates, and when it is greater than 90° the horizontal polarization predominates. Thus the antennas are good DX antennas — better than a horizontal dipole. They do, however, show many characteristics of the horizontal dipole, being less subject to man-made noise and more to high angle radiation than the vertical. For example, when I am transmitting to K1GZL in Berlin, N.H., he says my signal is about 20 dB better

from the inverted V than the vertical, but my vertical is about 3 S-units better in the Antarctic than the inverted V. When I am talking to W5VSR in New Orleans the situation varies. Some nights I am better on the V, and some nights on the vertical, and some nights I will fade out on one and come in strong on the other.

Although I am using baluns on both, there might be some advantage to not using baluns, since I am in the

northern part of the country. An inverted V without a balun tends to be directional toward the side of the antenna with the shield of the coax connected. Thus the pattern without a balun tends to be skewed to one side. Whether this is an advantage or disadvantage depends on where you are and what you want. I am of the opinion that the balun is unnecessary for general use, provided that your antenna is resonant at about the frequency you

work, and that the coax lead-in is a multiple of a half wave at that frequency.

Since I am using baluns, I am also using separate feed lines to the 40 and 80 meter antennas. Without baluns you can easily feed both from the same feed line, and just parallel them, thus saving quite a bit in these days of high costs (by not using two baluns and perhaps a hundred feet less of coax).

When you tune up an inverted V you will find that

*Jerrold A. Swank W8HXR  
657 Willabar Drive  
Washington Courthouse OH 43160*

## The Novice Inverted Vee

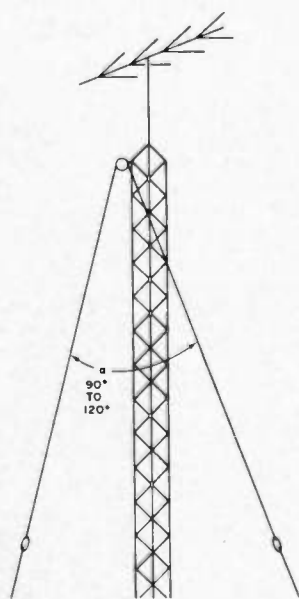

Fig. 1.

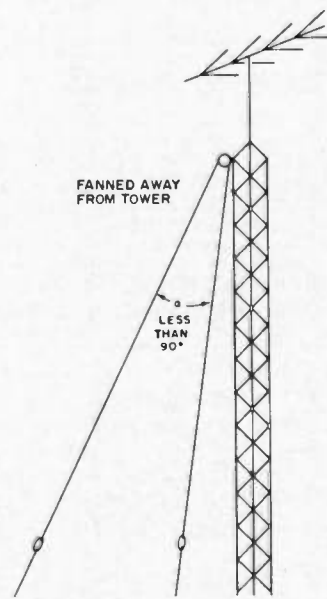

Fig. 2.

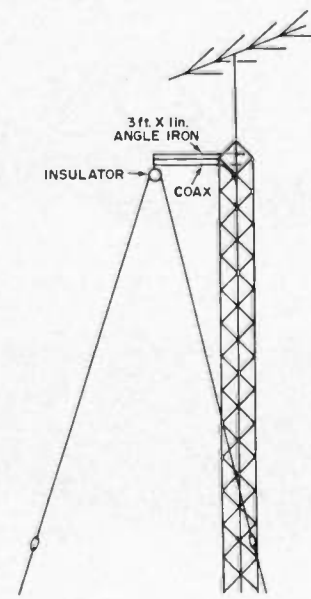
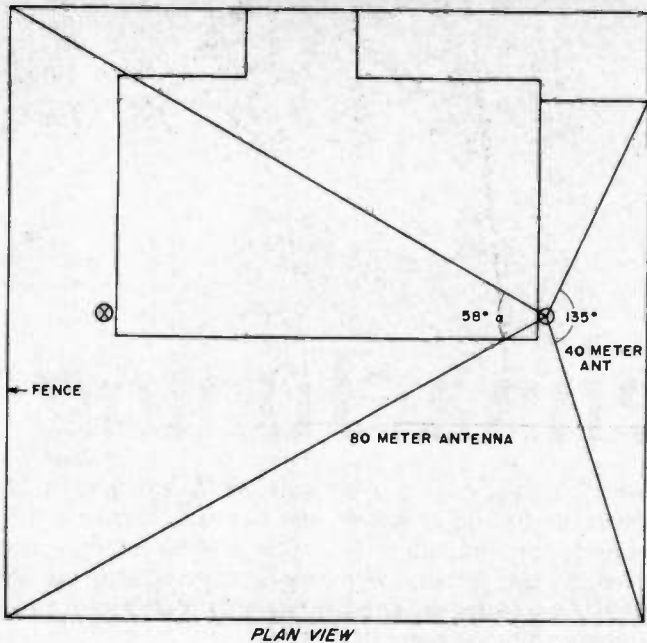

Fig. 3.



PLAN VIEW

Fig. 4.

it is very easy to tune and very easy to understand. It is best to cut it a little long, perhaps as much as two feet. When you measure it with an swr bridge it may look like it will never tune, but start taking off about six inches at a time and measure the bottom of the range you want. When it starts to go down toward 1:1 measure about 100 kHz on each side of the desired frequency, and find where the center of the range is. Don't worry if it will not go lower than 2:1 — just find the center. When you have it centered, then start to close or open the angle at the bottom, and raise and lower the legs a little. This will improve the swr, and if you

have enough room you can get it right down to 1:1. At this point you will find it quite broad tuning, and probably it will cover the whole range you want with swr less than 1:1.5.

Of course, if you have to, you can pull up an inverted V into a tree, or on the side of your house, or on a piece of masting attached with TV hardware to a soil pipe or chimney.

I think that every ham should have both a vertical and an inverted V or dipole. The signals often swing greatly from one to the other. I had a ham in the Antarctic tell me one night that he had two receivers tuned to me, one on a vertically polarized

antenna and the other on a horizontally polarized antenna. He put one on each side of the room so that he was seated between them and he said it was beautiful. The signal would fade from one to the other and he never missed a word.

I have given you the figures for the Novice bands, although my antennas are tuned several inches shorter for where I work.

The regular dipole at the center has an impedance of about 72 Ohms, so it is better suited to RG11 or RG59. However, the downward slope of the legs on an inverted V makes it an excellent match for RG8 or RG58.

Incidentally, at Novice powers don't waste your money on RG8. RG58 is quite adequate. The power rating of RG58 at 30 MHz is 430 Watts, and the loss of 100 feet of RG58 at 7 MHz is just one dB greater than RG8. That means you would barely be able to tell the difference. At 3.7 MHz it would be even less.

Incidentally, remember that you can use the 40 meter inverted V on 15 meters, and the 80 meter inverted V on 10 meters, so you can have an all band Novice antenna with a single feed line.

Also, if you have to put up a push-up mast or pole you can use the two inverted V antennas as guy lines. ■

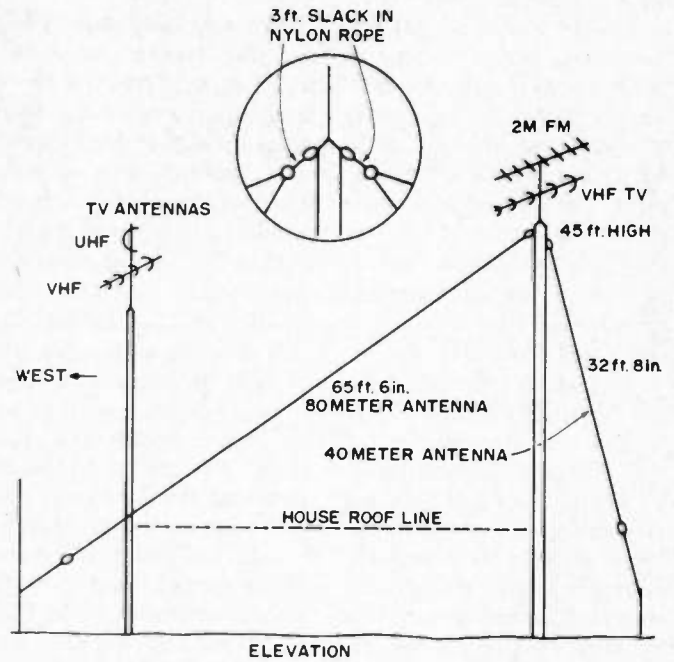

ELEVATION

Fig. 5.

# FAST SCAN AMATEUR TELEVISION EQUIPMENT

• BROADCAST QUALITY PERFORMANCE • SOLID STATE



AX-10 TRANSMITTER



AM-1A RCVR MODEM



**Aptron Laboratories**

Box 323 Bloomington IN 47401

# Closed Loop Antenna Tuning

**T**uning Yagi-Uda beams and quads can be a very time-consuming task, requiring many man-hours to perform. Usually several helpers are needed to make adjustments and to take field strength measurements. I have developed a technique which requires only one person to successfully tune an antenna with the aid of a couple of pieces of equipment. The method developed uses an rf source in the far-field and the station receiver as a sensitive field strength measuring device. A circuit is connected from the receiver to a speaker, which, in turn, can modulate a small 100 mW transmitter. The receiver for the 100 mW transmitter is carried by the person making adjustments on the antenna. Thus, a closed loop feedback system is used to permit optimum adjustment of the antenna. As a bonus, the far-field signal source can be used to make pattern measurements as the antenna is

rotated, the receiver monitoring relative field strength. Fig. 1 shows a block diagram of the system.

## Circuit Details

The far-field signal source is a small, low power oscillator (Fig. 2). Transistor Q<sub>1</sub> is used in a Pierce fundamental mode oscillator. A diode full wave rectifier is used as a frequency doubler. A small Amidon iron powder toroid is used to develop the push/pull signal needed for full wave rectification. Transistor Q<sub>2</sub> acts as an amplifier for the doubled frequency. Another transformer, T<sub>2</sub>, steps the output impedance down to a low value. The crystal is chosen such that the harmonics will fall within the amateur bands. I used a 7060 kHz crystal which permits field strength measurements at 14,120, 21,180, and 28,240 kHz. The output signal is rich in the 2nd, 3rd and 4th harmonics and produces a strong source

for the 20, 15 and 10 meter bands. The oscillator is powered by 2 six volt batteries connected in series to produce 12 volts. Since the current drain is low the batteries will last a long time. Two wires about 5 feet long are connected as an antenna to the output of the amplifier. Ideally, the far-field source should be at the same height as the station antenna, but useful results will be obtained by mounting the transmitter/antenna on the top of a tall ladder leaning next to a roof. The transmitter should be at least 5 wavelengths away for meaningful results.

The unit that connects to the receiver is a voltage-to-frequency converter. The voltage developed across the meter is used to vary the frequency of an audio oscillator. The maximum voltage developed across the meter can either be measured with a sensitive voltmeter or be computed. For the Heath SB-102,

the internal resistance is 100 Ohms, and the full scale reading is 1 mA. Thus, the full scale voltage across the meter is:

$$V_{MAX} = I_{F.S.} \times R_M = 1.00 \text{ mA} \times 100 \text{ Ohms} = 100 \text{ mV}$$

The 100 mV signal is amplified by a 741 operational amplifier as shown in Fig. 3. The gain of the amplifier is 40 dB. Thus the S-meter full scale voltage of 100 mV would become 10 volts at the output of the amplifier. This voltage is used to drive the modulation input on the 555 free-tuning oscillator. The 555 oscillator oscillates at a frequency determined by the resistor/capacitor combination connected across it. The frequency of oscillation is given by the equation:

$$F = \frac{1.44}{(R_A + 2R_B)C}$$

For the values given, the free running frequency is roughly 1 kHz. As the 741 amplifier drives a current into the 555, however, this frequency is a little lower than 1 kHz and becomes greater as the drive current is reduced. Thus, the effect is to hear a higher frequency for a lower S-meter reading, and a lower frequency as the S-meter reading becomes stronger. The 555 drives an 8 Ohm speaker. The 470 Ohm series resistor is used to limit the current to a

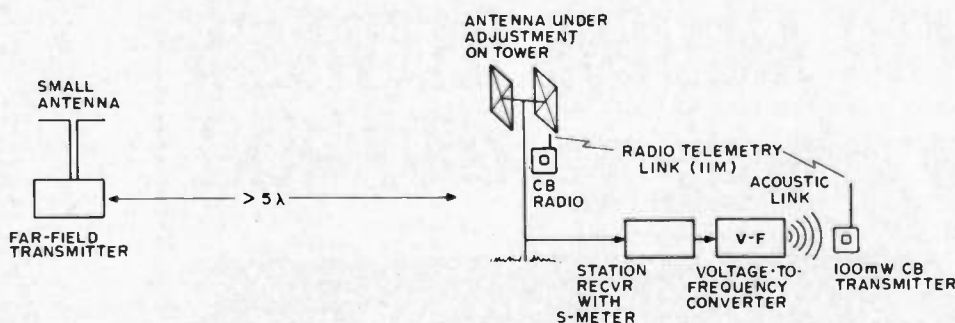

Fig. 1. Closed loop antenna adjustment block diagram. If CB radios are not available, a two wire speaker cable could be run up the tower for monitoring. Far-field transmitter is a milliwatt transmitter with harmonics falling inside the 20, 15 and 10 meter bands.



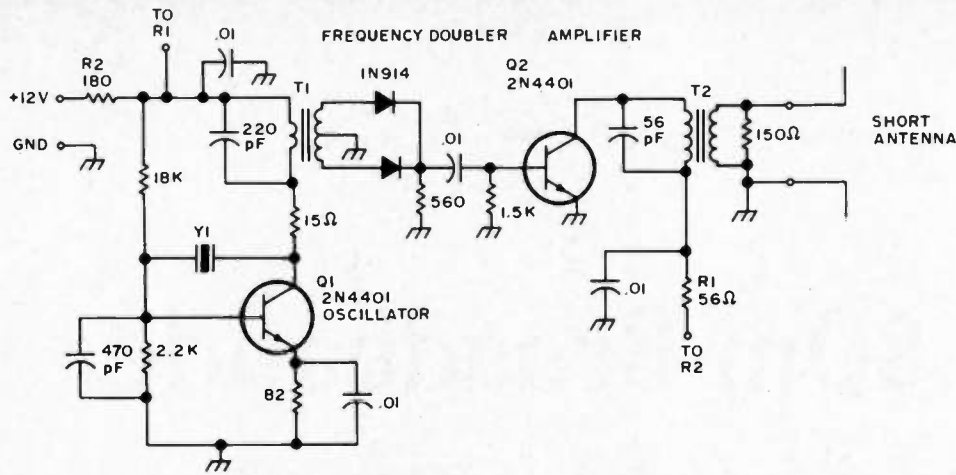

Fig. 2. Schematic of the milliwatt transmitter for the far-field source.  $Y_1$ : 7.00-7.115 MHz; harmonics fall within 20m, 15m and 10m bands;  $T_1$ : Amidon Core T50-2, primary 22 turns #28, secondary 20 turns #28, center-tapped;  $T_2$ : Amidon Core T50-2, primary 22 turns #28, secondary 5 turns #28.

safe value, and yet still permit a loud tone to be heard.

The tone from the speaker is monitored as an indication of relative field strength level. In the prototype, a 100 mW citizen's band walkie-talkie was used as a telemetry link between the receiver and the antenna on top of a tower. The walkie-talkie was taped "on," and the speaker was acoustically coupled to the unit. The walkie-talkie is a very good and inexpensive wireless telemetry link. Both units were bought for less than \$10 several years ago, and similar units are still available. Since the distance between the walkie-talkies is not far, the antennas on the units can be retracted somewhat to limit their range. If it is not possible to find any walkie-talkies, then a two wire system can be rigged to permit hearing the speaker at the antenna tuning site. The wireless approach is better because there are no wires to get tangled in, and the volume of the sound can be adjusted on site.

When coupling the voltage-to-frequency converter to the receiver, a battery or isolated supply should be used to power it. This is because the S-meter circuit may be at a high potential above ground, and

the return ground on the voltage-to-frequency will also be at this high potential. This high potential is called a common mode voltage. The 741 amplifier will not function if its common mode voltage is too great. If a common ground between the converter and the receiver is not used, the 741 operational amplifier will only detect the differential voltage across the S-meter and it will not respond to the common mode voltage.

### Operation

The voltage-to-frequency converter should be connected across the S-meter. As a signal is tuned in, the tone from the 555 oscillator will change pitch. The far-field source should then be placed several wavelengths away and

tuned in with the receiver connected to the antenna. If the front-to-back ratio is to be optimized, then the adjustment of the antenna should be done to minimize the S-meter reading while the antenna is pointed away from the far-field source. On a quad, for instance, the reflector stub should be varied until the receiver reaches a minimum signal strength. The tone from the 555 oscillator should be monitored for the highest possible pitch. The human ear can detect fairly small changes in pitch if a continuous tone is heard at all times. For front gain optimization, the beam would be pointed towards the source and the pitch from the telemetry link would be lowered as much as possible,

indicating maximum frontal gain.

Once the adjustments are made, the far-field source makes an ideal reference to make relative field strength measurements with. If a calibrated output signal generator can be found, then a matched S-meter reading can be taken between the antenna and the generator output. By plotting the relative output level from the generator vs. bearing, a polar plot of field strength can be taken. The S-meter is used solely as a matching device, matching the antenna output to the calibrated generator output. It is surprising how uncalibrated S-meters are in terms of real S units to absolute units (an S unit is defined as a 6 dB change in signal strength). For signals which barely deflect the S-meter, sides of beams for instance, an audio meter may be used to match the generator's output to the antenna's output.

For antennas such as quads it is gratifying to know that optimum adjustments can be made without a number of people needed. Since the quad is fairly easy to reach from a tower, it is very convenient to be able to make final adjustments while the antenna is in place. I hope this method will create interest in different approaches to solving an old problem — how to tune an antenna. ■

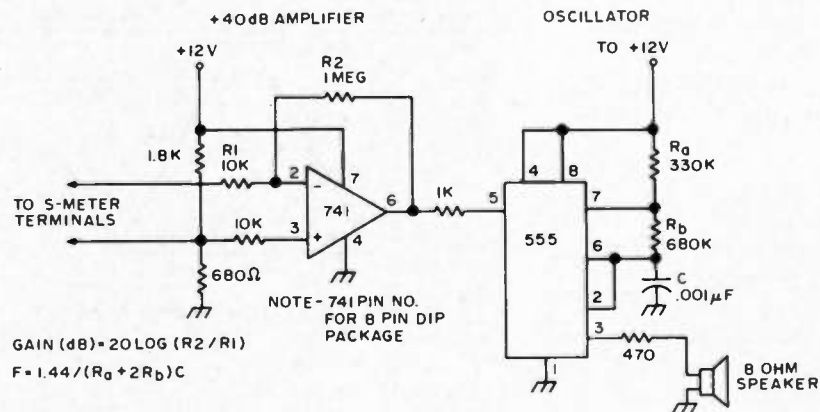

Fig. 3. Schematic of the voltage-to-frequency converter. A 100 mV input signal will cause a maximum frequency change at the output of the 555 astable oscillator.

# The 75-80m Broadbander

Some time ago, I operated with an all band multi-element dipole antenna. The antenna worked quite well (for a dipole antenna) but generally left me in the bottom of pileups on 20 and 15 meters. This eventually led me to a more competitive antenna for the higher frequencies. The multi-band dipole became redundant (and worse yet, tended to distort the quad's pattern).

However, I wanted to increase the bandwidth of the 80 meter dipole, as my operation generally is evenly divided between CW and SSB operation. After some thought, the elements of the dipole for 15 and 10 were removed, and an attempt was made to extend the 20 meter element to a length suitable for 75 meter operation. Reason told me that if you could combine dipoles for 20 and 40, etc., why not 80 and 75?

Due to space limitations in the K2VGD estate, the 80 meter antenna was folded into a "Z" shape, to fit a plot 75' wide. The apex of the antenna system was at 30 feet and the ends were attached to 4 television-type aluminum masts, fastened to the fence. In attaching the 75 meter antenna, I ran the elements

backwards across the two masts, thus overlapping the last 20 feet of each element. As one element was insulated, no problems with shorting were anticipated. The antenna is fed with a random length of RG-8/U and a W2AU balun.

In testing the design, the lowest swr was expected at 3550 and 3900 (the design length of the antennas). Much to my surprise the antenna

exhibited high swr below 3650, but less than 1.5 to 1 between 3650 and 4000 kHz, with no peaks or dips within this portion of the band. After several days of experimentation, the length of the CW section approached the length necessary for operation at 3400, with the 75 meter antenna cut for 3900. The swr plot is included in Fig. 1.

While I make no pretense of having the exact technical

explanation of the results, it would appear that the ends of the antenna, in overlapping, inductively and capacitively couple the two elements to one another in such a way as to cancel the reactance that would be present at the feed-point. Element lengths do not appear to follow theory exactly, which in all probability is due to the fact that the ends are ten feet off the ground, and the apex is but 30 feet high, far from the ideal  $\frac{1}{4}$  wave height. However, there has been no evidence of very high take-off angles, as no difficulty is encountered working either with the West Coast, Europe or even as far away as New Zealand on 75 (5x8 in ZL-land with 900 W PEP).

The 40 meter dipole does not appear to be affected by the 80 meter elements. If anything, it seems to have broader than normal characteristics.

No attempt is made to convince others that "this is THE antenna" for 80 meters, but rather, with the declining propagation on the higher bands, to encourage experimentation by others in limited space, broadband systems. Most of these types of antennas use wire elements, and thus are relatively inexpensive. ■

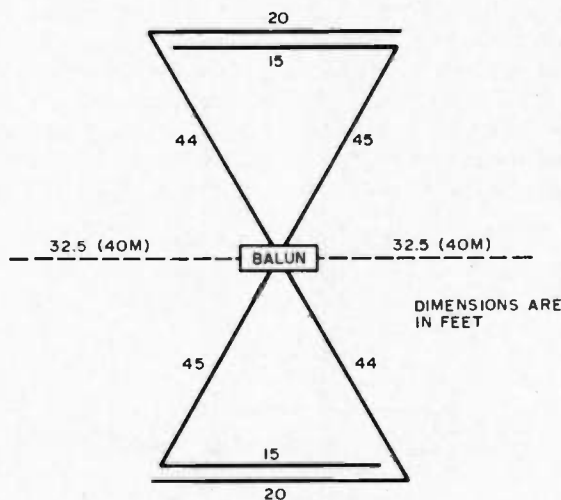
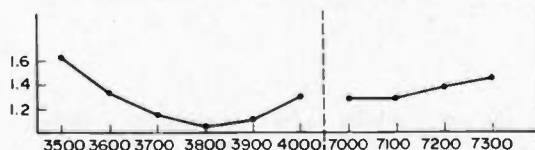

Fig. 1. Vertical view with swr plot.



# Special Crystal Deals

CALL OR WRITE  
FOR OUR LOW PRICES

*Now in stock*

*The latest in Synthesized and crystal rigs available  
OUR HAMS SERVE YOU!*



ICOM 22A 146 - 148



KLM Multi-2000 A 144-148  
FM-CW-SSB

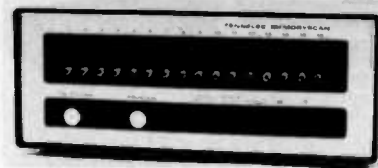

Tennelec Memory Scanner 30-50 146-170  
450-510 MHz



ICOM 230 146-148  
FM



Icom 21-A 146-148



Brimstone 144 142-149  
FM

See Audioland for all your HAM  
and AUDIO product needs

AUDIOLAND is now offering high trade-in prices for your used equipment. Write for trade-in prices and price quotes. Now in stock - CUSHCRAFT - REGENCY - SBE - HAL COMMUNICATIONS - NEWTRONICS - HY GAIN - AMPHENOL - TURNER - E.V. - SHURE - STANDARD - TEMPO. 3000 xtals for most rigs. Rotors and cables. Stereo and Quad equipment - and much more. N.P.C. regulated power supplies. All major charge cards accepted. Several finance plans available. Write for our latest trade-in listing.

**"SEE YOU AT DAYTON"**  
**Audioland**

36633 S. Gratiot, Mt. Clemens, Michigan 48043

Phone: (313) 791-1400



# HERE ARE THE BUYS FROM GENAVE

## GTX-100



**1 1/4-Meter FM  
100 Channel Combinations—12 watts**

Separate controls for independent transmit and receive frequency selection . . . Pre-selected paired frequency lock allows one knob operation . . . Backlighted.

Down from \$199.95 **\$149<sup>95</sup>**  
(Incl. 223.5 MHz)

## GTX-600



**6-Meter FM  
100 Channel Combinations—35 watts**

Separate controls for independent transmit and receive frequency selection . . . Pre-selected paired frequency lock allows one knob operation . . . Rear panel external speaker jack . . . Optional mic gain control and sub-audible tone mod possible.

Down from \$199.95 **\$149<sup>95</sup>**  
(Incl. 52.525 MHz)

**IN STOCK—  
NOW . . . GENAVE STOCKS MOST  
COMMON 2-M CRYSTALS  
FOR IMMEDIATE DELIVERY**

These crystals can be used in most makes that employ the following circuitry:

**Transmit:**  
12 times for use in 32 pf capacitance circuits  
**Receive:**  
3 times for 10.7 MHz IF in 32 pf capacitance circuits (low side)



**Use This Handy Order Form**

4141 Kingman Dr., Indianapolis, IN 46226  
(317+546-1111)

NAME \_\_\_\_\_ AMATEUR CALL \_\_\_\_\_  
ADDRESS \_\_\_\_\_ CITY \_\_\_\_\_ STATE & ZIP \_\_\_\_\_

Payment by:  
 Certified Check/Money Order  Personal Check  C.O.D. Include 20% Down  
Note: Orders accompanied by personal checks will require about two weeks to process.  
20% Down Payment Enclosed. Charge Balance To:

BankAmericard # \_\_\_\_\_ Expires \_\_\_\_\_  
 Master Charge # \_\_\_\_\_ Expires \_\_\_\_\_ Interbank # \_\_\_\_\_

Sub-Total: \$ \_\_\_\_\_  
TOTAL: \$ \_\_\_\_\_  
(minimum order \$12.00)

IN residents add 4% sales tax: }  
CA residents add 6% sales tax: { \$ \_\_\_\_\_  
All orders shipped post-paid within continental U.S.  
follow 8 weeks delivery.)

MADE IN  
**US**

**GTX-200-T**

2-meter FM, 100 channel combinations, 30 watts with factory installed tone encoder (Incl. 146.94 MHz)



**\$249<sup>95</sup>**

**GTX-200**

2-meter FM, 100 channel combinations, 30 watts (Incl. 146.94 MHz)



**\$199<sup>95</sup>**

**GTX-100**

1-1/4 meter FM, 100 channel combinations, 12 watts (Incl. 223.5 MHz)



**\$149<sup>95</sup>**

**GTX-10-S**

2-meter FM, 10 channels, 10 watts (Xtals not included)



**\$139<sup>95</sup>**

**GTX-2**

2-meter FM, 10 channels, 30 watts with pushbutton frequency selector (Incl. 146.94 MHz)



**\$189<sup>95</sup>**

**GTX-600**

6-meter FM, 100 channel combinations, 35 watts (Incl. 52.525 MHz)



**\$149<sup>95</sup>**

**GTX-1**

2-meter FM, 6-channel, 3.5 watts Hand-Held

**\$249<sup>95</sup>**  
(Bat. not incl.)



**GTX-1T**

Same as GTX-1, plus Factory Installed Tone Encoder

Operate Auto Patch  
**\$299<sup>95</sup>**  
(Bat. not incl.)

Ringo Ranger ARX-2 6 db 2-M Base Antenna @ \$29.95 \$ \_\_\_\_\_

Lambda/4 2-M and 6-M Trunk Antenna @ \$29.95 \$ \_\_\_\_\_

TE-I Tone Encoder Pad for plug-in installation on most amateur transceivers @ \$59.95 \$ \_\_\_\_\_



TE-II Tone Encoder Pad for installation on most Hand-Helds @ \$49.95 \$ \_\_\_\_\_

PS-1 AC Power Supply for use with all makes of transceivers 14 VDC-6 amps @ \$69.95 \$ \_\_\_\_\_

and the following standard crystals @ \$4.50 each \$ \_\_\_\_\_  
Non-standard crystals @ \$6.50 each: \$ \_\_\_\_\_

For factory crystal installation add 8.50 per transceiver.

### ACCESSORIES FOR GTX-1 and GTX-1T

- PS-1B Optional Nicad battery pack \$29.95 \$ \_\_\_\_\_
- PS-2 Charger for GTX-1(T) battery pack \$39.95 \$ \_\_\_\_\_
- GLC-1 Leather carrying case \$12.95 \$ \_\_\_\_\_
- TE-III Tone Encoder (for use with GTX-1) \$49.95 \$ \_\_\_\_\_

CLIP OUT AND ORDER NOW

CURSES!  
FOILED  
AGAIN!

STOP THE  
RIP-OFF  
ARTIST!



## IF HE CAN'T SEE THE ANTENNA (OR MOUNT) HE DOESN'T KNOW WHICH CAR TO HIT!

The SouthCom FOILER can save the loss of your valuable mobile unit by removing all evidence of your unit when you leave your car! It is well known that the mobile 2 way radio is now the prime object of thieves, now comprising up to half of the reported thefts in some areas! The thief knows that the quick way to find his target is to scout parked cars for antennas or antenna mounts. (The practice of removing the antenna and leaving the mount showing is no real deterrent.) The SouthCom FOILER allows you to stow your antenna and mount in your trunk in 10 seconds, leaving no external evidence of your unit to attract would be rip-off artists.

### CONSIDER THESE FEATURES THAT MAKE THE FOILER SUPERIOR TO ALL OTHER SYSTEMS:

- Economical; adapts to your existing antenna and trunk lip mount.  
No expensive antenna or mount replacement.
- Quick to install with only 2 screws.
- Once installed, permits mounting & demounting antenna in 10 seconds!
- Maintains sure "ground" connection for proper antenna function.
- Fits virtually all cars and trunk-lip mounts.
- Absolutely the best and most economical means of theft protection for your mobile unit.

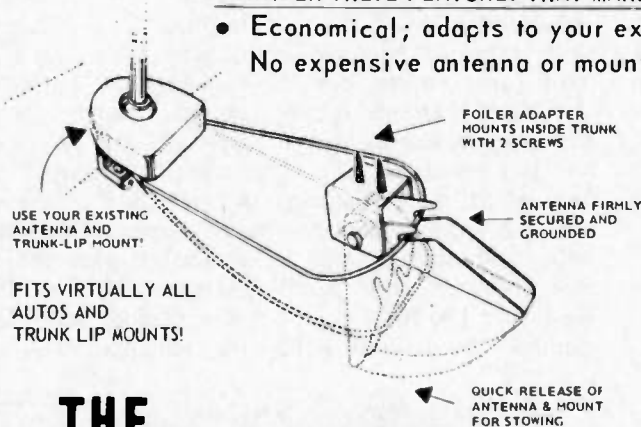

THE  
**FOILER**  
PATENT APPLIED FOR

ONLY **4.95**



South Com, Inc. P. O. Box 11212 • Ft. Worth, Texas 76109 • Phone (817) 293-6590

NOTE: If FOILER not yet available at your dealer, order direct. Add 50¢ Postage & Handling.

DEALER INQUIRIES INVITED

# The Magic of a Matchmaker

**I**t isn't necessary to settle for an inefficient antenna because you don't have the space to put up a beam or a good high dipole. Even if you don't have the time to put up an antenna farm before it's time to move, or if the landlord frowns on antennas in the yard, you can still put out a good signal. The key is the use of an antenna tuner. A tuner will allow you to use almost any length of wire, and if you plan ahead a bit, you might even get some gain.

I've used an antenna tuner before, with an end-fed one wavelength Zepp on 80, so when I needed an ail band antenna that I could put up in the trees, the solution was obvious. Unfortunately, someone had relieved me of the Johnson Matchbox that

had served me so well. It was necessary to build a tuner.

The unit that I eventually built was the product of a little thought and a lot of scrounging. I didn't have any of the major parts needed, so I had to rely on my friends' junk boxes. Vern WB4BER came up with a high voltage capacitor, and Lloyd WA4HYT furnished a toroidal tank coil. Armed with these parts, I decided that this was one project that would look decent enough to put next to the rig, so I bought a wooden cabinet from Radio Shack (\$2.00 on the "junk" table).

The special characteristics of toroids are well known. The one that interested me at this point was size. I had just bought a used FPM-300, and, if I could make a small enough tuner, maybe I could

put together a suitcase-sized station. The cabinet for the tuner was in fact just the right size to fit in the suitcase.

The circuit I would use had already been determined by the parts on hand: an "L" match and variations. With this in mind, I built a hay-wired matcher to test the idea. I didn't know if the toroid was suitable for high frequency use and had to find out before I got the whole project finished. Feeding a 14 meter wire, results were satisfactory, and I was able to match 300, 600 and 2000 Ohm loads on the five HF amateur bands.

I replaced the original front panel on the cabinet with a piece of sheet aluminum and mounted the coil on it. The coil is actually 18 turns of #12 wire wound on two T-250 cores, with two lucite end spacers, and is probably much larger than is needed for 150 Watts of rf. I mounted the coil to a 12

position tap switch so that the switch and coil would make a compact assembly, and put the switch right of center on the panel. The capacitor, which is a 240 pF Hammarlund unit, was mounted on a piece of fiberglass on the side of the cabinet, so that both the rotor and stator were isolated from ground. Input and output connections were placed on the back panel.

Again, operating results were good. However, when I tried to feed the antenna through coax, I was unable to get a match on any band. The cure for this was to increase the matching circuit variations available. This was done by wiring in a 3 pole 5 throw ceramic switch. This was originally a 4 pole unit, but between 10:30 and 11:00 pm I broke one of the wafers, and it took a little thought to come up with the circuit changes necessary. Incidentally, besides being ceramic, the switches have silicone

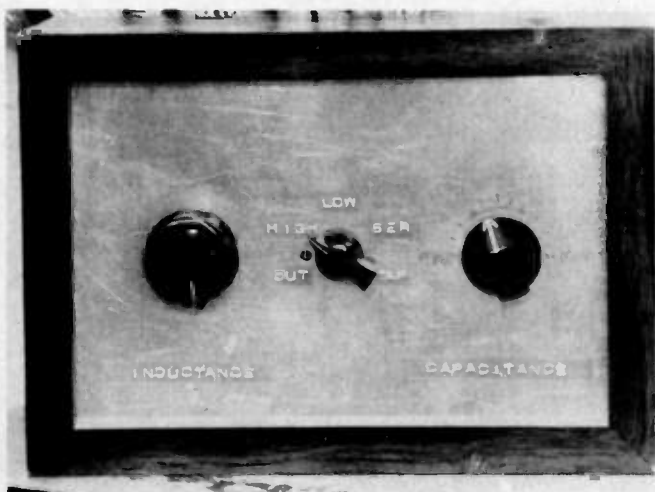

Front view of the Matchmaker, showing controls.

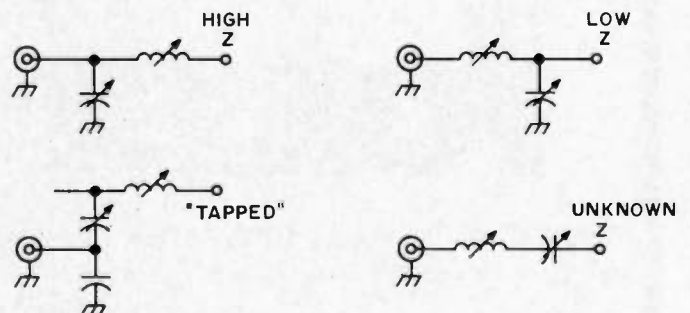

Fig. 1. The four different circuits used in the Matchmaker.





# How to Coax Your Antenna

**M**odern amateur transmitters are designed for a 50 Ohm unbalanced feedline. The classic basic dipole antenna wants to be fed with a 73 Ohm, balanced

feedline. The object of this article is to describe the design of an antenna and feedline that simultaneously satisfy the requirements of the transmitter and the

antenna.

Reducing the radiation resistance of the antenna from 73 to 50 Ohms only requires a reduction in antenna length. The literature<sup>1,2,3</sup> on

antenna theory is in good agreement and predicts a half length from  $0.207\lambda$  to  $0.231\lambda$ , depending upon antenna diameter and end conditions. A length of

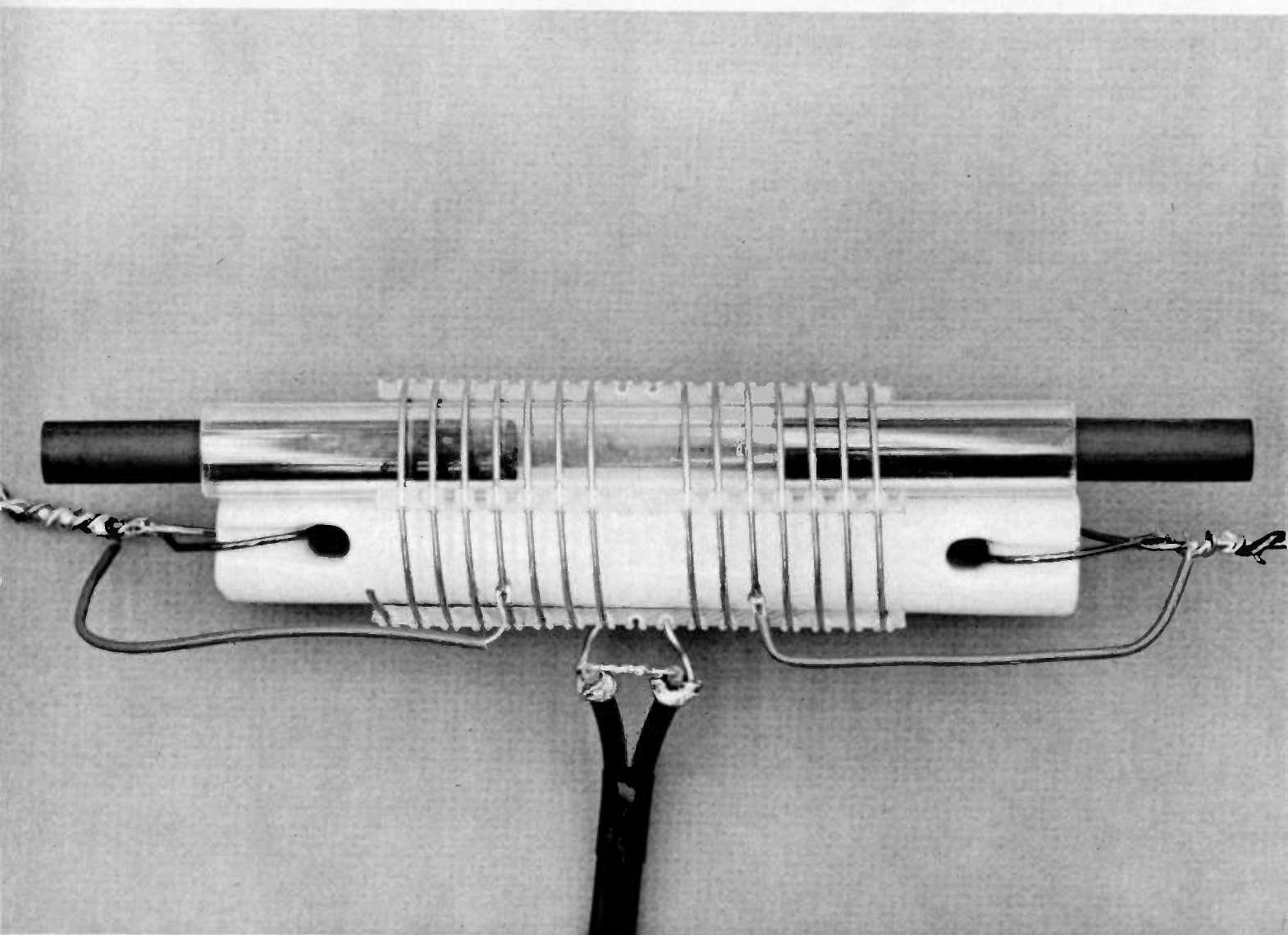

*Construction of resonating coil, ferrite tuning slugs, and balun feed.*

0.210λ is recommended to yield a shorter antenna and a radiation resistance of not more than 50 Ohms.

Reducing the antenna length also moves the antenna away from resonance and introduces a capacitive reactance in series with the radiation resistance. In order to restore resonance in the shortened antenna, an inductive reactance equal to the antenna's capacitive reactance must be added in series with the antenna. This resonating inductance is sometimes called a "loading coil." The literature shows that the capacitive reactance is very sensitive to changes in ratio of antenna diameter to wavelength. For a 0.210λ antenna, the capacitive reactance ranges from 34 to 230 Ohms, with 120 Ohms representing an average wire antenna.

Fig. 1 shows a configuration of the proposed antenna: radiating elements cut to approximately 0.210λ, two symmetrical variable inductors and a balanced 50 Ohm feedline.

Cutting the antenna to length is easy, but obtaining the variable inductors takes some care. The photo shows my approach to this problem. The inductor is made from B&W coil No. 3029 with two turns removed in the center. The coil is slipped over a Johnson No. 136-107 antenna insulator. A piece of plastic tubing, 0.75" OD x 0.50" ID x 7", is also squeezed inside the coil to support the two tuning slugs. These slugs, Amidon 12.5 x 100 mm ferrite rods, are used to tune the inductors to resonate the antenna. The range of tuning is large, from 2.0 to 3.75 μH for each coil. The coil is tapped to place the antenna resonance within the tuning range of the slugs. The coil and slug combination, as shown in the photo, can be used to resonate an antenna with a half length of

0.210λ for the 80 through 10 meter bands. If the two turns had been left in the center of the coil, it would also cover 160 meters.

Tuning of the antenna is done at this stage, prior to installation of the feedline, by coupling a grid dip meter to the antenna through a small one turn loop soldered across the feed points. With the antenna as high as possible, adjust the two

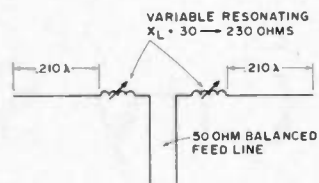

Fig. 1. The shortened, 50 Ohm impedance, resonant dipole.

ferrite slugs equally to resonance. To measure resonance of the antenna in its final position, couple the grid dip meter and its one turn coil to the antenna feed point by means of an open wire line. This line *must* be electrically  $\frac{1}{2}\lambda$  exactly, or multiples thereof, as measured with the grid dip meter; 300 Ohm twin lead is fine for this measurement. The resulting high standing wave ratio does not affect the measurement of resonance.

Now that the antenna has been designed, built and resonated, the next task is matching its balanced 50 Ohm impedance to the unbalanced 50 Ohm impedance of the transmitter. A device to do this is known as a "balun," a contraction for balanced-to-unbalanced. The amateur literature has numerous references for the design and construction of transformer-type baluns. These balun transformers have very large bandwidths and are particularly effective when used as interstage couplers. However, they are *not* effective for antenna applications unless the coax shield connection of the

transformer is at true rf ground potential, such as the one described by Sevick<sup>4</sup>. Imagine an antenna with a transformer-type balun located at its feed point. This point is high in the air, and far from rf ground. If the antenna is ever so slightly unbalanced, this will be reflected across the transformer to the coaxial feedline and cause antenna currents to flow on the outside of the shield; this current results in radiation, which couples to the antenna increasing the unbalance, which increases the feedline radiation, etc., etc. Unfortunately, this antenna feedline interaction is not self-stabilizing towards the balanced configuration; if it

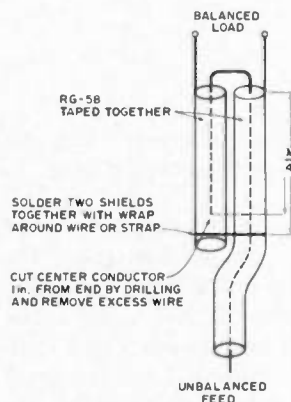

Fig. 2. Schematic representation of 1:1 antenna balun.

were, there would be no need for a balun.

The proposed balun design was first described by Roberts<sup>5</sup> in 1957, but has not been presented in amateur publications. Fig. 2 shows a schematic representation of the balun; some of the details are visible in the photo. From the antenna's viewpoint, it is being fed by two equal conductors in a balanced feedline configuration; from the transmitter's side, it looks like an unbalanced 50 Ohm load, the transition taking place over  $\frac{1}{4}\lambda$  length of the balun. Note that this balun is ground independent and that radiation

interaction between the feedline and the antenna elements is prevented by the equal and opposite current flowing in the two outer shield feedlines. The line from the balun to the transmitter will be electrically flat and can be any length. The reader can use reference 5 for the theory, construction details, and measured performance of this balun.

This article has described the design of a dipole antenna and balun that matches an unbalanced 50 Ohm line. The design procedure is valid for parasitic arrays as well as the simple dipole. The performance of the antenna-balun combination has been found to be very good, and it behaves very close to theory. I will not describe performance by means of the conventional swr vs. frequency plot because without very detailed and accurate descriptions of the test antenna (length of feedline, loss characteristics of feedline, conductivity and diameter of antenna, harmonic content of test signal, accuracy of swr meter, etc.) these curves have little value.

The builders of this antenna and/or its balun will enjoy:

- quick and easy tuning to resonance
- low swr at resonance
- minimum feedline radiation
- improved radiation patterns (F to B, gain, and direction)
- reduced harmonic radiation
- ground independence ■

#### References

1. R. King, C. W. Harrison, "The Impedance of Short, Long and Capacitively Loaded Antennas with a Critical Discussion of the Antenna Problem," *Journal of Applied Physics*, Vol. 5, 1944.
2. Jasik, Henry, *Antenna Engineering Handbook*, McGraw-Hill, 1961.
3. Shelkunoff, Sergi, *Antennas: Theory and Practice*, Wiley, 1952.
4. Sevick, Jerry, "The W2FMI 20 Meter Vertical Beam," *QST*, June 1972.
5. Roberts, Willmar, "A New Wideband Balun," *Proc. I.R.E.*, Dec. 1957, pp 1628-1631.



# 40m DXing -- City Style

Until recently, I thought that vertical antennas approached the ideal for forty meter DX contacts, in terms of signal strength and reasonably low costs. This judgment was based upon the usual city lot antennas, combined with a typical ham's budget. The experiments of Dave WA8TNO

proved otherwise. Let me first briefly describe these.

Dave's property consists of two and one half acres. The surrounding land is flat, almost treeless, only a few well-spaced houses. His verticals consisted of two well-matched, quarter wave elements made from aluminum

downspouting. Both elements were spaced one half wavelength apart for forty meters, with 180 degree (broadside) phasing. Each vertical element had 120 quarter wave insulated radials lying on the ground and equally spaced around. The earth in this part of northeastern Ohio is "usually moist," and consists of a loam and clay mixture. I believe that these are fairly good conditions for a land-based vertical system. It worked very well.

The single triangle element consisted of small gauge wire, with a total length of about one wavelength. The apex was supported at the 55 ft. level on an existing metal tower. Both lower corners went to ground stakes, and the bottom side was about 12 ft. high over the earth. This was fed directly, without a balun, with coax. The triangle's broadside "pointed" in the same directions as that of the vertical broadside array.

This hastily-erected triangle element had much lower noise pickup, and gave

stronger signal reports most of the time. Working Asia and Australia became a regular routine. In a word, the triangle was superior.

## City Lot DX Version

Naturally, this old vertical lover wanted to try this on a 50 ft. wide city lot, virtually surrounded by power and phone lines, high trees and aluminum-sided houses in all directions. I ended up with Figs. 1 and 2, after the conclusion of my own testing that used my (then) existing half wave vertical for a comparison.

I wanted some control over switching directions and nulls. My switching scheme in Fig. 2 is not original, but it works well. I used a Kurman<sup>3</sup> double-pole, double-throw rf relay with a 12 V dc coil. Surplus rf relays are fine if you can find them. The .01 uF ceramic capacitor across the relay coil is for stray rf protection. The relay is mounted in a black plastic "electronics" box from Radio Shack, and bracketed to the mast above the feedpoint. All

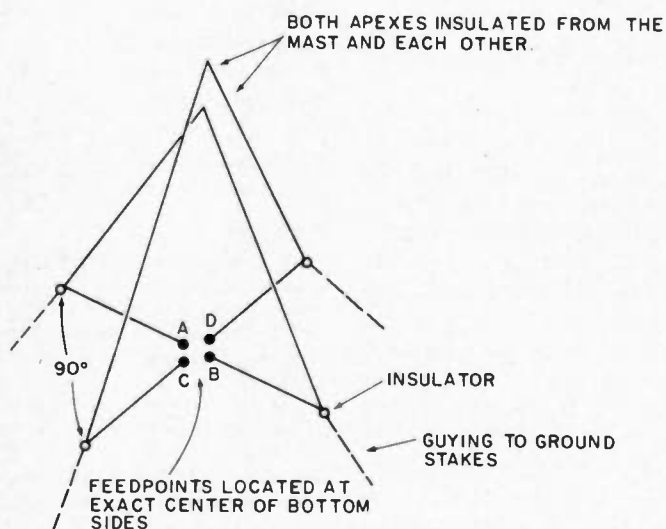

Fig. 1. 40m DX triangle antenna system. Each side = 45.5 ft. Total length of each triangle is subject to trimming for low swr at 7.100 MHz. Elements are #12 copper wire.

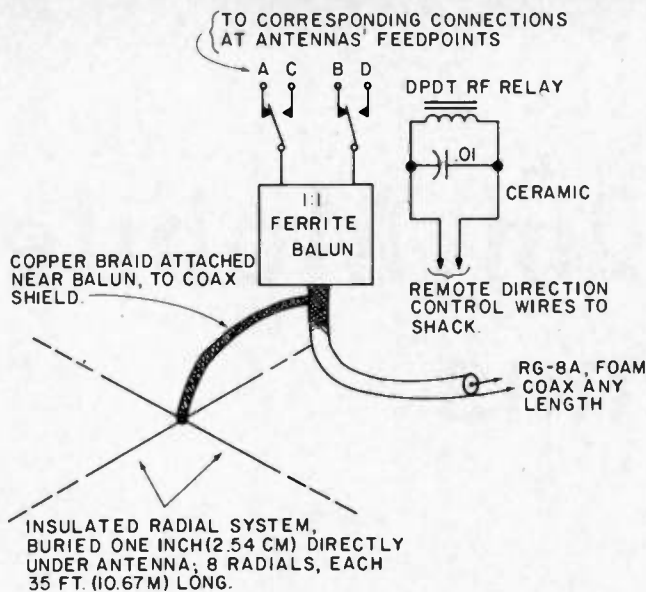

Fig. 2. Direction switching and feed systems.

connecting and control leads are routed through the box's bottom to keep out rain. Try to keep the two sections of feeder between the antennas and relay contacts reasonably short. Most important, make sure these same short sections are the same lengths and

spacings to keep the swr constant.

The radials are not an absolute necessity. This antenna system worked well without them. However, with the radials the DX stations seem to be stronger more often. The 1:1 ferrite balun

broadened the response, with very low swr out to the band edges.

I used #12 gauge enameled hard-drawn "antenna" wire for the antenna elements to help keep down the overall rf losses. Radiation resistance will do you more good than ohmic resistance!

Suggested apex supports can be an existing tower or tree. I used a 50 ft. telescoping TV mast. The actual extended height is 48 ft., with the insulated apexes attached near the top. Bottom height is 8 ft.

### Results

DXing from a city lot on 40 meters has finally become a real pleasure for me. Much of it has been easily worked. Getting through pileups is normal when running against the ordinary antennas encountered on this band. Perhaps the most pleasing aspect is getting comparable or sometimes better signal

reports than some of the fellows using beams! My rig is solely an FT-101 with no high power attachments.

### Conclusion

City lot dwellers, let's take down those ordinary urban antennas, and quit being "trapped" in our thinking. Now is the time to put up a real antenna. You too can have a respectable 40 meter signal, as well as some of our country cousins — and with a lot less grass to mow than they have! ■

### References

1. E. Noll W3FQJ, *73 Vertical, Beam and Triangle Antennas*, Editors and Engineers, Ltd., New Augusta, Indiana, pp. 126-144.
2. E. Noll W3FQJ, "Circuits and Techniques," *Ham Radio*, August 1971, page 56.
3. Kurman Instruments Corp. DPDT, 12 volts dc coil, rf relay, model 252C. Lafayette Radio Electronics Corp., 111 Jericho Turnpike, Syosset NY 11791. Stock no. 30-22183; \$7.95 plus 8 ounces postage.

### SUB-MINI \*TOUCH TONE ENCODER

SMALL - ONLY 5/16 D X 1 1/2 W X 2 H  
12 DIGIT - QUALITY PRODUCT  
COMPLETELY SELF CONTAINED  
XTAL CONTROLLED - EASY INSTALLED  
B PLUS, B MINUS AND TONE OUT  
GOLD PLATED DOUBLE FACED PCB

COMPLETE \$69.95 CWO  
COD 20 PERCENT DEPOSIT

GAMBER ELECTRONICS  
3400 Beaucrest, Harrisburg, PA 17111

SHIPPING AND HANDLING \$1.55  
PA Res Add Sales Tax \*Reg TM AT and T

### Do it in Jig Time!

HANDY  
DANDY

Both  
Hands  
Free



SOLDER CIRCUIT  
BOARDS EFFORTLESSLY

Rotates 360° - Great for all kits.

ONLY \$7.95

patent pending - kit shipped ppd. USA

W. N. WELLMAN CO.

Box 722, Fenton MO 63026  
MO residents add 20¢ tax

### Shortwave Listening

1976 World Radio TV Handbook - \$10.95  
Barlow Wadley & R. L. Drake Receivers  
1976 "Confidential" Frequency List - \$5.45

GILFER, Box 239, Park Ridge, NJ 07656

### MILITARY SURPLUS WANTED

Space buys more and pays more. Highest prices ever on U.S. Military surplus, especially on Collins equipment or parts. We pay freight. Call collect now for our high offer. 201 440-8787.

SPACE ELECTRONICS CO.

div. of Military Electronics Corp.  
35 Ruta Court, S. Hackensack, N.J. 07606

# NO MORE TIME OUTS!

The RT-1 R.F. actuated timer puts an end to timed out repeaters forever.

NO— Connections to your rig. (CARRIER TRIGGERED)

NO— Clocks to watch.

NO— Switches to throw.

The RT-1 leaves you free to concentrate on your driving and your QSO. Just preset the timer to any time from 0-3 minutes and forget it. Every time you transmit, your carrier triggers the unit which times until the preset value is reached then gives an audible tone. If your carrier is dropped before the end of the timing interval, the timer resets instantly and is ready for the next transmission.

Range: 0-3 Minutes in 5 sec. steps.  
Voltage: 12-16 Volts DC.  
Accuracy:  $\pm 3\%$  from +10 to +120 Degrees F.

WRITE FOR LITERATURE

## KRONOTEK

DIV. FRANKLIN UNIVERSAL CORP.

925 CLIFTON AVE., CLIFTON, NEW JERSEY 07013 (201) 778-0003



\$39.95

Plus \$1.50 postage and handling (NJ residents add sales tax).

# The Secret 2m Mobile Antenna

It may be difficult to accept, but there are many amateurs who are not interested in repeater operation. But, almost all amateurs recognize the unique communications capability that 2 meter repeater usage can provide, especially in the case of some emergency while mobile. This article describes a matching/isolation network that will allow one to use a regular auto antenna on 2 meters without interfering with the normal operation of the auto's AM or AM/FM radio. No relays or other type of switching is involved. One can leave the network connected to a 2 meter transceiver installed in the car or just bring it out to a BNC jack installed in the car. Then when a portable transceiver is used in the car, it can be plugged into the antenna system.

The performance of an auto antenna along with the matching/isolation network will normally not equal that of a rooftop  $\frac{1}{4}\lambda$  whip or similar antenna. But, no holes have to be drilled, extra antenna mounted, etc. The losses involved will vary from situation to situation, but should be low enough so adequate communication can be achieved over a local repeater with a few Watts of output power.

What is needed in a matching/isolation device is a matching network between the transmitter and antenna which will match impedances and also simultaneously act as a high-pass filter. Also, what is needed between the antenna and the auto radio is a filter to attenuate 2 meter energy only from getting into the radio. Both these functions are accomplished by the circuit of Fig. 1. The T network of C1, C2 and L1 performs matching and acts as a high-pass filter. The rest of the components act as a rejection filter tuned to the 2 meter transmitting frequency. They can be viewed as individual tuned circuits — 2 parallel resonant and one series resonant.

The entire network should be placed in a shielded enclosure and as close to the

base of the auto antenna as possible. But, it will also work if placed at the end of the auto radio's transmission line (at the auto radio's antenna input jack), but with greater losses, of course. Wherever it is placed, however, the auto antenna's extended length and the length of transmission line used to reach the antenna should remain unchanged after the network is tuned. Auto antenna lengths which produce low base feed point impedances are best, such as  $\frac{1}{4}\lambda$  ( $20\frac{1}{4}$ "') or  $\frac{5}{8}\lambda$  ( $50\frac{1}{2}$ "'), but other lengths can be used. A length greater than  $50\frac{1}{2}$ " should not be used since high angle radiation will increase sharply.

One can either crudely tune the network up and let it go (if communication can be established) or attempt to tune it up for overall

minimum losses. In any case, a bench check should first be made with a grid-dip meter. Short all the input/output points. Then resonate the C1, C2, L1 circuit (by coupling to L1) for resonance about 2 MHz below the transmitting frequency. After installing the network in its operating location, re-adjust C1 and C2 for maximum field strength reading.

If you want to tune up the whole network more properly, an SWR meter has to be inserted in the transmission line to the auto antenna. Leave the output terminal to the auto receiver connected. Adjust C1, C2 and L1, if necessary, for the lowest SWR. With an odd length of transmission line, it might even be necessary to add some inductance in series with C2 for lowest SWR. Then connect the SWR meter in the line to the auto receiver and, using only the "forward" or "set" reading, adjust the trap trimmers for a minimum reading. One then has to go back and forth several times with the SWR meter in each line to compensate for the detuning effect of each adjustment on the network.

When carefully adjusted, one can *simultaneously* use the auto antenna for 2 meter communication and AM or FM reception. ■

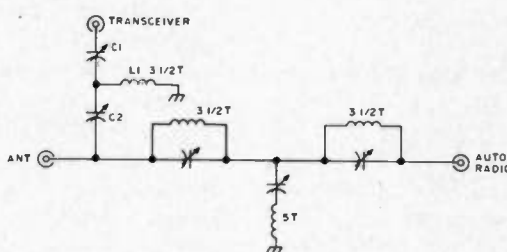

Fig. 1. Matching/isolation network. All capacitors are 27 pF trimmers. Coils are approximately  $\frac{1}{4}$ " diam.,  $\frac{1}{2}$ " long, of #16 or #18 wire with turns as indicated.



# Hy-Gain 272 2-meter antenna

## The first truly portable repeater.

At last! A high performance, 2-meter antenna that combines state-of-the-art electronics, corrosion-free fiberglass and take-apart design for true portable use.

The Hy-Gain 272 is an entirely self-supporting 21' omnidirectional antenna system that separates into three pieces for transport. It consists of 4 stacked 5/8 wave radiators with three 1/2 wave phasing coils and a 1/4 wave decoupling system.

Each section length is specifically computed to completely eliminate end-feed pattern tilt, keeping radiation angle flat and close to the ground for maximum efficiency.

The 272 is ideal for portable repeater, repeater, and home use. Take it with you, wherever you go. Mounts easily on any 1-1/4" to 1-1/2" masts and it's factory tuned, to eliminate re-tuning in the field. Recessed coax connector, mounting bracket and hardware included.

Get the first truly portable repeater antenna. Only from Hy-Gain.

Power	250 watts
VSWR at resonance	Less than 1.5:1
Input impedance	50 ohms
Produces 6 dB gain over 1/2 wave dipole	



Hy-Gain Electronics Corporation 8601 Northeast Highway Six;  
Lincoln, NE 68505; 402/464-9151; Telex 48-6424  
Branch Office and Warehouse 6100 Sepulveda Blvd., #322;  
Van Nuys, CA 91401; 213/785-4532; Telex 65-1359  
Distributed in Canada by Lectron Radio Sales, Ltd.;  
211 Hunter Street West; Peterborough, Ontario



# An Inverted Vee for 160/80m

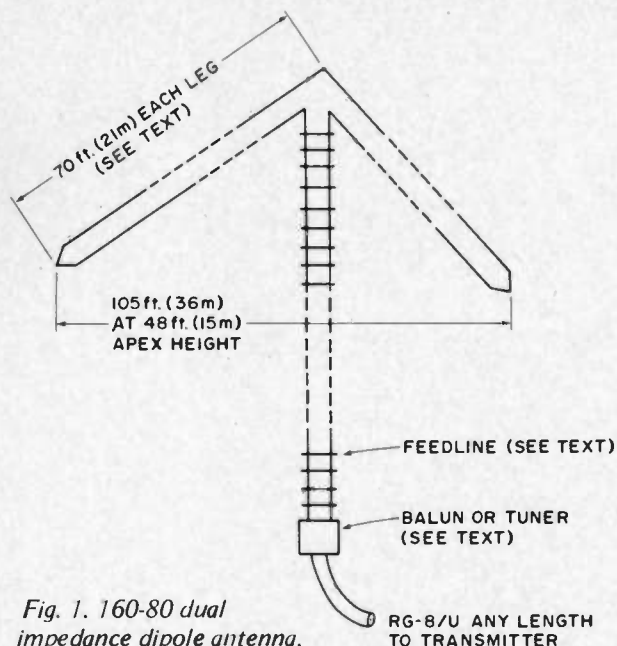

Fig. 1. 160-80 dual impedance dipole antenna.

John Skubick K8ANG  
1040 Meadowbrook  
Warren OH 44484

City lots and bank accounts have something in common for many of us. Both tend to be small! Here is a cheap antenna system that covers both 80 and 160 meters, but is the size of an 80 meter "inverted V," with *no* ground radials. If your city or suburban lot is typical, you'll barely have room for one 160 meter radial, let alone several!

On 80 it is an inverted, folded dipole. The feedpoint impedance is less than 300 Ohms because of the inverted shape. For 160 it becomes a half wave inverted dipole, with the ends folded back toward the middle, and "end fed." The feedpoint impedance now becomes very high. The flat top portion can be constructed from transmitting twinlead, TV twinlead, or 300 or 450 Ohm TV open wire. You can even make it out of ordinary "antenna wire" if the parallel wires are spaced up to 6 inches. The length is approximately 70 feet for *each* leg. More on leg length later.

Since both bands utilize the same feedpoint, we must have a simple and effective feeder system for both bands/impedances as follows:

#### Without a Tuner

Two baluns are required at the shack end of the feed line. A 4:1 for 80, and a 1:1 for 160. I used two Amidon<sup>1</sup>, "\$5.00 balun kits." I put two layers of plastic electrical tape over each core for better "arc-over" protection. Both baluns were easily wound within 30 minutes, per enclosed instructions. Use 36 inches of wire for each winding, leaving about two inches extra for lead connections. I put each balun into a 34¢ plastic, screw-lid, freezer container, with a coax socket attached. All possible openings were then generously sealed with a tube of G.E. Silicone Seal, sold by blister-pack in most hardware stores. Amidon's spec sheet states, "80-6 meter operation." However, these baluns seem to work just fine on 160 as well!

Use RG-8 between the balun(s) and the transmitter. The feed line between the

balun(s) and antenna should be "300 Ohms" type such as twinlead, or better yet 300 Ohm, TV, open wire "ladderline" for higher power handling. The dimensions for the balun-to-antenna feed line are 110 feet for solid dielectric twinleads or 130 feet for the open wire line.

Initial tuneup begins with 80 (or 75) meters, for your favorite section of the band, by trimming the ends of the flat top equally, a couple of inches at a time, for minimum swr (measured at the transmitter). A neat "trick" is to trim it for "75 phone," then hang clip-on single wire outriggers for "80 CW." Minimum swr will be about 1.5:1, using the 4:1 balun. Since the antenna is inverted and close to ground, the feeder is "seeing" less than 300 Ohms from the folded dipole.

Next is the 160 meter tuneup. Change over to the 1:1 balun. Now, trim the twinlead (or open wire) feed line for minimum swr in your favorite portion of 160. You can get this down to 1:1. That's it for "tunerless" operation.

With a Tuner (Antenna Coupler)

It's easy for you tuner lovers. From my experiments, it appears that the leg length can vary between 60 to 70 feet with no reduction in performance, for either band. Your coupler will "tune" this antenna and feeder system over the entire 160 and 80 meter (and 75) bands.

You have a wider choice of feed lines also. You can use TV and transmitting twinleads, 300 and 450 Ohm TV open wire "ladderlines," or even home brew open wire line. The length of balanced feed line, between the antenna and your coupler, may load easier if it is about 90 to 120 feet for the solid dielectric types, or 120 to 140 feet for the open wire types.

For the antenna coupler tuneup, first preset your transmitter's "tuning and loading" controls, by loading it directly into a 50 Ohm dummy load. (You *do* have a dummy load, don't you?) Now, switch the transmitter into the coupler. Do not touch the transmitter's "tuning and loading" con-

trols, because they are now preset for 50 Ohms. Do your tuning and loading with the coupler, which will transform whatever impedance and reactance is appearing at the "shack end" of the feed line into 50 Ohms for your transmitter. If you are a tuner fancier, and have read this far, chances are you already have a coupler for 80 meters and the higher bands. Fig. 2 shows a compatible type of coupler for 160.

### Antenna Supports

I used a 50 foot, 5 section, telescoping TV mast to support the apex. Actual extended height is 48 feet. The mast is hinged at the base, by driving two 3 foot x 2 inch pipes into the ground about 3 inches apart. I drilled a hole into each pipe, so that a suitable large bolt could be passed through both pipes and the existing hole at the base of the mast.

The antenna supports the

mast in the east-west direction. Two lengths of non-metallic clothesline also support the mast from the top, but in the north-south direction. No center guys were used.

The insulator ends of the antenna, and the ends of the clothesline, are attached to 5 foot x 1 1/2 inch pipes driven 3 feet into the ground.

The entire assembly isn't too heavy. It couldn't be, if skinny, stringbean-physiquest K8ANG has to lift it up and walk it into the vertical position!

A tree and a halyard can also be pressed into service for the center support. My trees are never properly located.

### Results

It certainly gets the rf out of my backyard! On 80, the performance is exactly that of a "regular" 1/2 wave inverted dipole, using the same height, center

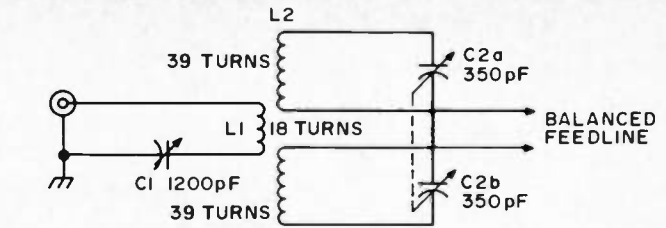

Fig. 2. 160m antenna coupler. L1-L2: Illumnitronic 2410 or Polycoils 1780, 10T/inch, 3 inch diam. C1: Three section "broadcast" type, all sections paralleled. C2: 200 pF per section may be used with 100 pF in parallel. Note: Do not ground any portion of L2 or C2 — leave them "floating" above ground on insulators.

supported. It also seems to be more broadband. On 160 I have worked coast-to-coast, and Canada easily, using a barefoot Japanese transceiver. I cannot compare it to a full size inverted dipole on 160, because this would be twice the size of my backyard!

### Conclusion

There have been many 160 and 80 meter antenna articles written these past few years. Not all of them will fit everyone's backyard or performance specifications. Maybe

this one will help to "fill the void" in your city lot antenna farm. ■

### References

1. Amidon Associates, 12033 Otsego Street, North Hollywood CA 91607.
2. Bonadio W2WLR, "Antenna Tuner for Optimum Power Transfer," *Ham Radio*, May 1970, p. 28.
3. Greenberg W2EEJ, "The Forty Meter Folded Dipole and Other Bands," *Antenna Roundup*, 1965, Cowan Publishing Corp., p. 89.
4. ARRL *Antenna Book*, 1968, pp. 206-207.
5. Orr W6SAI, *S-9 Signals*, Radio Publications, Inc., p. 44.

## Switch Your Antenna Where It Really Counts AT THE ANTENNA

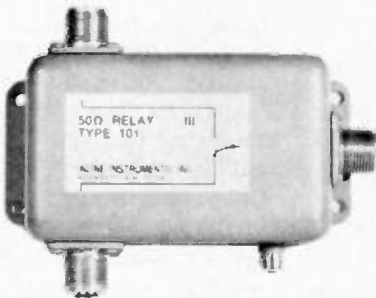

### The RELAY:

Inline\* TYPE 101 Relay can be controlled directly or remotely via the coaxial cable. It can be installed atop a tower or pole to switch two antennas without adding wires.

Frequency capability is from V.L.F. through V.H.F. Hermetically sealed switching element is capable of multimillion operations assuring years of trouble free, dependable service.

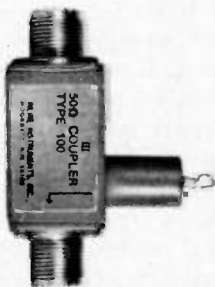

### The COUPLER:

Consisting of a coaxial isolator and resonator which determines the bandpass of the device. When DC or AC power/voltage is connected across the coupler injection port and ground, the signal cable acts as a metallic link without disturbing signal characteristics originally present. RF signal path is not directional.

Two couplers can be used, one locally and one remotely, with the arrows pointing to each other. The coaxial cable between the couplers is thus multiplexed whereby the inner conductor and shield act as a simple wire pair while simultaneously carrying RF signals within the rated passband. Power/voltage may be injected or recovered at either coupler.

## INLINE INSTRUMENTS Inc.

Box 473, Hooksett, New Hampshire 03106





# The Dipole Dangler

About ten years ago, the Summer Institute of Linguistics (SIL) here in Brazil was granted permission to use radios for communication between our centers and remote Indian villages. SIL is working here and in other countries with people who speak some of the more than 2000 unwritten languages of the world. Our purpose is to learn these languages, analyze them, teach the people to read and write their own language, and translate the New Testament for them. Here in Brazil, the linguistic-translation teams live in the Indian villages for periods of from about three to six months at a time, taking a radio with them each time to maintain contact with one of our five centers. We are using the Stoner SSB-20A radio, an excellent portable with about 15 Watts PEP output, powered by any 12 volt source including dry cells. The antennas are dipoles about 86 feet long. Communications distances range from about 100 miles to over 500 miles.

Because of the importance of the radio communications and because the equipment has to be set up and taken down each time by non-technical personnel, one area of potential problems was the

antenna system. The antennas had to be reliable, rugged, and easily handled. Because more than 40 stations were involved, they also had to be inexpensive and made from readily available materials. The purpose of this article is to share some of our experience with you with the hope that some of the ideas might prove useful to you for your home station antennas, or for portable antennas for

field day use, etc.

The construction of the center insulator is a very important factor in building a reliable dipole antenna. Purchasing a commercial unit was not practical for us because of cost and also the delay in obtaining it. The center insulator we have been using consists of a standard porcelain insulator to which is attached a piece of  $\frac{1}{4}$  inch plastic in the form of a cross.

See Fig. 1. The porcelain insulator provides the necessary strength, and the plastic gives support to the coax cable. The plastic is attached to the insulator with No. 18 solid copper wire, wrapped twice around the insulator and twisted together in back of the plastic. Three holes are drilled in the plastic to support the coax cable.

We have been using flexible, bare-copper antenna wire, and this has proved very adequate. To attach the wire to the center insulator, pass the wire through the hole twice and wrap the end around snugly for a distance of at least three inches. Attach both legs to the center insulator and attach the end insulators in the same way. Do not solder anything at this time. Before going any further, wrap the antenna legs on wooden forms as described below. This makes a neat package to take into the shop to attach the coax cable.

Cut the coax cable to length, unless you want to wait and install the antenna first. Pass the end of the cable through the holes in the plastic, starting from the back as shown in Fig. 2. Remove about 12 inches of the plastic jacket. Remove the center conductor from the braid by pulling it through the braid. Do not comb out the braid.

Use standard vinyl tape cut to about  $\frac{3}{8}$  inch in width to seal the point where the center conductor leaves the braid. Seal this junction very carefully. After the antenna is completed, we also seal this further with Q-dope or epoxy cement to make it as watertight as possible.

Pass each of the conductors (center conductor and braid) through one of the holes in the center insulator, drawing the braid side tighter than the other so that it will take the strain. Pass the braid through a second time and wrap it over the antenna wire,

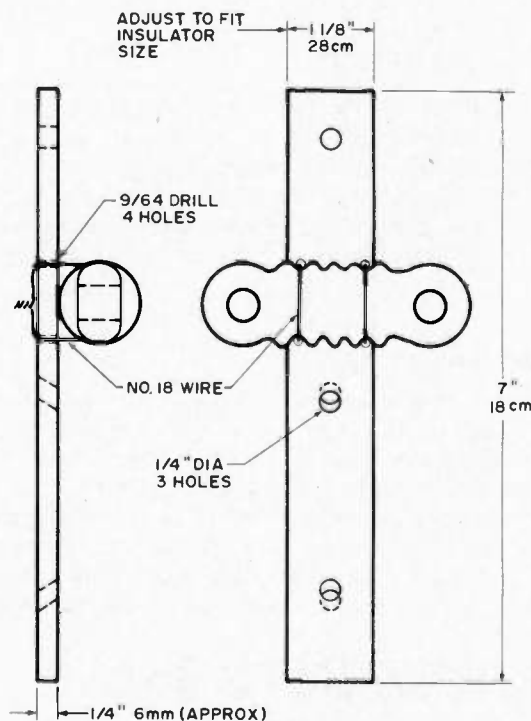

Fig. 1. Center insulator.

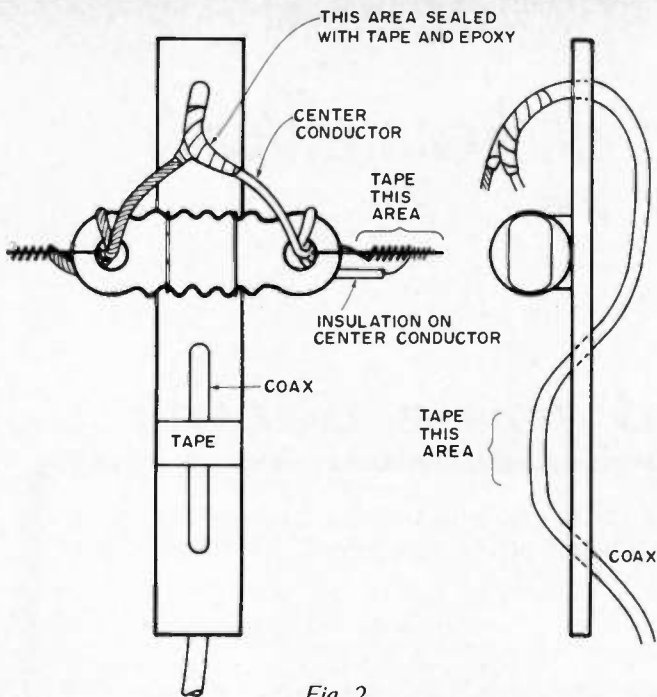

Fig. 2.

in the same direction as the original wrapping. Solder the braid to the wire in the middle of the wrapping, leaving the rest free to flex.

Pass the center conductor through the hole a second time and lay it alongside the wrapping on the antenna wire. Mark a half way point on the wrapping and strip the insulation to this point only. I have found it very easy to strip the insulation from coax by scoring the insulation with wire strippers every 1/4 inch or so and then crushing the insulation with long nose pliers to break the adhesion between it and the wire. After this, the insulation comes off relatively easily. Once the wire is stripped, wrap it around the

antenna wire a few turns. Do not tin the wire if it is stranded. Solder the center conductor to the antenna wire, making sure that the antenna can be pulled straight without straining the coax inner conductor. Solder only where the conductor attaches to the antenna wire. Reinforce the entire connection by wrapping vinyl tape securely around both the inner conductor and the antenna wire, starting from the center insulator and extending past the solder joint. This is very important because it secures the center conductor to the antenna leg, allowing a minimum of independent movement and reducing the threat of

breakage at what is probably the most fragile part of the whole antenna. Tape the coax cable to the plastic support between the lower two holes.

At this point, seal the "V" in the coax with epoxy cement or other sealer and let it dry. Install the coax plug and the antenna is ready for use.

After the antenna is constructed, care in handling is very important to long life (for the antenna). Many of you know the frustrating tangle that you can have with a long dipole antenna that has been coiled up and then uncoiled improperly. To avoid this, we are using wooden forms made from 1/4 inch plywood cut to approximately 5 by 7 inches. Each leg of the antenna is carefully wound on one of these forms to avoid tangling. To use the form, extend the antenna out full length on the ground and carefully check it for kinks. Starting at the end of one leg, carefully wind the antenna on the form by *winding the form onto the wire* while walking toward the center insulator. Do not coil the wire onto the form. Use one form for each leg. When you get ready to re-install the antenna, carefully unwind the wooden forms, leaving the antenna fully extended on the ground. Do not pull the wire from the forms or you will have a kinky mess. Carefully check for kinks or other problems before installing the antenna.

Multiple frequency antennas can be made using a modified center insulator as shown in Fig. 3. Spacers for separating the antenna legs can be made from 3/8 inch plastic electrical conduit, or the second antenna can be in the form of an inverted V. In this case, the antenna will need to be five per cent longer than a normal dipole.

Using this method of construction and using the wooden forms for handling the antennas, we have had a minimum number of problems with our antennas during these past years. ■

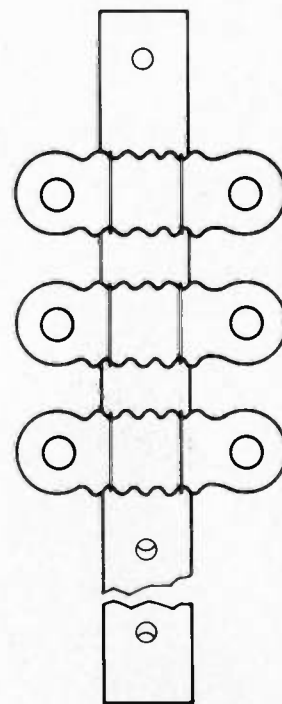

Fig. 3. Center insulator for multiple frequency dipole.

**FRANK CALIFORNIA**  
**WB6LON**  
AMATEUR RADIO

**AMATEUR RADIO CALIFORNIA**  
**WB6ZCT**  
LOS ANGELES

**DIE CAST CHROME LICENSE FRAME**

Your NAME, QTH, 73 etc. in vinyl letters (max. 12)  
Specify style desired

**\$3.45 each pp with vinyl letters**  
California residents add 6% sales tax

**WGRADIO** P.O. BOX 15 HAWTHORNE, CA 90250

**DUPLXERS**

From \$180. Cavity filters from \$32. Many models, 6-meters thru 450 MHz. Heavy copper construction. Superb stability. Compact, ruggedized, portable. Beautifully factory built; NOT A KIT. Maximize your repeater's performance. Write or call today!

**Varden Electronics Company**  
Box 791, Jackson, Michigan 49204 • (517)787-2299

**BYTE ISSUES #1 #2 #3 #4**

In case you are ONE OF THE PEOPLE who wants to complete his collection of BYTE magazine, a few of the early issues are still available ... until the limited supply is exhausted ... only \$3.00 each ... all four for \$10.

73 Magazine, Peterborough NH 03458

**YOU ASKED FOR IT! ECM-5B**  
**FM Modulation Meter**  
**ONLY \$132** less batteries and crystals

- 0-7.5 kHz deviation peak reading
- Meets commercial requirements
- Operates 30-500 MHz
- Crystal Controlled for easy operation
- Telescopic antenna

**NEW OPTIONS**

- NICAD power pak \$20.46
- Charger \$29.95
- Audio/scope output with earphone \$12.95

Write or call for complete info.

Send check or money order for \$132.00 plus \$1.50 for shipping. Indiana residents add 4% sales tax. Crystals for 146.94 MHz \$3.95. All other freq. \$7.10.

**ECM** ECM Corporation  
412 North Weinbach Ave.  
Evansville, Indiana 47711  
812-476-2121



# Like to have a weekend affair?

## We'll send you a beauty...

This beautiful Walkie-Talkie Kit is easy to build and can be assembled in one weekend. You save hundreds of dollars by building it yourself. The HT-144B offers exceptional performance at a budget price.



- 2 Watts minimum
- 4 Channels
- .35uV for 20dB of quieting
- Low battery drain . . . less than 10 Ma
- Now you can build a commercial quality walkie talkie at home at half the price.
- Designed with the ham in mind. Average assembly time, just 10 hours.
- Small and handy, yet large enough to be assembled with conventional tools.
- Attractive, scratch resistant textured finish.
- Lightweight, sturdy aluminum case.
- Black textured case 1-1/2 x 2-1/2 x 9-1/4
- All tunable coils are prewound
- Transceiver is on one G-10 predrilled board
- Parts layout silk-screened on boards for easy construction
- Crystal deck is separate predrilled board
- Weight less batteries — approximately 15 oz.
- Battery-case is AA size — accepts alkaline or nicad
- External battery charging/power supply jack furnished
- 1 dual gate mosfet 2 I.C.'s 15 transistors 7 diodes
- Antenna — collapsible 17" whip
- Covers any 2 Mhz segment between 140 and 170 Mhz
- Plenty of room in case for add ons (PL and tone)

**HT-144B RECEIVER SPECIFICATIONS:** SENSITIVITY better than .35uV for 20db quieting. SQUELCH THRESHOLD better than .25uV. STABILITY .002 typical (depends on crystal). ADJACENT CHANNEL REJECTION 60 db. SPURIOUS RESPONSES down 70db. FIRST IF 10.7 Mhz SECOND IF 455 KHz. FILTER 4 pole monolithic 10.7 Mhz crystal. DISCRIMINATOR pretuned ceramic 455 KHz. BANDWIDTH 15 KHz at 3db points. CRYSTAL 45 Mhz parallel at 20pf. CRYSTAL FORMULA receive frequency minus 10.7 divided by 3. AUDIO OUTPUT .5w typical. CURRENT DRAIN 10 ma squelched, 100 ma on voice peaks.

**HT-144B TRANSMITTER SPECIFICATIONS:** OUTPUT 2 watts minimum. 3 DB BANDWIDTH 2 Mhz typical. STABILITY .002 typical (depends on crystal). SPURIOUS outputs down 30db or better. MODULATION true FM with varactor in crystal circuit. NETTING separate trimmers for each channel. DEVIATION adjustable to 7 KHz. AUDIO limiter and active low pass filter. MICROPHONE speaker type. CRYSTAL 18 Mhz parallel at 20 pf. MULTIPLICATION FACTOR frequency times 8. CURRENT DRAIN 500 ma typical.

### LIMITED OFFER

Now an even better buy . . .

\$129.95 includes Walkie Talkie Kit, 1 set of crystals for 146.52 simplex and rubber duck antenna. Battery charger included free with purchase of \$29.95 1/2 amp NICAD Pack.

### ORDER FORM

Item	Price Each	Quantity	Total Price
HT-144B Walkie Talkie	\$129.95		
Rubber Duck Antenna	No charge*		
Crystals (pair) 146.52	No charge*		
12 Volt NICAD Battery	\$29.95		
Battery charger (for HT-144B)	No charge**		

\*With purchase of HT-144B Walkie Talkie \*\*With purchase of HT-144B Walkie Talkie and NICAD Battery

Name \_\_\_\_\_ Total \_\_\_\_\_

Address \_\_\_\_\_ Shipping \_\_\_\_\_

City \_\_\_\_\_ NYS Resident \_\_\_\_\_

State \_\_\_\_\_ Zip \_\_\_\_\_ Total \_\_\_\_\_

Master Charge or BankAmericard No. \_\_\_\_\_ Enclosed \_\_\_\_\_

Bank No. \_\_\_\_\_ Expiration Date \_\_\_\_\_

**SHIPPING INFORMATION:** All shipments are F.O.B. Binghamton, N.Y. 13902. Shipments will be made by the most convenient method. Please include sufficient funds to cover shipping and handling. Figure shipping charges on a minimum weight of 2 pounds per unit. Allow 3 to 4 weeks for delivery.

**TERMS:** C.O.D., cash or check with order. We also accept BankAmericard and Master Charge.

**CLAIMS:** Notify VHF and the carrier of damage within seven (7) days of receipt of shipment.

**RETURNS:** Obtain authorization from VHF before returning any merchandise.

**PRICES AND SPECIFICATIONS:** Subject to change without notice. Export prices are slightly higher.

Stop at our booth  
at the Dayton Hamfest . . .  
Register for free drawing.

**Vhf engineering**

DIVISION OF BROWN ELECTRONICS CORP.

320 WATER ST. • P.O. BOX 1921  
BINGHAMTON, N.Y. 13902 • 607-723-9574



WE HONOR  
master charge  
THE INTERBANK CARD



BANKAMERICARD



# Vhf engineering MINI-CATALOG 1976

THE WORLD'S MOST COMPLETE LINE  
OF  
VHF — FM KITS AND EQUIPMENT

TX144B Kit . . .	transmitter exciter — 1 watt — 2 meters . . . . .	\$ 29.95
TX144B W/T. . .	same as above — factory wired and tested . . . . .	49.95
TX220B Kit . . .	transmitter exciter — 1 watt — 220 MHz . . . . .	29.95
TX220B W/T. . .	same as above — factory wired and tested . . . . .	49.95
TX432B Kit . . .	transmitter exciter 432 MHz . . . . .	39.95
TX432B W/T. . .	same as above — factory wired and tested . . . . .	59.95
RX50C Kit . . .	30-60 MHz rcvr w/2 pole 10.7 MHz crystal filter . . . . .	59.95
RX144C Kit . . .	140-170 MHz rcvr w/2 pole 10.7 MHz crystal filter . . . . .	69.95
RX144C W/T. . .	same as above — factory wired and tested . . . . .	114.95
RX220C . . . . .	210-240 MHz rcvr w/2 pole 10.7 MHz crystal filter . . . . .	69.95
RX432C Kit . . .	432 MHz rcvr w/2 pole 10.7 MHz crystal filter . . . . .	79.95
RXCF. . . . .	accessory filter for above receiver kits gives 70DB adjacent channel rejection . . . . .	8.50

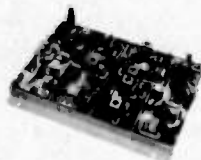

PS3 Kit. . . . .	12 volt — power supply regulator card . . . . .	8.95
PS15C Kit . . .	NEW — 15 amp — 12 volt regulated power supply w/case, w/fold-back current limiting and overvoltage protection . . . . .	79.95
PS15C W/T . . .	same as above — factory wired and tested . . . . .	94.95
PS25C Kit . . .	NEW — 25 amp — 12 volt regulated power supply w/case, w/fold-back current limiting and overvoltage protection . . . . .	129.95
PS25C W/T . . .	same as above — factory wired and tested . . . . .	149.95



HT144B Kit . . .  
2 meter — 2w — 4 channel — hand  
held xcvr with crystals for 146.52  
simplex . . . . . 129.95

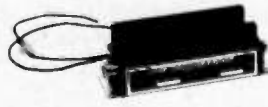

PA2501H Kit . .	2 meter power amp — kit 1w in — 25w out with solid state switching, case, connectors . . . . .	59.95
PA2501H W/T. .	same as above — factory wired and tested . . . . .	74.95
PA4010H Kit . .	2 meter power amp — 10w in — 40w out — relay switching . . . . .	59.95
PA4010H W/T. .	same as above — factory wired and tested . . . . .	74.95
PA144/15 Kit . .	2 meter power amp — 1w in — 15w out — less case, connectors and switching . . . . .	39.95
PA144/25 Kit . .	similar to PA144/15 kit except 25w out . . . . .	49.95
PA220/15 Kit . .	similar to PA144/15 for 220 MHz . . . . .	39.95
PA432/10 Kit . .	power amp — similar to PA144/15 except 10w and 432 MHz . . . . .	49.95
PA140/10 . . . .	10w in — 140w out — 2 meter amp — factory wired and tested . . . . .	179.95
PA140/30 . . . .	30w in — 140w out — 2 meter amp — factory wired and tested . . . . .	159.95

RPT144 Kit . . .	repeater — 2 meter — 15w — complete (less crystals) . . . . .	465.95
RPT220 Kit . . .	repeater — 220 MHz — 15w — complete (less crystals) . . . . .	465.95
RPT432 Kit . . .	repeater — 10 watt — 432 MHz (less crystals) . . . . .	515.95
RPT144 . . . . .	repeater — 15 watt — 2 meter — factory wired and tested . . . . .	695.95
RPT220 . . . . .	repeater — 15 watt — 220 MHz — factory wired and tested . . . . .	695.95
RPT432 . . . . .	repeater — 10 watt — 432 MHz — factory wired and tested . . . . .	749.95

## OTHER PRODUCTS BY VHF ENGINEERING

CD1 Kit . . . . .	10 channel receive xtal deck w/diode switching . . . . .	\$ 6.95
CD2 Kit . . . . .	10 channel xmit deck w/switch and trimmers . . . . .	14.95
COR2 Kit . . . . .	complete COR with 3 second and 3 minute timers . . . . .	19.95
SC3 Kit . . . . .	10 channel auto-scan adapter for RX Crystals . . . . .	19.95
	we stock most repeater & simplex pairs from 146.0-147.0 (each) . . . . .	5.00

# Amateur Weather Satellite Reception

One of the euphemisms that is often used to describe the times in which we live is the "space age." The gradual buildup of technology that enables mankind to travel and work in space and to visit other worlds has resulted in a whole new age of exploration as we gradually learn more about the larger universe in which we live. Probably no aspect of the space program has a greater effect on our lives than the tremendous strides in weather satellite technology. To many, such satellites are merely the "eyes in the sky" that serve to amplify the weather map on late night news, but they are far more important than that. They have contributed to new standards in weather forecasting and provide an early warning system that has saved uncounted lives and dollars by providing advanced warning of destructive tropical storms such as typhoons, cyclones,

and hurricanes. Mapping of snow and ice cover is still another spin-off from this useful program. At the time this article is being written there are seven operational U.S. weather satellites in orbit around our planet continuously scanning the ever-changing weather patterns that affect our lives.

It is now a decade since Wendel Anderson K2RNF first showed how it was possible to receive and display pictures from such satellites (2) and with today's technology the job is far easier than it was just ten years ago. With far less financial outlay than that required for even a modest sideband station it is possible for amateurs to receive and display pictures from most of the operational satellites, while for someone who is really hung up on the subject none of them is out of reach. The purpose of this article

will be to describe the status of the various satellite systems now in use and to provide numerous references for the construction of home satellite receiving stations. Such stations can provide daily glimpses of the world from space which few of us would ever see and are an interesting entry into the world of meteorology. The low cost of such ground stations make them attractive to small educational institutions where they can provide practical data for courses in weather and the earth and planetary sciences as well as providing worthwhile class projects in electronics.

There is certainly no "one way" to put together a satellite station — there are a multitude of options, each varying in terms of cost, operating ease, and system flexibility. I will discuss the various requirements for satellite ground stations and provide references from the widely scattered literature on the subject so that you can do some background reading on the kind of system you might like to set up. Some of the options are essentially jury-rigged affairs of casual interest but others can, at low cost, provide performance comparable to commercial or government installations. Ever since entering the weather satellite game amateurs have distinguished themselves by continually developing better ways to accomplish various tasks, usually far exceeding professionals in terms of the cost-quality equation. Amateurs, with their knowledge of electronic and communications systems, are often among the first to spot problems with operating satellite systems and thus provide a valuable service in monitoring these satellites. Weather satellite technology represents a very concrete example of how "amateurs" can make a significant contribution to space age technology. Why not give it serious thought — you are certain to have lots of fun and may

	APT Mode	SR Mode
Subcarrier Frequency	2400 Hz	2400 Hz
Subcarrier Amplitude:		
White	Maximum	Maximum
Black	Minimum	Minimum
Line Rate	240/minute	48/minute (present) 120/minute (future)
Frame Time	200 seconds	Continuous
Lines Per Picture	800	Depends on length of pass
Video Bandwidth	1600 kHz	450 Hz (IR) 900 Hz (visible)

Table 1. Characteristics of the video format of the APT and SR modes.

Name	Frequency (MHz)	Period	Inclination	Mode	Products
ESSA 8	137.62	114.7 min	101.5°	APT	Daylight real-time cloud cover pictures
NOAA 3	137.5 (primary) 137.62 (test)	116. min	102°	SR	Visible and infrared cloud cover pictures in daylight, IR cloud cover pictures at night
NOAA 4	Same as NOAA 3	115.0 min	101.7°	SR	Same as NOAA 3

Table 2. Polar orbiting weather satellites.

make some major contributions at the same time!

*Satellite Picture Modes.* The two video modes of greatest interest to amateurs are highlighted in Table 1. Both modes utilize a 2400 Hz audio subcarrier to transmit the video information. Subcarrier amplitude varies from maximum for white picture areas to minimum (approximately 4% of maximum amplitude) for black picture areas. Subcarrier amplitudes between these two extremes represent varying shades of gray. The two modes differ however in the line rate and picture organization. The first, the APT mode (APT is an acronym for Automatic Picture Transmission), transmits video lines at the rate of 240 per minute or 4 lines per second. A single picture or "frame" requires 200 seconds for transmission, resulting in an 800 line picture. The base-band video bandwidth of the system is 1600

kHz, so if audio filters are used to help remove noise from the satellite signal they should be centered on 2400 Hz with a 1600 Hz bandwidth. Narrower filters will result in progressive loss of picture detail. The 800 line APT picture is far sharper and has much greater resolution than a typical TV picture display.

The second mode — the SR or Scanning Radiometer mode — is based on the use of a mechanical scanning system on board the spacecraft. As the satellite moves along its orbital track a mirror scans the earth beneath in a narrow beam at right angles to the satellite's orbital track. Present SR systems use a 48 line per minute scanner. The SR system is capable of providing both visible light and infrared (IR) images of the earth below. The IR data occupies the first half of the scanning line with the visible data inserted from a tape loop during the second

half of the line when the satellite scanner is scanning up against the spacecraft. The SR data format can be considered as a 48 line per minute system with half the line being IR data and the other half visible data, or it can be treated as a 96 line per minute system of alternating IR and visible data lines. Display systems can be designed around either option. The SR picture is not broken up into discrete frames as it is in the APT mode — instead transmission of picture data is continuous as long as the spacecraft is in range with the vertical "scanning" provided by the movement of the spacecraft along its orbital track. Present systems utilize a 48 line per minute scanner but in 1978 a new SR system utilizing a 120 rpm scanner will be inaugurated. The principles of operation are identical to the 48 line system except that the pictures will be several times better in resolution. Various display systems for 48

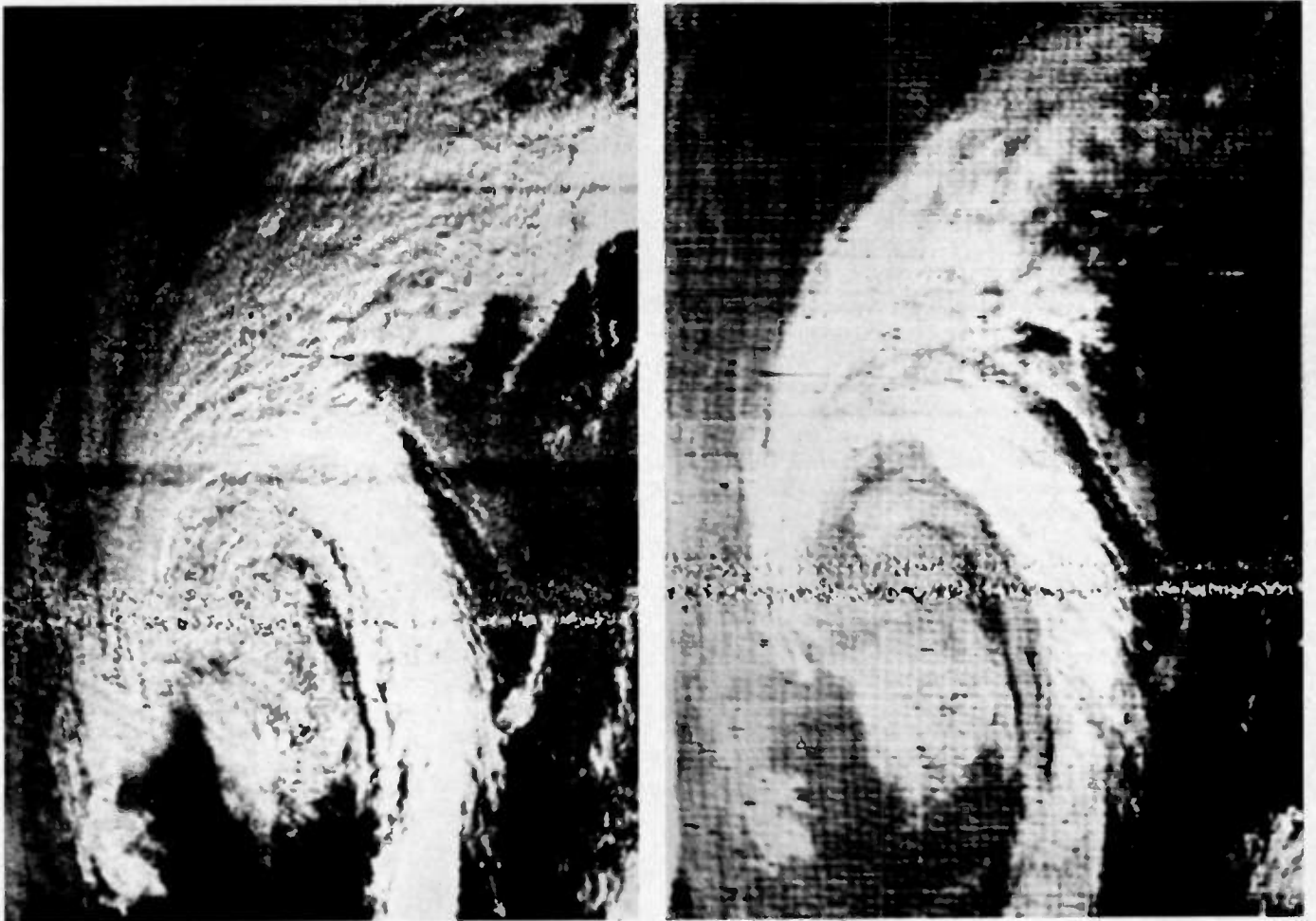

*Photo 1. Visible light (left) and infrared (right) readout from a single NOAA 4 pass over eastern North America on 20 November 1975. The differences in the two views, which represent the same area as seen at the same time, are due to the characteristics of the visible and IR imaging systems. The visible channel sensors respond to light in much the same manner as the human eye, and all cloud structures are shown where sufficient light exists. The upper right portion of the visible view (northwest) is dark because of low sun angle at high northern latitudes at this season and time of day (early morning). The IR channel responds to heat, with the lightest areas representing cold zones and with darker areas progressively warmer. Low clouds do not appear (as they are near ground temperature), while the Atlantic (lower right) appears darker than the land areas to the west because the ocean waters are warmer than the ground at this season of the year.*



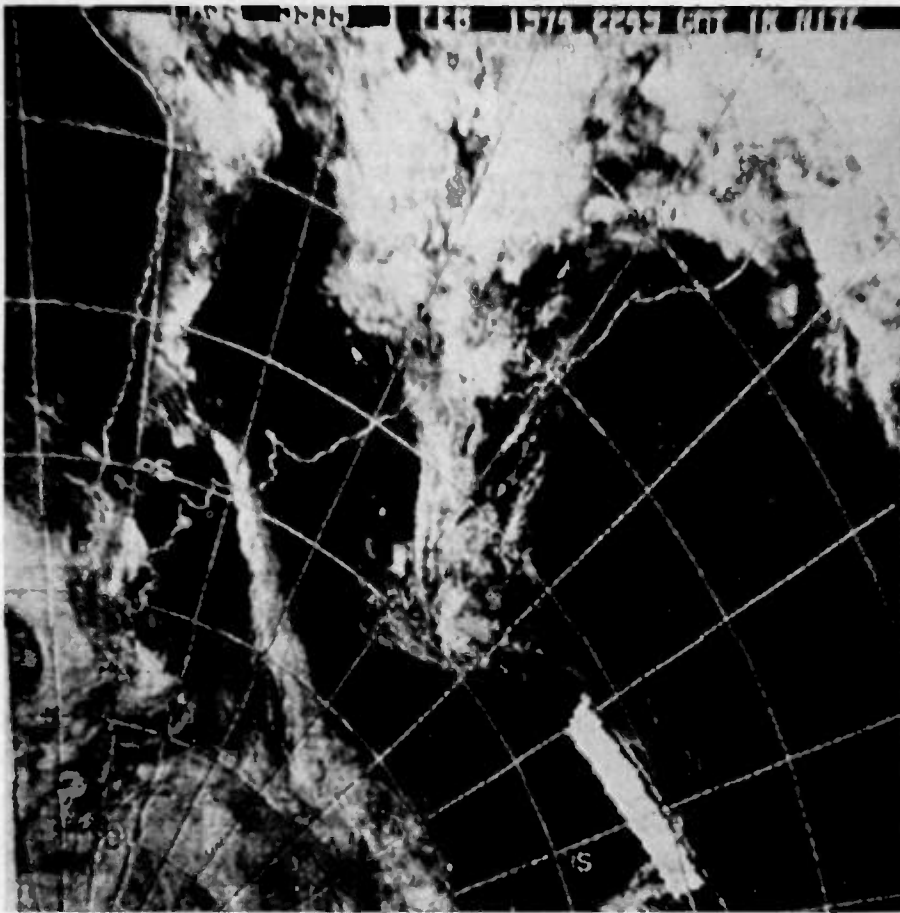

Photo 2. An example of an APT WEFAX transmission from ATS 3. Such computer gridded pictures are put together on the ground from NOAA SR data and are relayed through the geostationary satellite for worldwide distribution to any station within line of sight of the satellite. The view shown here represents ¼ of a polar projection of the southern hemisphere showing most of South America and part of Antarctica. In this case the picture was put together by computer analysis of NOAA IR readout. Grid lines were superimposed and the picture was then relayed through the satellite.

line SR service can be modified for 120 line display with comparatively little difficulty. Baseband video bandwidth for the IR "channel" of the 48 line SR system is 450 Hz while the visible channel bandwidth is 900 Hz. As with the APT mode, if 2400 Hz audio filters are used they should have a bandwidth at least equal to that of the channel in use to get full picture resolution.

**Operational Satellite Systems.** There are two general types of satellite systems of potential use to amateurs — polar orbiting satellites and geostationary satellites. Each will be discussed separately.

**Polar Orbiting Satellites.** Polar orbiting satellites, actually in near polar orbits, provide continuous real-time transmission of cloud cover pictures on a worldwide basis. Table 2 summarizes the data on operational polar orbiting satellites. Each of these satellites provides either 2 or 3 useful daylight passes per day within range of a given ground station, and an equal number of night passes. All of the systems provide useful daylight coverage and some provide night

pictures as well. ESSA 8, launched in late 1968, is the oldest of the operational polar orbiting spacecraft and is the last of its series. Using a TV camera tube and transmitting APT pictures on 137.62 MHz, this satellite provides as many as three useful pictures on a single pass during daylight

Name	Frequency (MHz)	Subpoint	Mode	Products
ATS 1	135.6	149° W	APT	WEFAX — Satellite predict messages, grey scale, computer gridded cloud cover pictures from NOAA data (western U.S., Pacific, E. Asia, E. Africa)
ATS 3	135.6	69° W	APT	WEFAX — Similar to ATS 1 except coverage centers on eastern U.S., Atlantic, Europe, West Africa, South America
SMS 1	1691	75° W	APT	WEFAX — Computer gridded visible and IR views derived from on board spin scan very high resolution radiometer, pictures sectorized from full earth disc
SMS 2	1691	115° W	APT	WEFAX — Similar to SMS 1

Table 3. Geostationary satellites transmitting weather picture data.

hours. The spacecraft is solar powered and is shut down on night sides of its orbit where the TV camera is non-functional. Early in 1975 the performance of camera #1 dropped past the useful level and camera #2 was switched on to replace it. Late that year the camera shutter on the spacecraft began to malfunction — a prelude to total system failure in earlier satellites in the ESSA series. It is probable that this particular satellite may well be shut down by the time this article appears in print and no future satellites of the series are planned.

The primary polar orbiting satellite series now in use and planned for use well into the 1980s is the NOAA satellite series, of which NOAA 3 and 4, operational at the time this is written, are prime examples. These satellites transmit SR pictures at a frequency of 137.5 MHz with monthly one-day tests at 137.62 MHz. Their orbits are essentially identical to that of ESSA and are chosen so that the satellite passes over a given location at about the same time every day. The SR systems aboard these spacecraft provide both visible and IR cloud cover pictures during daylight passes and IR pictures during evening passes. Photo 1 shows an example of both visible and IR data from a single pass. The data display is in the form of a continuous strip of picture material that is received as long as the spacecraft is above the horizon. The examples shown represent about 10 minutes of coverage from the pass in question. Such satellites are ideal for obtaining localized weather patterns, for it is possible to get a direct overhead view of local weather systems and for a single pass the weather pattern for about half of the North American continent — in a strip extending from Greenland to Yucatan — can be obtained for a station located in the north-central U.S. NOAA 4 is currently the primary spacecraft in the series with NOAA 3 serving as a backup. If the orbit of NOAA 3 brings it in conflict with NOAA 4, 3 is switched to 137.62 MHz. NOAA 5 is scheduled for launch in early 1976, at which point NOAA 3 will be deactivated and NOAA 4 will serve as the backup spacecraft if all goes well.

**Geostationary Satellite Systems.** Geostationary satellites are satellites whose orbital path lies over the equator. The altitude of the satellite is approximately 22,000 miles so its orbital period is exactly 24 hours. Since the satellite orbital period is equal to the period of rotation of the earth the satellite always maintains the same position over the equator. This position is known as the satellite *subpoint*. Since such a satellite maintains the same position over a point on the earth, as seen from the earth it appears to remain in the same part of the sky and hence need not be tracked — the antenna can merely be lined up and fixed in place. The extreme altitude of these satellites means that most of a hemisphere can be viewed from them and they are an ideal camera platform for viewing the full earth disc or relaying signals from a ground station to any station within view of such a satellite. Table 3 summarizes the geostationary satellite systems of interest to amateurs. ATS 1 and 3 (ATS is an acronym for *Applications Technology Satellite*) are both experimental satellites to test the feasibility of hemispherewide radio communications relays for a variety of purposes. One of the ways in which these satellites are used is in the transmission of WEFAX (weather facsimile) pictures in the APT mode. These pictures are transmitted on a frequency of 135.6 MHz on a regularly scheduled basis and include "predict" messages for calculating orbits of the various polar orbiting satellites, gray scale transmissions, and cloud cover pictures. The latter are computer gridded to show lines of longitude and latitude and geographic boundaries. Photo 2 shows a typical transmission of WEFAX data from ATS 3. If both satellites are in range of a given ground station it is possible to acquire cloud cover pictures spanning the entire world. Both of these satellites have been in operation for several years and should they fail they will not be replaced as they are strictly experimental. The WEFAX program, however, will be continued with a new series of geostationary satellites of the SMS/GOES type. The SMS satellites are prototypes of the operational system (SMS stands for *Synchronous Meteorological Satellite*) while the GOES satellites (*Geostationary Environmental Satellite*) will be the operational versions. GOES 1 is scheduled for imminent launch as this is being written while SMS 1 and 2 are presently in orbit. These satellites produce extremely high resolution pictures which are transmitted to special ground stations for computer processing. Although reception of the original pictures is still impractical (not impossible, it simply costs too much as yet), the computer processed versions are available, along with other products, as APT WEFAX transmissions. The major drawback of these satellites is that transmission takes place on S band at 1691 MHz. Suitable converters for converting S band signals to the 137 MHz range used for reception of

ATS and polar orbiting satellites can be put together from commercial components (8) but such an approach is prohibitively expensive for most of us. The subject of S band receivers will be discussed later. Just to show that the task is not beyond amateur capability, Photo 3 is included as an example of SMS WEFAX reception. This particular picture was received by Roy Cawthon of Atlanta, Georgia, who has the only amateur S band system in operation at the time this is being written. Just to show that amateurs are not lagging behind, Roy's station is one of only 5 in the world at the present time.

All APT and SR satellite transmissions, regardless of frequency, use FM modulation

with 9 kHz deviation.

**Assembling a Satellite Station.** There are very few references that provide all of the information you might require to set up a station from scratch. Vermillion's NASA report (23) describes a long crossed yagi antenna, a tube-type FM receiver and preamp, and a CRT display system with APT capability and modifications for an early type of SR display. Later government publications are available to update SR display for current standards. Kennedy (6) describes a completely up-to-date display system including an FM receiver with a PLL detector to eliminate Doppler effects. The three part article is very complete and is

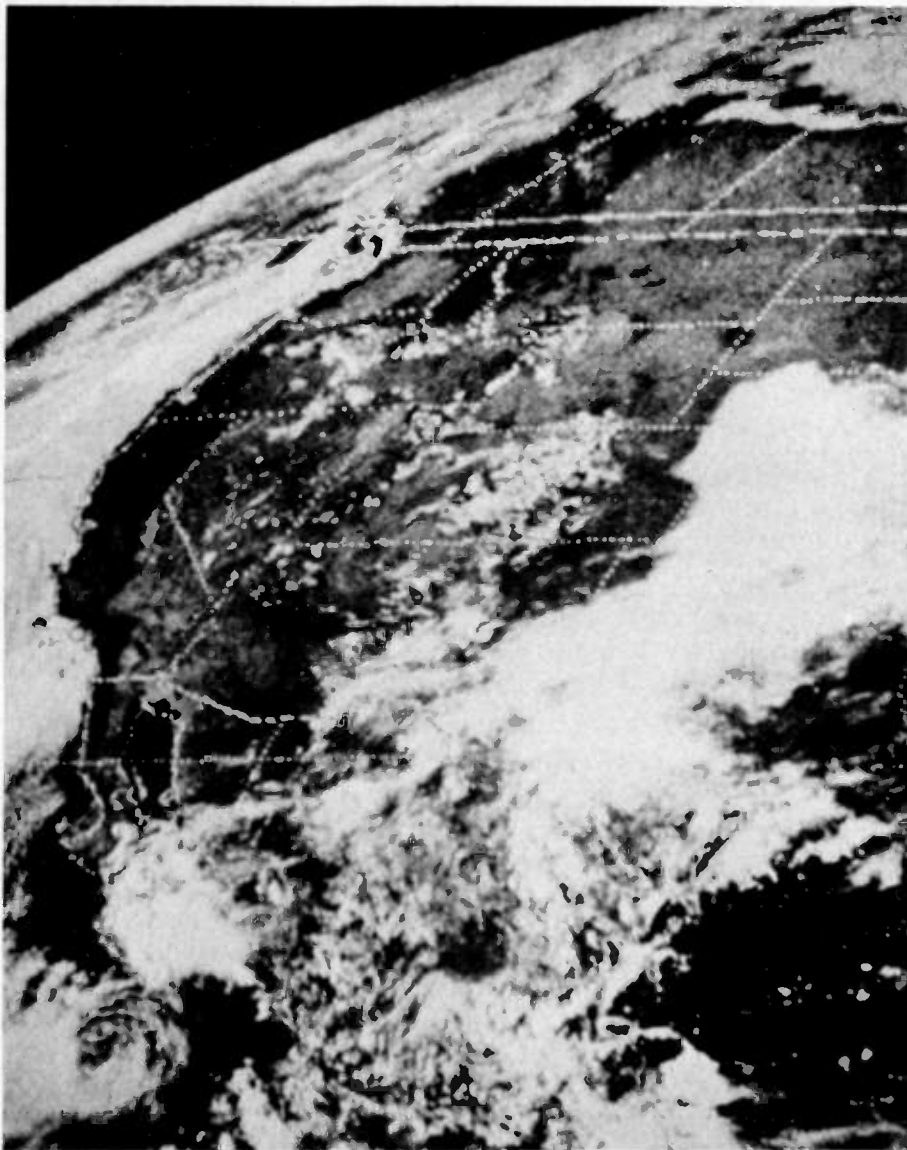

*Photo 3. An example of an SMS S band (1691 MHz) WEFAX transmission as received and displayed by Roy Cawthon of Atlanta, Georgia. Such pictures are derived from the very high resolution spin scan radiometer on the spacecraft, which takes both visible and IR pictures of the full earth disc as seen by the satellite. The pictures are gridded on the ground and re-transmitted through the satellite. Operational versions of this series (GOES satellites) will transmit such pictures and a variety of other WEFAX products. The development of effective, low cost S band converters is one of the major challenges facing amateur satellite experimenters.*

useful reading if you plan your own system design. The third source (21)<sup>1</sup> is one I am particularly partial to simply because I wrote it! This one book contains all of the information required to construct a complete satellite receiving station including numerous accessories. The construction articles are complete and various options are presented for most system requirements. Chapters include antennas, receivers and preamplifiers, CRT display systems, a FAX system, tracking, digital orbital timers, and ways to completely automate station operations. For those who would like to do additional background reading or who would wish to put together a station based on several different options, the following references, grouped by subject, will be useful reading.

**Antennas.** ATS or polar orbiting satellite reception requires the use of a circularly

polarized antenna with the gain requirements for ATS being somewhat more stringent than for the polar orbiting spacecraft. (9) describes a very simple yagi for manual tracking that is suitable for polar orbiting spacecraft if you have someone willing to stand outside and operate it! (21) describes the construction of a short crossed yagi antenna suitable for polar orbiting satellites and discusses various commercially available antennas suitable for ATS or polar orbiting systems. (23) describes a longer crossed yagi suitable for use with either ATS or ESSA and NOAA spacecraft. (22) includes some interesting ideas on antenna mounting which might prove useful. You will notice the emphasis on crossed yagi antennas for circular polarization. This is simply because they have proved far easier to construct and mount than helix antennas, the other major alternative (3), (7). (3) contains useful design and mechanical data for crossed yagis in the

Space Communications chapter.

Reception of S band SMS/GOES signals requires a dish antenna. NASA recommends a 10 foot dish but Roy Cawthon has gotten by with a 6 foot version. The use of modern low-noise transistors may make possible the use of still smaller dishes in the order of 4 feet. I certainly hope so since my own four-footer is mounted in the back yard pointing hopefully skyward! (3) contains construction details for a 10 foot stressed parabolic array but this antenna would have to be modified for permanent service. Numerous microwave antennas available on the surplus market are also an excellent approach.

**Satellite Receivers.** Satellite receivers for 135-138 MHz service should be FM with a 30 kHz i-f bandpass (15 kHz selectivity). This will accommodate maximum signal deviation (9 kHz) plus worst case Doppler shift (4.5 kHz). Crystal controlled channel selection with crystals for 135.6 MHz (ATS), 137.5 MHz (primary NOAA), and 137.62 MHz (ESSA and backup NOAA) will be required. Sensitivity should be 0.1-0.2 microvolts for 20 dB of quieting. Older receivers will require a preamplifier to set a desirable front end noise figure. A preamp mounted at the antenna is highly desirable as it effectively overcomes line losses that would otherwise degrade the system noise figure.

Reference (23) describes a tube-type receiver and mast-mounted preamp. (21) describes a kit, modifications to a commercial monitor receiver, commercially available preamps, and tips on selecting a surplus receiver strip for weather satellite conversion. (6) describes a solid state receiver with PLL i-f that is very effective. Passable results can also be obtained by modification of a commercial FM tuner (9) but this is a very makeshift approach.

**Display Systems.** There are two principal options for display of APT or SR pictures — a facsimile (FAX) recorder for printing pictures directly on paper and a cathode ray tube (CRT) display on a television-like screen in which the image is photographed for analysis. Both types of display systems are capable of resolving all of the picture details in either mode and each has its own advantages and disadvantages. FAX systems are mechanical devices which make the picture display immune to factors such as stray magnetic fields that might distort a CRT display, yet they require some care to construct and operate and need some maintenance to keep them in top operating condition. Some forms of FAX will give instant pictures with features visible during picture readout, while even the most involved photographic systems require only a few steps to view the picture. Some FAX systems excel at resolving fine structure in bright clouds that might be obscured by trace blooming in a poorly designed CRT system. The mechanical nature of FAX,

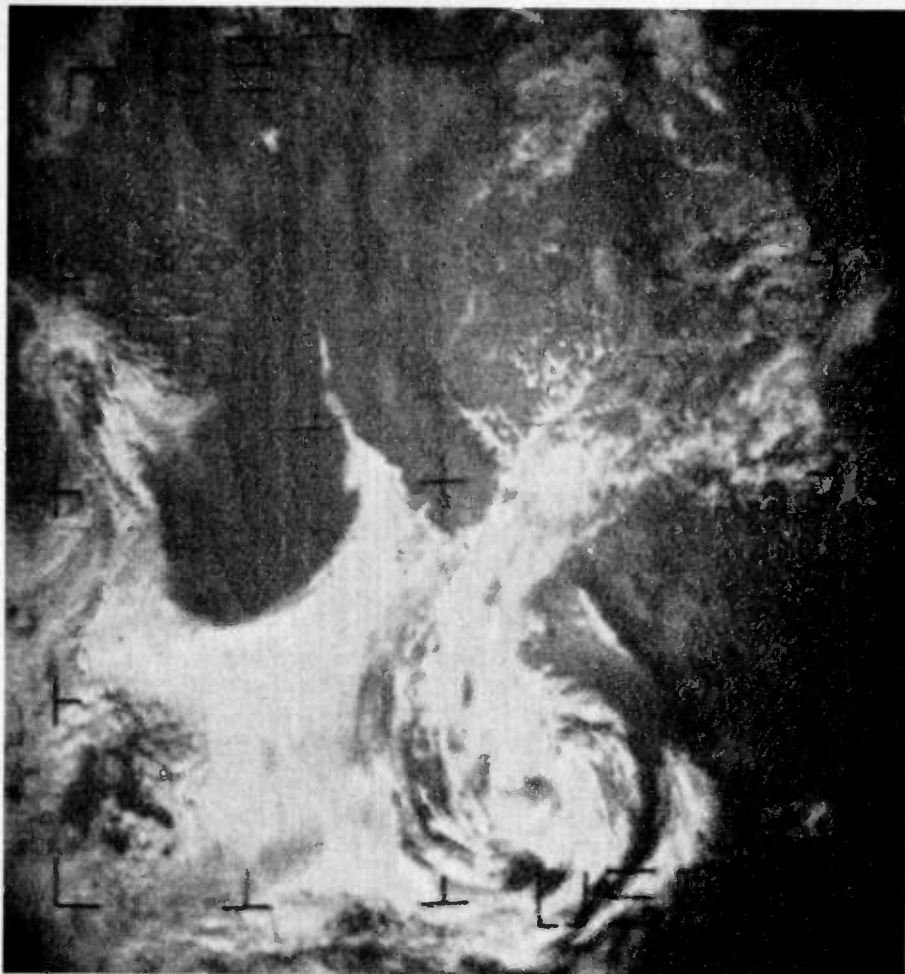

*Photo 4. Visible channel imagery from a NOAA 4 SR transmission as displayed on a photographic FAX system. In this case the images from the 48 line SR system were displayed at 96 rpm with alternate lines (the IR image) electronically blanked. Such FAX systems provide extremely high quality, especially in defining the structure of bright cloud features. This particular pass (7 August 1975) was directly over the Great Lakes, which are faintly visible in the center of the picture.*



however, means that you are fixed to a single size format and changing picture modes involves complex mechanical and/or electrical changes or the construction of a recorder for each mode you wish to operate. CRT systems, in contrast, are relatively easy to construct and building them for multi-mode service is an easy task. Direct viewing of pictures is difficult, however, and photographs are most desirable. This is one handicap of the CRT option. Polaroid film provides instant pictures but at some expense if you read out large numbers. Roll film provides very inexpensive recording of the pictures but at some delay while the film is processed and printed. Such photos can, however, be printed at any size desired. Use of a CRT system involves less "fuss" than a FAX display, which is a factor that makes it desirable in situations where only occasional use is required. Properly designed systems of both types will be about equal in overall performance so the selection task is complicated. Active satellite stations often have both types in operation to fit the needs at hand.

The facsimile options are quite varied and a number of tradeoffs must be considered to determine which might be best for your use. The three major systems involve direct printing on film or paper using a modulated light source, printing on electrolytic paper, or printing on electrostatic paper. There is little doubt that photographic FAX systems offer the highest quality pictures — but at some inconvenience. They must be operated in the dark or near darkness in the case of systems that print on paper, and photographic processing is required. Anderson's pioneering work (2) describes a photographic FAX system for APT use which prints on film. McKnight's modifications of this system (7) result in a system that is somewhat more convenient in that printing is done directly on paper, thus reducing cost and time required. Ruperto (11) describes a direct printing photographic system derived from the work of W6KT, and Taggart (20) provides a complete construction article for a 48 line NOAA system along the same lines. Although both (11) and (20) are designed for 48 line SR display, either could be modified for APT with little difficulty. (21) provides full construction information and design data for a FAX system for 48 or 96 line SR display with modification notes for upgrading to future 120 line SR systems (Photo 4). With very slight modifications this recorder (120 line version) could also be used for APT service. Printing on electrolytic paper results in some loss of image quality but this is compensated for in some situations by the fact that the pictures can be printed out for immediate viewing in a lighted room. Winkler's SSTV FAX system (25) could be easily modified for SR or APT use — in fact, the SSTV version was a spin-off from his various satellite recorders. Photo 5 shows a sample of Winkler's APT



*Photo 5. Display of an APT picture from ESSA 8 passing over the west coast. This picture was displayed by Linsay Winkler using a homemade continuous readout FAX machine and Alden electrolytic paper. Although such systems do not have the ultimate in fine detail of a photographic FAX or CRT system, they are still excellent. The slight degradation in image quality is compensated for by the fact that the image can be read out in normal room lighting and is visible as it comes out of the machine. Similar continuous readout recorders are excellent for present and future SR systems as well.*

readout on electrolytic paper — a picture from ESSA 8 in its better days! Electrostatic paper is perhaps the least satisfactory alternative, mostly due to the difficulty in getting a suitably good gray scale. Winkler's modification of a surplus Western Union Deskfax machine (26) is perhaps the quickest way to get some sort of FAX system going. While hardly the equal of these other systems in picture quality, Osborne's FAX recorder (10) certainly takes the prize for originality — it is built up around a windshield wiper motor and gear assembly!

CRT system options are quite varied and many approaches are possible depending upon equipment already on hand. Three alternatives are presently the most popular — display on an oscilloscope, display on conventional SSTV monitors, or construction of a monitor tailored for satellite picture display. The oscilloscope approach involves construction of a suitable "black box" that will provide Z axis video modulation to the

scope and appropriate waveforms for horizontal and vertical deflection. Osborne's circuit (9) is probably the simplest of these and will give satisfactory results in the APT mode if a better receiver is used. Toben's circuit (22) is more complicated but will produce somewhat more reliable results. Kennedy's system (6) is the most elegant of the group and will provide excellent results in both APT and SR service.

The popularity of SSTV has led a number of people to experiment with display of satellite pictures on slow scan monitors. (13) is a very simple APT adapter that can be used with a number of monitor circuits and suitable modifications for adding SR display are included in (14). Additional circuit ideas are incorporated in (17) that permit use of the adapter with Robot monitors or even TV sets. Owners of Robot SSTV equipment should consider contacting Robert Schloeman WA7MOV, who has designed an excellent adapter circuit specifically tailored for use with the Robot SSTV monitor.

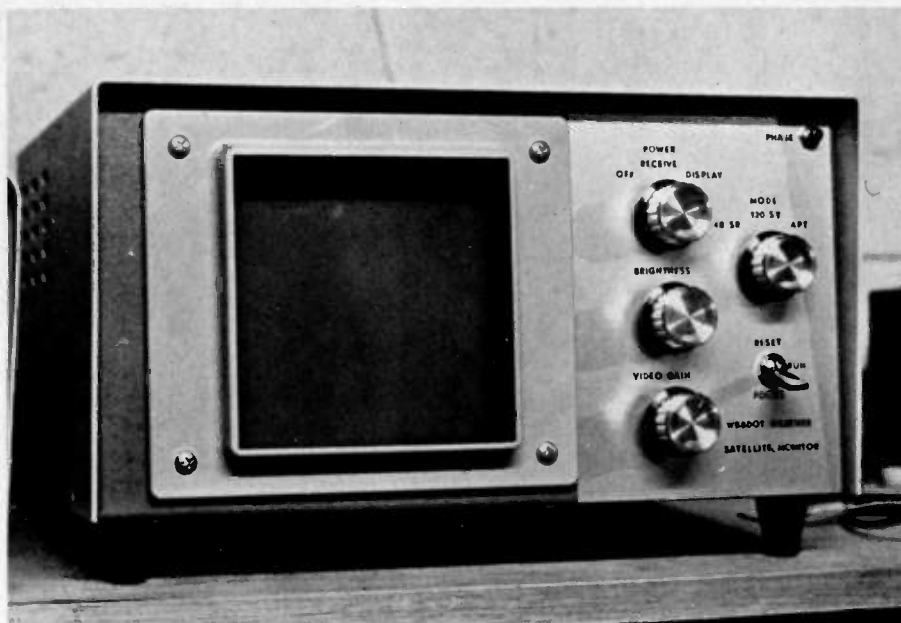

*Photo 6. A solid state multimode satellite monitor built by the author. This circuit is featured in the Weather Satellite Handbook (21) and has switch-selected options for display of 48 line SR, future 120 line SR, and APT picture modes. Such monitors are compact and are quite easy to operate, making them a highly desirable project for stations seriously interested in weather. Using all new components and high class packaging, such a monitor still costs less than \$300. Less elegant packaging and a search for junk box components can reduce costs to a fraction of this even in such a comparatively advanced project.*

The construction of a complete display monitor is perhaps the most reasonable approach for individuals lacking extra oscilloscopes or SSTV monitors. Vermillion's report (23) describes a monitor of sorts built around a commercially available oscilloscope module. Spillane (12) described an APT monitor using tube circuits that would still be useful with some modifications of the sync detection circuits. The advanced version of Osborne's circuit (9) is another choice for APT display. (21) describes a complete multimode solid state satellite monitor complete with printed circuit artwork and component layouts. Photo 6 shows a version of this monitor which is also described in (21). The latter reference includes data on the simple addition of 120 line SR capability which is incorporated in the unit shown (48 line SR, 120 line SR, and APT capability). Such a monitor certainly represents the ultimate in a compact display system.

**Satellite Tracking.** Although tracking of polar orbiting spacecraft appears to be an imposing task, it is not at all difficult to accomplish. (24) is interesting reading regarding satellite orbits in general and (15) outlines all the essential features involved in satellite tracking. (21) contains a full chapter on the subject which in addition to the tracking of polar orbiting satellites also includes aiming data for geostationary satellites, alternate sources of tracking data, and a simplified model for long term orbital predictions.

**Accessories.** These components include desirable station features that are not absolutely necessary but do improve operating convenience. (16) describes a digital orbital timer that eliminates the need to acquire daily prediction data or interpolate from a clock when tracking and (18) describes the use of such a timer to completely automate station operations, including turning on the recorder, tracking, and station shutdown at the end of a pass. (17) includes some useful accessories such as an active 2400 Hz filter and a crystal controlled 2400 Hz reference source, either of which would be a useful addition to many of the systems covered in these references. Brush (4) describes a novel circuit for contrast enhancement in the SR IR channel display and (23) includes a more complicated circuit to accomplish much the same task for FAX display.

This about covers most of the technical features. A very interesting summary of different weather satellite products is contained in a report by Hoppe (5) that not only describes the pictures from various satellite systems but also shows the different ways in which these are computer processed and mosaicked for greater utility. If you get a system in operation you might wish to learn a little more about how the cloud systems you see relate to surface weather. A wealth of information on this subject is contained in Anderson's paper (1) which, with a little study, will enable you to derive really meaningful data from your cloud pictures.

Now there are probably lots of readers of this article who might never consider setting up a satellite station. You have read this article out of curiosity and the desire to simply learn a little bit about another facet of this far-flung hobby of ours. This is one of the things that makes it interesting to receive your magazine every month. But even if you are not interested in weather satellites, let me outline a challenge that may appeal to some of you. I have mentioned previously the difficulties involved in putting together a suitable S band converter for use with the SMS/GOES satellite series. The commercial modules (8) are far too expensive for most satellite buffs and Roy Cawthon's success was due in large part to his willingness to invest a fair amount of money and a huge block of time in getting his system going. It is not one that could be easily duplicated by stations now receiving ATS WEFAX who would like to get in on the action up on S band. Several amateurs are actively working on the design and construction of suitable S band converters in the hopes of pushing down price and complexity to the point that others could think seriously about adding S band capability to their operations. It is too early to say if these efforts will be successful but it is a virtual certainty that a lot of you out there are seriously interested in UHF and microwave experimentation. A successful S band converter would be a boon to satellite stations throughout the world and there is no doubt that should any of you develop such a system, you could certainly put together a description of the circuit that would instantly be accepted by a magazine like 73. The specifications run something like this:

Input Frequency — 1691 MHz  
 Output Frequency — 137.5 MHz  
 Front end noise figure — 2.5-4.5 dB  
 Front end gain — 20 dB min.  
 Mixer noise figure — 9.5 dB max (assuming 1.5-2 dB first i-f noise figure)

NASA's solution is a \$900 preamp, a \$200 mixer, and a \$900 LO chain for a total converter cost of \$2000. With today's technology it would seem that amateurs could do the same job for \$200 — maybe a little more, perhaps somewhat less. Any UHF or microwave buffs out there who would like to give it a try? I would be happy to correspond with anyone who would. Any approach is valid although perhaps microstriplines are best from the point of view of easy duplication. Maybe you like to design but hate to build, in which case microstripline design data around specific rf transistors would be most welcome — needless to say full credit would be given for any successful design input. Perhaps you have access to suitable S band test equipment and would be willing to help set up gear that others might construct — if so I would certainly like to hear from you. An easily

duplicated S band converter would make you famous in weather satellite circles even if you never watch a single picture — see how easy it is to get involved? Hundreds of APT stations throughout the world will be out of business in terms of WEFAX if such a converter is not forthcoming before the ATS satellites expire. This one area is certainly a challenge to anyone with the expertise to once again show the “professionals” what amateur radio can accomplish. The more people who are working on this particular task the more certain will be an eventual solution!

Experimenting with weather satellites is certainly one of the more fascinating peripheral areas in which amateurs can participate. One of the simpler systems represents an ideal short-term project to discover if you might be interested, but even the most sophisticated systems, equal to commercial display units costing over \$10,000, need not be expensive. The multi-mode monitor shown in Photo 6 is capable of displaying pictures from present and future APT and SR systems and yet even with the comparatively “deluxe” packaging employed it can be built for less than \$300 — less than a commercial SSTV monitor. For less than what some amateurs are willing to spend on one of the newer FM transceivers it is possible to construct a complete satellite station that will operate when you aren't even home. Stations with fewer refinements have been constructed by students as science fair projects for a small fraction of this cost. Why not look through some of these references and give it a try? ■

#### Literature Cited

- (1) Anderson, R.K. *et al.* 1974. Applications of meteorological satellite data in analysis and forecasting. *ESSA Technical Report NESC 51* (reprint). \$1.75\*
- (2) Anderson, W. 1965. Amateur reception of weather satellite picture transmissions. *QST*, November.
- (3) *The A.R.R.L. Antenna Handbook*. American Radio Relay League, Newington CT. Chapter 12.
- (4) Brush, R.J.H. and P.E. Baylis. 1973. Contrast expansion processor. *Wireless World*, December.
- (5) Hoppe, E.R. *et al.* 1974. Catalogs of operational satellite products. *NOAA Technical Memorandum NESS 53*. \$3.00\*
- (6) Kennedy, G.R. 1974. Weather satellite ground station. *Wireless World*, November, December and January 1975.
- (7) McKnight, C. 1968. Evolution of an amateur weather satellite picture station. *QST*, April.
- (8) Nagle, J.H. 1974. A method of converting the SMS/GOES WEFAX frequency (1691 MHz) to the existing APT/WEFAX frequency (137 MHz). *NOAA Technical Memorandum NESS 54*. \$3.00\*
- (9) Osborne, J.M. 1971. Receiving weather pictures from satellites. *Wireless World*; basic system in October issue, advanced system in November issue.
- (10) *Ibid.* 1975. Facsimile scanner. *Wireless World*, October.
- (11) Ruperto, E.F. 1974. Weather satellite pictures picked up in the home. Amateur Scientist section, *Scientific American*, January.

- (12) Spillane, J. 1969. A cathode ray tube display unit for satellite weather pictures. *QST*, June.
- (13) Taggart, R.E. 1974. Western satellite pictures on your SSTV monitor. *73 Magazine*, September.
- (14) *Ibid.* 1974. A modified WB8DQT satellite. *73 Magazine*, December.
- (15) *Ibid.* 1975. How to find the satellite. *73 Magazine*, January.
- (16) *Ibid.* 1975. What time is the next satellite? *73 Magazine*, February.
- (17) *Ibid.* 1975. More weather satellite pictures. *73 Magazine*, June.
- (18) *Ibid.* 1975. Automating satellite reception. *73 Magazine*, July.
- (19) *Ibid.* 1975. How about a weather satellite monitor? *73 Magazine*, August.
- (20) *Ibid.* 1975. A satellite fax system you can build. *73 Magazine*, September, October.
- (21) *Ibid.* 1976. *The Weather Satellite Handbook*. 73, Inc., Peterborough NH 03458.

- (22) Toben, G.H. 1968. Electronic system for recording satellite transmissions. *Ham Radio*, November.
- (23) Vermillion, C.H. 1969. Weather satellite picture receiving stations. *NASA SP-5080*. \$3.00\*
- (24) Widger, W.K. 1974. A plotting device for predicting the orbit of an earth satellite. Amateur Scientist section, *Scientific American*, May.
- (25) Winkler, L. 1973. A fast scan facsimile system with SSTV compatibility. *73 Magazine*, March.
- (26) *Ibid.* 1974. Facsimile transceiver for weather satellite pictures. Technical Correspondence, *QST*, May.

\*References marked with a single asterisk are U.S. government publications which are available from the National Technical Information Service, U.S. Department of Commerce, Sills Building, 5285 Port Royal Road, Springfield VA 22151. Such government publications are also available from large public libraries or universities with holdings of government documents.



Photo 7. One drawback in improperly operated CRT display systems is that trace “blooming” often obscures fine features in very bright clouds. This photo of a NOAA pass over the central U.S. on a very cloudy winter day shows that properly operated CRT systems need not have this problem. This particular picture was displayed on the 5” CRT monitor described in reference (19).



**HAM  
DIES  
OF  
BURST  
BLADDER**

Word has just reached the 73 offices of the recent departure for that great DXpedition in the sky of a very avid 73 reader. Upon investigation it was ascertained that said ex ham had, shortly before his demise, received delivery of a bundle of back issues of 73. Apparently these so captured his attention that other functions were totally forgotten.

**BE WARNED.** Back issues of 73 should be taken in moderation. Even though they arrive in bundles of twenty, no more than two should be read at any one sitting.

Back issues are available in three different assortments — vintage, mid-years and recent. These are packed by the mentally handicapped (73 is an equal opportunity employer), so no specific issues can be requested . . . you take what you get . . . the only guarantee is that all will be different and some will be musty, particularly the VINTAGE BEAUTIES.

The supply of these FANTASTIC GEMS is very limited so run do not walk to your checkbook and flip the \$8.00 per bundle to us right now.

20 Back Issues of 73 . . . . . \$8.00

**BRAND NEW! DICTIONARY**

This new microcomputer dictionary fills the urgent need for all computer people, engineers, scientists, industrialists, communication people — as professionals, amateurs, teachers, or students — to become quickly acquainted with the terminology and nomenclature of a new revolution in computer control capabilities in areas that pervade most of man's daily activities.

Over 5000 definitions and explanations of terms and concepts (704 pages) relating to microprocessors, microcomputers and microcontrollers. There are also separate appendices on:

**MICROCOMPUTER**

**Dictionary & Guide**



programmable calculators; math and statistics definitions; flowchart symbols and techniques; binary number systems and switching theory; symbol charts and tables; summaries of BASIC FORTRAN and APL. In addition there is a comprehensive electronics/computer abbreviations and acronyms section.

**DICTIONARY . . . . . \$15.95**

**new REPEATER ATLAS**

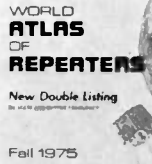

- More than twice the listings of any other repeater list.
- New Double Listing — by location and also by frequency.
- New Handler Grouping — by call areas — makes repeaters easier to find.
- New Simplified Listings for fast reading — easier to read in the car.
- New state maps of repeater locations.
- Know what repeater you can use and where.

FM Atlas . . . . . only \$1.95

**BIGGEST BARGAIN YET**

Tab's new 1001 circuits is available for only \$9.95 ppd. The next time you want a circuit for just about anything eat your heart out that you didn't send for this book the first time you read about it. You'd better order the book right away, before they run out.



1001 Electronic Circuits . . . \$9.95

**The ONLY Complete License Study Guides**

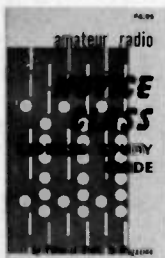

**NOVICE \$4.95**

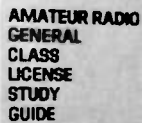

**GENERAL \$5.95**



**ADVANCED \$3.95**

**EXTRA CLASS \$4.95**

FCC exams got you scared? Frustrated by theory fundamentals? There's no need to worry. 73's four License Study Guides will help you breeze through any of the four tough exams! They are the ONLY guides which cover ALL the material you will have to know. Many amateurs find that one quick reading through our guides is enough to get them through with no sweat.

**Startling Learning Breakthrough**



**NOVICE THEORY TAPES Set of 4 Tapes only \$13.95**

You'll be astounded at how really simple the theory is when you hear it explained on these tapes. Three tapes of theory and one of questions and answers from the latest Novice exams give you the edge you need to breeze through your exam.

73 is interested in helping get more amateurs, so we're giving you the complete set of four tapes for the incredibly low price of ONLY \$13.95.

Scientists have proven that you learn faster by listening than by reading because you can play a cassette tape over and over in your spare time — even while you're driving! You get more and more info each time you hear it.

You can't progress without solid fundamentals. These four hour-long tapes give you all the basics you'll need to pass the Novice exam easily. You'll have an understanding of the basics which will be invaluable to you for the rest of your life! Can you afford to take your Novice exam without first listening to your tapes?

**SOLID STATE PROJECTS**

More than 60 projects of interest to anyone in electronics. The devices range from a simple transistor tester to a ham TV receiver. This collection will help you become more intimately acquainted with zeners, ICs and varactors, etc.



\$4



**2M FM HANDBOOK**

**\$5.95**

Contains almost every conceivable circuit that might be needed for use with a repeater. All circuits explained in detail. All aspects covered, from the operator to the antenna.

**VHF PROJECTS FOR AMATEUR AND EXPERIMENTER**

A must for the VHF operator. Opening chapters on operating practices and getting started in VHF, both AM and FM, followed by 58 chapters on building useful test equipment, modifying existing and surplus gear.

**\$4.95**



**DIGITAL CONTROL OF REPEATERS**

Here's a book for the F1er who wants to design and build a digital repeater control system. Contains sections on repeaters, basic logic functions, logic circuit design, control systems, support circuits, mobile installations, touch-tone, plus a special section on a "mini" repeater control system.

**\$5.00**

**SSTV HANDBOOK**

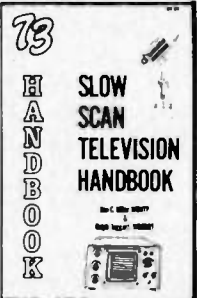

This excellent book tells all about it, from its history and basics to the present state-of-the-art techniques. Contains chapters on circuits, monitors, cameras, color SSTV, test equipment and much more. Hardbound \$7, Softbound \$5.

**LATEST RELEASES from 73 publications**

**RF and DIGITAL TEST EQUIPMENT YOU CAN BUILD**

RF burst, function, square wave generators, variable length pulse generators — 100 kHz marker, rf and rf sweep generators, audio osc, af/rf signal injector, 146 MHz synthesizer, digital readouts for counters, several counters, prescaler, micro-wavemeter, etc. 252 pages. \$5.95



**PRACTICAL TEST INSTRUMENTS YOU CAN BUILD**

37 simple test instruments you can make covers VOMs, VTVMs, semiconductor testing units, dip meters, watt meters, and just about anything else you might need around the test lab and ham shack. \$4.95







# NEW CODE SYSTEM

FOUR SPEEDS AVAILABLE

**5 WPM** This is the beginning tape for people who do not know the code at all. It takes them through the 26 letters, 10 numbers and necessary punctuation, complete with practice every step of the way using the newest blitz teaching techniques. It is almost miraculous! In one hour many people — including kids of ten — are able to master the code. The ease of learning gives confidence to beginners who might otherwise drop out.

**6 WPM** This is the practice tape for the Novice and Technician licenses. It is made up of one solid hour of code, sent at the official FCC standard (no other tape we've heard uses these standards, so many people flunk the code when they are suddenly — under pressure — faced with characters sent at 13 wpm and spaced for 5 wpm). This tape is not memorizable, unlike the zany 5 wpm tape, since the code groups are entirely random characters sent in groups of five. Practice this one during lunch, while in the car,

anywhere and you'll be more than prepared for the easy FCC exam.

**14 WPM** Code groups again, at a brisk 14 per so you will be at ease when you sit down in front of the steely eyed government inspector and he starts sending you plain language at only 13 per. You need this extra margin to overcome the panic which is universal in the test situations. When you've spent your money and time to take the test you'll thank heavens you had this back breaking tape.

**21 WPM** Code is what gets you when you go for the Extra Class license. It is so embarrassing to panic out just because you didn't prepare yourself with this tape. Though this is only one word faster, the code groups are so difficult that you'll almost fall asleep copying the FCC stuff by comparison. Users report that they can't believe how easy 20 per really is with this fantastic one hour tape. No one who can copy these tapes can possibly fail the FCC test. Remove all fear of the code forever with these tapes.

**ONLY \$3.95!** 73 is in the publishing business, not tapes, so these are priced much lower than anyone else could sell them. Have you ever seen one hour cassettes for under \$6? For 1<sup>st</sup> class mail add 25¢ per tape ordered.



Hot off the press, the NEW VHF Antenna Handbook details the theory, design and construction of hundreds of different VHF and UHF antennas ... antennas for FM, for DXing, for repeaters, for mobiles, for emergencies, for contests, quickies, mammoth arrays ... **EVERYTHING IS RIGHT HERE!**

A practical book written for the average amateur who takes joy in building, not full of complex formulas for the design engineer. Packed with fabulous antenna projects you can build.

This quality reference book would normally sell for as much as \$5 or \$6, but the publishers have agreed to keep the price at an inflation fighting price of \$2.95. Send cash, check or money order ... or give your Master Charge or BankAmericard number ... **ORDER TODAY!**

Dealer inquiries invited

**SPREAD the WORD!**



**ONLY .50c**

Ham radio is too great a hobby for us to keep it to ourselves. Let's tell the whole world about it! And what better way than by sporting this attractive lime-green bumper sticker on your car! It's only 50¢ — and it's phosphorescent so you can see it even at night. Go ahead ... **SPREAD THE WORD! Order yours TODAY!**

**QSLs!**

Get some you can be proud of... and—save money!

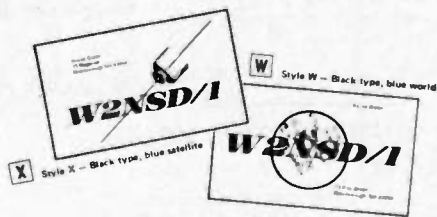

**ONLY \$6 for 250, \$10 for 500, \$15 for 1,000, and \$20 for 2,000.**

How can 73 make such beautiful cards, printed on the best coated stock, available for about half the regular cost? Our business is 73 Magazine and QSLs just help keep things going during slack days of the month. We do this at cost just to keep busy — you get the benefit. How many shacks have your QSL card proudly on display?

The world and satellite are printed in blue, your name, address and call are in black. The QSO information is a standard form on the back.

DOMESTIC ORDERS ONLY

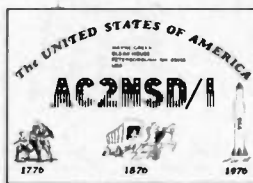

**BICENTENNIAL QSL CARDS**

**BE PROUD OF AMERICA!**

Be the first in your area with a special BICENTENNIAL QSL card. These cards are gorgeous — red, white and blue (you were expecting fuchsia and mauve?). And they are 100% custom made ... with the exception of the bicentennial design and contact report form on the back ... you can have your own call letters (unless you'd rather be AC2NSD/1 for a year (which is no bargain, believe it).

You also get your own name and address on the card (unless you happen to be another Wayne Green, which happens).

These cards are ganged up into large batches and run off the 73 presses in between other work, so you don't get overnight delivery, but you do end up with a fantastic QSL at a ridiculously low price (and there are a lot of fans for that sort of service these days).

Suggestion: order today, right now, not later, not next week. Send cash, check, money order, IRCs, Master Charge or BankAmericard numbers ... send something negotiable.

DOMESTIC ORDERS ONLY

Allow 4 weeks for delivery.

## 73 VERTICAL, BEAM AND TRIANGLE ANTENNAS

by Edward M. Noll W3FQJ

Describes 73 different antennas for amateurs. Each design is the result of the author's own experiments: each has actually been built and air-tested. Includes appendices covering the construction of noise bridges and antenna line tuners, as well as methods for measuring resonant frequency, velocity factor, and standing-wave ratios. 160 pages.

Just \$4.95

## 73 DIPOLE AND LONG-WIRE ANTENNAS

by Edward M. Noll W3FQJ

This is the first collection of virtually every type of wire antenna used by amateurs. Includes dimensions, configurations, and detailed construction data for 73 different antenna types. Appendices describe the construction of noise bridges, line tuners, and data on measuring resonant frequency, velocity factor, and swr. 160 pages.

Just \$4.95



## RTTY HANDBOOK

A comprehensive book covering all areas of radio teletype, from getting started with the basic principles, what equipment to procure and how to make it work.

RTTY Hdbk ..... \$5.95

TAPES from 73 MAGAZINE



by Peter R. Rony  
David G. Larsen WB4HYJ

**BUGBOOKS I AND II**

Sold as a set these two books outline over 90 experiments designed to teach the reader all he will need to know about TTL logic chips to use them in conjunction with microprocessor systems. You'll learn about the basic concepts of digital electronics including gates, flip flops, latches, buses, decoders, multiplexers, demultiplexers, LED displays, RAMs, ROMs and much, much more.

Only \$16.95 per set  
Ila ..... \$4.95

by Peter R. Rony  
David G. Larsen WB4HYJ  
Jonathan A. Titus

**BUGBOOK III**

Here is the book that puts it all together. Besides having much valuable text there are a series of experiments in which the reader completely explores the 8080 chip pin by pin and introduces you to the Mark 80 microcomputer, a unique easily interfaced system. It is recommended that you have the background of the BUGBOOKS I & II before proceeding with BUGBOOK III.

Only \$14.95

**COMPUTER PROGRAMMING HANDBOOK**

... Peter Stark K2OAW

A complete guide to computer programming and data processing. Includes many worked out examples and history of computers. \$8.95



**What To Do After You Hit Return**

PCC's first book of computer games ... 48 different computer games you can play in Basic ... programs, descriptions, muchly illustrated. Lunar landing, Hamurabi, King, Civil 2, Qubic 5, Taxman, Startrek, Crash, Market ... etc.

WHAT TO DO ..... \$6.95 pp.



**MY COMPUTER LIKES ME**

... when I speak Basic

... Albrecht

An introduction to Basic ... simple enough for your kids. If you want to teach Basic to anyone quickly, this booklet is the way to go.

MY COMPUTER ..... \$2.00 pp.

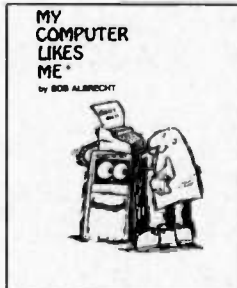

**BASIC ... by Bob Albrecht, etc.**

Self-teaching guide to the computer language you will need to know for use with your microcomputer. 324 pages. This is one of the easiest ways to learn computer programming.

BASIC ..... \$3.95 pp.

**IC OP AMP COOKBOOK**

by Walter G. Jung. Covers not only the basic theory of the IC op amp in great detail, but also includes over 250 practical circuit applications, liberally illustrated. Organized into three basic parts: introduction to the IC op amp and general considerations, practical circuit applications, and appendixes of manufacturers' reference material. 592 pages; 5 1/2 x 8 1/2; softbound. \$12.95

**TTL COOKBOOK**

by Donald Lancaster. Explains what TTL is, how it works, and how to use it. Discusses practical applications, such as a digital counter and display system, events counter, electronic stopwatch, digital voltmeter, and a digital tachometer. 336 pages; 5 1/2 x 8 1/2; softbound. \$8.95

**RTL COOKBOOK**

by Don Lancaster. Explains the how and why of RTL (Resistor-Transistor Logic) and gives design information that can be put to practical use. Gives a multitude of digital applications ranging from the basic switch to the sophisticated counter. 240 pages; 5 1/2 x 8 1/2; softbound. \$5.50

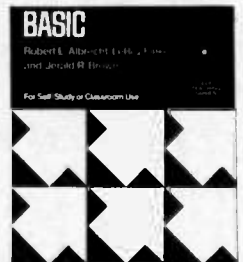

**TO ORDER, CHECK DESIRED ITEMS FROM THE FOLLOWING LIST:**

- Back Issues (8.00)
  - Recent
  - Midyears
  - Vintage
- Novice Theory Tapes (13.95)
- Code Tapes
  - 5 WPM (3.95)
  - 6 WPM (3.95)
  - 14 WPM (3.95)
  - 21 WPM (3.95)
- Bumper Stickers (.50)
- QSLs
  - Style W
  - Style X
    - 250 (6.00)
    - 500 (10.00)
    - 1000 (15.00)
    - 2000 (20.00)
- Bicentennial
  - 250 (7.50)
  - 500 (12.50)
  - 1000 (20.00)
- Microcomputer Dictionary (15.95)
- Repeater Atlas (1.95)
- Novice Study Guide (4.95)
- General Study Guide (5.95)
- Advanced Study Guide (3.95)
- Extra Class Study Guide (4.95)
- 1001 Circuits (9.95)
- Solid State Projects (4.00)
- VHF Projects (4.95)
- 2M FM Handbook (5.95)
- RF and Digital Test Equip (5.95)
- Practical Test Instruments (4.95)
- Digital Control of Repeaters (5.00)
- SSTV Handbook
  - Softbound (5.00)
  - Hardbound (7.00)
- VHF Antenna Handbook (2.95)
- RTTY Handbook (5.95)
- 73 Vertical Beam Antennas (4.95)
- 73 Dipole Antennas (4.95)
- Bugbooks I & II (16.95)
- Bugbook Ila (4.95)
- Bugbook III (14.95)
- Computer Programming (8.95)
- What To Do (6.95)
- My Computer Likes Me (2.00)
- Basic (3.95)
- IC Op Amp Cookbook (12.95)
- TTL Cookbook (8.95)
- RTL Cookbook (5.50)

Name \_\_\_\_\_ Call \_\_\_\_\_  Cash  Mastercharge

Address \_\_\_\_\_  Check  BankAmericard

City \_\_\_\_\_ State \_\_\_\_\_ Zip \_\_\_\_\_ Mastercharge # \_\_\_\_\_

Awards to be listed (W and X QSLs only) \_\_\_\_\_ BankAmericard # \_\_\_\_\_

Bicentennial Call (Bicentennial QSLs) \_\_\_\_\_ Expiration date \_\_\_\_\_

Mail to: 73 MAGAZINE, Peterborough, New Hampshire 03458

Signature \_\_\_\_\_ 5-76  
Coupon expires in 60 days.

Subscription

WOW!

Special

\$17.76

THREE YEARS OF 73. . . ONLY \$17.76 (while they last)

*This offer is good only through July 4th 1976 (unless we change our minds).*

Here's a chance to get a fantastic buy . . . \$54 worth of 73 magazines for only (only?) \$17.76. You don't get much better buys than that!

You may not have noticed how great 73 is these days . . . in case you haven't, just take our word for it. When have we ever lied to you?

Hey! That comes out to under 50¢ a copy . . . that's ridiculous! Considering the new postal rates it won't be long before the price will be \$17.76 for two years . . . then one . . . and, within the foreseeable future . . . \$17.76 for each issue. How about those fellows who bought LIFE subscriptions?

Oh, you may enjoy 73 now . . . perhaps you weren't one of those dragged kicking and screaming into FM a few years back when Wayne found out how much fun that was and decided to push the hell out of it for a while. You may get fed up with Wayne's enthusiasms . . . like when he decided that SSB would replace AM back in the 50's and he pushed that hard. Despite what you may hear from unmentionable sources, Wayne is not always wrong . . . no one is perfect, even at being wrong.

BUY CENTENNIAL BUY SALE

THREE YEARS OF 73 MAGAZINE. . . \$17.76! WOW!

Name \_\_\_\_\_ Call \_\_\_\_\_

Address \_\_\_\_\_

City \_\_\_\_\_ State \_\_\_\_\_ Zip \_\_\_\_\_

- |   |   |  |
|---|---|--|
| <input type="checkbox"/> New Sub          | <input type="checkbox"/> Start with May Issue | <input type="checkbox"/> BankAmericard |
| <input type="checkbox"/> \$17.76 Enclosed | <input type="checkbox"/> Renewal or Extension | <input type="checkbox"/> Master Charge |
|   |   | <input type="checkbox"/> Bill Me       |

Card Number \_\_\_\_\_

Signature \_\_\_\_\_

BUY CENTENNIAL BUY - 73 MAGAZINE - PETERBOROUGH NH 03458

# The UN-COMPUTER

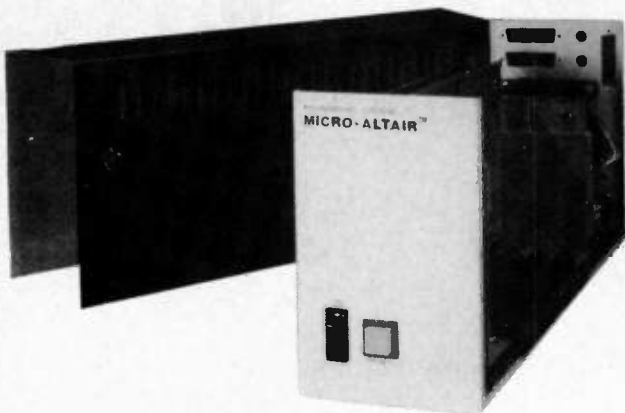

Introducing a new way to begin an Altair system. The MICRO-ALTAIR™ from Polymorphic Systems is a complete computer system, requiring just a keyboard and TV monitor (or modified receiver) for use.

The MICRO-ALTAIR™ consists of our video board with graphics capability, CPU/ROM/RAM board, backplane with power supply, and cabinet.

The CPU board includes an 8080 processor, 512 bytes of RAM, space for 3K bytes of ROM and vectored interrupts. Several CPU boards may be plugged into the same backplane for parallel processing.

The backplane design is unique in that it allows many backplanes to be plugged together for easy system expansion. Each backplane contains its own power supply (transformer mounted externally) rated at 8 volts at 6 amps and ±18 volts at ½ amp. 5 boards may mount in each backplane assembly.

Included with each system is a resident operating system contained on a PROM which plugs into the CPU board. The operating system implements a versatile file system, provides program debugging aids, handles input and output concurrently with program execution, provides job scheduling and a real-time clock. Data may be entered and listed in octal, hexadecimal, or ASCII and edited on the TV screen. Files may be read from or written onto external devices such as a cassette tape. Program debugging aids include software breakpoints which allow all CPU registers to be displayed at any point in the program execution.

An important feature of the MICRO-ALTAIR™ is its compatibility with Altair peripherals and software which are available from several manufacturers.

#### PRICES:

Cabinet and power supply	\$ 155.00
Processor board (includes RAM, real time clock and vectored interrupt)	195.00
Video interface board (with 8 bit input port)	160.00
Operating system on PROM	65.00
2 100 pin connectors	17.00
The complete system purchased separately	\$ 592.00
<b>SPECIAL: INTRODUCTORY OFFER</b>	<b>\$ 475.00</b>

This offer applies only to orders accompanied by check or money order and postmarked before April 15, 1976. We believe this is one of the best deals going in a computer kit, check our prices and compare. Delivery 60 days.



## VIDEO TERMINAL

- ALTAIR 8080 PLUG COMPATIBLE
- 16 lines of 32 or 64 characters
- Upper and lower case (7x9 font)
- Keyboard input port on board
- Graphics capability (48x64 or 128)

POLYMORPHIC SYSTEMS

**Video Interface.** Plugs into the Altair or IMSA1 8080 bus and connects to standard TV monitor (or modified receiver). 8 bit input connects to almost any keyboard. Characters are displayed as 16 lines of 64 or 32 characters each, in a 7x9 dot matrix. (64 character line requires a high resolution monitor or extensively modified receiver.) The character set includes 128 upper and lower case ASCII characters and 64 graphics characters for plotting a 48x128 (or 64) grid. Characters are stored in the onboard memory and may be accessed directly by the computer.

S160 Kit \$230 Assem. and tested (Add \$25 for 64 character option) delivery 30 days

**Analog Interface.** This board is a complete interface for a CRT graphics display or an X-Y plotter, and provides 8 channels of software-controlled A/D conversion. There are 1 or 2 channels of analog with 10 bits resolution (0-10v or ±5v out), 6 bits of latched digital output, and 8 analog comparators.

1 channel (0-10v): \$135 Kit \$175 Assem. and tested  
 2 channels (0-10v): \$185 Kit \$235 Assem. and tested  
 (Bipolar option (±5v) add \$8 for 1 ch., \$12 for 2) delivery 30 days

All prices and specifications subject to change without notice. Prices are USA only. Calif. res. add 6% sales tax.

**POLYMORPHIC SYSTEMS**  
 737 S. Kellogg, Goleta, CA 93017 (805) 967-2351

BankAmericard and Master Charge Accepted

# Oscar Orbits

#### Oscar 6 Orbital Information

Orbit	Date (May)	Time (GMT)	Longitude of Eq. Crossing °W	Mode
16196	1	0121:03	75.3	B
16208	2	0020:59	60.3	A
16221	3	0115:55	74.0	B
16233	4	0015:51	59.0	A
16246	5	0110:47	72.8	BX
16258	6	0010:43	57.8	A
16271	7	0105:38	71.5	B
16283	8	0005:34	56.5	A
16296	9	0100:30	70.3	B
16308	10	0000:26	55.2	A
16321	11	0055:22	69.0	B
16334	12	0150:17	82.7	AX
16346	13	0050:13	67.7	B
16359	14	0145:09	81.5	A
16371	15	0045:05	66.5	B
16384	16	0140:01	80.2	A
16396	17	0039:57	65.2	B
16409	18	0134:52	79.0	A
16421	19	0034:48	64.0	BX
16434	20	0129:44	77.7	A
16446	21	0029:40	62.7	B
16459	22	0124:36	76.5	A
16471	23	0024:32	61.5	B
16484	24	0119:28	75.2	A
16496	25	0019:24	60.2	B
16509	26	0114:19	74.0	AX
16521	27	0014:15	59.0	B
16534	28	0109:11	72.7	A
16546	29	0009:07	57.7	B
16559	30	0104:03	71.4	A
16571	31	0003:59	56.4	B

#### Oscar 7 Orbital Information

Orbit	Date (May)	Time (GMT)	Longitude of Eq. Crossing °W
6669	1	0028:10	56.8
6682	2	0122:27	70.4
6694	3	0021:48	55.3
6707	4	0116:05	68.8
6719	5	0045:25	53.7
6732	6	0109:42	67.2
6744	7	0009:02	52.1
6757	8	0103:19	65.6
6769	9	0002:39	50.5
6782	10	0056:56	64.0
6795	11	0151:13	77.6
6807	12	0050:34	62.4
6820	13	0144:51	76.0
6832	14	0044:11	60.8
6845	15	0138:28	74.4
6857	16	0037:48	59.3
6870	17	0132:05	72.8
6882	18	0031:25	57.7
6907	19	0125:42	71.2
6907	20	0025:03	56.1
6920	21	0119:28	69.6
6932	22	0018:40	54.5
6945	23	0112:57	68.0
6957	24	0012:17	52.9
6970	25	0106:34	66.4
6982	26	0005:54	51.3
6995	27	0100:11	64.8
7008	28	0154:28	78.4
7020	29	0053:49	63.3
7033	30	0148:06	76.8
7045	31	0047:26	61.7

# HAM HELP

The first thing I would like to say is that I think you have a very fine magazine. You sure did a good job of getting my interest back into ham radio. I picked up your November issue out of curiosity, as I was browsing around a magazine counter. I had a Novice license back in 1967 and 1968 when I was in high school. But after that I sort of lost interest. As a result of that issue, I also picked up your January issue, which was as good as the other, if not better. Your influence caused me to purchase your 14 wpm tape to help get the old code speed up to at least a tolerable level by the FCC.

Now for my problem. I would appreciate it if any of the readers in the Warminster, Pa. area have any information about ham clubs in this area. I would like to get involved with one, plus at the same time it will help me to get back on my feet again.

William K. Seitzinger  
 753 Cheryl Drive  
 Warminster PA 18974  
 675-6252

Put my name in your Ham Help page. I can help a Novice, Tech, or General with the basic theory, and if I don't know the answer to some of their questions I know a number of people who do.

David W. Thompson  
 1412 15th Ave.  
 Parkersburg WV 26101

Please add our names to ur list of Ham Helpers:

Lou (WB0NRU) and  
 Annette (WB0PZM) Hinshaw  
 PO Box 111  
 Hays KS 67601  
 Phone: 625-7768

Please add my name to your list of amateurs who are willing to lend assistance to aspiring newcomers to the fraternity of amateur radio. Also, may I say thanks for publishing a fine business ham magazine.

Ricardo H. Nabor K9GYO  
 4926 So Lotus Ave.  
 Chicago IL 60638

I need help brushing up on theory and putting my station back on the air.

Tony Carozzi WN1UHU  
 88 Bartlett St.  
 Brockton MA 02401

Help!

Bret Marquis  
 1843 Ocean Front  
 Del Mar CA 92014



enjoy the world's  
leading electronic  
kit catalog...



**FREE!**

## THE ALL-NEW HEATHKIT CATALOG

Open our newest, biggest catalog and you'll be into the spirit of kit building in no time. Learn about the fun, personal satisfaction and exceptional savings you can enjoy when you "build it yourself".

Send for your free copy today 

# FREE!

Heathkit Catalog for every  
interest, every budget

- Digital Color TV
- Stereo & 4-Channel
- Marine & Fishing
- Ham Radio
- Digital Clocks & Weather Monitors
- Metal Locators
- Auto Tuneup
- Test Instruments
- Radio Control
- Hundreds More

Mail this convenient coupon now

**Please rush my NEW  
Heathkit Catalog... FREE**

NAME

ADDRESS

CITY

STATE

ZIP

<input type="text"/>	<input type="text"/>	<input type="text"/>	<input type="text"/>	<input type="text"/>	<input type="text"/>	<input type="text"/>
----------------------	----------------------	----------------------	----------------------	----------------------	----------------------	----------------------

# HEATH COMPANY

Benton Harbor, Michigan 49022

**Put Stamp here.**  
The Post Office  
will not deliver  
mail without  
postage.



# FREE!

## World's largest electronic kit catalog

No other catalog brings you such a wide variety of exciting, easy-to-assemble kit products. And with over 400 different kits, you're sure to find something to please yourself or a friend. Declare your independence... get into the spirit of kit building today.



**SEND FOR YOUR FREE  
HEATHKIT CATALOG NOW!**



# HEATHKIT HAM GEAR

...a tradition for  
thousands



**HW-201 hand-held  
2-meter transceiver.**

1 watt out, 5 receive and 10 transmit channels gets you on 2 while you're walking, working, outdoors, anywhere. There's even the HWA-2021-3 auto-patch encoder you can build right in.



**HW-202 crystal-controlled  
2-meter transceiver.**

The one used by thousands because of its reliability, performance and low kit-form price! Delivers a solid 10 watts minimum, operates on up to 6 transmit and 6 receive channels.

**Over 400  
easy-to-build  
kits including:**

- Amateur, CB and SWL radio
- Stereo and Hi-Fi Components
- Test Equipment
- R/C Gear
- Marine, Aircraft, Automotive Accessories
- Color TV



**FREE** Heathkit Spring '76 Catalog.  
Send for it today.

When you buy Heathkit Ham gear, you continue a tradition established by thousands of Hams the world over. You get fine performing equipment that is designed for you to build, so you learn about your hobby as you contribute to it. And you save money in the process.

Best of all, you're dealing with a company whose reputation for fairness, honesty and outstanding customer satisfaction is the envy of the industry. When we say "We won't let you fail", we mean it! From the extensive troubleshooting and service guides in each of our manuals, to our technical consultant service, we strive to provide quality Ham products that perform better than any ready-mades. And the pride and satisfaction you get when you put it together yourself is a "built-in" bonus with every Heathkit product.

See the exciting line of Heathkit Ham Gear in our bright, new Spring Catalog! Mail postcard or coupon today!

Heath Company, Dept. 11-17  
Benton Harbor, Michigan 49022

HEATH  
**Schlumberger**

HEATH COMPANY, DEPT. 11-17  
BENTON HARBOR, MICH. 49022

Please send me my FREE Heathkit Catalog

Name \_\_\_\_\_

Address \_\_\_\_\_

City \_\_\_\_\_ State \_\_\_\_\_ Zip \_\_\_\_\_

AM-329

# Scan Your HR212

**W**anting some type of scanner for my Regency HR212, I got out all my ham magazines and came upon the scanner described by K2LZG in the February 1973 issue of *Ham Radio*. I had never built anything using ICs, so I said to myself you might as well get started now as never. After many nights of burning the midnight oil, I finally came up with the right hookup for the HR212.

The channel selector in the HR212 applies a ground to the appropriate rf choke (L501 through L512) which places a forward bias on the diode. This action provides

an rf path for the crystal to turn on.

I use a +2 volt signal to stop scan and a zero volt signal to enable scan. You can take the squelch voltage off the white jumper wire which is located near Q105 and C137 located on the i-f-audio board. You can pick up the 12 volts anywhere after the on-off switch; I took mine off the red wire on the on-off switch. To connect the six oscillators to the scanner I connected six wires, one to each rf choke (L501 through L506). Be sure to connect to the side of the choke going to the channel switch. I built my unit in a small plastic case obtained at the local Radio Shack. I used a small male jack mounted on

the back of the box and brought the nine wires out the HR212 to the female plug. Also, I mounted six SPST toggle switches in series with the oscillators to the scanner, so I can switch any channel out I don't want to monitor. I mounted a SPST switch in series with the 12 volts to the scanner to switch off the scanner when I want to transmit. I use a MAN-1 7 segment readout for the channel indicator.

To use as a scanner just turn the channel switch to any unused channel and flip on the 12 volts, and scan away to your heart's content. ■

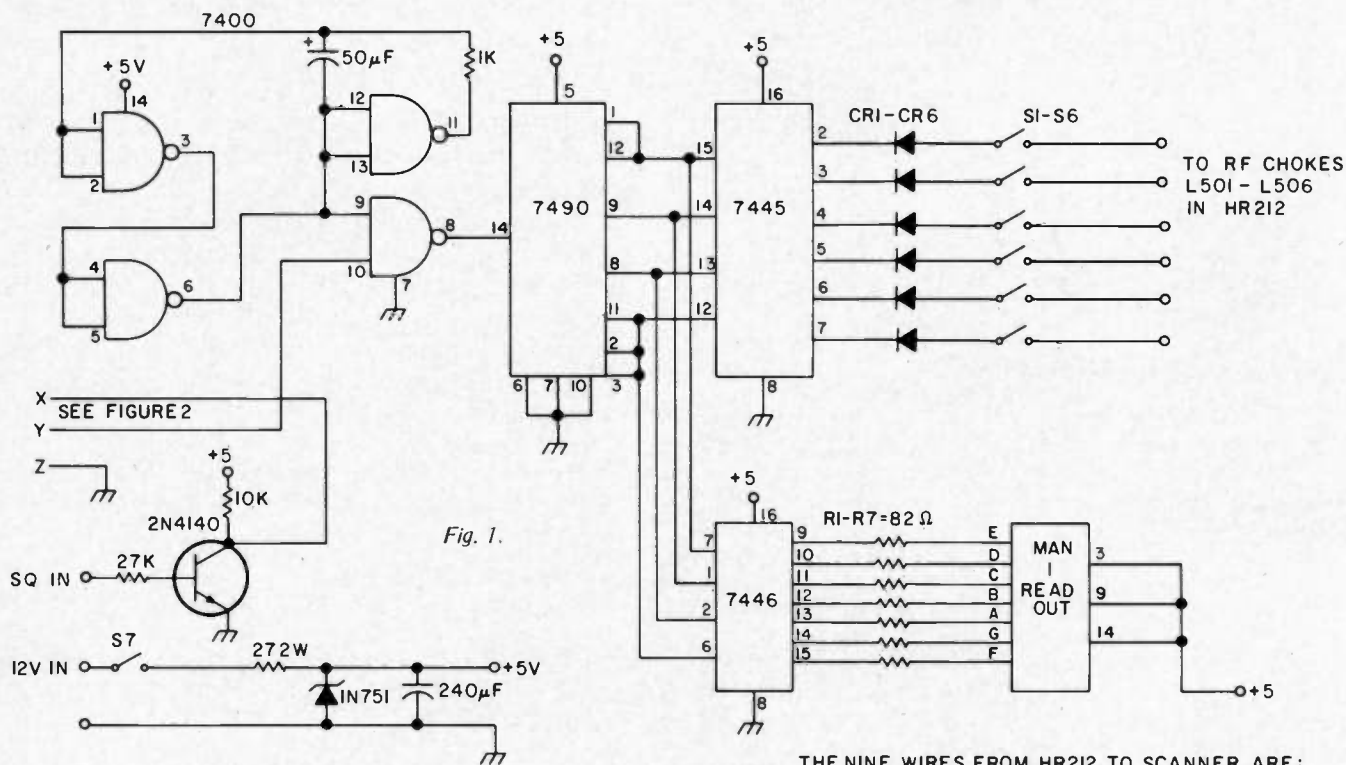

Fig. 1.

THE NINE WIRES FROM HR212 TO SCANNER ARE:

- 1. SQUELCH
- 2. +12V
- 3. GROUND
- 4. } OSCILLATORS
- 5. }
- 6. }
- 7. }
- 8. }
- 9. }

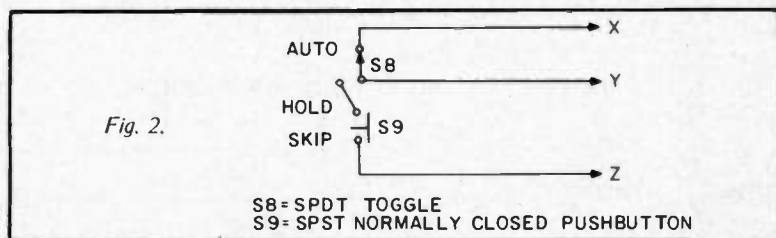

Fig. 2.



# Clegg

LANCASTER, PA. 17603

**WHY SPEND \$645. FOR AN**

## FM-DX

**WHEN SOME OTHER SYNTHESIZED**

**2 METER**

**TRANSCEIVERS**

**SELL FOR**

**\$200 LESS ?**



**LET US GIVE YOU MORE**

**THAN A DOZEN REASONS FOR DOING SO!**

- 1. TRANSMIT POWER** — Only the FM-DX offers 35+ watts. This is almost 6 db more than the “economy” units. Under many conditions this can be twice the range!
- 2. FREQUENCY VERSATILITY** — Only the FM-DX provides 5 full MHz of coverage on both transmit and receive. If you need more — for NAVY MARS or whatever — we can do that too. More important is its ability to provide good SIMPLEX operation to full specification performance over the full 2 mtr. band.
- 3. SIGNAL PURITY** — No synthesized radio has a cleaner spectrum. AND THE FM-DX DOES NOT SWISH ACROSS THE BAND EACH TIME THE TRANSMITTER IS KEYED.
- 4. RECEIVER PERFORMANCE** — State of the art design provides .25 microvolts sensitivity combined with low low intermodulation that exceeds most single channel, commercial service transceivers.
- 5. CONSTRUCTION** — If you haven't seen the guts of an FM-DX you should certainly do so. Even if you aren't interested in 2 Meter FM. Our extruded aluminum main frame and modular circuit boards set a new standard for ham equipment construction.
- 6. SERVICE** — Only Clegg offers a TOLL FREE line for you to use. Whether you just want information, to place an order, or to solve a service problem. We welcome your call. You get right to the proverbial HORSE'S MOUTH!
- 7. — 12. AND MORE!** CALL US TODAY FOR THE REST. (800) 233-0250 TOLL FREE

\*\*\*WE ALSO HAVE A HEAVY-DUTY VERSION OF THE MICROCOMPUTER POWER SUPPLY; IT HAS ALL FEATURES PLUS 117/230V, 50/60 Hz OPERATION, AND POWER:

- 5 VOLTS, 10 AMPS
- +12 VOLTS, 1 AMP
- 12 VOLTS, 1 AMP

AND ALSO THE ADJUSTABLE NEGATIVE BIAS SUPPLY.

GOOD FOR UPGRADING STOCK MICROCOMPUTER SUPPLIES!

**\$74.95 PLUS SHIPPING.**

- 5 VOLTS---5 AMPS
- +12 VOLTS---½ AMP
- 12 VOLTS---½ AMP
- AND ONE ADJUSTABLE NEGATIVE BIAS SUPPLY

Ideal for systems built around 8008, 8080, PACE, 6800, 6502 and other CPUs---with enough left over to power up to 16K bytes of RAM. Same size as JOLT supply. Just about goof proof, too; includes crowbar overvoltage protection on +5V & FOLDBACK current limiting --- regulation on the 5 volt supply is guaranteed better than 1% with line and load variations. A TOP QUALITY COMPUTER SUPPLY... INCLUDES CHASSIS AND ALL HARDWARE, but less line cord. For 117 VAC, 60 Hz.

PLEASE ADD SHIPPING FOR 8 LBS.

**micro-computer power supply \$44.95**

**NAKED RAM 4k x 8 \$79.95**



**10000 uF at 10V! \$1.25**

THE PERFECT TONIC FOR POWER SUPPLIES WITH A FARAD DEFICIENCY. AXIAL LEAD PACKAGE

THIS GENERAL PURPOSE BOARD IS DESIGNED SPECIFICALLY FOR JOLT SYSTEMS, BUT IS EQUALLY APPLICABLE TO OTHER BI-DIRECTIONAL BUSS SYSTEMS. IF YOU DON'T NEED THE ON BOARD REGULATION OR BUFFERS OF OUR "BIGGER BROTHER" 4K X 8 BOARD, THEN THIS IS THE WAY TO IMPLEMENT COST-EFFECTIVE MEMORY. LOW POWER --- UNDER 750 MA. SAME SIZE AS JOLT RAM CARD; WITH INSTRUCTIONS.

**and a special for I/O people:**

We've run into a bunch of 39 uF @ 10V TANTALUM capacitors. These are Kemet type T310, bullet shaped capacitors, with axial leads. Small---mounts on .6" centers. This capacitor is fine for bypassing with TTL and other logic families. Normally these go at 4/\$1.00; but if you get your order in by April 30th and mention the I/O page, you can get 20% off---5/\$1.00.

\*\*\*\*\* ALL THESE MEMORY BOARDS ARE PLUG-IN COMPATIBLE WITH THE ALTAIR 8800 \*\*\*\*\*

**EROM Boards**

NOW YOU CAN STUFF UP TO 8K OF SOFTWARE---EDITOR/ASSEMBLER OR WHAT HAVE YOU---ON A BOARD. Our EROM boards feature the same qualities as our RAM board: sockets, lots of bypassing, buffered addresses and outputs, on card regulation, and more. Our EROM boards are expandable, too; you can start with a 2K board, and populate it with more EROMs over a period of time until you've got the full 8K. PRICES: 2K by 8---\$115; 4K by 8---\$159.95; 8K by 8---\$249.95. All EROM boards feature low power consumption: the full 8K requires only ½A at 5 volts & 150 ma at -12 volts. With instructions and logic print.

**8080 SOFTWARE BOARD**

So you've got yourself a microcomputer...only to find out you need software to run it efficiently. Give your 8080 editor, assembler, and monitor routines with our 8080 software board. It uses the same configuration as our 4K by 8 EROM board, but the EROMs are pre-programmed and dedicated to making happier 8080s. Extra feature: because this board is EROM rather than mask based, you can make changes if desired...so we include 2 free updates in the event of corrections or patches. The cost is \$159.95. Kit includes instructions and software package.

**4K X 8 RAM KIT \$109.22**



With this kit you get sockets for all ICs, industrial-quality plated-through board, lots of bypassing, five voltage regulators to share the power load (less thermal problems, more reliability), typical 500 ns access time @ 25°C, and buffered addresses and outputs (no input presents more than 1 low power TTL load; output can drive 20 standard TTL loads). Requires 5V @ 1A at 25°C. Comes with assembly hints and logic print of the RAM board.

**GODBOUT**  
BILL GODBOUT ELECTRONICS  
BOX 2355, OAKLAND AIRPORT, CA 94614

YOU MAY PLACE MASTERCARD® OR BANKAMERICARD® ORDERS BY CALLING, 24 HOURS A DAY, (415) 357-7007

TERMS: ADD 50¢ TO ORDERS UNDER \$10. ADD SHIPPING WHERE INDICATED; OTHERWISE, ITEMS SHIPPED POSTPAID. CAL RES ADD TAX. NO COD---IT'S TOO MUCH PAPERWORK!



# EDITORIAL

## WANT TO MAKE A BUNDLE?

Not to be a name dropper, but sure as God made Yellow Transparent apples (to me the finest apples in the world) someone may make a fortune by coming up with a small computer system for small business and home use ... if he plays his cards right. Best of all, nothing further has to be invented to make this a reality ... some of the pieces have only to be put together.

Since a small black and white television set retails for around \$85, a keyboard for \$30, a microcomputer chip for \$20, a cassette recorder for \$20, how much could a small computer system cost embodying these elements? Oh, you'd need a display generator for the TV, an interface for the cassette, and some working memory. I'll bet someone could put such a contraption on the market for under \$1000 in six months ... and the price would be down to half that in six more ... and eventually down to maybe \$250 ... or \$125. The prices go down a lot when chips come available to handle each function ... and eventually the whole works.

They're already starting to put RAM memory on CPU chips ... and I/O interfaces too. Add a small built-in ROM operating system and a TV display generator ... and the price plummets for a complete small computer system.

Do you want to wait for someone else to get into the business or start working on it yourself? Here's a way for someone to invest some time and money in a project which could be worth millions in a couple of years. MITS had about 15 people when they entered the uP business ... now look at 'em!

## HAM COMPUTING

Most of us can think of a lot of good things we might do if we had a computer ... like keep track of stations contacted along with some details about them ... maintaining an index to ham magazine articles that we might want to look up ... determining Oscar intercept times and bearings ... running all the functions of a repeater ... playing any of the hundred or so popular computer games ... getting into computer art forms with a color television set ... experimenting with computer music ... keeping track of repeater channels and locations ... Morse code conversion ... RTTY operation ... things like that.

But the next question is a tough one ... what hardware will it take to get involved in my interest ... and, even more difficult, what programs

... and where can I either get the programs or get the training so I can develop my own programs?

Frankly, we could use a lot of input on both hard and software. Let's see some articles on this ... showing configurations of available gear which will do ham and hobby jobs.

If we look at the Sphere equipment we see that for most ham applications we will need their "200" system, their "B" package and BASIC on cassette. This comes to \$860 for the "200," \$205 for the extra 4K RAM memory and character generator ROM of package "B" and \$100 for BASIC on a cassette ... total \$1165 for the hardware. Now, if you buy the BASIC textbook by Albrecht (\$4), you will be ready to go with almost any program you want, doing your own programming. The DEC 101 Games in BASIC (\$7) will launch you into the game biz. You will need a television set for the display.

The Sphere system will give you the computer, a character generator so you can read out the input and output of the system on a television set, a keyboard for inputting, BASIC programming language which takes about 5K of RAM memory, leaving about 3K for your use, and an I/O for a cassette recorder for use in entering programs, storing programs for later use, and storing data in long-term memory. That's a fairly complete small system.

If you want to go the MITS route you'll need an Altair 680 (\$420), 12K of RAM memory (\$825), an I/O port to interface the 680 with a video display terminal (\$144), BASIC language on cassette (\$75), cassette interface I/O port (\$144), plus some sort of video generator and keyboard unit such as the Southwest Tech kit which runs about \$282 (and then you have to build it ... which is fun). The cost of this system would appear to come to around \$1890. If you want to go the Altair 8800 route ... and Ed Roberts points out in the Altair Computernotes publication that the 8080 chip is substantially better in his estimation than the 6800 chip ... this would increase the cost even more.

The Altair 8800 computer is \$621, expander boards are \$93, a cooling fan is \$20, three 4K RAM boards are \$825, the cassette I/O is \$174, the television typewriter I/O is \$144 and BASIC language on cassette is \$75, plus the \$282 for the TVT kit comes to \$2234.

To do any work involving data you want to keep on file you will need a couple more cassette control systems so you can use one cassette for your data base, a second for any update to the data base, and a third for the

updated data base. This means two more I/O interfaces and control systems ... it also means a lot of programming using BASIC. If you want to keep a file of every station you've contacted and be able to quickly get the data on someone, this is the system you'll probably want.

The same system would work fine for keeping track of magazine articles you might want to reference, recipes for the wife, addresses for a club, a file on music in your record collection, a list of repeaters, etc.

These systems will be a little slow in locating data in memory since they will have to scan your cassette tape for the data file wanted. It won't be long before we have relatively inexpensive tape systems which can be searched much faster ... and relatively low cost floppy disk memory systems are on the way. Disks don't hold much more than cassettes, but they search very rapidly.

There are a lot more small computer systems coming along, but I haven't got much data on them as yet. It is almost impossible to understand some of the advertising literature in this field and even talking with the manufacturers can be frustrating, for some of them are so busy designing and turning out parts of their systems that they haven't given much thought to what it will be used for ... or what problems the user may run into.

I would like to state that 73 is most anxious to hear from any ham computer hobbyists who have managed to put small systems together and get them to actually do something. Please let us know what you are using and how you programmed it. I would also be delighted to hear from any manufacturer who can state just what hardware and software is needed ... and how much it will cost ... to set up some hobby systems such as outlined above.

For instance, any of the small systems being marketed are quite capable of calculating the Oscar acquisition times, but where can you get the program for the calculation? Unless it is in either machine language for your particular chip or in BASIC, you won't be able to do much. And it has to be in a BASIC that is compatible with the BASIC you've got for your computer, just to make matters a little more complicated, for there are BASICS and then there are BASICS, from Mini-BASIC on up through Extended BASIC. Obviously we all need to know a lot more about this situation ... and get some counsel on where to get the programs we need for Oscar, moonbounce times, etc.

Now is the day of the true pioneer as far as microcomputers are con-

cerned ... like sideband in the mid-50s ... like FM in 1969 ... and RTTY in the late 40s. We are a long way from the appliance operator phase of uP systems and these are the days which separate the men from the boys. Let me emphasize again that having fun with computers does not take super brains ... it does not take a whole lot of money ... it does not take education ... all it takes is enthusiasm and persistence. And, if you are young in spirit, there is a very good chance that you can parlay your knowledge into a very comfortable living.

## THE MAGIC OF FRESH ORANGE JUICE

The other morning, as I was squeezing oranges, I had a depressing thought. I remembered a bit on a recent Today show lauding the wonders of Florida. It was a film about the citrus industry there and they mentioned that two thirds of the Florida oranges are now processed into frozen concentrate. How many years since you have had fresh orange juice for breakfast?

Once you get into fresh orange juice you have a tough time gagging down the frozen stuff ... or the "fresh" juice in cartons. You have to totally forget what orange juice tastes like to accept frozen. An electric juicer runs around \$10 to \$12.50 (Unity or Sears) and you can crank out a glass in about a minute ... you don't thaw out a can of frozen much quicker.

Just as we have all come to accept the frozen juice alternative to do-it-yourself juice, with a loss of substance, most of us hams have come to accept our ham gear as either ready-built or in kits (paint by the numbers?). I have a strong feeling that the computer revolution in amateur radio will bring back a lot of the home squeezed flavor to our hobby ... for, even if you work from an assembled or kit computer, you are still only about 25% of the way toward your goal. This is one field where the hardware is only the start and merely opens the gates for self-expression and creative fun via the programming you will be doing.

I hope that the manufacturers of computers won't be angry at me for letting the cat out of the bag, but the fact is that getting your equipment working is only a small part of the fun and challenge. Oh, in time a lot of the work will be done for you and will be available on tape or something ... perhaps ROMs. At least, programs will be available for ordinary uses of the equipment ... you will still be on

Continued on page 95

# Computer Languages-- Simplified

**A**nyone who wants to use a computer has to have a way to communicate with it. This article is a simple introduction to some of the languages which are used for that purpose. It is intended for rank beginners, so all of the programmers, software freaks and computer hot dogs in the audience might as well stop here. For anyone else, I'm going to try to keep everything in English (which is not a computer language, unfortunately) and avoid as much computerese as possible. So here goes.

One might start by asking, "Why have computer languages at all?" Back in the dark ages 25 or 30 years ago they didn't — the machines were wired up to do a certain thing and that's what they did. But, somewhere along the road, some bright fellow realized that it would be much more efficient if you could feed the machine a fairly long set of instructions and let it follow them. This also made for much greater flexibility, since you could give the machine different sets of instructions. These instructions are what a computer language communicates, and this article will go over some of the more common ones, to wit: Assembler, BASIC, FORTRAN, PL/1, COBOL and a little bit about some of the more specialized ones. But first let's look a little bit more at the nature

of the beast we're dealing with.

It is helpful to think of a computer as a glorified electronic calculator. In fact, some of the more modern calculators really are computers. But let's look at the average four function calculator. It has a display, which is called an output device in computerese, and it has a keyboard, which is an input device. To do anything with it, you have to enter the numbers through the keyboard and then enter what you want done with them, be it to add them or whatever.

---

Machine language is the closest we can get to what the machine actually speaks.

---

But suppose you want to do a mortgage calculation — say, figure out what your interest payments and principal payments are going to be each month for the life of the 20 year mortgage. This means that you're going to have to do a very repetitive calculation 240 times. It is to avoid this sort of hassle that real computers (and some fancy calculators) have stored program capacity — a stored program being nothing but a set of instructions inside the

machine which get done without your standing there pushing all of the buttons each time. But now we have to get this set of instructions inside the machine, and that is where programming languages come in. We need a way to communicate the instructions to the machine.

In the case of a calculator, this isn't much of a problem. The "Instruction Set" (list of all of the instructions which the machine is able to follow) is hard-wired in. If you want it to add, you push +. This is obviously not too good an idea for a large computer, since the number of buttons

see, we usually represent it with ones and zeros, or on and off lights. The whole thing is like trying to communicate using RTTY but doing it by ear instead of with a TTY machine, which is to say that it's a royal pain. Anyone who's into interpreting things like 01001101 01100001 and so forth can really get off on it, but for most of us there's gotta be a better way. Fortunately there is. Incidentally, if you ever get a microcomputer, those switches and lights on the front panel are used to communicate with the thing in machine language.

The next sort of language developed, and the one which is most widely available for microprocessors these days, is the assembler. Each type of computer has its own version; what it is, in short, is machine level logic — but using symbols and normal numbers rather than ones and zilches. Assembler is related to what you do with a calculator — in fact, any of you who own or use HP calculators have been using a version of assembler language usually known as Reverse Polish Notation. With an assembler language, you specify what number you want, where you want it put and what you want done with it; for example (to use HP assembler): "12, ENTER [which puts it in the region where the arithmetic is done], 2, x" multiplies 12 times 2 and comes up with



24. All assembler languages work this way, although many of them have dozens of commands and hundreds of locations where things can be put or obtained. This sort of computer language has a lot of advantages. It's very efficient not only where memory is concerned, but also with regard to execution time. This means that it's cheap to use. The assembler (the program which translates it into machine language) doesn't take up much memory either, which means it can be used in a microprocessor which doesn't have much memory (and memory costs like the devil, even these days). Using assembler, you can also anticipate situations where the machine might do something unexpected, since you're on the machine's logical level. Of course, it's got its problems too. It's hard to learn, not easy to use well, hard to debug (find errors) and is "machine dependent," which means that each machine has its own. To sum it up, a lot of people don't like to have to write: "12, enter, 2, x." They'd rather write "A=12 x 2." This

is what "high level" languages let you do, along with all sorts of other convenient things. For this reason, almost all programming these days is done with one of the various high level languages, and the rest of this article will be about some of the more common of them.

First of all, a high level language is a computer language that is based on some combination of English and algebra. So, to write two plus two you would usually write "2+2." To tell the machine to print, you write PRINT, WRITE or something of that nature. The one thing to watch out for is that, although there are many different ways of writing one thing in English (and to a certain extent in algebra), a high level computer language has a very narrowly defined structure and vocabulary. This means that the computer equivalent of "I ain't got none" will be rejected. In other words, you have to be very careful when writing any sort of program for a computer, since errors (the computerese term is glitches) get caught faster than they would

be by an old-fashioned high school English teacher.

Continuing the comparison with human languages, there are lots of different ones for computers, too. At first each company developed its own; now many of them are standard and thus can be used on any machine with few, if any, changes — unlike assembler languages. We still have a lot of computer languages, though. For example, the last time I checked the documentation, there were something like 35 different high level languages available for use with the University of Michigan computer system. The reason for having so many is that each language is designed to do some particular thing well (in jargon, they are problem based rather than machine based). This means that one language is good for mathematics (also called number-crunching), one is good for electronic circuit design, another for library use, and so forth. There are also a couple of general purpose languages — which happen to be the most popular for obvious reasons.

It would be a pain to have to spend a few weeks mastering a new computer language every time you wanted to do something different with a computer — not to mention that you have to buy (or write) a special translating program (called a compiler) for each one — and that can get very expensive (much more than the cost of the computer itself). So let's look at some useful, fairly general purpose languages.

BASIC, which stands for "Beginners' All-purpose Symbolic Instruction Code," was developed at Dartmouth College a number of years back. It was designed for people who knew nothing about computers but who wanted to use them. Few dyed-in-the-wool programmers care much for it, but most non-programmers love it. It's based on algebra, and the non-algebra parts of it are in plain English. For example, to enter two numbers into the machine, multiply them, divide one by the other and print the results, you would write:

```
1 IN A, B
2 LET C = A * B
3 LET D = A / B
4 PRINT C, D
```

(\* is the standard symbol for "times" on a computer)

This language has quite a few advantages. It's easy to learn, easy to use, and there are lots of books around which help people learn it. Equally important, there are lots of programs already written and published in it (these are called canned programs), and quite a few computers can use it. In particular, Altair has two (going on three) versions out at the moment, and other micro-computer manufacturers are making noises about supplying it — or so I read. The compiler (remember, that's the program which translates the things you write into the machine's language) doesn't take up too much memory

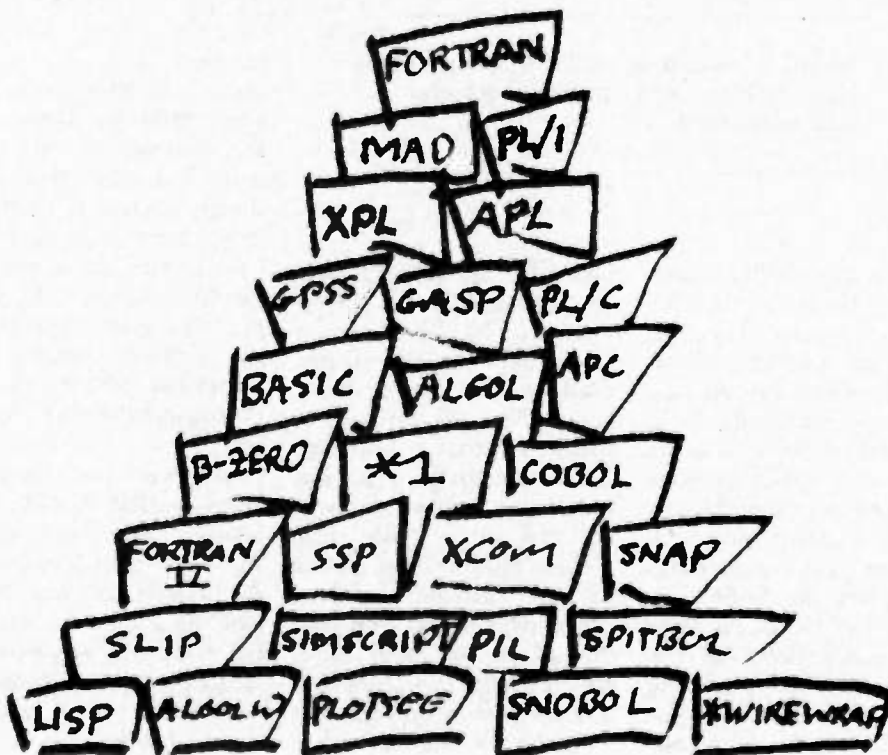

either, which means that BASIC is suitable for small computer systems where memory is limited. A final advantage is that BASIC is fairly flexible — especially the advanced systems. You can do many if not most of the same things with it as you could do with FORTRAN or PL/1, although the programming effort might be greater.

It does have some disadvantages, though. BASIC has no mnemonic variables. This means that you have to remember that A stands for current, E for voltage and so on. In a more advanced language you could write AMPS, EMF, etc. This isn't so bad if you're working with standardized symbols, but gets to be a disadvantage when you try to remember which was Accounts Payable and which was Accounts Receivable. Also, BASIC is somewhat limited as to what you can do with Input/Output. This only makes a difference if you are working with a big system that gives you lots of choices — it isn't of too much concern for a home computer system or a small business one. Finally, BASIC is structured somewhat along the same lines as FORTRAN, which is the oldest computer language still in use. This means that it does a lot of things in harder more roundabout ways than some of the newer languages, like PL/1. For example, its "either-or" choice is rather cumbersome to write. It's still a great language to play around with, though.

FORTTRAN is probably the best known of the various computer languages, partly because it's one of the oldest. The name stands for FORMULA TRANSLATION, and it was developed by IBM back in the early 1950s. It and the B-Zero language developed by Univac were the first high level languages used. No one uses B-Zero today (few have even heard of it), but

FORTTRAN is probably the most widely used computer language in the United States. Of course, the FORTRAN we use now isn't the same as the FORTRAN introduced back in 1957 — just as the English we speak now isn't the same language as the people in England spoke back in 1066. There have been three official versions of FORTRAN: FORTRAN (the original), F O R T R A N II and FORTRAN IV. Number three got lost in the middle somewhere. Most computers these days use FORTRAN IV, although there are some mini-computers around that still use FORTRAN II; some of these compilers might be adaptable to microcomputer use. Anyway, as you might guess from the name of the beast, FORTRAN is basically a scientific computer language; it was developed to make it easier to solve mathematical-type problems for science and engineering. Over the years the language has expanded to the point where it is usable as a general purpose language, so it can do a

---

BASIC . . . was designed for people who know nothing about computers, but who want to use them.

---

lot more than simply crunch numbers. Moreover, since it's such a popular language, there are who-knows-how-many programs written (and sometimes published) in it, which makes it much easier to solve a given problem (since you can frequently just type in a canned program). The same structural problems encountered in BASIC are part of FORTRAN, but these have already been covered. Perhaps more important for anyone who wanted to use FORTRAN on a microcom-

puter, the compiler (remember? the program which translates it into machine language) takes up much more memory than a BASIC compiler, though much less than one for most other high level languages. One keeps hearing hints that one of these days someone may develop a version which is usable on a microcomputer, but I haven't seen any announcements yet.

While FORTRAN was developed for scientific use, COBOL was developed for business use. It's the language used by the U.S. government for a lot of their stuff, so it's got a pretty wide circulation. Needless to say, many businesses use it, too. From the little work I've done with it myself, it seems that you spend most of your time defining what your printout is going to look like and what the information which you feed into the thing is going to look like (the jargon for this is format definition). It also takes lots more memory than one would probably want to pay for in a microcomputer —

unless he wanted to do subcontracting for the government.

Up until the early 1960s, most computers were either scientific- or business-oriented, and a machine which was designed for one didn't usually work too well for the other. Then IBM started making their general purpose machines, and most other people followed suit. At about the same time, people started to worry about a general purpose computer language. A number were

developed, of which my favorite (just for the name) is MAD (Michigan Algorithmic Decoder) which was brought to us by the folks at the University of Michigan Computing Center. Then IBM got into the act, and, lo and behold, out popped PL/1 (Programming Language One). The best description that I can think of is that it was designed to out-fortran FORTRAN and to out-cobol COBOL all at the same time. It does a pretty good job of it, too. I'm always amazed at all of the nice things you can do with PL/1; to use the computerese phrase, it has more bells and whistles (extra options) than you can shake a stick at. Unfortunately, it also uses more memory than you can shake a stick at, which makes it too expensive for microcomputer use (or even timesharing use if you have to watch your costs). But never fear, one of these days we may be seeing a scaled down version of PL/1 (called PL/M) which keeps a lot of the nice features without taking up more memory than most of us mere taxpayers can afford. To give an example of the sort of nice thing the language can do (among others), it lets you write a simple either/or statement (if this is true, do one thing; otherwise do this other thing), whereas to do that in most other languages you have to play hopscotch with the line numbers. In short, PL/1 is a great language, and if a cheap compiler ever comes out, I hope I own the microcomputer it's written for!

Another new language, again by IBM, is APL. I will confess here and now that I've never used it, so what I say is taken from what people who have used it have told me. This is a very powerful language; it can do in one line what most other languages require five or more to do. It

is not yet widely used; unless I'm mistaken (which is quite possible) IBM is the only company which makes compilers for it. It is, however, designed for the sort of sit-down-at-your-computer use that most hobby users probably have in mind. And good news! It's available for a microcomputer. The bad news is that said machine is the IBM 5100 and it runs about 10k — and those are kilobucks, not kilobytes. Anyway, the scuttlebutt has it that APL is one of the languages to watch, so keep your eyes peeled.

I mentioned a while back that, in addition to the general purpose languages I've discussed so far, there are quite a few special purpose ones. For a hobby user (or would-be user) these aren't too important, but just to be more or less complete I'll mention a few which are good with which to impress people (besides being good to

know about if you tend to be around computer hot dogs who like to talk about such things). There is RPG, which is a Report Generating language, and therefore much used for business and that sort of computing. Then there are several languages used to write simulations. (A simulation is like a computer

---

FORTTRAN ... does things in harder more roundabout ways than some of the newer languages, like PL/1.

---

game except people take it seriously. Come to think of it, I know a couple of people who take the Star Trek game seriously, but we'll ignore that.) These languages are things like GASP, GPSS and so forth. There are a fair number of languages used for crunching words instead of numbers — SNOBOL,

SPITBOL and so forth. Finally, there is at least one language used to design electronic circuits — unfortunately all my electrical engineering friends seem to be able to tell me is that it exists and Professor Zilch mentioned it.

As a brief review, one needs some sort of language

tion into machine language. Finally, you can use a combination of human logic and normal words and symbols, which is called a high level language. This requires a program to translate it into machine language again, and such a program is called a compiler. The principal advantages of high level languages are that they are easy to learn, easy to use, and are the same for any machine. They are not nearly so efficient as assembler language from the computer's point of view, but they are much more efficient from our point of view — and that's usually what counts. ■

#### References

1. *BASIC*, Albrecht, Finkel and Brown. Wiley & Sons, 1973.
2. *Digital Computing, FORTRAN IV, WATFIV, and MTS*, Carnahan and Wilkes. Chemical Engineering Dept., University of Michigan, 1973.
3. *High Speed Data Processing*, Gotlieb & Hume. McGraw-Hill, 1958.

## SP 600 — Still the great all time general coverage receiver.

540 kHz to 54 MHz. Selectivity down to 200 Hz. Xtal calibrator, noise limiter — double conversion. The perfect SWL receiver. A great 2nd receiver for the shack. A very limited quantity completely overhauled and guaranteed ... **HURRY ! HURRY ! Only \$300.00.**

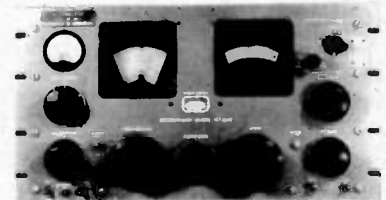

ANCOM maintains an extensive inventory of military and commercial equipment and publications. We continuously research methods of utilizing surplus military equipment. Write or call stating your requirements.

# ANCOM

## ELECTRONIC CORP.

5521 Cleon Avenue, No. Hollywood, Ca. 91601  
213-769-5518



ou goons don't ever proofr  
easy man... bunch of rocks are...  
**LETTERS**  
you ignored my comments in  
I insist that you print ev

from page 8

you KNOW you have the signal right on the nose.

I'm playing around with a phase shift TTY converter which seems to promise great things. I wonder if you would have any interest? (Of course ... Wayne.)

New subject: mini-computers (micro if the shoe fits). I think one of the great problems facing the would-be computer hobbyists is that the manufacturers, in their ads and more amazingly in their literature, seem to be quite reluctant about two things: one, a simple block diagram showing the necessary basic cards/modules and how they plug together; and two, a simple format of how a program on their machine looks and what the owner has to do to make the thing work. Hiding these things, either on purpose or by oversight, may prevent many would-be's from getting into the act.

I have been fooling around with systems analysis and programing computers for quite a few moons now, particularly as they relate to communications services and facilities, and it seems to me that the manufacturers are missing a good selling tool by not explaining, in English, what's going to happen when he does this and that. None of the literature that I have received (and I've got them all) from any of the manufacturers has given me the slightest clue as to what to expect or indeed what to buy to do such-and-such.

Eugene F. Locke W2SKK  
Sea Cliff NY

**UPKEEPING**

I think you've got the best magazine in ham radio — and, hobby electronics in general too, since *EI* went out. Keep up the good work.

Eric Williams  
Scotts Valley CA

**FAR OUT**

I almost had a heart attack today (and I'm only 19). I received my March issue of *73*! None of the other ham magazines has gotten here that quick ... FAR OUT!!! Keep up the interesting articles. I hope sometime in the future I see articles on building ATV stations and more on microprocessors (I'm getting interested and can use some info).

Bob Billson WA2TXY/AA2TXY  
Westfield NJ

**SNOBBISH?**

I guess you talked me into becoming an amateur. I've been reading *73* for a couple of months now and I finally decided to take the steps necessary to acquire my ticket. Enclosed is \$13.95 for a full set of the code tapes. As an amateur, you have a refreshing outlook on the CBer and his or her potential as an amateur recruit. This, in addition to the fine articles in the magazine, is the reason why you got my twenty bucks for a 3 year subscription to *73*.

I have been servicing citizens band and amateur gear for a couple of years now, and the snobbish outlook of amateurs has kept me out of amateur radio until now. There must be more amateurs in this country with your outlook on the CBer, and I have decided to take the time to find some of them.

Thanks for the fine magazine.

Michael L. Aber  
Vallejo CA

**ILL WINDS**

I recently subscribed to your magazine as a result of again becoming interested in ham radio. Although I have been active in years past (formerly W8LST, KR6OX and 5A2TY), I have not been active since my last license expired in 1963.

I just received the March issue and as I was scanning through it, the article, "Inherit the Wind," came to my attention.

The first time I read the author's instructions for building the anemometer, particularly his logic used in calculating the 2.80" radius for locating the 1/8" hole in the disk assembly, I couldn't believe that I was interpreting his logic correctly. After reading it a second time, I concluded that he either goofed in his line of reasoning or he is trying to test for reader response.

He indicates that the 1/8" hole should be drilled in the disk at a distance of 2.8" from the center. The only purpose for the hole, as I see it, is to allow a pulse of light to reach the photoelectric device once per revolution of the disk, and this can be done whether the hole is 2.8" or 2.8 feet (or 100 feet) from the center, as long as the photoelectric device is aligned at the same distance to match the hole when it comes around.

In order to receive one pulse of light per second per mph of wind velocity, it will be necessary to space the cups on the anemometer cup

assembly properly from the center of rotation so that the circumference corresponds to the distance that the wind molecules travel in one second at one mph (assuming 100 percent efficiency), and I will accept his calculation of 2.80" for this radius.

Although I haven't built this anemometer, it seems that 2.80" might be a little short to obtain good efficiency. I would suggest therefore, that the radius figure be doubled or tripled to overcome this possible drawback.

Doubling or tripling the radius would of course reduce the revolutions per second by 1/2 or 1/3 respectively. This could be offset by drilling 2 holes or 3 holes, respectively, equally spaced around the disk at whatever radius the builder decided was most desirable. This would still allow the photoelectric device to see one pulse per second per mph of wind velocity.

Gene W. Creighton  
Findlay OH

**FOREVER GRATEFUL**

I am a tolerant ham wife. I don't make plans for Sundays when there are hamfests. I don't complain when I am "widowed" on contest weekends. I have accompanied my husband to several conventions when nobody else could go. I read *73* (at least the "Letters" section — I understand that!!). I even put up with being called an XYL when I'm not really sure whether the X means I'm no longer young or no longer a lady! But now I have a request of all of the hams, and as it probably is not unique with me, I feel it bears voicing.

OM, when you come to eyeball with my husband or to work on equipment, please leave your toddlers at home. I will carry coffee or beer to the shack. I will hold wires while you solder. But please, please don't ask me to babysit. If I weren't at home, you would be responsible for your child's welfare. You know how impervious you are to your surroundings when you get involved in a project. Would you want your child loose in your shack at such a time? I know your wife deserves a break, but not at my expense. So I promise you, I won't let my husband bring our child to your house if you don't bring yours to my house. Give your wife her break some other time, and I will be forever grateful.

The X-babysitter  
(Name and address submitted)

**ADS TOO, DREAMS (?)**

Mahalo, keep up the good work. I look for the *73* for days before it arrives, and it disturbs my sleeping habits until I read it cover to cover (ads too, dreams).

Everett W. Curry, Jr.  
K6VGL/KH6  
Honolulu HI

**THE METRIC SCOOP**

Why don't you scoop *QST* by being the first to go the metric paper size? Eventually, why not now?

Ken Lewis WA4QHZ  
Albany GA

Excellent idea! Behold ... *73* Magazine, the first of the 21 x 27.5 cm magazines! — Wayne.

**EERIE**

Thank you for the special surplus section in your March issue. To a "surplus hound" like me it was interesting reading. Keep it up!

J. K. Bach, who wrote the article titled, "Adventure," might be interested in some information concerning the calculator he bought. He has a *Lloyds Accumath R 60*. It sold for about \$60 to \$85 new and was discontinued two years ago. The unit was built by North American Rockwell (this is where I came in contact with it) and probably assembled in Mexico. Readers who have this calculator might be able to obtain replacement parts by writing Lloyds' service department located in Compton, California. I must say it is an eerie feeling to read about a product you have worked with since its design stages described by someone with pinpoint accuracy who doesn't know what he has!!!

Gary McClellan  
Project Engineer  
Gary Electronics Co.  
La Habra CA

**WORTH A TRY**

The following is a little tip that I've "re-invented" and which might be of some interest to your readers. At first I was somewhat puzzled by the occasional "zeroing" of my digital LED wristwatch for no apparent reason. I thought about intermittent internal connections (ugh), strong rf fields, etc., but then finally narrowed it down to simply a static charge build-up on the red plastic faceplate of the watch itself. Going back through my memory bank, I remembered the sure-fire cure for static build-up on plastic meter faces used by hams all over for the last dozen or so years and my problem was solved. In case you've forgotten, the cure involves merely placing a couple of drops of liquid detergent (Ivory in my case) on the faceplate, spreading it around with a finger-tip, letting it stand for a minute or so, and finally wiping the bulk of the detergent off. A thin film of detergent seems to remain behind to protect against further build-up for some time, but it is a good idea to re-coat the faceplate every couple of weeks, especially during the cold, dry winter months. No one can guarantee that this pro-



cedure will work for all digital watches, but it certainly is worth a try before packing it off to the manufacturer for repair.

David F. Miller K9POX

### CREDIT LIMARC

At a hobby exposition on Sunday afternoon, January 25th, sponsored by the Plainedge Public Library in Massapequa, N.Y., members of the LIMARC ATV technical group gave an on-the-air demonstration of amateur television two-way transmission between W2WLS/2 and W2NIP. Amateur color TV transmissions were also demonstrated as was a complete solid state ATV transmitter developed by W2TRP. Other participating ATVers were WA2APJ, W2ZUC, WA2FHF and W2KPO.

Also shown were exhibits of slow scan TV, repeater operation, and an exhibit of a precision radio controlled boat built by WB2AQM.

K2OPF, emergency coordinator for the town of Oyster Bay, demonstrated traffic handling during the simulated emergency test on this date. Other groups who joined in with exhibits were the Wantagh Radio Club, the Farmingdale Radio Club and the Long Island DX Association represented by WA2BVU and W2AWK. Amateur radio in the scouting movement was

ably handled by WB2YYV. Outside the library a mobile van containing an "Oscar" satellite terminal was manned and demonstrated by K2REC and WB2AMX.

The show was very well attended by many people who were drawn in by newspaper, cable TV and word of mouth advertising over local repeaters.

K2LIO, LIMARC president, and WA2WKV, who organized the event for LIMARC, feel that cooperative effort by many radio groups such as this can bring much positive interest and credit to the amateur radio image.

Ed Piller W2KPO  
LIMARC

### THE WHITE HOUSE?

Just a short note to compliment you on the mag. Arrival of 73 is the high point of my month. Unlike all other mags, every article in 73 is usually of interest to me rather than just 5 pages or so out of 150 pages. I am fairly knowledgeable in the field but I can't make heads or tails out of most of the stuff in QST and the others. Too bad *Hotline* went west — *HR Report* is really playing it up big in their ads.

It sounds like the gang at 73 really swings. You talk about things up there a lot and it has aroused the curiosity of myself and probably lots of others.

How about a piece in 73 with pictures of the gang, pix of the 73 bldg, antennas, rigs, surrounding countryside, etc? We all would be very interested in this — sort of like a tour of the White House or something.

Well — thanx for the consideration. Maybe one man's opinion might be worth something. Really enjoy 73 — Star Trek communicators and all that.

Steve Uhrig WA3SWS  
Columbia MD

### UNLOCKING PLL'S

I wish to bring to the attention of Dr. Thomas A. Reilly and Calvin McCarthy, and any interested readers, that the book *Phase Locked Loop Systems*, published by Motorola and reviewed in the Nov/Dec 1975 issue of 73 under the heading "For Your Eyes Only," is no longer available.

Immediately after reading the review I sent off a check to Motorola for a copy of this book. I was extremely disappointed today to have it returned with a note that it is no longer available. For some time now I have been trying to obtain a book dealing with PLLs, but so far without success. If there are any readers/hams out there who may have a copy of this book and are prepared to part with it, please let me know for how much and I will remit the necessary amount. I

would also appreciate knowing of any other publications dealing with PLLs that may be available.

Finally, let me compliment W0ACR on his really great scope article titled "Eyes for Your Shack" in the same issue. It was really quite an achievement and a number of friends in this part of the world are considering duplicating it either in part or in its entirety.

John C. Webster VP2DN  
62, Milner Hall  
University of the W.I.  
St. Augustine  
Trinidad W.I.

### SEA W

I thought I'd drop you another line on the status of CW in the U.S. Army. Just last year, the required level of proficiency for all CW radio operators (except for high speed *intercept* operators) dropped from 15 wpm to 10 wpm. It looks like in this day of microwave, troposcatter, and satellite communications, the need for HF communications (which is about the only place CW has a real advantage) is diminishing rapidly.

In contrast, my unit (Special Forces, or the "Green Berets"), who use HF almost exclusively, has upped

*Continued on page 100*



Ed Piller W2KPO, LIMARC ATV Chairman, discussing ATV details with Leo Staschover, president of North Hills Electronics Corp. WA2FHF is in foreground left and WB2DJK is in background right.



Phil Bettan K2LIO, LIMARC president, and George Gluck WA2WKV, LIMARC exhibit chairman. LIMARC ATV poster in background.



Jay Rosenzweig WA2APJ, LIMARC vice president, demonstrates live ATV link.



Scoutmaster Larry Weil WB2YYV mans the "Ham Radio in Scouting" exhibit at the LIMARC showing.

# Computer BONANZA!

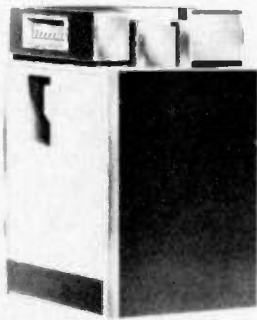

Card Reader

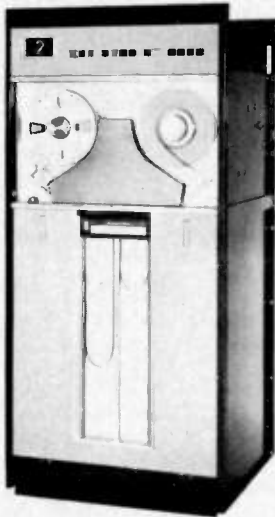

Uniservo

Drums  
Cables  
Tapes  
Core  
Tubes  
Meters  
Card Sorter  
Card Punch  
Power Supplies  
Transformers  
Computer Boards  
Reproducing Punch  
AC Voltage Stabilizer

Card Read-Punch Unit

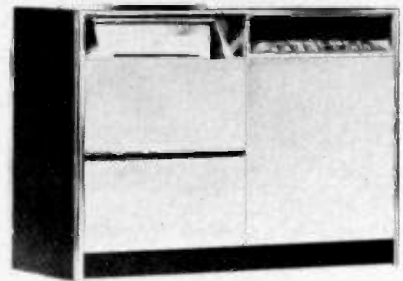
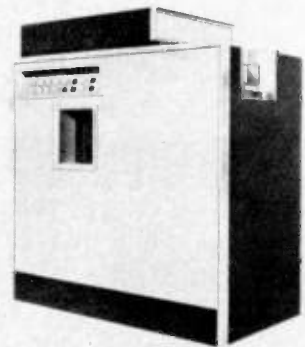

HIGH SPEED Printer



TELEVISION  
PICTURE  
TUBES

**STOP!**

*DON'T JUNK THAT TELEVISION SET. ASE manufactures the world's most complete line of television picture tubes. No other company offers:*

- Over 1700 types of television picture tubes.
- Most types immediate delivery.
- Transportation in the Midwest – paid, ½ transportation paid in other states.
- Tubes for Old or New Models.
- Complete line of both black & white and color.
- Full 2 year factory warranty.
- Lowest prices anywhere.
- Finest quality.

Write today for more information.

Due to updating our computer installation we are offering a majority of our Univac computer systems at unbelievable prices. Manuals furnished. Many items offered by the pound. Most equipment taken out of service in working condition.

FIRST COME FIRST SERVE!

Examples: Computer tapes – \$2.00 ea.  
Interfiling reproducing punch – \$.10 per lb.  
Key punches – \$.25 per lb.  
Electronic counting sorter – \$.10 per lb.  
600 line per minute high speed printer – \$.50 per lb.

Write for detailed list and prices to:



**Allied Sales & Engineering, Inc.**  
Dept. 25 Pimento IN 47866  
Telephone 812-495-6555



by looking in the yellow pages under junk dealers and electronic surplus houses. Make a few phone calls, ask questions, and follow leads. There are mail order companies that have teleprinter

equipment. Check the back pages and classified ads of amateur and computer hobbyist magazines. Write a few inquiries and get quotations — ask for the specific machine you want. Get in

touch with local radio amateurs and see if they can help. Hams generally have a good attitude toward hobbyists of other persuasions and go out of their way to help. You might find a ham with a spare

Teletype that he would be willing to loan out until you can get your own.

Give Western Union and Bell Telephone a call. If you can get through to the right people you may have a chance of getting a free machine. I have heard of this approach yielding success more than once. In these inquiries be sure to emphasize the "hobby" nature of your interest! Above all don't get disappointed and give up too soon. There are thousands of these machines out there — probably one with *your* name on it!

### The Care and Feeding of a Model 15 (or Similar)

As the owner of a Baudot Teletype you should take some pride in your new possession. Over the years the Model 15 Teletype has gained an excellent reputation among people who appreciate well-engineered mechanical devices. Most of its moving parts are made of case-hardened steel. When a part does wear there is generally an adjustment somewhere to take up the slack. If you can find a maintenance manual, get it and use it. Your efforts will pay off in many years of reliable service. I have often heard Model 15 owners say not to worry with cleaning the working parts — the worse it looks the smoother it operates. A friend has a Model 15 with several more layers of dirt and grease than mine. Not only does his keyboard have a lighter touch but his printer is several decibels quieter! Remember to keep machine oil in the cups and on the clutch felts. With reasonable care your machine should serve you well for years to come.

### The Interfacing Problem: At the Teletype End

Normally the Teletype will have two connecting cables: one for send (the keyboard) and the other for receive (printer magnet). For testing

LABEL	OCTAL ADDRESS	OCTAL CODE	MNEMDNIC	COMMENTS
INPUT	Low- 000	001	LXI B	ZERO C; COUNT IN B
	001	000		
LOOP1	002	005		
	003	333	IN	LOOK FOR START PULSE
	004	376		
	005	037	RAR	
	006	332	JPC	JUMP BACK IF NO START
	007	003	LOOP1(L)	
	010	000	LOOP1(H)	
	011	026	MUI D	SET FOR 1½ TIME UNITS
	012	030		
	013	315	CAL	CALL TIME OUT ROUTINE
LOOP2	014	110	TMOUT(L)	
	015	000	TMOUT(H)	
	016	333	IN	COLLECT 5 DATA PULSES INTO C
	017	376		
	020	037	RAR	
	021	171	MOV A, C	
	022	037	RAR	
	023	117	MOV C, A	SAVE A
	024	026	MUI D	SET FOR 1 TIME UNIT
	025	020		
OUTPUT	026	315	CAL	CALL TIME OUT ROUTINE
	027	110	TMOUT(L)	
	030	000	TMOUT(H)	
	031	005	DCR B	CHECK COUNT
	032	302	JNZ	JUMP BACK IF NOT FINISHED
	033	016	LOOP2(L)	
	034	000	LOOP2(H)	
	035	171	MOV A, C	RETRIEVE A
	036	017	RRC	ADJUST A TO PLACE BAUDOT IN LOWER 5 BITS
	037	017	RRC	
LOOP3	040	017	RRC	
	041	311	RET	END INPUT ROUTINE
	042	006	MUI B	COUNT IN B
	043	005		
	044	007	RLC	
	045	117	MOV C, A	SAVE A
	046	227	SUB A	CLEAR A
	047	323	OUT	OUTPUT START PULSE
	050	376		
	051	026	MUI D	SET FOR 1 TIME UNIT
LOOP4	052	020		
	053	315	CAL	CALL TIME OUT ROUTINE
	054	110	TMOUT(L)	
	055	000	TMOUT(H)	
	056	171	MOV A, C	
	057	017	RRC	
	060	117	MOV C, A	
	061	346	ANI	MASK OFF ALL BUT 0 BIT
	062	001		
	063	323	OUT	OUTPUT DATA PULSES - 5 IN ALL
TMOUT	064	376		
	065	026	MUI D	SET FOR 1 TIME UNIT
	066	020		
	067	315	CAL	CALL TIME OUT ROUTINE
	070	110	TMOUT(L)	
	071	000	TMOUT(H)	
	072	005	DCR B	CHECK COUNT
	073	302	JNZ	JUMP BACK IF NOT FINISHED
	074	056	LOOP3(L)	
	075	000	LOOP3(H)	
LOOP4	076	076	MUI A	
	077	001		
	100	323	OUT	OUTPUT STOP PULSE
	101	376		
	102	026	MUI D	SET FOR 1½ TIME UNITS
	103	030		
	104	315	CAL	CALL TIME OUT ROUTINE
	105	110	TMOUT(L)	
	106	000	TMOUT(H)	
	107	311	RET	
LOOP4	110	076	MUI A	ADJUST TIME DELAY
	111	XXX		170 <sub>8</sub> for 60 wpm; 135 for 75 wpm
	112	075	DRC A	(MITS STATIC MEMORY TESTED VALUES)
	113	302	JNZ	JUMP BACK IF NOT FINISHED
	114	112	LOOP4(L)	
	115	000	LOOP4(H)	
	116	025	DCR D	
	117	302	JNZ	JUMP BACK IF NOT FINISHED
	120	110	TMOUT(L)	
	121	000	TMOUT(H)	
	122	311	RET	

Fig. 2(a). Serial I/O: Software technique for Fig. 2.



purposes the two can be series-connected with a power supply and current limiting resistor. Connected in this way the machine will type to itself. Teletype users call this "local loop" operation. For computer use the send and receive cables must be connected separately. Fig. 1 shows a transistorized switching circuit that provides the necessary TTL level signals for a computer interface.

The following notes refer to Fig. 1:

1. The use of a high voltage supply (100 to 120 volts) is recommended since it provides the simplest and most reliable operation. Of course, the driver transistor *must* be a high voltage type similar to the one shown.

2. Make certain that the local-line switch is a *non-shorting* (break-before-make) type. 120 volts is not a TTL level! A telephone type lever switch is ideal.

3. The printer magnets (usually there are two mounted side by side) can be connected in series or parallel. The circuit shown assumes a parallel connection. Adjust the slide on the power resistor for 60 mA in the magnet circuit.

4. Notice that in the local position the keyboard contacts are switching the full 60 mA at 120 volts. The contact arcing seems to do wonders for cleaning up noise problems in the keyboard. In the line position, the keyboard is switching to ground and the printer will accept TTL logic levels.

5. Make *absolutely* certain that the Teletype and all computer circuits share a good ground system. In fact, connect the Teletype chassis to the computer ground with a separate heavy wire. We have experienced ac transients on interface lines when the ground connection on the Teletype was inadvertently broken. On one occasion we lost some TTL in our Altair during such an occurrence.

LOWER CASE	5 LEVEL	6 LEVEL	UPPER CASE	5 LEVEL	6 LEVEL
A	003	003	-	003	043
B	031	031	?	031	071
C	016	016	:	016	056
D	011	011	\$	011	051
E	001	001	3	001	041
F	015	015	!	015	055
G	032	032	&	032	072
H	024	024	#	024	064
I	006	006	8	006	046
J	013	013	Bell	013	053
K	017	017	(	017	057
L	022	022	)	022	062
M	034	034	.	034	074
N	014	014	,	014	054
D	030	030	9	030	070
P	026	026	0	026	066
Q	027	027	1	027	067
R	012	012	4	012	052
S	005	005	'	005	045
T	020	020	5	020	060
U	007	007	7	007	047
V	036	036	:	036	076
W	023	023	2	023	063
X	035	035	/	035	075
Y	025	025	6	025	065
Z	021	021	"	021	061
CR	010	010	CR	010	050
LF	002	002	LF	002	042
SP	004	004	SP	004	044
BLNK	000	000	BLNK	000	040
FGS	033	033	FGS	033	073
LTR	037	037	LTR	037	077

Table 2. Baudot-octal conversion.

#### The Interfacing Problem: At the Computer End

There are several schemes available to perform the serial input/output function at the computer. A UART (Universal Asynchronous Receiver Transmitter) is readily adaptable to five level Baudot code. The UART represents a hardware solution to the problem. The serial/parallel conversion can also be handled by computer software. This simplifies the hardware requirement but ties up the CPU during input/output operation. The circuit in Fig. 2 and the accompanying software listing will illustrate this latter technique as applied in an Altair 8800 system.

Although the software I/O system is probably not a good long-term solution to your I/O needs, it does offer a quick and simple approach to getting your Teletype on-line. Fig. 2 is very similar to the interface circuitry necessary for a cassette interface of the Suding type. If you later change your I/O to a UART

type, you can use this circuit to build up a cassette interface.

To check out the software I/O, make the following test:

1. At a memory location above the I/O routines, load a main program similar to:

```

LXI SP, LOOP + 10
LOOP CALL INPUT
      CALL OUTPUT
      JMP LOOP

```

2. EXAMINE the starting location of the main program and begin execution.

3. The printer should now echo keyboard entries.

In our Altair 8800 system we have used several home brew I/O interfaces with success. Our original circuit followed in design the "Basic Stunt Box" on page 299 of *RTTY Handbook*. This circuit was modified and improved through several generations. Most recently we have used a MITS SIOC interface board with a few simple modifications (see below). The MITS board is UART-based, with a software controlled interrupt scheme we

have found very useful. Processor Technology's board is currently being used by Frank Corlett WASBNK with his Altair 8800 and a Model 28. After a great deal of experimenting, we have little doubt that a UART-based I/O interface is best.

The MITS SIOC board was originally intended for use

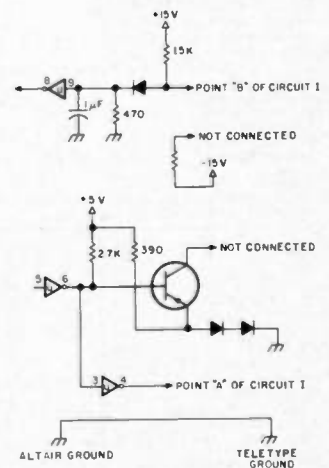

Fig. 3. Teletype drive circuits for MITS SIOC interface with modification for connection to a Model 15 Teletype.



with a Model 33 Teletype. To use it with a Model 15 or similar machine, make the modifications shown in Fig. 3.

In preparing the MITS board, the number of stop bits must be selected. The five level Baudot code consists of a start, stop and five coded data pulses. The start and data pulses are 22 ms each (60 word per minute machines) while the stop is 31 ms, about 1½ times the others. Theoretically, the stop pulse generated by the serial I/O circuit should be 1½ times the length of the start and data pulses. The MITS SIOC board has provision for 1 or 2 stop pulses only. Our experience has shown that both choices work satisfactorily. One stop pulse types a little faster than normal, 2 stop pulses a little slower. We have used the 1 stop bit set up for some time without any problems. A UART is available that pro-

vides the correct 1½ stop bits but we don't believe you need to be too concerned about getting one.

As you implement a Baudot system, knowledge of the Baud rate will be required. For instance, the MITS serial board instructions do not provide directly the Baud rate hookup for a 60 wpm Baudot machine. After a little head scratching we were able to figure out the circuit connections. For those contemplating a MITS board, Table 1 gives the necessary data for strapping the Baud rate counters. If you purchase some other I/O board, be sure to ask the manufacturer for details on setting the Baud rate for your Baudot machine. By the way, not all Baudot machines are 60 wpm. Some are 65 and 75 wpm. Gear sets are available from surplus dealers to change speeds. Model 15s work well at 75 wpm. Model 28s are 100 wpm standard.

**How Does Baudot Look in the Computer?**

The answer to this question depends upon the configuration of the interface system. Consider, for instance, a typical keyboard entry to the CPU accumulator. The normally closed keyboard contacts can produce a logic 0 or a logic 1 depending on the number of inversions that take place in the I/O interface. In addition, the interface circuit will determine the location and order of the five level code in the eight bit accumulator. As an example, consider the letter T as it might finally appear in the accumulator:

[T] \* 020 001 017 036

These examples assume the lower five bits of the accumu-

\* This bracket set will be used to mean the octal value of a five level Baudot character.

lator are used. A choice must be made from this group if standardization is to be achieved. After consulting a few sources, 020 appeared the best representation. The MITS and Processor Technology boards produce this representation. Table 2 presents the full Baudot character set as it would appear in octal notation.

For those not familiar with the Model 15s, upper or lower case is set by FGS or LTR keystroke respectively. A mechanical flip flop holds the case until another FGS or LTR keystroke produces a change. It is convenient in some systems to use a sixth bit to indicate which case is desired or the status of the machine. With the sixth bit, software can be written to control the FGS/LTR function. This relieves some of the difficulties encountered in keeping track of the case. An example will be presented subsequently. ■

### ALDELCO SEMI-CONDUCTOR SUPERMARKET

#### RF DEVICES

2N3375 3 W 400 MHz . . . 5.50	2N3866 1 W 400 MHz . . . 99
2N5590 10 W 175 MHz . . . 7.80	2N5591 25 W 175 MHz . . . 10.95
2N6080 4 W 175 MHz . . . 5.40	2N6081 15 W 175 MHz . . . 8.45
2N6082 25 W 175 MHz . . . 10.95	2N6083 30 W 175 MHz . . . 12.30
2N6084 40 W 175 MHz . . . 16.30	2N4041 1 W 400 MHz . . . 5.25

#### HEAVY DUTY RECTIFIERS

200 Volt 100 Amp D08 . . . . .	5.50
200 Volt 250 Amp D09 . . . . .	8.50
400 Volt 2 Amp Silicon Rectifier RCA . . . . .	15 for .99
1000 Volt 2 Amp Silicon Rectifier RCA . . . . .	10 for .99
10,000 Volt Silicon Rectifier Erie . . . . .	2.95

#### SILICON TUBE REPLACEMENTS

1N2637 Replaces 866, 866A, 3828 . . . . .	9.80
1N2389 Replaces 5U4, 5Y3, 5W4 . . . . .	5.25
S872 Replaces 872 . . . . .	28.50

Send stamp for complete replacement list

#### STUD RECTIFIERS

50 Volt 40 Amp . . . . .	.99	2 Amp Epoxy Bridge Rectifier	
100 Volt 40 Amp . . . . .	1.39	100 Volt . . . . .	.25
200 Volt 40 Amp . . . . .	1.59	200 Volt . . . . .	.35
400 Volt 40 Amp . . . . .	1.79	400 Volt . . . . .	.45
		600 Volt . . . . .	.55

#### ZENERS

1N746 to 1N759 400 Mw ea .25	1N4728 to 1N4764 1 w . . . . .	.35
10 assorted zener diodes unmarked . . . . .		1.98

2N2222 or 2N2907 . . . . .	10/.99	TTL's			
2N3055 . . . . .	.90	7400 . . . . .	.20	7475 . . . . .	.80
2N3713 . . . . .	.45	7401 . . . . .	.20	7490 . . . . .	.80
2N2926 NPN . . . . .	10/.99	7403 . . . . .	.20	7492 . . . . .	.80
2N3904 or 2N3906 . . . . .	10/.99	7404 . . . . .	.25	74121 . . . . .	.60
2N5496 or 2N6108 . . . . .	.35	7405 . . . . .	.25	74123 . . . . .	1.10
FT0601 FET . . . . .	.99	7406 . . . . .	.45	74162 . . . . .	1.25
2N3819 FET . . . . .	.35	7407 . . . . .	.45	74165 . . . . .	2.00
741 or 709 14 Pin DIP . . . . .	.25	7411 . . . . .	.30	74166 . . . . .	1.75
555 Timer . . . . .	.75	7413 . . . . .	.85	74177 . . . . .	1.35
556 Dual 555 . . . . .	1.75	7430 . . . . .	.20	74181 . . . . .	3.90
200 Volt 25 Amp Bridge . . . . .	.49	7437 . . . . .	.50	74192 . . . . .	1.50
1N914 - 1N4148 10 for 99		7442 . . . . .	1.10	74193 . . . . .	1.45
1N34 - 1N60 - 1N64 10 for 99					

We quote on any device at any quantity. All items postpaid. \$5.00 min. order. Send stamp for catalog. NYS add tax.

# ALDELCO

P.O. Box 341 A, Lynbrook NY 11563

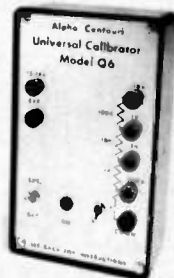

## UNIVERSAL CALIBRATOR

volts — ohms — mA  
Accuracies to .01%

### \$79.95

Send for special offer on meter kits.

# ROTO-KIT INC.

BOX 301, 415 KAY AVE.  
ADDISON IL 60101

## LOGIC PROBE KIT



**\$14.95**  
(plus shipping)

Now! A Digital Logic Probe kit at a realistic price. Red, Green, and Yellow light emitting diodes signal the presence of logic levels encountered in digital circuitry. Utilization of transistor and integrated circuit switching techniques permit the DIGAPEAKE-A to indicate logic 1, logic 0, and pulsing circuit conditions. Complete kit including easy instructions is available now from . . .

Chesapeake Digital Devices Inc.  
P.O. BOX 341  
Havre de Grace, Md. 21078

# Govt. SURPLUS ELECTRONIC EQUIPMENT CATALOG

New ITEMS . . . New BARGAINS!  
**FREE UPON REQUEST!**

If you haven't received our new Catalog, write for free copy today. Address: Dept. 73

**FAIR RADIO SALES**  
1016 E. EUREKA • Box 1105 • LIMA, OHIO • 45802

featuring MITS Altair Computers

# FULL SERVICE COMPUTER STORE

**Byte'Tronics is the hobbyist's dream come true.** A full service computer store featuring the full line of Altair Computer products backed by the most complete technical service available.

**The prices at Byte'Tronics are MITS factory prices** and most items are available on an off-the-shelf basis.

Byte'Tronics sponsors the local Altair Users Group of East Tennessee and Byte'Tronics is interested in communicating with computer hobbyists throughout the world.

**If you have a question about Altair hardware** (whether or not you are a **Byte'Tronics** customer), we will put you directly in touch with our Technical Director, Hugh Huddelston. Hugh is an expert troubleshooter who has a thorough knowledge of each portion of each Altair board. And he can answer all your questions about custom interfacing.

**If you have questions about software** or if you want some custom programming, our Software Director, Johnny Reed, is the expert who can take care of your needs. Johnny has had years of programming experience, and he is familiar with Altair BASIC, assembler and machine language programming.

If you have questions about the availability of a MITS product or its price or specifications, we will let you talk to Bruce Seals, our Director of Marketing.

At Byte'Tronics we want you to understand your Altair and we are willing to give you all the technical support you need.

**Byte'Tronics sells computers. Byte'Tronics sells service.**

For more information, visit our store in Knoxville—or write or call us. We want to hear from you.

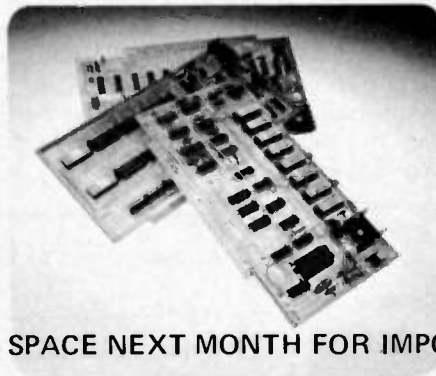
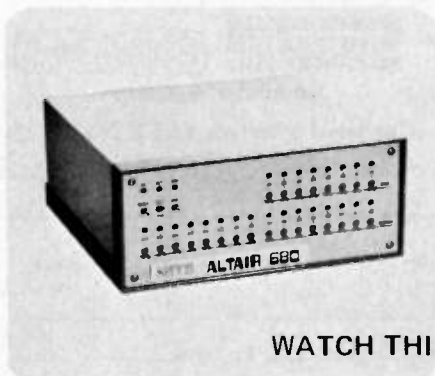

WATCH THIS SPACE NEXT MONTH FOR IMPORTANT NEWS

# BYTE'TRONICS

5604 Kingston Pike, Knoxville, Tennessee 37919 Phone 615-588-8971

Office hours: 10 a.m. to 10 p.m. Monday-Friday and 9 a.m. to 10 p.m. Saturday.

# WHY SETTLE FOR LESS— THAN A COMPLETE 6800 SYSTEM

## MEMORY—

All static memory with selected 2102 IC's allows processor to run at its maximum speed at all times. No refresh system is needed and no time is lost in memory refresh cycles. Each board holds 4,096 words of this proven reliable and trouble-free memory. Cost—only \$125.00 for each full 4K memory.

## INTERFACE—

Serial control interface connects to any RS-232, or 20 Ma. TTY control terminal. Connectors provided for expansion of up to eight interfaces. Unique programmable interface circuits allow you to match the interface to almost any possible combination of polarity and control signal arrangements. Baud rate selection can be made on each individual interface. All this at a sensible cost of only \$35.00 for either serial, or parallel type

## PROCESSOR—

"Motorola" M6800 processor with Mikbug<sup>®</sup> ROM operating system. Automatic reset and loading, plus full compatibility with Motorola evaluation set software. Crystal controlled oscillator provides the clock signal for the processor and is divided down by the MC14411 to provide the various Baud rate outputs for the interface circuits. Full buffering on all data and address busses insures "glitch" free operation with full expansion of memory and interfaces.

## POWER SUPPLY—

Heavy duty 10.0 Amp power supply capable of powering a fully expanded system of memory and interface boards. Note 25 Amp rectifier bridge and 91,000 mfd computer grade filter capacitor.

## DOCUMENTATION—

Probably the most extensive and complete set of data available for any microprocessor system is supplied with our 6800 computer. This includes the Motorola programming manual, our own very complete assembly instructions, plus a notebook full of information that we have compiled on the system hardware and programming. This includes diagnostic programs, sample programs and even a Tic Tac Toe listing.

Mikbug<sup>®</sup> is a registered trademark of Motorola Inc.

**SWTP 6800**  
Computer System

with serial interface and 2,048 words of memory. . . . . \$395.00



- Enclosed is \$395 for my SwTPC Computer Kit       Send Data  
 or BAC \_\_\_\_\_ # \_\_\_\_\_  
 or MC \_\_\_\_\_ Ex Date \_\_\_\_\_

NAME \_\_\_\_\_

ADDRESS \_\_\_\_\_

CITY \_\_\_\_\_ STATE \_\_\_\_\_ ZIP \_\_\_\_\_

Southwest Technical Products Corp., Box 32040, San Antonio, Texas 78284





# Code Converter Using PROMs

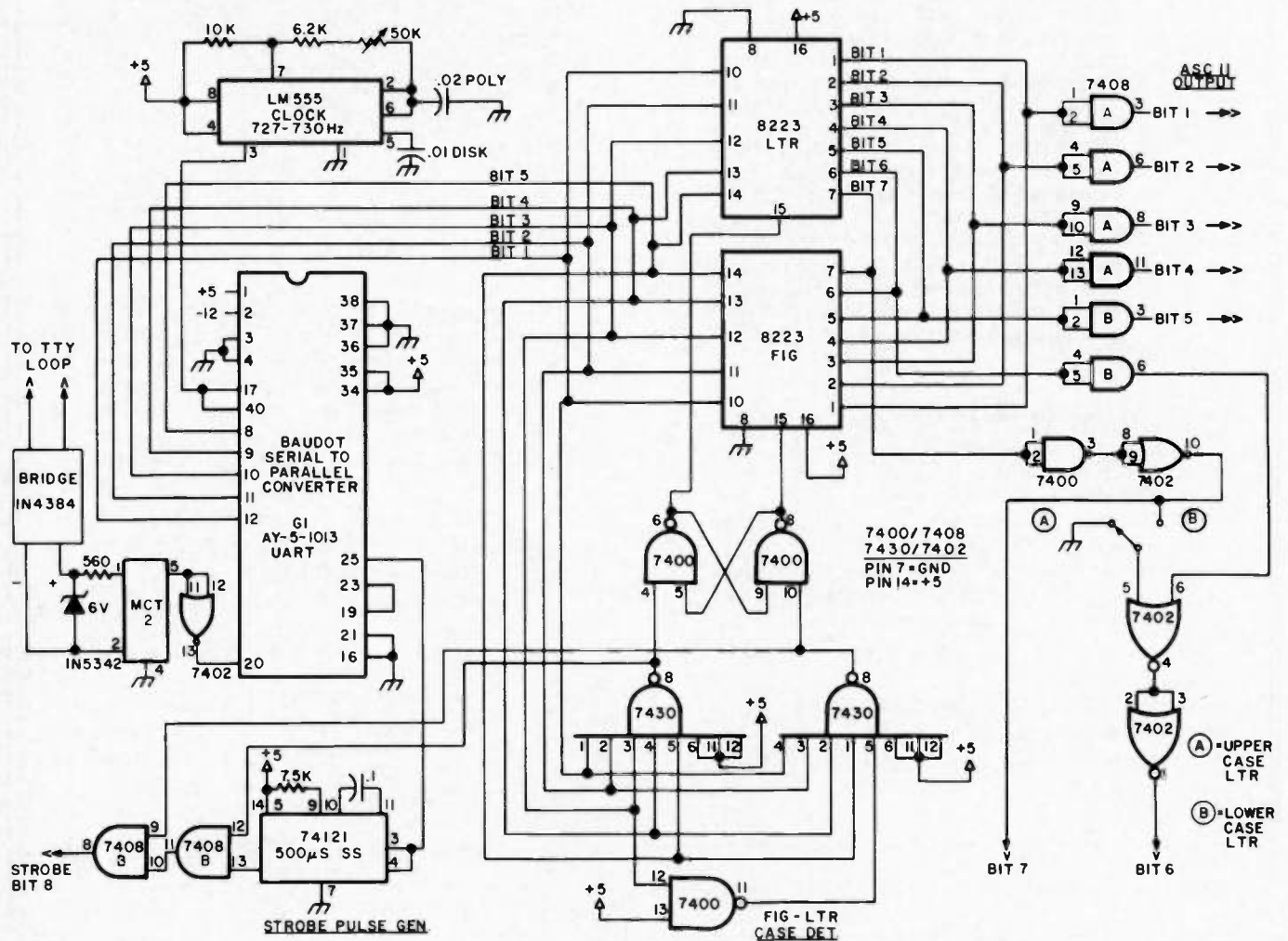

Fig. 1. Schematic.



SYMBOL	LETTERS PROM												
	BAUDOT				LTR PROM Pin 15 State		ASCII						
	B1	B2	B3	B4	B5	B6	B1	B2	B3	B4	B5	B6	B7
A	1	1	0	0	0	1	1	0	0	0	0	0	1
B	1	0	0	1	1	1	0	1	0	0	0	0	1
C	0	1	1	1	0	1	1	1	0	0	0	0	1
D	1	0	0	1	0	1	0	0	1	0	0	0	1
E	1	0	0	0	0	1	1	0	1	0	0	0	1
F	1	0	1	1	0	1	0	1	1	0	0	0	1
G	0	1	0	1	1	1	1	1	1	0	0	0	1
H	0	0	1	0	1	1	0	0	0	1	0	0	1
I	0	1	1	0	0	1	1	0	0	1	0	0	1
J	1	1	0	1	0	1	0	1	0	1	0	0	1
K	1	1	1	1	0	1	1	1	0	1	0	0	1
L	0	1	0	0	1	1	0	0	1	1	0	0	1
M	0	0	1	1	1	1	1	0	1	1	0	0	1
N	0	0	1	1	0	1	0	1	1	1	0	0	1
O	0	0	0	1	1	1	1	1	1	1	0	0	1
P	0	1	1	0	1	1	0	0	0	0	1	0	1
Q	1	1	1	0	1	1	1	0	0	0	1	0	1
R	0	1	0	1	0	1	0	1	0	0	1	0	1
S	1	0	1	0	0	1	1	1	0	0	1	0	1
T	0	0	0	0	1	1	0	0	1	0	1	0	1
U	1	1	1	0	0	1	1	0	1	0	1	0	1
V	0	1	1	1	1	1	0	1	1	0	1	0	1
W	1	1	0	0	1	1	1	1	1	0	1	0	1
X	1	0	1	1	1	1	0	0	0	1	1	0	1
Y	1	0	1	0	1	1	1	0	0	1	1	0	1
Z	1	0	0	0	1	1	0	1	0	1	1	0	1
FIG													
LTR	1	1	1	1	1	1	0	0	0	0	0	1	0
CR	0	0	0	1	0	1	0	0	0	0	0	1	0
LF	0	1	0	0	0	1	0	0	0	0	0	1	0
SPACE	0	0	1	0	0	1	0	0	0	0	0	1	0

SYMBOL	FIGURES PROM												
	BAUDOT				FIG PROM Pin 15 State		ASCII						
	B1	B2	B3	B4	B5	B6	B1	B2	B3	B4	B5	B6	B7
1	1	1	1	0	1	0	1	0	0	0	1	1	0
2	1	1	0	0	1	0	0	1	0	0	1	1	0
3	1	0	0	0	0	0	1	1	0	0	1	1	0
4	0	1	0	1	0	0	0	0	1	0	1	1	0
5	0	0	0	0	1	0	1	0	1	0	1	1	0
6	1	0	1	0	1	0	0	1	1	0	1	1	0
7	1	1	1	0	0	0	1	1	1	0	1	1	0
8	0	1	1	0	0	0	0	0	0	1	1	1	0
9	0	0	0	1	1	0	1	0	0	1	1	1	0
0	0	1	1	0	1	0	0	0	0	0	1	1	0
•	0	0	1	1	1	0	0	1	1	1	0	1	0
,	0	0	1	1	0	0	0	0	1	1	0	1	0
(	1	1	1	1	0	0	0	0	0	1	0	1	0
)	0	1	0	0	1	0	1	0	0	1	0	1	0
?	1	0	0	1	1	0	1	1	1	1	1	1	0
/	1	0	1	1	1	0	1	1	1	1	0	1	0
:	0	1	1	1	0	0	0	1	0	1	1	1	0
;	0	1	1	1	1	0	1	1	0	1	1	1	0
!	1	0	1	1	0	0	1	0	0	0	0	1	0
"	1	0	0	0	1	0	0	1	0	0	0	1	0
'	1	1	0	1	0	0	1	1	1	0	0	1	0
&	0	1	0	1	1	0	0	1	1	0	0	1	0
\$	1	0	0	1	0	0	0	0	1	0	0	1	0
STOP	0	0	1	0	1	0	0	0	0	0	0	1	0
-	1	1	0	0	0	0	1	0	1	1	0	1	0
BELL	1	0	1	0	0	0	0	1	1	0	1	0	0
FIG	1	1	0	1	1	0	0	0	0	0	0	1	0
LTR													
CR	0	0	0	1	0	0	0	0	0	0	0	1	0
LF	0	1	0	0	0	0	0	0	0	0	0	1	0
SPACE	0	0	1	0	0	0	0	0	0	0	0	1	0

Table 1. Code conversion table for programming the 8223 PROM in the Baudot to ASCII RTTY TVT.

nected the bridge into the TTY loop circuit. A check was made to assure that the parallel Baudot output code was appearing properly on pins 8 through 12 on the UART. The Strobe Pulse Generator was wired next and again checked to be sure that the 500 microsecond pulse was being generated when a key was depressed on the keyboard. The FIG/LTR case detector was then wired and a circuit check was made to confirm that pins 6 and 8 of the 7400 FF changed state when the FIG and LTR keys were depressed on the keyboard. Then the final wiring was made on the 8223s and the output buffers. The board was again plugged into the system and a check of all letters and figures was made to be sure that the PROMs were correctly coded. It all worked just as planned.

The PROMs have been programmed so that the RTTY TVT screen does not print any Greek alphabet garbage when the CR, LF and other selected non-wanted characters are struck. On the old preprogrammed 5220 BL/N you had a few Greek characters show up every time the FIG, LTR, Bell, or STOP characters were received or transmitted. When you do your own programming, you can prepare it so that this does not happen. Another blow for those who build their own gear.

This new version of the RTTY TVT code converter board should enable the builder to fabricate his unit with much less fuss over trying to locate hard-to-get components and in the process reduce the cost of the unit. ■

#### References

- "K20AW Synthesizer PROM-oted," Wm. J. Hosking WJWSW, *73 Magazine*, November/December, 1975.
- "A Versatile Read Only Memory Programmer," Peter Helmers, *BYTE Magazine*, November, 1975.



# You'll go nuts over our computers!



## And the Sphere Computer System costs less than anyone else's terminal.

Completely intelligent micro-systems . . . that's what we offer. Just look at the features, and the prices. No compromising, with no short cuts! Recently at WESCON, SPHERE also demonstrated its new, full-color and B/W graphics terminal — and we have other new products, to be just as revolutionary as the SPHERE 1 SYSTEM was when we released it last June. SPHERE 'R & D' will keep ahead of your demands, no matter the state of the art. Take one look at our catalogue, then call or write us today.

<b>KIT</b> 5860	<b>ASM</b> \$1400*	<b>SPHERE 1:</b> This system includes the Motorola 6800 microprocessor, 4K RAM, 1K EPROM (containing an EDITOR, ASSEMBLER, DEBUGGER, COMMAND LANGUAGE, CASSETTE LOADER, DUMPER, UTILITIES), a REAL-TIME CLOCK, plus 512 character video interface, with full ASCII keyboard and numeric/cursor keypad, power supply, chassis, manuals, and associated parts.	<b>KIT</b> \$6100	<b>ASM</b> \$7995*	<b>SPHERE 4:</b> Includes all of the features of SPHERE 3, except the cassette has been replaced by an IBM-compatible Dual Floppy Disk System. This system includes a Disk-operating system and BASIC Language and a 65 LPM line printer.
999	1499*	<b>SPHERE 2:</b> Includes all features of SPHERE 1, plus serial communications, and audio cassette or MODEM Interface.	(various)		<b>OTHER SPHERE PRODUCTS:</b> Light pen option; full color and B/W video graphics system; low cost Dual Floppy Disk System; and full line of low cost peripherals.
1765	2250*	<b>SPHERE 3:</b> Includes all the features of SPHERE 2, plus memory totaling 20K which is sufficient to run full extended BASIC Language.			*This ASSEMBLED SPHERE System includes the complete chassis, and video monitor as pictured below.

### The Whole System:

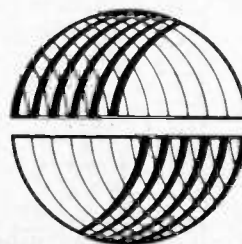

**SPHERE**  
**CORPORATION**

791 South 500 West Dept. 1211  
Bountiful, Utah 84010

(801) 292-8466

# A Nifty Cassette - Computer System

The most practical and economical way to store programs and large quantities of data for small computer systems is with the common tape cassette recorder. Cheap and plentiful, audio-type cassette equipment is capable of storing several times the amount of data that an equivalent volume of paper tape can hold, with the added benefits of erasability and easier operation. Floppy disks may be faster, but are beyond the price range of most hobbyists.

While computer manufacturers and software houses have long been supplying their programs on audio cassettes, there has been a major problem with compatibility. Every manufacturer has had his own pet system of recording, and a tape recorded for use with one brand of computer is utter gibberish to another brand of computer. For this reason, several manufacturers decided to adopt a standard system of tape interfacing.

The proposed standard, as

implemented by Pronetics Corp., calls for a frequency-shift keying standard not entirely dissimilar to that used for RTTY, but with several crucial differences. The two tones to be recorded are ideally to be square waves, with Mark (logic 1) to be 2400 Hz, and Space (logic 0) to be 1200 Hz. With a standard tape exchange speed of 300 baud (bits per second), Mark would consist of eight cycles, Space of four. This could be divided to 600 or 1200 baud, in which case one cycle would be a space (1/1200 sec). Higher density would be impractical. For comparison, 300 baud corres-

ponds roughly to 30 characters per second.

Within each character, the first recorded tone should consist of a Space (start) bit, followed by eight data bits (least significant bit first, parity last) and two Mark (stop) bits. All undefined bits, as well as the interval between characters, would be Mark (2400 Hz).

This system has several beneficial features. It is self-clocking. The first bit of any character is Space and must follow the Mark tone that ends previous characters and exists between characters. It is possible to tolerate as much as a 30% speed variation with this system, which can be an important factor with inexpensive tape equipment.

## Do I Need a Good Recorder?

Almost any cassette recorder can be used for data storage using this FSK standard system. But for convenience and accuracy, there are a few criteria for selection that differ from hi-fi quality.

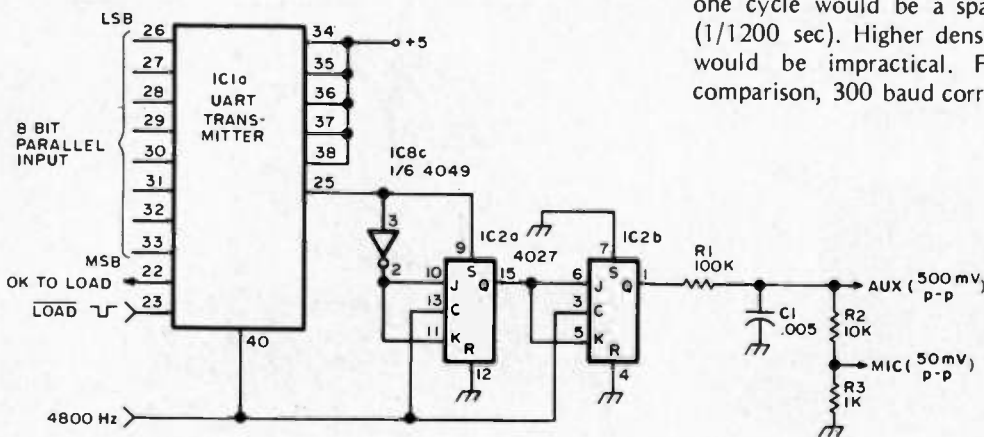

Fig. 1. Cassette digital modulator. This circuit converts 8-bit parallel input data to a series of 2400 and 1200 Hz tones for recording on cassette tape.

You want a clean, reliable machine. Dirty heads and mechanism can spoil data very easily. If you don't have a cassette recorder already, a used model is adequate, but it shouldn't show signs of mistreatment. It should also have capstan drive — a few miniature units don't.

A digital tape counter is also a great convenience. Without one, identifying programs on a tape can be difficult, and could lead to accidental erasures. These are found on many hi-fi type machines, and occasionally on portable units.

An important electrical feature is ac bias/erase. Some recorders, and most of the under-\$100 category, use dc for erasing and record biasing. This results in higher noise and less frequency response. While frequency response is not as critical with this system as with music recording, it still helps to have a good clean treble response, which can help preserve the square wave shape. Low noise means fewer errors, so a high signal-to-noise ratio aids reliability.

Stereophonic capability is unnecessary. If you have a stereo recorder, be sure to record both tracks simultaneously, and bulk erase the tape before using it.

Your tape recorder must have an auxiliary or microphone input jack, as well as an earphone or line output. Acoustic coupling is unsatisfactory. The choice of levels can be performed in the computer interface circuitry, so either mike, line, or speaker levels can be used.

#### What About Tape?

While the choice of tape recorder is uncritical, the tape itself is the weak link in the chain. Do not skimp on tape. Use the best tape you can get your paws on. Since dropout on the tape means loss of data, the tape must have a

---

In a meeting organized by the staff of 73 Magazine, the microcomputer industry accepted this cassette system as the industry standard.

---

high manufacturing standard. Some cassettes jam easily, and the thin tape found in C90 and C120 cassettes is too thin and fragile to be reliable. A premium grade C60 tape is ideal. Perfectionists might want to spend the extra money for chromium dioxide tape. The extra response can't hurt.

Store the tapes in a dust-free location, in their own container. Do not smoke near the tapes or the recorder, and clean the heads frequently. Tape cleanliness and quality are far more important in digital applications than in music.

#### The Recording Interface

Digital information from your computer is generally available as 8 bits parallel from either an I/O port or data bus. The tape is recorded serially; the conversion is best accomplished with a Universal Asynchronous Receiver/Transmitter (UART) IC.

The modulator is shown in Fig. 1. The serial output of the UART has logic 1 as a high level and logic 0 as a low level. IC2a and IC2b form a clock divider circuit, dividing the 4800 Hz clock signal by 2 or 4, depending on the UART output level. The output is a series of square waves which feed the tape recorder's input.

The poor frequency response of some tape recorders, especially those with dc bias, causes the manufacturers to exaggerate the treble being recorded, which distorts the square wave. Sine waves record better, but are

harder to generate digitally. In some cases using a low pass filter makes the waveform usable; R1 and C1 perform this function. A smaller value for C1 may increase effectiveness with better recorders. Fig. 2 shows the effect of the recording process on digital waveforms.

The AUX output of the interface is 500 mV peak-to-peak and is for use with high impedance high level inputs. The MIC output is 50 mV, suitable for most units with microphone inputs.

The 4800 Hz signal must be capable of driving two TTL loads. While a crystal oscillator and divider chain work best, and a phase locked loop referencing the 60 Hz power line is also very good, the oscillator in Fig. 3 is simple and quite satisfactory (but requires calibration with a frequency counter).

If the available digital information from the computer is already in serial form with the necessary start and

two stop bits, and is properly timed at 300 baud, the UART is not necessary. However, the 4800 Hz clocking signal should be synchronous with the serial data, with 16 clock pulses per bit. If the serial data is not at 300 baud, a UART receiver must first be used to convert the data to parallel form. It then is clocked through the UART transmitter as shown.

The OK TO LOAD line on the UART goes high when it is ready to accept a byte of parallel data. The data is then loaded into the UART transmitter by pulsing the LOAD line low for at least one usec or until the OK TO LOAD line goes low. The transmitter will then start transmitting the byte when the LOAD line is returned to the high state. When not transmitting, the output is high, causing the modulator to generate the 2400 Hz Mark signal.

#### The Playback Interface

There are several possible ways to recover the FSK signal from the tape. An FM discriminator or a phase locked loop demodulator can be used, just as with an amateur RTTY signal. Users of previous nonstandardized cassette interfaces can readjust them to decode the 1200/2400 Hz tones, but the most accurate system uses

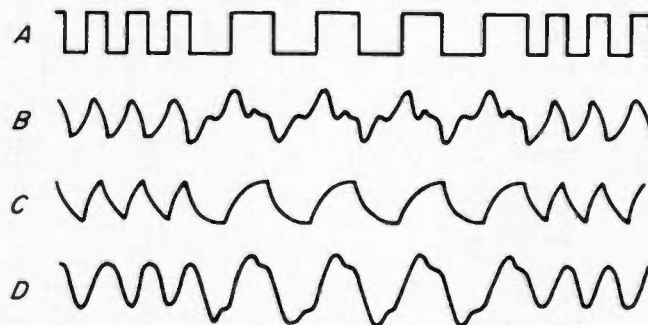

Fig. 2. If a square wave signal such as waveform A is recorded on a low cost cassette recorder, the playback response may look like waveform B, which is very difficult to demodulate. If the square wave is filtered with a low pass filter before recording (waveform C), the playback response will appear like waveform D, a usable signal.

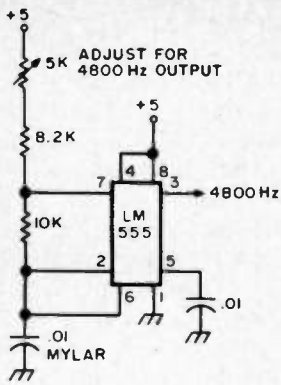

Fig. 3. Circuit of 4800 Hz oscillator. Use this circuit if a more precise and stable source of 4800 Hz is not available.

digital recovery to extract timing information from the recorded signal and uses that information to retim the recovered data.

Fig. 4 is a complete schematic of the playback demodulator. The signal from the cassette player is conditioned by IC3, an op amp used as a Schmitt trigger. The output of a Schmitt trigger is, by definition, either fully high or

low, so it regenerates pure square waves from the distorted tape input. IC4 is a retriggerable one shot with a period set to 555 microseconds. As long as the input signal is 2400 Hz, the one shot is retriggered before it times out. Flip flop IC5a remains high, which is interpreted as logic 1. The 1200 Hz signal, on the other hand, has a period between pulses of greater than 555 usec, so the one shot times out, re-setting IC5a. It stays at logic 0 as long as 1200 Hz is being received because the one shot is timed out whenever the next triggering edge occurs. When the 2400 Hz signal returns, the one shot stays high, permitting IC5a to switch back to high state. The output of this flip flop is the serial data.

While that simple circuit will work well if the tape speed is accurate to better than  $\pm 6\%$ , such is frequently not the case. Since tape speed variations will be reflected in pitch variations in the recovered tones, it is possible to

use the 1200 and 2400 Hz signals from the tape to retim the recovered data. Flip flops IC6a and IC6b extract this timing information. When the 1200 Hz signal is received, IC6a is preset with a pulse generated by C8 and R15 every time the one shot times out. The effect is to cause IC6 to divide by two. When 2400 Hz is being received, the one shot does not time out and IC6 divides by four. The result is a clock at the output of IC6b, at 600 Hz.

Instead of clocking the data into a shift register, the receiver portion of UART IC1 is used. It has built-in circuitry to identify the start and stop of each byte automatically. It also has three-state output (logic low, logic high, and functionally disconnected), which permits direct connection to most data buses and I/O ports. The UART needs a 16x clock, which is formed by phase locking a 4800 Hz oscillator to the 600 Hz output of IC6b. The PLL is adjusted to

oscillate at 4800 Hz in the absence of any input signal. IC5b and IC9 divide the PLL output by 8 to drive one of the phase detector inputs, while the other input is driven by IC6b.

The UART receiver raises its DATA AVAILABLE output to logic 1 when it recognizes that it has received a complete character. Since the UART outputs are three-state, it is necessary to drive the RECEIVED DATA ENABLE input to logic 0 to read the parallel output data. After the parallel data has been read it is necessary to pulse the RESET DATA AVAILABLE line to prepare the UART to output the next byte. The pulse must remain at logic 0 for at least one usec, or until the DATA AVAILABLE line drops to logic 0.

#### Circuit Adjustments

The only adjustment necessary for the recording modulator is to put the 4800 Hz signal exactly on frequency. Since a Mark byte

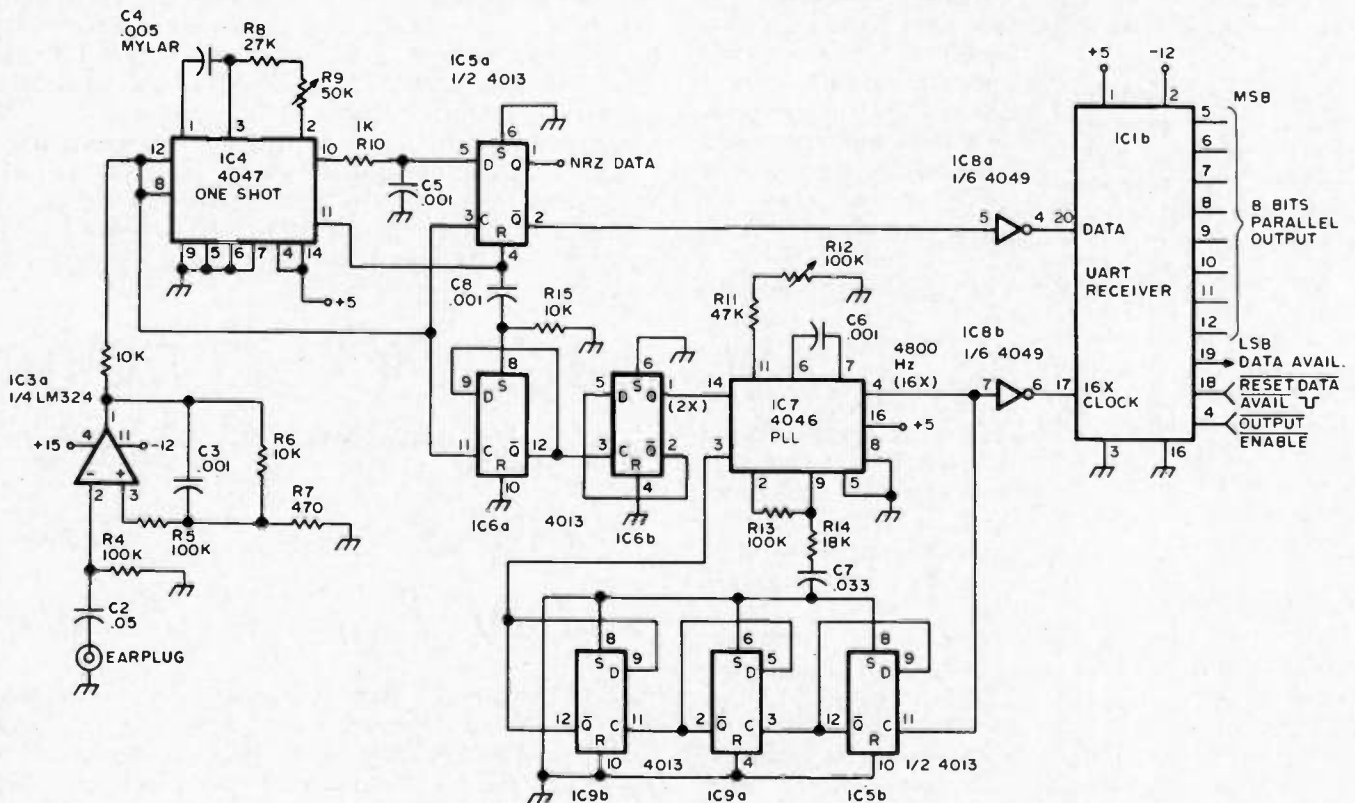

Fig. 4. Cassette data recovery circuit. Refer to text for circuit operation.



consists of eight (not seven or nine) cycles at 2400 Hz, this is fairly critical.

The data recovery one shot and PLL oscillator must be accurately adjusted for best results. The one shot is critical. To adjust it, set a well calibrated audio source to 1800 Hz with 1.5 to 3.5 V rms output. Adjust R9 until the data output of IC5a pin 1 just changes, measured on a high impedance voltmeter. Adjust R9 to as close to the point of change as possible.

The PLL oscillator is adjusted by R12 with no input to the playback input. If no counter is available, the oscillator output at IC7 pin 4 should be compared to the 4800 Hz signal used for the UART transmitter.

#### Circuit Operation

The circuit as shown will recover data most accurately if the earplug output signal of the tape recorder is between 4 and 10 volts peak-to-peak.

Most portable recorders have that capability. If the cassette deck does not have a speaker amplifier, a low gain amplifier may be necessary. If the recorder uses dc bias, there may be too much treble, which necessitates turning down the tone control.

To comply with the standard for tape exchange, the recorded data should be preceded by at least 5 seconds of 2400 Hz tone before the data begins. This is accomplished by operating the recorder in the record mode for five seconds or longer before sending data to the UART transmitter. With the UART idle, the modulator generates 2400 Hz.

During playback, wait a couple of seconds before allowing the computer to accept the UART receiver output, to avoid reading the garbage generated by turning the recorder on and off. It is possible to have the computer control, via a relay, the

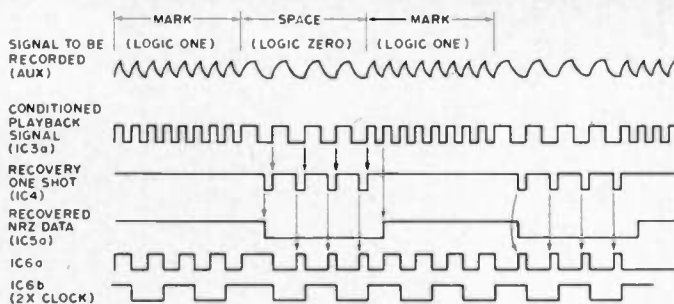

Fig. 5. Cassette modulator/demodulator waveforms.

remote control switch of the tape recorder under program control. It is still necessary to wait a few seconds before accepting data, due to the time spent starting and stopping the tape. The 2400 Hz leader provides that interval on the tape.

#### Conclusion

Using this type of hardware for tape cassette modulation and demodulation simplifies programming for a cassette-oriented computer system. In some circumstances it may be possible to

connect the interface hardware directly to the computer, while some computers may require peripheral interface adaptors to get the data in and out of the computer. ■

*The cassette interface described here is manufactured by Pronetics Corporation. It is available fully assembled and tested on a 4.5" x 6.5" circuit card with standard edge connector. For price and other information write: Pronetics Corporation, PO Box 28582, Dallas TX 75228. — Ed.*

**PRINTED CIRCUIT**  
Positive Acting Photo Resist; Carbide bits; Bubble etchers; Artwork; Epoxy Glass Boards.  
Send stamp & address label for flyer  
**TRUMBULL**  
833 Balra Dr., El Cerrito, CA 94530

**6-METER REPEATERS** are easy...  
with our compact and cute 6-meter cavity filters featuring heavy copper construction, permanent stability and easy implementation. Factory built and ready to hook-up. Call or write for details.  
**Varden Electronics Company**  
Box 791, Jackson, Michigan 49204 • (517)787-2299

**500 MHz FREQUENCY SCALER**  
Designed by K2OAW. P.C. board with instructions \$7. Still available — K2OAW Counter boards \$15, SWR Computer boards \$10. NYS residents add tax.  
STAR-KITS, GPO Box 545, Staten Island NY 10314.

**KAUFMAN BALUN**  
KAUFMAN water tight BALUN new and improved molded plastic  
1:1 impedance match with or without BALUN  
Patent No. D219106 For dipoles, beams, inverted "V", and quads  
KAUFMAN Center Insulator with BALUN \$13.50  
KAUFMAN Center Insulator without BALUN \$ 8.50  
Dragon Fly antenna construction sheet and drawing postpaid USA \$ 2.00  
3 Kw PEP KAUFMAN INDUSTRIES  
4 Ounces BOX 817  
Q1 Ferrite REEDS FERRY, NH 03054

**DURHAMFEST**  
FM CONVENTION AND FLEA MARKET  
MAY 15&16, 1976  
Downtown Ramada Inn, Durham, North Carolina  
FEATURING  
Technical Seminars  
Ladies Activities  
Saturday Night Banquet and  
2 Day Covered Flea Market  
GRAND PRIZE — YOUR CHOICE  
Atlas 210X Complete station or IC 21A/DV-21  
Advanced Registration \$2.00  
\$3.00 at door — Children Free  
For Reservations (Banquet and Accommodations)  
WRITE: DURHAM F.M. ASSOCIATION, INC.  
Post Office Box 8651  
Durham, North Carolina 27707

TUNE IN THE SPIRIT OF '76  
**ARRL NATIONAL CONVENTION**  
DENVER, JULY 16, 17 & 18  
FOR ADDITIONAL INFORMATION AND RESERVATIONS, WRITE TO:  
ARRL NATIONAL CONVENTION,  
C/O SLATS COUNCIL,  
2450 SOUTH QUITMAN  
DENVER, COLORADO 80219

**ACS** Surplus Test Equipment  
Free Information  
**AMERICAN CALIBRATION SERVICES**  
P.O. Box 8104 Athens, Georgia 30601

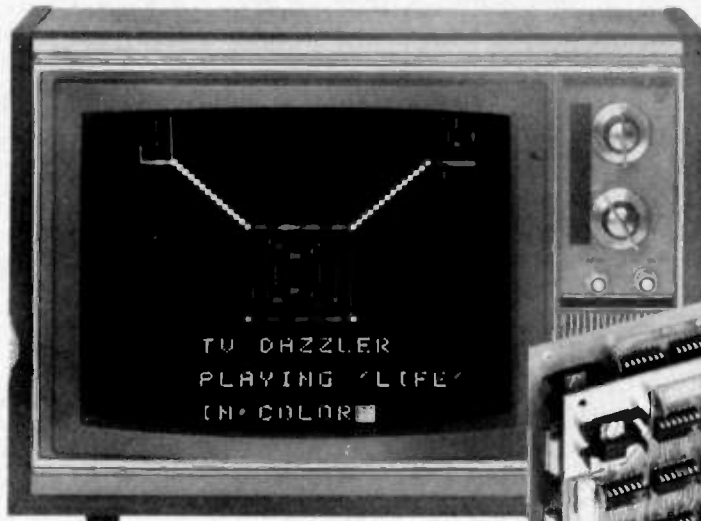

alphanumeric display  
generated with  
Dazzle-Writer software  
(see below)

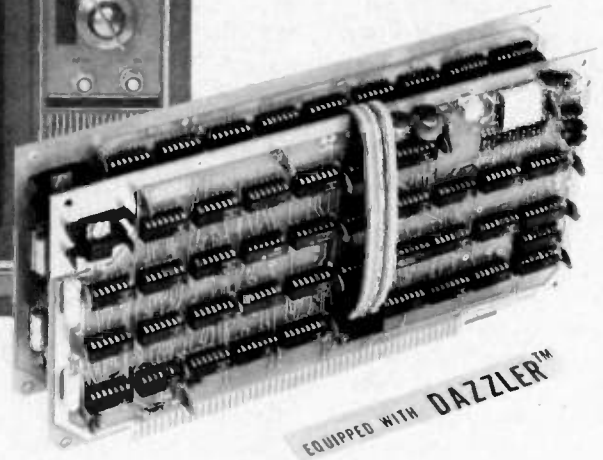

# Now your color TV can be your computer display terminal

## New capabilities, too

Cromemco's new computer/tv interface circuit lets you have a full-color computer display terminal for little more than a black-and-white terminal.

The Cromemco interface also lets you do vastly more with your color terminal than you can do with ordinary black-and-whites.

We call our interface the TV Dazzler®. It consists of two circuit boards that plug directly into your Altair 8800 or IMSAI 8080 computer.

## Alphanumerics plus action, and graphics

The Dazzler® maps your computer memory content onto your color tv screen in full color.

That doesn't mean just that you see alphanumerics in color. You can display *any* information in memory. And do so in color.

## LIFE in color

You can display computer games or animated shows (rocket ships). What's more, you can display business or technical graphics — multi-colored charts, graphs, histograms, educational material — all from computer memory. Even light shows. Not even the biggest computer manufacturers offer all this in color.

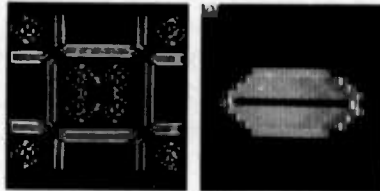

## Needs only 2K memory

Technically, the Dazzler® scans your computer memory using direct-memory access (DMA). It formats each memory bit into a point on the tv screen to give a 128 x 128-element picture. Only a 2K-byte computer memory is required (only 512 bytes for a 32 x 32 picture). The quality of the pictures is evident in the photos.

The Dazzler® output is a video signal that goes directly to the tv video amp or to the antenna terminal through an inexpensive commercially-available device.

## Inexpensive — and so much better

You can see from the list below that the Dazzler® is little if any more in price than an ordinary b/w interface or tv typewriter. But it does so much more.

## Order now

### By mail or at your computer store

If you're into computers (or want to be), if you want to invent these beautiful displays or games, or to plot colorful material inexpensively at home or in business, the Dazzler® is for you.

Not only is it reasonable, but it's sold at computer stores from coast to coast.

Or order directly by mail on your bank card.

TV DAZZLER® (complete kit)	... \$215
TV DAZZLER® (fully assembled and tested)	... \$350

## SOFTWARE

(punched paper tape with documentation)	
LIFE in full color	... \$15
KALEIDOSCOPE in full color	... \$15
DAZZLE-WRITER (for alphanumeric displays in color)	... \$15

Shipped prepaid if fully paid with order.  
California users add 6% sales tax.

Mastercharge and BankAmericard accepted with signed order.

Delivery: from stock for immediate shipment.



## **Cromemco**

Specialists in computer peripherals

One First St., Los Altos, CA 94022 • (415) 941-2967

# You can buy this microcomputer for \$39.95, but...

We would be a bit surprised if you could do anything meaningful without additional hardware and software.



MC 6800

In fact every part including the powerful MC 6800 CPU and the 8K dynamic RAM is guaranteed for 120 days. It has the best

Wave Mate's Jupiter II™ isn't the kind of microcomputer kit you only stare at... when you've completed your Jupiter II just plug in your terminal and you're ready to go. That's because it goes beyond the sum of its high quality parts. It's the ultimate micro kit experience. **In performance, in documentation, in reliability.** First, consider its superb features. It has small pluggable wire wrapped cards easily tailored to suit your modifications. Every IC is socketed and 100% burn-in tested.

software around, System Monitor and Debug programs (ROM). Includes powerful text editor and Motorola compatible assembler. And BASIC at no extra cost. Because we've been making microcomputer systems for over 4 years, we can offer you the broadest line of interfaces including TV terminal and dual audio cassette. Impressive. And yet the grandest feature is the experience of completing a kit that works. Guaranteed.



**ACT NOW AND SAVE.** Good until May 1, 1976  
SPECIAL price \$1445.00 (assembled \$1950.00)

#### Jupiter II Microcomputer Kit Includes:

- Modular plug-in power supply
- 9 module PC backplane
- CPU module
- System monitor module
- 8K dynamic RAM module
- Serial RS 232 communication interface module
- Front panel module
- Front panel
- Wire, cut, stripped, color coded
- Rack mount module cage
- Wire wrap tool
- Wire unwrap tool
- Cables, connectors, all other necessary hardware
- Software (editor, debug, assembler, BASIC)
- Assembly manuals
- Operators manuals
- Theory of operation manuals
- Annual membership in users group



**NEXT MONTH WATCH FOR STUPENDOUS ANNOUNCEMENT !!**

- Send Jupiter II micro kit.
- Kit  Assembled
- Send details on kit-a-month
- I'm not convinced; send me 101 reasons why.
- Please send free Jupiter II System catalogue.

Check enclosed for \$ \_\_\_\_\_  
Include \$10.00 for postage and handling. California residents add 6% tax Delivery 60 days ARO

Name \_\_\_\_\_

Address \_\_\_\_\_

City/State/Zip \_\_\_\_\_

WAVE MATE  
1015 West 190th Street Gardena, California 90248  
Telephone (213) 329-8941



**WARRANTY**  
120 days on all parts,  
materials and workmanship.

# Is Digital All That New?

**T**o meditate on an experiment, a serious experimenter often shelves today's experiment, perhaps never to take it up again. The "light" was in the meditation and not in the experiment. This brings me to the point at hand — meditation as related to digital.

For several years now, a transition from analog to digital has been in the process. To many people, digital is considered as a rather new development, but I ask, "Is it really all that new?" The question may suggest the answer that digital has been around for some time.

Just for the fun of it, let us take a brief and somewhat abstract view of digital devices or communications through the age of man.

From man's beginning, he had a very good calculator at his fingertips as well as a computer with all the software that is necessary for its operation, although he had very little need for either in his primitive culture. It was 2 to 3 million years before man saw the need to communicate between computers. Man has, over the last 20,000 years, developed ways to communicate between computers.

If the old axiom is true that a picture is equal to a thousand words, and if we should equate the picture to a

computer address and equate the thousand words to the memory of the computer, then the cave man had the basic idea in his cave drawings some 20,000 years ago. Programming his computer to accept more addresses (more pictures), he was able to develop a memory system called hieroglyphics, which used approximately 900 pictures. Up to this time man had almost exclusively used analog, which is called the spoken language. Hieroglyphic programming was too complex for most computers, so a much simpler system was developed using only about 24 pictures. Hierotics, as this system is called, was very effective digital-wise, but lacked the ability to communicate with analog systems. About 3,000 years ago a digital to analog and analog to digital system was developed. This system is often called phonic writing. Soon to follow was a digital system that was much more simple and was easily converted to analog. This system was made by the combining of the Phoenician phonic system and the Roman alphabet. Because this system had only 26 digits or letters and could be formed into word groups, it was adaptable to programming. Such programs are placed into a

machine called a printing press and are read out into a permanent storage unit known as a book, which is a type of read only memory. With this type of ROM, the 2 or 3 million year old computer design has almost unlimited capacity to perform the most complex problems.

In Aristotle's theory of the universe formulated sometime around 400 BC, it was suggested that a binary system was possible. Such a system would consist of such variables as hot and cold, wet and dry, light and dark, etc.

Much experimenting in digital communications was taking place by the mid-1700s, parallel versus serial as each form was being developed. Static or friction electricity and its pith balls came first as a parallel system (i.e., one set of pith balls for each letter). Soon to follow was a synchronized serial form using only one set of pith balls.

Galvan electricity and the use of magnetic needles went through the same parallel and serial development. However, a new wrinkle was added. The new wrinkle was code — that is, left or right, operated or non-operated. Its form was much like that of Morse code.

From its inception in the mid-1800s, the electromagnetic (telegraph) system used

a code in serial form. It was the search for the conversion of the electromagnetic digital system to analog that led to the development of the telephone — which just happens to be an analog device. It was only a few years ago that the conversion of digital to analog and analog to digital was electronically accomplished. Its form is called pulse code modulation.

Just as in the addressing of electronic computers, we have been simplifying the addressing to the 2 or 3 million year old design. Some examples include changing "The United States of America" to USA, and other conversions resulting in terms such as IRS, FCC, IBEW, NAACP, FBI, CIA, 73 and others.

What is the answer to the question, "Is digital all that new?" I would say no. I would go so far as to say that at present we are not really in a truly transitional period but rather in a sort of jockeying position. As we turn the corner, I predict that the next big development will be a 3D computer that will make the present computer look like a small contribution to the overall communications system — but I see no way that the old 2 or 3 million year old design will ever be replaced. ■



from page 69

your own if you want to customize the programs to fit your exact needs or if you want to use the gear for some new application. Who knows, once you're set up you might want to score a ham contest and program your computer to cross check every reported contact on the incoming logs ... that program would keep you out of trouble for a while. Or you might want to analyze Oscar contacts for anomalies to see if there are indications of over the horizon propagation at times.

The uses for your computer will be expanding constantly as you discover new things you want to do ... and learn more about how to program the beast to do what you want. When you have worked several weeks in your spare time to perfect a program, you are on the one hand a bit reluctant to just give away all that work to anyone who comes along ... on the other hand you are so proud of what you have accomplished that you want others to see how neat it is. I don't know how this will work out in the long run ... perhaps there will be some programming sales services to help you get a small royalty for your effort ... selling your program to those who want it for a few bucks. On the other hand, the magazines of the future may devote pages to new programs ... we'll see.

Right now you can buy some programs on cassettes ... such as BASIC Language ... a ham package from The Digital Group ... and a few things like that. Much more is available in printed form ... *What To Do After You Hit Return* is a book full of game programs and sample runs of the games to give you the idea. Digital Equipment Corporation has a book (which they don't want us to sell) of 101 games in BASIC. Much of this is pretty much the same as the *What To Do* book which is published by People's Computer Company and is available for \$6.95 from Z3 ... (ahem ... commercial).

The people who are selling programs on cassettes get bent out of shape if you run off a copy for a friend. They spent a lot of time (which is money) writing the program and getting it perfected (debugged) and they feel that you are stealing from them if you don't pay the freight. A letter was just sent around to this effect by the chaps who developed the BASIC program for MITS.

Software such as the MITS BASIC program is usually copyrighted, but this is difficult to protect. It may be that programmers will develop some smarts in this line ... perhaps taking a hint from map publishers. Every map you see that is copyrighted has some extra squiggles in the borders of a state or a country, or something which is not there in real life. Then, when you innocently take a gas company map and trace out the part you want and use it as an illustration for

your article or in a book, wham! One large map maker pulls in over a million dollars a year in copyright infringement cases, I am told. The fact is that it is awfully difficult to explain why your map has that squiggle over there or perhaps an extra town that just doesn't exist (a Cleartype Map favorite) ... particularly when the case is scheduled to come up in court soon.

Would it be that difficult to customize each copy of BASIC with a

little identifying (but non-printing or operating) character? It would be hard to find and would make each copy of the program individually identifiable ... and might put some teeth into contracts. Just an idea ... I'm sure ways will be found to solve the software sales problems ... of course it might happen that programs will eventually just be part of the hardware cost and be available essentially free.

Yes, with this software you will be

able to get your computer to do a lot of nice things ... like play games. But you will still have to learn how to do your own programming for anything off the beaten track. To put it into a percentage ... argue with me if you like ... figure 25% hardware ... 25% language programming and 50% your own programming efforts. Once you get into computers you are going to have your hands full ... and you will have a ball. You may even decide to go back to fresh orange juice.

# GET FAMILIAR WITH MICROCOMPUTERS AT MICROCOST.

\$229.

The EBKA *FAMILIARIZOR* is a complete microcomputer system. No expensive terminal is required. Everything is built-in to a single PC board, including a hexadecimal keyboard and display.

Easy-to-understand Hardware and Programming Manuals guide you every step of the way. You will gain a practical knowledge of microprocessing, plus invaluable "hands-on" experience. All at microcost.

The heart of the EBKA *FAMILIARIZOR* is a MOS TECHNOLOGY 6502 Microprocessor, an eight bit processor that can address up to 65K bytes of memory. On-board memory consists of 1K bytes of RAM for user programs and two eight bit ports (one input and one output). A 256 byte monitor program, supplied in one 1702A erasable PROM, enables you to load, examine, run, debug and modify your own programs. Each function can be implemented at any address in memory. Breakpoints can be entered at any location in your program to display internal registers or branch to a separate routine.

You may also expand the capabilities of your *FAMILIARIZOR* in easy, inexpensive stages. To store your own programs in PROM, the PC board is designed to accept three additional 1702A PROMS (768 bytes). A low cost PROM programmer is also available. The system bus allows easy expansion. Add-on memory, interface and special function cards are available.

Whether you're a beginner or an experienced engineer, EBKA offers you a microcost way to get familiar with microcomputers. Order your EBKA *FAMILIARIZOR* today.



## ORDER FORM

Please send me:

- Complete 6502 *FAMILIARIZOR* Kit .....\$229
- Assembled .....\$285
- IC Socket Kit .....\$14.50
- Power Supply .....\$58
- Check here if you wish to receive literature on the complete EBKA line.

Enclosed is my check or money order for \$ \_\_\_\_\_

Charge my  Bank Americard or  Master Charge exp. date \_\_\_\_\_

Account No. \_\_\_\_\_

M.C. Bank No. \_\_\_\_\_

Signature \_\_\_\_\_

Name \_\_\_\_\_

Address \_\_\_\_\_

City, State, Zip \_\_\_\_\_

Oklahoma residents, add sales tax.

Make payable and mail to:



6920 Melrose Lane 405/787-3671  
Oklahoma City, Oklahoma 73127

# The Ins and Outs of TTL

The design of digital circuits using TTL integrated circuits can be much less frustrating if some simple rules are followed. I am referring to the rules that dictate how and why interconnections between the various circuits and the outside world are made. If you follow the rules, you should

be able to put together a digital circuit from TTL ICs and only have to worry about wiring errors, logic goofs, and bad ICs. The information is from the manufacturers' literature and my own experiences on the bench.

## Ins

The most common and

most easily overlooked input of TTL circuits is the power supply. One look at any TTL circuit and you quickly know the value of the supply voltage is +5 V. For those who worry about such things, the tolerance is  $\pm 5\%$  (military versions are  $\pm 10\%$ ). In other words, the manufacturer only guarantees proper operation

of his ICs when the supply voltage is between +4.75 V and 5.25 V. This is not to say they won't work at other voltages — only that there is no guarantee.

When TTL circuits switch they generate very high frequency current spikes on the power supply lines. These current spikes traveling through the high frequency impedances of the power supply lines cause voltage spikes which can couple to other circuits and trip flip flops, clock counters, and do all sorts of nasty (and very difficult to find) things. To protect yourself from this problem these power connection rules should be followed:

1. Connect a .01 uF disc capacitor from the +5 connection to the ground connection of each IC. Locate the capacitor as close as is practical and use short leads. A miniature disc with a voltage rating of 10 volts or more is a good choice.

2. Use fairly heavy wire (I recommend #18 or larger) for +5 and ground lines and

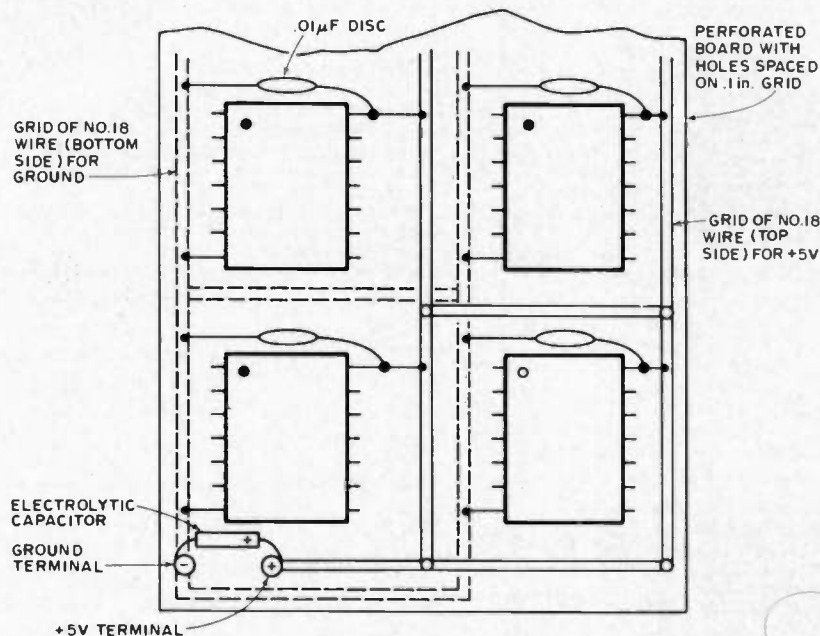

Fig. 1. Illustration of rules for power supply connections.

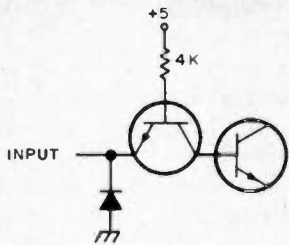

Fig. 2. Standard TTL input circuit.

arrange them so there are many connections. Try to simulate a ground plane and a +5 plane.

3. For every 20 ICs or so in your circuit put in one electrolytic capacitor from +5 to ground. Any value between approximately 4 and 25  $\mu$ F and 10 volts or more rating is OK. If only one is used, try to locate it where the +5 first comes onto the board. If more are used, distribute them more or less evenly over the board.

4. Use a regulated supply for the +5 V. There are many circuits for making a regulated supply. Look at almost any article using ICs and pick one that suits your requirements.

Some of the above rules may seem obvious while others are not so well known, especially to the newcomer. Fig. 1 illustrates one method of construction employing point to point wiring following the above rules.

Next on the list of TTL "ins" let's investigate a typical input circuit as shown in Fig. 2. In order to guarantee that the transistor is turned on we must do two things. First, we must make the input voltage less than .8 V, and second we must draw out of the emitter 1.6 mA of current. In order to guarantee that the transistor is turned off we must also do two things. First, we must make the input voltage greater than 2 V, and second we may have to supply up to 40  $\mu$ A of leakage current. The diode is not necessarily present in all circuits. Its purpose is to limit

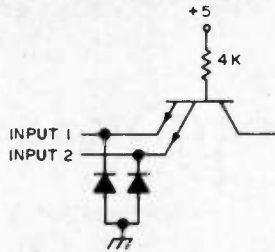

Fig. 3. Input circuit of 2-input gate.

negative pulses on the input that may occur due to transmission line effects on long interconnections. This input characteristic is called 1 unit load (UL) and a circuit such as Fig. 2 which contains 1 UL is said to have a fan-in of 1.

If a second emitter is added to the circuit of Fig. 2 we have a 2-input gate configuration, as shown in Fig. 3. Each input has its own protection diode. If either input satisfies the "on" requirements the transistor will be on. Obviously, both inputs must satisfy the "off" requirements in order to turn the transistor off. By adding more emitters the manufacturers make multiple input gates. The 7430, for instance, has 8 emitters.

What about the undefined area of the input characteristic which lies between .8 V and 2 V? It is just that, undefined. This is a "grey area" where nothing is guaranteed and, except for some special circuits (discussed later), it should be passed through as quickly as possible (less than 200 ns). If the input passes through this region too slowly the output can actually break into oscillation. In fact, this is how a TTL oscillator gets started: by being biased deliberately into this "grey area" until oscillation occurs and then having the frequency of oscillation controlled by external components.

#### Inputs from the Outside World

TTL circuits connect to

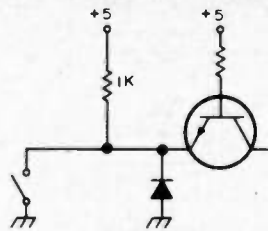

Fig. 4. Using a normal switch to drive TTL.

themselves very nicely, but the outside world is not necessarily TTL compatible. How do you satisfy the input requirements outlined above? It is very easy to get a voltage less than .8 V and able to sink 1.6 mA: Just short the input to ground with a switch. What about the other limit? How do we get the high voltage and current source? Fig. 4 shows one way. The 1k resistor guarantees that even with 40  $\mu$ A being drawn, the voltage will be above the required 2 V minimum.

When the input is relatively slow in changing you can avoid the "grey area" problem by using TTL ICs which have a special hysteresis built into them. These are called Schmitt triggers and have different switching points depending on whether the signal is positive or negative going at the time. The 7413, 7414, and 74132 are examples of this Schmitt trigger type of circuit.

When considering switches as the connection to the outside world another potential problem arises. The contacts of the switch don't close "cleanly." They actually hit and bounce apart one or

more times before remaining closed. Normally this is no problem, but if you were attempting to count switch closures it would not be possible. Fig. 5 shows how to use an SPDT switch and two NAND gate elements to form a flip flop which debounces the switch. This is a very common form of circuit configuration called cross-coupled NAND gates.

Often when you are finished with a logic design you will find yourself with unused inputs to some circuits. *Never*, repeat, *never* leave any unused input to float; it will cause nothing but trouble. Even though an open input is theoretically the same as a high, in practice it is very sensitive to any kind of noise and can cause the output to change for no apparent reason.

What do you do with unused inputs? There are several choices:

1. If it will not prevent normal operation of the circuit you can ground the unused input or connect it to a high source.

1a. The high can be obtained by connecting directly to +5 V. The manufacturers don't recommend this since, if the input goes above +5.5 V, it is possible to damage the input if the current is not limited in some way. I do it all the time with no problems (yet). I recommend connecting to the +5 V connection on the chip itself.

1b. Connect the unused input to +5 V

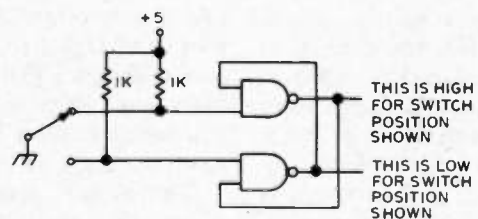

Fig. 5. Using cross-coupled NAND gates to debounce a switch.

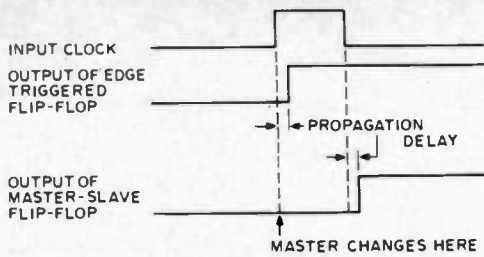

Fig. 6. Timing diagram showing difference between edge-triggered and master-slave flip flops.

through a 1k resistor. One resistor can tie as many as 50 inputs to +5 V.

1c. Use an unused inverting element and ground the input(s) to force the output high. This high output can then be used to pull up as many inputs as its fan-out is rated (see output section).

2. Unused inputs of gates can be connected in parallel with used inputs. There is no increase in load for low inputs. The total current required for the two inputs in parallel is still 1.6 mA. Actually you can tie as many in parallel as you wish and the total low fan-in will not exceed 1 UL. The high fan-in does increase, however, as each emitter may require the 40 uA leakage current. As long as the high fan-out capability of the driving circuit is not exceeded you can parallel gate inputs.

One more input characteristic of TTL circuits is worth mentioning. This is the difference between so-called edge-triggered and master-slave flip flops. The outputs of both circuits react according to the status of the control lines at the time the clock pulse occurs. An edge-triggered flip flop output reacts essentially immediately. The small delay is called propagation delay. A master-slave flip flop is more subtle. On the leading edge of the clock pulse the master reacts like an edge-triggered flip flop. The output, however, is from the slave and it does not react until the

trailing edge of the clock pulse. Fig. 6 shows this difference in graphic form. The main point to remember is that a master-slave flip flop requires a complete clock cycle, not just one edge.

### Outs

There are three basic forms of output circuit used in TTL. The most common form is shown in Fig. 7. This is the so-called totem pole configuration. In the low output state the bottom transistor is on and the top transistor is off. The bottom transistor sinks the current from the connected inputs. In the high state the bottom transistor is off and the top transistor is on. The top transistor now supplies the leakage currents for the connected inputs. This is the normal version. There are minor variations on this circuit but they all operate the same way.

The number of unit loads an output can drive is called its fan-out. The standard TTL IC has a low fan-out of 10 UL and a high fan-out of 20 UL. In other words, a standard TTL output can sink 16 mA (10 times 1.6 mA) and the output is guaranteed to be no higher than .4 V or it can source 800 uA (20 times 40 uA) and the output is guaranteed to be higher than 2.4 V. If you compare these output specs with the input specs you will find there is a .4 V safety margin.

There are several ICs which are specifically designed to drive larger loads. The 7437, 7438, 7439 and

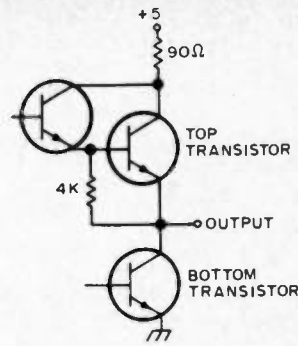

Fig. 7. Totem pole TTL output circuit.

7440 will all sink 30 UL. The 7437 and 7440 will also source 30 UL.

The 7438 and 7439 belong to another class of output circuit called "open collector." In this configuration the top transistor is missing and the bare collector of the bottom transistor is brought out. With this circuit you need an external load resistor of some sort to provide the pull-up to +5 V. If the voltage rating of the IC output is high enough (the 7407 is rated for 30 V, for example), you can switch much higher voltages, and even drive relays and lamps if the current rating is not exceeded.

The open collector circuit is also used in a logic configuration known as both "wired-and" and "wired-or." Fig. 8 shows how this works. All the open collector outputs are tied to a common

pull-up resistor. If any output goes low they all go low (wired-or), and the output will only be high when all the output transistors are off (wired-and, hence both terms). There is a practical limit to how many outputs you can connect together. The pull-up resistor must supply the leakage current for all inputs and all outputs when they are all off and still maintain the voltage above 2.4 V. However, it must still be large enough to limit the total current of resistor plus inputs to 16 mA (10 UL) when any output is on.

Contrary to what you may have read previously, it is OK to connect TTL outputs in parallel, provided you also connect the inputs in parallel so the outputs are doing the same thing at the same time. In fact, the manufacturers recommend this technique as one way to increase fan-out when the load is too much for one output. However, you should restrict this paralleling to elements in the same package because large transient currents are generated and can cause problems if they are not closely confined.

The third and newest type of output configuration is the so-called tri-state or 3-state output. This is a normal TTL totem pole output where both transistors can be turned off. An extra "enable" input

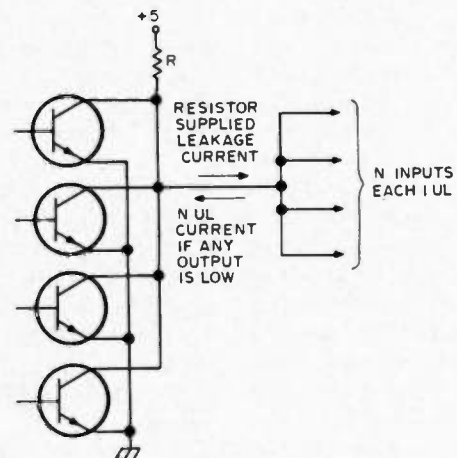

Fig. 8. Using open collector outputs for wired-or configuration.



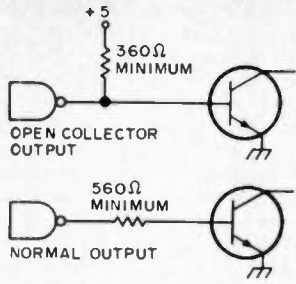

Fig. 9. TTL driving transistors.

is added to the circuit and when enabled the output functions as a normal TTL output. When disabled the output is essentially disconnected. This allows one common wire with many tri-state outputs connected to it to carry all sorts of different information (even in different directions) on a time division multiplex basis. All you have to do is enable the appropriate outputs and inputs at the proper time. This "bus structure" is very common in the world of computers and microprocessors. I have used tri-state circuits to latch 336 bits of data at one time and then output them 8 bits at a time. That is 42 different outputs on each data line.

Someplace in your design you have to connect outputs to the outside world. There are special ICs for driving displays of different kinds as this is one of the most common outputs encountered. I have also mentioned using high voltage open collector outputs. If you need more current or voltage, you can use a circuit such as shown in Fig. 9. In both versions the resistors limit the base current to a safe value. When driving an external circuit of any kind it is best to use an

output dedicated to only that load. That way, if any stray signals are picked up and fed back on this line to the outside world they won't be able to couple into another input and disrupt operation. Also you should never use the output of a flip flop (this includes counters, shift registers, etc.) to connect to the outside world. It is too easy for a stray signal to sneak back, get inside the flip flop, and do weird things.

When it becomes necessary to switch large output loads, often there are transients generated that ride back in on the ground and cause stray triggers of flip flops and other nasty things. A relatively new circuit element called an opto-isolator eliminates this problem completely. Even when driving all 8 channels plus sprocket advance of a high speed paper tape punch there is no problem — and that represents 9 A at 24 V every 9 ms. The opto-isolator (see Fig. 10) consists of an infrared LED and phototransistor. The LED is driven from an open collector output and its energy is coupled optically (no physical connection) to the phototransistor, which is then used as a low level switching stage in a totally electrically isolated circuit.

The preceding rules and suggestions will not eliminate all your digital logic problems but they will greatly reduce them, especially those frustrating random ones. Remember the manufacturers only guarantee proper operation if you stay within the specs. Exceed the specs and all bets are off. ■

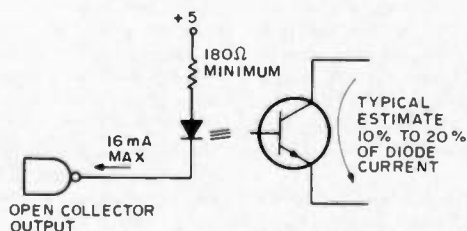

Fig. 10. Using an opto-isolator.

COMPUTERIZED

# SUPER PONG

for  
**YOUR TV**  
NOW  
INCLUDES  
**BUMPER**

Assemble your own electronic 'Super Pong' set that connects to any TV. It's easy! Complete plans, p/c boards, kits, assembled boards. Our design includes up-down and in-out paddle motion, lob-spin-smash ball action, computer-control paddle, sound effects and optional on-screen scoring module.

Main p/c board (with all functions except on-screen scoring) includes a second game BUMPER with lots of rebound action and change of pace when BUMPER "swallows" the ball.

Typical component cost including 18 TTL and 8 Cmos chips is \$45 plus p/c board.

Send \$28.50 for main p/c board with aligned horizontal and vertical sync oscillators and plans ... or send \$1.00 (refundable) for info pack describing circuit functions, component line-up, kits, p/c boards, accessories, assembled boards.

**visulex**  
P.O. BOX 4204-S MOUNTAIN VIEW, CA 94040

## WHY PAY MORE FOR ALTAIR MEMORY

8,192-8 BIT WORD KIT  
ON SINGLE CARD

**\$285.00**

- PLUG DIRECTLY INTO 8800
- 8800 RUNS AT FULL SPEED - 520 nS ACCESS
- LOW POWER STATIC RAM - <255 mA/1k
- 100% INDUSTRIAL COMPONENTS
- EASY INTERFACE TO HOMEBREW
- 50/50 GOLD PLATED EDGE CONTACTS
- EPOXY BOARD W/PLATED THRU HOLES
- 8K or 4K WITH EXPANSION
- JUMPER PROGRAM 4K or 8K SLOT
- DETAILED THEORY AND ASSEMBLY

8K LOW POWER RAM KIT: 8KLST .....	\$285.00
4K LOW POWER RAM KIT: 4KLST .....	\$159.00
4K EXPANSION FOR 4KLST: 4KXLST .....	\$139.00

PLUS SHIPPING

Write to Dave (K6LKL) at

# DUTRONICS

- CA RES. ADD SALES TAX
- MASTER CHARGE
- BANKAMERICARD

P.O. Box 9160, Stockton CA 95208

ou goons don't ever proofr  
 lousy man... bunch of trooks are...  
**LETTERS**  
 you ignored my comments in  
 I insist that you print ev

from page 75

the requirement to 18 wpm — an interesting contrast!

Another interesting note — a *Stars and Stripes* article (I wish I'd saved it) of a few weeks ago told of the Navy having trouble coordinating with an allied nation's navy because none of the navy radiomen could handle CW — and the foreign navy didn't have our fancy RTTY and digital equipment!

At any rate, congratulations on a great magazine, Wayne, and I hope you get the bugs caused by the size change worked out soon.

Hartley J. Gardner WA1KNG/DL  
 APO NY

#### ZL CHANGE

Please note change of address for the New Zealand QSL Bureau: P.O. Box 40-212, Upper Hutt, NEW ZEALAND.

G. C. Blackwell ZL3NT  
 General Secretary

#### DOING YOURSELF OUT

I thought I would enclose a quick note along with my reader service requests to tell you what a great mag you put out. Anyone with an interest in amateur radio, and with your new section on microprocessors, would be doing himself out of a great deal of enjoyable reading by not subscribing to 73. Keep up the good work.

Bruce McCreath VE3EAR  
 Goderich ONT

#### TO THE TROOPS

Got my brand new format 73 yesterday over here at APO 09189 (southwest Germany), and I must say that I am impressed! I really like the new size, even though I was skeptical when I first heard that you were switching over.

Really a nice idea to have the Heath and the Hickok catalogs within the same covers. The new 73 is even

better than before, and I have taken steps around my house to convert my bookshelves over to the new 73. I appreciate the skill and preplanning that went into your conversion as per page 3.

Kinda feel for a guy like Fred Lichtgarn who is quitting before starting.

The new 73 made it to my APO, and then to me, in beautiful condition, so your mailer system is working fine.

Many thanks Wayne, and to the troops at 73, who continue to keep better and better 73s coming this way!

SSGT Howard H. Ragan  
 K7ATU/DA4AU  
 1141-2 USAF SAS  
 APO NY 09189

#### AIR BLUSH

I am writing to confirm your claim for the efficacy of your tapes (code). They have worked for me. I cannot truthfully give you the exact number of hours I used the 5 wpm tape, but I will approximate it at 6 hours, over a period of a few weeks. After that time, I joined a ham radio class at Cerritos College, Cerritos, California. The instructor, Roy Tucker K6UZB, has his own code tapes to loan to the students. I tried his and found them too simple, since after five weeks of class sessions I passed the test run for

the Novice code. I believe that it was my previous study of your tape that made this possible, plus the fact that I am a musician and am quite accustomed to listening for rhythms and memorizing them. It was not difficult for me at all. I am presently working on upgrading to a General license (hopefully) and am just starting on the 13 wpm tape now. I will attempt to keep a check on the length of time it takes to achieve this speed. You may also find it interesting to know that Mr. Tucker uses the same principle that you do of recording the code character at 13 wpm and increasing the spacing between for ease of identification. He adds the device of naming the letter it represents. This is good at the start, but becomes irksome.

There is something else on my mind, Wayne. I feel I have something to say to your readers from the point of view of a white, female Caucasian, presently 53 years of age, married, the mother of two girls, and a successful pianist and teacher. I was dragged into this radio thing by my husband, who was formerly a ham and had dropped it as a young man. My attitude was pretty bad — the best you could say about it was that I was ambivalent and couldn't see the point of it for myself. It was obviously good for my husband, and I was touched that after 16 years of marriage he still wanted me to share his interests. I simply

Continued on page 154

The ONLY QSL Bureau that will forward ALL of your cards . . . from anywhere to anywhere — Still \$.06 for OX cards . . . \$.10 intra-U.S.A. and Canada . . . SASE brings details.

**DX'ERS SPECIAL** — For QSLs to Foreign stations only. Send 20 or more cards at a time and include just five cents each! For 100 or more cards at a time the price is four cents each.

Suggestion: Form a CARD POOL with your Buddy or Radio Club and split the extra savings.

73s Orm Meyer K6QX

••••111 FARM HILL WAY LOS GATOS, CALIFORNIA 95030 U.S.A. ••••

**WORLD  
 QSL  
 BUREAU**



...de W2NSD/I

EDITORIAL BY WAYNE GREEN

from page 4

charge admission to the same party . . . or you may not.

Be sure to have someone with imagination and some business experience with relatively large sums of money involved so you don't penny ante the hamfest. You are working with thousands of dollars, so you

can't afford to be too stingy on things. If you pull it off well, you will be able to keep the hamfest going year after year, building up in displays and hamfests.

How about some articles on successful hamfests to spur interest in this activity?

#### VHF ENGINEERING

Bob Brown W2EDN, just back from one of the Windjammer cruises of the Caribbean, is really hot for a good design engineer to help him work up some new products. If you know of anyone who likes to do that sort of "work," have them get in touch with Bob. Bob is looking for someone with a lot of background in PC board layout and design . . . and he's got a darned good salary ready for someone. The Binghamton area is a nice one . . .

I gather that Bob and his family enjoyed the cruise . . . we've been advertising them in 73 off and on and had quite a few enthusiastic letters

and calls from happy cruisers. They are strictly informal and low key . . . almost do-it-yourself vacations.

#### 73 IS LOOKING, TOO

We're still in need of someone with a good ham background to help put together books. A good technical background will help . . . as will an ability to write. And New Hampshire is even better than Binghamton for living. You could do worse.

As long as you have to work for a living, why not work in your major hobby and enjoy every minute of it? And as long as you have to live, why not live where others come for vacation all year 'round?

# Stay tuned for future programs.



The HAL ST-6000 demodulator/keyer and the DS-3000 and DS-4000 KSR/RO series of communications terminals are designed to give you superlative TTY performance today—and in the future. DS series terminals, for example, are re-programmable, assuring you freedom from obsolescence. Sophisticated systems all, these HAL products are attractively priced—for industry, government and serious amateur radio operators.

The HAL ST-6000 operates at standard shifts of 850, 425, and 170 Hz. The tone keyer is crystal-controlled. Loop supply is internal. Active filters allow flexibility in estab-

lishing different tone pairs. You can select AM or hard-limiting FM modes of operation to accommodate different operating conditions. An internal monitor scope (shown on model above) allows fast, accurate tuning. The ST-6000 has an outstandingly high dynamic range of operation. Data I/O can be RS-232C, MIL-188C or current loop.

The DS-3000 and DS-4000 series of KSR and RO terminals provide silent, reliable, all-electronic TTY transmission and reception, or read-only (RO) operation of different combinations

of codes, including Baudot, ASCII and Morse. The powerful, programmable 8080A microprocessor is included in the circuitry to assure maximum flexibility for your present needs—and for the future. The KSR models offer you full editing capability. The video display is a convenient 16-line format, of 72 characters per line.

These are some of the highlights. The full range of features and specifications for the ST-6000 and the DS series of KSR and RO terminals is covered in comprehensive data sheets available on request. Write for them now—and tune in to the most sophisticated TTY operation you can have today... or in the future.



HAL Communications Corp., Box 365, 807 E. Green Street  
Urbana, Illinois 61801 • Telephone: (217) 367-7373

# Build a CW Memory

**W**hile building a random access memory (RAM) for my keyer, it occurred to me that my CW operating habits did not require the versatility of the RAM

and that my memory requirements could be satisfied with one or more programmable read only memories (PROMs).

Although the control logic for the read

modes are similar for RAMs and PROMs, PROMs offer a non-destructible memory (within their recommended operating parameters) after their initial programming,

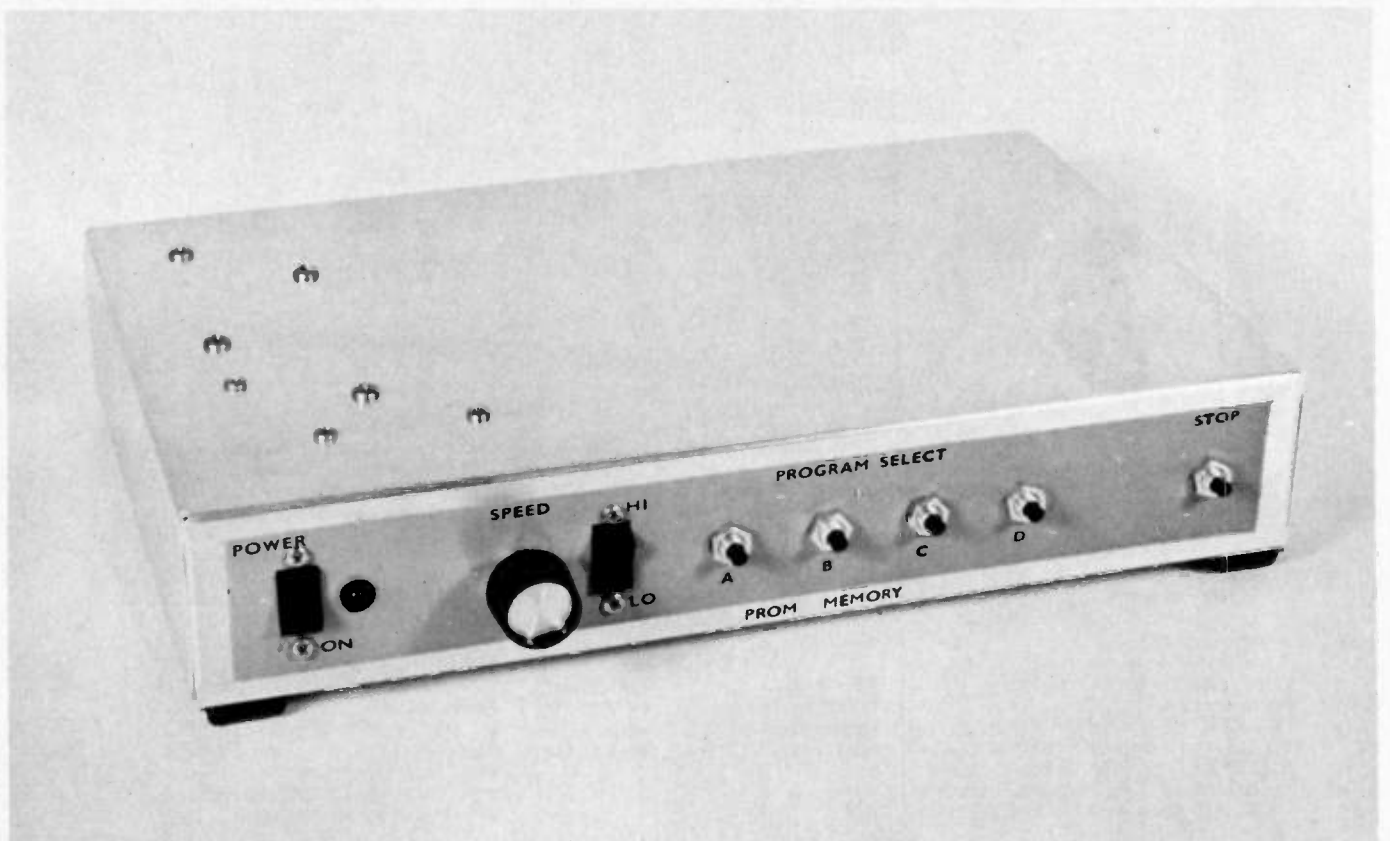



without the need to frequently refresh the memory as is necessary with RAMs.

The memory described is self-contained and need not be used with a keyer. The output circuitry is designed to drive grid-block keyed transmitters with key-up voltages not exceeding -100 volts. TTL inputs are available for keying the transmitter from an external source (i.e., the digital output from additional memories, a keyer, or CW identifier).

### Circuit Description

Fig. 1 shows a simplified block diagram of the PROM memory. The memory uses four Intersil IM5600C PROMs. These PROMs are fully decoded TTL Bipolar 256-bit custom programmed read only memories organized as 32 words by 8 bits (U7-U10). Open collector outputs and chip enables insure simple memory expansion. An effective memory capacity of 1024 bits is obtained by ORing the four 256-bit chips together. I chose a 256-bit PROM because it offers a convenient memory length of approximately 22 characters. Memory retrieval is initiated with the appropriate program select push-button switch (S2-S5). The program can be stopped at any point with the stop push-button switch (S1).

U3 and U4 are 7476 Dual J-K flip flops with preset and clear, used as start/stop flip flops. The stop push-button switch, S1, is connected to the preset inputs (pins 2 and 7) of U3 and U4. Grounding this bus forces the Q outputs to logic 1, disabling the clock and U6, stopping the program (a logic 1 on pin 7 of U6 forces pin 5 low). The clock inputs (pins 1 and 6) are connected together. A negative edge at the clock inputs, corresponding to the end of the 256th bit, will clock Q to logic 1, disabling the clock and U6, ending the program. Individual program select switches are connected to the clear inputs (pins 3 and 8) of U3 and U4. Grounding one of these pins will start the program corresponding to the PROM selected. The Q outputs of U3 and U4 (pins 11 and 15) are connected to the chip enable inputs (pin 15) of the four PROMs. The appropriate PROM is enabled by forcing one of the outputs of U3 or U4 to logic 0, enabling the clock and U6, starting the program. Starting the program resets the eight bit binary address counter U1 and U2.

U1 and U2 are 7493 TTL MSI 4-bit binary counters used to address PROMs U7-U10 and U6, a 74151 TTL MSI 8-line-to-1-line data selector. The first three bits from the counter address U6, while the remaining bits address PROMs U7-U10. In this fashion U6 multiplexes the PROM outputs of eight lines to one line before the address counter selects the next word.

U5 is a 7420 TTL Dual 4-input positive NAND gate. It is the enable/disable gate for the clock and U6 and the reset gate for the eight-bit binary address counter. U11 is a 7403 TTL Quadruple 2-input positive

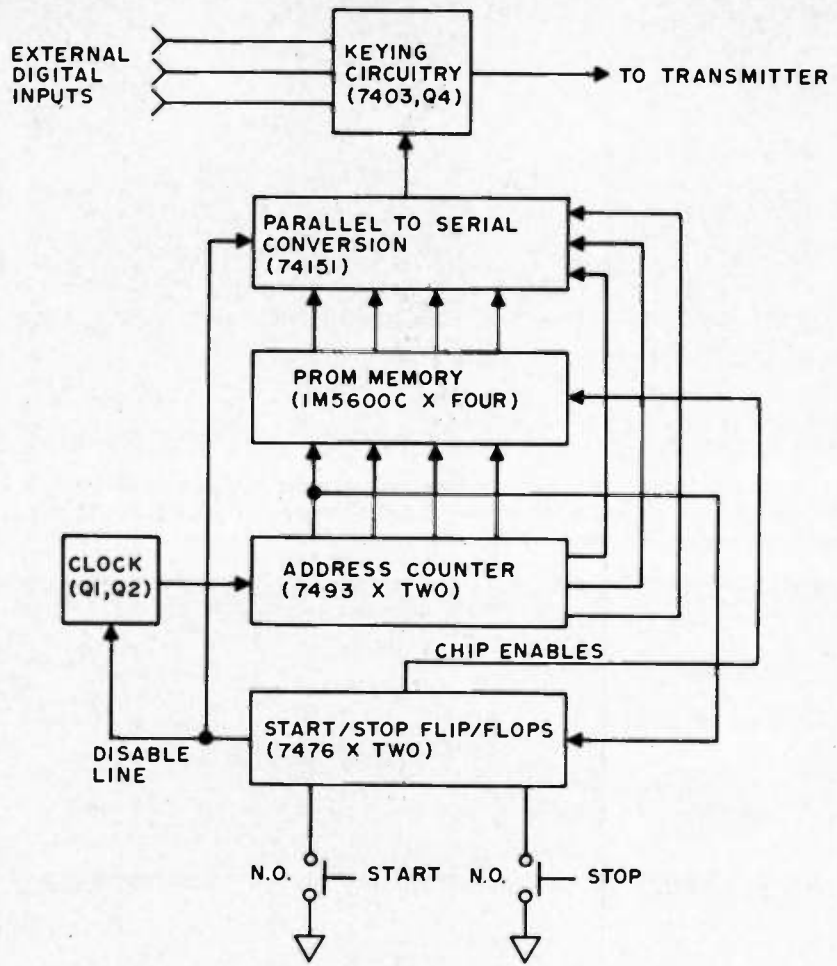

Fig. 1. Block diagram of the PROM CW generator.

NAND gate with open collector outputs used as the input for the transmitter keying circuitry.

Clock pulses for the memory are generated by a relaxation oscillator consisting of Q1 and Q2 and associated parts.<sup>1</sup> The oscillator is the same one used in my keyer and was selected so that the speed controls could be ganged and would track in the event that the keyer would be packaged with the memory (it wasn't).

### Programming

PROMs are fabricated with all logic levels at zero. The programming procedure opens circuits metal links which results in a logic 1 at selected locations in the memory. Intersil, instead of using a metal link, forces a resistive shaft through the junction of one diode in the memory cell resulting in a logic 1 at selected locations in the memory. Once the memory cell has been programmed to a logic 1, that bit cannot be altered (reprogrammed).

Distributors of PROMs offer custom programming services or the reader may program his own. Design data sheets and application notes describe the programming procedures in detail.<sup>2</sup> Read these instructions carefully and fully understand the address methods as programming errors can be costly.

Fig. 2 illustrates a typical programming card for the following program: DE WA6VVL WA6VVL WA6VVL K. Standard spacing should be used in writing the program. For example, use 7 bits for a word space, 3 bits for a letter space, 3 bits for a dash and 1 bit for a dot.

The quoted price from R.V. Weatherford included programming costs. One advantage of a distributor programming your PROM is that they verify its program before they send it to you.

### Power Supply

The 5 volt supply illustrated in Fig. 3 can be built to satisfy the requirements of the memory circuitry. U12 should be mounted on a heat sink similar to the Wakefield 680-.75A or 621-A.

U12 dissipates only 1½ Watts at nominal line using a 6.3 V transformer. However, at low line, ripple feeds through the regulator. No problems with the memory have been experienced under low line conditions to date. A slight improvement in low line operation can be gained by using a 12.6 VCT transformer and a full wave center-tap rectifier.

If you anticipate using your keyer with this memory, do not attempt to power the memory circuitry from your keyer power supply unless it is capable of supplying an

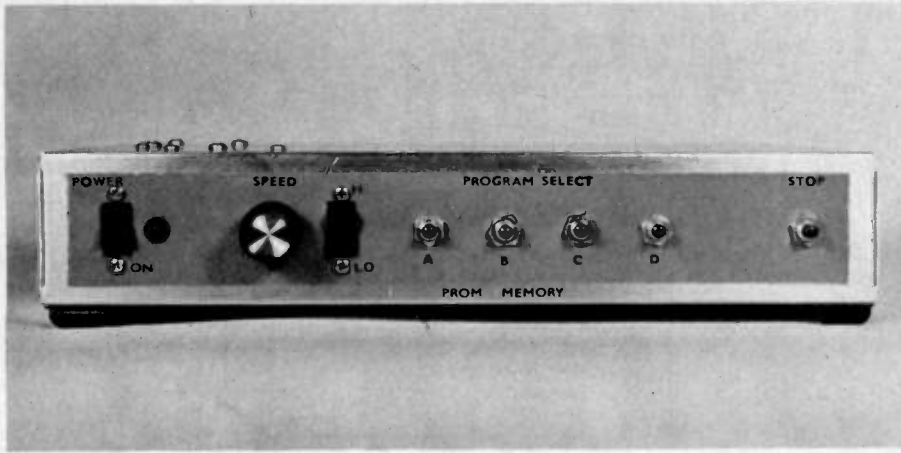

The program is selected with the appropriate program select push-button switch A, B, C or D. The program can be stopped at any point with the stop push-button switch. A single 20k speed control can be used and the HI/LO switch deleted.

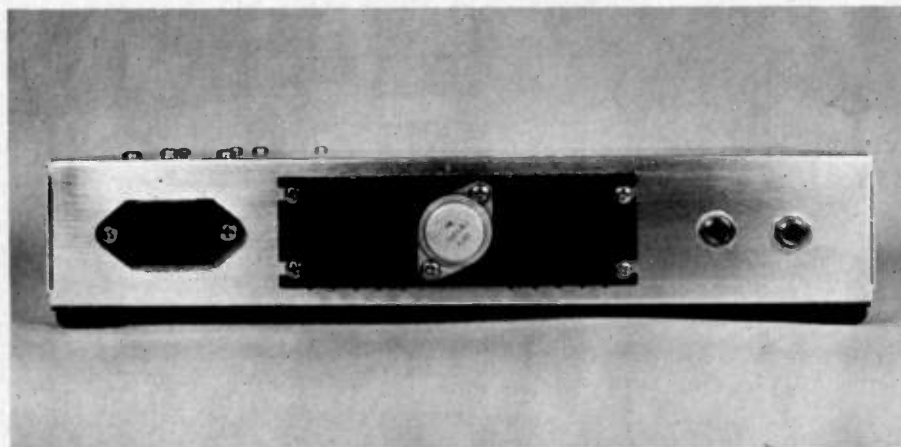

U12 is shown mounted on its heat sink. The two open-circuit phone jacks are connected in parallel, providing an input for the author's keyer and an output for the transmitter. A line cord and grommet may be substituted for the 115 V ac connector.

additional 450-650 mA.

**Construction**

The memory is housed in a Cal Chassis 7" x 11" x 2" aluminum chassis base. The

majority of the memory components are mounted on a single-sided 8" x 5" glass-epoxy circuit board. The board is fabricated to fit a standard 22-pin card edge connector.

Since the memory utilizes four PROMs in

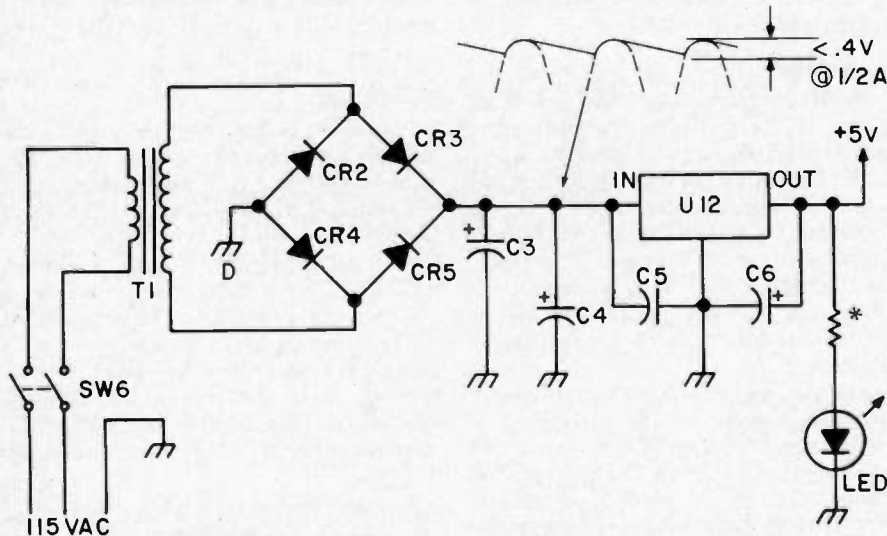

Fig. 3. Power supply. \*Select for appropriate current through LED selected. 150 Ohms was adequate with a Hewlett-Packard 5082-4440 LED.

**WEATHERFORD**  
See other side for full instructions.

Notes	Word No.	D <sub>7</sub>	D <sub>6</sub>	D <sub>5</sub>	D <sub>4</sub>	D <sub>3</sub>	D <sub>2</sub>	D <sub>1</sub>	D <sub>0</sub>
	0								
	1								
	2								
	3								
	4								
	5								
	6								
	7								
	8								
	9								
	10								
	11								
	12								
	13								
	14								
	15								
	16								
	17								
	18								
	19								
	20								
	21								
	22								
	23								
	24								
	25								
	26								
	27								
	28								
	29								
	30								
	31								

Card No. ONE of ONE  
 PROM identification no. 001  
 Company name D.W. ISHMAEL

Fig. 2. Programming card (65%). The above program, DE WA6VVL WA6VVL WA6VVL K, is read from right to left, top to bottom. The program is written in the same fashion.

**Weatherford  
P/ROM  
Programming Card**

**Ordering Information**

- Company name D.W. Ishmael
- Company address 1118 Paularino Ave., Costa Mesa, Calif
- Requisitioner's name Above
- Telephone number (714) 379-5858
- P/ROM manufacturer's part number 145600C
- Quantity of P/ROMs required 1
- Quoted price per P/ROM \$6.00
- Requisitioner's purchase order number \_\_\_\_\_
- Special P/ROM marking instructions 001
- Shipping instructions UPS

**How to use this card**

- Use a soft pencil (No. 2)
- On the "program" side of every card mark blank spaces for the logic "1" (high output state) data-bit locations in your program.
- Write anywhere on the shaded portion of the card. DO NOT mark in the unshaded portion unless you are indicating a "1" data-bit location.
- DO NOT ERASE in the unshaded data-bit portion. If an error is made, destroy the card.
- On card No. 1 of each program, complete the "Ordering Information" section above.
- Peck cards with stiff backing to avoid damage.

Take completed cards to your nearest Weatherford sales office or send to:  
 Weatherford Programming Center  
 6921 San Fernando Rd.  
 Glendale, CA 91201



## SYSTEM 21 DATA MANAGEMENT STATION

VIATRON'S System 21 is a family of data processing devices designed for data management, including data entry, control, display, communication, storage and retrieval. With its modular structure, System 21 can be configured to perform a wide variety of data processing operations.

A typical System 21 configuration includes a Microprocessor, two Tape Channels, a Keyboard, two Data Channels, and a Video Display. Central to the System 21 structure is the Microprocessor which contains hard-wired microprograms that perform a fixed set of logical operations. The hard-wired microprograms in the Microprocessor accomplish the same functions as a general-purpose computer operating system or assembler. Because the microprograms are hard-wired, however, there is no need for extensive programming.

There are two modes of system operation—manual control and program control. In the manual mode of operation, the operator initiates all Microprocessor functions. Under program control the Microprocessor performs certain functions automatically through the use of a control program.

The Microprocessor has four input/output channels, two Tape Channels and two Data Channels. The Tape Channels are devoted to either VIATAPE Recorders or Computer Tape Recorders, one recorder per channel. The two Data Channels can communicate with optional input/output devices. They can be connected, for example, to a Model 6001 Card Reader/Punch Adapter for reading and punching cards, or to a Model 6002 Printing Robot for providing hard copy. The Data Channels can also be interfaced with a Model 6003, 6004, or 6005 Communication Adapter for providing a link with another System 21 Data Management Station, a computer, or virtually any other device capable of USASCII interface. The Keyboard has its own Channel dedicated to providing data input and control to the Microprocessor.

Unused, packed in 4 cartons. System consists of video display, power supply, microprocessor, two cassette tape decks mounted in microprocessor panel, keyboard, all as pictured. Sold "as is." Due to 4 years of storage, may require some adjusting/cleaning. With instruction book. Shipment within 24 hours if paid by MC, BA, or certified check. Sold FOB Lynn Mass.

**\$ 425<sup>00</sup>**

*Meshna*

MESHNA PO Bx 62 E. Lynn Mass. 01904



### Parts List

C1	4.7 mF 10 W V dc tantalum capacitor	R12	2700 Ohm ½ Watt carbon resistor
C2	.001 mF ceramic capacitor	R13	10,000 Ohm 2 Watt linear taper potentiometer
C3-4	4700 mF 16 W V dc electrolytic capacitor	R14	82 Ohm ½ Watt carbon resistor
C5	.33 mF ceramic capacitor	R25	10,000 Ohm ½ Watt carbon resistor
C6	2.2 mF 10 W V dc tantalum capacitor	SW1-5	Normally open push-button switch. Similar to Alcoswitch MSPS-103C SPST.
C7	.1 mF 10 W V dc disc ceramic capacitor	SW6	DPST miniature rocker switch. Similar to Alcoswitch MSL-203N-7.
CR1	1N914 silicon signal diode	T1	6.3 V ac Filament Transformer, 1 A. Similar to Allied 6K9HF or Triad F-14X.
CR2-5	1N4001 or equivalent 50 V piv rectifier diode	U1-2	7493 TTL MSI 4-bit binary counter
Q1	2N5086 or equivalent PNP transistor	U3-4	7476 TTL Dual J-K flip flops with preset and clear
Q2	2N5961 or equivalent NPN transistor	U5	7420 TTL Dual 4-input positive NAND gate
Q3	2N5224 or equivalent NPN transistor	U6	74151 TTL MSI 8-line-to-1-line data selector
Q4	2N4888 or equivalent HV PNP transistor	U7-10	Intersil IM5600C 256-bit PROM
R1-R5,R16	470 Ohm ½ Watt carbon resistor	U11	7403 TTL Quadruple 2-input positive NAND gate
R6,7,15,17-24	4700 Ohm ½ Watt carbon resistor	U12	7805 or LM309 Three terminal regulator
R8	22 Ohm ½ Watt carbon resistor		
R9	27,000 Ohm ½ Watt carbon resistor		
R10	39,000 Ohm ½ Watt carbon resistor		
R11	15,000 Ohm ½ Watt carbon resistor		

parallel on a single-sided board, there are a number of jumpers (92) and holes (434) on the circuit board. The jumpers are installed first with the rest of the components following. Sockets are advisable due to the cost of the integrated circuits and PROMs. They not only speed troubleshooting when the need arises, but also prevent overheating during the soldering operation. The power transformer, filter capacitors, regulator, panel switches and controls are mounted on the aluminum chassis.

Total assembly time for the board, including drilling the holes, was under 4 hours. Mechanical and chassis wiring consumed another 10 hours.

After assembly, connect pins 1 and 20

together on the connector. This connects the digital output of the memory to the first input of the transmitting keying circuitry. If there are no additional inputs, ground pins 2, 3 and 4.

After checking the power supply voltage, connect the power supply, start/stop push-buttons and speed control, and the memory is ready for use.

Two open-circuit phone jacks have been provided on the rear apron of the chassis. They are connected in parallel providing an input for my keyer and an output for the transmitter.

Turn the PROM memory on "off the air" as it will take a few seconds for the memory to clear itself, the actual time dependent upon the setting of the speed control.

the PROMs selected in this article, there are a number of PROMs available from which the reader could choose. Texas Instruments, for example, offers the 74186 (512-bit, 64 words by 8 bits), 74187 (1024-bit, 256 words by 4 bits) and the 74188A (256-bit, 32 words by 8 bits). There are pin-compatible equivalents available from other manufacturers. The Intersil IM5600C is pin-compatible with other 256-bit PROMs including the Texas Instruments 74188A and Signetics 8223.

If the reader was reasonably sure that his program would not change, the 1024-bit PROM might be a better choice with simpler supporting logic. Additional benefits include less than 2¢/bit (compared to about 2½¢/bit for 256-bit PROMs) and one third the board area. One possible disadvantage is the eight programming cards which need to be filled out.

### Pin Assignments

- 1 TTL input. Logical 1 (+2.5-5.25 V) will key transmitter. Ground if not used.
- 2 TTL input. Logical 1 (+2.5-5.25 V) will key transmitter. Ground if not used.
- 3 TTL input. Logical 1 (+2.5-5.25 V) will key transmitter. Ground if not used.
- 4 TTL input. Logical 1 (+2.5-5.25 V) will key transmitter. Ground if not used.
- 5 A spare } May be used to externally enable
- 6 B spare } the PROMs instead of U3 & U4,
- 7 C spare } or connected to the chip enables
- 8 D spare } to drive external LED displays.
- 9 Keyer output. Designed to drive transmitters utilizing negative grid-block keying. The PNP driver transistor specified will withstand -100 volts under key-up conditions. Do not use with cathode keyed transmitters.
- 10 Digital output. Do not use for keying transmitter. Output is low as transmitter is keyed. Logical 1, +2.5-5.25 V. Logical 0, 0 to +.4 V.
- 11 N.C.
- 12 N.C.
- 13 Start program A. Momentary contact closure to ground to start.
- 14 Start program B. Momentary contact closure to ground to start.
- 15 Start program C. Momentary contact closure to ground to start.
- 16 Start program D. Momentary contact closure to ground to start.
- 17 Stop program ABCD. Momentary contact closure to ground to stop.
- 18 To speed control.
- 19 To speed control.
- 20 Memory digital output. Do not use for keying transmitters. Output is high as transmitter is keyed. Logical 1, +2.5-5.25 V. Logical 0, 0 to +.4 V.
- 21 DC volts input. +4.75 V to +5.25 V.
- 22 Digital Ground.

### Alternatives

If the reader was not satisfied with using

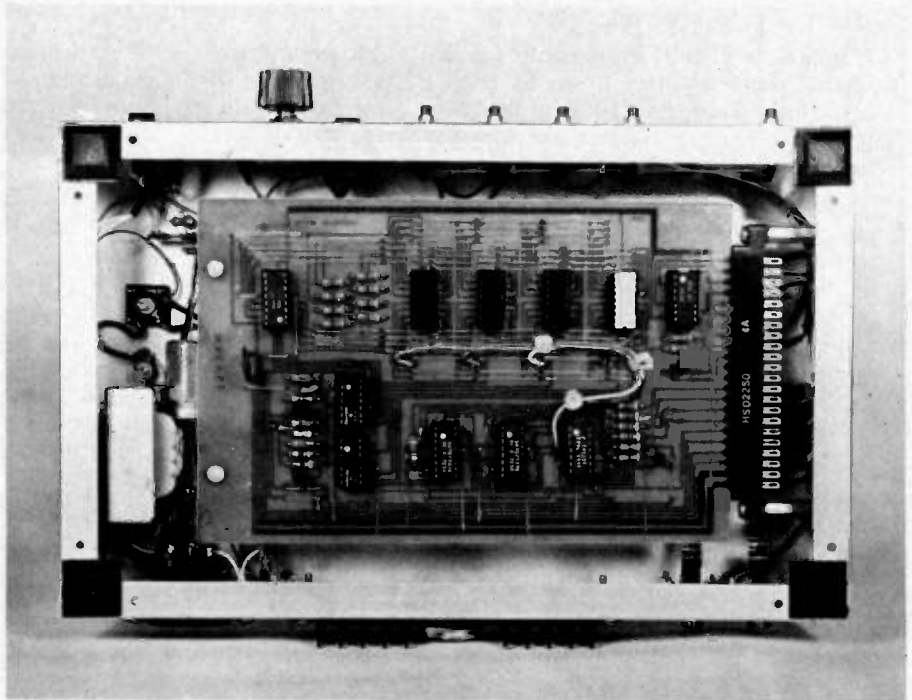

This PC board is the prototype version. The revised board has two additional jumpers. The filter capacitors are mounted under the circuit board. C3 is partially visible. C5 and C6 are connected directly to U12 and are not visible.



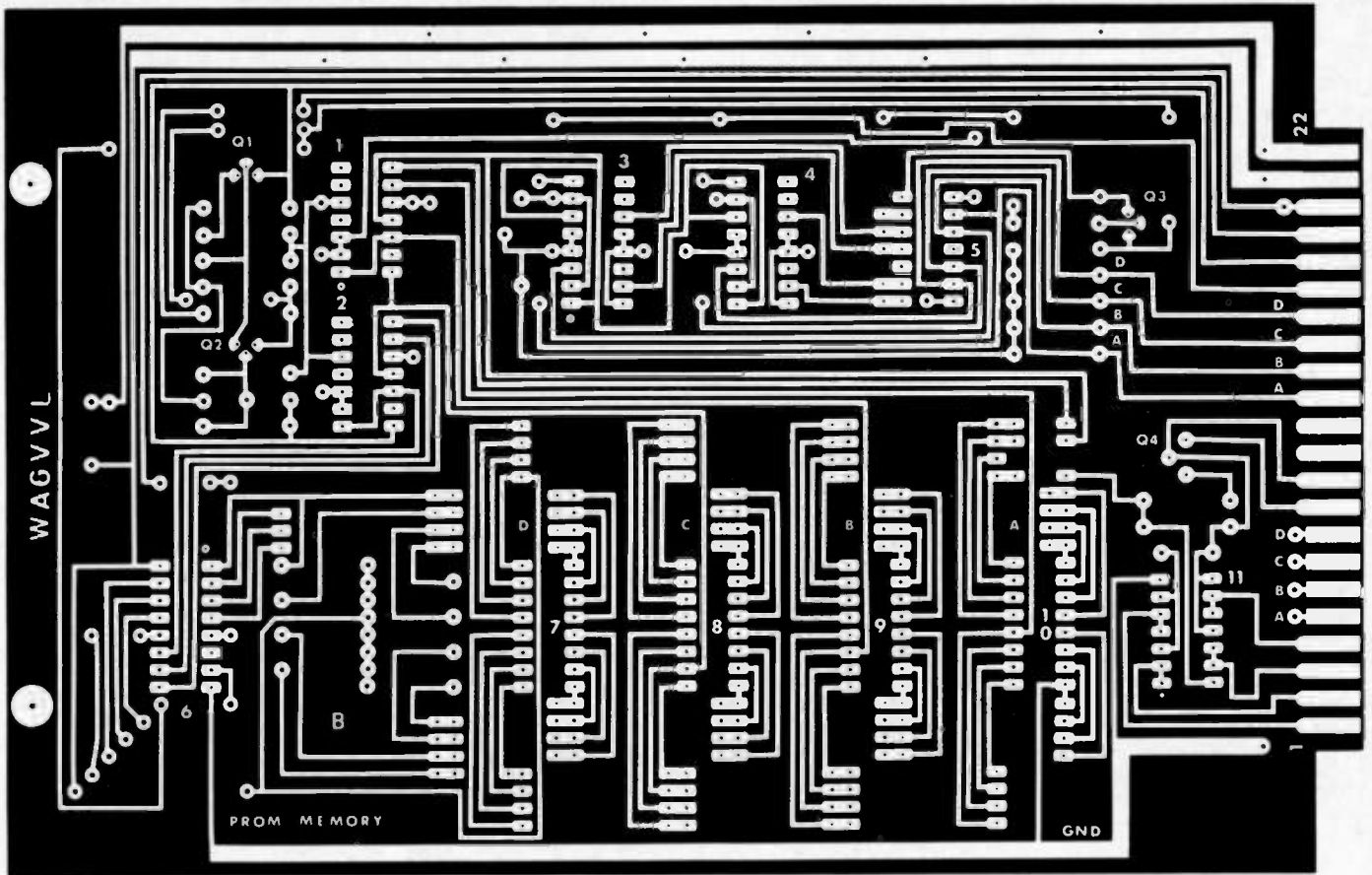

Fig. 4. PC board (full size).

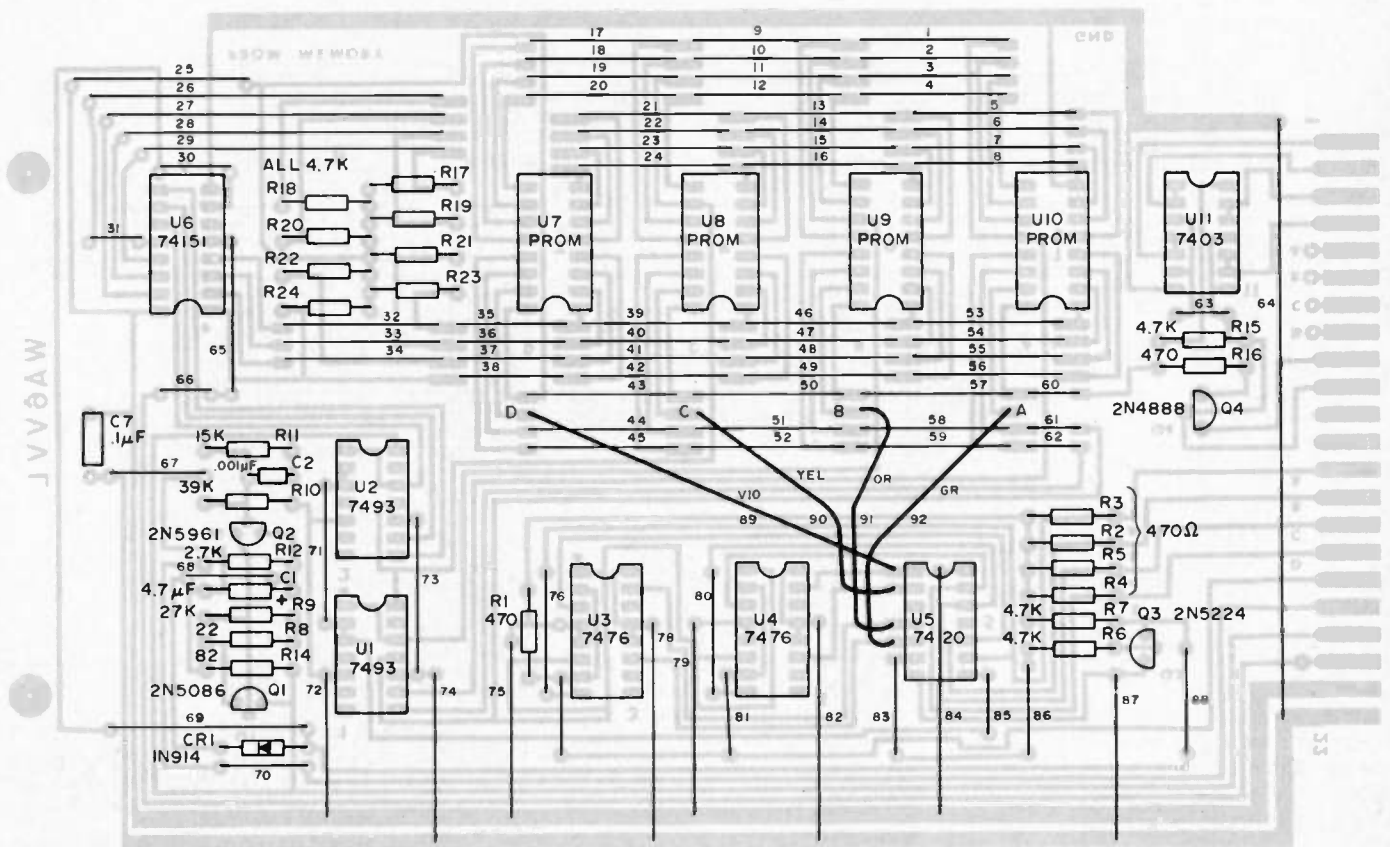

Fig. 5. Component layout.

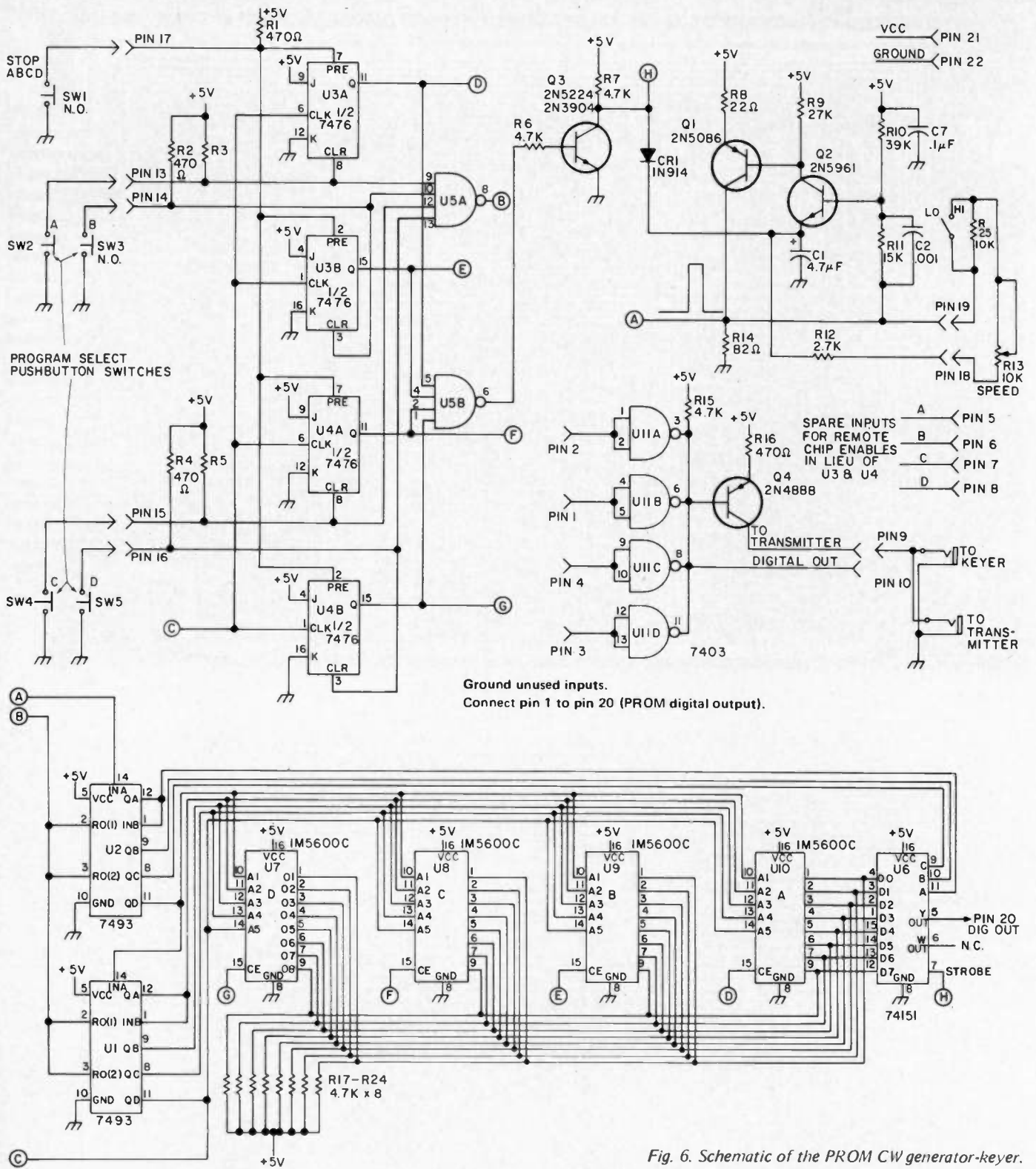

Fig. 6. Schematic of the PROM CW generator-keyer.

### Conclusion

The memory described here has been designed specifically for my CW operating habits. Many variations in construction, chip enable and address circuitry, memory size (bits), and PROMs are possible.

Using my board, total construction costs should not exceed \$60.00 assuming the

reader had to purchase all the parts. Approximately 40% of the cost is for the PROMs.

I would like to thank Alan Burgstahler WA6AWD for providing negatives and prototype circuit boards while developing the memory. ■

### References

<sup>1</sup> James Garrett WB4VVF, "The WB4VVF Accu-Keyer," *QST*, August, 1973, pages 19-23.

<sup>2</sup> Designing with TTL PROMs and ROMs from Texas Instruments, Bulletin CB-162.

### Additional References

The Weatherford Universal P/ROM Programming Center, Bulletin W-2123. Weatherford, 6921 San Fernando Rd., Glendale CA 91201.  
Intersil IM5600C Data Sheet.  
Intersil IM5600 Reliability Evaluation Data Sheet.  
*The TTL Data Book For Design Engineers*, Texas Instruments Incorporated.



# Tri-Tek

## Series 1750, 1751 Display Mounting Hardware

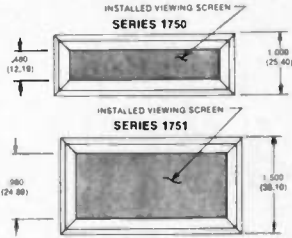

Molded socket block accepts standard 7 segment LED readouts with .3" row spacing. Pins are .65" long wire wrap type. Bezel and socket block are black molded plastic with viewing screen available in red, amber, or smoky neutral, circularly polarized for glare reduction. Unique mounting system is self fastening to panel cutout. Two sizes available. 1750 series for use with up to .4" high readouts. 1751 series for use with up to 1" high readouts. **IMPORTANT!** Last 2 digits of part numbers shown below denote number of readout positions. (specify screen color)

1750-04...\$7.00	1750-06...\$9.00	1750-08...\$11.00
1751-04...\$7.27	1751-06...\$9.31	1751-08...\$11.34

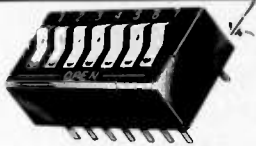

**MINIATURE ROCKER DIP SWITCHES**  
Dual in-line SPST switch arrays for P.C. mounting. Spring loaded sliding ball contact system for positive, tease proof contact. Comes in contact arrangements from 4 to 10 per pack. Fits standard DIP sockets. Last two digits of stock number indicate number of switches.

- DIS-76-B04.....\$3.10
- DIS-76-B06.....\$3.50
- DIS-76-B07.....\$3.75
- DIS-76-B08.....\$3.95
- DIS-76-B10.....\$4.35

### IC SOCKETS - HIGHEST QUALITY!!

- PC Mount... Solder Tail
- Skt-0802.. .8 pin..10/\$2.25
  - Skt-1402..14 pin..10/\$2.40
  - Skt-1602..16 pin..10/\$2.70
  - Skt-1802..18 pin..10/\$4.25
  - Skt-2202..22 pin..10/\$5.50
  - Skt-2402..24 pin..10/\$6.00
- WIRE WRAP TAILS
- Skt-1400..14 pin..10/\$4.50
  - Skt-1600..16 pin..10/\$5.00

**IM6100 CPU.** Intersil's 12 Bit CMOS CPU chip is the microprocessor which recognizes the famous PDP8/E instruction set. Single power supply, 4-7V @ 400 microamps. Now, a new low price..... **\$52.50**  
Full data packet.....\$4



**LM317 Voltage Regulator.** 1.5A, 3 terminal adjustable regulator in TO-3 case. Adjusts from +1.2V to +37V. Complete overload protection. .1% load regulation, .01% /V line regulation. No need to stock assorted regulators-just stock resistors.....\$4.99



# AMP L'ANNY Says

WHY EXPOSE YOUR BODY TO THE ELEMENTS? AVOID GETTING SOAKED BY HIGH PRICES AND MAILING FEES. SAVE TIME, MONEY, GAS AND COLD REMEDIES. BRIGHTEN UP YOUR DAY, SHOP THE TRI-TEK WAY!!!

Exclusive!

## RCA GOLD CHIP

Linear Integrated Circuits

Brand new process by RCA in which the aluminum metalization has been replaced by gold. The chip is then hermetically sealed. What this means to you is unprecedented reliability and uniformity. Plastic parts that meet mil specs! Tri-Tek is proud to be the first to bring this new level of performance to you at **SURPLUS PRICES.** Why buy regrades???

- CA301A..Improved, general purpose op-amp, 8 pin dip.. 59¢
- CA307..Super 741 op-amp, 8 pin dip..... 52¢
- CA324..Compensated quad op-amp, 14 pin dip.....\$1.80
- CA339A..Low offset quad comparator. 14 pin dip.....\$1.59
- CA741C..Famous general purpose op-amp, 8 pin dip... 45¢
- CA747C..General purpose dual op-amp, 14 pin dip... 82¢
- CA748C..Externally compensated 741, 8 pin dip.....49¢
- CA145B..General purpose dual op-amp, 8 pin dip..... 69¢
- CA3401..Quad single supply (5-18V) op amp. 14 pin... 89¢

Another super buy from RCA. CA555 timer, 8 pin dip... 59¢

## 8080A

Improved performance version of the popular 8-bit micro-processor by INTEL.....\$39.95

## ECL

- 11C06 750MHz High Speed Prescaler..... \$12.30
- 11C24 Dual VC Multivibrator. DC-30 MHz... 5 3.30
- 11C44 Phase/Frequency Detector..... \$ 3.30
- 11C58 Voltage Controlled Multivibrator. 155MHz 4.63
- 11C90 650MHz prescaler. Divide by 10 or 11 \$19.95
- 95H90 250 MHz prescaler. Divide by 10 or 11 \$10.50
- 95H91 320 MHz prescaler. Divide by 5 or 6... \$10.50 (Specs for any of the above, 50¢ ea)

- SN75491.....Segment driver.....59¢
- SN75492.....Digit Driver.....59¢

### MAY SPECIALS!!!

- MC7805, 5V, 1A regulator, house numbered..... 99¢
- MK-20 TO-3 mounting kit.....10/\$2.50
- Electrolytic Cap. 500ufd, 50VDC..... 10/\$2.17
- Miniature CTS PC pats, 1K.....12/ 97¢
- Ceramic Base Pot arrays, assorted values..... 15/ 99¢
- 24 Pin DIP socket, gold, solder tail leads..... 10/\$3.88
- RTL Flip-Flop TO-5 metal can..... 10/..99¢
- Transmitting Mico Capacitor .01ufd, 2.5KV... 5/..99¢
- Koil Kard. 4 color coded conductors. 4 feet... 2/..99¢
- Midget Collapsible Antenna. 7" extended.... 3/..99¢
- Heat Shrink Tubing 3/8"dia X 2' long, black 4/..99¢
- Ferrite Beads. 1/8"X1/8" dia.....20/..99¢
- Computer Grade Cap..4000ufd/50V..... 2/\$1.99
- 100V, 3A epoxy diodes, full leads..... 25/\$1.98
- 1N4148 High speed signal diode (like 1N914)..20/ \$1.00

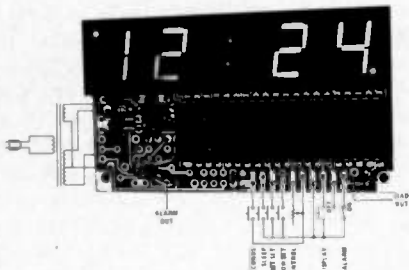

**NEW!!! FROM NATIONAL SEMICONDUCTOR**  
The MA1001 electronic clock module combines a monolithic MOS-LSI clock circuit, 4 digit 0.5" LED display, power supply and other associated components on a single PC board to form a complete electronic clock. All you add is a transformer and switches to construct a pretested digital clock. Features: Clock-radio control; 12 hr display; 60Hz operation; power failure indication; brightness control; "sleep" and "snooze" timers; alarm "on" and PM indicators; low cost, compact design.  
MA1001A.....With Diagrams.....\$18.88



## tri-tek, inc.

6522 NORTH 43RD AVENUE.  
GLENDALE, ARIZONA 85301  
phone 602 - 931-6949

Minimum order \$10 US/\$15 Foreign in US Funds. All orders postage paid. Please add insurance. Master Charge and Bank America cards welcome, (\$20 minimum.) Telephone orders may be placed 11AM to 5PM daily, Mon thru Fri. Call 602-931-6949. Check reader service card or send stamp for our latest flyers packed with new and surplus electronic components.

# AM is not Dead -- It Never Existed at All

Over the years, amateurs have used various modes of transmission. In the past, the rules and regulations specifically permitted types of modulation on certain frequencies. Unfortunately, these rules made unclear the actual facts relating to modulation. Best use of the spectrum requires that we select our modes of transmission carefully, and to do this we must understand their characteristics.

The simplest is AM. When radiotelephony was invented, it utilized amplitude modulation. This mode was erroneously believed to consist of the varying of transmitted carrier power in step with the audio. Some persons still believe that this is true.

To understand AM, one must simply understand mixers. When two signals are added together in a mixer, the two original signals appear in the output, as well as the sum and difference of the inputs. Thus, if a 1 MHz signal is mixed with a 1 kHz signal, the output consists of four frequencies: 1 MHz, 1 kHz, .999 MHz, and 1.001 MHz.

That is what happens in an AM transmitter. The carrier signal passes through the mixer, as well as the audio signal. The audio is not passed to the antenna, being far too low in frequency. But the sum and difference products do pass, and they are the sidebands that are transmitted. All intelligence is transmitted on the sidebands, and the carrier never varies.

In the receiver, the same process is applied to the composite signal. The sidebands mix with the carrier, producing audible difference frequencies. It is obvious that the carrier serves no necessary function,

so it can be eliminated in transmission. The two sidebands are also identical, so one of them can be eliminated, resulting in great bandwidth reduction. The bandwidth of AM is equal to twice the highest modulating frequency. For voice, we assume 6 kHz; the bandwidth of single sideband without carrier is equal to the highest modulating frequency minus the lowest modulating frequency, in this case 2.7 kHz. This permits more stations to occupy the same band.

The carrier signal is regenerated in the receiver when suppressed carrier is used. If one transmits carrier, it will show up as an audible note on any AM signal it is near. This heterodyning caused tremendous interference when AM was the dominant mode of transmission, and plagues today's CBers. It is especially disturbing when one realizes that a majority of the transmitter's output power is being wasted on carrier. The carrier, in AM, must be greater in amplitude than the sum of the sidebands when 100% modulation is used. Besides causing QRM, the carrier serves to help the transmitter heat the shack and generate business for replacement tubes and power supplies. A "200 Watt" SSB transmitter is far lighter than a "200 Watt" AM transmitter, because of the easier duty cycle.

## Frequency Modulation?

More recently, hams have taken to a mode called "frequency modulation." While AM does not actually consist of a varying carrier amplitude, FM is frequently believed to consist of a varying carrier frequency. Once again, many hams have made the same

mistake. Modulation consists of the generation of sidebands, not the manipulation of a carrier wave.

How wide is FM? The bandwidth of double-sideband AM is equal to twice the maximum modulating frequency. But the bandwidth of FM — *all* useful FM — is greater than the bandwidth of the equivalent AM signal. This is because FM transmission consists of a carrier, *whose amplitude varies*, and multiple sidebands. The higher audio quality of FM, and the superior noise limiting, are due to the redundancy inherent in FM.

Let's examine an FM signal and see what makes it tick. First a couple of terms: Modulation index is the deviation of the carrier divided by the audio frequency causing this deviation. Deviation ratio is the highest deviation divided by the highest modulating frequency. The deviation ratio indicates the maximum deviation actually found.

Deviation? That's a bit tougher to explain. Deviation is the *apparent* variation in carrier frequency, extrapolated from the effect of lowering the modulating frequency towards zero. By itself, it's a far less useful term than we like to think. The carrier frequency of an FM signal does not vary! The average frequency is varied by modulation, just as the average amplitude of an AM signal is varied by modulation, by adding sidebands.

In AM, the two sidebands are in phase. Since they rise and fall together, the apparent frequency of the envelope does not



vary. In FM, the sidebands are out of phase. Either the upper or lower sidebands are more powerful at any given portion of the modulating waveform. Therefore, the average power in the signal varies in frequency.

This phase relationship has some interesting effects. Since the overall amplitude does not change, it is possible to generate as many sidebands as one might want. That means greater redundancy, and redundancy in any system makes for greater fidelity and accuracy. The carrier power is distributed among the various sidebands, and reaches zero at several values of modulation index. One can measure the deviation of a wideband signal by determining how many times the carrier dips to zero as the modulation index is increased.

To determine the relative phase and strength of each sideband, one looks at a mathematical concept called a Bessel Function. Looking at the Bessel chart, one can tell which sideband is doing what, when. Each significant sideband begins to come up rapidly at a given index. One could use the chart to determine the bandwidth of an FM signal, if the modulation index and frequencies are known. An easier way is to approximate: Bandwidth equals twice the deviation plus twice the maximum modulating frequency. Don't forget that last half like the FCC did!

The phase relationship between sidebands is complex, but one feature is fairly easy to understand. The phase of the odd-numbered sidebands is different between the upper and lower sides of the carrier, while even-numbered sidebands are in phase with each other. AM signals have only one set of sidebands, the first (odd-numbered), and they are in phase. That is a crucial difference, which becomes important in phase modulation.

Phase modulation is similar to frequency modulation, but there is one major functional difference. The frequency response of FM is linear, with equal amplitude tones producing equal deviation. PM has a rising audio response, with higher frequencies generating more deviation, at a rate of 6 dB/octave. PM deviation is directly proportional to modulating frequency.

Phase modulation can be used as FM if the audio response is corrected. Communications FM, such as hams use, is actually PM in most cases, with an audio response that rises within the speech range. This is called pre-emphasis. Most FM systems use some pre-emphasis. With broadcasting, it is set to begin at about 400 Hz, and rises to about 17 dB at 15000 Hz, the high end. Even tape recorders and phonograph disks use pre-emphasis, because noise is linear with regards to frequency, and thus most of it is in the treble range. Receivers incorporate de-emphasis which restores the tonal balance while reducing the noise.

Pre-emphasis is needed with FM for another reason. Since the quality of recep-

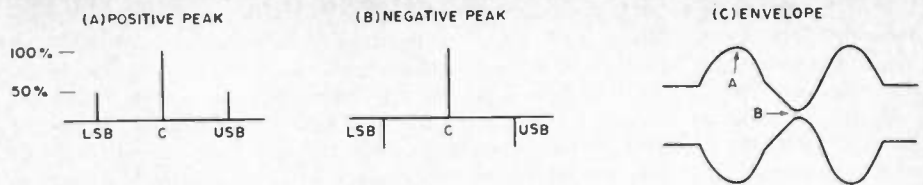

Fig. 1. AM sidebands vs. effective envelope. Direction of sideband indicates phase.

tion is dependent upon the modulation index, and the modulation index falls as the modulating frequency rises, pre-emphasis helps keep the treble range index high enough to overcome noise and interference.

One great benefit of FM's redundancy is the capture effect. A signal will completely cover a weaker one on the same frequency once the capture ratio is attained. This works with noise too; a "full quieting" FM signal can be just 3 dB stronger than a totally unreadable one with a good detector and a deviation ratio of about 5, which is the broadcast standard. But if the deviation is reduced, the capture effect lessens. Narrowband FM such as is used on 2 meter repeaters has very little capture effect, with its deviation ratio of 1.6 or less (5 kHz deviation and 3 kHz modulation).

But phase modulation reveals how similar narrowband FM and AM really are. One can generate PM by actually shifting the phase of a carrier. One radian of shift equals a modulation index of 1, but in practice only about half that can be achieved with a phase modulator, and undistorted broadcast quality must have less shift. If we accept that a phase modulator only produces enough shift for one set of significant sidebands, we can use the Armstrong method of modulation, developed by the inventor of FM, Major Edwin Armstrong.

Armstrong knew that PM and AM differed mainly in phase relationship, so he generated a double sideband signal in a balanced modulator, shifted it ninety

degrees, and reinstated the carrier. The result, provided the carrier was strong enough, was PM. This system has been used in broadcast transmitters, but the amount of frequency (and hence, deviation) multiplication needed is very great. For wideband use, direct FM is easier. Note that there is no pretense of shifting the carrier frequency with the Armstrong method. What slight amplitude modulation results is quickly lost in the Class C multipliers needed. Try feeding AM into Class C multipliers, but not with an antenna!

### FM Reception

The simplest way to receive AM is with a diode demodulator. The best way is with a synchronous detector, which takes advantage of the redundancy of the two sidebands, but that practice is not yet common. Diode detectors don't work with FM, since the sidebands all cancel each other's amplitude variations and beat frequencies. Thus, to detect FM, a different system was invented. The most common is the discriminator.

The discriminator compares the amount of signal above the center frequency with the amount below the center frequency. The resultant voltage reflects the modulation. Whether there are sidebands or a swinging carrier does not matter here. The ratio detector is a variant of the discriminator that automatically cancels amplitude variations, such as AM and noise. Both forms are common.

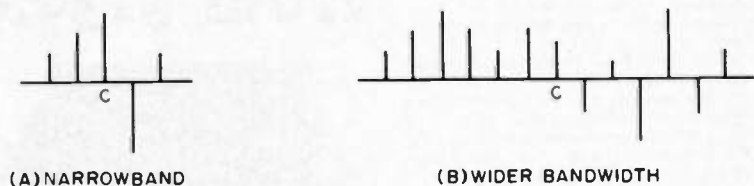

Fig. 2. Narrowband vs. wideband FM.

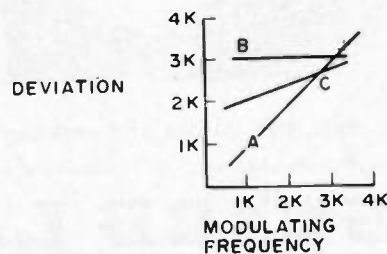

Fig. 3. Modulation frequency vs. deviation. (a) Phase modulation. (b) Direct FM. (c) Compromise pre-emphasis.

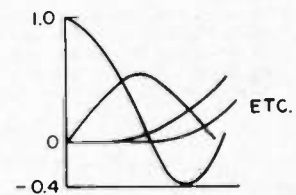

Fig. 4. Bessel function showing amplitude and phase of various sidebands.

One newer way is to use a phase locked loop. The PLL is a necessary part of an AM synchronous detector, where its advantages are drastic over the older diode system. With FM, the PLL detector attempts to lock an oscillator onto the frequency of the input, which appears to vary as the average of the sidebands swings back and forth (it acts almost as if there really were a swinging carrier). The important advantage is that a PLL need not receive the entire FM signal, but only the first two sidebands on each side. It will then have enough to lock onto. By receiving a wideband signal as if it were narrowband, the receiver can slice out noise and interference among the outer sidebands, at the expense of wideband's quieting. A PLL detector also inherently tracks drift with less distortion than a discriminator, without an automatic frequency control circuit.

### So What's CW?

We have already seen that the carrier does not vary in amplitude when we transmit AM, and that the carrier does not vary in frequency when we use FM. Let's apply our understanding of AM type A3 telephony to type A1 telegraphy — good old CW.

CW is a form of AM, and thus has a bandwidth and sidebands. The sidebands are generated by the keying, since a change in effective amplitude necessarily causes side-

bands. The bandwidth of a CW transmitter is determined by the key click filter. If the transmitter's rise time is short (sharp keying), there may be clicks, which are wider sidebands than necessary. If the rise time is made very long, the dits will get mushed with fast code. Contrary to common belief, keying speed does not affect bandwidth. Potential keying speed does, and a Novice probably shouldn't use as little keying filtration as a fast brass-pounder.

Now for the clincher: Since CW is a form of AM (modulated by squared waves, so to speak), it follows that keying (modulation) should not affect the carrier. Here's a logical sequence, all of which is true in its own way:

1. In conventional full-carrier AM, the amplitude of the carrier is not affected by modulation. Sidebands are generated which carry the information; the composite amplitude of the carrier plus sidebands varies by the addition and subtraction of carrier and sidebands.

2. Assume series-gate AM transmission (grid modulation). When the modulating waveform is at its most negative, the modulated grid reaches the point of zero tube output. At its most positive, the tube reaches maximum output. This system produces a carrier and sidebands as per above.

3. Assume a square wave is fed into the modulated stage. During one half the cycle, the tube is entirely cut off; during the other

half, the tube conducts completely. The ironclad rule of AM — carrier unmodulated by sidebands — still stands; the high harmonic content of the square wave produces broad sidebands. Softening the waveform by the addition of a low-pass filter to the modulation reduces the width of the sidebands.

4. Replace this square wave with a telegraph signal. There are still sidebands and an unaffected carrier, even though the tube is cut off during part of the waveform. This is common grid-block keying CW. Even with the key up, the carrier is still there!

Now you know as well as I do that when a key is lifted, the carrier goes away, right? But put in a *narrow* CW filter, say 40 Hz, and key rapidly. It will be noticed that the keying is softened if not obliterated by the "ring" in the filter. This ring can be reduced by proper filter design, but a certain amount is inherent in any given bandwidth, because the higher order sidebands are being cut off by the filters! If one were, theoretically, to narrow the bandwidth to a fraction of a Hz, the signal would ring for several seconds. Narrow the filter infinitely, and the carrier remains infinitely present. The sidebands are close to, and out of phase with, the carrier.

In case you're thoroughly confused, just remember that a carrier wave is really only a mathematical concept, and like most mathematical concepts, carries very little intelligence to most of us! ■

# Vanguard now has the World's Largest Selection of Frequency Synthesizers

## from \$139.95

- Smallest size of any commercially available synthesizer — only 1-3/8" x 3-3/4" x 7".
- Excellent spectral purity since no mixers are used.
- .0005% (5 parts per million) accuracy over the temperature range of -10 to +60 C.
- Immune from supply line voltage fluctuations when operated from 11 to 16 volts dc.
- Up to 8000 channels available from one unit. Frequency selected with thumbwheel switches.
- Available from 5 MHz to 169.995 MHz with up to 40 MHz tuning range and a choice of 1, 5 or 10 kHz increments (subject to certain restrictions depending on the frequency band selected).
- Top quality components used throughout and all ICs mounted in sockets for easy servicing.
- All synthesizers are supplied with connecting hardware and impedance converters or buffers that plug into your crystal socket.



Vanguard frequency synthesizers are custom programmed to your requirements in 1 day from stock units starting as low as \$139.95 for receive and transmit synthesizers. Add \$20.00 for any synthesizer for 5 kHz steps instead of 10 kHz steps and add \$10.00 for any tuning range over 10 MHz. Maximum tuning range available is 40 MHz but cannot be programmed over 159.995 MHz on transmit or 169.995 MHz on receive (except on special orders) unless the I-f is greater than 10.7 MHz and uses low side injection. Tuning range in all cases must be in decades starting with 0 (i.e. — 140,000 — 149,995 etc.). The output frequency can be matched to any crystal formula. Just give us the crystal formula (available from your instruction manual) and we'll do the rest. We may require a deposit for odd-ball formulas. On pick-up orders please call first so we can have your unit ready. Call 212-468-2720 between 9am and 4 pm Monday through Friday.

Available for aircraft, fire, police and amateur frequencies.

We ship open account only to U.S. and Canadian government agencies, universities and selected AAA rated corporations.

# VANGUARD LABS

196-23 Jamaica Ave., Hollis, New York 11423

*You'll never  
have to buy crystals  
again!*

SEND NO MONEY.  
WE SHIP C.O.D.  
ORDER BY PHONE  
AND SAVE TIME.

## TS-520 Specifications

MODES: USB, LSB, CW  
POWER: 200 watts PEP input on SSB, 160 watts DC input on CW  
ANTENNA IMPEDANCE: 50-75 Ohms, unbalanced  
CARRIER SUPPRESSION: Better than -45 dB  
UNWANTED SIDEBAND SUPPRESSION: Better than -40 dB  
HARMONIC RADIATION: Better than -40 dB  
AF RESPONSE: 400 to 2600 Hz (-6 dB)  
AUDIO INPUT SENSITIVITY: 0.25 $\mu$ V for 10 dB (S+N)/N  
SELECTIVITY: SSB 2.4 kHz (-6 dB), 4.4 kHz (-60 dB) CW 0.5 kHz (-6 dB), 1.5 kHz (-60 dB) (with accessory filter)  
FREQUENCY STABILITY: 100 Hz per 30 minutes after warmup  
IMAGE RATIO: Better than 50 dB  
IF REJECTION: Better than 50 dB  
TUBE & SEMICONDUCTOR COMPLEMENT: 3 tubes (2 x 6146B, 12BY7A), 1 IC, 18 FET, 44 transistors, 84 diodes  
DIMENSIONS: 13.1" W x 5.9" H x 13.2" D  
WEIGHT: 35.2 lbs.  
SUGGESTED PRICE: \$629.00

### VFO-520

Provides high stability with precision gearing. Function switch provides any combination with the TS-520. Both are equipped with VFO indicators showing at a glance which VFO is being used. Connects with a single cable and obtains its power from the TS-520. Suggested price: \$115.00.

### SP-520

Although the TS-520 has a built-in speaker, the addition of the SP-520 provides improved tonal quality. A perfect match in both design and performance. Suggested price: \$22.95.



**SOLD**

Kenwood's TS-520 has sold itself to thousands of amateurs the world over.

The value of its features and specifications are obvious. But just as important is the kind of quality that Kenwood builds in. Hundreds of testimonials on the air attest to its performance and dependability. You probably have heard of some of the same glowing praise.

The TS-520 operates SSB and CW on 80 through 10 meters and features built-in AC and 12VDC power supply.

VOX, RIT, noise blanker, 2-position ALC, and double split frequency controlled operation are only some of its fine features.

Kenwood offers accessories guaranteed to add to the pleasure of owning the TS-520. The TV-502 transverter puts you on 2-meters the easy way. (It's completely compatible with the TS-520.) Simply plug it in and you're on the air. Two more units designed to match the TS-520 are the VFO-520 external VFO and the model SP-520 external speaker. All with Kenwood quality built in.

### TV-502

TRANSMITTING/RECEIVING FREQUENCY: 144-145.7 MHz, 145.0-146.0 MHz (option)  
INPUT/OUTPUT IF FREQUENCY: 28.0-29.7 MHz  
TYPE OF EMISSION: SSB (A3J), CW (A1)  
RATED OUTPUT: 8W (AC operation)  
ANTENNA INPUT/OUTPUT IMPEDANCE: 50 $\Omega$   
UNWANTED RADIATION: Less than -60 dB  
RECEIVING SENSITIVITY: More than 1 $\mu$ V at S/N 10 dB  
IMAGE RATIO: More than 60 dB  
IF REJECTION: More than 60 dB  
FREQUENCY STABILITY: Less than  $\pm 2.5$  kHz during 1-60 min after power switch is ON and within 150 Hz (per 30 min) thereafter.  
POWER CONSUMPTION: AC 220/120V, Transmission 50W max., Reception 12W max. DC 13.8V, Transmission 2A max., Reception 0.4A max.  
POWER REQUIREMENT: AC 220/120V, DC 12-16V (standard voltage 13.8V)  
SEMI-CONDUCTOR: FET 5, Transistor 15, Diode 17  
DIMENSIONS: 6 $\frac{1}{2}$ " W x 6" H x 13 $\frac{1}{4}$ " D  
WEIGHT: 11.5 lbs.  
SUGGESTED PRICE: \$249.00

### CW-520

500 Hz CW Crystal Filter: \$45.00.

Prices subject to change without notice



# Is Extraterrestrial Communication Possible?

**T**hroughout human history the art of long-distance communication by audible, visual, or electromagnetic methods has played an important role in advancing the culture of the human race. When *Homo erectus* emerged from the mists of antiquity a couple of million years ago, his upright position freed his hands for the delicate manipulation of tools and led to the development of a larynx and speech box that set him apart from all other animals. One can imagine early man communi-

communication succeeded with the advent of telegraphy. In that same century a few adventuresome dreamers had already set their sights much farther out. Among the elaborate schemes that had been concocted to signal our presence to other worlds in the solar system were the following: the planting of a ten-mile-wide strip of pine trees in Siberia in the form of a right triangle; a twenty-mile circular ditch filled with water over which kerosene would be poured and set afire; a powerful con-

In 1899 the eccentric electrical pioneer, Nikola Tesla, undertook to transmit a powerful electrical signal into space from his Colorado laboratory and to detect any possible replies. He employed a large primary coil 75 feet in diameter and a 3 foot copper ball mounted on top of a 200 foot tower. He figured that powerful alternating surges of electricity introduced into the copper ball and into the ground would interact with the earth's magnetic field to increase the power of the radiated signal. Although there were no extraterrestrial responses to his efforts at the time, it was reported that incandescent lights were set glowing 26 miles away. A year later he claimed to have picked up interplanetary signals.

In 1921 Guglielmo Marconi believed he had detected regular pulsed signals from outer space in the high meter band while conducting atmospheric tests aboard his experimental yacht, the *Elettra*. In 1924, when Mars was closest to the earth (35 million miles), the astronomer David Todd arranged to have the U.S.

government's high-powered transmitters turned off every five minutes before the hour between August 21 and August 23. During these five minute silent intervals he used a special receiver tuned between 50 and 60 kHz to record on tape any signals coming through. Out of a hodgepodge of dots, dashes and jumbled code groups, which he and listeners throughout the country heard, nothing definite could be ascribed to an outside source. Today we know that such very low outer-space frequencies are reflected back into space by the ionosphere.

Throughout the following quarter century interest in extraterrestrial communication more or less lapsed until the growth of radio astronomy after World War II. As radio telescopes grew in size and observing techniques improved, the time seemed opportune to speculate once more on the feasibility of detecting extrasolar signals from intelligent sources in space. In a September 19, 1959 issue of the prestigious British scientific journal *Nature*, physicists Giuseppe Cocconi and Philip Morrison

---

For all we know, CQs may be coming our way, unbeknown to us, by sophisticated communication techniques beyond our comprehension, just as the New Guinea natives who communicate with drums are unaware of the international radio traffic passing over their heads . . .

---

cating over distances with his brethren by means of strident calls, and his successor, *Homo sapiens*, by means of fire or smoke signals, drum beatings, sunlight flashes from shiny objects, and other primitive methods.

It was not until a century ago that man's effort to overcome great distances by rapid

cave mirror that would focus sunlight on Mars and burn simple numbers in the desert sands of that planet; a network of large sunlight-reflecting mirrors strategically positioned in several European cities to conform to the configuration of the Big Dipper in the constellation Ursa Major as a sign of intelligence on earth.



presented logical reasons for instituting a search to detect artificial signals in outer space with large radio telescopes. They concluded that the probability of finding any was difficult to estimate, but if we never search, the chance of success is zero.

In 1960 the first modern attempt to look for artificial signals in space was conducted by Frank Drake at the National Radio Astronomy Observatory in Green Bank, West Virginia. This was the famous *Project Ozma* named after the legendary princess in the imaginary land of Oz. The 85 foot radio dish was pointed, when time permitted, in the direction of two relatively close solar-type stars, Tau Ceti and Epsilon Eridani, about eleven light-years distant. After 150 hours of unrewarded observing from May through July, the search was abandoned.

In 1967 there was a brief flurry of excitement when the first pulsar was discovered. Perhaps "little green men" were trying to contact us with their very precisely-timed pulsed radio signals. We have since found over one hundred pulsars in different parts of the sky flashing radio pulses up to thirty times per second. They are the natural consequence of certain stars that have gravitationally collapsed after exhaustion of their available nuclear fuels into small, rapidly-spinning, highly-condensed objects emitting beamed radio pulses which the earth intercepts.

In the ensuing years there have been a few sporadic attempts undertaken to detect artificial signals in outer space, particularly since 1972. So far several American and Canadian radio astronomers have been unable to locate anything resembling intelligent coded signals from a number of nearby sunlike stars. Neither have attempts by two groups of Soviet astronomers, seeking pulsed

intelligent signals over the entire sky from any source, been successful to date. The most unusual search in progress is that conducted with the Arecibo 1000 foot radio telescope in Puerto Rico. Here several nearby galaxies with their billions of stars are being monitored intermittently on several microwave channels. There are presently too many other immediate and rewarding uses of radio telescopes than to spend time looking for coded extrasolar signals with little hope for success.

It would seem that 1420 MHz is a logical search frequency of universal significance. It is the emission frequency of the dark, neutral hydrogen clouds that outline the spiral arms of our galaxy. This frequency happens to lie in the quietest terrestrial portion of the microwave spectrum between 3 and 30 centimeters where the effects of atmospheric absorption and cosmic background noise are at a minimum. If other galactic inhabitants are also surveying the hydrogen distribution in the galaxy, their receivers and ours, tuned to the same spectral region, might offer the best chance of the successful receipt of coded transmissions around the hydrogen-emitting frequency. However, it is conceivable that an advanced galactic society, desiring to leave this channel open for exploration of the galactic structure just as we do, will not beam CQs on or near this frequency. A more suitable communication frequency might be the microwave region between the emission lines of hydrogen (H) at 1420 MHz and hydroxyl (OH) at 1668 MHz observed in the interstellar clouds of our galaxy. This microwave section has been called the *water hole* because H and OH are the dissociation products of water (H<sub>2</sub>O). If water-based life is prevalent else-

where, it might be natural for advanced societies to employ a precise frequency related to the center of mass of the water molecule. This communication frequency lies at 1652.42 MHz.

We must remind ourselves that we are tyros in the communication enterprise. For us, passive listening is presently far more advan-

binary-coded, beamed signal in the direction of the great globular star cluster in Hercules. Even though its distance is 24,000 light-years, this object was chosen because the beam width of the arriving signal 24,000 years from now would just span the diameter of the cluster, thus wasting no power; secondly, there might

---

*Project Cyclops* involves an array of some one thousand 100 meter dishes spread out over a circular area ten miles wide at a cost of 10 billion dollars, about one-third the cost of the manned missions from Mercury to Skylab. The installation would be capable of intercepting coded beacon signals from civilizations out to 1,000 light-years . . .

---

tageous than active beaming which requires enormous expenditures of energy. Obviously, if there are no civilizations with the will to transmit as well as to receive out of the hundreds of thousands that presumably exist in our galaxy of several hundred billion stars, interstellar communication will never materialize. For all we know, CQs may be coming our way unbeknown to us by sophisticated communication techniques beyond our comprehension, just as the New Guinea natives who communicate with drums are unaware of the international radio traffic passing over their heads. The acquisition of a message obviously is the most difficult part in establishing an interstellar dialogue. Once acknowledged and replied to, assuming we can decipher it, arrangements can be made with respect to channels of operation, power requirements, and communication modes for the proper exchange of knowledge between two galactic cultures, even if this takes centuries.

Our first active attempt to beam a message to a distant stellar outpost was made in November, 1974. The newly-resurfaced 1000 foot radio dish at Arecibo, Puerto Rico focused a 450 kilowatt,

be a sufficient number of civilizations out of the million stars in the cluster capable of intercepting the "astrogram." The binary-coded message contained information about the earth's biology pertaining to the composition and structure of the DNA molecule, the human population, an inventory of the solar system, and a schematic of the radio telescope that beamed the coded signal.

Lastly, there remains for discussion the most grandiose project of all: the Cyclops system of communication proposed by Dr. B. Oliver, a vice president of the Hewlett-Packard Company. *Project Cyclops* involves an array of some one thousand 100 meter dishes spread out over a circular area ten miles wide at a cost of 10 billion dollars, about one-third the cost of the manned missions from Mercury to Skylab. The installation would be capable of intercepting coded beacon signals from civilizations out to 1,000 light-years, or eavesdropping on the radio leakage from local transmissions broadcast by communicating societies up to distances of 100 light-years. The array could also be used to radiate directional signals with extremely narrow beam

lobes. A large fraction of its time would, in addition, be devoted to investigations of natural radio sources on the sky. It is estimated that within 1,000 light-years there are some 1.7 million suitable stars. By "suitable" we mean solar-type stars which possess sufficiently long life spans to permit the slow, orderly biological planetary evolution of an intelligent species. For example, our sun is about 4.5 billion years old and biologi-

cal evolution on earth required about 3.3 billion years to produce modern man. Under the optimum conditions wherein interstellar beacons operate continuously and we can monitor all likely channels simultaneously in the microwave region with a receiver having at least one billion outputs, the search could be completed in about 30 years. Otherwise we should be prepared to spend centuries of

effort in a project with some chance of success in the distant future.

In the meantime, there remains the slim prospect of serendipitous contact. We might accidentally stumble onto artificial signals being randomly directed our way, intercept signals being exchanged between two other worlds, locate signals between a cruising spaceship and its parent planet, detect signals from an automated probe

monitoring our solar system and reporting to its home station or mimicking our communication to gain recognition (an unlikely source of long-delayed echoes), or eavesdrop on a galactic network exchanging information among its member societies. Once interstellar communication is initiated, it will mark the end of our cultural isolation and establish our entry into the galactic club of civilized societies. ■

## Autobiography of an Ancient Aviator

W. Sanger Green  
1379 E. 15 Street  
Brooklyn NY 11230

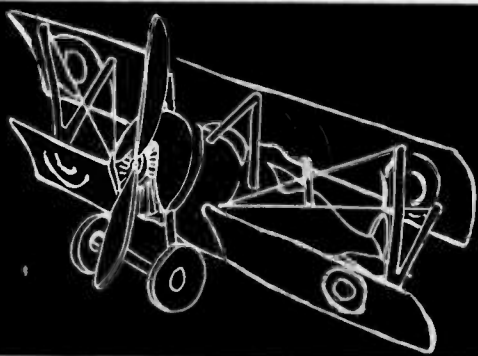

### MORE DEPARTMENT OF COMMERCE STUFF

Last month I told you about my official headquarters being changed from Washington to Philadelphia. It was much better than traveling out of Washington for 30 to 40 days without seeing my family. So, as I told you, the first thing I did after receiving the assignment was to move my wife and Wayne to Philadelphia.

In those days there were only three classes of pilot licenses: Transport, Limited Commercial and Private, each with its limitations. All required a written examination and a flight test. It was up to the applicant to furnish the airplane for his flight test. If the flight test was in a dual control ship, I'd ride with him to see how much he slipped and skidded on his turns, figure 8s, 180s and 360s — in other words, to see whether he was flying the ship or the ship was flying him. Also, I very seldom licensed an airplane without test flying it myself. I had three inspectors assigned to my region, so the first thing I did was make up a schedule of dates and places where one of us would be available to inspect aircraft and to examine and test for pilot and mechanic licenses. This was sent to all the active airports in the region and to all applicants.

On one of my trips to the Richmond Flying Field I had an application for a license for Roscoe Turner's "Flying Cigar Store" ship. If I remember correctly, it was a large single engine biplane that, I believe, was an early Igor Sikorsky stick and wire job. It was very well built and, according

to Roscoe, was very nice to fly. It had to be good since the runway he operated out of, across the field from the Pitcairn hangar, was only about 30 feet wide and had deep ditches on each side. At that time Roscoe had a pet crow that he took everywhere with him. The crow had a habit of picking up anything that was shiny such as a wrench, pliers, etc., and hiding it. What fun. As you may possibly remember, Roscoe was always dressed in smart uniforms. I asked him where he got them and he said that his wife designed and had them made for him. Anyway, uniform or not, Roscoe was an excellent pilot.

In late 1927 and early 1928 I spent quite a little time based at Langley Field, Virginia. I was stationed there in 1925, so I still had a lot of friends there. They put me up in the B.O.Q. (Bachelor Officers' Quarters) and, for a very nominal fee, fed me at their mess. The NACA (National Advisory Committee for Aeronautics) very kindly hangared my plane. Quite a few of the pilot personnel at Langley and at the Naval Air Base at Norfolk wanted to qualify for civilian pilot licenses, so I processed their applications. Also, some of the "Non Coms" and Specialists qualified for airplane or engine mechanics licenses. The NACA had quite a stable of planes in their hangar, some of which they were nice enough to let me fly. For my money, their Fokker D7 was the best handling ship of the lot. Tom Carrol, an old friend of mine, was chief test pilot for the NACA at that time.

On the morning of the 15th of November 1928, I answered the phone at my office at the Philadelphia Airport and heard someone say, "This is the White House Vacuum Cleaner Department" (Hoover was then the Secretary of Commerce). I knew right away that it was Ralph Lockwood, the Supervising Inspector in Washington and my boss. I asked him why he was wasting the taxpayer's money on long distance phone calls. He said they had a problem and needed my help. He said, "You know that nice new Stearman we have in our Bolling Field hangar?" I said, "Yes." "Well," he said, "Clarence Young (Chief Air Regulation Division, and Lockwood's boss) is going to make a tour of Europe next month and wants to take the Stearman along. However, in order to do this, the ship needs some additional instruments and a radio installation that can only be done at the Stearman factory in Wichita. So Clarence wants you to ferry it out and back." I told him that it would be sort of difficult for me to get away just then as we had just raised the price of an untested pilot license to \$100 and the price of covering up a dry rotted longeron to \$150, and we were busy running to the bank. His answer was for me to throw a couple of shirts in my flight bag and fly down to Washington that afternoon. They would have the Stearman on the line, all gassed, warmed up and ready to go first thing in the morning. Well, an order is an order — so I complied.

Instrumentation in most civil aircraft in those days was pretty sketchy. Many were equipped with only a

compass, altimeter and air speed indicator, some with a turn and bank indicator. This was about the story for flying and navigating instruments. The Stearman had all these for the outbound trip plus a rate of climb indicator and radio on the return trip. An 1100 to 1200 mile cross-country trip, especially if it was not over established airways, was a bit more complicated in 1928 than it is now. To be sure, there were airway strip maps to be had, but once you were off those, the Rand McNally state maps were about the only maps available. So you drew your flight line on the state maps and tried to follow it. Following railroads in mountainous country was not recommended as they sometimes went into tunnels without warning. A combination of visual and compass navigation was what I generally used.

The trip out was normal for late November — high head winds, snow, sleet, etc. I had to make an unscheduled landing and overnight at Terre Haute because the ground was getting a little too close. There were a lot of heavily flooded areas between Anglum and Kansas City, and snow from there to Wichita. Upon my arrival, I phoned Stearman and told him I had arrived with the package he had been expecting from Clarence Young. He said he'd send a pilot to take the ship over to his postage stamp sized factory landing place. It took them four days to do the work on the ship. Then, while I was testing it, prior to returning to Washington, the lever controlling the horizontal stabilizer let go and put me into a dive I couldn't control with the elevators. I lost about 800 or 900 feet before I realized what had happened and I corrected it just in time. All I had to do was to pull the stabilizer control lever up and hold it with my left hand while I operated the control stick and throttle with my knees and right hand to come in for a landing. It didn't take Stearman more than a couple of hours to make the necessary repairs, so I was on my way by noon.

I got back to Washington the afternoon of November 24th just in time to jump into my Travelair and make Philadelphia before dark. ■

# ME-8 EIGHT TONE ENCODER

Compatible with all sub-audible tone systems such as:  
Private Line, Channel Guard, Quiet Channel, etc.

- Powered by 6-16vdc, unregulated
- Field replaceable, plug-in, frequency determining elements
- Excellent frequency accuracy and temperature stability
- Output level adjustment potentiometer
- Low distortion sinewave output
- Available in all EIA tone frequencies, 67.0 Hz-203.5 Hz
- Complete immunity to RF
- Reverse polarity protection built-in
- All connections to board made with push-on connectors, color coded wires supplied
- Instant start-up
- Frequency selection made by either a pull to ground or supply on control lead
- Full 1 year warranty
- Mounting hardware supplied

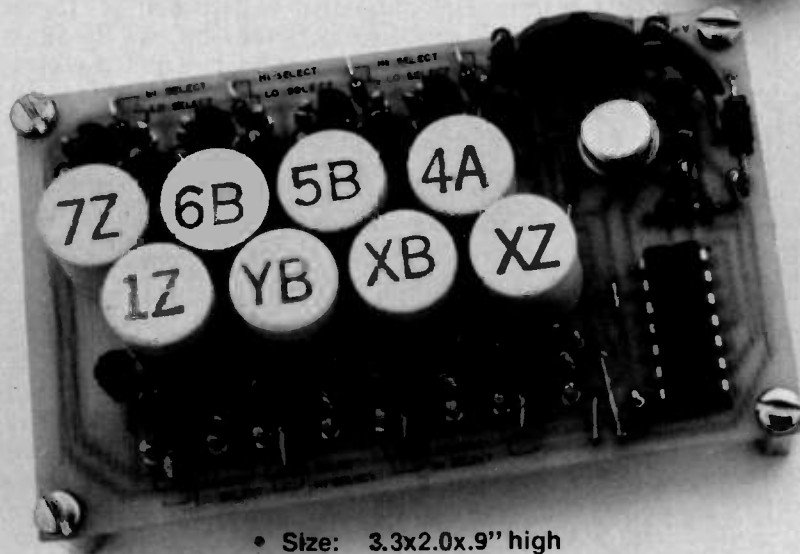

## FREQUENCIES AVAILABLE

67.0	XZ	118.8	2B
71.9	XA	123.0	3Z
74.4	WA	127.3	3A
77.0	XB	131.8	3B
79.7	SP	136.5	4Z
82.5	YZ	141.3	4A
85.4	YA	146.2	4B
88.5	YB	151.4	5Z
91.5	ZZ	156.7	5A
94.8	ZA	162.2	5B
97.4	ZB	167.9	6Z
100.0	1Z	173.8	6A
103.5	1A	179.9	6B
107.2	1B	186.2	7Z
110.9	2Z	192.8	7A
114.8	2A	203.5	M1

Frequencies to 263Hz  
available on special order

- Size: 3.3x2.0x.9" high
- Frequency accuracy:  $\pm .35\text{Hz}$
- Frequency stability:  $\pm .1\text{Hz}$  from  $-30^{\circ}\text{C}$  to  $+85^{\circ}\text{C}$
- Powered by: 6vdc at 9.6ma  
12vdc at 21ma  
16vdc at 37ma
- Output voltage: 6vdc input-1.8vRMS  
12vdc input-3.5vRMS  
16vdc input-4.0vRMS

\$79.95 each

Wired and tested, complete with  
8 K-1 elements (specify frequency)

K-1 Field replaceable, plug-in,  
frequency determining  
elements **\$3.00 each**



# 5/8 Wave Power for Your HT

The majority of the commercially made two meter FM hand-held transceivers today have 1 or 2 Watts output into quarter wave antennas or rubber ducks. There are many times when an FM operator would like to have a little more gain to work out better from poor locations. This article describes a tunable 5/8 wave telescopic antenna to use with a rig such as the Drake TR-22 transceiver.

The antenna design is not a new one. However, the adaptation for use with portable equipment and base stations is novel. It basically consists of four parts: (1) a 44" or 45" telescopic transistor radio replacement antenna rod; (2) acrylic 1/2" OD, 1/4" ID, 2-1/2" long plastic insulator; (3) a 4 turn coil and an NPO 3-12 pF ceramic trimmer; (4) PL-259 coaxial connector. Use with the TR-22 transceiver requires an additional 90° elbow, a barrel connector and a double male connector.

Construction of the antenna is a little unusual, but can be done easily in about an hour. First, with the 2-1/2" acrylic rod, drill a 5/16" hole, 1-1/2" into the

center of the rod tube. The metal telescopic rod will fit into this later. Next, prepare a 1" by 1/4" wooden dowel rod. Drill a small hole through the end of the dowel

to pass a center conductor wire. Glue the wooden dowel into the bottom of the plastic insulator tube and drill a small angular hole through the side of the plastic rod to

coincide with center hole of the dowel. Solder a 3" piece of center conductor from RG-58 coax to a PL-259 coaxial connector. Fish the loose end of wire up through the wooden dowel and out the side of the plastic insulator. Next, fill in the PL-259 connector with epoxy and set the wooden dowel into the connector. Be sure to pull the center conductor wire as you work the dowel into the epoxy. Let epoxy set up until hardened. Next, wind a coil using #12 copper wire (1/2" ID, 4 turns). Bend the ends of the coil and leave plenty of excess wire to make the hookup. Position the coil over the plastic insulator and slide it down until the first turn reaches the PL-259. File off the chrome plating from a spot on PL-259 and solder the bottom end of the coil. Solder to the coil the center conductor wire coming through the side of the plastic insulator, at 1 turn from the grounded end.

Insert the 44" telescopic antenna rod into the top of the insulator. Drill a 1/16" hole through the insulator and antenna rod. Secure with a #3-48 screw, nut, star washer and lug. Solder the

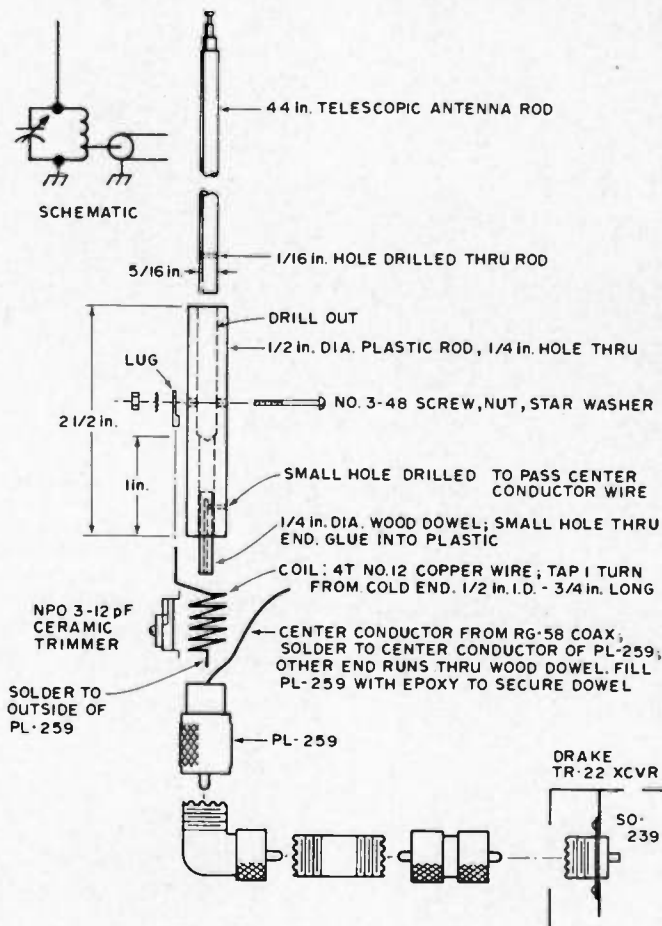

Fig. 1.



top end of the coil to the lug and tighten it down. Finally, solder an NPO 3-12 pF ceramic trimmer between the top and bottom of the entire coil. Extend the antenna rod to full length and check for rigidity. This completes the construction.

With a Drake TR-22, an additional 90° elbow coaxial connector, a barrel connector, and a double male connector must be used to adapt the antenna to the

TR-22 coaxial S0-239 output connector at the rear of the unit.

Tune-up procedure is very simple; there are two ways. First, using a field strength meter in close proximity, key the transmitter and adjust the NPO capacitor with an insulated tuning wand for maximum meter indication. Or, while listening to a weak signal, adjust the NPO capacitor for maximum S-meter indication. Both

methods are with the antenna in place and the rod fully extended.

The antennas constructed thus far have been very effective, with increased receive and transmit gain over the built-in quarter wave type antennas. Many repeaters in excess of 35 miles have been worked using this antenna and a 1 Watt rig. It is very useful in the home and shop, and at picnic outings and other portable locations. It is

a fun little antenna to build and can be used not only for hand-helds but also for Regency HR-2 type rigs, too. Those who have the problem of no antenna allowed outside can use this antenna and have many surprising results, especially from the second floor of a structure. In most cases it will mount on the S0-239 at the rear of the rig. Be sure to re-tweak the NPO capacitor when changing rigs for optimum performance! ■

## If you are on 2-meters now

... but you're tired of being stuck with too few channels

... and you'd like more versatility

... and you really do need tunable VFO

... and SSB-CW (don't forget OSCAR!)

# ... you need Kenwood's NEW



## TS-700A

It solves all of these problems and lots more. And best of all ... the TS-700A reflects the type of quality that has placed the Kenwood name out front.

- Operates all modes: SSB (upper & lower), FM, AM and CW
- Completely solid state circuitry provides stable, long lasting, trouble-free operation
- AC and DC capability. Can operate from your car, boat, or as a base station through its built-in power supply
- 4 MHz band coverage (144 to 148 MHz) instead of the usual 2
- Automatically switches transmit frequency 600 kHz for repeater operation ... reverses, too

- Outstanding frequency stability provided through the use of FET-VFO
- Zero center discriminator meter
- Transmit/Receive capability on 44 channels with 11 crystals
- Complete with microphone and built-in speaker
- The TS-700A has been thoroughly field-tested. Thousands of units are in operation throughout Japan and Europe

*The TS-700A is available at select Kenwood dealers throughout the U.S. For the name of your nearest dealer, please write.*

# KLAUS RADIO Inc.

8400 N. Pioneer Parkway, Peoria IL 61614, Phone 309-691-4840  
Cliff Morris W9GAO - Jim Plack WB9BGS

# Gone in a flash... -STROBING- ... Only to return

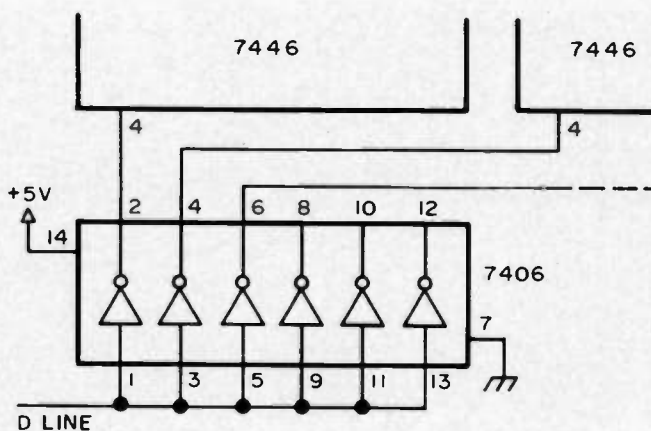

Fig. 1.

**H**aving just recently read an article by WB4DCV in the Nov/Dec 1975 issue of *73 Magazine*, and another by WB2DFA in the Jan 1976 issue of *Ham Radio*, I thought it might be timely to write up some of the ideas used around here for strobing and general control of displays. If I didn't strobe or timeshare some of them, I could not afford my light bill each month.

While this is not a construction article, it might help some of your present or future projects. Since nearly all digital projects do their "thinking" in a binary or BCD code, a transition usually occurs somewhere in an IC (or ICs) that converts this code to the required seven-segment code and the readout numbers we understand. Further, this generally occurs in a 7446, 7447, 7448, etc., family IC or CMOS

equivalent. These little multi-pin "black boxes" more often than not have a group of gates that seem to get overlooked quite often. Blanking, strobing, etc., are the very reasons these gates were built into the IC, so it is a shame to overlook them at the expense to our pocketbooks!

There are two pins on most of these ICs, referred to as the ripple blanking output (RBO) and the blanking or ripple blanking input (RBI) lines. Hooked together properly, these pins can be used to blank out what are called the leading zero figures on a display, or the zero(s) preceding the actual number desired (i.e., the 00123 in the number 123). Another example: In a 5 digit counter like the K2OAW counter that I wrote up some additions for earlier (*73 Magazine*, June, 1973), a very worthwhile further addition can be

realized by using these RBO/RBI lines wired properly for the leading edge zero blanking. By tying pin 5 of the most significant digit (left figure as viewed by user) IC SN7446 to ground, then tying pin 4 of the same IC to the next lesser significant figure IC SN7446 pin 5, and carrying pin 4 of one IC to pin 5 of the next IC to the right, on down until only the right-hand pair of digits (their 7446s) are not modified, you will blank all zero figures to the left of the right-hand pair. Examples: 00001 will read 01, 00011 will read 11, 00111 will read 111, 01111 will read 1111, and 11111 will read 11111. If 10001 is the number, then 10001 will read out. Only insignificant zero figures are deleted and blanked. Leave at least two right-hand digits unaffected in order to tell that the counter is indeed running and working.

Also, in a switched range counter such as the K2OAW model, always begin by counting in the upper range. This avoids the obvious errors that could occur using the zero-blanked version (i.e., 1,140,003 Hz on lower range reads as 03 Hz). I doubt anyone looking in a place for 1 MHz signals would buy the 03 Hz answer, but, done in high range first, he can't go wrong, getting first a 1140 (zero of 01140 blanked) answer, to which he adds the 03 for a 1,140,003 correct answer.

The blanking arrangement is easily defeated by a switch (if so desired) for high frequency measurements over, in this case, the low range limit of 99,999 Hz. Especially in audio measurements in most model counters, it is much easier to read 420 Hz or 1200 Hz, etc., than 00420 or 01200.

To get back to strobing, these same blanking lines can be controlled by ripple through counting devices as in the WB4DCV article (a 7490 to 7441 pair), and the blanking lines will perform the "strobe" function by sequentially blanking or unblanking a readout tied to that particular IC. Since the

# LATEST EQUIPMENT

*at  
the*

# GREATEST PRICES



**GET THIS FREE!**

**NEW HT-SRC-146A  
WALKIE/TALKIE**

worth **298<sup>00</sup>**

**WHEN YOU BUY THIS  
AT REGULAR PRICE!**

**MODEL SRC 851T  
VHF-FM 25 WATT  
BASE/MOBILE 2-WAY  
RADIO TELEPHONE**



- 12 CHANNEL CAPABILITY
- 148 to 174 MHz, 12 VDC
- MOS-FET TRANSISTORS & THREE SEPARATE FILTER NETWORKS FOR OUTSTANDING SELECTIVITY
- UNUSUALLY LOW POWER DRAIN

only **659<sup>00</sup>** Complete with microphone, remote dynamic spkr and MOUNTING BRACKET

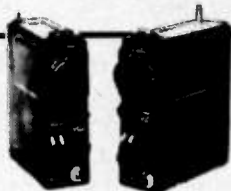

**TRY THE  
NEW ICOM  
SSB TWINS**

Take these low cost twins anywhere! Two portable watts PEP on 2 meters or 6. HELLO DX! No need for converters or low band rigs to get started in SSB-VHF. Just add your linear amp, connect to the antenna and DX. With the 202, you can talk through OSCAR VI and VII --- even transceive with an "up" converter! So many things to try, it's like opening a new band.

**IC-202 2 Meter SSB**

144.0, 144.2 + 2 more! True if noise blanker, switched dial lights. 200 KHz VSO tuning. RIT.

only **269<sup>00</sup>**

**IC-502 6 Meter SSB**

True if noise blanker, switched dial lights. 800 KHz VFO. RIT.

only **259<sup>00</sup>**

**FREE! \$50. WORTH OF XTALS!**

with the Famous  
**REGENCY HR-2B**  
2 METER FM  
TRANSCEIVER



- 15 WATT OUTPUT
- CAN RECEIVE 12 CHANNELS, TRANSMIT 12
- SPECTACULAR PERFORMANCE

REGULAR PRICE **229<sup>00</sup>** including 1 set of XTALS

**FREE FROM HAMTRONICS**  
10 EXTRA Xtals of your choice.

**FREE! \$50. WORTH OF MERCHANDISE!**  
WITH THE ICOM IC-22A 145/147 MHz FM TRANSCEIVER

- 10 WATT FM OUTPUT, ZENER REGULATED XTAL OSCILLATOR
- 22 CHANNELS
- LOW NOISE (0.4 UV) FET FRONT END
- COMPLETE WITH MIKE AND MOUNTING BRACKET



Regular price only **249<sup>00</sup>**

**FREE FROM HAMTRONICS:**  
\$50 worth of Hamtronics merchandise of your choice with purchase of IC-22A



**NEW!  
KENWOOD  
TS-700A 2 METER  
TRANSCEIVER**

- MORE CHANNELS 4 MHz BAND COVERAGE (144 to 148 MHz) INSTEAD OF USUAL 2.
- ALL MODES: SSB (upper & lower), FM, AM & Ch
- TUNABLE FET VFO
- AC & DC. OPERATES FROM CAR, BOAT OR AS BASE STATION
- TRANSMIT/RECEIVE CAPABILITY ON 22 CHANNELS WITH 11 CRYSTALS

only **699<sup>00</sup>**

**MILLION DOLLAR INVENTORY OF NEW & USED HAM GEAR • ALL MAJOR BRANDS • GENEROUS TRADE-IN ALLOWANCES • LOWEST PRICES • FREE DELIVERY ANYWHERE ON ALL ORDERS • Call or write for prices and information before you buy elsewhere.**

**(Telephone us FREE from anywhere in U.S.A. Send copy of phone bill and we'll send you a check!)**

# HAMTRONICS

DIVISION OF TREVOSE ELECTRONICS  
4033 Brownsville Rd • Trevese, Pa. 19047  
(215) 357-1400/(215) 757-5300

exact seven-segment decoder used may require the opposite polarity than that provided by the 7441, the outputs from the 7441 may be tied to the inputs of hex inverter ICs to reverse the "sense" of the outputs (two ICs being required, with two gates or inverters left over). Just remember, to get true strobing where only one number is on at a time, make sure your outputs (from 7441 or inverters) cause all numbers to be off except the one to which the counter (7490) has driven the 7441. Note the following example.

It is further recommended that, on a 5 digit counter like the K2OAW model, the blanking lines be tied to all the decoder even or odd number outputs (or their inverted not-lines for some seven-segment decoders) of the 7441 decoder. This allows the following sequence in an all-tied-to-odd-lines version (7441 positions): (0) no lights on - NLO; (1) one light readout) on - OLO; (2) NLO; (3) OLO; (4) NLO; (5) OLO; (6) NLO; (7) OLO; (8) NLO; (9) OLO - and you have strobed 5 digits (count all OLO positions). Between digits, there is no power drawn, and, in 5 positions of the decoder 7441, only one readout is lit. If you are modifying a present counter, just leave the power supply for the lamps alone after the modification - it will just run cool for long life. If designing

a new project, take the reciprocal ( $1/x$ ) of  $x$  number of readouts used, times the current per readout (7 times the per segment figure in a seven-segment device), times two. The times two is a safety feature that should appear as a 1.5 to 2.0 figure in all of your power supply designs, unless you like the smell of smoke (transformers, resistors, etc.).

A recent development of my own may also be of

eye, so they appear to be always on (see Fig. 1).

Now some comments on counters in general, and specifically the K2OAW model I have. Mine has been in constant use since I built it over three years ago. One of the modifications I suggested in my original article was (as Peter Stark K2OAW pointed out) contrary to good TTL practice, but the entire counter has worked perfectly as described

will use the input metering circuit of that article, as a little metering would sure be reassuring at times.

I had some months ago changed the first 7473-7490 combination in the counter chain over to a 74196 as in the WB2DFA circuit, and it did indeed count to 63 MHz on mine, using a discrete buffer after the 3N200 to shape the waveform for TTL (instead of the 7413) and a 74S00 for the input selector IC. I have since tried the 74S196 for the 74196 (pin for pin OK), and using the same 74S00 I can count to just over 100 MHz. I have determined that the 74S00 is the limiting factor, and, if you try the same idea, the results may vary from 80 to 120 MHz depending on your choice of 74S00 and 74S196.

I have not laid this out as a construction article, but for those of you who want to see my 3N200 arrangement, etc., on paper, please send an SASE and I'll copy up a sheet or two with all the collective information on it. It's all there for you to dig out of the articles mentioned if you have them.

In a short article like this, a pin-by-pin type of description is impossible, but the above articles and their schematics should straighten out any questions or problems on what I have described. By all means strobe, but don't make a hard job of it when it need not be! ■

---

By all means strobe, but don't make a hard job of it when you need not!

---

interest. By simply tying the D line output of one of your crystal timebase dividers whose frequency is 100 to 1000 Hz to all inputs of a hex inverter IC (I used a 7406), and tying one each of the outputs to one of the blanking lines of the 7446s, an alternate means of strobing occurs that gives you an 80% reduction in power required. This may be adequate in some applications, and certainly requires the minimum of hardware. In this case all readouts are off 80% of the time, and on 20% of the time, but at a rate faster than you can at follow with the human

for over three years now. I have, since writing my article, made some of the modifications to my counter that have appeared in subsequent articles by Pete and others. One of these is the input circuit change by Pete himself in the Nov 1974 73 *Magazine*. This, coupled with the change from a 40673 FET to a 3N200 FET, greatly improved the input sensitivity. If I had it to do all over again, I would make this input circuit a plug-in module of some sort, since I am now building the WB2DFA *Ham Radio* input buffer circuit for comparison. Either way, I



**NEW** order now and save

**FOR AMATEUR USE**  
50 OHM JACKETED HARDLINE

- very low loss per 100 ft.
- improved receiver sensitivity
  - .45 DB to 50 MHZ
  - .90 DB to 146 MHZ
  - 1.90 DB to 450 MHZ
  - 4.20 DB to 1296 MHZ
- longer life

**SALE .39¢ per foot**

Call us...  
We are ready to serve you...

**WIRE CONCEPTS INC.**  
WIRE CONCEPTS INC.  
**WG**  
"The Wire People"

**201-227-1751**  
198 Passaic Ave.,  
Fairfield, N.J. 07006

**SPECIALISTS  
IN  
ELECTRONIC  
WIRE  
AND  
CABLE ...**





## THE FM LEADER

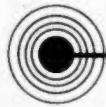

**2 METER**  **220 MHz**   
**6 METER**  **440 MHz** 

FEATURING THE ...

### HR-2B

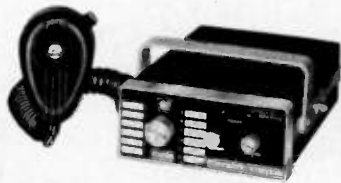

12 Channels  
15 Watts  
\$229.00 Amateur Net

### The Master in 2 Meter FM

Positive performance at a practical price makes our HR-2B tops on 2 meters. Individual trimmer capacitors give bull's-eye accuracy for working repeaters or point-to-point. The .35 $\mu$ V sensitivity and Hi/Lo power switch insure your hearing and being heard ... clearly and reliably ... the Regency way.

... AND THE

### HR-440

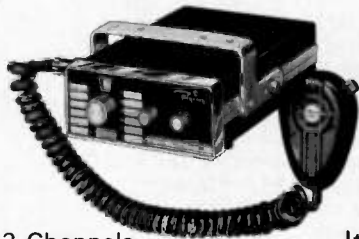

12 Channels  
10 Watts  
\$349.00 Amateur Net

### UHF—The Ultimate in FM

440 is fresh ... it's new ... and with our HR 440 you can use UHF without using-up your budget. So, pioneer some new ground! Put a compact HR 440 under your dash or at your desk. It's the best way to usher yourself into UHF.

BAUDOT to ASCII converter kit \$29.95  
 ASCII to BAUDOT converter kit \$34.95  
 COMBINATION kit - conversion in both directions \$59.95  
 Includes encoded PROMs, TTL, res, caps, PC board.  
 Special Altair model will be available.

TV TERMINAL III \$134.95  
 Displays 16 X 32 lines on television monitor or modified tv set from ASCII keyboard. Complete w/ PC boards and all IC's, res, caps. Special BAUDOT model \$159.95

	CPU's	
8008 CPU		9.95
8080 CPU		32.95
8080A CPU		37.95
M6800 CPU		49.95
All components prime - no surplus, seconds		

UARTS - pin for pin with industry standard, requires only 5 volt supply REG. 9.95  
 SPECIAL 7.95

Three 8080 based minicomputer systems and two 6800 minicomputer systems available.

Lowest prices and most complete line of computer kits in the industry.

### R-M TERMINAL

The R-M Terminal is a surplus, hotel reservation terminal, ideal for adaptation to a computer terminal or for modification to a ham R TTY use. The keyboard output is BAUDOT code, with electronic parallel to serial conversion, and provision for storing and editing 512 characters. The case will hold a Teletype 32 or 33 printer. Manual and schematics furnished. With solid-state Hall-effect keyboard, illuminated switch panel, card guides, case, and multi-voltage power supply, \$109.95, plus shipping. With ASCII converter \$134.95. All 9 PC boards, with edge connectors, complete with harness and documentation, as removed from Terminal, \$19.95. (Only \$10 if ordered with \$109.95 Terminal) Complete manual and schematics may be purchased in advance for \$5 with full credit towards purchase within 90 days. Shipping additional, UPS or Parcel Post. Shipping weight 60 pounds.



Send stamped, self-addressed envelope for prompt response.

**MiniMicroMart**  
 1618 James Street  
 Syracuse, New York 13203  
 (315) 422-4467

# NEW PRODUCTS

## TRICKS WITH ANTENNAS

In our September, 1975 issue, under *New Products*, there appeared a description of a coaxial coupler and a remote control relay by Inline Instruments, Inc. We had installed one of each, and the results made our 2 meter operation and UHF listening much more interesting.

The coupler was inserted inline on the coaxial cable at the transceiver and the relay was clamped to the rotating pole on top of the tower. An omnidirectional vertical was added to the top of the pole and connected to one port of the relay, and the beam was connected to the other port. The existing coax carries the energizing power to the relay, so nothing else had to be added. The plug lead of the 12 volt power supply was run to the injection port of the coupler through a switch, and the antennas could then be selected (Fig. 1). By switching from the vertical to the beam at different angles of rotation, side lobe response, front-to-back ratio, and other reflections were easily noticed by direct comparison. We discovered

the true characteristics of the beam.

Being by nature tinkerers, we decided to try other schemes. Our Bearcat III VHF-UHF scanner always had low gain on UHF because of the single VHF antenna common to both bands. The Inline literature showed the relay transfer time to be one millisecond, so it was felt that it should follow the step response time of the scanner. A two transistor interface switch was built up on a vector-board and installed in the scanner.

The coupler was transferred to the scanner coax line. A UHF antenna and the relay were added to the pole. Both antennas were connected to the relay. The scanner power supply powered the transistor switch and the relay with no problems. The relay easily followed the scanner band transfer and formerly noisy UHF signals became full quieting. There was no audible noise induced by the relay/antenna switching. The life expectancy of the relay is such that even with the high rate of switching it should last for years. Most other scanners use similar crystal and band

switching techniques, so the circuit shown should be usable without modification.

Time has prevented more ideas from actually being tried out, but we would like to pass on a few application hints which might suit individual requirements.

First: Repeater antennas can be switched by tone from mobiles or remote points to provide more favorable selected area communication. A timer or second tone can restore normal condition.

Second: Two antennas can be switched in a mobile to offset undesired directional conditions.

Third: Skilled UHF operators can install converters, preamps, or varactor multipliers on the tower near the antenna. Both the accessory power and the rf is supplied via the

coax line. A suggested system is shown in Fig. 2. Cable losses are greatly reduced. Note: The relay shown is not a remote control type. Since power is also required at the converter, a second coupler supplies both the converter and relay power for UHF operation.

Fourth: FM communication on VHF-UHF uses mainly vertical polarization. Fixed station to fixed station operation, using simplex frequencies, can communicate over longer distances by using horizontal polarization with minimum interference from mobiles. Horizontal to horizontal and vertical to vertical QSOs can thus be carried on at the same time. A horizontal antenna can easily be added with the use of the subject devices.

It should be noted that coaxial cable is not only costly but adds wind loading and stress to a tower or pole. Maintenance will be reduced and the shack will be neater with less cables.

Installation of the coupler and relay showed no apparent attenuation, noise or change in swr over the VHF-UHF range.

More information can be obtained by writing directly to Inline Instruments, Inc., Box 473, Hooksett NH 03106.

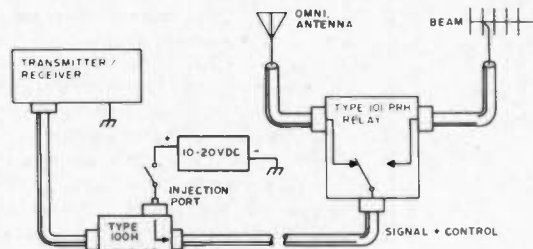

Fig. 1.

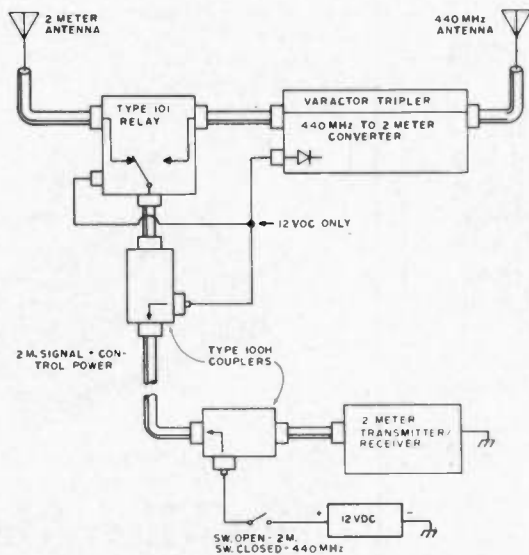

Fig. 2.



NEW MFJ CMOS-8043  
ELECTRONIC KEYSER  
by Morgan Godwin W4WFL

Except for the omission of the model number on the lower portion of the front panel, MFJ Enterprises' new CMOS-8043 electronic keyer looks exactly like its predecessor, the CMOS-44ORS. However, appearances can be deceiving. Inside, the electronics of the CMOS-44ORS have been completely replaced by electronics based on the Curtis 8043 IC keyer chip. Thus, while retaining all of the features of the older model, the new circuitry provides the additional advantages of 1) dot memory; 2) iambic operation with external squeeze key; 3) variable weight control; and 4) reliable solid state keying for grid block and cathode keyed equipment and solid state rigs.

Completely self-contained in MFJ's standard 4 x 3-1/4 x 3-3/16 inch enclosure, the CMOS-8043 is powered by four penlight cells. The sidetone oscillator utilizes a 2N3904 which provides ample volume with the built-in speaker. Tone and volume are adjustable with internal trim pots. The unit features self-completing dots and dashes with jam-proof spacing and instant start with keyed timebase. Weighting is variable with an internal trim pot. The speed range is adjustable from 8 to 50 wpm with a control on the rear panel. Also on the rear of the unit are the tune-off-on-sidetone off switch and phono jacks for keying output and external paddle. For operation in the iambic mode an external

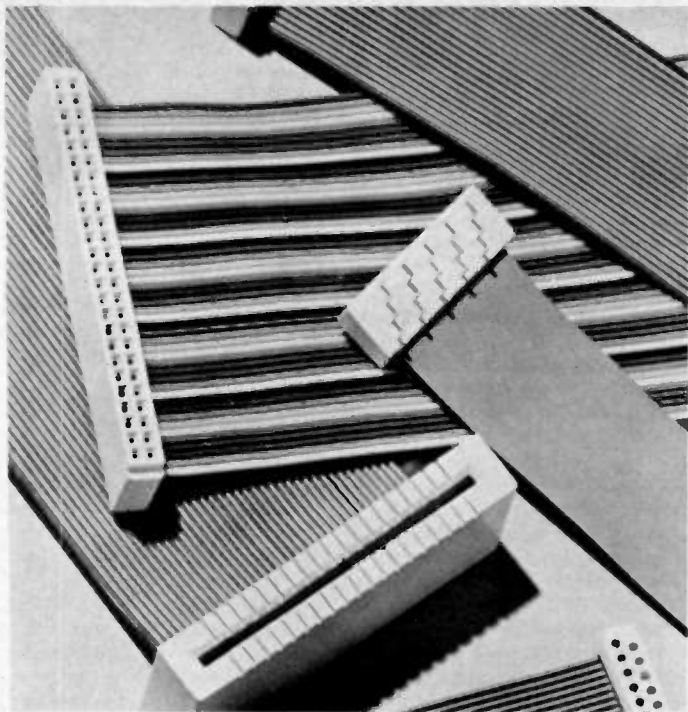

### NEW FLAT RIBBON JUMPERS FEATURE MOLDED-ON CONNECTORS AND FACTORY TESTING

Since February, A P Products Incorporated has had a directly interchangeable, fully assembled jumper line that is a cost effective alternate to

the customer assembled mass terminated flat cables. In addition, the A P jumpers feature molded-on connectors with strain reliefs and line by line probeability. Relative to cost effectiveness, the Ohio company states that it will supply two fully assembled and tested jumpers for the price of the component parts of a

competitive unassembled, untested jumper. This cost advantage is possible because all manufacturing and testing is automated, and lower-cost trinary copper alloy is used as contact material for the flat cable termination.

Three basic end terminations are available — these are socket connectors, printed circuit board connectors, and card-edge connectors. Each of these termination types is offered in the five most standard widely used sizes: 20, 26, 34, 40 and 50 contacts.

With the types and sizes listed, A P offers 60 standard single end configurations and 135 double end configurations. Additionally, A P can provide daisy chain assemblies tailored to customer requirements using any mix of end termination types. Standard ribbon cable for the line is 28 awg vinyl laminated cable which is electric pink in color. A red stripe on one edge provides a means of cable orientation. Rainbow cable with a teardown feature is optionally available on single-ended assemblies.

Even though all jumpers are built complete and tested at the factory, turn around time is targeted to be only two weeks. Additionally A P offers a special 3 day turn around service, at no extra charge, when requested.

For more information contact Robert J. Gabor, A P Products Incorporated, Box 110E, Painesville OH 44077. Phone: (216) 354-2101; TWX: 810-435-2250. Direct all inquiries to Rita Mercer.

### KENWOOD TS-700A 2 METER TRANSCEIVER By Fred Goldstein WA1WDS

Two meters has come a long way since the days of Twoers and Gooney Boxes. While FM is the most popular mode of activity, there's plenty of SSB and even CW on the band nowadays, particularly in the OSCAR segments.

It takes a pretty good radio to get full enjoyment out of the band, and the Kenwood TS-700A is more than just a pretty good radio. Full band coverage is provided in four segments, with VFO or crystal control. You get FM, CW, upper and lower sideband, even AM. Power output is conservatively rated at ten Watts. The built-in power supplies are for both 117 V ac and 12 V dc.

The design is quite modern and innovative. On SSB, the unit is single conversion, with a crystal lattice filter at the 10.7 MHz i-f. The crystal bandswitched oscillator is premixed with the 8 MHz VFO and extensive bandpass filtering provides very low spurious response and emission. For FM, a second i-f at 455 kHz provides additional selectivity and improved audio recovery.

Kenwood didn't spare expense when it came to putting in the filters. There's a 20 kHz crystal filter coming out of the first mixer into the noise blanker. The blanker compares the noise across that bandpass with the noise within the SSB bandpass, and the blanking action is amazingly good. There's probably at least 30 dB of blanking available, if the noise gets bad enough. At my QTH, it never was strong enough to get through the blanker, and my other FM rig is driven batty by passing cars and trucks. When the SSB is less prone to noise than an FM receiver, that's a good blanker!

Coming out of the blanker, the SSB is cleanly tailored to its bandpass and sent to the i-f amplifiers and detector. For FM, the signal is converted down to 455 kHz, where two ceramic filters result in phenomenal selectivity. Splinter channels are no problem whatsoever with the TS-700A. I could listen to 146.625 and hear nothing but an occasional splattering voice peak even though the repeaters on .61 and .64 are very strong here. This is even better than the results I had with other expensive synthesized rigs. If everyone had a radio this sharp, the 2 meter band wouldn't seem half as crowded as it does now.

Not that the sensitivity isn't good. I was hearing signals on the TS-700A that most other radios couldn't tell were there. The VFO helps, too, since there are no "secret" frequencies with one. For repeater use, the transmitter is 600 kHz low in the 146 portion, 600 kHz high in the 147 portion. Putting the repeater switch on "reverse" inverts the operation, which is necessary for California plan inverted splits.

The VFO calibration is good within 1 kHz across the band, and the center

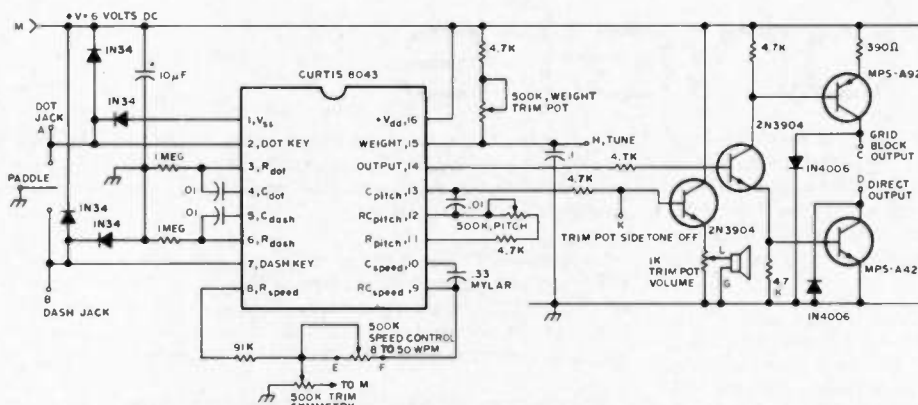

Fig. 1. Circuit diagram of MFJ CMOS-8043 electronic keyer. Jack connections: A — dot; B — dash; C — grid block output; D — direct output. Switch connections: K — sidetone off; H — tune; I — Vcc; G — ground. Other connections: L — speaker; E, F — speed control; M — +Vcc.

squeeze-type keyer paddle is necessary. Also, operators who, like this writer, are real key thumpers, will probably prefer an external paddle with a weighted base to keep it in place during use.

Its small size, light weight and self-contained batteries should make the CMOS-8043 especially popular with campers, backpackers and DXpedition types who have learned to make every cubic inch of space and ounce of weight count. It also merits the attention of stay-at-home, fixed-station operators, whether their operating preference be traffic handling, DXing

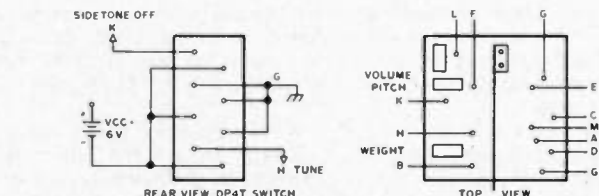

Fig. 2. (a) Rear view showing connections to DP4T function switch. (b) Top view showing position of paddle, adjustable trim pots and various circuit connections.

or just old-fashioned ragchewing. Priced at \$39.95, the CMOS-8043 electronic keyer is available from

dealers or direct from MFJ Enterprises, P.O. Box 494, Mississippi State MS 39762. ■



tuning position on the meter helps put you right on frequency. There's a 100 kHz crystal calibrator just in case you like to be exact. The unique "S-meter" circuit helps tuning on FM, too. The meter is left on the SSB i-f strip, so the repeater carrier has to be within the SSB bandpass to get a reading. The meter doesn't pin on strong signals like on most FM rigs, so you can accurately give a signal strength report or turn the beam using the meter as a guide.

If tuning a VFO while mobile seems a bit too difficult, there is room for eleven crystals. Since each crystal is at the VFO equivalent frequency, there's no need to use separate receive and transmit crystals. If your area has a repeater with 146.46 in and 147.06 out, a crystal for 1.006 MHz above the bottom of the 146 segment will put you there. Tuning in 147.06 would normally result in a 147.66 repeater input, so you need the crystal. If your area conforms to the usual American bandplan, you don't need any crystals.

There are other good features to the TS-700A. There are several varactor-tuned stages, including the front end, that optimize performance as you change band segments. The final has a tuning control, and there's even driver peaking, so you don't have to worry about losing sensitivity at one end of the band or the other. VOX is available as an accessory. If you really want some fun on two meters, the TS-700A will really deliver.

# SOCIAL EVENTS

## COLUMBUS GA MAY 8-9

The Columbus Amateur Radio Club (Georgia) is holding its annual Hamfest on Saturday and Sunday, May 8 and 9th. The hamfest will be at the Fine Arts Building, Columbus Municipal Fairgrounds, Columbus, Georgia. For further information contact Dennis Hand, Jr. K4ICR, Route 1, Box 172A, Cataula GA 31804.

## AMBOY IL APRIL 25

The Rock River Hamfest will be held April 25, 1976, Amboy, Illinois Lee Co. 4-H Center Jct. 30 & 52. Same place as last year. \$1 advance, gate \$2, write Carl Karlson W9ECF, PO Box 99, Nachusa, Illinois 61057. Rain or shine — indoor or out, camping, large swap shop, food, and many prizes. Short trip west of Chicago. Talk-in 146.94.

## SULLIVAN IL APRIL 25

The Moultrie Amateur Radio Klub announces its 15th Annual Hamfest at the American Legion Pavilion in Wyman Park, Sullivan, Illinois on the 25th of April, 1976. Rain or shine, same place as always.

## CADILLAC MI MAY 1

The Wexauke Amateur Radio Association announces their 16th Annual Swap-Shop and Eyeball that will be held May 1st in the National Guard Armory in Cadillac, Michigan, starting at 9 am. This Swap Shop is open to all radio amateurs, citizens banders, and anyone interested in radio communications. Lunches will be available at noon and there is lots of free parking. Tickets available at the door.

## MEADVILLE PA MAY 1

The Northwestern Pennsylvania Swapfest will be held May 1, 1976 at the Crawford County Fairgrounds, Meadville PA. Free admission. \$1 to display. Flea market begins at 10 am. Hourly door prizes and refreshments. Commercial displays welcome. Indoors if rain. Talk-in 146.04/64 and 146.52 MHz. Details: Crawford Amateur Radio Society, Box 653, Meadville PA 16335.

## BIRMINGHAM AL MAY 1-2

The Annual Birminghamfest Amateur Radio Convention will be held May 1 and 2 at the Alabama State

Fairgrounds in Birmingham. Headquarters hotel: Sheraton downtown (on I-65). Features: giant two-day indoor/outdoor swap circle, manufacturers' exhibits, forums, displays, family activities, prizes galore, free Saturday night party, much more! Talk-in: 34/94 (WR4ADD), 3965 kHz. Information: B.A.R.C., PO Box 603, Birmingham, Alabama 35201. Sheraton reservations: 1-800-325-3535.

## KANSAS CITY MO MAY 2

The P.H.D. Amateur Radio Association, Inc. will sponsor the Seventh Annual Northwest Missouri Hamfest Sunday, May 2, 1976 at the Kansas City Trade Mark, Exhibit Hall 3 (Old Municipal Airport Terminal Building) starting at 9 am. Admission \$1.50 in advance, \$2 at door. Refreshments available; swap tables for a fee; forums, contests, prizes, commercial exhibits, women's and children's programs. Talk-in on 34/94 and 3925.

## WESTMINSTER MD MAY 2

The Potomac Area VHF Society will hold their annual hamfest on Sunday, May 2, 1976, at the Agricultural Center in Westminster, Maryland.

## briefs

The FCC continues on its course of deregulation as Docket 20686 (see page 148) proposes deletion of rules concerning portable and mobile operation. The proposal would permit amateurs to operate portable or mobile without advance notice to the Commission and without having to identify as such. FCC monitors in several states have been citing amateurs for such violations as signing "mobile" instead of "mobile eight"; Washington apparently feels enough is enough.

In other FCC news, it appears that ASCII 8-level teletype code will be permitted in the very near future. Results from the AMSAT Special Temporary Authorization for ASCII on the OSCAR satellites have been favorable, while computers are becoming more and more popular among hams. Also, the 220 MHz CB proposal is dead. While it is probable that CB will be granted new frequencies, they won't be taken from hams. 220 MHz repeater activity is growing rapidly in many areas and is almost on a par with 2 meters in some areas.

One very probable place for CB expansion is on eleven meters. While there has been a rulemaking under consideration for some years to provide additional channels for CB sideband operation, the number of scowflaws operating above 27.3 MHz has been increasing rapidly, using bogus call numbers in the "HF" series as making up others. The FCC has been unable to handle the problem; legalization of the so-called "HF" band may result.

Gus Browning W4BPD has departed on another DXpedition comparable to the one he took over ten years ago. He promises to visit as many countries as he can afford to; Bhutan will receive special attention as Gus will be helping the government of that remote Himalayan kingdom to modernize their communications facilities.

Repeater/police interface idea catching on; groups in various areas are contemplating touching the lead of several Chicago area clubs whose systems have a direct touchtone-activated tie line to the 911 dispatcher. Hams are thus able to treat autopatches as a public service rather than simply a convenience;

this should counter some of the criticism received due to questionable uses of autopatch. Hams and the FCC are both uncertain as to what is considered acceptable on an autopatch, with citations given out in some areas for practices considered acceptable in others.

Good publicity for amateur radio in various newspapers, as WA2CFA and others arrange for emergency shipment of medicine to Ecuador to help save the life of a 1½ year old girl. A *New York Times* story described the efforts of the various parties to rush the drug to South America, with ham radio getting the leading role. Hams' massive Guatemalan effort has also generated great PR.

Microprocessor technology is leaping ahead with National Semiconductor's announcement of their new SC/MP chip. While slower than some other microprocessors, the SC/MP (simple, cost-effective microprocessor) is designed to sell for under ten dollars and require a minimum of interfacing. The object is to have a microprocessor included as a component in devices that ordinarily wouldn't, such as cash registers and appliances. Most hobbyist applications don't require much speed anyway, so the day of the hundred dollar computer system can't be far off. Other microprocessor prices are falling; Texas Instruments has announced their T18080 chip, equivalent to other 8080 chips, with a price of under \$35 in single quantities.

A "Treasure Hunt" coordinated by the Keene (NH) Radio Amateur Society recovered two sacks of canceled checks stolen from an interstate bus while en route to the Cheshire National Bank in Keene. About fifty Boy Scouts, with ten ham mobiles using 146.52 for communications, helped find the checks which the thieves, who thought they were taking cash, had ditched in the woods in Winchester.

The FCC has acted on Docket 20119, shifting the hundred milliwatt "walkie talkies" that may be operated without a license from the 27 MHz Citizens Band to 49.82-49.90 MHz. Manufacture of the CB units may continue for a year; use will be permitted until 1983.



land, between the hours of 9 am and 5 pm. There will be a registration of \$3. Talk-in on 146.94 and 52. For more information contact K3DUA or WA3NZL.

**BROWNFIELD TX  
MAY 2**

The Brownfield 76 Centennial Swapfest will be held on May 2, 1976 in the National Guard Armory, Brownfield, Texas. Door prizes will include a 2 meter FM rig and a Johnson Messenger CB transceiver. Advanced registration \$1.50 and \$2.00 at the door. Social get-together the evening before in the Armory. Write Viola Simmonds W5FBM, 1603 E. Tate St., Brownfield TX 79316 for info and/or registration.

**SEABROOK NH  
MAY 8**

The Hosstraders Third Annual Tailgate Swapfest will be held Saturday, May 8, at 11 am at Addams' Campground, Route 286, Seabrook NH off Route 95 at the Mass-NH border.

Admission 75¢, dealers included, no commissions or percentages. Excess revenues benefit March of Dimes birth defects campaign. FM clinic sponsored by Saddleback Repeater Association. Talk-in .52, .40-00, and/or 3940 kHz. If any questions, SASE to WA11VB, Box 32, Cornish, Maine 04020.

**FORT WALTON BEACH FL  
MAY 9**

The Playground Amateur Radio Club will hold its Sixth Annual Swapfest Sunday, May 9, 1976, from 8 am until 4 pm at the Fort Walton Beach Fairgrounds. Registration \$1.50 advance - \$2 at door. Free swap tables. For hotel and other information write: Swapfest Committee, PO Box 873, Fort Walton Beach FL 32548.

**JAFFREY NH  
MAY 15**

The 1st Annual Fly In and Flea Market will be held Saturday, May 15, 1976 at the Jaffrey Municipal Airport (Silver Ranch) in Jaffrey, New Hamp-

shire. 73 Magazine will host the event. Picnic facilities, food stand, great ice cream, horseback riding available at Silver Ranch stables across the road from the airport (200 yds). Plenty of hangar space for exhibitors, etc. Come one - come all - if you can't fly - drive - but get here. Jaffrey is 6 miles south of Peterborough on U.S. Rte. 202.

**WEST LIBERTY OH  
MAY 16**

The Champaign Logan Amateur Radio Club is holding its 6th Annual Flea Market and Auction on May 16, 1976 starting at 12 pm at the West Liberty Lions Park at West Liberty, Ohio. Free admission, trunk sales and tables \$1.00, door prizes. Talk-in on 146.52 and 146.13/73.

**LAKE DELTON WI  
MAY 22**

The Yellow Thunder Amateur Radio Club will sponsor their 6th annual hamfest on Saturday, May 22, 1976 at the Dell View Hotel in Lake

Delton, Wisconsin, starting at 10 am. Meetings and events include: swap shop, DX, VHF, RTTY, MARS, ARPSC, hidden transmitter hunt, ladies activities, liars contest and an evening banquet with entertainment including something new: "The Kitchen Maids." Grand prize: Regency HR2-B. Admission \$7 in advance or \$7.50 at the door. (\$1.50 or \$2.00 without the banquet.) For further information contact Kenneth A. Ebner K9GSC, 822 Wauona Trail, Portage WI 53901.

**SANDUSKY OH  
MAY 23**

The Vacationland Hamfest will be held on Sunday, May 23, 1976 at the Erie County Fairgrounds from day-break till 3 pm. Featuring - free camping Saturday night, free transportation to Cedar Point ferry boat dock. Bring the family and let them visit the greatest amusement park in the U.S.A. Plenty of flea market tables, dealers welcome, 8 acres for trunk sales. 1st grand prize: 1200 Watt ac gasoline generator. Tickets are \$1.50 in

# The Grabbers!

## 6-DIGIT COUNTERS!

6-Digit Kit  
**\$ 69<sup>95</sup>**  
(30mHz)



6-Digit Kit  
**\$ 119<sup>95</sup>**  
(250mHz)

We have a whole wonderful line of unbelievable counters starting at \$45.95! All counters are also available factory wired and tested. Drop us a line or give us a call today.

**Hufco** ... P.O. Box 357, Dept. 25, Provo, Ut. 84601... (801) 375-8566

# PARTS PANIC!!

Having parts problems such as Minimum Orders, Unanswered Letters, Uninterested Suppliers, Too Much Time at Flea Markets?

Let G. R. Whitehouse & Co., the New Parts Specialists solve your problems.

### NOW IN STOCK

Transmitting Variables — Roller Inductors — Counter Dials  
Air Wound Coils — Couplings — Knobs — Receiving Variables  
Toroids — R.F. Chokes — Coil Forms and more

From

Millen - E. F. Johnson - Barker & Williamson - JW Miller - Hammarlund

Send First Class Stamp for Flyer

## G. R. WHITEHOUSE & CO.

17 NEWBURY DRIVE, AMHERST, N. H. 03031

"The Parts Finders"



**NOW**  
is the time to order  
**YOUR**  
**76**  
callbook

Don't wait until 1976 is half over. Get your new Callbooks now and have a full year of the most up-to-date QSL information available anywhere.

The new 1976 U. S. Callbook will have over 300,000 W & K listings. It will have calls, license classes, names and addresses plus the many valuable back-up charts and references you have come to expect from the Callbook.

Specialize in DX? Then you're looking for the new, larger than ever 1976 Foreign Callbook with over 225,000 calls, names and addresses of amateurs outside of the USA.

On dealer shelves Dec. 1, 1975

Foreign Radio Amateur Callbook DX Listings	<b>\$12.95</b>
with 3 Service Editions	<b>\$18.95</b>
United States Callbook All W & K Listings	<b>\$13.95</b>
with 3 Service Editions	<b>\$19.95</b>

**RADIO AMATEUR callbook INC.**

Dept. B  
925 Sherwood Drive  
Lake Bluff IL 60044

Order from your favorite electronics dealer or direct from the publisher. All direct orders add \$1.00 shipping and handling per Callbook.

## FM YOUR GONSET

(or your Clegg 22'er, Ameco TX-62, Polycorn 2 or PC-42, Johnson 6N2, Heath Seneca VHF-1, Hallicrafters SR-34)



● Plug-in modulator puts the Communicator transmitter on FM.

● No modification or rewiring on your Communicator. Just plug into mike jack and crystal socket.

● For 2-meter band only.

- Works with Communicator I, II, III, IV and GC-105 and other rigs listed.
- Frequency adjust for netting built in.
- FM at a tenth the cost of a new rig.
- Sharp, clean FM.
- In daily use by MARS and Civil Defense nets nationwide.
- Free brochure on request.
- Order direct. \$37.50 postpaid U.S. & Canada. Specify transmitter model. California residents add 6 percent sales tax. (HC-6 / U crystal and 9-volt transistor battery not supplied).

## PALOMAR ENGINEERS

BOX 455, ESCONDIDO, CA 92025

Phone: (714) 747-3343

NEW • UNEQUALLED • VALUE  
MINIATURE SOLID STATE

## VIDEO CAMERA KIT

A UNIQUE CAMERA KIT  
FEATURING A . . . 100 X 100 BIT  
SELF SCANNING CHARGED  
COUPLED DEVICE

INCLUDES THE FOLLOWING  
UNIQUE FEATURES . . .  
FOUND IN FAR MORE  
EXPENSIVE CAMERAS  
IF AVAILABLE

- LOW VOLTAGE SUPPLY (OR BATTERIES) +5 AND ± 15 VOLTS
- SENSITIVE TO INFRARED AS WELL AS VISIBLE LIGHT
- MAY BE USED FOR IR SURVEILLANCE WITH AN IR LIGHT SOURCE
- EXCELLENT FOR STANDARD SURVEILLANCE WORK BECAUSE OF ITS LIGHT WEIGHT AND SMALL SIZE
- ALL COMPONENTS MOUNTED ON TWO PARALLEL 3" X 5" SINGLE SIDED BOARDS. TOTAL WEIGHT UNDER 2 LBS.
- MAY BE WIRED BY PERSON WITH SOME TECHNICAL EXPERIENCE IN 4-6 HRS.

ONLY **\$225<sup>00</sup>**



MAY BE USED  
WITH AMATEUR  
RADIO FOR VIDEO

USED FOR CHARACTER  
RECOGNITION  
FOR COMPUTERS  
WITH EXTERNAL  
CIRCUITS

MAY BE USED IN  
A VACUUM, UNDER  
WATER, HIGH  
ALTITUDE, AND  
IN MAGNETIC  
ENVIRONMENT  
BECAUSE THERE  
IS NO HIGH  
VOLTAGE OR  
MAGNETIC  
DEFLECTION

WE SUPPLY ALL  
SEMICONDUCTORS,  
BOARDS, DATA SHEETS,  
DIAGRAMS, RESISTORS  
AND CAPACITORS.

WE DO NOT FURNISH  
THE CASE, THE LENSE, THE  
BATTERIES (OR SUPPLY).  
ADD \$2.00 POSTAGE AND  
HANDLING, PLUS \$6.00 FOR  
ALL IC SOCKETS (OPTIONAL)

SOLID STATE SALES

P.O. BOX 74  
SOMERVILLE, MASS 02143  
TEL (617) 547-7053

## SUPER SYNTHESIZED SCANNER



10 Channel. LO VHF 30-50 MHz.  
HI VHF 146-174 MHz. UHF  
440-512 MHz. Mfg. price \$329.00

TENNELEC

MS-2 16 channel. 31.18-50,  
146-148, 151.18-170, 451.2-470,  
490-508.825 MHz. Mfg. price  
\$339.95

BEARCAT 101

Covers 16000 Public Service Frequencies including 2 and 3/4 meter Ham Bands. Mfg. price \$349.95

30-50 MHz; 146-174 MHz  
450-512 MHz

Write for info on Porta Clip — Carry your Handie Talkie the easy way. Prices \$6.50 up

Regency ACT-R 10 H/L/U with ten free crystals . . . \$169.00.\*  
Regency or Bearcat high accuracy monitor crystals . . . \$3.75.  
Call or write for complete 1976 flyer. \*SPECIAL



COMMUNICATIONS  
ENGINEERING

P.O. Box 415,  
Cadillac, Michigan 49601  
Phone 616-775-0881  
CABLE COMENG

Name \_\_\_\_\_  
Address \_\_\_\_\_  
City \_\_\_\_\_ State \_\_\_\_\_ Zip \_\_\_\_\_  
 Cash  Check  Bank Americard  Master Charge  
Card No. \_\_\_\_\_ Expiration date \_\_\_\_\_  
Signature \_\_\_\_\_  
Total enclosed \$ \_\_\_\_\_

24 hour Mastercharge-Bank Americard order & info line: 616/775-0881.  
Prepaid shipping. Certified check or charge card on mail orders for  
immediate shipment. Dealer inquiries invited. Michigan residents add  
tax.

advance — \$2 at gate. Flea market vehicles \$1 each. For further information or reservations write: E.A.R.S., PO Box 2037, Sandusky, Ohio 44870. Call in on 52-52.

WABASH IN  
MAY 23

The Wabash County Amateur Radio Club will hold their 8th Annual Hamfest Sunday, May 23, 1976 at the 4-H Fairgrounds in Wabash, Indiana. The hamfest will be held rain or shine. There will be a large flea market (no table or set-up charge), technical forums, bingo for the XYLs, free overnight camping with ac hookup, and plenty of parking. Lots of good food at reasonable prices. Admission is \$1.50 for advance tickets, \$2 at gate. For more information or advanced tickets write to Bob Mitting, 663 North Spring Street, Wabash, Indiana 46992.

POTTSTOWN PA  
MAY 23

The Pottstown Area Repeater Team Hamfest and Flea Market will be held on Sunday, May 23 at 9 am to 4 pm at Rt. 422, Hiway Drive-in 8 miles east of Pottstown. There will be prizes, auction, contests, and refreshments. Talk-in 52/52, 81/21, 66/06. Registration \$2 — tailgate \$1. For more information contact A. Jefferson WA3VYS, 444 Roland Avenue, Pottstown PA 19464.

KNOXVILLE TN  
MAY 29-30

The Radio Amateur Club of Knoxville will hold its annual Greater Knoxville Hamfest on May 29 and 30th at the National Guard Armory, 3330 Sutherland Ave., N.W. Activities will include an indoor and outdoor flea market. Door admission \$1 and a chance for a door prize. Tables and space rental for indoor flea market will be \$2.50 per table. There will be a banquet on the 29th at 8 pm at Howard Johnson's, West Town at \$6 per person. Talk-in on 16/76 — 34/94 and 3980. More information by SASE from Edward L. Melton WB4JGF, 749 Elkmont Rd., Concord TN 37922.

BURLINGTON KY  
MAY 30

The Kentucky Ham-O-Rama will be held Sunday, May 30, 1976 (Memorial Day weekend) at Boone County Fairgrounds, Burlington, Kentucky. Ten minutes south of Cincinnati, Ohio near I-75. Prizes, forums, XYL program, exhibits and flea market. Tickets \$1.50 advance. For more information contact: NKARC, PO Box 31, Fort Mitchell, Kentucky 41017.

## WYOMING — UTAH

Ranch land. Antelope, deer, elk, wild horses — Your "Antenna Ranch." 10 Acres \$30 down, \$30 month. FREE info — maps — photos. Owner: Dr. Michael Gauthier, K6ICS  
9550 E. Gallatin Rd., Downey CA 90240

An Authorized Bicentennial Program of  
73 MAGAZINE

Show Your Pride  
In America's Past,  
Your Faith In Her Future

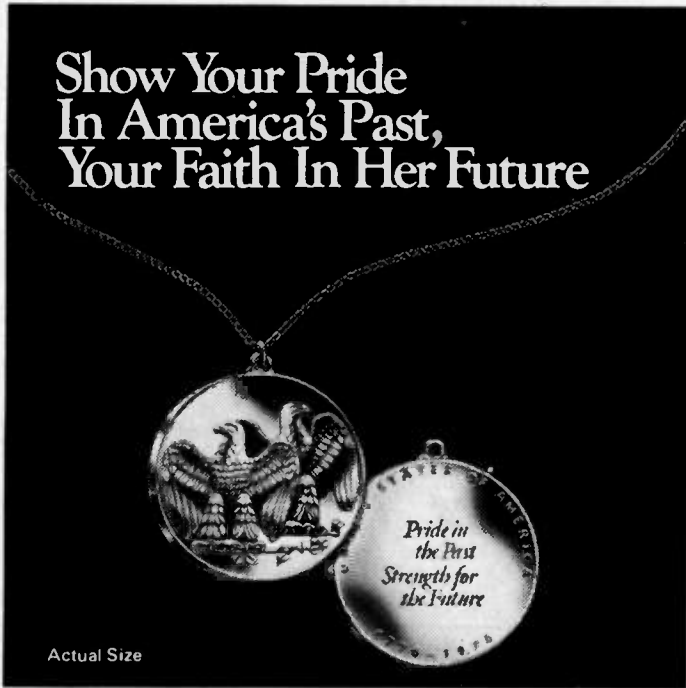

Own and Give the Double Eagle Pendant  
as a Permanent Keepsake  
of the Bicentennial-only \$7.<sup>95</sup>

Two delicately chiseled majestic American eagles, symbolizing the first two hundred years of the United States of America, form the design of this beautiful keepsake authorized by the U.S. Historical Society. One eagle looks proudly to America's past, the other confidently to the future.

Created for the Society by the famed Medallion Art craftsmen who designed and made the official Inaugural Medallion for Presidents Ford, Nixon, Johnson, Kennedy, Eisenhower, Truman and Roosevelt.

*Coin Collectors: Also available as a bas relief medallion.*

This valuable American work of art is available in silver plate, 24-karat gold plate, antique bronze and solid sterling silver.

Acquire the official Double Eagle medallion or pendant for yourself, for members of your family and for your friends as a sign of your pride in America's past and your faith in her future.

Mail to: 73 MAGAZINE  
c/o U.S. HISTORICAL SOCIETY  
FIRST AND MAIN STREETS  
RICHMOND, VIRGINIA 23219

Yes, I want to show my pride in America's past, faith in her future. Please send the following authorized gift boxed Double Eagle medallion(s) and/or pendant(s) with neck chain(s). Full refund if returned within 30 days.

	QUANTITY		COST
	PENDANT WITH NECK CHAIN	MEDALLION	
SOLID STERLING SILVER @ \$29.95			
24-KARAT GOLD PLATE @ \$10.95			
SILVER PLATE @ \$9.95			
ANTIQUÉ BRONZE @ \$7.95			
Please add \$.75 per pendant/medallion For postage and handling.			
TOTAL			

I enclose a check for \$ \_\_\_\_\_.

NAME \_\_\_\_\_

ADDRESS \_\_\_\_\_

CITY \_\_\_\_\_ STATE \_\_\_\_\_ ZIP \_\_\_\_\_

Virginia residents add 4% sales tax.

Please allow 30 days for delivery.

5



For an up-to-the minute source  
of microcomputer terminology  
and definitions . . . send for this

## NEW MICROCOMPUTER DICTIONARY

TITLE: *Microcomputer  
Dictionary & Guide*

AUTHOR: *Charles J. Sippl and  
David Kidd*

This new microcomputer dictionary fills the urgent need for all communications people, computer people, engineers, scientists and industrialists to become quickly familiar with the terminology and nomenclature in a new revolution in computer control capabilities.

Over 8000 definitions and explanations of terms and concepts (704 pages) relating to microprocessors, microcomputers and microcontrollers. There are also separate appendices on: programmable calculators; math and statistics definitions; flowchart symbols and techniques; binary number systems and switching theory; symbol charts and tables; summaries of BASIC FORTRAN and APL. In addition there is a comprehensive electronics/computer abbreviations and acronyms section.

(Also available from technical book stores and selected electronic distributors) Price: \$17.95

### MATRIX PUBLISHERS, INC.

Dept. SM, 207 Kenyon Road,  
Champaign, IL 61820

Please send me the new MICROCOMPUTER DICTIONARY under your 15 day no risk trial guarantee. If payment accompanies order we pay all shipping and handling charges. Ill. customers add 5% sales tax.

Name \_\_\_\_\_

Address \_\_\_\_\_

City \_\_\_\_\_ State \_\_\_\_\_ Zip \_\_\_\_\_

## NEW LOCATION

Yes, we have moved to larger, modern facilities. SASE for new and used equipment listing.

Serving amateurs since 1928

Master Charge BankAmericard

**FRECK** radio & supply  
co., inc.

252 Patton Ave., Asheville, N.C. 28801.  
PHONE: (704) 254-9551

### SST T-1 RANDOM WIRE ANTENNA TUNER



All band operation (160-10 meters) with most any random length wire. 200 watt power capability. Ideal for portable or home operation. A must for Field Day. Size 2 x 4 1/2 x 2 3/8. Built-in neon tuneup indicator. Guaranteed for 90 days.

COMPACT - EASY TO USE.

●●● only \$29.95

POSTPAID. (ADD SALES TAX IN CALIF.)  
SST Electronics, P.O. Box 1, Lawndale CA 90260

## 6-Meter TVI? 2-Meter TVI?

Our beautiful twin-cavity bandpass filters provide BRUTE-FORCE protection from receiving or radiating interference outside the Amateur band, eliminating dense and intermod from commercial signals while purifying your emissions and insuring against TVI.

**Varden Electronics Company**  
Box 791, Jackson, Michigan 49204 • (517) 787-2299

Resistors available in standard values — 1/2 watt — 10% 4.5¢ each, 4.25¢ multiples of 20 per value, 4.0¢ multiples of 100 per value. SASE for free price list. "If we don't list it, request it, we'll get it."

Eldor Electronic Sales

Box 530, Chase, B.C. Canada V0E 1M0



# SPEC COMM 512/560 The Lightweight Champ That Brings The Performance Title Back To The States!

**2M FM**

... Not to mention the  
top American Made  
Quality!



BA-1 25 wt. Amp "Snap-Pack" Module. For Mobile or Fixed station use. \$84.95.

AC-1 AC Power Supply "Snap-Pack" Module. For the basic xcvr. \$49.95.

BP-1 Portable Pkg. — Includes Heavy Duty Nicad Btry. "Snap-Pack" Module, H. D. Charger, 19" whip & Carrying Strap. \$89.95.

SPEC COMM 512  
12 chan. \$249.95

SPEC COMM 560  
6 chan. \$224.95

MB-1 Mobile Mt. \$8.50

● The unique "Snap-Pack" Modules merely Snap-On and automatically interconnect. No messy wires or cables to hook-up.

● One transceiver performs the functions of 3 — WITHOUT COMPROMISE!

Definitely not your typical heavy-weight imported radio — with their cheap parts, super-tight layout ... (almost impossible to service), tiny "penlite" batteries which poop-out in a few hours, limited versatility, and needless frills.

Spec Comm gear is completely engineered & built in the USA — with portability in mind — *light-weight, yet very rugged*. We are committed to **Quality, Performance & Versatility**. How many of the competitors can boast of top quality components as used in Spec Comm gear? Like — Hewlett-Packard, RCA, Motorola, Fairchild, CTC, Allen-Bradley, Sprague, & Turner — to name a few. You know you'll have optimum, *reliable* performance year after year!

Talk about performance & versatility ... How many competitors offer a *full 5 Watt* portable — *also* suitable for Mobile or Fixed operation (without compromise) — expandable to *25 Watts* with a small plug-in module — which *also* has a 1.2 Amp Hr. (13.75 V) NiCad Battery Module that snaps on or off in seconds? (Incidentally, our H. D. "Snap-Pack" Battery has about *3 Times the Capacity* of any competitive unit — while our 5 Wt. xmtr. draws

only about twice the current of the usual 1-2 watters! — For many hours of operation.)

The transmitter features "Crispy-Clear" Modulation, with excellent fidelity & 'punch'. With Spec Comm, *Intermods and rcvr. overload are virtually eliminated* — thanks to our revolutionary and *exclusive Hot Carrier Diode Mixer!* Selectivity is excellent: -80 to 90 dB @ ±30 kHz, -55 dB @ ±15 kHz, Sens. 0.3uV typ./20 dB Qt.

Often compared to commercial or military equipment, notice there are *no frills — no meters* ... (You don't see them on Motorola or G.E. either, do you? ... After all, on FM, you're either noisy or F.Q.!) Also, most FMers feel 12 channels is more than enough to cover all of their favorite frequencies.

Think about it ... The good solid Performance, the Quality, the Versatility — *and*, the Expandability — accessory modules can be added at *anytime*. All this at a *price you can afford!* See what our customers say — pg. 126 Nov/Dec 1975 73 Magazine.

Available at Selected Dealers (or Factory Direct). On direct orders, add \$3.50 ship./handl. (PA residents add 6% tax.) Precision xtals — \$4.95 ea.

DEALER INQUIRIES INVITED

See Review Article in April 73 Mag.  
Send for Data Sheet

Inquire about our Repeater Rcvr. & Xmtr. Boards

**SPECTRUM COMMUNICATIONS**

BOX 140, WORCESTER PA 19490 (215) 584-6469





# Dentron

## 80-10AT SKYMATCHER™

Here's an antenna tuner for 80 through 10 meters, handles full legal power and matches your 52 ohm transceiver to a random wire antenna.



- Continuous tuning 3.2—30 mc
- "L" network
- Ceramic 12 position rotary switch
- SO—239 receptional to transmitter
- Handles maximum legal power
- Random wire tuner
- 3000 volt capacitor spacing
- Tapped inductor
- Ceramic antenna feed thru
- 7" W. 5" H. 8" D., Weight; 5 pounds

# \$59.50

"Request complete Dentron catalog"

Everything in Ham Gear - for over 37 years

ELECTRONIC DISTRIBUTORS, INC., 1960 Peck St., Muskegon, MI. 49441  
Phone (616) 726-3196 Telex: 22-8411

## We're Fighting Inflation... No Price Rise for '76

### FOR FREQUENCY STABILITY

Depend on JAN Crystals. Our large stock of quartz crystal materials and components assures Fast Delivery from us!



Two CRYSTALS FOR  
Meter Citizens Band  
Monitor Marine Receivers  
Radio

### CRYSTAL SPECIALS

Frequency Standards  
100 KHz (HC 13/U) ..... \$4.50  
1000 KHz (HC 6/U) ..... 4.50  
Almost all CB sets. TR or Rec ..... \$2.50  
(CB Synthesizer Crystal on request)  
Amateur Band in FT-243 ..... ea. \$1.50  
..... 4/\$5.00  
80-Meter ..... \$3.00 (160-meter not avail.)  
For 1st class mail, add 20¢ per crystal. For Airmail,  
add 25¢. Send check or money order. No dealers,  
please.



Div. of Bob Whan & Son Electronics, Inc.  
2400 Crystal Dr., Ft. Myers, Fla. 33901  
All Phones: (813) 936-2397  
Send 10¢ for new catalog

## K-ENTERPRISES

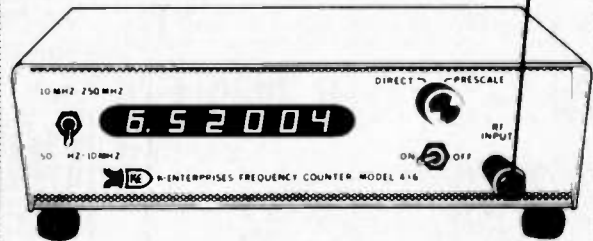

MODEL 4X6C  
50 HZ—250 MHZ ..... \$270.00

### 300 and 500 MHZ PRESCALERS

### FREQUENCY STANDARDS

### MARKER and PEAKING GENERATORS

### POWER SUPPLIES AMPLIFIERS

### WRITE FOR FREE CATALOG



Phone:  
405-273-9024



K-ENTERPRISES

1401 N. Tucker

Shawnee, Okla. 74801

# It Happened to Me...

Charlene Knadle WB2HJD  
316 Vanderbilt Parkway  
Dix Hills NY 11746

I decided to improve the hamshack. The O.M. was out and there couldn't be a more perfect time. The Fibber-McGee hamroom closet was sixty percent empty. O.M. and friends were on a mountain-topping expedition, and they'd packed like it was for forever. I had time. They would be gone the entire weekend.

Lug the rest of the heavy stuff out of the closet. Clean the floor — hadn't been vacuumed since we moved in (too equipment-covered).

Bring up a steel-shelf unit from the basement. Wouldn't miss one there. Put it in hamroom closet. Fits fine. Lug the heavy stuff back into closet — this time onto lowest shelf.

Add another bookcase — this one wood-grained and handsome. Fill it with QST's, 73's, Ham Radio's and CQ's (O.M. needs them for quick reference while on the air) so there won't be space left for voltmeters, power supplies, and supply supplies.

Dust and wax desk and two tables. Clean floor. Stand back and admire. What could be better than this? Something could. There could be an acoustical ceiling.

## NEW! GLOW-IN-THE-DARK "TT" PADS

GUARANTEED RF PROOF  
WILL MODULATE ANY TRANSMITTER  
LED TONE & BATTERY INDICATOR...  
ADJ. LEVEL CONTROL 6-16 VDC @ 15 mA max.  
XTAL CONTROLLED DIGITAL CMOS

TEK SERIES  
(All .40" THICK)

TEK-125  
1.58" x 2.08"  
**\$57.50**

TEK-165  
2.08" x 2.08"  
**\$65.00**

CLUB DISCOUNT  
ON 10 OR MORE

SHIPPED  
FROM STOCK

SINGLE UNIT ABS CASE — FALSE TONE PROOF  
SCHEMATICS FOR 3 WIRE HOOKUP ON REQUEST  
SPECIFY POS OR NEG GROUND

(Quantity & OEM prices on application)  
(714) 627-4287 - (714) 627-1753

MONEY BACK GUARANTEE  
SEND CHECK or M.O. (CA RESIDENTS ADD 6% TAX)  
WITH MAKE & MODEL OF TRANSMITTER TO:

**ELECTROGRAFIX** P.O. BOX 869  
CHINO, CA 91710



## YOUR HAM TUBE HEADQUARTERS!

TUBES BOUGHT, SOLD AND TRADED  
SAVE \$\$\$ — HIGH \$\$\$ FOR YOUR TUBES

### MONTHLY SPECIALS

3CX1000A7/8283	\$225.00	811A	\$ 7.00
3CX1500A7/8877	205.00	813	18.00
3-500Z	48.00	6146B	4.25
3-1000Z	120.00	6360	3.75
4-125A	42.00	6883B	4.50
4-400A	45.00	8122	39.00
4-1000A	165.00	8236	22.00
4CX250B	24.00	8908	5.25
572B	22.00	8950	4.75

Eimac Tubes & Accessories In Stock  
Write or phone for types not listed

BRAND NEW\*\*\*\*FACTORY GUARANTEED

TOP BRAND Popular Receiving Tube Types.  
BRAND NEW 75%+ Off List\*Factory Boxed.  
FREE LIST Available — Minimum Order \$25.



COMMUNICATIONS, Inc.

2115 Avenue X  
Brooklyn, NY 11235  
Phone (212) 646-6300

SERVING THE INDUSTRY SINCE 1922

## 500 MHZ SCALER MODULE



Only 1.55 x 1.65 x .4 inches

Fits right into existing equipment

High sensitivity: 35 mv, at 500 MHz  
15 mv, at 150 MHz

Input impedance: 50 Ohms

Requires 12 to 15 V dc at 100 mA max.

TTL compatible output  $F_{IN}/10$

Overload protected

PS-M prescaler module wired & tested

**\$99.00** plus \$.85 shipping

WRITE FOR DATA ON ENTIRE LINE OF  
PRESCALERS

All orders please add \$.85 for shipping Calif.  
residents add 6% sales tax

**LEVY ASSOCIATES**  
P.O. Box 961, Temple City, CA 91780

## CAVITY & DUPLEXER Reference Manual

Thirty-four page technical digest with thirty-six diagrams and charts which detail characteristics, configurations and implementation plus the causes of and cures for interference including intermod, desense, noise and spurious. **\$1.50** POSTPAID.

**Varden Electronics Company**  
Box 791, Jackson, Michigan 49204 • (317) 787-2299

## DIPOLE ANTENNA CONNECTOR



HYE-QUE (HQ-1) dipole connector has coax SD-239 socket molded into glass filled plastic body to accept coax PL-259 plug on feedline. Drip-cap keeps coax fittings dry. Instructions included. Guaranteed. At your dealers or \$3.95 postpaid. Companion Insulators 2/\$.95.

**BUDWIG MFG. Co.** PO Box 97B, Ramona CA 92065

## NEW MULTI-BAND ANTENNA



The UR "TRIPOL"™

Guaranteed. Pat. Pend.  
90 to 6 Meters plus 160! 5 SWL Bands.  
Built-in balun. 1 kW ICA5 rating.  
80 to 120 ft inverted-V or horizontal.  
Available in kit form or assembled.  
Kit 80K \$54.95 cash PPD in USA.  
Kit 80K+8F with 100 ft 8/U foam cable and two PL259 \$82.95 cash PPD in USA.  
Texas residents add 5% sales tax.  
Order direct. Master Charge accepted.  
Send stamped envelope for information.

Universal Radio Co. Dept S1  
Box 26041 El Paso, TX 79926  
Telephone (915) 592-1910

Too bad I thought of it. OM returns aghast and delighted. Adds pegboard back to closet. Puts things on shelves neatly. Devises wire-hanger for side wall. Progress!

Pass the word I want egg boxes to use as acoustical tiles. NASTAR office says they seem to work (NASTAR, we remember you), though they never measured to be sure. Friends and relatives give egg boxes. Especially Grandmother, whose friends run a delicatessen. Can't just tack them up. Got to paint. (Worst mistake).

Line basement floor with newspapers; spread the cartons. Dab the paint, twist; dip, dab, twist. Slow going. Must be a better way. An idea lights. Use an insect sprayer. Got one for \$2.39.

"Why don't you just buy ceiling tiles? The suspended ones are great."

"The idea is to do this cheaply."

"Have you considered your labor?"

"I want to do something different. Be creative."

"You don't even know if it'll work."

"We'll measure it."

"Why paint first?"

"I've already started. Leave me alone."

Remove insect-sprayer cap. Hole small. Sacrifice soup ladle and kitchen funnel. Fill it. Push! Hard going. Clogs. Paint too thick; hole too small. Scratch \$2.39 plus ladle and funnel. Back to the brush. Dip, dab, twist; dip, dab, twist. This is going to take forever.

Six painting sessions later, enough done to cover one fourth of hamshack ceiling. Tall stack unpainted; short stack painted, wet ones on floor.

Enthusiasm not lost, just new projects gained. Let it ride. Months later: "I'm not so sure I like the idea. Why don't you drop it."

"Never. After all those people contributed cartons? After all my work?"

"Think of what there is yet to do."

I did. And I didn't do. Too many other things. (Sew, study, have another baby.)

Rain seeps into basement. Dries. Seeps again. Dries. O.M. disgusted with clutter there (of all places). Goes on binge. Cleans unmercifully. Fills garbage cans. Sells valu-

able gear. I'm busy upstairs.

"By the way," (weeks later) "I threw away those old egg cartons. It would never have worked. And you weren't going to finish them anyway."

Could he be wrong? (Might it work?) Anyone want to find out? ■

### ATTENTION METRUM II OWNERS



**VANGUARD** has a high quality synthesizer made for your rig. You get 2,000 thumbwheel selected channels from 140.000 to 149.995 MHz in 5 kHz steps at .0005% accuracy over the temperature range of -10 to +60 C and your cost is only \$159.95. With the Metrum, one Vanguard synthesizer covers both transmit and receive frequencies.

For complete details and photo see our half-page ad in this magazine.

### VANGUARD LABS

196-23 Jamaica Ave., Hollis, New York 11423

## CS<sub>dc</sub> WHILE THEY LAST POWER SCR's & TRIACS

BY LEADING U.S. MANUFACTURER



### SEND NOW FOR YOUR POWER PACKAGE KIT WHICH INCLUDES:

- ALL 200 VOLT OR HIGHER SCR's & TRIACS
- 2 TRIACS IN THE CURRENT RANGE OF 6 to 15 ARMS
- 1 TRIAC OR SCR WITH 25 ARMS RATING
- 1 GATE PROTECTION DIODE
- RATING/DEVICE DESCRIPTION INFO.

SEND CHECK OR MONEY ORDER FOR \$6.25 TO:  
POWER PACKAGE  
CS<sub>dc</sub>  
Post Office Box 816  
Wayne, N. J. 07470

## GATEWAY ELECTRONICS

8123 Page Blvd.  
St. Louis MO 63130  
(314)427-6116

2839 W. 44th Ave.  
Denver CO 80211  
(303)458-5444



### IC SOCKETS

	8	14	16	18	24	28	36	40	
Commercial CS	.24	.28	.30	.36	.53	.67	.84	.89	Gold
	.21	.25	.27	.35	.52	.64	.82	.86	Tin
Low Profile LS	.26	.34	.36	.40	.59	.70	.88	.94	Gold
	.23	.33	.35	.39	.58	.67	.86	.91	Tin
Standard CA	-	.36	.38	.42	.62	.74	.93	.99	Gold
	-	-	-	-	-	-	-	-	Tin
Standard Wire Wrap CA WW	-	.39	.41	.45	.79	.95	1.08	1.14	Gold
	-	-	-	-	-	-	-	-	Tin

IC sockets may be assorted for quantity discounts. 1 to 9 pcs. NET, 10 to 24 pcs. LESS 5%, 25 to 99 LESS 10%, 100 to 499 LESS 20%. WRITE FOR LARGE QUANTITY QUOTATIONS, D.I.P. plugs and covers also available.

## MINIATURE THUMBWHEEL SWITCHES

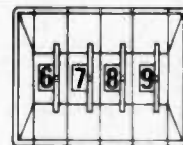

BCD ONLY	\$2.50
COMPLIMENT ONLY	2.75
BCD & COMPLIMENT	4.00
DECIMAL	2.50
END PLATES (PAIR)	.50
HALF BLANK BODY	.40
FULL BLANK BODY	.40
DIVIDER PLATE	.40

MINIATURE SIZE 0.315 X 1.3 X 1.78

All switches are black with white figures and snap-in front mounting.

\$5.00 minimum order —  
Please include sufficient postage.

VISIT US WHEN IN ST. LOUIS OR DENVER

# 555 Timer Sweep Circuit for SSTV

The circuit described in this article uses a 555 timer IC chip as both the oscillator and linear sawtooth generator circuit for an SSTV monitor. Most SSTV monitor sweep circuits that have been published use a transistor-discharged capacitor sweep circuit to produce the 15 Hz and 1/8 Hz sawtooth waveforms required for horizontal and vertical deflection. Separate oscillator circuits are required to drive the discharge transistors to produce a raster in the absence of sync pulses, or else the beam will stay at maximum deflection until sync pulses return.

I have been intrigued for some time with the 555 and its versatility in many applications. So, when I was building my SSTV monitor, I decided to experiment to see if the 555 could be successfully used as both the linear ramp generator and oscillator.

The entire sweep oscillator circuit described uses a pair of 555s, one for the horizontal sweep, and the other for the

vertical. A single 556 chip, which is merely two 555s in a single 14 pin DIP package, could also be used.

## The 555 Timer

For those not familiar with the 555, let me first describe its basic design and use as a simple oscillator. Such information is basic to the understanding of the SSTV sweep circuit.

A block diagram of the 555 is shown in Fig. 1. It contains a precision voltage divider string consisting of three equal resistors, two comparators, and a control flip flop. Also included are an inverting buffer amplifier capable of sourcing or sinking 200 mA and a discharge transistor whose collector is available at pin 7. The comparators set or reset the control flip flop when their inputs are equal to 2/3 or 1/3 of the supply voltage, respectively. When the flip flop is in the "set" condition, the output on pin 3 is at ground and the discharge transistor is "on"

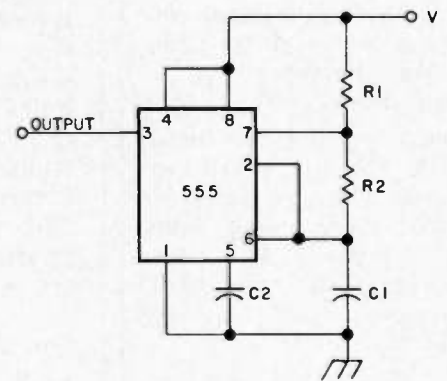

Fig. 2. Basic oscillator.

in the saturated condition. The 555 is available in an eight pin "Mini-DIP" package or in an eight lead TO-5 can.

## Basic 555 Oscillator

The use of the 555 as an astable oscillator is shown in Fig. 2. Circuit operation is as follows: Upon application of the supply voltage, which can be between 5 and 15 volts, capacitor C<sub>1</sub> will start to charge through R<sub>1</sub> and R<sub>2</sub>. When the capacitor voltage becomes equal to 2/3 of the supply voltage, the threshold comparator sets the control flip flop, turning on the discharge transistor. The capacitor then discharges through R<sub>2</sub>, until its voltage is equal to 1/3 of the supply voltage. The trigger comparator then resets the flip flop, turning off the discharge transistor, allowing the cycle to repeat. The waveforms produced are shown in Fig. 3. Since the comparator switching points are directly determined by the supply voltage, which also determines the charging rate of the capacitor, the oscillator frequency is insensitive to changes in the supply voltage. The oscillator frequency can be calculated by:

$$f = \frac{1.44}{(R_1 + 2R_2) C_1}$$

Capacitor C<sub>2</sub> is merely a by-pass to keep noise out of the reference voltages.

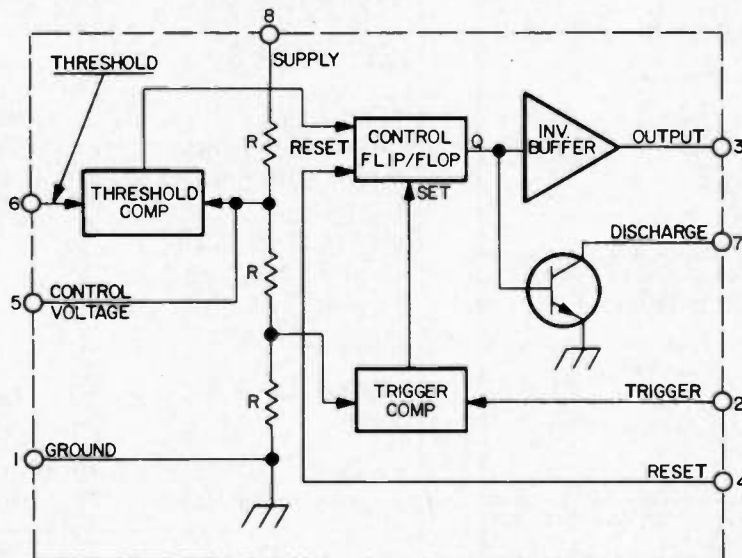

Fig. 1. Block diagram of 555 Timer Chip.



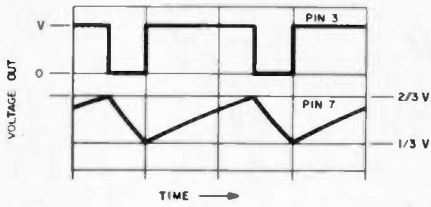

Fig. 3. Oscillator waveforms.

### Linear Sweep Oscillator

This basic circuit had some basic deficiencies which made it initially unsuitable for SSTV sweep application. The main objection was that its output waveform was exponential rather than linear. The other objection, rather minor, was that it did not return to zero but began recharging at 1/3 supply voltage. Both these problems were overcome with the circuit shown in Fig. 4.

Linear charging of the capacitor was achieved by using a transistor constant current source in place of R<sub>1</sub> and R<sub>2</sub>. The collector current of the PNP transistor is constant as long as the capacitor voltage is not equal or greater than the base voltage, allowing the transistor to conduct normally. The transistor operates to maintain the same

voltage drop across the emitter resistors R<sub>3</sub> and R<sub>4</sub>. The collector current for a high gain transistor ( $\beta > 300$ ) is for all practical purposes the same as the emitter current:

$$\frac{I_c}{I_e} = \frac{\beta}{\beta + 1} = \frac{300}{301} \approx 1$$

The result is a constant current that can be varied by changing R<sub>4</sub>. The amount of current will determine the charging rate of the capacitor, and hence establish the oscillator frequency.

To allow the waveform to return to zero volts before restarting the sweep, the trigger

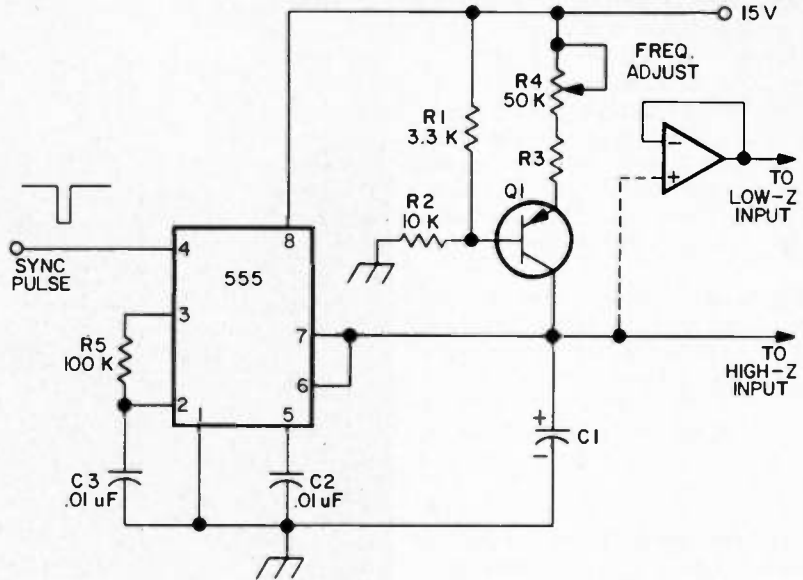

Fig. 4. Basic 555 sweep circuit. Q1 - 2N2907 or equiv.; C1 - 1 uF horiz., 10 uF vert.; R3 - 10k horiz., 250k vert.

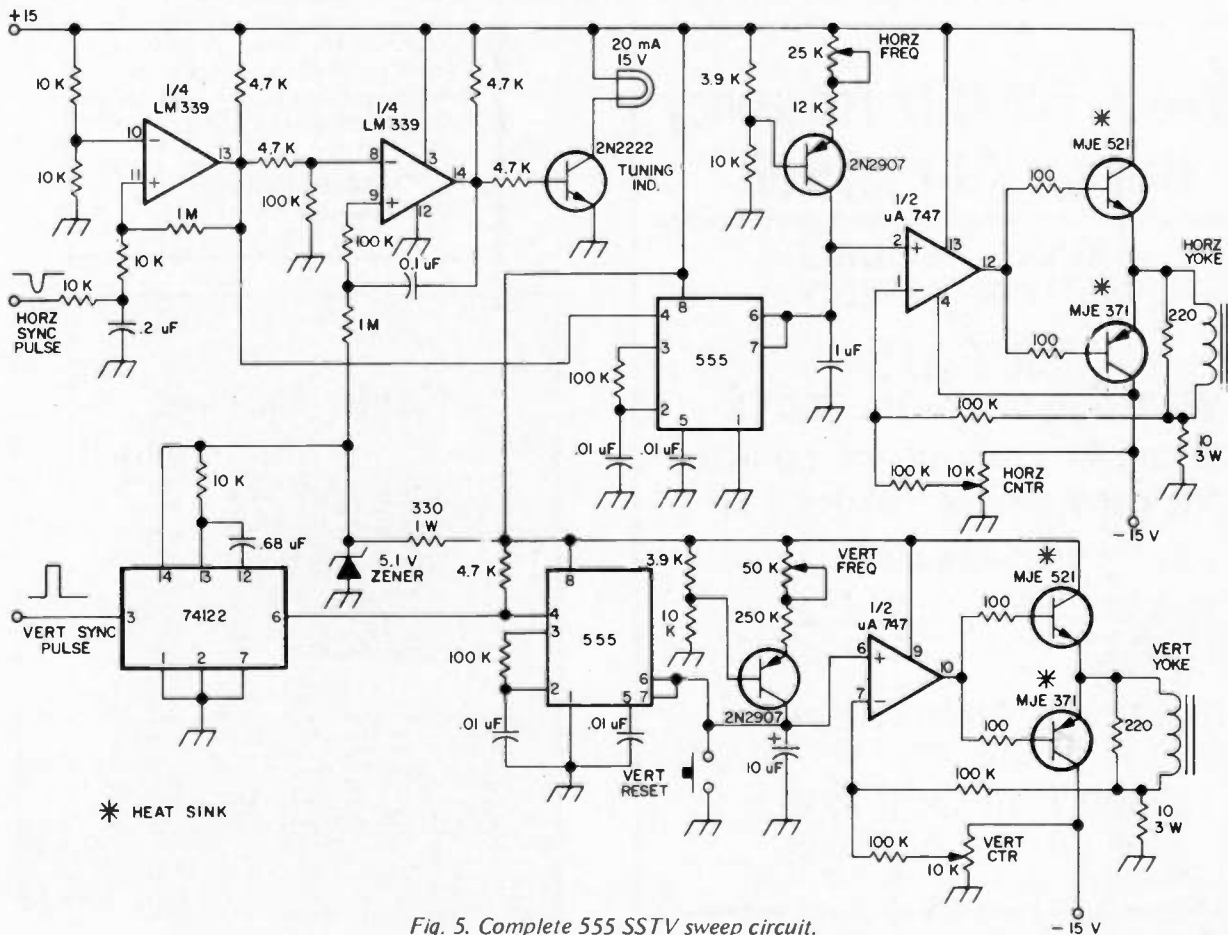

Fig. 5. Complete 555 SSTV sweep circuit.

input was connected instead to the output, pin 3, through a delay network R<sub>5</sub> and C<sub>3</sub>. Approximately 1 millisecond after C<sub>1</sub> is discharged and the output voltage goes low, the trigger voltage falls below 1/3 the supply voltage and a new sweep is started. The discharge of C<sub>1</sub> is quite rapid, allowing for rapid retrace. The 1 millisecond delay, however, insures that the capacitor does discharge completely before starting a new sweep.

In operation, the frequency of the oscillator is set by adjusting R<sub>4</sub> so that the period of oscillation is just slightly longer than the time between sync pulses. The presence of a negative-going sync pulse on the "reset" input (pin 4) will discharge the capacitor for retrace at the proper time and initiate a new sweep.

The sawtooth sweep is taken from pin 7. This is a high impedance point, and needs to be buffered with a voltage follower operational amplifier circuit if it must drive a low impedance input circuit. In this application, however, I was able to drive the positive input of the operational amplifier in the sweep driver stage without loading problems on C<sub>1</sub> or the current source.

#### Summary

The oscillator circuit is very stable, and will run very close to the correct frequency if sync pulses are QRM'd or otherwise lost. The "retriggering" aspect of its design makes it possible for the sweep to lock in again

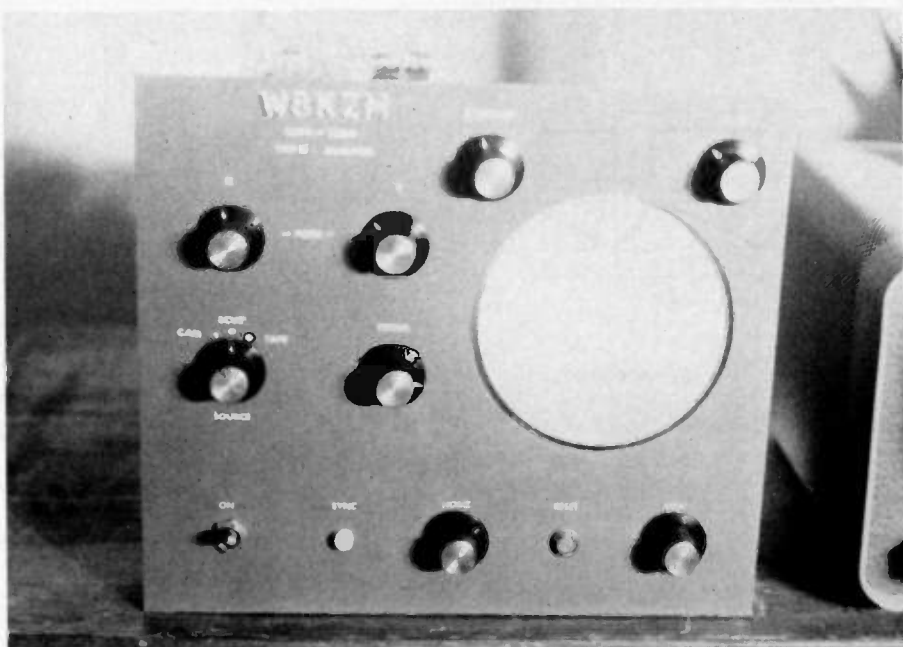

Home brew SSTV monitor using the 555 sweep circuit.

instantly on the first new pulse after previous pulses were lost.

Fig. 5 is a complete schematic of the sweep circuit used in my SSTV monitor. Included also in this circuit is a pulse "stretcher" and lamp driver that operates from the horizontal sync pulses and is used as a tuning indicator. The circuit has been in

use in my home brew SSTV monitor since November 74. The rest of the monitor is basically the W9LUO<sup>1</sup> design. The operation of the 555 oscillator/ramp generator has produced good results and stable pictures under many adverse conditions. ■

<sup>1</sup>"A Solid State SSTV Monitor-Mark II," Robert Tschannen W9LUO, *QST*, March, 1973, p. 27.

## New! 500 MHz Frequency Counter Kit - \$175.00

HAVING TROUBLE  
GETTING PARTS ?

**TRY US**  
WE HAVE THEM IN STOCK  
OUR 300 MHz FREQUENCY COUNTER  
STILL ONLY \$140.00 COMPLETE KIT  
\$105.00 BASIC

RANGE: 60 cycles to 300 MHz  
SENSITIVITY: less than 100 mV  
INPUT: 50 Ohms  
ALL TTL LOGIC

8 digit LED readout  
All parts including  
Case, bezel, IC sockets, etc.  
Comes with complete kit

KRP ELECTRONIC SUPERMART INC.  
219 W. SUNRISE HIGHWAY ■ FREEPORT, N.Y. 11520  
516 - 623-3346

SEND FOR OUR FREE  
24 PAGE CATALOG

PLEASE SEND 25 CENTS FOR POSTAGE AND HANDLING

Custom embroidered patches, no minimum, no shape or color limits. Doubleknit vests, nylon jackets, custom imprinted tee-shirts.

LePhCo  
2860H Pinkerton  
Zanesville OH 43701  
(614)453-6966

## Keyer Module

\$40



This new, low-cost, two-ounce keyer module has full squeeze or normal operation, yet draws less than one ma., key down! Attach a 9v transistor battery and forget it! Has dot, dash and space memories. Use with any key lever and 4 to 15 vdc source. Write or call for brochure. (303)794-7234. Dealer inquiries invited.

**CONTROL SIGNAL CO** 5004 W. COLUMBIA PLACE  
DENVER, COLORADO 80227

# 4 DIGIT ALARM CLOCK

## \$15.95

KIT No. 1 (with PC Board)

Features the only LED direct drive clock chip on the market. Kit includes all parts (except transformer) for a 4-digit alarm clock kit. Uses .25 inch LED readouts.

Transformer for Kit No. 1 ..... \$ 2.00

Kit No. 2 - Complete Kit With Woodgrain Case and Display Window .....\$21.50  
Kit No. 3 - Same as Above but with 1/2 inch Readouts .....\$22.50

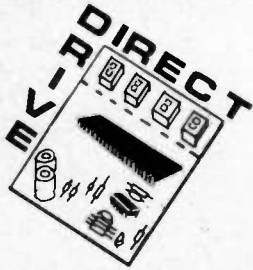

# THE KING OF ALTAJ



Follow the King in future issues, and he will introduce a series of fantastic Maidens representing Sophisticated circuits designed Especially for the KING.



## DIGITAL ALARM CLOCK

### THE KING-FEATURES:

- 1.) 6 digit, 12 or 24 hour, 50 or 60 cycle alarm clock.
- 2.) Time sharing capability for display of additional information.
- 3.) Built-in alarm generator and automatic output for intensity control of LED's.
- 4.) Single 12v. supply and a minimum of Interface components.
- 5.) AM-PM and automatic power failure indications.
- 6.) 10 minute snooze.
- 7.) Complete data and construction manual enclosed.



## \$23.50

Kit No. 70250 1R (Red readouts)  
Kit No. 70250 1Y (Yellow readouts)  
Kit No. 70250 1G (Green readouts).....\$23.50  
Kit No. 70250 2R (DL727 readouts)  
Kit No. 70250 3R (DL747 readouts).....\$28.50

Upon conclusion of our introductions you will have the most advanced timepiece on the market. Watch next issue for the King's first addition to his harem.

## DL747

Jumbo .6 in. high, and only 20mA. per segment. Common Anode

2.75

NEW HP7730 1.20

.33 in. high read very bright readout, 25mA per segment Common Anode

## BURROUGHS 12 DIGIT DISPLAY

.75 in. high, Orange digits Ionization voltage 110V DC. We will encl. a free socket as a bonus.

3.25

## MAN 5 GREEN MAN 7 RED MAN 8 YELLOW

Why not make a clock in 3 diff. colors, we tried it and it looks nice. .27 in. high digit. Common Anode

1.25

## DL707

Red, .30 in. high 15 mA per segment Common Anode

1.25

## 727

Common Anode One of our best Readouts, .5 in. high, 20mA per segment

3.75

## DL33

1.45

## FND503

We like it, you will love it, our new .5 in. common cathode type by Fairchild.

1.60

## 5FOR-750

## TEXAS INSTRUMENTS 6 DIGIT DISPLAY.

A perfect choice for your mini 6 digit clock or why not a stop watch Fully multiplexed, common cathode. 1 Class and goldplated.

1.30

## LEDs

Mini Red 12 cents ea.  
Jumbo Red 15 cents ea.  
Jumbo Green 20 cents ea.  
Jumbo Yellow 25 cents ea.

1.50

## LSI INTEGRATION

MM5314	6 digit digital clock 24 pin dip w/spec.	\$ 3.75
MM5316	4-6 digit alarm clock 40 pin dip w/spec.	\$ 4.25
7002	4 digit counter/latch decoder; 7 segment and BCD outputs. 28 pin dip w/spec.	\$12.50
7005	4 digit counter/latch decoder; 7 segment output only. 24 pin dip w/spec.	\$ 9.50
7007	4 digit counter/latch decoder with BCD output only. 16 pin dip w/spec.	\$ 7.00
70250	4-6 digit alarm clock 28 pin dip w/spec.	\$ 5.50
70380	4 digit non-multiplexed radio alarm clock featuring direct drive display output 40 pin dip w/spec.	\$ 6.50
PC Board for 70250		\$ 4.25
PC Board for 70380		\$ 3.75
PC Board for 6 Displays type Man or DL707		\$ 2.25
PC Board for 4 Displays type FND503		\$ 2.00
PC Board for 6 DL747 or 3 DL727		\$ 3.00

## TTL C-MOS

7400-16	
7402-16	
7404-16	
7406-24	
7408-16	
7410-16	
7413-49	
7420-16	
7422-24	
7430-16	
7437-39	
7438-35	
7440-16	
7442-69	
7447-89	
7448-89	
7453-37	
7473-37	
7474-37	
7475-65	
7476-39	
7483-85	
7490-69	
7492-75	
7493-75	
7495-75	
7496-75	
74121-38	
74123-75	
74151-75	
74153-89	
74154-95	
74161-99	
74163-119	
74164-189	
74165-149	
74174-129	
74175-139	
74181-275	
74192-125	
74193-125	
74195-79	
74197-79	

## TRANSISTORS

2N3055 NPN	115W TO3 Power	0.85
RCA 200V	115W TO3 Power NPN	1.25
GE D40C	NPN Darlingtion, Cut leads	0.25
2N4443 SCR	400V @ 8Amp. TO220	0.65
2N2222 NPN	Gen. Amplification	0.20
2N2924 NPN	Gen. Amplification	0.15
2N3904 NPN	Driver	0.15
2N3906 PNP	Complimentary 2N3904	0.15
2N4400 NPN	Low level noise	0.20
2N4402 PNP	Complimentary 2N4400	0.25
2N4249 PNP	Low noise, High gain	0.25
2N4969 NPN	Similar to 2N2221	0.20
2N5401 PNP	Nixie driver 160V.	0.25



555 Timer	Mini dip. Low Price	0.45
553 Timer	Quad. 14 pin dual.	2.25
8038	Function Generator	4.25
RCA 3043	FM, IF, Audio Preamp.	1.20
565	Phase Locked Loop.	0.95
567V	Tone Dec. Phase Locked Loop.	1.50
LM 723	Pos. Voltage Regulator	0.65
LM 309	5 Volt 1 Amp. Regulator	1.10
LM 741	Operational Amplifier	0.25
LM 324	Quad Operational Ampl.	0.95

## LOOK!

From Altaj to you, a special offer.  
Power Supply Kit; 5 Volt 1 Amp, regulated, Lineregulation .005% Loadregulation 50mV.  
Kit includes: Components, PC board, Transl., Fuse, Pilot Light.  
Nothing else to buy: \$ 5.50

## CPU'S

8008	8 bit parallel CPU	19.50
2102	1K Static RAM for 8008	2.25
MM5203	2K UV. erasable PROM.	12.25

## 6 Function Calculator

Chip 7020 with direct Segment Drive .8 digit.  
Priced to Sell: \$2.25

## RCA 3062

Photodetector with power-amplifier.  
\$2.25

## LED Driver ICs

75491	Segment	.35
75492	Digit.	.45

## CAPS

Tantalum	1 uF	10V	20% tol.	0.20
Tantalum	4.7 uF	10V	20% tol.	0.25
Electrolytic	10 uF	25V	PC.	0.15
Electrolytic	50 uF	25V	Ax.	0.20
Electrolytic	100 uF	15V	PC.	0.20
Electrolytic	200 uF	25V	PC.	0.25
Electrolytic	470 uF	16V	Ax.	0.30
Electrolytic	1000 uF	16V	PC.	0.35
Electrolytic	2000 uF	16V	PC.	0.45
Electrolytic	1500 uF + 2000 uF			
dual 30 Volt metal can, twist				0.85
Electrolytic	300 uF	250V	PC.	0.45
Ceramic Discs	.01uF	25V		0.05
Ceramic Discs	68pF	50V		0.05
Ceramic Discs	220pF	50V		0.05
Dipped Mica	150pF	100V	5%	0.10

## LIGHTS \$1.50

MUSIC 60 Watt COLOR ORGAN. Completely self-contained unit, with 120 volt power cord included.

## TTL BOARDS

MEMOREX computer boards with TTLS, Diodes and Transistors, etc.  
5 Boards containing 150-250 ICs. \$3.95

## TRANSFORMERS

No 1	8V .5 Amp	1.05
No 2	12V CT. .5 Amp	2.00
No 3	10V 3 VCT. 1 Amp.	1.95

## DIODES

1N4004	400PIV	15 for 1.00
1N4007	1000PIV	10 for 1.00
1N746	3.3V Zen.	4 for 1.00
1N4148	Switch	20 for 1.00

## FM Transformers \$1.00

Includes FORD 19 KHZ, 38 KHZ, Osc. Coils, etc. Used in AM-FM car radios. All New 10 PC. ASSMT.

## FREE! 9 Volt Battery with \$10.00 or more purchase

CSC 100  
NEW Proto Board  
\$19.95  
(Complete Kit)  
(Allow 2 weeks for Delivery)

GE Transistor Assortment  
T098 cased Darlingtons, SCRs, NPN, PNP, etc. Sample test shows very high yield.  
50 for .95  
100 for 1.75  
300 for 5.00  
Satisfaction Guaranteed

**ALTAJ ELECTRONICS**  
P.O. BOX 38544 M., Dallas, Texas 75238  
TERMS: Check or money order. No COD.  
Telephone (214) 278-3561  
Texas Residents Add 5%

Altaj Electronics  
Now offers a full line of Continental Specialties Proto Boards, Quick Sockets, Clips, Design Mats, Monitors, etc.  
**ALTAJ THANKS YOU**

from page 12

Ramada Inn in Culver City was contacted and they provided a room and telephone facilities. A portable two meter station, operating under the club's W6GAA callsign, was activated from that location on the club's WR6ABB repeater and all normal repeater activity other than that of an emergency nature was suspended. In place of the normal 'ABB activity, a PARC sponsored "Guatemalan Disaster Relief Net" was called. The purpose of this net was to take traffic input from all over the LA area, collate this traffic as to type (i.e., priority, emergency, health and welfare, etc.) and then disseminate same to the proper channels for delivery. Shelly WB6KED, who had already been working with the consulate, was dispatched on a rather permanent basis to set up a portable two meter station at their location. With the generous cooperation of Mr. John Smith, Supervisor of Airport Operations at Los Angeles International Airport, space and power was made available for a portable station to be set up at the Pan American Airlines terminal. This station was initiated and manned by a non-PARC member who volunteered both his equipment and time to get things started: Mr. Bill Orenstein KH6IAF/6, mentioned earlier in this column, along with the assistance of his "date" for the evening, Miss Karyn Ericksen. Bill and Karyn began the airport operation around 6 pm Saturday afternoon and continued on to about 5:30 am Sunday morning when relief operators finally arrived. The Pan Am terminal was chosen since they are the only carrier from this area with regularly scheduled flights to Guatemala City and were therefore bearing the brunt of the transport job of both people and supplies. Many people with relatives were going to that terminal in hopes of finding a way to send a message "back home," and it was thought that a station set up for easy public access would be ideal at that location. It was.

As soon as everything was ready to

go, Lenore Jensen W6NAZ, Chairman of the Southern California Amateur Radio Public Relations Committee, was asked to contact the news media and pass along the location of the airport station and the "Command Center" telephone number. In short order, the majority of Los Angeles broadcast media outlets were carrying the necessary information to the public and things began to get busy. While no exact figures are yet at hand, in the two days that this phase of the operation took, approximately 2,000 messages were collected and placed en route to Guatemala in two ways. Emergency and priority traffic was immediately handed off to stations in direct HF contact with Guatemala through a number of HF Disaster Relief Nets operating 20 meters during the day, and 40 or 80 in the evening. Through the efforts of WB6VDE, WA6IFU and WA6CPS, a portable 80 meter station was set up in the Ramada Inn parking lot housed in Roy WA6CPS's van; however, most of the aforementioned high priority was handled by other volunteer stations, many non-PARC members. Word had spread quickly as to what PARC was doing and the necessary HF stations soon made their presence and willingness to help known.

Health and welfare of a non-priority nature was handled in another way. The majority of it was placed in the hands of the crew of an airliner en route to Guatemala City with instructions that it be delivered to the proper authorities down there. This was done to alleviate the strain on the HF nets so that they could handle traffic on the aforementioned priority level. Two such packets went out on Sunday the 8th — one at about 9:45 am and another about 9 pm with the final batch to follow this coming am. At around midnight Sunday, this phase of the operation was terminated. I say this phase, since there will be more to come in the days and weeks ahead. We will continue to run communication liaison for the Consul General, accept and disseminate return communication, keep information on what is transpiring headed to the media, and anything else we are called upon to do. In fact, earlier this evening Dan and I found



Recording it all at SAROC is the author, as captured in this photo by Mrs. ITF.

ourselves working hand in hand with both the Guatemalan and Panamanian Consul Generals weighing relief supplies in the Pan Am air freight building prior to shipment. Earlier, I had found myself directing people who spoke little or no English to John WA6HQL, another non-PARC member who had been quick to offer his services when someone who was bilingual in Spanish and English was found a necessity at the airport operation. John spent about 10 hours cramped behind a desk writing messages in English that were being dictated to him in Spanish.

Then there was Bobby WA6ORR, who made sure that all operations had the necessary food to survive on. She ran around in the rain gathering donated food from McDonald's Hamburgers and Shakey's Pizza so that everyone would have lunch and dinner. As if that were not enough, she also spent about five hours manning a message-gathering position at the airport facility; the limited amount of Spanish that she knows was sure handy. The list of volunteers for this operation goes on and on and I could fill an entire column with just names. What's really important, though, is that when people in another part of the world were in need of help, people here, amateurs

such as you, were able and willing to provide that help. Not only am I proud that PARC took on this humanitarian project, but I'm proud of every amateur and non-amateur alike that volunteered his or her time to make its success unquestionable.

I think that Karyn Ericksen may have summed it up best last evening when I spoke with her and Bill at the airport. To paraphrase what she said: When things such as a disaster like this take place, one's instinct is to try and find some way to help. What these ham operators are doing is one of the finest and most sincere efforts she had ever seen and she was thrilled to be a part of it. There was no doubt in my mind that she really was impressed; the excitement in her voice was a give-away that she was witness to something beautiful.

Next month: A bunch of wrap-ups along with a meeting, so get ready for another long one. More on auto-patches, the windup on WR6AJP, the windup on SAROC and what that beautiful guy Johnny Johnston K3BNS told us about future FCC plans, and the windup on this story along with coverage of the February 22 SCRA meeting in San Diego. Just may be some big surprises from that one. ■



Bill Orenstein KH6IAF/6 relays earthquake information from Dr. Stark of "Food for the Hungry" (one of the first returnees) to the Los Angeles Guatemalan Consulate.



"Operation Save-a-Nation": PARC's portable station at L. A. International. Here, John Barreiro WA6HQL translates a health and welfare message into English. More than 3000 messages were handled.

Photo processing courtesy of NBC Network Press, West Coast Division.



# BC DIGITONE ENCODER



## FEATURES:

- Crystal Controlled - Digitally Synthesized Tones.
  - Low Current Drain CMOS Logic.
  - RFI Immune.
  - 16-Button Tactile Feedback Keyboard.
  - Will Interface to Transceivers Using Dynamic Microphones with Only Two Wires.
  - Provisions for Three Wire Interface Are Provided.
  - Gold-Plated Keyboard Contacts Provided for Maximum Reliability.
  - Operating Voltage Range 9-18VDC.
  - Size: 2.1" x 2.1" x .250" Without Case. 2.1" x 2.1" x .312" With Case.
  - 2" Square Velcro Available for Convenient Mounting - Dashboard - Sun Visor - Radio - Etc.
- |                          |         |
|--------------------------|---------|
| Touch-Tone Encoder ..... | \$29.50 |
| Case .....               | \$ 2.00 |
| Velcro .....             | \$ .50  |
- 12-Button Touch-Tone Encoder (Case and Velcro not Available) . . . \$29.50.

OHIO RESIDENTS ADD 4.5% SALES TAX  
SEND CHECK OR MONEY ORDER TO:

**The Barber Corporation**

P.O. Box 271A, Waynesville, Ohio 45068 513-897-2926

Open Tuesday and Thursday Evenings Until 7:00 PM EST

# CUSTOM TRANSFORMERS

- Plate Power
- Filament
- Low Capacity
- Chokes
- Saturable Reactors
- Ferrites
- Toroids
- Audio
- Specials

Write today for a free quotation on your transformer requirements.

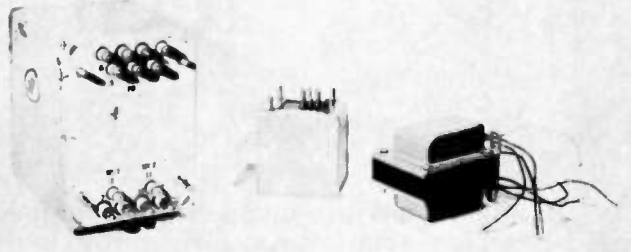

## HEAVY DUTY REPLACEMENT TRANSFORMERS\*

Collins 30S-1 Plate Transformer .....	\$150.00
Collins 516F2 Power Transformer .....	85.00
Hunter 2000B Plate Transformer .....	125.00
Alpha 77 Plate Transformer .....	125.00

\*All heavy duty replacement transformers are designed to run cooler and last longer than the original equipment transformer.

## SPECIALS

- HIPERSIL PLATE TRANSFORMERS: 3500 VAC at 1.0A ICAS; 230 VAC Primary; 6-7/8"H, 8-5/8"W, 7-3/8"D; 50 lbs.; \$125.00
- HIPERSIL PLATE TRANSFORMERS: 3000 VAC at 0.7A ICAS; 115/230 VAC Primary; 5-5/8"H, 8-1/2"W, 6-1/2"D; 35 lbs.; \$95.00
- 4-1000A FILAMENT TRANSFORMERS, 7.5 VCT at 21 amps, 117 V Primary, 4-1/2"H, 3-3/4"W, 4"D, fully enclosed; \$27.95.

ALL TRANSFORMERS GUARANTEED FOR 24 MONTHS!

**Peter W. Dahl Co.**

5325 Annette · El Paso, Texas 79924  
Telephone (915) 568-9702 or (915) 751-4856

*"New England's  
FRIENDLIEST HAM STORE"*

*Has been appointed  
Yaesu Distributor*

SEE OR CALL YOUR FRIENDLY SUPPLIER

**TUFTS** Radio Electronics  
386 Main St., Medford MA 02155  
Phone: 617-395-8280

# Tech Manuals

So! Now you're having second thoughts about that beautiful piece of electronic gear you bought at the surplus sale. It's beginning to look more like a boat anchor all the time. But, you say to yourself, if I only had a technical manual for it, I might be able to do something besides cannibalize it. Well, my friend, take heart. It is possible that you can get a manual for it. Public Law 90-23 allows the sale of

unclassified technical manuals directly to the public. This article will tell you how to go about ordering a manual and approximately how much it will cost.

Each agency, i.e., Army, Navy and Air Force, is responsible for determining the releasability and cost of the manuals under its jurisdiction. In the case of the Army and Navy, each has a single office where you

can send your request, but within the Air Force there are five different activities depending on the type of equipment involved.

Determining which of the first categories your goodie fits in will probably be obvious by the type sale where you purchased the item (Army, Navy, AF). If it is an Air Force item, you must further determine which activity in the Air Force can satisfy your request. But even if you goof and mail

your request to the wrong place, no harm will be done, except maybe some delay in getting the information you want. Each service has a similar way of identifying its manuals: the Army precedes a number or group of numbers usually with TM; the Navy with NAVSHIPS; and the Air Force with T.O. If there is any reference to this type number associated with the equipment when you get it, by all means

## Two Times

### TWO-TIMING CLOCK & STATION TIMER -

Displays either of two completely independent times - i.e. - GMT and local time - any combination you choose. Clock operates in three modes, 12-12, 12-24, or 24-24 hr. and includes a station I.D. timer which flashes the 6 digit L.E.D. display at 9.5 minute intervals. ID timer may be disabled when not in use. AC, DC, or Battery operation, emergency standby power provisions, .01% crystal controlled timebase and easy to follow instructions. Kit includes etched and drilled P.C. Boards, instructions, and all parts except case and transformer.

Kit with .3 in. Displays \$45.95 ppd.  
 Kit with .6 in. Displays \$55.95 ppd.  
 Wall plug Transformer \$ 3.95 ppd.

6 digit AUTOMOTIVE CLOCK KIT complete with a CRYSTAL TIMEBASE accurate to .01 percent. 12 volts d.c. operation - built in noise suppression and voltage spike protection. Readouts blank when ignition is off - draws 25 mA in standby mode. Has .3 in. readouts. Use it in your car or for all applications where a battery-operated clock is needed. Approximate size 3" x 3.5" x 1.75"

WITH BLACK PLASTIC CASE \$34.95 ppd.  
 WITHOUT CASE \$29.95 ppd.  
 ASSEMBLED AND TESTED \$45.95 ppd.

CMOS CRYSTAL TIMEBASE KITS with .01 percent accuracy. 5-15 v.d.c. operation. Draws only 3 mA at 12 volts. Single I.C. - very small size - the P.C. board is 7/8" x 1-5/8". Choose a main output of 50 or 100 Hz., 60 Hz., 500 or 1000 Hz., or 1 Hz. Several related frequencies are also available on each board, in addition to the main ones listed above. Be sure to specify the Frequency you want. All kits are \$10.95 ppd.

## PONG!

The world's second greatest indoor sport! For the price of 240 games of the commercial version of pong, you can enjoy endless hours of pong on your home TV. This kit generates adjustable ball and paddles, adjustable upper and lower court boundaries, audio sound effects, and a non-numeric score indicator on your TV set. Includes controls to allow horizontal and vertical paddle movement. Although the kit consists of standard TTL parts, it is fairly complex and requires some knowledge of electronics to build it and access to an O-scope to adjust it. The kit comes complete with an etched and drilled, double-plated-through P.C. board, instructions, and all parts including control pots, but less case. We pay the postage, unless you want it sent Air Mail and Insured, which is one buck extra.

TV Pong Game Kit \$59.95 ppd.

TO ORDER OR REQUEST INFORMATION WRITE:



**NEXUS**  
 TRADING CO.

Kits include all parts, instruction sheet, and etched and drilled P.C. board. Calif. residents add 6% sales tax. We also carry the MM 5320, the 5312, and other chips listed in our flyer. Interested? Write for it or circle the bingo card today.

• Box 3357 San Leandro, Ca 94578

mention this in your request. It may save you both time and loot, because if an agency has to perform research in excess of an hour or so to locate the number, you may have to pay for this research. However, most research requires much less time than this, so you don't have to worry about it.

The manufacturer installs a nameplate on each item of equipment before it is delivered. The nameplate contains, among other things, the Joint Electronics Type Designation Number or AN number as it is often referred to. This number tells you what the item is and, in the case of the Air Force, gives you a clue as to what activity is responsible for the technical manual.

As was stated earlier, if it is Army or Navy equipment, you need only mail your request to the appropriate address which is also listed at the end of the article. If it is Air Force equipment, mail your request to one of the five Air Force bases listed, after determining the appropriate one by reviewing the type equipment managed by each one.

Now for the cost. It is nominal as the government barely recovers printing costs. There is a minimum charge of \$2.00 for manuals up to six pages and an additional one-cent-per-page charge for all pages in excess of six. For example, a manual with 100 pages would cost about \$3.00. Be sure to specify what type manual you want, i.e., maintenance, operation, or parts list. Do not send any money with your original inquiry. As soon as the agency receives your request they will

determine if a manual is available. If it is, they will notify you what the cost is, how to make out your check or money order and tell you where to mail it.

That's all there is to it, so don't let that goodie gather dust on the shelf. Get yourself a technical manual and put it to work.

#### ADDRESSES

##### Navy

Director, Navy Pubs.,  
Hand Printing Service  
Naval District Washington  
Washington Navy Ship-  
yard  
Washington DC 20390

##### Army

Hq, DAAG-PAS  
Forrestal Bldg

Washington DC 20314

##### Air Force

Oklahoma City  
ALC/MMST  
Tinker AFB OK 73145  
Navigation Instruments,  
Flight Instruments, Auto-  
pilots and Airborne Gyro  
components.  
Ogden ALC/MMST  
Hill AFB UT 84406

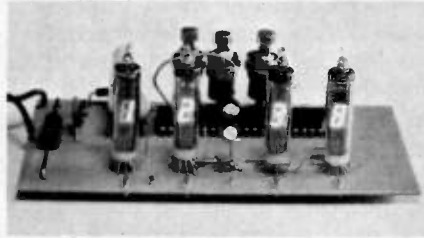

#### CLOCK KIT \$14.00

Includes all parts with MM5316 chip, etched & drilled PC board, transformer, everything except case. #SP284 \$14 2/\$25

#SP284 \$14 2/\$25

5 VOLT 1 AMP REGULATED power supply kit for logic work. All parts including LM 309K #PK-7 \$7.50

DUMMY LOAD resistor, non-inductive, 50 ohm 5 watts 3% \$1.00

AA NICAD CELLS brand new, fine biz for handy talkies. \$1.25 ea 9/\$9.00

ASCII KEYBOARD brand new w/ROM chip, data package \$45.00

#### POWER SUPPLY MODULE

New, plug-in module. Plugs into AC outlet provides 12 volts AC at 1/2 amp by two screw terminals. Great for various clocks, chargers, adding machines, etc. New

\$2.50 ea. 5/\$10.00

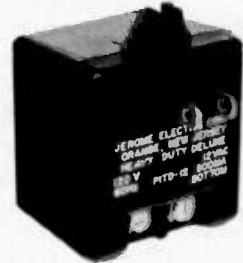

#### LASER DISCHARGE CAP

Sangamo, new, 40 mfd 3,000 volts, 180 Joules. May be used for filtering, linears, etc., by derating to 2,000 volts. Shipping wgt. 10 lbs. Measures 3 3/4 x 4 1/2 x 9 1/2 inches. \$25.00 each 5/\$110.00

#### TELEPHONE TOUCH PADS

New, by Chromerics, standard telephone format. Measure 2 1/4 x 3 inches. Great for repeaters, phones, computers, etc. \$4.50 each 6/\$25.00



C-MOS LINEAR by RCA, brand new, gold bond process.

301	\$ .60	747	\$ .82	MM5314	\$3.00
307	.52	748	.50	MM5316	3.00
324	1.80	1458	.96	7001	8.00
339A	1.60	3401	.80		
741	.50	555 timer	.60		

Please add shipping cost on above.

P.O. Box 62  
E. Lynn, Massachusetts 01904

FREE CATALOG  
SP-7 NOW READY

*Meshna*

Cameras, motion and still picture [all photo equipment]

San Antonio ALC/MMST Kelley AFB TX 78241  
Most all general purpose test equipment [i.e., scopes, VTVM's Tube testers, etc]

Sacramento ALC/MMST McClellan AFB CA 95652

Ground communications equipment [Navigation, Radar, communications] motor generator sets, teletype and facsimile equipment

Warner Robins ALC/MMST Robins AFB GA 31098  
Airborne Communications equipment [Navigation,

radar, communication, interphone] night vision equipment and miscellaneous communication equipment

NOTE  
It is not possible to list all categories. Those listed are general and the ones in which Hams would be most interested. ■

Si Dunn K5JRN  
3607 Binkley  
Dallas TX 75205

# RF and Mod Monitor

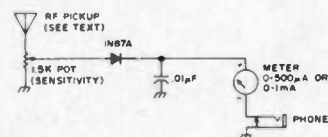

Around most ham shacks, several uses can be found for a simple rf and modulation monitor. This one is little more than a glorified crystal detector, but it monitors outgoing rf, aids in the tuneup of transmitters and antennas and lets you hear how your transmitted signal sounds.

Of course, single sideband — if the carrier is properly suppressed — will sound through this monitor like you're talking with a mouthful of wet cement. Amplitude modulated signals should sound clean and natural.

I built this circuit in a small phenolic box measuring 3-3/4 x 2-5/8 x 1-3/8 inches. A metal minibox also can be used. The rf probe is 5 feet or so of #22 enameled copper wire folded and taped into a "whip" about a foot long and soldered to a phono plug. At low frequencies and low power levels, a longer piece of wire may be necessary for sufficient rf pickup. Most any germanium diode should work, but a 1N87 gave higher output than a couple of other general purpose diodes. ■

## 2 METER CRYSTALS IN STOCK

We can ship C.O.D. first class mail. Orders can be paid by: check, money order, Master Charge, or BankAmericard. Orders prepaid are shipped postage paid. Phone orders accepted. Crystals are guaranteed for life. Crystals are all \$5.00 each (Mass. residents add 25¢ tax per crystal). U.S. Funds Only

We are authorized distributors for: Icom and Standard Communications Equipment. (2 meter)

Note: If you do not know type of radio, or if your radio is not listed, give fundamental frequency, formula and loading capacitance.

LIST OF TWO METER CRYSTALS CURRENTLY STOCKED FOR RADIOS LISTED BELOW:

- |   |                      |
|---|----------------------|
| 1●. Drake TR-22                         | 6●. Regency HR-2B    |
| 2●. Genave                              | 7●. S.B.E.           |
| 3●. Icom/VHF Eng.                       | 8●. Standard 146/826 |
| 4●. Ken/Wilson /Tempo FMH               | 9●. Standard Horizon |
| 5●. Regency HR-2A/HR212/Heathkit HW-202 | 10●. Clegg HT-146    |

The first two numbers of the frequency are deleted for the sake of being non-repetitive. Example: 146.67 receive would be listed as — 6.67R

- |          |            |           |           |           |           |           |           |
|----------|------------|-----------|-----------|-----------|-----------|-----------|-----------|
| 1. 6.01T | 9. 6.13T   | 17. 6.19T | 25. 6.31T | 33. 6.52T | 41. 7.03R | 49. 7.15R | 57. 7.27R |
| 2. 6.61R | 10. 6.73R  | 18. 6.79R | 26. 6.91R | 34. 6.52R | 42. 7.66T | 50. 7.78T | 58. 7.90T |
| 3. 6.04T | 11. 6.145T | 19. 6.22T | 27. 6.34T | 35. 6.55T | 43. 7.06R | 51. 7.18R | 59. 7.30R |
| 4. 6.64R | 12. 6.745R | 20. 6.82R | 28. 6.94R | 36. 6.55R | 44. 7.69T | 52. 7.81T | 60. 7.93T |
| 5. 6.07T | 13. 6.16T  | 21. 6.25T | 29. 6.37T | 37. 6.94T | 45. 7.09R | 53. 7.21R | 61. 7.33R |
| 6. 6.67R | 14. 6.76R  | 22. 6.85R | 30. 6.97R | 38. 7.60T | 46. 7.72T | 54. 7.84T | 62. 7.96T |
| 7. 6.10T | 15. 6.175T | 23. 6.28T | 31. 6.40T | 39. 7.00R | 47. 7.12R | 55. 7.24R | 63. 7.36R |
| 8. 6.70R | 16. 6.775R | 24. 6.88R | 32. 6.46T | 40. 7.63T | 48. 7.75T | 56. 7.87T | 64. 7.99T |

CRYSTALS FOR THE IC-230 SPLITS IN STOCK: 13.851111 MHz; 13.884444 MHz; 13.917778 MHz. \$6.50 ea.

BACK IN STOCK!

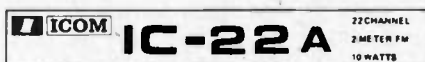

Special! Only \$249.95. Get 8 crystals of your choice for only \$2.50 more with purchase of IC-22A.

READY TO GO ON:

- |   |       |   |       |   |       |
|---|-------|---|-------|---|-------|
| 1 | 94/94 | 3 | 22/82 | 5 | 52/52 |
| 2 | 34/94 | 4 | 28/88 |   |       |



RECEIVER: VHF FM

Reception Frequencies	22 channels for 144 MHz band. Built-in crystal units for 5 channels.	144.00 to 148.00 MHz using 22 channels
Reception System	Double Superheterodyne	Transistors ..... 23
Intermediate Frequencies	1st intermediate: 10.7 MHz 2nd intermediate: 455 kHz	FET ..... 3
Sensitivity	a. Better than 0.4 u v 20db quieting	IC ..... 3
		Diodes ..... 16

STORE HOURS: MON-FRI: 9 A.M. - 9 P.M. SAT: 9 A.M. - 6 P.M.

**Kensco Communications INC.**  
Box 469  
Dept. 4576, Quincy MA 02169  
617-471-6427





Michael Wheeler WB4YDX  
3259 Roxbury Drive  
Lexington KY 40503

## A Failure to Communicate

I may give up ham radio. Band conditions have been getting progressively worse and recently it's been so bad, I haven't even been able to get through a complete QSO.

Last week was particularly frustrating; for example, on Sunday I was talking to a TV weatherman out in six-land and he told me about a wealthy friend of his who'd spent a bundle on a fancy antenna farm. It had separate towers with monoband beams for each band and the rotors were powered by specially designed batteries. They required a critical amount of internal pressure which was provided by an external compressor unit.

It seems that during the recent DX contest this fellow left the compressor on and the batteries built up so much pressure that they exploded, sending all kinds of debris into the air.

Naturally, when I heard about that, I commented that the skies must have been partly crowded with shattered towers, due to a high pressure cell. I figure

the band must have fallen out about then 'cause he didn't come back after that.

Then on Wednesday, I was up on Twenty, talking to a foreign sounding guy who kept referring to his transmitter as his E-mitter. He probably called it that because of its A-1

emissions (they sounded pretty good to me anyway). He told me about a run-in he'd had with the local tax collector who'd tried to impound his radio equipment. When they went to court over it, the judge, who turned out to be the tax collector's brother-in-law, told the

ham to hand over his gear.

I asked him if the judge had a deep voice, and when I found out that he did, I said, "It's obviously another case of a short circuit from E-mitter to collector due to an improperly biased bass."

The band dropped out on us. ■

*If you want to use*  
**ONE ANTENNA**

*There's only*  
**ONE DUPLEXER**

# MICROPLEXER®

*The Micro Strip Duplexer*

### FOR 2 METERS!

More than 105 db isolation  
Less than 1.5 db insertion loss  
250 watts  
Only \$350.00

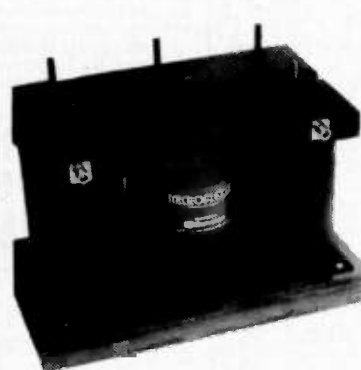

### FOR 220 MHZ!

More than 90 db isolation  
Less than 1.0 db insertion loss  
250 watts  
Only \$250.00



### FOR 450 MHZ!

More than 90 db isolation  
Less than 1.5 db insertion loss  
300 watts  
Only \$350.00

Call or write for our free catalog of  
Duplexers, Filters and Helical Resonators

 **SWIVETER**

105 No. Amphlett Blvd.

San Mateo, CA 94401

(415) 348-3858

**CONTINENTAL SPECIALTIES**

**PROTO BOARDS**

Build & test circuits as fast as you think!

**PB100** 10 IC cap breadboard kit, 4.5 x 6.0 x 1.35" \$19.95  
**PB101** 10 14-DIP cap, 5-way post, 940 solderless tie points, 5.8 x 4.5" \$29.95  
**PB102** 12 14-DIP cap, like PB101 with 1,240 tie points, 7.0 x 4.5" \$39.95  
**PB103** 24 14-DIP cap, 4 5-way posts, 2,250 tie points, 6.0 x 4.5" \$59.95  
**PB104** 32 14-DIP cap, 3060 solderless tie points, 8.0 x 9.75" \$79.95



**LOGIC MONITOR**

Simultaneously displays static and dynamic logic states of DTL, TTL, HTL or CMOS DIP ICs. Pocket size. \$84.95.

**PROTO-CLIP**

For power-on/hands-off signal tracing. Bring IC leads up from PCB board surface for fast trouble shooting.

PC15 14 pin \$4.50  
 PC16 16 pin 4.75

**SOCKETS & BUS STRIPS**

Plug-in, wire, test, modify or expand without patch cords or solder. Snap together to form breadboard needed.

Part Description	H. Hole	to Hole	Term. Price
QTS95 Socket	6.5"	6.2"	118 \$12.50
QTS98 Bus	6.5"	6.2"	20 2.50
QTS95 Socket	5.3"	6.0"	94 10.00
QTS98 Bus	5.3"	6.0"	16 2.25
QTS95 Socket	4.1"	3.8"	70 8.50
QTS98 Bus	4.1"	3.8"	12 2.00
QTS95 Socket	2.4"	2.1"	36 4.75
QTS98 Bus	1.8"	1.5"	24 3.75
QTS95 Socket	1.4"	1.1"	16 2.50
QTS98 Bus	1.3"	1.0"	14 3.00

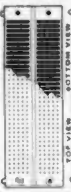

**LINEAR IC's**

H-TO-5	N-DIP	M-MINI-DIP	D-CER-DIP	K-TO-3
LM105H 3.90	LM311H 1.20	LM710CH 90	LM710CH 90	
LM114H 3.00	LM311M 1.75	LM711CH 90	LM711CH 90	
LM300H 1.20	LM312H 1.75	LM712CH 90	LM712CH 90	
LM300H 1.20	LM318H 1.50	LM716CH 3.50	LM716CH 3.50	
LM301AH .50	LM318M 2.40	LM715CD 4.60	LM715CD 4.60	
LM301AM .80	LM324A 1.90	LM723CH 1.40	LM723CH 1.40	
LM301AN 1.10	LM331N 1.25	LM723CN 65	LM723CN 65	
LM301N .95	LM336K 2.40	LM725CH 5.00	LM725CH 5.00	
LM302N 1.30	LM339N 2.20	LM725CD 1.50	LM725CD 1.50	
LM302M 1.40	LM340 2.90	LM733CH 1.40	LM733CH 1.40	
LM304H 1.20	LM320 5T 2.80	LM733CD 3.50	LM733CD 3.50	
LM305H .85	LM320-1K 2.90	LM733CN 1.30	LM733CN 1.30	
LM305AH 1.05	LM320-12T 2.50	LM741CH 4.00	LM741CH 4.00	
LM305N 1.00	LM340 5K 2.60	LM741CD 1.28	LM741CD 1.28	
LM307H .60	LM340 8K 2.60	LM741CN 3.9	LM741CN 3.9	
LM307M 1.50	LM340 12K 2.60	LM747CH 75	LM747CH 75	
LM308H .85	LM340 16K 2.60	LM748CM 55	LM748CM 55	
LM308AH 5.00	LM340 24K 2.60	LM777CH 2.15	LM777CH 2.15	
LM308M 1.00	LM355CM 1.30	LM304CN 95	LM304CN 95	
LM309H 1.75	LM556CM 1.30	LM3054CN 1.50	LM3054CN 1.50	
LM309M 1.50	LM567CM 1.70	SG4501N 2.40	SG4501N 2.40	
LM310H 1.50	LM709CH 75	SG4501N 2.40	SG4501N 2.40	
LM319M 1.80	LM709CK 75	LM5000K 7.50	LM5000K 7.50	

**MICROPROCESSORS and LS 1**

	1-9	10 up	1702	1700
P1101A	2.20	2.10	PR101	5.50
P1101A1	3.50	3.30	PR102	6.00
P1102-1	3.90	3.70	PR102-2	6.00
91L02	6.90	3.20	PR112	4.00
91L02-1	3.90	3.20	PR112-2	6.00
8080A		38.50	9102PC	4.00

**COMPUTER INTERFACE BIPOLAR MEMORY MOS-LSI**

DM8820N	2.40	C3101	6.50	1402AN	3.80
DM8820AN	6.90	P3101	4.90	1403AH	4.00
DM8830N	2.40	C3101A	7.30	1403AN	3.80
DM8831N	5.20	P3101A	5.80	1404AN	4.50
DM8832N	6.00	IM5510CDE	7.30	1404AN	4.50
N8T268	4.40	IM5510CPE	6.80	1405A	4.00
9600PC	1.30	MM5560D	7.30	1406	8.40
9614PC	1.20	MM5560N	5.80	1407	8.40
9620PC	1.95	DM8899N	5.80	1507	3.00
9616PC	5.00	93403PC	5.80	1602	33.00
9617PC	3.50			P2101	5.00
9620PC	4.00			P2101-2	5.50
9621PC	4.00			P2111	5.80

**1024 BIT N Channel RAM**

	C2102	5.00	P2102-1	6.00	
75107BN	2.60	C2102-1	5.80	P2111-2	6.00
75108BN	2.30	P2102-2	3.90	P2112	5.90
75109N	2.20	C2102-2	6.00	P212-2	5.90
75110N	2.20	P2102-2	3.90	P2401	9.00
75115N	2.25	P2102A	8.00	P2405	9.70
75138N	2.95	P2102A-2	9.50	2505K	3.30
75154N	3.10	P2102A-4	6.00	2512K	4.00
75208N	2.70	2601-1	11.40	2525V	2.50
75234N	2.50	2602B	3.80	2533V	7.90
75450N	1.28	2602-1B	4.40	2803PC	4.00
75451N	1.00	2602-2B	4.00	2804PC	4.00
75452N	1.00	7552-1CPE	6.00	2807PC	2.70
75453N	1.00	7552-1CPE	6.00	2808PC	4.00
		7552-2CPE	6.00	TMS3114J	9.40

**7520 SERIES SENSE AMPS**

7820N	4.00	TMS4033JL	9.00	TMS3120C	7.00
7521N	2.00	TMS4034JL	4.20	TMS3120C	6.00
7522N	4.25	TMS4034L	9.00	TMS3133NC	7.50
7523N	1.78	TMS4035L	9.00	3341APC	7.00
7524N	2.00	TMS4035NL	4.20	3347OC	5.80
7525N	4.50			3352PC	4.60

**TWO PHASE MOS CLOCK DRIVER**

MM404H	12.00	7552-1	4.95
MM405H	23.00	7552-2	5.40
MM406H	6.50	MM4055D	12.00
MM407H	6.50	MM4056H	9.70
MM451H	11.40	MM4057D	13.00
MM454F	18.00	MM5028N	20.00
MM500H	2.00	MM5029N	20.00
MM506H	3.00	MM5027N	20.00
MM507H	3.20	MM5055N	5.50
MM508H	8.90	MM5056N	5.80
MM511H	5.60	MM511H	5.80
MM555H	5.60	MM5058N	5.50

**MM**

MM404H	12.00	7552-1	4.95
MM405H	23.00	7552-2	5.40
MM406H	6.50	MM4055D	12.00
MM407H	6.50	MM4056H	9.70
MM451H	11.40	MM4057D	13.00
MM454F	18.00	MM5028N	20.00
MM500H	2.00	MM5029N	20.00
MM506H	3.00	MM5027N	20.00
MM507H	3.20	MM5055N	5.50
MM508H	8.90	MM5056N	5.80
MM511H	5.60	MM511H	5.80
MM555H	5.60	MM5058N	5.50

**IC SOCKETS WIRE-WRAP GOLD**

PIN 1-24	25 100	PIN 1-24	25 100	TEFLON TO-5				
8	21	19	17	14	45	41	37	3 PIN .85 EA
16	28	25	23	16	54	49	44	4 PIN .85 EA
24	67	61	55	16	28	25	23	6 PIN .90 EA
28	98	80	72	16	34	31	28	8 PIN 1.10 EA
36	109	98	89	14	34	31	28	10 PIN 1.40 EA
40	124	112	92	16	37	34	31	

**LEDs**

125" dia.	160" dia.	200" dia.
209 RED .25	216 RED .25	220 RED .25
209 YELLOW .35	216 YELLOW .30	220 YELLOW .30
209 GREEN .35	216 GREEN .30	220 GREEN .30
226 RED .25	5053 RED .35	MV50 RED \$3.30
226 YELLOW .30	5053 YELLOW .40	
226 GREEN .30	5053 GREEN .40	
226 DRANGE .30	5053 DRANGE .40	

**DISPLAYS**

OPCA	SLA1	RED	2.25	XCITON	KAN72	RED	2.00
DL80	RED	6.00	DL44	RED	6.00		
DL81	RED	6.00	DL402	RED	4.00		
DL10	RED	6.00	DL701	RED	3.40		
DL10A	RED	4.00	DL702	RED	2.25		
DL101	RED	4.90	DL707	RED	2.35		
DL87	RED	9.90	DL747	RED	2.50		
DL61	RED	12.00			1-9 10 up		
DL33	RED	4.00			DL747 RED 2.50 7.40		

**CARBON FILM RESISTORS**

150 STANDARD VALUES X WATT 5% \$1.69 per 100  
 10 ohm to 10 megohms . . . Only in multiples of 100 per value

**9-DIGIT DISPLAY**

EP 9125	\$7.90	ELECTRONIC ARRAYS
1/8" Character HL		EA1500AJ
Compact, Thin PC		1.24 12.00
Pkg., Wide Viewing Angle		25 16.80
		100 14.00
		EA1500ASJ
		1.24 16.00
		25 14.40
		100 12.00

**OPTOISOLATORS**

MONSANTO	LITRONIX
IL1	1.30
IL2	1.40
IL3	1.70
IL4	1.35
IL7	1.78
IL8	1.40
IL9	1.74
IL10	1.78
IL11	1.40
IL12	1.74
IL13	1.40
IL14	1.74
IL15	1.40
IL16	1.74

**STANDARD MICROSYSTEMS**

	1-9	10 up
COM2502	\$13.20	\$10.60
COM2502P	8.00	6.85
COM2017	13.20	10.60
COM2017P	8.00	6.85
COM2502H	25.00	20.00
COM2017H	25.00	20.00
COM2601	30.00	24.00
COM5016	12.00	9.60
KR2376-ST	20.00	17.50
KR3600-ST	20.00	17.50
NMX5010	12.00	9.60
CAL1022	60.00	52.00

**C-MOS**

P/N	1-9 10 up	P/N	1-9 10 up	P/N	1-9 10 up
4001AE	24 23	4027AE	55 53	4070AE	60 59
4001AE	24 22	4028AE	95 88	4071AE	25 23
4002AE	24 22	4029AE	125 122	4072AE	34 31
4004AE	4.00 3.99	4030AE	44 40	4073AE	38 35
4006AE	1.20 1.20	4032AE	60 54	4075AE	38 35
4007AE	24 23	4035AE	125 114	4076AE	124 122
4008AE	1.79 1.65	4040AE	1.58 1.50	4077AE	70 69
4009AE	59 51	4041AE	1.82 1.75	4078AE	38 35
4010AE	80 49	4042AE	78 75	4081AE	25 23
4011AE	24 23	4043AE	2.60 2.60	4082AE	34 31
4012AE	24 22	4044AE	80 75	4095AE	2.00 1.99
4013AE	46 40	4047AE	2.78 2.		

# INDUSTRIAL QUALITY

# E-Z-HOOK®

E-Z Hooks have been designed and field tested throughout the industry to save time and money in commercial electronic production and servicing. The spring-loaded hook attaches firmly, yet so gently it will not damage component — frees hands while testing. Durably constructed and fully insulated to a single contact point assuring true readings. Meets exacting laboratory and space, age computer technology requirements. **AVAILABLE IN 10 RETMA COLORS:** Red, black, blue, green, orange, yellow, white, violet, brown or gray. The most unique field-serviceable test connectors available. Fast, safe, sure and trouble-free. **NOW AVAILABLE FROM ANCRONA...** the source you can trust for fine quality, industrial-grade electronic components and accessories.

## SOLVE YOUR TEST CONNECTION PROBLEMS WITH E-Z-HOOK®

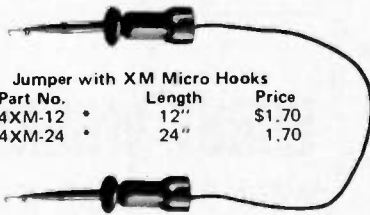

**Jumper with XM Micro Hooks**

Part No.	Length	Price
204XM-12 *	12"	\$1.70
204XM-24 *	24"	1.70

### MICRO HOOK



XM Micro Hook (1.75" long, <1 gram) for difficult IC Testing. Permits hookups to delicate wires where weight and leverage may damage component. **\$.80 ea.**

### MINI HOOK



X100W Mini Hook (2.25" long) combines rugged construction, miniature size and Finger-eze Hypo Action for all the best test connections. The hook is large enough for component leads, yet small enough to get into tight places. **\$.75 ea.**

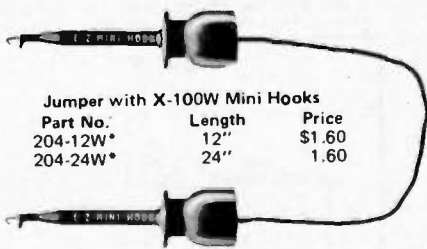

**Jumper with X-100W Mini Hooks**

Part No.	Length	Price
204-12W*	12"	\$1.60
204-24W*	24"	1.60

### EXTRA LONG MINI HOOK

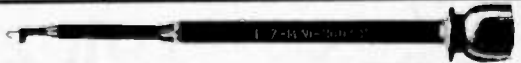

XL-1 Mini Hook (5.0" long) combines all the proven features of the X100W with an extra long body. It will make safe, short-free test connections in card racks and through deep wiring nest up to 4". **\$1.25 ea.**

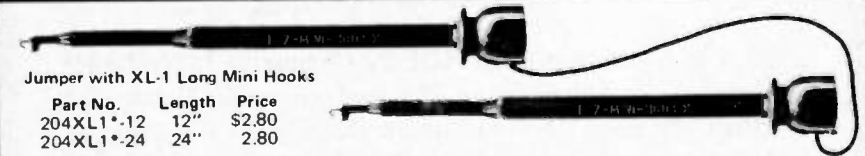

**Jumper with XL-1 Long Mini Hooks**

Part No.	Length	Price
204XL1*-12	12"	\$2.80
204XL1*-24	24"	2.80



**Jumper, XM Micro Hook to Banana Plug**

Part No.	Length	Price
201XM*	32"	\$1.40

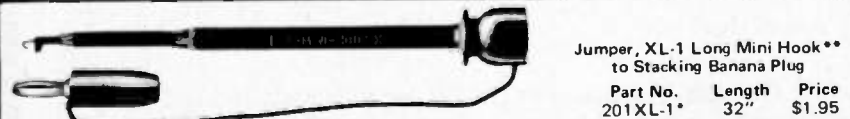

**Jumper, XL-1 Long Mini Hook\*\* to Stacking Banana Plug**

Part No.	Length	Price
201XL-1*	32"	\$1.95

\*Specify color. \*\*Square hole tip for hooking laterally to leads or vertically over square wire-wrap pins.

**ANCRONA... YOUR FIRST SOURCE FOR INDUSTRIAL QUALITY ELECTRONIC COMPONENTS AND ACCESSORIES**

Prices effective through April 30, 1976  
 Minimum order \$10.00. Add \$1.00 to cover postage and handling.  
 California resident add 6% sales tax.

SEND CHECK OR MONEY ORDER TO:



Mail order: P.O. Box 2208M, Culver City, CA 90230. Phone order: (213) 641-4064  
 Visit our Electronic Shop: 11080 Jefferson Blvd., Culver City, CA  
 (Studio Village Shopping Center)  
 Prices may vary at over-the-counter locations.

**Jumper X-100W Mini Hook\*\* to Stacking Banana Plug**

Part No.	Length	Price
201W*	32"	\$1.35



# Clegg ECONOMY LINE

## Two New VHF FM Transceivers at \$189.<sup>50</sup> Each

(special package prices for club groups)

### THE ALL NEW **FM-76**



WITH  
10  
WATTS  
FOR 220 MHz

### AND THE **MARK-3**



WITH  
15  
WATTS  
FOR 2 METERS

Both of these units PROVIDE 12 Channels • Individual trimmers for Receiver and Transmitter crystal Netting • Big Clear Panel Meter • Superb Receiver • Crisp Clear Audio on Receive and Transmit • Rugged, Compact, Attractive.

Crystals in stock only \$8.00 per pair installed and netted.

Call toll free  
today for descriptive literature  
or to order any Clegg products.

**Clegg**

208 Centerville Road, Lancaster, PA 17603  
Toll free sales & services - Phone (800) 233-0250  
In Pa. call (717) 299-7221 (collect)

**SGS-ATES AUDIO AMPLIFIERS**  
**LOTS OF WATTS**  
**IN LESS SPACE**  
FOR A WIDE RANGE  
OF APPLICATIONS

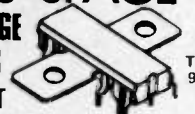

TCA  
940

10 WATT

Type	Supply Voltage Range (V)	Pout (THD=10%) (W)	RL (Ω)	V <sub>cc</sub> (V)	Closed Loop Gain Range (dB)	Key Features	Price
TAA 611B12	6 to 15	115 210	8	9 12	28 to 53		\$1.95
TAA 621A11	6 to 27	2.80 2.20 4.00	8 16 16	18 18 24	30 to 57		3.00
TAA 621A12	6 to 27	1.40 2.20	8 16	12 18	30 to 57		1.80
TBA 641B11	6 to 18	2.20 4.50	4 4	9 14	30 to 46		3.00
TBA800	5 to 30	4.70 2.80 5.00	8 16 16	18 18 24	30 to 53	Wide Supply Voltage Range	2.55
TBA 810AS	4 to 20	2.50 6.00 7.00	4 4 4	9 14.4 16	28 to 51	Thermal Shut-Down	3.00
TBA820	3 to 16	.75 1.80 2.00	4 8 8	6 9 12	30 to 52	Low Voltage Operation	1.65
TCA830	5 to 20	2.00 3.50	4 8	9 12	28 to 51	Thermal Shut-Down	2.25
TCA940	6 to 24	6.50 10.00	8 4	20 20	28 to 51	Fully Protected	4.50
TOA 2020	±18	10.00 15.00 (THD=1%)	8 4	±15 ±15	40	Fully Protected	7.80

Minimum Order \$10.00. Add \$1.00 for Postage. Data Sheets \$25 ea.

IF IT ISN'T INDUSTRIAL QUALITY OR BETTER,  
WE WON'T SELL IT TO YOU.

SEND CHECK OR MONEY ORDER TO:  
**ANCRONA CORP.**  
P.O. BOX 2208M  
CULVER CITY, CA 90230 • (213) 641-4064

## HOBBY/WORKSHOP WALL STORAGE CENTERS

These high-quality, exceptionally convenient units are perfect for the hobbyist or handiman with lots of tools and no place to store them. Also ideal for storage of small parts, hardware and components. Budget priced complete with pegboard wall.

27" - 68 cm

27" - 68 cm

27" - 68 cm

20" - 49 cm

10" - 26 cm

**WWSC3  
HOBBY STORAGE  
CENTER  
\$29.95**

30" - 87 cm

10" - 26 cm

**WWSC5  
TRADESMAN  
STORAGE  
CENTER  
\$69.95**

27" - 68 cm

29" - 73 cm

10" - 26 cm

**WWSC4  
HANDIMAN  
STORAGE  
CENTER  
\$48.50**

ADD \$1.00 TO COVER POSTAGE

WE OFFER ONLY THE  
FINEST QUALITY PRODUCTS AVAILABLE

SEND CHECK OR MONEY ORDER TO:  
**ANCRONA CORP.**  
P.O. BOX 2208M  
CULVER CITY, CA 90230 • (213) 641-4064



# HAVE I GOT A NUMBER FOR YOU!

toll free

# 800-325-3636

call

**HAM RADIO CENTER  
ST. LOUIS  
FOR NEW AND USED  
AMATEUR RADIO EQUIPMENT**

*We Trade on New or Used  
Charge it on Master-Charge or BankAmericard*



HK-1

**THE HAM-KEY  
Now 4 Models**

**MODEL HK-1 \$29.95 DELIVERED**

- \*DUAL LEVER SQUEEZE PADDLE
- \*FOR USE WITH ALL ELECTRONIC KEYS
- \*HEAVY BASE WITH NON-SLIP RUBBER FEET
- \*PADDLES REVERSIBLE FOR WIDE OR CLOSE FINGER SPACING

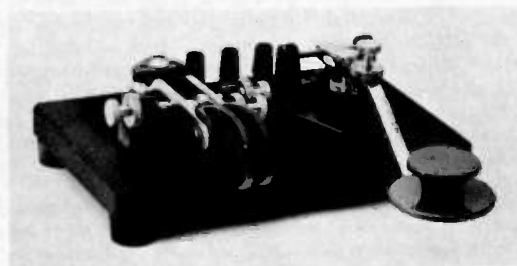

HK-4

**MODEL HK-4 \$44.95 DELIVERED**

- \*COMBINATION DUAL LEVER PADDLE AND STRAIGHT KEY ON SAME BASE
- \*STRAIGHT KEY MAY BE USED CONVENTIONALLY OR AS A SWITCH TO TRIGGER A MEMORY

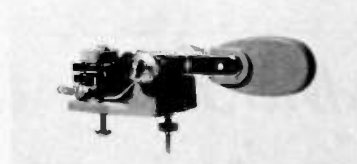

HK-2

**MODEL HK-2 \$19.95 DELIVERED**

- \*SAME AS HK-1, BUT LESS BASE FOR THOSE WHO WISH TO INCORPORATE IN THEIR OWN KEYS

- ALL KEYS ARE COMPLETELY ADJUSTABLE
- ALL PLASTIC PARTS HI-IMPACT STYRENE
- ALL HAVE COLOR CODED BINDING POSTS



HK-3

**MODEL HK-3 \$16.95 DELIVERED**

- \*DE LUXE STRAIGHT KEY
- \*VELVET SMOOTH ACTION
- \*HEAVY BASE WITH NON-SLIP RUBBER FEET
- \*NO NEED TO ATTACH TO DESK

## HAM RADIO CENTER INC.

8342 Olive BL.

P.O. Box 28271

St. Louis, MO 63132

# Docket 20686

Before the  
Federal Communications Commission  
Washington, D.C. 20554

In the Matter of

Deregulation of Part 97 of the Commission's Rules concerning portable and mobile operation of stations licensed in the Amateur Radio Service

DOCKET NO. 20686

## NOTICE OF PROPOSED RULEMAKING

Adopted: January 14, 1976;

Released: January 27, 1976

By the Commission:

Commissioner Lee absent.

1. In this Notice of Proposed Rulemaking the Commission proposes to simplify greatly the procedures involved in operating a station licensed in the Amateur Radio Service at a portable or mobile location. We propose to delete those sections of Part 97 of the Commission's Rules requiring that licensees operating their stations portable or mobile identify their transmissions as originating from a portable or mobile location. Section 97.313, concerning the station identification required of stations operated in the United States by aliens pursuant to international reciprocal agreements, would not be affected by the amendments proposed herein.

2. By way of background, an amateur licensee is presently permitted by Section 97.95(a) of the Rules to operate his station away from the permanent station location anywhere in the United States, its territories, or possessions as a portable or mobile station. Under Section 97.95(b) a licensee may, with certain restrictions, operate his station as a portable or mobile station outside the limits of the United States, its territories, and possessions. Sections 97.95(a)(3) and 97.95(b)(3) require that advance notice of such portable or mobile operation be given the Commission, pursuant to the provisions of Section 97.97, which specifies the content of the required notice, and states, further, that such notice need be furnished only if the contemplated portable or mobile operation is or is likely to exceed 15 days. Finally, Sections 97.87 (b) and (c) provide that the transmissions of stations being operated at portable or mobile locations be identified as such.

3. We believe those sections of the Rules cited in the preceding paragraph to be superfluous. Such requirements have never been shown to be of use to the Commission in its regulatory program, and while amateur licensees would in

the future, as now, be afforded the option of operating their stations at portable and mobile locations, we perceive no purpose to be served in requiring advance notice to be given the Commission or in requiring that transmissions of stations being operated at portable or mobile locations be identified as such. We would stress, however, that in eliminating these requirements we would not be prohibiting those licensees wishing to do so from continuing to identify their portable and mobile transmissions in the traditional manner. We would simply no longer require it.

4. In proposing that the portable operation station identification become optional, we recognize the probable impact on certain amateur operating practices and operating award programs neither regulated nor sponsored by the Commission. For instance, under the proposed rules, the control operator of a station in portable operation at a location outside its fixed operation call sign area [§97.51(b)] would no longer be in violation of the Commission's Rules should he choose not to include the portable designator when identifying the station. In these instances, listeners would not be able to determine from the identification that the station was located outside the fixed operation call area. Call areas would, in a de facto sense, be partially eliminated. For this reason, we particularly wish to receive comments on the issue of whether those amateur operators who would otherwise not elect to identify their stations as being in portable operation should be inconvenienced in order to eliminate any impact upon ongoing amateur practices and programs. While adoption of this proposal might ultimately cause a substantial dilution of the significance of amateur call sign areas, it would provide the Commission with important indicia of the extent to which the Service is capable of self-regulation and the extent to which our deregulatory program is likely to be successful.

5. For the reasons cited heretofore we therefore propose to delete in their entirety Sections 97.87 (b) and (c), 97.95 (a)(3) and (b)(3), and 97.97 of the Commission's Rules. The remaining sections of Section 97.87 would be redesignated to reflect the deletions.

6. The proposed amendments to the Rules, as set forth in the Appendix, are issued pursuant to the authority contained in Sections 4(i) and 303 of the Communications Act of 1934, as amended.

7. Pursuant to applicable procedures set forth in Section 1.415 of the Commission's Rules, interested persons are invited to file comments on or before February 27, 1976\*, and reply comments on or before March 8, 1976. All relevant and timely comments and reply comments will be considered by the Commission before final action is taken in this proceeding. In reaching its decision in this proceeding the Commission may also take into account other relevant information before it, in addition to the specific comments invited by this Notice.

8. In accordance with the provisions of Section 1.419 of the Commission's Rules, an original and eleven copies of all statements, briefs, or comments shall be furnished to the Commission. Responses will be available for public inspection during regular business hours in the Commission's Public Reference Room at its headquarters, 1919 "M" Street, N.W., Washington, D.C. 20554.

FEDERAL COMMUNICATIONS COMMISSION

Vincent J. Mullins  
Secretary

\*This Notice was received too late for inclusion in the February, March and April issues.

Please be advised that we have the unique situation of having recovered a Unimetrics Ultracom 25 with no obvious ID or serial no.

Would you please change your lost column in 73 to include "found"? Request that interested people contact David M. Stoner K8LMB, 619 Doepke Lane, Cincinnati OH 45231.

Keep up the good work with 73 — I love it.

David M. Stoner  
Cincinnati OH

HIJACKED: RF Comm. Inc. RF-403 two meter transceiver, s/n unknown. 4 Chan. 80 Watts approx 4" h x 12" w x 12" d. Set up for MARS frequencies, 34-94 and possibly other amateur frequencies. Color is black. Please notify FBI or Wallace Moore WB0AWH, 12053 W. Virginia Ave., Lakewood CO 80223, phone: (303) 986-3909.

KIDNAPPED: ICOM IC230 two meter transceiver, s/n 2403009. Rig was taken without the mike on December 9, 1975 in Cleveland, Ohio. Contact Ferd H. Nye, Jr. WA8NXT, 31497 Hilliard Blvd., Westlake OH 44145.

ROBBED: SB-144 two meter transceiver, s/n 620962 with "W5PJ" stenciled on the set. The wires were cut and the set with microphone was removed. It was equipped with 34-94; 94-94; 16-76; 22-82; and 52-52. It also had county and one city receiving police frequency. Taken on January 17, 1976. Please contact Dr. Shailer Peterson W5PJ/K4HL, 5511 Keystone Drive, San Antonio TX 78229, phone: (512) 684-0449.

ABDUCTED: Heathkit HW 202 two meter transceiver, s/n 07429. Taken from auto of Dick Cullen WB0AGT. Mike has broken switch bar. "Stolen from WB0AGT SSN 410-66-8452" engraved on back. Has home brew synthesizer installed on top of set in mini box approx. same size as HW202 and is painted black. Has 2 RG-174 interconnect cables. Xtals installed: 37-97, 34-94, 28-88, 07-67 and 52-52. Please notify Dick Cullen WB0AGT, 1515 Newcastle St., Colorado Springs CO 80907, phone: (303) 598-1849.

LIFTED: HR-2 Regency two meter transceiver, s/n 04-02689. Xtals installed: 34-94, 94-94, 16-76. Please notify Dick Sucher WA0ZLY, 3410

N. Prospect St., Colorado Springs CO 80907, phone: (303) 473-4186.

LOOTED: Unimetric Co., Ultra Com 25 — 12 chan. two meter FM transceiver, s/n 080-114. Taken from car in Akron, Ohio on September 12, 1975. Contact Herman Freeder WB8VQI, 944 Jason Avenue, Akron OH 44314.

RUSTLED: Heath HW-202 two meter transceiver. Crystals installed: 34/94, 94/94, 07/67, 16/76, 88/88. Can be identified by wrong size wire on PC board, modulation is set HOT, so normal use will clip out on repeaters. Please do not discuss this incident on any of the above frequencies. Stolen from Doc. A. L. Stigers, Golden CO 80401, phone: (303) 237-3296.

## Tracking the HAMBURGLAR

"HELLOooo, CAVE... THIS IS BILL GODBOUT. I'VE GOT THE STUFF RIGHT HERE FOR THE 73 AD... UNDER THESE THINGS HERE... OH YES. I'VE GOT SOME REAL SCREAMING SPECIALS, SO GET YOUR PENCIL THERE... READY? FIRST OF ALL, HOW'S THIS FOR A HAM SPECIAL:

## HAM SPECIAL 1

3 GHZ NPN TRANSISTORS---FOR OSCILLATOR/AMPLIFIER APPLICATIONS. GUARANTEED 100 MILLIWATTS OUT AT 1.5 GHZ. TO-18 CASE.

**3/\$1.95**

"AND I GOT A LOAD OF .01 DISC CERAMICS. HOW DOES 25/\$1.00 SOUND? THINK PEOPLE WILL BUY THEM AT THAT PRICE? YES? THEN HOW ABOUT ANOTHER HAM SPECIAL:

## HAM SPECIAL 2

.01 DISC CERAMIC CAPACITORS.....

**25/\$1.00**

"IS THIS THE APRIL ISSUE? CAN WE DO A SECOND ANNUAL APRIL FOOLISHNESS? OH, IT'S THE MAY ISSUE... LET'S SEE, ANOTHER HAM SPECIAL:

## HAM SPECIAL 3

100 uF, 35V ALUMINUM ELECTROLYTICS.....

**6/\$1.00**

"AND LET'S MENTION THE UHF/UHF FETS (NJFET, VHF/UHF RF AMP, SIMILAR TO 2N4416, 3/\$1; DUAL NJFET, VHF/UHF AMP ALSO 3/\$1), THE BUILDERS WILL PROBABLY LIKE THOSE. I'D LIKE TO HIT THE REAL BUILDERS IN THIS AD. HEY! DID YOU PUT THE CHERRY SWITCHES AND THE PUSHBUTTONS IN THE APRIL AD? AND DON'T FORGET ALL THOSE TANTALUMS I JUST GOT.

### CHERRY Switches and keytops

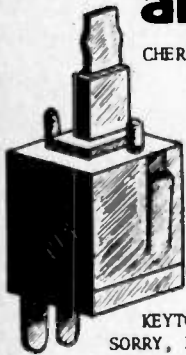

CHERRY STOCK # M61-100.

Lists for \$1.29-- 5 times our price

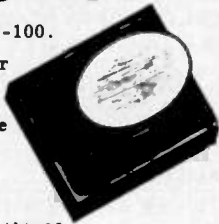

SWITCHES: 5/\$1.00 SWITCH/KEYTOP combination 5/\$1.25.

KEYTOPS WHILE THEY LAST! SORRY, NO CHOICE OF LEGEND.

### TANTALUM CAPACITORS

4 OF ANY ONE VALUE FOR A DOLLAR. VALUES AVAILABLE:

2.2 uF @ 20V	2.7 uF @ 20V
3.3 uF @ 15V	4.7 uF @ 10V
22 uF @ 10V	39 uF @ 10V



### PUSHBUTTON SWITCHES 4 FOR \$1.00 SPST MOMENTARY



"OH YES -- IT'S TIME TO SPRING THE ECONORAM ON THE WORLD, TOO....

4K BY 8 RAM KIT --- ALTAIR 8800 DIRECT, PLUG-IN COMPATIBLE!

\*LOW POWER: Typical current consumption at room temperature 1 Amp.

\*BUFFERED addresses and buffered data outputs.

**ECONORAM™**  
**\$89.95**

\*On board regulators

\*Fully static operation

\*Complete with instructions, sockets for all ICs, lots of bypassing, quality double-sided plated-through board, and like Bill says--- "The only thing we skimped on was the price".

"THE ONLY THING WE SKIMPED ON WAS THE PRICE... TELL 'EM THAT IN THE AD. OF COURSE I'M ANNOUNCING IT FIRST IN 73... THE READERS HAVE ALWAYS BEEN GOOD TO US... BESIDES, I LOVE READING THEIR LETTERS; 73 PEOPLE ARE A NEAT BUNCH. HEY-MAKE SURE YOU TELL 'EM I'LL BE LOOKING FOR THEM AT DAYTON! GOTTA GO, BOB MULLINS IS HERE. YOU'LL GET THE AD ON WEDNESDAY? GREAT! BYE-BYE"

TERMS: Add postage where indicated; add 50¢ to orders under \$10. No COD orders; it's a lot of paperwork for us. Californians add tax. To place BankAmericard® or Mastercharge® orders, call (415) 357-7007, 24 hours a day. Please remember this is an answering service, and is not set up to handle technical questions. Want to know about all the other stuff we sell? Send for our FREE FLYER!

**GODBOUT**  
BILL GODBOUT ELECTRONICS  
BOX 2355, OAKLAND AIRPORT, CA 94614





**DRAKE**

R-4C RECEIVER	599.00
T-4XC TRANSMITTER	599.00
TR-4C TRANSCEIVER	599.95
AC-4 POWER SUPPLY	120.00
MS-4 SPEAKER	24.95
SPR-4 RECEIVER	629.00
DSR-2 VLF-HF DIGITAL RCVR	2,950.00
TR-22C FM TRANSCEIVER	229.95
4NB NOISE BLANKER R-4C	70.00
250Hz, 500Hz, 1500Hz FILTERS R-4C, EACH	52.00
34PNB NOISE BLANKER TR-4C	599.95
RV-4C VFO TR-4C	120.00
MN-4 ANTENNA MATCH BOX	110.00
MN-2000 ANTENNA MATCH BOX	220.00
W-4 WATTMETER 1.8 TO 54MHz	72.00
WV-4 WATTMETER 20 TO 200MHz	84.00
RCS-4 REMOTE CONTROL ANTENNA SWITCH	120.00
L-4B LINEAR AMPLIFIER	895.00
SSR-1 COMM RECEIVER	350.00

**SWAN**

700CX TRANSCEIVER	649.95
MB-40A TRANSCEIVER 40 MTRS	329.95
MB-80A TRANSCEIVER 80 MTRS	329.95
P1215A P/S MB-40A/80A	75.95
117XC AC/CONSOLE P/S 700CX	159.95
VX-2 VOX	44.95
FP-1 PHONE PATCH	64.95
510X OSCILLATOR	67.95
1200X LINEAR AMPLIFIER	349.95
SWR-1 rf WATTMETER 0 TO 1 kW, 3.5-150MHz Power Meter/SWR Meter, SO-239 Connectors	21.95
WM-2000 POWER/SWR METER	49.95
WM-3000 POWER/SWR METER	66.95
45 ANTENNA ALL BAND 1kW PEP, Manual switching, No coil switching	114.95
742 TRI BAND 20-40-80 MTR., Electronically automatic band switchline 500W PEP	79.95

**COLLINS**

KWM-2A TRANSCEIVER	2,120.00
75S-3C RECEIVER	1,593.00
32S-3A TRANSMITTER	1,840.00
516F-2 POWER SUPPLY	265.00
30L-1 LINEAR AMPLIFIER	973.00
312B-4 CONSOLE	360.00
312B-5 CONSOLE/VFO	759.00
51S-1 RECEIVER	2,927.00
55G-1 PRESELECTOR 51S-1 200Hz to 2 MHz	373.00

**SHURE**

444 SSB DESK TOP MICROPHONE with OFF-ON VOX switch or PTT	32.50
444T SSB DESK MICROPHONE with OFF-ON VOX switch or PTT, built-in transistorized pre-amp	42.50
404C HIGH IMPEDANCE MAGNETIC HAND-HELD MICROPHONE, for SSB, PTT, ideal for Atlas or SWAN	27.00

**REGENCY**

HR-2B FM 2 METER TRANSCEIVER	229.00
HR-212 FM 2 METER TRANSCEIVER	259.00
HR-220 FM 220 MHz TRANSCEIVER	239.00
HR-440 FM 440 MHz TRANSCEIVER	349.00
HR-6B FM 6 METER TRANSCEIVER	239.00
AR-2 2 METER LINEAR AMPLIFIER	119.00
P-110 POWER SUPPLY 117V to 13.8 DC 5 AMP	49.95

**BRIMSTONE**

144 2 METER FM TRANSCEIVER, 25 Watt, 143.00 to 149.99 MHz, Digital Dialed 5KHZ steps, No crystals to buy. 142 MHz MARS coverage optional	\$650.00
--	----------

**COMCRAFT**

CST-50 VHF TWO BAND TRANSCEIVER, 2 and 1 1/4 Meters, Digital Frequency Synthesis 142 to 149.995 MHz and 220 to 225 MHz, 25 Watts	\$869.00
--	----------

**MILLEN**

92200 ANTENNA MATCHBOX All Band 2 KW	199.00
92201 JR ANTENNA MATCHBOX All Band 300 Watts	138.00
90652 SOLID STATE GRID DIP OSCILLATOR, 9 volt battery operated and coil 1.7 thru 300 MHz supplied	138.00

**CUSHCRAFT ANTENNAS**

A147-4 146-148MHz 4EL BEAM	14.50
A147-11 146-148 MHz 11EL BEAM	23.95
A147-22 146-148MHz 22EL BEAM	68.50
AFM-4C J. POLE 144-148MHz	52.50
ARX-2 RINGO RANGER 135-170MHz	26.50
ARX-220 RINGO RANGER 220-225MHz	26.50
ARX-450 RINGO RANGER 435-450MHz	26.50
AR-6 RINGO 50-54MHz	23.50
DX-120 144MHz 20EL DX ARRAY BEAM	38.00
A147-VPK VERT POLE STACKING KIT TWO 147-4	19.95
A147-VPK VERT POLE STACKING KIT TWO 147-11	22.95
CR-1 RINGO CB ANTENNA	26.50

**ANTENNA SPECIALISTS**

ASP558 TWO METER 5/8 WAVELENGTH 3dB MOBILE ANTENNA, mag. mounting, no holes to drill	36.50
--	-------

**BARKER AND WILLIAMSON**

375 PROTAX ANTENNA SWITCH with automatic grounding, 6 position rear mounted SO-239 connectors	18.50
376 SAME AS ABOVE, 5 position side mounted SO-239	18.50

**ATLAS**

210X 80 THRU 10MTRS	649.00
215X 160THRU 15MTRS	649.00
220CS AC SPKR CONSOLE	139.00
200PS PORTABLE AC SUPPLY	95.00
DMK PLUG-IN MOBILE MOUNT	44.00
MT-1 MOBILE ANTENNA MATCHING TRANSFORMER	24.00
PC-120 NOISE BLANKER	48.00
VOX ACCESSORY	45.00
10X CRYSTAL OSCILLATOR	55.00

TRADES TAKEN ON NEW EQUIPMENT. WE PAY SHIPPING VIA U.P.S. OR BEST WAY ON ALL ABOVE ADVERTISED ITEMS. SATISFACTION GUARANTEED, ALL ORDERS EXPERTLY HANDLED TO ASSURE SAFE ARRIVAL. WE ACCEPT MASTER CHARGE. N.C. RESIDENTS ADD 4% SALES TAX. PHONE BILL SLEP (704) 524-7519.

**Slep  
Electronics  
Co.**

P.O. BOX 100, HWY. 441, DEPT. 73, OTTO, NORTH CAROLINA 28763



# The Black Watch kit

At \$29.95, it's

★**practical**—easily built by anyone in an evening's straightforward assembly.

★**complete**—right down to strap and batteries.

★**guaranteed.** A correctly-assembled watch is guaranteed for a year. It works as soon as you put the batteries in. On a built watch we guarantee an accuracy within a second a day—but building it yourself you may be able to adjust the trimmer to achieve an accuracy within a second a week.



The Black Watch by Sinclair is unique. Controlled by a quartz crystal . . . powered by two hearing aid batteries . . . it's also styled in the cool prestige Sinclair fashion: no knobs, no buttons, no flash . . . just touch the front of the case to show hours and minutes and minutes and seconds in bright red LEDs.

The Black Watch kit is unique, too. It's rational—Sinclair have reduced the separate components to just four.

It's simple—anybody who can use a soldering iron can assemble a Black Watch without difficulty. From opening the kit to wearing the watch is a couple of hours' work.

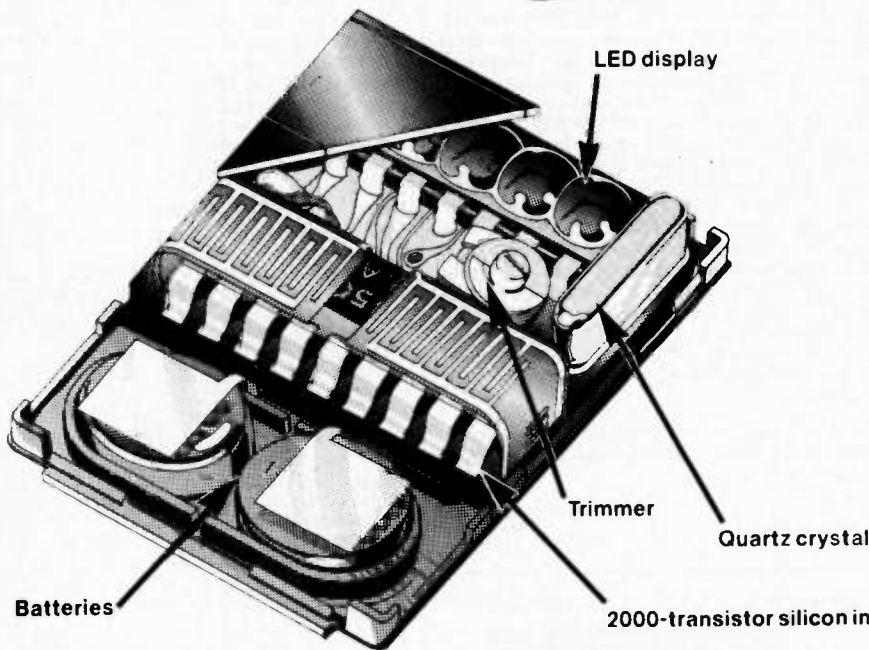

## Complete kit \$29.95!

### The kit contains

1. printed circuit board
2. unique Sinclair-designed IC
3. encapsulated quartz crystal
4. trimmer
5. capacitor
6. LED display
7. 2-part case with window in position
8. batteries
9. battery-clip
10. black strap (black stainless-steel bracelet optional extra—see order form)
11. full instructions for building and use.

All you provide is a fine soldering iron and a pair of cutters.

Please send me

\_\_\_\_\_ Black Watch Kits @ \$29.95

\_\_\_\_\_ plus \$2.50 shpg. & hndlg.

\_\_\_\_\_ Stainless steel bands

@ \$5.50

NY residents please add sales tax

I enclose my check/MO for \$ \_\_\_\_\_

Name \_\_\_\_\_

Address \_\_\_\_\_

73-5

### IMPORTANT

Print your name and address here →  
for use as a shipping label.  
Thank you.

Name \_\_\_\_\_

Address \_\_\_\_\_

zip \_\_\_\_\_

### FREE 10 DAY TRIAL

If you decide not to keep your Black Watch Kit, return it undamaged within 10 days for a full refund on the kit.

Mail to:

**sinclair**  
**SINCLAIR RADIONICS**  
Suite 400  
888 7th Avenue  
New York NY 10019

**NOW UNDER  
NEW  
MANAGEMENT**

**SUPER - SUPER - SURPLUS OUR 1st AD IN OVER 2 YEARS  
OUR CATALOG NOW BIGGER & BETTER THAN EVER...SEE BELOW**

**90% Material in  
stock & shipped  
in 24 Hours....**

**CHOMERICS PHONE TOUCH PAD -**

New packaged surplus keyboards by Chomerics. Use with our AY-5-9100 telephone dialer chip for complete Touch-Tone dialer phoning. Size: 2 1/4 x 3 1/4" thick. Useful for GI and Motorola Dialer chips. Quantity limited. Priced for quick sale: \$4.50 each, 10 and up \$4.25 each, 50 and up \$3.98 each, 100 and up \$3.60 each.

Sh. Wt. 4 oz. 5MI00349 \$4.50  
3 for \$13.00 5MI00349 \$13.00/3



**GET A COPY  
OF OUR SUPER  
CATALOG !!!!  
BARGAINS!!...**

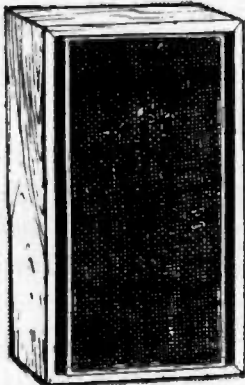

**KLH SPEAKER ENCLOSURES \* \* \*  
ANOTHER SPECIAL PURCHASE**

These Model 23 enclosures were designed for a 2 way system 12" Woofer and 2" Tweeter (easily modified by adding holes for other speakers), in a handsome real Walnut wood cabinet. We have a super deal on these fine cabinets less speakers and grill cloth. We supply two (2) cabinets, less speakers, for \$37.50, which is a steal for these super cabinets. You supply your own speakers and **SAVE REAL MONEY!** These sell with speakers for \$299.00 a pair. . .

Sh. Wt. 42 Lbs ea. 5Z00428 \$25.00 ea  
2 for \$37.50 5Z00428 \$37.50/2



**LOUDSPEAKER COMPONENT SPECIAL**

We have made an excellent purchase of an excess inventory of a local manufacturer's speaker systems, although we are not allowed to mention the mfr's name, the specs should make it self-evident. The woofer is a 12" free-edge (acoustic suspension) unit, with 2" voice coil and a No. 2 magnet. The mid-range is a 5" sealed back speaker and 3 1/2" flare dome tweeter for best high frequency dispersion. Crossover between woofer and mid-range is by an R-L-C network, while high frequency crossover is by an R-C network. Balance controls are provided for both mid-range and tweeter. Plans for a suitable enclosure are provided. The level controls provide frequency response to suit room acoustics, with realism that will delight even the most critical listener. Response: 25 to 20K + Hz. Power: 65 watts RMS. Impedance: 8 ohms

Sh. Wt. 12 Lbs. LSCS \$47.50  
2 for \$85.00 LSCS \$85.00/2

**DATA MANAGEMENT STATION  
SYSTEM 21**

**We have located a few VIATRON  
SYSTEM 21 COMPUTERS . . .**

**\$669.50**



**CLOSE OUT SALE**

A typical System 21 configuration includes a Microprocessor, two Tape Channels, a Keyboard, two Data Channels, and a Video Display. Central to the System 21 structure is the Microprocessor which contains hard-wired microprograms that perform a fixed set of logical operations. The hard-wired microprograms in the Microprocessor accomplish the same functions as a general-purpose computer operating system or assembler. Because the microprograms are hard-wired, however, there is no need for extensive programming.

The Microprocessor has four input/output channels, two Tape Channels and two Data Channels. The Tape Channels are devoted to either VIATAPE Recorders or Computer Tape Recorders, one recorder per channel. The two Data Channels can communicate with optional input/output devices. They can be connected, for example, to a Model 6001 Card Reader/Punch Adapter for reading and punching cards, or to a Model 6002 Printing Robot for providing hard copy. The Data Channels can also be interfaced with a Model 6003, 6004, or 6005 Communication Adapter for providing a link with another System 21 Data Management Station, a computer, or virtually any other device capable of USASCII interface. The Keyboard has its own Channel dedicated to providing data input and control to the Microprocessor.

These systems are sent checked out and are in running condition. At this time we have only 25 System 21's.

**SYSTEM 21 . . . . . \$669.50**

**MUSE - MUSIC COMPUTER COMPOSER**

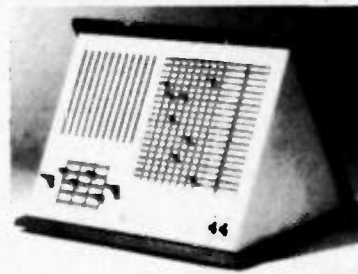

This compact digital computer uses the latest electronic technology to compose and create your own synthesized electronic music, it's ahead of its time! Complete new packaged system with its own instruction booklet. List price was \$347.50 . . . Yours for only \$139.50. Quantity is limited. An outstanding, unique experience for the buyer. A close out bargain.

Sh. Wt. 15 Lbs. MUSE \$139.50

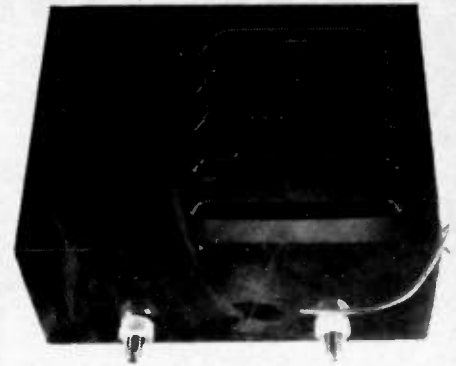

**"OSHA" TRUCK BACK-UP  
ALARM**

Yelping noise source/back-up alarm for fork trucks or whatever. Units contain a waterproof speaker, electronics and driver circuits to yelp. Quantity is limited. This system originally cost \$49.50 - yours for a fraction of that price. Includes back-up alarm switch. For 12 or 24 volt applications (state choice).  
Sh. Wt. 10 Lbs. 5Z00451 \$19.50  
4 for \$60.00 5Z00451 \$60.00/4

\*\*\*\* Same as above but with weather proof horn for 12 or 24 volts (state choice).  
Sh. Wt. 10 Lbs. 5Z00452 \$19.75  
4 for \$60.00 5Z00452 \$60.00/4

- 24 Volt Xformer, 5 Amp...\$4.00, \$15.00/5
- 1103- 1024 Bit RAM.....\$15.00/10,\$2.00 ea.
- MAGNUS - 3 OCTAVE KEYBOARD \$10.00
- 115V Alarm Horn.....\$1.50 ea.\$5.00/4
- Fly Back Xformer..New with data.....\$1.00/6
- 2 Amp Bridge....400PIV.....\$.75 ea.\$5.00/10
- 6 Amp Bridge....200PIV.....\$1.50 ea.\$5.00/4
- NE555 Timer.../Circuits.....\$.95 ea.\$5.00/6
- Key Alarm Switch...Hudson".....\$2.00
- Calcu. Keyboard..1x18 Matrix.....\$2.00
- Calcu. Keyboard..4x4 Matrix.....\$1.50
- Laser Cap.180Joules. 40MFD,3KV New \$24.00
- B&L Helium-Neon Gas Laser Power Supply Complete less tube ..on 115 VAC.....\$15.00
- 3 lead Voltage Regulator.....14 Watts...  
5 V L129 \$1.25 ea.. \$5.00/5  
12V L130 \$1.25 ea.. \$5.00/5  
15V L131 \$1.25 ea.. \$5.00/5

- Omni-Directional Head-Phone® \$2.00
- LASCR" .....200PIV..... \$1.50ea.. \$5.00/4
- Quad Rac...4 Amp..400 PIV.....\$1.00
- Triac..GESC240DX210..10A400PIV \$1.50
- IR LASCR...200PIV..1A.\$2.50,\$10.00/5
- 2N3055 NPN, Sil, 115W....\$1.25ea..\$5.00/5
- 2N2904 PNP, Sil, 90W....\$1.00ea..\$5.00/6
- 2N5838 NPN, TO-3,100W,300V.\$1.25,\$5.00/5
- D44C6B,NPN, 30W,Plas. \$.50ea., \$1.25/3
- D45C5B,PNP,30W, Plas. \$.50ea., \$1.25/3
- FET Op. Amp. DDC185 \$2.00, \$5.00/3
- SCR.s - 6A , 200V, TO-66 \$1.25/2, \$5.00/10
- Clock Xformer 11V, 150 ma.,\$1.25/2,\$5.00/10
- "AA" Ni-Cad Gould \$1.50,\$2.50/2,\$4.00/4
- Send for Test Eqpt List..Price Right.....

Get copies of our exciting new catalogs, containing over 5,000 bargain items. 2 new exciting illustrated catalogs totalling to 48 big pages (11x17" ea). An order gets you a copy and puts you on our mailing list for one year. Over 500,000 catalogs mailed each year. Get on our list!

**PLEASE ADD SHIPPING COSTS TO ALL**

**CHARGES WELCOME!**  
Phone in charges to 617 531-5774 or 617 532-2323.  
Bank Americard - Mastercharge. \$10.00 minimum. No C.O.D.'s please.

**B&F ENTERPRISES  
119 FOSTER STREET  
PEABODY, MASS. 01960  
(617) 531-5774 / 532-2323**

# OPTOELECTRONICS, inc.

BOX 219 • HOLLYWOOD, FLA. 33022 • (305) 921-2056



**25 AMP  
FULL WAVE BRIDGE 100 PIV**



**\$1.95 ea.  
3/\$5.00**

## 6 Digit LED Clock Kit - 12/24 hr.

**\$9.50 ea.**

**QTY OF  
1 to 5**

**\$8.50 ea.**

**QTY OF  
6 or MORE**

**\$6.95 ea.**

Qty of 6 or more when each kit is purchased with a transformer, PC board, and cabinet.

- KIT INCLUDES**
- INSTRUCTIONS
  - QUALITY COMPONENTS
  - MONEY BACK GUARANTEE
  - 50 or 60 Hz OPERATION
  - 12 or 24 HR OPERATION

**KIT #850**  
An Incredible Value

- 6 LED Readouts (FND-70 .25 in. RED)
- 1 MM5314 Clock Chip (24 pin)
- 13 Transistors
- 3 Switches
- 3 Capacitors
- 5 Diodes
- 9 Resistors
- 24 Molex pins for IC socket

"Kit #850 will furnish a complete set of clock components as listed. The only additional items required are a 7-11 VAC transformer, a circuit board and a cabinet, if desired."

Printed Circuit Board for above (etched & drilled Fiberglass)	\$2.95
Standard Transformer 115VAC/8 VAC	1.50
Molded Plug Transformer 115 VAC/8 VAC (With Cord)	2.50
Plexiglas Cabinet II Red Chassis, White Case, 2 1/2" H x 4 1/2" W x 5 1/2" D (see below)	5.95

## 6 Digit LED Clock-Calendar-Alarm Kit

- 12/24 HR TIME ● JUMBO DIGITS (MAN-64) ● 28-30-31 DAY CALENDAR ● AC FAILURE/BATTERY BACK-UP ● 24 HR ALARM - 10 MIN. SNOOZE ● ALTERNATES TIME (8 SEC) AND DATE (2 SEC) OR DISPLAYS TIME ONLY AND DATE ON DEMAND ● THIS KIT USES THE FANTASTIC CT-7001 CHIP. FOR THE PERSON THAT WANTS A SUPER CLOCK KIT (TOO MANY FEATURES TO LIST)!

COMPLETE KIT, including  
50/60 Hz OP Power Supply, Line Cord,  
Drilled PC Boards, etc.

**39.95** ORDER KIT  
#7001B  
(CASE NOT INCLUDED)

Kit #7001-C same as #7001-B but has different LEDs. Uses 4 DL-747 .63" digits & 2 MAN-7 .3" digits for seconds. Complete kit, less case. **\$42.95**

### CABINET I

3" HIGH  
6 1/2" WIDE  
5 1/2" DEEP



**GREAT FOR  
CLOCK KITS.**  
White Plexiglas Case  
Specify RED or GRAY  
Plexiglas Chassis

Chassis Serves As Bezel To Increase Contrast of Digital Displays. Use Gray With Any Color - Red With Red Displays Only (Red LED's with Red Chassis Brightest) **\$6.95 ea.**

### CABINET II

2 1/2" HIGH  
4 1/2" WIDE  
5 1/2" DEEP



**GREAT FOR  
SMALLER  
CLOCK KITS**

NEW!

(Ideal for Kit #850 above.)  
All Plexiglas Red Chassis, White Case.  
Red Chassis Serves As Bezel To Increase Contrast of LED Displays. **\$5.95 ea.**

### PLEXIGLAS FOR DIGITAL BEZELS

Gray or Red Filter **95¢ ea**  
3" x 6" x 1/8" Approx. Size  
4 for \$3.00

### XTAL TIME BASE KIT for Clock-Calendar-Alarm Kit

(115 VAC or 12 VDC operation)  
Uses 100.800 KHz xtal. For #7001 Kits only. **\$9.95**

## 7-SEG LED READ OUTS

Common Anode					
MAN-64 AL	RED	.4"	\$1.55 ea.	10/\$15.00	
MAN-5	GREEN	.3"	1.25	11.00	
MAN-8	YELLOW	.3"	1.25	11.00	
MAN-7	RED	.3"	.95	8.50	
DL-707	RED	.3"	1.25	12.00	
DL-747	RED	.63"	2.50	20.00	
FND-510	RED	.5"	1.85	17.50	
Common Cathode					
HP5082-7702	RED	.3"	\$1.25 ea.	10/\$11.50	
FND-70	RED	.25"	.65	5.95	
FND-503	RED	.5"	1.85	17.50	
DL-750	RED	.63"	3.50	30.00	
DL-704	RED	.3"	1.25	12.00	
DL-33MMB	RED	3x.1"	.95	8.50	

### DIODES

1N4002	25/\$1.95
1N4004	25/\$2.25
1N4007	25/\$2.45
1N5400	10/\$1.50
1N4148	25/\$1.50
1N914	25/\$1.75

### TRANSISTORS

(some unmarked - all guaranteed)

2N2369 (Marked)	10/\$1.90
2N2222 (Equiv.)	10/\$1.50
2N3394 (Marked)	10/\$1.90
2N3646 (Equiv.)	10/\$1.25
2N3904 (Equiv.)	10/\$1.25
2N4249 (Marked)	10/\$1.90
2N4403 (Equiv.)	10/\$1.25

### IC SOCKETS SOLDER TAIL

14 or 16 pin	4/\$1	25/\$5.
24 or 28 pin	75¢	8/\$5.
Transistor Sockets		12/\$1.
Power Transistor Sockets with assoc. hardware		4/\$1.

### MOLEX PINS

1000 for \$7.50

### ROCKER SWITCH

SPDT	4/\$1.	100/\$20
------	--------	----------



4A 125 Vac/.5A 125 Vdc/1.5A 250 Vac

Slide Switches DPDT 12/\$1.95

### IC SPECIALS

TCA 430	Tone Gen	\$1.95
4250	P. Op Amp	.95
741	Op Amp	3/1.00
1458	Dual 741	.95
555	Timer	.65
556	Dual 555	1.25
565	Phase Locked Loop	.95
566	Function Gen	1.50
567	Tone Decoder	1.75
MM5314	Clock only	3.95
CT-7001	CLK-CAL-ALM	7.95

### Regulators

723	±40 V.	.75
LM309	5V.	1.25
LM340K-12	12V.	1.75

### FACTORY PRIME .3" RED 7-SEG. LED MAN-7

.95 ea., 10/\$8.50, 100/\$79  
In Sealed Factory Pkg.  
COMMON ANODE 14 PIN DIP

### SUPER BRIGHT 7-SEG. LED

PRIME MAN-64AL RED  
15MA/SEG.  
COMMON ANODE 14 PIN DIP .4" CHAR. HT.  
\$1.55 ea., 10/\$15, 100/\$125

# OPTOELECTRONICS, inc.

Box 219, Hollywood FL 33022

Phone: (305) 921-2056  
BankAmericard, Master Charge  
and COD orders accepted.

We pay all shipping in continental  
USA. Orders under \$15.00 add  
\$1.00 handling. Florida residents  
add 4% tax.



ou goons don't ever proofr  
 leasy men... from bab  
 bunch of trocks fre...  
 you ignored my comments in  
**LETTERS**  
 I insist that you print ev  
 ou goons don't ever proofr

from page 100

couldn't turn that down. I feel that my experience in coming to see how radio has enriched my life, not just my husband's, might have some effect on other XYLs. It seems to me that you fellows are missing the boat in not bringing in the nearest and dearest to swell the ranks. Our instructor has his wife helping him in class as well as his two sons, all of whom have their own licenses. They made it a family hobby! With all the talk about bringing in more people, why not begin at home? You may counter by telling me that wives don't feel they can hack it (! know); that they are really not at all technically inclined (! know); that they don't have all that time to yak (me, too), etc. Would you be interested in an article of two from me? My first title could be "Confessions of a Formerly Ambivalent XYL," followed by "Confessions of a Formerly Ambivalent Novice," or something like that.

I am as surprised as you may be to see this offer - I really don't need anything more to keep me busy, but I do feel I have something to say to hams and their families. Another point I want to make is the fact that radio should be a very appealing hobby to lonely people. Here in California there are so many singles and families who have little community involvement due to being transplanted or to shyness or what have you. They would constitute a tremendous number of people who could be brought into the radio family and it would enrich their lives a great deal. I see these people in my piano classes at night school and my women's chorus sings at hospitals, churches and clubs, where the same observation goes in spades. I could wish that the code were not so absolutely necessary and that the exams were not so difficult (you get the idea sometimes that the FCC is deliberately trying to trick you

on the answers). However, I can also understand the pride hams have in having mastered their skills themselves and their consequent unwillingness to bring in others with less skill. Sometimes, people have to compromise with reality, though, if they really want more members in the group.

I personally feel that the public relations for ham radio is stuck in old concepts and needs to be brought up to date and broadened - lots more people of all kinds could benefit from the friendliness and increased people-to-people communication. This is undoubtedly one of the reasons for the wild rush into CB. As to upgrading skills, I feel that an appeal to more specific talents could be made from the broader beginning base. People seem to love awards. Even if they came into ham radio without code, they could be motivated by awards and contests to learn it just for the hell of it - rather than making it a grim requirement which turns off quite a few. Frankly, I think that it would not be too difficult to teach code to anyone but for the psychological component. I work against this everyday in my own classes - the no-confidence syndrome. Incidentally, I have had absolutely no background in radio and I avoided math and science classes like the plague when I was in school. I was convinced that I was a moron in math and had absolutely no ability in technical things. I do believe that I have above-average

intelligence and I am stubborn when I make up my mind to try something. I have been advised to memorize the handbook in order to make the General exam, but I prefer to try to understand what I am doing instead. It has already given me quite a lift to discover that I have been psyching myself out all my life and that I can, with study, learn some of these things which I formerly believed the province of men. I am sure that I represent many other women in this respect. I am also remembering the wistfulness I have heard in the men's voices on the radio telling my husband how great it is that I am joining him in class, how much they wish their wives would do the same. How about it, do you think we can make radio more human to XYLs?

Froma Reiter WN6IWT  
 Fullerton-CA

P.S. Obviously, none of this could have come about for me without my husband's strong, warm support and his obvious pride in my accomplishments. He bragged about my getting the Novice license so much that I was sure my blushes could be heard over the air waves. Whether you are interested in any further confessions, thanks for listening.

Sounds great, Froma ... let's see those articles and maybe we can get more XYLs into the act ... and on the air - Wayne.



**Glade Valley School Radio Session**  
 17<sup>th</sup> Year July 31 - August 13, 1976

**Courses Taught:**

- General Theory and Code
- Advanced Theory and Code
- Amateur Extra Theory and Code

**UPGRADE YOUR HAM TICKET**  
 BE READY FOR ANY FCC RESTRUCTURING

The Glade Valley Radio School is the only place in the country where you can get two solid weeks of concentrated radio theory and code - all taught by instructors with Extra Class licenses and years of experience in teaching. You meet fine people of all ages and backgrounds. All with a sincere interest in ham radio. During the 15 years of this school's operation, over 900 have attended, and many long lasting friendships have developed. Instruction is given at the General, Advanced and Extra Class levels, with small groups for personal attention. Excellent rooms and meals are provided and the schedule is planned for a healthy mixture of learning and recreation, all in the beautiful mountains of cool North Carolina. Facilities are available for single people as well as for married couples.

*Have a Vacation with a Purpose.*

C. L. Peters K4DNJ DIRECTOR  
 Box 458 Glade Valley NC 28627

Please send me the booklet and application blank for the Glade Valley School Radio Session.

Name \_\_\_\_\_ Call \_\_\_\_\_  
 Address \_\_\_\_\_  
 City/State/Zip \_\_\_\_\_

**MORROW'S** BOX 6194 ALBANY, CA 94706  
**Micro-STUFF**

"I have a tremendous amount of fun creating these products and I'm happy to be able to offer them to you." --- George Morrow

**Intelligent Cassette Interface**  
 ALTAIR 8800/IMSAI owners: talk to 3 cassette machines for mass storage. Uses industry standard bi-phase recording method. THIS KIT IS SMART! Includes its own software and data buffers (512 bytes of ROM + 512 bytes of RAM) so you can get going as soon as you connect power. With sockets, board, parts, even a cassette. **\$72.00**

**8080 Microprocessor Board**  
 8080 based microcomputer system on a board. You get: \*512 bytes of RAM (expands to 1K; just add ICs) \*512 bytes of ROM (expands to 4K) \*data & address buffers \*xtal clock \*TTL support ICs \*16 key keyboard + nine 7 segment displays, so you can painlessly load and examine memory. OPTIONS: Cassette Interface (+\$30), editor/ assembler (+\$99), RS-232/TTY interface (+\$20). COST-EFFECTIVE & PROVEN. Less pwr supply. **\$139.95**

**We even have parts:**  
 8T97 buss dvr \$1.45  
 TMS8080 \$27.95

WE PAY POSTAGE--Cal res add tax--no CODs.  
 FIND OUT MORE: circle the reader service #



Have you ever heard a perfect dot?

you can!  
 The all new ETK (Electronic Touch Keyer) stores your instructions, then sends perfect code from memory circuits ... 7 to 55 words per minute ... mode controls (tune, spacing off, auto) ... speaker w/ level control ... dot-dash LED lights ... all new clock circuits minimizing long first cycle ... 17 integrated circuits.

**CRS Co.** for only **145.00**  
 Order direct from:  
 P.O. Box 1125  
 Kent, Washington 98031



### 7400N TTL

SN7400N	13	SN7453N	27	SN74150N	1.10
SN7401N	16	SN7454N	41	SN74151N	1.25
SN7402N	21	SN7455N	23	SN74152N	1.35
SN7403N	16	SN7460N	22	SN74154N	1.25
SN7404N	16	SN7470N	45	SN74155A	1.21
SN7405A	24	SN7471N	69	SN74156N	1.30
SN7406A	45	SN7472N	39	SN74157N	1.30
SN7407A	48	SN7473N	39	SN74158N	1.75
SN7408A	25	SN7474N	32	SN74161N	1.35
SN7409N	25	SN7475N	59	SN74163N	1.45
SN7410N	16	SN7476N	32	SN74164N	1.65
SN7411N	30	SN7477N	30	SN74165A	1.65
SN7412N	42	SN7478N	50	SN74166A	1.60
SN7413N	85	SN7482N	1.75	SN74167N	5.00
SN7414N	70	SN7483N	1.15	SN74170N	3.00
SN7416A	43	SN7485N	1.12	SN74172N	18.00
SN7417A	43	SN7486A	45	SN74173N	90
SN7418N	28	SN7488A	3.50	SN74174N	1.05
SN7420N	21	SN7489N	3.00	SN74175N	1.95
SN7421N	39	SN7490N	49	SN74176N	90
SN7422N	1.50	SN7491N	1.20	SN74177N	90
SN7423N	37	SN7492N	82	SN74180N	3.05
SN7425A	43	SN7493N	57	SN74181N	1.55
SN7426A	31	SN7494N	91	SN74182N	95
SN7427N	37	SN7495N	91	SN74184N	2.30
SN7429N	42	SN7496N	91	SN74185N	2.20
SN7430N	26	SN7497N	1.00	SN74186A	5.00
SN7432N	31	SN74100N	1.00	SN74187N	6.00
SN7437N	47	SN74107N	49	SN74199N	1.50
SN7438A	40	SN74127N	45	SN74191N	1.50
SN7439N	28	SN74129N	49	SN74192N	1.19
SN7440N	21	SN74123N	70	SN74193N	99
SN7441N	1.10	SN74125N	60	SN74194N	1.45
SN7442N	1.06	SN74126N	81	SN74195N	1.00
SN7443N	1.05	SN74132N	3.60	SN74196N	1.00
SN7444N	1.10	SN74136N	1.80	SN74197N	1.00
SN7445N	1.10	SN74141N	1.15	SN74198N	2.25
SN7446N	1.15	SN74142N	4.00	SN74199N	2.25
SN7447N	79	SN74143N	4.50	SN74200N	7.00
SN7448N	99	SN74144N	4.50	SN74209N	2.50
SN7450N	26	SN74145N	1.15	SN74215N	5.00
SN7451N	27	SN74147N	3.00	SN74284A	6.00
SN7452N	27	SN74148N	2.90	SN74285A	6.00

MANY OTHERS AVAILABLE ON REQUEST  
20% Discount for 100 Component 7400's

### CMOS

CD4001	25	74C04N	75
CD4001	25	74C10N	65
CD4002	25	74C20N	65
CD4005	2.50	74C20N	85
CD4007	25	74C42N	2.15
CD4009	59	74C43N	1.50
CD4010	59	74C73N	1.15
CD4011	25	74C90N	2.00
CD4012	25	74C94N	2.00
CD4013	47	74C107N	1.28
CD4016	58	74C151	2.90
CD4017	1.35	74C154	3.00
CD4019	55	74C154	3.00
CD4020	1.49	74C160	3.25
CD4022	1.25	74C161	3.25
CD4023	25	74C163	3.50
CD4024	1.50	74C164	3.25
CD4025	25	74C173	2.60
CD4027	69	74C193	2.75
CD4028	1.65	74C195	2.78
CD4029	2.90	MC4044*	5.50
CD4030	65	MC4010*	4.50

### LINEAR

LM300H*	3/1.00	LM1351N	1.65
LM301CM*	3/1.00	LM1414N	1.75
LM302A	1.75	LM1458N	85
LM304A	1.00	LM1496N	85
LM305A	95	LM1565V	1.85
LM307CN	55	LM2111N	1.95
LM308H	1.00	LM2901N	2.25
LM308CN	1.00	LM3065AN	8.00
LM309H	1.00	LM3900N	55
LM309CN	1.00	LM3905N	60
LM309K	1.28	LM3909	1.95
LM310CN	1.15	LM3558N	1.85
LM311H	90	MC5558V	1.00
LM311N	90	LM7525N	2.20
LM318CN	1.50	LM7528N	2.20
LM319A	1.30	LM7534N	2.20
LM320A	8.00	LM7535N	1.25
LM320A-5	1.35	8038*	4.95
LM320A-2	1.35	LM7545D	4.9
LM320A-12	1.35	LM7547CN	3.9
LM320A-15	1.35	LM7548CN	3.9
LM320A-17	1.75	LM7549CN	3.9
LM320A-18	1.75	LM7550CN	3.9
LM320A-120	1.75	LM7551CN	3.9
LM320A-120*	1.75	LM7552CN	3.9
LM320A-120*	1.75	LM7553CN	3.9
LM320A-120*	1.75	LM7554CN	3.9
LM320A-120*	1.75	LM7555CN	3.9
LM320A-120*	1.75	LM7556CN	3.9
LM320A-120*	1.75	LM7557CN	3.9
LM320A-120*	1.75	LM7558CN	3.9
LM320A-120*	1.75	LM7559CN	3.9
LM320A-120*	1.75	LM7560CN	3.9
LM320A-120*	1.75	LM7561CN	3.9
LM320A-120*	1.75	LM7562CN	3.9
LM320A-120*	1.75	LM7563CN	3.9
LM320A-120*	1.75	LM7564CN	3.9
LM320A-120*	1.75	LM7565CN	3.9
LM320A-120*	1.75	LM7566CN	3.9
LM320A-120*	1.75	LM7567CN	3.9
LM320A-120*	1.75	LM7568CN	3.9
LM320A-120*	1.75	LM7569CN	3.9
LM320A-120*	1.75	LM7570CN	3.9
LM320A-120*	1.75	LM7571CN	3.9
LM320A-120*	1.75	LM7572CN	3.9
LM320A-120*	1.75	LM7573CN	3.9
LM320A-120*	1.75	LM7574CN	3.9
LM320A-120*	1.75	LM7575CN	3.9
LM320A-120*	1.75	LM7576CN	3.9
LM320A-120*	1.75	LM7577CN	3.9
LM320A-120*	1.75	LM7578CN	3.9
LM320A-120*	1.75	LM7579CN	3.9
LM320A-120*	1.75	LM7580CN	3.9
LM320A-120*	1.75	LM7581CN	3.9
LM320A-120*	1.75	LM7582CN	3.9
LM320A-120*	1.75	LM7583CN	3.9
LM320A-120*	1.75	LM7584CN	3.9
LM320A-120*	1.75	LM7585CN	3.9
LM320A-120*	1.75	LM7586CN	3.9
LM320A-120*	1.75	LM7587CN	3.9
LM320A-120*	1.75	LM7588CN	3.9
LM320A-120*	1.75	LM7589CN	3.9
LM320A-120*	1.75	LM7590CN	3.9
LM320A-120*	1.75	LM7591CN	3.9
LM320A-120*	1.75	LM7592CN	3.9
LM320A-120*	1.75	LM7593CN	3.9
LM320A-120*	1.75	LM7594CN	3.9
LM320A-120*	1.75	LM7595CN	3.9
LM320A-120*	1.75	LM7596CN	3.9
LM320A-120*	1.75	LM7597CN	3.9
LM320A-120*	1.75	LM7598CN	3.9
LM320A-120*	1.75	LM7599CN	3.9
LM320A-120*	1.75	LM7600CN	3.9

### EXAR

XR-2206KA	SPECIAL \$17.95
XR-2206KB	SPECIAL \$27.95
XR-555CP	\$ 6.69
XR-320P	1.35
XR-556CP	1.85
XR-2556CP	3.20
XR-2240CP	3.25
XR-205	8.40
XR-2205CP	4.49
XR-2207CP	3.85
XR-215	6.50
XR-567CP	1.85
XR-2567CP	2.99
XR-4136	2.00

### DATA HANDBOOKS

7400	Pin-out & Description of 5400/7400 ICs	\$2.95
CMOS	Pin-out & Description of 4000 Series ICs	\$2.95
LINEAR	Pin-out & Functional Description	\$2.95

ALL THREE HANDBOOKS \$6.95

## CONSUMER ELECTRONICS

### exelar

DIGITAL WATCH  
This watch is manufactured by National Semiconductor. It provides 5 functions: hours, minutes, seconds, date, A.M. Indicator dot. Accuracy is assured to 5 seconds per month by precision quartz crystal. If something should go wrong with the watch, replace the assured within 48 hours after it is received. Complete with steel black leather band.

ES4-WS  
Chrome Plate Bezel  
\$27.95  
Ella-WS  
3 Micron Gold Plate Bezel  
\$29.95

NOT A KIT

### Novus

DIGITAL ALARM CLOCK  
This 4 digit Novus Alarm Clock is a very reliable and snarley styled unit. It provides such features as an alarm settable to any minute of the day, a 7 minutes snooze alarm, a power failure indicator, and even an A.M., P.M. indicator.

NOT A KIT \$19.95

### XCITON OPTO ELECTRONICS

#### LITRONIX MONSANTO DISCRETE LEDS

XC209R	5/81	XC526R	5/81	XC111R	5/81
XC209G	4/81	XC526G	4/81	XC111G	4/81
XC209Y	4/81	XC526Y	4/81	XC111Y	4/81
XC209O	4/81	XC526O	4/81	XC111O	4/81

125" dia. 185" dia. 190" dia.  
200" dia. 200" dia. 085" dia.

### DISPLAY LEDS

FD707	MAN 2	MAN 3	MAN 4	MAN 7	DL747	DL38
-------	-------	-------	-------	-------	-------	------

TYPE POLARITY COMMON ANODE NT  
MAN 2 5 x 7 DOT MATRIX 300 4.95  
MAN 3 COMMON CATHODE 125 3.9  
MAN 4 COMMON CATHODE 187 1.95  
MAN 7 COMMON CATHODE 300 1.50  
MAN 7G COMMON ANODE-GREEN 300 2.50  
MAN 7Y COMMON ANODE-YELLOW 300 2.50  
MAN 7Z COMMON ANODE 300 1.50

### IC SOLDERTAIL - LOW PROFILE (TIN) SOCKETS

8 pin	1-24	25-49	50-100	24 pin	1-24	25-49	50-100
14 pin	5-17	16-19	20	28 pin	5-17	16-19	20
16 pin	22	21	18	36 pin	45	44	43
18 pin	29	28	27	40 pin	60	59	58
22 pin	37	36	35	40 pin	63	62	61

SOLDERTAIL STANDARD (TIN)  
SOLDERTAIL STANDARD (GOLD)  
WIRE WRAP SOCKETS (GOLD) LEVEL #3

### 50 PCS. RESISTOR ASSORTMENTS \$1.75 PER ASST.

ASST. 1	5 ea.	10 OHM	12 OHM	15 OHM	18 OHM	22 OHM	27 OHM	1/4 WATT 5% - 50 PCS.
ASST. 2	5 ea.	180 OHM	220 OHM	270 OHM	330 OHM	390 OHM	470 OHM	1/4 WATT 5% - 50 PCS.
ASST. 3	5 ea.	1.2K	1.5K	1.8K	2.2K	2.7K	3.3K	1/4 WATT 5% - 50 PCS.
ASST. 4	5 ea.	8.2K	10K	12K	15K	18K	22K	1/4 WATT 5% - 50 PCS.
ASST. 5	5 ea.	56K	68K	82K	100K	120K	150K	1/4 WATT 5% - 50 PCS.
ASST. 6	5 ea.	150K	180K	220K	270K	330K	390K	1/4 WATT 5% - 50 PCS.
ASST. 7	5 ea.	1M	1.2M	1.5M	1.8M	2.2M	2.7M	1/4 WATT 5% - 50 PCS.

ALL DTRHER RESISTORS FROM 2 3 3M 3.9M - 5.6M AVAILABLE IN MULTIPLES OF 5 ea  
5-25 PCS: 05 ea 30-95 PCS: 04 ea 100-995 PCS: 03 ea 500-995: 027 ea

### 14 PCS. POTENTIOMETER ASSORTMENTS

ASST. A 2 ea 10 OHM 20 OHM 50 OHM 100 OHM 200 OHM 250 OHM 500 OHM  
ASST. B 2 ea 1K 2K 5K 10K 20K 50K 100K  
ASST. C 2 ea 50K 100K 200K 250K 500K 1M 2M

\$9.95 Per Asst.

### JAMES

P.O. BOX 822, BELMONT, CA. 94002  
PHONE ORDERS - (415) 592-8097

### 74LS00 TTL

74LS00	39	74LS55	39	74LS151	1.55
74LS02	39	74LS57	85	74LS153	1.89
74LS03	39	74LS74	65	74LS157	1.55
74LS04	45	74LS75	79	74LS162	2.25
74LS05	45	74LS76	65	74LS163	2.25
74LS08	39	74LS83	2.19	74LS164	2.25
74LS10	39	74LS86	65	74LS181	3.69
74LS13	79	74LS90	1.25	74LS190	2.85
74LS14	2.19	74LS92	1.25	74LS191	2.85
74LS20	39	74LS93	1.25	74LS192	1.89
74LS26	49	74LS95	2.19	74LS193	2.85
74LS27	45	74LS96	1.89	74LS194	2.25
74LS28	49	74LS107	65	74LS195	2.25
74LS30	39	74LS112	65	74LS257	1.89
74LS32	45	74LS132	1.55	74LS260	55
74LS40	49	74LS136	65	74LS279	79
74LS51	39	74LS138	1.89	74LS270	5.95

### DIP SWITCH

These switches feature four SPST Rocker switches in a molded dip. They are ideally suited for microprocessor applications.

\$1.95

### PUSH BUTTON

Model 1 Quantity net prices  
Model 2-9 10-29 30-99  
Pb-123 \$2.35 \$1.95 \$1.47 \$1.30

### THUMBWHEEL SWITCHES

These switches are a / position on position, rotary switch enclosed in a T-5 can. They have a standard 5 pin connector and will mount perfectly on printed circuit board.

### 8 POSITION ROTARY SWITCH

These switches are a / position on position, rotary switch enclosed in a T-5 can. They have a standard 5 pin connector and will mount perfectly on printed circuit board.

### ZENERS-DIODES-RECTIFIERS

1N4745	3.00V	41.00	1N4001*	500 PIV	1 AMP	10/1.00	
1N751A	5.1	400m	41.00	1N4006*	800 PIV	1 AMP	10/1.00
1N752	5.6	400m	41.00	1N4007*	1000 PIV	1 AMP	10/1.00
1N753	6.2	400m	41.00	1N4300	50	200m	6/1.

# HEWLETT PACKARD



## H.P. IS BACK!

No Rejects or Reworks here — You Want Quality? You have it with this popular 0.3" L.E.D. by Hewlett Packard. Fits Standard I.C. Socket. Right hand DP.  
5082-7740 — Common Cathode ..... \$1.25  
6 for \$6.00



### FAIRCHILD BIG LED READOUTS

A big .50 inch easy to read character. Now available in either common anode or common cathode. Take your pick. Super low current drain, only 5 MA per segment typical.

**YOUR CHOICE**  
FND - 510 Common Anode \$1.50 each — 6 for \$7.50  
FND - 503 Common Cathode

### DO YOU NEED A LARGE COMMON ANODE READOUT AT A FANTASTIC PRICE?

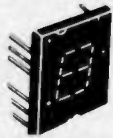

S. D. presents the MAN-64 by Monsanto - .40 inch character. All LED construction - not reflective bar type, fits 14 pin DIP. Brand new and factory prime. Left D.P.  
\$1.50 ea. 6 for \$7.50

### 12 DIGIT READOUTS — \$1.75

Mfg. by National Electronics. Big .40 in. char. size. Gas discharge type, for use in desk top calculators, frequency counters, clocks, etc. #NDP 1253-12. Originally cost a calculator mfg. \$16.77 ea. in quantity. S.D. Price \$1.75 ea.

HIGH V. TRANSFORMER for above readout. Primary 117V, two secondaries: 24 VAC 500 MA 175 VAC 100 MA. \$1.25 ea.

### 2102 1K RAM's - 8 FOR \$12.95

New units — We bought a load on a super deal, hence this fantastic price.  
Units tested for 500NS Speed.

### INTEL 1702A 2K ERASEABLE PROM'S \$6.95

We tell it like it is. We could have said these were factory new, but here is the straight scoop. We bought a load of new computer gear that contained a quantity of 1702A's in sockets. We carefully removed the parts, verified their quality, and are offering them on one heck of a deal. First come, first served. Satisfaction guaranteed.

### SIGNETICS 1K P-ROM

82S129. 256 X 4. Bipolar, much faster than MOS devices. 50 NS. Tri-state outputs. TTL compatible. Field programmable, and features on chip address decoding. Perfect for microprogramming applications. 16 pin DIP. With specs. \$2.95 ea

### PROMS!



\$2.95

### PROFESSIONAL QUALITY STEREO HEADPHONES

Here is the kind of super deal that S. D. is famous for. Treat your ears to a super sound at a super price. Soft padded ear cushions, lightweight, fully adjustable headband, long coiled cord, wide response. \$6  
**NEW IN ORIGINAL FACTORY BOXES**

### INSTRUMENT KNOBS

Black with brushed aluminum insert. Medium size, very attractive style.  
**SPECIAL 5 FOR \$1**

**MV-50 TYPE LED'S**  
by LITRONIX  
**10 for \$1**  
Factory Prime!

### 3 DIGIT LED ARRAY — 75c

by LITRONIX  
DL33MMB. 3 MAN-3 Size Readouts in one package. These are factory prime, not retested rejects as sold by others. compare this price! 75c 3 for \$2.



### SALE ON CUT LEAD SEMICONDUCTORS

Leads were cut for PCB insertion. Still very useable.

1N914/1N4148 ..... 100/\$2  
1N4002 1 Amp 100 PIV ..... 40/\$1  
1N4745A 16V 1W Zener ..... 20/\$1  
EN2222 NPN Transistor ..... 25/\$1  
EN2907 PNP Transistor ..... 25/\$1  
2N3904 NPN Driver Xstr. .... 25/\$1  
2N3392 GE Pre-amp Xstr. .... 25/\$1  
C103Y SCR. 800MA. 60V. .... 10/\$1

**ALL NEW.  
UNUSED.  
SOME ARE  
HOUSE #**

### NATIONAL MM5375AA ALARM CLOCK CHIP

Second generation alarm chip. Six digits, internally generates alarm tone, snooze, power failure indicator, etc. Very easy to use. Outperforms older types like 5316, 5370, etc. Perfect for use with our HP 5082-7740 LED readouts.  
S.D. SPECIAL PRICE: \$3.50  
WITH DATA

### MOSTEK MK50380 DIRECT DRIVE ALARM CHIP

Drives LED readouts direct, eliminates transistor or IC interface circuitry. 4 digit output is non-multiplexed to eliminate RFI in clock radio applications. Has sleep and snooze features. 40 pin DIP. Makes a JUMBO alarm clock by using our FND 503 readouts. We show you how.  
**INTRODUCTORY PRICE: \$3.95**

### SLIDE SWITCH ASSORTMENT

Our best seller. Includes miniature and standard sizes, single and multi-position units. All new, first quality, name brand switches. Try one package and you'll reorder more. Special — 12 for \$1 (Assortment)



### DISC CAP ASSORTMENT

PC leads. At least 10 different values. Includes .001, .01, .05, plus other standard values.  
**60 FOR \$1**



### UPRIGHT ELECTROLYTIC CAPS

47 mfd 35 V-10/\$1 68 mfd 25V-8/\$1  
Brand new by Sprague. PC leads.



### 1000 MFD FILTER CAPS

Rated 35 WVDC. Upright style with P.C. leads. Most popular value for hobbyists. Compare at up to \$1.19 each from franchise type electronic parts stores. S.D. Special 4 for \$1

### RESISTOR ASSORTMENT

1/4 W 5% and 10%. PC leads.  
A good mix of values. 200/\$2



### LARGE SIZE LED LAMPS

Similar to MV5024. Prime factory tested units. We include plastic mounting clips which are very hard to come by.  
Special 5 for \$1



### VERNIER DIAL

From a close out of metal detector manufacturer. 1/2 Turn, 8 to 1 ratio. Internal stops easily removed to make unit multi-turn.

### LIMITED QUANTITY - \$.99 EACH

#### 741C OP AMPS

Prime, factory tested and marked. Full spec on all parameters. Not re-tested, functional only, units as sold by others.  
741 CH -TO-5 8 Lead Metal Can . . . 3/\$1  
741CV - 8 Lead Mini Dip . . . . . 4/\$1



### DUAL 741C (5558) OP AMPS

Mini dip. New house numbered units by RAYTHEON.  
**4 FOR \$1**

### FET'S BY TEXAS INSTRUMENTS — SPECIAL 5 for \$1

#TIS-75 but with an internal house number. TO-92 plastic case. N. Channel, Junction type FET.

Signetics, TRI-State Hex Buffer. MOS and TTL Interface to TRI-State Logic.  
Special: \$1 8T97B

TRANSISTORS  
2N3904 - NPN  
2N3906 - PNP  
8 for \$1

### TI POWER TRANSISTORS

TIP29 NPN Silicon. TO-220. 4/\$1

**CT-5005  
WITH FOUR-  
FUNCTION MEMORY!**

### CALCULATOR CHIP

By CalTex. 12 Digits.  
With Specs. \$1.49  
Factory prime. Not retested

We do not sell junk. Money back guarantee on every item. No C.O.D. Texas Res. add 5% tax. Postage rates went up 30%! Please add 5% of your total order to help cover shipping.

## S. D. SALES CO.

P.O. BOX 28810  
DALLAS, TEXAS 75228

S.D. SALES ATLAS WINNER  
END OF CONTEST

R.P. Taylor Jr. WB6EWO  
1707 N. Concerto  
Anaheim CA 92807

## SIX DIGIT LED ALARM CLOCK KIT

**S. D. SALES CO.**

P. O. BOX 28810 DALLAS, TEXAS 75228

Thousands of hobbyists have bought and built our original clock kit and were completely satisfied. But we have received many requests for an alarm clock kit with the same value and quality that you have come to expect from S.D. So, here it is!

### THE KIT INCLUDES:

- 1 Mostek 50252 Alarm Clock Chip
- 6 Hewlett Packard .30 in. common cathode readouts.
- 15 NPN Driver Transistors
- 1 Etched and Drilled P.C. Board set
- 1 Step Down Transformer
- 2 Switches for time set
- 2 Slide Switches for alarm set and enable
- 1 Filter Cap
- 4 IN4002 Rectifiers
- 1 IN914 Diode
- 1 .01 Disc Cap
- 15 Resistors
- 1 Speaker for alarm
- 1 LED lamp for PM indicator.

**\$16.<sup>50</sup>**

(COMPLETE KIT)

**Why pay MORE MONEY for our competitor's clock that has LESS DIGITS that are SMALLER in size?**

Please take note that we use only first run parts in our kits and include ALL the necessary parts. Not like some of our competitors who use retested readouts and chips or who may not even include switches in their kits.

## 60 Hz. Crystal Time Base

FOR DIGITAL CLOCKS **\$5.<sup>95</sup>**  
S. D. SALES EXCLUSIVE!

The kit you have been waiting for is here **NOW**, and at an unbelievable price! Thanks to S.D. Sales you can turn that digital clock of yours into a superbly accurate, DC operated, time piece.

### KIT FEATURES:

- A. 60 Hz output with accuracy comparable to a digital watch.
- B. Directly interfaces with all MOS clock chips.
- C. Super low power consumption (1.5 Ma typ.)
- D. Uses latest MOS 17 stage divider IC.
- E. Eliminates forever the problem of AC line glitches.
- F. Perfect for cars, boats, campers, or even for portable clocks at ham field days.
- G. Small size, can be used in existing enclosures.

**BUY TWO FOR \$10.00**

Kit includes crystal, divider IC, P.C. Board plus all other necessary parts and specs.



# ENCLOSURES!



## DOSY BOXES

### Deluxe Electronic Equipment Enclosures

DOSY BOXES are fabricated of heavy cold rolled steel. The front panels are of 20 gauge brushed chrome steel, line screened and have a red Rocker DPDT switch installed (except "A" box) with gold plated contacts and terminals. Covers are finished with baked on wrinkle enamel.

All cabinets are completely assembled and supplied with 4 rubber feet riveted in, individually packed in a heavy duty corrugated muller carton. Chassis "C" thru "H" are CRS, nickel-plated over copper for excellent RF conductivity.

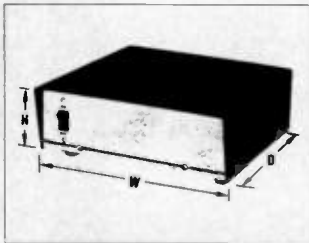

A	5 5/8 x 2 1/2 x 3	\$4.35
B	5 11/16 x 3 3/8 x 3 3/4	5.85
C	7 1/4 x 3 3/8 x 5	8.75
D	8 x 2 1/2 x 8 (mobile mtg. avail.)	10.50
E	6 1/2 x 3 15/32 x 7 1/16	9.50
F	7 1/2 x 4 1/2 x 10	11.25
G	10 1/16 x 3 5/16 x 9	11.25
HA	5 1/8 x 5 1/2 x 4 (Blank Panel)	8.50
J	5 x 3 1/2 x 5 3/4 (Sloping Panel)	8.50
K	4 1/4 x 7 3/8 x 11 w/handle	15.75
L	11 1/8 x 6 1/8 x 12 3/4	23.75
M	11 1/8 x 6 1/8 x 16 3/4	25.50
DI	Mtg. bracket set for D	.45

# BUD

The clean design of this Bud enclosure results in excellent visibility of panel mounted components. Since the cover is one piece, it is easily detached for quick access to the interior. Base is 1/8" aluminum with black texture finish; the cover is .057 aluminum with smooth white enamel finish. No fasteners are exposed on the visible surfaces. Rubber feet furnished.

## Compucab series

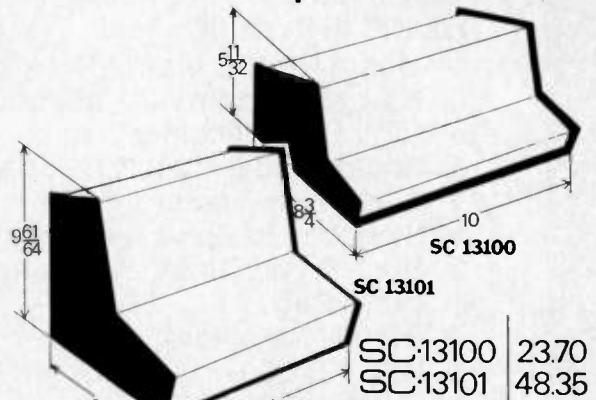

SC-13100	23.70
SC-13101	48.35

## Slope

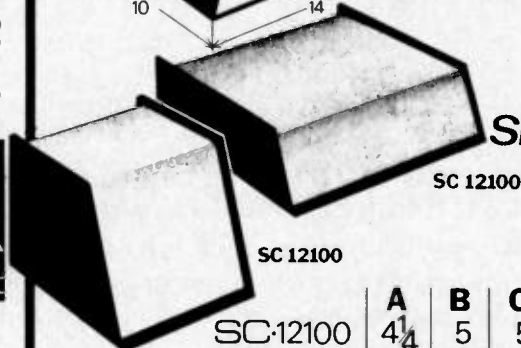

SC-12100	A 4 1/4	B 5	C 5	10.60
SC-12101	3 1/4	12	10	22.05

## Linear

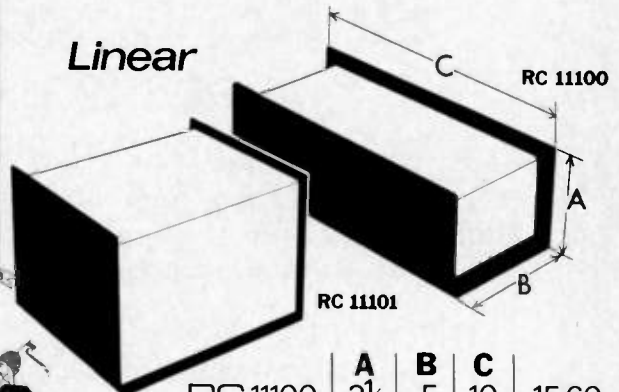

RC-11100	A 3 1/4	B 5	C 10	15.60
RC-11101	8	12	10	34.30

# MODU-BOX

by intra fab inc

### EASE OF ASSEMBLY

Just four screws assemble or disassemble the

### COLORS

MODU-BOX cabinets are finished with baked-on vinyl Organosol in designer coordinated color combinations. Cabinets have a textured wrap around base with a smooth sloped front insert. Our standard colors are blue (blu), tan (t), gray (gy) and black (blk) texture for the wrap around and gray (gy), white (w) or black (blk) on the front insert.

### CONSTRUCTION

Our cabinets are made entirely of Aluminum, for strength and ease of handling.

MBS 3-4-6	3"	4"	6"	\$7.36
MBS 3-7-6	3"	7"	6"	7.94
MBK 2-5-5	2"	5"	5"	6.89
MBK 2-7-6	2"	7"	6"	7.91
MBK 3-10-11	3"	10"	11"	12.47
MBS 4-10-10	4"	10"	10"	12.49
MBK 5-10-10	5"	10"	10"	14.41
MBK 6-12-10	6"	12"	10"	15.96

NOT ALL COLORS & STYLES ARE STOCKED / PLEASE ALLOW 2 - 3 WEEKS DELIVERY

# MODULINE

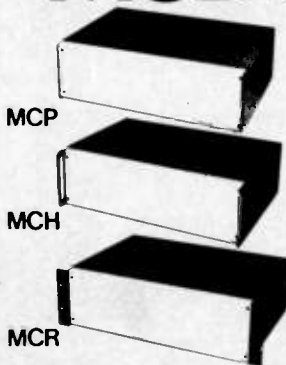

	3 inch	5 inch	7 inch	10 inch
3-4-5	\$14.90	\$4-5 \$15.90	7-5 \$16.74	10-4-5 \$21.50
3-4-7	15.50	5-7 16.68	7-7 17.11	10-4-7 23.15
3-4-9	16.26	5-9 17.89	7-9 19.34	10-4-9 25.37
3-4-12	18.65	5-12 20.60	7-12 22.50	10-4-12 30.20
3-5-5	15.00	5-5 15.98	7-5 16.85	10-5-5 21.66
3-5-7	15.64	5-7 16.81	7-7 18.26	10-5-7 23.35
3-5-9	16.44	5-9 18.06	7-9 19.54	10-5-9 25.61
3-5-12	18.31	5-12 20.87	7-12 22.79	10-5-12 30.54
3-6-5	15.12	5-5 16.16	7-5 17.05	10-5-5 21.90
3-6-7	15.77	5-7 16.99	7-7 18.46	10-5-7 23.59
3-6-9	16.57	5-9 18.24	7-9 19.74	10-5-9 25.88
3-6-12	19.20	5-12 21.20	7-12 23.15	10-5-12 30.95
3-7-5	15.78	5-7 16.36	7-7 17.27	10-7-5 22.30
3-7-7	15.96	5-7 17.23	7-7 18.72	10-7-7 24.02
3-7-9	16.81	5-9 18.53	7-9 20.04	10-7-9 26.33
3-7-12	20.11	5-12 21.71	7-12 23.69	10-7-12 31.64
3-8-5	15.52	5-5 16.64	7-5 17.59	10-5-5 22.82
3-8-7	16.30	5-7 17.59	7-7 19.13	10-5-7 24.65
3-8-9	17.33	5-9 19.08	7-9 20.64	10-5-9 27.13
3-8-12	20.34	5-12 22.87	7-12 24.88	10-5-12 32.62
3-9-5	15.52	5-5 16.64	7-5 17.59	10-5-5 23.02
3-9-7	16.30	5-7 17.59	7-7 19.13	10-5-7 24.83
3-9-9	17.36	5-9 19.12	7-9 20.69	10-5-9 27.36
3-9-12	20.41	5-12 23.21	7-12 24.96	10-5-12 32.87
3-12-5	16.85	5-12-5 18.13	7-12-5 19.36	10-12-5 25.01



**THE PROBLEM SOLVERS**  
214/634-7870

KA ELECTRONIC SALES  
1220 MAJESTY DR · DALLAS, TEXAS 75247



# Poly Pak's

100'S OF BARRELS PURCHASED!  
BUY 'EM FROM THE "BARREL" AND SAVE!



## EXCLUSIVE 'BARREL'

THE BIGGEST INFLATION-FIGHTING VALUE EVER!

TEST 'EM YOURSELF 'N SAVE!

Every kit carries money back guarantee.

For the first time anywhere, Poly Pak merchandisers introduce a new way in buying the economical way. Raw

stock from the "barrel". Remember the "good ole days"? They're back again. The same way merchandisers throughout the United States buy from various factories... their overruns in barrels. Poly Pak has done the same. Therefore you are getting the same type of material as the RE-TESTERS DO!

<b>BARREL KIT #1</b> SN7400 DIP IC'S <b>75 for \$1.98</b> Marked 14 and/or with 16 pin dips, may include gates, registers, flip flops, counters. Who knows! GUARANTEED SATISFACTION! Cat.No.4A2415 Untested.	<b>BARREL KIT #2</b> VAR OP AMPS DIPS <b>75 for \$1.98</b> May include 709's, 741's, 703's, 680 series, 555 included, marked and unmarked. Cat.No.4A2416	<b>BARREL KIT #3</b> VAR OP AMPS SWITCHING DIODES <b>100 for \$1.98</b> You never saw this before. Imagine famous switching diodes at these prices! Cat.No.4A2418 Untested.	<b>BARREL KIT #4</b> "4000" RECTIFIERS <b>100 for \$1.98</b> These are the famous micro miniature rectifiers of the 1N4000 series. May include 25, 50, 100, 200, 400, 600, 800 and 1000 voltages. Cat.No.4A2417	<b>BARREL KIT #5</b> SCRS, TRIACS, QUADRACS <b>40 for \$1.98</b> All the famous plastic power tab type. Raw factory stock! All the 10 amp types. Cat.No.4A2419 Untested.	<b>BARREL KIT #7</b> VOLUME CONTROL BONANZAI <b>40 for \$1.98</b> 100% good Singles, duals, variety of values, styles, big ones small ones. Cat.No.4A2421	<b>BARREL KIT #8</b> SUBMINIATURE IF TRANSFORMERS <b>100 for \$1.98</b> Amazing, includes 455K's, oac, antenna, who knows! From transistor radio manufacturers. Cat.No.4A2422	
<b>BARREL KIT #10</b> ROMS-REGISTERS <b>50 for \$1.98</b> Untested 28 to 40 pin devices, marked, internal factory numbers, etc. Cat.No.4A2424	<b>BARREL KIT #12</b> POWER TAB TRANSISTORS <b>40 for \$1.98</b> PNP, plastic TO20 type. Marked only. Long leads. Cat.No.4A2426 Untested.	<b>BARREL KIT #13</b> RESISTOR NETWORKS <b>60 for \$1.98</b> Untested. By Corning Glass, in 14-pin dip paks. Cat.No.4A2427	<b>BARREL KIT #14</b> PRECISION RESISTORS <b>200 for \$1.98</b> Cat.No.4A2428 Marked and unmarked 1/4, 1/2, 2 watts.	<b>BARREL KIT #15</b> MOSFET TRANSISTORS <b>60 for \$1.98</b> All 4 leaders TO-18 case, includes DUF transistors tool. Cat.No.4A2429	<b>BARREL KIT #17</b> LINEAR & 7400 DIPS <b>100 for \$1.98</b> Marked and unmarked, internal numbers of raw factory stock. Cat.No.4A2431	<b>BARREL KIT #18</b> ZENER-RECTIFIER MIX <b>200 for \$1.98</b> Subminiature, DOT's, includes asst. zeners and rectifiers. It's mixed at the factory, we cannot separate. Cat.No.4A2432 Untested.	
<b>BARREL KIT #19</b> DIPPED MYLARS <b>60 for \$1.98</b> Finest capacitors made, whiny finish. Imagine factory dumping 'em in barrels. Cat.No.4A2597 100% good.	<b>BARREL KIT #20</b> LONG LEAD DISCS <b>150 for \$1.98</b> Factory distributor stock "auction sale". Prime. Mostly 1/2 watters, 1% to 5% tol. & a barrel of values. Cat.No.4A2609	<b>BARREL KIT #24</b> HIGH VOLTAGE RECTIFIERS <b>160 for \$1.98</b> Untested. Up to 12,000 volts, 4 min. epoxy, axial leads. Cat.No.4A2602	<b>BARREL KIT #25</b> METAL CAN TRANSISTORS <b>100 for \$1.98</b> Untested. Includes T0-18, T0-18, etc., assorted ZN numbers, unmarked etc. Cat.No.4A2603	<b>BARREL KIT #26</b> PLASTIC TRANSISTORS <b>100 for \$1.98</b> Untested. Type TO-92 (T0-18), all manufacturers, variety of 2N 2's. Cat.No.4A2604	<b>BARREL KIT #28</b> CERAMIC CAPACITORS <b>200 for \$1.98</b> Not only do the barrels contain dogboxes, but factory dumped, Erie Central lab, molded types tool. Cat.No.4A2606 100% good.	<b>BARREL KIT #29</b> VITAMIN Q CAPS <b>75 for \$1.98</b> 100% good. Every type of oil-impregnated caps, some worth \$2. Buy direct, axial includes all types of voltages to 1KV. Cat.No.4A2615	
<b>BARREL KIT #30</b> PREFORMED RESISTORS <b>250 for \$1.98</b> We got barrels of 1/4 and 1/2 watters for pc use. You'll get every amount, 100: 1/4, 100: 1/2 watters. Cat.No.4A2608 100% good	<b>BARREL KIT #31</b> METALLIC RESISTORS <b>100 for \$1.98</b> 100% good. Made mostly by Corning, the finest resistor made. We've got 1/2 watters, 1% to 5% tol. & a barrel of values. Cat.No.4A2609	<b>BARREL KIT #32</b> TRANSISTORS WITH A HOLE IN IT <b>50 for \$1.98</b> Cat.No.4A2610 Untested. Can't name factory but we bought barrels of 26 watters with mtg. hole in middle. PNP's and NPN's.	<b>BARREL KIT #34</b> TUB SOCKET <b>100 for \$1.98</b> Good ole tube sockets, still in demand! Barrels and barrels: 4's, 5's, 7, 8, 9, even computer types. Cat.No.4A2612 100% good.	<b>BARREL KIT #35</b> NEON LAMPS <b>40 for \$1.98</b> 100% good. Famous NE-2's. All prime, but factory made millions and barreled 'em. Your advantage. Cat.No.4A2613	<b>BARREL KIT #36</b> GERMANIUM DIODES <b>200 for \$1.98</b> Famous maker, popular item. Never grows old. But this is the way the RE-TESTERS buy 'em from the factories. Cat.No.4A2614	<b>BARREL KIT #37</b> 1 AMP "BULLET" RECTIFIERS <b>100 for \$1.98</b> Famous style, asst. voltages, silicon, axial includes all types of voltages to 1KV. Cat.No.4A2615	
<b>BARREL KIT #38</b> 2 AMP RECTIFIERS <b>75 for \$1.98</b> Untested. "CYLINDER" type, silicon. Mallory, includes all voltages up to 1KV. Axial leads. Cat.No.4A2616	<b>BARREL KIT #39</b> PNP HOBBY TRANSISTORS <b>15 for \$1.98</b> 100% good. From factory to you, these fallouts of the famous 2N3055. We have 10 barrels. Cat.No.4A2617	<b>BARREL KIT #40</b> PNP HIGH-POWER TRANSISTORS <b>20 for \$1.98</b> Popular germanium TO-3 case units, now available at "good ole barrel" prices. Cat.No.4A2618 100% good.	<b>BARREL KIT #42</b> ITT "GLASS 4000" RECTIFIERS <b>150 for \$1.98</b> Just in! 1N4000 silicon rectifiers in epoxy, now in glass encased at barrel prices 50 in 1000v tool. Cat.No.4A2620	<b>BARREL KIT #46</b> G.E. 3.5 WATT AMPLIFIERS <b>25 for \$1.98</b> Untested. Hobby type, factory fallouts, we purchased them in barrels. These are unknowns. Cat.No.4A2624	<b>BARREL KIT #49</b> QUADSI QUADS! <b>50 for \$1.98</b> LM 3900 Untested. 4 mirror op amps in one package. Why the factory barreled these we don't know. Cat. 4A2627	<b>BARREL KIT #60</b> SIGNAL SILICON DIODES <b>200 for \$1.98</b> Includes many, many types of switching, signal silicon types, all axial leads. Some may be zeners. Cat.No.4A2628 Untested.	
<b>BARREL KIT #51</b> HOBBY OPTO COUPLERS <b>40 for \$1.98</b> We got 1,000's unknown both the sensor or transmitter may be good, or both. WE DON'T KNOW! We don't know the types, 1000's in circulation. Cat.No.4A2629	<b>BARREL KIT #52</b> DISCS! <b>500 for \$1.98</b> Cat.No.4A2630 100% good The bargain of a lifetime! First time ever offered by Poly Pak for the economy-minded bargain hunters.	<b>BARREL KIT #53</b> JUMBO RESISTOR PAK <b>100-pc. \$1.98</b> Cat.No.4A2721 Assortment metal films, precision, carbons, metal oxide powers, from 1/2 watt to 7 watts. Color coded & 100% good. Worth \$10.	<b>BARREL KIT #55</b> 3 DIGIT READOUTS <b>15 for \$1.98</b> National cleaned tin warehouse... now we have barrels of NSN-33 type. Untested. Cat.No.4A2723	<b>BARREL KIT #57</b> HI-POWER RECTIFIERS <b>15 for \$1.98</b> 50-amp studs; 6, 12, 24, 48V. 100% material. Factory rectifier "line" rejects. Cat.No.4A2725 100% good.	<b>BARREL KIT #58</b> SLIDE SWITCHES <b>30 for \$1.98</b> All shapes, sizes, appt. dpdt, momentaries, etc. Tremendous shop pak for 100's of switching projects. Cat.No.4A2726 100% good.	<b>BARREL KIT #59</b> POWER TRANSISTORS <b>40 for \$1.98</b> 15 watt Bendix B-5000 pellet transistors, npn, all good, purchased from a pretreater, have millions of 100% good. Cat.No.4A2727	
<b>BARREL KIT #60</b> OTL'S IC'S <b>75 for \$1.98</b> Untested. This is prime barrel material. Who wants OTL's? 530, 936, 940's. Your gain is our loss. They're marked too. Cat.No.4A2728	<b>BARREL KIT #61</b> POLYSTYRENE CAPS <b>100 for \$1.98</b> Finest caps made. As a general rule we bought 10 barrels from factory, mixed values; all good. Cat.No.4A2729	<b>BARREL KIT #65</b> MIXED READOUTS <b>30 for \$1.98</b> Factory returns - such numbers as MAN-4's, MAN-7's, MAN-9's, 11 barrels & no time to separate. Cat.No.4A2733 Untested.	<b>BARREL KIT #67</b> 2-WATT AMPLIFIERS <b>50 for \$1.98</b> Untested. Buy from the barrel 'n save! 8-30 types in dip paks. Are they good? We don't want to find out we got millions. Cat.No.4A2734	<b>BARREL KIT #68</b> 2 WATTERS <b>100 for \$1.98</b> 100% good. Nobody seems to want em! 8-30 types in dip paks. No many suppliers don't stock, but throw 'em in the barrel, it's a lil' gold mine. All marked. Cat.No.4A2735	<b>BARREL KIT #71</b> CAPACITOR SPECIAL <b>100 pcs. \$1.98</b> Emptied stockpiles into barrels of mylars, poly's, mica's, mullides, plastics, ceramic's, discs, etc. Nifty 100% good. Cat.No.4A2738	<b>BARREL KIT #73</b> TRANSISTOR ELECTROS <b>50 for \$1.98</b> It "bugs" us why the factories dump 'em in barrels. We don't wish to separate wide asst voltages & values up to 300 mf. Cat. 4A2747	
<b>BARREL KIT #75</b> 400MW ZENERS <b>100 for \$1.98</b> Factory out of biz! Amazing offer: 6, 8, 10, 12 to 15V. You test, Hermetically sealed glass pak. Double plug. Cat.No.4A2740 Untested.	<b>BARREL KIT #76</b> 1-WATT ZENERS <b>100 for \$1.98</b> Factory same as 400-mw's. Never-to-see-again offer: 6, 8, 10, 12, 15V. under glass. Double plug. Cat.No.4A2741	<b>BARREL KIT #77</b> "BROWN" BODY TRANSISTORS <b>40 for \$1.98</b> G-E D-40 series; has hi-voltage. Darlington's, hi-current, npn's. Factory line discontinued. Power tabs. Cat.No.4A2742 Untested.	<b>BARREL KIT #78</b> "RED" BODY TRANSISTORS <b>40 for \$1.98</b> D-42 series. You test - go into your own biz! High current, hi-V. NPN. Untested. Cat.No.4A2743	<b>BARREL KIT #81</b> SUBMINI RESISTORS <b>200 for \$1.98</b> 100% good. PC, upright type, color coded, 1/2 watt. Asst values. Came to us in a barrel. Cat.No.4A2746	<b>BARREL KIT #82</b> 8000 SERIES ICS <b>50 for \$1.98</b> By National. From factory to you. Assortment of popular series. Factory fallouts, overruns. Untested. Cat.No.4A2634	<b>BARREL KIT #83</b> LM-340T UNTESTED VOLTAGE REGULATORS <b>15 for \$1.98</b> Factory rejected them for length of leads. May include 6, 8, 12, 15, 18, 24 volts. Power tab. Cat.No.4A2635	
<b>BARREL KIT #84</b> HOBBY LEDS <b>25 for \$1.98</b> Untested. MAN- "THE CLAW", 5V 15 ma. LED hobby or experimental use, for understanding the working of "mix" or calculator readouts. A segment may be missing. No.4A2679	<b>BARREL KIT #86</b> HOBBY LEDS <b>40 for \$1.98</b> Untested. Wow! A Litronics dump of all kinds of mixed digital LEDs, shapes, colors, good, poor, etc. Cat.No.4A2889	<b>BARREL KIT #87</b> NATIONAL IC BONANZA <b>100 for \$1.98</b> Factory dumps into barrels. Types 8000, 7400 series. OTL's, registers, clock & calc. chips, linear's, etc. Cat.No.4A2860 Untested.	<b>BARREL #91</b> SILVER MICAS <b>100 for \$1.98</b> Cat.No.4A3018 For the first time silver mica's so low in price! Axial, red case, variety of physical types & values. Big savings from distributor prices. Wt. 1 lb.	<b>BARREL KIT #94</b> "BUBBLE" READOUTS <b>12 for \$1.98</b> DIP-238 bubble magnifiers. Size missing. Truthfully so many of 'em we don't care. Untested. 3 oz. No.4A3048	<b>BARREL KIT #99</b> PHOTO ELECTRIC CELLS <b>10 for \$1.98</b> Asst. GE types, CDS types. Mixed by factory. Big job for us to separate. 100% good. Cat.No.4A3082	<b>BARREL KIT #102</b> CLOCK CHIPS <b>5 for \$1.98</b> National is dumping MM-5316 what's wrong with 'em, we don't know, but we got barrels. Hobby special. Wt. 2 oz.	
<b>BARREL KIT #104</b> SLIDE VOLUME CONTROLS <b>10 for \$1.98</b> Cat.No.4A3057 Used in hi-fi, volume control maker unloads. Asst values, what a buy. Worth \$1 ea. We've got barrels of 100% material.	<b>BARREL KIT #107</b> SQUARE OHMS <b>60 for \$1.98</b> Cat.No.4A3098 Factory "pegs" are some times "squares" when they topple prime square ohms mix 'em up in barrels. Asst. values waste. Wt. 1 lb.	<b>BARREL KIT #108</b> TO-3 PLASTIC TRANSISTORS <b>40 for \$1.98</b> Cat.No.4A3101 Includes PNP, NPN, 2N-3638, 2N3641, 2N5000 series, etc. Untested, but guaranteed to a 60% yield.	<b>BARREL KIT #109</b> TERMINAL STRIPS <b>150 for \$1.98</b> Wide asst. of terminal strip connectors, from 1 cent up. Strip manufacturers barrel dump is your gain. Wt. 1 lb. Cat.No.4A3136	<b>BARREL KIT #110</b> SUPPRESSOR DIODES <b>50 for \$1.98</b> Cat.No.4A3137 Keeps ignition noises out axial. Untested, but the of your capt, car, industrial, etc. Double plug.	<b>BARREL KIT #111</b> MULTI DIGIT READOUTS <b>8 for \$1.98</b> Barrels of bleached 3, 4 and/or 8 digit readouts to USA for "dump". Untested. Cat.No.4A3138	<b>BARREL KIT #112</b> MICRO MINI LEDS <b>40 for \$1.98</b> All the tiny leds, axial, upright of Monsanto, Litronics, variety of colors. Yield 50% or better. Cat.No.4A3139	
<b>BARREL KIT #113</b> STABILIZERS <b>50 for \$1.98</b> Cat.No.4A3140 Regulator, sensing and computer circuitry. Axial double plug type. Discontinued factory line. 20 volt. 80% yield. U test 'n save!	<b>BARREL KIT #114</b> PLASTIC SCRS <b>25 for \$1.98</b> Factory shanjin style, top grade yield 80% to 90%. Includes 15, 20, 80, 100, 160, 200 volta. TO-92. A buy! You betcher! Cat.No.4A3143 Untested.	<b>BARREL KIT #115</b> MOLEX SOCKETS <b>300 for \$1.98</b> 100% good. Calculator maker dump! We got a million of 'em. Used for IC sockets etc. Cat.No.4A3144	<b>BARREL KIT #116</b> BUTYONS, N FEEDTHRU'S <b>100 for \$1.98</b> 100% good. Truthfully worth a small fortune. Wide asst. of butyons-feedthru caps. FAMS TABS, NOTE RE, IIF, etc. Wt. 1 lb. Cat.No.4A3141	<p>Terms: Add postage Rated: net 30 Phone: Wakefield, Mass. (617) 246-3829 Retail: 16-18 Del Carmine St., Wakefield.</p>			<p>C.O.D.'s MAY BE PHONED</p>

**POLY PAKS** 20¢ CATALOG on 'IC's, Fiber Optics, Semi's, Parts  
P.O. BOX 942 LYNNFIELD, MASS. 01940

# 73 READER SERVICE

Circle appropriate Reader Service # for desired company brochures, data sheets or catalogs and mail in to 73. Include your zip code, please. Send money directly to advertisers. *LIMIT: 25 requests.*

## ADVERTISER INDEX

- |                            |                                |
|----------------------------|--------------------------------|
| A2 Aldelco 80              | K6 Kaufman 91                  |
| A4 Allied Sales 76         | K1 Kensco 142                  |
| A10 Altaj 137              | K2 K-Enterprises 131           |
| A8 American Calibration 91 | K3 Kenwood 5, 113              |
| A11 Ancom 73               | K7 Klaus 119                   |
| A12 Ancrona 144-146        | K4 KLM 9, CIV                  |
| A6 Apron 31                | K5 Kronotek 43                 |
| A7 ARRL 91                 | L2 LePhCo 136                  |
| A9 Audioland 35            | L1 Levy 132                    |
| B3 Barber 139              | M1 Matrix 129                  |
| B4 B & F 152               | M2 Meshna 105, 141             |
| B5 Budwig 132              | M6 Mini Micro Mart 123         |
| B6 Byte 49                 | M7 Morrow's 154                |
| B2 Byte'tronics 81         | N1 National Multiplex 83       |
| C1 CeCo 132                | N2 New-tronics CII             |
| C13 Chesapeake Digital 80  | N3 Nexus 140                   |
| C3 Clegg 67, 146           | O3 Optoelectronics 153         |
| C6 Comm. Specialists 117   | P1 Palomar 128                 |
| C5 Comm. Eng. 128          | P4 Polymorphic 64              |
| C16 Control Signal 136     | P2 Poly Paks 159               |
| C15 Cromemco 92            | R1 Radio Am. Calibook 127      |
| C14 CRS 154                | R2 Regency 123                 |
| C11 CSdc 133               | R5 Roto Kit 80                 |
| D6 Dahl 139                | S2 S. D. Sales 156, 157        |
| D7 Durhamfest 91           | S17 Sinclair 151               |
| D5 Dutronics 99            | S4 Siep 150                    |
| E6 Ebka 95                 | S14 Smitty's Radio 19          |
| E1 ECM 49                  | S5 Solid State Sales 128       |
| E7 Eldor 130               | S19 South Com 37               |
| E2 Electrografix 132       | S6 Southwest Tech. 82          |
| E3 Elec. Dist. 131         | S7 Space Elec. 43              |
| E5 Elec. Supermart 136     | S8 Spectrum Comm. 130          |
| F1 Fair 80                 | S9 Sphere 87                   |
| F3 Freck 130               | S10 SST 130                    |
| G7 Gamber 43               | S15 Star Kits 91               |
| G1 Gateway 133             | S13 Swivetek 143               |
| G2 Gauthier 128            | T1 Tri-Tek 109                 |
| G3 GENAVE 36               | T2 Trumbull 91                 |
| G6 Gifer 43                | T3 Tufts 47, 139               |
| G8 Glade Valley 154        | U1 Universal Radio 132         |
| G4 Godbout 68, 149         | U3 US Bicentennial Pendant 129 |
| H6 Hal Comm. 101           | V1 Vanguard 112, 133           |
| H7 "Ham" Burger 1          | V2 Varden 49, 91, 130, 132     |
| H2 Ham Radio Center 147    | V5 VHF Eng. 50, 51             |
| H8 Hamtronics 121          | V6 Visulex 99                  |
| H5 Heath 65                | W5 Wave Mate 93                |
| H3 Henry 29                | W1 Wellman 43                  |
| H10 Hufco 127              | W7 Whitehouse 127              |
| H4 Hy-Gain 45              | W2 Wilson 20, 21               |
| I1 ICOM 2, 10              | W3 Wire Concepts 122           |
| J1 James 155               | W4 World QSL Bureau 100        |
| J2 Jan Crystals 131        | W6 W6Radio 49                  |
| K8 KA Elec. 158            | Y1 Yaesu CIII                  |

From 73 ...  
60-63

NEWSSTAND  SUBSCRIPTION

## READER SERVICE

73 Inc., Peterborough NH 03458  
MAY 1976

Please print or type.

Name \_\_\_\_\_ Call \_\_\_\_\_  
 Address \_\_\_\_\_  
 City \_\_\_\_\_  
 State \_\_\_\_\_ Zip \_\_\_\_\_

Coupon expires in 60 days . . .

# PROPAGATION

by  
J. H. Nelson

## EASTERN UNITED STATES TO:

	GMT:	00	02	04	06	08	10	12	14	16	18	20	22
ALASKA	7A	7A	7	7	7	7	7	7	7	7	7	7	7
ARGENTINA	14	14	7	7	7	7	14	14	14	14A	14	14	14
AUSTRALIA	14	14	7B	7B	7	7	7	7	7	7	7	14	14
CANAL ZONE	14	14	7	7	7	7	7	14	14	14	14	14	14
ENGLAND	7	7	7	7	7	7	7	14	14	14	14	14	14
HAWAII	14	14	7B	7B	7	7	7	7	7A	14	14	14	14
INDIA	7	7B	7B	7B	7B	7B	7A	14	14	14	7A	7	7
JAPAN	14	7	7	7	7	7	7	7	7	7	7	7	14
MEXICO	14	14	7	7	7	7	7	7	14	14	14	14	14
PHILIPPINES	14	14	7B	7B	7B	7B	7B	7	7	7	7A	14	14
PUERTO RICO	14	7	7	7	7	7	7	7	14	14	14	14	14
SOUTH AFRICA	7	7	3A	7	7B	7B	14	14	14	14A	14	14B	14
U. S. S. R.	7	7	7	7	7	7	7A	14	14	14	14	14	7
WEST COAST	14	14	7A	7	7	7	7	7A	14	14	14	14	14

## CENTRAL UNITED STATES TO:

	7A	7A	7A	7	7	7	7	7	7	7	7	7	7
ALASKA	7A	7A	7A	7	7	7	7	7	7	7	7	7	7
ARGENTINA	14	14	7A	7	7	7	7	14	14	14	14	14	14
AUSTRALIA	14	14	7A	7B	7	7	7	7	7	7	7	14	14
CANAL ZONE	14	14	7	7	7	7	7	14	14	14	14	14	14
ENGLAND	7	7	7	7	7	7	7	7A	14	14	14	14	7A
HAWAII	14	14	7B	7	7	7	7	7	7	14	14	14	14
INDIA	14	14	7B	7B	7B	7B	7B	7B	7	7	7	7	7
JAPAN	14	14	14	7	7	7	7	7	7	7	7A	14	14
MEXICO	14	7	7	7	7	7	7	7	7	7A	14	14	14
PHILIPPINES	14	14	14B	7B	7B	7B	7	7	7	7	7A	14	14
PUERTO RICO	14	14	7	7	7	7	7	14	14	14	14	14	14
SOUTH AFRICA	7	7	3B	7	7B	7B	7A	14	14	14	14	14B	14
U. S. S. R.	7	7	7	7	7	7	7	7	7	7A	14	7	7

## WESTERN UNITED STATES TO:

	7	7A	7	7	7	7	7	7	7	7	7	7	7
ALASKA	7	7A	7	7	7	7	7	7	7	7	7	7	7
ARGENTINA	14A	14	7A	7	7	7	7A	14	14	14	14	14	14
AUSTRALIA	14	14A	14	14	7A	7	7	7	7	7	7	14	14
CANAL ZONE	14	14	7	7	7	7	7	14	14	14	14	14	14
ENGLAND	7	7	7	7	7	7	7	7	7	7	7	7	7A
HAWAII	14	14A	14	14	7	7	7	7	7	14	14	14	14
INDIA	14	14	14	7B	7B	7B	7B	7B	7	7	7	7	7
JAPAN	14	14	14	7	7	7	7	7	7	7	7A	14	14
MEXICO	14	14	7	7	7	7	7	14	14	14	14	14	14
PHILIPPINES	14	14	14	14B	7B	7B	7	7	7	14B	14	14	14
PUERTO RICO	14	14	7	7	7	7	7	14	14	14	14	14	14
SOUTH AFRICA	7	7	3B	7	7B	7B	7B	7A	14	14	14	14B	14
U. S. S. R.	7	7	7	7	7	7	7	7	7A	7A	14	7	7
EAST COAST	14	14	7A	7	7	7	7	7A	14	14	14	14	14

A = Next higher frequency also may be useful  
 B = Difficult circuit this period  
 N = Normal  
 U = Unsettled  
 D = Disturbed

1976				MAY			1976			
SUN	MON	TUE	WED	THU	FRI	SAT				
1 D	2 U	3 U	4 U	5 U	6 U	7 U	8 N	1 U		
9 N	10 N	11 U	12 U	13 U	14 N	15 N				
16 N	17 U	18 U	19 U	20 D	21 D	22 D				
23 D/U	24 U/U	25 U	26 N	27 N	28 N	29 N				

# Something new from Yaesu



FT-221  
**VHF Mobile/Base Station**  
2 Meter Transceiver

Here is a compact, versatile transceiver designed for the active 2 meter enthusiast. The FT-221 features all mode operation—SSB/FM/CW/AM—with repeater offset capability. Advanced phase lock loop circuitry offers unsurpassed stability and clean spurious free signals. Modular, computer-type construction offers reliability and ease of service. Preset pass band tuning provides the optimum selectivity and performance needed on today's active 2 meter band. Join the fun on FM, DX, or OSCAR, with the FT-221 transceiver—another winner from the world's leader in amateur communications equipment.

## Features

- Complete 144-148 MHz coverage in 8 band segments—11 crystal channels per band segment. (11 xtals = 88 crystal controlled channels)
- SSB output 12 watts PEP—FM/CW output 14 watts—AM output 2.5 watts
- Dual rate, concentric VFO dial drive with better than 1 kHz readout
- Three way metering: S-meter, power output, and FM discriminator
- Built-in AC & DC power supplies and speaker
- Built-in tone burst—adjustable 1500-2000 Hz

See your Yaesu dealer or write:

Yaesu Musen USA Inc., 7625 E. Rosecrans,  
No. 29, Paramount, California 90723

Yaesu Musen USA Inc.,  
613 Redna Terrace, Cincinnati, OH 45215  
Eastern Service Center

**YAESU**  
**The radio.**





**KLM Multi-2000 ... already locked in  
as the greatest feature-per dollar VHF transceiver ...**

# Now... both USB & LSB for even greater value... lower, beat-inflation pricing!

The great response to the KLM, Multi-2000 VHF transceiver by amateurs world-wide has now made it possible to manufacture this fine set in quantities substantially larger than the original production runs. Result ... new, value-added features, lowered manufacturing costs.

KLM will now have more sets to sell so, with the Multi-2000A, encourages the buyer by passing along a substantial portion of the production savings. Example: Former price, 795.00. Your inflation-fighting price today is 679.00 ... **a saving of 116.00!** But without extra cost you now get Lower Sideband, making the KLM Multi-2000A **four mode** equipment with NBFM, WBFM, SSB (with both USB and LSB) plus CW. Power output remains at 10 watts.

Here truly is the **complete** full feature VHF station for base or mobile. It has both 12VDC and

- 144-148MHz. Phase lock loop synthesizer.
- Separate VXO and RIT for full, between-channel tuning.
- Simplex and/or 600kHz repeater capability.
- NBFM/WBFM/SSB (USB & LSB)/CW.
- Built-in AC & DC power supplies.
- Noise blanker • Squelch • RF gain control.
- Selectable 1/10W power output.
- High sensitivity (0.3uV for 12db SINAD).
- Superior immunity to cross mod./Inter mod.
- Built-in test (call) tone and touch-tone provisions.

115VAC supplies built-in, is actually ready to operate right out of the shipping carton. It offers highest versatility and crystal stability. Any of 200 channels can be selected instantly in 10 kHz steps by three dials controlling the phase lock loop frequency synthesizer setup. Continuous interpolation within the 10 kHz segments (144-148 MHz) is afforded by VXO for trans./rec. and RIT for receive. There are also three FM crystal positions for frequently used channels.

Check the Multi-2000A panel in the photo. Note the convenient, "people engineered" control arrangements, the simple, positive channel setup and the many refinements that contribute to relaxed, enjoyable conversations in any of four different modes.

**At your favorite dealer or write direct.**

## Economically priced 160W solid-state Linear Amplifier



160W power out from Multi-2000A (or other models/brands) with 5-15W input, SSB, CW, AM, FM. Broad band ... 144-148MHz with-

out tuning. Automatic RF switching. 13.5 VDC. Also 144, 220, 450MHz models, 12 to 120W out.

# KLM electronics

17025 Laurel Road, Morgan Hill CA 95037  
(408) 226-1780, (408) 779-7363