

# Practical Radio and Electronics Course

## *For Home-Study*

---

Revised 1960 Edition



Prepared under the direction of

**M. N. BEITMAN**

---

**SUPREME PUBLICATIONS**

PRICE **\$3<sup>95</sup>**



# PRACTICAL RADIO AND ELECTRONICS COURSE



PREPARED UNDER THE DIRECTION OF

M. N. BEITMAN

B.S. in Mathematics, Illinois Institute of Technology  
Radio Instructor, Chicago High Schools  
Formerly, Engineer, U. S. Signal Corps  
Associate, Institute of Radio Engineers  
Holder of Radiotelephone First Class License  
Author of Many Radio Books and Articles

SUPREME PUBLICATIONS

# *A Welcome and Introduction to You*

You must understand how to study the course. On each page, you will find two columns. In the wide column is the text material just like a book used at school. In the narrow column you will find the instructor's comments, helpful suggestions, additional pictures and remarks to simplify the difficult parts. You study by reading the text in the wider column. The comments in the narrow columns are read as they are found adjacent to the other reading matter.

The review questions and problems must be carefully answered in writing. A notebook should be kept with all the answers. Occasionally you will find hints and suggestions to help you with the problems. In many cases, the answers are stated so that you can check the corrections of your own results.

Assign certain periods of each day to your radio and electronics studies. Tackle this study in a happy spirit, always thinking of the accomplishments that lie ahead. Progress along as quickly as you are able, but do not pass any section until you have mastered the contents.

We know you will succeed in learning the interesting and essential facts about practical radio and applied electronics. Good luck in your studies and work.

M. N. Beitman



This is the fifth edition of the three volume "Practical Radio and Electronics Course" completely revised and published in 1960 as this combined, single manual.

© by Supreme Publications, 1960.

All rights reserved, including the right to reproduce or quote the contents of this book, or any portion thereof, in any form. Book reviews may include quotations of brief passages to illustrate the style or contents.

# LESSON 1

## What Makes Up a Radio Receiver

**THE INSIDE OF A RADIO.** You are going to begin your study of radio in a *practical* way. The small radio set you probably have in your home or can obtain from a friend will be your first laboratory. You will only look at the parts and examine the connections. You will not make any changes and will be careful in your work. The radio set will remain in fine shape and you will gather a world of knowledge about the parts used in all types of radio equipment.

The radio you select for these visual observations first of all must be tested. You already know how to *rough-test* a radio. Simply make certain that the required electrical connection for power is made. In electric sets this means that the plug must be connected. If used, the antenna wire also must be connected. Then tune in one or two stations to check if the radio set is operating properly.

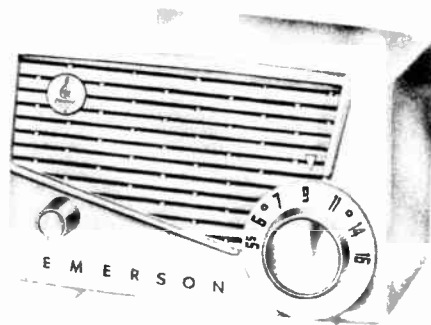

Figure 1. Any small, home radio receiver can be used for the simple experiments described. Complete instructions are given for the work to be performed.

After this test, remove the power plug from the receptacle and disconnect the antenna wire. Begin at once to practice the correct way for doing every radio task. An expert radio man plans his every step and performs the task first in his mind. Then the expert follows through with the actual operation. For example, plan in your mind how you will remove the plug. Make certain you will not bump something with your elbow, and pull on the plug and not the wire.

**REMOVING THE KNOBS.** Now examine the front of the radio you are using. It probably has several knobs, for selecting the desired stations, for controlling the volume, and for other purposes. These knobs usually must be removed to take the radio chassis (the actual radio) out of the cabinet. Most knobs fit over the shafts of the parts of the radio, and are held in place by small set screws. Look at the side of a knob instead of the front. Rotate this knob. Do you see a small opening and, inside of this opening, the head of a tiny screw? The knob may be removed by first loosening this set screw. After this the knob can be taken right off. You know, of course, that standard screws are loosened by turning a screw driver

In this column you will find additional explanations, hints, suggestions for study, and other remarks usually expressed by the instructor in a class room. You are to read the main text in the wide column first. The *explanation* notes in the narrow column should be noticed as the main text along-side is read.

The choice of a radio for these safe *examination* experiments is not critical. A small table radio is easier to handle. You must be careful in handling the receiver; by following the directions exactly, you will make certain that the set will operate properly when your work is completed.

Will your radio operate without any antenna wire? Try it out. What do you think the antenna wire does? You are right, if you understand that it picks up the radio signals.

## REMOVING THE CHASSIS

Majority of this information applies directly to television receivers, but this course will stress applications to radio and electronic equipment.

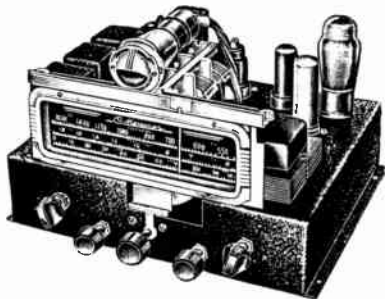

Courtesy Meissner Mfg. Co.

Figure 3. Your radio receiver may look somewhat like the chassis illustrated.

Since radio repair work must be performed inside the radio chassis, special supports are available which will hold the chassis in a suitable position to permit the serviceman to reach underneath to make the required measurements and tests.

You are always safe in touching *insulating* parts such as glass of the tubes, wax cardboard containers. Any single metal connection may be touched with an insulated screw driver provided the metal of the blade does not touch other parts at the same time.

Volume 1 - Page 4

to the left, i.e. counter-clockwise, in the opposite direction in which clock hands turn. If you do not have a small screw driver to fit the small openings in the knobs, a small knife or a nail file may do the trick. Later when you replace the knobs, tighten the set screws just enough to make the knobs turn the needed controls and not slip on the shafts.

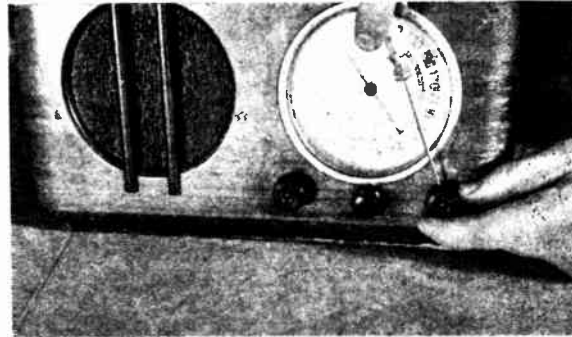
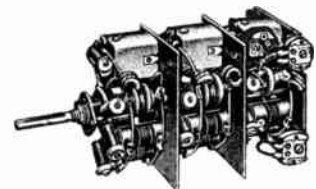
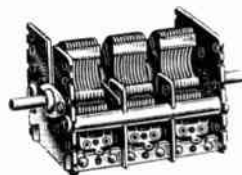

Figure 2. Most radio control knobs may be removed with the aid of a small screwdriver.

You may find that the knobs on your radio set do not have set screws. If this is the case, the knobs may be removed by simply pulling on them. After pulling these knobs off, notice how they fit on the shafts and plan to replace them in exactly the same way.

**REMOVING THE CHASSIS.** Now you must examine the entire cabinet, especially the back and bottom, to see how the radio metal-chassis is held in place. Probably several bolts hold the chassis in place and the bolts have their heads coming out at the bottom of the cabinet. If this is so, remove these bolts. The back of the cabinet may have a panel which also must be removed. When all required bolts have been taken out, the chassis will slide out easily from the cabinet. Be careful of the dial assembly. Notice how the equipment fitted together, so that you can assemble things back in place easily and quickly.

Since the radio is not connected, you are safe in placing your hands on all parts. Be careful, however, not to exert too much force on the tubes which are usually made of glass. Be careful also not to punch a hole in the cardboard cone of the loud speaker.



Courtesy Meissner Mfg. Co.

Figures 4 and 5. Here you have an illustration of a three gang variable condenser and an all-wave band switch.

After the chassis is removed from the cabinet, you should place the control knobs back in place. Then connect the power plug and the antenna wire. Now you may try to operate the radio. The radio will *play* without the cabinet, but the tone will not be as good. After this second operating test, disconnect the radio once again.

**WHAT DO THE KNOBS DO?** Notice that the knob, which is used to tune in the radio station, is attached to a part made up of a group of movable plates. This part is known as a variable condenser. A three-gang type variable condenser together with associated coils is illustrated on this page. You will learn in later chapters how a condenser tunes in the wanted radio stations. The other knobs may control parts mounted under the chassis, and you may turn the radio over to find these parts.

The knob which controls the volume and the knob which changes the tone (if used) rotate the shafts of potentiometers, or variable

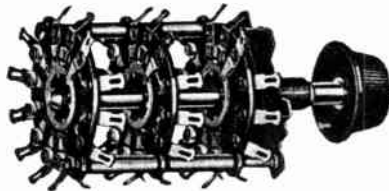

*Courtesy P. R. Mallory & Co.*  
 Figure 7. This is the kind of switch used in all-band radio sets and also in test equipment.

resistors. These units are discussed in great detail later and a typical potentiometer is illustrated on this page. Another knob controls a band-switch which is used to select the band of operation, i.e. broadcast, police, or short-wave.

**PARTS ABOVE THE CHASSIS.** Now let us return to the top of the chassis. If you have a relatively modern radio, it will be somewhat like the set we illustrate. Observe the following parts with which we will now become familiar: vacuum tubes and sockets, filter condensers, cans containing coils, and the power transformer.

The vacuum tubes may be of various types and may have glass or metal envelopes. Examine with care the tubes used. Remove them one at a time. Notice how they plug into the sockets. Look under the chassis and see how a socket makes contact with the prongs of the tube. Notice the type numbers stamped on the tubes. Are any of the tubes in your radio marked with the type numbers: 6D6, 12AV6, 35W4? How many prongs do the tubes have? Do some have more than others? Are all the prongs of any one tube of the same size? These are important facts and will help you study Lesson Nine where you will learn how vacuum tubes operate.

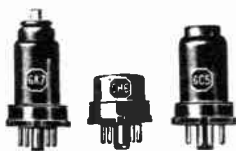

Figure 9. Metal radio tubes have different physical appearances, but always use octal sockets.

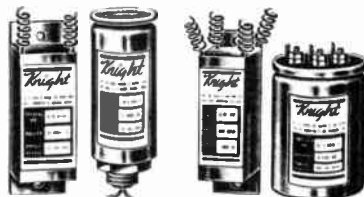

Figure 10. Filter condensers are supplied in different containers.

The filter condensers may be in various shapes. Sometimes they are supplied in metal containers mounted above the chassis. In other sets, the filter condensers may be in cardboard boxes mounted below the chassis. Locate the large filter condenser which is present in almost every radio.

## WHAT THE KNOBS DO?

You must understand what part each knob controls and for what purpose this part is used.

A three deck switch is shown in Figure 7. Band-switches are obtainable with different number of decks and may have from two to about seventeen terminals per deck.

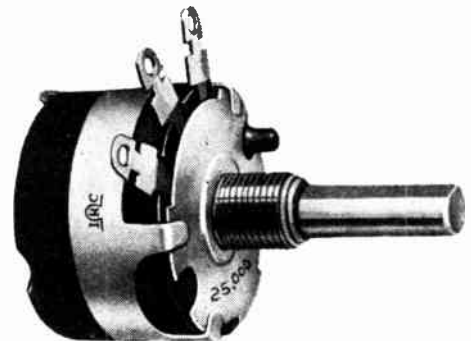

*Courtesy International Resistance Co.*  
 Figure 6. A potentiometer, used to control the volume output of a radio set, may contain the power switch as in the unit illustrated.

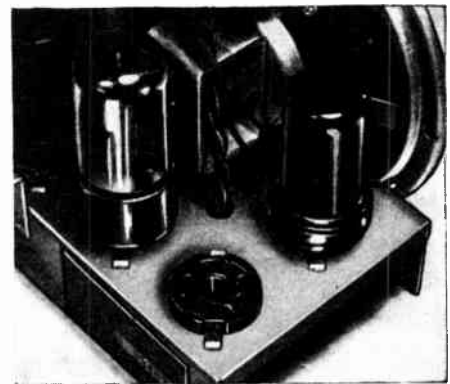

*Courtesy American Phenolic Corp.*  
 Figure 8. Radio tubes may be removed with an upward motion while slightly shaking your hand from side to side.

## HOW THE PARTS ARE MOUNTED

A container that has but a single condenser usually has but two leads. Probably the filter condenser in your radio has several leads indicating that several condensers are housed in the container.

Some radio receivers, known as AC-DC types, do not have a power transformer. Sometimes these sets have a *heater resistor* in the power line cord. If this is true of your radio, you will notice the line cord becomes warm when the set is in operation.

The workmanship under the chassis will tell you about the quality of the receiver you have. The better sets have the parts neatly placed and sturdily held in place. The wire leads are short, direct, and well soldered.

You probably will find several light-colored metal cans mounted above the chassis. Keeping in mind the spot where the cans are mounted, turn the chassis upside down, and notice that there is a round opening directly under each can. Connecting wires come through this opening. By looking through this opening, you can see a radio coil inside the can. These cans are called shields by radiomen.

If your radio is designed only for A.C. (alternating current) power operation, you will find that it contains a power transformer. The type of transformer illustrated is known as a half-shell, but some radios use upright transformers.



Figure 11. Radio coils are housed in metal cans.

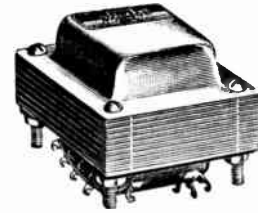

Figure 12. This illustration shows a half-shell power transformer.

**UNDER THE CHASSIS.** We now return to the parts under the chassis. Besides the sockets for tubes, potentiometers which we already mentioned, and switches, we find resistors of all types, and small condensers. Also there is a maze of wires inter-connecting



Figure 13. Carbon resistors are made in different resistance values and power handling sizes.

the equipment. Look carefully at all these parts and be sure that you can name all of them. This is what we have tried to accomplish so far. You must learn the names of parts, you must know the main points of appearance of every radio part before you can go on.



Figure 14. You will find many condensers of the type illustrated used in all radio receivers.

**HOW THE PARTS ARE MOUNTED.** Notice now how the different parts are mounted. It will be good practice for you to take a sheet of notebook paper and divide the page into four columns. Write the name of the part in the first column. In the next column describe how this part may be mounted or supported. Sockets may be riveted or bolted, resistors may be suspended on their lead-wires, etc. In the third column, you will suggest another method for mounting the same part if this is possible. And in the last column, you will state how many wire leads actually go to the terminals of the part. For example, a resistor may have only two terminals, but to one terminal there may be connected five different wires, while to the other only one. This will make six wires in all. Notice that every terminal of a part always has at least one wire.



In order to explain why certain parts are made entirely of metal, while others contain only small metal sections, and still other parts are made of bakelite, hard rubber, or cloth, we must present a brief theoretical explanation about electricity.



Figure 15. It is interesting to note that tube sockets may be mounted with bolts or rivets. A volume control is usually mounted by means of the threaded section around the shaft.

**WHAT IS ELECTRICITY?** Electricity plays an important part in making possible radio communication. In an ordinary house radio, electric power is changed in form, increased and decreased in voltage, and made to conform exactly to the electrical radio waves picked up by the antenna. We are able to control and use electricity to our advantage, but we have only a workable theory regarding the exact nature of this force.

According to this theory all matter is made up of 92 different atoms. These atoms, however, are in turn made up of identical negatively charged particles called *electrons* and heavier positive particles. We are primarily interested in the negative electrons since these make up the electric current.

The electrons are very small and millions upon millions are required to make up the current to keep a radio tube in operation. These electrons not only make up the atoms of matter, but are present as free electrons ready to move to any positive body which attracts them. In nature, negative particles, small or large, are attracted by positive bodies and repelled by other similarly charged negative bodies.

These free electrons tend to be present in equal quantity everywhere. If a body has too many electrons, they will move to other bodies to equalize this distribution. And for the same reason, a body short of free electron, will attract the electrons. This movement of electrons constitutes actual electric current.

**CONDUCTORS AND INSULATORS.** Electric current, made up of electrons, may pass along certain substances known as conductors. Silver, copper, and other metals are considered conductors. Many materials pass very little electric current. Known as insulators, these materials actually stop the current. Rubber, cloth, mica, slate, and many other materials are used to insulate radio parts.

If electric current is required to pass from one radio part to another, these parts must be connected by hook-up wire. On the other hand, if parts are not to be in electrical contact, they must be insulated. Separation is enough since air is a good insulator.

**RADIO CIRCUITS.** You have already learned that the various radio parts used in the receiver are interconnected with copper wire having either a cloth or rubber insulation. Radio engineers and repairmen must be able to obtain an understanding of the circuit employed in the radio set requiring adjustment or repair. This can be done by tracing out the various connections and making a pic-

## ELECTRICAL FACTS

Many times metal parts of radio components are not in electrical contact with the circuits and do not carry any electric current. The frame of a power transformer or the metal shaft of a volume control ordinarily are not connected to the circuits of the radio.

There are 92 natural elements (atoms) and 9 additional synthetic elements discovered to date. Besides electrons and heavier positive particles there are other less understood particles in nature.

Air separation or insulation with certain materials is sufficient if the voltages are small. Very high voltages will force a spark to jump across an air gap or puncture a thin piece of insulation.

# RADIO PARTS SYMBOLS

There are additional symbols besides those illustrated in Figure 16. Some of the symbols shown serve for similar components. For example, the symbol for an ammeter can be used for any meter provided the notation explains this. The scale of the meter, the value of a resistor, the voltage of a battery can be indicated with a brief notation along side the symbol.

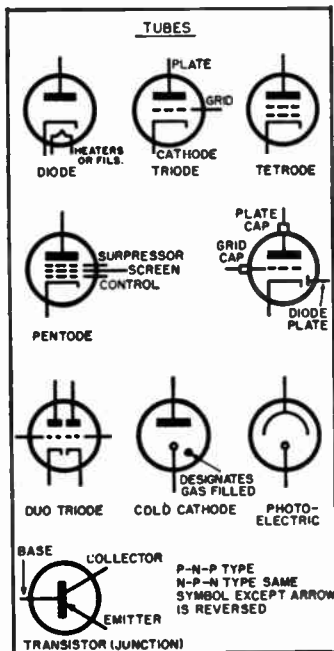

ture of the parts and wiring. It is difficult, however, to make pictures of parts. When a picture drawing is finished, it is almost as confusing as the maze of wires one sees by looking at the bottom of a chassis. To simplify this task, radio engineers have decided to use symbols to represent the different radio parts. The connecting wires are represented by straight lines.

This is a logical solution. We are experienced in using symbols in almost all fields. The fact that an animal with four legs and of a certain appearance is called a dog and is spelled d-o-g, shows an application of symbols.

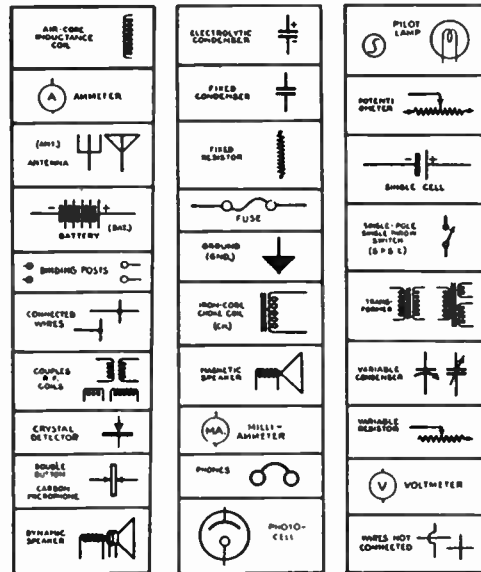

Figure 16. These are symbols of commonly used radio parts and must be carefully studied by you.

The radio parts you have examined, as you read the first part of this chapter, all have easy-to-remember symbols. These symbols are illustrated and must be carefully studied. Practice making these radio symbols. You must be able to look at any radio part, call it by the correct name, and make a drawing of the proper symbol which is used to indicate this part in radio diagrams. A few additional symbols will come up as you progress with your studies.

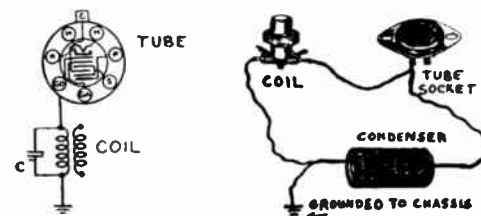

Figure 17. Please observe that the schematic and pictorial diagrams indicate the same connections.

Let us suppose that a certain radio set has a coil (inductance) terminal wired to a connection on a socket of a vacuum tube. How do you indicate this fact on a schematic diagram? You probably

know that first you will make the correct symbols for the particular coil and vacuum tube. Then you will draw straight lines, preferably with a ruler, connecting the proper terminals of these symbols. Examine the illustration showing this schematic drawing and also a picture representation of this wiring. Besides the parts mentioned, our schematic diagram also shows a condenser connected directly across one of the windings of the coil. Notice that this makes one side of the condenser common with the terminal of the vacuum tube.

In complete diagrams, straight lines are used to indicate the connections between parts, but these lines do not indicate the actual wires. The parts may be wired in any fashion as long as exactly the same component parts are connected with the lines and are also wired to permit the passage of current.

This example illustrates that the actual wires and the diagrammatical lines will permit the same passage of current and are, therefore, considered the same connections. But the lines are not exact representation of the wires for circuit tracing purposes.

**REVIEW QUESTIONS AND PROBLEMS.** 1. Make a rough sketch of the top view of the radio chassis you examined. Print in the names of the parts. How can you use such a sketch as an aid in getting the tubes back in the right sockets?

2. If the power plug is of the removable type, study the manner in which the cord is connected. Remove the cord with the aid of a screw driver and then re-assemble.

3. Using a small ruler, measure the inside diameter of the knob opening. While the knob is unmounted, turn-in the set screw until it becomes visible through the "shaft" hole.

4. Place your finger against the loudspeaker cone. Do you feel the vibrations which correspond to the sounds you hear? Does the tone change any because of your finger?

5. Do any of the tubes in your radio have a grid-cap connection at the top of the bulb? How is this connection made to the radio circuit?

6. What is the diameter of the coils used in your radio?

7. Why are rivets used instead of bolts in many cases?

8. Name three commonly used conductors of electricity.

9. Name three insulators used in radio parts.

10. Make a schematic showing two coils connected in a manner which will permit the current to enter one coil, pass on to the second coil, and then pass on to a long lead.

11. If two students wire two separate radios from a single schematic, will the radios match wire for wire? Explain.

12. What is the maximum number of wires which may terminate at a single point? What was the maximum number you found in your radio?

## SELF-TESTING QUESTIONS

For practice, the student should make the symbols of several radio parts (any parts at all) and inter-connect them in some fashion. Make another drawing of the same symbols (parts), but now connect them in the same *electrical* way using somewhat different pencil lines.

1. Hint: In lettering a radio drawing be sure that all printing can be read from the normal position or from the right hand side.

4. Notice what part of the loudspeaker cone vibrates the most. Does this remain the same for high pitched and for low frequency sounds?

5. The grid caps are made in two different sizes for receiving tubes. Glass tubes require the larger size; metal and —G type tubes use smaller grid caps.

6. The diameter of the core of the coil is wanted. Probably anywhere from  $\frac{1}{2}$  to  $1\frac{1}{4}$  inches. Do not take any coils apart to get this dimension.

7. Probably quicker to fasten the parts.

8. Silver is often used for contact points on telegraph keys.

9. Are all these insulators suitable at high temperatures?

# LESSON 2

## Mechanics of Radio

This lesson will tell you what tools are needed to do radio work and how the mechanical operations of mounting, replacing, and repairing radio equipment are performed.

WHAT MAKES-UP A RADIO? A great many components are needed to make up a complete radio receiver. Usually we think of the radio as a unit having these components correctly inter-connected with wires. But it is also important to have these parts properly mounted. The parts must be mounted solidly and in positions to permit convenient and short connecting wires.



Figure 18. The components of a radio receiver must be assembled and properly wired to obtain the required operation. The photograph illustrates a radio class busy assembling simple radio receivers.

The tools illustrated at the right are required for successful radio repair work. Probably you are familiar with the use of these tools, but will find their application in radio work somewhat different. If you are not experienced in the mechanical work, it is advisable to get an old junk radio to practice dismantling the components and remounting a few of the parts in different positions.

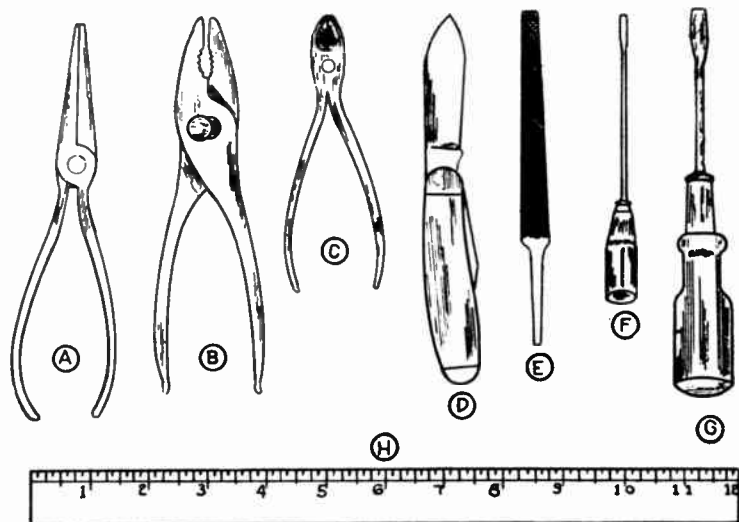
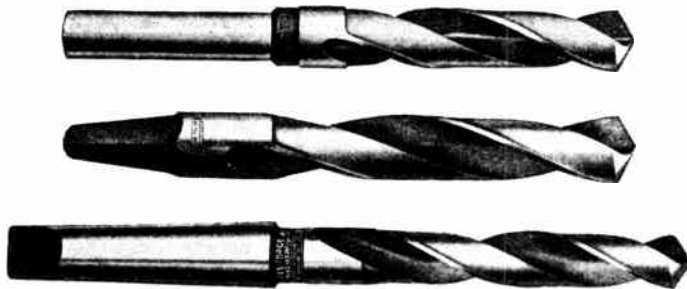

Figure 19. These are common radio tools needed for radio repairing and construction work. (A) Long-nose pliers, (B) Gas pliers, (C) Diagonal cutters, (D) Pocket knife, (E) Flat file, (F) Small screwdriver, (G) Medium-size screwdriver, (H) Scale.

**METAL CHASSIS BASE.** The radio parts are assembled on a metal base and are wired according to the circuit. The base is usually made of sheet metal which has been properly shaped, cut, punched and drilled. The metal used is usually cadmium plated iron alloy, aluminum, or galvanized sheet iron. As you have already seen in the radio you examined, the tube sockets are so mounted that the tubes are above the chassis. A few additional parts may be above the chassis, but most of the wiring and almost all of the smaller parts are placed below the chassis base.



*Courtesy Cleveland Twist Drill Co.*

Figure 20. Twist drills are used to make the needed holes in radio chassis bases.

If you are called on to make a chassis for a piece of radio equipment, the first step is to lay out the top allowing room for all parts to be mounted. Once your lay-out is completed, you will know what dimensions the top of the base will have. The sheet metal you will use must be laid out to allow about 2 inches additional along each edge for the sides of the chassis. Commercial chassis bases are available in many sizes and are reasonably priced.

If you are able to obtain some sheet metal and have the necessary tools, it is recommended that you make a small radio chassis. Plan to prepare this chassis for mounting upon it the radio parts that you have on hand. In obtaining a radio job, you may be questioned about the mechanics of radio to the same degree that you will be asked about radio theory.

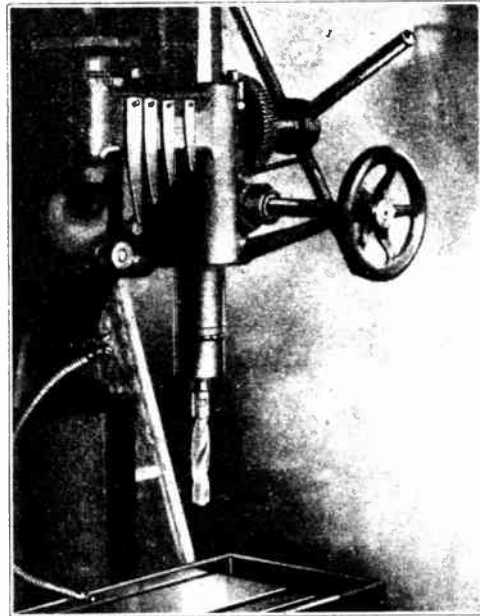

Figure 21. This type of socket punch is employed by radio servicemen and in experimental laboratories for punching the required cut-outs for tube sockets.

*—Courtesy American Phenolic Corp.*

Most radio parts are attached with bolts or rivets and, for this purpose, holes must be drilled. The correct twist drill for the job should make a hole just large enough for the threaded part of the screw to slip in. Self-tapping screws make threads in the metal as they are screwed in place. These self-tapping screws and rivets are used without lock washers.

Large circular holes may be made with a circle-cutter or with a socket punch. The punch may be in the form of a die. The socket punches are made in various sizes commonly needed for radio construction, while the circle-cutter is adjustable to various diameters.



*Courtesy Cleveland Twist Drill Co.*

Figure 22. For quickly drilling required holes, the drill press is very useful.

The planning of the placement of different radio parts on a radio chassis is made while considering many important factors. Parts that become hot in operation must be kept away from components such as condensers which are easily damaged by heat. All parts must be placed in relation to each other so that certain of the connecting wires are as short as possible. While all the wires should be short, you will learn later on that the grid and plate wires must be very short for proper operation of the equipment.

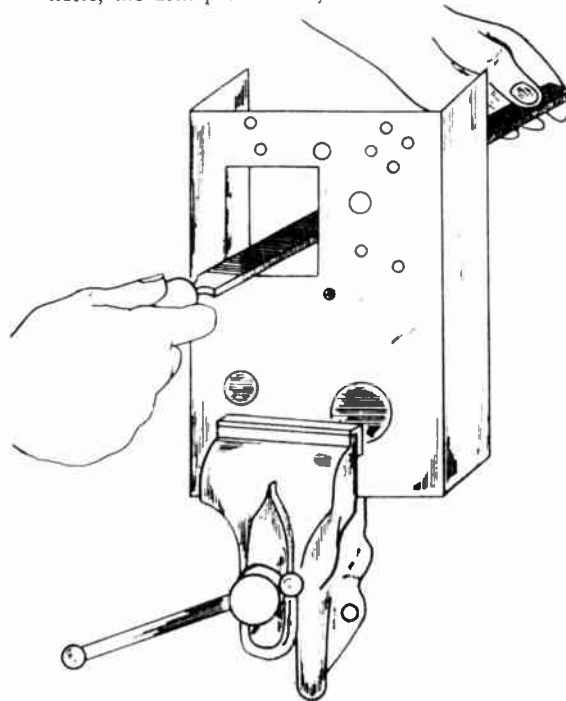
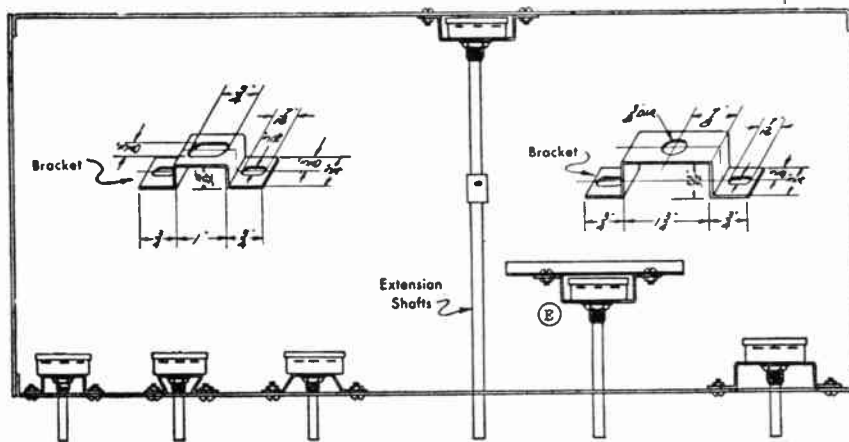

Figure 23.\* When a square cut-out is made for mounting the transformer, the metal sides must be filed smooth.

\*Figure 23 above, as well as Figures 19, 27, 29, 35, 111, and 115, are reproduced from "Mechanic Learner—Radio" which was issued by the Commonwealth of Pennsylvania, Department of Public Instruction, and was prepared with War Production Training funds in cooperation with the U. S. Army Signal Corps and the U. S. Office of Education.

In using a circle-cutter, care should be exercised in setting it to the exact dimensions needed. Of course, a hole cannot be made smaller, and only by difficult filing can the hole once drilled be increased in size.

Half-shell power transformers require rectangular openings in the chassis. The metal to be cutout is marked off and tiny (about  $\frac{1}{8}$  inch) holes are drilled next to each other along the lines indicating the needed cut-out. After the holes are drilled all the way around, a chisel is used to cut the metal between the holes. When the job is completed, the rectangular blank will fall out. The opening is then filed smooth.



Courtesy P. R. Mallory & Co.

Figure 24. Volume controls may be mounted on special stand-off brackets as illustrated. However, in the majority of radio equipment, volume controls are mounted directly on the side of the radio chassis.

In some circuits, the volume control or other adjustable components are mounted some distance away from the front panel and the control knob on the front panel is attached to an extension shaft (either flexible or solid) as shown in Figure 24.

**HOW RADIO PARTS ARE MOUNTED.** Your attention was called to the method used for mounting radio parts, while you were studying in Lesson One. Small parts, such as resistors, condensers, and R.F. chokes, are supported with their own leads. Tube sockets are fastened to the chassis with machine screws or rivets. Large condensers (used in the power supply of receivers) are mounted with bolts or with stud-nut over the threaded section of the metal container. Power transformers are bolted in place, using the screws

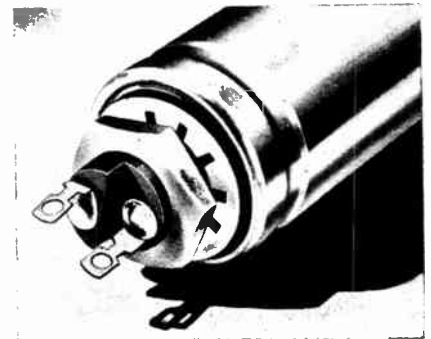

Figure 25. This is an illustration of an octal socket showing the two mounting holes. Sockets have different dimensions and the required holes must be drilled to measure.

that hold the frame to the laminations in the case of the half-shell type, or with machine bolts in case the transformer is of the upright type. Volume controls (potentiometers) are mounted behind the side of the metal chassis. The shaft comes through a threaded section which is attached to the case. This section is tightened against the chassis. The shaft may be cut to the needed length. The switch, used with many volume controls, is mounted in place on the back plate of the volume control unit.

## HANDLING HOOK-UP WIRE

In many large sets, the ground bus wire (for all common chassis connections) may be bare.

No. 18 or 20 push-back wire will serve for most radio circuits. For some filament circuits, where currents of several amperes must be carried, No. 14 wire is recommended.

Wire connections should not rub against sharp metal parts since the insulation may be rubbed off with age and a short circuit will result. A short circuit is any unwanted connection that will prevent the proper operation of the equipment.

**Volume 1 - Page 14**

**MAKING WIRE CONNECTIONS.** Radio parts are inter-connected with hook-up wire. The wire electrically joins the terminals to be connected. The hook-up wire should be insulated along its path, but is made bare and clean at the place where it comes in contact with the terminals. Push-back braided cotton covered wire is

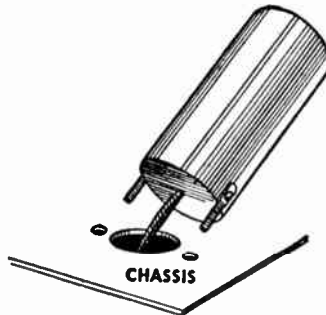

Figure 26. Some filter condensers are supplied in cardboard containers with spade lugs for bolting the condenser to the chassis.

*Courtesy P. R. Mallory & Co.*

easiest to handle. Enough insulation is pushed back to make the needed connection, and then the insulation is pushed back over the wire up to the terminal. The illustration shows the proper method used for pushing back the insulation on both solid and stranded wire. When the insulation cannot be pushed back far enough with

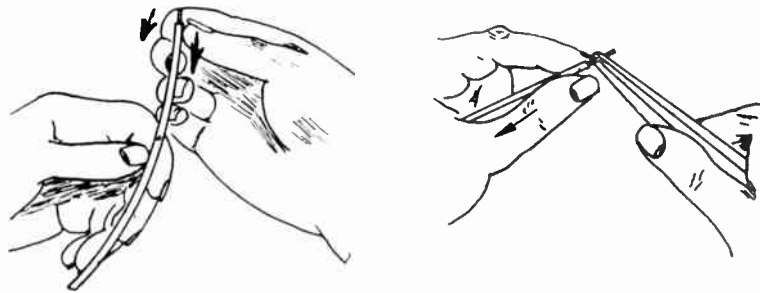
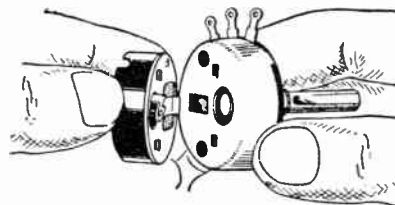

Figure 27. This illustration explains how you are to hold a piece of hook-up wire and push back the insulation. Once the bare wire becomes visible, the push-back insulation can be forced back a greater distance with the aid of long-nose pliers.

the fingers, it will be easier to grasp the bare end of the wire with long-nose pliers. Then, holding the wire in this manner, it is a simple matter to push the insulation back with the fingers as much as required.



*Courtesy P. R. Mallory & Co.*

Figure 28. The switch mounted in back of a volume control is removable, as illustrated.

Rubber covered hook-up wire and wire having rubber and cotton insulation is often used as the leads of radio parts such as transformers and filter condensers. The insulation is crushed with long-



nose pliers and then removed with diagonal pliers or a knife. Care should be taken that the wire is not nicked or cut in the process. Hook-up wire comes in sizes 16 to 20, B. & S. gauge.

The purpose of crimping wires to a terminal of any type is to insure a uniform, easily made, strong mechanical connection. If the terminal has a hole, the wire is bent into a half-loop with the aid of the long-nose pliers. After this, the tip of the wire is inserted

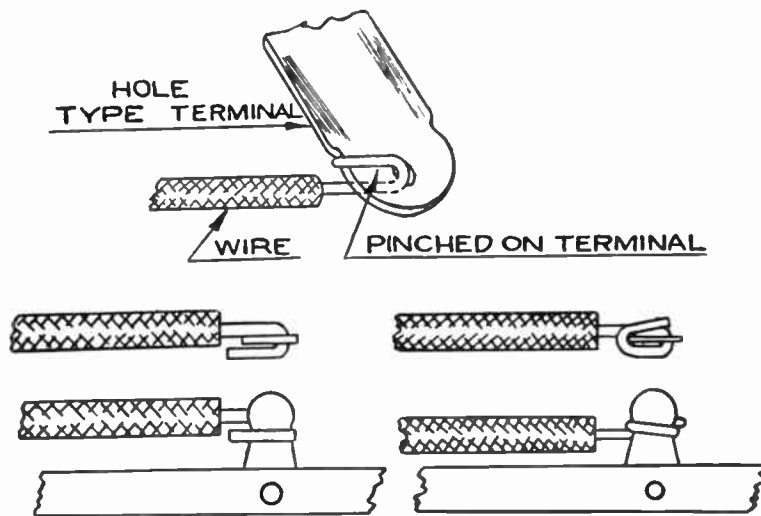

Figure 29. These several illustrations will explain how hook-up wire is attached mechanically to lugs or terminals. The contact must be made mechanically secure before solder is applied.

into the hole of the terminal, and the wire is squeezed (crimped) against the terminal. In case the terminal is of the lug type and does not have a hole, the wire is also made into a half-loop and crimped against the terminal. It is better to wrap the wire around the blank type terminal, crimping the wire from both sides.

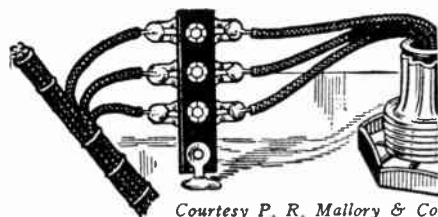

Figure 30. In a radio receiver, wires are joined together at a terminal point or "lugs." Notice how the condenser leads are attached to extension wires using a terminal block.

**SOLDERING.** All electrical connections must be soldered to insure low resistance electrical contact under all conditions. Make it your rule to solder every connection you make, even if the equipment you are building is for temporary use.



Figure 31. The 100 watt soldering iron is useful for radio work.

## MAKING WIRE CONNECTIONS

You should practice handling different kind of hook-up wire. Practice stripping the insulation, bending the wire into required shapes to complete the connection, and crimping the wire to lugs and terminals.

A mail order radio jobbers' catalog (available from several large radio dealers) shows illustrations of many terminals and will help you learn about the type of connectors and supports used in radio construction work.

## SOLDERING PRACTICE

The best solder for radio work is made up of 63% tin and 37% lead, and has a melting point at 358° F. Solder cannot make a perfect bond with any metal when a layer of oxidation is present.

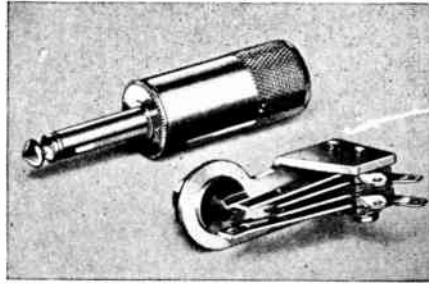

*Courtesy P. R. Mallory & Co.*

Figure 32. Connection to radio equipment may be made with the aid of plugs and jacks.

You should practice using *wire* solder and also regular bar solder and soldering paste. Unless you had extensive experience in soldering, you must spend hours perfecting your ability to solder quickly and expertly.

Flux, when heated, removes oxides and prevents oxidation during the soldering process. This enables the solder to adhere to the metal surfaces. Rosin flux should be used by a radioman. Acid flux has corrosive action and should not be employed. Most radio technicians prefer solder obtainable in the form of thick wire with a core of rosin flux. Because the rosin has a lower melting point than the solder, the rosin flows out first to clean the surface when heat is applied.

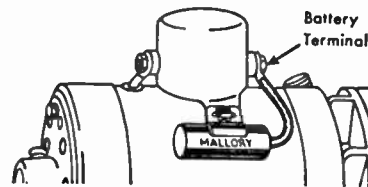
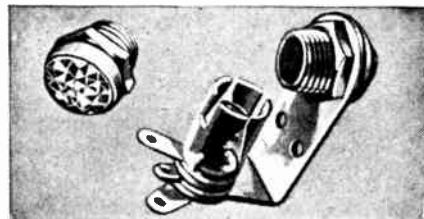

Figure 33. For some requirements, connections are made mechanically secure and do not require soldering.

If you cannot obtain an electric soldering iron, or if you do not have power electricity in your community, be sure to obtain the needed soldering practice with a regular iron which may be heated over a stove or with the help of a blow torch. It is even harder to use a copper tip regular iron than an electric type, and so you will be getting even more extensive practice.

To provide the heat necessary for soldering, several methods are used. To solder exposed wire, where near-by parts cannot be damaged, a gasoline torch may be used. For most radio work an electrically heated iron is preferred. These irons are rated in watts of electrical energy they consume. A 100 watt iron is most popular



*Courtesy P. R. Mallory & Co.*

Figure 34. Bulls' eyes are used to indicate the presence of power in different circuits.

for radio work. The heating element of the iron is located inside the metal barrel. The heat travels to the copper tip which is used for soldering. Where electricity is not available, flame heated soldering irons are employed. These can be heated with a gasoline torch.

To do a good soldering job, the tip of the soldering iron must be properly shaped and tinned. Tinning an iron is a process whereby a thin, uniform layer of solder is formed upon the tip of the iron. The transfer of heat from the tip to the work occurs most easily if the surface is bright as the result of tinning. When the tip of the iron becomes "pitted" by the action of the rosin core in the solder, the iron must be filed and re-tinned. The iron can be kept clean for long periods of time by wiping the tip with a rag whenever corrosion accumulates.

The soldering iron must actually heat the joint to be soldered to a temperature that will readily melt solder. The solder will then run into each crack in the joint and form a good electrical bond. Hot smoothly flowing solder has a bright silver luster; as it cools, its appearance changes to a duller gray, setting shortly after this change. If the joint cools with a rough surface, the soldering job is not well done; a dirty contact, improper heating, or movement of the wires may have been the cause.

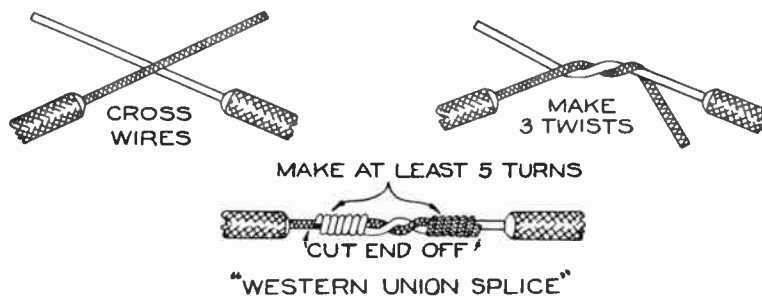

Figure 35. The Western Union splice is used to join wires outside of equipment and is made in the manner illustrated.

**WIRE SPLICING.** Splices are used to join two or more wires for the purpose of making an electrical connection. This connection should be mechanically secure and not require any mechanical fastening device. All splices should be soldered to assure continued good electrical contact. Splices are found in antenna connections and in telephone lines. In a radio chassis, the junction should be made at a tie-point or a terminal. For all splices, the bare ends of the wire must be cleaned before the splice is made. Solder is applied. The bare parts of the splice are taped with electricians tape to complete the job.

**REVIEW QUESTIONS AND PROBLEMS.** 1. Using your radio set as a guide, lay out a drawing of the chassis indicating all dimensions and places for all holes. Sections of the chassis which cannot be reached, may be omitted.

2. What are the advantages of rivets over machine bolts in mounting radio parts? What are the disadvantages?

3. Why is hook-up wire usually insulated?

4. Explain how you would tin an iron?

5. If you have had but little experience in soldering, obtain bits of wire, an old chassis base or piece of galvanized iron, some old radio parts, and practice soldering. Only practice can make you expert in soldering.

If the point of the iron becomes pitted, a smooth metal file is used to remove the foreign deposit and shape the copper point. The iron may be locked in a vise or may be held by the handle and rested against a metal surface.

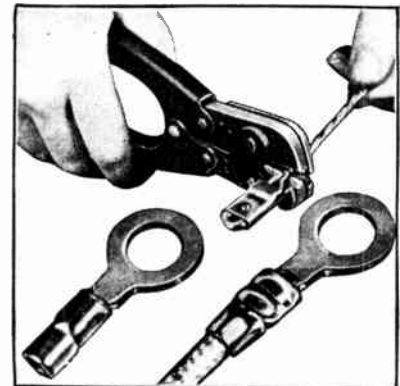

Courtesy Aircraft-Marine Products, Inc.

The solderless terminals illustrated are easily attached to conductors with special crimping tools. Several terminals can be used to form a junction on a single stud block.

1. This drawing should be made large and neat. A piece of light colored wrapping paper, 17 x 22 inches, is excellent for this purpose.

2. Do you, as a future radio and electronic equipment repair man, prefer rivets or bolts? Why?

3. Stiff bus-bar wire may be used bare, but the hook-up wire employed in radio equipment is not stiff enough.

4. Go over all points in detail. Actually do the work before writing the answer in your notebook.

# LESSON 3

## Mathematics of Radio

Good practical men have failed to perform relatively simple radio tasks because they lacked the knowledge of elementary mathematics and could not use basic radio formulas. Enough mathematics has been included in this course to give you the essentials of the required mathematics.

If you had very little arithmetic in school or have forgotten this work, please write to M. N. Beitman, care of the publishers, and enclose a statement of your training and present knowledge in arithmetic and algebra. We will recommend an inexpensive supplementary book to help you. Please enclose a self-addressed and stamped envelope for a speedy reply.

**WHY MATHEMATICS?** The work of radio engineering is accomplished with the aid of mathematics. Practical radio tasks can be performed without the aid of mathematics. But the knowledge of a few simple formulas and the most elementary mathematical operations will enable you to save time on many jobs and will eliminate trial and error attempts and guess work.

For example, if you wish to install a transmitting antenna, you may try various lengths until the best results are obtained. A more sensible method is to use the correct formula, substitute for the letters the known facts about the station transmitter, and solve for the exact size of antenna required.

Mathematical formulas are short-hand statements of facts about radio physics. A simple formula interconnects facts and permits you to find the value of one of the facts when the others are known. The actual facts, of course, are numerical quantities expressed in suitable units. We are going to assume that you have forgotten the mathematics you may have studied at school. We will begin with simple arithmetical problems and help you to grasp the mathematics you will need to be successful in doing practical radio work.

**NUMBERS.** There certainly is nothing hard about numbers. Since you have been a small child, you have been counting 1, 2, 3, 4, 5. Later at school you learned the multiplication tables. You learned that all numbers can be formed from the symbols, 1, 2, 3, 4, 5, 6, 7, 8, 9, and 0. The zero is important since it really enables us to write all numbers with only ten symbols. And you better remember that multiplying any number by zero, or multiplying zero by any number, results in zero.

**FUNDAMENTAL OPERATIONS.** There are four fundamental operations. You have used them in school and in every day business. One of these operations is *addition*. Addition means to combine items. Only similar items can be combined. If one radio set uses six (6) vacuum tubes and another employs five (5) tubes, by adding ( $6 + 5 = 11$ ) we learn that the two radios together require eleven tubes.

*Subtraction* means to take away, to remove one quantity from another. If you had a dozen machine bolts and used three in mounting a radio chassis, then you would have nine bolts left.

$$12 - 3 = 9$$

After your wages are computed, the amount for Old Age Pension is deducted (subtracted), and you receive the balance.

*Multiplication* is a process of continued addition. By memorizing tables, the work of multiplying is greatly simplified. Number 8 multiplied by number 6, is equivalent to adding number 8's six times. The symbol  $\times$  stands for the multiplication operation. The statement

$$8 \times 6 = 48$$

is read: Eight times six is equal to forty-eight.

If two letters are written next to each other, but without a symbol between them, these letters are to be multiplied together. For example, fL means f multiplied by L. Sometimes a dot like this • also stands for multiplication.

*Division* is the inverse of multiplication. You read

$$24 \div 6 = 4$$

as: Twenty-four divided by six is equal to four.

This problem may also be stated as:

$$\frac{24}{6} = 4$$

Please notice that this means that the quantity above the long dash is to be divided by the number below the dash-line. Most formulas which involve division are written in this manner.

**FRACTIONS.** Many times in radio work, quantities are parts of a whole unit and are called fractions.  $\frac{1}{2}$  volt is a part of an electrical unit known as a volt. The number written behind a slant-line, as the 2 in  $\frac{1}{2}$ , or below a long dash is called the denominator. It tells into what portions the entire unit is divided. The number in front of the slant-line or above a long dash is called the numerator. This number tells us how many of the parts are included. For example, the fraction  $\frac{5}{8}$  tells us that the division is made into eight parts, and that five of these parts are included. Since in this fraction there are eight parts in all, and five are included in the fraction we are considering, three more such parts would complete a unit. This means that  $\frac{3}{8}$  more are needed to make  $\frac{5}{8}$  a complete unit. And we add these fractions by combining the numbers in the numerators, keeping the same denominators which must be alike to permit addition. From this we see that  $\frac{3}{8}$ , or for that matter any fraction whose numerator and denominator are equal, is really one whole unit.

We have tried to recall a few facts about fractions to you. Most practical radio problems are worked in decimals and are of such simple nature that very little additional knowledge of fractions is needed.

**DECIMALS.** We write whole numbers in the regular way and place a period, called a decimal point, at the end. For example, the number forty-eight is written as 48. Fractions must be changed to have a denominator of 10, 100, 1000, or some larger number of this type involving 1 followed by zeros. If the fraction is  $\frac{2}{5}$ , it may be changed to  $\frac{4}{10}$ , and is written as .4; this means that the number after the decimal point is the numerator of a fraction whose denominator is 10. The number 2.57 is read as two and fifty-seven hundredths. Notice that there are two figures after the decimal point and this accounts for the "hundredths."

Decimals are more convenient to use than fractions. Multiplication or division by ten, or some multiple of ten, simply shift the decimal point. The number 2.57 when multiplied by 100, simply requires the shifting of the decimal point to the right two places to correspond to the two zeros of the 100. The answer is 257. If this original number is divided by 100, the decimal is shifted to the left two places and the answer is .0257, the extra zero must be placed to show that the decimal point was moved two places to the left.

To add or subtract fractions, the denominators must be alike. If they are not alike, a number is selected which can be divided by both denominator *numbers*. If the smaller denominator *goes into* the larger, this larger denominator is the one you want. The number of times the denominator goes into this common number, is the factor for multiplying the numerator (top) and denominator of the fraction considered. For example, the fractions may be  $\frac{1}{3}$  and  $\frac{2}{5}$ . Both denominators will go into 15, and this is the smallest number that will permit division by both 3 and 5. The number 3 will divide into 15, five times. Therefore, the fraction  $\frac{1}{3}$  must be multiplied by five, resulting in  $\frac{5}{15}$ . Notice that both the denominator and numerator are multiplied by this factor. In a similar way, 5 (the other denominator) will go into our selected number 15, three times. We now multiply the second fraction,  $\frac{2}{5}$  by three, and obtain  $\frac{6}{15}$ . The denominators are now alike and they may be added or subtracted as required. If they are added, the result is  $\frac{11}{15}$ . Only the numerators are added, the common denominator is kept for the answer. If these fractions are subtracted, the result is  $\frac{6}{15} - \frac{5}{15} = \frac{1}{15}$ .

When two fractions are multiplied, no such changes are needed. The numerators are multiplied together and form the new numerator. Also the denominators are multiplied separately and form the denominator of the answer. For example,  $\frac{1}{3} \times \frac{2}{5} = \frac{2}{15}$ .

## ELECTRICAL UNITS

When powers of ten (such as  $10^3$ ,  $10^7$ ) are to be multiplied, the exponents need only be added together to obtain the power of ten of the answer. For the example, the answer would be  $10^{10}$ .

The unit of electric charge equal to about  $6.3 \times 10^{18}$  free electrons, is called a coulomb. The ampere is a unit of electric flow. The passage of one coulomb past a given point in one second represents an ampere.

It is important that you visualize voltage as electrical pressure. This electromotive force may be generated by means of chemical batteries, rotating magnetic machines known as dynamos, or by heating the contact point of two different metals.

**HOW TO WRITE LARGE NUMBERS.** In radio work many times very large numbers must be expressed. A special short-hand method for doing this is used. When any number is multiplied by itself, it is said to be squared, or raised to the second power. For example, 10 times 10, which equals 100, may be written as:

$$10 \times 10 = 10^2$$

The little number two is called the exponent and indicates how many *tens* have been multiplied together. In the same manner,  $10^3$  would indicate  $10 \times 10 \times 10$ , or 1,000. A million can be written as  $10^6$ . You will notice that the exponent also indicates the number of zeros in the number.

Now if we have a number as 240,000, it may be written in our short-hand as:  $24 \times 10^4$ . This means that the original number is equal to 24 times 10,000 and the 10,000 may be written as ten to the fourth power.

**ELECTRICAL UNITS.** For comparative purposes of the qualities encountered in electrical circuits, selected units are employed. These units are inter-related and are based on absolute basic reactions. Because of the nature of electricity and the associated force, magnetism, we cannot measure or note these forces directly with our senses of touch, sight or smell, but must resort to indirect indicators (meters, lights, etc.) operated by these forces.

**CURRENT.** Electric current needed to light an electric bulb or to heat the filament of a radio tube consists of millions of moving electrons. A practical unit of electric current is an ampere which represents the passage of a tremendous number of electrons per second. It is easy to see that when one circuit has a current of 15 amperes, it has five times as much current as another circuit which has only 3 amperes.

While in power work an ampere is a convenient unit, some radio circuits have very little current, sometimes only a thousandth or a millionth part of an ampere, and a smaller unit is more applicable. A milliamper\* is one-thousandth of an ampere. It takes 1,000 milliamperes to make up one ampere. A microampere\* is one-millionth part of an ampere. It takes one million microamperes to add up to a single ampere. Formulas usually are expressed in amperes of current, and if the problem has other units of current, these must be changed to amperes.

**VOLTAGE.** The force which produces current (electron movement) from one body having an excess of electrons to another body having less electrons, acts as a pressure. This electrical pressure is called electromotive-force and its unit of measure is the volt. You know that an ordinary battery dry cell used in flashlights has an electromotive force of  $1\frac{1}{2}$  volts. At times electromotive force is abbreviated EMF, and may be called voltage, potential difference, or just potential. In radio work, we use voltages from a few volts up to 1,000 volts. A thousand volts is also known as a kilovolt\*. Very small potentials are measured in microvolts and millivolts.

**RESISTANCE.** The unit of resistance is the ohm. Special units having very high resistance are used in some radio circuits. In case the resistance runs past one million ohms, it is expressed in megohms. A megohm is equal to one million ohms. The concept of resistance will be presented in Lesson Four.

\*The prefix *milli* means one-thousandth part, *micro* means one-millionth part, and *kilo* means one thousand times.

**FORMULAS.** Mathematics is a symbolic way of explaining and analyzing physical occurrences. Arithmetical numbers represent quantity. Ten volts is ten times the standard measure—the volt. Numbers tell how many, is it larger or smaller, is it too small . . . all these are measures of quantity. Algebraic symbols (usually letters of the English and Greek alphabets) represent specific measureable quantities. For example E usually stands for voltage in electrical work. This is really another way for writing “voltage,” i.e. we say E instead of the word voltage. In a like manner we usually write I for current, and R for resistance. A Greek letter  $\pi$  appears in many radio formulas and is a constant always equal to 3.14.

Using letters saves time and greatly simplifies the writing of formulas. The Ohm’s Law may be written in words as:

$$\begin{array}{ccccc} \text{Voltage} & = & \text{Current} & (\text{multiplied by}) & \text{Resistance} \\ E & = & I & \times & R \end{array}$$

or in algebraic symbols directly under. Of course, the algebraic way of writing is much simpler to write and remember.

Sometimes in the same problem, there are two different voltages, such as the grid and plate voltages in a vacuum tube. Here again we may use some letter, as “E,” to represent voltage and use small letters after E and a little below it, to stand for grid and plate voltages respectively. As:

$$\begin{array}{l} E_g \dots\dots\dots \text{grid voltage} \\ E_p \dots\dots\dots \text{plate voltage} \end{array}$$

**HOW TO USE FORMULAS.** There are many practical formulas which you will have to use in your work. You will find every formula a short-hand statement of facts. Study this statement (formula) so you understand it. Now determine what fact is unknown and must be found with the aid of the formula. Leave the letter representing this fact alone, and consider the other letters. Each letter represents some other fact about the circuit or problem. Find the numerical value of these facts, but make sure that they are in the units required. If the formula requires current to be in amperes, and the problem mentions the current in milliamperes, change the milliamperes to amperes by dividing by a thousand (one thousand ma. equals an ampere). After making these numerical substitutions simply solve for the unknown letter. This calls for getting all numbers on one side of the equal sign, and keeping the unknown letter alone on the other side.

**GRAPHS.** Certain facts may be best represented or analyzed by presenting the data in the form of a graph. A graph shows the relation between two facts or group of facts. As for example, the graph illustrated represents the rise of current in milliamperes through a 1,000 ohm resistor, as the voltage is increased from 0 to 100 volts. The voltage is plotted as the ordinate (vertical scale) beginning with 0 and running up by equal subdivisions to 100 volts. The current begins with 0 and increases to the right; it is plotted as the abscissa (horizontal scale).

This graph illustrates that the current varies directly with the applied voltage (varies in a straight line). For a 1,000 ohm resistor values of current may be obtained for any voltage covered by the scale, and vice versa. At 50 volts, for example, following the dotted line, the value for current is 50 milliamperes.

Additional mathematical facts will be presented in connection with problems as they come up in later chapters. The student

There is no special reason why certain letters should be used for definite electrical quantities in electrical formulas, but usage dictates certain choices. Usually the letter employed is the initial of the term. For example, R for resistance, E for electromotive force. Since C stands for capacity, the letter I, was selected for current.

The unknown quantity should remain alone on one side of the equal sign of the formula; all other terms should be on the other side. If the formula in this form is not known, the regular equation expressing these facts can be solved by algebraic operation to take this form.

The financial pages of large city newspapers have graphs to illustrate certain price trends. While these have nothing to do with radio, you will find it good practice to examine and study these graphs.

## REVIEW PROBLEMS

1. You probably recall that any number multiplied by zero results in zero. Also remember that division by zero is impossible.
2. You should get an answer of 24 inches, or 2 feet.
3. You still have 98 feet left.
4. See the explanation on page 23. Your answer should be  $\frac{5}{6}$ .
5. Each group of eight men will have one iron.
6. Divide 1 by 3. Do this by long division. Place a decimal point after 1., and add zeros. The answer: .33333 etc.
7.  $4 \times 10^6$ .
8. This is 60 ma.
9. This is a quarter of a megohm, or 250,000 ohms.
10.  $E_f$  is commonly employed.
11. 2,260.8 is the answer.

should review arithmetic and elementary algebra in any standard text-book if he has difficulty following the practical mathematics which are included in this chapter.

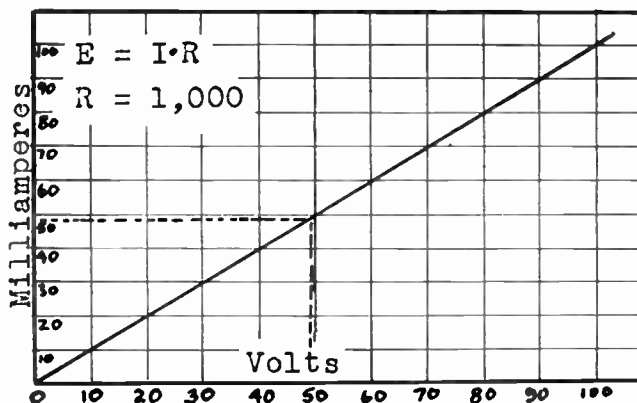

Figure 36. This graph illustrates the relationship between voltage and current in a circuit which contains a 1,000 ohm resistor.

REVIEW QUESTIONS AND PROBLEMS. 1. If 10,000 is multiplied by zero, what is the answer?

2. To wire a radio set the following pieces of wire are needed: 3 inches,  $3\frac{1}{2}$  inches, and  $13\frac{1}{2}$  inches. The mechanic knows that the extra amount for bending around terminals is usually 20% additional. How much wire will be needed for the job?

3. From a roll of wire initially having 100 feet, six pieces of 4 inches each are cut. Remembering that 12 inches equals one foot, how much wire is left on the roll?

4. Add  $\frac{1}{2}$  and  $\frac{1}{3}$ .

5. A Signal Corps Company consists of 256 men and is supplied at a certain time with 32 soldering irons. One soldering iron is expected to serve how many men?

6. Write  $\frac{1}{3}$  as a decimal correct to two places.

7. Express four million in short-hand notation.

8. How will you write .06 amperes in milliamperes?

9. A resistor of 0.25 megohms, is how many ohms?

10. What is a logical symbol-letter for filament voltage?

11. If a formula states that  $X = 6.28 \times f \times L$ , and  $f$  is 60, and  $L$  is 6, what is  $X$ ?

12. Refer to the graph illustrated in this chapter, and plot in it the points corresponding to 75 volts and 50 ma., and 90 volts and 60 ma. Connect these two points with a straight line.



# LESSON 4

## Circuits Using Resistors

**RESISTANCE.** Even the best electrical conductors such as silver, copper, and aluminum, oppose the passage of electric current. Insulators have so much opposition that we say that they do not pass any electricity at all. Iron wire is not an insulator, but it is a much poorer conductor than the metals mentioned. One may think of iron as having greater opposition to the passage of electric current—greater *resistance* to the freedom of electric current movement. Copper has little resistance. Wax paper has very high resistance. In general, the better conductors have very little electrical resistance, the insulators have very high resistance.

**RESISTANCE AND THE SIZE OF THE CONDUCTOR.** If a piece of copper wire has a definite resistance, a piece twice as long will have twice the resistance. A piece of wire may be thought of as a water pipe. Any pipe has opposition to the passage of water. If the pipe is made twice as long, somewhat as in the above example, the opposition or resistance will be doubled.

If you cut a piece of wire with a very sharp tool and looked right at the side of the cut, you would see a circular cross-section of the wire. This cross-section has a definite area. Now if the wire is made thicker, the cross-section will be increased and a larger path will be provided for the movement of electrons forming the electric current. A larger path will offer less resistance. This illustrates that two wires made of the same material have resistance, per unit length, inversely proportional to the cross-section area. The thicker the wire, the less resistance.

**UNIT OF RESISTANCE.** We already learned that the unit of resistance is the *ohm*. Hook-up wire, No. 18 B. & S. gauge, has a resistance of .0065 ohms per foot. A mile of this hook-up wire has a resistance of about 34 ohms. The cloth insulation of this same wire has insulation-resistance which is measured in millions of ohms.

The electrical resistance of most substances varies with temperature. Electrical conductors made of metal have an increase in resistance as the temperature is raised. However, this change is small and may be ignored in practical radio work.

**COMPOSITION-TYPE RESISTORS.** Carbon is a fair conductor and, therefore, has low resistance. Bakelite and many other plastics have very high resistance. If we take powder made of carbon and mold it into the shape of the resistors you examined in the radio set, we will find this "resistor" will have a very low value of resistance. The "resistor" made from the bakelite powder, on the other hand, will have very high resistance. Now we can mix the two powders in any proportion we wish and, by this means, produce any value resistor needed. The carbon type resistors used in radio are actually made in this fashion and the connecting leads are attached to both ends.

The metallized resistors have the mixture, which will give the desired resistance value to the finished product, baked on an insulating form. Usually these resistors are coated also with a ceramic insulation material and this permits mounting the resistors near metal parts without the possibility of a short circuit occurring.

You should realize that when the diameter (or radius) of a piece of wire is doubled, the cross sectional area is increased four times.

This means that the same conductor may have higher resistance if the surrounding temperature is increased.

While the commercial carbon composition resistors are made in this fashion, the actual materials used are not necessarily bakelite and carbon, but may be other forms of powdered conductors and insulators.

In small midget radio receivers, many parts are placed very close together and insulated resistors are recommended.

The range of these carbon resistors runs between 100 ohms and 20 megohms. As you probably know, one megohm equals one million ohms. Carbon resistors are capable of handling only small amount of electrical power and this subject is discussed later in this chapter.

**RESISTOR COLOR CODE.** The composition resistors are color coded in a special way to indicate the resistance value of the unit. Study carefully the chart illustrated below. You need not memorize these facts, but you should practice using the color code chart until you are expert at this work.

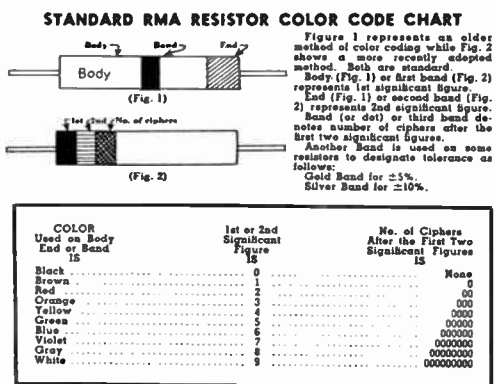

EXAMPLE: Take the number 62,000. 6 is the first significant figure, 2 is the 2nd significant figure and the number of ciphers after the first two significant figures is 3.

Figure 37. Carbon composition resistors are color coded to indicate their resistance value. You must practice using this code so that you are proficient in telling the value of resistors upon examination.

As another example, let us suppose you find a resistor all red. There is no visible dot or end color. You may, in this case, assume that both the end and dot are also red and, therefore, could not be painted on the red body. Now to find the actual resistance value. The red body tells us that the first figure is 2. We assumed the end is also red, that makes the second figure also a 2. The dot is also red. This means that there are *two* more zeros. The total value is 2,200 ohms.

**MECHANICS OF COMPOSITION RESISTORS.** These resistors are one-half to two inches long and have leads of tinned copper wire. These leads are about two inches long. Usually the resistor is mounted directly between the required terminals. If the leads are too long, they may be shortened. If the bare leads pass close to other non-insulated parts, a sleeve of insulation material should be placed over the bare leads. If the two terminals for the resistor, which is to be mounted are far apart, find a supporting dummy terminal of some sort near one of the required terminals. Mount the resistor on these two supports. Then wire the dummy terminal to the second required terminal using a piece of hook-up wire of the proper size. Terminals of parts not used and not connected in any way may be used as dummy supports. (For example, extra terminals on tube sockets.) On a socket for a 6K7, the number six terminal is not used for any purpose and can be employed as a support. Special stand-off brackets with several terminals are also available for this purpose.

At this point, it is worth while to go back to the midget radio set you examined before and find the size of each resistor using the

For practice, you may determine the actual sizes of the carbon resistors used in your radio receiver. Use the color code. In some units, a small dot is used instead of the center band.



*Courtesy General Radio Company.*

Figure 38. Sensitive test equipment, as the impedance bridge illustrated, is used to test various radio components. The proper operation of any radio device depends on the correct function of each part incorporated.

color code and also notice the method employed for supporting the carbon resistors used. Do you think the radio set you are using was assembled in good style?



Figure 39. Some radio sockets are supplied with several of the terminals already interconnected as may be required in a particular circuit.

**INCREASING RESISTANCE.** It is possible to increase the resistance of a carbon resistor by cutting several notches with a file in the body of the resistor. Since these notches will make the cross-section area somewhat smaller, the resistance will be increased. In a later chapter you will learn how to measure the resistance with an ohmmeter, and this instrument will permit you to know just how much of a change you may make with this trick method.

The degree of accuracy used for testing radio components depends on the application. When radio parts are to be used for research or laboratory experiments, special sensitive test units are employed to detect possible faults and to determine the exact size of the units.

Do not try to increase the resistance of a unit more than 20%. It is better to cut several notches instead of a single large one.

**Volume 1 - Page 25**

## ACCURACY OF RADIO PARTS

You recall, of course, that 100% is the entire quantity, while 1% is one-hundredth part of the total.

**ACCURACY OF RESISTORS.** One percent of any amount is one-hundredth part of this amount. Ten percent is 10/100 of the particular amount being considered. Most commercial carbon resistors are accurate to within 10% of the marked or indicated value. This means that any resistor may be of a resistance value 10% larger or smaller than the value indicated by the color code. A resistor of 50,000 ohms, plus or minus 10% accuracy, may be anywhere from 45,000 to 55,000 ohms. Please remember that the value may be anywhere between these two extremes and, by chance, may be very close to 50,000 ohms. Consider several of the resistors you found in the radio set as being of 10% accuracy, and calculate between what limits of resistance they may actually be.

Probably you are somewhat surprised that radio parts can be so much off the required value and yet give good results in the circuit. Not all sections of a radio receiver permit such variation in resistance values. However, carbon resistors are usually employed in circuits where several values of resistors would work successfully. An audio amplifying tube may have a resistor connected between its terminal known as the cathode and the chassis which serves as the ground or grid return circuit. A 1,000 ohm resistor would serve the purpose. But a 2,000, or 3,000 ohm resistor would give



Figure 40. Certain circuits require the use of resistors of very high accuracy. A precision resistor used in meter circuits is illustrated.

as good operation and you could not tell the difference. Even 5,000 ohm resistor would give fair operation. Now if we choose a 2,000 ohm resistor for this purpose, and remember that it is only 10% accurate, we realize that actually we may be placing into the circuit a resistor having a value anywhere between 1,800 and 2,200 ohms. But from our explanation we can see that any of these values will give proper results.

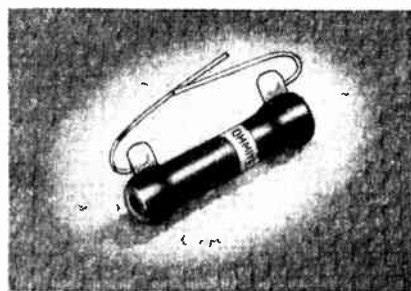

*Courtesy Ohmite Mfg. Co.*

Figure 41. This is a type of wire wound resistor employed in radio circuits.

Many times, very sensitive electronic equipment will give excellent results with resistors of commercial accuracy. It is the circuit that determines the requirements and not the function of the complete unit.

The fact that a piece of equipment is intricate or expensive does not indicate that very accurate resistors are needed. The circuit application of the part determines the accuracy needed. For meter multiplier circuits, for example, resistors accurate to within 1% are usually used. Most, ordinary radio equipment is so designed that resistor values are not critical.

**WIRE-WOUND RESISTORS.** When resistors must handle greater power or have better stability, they are made of high resistance nichrome or similar wire. Commercially, these resistors are made by winding the wire on strips of fiber or porcelain tubes. The turns are separated from each other. The type of resistance wire employed, thickness of wire, and total length used, determine the resistance value of the finished unit. These resistors are usually encased in a protective coating of baked enamel or special cement. This covering protects the fine resistance wire and prevents resistance changes which may occur due to moisture.



*Courtesy P. R. Mallory & Co.*

Figure 42. Usually wire wound resistors have a metal band on which the value and description of the unit are stamped.

Usually the resistance wire is started and terminated in suitable connector-lugs. Sometimes extra connections are made in the middle of the resistor by means of extra terminal-lugs. Semi-variable type wire-wound resistors have a bare strip along the length, which is not

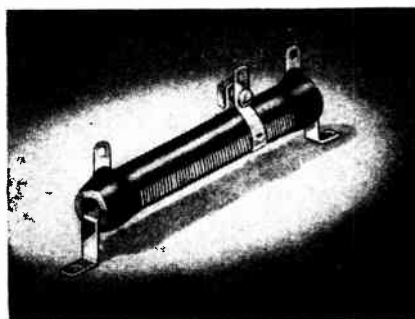

*Courtesy Ohmite Mfg. Co.*

Figure 43. Some wire wound resistors have adjustable taps. The set screw holding the band of the tap must be loosened before the contact is moved.

covered with the insulating cement, and permits contact with the resistance wire. Sliding lugs are used to make contact with the wire and the connections may be adjusted for the resistance value needed. Examine the illustrations included.

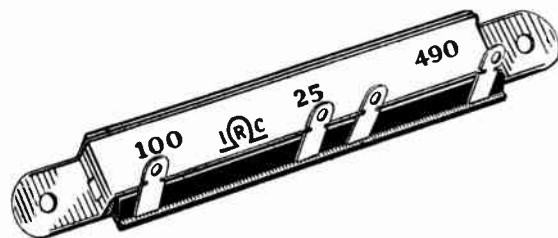

*Courtesy International Resistance Co.*

Figure 44. Some fixed resistors are supplied with several fixed taps to give different resistance values.

## RESISTORS FOR HIGHER POWER



*Courtesy Clarostat Mfg. Co.*

By combining a number of variable resistors connected in series, it is possible to obtain any value of resistance needed for test purposes. One knob controls a potentiometer of 10 ohms, and permits adjustment in steps of one ohm, up to 9 ohms maximum. The next unit permits adjustment in steps of 10 ohms, up to a maximum of 90. The next control permits adjustment in steps of 100 ohms each, up to 900 ohms. In this manner, any needed resistance value can be obtained. The complete unit is called a decade resistance box.

Wire-wound resistors should not be supported on their leads alone, but should be held in place on support legs as shown in Figure 43, or soldered to stand-off lugs.

## VARIABLE RESISTORS

Wire-wound resistors are made in resistance values from a fraction of an ohm to about 100,000 ohms. It is not practical to make these resistors in higher resistance values. Physically resistors are made in various sizes to serve different heat or power dissipating requirements. Wire-wound resistors of the larger size are supplied with mounting-feet and are bolted to the chassis.

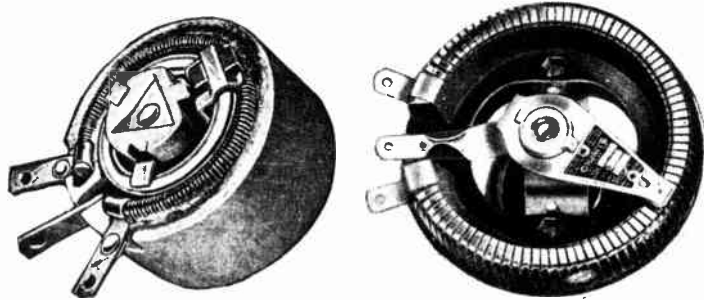
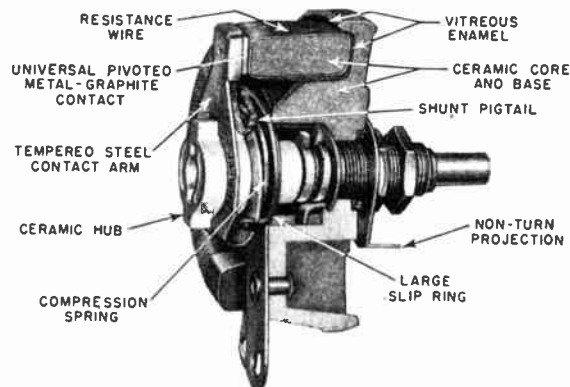

Figure 45. The heavy-duty rheostats illustrated are employed in circuits where a quick change of resistance is needed from time to time.

The arm of the rheostat should be in contact under pressure with the wire element. Good, positive contact will prevent arcing and will increase the life of the unit. The contact pressure may be checked and adjusted. A little vasoline may also be applied to the surface.

**VARIABLE RESISTORS.** In many radio applications the value of a resistor must be changed for the purpose of adjusting the circuit. When you turned the knob to change the volume output of your radio, you really were adjusting a resistor. Variable resistors are made so that a sliding contact, easily controlled by means of a knob, permits the changing of the resistance value between almost zero ohms and the maximum resistance incorporated in the unit. Such units require but two terminals. One terminal is the end connection, the other is the sliding contact. When the sliding arm is near the fixed terminal, the resistance is at a minimum. As the arm is moved away, the amount of resistance between the arm and the fixed terminal increases. Such units are known as *rheostats*. Usually rheostats are made in low resistance values and are used to control power circuits.



Courtesy Ohmite Mfg. Co.  
Figure 46. A cross-section of a rheostat illustrating the manner of assembly.

The terms *rheostat* and *potentiometer* have been loosely employed in literature. The correct definition of a rheostat implies a continuously variable resistor having two terminals. A potentiometer has three terminals. Sometimes, however, all heavy duty variable resistors are called rheostats, even if they have three connecting terminals.

**POTENTIOMETERS.** Potentiometers are very similar to rheostats, but have three connecting terminals. Both end terminals are used, and the third terminal is connected to the movable arm. As the resistance between the movable arm and one of the fixed terminals is increased, the resistance between the arm and the other fixed terminal is decreased. These two sections of resistance always add up to the total resistance marked on the potentiometer.

Most potentiometers are mounted on the side of the chassis and require a single 1/2 or 3/8 inch hole. Several makes of potentiometers have an extra rib which requires a small hole besides the large one. This protruding rib prevents the entire unit from re-

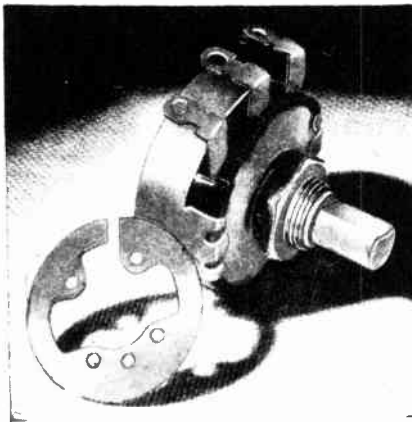

Courtesy Clarostat Mfg. Co.  
 Figure 47. Potentiometers are used to control and adjust radio circuits. Notice the slotted shaft for a special knob. The resistance element is illustrated separately.

volving as the shaft is turned. The shafts of potentiometers are supplied quite long and must be cut to size. Since very soft metal is used, the job is easily done with a hack-saw. Sometimes the shaft comes notched in many sections and this permits breaking off the extra length with a pair of pliers. You may also remove the extra length by filing a little all around the point where you wish to break the shaft. Use a small three-cornered file for this purpose. After filing, grasp the shaft with a pair of pliers on each side of the cut. Two pairs of pliers will be needed. A side twist with the pliers and the extra portion of shaft will break off.

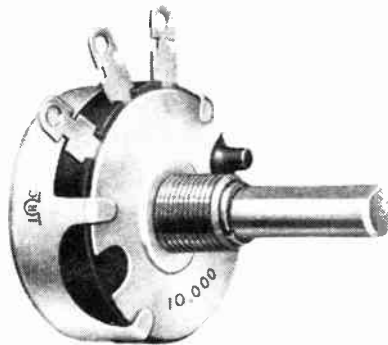

Figure 48. Potentiometers are used as volume controls in radio receiving sets. Notice the threaded section around the control shaft. This section is placed through a hole in the side of a chassis and a nut is employed to tighten the potentiometer in place.

Courtesy International Resistance Co.

Potentiometers are often called volume controls since they are used for this purpose in radio receivers. However, this is not a good name since potentiometers are also used for adjusting tone control circuits, oscilloscopes, test instruments, and for hundreds of other applications.

Some potentiometers are made with resistance wire in a manner similar to wire-wound resistors. Wire-wound potentiometers are used primarily where low value resistance units are needed and electrical power is handled by the circuit. The values of wire-wound potentiometers are between several ohms and a maximum of about 10,000 ohms. Potentiometers using a carbon deposit as

Some potentiometers use very special type of shafts. If the correct replacements cannot be secured, you may make a repair with a potentiometer of the correct type, but with a standard shaft. This regular shaft is cut short and a section of the original special shaft is cut off and attached to the unit.

Two nuts may be used to mount a potentiometer a short distance behind the chassis. First, one bolt is *screwed on*, then the potentiometer is placed through the opening in the chassis, and the second bolt is used to tighten the assembly in place.

## POTENTIOMETER CONNECTIONS

In some battery sets, the switch mounted on back of the potentiometer is of a dual type — it controls two individual circuits at the same time. Such a switch may have three or four connecting terminals.

You must understand that the total resistance between the two extreme potentiometer terminals remains almost constant at any setting of the arm. The moving contact, connected to the center terminal, moves between these two fixed extreme connections. As the moving arm may be rotated closer to one fixed terminal, and thereby, reduce the resistance between this terminal and center connection; the resistance between the moving arm and the remaining fixed terminal will correspondingly increase.

the resistance element are used more commonly and are obtainable in resistance values from 1,000 ohms to 10 megohms.

Since potentiometers are the units used for adjusting the circuits, they receive much mechanical use and are a source of trouble. Occasionally, the control may be opened and repaired by bending back the rubbing prongs of the rotating arm and cleaning the carbon element. Usually it is best to replace the faulty unit.

In a few units, the arm, having the center terminal for its connection, is grounded to the shaft and the metal framework of the potentiometer. But in most units, the elements of the potentiometer are entirely insulated from the metal framework. The "on-off" switch for the equipment may be placed on the back of the potentiometer and the first rotation of the shaft will operate this switch. Remember that this switch has no electrical connection with the resistance element of the potentiometer.

**CONNECTING THE POTENTIOMETER.** You know that a potentiometer has three terminals. The center terminal is connected to the movable arm. It is indicated in the symbol for a potentiometer as the center arrow. The choice of the other two terminals, however, is very important. Assume that you are holding a potentiometer in your left hand with the shaft pointing directly at your face, and the connecting terminals at the bottom of the unit. Now turn the shaft all the way to the left, counter-clockwise. There is now almost no resistance between the terminal on the left and the center terminal. But between the right hand terminal and the center terminal there is a maximum resistance. Now as you rotate the shaft to the right, clockwise, you increase the resistance between the left terminal and center, and decrease the resistance between the right terminal and center arm.

Usually the output of the radio equipment is increased as the control knob (on the shaft of a potentiometer) is turned to the right, clockwise. And the potentiometer must be connected so that the circuit will be changed by the right hand rotation of the slider to increase the output. You will be able to apply this knowledge when you begin to study actual radio circuits.

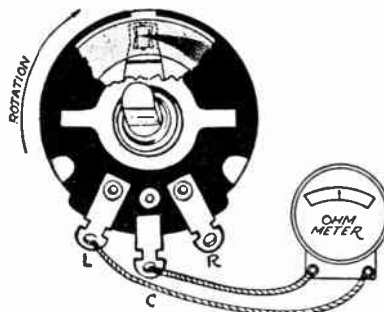

Courtesy P. R. Mallory & Co.

Figure 49. An instrument used to measure resistance, called an Ohmmeter, is employed to determine the total resistance of a potentiometer and the taper incorporated.

**TAPER.** Let us consider what resistance we will get between the left-hand terminal and the center terminal for different positions of the rotating arm. If we start with the rotating arm in the extreme left-hand position, we will have about zero resistance. Actually, in high resistance potentiometers, this minimum resistance may be several hundred ohms. Since we have not as yet turned the shaft,



we can call this position of the rotating arm 0% of the effective rotation from left to right.

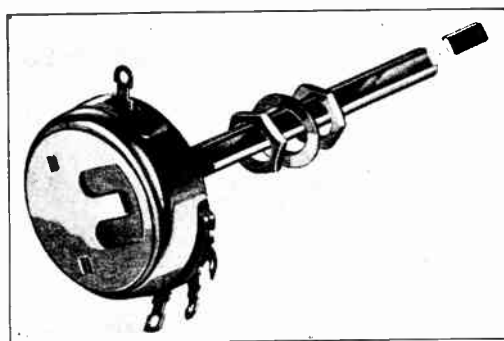

Courtesy P. R. Mallory & Co.

Figure 50. Potentiometers are supplied with long shafts which can be easily cut to the size required.

If the potentiometer we are using for our example, is made of a *uniform* deposit of resistance-carbon material, at the mid-point of rotation (corresponding to 50% of effective rotation) we would have one-half of the total resistance of the unit. This potentiometer

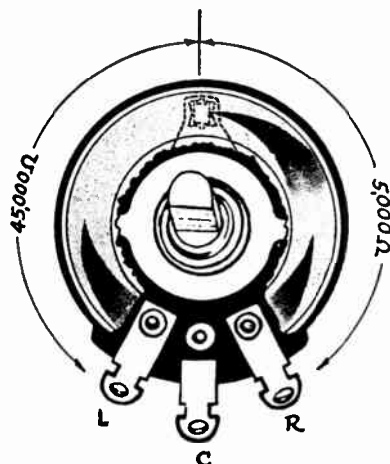

Courtesy P. R. Mallory & Co.

Figure 51. In the potentiometer illustrated, the total resistance of 50,000 ohms is divided as shown to give a non-linear taper.

has a *linear taper*. This means that the resistance between the terminals we are considering varies linearly (directly) with the rotation. At 75% effective rotation, i.e. three-quarters around to the right, we will have three-quarters of the total resistance. If the unit we are using is a 10,000 ohm potentiometer, than at the 75% effective rotation setting, we would have 7,500 ohms resistance between the terminals.

**NON-LINEAR TAPER.** For most control applications non-linear taper types of potentiometers are needed. These potentiometers do not have equal change of resistance for equal changes of rotation. In some of these units, the first 50% of rotation brings only a very small change in resistance between a set of terminals, but the bulk of resistance change occurs at the end of the rotation. In other potentiometers, a great deal of resistance change occurs as the rotation is started, but then the change becomes gradual. Study the

The potentiometer illustrated in Figure 50, is interesting because it has an extra tap connection. This tap is a fixed connection to a point along the resistance element. This extra connection is useful in special circuits and for tone-quality automatic adjustment with volume setting.

You may understand the meaning of *linear taper* a little better if you will realize that adjustable wire-wound resistors have uniform taper — equal resistance change for equal movement of the adjustable slider.

## RESISTORS IN SERIES

Beginner radio students often wonder what faults in operation are noticed if a replacement potentiometer has the correct resistance value but the wrong taper for the application. Usually, the equipment will operate, but the tone or volume level adjustment with the replacement potentiometer will be difficult. The settings will be critical and the useful portion of the total rotation will be very small.

curves showing the various tapers. Later you will understand in what type of circuits the different tapers are used.

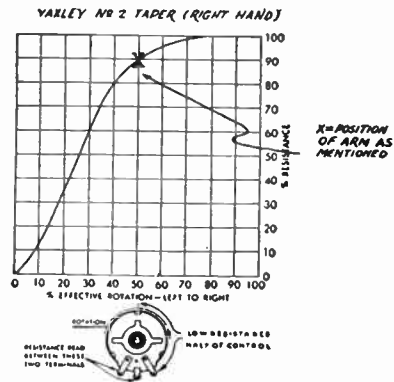

Courtesy P. R. Mallory & Co.

Figure 52. This is the taper for the potentiometer shown in Figure 51.

**RESISTORS IN SERIES.** Two resistors may be connected, one after the other. This is a *series* connection. More than two resistors may also be connected in series. In radio work, resistors of various sizes are connected in series. The value of the equivalent resistance of the circuit formed by several resistors connected

Figure 53. Potentiometers are made in various resistance values and tapers. Some commonly employed tapers are illustrated in the graph.

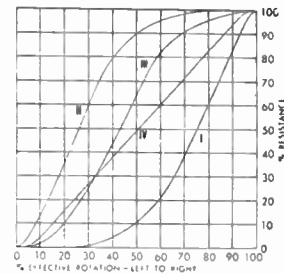

Usually, when two or more resistors are connected in series, an additional connection is made to the junction point. However, resistors may be connected in series to give a value of resistance not obtainable in a single unit, to give greater power handling ability than is obtainable from a single resistor, or to reduce the total voltage placed across each resistor, and in each of these cases *no* additional connection need be made to the junction of the units.

in series is obtained by adding the resistance values of all individual resistors. For example, if a 200 ohm and a 450 ohm resistors are connected in series, the equivalent resistance of the combination is 650 ohms. In mathematical terms, the total series resistance  $R_s$  equals the sum of the resistors making up the network, and these resistors may be  $R_1$ ,  $R_2$ ,  $R_3$ , etc.

$$R_s = R_1 + R_2 + R_3 + \dots$$

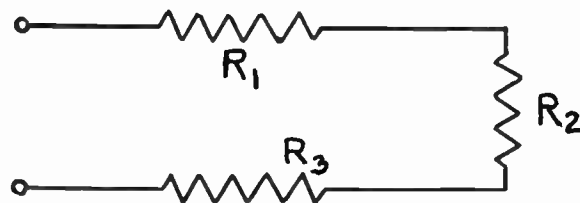

Figure 54. Several resistors may be connected in series. The total resistance is the sum of the individual resistors. The current in every resistor is the same, but the voltage drop across each resistor will be different, unless the resistors are all alike.

Resistors are connected in series to give values of resistance not obtainable in a single resistor. For example, 170 ohms can be obtained by connecting in a series a 100 and 70 ohm resistors, since no single 170 ohm resistor is commercially available. Sometimes resistors are connected in series to provide a tap-connection between the resistors.

**RESISTORS IN PARALLEL.** Suppose we wire two resistors in such a fashion that one of the terminals (leads) of each resistor are joined together, and also the other leads are joined. The current in this type of network will pass through each of the resistors. This connection places the resistors in *parallel*. The equivalent resistance will be less than the value of the smallest resistor. Several resistors may also be connected in parallel. The equivalent total resistance of several resistors connected in parallel can be calculated from this formula:

$$R_p = \frac{1}{\frac{1}{R_1} + \frac{1}{R_2} + \frac{1}{R_3} + \dots}$$

Usually not more than two resistors are wired in parallel and the formula simplifies to:

$$R_p = \frac{R_1 \times R_2}{R_1 + R_2}$$

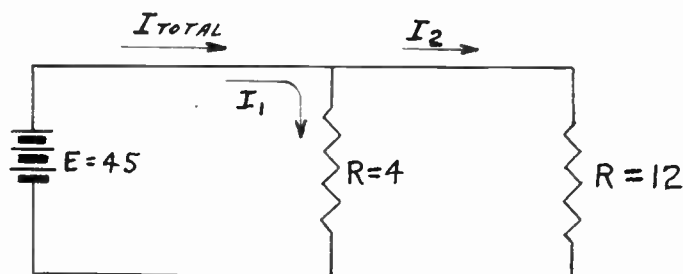

Figure 55. Two or more resistors may be connected in parallel. In a parallel resistor circuit, the voltage across each resistor is the same, but the currents may differ.

If we connect a 4 and 12 ohm resistor in parallel, we can use this formula to find the equivalent resistance.  $R_1$  will be 4 ohms, and  $R_2$  will be 12 ohms. Substituting in the formula, we obtain:

$$R_p = \frac{4 \times 12}{4 + 12} = \frac{48}{16} = 3 \text{ ohms}$$

This means that these two resistors connected in parallel will act as a single 3 ohm resistor.

Usually only identical resistors are connected in parallel. If two 600 ohm resistors are connected in parallel, the equivalent resistance is reduced to one-half (divided by two since there are two resistors) of the 600. The resistance is then 300 ohms. If three such 600 ohm resistors are connected in parallel, the equivalent resistance is 600 divided by 3, or 200 ohms. In such case, each resistor handles its proportion of power.

In practical electronic and radio circuits, parallel connection of resistors are not employed very often. However, in analyzing the function of many circuits, one often finds the equivalent of parallel combinations of resistances. The same simple mathematical formulas can be applied in either case.

If the two resistors connected in parallel differ greatly in resistance values (for example, one ten times larger than the second), the equivalent parallel resistance may be assumed equal to the smaller unit.

## CONNECTING DRY CELLS

Single cells are often called batteries, but this is not correct.

The life of a dry cell depends on the amount of electric current *taken* and how the current is removed. A cell will last longer if the current taken is not excessive and there are idle periods between times current is consumed.

If several cells are available for an application requiring but one, do not keep the balance as spares, but connect all cells in parallel. This will reduce the drain from each cell. Batteries have a definite *shelf-like*, and will go *dead* within a year.

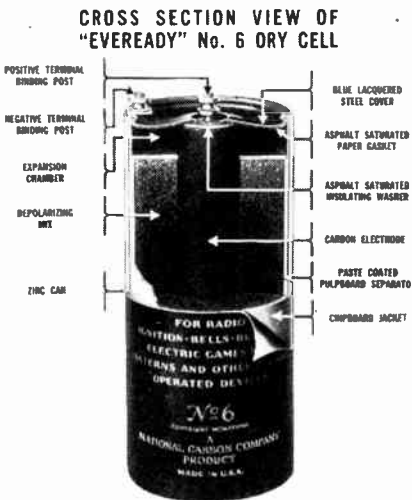

Figure 59. Inside view of a dry cell, showing the construction and materials used.

**BATTERIES.** An important source of electrical energy for portable radio equipment is the electric cell or battery of cells. A cell is a unit "battery" that produces electrical energy by means of chemical action. A battery is a combination of two or more cells connected in series or parallel. A primary cell is a unit which produces electric pressure (voltage) because of a chemical reaction. Once the chemically active materials are used up or an equilibrium is reached, no further appreciable current can be obtained.

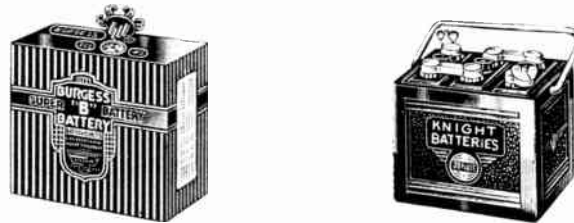

Figure 58. In localities where electric power is not available, storage batteries and dry batteries supply the power needed to operate radio equipment.

**DRY CELL.** The ordinary flash-light cell is of this type. The larger batteries used in portable sets, rural-district radios, and Signal Corps portable equipment, are made up of a large number of such cells. This "dry" cell has an outside foil of zinc which acts as the negative electrode. The center positive electrode is made of carbon. There is also a chemical solution in paste form. Additional chemicals are included to give the cell longer life. These cells produce about  $1\frac{1}{2}$  volts. The larger ones, of course, can supply greater current and will last longer than smaller size cells. All the cells produce the same voltage. The cells are connected in series and parallel to supply various requirements.

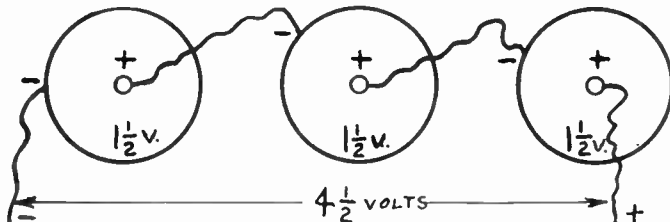

Figure 60. Several dry cells can be connected in series. Greater voltage can be obtained with this connection, but the life of the cells is not increased.

**STORAGE BATTERIES.** The lead storage battery is used in connection with some radio equipment. It consists of a positive plate of lead peroxide and a negative plate of spongy lead. These plates are placed in a solution of dilute sulphuric acid.

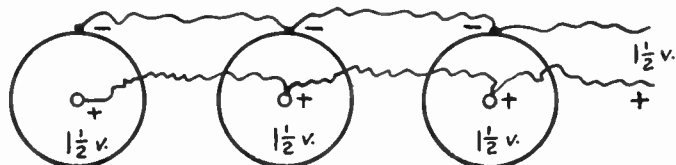
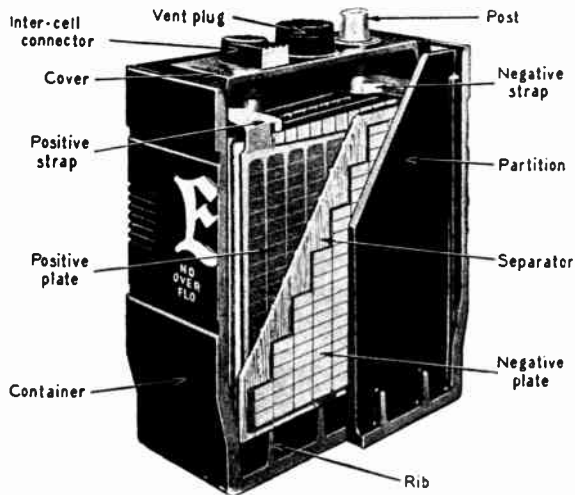

Figure 61. Dry cells may also be connected in parallel. The usual  $1\frac{1}{2}$  volts will be obtained, but the life of the cells will be increased. With this circuit, higher current may be taken.

## STORAGE BATTERY TESTING

The storage battery is a secondary battery because it cannot produce electric current of itself, but must be *charged* at first. The charging current is "stored" and may be obtained from the battery



*Courtesy Electric Storage Battery Co.*

Figure 62. A cross-section view of one cell of a storage battery. Notice how the positive and negative plates are interlaced.

when needed. The battery actually does not store electricity, it stores chemical energy produced by the charging current. When the current is used during the discharge period, this chemical energy is used up. Radio storage batteries are tested with a hydrometer since the specific gravity (lifting power) of the solution changes

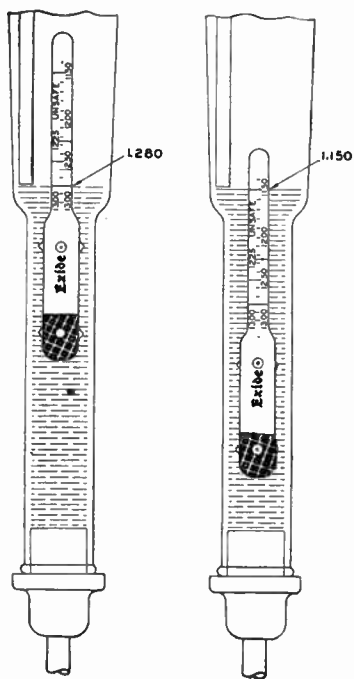

Figure 64. The reading on the float of a hydrometer, in line with the liquid from the storage battery, indicates the condition of the battery "charge."

*Courtesy Electric Storage Battery Co.*

Only water need be added since sulphuric acid employed in the solution has a very high boiling point and does not evaporate to any degree.

Storage batteries are rated in ampere-hours of capacity. This figure tells the number of amperes for the period of hours the battery will supply. Roughly, a 100 ampere-hour battery will deliver one ampere for 100 hours, or 5 amperes for 20 hours, or 8 amperes for about 12½ hours.



Figure 63. Positive plate above and negative plate below.

## CIRCUIT CALCULATION

Radio and electronic components must be connected in some fashion to give the required operation. On this page, we are considering the first complete and, perhaps, applicable circuit. An electrical circuit consists of several parts connected to permit the passage and control of electric current in the required manner.

The predetermination of electrical values in a circuit permits the proper design for the purpose on hand. While the analysis presented on these pages is simple, it is the basis for all circuit design and understanding.

with the "charge" condition of the battery. The float in the hydrometer should have the number 1.275 on the level with the acid solution taken from a fully charged battery. The battery must be recharged when the level reaches the 1.150 point. Additional charge may be given to the battery any time it is not fully charged.

The batteries are recharged with special equipment which may operate from the 110 volt A.C. power line, or may be a gasoline-motor driven generator. In an emergency, a storage battery may be charged from a 110 volt D.C. line (direct current) by connecting the battery in series with a large size electric light, or several lights in parallel. Proper polarity, of course, must be observed.

**CIRCUITS.** We are now ready to deal with a real but simple electrical circuit. Let us connect enough dry cells in series to obtain 45 volts. Since each dry cell produces  $1\frac{1}{2}$  volts, a total of 30 cells will be needed to make up this battery. The symbol for all batteries is the same, but the figures written along side can be used to indicate the voltage. Since voltage or electro-motive force is abbreviated E, we can write  $E = 45$ . Now let us connect a 15 ohm resistor across this battery. Notice how this is done in the schematic drawing. In actual practice you would use two pieces of insulated wire to make these connections. The symbol for all fixed resistors is the same, but here we can write  $R = 15$ , to indicate that the resistor is 15 ohms. This completes our circuit.

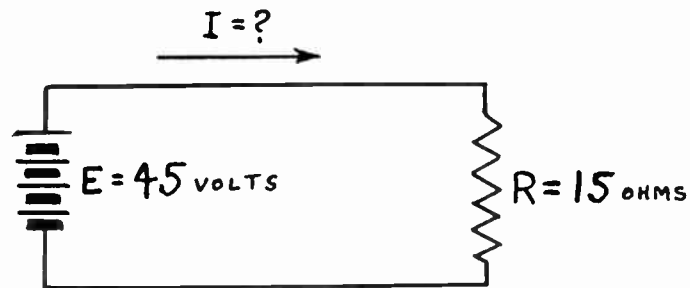

Figure 65. A simple circuit may consist of a resistor connected to a battery. Ohm's Law permits you to find the current when the voltage and resistance are known.

Now since the circuit is completed, electric current is flowing through the resistor. How much current is passing through the resistor? You may already know that current is measured in amperes, and so our question really asks, "How many amperes are passing through this circuit? How many amperes are supplied by the battery and pass around the circuit." In a later chapter we will learn that a meter can be used to measure this current, but now we will find out how the current can be found with the aid of a mathematical formula and the known facts about this circuit.

**OHM'S LAW.** In all direct current circuits (batteries supply D.C.) there is an important relationship between voltage, resistance, and current. Using the following symbols:

E = voltage in volts

R = resistance in ohms

I = current in amperes

Ohm's Law states that the voltage is equal to the product of current and resistance in the above units. Since this relationship is

very important in solving radio problems, we will state it mathematically in several ways:

$$E = I \times R \qquad I = \frac{E}{R} \qquad R = \frac{E}{I}$$

To use these formulas, first make certain that the known facts of the problem are expressed in the required units. If the resistance in a certain problem is expressed in megohms, change the value to ohms. Then use the formula which starts with the letter-symbol of the quantity you wish to find. Substitute in this formula the known facts as numbers in place of the other letters and solve.

In our earlier example, we were trying to find the current; then let us choose the formula which starts with the letter I. All units are already expressed correctly so no changes are needed. Substitute number 45 for E, and number 15 for R. Solve and you obtain the answer of 3. This means that the current is 3 amperes.

Please consider this additional example. A 1,000 ohm resistor is used in a certain radio circuit. It is known that the current passing through this resistor is 6 milliamperes. What is the voltage drop across this resistor?

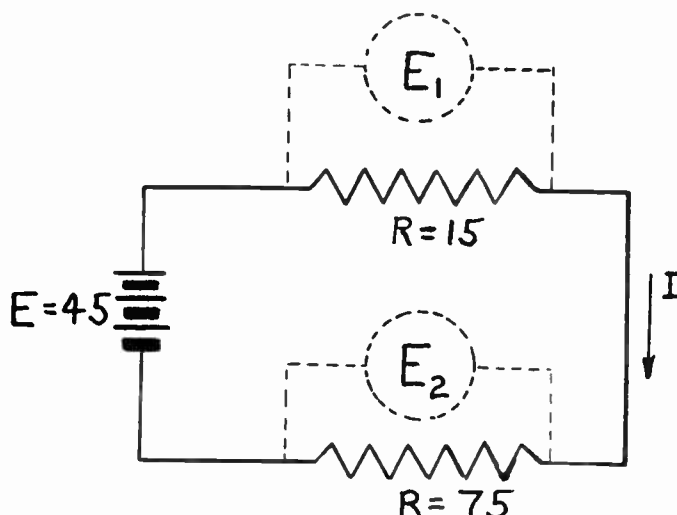

Figure 66. The voltage drops across the different elements making up the circuit, must equal the voltage supplied by the source (the battery in this case).

Here we are trying to find E and must use the formula which starts with this letter. Resistance is expressed in ohms, but the current is in milliamperes. Since each milliampere is one-thousandth part of an ampere, 6 milliamperes are .006 amperes, i.e. 6/1000 of an ampere. Now substitute in the formula. Multiplying the current of .006 by resistance of 1,000, we obtain an answer of 6 volts. That is the voltage drop across this resistor.

**POWER.** Besides being rated in ohms, every resistance possesses another electrical rating corresponding to its power handling ability or "wattage." The current flowing in a resistance, causing a definite voltage drop, results in a certain dissipation of power measured in watts and is equal to the current squared times the resistance. Symbol for watts is W.

$$W = I^2R$$

This is the most commonly used formula for wattage computation, although others made up of related factors are also used:

## VOLTAGE DISTRIBUTION

The Ohm's Law relationship is so important and is so often used in practical radio work, that you must make certain you understand this material and are able to apply these formulas to simple problems.

Although the Ohm's Law stated is intended for direct current circuit only, it may also be applied to A.C. circuits (such as electric power supplied to most homes) if only resistive loads are considered. Electric bulbs behave very much as resistors. If a bulb is operated from 110 volts, and draws 0.2 amperes, the resistance of the bulb may be found from the Ohm's Law relationship. Using the expression where R stands alone on one side of the *equal* sign, we substitute the known values and obtain an answer of 550 ohms.

Electrical *power* converted to another form of power (energy) is measured in watts. An electric motor may use a definite quantity of electrical power in watts. This *power* will be changed to mechanical energy; i.e., power of mechanical type to drive some mechanical devices. Electrical power dissipated in heat is also measured in watts.

## POWER CALCULATION

Since a fuse is a safety device, its purpose is entirely defeated if it is replaced by another fuse of too large capacity (which will not provide any safety factor for the particular circuit), or if the fuse is shorted out with a piece of wire or metal.

You should make up similar simple problems to get the needed practice in using the formulas for computing power dissipated in circuits having resistors.

$$W = I \times E \qquad W = \frac{E^2}{R}$$

Composition-type carbon resistors are rated from  $\frac{1}{4}$  to 2 watts depending on their size. Wire-wound resistors begin with about 5 watt size and go up to very large sizes that are used in transmitting equipment.

**FUSES.** The electric wires carrying current heat up if the current increases beyond a safe value. If the wires are permitted to become too hot, the insulation may start burning. Certain faults in circuits may cause the current to increase beyond a safe value. As a safety precaution, fuses are inserted in all power circuits. A fuse is made of a special metal which will melt and break the circuit when the current becomes excessive, but not large enough to damage the actual wiring.

**WATTAGE RATING.** The power dissipated by the resistor is changed to heat; if the heat is excessive due to overloading the resistor by more than just the normal current flow, the heat so developed may injure the resistor element. The ratings given are for open air mounting and where there are no close parts that may be injured by the heat. In mounting resistors in a closed chassis adjacent to other easily harmed parts, it is best not to load the resistors more than 50% of their rated wattage.

**EXAMPLES.** If a resistor of 3 ohms, carries a current of 2 amperes, what is the wattage dissipated?

$$W = I^2R = 2^2 \times 3 = 2 \times 2 \times 3 = 12 \text{ watts}$$

A biasing resistor causes a drop of 30 volts, with a current of 15 milliamperes (.015 amperes). What is the wattage of the resistor?

$$W = I \times E = .015 \times 30 = .45 \text{ watts}$$

In this case a half watt resistor would do, but it would be better to use a one watt unit. More examples will appear later.

**MAXIMUM CURRENT.** The question of what current is permissible once the wattage and resistance of a unit are known comes up quite often. The formula below, derived from the regular wattage formula, will enable us to do this.

$$I = \sqrt{\frac{W}{R}}$$

The following problem may be taken as an example. What current may a 2 watt, 800 ohm resistor carry as a maximum?

$$I = \sqrt{\frac{2}{800}} = \sqrt{\frac{1}{400}} = \frac{1}{20} = .05 \text{ amperes}$$

The table below may be used for this purpose. This table may also be used to determine what wattage to use with a certain resistor and current flowing through it. Usually this is the information known and, therefore, the table will be very handy. For example, if you are using a 10,000 ohm resistor and the current is 25 milliamperes (.025 amperes), then the wattage required will be greater than 5 watts, and therefore, a 10 watt unit should be used.



## USING OHM'S LAW CHART

WATTS	½	1	5	10
Resistance	current I in amperes			
1	.707	1.000	2.236	3.163
2	.500	.707	1.580	2.236
5	.316	.447	1.000	1.414
10	.224	.316	.707	1.000
25	.141	.200	.446	.632
50	.100	.141	.316	.447
100	.071	.100	.224	.316
200	.050	.071	.158	.223
300	.041	.058	.129	.182
500	.032	.045	.100	.141
700	.027	.038	.085	.129
1,000	.022	.032	.071	.100
1,500	.018	.026	.058	.081
2,000	.016	.022	.050	.071
2,500	.014	.020	.045	.063
3,000	.013	.018	.041	.057
4,000	.011	.016	.035	.050
5,000	.010	.014	.032	.044
7,000	.008	.012	.027	.038
10,000	.007	.010	.022	.031
15,000	.006	.008	.018	.025
20,000	.005	.007	.016	.022
25,000	.004	.006	.014	.020
50,000	.003	.004	.010	.013
75,000	.003	.004	.008	.011
100,000	.002	.003	.007	.010
200,000	.002	.002	.005	.007
300,000	.001	.002	.004	.006
500,000	.001	.001	.003	.004

If you wish to use the table to find the maximum permissible current in amperes which can be safely handled by a given resistor, proceed as follows: Find the "ohm" value of resistor in the first column. Closest value in the table will serve. Proceed across from this value until you reach the column where the power of the resistor is stated at the top of the column. The value given in this column is your answer in amperes. For example, given a 5,000 ohm resistor. Find it in the first column. Proceed across. For one watt size (if this unit is one watt) find the proper column. Do you see the value, .014 amperes? This is maximum; of course, lower value current is permissible.

If the resistor and current are known, you can find what size (wattage) will be required. Find the "ohm" value of the resistor in the first column, and then *travel* across until you come to a current value which is first along the way from the left, but is larger than the given value of current. Look at the top of the column; the wattage of the resistor needed is given there.

**HOW TO USE THE OHM'S LAW CHART.** The alignment chart, prepared by the Ohmite Mfg. Co., enables graphical solution of Ohm's Law problems. To use, place a ruler across any two known values on the chart; the points at which the ruler crosses the other scales will show the unknown values. The *italic* figures (on the left of the scales) cover one range of values and the roman figures cover another range. For a given problem, all values must be read EITHER in the *italic* numbers or in the roman numbers.

Example No. 1. The current through a 12.5 ohm resistor is 1.8 amperes. What is the voltage across it? The wattage? Answer: Dotted line No. 1 through R = 12.5 and I = 1.8 shows E to be 22.5 volts and W to be 40.5 watts.

Example No. 2. What is the maximum permissible current through a 10 watt resistor of 2,000 ohms? Answer: Dotted line No. 2, through W = 10 and R = 2,000, shows I to be 70 milliamperes.

**RESISTOR CIRCUITS IN RADIO.\*** Please refer to the illustration (A) of Figure 68. Here we have a choke commonly used in a power supply of a radio set. We know that this choke has a resistance of 100 ohms, and that it produces a voltage drop of 50 volts. Applying the Ohm's Law statement, we can solve for the current, I.

$$I = \frac{E}{R} = \frac{50}{100} = .5 \text{ amperes}$$

\*These examples were taken from: *Radio Service Encyclopedia*. Second Edition, published by P. R. Mallory & Co.

This chart is on the next page. Obtain the needed practice by following the examples given and then working a few additional problems which you can make up yourself.

## EXAMPLES IN USING THE CHART

The explanation for using this chart shown under Figure 67, is given on page 39.

These examples refer to the illustration shown in Figure 68.

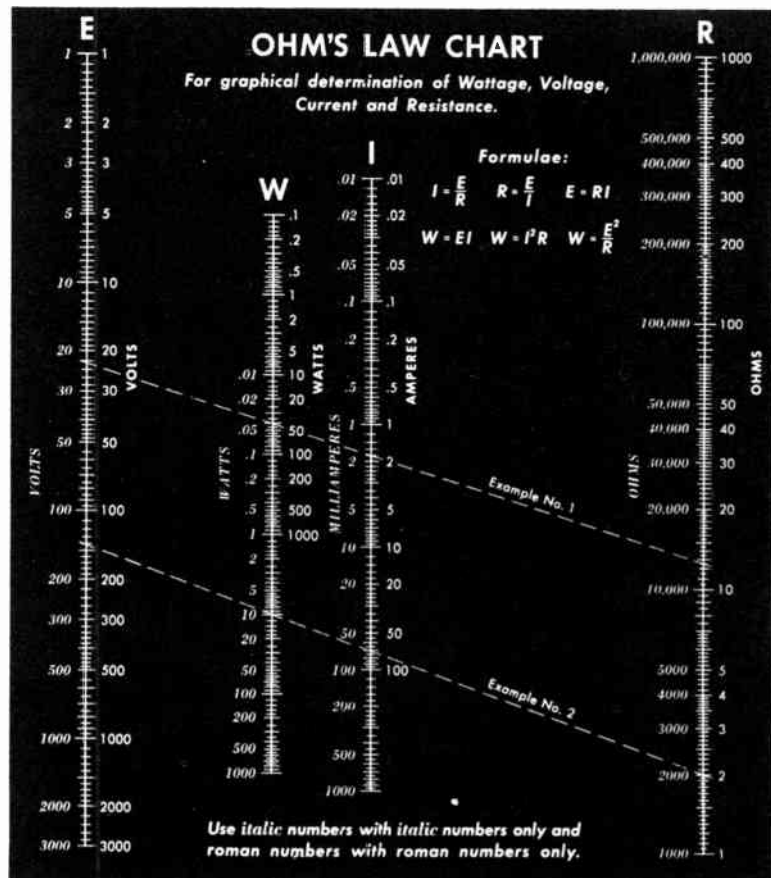

Figure 67. In practical radio work, approximate values are accurate enough. With the aid of this chart you can work most resistance problems.

In illustration (B) you will notice that the voltage from one side of the resistor to ground is 250 volts as indicated by the meter. From the other side of the resistor to ground the voltage is 300 volts. This indicates that 50 volt drop occurs across the resistor. The current, I, is .005 amperes, as indicated on another meter. We use another form of the Ohm's Law, to solve for R.

$$R = \frac{E}{I} = \frac{50}{.005} = 10,000 \text{ ohms}$$

In illustration (C) the current passing through the tube and indicated on the meter as .005 amperes, will also pass through the resistor wired in the cathode circuit. We know this resistor is 2,000 ohms. What will be the voltage drop across this resistor?

$$E = I \times R = .005 \times 2,000 = 10 \text{ volts}$$

In the figure above, we wish to know what power will be dissipated in the 2,000 ohm resistor. Using the formula below and making the needed substitutions, we obtain the answer.

$$W = I^2R = .005 \times .005 \times 2,000 = .05 \text{ watts}$$

**KIRCHHOFF'S LAWS.** These laws constitute a further application of Ohm's Law to more complicated circuits. *Kirchhoff's First Law*

states: "Any current flowing to a point in any electrical circuit is equal to the sum of the currents flowing away from that point."

## KIRCHHOFF'S LAWS

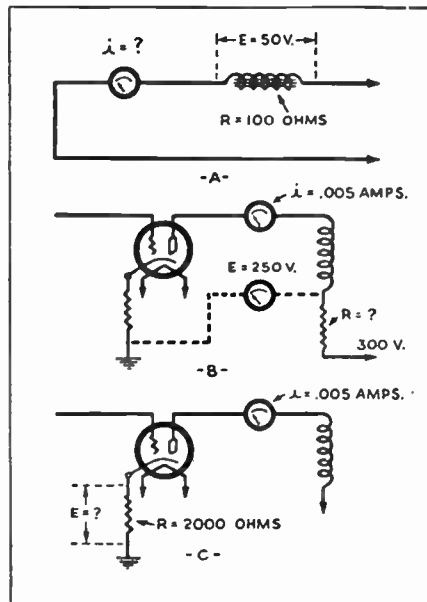

Reprinted from Mallory Radio Encyclopedia

Figure 68. Circuits illustrating fundamental calculations which require familiarity with Ohm's Law. (A) Solving for current flowing in a circuit; (B) the resistance which is needed to produce a given voltage drop; (C) the voltage drop produced by a given resistance.

*Kirchhoff's Second Law* states: "In any closed electrical circuit the sum of the impressed voltages will equal the sum of the voltage drops." The voltage drops must be in the same direction or they must be combined algebraically. We have already used this law, when we noticed that the sum of the drops in two series resistors equalled the battery voltage.

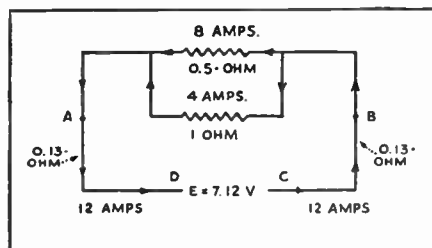
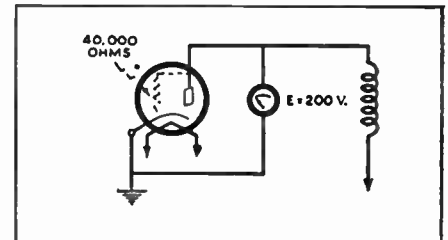

Figure 69. Illustration of Kirchhoff's First Law, "A current flowing into a circuit is equal to the current leaving the circuit."

In the figure, you will note that the sum of the currents, 8 amperes and 4 amperes, flowing towards point A, is equal to the current, 12 amperes leaving point A. This illustrates the First Law.

Kirchhoff's Second Law is also numerically illustrated in this figure. Assume that the resistance of the various parts of the circuit are as marked, and that the total internal resistance of the battery is .6 ohms. Then according to the statement of the Second

### Additional Questions



Courtesy P. R. Mallory & Co.

Figure 71. A radio tube has its plate resistance equal to 40,000 ohms. Assume that the D.C. resistance equals plate resistance in this case, and that the tube will act as a resistor of this value. A voltage of 200 volts is applied to the plate. What current will pass through the tube?

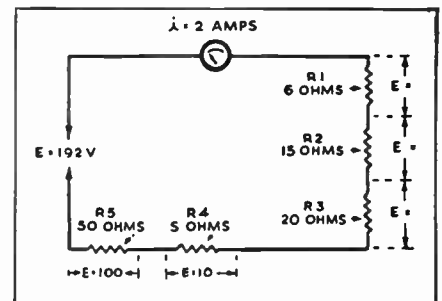

Figure 72. A circuit consists of five resistors connected to a battery as shown. The ammeter indicates that 2 amperes of current passes through the circuit. Find the voltage drops across each resistor. The total of all voltage drops should equal the battery voltage of 192 volts.

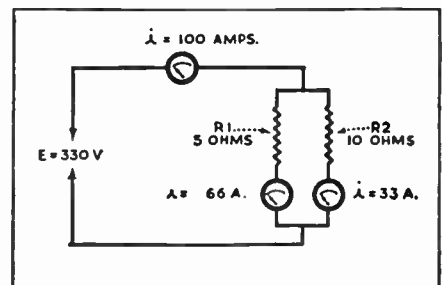

Figure 73. Check the values of current as indicated by the ammeters connected in the circuits. Do you agree with the results?

## REVIEW QUESTIONS

1. Find the resistance per foot and then multiply by 17.

4. What is the resistance of a pure carbon resistor? Does this suggest the answer?

5. There are two right answers to the first part of the question. Remember the usual accuracy of resistors when answering the last part.

8. If you have a radio parts catalog, look up the prices of various wire-wound resistors.

10. Can you *invent* additional applications for potentiometers?

11. You may also make up similar problems, yourself.

The B— connection of the battery is made to the ground or chassis. Electrons may be considered starting from B—, pass through the cathode resistor, from the heated cathode inside the tube to the plate, through the plate meter, and back to the B+ of the battery. This action will be clearer when you study the behavior of vacuum tubes.

13. You can work this out from formulas or get the answers by using a suitable table for each case.

Law, if the impressed voltage is 7.12 volts: Impressed Voltage = sum of voltage drops in the circuit, or the drops will be, (C to B)  $12 \times .13$ , plus (B to A) only one branch needs to be considered since the voltage across the branches is the same,  $4 \times 1$  (or  $8 \times 0.5$ ), plus (A to D)  $12 \times .13$  to complete the circuit. When you add up the results, you will find the answer will check with 7.12 volts.

REVIEW QUESTIONS AND PROBLEMS. 1. A piece of nichrome resistance wire six feet long has a resistance of 100 ohms. A piece 17 feet long of this same wire will have how many ohms resistance?

2. If another wire of twice the cross sectional area, also six feet long, is used how many ohms will it have?

3. From a practical point of view, does the resistance of a copper conductor change any when an insulation is placed on the wire? What if the wire is stretched?

4. Why do you think it is not practical to make carbon resistors in values less than 100 ohms? What do you use when you need a resistor of only 20 ohms?

5. How can a resistor be color coded to represent 70 ohms? Can you represent 175 ohms by means of the color code? Why is this question only of theoretical importance?

6. Does the physical size of a carbon resistor (length and thickness) tell you anything about the electrical resistance? Why?

7. What are the extreme values of a 200,000 ohm resistor only accurate to within plus or minus 20%?

8. If a section of a wire-wound resistor with taps burns out, how can the repair be made most economically?

9. What are the main differences between rheostats and potentiometers?

10. Name two uses for potentiometers in home-type radio receivers?

11. Solve the combination circuit problem of this chapter (involving resistors in mixed circuit), but changing the values of the five resistors.

12. A 60 watt lamp connected to a 110 volt line uses how much current? What is the resistance of this lamp?

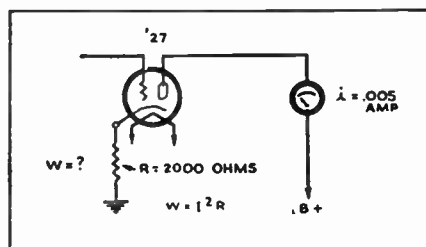

Courtesy P. R. Mallory & Co.

Figure 70. A cathode biasing resistor of 2,000 ohms is connected as shown. The plate current of .005 amperes must pass through this resistor. What power in watts is dissipated by this resistor?

13. A resistor used in a radio set causes a drop of  $7\frac{1}{2}$  volts when a current of .005 amperes passes through it. What is the resistance? How many watts are handled by this resistor? What commercial size resistor can be used for this purpose?

14. How can an 800 ohm equivalent resistor be formed from several 600 ohm resistors which are the only ones available for the purpose?

# LESSON 5

## Properties of Coils and Transformers

**MAGNETISM.** Magnetic force is important for the operation of many radio component. Relays, transformers, and loudspeakers operate on the principle of magnetism. Being similar to electricity, we cannot actually see or feel magnetism, but the effects of this force can be noticed and accurately measured.

Natural magnets exist. If a piece of hard steel is stroked in the same direction with a piece of natural magnet, the steel will become permanently magnetized. For practical use, a small percentage of nickel, chromium, or cobalt is added to steel for making permanent magnets which have greater magnetic strength and other desirable properties.

Just as in the case of electrical charges,

**UNLIKE MAGNETIC POLES ATTRACT EACH OTHER,  
LIKE MAGNETIC POLES REPEL EACH OTHER.**

Also it is important to remember that the force of attraction or repulsion between two magnets is inversely proportional to the square of the distance between the poles of the magnets. A north pole of one magnet will attract the south pole of another magnet four times as much at a 1 inch distance as at a 2 inch distance. This is the reason why the space between the moving coil and the fixed magnet of a loudspeaker is made so small.

If either end of a bar magnet is dipped in iron filings, most of the filings will stick to the pole, indicating that the attractive force is greatest at the poles. This magnetic effect is noticeable for a considerable distance around the magnet. This attractive force is the magnetic field. We speak of lines of force being present and connecting the two poles of a magnet. The filings around the magnet follow the lines of force.

If a strong magnet is dipped in a barrel of nails which are made of soft iron, many nails will stick to the magnet. Some nails, in turn, will hold other nails, becoming temporary magnets. However, once the nails are removed from the magnet, their magnetism is lost. Hardened steel substances, on the other hand, will retain some magnetism once they are brought into contact with a permanent magnet.

**ELECTROMAGNETISM.** Although many devices employed in radio circuits depend on permanent magnets for their operation, magnetism produced by the flow of electric current through a conductor finds even greater application. Every wire carrying electric current has an associated magnetic field proportional to the current strength and the arrangement of the wire.

The fact that an electric current in a conductor has an associated magnetic field may be proven easily. If a compass is held near the wire, the needle of the compass (actually a small magnet on a pivot) will take a position at right angles to the wire. If no current is present in the wire, the needle will assume its natural position pointing North.

If you are able to obtain two toy horse-shoe or bar magnets, we suggest that you observe their actions. Notice how the like poles repel each other. If iron filings are available, you may experiment further in observing the *lines of force* of the magnets. To do this, place a thin cardboard on the magnetic poles and sprinkle the filings on the cardboard.

A simple electromagnet may be made by winding a number of turns of wire on a large nail or spike. The beginning and end of the coil may be connected to the terminals of a small battery for a few minutes while you observe that this electromagnet behaves in exactly the same way as a similar fixed magnet. Notice also that no magnetic properties are present if the electric circuit is broken.

## ELECTROMAGNETIC PRINCIPLES

If you have constructed an electromagnet, you may further observe the change in the magnetic strength when the voltage of the battery is increased. Two or more batteries may be connected in series to increase the voltage supplied.

An electromagnet is made by winding a number of turns of wire in the form of a coil. A much stronger magnetic field can be created since the fields of all the individual turns will add up. Since the magnetic field of force of each turn adds to that of the next turn, the greater the number of turns of wire the coil has, the stronger will be the magnetic field.

The total magnetic flux (lines of force) depends on the number of turns and the current strength. If the current is strong, relatively few turns of thick wire will be needed to produce a given magnetic field. On the other hands, if the current is very minute a great many turns of fine wire will be needed.

If a bar of iron is placed in the center of the coil the iron will become magnetized when the current flows through the coil, but will lose its magnetism once the current is stopped. This principle is used to operate relays, door bells, and other devices.

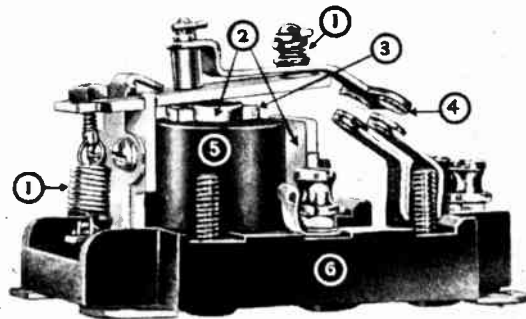

*Courtesy Struthers Dunn, Inc.*

Figure 74. A detailed illustration of a radio relay.

Relays are employed for a variety of electronic applications. As remote controls, they serve to release bombs, select telephone connections on dial telephone exchanges, and to warn operators concerning the improper operation of equipment. Relays are basic components of all equipment which employs photo-cells.

**RELAYS.** All relays use an electromagnet, see part marked 5, in the illustration. Near the magnet is a movable armature made of magnetic material. Normally, a small spring, number 1 part at the left, keeps the armature slightly away from the electromagnet. The core of the magnet is marked 2 and 3. When the coil carries the required amount of current, the armature moves down, and contact is made by terminals marked 4. This completes an outside circuit. By controlling the small current required for the operation of the electromagnet, it is possible to move the armature up and down, thereby closing or opening a different circuit which may be carrying larger current.

Relays are used for remote control, for safety as "fuses," for controlling segregated circuits, and for automatic operation.

**MAGNETIC SATURATION.** After a certain value, the increasing effect of the applied electric-magnetizing force will be diminished and, if the force is increased beyond a definite limit, no further increasing effect will be noticed. The substance being magnetized is then said to be saturated. For example, Wrought Iron will have a very strong flux when inserted in a copper wire coil rated at 10 ampere-turns. This rating means that the number of turns multiplied by the current in amperes must equal 10. Now if this arrangement is altered so that the magnetic force is 20 ampere-turns, the lines of force per square inch will be increased only to 97,000 from the previous figure of 89,000. At 40 ampere-turns this figure is only 106,000 lines per square inch. Saturation is reached when an

additional increase in ampere-turns has no further effect on the flux density measured in lines per square inch.

**INDUCTANCE.** All coils have an interesting property called inductance which is very useful in electricity and radio. It is easy to understand what this property does and we will explain these facts by describing an experiment which is historically important.

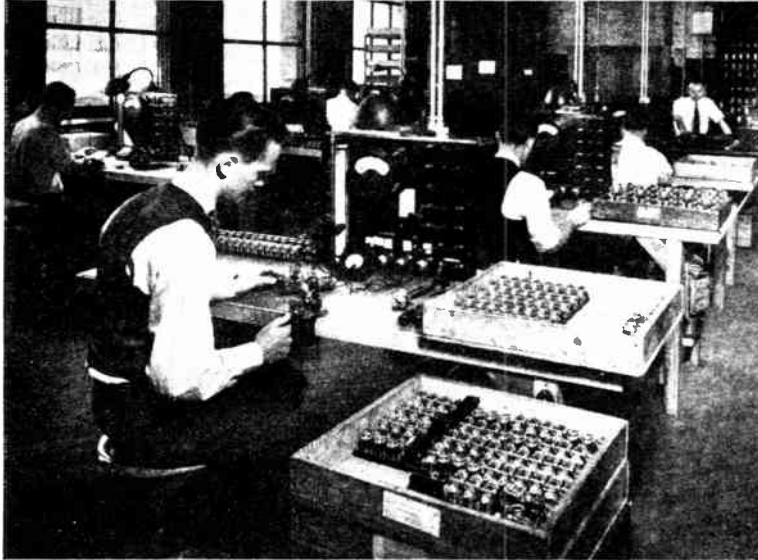

*Courtesy Struthers Dunn, Inc.*

Figure 75. Many interesting well paying positions in the Radio and Electronics fields will be opened to you after you complete your study of this course.

We have already learned that an electric current in a conductor sets up an associated magnetic field. The magnetic field will be stronger if the wire is made in the form of a coil. If this conductor (preferably in coil form) is moved across the magnetic field of a permanent magnet, a current or voltage will be noticed to exist in the circuit. The needle of the sensitive meter connected to the

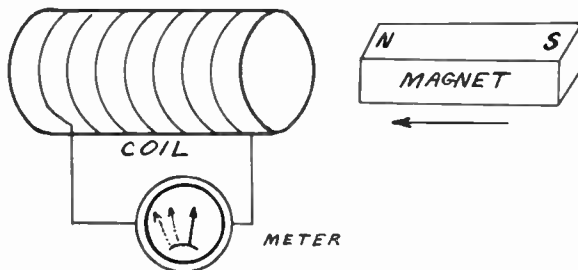

Figure 76. A conductor has a voltage induced when it cuts magnetic lines of force. The meter indicates the presence of voltage. Either the coil of wire or the magnet may be moved to produce the effects.

coil will indicate the existence of a voltage. If the coil remains fixed in relation to the magnet, no indication will be shown by the meter. As the direction of motion is altered, the needle will swing to the left and then to the right. This shows that the voltage generated by the motion is altering its direction.

## EXPLANATION OF INDUCTANCE

You should realize that the conductor (copper wire of the coil) must *cut* the magnetic lines of force. This is possible if either object is in relative motion in respect to the other. Either the coil or the magnet may be moved to induce the voltage in the coil. Even both the coil and the magnet may be in motion, but they must not be moved in the same direction at the same rate. Later on, you will learn that by using an electro-magnet (instead of a fixed magnet), no motion will be needed provided the electric current used to excite the electro-magnet is of a changing (alternating) type.

## MAGNETIC CIRCUITS

It is recommended that you memorize and be able to repeat at least in your own words this important relationship of electro-magnetic circuits.

You can see that the property of self-inductance makes the coil act as if it had higher resistance. This action will be explained in greater detail

Please remember from this experiment that the voltage is present only when there is motion, that the intensity of voltage (meter movement) is proportional to the rate of motion, the number of turns in the coil, and the flux density of the magnet used. This principle of voltage generation is employed in all electric dynamos.

**LENZ'S LAW.** The effects observed in this experiment have been summarized and are known as Lenz's Law. We say that when there is any variation of a magnetic field with respect to a conductor, the voltage induced in the conductor is in such a direction as to produce a current which will tend to prevent the original variation. Work was done in our experiment since we had to overcome this tendency of the coil to prevent any change.

**SELF-INDUCTANCE.** We can use this interesting law to explain the tendency of an inductance (coil) to prevent a change in the current passing through it. If a coil is connected to a battery, at the first instant only a tiny current would pass, let us say, due to the passage of the very first few electrons. This current will create a small electromagnet which will act in the same way as a correspondingly small permanent magnet. Since the current is increasing, the flux is increasing and appears, to the turns of wire, as a moving magnetic field. But this action, by Lenz's Law, will tend to prevent any further change by producing a counter voltage. This is actually what happens and a short time passes before the current rises to a maximum value. But if the same wire was strung out and connected to the battery, the maximum current would occur almost instantly.

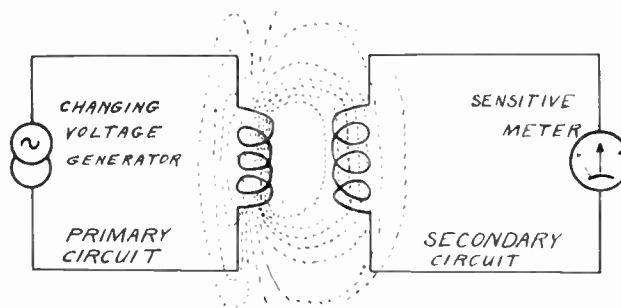

Figure 77. A varying current flowing in the primary circuit, produces a varying magnetic field which induces a voltage in the secondary circuit. This is the principle of the transformer.

**TRANSFORMER ACTION.** It is also possible to induce a current in one conducting circuit by means of the changing magnetic field produced by the current flowing in another associated circuit, which is not electrically connected to the first circuit. The flux set up by the first circuit induces a current in the second circuit. This action takes place only while the current in the first circuit is changing (increasing or decreasing) as in the case when the first circuit is connected to a source of current that is periodically rising and falling. The circuits must be located closely together, that is coupled together. A device used to transform electrical energy by induction is called a *transformer*. A transformer does not create energy, it simply separates two circuits, and steps the voltage up or down. When any voltage is stepped up by means of a transformer, the current correspondingly in the same ratio is stepped down.



**TRANSFORMER.** The coil receiving the original current is called the primary, and the coil in which the current is induced by electromagnetic induction is called the secondary. In the illustration it is evident that since only a part of the lines of force set up by the primary link the secondary coil, the current induced is not as great as would be in case all the lines of force linked the secondary. The lines of force not linking the secondary and, therefore, not being useful are termed the leakage flux. To keep the lines of force in the desired path soft steel material is used for the core. Usually thin sheet laminations are employed to reduce losses.



Figure 78. Transformers used with low (power or audio) frequencies have iron cores. The illustration shows an upright type power transformer used in radio sets. Wire leads come out of the bottom. The transformer is bolted to the chassis and the wire leads go through an opening in the chassis.

Transformers and inductors having air cores are used in radio receiving circuits where the frequencies encountered are very high and would create heavy losses due to *eddy* currents and *hysteresis* if iron cores were used. Where the frequencies are relatively low, as in the case of audio (sound) frequencies and power frequency of 60 cycles, iron laminated cores are used.



Figure 79. The antenna coil illustrated is a transformer used for radio frequencies. An air core is used and the wire is wound on insulated tubing. Connections are made to lugs.

**UNIT OF INDUCTANCE.** The unit of inductance is the *Henry*. A coil has an inductance of one henry if a current change of one ampere per second will produce one volt pressure in the coil. The letter *L* is used as the symbol for inductance.

The henry is a relatively large unit and while some audio coils having special iron cores have an inductance of several hundred henries, the inductance encountered in coils used in radio frequency work and having air cores is only a small fraction of a henry. One thousandth of a henry is a millihenry, and one millionth part of a henry is called a microhenry. Coils used for tuning the broadcast frequencies are in the order of 220 microhenries.

Inductive coils may be connected in series, in parallel, and in other combinations *without* the magnetic fields interlinking to any degree. When inductors are connected in series, under these conditions, the total effective inductance is the sum total of the individual inductances.

**MUTUAL INDUCTANCE.** If two coils are connected in series and do have their magnetic fields interlinking, the total inductance for the two coils may be greater or less than the sum of the individual inductances. The reason for this is easy to explain. If one coil's magnetic field links the second coil, the turns of this second coil may be considered as adding to the turns of the first coil. Now it is obvious that the inductance increases with the number of turns,

The primary coil which carries the *exciting* current in the transformer produces the magnetic field and this field, which must be of a changing type, may link one or more secondary coils. Iron cores concentrate the magnetic field. In air coils, only a small percentage of the total lines of force links the secondary coils.

If two coils are separated by a distance of several feet or are shielded with metal cans, they may be assumed not to have their magnetic fields interlinking.



Wire-wound resistors, using cylindrical cores, have considerable self-inductance which is not permissible in some circuits. If the resistance wire is wound in a special way on flat strips, the units will have almost no inductance.

The coefficient of coupling in iron core transformers is almost equal to 1. In radio air core coils, the coefficient of coupling is very small, around 0.05.

and the coil will have an *apparent* higher inductance. This same reasoning will apply to the second coil inductance in relation to the first coil.

We have assumed that the turns of one coil were equivalent to the turns added to the second coil. This, of course, requires that both coils have the turns wound in the same direction and be placed in a position to have the magnetic fields attract each other. If this process is reversed, as when the turns are wound in the opposite direction, or the magnetic fields buck each other, then the second coil will act to "subtract" the effect of some turns on the first coil. Less turns on the coil will reduce the effective inductance. Coils which are spaced a great distance apart, or are separated with metal shields, or are at right angles to each other, have very little effect on each other.

The change of the inductance value of a coil, because of the action described, is really equal to another coil being connected in series. It is as if this imaginary coil had a definite value of inductance which was added or subtracted from the inductance of the real coil. This additional inductance which must be considered in practical circuits is known as mutual inductance.

**COEFFICIENT OF COUPLING.** When two coils are arranged so that some definite mutual inductance exists, the coils are said to be magnetically coupled. In many practical calculations, as you will see later, it is more convenient at times to express the amount of coupling as a fraction of the maximum coupling possible rather than the numerical value of mutual inductance. If the fields of two coils are almost in common, the coefficient of coupling approaches 1, but if the coils are segregated the coupling coefficient becomes zero. Mathematically, the coefficient of coupling, *k*, may be expressed in terms of the mutual inductance *M*, and the self-inductance of the coils, *L*<sub>1</sub> and *L*<sub>2</sub>.

$$k = \frac{M}{\sqrt{L_1 L_2}}$$

**GENERATORS.** Electric power is produced in the power stations with aid of dynamos. Although dynamos are complex machines they depend on a very simple principle familiar to us. Conductors cut across a magnetic field and have a voltage induced. As any one conductor cuts across the poles of a magnet, it may at one time move almost parallel to the lines of force and, at that instant, produce no voltage in the output of the machine. An instant later, in revolving in the magnetic field, this same conductor begins to cut across a few magnetic lines, but it is still moving somewhat parallel to the lines of force. The voltage in the output is increasing. As the conductor cuts through the center of the magnetic lines and at right angles to these lines, the output voltage is maximum. After this the voltage begins to diminish and finally drops to zero again.

Now the conductor begins to revolve closer to the other pole, and the voltage will rise and fall again as before, but in the opposite polarity. Although dynamos have large coils instead of a single conductor, and many pole pieces, the voltage generated has this characteristic of starting at zero, rising to a maximum, dropping to zero, rising to a maximum in the opposite direction, and then returning to the original position. This type of voltage is alternating in character.

## SINE WAVE GENERATION

**SINE WAVE.** In our discussion of batteries, we talked about direct current, D.C. This current is either of a constant or varying value but flows in one direction all the time. One terminal in a D.C. circuit is always positive, the other terminal is always negative. When the magnitude of D.C. changes, we call this pulsating direct current. Alternating current (A.C.) has a constantly changing magnitude and periodically changing direction. In an A.C. generator, first one terminal is positive, and the voltage is rising, see

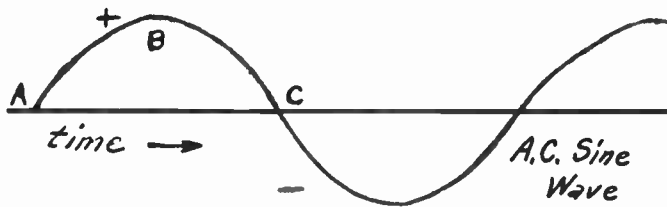
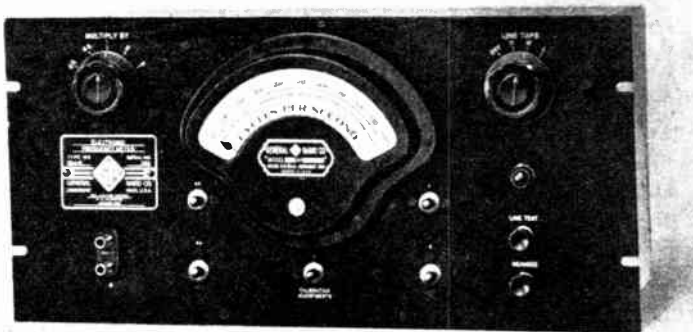

Figure 80. A sine wave is important in the study of radio principles. Certain generators produce sine waves. Since any wave, no matter how complex, can be resolved into the sum of sine waves, this function is basic in our study.

chart, part *A* to *B*. Then the value of voltage begins to fall, but the same terminals remain positive and negative, see *B* to *C*. At *C* the voltage present is zero, and then it begins to rise in the opposite direction. The process described in this paragraph is repeated but the terminal voltage is reversed. The usual generators of A.C. produce sine waves of the type illustrated.



Courtesy General Radio Co.

Figure 81. Special units can be constructed to indicate the frequency directly in cycles. The fact that most power line frequencies are exactly 60 cycles, permits electric clocks to keep accurate time.

**CYCLE.** After the voltage has started from zero, has risen to its maximum value in one direction, returned to zero, risen to the maximum value in the opposite direction, and then returned to zero, one complete cycle has been completed. You should draw a sine wave of several cycles, and mark off the cycles. The number of cycles present per second determines the frequency. The common power line frequency is 60 cycles per second; this means that sixty such changes occur every second. This explains why in dealing with A.C., time must be considered.

**PERIOD.** The amount of time needed for one cycle to be completed is known as the period. If the number of cycles per second

It is easier to generate A.C. with electric dynamos. Further, A.C. produces a changing magnetic field in transformers and permits the voltage to be stepped up or down as may be required.

In every cycle, there are two minimum values of voltage and two maximum values of voltage — the maximum values being of opposite intensity.

The information and numerical factors given apply to sine waves. Sometimes, A.C. wave has characteristics very far removed from a pure sine wave and, in such instances, the effective and maximum values are related in a different manner.

is known, then the period can be found by dividing one by this number. For example, the period of 60 cycle current is:  $1/60$  or one-sixtieth part of a second.

Usually one cycle is produced by rotating machinery when a conductor sweeps all the way around, that is completes a circle. We know that a circle has  $360^\circ$ . This permits us to divide the space taken by a sine-wave single cycle into  $360^\circ$ . In radians,\*  $180^\circ$  is equal to the Greek letter  $\pi$ , and fractions of  $\pi$  are used at times to represent division points. Notice that if a voltage, in the form of a sine wave, has zero value at  $0^\circ$ , then it has a maximum at  $90^\circ$ , zero value again at  $180^\circ$ , and another maximum at  $270^\circ$ . The wave is the same at  $0^\circ$  and  $360^\circ$ .

**EFFECTIVE VALUE.** At different parts of the cycle, the A.C. voltage is equal numerically, without reference to the positive-negative terminals, to some value between zero and maximum voltage. The instantaneous voltage is changing all the time. The value of this varying voltage as indicated by the usual A.C. voltmeter is the root-mean-square, RMS, value. The RMS value is equal to .707 of the maximum value. If in a circuit the peak (highest, maximum, greatest) voltage is 100 volts, then the RMS value indicated by a meter will be 70.7 volts. The RMS value is also called *effective* value since a D.C. voltage of this same value would cause as much heat in a resistor as this A.C. voltage. The house power circuits of 110 volts A.C. really means 110 volts RMS or effective, and an electric iron will give the same heat from this voltage as from 110 volts D.C.

In application, it is sometimes important to know the maximum or peak value of A.C. voltage when the RMS only is measured. The maximum voltage is equal to the RMS value multiplied by 1.4 approximately. From this we see that the maximum A.C. voltage or current is about  $1\frac{1}{2}$  times the RMS value as indicated on a meter.

**INDUCTIVE REACTANCE.** We have already learned that an inductance tends to prevent any changes in current intensity. If a circuit containing an inductance (coil) is connected to a source of D.C., such as a battery, a short time will be required for the current to rise to its steady maximum value. This is because the current starts from zero at the instant the circuit is completed, and the inductance will oppose a sudden change to the maximum value.

Now consider the same inductance being connected to a source of 60 cycle A.C. Let us complete the circuit at the very instant the voltage is zero and is just starting to rise. The current will have to change from zero to some maximum value in relation to the voltage, but will be reduced in value because it will always lag behind the value it would have if the inductance were not present. The inductance will make the value of current lag and when the current reaches a value, still considerably under the maximum it would be with a corresponding D.C. voltage, the A.C. voltage will drop back to zero. The current, therefore, will never reach the maximum value it had with D.C., and it seems that an inductance has a sort of special opposition to alternating current.

The more times per second the voltage drops to zero, the less chance the current will have to rise and will remain at lower values. We can see from this that the higher the frequency (greater number

\*The angle sustained by an arc of a circle which has its length equal to the radius, is equal to one radian.

of cycles per second) the greater will be this special inductive opposition. This action of an inductance to limit current in an A.C. circuit is known as inductive reactance. Inductive reactance is very similar to resistance, but is different for various frequencies, and increases with the frequency. Inductive reactance is also measured in ohms.

The symbol for reactance is letter X. For inductive reactance we use the special symbol,  $X_L$ . Inductive reactance can be calculated from a very simple formula:

$$X_L = 6.28 \times f \times L$$

The constant 6.28 is really equal to  $2\pi$ ,  $f$  is the frequency in cycles per second, and  $L$  is the inductance in henries.

Let us work a simple problem. A choke of 10 henries is used in a power supply to filter 60 cycle hum. We use the above formula and make the needed substitution.

$$X_L = 6.28 \times 60 \times 10 = 3,768 \text{ ohms}$$

This means that the 10 henries choke will have opposition to 60 cycle hum, the equivalent of 3,768 ohm resistor. But while a resistor will also have this same opposition to the D.C., the choke will have negligible resistance (reactance) to direct current.

**RADIO COILS.** Radio receivers and transmitters use radio coils with air cores. These coils are made from various sizes of copper wire, and are wound on insulated tubing varying in diameter from  $\frac{1}{2}$  to  $1\frac{1}{2}$  inches in modern receivers and from  $1\frac{1}{4}$  to 4 inches in small transmitters. We will now study these coils.



*Courtesy Meissner Mfg. Co.*

Figure 82. To prevent inductive coupling, radio coils are usually shielded in metal cans. Notice that the coil is supported with a bracket to the wall of the shield. Connecting terminals are at the bottom.

Most radio receiver coils, used in the radio frequency sections, consist of a primary and secondary. These coils are wound in a special manner to reduce capacity effects. The primary usually occupies less space and sometimes is a separate small coil mounted



Figure 83. An inside view of an I.F. transformer. The primary and secondary coils are mounted on a wood rod, and are spaced apart. The two trimmer condensers are mounted at the top of the shield.

within the coil form. These coils ordinarily are wound on one inch varnished or waxed cardboard tubes. The coils are mounted with the aid of metal brackets, or are attached to metal shields which support the coil and provide spade lugs for mounting the

After understanding the reason for inductive reactance, you should make up a few problems involving coils and frequencies of various values and solving these conditions for the resulting inductive reactance.

Recalling that the secondary of a R.F. coil has about 220 microhenries, calculate the inductive reactance of this coil at a frequency of 1,000,000 cycles. Assume that there is no condenser in the circuit. One million cycles corresponds to the frequency of 1,000 KC.

## I.F. TRANSFORMERS

The color code for the power transformer indicates the variety of windings with center taps. Of course, the transformer may have fewer windings and may not have some of the center taps.

entire assembly. Small terminal lugs are rivetted to the bottom of the tubing and the wires of the coils terminate there.

Intermediate transformers (I.F.) are almost always shielded. The coils are small, identical, and are separated on the supporting core made of wood doll-rod. See the illustration. The four leads may

### POWER TRANSFORMER LEADS

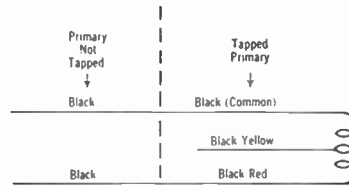

### I F TRANSFORMER LEADS

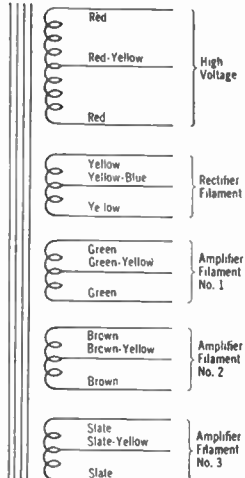
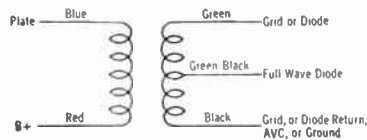

Courtesy Allied Radio Corp.

Figure 84. The majority of commercial power transformer and I. F. coil wire leads are color-coded according to the scheme indicated.

come out of the bottom of the shield-can, or the grid lead may come out through the top of the can. Most I.F. transformers are correctly color coded:

- Grid connection . . . . . green wire
- Plate connection . . . . . blue wire
- B+ voltage . . . . . red wire
- AVC or ground . . . . . black wire

Small trimmer condensers are enclosed in the can. These condensers are mounted at the top and the adjustment screws can be reached through the openings at the top. These adjustments are used for alignment of the radio.

In superhet sets oscillator coils are used. These are made in a variety of styles to fit the circuit used, but usually the oscillator coils are small, unshielded, wound on 1/2 inch rod, and appear to have a single inductance. However, there are usually two coils wound on top of each other, with leads going to four terminals.



Figure 85. A multi-band coil combines several coils in a single shield. Small trimmer condensers for each band are also included in the shield. In some radio sets, each coil is individually shielded and the trimmers are placed outside of the shield.

Courtesy Meissner Mfg. Co.

You will learn that because of inductive effects, radio frequencies (currents) travel on the outside of the conductor. This phenomenon is known as *skin effect*. This explains why some transmitter coils are wound with hollow copper tubing.

Transmitter coils are wound on ceramic forms, using thicker wire (No. 14 or heavier), and having means for changing the entire coil or tapping a section of the coil. These coils will be discussed in greater detail in the section dealing with Class C amplifiers.

**LOSSES IN COILS.** Certain losses are due to the resistance of the copper wire. Using thicker wire eliminates this to a large extent. However, at radio frequencies the effective R.F. resistance of wire is many times greater than the D.C. resistance given in tables or measured with an ordinary instrument. This effect is due to the movement of R.F. current on the surface of the wire only. Since only the surface is being used, the cross sectional area is greatly reduced. Actually for R.F. work, the center of the wire may be left out without increasing the R.F. resistance of the wire. When many fine conductors are used to form a cable for winding the coil, a larger surface area is possible for a given quantity of copper. Litz (Litzendraht) wire is of this type.

Eddy current losses occur in the shield if used. This fault can be minimized by using a large shield and one made of a good conductor. Copper or aluminum are best. Magnetic materials produce very high R.F. losses.

Dielectric losses are due to the material used for the tubing, wire insulation, and terminal strips. Because of economy factors not much attention is paid to these last items.

**POSSIBLE FAULTS.** Coils may open and, thereby, prevent the completeness of the circuit. Turns sometimes short and sensitive signal tracing equipment must be used to detect this fault. In new equipment, coils may be connected incorrectly. Commercial coils are supplied with terminal connecting charts. The standard color code for I.F. transformers has already been stated. For antenna and R.F. coils the location of the terminals is an easy matter. In both cases, the top end of the large coil, which is the secondary, comes down through the inside of the tube to the grid-connection terminal. This connection usually leads to the control grid of the next stage tube. The other end of the secondary coil goes to the ground or AVC if used. One of the terminals of the primary coil will have an extra wire connected to it. This wire will run up along the coil and make a loop or two at the top of the coil. This loop is known as a gimmick and serves as a small condenser in the order of 3 to 10 mmfd. This terminal is for the antenna connection in antenna coils, or for the plate connection in R.F. coils. The remaining terminal of the primary is connected to the ground (chassis) in the case of antenna coils, and to positive voltage (B+) in the case of R.F. coils.

**IRON-CORES.** It is possible to obtain somewhat higher gain from radio coils by using a core made of special powdered-iron. The same value of inductance can be obtained with less copper wire which means less losses. Smaller losses give higher gain for the coil. You will find many commercial I.F. transformers using iron-cores, but some antenna and R.F. coils also use special core materials.

**FILTER CHOKES.** A coil with a laminated iron core is used in power supply circuits. The iron core greatly increases the inductance of the coil. This arrangement opposes changes in current and, thereby, reduces the A.C. ripple, but has almost no effect on the direct current which serves the radio. Since this coil actually "filters" the power supply, or "chokes" out the ripple which may cause hum in the output, we call this coil the filter choke.

Filter chokes are rated in henries, and have values between 5 and 30. However, these values usually indicate inductance without a load; that is, with no current passing through the choke. When a

No special precautions are taken to prevent normal losses in coils. The reason for this is due to the simplicity with which the required gain can be obtained with modern vacuum tubes to make up for the losses encountered in coils.

It is not very common that faults develop in radio coils.

## IRON CORE TRANSFORMERS

This reduction of inductance (in the choke) with the increase of current is not permissible in some circuits. Special *swinging* chokes are used in such cases. These chokes have a large gap in the iron core and have lower initial inductance under no load condition. However, with an increasing load, saturation does not occur to any large degree and the inductance remains more constant with changing currents and their corresponding changing magnetic fields.

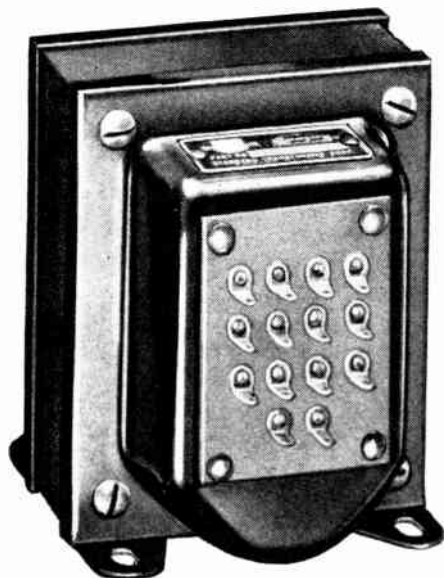

Courtesy Standard Transformer Corp.

Figure 87. Power transformers, of course, can be made in large sizes for radio transmitters. The principle of operation for all transformers is the same.

The diameter of the turns of a secondary winding of a transformer is of no practical importance; the number of turns determine the voltage induced. In most radio transformers, the primary is placed next to the core, then comes a high voltage secondary, then several filament voltage secondaries. The diameter of filament secondary coils may be twice as large as the primary coil diameter which is next to the core.

heavy current does pass through, as it must in an actual application, the inductance is greatly reduced. Most inexpensive chokes have an inductance of only one or two henries when used in actual circuits. Chokes are also rated in terms of the maximum current they may pass. A choke, of course, may be used in a circuit where the current is less than this maximum, but to overpass this value invites trouble and may cause the insulation to start burning. At times, the value of the D.C. resistance of the wire used in winding the choke is also stated. Always try to use a choke of proper inductance, but with as low as possible D.C. resistance value. The D.C. resistance causes losses to occur in the choke coil.

**IRON CORE TRANSFORMERS.** By placing the primary and the secondary coils of a transformer upon an iron core (laminated), it is possible to have almost all the magnetic lines set up by the primary inter-link the secondary coil. The transformers take different shapes; sometimes the coils are separated on different legs of a square shaped iron core, but more often modern transformers have one coil wound directly on top of another and placed on the center leg of an "E" shaped pile of laminations. Just think of a pile of such E laminations with the wound coils slipped over the center leg, and a pile of I-shaped laminations placed along side to complete the magnetic path. At times, the E laminations are inserted, a few from either side, to make a magnetic path with less air gaps.

Transformers and chokes using iron cores are used for power frequencies (25 and 60 cycles) and for audio frequencies (30 to about 10,000 cycles), for radio frequencies, we have already explained, air core coils are employed.

If a transformer has its primary coil connected to a source of A.C., the voltage will divide itself among the turns. For example, if we are working with 110 volts, and the primary has exactly 330 turns, we will have 3 turns per volt, or each turn will have a drop of  $1/3$  of a volt. Since the very same number of magnetic lines will link the secondary turns (we are assuming the transformer is perfect, it is nearly so in practice), each turn of the secondary will also have a  $1/3$  of volt. Now if the secondary also had 330 turns, you would measure 110 volts also across its connecting terminals. But if it had 660 turns, then you would obtain  $660 \times 1/3$ , or 220 volts. Or if the secondary had but 15 turns, you would have  $15 \times 1/3$ , or 5 volts. You can see that a transformer can be used to step voltage up or down.

You really do not gain anything with a transformer. The amount of power taken by the secondary, ( $W = I \times E$ ), is the power delivered to the primary. In other words, if the voltage is greater in the secondary, the current is greater in the primary in the same proportion. Besides, every practical transformer has some additional losses in the unit itself.

**TURNS RATIO.** The turns ratio is the number obtained by dividing the number of turns of the secondary,  $N_s$ , by the number of turns of the primary,  $N_p$ . It is also the voltage ratio of the secondary,  $E_s$ , to the voltage of the primary,  $E_p$ .

$$\text{Turns Ratio} = \frac{N_s}{N_p} = \frac{E_s}{E_p}$$

**AUTO-TRANSFORMER.** The primary and secondary of a transformer need not be entirely separate. The entire winding, for



example, may be used as the primary and only a fraction of all turns used as the secondary. The same calculations will apply. However, the actual wire must be of the correct size to carry the maximum current of the circuit. In case some of the turns are used for both the primary and secondary, the wire of those turns must be able to carry the currents of both circuits.

**TRANSFORMER LOSSES.** We have already mentioned that practical transformers are not perfect machines. There is some copper wire resistance in the primary and secondary and this causes a voltage drop and a loss of power. A small percentage of magnetic lines produced by the primary may not actually link the secondary turns. The iron core itself acts as a conductor and has currents induced in it. These currents, of course, also represent a loss. A small radio power transformer may have an input power of 60 watts, but produce only 40 watts of useful power. Such a transformer is

$$\frac{40}{60} \times 100 = 66.7\% \text{ efficient}$$

Most of the larger commercial power transformers are 90% efficient. Efficiency is always equal to the output divided by input; multiplied by 100 to obtain the answer in percentages.



Figure 89. A half-shell power transformer may be supplied with connecting lugs at the bottom, or connecting leads may be used, as in the model illustrated.

**RADIO POWER TRANSFORMERS.** A transformer may have more than one secondary. Radio transformers usually have several separate secondaries. One of these secondaries supplies 5 volts (in most sets) for the rectifier tube filament. Other low voltages are supplied by other secondaries for the balance of the tubes used. A high voltage (total about 700 volts in most sets) is obtained from another secondary winding. This high voltage secondary is center-tapped, i.e. a connection is made to the exact electrical center of the winding. The different secondaries are insulated from each other and from the primary winding. A 60 cycle transformer has the core laminations piled to a certain thickness. A transformer designed for 25 cycle operation usually has the laminations stacked to twice the height. A 25 cycle transformer may be used for 60 cycle operation, but do not use a 60 cycle transformer for 25 cycle operation.

Power transformers may be of the upright type and require bolting to the chassis. These transformers have color coded wire leads.

## RADIO POWER TRANSFORMERS

Efficiency of any machine (a transformer is an electrical machine) is measured by dividing the output (useful) power by the input power. The result is a fraction less than one. The answer may be obtained in percent, by multiplying this fraction by 100.



Figure 88. As you can see from the terminal panel of this Variac type transformer, the tap of the auto-transformer can be changed by rotating the handle and any voltage from zero to maximum can be obtained. The efficiency of a Variac is almost the same for all settings.

A power transformer will have its primary *burn-out* if it is connected to D.C. source of corresponding voltage. This is due to very little D.C. resistance present in the winding, and the inductive reactance not *resulting* with D.C., that is, with current of zero frequency. With very little electrical opposition present, excessive currents will flow and overheat the copper wire of the coil.

## RADIO AUDIO TRANSFORMERS

Audio transformers are used with a band of frequencies instead of with a single frequency as in the case of power transformers. Even the best audio transformer will have changing characteristics to various frequencies and the unit will not perform equally well for all frequencies of the audio band. Usually, at low frequencies (under 200 cycles), the inductive reactance is low and the gain of the unit (as used with a vacuum tube) is far down. The gain increases as the frequency rises, fluctuates a little with changes in frequency, and reaches a peak at some frequency between 3,500 and 6,000 cycles. There is a sharp drop in gain after this frequency because of capacity effects present in the transformer. But as the frequency is further increased, there may be another peak after 10,000 cycles.

Or these transformers may be of the half-shell type, mounted over a rectangular cut out in the chassis, and usually have numbered terminals for connections.

**AUDIO TRANSFORMERS.** We have already learned that transformers can be employed to change voltage and to separate electrically two circuits connected to the primary and secondary. Transformers can be used also to match circuits together. In such instances, transformers act very much as gears in an automobile used to match the speed of the motor to the required load. In accomplishing this electrical matching, transformers may also isolate two circuits and step the voltage up or down. In fact, transformers actually perform these three things together, but they may be used only to accomplish one or more of these things in a particular circuit.

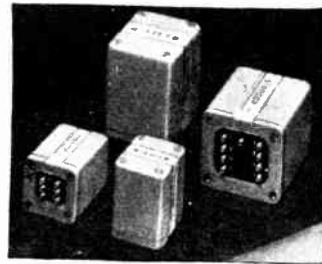

*Courtesy Standard Transformer Corp.*

Figure 90. Good quality audio transformers may be similar in appearance to power transformers. However, the core material is of better quality and the windings employ much finer wire.

Audio transformers are physically smaller than power unit types, and they use better quality laminations to give better characteristics and have lower losses. Transformers may be used to match the loudspeaker to the output tube and are called output transformers when employed for this purpose. Audio transformers are also employed to couple audio stages. Here they not only serve as a match, but also isolate the circuits and give additional gain because of voltage amplification (step up).

**REVIEW QUESTIONS AND PROBLEMS.** 1. Name several radio parts which depend on magnetism for operation.

2. Explain how you could make a simple electromagnet.

3. If an electromagnet is made with an air core, and then an iron core is inserted, will the magnet become stronger? Explain your answer.

4. One electromagnet has 700 turns, and is passing  $\frac{1}{2}$  ampere, another magnet has but 70 turns with a current of 10 amperes. Which electromagnet is stronger under the conditions given?

5. Make a sketch to show how a single relay can be used to control two separate circuits, closing one while opening the second. You understand that a relay may have more than a single armature and contact points.

6. Explain magnetic saturation in your own words.

1. Notice if any of these parts use iron.
2. Is iron needed for this construction?
3. What shaped iron will make this electromagnet the strongest?
4. The product of the turns by the current in amperes gives the comparative strength of an electromagnet.

## SELF-TESTING QUESTIONS

7. Does a straight piece of hook-up wire have inductance?
  8. Will you be doing actual work in moving a shorted turn of wire past a magnet? Explain your answer.
  9. Make a sketch showing two coils with mutual inductance. Also make another sketch, showing the coils close together, but possessing almost no mutual inductance.
  10. Make a drawing of a sine wave. Label the degrees on the base line. Make a mark for every  $45^\circ$ . Where are the maximums and the minimums? If you left the base line alone, but moved the actual curve so that its zero starting point is at  $90^\circ$ , where would the maximums occur?
  11. Two coils are coupled. One has an inductance of 2 henries, the second 8 henries, the mutual inductance is  $\frac{1}{2}$  henry. What is the coefficient of coupling,  $k$ ?
  12. When a man receives an electric shock from a 125 volt A.C. line and says, "It was like a million volts," just what peak voltage could he have felt?
  13. What is the inductive reactance of a  $\frac{1}{10}$  henry choke coil when used with a source of 500 cycles? What happens if the frequency doubles to 1,000 cycles?
  14. Make a sketch of the antenna coil you have in the radio you examined. Where do the connections from this coil go?
  16. If you can obtain a burned-out power transformer, take the laminations out and study the method of assembly.
  17. A transformer for 110 volt operation has a 275 turn primary. Assuming perfect operation, how many turns will be needed for the secondary to produce 5 volts? How about 6.3 volts, and 700 volts?
  18. Explain how a transformer can be used to perform all three of its functions in a single circuit.
7. Remember that the magnetic lines of force set up by any small section of the wire will link all other sections.
11. Simply substitute the values in the formula for the coefficient of coupling.
18. The three functions are: voltage changing, impedance matching, and segregation of circuits.

# LESSON 6

## Properties of Condensers

This is an important lesson because condensers are the most commonly employed parts of radio circuits.

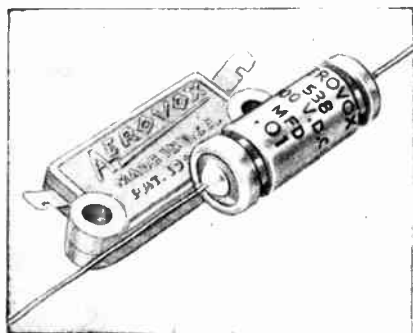

Ultra-small oil-impregnated oil-filled capacitors for use in assemblies where both space and weight are at absolute minimum.

**ELECTRIC CONDENSERS.** When two metal plates are placed close together but separated by an insulator, a condenser is formed. If a condenser is connected to a source of D.C. potential such as a battery, the negative side will become charged with electrons. If the battery connections are removed and the leads to the condenser shorted, a spark will jump across the point of contact, and the two plates will again be in electrical equilibrium; that is, will be neutral. The strength of the charge will depend on a number of factors as we shall see later.

**DIELECTRIC MATERIAL.** A condenser must have two plates made of conducting material, and a separation of a non-conducting material or vacuum. The material between the plates is called the *dielectric*. Any insulator will serve as the dielectric, but only a limited number of insulators have characteristics that make them especially well suited for this application. Mica, wax-paper, air, and oil are used as the dielectric material in radio condensers. The dielectric constant of air is taken as one. Other substances, used as dielectric materials in condensers, have various values usually greater than one. Mica may have a dielectric constant of 7; this means that if two identical condensers are made, one using air and the second using mica as the dielectric, the capacity or storing ability of the one with mica will be seven times greater.

**LOSSES IN CONDENSERS.** Every condenser has certain losses which are almost negligible in a high quality unit. For one thing, there is an actual resistance loss in the conducting plates of the condenser. The dielectric, while having very high insulating value, does permit a certain leakage. A practical condenser, therefore, may be assumed to be a perfect condenser with no losses, and having a resistor connected in series to represent the loss in the conducting plates, and a resistor in parallel to represent the leakage. Because of the leakage loss, a charged condenser will soon lose this electrical charge. There are also other losses, but they are not of importance from the practical point of view.

**UNITS OF CAPACITY.** The degree of ability of a condenser to store electrical charges is known as the *capacity* of the unit. Since the quantity of the electrical charge depends directly upon the voltage of the source, capacity is defined in terms of not only how much charge is stored, but also on how much voltage is applied. The unit of capacity is the *farad*. The farad is the capacity of a condenser that will store one coulomb of electricity at the pressure of one volt.

The farad is much too large a unit for radio applications, the microfarad or mfd., equal to one-millionth of a farad, is commonly used. Condensers of very small capacity also are rated in still smaller units of micro-microfarads or mmfd. which are equal to one-millionth of a microfarad.

**CONDENSER CIRCUITS.** Condensers, similarly to resistors, may be connected in series and in parallel. When condensers are con-

nected in parallel, the final capacity is greater than that of any condenser used in the combination. The total is equal to the sum of all the individual condensers connected in parallel.

$$C_p = C_1 + C_2 + C_3 + \dots$$

Where  $C_p$  is the total capacity of the units in parallel. This formula suggests a means of obtaining larger capacity from a number of smaller units. Each condenser used, however, must be able to withstand the applied voltage of the circuit. Should 15 mfd. be required and only 5 mfd. units be on hand, three of these may be employed connected in parallel with equally satisfactory results as might be obtained from a single 15 mfd. condenser.

Please observe that the formula for condensers in parallel corresponds to the formula for resistors connected in series.

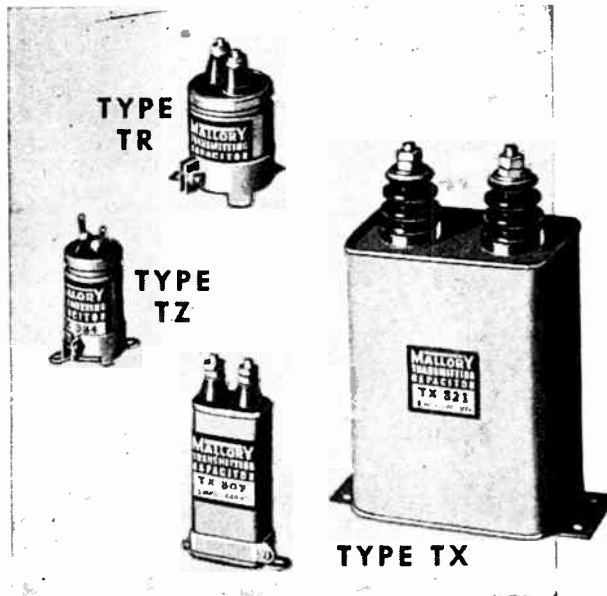

Figure 91. If a condenser is to be used with high voltage circuits, the dielectric must be thick to withstand the high voltage, and the units are quite large. Stand-off insulators are used to prevent arcing to the metal container.

When condensers are connected in series, the final capacity of the combination is always less than that of the smallest condenser used in the combination. It is very rarely that condensers are used in series, except when all are of the same capacity. In such cases the total capacity

$$C_s = \frac{C}{n}$$

where  $n$  = number of condensers of capacity  $C$ , connected in series.

**FACTORS INFLUENCING CAPACITY.** There are three factors affecting the capacity of a condenser.

- (1) The type of dielectric used
- (2) The area of the plates in contact with the dielectric
- (3) The actual thickness of the dielectric; or, what is the same thing, the separation between the plates.

It has been found that the capacity of a condenser; using air or other substances for the dielectric, changed for each definite substance used. For example, certain wax-paper employed for the

A certain minimum spacing between plates must be employed to prevent the voltage existing on the condenser from puncturing the insulation.

## CONDENSERS USED IN RADIO

dielectric made a condenser have twice the capacity than this same condenser had with an air dielectric. Bakelite gave a value  $6\frac{1}{2}$  times as large as air; etc. This property of different materials used for the dielectric of condensers is known as the dielectric constant.

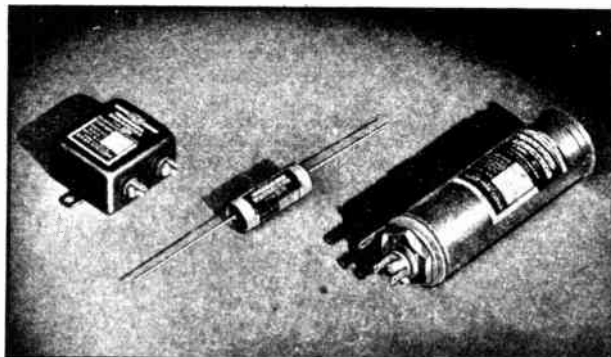

*Courtesy Solar Mfg. Co.*

Figure 92. Here are three types of commonly used radio receiving set condensers; a paper condenser in a metal can, a tubular paper-dielectric condenser, and a metal-can electrolytic condenser.

Usually the capacity of the condenser is marked on the label of the unit and the maximum permissible voltage, which may exist in the circuit where this condenser is used, is also given.

The actual capacity of different condensers may be calculated from formulas, but the serviceman uses commercial units, supplied with the capacity indicated and, for the serviceman, there will be little need for such calculations. Certain test-analyzers have provisions for indicating the capacity of paper and electrolytic condensers directly.

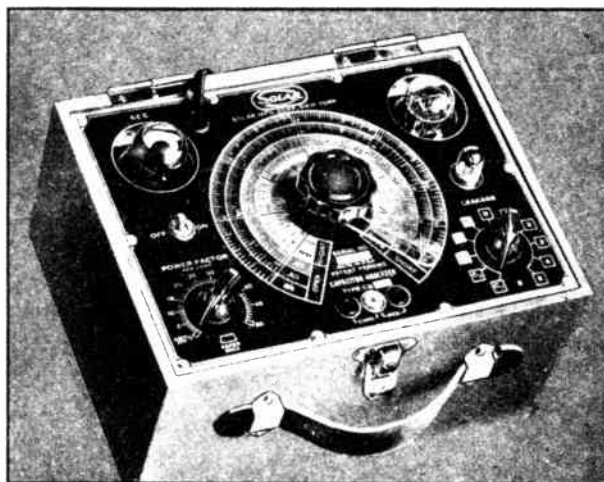

Figure 93. Special condenser testers are available. The unit illustrated gives direct reading of the capacity of the condenser under test.

**FIXED CONDENSERS.** Condensers commonly used in radio sets are so constructed that their capacity is fixed at one definite value. The exception is the variable condenser used for tuning the radio circuits to receive definite stations. For low capacity, under .02 mfd., mica insulation may be employed. Such condensers are molded in bakelite and are unaffected by moisture. The value of capacity is marked on the case or a color code scheme is used to indicate capacity. Usually three color dots are employed. The

first dot represents the first figure, the second dot represents the second figure, and the third dot tells us how many zeros follow. The number obtained is the capacity of the condenser in micro-microfarads. Use the standard resistor color code scheme. Larger condensers are made with paper dielectric, in tubular form. We urge

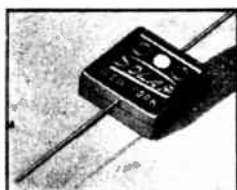

Figure 94. Small size capacitors use mica as the dielectric. These condensers have high voltage break down. The condensers are encased in bakelite and have wire leads.

you to note carefully, (1) the relation of capacity, breakdown voltage or the working voltage, and the physical size, (2) the general appearance of the units, and (3) the general methods used for connecting the units into the circuits.

**SIMPLE TESTS.** While special condenser testers may be used to detect the faults in condensers, a simple practical test will serve the purpose. Connect the condenser momentarily to a source of D.C. potential between 25 and 100 volts. Quickly disconnect the condenser and connect the terminals together. A spark should be noted at the point of contact if the condenser is in good condition.

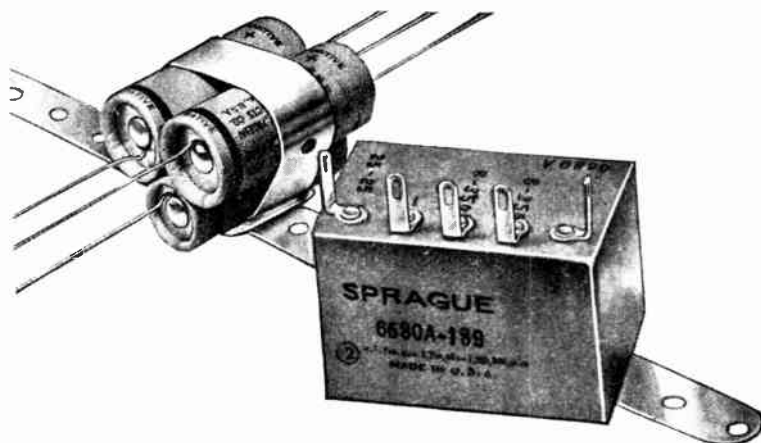

Figure 95. Several different condensers may be enclosed in a single container. In making a repair, only the section at fault need be replaced.

**MAKING REPLACEMENTS.** In replacing fixed condensers, the serviceman need not be too critical. A slight difference of capacity will ordinarily not upset the circuit and this is especially true if the unit is used as a filter. 8 or 12 mfd. units may be used for 10 mfd. However, the rated working voltage is important and must not be exceeded. Condensers rated at 550 volts D.C. may be used on any voltage up to this maximum rated voltage, but not above. A.C. voltage peaks are 1.4 times higher than the measured and indicated RMS voltage. For example, 110 volts A.C. has a peak voltage of  $110 \times 1.4$ , or 154 volts.

**ELECTROLYTIC CONDENSERS.** An electrolytic condenser is a fixed condenser of high capacity and compact size suitable for use with voltages not exceeding about 550 volts. These condensers must further be used only with D.C. or pulsating D.C. Because of these characteristics, electrolytic condensers are especially well suited for use in radio filter circuits where these advantages over paper type

The gradual change of capacity is not noticed by observing the operation of the equipment, but changes that occur frequently cause intermittent operation and these faults are difficult to detect.

In a later section, you will learn how to test condensers with simple service instruments.

In all instances, try to use a condenser of higher working voltage than the original. This will eliminate the possibility of another failure in the same part.

## ELECTROLYTIC CONDENSERS

Special types of electrolytic condensers have been designed for use on A.C. Condensers are commonly employed with refrigeration motors to form special starting circuits. These motors are A.C. operated.

The best way to learn how condensers are mounted and connected is to look at several radio chassis. It is recommended that at this point in your studies, you remove the chassis of other radio sets, besides the model with which you have worked at first, and carefully study the construction of these sets.

**Volume 1 - Page 62**

condensers are fully realized, and the limitations mentioned are of no consequence.

The electrolytic condenser consists of an anode to which the positive connection is made, the cathode used in conjunction with the negative connection, and the electrolyte. Aluminum is usually used as the anode in condensers for radio application. Other metals such as tantalum and magnesium find some use; the chief advantage of tantalum being its ability to withstand acid corrosion. For the cathode, either aluminum or copper is used in connection with the aluminum anode.



Figure 96. Many modern type electrolytic condensers are of the plug-in type. These condensers may be easily tested and replaced.

Many different electrolytes are used and their choice depends greatly upon the voltages to be applied to the condenser. Sometimes mixtures of two or more compounds are used. The density of the electrolyte varies from a liquid, which contains a fairly large percentage of water, to a paste which is commercially called dry.

The dielectric film forms electro-chemically on the surface of the anode. The properties of the electrolytic condenser are due to this film formation. The exact nature of this film is not known, but it is extremely thin making possible high capacity per unit area. The capacitance of a film formed at 300 volts on aluminum is 0.12 mfd. per square inch, about eight hundred times that of a paper condenser for this voltage. The film is formed by applying a potential of the proper value. The capacity is almost inversely proportional to the potential at which the film is formed.

In the actual circuit, when the potential is first applied, the current is only limited by the resistance of the electrolyte and the external resistance present. Naturally, under this condition high currents flow. The film forms quite rapidly, however, and the leakage current drops to a safe value of about 0.2 milliamperes per microfarad. A radio rectifier circuit takes care of this leakage current without difficulty. The rectifier tube does not heat-up instantaneously and, because of this, the voltage at first is of a small value. This voltage partially forms the film which reduces the leakage current when the rectifier tube heats-up to the full value and supplies the maximum voltage.

**PRACTICAL CONSIDERATIONS.** Small mica and paper condensers are supported in position with their own leads. Usually these leads are long enough to permit direct wiring of the terminals to be connected through the condenser. The electrolytic condensers are larger in physical size and capacity and must be mounted in place. A single cardboard container or metal can may house several separate condensers, each intended for a specific purpose. At times, some of these sections are interconnected in the container and, therefore, require fewer outside connections.



Cardboard containers may be mounted with rivets or small bolts. Some round, upright type cardboard electrolytic condensers have studs which permit the condenser to be bolted to the chassis. Most of the older style metal-container type condensers come with a large nut on a threaded section. In mounting, a hole of the proper size is made in the metal chassis base, the threaded section inserted, and the nut tightened from under the chassis.

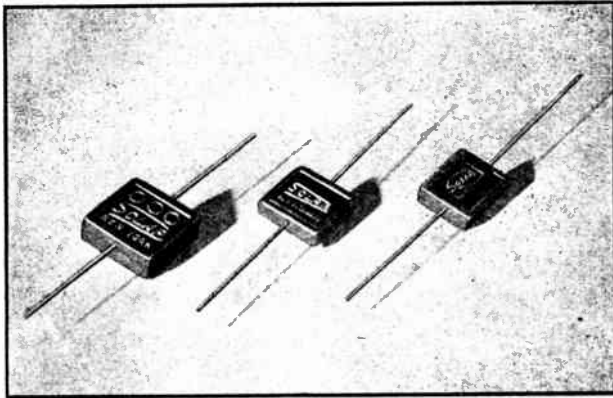

Figure 97. Mica condensers are used in circuits requiring very small fixed capacity, or in circuits where the voltage is above 600 volts, or in applications where the capacity must remain constant for long periods of time.

Mica condensers may be connected with either lead to one of the terminals. No care need be exercised in selecting one of the leads in preference to the other. In the case of paper-dielectric condensers, usually they may be connected also in either fashion as far as the leads are concerned. However, if one lead of the condenser goes to the radio "ground" or chassis, and if the condenser has one lead marked with the word *ground*, then use this lead for the ground connection.

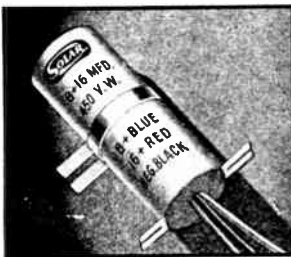

Figure 98. The color code for multi-section condensers is marked on the container. Dry electrolytic condensers may be mounted in any position.

The electrolytic condensers, of course, must be connected correctly as far as polarity. The condensers housed in metal cans usually have the can serve as the negative terminal. The other terminal of such a condenser is connected so that a positive voltage is always present on it in relation to the negative terminal. In some units, the metal can may be insulated from all condenser sections contained. In such instances, you will find several colored, insulated, connecting wires coming from the condenser. If the condenser has but one section, only two leads will be needed. Commonly, the red lead refers to the positive connection, the black lead refers to the negative connection. If there are more sections, the color code of the leads is usually printed on the label of the can.

Condenser catalogs, showing the different type units and giving the technical description, are available from the larger condenser manufacturers. You can find these firms' advertisements in radio magazines, and their addresses may be obtained in this manner.

## CONDENSERS FOR TUNING

**VARIABLE CONDENSERS.** Condensers which permit changing of the capacity by means of a manual adjustment are of the variable type. Of such types, the condensers used for tuning will be considered first. You have already examined one of these units in the radio you studied. These tuning condensers may have but a single section. However, most modern radio receivers use tuning condensers which have two or three gangs, or sections.



Figure 99. Tubular paper dielectric condensers are most commonly used in radio receivers. Electrolytic condensers are also made in tubular shapes as is the unit illustrated.

The frame of the condenser is connected to all rotary sections of every gang. This means that all rotary sections are connected together electrically and, if the condenser is mounted on the metal chassis, these rotary sections will automatically become connected to the radio ground. In some radio sets, an extra wire may be used to *ground* the frame of the condenser, but it is not needed if a good job of mounting is done.

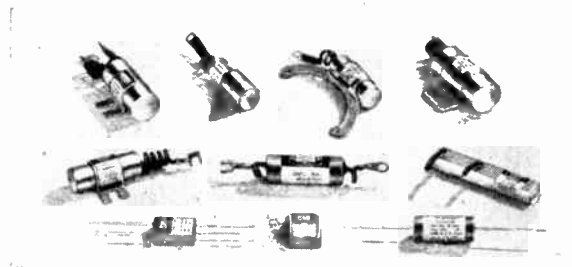

Figure 100. Condensers used for filtering purposes in automobile ignition systems (to eliminate radio interference) are housed in metal containers and are provided with special mounting brackets.

High quality variable condensers use very little insulating material to eliminate dielectric losses and are sturdily constructed so that the corresponding setting will always give the same capacity, and slight jarring of the equipment will not upset the adjustment.

The stationary sections (plates) of each gang are insulated from each other and have separate connections. In fact, each stationary section has two different terminals on each side of the condenser, but electrically these terminals are identical. The reason

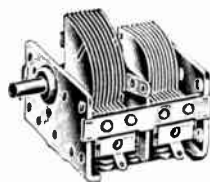

Figure 101. Some variable condensers have one section (gang) supplied with somewhat smaller rotating plates. Such units are called cut-section condensers.

two terminals are included, although they are electrically the same, is to permit wiring to either side of the condenser and, thereby, making the leads shorter. Each gang of the variable condenser is used for tuning a different circuit. Since the capacity of each gang

is changed at the same time as the condenser plates are turned (capacity increased or decreased), these circuits are tuned together and kept in step.

Certain circuits require that one gang of the condenser be smaller in capacity at all settings. This is easily accomplished by making one set of rotary plates slightly smaller, so that the capacity of this gang is always smaller. This special type variable condenser is known as cut-plate type, or cut-section type.

In many circuits condensers are needed which must be adjusted on occasion, but once set need not be altered for long periods of time. Such small, adjustable condensers are known as trimmers and padders depending on their application. They are available in maximum capacities from 25 to 1,000 mmfd. As a comparison,

## MAXIMUM-MINIMUM CAPACITY

When an extremely large capacity trimmer is needed and this trimmer need be adjusted over a limited range, it is possible to connect a small capacity trimmer in parallel with a fixed condenser.

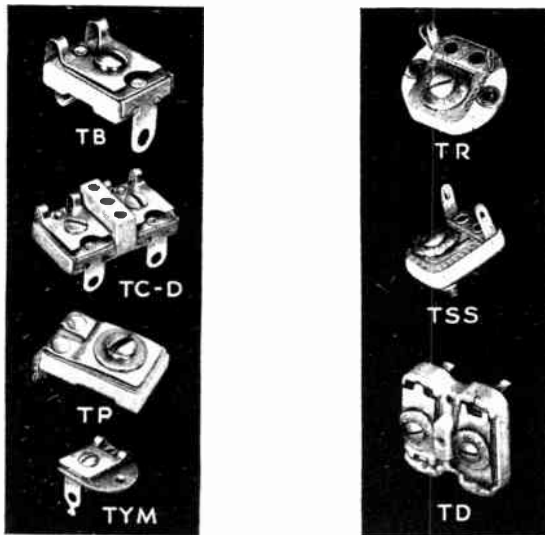

*Courtesy Solar Mfg. Co.*

Figure 102. Trimmers and padders are available in various shapes and sizes. Some are dual units. All are semi-adjustable condensers.

usual home radio set tuning condensers have a maximum capacity per gang of 360 mmfd. A good quality condenser having a certain maximum capacity, will give a minimum capacity of about 1/10 the value. For example, if the maximum capacity of a tuning condenser is 360 mmfd., the minimum value, rotating the plates all the way out, will be about 35 mmfd. Please remember this; no variable condenser can be adjusted to give zero capacity.

**CAPACITANCE REACTANCE.** A condenser connected to a source of voltage, becomes charged with this potential, and tries to keep the voltage unchanged. A condenser attempts to prevent voltage increases by slowing down the action, and tries to overcome voltage decrease by supplying the voltage required. This explanation is not rigorous, but will give you the needed understanding about condenser action. In many ways, a condenser limits changes in voltage in a manner similar to an inductance limiting the action of changes in current.

The tendency of a condenser in preventing the alternating voltage of the source to rise to its true value at the instant, limits the

This action is similar in the *voltage-sense* to inductive reactance when considering its action on current.

## CAPACITIVE REACTANCE

You should make up a few problems assuming a suitable frequency and capacity and find the capacitive reactance of the condenser at the frequency assumed. Please notice that as the frequency is increased, the capacitive reactance is decreased.

2. Observe that the larger capacity condensers are almost all of the electrolytic type.

6. Can you tell now why the grid and plate wires should be made as short as possible.

11. The frequency, in this case, is equal to 120 cycles.

12. In practice, after the initial charge, the condenser will not pass D.C.

**Volume 1 - Page 66**

current in the circuit, and is, therefore, similar to the effect of a large resistor which could have been in the circuit. This opposition which a condenser offers to the flow of current is known as capacitive reactance, symbol  $X_c$ , and is also measured in ohms. We have a formula for calculating capacitive reactance.

$$X_c = \frac{1}{6.28 \times f \times C}$$

where  $f$  is the frequency in cycles per second, and  $C$  is the capacity in farads. Since most circuits use condensers which are measured in microfarads, we can use a more convenient formula, where the value in *microfarads* can be substituted for  $C$ .

$$X_c = \frac{159,236}{f \times C}$$

REVIEW QUESTIONS AND PROBLEMS. 1. If sheets of paper are inserted between the plates of an air variable condenser, will the capacity be increased? Explain.

2. What capacity condensers did you find in the radio set you examined?

3. Using only 8 mfd. condensers, how can you connect these units to obtain 20 mfd. capacity?

4. Can a .01 mfd. 600 volt condenser be used to replace a .01 mfd. 400 volt unit? Explain your answer.

5. On what factors does the capacity of a condenser depend?

6. Is there some small capacity between every two separated conductors? Is this fact of any practical importance?

7. How can a 2 mfd. paper condenser be tested when special equipment is not available?

8. What are the advantages of electrolytic condensers?

9. Why must an electrolytic condenser be connected in the proper fashion?

10. What is the minimum number of separate connections which must be made to a three-gang variable condenser which is mounted on the metal chassis? Can more wires terminate at the connections of this unit?

11. What is the capacitive reactance of a 10 mfd. filter condenser used in a radio power supply which has 120 cycle hum?

12. What happens to the value of  $X_c$  as  $f$ , the frequency, becomes smaller and smaller? Assume  $C$  does not change. What would you conclude as to the value of  $X_c$ , as  $f$  approaches zero, that is for D.C.?

# LESSON 7

## L, C, and R, Combined Circuits

**PRACTICAL INDUCTIVE CIRCUITS.** In discussing circuits incorporating an inductance, we have assumed that resistance was not present. In practice, of course, every coil is made of wire which in turn has more or less resistance. Therefore, an inductance has resistance which behaves as if it is connected in series with the inductance. This behavior permits us to assume, in solving problems, that the inductance has no resistance, but that a separate resistor is connected in series and has the resistance value of this coil resistance.

**PHASE RELATIONSHIP.** In a pure resistive circuit, the current varies with the voltage in accordance with Ohm's Law. The current increases in step with the voltage, and falls to zero when the voltage is zero. In a pure inductive circuit\* this is not so. The property of inductance tends to prevent current variations, and although these variations follow the voltage changes, they are somewhat behind in time. There is a period of time after the voltage reaches a maximum value, before the current reaches its maximum value. As the voltage begins to get smaller during a part of the A.C. cycle, the current tries to remain the same, and is replenished in part by the breaking down of the magnetic field. When the voltage returns to zero, the current is still very much present. This phase relationship or time difference between voltage and current is always present in inductive circuits. The current *lags* behind the voltage. In other words, the voltage leads the current. In pure inductive circuits the current lags behind the voltage by 90°. This means that 90 electrical degrees (of time) separate the peak values of voltage and current.

If a circuit has both inductance and resistance, as all real inductive circuits do, the time relationship or phase angle is neither zero as in the case of pure resistance, nor 90° as in the case of pure inductance, but is some value between 0° and 90°. If  $X_L$  is much larger in value than the resistance, then the angle is very close to 90°. In a circuit having a large resistance value and very little inductive reactance, the phase angle is close to zero degrees.

**IMPEDANCE.** Now both the resistance and the inductive reactance of the circuit oppose the passage of electric current. The opposition, however, is not the same since the phase angle causes a difference in the voltage to current relationship. The total equivalent opposition of the two can be found. This total combined opposition is known as impedance and is also measured in ohms. The symbol for impedance is  $Z$ .

$$Z = \sqrt{R^2 + X_L^2}$$

The impedance can be found with the aid of this formula if the inductive reactance and the resistance of the circuit are known. In most circuits, the inductive reactance is so much greater than the resistance, that you may assume that  $Z = X_L$ .

\*This is true to a limited degree in all circuits where inductance is present.

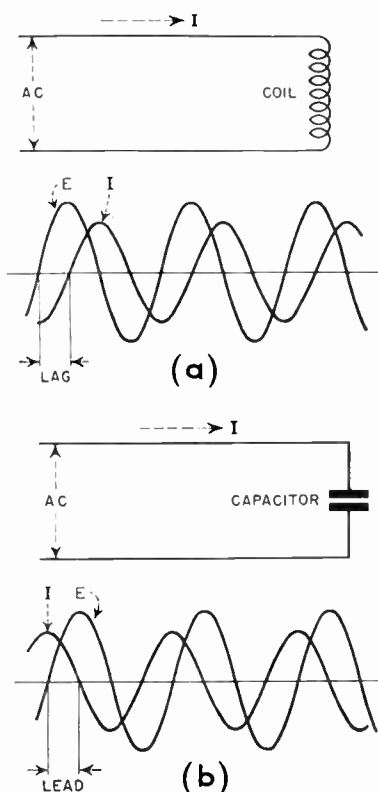

The above illustrations show the relationship between the voltage and current in an inductive circuit and also in a capacitive circuit. It is important to notice that the current and voltage reach their maximum values at a time interval apart. If the circuit is of a pure inductive type, the current will lag 90° behind the voltage. This means that it will take 90 electrical degrees of time for the current to reach the peak point as compared to the instant when the voltage reaches its peak value. Ninety electrical degrees means  $\frac{1}{4}$  of 360° which is equivalent to one cycle. Since in a 60 cycle current, each cycle occupies  $\frac{1}{60}$  of a second, 90 electrical degrees, in this case, will correspond to  $\frac{1}{240}$  of a second.

## VECTOR REPRESENTATION

In making geometric representations, the value of resistance is shown as a horizontal line extending to the right. Reactance values are at right angles to the resistance line and are, therefore, vertical. Inductive reactance line is made upwards and capacitive reactance is made in the opposite direction (downwards) since it acts to neutralize inductive reactance.

If the equivalent reactance is considered one side of a triangle, with the resistance line forming another side, the triangle can be completed with a third line joining the extreme points of these lines indicating reactance and resistance. The phase angle (the angle in degrees indicating the phase difference between voltage and current in the circuit) can be measured by the actual angle formed by this connecting *slant* line and the base line which is representative of the resistance. If the reactance is missing, the angle will be zero (there is no angle formed), and this is as expected. In a pure inductive circuit only reactance will exist and there will be no resistance. In this case, the angle will be formed by the vertical reactance line and will indicate  $90^\circ$ , the correct value. For capacitive reactance the angle is negative and this indicates that the voltage lags instead of current.

This is not a formal definition of  $Q$ . By expressing  $Q$  in terms of energy stored and used per half cycle, the figure of merit can be applied to cavity resonators and other special (not coil types) tuned circuits.

**GEOMETRIC CONSIDERATIONS.** It is possible to represent resistance value by a straight line. The actual size of the line will depend on the resistance. You may let one unit of size equal one ohm of resistance or perhaps five ohms. Referring to the illustration, you will see that the line  $R$  represents the resistance as 7 units long.

In order to represent reactance (either inductive or capacitive), another line may be used. Here again, the unit of size represents a number of ohms of reactance. Since the voltage across the

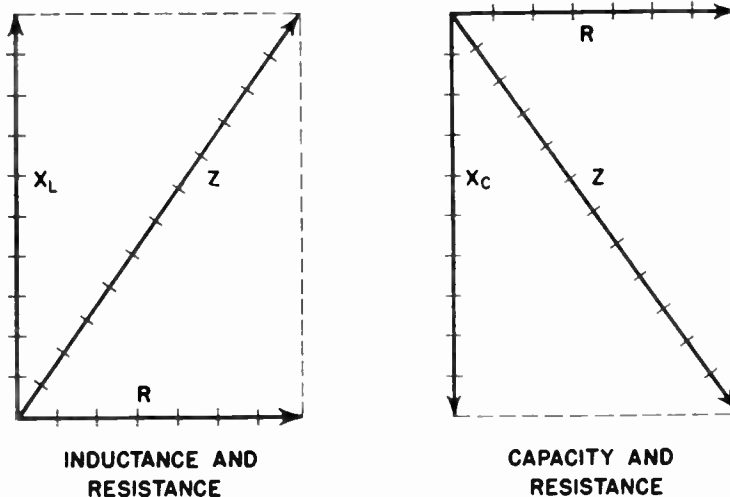

Figure 103. The value of impedance can be obtained with the aid of vector diagrams.

resistor and the reactance are  $90^\circ$  out of phase, these two lines are illustrated at right angles ( $90^\circ$ ) in respect to each other.

It is possible to combine resistance and reactance of a series circuit without any formulas, but by using geometric means instead. To do this, the value of resistance and reactance are indicated as straight lines at right angles to each other. (See figure.) Then, using these two lines as two sides of a rectangle, the other sides are sketched in as shown by the dotted lines. Then, the diagonal line is placed and is equal to  $Z$ , the impedance, of the combination. By measuring the number of units the  $Z$  line occupies, you can find the actual value of impedance. A similar process is used for inductive or capacitive circuits.

**WHAT IS  $Q$ ?** Usually reactance is the desired characteristic of a coil while resistance is not. A figure of merit for coils is needed to enable us to judge between various coils. We call this figure of merit for comparative purposes,  $Q$  and consider it equal to the inductive reactance divided by the R. F. resistance.

$$Q = \frac{\text{Reactance}}{\text{Resistance}} = \frac{X_L}{R} = \frac{6.28 \times f \times L}{R}$$

Since both the reactance and resistance increase with frequency, but not in the same order, the  $Q$  of coils will vary with the frequency used for the test. In the broadcast band, 540 to 1,750 kilocycles, the  $Q$  of coils increases for higher frequencies and special methods are used to "even it out" for the entire band. The  $Q$  determines the gain one obtains from a coil. The voltage step-up is approximately equal to the  $Q$  of the coil. Broadcast coils have a value of  $Q$  between 75 and 200.

**LOSSES IN COILS.** Certain losses are found in all coils and these act in the manner to make the equivalent R. F. resistance appear higher, thereby lowering the  $Q$  of the coil. The losses may be due to resistance of the copper wire, dielectric losses in the core material and wire insulation, presence of metal in the coil supports and lugs, losses in the shielding material, and increased resistance due to the tendency of the R. F. current to remain on the surface of the conductors.

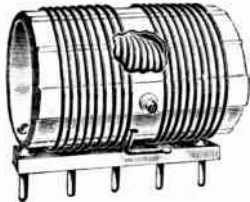

Figure 104. Radio transmitter coils have small losses and may be of the plug-in type to permit easy exchange. Notice that the cut-out shows a small variable coil inside the larger coil form.

Courtesy E. F. Johnson Company

**CIRCUITS WITH C AND R.** We have already mentioned that all condensers had losses and these could be represented as the losses created by a resistor connected in series with a perfect condenser of the same capacity as the unit we are considering. In many circuits, an actual resistor may be connected in series with a condenser to accomplish the results required by the circuit. Here, as in the case of a L and R circuit, the phase relationships differ and the reactance of the condenser and the resistance of the resistor must be combined in a special way to obtain the total opposition or impedance of the combination. The impedance in this case is,

$$Z = \sqrt{R^2 + X_C^2}$$

In solving a problem,  $X_C$  is found first from the formula you already know, then this value and the value for  $R$ , are substituted in the above formula, and the answer for the impedance is obtained.

**TIME CONSTANT.** If a condenser is made to discharge through a resistor, a period of time will pass before the condenser loses a fraction of its charge. The time required for a condenser to lose that part of its charge which will cause the voltage to fall to 37% of its initial value, is called the *time constant*. Expressing time in seconds as  $t$ , resistance  $R$  in megohms, and  $C$  in microfarads, we have a very handy formula,

$$t = R \times C$$

Time constant is very important in the study of automatic volume control circuits which will come up in a later chapter.

**CIRCUITS WITH C AND L.** You probably recall that an inductance causes the voltage to lead the current (or the current to lag behind the voltage). You also know that, on the contrary, capacity alone causes the voltage to lag the current. The effects are opposite to each other. Now if a circuit has both capacity and inductance, one will partially overcome the effects of the other. The entire circuit will act as either inductive or capacitive reactance depending on whether  $X_L$  or  $X_C$  is larger for the particular frequency. If the inductive reactance is greater than the capacitive reactance, then some of this  $X_L$  will overcome the  $X_C$ , and the balance of the inductive reactance will be left.

Notice the similarity of this formula with the one for obtaining the impedance in an inductive circuit.

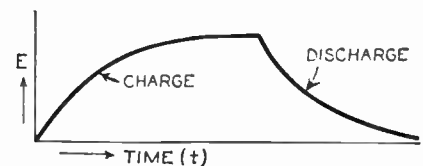

This curve shows the actual voltage that exists on a condenser which is initially connected to a source of voltage. You recall that a condenser tries to keep the voltage of the circuit at a fixed value. Since the condition, before the connection is completed, represents zero voltage; the voltage across the condenser will increase slowly with time. Theoretically, the total voltage of the source never appears across the condenser. From a practical point of view, however, the full voltage (as close as can be measured with instruments) appears across the condenser after a very short time. Both the charging and discharging curves are similar in character. They are steep at first and then become almost horizontal indicating little additional change in value.

## RESONANCE PHENOMENON

The student is reminded once again the inductive reactance and capacitive reactance have neutralizing effects upon each other. It is the nature of electricity to behave in this fashion in conjunction with inductance and capacity. It is this remarkable property that permits radio transmission and reception.

**VARIATIONS WITH FREQUENCY.** In working several problems, we have already noticed that inductive reactance increases with the frequency, and becomes very large at high frequencies. But capacitive reactance decreases as the frequency is increased, and is almost zero at very high frequencies. It is obvious that given any coil or any value capacity, we can make the reactance any value we please provided we can change the frequency.

**RESONANCE.** If we have a circuit where a condenser and coil are connected in series, we can select a frequency for which the inductive reactance will be exactly equal to the capacitive reactance. In such instance, the reactance will be entirely eliminated, and only the resistance of the circuit will be present. Let us see what special frequency will cause the reactive components to disappear and produce *resonance*. This condition requires  $X_L$  to equal  $X_C$ , so we will place the terms defining these reactances equal to each other:

$$6.28 \times f \times L = \frac{1}{6.28 \times f \times C}$$

where  $L$  is in henries, and  $C$  is in farads. When we solve this equation for  $f$ , we obtain:

$$f = \frac{1}{6.28\sqrt{LC}}$$

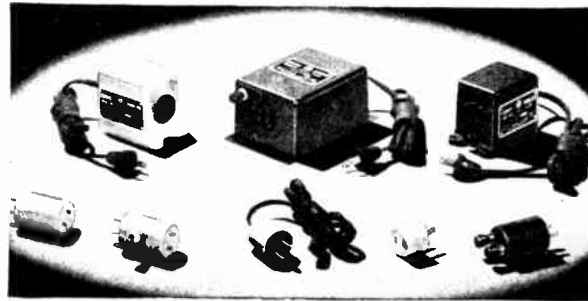

Courtesy Cornell-Dubilier Elec. Corp.

Figure 105. Condensers and condenser-inductance combinations are used in interference filters to prevent man-made static from reaching radio receivers.

In any circuit where the inductance and capacity are lumped\* there is one, and only one frequency, for which the circuit will behave as if only resistance is present and will offer the least impedance. This fact permits the selection (tuning) of a single frequency.

\*An inductance or capacity is lumped if the part has only the characteristic of a fixed value of inductance or capacity for all frequencies employed with the component. Most commercial coils and condensers are of this type.

You can see from this important formula that many different values of  $L$  and  $C$  will produce resonance at a given frequency. Tuning is accomplished in this manner. The coil,  $L$ , is fixed, and the condenser,  $C$ , is varied to obtain the frequency of the desired station. At resonance, the current in a series circuit is a maximum, and the voltage across either the coil or condenser is also a maximum. At resonance, the voltage across the coil is about equal to  $Q$  times the impressed voltage. This explains why a tuning coil and condenser give a voltage gain about equal to the  $Q$  of the coil employed.

An interesting experiment can be performed to illustrate the action of resonance. A regular electric light is connected to a 110 volt circuit and, of course, lights up brightly. Now, a large choke coil (inductance) is connected in series with the bulb, and the bulb lights up very dimly. The choke is then replaced with a condenser of large capacity and again the bulb does not light



very brightly. As the final step, we connect the bulb, choke, and condenser in series across the 110 volt line. If we have properly selected the C and L to give resonance at 60 cycles, the bulb will light just as brightly as it did when it was alone in the circuit.

A series resonant circuit will offer very low impedance to frequencies near the resonant frequency. Impedance to frequencies away from resonance will be high. At the resonant frequency, the series circuit consisting of L, C, and R, will act as a pure resistance. At frequencies above resonant frequency, the circuit will behave as if only inductance and resistance are present. Below resonant frequency, the circuit will show effects of capacitive reactance and resistance.

The current in a series L, C, and R, circuit is greatest at resonant frequency and is of the same value in all three components. The voltage, however, need not be the same in the elements used. Since the voltage across any element is the product of the current and the reactance or resistance of that element, it may vary for different frequencies. For example, to find the voltage drop across a condenser, the  $X_C$  of this condenser at the frequency used must be calculated. Then the current in the circuit must be figured out and multiplied by the value of reactance obtained. At resonance, the voltage drops across the inductance and capacity are equal in value but opposite in sign.

**PARALLEL RESONANCE.** When you have a coil and condenser connected in parallel, you must bear in mind that both components have losses which are equivalent to small resistors being connected in series with each item. The calculations then become very difficult. It is common in practice to assume that the condenser has no losses; this is permissible since the losses are very small. The coil Q is calculated by using the formula and substituting the values of R, L, and the frequency employed. After this operation, the coil *series resistor* is also ignored, but instead a fictitious resistor is assumed to be connected in *parallel* with the coil and condenser. This resistor will permit the needed calculation to be performed in a simplified form and is equal to the coil resistance multiplied by Q of the coil, squared.

$$\text{Imaginary parallel resistor} = R \times Q^2$$

For example, considering a parallel circuit where the operating frequency will be 2 megacycles, or  $2 \times 10^6$  cycles; L is 100 uhy. or 1/10,000 henry; R, the resistance of the coil, is equal to 20 ohms. Calculating Q, we obtain about 63. Now we can assume that the circuit is made up of the coil and condenser, and a new parallel resistor having a value equal to  $RQ^2$ , or  $20 \times 63 \times 63 = 7,938$  ohms. Please notice that the higher the Q, the greater will be this equivalent parallel resistor.

In a low loss parallel L-C circuit, it is possible to obtain the resonant frequency, using the very same formula employed in series resonance. Please notice these differences. The voltage across the inductance and capacity is equal at all times, but the current may differ a great deal. The impedance of the combination is very high at resonance, approximately equal to the imaginary resistor we have considered. The circulating current between the branches may be very high. At frequencies above resonance, a parallel L-C circuit acts capacitive; at frequencies below resonance the circuit acts inductive; and at resonance, the circuit behaves as pure resistance.

## BEHAVIOR AT RESONANCE

Actually, you are performing a similar experiment every time you tune your radio and adjust it to receive a definite station.

The voltages across the reactive elements of a series circuit may be many times greater than the impressed voltage. In working with radio frequency circuits, you must make certain that the condensers employed can withstand the extremely high voltage which may occur at times. For by-pass purposes, mica condensers are recommended.

This method of calculation is well adaptable to practical problems. A parallel resonant circuit, made up of a low loss condenser and coil, at resonance, will have very high equivalent resistance.

If a parallel L-C circuit is to act as an inductance, the impressed frequency should be lower than the natural resonant frequency of the circuit.

## QUESTIONS AND ANSWERS

2. You substitute zero for X in the formula.

5. For how many different frequencies is your answer applicable?

6. The answer is: 1,592,000 cycles, or about 1,600 KC.

8. In practical circuits, of course, resistance is always present.

9. You should understand and remember this answer. This is a very important fact and is used in adjusting radio transmitters.

**Volume 1 - Page 72**

REVIEW QUESTIONS AND PROBLEMS. 1. Explain the phase relationship between voltage and current in an inductive circuit. What is the relationship in a resistive circuit?

2. In a circuit made up of two 20 ohm resistors what is the total impedance of the circuit? Can the regular formula for Z be used?

3. What must be known about a coil in order to calculate its Q?

4. How long will it take for .5 mfd. condenser to lose 63% of its voltage while discharging through a 500,000 ohm resistor?

5. Is it possible for a circuit having both inductance and capacity to act as a pure resistor? Explain your answer.

6. A coil of 100 microhenries and a condenser of 100 mmfd., are used in a series circuit. What is the resonant frequency of this circuit? Hint: Write 100 uhy. as  $10^{-4}$ , and 100 mmfd. as  $10^{-10}$ .

7. At a frequency higher than resonant frequency, does a series L-C circuit act inductively or capacitively? What about a similar circuit, but of a parallel type?

8. If a parallel L-C circuit has no losses (that is, has no resistance), will the Q of the coil be very high? Will this make the circuit have very high impedance at resonance? Give reasons.

9. In order to make a parallel L-C circuit act inductively, must the exciting frequency be higher or lower than the resonant frequency?

# LESSON 8

## How Meters Work

**ELECTRICAL MEASUREMENTS.** The factors associated with electricity are measured, in most practical applications, with the aid of meters. As you probably know, a meter has one or more scales and a movable pointer. For any one condition of measurement, the needle (pointer) stops at a definite place and the corresponding reading of the scale indicates the value being measured. Many electrical measurements are made directly with a meter. For example, voltage is measured with a voltmeter which gives direct reading. Inductance, on the other hand, may be measured directly only with a complex circuit and a specially calibrated meter; simple meters will serve to give indirect measurement and will necessitate the use of a formula for the solution.



Figure 106. Meters, used individually or in radio test equipment, depend on magnetic effects for their operation.

Meters are used to inform the operator that the circuits are functioning correctly at all times; meters help a radio serviceman locate the faults in a piece of equipment; meters help a radio design engineer work out a new circuit with the least guess-work. The radio serviceman, while trouble-shooting, tries to discover the presence of an incorrect electrical quantity in the circuit and such a discovery helps the radioman to locate the actual fault.

While magnetic, heating, or electro-chemical effects may be used to measure electric current, for D.C. and A.C. of lower frequencies, the magnetic effect is employed. For higher A.C. frequencies (such as R.F.), the heat produced is used as the indicating effect. It is important to realize that electric *current* operates all meters. Even when voltage is being measured, it is the current that operates the meter and is the quantity really being measured. But the amount of current present depends on the voltage and, therefore, the scale can be calibrated in terms of voltage.

**D.C. METER MOVEMENT.** Most of today's direct current meters use D'Arsonval type movement. This movement is sometimes called the permanent-magnet moving-coil type because of the components used. You will notice that in the cut-away view, a large horse-shoe magnet forms the bulk of the unit. Between the pole pieces, a light movable coil is suspended on pivots. You can see one spring in front of this coil, while a second spring, tending to

The meter needle may be of the knife edge type or may be in the shape of an arrow. The knife edge permits finer degree of reading. The thicker arrow pointer is easier to follow and the needle is stronger. The meter scale should always be read from a position directly in front. If a mirror slot is included behind the needle, your eyes should be in a position where you can see the actual pointer but not the image of the pointer in the mirror which will then be blocked with the actual object.

Lately, cathode ray visual equipment is replacing meters for many of these applications.

The fact that current is used to operate all meters is also true in case the meters are of the A.C. type. The more sensitive meters take very little current for their operation.

## D'ARSONVAL MOVEMENT

This phantom view of a meter movement should be studied carefully. The understanding of meter construction will help you to use the meters properly and exercise needed care.

A set screw on the face of the meter may be used to preset the needle to the zero position. This adjustment is made while the meter is not connected; the adjustment may be required from time to time since the springs may give from constant tension.

The meter movement is pivoted on fine jewels as used in fine watches.

Many very sensitive meters require considerably less current for maximum deflection. However, one milliamperere movement meter is very popular in radio service work.

turn the coil in the opposite direction, is behind the coil. Since the two springs try to turn the movable coil in opposite directions, it remains in the normal position indicated. The springs are used also to conduct current to the coil from the fixed terminals.

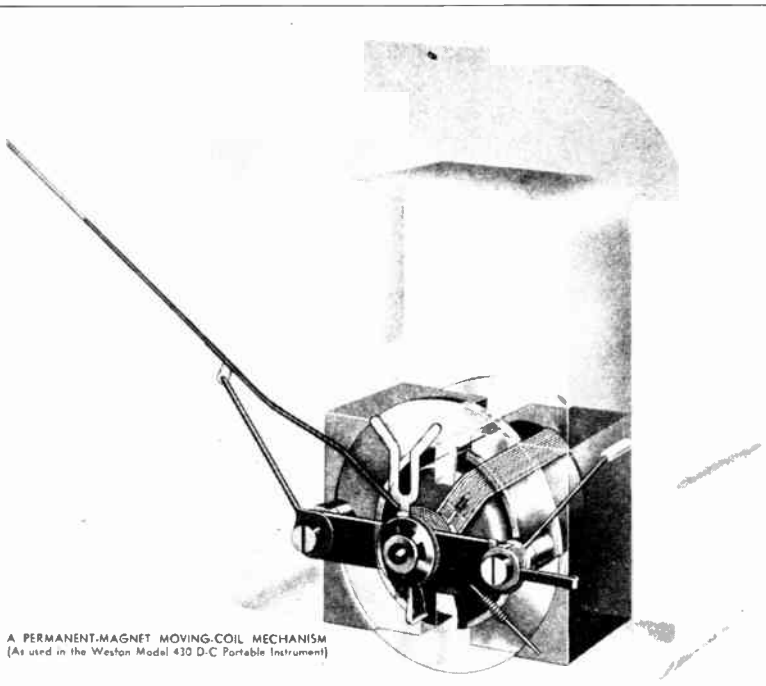

A PERMANENT-MAGNET MOVING-COIL MECHANISM  
(As used in the Weston Model 430 D.C. Portable Instrument)

*Courtesy Weston Electrical Instrument Corp.*

Figure 107. This illustration will permit you to understand the operation of a D'Arsonval type movement. The entire movement, in practical units, is housed in a case, and the meter scale is directly under the pointer.

When current flows in the movable coil, an electromagnetic field is produced. The field of this magnet bucks the field of the fixed magnet, and the coil tries to rotate to the right and line up better with the lines of force of the permanent magnet. The intensity of this effort is proportional to the current and also depends on the design of the meter. Since the same amount of current will always rotate the coil and the attached needle to a definite position, a calibrated scale can be mounted on the meter movement, behind the pointer, to indicate the actual value of the current present.

**INCREASING CURRENT SCALES.** Since a great many turns of very fine wire are used for the coil of a meter, and the movement is finely balanced requiring very little power for rotation, small amounts of current will rotate the coil and pointer to the maximum position. A great many meters used in radio work have a 1 ma. movement. This means that only one milliamperere will be needed to swing the pointer to the extreme right hand position. Greater current than this will tend to swing the needle beyond this point and may bend the pointer. Excessive currents may also burn out the coil.

Currents which must be measured in radio work are usually greater than the small current required for maximum movement of the meter pointer. Some method is needed to make a sensitive meter read any current that may be encountered in radio and

electrical work. We have already found out that meters are rated in terms of the current needed to cause maximum deflection of the pointer. Meters are also rated in terms of the D.C. resistance of the moving coil. This resistance varies in different units, but for our discussion we will assume that our meter is of 100 ohms internal resistance, and is of one milliamperere sensitivity. Let us require a meter than must measure currents up to 10 ma. This means that the maximum point on the scale of this meter must be 10 ma., and the normal position, of course, will indicate zero. What circuit must be used to accomplish this?

If we connect a resistor in parallel with the meter, a part of the current being measured will pass through the resistor and a part will pass through the meter. If we wish to measure exactly 10 ma., and if we want the meter to have the needle at the extreme right hand position for this current, we must work out a circuit of this type selecting the value of the resistor to leave only one milliamperere for the meter. You probably recall that 1 ma. is the current required to deflect the needle to the extreme right hand position. Now if *one* milliamperere is to pass through the meter, when we are measuring *ten* milliamperes, then 9 ma. must pass through the parallel (shunt) resistor. The resistor, in this case, must pass nine times the current of the meter. The resistor, therefore, must be smaller in resistance than the meter; it must offer less opposition. In fact, the resistor must be  $1/9$  the size of the meter resistance to pass nine times the current.

Recalling that the meter resistance, in our example, is 100 ohms,  $1/9$  of this amount gives about 11.1 ohms. This is the value of the shunt resistor needed. This resistor must be accurate (one or two percent in practice) to give a fair degree of accuracy when used with the meter. For any other current scale requirements, the same process is applied. You will notice that if the scale is to be multiplied by a factor  $n$  ( $n$  may be any number, in our example  $n$  was equal to 10), the shunt has a value equal to the meter resistance divided by a number equal to  $n$  less one, ( $10 - 1 = 9$  in our example).

The scale of a meter may be marked off in divisions, with 10 marking the last point at the right hand side. Marks within each division help you to estimate the exact reading as indicated by the needle. If you are using a scale where the maximum reading is 500 milliamperes, then you must understand that this mark 10 corresponds to 500 ma. In the same fashion, the point 4 corresponds to 200 ma., and a point  $2\frac{1}{2}$  corresponds to 125 ma. In these cases, each division is equal to 50 ma., since 10 divisions equal 500 ma. For another maximum current consideration, a different shunt resistor is used and each division may represent a different amount.

**MAKING A D.C. VOLTMETER.** The meter we have used in our examples was said to be of the one milliamperere movement type and of 100 ohms internal resistance. What voltage will be needed to swing the needle to its maximum position? This is the voltage which will cause one milliamperere (.001 ampere) to flow through the meter resistance of 100 ohms. Using Ohm's Law, we multiply  $I$  by  $R$ , and obtain  $1/10$  of a volt. We see from this that the same meter (it is a current meter called a milliammeter) can be used to measure voltages up to  $1/10$  of a volt. A  $1/20$  of a volt will cause the current to be only  $1/2$  ma., and the needle

## EXTENDING METER RANGES

Meter scales are usually multiplied in units of ten since this simplifies the readings.

When two resistors are connected in parallel, the smaller resistance passes more current.

The shunt resistor should be within 1%, or better, of the required value. The calculation of the resistor size should be carried out to better than 1%. Notice that in our example, we carried out the calculation to within one decimal place, so that the error, at most, could be .05 of an ohm, or about 0.45% (a little under  $1/2$  of 1%) of the total shunt resistor value of 11.1 ohms.

The reading of meter scales is similar to reading the scales on a slide rule. Perhaps you had experience in using a slide rule.

## MAKING A VOLTMETER

Remember that this meter is still measuring current, but the amount of current depends on the voltage of the source.

A meter is most sensitive and can be read most accurately when the values being measured deflect the needle to about the center of the scale. Poor accuracy is obtained when the reading is taken at either extreme of the scale.

Read this paragraph again. Be sure you understand it. Write the meaning of this paragraph in your own words.

You may think of the meter and the series resistor acting as two resistors in series. There is a voltage drop in each resistor. The design of the voltmeter requires the choice of the series dropping resistor of a value that will cause the voltage drop in this resistor and the meter to be in proper proportion to give needed results.

Later lessons will explain the use of voltmeters for electronic equipment measurements and service work.

will stop in the half-way position.\* Yes, we can use a milliammeter for measuring voltage without any other parts, but only voltage up to 1/10 of a volt in this case. Most voltages encountered in radio work are from one volt to several thousand volts. We must work out some voltage multiplier.



Figure 108. To increase the reading of meters, series and shunt resistors are needed. These resistors are of the precision type, usually 1% accuracy.

We will first consider how to make our meter read up to 10 volts at maximum deflection. If the meter can be made to do this, it will be adaptable to read other values of voltage less than 10 volts. Let us connect a resistor in series with the meter. Please notice that we now connect the resistor in series and not in shunt as before. How large must this resistor be, so that when we are measuring a total of ten volts, the meter pointer will move only to its extreme right hand position, but not beyond? For this condition, the meter requires 1/10 (or 0.1) of a volt, as we have already found out, and since we have a total of 10 volts, 10 — 0.1 or 9.9 volts of this must be lost in the resistor. But the current passing through the circuit must be 1 ma. (.001 amperes) when the needle shows maximum deflection, and we can apply Ohm's Law once again. To get resistance, we divide voltage by current. Dividing 9.9 volts by .001 amperes, we obtain 9,900 ohms. Since a 10,000 ohm resistor will represent an error of only one percent, it may be used in a practical circuit. The marked resistor value, however, must be accurate to within 2% to 5%.

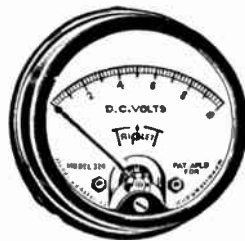

Figure 109. Even a voltmeter is a current measuring device. Since the current is proportional to the voltage, the scale can be calibrated in volts.

*Courtesy Triplet Electrical Inst. Co.*

For any other value of maximum voltage scale, the same procedure of calculation is employed. For example, for 100 volts a resistor of 99,900 (or 100,000) ohms is needed. The switching in of the different resistors may be accomplished with a rotary switch and the scale required may be easily selected.

**HIGH RESISTANCE OHMMETER.** A milliammeter may be used to measure the value of resistance. Let us see how the milliammeter, we have used for the previous examples, can be made to measure resistance. In your notebook, make a drawing indicating the

\*The majority of D.C. instruments have linear scales; equal scale distance for equal electrical units.

meter, a  $4\frac{1}{2}$  volt battery, and a 4,400 ohm resistor connected in series. The total resistance of this circuit will be 4,500 ohms, obtained by adding the resistance mentioned to the 100 ohm resistance of the meter. Using a  $4\frac{1}{2}$  volt battery with this total resistance, makes the current in the circuit equal to .001 ampere, or 1 ma. With this current passing through the meter, the needle will indicate the extreme right hand position.

Draw the circuit once again, but this time leave a break in the connecting wires at any one point. Indicate terminals at each end of the wire at this break. The two test wires or test leads will be connected to these two terminals. If the terminals are shorted, i.e. connected with a short piece of wire of almost no resistance, the needle will swing to the right. Since the wire has about zero resistance, we mark this point at the extreme right hand of the ohmmeter scale, *O*. Now let us leave the terminals open, i.e. apart. We are actually measuring under these conditions, the resistance of the air between the terminals. This resistance is very high, running in millions of ohms, and for practical purposes may be considered infinite or the greatest possible value. The symbol  $\infty$  (eight sideways) represents infinity, and since the needle in this case will be all the way to the left, the normal position, we will mark this point, infinity. If we measure a resistor of exactly 4,500 ohms, the total resistance of the circuit under these conditions will be obtained by adding this resistance to the actual resistance of the circuit. Since the result will be 9,000 ohms, twice the circuit resistance, the current will be one-half the maximum value, and the mid-point of the scale will be marked, 4,500. Other points will be obtained in the same fashion.

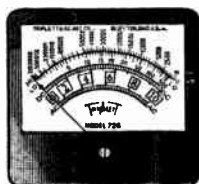

Figure 110. A meter may have several scales and, when used with a selector switch and the required network of resistors, will indicate various values of current, voltage, and resistance.

*Courtesy Triplett Electrical Inst. Co.*

An ohmmeter scale is more spread out at the right for low values and is very congested for extremely high values. The ohmmeter we described can be read for values up to about 500,000 ohms, after that the total space of the scale remaining before the infinity mark is reached is so small that no accurate reading is possible. Some ohmmeters, of course, are made to read up to several megohms.

**METER ACCURACY.** All meters lack perfection of accuracy. In practical work very rough reading is usually sufficient and 5% accuracy is very satisfactory. The errors are due to several causes. The meter cannot be calibrated perfectly. The scales are printed from a drawing which is based on a typical meter of the type considered. However, not all bearings, springs, magnets, and coils are exactly alike and slight variations in responding to the same current always result. The same current, therefore, may give slightly different readings in several similar meters. Errors are also due to the associated resistors and to the width of the pointer.

**HOW TO READ METER SCALES.** The illustration shows a typical meter panel which incorporates scales for reading various values of voltage, current in milliamperes, and resistance in ohms. This panel agrees with our discussion so far. The rotary switch used

## OHMMETER CONNECTIONS

Actually the 100 ohm meter resistance is only 2.2% of the required series resistor. Since this resistor may be accurate only to within 5% in commercial units, a 4,500 ohm resistor will serve. In commercial ohmmeters, this series resistor is made variable to permit adjustment to compensate for age changes of the series battery.

Most students make the error of thinking that when the terminals are apart, the resistance being measured is *zero*. This is wrong, of course. There is very high resistant between separated terminals, millions of ohms.

To read very high resistance values with some degree of accuracy, the meter movement must be very sensitive or else a very high voltage, series battery and series resistor must be used. For example, a meter of the type we used in our description can be made to read 450,000 ohms in the center (and much higher values at the left side of the scale) if the series resistor is made equal to 450,000 ohms, and a 450 volt supply is used.

## READING METER SCALES

It is most urgent that you become expert in reading meter scales correctly. If you have a friend who had more experience in radio work, ask him to test your knowledge in reading meter indications.

While the principle of meter scale reading is the same for all units, the actual scales may vary.

Always use a scale that gives the reading near its center.

When the same meter is used for D.C. and A.C. reading, the rectifier unit is switched-in for A.C. use. A new scale must be included for A.C. reading since the meter with the rectifier no longer gives linear scale reading as in the case of D.C.

**Volume 1 - Page 78**

for the selection of the scale to be employed is usually marked with the multiplication factor and an indication as to whether it is related to voltage, current, or resistance. Let us assume that we are measuring voltage and the multiplication factor is such that the maximum deflection will equal 50 volts. Look at the extreme right row of numbers of the scales on the meter and find a number which goes into 50, once, or ten times, or a hundred times. This number, in this case, is 5. Five goes into fifty, ten times. Read the values indicated by the pointer by making reference to this middle lower scale (the one that has numbers: 0, 1, 2, 3, 4, and 5). Multiply what you read by ten, because of the fact that the full scale deflection in this case is 50 and not 5. Make up a few problems yourself by naming a scale and making a mark for the pointer.

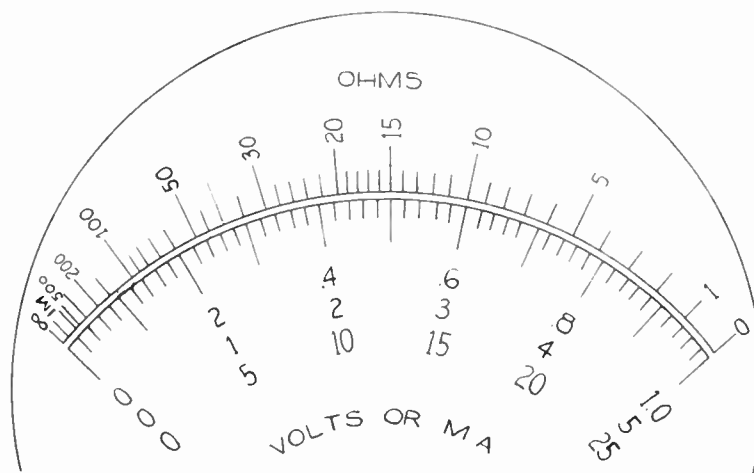

Figure 111. Very often the scale of a volt-ohm-milliammeter test unit will be similar to the scale illustrated. As a future radio serviceman, you must be able to read such scales.

As another example, let us measure resistance and use a position of the switch which calls for multiplying the results read on the scale by a factor of 100. If the pointer stops at 15, you are really reading  $15 \times 100$ , or 1,500 ohms. What if the pointer stops at the short line after the mark 30, on the upper ohm scale? You see that the mark lies between 30 and 50. The long line between 30 and 50, indicates 40. The short line, where our pointer stopped, lies between 30 and this longer line which indicates 40. It is evident that the pointer must be at a value corresponding to 35. But we are using a scale which requires multiplication by 100, and so our answer is 3,500 ohms.

**CONVERSION TO A.C.** The meters we have discussed so far can be used with D.C. only. It is possible to use a regular D.C. meter for measuring alternating current or voltage with the aid of a rectifier unit. The rectifier changes A.C. to D.C. and the value of A.C. voltage or current is measured on special scales. Usually these scales are calibrated for a given A.C. frequency, and considerable variation in frequency will cause additional errors. The rectifier elements are made of copper oxide and the current is permitted to pass only in one direction.



A sensitive D.C. meter may be used with a thermocouple to measure alternating currents up to ultra-high R.F. The current to be measured heats a small wire which is placed near a junction of two different metals. When a point of contact of two different metals is heated, a slight voltage is produced. This voltage is D.C. and is impressed on the sensitive D.C. meter.

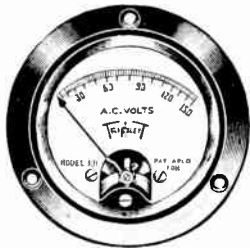
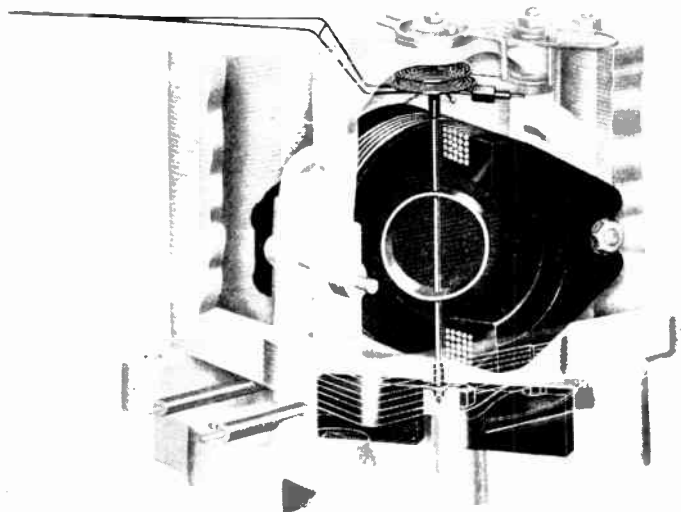

Figure 112. A.C. meters have the same outward appearance as similar D.C. instruments. However, the movement must be different, or the A.C. must be converted to direct current.

**DYNAMOMETER METER.** A meter can be constructed to operate directly from A.C. If a D'Arsonval movement meter is connected to alternating current, the needle will try to follow the variations in the current and will appear to be vibrating. No true reading will be possible. Notice the different construction of the electro-dynamometer mechanism which can be used to measure A.C. directly. The large stationary coils are connected to the source of A.C., and a part of this current is conducted through the small



AN ELECTRODYNAMOMETER MECHANISM  
(As used in the Weston Model 432 D.C. and Sine-Power A.C. Meters)

*Courtesy Weston Electrical Inst. Corp.*

Figure 113. Here is an inside view of an electro-dynamometer movement. Notice the large fixed coils and the small rotating coil attached to the pointer.

movable coil. The small coil is mechanically connected to the pointer. Since the current in both the stationary and movable coils reverses at the same time, the torque (movement, rotation) is in the same direction and is proportional to the square of the current.

## METERS FOR A.C. MEASUREMENTS

Since different thermocouples convert electric current to heat and heat back to D.C. current in different degrees of efficiency, such an A.C. meter must have its scale calibrated for the particular thermocouple employed.

In practice, if a D.C. meter is connected to A.C. in error, the needle may either vibrate or jump to an extreme position.

The moving and stationary coils buck (push) each other in the same relative direction even when the current reverses. There are instants (two in every cycle) when the current is zero and no magnetic field exists, but these instants are short in duration. During such instances, the needle does try to return to the initial zero position, but before it can get started, the magnetic field starts building up once again.

## MOVING IRON-VANE METER

Regardless of the type of movement in the meter, the scales are read in the manner already explained under D.C. type meters. It is more difficult to increase the scale reading of A.C. instruments since the meter does not behave as a pure resistor, but as a complex impedance.

Such meters may be used also for D.C., but they are not as sensitive as the D'Arsonval movement types. Dynamometer movements may be used in ammeters, voltmeters, or wattmeters.

**MOVING IRON-VANE METER.** This type of meter has a fixed coil which is connected to the circuit having the current to be measured. Usually there is a fixed iron plate and a moving iron-vane. In the normal position, these iron plates are close to each other. The moving iron-vane is connected to the pointer. When current passes through the coil, it creates an electromagnet which in turn magnetizes the iron plates. Since these plates are of the same magnetic polarity at all times, although the magnetic fields of both reverse with changes in the direction of the current, the iron plates repel each other in proportion to the current. This repelling action makes the moving-vane rotate against the tension of the spring. The amount of rotation indicates the quantity of current being measured.

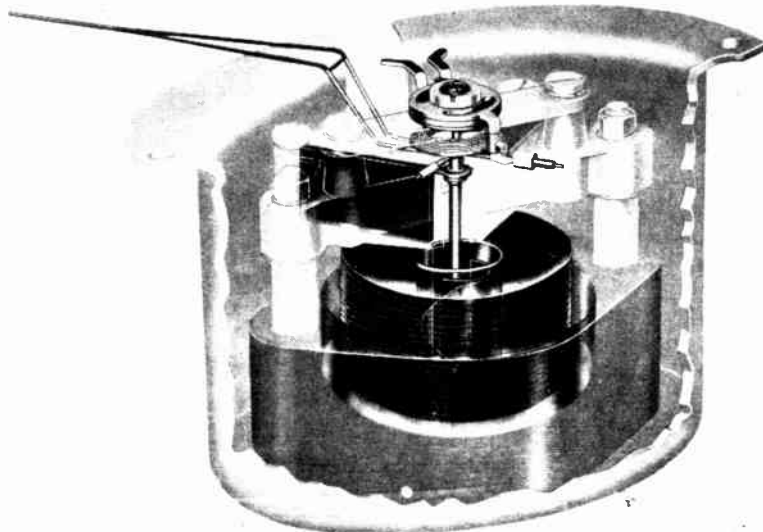

A MOVING IRON VANE MECHANISM  
(As used in the Wessex Model 433 A.C. Portable Instrument)

*Courtesy Weston Electrical Inst. Corp.*

Figure 114. The moving iron vane meter can be used for A.C. measurements. This movement is not as sensitive as the D'Arsonval movement and, therefore, is not recommended for D.C.

1. How is such a meter made to read zero in the center, and values to the right and left?

2. Answer: 2.08 ohms.

3. Exact size: 499,950 ohms.

REVIEW QUESTIONS AND PROBLEMS. 1. With a rough drawing, explain how a D'Arsonval type movement works.

2. What shunt resistance is needed to make a 0 to 1 ma., 50 ohm meter, read 25 ma. at maximum deflection?

3. What series resistance will be required to make the meter of Question 2, indicate 500 volts at full scale deflection? What practical value resistor will be used? How accurate is this resistor in practice?

PRACTICE QUESTIONS

4. The sensitivity of a voltmeter is measured in "ohms per volt" and is obtained by dividing the voltage needed for maximum scale deflection by the total series resistance of the circuit. What is the ohms/volt sensitivity of the voltmeter in Question 3?

4. This division may be made for any one voltage scale, or for the original meter.

5. Name two methods used to convert D.C. meters to A.C. use.

6. Copy the chart shown, in your notebook. By following the lines marked by different letters, A, B, C, etc., fill in the readings corresponding to different scales. Notice the few sample answers as given.

6. This assignment should be carefully worked out. An answer book should be purchased from the publishers of this course. This answer book will permit you to check the correctness of your work. All questions are answered in this booklet which is priced at 25c. post-paid. Do not look up the answers, however, until you worked out the problems yourself.

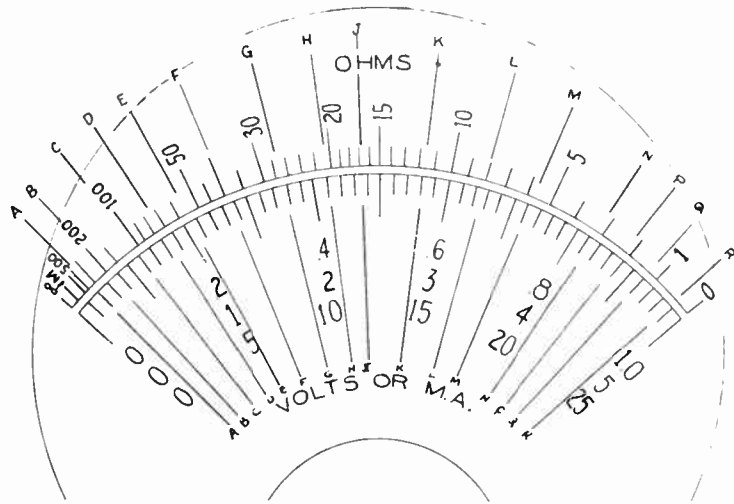

DEFLECTION	RANGE SWITCH SET TO							
	10 V	100 V	500 V	1 MA	5 MA	25 MA	Ohms x 1	Ohms x 100
A	4							
B							200	
C	DO NOT WRITE IN THIS CHART						3	
D								
E								
F								
G								
H								
I								
J								
K								
L								
M								
N								
P								
Q								
R								

Figure 115. You are to assume that the pointer of the instrument stops at the lines indicated by the different letters, and obtain correct reading with the range switch set at the maximum deflection values indicated in the table.

# LESSON 9

## Vacuum Tubes

The operation of all electronic equipment is dependent on vacuum tubes. The same types of tubes are employed in radio receivers, small transmitters, and electronic circuits. While the majority of examples presented suggest radio circuits, the same or similar arrangements are used to produce the function of electronic equipment.

**ELECTRON EMISSION.** You already know that vacuum tubes are used in almost all radio units. The basis of vacuum tube operation, be they rectifiers or multi-purpose tubes, in glass or metal envelopes, is electron emission. Electrons are emitted from an electrically heated filament. This means that an ordinary electric bulb also emits electrons. In electric bulbs, the electrons form a cloud around the heated filament and, as more electrons are emitted, others return to the filament. Electric bulbs and vacuum tubes must have the air removed from the container in order to obtain the needed action and prevent the filament from burning up.



Figure 116. The majority of metal tubes have glass envelope equivalents. All tubes depend on electron emission for their operation.

**DIRECTLY HEATED TUBES.** Vacuum tubes which have the actual filament emitting the electrons are known as directly heated types. Most battery set tubes, rectifiers, and power tubes are of this type.

**INDIRECTLY HEATED CATHODE TUBES.** In many tube types, the electrons are emitted from a metal sleeve. This sleeve is placed over the filament, but is insulated from it. The filament then serves only as a source of heat and does not actually emit the electrons used for operation. Most A.C. operated radio tubes used in "sensitive" circuits are of the cathode type. The element emitting the electrons is always called the cathode. Some substances are far better emitters than others. Coating a poor emitter with an oxide of certain metals may raise the emission a thousand times. The emission also increases with the temperature.

**DIODES.** In 1883, Thomas Edison discovered that when an additional electrode was placed inside an incandescent lamp and this electrode connected to a positive potential with respect to the filament, a current passed through the tube. This is actually a simple vacuum tube of the *diode* type. It contains but two elements, the cathode to emit and the plate (anode) to receive the electrons. Under the influence of a positive potential applied to the plate, electrons will flow from the cathode to the positively charged plate. An increase in the plate potential will increase the plate current. The complete action is easy to analyze.

This paragraph has much "meat" in it. Study it carefully.

If the filament is used to emit electrons, it is also called the cathode. In indirectly heated tubes, the cathode is a separate element from the filament.

Diode vacuum tubes are used for many special electronic applications. Such tubes are especially useful for producing *square* shaped waves.

From a heated cathode many electrons venture out, forming a cloud around it. If a negative potential is applied to the plate, the electrons will be repelled back into the cathode and no current will pass between these two elements. If, however, the plate becomes positive with respect to the cathode, the electrons around the cathode will be attracted to the plate, since unlike charges attract, and current will pass.

**SPACE CHARGE.** Of the electrons leaving the cathode, not all, of course, reach the plate. Many return to the cathode while others remain for short periods of time between the cathode and the plate forming a *space charge*. The space charge, being made up of electrons, is negative.

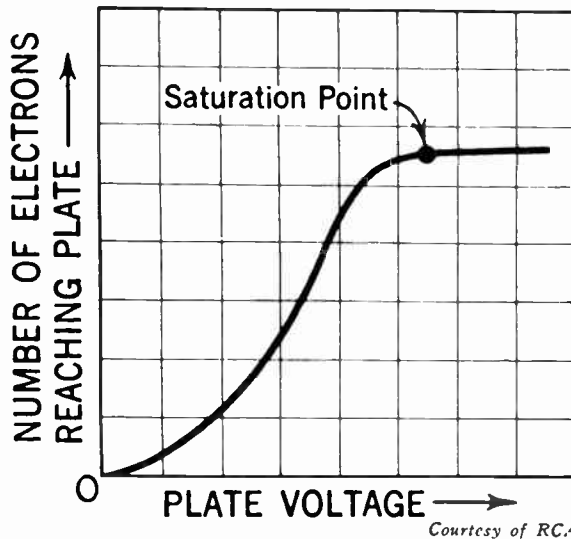

Figure 117. When the voltage on the plate is increased to a value which will force all available electrons to reach the plate, a further voltage rise will not increase the current made up of these electrons.

**SATURATION.** As the plate of a diode tube is made more positive, a greater number of electrons will be attracted across the space in the tube. Finally, the plate can be so positive that *all* electrons emitted by the cathode will be going to the plate. If the plate is made even more positive beyond this point (this can be done by connecting more batteries to the plate), all the available electrons will continue to be received by the plate. There will not be any increase since there are no more electrons emitted. Now, you know that electric current is made up of electrons, and so a maximum current will be reached. Raising the plate potential (voltage) will no longer increase the current after this saturation point. Up to the saturation point, of course, an increase in plate voltage increases the plate current in the diode. Vacuum tubes are not operated near the saturation point and the plate voltage is kept at a value to prevent saturation current.

Large values of plate current can be obtained by closely placing the cathode and plate in a diode tube. In some rectifier tubes, mercury vapor is introduced to increase the plate current. In such mercury vapor tubes, the voltage lost in the tube itself is very small.

**TRIODES.** Tubes having a third electrode for control purposes are known as triodes. This control electrode is usually called the

If the plate potential is only slightly negative, a very limited number of electrons (constituting a minute current) may still pass through the tube, from the cathode to the plate.

Please note that under the condition of saturation, a further rise in plate voltage will not increase the plate current. However, an increase in filament voltage which may make the filament (and cathode) operate at a higher temperature, will result in greater emission of electrons and will permit an increase in current. For most circuits, the filament voltage remains fixed at a value needed for the best operation of the particular vacuum tube.

Most vacuum tube circuits are so adjusted that the operation (the average plate current condition) corresponds to the mid-point of the curve shown in Figure 117. Sometimes, certain circuits require operation near the zero-current point.

## TETRODES AND PENTODES

Be sure you understand the controlling action of the grid. Try to explain in your own words how the grid reduces or increases the number of electrons reaching the plate.

With the additional knowledge you have gained since last looking at the tubes in your *model* radio, examine the tubes once again. Try to see the inside construction. If you have any burned out or *bad* tubes, break\* them. Examine the inside construction and the placement of the elements.

The words *tetrodes* and *pentodes* should suggest to you four elements and five elements, respectively.

\*To break the glass of a vacuum tube, wrap the tube in a moist rag. Then hit the glass with a flat surface. A heavy book is excellent for this purpose. This will prevent the glass from *flying* when the tube is broken and the air rushes inside.

Volume 1 - Page 84

grid because it is made of fine wire in the form of a mesh. The grid is placed much closer to the cathode than the plate. The purpose of the grid is to control plate current. With a negative voltage on the grid, the grid exerts a force on the electrons in the space between cathode and grid. This force drives the electrons back to the cathode. In this way, the negatively charged grid opposes the flow of electrons to the plate. When the voltage on the grid is made more negative, the grid exerts a stronger repelling force on the electrons and the plate current is decreased. When the grid voltage is made less negative, there is less repelling force exerted by the grid and the plate current increases. When the voltage on the grid is varied in accordance with a signal, the plate current also varies with the signal. Because a small voltage applied to the grid can control a comparatively large amount of plate current, the signal is amplified by the tube.

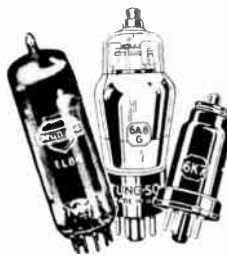

Figure 118. Although radio receiving tubes have different physical appearances, it is the inside construction that makes the real difference.

The grid, plate, and cathode of a triode form an electrostatic system, each electrode acting as one plate of a small condenser. The capacitances are those existing between grid and plate, plate and cathode, and grid and cathode. The capacitance between grid and plate is of greatest importance and, in high gain radio-frequency circuits, this capacitance may produce undesired coupling between the input and output circuits.

**TETRODES.** The detrimental effect of the grid-plate capacitance is reduced greatly by the introduction of a fourth electrode, called the *screen grid*, placed between the grid and the plate. This screen, in ordinary application, is connected to a positive potential somewhat lower than the plate potential. Since the screen voltage largely determines the electron flow, large variations in the plate voltage will have but little effect on the plate current.

Electrons striking the plate dislodge other electrons from it. This indirect emission of electrons from the plate is called secondary emission in contrast to primary emission from the heated cathode. In the diode or triode this action does not cause any difficulties because of the absence of any positive bodies in the vicinity of the plate. In the screen grid type tetrode, however, the screen is positive and close to the plate and does attract electrons emitted by the secondary emission action. This effect lowers the plate current and limits the permissible plate swing.

**PENTODES.** This limitation of secondary emission, in turn, may be removed by a further introduction of another electrode, known as the suppressor, between the screen and the plate. The suppressor may be connected directly to the cathode or, as in some tubes for special applications, have an external prong. Since such tubes have five elements,\* they are called pentodes.

\*The elements are: cathode, control grid, screen grid, suppressor grid, and plate.

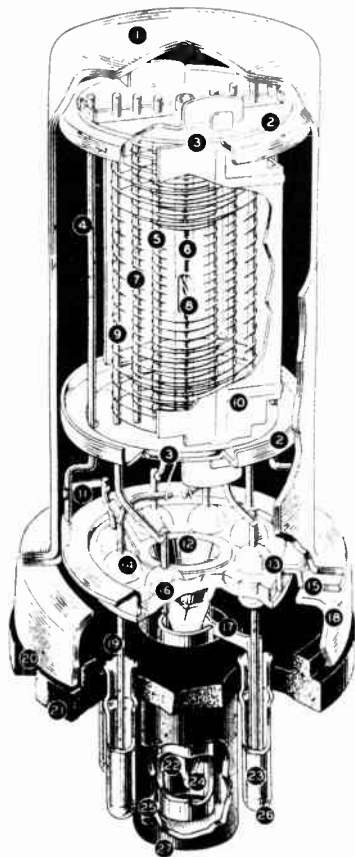
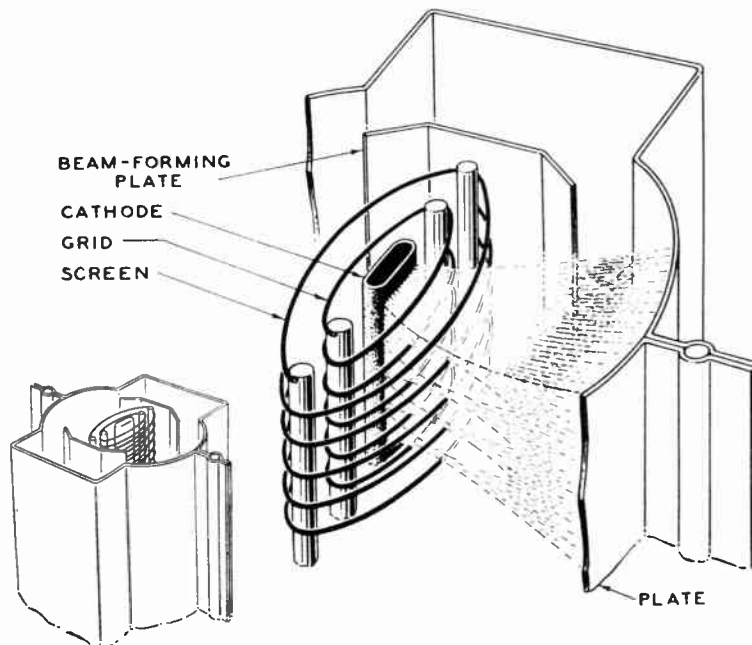

Figure 119. The structure of a metal tube is of interest to the future radio technician. (Courtesy of RCA).

1. Metal envelope
2. Spacer shield
3. Insulating spacer
4. Mount support
5. Control grid
6. Coated cathode
7. Screen grid
8. Heater (filament)
9. Suppressor grid
10. Plate
11. Batalum getter
12. Conical stem
13. Header
14. Glass seal
15. Header insert
16. Stem seal
17. Base shield
18. Header skirt
19. Lead wire
20. Crimped lock
21. Octal base
22. Exhaust tube
23. Base pin
24. Exhaust tip
25. Aligning key
26. Solder
27. Aligning plug

**BEAM POWER TUBES.** A beam power tube makes use of a different method for suppressing secondary emission. In this tube there are four electrodes, a cathode, a control grid, screen grid, and

Beam power tubes are used primarily for handling considerable power in audio output stages of radio receivers. These tubes also offer certain advantages in radio transmitter circuits. The numbers assigned to beam power tubes incorporate the letter L or V. Did your radio have any beam power tubes?



Courtesy of RCA

Figure 120. The placement of the elements in a beam power tube, and the form of the electron stream. Because of the electron velocity distribution, pentode action is obtained in a beam power tube without a suppressor grid.

## EXPERIMENT WITH A TRIODE

Multi-unit tubes give economy of space and a little simplification in the wiring. You will learn that such a tube costs about as much as two single purpose tubes needed to perform the same function.

If you have the needed equipment, you should actually perform this experiment. You will need any standard triode tube, several B batteries (or a power supply with an adjustable voltage output), about six dry cells (or another source of low D.C. voltage), and a D.C. milliammeter.

In practical circuits, of course, batteries are replaced with power supplies which deliver the same types of voltages.

Such wide variation is needed in order to make the complete set of curves as shown in Figure 122. To check one or two curves, only the voltages expected to cause the points on these curves will be required.

**Volume 1 – Page 86**

plate so spaced that secondary emission from the plate is suppressed without an actual suppressor. Because of the way the electrodes are spaced, electrons traveling to the plate slow down when the plate voltage is low, almost to zero velocity in a certain region between the screen and plate. In this region, the electrons form a stationary cloud, a space charge, which repels secondary electrons emitted from the plate and causes them to return to the plate. In this manner, secondary emission is suppressed. Another feature of the beam power tube is the low current drawn by the screen. Beam power tubes act as pentodes, but have only four elements.

**MULTI-UNIT TUBES.** Some commercial vacuum tubes combine several tubes in one envelope. For example, a tube may combine two triode sections, having two sets of cathodes, control grids, and plates, but only a single filament. Or another tube may combine a pentode audio output tube and an indirectly heated rectifier.

Certain tubes contain additional elements to serve special purposes. Usually the pentagrid-converter tubes, used in superhet circuits which you will study later, are of this type.

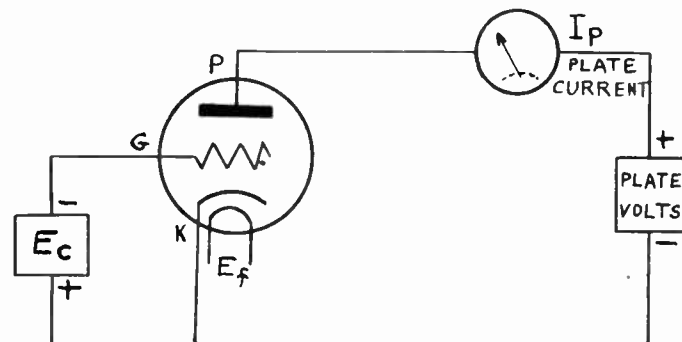

Figure 121. The circuit for the experiment to determine the characteristics of a triode vacuum tube.

**PLATE CURRENT OF A TRIODE.** You will now learn about a very practical experiment. If the equipment is available, you may follow these instructions and also perform this work. But you will learn a great deal just by reading our explanation of this work. Using any indirectly-heated cathode type triode, such as 6C5, or 76, we will connect the circuit as shown. The proper filament voltage will be applied to the terminals marked  $E_f$ . The other elements of the tube will be connected as illustrated.

Please check our description carefully against the drawing and make certain that you agree with our discussion. The plate (P) of the tube is connected to the source of plate voltage through a meter which shows the amount of plate current,  $I_p$ . Notice that the positive side of the battery is connected to the plate, while the negative side is returned to the cathode (K) of the tube. Now refer to the grid (G). Here also we have a battery,  $E_c$ , known as the C battery. The negative side is connected to the grid to keep it at a negative potential and prevent the grid from attracting electrons. The batteries are such that their voltage can be easily changed. For example, you may obtain any voltage from 0 to  $-28$  volts on the grid, and from 0 to 500 volts on the plate.

The actual plate current of the tube will be indicated on the meter placed in the plate circuit. As you will recall from the explanation of the triode, the greater the plate voltage the greater will be the plate current. The grid also will have an effect on the



## CHARACTERISTIC CURVES

plate current. The greater *negative* voltage we place on the grid, the smaller the plate current will become. You can see, therefore, that the actual plate current will depend on the instant potential of both the plate and grid. The changes in the plate current cause the operation we need. These changes may be made by altering the plate voltage or by varying the grid voltage.

**MAKING A GRAPH.** To understand the operation of vacuum tubes, we will need a simple graph as an aid. We use some graph paper and let the vertical scale represent the plate current. You will notice that we marked each two divisions 4 milliamperes. This means that each division is 2 milliamperes. Starting with the zero base line, count up six spaces. Each space is 2, so six is equal to 12 milliamperes. For the time being, ignore the curves drawn in the center, but place a dot with a pencil anywhere in the graph. Follow straight to the left with your eye and read the current in milliamperes. If your dot leads you between two values of plate current, estimate by guessing the approximate value of the plate current. Select a few other points and be sure you can read the value of current which corresponds to the position of these points.

It takes quite a bit of negative voltage on the control grid to completely eliminate (reduce to zero) the plate current.

Each division is ordinarily marked with the number of units that will be convenient to make the maximum values required fit the available space.

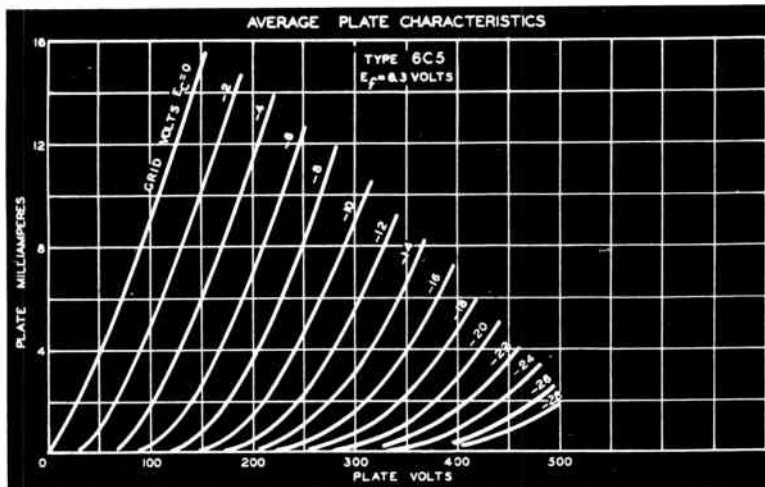

Figure 122. The family of curves obtained by carrying out an experiment similar to the one described in the text. Such average plate characteristics are known as the  $E_p$ - $I_p$  curves.

*Courtesy of R.C.A.*

The horizontal scale is used to indicate plate voltage. Here we also start with zero, but each division stands for 50 volts. Is that right? Go back to your dots, and by running your sight straight down, you will be able to read the voltage. You can see that each dot, or point, corresponds to one value of plate current and one value of plate voltage. We have selected a graph with a maximum current 16 ma. and maximum voltage of 500, because the tube we will consider is operated with less than 500 volts, and the plate current never rises above 16 milliamperes.

**PLATE CHARACTERISTIC CURVES.** Now we shall find out how the curves were obtained. First we will set the grid voltage battery at a fixed value. Let us make this voltage 0 volts, although usually tubes are operated with negative values on the grid. Now when we performed this experiment, we first reduced the plate battery

The curves for other triodes may be similar, but will not be exactly the same.

Since you will refer to plate characteristic curves from time to time in your radio and electronic work, be sure that you are able to read the values indicated by the curves or any point lying in the graph.

## USING $E_p$ - $I_p$ CHART DATA

If you are performing the actual experiment, the values you may obtain with the different voltages may not be exactly the same. But you will obtain curves which are similar in general appearance.

The student must follow this explanation with great care. Do the things the text suggests. The balance of this page will tell you how the amplification of a vacuum tube is computed.

The plate current change must be small and must be the same when considering the plate and grid voltages. However, it need not be any special value; 1 ma. used in the example was convenient.

to zero also, and found the plate current was also zero. So we went to the graph and marked the point which indicates plate current,  $I_p = 0$ , plate voltage,  $E_p = 0$ . This point is right in the lower left hand corner of the graph. Place a mark there.

Now we raised the plate voltage,  $E_p$ , to 50 volts. The meter showed that we had 4 ma. of plate current  $I_p$ . Mark the point where 50 volts crosses 4 ma.

We continued with our experiment, raising the plate voltage to 100 volts. The plate current was 9 ma. See if you can find this point. We also tried  $E_p = 150$ , and found  $I_p = 15$  ma. Now we have three points, and by connecting them with a curved line, we obtain the curve marked as corresponding to "Grid Volts  $E_c = 0$ ," since that was the value of grid voltage.

After this, we repeat the experiment with a slightly different value of grid voltage. Let us say, we use  $E_c = -2$  volts. Again we obtain several points and connect them with a curved line. We find we get a curve almost the same as before, but moved over a little to the right.

This experiment was performed a great many times for various values of grid voltage, and the curves shown were obtained. These curves collectively are known as plate characteristic curves. They are useful for finding the operating details of the tube. Curves of this type have been made for all commercial vacuum tubes and many are included in tube manuals\*.

**AMPLIFICATION FACTOR.** A plate voltage change will produce a change in plate current. Let us say we operate the tube with  $E_c = -6$ , and 200 volts on the plate. You can see from the graph that the plate current will be 7 ma. Find this value before going on.

If we keep  $E_c$  at the same value, how much must we increase the plate voltage to increase the plate current 1 ma., to total 8 ma.? Go back to the graph. Stick to the curve which represents grid voltage  $-6$ . Find the place where the line from 8 ma. crosses this curve. From this point of intersection, follow down and read the plate voltage. Do you agree that it is about 210 volts? About 10 volts more than before. We have just learned that a 10 volt change in plate voltage produces a change of 1 ma. in plate current.

Let us go back to the original conditions;  $E_c = -6$ ,  $E_p = 200$ . How much of a grid voltage change will be needed to produce a change of 1 ma., as before. This change makes  $I_p = 8$ , keeps  $E_p$  at 200, find the intersection of these two. There is no curve right through this intersection, but the curve to the left is for grid voltage of minus 4, the one to the right of this point is for minus 6 volts. By careful estimating, you can say that if a curve for  $E_c = 5\frac{1}{2}$  negative volts be constructed, it would pass right through the point we are considering. Five and one-half volts is  $\frac{1}{2}$  volt less than the original, and this  $\frac{1}{2}$  volt also produces a change of 1 ma. in current just like 10 volts of plate voltage.

It is strange and interesting that  $\frac{1}{2}$  volt of grid voltage will do the same as 10 volts of plate voltage, but this is just what permits a tube to amplify. The amplification factor, called mu and written as the Greek letter  $\mu$ , is for practical purposes,

$$\mu = \frac{\text{Change in } E_p}{\text{Change in } E_c} \quad \text{both changes}$$

\*A tube manual is a valuable aid to a radio repair man. Manuals of this type are issued by RCA Manufacturing Co., Inc., and by Sylvania Electric Products, Inc.

required to produce the same small change in plate current. Triodes have amplification factors from 3 to 20. A few of the high-mu triodes have amplification up to 100. An average tetrode may have an amplification of 300, while a pentode may have a mu over 1,000.

**PENTODE PLATE CHARACTERISTIC CURVES.** As you can observe from the plate characteristic curves of a type 6K7 tube (a commonly used pentode), the plate current does not change much with plate voltage variations. This is because the screen grid is positive at a fixed potential at all times. Since a very large plate voltage change is needed in a pentode to produce the same change in  $I_p$  as a small grid voltage, the ratio of "change in  $E_p$ " to "change in  $E_g$ " is large, making mu also very large.

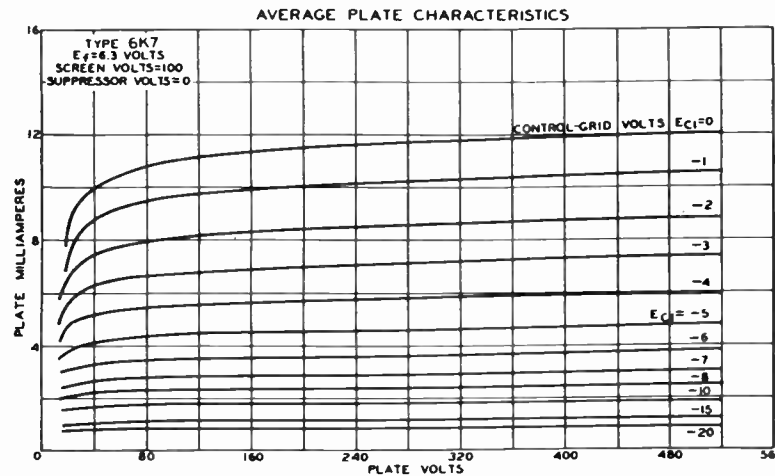

Figure 123. Because the plate voltage of a pentode has little effect on the plate current, the average plate characteristics of a pentode have a different appearance than the family of curves for a triode. Since the grid voltage has so much more effect than the plate voltage, the amplification factor is very high.

**PLATE RESISTANCE.** Even with zero grid voltage in our experimental circuit, plate current was present with a definite plate voltage. The tube must have presented some impedance to limit the current. We are interested in the opposition to A.C. current which results if the voltages are varied. We use the symbol  $r_p$  for plate resistance described, and write instead of "a small change," the letter d, in front of the symbol, like this:

$$r_p = \frac{dE_p}{dI_p} \quad \text{when } E_g \text{ is constant}$$

This value may be obtained from the plate characteristic charts in a manner similar to that we have used to calculate the value of mu.

**TRANSCONDUCTANCE.** This is an important factor which tells us much about the vacuum tube. As you can see from the formula below, it is equal to a small change in plate current divided by a small change in grid voltage which causes it, while the plate voltage is fixed. The symbol for transconductance is  $G_m$ .

$$G_m = \frac{dI_p}{dE_g} \quad E_p \text{ constant}$$

By ratio, we mean the division of one quantity by the other.

Notice that the characteristic curves are not spaced apart equal amounts for equal grid voltages. This property of certain radio frequency pentodes is obtained by placing the grid wires in a special shape. Remote cut off characteristics (small plate current change for large negative grid voltages) permits a tube such as 6K7 to be used in manual volume control circuits, while regular pentodes would cause distortion when operated in radio circuits handling strong signals from local broadcasting stations.

Plate resistance,  $r_p$ , is a dynamic quality and is useful in considering the operation of a tube in a circuit. The value of plate resistance is obtained from the formula stated and it *cannot* be obtained by simply dividing the plate supply voltage by the average plate current.

## SPECIAL VACUUM TUBES

A great deal more information on the function of photo-electric equipment will be presented in a complete lesson in Volume 3. This introduction is included to make the presentation on vacuum tubes complete.

**PHOTO-ELECTRIC CELLS.** Surfaces treated with certain chemicals will emit electrons under the influence of light. This action is very similar to the emission of heated cathodes. If a positive plate is placed in the bulb, the electrons will be attracted to the plate.



Figure 126. This is an illustration of a photo-cell used in motion picture sound equipment. The large plate is the cathode, the center wire is the anode.

*Courtesy Continental Electric Co.*

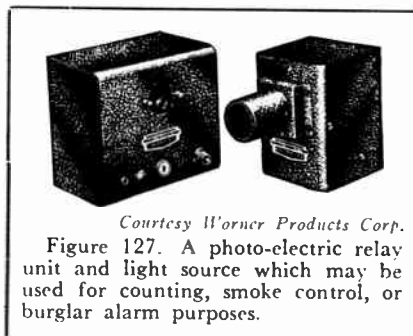

*Courtesy Worner Products Corp.*

Figure 127. A photo-electric relay unit and light source which may be used for counting, smoke control, or burglar alarm purposes.

Since more electrons are emitted when the light shining on the photo-cell is bright, light can be used to control the number of electrons leaving the photo-sensitive cathode.

**REVIEW QUESTIONS AND PROBLEMS.** 1. Increasing the temperature of the cathode will have what effect on the number of electrons emitted?

2. Explain the action of a simple diode.

3. How does the grid control the number of electrons reaching the plate?

4. Do you understand why the grid and plate of a triode form a condenser? What items make up the two condenser plates? What is the dielectric?

5. What is the usual potential on the screen grid? Is it ever made negative?

6. Name the five elements of a pentode. In what order are the grids placed, starting with the control grid?

7. Can you think of any advantages of multi-unit tubes?

8. Why is the control grid usually operated at a negative potential?

9. Referring to the characteristic curves of type 6C5, find the plate current with the plate voltage at 250, and the control grid voltage at minus 8 volts.

10. Explain how you can calculate the amplification factor by using information from characteristic curves.

11. Find the plate resistance of type 6C5 tube using the characteristic curves. Please notice that you will obtain the wrong answer by simply dividing plate voltage by plate current.

10. How can the calculation of the amplification factor be carried out without the characteristic curves? What equipment will be needed?

# LESSON 10

## Power Supplies

Consider very carefully the simple power supply circuit illustrated. You see a transformer which has its primary connected to 110 volts A.C. This transformer has two separate secondaries. One, marked LV for low voltage, is connected to the filament of the rectifier type diode tube. Please follow these connections through. For the time being, do not consider the resistor marked "load." Now trace through the connections from the HV or high voltage secondary. You see that one connection goes to the plate of the tube, while the other is grounded and should become the negative return of the plate supply. This is a complete circuit of a half-wave rectifier.

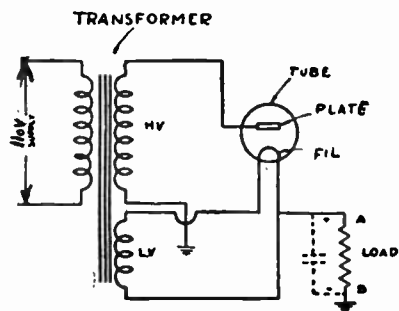

Figure 130. This is a basic circuit of a half-wave rectifier. It is important that you understand the function of this circuit since it is the basis for all usual power supplies.

If our transformer is connected to a 60 cycle power supply, we know that sixty times per second, one lead of the HV winding will be positive while the other lead will be negative, and sixty times per second, the polarity of these two leads will just reverse. Let us say that at one instant, the lower terminal of HV winding is negative. The electrons will be in excess at that point. They will pass through the chassis (ground), pass through the load, and come up to the filament. Now while the terminal we considered is negative, the upper terminal of HV is positive and is connected to the plate. The plate, therefore, will be positive also, and the electrons in the tube will be attracted across. The circuit will be completed, and current will pass through the load resistor.

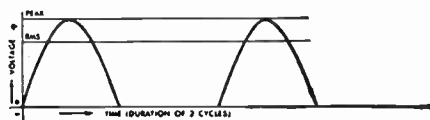

Figure 131. This is an illustration of the voltage variations as delivered by a half-wave rectifier.

As the voltage of the half cycle was building up, the current in the load resistor was building up in very much the same fashion. See the illustration. Of course, if an A.C. voltmeter is connected across the transformer winding, it will read only the RMS value. If a D.C. voltmeter is connected across the load resistor, it will read a fixed voltage since the changes are happening too fast for

This is a practical circuit and may be made to function in a power supply. In practice, the high voltage secondary may supply between 325 and 400 volts, while the LV secondary is designed to supply the required voltage for the filament of the rectifier tube employed.

Such power supply rectifier circuits are used with A.C. of any commercial power frequency.

The curve of the output voltage may be obtained with the aid of an oscilloscope which uses a cathode ray tube and shows the wave shape of the voltage present in the circuit.

**Volume 1 - Page 91**

## VACUUM TUBE RECTIFIER

In the half-wave rectifier, current flows through the tube only half the time. This explains the name of the circuit.

For most applications, the plate supply voltage must be pure D.C., similar to the current obtainable from batteries.

Several sections each consisting of a large capacity condenser and a large inductance (forming the filter) will succeed in keeping the output voltage at a constant value.

As you will probably notice, a full-wave rectifier actually consists of two ordinary half-wave rectifiers connected in a fashion so that one operates while the second is not conducting.

The pages following present essential data on all receiving type vacuum tubes.

**Volume 1 - Page 92**

the needle of the meter to follow.

When the top terminal of the HV winding becomes negative, as it will in the next half cycle, the plate will repel the electrons and no current will flow in the circuit. No current, please understand, will be flowing in the resistor and the voltage across the load resistor during this half cycle will be zero. And then the action will repeat itself.

We have already obtained from A.C., pulsating (varying) D.C., but we must have pure D.C. for proper operation of radio equipment. The current will be much smoother if we can incorporate a reservoir to absorb current when it is available in excess, and supply current when it is lacking. A condenser provides this reservoir action; it is connected across the load as indicated by the dotted lines. The condenser becomes charged when voltage is present across the load resistor, and then the condenser discharges when the voltage is missing. You probably recall that a condenser tends to keep the voltage constant which is just what we want. A condenser, of course, does not succeed in making the voltage absolutely constant, but, as you can see from the graph below, the voltage

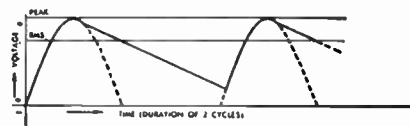

Figure 132. The action of a condenser in the power supply circuit tries to keep the voltage constant.

is more steady than it was before. The larger the capacity of the condenser, the smoother the output obtained.

**FULL-WAVE RECTIFIER.** In the half-wave rectifier we just studied, we noticed that rectification took place only during one half of each cycle, and the condenser was used to smooth out and fill in the gap as illustrated by the voltage graph. A full-wave rectifier uses a slightly different circuit with almost the same parts, but is much easier to filter, i.e. smooth-out.

Please study the circuit of the full-wave rectifier. Notice that the rectifier tube now has two separate plates, and the HV winding is center-tapped. Actually this winding produces as much voltage between this tap and each end, as the previous transformer secondary did across the entire untapped HV winding.

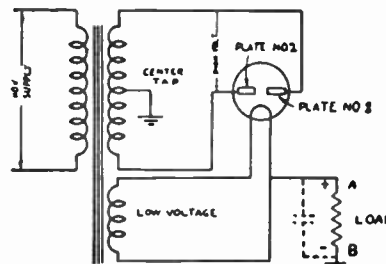

Figure 133. The full-wave power supply is used in almost all A.C. operated radio receivers.

In studying the circuit, assume that the center-tap is at zero potential. This means that while one terminal of the HV winding is positive, the other is negative. Only that plate connected to the

terminal which is positive at the instant, will conduct electric current. At the same instant, the second plate will not conduct. In the next half cycle, the action of the two plates will reverse. Only one of the plates will conduct at a time. See the graph of the voltage across the load resistor.

The condenser, as before, will smooth out the voltage variations. Follow the action through for several cycles, tracing the movement of electrons in parts of the circuit.

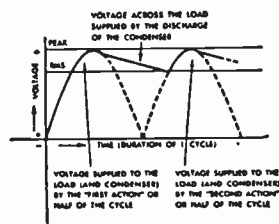

Figure 135. In a full-wave power supply, the filter condenser tends to even out the output voltage. The condenser action is similar to the action of a fly-wheel in an automobile.

*Courtesy P. R. Mallory & Co.*

**FILTERING.** In order to smooth out the voltage delivered by the rectifier, filters are used. Ordinarily, the filter consists of two or three condensers and one or two inductors known as chokes. Best filtering action is obtained when the chokes have low internal resistance, and the condensers are of large capacity. Most commercial power supplies are made up of two condensers across the D.C. voltage supply; one of these condensers is placed on each side of the choke.

In commercial practice, electrolytic condensers are used. A radio receiver having a full-wave rectifier may employ two 8 mfd. condensers. A half-wave rectifier is always of the condenser-input type and has the first condenser of at least 20 mfd. (40 mfd. is common for AC-DC sets). The actual capacity is not critical and this is something to remember when servicing power supplies.

The filter eliminates the ripple or slight variation in the output voltage of the power supply. A well filtered commercial power supply has a very slight ripple present, but this is not noticeable in the operation of the radio. It is possible, by using several filter sections, to make the output as pure as that which is obtained from batteries, but such perfection is not needed for ordinary application.

**COMPONENTS OF A POWER SUPPLY.** What factors must be considered in selecting components for a new power supply or for replacement purposes? First, let us consider the power transformer. This part is used in all full-wave rectifier type power supplies, but not in AC-DC half-wave rectifier type supplies. In the AC-DC sets, the 110 volt A.C. is applied to the plate of the rectifier, and the filament is wired in series with other tubes. But if the transformer is used, it must be selected on the basis of several factors. You must know from what voltage, of what frequency, the power supply will operate. Usually this source of power is 110 volts, 60 cycles. Next, you must know what filament voltages will be needed. The secondaries must supply the needed voltages and have sufficiently high rating to provide the needed current.

The condensers are selected with a voltage rating high enough for the power supply. The working voltage (WV) rating of the condenser indicates the maximum actual voltage of the power supply that may be used safely with this condenser. If a supply delivers 325 volts, pulsating D.C., and although the peaks may be

## PARTS OF A POWER SUPPLY

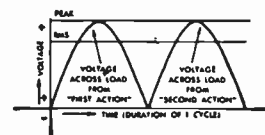

Figure 134. The voltage is delivered at all times and takes advantage of the two plates incorporated in the rectifier tube.

Since every radio receiver for power line operation and almost every other electronic device uses a rectifier of this type, it is important that you understand the action explained. This information will be very useful when you will be called upon to service rectifier circuits.

In low priced radio receivers and in other equipment where the current is very low (a few milliamperes as in the cathode ray power supply), a resistor of about 3,000 ohms may be used instead of the filter choke. The filtering action is not as good with a resistor and the voltage drop across the resistor will be greater than the drop across a choke.

The audio hum caused by the presence of the ripple in the voltage of the power supply can be detected by carefully listening to the speaker of the set while the volume control is turned down. Only A.C. operated receivers, of course, will have the audible hum.

## VIBRATOR ACTION

The contact points of the vibrator unit are designed to *wipe* each other on contact. This action keeps the surfaces smooth and presents a large contact area for the passage of the current.

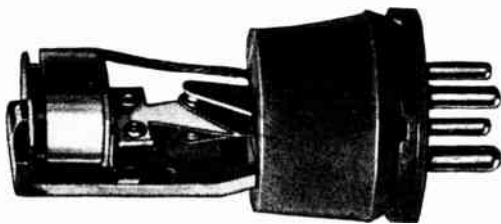

Figure 143. This is inside view of an automobile radio power supply vibrator.

The shape of the voltage waves is almost square.

The vibrator power supply transformer must be designed for the frequency of the interrupted current.

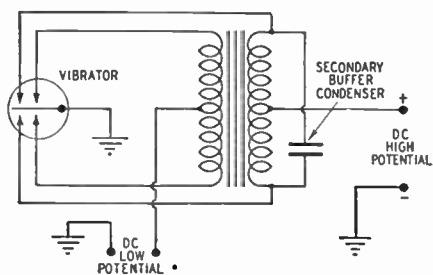

Figure 146. Full-wave power supply using a synchronous vibrator.

These contacts are insulated from each other, but the moving contacts may be common for these two sets. As you see from the diagram of the synchronous vibrator circuit, such arrangement of terminals is required.

much higher than this voltage, a condenser rated at 325 WV, or higher, may be used. If a condenser is rated at break down voltage only, make sure this voltage rating is at least 1.4 times greater than the D.C. voltage measured. In most full-wave power supplies, 450 WV condensers should be used; in AC-DC half-wave supplies, you are safe with condensers rated at 150 WV. The capacity will depend on the equipment the power supply is to serve, but the larger the capacity the better.

**VIBRATOR.** A transformer will work only with changing voltage. The voltage need not be of sine wave type, but it must be changing. If a transformer is connected to a six volt battery through a switch and this switch is closed and opened very fast, the D.C. voltage of the battery will be interrupted. The voltage will change from zero to six volts many times per second and the transformer will operate. It is possible to produce this type of interrupted voltage even more efficiently with the aid of a special vibrator.

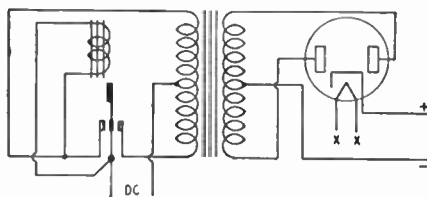

Figure 144. In a vibrator power supply, the low voltage is interrupted to permit the stepping-up of the voltage with a power transformer.

Examine the left hand side of the illustration above. Notice that the D.C. (6 volts in the case of most units) has one lead connected to the primary center-tap. The other side of the D.C. is connected to the center vibrating reed and also to a small electromagnet near this reed. Now trace the circuit through and you will see that the current passes through one-half the primary. Enough current goes through to make the small electromagnet attract the reed to the left, completing the circuit between the reed and the left-side terminal. This action *shorts* the electromagnet, but increases the current through the upper half of the primary. Now, since the electromagnet has lost its attraction, the reed will swing back all the way and make contact with the right-side terminal. The current will not be present in the upper half of the primary, but will now flow in the lower half and in the opposite direction. This is very much like the two loops of the A.C.

The reed is flexible and vibrates back to the center position. At that instant, the entire cycle repeats itself. This action takes place about 115 times per second, and we have a type of A.C. for the operation of our transformer. This transformer steps up the voltage to the required value and the balance of the power-supply is made up of the usual rectifier (shown) and filter (not shown).

**SYNCHRONOUS VIBRATOR.** The armature of a synchronous vibrator closes another set of contacts which serve to rectify the current in the secondary. The figure shows this principle. When the armature moves downwards, it not only closes the primary circuit but also the secondary; when it moves up, the other halves of both the primary and secondary are closed. A buffer condenser is again employed in the secondary to improve the wave form. The usual R.F. filters and the ripple filter are used as in the other vibrator system.



**BUFFER CONDENSERS.** There are some special precautions to be taken in the design of vibrator systems. When the contact is made, there is such a sudden increase of current that a high voltage peak is induced in the secondary. Furthermore, sparks are likely to appear at the contacts. Various ways have been devised to eliminate the interference caused by the vibrator. Buffer condensers are generally placed across the secondary and sometimes across the primary. The buffer condensers used in the primary may be .5 mfd. 600 volt types, one across each half. The buffer condensers in the secondary circuit may be .008 mfd. tested at 2,000 volts. Other manufacturers connect a center-tapped resistor across the primary. The buffer condensers will absorb the sudden charges and, thereby, improve the waveform. Yet this alone is not sufficient to insure noise-free reception. The supply filter may contain an R.F. filter in addition to the regular filter and the filament circuit may be filtered too. Also the filament circuit should not have any part in common with the vibrator circuit except the battery, of course.

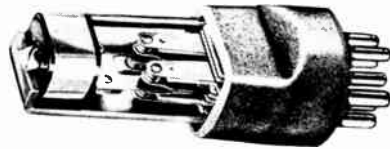

Figure 145. Vibrators may be constructed with extra sets of contacts in order to handle greater current.

**DRY PLATE RECTIFIERS.** For rectifying A.C. at low voltages, chemically covered plates are well suited. When a magnesium treated disc is brought in proper contact with a disc of copper sulphide and a current passed so that a reaction takes place, this combination conducts only in one direction. This single direction conduction is similar to the action of a diode rectifier and can be used for the same purpose.

**REVIEW QUESTIONS AND PROBLEMS.** 1. Why is power needed for operating radio equipment?

2. Can batteries supply the power needed by any type radio unit? If your answer is yes, is such practice practical?

3. Explain the construction of a "B" battery.

4. How does a diode rectify A.C.?

5. What *number* tube can be used as a full-wave rectifier? Can this same tube be used as a half-wave rectifier?

6. If a power supply without a filter is used with a radio receiver, what fault will be noticeable?

7. What factors must be considered in choosing a power transformer? Can a 25 cycle transformer be used for 60 cycles?

8. How are chokes rated?

9. Why do some sets have a voltage-divider?

10. How does a vibrator change D.C. to suitable current for operating a transformer?

11. Why are buffer condensers needed?

12. What advantage is there to the synchronous vibrator?

13. Can full-wave rectification be obtained by using several dry disc rectifiers? Can you sketch the circuit?

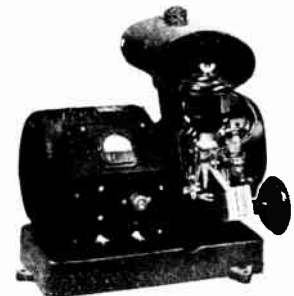

Figure 151. Gasoline-motor-driven generators are used to generate electric power for portable requirements.

4. Explain this action detail. Use sketches.

5. Refer to the tube characteristic charts and observe what facts are stated about rectifier tubes that are not presented for other vacuum tubes. You probably know a few rectifier tube types,

6. If you have a radio available for experimentation, you are safe in disconnecting the two filter condensers employed in the power supply. Only one lead of each condenser need be broken. What happens to the operation?

# LESSON 11

## Audio Amplifiers and Accessories

This lesson presents important facts on the fundamentals of *public address* which is the special name for electronic amplification of sound.

In this lesson especially, you may find many new words not familiar to you. These words should be looked up in the dictionary. We suggest that you write the meaning in the margin alongside the difficult word so that you will be reminded of the definition.

The letter F. stands for the Fahrenheit thermometer measurements. This thermometer is used in the United States. At 32 F., water freezes, and at 212 F., water boils.

**SOUND TO ELECTRIC ENERGY.** In order to amplify sound, speech or music, the sound energy must be changed to the equivalent electrical energy. Once the sound takes the electrical form, it may be handled by radio equipment and, finally, in the receiver changed back to sound energy. We must learn a little about sound and about the devices used to change sound to electrical energy.

**NATURE OF SOUND.** Sound must be conducted through some medium. In general, solids are very good conductors of sound, but porous materials such as cotton, sawdust, etc., are poor conductors. Liquids are better media for sound conduction than gases. For us, the air is the most useful medium for sound conduction.

The physical meaning of sound is the existence of a disturbance in the air or other media consisting of a succession of alternate waves of *compression* and *rarefaction* that tend to travel outwardly in all directions away from a vibrating body.

The velocity or speed of sound in air has been carefully determined. In air at 32° F. temperature, the velocity of sound is 1,090 feet per second. As the temperature rises, the velocity also increases. This rate of increase is about one foot per second per degree F.

The velocity of sound in many other media also has been determined. In water, it is approximately four times as great as in air. The velocity in any medium is inversely proportional to the square root of the density. A solid having greater weight per unit volume, all other factors being equal, will have lower velocity. The velocity is also directly related to the elasticity of the material. The elastic constant of any substance is the degree that the substance resists deformation. Soft rubber has a very low elastic constant.

Vibrations are transverse or longitudinal. Water waves are transverse to the line of motion. There is no forward movement of the water itself, but there is a rising and falling motion as the water wave advances. Any particle of water on the surface will rise and fall, but will move neither forward nor backward. If the motion of the particle was plotted against time, it would describe a curve similar to the wave. The wave itself, of course, results because a great many such particles move up and down in the correct order.

When a body vibrates, the air immediately in front is first compressed and then released. In this way, a series of condensations and rarefactions is produced. This train of waves is longitudinal, since it takes place in the direction of motion. There is but little movement of the air forward since each pulse communicates its energy to the air directly in front.

Any sound wave, no matter how complex, may be shown to be made up of a number of simple sine waves. One of these is the original wave and the others the harmonics or overtones of this wave. The character of sound depends only on three things: (1) pitch, (2) loudness, and (3) quality.

The pitch is the characteristic which enables us to distinguish between notes of various frequencies, the high, medium, low-frequency notes for instance. Pitch is a direct function of the frequency of the vibrations. In simple and complex tones, the pitch is usually determined by the fundamental frequency. In some complex tones, however, this is not the case as shown by recent research work.

The second characteristic, loudness, depends on the energy of the vibration. Our ears respond to loudness in logarithmic proportion and not in direct ratio. A ten-fold increase of loudness would appear to the average listener only as twice as loud. Signals of equal intensity but of different frequencies usually appear to be of different loudness.

Quality of *timber* of sound is the characteristic that enables us to distinguish sounds of identical pitch and loudness but produced by different people or instruments. Every one knows that the same notes played on a violin and piano equally loud will sound entirely different. This is because both are of the same pitch and have the same fundamental frequency, but the harmonics present in each greatly differ in number and their relative intensities.

**ACOUSTICS.** *Acoustics* is that branch of science that deals with the action of sound. All sounds created proceed outwards in spherical waves until they strike the boundaries of the room. Upon striking the walls, sounds are absorbed, reflected, and transmitted in varying amounts depending upon the character of the walls. Sound energy is diminished with each reflection because of the absorption, and this finally results in the sound dying out. Continuous reflection has the advantage of loudness, but always introduces prolonged existence of each sound. This prolongation, or *reverberation*, is the most common acoustic fault found in auditoriums.

A person talking in an auditorium having a high reverberation time can be understood only with difficulty. Each sound instead of dying out quickly persists for some time, so that spoken words blend with their predecessors and set up a mixture that produces confusion. This acoustic difficulty may be corrected by the introduction of sound-absorbing materials to reduce the reverberation time.

In the case of music similar, but less objectionable, effects are produced because of prolonged reverberation. Good acoustical conditions are obtained when sound rises to a suitable intensity, with no echoes or other types of distortion, and then dies out quickly enough not to interfere with the succeeding sounds. This is a very hard condition to fulfill, but considerable departure from the ideal is not very objectionable to an average listener.

**CARBON MICROPHONE.** A microphone is a machine for transforming the sound waves into corresponding electrical energy. How truthfully it performs this task is the test of its excellency. The carbon microphone was commonly used in the early days of broadcasting and is still the type employed in telephone work. A cup containing small carbon granules is so placed and mechanically connected to a diaphragm that sound vibrations, striking the diaphragm, cause fluctuations of the diaphragm and of the carbon granules. These granules are compressed as the direct result of the sound waves striking the diaphragm. The resistance of the carbon granules (collectively) varies as a function of the sound

Harmonics of any frequency are frequencies which are multiples of this fundamental frequency. For example, a 400 cycle note, may have a second harmonic of 800 cycles, a third harmonic of 1,200 cycles, etc.

*Absorbed:* consumed, used up, killed.

*Reflected:* bounced off, returned.

*Transmitted:* passed on, gone through.

Reverberation time of an auditorium may be shortened with the aid of sound absorbing material. Drapes and carpets help. The wall and ceiling may be lined with special sound absorbing blocks.

## TYPES OF MICROPHONES

This current is only the exact electrical equivalent of the sound in the practical sense. Certain amount of distortion and change is introduced by the microphone.

The impedance of each microphone button, acting as a voltage generator in conjunction with the battery, for the average audio frequency handled is about 200 ohms. The transformer is designed to match this impedance to the secondary circuit. Although the grid circuit theoretically presents an infinite impedance, because of leakage in the transformer terminals and capacity effects, the actual impedance is in the order of 100,000 ohms.

By upper end of audible frequency range we mean the high audio frequencies not used for radio work.

The condenser microphone is interesting only from the historical point of view.



Astatic crystal microphone.

waves. Since the resistance varies, the current, passing through the microphone and supplied by a battery, also varies. This current is an exact electrical equivalent of the sound reaching the microphone. In the two-button microphone, one button is placed on each side of the diaphragm and so operate exactly out of phase. This electro-acoustical push-pull arrangement cancels out the even-order harmonics and improves the quality of reproduction.

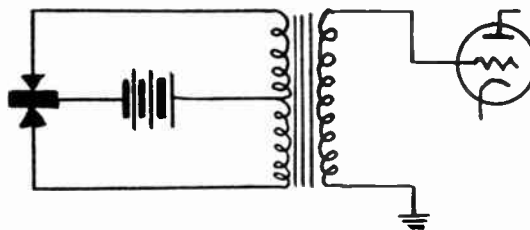

Figure 152. A circuit of a double-button microphone. Notice how the unit is connected to the center-tapped primary of the microphone transformer. The secondary is designed to match a high impedance and may be connected directly to the grid of the first tube used in the audio amplifier.

The thin metal diaphragm will resonate at a certain frequency and cause an increased undesirable output at this audio (sound) frequency. The better grade microphones have their diaphragms stretched so that resonance occurs at the upper end of the audible frequency range. This bad feature may be further reduced by air damping. The output of a carbon microphone is larger than that obtainable from other units. You will learn about decibels later in this chapter and will then understand what we mean when we say that this microphone has an output of about minus 40 decibels. The output impedance of each button is 200 ohms, and a transformer is used to match this to the equipment used.

**CONDENSER MICROPHONE.** At one time the condenser microphone was very popular, but it is not used at present. If a variable condenser is connected to a source of voltage, the charging current will vary with changes in the capacity. The diaphragm of a condenser microphone constitutes one of the plates of a condenser, while the fixed back plate acts as the other plate. The capacity so formed is in the order of only 200 micro-microfarads, and the maximum variation in capacity is only 0.01%, that is about .02 micro-microfarads, a very small amount.

Usually the head of the condenser microphone contained a built-in pre-amplifier to bring up the output signal to the level delivered by a carbon microphone.

**CRYSTAL MICROPHONE.** The crystal microphone employs a piezo-electric crystal as a generating element. A crystal when subjected to stresses of sound waves produces corresponding electrical changes in current which is generated by the crystal element. The output level of a crystal microphone is, of course, much lower than that of a carbon microphone, usually in the order of -60 db., and requires either a suitable pre-amplifier or a main amplifier of a high gain type. The crystal microphone has absolutely no background noise and the response is not effected by the position of the microphone or by reason of moving it about while in use.

By using specially shaped and treated housing cases for crystal

elements, it is possible to obtain crystal microphones which have desirable directional characteristics. It is an advantage, for example, to have a microphone which does not pick up sound originating from the side facing the audience.



Figure 153. Crystal microphones are commonly used for public address and broadcasting requirements. The microphone itself is mounted on a desk or floor stand.

*Courtesy Shure Bros.*

**VELOCITY MICROPHONES.** The velocity microphone has been more recently developed and because of its excellency is finding extensive application. Velocity microphones have an output of about the same value as the output of crystal types, and may be obtained in high-impedance types for direct coupling to the control grids of vacuum tubes.

The velocity microphone has highly directional qualities and will not pick up background noises. This greatly assists in reducing the possibility of reproducing undesirable noises. This type of microphone further has no internal "hiss noises" and possesses quite flat response characteristics over a wide audio frequency band.



Figure 154. The dynamic microphone illustrated has desirable directional pick-up qualities.

*Courtesy Shure Bros.*

Microphones, in general, are mounted on suitable floor or table stands. Ring and spring mounting is used for carbon microphones while other types screw directly on the stand.

**PHONO-PICKUPS.** A pickup arm may consist of a permanent magnet within which is pivoted a coil of wire directly connected to the needle. As the needle *works* along the groove of a record, the unevenness of the grooves sets the needle in vibration. Since the needle is connected to the coil by mechanical means, the mo-

## VELOCITY MICROPHONE

Most modern microphones mount directly on floor and desk stands. The stands have threaded male ends while the microphone housing has female threads. Adapters are available to match the microphone to a stand which may have different size threads or pipe size.

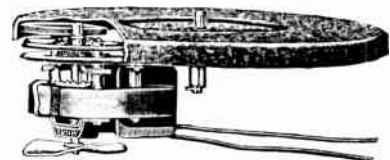

*Courtesy Alliance Manufacturing Co.*

Cut-away view of a phono motor and turn table. The small fan circulates air to keep the motor cool.

**PHONOGRAPH PICKUPS**

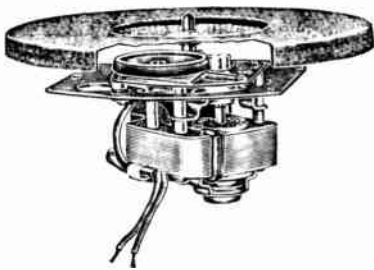

*Courtesy Alliance Manufacturing Co.*

An illustration of another rim driven phono motor and turn table.

Mathematically the relationship between gain or loss of audio power, compared in terms of decibels, is:

$$DB = 10 \log_{10} \frac{P_{out}}{P_{in}}$$

This means that the gain or loss in decibels is equal to ten times the logarithm (to the base ten) of the power "out" divided by the power "in."

tion is transferred to the coil which, in moving, cuts the lines of force of the permanent magnet. A current is set up in the coil. This current corresponds to the recorded sound.

Phono-pickups of this type are called magnetic and may be obtained in high-impedance output types for direct connection to the input control grid of the vacuum tube used as an amplifier. Some of the older magnetic pickups are of low impedance types and must be matched with suitable transformers to the input.



*Courtesy Astatic Corporation*

Figure 155. Crystal pickups are used in record reproducing equipment.

Crystal pickups are very similar in operation to crystal microphones, but have the needle instead of the diaphragm actuate the crystal element. Crystal pickups develop greater output than most magnetic types and are always of the high impedance type.

**INTENSITY OF SOUND.** The sound intensity of an explosion is so many times greater than the sound of a pin dropping in a quiet room, that the human ear *adjusts* these levels to each other in a different proportion. When sound is actually ten times louder by the measurement of power in each case, the sound will appear to a human listener only as twice as loud. A convenient way for measuring sound or any other energy related to the auditory sense is to use the logarithmic unit called the decibel and abbreviated DB.

It is best to calculate the gain or loss in decibels by using a table rather than the exact mathematical formula. To use the table below, first get the ratio of the powers under consideration. If there is a power gain, the ratio will be a number greater than one.

Gain in DB	Power Ratio	Loss in DB	Power Ratio
40	10,000	0	1.
35	3,162	1	.8
30	1,000	2	.6
29	800	3	.5
26	400	4	.4
23	200	5	.32
20	100	6	.25
15	32	7	.2
12	16	8	.16
10	10	9	.12
9	8	10	.1
8	6.3	11	.08
7	5	13	.05
6	4	15	.03
5	3.2	17	.02
4	2.5	20	.01
3	2	25	.003
2	1.6	30	.001
1	1.3	35	.0003
0	1	40	.0001

If power is lost, the ratio will be a quantity less than one. Not all ratios are listed in the table, but the closest one to the value you need, will give you the answer accurate enough for practical work.

If power is increased from 2 watts to 64 watts, the ratio will be 32. Please notice that to obtain the ratio, you divide the output power by the input power. Looking up the gain of 32, you find this corresponds to a gain of 15 DB.

Of course, this table is also applicable when the gain or loss in decibels is known and power ratio is required. For example, in passing through a single audio stage the signal is increased 20 DB; what is the power ratio of the output to the input? An increase in 20 DB is a gain in 20 DB, and looking this up in the table, we find the corresponding power ratio equal to 100.

Since DB is always a ratio, when we speak of an amplifier as having so many decibels gain, we assign an arbitrary level of comparison. Usually 0.006 watts is taken as this figure. If one amplifier has 75 decibels in comparison with a given arbitrary level, while another has 60 decibels in comparison to this same level, the first has (75-60) or 15 DB more gain.

The transmission unit is employed to express any ratio of power, mechanical loss or gain, etc. related in some way to the auditory sense. The gain in voltage may also be considered in terms of decibels, but the voltages must be considered across equivalent impedances. In case you are considering voltage ratios and use the table above, the answer in decibels must be doubled. For example, a voltage ratio of 100, corresponds to 40 DB (and not 20), and the voltages must be measured across equal impedances.

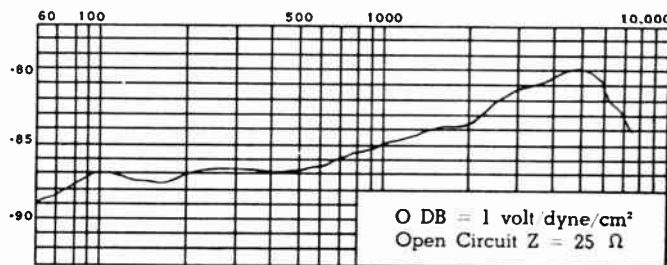

Courtesy Electro-Voice Mfg. Co., Inc.  
 Figure 156. The output of a good quality microphone varies a little when used at different frequencies. The graph illustrates the output level of a good quality velocity microphone.

**VOLTAGE AMPLIFICATION.** Once sound is converted to electrical energy it is of very low intensity and must be increased or amplified. Vacuum tubes are ideal for this purpose and are used extensively in circuits known as audio amplifiers. We will first discuss the circuits which amplify the signal voltage and feed this voltage to the next stage which, in turn, also operates from a voltage signal alone and does not require power. Later we will explain the function of *power* amplifiers which are used to deliver actual audio power to loudspeakers.

We have in the figure a curve which represents the characteristics of a vacuum tube with a fixed plate voltage. You will notice that the vertical scale represents the plate current, while the horizontal scale represents grid voltage. As the grid voltage becomes more negative (to the left), the plate current is diminished.

In some instances, a comparison level of .001 watts is used instead.

This doubling results from the mathematical fact that power is a function of the voltage squared: i.e.

$$W = \frac{E^2}{R}$$

The basis for sound comparison also can be made on the assumption that 0 DB is equivalent to the development of a certain voltage with a given air pressure. For example, in the case covered by the graph, 0 DB is equal to the development of a voltage change of 1 volt with the air pressure of one dyne per square centimeter of surface.

Any amplifying stage requires some power in the form of the exciting signal. However, this power is so trivial that, for practical considerations, we can assume only a signal *voltage* is needed. Of course, the real power needed for operation of the stage comes from the power supply.

## VOLTAGE AMPLIFICATION

To fix these ideas more clearly, assume that the tube is operated with minus 5 volts on the grid. With no signal, the voltage of the grid (in respect to the cathode) is  $-5$ . For simplicity, we will assume that the signal is a sine wave having a peak value of 3 volts. When this signal, for an instant or so, reaches a peak of positive 3 volts, the actual voltage on the grid will be the algebraic sum of these voltages, or  $-2$  volts. At another instant, the signal may reach its negative peak of 3 volts. At that moment, the grid will have a potential of  $-8$  volts.

Notice the incoming signal represented by a succession of waves as shown in the lower left hand corner. This incoming signal will vary the fixed grid voltage, at times making it more negative and at other times making it less negative. The operating point X, therefore, will shift up and down the characteristic curve in accordance with the incoming signal.

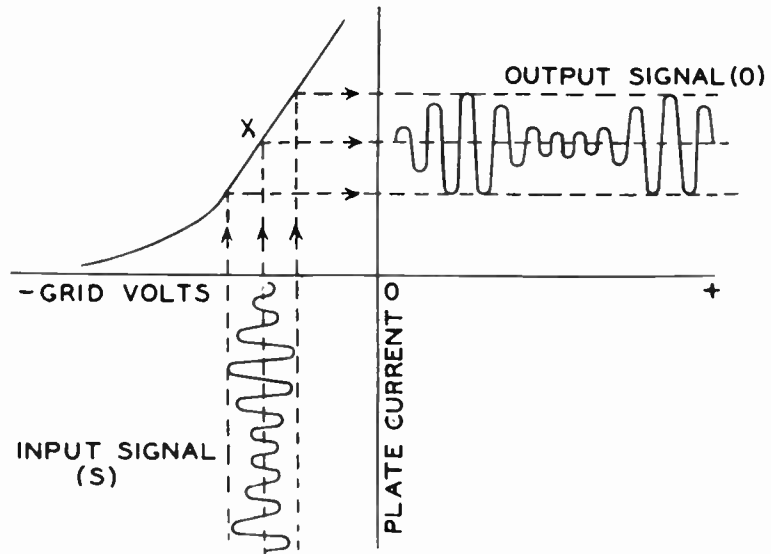

*Courtesy RCA*

Figure 157. Please observe that the input signal will change the grid voltage on the control grid of a vacuum tube. This in turn will vary the plate current and produce a larger voltage change across the load impedance.

This changing of the grid voltage will correspondingly vary the plate current, and the actual current can be represented by a similar but larger set of waves marked, "Output Signal."

If this variation in current, which you understand is an exact duplication of the incoming signal, can be used to produce a voltage variation across the plate resistor or impedance this new voltage will be larger than the original signal. In this manner amplification will take place.

**TRANSFORMER COUPLING.** Let us assume that the radio tube we have been considering is so connected that the plate current must pass through an inductance in order to reach the plate. This simply means that a coil is connected between the B-plus terminal and the plate connection of the vacuum tube. Since audio frequencies are involved, the inductance will have an iron core.

The current variations, which are occurring because of the incoming signal, will produce a changing voltage drop and set up a changing magnetic field in accordance with these variations. The voltage so developed will be larger than the incoming signal by a ratio a little less than the amplification factor of the vacuum tube. For example, if the vacuum tube has a  $\mu$  of 20, the gain will be in the order of 17.

In order to isolate the positive plate voltage from the tube grid of the next stage, a transformer is employed. To construct a transformer from the plate inductance we have described, it is only necessary to place the secondary coil on the same core. In this fashion, the proper grid bias can be applied to the next stage, and

Current passing through an impedance produces a voltage drop in proportion to the current.



at the same time the plate voltage of the preceding stage can be kept out of the grid circuit. The voltage developed in the primary inductance will be transformed to the secondary (grid) inductance. The turns ratio may be made about 3 to 1, and a further step up of the voltage by a factor of three will result. Besides doing all this, an interstage coupling transformer will also, to a large degree, match the impedance of the plate circuit of one tube to the grid circuit of another.

Transformer coupling always produces some audio distortion and the tone quality from equipment using inexpensive transformers is not as good as resistance coupling which we will describe next.

**CLASS OF OPERATION.** By referring back to the characteristic curve on the previous page, you will see that under all conditions of operation considered, some plate current is present. With no signal the current is indicated by the operating point X. As the signal is impressed, the operating point may shift, changing the plate current, but always permitting at least some small value of plate current to exist. If plate current is always present in a circuit, the tube is operated in *Class A*.

If the operating point is located at the extreme left hand side of the curve making the plate current almost zero with no signal, this is known as *Class B* operation. You will notice that, under this condition, if the signal makes the grid more negative than this assumed cut-off point, no plate current will be present. However, when the signal is positive, the operating point will shift sufficiently to the right, from this cut-off point, to permit plate current.

Sometimes vacuum tubes are operated with the bias twice the negative amount required to stop plate current, i.e. twice cut-off value. In such operation, only during the extreme peak positive operation of the signal does the plate current flow. This means that during the greater portion of any cycle of the signal, no plate current is present. This type of operation is known as *Class C*, and is used in transmitters.

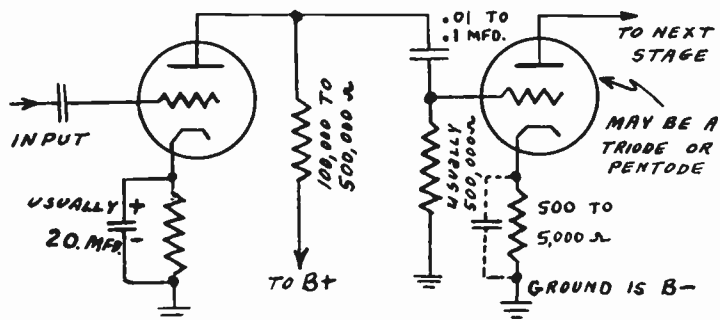

Figure 158. Resistance coupled stages are used in the audio section of radio receivers. The value of the parts employed is not critical. Resistance coupling gives better quality than is obtainable with inexpensive inter-stage transformers.

**RESISTANCE COUPLING.** For economy reasons and for better tone quality, the plate circuit of a voltage amplifying tube is loaded with a resistor. Usually a resistor of 100,000 or 250,000 ohms is connected from the plate of the vacuum tube to the positive potential of the plate supply. This resistor, in other words, replaces the primary of the interstage transformer.

The voltage drop across this resistor will be a function of the plate current, and will, therefore, vary with the signal. Please

## A, B, OR C CLASS OF OPERATION

In the usual triode, a plate load of about 10,000 ohms will give best results. The grid input impedance is in the order of 100,000 ohms. These impedances must be matched with the transformer.

The operational point of a *Class A* amplifier is selected to permit the operation over a straight portion of the characteristic curve.

With *Class B* operation, the plate current is practically zero with no signal. Additional negative potential caused by a negative peak of the signal will make the grid more negative and still keep the current at zero.

The object of circuits using *Class C* operation is to shoot out pulses of plate current at the extreme positive peaks of the signal voltage.

The plate current of the first tube of the circuit produces a voltage drop across the plate load resistor. (This current must pass through this resistor and an IR drop will result.) As the current changes (due to the action of the signal on the grid), the voltage drop across this plate resistor will also change. This changing voltage drop is re-impressed upon the grid of the tube in the next stage.

## RESISTANCE COUPLING

These voltage relationships are very important and must be clear to you. The amplifying action of the stage and the phase relationship are explained in these paragraphs.

For the practical technician working with radio and electronic circuits, the operating data for different vacuum tubes employed can be found in tube manuals.

What happens if the grid resistor is too small? Since the signal developed across the plate resistor (refer to page 135, Figure 158) is placed across the plate coupling condenser and grid resistor in series, the available voltage will divide itself. The condenser has a definite value of capacitive reactance at any one frequency, and this reactance (impedance) is in series with the grid resistor. If the grid resistor is too small, only a small fraction of the total signal developed will excite the grid of the next stage and the circuit will have poor bass response since the capacitive reactance will be higher for low frequencies.

understand that when the grid signal of the tube is becoming more positive, the plate current will increase, and so will the voltage drop across the resistor. Since the supply voltage is fixed, the available voltage on the plate of the tube will become smaller. The voltage on the plate is always equal to the plate supply voltage minus the voltage drop in the plate resistor.

If a voltmeter is connected across the plate resistor, the negative terminal will be at the side of the resistor which is connected to the plate. If the voltage drop across the plate resistor increases, that point actually becomes more negative. You can see, therefore, that a positive, increasing grid-signal will produce a greater current, greater voltage drop, greater negative voltage at the point of the plate resistor which is near the plate of the vacuum tube. From this action, you can see that the tube apparently reverses the direction of the signal and also amplifies it at the same time.

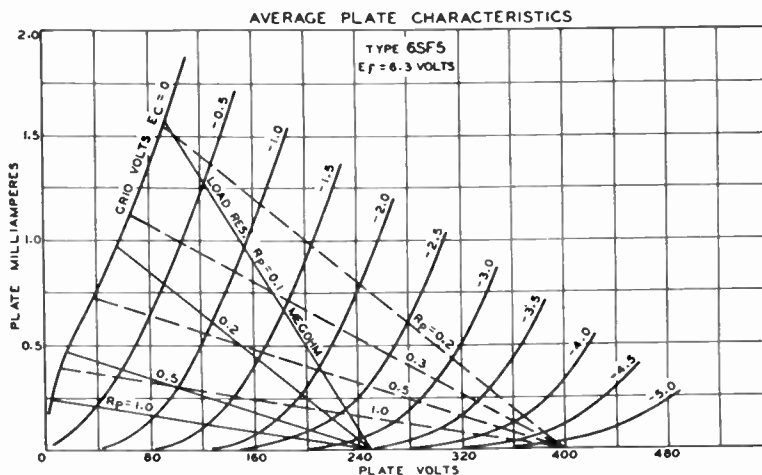

Courtesy RCA

Figure 159. Average plate characteristic curves may be used to determine the operation to be expected under different conditions. The illustration shows the expected operation with different load resistances.

The next audio stage may be connected directly to this point of the plate resistor, but it needs to be isolated to keep the D.C. plate voltage out. For this purpose, the plate coupling condenser is connected between the plate of the vacuum tube we have described, and the next stage tube control grid. This condenser should be rated at 400 or 600 volts and may be almost any size between .01 and .1 mfd.

The grid of the tube in this next stage must have a return circuit to the ground (chassis) in order to permit the leaking off of electrons. The grid resistor is used for this purpose. This resistor may be of small power rating, and in most circuits has the resistance value from 250,000 to 1,000,000 ohms. This resistor is connected from the grid of the tube to the ground.

**HOW GRID BIAS IS OBTAINED.** In radio receiving tubes, the grid must be biased to a negative potential. The value of this voltage must be such that it will keep the grid negative even on the most positive peaks of the incoming signal. This means that the bias voltage must be greater than the strongest signal. In the experiments we discussed, we used a small battery to provide the grid voltage. Such a battery is called the C battery. Since the grid circuit does not pass current, the battery will last a very long time. However, even when not used, batteries age and become

*dead* with time. For this reason and because we want our radio receivers to be completely A.C. operated, battery bias is not ordinarily employed.

In radio sets using a voltage divider, it is possible to connect a tap delivering some small positive voltage to the cathode of the tube to be biased. A lower tap (representing a negative voltage by comparison) is connected to the grid return which may be the grid resistor in a resistance-coupled stage. This arrangement automatically will supply a negative voltage of the chosen value to the grid in respect to the cathode of the tube.

In some sets, the filter choke is placed in the negative leg of the power supply. This choke has D.C. resistance and will produce a voltage drop in relationship to the current the set draws. Please understand that the average plate current in a *Class A* tube, as used in radio receivers, is almost constant. This means that the total plate current of the radio set operating is almost a constant. The voltage drop across the choke may be used to supply the needed bias to one or more tubes. If the entire voltage drop is not needed, a part of the drop may be *tapped-off*.

The self-biasing method is most often used in radio receivers. In such circuits, the grid return is connected to ground (chassis) which also is the negative side of the plate supply. The cathode is connected to the ground through a suitable resistor. Now the plate current passing through the tube must go through this cathode resistor to the plate supply negative terminal (the ground in our circuit). When current passes through a resistor, it produces a voltage drop which is equal, at all times, to the current multiplied by the resistance. For example, let us say the tube we are using has a plate current of 5 ma. or .005 amperes, and the resistor used is 2,000 ohms. Multiplying these, we obtain a voltage drop of 10 volts. This is the actual voltage across the cathode resistor.

Now one side of this resistor is connected to the cathode of the tube. The other side of the resistor is connected to the ground—the very same point where the grid return of the tube is connected. So you see that the voltage across this resistor is impressed on the grid in relationship to the cathode. Please notice that no voltage drop occurs in the grid resistor (the one which is usually 250,000 ohms to 1 megohm) since the grid does not pass any current.

We see that there is a voltage between the grid and cathode, but is the grid negative as needed? We already mentioned that the ground is the most negative point of the power supply. Of course, the plate of the tube is positive. Since the cathode is between the plate and ground, it is more positive than ground. But ground potential is also the grid potential, since they are connected together through the grid resistor. And so the grid is more negative than the cathode, as required.

The voltage across the cathode resistor, which is our bias voltage, is a direct function of the plate current at the instant. This plate current is varying up and down with the signal. The rate of this up and down change depends on the frequency of the audio signal being received. But we want the bias to be fixed and not change with the signal. To accomplish this, we by pass the signal variations around the cathode resistor with a by-pass condenser. In practice, in the audio stages, this cathode by-pass

This is the important method of obtaining bias.

Since this bias voltage in reality is supplied by the power supply, the voltage of the power supply serving the plate circuit is actually reduced by the amount lost in the cathode bias resistor.

The voltage drop produced in any resistor is the product of the resistance by the current. If the current is zero, the product of any resistance by zero, is zero.

The plate current passes through the tube and, since the electrons originate from the cathode, the same current must pass through the cathode resistor at every instant.

This increase in current at certain instances exactly corresponds to the decrease at corresponding instances a moment later in the cycle. The instantaneous currents integrated over a period of time will correspond to the average *no-signal* current.

A generator will deliver maximum power to a load of a value exactly equal to the generator impedance. If power is of no importance (as in voltage amplifiers), a load having higher impedance (usually a resistor) will produce a larger voltage drop.

Almost any pentode may be turned into a triode by connecting together the screen grid and plate.

condenser is large, about 10, or 25 mfd. An electrolytic condenser may be used since the cathode is always positive in respect to the ground. The working voltage required is about 35 volts. If the by-pass condenser is omitted, a certain amount of degeneration and distortion will result.

**TRIODE POWER AMPLIFIER.** In any power amplifier the object is to develop power with little distortion. We have already studied how a vacuum tube is used to produce voltage amplification. In order to produce as much power as possible, the tube must be operated with as much plate current change as possible. However, to keep distortion to a minimum, only a little of the extreme parts of the characteristic curves may be used. The center, straight portion is used primarily. The operating point (no signal point) is in the center representing the plate current with no signal. With signal, the plate current may almost double on positive peaks, and be reduced almost to zero on the negative peaks. Over a period of time, however, the average plate current remains constant. This is why a meter in the plate circuit will show no change in the plate current except for minute variations due to harmonics.

The power amplifier stage must be driven with a signal which has peaks equal (almost) to the bias voltage. This will cause the instantaneous grid voltage to vary from zero to twice negative bias voltage on peak signals. Since triode power amplifier tubes have low amplification factors, the signal voltage needed is quite high. The triode power amplifiers have low power sensitivity. Types 45, 2A3, 71A, are power amplifier triodes.

The power amplifier tube acts as an A.C. generator and must be correctly *loaded* to deliver maximum power output with the least distortion. Usually power amplifier triodes are loaded with an impedance which is exactly equal to their dynamic plate resistance. Voltage amplifiers, on the other hand, are loaded with resistors from twice to several times the plate resistance, and this practice gives better results for voltage amplification.

**PENTODE POWER AMPLIFIER.** Pentodes designed for the audio final stage have higher power sensitivity and, therefore, require less exciting voltage. Most receiving type pentodes have power outputs around 4 watts, while triodes average as a class around 2 watts. The signal needed for some pentodes is as little as 12 volts peak, while many triodes need a peak signal of 50 volts. Since pentodes have extremely high plate resistance, they are loaded with impedance values considerable lower than this plate resistance. Usually the value of the load is determined by radio engineers, considering the amount of distortion and power output. A value is selected which will give the maximum power output consistent with permissible distortion. In stages using a single pentode output tube, 10% is considered permissible amount of total distortion.

The type 6F6 power output pentode is often used in radio circuits.

Pentodes have greater amplification for the higher frequencies and a small by-pass condenser, to neutralize this effect, is connected from plate to ground. Since the screen grid may be considered at ground potential as far as the audio frequencies, the by-pass condenser, we described, may be connected between the plate and screen grid. The screen grid, of course, is at a high D.C. potential

in respect to ground. This by-pass condenser may be about .006 mfd. rated at 600 volts.

**BEAM POWER AMPLIFIER.** When a beam power output tube is used in the final audio stage, it acts very much like a pentode. However, less filtering of the power supply is needed. In some circuits, the plate supply is taken right off the rectifier with but a single filter condenser doing the filtering up to that point. The screen grid voltage, however, must be better filtered and is usually of a lower potential than the plate. Check the operating details of a 6L6 tube, used as a single-ended final amplifier.

**TUBES OPERATING IN PARALLEL.** In order to obtain greater power, two or more power amplifier tubes may be connected in parallel. When two tubes are connected in parallel, the plates are tied together and the other elements are also correspondingly connected together. In such instance, twice the amount of power obtainable from a single tube can be secured from the stage consisting of two tubes connected in parallel. The plate resistance of the combination will be one-half the plate resistance of a single tube. No special advantage\* is obtainable from this operation.

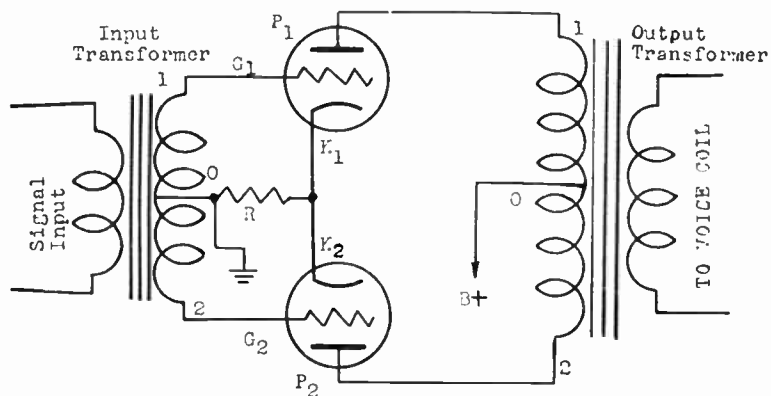

Figure 162. A basic push-pull audio circuit. The operation and advantages of this circuit are explained in this chapter.

**ADVANTAGES OF PUSH-PULL OPERATION.** Two identical power amplifier tubes may be connected in a special circuit to deliver more than twice the amount of power available from a single tube and at the same time offer other advantages. Please examine the transformer coupled push-pull stage as illustrated. Two similar type of power amplifier tubes are employed and only the cathodes are joined together. The plate current from both of these tubes must pass through the cathode resistor R, in order to reach ground which is the negative terminal of the plate power supply. Therefore, the voltage will be developed across R, and since the grids of both tubes are connected through the windings of the input transformer to the ground, bias will be obtained.

Please notice that the terminal marked B+ is connected to the positive side of the plate power supply. In a push-pull stage, the plate supply need not be filtered very well since the A.C. ripple present will pass to both tubes, traveling through the primary of the output transformer. The winding of this transformer is con-

\*Tubes operated in parallel increase the power handling ability in proportion to the number used and also lower the equivalent plate resistance of the combination. In some transmitters, this latter fact is of an advantage.

In such circuits, since the screen grid of the power tube and all other stages take but little current, a 3,000 ohm resistor is used instead of a filter choke.

Some electronic circuits require very low plate resistance,  $r_p$ , and this can be achieved by connecting several tubes in parallel.

A push-pull stage need not be self-biased. Other biasing methods, as in the case of single-ended tubes, may be used instead.

By identical tubes, we mean the same types and also matched to each other so that their characteristic curves are almost exactly the same.

## ADVANTAGES OF PUSH-PULL

The grids have equal and opposite polarity changes as compared with the ground potential.

We assume that the tubes are operated over the straight portion of their characteristic curves. This is true to a large degree in a practical case.

Reference is made to the output transformer which couples the tubes to the speaker. This transformer is known as a push-pull output type.

The recommended load for pentode push-pull tubes may be very much different than twice the load for a single tube.

As compared to the voltage at the center tap, the voltages at the two end terminals of a push-pull input transformer are  $180^\circ$  out of phase with this tap.

tinuous and the current, in going to the two tubes, will travel in opposite directions from the center. Therefore, the magnetic fields, set up in each half of the winding because of the ripple, will be opposing and the ripple will not re-appear in the output of the voice coil. The first advantage of a push-pull stage, as you can see, is less filtering needed in the power supply.

Referring now to the input transformer, please observe that an input signal produces a voltage across the entire secondary winding. If we consider center point, marked O, as neutral, then when point number 1 becomes positive, point number 2 is of exactly the same voltage, but correspondingly negative. Therefore, the two grids, marked G-1 and G-2, have equal but opposite polarity voltages at all times.

Since the grids will always have equal and opposite polarity voltages, the current while decreasing in one is correspondingly increasing in the other tube. For example, if these tubes are of such type as to have 40 ma. plate current per tube with no signal; the instant the plate current of one tube increases to 55 ma., the current in the second tube will correspondingly decrease to 25 ma. Since the plate currents of both tubes must pass through the biasing resistor R, and since, as you can see, the current for both tubes when added together will always equal a constant quantity (80 ma. in this case), the voltage drop across the resistor, R, will also be constant as required. Also because this voltage drop will not follow the audio variations, as the case of a single ended amplifier, no cathode by-pass condenser is needed. This is an important economy feature.

The varying currents from the two tubes, representing the signal, are added in the primary of the transformer, and a corresponding voltage is induced in the secondary which is connected to the voice coil. Since the magnetic fields produced by the D.C. currents are opposite in the two halves of the output transformer primary, no magnetic saturation can result and a lower priced output transformer will give as good results as a larger, more expensive transformer when it is used with a single tube. The push-pull action eliminates even order harmonics to a large extent and, therefore, with the same amount of permissible distortion, the vacuum tubes may be operated over a wider portion of their characteristic curves and deliver more than twice the rated power output of a single tube.

Besides triodes, pentodes and beam power tubes may be used in push-pull operation. The output transformer must be obtained to match the plate-to-plate impedance, and the required values are given in tube charts.

**PHASE INVERTER.** You have already learned that the two tubes used in a push-pull stage must have the signals  $180^\circ$  out of phase. In transformer coupled circuits, the proper phase is obtained automatically with the connections used. However, transformer circuits do not give as good quality as resistance-coupled circuits, and good quality transformers are expensive.

If a signal available in the pre-amplifier, used to drive a push-pull stage, is of a single phase only, some method is needed for inverting (shifting  $180^\circ$ ) the signal for one of the tubes used in the push-pull stage.

The phase inverter circuit employs two triodes or a single tube containing two triode sections. One of these triodes is simply an amplifier, while the second adds nothing to the gain but does re-

verse the phase  $180^\circ$ . The circuit of a phase inverter is illustrated.

Please observe that a single-phase input is fed to one of the triodes. The output of this tube represents an amplified signal  $180^\circ$  out of phase with the original input signal. This output goes to the control grid of one of the push-pull tubes. But besides this, a small portion of the voltage of this signal is re-impressed on the grid of the second triode tube used in the phase inverter. Only that fraction of the total amplified signal is fed to the grid of the lower phase inverter tube, which will make the signal to this tube exactly equal to the original signal at the input to the inverter stage. Bear in mind, however, that this signal to the second tube is  $180^\circ$  out of phase with the original.

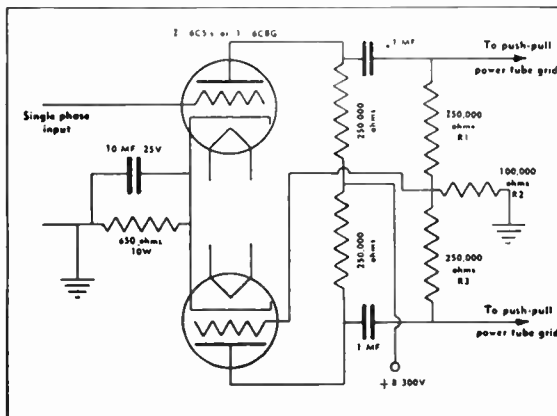

Courtesy Allied Radio Corp.

Figure 163. A self-adjusting phase inversion circuit employed for the purpose of driving the push-pull stage from a source of single-phase signal.

This second tube of the phase inverter also reverses the phase (places it again  $180^\circ$  out of phase), and the signals delivered to the two grids of the push-pull stage are  $180^\circ$  out of phase.

Although a 10 mfd. by-pass condenser is used across the cathode resistor, it is not really needed. The currents through the two tubes of the phase inverter are always increasing and decreasing exactly opposite to each other and their total is a constant. Therefore, as in the case of a push-pull stage, no audio variations appear across the cathode resistor and no by-pass condenser is required.

The fraction of the signal from the first inverter tube, which is fed to the second tube, is automatically made to be of the correct value. If this signal is too large, the output from the second phase inverter tube will also be large. This output signal produces a voltage drop across R-2, out of phase with the original voltage which comes from the tube in the upper section of the circuit. It will, therefore, reduce this signal until it is of the correct value.

**CLASS B AMPLIFIER.** Certain tubes such as type 46, pass very little current without the presence of a signal. Other tubes may be biased negatively to a point where the plate current will be zero. Let us assume two such biased tubes are connected in a push-pull circuit. We will learn that the circuit will not behave as a push-pull arrangement. You must also understand that tubes cannot be biased to cut off (zero plate current) with a cathode resistor. With

## PHASE INVERTER CIRCUIT

You have already learned that an amplifier tube inverts the phase of the signal by 180 degrees.

Read this paragraph again and fix the idea clearly in your mind.

Trace this through in the circuit.

This is a special feature of this particular phase inverter circuit.

*Class B* operated tubes are used for high audio power requirements and for certain stages of radio transmitters.

**Volume 1 - Page 109**

## CLASS B AND A' OPERATION

While the usual interstage transformer does not handle any real power, the transformer driving a *Class B* stage does handle power on signal peaks.

The *Class B* power output stage using (for example) type 59 tubes connected as triodes, has a current drain of 26 ma. with no signal, and a possible peak plate current of 200 ma. This certainly is considerable variation.

Headphones are still used extensively in communications work. The understanding of the principles which permit the operation of headphones will help you follow the explanation about loudspeakers.

**Volume 1 – Page 110**

no plate current, there will be no voltage drop in the resistor. Separate bias supply must be used.

The figure of a push-pull circuit, a few pages back, will help you follow the explanation. When a signal is present, during the first instant one of the grids is receiving a positive signal voltage, while the grid of the other tube receives a negative signal voltage. The grids are already biased to cut off and, if a grid is driven more negative, the plate current will still remain at zero. However, a positive voltage will reduce the cut off bias and plate current will be present. The amount of plate current through the tube will depend on the strength of the signal. Please notice that only one tube is conducting at a time. As the voltage on the two grids reverses, the other tube will conduct, but the one with the negative voltage will have no plate current present.

The action suggests a *push-push* arrangement; one tube "pushes" at a time. Since at times the grids are driven positive, the preceding stage must be capable of supplying the power drawn by the grids under this condition. This is accomplished by using for a driver stage a *Class A* power amplifier of suitable size, coupled by a transformer possessing the proper characteristics. The transformer is usually of a step down type.

With *Class B* it is possible to obtain high power output with comparatively small tubes operating at ordinary plate potentials. Since very little power is consumed with no signal, economy is another advantage. To offset these, the distortion present is always somewhat larger than for class A operation and the power supply must have very good regulations to maintain proper operating voltage with considerable current variations.

**CLASS A'.** It is possible to operate a power amplifier stage intermediary between *Class A* and *Class B*. This type of operation is called *Class A prime*, or *A'*. The bias used is greater than for the same tubes in *Class A*, but not enough to cause cut off. On low signals, the circuit behaves as a *Class A*, while on powerful signals the *Class B* action allows the handling of large power.



Figure 164. Head phones are employed to convert electrical energy at audio frequencies to corresponding acoustical (sound) energy.

*Courtesy Trimm Mfg. Co.*

**HEADPHONES.** Telephone headphones are used to convert electrical energy of suitable intensity back to sound energy. A diaphragm of magnetic material is placed close to one or two electromagnets. These electromagnets are usually connected in series and their resistance is of the order of 1,000 or 2,000 ohms. A fixed magnet is also included in the assembly and acts upon the diaphragm. Because of the fixed magnet, the diaphragm is always attracted inwards, but as the electromagnets become magnetized with the A.C. corresponding to the sound received, the magnetic fields add to and subtract from the existing field of the fixed magnet. This makes the total magnetic strength increase and decrease in accordance with the current variations. As you can see, the



vibration of the diaphragm is a function of the current which in turn is the electrical equivalent of the sound. If the permanent magnet was missing, the diaphragm would be attracted twice for each cycle (both on the positive and negative peaks) and the reproduction would not be true.

**BAFFLE REQUIREMENTS.** The speakers must always be used with some form of baffle to prevent the tendency of the front and rear sound waves from cancelling-out each other. If the baffle were omitted, sound compression produced in front of the speaker cone, when the cone moves forward, would cause the air to rush around the edges and relieve the rarefaction in the rear. To be equally effective to the middle and lower frequencies a baffle must be fairly large. In practice a 6" of 8" speaker will require a baffle with 40 inch sides.

A speaker mounted in a flat baffle made by ply-wood, celotex, or masonite will radiate sound almost uniformly in all directions. If the installation requires the projection of the sound forward, directional flares or special horn baffles must be employed.

**DYNAMIC SPEAKER.** The most popular loudspeakers in use are of the electrodynamic types. These speakers have the cones made in various sizes from 3 to 14 inches. The cone has a small coil mounted at the center. The coil-form rides over a pole piece of magnetic material, but does not touch this cylindrical piece. The coil itself is made of several turns of copper wire (about No. 20), having a D.C. resistance, in many speakers, of 6 ohms, and the A.C. impedance, to audio frequencies at about 400 cycles, of 8 ohms. The pole piece, we mentioned, passes through the center of a large electro-magnet. This electromagnet is called the field coil and in an average loudspeaker consumes about 5 watts of power. The D.C. resistance of the field may vary and is designed to match the circuit. Usually this value of field resistance is between 800 and 3,000 ohms. The field, in radio receivers, must be energized from a source of D.C. voltage and may be used as the filter choke. The usual loss of energy in the filter choke, therefore, is utilized for the required magnetic field and further the cost of the choke is saved since it will not be needed.

In operation, the dynamic speaker is so connected that the field winding is magnetized. The voice coil, being of very low impedance, is properly matched to the output stage of the radio or amplifier with the aid of an output transformer. As the voice coil receives alternating current which corresponds to the sound to be reproduced, the coil sets up its own magnetic field which may oppose or be attracted by the field of the larger electromagnet (field coil) of the loudspeaker. Since the voice coil is fastened to the cone, the cone will move (vibrate) in accordance with the current entering the voice coil. This action, as in the case of magnetic speaker, will produce sound. At low frequencies, the cone acts as a piston of a cylinder, moving up and back at the audio frequency rate. At high audio frequencies, the cone vibrates.

The smaller dynamic speakers, under 8 inches, can successfully reproduce up to about 3 watts of audio power. Some of the larger 12 inch speakers, used especially for serving large groups of people with sound, can handle up to 15 watts of power.

Care must be exercised in using speakers not to puncture a hole in the cone. The tone quality of the speaker will be ruined if a break develops in the cone. The cone may be replaced and replacement units are available on the market.

## DYNAMIC LOUDSPEAKERS

The magnetic field is present at all times. It is increased and decreased with the current passing through the electromagnet.

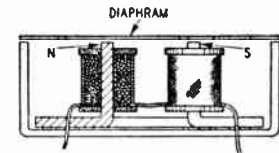

Figure 165. The inside view of a headphone showing the position of the electro-magnets and the permanent magnet.

The voice coil of the cone may be centered around the pole piece and kept in position by the cone itself which is glued around its outside rim to the metal frame work of the speaker. The cone may also have center flexible ribs attached to the voice coil and supporting the assembly at this point to the metal frame.

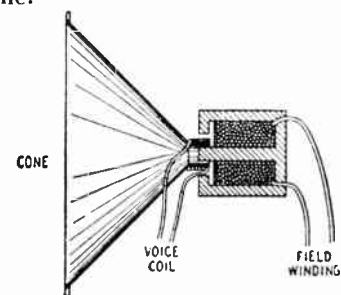

Figure 167. Cross-sectional view of a dynamic speaker showing the position of the voice coil and the field winding.

Output tubes may require a load of several thousands ohms which must be matched to the voice coil impedance of several ohms.

Speakers possessing fair response characteristics have been made with a three inch diameter cone.

## SPEAKER IMPEDANCE MATCHING



A 12" dynamic speaker used for sound installation work.

For example, if the turns ratio is 3 to 1, the impedance ratio will be 9 to 1.

A matching transformer must be used for the purpose intended with both the primary and secondary connected to proper values, otherwise the expected action will not be obtained.

These new values of impedances should not vary more than 50% from the design values if distortion is to be avoided.

**Volume 1 - Page 112**

**P.M. SPEAKERS.** The development of very powerful fixed magnets, has permitted the replacement of the electro-magnetic field with a small permanent magnet. In all respects, permanent magnet (P.M.) speakers operate exactly as dynamics, but the field coil is omitted. Certain manufacturers, in fact, have similar models available in either dynamic or P.M. types.

**IMPEDANCE MATCHING.** To transfer maximum power from one electrical unit to another, the impedances of the units must be the same. This is possible in many cases and equipment is designed with this in view. But many other times, the equipment, which must be connected together, cannot be made with equal impedances. We have an example of this with the power output tube, and the loudspeaker. An output type tube may require 3,600 ohm load for maximum power output and least distortion. But the best speaker to use may be of the dynamic type which has a light weight voice coil of a few turns of wire. Only a small impedance can be obtained from a few turns of wire. We have already mentioned that 8 ohms impedance was common for a voice coil. How can these two units be used together and not produce a bad mismatch?

A transformer comes to our rescue. It is possible to connect widely different impedances to the two windings of a matching transformer! By making the turns ratio of the primary to secondary correct, each impedance "will see" a value corresponding to itself. The turns ratio, which must be used, is equal to the square root of the impedance ratio. Letting  $N_p$  represent the turns of the primary,  $N_s$  for the secondary, and  $Z_p$  the impedance of the primary,  $Z_s$  impedance of the secondary, we have an important formula:

$$\text{TURNS RATIO} = \frac{N_s}{N_p} = \sqrt{\frac{Z_s}{Z_p}}$$

In our example of the previous paragraph, we had a voice coil of 8 ohms, and it is connected to the secondary, that is  $Z_s$  must represent an impedance of this value. Please understand that  $Z_s$  will appear to the voice coil as an 8 ohms impedance only if the primary is correctly connected also. The actual secondary coil does not necessarily have 8 ohms impedance. The primary must be used for the load of the tube which requires 3,600 ohms. Then  $Z_p$  must appear as 3,600 to the tube; here again the actual impedance of the primary coil is nothing like the impedance it is to represent. Let us use our formula to find the turns ratio of the transformer.

$$\sqrt{\frac{Z_s}{Z_p}} = \sqrt{\frac{8}{3600}} = \sqrt{\frac{1}{450}} = \frac{1}{21.2} = .0472$$

Most transformers employed for matching impedances are rated in actual impedance values. But by knowing the formula, you may calculate many other values of impedances for which the same transformer will be suitable.

## LOSSES DUE TO MISMATCHING

**EFFECT OF MISMATCHING.** A great deal of stress has been placed on the necessity of exact matching from source to load. While this generally holds true when the mismatching is considerable, a slight mismatch is not serious, as can be seen as shown by the chart.

In order to properly determine correct matching, the impedance of the voice coil must be known. This impedance is not a constant figure, but varies with frequency. For all general applications, however, the impedance is measured at 400 cycles. In the event that the impedance of a speaker is not known, the approximate value can be obtained by multiplying the D.C. resistance by a factor of 1.25.

For example, if the measured D.C. resistance of a voice coil is 6 ohms; the impedance is  $6 \times 1.25$ , or  $7\frac{1}{2}$  ohms.

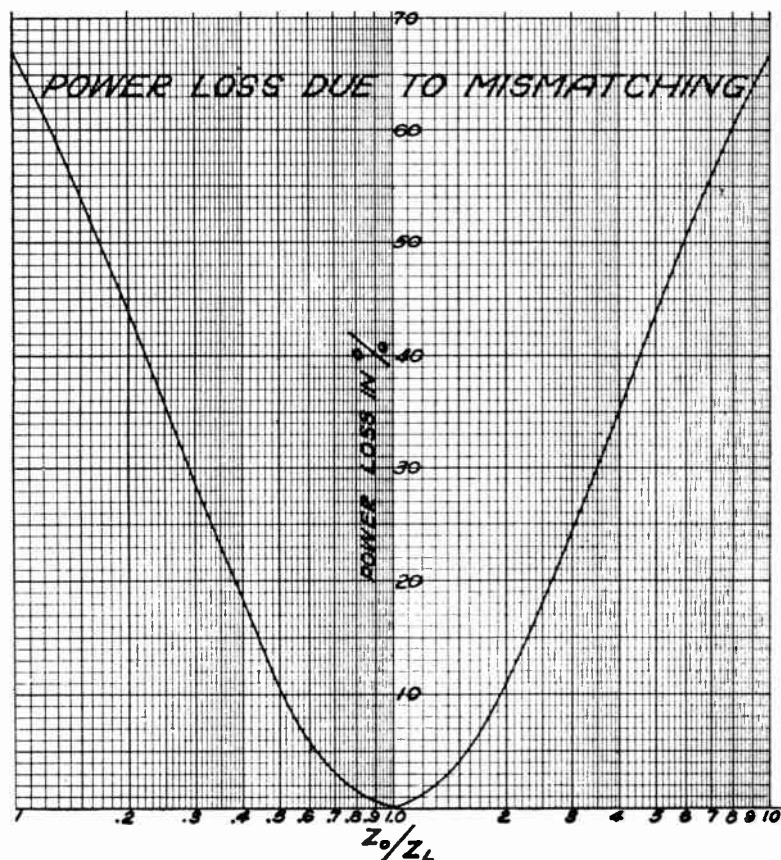

*Courtesy Oxford-Tartak Radio Corp.*

Figure 170. You can tell the amount of audio power lost because of mismatching, by using this graph. An explanation how to use this graph is given in the text.

To consider the usefulness of the graph, let us take the problem where the only speaker available is one with a 6 ohm voice coil, and the amplifier output is available as either a 4 ohms or 8 ohms. The question in this case is what tap on the amplifier will give the best results. The ratio of  $\frac{Z_{\text{output}}}{Z_{\text{load}}}$  in the case of the 4 ohms output is .666, and in the case of the 8 ohms output is 1.33. In checking these figures on the graph, we find that in the case of 4 ohms where the ratio is .666, the loss is approximately 4%, and similarly, on the 8 ohms, the loss is only  $2\frac{1}{2}\%$ . It is quite obvious that the best results will be obtained if the speaker is connected to the 8 ohms. Generally, the results are better if the speaker is mismatched to a higher rather than a lower impedance.

Besides the power loss encountered because of mismatching, distortion also will be introduced in case of a mismatch. If the output stage uses a triode vacuum tube, less distortion will be present if the mismatch is due to the load impedance being too high as compared to the load being correspondingly too small.

4 ohm output, 6 ohm load, in one case; and 8 ohm output, 6 ohm load in the second case.

## INVERSE FEEDBACK CIRCUIT

The change of the tube characteristics with age has little effect on the operation of the equipment if degeneration of a sufficient degree is employed. This fact is very important in telephone repeater amplifiers.

However, if the speaker has only a 2 ohm voice coil, and the only output available on the amplifier is 8 ohms, the ratio of the two impedances is 4. From observation on the graph, the loss is 35%, which is quite serious and this mismatching is not recommended.

**INVERSE FEEDBACK.** The student will be told a little about audio degeneration or inverse feedback. This action is obtained by making minor changes in audio circuits and gives certain advantages. The results of degeneration may be summarized as follows:

1. Power output remains more constant.
2. Audio distortion is decreased.
3. Frequency response is improved.
4. Signal voltage must be larger.

Audio degeneration is obtained by feeding part of the output signal back, in proper relationship, to be exactly out of phase. The feedback path may be such as to include several tubes in the circuit, but is usually confined to one or two tubes.

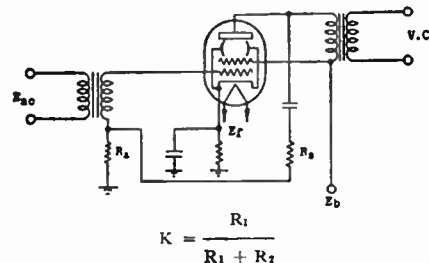

Figure 171. A simple degenerative circuit which can be understood by analyzing the action of the feedback voltage supplied through resistors  $R_2$  and  $R_1$ .

$$K = \frac{R_1}{R_1 + R_2}$$

Let us consider a simple feedback circuit. In the figure, we have a beam power output tube. It is excited by a signal, marked  $E_{ac}$  in the drawing, and is a basic circuit except for  $R_1$ ,  $R_2$  and the coupling condenser. For the moment, we will study the regular function of this circuit. The input signal is induced in the secondary of the interstage audio transformer and excites the control grid of the tube. The resistor  $R_1$ , is small and need not be considered for the moment. The tube is self biased with the resistor in the cathode circuit. This resistor is by-passed with a large capacity (about 20 mfd.) electrolytic condenser which is not marked in the drawing. The screen grid of the tube receives the plate voltage directly, terminal  $E_b$ . The plate current for the tube is supplied through the primary of the output transformer. This transformer *matches* the tube to the voice coil. The required size of this transformer, by the way, will be different with degeneration, in the case of most vacuum tubes.

Now let us consider the additional circuit which produces degeneration. Trace this circuit from the plate of the tube, through the blocking condenser, and through the two resistor  $R_1$  and  $R_2$ . The blocking condenser, we mentioned, is used only to keep D.C. of the plate supply out of the resistor network. This condenser may be considered as having zero impedance to the audio signals. You can see that the audio signals coming out of the tube, divide them-

This means that with degeneration, the output tube will have different characteristics.

selves across the two resistors. The amount of signal across  $R_1$ , in terms of the total available signal at the plate, will be a factor  $K$ , equal to the simple formula stated under the illustration. Since only a small amount of signal is fed back,  $K$  will be much less than 1.

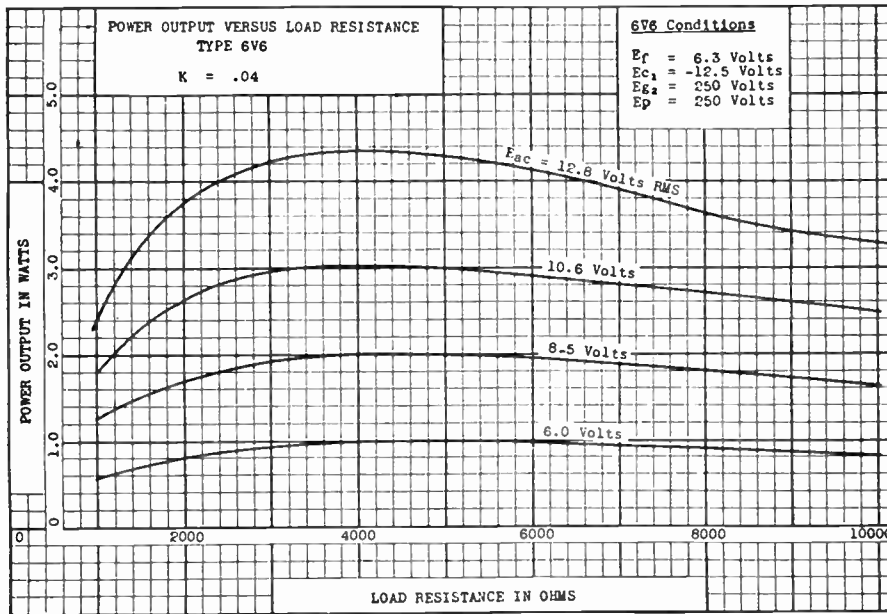

Courtesy P. R. Mallory & Co.

Figure 172. The power output of a radio tube varies less with changing load resistance if inverse feedback is employed. The curves show the results with different excitation voltages.

Another way to analyze this action is to realize that if  $R_2$  is large, and  $R_1$  is small, little voltage will develop across the smaller resistor. By changing the size of these resistors, the voltage across  $R_1$  may be made any value required in terms of the total voltage available at the plate of the tube. Notice that the voltage across  $R_1$  adds in series with any voltage induced across the secondary of the input transformer, and both of these voltages are impressed on the control grid.

Now, it is a well known fact that a vacuum tube shifts the phase of the signal  $180^\circ$ . When the grid is becoming more positive, the plate current is increased, the impedance of the load causes a larger voltage drop, and less of the total battery voltage is left for the tube. This means that while the signal is becoming more positive, the voltage fed back by the degenerative system is negative in relationship. When signal is either positive or negative, the voltage fed back is just the opposite. This is degeneration and produces the effects we described.

Another negative feedback circuit is shown and this type of circuit is well suited for use with resistance coupled stages. Please notice that only  $R_2$  and the blocking condenser form the degenerative system. The action is very similar to the one described. Many commercial circuits not having audio degeneration, can be converted to include this feature by the simple addition of this condenser and resistor. The condenser may be .01 mfd., 600 volt type, the resistor should be about 5 megohms. However, bear in mind that the same transformer will no longer correctly match the

With inverse feedback, the power output changes less with variations in load impedance than would be the case without degeneration.

The understanding of inverse feedback has its difficult points. Please reread this section until the function of the degeneration circuit of Figure 171, is clear to you.

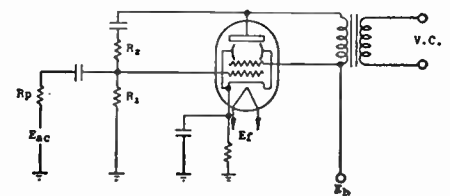

Figure 173. Another inverse feedback circuit which can be added to almost any radio set.

## PUBLIC ADDRESS SYSTEMS



The input may be a microphone for voice or music, a phono pickup for record reproduction, a radio tuner, a photo-cell excited by a sound-on-film track, or a magnetic recording on a steel tape.

If the microphone cable is broken and joined at some point, the shielding must cover the junction. Shielded plugs may be used for this same purpose.

Catalog material on amplifiers and public address systems will help you learn about commercial units.

This amplifier is designed to supply low power and can be constructed economically.

**Volume 1 – Page 116**

tube to the voice coil and may nullify the advantages of the feedback circuit.

**PUBLIC ADDRESS.** When a large group of people is to be served with a common program, public address equipment finds its application. Most often a speaker's voice is amplified to a suitable volume to make him audible to all present. Radio programs and phonograph records also serve as a means of the input. If the program originates some distance from the amplifier, a line is used to connect it to the input. In sound moving picture work, a photo-cell serves as a means of input and requires a special amplifier.

Essentially a P.A. system consists of one or more of the sources of input mentioned, the amplifier or any pre-amplifiers necessary, and the output in the form of one or more loudspeakers so placed as to take the greatest advantage of the acoustics.

We have already discussed the different sources of input, the voltage and power amplifiers which make up the P.A. amplifier unit, and the function of loudspeakers. It is essential, however, to consider all these factors together.



*Courtesy American Phenolic Corp.*

Figure 176. Microphone cables are joined together or connected to the input of an amplifier with a shielded metal connector.

Today, most public address systems use crystal or velocity microphones. These are connected to the amplifier input terminals with rubber covered shielded cable. Ordinarily, this cable has but one central conductor and the shield serves as the return. If the microphone is of the high impedance type, it is coupled directly to a grid of an input stage. In such cases, the microphone cable should be shorter than 100 feet. Low impedance microphones may be used with longer cables, but require an impedance matching transformer at the input to the amplifier. Since microphone circuits are very sensitive and will pick up stray electrical interference, the shielding must be continuous. At the microphone and the input to the amplifier, special shielded type plugs are used.

The output of the microphones used is quite low and most amplifiers employ three stages of voltage amplification and one stage of power amplification. Phonograph-pickup input is coupled to the second stage (eliminating the gain of the first tube) since the output from a phone pickup is much higher than that obtained from a microphone.

The circuit of an amplifier illustrated is a little different. Here we have but two voltage amplification stages, and the power amplifier is of the push-pull type. Total gain of this amplifier is employed for the microphone input. The shield of the microphone cable is grounded to the chassis. Condenser C-17 insulates the ground from the side of the A.C. line. Resistor R-5, 5 megohms, serves as the grid return in case a crystal microphone is employed. The phono input goes directly to the second stage. Although both inputs may be used at the same time, these cannot be mixed in any special proportions. Both input are controlled with the same

potentiometer, R-59. The tap of this control permits a corrective tone control circuit to be incorporated. At low volume settings, the resistor R-18 and condenser C-16, by pass a great deal of the higher frequencies and the equipment stresses bass. As the volume is increased, the slider of the potentiometer is moved upwards. This adds part of the resistance of the potentiometer to R-18, decreasing the by-pass action of the condenser.

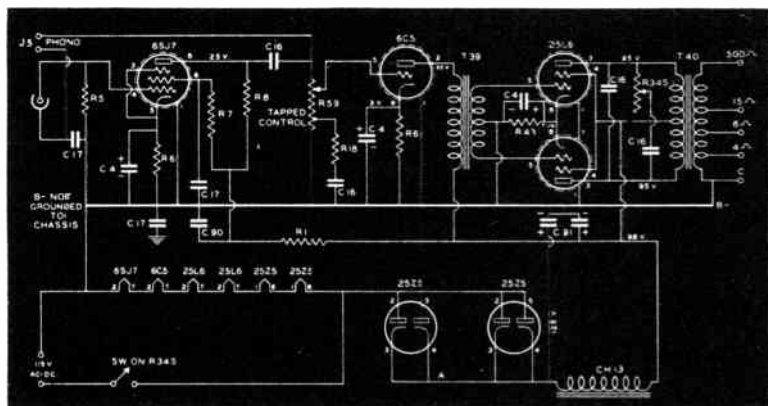

Figure 177. Circuit of a small, efficient amplifier. Please observe that the filaments are wired in series and, since the total voltage adds up to about 115 volts, no dropping resistor is needed.

The stage using type 6C5 tube increases the voltage gain. The dotted circle around the tube symbol indicates a metal shield either around the entire tube, or about the sections having the control grid connection.

This voltage amplification stage is transformer coupled to a pair of 25L6 beam power tubes. The transformer places the grids of the two tubes 180° out of phase and permits push-pull operation. There is a tone control in this stage. The output transformer has several taps on the secondary and, thereby, furnishes several commonly used impedances. The socket permits easy connection of the speaker.

The power supply is of a half-wave rectifier type. Two type 25Z5 tubes are employed since the current drain is quite heavy. Notice that the filaments connected in series add up to 112.6 volts and, therefore, no series resistor is needed. The output of this amplifier is rated at 4.5 watts, and the unit is suitable for many applications where a low priced, low power unit is needed.

The larger amplifiers incorporate many refinements. They may have inputs for several microphones and phono pickups, and permit the mixing of these different channels. The circuit may be more refined, incorporating inverse feedback for better results. The power output may be anything from 4 watts to 50 or 100 watts when using receiving type tubes. With transmitting type audio tubes the power may be in thousands of watts.

**SPEAKER PLACEMENT.\*** In all public address installations, loudspeakers are more than just an accessory of the system; they must be considered as the all important devices used to convert the electrical audio output to the needed acoustical energy—sound. The speakers of any well matched sound system are selected with

\*Parts of this section are reprinted from "Oxford Techni-Talks" originally prepared by M. N. Beitman.

## PUBLIC ADDRESS AMPLIFIER

Actually, the *highs* are killed to a large extent and the bass is left.

The condenser, C-4, is included since at peak signals the tubes in this stage may not be operated in push-pull.

### ELECTRICAL VALUES

#### Condensers

C4	10 mfd., 25 volts
C16	.01 mfd., 400 volts
C17	0.1 mfd., 400 volts
C90	.25 mfd., 400 volts
C91	15-15 mfd., 300 volts

#### Resistors

R1	50,000 ohms, 1 watt
R5	5 megohms, ½ watt
R6	3,000 ohms, ½ watt
R7	2 megohms, 1 watt
R8	250,000 ohms, 1 watt
R18	25,000 ohms, 1 watt
R34S	100,000 ohms, potentiometer
R43	100 ohms, 10 watts
R59	500,000 ohms, potentiometer

If a load is connected to any one impedance tap, the other taps will no longer offer the impedance values as marked. Terminal C is common for all connections.

If the amplifier is operated from a source of 110 volts, D.C. power, the rectifiers are left in the circuit but then do not serve any useful function.

## LOUDSPEAKER PLACEMENT

Speaker connections are made to a socket which is usually located in the rear of the amplifier. A rotary switch may be incorporated to *select* the proper impedance. In some units, a terminal connecting board is used.



*Courtesy Clarostat Mfg. Co.*

Figure 179. A constant impedance output attenuator is used to control individual loudspeakers without unbalancing the circuit.

care so that the response characteristics and power handling ability will give the desired results with the associated equipment. But the proper placement of the speakers and the use of correct baffles or directional horns is necessary to permit the P.A. technician to secure the best results from the sound system in any particular installation.



*Photograph Courtesy Standard Transformer Corp.*

Figure 178. Front-top view of the amplifier described. Notice the input connectors for phonograph and microphone at the left hand side of the chassis. The controls are on the front panel.

In average installations, it is best to use one or two speakers. A single 10 inch dynamic speaker will serve in class rooms, hallways, small stores, and in almost all other installations requiring less than six watts of power. For auditoriums, churches, gymnasiums, dance halls, two speakers of good quality should be able to handle the audio volume from amplifiers supplying 15 to 30 watts. These speakers must have a conservative power handling capacity of at least 15 watts each. For use with amplifiers supplying greater power, employ directional trumpet speakers or at least four well made 12 or 14 inch dynamics.

The speaker location is selected with two objectives in mind: (1) to make the program sound natural to all present, and (2) to reduce the possibility of acoustical feedback. The loudspeakers should be placed so that sound originating from the actual source (be it a singer or a complete orchestra) and the sound emitted by the loudspeakers should reach the majority of the audience at the same instant. This is why two speakers are used in auditoriums and dance halls, one on each side of the stage. This type of installation permits the original sound to be supplemented or reinforced by the amplified output. It certainly would not do to have a single speaker in the back section of a long and narrow hall. Under such a condition, the listeners sitting in the first front rows and those in the extreme rear would hear the original sound and the amplified sound at a considerable time interval.



**SOUND FEEDBACK.** In all installations, some of the sound emitted by the loudspeakers will reach the microphone of the system. Feedback will result if the sound reaching the microphone is greater in intensity than the original sound input. Consider, for example, a typical auditorium with an orchestra playing. A definite sound level produced by the instruments of the orchestra is picked up by the microphone. After amplification, a correspondingly higher power level of sound is emitted by the loudspeakers. Of course, the actual ratio of the input to the output power is the net gain of the amplifying equipment at the volume control setting employed. Now if the sound coming back to the microphone, either through direct radiation or by reflection from walls, is about equal in intensity to the original input, twice as much output will result. This larger output will in turn cause twice as much sound energy to be returned to the microphone and again the output level will be doubled. This doubling process will continue, under such condition, at a rate equal to the time required for the sound to pass acoustically from loudspeaker to microphone and electrically through the amplifying equipment. In several seconds, the amplifier will be overloaded, and a continuous loud whistle will be the only output present.

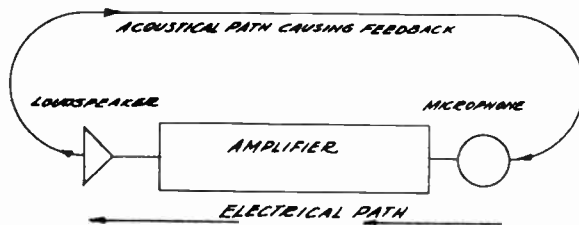

Figure 180. A certain amount of acoustical energy released by the loudspeaker reaches the microphone. If the intensity reaching the microphone is sufficiently large, feedback will result. Methods for eliminating and preventing feedback are described in the text.

Should the sound returning to the microphone be greater in intensity than the original, the feedback action will start just so much faster. If the sound intensity is but a little less than the original input, a hang-over effect or echo will be present. All these conditions are equally bad and can successfully be eliminated.

**SOLUTION OF THE FEEDBACK PROBLEM.** Reduction of amplification will always solve the feedback problem. But this is a poor solution, since the output in majority of cases must be reduced to so low a point that the sound system no longer serves its purpose. In some installations, certain groups of frequencies are the only cause of feedback. Perhaps this is due to greater amplification at these frequencies or to the resonant effect of the room. Tone control adjusted to reduce the gain at these frequencies, will eliminate the feedback due to this cause. But this, too, is a make-shift solution, for the tone control adjustment not only may solve the feedback problem, but also may distort the natural qualities of the program.

The way to eliminate feedback is to prevent sound from the speakers reaching the microphone of the system. If the speakers are focused in a direction away from the microphone, direct feed-

Read this paragraph with care. Here you will find the explanation for sound feedback. Observe that the complete path of the sound oscillations requires the travel of the sound in the air of the room and the passage of corresponding electrical energy through the amplifying equipment.

If you have a chance to operate a sound system and an opportunity presents itself, try to produce the various degrees of sound feedback as described in the text.

Reduction of the volume level is the immediate solution if the oscillations start while the "show" is going on.

## PRACTICAL REVIEW QUESTIONS

Moving the speakers and microphone may reduce the tendency of the system to oscillate.

2. Give several possible reasons due to the acoustics and the amplifier installation.

5. You will have to use the decibel chart.

6. A tenfold increase in power is needed.

7. And what is the voltage ratio? Is this quantity obtainable from a practical circuit?

12. Make a diagram to make your answer clear.

14. Use the formula  $X_c = \frac{159,236}{f \times C}$ , where the value of C is expressed in microfarads.

19. Notice that a phase (time) difference may exist between voltage and current, or two voltages, and in the same or different circuits.

back will be eliminated. However, sound reflected from walls, ceiling, and floor will reach the microphone. The sound in being reflected, loses some of its energy, so that in striking several walls in its return path to the microphone, the sound intensity may be reduced to a low value where it will no longer create any feedback. Since sound-absorbing materials deaden the sound and absorb its energy, the use of carpets, heavy curtains and drapes, and special sound-absorbing materials strategically placed will permit the use of the public address system at the required volume level without encountering feedback.

REVIEW QUESTIONS AND PROBLEMS. 1. The velocity of sound on a very cold day is less than 1,090 feet per second. Explain why this is a true statement.

2. Why is it difficult to understand the speaker in certain auditoriums?

3. Explain the method involved in the carbon microphone for changing sound to electrical energy.

4. Name several advantages of crystal microphones.

5. What is the voltage output of a phono-pickup?

6. How many DB increase is needed in order to make sound appear twice as loud? You remember that an increase of tenfold is needed before the sound appears twice as loud.

7. An amplifier stage having a gain of 31 D.B., represents what power ratio? (Approximate.)

8. On what main factor does the amplification of an audio stage depend?

9. Does the audio transformer increase power or does it increase voltage? Explain the answer.

10. In your own words, define different *Classes* of tube operation.

11. What are some of the advantages of resistance coupled audio stages? What are the disadvantages?

12. In a resistance coupled stage, the increase in plate current will cause the *actual* voltage present at the plate to increase or decrease? How do you explain the results?

13. Make sketches of identical audio stages which obtain their bias by several different ways.

14. What is the capacitive reactance of a 20 mfd. cathode by-pass condenser to an audio frequency of 100 cycles?

15. If in the circuit of Question 14, a 400 ohm resistor is used, which path (the condenser or resistor) will offer less opposition to the audio current of 400 cycles?

16. Explain three different kinds of distortion which may be present in an audio amplifier.

17. How does a vacuum tube amplify?

18. Name several advantages of push-pull operation.

19. How can a change of phase be produced? Name the two methods described in the text.

20. What are the advantages of Class B amplifiers?

21. How does the dynamic loudspeaker work?

22. What is the turns-ratio between the primary and secondary of a transformer which must match the tube plate impedance of 4,500 ohms to a 5 ohm voice coil?

# LESSON 12

## Radio Frequency Voltage Amplifiers

**NEED FOR R.F. AMPLIFIERS.** The radio frequency energy received by the antenna is very weak. Since vacuum tubes used in a radio receiver, except for the power output stage, are voltage operated devices, we are interested primarily in increasing the voltage of the wanted station as received by the antenna system. We know that the amplification can take place at audio frequencies after the audio component has been removed from the R.F. wave. However, the audio section can only amplify the intensity of the signal, while the circuits used for radio frequency amplification not only amplify the incoming signals, but also select the desired signal from all the signals which excite the receiving antenna. Radio frequency amplifiers, in other words, *tune-in* the desired station and suppress the signals of the stations which are transmitting but are not wanted at the moment; besides amplifying the signals of the desired station.

**INPUT CIRCUIT.** The input circuit to a radio frequency amplifier tube consists of a radio frequency transformer. If the transformer serves the first R.F. stage, it has its primary coupled to the antenna circuit. The secondary is loosely coupled to the primary and is tuned with a section of a variable condenser. One terminal of the secondary is connected to the control grid of the tube used, while the other terminal is connected to the grid return.\* Sometimes this ground end of the secondary is connected to the cathode through a by-pass condenser. While this condenser may block D.C., it presents almost no reactance to the R.F. voltage. Although the *transformer* action actually steps the voltage down (since the mutual inductance is small), the Q of the secondary is high and a voltage gain results. It is proper to think of the primary as a generator inducing minute voltages in each turn of the secondary and all these small voltages adding together. The current, as you can see, will circulate around the circuit which includes the tuning condenser, and we have the equivalent series circuit. The voltage drop across the condenser will be impressed on the grid of the R.F. tube. This voltage, present across the tuning condenser, will be exactly the same as developed across the inductance of the secondary circuit. You must recall that at resonance in a series circuit, the voltages across the condenser and coil are equal in value.

The frequency of the station wanted is *tuned-in* with the variable condenser. Energy of a frequency will develop the maximum voltage across each reactance of the series secondary circuit when that circuit is resonant to this frequency. At the same time, the stations operating on other frequencies will develop very small interfering voltages. To be absolutely correct, we must admit that the condenser really tunes both the primary and secondary coils to be resonant at a frequency which will give the best total result for the particular station wanted.

\*Grid return is considered the remaining connection from the component part which has its other terminal connected to the control grid. In this case, it is one of the terminals of the secondary coil.

The tubes employed in radio frequency stages amplify all signals delivered to them, but the tuned circuits used in these stages select and increase the voltage of the wanted frequencies.

This is true for the resonant frequency and this is the frequency in which we are interested.

The L-C combination is made resonant to the wanted frequency by adjusting the value of C.

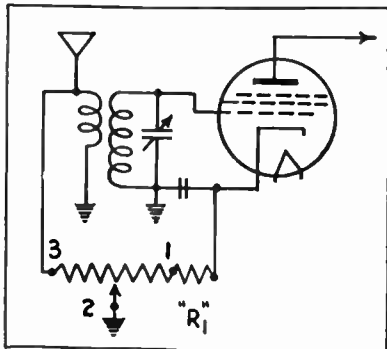

Courtesy International Resistance Co.  
 Figure 181. A circuit of a R.F. amplifying stage showing the details of the volume control.

When a coil is used to couple the first R.F. stage to the antenna, it is called the antenna coil. When a similar type transformer is used to couple two R.F. stages, the coil is called the R.F. coil. Less impedance may be used for the primary of the R.F. coil and the coupling employed is further reduced in some coils. The primary is connected to the plate of the tube of the preceding stage and to the positive plate supply. The secondary is connected to the grid of the tube in the following R.F. stage and to the grid return.

**TUBES USED FOR R.F. AMPLIFIERS.** When only triodes were available, naturally they were used for R.F. amplifiers. However, because of capacity effects between the elements, triodes permitted only limited amplification and had to be operated in a special bridge circuit which permitted the grid to plate capacity to be neutralized out. Great progress was made possible with the invention of the tetrode. This later tube eliminated the need for neutralization since the grid to plate capacity was reduced and this reduction permitted much higher amplification per stage. The pentode type tubes are now used in the R.F. voltage amplifier stages and give even higher gain. The variable mu pentode amplifier tubes permit the control of gain by the method of increasing or decreasing the negative grid bias. Other type of tubes would cause cross modulation or other type of distortion.

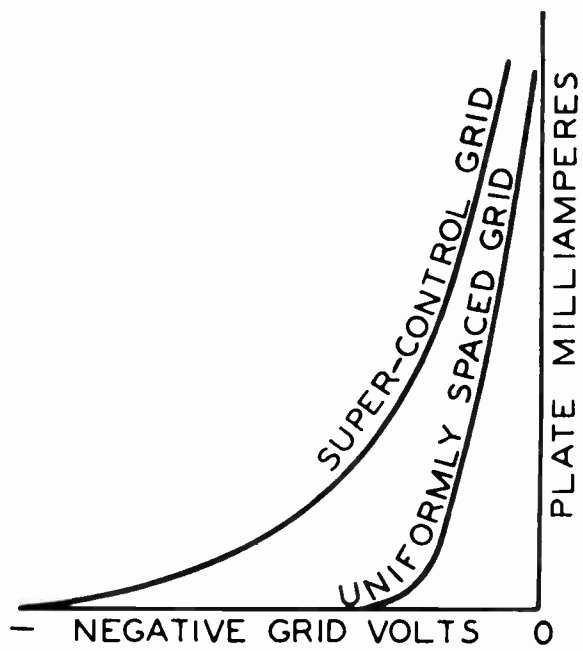

Figure 182. In vacuum tubes with uniformly spaced grid wires, the grid-voltage plate-current curve is straight for operating conditions when the grid bias voltage is not too large. If the negative grid voltage becomes larger, as required in adjusting the volume for a local station, operation takes place over the curved portion. In the super-control grid tubes, any small section of the curve is relatively straight.

**OUTPUT CIRCUIT.** The tube used in a R.F. stage must be loaded with an impedance that is high to radio frequencies. A resistor of several megohms would not do because it will also cause a D.C. voltage drop when the plate current passes, and this drop will leave

## R.F. STAGE OUTPUT

very little voltage at the plate of the tube. However, a parallel tuned circuit in the plate lead would offer very high impedance to R.F., while the low D.C. resistance of the coil would permit an easy passage for the D.C. plate supply current.

In practice, the plate is loaded with the primary of a R.F. transformer (R.F. or I.F. coil) and this coil winding has the proper value of capacity shunted through the action of mutual inductance of the secondary circuit. In adjusting the tuning condenser connected across the secondary of the R. F. coil, you are also tuning the primary to resonance.

A parallel tuned circuit has different values of impedance to various frequencies. The maximum impedance is present to the resonant frequency; i. e., the frequency to which the circuit is adjusted. All other frequencies find less impedance. The further away a frequency is from the resonant frequency, the less impedance the tuned circuit presents to this off-resonance frequency. The voltage developed across the load impedance and indirectly transferred to the control grid of the following stage, depends on the product of the impedance and the current,  $E = I \times Z$ . Since the impedance,  $Z$ , is greatest for the resonant frequency which is wanted, this frequency will produce the greatest voltage on the grid of the next tube. All other frequencies will produce much smaller voltages.

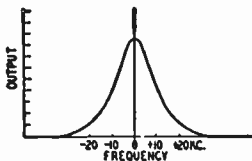

Figure 183. The output voltage of a circuit adjusted to one frequency, will vary as the frequency is changed.

**RESPONSE CHARACTERISTICS.** The graph we have included on this page illustrates the voltage in the output of the stage at different frequencies away from the resonant frequency. The resonant frequency is marked 0, and frequencies above and below this value are considered. Points marked +10, +20, indicate frequencies greater by 10 and 20 kilocycles, while the points marked -10, and -20, indicate frequencies lower than the resonant frequency by 10 and 20 kilocycles. Notice how the output drops off as the frequencies (off the resonant signal frequency) move away from this resonant frequency. Twenty kilocycles away, very little voltage output is present.

As you will learn in the next chapter, a broadcasting station transmits audio frequencies up to about 5,000 cycles, and this causes the radio waves of the station to include frequencies that vary up to 5,000 cycles from the carrier frequency, at certain instants. A station transmitting at 950,000 cycles per second (950 KC.) may at times have frequencies of 950,000 cycles, plus and minus 5,000 cycles. The side-bands, as these new frequencies are called, will be in this case 955 KC. and 945 KC., a variation of +5 KC. and -5 KC. from the carrier frequency.

At resonance, a parallel tuned circuit offers very high impedance.

For simplicity, we assumed that all frequencies present had the same value of current.

If the tuned circuits are adjusted to some new frequency, this new frequency, in turn, will produce the maximum voltage drop while all other frequencies (and including the one previously predominating) will produce much smaller values of voltage.

## TYPES OF RESPONSE CURVES

A radio station does not transmit a single frequency. A band of frequencies are transmitted, in reality. The tuned circuits should be capable of passing this entire band, with but little variation in the amplification.

Various I.F. frequencies are used by different receiver manufacturers. Values of 175, 456, 465 KC. are quite often used.

The resistance is a function of the frequency when used at radio frequencies.

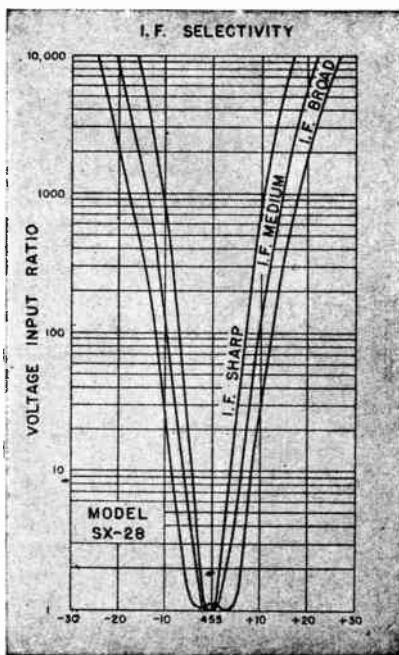

I.F. selectivity curves obtainable with the different adjustments incorporated in *Hallcrafters* SX-28 receiver. Base line is graduated in KC. off the I.F. frequency of 455 KC. Ordinate scale indicates loss ratio of voltage.

Volume 1 – Page 124

A good R.F. amplifier stage will have a response that gives a curve which is flat across the top. This approximate flatness should extend to 5 KC. on each side of the resonant frequency being received. In this way, the carrier and the side-bands up to 5 KC. will be received with equal amplification giving a constant output. Frequencies beyond this point will represent interfering stations when this one particular adjustment is made. Therefore, the curve should be flat across the top for 5 KC. on each side of the resonant frequency, and then the curve should drop very steeply to the base line representing no output beyond these points. Such an ideal curve cannot be obtained in practice, and the curve illustrated represents good achievement.

**INTERMEDIATE FREQUENCY AMPLIFICATION.** In the superhetrodyne receiver, as explained in Lesson Fourteen, the frequency of any wanted station is changed to a fixed frequency usually about 450 KC. The original side-bands of the station being received become corresponding side-bands of this new intermediate frequency or I.F. The transformer, I.F. coil used to couple such stages, may be designed to give better results than the R.F. coil which is tuned to resonance for each station to be received. Let us consider the limitations of R.F. transformers, which are used to receive many frequencies, and see how the I.F., which is a single frequency transformer, eliminates these faults.

We have already learned what type of response curve is ideal for a broadcast type R.F. amplifier stage, and what type of response curve is obtainable in practice. You must also understand that the height of the curve, i. e. the voltage of the output, depends on the resistance of the circuit. The radio frequency resistance of a coil (because of the skin effect) changes for different frequencies and is greatest for high frequencies. This factor makes the amplification change for various frequencies of the broadcast band, which is 540 to about 1,750 KC.

The shape of the curve obtained depends on the  $Q$  of the coil. If the  $Q$  is large, the curve is narrow and has steep sides. If the  $Q$  is small, the selectivity curve spreads out and is almost flat over a large frequency variation. Since the value of  $Q$  is computed by multiplying the fixed quantity 6.28 by the inductance of the coil in henries by the frequency of the circuit, and dividing the result by the resistance which changes but little, the  $Q$  varies primarily with frequency. In the broadcast band, the value of  $Q$  may vary by a ratio of  $2\frac{1}{2}$ , from the lowest to the highest frequency of the band. This variation, of course, gives different degrees of response to different frequencies. If the R.F. coil is designed to give proper response at one frequency in the center of the band, the response may be too sharp at one end and too broad at the other end.

If the tuned circuit can be made to operate at a definite single frequency, it may be designed to give optimum results at this frequency. This is just what is done in the case of the I.F. transformer. High gain is obtained and the response curve indicates that the output is almost flat within the required band width of 5 KC. on each side of the I.F., and falls off sharply after these frequencies.

**I.F. TRANSFORMERS.** The intermediate frequency transformers used in commercial equipment have taken many forms, but most commonly these transformers consist of a primary and a separate secondary coils, each coil tuned with a semi-adjustable trimmer condenser. A few I.F. transformers have only the secondary tuned. In most cases the primary and secondary are identical coils, mounted

on a wood doll-rod. The assembly is placed inside a shield-can, and the one or two trimmers are mounted in the upper section of this can. Although the  $Q$  of the coils is fairly high, the mutual inductance is small (coefficient of coupling,  $k$ , is very small, i. e. coupling is loose) and the over-all voltage gain of the I.F. transformer is about one or two. The I.F. transformer is very selective and is especially useful for this reason. The required gain is easily obtained in the high-gain pentode tubes used in the I.F. stages.

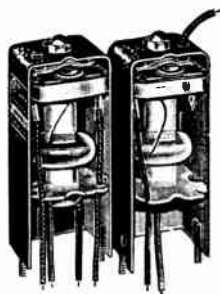
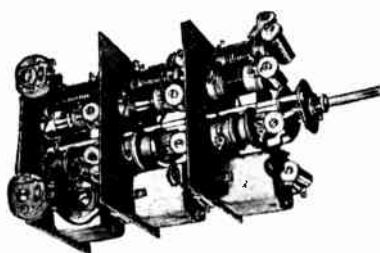

Figure 184. Inside views of an I.F. transformer. The output type I.F. transformer is usually connected to a diode detector and has four leads coming out of the bottom. The interstage or input type I.F. transformer has the grid lead at the top.

*Courtesy Meissner Mfg. Co.*

**MULTI-BAND RECEPTION.** The frequency covered by any L-C circuit depends on the value of inductance and capacity. In most practical circuits, the inductance is of a fixed value selected to give the required frequency coverage with the variable condenser employed. The inductance and the maximum capacity of the variable condenser, will tune to the lowest frequency; while this same inductance and the minimum capacity of the condenser will tune to the highest frequency covered by the L-C combination. It is practical to manufacture variable condensers which have a ratio of 9 to 1 between the maximum capacity and minimum capacity, with the stray capacities of the circuit included in these figures. This capacity ratio will give about 3 to 1 frequency ratio. For example, the broadcast band is about 3 to 1 ratio (540 KC. goes into 1,750 KC. a little over three times). What must be done to receive frequencies beyond this band?



*Courtesy Meissner Mfg. Co.*

Figure 185. The coils for multi-band reception may be mounted around the band-switch for convenience and to permit short connecting wires.

In order to receive frequencies outside of the broadcast band, usually higher frequencies, either the coil or the tuning condenser must be changed. It is not practical to change the variable condenser gang, and a change in the inductance is made instead. If only another band above the frequencies the broadcast band is to be covered, it is possible to tap only a part of the windings of the coil (secondary) used for the broadcast band. A lower inductance

## I.F. AND MULTI-BAND COILS

How single frequency transformers (I.F. coils) can be utilized to receive a variety of stations operating at different frequencies, is explained in Lesson 14.

The adjustable condensers are at the top of the can. These condensers are adjusted for proper operation and then need not be altered

Highest frequency is received when the rotor plates of a variable condenser are all the way out.

Multi-band reception is preferred since many interesting programs and foreign stations may be received on frequencies outside of the broadcast band.

## MULTI-BAND COIL CONNECTIONS

In some all-wave sets, the trimmers of the variable condenser are used for one of the bands and separate trimmer condensers are provided for the coils used for the remaining bands.

then will be obtained. A switch may be used to make this change from total inductance to a part of the inductance. A multi-section switch completes this change in several coils (antenna, R.F., etc.) at the same time.

The better radio receivers, of course, are designed for the reception from several bands, and for best results separate coils are used for each band. A multi-contact switch does the required switching. The leads to the switch must be very short. In some sets, the unused coils are left unconnected, but in others the coils, not used when the switch is in any one position, are grounded or shorted to ground to eliminate dead-spots in the band being received. Each group of coils may be included in a single shield. One shield may have four antenna coils for four bands, while another shield may have four R.F. coils. Since the same variable condenser is used for all bands, the trimmers of the condenser gang cannot be used, and each individual coil employed has a separate trimmer to compensate for circuit differences.

The intermediate frequency transformers of a given frequency serve the multi-band receiver just as well, since on all bands the superheterodyne action changes the incoming frequency to the fixed I.F. The circuits used are similar to a regular, single-band receiver, but extra sets of coils are included.

1. Consider the entire stage.

REVIEW QUESTIONS AND PROBLEMS. 1. What two functions does a R.F. amplifier perform?

2. How do you explain that the usual R.F. input circuit appears to be a parallel circuit, but behaves as a series circuit?

3. What types of tubes are used in practice? Why were type 27 triodes used as R.F. amplifiers at one time?

3. Why do pentodes make better R.F. amplifiers than triodes?

4. How does the impedance of a parallel tuned circuit varies with frequency? Why is this useful for radio work?

5. Make a graph of an ideal response curve. Make a graph of a very poor response curve.

6. The extreme frequencies are wanted for the answer.

6. A broadcast station operating on 670 KC. may be sending out what frequencies during some instants?

7. Is this response curve suitable for a high fidelity receiver?

7. Sketch a response curve of a circuit having very high Q and very low resistance.

8. Can this change be made in a small midjet receiver?

8. What simple change will be required in a R.F. amplifier circuit which has been designed for broadcast reception, to receive police band signals of about 1,900 KC.?

Volume 1 - Page 126

9. Why must the leads to the band-switch be short?



# LESSON 13

## Detection

**WHAT HAPPENS AT THE RADIO STATION.** In order to understand the need for detection in the radio receiver, we must consider what takes place at the transmitting station. Detail explanation about transmitter circuits will be given in a later chapter, but now we will learn the general function of the transmitting station. A special vacuum tube circuit produces the radio frequency which is assigned to the particular station. If the station is operating in the United States broadcast band, the frequency may be between 540 and 1,750 kilocycles. The radio frequency energy of this circuit is amplified by many additional stages. The last stage is coupled to the transmitting antenna which radiates electromagnetic waves into space. It is these waves that induce a corresponding radio frequency voltage in every receiving antenna.

The radio frequency waves induce an alternating voltage in the receiving antenna. Since the RMS value of this induced voltage does not vary, no information is transmitted from the station to the receiver. We can think of the radio frequency wave as a truck designed to carry loads, but arriving at the destination (receiver) without any load. The truck itself serves no purpose; it is the load (that is speech, music, telegraphy, or television) in which we are interested. It is obvious, therefore, that the radio frequency energy transmitted by the station must be *loaded* with "communication" we wish to transmit to the receiver.

In radio telegraphy, the radio frequency energy or the carrier frequency is interrupted in accordance with a code which is used to spell out words. Such transmitters are called CW (continuous wave) and are *keyed* by the operator. It is also possible to begin with sound, voice or music, amplify this sound with the equivalent of a public address amplifier system, and use the audio energy available to vary the intensity of the radio frequency wave transmitted by the station. Please observe that the *frequency* of the radio frequency wave is not altered, but the *amplitude* (height) of the wave is varied in accordance with the audio frequency variations.\* When the carrier wave is so varied or *modulated*, the voltage induced by this station in the receiving antenna will also vary in accordance with the audio frequencies originating in the studio at the station. The information needed is carried by the radio wave, but the actual information is of an audio frequency.

**WHAT HAPPENS IN THE RECEIVER.** Among all other signals, the antenna of our receiver is having a voltage induced upon it corresponding to the frequency of the station we wish to receive. This radio frequency signal is varying in intensity (amplitude) in accordance with the audio variations of the sound being transmitted. The radio frequency of this varying amplitude is amplified by the R.F. and I.F. section of the receiver. The resulting voltage delivered to the detector stage, which is located before the audio section of the receiver, is similar to the varying voltage received by the receiving antenna but is much larger in value. The job now is

\*Reference is made to the more commonly employed type of amplitude modulation. In frequency modulation (F.M.), the frequency is varied.

Here is an explanation of radio transmission.

The instantaneous value does vary at a radio frequency rate, but produces no effect as far as the response from the speaker of the receiver is concerned. The *average* value over several cycles must vary to produce an audio response in the speaker.

Actually, the power transmitted is increased.

The voltage on the receiving antenna will vary with the audio energy.

Not only is this wanted voltage amplified, but all other voltages (of stations operating on other frequencies) are reduced and suppressed in the same process.

**Volume 1 - Page 127**

## CHANGES IN R.F. WAVES

More commonly, demodulation is simply called detection.

You are really visualizing the appearance of the voltage variations over a period of time. The vertical scale is used to represent the value of the voltage, while the horizontal scale represents time with the later instants of time to the right.

The R.F. carrier waves are sine waves.

to remove the audio variations which were placed on the radio frequency carrier at the transmitting station. As you can see, in the audio section of the receiver we no longer need the R.F. carrier. Thinking of the carrier once again as a truck and of the audio frequencies as the load, we are now at the place where the load must be removed. Since we have plenty of our imaginary trucks, once the loads are removed the trucks can be junked. The detector performs this function of removing the audio signals. Since the process of placing the audio on the carrier is called modulation, the removal of the audio may be called demodulation.

**APPEARANCE OF THE RADIO-WAVE VOLTAGE.** It is possible to visualize the appearance of the voltage produced by the radio wave from instant to instant. A transmitter, when no modulation is present, impresses pulses on a parallel inductance-capacity circuit tuned to resonance, and sine waves of the natural frequency of this circuit are produced. There are as many such waves per second as the numerical value of the frequency in cycles per second. Audio modulation increases or decreases the intensity of the pulses delivered to the L-C circuit, and the resulting wave form will be increasing or decreasing in accordance with these audio variations. Since a larger voltage of the pulse, shocking the circuit, will produce a sine wave which will be larger, both the lower and upper sections of the train of sine waves will increase. As the illustration shows, the constant maximum amplitude R.F. carrier is increased or decreased in voltage (height, amplitude, intensity) in accordance with the audio signal. The envelope of the modulated R.F. wave

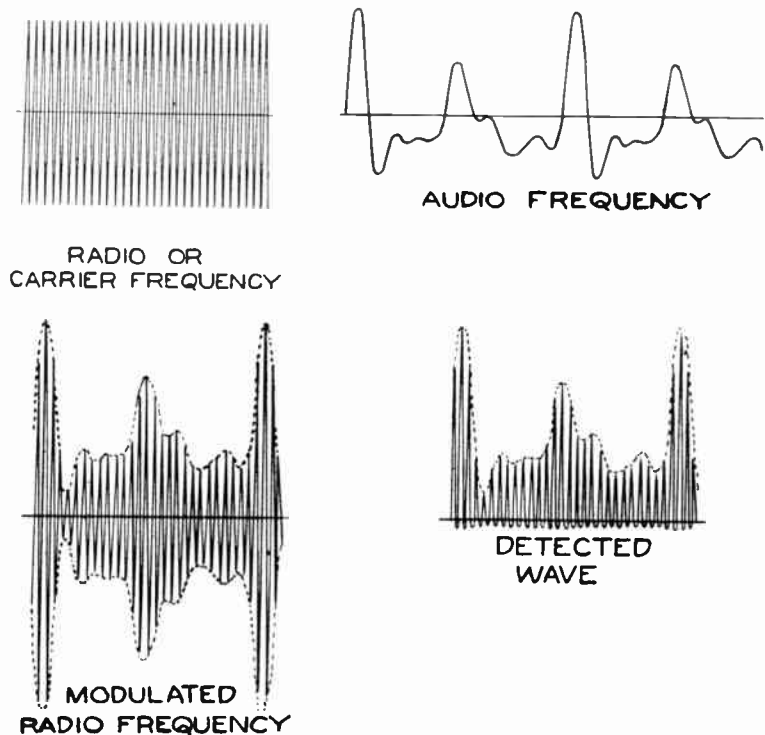

Figure 186. The radio frequency carrier is a succession of sine waves at a definite frequency and of equal maximum amplitude. The audio frequency, produced by a musical instrument or voice, has a changing frequency between about 25 and 5,000 cycles, as used in radio work. The audio frequency varies the amplitude of the carrier, as illustrated. The detected wave contains only the upper portion of the received, modulated radio frequency.

forms a pattern above and below the wave train, and this pattern is the representation of the audio frequency which is modulating the signal. Notice that the lower envelope is this audio frequency also, but in reverse.

With any varying signal, the average voltage over several cycles will be zero. This is so because the voltage of the wave increases and decreases by the same amount over the adjacent R.F. cycles. The detector must eliminate (or greatly reduce) the lower portion of the R.F. voltage curve. Further, the remaining upper portion of the R.F. voltage train (as modulated by the audio frequency) must be smoothed out so that an average audio signal will remain. Several different type of detectors are used in commercial practice.

**CRYSTAL DETECTOR.** Although in modern radio sets, vacuum tubes are used as the detectors, in the early days of radio and for micro-wave work at present, crystal detectors found a ready application. A crystal detector consists of a mounted crystal of some special material such as galena, iron pyrites, or carborundum, and uses a thin copper wire to make the needed contact. When an alternating current of any frequency is applied to the crystal, it flows in one direction only. When the voltage reverses its polarity, the crystal presents a very high resistance. Since the upper portion of the wave train of the R.F. represents polarity in one direction, while the lower half represents polarity in the opposite direction, detection will take place.

A small capacity condenser (about .0003 mfd.) is placed across the crystal output circuit. This condenser must not be so large as to by-pass audio signals, but it must be large enough to smooth out the gaps between the *half-sine-waves* and produce an average value of voltage which will correspond to the audio voltage originally used to modulate the wave at the transmitter.

**DIODE DETECTOR.** A diode section of a vacuum tube can be used in place of the crystal detector. A diode, of course, conducts only when the plate is made positive. This fact will permit detection to take place. The voltage is developed across the load resistor, and then is impressed on the audio amplifier. The small condenser shunts this load resistor and smooths out R.F. variations. In prac-

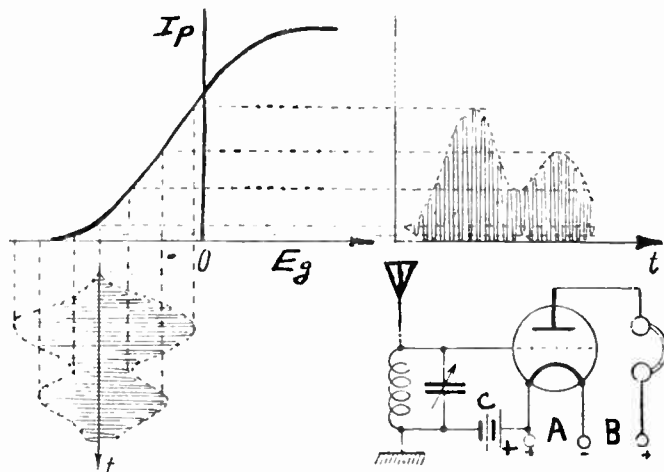

Figure 187. A biased or power detector is operated at that point of its characteristic curve where a much greater plate current change occurs on positive peaks than on the negative peaks.

To be absolutely correct, we must realize that *either* the lower or upper portions of the R.F. voltage wave must be eliminated.

A crystal used for detection passes electric current in one direction only — just as any diode rectifier.

A condenser of this type is often used with other types of detectors for the same purpose.

Examine the diode detector circuit under B, Figure 188, on the next page. The resistor in the cathode is the load resistor, while the by-pass condenser, we mentioned, is across this load.

A practical power detector, of course, does not use batteries. The required *high* bias voltage is obtained with a 10,000 to 50,000 ohm cathode resistor (see circuit C, Figure 188).

## OTHER TYPES OF DETECTORS

Illustration below, circuit C.

To understand the curves placed on the right of the circuits, you must realize that they show the relationships between grid voltage and plate current. The instantaneous grid voltage is plotted on the horizontal scale, while the plate current is indicated on the vertical scale. To fix the idea, consider the bottom curve for a power detector. With no signal, the grid voltage will be at the point crossed by the dotted line of the  $I$  scale. Very small current will be present. If the signal is positive at the instant, shifting the instantaneous grid voltage to the right (positive direction), the plate current,  $I$ , will increase an amount indicated by the dotted lines. A corresponding instantaneous negative signal voltage will shift the grid voltage to the left (negative direction). However, in this latter case, the plate current decrease will be smaller (much smaller) than the rise with a corresponding positive signal voltage.

tice, the load resistor may be 500,000 ohms, while the condenser may be .0001 mfd. mica type.

**PLATE DETECTOR.** It is possible to adjust the bias of a triode tube, so that the plate current is near cut-off. The grid bias required may be obtained from an outside circuit or the tube may use a cathode-resistor circuit. In the usual practical circuit, the cathode resistor is between 10,000 and 50,000 ohms. As you can see from the illustration, the positive portions of the R.F. will be amplified a great deal, while the negative portions will reduce the minute minimum (no signal) current very little. The plate current passing through the tube, therefore, will depend primarily on the positive portion of the R.F. and will reproduce this wave-shape greatly amplified.

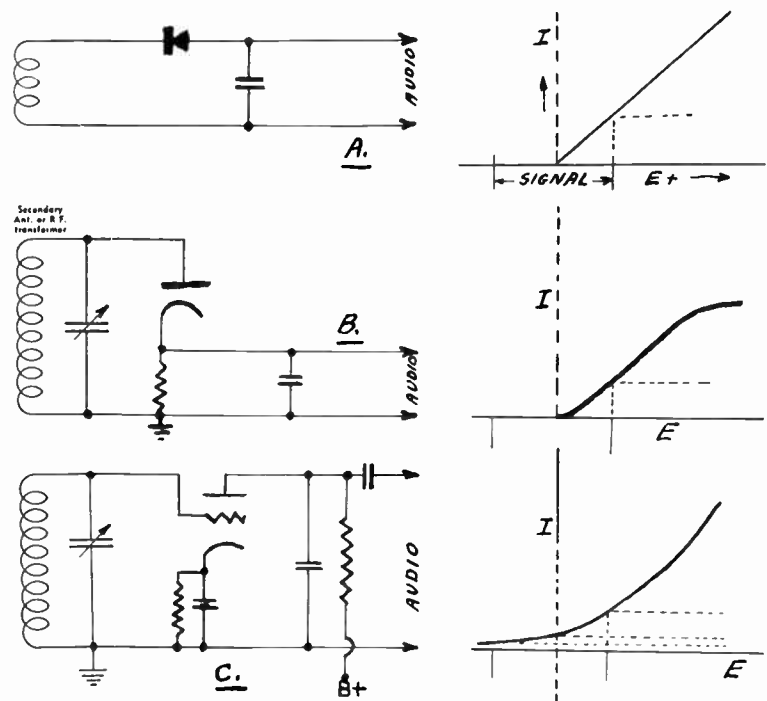

Figure 188. A crystal detector circuit is shown in (A). This detector is essentially linear to the signal in one direction and has infinite resistance to the signal in the opposite direction. In illustration (B) a diode detector is shown. The principle of operation is similar. A power detector, using a self biasing resistor, is shown schematically in (C).

The result is similar to what we have obtained from other type detectors, but here we not only produced detection but have amplified the signal at the same time. This type of detector employs a process called *plate detection*. Plate detection is especially useful for handling large signals and may be used to drive the final power output audio tube directly.

**GRID LEAK DETECTOR.** This type of detector has a longer history behind it and is more sensitive than the plate circuit detector. The grid leak detector has limited power handling ability and is seldom used in modern radio receivers.

An examination of the circuit will reveal that the grid does not have any negative bias from any outside circuit. However, even at zero or slightly negative bias, the grid will attract some electrons

and a very minute current will pass through the grid circuit. The grid leak resistance will produce a voltage drop because of this current. The polarity of this voltage drop is such that the grid will be at the negative side, while the cathode will be at the positive side of the grid leak.

The R.F. signal reaches the grid through the grid condenser. The value of this condenser must be large enough to pass R.F. without much opposition, but if it is too large the corresponding audio voltages built up across the grid leak will be by-passed. The voltage on the grid at any instant will depend on the incoming signal. The incoming signal will be controlling the voltage of the grid and, thereby, the current in the grid circuit. But this current will vary the grid bias; it is this current that produces the voltage drop across the grid leak resistor.

We see that the voltage on the grid will depend on the signal. We must also realize that the grid-voltage-grid-current relationship is such that a negative signal will alter the value of the voltage many times more than a corresponding positive signal.

Since the plate current of this triode vacuum tube depends on the grid voltage, it will vary with the changes in the grid signal voltage. A negative portion of the R.F. signal reaching the grid will make the grid more negative, in addition to the negative bias, with a corresponding change in plate current.

**COMPARISON OF DETECTION METHODS.** The crystal, diode, and grid leak detectors draw current from the tuned circuit and, thereby, lower both the selectivity and gain of the tuned circuit. A properly designed diode detector gives little distortion and is superior in this respect to the other types of vacuum tube detectors. Grid leak detection was formerly used extensively for detection of weak signals, but the development of improved radio frequency amplifiers has made this detector almost obsolete except for simple, experimental circuits.

**A SIMPLE RECEIVER.** The most basic receiver may consist of nothing more than a tuned circuit to select the frequency of the wanted station and any detector to separate the audio from the carrier frequency. Years ago, crystal sets used a simple tuning

The operation of a grid leak detector circuit is difficult to understand and you may have to read this explanation several times to grasp the ideas.

If the circuit across L-C draws current, it has relatively low resistance. This resistance shunts the coil and lowers the Q.

If you can obtain the needed parts, you may be interested in constructing this receiver. Remarkable long distance reception is possible with such a simple radio on short-wave. If you wish, you may use type 30 tubes instead. In such case, the screen grid connection (SG) of the 1N5-G is not used, and 2 volt A battery will be needed.

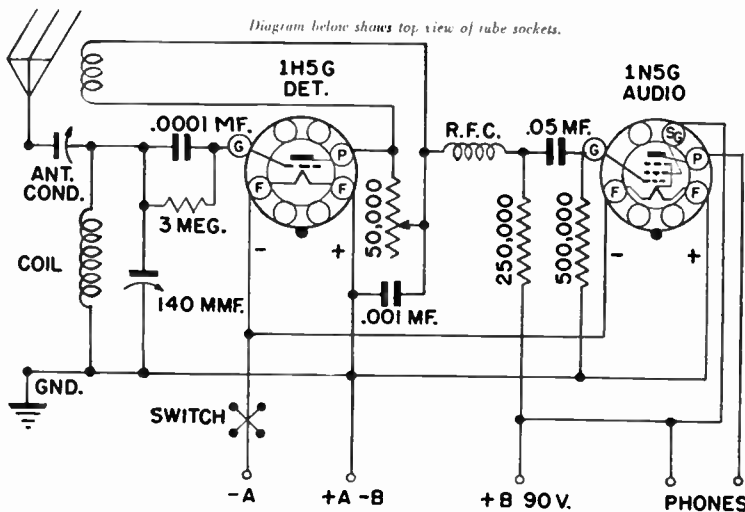

Figure 190. Circuit diagram of a two tube short-wave radio receiver consisting of a regenerative detector and a resistance-coupled audio stage.

## FREQUENCY TO WAVE-LENGTH



*Courtesy Meissner Mfg. Co.*

Figure 191. A short-wave plug-in coil with adjustable trimmer condenser. This coil is wound on a four-prong form, but five and six prong forms are used quite often.

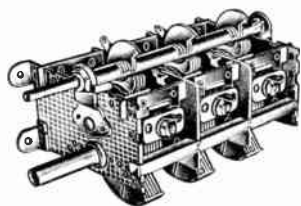

*Courtesy Meissner Mfg. Co.*

Figure 192. By placing low capacity condensers in parallel with the larger capacity gangs, finer adjustment can be obtained.

4. Can you find a tube that could be used as a diode detector and also includes a high gain triode section for audio amplification?

arrangement and a crystal detector. Of course, all radios also require headphones or a loudspeaker to change the audio electrical energy to sound.

A more advanced two tube receiver is illustrated in picture form and by means of a schematic diagram. This is an interesting practical radio,\* capable of receiving stations from great distances, and designed to cover wave-lengths from 9.5 to 550 meters with the aid of plug-in coils. Since the frequency of any radio station is related to its wave-length, you should know how to change one to the other.

$$\text{Frequency in kilocycles} = \frac{300,000}{\text{Wave-length in meters}}$$

$$\text{Wave-length in meters} = \frac{300,000}{\text{Frequency in kilocycles}}$$

First let us examine the circuit. Two low-drain battery tubes are used. We already described the regenerative detector. The antenna is coupled to the grid coil through a small antenna condenser which matches the antenna to the circuit. The tuning is accomplished with the 140 mmfd. variable condenser. Six plug-in coils are used to cover the frequencies from 545 KC. to 31,600 KC. (or 31.6 MC.). The audio stage uses a resistance coupled pentode. The headphones serve as the load for the plate circuit of this tube. Notice that the switch for turning off the unit is placed in the A -- lead. This switch will break the circuit to the filaments of the two tubes. But if the tubes are not heated, they will not conduct any plate current. Therefore, although the B battery remains connected, it will not supply any current when the A battery circuit is broken with the switch.

REVIEW QUESTIONS AND PROBLEMS. 1. Explain how a music program is transmitted "through the air"?

2. Sketch a radio wave train which is modulated with an audio frequency.

3. What property of galena crystal permits it to be used as a detector?

4. Find a type of vacuum tube which could be used as a diode detector. Use the characteristic charts.

5. Can the cathode resistor of a plate detector be omitted? Explain your answer, showing the needed circuit in schematic form.

6. What will happen if the grid leak of a detector is made too large? Analyze the effects by going over the operation of the circuit.

7. What special advantages are there to a plate detector?

\*Circuit diagram reproduced from the "Radio Builder's Handbook" published by Allied Radio Corp.

# LESSON 14

## Receiver Circuits

**PURPOSE OF THE RECEIVER.** The electro-magnetic waves from all radio stations induce voltages in the receiving antenna. Of course, the amount of voltage depends on the power of the transmitting station, the distance to the station, and the type of antenna. It is the function of the radio receiver to select the signal of the desired station, amplify this signal, detect the original audio signal, and deliver these audio electrical variations to the loudspeaker. All this is accomplished with the aid of the circuits we have already studied.

**SELECTIVITY.** A radio receiver must separate the signals of any station wanted from the signals of all remaining operating stations. The degree of selectivity is the ability of the receiver to perform this function. Since the broadcast band stations are separated by 10 K.C., selectivity that is sufficient to separate stations 10 K.C. apart is employed in broadcast receivers.

**SENSITIVITY.** The receiving set must also amplify the incoming signal voltage to a sufficient degree to operate the loud-speaker. The sensitivity of a receiver is the measurement of overall amplification from the antenna input to the loud-speaker connections. Sensitivity should be as large as practical; it is possible to over do this in modern high gain sets.

All noise picked up by the receiver, collectively is known as the *noise level*. If a station's signal has less strength than the stray impulses forming the noise level, that station cannot be received successfully. Therefore, a radio set that can "go down" to the noise level is as sensitive as is required.

**FIDELITY.** The exactness with which the receiver reproduces speech and music is an indication of its fidelity. The radio receiver should not distort, add, change, or alter the original broadcasted sound in any way.

The required qualities of a radio receiver, which we discussed, are inter-related. The tuning arrangement permits the selection of the wanted radio station and, therefore, serves to give selectivity. But the inductance-capacity, used for tuning, also gives a voltage gain which makes the receiver more sensitive. In most R.F. circuits, as you can see, selectivity and sensitivity go hand in hand. A very selective radio will be very discriminating against all frequencies except the frequency to which it is adjusted. But a broadcast station transmitting music must have a channel of about 5 kilocycles on each side of its carrier frequency. The idea of the channel width implies that the frequency transmitted, and which must be received for good quality reproduction, shifts around in the channel. If the radio receiver is sharp (has extremely good selectivity), it will not amplify all the frequencies in the channel with equal intensity. But you understand that the amplification of all frequencies in the channel of a station with almost equal intensity is the requirement for high fidelity. In designing equipment, a compromise is made between sharp selectivity and fidelity, since these factors have limiting effects on each other.

The majority of radio occupations deal with the building and repairing of radio receivers. This fact makes this lesson especially important.

Radio receivers are successful in performing this function of selecting the wanted station because radio stations are *separated* in the frequency spectrum.

The amplification may take place at radio or audio frequencies and is of voltage amplification type until the last stage where power amplification takes place.

This is the requirement for a perfect receiver. Small discrepancies exist and are permissible.

We already mentioned these requirements in talking about the selectivity curve of an R. F. amplifier.

Volume 2 - Page 133

## DISADVANTAGE OF TRF SETS

The coil coupling the last R. F. stage to the detector is also called an R. F. coil.

This trimmer adjustment (alignment) in TRF receivers is made at the high frequency end of the band (1,400 KC. for broadcast band). Since at high frequencies the tuning condenser has minimum capacity, the shunting stray capacities have the most effect under such conditions. This is the reason why these stray capacities are equalized at a frequency where they have the most effect. Once adjusted at the high frequency end of the band, the TRF receiver will tune properly at other points of the dial.

This one paragraph suggests the reason for the popularity of the superhet circuit. You better read it once again.

**FIELD STRENGTH.** The transmitted radio energy is spread out in all directions and is quickly reduced to a very low comparative value. In order to have a method of comparison between the signals received from various stations and as well as between the sensitivity of different receivers, it is practical to call the voltage induced in the receiving antenna, the field strength of the transmitter at a particular point on the earth's surface. The voltage induced in a higher antenna will be greater than that set up in a lower one. Since the voltage in the average antenna is a few thousandths of a volt (millivolts), the field strength is rated as so many millivolts or microvolts per meter of the effective antenna height. An antenna having an effective height of 3 meters and receiving a signal 15 microvolts, will have 5 (15/3) microvolts per meter field strength.

**TRF RECEIVERS.** A tuned radio frequency (TRF) amplification stage essentially consists of an input tuned transformer and an output tuned transformer; the latter also serves as the means of input for the next R.F. stage. These transformers are familiar to us as coils. If the coil is used to couple together two R.F. stages, it is called an R.F. coil; if the coil is used to connect the antenna to the first R.F. stage, it is called the antenna coil.

It is possible to use a number of such TRF stages before the detector to obtain the needed sensitivity and selectivity. The variable condensers used to tune the coils are ganged together for single dial control. Each condenser section is identical and is of about .000365 mfd. capacity. Since the condenser sections rotate together and because the distributed capacity of each R.F. stage is not necessarily the same, small trimmer condensers shunt each section and are adjusted to make up for this difference in distributed capacity.

Some of the older receivers, before 1927, used triodes in the R.F. sections. These tubes give but little gain, therefore, it was common to employ four such stages. These stages were followed by the detector. Since five coils were needed, one *between* each of the stages and one between the first stage and antenna, the tuning condenser was of the five gang type. Tetrodes and pentodes used after this period gave much greater gain per stage. Only two R.F. stages were used in many TRF sets.

The TRF receiver is made up of several R.F. stages, detector, and an audio amplifier which usually consists of one voltage amplifier stage and the power stage connected to the loudspeaker. Since TRF circuits have not been very popular since the real development of the superhetrodyne circuit around 1930, we will not give tuned radio frequency receivers any more space.

**SINGLE FREQUENCY AMPLIFIERS.** An R.F. amplifier can be designed to give exceptionally good results, from the tone quality point of view, if it is to be operated with the *channel* frequencies of a single, pre-fixed carrier frequency. In a regular TRF receiver, the R.F. stages must be adjusted to many different frequencies for the purpose of receiving various stations. If a way could be found to change the frequency of any desired station, to a fixed frequency of the pre-arranged amplifier, but at the same time change the stations not wanted to some other frequencies, we could obtain much better results from our equipment. And this is exactly what is done in the superhet circuit.

**MIXING IN A NON-LINEAR IMPEDANCE.** Let us assume that we have two generators producing two different frequencies. These



generators may be connected to a resistor, and both frequencies will be present in the circuit. The resistor is considered a *linear* impedance because its graph of voltage against current is a straight line. The two frequencies superimposed on the resistor will be present, but no new frequencies will be produced.

A very interesting thing happens when two different frequencies are superimposed upon a non-linear impedance. A non-linear impedance is associated with a circuit which causes the current-against-voltage graph to appear as a curve. Some sections of all tube characteristic curves are of this type. Suppose we arrange a circuit using a vacuum tube so that two different frequencies are superimposed and the tube is operated over the curved (non-linear) portion, what frequencies will be present? Here we have a surprise. Extensive practical experiments as well as mathematical development have shown that besides the two original frequencies imposed on the circuit, two new frequencies will also be present. These two new frequencies (created in the circuit) will be equal to the sum and difference of the original frequencies. For example, if the original frequencies were 7 and 12 cycles, the new frequencies are  $12-7=5$  cycles, and  $12+7=19$  cycles. Or if the original frequencies are 550 KC. and 1010 KC., the resulting frequencies will be the original two frequencies and also 460 KC. and 1560 KC.

Let us assume that such a mixer tube is connected to a tuned circuit. The frequency of the station we want is received and is one of the original frequencies. Now we have a little transmitter (oscillator) built in the radio which can be adjusted to give any required frequency. We also follow this mixer tube with several stages of amplifiers designed for a single frequency reception. Let these amplifiers be made for 460 KC. and, since this frequency lies between audio and radio frequencies, we call it intermediate frequency, or abbreviated I.F.

If we wish to receive the program of a radio station which is operating on 670 KC. (WMAQ in Chicago for example), we adjust our tuning arrangement for this frequency. At the same time, we adjust our oscillator unit for 1,130 KC. The frequencies reaching the mixer tube are predominantly this 1,130 KC. oscillator frequency, and the 670 KC. of the desired radio station. These frequencies are combined in the non-linear mixer, and four frequencies are supplied by the stage incorporating the mixer tube. These four frequencies are the two original frequencies and the sum of the two frequencies, and, what we really need, the difference of the two frequencies. The difference of the two original frequencies will be 460 KC., just what is required for the I.F. amplifier stages. If another station is to be tuned in, both the station tuning arrangement and the oscillator must be retuned. If this station is one operating on 970 KC., then the station tuning must be adjusted to this frequency, and the oscillator must be set to 1,430 KC., to produce the required I.F. (460 KC. in this case).

**BLOCK DIAGRAM OF A SUPERHET.** It is possible to represent each stage of a superheterodyne by a box. The relationship between the stages is shown by the arrangement of these boxes which suggest the circuit of the receiver. Such diagrammatical drawing is called a block diagram. Please examine the illustration below.

Beginning with the antenna, we find a stage labeled, R.F. PRE-SELECTOR. This section may actually consist of one or two R.F. stages which are tuned to the frequency of the wanted station. In the lower priced radios, the pre-selector is omitted, and the antenna is connected directly to the tuning coil at the input to the mixer.

## RESULTS OF FREQUENCY MIXING

Here the word curve is used to suggest curvature. In the mathematical sense, even a straight line is a curve.

Your future ability to service superhet receivers will depend to a very large extent on your understanding of the basic principles explained on this page. Be certain you understand the action described. The explanation is simple and is carefully covered.

Check this figure.

Is this right?

Block diagrams are excellent for introducing complex circuits to the beginner. The student may obtain a general view and then learn about the circuits used in each stage.

**Volume 2 - Page 135**

## SUPERHETERODYNE RECEIVER

Any radio receiver may be tested by injecting a suitable signal in each stage. Usually, it is best to start with the output stage and proceed back to the antenna. When making this test at any one stage, you fail to obtain a response in the speaker (while you did obtain a response when testing the stage to the right of this point), the stage under the present test must be at fault.

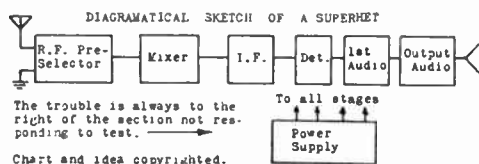

Figure 193. A block diagram shows the relationship of the different sections of a radio receiver. The signal is changed in form and intensity as it proceeds from antenna to loud-speaker.

As we have already mentioned, in some sets a separate oscillator tube is used, but our block diagram indicates that the mixer tube combines the function of the oscillator and mixer. Incidentally, you may find that some books call the mixer, a first detector tube.

Although following the mixer stage, we have the original frequency of the station tuned in, the oscillator frequency, and also the sum and the difference of these frequencies, the I.F. stage passes and amplifies only the frequency which is the difference of the frequencies imposed. Most sets have one or two I.F. stages. If only one I.F. stage is used, two I.F. transformers are needed. One is connected to the input of this I.F. stage, while the second is coupled to the output and feeds the detector. If two I.F. stages are used, three I.F. transformers will be needed. It is well at this point to return to Lesson Five, and review the material on I.F. transformers.

Any of the vacuum tube detectors we have studied may be used successfully with a superhet circuit. Usually a diode detector is employed, but this is not a requirement. The stage we have indicated as the detector in the block diagram, is sometimes called the second detector to differentiate it from the mixer stage which is called the first detector by some authors.

The stages which follow the detector are used to amplify the audio output from the detector. As indicated, it is common to find the larger superhets employing a voltage amplifier (1ST AUDIO) and a power amplifier (OUTPUT AUDIO). The plate voltage is supplied by the power supply, indicated as a separate stage. If a transformer is used in the power supply, it also supplies the filament voltages.

**SIMPLE SUPERHET CIRCUIT.** Now you are ready to study a complete circuit of a simple superhet. Look over the schematic diagram of this radio. Observe that five tubes are used; notice that the filament connections are not shown, but are indicated by X, that they are to be connected to a winding on the power transformer. Notice that pilot-light is also placed across this transformer winding. Examine each part-symbol as included in the drawing. The numbers beside each part refer to the parts list which gives a complete description of the parts. Become familiar with these parts. A complete explanation of the circuit will be given now.

Coil 16 and condenser 11, form a wave trap for the purpose of keeping out undesirable signals which may cause interference at all settings of the tuning dial. This wave trap is adjusted once at the factory and need not be touched. Switch 25 is used to give an extended range for police station reception, but in our discussion we will assume that it is placed in the normal position, as illustrated.

You already have noticed that 17 is the antenna coil and 18 is the oscillator coil. Both of these coils are tuned with the two gang condenser. This tuning condenser is of a cut-section type and the rotating plates of the two gangs are not alike. Since the section

A circuit diagram of a radio receiver or an industrial electronic device gives hundreds of helpful facts about the equipment. Only a small number of all the facts included in the schematic diagram are mentioned in the discussion.

In the normal position, the switch is completely out of the circuit.

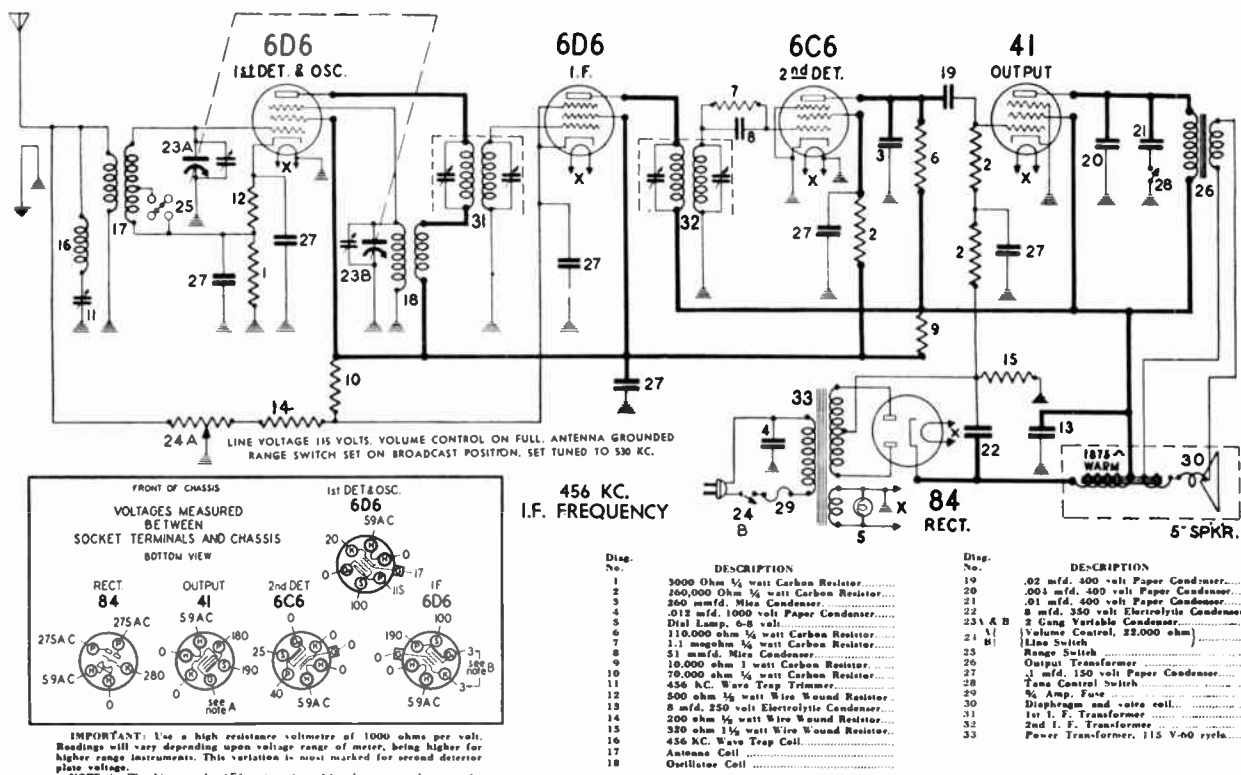

### STEWART-WARNER MODEL R-144AS CHASSIS

Figure 194. The different principles which we studied are used in a complete radio receiver. A radio circuit tells you which parts are employed, how these parts are connected, and how the equipment operates.

marked 23B, used with the oscillator, has smaller plates, the capacity will be smaller and the frequency produced by the oscillator will be higher. Of course, the condenser and coils are so chosen that the higher frequency is always greater by 456 K.C., because this is the I.F. frequency of the radio. The little, semi-adjustable trimmers, shown connected in parallel with the condenser sections, are used to make needed adjustment so that the incoming frequency and the oscillator frequency will always differ by the required amount, that is by 456 KC. in this case.

Let us review the operation of the mixer-oscillator stage which uses a type 6D6 pentode and is called "1st DET. & Osc." in the drawing. We turn the variable condenser (23A and 23B) until the antenna coil and the condenser are tuned to receive the station we want. This station's frequency is impressed on the grid which is adjacent to the cathode. Observe that the grid return, made through the secondary of coil 17, is connected to a tap (junction) of the resistors used for cathode bias (resistors 12 and 1). This circuit, therefore, places less negative grid voltage on the grid we are considering than on the suppressor grid adjacent to the plate. You recall, of course, that the ground may be considered most negative. Coil 18, and the tuning condenser are so connected to the elements of this tube that oscillation (production of radio signals) will occur at a frequency determined by the coil-condenser combination. The frequency which will be produced at the setting we have made will be just 456 KC. (the I.F.) higher than the frequency of the station we wish to receive. The mixer tube will produce the sum and difference of these frequencies, but only the

Refer back to the schematic diagram as you read this description.

It is assumed that the receiver is properly adjusted to produce these results.

## UNUSUAL BIAS SUPPLY

Since these resistors are connected in series, the same current passes through each and the voltage drops in each will be proportional to the resistance.

The voltage drop in resistor 14 is always between the grid and cathode of the 6D6 tube.

The field coil of the loudspeaker is used as the filter choke. This coil has a D.C. resistance of 1,875 ohms. The average total plate current for all the tubes is about 60 ma. (.06 amperes). Since this current must pass through the field coil, we have a voltage drop across this field equal to 112.5 volts. The power dissipated in the field is equal to  $6\frac{3}{4}$  watts. Look up the needed formulas and check the answers given.

The serviceman takes measurements at the points indicated and compares results observed with the values given. Wide differences suggest possible faults.

**Volume 2 – Page 138**

difference (exactly 456 KC.) will pass through the I.F. transformer, part 31, and will be further amplified. The I.F. transformers, of course, are adjusted for the frequency required. These adjustments remain correct for long periods of time, but occasionally will need re-alignment.

The I.F. amplifier stage uses a type 6D6 tube. There is nothing unusual about this stage except the cathode return circuit. This circuit is related to the volume control. Notice that the plate supply voltage of about 190 volts is dropped to ground through the series network of resistors 10, 14, and the sections of the potentiometer 24A which is to the right of the slider. Be sure that you have the resistance values of these units clearly in mind. If the slider is all the way to the right, only resistors 10 and 14 form a voltage divider network. Both the bleeder current and the plate current of the 6D6 I.F. tube flow through resistor 14, to ground and produce a negative bias from cathode to ground of 3 volts. As the setting of the volume control (potentiometer 24A) is changed, the negative bias is increased to a maximum of 30 volts. Of course, the changing of the volume control setting also causes losses of the antenna signal to ground to increase, as the slider is moved to the left. Resistor 14 is used to guarantee a minimum required negative bias.

A type 6C6 tube is used as the detector (2ND DET.) and is of the grid leak type. Do you recall the action from the circuit of the two tube set in Lesson Thirteen? The audio output from the detector is sufficient to drive a sensitive type 41 pentode output tube. Condenser 20 is the usual tone correction condenser used with pentodes. Switch 28 permits the insertion of another larger capacity condenser for further reduction of high frequency audio response and the apparent stressing of bass. The output tube is coupled to a dynamic speaker through an output transformer. Notice that the field coil of this speaker is employed as the filter choke. In general, the heavy lines in the circuit indicate places where plate voltage is present.

You will notice that the cathode of the type 41 tube is at ground potential although the grid must be at a negative 14 volts. How is this bias voltage obtained? The entire plate supply current for all tubes comes from the high voltage winding of the power transformer. The center tap of the transformer winding serves as the return path, but instead of being connected directly to ground, it is connected to ground through a 320 ohm resistor, part 15. The plate current for all tubes must pass through this resistor and will produce a voltage drop of 14 volts across this resistor. The side of this resistor connected to the center tap of the transformer winding is most negative. The cathode of the 41 tube and the positive side of this resistor (part 15) are grounded. Can we connect the grid of the 41 tube, to the other side of the resistor to obtain the negative voltage needed on the grid? Yes, we can and have done this in the circuit using a network of two resistors. One of these 260,000 ohm resistors would be enough, but a certain amount of ripple voltage would then be fed to the grid and result in a loud hum in the output. The extra resistor and by-pass condenser 27, eliminate this.

Very helpful information can be given to a radio serviceman in the form of a socket voltage chart. A chart of this type simply shows the sockets of the tubes and tell what voltages exist at the different terminals in relation to the ground. Please see if these readings appear normal to you and agree with your expectation.

**AUTOMATIC VOLUME CONTROL.** There are numerous varieties of automatic volume control (AVC) circuits, but they all work on the

same principle. The AVC arrangement is intended to maintain the strength of the signal arriving at the detector nearly constant, thus compensating for different signal strengths of different stations and for fading. It does this by varying the sensitivity of the R.F. and

## AUTOMATIC VOLUME CONTROL

All modern radio receivers incorporate automatic volume control circuits.

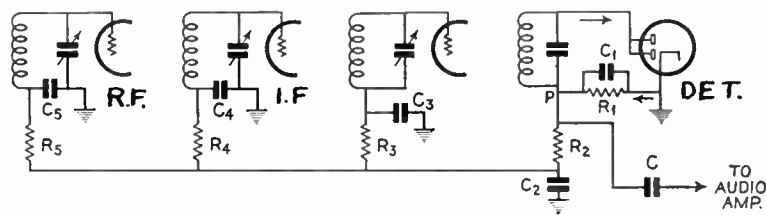

*Courtesy Acrovox "Research Worker"*

Figure 196. The basic circuit showing the voltage distribution in a modern AVC system.

I.F. amplifiers. Actually, AVC changes the bias on these amplifier tubes to obtain this action. The actual volume is of course not kept constant because it depends on the percentage of modulation at the transmitter. This is being varied in accordance with the volume of the transmitted sound and music. To try keeping this constant would be ruining the effect of music.

The schematic above illustrates an AVC system often used in up-to-date sets. Forgetting for the moment the grid return resistors in the R.F. circuits, let us begin with the detector. The signal is rectified by a diode. Current can flow only when the diode becomes positive and the coil must then be considered as the generator. This will perhaps help to explain why the resistor  $R_1$  will carry current in the direction of the arrow, making the point P negative with respect to the cathode and the chassis. This seems to be difficult to understand by many. The current flowing between P and the chassis consists of a direct current component, a radio frequency component, and an audio frequency component. The condenser  $C_1$  has been placed across the resistor to pass most of the radio frequency currents and the audio frequency component is taken off to be applied to the audio tube grid by means of the coupling condenser C. The steady voltage at P, which is proportional to the strength of the incoming signal, must now be fed back to the R.F. and I.F. amplifiers, but the A.F. component must be filtered out and precautions for interstage coupling must be taken. This latter requirement is accomplished by the network of resistors and condensers. Since the grids of the amplifying tubes are never drawing current, it does not matter, within limits, how much resistance there is between the point P and the individual grids.

Resistor  $R_2$  and condenser  $C_2$  form a resistance-capacity filter which smoothes out most of the audio frequency fluctuations. That it does so is best seen from a consideration of the laws of alternating currents. Since the condenser which is in series with the resistor  $R_2$ , forms a path for alternating currents, a great part of the audio signal will pass through  $C_2$  in preference to following the paths through  $R_3$ - $C_3$ ,  $R_4$ - $C_4$ ,  $R_5$ - $C_5$ .

**AC-DC SUPERHET WITH AVC.** A very interesting, modern superhet will be explained next. Quickly examine the circuit. The antenna coil is in the form of a large loop and, thereby, serves as the coil and the source of signal pickup. Provisions are incorporated for connecting an outside antenna if desired. No outside ground should be used with an AC-DC type radio set. A separate oscillator tube, type 12J5-GT, is used. This tube is wired in a form of a Hartley oscillator which will be explained in detail in

Follow this explanation by carefully tracing the action explained.

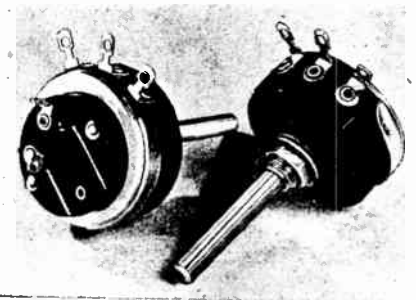

*Courtesy Clarostat Mfg. Co.*

Figure 197. The same types of volume controls may be obtained with or without line switch.

Volume controls are a common source of trouble in radio receivers. This is to be expected since volume controls receive the most mechanical wear of all parts used in the radio.

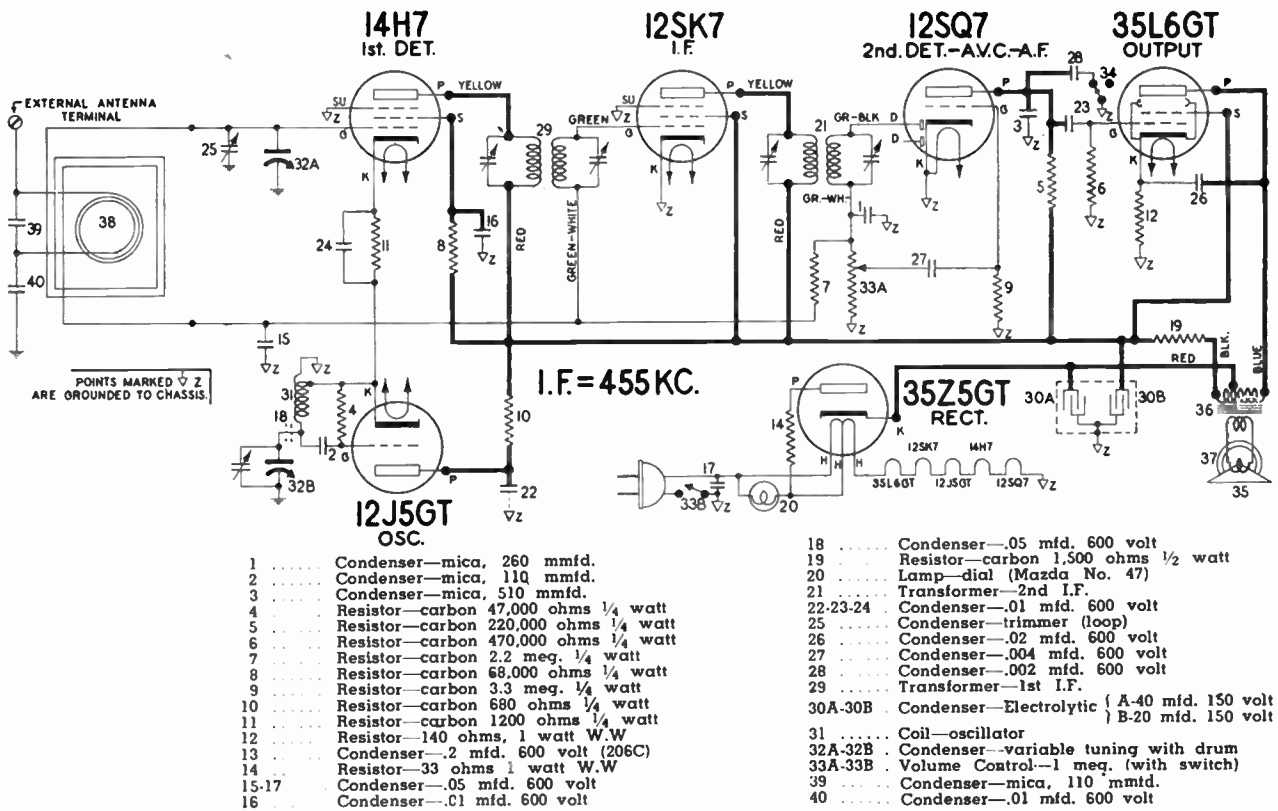

Figure 201. The circuit of Stewart-Warner Models 206B and 206C radio receivers. This circuit represents the modern trend in the smaller AC-DC radio sets.

Lesson Fifteen. Please notice that the cathode (K) of the oscillator tube is connected to a tap of the oscillator coil (part 31) and not to the ground. The cathode bias resistor of the 14H7 mixer is also returned to this tap. The oscillator signal is, therefore, injected into the mixer (1st DET.) through the cathode. You have probably noticed that the smaller superhet, we have studied so far, did not have a R.F. pre-selector.

The I.F. stage is of a familiar type. The type 12SK7 tube is similar to the type 6D6 used in the first superhet we analyzed. Notice the color code used for the leads of the I.F. transformers. The I.F. transformer feeding the diode detector is of a special type with the primary and secondary of the transformer placed closer together. The type 12SQ7 tube combines a diode detector which also supplies the AVC voltage, and besides contains a triode section which amplifies the audio signal. Review in your mind the complete action of this stage. It will give you a good review of diode detector action, ACV, and audio amplification. No provisions have been made for grid bias in the triode section of the 12SQ7, but a very small voltage difference exists because of the fact that different materials are used for electron emission (cathode) and for the grid, and this voltage\* is sufficient for the bias.

A half-wave rectifier is used. The filaments are wired in series and add up to about 120 volts supplied by the power line. Notice that the plate current and part of the filament current for the 35Z5-GT tube passes through the pilot bulb. However, if the bulb burns out, the filaments will still light.

\*This voltage difference, about one volt, is called the contact potential.

You probably are beginning to see the similarity of radio receivers.

The filament connections are shown separately.

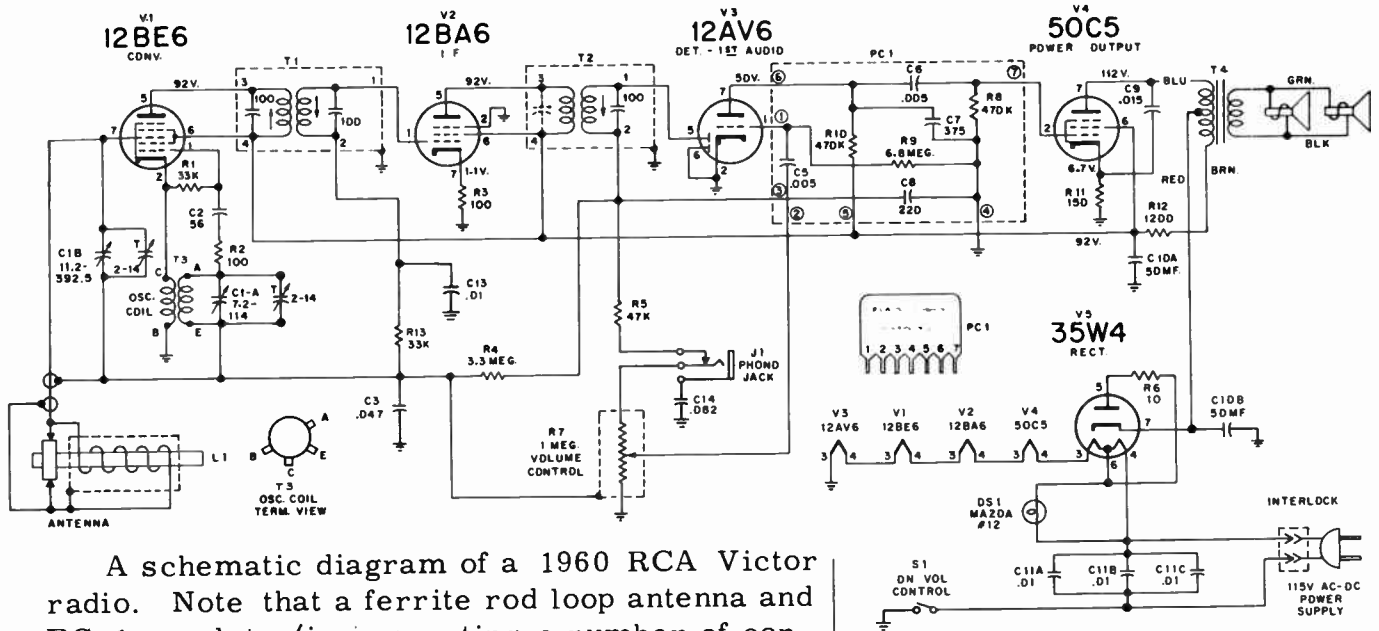

A schematic diagram of a 1960 RCA Victor radio. Note that a ferrite rod loop antenna and PC-1 couplate (incorporating a number of condensers and resistors) are used. Later types of tubes are used, but the superhet circuit shown is basically like the ones we just studied.

K=1000  
ALL RESISTANCE VALUES IN OHMS. ALL CAPACITANCE VALUES LESS THAN 1.0 IN MF. AND 1.0 AND ABOVE IN MMF. EXCEPT THOSE INDICATED.

RCA Victor X-4 Series Sets

**NEED FOR ALIGNMENT.** In order for a radio receiver to select the signal of a single station at one time, the various stages must operate, for any one setting of the dial, in a correct manner. In the TRF set, all tuned sections should be tuned to the desired station and must be aligned (adjusted) to receive the same frequency at the same setting of the tuning condenser.

In the TRF receiver, if the various tuned stages are not adjusted to receive the same station for any one setting, several stations may be heard at the same time.

In the superhet, the problem of alignment is a little different. In selecting any station, the R.F. section must be tuned to the frequency of this station, but the oscillator is tuned, at the same time, to a frequency equal to the incoming station frequency plus the frequency of the I.F. stages. For example, you tune in a station operating on 900 KC. The I.F. of this set is 456 KC. For proper operation at this point the oscillator frequency must be  $900 + 456$ , or 1,356 KC.

It is not often that a set needs alignment. For best results, a signal generator and an output meter should be used for alignment; but for the broadcast band, a passing job can be done without equipment. The methods will be outlined below. The use of a signal generator and other test equipment for this purpose will be given in Lesson 19.

Your hearing is more sensitive at low volume levels.

**ALIGNMENT OF SUPERHETS WITHOUT EQUIPMENT.\*** In all cases of alignment, the manual volume control is advanced until the signal is audible. As the alignment makes the set work better, the output will become louder. This can be corrected by reducing the volume with the control as need arises. In sets with AVC, adjust

\*See author's book, *Simplified Radio Servicing by Comparison Method*, for more details on radio alignment and repair without equipment.

## ALIGNMENT SIMPLIFIED

In aligning, you actually tune in the station in the regular way (with the variable condenser) and then you supplement this tuning with exact adjustment of the trimmers and padders.

Reference is made to Figure 202.

1. What does a tuned circuit do?

for maximum volume also, but remember that the automatic volume control will try to keep the output at a fixed level. Because of this, let the amount of background hiss and noise help you judge the proper point of alignment. Minimum background noise with maximum volume for any setting of the volume control should be your guide.

If a tuning meter or tube is a part of the radio, this may be used as the indicator. The indication of correct tuning will also serve to indicate correct alignment.

In the superhet, the I.F. transformers must be set for the frequency of this section. At first, it is safe to assume that the I.F. transformers are not much off and may be left alone. Now tune in a strong local station having a frequency of about 1,500 KC. Let us say in your locality you have a station operating at 1,350 KC. You turn the dial to 1,350 KC., but find that the station will come in best at 1,370 KC., or 137 on the dial. Set the dial on 1,350 KC. anyway. Find the trimmer mounted above the condenser gang which tunes the oscillator coil. (In multi-band sets, this trimmer will be inside of the can housing the oscillator coil). Turn this trimmer until the signal comes in as loud as possible without changing the volume control. This trimmer is No. 5, in the diagram.

Now turn the trimmer of the antenna section gang (also R.F. if used in the set). The set screw may have to be turned in one direction or another. This is adjustment No. 6.

Now tune in a station at around 650 KC. Find the padder condenser which is usually mounted near the oscillator coil. While the station comes in, rock the tuning dial a little up and back past the point where the station comes in, and adjust the padder for loudest response. If the super uses a cut section tuning condenser, the outside moving plate of the oscillator section may have to be bent a little. The metal plates of a condenser must not touch, however. The set we described has a cut section condenser.

Now go back to about 1,400 KC. and check up on your work. Readjust a little. The trimmers of the I.F. transformers may be turned a little at this time. Be careful not to turn these too much.

REVIEW QUESTIONS AND PROBLEMS. 1. Is it possible to increase the selectivity of a radio receiver without increasing the sensitivity? Explain your answer.

2. How do you explain why a long antenna picks up more of the radiated energy?

3. What are the limitations of TRF receiver?

4. What is your understanding of a non-linear impedance?

5. Make a block diagram of a TRF receiver following the type shown for the superhet set.

6. In the circuit of the Stewart-Warner Model R-144 receiver, what are the values of the following parts:

- a. Grid leak,
- b. Tone control condenser,
- c. Voltage of the pilot bulb,
- d. Volume control,
- e. Resistance of the field coil,
- f. Line fuse.

7. In the circuit of the AC-DC receiver, how many diodes does the type 12SQ7 tube have? Are all these diodes used?

8. In the receiver mentioned in question 7, what is the purpose of part 27?



# LESSON 15

## Electronic Oscillators

**NATURE OF OSCILLATIONS.** Let us connect a good quality condenser to a battery. After a short period of time, the condenser will be charged approximately to the potential of the battery. Now we will disconnect the condenser from the battery, being careful not to short the terminals of the condenser, and connect this condenser to a low-loss coil. What will take place is of prime importance, for this same action permits radio transmission. Even before we had equipment to detect the effects of the action which will take place in this circuit, scientists knew from mathematical analysis what was to be expected. Since then, we have studied the action of such simple circuits, made up of a charged condenser and an inductance, and know exactly what takes place.

As soon as the condenser is connected to the inductance, it will start to discharge and a current will flow through the inductance. A current in the inductance will set up a magnetic field. After a short time, the condenser will be completely discharged and have no stored energy, while the magnetic field around the inductance will be maximum. Now the magnetic field will break down, sending current through the coil in the opposite direction and charging the condenser with the reverse polarity. Then the cycle will repeat itself. As you can see, the current in the circuit is of an alternating nature, constantly increasing or decreasing with time, and the action is repeated periodically. The coil and condenser, and no other parts, have created an alternating current from the D.C. of the battery used to charge the condenser.

This exchange of energy between the capacity and inductance would continue forever were it not for the losses occurring in the circuit. The condenser has some losses and, of course, the inductance has resistance present. All the losses of the circuit may be expressed as an additional resistor connected in series with the condenser and inductance. If this is done, the condenser and inductance may be assumed to be perfect without any losses; the losses have been included in the resistor described. As the alternating current surges up and back through the circuit (oscillates is a good way to describe this), a certain amount of power is wasted in the series resistor. In a pure condenser or inductance, the current and voltage are  $90^\circ$  out of phase and no power is lost. As each repetition of the current reversal happens, some energy is used up in the resistor, and the intensity of the remaining electrical energy is diminished. Notice the effects on the wave form produced by the presence of the resistance; the figure shows three different conditions. If the resistance is very high, so much of the energy delivered by the charged condenser is used up on the first half of the cycle of the oscillating action, that no additional repetitions occur. This statement tells us that if the resistance of the circuit is too high, no oscillations will take place.

What determines the frequency of the oscillatory current? We know that a series L-C circuit has the least opposition to its natural

Oscillator circuits are employed to produce high frequency currents for radio transmission. Practical electronic oscillators obtain power for operation from a D.C. source — batteries or a power supply.

Perhaps you are wondering about the voltages existing in this oscillating circuit. The voltage across each component (inductance, capacity, or resistance of the wires making up the connections) is changing also. Since the voltage across the inductance is leading the voltage drop across the resistance of the circuit, while the voltage across the capacity is lagging behind this voltage drop of the resistance, the voltages across the inductance and the capacity are  $180^\circ$  out of phase. When the voltage across the inductance is increasing, the voltage across the capacity is correspondingly decreasing. This is to be expected from the explanation in the text.

Refer to Figure 212, on the next page.

**Volume 2 – Page 143**

## NATURAL FREQUENCY

In this formula,  $f$  is in cycles,  $L$  is the inductance in henries, and  $C$  is the capacity in farads. If  $L$  is expressed in microhenries and  $C$  in microfarads, the answer for  $f$  will be found in megacycles (MC.).

Memorize these two very important sentences.

Even with very little resistance (losses), some energy is lost during each cycle with the corresponding reduction of the circulating current,  $I$ .

More advanced radio books present special development for the parallel circuit.

Make a simple pendulum using a string and a weight, and experiment setting this pendulum into oscillation.

frequency and would favor this frequency. The frequency is, therefore, determined by the expression:

$$f = \frac{1}{6.28 \sqrt{LC}}$$

which is familiar to us from our work in Lesson Seven. This formula tells us many things. We can tell from the formula that the frequency depends on the inductance and capacity. The frequency has nothing to do with resistance in a series circuit. Increasing  $L$  or  $C$ , lowers the frequency. Many values of  $L$  and  $C$ , will give the same frequency, provided that the product of the two gives the same number.

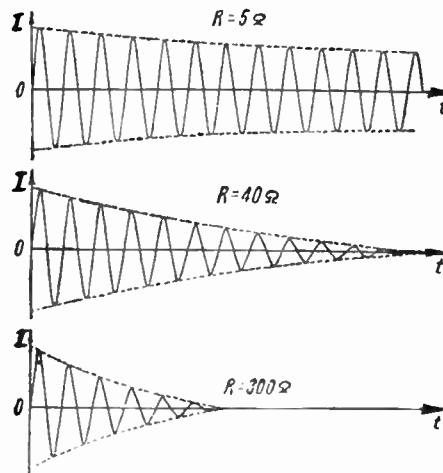

Figure 212. The oscillations produced by the same L-C circuit but with different values of series resistance.

The action of a parallel L-C circuit is very similar and, for practical problems, the same formula can be applied. However, the resistance has a minor effect on frequency and for absolutely correct results a somewhat different formula is needed.

The understanding of the function of an oscillatory circuit is so important that we will now associate the idea with a mechanical analogy. Imagine a pendulum—perhaps a weight suspended on a fine string, or perhaps a child's swing. We swing the weight all the way to one side. This is equivalent to charging the condenser. Now we will let the weight go. It comes down, pauses in its normal position, and then swings up. The normal position corresponds to the condenser being discharged and all the energy being present in the inductance. The swinging-up action corresponds to the charging of the condenser in the opposite direction. The swinging will continue, but will it be as great each time? The losses of the mechanical system, just like the resistance losses in the electrical circuit, will reduce the amount of the swing and finally will bring the pendulum to rest. We will come back to this mechanical analogy again when we talk about producing continuous waves.

It is clear that no particular amount of energy is needed to start a L-C circuit oscillating. Any amount is sufficient. But the intensity of the oscillations will depend on the initial amount of energy sup-

plied to the circuit. The reason for the oscillation is due to the properties of the inductance and capacity. These properties are determined experimentally and are as decreed by Nature.

**CONTINUOUS OSCILLATIONS.** If our L-C combination can be made without losses, all the re-occurant waves would be of the same intensity and the oscillations, once started, would go on for all time. Of course, all L-C circuits have losses, but this problem can be solved another way. The losses use up a certain amount of energy every cycle. If we could replace the lost energy with an equal amount, the oscillations would be the same, i.e. continuous, of the same size, and not damped. This is exactly what is done with the aid of vacuum tubes.

Let us return to our mechanical analogy of the swing. The swing loses very little of its movement (energy) each time it swings up and back. Suppose we gave the swing an added push when it returned to the approximate original starting place, then the swing action would go on without reduction and without a stop. This added push must come at the right instant and must be about right in intensity. It would help little to push too hard or not enough, and it would be detrimental to push in the wrong direction against the motion of the swing. The best place to add the energy needed is at the end of the swing, at the highest point of the swing, when the motion is about ready to reverse.

**TICKLER COIL OSCILLATOR.** All modern transmitters use vacuum tubes for the production of radio frequency oscillations. We know that a vacuum tube amplifies and this suggests the possibility of taking a little extra energy from the plate side and feeding this energy back to the grid L-C circuit to make up for the losses. This is exactly what the circuit accomplishes and we will see why this is so.

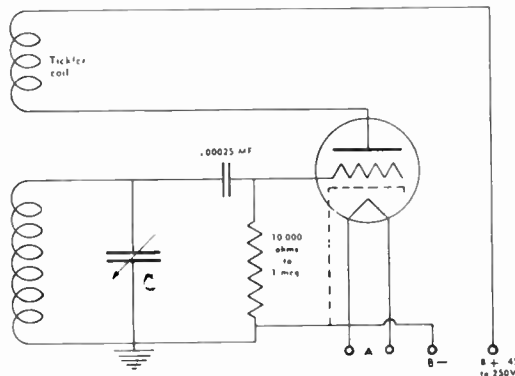

Figure 214. A basic vacuum tube oscillator employs some method for returning a little of the energy from the plate circuit to the grid circuit.

Let us assume that some disturbance, no matter how minute, has produced a charge on the variable condenser. Stray fields in the air or a slight potential change in the filament or plate supply would be enough for this purpose. Oscillation in the L-C circuit will take place. The voltage across the condenser will be changing at the frequency of the circuit, and this voltage will be impressed on the control grid of the tube. This grid voltage change, in turn, will vary the plate current producing a voltage drop across the tickler coil. Please refer to the diagram and follow this reasoning. For the moment we will not consider the .00025 mfd. grid condenser,

It is assumed, of course, that the losses per cycle are small.

Using the pendulum you constructed, see if you can keep it in continuous oscillation by adding, during each swing-cycle, the energy lost.

The fact that a vacuum tube amplifies, implies that there is much more energy in the plate circuit than in the grid circuit.

Oscillations would take place since the condenser would have a higher (or lower) potential than present, a moment before, for an equilibrium condition.

## FEEDBACK OSCILLATOR

This impedance (reactance) of the .00025 mfd. condenser is so low for radio frequencies that its opposition to R.F. currents may be considered equal to zero.

The oscillations (in a practical circuit) build up to the maximum value very quickly — in a fraction of a second.

Actually, electrons are attracted from the cathode to the grid which is positive at the moment.

Be sure you understand this action. Circuits of a similar nature are used in electronic equipment.

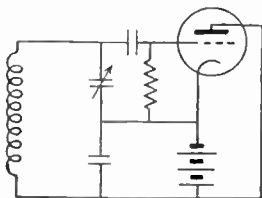
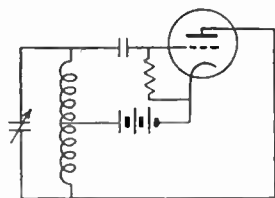

Above are the basic circuits of Hartley and Colpitts oscillators.

since it acts as a short circuit to the R.F., or the grid leak resistor of the value indicated which is required to supply a grid return path and bias.

The energy in the tickler coil can be made of the proper intensity and correct phase relationship to feed back to the coil of the L-C combination the required amount of energy to overcome the losses. In practice, however, more than this amount of energy is returned to the L-C circuit, and so the intensity of the oscillations is increased with each cycle. This increase continues until the characteristics of the tube used, limit any further increase. If the tickler is in the wrong phase relationship, it will prevent oscillation. This is equivalent to pushing the swing in the wrong direction, to come back to our mechanical analogy. If not enough energy is returned to the L-C circuit, the oscillations will be sustained for a few cycles, becoming smaller each time, and finally dying out.

In the circuit of a tickler oscillator, no regular cathode resistor is incorporated and the required grid bias is obtained in a special way. The pulses supplied to the grid are of alternating nature, and the grid is driven positive during a part of the cycle. When the grid is positive, it acts as an anode (plate) and conducts current to the cathode. Under these conditions, the .00025 mfd. condenser in the grid circuit is charged, and during the balance of the cycle this condenser discharges through the grid leak resistor which may be between 10,000 ohms and 1 megohm. Notice that the condenser took a charge which made its grid side negative and the coil side positive. While the condenser discharges, the circuit is completed by the resistor and the coil. It is possible for the coil to be the R.F. inductance and at the same time offer a low D.C. path for the current leaking off the condenser. In this circuit, the grid leak resistor will be negative at the grid side and positive at the cathode (ground) side. The voltage developed across the grid resistor will serve as the bias since it is applied between the grid and cathode. Since the energy in the condenser is replenished every cycle, and since the discharge rate of the .00025 mfd. condenser through the grid leak resistance is relatively slow, the bias is kept about constant. The oscillator tube is biased to give Class C operation.

**HARTLEY OSCILLATOR.** Many circuits use a tapped coil and a single tuning condenser to form our L-C circuit. The energy is fed back through magnetic coupling between sections of the inductance connected in the plate and grid circuits. If the coil has a tap and is connected to the grid and plate, or to the grid and screen grid in pentodes, the circuit used is a form of a Hartley oscillator.

**COLPITTS OSCILLATOR.** In many circuits, only a single coil is used and the tap is brought to a junction of two capacitors. Such circuits are named after Colpitts, the inventor of the basic circuit of this type.

**NEGATIVE RESISTANCE CONCEPT.** Physically, negative resistance does not exist. It is possible, however, to create circuits which will nullify or reduce the actual resistance physically present in a circuit. We say that such circuits possess negative resistance which overcomes regular (positive) resistance. If negative resistance can be combined with an inductive-capacitive circuit, and kept at a value which will just nullify the actual resistance present, the L-C circuit would oscillate without a stop. This technique is used in some oscillators.

## OSCILLATOR STABILITY

A coil-condenser combination is connected to the grid side of a vacuum tube. Another coil-condenser combination is connected in the plate circuit of this vacuum tube, but there is no magnetic coupling between these coils and no electrical connection between these L-C circuits. And yet the inter-electrode properties of the triode permit the operation of this circuit as an oscillator. This oscillator is called tuned-grid tuned-plate, or TGTP type. Since the tetrode and pentode have very little grid to plate capacity, they are not used to produce negative resistance in this fashion.

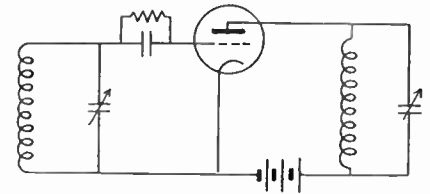

A tuned-grid tuned-plate oscillator.

**LIMITATIONS OF SELF-OSCILLATORS.** We have already learned that the frequency of a parallel L-C circuit depends primarily on the values of the inductance and capacity and to a limited degree on the resistance present in this circuit. If the inductance, capacity, and losses of the parallel L-C circuit used in the oscillator could be kept constant, the unit once adjusted would deliver the very same frequency at all times. However, all these factors change with temperature, age, voltage, and other conditions. As the value of inductance, capacity, or resistance changes because of the conditions mentioned, the frequency will also change. An oscillator which has its frequency varying is not stable. A transmitter, using an oscillator with poor stability, will not stay in the same spot in the receiver. The signal will appear to fade and constant retuning of the receiver will be needed. Stability is very important; frequency drift cannot be tolerated; broadcasting stations must not vary more than 20 cycles from their assigned frequency which may be 1,000,000 cycles (1,000 KC.), for some stations.

For example, variations are caused by vibration of the condenser plates, wires of the coil, moisture deposits on the coil changing the inductance, change of tube characteristics with age, changes in the voltage delivered by the power supply.

The amount of energy taken from the oscillator has an effect on the voltage fed back and also on the function of the tube. As the load is varied, the frequency of the oscillator will also shift.

Reference is made to U. S. broadcasting stations.

**ELECTRON-COUPLED OSCILLATOR.** In order to eliminate the frequency shift which may be due to changes in the load circuit, a special circuit was developed and employs a pentode radio tube. Any of the oscillator arrangements we have described can be employed, but the screen grid is used as the anode (plate) for the circuit. The plate of the pentode is wired to the load and, since the plate is not one of the tube elements which function in the oscillator circuit, the load has little effect on the frequency. The plate current, of course, is of the frequency produced in the grid oscillatory circuit. The load may be in the form of a parallel tuned circuit or a pure resistor. Electron-coupled oscillators give the best stability of all self-excited oscillator types.

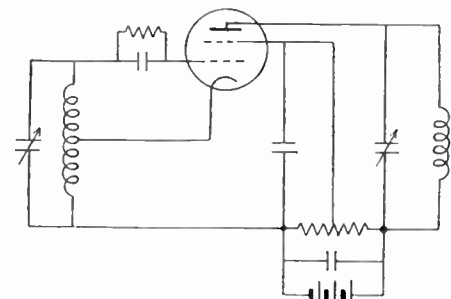

A circuit of an electron-coupled oscillator. You will observe that a basic Hartley oscillator circuit is employed.

**QUARTZ CRYSTALS.** All oscillators of high stability employ quartz crystals and the study of this material and the circuits employed is of importance to the radio technician. When quartz is distorted mechanically, an electric charge will be developed; and mechanical distortion will result if the substance is placed in an electric field. This property permits quartz crystals to be used in electric frequency-control circuits.

The action of an oscillating quartz crystal may be analyzed by reference to its equivalent electrical network as illustrated.\* The L, C, and R represent the actual crystal equivalent, while the capacity C<sub>1</sub> is formed by the metal electrodes used to hold the

\*Many of the illustrations dealing with crystals and their circuits are reprinted from "Frequency Control with Quartz Crystals."

## QUARTZ CRYSTALS



Courtesy Bliley Electric Co.

Figure 215. A group of natural quartz crystals.

Type of reactance offered by a quartz crystal at different frequencies. Positive (+) reactance is inductive, while negative (-) reactance is capacitive. At the resonant frequency where the quartz behaves as a series circuit, the reactance is zero (center horizontal line represents zero reactance). At a somewhat higher frequency, the circuit behaves as a parallel resonant circuit offering almost infinite reactance as the equivalent reactance shifts from inductive to capacitive.

Using the formula for the frequency of a series resonant circuit (see page 70), solve for the value of  $C$ , for the case where  $L$  is 100 henries, and  $f$  is 10 million cycles. (10 MC. frequency is used for short wave transmission). It is more important for you to realize how small  $C$  is, rather than to get the exact answer.

Volume 2 - Page 148

crystal in place.  $C_2$  capacity is present if the electrodes are not in direct contact with the crystal. We will not consider this capacity in our discussion. From your knowledge of resonance, you can see that at some frequency  $L$  and  $C$  will have their reactances exactly equal and we will have these two behaving as a series resonant

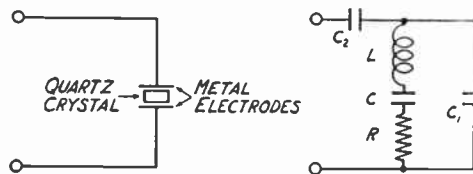
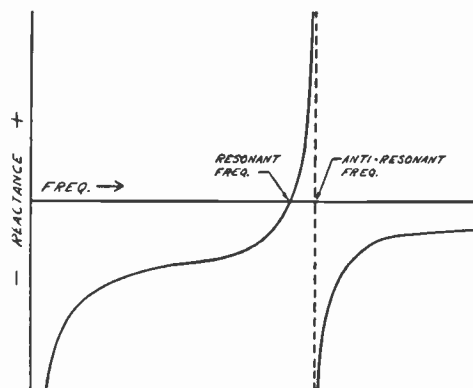

Figure 216. The equivalent electrical circuit of an oscillating quartz crystal.

circuit. This frequency is also called the natural frequency of the crystal. At a slightly higher frequency, the effective reactance of  $L$  and  $C$  combined will be inductive. You recall that a series  $L$ - $C$  circuit behaves inductively at frequencies above resonance. Now if  $L$  and  $C$ , acts as an inductance, there will be a frequency at which



Courtesy Bliley Electric Co.

Figure 217. Reactance curve of a quartz crystal. Please notice that at a certain resonant frequency, the equivalent series circuit behavior is obtained. At a somewhat higher frequency, the parallel circuit anti-resonant action results.

this equivalent inductance and the capacity  $C_1$  will form a parallel resonant circuit. You must realize, from this explanation, that at one definite frequency the crystal behaves as a series circuit at resonance, while at another frequency the circuit acts as a parallel or anti-resonant circuit.

The inductance,  $L$ , of a crystal is very large, reaching 100 henries in extreme cases. To operate at high frequencies, the  $C$  of the equivalent circuit must be very small. Since the  $Q$  of the circuit is obtained by dividing inductive reactance by the resistance, the  $Q$  of a crystal is in the order of 6,000 to 30,000. This makes the crystal circuit have a very steep resonance curve. If any reactance of the circuit changes (this may be the changes we mentioned and which have an effect on frequency), a very minute shift in frequency will be enough to bring conditions back to resonance. This explains why crystals are adaptable for frequency control work.

Usually crystals are supplied in holders which plug into five or six prong sockets. Only two prongs are used and the crystal holder may fit into the socket in several different ways. Always be certain that you are using the terminals of the socket which are connected to the circuit. Most of the usual cut crystals have a slight frequency variation with temperature. For extremely accurate requirements, the crystals are housed in thermostat controlled heated containers and all temperature variations are prevented.

**CRYSTAL POWER.** An oscillating crystal is a mechanically vibrating body. Internal stresses are present and heat is developed as a result of the motion. If the vibration amplitude is permitted to become too great, the stresses can reach a value sufficient to shatter the crystal. As a precaution in practice, you should check the crystal current when a new application is tried. A thermomilliammeter (which reads R. F. currents) may be connected in series with the crystal. Most crystals should have currents less than 100 ma. If a suitable meter is not available, a pilot lamp can be used instead. Standard pilot bulbs rated at 2 volts, .06 amperes, or the type rated at 6.3 volts, .15 amperes, can be employed. The current is estimated by judging the brilliancy and comparing to the information presented in the graph.

**CRYSTAL CLEANING.** Foreign matter, especially oil or wax, on the surfaces of a crystal may prevent oscillations. The best cleansing agent is carbon tetrachloride, but soap and water can be used. The crystal should be carefully washed and then dried with a clean lint-free cloth.

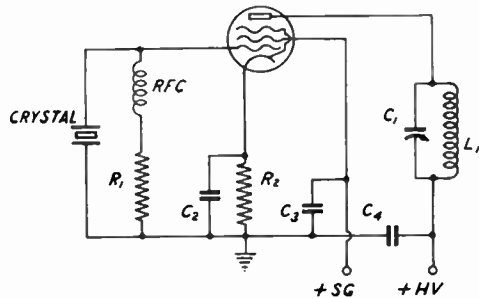

Figure 222. The basic crystal controlled oscillator. The crystal replaces the L-C circuit.

**CRYSTAL CONTROLLED OSCILLATORS.\*** Almost any type of an oscillator can be made crystal controlled by connecting the quartz crystal into the circuit in a manner which will permit the crystal to become the frequency determining element. For example, the crystal may replace the grid circuit L-C in a tuned-plate tuned-grid oscillator we talked about early in this chapter. Very little energy is used by the oscillating crystal and, therefore, little power must be fed back to the grid circuit. Even screen grid tubes will have enough plate to grid capacity to permit oscillation. With some tubes, however, a small condenser is connected between the control grid and plate to add capacity.

Grid leak bias can be used. In general, the larger the value of the grid leak, the greater the bias, and this will be accompanied

\*See the footnote.

## QUARTZ CRYSTAL HOLDERS

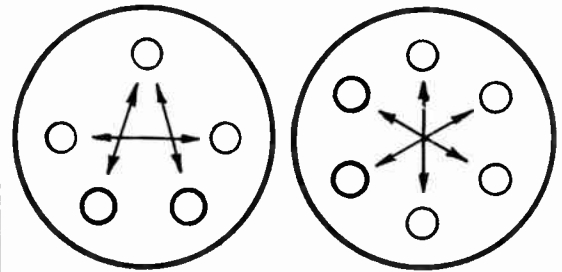

Arrows point to the two corresponding terminals of a 5-prong and a 6-prong socket that are used together for a standard two-prong crystal holder. Notice that there are several alternate choices.

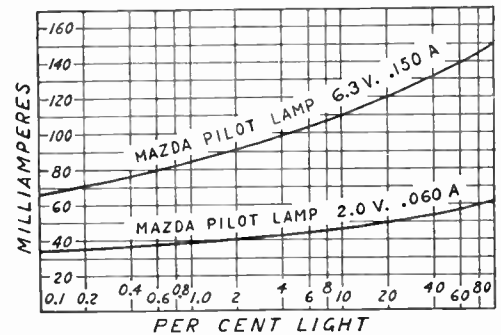

Courtesy Biley Electric Co. and General Electric Co.

Figure 221. Pilot lamp current characteristics.

This is actually a tuned-grid tuned-plate oscillator. As illustrated, a pentode is used in the circuit, but a triode could be employed instead.

The by-pass condensers,  $C_2$ ,  $C_3$ ,  $C_4$ , should be .002 mfd. or larger. The suggested values for the resistors are given in the text on the next page.

This extra grid to plate capacity should be very small. Usually, sufficient capacity can be obtained by bringing a wire from the plate close to a grid connecting wire. A small (10 mmfd. capacity) variable condenser may be used.

## CRYSTAL OSCILLATORS

The circuit mentioned is illustrated under Figure 222.

Tubes incorporating letters *RK* are of Raytheon make. Transmitting tubes of the 800 series are made by RCA and other manufacturers.

Where low transmitting power is sufficient, the oscillator may serve as the complete transmitter. Because of regulations, this is permissible only for code transmission.

3. If you substitute the quantity in mmfd. for *C*, and microhenries for *L*, in the regular formula, you will obtain your answer in megacycles.

6. Is it possible to omit the grid leak resistor in an oscillator?

7. A part not connected in any special way.

10. Write the formula for *Q*. What effect does *L* have on the value of *Q*? Is *L* large in a crystal?

with higher crystal excitation. The higher bias will cause an increase of crystal current and a small gain in power output.

**PENTODE AND TETRODE OSCILLATORS.** The circuit illustrated is commonly used in practice. A combination grid leak and cathode bias is used.  $R_1$  is the grid resistor and may be 10,000 ohms, while the cathode resistor,  $R_2$ , should be about 300 ohms. The screen grid must be by-passed and is operated at a voltage lower than the potential on the plate. Notice the use of by-pass condensers.

Pentode and tetrode tubes, having a high amplification factor, will provide greatest power output for a given crystal current. Furthermore, the frequency stability with such tubes is much better than obtainable with conventional triode oscillators. With tubes such as the RK-23, 802, and 807 (these are transmitting tubes and are not listed in the tube data charts in this book), power outputs of 10 to 15 watts can be obtained at frequencies above 1,000 KC. with a reasonably low crystal current.

**PURPOSES OF OSCILLATORS.** Much has been said about oscillators, but the reader may wonder how oscillators are used and what practical function they perform. An oscillator is a generator of radio frequency energy. The power for operation comes from a D.C. source—batteries or power supply. This radio frequency energy can be used as the carrier of a transmitter. Usually, the power available from the oscillator is not sufficient even for a small transmitter and additional R.F. amplification is employed. But the original generation of R.F. is accomplished in the oscillator. In an emergency, any oscillator can be used as a transmitter. The antenna is coupled to the tank coil, and code can be sent by interrupting (breaking) the cathode circuit.

**REVIEW QUESTIONS AND PROBLEMS.** 1. What is the minimum voltage required to set a L-C circuit into oscillation?

2. What determines the frequency of oscillation of a series L-C circuit?

3. At what frequency will a circuit consisting of 100 mmfd. condenser and 100 microhenries choke oscillate? Refer to earlier chapters for required method to change the units to farads and henries for use in the formula.

4. What determines the rate with which the oscillations produced by a L-C circuit, die out?

5. What is the main difference between a Hartley and a tickler-feedback oscillator?

6. What is the purpose of a grid leak resistor?

7. Can a single radio part possess negative resistance? Explain your answer.

8. What are the limitations of a self-oscillator?

9. Explain the function of a crystal using the equivalent circuit to help you with the explanation.

10. Why is the *Q* of a quartz crystal very high?

11. For what purpose are oscillators used?



# LESSON 16

## Radio Transmitter Circuits

A CRYSTAL CONTROLLED TRANSMITTER. You probably recall that any oscillator may serve as a low power transmitter. We will begin our study of practical transmitters by considering a unit which employs a type 6L6-G tube as a crystal oscillator and contains the required full-wave power supply in the same chassis. This simple transmitter will give excellent results and has been used by thousands of beginner amateur radio operators.

As the first step, study the schematic diagram. The list of parts is given and you must know to some degree of accuracy the actual values of the different parts used. Notice that the complete schematic illustrates a crystal oscillator similar to the types you have already studied, and also a power supply which is very well known to you. The few unusual features will be discussed in detail when we review the function of the circuits.

Thousands of individuals in the United States have operated their own amateur radio stations and carried on two way communication. Many of the facts about transmitters presented in this lesson will stress application for amateur radio requirements.

Ten to fifteen minutes should be spent studying this circuit.

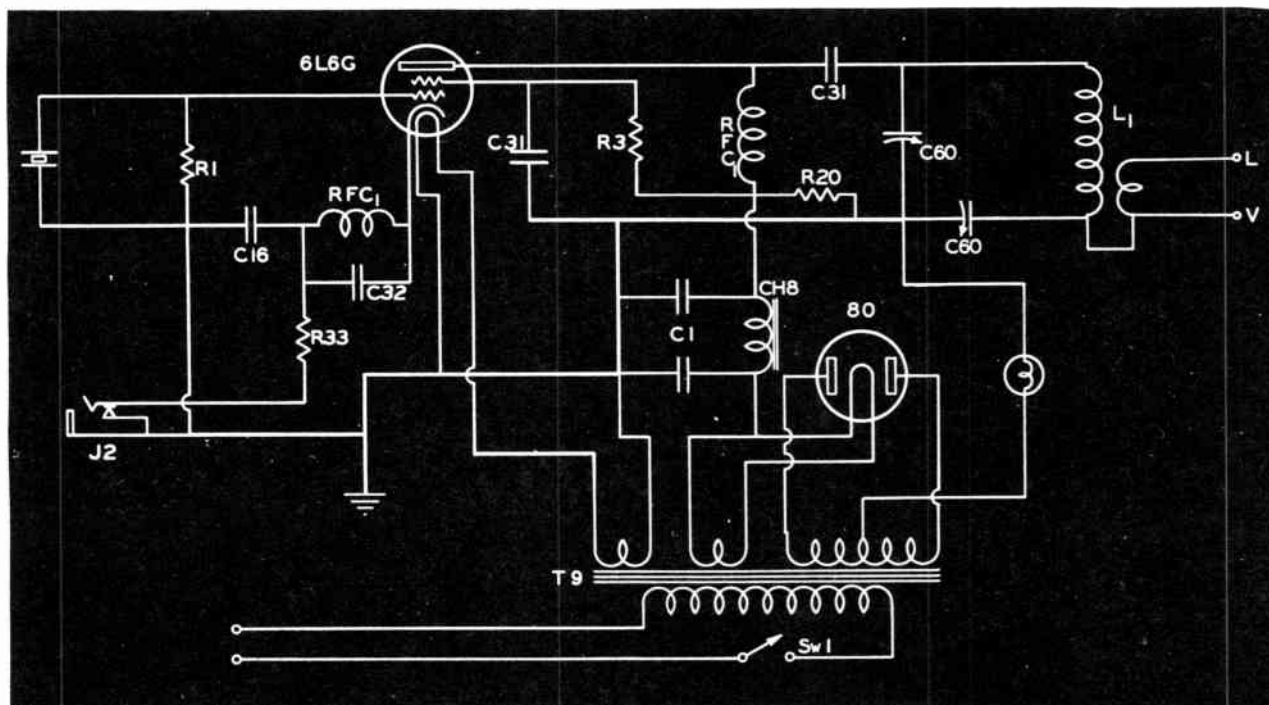

Figure 228. The circuit of a crystal oscillator transmitter.

*Courtesy Standard Transformer Corp.*

### COMPONENTS

C 1 8-8 mfd. 450 volt electrolytic  
 C 16 .01 mfd. 400 volt paper condenser  
 C 31 .002 mfd. mica dielectric condenser  
 C 32 100 mmfd. mica dielectric condenser  
 C 60 100 mmfd. midget variable  
 R 1 50,000 ohms, 1 watt carbon resistor  
 R 3 25,000 ohms, 10 w. wire-wound type  
 R 20 40,000 ohms, 10 w. wire-wound type  
 R 33 400 ohms, 2 watts, resistor

T 9 Stancor P6335 power transformer  
 CH 8 Stancor C2305 filter choke  
 RFC 2.5 uhy. 125 ma. R.F. choke  
 J 2 Closed circuit jack  
 SW 1 S. P. S. T. toggle switch

## SIMPLE RADIO TRANSMITTER

Refer to the schematic diagram on the previous page.

The A.C. cord comes through a protecting rubber grommet. The two stand-off feed-thru insulators are for the antenna connections.

Since the rotors of the variable condensers are at ground potential (see schematic), they are mounted directly on the metal chassis.

Circuit diagram, Figure 228. Chassis illustrations, Figures 229 and 230.

A 150 ma. 6.3 volt bulb is suitable for this application.

**Volume 2 – Page 152**

Compare the schematic diagram with the top and bottom views of the chassis. You should be able to locate every part indicated in the schematic in either of these two photographs. If you wish, you may mark the parts in the photographs with the actual symbol numbers as shown in the schematic diagram. See how neatly the unit is wired and resolved to do as good work when you build radio equipment.

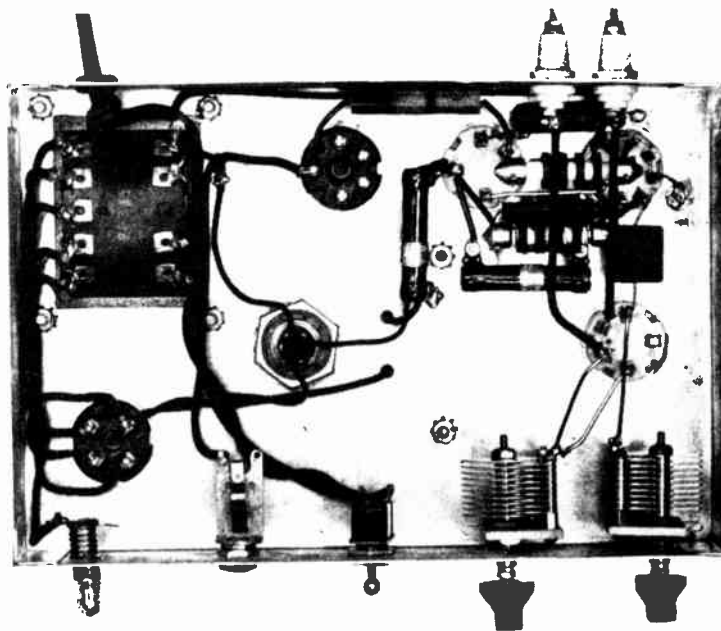

*Courtesy Standard Transformer Corp.*

Figure 229. Bottom view of the small transmitter described in the text. It is important that you are able to locate all the parts, as shown in the schematic diagrams, in the corresponding photographs of the unit.

Let us review how the power supply operates. The power transformer, T-9, is designed for the available A. C. power line voltage and frequency. In most cases, this power supply is 110 volts, 60 cycle, A.C. The switch, Sw-1, places the unit in operation by completing the circuit of the transformer primary. Please follow our discussion by referring to the circuit diagram and the two chassis illustrations.

The power transformer has three secondaries. The first one, at the left, as shown on the schematic diagram, supplies 6.3 volts for the filament of the 6L6-G tube. Please trace this connection through and notice that one side of this filament winding is grounded to the chassis. The middle secondary supplies 5 volts for the filament of the type 80 rectifier. The remaining secondary winding is the center-tapped high voltage secondary. Usually, in full-wave power supplies, the center tap of the high voltage secondary is grounded. In our circuit, this center tap completes the circuit to ground (this is the negative plate voltage connection) through a small pilot-bulb. This bulb acts as a fuse since it will burn out if the current, taken from the power supply and passing through the bulb, is too great. The bulb may be used also to indicate approximately the amount of plate current taken by the oscillator. In this manner, the bulb may be used as an aid for properly adjusting the oscillator. Of course, a meter, 0 to 100 ma.

D.C., may be connected in place of the bulb or may be connected instead into jack, J-2, which is employed for the transmitting key.

From your early study of power supplies, you probably recall that positive plate voltage is taken from one side of the rectifier filament connection (or center-tap of the filament secondary if available). Find this point, and remember for future reference that this is the most positive voltage point of any power supply. Notice that the filtering is accomplished with a two section electrolytic condenser, marked C-1, and a filter choke, CH-8.

By any power supply, we mean types using similar circuits.

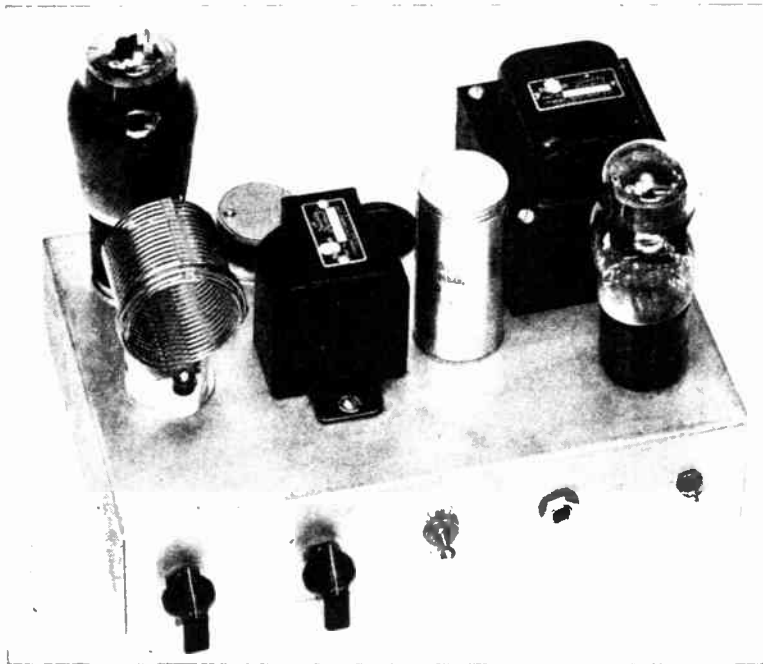

Figure 230. Top view of the transmitter. The tank coil and antenna coupling link are self supporting and are mounted on a form which plugs into a five prong socket.

Such close placement of parts is permissible in small transmitters.

Now we can study the circuit of the oscillator. The grid side of the 6L6-G, oscillator includes the quartz crystal and resistor R-1 used as the grid leak. Placing an R.F. choke (called an aperiodic coil in this application) in the cathode circuit, produces regeneration. The effect of this action provides harmonic output and permits operation on several bands with a single crystal. Frequency doubling procedure is important and will be explained later in this chapter.

For economy reasons, the amateur operators prefer to use but a single crystal for operation at different frequencies on several bands.

This oscillator uses a circuit known as parallel-plate-feed. Notice that the positive plate voltage reaches the plate of the 6L6-G through RFC<sub>1</sub>, a choke coil. No D.C. from the power supply can enter the plate inductance L<sub>1</sub>, since condensers C-31 and C-60 block the passage of direct current. The radio frequency energy supplied by the tube, on the other hand, cannot enter RFC<sub>1</sub>, since this choke has very high impedance (opposition) to R.F. The radio frequency energy from the tube finds a path through the condensers C-31 and C-60, to the tank coil, L<sub>1</sub>. Since the plate choke, RFC<sub>1</sub>, and the plate inductance, L<sub>1</sub>, may be considered in parallel, we have the name parallel-plate-feed.

Follow this explanation making reference to the circuit.

## RECEIVING C.W. AND PHONE

The Continental telegraph code is used for radio transmission. It is presented below.

LETTERS	
A	N
B	O
C	P
D	Q
E	R
F	S
G	T
H	U
I	V
J	W
K	X
L	Y
M	Z

NUMBERS	
1	6
2	7
3	8
4	9
5	0

PUNCTUATION	
Period	
Comma	
Question Mark	

Power is required to drive a radio frequency amplifier in a transmitter. Since the grid is driven positive, it will *take* current and this current must be supplied by the previous stage.

The L-C load for the oscillator is formed by the coil and the two condensers, C-60. The lower condenser, C-60, further may be used to *match* the antenna line. The plate inductance  $L_1$ , and the small winding for antenna connection, are of the self-supporting air core type. A different coil is used for each one of the amateur bands and, since these coils are of the plug-in type, they are easily interchanged.

It is possible to double the crystal fundamental operating frequency with many transmitter circuits.

The transmitter we have described is intended for low power requirements and can be used to send code telegraphy. If the transmitter is placed in operation and an antenna connected, a carrier wave will be transmitted. Receivers with regenerative detectors or with a beat-frequency-oscillator (B.F.O.) incorporated in the circuit, can receive such transmission which will sound as a *buzz* of a definite frequency. If the transmission is interrupted according to the telegraph code, words and phrases can be sent. The interruption, or keying, is accomplished by breaking the cathode return circuit. A key is connected to the jack, J-2, and the cathode circuit is only completed when the key is depressed. When the cathode circuit is broken, the oscillator stops operating.

When operating the transmitter on the crystal fundamental frequency or when doubling, the tuning is performed with the tank condensers. The adjustments are made so as to deliver the maximum energy to the antenna, with the minimum plate current. The pilot bulb or plate current milliammeter may be used as the indicator for minimum plate current. Another pilot bulb, connected to a one or two turn loop which may be held near the tank coil, will indicate maximum energy being delivered to the antenna when it is brightest. An R.F. ammeter is better for this purpose.

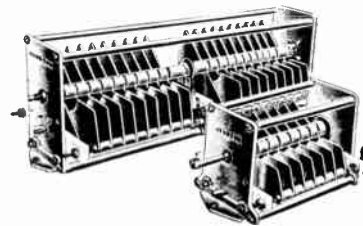

Figure 232. Large transmitters use tuning condensers which have greater spacing between plates.

**NEED FOR ADDITIONAL AMPLIFICATION.** The power output from a crystal oscillator is limited. The crystal current must be kept within the safe value and even pentodes have a limit to their power amplifying ability. The question, "Can the radio frequency energy delivered by the oscillator be amplified further in another stage?" comes up. Certainly another stage, using larger tubes, can be constructed and excited with the output from the crystal oscillator stage. But we must look out for possible limitations and see how these are eliminated in practical circuits.

We realize that the voltage, which will be developed across the plate tank-inductance of the crystal oscillator, will be used to excite the next amplifying stage we are considering. Will this voltage be of the correct radio frequency of the crystal even if the tank L-C circuit of the crystal stage is slightly detuned? You recall that the plate L-C circuit actually is detuned in practice to make the

tube *look into* an inductive circuit. This condition (to return to our analogy using the mechanical swing), corresponds to the swing having a natural period of movement different (slightly) from the period of the force driving it. When the driving force is applied to the swing, it will begin to move under its influence and assume its frequency. Since the driving force is present for only a short period, the swing will try to change its pace (frequency) while acting on its own, but before this change can become noticeable, the force is applied again and brings the frequency back under its influence.

The plate L-C circuit acts very much the same. It is shock-excited by the energy which has the crystal frequency. After the shock, while the tank L-C circuit acts on its own, it tries to shift into its natural frequency, but before much change is accomplished in the fraction of the cycle, the next shock-excitation brings the frequency in line. We can see, therefore, that the exact voltage of the crystal frequency is available across the plate L-C circuit to excite the next amplifying stage.

**METHODS OF COUPLING.** The radio frequency voltage from one stage must be impressed across the grid to cathode circuit of the next stage. The required grid bias for this stage may be obtained by any of the methods described, but since grid current is present during a portion of the cycle, the grid-leak method is commonly employed. The grid circuit of the stage to be excited may use a tuned circuit, but since this will require an extra adjustment it is not often employed. The plate voltage of the preceding stage is kept out of the grid circuit with a blocking condenser. This condenser is of sufficient capacity to offer negligible reactance to the radio frequencies. Since the grid is driven positive, grid current will flow during a fraction of the cycle. A D.C. milliammeter inserted in the grid circuit will indicate the *average* amount of grid current.

**NAMES OF R.F. POWER AMPLIFIERS.** The stages, which follow the crystal oscillator, amplify radio frequency power. They are power amplifiers and require driving power to excite their grid circuits. The R.F. power amplifier stage, which is connected to the antenna circuit, is called the *final* power amplifier. Several R.F. power amplifiers may be used, each succeeding stage handling more power and requiring greater driving power. If three stages are used, the stage, between the oscillator and the final power amplifier stage, is called the *buffer stage*. If frequency doubling is accomplished in this buffer stage, it may be called the *doubler*. If several stages are placed between the oscillator and the final, these may be called the first buffer, the second buffer, etc. In some stages, two or more tubes may be used and these may be connected in parallel or in push-pull.

**NEUTRALIZATION REQUIREMENTS.** In transmitters having several stages, only the oscillator stage should oscillate. The other stages must amplify the signals delivered to them. But if any tube has a fraction of the plate energy returned to the grid side, oscillation will begin. If the stage uses a tetrode or pentode vacuum tube, very little capacity coupling exists between the grid and plate circuits of the tube. In the case of the triode type radio frequency amplifiers, however, the energy fed back to the grid circuit, because of the grid to plate capacity, must be balanced out. With the aid of a small adjustable condenser (capacity usually under

## ADDITIONAL AMPLIFICATION

This is forced oscillation.

The *shocking* frequency is close to the natural frequency of the L-C used in the plate circuit.

In considering the coupling of a plate circuit of one R.F. stage to the grid circuit of another stage in a transmitter, the plate load may be tuned L-C, untuned L-C, or untuned L, the grid circuit may be any of these or a high resistance, and any of these (except the high R) may be used with capacity coupling, link coupling, or mutual coupling.

A popular transmitter with active amateurs is the type which uses a self-excited oscillator and a final amplifier. From the names *master oscillator and power amplifier*, we have the abbreviation MOPA.

Neutralization is required to prevent radio frequency amplifiers (using triodes) from acting as oscillators.

**Volume 2 - Page 155**

## NEED FOR NEUTRALIZATION

Good quality neutralizing condensers must be able to withstand high voltage, be easily adjusted, and present the same (unchanged) capacity for long periods of time.

If a stage of a transmitter which is to be employed for frequency doubling does incorporate a neutralizing condenser, it may be left at the setting made for neutralizing this stage for straight amplifying.

It is important that you know how to neutralize a radio frequency amplifier: This process is a part of placing a complete transmitter in operation.

25 mmfd.), a voltage is fed back to the grid circuit out of phase with the voltage developed because of the tube inter-electrode capacity, and oscillation in this stage is prevented.

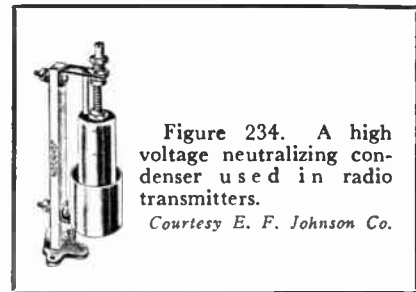
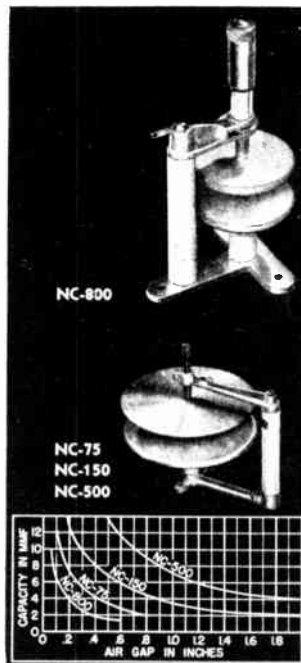

Figure 235. Illustrations of *National* neutralizing condensers with the variation in capacity expressed in terms of the air gap between the plates.

A portion of the R.F. plate voltage may be fed back to the grid through the neutralizing condenser. A tap on the tank coil may be used for the purpose of obtaining the correct value of voltage and proper phase relationship. Such arrangements are called plate neutralizing circuits. If the entire plate R.F. voltage is used and delivered to the grid circuit through the neutralizing condenser, a tapped grid inductance (or capacity) provides correct voltage value and phase relationship. These arrangements are called grid neutralizing circuits.

If an amplifier is used for frequency doubling purposes, it will not require neutralization even if a triode vacuum tube is employed in that stage. In a frequency doubling stage the main energies of the plate and grid circuits are of different frequencies, and no oscillation will result even if there is considerable coupling between the grid and plate circuits.

**HOW TO NEUTRALIZE A R.F. AMPLIFIER.** If a radio frequency amplifier uses a triode and is *not* employed for frequency doubling, it must be neutralized. The stages before the one to be neutralized must be in operating condition properly adjusted. This will permit the stage which is to be neutralized to receive grid excitation. In all cases, the plate supply voltage, to the tube of the stage to be neutralized, is removed. Sometimes, a special switch is provided for breaking the plate supply circuit. If such a switch is not incorporated in the circuit, the B+ wire may be disconnected. The filament of the tube used should be heated from the power supply while making these adjustments.

When a radio frequency amplifier (using a triode) is properly neutralized, the grid circuit may be excited, but no R.F. energy should be present in the plate circuit while the B+ is not present.

## NEUTRALIZATION METHODS

A sensitive indicator of R.F. is needed for the plate circuit for this test. A neon bulb, in contact with the plate connection of the tube, may be employed for this purpose. A small pilot-bulb, connected to several loops of wire held close to the plate coil, may also be used. With conditions as described above and the indicator in place, rotate the plate circuit tuning condenser for maximum indication of R.F. shown by the maximum brightness of the bulb indicator. This will occur at resonance and indicate the need for neutralization. Now turn the neutralization condenser until the light of the indicator goes out. It may be possible to bring the light back (probably very dimly) by rotating the plate tuning condenser once again. Adjust the neutralizing condenser again for minimum light. If required, repeat this procedure once again.

One terminal of the neon bulb is brought in contact with the plate terminal. The circuit is completed through the capacity existing between the bulb and the chassis.

If the light does not go out completely, minimum light will indicate correct adjustment.



Figure 237. Inside, top view of a two-stage modulated transmitter. See if you can find the corresponding parts in the schematic diagram.

If the stage being neutralized has a grid current meter, it may be used to check your adjustment. In a properly neutralized R.F. amplifier, the grid current will remain constant as the plate L-C tuning condenser is tuned past resonance. If the neutralization was not carried out correctly, a flicker of the grid current meter needle will be observed as the plate circuit is tuned through resonance.

**A TWO STAGE TRANSMITTER.** You will notice that the crystal oscillator stage of this transmitter is not tuned. The output of this untuned stage drives a final amplifier which uses a 6L6 tube and is tuned with condenser C-60. If a key is wired to a plug and inserted into the jack, J<sub>3</sub>, the transmitter may be used for telegraphy (C.W.) and the audio stage, in the lower left hand corner of the schematic, is not used. Please observe that when the key plug is inserted, the secondary of the output (modulation) transformer T-8 is shorted, and the cathode circuits of both R.F. tubes are connected to ground only when the key is depressed.

The placement of parts on the chassis of this transmitter is logical and simplifies the wiring.

After neutralization, the plate voltage is applied and the stage is tuned for proper operation.

That is, this stage is not tuned manually. The signal produced is of the crystal frequency.

**Volume 2 – Page 157**

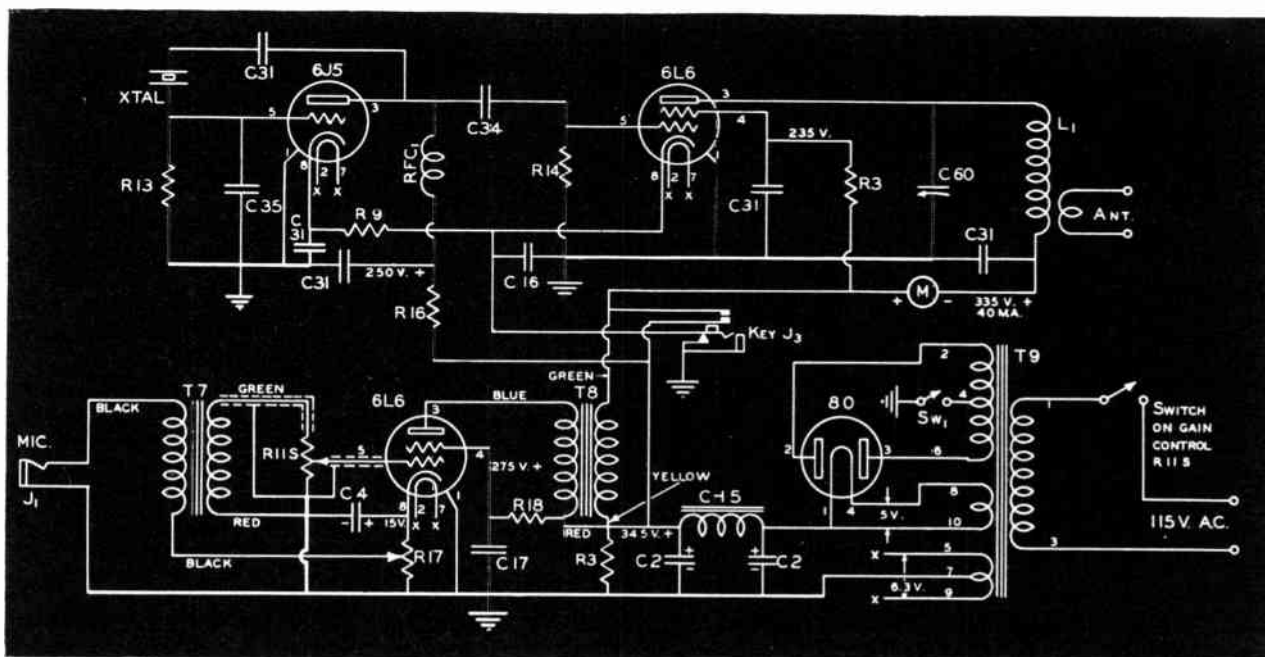

Figure 238. Stancor-10P transmitter.

#### COMPONENTS

C 2	4 mfd. 450 volt electrolytic
C 4	10 mfd. 25 volt electrolytic
C 16	.01 mfd. 400 volt paper condenser
C 17	.1 mfd. 400 volt paper condenser
C 31	.002 mfd. mica dielectric cond.
C 34	250 mmfd. mica dielectric cond.
C 35	50 mmfd. mica dielectric cond.
C 60	100 mmfd. midget variable cond.
R 3	25,000 ohms, 10 w. wire-wound
R 9	1,000 ohms, 1/2 w. carbon resistor
R 11S	500,000 ohms potentiometer
R 13	25,000 ohms, 1/2 w. carbon resistor
R 14	100,000 ohms, 1 w. carbon resistor
R 16	5,000 ohms, 1 w. carbon resistor
R 17	300 ohms, 10 w. wire-wound
R 18	25,000 ohms, 1 w. carbon resistor
T 7	Stancor A4706 microphone transformer
T 8	Stancor A3871 modulation transformer
T 9	Stancor P6335 power transformer
CH 5	Stancor C2303 filter choke
RFC	2.5 uhy. 125 ma. R.F. choke
Sw 1	S. P. S. T. toggle switch
J 1	Open circuit jack
J 3	Two circuit control jack
Meter	O-100 ma. D. C. type

Review these steps in this order: From your understanding of audio amplifiers, you know that the voltage developed across the primary of the modulation transformer is controlled by the sounds reaching the microphone. This voltage is transformed to the secondary of T-8. This new voltage adds or subtracts from the supply voltage connected to the final amplifier tube. The intensity of the oscillations produced by the L-C tank circuit (C-60 and L<sub>1</sub>) is proportional to the actual voltage present at the moment.

**Volume 2 - Page 158**

Only one adjustment is needed. Condenser, C-60, is adjusted to give minimum plate current as indicated on the 0-100 ma. plate milliammeter. Loaded, the correct value will be about 40 ma. The transmitter can be used for doubling.

The power is turned on with the switch in the transformer primary circuit. The switch, Sw<sub>1</sub>, in the center tap connection to the high voltage secondary, breaks the plate voltage circuit and stops the transmitter from operating. This switch is used to shut off the unit during the stand-by periods while signals are being received. Since the tube filaments are kept heated, the instant the plate supply circuit is completed with this switch, the transmitter is ready for operation and no delay results.

**MODULATION.** To transmit music or voice, sound must be changed to electrical energy and amplified. This is accomplished with a microphone and a simple audio amplifier. Please notice that our modulator (incorporated in the transmitter chassis) is designed for a carbon microphone. The microphone current is obtained from the cathode circuit of the modulator 6L6 tube. A single tube serves in this circuit, but modulators may consist of many audio stages.

Please notice that the plate current for the 6L6 final R.F. amplifier must pass through the secondary of the modulation (matching) transformer, T-8. This secondary winding may be considered equivalent to a series voltage generator. This series voltage generator may add or subtract voltages from the power supply voltage and, thereby, alter the amplitude of the R.F. carrier produced by the final stage. But the actual voltage impressed on the secondary of the modulation transformer is a function of the audio signal, and so you can see that the carrier is being varied at the audio rate. This is the condition required for the carrier to be amplitude modulated. Other forms of modulation are also used and the modulator must supply the proper amount of audio power for correct percentage of modulation.

For power economy reasons, the radio frequency tube modulated usually is operated in *Class C*. The tube modulated may be the



one which is the final stage of the transmitter and is connected to the antenna. However, if the modulated stage is not the final, and additional stages follow, these stages are (in practice) *Class B*; *Class C* cannot be used after the modulated stage.

**TUNING PROCEDURE.** The majority of commercial, medium-power transmitters (100 to 500 watts input) are placed in operation, or *fired up*, in a similar manner. If the transmitter is intended for 'phone transmission, the modulator is shut off. If terminals for a key are provided, these must be shorted. A careful examination of the power controls must be made. You are safe in placing filament voltage on all tubes, but keep the plate power off for the time being. The plate power should be applied first only to the oscillator stage. Usually a plate current meter is included in the circuit of the oscillator. In some units, the proper meter can be switched in this plate circuit. In such transmitters, one meter may serve several circuits. The oscillator can be adjusted according to the explanation given in the previous chapter.

Plate power is now applied to the very next stage. Watch the meter in the plate circuit of this stage and tune for minimum plate current. Turn the condenser quickly and stop at the approximate position for minimum current. Allowing excessive plate current for a few minutes may damage the tube or other equipment. Once the approximate position is found, exact adjustment can be made with care.

You may now proceed to the next stage. The plate power is turned on and the same adjustments are performed. The final stage should be adjusted with the antenna connected, or a re-adjustment will be necessary when the antenna is connected. If grid current meters are included in the last stages, these may be employed as a further aid in obtaining the best operation from the transmitter. You may go back and retune the different stages slightly striving for maximum grid current in each following stage. Of course, the oscillator is never re-adjusted after the initial correct setting.

**REVIEW QUESTIONS AND PROBLEMS.** 1. How could a simple crystal controlled transmitter, described in this chapter, be converted for battery operation? What parts could be left out in this case?

2. Describe the condensers which are used to by-pass R.F. currents and tell of their position in the circuit.

3. What type of socket is used for the crystal? You can find the answer in one of the illustrations.

4. If the pilot-bulb burns out and a replacement is not available, how can an emergency repair be accomplished?

7. Why are several stages used in most transmitters?

8. Why must a R.F. triode amplifier be neutralized?

9. Tell in your own words how you would neutralize a stage of a transmitter.

10. What precautions must be taken in *firing-up* a transmitter?

## MODULATION AND TUNING

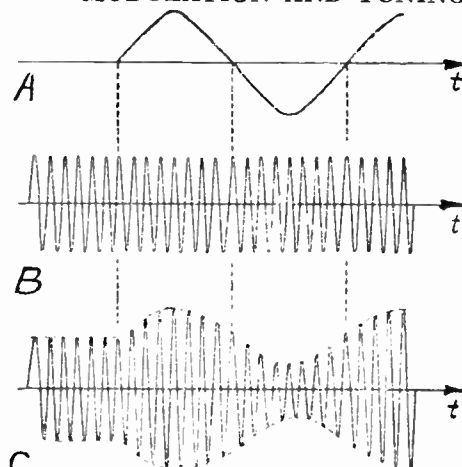

Figure 240. The audio wave shown in (A) is made to act upon the circuit producing R. F. carrier (B), and the modulated wave (C) is the result.

This process is continued for all the stages of the transmitter. If neutralization is needed in any one stage, this is carried out before that stage is tuned.

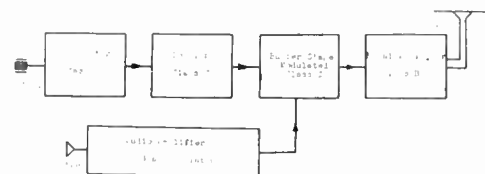

Figure 241. A block diagram of a typical 'phone transmitter of about 100 watts power. The modulation may take place in any stage except the oscillator, but all stages following the stage which is modulated are operated as *Class B* amplifiers. The buffer stage is shown in the block diagram as the stage being modulated.

4. Reference is made to the pilot bulb used in the one stage transmitter.

7. Is there a limit to the number of stages that could be used?

# LESSON 17

## Lines, Antennas, and Radiation

In fact, every conductor (in the broadest sense) has the properties of inductance, capacity, and resistance. In the practical sense, only one of these properties predominates.

At low frequencies (power frequencies, for example) these effects may be ignored.

These fields are always at right angles to each other, but their complete analysis requires the knowledge of higher mathematics.

**CIRCUITS WITH DISTRIBUTED CONSTANTS.** You must realize that even a straight short piece of wire has both capacitance and inductance. In considering a piece of wire, focus your attention on a very tiny piece of the wire at one end and another tiny piece of the wire a short distance away. Certainly these metal pieces, as such, are separated by the wire between them which may be considered as a resistor. This wire does have resistance. The two tiny pieces of wire, we are considering, form the two plates of a condenser, with the surrounding air serving as the dielectric. No fixed quantity of air, or any special section of air serves as the dielectric, but all air (and all other insulators in the universe for that matter) serve as the dielectric of this condenser which we described. In a similar fashion, all other tiny portions of our wire, form condensers with each other.

In a like manner, it can be shown that the magnetic field, produced by any infinitesimally small portion of the wire, cuts other sections of the wire and the effects of self-inductance are present. We begin to see that any wire, which may form a transmitting antenna, has both capacity and inductance and is, therefore, resonant to some frequency. An antenna acts as a resonant circuit to a definite frequency, and (under such conditions) appears as a pure resistance.

**RADIATION.** In any oscillating circuit, and this includes a properly operating antenna, the energy of the circuit is continuously exchanged between the inductive and capacitive members. While the energy oscillates between these members, it produces a magnetic field when the energy is stored mainly in the *inductance*, and an electrostatic field when most of the energy is stored in the equivalent *capacitors* of the circuit. You must realize that as the magnetic field is becoming smaller, the electrostatic field is increasing, and vice versa. The two fields always exist together, continuously exchanging the total energy between themselves, not only in the circuit but also in the surrounding space.

The process of building up a magnetic field around the circuit (or antenna), having this magnetic field collapse as the energy takes the form of an electrostatic field, which in turn collapses and serves to build up the magnetic field once again, takes place in all circuits at all frequencies. These alternations, however, occur at a very high rate in radio frequency circuits, and before the energy can collapse back into the antenna circuit, the next oscillation occurs to re-inforce the energy escaping, and radiation takes place. The desirable radiation is greatest when the antenna is resonant to the frequency of the exciting current and when the antenna is mounted in space free of obstacles.

**RESONANT LINE.** Using a high frequency generator (transmitter), let us connect two adjacent, parallel wires to this generator. In a practical experiment, these parallel wires (or line) could be made by mounting two lengths of copper wire on supporting insulators, so arranged that the wires would run parallel, perhaps two inches apart. The line could be coupled to the transmitter, by being connected to a link coil placed near the final tank coil.

The energy which flows along this line from the transmitter is not delivered instantaneously to the far end of the line once the equipment is placed in operation. The energy proceeds along the line at a definite rate. If our transmitter is producing a sine wave voltage, sine wave currents and voltages occur at all points along the line but at a time displacement which depends on the distance from the generator. The end of the line will reflect voltage and current waves. These may re-inforce or reduce the original waves. In particular, if the line is an odd multiple of a quarter wave length ( $1/4$ ,  $3/4$ ,  $5/4$  of a wave length), the reflected energy will be in phase with the new waves, and large standing waves will be developed.

This energy moves with almost the speed of light.

To fix the idea, assume that at the instant the generated voltage is maximum. An instant later, this maximum voltage value will be a distance down the line, while the voltage at the connection of the line to the generator will be of a somewhat lower value. Each value of the voltage exists at definite points along the line at certain instants.

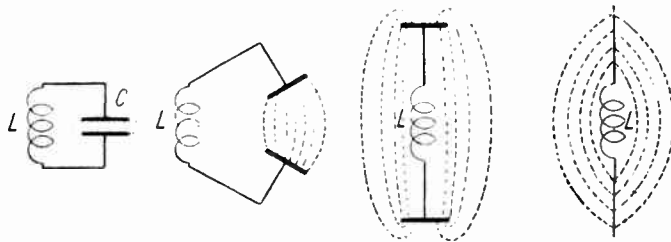

Figure 243. Progressive steps showing how a L-C circuit may be made to appear as a radiating antenna. The electrostatic and magnetic lines of force exist everywhere in space and originate at the antenna.

The fields produced by the two wires of a line oppose each other and very little radiation takes place. The main losses are the actual resistance losses of the conductors used. A resonant line, therefore, has small losses and a high Q. As the two wires of a resonant line are spread apart, radiation increases. Radiation resistance (losses of energy from the system because of radiation) also increases. If a quarter wavelength line is spread apart completely, we have a half wavelength long wire with the high frequency generator connected in the center. Such an antenna is known as a *dipole* and has the equivalent radiation resistance of about 70 ohms.

You may think of this cancellation as being due to the current moving in opposite directions in the two wires of the line.

Under the usual conditions in a practical installation.

**INFINITE LINE.** If the line we used for our explanation were made infinitely long, there would be no reflection from the far end since this end would never be reached. There would be no standing waves on the line for any frequency. In looking into the line, the generator would see a definite value of impedance which depends on the spacing of the conductors, size of wire used, and the dielectric employed. This impedance is called the *surge* or characteristic impedance. Suppose we cut our line a short distance from the generator, and consider what this short line sees when it looks into the balance of the infinite line remaining. You must understand that a few feet of wire removed from an infinitely long

Infinitely long means without end and not just very long.

This characteristic impedance depends on the capacity and leakage between the wires, and on the resistance and inductance of the conductors.

## ANTENNA FEEDER SYSTEMS

When looking into an infinite line, the characteristic impedance is always seen.

What is more, the short-line can be any size (length), but it must be of the type that would have the terminating characteristic impedance value if this short-line were made infinitely long.

By selecting different dual set of points along the antenna, various values of impedance may be secured.

The same line may be resonant or non-resonant depending on the termination impedance.

Volume 2 - Page 162

line, leaves the line just as long from any point of view. Looking into the infinite line remaining, the short-line connected to the generator will see the characteristic impedance of this infinite line. Let us say that in this case the characteristic impedance is 100 ohms. If we replaced the infinite line with a 100 ohm resistor, the short-line connected to the generator would behave exactly the same and would not distinguish between a 100 ohm resistor, or a 100 ohm characteristic-impedance infinite line. In turn, the radio frequency generator connected to the input of our short-line would see a 100 ohm impedance whether the line is infinite in length and has a 100 ohm characteristic impedance, or whether it is of finite size and is terminated in its characteristic impedance of 100 ohms, as in this case.

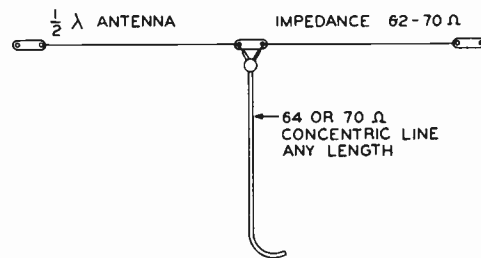

Figure 244. A half-wave horizontal antenna, current-fed with a coaxial cable which has a characteristic impedance to match the antenna.

**FEEDER SYSTEMS.** A non-resonant parallel wire line radiates a negligible amount of energy and does not produce standing waves if it is terminated in its characteristic impedance. The line may be any size within reason. The effective voltage and current vary along an antenna, giving different impedance values between any two points along the antenna. A non-resonant line may have its two wires make contact to the antenna, a short distance on each side of the antenna center. By moving the contact points closer together or further apart, the impedance needed to match the line is obtained. Maximum power transfer will also occur when impedances are correctly matched.

A single wire feed may be used. In this case, the wire is connected to a point of correct impedance. This point is usually some distance away from the center of the antenna. The return circuit is completed through the antenna-to-ground capacitance. The proper adjustment of a non-resonant line can be checked by striving to obtain the absence of current or voltage maximum points along the line. The presence of current maximums can be detected with a bulb connected to a loop containing several turns of wire. Test for voltage maximums with a neon bulb in contact with the wire under test.

If a transmission line is not terminated in its characteristic impedance, it will act as a resonant line. The line may be considered a part of the antenna wire folded back upon itself. The line will radiate very little since the fields, produced by each of the wires of the line, will cancel each other. If the line is connected to a dipole antenna in the center, the two halves of the dipole are sepa-

rated and each half is connected to one of the wire leads. Maximum current is needed in the center of the dipole antenna, therefore, the end of the line connecting to the dipole must have maximum current. If such a line is a quarter of a wavelength long (or some odd multiple of a quarter wavelength), then the side which couples to the antenna has maximum current and minimum voltage. The input to this line will require a source of maximum voltage and minimum current. Such a line is voltage fed. It may be connected across the final parallel L-C circuit.

For every quarter wavelength size of the resonant line, voltage and current maximums will reverse.

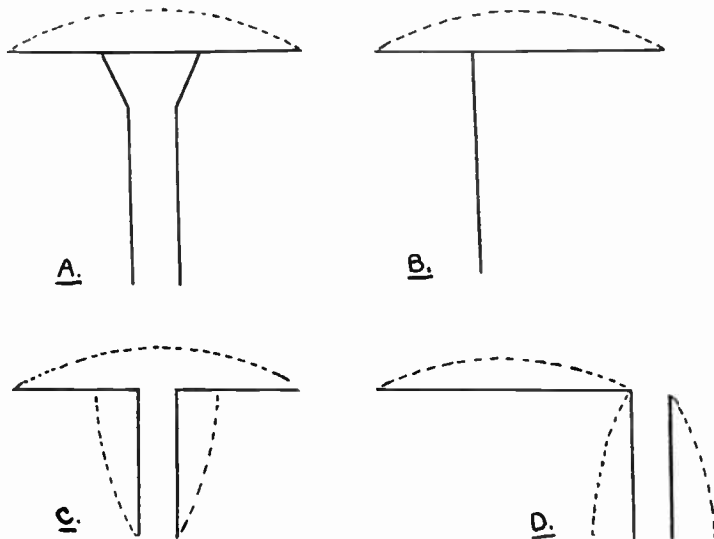

Figure 245. The dipole antenna may be fed in many different ways. In (A) the characteristic impedance of the line is matched correctly by terminating the line the proper distance away from the center. A single wire fed line is used in (B). A resonant line is used in (C) to current feed the antenna. In (D), the antenna is voltage-fed with a resonant line.

These illustrations show four practical antenna feeding methods. Study and become familiar with these basic methods.

A dipole may be voltage excited; then the line is connected to an end of the dipole. Only one wire of the line is connected directly to the dipole. See the illustration. This line is also resonant and is an odd multiple of a quarter wavelength long. It is fed from a source of high current and low voltage in the transmitter.



Courtesy American Phenolic Corp.

Figure 246. Coaxial cables consist of an external conductor with the inner conductor placed in the exact center position internally. The characteristic impedance of coaxial lines is well suited for antenna feeder requirements and, further, these lines have the advantage of radiating almost no energy even if terminated incorrectly. Notice that beads are used to keep the center wire in the proper position even when the cable is bent.

A coaxial cable is a two wire line with one conductor completely surrounding the second. The characteristic impedance of any line may be computed from the formula:

$$Z_0 = \sqrt{Z_{oc} \cdot Z_{sc}}$$

where  $Z_0$  = characteristic impedance  
 $Z_{oc}$  = open circuit impedance  
 $Z_{sc}$  = short circuit impedance

**ANTENNA TYPES.** A dipole antenna has its physical length equal to one-half of the wavelength of the energy to be radiated. In a dipole antenna, the current is maximum in the center, and minimum at the ends. The voltage, in a dipole antenna, is almost

## TYPES OF ANTENNAS

Sketch this distribution of current on a full wavelength antenna.

The antenna in the illustration is connected to a quarter wavelength resonant line.

This is a practical example and is applicable in case you are called upon to design an antenna system for an amateur radio station.

Both Hertz and Marconi antennas are described on this page, directly above.

**Volume 2 – Page 164**

zero in the center and is maximum at the ends. If an antenna is excited with energy of the second harmonic (frequency) the new energy will be of one-half the fundamental wavelength, and the same dipole antenna will appear as one whole wavelength long. The minimum points of current will be at the ends and in the center. The maximum points of current will lie between these minimum points. If an antenna, designed for any one frequency, is to be employed with the transmitter *doubling* (say fundamental of 80 meters doubling to 40 meters), the feeding method must be changed to take care of the altered points of maximum current, or voltage, distribution. Such ungrounded antennas are called *Hertz* antennas.

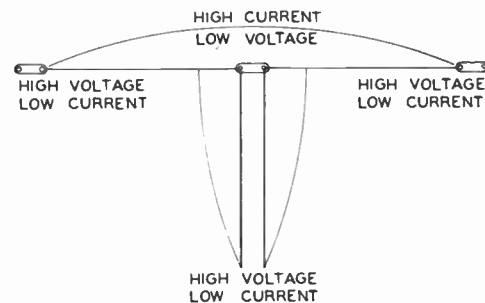

Courtesy E. F. Johnson Co.

Figure 247. Diagram showing the current distribution in a half-wave horizontal antenna with quarter-wave open wire feeders.

The earth behaves as an extensive conducting plane and may be considered an electrical mirror. If a quarter-wavelength antenna is grounded at one end, the electrical reflection of the antenna in the earth will appear as another quarter-wavelength, making an equivalent half-wavelength, or dipole, antenna. Such grounded antennas are known as *Marconi* types. These antennas may be analyzed in terms of Hertz antennas if you will remember to add the reflection-length which is due to the earth.

For example, if you have a radio station operating on 80 meters and wish to construct an antenna, you proceed as follows. You recall that a meter is equal to about 3.28 feet. A dipole for 80 meter operation, will be 40 meters, or 131.2 feet, long. In practice, the antenna should be made 5% longer than the calculated size. If the antenna is to be current fed, the resonant line is coupled to the center of the antenna; if the antenna is to be voltage fed, the line is coupled to an end point where maximum voltage must be present.

To use this Hertz antenna for energy of half the frequency; i.e., 160 meters, the antenna may be grounded and, thereby, made into a Marconi type. Electrically this same antenna is now a dipole for 160 meters. This antenna may be current fed by the same system, but the line will come between the end of the antenna wire and ground connection since this is the new point of maximum current.

**ANTENNA LOADING.** If a single antenna is to be used for the transmission of several frequencies which are not in harmonic relationship with each other, it is not practical to change the physical

length of the antenna for each such alteration. The electrical length, however, can be changed by lumped-impedance loading. An antenna which is too short may be increased in size electrically by adding inductance in series. An antenna which is too long for the application on hand may be shortened electrically with the aid of a condenser connected in series. If these reactive members are made variable, adjustment to a value suitable for the conditions present may be made with ease.

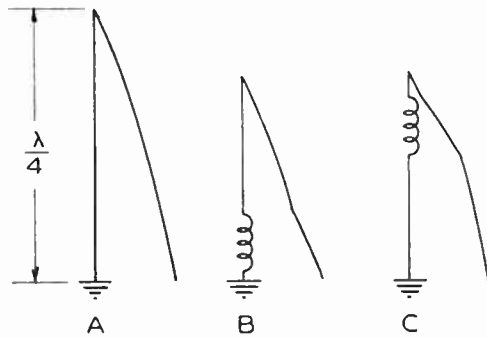

Figure 248. Various current distributions in quarter-wave, grounded, vertical antennas. In (A) a regular quarter-wave antenna is shown. Illustration (B) indicates a physically short antenna loaded at the base. In (C), we have a top-loaded quarter-wave antenna. The exact size of the loading coils will depend on the height of the antenna and position of the coil.

**PROPAGATION OF RADIO WAVES.** The electro-magnetic radiation from an antenna may be considered to consist of two parts. The energy which travels along the surface of the earth is called the *ground wave*. The energy which is propagated at an angle above the earth is called the *sky wave*. The ground wave of high frequency transmitters is quickly lost. At broadcast frequencies, the ground wave may be of some importance.



Figure 249. Diagram showing a simple half-wave antenna or dipole. Regardless of how power is fed to the dipole from the transmitter, it always has the same characteristics. For maximum radiation, it must be cut to exactly the right length.

The sky wave may reach the ionized layer, which surrounds the entire earth, and be bent back to reach a receiving antenna many miles away. This phenomena permits communication over great distances with low power transmitters. Frequencies above about 30 MC. are not *reflected* from the ionosphere and, therefore, can be transmitted over visual distances only.

The direction in which the maximum amount of radio energy is radiated from an antenna is of importance to a radio operator. A half-wave (dipole) antenna will radiate maximum energy broad-side. If the antenna is placed horizontally in the East-West direction, maximum energy radiation will take place North and South.

## PROPAGATION OF RADIO WAVES

Loading the antenna with a *small* adjustable lumped-impedance is helpful since it is difficult to install an antenna of the exactly correct size.

Current distribution is altered on any antenna if lumped-impedance is used.

The radiation characteristics of a dipole antenna remain the same with any type feeder arrangement.

The ionized layer, also called Kennelly-Heaviside layer or the ionosphere, consists of charged particles known as ions, and acts as a reflector of radio waves. Changes occurring in this layer are responsible for fading.

## DIRECTION OF RADIATION



Since a loop antenna has directional pick-up characteristics, a special radio receiver with a loop antenna may be used to locate sources of radio interference — creation of man-made static.

Bear in mind that the change from the direction of maximum radiation to minimum radiation is gradual.

Since the maximum radiation will take place at right angles to the wire direction, it will also occur sideways and upwards, at right angles to the wire. If the antenna is vertical, the radiation is uniform in all directions along the earth.

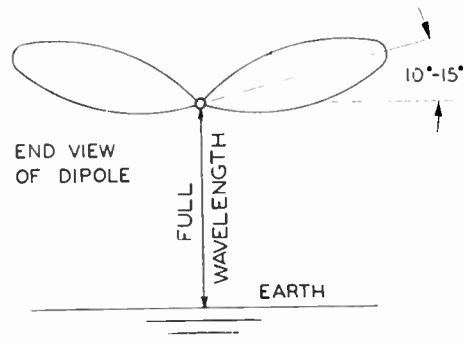
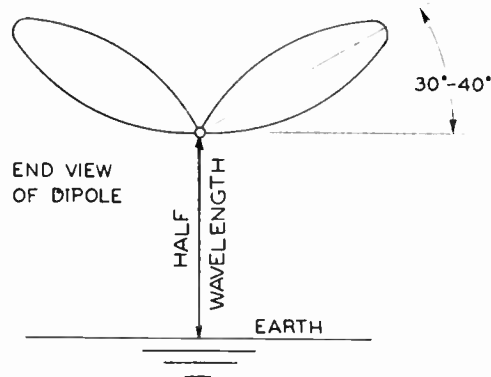

Figure 250. Method for plotting the angle of radiation for an antenna. The lobes imply the maximum direction of radiation, but some radiation, of course, occurs at all angles.

If a full-wave antenna is employed, the energy distribution is such that four lobes of maximum radiation results. If the antenna is extended East-West, the maximum radiation will be in the four directions of North-West (half-way between North and West), North-East, South-West, and South-East. Still more complicated patterns are obtained if longer antennas are employed. If the antenna is several wavelengths long, most of the radiation will occur from the ends.



Courtesy E. F. Johnson Co.

Figure 251. Diagram showing the angle of radiation from a horizontal antenna. Compare the height and angle of radiation of this antenna with the one illustrated in Figure 250.

Antennas are placed above the ground and much of the energy radiated towards the ground is reflected back into space. The reflected energy reinforces the original space radiation at certain angles and cancels the radiation at other angles. These factors must be considered in connection with reflection from the ionosphere in order to obtain the type of radiation which will give maximum energy at the location of the receiving station.



The characteristics of an antenna such as the dipole may be greatly improved by placing one or more additional dipoles in front or behind the radiating antenna. These extra dipoles may be excited in proper phase relationship or may be parasitically driven

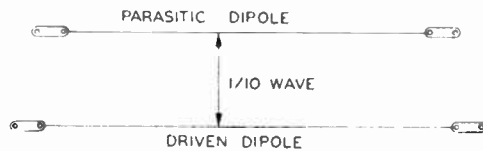

Figure 252. An additional dipole may be placed some distance away from the dipole which is excited, and parallel to this dipole. Better directional characteristics may be obtained from such simple arrays.

from the energy of the main radiator. The radiation from these extra dipoles change the radiation pattern in a manner which may be helpful. For example, such an array of dipoles may lower the vertical angle of radiation or eliminate the unwanted signals radiated to the rear of the direction of the receiving station. Further, this rear signal can be employed to reinforce the forward radiation.

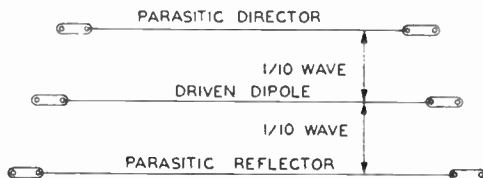

Figure 253. Diagram showing a driven dipole or antenna located between a director and a reflector. There is no electrical connection between them.

**COUPLING METHODS.** The problem of coupling the feed line to the transmitter is largely one of properly matching impedances. Since the impedance across the entire tank is usually several thousand ohms, and the impedance of the feed line to be coupled to the transmitter is much lower, some sort of transformation must be accomplished. This may be done by tapping directly a section of the tank inductor or by using an inductively coupled link of a few turns.

**REVIEW QUESTIONS AND PROBLEMS.** 1. Using a sketch, explain that a short piece of wire has capacity.

2. Make a drawing of a resonant line and mark the distances to represent two wavelengths. Show the line coupled to a high frequency generator. At the instant that the generator voltage is maximum, show the voltage distribution along the line. Assume that the generator produces sine waves.

3. In looking into a coaxial cable of 70 ohms surge impedance, what does a circuit see? The cable is terminated in a 70 ohm resistor at the other end.

4. Make a drawing of a dipole antenna with a resonant line feed coupled to a point of maximum current. Indicate dimensions in terms of wavelength ( $1/4\lambda$ ,  $1/2\lambda$ , etc.).

Radio locators (RADAR) must use directional antennas to send the signal in a single direction.

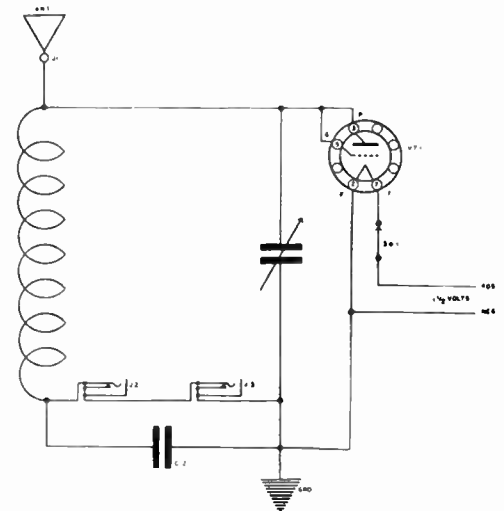

Field strength measurements may be made with a simple absorption meter. The unit is tuned to the frequency of the radiation. A sensitive meter and phones are used as indicators and are plugged into the jacks. The unit may be used to compare the transmitter output under different adjustments, to help neutralize the transmitter, to check antenna adjustment, and for obtaining field strength patterns.

2. In this case, the voltage sine wave will be maximum right at the generator. At the next quarter wavelength this voltage will be minimum, and a quarter wavelength further along the line, the voltage will be maximum in the opposite direction.

4. Refer to Figure 245.

# LESSON 18

## Test Equipment Using Meters

This lesson deals primarily with the purpose of test equipment and the circuits and operation of testers which use meter indicators.

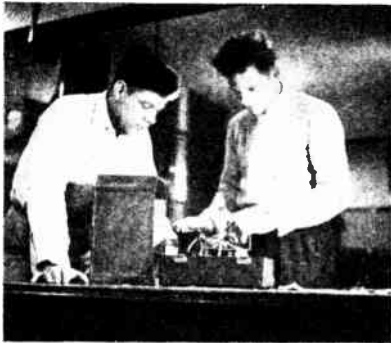

Figure 262. Radio faults are discovered with the aid of test equipment.

If there is no voltage difference between the two points selected, the voltmeter will indicate *zero* volts.

Because the circuit must be actually broken to make a *current* measurement, these measurements are not made very often in servicing and measurements of voltage and resistance are preferred.

If you follow the suggestion in this paragraph, you will never damage a meter.

**Volume 2 – Page 168**

**NEED FOR TEST EQUIPMENT.** The correct function of radio circuits can be established by determining the presence of the proper electrical values at several points in each stage. Since it is easiest to measure voltage and current directly, and resistance by an indirect (but simple) method; these measurements are most commonly employed. Visual and aural tests are also employed. The oscilloscope, using a cathode ray tube and described in the next chapter, is especially well suited for visual observation of the signal behavior in its progress through sections of radio equipment.

The correct operation of a newly developed or experimentally constructed circuit can be determined with the aid of test equipment. In a similar manner, knowing what electrical values to expect at different points in various circuits, we can make the measurements required. The proper or improper measured values obtained will guide the radio technician to the stage and then to the actual part or item at fault.

**USING INDIVIDUAL METERS.** The voltage between any two points in a radio circuit can be measured with a voltmeter having a suitable scale. In all cases, the meter must be able to measure the maximum voltage anticipated. Further, the reading obtained should be indicated somewhere in the center of the scale employed. It will not do to use a meter having a scale reading from 0 to 1,000 volts, and expect to get an accurate reading of a voltage around 2 volts. To obtain a correct reading when the value expected is 2 volts, a meter with a maximum scale of 5 or 10 volts should be used.

Usually voltage measurements in radio equipment are made between any point in question and the ground potential which in most instances is the negative return from the power supply. However, voltage measurements can be made between any two points.

Measurements may be made to determine the amount of current passing through a circuit. Most radio circuits depend primarily on a D.C. source of power and D.C. meters are employed. To make a current measurement, the circuit must be broken (the wire may be cut or unsoldered at a point). A current measuring meter, usually a milliammeter with a suitable scale, is connected in the *circuit-break* observing the proper polarity. If a D.C. meter is connected in reverse as far as the polarity is concerned, the indicating needle will tend to move in the wrong direction.

A meter with the proper scale should be chosen for the required measurement. If the electrical value, such as voltage or current, is not known, it is safe to start with a meter which has a high maximum value, and if the reading obtained is trivial compared to the scale employed, a scale (or meter) with a lower maximum value can then be tried.

Values of resistance can be measured with an ohmmeter. You

understand, of course, that an ohmmeter actually indicates the amount of current flowing in the meter-circuit and in the external part to be measured, and this current is supplied by a battery incorporated in the unit. However, the amount of current, moving through this circuit, and that which causes a deflection of the meter needle, is proportional to the resistance being measured. Therefore, it is possible to calibrate the meter scale directly in ohms.

**COMBINATION VOLT-OHM-MILLIAMMETER.** We have already learned from the contents of Lesson Eight that a single meter (usually a low value milliammeter) can be employed with a suitable selector switch and resistance network to permit various measurements of voltage, current, and resistance. Such a combination instrument is called a volt-ohm-milliammeter or a multimeter. Since different types of measurements are required in radio servicing, a single instrument of this type is more convenient and less expensive than a collection of individual meters.

**WHAT THE WRONG METER-READING INDICATES.** Your knowledge of radio circuits, the information contained under various topics, and especially the tube characteristic data charts, suggest proper values of voltage, current, and resistance for various parts of

## MAKING TESTS WITH A METER

Review the explanation about an ohmmeter given in Lesson 8.

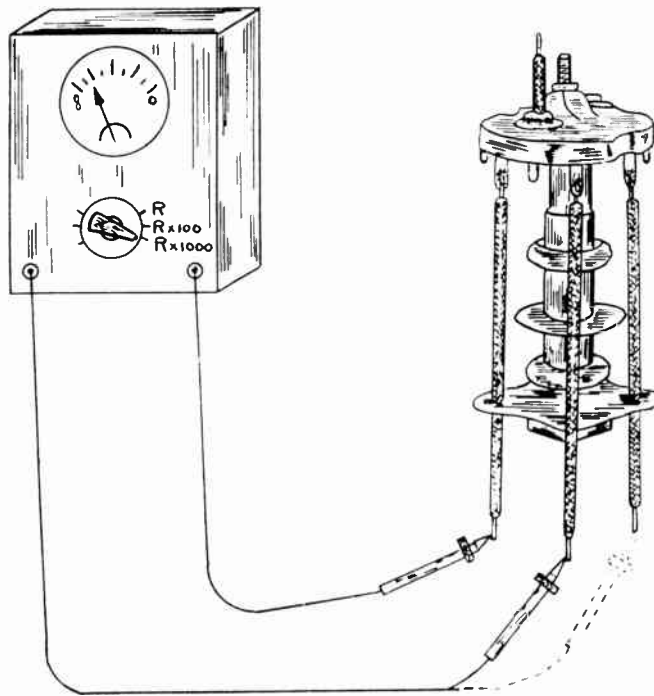

The actual terminal contacts shown in the illustration may be made at any of the points where the leads from the I.F. transformer happen to terminate.

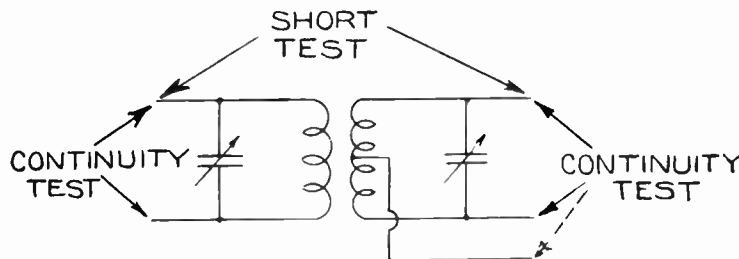

Figure 264. A method for testing coils for short circuit, and continuity. Short circuits, which should not exist, will be indicated on the ohmmeter as zero ohms resistance. Continuity will be indicated as low values of resistance.

## TROUBLE-SHOOTING METHOD

It is important to understand that meters and test equipment do not actually say, "This part is bad — replace it," or "That circuit is open." Meters simply indicate what values of voltage, current, resistance, etc., exist in different circuits and this information, coupled with your knowledge of the correct values expected suggests a *possible fault* or the realization that the particular section of the circuit is functioning properly.



A circuit diagram of the receiver to be serviced, of course, will prove of great help. The publishers of this *course* have issued manuals of most-often-needed radio diagrams.

A very similar servicing technique is employed with electronic equipment.

**Volume 2 – Page 170**

any circuit. The usual servicing technique is to proceed to ascertain whether the values at different points are as expected. If the values are not right, then you can determine with further tests what actual components or items are at fault and are upsetting the operation to the extent of giving you the incorrect reading.

Let us consider an example. You turn on a radio receiver and find that it does not operate. Noticing that the vacuum tube filaments glow a dark red, you will know that power is being supplied to the radio and is being delivered to the filaments. Next you choose a voltmeter with a sufficiently high scale (usually 300 volts) and measure between the point of B+ voltage and ground. Your knowledge of power supply circuits will enable you to locate this point. If you obtain the expected reading (anywhere from 200 to 300 volts in an A.C. radio receiver) then you may assume that the fault does not exist in the power supply and you may proceed to make other tests. On the other hand, if the voltage obtained is unusually low or is missing completely, then the power supply is at fault and only this stage need be tested further to locate the actual trouble.

**WHAT MEASUREMENTS HELP YOU TO FIND THE FAULT.** Before any measurements are made, the radio unit to be repaired must be carefully examined visually. You should try to find some very obvious fault which may exist and also become familiar with the type of circuits that are combined to make up the complete radio unit. On one job, you may find that the radio receiver is of the A.C. operated type, has six tubes, and is a superhet. You will also notice the function of each tube. This radio set is made up of a pentagrid converter mixer stage, one I.F. stage, a separate diode detector also supplying AVC, an audio voltage amplifier stage, and the power output stage. One tube is also used as the rectifier for the power supply.



Figure 266. The presence of voltage may be observed with the aid of a resistor and test leads. This is an emergency method for locating faults and should not be used if test instruments are available.

If the tubes light when the power is turned on, a voltmeter may be used for a quick test to determine that plate voltage is present at several points. Tests are made to determine that circuits under suspicion are not at fault. A great many tests may be required before the actual fault is localized. If power failure is detected, the ohmmeter may be employed. The set must be in operating position (power switch *on*) for voltage tests; but the power must be *off* for ohmmeter tests. Besides measuring the actual values of resistors, the ohmmeter may be used to test for continuous (unbroken) leads, and for open circuits and short circuits. For example, if two points (terminals) are wired with a piece of hook-up wire, they will *test zero ohms*. A paper condenser, when not at fault, will show open circuit; i.e., very high resistance. Windings of coils will test as low resistance, 5 to 70 ohms.

Occasionally it is advisable to make a current measurement. The proper setting is made on the multimeter, and the circuit to be tested is broken for the insertion of the test-meter.

**TUBE TESTERS.** Although faults in vacuum tubes can be detected without the aid of a tube tester, to make a positive statement that a vacuum tube is in good operating condition requires the use of a good tube tester. Testing and replacing tubes constitutes a large amount of work of radio servicemen. A very large number of apparent radio receiver defects do not actually require any repairs, but merely a replacement of one or two tubes.

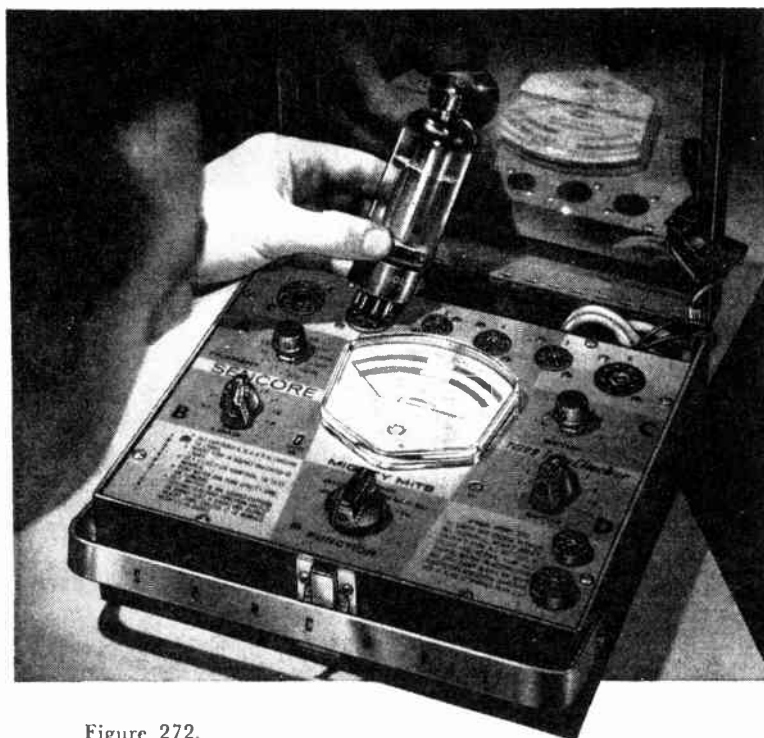

Figure 272.

Different test methods are used by the various tube-tester manufacturers. Tube checkers and testers are usually A.C. operated and employ from six to as many as twenty-five sockets. The grid-shift method is commonly used in the testers. The grid voltage is altered a small amount which in turn causes a corresponding change in the plate current. This change in the plate current is the index by which we judge the condition of the tube and this current is indicated on the meter. The tube-tester meter is usually marked GOOD-BAD, so that the public can understand the results. If A.C. is employed as the grid voltage, the test is called dynamic. If D.C. is used, the test is static.

In some testers, the majority of the elements are tied together, in others each element receives a relatively correct potential for the test. In the emission type tester, all the elements are tied together with the exception of the cathode and the filaments and the current passing to the cathode is measured. Obviously, if the screen grid prong of a tube is completely missing, the tube will still test GOOD and, this is why, the grid shift dynamic testers are superior and do detect such faults.

## VACUUM TUBE TESTERS

If a tube in electronic equipment is suspected as being at fault, you may substitute for this tube one known to be good and see if the operation of the equipment is restored to normal. If this is the result, the tube *tested* was at fault.

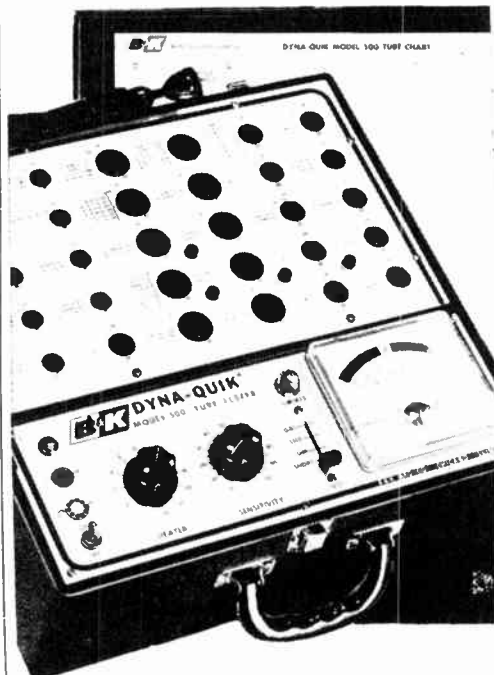

Courtesy Triplett Electrical Inst. Co.  
Figure 273. Transistor tester quickly, easily and accurately tests power and signal transistors under simulated operating conditions.

## TUBE AND CONDENSER TESTERS



Figure 274. A tube tester with its meter scale calibrated GOOD-BAD. This permits the non-technical customer to see for himself the results of the test.



Courtesy Sprague Products

Figure 275. A condenser tester employing a bridge circuit is a handy instrument for the laboratory or the more advanced radio shop.

5. Make a sketch of the circuit involved.

7. A circuit of the parts involved will help you answer this question.

The emission type tester is much simpler and is much cheaper to build than the dynamic type. For modern tubes and requirements, the emission test proved to be accurate enough and does serve the purpose. Instructions for operating different testers are usually included with the unit.

Besides low emission, about the only other defect that occurs in a tube is a short between some elements. Modern tube testers of all makes incorporate a *short-test*, placing a high potential between the different elements and using a sensitive neon bulb for the indicator.

**CONDENSER TESTER.** Special testers to determine the capacity, leakage, and power factor of commercial condensers are available. Of course, such testers may also be employed to determine if the condenser under test is in good operating condition. Detailed instructions for operating different units are supplied with the tester. The majority of condenser testers use a bridge circuit with a sensitive meter or tuning eye tube employed as the indicator. The condenser under test serves as one arm of a bridge circuit, and some other arm is adjusted to give the required balance. This variable arm usually consists of a variable resistor and is employed with a scale which is calibrated to indicate the capacity being tested.

Bridge circuits are used often in laboratories where very accurate tests are required. The four arms of a simple bridge consist of three known impedances and one unknown which is to be determined. Some of the known impedances are altered until balance is achieved and then the unknown impedance can be calculated.

**REVIEW QUESTIONS AND PROBLEMS.** 1. What measurements are commonly employed by radio servicemen?

2. Will a single scale voltmeter serve to make all necessary measurements in a radio receiver? What limitations may come up?

3. How can the plate current of a vacuum tube, used in a radio set, be measured? What equipment will be needed?

4. Can a multitester be made to measure only voltage and resistance, but not current? Can you show the circuit?

5. Using a voltmeter, you find the correct value of voltage on one side of the I.F. transformer primary. The other side, which goes to the plate of the I.F. tube, gives no reading. The negative prod of the voltmeter is held to ground for both tests. What may be wrong?

6. Why must the radio be *off*, when using the ohmmeter for tests?

7. The screen grid of a tube receives its voltage through a two megohm resistor. The correct voltage for this screen grid is 100 volts. What voltage would you expect if the measurement is made with 1,000 ohms/volt meter? (Measurement between screen grid and ground.)

8. What two tests are usually made to determine whether a vacuum tube is in good operating condition?

# LESSON 19

## Electronic Test Equipment

**AUDIO FREQUENCY SIGNAL GENERATORS.** A vacuum tube oscillator may be constructed, with suitable values of inductance and capacity in the tuned circuits, to produce energy at audio frequencies. Audio oscillators, as such instruments are commonly called, produce frequencies between 30 and 15,000 cycles per second. The frequencies produced may be selected with the aid of a dial adjustment. The intensity of the output signal is also adjustable with an attenuator control.

Oscillator circuits, similar to the R. F. types we have discussed, may be employed to produce audio frequencies. Of course, the L-C circuit must resonate at the required audio frequencies. Suitable inductors and capacitors would be quite large and could be made variable only with the greatest difficulty. However, it is possible to produce audio frequencies by *beating* (combining in a non-linear impedance) two radio frequencies differing in frequency by the number of cycles required to produce the audio frequency. In practice, two R.F. signal generators are built-in a single case. One produces a fixed R.F., while the second has its frequency variable and easily altered with a regular tuning condenser. If the frequencies of the two R.F. generators, for any one adjustment, differ (for example) by 800 cycles, then 800 cycle audio signal is produced. A few lately developed types of sine wave audio signal generators use circuits without any inductance. The required wave form is produced with novel R-C vacuum tube circuits.

**R. F. SIGNAL GENERATORS.** An electron-coupled oscillator circuit is employed to produce adjustable radio frequencies. With this type of oscillator, the variations in the load have little effect upon the frequency. Tuning (adjustment of the frequency produced) is accomplished with a variable condenser. The control dial is carefully calibrated and is usually accurate to within 1%. The frequencies are generated with several different coils which are selected and connected to the tuning condenser of the circuit with a band-switch. A practical R.F. signal generator may cover frequencies from 100 KC. to 90 MC. This includes all I.F. frequencies used and the usually employed communications frequencies. The coverage may be obtained in six or seven steps. In most units, the higher frequencies are not actually generated as fundamentals, but are harmonics of the highest frequency band for which L-C is provided.

A small audio signal generator is usually included in the cabinet of the R.F. signal generator. The audio signal may be of a single frequency (400 cycles commonly used), or several different frequencies may be available for selection. The intensity of the audio signal superimposed on the R.F. carrier may be controlled. This is known as the percentage of modulation. The audio frequencies may be used separately if need arises.

A signal generator may be used for locating faults in radio receivers and as an aid for properly aligning all types of sets. With

To test stages which are designed to handle audio frequencies, an audio frequency signal generator is employed to produce the needed signals.

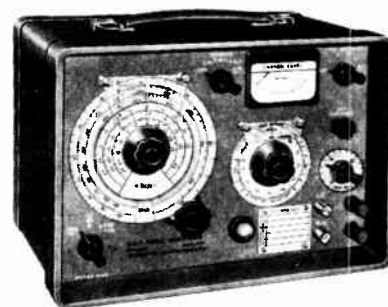

Figure 276. A good quality R.F. signal generator incorporating a decibel meter for measuring the output signal level of a radio receiver.

Since the R.F. signal generator needed for service work must produce a variety of frequencies, a crystal controlled oscillator will not do. However, for a single frequency adjustment, a crystal controlled oscillator may be used.

Most R.F. signal generators incorporate an audio frequency generator for modulating the R.F. carrier. In some units, several audio frequencies are available and the percentage modulation (ratio of audio power to radio frequency power) may be controlled.

**Volume 2 - Page 173**

## VACUUM TUBE VOLTMETER

These are the basic applications of a signal generator.



Figure 277. A signal generator can be used as an aid in testing the various stages of a radio receiver.



a signal generator, you can produce a similar signal to the one which can be handled by any stage of the receiver. For example, you can generate a powerful audio signal to drive the output stage. Or you can produce a relatively weak I.F., of the correct frequency and with about 30% modulation, to excite the input of the first I.F. transformer. The signal is applied to any one stage, and if the output is present in the loudspeaker, this stage and the balance of stages leading to the speaker may be assumed to be operating.

By adjusting the signal generator to the I.F. frequency of the receiver, the I.F. transformers can be correctly peaked. It is best to feed the signal into the primary of each I.F. transformer and adjust the trimmers for maximum results. You may judge the results by the sound reproduced by the speaker, but it is better to have an output indicator. A cathode ray oscilloscope may be used for exacting results since it shows the exact response curve.

In a manner similar to the alignment procedure explained in Lesson Fourteen, a signal generator may be used for alignment. Instead of tuning in a station of about 1,500 KC. and then one of 650 KC., these frequencies can be generated with the signal generator.

In aligning the circuits of the short-wave bands, the same procedure is followed. However, the frequencies used are located at the upper limit and at the lower end of the band to be aligned. Separate trimmers and padder condensers are provided for each band. The I.F. transformers, of course, need not be touched once they are adjusted for any one band.

**VACUUM TUBE VOLTMETER.** When a vacuum tube (triode or pentode) is operated over its *curved* characteristic, the D.C. plate current will depend on the voltage applied to the grid. It is possible, therefore, to calibrate a plate current meter in terms of the voltage which is applied to the grid. The zero-grid-voltage plate current is balanced out with another, separate circuit which passes current through the plate meter in reverse. The zero meter adjustment, required on all types of vacuum tube voltmeters (this instrument is abbreviated VTVM), is the adjustment for this balancing circuit. Since the input grid circuit of a negatively biased vacuum tube draws no current, zero current is taken from the circuit in which the measurement is being made by the VTVM. Since the circuit connected to the VTVM may not complete the grid to ground return (does not offer a D.C. path from grid to ground), a high valued resistor is placed in the circuit across the input terminals for this purpose. This resistor may be 10 or 20 megohms for the 10 volt scale. This makes the unit have the equivalent sensitivity of one megohm per volt. For higher voltage readings, additional resistors are wired in a voltage divider circuit, and the same high sensitivity exists. From a practical point of view, a vacuum tube voltmeter takes no current from the circuit under test.

The lead from the grid input terminal has a certain amount of capacity to the return terminal which is at ground potential. There is also capacity between the control grid and cathode of the tube employed. At ordinary frequencies (as high as one megacycle in good VTVM), this total capacity has extremely high capacitive reactance and may be ignored. However, at frequencies above the broadcast band, the capacity of the input practically shorts the signal to be measured and reduces the sensitivity of the instrument. Special precautions are taken to reduce the capacity of the input circuit.



**CATHODE RAY TUBE.** Cathode ray tubes are the basis of modern television reception and also are used extensively in visual analysis of electrical phenomenon. In its simplified form, the cathode ray tube consists of an electron gun to generate an electron beam of high velocity, a dual-set of perpendicular electrostatic or magnetic deflecting devices, and a fluorescent screen to make visual the actual path described by the end of this electron beam.



Figure 281. Most oscilloscopes employ three inch cathode ray tubes and have the required controls for adjustment to "see" signals of various types.

Courtesy Hickok Electrical Inst. Co.

In the figure below, the components of a basic cathode ray tube are enclosed inside the glass bulb (E), which also maintains a vacuum in the tube. The cathode (K) is employed for the production of free electrons; the electrode (H) accelerates the electrons; the focusing electrode (F) concentrates the electrons into a "cathode

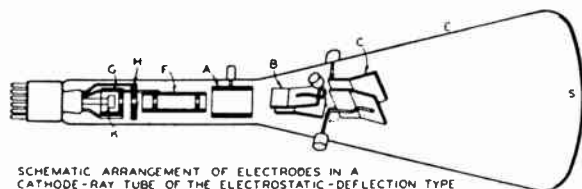

SCHEMATIC ARRANGEMENT OF ELECTRODES IN A CATHODE-RAY TUBE OF THE ELECTROSTATIC-DEFLECTION TYPE

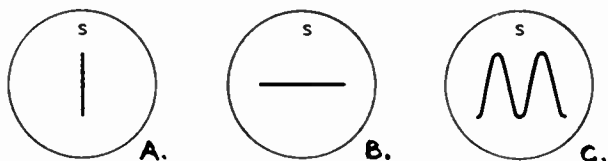

Figure 282. Position of electrodes inside of a cathode ray tube, and simple patterns obtained on the screen.

ray" or beam; the high-voltage anode further accelerates the electrons. The control grid (G) controls the beam current, increasing or decreasing the intensity of the beam. Two sets of electrostatic deflecting plates (B) and (C) are used for deflecting the electron beam. The screen (S) is coated on the inside surface of the enlarged end of the bulb. The screen is made of material which shows a fluorescent glow at the point of impact of the electron beam.

**CONSTRUCTION OF A C.R. TUBE**

The electron beam narrows down to a small point where it meets the screen. The fluorescent screen (inside front of tube) glows with light when the electron beam strikes it and continues to glow for a short time after the beam moves on to another spot.

Cathode ray tubes using electrostatic deflecting plates (most small C-R tubes are of this type) operate from the voltage impressed. To be influenced by current, the current to be measured must produce a voltage drop in an associated resistor.

Since there are many connections to a cathode ray tube, a twelve terminal socket may be used and additional connections may be brought out through the sides of the glass container.

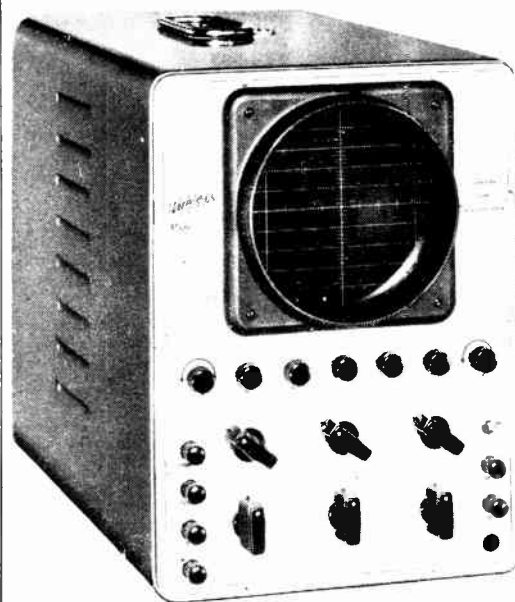

## OPERATION OF A C.R. TUBE

The focusing of the electron beam is similar to such processes used with light lenses.

The electron beam consists of rapidly moving electrons and is an actual electric current responding to both electrostatic and electromagnetic influences. The beam has negligible mass and inertia and responds instantly to electrical forces. Certain initial adjustments are made so that the end-spot of the beam strikes the screen exactly in the center. The control grid is adjusted to give the fluorescent glow, resulting from the electron beam impact, the required visibility. The tube is so placed in its socket, that the operator looks directly at the screen, and has one set of deflecting plates at the left and right (for horizontal sweep), while the second set of plates are above and below (to serve as the vertical sweep). Controlling voltages may be applied independently to either set of electrostatic plates. Let us study the effects on the electron beam pattern as these voltages are varied.

First, we will connect a battery to the two *vertical* plates. The plates act as a low capacity condenser as far as the voltage supply is concerned. The beam will be attracted (to some degree) towards the positive plate and repelled from the negative plate. The spot will move up (and stay there) if the upper plate is the one connected to the positive terminal of the battery. Now let us connect an alternating voltage (A.C.) to the vertical plates. The potential of the plates will increase and decrease periodically, and the plates will alternately become positive. The beam and the end-spot, therefore, will move up and down in accordance with these voltage variations. Since the screen retains the fluorescent glow for a short time, the many *moving* dots will form a straight line, as in the screen view A, of the illustrations included on the previous page.

In a similar manner, various voltages could be applied to the horizontal plates, and the beam would move horizontally. Usually

This is true provided the frequency is high enough. In the usual unit, even 25 cycles per second will produce a *picture* of a straight line.

## OSCILLOSCOPE CIRCUIT

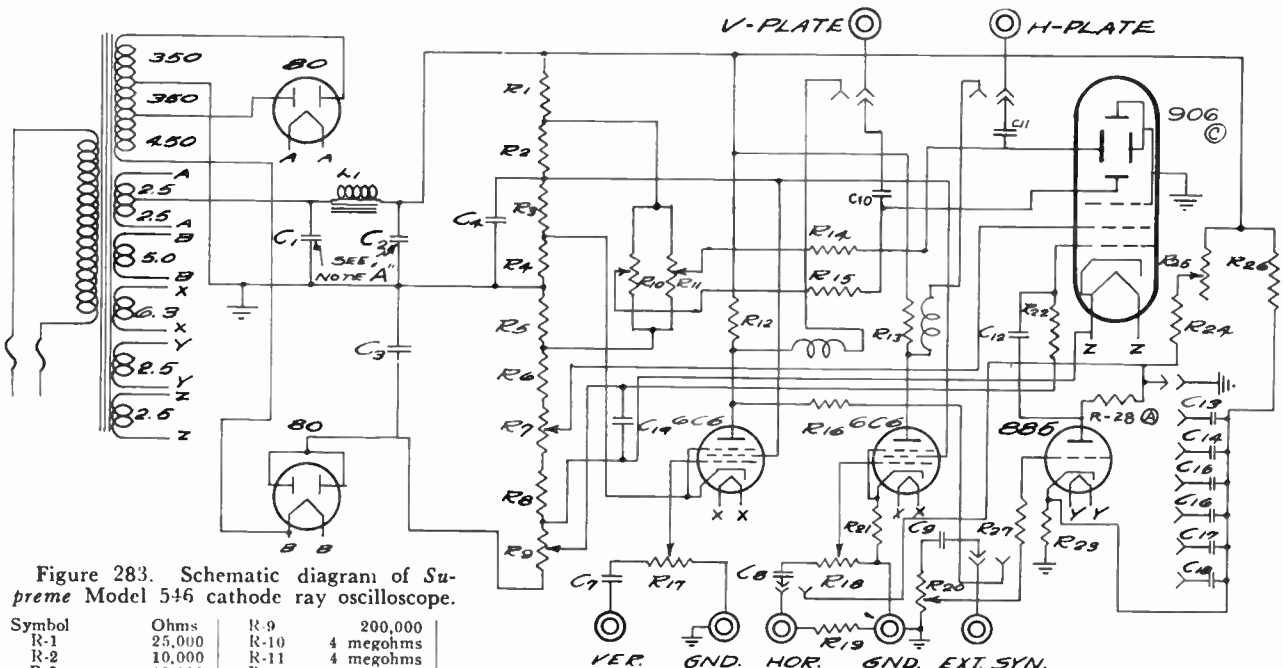

Figure 283. Schematic diagram of Supreme Model 546 cathode ray oscilloscope.

Symbol	Ohms	R-9	200,000
R-1	25,000	R-10	4 megohms
R-2	10,000	R-11	4 megohms
R-3	10,000	R-12	50,000
R-4	250	R-13	100,000
R-5	250,000	R-14	1 megohm
R-6	750,000	R-15	500,000
R-7	500,000	R-16	1 megohm
R-8	100,000	R-17	1 megohm

R-18	4 megohms	R-23	1,000
R-19	1 megohm	R-24	1 megohm
R-20	15 megohms	R-25	4 megohms
R-21	1,000	R-26	100,000
R-22	500,000	R-27	100,000
		R-28	500

Symbol	Mfd.	Symbol	Mfd.
C-1	4.0	C-9	0.05
C-2	4.0	C-10	0.5
		C-11	0.25

Symbol	Mfd.	Symbol	Mfd.
C-3	0.5	C-12	50 mmfd.
C-4	8.0	C-13	0.37
C-7	0.1	C-14	0.04
C-8	0.1	C-15	0.01
C-9	0.05	C-16	0.0025
C-10	0.5	C-17	600 mmfd.
		C-18	200 mmfd.
		C-19	0.5

## OSCILLOSCOPE CIRCUIT

the horizontal set of plates is employed with a special sweep circuit which moves the beam from left to right at a pre-selected uniform rate, and then quickly returns it to the starting position at the extreme left to repeat the movement. If the vertical plates are not excited, even this *saw-tooth* horizontal sweep will appear as a straight horizontal line, see B of the figure. By applying a signal voltage to the vertical plates, and employing the horizontal plates for the sweep action, various patterns can be reproduced on the screen of the cathode ray tube.

In figure C, we have the reproduction of a sine wave. The number of cycles appearing depends on the sweep frequency. This sweep frequency can be varied and locked in step with the signal applied to the vertical plates.

**OSCILLOSCOPE CIRCUIT.** An examination of the circuit schematic indicates the power supply at the left. The voltage outputs of the full-wave and half-wave rectifiers are combined to serve the cathode ray tube, amplifier tubes, and the type 885 thyratron sweep generator. The voltage input to the vertical and horizontal plates may be amplified. Ordinarily, however, the horizontal plates are used in conjunction with the sweep circuit which is locked in step with the incoming signal to be observed and applied to the vertical plates.

**HOW TO OPERATE THE OSCILLOSCOPE.** The circuit supplying the voltage to be observed is usually connected to the vertical amplifier input. The unit is turned *on* by advancing the *intensity* control. Keep both amplifier gain controls in the *off* position. Advance the *intensity* control until the spot is just visible. Using the *horizontal* and *vertical position* controls, center the spot. Adjust the *focus* control for maximum clearness of the spot. Carry out these operations quickly. Do not permit the spot to remain in a single position for any period of time. Keep the brilliance down while making adjustments.

You will be using *internal synchronization* and the *internal sweep*, so keep the toggle switches in the position illustrated to obtain this operation. Adjust the *sweep frequency* control to the value closest to the frequency of the signal to be observed. Advance the *horizontal gain* control until the spot is moving across (forms a horizontal line) almost the entire screen of the cathode ray tube. Now advance the *vertical gain* control until the spot moves up and down, keeping within the confines of the screen. The intensity may be advanced to make the pattern clearer. Now adjust the *fine frequency* control until the pattern appears as stationary as possible. The *synchronizing control* may be used now to stop all motion.

**REVIEW QUESTIONS AND PROBLEMS.** 1. Name and describe the three methods commonly used for producing audio frequencies in signal generators.

2. Explain the reason for modulating a R.F. signal generator which must be used for aligning a radio receiver.

3. Explain in detail the process of aligning one of the superhet receivers described in Lesson Fourteen.

5. What effect does frequency have upon the sensitivity of a vacuum tube voltmeter?

6. Refer to the schematic diagram of the cathode ray oscilloscope and label the elements which correspond to the ones described in the text.

The return sweep is performed so quickly that the electron beam does not leave any visible trace on the fluorescent screen.

The speed of the sweep across, from left to right and the quick return, is locked in step with the voltage applied to the vertical plates and which is *reproduced* on the screen.

The oscilloscope is used for design, service, adjustment, and production testing of electronic equipment and as the indicating instrument in industrial test equipment.

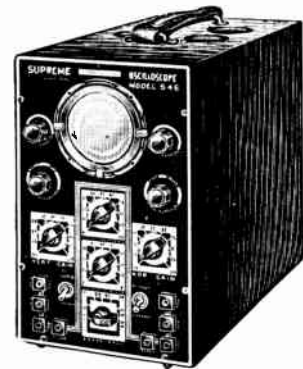

This is a small illustration of the *Supreme* oscilloscope described in the text.

It is possible to cause the trace to go off the screen by applying excessive voltages to the deflecting plates.

3. Tell what adjustments would be turned in what order and what effect these adjustments will have on the operation of the circuit.

# LESSON 20

## Thyratron Tubes

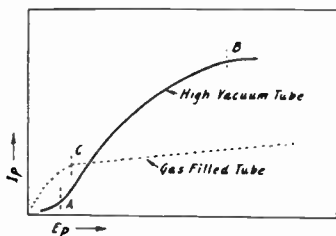

Current variations with increasing plate potential in high vacuum and gas filled tubes. Up to point A current is limited by space-charge, after point B by limited emission. After a voltage corresponding to C, the current of a gas filled tube is almost constant.

When an atom loses one or more electrons, it becomes a positive ion.

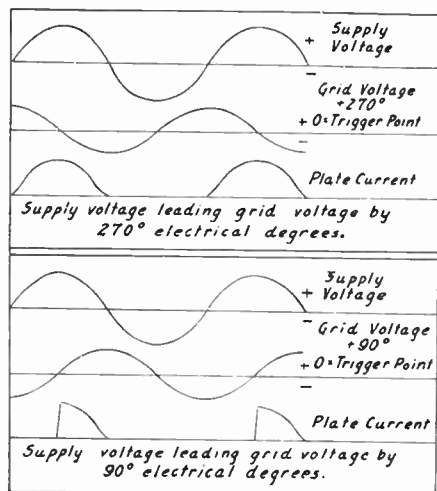

Figure 289. The above graphs show the relationship between the supply and grid voltages, and the plate current, for two different conditions of operation of a thyratron tube.

Thyratron tubes are made in various sizes and in special shapes for different applications.

**COMPARISON OF A THYRATRON TO OTHER TUBES.** Essentially, a Thyratron\* is a vacuum tube possessing a hot cathode as a source of electrons and is filled with some inert gas or mercury vapor. Very much like the high vacuum triode, it possesses a grid control element. However, because of the presence of the gas or vapor, the plate current, plate voltage characteristics are entirely different and are utilized for applications where the high-vacuum tubes would not do.

In an ordinary vacuum tube, the plate current is limited at low plate voltages by the presence of the space charge. Once the plate voltage is raised to remove the influence of the space charge, the plate current will vary with the voltage until the current will be limited by the emission.

In the thyratron, the action of the plate current is entirely different and is due primarily to the formation of positive ions from neutral gas atoms. These ions are very heavy by comparison to electrons (thousands of times heavier) and do not move rapidly. However, the presence of these ions permits the flow of large electron currents by altering the space potential.

In a high vacuum tube, electrons travel in a continuous path from cathode to the plate. In a gas filled tube, however, the average length of an uninterrupted path is very much shortened by the continued collision of electrons with gas molecules. These collisions result in the creation of positive ions and additional free electrons. The positive ions so formed raise the space potential and, thereby, permit more electrons to escape from the cathode. If the rate of ion generation is large, the voltage change is negligible in the space between the anode and cathode, except in the region near the cathode and the anode themselves. These regions adjacent to the two elements of the tube are subject to large potential change and are called the *sheaths*, and the region of little change is called the *plasma*.

Such a two electrode gas filled tube finds application as a rectifier of relative high current capacity and possesses a small constant voltage drop. The commercial mercury vapor tubes and mercury rectifiers of the radio type such as the 83, are examples.

**ACTION OF THE THYRATRON.** In the thyratron, as mentioned previously, a third element, the grid, is incorporated as a means of control. The starting of the current flow between the cathode and the plate of a gas filled tube depends on the formation of positive ions in the interelectrode space. The rate of this ion formation to form the plasma is dependent on the geometrical construction of the electrodes and the applied positive plate voltage. In a two-element gas-filled tube, the anode (plate) current is started by making the anode voltage sufficiently positive to form the plasma.

\*The Thyratron is a trade name of General Electric Company through whose courtesy much of this information has been obtained.

# LESSON 21

## Photo-Cell Equipment

**APPLICATION OF PHOTO-CELL EQUIPMENT.** The photo-electric cell and the associated equipment can be employed to *see* more accurately than the human eye and respond more quickly than the human hand, and to do so continuously, unflinchingly, at all times. With unerring precision, photo-cell equipment can be made to signal, grade, match, compare, start, stop, count, control, and time. The mysteriously swinging doors, automatic sorting devices, safety controls on punch presses, burglar alarms, blackout light controls, combustion controls are just a few modern applications of electronic photo-cell devices. Photo-cell equipment is also used for color matching, comparing opacity of materials, window light control, and highway speed timing.



*Courtesy "Radio News" Magazine*

Figure 304. Photo-cell equipment is used for proper adjustment of lights and camera setting for best photographic results.

**PHOTO-ELECTRIC CELLS.** Surfaces treated with certain chemicals will emit electrons under the influence of light. This action is very similar to the emission of heated cathodes. If a positive plate is placed in the bulb, the electrons will be attracted to the plate. Since more electrons are emitted when the light shining on the photo-cell is bright, light can be used to control the number of electrons leaving the photo-sensitive cathode. The number of electrons, of course, forms the current which in turn is controlled by the light source.

The cathode is usually a concave (rounded) surface on which the light sensitive material has been deposited. The anode takes the form of a centrally located wire which attracts and collects the electrons emitted from the cathode. The number of electrons emit-

Many devices using photo-electric cells and performing various industrial services could not be replaced with any other equipment or merely by an operator. While in many applications, photo-cell equipment replaces other means of doing the same job and offers some advantage of accuracy, speed, or reduction of cost; in many instances, photo-cell equipment is unique in its ability to perform the task required.

Extensive information on the photo-cells used in commercial units is purposely omitted. Detailed information on commercial photo-cell tubes is available from the manufacturers of the units.

**Volume 3 - Page 179**

## RESISTANCE OF A PHOTO-CELL

To think of the photo-cell as a variable resistor is especially advantageous in analyzing the action of circuits.

The subject of *illumination* may be looked up in a text-book on Physics or in an Encyclopedia.

ted and forming the photo-electric current to the anode is a function of the light falling on the cathode surface. The student may also consider the photo-cell as being a variable resistor with a value of resistance dependent on the light falling on the cathode surface. In the dark, the equivalent resistance is very high, while with strong light the resistance is greatly reduced. A typical cell with light of 5 foot-candles\*, under normal operating conditions, has the equivalent resistance of almost 100 megohms. With 70 foot-candles of illumination, the resistance corresponds to 10 megohms.

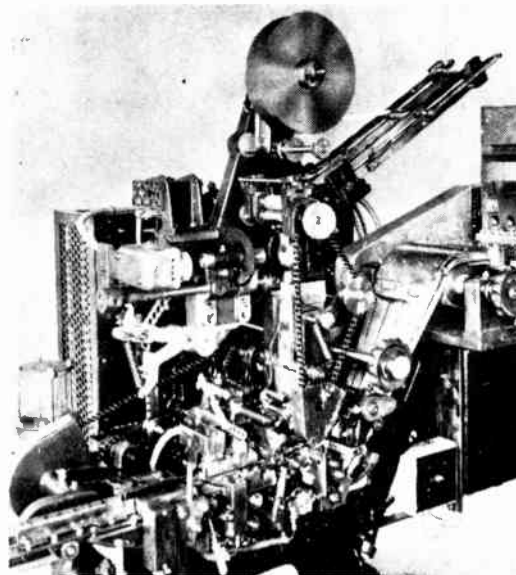

*Courtesy "Radio News" Magazine*

Figure 305. Cellophane wrapping machine using a photo-electric relay to synchronize the cutting and printing.

**A SIMPLE PHOTO-CELL UNIT.** In order to introduce you to a complete photo-cell unit, we will describe a simple practical circuit which can be operated from 110 volts A.C. or D.C. and employs a type 25A6 pentode as the amplifier and rectifier.

There are many other practical circuits which employ a photo-cell and a single amplifier tube. Two or more stages of amplification could also be employed. The photo-cell shown in this circuit requires a polarizing voltage of 90 volts.

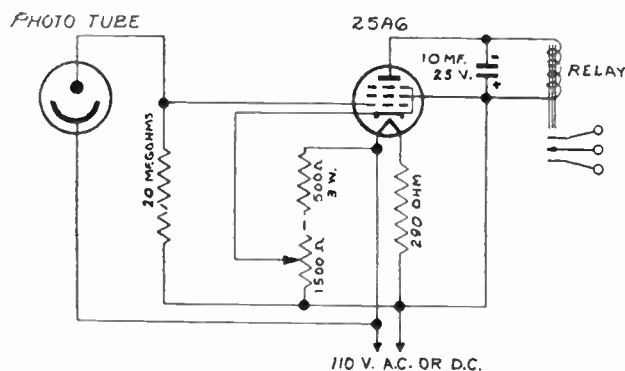

*Courtesy Allied Radio Corp.*

Figure 306. A circuit of a simple photo-electric relay using a single tube for an amplifier. This unit may be operated from a 110 volts A.C. or D.C.

\*A foot-candle is the amount of light received from a standard candle at a distance of one foot.

Consider the circuit at the point where a positive potential\* exists on the side of the line connected to the relay and screen grid of the 25A6 tube. If the control grid of this tube is not biased to a cut-off point, a certain amount of current will pass through the plate circuit and activate the relay. The actual bias of the grid will depend on the internal resistance of the photo-tube and also on the setting of the potentiometer.

With the photo-cell receiving a definite amount of light, the potentiometer may be adjusted so that the plate current is just below the point where the relay will have sufficient energy to pull down the armature.

Now, if the source of light is reduced, the internal resistance of the photo-tube will rise and cause a higher positive potential to be applied to the grid and counteract the negative potential obtained through the drop in the potentiometer circuit. The net rise of the control grid voltage will cause the additional plate current to pass and the armature to move down to the magnet pole. Since the armature has a contact on each side, it will make another circuit and break the one previously made. In this manner, equipment associated with the photo-cell unit may be started or stopped with the increase or decrease of light.

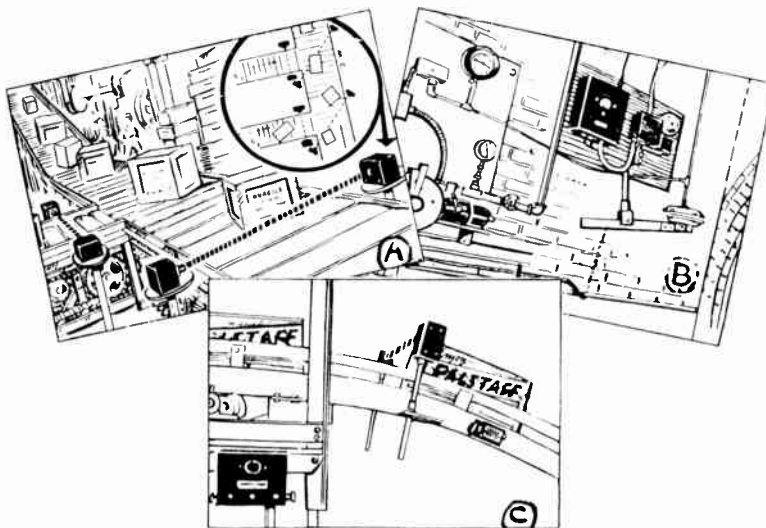

Courtesy Warner Products Corp.

Figure 307. The control of conveyors can be easily accomplished with photo-cell equipment. Illustration A. Boxes of all sizes may be sorted. In B, you have a view of an installation controlling a furnace to give proper combustion. Packages on a conveyor belt may be easily counted with photo-cell equipment, as illustrated in C.

**PRACTICAL INSTALLATIONS.** Let us consider a few exact uses for photo-cell equipment. A simple photo-cell unit may be used to turn on lights at dusk and possibly turn these lights off after day-break. Since sundown-time changes each day, this type of installation will insure correct time for switching on the lights and will prevent waste of electric power.

When improper combustion occurs, excessive smoke is present. By placing a photo-cell relay unit and a light source facing each other inside the chimney, excessive smoke will be instantly detected,

\*When the negative potential exists at this point (during each half cycle in A.C. operation), the unit is not operating and the condenser across the relay acts as the time delay.

## CIRCUIT EXPLANATION

Observe that the 1,500 ohm potentiometer and the 500 ohm resistor are connected in series across the 110 volt line. The photo-cell and 20 megohm resistor are also connected across the line. For any one light condition, the photo-cell will have a definite *resistance* and the line voltage will furnish some value of potential at the junction connected to the control grid of the 25A6. The setting of the 1,500 ohm potentiometer permits the adjustment of the potential on the cathode to be higher or lower than this grid voltage. In this manner, a condition (grid voltage) for proper operation can be selected to meet the requirements imposed by the light falling on the photo tube.

Two or more photo-cell units may be so connected that certain operation occurs only if both are energized in a certain order.

It is important for you to understand that a photo-cell unit may be used to sound an alarm, count, permit or prevent an operation, start or stop an action, measure light intensity, indicate color, and that all of these operations really are nothing more than the control of electric circuits which may perform these operations.

## PHOTO-CELL APPLICATIONS

Color or shape of boxes may also be used as the factor for operating the sorting equipment.

and associated electrically operated equipment can carry out the adjustment of the furnace controls.

Sorting of various size boxes can be easily accomplished. The smaller boxes may not interrupt the light beam, while the larger boxes will. Counting of items which pass in front of the equipment is carried out in the manner illustrated. The relay operates an electric counter in such applications.

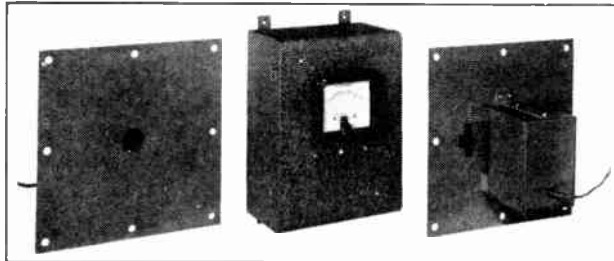

*Courtesy Warner Products Corp.*

Figure 308. These three units make up the equipment needed to supervise and control combustion. The light source, shown at the left, and the photo-cell at the right, may be mounted in the chimney, while the control cabinet is placed near the furnace to be controlled.

Another application exists in a restaurant which has several tables placed near the wall. A narrow beam of light is projected parallel with the wall about 30 inches above the table tops. At the opposite end, the beam strikes the lens of a photo-cell unit. Any person sitting at one of these tables can interrupt the beam of light by merely raising his hand. This can cause an alarm bulb to flash and inform the waiter that he is wanted at one of the tables.

In connection with printing presses, photo-electric equipment is used to assure proper register; i.e., proper position of the different colors on the printed page. The machinery will be stopped automatically and an alarm will sound if the register is not correct.

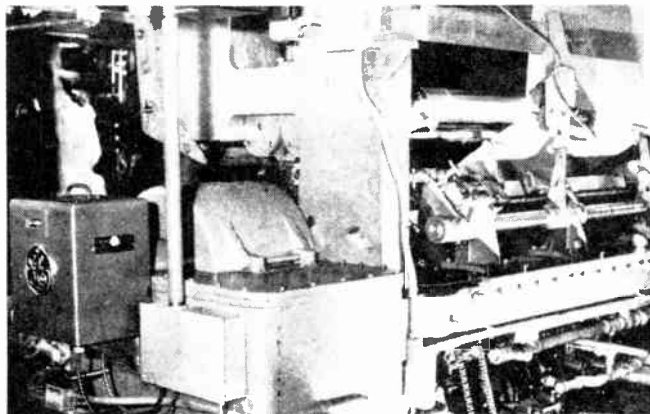

*Courtesy "Radio News" Magazine*

Figure 309. Photo-electric color register control for multi-color gravure press. View of drive side, showing complete color-unit equipment.

When infra-red light source is used, a photo-cell is selected which has high sensitivity to the wavelength of this light.

During the War period, photo-cell equipment can be used for anti-sabotage purposes. The system can be made to fit any requirement and provides fullproof protection which cannot be bribed. Usually the light source provides a beam of invisible infra-red light, projected towards the photo-cell unit. When this light beam is interrupted, the relay of the photo-cell unit is actuated and, in turn, operates an alarm. The alarm may consist of bells, lights, or sirens, and may be local or may be connected directly to the police headquarters.



**TECHNICAL CONSIDERATIONS.** You must bear in mind that the distance covered by any photo-cell installation depends upon the power of the light source, the sensitivity of the relay, and the light conditions present. At all times, in a darker place, a given amount of light and a definite type of photo-cell unit will operate over a much longer distance. The presence of stray light or a strong nearby illumination will considerably decrease the sensitivity of the equipment.

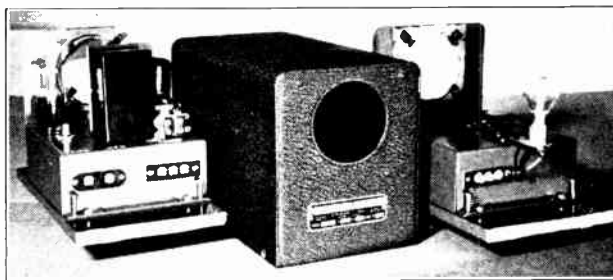

*Courtesy Worner Products Corp.*

Figure 310. The light source and photo-cell amplifier are shown outside of the weatherproof case. This system is designed especially to serve as a guard and protect life and property against sabotage.

Several interesting photo-cell installation lay-outs are illustrated in this lesson. These examples will help you understand the application of photo-cell equipment and design other installations for some special requirements. Notice that the light can be directed at the photo-cell unit, or it can be reflected at several angles with the aid of mirrors. The angle formed by the beam of light striking the mirror and by the beam being reflected, should never be greater than 90 degrees for good results.

A lens is employed at the light source to concentrate the light from the bulb into a straight beam. The bulb may be an automobile headlight type since it has a suitable small filament. Another lens may be used with the photo-cell to collect the incoming light and focus it on the cathode surface of the cell.

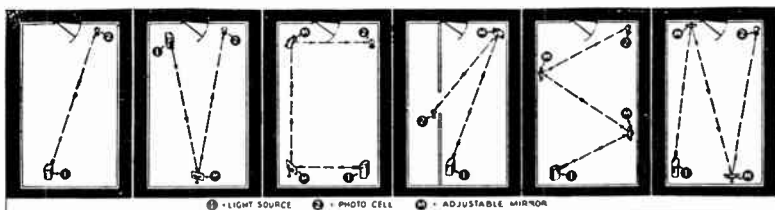

Figure 311. Suggestive installations using a single light source and photo-cell unit. With the aid of mirrors the path of the light can be controlled.

**HINTS FOR SERVICING UNITS.** As a simple test, place any suitable light source near the photo-cell relay unit, and turn the sensitivity adjustment until the relay just *clicks*. Now *back-up* with the control until the relay is returned to its natural position. The removal of light, or even a decrease of the light intensity, should immediately cause the relay to click again. This test, of course, is performed on the type of unit which has its circuit designed to close the relay with a *decrease* of light. For photo-cell units which close the circuit with an increase of light, the same test should be performed in darkness, whereupon flashing a light on the photo-cell will cause operation.

## INSTALLATION SUGGESTIONS

Stray light may be eliminated or reduced with a suitable visor or shield.

The reflecting mirror should be placed in a position where stray light will not be reflected.

The usual photo-cell unit uses such a simple circuit that you will be able to trace it out in a matter of minutes. By following the service suggestions given, we are confident you will be able to repair successfully any faulty photo-cell device.

**Volume 3 - Page 183**

## UNUSUAL APPLICATIONS



*Courtesy Central Scientific Company*

Interior view of the *Photometer* showing the sensitive microammeter with lamp for illuminating its scale. The adjustment for precise setting of the meter pointer is on the right-hand panel of the housing. The photo-cell is located within the holder which is held in place under pressure of the springs on its support rods.

If too much light change is needed to cause the operation to take place, probably the difficulty lies in the photo-cell or the amplifying tube employed, and these should be replaced as the first test. If no operation at all is obtained, the power is not coming from the line; or some resistor or other associated part of the circuit is at fault. Since only one or two resistors and one or two condensers are employed in the usual circuit, these can be easily checked or replaced for testing purposes.

**PHOTO-ELECTRIC PYROMETER.** The photo-electric pyrometer is employed for indicating, recording, and controlling associated apparatus, in the process of working on hot incandescent bodies. The radiant energy from a hot body (molted metal, hot steel bars, etc.) is directed to the photo-cell of the device and causes it to pass current which bears a definite relationship to the temperature of the hot body. This current is amplified by a stable vacuum tube amplifier and the amplified current, in turn, is passed through the indicating or recording instrument, or is used to control and adjust associated equipment.

**PHOTOMETRY APPLICATIONS.** A *photometer* evaluates the concentration of a solution by the deflection of the pointer of a sensitive meter; the amount of deflection depends upon the light transmittancy of the solution under test. By a comparison to standard records valuable chemical tests can be quickly made. A suitable photo-cell, of course, is used in this practical scientific tool.



*Courtesy Central Scientific Company*

Figure 312. Photo-cells find many unusual applications. The photograph shows a chemist preparing a *Photometer* for chemical solution analysis.

**REVIEW QUESTIONS AND PROBLEMS.** 1. Can you name several additional applications of photo-cell equipment not mentioned in the text of the lesson?

2. Can a photo-cell, sensitive relay, and a suitable battery be connected in series to serve as a photo-cell unit? Would this circuit have serious limitations? How about advantages?

3. How can stray light be kept away from the photo-cell?

4. Name a few possible faults which could develop in a photo-cell unit.

# LESSON 22

## Radio Compass

**PURPOSE OF A RADIO COMPASS.** The position of a ship equipped with a radio compass can be determined. The exact location of a nearby radio station (preferably two stations) must be known and a scale map of the waters in which the ship is located must be available. The radio compass will permit the calculation of the distance from the ship to any shore point and will also permit the checking of the regular magnetic compass.

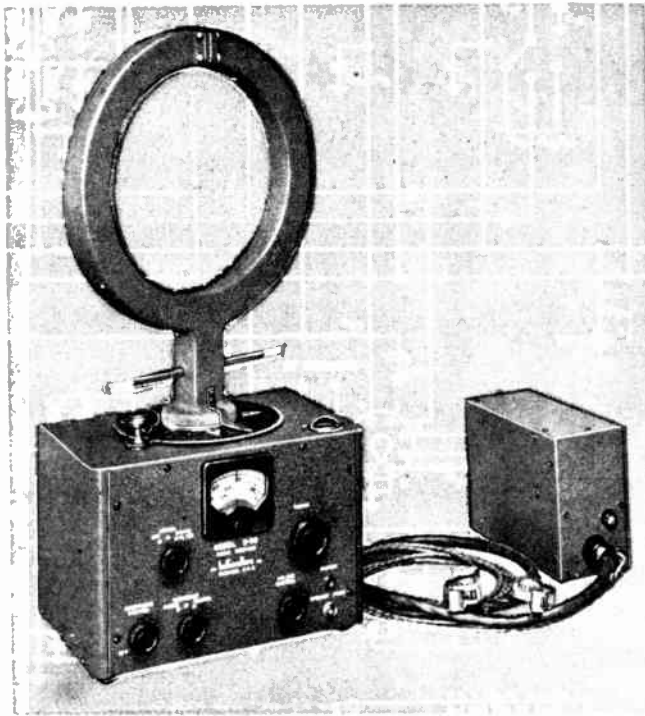

Figure 328. A radio compass receiver and power supply. The use of this radio compass will permit the operator to determine the exact position of the ship on which the compass is installed.

**RADIO COMPASS RECEIVER.** Essentially, the *Hallicrafters* model S-30 radio compass is a sensitive receiver using a loop antenna. The loop antenna may be rotated and its position (azimuth) is indicated by a pointer on a calibrated dial. The signals from any one station will be maximum when the loop is parallel to or pointing at the station. In using the compass, usually the loop is adjusted for minimum signal or *null* point and is then at right angles to the parallel line to the station. The null or minimum signal point can be detected in the headphones and also on the tuning eye indicator.

The use of the radio compass is intended for approximately determining the position of a ship in waters near shore.

If you have a loop antenna portable radio, observe the effects on the operation as the radio is rotated. The variation in volume would be more noticeable if no AVC action were present.

**Volume 3 – Page 185**

## USING THE RADIO COMPASS

Special converters may be obtained.

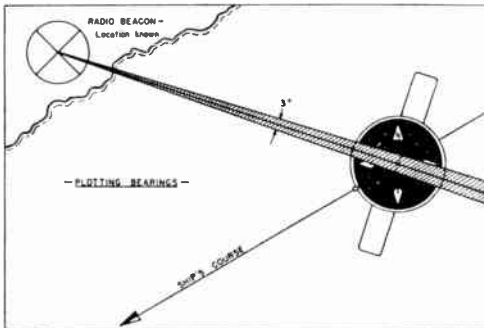

Figure 329. This illustration shows the method for plotting the ship's bearing. The ship is located somewhere within the 3° cone.

It is possible to find one's position even if only a single known radio station can be received. The bearing is taken at short intervals of time (and distance) apart. The magnetic compass will give your direction of travel during the test period. The angle between the line of the station and the line of travel can be obtained from each of the two bearings. If the distance of travel can be approximated, the new position can be obtained by solving a simple problem in trigonometry.

The receiver covers the following frequencies in three ranges:  
*Beacon Band*, 220 to 540 KC.  
*Broadcast Band*, 535 to 1,340 KC.  
*Marine Band*, 1,200 to 3,000 KC.

The unit is supplied with a power supply for operation from a 6 volt storage battery.

**INSTALLATION SUGGESTIONS.** The radio compass should be mounted on a separate bulkhead. The rose of the loop should be well below the eye level and sufficient head room should be available for 360° rotation of the loop itself. In selecting the location for the radio compass remember that it should be as close as possible to the regular compass and chart table. Do not mount the radio compass close to wiring, pipes, or metal objects which would distort the field of the received signal and seriously affect the accuracy of the results.

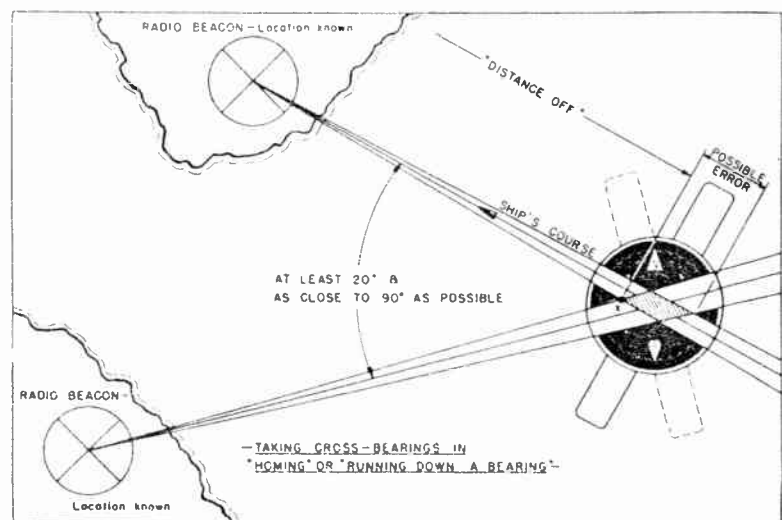

Figure 329-A. A chart showing the method for obtaining the cross-bearing. The possible error area is also shown.

**GETTING YOUR BEARING.** There are several ways for finding the ship location, but we will describe the one most often used and which requires the known positions of two radio stations. The positions of the stations are marked on a map you may be using. A bearing is taken for one of the stations and a cone (3° wide) is drawn at the angle indicated by the radio compass in relationship with the magnetic compass. Then a similar bearing is taken for the second station. The intersection of these cones determines the position of the ship.

**REVIEW QUESTIONS AND PROBLEMS.** 1. What makes up a radio compass?

2. What accessories are needed to use the radio compass?

3. Obtain an *automobile* map of a single state which includes a part of a large lake or an ocean coast line. Guess the probable location of two or more radio stations. By assuming that you obtain certain readings on a radio compass, locate your ship. Select angle values which will permit the ship to be somewhere in the nearby waters.

# LESSON 23

## High Frequency Heating

**BASIC PRINCIPLES.** Energy cannot be created or destroyed, but it can be changed in form. The changing of the form of energy is essential for its economical transmission or for proper application. Many industrial problems can be overcome by applying heat to substances with the aid of high frequency generators. Heat can be induced in metallic and non-metallic materials from an associated radio transmitter. Proper coupling must be made for magnetic or dielectric transmission of energy from the high frequency generator to the substance to be heated. The generator must be easily controlled, but the exact frequency produced and slight drift are not important and simple self-rectifying self-excited oscillators are used. The main advantages of high frequency heating lie in uniform distribution of heat within the substance and the relative coolness of the nearby surroundings.

**GENERATING EQUIPMENT.** The high frequency oscillators used to generate the power needed are available commercially in sizes from a few watts to about 600 kilowatts. The basic circuit of the generator is shown in the diagram. You will notice that this is a push-pull self-excited oscillator circuit with separate rectifiers to convert the stepped-up high voltage 60 cycle A.C. to D.C. This circuit shows the main elements and is not to be considered as complete.

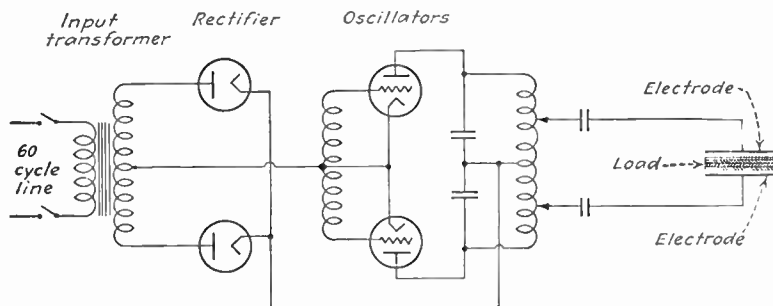

The values of the inductance and capacity are selected to give the proper frequency for the application at hand. Correction may be incorporated in the design for the effects of the load. The circuit shows the dielectric method for applying energy to non-metallic materials. Specially shaped coils, or perhaps the actual inductance of the unit, are used for delivering the energy to metallic substances.

Since the output high frequency wave-form and stability are not important in applying high frequency heating, some commercial generators use spark-gap oscillators.

For heating dielectrics (non-metallic substances) there is considerable advantage in using very high frequencies. Higher frequencies usually produce lower voltages across a given space of the dielectric and permit greater concentration of power. However, the efficiency of the generating equipment falls off as the frequency is increased and the actual choice of the operating frequency is a compromise. Practical experience has shown that frequencies in the five to fifteen megacycle range can be generated economically for



Photograph courtesy of RCA

Figure 334. To attach together sheet thermoplastics and thermoplastic coated fabrics, RCA has developed the electronic "sewing" machine. This modern machine uses high frequency heat to solve another industrial problem.

Figure 335. The basic circuit of an electronic R.F. generator suitable for producing the power needed for high frequency heating.

Reprinted through the courtesy of "Chemical & Metallurgical Engineering" and The Girdler Corp.

The hardening and annealing of steel, drying of glue in ply-wood, and setting of certain plastics are a few industrial applications.

Less power output is obtained from the same transmitter as the frequency is increased.

**Volume 3 - Page 187**

## APPLICATIONS OF H-F HEATING

You can read more about *heat* in any elementary book on Physics.

Figure 336. A pictorial view of the essential components which make up a high frequency generator used for drying ply-wood.

Reprinted from "Aviation" with permission of The Girdler Corp., Thermex Division

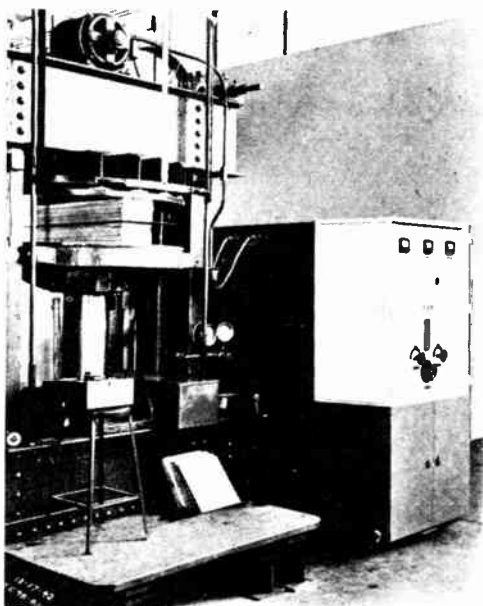
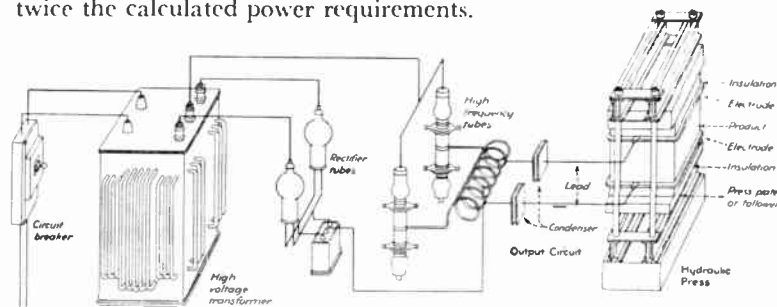

Figure 337. A view of a press and a high frequency generator which is manufactured by The Girdler Corporation. The photograph shows high frequency heat being used to cure glue joints in two 4½ inch wood blocks.

such applications. Units built for producing heat in metallic objects are operated in the 100 to 300 KC. range.

**PHYSICS OF HEAT.** Heat energy is measured in B.T.U.'s. Electrical energy is measured in watts, or in kilowatts, per period of time. One kilowatt hour (1,000 watts applied for one hour) is equal to 3,413 B.T.U.'s. In order to determine the requirements for high frequency heating, it is necessary to know the weight, specific heat\* of the substance, and the temperature rise needed. With this information it is possible to calculate the B.T.U.'s required for the task, and by converting this to kilowatts understand how large a high frequency generator will be needed. Efficiency of 50% may be assumed, and this means that the equipment needed must be rated at twice the calculated power requirements.



**APPLICATION TO NON-METALLIC SUBSTANCES.** Most often the object of using high frequency heating of non-metallic materials is to (1) heat materials uniformly and at a rapid rate or (2) to bring about chemical reactions. Practically all non-metallic items can be rapidly and uniformly heated with high frequencies. During War-time, high frequency heating is especially important in speeding the production of ply-wood which is used for certain types of boats and airplanes. High frequency dielectric heating can be applied to reduce the drying time of paper, textiles, powders, ceramics, and tobacco. This type of heating is essential in the manufacture of certain type of plastics. Thick sections of rubber can be speedily cured, or rapidly softened for masticating purposes with high frequency heating. The heat generated with the aid of high frequency equipment can be used to destroy infestation in grain and cereal without harming the products.

**APPLICATION TO METALLIC SUBSTANCES.** High frequency heating has been applied to ferrous and non-ferrous metals for hardening, annealing, melting, brazing, soldering, bombarding, and coating. The section of the metal object to be heated is placed within copper tubing, made in the form of a coil large enough to surround the section under treatment. The heat energy is induced only in the area lying within the turns of the *work coil* (as this inductance is called), and the effect is so instantaneous that it is a relatively simple matter to apply the coil or connected coils to one section or single part, or simultaneously to two or more sections and to heat those sections in a manner that will produce no distortion or structural changes in other sections of the heated part. By connecting a group of suitable coils in series, many similar items can be treated at one time, thereby speeding up production.

\*Specific heat is the number of B.T.U.'s required to raise one pound of a material 1 degree F. Water is used as a standard and is assigned the specific heat of 1. That is, it requires 1 B.T.U. to raise 1 pound of water 1 degree F. (at about 64° F.). For example, most wood products at normal moisture content have an average specific heat of .45.

# LESSON 24

## Electronic Shaping Circuits

**PURPOSE OF SHAPING CIRCUITS.** Electronic shaping circuits change the shape of current and voltage waves with the aid of vacuum tubes. For example, the appearance of a sine wave before and after shaping is shown below. These circuits and their effects are essential in television and radar work, and are also used in many industrial electronic devices. In television work for example, these circuits are used in blanking and synchronizing.

You already have learned that radio circuits are a combination of resistors, coils, condensers, and vacuum tubes. This is true, also, of course, for electronic shaping circuits. Therefore, since you have a thorough understanding of the action of these basic units, you need only find out how these components behave in combination with each other to form various shaping circuits.

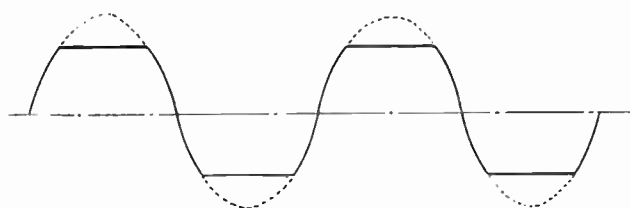

Figure 338. A graph of a sine wave showing the effect of clipping the upper and lower peaks.

**CLIPPER CIRCUITS.** Usually, clippers are used in forming square waves out of sine waves which, in turn, are produced with a regular oscillator. The result of this process was illustrated above. Recall the explanation of a sine wave as given on page 49, Volume I. The sine wave may start at a minimum value of intensity, rise smoothly to a maximum in one direction, fall back to a minimum, then the polarity is reversed and the action is repeated. Examine the drawing of a sine wave. Notice that the maximum and minimum values occur at single specified instants of time. The entire variation is smooth — there are no abrupt changes or discontinuities.

We can change the shape of this sine wave by cutting off the extreme top and bottom parts. With this change, the maximum and minimum values will no longer occur at a single instant of time, but will now occur over a longer period of time. The wave is no longer smooth — abrupt changes in values have been introduced, and we call this new type of wave a modified *square wave*. The square wave has important electronic applications because many shaping circuits depend for their operation on abrupt changes which are present in the square wave.

**DIFFERENTIATOR CIRCUIT.** The differentiator is a circuit producing a voltage or current proportional to the *speed* with which the applied wave changes in value. This circuit is used primarily to obtain narrow pulses (pulses of very short time duration) from broad pulses.

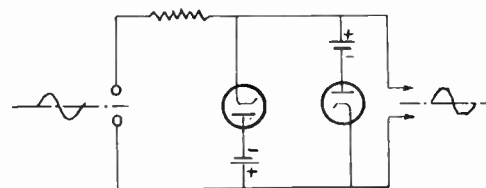

Figure 339.

This is a basic clipper circuit using two diodes. In commercial circuits no separate batteries are used, but the circuit is so arranged that the correct polarities are obtained from a single power supply.

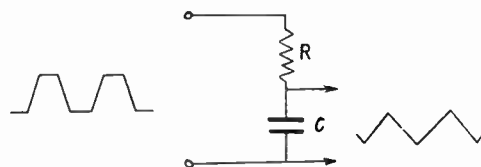
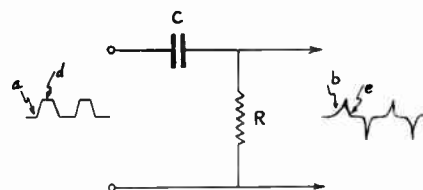

Figure 340.

A basic differentiator circuit is shown above; an integrator circuit is below it.

# LESSON 25

## Aircraft Direction Finders and Beacons

**NEED FOR GUIDANCE IN FLIGHT.** In order to travel between two points, sign posts, a trail, or familiarity with the terrain is essential. These factors are not present in flight, and the science of *avigation* depends on radio equipment to supply artificially these signs and directions. The road is created for the pilot by using the radio range or beacon system. Even with a road to travel, confusion can exist unless there is a means for identifying the passing localities. Radio *markers* are indicated on maps used by pilots and are found with radio equipment. Further, by using a direction finder, a pilot can take his bearing and determine his location. This is a great aid in taking detours out of storm areas, checking progress toward the destination, or being able to return to the range (beacon) after leaving it for some reason. Radio equipment is also used to determine the height of the plane above ground and for landing under adverse conditions.

A review of Lesson 22, dealing with the radio compass, will help you in understanding this material.

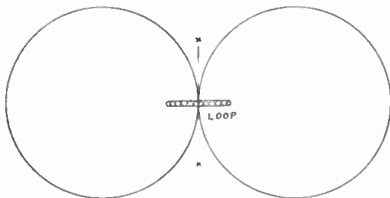

Radiation pattern from a compact loop antenna. To fix the idea in your mind, stand a coin on its edge directly above the view of the loop. Assume the coin is the loop antenna. If the page of the book is held flat, the figure-eight radiation extends away from all edges of the coin; in the directions shown and also to the top, bottom, and at all angles.

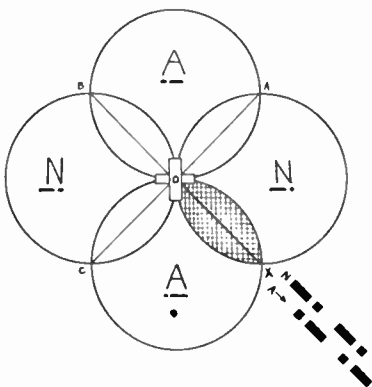

Radiation pattern from a beacon station. You must understand that either the code of letter *A* or letter *N* predominates in various areas, but these are of equal intensity along the lines marked *OX*, *OA*, *OB*, and *OC*.

**RADIO BEACON SYSTEM.** A loop antenna has highly directional characteristics. The radiation is in the form of figure eight, with each circular lobe extending in the opposite direction and in the direction of a line drawn through two opposite sides of the loop (see the figure). If two such loop antennas are placed very close together but at right angles, the field strength pattern illustrated results. In the line marked *OX*, single lobes of each loop antenna deliver equal signal. There are four such lines to any one radiating system of this type; lines *OA*, *OB*, and *OC*. If one loop antenna is connected to a transmitter which automatically sends letter *A* ( - — in code), while the second antenna serves a transmitter which send out letter *N* ( — - in code), one or the other code letter will be heard if the plane is in the area predominantly under the influence of *one* lobe only. The code letters *A* and *N* are synchronized, so that the dot of one letter fits into the space between the dot and dash of the letter from the second loop. The dash of each *N* occurs during the time the blank space is present at the end of one *A* and beginning of another *A*. And similarly, for the dash of each *A*.

You can readily see that if a pilot is flying on the course (line *OX*) he will receive the letter *A* and *N* equally well, these will *fit* together, and no aural response will be received. But if the plane deviate from the beacon, either the letter *A* or the letter *N* will be heard, and this will tell the pilot in which direction he has moved off the range. The intensity of the aural signal suggests the distance off the beacon path.

The radio beacon system in the United States operates on frequencies in the range from 200 to 400 KC. The stations are spaced at distances of about 200 miles. The *A* and *N* signals are sent for about 30 seconds, then there is an interruption followed by a code signal sent first from the *N* loop, then from the *A* loop. The code signal is used to identify the station being received. By referring to a map, the pilot knows what station is serving him and at what point to tune in the next beacon station in his line of travel.



# LESSON 26

## Electron Microscope

**NEED FOR HIGHER MAGNIFYING POWER.** In the 17th century, lenses were arranged to serve as the first microscope. The science of medicine was revolutionized when it was discovered that many diseases were caused by bacteria which could be seen under the microscope but whose existence has not been suspected previously. As the regular type of microscope became more generally used, it became apparent that there were many things too small to be seen even with the finest instruments. We now know that this limitation is not due to the lack of skill on the part of the designer but to the very nature of light. *Resolving power* is a technical word for the power of being able to discriminate between two very small objects which are close together. Besides other technical factors, resolving power depends on the wavelength of the light used for observation. Since ultra-violet light is of a smaller wavelength than visible light, it has been used for photographic specimens not to be seen with ordinary visible light. Under the most favorable conditions, the discrimination of objects separated by less than 0.1 micron (a micron is about 1/25,000 of an inch) is not possible. This corresponds to magnification of about 3,000 diameters.

The seriousness of this limitation was evident to the bacteriologist who realized that many tiny and unseen particles were the cause of many ailments. In the industrial fields, certain limitations on the study of colloids and finely divided particles were also present. The use of X-rays permitted the photographing of somewhat smaller objects, but the need was for visual observations of objects requiring direct magnification of 10,000 to 30,000 diameters. Such magnification was made possible with the electron microscope and photographic enlargements can be used to increase the magnification to a total of 200,000 times life-size.

**ELECTRON OPTICS.** There is a close analogy in the behavior of light and electrons. The main similarity, of importance to us, lies in the action of lenses on light as compared to electric fields influencing the motion of electron streams. Electron optics are used in all cathode ray tubes to fashion a pencil of electrons from the wide stream emitted from the cathode gun. The science of electron optics has made possible the electron microscope. In an electron microscope we are able to make highly magnified images with such an electron optical system by combining two or more electronic "lenses." The great advantage of such a microscope lies in the fact that we are no longer limited by the wavelength of visible light. Under the application of 100,000 volts, the wavelength action of an electron is only 1/100,000th of the wavelength of visible light. The present instruments have permitted examination of such tiny particles as the tobacco mosaic virus which is rod-shaped and is about 1/100,000th an inch long.

**DESCRIPTION OF THE RCA ELECTRON MICROSCOPE.\*** A high power electron microscope for observation by transmission is con-

\*This description is reprinted in part from "Electron Microscope," a booklet issued by RCA Manufacturing Co., Inc.

The electron microscope is an outstanding achievement in the field of electronics. The operating principles of the electron microscope are similar to some of the functions of a cathode ray tube described in Lesson 19.

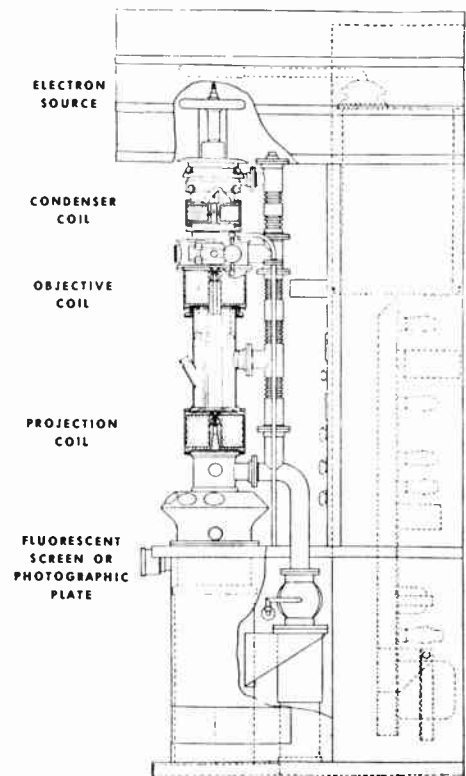

Figure 353.  
Simplified drawing showing the construction of the electron microscope.

## MAGNIFICATION OBTAINED



Figure 359. A complete view of an RCA electron microscope in application. Notice the six observation windows.

These windows are visible in the photograph above.

constructed with the same types of essential elements as a light microscope. Light microscopes consist of a light source (often separate from the microscope, but built into one unit on modern instruments); a condenser lens which concentrates the light beam on the specimen; a stage, with an adjusting motion; and an eyepiece for visual observation or a projection lens for recording on a photographic plate. A similar nomenclature is used to define the different elements of an electron microscope, the only difference being that every *light* element is replaced by a corresponding *electronic* element. Thus the light source becomes an electron source; and lenses become suitably shaped fields. Elements like the stage appear quite different because of the necessity for operating in vacuum. This is easy to understand since electrons can travel without hindrance only in a vacuum and their paths are altered by any material object and, therefore, the usual glass slides of light microscopes cannot be used.

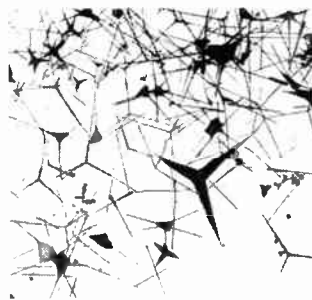

Figure 358. An electron "photograph" or micrograph of zinc oxide smoke magnified about 22,000 diameters.

Its manipulation differs somewhat from that of a light microscope. In the light microscope we have a fixed optical system which can be moved up and down, and focusing is done by changing the position of the specimen with respect to the lenses. In the electron microscope, we have constant distances and the lens power is varied. This can be done because the lenses are created, in the case of magnetic optics, by a current flowing through a coil.

The RCA electron microscope is a very compact, self-contained instrument. The electron source is operated at voltages between 30,000 and 60,000, and, to provide ample protection of the operator from the high voltage and X-rays, is enclosed in a lead encased upper hood. The electron beam coming from this source is concentrated on the specimen by the field produced in the condenser lens coil. The specimen, which is supported on a very thin nitrocellulose membrane suspended across the opening of a fine mesh screen, is clamped in the tip of a cartridge very close to the second field lens produced in the objective coil. A plate which supports the specimen cartridge constitutes the movable stage. The specimen motion is transmitted to this plate from the exterior of the evacuated system by means of fine screws and metal flexible bellows. The electrons, after passing through the specimen, are focused by the object lens coil into an intermediate image and the projection lens coil produces a further magnified image on the large fluorescent screen in the final viewing chamber. Six observation windows, which are placed to allow binocular vision for careful observation, enable a number of spectators to view the image simultaneously. After a selected field of view is focused, and the magnification adjusted to the desired value, a photographic record may be made by merely removing the fluorescent screen and allowing the electron image to strike a photographic plate, which is carried in a holder in the vacuum, immediately below the screen.

# LESSON 27

## Electric Strain Gages\*

**PURPOSE AND FUNCTION.** The usual electric strain gage is fundamentally an A.C. bridge circuit in which one or more impedance branches are acted upon by the quantity to be measured. The calibrated amount of bridge unbalance is indicated on an instrument which may be remotely installed at any convenient location. Electronic tubes are used to amplify the sensitivity of the equipment and to stabilize input voltage.

With some exceptions, reactance-type gage elements serve as the active bridge members. Whenever their application is possible, gage elements of this type are preferred over elements of other types because of their relatively low inherent impedance, large useful range, good stability, and immunity to electrostatic and magnetic interference effects.

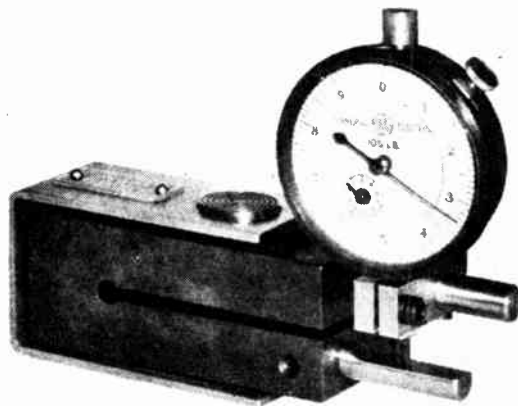

*Courtesy General Electric Co.*

Figure 360. A view of an electronic gage employed for indicating the pressure between the electrodes of a welding machine. This gage will indicate forces applied to the pressure pads up to 4,500 lbs., with each small division representing 10 lbs.

**DESIGN AND SENSITIVITY.** In its simplest form an active electromagnetic impedance element consists, for example, of a U-shaped iron yoke and an iron armature placed near the open ends of the U, leaving small air gaps. A coil is placed on the iron yoke and is connected in the A.C. bridge circuit. It is evident that when the air gap between the iron yoke and the armature decreases, the reactance of the coil increases. In this case, the bridge output is a function of the armature displacement and may therefore be calibrated in terms of this displacement.

An arrangement of this type may be made exceedingly sensitive, depending on the initial air-gap setting. Assuming, for example, that the initial air-gap setting is 0.002 in., closing the gap by 0.001

\*This lesson is reprinted from an article by H. P. Kuehni of the *General Electric Co.* whose permission was obtained for this purpose.

A bridge circuit consists of four reactive or resistance arms of suitable values to produce zero voltage across an indicating device. Usually, one or more arms of the bridge may be adjusted to produce the needed balance. The impedance of one arm is varied under stress and, in this manner, the variation produces a voltage change.

The indicating instrument may be calibrated in suitable units—pounds of pressure in this case.

See the figure on the next page.

## GAGE APPLICATIONS

The meter calibration changes somewhat for different temperatures.

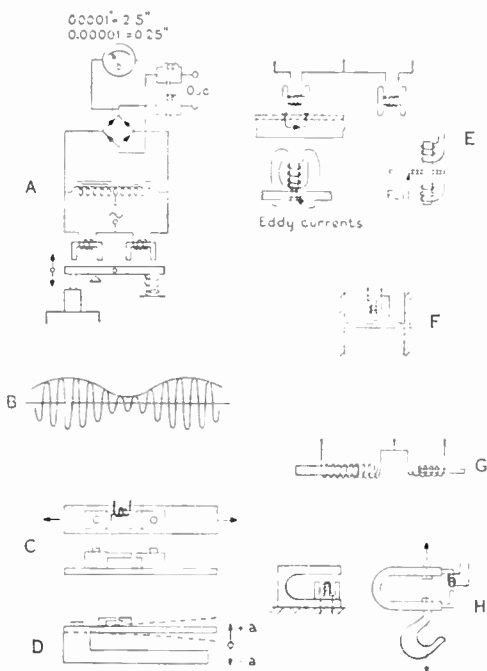

Courtesy General Electric Co.

Figure 362. Schematic representations of electric gage circuit applications. (A) one of a variety of electric gage bridge circuits. (B) a representation of the fundamental frequency employed and its modulation by variations in the quantity being measured. (A) and (C) to (H) are representations of several different applications of the electric gage; (A) comparator; (C) strain; (D) acceleration; (E) thickness; (F) pressure; (G) displacement; (H) weight.

in. will produce approximately a 100 per cent reactance change and a correspondingly large bridge circuit output. While the sensitivity may be increased much further by simply reducing the initial air gap, practical limits are reached because of temperature expansions of the gage members and of the parts to be gaged. In general, reliable readings of one hundred-thousandth inch are obtainable; and under carefully controlled conditions armature displacements as small as one millionth inch may be read.

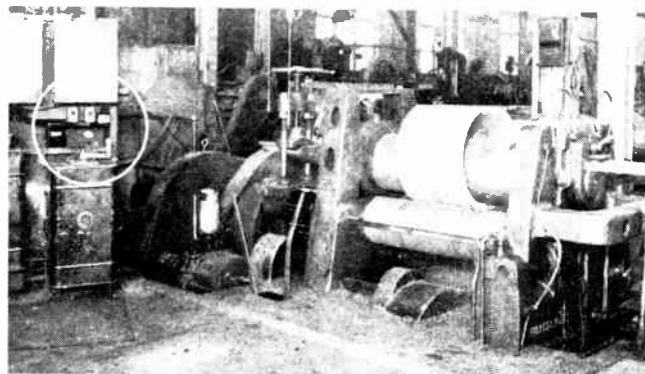

Courtesy "Radio News" Magazine

Figure 361. A bending roll machine equipped with electromagnetic strain gage as shown within the circle. The equipment is adjusted to give an alarm when the machine is overloaded.

**TYPES AND APPLICATION.** In the foregoing example, a reactance change was obtained by varying the air gap in a magnetic circuit. As far as the bridge circuit is concerned, it is immaterial how the coil reactance or impedance change comes about. For example, an impedance change may also be obtained by placing in the air gap, which is made large in this case, a sheet of conducting material.

In the figure are shown schematically some representative applications of the electromagnetic gage principle. In this illustration is shown how the principle is applied to comparator, thickness (air-gap and eddy-current types), displacement, pressure, strain, acceleration, and weight gages.

When the quantity to be gaged varies, the alternating output voltage from the bridge circuit also varies accordingly. The fundamental bridge frequency, however, is retained except that it is modulated corresponding to the frequency of the variations. Slow variations can be followed by an indicating instrument, but more rapid variations require the use of a fast-responding recorder or an oscillograph. In order to reproduce the variations faithfully, there must be available a sufficient number of loops of the fundamental frequency for their reproduction. In general, it may be said that the frequency applied to the bridge circuit should be at least four times as high as the frequency of the variations which are to be recorded. Thus, with a bridge excitation of 60 cycles per second, good reproductions may be obtained of variations up to 15 cycles; and with a bridge excitation of 2,000 cycles, variations up to 500 cycles may be recorded.

In another type gage used for the measurement of strain, resistance elements are often used. These elements are cemented on the test members and the resistance of these elements changes slightly (a fraction of one per cent) under strain.

# LESSON 28

## Film-Thickness Gage

**PURPOSE AND APPLICATION.** A film-thickness gage will measure the thickness of vitreous enamel, lacquer, other similar non-magnetic coatings, and silver or copper plating on steel or iron base. Since the exploring element is only held in contact with the surface, no injury results to the coating. The gage may be used also for measuring the thickness of glass, paper, mica, zinc, tin, or other non-magnetic materials which are placed or coated on steel or iron. The measurements may be made on all types of surfaces provided the base is .007 of an inch or more in thickness and is of magnetic material. Extreme curvature of the surface to be tested is to be avoided. Correction charts are supplied for making measurements on high-carbon steel, alloy steel containing nickel or chromium, very thin sheets, or highly irregular and extremely curved surfaces.



*Courtesy General Electric Co.*  
Figure 364. Film-thickness gage complete with probe.

**CIRCUIT AND OPERATION.** The operation of this gage is based also on the principle of the Wheatstone bridge as shown in the figure in the margin. Two arms of the bridge are formed by the iron core reactors. These are balanced against each other to balance the bridge. One of these reactors is incorporated in the case of the gage, while the second reactor is inclosed in the exploring probe. Adjustment is carried out for *zero* thickness with the aid of the potentiometer while the probe is held directly against a bare magnetic material. The magnetic circuit of the reactor in the probe is completed through the magnetic material used as the base. Since the greater part of the reluctance (opposition to magnetic field) of this magnetic circuit is produced by the air gap or the non-magnetic material that separates the gage head or probe from the steel or iron, the indicating meter shows directly the thickness of the non-magnetic material.

The indicating unit is readily adjusted by placing a thickness standard between the gage head and a sheet of steel or iron, which should be of the same grade and thickness as the metal over which the non-magnetic material is placed or coated. The potentiometer controlled by the knob on the front panel is adjusted until the instrument needle indicates the same thickness as that of the standard that is being used.



*Courtesy General Electric Co. and Ford Motor Co.*

Figure 363. Measuring thickness of lacquer on an automobile body.

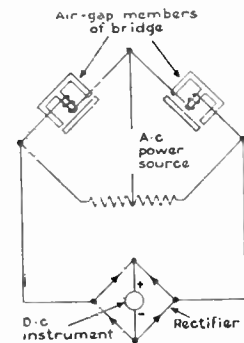

The basic circuit of the *General Electric* film-thickness gage.

# LESSON 29

## Surface Analyzer

In a recent magazine article, Mr. H. S. Kartsher, of the *Brush Development Co.*, defines surface irregularities in the following manner:

**ROUGHNESS**, created by the removal of metal from the surface by production methods such as turning, grinding, or lapping.

**WAVE**, is caused by chatter, non-rigidity of the machining elements, grinding wheel feed, or diamond marks.

**TRUTH**, is the degree of flatness in flat work or roundness in round work. It is the geometric quality of the surface, larger than the first two qualities described.

**FLAWS**, may be caused by handling, scratches from stray grains, etc.

**PATTERN** (also called *lay*), is an indication of the type of operation performed. A circumferential pattern is produced by the ordinary grinding operation.

**APPEARANCE**, takes up the matter of polish, reflectivity, and sand blasting.

The analyzer described in this lesson is used primarily for inspection of roughness as defined above.

**IRREGULARITY OF METAL SURFACES.** Metal surfaces may be finished to various degrees of smoothness and the irregularities present may be of different types. Surface irregularities in the form of waves or bumps are present in machined surfaces. These usually have wavelengths that are shorter than  $\frac{1}{32}$  of an inch, and have peak-to-valley amplitudes in excess of one millionth of an inch (1 micro-inch). In order to meet rigid specifications and to quickly inspect metal surfaces in production, an electronic surface analyzer is employed. This unit employs an analyzer head, a calibrated amplifier, and a direct inking oscillograph which makes a permanent record.

**DESCRIPTION OF THE ANALYZER HEAD.** The analyzer head consists principally of a calibrated crystal type pickup unit housed in a projecting arm, and the drive unit with its stand. The drive unit contains a 110 volt, 60 cycle A.C. synchronous motor which operates a cylindrical cam. This cam imparts a straight line reciprocating (up and back) motion to the pickup arm, about .060 inch long in each direction. This motion is accomplished at a uniform velocity and one complete cycle requires ten seconds.

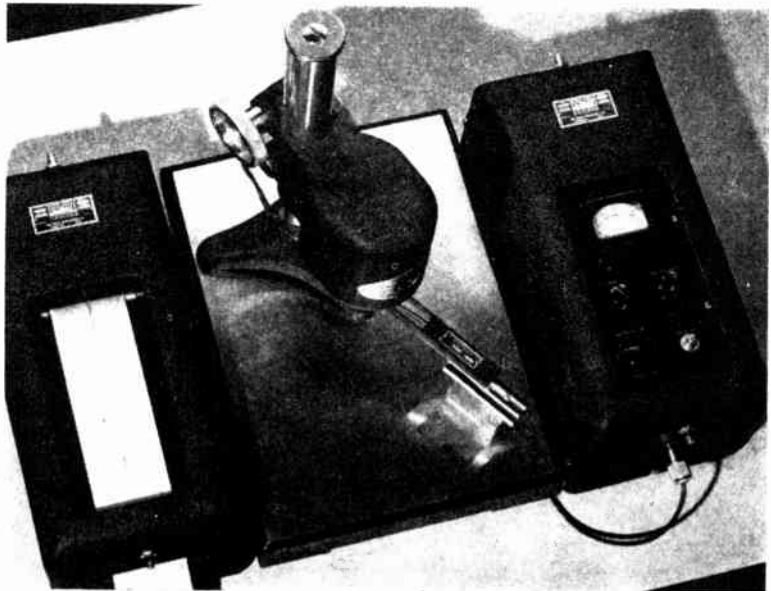

Figure 365. The units which make up a complete surface analyzer. The analyzer head is in the center, with the direct inking recorder at the left and the amplifier at the right.

The pickup arm is pivoted in conical bearings located in the drive unit. This arm is provided with a diamond tracer point having a spherical radius of .0005 inch, which can be used to measure the minute depth irregularities in metals as described above. This point is positioned by a spring and can be adjusted.

**CALIBRATING AMPLIFIER.** A two stage amplifier is employed to supply the necessary gain (magnification) between the pickup and the direct inking oscillograph.

# LESSON 30

## Facsimile Equipment

**PURPOSE AND RESULTS OBTAINED.** The technique of transmitting printed material, drawings, and photographs by means of radio equipment, and to have this material reproduced directly on white paper is the method of facsimile. In order to transmit a view of a printed page or a picture, the object to be transmitted must be sub-divided into elementary areas by the scanning apparatus. This work can be carried out with the aid of a photo-cell and after suitable amplification the dots making up the object to be transmitted may be employed to modulate the carrier of a radio station.

At the receiving station, a suitable facsimile receiver may have its own radio apparatus or may be used in conjunction with a regular broadcast receiver. White paper comes off a roll at a fixed and synchronized speed and, in some units, carbon paper rides just above this white paper. For each dot to be formed, a single point of contact is established by the raised line of the helix on the surface of the roller and the movable bar above the paper and roller, see figure. The pressure is proportional to the *tone* of the corresponding element of the original material being transmitted. With proper synchronization, a complete document, copy of a telegram, a military map, or an entire newspaper (in condensed form) could be transmitted over a period of night hours.

**SCANNING EQUIPMENT AT THE TRANSMITTER.** A unit of the most modern design will be described. The scanning equipment is housed in a metal cabinet and is complete in every detail. The operating power may be obtained from a regular power line and the output from the unit may be fed to a broadcast station by making a connection to a telephone line. The material to be transmitted is mounted on the subject-drum which rotates 75 r.p.m. being driven by a synchronous 60 cycle motor through a set of gears.

The incorporation of a clutch between the motor and the drum carrying the copy permits the changing of the copy without losing the relative frame position. The motor continues to run during this loading operation and a commutator on the spindle shaft supplies an artificial frame-line signal which is transmitted at the required intervals and keeps the recorders (at the receiving stations) in step.

During transmission the scanning head, which contains the optical system and the photo-cell and is mounted behind the subject drum, traverses slowly down the length of the copy. It is driven by a lead screw and suitable gearing from a separate motor and its rate of progress is such that 125 scanning lines are drawn per inch of drum length.

**FACSIMILE BROADCAST RECEIVER.** Since there are always several facsimile recorders to every transmitter, even in experiment work, and there will be thousands, or even millions of facsimile recorder-receivers in the near future when facsimile broadcast transmission will be enlarged, you are primarily interested in such receivers.

Although facsimile equipment has found extensive use in military application and for news transmission, the big future lies in the use of this equipment in the homes for receiving directly *printed* newspapers.

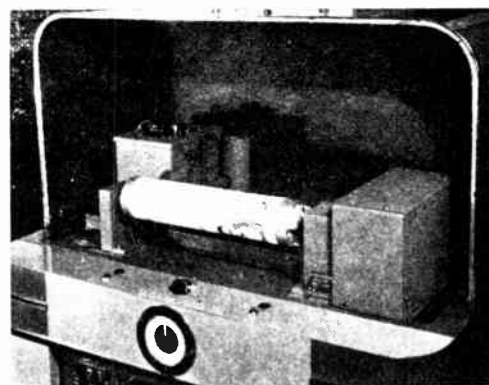

*Courtesy of R.C.A*

Figure 366. A view of the subject-drum and scanning apparatus of a facsimile unit.

Refer to the illustration above.

## FACSIMILE RECORDER

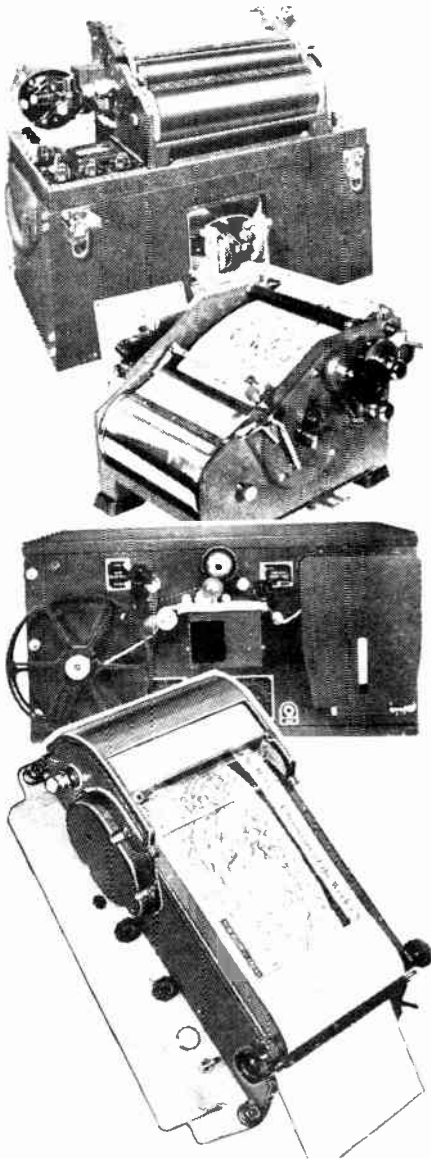

ALDEN PRODUCTS COMPANY

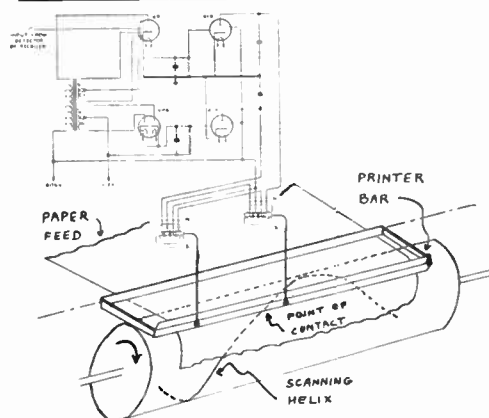

Volume 3 - Page 198

The present day commercial facsimile receivers are complete self-contained machines. They include the needed radio receiver, time switch, and the facsimile unit; thus they require only the connection to an antenna and a source of power. While it is possible to use a regular good-quality broadcast radio for the receiver, certain advantages are offered by the separate receiver. According to the latest plans, the schedules are to be sent out over regular broadcast stations between midnight and six in the morning, a period when most radio channels are idle. The recorders are to be turned on and off by the time switch at the proper hours. If a regular radio is to be used, it has to be adjusted for the right station and connected to the time switch before the owner retires. This is too much to expect from an average person with many things to tax his memory. Also, a special radio chassis designed for facsimile reception can be made more efficient for the purpose on hand.

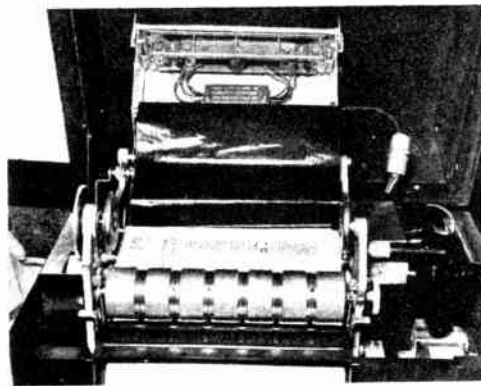

Courtesy of RCA

Figure 367. Inside view of the facsimile recorder. Ordinarily, the cover protects this machinery and the printed paper comes out through the slot in the cabinet.

The facsimile recording machine is mounted in the upper section of the cabinet. The recording drum with the raised helical ridge on its surface rides below the white and carbon papers. The carbon paper is wound up after use on the core at the top; the white paper is fed out from the front of the cabinet by a cylinder like a typewriter roll. The printer bar is movable and presses against the carbon paper to leave an impression on the white paper. The motion of the printer bar is controlled by two electromagnetic drivers.

Whenever a signal for black is received, the printing bar pinches the carbon paper against the white at the point where its edge intersects the single turn raised helix; and, because of the rotation, this intersection point repeatedly scans across the page right in step with the traverse of the light spot across the original at the scanner. With complete synchronization, the dots will organize themselves into a facsimile of the original subject.



# LESSON 31

## Inter-Communicators

**PURPOSE AND APPLICATION.** Inter-communicators permit direct conversation between two or more remote points and employ audio amplifiers which use electronic tubes. Extensive use is made of inter-communicators on bombers and naval vessels. Here, quick direct two-point conversation permits exchange of vital information at an instants notice. In offices and factories, inter-communication systems supplement the telephone, reduce the burden at the switch-board, and eliminate delays and errors caused by the telephone operator. On a moments notice, the manager can ask the shipping clerk about a certain order, a Mr. Brown can be *paged* anywhere in the building, or the president and the manager can have a private conference with the aid of an inter-communication system.

**BASIC INTER-COMMUNICATION PRINCIPLES.** When someone, perhaps 20 years ago, placed the loudspeaker some distance away from the audio amplifier and microphone, the first inter-communicator was born. The loudspeaker could be located in a room different from the one containing the amplifier and *mike*. By using a second system and placing the equipment *in reverse* to the first system, a two way conversation could be carried on. If both systems were left in the operating position, a loud howl would develop because of the electro-acoustic feedback. Means, therefore, were provided for breaking the circuit of each system at some point. The individuals using the equipment controlled these switches as the conversation shifted up and back between the two points.

The realization that a magnetic or a P.M. speaker could serve as a microphone for voice frequencies made a great change in the design of inter-communicators. Assume you have a simple audio amplifier (see the schematic) incorporating a suitable input transformer to match the P.M. voice coil impedance to the *grid* and another transformer in the output to match the 50L6 tube to the

Present day inter-communicators employ wires for connecting the outlying stations. It is possible, of course, to use radio transmission between stations, and one such system was popular some years back.

The volume level of the sound produced by any one speaker, should be controllable at that location.

Analyze the action of this circuit in detail. Study the effects of changing the position of the *talk-listen* switch.

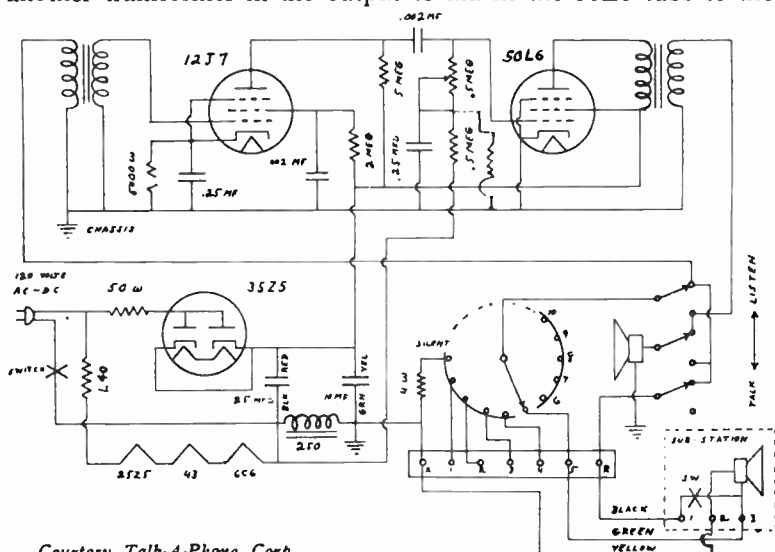

Courtesy Talk-A-Phone Corp.

Figure 370. A schematic diagram of a master station showing the method for connecting one sub-station to the unit.

## TYPES OF SYSTEMS

An ordinary loudspeaker does not make a good *microphone*, but by using special units good results can be obtained with voice frequencies.

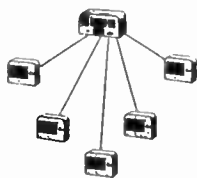

Diagrammatical illustration which shows how a single master is connected to several sub-stations.

Distortion results because of phase shift in long lines. Considerable power is lost in extra long connecting cables.

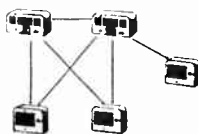
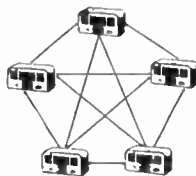

same type of speaker. Also, assume you have two identical P.M. speakers. Call these speakers No. 1, and No. 2. By connecting one speaker to the input of the amplifier, and the other speaker to the output, conversation may proceed from No. 1 *speaker* (used as a mike, at this time) to No. 2 speaker. The No. 1 *speaker* may be in one room with the amplifier, while No. 2 speaker is connected with a long cable and is placed in another room. By employing a suitable switch, the connections of speaker No. 1, and speaker No. 2, could be reversed. Conversation can now originate at *speaker* No. 2 (used as a mike, now), and reproduced from speaker No. 1. The physical position (placement) of the speakers may remain the same. The controlling switch for the speaker-connections is included in the cabinet of the amplifier.

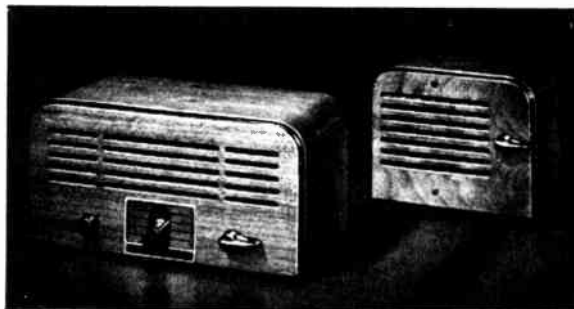

Figure 371. An illustration of a *Talk-A-Phone* intercommunicator showing the master and one sub-station.

**MASTER SELECTIVE SYSTEM.** The natural outgrowth from the basic system described, is the *master selective* system. One amplifier unit with its speaker is still used at one location, but instead of one speaker at some other single point, several speakers are used and each is located at a different desk, or room, or station. In the commercial units, facilities are provided for ten such sub-stations, but any number less than ten can be used. The *Talk-A-Phone* KR-40 system permits private two-way communication between the amplifier (known as Master) station and any of the sub-stations. The master station can call all sub-stations simultaneously if need for this operation arises. The sub-stations can answer and call the master station, but cannot call one another. It is possible to place the units as far as 3,000 feet apart from each other, but shorter distances are recommended. The person operating the master unit, of course, must control the *talk-listen* switch.

**SUPER-SELECTIVE SYSTEM.** A complete system may be made up of master stations only to permit great freedom and versatility of operation. For example, in a system made up of ten such master stations five two-way private conversations can be held simultaneously without interference or cross-talk. Each station can call any other regardless of whether the station being called has the power "on" or not.

**COMBINATION SYSTEMS.** It is possible to combine master stations, sub-stations, and special booster units to serve special requirements. You can readily understand that certain applications may require the master stations to have facilities to call any other master or any sub-station, but the sub-station may not require to originate the calls. Headphones may be incorporated for privacy of conversation. A booster unit is a high power amplifier which is used in connection with a sub-station for louder reproduction and paging.

# LESSON 32

## Sound-Level Meter

**PURPOSE AND RESULTS OBTAINED.** A sound-level meter is used to determine the intensity of sound in certain localities or produced by specific devices. With certain modifications, the same unit may be used to measure vibration of machinery and point to possible improvements in design. In ordinary application, a crystal microphone serves as the pickup and is connected to a portable, specially designed audio amplifier. The sound intensity is indicated on a calibrated decibel meter, but headphones, an oscilloscope, or a recording instrument may also be connected. The results obtained may be made to conform to the sensation-response characteristics of the human ear, or to give equal response to all frequencies. Since the human ear has somewhat different response to sound of different intensity levels, two corrective networks are provided; one for sound levels closest to 40 decibels, and another for very loud sounds around 70 decibels. The sound-level meter is calibrated directly in decibels above the standard reference level of  $10^{-16}$  watts per centimeter. The range of such instruments may be from 24 to 130 decibels, which is sufficient for measuring all sounds commonly encountered — from those scarcely audible to sounds that are painful to the ear.

**CIRCUIT DETAILS.** Essentially, the sound-level meter of the usual type consists of a battery operated high gain audio amplifier capable of substantially uniform amplification throughout the frequency range of 50 to 8,000 cycles per second. Low drain battery tubes are employed and the entire unit with the batteries is housed in a convenient carrying case. The microphone is mounted on an extended arm so that it will not be affected by reflections of sound from the carrying case.

The sound-level meter may be calibrated with the aid of a mouth-blown whistle which is supplied with the unit. This whistle generates a tone of approximately 1,500 cycles of a definite intensity and is easily and quickly applied to the microphone for calibration adjustment.

**APPLICATION METHODS.** For ordinary measurements, since the microphone is non-directional, it is only necessary to place or hold the unit in the location where the measurement is to be made. The microphone may be mounted on a separate stand, if the application requires this action, and connected to the sound-level meter with a suitable shielded cable.

Sound level measurements may be made to determine if a room is too noisy for certain types of work, the effects of acoustical treatment, or the best design for reduction of the noise level. Sound level and vibration measurements are used in industry for improving many devices such as pumps, fans, refrigerators, etc. The reduction of noise and vibration not only reduces the noise level at the place of the installation, but also increases the life of the equipment.

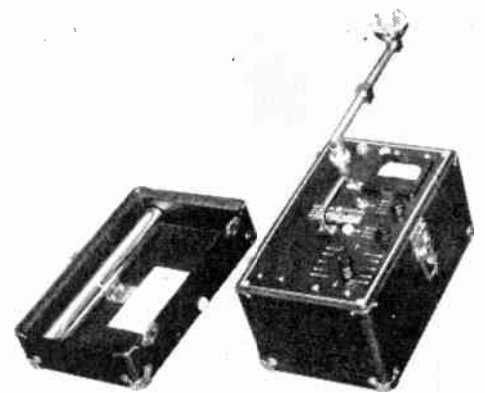

Figure 372. An illustration of a *General Electric* sound-level meter showing the extending microphone support. The calibrating unit is inside of the case cover.



*Courtesy General Electric Co.*  
Figure 373. A sound-level meter being used to measure airplane-cabin noise.

**Volume 3 – Page 201**

# LESSON 33

## Radio Servicing Technique

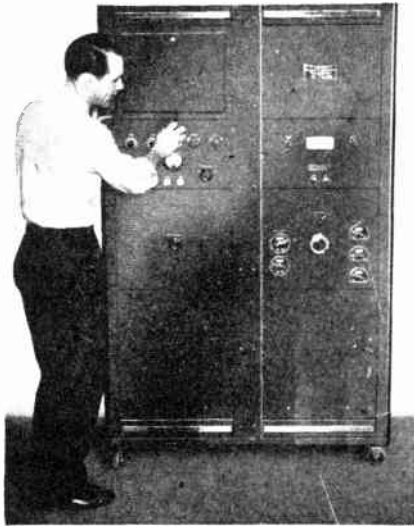

The movable rack assembly illustrated is used electronically to check powder charges used in shells. This equipment was developed by engineers of the *Du-Mont Laboratories*. Radio servicemen may find interesting work building, operating, or repairing such electronic equipment.

On most jobs, it takes a great deal more time to find the fault than to complete the actual repair.

In this section an assumption is made that you will operate your own radio repair shop or store.

**OPPORTUNITIES IN RADIO SERVICING.** As radio receiver circuits became more complex, the high school experimenter, amateur electrician, and the jack-of-all trades who attempted to repair everything, had to resign radio repair work to men who spent time in studying and were prepared for this important work. The additional information presented in this and the next lesson should enable you to repair successfully any radio set which developed a fault. The basic principles you have learned in the earlier lessons will now be applied. You will find yourself ready and able to repair radio receivers quickly and efficiently. Your customers will be pleased with your work and will be willing to pay a fair price.

**WHAT IS EXPECTED FROM A RADIO SERVICEMAN?** Usually, a radio serviceman operates from a small shop or his home and undertakes to repair, adjust, and improve radio receivers. He may be called upon to repair electronic equipment of the simpler type — the more complex devices are usually serviced by the manufacturer. The needed repair may be performed in the home of the customer, but greater freedom from possible annoyance and better facilities can be obtained in your own shop.

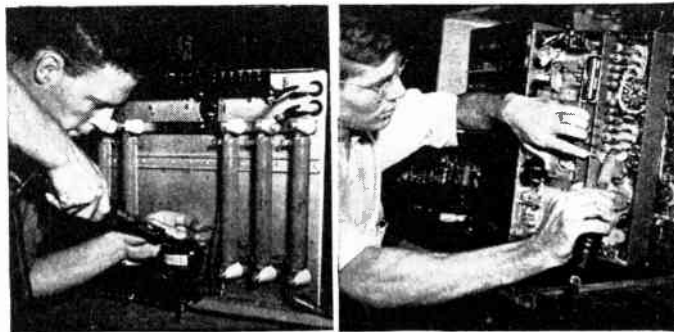

Courtesy Pan American World Airways

Figures 376 to 379. The work of testing and repairing radio receivers and transmitters is a highly technical occupation. The work is interesting and the salaries are good.

Honesty pays in all work and radio servicing is no exception. Make a fair charge for the work and parts needed, explain these charges to your customer, guarantee your work. Perform no actual work free of charge. Your prospects do not expect you to be a good radio serviceman if you inspect radios free, test tubes free, and offer other inducements.

**METHODS FOR SECURING WORK.** We live in a highly competitive society and, in normal times, a serviceman must *hustle* for his work. If you want more service business, if you want the business of people who never heard of you, you must let all know of your existence, your good points, and your special abilities to be of service. You must approach these prospects many times in many different ways. Various forms of advertising will do this job for you.

## HOW TO OBTAIN WORK

Among the various forms of advertising suitable for a radio service business, advertising in publications such as local newspapers and telephone books is most common. An advertisement may be sent directly to a prospect at his home address. A postal card, letter, or a special mailing piece may be employed for this *direct mail*. Posters, window displays, and signs are very effective ways for obtaining additional work.

Advertising in any form must get attention to be useful. Attention may be obtained by sheer size, black type, white space, color, novelty, illustration, or catch-phrases. Once the attention is arrested, the interest of the reader must be held. The story, the picture, the idea must compel the reader to continue. With the reader expressing a not personally realized interest in your advertisement, the next step is to create a *desire*. A desire for better tone, superior reception, improvements possible with a new set of tubes.

Once the desire is aroused, the reader must be impressed with the conviction that your tubes, your service, or your appliances are what he wants. Your items or service must appear to him as the logical solution of his needs. And the final step, you must make the reader act. Action will make your future customer pick up the phone and call you or perhaps stop at your store.

**INFORMATION SUPPLIED BY THE OWNER.** In all cases, it is a good idea to ask the owner of the radio set requiring the repair to explain just how the faulty operation developed. In many instances, the information supplied will be of no particular use, but the occasional possible hint may save much time in locating the fault. The owner, for example, may say that smoke came out from a part and point to the power transformer. This would immediately suggest to you that some fault developed which caused excessive current drain from the transformer, or perhaps a short-circuit occurred in the transformer itself.

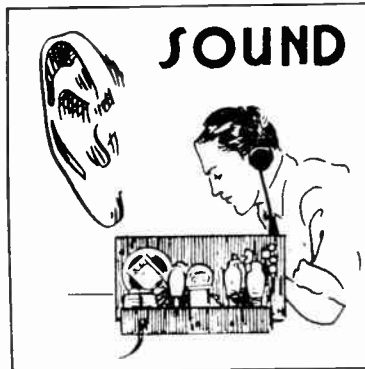
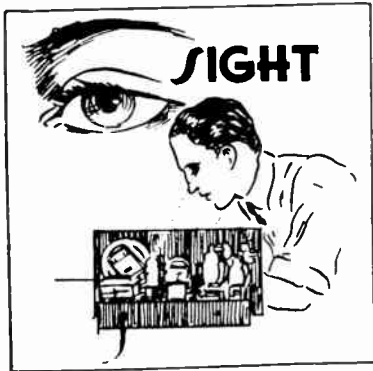

Figures 380 and 381. Many radio faults can be detected by a simple visual examination of the radio chassis. Certain unusual sounds heard with the aid of the loudspeaker or with a pair of headphones connected to the audio stages can be used to suggest the possible trouble in the circuit.

**VISUAL EXAMINATION.** Surprising number of radio faults can be discovered by a simple visual examination of the radio chassis requiring repair. Suppose the complaint was poor tone. You notice that a push-pull output stage, 45's used, one of the 45's had no glow of the filament with the set turned on. Yes, the *no-glow* 45 tube was burned out, the circuit out of balance, the biasing resistor too small for the single operating tube, and possibly no by-passing of the resistor, thus reducing sensitivity.

If there are other radio shops in your city, you may get valuable ideas by studying the methods used by others. Try to be original and improve on the work of others.

The usual advertisement placed by a radio serviceman is very simple. Words like: *Quality Radio Repairing* or *Let Us Repair Your Radio* are used, followed with a suggestion that rates are reasonable and the work is guaranteed. Make it easy for the prospects to find you or to call you. Give your complete address and telephone number.

The owner of the radio to be repaired likes to be of assistance and is flattered by your questions.

The faults mentioned are only suggestive. There are hundreds of possible faults that can be discovered with a visual examination.

**Volume 3 - Page 203**

## HINTS AND SHORT-CUTS

The fact that you own good service equipment does not mean that you must use it on every job. You can eliminate the wear and possible damage to your equipment, and save time besides, by following the suggestions given.

The many diagrams of typical circuits presented in the latter part of this lesson will help you locate the various stages (and the order) in radio receivers you will be called on to service.

Since the voltage on the grid of any tube used in a radio receiver is very low, you are safe in touching this connection. To eliminate the possibility of receiving even a small shock, do not touch any metal or the chassis while making this test. The lead-in from an outside antenna (if one is used) may be used instead of the finger for this test.

Such faulty electrolytic condensers should be removed from the radio and junked. Do not leave such capacitors in the circuit after you connect a replacement in their place.

If you have already repaired a few radios, you will certainly agree with the author on this point.

Faults such as burned out vacuum tubes, slipping dial cables, leaking electrolytic condensers, can be discovered by visual examination. In the case of a noticeably burned carbon resistor, suspect a shorted associated by-pass condenser. This resistor should also be replaced in such cases. It pays at all time to try to locate the difficulty by a quick examination before using test equipment.



Figures 382 and 383. A smoking part will indicate a probable fault in the associated circuit. Touching the grid caps and other *sensitive* points will produce results which may suggest the stage or part at fault.

**SIMPLE TESTS FOR LOCATING THE FAULT.** In your studies, you have already learned about many short cuts for finding the particular section of radio receivers or electronic equipment which is at fault. The usual practice with or without test equipment is to determine whether each stage in progressive order is in proper operating condition. In radio receivers, the test procedure resolves around the introduction of a suitable signal in each stage beginning with the last audio stage that is coupled to the speaker. It is possible to use a moist finger in contact with the grid as the means of creating the signal needed. Touching, for example, the grid of the audio voltage-amplifier tube would cause a loud hum to be produced, provided, of course, that this stage, the last audio stage, and speaker are in operating condition.

There are many short-cuts in servicing that will completely eliminate difficulties and are very easy to apply. Consider the instance of hum developing on strong local stations. This fault often may be completely solved by connecting a .1 mfd. 600 volt paper condenser from one side of the transformer primary to the chassis of the radio set. This keeps the radio set from being modulated by A.C. when tuning in a strong carrier and many sets are supplied with such condenser arrangement.

Electrolytic capacitors sometimes fail to filter properly the circuit and under careful test will show only a fraction of their original capacity. If the electrolytic condensers do not appear to be in good shape and the set has a loud hum, it is best to replace these units. If the complaint of hum really has no bearing, but is due to too critical a listener, an 8 mfd. or larger condenser placed across the filter circuit will solve this problem.

**SERVICE PROCEDURE.** The task of repairing a radio set may be considered to consist of (1) the finding of the fault and (2) the actual repair. The task of locating the actual fault is usually the more difficult and requires a longer period of time than the actual mechanical repair. The finding of the fault resolves in the use of such equipment which will suggest the location of the improperly functioning part or circuit. The knowledge of properly operating

circuits of a similar type will serve as a guide. Once the fault is discovered, the repair becomes a simple matter of removing the short, completing the broken circuit, replacing the damaged part, or making the needed adjustment.

Let us discuss the method for locating the fault in a radio receiver. If the receiver is *dead* (no sound can be obtained from the loudspeaker), make certain that the power connection is made. Check availability of power at the socket by connecting a lamp or a test bulb. See that some antenna wire is connected to the radio. Your finger in contact with the antenna wire will complete the circuit which will permit your entire body to act as an antenna for test purposes. If no operation is obtained, remove the chassis from the cabinet. Suggestions for this work were given in Lesson 1.

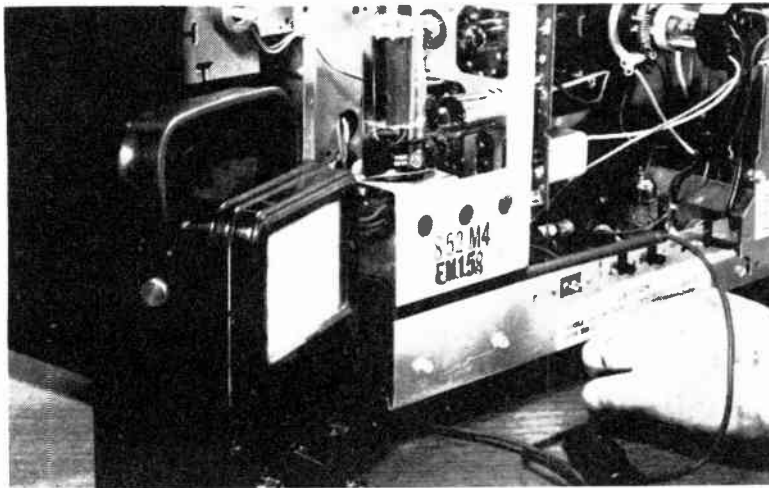

You may learn that the owner of the radio already made all these simple tests.

Figure 384. While many radio faults may be detected without the aid of instruments, test equipment is of great help on some jobs. A volt-ohm-milliammeter, like the one illustrated, is very helpful for localizing the fault quickly.

The power supply should be examined next. The presence of filament voltages may be tested with an A.C. voltmeter. The presence of plate voltage can be checked at one or two points. For this purpose a high voltage (0-500 volts) D.C. voltmeter is used. If equipment is not available, the filament voltage can be checked by noticing the glow inside the glass type tubes. In A.C. type sets, the filament connections to any one tube may be shorted with a piece of wire and the presence of a spark will indicate the presence of voltage. The fact that plate voltage is available may be observed with the aid of a paper or electrolytic condenser. Connect the condenser momentarily to a point where positive plate potential should be present and to the chassis. The condenser should take a charge. Now disconnect and bring together the two leads from this test-condenser. A spark will be noticed at the point of contact if a voltage (of 50 volts or more) was present between the points of the circuit mentioned.

If you fail to obtain the voltages expected, the fault lies in the power supply. However, if the apparently correct voltages are obtained, the different stages of the receiver must be tested in order. The technique which is explained next is also applied in case the radio is operating very poorly.

By injecting a signal from a suitable signal generator in one stage at a time, the portion of the receiver failing to give proper operation can be discovered. We have already mentioned this method earlier. In case a signal generator is not available, a moist finger or a long piece of wire in contact with the control grid of the tube in the stage under test, will serve as the source of signal. The use of a signal generator, of course, will give much more

A capacitor from 1 to 4 mfd., 450 WV., is recommended for such tests. With an electrolytic condenser, polarity must be observed.

If you are asked to repair a radio which has the fault appear from time to time, but the shaking of the cabinet, movement of the volume control, or turning on an electric light will make the radio operate normally for a time, you have real trouble on your hands. Such condition is called *intermittent operation* and is difficult to repair. Experts usually replace condensers and resistors one at a time until the one causing the trouble is found.





# LESSON 34

## SERVICING PRINTED CIRCUITS

There are many types of printed circuits in use today. The use of printed circuit boards are very much on the increase and will continue to increase.

Although no actual printing process is employed to produce printed circuit boards the term "printed circuit" is most frequently used to describe this type of construction.

Printed circuits are manufactured in many different ways but the method known as the etched copper process, developed by RCA, will be explained here.

The production of a printed circuit board begins with a layout drawing of the required circuit. A photographic negative is made of this drawing. A

basic board made of a phenolic laminate, the "chassis" on which the circuit is constructed, has bonded to it a very thin sheet of copper. The copper sheeting is coated with a substance which makes it photosensitive. A contact print of the photographic negative of the circuit drawing is made on the copper sheeting after which it is photographically developed. After development of the photographic image on the copper sheeting, the entire board is placed in an etching solution. In the etching process the unexposed portions of the copper are eaten away, leaving an accurate, sharply defined copper reproduction of the desired circuit bonded to the board. (See figure 1.)

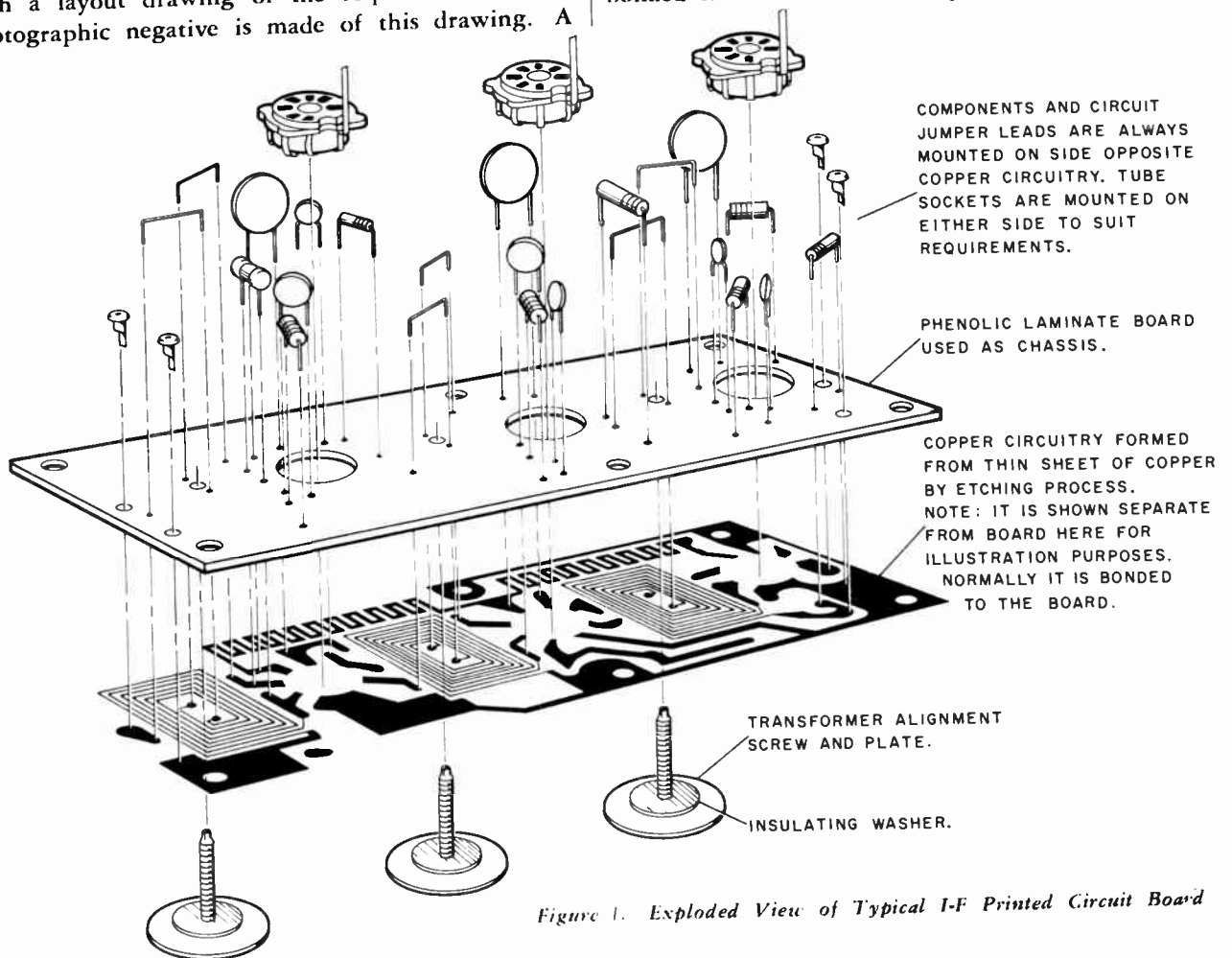

Figure 1. Exploded View of Typical I-F Printed Circuit Board

This supplementary lesson on printed circuits is reproduced through courtesy of RCA Victor.

Volume 3 - Page 207



Top View of Conventionally  
Wired I-F Strip

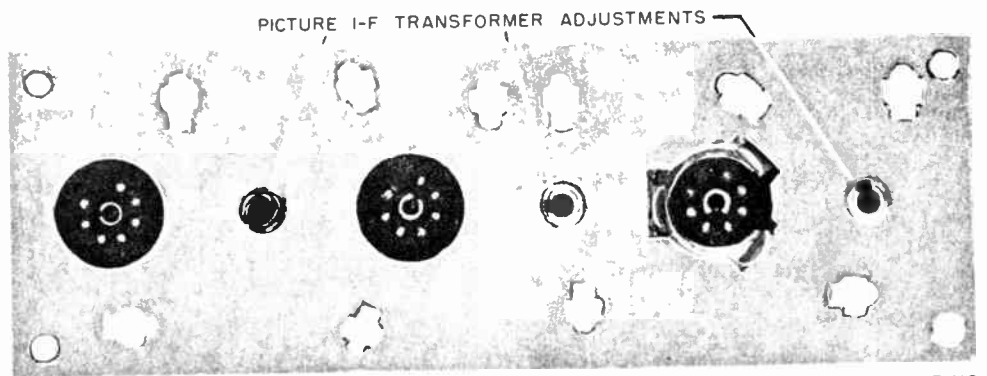

NOTE: COMPONENTS ARE MOUNTED BENEATH STRIP CONNECTED WITH CONVENTIONAL WIRING

Top View of Printed Circuit  
Type I-F Strip

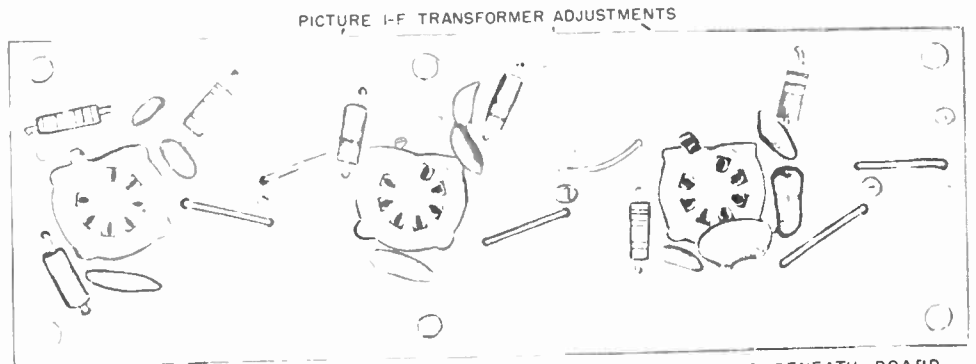

NOTE: COMPONENTS ARE MOUNTED ABOVE BOARD CONNECTED BY PRINTED WIRING BENEATH BOARD

Bottom View of Conventional  
Wired I-F Strip

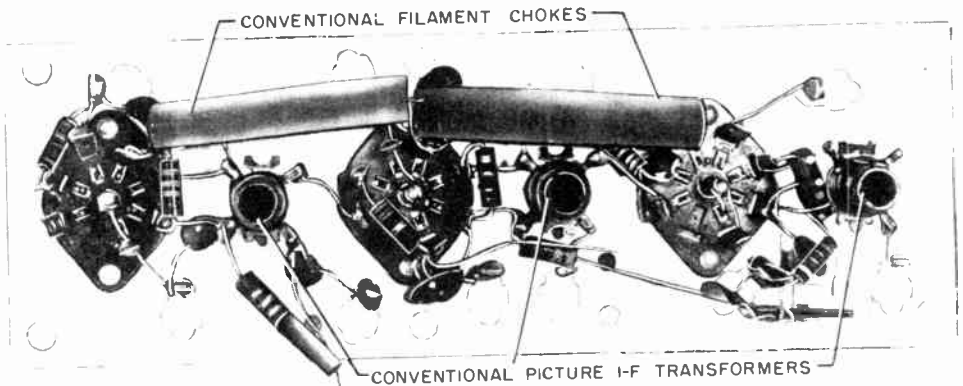

Bottom View of Printed  
Circuit Type I-F Strip

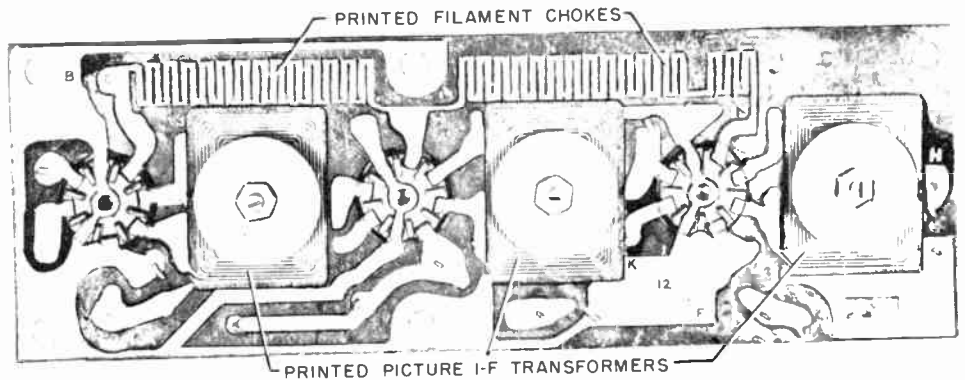
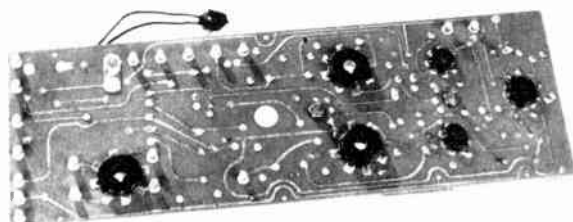

Figure 3. Comparison of Printed I-F Circuit Board  
with Equivalent Circuit in Conventional Form

cuit assemblies in conjunction with the schematic diagram of the respective chassis. These are provided in the related Service Data. However, to further facilitate servicing the printed circuit boards, specific service data is presented in this publication covering recommendations, precautions, suggestions and additional information that will help the technician service printed circuit boards effectively. When this information is absorbed and properly applied, servicing printed circuit boards should be less difficult than servicing conventional circuitry.

Normally, printed circuits can be analyzed without removing the board from the chassis. In most cases tube socket voltages are readily accessible. If this is not the case, voltages may be checked at points common to tube socket connections or a tube socket voltage test adapter may be employed.



The completed electronic assembly — radio, television or computer component — is ready for use. Illustrated are top and bottom views of a high-fidelity amplifier.

Standard components are used on printed circuit boards and can be removed and replaced easily. Replacements should be made with duplicate parts for convenience of mounting. Resistance or continuity measurements of coils, resistors, and some capacitors, can be made from the component side of the board. Voltage measurements can be made on either side of the board.

However, since the sockets on some boards are

mounted upright on the wiring side of the board, the tube pin connections must be counted in a counter-clockwise direction. The clockwise direction is the usual practice when the socket is mounted on the component side of the board.

A small break in the continuity of printed wiring can normally be found easily by a visual examination of the circuitry. The use of a magnifying glass can be of help in locating small "hairline" breaks in printed wiring.

There are no special tools required when servicing printed circuit boards. The complement of tools normally employed by the television service technician are all that are necessary. However, the soldering iron used when working on the printed circuit board should not exceed 100 watts, since excessive heat can readily damage the board.

### Replacement of Components on Printed Circuit Boards

The individual components mounted on printed circuit boards may be easily replaced when the proper technique is used. Only extensive damage to the printed connecting strips or breakage of the board should necessitate replacement of the complete board. When removing and replacing components every possible precaution should be taken to prevent damage to the connecting strips bonded to the phenolic laminate board and to the board itself.

Soldering should be made with care to prevent excessive heat from damaging the board and excess solder from causing shorts.

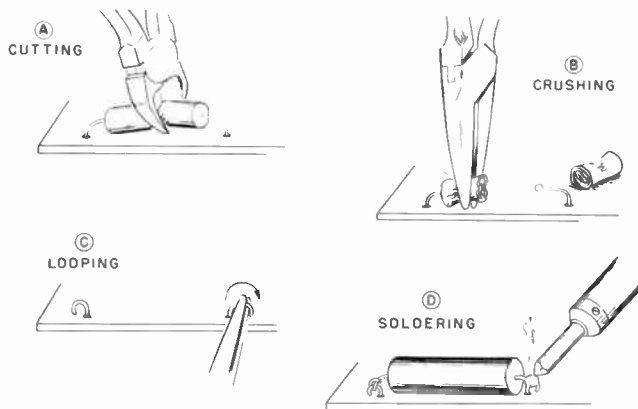

Figure 4. Component Replacement Procedure

To replace capacitors or resistors on printed circuit boards without removing the boards from the chassis proceed as follows:

Refer to figure 4.

1. Cut the component in half with a pair of diagonal cutting pliers.
2. Remove the body of the component from the

connecting wires leaving as much wire as possible for connecting purposes.

3. Prepare connecting points for the replacement component by cutting the wire leaving  $\frac{1}{4}$ " to  $\frac{5}{16}$ " and form a connecting loop as shown in figure C.
4. Thread the leads of the replacement component through the loops of wire, bend component leads to form a good connection and then solder. Cut off excess wire from component leads.

If the printed circuit board has been removed from the receiver chassis for reasons other than component replacement, the parts may be removed simply by applying heat to the point on the connecting strip where the leads come through the board, bending the leads upright with a soldering aid, and lifting the part from the board. In the process of removing the solder, caution must be taken to prevent excessive heating. Use a small wire brush if necessary to quickly brush away the excessive solder from the connection. Do not leave the soldering iron on the connection when brushing away the solder. Melt the solder, remove the iron and quickly brush away the solder. It may require more than one heating and brushing process to completely remove the solder. The new part can then be mounted in place of the part that has been removed and secured in the original manner.

#### Removal of Printed Circuit Board From Chassis

When removing a printed circuit board proceed with caution. *Do not attempt to force the board from each of its mounting lances since excessive flexing of the board can cause damage. Disconnect the wires where necessary from the printed circuit board. (Cut and leave  $\frac{1}{8}$ " of the color-coded wire covering to provide references facilitating the reconnection of the wires. These are wire-wrap connections, and once the wire wrap connection is disconnected it should be reconnected by soldering.)*

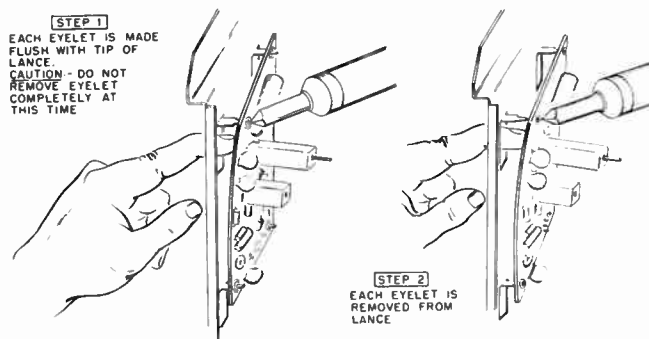

Figure 5. Removal of Printed Circuit Board from Receiver Chassis

To remove the board, apply heat to the point where the board eyelet is soldered to the lance and at the same time apply pressure to the back of the board through the hole in the chassis. When the solder melts push the board out so that the lance is flush with the eyelet in the board and let cool. Do not attempt to clear lance from eyelet at this point. Continue around the perimeter of the board systematically doing the same at each lance. After each lance has been made flush with the eyelet, use the same technique to remove each lance completely from its eyelet freeing the board from the chassis.

#### Replacement of Sound I-F Transformers

To remove sound I-F transformers apply just enough heat to the terminals and can supports to melt the solder so that the terminal may be pushed away from the connecting strips.

When working on the boards it is advisable to place them in a secure stationary position such as between two blocks of wood as illustrated in figure.

When installing the transformer can, the terminals and can supports should be positioned to contact the connecting strips, and then soldered at these points.

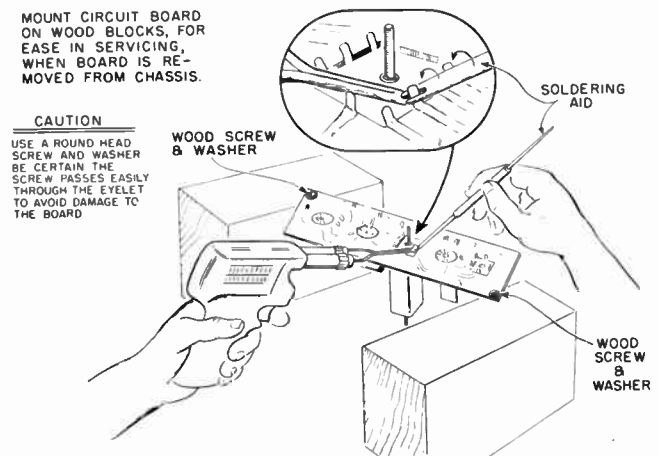

Figure 6. Sound I-F Transformer Replacement

If it is necessary to check the operation of the printed circuit board after it has been removed from the chassis, the wires previously removed may be temporarily reconnected.

When replacing the printed circuit board make certain that all the eyelets on the perimeter of the board are clear and all excess solder is removed from the mounting lances. Place the board in the approximate mounting position and reconnect all wires previously removed. Position the board so that all the lances protrude through the eyelets and solder in place.

## Repair of Printed Wiring Connections

If one of the connecting copper strips on the printed circuit board is cracked or broken it may be repaired easily. A short length of tinned copper wire should be placed across the break. The joint is then soldered by flowing solder over the break and the length of wire. Care should be taken to prevent solder from shorting one connecting strip to another. When the printed wiring on the board is not exposed an open section may be repaired by jumping this section with an ordinary piece of hook-up wire on the component side of the board. Connect the hook-up wire between two components that the open section of printed wiring would normally connect.

## Replacement of Tube Sockets

Refer to figure 7.

In order to replace a tube socket it is necessary to remove the printed circuit board from the chassis in the majority of cases. Apply heat to the socket terminals, melt and shake off all excess solder, or use a small brush to clean off the excess solder at the socket contacts using the technique described previously under Replacement of Components on Printed Circuit Boards. Wedge a flat blade, such as pen knife blade, under the socket contact and pry it up from the connecting strips. Also unsolder and pry up the center pin ground connection.

When replacing a socket, use the proper replacement for the particular board and insert it in position as indexed by the key. Solder the pins and center pin ground connection to the connecting strips. On some boards the contacts must be first bent back so they may be soldered on the tube side of the board.

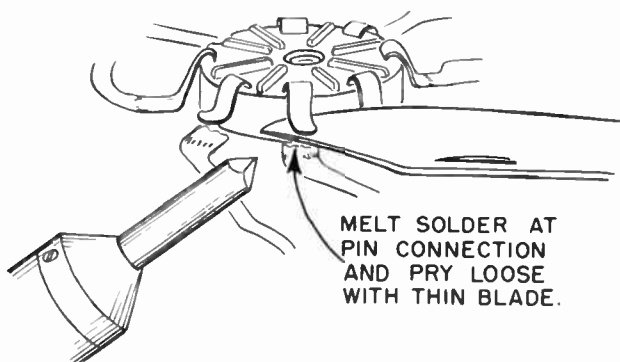

Figure 7. Removal of Tube Socket from Printed Circuit Board

## Checking Intermittent Circuitry

The technique employed in the construction of printed circuits minimizes the possibility of intermittent circuit conditions. If an intermittent condition does exist it may be localized by a slight flexing of the board and probing of the component leads. Caution should be exercised in excessive flexing of the board, although the board is sturdy in construction it may crack or break if proper care is not taken when servicing.

When an intermittent point or area is localized it usually can be corrected by simply heating the leads of the components, at that point or area, with a soldering iron. This will fuse the intermittent point forming a secure connection.

## Replacement of Picture I-F Transformers

The printed coils of the picture I-F transformers on PC102 may be replaced with a conventional bi-filar transformer, stock number 76433.

This is done as follows:

1. Remove alignment screw and plate. See figure 2.
2. Break the four connections to the printed coils (two on top of the board and two on the bottom).
3. Enlarge the screw hole in the board to accommodate a bi-filar transformer.
4. Remove the clip fastener from the end of the bi-filar transformer.
5. Cement the transformer in place so that the coils and four terminals are underneath the board and positioned to facilitate wiring. See figure 8.
6. Connect the coils as indicated in the drawing shown in figure 8. Loading resistors must be installed across the primary winding of the replacement transformer in certain instances as indicated in the note next to the drawing.
7. Align the picture I-F transformers

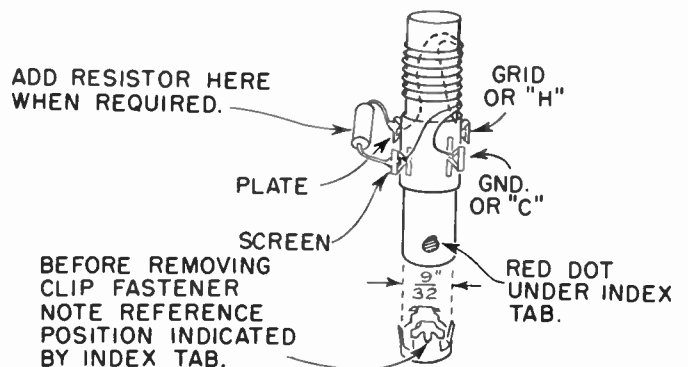

Figure 8. Replacement of I-F Transformer

# LESSON 35

## PRACTICAL FACTS ABOUT TRANSISTORS

While transistor theory is at least as complex as that of vacuum tubes, the servicing of transistor radios is no more difficult than the servicing of any other radio. These few pages contain the basic information required for the successful servicing of transistor radios by the radio technician with no previous knowledge of transistor operation.

The transistor can perform many of the functions formerly possible only with vacuum tubes, and with advantage. The transistor is much smaller than a tube, weighs less, requires no heater power, is more efficient in its use of power supply voltages, is non-microphonic and will operate in any position. Because of its low mass and the strength of the materials of which it is made, a transistor is mechanically more rugged than a tube. No one knows how long a transistor can operate, but the life expectancy is much greater than that of a vacuum tube.

There are two basic kinds of transistors, the point contact, and the junction transistor. Each type has its own advantages and best applications. Since junction transistors are used in radios, only this type will be described.

Transistors can be made from several semi-conductor materials including germanium, silicon and selenium. Most transistors, and all those used in radios, are made of germanium, such as that used in the familiar germanium crystal diode.

A junction transistor is essentially a wafer of an extremely pure germanium crystal into which three distinct conductive regions or layers have been introduced by adding controlled amounts of certain chemical impurities. Depending on what chemical is added as an impurity, the conductive region is called N or P type germanium. A transistor then, is a crystal sandwich of a region or layer of N type germanium between two layers of P type germanium, or conversely a layer of P type between two layers of N type. Leads are soldered to each of the three layers and the crystal is enclosed in a hermetically sealed case.

The arrangement of the different conductive layers of the transistor germanium crystal is illustrated by Figure 1A. Figure 1A shows the cross section or pictorial representation and the schematic symbol of the NPN type junction transistor. Figure 1B shows the pictorial and schematic symbols of the PNP type junction transistor.

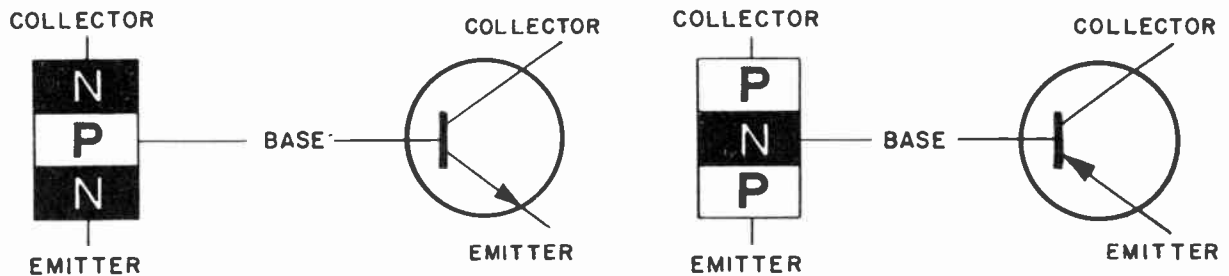

FIGURE 1A. NPN

FIGURE 1B. PNP

In each type, one outer layer is called the emitter, the center layer is called the base, and the other outer layer the collector. Emitter, base, and collector correspond very roughly to cathode, grid, and plate of a triode tube.

The individual NP and PN junctions in the transistor germanium crystal act like crystal diodes in that current flows more easily in one direction than in the other. If any N region is made Negative, and the P region Positive, the resistance of the junction is low and a high current flows. Conversely, when the N region is positive and the P region negative, the resistance of the junction is high and a low current flows.

This supplementary lesson on transistors is re- | **Volume 3 - Page 213**  
produced through the courtesy of Admiral Corp.

The emitter is so called because this element when dc biased in respect to the base for forward or high current flow, effectively injects or emits current carriers into the center or base region of the germanium crystal wafer. The collector even though dc biased in respect to the base for reverse or low current flow apparently collects most of the current carriers injected by the emitter. This increases the collector current over what it would be without the addition of the current carriers injected by the emitter. Thus, by varying the voltage applied between the emitter and the base it is possible to control the collector current, just as varying the voltage between cathode and grid of a tube, controls the plate current.

A transistor can be compared in many ways to a vacuum tube. In a tube, the cathode emits electrons; and in a NPN transistor, the emitter also emits electrons. The plate of a tube collects the electrons emitted by the cathode; the collector of a transistor collects the electrons from the emitter. In a tube, the grid to cathode voltage controls the number of electrons flowing between cathode and plate. In a transistor, the base to emitter voltage controls the collector current. Unlike the grid in a vacuum tube, the base of a transistor must conduct an appreciable amount of current. In this sense, a transistor can be likened to a triode vacuum tube with a positive grid bias.

In the NPN transistor, the injected current carriers are electrons from the N emitter layer. The N type germanium has free electrons available for conduction. In the PNP transistors, the current carriers are for all practical purposes positive charges from the P emitter layer. These positive charges result from a lack of electrons in the atomic structure of the P type germanium and are frequently referred to as "holes". These positive charges behave about the same as electrons but are of opposite polarity.

The important thing to remember, is that the same final results can be obtained with either type of transistor, for their circuit operation is similar except that opposite polarities are required. Both NPN and PNP transistors are often used in the same radio.

Stop a minute, and try to remember the following:

1. The emitter voltage  $E_e$ , must always bias the emitter junction in the forward, low resistance, high current direction. (Positive to P and Negative to N.)
2. The collector voltage  $E_c$ , must always bias the collector junction in the reverse, high resistance, low current direction.
3. The polarity of the dc voltage applied to the emitter in respect to the base is always opposite to that applied to the collector.
4. The collector of a NPN transistor always has a Positive voltage applied in respect to the base.
5. The collector of a PNP transistor always has a Negative voltage applied in respect to the base.
6. In the schematic symbol, the "emitter arrow" always points in the direction of easy current flow. Electron flow is in the opposite direction to current flow.

A typical common emitter NPN transistor amplifier is illustrated by Figure 2. The negative terminal of the power supply battery is connected to the emitter and the positive battery terminal is connected to the collector. Because the collector-base resistance is much higher than the base-emitter resistance as a result of the dc bias polarities, the collector-base voltage can also be much higher than the base-emitter voltage. Resistor R1, connected between the positive battery terminal and the base, establishes the correct dc bias of the base-emitter junction (base positive - emitter negative).

Electrons are effectively injected into the base by the emitter. Most of these electrons are attracted to the high positive voltage of the collector and only a few flow to the base. Note that electron flow is in an opposite

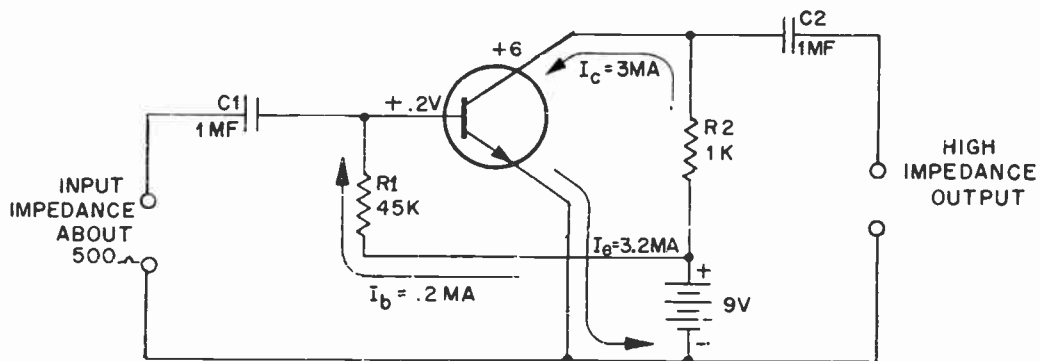

Figure 2. A Simple Transistor Amplifier (NPN).



direction to the current flow indicated by the arrows. In more advanced study of transistor circuits, it is convenient to consider conventional current flow rather than electron flow. The collector current  $I_c$ , and the base current  $I_b$ , added together equal the emitter current  $I_e$ .

Now, if an ac signal is applied to the base through coupling capacitor C1, the voltage across the base-emitter junction will vary as does the signal voltage. Since the total resistance from the base to the emitter terminals of this typical transistor is about 500 ohms, an ac voltage of only .025 volts will cause an ac base current flow of 50 microamperes. This small ac signal will result in an ac emitter current of about 1.05 milliamperes and an ac collector current of about 1 milliampere. This 1 milliampere ac collector current flowing through the 1,000 ohm load resistor R2, will develop an ac voltage across the load resistor of 1 volt. Thus, this simple transistor amplifier produces a voltage gain of 40 and a power gain of 800. By using different values of load resistance, much higher voltage or power gains can be obtained.

A PNP transistor could be used in the same amplifier circuit: all that would be required is reversal of the power supply battery polarity.

The amplifier shown in Figure 2, is called a common or grounded emitter amplifier because this terminal is common to both the input and output circuits. This type of amplifier circuit roughly corresponds to the familiar grounded cathode vacuum tube amplifier and is frequently used because in general it affords the highest gain consistent with a relatively high input impedance.

The transistor can be used in common base amplifier circuits which correspond to the grounded grid vacuum tube amplifier. The collector can also be the common terminal, and in this case becomes the transistor equivalent of a grounded plate or cathode follower vacuum tube amplifier.

In the common emitter transistor amplifier illustrated by Figure 2, a slight change in base current  $I_b$ , results in a large change in the collector current  $I_c$ . This ratio of change in collector current to change in base current is called the Beta ( $\beta$ ). Beta values of presently available junction transistors range from less than 10 to more than 100.

Also, a change in emitter current  $I_e$ , results in a change in collector current  $I_c$ . This ratio of collector current change to emitter current change,  $I_c/I_e$  is the emitter-collector current gain and is called Alpha ( $\alpha$ ). In three element junction transistors, this is always less than 1, with Alpha values of .80 to .99 being available in commercial transistors.

Beta, the base-collector gain, is related to Alpha, the emitter-collector gain: 
$$\text{Beta} = \frac{\text{Alpha}}{(1-\text{Alpha})}$$

The servicing of a transistor radio is little different than the servicing of any other radio. The same circuit functions exist and the arrangement of circuit functions is the same as in the majority of small radios using vacuum tubes. The same troubles and trouble symptoms can exist. Familiar troubleshooting methods can still be used.

Really, the only important difference in the servicing of transistor radios follows from the precautions that must be taken to prevent damage to transistors and other components designed to operate with relatively low supply voltages by technicians accustomed to the higher voltages and temperatures in vacuum tube circuits.

A transistor is a physically rugged device, but generally it cannot tolerate excesses of current and temperature as well as a vacuum tube. Susceptibility to damage by heat is the transistors greatest weakness. They may be damaged by external heat or by heat generated within by excessive current flow.

Most transistors are hermetically sealed. If the seal is broken by rough handling or bending and pulling the leads so that the crystal is exposed to air and moisture, the performance of the transistor will be seriously affected.

To prevent any possible damage to the transistors while servicing the radio, remember these few basic rules:

1. Soldering . . . When replacing components connected to a transistor socket, remove the transistor before doing any soldering. If the transistor should be wired into the circuit without the use of a socket, grasp the lead between the transistor base and the soldered junction with long nose pliers before doing any soldering or unsoldering. The pliers will help dissipate the heat.
2. Power Supply Voltages . . Watch battery polarity closely. Reversing battery may damage a transistor.

3. Replacing Transistors . . . Never remove or replace a transistor without turning the receiver off. In some circuits the resulting voltage transient could do harm.
4. Ohmmeter Checks . . . The current supplied by most ohmmeters on low resistance ranges is great enough to damage a transistor. Generally, vacuum tube ohmmeters with battery supplies of 3 volts or less are OK if used only on the R x 1,000 or higher range.  
In general, circuit checks made with an accurate voltmeter are more useful than ohmmeter checks.
5. Troubleshooting . . . Watch your test probes! If a slip of a test probe shorts the transistor base to the collector, the transistor may be damaged.
6. Capacitor Checks . . . Most transistor radios use a number of electrolytic capacitors with low voltage ratings. Many capacitor checkers apply a voltage to the capacitor sufficient to damage it. Even a small voltage of incorrect polarity can cause damage. This must be remembered in making ohmmeter checks of the circuit.
7. Use of Signal Generators . . . Before connecting any signal generator to the radio circuits, adjust the output attenuator for minimum output. Signal generators designed for vacuum tube circuits can furnish more signal than a transistor can handle without harm.

### TRANSISTOR TESTING

The best way to check a transistor is by substitution.

The next best way to check a transistor is to use one of the simple transistor test-sets that are available.

Transistors can, in an emergency, be checked for opens or shorts with an ohmmeter providing a reasonable amount of care is taken. An ohmmeter check is not a particularly good check.

Never use an ohmmeter with a battery greater than 3 volts.

Never use the low resistance ranges; instead use the R x 1,000 or higher range.

In general, the forward current through a transistor should never be allowed to exceed 15 ma. A milliammeter can be used to determine whether any particular ohmmeter is safe to use in testing transistors.

A junction transistor is more apt to become shorted than open. Transistors often become shorted because of excessive current flow, so a shorted transistor may be indicative of a circuit fault. If a transistor is found to be shorted, check the circuit carefully before installing a new one.

A shorted transistor will most often result in increased power supply current drain. Thus, a quick and useful check is to measure the current drain with a milliammeter connected in series with the leads from the battery power supply. The current drain for Admiral transistor radios will be found in the service manuals.

For ohmmeter testing purposes a transistor can be considered as two germanium diodes connected back-to-back as illustrated by Figure 3.

Figure 4, illustrates the relative resistances for both the NPN and PNP type transistors. The polarity signs shown in the illustration indicate the polarity of the ohmmeter leads. The transistors must be removed from their sockets to make this check. Low resistances will range between 50 and 500 ohms or more. High resistances will range from .1 megohm to several megohms, depending on the ohmmeter used and the transistor type.

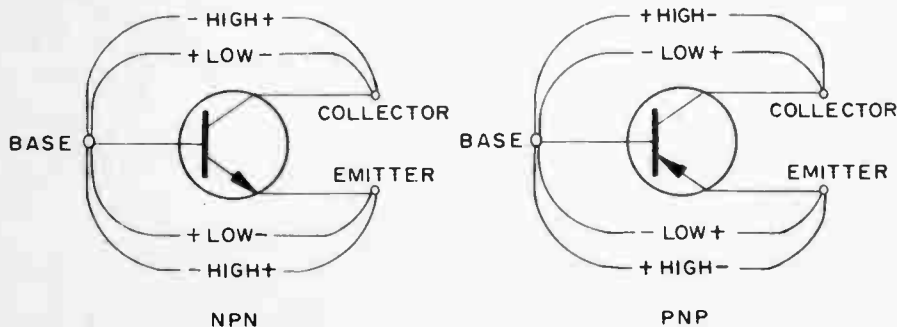

Figure 4. Ohmmeter Check of Transistors.

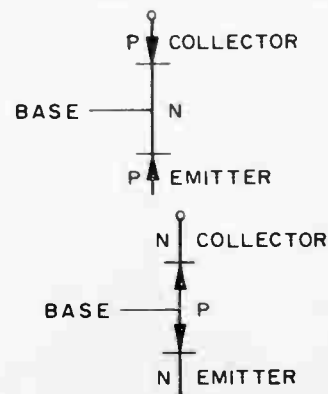
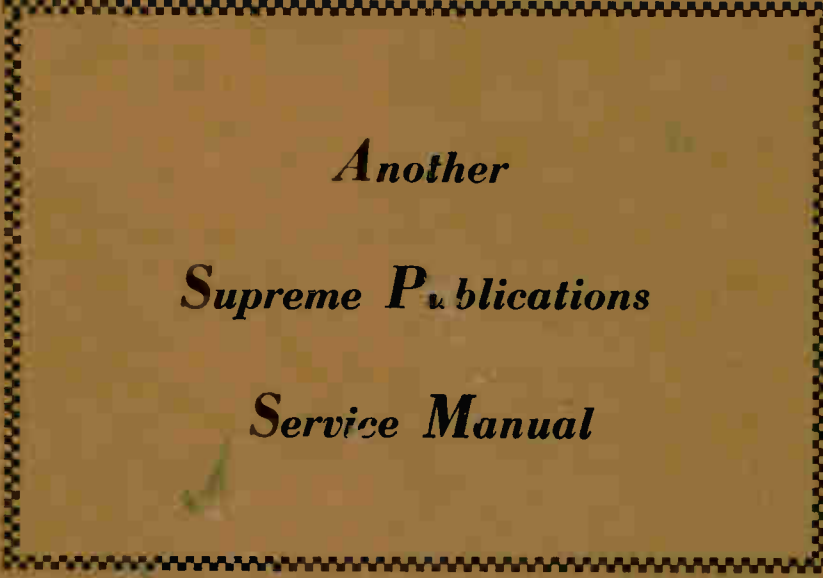

Figure 3.





*Another*  
*Supreme Publications*  
*Service Manual*

**Supreme Publications are Available at All Leading Parts Jobbers**