

# TELEVISION

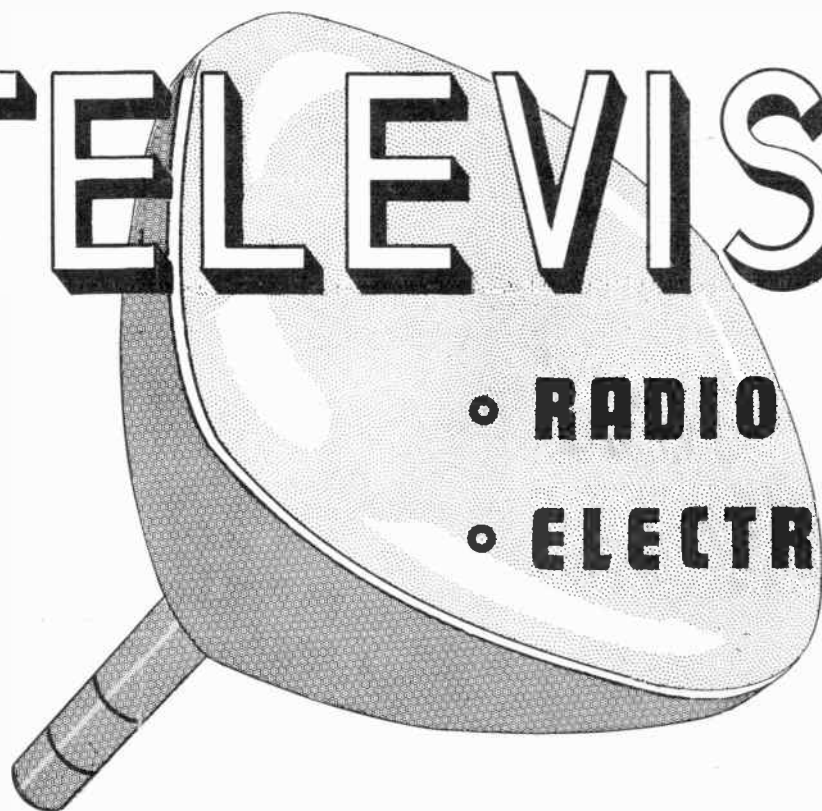

◦ **RADIO**

◦ **ELECTRONICS**

---

**LESSON 1 — HOW TELEVISION GREW UP**

---

***Coyne School***

*practical home training*

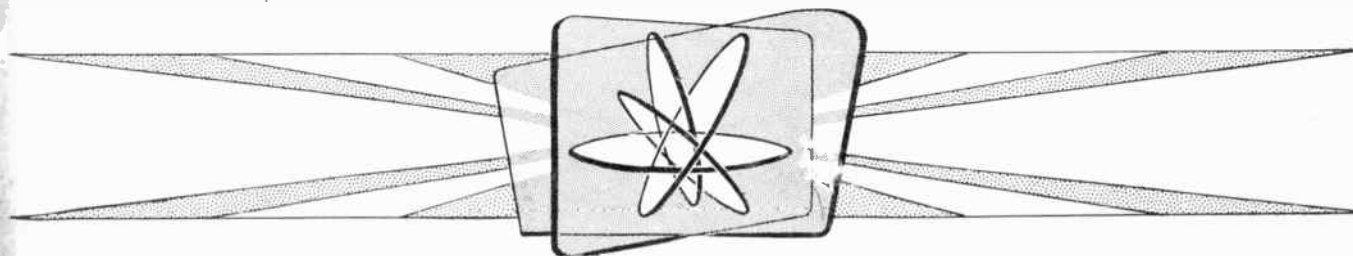

*Chicago, Illinois*

1. HOW TELEVISION GREW UP
2. WHAT HAPPENS IN A TELEVISION RECEIVER
3. HOW TO MAKE WIRING CONNECTIONS
4. THE PARTS OF WHICH RECEIVERS ARE MADE

5. HOW RESISTORS ARE USED
6. ADJUSTABLE RESISTORS FOR CIRCUIT CONTROL

7. TROUBLE SHOOTING WITH THE OHMMETER

8. TROUBLE SHOOTING WITH THE VOLT-OHMMETER

9. TROUBLE SHOOTING IN A PLATE CIRCUIT

10. THE LOW VOLTAGE POWER SUPPLY

11. POWER SUPPLY FILTERING

12. IMPROVING THE POWER SUPPLY

13. TRANSFORMERLESS RECEIVERS

14. TRANSFORMERLESS POWER SUPPLIES

15. CONTACT RECTIFIERS AND VOLTAGE MULTIPLIERS

16. ELECTRONIC TUBES

17. SIGNAL AMPLIFICATION

18. PENTODE VOLTAGE AMPLIFIERS

19. TUBE TYPES AND STRUCTURES

20. FIXED CAPACITORS AND HOW THEY ACT

21. GRID BIASING

22. RESISTANCE-COUPLED AMPLIFIERS

23. INDUCTORS FOR TV & RADIO

24. RESONANCE & SIGNAL SELECTION

25. CAPACITANCE TUNING

26. INDUCTANCE TUNING

27. TRANSFER OF SIGNAL VOLTAGES (PASS BAND FOLLOW)

28. THE SUPER HETERODYNE

29. BROADCAST RECEIVERS

30. THE I-F AMPLIFIER & THE DETECTOR

31. METERS & INSTRUMENTS

32. SIGNAL GENERATORS

33. RECEIVER ALIGNMENT

34. THE VTVM

35. TV SIGNAL

36. TV I-F AMPLIFIER

37. IF TRAPS & VIDEO DETECTORS

38. TV ALIGNMENT

39. ALIGNMENT WITH THE VTVM

40. TV CONTROLS

Copyright, 1954 by Coyne Electrical School  
 Chicago 12, Illinois  
 All rights reserved.



# Lesson 1

## HOW TELEVISION GREW UP

The man who stepped out to buy the latest in television sets during the early twenties came home with what looked like a radio receiver the approximate size of an orange crate. This receiver had no speaker, for it was supposed to work with pictures, not sounds. Instead of a speaker, the hopeful television fan brought along the "scanner" pictured by Fig. 1.

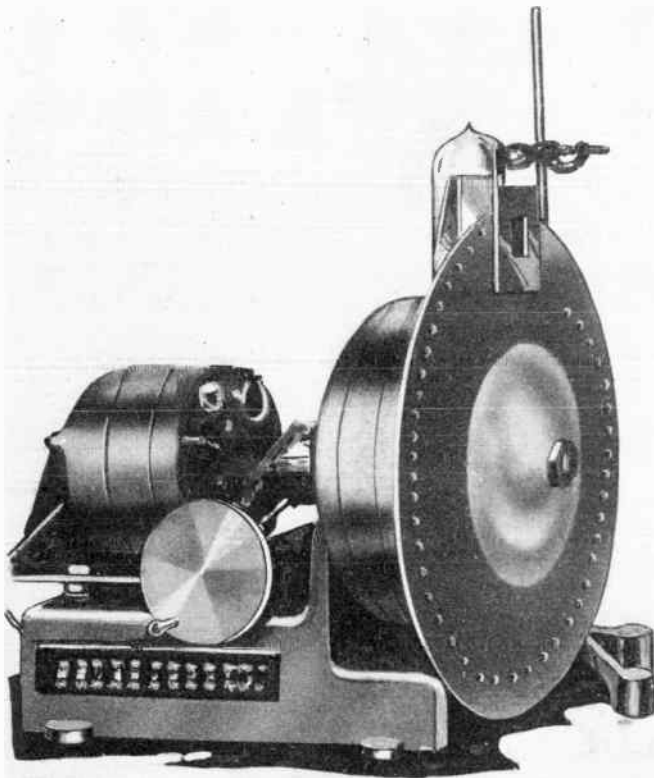

Fig. 1. The latest thing in television, during the early twenties.

The scanner was a simple contrivance. A husky electric motor on one end of a shaft drove a big disc at the other end. Near the outer edge of the disc was a series of small holes about an inch and a half apart, all at slightly different distances from the center. A "mask" supported in front of the disc contained an opening about one and a half inches square, through which the holes could be seen. Behind the disc, directly in line with the opening of the mask, was a neon glow lamp.

The sole job of the receiver section of this apparatus was to vary the brightness of a plate inside the glow lamp. The brightness varied in accordance with the received television signal, in case there were such a signal. Only rarely would there be experimental transmission for the fans to pick up. When this did happen, the would-be viewer turned on the motor, peered through the little opening in the mask, and adjusted the speed control. Then, were the actual televised scene to be the picture below in Fig. 2, he might



Fig. 2. The difference between an image and how it was reproduced by old time television sets.

see something roughly similar to the silhouette, above, but probably not so clear.

## COYNE - *television home training*

Inventors and experimenters, not to mention the manufacturers, traveled a long and thorny road between those sets of the early twenties and present television receivers like the one of Fig. 3. The driving motor disap-

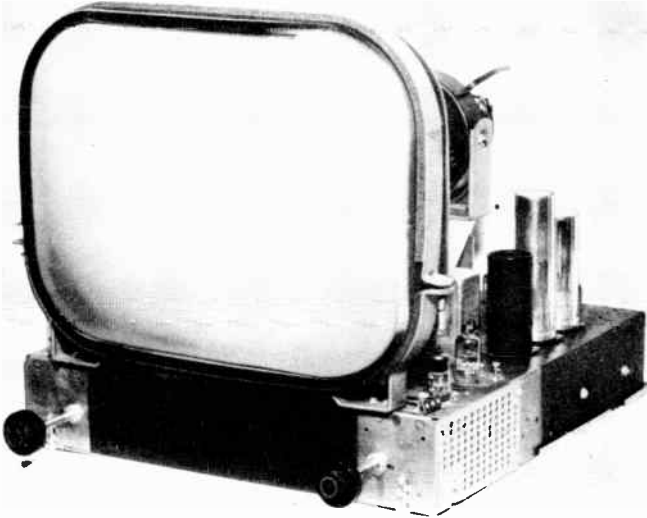

Fig. 3. *The largest part on a modern television receiver is the picture tube.*

peared, and so did the whirling disc, and the little square opening in the mask grew to several hundreds of square inches on the screen of our modern picture tubes. Yet the fundamental principle that allowed seeing the dim, jerky, fuzzy reproductions in the beginning of television is still the basis for the brilliant, smoothly moving, and sharply detailed pictures of today.

The basic principle of television consists of dividing the original scene or image into a great many thin horizontal lines, and of reproducing the same lines to form the finished picture at the viewing end of the system.

What happens with the whirling disc is illustrated by Fig. 4. As each hole in the disc speeds rapidly from one side to the other of the mask opening, the observer can see through this hole a thin streak of light extending from side to side across the glowing plate of the neon lamp. Just as this first hole passes beyond one side of the mask opening and away from in front of the lamp, a second hole located just a little lower down allows seeing a second streak of light im-

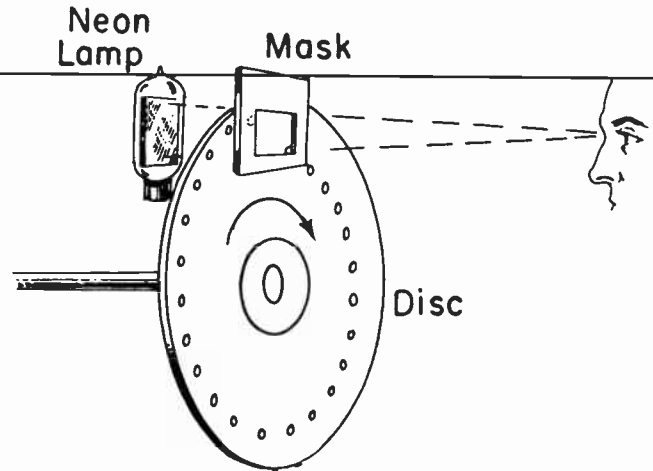

Fig. 4. *The disc, mask, and neon glow tube for one of the first television sets.*

mediately below the first one. This continues until all the holes have passed the lamp during one revolution of the disc, and until all of the glowing plate has been seen as a succession of slightly curved but essentially horizontal streaks of light. Then the whole thing repeats, over and over again as the disc continues to spin.

The motor spins the disc so fast that the observer doesn't seem to see a succession of separate lines. He seems to see the entire illuminated plate of the neon lamp during all the time the disc continues to whirl. This comes about because everyone continues to see a light for about  $1/10$  to  $1/20$  second after the light no longer is there. The effect is called persistence of vision. Persistence of vision is just as necessary for viewing television today as it was thirty or forty years ago.

Of course, a mere succession of luminous lines seen through the holes of the disc does not constitute a picture, for there are none of the lights and shadows of which all pictures are formed. But the rest is easy. It remains only to rapidly vary the brightness of the neon lamp. At the instant in which one of the little holes is in a position where the picture image is to be bright, the television signal coming through the receiver makes the neon lamp glow brightly. When the hole reaches a point where the picture is to be less bright, the signal makes the lamp glow less brightly, or may darken it entirely. Since light from

# LESSON 1 – HOW TELEVISION GREW UP

only one tiny spot of the neon plate reaches the eyes of the observer at any one instant, the whole plate appears covered with the lights and shadows which form a picture.

When all the holes which are around the edge of the disc have passed across the glow lamp and across the mask openings the observer will have seen one complete picture. This happens during each revolution of the disc. During the following revolution the observer will see another complete reproduction. In many of the old time television systems the disc completed one revolution every  $1/15$  second. This allowed the viewer to see 15 complete pictures per second. When televised persons or objects were in motion, the changes of position between successive pictures were only those occurring during  $1/15$  second intervals. If nothing moved too fast, the observer seemed to see things progress steadily from place to place.

This method of causing the illusion of continual motion with a succession of pictures is even older than the earliest television. It always has been used for the projection of motion pictures in theatres. In the movies the "repetition rate" is 24 per second, and positions of objects in motion can differ in succeeding pictures only by the distances they move during  $1/24$  second.

Persistence of vision merges each picture with those preceding and following, and we seem to see only one continual picture with objects in steady motion. The movie rate of 24 pictures per second greatly lessens the jerkiness or flicker as compared with the early television rate of 15 per second. But we do even better in modern television.

The principle of dividing pictures into horizontal lines is fine, so good that it still is with us. But the practice, when employing a whirling disc, turned out to be something sad to look at. After scientists, inventors, and experimenters had struggled for years with discs, drums, lenses, mirrors, and all manner of optical and mechanical tricks they had to give up. It became apparent that television with moving mechanical parts never could be satisfactory. It was physically impossible to divide the image into parts small

enough, and reproduce them fast enough to show fine details in a picture much larger than a postage stamp.

To have acceptable detail in large pictures which appear rapidly enough to give the illusion of motion, and to transmit those pictures either by radio or by cable, each picture must be divided into hundreds of lines, and the intensity of light must be varied at the rate of millions of times per second. No matter how little the weight of moving mechanical parts, the necessary fine division and rapid reproduction of successive pictures with rotary devices could not even be approximated.

In 1933 and 1934 the science of electronics came to the rescue of television, and since has overcome all the problems which seemed insurmountable. A beam of electrons inside a television camera tube changes the lights and shadows of a televised scene or image into varying electric currents. Forces derived from the varying currents are transmitted by radio or wire line to distant receivers. Then another electron beam inside the picture tube at the receiver changes the varying electric forces back into the lights and shadows of a reproduced picture.

There is no practical limit to the speed at which a beam of electrons may move, nor to the rate at which the intensity or force of the beam may be varied. To travel from one side to the other on the screen of the biggest picture tube at a speed of 300 to 400 miles a minute is nothing at all for the electron beam, and during each such travel the intensity of the beam and the resulting light or shadow may be changed a thousand times if necessary.

**THE TELEVISION PICTURE.** Now let's see how our present television pictures are related to those of long ago. When you have a good chance to look very closely at the picture being formed by any television receiver it will appear as shown by Fig. 5, which is an enlargement of a photograph of a real television picture. Here we have the succession of horizontal lines which vary in brightness from one side to the other of the picture.

The portion of a picture which you see



# COYNE - *television home training*



Fig. 5. A television picture is not continuous, but consists of many horizontal lines.

in Fig. 5 actually extended over a height of less than  $1\frac{1}{2}$  inches on the screen of the television picture tube. (Incidentally, this screen is a coating on the inside of the visible face or front end of a picture tube. When the screen coating is made luminous by the electron beam you see the resulting picture through the front of the glass face.)

Any television picture consists of hundreds of horizontal lines, about 490 to be exact. Even on a large picture tube the individual horizontal lines are too narrow and too close together for easy examination of just how they are formed. For convenience in study we shall imagine that each line is about five times its normal height, or that the picture is divided into only 100 horizontal lines, as in Fig. 6. By enlarging part of this picture, in Fig. 7, it becomes possible to examine the makeup of any line and to note the succession of blacks, whites, and intermediate grays which form the line as it is reproduced from left to right.

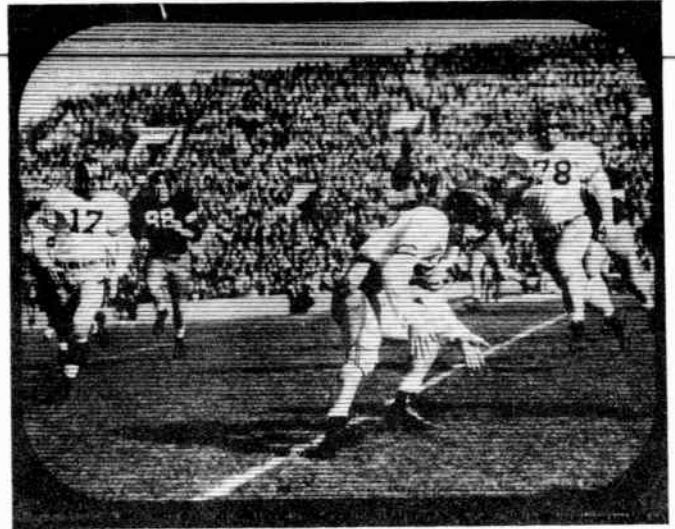

Fig. 6. The lines in this picture are about five times as high as those formed on a television screen.



Fig. 7. Every horizontal line consists of small areas which are white, black or gray.

Let's examine, in Fig. 8, two lines which pass through the numerals "17" and "88" on the jerseys of two players. If you look along either line it is plain that there are different degrees of illumination which continue through varying distances along the line, then change to either greater or less intensity.

Any line which thus consists of varying intensities of illumination might be formed on the picture tube screen were we to have inside the tube a tiny searchlight shooting a needle fine beam onto the back of the screen. Shifting this light beam rapidly from left to right would cause a horizontal streak of light

# LESSON 1 – HOW TELEVISION GREW UP



Fig. 8. The degree of brightness undergoes many changes along every horizontal line.

to become visible from the front of the screen. The traveling spot of light would appear as a streak because of persistence of vision.

Now, if the intensity of the light beam were varied from bright to dark and back again at precisely the correct instants during its horizontal travel, you would see from the front of the picture tube the shadings of either line of Fig. 8, or any other imaginable succession of whites, blacks, and grays.

There is no search light inside the television picture tube, but there is something far more wonderful. At the back of the small end or neck of the picture tube, farthest from the face, is an electron gun. This gun shoots particles of electricity toward the screen at an average speed of about 17,500 miles per second. The coating which we call the screen contains chemical compounds called 'phosphors'. Wherever the particles of electricity hit the phosphor it glows for a brief instant, then becomes dark again as the stream of electric particles moves away.

Fig. 9 is a photograph of a television picture tube with the parts named. The face is

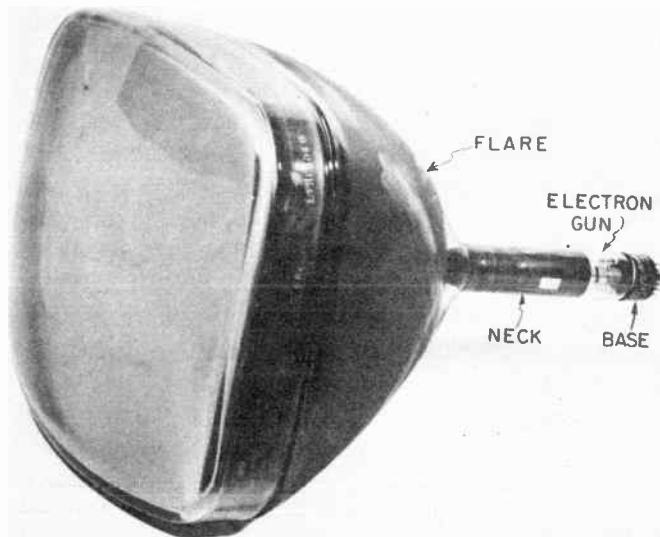

Fig. 9. Important parts of a television picture tube.

made of glass about  $5/16$  to  $3/8$  inch thick. You cannot see inside the tube through the face because the inner screen coating is translucent, not transparent. But when the phosphor glows you can see the light. At the other end of the tube is its base, to which various electrical connections are made through small metallic pins. Just ahead of the base, in the small cylindrical neck of the tube, is the electron gun. Between the neck and the face is the flare, which spreads out to allow shifting the stream of electric particles across the screen during formation of the horizontal lines.

All that we need do in forming a horizontal line of varying illumination is to vary the quantity of electric particles being shot out from the electron gun. We don't vary the speed of the particles, but only their quantity. It is as though you were squirting water from a hose while opening and closing the nozzle. This would not change the speed of the water stream, for that is determined by pressure acting in the hose, but it would change the quantity of water issuing from the nozzle. To be correct we should speak of varying the "rate of flow" of the water.

The greater the rate of flow of electric particles from the electron gun the brighter becomes the phosphor where they strike. Reducing the rate of flow lessens the brightness, or causes grays to appear. Decreasing the rate of flow to zero leaves the phosphor unexcited, and produces black. The particles of electricity being shot toward the picture tube screen are electrons. The stream of electrons passing through the inside of the picture tube is called the electron beam.

One electron is not very large, nor very heavy. If 207 men could have commenced at the beginning of the Christian Era to lay electrons side by side in a straight line, and if everyman had laid down one electron every second, and if they still were doing so, the line of electrons today would be an inch long.



## COYNE - *television home training*

The weight of all those electrons would be too little to measure with any scale or balance in existence. If every man, woman, and child now in the United States could live forever and continue adding an electron every second to the line now an inch long, the whole collection would weigh one ounce at the end of another six millions of millions of years. All this means simply that we cannot comprehend the dimensions or weight of an electron.

To light an incandescent lamp rated at 100 watts and 115 volts, electrons must pass into and out of its filament at the rate of about 6-1/4 billions of billions per second. Were one ounce of electrons to divide equally between a million such lamps, and flow at this rate through each filament, all the lamps would remain at full brilliancy for 5,000 years, unless they burned out.

To form any one line of a picture the electron beam must be made to move all the way across the screen of the picture tube. This isn't difficult, for it is easy to bend a stream of electrons. The electrons shooting out of the electron gun in a straight line might be compared with water squirting straight out of a hose nozzle. If the stream of water encounters a strong wind the stream is blown to one side. It will remain a stream of water if the particles are traveling fast enough and with enough original force.

The part of a television receiver which bends the electron beam is around the neck of the picture tube close to the beginning of the flare. This part is marked deflecting yoke in Fig. 10. In the yoke are produced forces that bend the electron beam so that its end striking the screen moves from side to side. We don't often speak of bending the electron beam, instead we say that the beam is deflected. When the beam is forced to move from side to side of the screen we call the action horizontal deflection.

As the electron beam moves across the screen there appears a horizontal line of light on the screen. This line may be called a trace. The intensity of the light at various points along the trace is altered by varying the rate of electron flow in the beam.

As soon as one line has been traced all the way to the right, the electron beam is shut off. Then it is started again at the left hand side of the picture, but just a fraction of an inch lower down, and another line is traced. This process continues, with the electron beam tracing one horizontal line after another until the picture is completed. All the lines which form the complete picture are traced within 1/30 second. You continue seeing the lights and shadows of each horizontal line while all of them are being formed, for vision persists during about 1/20 second, and the whole picture area is covered with these lines in 1/30 second.

When the electron beam has traced the last horizontal line at the bottom of the picture the beam is shut off. Then, after about 1/800 second, the electrons again are turned on and a whole new picture is begun at the top of the area. Like the first one, this new picture is completed during 1/30 second. The process continues so long as the television receiver remains in operation and the station continues its programs.

Succeeding television pictures are formed much as a succession of pictures is formed on a movie screen. But you don't see the different pictures, you don't even notice a flicker. You seem to see people and objects in continual motion because their positions change so little between pictures.

Accompanying the television picture we have speech, music, and sound effects. The signal that brings the sound program is entirely separate from the one that brings the picture, but the two signals are so arranged and transmitted that when you select a picture in a given channel the sound from that channel is received at the same time. The portions of the television receiver that reproduce sound are separate from those that reproduce pictures. For the time being we shall concentrate on the pictures, and talk about television sound later on.

SCANNING. The production of good pictures, or of any pictures at all, depends wholly on what happens to the electron beam within the picture tube, so let's see what must happen in forming one complete picture.

## LESSON 1 – HOW TELEVISION GREW UP

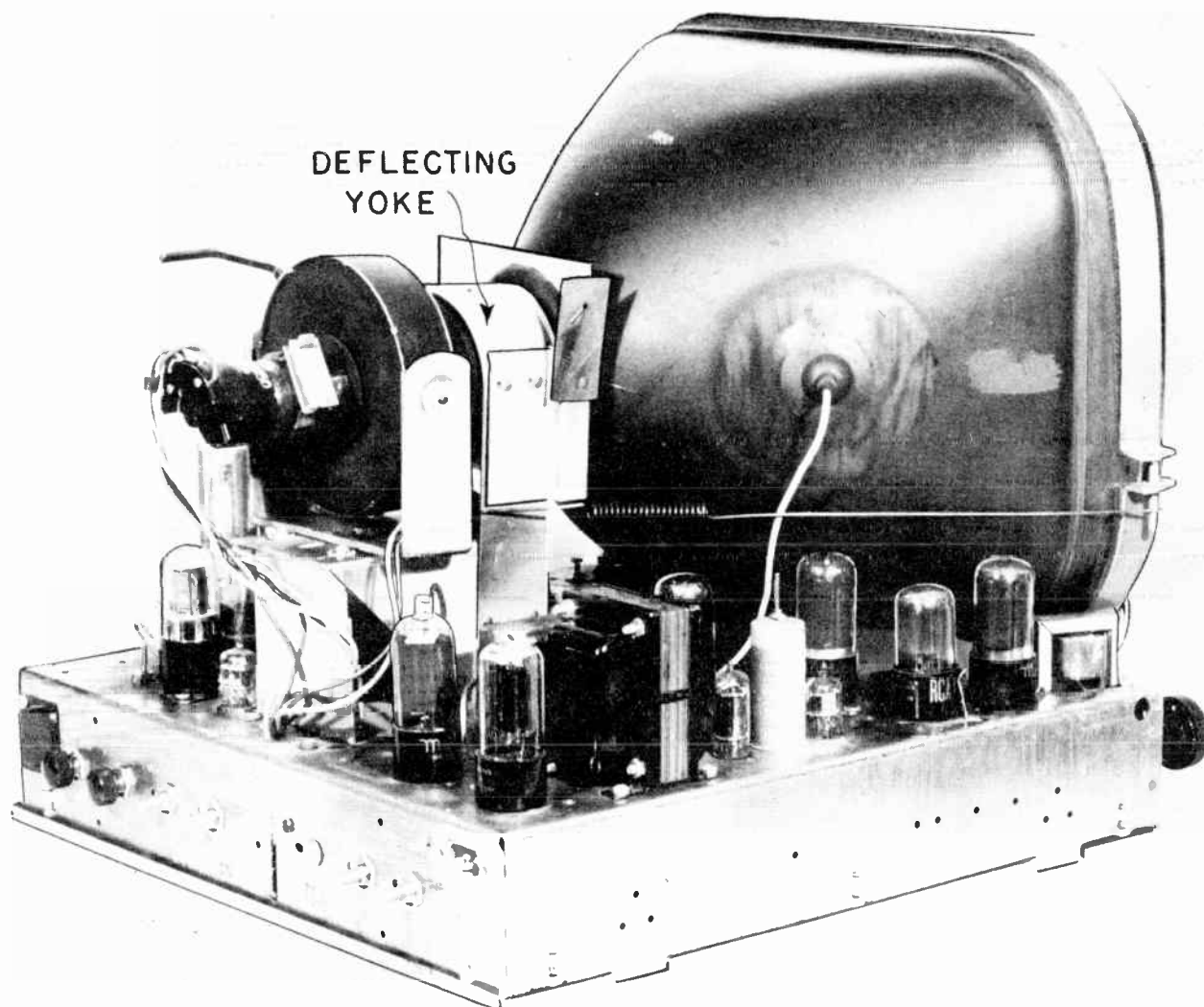

*Fig. 10. Around the neck of the picture tube is the deflecting yoke which bends the electron beam.*

The electron beam commences its travels at the upper left-hand corner of the picture area on the screen, as you look toward the visible front face of the picture tube. Then, in traveling all the way to the right, the beam traces the first horizontal line of the picture. There the beam is shut off. When talking the language of television we shouldn't say that the electron beam is shut off, we should say that it is blanked. After a very brief fraction of a second the beam is again turned on, back at the left-hand side of the picture area, and another line is traced below the first one.

It would be natural to expect that, after tracing one line, the beam would be dropped

just far enough to trace the adjacent horizontal line of the picture, but it isn't done that way. After forming the first line at the top of the picture the beam skips the second line, and is dropped far enough to trace the third line. Then the beam is dropped to the fifth line, and thus traces alternate lines all the way to the bottom of the picture.

In order to trace one line below another, and keep this up all the way to the bottom of the picture, the electron beam must be moved downward at the same time it is moved horizontally. This is done by moving the beam steadily downward while all the horizontal lines are being traced. After tracing each horizontal line the beam isn't jerked

# COYNE - *television home training*

down to the position for the next line, it is moving downward at all times. Although this gives each line a slight downward slope toward the right, you don't notice the slope because the deflecting yoke is tilted just enough so that all the lines appear truly horizontal.

Fig. 11 illustrates the principle of tracing alternate lines. Here the beam is as-

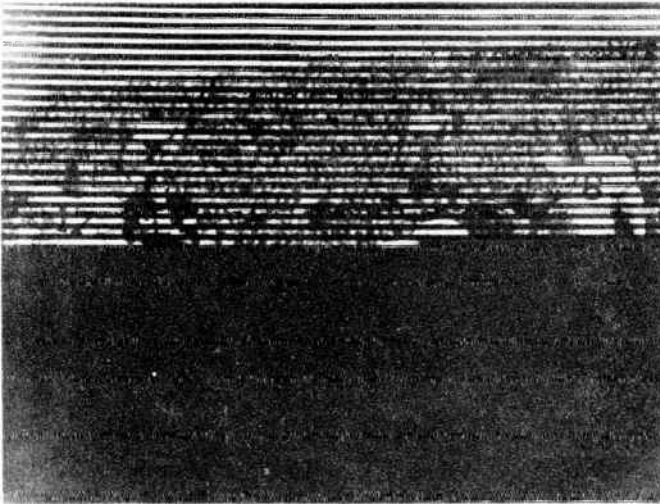

Fig. 11. Alternate picture lines are formed in this manner during downward travel of the electron beam.

sumed to have completed about half of the first set of alternate lines which are part of our football picture. Spaces between these alternate lines still are dark, as is also the entire lower part of the picture area which has not yet been reached by the electron beam.

As the beam completes its downward travel, the remaining intervening lines will be completed as in Fig. 12. This much of the picture is called one field. Now the electron beam is blanked (shut off) for another fraction of a second. We call this fraction of a second the vertical blanking period, because it follows vertical downward travel of the beam.

At the completion of the vertical blanking period the electron beam is once more started at the top of the picture area of the tube screen and commences to trace the second field. This second start is not at the left-hand edge of the picture, rather it is just half way across the width. After tracing the



Fig. 12. The first field is completed when the entire picture area has been covered with alternate lines.

remaining half distance or half-line, and reaching the right hand edge of the picture, the beam is lowered by the space of two lines and commences a full-line trace at the left-hand edge.

The traced horizontal lines slope slightly downward toward the right, as you can see in Figs. 11 and 12, also, with more emphasis on the sloping, in Fig. 13. This effect is due to

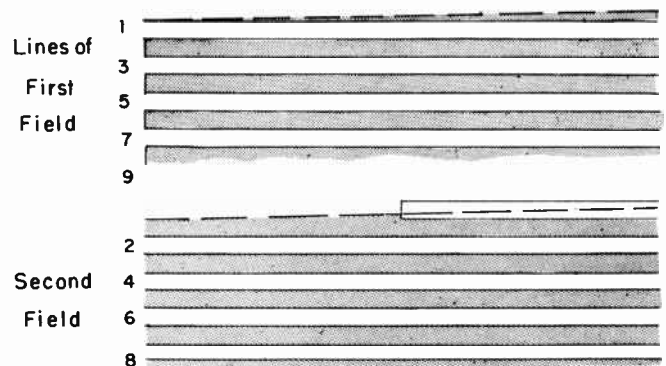

Fig. 13. The force that moves the electron beam downward acts continually throughout the entire period of each field.

the continual action of the force which moves the electron beam from top to bottom of the picture. This downward force acts during the whole time in which lines are being traced and continues through the blanking between lines. It is this force, moving the electron beam steadily downward, that brings the beam into position for tracing each line lower than



# LESSON 1 – HOW TELEVISION GREW UP

the preceding one. Only during vertical blanking does this downward force cease to act on the beam.

By starting the second field with a half line, then letting the electron beam drop by the distance between two lines, the first full line of this second field falls midway between the two lines traced at the top of the first field. The action continues, with each line of the second field falling between alternate lines of the first field. When the second field is about half completed, as in Fig. 14, the

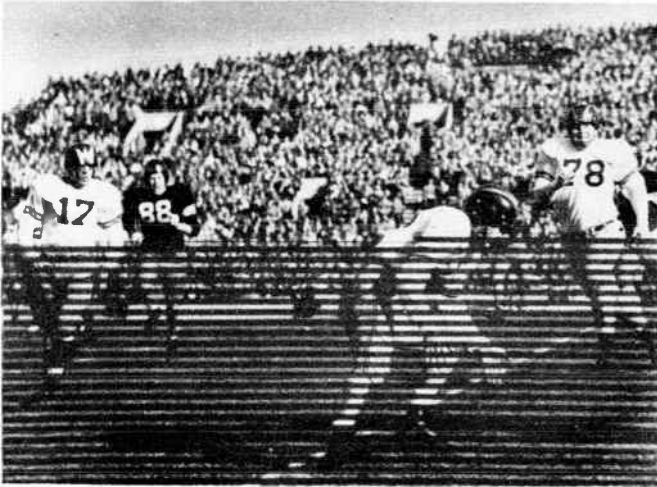

*Fig.14. As the second field is traced it fills in the missing parts between lines of the first field.*

upper part of the picture will be all filled in, while the lower part still consists of only alternate lines.

Upon completion of the second field the electron beam will have traced another 244 horizontal lines. Since this second series of lines commenced with a half line, and consists of a whole number of lines, it must end with a half line at the bottom. The beam is blanked just as it gets half way across the last line. Then follows another vertical blanking period.

All the lines which are used to form one complete picture, plus all the horizontal and vertical blankings which occur during the same time, make up what is called one frame. One frame includes two fields, or we might say that it requires two fields of alternate lines to make up one complete frame. Each

frame or each complete picture commences with the electron beam at the upper left-hand corner of the picture area on the screen. At the end of every frame, or picture, the beam starts all over again at the same upper left-hand corner and goes through the deflections and blankings for another frame to form another complete picture.

Formation of a complete picture by tracing separate horizontal lines is called scanning. Tracing of alternate lines, then filling in the intervening lines, is called interlaced scanning. The first field, with its lines and following vertical blanking, is completed in just  $1/60$  second. The second field, with vertical blanking, takes up another  $1/60$  second. Thus the entire picture, or one frame, is completed in  $1/30$  second.

Interlaced scanning is employed for the very good reason that it avoids the possibility of noticeable flickering in the reproduced pictures, even with high brightness and viewing from a short distance. Obviously, the greater the number of pictures per second the less is the chance for noticeable flicker. With interlaced scanning we have the effect of a complete picture every  $1/60$  second, or every field. This is apparent from Fig. 12, where you get the impression of the entire picture with only alternate lines, and where the impression would be vastly better with the far greater number of alternate lines in a real television picture. Although the pictures actually are filled in at the rate of only 30 per second, the rate is 60 per second so far as avoidance of flicker is concerned.

**TELEVISION SIGNAL.** We may obtain some conception of the problems to be met in forming each complete picture by considering what must be done with the electron beam during every frame or during every  $1/30$  second. Here is a list.

1. During each active horizontal line or trace, the rate of electron flow must be increased, whenever brightness is to be increased, decreased when brightness is to be reduced, and stopped where the picture area is to be black. Usually there are many changes of brightness along each line. The rate of electron flow may require changing hundreds of times during one line.

## COYNE - *television home training*

2. The beam must be blanked at the end of every horizontal line.

3. The beam must be re-established at the beginning of every line.

4. At the completion of each field the beam must be blanked.

5. The beam must be re-established at the beginning of the following field.

6. Alternate fields must start at the left side of the picture, and intervening fields must start half way across.

Every one of these variations of the electron beam must be precisely in time with similar changes occurring at the television camera which is viewing the original scene or which is scanning a motion picture film whose pictures are being transmitted. A timing error of one one-millionth of a second between the distant camera and the controls for the electron beam in your receiver would throw parts of a picture a quarter-inch out of place in relation to other parts on a 16-inch picture tube.

The signal coming from the transmitter must bring not only all the lights and shadows for every line, but all the timing impulses as well. The timing impulses control the functions numbered 2 to 6 in the preceding list. No one of the timing impulses may occur at the same instant as any other, and none may occur during formation of picture lines. How would you like to devise such a signal, and the parts which utilize it in your receiver?

**THE RASTER.** The electron beam is shifted from left to right across the picture area in forming the horizontal lines. We may speak of this movement of the beam as "horizontal deflection" or as "horizontal sweep". Movement of the electron beam from top to bottom of the picture area in forming the fields and frames is called "vertical deflection" or "vertical sweep".

The electron beam is deflected or swept both horizontally and vertically by the action of tubes and other parts within the receiver. The timing of these tubes and parts, or the

instants at which they perform their functions, is controlled by the television signal coming from the distant transmitter. Aside from the picture tube there are ten smaller tubes visible in Fig. 10. Six out of the ten operate in one way or another to deflect or sweep the electron beam in the picture tube.

If the beam is being deflected horizontally and vertically by the tubes and parts within the receiver, but no picture signal is being received from any transmitter, all the horizontal lines will be white and of uniform brightness all the way across. These lines will fill the picture area on the screen of the picture tube, for there will be the same number of lines and the same distribution of lines as when viewing a picture.

The luminous pattern of horizontal lines produced by horizontal and vertical deflection, in the absence of picture signals, is called the "raster". A raster, or the portion of it which is visible on a certain television receiver, is pictured in Fig. 15. You can pro-

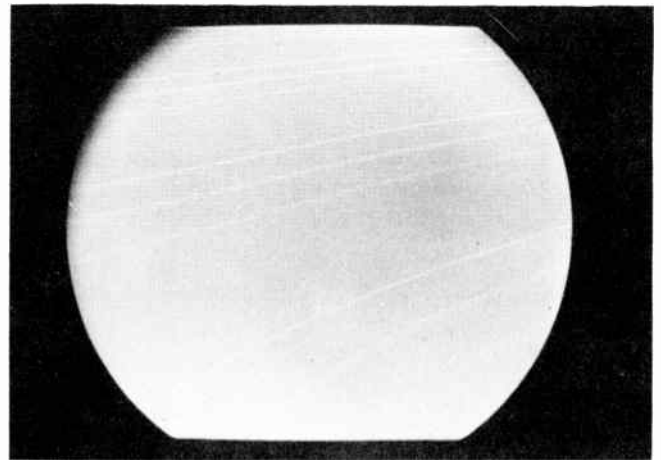

Fig. 15. This is a photograph of a raster.

duce a raster on the picture tube of any receiver by turning the channel selector to a channel on which no station operates within your reception range, and turning up the brightness control until the screen becomes bright.

**PICTURE SIZE.** In the camera tube which is viewing a televised scene or a motion picture film the picture area always is of certain proportions. It is as though you were to take snapshots with a certain camera.



## LESSON 1 – HOW TELEVISION GREW UP

Supposing your camera uses film of the popular 3-1/4 by 4-1/4 inch size. No matter what you photograph, the "negative" from which prints will be made always will measure 3-1/4 inches in one direction and 4-1/4 inches in the other direction. Furthermore, your negatives always will have square or slightly rounded corners, and the opposite sides as well as the top and bottom always will be parallel to each other.

You may make a print or finished photograph from only part of the negative, and the print may be of any proportions or of any shape. But unless the print is of the same proportions as the negative, or has a "ratio" proportional to 3-1/4 by 4-1/4, the print cannot include everything that is on the negative unless some parts of the print remain blank.

In a television camera tube the image which is focused onto the light-sensitive material through the camera lens always is 1-1/3 times as wide as it is high. To say this the other way around, the height always is 3/4 of the width. These are the proportions of all the television pictures transmitted and picked up by your receiving equipment.

If everything seen by the television camera tube is to appear on the screen of your picture tube, with no blank areas, the reproduced picture must be 1 1/3 times as wide as it is high, or the height must be 3/4 of the width. For example, if the picture reproduced on the screen is 12 inches wide it must be 9 inches high to include everything in the televised image with no blank areas at top, bottom or sides. This width of 12 inches is 1-1/3 times the height of 9 inches. The 9-inch height is 3/4 of the 12-inch width. The picture you see from the receiver may be of other proportions, but then it cannot take in all of the televised scene without leaving some areas blank.

When the height of a television picture is 3/4 of the width, the width has to be 4/3 of the height. This ratio of 4/3 or four-to-three is called the standard television aspect ratio. With a rectangular picture tube such as used on the receiver of Fig. 16 the proportions of the screen are very nearly those of the

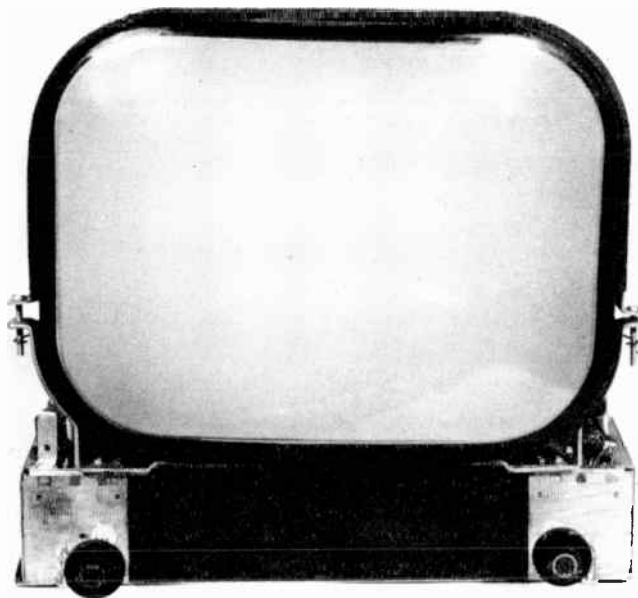

Fig.16. Width and height of the screen in a rectangular picture tube are of nearly the same proportions as the standard aspect ratio.

standard aspect ratio, 4 units wide and 3 units high. Only the corners of the transmitted picture are rounded off and removed from view by the rounded corners of the screen.

**TIME AND TELEVISION PICTURES.**  
When you sit looking at television, and an actor saunters across the scene, it may not seem as though anything were moving very fast in that picture. But let's find out what really is happening. The actor might take several seconds to move across the scene, and his image would take several seconds to move across the screen of the picture tube. (But 30 times during every second the electron beam is making 490 trips from left to right. Were it not for the blanking periods the beam would have time for 525 line traces 30 times during every second.)

(To determine how many lines could be formed per second, neglecting the vertical blanking periods, we need only multiply 525 by 30. The answer shows that there are 15,750 line periods per second. This number, 15,750, will turn out to be one of the most important numbers in the working life of a television technician.)

# COYNE - *television home training*



Fig. 17. How the rate of electron flow in the beam must vary during part of a horizontal picture line.

Now let's see how many times the rate of electron flow in the electron beam of the picture tube may have to change during any one horizontal line. Look at Fig. 17. Here we have the same portions of the same two horizontal picture lines as in Fig. 8. During travel of the electron beam from left to right along one of these lines the rate of electron flow must increase every time the shading varies from darker to lighter. And the rate of electron flow must decrease every time the shading changes from lighter to darker.

Along the bottom of Fig. 17 are represented the changes in rate of electron flow which form the lights and shadows of the lower one of the two picture lines illustrated. The jagged line representing electron flow goes up when there is an increase, remains level when there is no change, and drops when there is a decrease in the flow. If you count the ups and downs you will find 19 increases and 18 decreases in this portion of line, which is only about 30 per cent of the full line width in the original picture. With the same rate of change along a whole line there would be about 60 each of the ups and downs.

Now look back at Fig. 6 and imagine that we are scanning along one of the upper lines which passes through the bank of spectators. It is easy to realize that along one such line there may be hundreds of changes between light and dark, and hundreds of changes of electron flow may be needed to reproduce every such line in the reproduced picture.

Supposing that it takes only 220 ups and downs of light and of electron flow during one complete line period. There are 15,750 line periods during every second. Then how many times may the electron flow have to change during one second? To find out we multiply 15,750 (line periods per second) by 220 (changes per line) to learn that there might be as many as 3,500,000 changes, approximately,

from light to dark and back again during one single second.

All that has been said in the preceding paragraph would be summed up by the television technician this way. "You need a video response up to  $3\frac{1}{2}$  megacycles." Maybe that sounds technical, but quite likely you or any of your friends will say, "It whistled over first for a single, but then Bob rapped a slow bouncer which was scooped for a force out". Television never gets so technical as that.

We have become acquainted with the meanings of many words and terms which are important in television. A list follows. How many of the meanings could you explain to someone else?

Aspect ratio	Field	Phosphor
Blanking	Flare	Raster
Deflection	Frame	Scanning
Electron	Horizontal line	Screen
Electron beam	Interlaced scanning	Sweep
Electron gun	Neck	
Face	Persistence of vision	

There is one more technical word which is used in all kinds of meanings by all kinds of people. This word is video. When used correctly, video refers to the television picture plus everything which keeps the reproduced picture correctly in time with images formed at and transmitted from the television camera. The video signal means the portion of the transmitted television signal that forms lights and shadows of pictures and that also controls timing for both horizontal and vertical deflections of the electron beam. In other words, the video signal includes everything except that portion of the transmitted signal which brings the accompanying speech, music, and assorted sound effects.

To learn television, radio, and the funda-

## LESSON 1 – HOW TELEVISION GREW UP

mentals of electrons at the same time we need study only television. Then a rather small part of what you learn will make you a first class radio service man, while all of it together makes you a television technician. Anyone who can service television receivers can service broadcast radio receivers with the greatest of ease. Asking a competent

television technician to service a broadcast radio receiver is much like asking an expert automobile repair man to fix a bicycle. As you learn to work with television receivers you are learning to work with radio receivers at the same time, and are learning also the basic facts and principles of the whole broad subject of electronics.

# TELEVISION

◦ RADIO

◦ ELECTRONICS

---

---

**LESSON 2—WHAT HAPPENS IN A TELEVISION RECEIVER**

---

---

***Coyne School***

*practical home training*

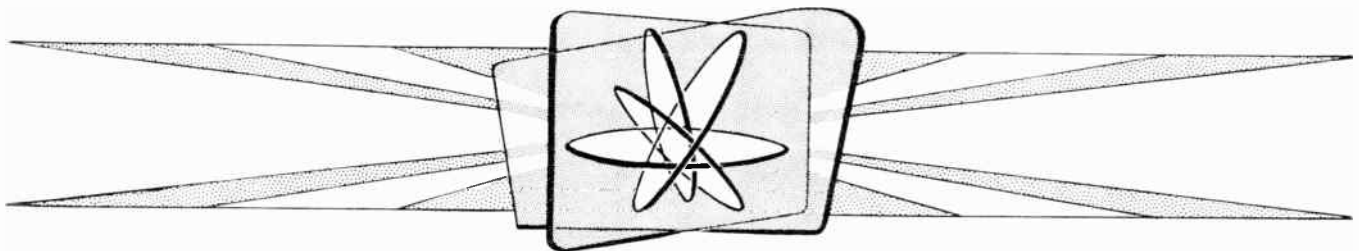

*Chicago, Illinois*

---

*Copyright, 1954 by Coyne Electrical School  
Chicago 12, Illinois  
All rights reserved.*

Litho. in U.S.A.



## Lesson 2

# WHAT HAPPENS IN A TELEVISION RECEIVER

The features of a television receiver which most often concern the technician are underneath the chassis. The chassis, as you probably know, is the large sheet-metal housing or box-like structure which supports all the other parts of a receiver. Fig. 1 is a photograph of some of the wiring and parts on the underside of the chassis of a certain television receiver. Try turning this picture upside down. Then turn it so that either side is at the bottom. No matter how you look at it, we seem to have merely a jumble of larger and smaller parts and their wire connections.

The underside of any television chassis looks to the novice like a disorganized collection of parts and random connections. The trained technician doesn't see things that way. He can look at even one portion of a chassis, in our photograph, and identify with practical certainty one end of the i-f amplifier system, the low-voltage power transformer, one of the deflection or sweep transformers, and what undoubtedly are the adjustments for horizontal width and linearity. The technician can recognize all the resistors and capacitors, and by looking at their color codes read the value of every one.

There may be 400 odd parts between the antenna connections, where the video signal goes in, and the connections to the picture tube - not counting screws, nuts, clips, wires, insulators, and other small items too numerous to mention. As you progress in this work you no longer will think about the 400 separate parts, but you will see certain distinct sections of the receiving apparatus.

You will see the tuner, the i-f amplifier, the video amplifier, the sync section, the sweep oscillators and controls, the deflection amplifiers, the sound section, and other smaller groups of parts. Every group or every section will appear distinct from every other. You will see, in your mind's eye, how the video signal passes through one of these sections after another until it gets to the picture tube.

In this lesson it is our purpose to get acquainted with the principal sections by looking at some television receivers. Every receiver, no matter what its make and model, must contain the same principal sections. Take, for example, the tuner. Any tuner must perform the same functions in the same general way everytime. Doubtless, there are in use and have been used at least forty different kinds of tuners, but the differences are in details, not in basic operating principles. There are and have been at least a score of automatic controls for horizontal deflection, but all must operate to hold the picture steady on the screen.

To look at structural details of a receiver you first must take it out of the cabinet or console. Ordinarily you will commence by pulling off the front control knobs, then you will take off the back cover with its attached power cord, disconnect the speaker from the chassis, disconnect the antenna lead, take out the bolts or screws that hold the chassis in the cabinet, and carefully withdraw the chassis through the back of the cabinet.

Although this is the usual way of doing it, don't try taking a chassis out of its cabinet just yet. For one thing, you might bump and crack the glass of the picture tube, with disastrous results. On the outside of the picture tube there is pressure of about 14.7 pounds per square inch in the air which is all around us. Practically all air and other gases have been pumped out of the inside of the tube, leaving a nearly complete vacuum and almost no pressure at all. Depending on the size of the picture tube, the difference between total outside and inside pressures is something between two and one-half and four tons. If cracked, the tube will implode, meaning that particles of glass are driven inward by this great pressure. Then the particles rebound outward. You can suffer serious injury unless protected with suitable clothing and shatterproof goggles.

As a chassis comes out through the back

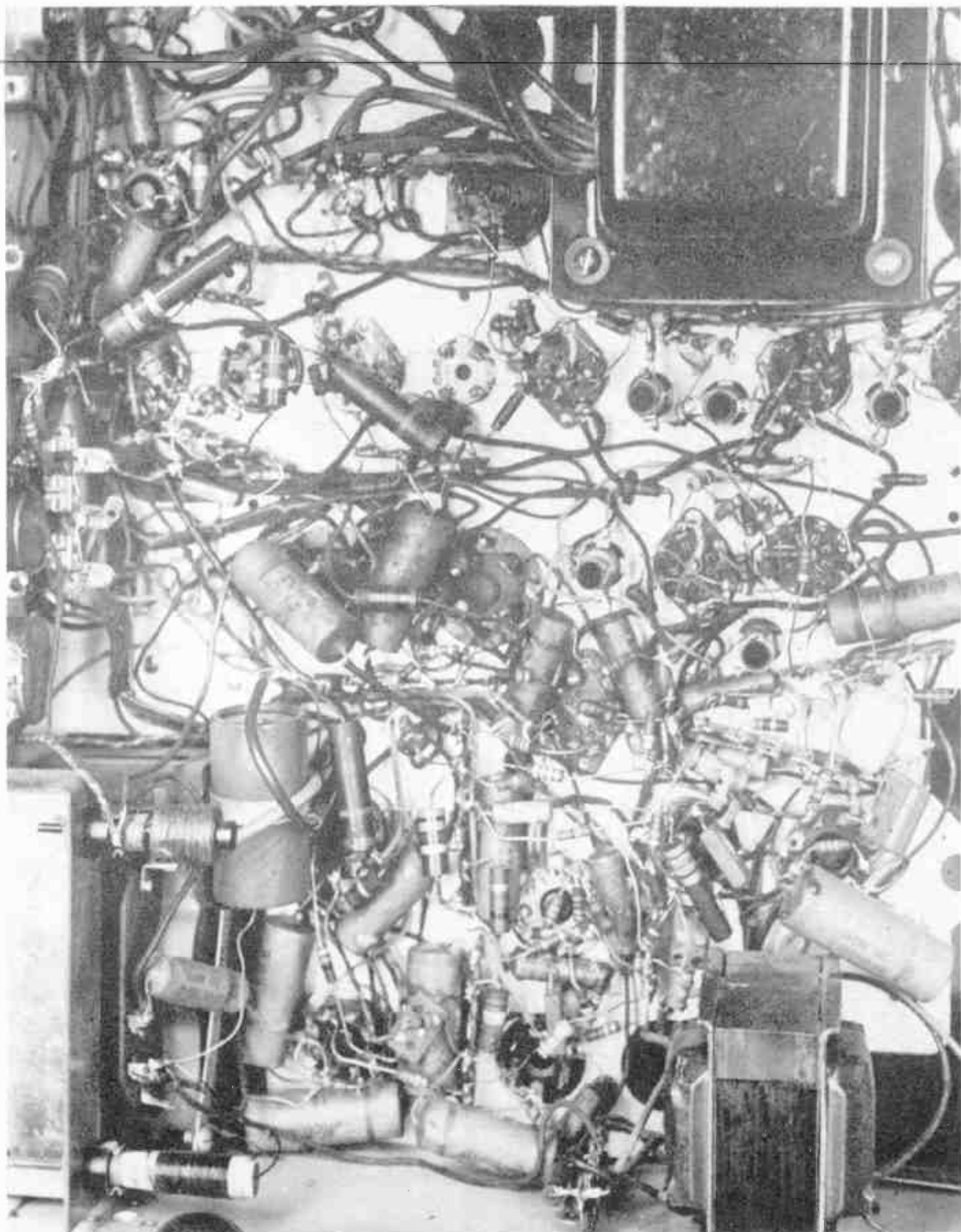
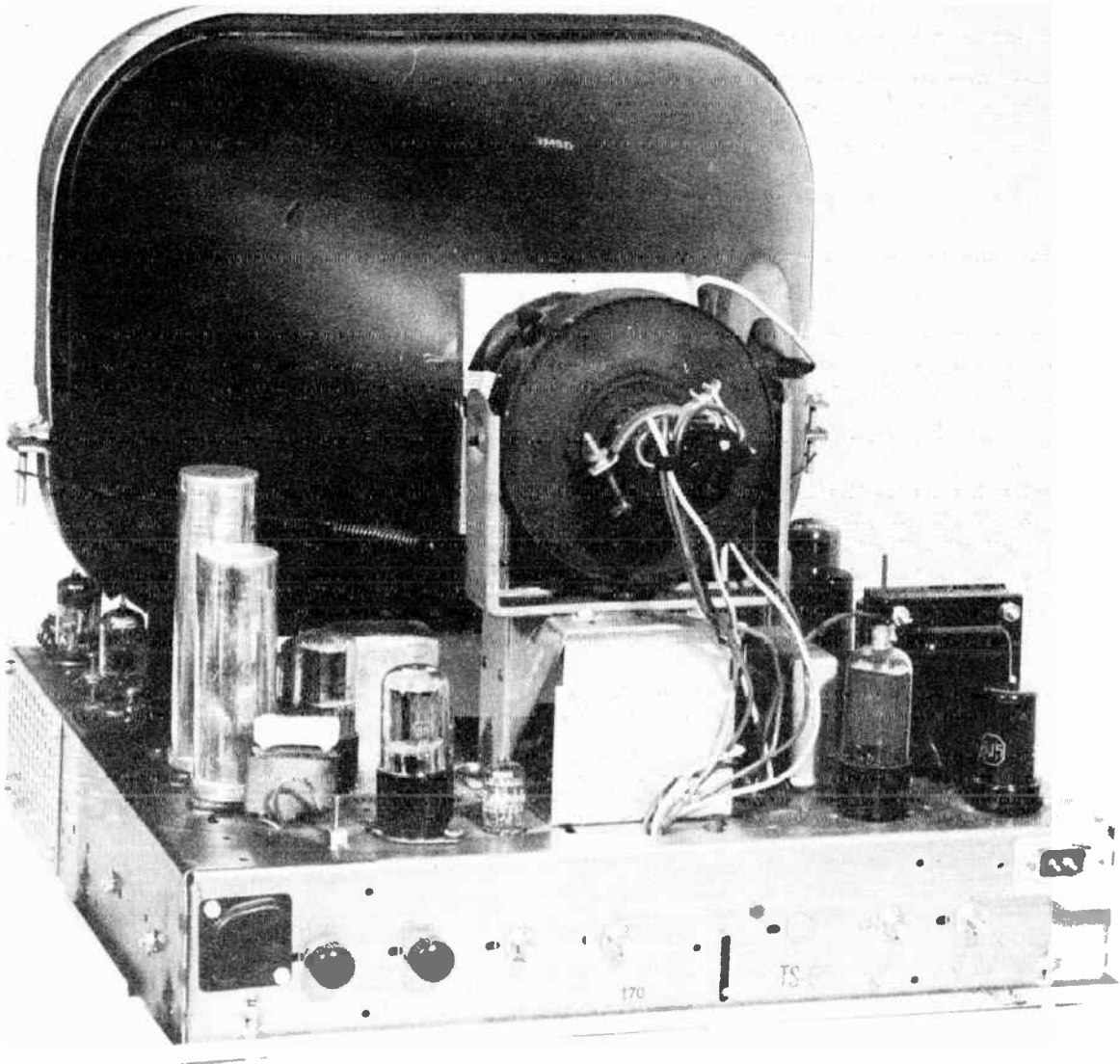

Fig. 1. *The underside of a television chassis appears to the novice as a jumble of small parts and connections.*

## LESSON 2—WHAT HAPPENS IN A TELEVISION RECEIVER



*Fig. 2. The television receiver as it is withdrawn from a cabinet or console.*

of its cabinet it looks like Fig. 2. The biggest thing in sight is the picture tube. This tube is supported around the face or at the front of the flare by suitable cushioned brackets and clamps. Around the neck are coils of wire which act as magnets to deflect the electron beam horizontally and vertically. There is another magnet which focuses the stream of electrons so that they come together on a very small spot at the screen of the tube. These coils or magnets are carried by brackets, and thus the neck of the tube is supported.

Many of these details may be seen more clearly by looking at the side of the chassis, in Fig. 3. Inside the deflecting yoke are four coils of wire which, when carrying varying

electric currents, act as magnets to sweep the beam horizontally and vertically. The deflecting yoke is adjustably mounted so that it may be rotated one way or the other around the picture tube neck to correct any tilting or "skew" of the picture as it appears within the mask.

The magnet coil for focusing is adjustably mounted in a trunnion bracket which, with another pivot not visible in the picture, forms a gimbal support somewhat like that for the compass of a ship. This arrangement allows tilting the focus coil at various small angles with reference to the neck of the picture tube. Although this is a focus coil, the tilting does not alter the focus. It allows centering the picture within the mask. Fo-



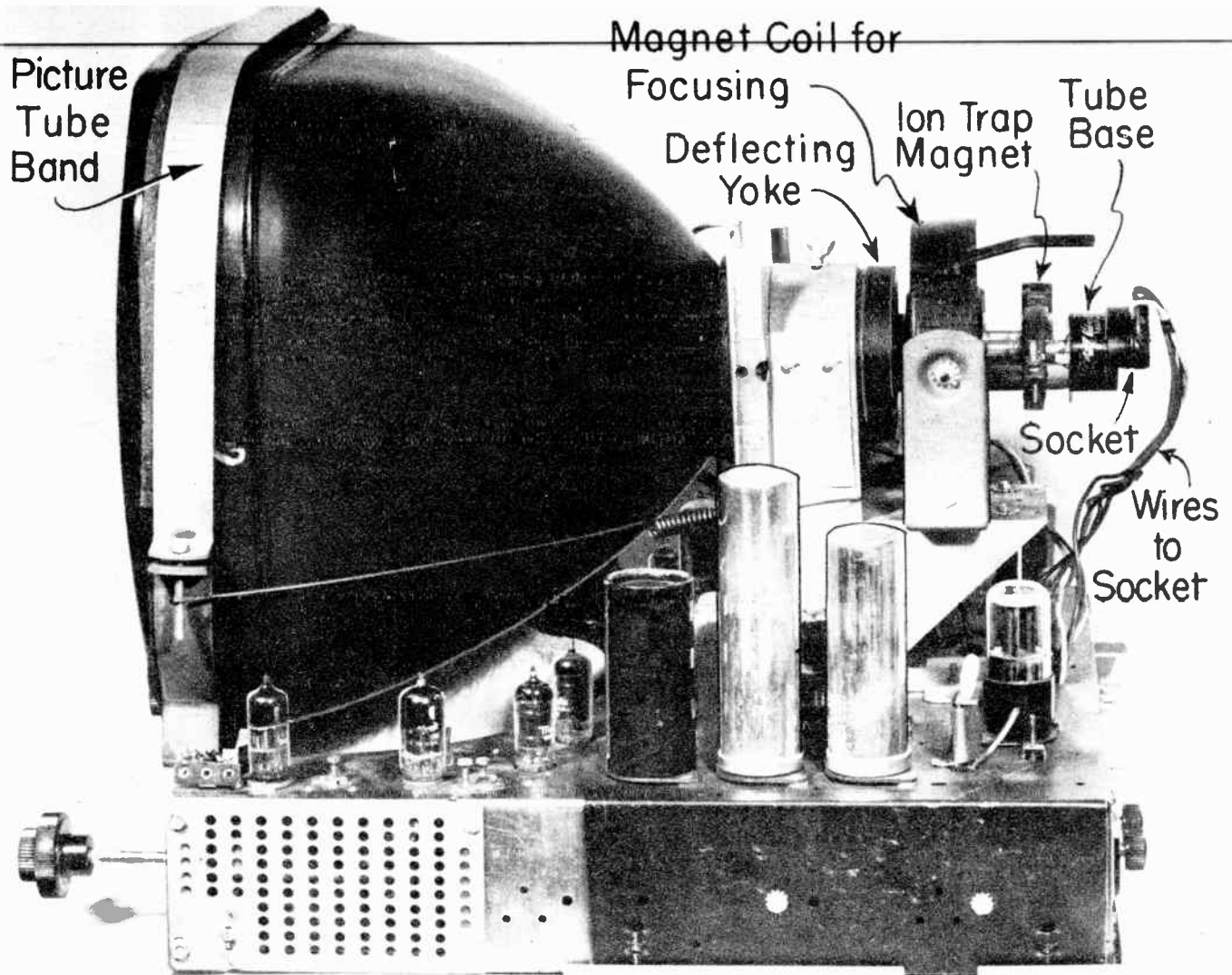

Fig. 3. Parts which are mounted around the neck of the picture tube.

cusing is accomplished by varying the electric current that flows in the coil.

Between the focus coil and the base of the picture tube is a small magnet which forms part of an "ion trap". The purpose of the ion trap is to prevent permanent darkening near the center of the picture tube screen by streams of ions. An ion of the kind that affects the screen, is an atom of gas which has taken on one or more extra electrons.

Don't be too much concerned because of the fact that we merely mention so many technicalities during this preliminary examination of television receivers. Later we shall deal at length with each one, at least with their significance in service operations.

As an example, the ion trap magnet is adjustable. Correct adjustment helps to form a bright, clear picture. Incorrect adjustment may darken the picture, blur the details, cause deep shadows in the corners, "burn" the screen, or ruin the electron gun.

As you well know, all the tubes in an ordinary radio set are supported by their bases, from which metallic pins extend into sockets fastened to the chassis metal. But the base of the picture tube takes no part in supporting this tube. In fact, the base supports the socket. The wires which carry electrons to and from the electron gun are flexible. All of them are soldered to lugs of the socket. The socket slips onto the base of the picture tube.

## LESSON 2—WHAT HAPPENS IN A TELEVISION RECEIVER

The smaller tubes of television receivers are supported by their base pins in chassis-mounted sockets, just as in radio sets. Many of these smaller tubes may be seen in Figs. 2 and 3. The bottoms of many tube sockets are visible in Fig. 1.

**TUNERS.** Now let's commence following the video signal from antenna to picture tube. Many television receivers are operated with outdoor antennas, which you can see on the rooftops of houses, apartments, and all manner of buildings. Sometimes an antenna of the same general style is mounted in an attic. Most of the more recent television receivers are equipped with built-in antennas mounted within the cabinets or consoles. A built-in antenna can pick up a signal of satisfactory

strength if it is close enough to one or more transmitters, otherwise you have to use an outdoor type or one placed in a high attic.

Fig. 4 shows a tuner which is used and has been used in many makes and models of television receivers. This unit has been taken out of the chassis. On top are two tubes, and partly concealed by one tube is a coil of wire wound on an insulating form. Down below is a large cylindrical drum, part of which extends below the housing. This drum is turned by the shaft extending out to the left. To the shaft is attached the channel selector dial or pointer. When the drum is turned to various positions it changes the tuner connections or circuits to allow reception from any television station that is within range. This type is called a "turret tuner".

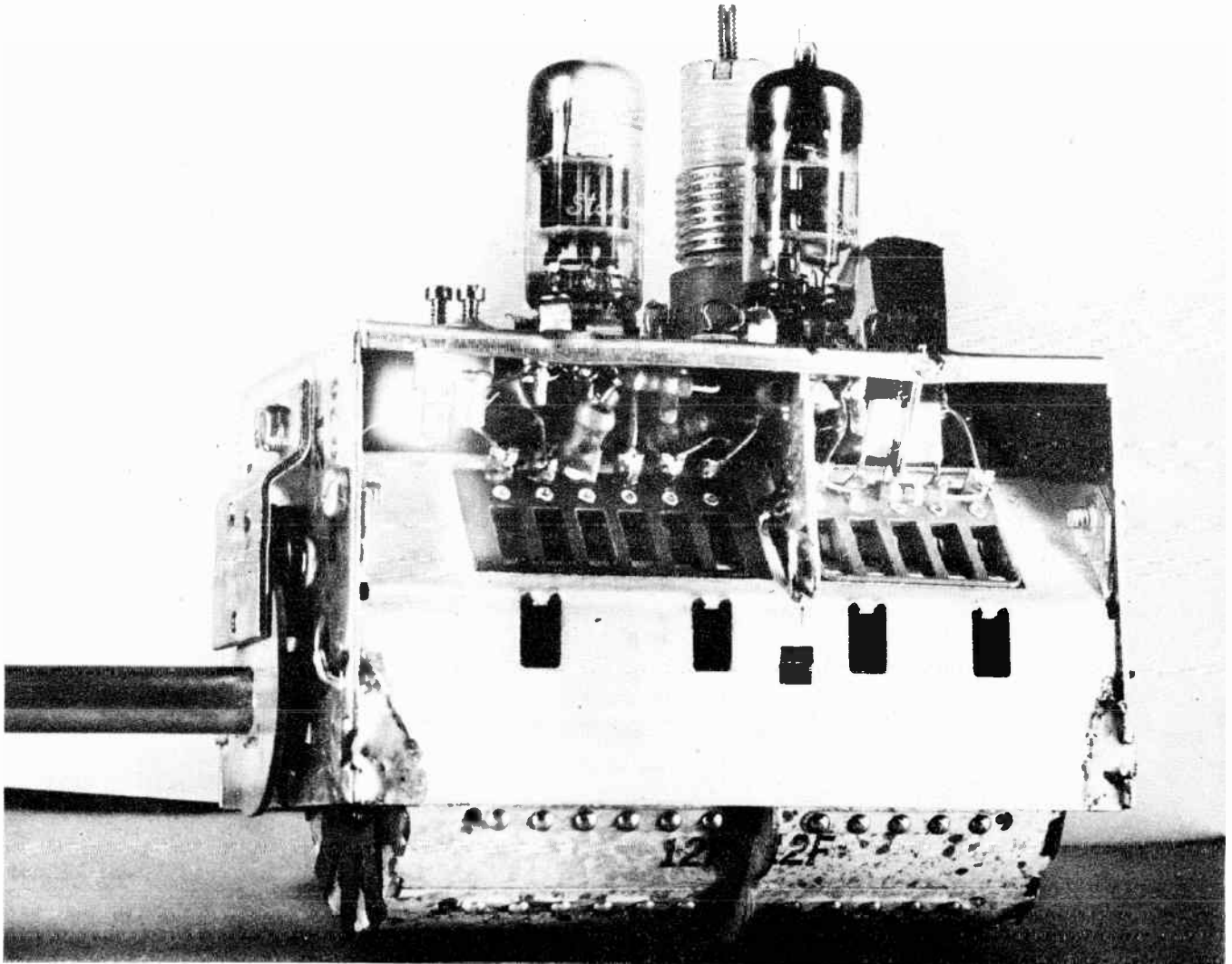

Fig. 4. A turret tuner for selecting the television channel in which reception is desired.



## COYNE - *television home training*

The left-hand tube on this tuner is a twin type. It is the equivalent of two separate tubes, but both sets of "elements" are built into a single glass "envelope". The elements of a tube include all the internal parts that control the flow of electrons through the tube. The envelope is the outer enclosure, which is of glass for some tubes and of metal for others. Practically all air and other gases have been removed from inside the envelope, leaving a partial vacuum. We say that the tubes are highly evacuated.

A tuner not only selects the desired program or channel, it changes the frequency of the received signals. To understand why this is necessary we must know something about the character of these signals.

A television or radio transmitter sends through space neither electricity, electrons, or any other material thing. The transmitter sends out only a kind of radiation which is of the same general nature as light and heat which are radiated through 93 million miles of empty space from the sun to the earth. Television and radio signals, as well as radiant light and heat, require no form of matter to take them from place to place. When the announcer says, "We are on the air", he should say, "We are on space", for air only hinders the progress of all radiated waves.

Two kinds of forces move out and away from the transmitter and come to the antenna of your receiver. One is an electric force, the other is a magnetic force. Every pulse of electric force moves along between two pulses of magnetic force, and each magnetic pulse is in between two electric pulses. A pair of pulses, one of each kind, make up what is called an electromagnetic wave or a radio wave in space. Television waves are just one variety of radio waves.

The number of complete waves leaving the transmitter during each second of time is the frequency of the radiation. The waves which bring signals from the transmitter to your receiver are at very high frequencies. In television channel 2 the frequencies are between 54 and 60 megacycles per second. They are higher in each succeeding channel, until in channel 13 the frequencies are up be-

tween 210 and 216 megacycles per second. The frequencies in the ultra high frequency channel 83 is between 884 and 890 megacycles.

At the transmitter the radiated waves are varied in strength in accordance with the video signal. Maximum strength is used for timing the horizontal and vertical deflection of the electron beam in the picture tube. Minimum strength is used when picture areas are to be made white. Intermediate strengths are used when picture areas are to be gray or black. When the radiated waves are thus varied in strength to conform to the video signal we say that they are "modulated" by the signal.

The radiated waves are called carrier waves because, by means of the modulation, they carry video signals from transmitter to receiver. The frequencies of the radiated waves are called carrier frequencies. As the waves leave the transmitting antenna their average force or average strength is very great. The strength varies in accordance with the video signals, but it remains at a high average level. As the waves spread out in all directions through space they become weaker and weaker in average strength, although still retaining the video-signal variations. The radiated waves are affected by distance just like the rays radiated from a light. The farther you are from the source of light the weaker is the illumination received. Your receiving antenna is so small, and is so far from the transmitter, that it picks up only a little of the weakened wave forces. These small forces must be tremendously strengthened in the receiver before they are able to control the intensity and the deflection of the electron beam in a picture tube.

There are two reasons why the tuner is designed to change the frequency of the received signals. First, it is difficult to construct a receiver which will build up the strength of the signals to a sufficient degree when all the parts operate at the very high carrier frequencies. Any given number of tubes and associated parts in a receiver will be far more effective at lower frequencies. Therefore, the tuner takes in signals at car-

## LESSON 2—WHAT HAPPENS IN A TELEVISION RECEIVER

rier frequencies and turns out signals at lower "intermediate frequencies".

Intermediate frequencies in television receivers are between 20 and 50 megacycles per second, at which it is much easier to build up the strength or to "amplify" the signals than at carrier frequencies. The output from the tuner, at intermediate frequencies, still retains the modulation of the video signal.

The second reason for changing the frequency of received signals is that all the different carrier frequencies in all the different television channels can then be made to produce the same intermediate frequencies in any one receiver. When this is done, all the parts which follow the tuner may be designed

to work at the same intermediate frequency no matter what channel is being received. Construction is greatly simplified, because, so far as these following parts are concerned, it is as though the receiver remained tuned to the same channel all the time.

There are many varieties of tuners, just as there are many varieties of nearly every other part or section in television receivers. Fig. 5 is a picture of a tuner mounted in a chassis, as you can tell by the wires connected to it on the right. The electrical design and construction of this unit are decidedly different from those of the tuner in Fig. 4. However, both tuners change the incoming carrier signals to signals at intermediate frequencies while retaining the modulation that represents video signals.

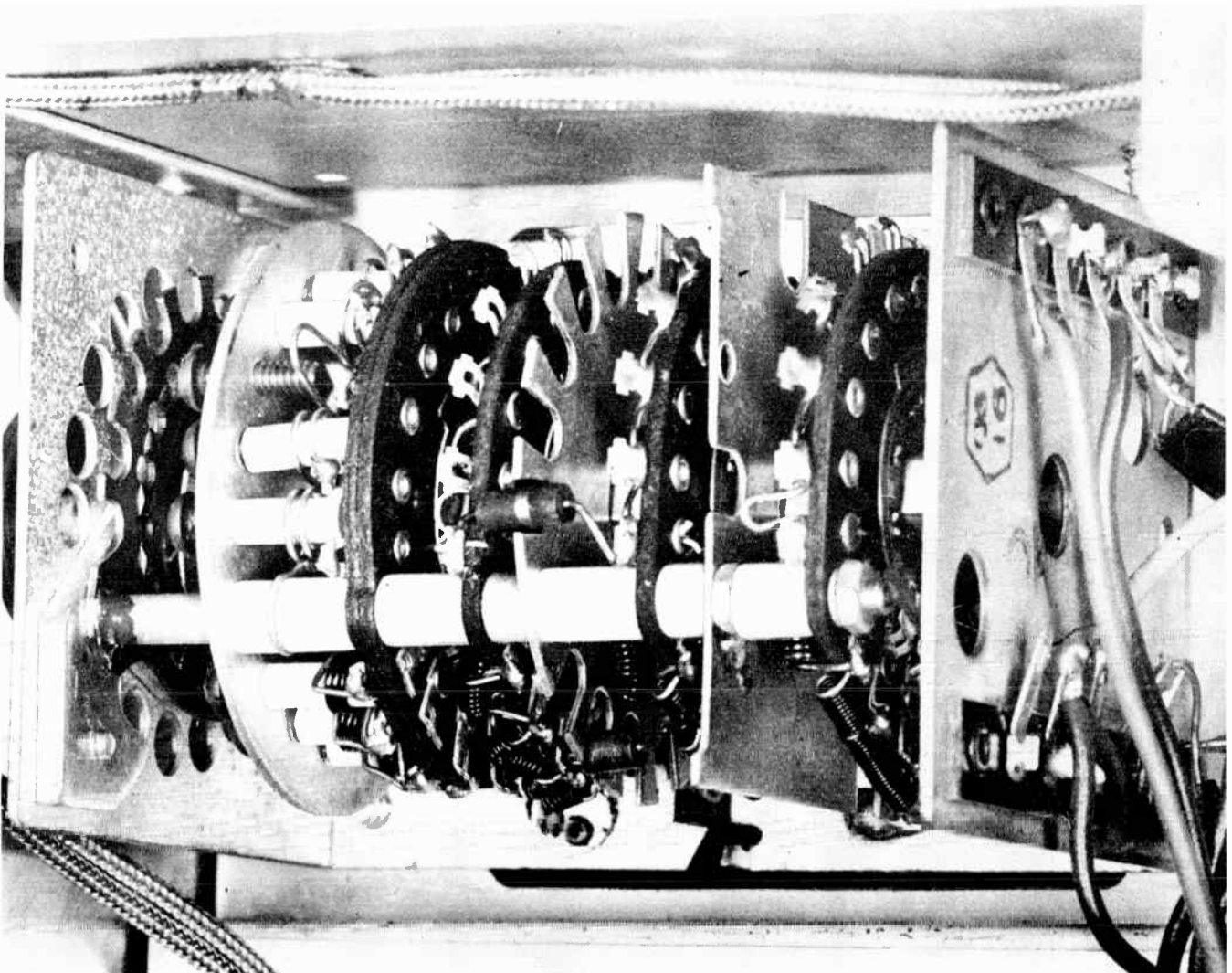

Fig. 5. This is one form of "incremental" tuner, a type used in many television receivers.



## COYNE - *television home training*

**INTERMEDIATE-FREQUENCY AMPLIFIERS.** When the modulated signal at intermediate-frequencies comes out of the tuner it must be strengthened or amplified. The section of the receiver in which this is done is called the intermediate-frequency amplifier. The words "intermediate-frequency" are so long, and are used so often, that nearly always they are abbreviated to "i-f" or sometimes to "if".

In Fig. 6 we are looking at one side of the chassis of a television receiver. At A, B, and C are the three tubes of the tuner. Earlier we looked at a tuner having only two tubes, but one of them was a twin type. That made the equivalent of three tubes. Here we have three separate tubes performing the same functions.

The parts of the i-f amplifier which are on top of the chassis in Fig. 6 are numbered from 1 through 7. Part number 1 is an i-f transformer that "couples" the signal output of the last tube in the tuner to the first i-f amplifier tube, numbered 2 in the picture. In order that tubes may be forced to do useful work of any kind, such as amplifying a signal, we must connect them together through some type of coupler or coupling. A transformer is one kind of coupler. The first tube of any pair does its work on the coupler, and the results of this work are applied from the coupler to the following tube.

Part number 3 is another transformer, and number 4 is the second i-f amplifier tube. Then comes still another transformer, number 5, followed by the third i-f amplifier

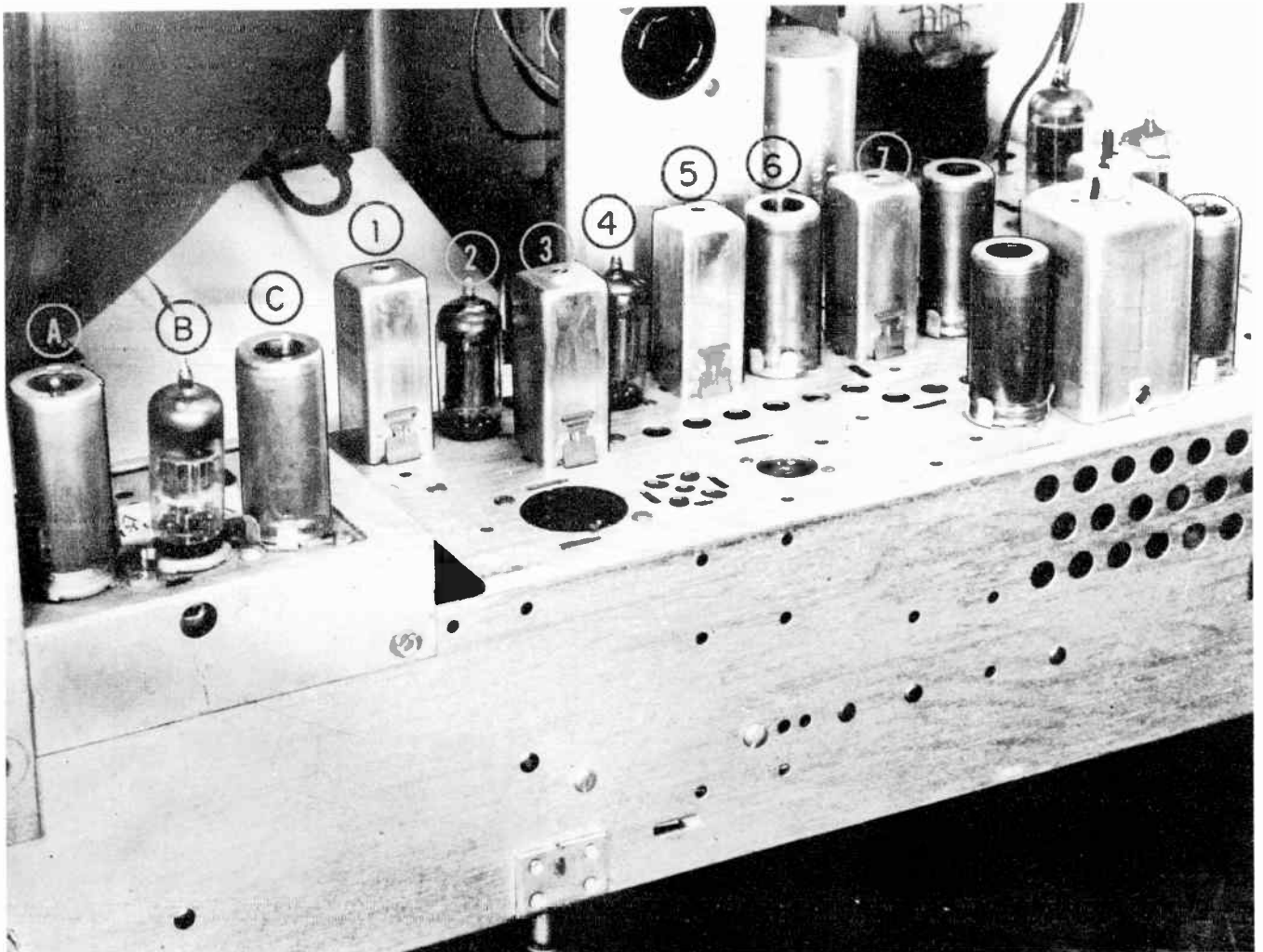

Fig. 6. Tubes and coupling transformers for the tuner and i-f amplifier as they appear above the chassis in one receiver.

## LESSON 2—WHAT HAPPENS IN A TELEVISION RECEIVER

tube, number 6. The output of this third and last i-f amplifier tube goes to the transformer numbered 7.

You cannot see the actual internal construction of the coupling transformers because they are enclosed within sheet metal "shields". These shields are used to prevent undesirable effects of radiation within the receiver itself. There may be both magnetic and electric radiations from any parts which are carrying electric currents. Usually these radiations are not very strong, but they may have considerable effect on other parts only a few inches away. Such effects are reduced or eliminated by the shielding enclosures which are in direct contact with chassis metal.

Note that there are cylindrical metal shields around two of the tuner tubes, A and C, also around the third i-f amplifier tube, number 6. By looking closely you will see that all the shields are held securely on the chassis by spring clips. The technician often calls a shield a "can".

The amplified i-f signal which appears on the output side of the last i-f transformer is far stronger than the signal which enters the i-f amplifier section from the tuner, but the form of the signal is unchanged. That is, at the output of the i-f amplifier section we still have a signal at the intermediate frequency, modulated with the variations of strength that represent the video signal. The video signal frequencies of 30 cycles to something like 4 mc still are being carried along, on an intermediate frequency.

One amplifying tube together with one transformer or coupler of any kind connected to the output of the tube make up what is called one stage of amplification. How much the signal is strengthened in each stage depends on the type of tube and on how it is operated, also on the design and construction of the coupling device. The number of times that signal strength is increased in one stage may be called the amplification of that stage, but more often we call it the "gain" or the "stage gain".

The total gain or overall gain of an am-

plifier section is the product of the several stage gains. Supposing there are three stages, each with a gain of 20. The original signal strength will be multiplied by 20 at the output of the first stage. This output of 20 will be multiplied by 20 more in the second stage, whose output they will have a strength of 400, or 20 times 20. The third stage will multiply this 400 by another 20 times, and at the output of the third stage we have a signal 8,000 times as strong as at the input to the amplifier section.

**VIDEO DETECTOR AND AMPLIFIER.**  
Now let's look at our receiver from a slightly different angle, in Fig. 7. This view is from the same side of the chassis, but we are now looking from the rear toward the front. Tubes A, B, and C, in the tuner, are the same as the similarly lettered tubes in Fig. 6. The parts of the i-f amplifier numbered from 1 through 7 are the same as the similarly numbered parts in Fig. 6. At the output of i-f transformer number 7 we have the greatly strengthened i-f signal carrying the modulation which represents the video signal.

Now we shall get rid of the portion of the signal which is at the relatively high intermediate frequencies, between 20 and 50 mc, and retain the video signal whose frequencies range from 30 cps to about 4 mc. This is done by the video detector tube, which is inside the shield numbered 8 in Fig. 7.

Away back at the transmitter the signal radiated at carrier frequencies is modulated by the video signal. The carriers deliver the video signal to our receiving antenna, from where it passes into the tuner. The tuner takes in modulated carrier frequencies and furnishes modulated intermediate frequencies to the i-f amplifier. The i-f amplifier strengthens the modulated intermediate frequencies and delivers them to the video detector.

The video detector "demodulates" the i-f signal, to recover the video signal that was put onto the carriers at the transmitter. In the type of detector used for video demodulation in television receivers there is no gain, instead there is some loss of signal strength. But the signal has been amplified sufficiently to stand this loss.



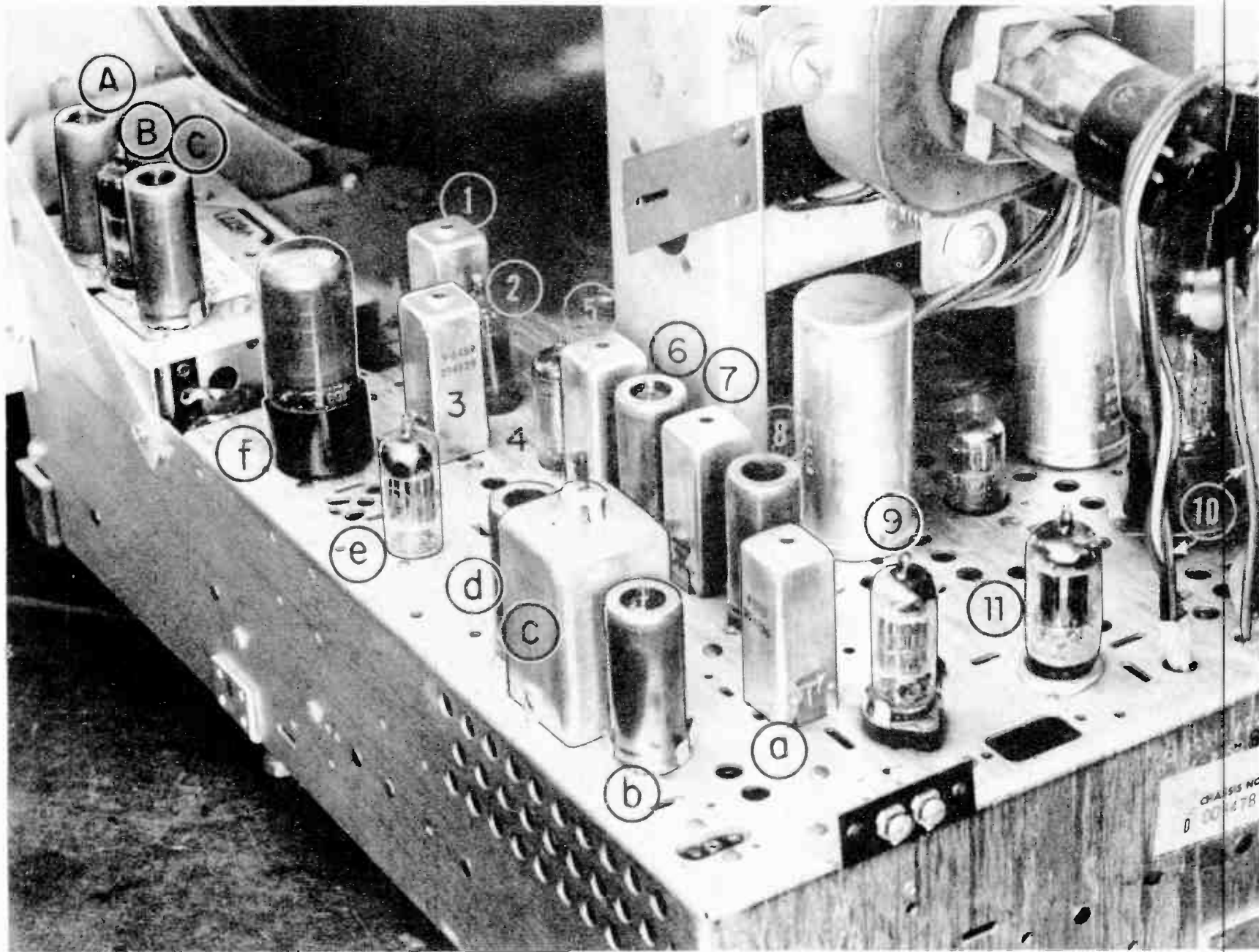

Fig. 7. Here appear also the video detector and amplifier, one of the sync tubes, and tubes and transformers for the sound section.

## LESSON 2—WHAT HAPPENS IN A TELEVISION RECEIVER

Through a coupling arrangement which is underneath the chassis the video signal from the video detector goes to the video amplifier tube, number 9 in Fig. 7. This video amplifier greatly strengthens the video signal. Through another coupling device which is underneath the chassis the strengthened or amplified video signal goes through two of the wires at 10 to the socket which you can see on the base of the picture tube, then to the electron gun inside this tube. We have followed the video signal all the way from the transmitter through to the electron gun in the picture tube of our television receiver.

You will recall that the video signal consists of variations which represent lights and shadows of reproduced pictures, also of the impulses that time the deflection of the electron beam. To keep things straight it should be mentioned that the entire video signal goes from the video amplifier tube to the electron gun of the picture tube. But the picture tube is operated in such manner that only the signal variations for lights and shadows are used by the electron gun. The picture tube automatically rejects the timing pulses, and allows the rate of electron flow in the beam to be varied only by the portion of the video signal that corresponds to picture shades and tones.

The entire video signal, including the timing pulses, goes from the video amplifier tube also to another section of the receiver. This is the sync section. The word "sync" is an abbreviation for "synchronizing". To synchronize means to maintain the operation or action precisely in time with, or in step with the operation or action of something else. The purpose of the sync section of a television receiver is to extract from the video signal the timing pulses which eventually will control deflection of the electron beam. The first tube in the sync section of this particular receiver is numbered 11 in Fig. 7.

Just as the picture tube is operated in such manner as to utilize only the picture forming portions of the video signal, so the first tube or tubes in the sync section are operated to utilize only the timing pulses of the video signal. Later we shall have much more to say about the sync section and parts which follow it.

In Fig. 7 you will see another series of coupling transformers and tubes lettered from a through f. These are parts of the sound reproduction system or parts of the sound section of our receiver.

Up to this point we have followed the television signal through the path shown in simplified form by the block diagram of Fig. 8. Such block diagrams, but with all sections included, often are found in the service manuals issued by manufacturers. They help to indicate the relations between sections and to show the paths followed by the video signal through the receiver.

Before continuing the investigation of what happens to the video signal, supposing we turn the chassis of our receiver upside down, as in Fig. 9. Later on, when you are "trouble shooting", you will be working on the parts shown here more than on those which are accessible from on top. In the upper left-hand corner of the photograph, which is at the front of the receiver, we see the underside of the tuner.

The bottoms of the sockets of the three i-f amplifier tubes are marked 2, 4, and 6 on the bottom view of the chassis. The tubes are marked with similar numbers on the top views of Figs. 6 and 7. The bottoms of the coupling transformers, on the view underneath the chassis, Fig. 9, are between the tuner and first i-f amplifier, between the amplifiers, and between the last i-f amplifier and the video detector.

The sockets for the video detector and video amplifier tubes are numbered 8 and 9 on the bottom view, just as these tubes are similarly numbered on the top views. The first sync section tube, and its socket, are marked 11 on all the views. In Fig. 9 the tube sockets for the sound section are visible at b, d, e, and f, corresponding to similarly lettered tubes in the other views.

Now let's look at some of the important sections of the receiver as the competent technician sees them when looking at the bottom of the chassis. You see Fig. 9, he sees Fig. 10. The output tube of the tuner happens to be the one at the center of that

## COYNE - *television home training*

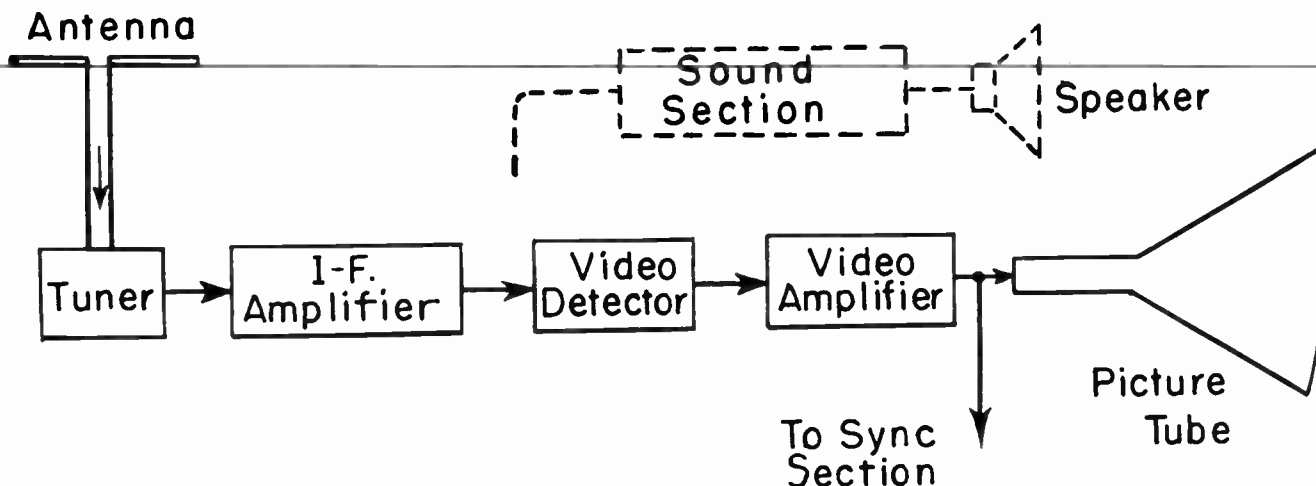

Fig. 8. This block diagram shows signal travel from antenna to electron gun in the picture tube.

unit in this particular receiver. From the output of the tuner the i-f signal goes to the i-f amplifier, in which there are three tubes numbered 2, 4 and 6. In some receivers this amplifier might have only two tubes. Again it might have four or even five tubes. Regardless of the number of tubes, the i-f amplifier strengthens the modulated i-f signal without changing its form.

From the i-f amplifier the strengthened signal goes to the video detector, (tube #8) where the i-f part disappears to leave only the video signal. The video signal goes to the video amplifier (tube #9) to be strengthened. The video amplifier might contain one, two, or three tubes, or it might have a twin tube with two sets of amplifying elements in a single envelope.

From the video amplifier the video signal goes two ways. It goes to the electron gun of the picture tube, where the picture-forming portion of the signal is utilized. The video signal goes from the video amplifier also to the sync section, where the timing or synchronizing portions of the signal are separated from the picture portions and treated in various ways whose need will appear as we progress in our work.

In the particular receiver being examined, the sound signal has come from the antenna through the tuner, the i-f amplifier, and the video amplifier. Although the television sound signals are entirely separate

and of entirely different character than the video signals, these sound signals may be handled by the same tubes. Any tube can be made to amplify and perform other operations on two or more signals at the same time so long as the signals are of different kinds. The amplified sound signals here go from the video amplifier (tube #9) to the sound section, noted by b, d, e and f, from which they are delivered to the speaker in the form of speech and music.

In other receivers or other types of receivers the sound signals do not go through the i-f amplifier, video detector, and video amplifier. They do, however, go through the same tuner as the video signals, and are taken to the sound section from the output of the tuner. In a few minutes we shall look at an example of the other type of receiver or at the other type of sound section.

Getting back to the sync section of Fig. 10, the timing portions of the video signal are delivered from the output of the sync section to the vertical sweep section and to the horizontal sweep section. By a very ingenious arrangement of capacitors and resistors the sync output is "filtered" so that the signal pulses for timing vertical deflection of the electron beam go to the vertical sweep section, while the pulses which are to time the horizontal deflection go to the horizontal sweep section. The outputs of the sweep sections go to the magnet coils in the deflecting yoke, and cause the electron beam



# LESSON 2—WHAT HAPPENS IN A TELEVISION RECEIVER

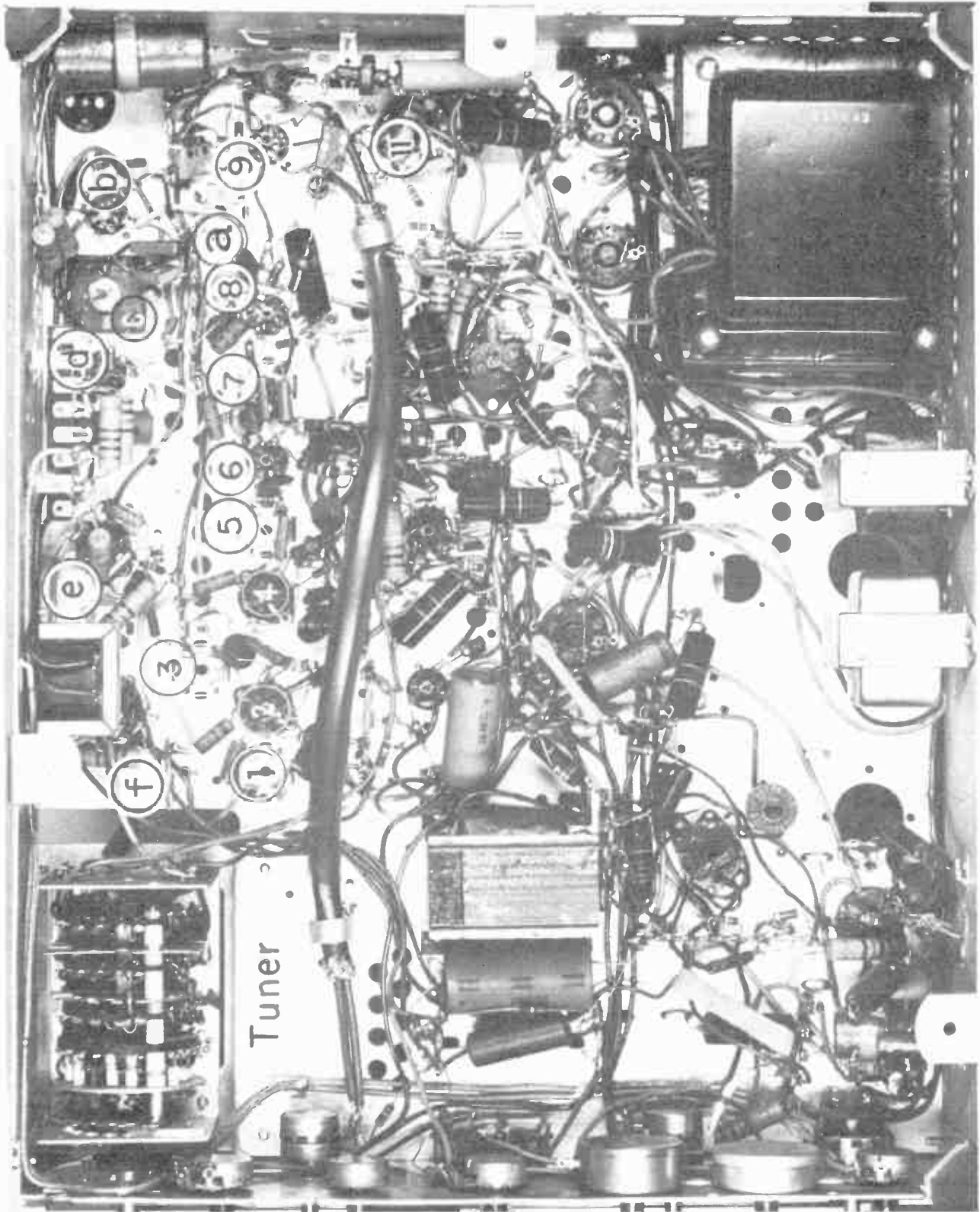

Fig. 9. Underneath the chassis may be seen the tube sockets and their connections to and from the various coupling devices.

# COYNE - *television home training*

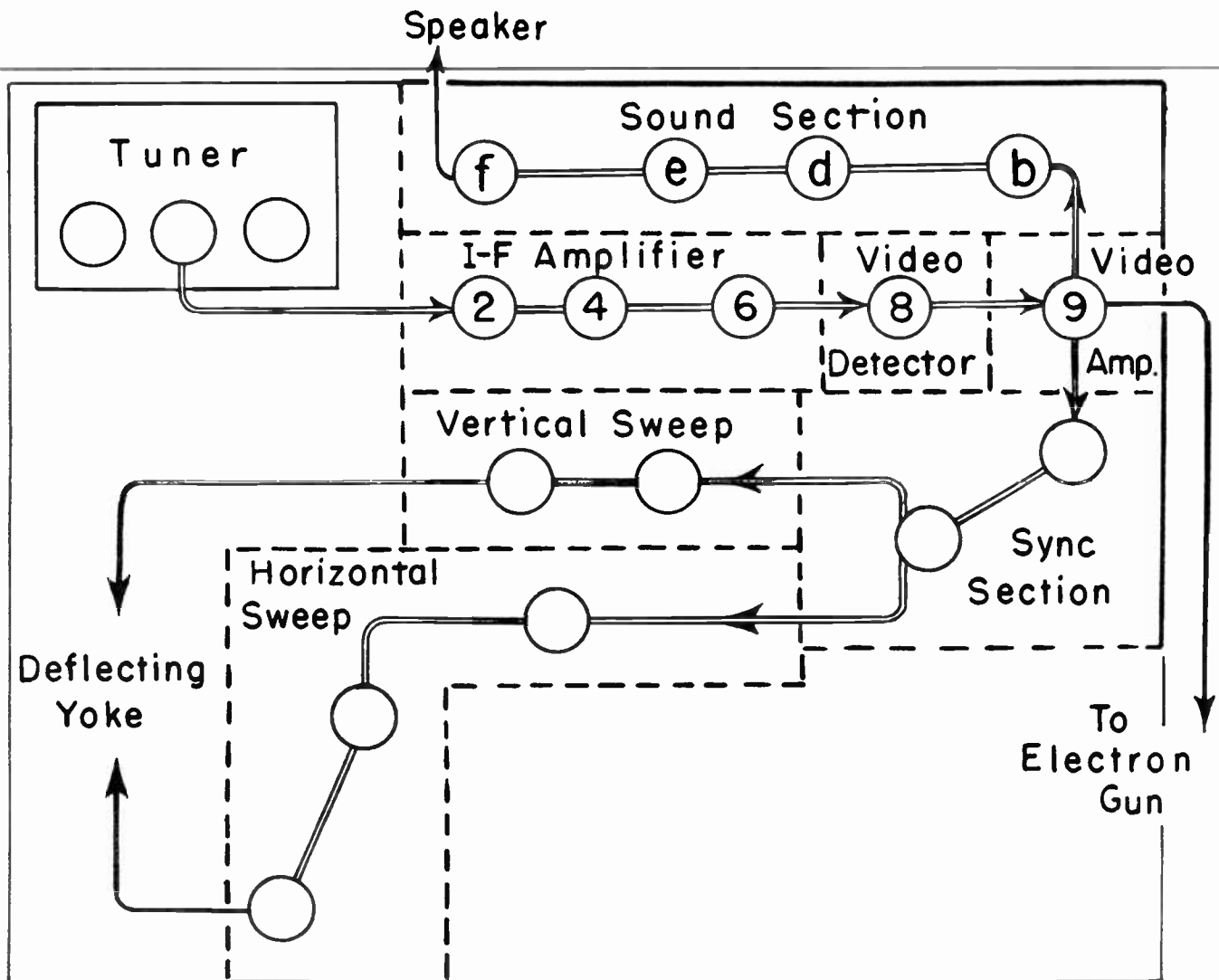

Fig. 10. The trained technician sees these sections of the receiver when looking at the parts and connections pictured in Fig. 9.

to deflect horizontally at the rate of 15,750 times per second, and vertically at the rate of 60 times per second.

Now we may add to the block diagram begun in Fig. 8 the sync and sweep sections as shown in Fig. 11, and also may show the sound section connected to the output of the video amplifier. Signal paths are indicated by arrows. Note especially how part of the video signal goes to the electron gun of the picture tube and how other parts, after much modification, go to the deflecting yoke on the picture tube.

Let's pause for a few moments to consider what this "sectionalizing" of a television receiver can mean when it comes to trouble

shooting. The picture may suffer from any of hundreds of faults, and sound reproduction may be anything but good. If you were faced with just one, out of the hundreds of possible troubles, and had to stab blindly into the hundreds of parts and connections of a receiver in trying to locate the cause, the task would be almost hopeless. At least the work would take so long in ninety out of a hundred times that all chance of a profitable service job would disappear.

But after you have learned the principles which govern the performance in each section, and know exactly what each section is designed to accomplish, you will be able to say nearly every time that the trouble must be in ONE certain section. No one section,

## LESSON 2—WHAT HAPPENS IN A TELEVISION RECEIVER

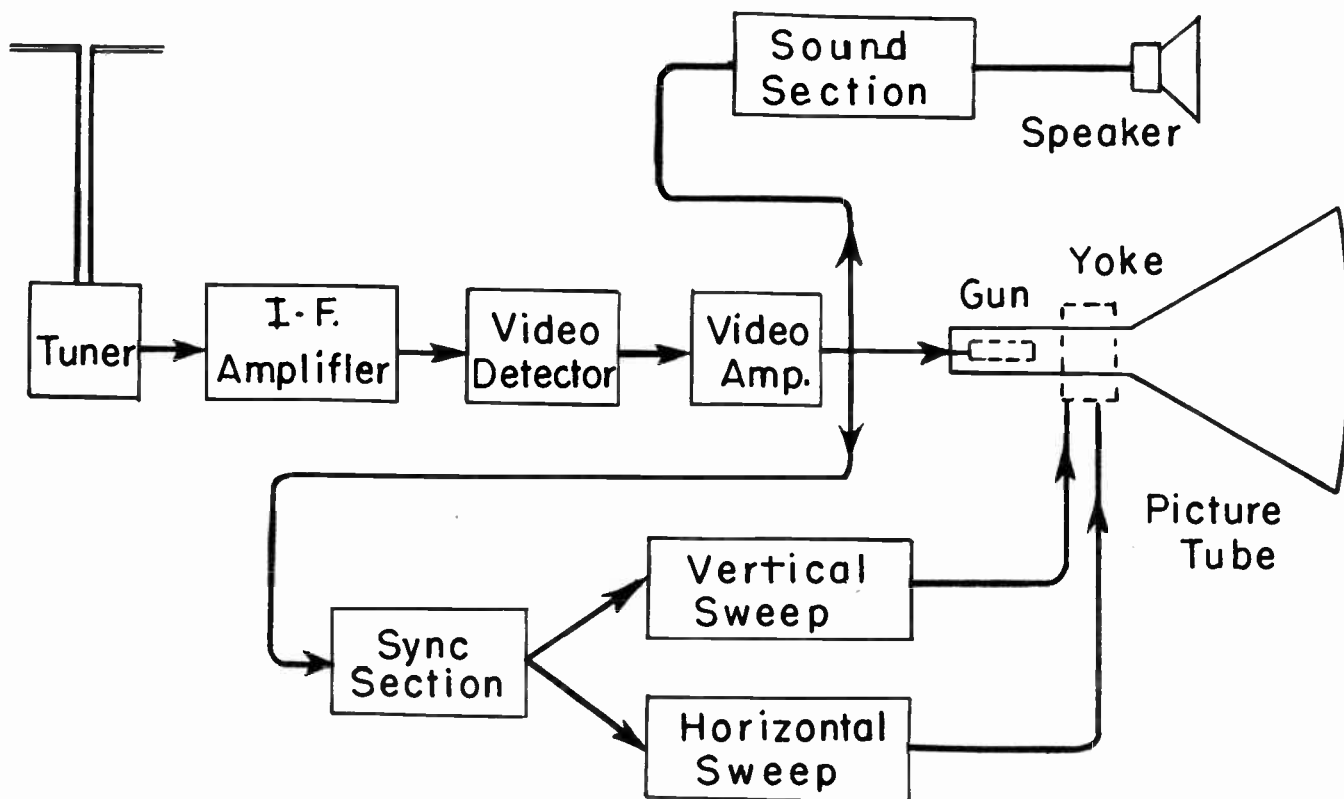

Fig. 11. The sync and sweep sections have been added to this block diagram, and the sound section is connected to the output of the video amplifier.

by itself, is nearly as complicated as a small radio set, and it will be easy to check the tubes and other parts of the one suspected section. If you are not sure that the trouble is in a certain section it will be necessary only to check the signal and other electrical characteristics at the input and output of the section. If input is good and output is bad, your diagnosis was correct. If both input and output are good, you look for the trouble in some following section. This, in brief, describes the process of scientific trouble shooting in television.

**OTHER LAYOUTS.** Although all television receivers must consist of the same major sections, the layouts or relative positions of parts are far from being alike in different makes and models.

As an illustration, compare Fig. 12 with the pictures we have been looking at. Here we are looking down on the top of a chassis whose front end is at the left. This means that we are looking at the left-hand side of the chassis, with left and right considered as you face the front of the receiver. Every-

thing that we found on the right-hand side of the receiver back in Figs. 5 and 6 is on the left-hand side of the one in Fig. 12.

The carrier signal enters the tuner of the present receiver through a double wire that comes from the antenna. The tuner carries two tubes, A and B. One of them is a twin type, so, as usual, we have the equivalent of three tubes in the tuner. A little later we shall learn why at least three tubes, or their equivalent with a twin tube, are needed in every tuner.

In Fig. 12 all the tubes have been removed except those in the tuner, those in the i-f amplifier, the video detector, and the video amplifier. The first, second, and third i-f amplifier tubes are numbered respectively 1, 2 and 3. The video detector tube is number 4. The video amplifier tube is number 5. There are coupling transformers between the tuner output and first i-f amplifier, between the i-f amplifiers, and between the third amplifier and the video detector, but you do not see the transformers. They are underneath the chassis in this receiver.



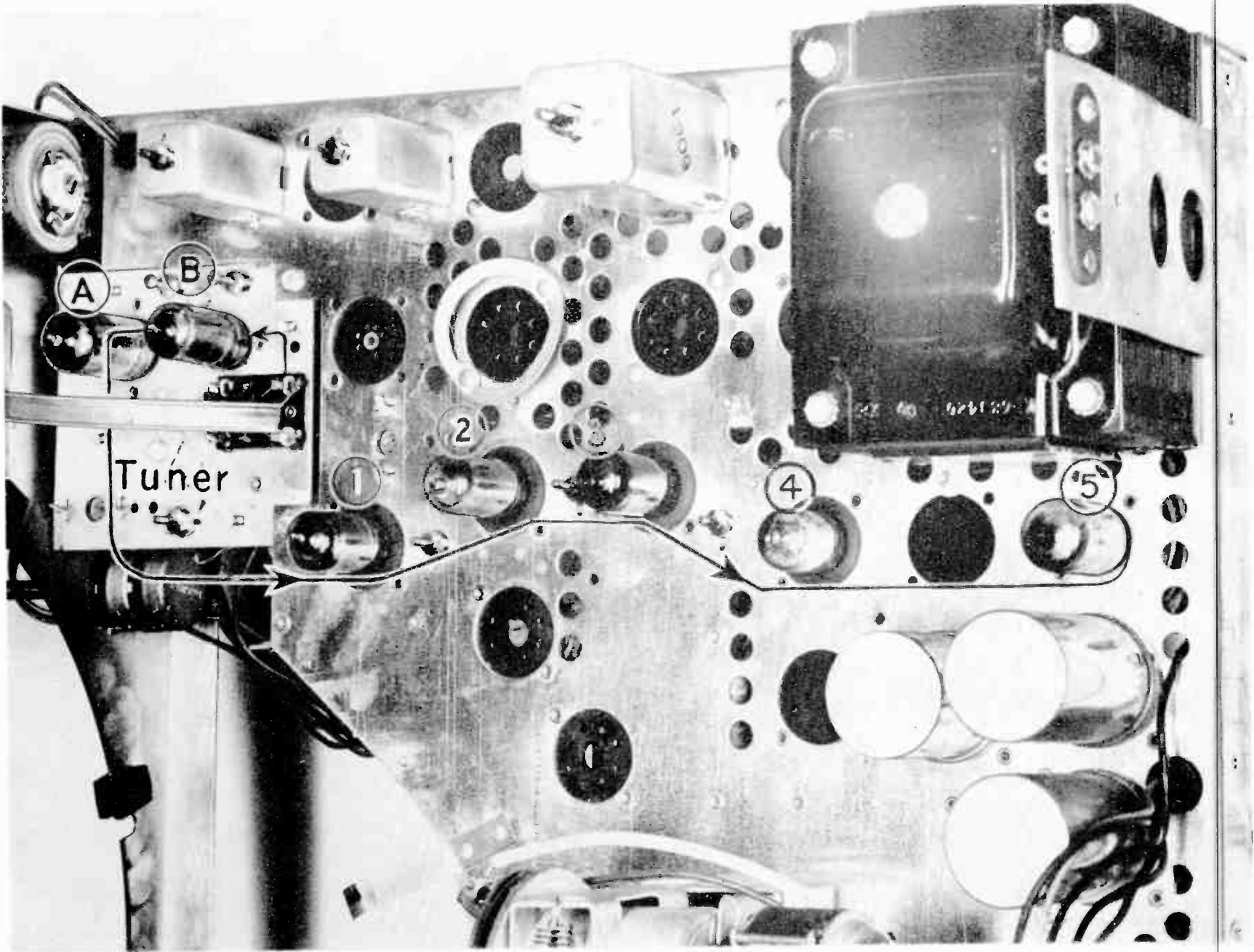

Fig. 12. Although the layout is different, we still have the same path of the video signal from tuner to video amplifier.

## LESSON 2—WHAT HAPPENS IN A TELEVISION RECEIVER

The video signal follows the same path as in all receivers. The long line with arrow-heads shows how the signal goes through the tuner, then through the i-f amplifier, the video detector, and the video amplifier. The tuner changes the frequencies from carrier to intermediate, and puts out the same range of intermediate frequencies no matter what channel is being received. The i-f amplifier tubes 1, 2, and 3 strengthens the signal without changing its form. The video detector tube 4 demodulates the signal. The video amplifier tube 5 strengthens the video signal which remains after demodulation.

From the video amplifier the video signal goes to the electron gun of the picture tube and also to the first tube in the sync section. But in this receiver the sound section does not get its signal from the output of the video amplifier, rather from the output of the tuner.

In Fig. 13 we have removed the i-f amplifiers, the video detector, and the video

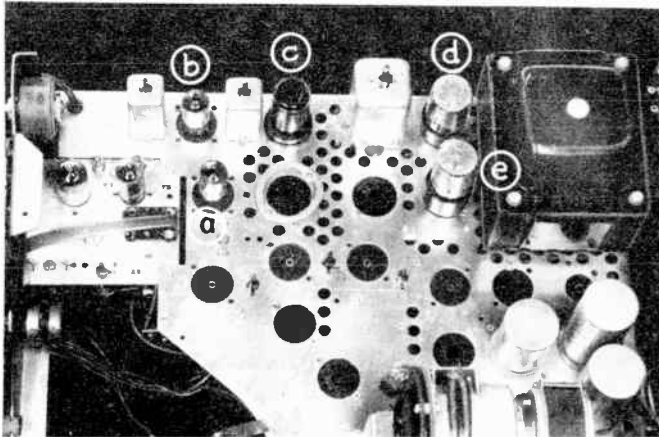

Fig. 13. Here are the tubes which are used exclusively for the sound section.

amplifier, and have put in the tubes that are used exclusively for sound. These tubes of the sound section are lettered from a through e, indicating the order in which the sound signals travel. The output of tube e, which is an amplifier, goes to the speaker.

A block diagram for this method of handling sound signals would appear as in Fig. 14. The method is variously named dual sound, split sound, or divided sound. The system shown by Fig. 10 is called intercarrier sound. With a dual sound system the i-f amplifier

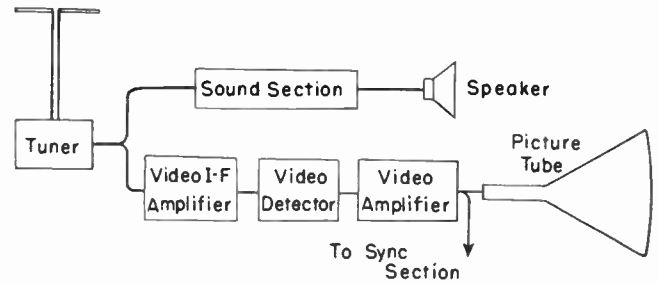

Fig. 14. With a dual sound system the sound section takes its signals directly from the tuner.

leading from tuner to video detector carries only the video signals, not the sound signals, and it often is called the video i-f amplifier. Dual sound was used in all of the earlier television receivers. Intercarrier sound is a more recent development and is being used in most presently manufactured sets, although dual sound still is employed by a number of leading makers.

**POWER SUPPLY.** Our television receivers might contain all the parts and sections that have been discussed, and we might have strong carrier signals from any number of stations, yet the whole apparatus would be useless - until you plugged in the power cord to a live receptacle and turned on the switch.

Signal power obtained through the antenna must be multiplied hundreds of thousands of times in order to control the electron beam in the picture tube. Signal power is multiplied, in effect, by using the signals to control electric power taken from the lighting circuits in the building where the receiver is installed.

Signal power may be multiplied in strength because all the amplifier tubes are electric valves. This is so true that the English and others call them valves, not tubes. An amplifier tube acts much like the faucet on a water line. To open and close the faucet you may exert only a few ounces of pressure on the handle or lever. This will control the rate of flow of water which is at a pressure of 30, 40 or more pounds per square inch, and which may pass through the faucet in great quantity.

Voltage, in electricity, is the equivalent



## COYNE - *television home training*

of pressure in hydraulic or water systems. To one of the elements of an amplifier tube we may apply a signal whose electrical pressure is only a tiny fraction of a volt. In a coupling transformer that follows the tube this weak signal will control electrical pressures or voltages many times as great as in the signal. This is the process of amplification.

Voltage obtained from the building power line usually is either too low or too high for use in the receiver tubes. Also, the electricity in the power line is surging back and forth many times per second, which means that the line furnishes "alternating" current. But the elements of the tubes require electricity that moves always in the same direction. This is "direct" current. To change the power line voltage to more suitable values, and to provide direct current, we need another section in the receiver. This section is the low-voltage power supply. What we call low voltages, for television and radio receivers, range from 6 to 300 or 400 volts.

Fig. 15 is a picture of the resistors and capacitors which appear below the chassis of a low-voltage power supply. On top of the chassis will be one or two tubes and additional capacitors. The tall shiny cylinders on top of the chassis and toward the rear in Fig. 3 are capacitors for a low-voltage power supply. At the lower left in Fig. 9 and at the upper right in Figs. 12 and 13 you can see the big transformers for the low-voltage power supplies, which change voltage from the building power line into any values that may be required.

The low-voltage power supply serves the needs of amplifiers and other small tubes, and a portion of the needs of the picture tube. But to pull electrons away from the inside of the electron gun, and speed them to thousands of miles per second at the screen, takes a lot more than a few hundred volts - it takes thousands of volts. So, to "accelerate" the electrons in the beam, we must have a high-voltage power supply.

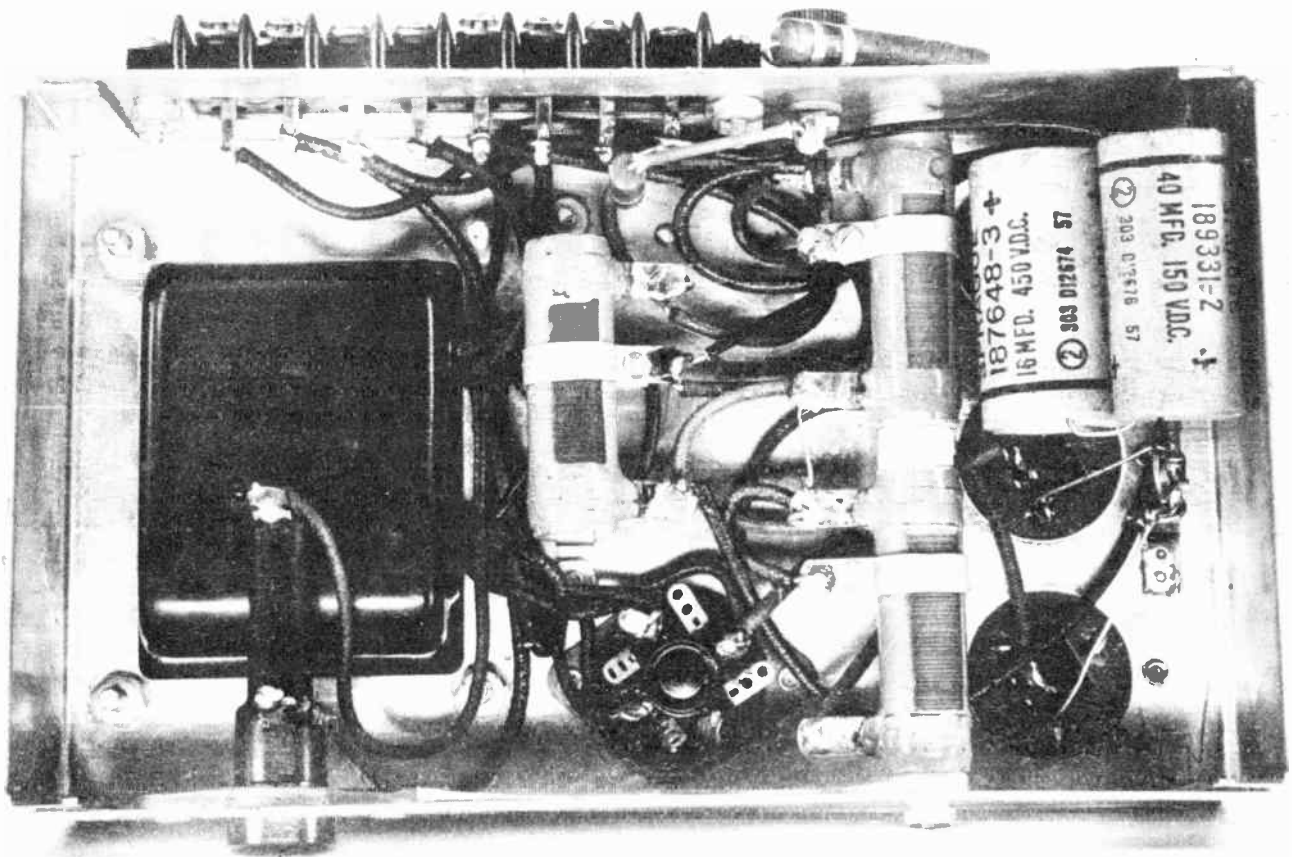

Fig. 15. Parts which are under the chassis of a low-voltage power supply.



## LESSON 2—WHAT HAPPENS IN A TELEVISION RECEIVER

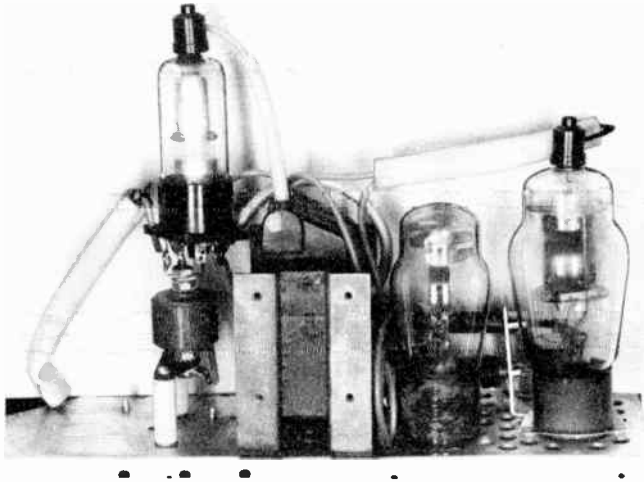

Fig. 16. Here are the tubes and most of the parts which enter into a "flyback" type of high-voltage power supply.

One kind of high-voltage power supply is pictured by Fig. 16. At the base of the tube toward the left, the one that is elevated above the chassis, the electrical pressure is about 11,000 volts. This is approximately 100 times the voltage in the building power line. This high voltage can give you quite a jolt, to put it mildly. Consequently, the high-voltage power supply is enclosed by its own sheet metal housing, or may be underneath the receiver chassis. The receiver connections are such that the high-voltage power supply is turned off when anyone removes the back of the cabinet or console.

The electron-accelerating voltage from the high-voltage power supply does not go to the socket and base pins of picture tubes such as found in most modern receivers. This voltage is taken to a connection on the flare of glass picture tubes. The high-voltage wire or lead in Fig. 17 is white, and you may plainly see where it connects to one side of the picture tube. With picture tubes having metal shells or metal cones the high-voltage lead goes to the front edge of the shell or cone, to the edge that is around the face of the tube.

Now we may complete our block diagram for a typical television receiver, as in Fig. 18. There are connections between the low-voltage power supply and every other section of the receiver. This power supply itself is

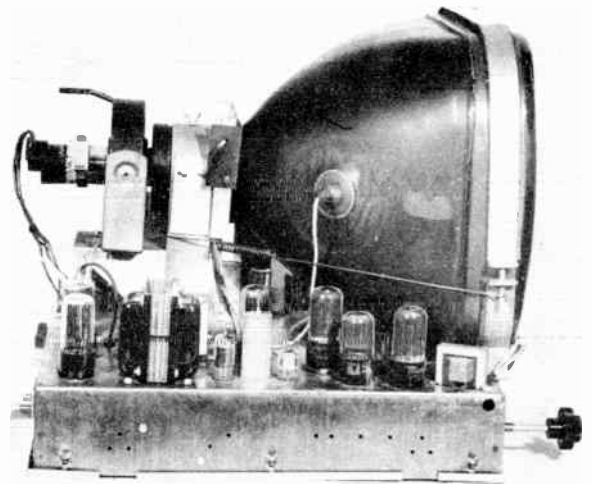

Fig. 17. High voltage for electron acceleration does not go to the picture tube socket, but to a connection on the flare of this glass tube.

connected to the building power line through a cord and plug. Here it is that electric power goes into the receiver while signal power, what little there is of it, goes by way of the antenna. The results come out at the picture tube and the speaker.

Following is a list of some of the new things with which we have become acquainted in this lesson. Can you recall what each one means?

Built-in antenna	Ion trap
Carrier waves and frequencies	Low-voltage power supply
Chassis	Modulation
Dual sound	Radiation
Electromagnetic wave	Shields
Envelope	Stage of amplification
Focus coil	Sync section
Gain	Tuner
High-voltage power supply	Turret tuner
I-f amplifier	Video amplifier
Intercarrier sound	Video detector
Intermediate frequency	Yoke

This is our second listing of television words and terms, the first having appeared at the end of the preceding lesson. Half of all the words in this new list apply to standard broadcast and f-m radio as well as to television. In every radio receiving system we deal with carrier waves and frequencies,

## COYNE - *television home training*

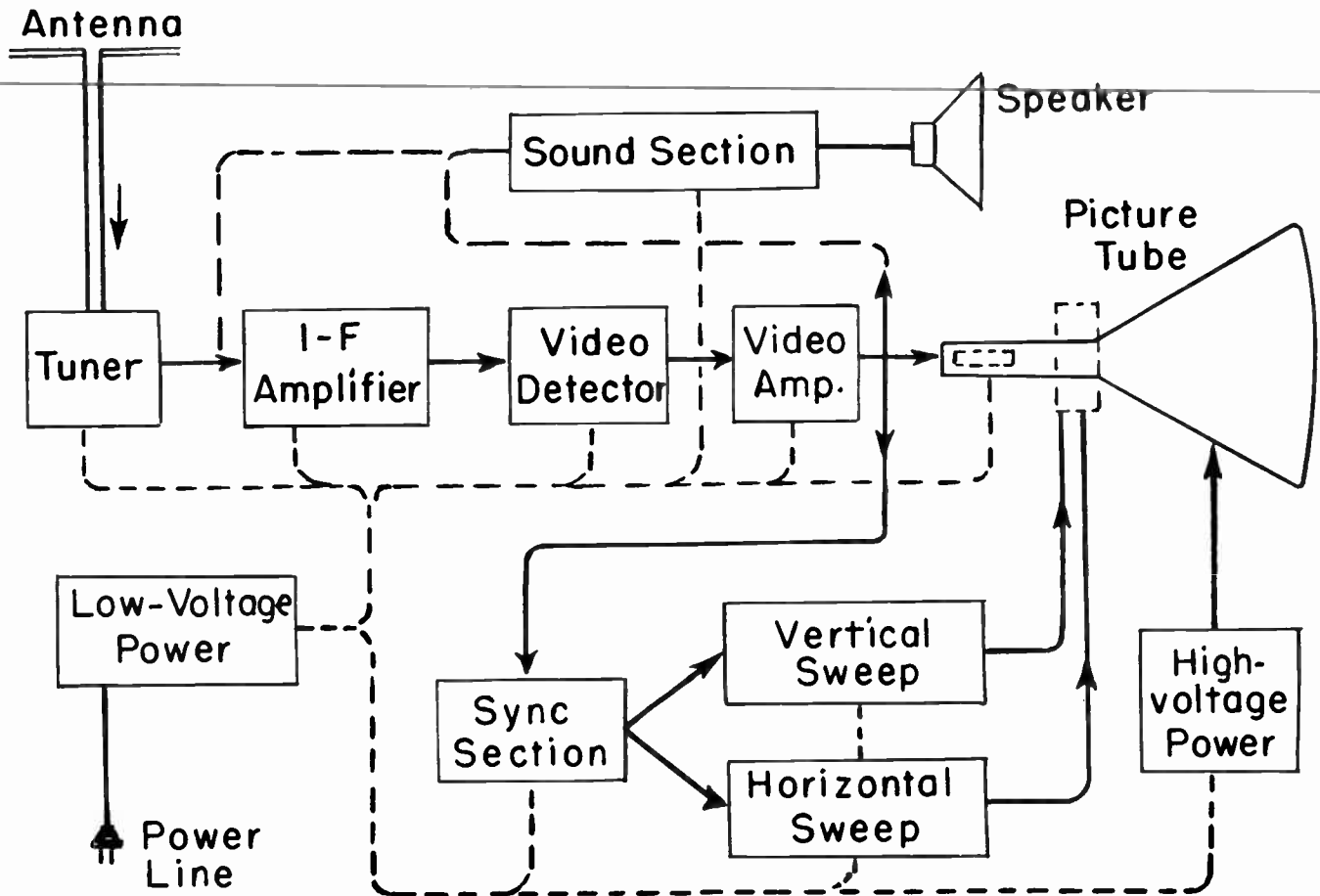
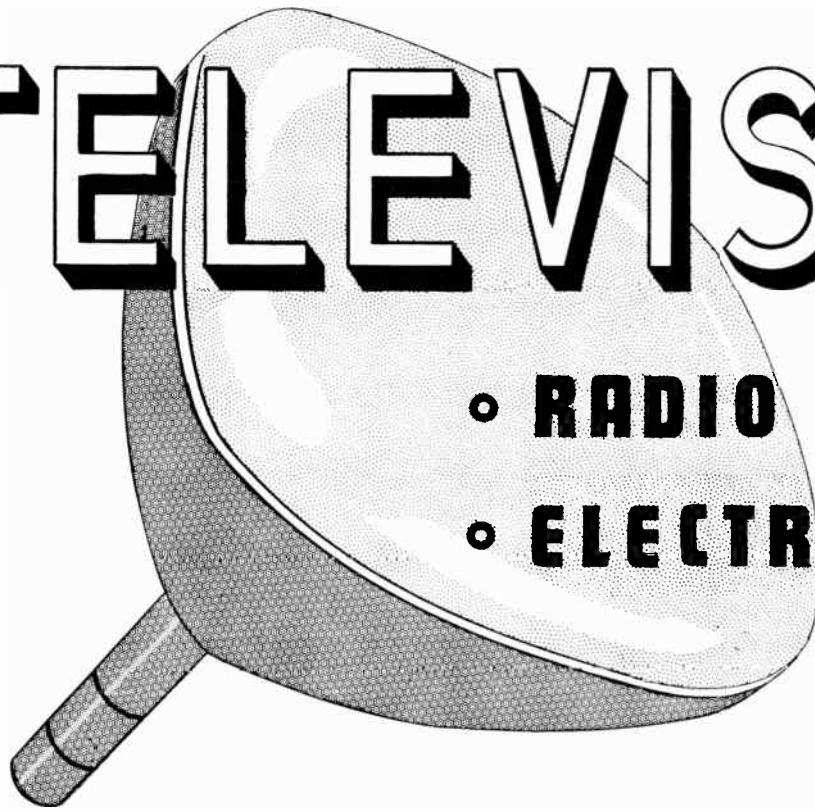

Fig. 18. The low-voltage power supply furnishes electric power in the form of voltage and current to every other section of the receiver.

with electromagnetic waves, radiation, and modulation, with intermediate frequencies and i-f amplifiers, with gains and stages of amplification, with chasses, shields, and tube envelopes, and with low-voltage power supplies exactly like those for television sets. Furthermore, the detector for sound signals

in standard broadcast radio receivers is just like the videodetector of television receivers. Always it is true that in learning about television we are learning also about sound radio, but with many things added, and always we are learning the principles of electronics in any and all of its many applications.

# TELEVISION



• **RADIO**

• **ELECTRONICS**

---

---

**LESSON 3 – HOW TO MAKE WIRING CONNECTIONS**

---

---

***Coyne School***

*practical home training*

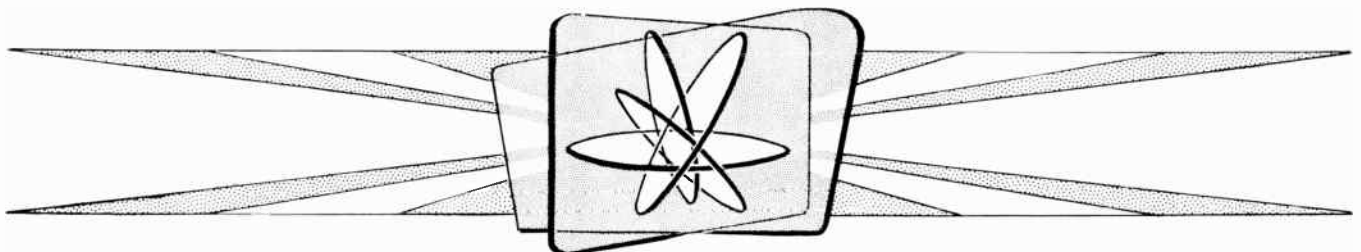

*Chicago, Illinois*



---

*Copyright, 1954 by Coyne Electrical School  
Chicago 12, Illinois  
All rights reserved.*

Litho. in U.S.A.

## Lesson 3

# HOW TO MAKE WIRING CONNECTIONS

The particles of electricity that flow in the electron beam of the television picture tube and in all other parts and wiring connections of the receiver are too small to be seen, heard, felt, or weighed. Yet these electrons or electric particles are just as real as the particles of water in the piping of a plumbing system or in the stream of water

ejected from a hose nozzle. When once you realize that electrons are not imaginary things, but that they really do move about, it isn't much harder to understand why things happen in electrical systems than to understand the action of water in a piping system.

A piece of wire in which electricity can

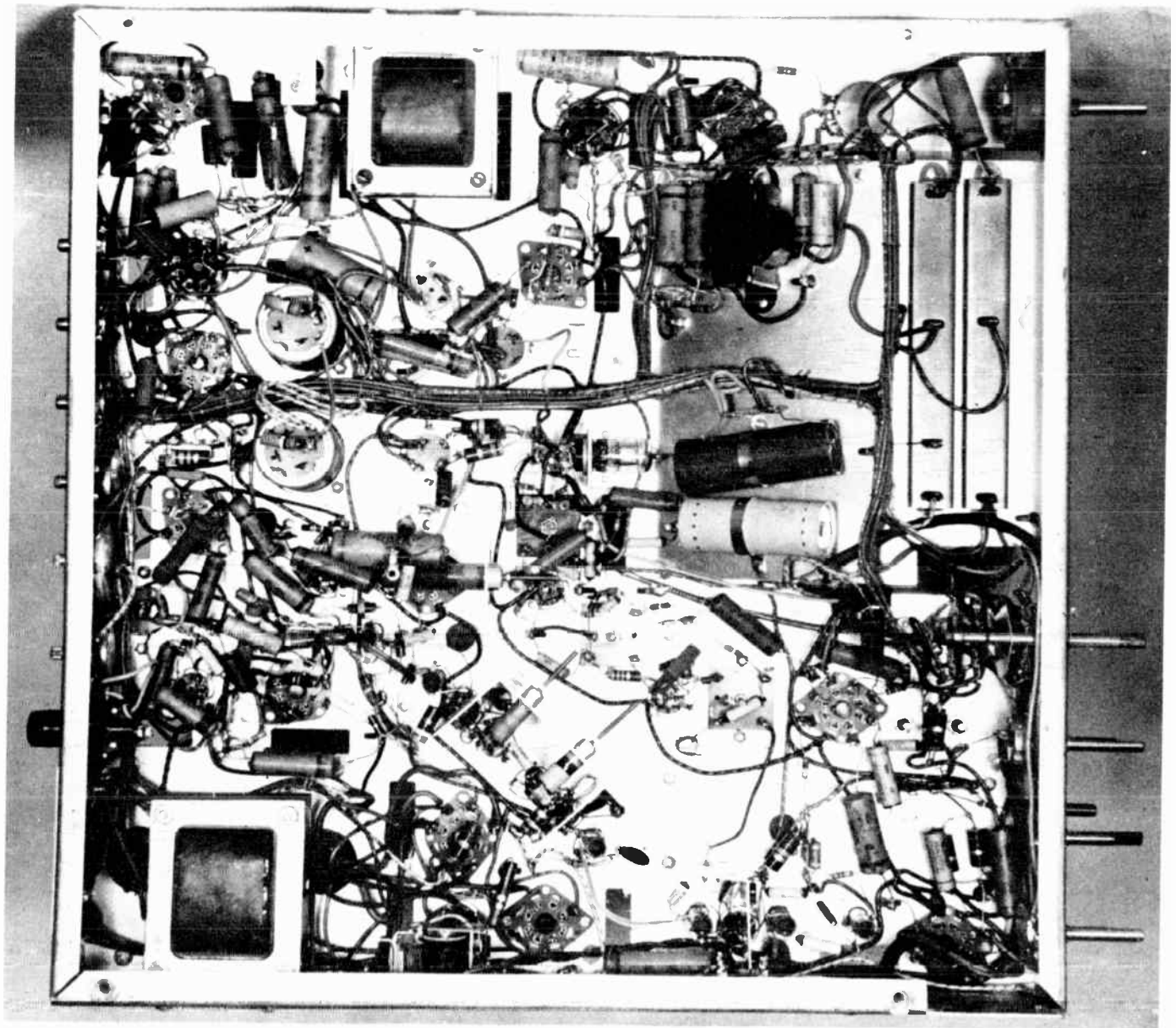

Fig. 1. Electrons flow in all these parts and in the wiring connections between them.

## COYNE - *television home training*

flow appears absolutely solid. It seems strange that anything could move through that solid wire without breaking the metal into bits. But could you look at the wire through a microscope far more powerful than the strongest that ever has been made, the wire would not appear solid. You would see that the wire consists of very small atoms of metal, about 250 million of them to the inch. Moving from atom to atom and through the minute spaces between atoms you would see countless numbers of electrons, each only about  $1/50,000$  the size of an atom.

Within the metal of the wire all its atoms remain fixed in relation to one another, unless, of course, the metal is bent, stretched, or otherwise deformed. The atoms form the body and substance of the metal, they are what makes the metal seem so solid and strong. The electrons can and do move, and they are the only thing that does move. When we speak of electricity and of the flow of electricity we are referring to the electrons which move in the spaces between atoms.

Electrons which move or are able to move in spaces between atoms are called free electrons. In addition to these free electrons there are other electrons inside each of the atoms. Every once in a while one of the electrons which is inside an atom pops out and becomes a free electron. Just as often one of the free electrons enters an atom, and no longer is a free electron.

When all of the electrons which are momentarily free in a wire or other substance are caused to move in one direction we speak of this movement as an electron flow. A name more commonly given to electron movement or flow is electric current or simply current. An electron flow and an electric current are one and the same thing.

In some substances there are more free electrons than in others. The greatest quantities are found in metals. When a force which tends to move the electrons is applied to a metal, to a copper wire for example, immense quantities of free electrons move through the metal, and we have a high rate of electron flow or a large electric current. A substance in which an electron-moving force

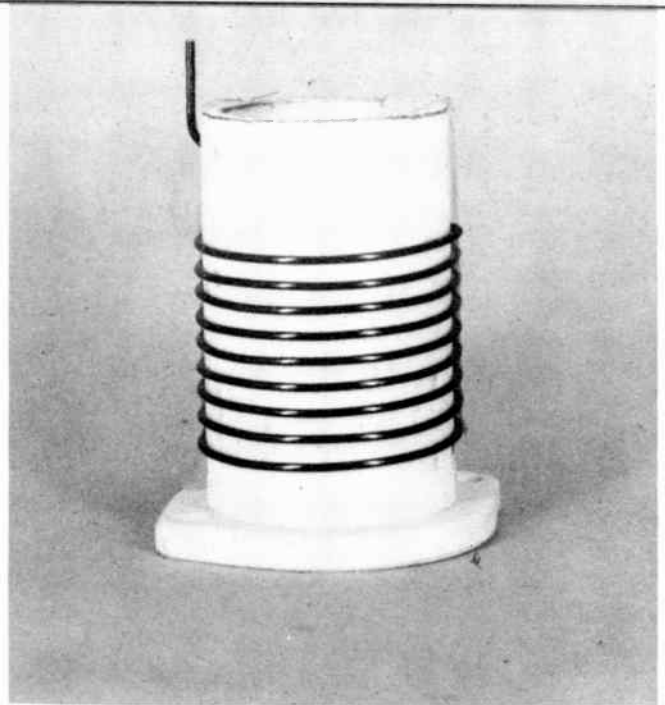

Fig. 2. *Electrons flowing in the turns of copper wire are prevented from escaping by a coating of enamel on the wire, by air spaces between turns, and by the insulating material of which the coil form is made.*

causes a high rate of electron flow or a large current is called an electrical conductor or simply a conductor.

Among the metals commonly used for conductors in television and radio receivers

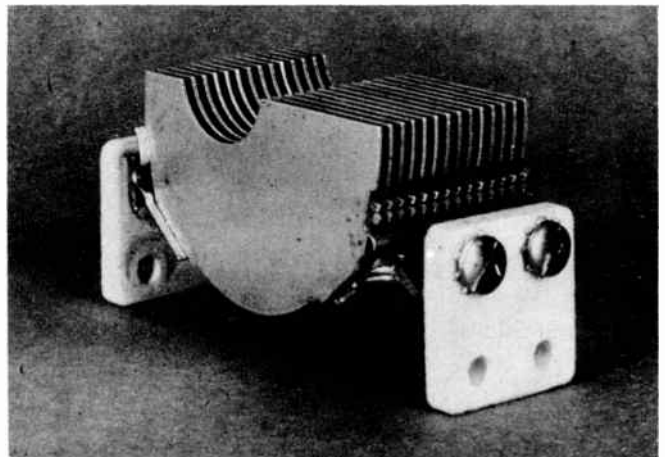

Fig. 3. *The metal plates of this tuning capacitor are supported by blocks of ceramic insulation.*



## LESSON 3 – HOW TO MAKE WIRING CONNECTIONS

are copper, silver, aluminum, brass, iron, and steel. All metals are good conductors, and any or all of them may be used for carrying electric currents.

In many substances there are very few free electrons. When an electron-moving force is applied to these substances there can be only a small rate of electron flow or only a small current, perhaps no current at all. This is because there are so few free electrons that hardly any can be kept in motion. They tend to pass into the atoms and to remain there in spite of any applied force which tends to move them. Such substances are called non-conductors or, more commonly, are called insulators.

Among the insulators or insulating materials generally employed in television and radio are plastics such as Bakelite and polystyrene. Other common insulating materials include ceramics or porcelain-like sub-

stances such as Isolantite and steatite, also glass, paper, fibre, mica, and various waxes and oils. One of the most important of all insulators is air. It is very difficult to force free electrons to flow through an air space.

When we wish to make it possible for free electrons or an electric current to pass from one place to another we connect a conductor or conductors between the two places. This forms a conductive path from one point to the other. In order to keep the moving electrons within this particular path, and prevent them from escaping to other conductors, the path must be surrounded with insulation. Here we must remember that air is an insulator. A bare wire or any other bare metallic conductor surrounded by air is insulated by the air, and electric current is confined to the conductor.

If we press the surfaces of two conduc-

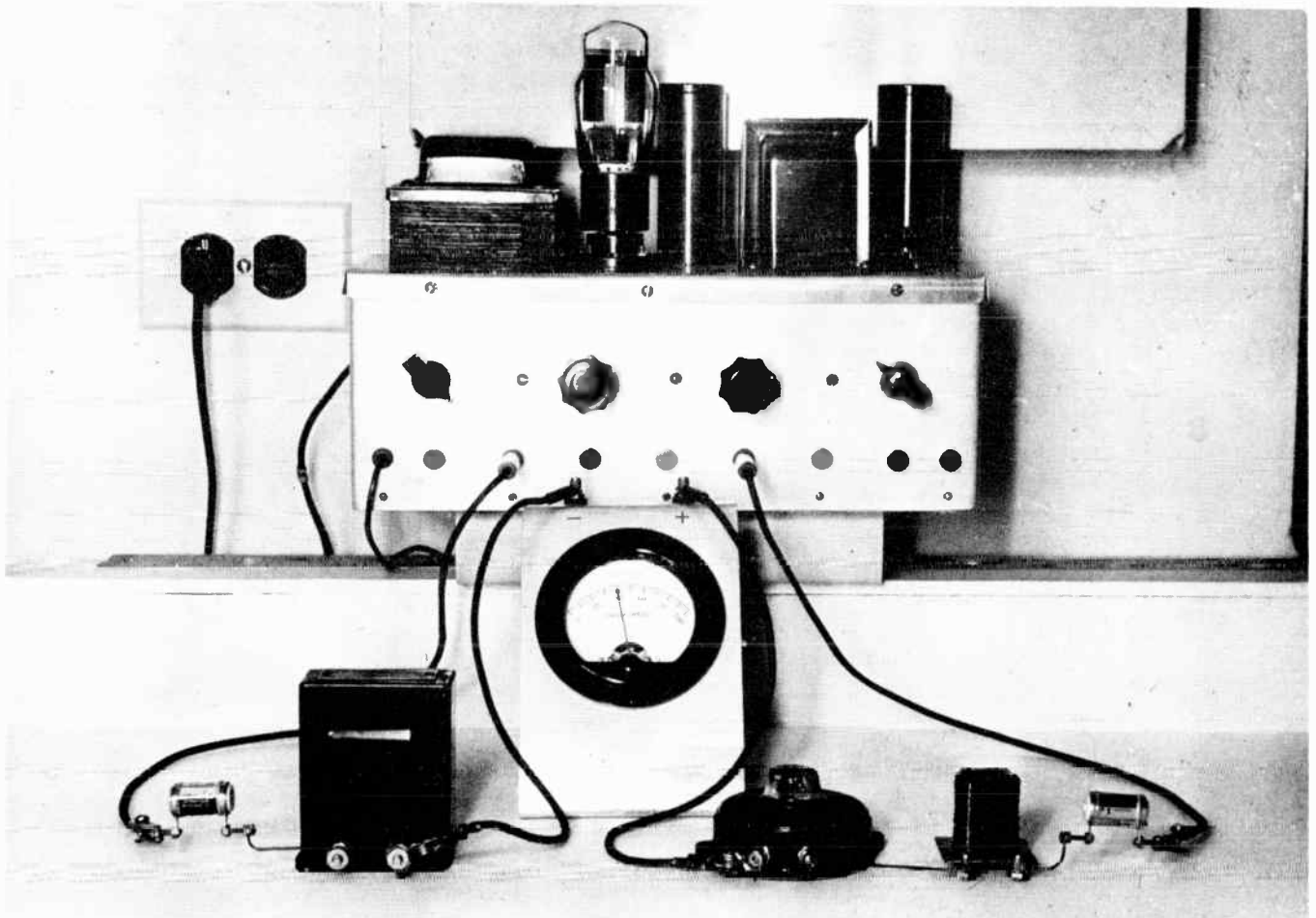

*Fig. 4. The current meter shows that electrons are flowing from the power supply through all the parts which are connected together by copper wires.*

## COYNE - *television home training*

tors together so that there is close contact between them, free electrons or an electric current may flow from either conductor into the other. If you ever wired a socket for an electric lamp you commenced by removing the insulating covering from the ends of the wires that were to go into the socket. Then you turned each wire end around a metal screw and tightened the screw against a metal terminal of the socket. This forced all the metal surfaces together, and electric current could flow through all the metal parts just as though they were a continuous single conductor.

In television and radio receivers we seldom make screw connections. They are not good enough. We insure permanent and practically perfect electrical contacts by soldering the wires and terminal connections. In Fig. 5 the coils of wire are supported on a

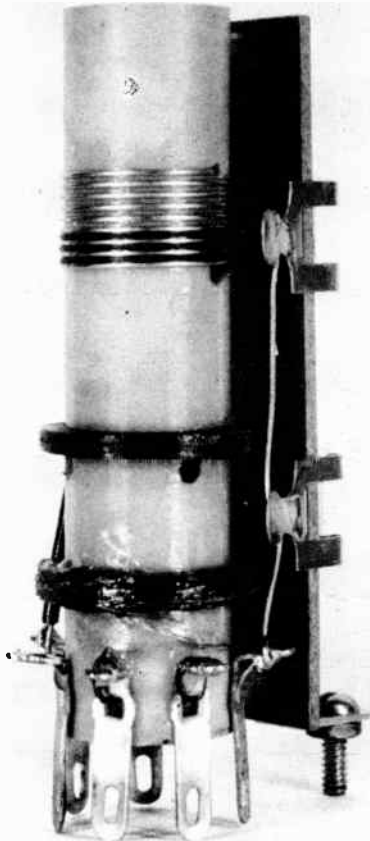

Fig. 5. All connections to the coils of wire are made through soldered joints.

cylindrical form of insulating material. The ends of the coil wires are soldered to metal terminals, and lengths of wire leading downward are soldered to the same terminals. These wires, in turn, are soldered to metal lugs at the bottom of the form. To these lugs will be soldered all wires which go to other parts of the receiver.

Wherever we don't want electricity or free electrons to escape from a wire, the metal part of the wire must be surrounded with some kind of insulating material. A wire in air is surrounded by insulation, because air is an insulator. The atoms in air are so far apart, compared to those in metals, that there are very few of them to attract any free electrons. Air isn't so good an insulator as glass, but if a layer of air is 100 times as thick as a sheet of glass, the air is just as effective as the glass so far as flow of electrons is concerned.

Free electrons must flow in all the wires entering and leaving the power transformer of Fig. 6. These free electrons must flow in parts to which these wires will be

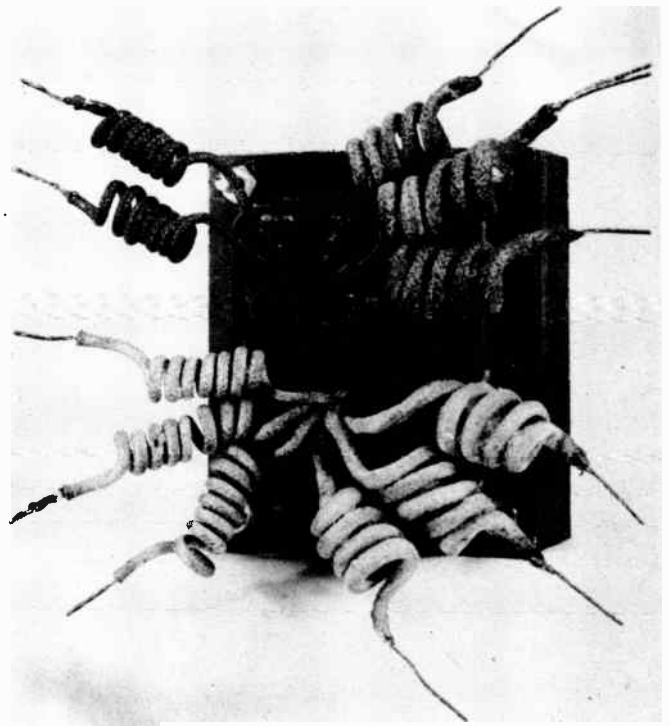

Fig. 6. Insulation on these wires confines the free electrons to paths in which they should move.

## LESSON 3 – HOW TO MAKE WIRING CONNECTIONS

connected. To permit electron flow, the ends of the wires are bared down to the metal. These bared ends will be soldered to various parts in a receiver. Electrons must not enter or leave the transformer wires except at the soldered ends, so the remainder of the wires is covered by insulation of woven fabric. This insulating covering allows all the wires to pass through small openings in the conductive metal housing of the transformer, and allows many wires to run close to one another through each opening, all without any electrons passing from one wire into another or into the metal of the transformer housing.

**HOOKUP WIRE.** Copper wire of various types used for connecting together the parts in television and radio chassis is called hookup wire. Most hookup wire is covered with flexible insulation of some kind, but bare or uninsulated wire often is used for short, direct connections which have little chance of coming on contact with any other metals.

Usually we speak of the copper part of an insulated wire as the conductor. The combination of conductor and insulation is called wire. Copper wire is used for receiver circuits, and most other electrical wiring, because copper conducts electrons more easily than any other metal except silver, and is much lower in cost than silver. The copper conductor, or bare wire when used, is thinly coated with tin or with alloys consisting largely of tin. The tinned conductor does not oxidize or corrode as does exposed copper, and the tinning allows solder to bond readily with the surface of the conductor.

Conductor diameter is commonly specified according to wire gage numbers. The smaller the gage number the bigger is the wire, as you may note from the following list of sizes most often used for hookup wire.

Gage Number	Diameter, Thousandths of an inch	Cross Sectional Area	
		Square inch	Circular mils
14	64	0.00323	4,110
16	51	.00203	2,580

Gage Number	Diameter, Thousandths of an inch	Cross Sectional Area	
		Square inch	Circular mils
18	40	.00128	1,620
20	32	.000802	1,020
22	25.3	.000505	642
24	20.1	.000317	404

The cross sectional area of a wire is the area or size of the surface which would be exposed on one end of the conductor when cut straight across, at right angles to the length. This cross sectional area most often is given in circular mils rather than in fraction of all square inch. One circular mil is the area of a circle whose diameter is 1/1000 inch.

The bigger a wire or the greater its cross sectional area the more free electrons will exist in any given length of the conductor. Then the rate of electron flow will be greater when applying any force which can cause such flow. Doubling the cross section will double the quantity of metal and the quantity of free electrons in any given length of conductor, consequently will allow double the rate of electron flow. Halving the cross section halves the quantity of free electrons, and halves the rate of electron flow for any particular applied force.

The conductor in hookup wire, or in any other type of wire, may be either solid or stranded. A solid conductor consists of a single piece, as in the two samples at 1 and 2 of Fig. 7. Shown at 3 is a 7-strand wire with the strands spread apart. Actually the strands are twisted together, as in the wire illustrated at 4 in this picture. The number of strands in hookup wire most often is 7, 10, 16, 19, or 26.

The gage number of a stranded wire is the gage number of a solid wire having the same cross sectional area as the total of cross sections of all the strands. Therefore, a number 20 stranded wire, for example, has the same ability to permit electron flow as has a number 20 solid wire. Stranded wire may be described by giving the number of strands and the gage size of each strand. For instance, a 10x30 wire has 10 strands of number 30 gage size. This makes it almost exactly the equivalent of a number 20 solid



fabric. The two wires at 3 and 4 have plastic, or possibly rubber, directly over the conductors and have an outer covering of braided fabric. Some hookup wire has one or two inner layers of spirally wound fabric with an outer covering of braid.

The insulation of hookup wire often is of different colors for different electron paths or circuits, making it relatively easy for you to trace any given wire or circuit as it passes among many others. Colors most often used include red, blue, green, yellow, and black. Less often used are brown, orange, white, and gray.

The braided coverings of the two wire samples at 3 and 4 in Fig. 7 each are in two colors. Most of the insulation surface is of one color, with a tracer pattern of some other color. Some one section of a receiver might have connections of the same body color, such as red. Then various smaller divisions of the section could have red with green tracer, red with yellow tracer, red with white tracer, and so on.

Some wires may be shielded to prevent radiation from them or pickup of radiation by them, just as various parts are shielded for the same reasons. At the top of Fig. 8 is a stranded conductor covered with rubber, plastic, or fabric insulation, and having around the outside a metallic shield woven from very small tinned copper strands. In the center is a conductor having plastic insulating around which is a spirally wound shield of small tinned copper strands. The shielding is protected by an outer covering of rubber insulation.

At the bottom of Fig. 8 is a flat braided conductor. The braid is formed from very small tinned copper wire, like the shield in the top picture, but contains no other wire or conductor and is used where flexible connections are needed for carrying high rates of electron flow.

Shielded wires often are called shielded cables. Strictly speaking, the name cable should be applied only to two or more separately insulated conductors which are enclosed and held together by a common outer cover-

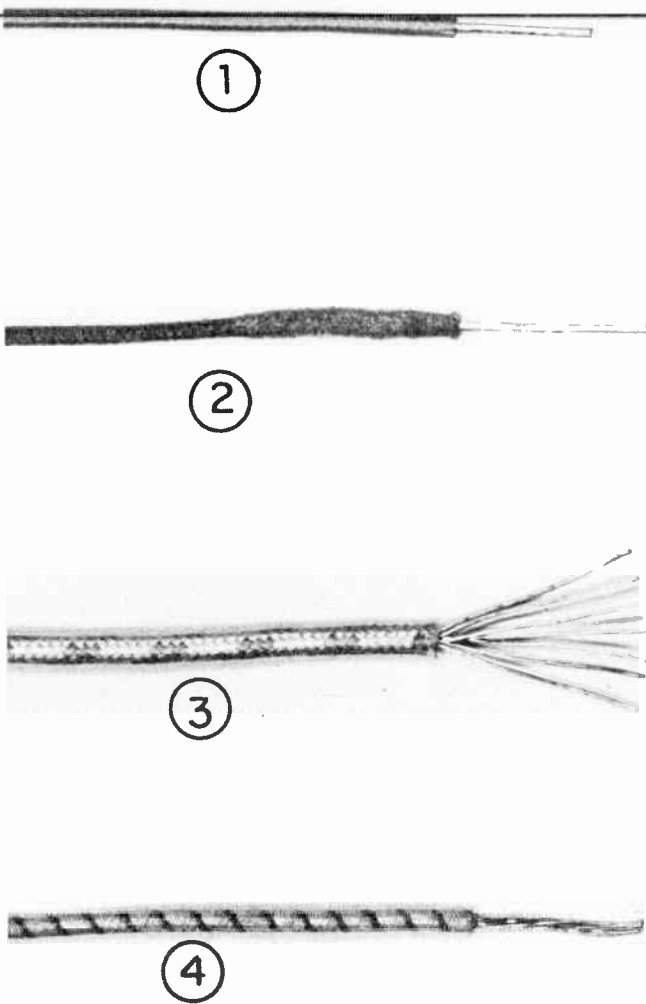

Fig. 7. Solid and stranded types of insulated hookup wire.

wire so far as electrical conductivity is concerned.

For any given size or gage number, the greater the number of strands the smaller each will be, and the greater will be the flexibility of the wire. The highly flexible lead wires for service testing instruments often have 41 or 65 strands of very small wire, and, of course, have very flexible insulation.

The wire shown at 1 in Fig. 7 has a single layer of plastic insulation, the piece numbered 2 has a single layer of braided

## LESSON 3 – HOW TO MAKE WIRING CONNECTIONS

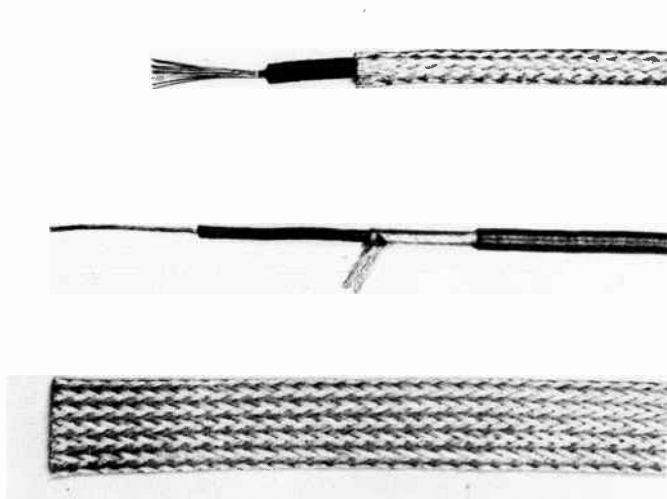

Fig. 8. Shielded wires, and metal braid used as a conductor.

ing. In practice the name cable may be applied to any fairly large insulated wire.

Oftentimes a wire is run bare for most of its length, but requires insulation at certain points where there is danger of unwanted metallic contacts. Such insulation is provided by slipping over the wire a short length of "spaghetti". Spaghetti, in television and radio, is insulating tubing made of woven fabric, of plastic, or of some combination. Some spaghetti is very flexible, some is nearly rigid, and there are all kinds in between. Some is shiny, other kinds are of dull finish. Colors are any and all of those found in hookup wire. Pieces of spaghetti are shown in Fig. 9.

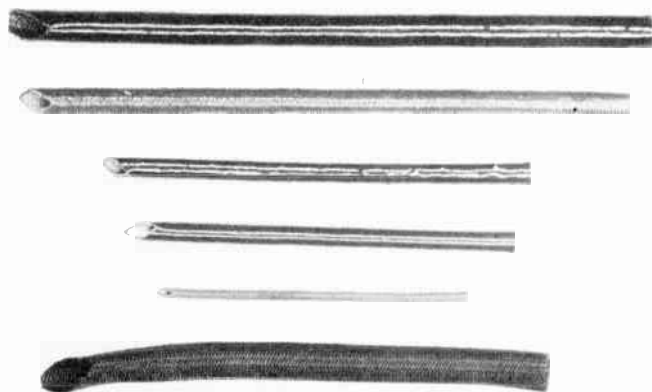

Fig. 9. Spaghetti is made of various insulating materials and in many sizes.

Spaghetti is purchased in lengths, usually of 24 or 36 inches, and is cut off in pieces to suit the job, by using your wire cutting pliers. Specifications usually include the kind of material, the color, the maximum allowable electrical pressure or voltage, and the diameter. Diameter, in fractions of an inch, is the size of the opening through the spaghetti, or it may be given in accordance with the gage number of bare wire that will easily slide through the opening. The smallest piece in Fig. 9 has inside diameter of 0.034 inch, and the largest measures 1/4 inch on the inside.

**SOLDERING.** When you stop to think of all the hundreds of parts in a television receiver which are conductively connected into their circuits through soldered joints in the wiring, it isn't hard to realize that nothing in service work is much more important than good soldering. One poorly soldered joint can wreck the performance of the whole receiver, and may take hours of work to locate.

First you need an electric soldering iron, which usually will be similar to those pictured by Fig. 10. At the business end of

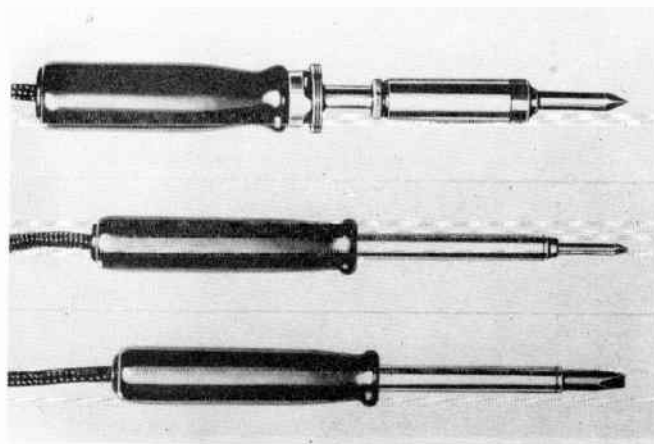

Fig. 10. Electric soldering irons of sizes commonly used for service work.

the iron is a copper or bronze tip which becomes hot enough to heat the joint and melt the solder into the joint. The tip is inserted into a heating element carried within the long shank which extends from a handle of wood or plastic. The power cord runs from this heating element out through the handle.

## COYNE - *television home training*

Soldering iron tips may be held by screwing them into place, by pushing them in and locking securely with one or more set screws, or by some form of lock nut arrangement. Tips always are replaceable, since they gradually burn away and must be dressed down to maintain the desired shape at the point. In irons of good quality the heating element may be replaceable in case of burn-out.

Tips usually are  $1/4$ ,  $5/16$ , or  $3/8$  inch in diameter for general service work. Some are bent at various angles, as in Fig. 11, to

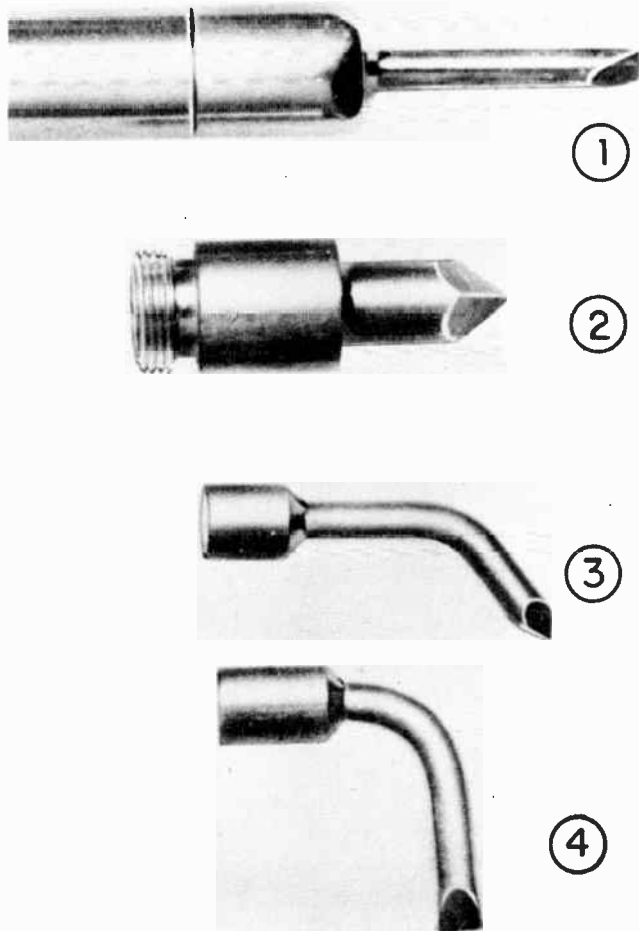

Fig. 11. The tips of soldering irons may be formed to more easily reach into difficult places.

reach into difficult places. Tips at 1 and 4 have spade or chisel points. At 2 is a pyramid point, and at 3 is a three-cornered point. Any tip may be filed to any shape you prefer or find most convenient, and the shape may be changed at any time so long as the tip

doesn't get too short. A very short tip is difficult to use, and gets too hot.

Soldering irons are rated according to their electric power consumption, all the way from 20 to 200 watts. From top to bottom of Fig. 10 the sizes are respectively 100, 60, and 50 watts, these being the ones most often used in service shops. Fig. 12 shows a light

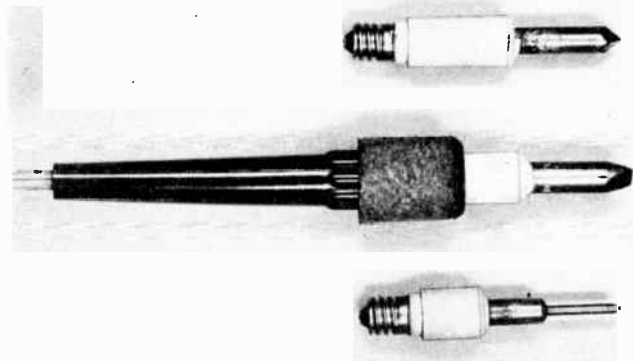

Fig. 12. A small soldering iron with heaters and tips that can be screwed into the handle.

weight 20-watt soldering iron which is convenient for small work of all kinds. The tip and heating element are made as a single unit that screws into the handle like a small electric lamp bulb.

In addition to a soldering iron you will need diagonal cutting pliers, as pictured at 1 in Fig. 13, for cutting off wires and spaghetti. These pliers are called diagonal because the sharp edges of the cutting blades are at an angle with the handles. It is necessary also to have pliers for holding wire ends, bending them, and getting wires into and out of terminal lugs or any tight places. Most technicians use long nose pliers, of which one size is shown at 2. Of great usefulness in among the intricate wiring of television chassis are the needle nose pliers with extra long jaws illustrated at 3.

Solder is a mixture of tin and lead in various proportions, usually with a small quantity of antimony added. Pure tin melts at  $450^{\circ}$  F., pure lead at  $621^{\circ}$  F. Solder mix-



## LESSON 3 – HOW TO MAKE WIRING CONNECTIONS

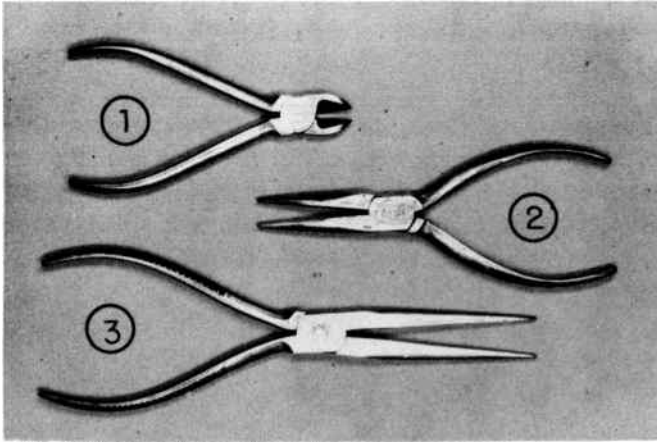

Fig. 13. Types of pliers which are convenient for soldering operations.

tures melt at various temperatures from 360° to 370°, and become completely liquid between 360° and 485° F., depending on the composition.

Heat and solder alone will not make a good soldered joint, because when wires and other parts are heated their surfaces almost instantly become oxidized, and the oxide prevents the solder from uniting closely with the other metals. The oxide must be removed by using some kind of soldering flux. For television and radio, and for most other kinds of electrical work as well, the most satisfactory flux is rosin or some of the rosin compounds sold for this class of work. Fluxes made with acids of any kind work faster and more energetically than rosin, but the acid fluxes cause the joint to corrode sooner or later. Then the electrons have a hard time getting through.

Flux may be put onto a joint with any convenient small tool before or while the heat is applied, but a more convenient method is to use rosin core solder. This consists of a small tube of solder metal having the inner opening or core filled with flux. The flux, in suitable quantity, runs out of the core onto the joint when you apply heat. Cored solder 1/16 inch in diameter is easy to use on small joints, where a minimum quantity of solder metal should be added. Larger diameters may be used for heavy work.

For certain classes of work it will be

necessary, or at least desirable, to use a non-corrosive soldering paste. Such pastes come in cans or jars. They are put onto the joint, not onto the soldering iron, in very small quantity just before the iron is used. Paste is a great help when it is necessary to solder to any untinned copper wires or directly to the surfaces of chassis metal and other parts which are coated with cadmium or other non-rusting coverings which do not take solder easily.

It is easy to solder onto copper, brass, bronzes of most kinds, and metals coated with zinc, tin, lead, or mixtures of these things. You cannot solder directly to steel or iron with any ordinary equipment. Soldering to aluminum requires special flux and a high-temperature iron.

Before an iron can be used the point of the tip must be tinned, which means to coat it with a thin layer of solder. New tips sometimes come with tinning applied. All tips gradually oxidize and become pitted or rough, which calls for retinning.

While the iron is cool use sandpaper to clean the point down to bright metal. If the tip is very rough or is burned out of shape it will be necessary to use a fine file for cleaning and shaping. Then connect the iron to a live outlet, and while it is heating, occasionally try rubbing the end of a piece of cored solder onto the point, until temperature becomes high enough to melt the solder and cause it to spread over the cleaned surface. Some men prefer to clean and tin only two opposite sides of a pyramid or chisel shaped point, so that solder won't get where they don't want it in case the uncoated surfaces touch other metal.

**SOLDERING THE JOINTS.** To prepare an insulated wire for soldering, the end of the conductor must be bared for a length of 1/4 to 1/2 inch, depending on how much will extend into the joint. Some hookup wire is of the "push-back" type, with which the insulation may simply be pushed back from the cut end to expose the conductor. The wire which is numbered 2 in Fig. 7 is a push-back variety. Originally the insulation was as long as the bared end. When pushed back, the insulation bunches up, as you can see in that

## COYNE - *television home training*

picture, and may be pushed forward again after the joint has been completed.

Other kinds of insulation are cut with a knife blade, then pulled off the end of the wire: Do not make a square cut, as at the top of Fig. 14. This is sure to nick the wire



Fig. 14. The ends of insulated wires should be bared or "skinned" with tapering cuts, not square cuts.

and to weaken it out of all proportion to the depth of nicking. If a nicked wire is held securely by solder close to the nick, the wire is almost certain to break off when it is moved once or twice. Cut the insulation as though you were trying to make a long taper, as in the lower picture. Or small wires you won't be able to see the taper so clearly, but cut with the blade of the knife or other tool almost flat against the length of the wire.

Plastic insulation, not combined with fabric, can be removed by squeezing the end of the wire between flat jaws of any pliers. The plastic will break or crack through, lengthwise of the conductor, after which the insulation may be bent outward and snipped off with the diagonal cutters.

With two or more layers of fabric insulation it is advisable to draw the knife along only one side of the wire, instead of trying to make a cut all the way around. Then the insulation may be pulled away from the conductor and snipped off.

Wire used in coils and some other parts, not for hookup purposes, may be insulated with baked-on enamel. The enamel coating

may be scraped away with a knife blade, or removed by rubbing it off with a small piece of sandpaper folded over the wire end. It is necessary to get down to clean, bright copper.

With shielded wire such as shown by Fig. 8 the inner conductor will be used for the principal circuit connections, but nearly always the shield must be electrically connected to chassis metal. Wire such as shown by the upper picture is handled as follows:

Loosen the end of the shield from the insulation with a small pick, then push the back until it bunches where the conductor and shield are to be separated. Bend the wire double at the point where the shield is bunched, and use the pick to make an opening through the braid large enough to pass the insulated wire. Break no more of the shield strands than necessary. Push the pick through under the insulated wire, and pull the free end of the wire out through the shielding. Bare the end of the inner conductor as usual, leaving about 1/4 inch of insulation extending beyond the shield. Twist the loose end of the shielding so that it may be soldered like a bare wire.

Any joint is supposed to be made mechanically secure against loosening before solder is applied. This has been done at 1 in Fig. 15, where the bared end of the wire has been passed through the lug and bent around on itself. Solder has very little mechanical strength. Its purpose is only to make effective electrical contacts. At 2 the joint has been completed with the minimum amount of solder which fully covers the wire end and the part of the lug through which the wire passes.

When you are ready to apply solder, first wipe the tip of the soldering iron on a piece of coarse cloth in order to have the tip and its tinning appear bright and clean. Do this every time the iron is to be used. The clean point of the iron tip should be held so that it touches and heats both the wire and the part to which the wire will be fastened. Both must be made hot enough to cause solder to flow into and through the joint. It may be necessary to start the flow by momentarily touching the end of the solder to the tip of the iron,

## LESSON 3 – HOW TO MAKE WIRING CONNECTIONS

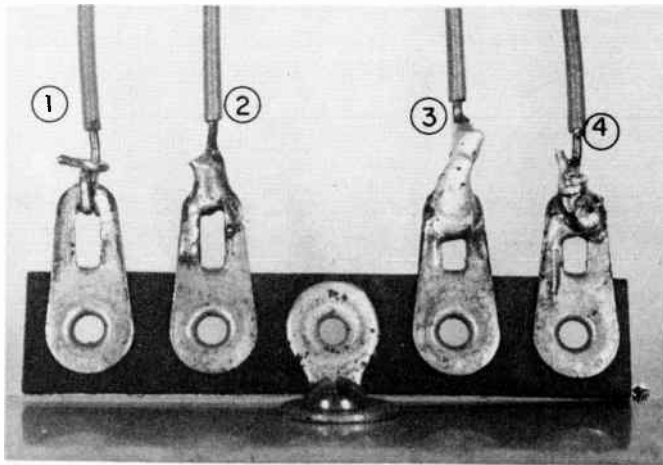

Fig. 15. The making of a good soldered joint, and two bad joints.

but then the solder should be applied to the joint, not to the iron.

Although the solder should cover the wire end and the part to which it connects, avoid using any more solder than will do this. Entirely too much solder has been applied to the joint at 3 in Fig. 15. This does no particular electrical harm, but it makes "sloppy" looking work. Make certain that there is no relative movement between the wire and the part to which it fastens until after the solder sets. The solder has set when its surface changes from shiny bright to relatively dull.

It is essential that both elements in the joint be made hot enough for solder to flow freely. This calls for a hot iron. The joint at 4 was made either with an iron not hot enough or else with one whose tip had not been wiped clean. The solder has been merely pasted on. This usually causes a "rosin joint" or a cold joint with little or no electrical contact, since rosin is a very good insulator. A bad joint could result also from letting either the wire or the lug move before the solder sets.

Not always realized is the fact that the temperature of the tip should be high enough to bring parts to soldering temperature in the least possible time, that solder then should be applied as quickly as possible, and the tip taken off the joint. The reason is that heat from the iron then won't have much time for getting into parts to which the wire is connected. Capacitors, small inductors, crystal

diodes, and many other small parts can be ruined by overheating them. Heat travels rapidly through copper, and thus may reach the delicate parts in damaging amount if you have to wait unduly long for the solder to melt and flow.

High heat is especially necessary when two or more wires are held in a single lug or terminal. Solder must flow onto every wire, and all through the joint. After each joint is finished, and the solder is well set, make it an invariable rule to pull on each wire with your pliers. You will discover that many wires still are loose, until you realize the importance of sufficient heating. With an iron of given power rating, in watts, a short tip or a thin tip will run hotter than one that is longer or thicker. High heat is necessary also when soldering to untinned copper wires. Such wires always require scraping clean with a knife blade or sandpaper just before the soldering is done.

Untinned wires or any leads which prove difficult to solder often may be pre-tinned to advantage. First scrape the wire or part down to bright metal. Lay it over the edge of the bench, held on the bench with some fairly heavy tool, then apply to the lead a thin coat of solder. Paste flux may be used in stubborn cases.

When a lead or a "pigtail" on some small part is not long enough to make a desired connection we use the method illustrated at the left in Fig. 16. The short pigtail and an

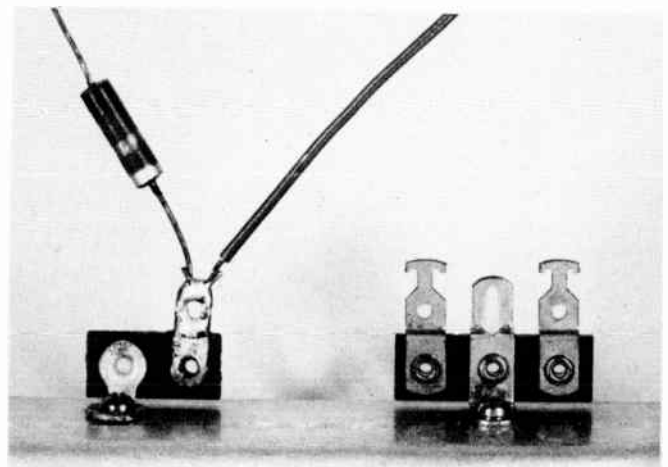

Fig. 16. Two or more wires or leads may be joined together on a terminal strip.



## COYNE - *television home training*

extension wire of any length are soldered together into the same lug of a terminal strip or tie strip. Many such strips, with various numbers of lugs, will be found in almost every chassis. A 4-lug terminal strip was used to illustrate the joints in Fig. 15.

The lugs on a terminal strip are fastened to and supported by a piece of insulation. This insulation is, in turn, fastened to the chassis by one or more screws or in any suitable way. Note that in Fig. 15 and at the left in Fig. 16 all the lugs to which wires are fastened are completely insulated from chassis metal. At the right in Fig. 16 is a 3 lug terminal with which the center lug is part of the bracket attached to the chassis. Any wires soldered to this center lug then make electrical connection with chassis metal, while those on the two outside lugs are insulated from the chassis. The chassis, being of metal, is used as an electrical conductor in many circuits.

It is poor practice to extend a wire or lead by soldering a piece of wire to it with no other support. Should you have to do this, twist the conductors together and make certain that each twists around the other. Do not twist one conductor around another one which remains straight. Solder the joint, then cover it with a piece of spaghetti.

Some of the lugs on some tube sockets may be used as tie points for wires. There are quite a few tubes having more base pins than internal elements, or having base pins in only part of the positions for which there

are openings and terminal lugs on standard sockets. The socket lugs not needed for connections into the tube elements then make convenient tie points for wires in other circuits.

Electrical connections to chassis metal sometimes are made without the use of a regular terminal strip as at the right in Fig. 16. One method is shown at 1 and 2 of Fig. 17. Using a hot iron, paste flux, and some rubbing of the iron on the chassis, it is possible to deposit a small "blob" of solder where the connection is to be made. Then the tip of the iron is used again to melt this solder sufficiently to take the end of a tinned conductor. In many chasses there are numerous small projecting nibs punched in the metal for the express purpose of soldering wire ends to them. Chassis metal is coated with zinc, cadmium, or alloys which take solder. Chassis connections may be made also as at 3, by holding a solder lug tightly to the metal by means of a screw and nut, the nut always being secured by a lock washer.

At 4 in Fig. 17 a small bracket has been "sweated" to chassis metal. First deposit on the chassis a spot of solder at least as large in area as the bracket surface to be attached. Use the same method as described for illustrations 1 and 2. Then coat with solder the bracket surface which is to go on the chassis. Finally, hold the bracket firmly in place by means of pliers, and hold the tip of the hot iron on top of the bracket until the two layers of solder melt and run together. It is absolutely necessary that the bracket be held

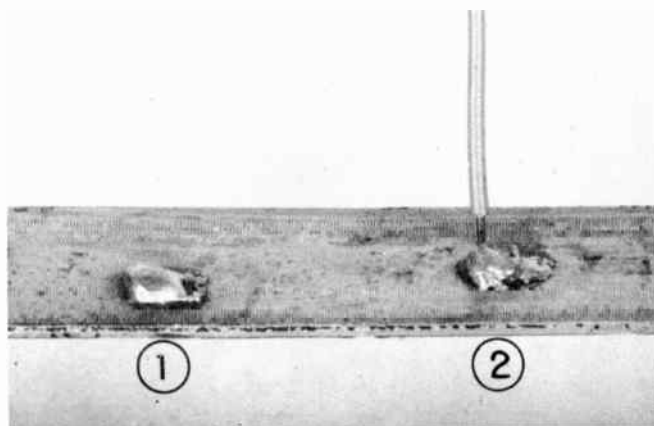

Fig. 17. Left - How electrical connections may be made to chassis metal.

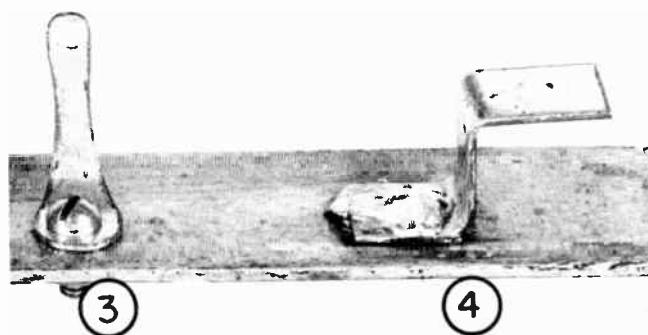

Fig. 17. Right - How electrical connections may be made to chassis metal.

## LESSON 3 – HOW TO MAKE WIRING CONNECTIONS

with no movement until the solder is well set.

When a defective part is to be removed and replaced with a new one, or when a connection must be opened for making certain tests, it may be necessary to know how to unsolder as well as to solder. This is necessary only when the part removed is to be replaced in the same position or, for any reason at all, is to be removed without shortening its leads. Otherwise it is far more economical of time to cut the leads free from terminal strips or lugs, using the diagonal cutters. Even when a part is to be used again, if its leads are reasonably long they may be cut free. This will leave part of the lead still soldered into the terminal or lug. Often it may be pulled out by grasping the exposed end with pliers and heating the solder. Otherwise it is possible to make an opening large enough for a new lead by heating the terminal or lug while poking through it with a fine pointed tool.

To remove a lead intact from a terminal or lug the end will have to be untwisted and partially straightened out. Tools such as illustrated by Fig. 18 are helpful. At the top

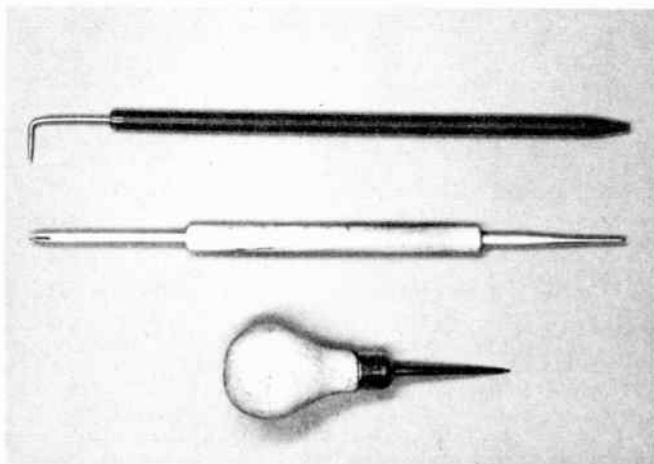

Fig. 18. Tools which are handy when removing wires or leads from soldered joints.

is a sharply pointed hook held in a fibre handle. At the center is a tool having one end forked and the other a pick which is flat on

one side and rounded on the other. The fork can be slipped over the end of a twisted wire and the wire unrolled or straightened quite easily. At the bottom of the figure is a tapered pick with a sharp point.

First it is necessary to determine the direction in which the end of a lead is twisted, and usually this requires removing some of the solder. If the chassis can be tilted, hold it so that melted solder will run down onto the tip of a hot iron, then shake the solder off the tip before going after more. Otherwise, place a piece of coarse cloth under and around the joint, and use a small, stiff, bristle brush to carefully remove solder immediately after it is melted. If you accidentally brush particles of solder into other parts of the chassis it may mean plenty of trouble later on.

Heat the joint for only a few moments at a time, to avoid damaging the parts to which the leads connect. Remove some of the solder, or pick and turn the ends of the leads as much as possible before the solder sets. Then repeat the operation. You are quite likely to spend a half hour of time saving a ten cent part, so don't try to preserve the leads unless it is really necessary.

It happens that all of the new words and the many operations explained in this lesson apply equally to service work in the fields of television, sound radio, and commercial or industrial electronics. Here is the list of words and terms. Can you give a brief definition or description of each one?

Conductor	Rosin joint, or cold joint
Electricity	Shielded wire
Electric current	Solders
Flux, soldering	Spaghetti
Free electrons	Sweating
Enameled wire	Tie strips
Hookup wire	Tracer colors
Insulation and Insulators	Wire gage
Cross sectional area	
Push-back wire	





# TELEVISION

• RADIO

• ELECTRONICS

---

LESSON 4 – THE PARTS OF WHICH RECEIVERS ARE MADE

---

***Coyne School***

*practical home training*

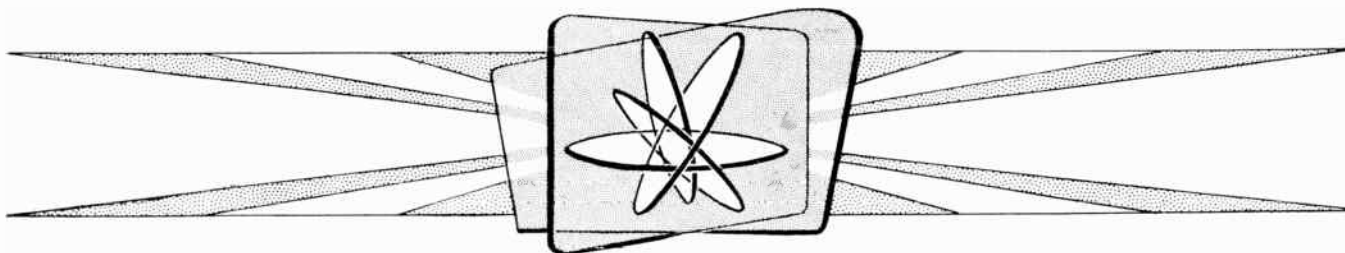

*Chicago, Illinois*

---

*Copyright, 1954 by Coyne Electrical School  
Chicago 12, Illinois  
All rights reserved.*

Litho. in U.S.A

## Lesson 4

### THE PARTS OF WHICH RECEIVERS ARE MADE

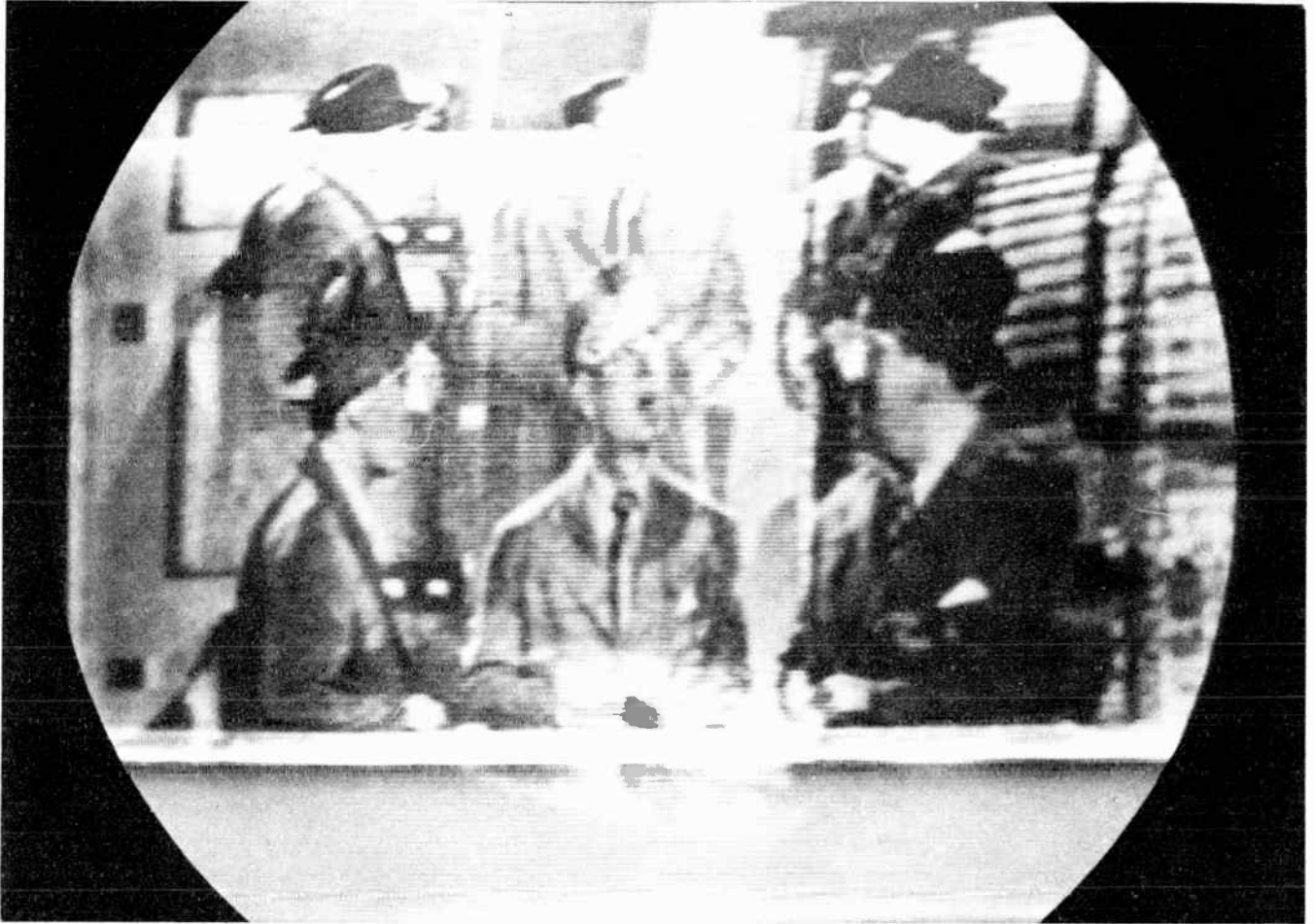

Fig. 1. When pictures look this way the technician looks for trouble in the vertical deflection system.

Television servicing seems simple to the trained technician, but to the novice it appears immensely complicated. It's all in the way they look at things. The technician knows how all of the hundreds of individual parts work together in small sections, each section doing a certain job. If pictures on the television screen appear like Fig. 1, the technician looks first for trouble in the section which deflects the electron beam from top to bottom in the picture tube.

This vertical deflection section need not be all in one place. Even though its parts are spread through much of the chassis, they still work together as a group. In Fig. 2 there are circles around everything under-

neath a chassis which is directly concerned with vertical deflection. The section doing any other certain job may be picked out similarly.

Servicing is immensely simplified by having to deal with only one section at a time. It is made even simpler by the fact that, no matter which section you consider, it can consist of only some combination of two or more of these parts.

- |               |               |               |
|---------------|---------------|---------------|
| 1. Tubes      | 3. Resistors  | 5. Capacitors |
| 2. Conductors | 4. Insulators | 6. Inductors. |

These are the six things which make it possible to receive all television and radio



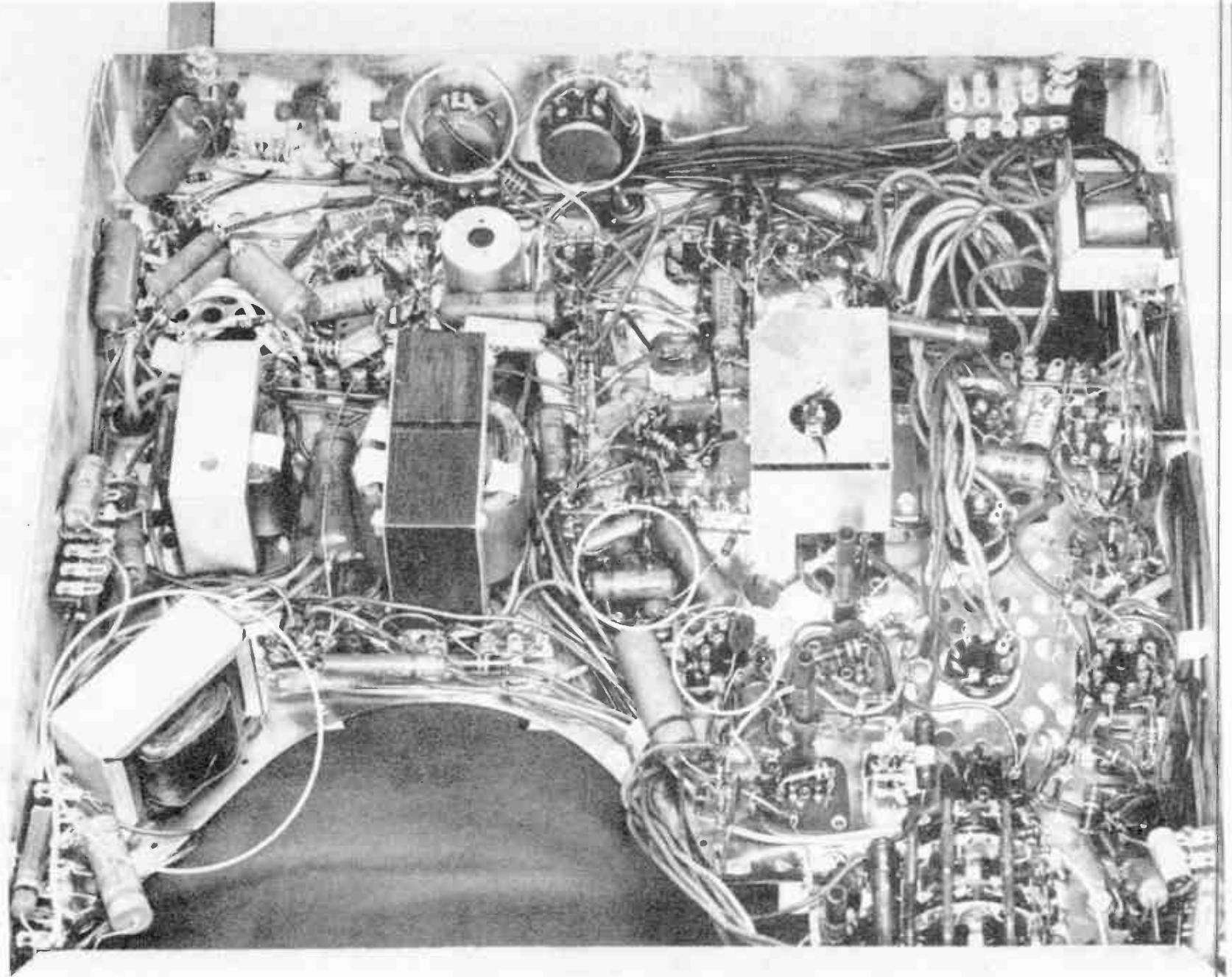

Fig. 2. The parts in which trouble may exist can be widely separated, but they work together as a group.

## LESSON 4 — THE PARTS OF WHICH RECEIVERS ARE MADE

programs. Were you to remove from a receiver everything which may be classed as one of these basic units, the remainder would consist of the cabinet and enough small parts to fill a cigar box. Not even the chassis would remain, for it is among the most important of the parts which we class as conductors.

Each of our six basis parts does a particular job which is necessary for reception. Here are the jobs.

1. Tubes regulate or control the flow of electrons.

2. Conductors, which may be wires or other metallic parts, provide paths for flow of electrons.

3. Resistors really are a special variety of conductor. They are conductors because they allow electrons to flow in them, but they make it difficult for the electrons to flow. Resistors retard or limit the flow of electrons when this is necessary.

4. Insulators prevent escape of electrons from paths in which the electrons should flow. It is practically impossible for electrons to flow in an insulator.

5. Capacitors, so far as electrons are concerned, are like tanks for water or for compressed air. You can put greater or less quantities of electrons into a capacitor, just as you can put greater or less quantities of water or air into a tank. The capacitor will retain the electrons, and later discharge them

6. Inductors usually are coils of wire. They affect the flow of electrons in much the same way that weight affects the movement of more familiar things. If you have a heavy ball of iron, concrete, or anything else, the weight makes it hard to get the ball rolling. Once the heavy ball is in motion, the weight makes it hard to stop. An inductor acts that way for electron flow. When the flow tries to increase, the inductor tries to prevent the increase. But when flow of electrons in the inductor tends to decrease, the inductor tries to continue the original flow rate.

Although we deal with only six basic kinds of parts, there appears to be an almost endless variety because each kind may be constructed in many different ways to suit many particular applications. Several types of resistors are illustrated by Fig. 3. No

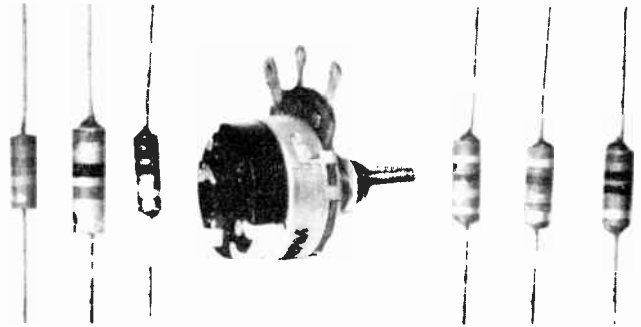

Fig. 3. Resistors may be of various types and shapes.

matter what the form, all are resistors and all oppose the flow of electrons.

We have this situation in every field of work. For example, carpenters and cabinet makers use a great variety of wood screws. There are long screws and short ones, there are round, flat, and oval heads, some screws are made of steel and others of brass. Each kind is just right for some particular application, but the primary purpose always is to hold parts together.

Capacitors may be made in many different ways, but all of them are "electron tanks" for receiving, holding, and discharging electrons. Fig. 4A&B show a few styles. When

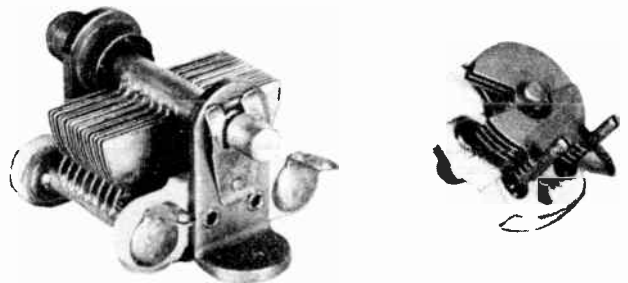

Fig. 4A. No matter how capacitors are constructed, their fundamental principles are the same.

## COYNE - *television home training*



Fig. 4B. Another type of capacitor

you know the operating principles of capacitors in general, the type of construction makes no great difference in understanding what must happen.

It is the same with inductors or coils. There are big ones and little ones, long ones and short ones, thick ones and thin ones. At the left in Fig. 5 are inductors of a style commonly used in television receivers, and at the right is a type found in many radio receivers. No matter how the wire is coiled or how it is supported, we still have an inductor which opposes every change of electron flow. The inductor tries to keep the flow from either increasing or decreasing.

It is hardly necessary to illustrate conductors, for every piece of metal is a conductor in which it is easy for electrons to flow. A piece of metal such as a bracket or stud might be used solely for supporting some part, and not for carrying electrons from place to place. Although that particular metal is not being used as a conductor, it could act as a conductor if necessary. It could remain as a support and be used also as a conductor if that were convenient in designing a receiver.

There is one substance commonly used in television and radio apparatus which is not a metal, yet is a conductor. This substance

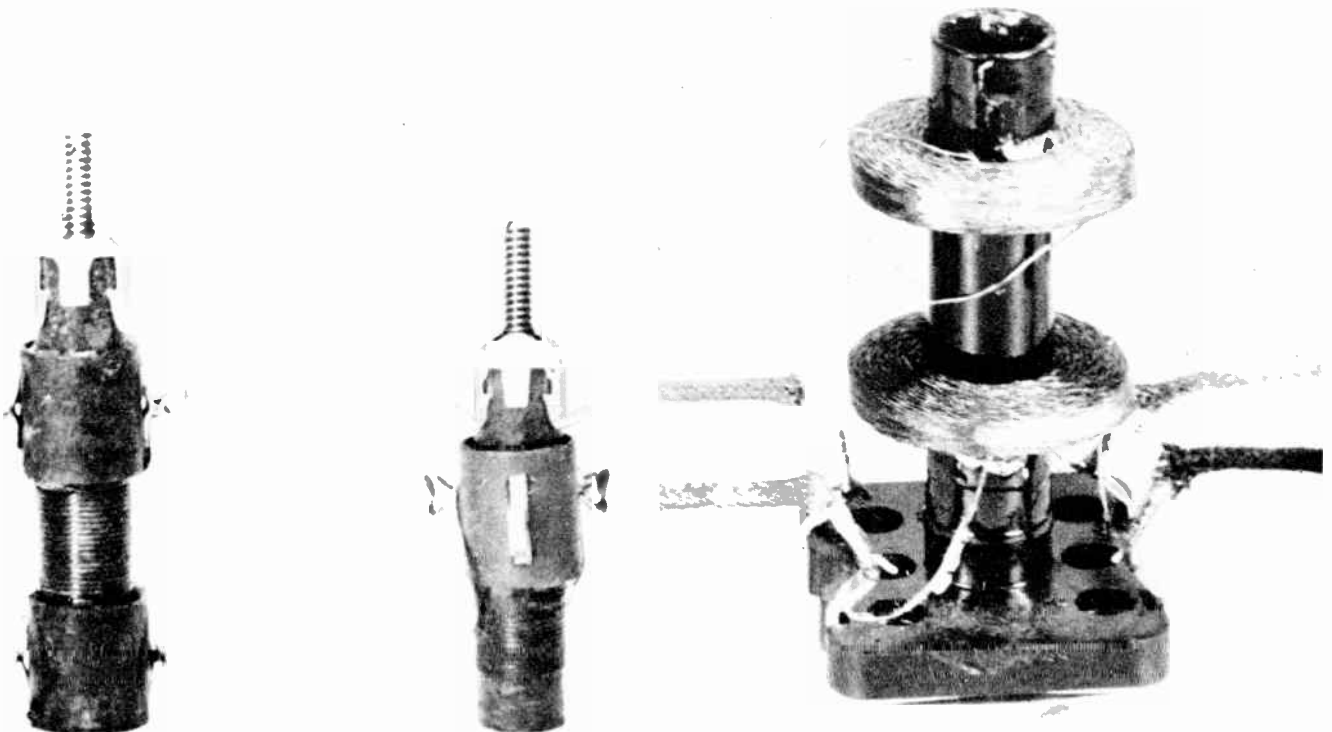

Fig. 5. Inductors or coils of kinds used in television and radio receivers.



## LESSON 4 — THE PARTS OF WHICH RECEIVERS ARE MADE

is carbon. Although carbon will allow electrons to flow in it, the carbon has a lot of opposition to such flow. Depending on the grade and hardness of the carbon, it is from 500 times to maybe 3,000 times as difficult for electrons to flow in the carbon as in a piece of copper wire having the same dimensions.

Because of its great opposition to electron flow, while still allowing the flow to continue, carbon of one variety or another is found in many resistors. All of the resistors in Fig. 3 contain carbon to oppose flow of electrons.

Conductors are of great interest in television and radio apparatus for the reason that every part which is doing or can do any active work contains conductors. All resistors contain a conductor, either carbon or else some mixture (alloy) of metals which has more than ordinary opposition to electron flow. All capacitors contain conductors. In the capacitors in Fig. 4B the conductors are thin sheets of metal rolled up inside where you cannot see them. You can see plainly that the capacitors on page 3 consist chiefly of thin plates of metal separated by air spaces.

All inductors are made with conductors, because the metal wire of which the coils are made is a conductor. The parts which are inside a tube are made of metal and are conductors. You can see these metal parts and their metal supports in Fig. 6, where the outer bulb or envelope has been removed from a tube.

When it comes to insulators we may say, in a broad sense, that everything which is not a conductor is an insulator. This would be the same as saying that everything not made of metal or carbon is an insulator. Of course, there are differences in the effectiveness of various materials as insulators. For instance, ordinary fibre does not confine electrons nearly so well as glass and some other materials in damp localities. However, both fibre and glass are classed as insulators, for it is very nearly impossible for free electrons to move in either of them under ordinary conditions.



Fig. 6. The elements inside a tube are conductors because they are made of metal.

Just as conductive metals may be used for supports rather than as conductors, so insulating materials often are used as supports instead of for their ability to confine electrons. Also, there are many solid insulators which support metallic parts and at the same time prevent electrons from escaping from those parts.

The white material which you can see in Fig. 4 is ceramic insulation which both supports and insulates the capacitor plates. The coils or inductors of Fig. 5 are supported by solid insulation, while the wire of which the coils are made is covered with flexible insulation. Glass insulation is used in the tube of Fig. 6 to support the wires on which are mounted the metallic elements.

QUANTITIES OF ELECTRONS. By this time you must have noticed that no matter

## COYNE - *television home training*



Fig. 7. Just as people like to move from an overcrowded car to one nearly empty, so electrons like to flow from where there are a great many to wherever there are fewer.

which of our six basic elements we talk about, the discussion always relates to flow of electrons. If you pick up a loose piece of wire or any other metal, or anything of which metal forms a part, the metal contains great quantities of free electrons.

These free electrons are moving from atom to atom, not going anywhere in particular, but just milling around within the metal. There is none of what we call electron flow, for that means movement of all the free electrons in one direction. There is no electron flow because the piece of metal is not connected to anything or influenced by anything which can cause electron flow. Now we intend to find out what will cause all the free electrons to move together in the same direction.

In our piece of metal within which the free electrons are merely milling about in random directions there must be some certain quantity of these electrons, a quantity which depends on the kind of metal and its size. We aren't interested in how many free electrons there are, but only in the fact that the quantity must be that which naturally exists in the kind and size of metal considered. This we shall call the normal quantity of free electrons. When a conductor contains its normal quantity of free electrons, neither more nor less, we say that the conductor is neutral.

It is possible to put into the metal more than its normal quantity of free electrons, just as more people can be crowded into a railway car than the car is supposed to hold. When a car is jam packed with people, as at the left in Fig. 7, all the people would like to get farther apart. If the doors are opened to another nearly empty car, as at the right, enough people will leave the first car and move into the other one to have nearly equal numbers in both cars.

When a conductor contains more than its normal quantity of free electrons, the electrons try to get farther apart. They actually repel one another. If another conductor which is not overcrowded with electrons is touched to the first one, many free electrons will pass into the second conductor, and the quantities will become equalized in both conductors.

**ELECTRIC CHARGES.** There is a name for the condition of too many electrons. We say that the overcrowded conductor has a negative charge. It seems rather strange that a condition of too much of anything is called negative, you would think it should be called positive. The reason for calling an excess of negative electrons a negative charge is that electrons themselves are considered to be particles of negative electricity.

This brings up the question as to why electrons are considered to be negative. Why aren't they positive, which is the opposite of negative? The answer to this is that there is no good reason. It just started out that way, and at this late date it would be too confusing to try changing the name.

When you come to think about it, the name of anything is only the word which you have learned to associate with that thing. Supposing you had been taught, from infancy, that a teacup should be called a bathtub, and that a bathtub should be called a teacup. Then today you would be drinking from a bathtub and taking baths in a teacup. It is this way with the words negative and positive. They were assigned to certain conditions and things long years ago, and there is nothing we can do about it.

If too many free electrons are called a negative charge, what should we call too few free electrons or fewer than the normal quantity of free electrons? The sub-normal

## LESSON 4 — THE PARTS OF WHICH RECEIVERS ARE MADE

quantity must be called a positive charge. Just as we may crowd too many free electrons into a conductor and have a negative charge, so we may take out part of the normal quantity and leave a positive charge.

Imagine two conductors, one having a normal quantity of free electrons (neutral) and the other having too few electrons (a positive charge). When these two conductors are touched together what will happen? What happened in Fig. 7 when the doors were opened between the car having only a few passengers and the one having a great many passengers? A lot of people left the full car and moved into the other one, until both cars had about the same number of passengers.

It is exactly the same with the two conductors. Enough free electrons leave the normally charged (neutral) conductor and go into the positively charged conductor to make the quantities equalize in both conductors. Now give this some careful thought: To begin with, one conductor had too few electrons and the other had only its normal quantity. When you average these two quantities the result is fewer than a normal quantity of electrons in both conductors. Only one had a positive charge in the beginning. Now both are positively charged.

As we have just seen, one way of causing a flow of electrons from one conductor to another is to have unequal charges in the two conductors. Electrons then will flow out of the conductor having the greater quantity and will pass into the one having the lesser quantity. The flow will continue until the quantities become equalized in both conductors.

**CAPACITORS.** The action and usefulness of capacitors depend on electric charges. A capacitor, which acts like an electrical tank, consists of two conductors or of two groups of conductors separated by insulation. One such construction is illustrated by Fig. 8, where picture A shows a complete capacitor as made with two groups of metal conductors. The several conductors in each group consist of thin plates of metal with rather wide air spaces between adjacent plates. All the plates of each group are

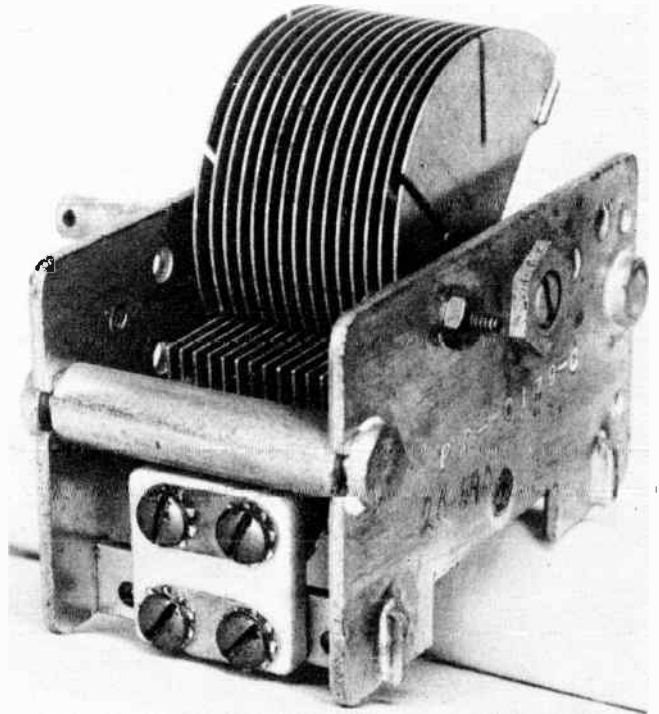

Fig. 8A.

joined together to make what amounts to a single larger conductor.

One group of plates is shown by itself at B. All these plates are attached to the metal shaft that supports them, making one con-

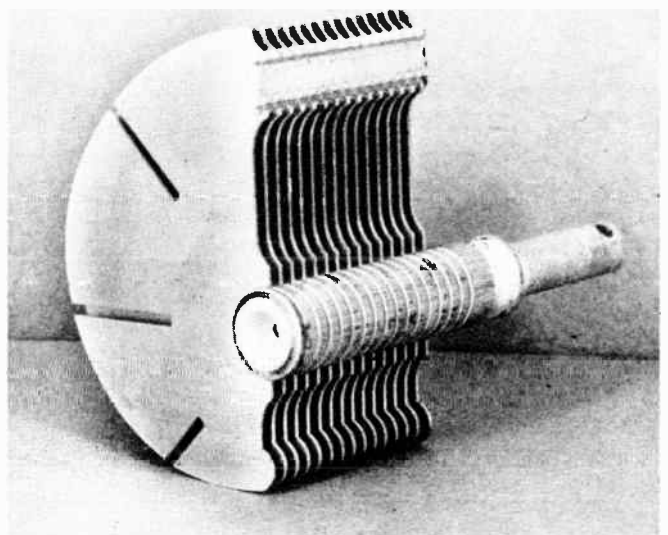

Fig. 8B.



plates with their equal and normal quantities of free electrons are represented by the two parts of a tank, each part half full of water.

We might put additional water into one side of the tank, as at B. This is equivalent, to putting extra electrons into one group of plates of the capacitor, giving that group a negative charge.

If the two sides of the tank now are connected through an external pipe, as at C, water will flow through this pipe from the high-level side to the low-level side, and will continue to flow until the levels are equal in both sides as at D. Similarly, if the two groups of capacitor plates are connected together through an external conductor, such as a copper wire, electrons will flow through this conductor from the negative plates to the neutral plates until the charges become equal in both groups.

Now both groups of capacitor plates will have more than their normal quantities of free electrons, or both will be negative charged. As soon as the two charges become equalized there will be no further flow through the external conductor, any more than there would be flow through the external pipe after water levels in the two sides of the tank become equal.

Next, as at E in Fig. 9, we might take water out of one side of the tank while leaving a normal quantity in the other side. This would be comparable to taking some electrons out of one side of the capacitor, making that side positive, while leaving the other side neutral.

When the two sides of the water tank now

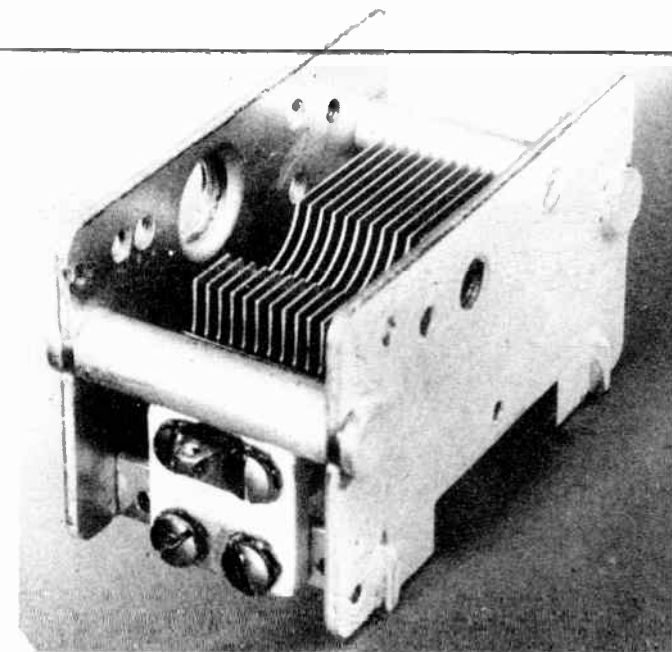

Fig. 8C.

tinuous conductor. In the part of the capacitor that remains, pictured at C, is another group of plates all joined together by small strips of metal along their edges. This second plate group is supported by pieces of solid insulation. There are rather wide air spaces between adjacent plates of this group. When the capacitor is completely assembled, as at A, the plates of one group fit in between those of the other group, but the two sets do not touch each other. They are separated by the air spaces.

After the capacitor has been inactive for some time both groups of plates will be neutral, they will have normal quantities of free electrons. This condition might be illustrated as at A in Fig. 9, where the two groups of

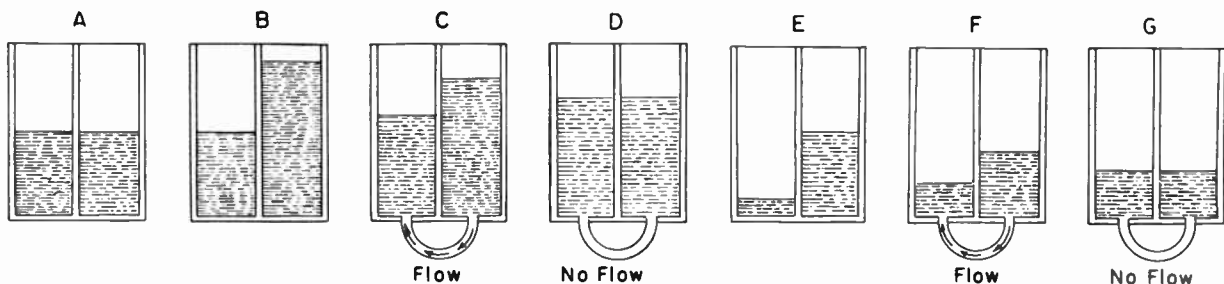

Fig. 9. Electrons flow from a higher to a lower potential or from a greater to a lesser charge, just as water flows from a higher to a lower level.

## LESSON 4 — THE PARTS OF WHICH RECEIVERS ARE MADE

are connected through an external pipe, as at F, water will flow from the side having a higher level into the side having a lower level. Similarly, connecting the two groups of capacitor plates through an external conductor would allow electrons to flow from the neutral (higher level) side into the positive (lower level) side through the conductor.

As soon as the water levels become equal, in diagram G, the flow of water through the external pipe will cease. It was only the difference between levels that caused a flow in the first place. In the case of the capacitor, as soon as the two charges become equal the electron flow through the external conductor will cease, for it was only the difference between electron quantities or charges that caused the flow. Water levels in both sides of the tank now are below normal. Electron quantities in both groups of capacitor plates likewise are below normal, and both groups are positively charged.

It is only in diagrams B, C, E and F of Fig. 9 that water in one side of the tank has the ability to flow through the external pipe to the other side. The only reason why the water has "flow-ability" is because there is a difference between the levels. The greater height of water in the high-level side exerts a greater downward pressure than does the lesser height in the low-level side. Instead of saying that the flow-ability results from a difference in levels, we might say that it results from a difference in pressures, and mean the same thing.

The ability of electrons to flow from one conductor to another results from a difference between quantities of electrons in the two conductors. Electrons always tend to flow from where there are more of them to some other place where there are relatively fewer. The correct name for electron flow-ability is potential. Electric potential is comparable to height of water in a tank or to the level of water in a tank. Electrical potential is comparable also to water pressure. Electrons always try to flow from a greater to a lesser potential.

**ELECTRON PUMPS.** In order to vary the quantities of electrons, and produce elec-

tric potentials, we must have some way of putting more than the normal quantity of electrons into a conductor. Also, we must have some way of taking electrons out of a conductor to leave less than the normal quantity. In other words, there must be some means of charging conductors negatively and positively.

The most common way of moving electrons and producing potentials in television and radio receivers is to use a power supply section. A power supply unit constructed on its own separate chassis is pictured by Fig.10.

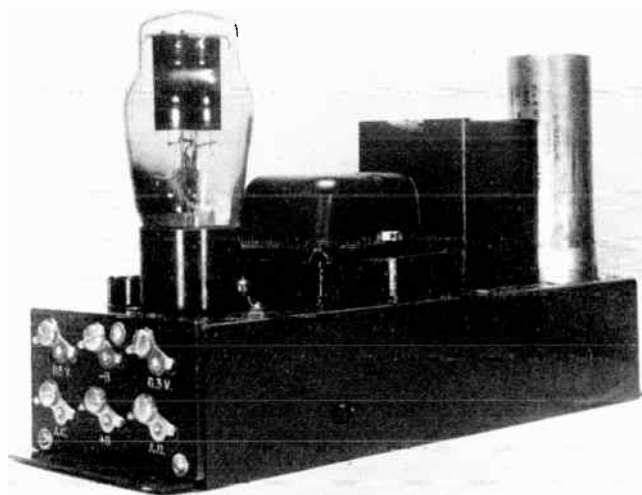

Fig.10. The chief purpose of a power supply unit, such as this one, is to move electrons and produce desired potentials.

The simplest means for moving electrons from one place to another and of producing negative and positive charges is a dry cell of the kind commonly used in electric flash lamps. A dry cell is a sort of electron pump. It pumps electrons away from its positive terminal and toward its negative terminal. The negative terminal of the cell is its outer can or metal container. The positive terminal is the small metal disc or button at the center of one end.

At the left in Fig. 11 the two terminals of a dry cell are connected to two conductors, which are metal plates. When we connect the terminals of the cell through the two wires to the plates, the cell pumps enough electrons into the plate connected to its negative terminal to give this plate a negative charge.

## COYNE - *television home training*

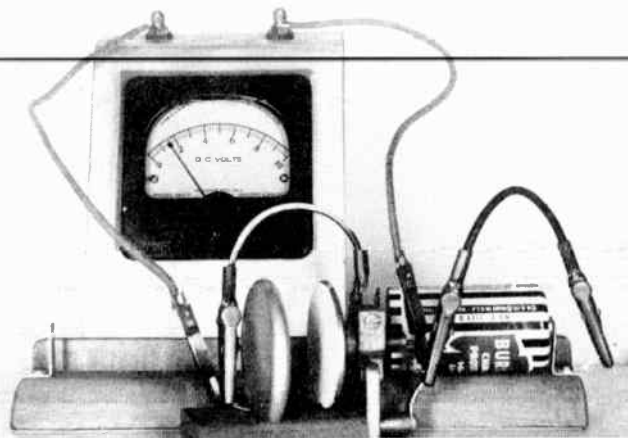
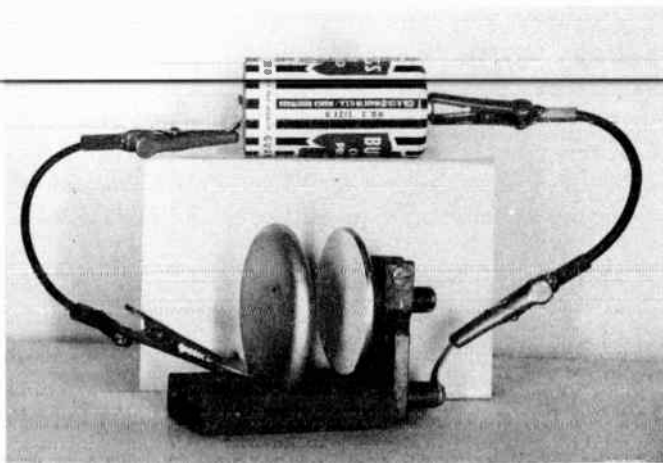

Fig. 11. Because it measures differences of potential, a voltmeter indicates the presence of electric charges.

At the same time the cell is pumping enough electrons out of the plate attached to the positive terminal to leave that plate with a positive charge.

No electrons are furnished by the dry cell any more than water is furnished by the water pump. The pump can send out of one side only the same quantity of water that it takes in on the other side, no more and no less. The dry cell can pump out of its negative terminal only the same quantity of electrons that it takes in at the positive terminal, no more and no less.

The two conductors appear no different when charged than when neutral. Then how do we know that the conductors are charged? We can prove it by connecting a voltmeter to the plates, as at the right. The instrument called a voltmeter doesn't indicate and measure electric charges directly, it indicates differences of potential. But where there are differences of potential there must be differences between electron quantities and there must be charges.

Electric potential is measured in the unit called a volt, hence the name voltmeter. As you can see in the picture, the voltmeter indicates a potential difference of  $1\frac{1}{2}$  volts. Probably you know that this is the voltage of a single dry cell. It is the maximum voltage or maximum potential difference that can be produced by a single cell, and is a measure of the maximum strength of charges that can be produced by one cell. Although the dry

cell and other devices for producing potential differences are electron pumps, we call them voltage sources or simply sources.

To get acquainted with potential differences between conductors when a voltage source is involved, we again may compare electron quantities or charges with quantities of water in the two sides of a tank. As at the left in Fig. 12 we must add a water pump to represent the voltage source that charges the two conductors connected to the source terminals.

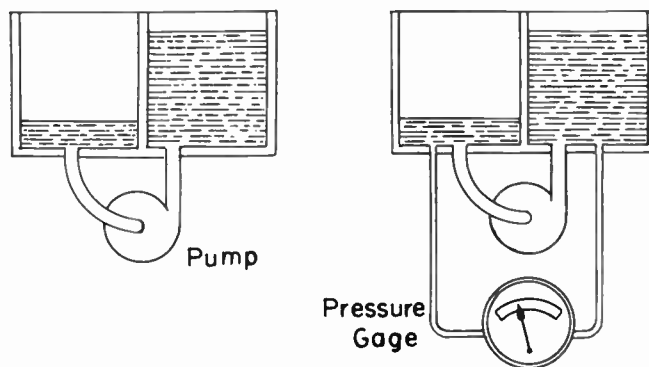

Fig. 12. A pump in a water system is equivalent to a voltage source in an electrical system, and a water pressure gage is equivalent to a voltmeter.

The pump has drawn water out of one side of the tank and has forced this water into the other side, until the level in the second side has been raised as high as the ability of the pump can drive it. Now we have too much water in one side and too little in the other side of the tank.



## LESSON 4 — THE PARTS OF WHICH RECEIVERS ARE MADE

A comparable situation exists in the electrical system when the dry cell has pumped electrons out of one conductor and into the other to the limit of the ability of the cell. Then we have a positive charge in one conductor and a negative charge in the other one. To measure the differences between water pressures in the two sides of the tank we may use a pressure gage, as at the right in Fig. 12. This pressure gage in the water system is the counterpart of the voltmeter in the electrical system.

There is enough difference between pressures in the high-and low-level sides of the water tank of Fig. 12 to make the water flow back into the low-level side. But this backward flow cannot take place because the pump still is working, and is maintaining the difference between levels. Similarly, in the electrical system there is enough potential difference between the two conductors to make electrons flow backward from the negative to the positive conductor. This flow cannot take place because the dry cell is holding the charges where they are.

Should we wish to cause a greater difference between electron quantities, or greater charges in the two conductors, it would be necessary only to use more dry cells as the voltage source. In Fig. 13 the

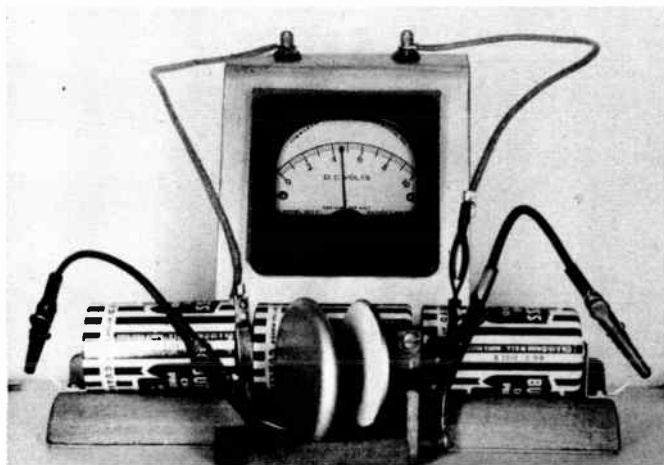

Fig. 13. *Increasing the voltage of the source will increase the difference between charges and will increase potential difference.*

source has been changed to three dry cells and the potential difference is  $4\frac{1}{2}$  volts, which is  $1\frac{1}{2}$  volts per cell. Now there are more

electrons than ever in the negative conductor, and fewer in the positive conductor. Electrons in the negative charge are trying even harder than before to get back to the positive charge, but the stronger source prevents such flow and maintains the charges.

**ELECTRIC FIELDS.** Electrons in the negatively charged conductor don't care how they get back to the positive conductor, just so they get there. Since the electrons cannot get back through the source, they try to pass through the air space between the two conductors.

Although the electrons try, they cannot pass through the air space for two reasons. First, the air is an insulator. Second, the electrons cannot escape through the surface of the negative conductor to get into the air space. We shall help the electrons overcome both difficulties, and the result will be a radio tube.

A radio tube or television tube, as you well know, has on the outside either a glass or a metal bulb or cylinder called the envelope. Almost every bit of air has been removed from inside the envelope to leave a nearly perfect vacuum. This is why we sometimes use the name "vacuum tubes". If our two conductors are inside a tube from which the air has been removed, there is no longer the insulation of air between them and the first difficulty has been removed.

In order to let electrons out through the surface of the negative conductor we must raise the temperature of this conductor to a dull red heat. In addition we must make the conductor surface of some material from which it is easy for electrons to escape when this material is hot.

To see how this is accomplished let's look at the parts of a tube pictured by Fig. 14. The envelope of this tube has been broken away to more clearly expose the internal elements. The outermost element is a cylinder of thin metal. This is the conductor which always is given a positive charge. It is called the plate of the tube.

At the very center of the tube is a small metal cylinder coated on its outside with a

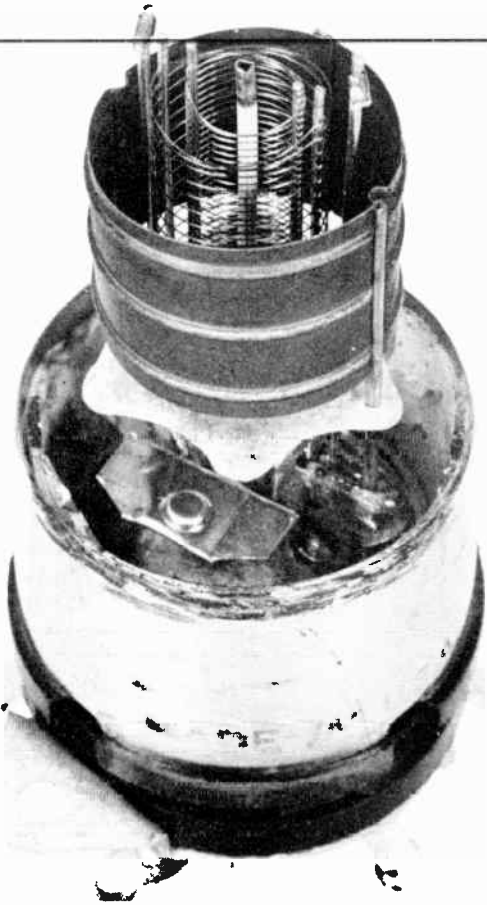

Fig.14. One of the elements of the tube is a cylindrical metal plate, and another is a cathode from which electrons are emitted.

white substance. This central cylinder is given a negative charge. The white substance is that from which electrons easily escape when it is hot. This part of the tube is called the cathode.

Between the cathode and plate are spirals of small wire which, as we shall learn later, help to control the flow of electrons in the tube. Inside the cathode cylinder is a heater wire through which electricity is passed to make the heater, the surrounding cylinder, and the cathode material red hot. When the envelope of the tube is in place and evacuated we have within the envelope a negative conductor, the cathode, from which electrons may escape and flow through a space to a positive conductor, the plate.

When a source of voltage is connected to the tube in such a way as to make the plate

positive with reference to the cathode, there will be electron flow from the cathode to the plate through the evacuated space. It is the heat that causes electrons to boil out of the cathode surface, much as steam or water vapor boils out of the surface of heated water. This boiling of the electrons out of the cathode surface is called electron emission. We say that the electrons are emitted.

It isn't the heat or the boiling that drives the emitted electrons from near the surface of the cathode through the space to the plate. This is caused by an invisible force that is acting in the space between plate and cathode. With the plate positive with reference to the cathode, the plate exerts strong attraction on the emitted electrons and pulls them through the space. This attraction extends all the way through the evacuated space and acts on the electrons emitted from the cathode.

In the space wherein we have the force of attraction between positive and negative conductors there is said to be an electric field. An electric field means simply a space in which there is a force which will cause electrons to move when conditions make such movement possible. The electric field is there whether or not there can be electron flow through it. We may represent an electric field as in Fig. 15. There are electric

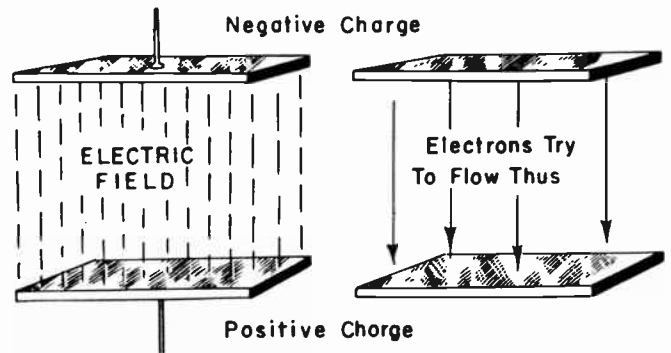

Fig.15. Electrons try to flow through an electric field from the negative charge in the positive charge.

fields between the positive and negative conductors of Fig.11 and 13, even though there is no electron flow through the fields. The force in a field always acts in a direction which should cause electrons to move through the field toward the positive conductor.

## LESSON 4 – THE PARTS OF WHICH RECEIVERS ARE MADE

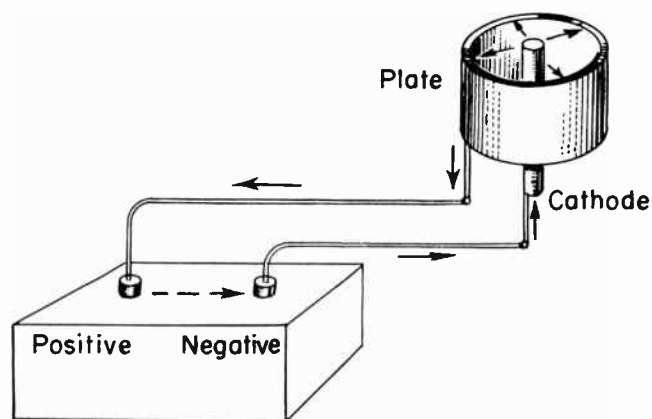

Fig. 16. Directions of electron flow in a source, the elements of a tube, and the connecting wires.

**ELECTRIC CIRCUITS.** In Fig. 16 are represented the plate and cathode of a tube, also a source in which are a number of dry cells working together, and wire conductors between the battery and the tube elements. The direction of electron flow is shown by arrows. From the negative terminal of the battery the flow is to the cathode of the tube. Electrons flow inside the tube from cathode to plate, and from the plate they return to the positive terminal of the battery. Inside the battery the electron flow is from its positive terminal to its negative terminal. We have here an electric circuit.

A circuit is any path in which electrons flow or may flow. The parts shown by Fig. 16 might be called a plate circuit, because they include the plate of the tube. Strictly speaking, a circuit should include a source of voltage which causes electron flow. In common practice, however, we usually call any conductive path a circuit whether or not a source is included. The parts in the diagram still might be called a plate circuit even were the battery removed.

**AN AMPLIFIER CIRCUIT.** As we learned earlier, one of the principal uses of tubes in television and radio receivers is to strengthen or amplify the signals. To amplify means to increase the voltage. A signal going into one end of an amplifier may have a potential difference of one volt, and may come out the other end with a potential difference of ten volts. To see how some of our recently acquired information applies to

the process of amplification we shall examine a real voltage amplifier.

Fig. 17 is a picture of the amplifier system. The tube at the left is the amplifier tube. Over at the right is a power supply unit which is the voltage source for the amplifier circuits. Near the amplifier tube are a large resistor and a smaller one. The voltage to be strengthened is applied across the smaller resistor, and the amplified voltage appears across the larger one.

In the center of the amplifier setup is a meter. This is not a voltmeter for measuring voltage, it is a meter for measuring rates of electron flow. It is important to understand that a rate of flow is not the same as a rate of speed. Here is an example. Supposing that the rate of water flow in a pipe is ten gallons per minute. This tells nothing about the speed of the water. Were the pipe a big one we could have a flow rate of ten gallons per minute with the water moving at slow speed through the big pipe. But were the pipe a small one, the speed of the water would have to be much faster to have the same rate of flow.

When talking about movements of free electrons through conductors or spaces we have been using the term "electron flow". This is strictly correct, but it is far more common practice to apply the name "current" to such movements of free electrons. In the future we shall use either or both of these names. Just remember that current and electron flow are merely two names for the same thing.

The rate of electron flow or the current may be measured in a unit called the ampere. When electrons move past some point in a circuit at the rate of a certain quantity per second, the current or the rate of electron flow at that point is one ampere.

A current of one ampere in the circuits of television and radio receivers would be considered very great. Most receiver currents are so small as to be measured in thousandths of an ampere. One one-thousandth of an ampere is called a milliamper. The meter of Fig. 17 is a milliammeter, because its scale is marked in numbers of milliamperes



## COYNE - television home training

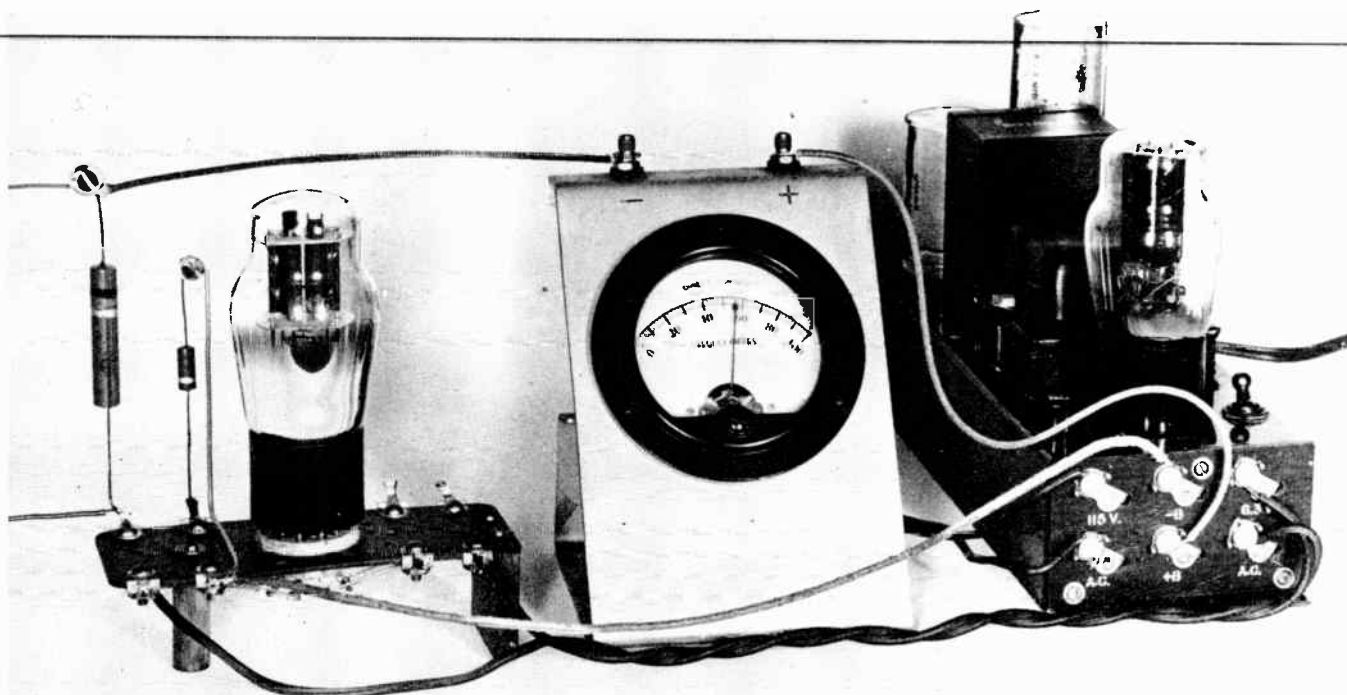

Fig. 17. From left to right this setup includes a voltage amplifier tube, a current measuring meter, and a power supply unit.

and it is designed to measure only small currents.

In some television and radio receiver circuits the current is so small as to be conveniently measured in millionths of an ampere. One one-millionth of an ampere is called a microampere. A meter for measurement of microamperes of current is called a microammeter. Fig. 18 shows the dial scale of an instrument having a maximum range or

max. range of 50 microamperes, which is 50/1000000 of an ampere.

Electrons flowing at a rate of one ampere in wire of the smallest size used for electric lighting lines in homes (number 14 gage size) move at a speed somewhat less than 3-1/4 inches per second. In larger wire the speed would be still slower for the flow rate of one ampere, and in a smaller wire the speed would be faster in order to have the same rate of flow.

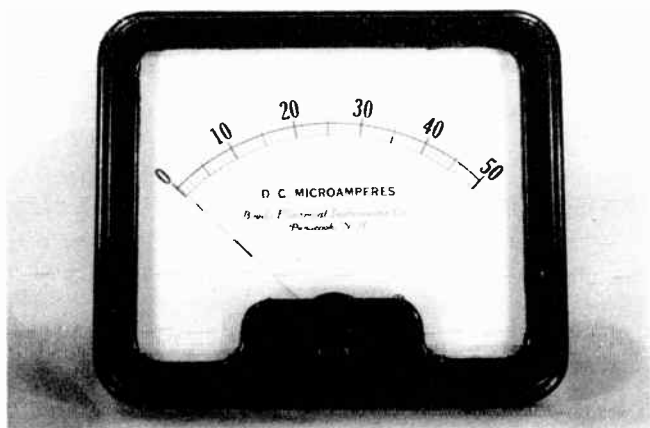

Fig. 18. A current meter which will indicate flow rates in millionths of an ampere or in microamperes.

People often mistakenly say that electricity travels through wires with the speed of light. They confuse electricity (electrons) with electromagnetic waves such as carry television and radio signals through space. These radiant waves do travel at the speed of light, but electricity barely crawls through wires.

Since electrons move so slowly, you may question why an electric lamp in one room of a building lights at the same instant a switch is closed in another room, or some place even farther away. This happens for the same reason that water in the entire length of a pipe leading away from a valve com-

## LESSON 4 — THE PARTS OF WHICH RECEIVERS ARE MADE

mences to move at the same instant the valve is opened.

Any particular particle of water may take a long time to go all the way from the valve to the far end of the pipe, but water already at the far end commences to move as soon as the valve is opened. Wires in a lighting circuit or any other circuit always are full of free electrons, just as a pipe may be full of water. The instant you close a switch anywhere in an electric circuit containing a voltage source, all the free electrons in the circuit commence to move at the same time. The effect of the electron movement appears far from the switch. But this effect is not due to electrons flying at the speed of light from the switch to a lamp.

Electrons moving through a vacuum, as between the elements inside a radio tube, may reach tremendous speeds. In the tube whose internal elements are exposed in Fig. 6 the distance from the central cathode to the outer cylindrical plate is about  $3/8$  inch. Were there to be 200 volts between cathode and plate, with the tube operating normally, a free electron starting from the cathode would reach the plate in much less than one 500-millionth of a second. This is an average speed of about 2,600 miles per second, yet it is only about  $1/70$  the speed of light or of electromagnetic waves in space.

The power supply unit at the right-hand side of Fig. 17 does not create electric power, it takes such power from the electric lighting lines of the building and uses it to furnish whatever voltages and currents are needed by the amplifier tube and other parts of the amplifier circuit.

As doubtless you know, in the electric lighting lines of the building there is alternating voltage and alternating current. This means simply that electrons in these lines are moving in one direction for a brief fraction of a second, then in the opposite direction for an equal time before again reversing, they are alternating. Were the electrons to move always in the same direction, as they do in some power lines, we would have what is called direct voltage and direct current.

Our power supply unit for the amplifier system, and also the power supply sections of television and radio receivers, perform a number of functions. For one thing, the present power supply unit "steps down" the line voltage from 110 or 120 volts to 6.3 volts and supplies for the heater of the amplifier tube an alternating current at this lower voltage.

The two wires for the heater extend from the right-hand side of the power-unit terminal strip across in front of the meter case to two terminals on the small shelf that supports the amplifier tube. From these latter terminals other conductors go to the tube socket, thence to the base pins of the tube and to the heater within the tube.

Although the wires and parts of the amplifier system in Fig. 17 have intentionally been arranged to show their connections as clearly as possible in a photograph, you will observe that the circuits or paths for electron flow could not be followed by looking at this picture. Too many portions of the circuits are out of sight. In order to trace any circuit in television and radio apparatus it is desirable to have a circuit diagram. Fig. 19 is a greatly simplified diagram applying to the amplifier system being examined.

The heater connections for the amplifier tube are not included in the circuit diagram. The only purpose served by the heater in any tube is to raise the temperature of the cathode so that free electrons may more easily escape from the cathode and pass into the evacuated space within the tube. Current in the heater circuit takes no direct part in amplification or in any other jobs performed by electron tubes. Consequently, heater circuits often are omitted from diagrams intended to illustrate the performance of tubes and associated parts.

The tube which you can see mounted on the power supply unit of Fig. 17, and which is shown in the circuit diagram, is a rectifier. When alternating or back-and-forth voltage is applied to a rectifier, the current through the rectifier can flow in only one direction. This one-way current or one-way electron flow is called a direct current. A rectifier produces direct current from alternating voltage.

## COYNE - television home training

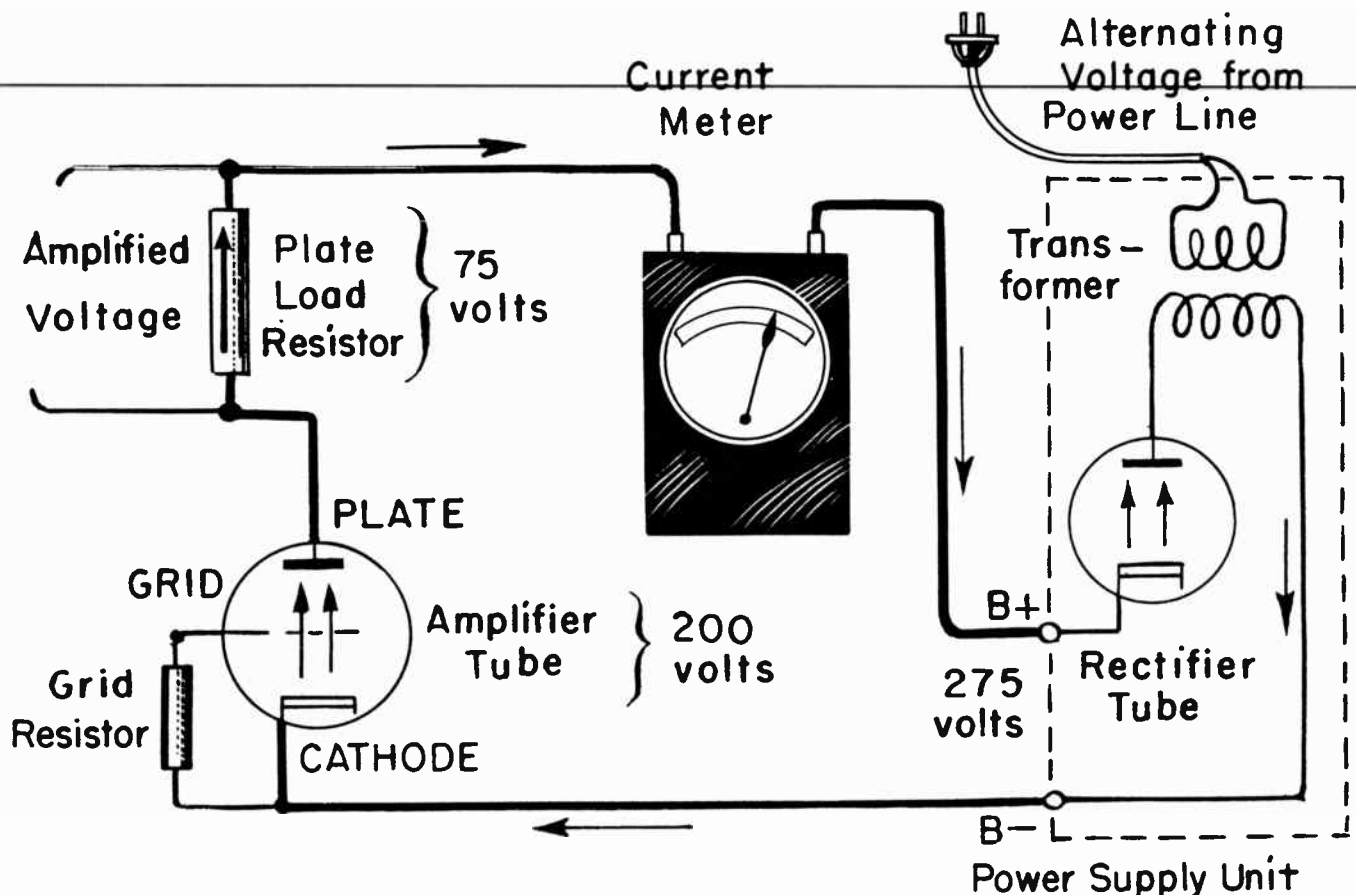

Fig. 19. A simplified circuit diagram showing directions of electron flows and voltages at various points in the amplifier system.

Oftentimes we use the term "alternating-current" to describe some part or some action which utilizes alternating currents. When the term is thus used, as an adjective, it usually is abbreviated to a-c. Similarly, the term "direct-current" used as an adjective may be abbreviated to d-c. These two abbreviations are used to describe anything and everything operated by or in any way associated with alternating current or with direct current, respectively.

Using these abbreviations lead to some rather peculiar results. For instance, it is common to speak of an "a-c voltage". Were you to pronounce the abbreviated words it would be necessary to say "alternating current voltage", which sounds rather foolish. The real meaning is alternating voltage, or a voltage associated with alternating current. Similarly, we often speak of "d-c voltage" when referring to a direct or one-way voltage, or to a voltage associated with direct current. When reading or otherwise using

the abbreviation a-c, do not say "alternating-current" but say "ay-see", and when reading the abbreviation d-c say "dee-see".

Another function of the power supply unit is to "step up" the a-c line voltage to about 330 alternating volts for application to the rectifier. This step-up action occurs in the transformer which is part of the power unit. Quite a bit of this stepped-up voltage is used in forcing electrons to flow through the rectifier tube and through other parts in the power supply, with the results that only about 275 volts of potential difference remains available at the output of the power unit.

We must keep in mind that voltage refers to a difference of potential, or refers to the force which causes electrons to flow. It is not easy for electrons to flow through the evacuated space within the rectifier tube, nor to flow in other parts of the power unit, and some of the total voltage from the transformer must be used to cause this flow. An-



## LESSON 4 — THE PARTS OF WHICH RECEIVERS ARE MADE

other thing to keep in kind is that the values of voltage being mentioned hold good only for the particular amplifier and power supply system being illustrated and described. They might be quite different for some other system.

The heavy lines of Fig. 19 represent the conductors and the entire current path included in the "plate circuit" of the amplifier tube. Directions of electron flow are shown by arrows. The negative terminal of the power supply is marked B - or B-minus, and its positive terminal is marked B + or B-plus. All voltages for plate circuits of tubes in television and radio apparatus are designated by the letter B. In the present case we have 275 volts of B-voltage at the output of the power unit. This is a direct or one-way voltage, or it is a d-c voltage, because it is obtained from one-way electron flow through the rectifier.

Electrons flow from the B - terminal of the power supply through a wire to the cathode of the amplifier tube. It is so easy for electrons to flow in this copper wire that in it there is no appreciable loss of voltage or potential. The electrons then flow from cathode to plate inside the amplifier tube. It is difficult for electrons to get through the internal vacuum of this tube, and about 200 volts of our total force from the power unit is used up in this portion of the circuit.

On the way from cathode to plate inside the amplifier tube the electrons pass through a third element which is called the grid. It is the action of this grid that results in voltage amplification. The how and why of such action will be the subject of future lessons. It is a rather long story, but an exceedingly interesting one. The grid, as actually constructed, is a spiral of very small wire surrounding the cathode. Fig. 20 shows a tube cathode, the small white cylinder, around which is the grid wire. Outside the grid would be the plate when the element structure is complete.

The electrons which leave the plate of the amplifier tube go to and through the

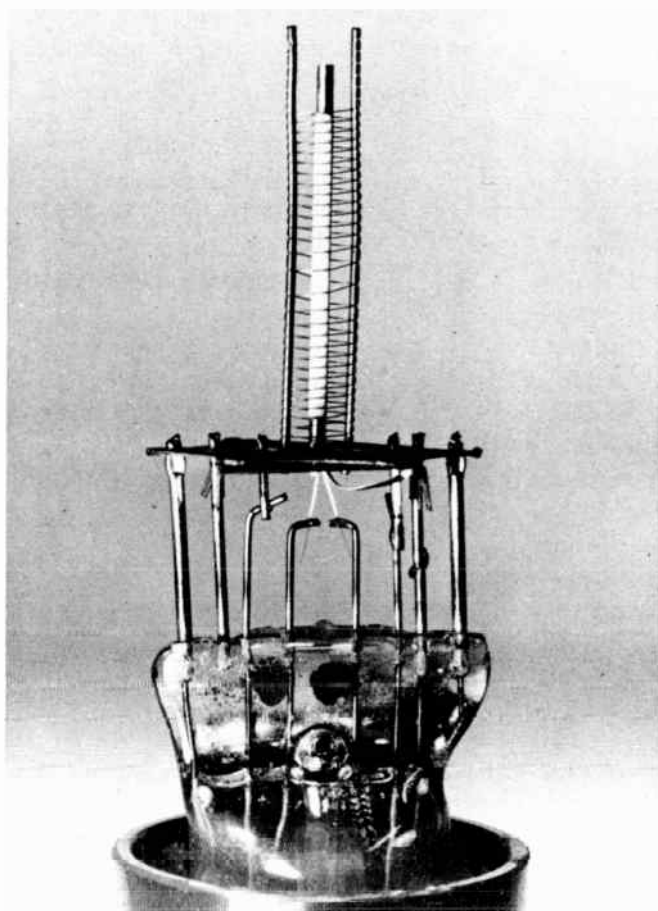

Fig. 20 This is the cathode of a tube, surrounded by the grid. The plate has been removed.

"plate load resistor". This is the larger resistor of Fig. 17, the one across which appears the amplified voltage. You will recall that a resistor is a unit which opposes flow of free electrons. Consequently, we find that about 75 volts of our total B-voltage from the power unit is used in forcing electrons through this load resistor. How and why the voltage is amplified or strengthened will come out when we learn how the grid performs.

Finally, the electrons which leave the plate load resistor flow through the current meter or milliammeter and go to the B + terminal of the power supply unit. In the current meter and in wires connected to it there is so little opposition to electron flow that negligible potential difference or force is used in getting electrons through this portion of the circuit.

## COYNE - *television home training*

Here is a list of some of the new words and terms whose meanings have been explained in this lesson.

A-c	Microampere
Ampere	Milliammeter
B-minus	Milliampere
B-plus	Negative charge
B-voltage	Negative potential
Capacitor	Neutral
Cathode	Plate, of tube
Charges, electric	Positive charge
Circuit	Positive potential
Current	Potential
Current meter	Potential difference
D-c	Rectifier
Electron flow	Resistor
Fields, electric	Volt
Inductor	Voltage
Microammeter	Voltmeter

There are several other things of a somewhat more technical nature in which you will be interested either now or later. Keep in mind where the following explanations may be found when you want the information.

**Coulomb:** Electric charges and any other quantities of electricity are measured in a unit called the coulomb. One coulomb consists of about 6,280,000,000,000,000 free electrons. A rate of electron flow of one coulomb per second is a rate of one ampere.

**Electromotive force:** Any force which can move electrons and thus produce charges and potential differences is called an electromotive force. The name electromotive force is such a long one that nearly always

we abbreviate it to emf, and call it "ee-em-eff". Emf is produced inside of voltage sources. It results from a change of some other kind of energy into electric energy. For example, in a dry cell there is a change of chemical energy into electric energy.

**Electrostatic:** This word has the same meaning as the word "electric" as used in this lesson. We might speak of electrostatic charges, electrostatic fields, and electrostatic potentials - and means the same as when saying electric charges, fields and potentials.

**Polarity:** Any point in a circuit which is positive with reference to other points may be said to have positive polarity, and any point which is negative may be said to have negative polarity. The word polarity means much the same as positive or negative potential.

**Potentials:** Wherever there is a normal quantity of electrons, and the electrical condition may be called neutral, we may say that there is zero potential. The earth is assumed to be at zero potential, because the quantity of free electrons in the earth is so vast that no possible additions or subtractions could make any appreciable change. Earth potential, considered as zero, often is called ground potential.

In television and radio apparatus we often consider the chassis metal to be at zero potential. The chassis may be called chassis ground, or simply ground. Anything directly connected to the chassis through good conductors is normally at chassis ground potential.

# TELEVISION

• RADIO

• ELECTRONICS

---

LESSON 5 – HOW RESISTORS ARE USED

---

***Coyne School***

*practical home training*

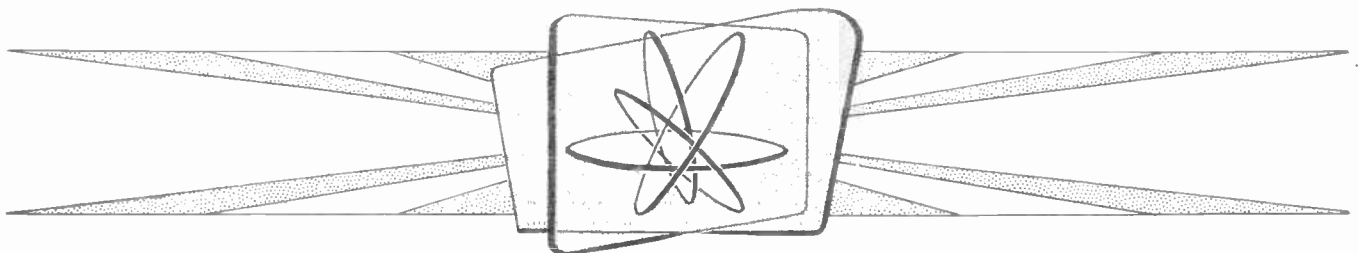

*Chicago, Illinois*



---

*Copyright, 1954 by Coyne Electrical School  
Chicago 12, Illinois  
All rights reserved.*

## Lesson 5

### HOW RESISTORS ARE USED

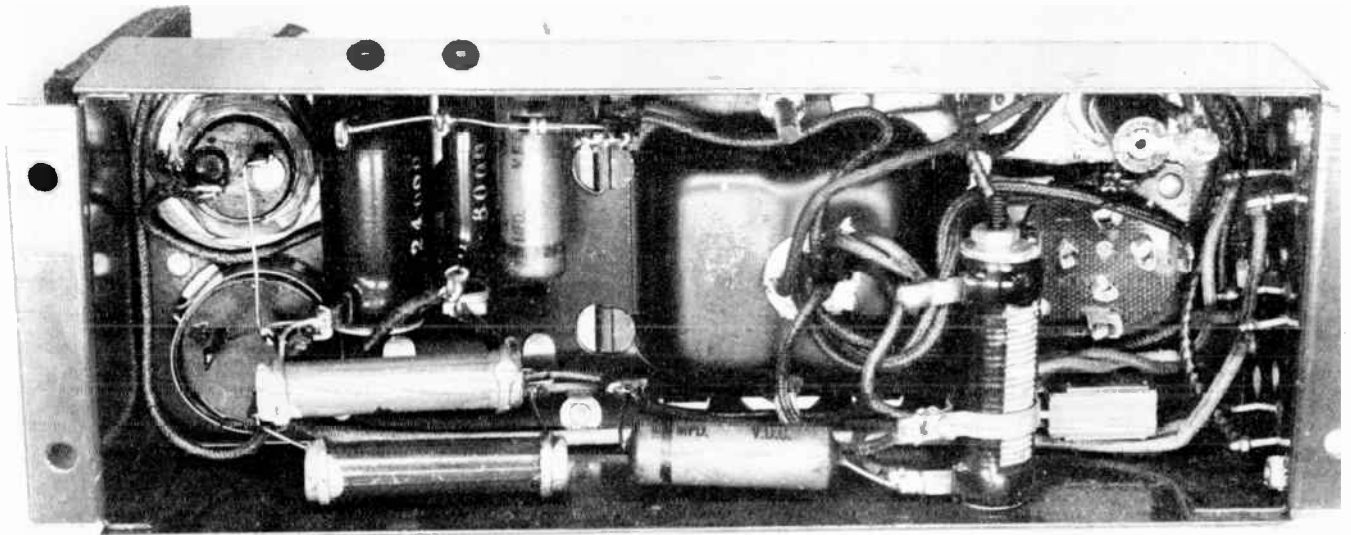

Fig. 1. Many resistors and capacitors are needed in the power supply unit.

Inside the chassis of the power supply unit used in the preceding lesson for operating a voltage amplifier are the parts pictured by Fig. 1. Those parts with which you would be most concerned in case of serious trouble include five resistors and five capacitors. In all television and radio apparatus it is resistors and capacitors which largely determine the values of voltage and current in the various circuits, and it is in these parts that we look for causes of trouble which cannot be remedied by such easy methods as tube replacements.

In diagrams designed to help you trace circuits during service operations all the parts and their connections are represented by symbols. The great majority of circuits can be shown by the few simple symbols of Fig. 2. Wire conductors are represented by lines. Where two wires are to be shown crossing each other without any electrical or conductive connection between them, or with the wires insulated from each other, the two lines may be simply crossed or else one wire may be shown looped over the other.

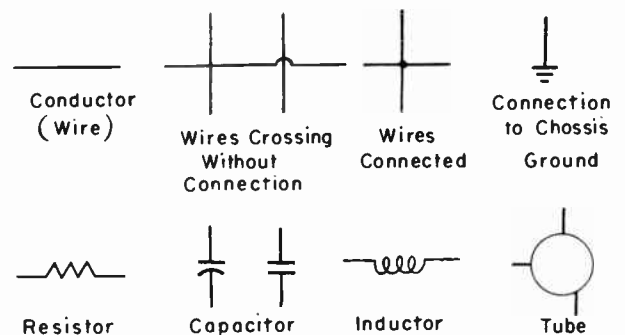

Fig. 2. The symbols which represent principal circuit elements and connections.

If wires are electrically connected, as at a soldered joint or a tie point, this fact is indicated by a small black dot or sometimes by a small circle at the junction point. Connections to chassis metal or to chassis ground are shown by several little horizontal lines close together and of decreasing lengths.

A resistor of any type is represented by a zig-zag line. The number of zigs and zags has no particular relation to the amount of resistance. Capacitors of any kind or size

most often are shown by a straight line and a curved line close together, although two short straight lines sometimes represent a capacitor. Inductors are shown by several loops, because an inductor ordinarily consists of a coiled wire.

A tube, other than a television picture tube, most often is shown by a circle, which represents the glass or metal envelope of the tube. Inside the circle will be various small symbols indicating the internal elements found in each particular type of tube. Extending out from these internal elements will be lines which represent the conductors going to other parts of the circuits. A tube sometimes is shown by an oval or oblong outline instead of by a circle.

Fig. 3 is part of a manufacturer's service diagram showing the video amplifier section of a television receiver. All the parts and all their connections are represented by symbols for wire conductors, for chassis grounds, for resistors, capacitors, inductors,

and tubes. In this diagram are symbols for 17 resistors, 9 capacitors, 5 inductors, and 4 tubes.

We shall take resistors as our first point of attack in servicing and trouble shooting, partly because there always are so many resistors, and also because everything else possesses in greater or less degree the property of resistance - which is concentrated in resistors.

A resistor is a unit in which is concentrated within small space a considerable opposition or resistance to electron flow. Resistors are used wherever we wish to hold back or lessen the rate of electron flow. This property of resistance exists also to some extent in every wire or other kind of conductor, in every capacitor, every inductor, and every tube.

Resistance is one of the three things which are of supreme importance in all circuits. The other two are voltage and current.

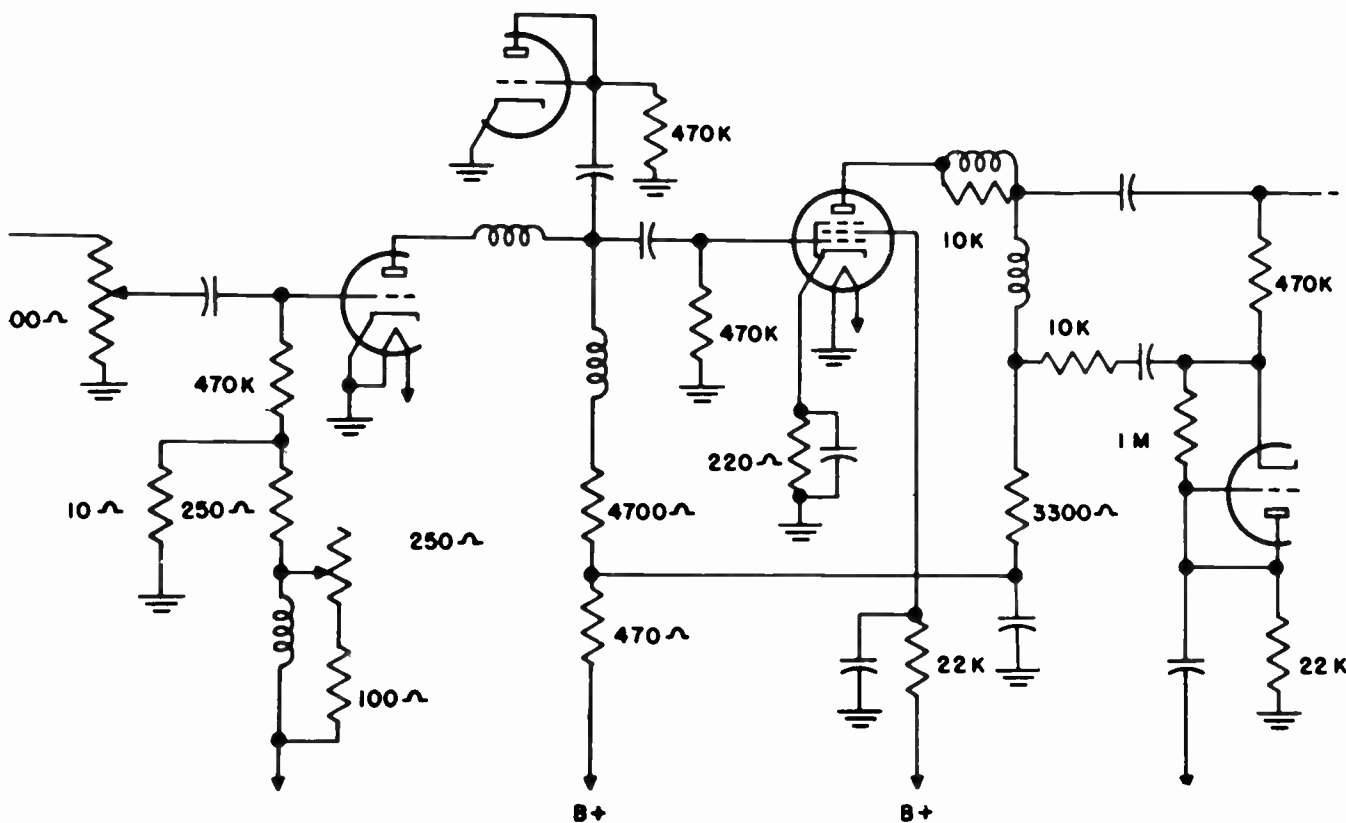

Fig. 3. Various parts and their connections are clearly shown by service diagrams made up from symbols.



## LESSON 5 – HOW RESISTORS ARE USED

It would be difficult to say which of these three is most important, but there is no doubt that a big percentage of all our difficulties with voltages and currents can be traced to wrong resistances.

There is enough difference between the atoms of different substances to make it much more difficult to force free electrons from atom to atom in some materials than in others. Supposing that you have samples of the following substances, all of exactly the same size and shape. The relative difficulties of getting free electrons through these materials, or their relative resistances, would be as listed. We are taking copper as a standard, and giving it a resistance rating of 1.00.

Silver .....	0.94	Steel wire .....	6.44
Copper .....	1.00	Nichrome IV wire ..	60.00
Aluminum .	1.63	Soft graphite .....	462.00
Brass... ..	4.71	Hard carbon .....	2290.00

When making tests to determine the exact location of a fault it becomes necessary to make measurements of voltage, of resistance, and sometimes of current. To specify the values of these factors we must have units of measurement. For measuring voltage the unit is the volt. For measuring current or rate of electron flow the unit is the ampere. For measuring the resistance or opposition to electron flow we employ a unit based on the number of volts required to maintain some certain current, or on the ratio of voltage to current. The greater the potential difference or electric force required to maintain any given current, the greater must be the resistance or opposition to electron flow.

In Fig. 4 are illustrated some relations between voltage, current, and resistance. To simplify the examples, all of the resistance is considered to be in the heavy line conductor at the tops of the diagrams, and none in other parts and connections. We might imagine this conductor to be a pencil "lead", which really is mostly graphite. In an ordinary pencil of number 2 or 3 grade there is as much resistance in two inches of the graphite core as in about 10,000 inches of copper wire such as employed for house lighting circuits. Therefore, when using only a few inches of

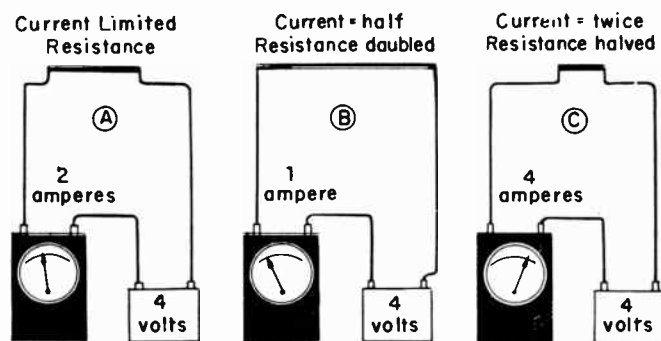

Fig. 4. How changes of resistance affect the current when the potential difference remains unchanged.

copper wire to make circuit connections, we are justified in assuming that all resistance is concentrated in the heavy-line conductors of the diagrams.

Supposing, as at A in Fig. 4, that 4 volts is applied across the heavy-line conductor, and that current measures 2 amperes. If, as at B, the same 4 volts applied across another similar but longer conductor causes current of only 1 ampere, this second conductor must possess more resistance to electron flow than the first conductor - because the current is reduced. If we shift the 4 volts to a third conductor, as in diagram C, and find that current increases to 4 amperes, there can be no question but what this third conductor offers less resistance to electron flow than either of the others - for it allows current to increase.

Resistances of the three conductors might be specified as so many "volts per ampere". At A, with 4 volts and 2 amperes, the resistance would be 2 volts per ampere. At B, where the 4-volts causes current of only one ampere, the resistance would be 4 volts per ampere, which is an increase of resistance. At C, with 4 volts and 4 amperes, the resistance would be 1 volt per ampere, which is less than either of the other resistances. It is the differences between resistances shown in these diagrams that changes the currents with the same voltage applied in all cases.

Take careful note of these facts, which are illustrated by Fig. 4. When current drops to half its original value, as from 2 amperes to 1 ampere, it means that the re-

sistance has doubled. Should the current double, as from 2 amperes to 4 amperes, it means that the resistance has been halved

In Fig. 5 the currents are being held constant at 2 amperes in the three different resistances. This requires changing the voltages applied to the different conductors. At A we have 4 volts causing the 2-ampere current, which indicates resistance of 2 volts per ampere. At B it is taking 8 volts to maintain the 2 ampere current. This figures out to a resistance of 4 volts per ampere. At C a potential difference of only 2 volts is maintaining the 2-ampere current, and the resistance must be 1 volt per ampere.

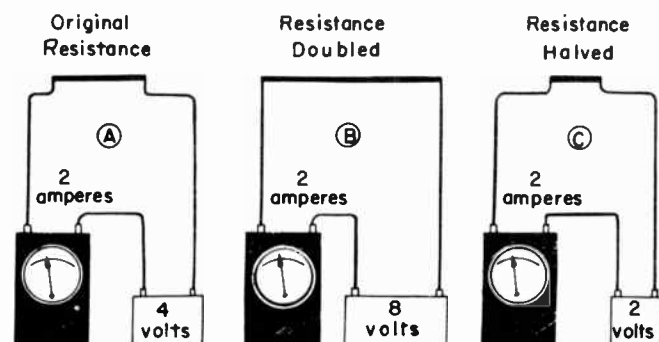

Fig. 5. Some relations between resistance and potential difference when current remains constant.

Now make careful note of two more facts, illustrated by Fig. 5. When the voltage must be doubled, as from 4 to 8 volts, in maintaining the same current it means that the resistance has doubled. When the voltage may be halved, as from 4 to 2 volts, while maintaining the same current it means that the resistance has been halved.

The lengths of the three conductors in Figs. 4 and 5 are shown as proportional to their resistances. The conductor having twice the original resistance is represented as of twice the length, and the one of half the original resistance is shown as of half the original length. These are correct representations of lengths in relation to resistances. When conductors are of the same material and of the same size or diameter, their resistances are directly proportional to their lengths.

This direct relation between resistance and conductor length is entirely logical. If some certain voltage or force is needed to drive a given rate of electron flow through one foot of a wire, it must take twice as much force to drive electrons at the same rate through two feet of the same wire. And it must take only half as much force or voltage to cause the same flow rate in a half-foot of the same wire.

Instead of changing the length of conductor or wire, supposing we change its diameter or size, or, in more general terms, change its cross sectional area. Then what will happen to resistance? Look at Fig. 6.

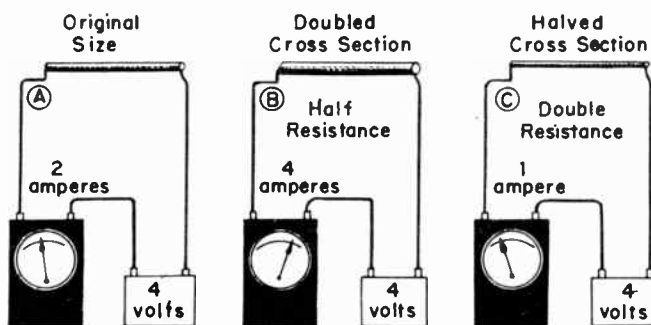

Fig. 6. How the cross sectional area of a conductor affects its resistance and the current which may flow.

With double the cross section, as at B, and no change in length or kind of material, there must be twice as many free electrons on which the potential difference or the force in the electric field may act. Then twice as many electrons will be moved by the same force or voltage, and current will be doubled. Doubling the current with the same applied voltage means that resistance has been halved, so doubling the cross section of the conductor has halved its resistance.

Similar reasoning shows that in a cross section only half as great, at C, there must be twice the original resistance. In half the original cross section there can be only half as many free electrons on which the field force may act. With half as many free electrons flowing, the flow rate will be cut in half. With half the flow rate or current, and the same applied voltage, we know that the original resistance has doubled.

# LESSON 5 – HOW RESISTORS ARE USED

The unit of resistance which we have called a "volt per ampere" is universally employed, but under another name. The other name is ohm. One ohm is the resistance in which a potential difference of one volt will cause a current of one ampere. Therefore, any resistance expressed as some number of ohms could be specified as that same number of volts per ampere.

The unit of resistance is called an ohm in honor of Georg Simon Ohm, a German physicist who lived during the early part of the nineteenth century. The ampere, our unit of current, is named after Andre Marie Ampere, a French scientist and writer. The volt, our unit of potential difference, is named

after Count Volta, a famous Italian physicist and experimenter. Nearly all electrical units are given the names of famous scientists.

Many resistances in television and radio circuits are so great as to be measured in millions of ohms. Resistance of one million ohms is called one megohm. In a few cases we encounter resistances so small as to be measured in millionths of one ohm. Resistance of one one-millionth ohm is called a microhm. Electrical units which are either multiples or fractions of some fundamental unit are named by placing certain prefixes before the name of the fundamental unit. Here is a list of the prefixes, their meanings, and some examples of their uses.

PREFIX	MEANING	EXAMPLES		
		Resistance	Voltage	Current
Meg- or mega-	Multiply by 1,000,000	Megohm		
Kilo-	Multiply by 1,000		Kilovolt	
Milli-	Divide by 1,000		Millivolt	Milliampere
Micro-	Divide by 1,000,000	Microhm	Microvolt	Microampere

Where no examples are listed we do not find such multiples or fractions in common use. We do not encounter either thousands or millions of amperes, nor millions of volts. We often deal with thousands of ohms, but do not use a unit of one kilo-ohm, and we often deal with thousandths of ohms, yet do not speak of milliohms.

The first letter of the prefix kilo- is, however, used for specifying resistances in thousands of ohms. Any number of thousands of ohms of resistance may be followed by the capital letter K. For instance, a resistance of 56,000 ohms may be marked 56K, a resistance of 220,000 ohms may be marked 220K, and one of 8,800 ohms might be shown as 8.8K

When the capital letter M follows a number written near a resistance symbol it

means megohms or millions of ohms. For instance, 2.2M means 2.2 megohms or 2,200,000 ohms. Megohms also may be indicated by the abbreviation MEG after a number showing resistance in megohms. A fairly common symbol for resistance in ohms is the Greek letter omega, which appears like this  $\omega$ . Should you see 250  $\omega$  it means 250 ohms.

Any resistor shown on a service diagram may be identified by a part number preceded by the capital letter R. As an example, a resistor marked R-37 is resistor number 37 in the particular diagram where it appears. Parts numbers of capacitors usually are preceded by the capital letter C. The number C-37 would identify capacitor number 37 on a diagram. It is common practice to precede the parts numbers of inductors by the capital letter L, which would mean that a part marked



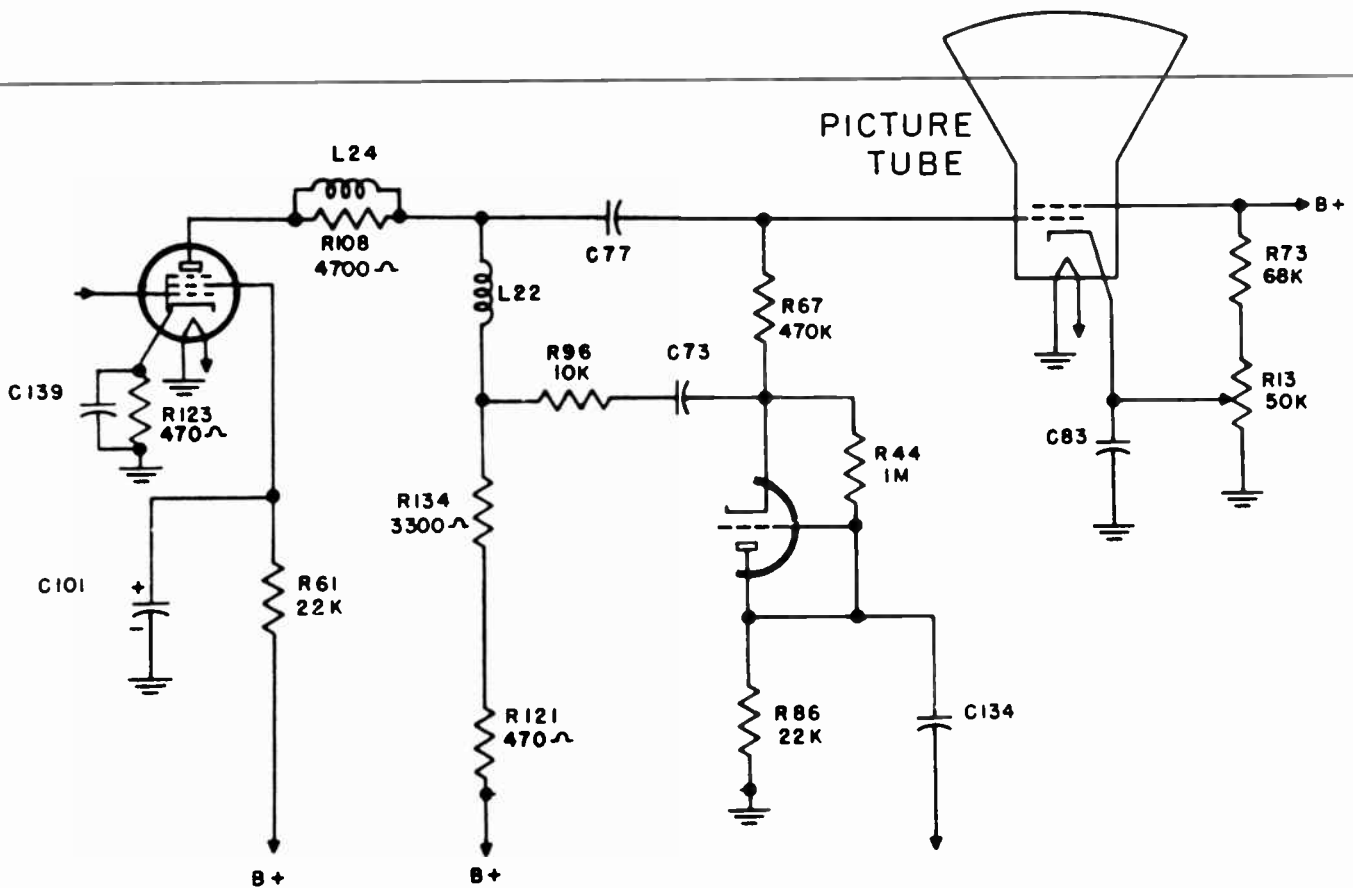

Fig. 7. Parts numbers for resistors (R), for capacitors (C), and for inductors (L) usually are shown on service diagrams.

L-37 is inductor number 37 in that piece of apparatus.

Fig. 7 shows a portion of a manufacturer's service diagram with resistors, capacitors, and inductors identified by parts numbers, and on which resistance values are shown by letter symbols just mentioned.

outer covering made of hard-molded insulating material. Usually this insulation will withstand an alternating voltage of 350 volts or more without breakdown. Consequently, the body of a resistor which has axial pigtailed (extending in line with the axis) may come in

**FIXED RESISTORS.** A fixed resistor is one whose resistance in ohms is determined at the time of manufacture, and which cannot be altered after the unit is in use. Fig. 8 is a picture of several fixed resistors of the style most often used. Extending from each end of a fixed resistor are pigtailed, which are pieces of copper or bronze wire, usually tinned for easy soldering. These pigtailed are used for conductively connecting the resistor into its circuit, while at the same time supporting the unit in position.

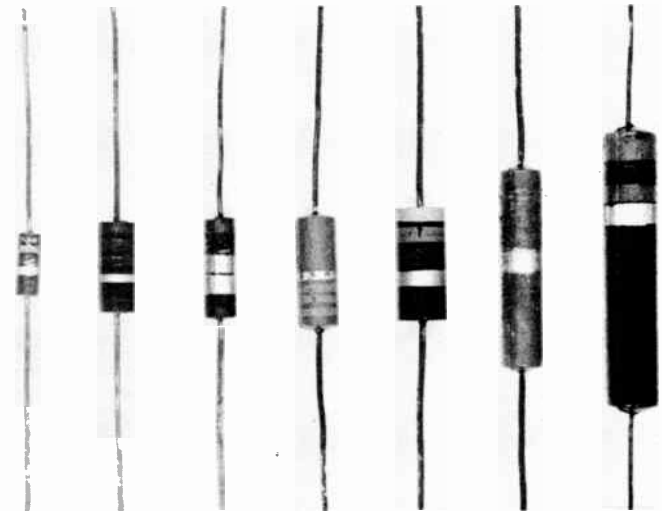

Fig. 8. Some fixed resistors of the style commonly used in television and radio receivers.

## LESSON 5 – HOW RESISTORS ARE USED

contact with exposed or bare conductors without danger of current leakage through the insulating shell or cover provided the allowable voltage is not exceeded. The pigtail leads are not coated with insulation. Where there is possibility of these leads making contact with some other conductor, the pigtail should be protected by a length of spaghetti insulation tubing.

The resistance element may be either of two general kinds, it may be composition or wire wound. In a composition resistor the element may be of carbon or graphite mixed with other less conductive substances in such proportions as to provide the desired resistance. This element is molded into cylindrical form. Such a construction is illustrated by Fig. 9. The inner ends of the pigtails are molded into the carbon core. A unit of this kind may be called a carbon resistor.



Fig. 9. A carbon type composition resistor cut open to show the internal resistance element and the outer protective insulation.

With another type of composition resistor the element consists of a small tube or rod of glass or other insulating material, on the inside or outside of which is deposited a metallic coating so thin as to have great resistance, or any required value of resistance. The pigtail leads are fused into the ends of the insulation which carries the metallic film. This entire element is molded within a body of hard insulating material.

A wire wound resistor, as the name implies, is one in which the resistance element consists of wire wound onto an insulating form. Several common styles are pictured by Fig. 10. At A is a complete wire-wound resistor, while at B is a similar unit from which part of the insulating coating has been removed to expose the turns of resistance wire. This wire is of small diameter and of a material, such as Nichrome, which has a great deal of resistance in every inch of

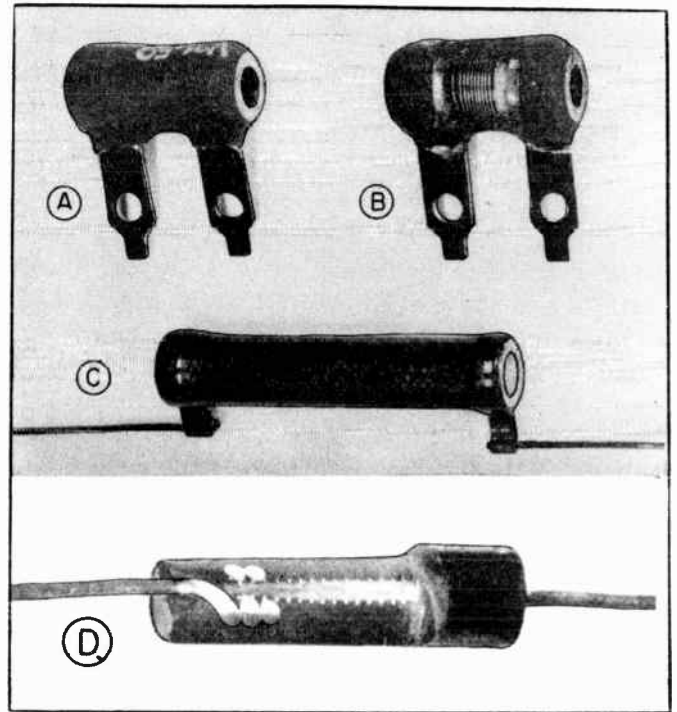

Fig. 10. Types of wire-wound fixed resistors. The units at B and D have been cut open to show their internal construction.

length. This resistance wire is wound on an insulating form or tube and connected to end ferrules and soldering lugs. The entire unit is coated with some kind of hard insulating material.

At C in Fig. 10 is a vitreous enameled wire-wound resistor. Vitreous enamel is a coating of glass-like material which is fused at red heat onto the resistance wire and the supporting form. Such resistors are capable of withstanding moisture, acids, and high temperatures.

The unit at D in the picture is a wire-wound resistor which appears, from the outside, identically like composition or carbon resistors having axial leads. The wire winding is on a small inner insulating cylinder, and this element is embedded within a larger cylinder of hard insulating material, part of which has been removed to show the inner core on which is the resistance wire. The wire on many such elements is no more than  $1\frac{1}{2}$  thousandths of an inch in diameter. In Fig. 8 some of the resistors are composition types and others are wire-wound.

# COYNE - *television home training*

**PREFERRED NUMBERS.** By looking at Figs. 3 and 7, and at other service diagrams, you will notice that many resistors have values for which the first two figures are 10, 22, 33, 47, or 68. There are, for example, resistors of 470 ohms, 4,700 ohms, and 470K (470,000 ohms). This does not mean that when replacing these units you always must provide a number of ohms exactly equal to the rather odd values shown. It means that these values are given in "preferred numbers" according to a practice which in recent years has greatly reduced the variety of resistance values carried in stock by service organizations.

To explain how this object has been attained we first must consider the matter of "tolerances" in resistances. Tolerance refers to the percentage by which actual resistance may vary from a "nominal" marked value while still allowing satisfactory performance in a given circuit. Probably the most commonly employed tolerance is one of 10 per cent. In some circuits the tolerance may not exceed 5 per cent. Many resistances are satisfactory when the tolerances is 20 per cent.

Consider a resistor rated at 20 per cent tolerance and marked 470 ohms. This means a nominal value of 470 ohms. The actual resistance may be as low as 376 ohms, which is 20 per cent under 470, or it may be as great as 564 ohms, which is 20 per cent high, or it may be anywhere in between these limits. Similarly, in a resistor having a nominal or marked value of 330 ohms, and 20 per cent tolerance, the actual resistance may be anything between 264 ohms (20 per cent low) and 396 ohms (20 per cent high).

Now note this. The high limit of the nominal 330 ohm unit is 396 ohms. The low limit of the nominal 470 ohm unit is 376 ohms. These limits overlap by 20 ohms. Then, if tolerance of 20 per cent is satisfactory or allows satisfactory performance in circuits considered, there would be no object in having on hand any nominal values between 330 ohms and 470 ohms. These two would cover all your needs from 264 ohms up to 564 ohms.

Only six nominal values of resistors having 20 per cent tolerance will cover all needs from 80 ohms to 816 ohms, like this.

NOMINAL OHMS	RANGE COVERED	
	20% Low	20% High
100	From 80 ohms to 120 ohms	
150	From 120 ohms to 180 ohms	
220	From 176 ohms to 264 ohms	
330	From 264 ohms to 396 ohms	
470	From 376 ohms to 564 ohms	
680	From 544 ohms to 816 ohms	

By adding one cipher to each nominal value it becomes possible to cover all resistances between 800 and 8,160 ohms, when tolerance is 20 per cent. This would call for only six additional nominal values, of 1,000 ohms, of 1,500 ohms, and so on. With two ciphers added, requiring six more nominal values, the range would extend from 8,000 to 81,600 ohms. By adding ciphers, and six additional nominal values each time, we may reach any desired ranges of resistance.

Dividing the original nominal values by 10 will give a range from a high of 81.6 ohms down to a low of 8.0 ohms. Continuing to divide by 10's would bring the low limit anywhere required. Here are the first two significant figures for all resistors of 20 per cent tolerance: 10, 15, 22, 33, 47, and 68. If the tolerance is to be 10 per cent we would need twelve pairs of significant figures, and for tolerance of 5 per cent we would need twenty four pairs of significant figures.

In the accompanying table is a complete listing of preferred numbers, or of the first two significant figures, for tolerances of 20 per cent, of 10 per cent, and of 5 per cent. To these first two figures may be added any number of ciphers, or they may be divided by 10 one or more times, in reaching the greatest and the least resistances employed in television and radio apparatus. Thus you will arrive at the nominal values of practically all fixed resistors required and regularly stocked for servicing.



# LESSON 5 – HOW RESISTORS ARE USED

## PREFERRED NUMBERS

20% Tolerance	10% Tolerance	5% Tolerance
10	10	10
	12	11
		12
		13
15	15	15
	18	16
		18
		20
22	22	22
	27	24
		27
		30
33	33	33
	39	36
		39
		43
47	47	47
	56	51
		56
		62
68	68	68
	82	75
		82
		91

**RESISTOR COLOR CODE.** Fixed composition resistors, and wire-wound units having the same appearance as composition types, carry colored bands which indicate their nominal resistances. The different colors and the order in which they are placed show various combinations of significant figures and of ciphers in the number of ohms

resistance. The meanings of the various colors are given in the accompanying table. Color code bands may be seen on some of the resistors in Fig. 8. All those units are banded, but some colors do not show up clearly in this black-and-white photograph. The advantage of indicating resistance values by color coding rather than marking with numbers is that the color bands may be read regardless of the position in which a resistor is mounted, while numbers might be on the concealed side.

As shown by Fig. 11 there may be three bands or four bands. The group of bands al-

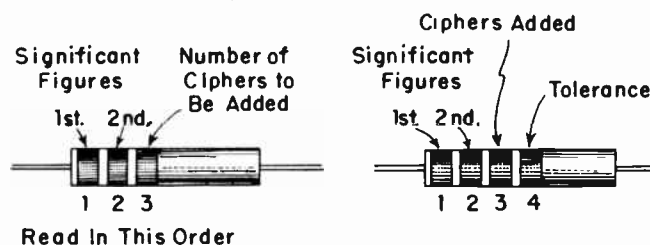

Fig. 11. On fixed resistors having axial leads the nominal resistances and the tolerances are indicated by colored bands.

ways is closer to one end of the resistor than to the other end. The colors and the numbers for which they stand are read by commencing with the band closest to one end of the resistor, and reading in order toward the opposite end. Colors of the first and second bands indicate the two significant figures for the number of ohms resistance. The third band tells how many ciphers are to follow the significant figures or tells how the significant figures are to be divided in arriving at the resistance value.

The significant figures of any number are those which remain when all the ciphers are taken away. As a general rule, the significant figures are those from 1 to 9 inclusive, although in the color code a cipher indicated by black may be considered a significant figure. Any number which includes ciphers is shown by two color bands for the significant figures, and a third for the ciphers to be added.

# COYNE - *television home training*

## R.T.M.A. COLOR CODE FOR RESISTORS

<u>Color</u>	<u>Significant Figures</u>	<u>Ciphers To Be Added</u>	<u>Division To Be Made (3rd band)</u>	<u>Tolerance (4th band)</u>
Black	0	None		
Brown	1	0		
Red	2	00		
Orange	3	000		
Yellow	4	0 000		
Green	5	00 000		
Blue	6	000 000		
Violet	7			
Gray	8			
White	9			
Silver			Divide by 100	10%
Gold			Divide by 10	5%

If there is a total of only three color bands the tolerance of the resistor is 20 per cent. When the tolerance is 10 per cent there will be a fourth band of silver. When tolerance is 5 per cent there will be a fourth band of gold. It is the presence of only three bands, or the absence of a fourth band, that indicates 20 per cent tolerance.

The table lists in the first column the colors that are used. The second column shows the significant figures corresponding to each color. The third column gives the number of ciphers which are to follow the significant figures. The fourth column shows that when the third band is gold, the number formed by the two significant figures is to be divided by 10, and when the third band is silver, the number formed by the two significant figures is to be divided by 100 in arriving at the number of ohms of nominal resistance. We must keep in mind that gold or silver in the third band indicate division of the significant number, while gold or silver in a fourth band indicates tolerances respectively of 5 per cent and of 10 per cent.

Fig. 12 illustrates several examples of resistor color coding. Examples numbered from 1 through 5 show a total of only three color bands. Consequently, all these resis-

tors have tolerances of 20 per cent. Examples numbered 6 through 10 show a total of four color bands, so all these units have tolerances of 10 per cent or of 5 per cent, depending on whether the fourth band is silver or gold.

Several of the examples illustrate features of color coding which should be given special attention, as follows: In example 1, red in the first band stands for the figure 2, but in the third band this color stands for two added ciphers. In example 2 the number of ohms (1,000,000) contains six ciphers following the figure 1, but only five of these ciphers are added to the two significant figures, which are 10. These significant figures are indicated by brown, for the figure 1, and by black for a cipher. The green color in the third band shows that five ciphers are to be added to the two significant figures.

In example 4 the entire number of ohms, 39, is the same as the number formed by the two significant figures as indicated by the colors orange for 3 and white for 9. The fact that no ciphers are to be added is shown by using black for the third band, since black means that the number of ciphers to be added is "none".

## LESSON 5 – HOW RESISTORS ARE USED

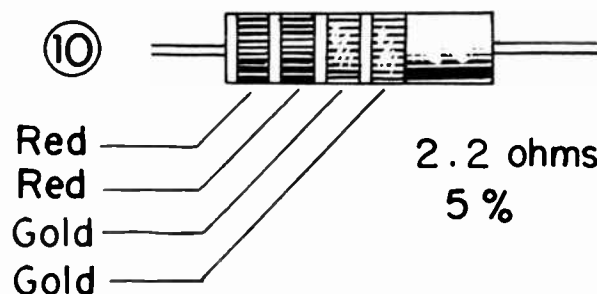
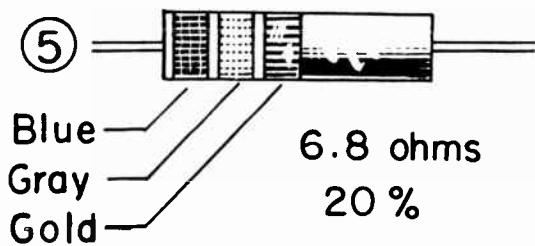
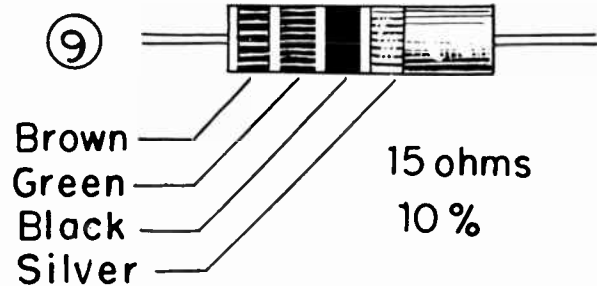
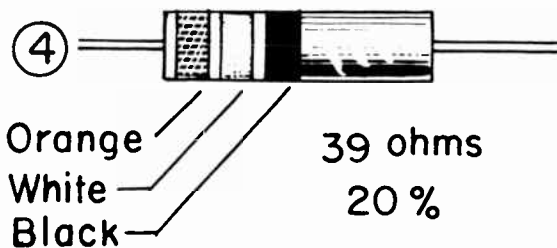
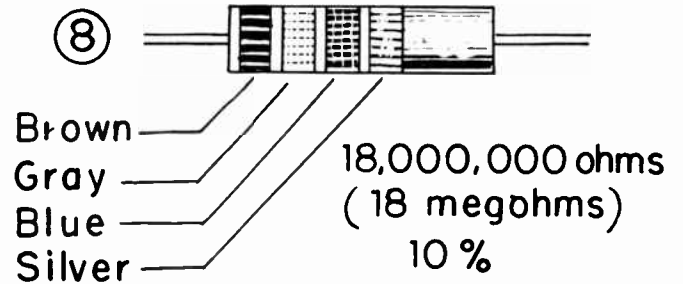
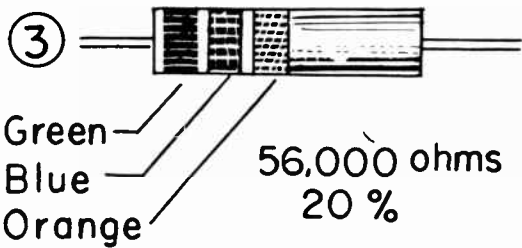
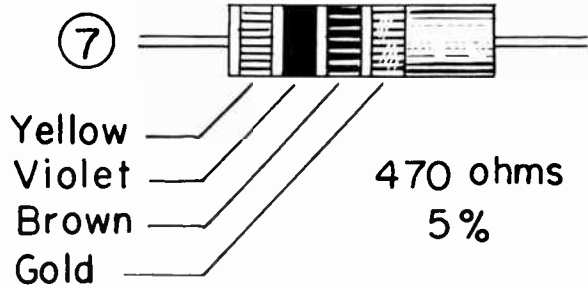
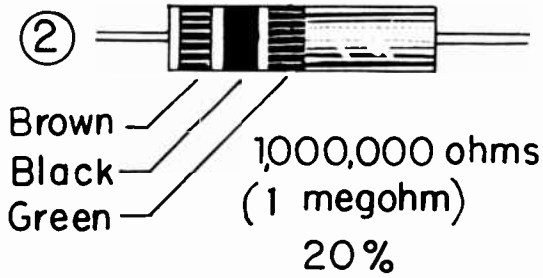
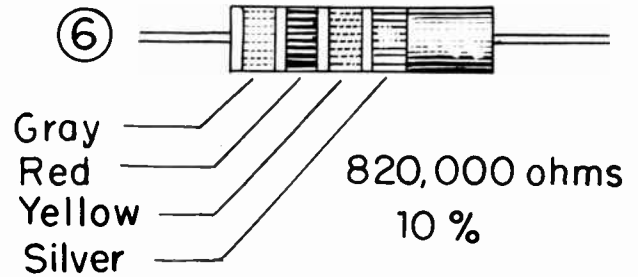
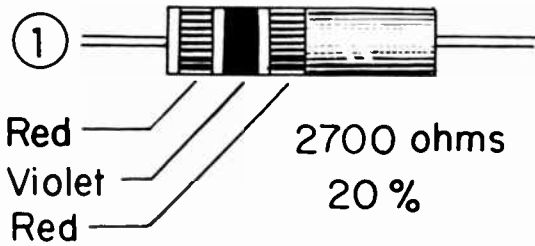

Fig. 12. Examples of resistance color coding as applied to fixed resistors having axial leads.



## COYNE - *television home training*

There may be no fewer than three bands on any resistor, and the third always shows multiplication (ciphers added) or division. Then always there must be at least two significant figures. To indicate a number of ohms less than 10, which is the smallest number formed by two figures, we must resort to division of the number formed by two significant figures. Such a case is illustrated by example 5. To indicate 6.8 ohms we use blue and gray to form 68 as the significant figures. Then gold is used for the third band, indicating division by 10. When you divide 68 by 10 the result is 6.8. Any number of ohms fewer than 10 may be formed in a generally similar manner, by using the third band to indicate the required division.

Examples 6 through 8 illustrate straightforward use of the color coding system. In example 9 is another illustration in which the total number of ohms is shown by the two significant figures, with black in the third band indicating the addition of no ciphers. Compare this with example 4. Example 10 illustrates another case of indicating a number of ohms less than 10. The first and second bands in red form the number 22. The third band in gold shows a division by 10, which gives 2.2 ohms. The fourth band in gold shows 5 per cent tolerance.

**RESISTANCE AND HEAT.** Were you to go to a supply store and ask for a 56,000-ohm composition resistor of 10 per cent tolerance the clerk wouldn't know what to give you. He would ask, "How many watts?" This means, "How much power must the resistor be capable of changing into heat without danger of breakdown?"

Heat is produced whenever free electrons move in a resistor or any other conductor, because the electrons have to work hard escaping from atoms and continuing on their way. Any kind of work will produce heat. If you press your hands together and do the work of rubbing them back and forth there is heating, which you feel. Every piece of machinery which moves and works must produce heat, frictional heat. This you know from the fact that any machine gets warmer when it works.

When a television receiver is in opera-

tion a very small portion of all the work done by flowing electrons is really useful in producing illumination at the picture tube. Another small portion of work done by electrons is really useful in vibrating the cone of the speaker to produce sound. But all the rest of the work does nothing but produce heat. This is why the inside of a television cabinet gets so warm after the set has operated for a short time. We don't want to produce this heat, but it is the penalty paid for moving the electrons through conductors to places where they do things really desirable.

When moving electrons must overcome a great deal of resistance and work hard as they flow, there is a great deal of heating. Also, if there is a large current, meaning that great quantities of electrons are working, there is proportionately greater heating. It is such heating that makes the filament of an electric lamp so hot as to become incandescent and give light. This is the action that makes an electric flatiron get hot. The only reason why all the wires in a building don't get red hot when you turn on any electrical device is that these wires have so little resistance in relation to the current that flows.

There are various units in which we might measure work, but we seldom are concerned with work measurements. We are, however, greatly concerned with the time rate at which work is done. Here is an example. Supposing that you must lift 1,000 pounds to a height of 10 feet. That is work. But if this total weight were to be divided into 1,000 parcels of one pound each, and were you to lift one pound only every two or three minutes, you wouldn't get overheated - because you would take a long time to do the work. On the other hand, were you to finish the job in five minutes you would get a lot warmer, because you would be doing the work in little time. The difference is in the time rate at which the work is done.

The name for the time rate of doing work is power. The most familiar unit of mechanical power is the horsepower. When 33,000 pounds is raised one foot in one minute work is being done at the rate of one horsepower. The most familiar unit of electrical power is the watt. When electrical work is

## LESSON 5 – HOW RESISTORS ARE USED

done at the time rate of one watt it is the equivalent of raising 44-1/4 pounds to a height of one foot in one minute.

Electric power may be used to raise weights, as when electricity flows in a motor, but now we are interested in how electric power produces heat. Every bit of the energy which forces electrons to flow in a resistor or other conductor is changed into heat. A resistor opposes electron flow only because the electrons use up most of their working ability in producing heat. Supposing a resistor is using electric power at the rate of 5 watts. Were this resistor inside a box holding one cubic foot of air, and were no heat to escape, the air temperature would go from 70° to 1,013° F. in one hour, if the box didn't take fire.

There are several ways of computing electric power in watts when we know the current, the voltage, or the resistance. Assume that the resistor of Fig. 13 is carrying

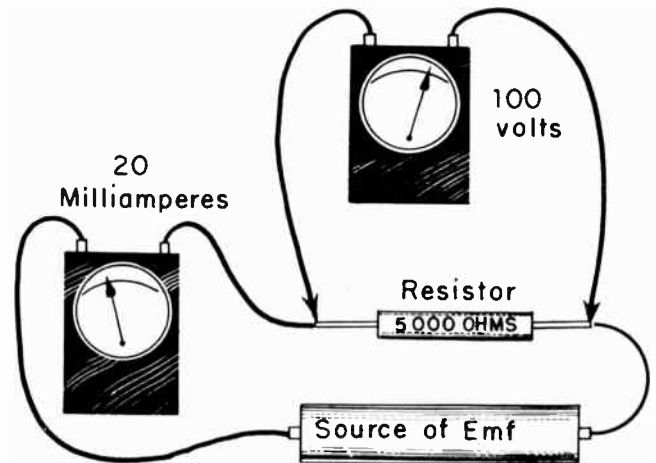

Fig. 13. The resistor is producing heat at the rate of two watts, or is changing two watts of electric power into heat.

current of 20 milliamperes, that the applied potential difference is 100 volts, and that the resistance is 5,000 ohms. Following are three ways of computing the power in watts that is going into production of heat.

Method A. 1st. Multiply the number of milliamperes by the number of volts.

2nd. Divide by 1,000. This gives the number of watts.

Example: (See Fig. 13)

$$20 \times 100 = 2000 \quad 2000 \div 1000 = 2 \text{ watts.}$$

Method B. 1st. Square the number of volts, or multiply the number by itself.

2nd. Divide by the number of ohms resistance.

Example:

$$100 \times 100 = 10,000 \quad 10,000 \div 5,000 = 2 \text{ watts.}$$

Method C. 1st. Square the number of milliamperes.

2nd. Multiply by the number of ohms.

3rd. Divide by 1,000,000.

Example:

$$20 \times 20 = 400 \quad 400 \times 5,000 = 2,000,000$$

$$2,000,000 \div 1,000,000 = 2 \text{ watts.}$$

# COYNE - *television home training*

## WATTAGE RATINGS OF RESISTORS.

The greater the power in watts which is changed into heat in a resistor the larger must be the physical size of the resistor. It must be longer, or of greater diameter, or both. This is necessary in order that there may be increased surface area from which the extra heat may be radiated or dissipated.

The exact dimensions of resistors having given power ratings in watts or fractions of a watt depend on the type of construction and on the make. Fig. 14 shows relative lengths

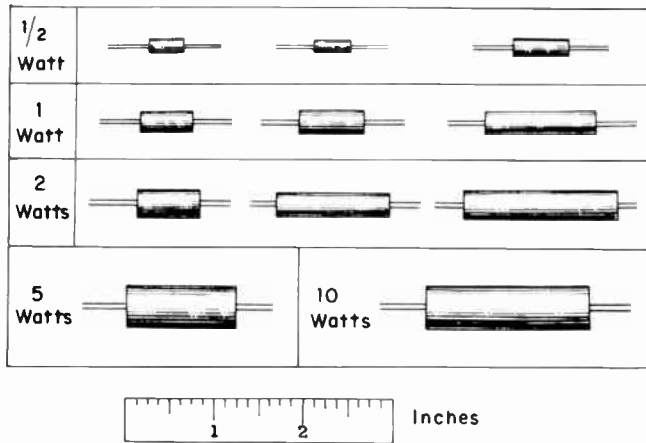

Fig. 14. Relative lengths and diameters of fixed resistors having various wattage ratings.

and diameters of typical composition and wire wound resistors having power ratings of 1/2 watt, 1 watt, 2 watts, 5 watts, and 10 watts. An inch scale is included for reference at the bottom of the figure. These are standard power ratings of stock resistors. No other ratings are usually available. If you need something a little more than 1/2 watt you have to go to 1 watt, for anything between 1 watt and 2 watts you have to use a 2-watt unit, and so on.

Resistors are rated at numbers of watts with which the resulting temperature rise will not damage the resistor itself when the unit is so mounted as to allow free circulation of air all around it. Seldom if ever is there free air circulation in the chasses of television and radio receivers. Even though the resistor does not reach a temperature damaging to itself, it easily may radiate enough heat to harm surrounding parts, especially

the fixed capacitors which ordinarily have fillings of insulating compounds and waxes that are likely to melt at moderately high temperatures.

At A in Fig. 15 is a 2,200-ohm 2-watt resistor that was the victim of a "short cir-

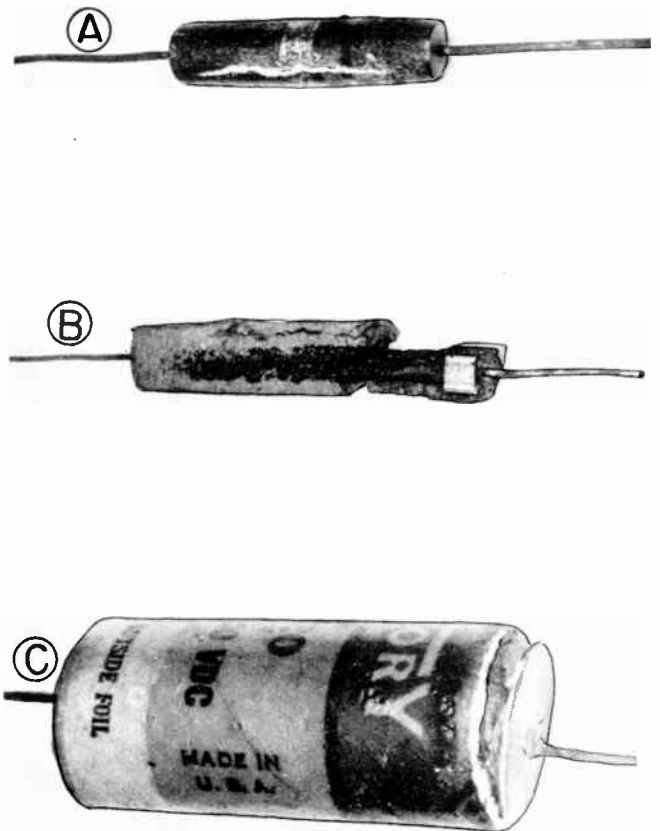

Fig. 15. Some of the things which happen when there is too much current, too much voltage, or too much power in watts changed into heat.

cuit" which subjected this resistor to a potential difference of about 163 volts. This meant a heat dissipation of about 12 watts, in a 2 watt unit. In less than three minutes the inner core became so hot as to burst an opening through the outer insulation. When there is an overload so great as this the resistor may give way with a puff of smoke and sometimes a visible flash. Sometimes the unit will open its circuit to stop the damaging current, but again its resistance may drop so low that current becomes even greater. Then some other part in the circuit will burn out.



## LESSON 5 – HOW RESISTORS ARE USED

At B are the remains of a wire-wound resistor that became badly overheated from excessive voltage and current. This unit has been cut open to show the internal damage. At C is a capacitor from which some of the insulating compound has been forced by heat. In this case the heat was due to too much alternating current in the capacitor itself, combined with a mounting position too close to several high-wattage resistors.

The heat produced in a resistor depends on the watts of power used up in the resistor itself. If this heat can be rapidly radiated or otherwise dissipated the temperature of the resistor won't go too high if the wattage rating isn't exceeded for too long a time. But should the resistor be mounted near other high-temperature parts, such as rectifiers or any other large tubes, or near a power transformer, these other parts add their heats to that produced in the resistor and everything in the vicinity gets hot. How rapidly the heat of a resistor may be gotten rid of or dissipated depends on the ambient temperature as well as on air circulation. Ambient temperature is the temperature of air surrounding the resistor.

It is a generally safe rule never to use a resistor whose wattage rating is anything

less than double the actual number of watts to be dissipated, as computed according to one of the three methods outlined earlier. If the resistor is to be mounted near parts which cannot be harmed by high temperature the wattage rating of the resistor might be closer to the actual power dissipated. But if the resistor must be mounted near parts which can be harmed by high temperature the wattage rating should be four or more times the actual power dissipation in watts.

When replacing a damaged resistor, if you use another of the same nominal resistance and of the same size or wattage rating, this should take care of the matter of heating. The power ratings of resistors have been considered carefully by the manufacturer, and are on the safe side.

Should a resistor suffer complete breakdown due to overheating it won't do any good to replace the blown unit with a new one until you locate the cause for excessive voltage or current that caused the damage. A new resistor would blow for the same reason the first one gave out. To begin with you must determine the real cause of the trouble, then correct this cause, and finally replace the damaged parts.

# COYNE - *television home training*

## CONDENSED INFORMATION FOR READY REFERENCE

Circuit factors.	Current	The electron flow rate.
	Voltage	Causes current to flow.
	Resistance	Opposes the flow.

When voltage remains constant  
 More resistance = less current  
 Less resistance = more current

When current remains constant  
 More resistance = more voltage  
 Less resistance = less voltage

One ohm = resistance in which one volt causes current of one ampere.

Ohms = volts per ampere  
 Ohms =  $\frac{\text{volts}}{\text{amperes}}$  (volts divided by amperes)

Resistance values.  
 K = thousands of ohms  
 M = millions of ohms, or megohms

Parts numbers.  
 R = resistor  
 C = capacitor  
 L = inductor

Tolerances.  
 Always mean "plus or minus" (high or low)  
 20% Where wide variations allowable.  
 10% Most commonly used.  
 5% Where close accuracy required.

$$\text{Watts} = \frac{\text{milliamperes} \times \text{volts}}{1000}$$

$$\text{Watts} = \frac{(\text{volts})^2}{\text{ohms}}$$

$$\text{Watts} = \frac{(\text{milliamperes})^2 \times \text{ohms}}{1,000,000}$$

Standard or stock resistors.  $\frac{1}{2}$  watt 1 watt 2 watts 5 watts 10 watts

Heat  
 Directly proportional to resistance.  
 Directly proportional to watts actually dissipated.  
 Proportional to current squared.  
 Proportional to voltage squared.

Prefixes. Meg or mega- = x 1,000,000  
 Kilo- = x 1,000  
 Milli- = ÷ 1,000  
 Micro- = ÷ 1,000,000

### Preferred Numbers

5%	10	11	12	13	15	16	18	20	22	24	27	30	33	36	39	43	47	51	56	62	68	75	82	91
10%	10		12		15		18		22		27		33		39		47		56		68		82	
20%	10				15				22				33				47				68			

Color Code	Black = 0	Green = 5 or 00000	Silver: 10% tolerance, or divide by 100.
	Brown = 1 or 0	Blue = 6 or 000000	
	Red = 2 or 00	Violet = 7	
	Orange = 3 or 000	Gray = 8	Gold: 5% tolerance, or divide by 10.
	Yellow = 4 or 0000	White = 9	

# TELEVISION

• RADIO

• ELECTRONICS

---

LESSON 6 – ADJUSTABLE RESISTORS FOR CIRCUIT CONTROL

---

***Coyne School***

*practical home training*

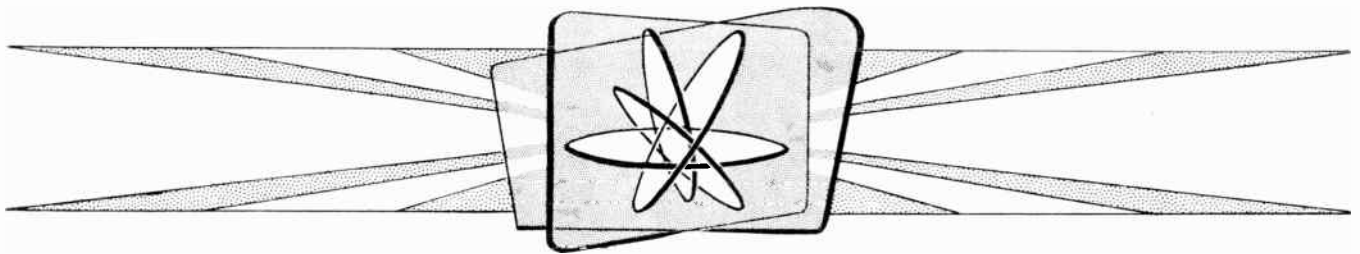

*Chicago, Illinois*



Channel  
Selector

Fine Tuning

Contrast

Brightness

Vertical  
Hold

Horizontal  
Hold

Volume

Linearity

Vertical  
Size

Sound  
Detector

Sweep  
Frequency

Drive

Focus

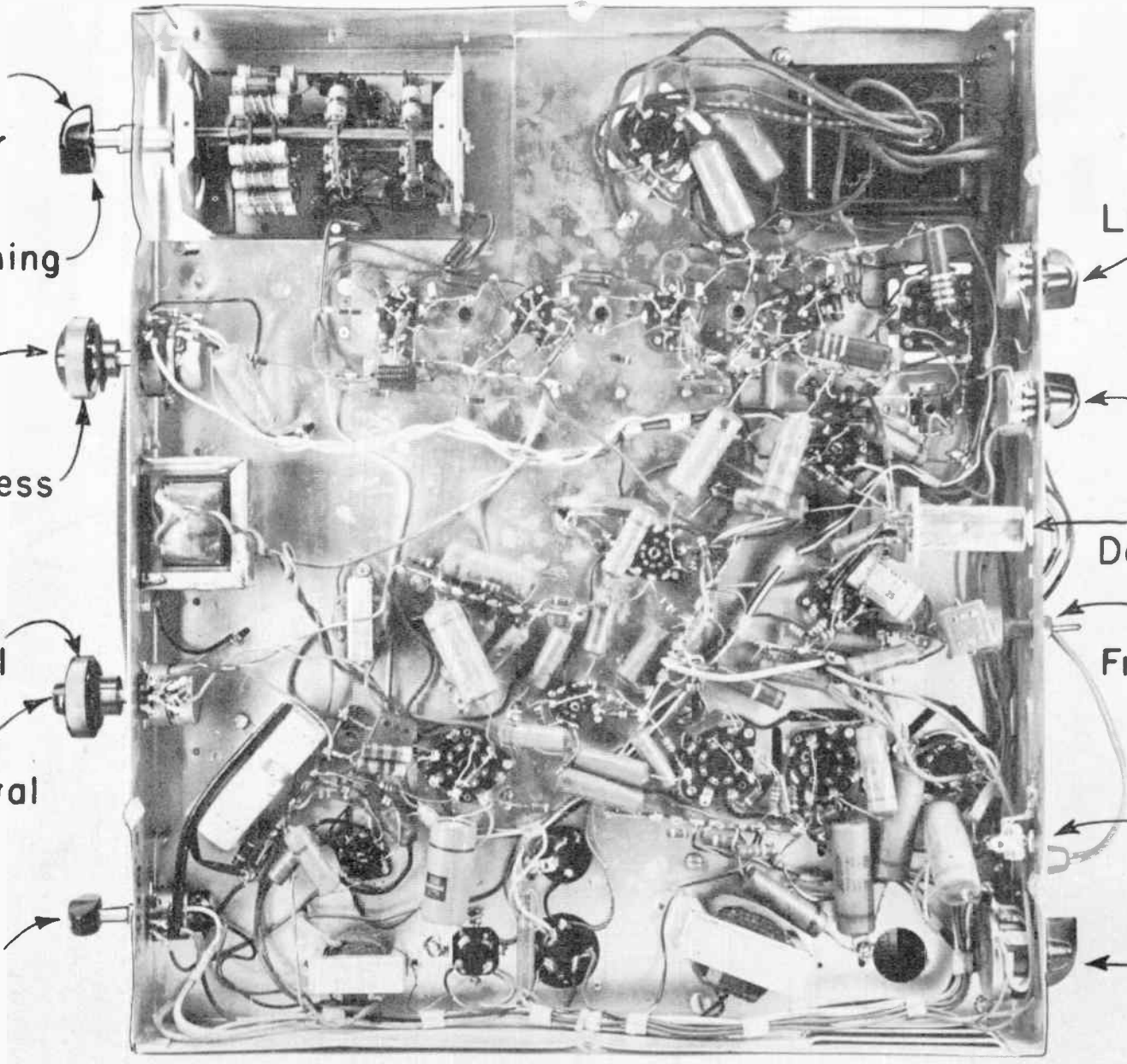

Fig. 1. Some of the adjustable controls for operation and servicing of a television receiver.

## Lesson 6

### ADJUSTABLE RESISTORS FOR CIRCUIT CONTROL

There are many places in television receivers where resistors of fixed values would not allow continued satisfactory performance. At these points it is necessary to use resistors whose effective value may be varied or adjusted while the receiver is in operation. On the front of the television chassis in Fig. 1 are operating controls for sound volume, for holding the picture horizontally and vertically, for brightness, for contrast, for channel selection, and for fine tuning. On the rear of this chassis are service adjustments or controls for focus, for "drive", for sweep frequency, for the sound detector, for picture size, and for maintaining picture lines of correct shape and proportions.

Eight of these controls consist of adjustable resistors, three are adjustable inductors, and two are adjustable capacitors. We might also find adjustable resistors used for regulating the sensitivity or gain, for centering the picture, and for other purposes. In a sound radio receiver there might be adjustable resistors for varying the volume, both manually and automatically, for altering the tone, and for changing the signal sensitivity.

Some of the controls used by the set operator allow suiting the reproduction of pictures and sound to individual preferences. But other operating controls, and all of the service adjustments, are needed for other reasons. First, all receivers of a given model do not perform just alike when they come off the assembly line. There are slight variations (tolerances) in the various components, and compensation must be provided in adjustments. Second, the characteristics of all tubes of any given type are not precisely alike, so the circuits must be adjusted to suit the tubes. Third, during normal use of any receiver there are gradual changes in the circuit parts as they age, and this must be compensated for to keep the parts in operation. Varying the resistance of an adjustable resistor will vary the voltage or will

change the current in a connected circuit, and thereby bring about necessary corrections.

Construction of one style of adjustable resistor is shown by Fig. 2. At A is the complete unit on which are three projecting terminals for wiring connections, and from which extends a shaft that is rotated when resistance is to be altered. At B is the resistance element which, in this design, consists of wire supported on insulation which is bent into circular form. At C is the rotor element, which includes the shaft with an attached slider or tongue that rests on the resistance element and makes contact at various points along the resistance as the shaft is rotated. At D is the housing in which parts, A-B & C are assembled.

We should note, with reference to Fig. 2, that only a few adjustable resistors are constructed to allow removal and replacement of a damaged resistance element. In the majority of designs such replacement is impracticable. In view of the moderate cost of complete new units, the time spent in making a replacement would not be worth while.

Adjustable resistors of any style are indicated on circuit diagrams by the symbol at 1 in Fig. 3 or by the one at 2. The electrical design is shown more clearly at 3. The resistance element is connected to the two outer terminals. The movable slider is connected to the center terminal. Any adjustable resistor having three terminals, two for the element and one for the slider, usually is called a potentiometer. Most service men call them "pots". Another name is variable resistor.

To see some of the things which may be done with a potentiometer we shall look at the remaining diagrams in Fig. 3. The two outer terminals are marked a and b. The center terminal, for the slider, is marked c. Assume, for illustration, that the total resistance of the element between a and b is

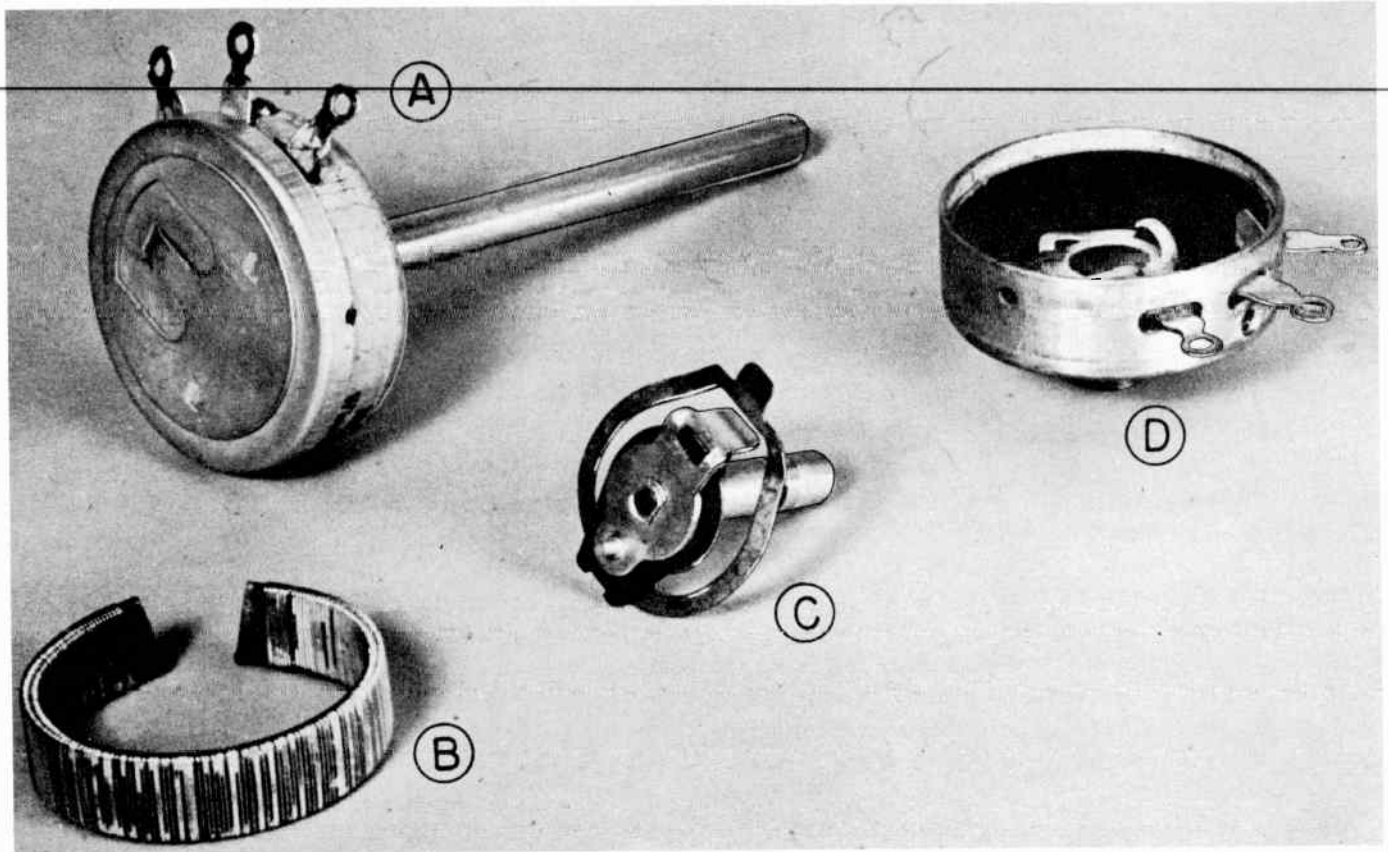

Fig 2. An adjustable resistor and its principal parts.

1,000 ohms. If, as at 4, the circuit wires are connected to terminals a and c, and the slider is moved one-fourth of the distance around the element, starting from a, the portion of the total resistance inserted in the circuit will be one fourth, and the inserted resistance will be 250 ohms.

With circuit connections unchanged we now rotate the slider clockwise, as at 5, until three-fourths of the total resistance is included between a and the slider, or c. Then we have three fourths of the total resistance, of 750 ohms, cut into the circuit. Any portion of the total resistance might be put into the circuit by turning the slider to the appropriate position on the element.

In diagram 6 the circuit wires are connected to terminals b and c, rather than to a and c. To have 250 ohms of inserted resistance the slider now has to be closer to b than to a. In order to increase the inserted resistance from 250 ohms to 750 ohms the slider must be rotated counter-clockwise as in diagram 7, rather than clockwise as in di-

agram 5. Whether the slider must be turned one direction or the opposite to increase the inserted resistance depends on whether the circuit is connected to one or the other of the two outer terminals. One side of the circuit always must go to the slider.

As a general rule a slider should turn clockwise, looking at the control shaft, in order to increase any desired effect. For instance, sound volume should increase when the volume control knob is turned clockwise. Picture brightness should increase when the operator turns the brightness control clockwise. These and other effects may be increased by either an increase or decrease of inserted resistance, depending on the type of circuit employed. Correct relations between direction of rotation and the desired effect always may be secured by connecting the circuit wires to either one end or the other end of the resistance element of a control pot, and to the center terminal. It is important to know and remember this when making any service replacements of potentiometer controls.



## LESSON 6 – ADJUSTABLE RESISTORS FOR CIRCUIT CONTROL

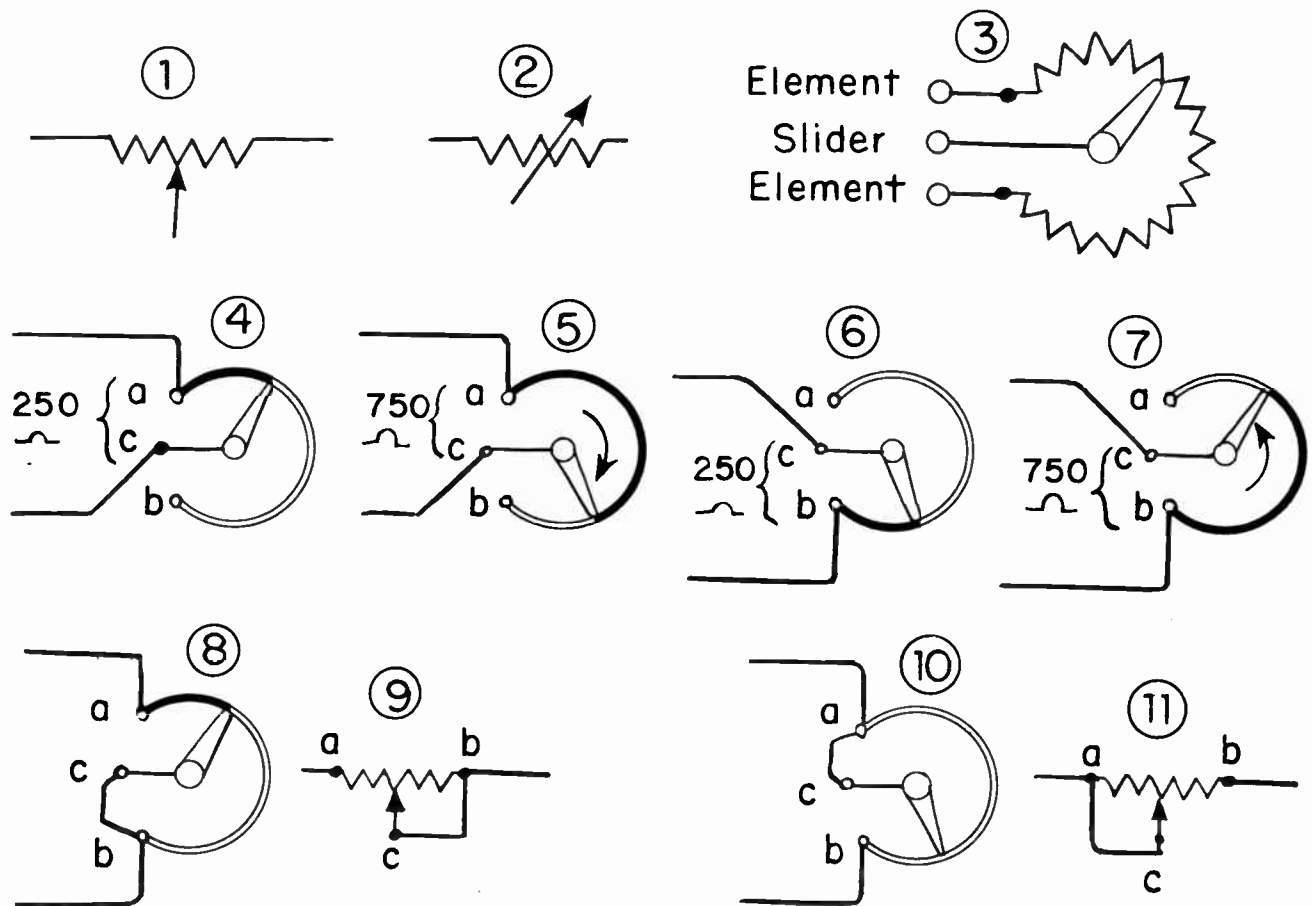

Fig. 3. Symbols for adjustable resistors, and how connections may be made to potentiometers.

In diagram 4 of Fig. 3 the current of the connected circuit flows in the resistance element between a and c, none flows in the portion between b and c. As shown by diagram 8 it is common practice to bridge the unused portion of the resistance element by a short wire "jumper" between the unused terminal and the slider terminal. The circuit wire which goes to terminal c in diagram 4 then may be connected to either c or b when the jumper is used. This jumper connection would be indicated on a circuit diagram by the symbol at 9 in the figure.

Jumper wires across the unused portions of resistors prevent the circuit from becoming completely open in case the resistance element breaks or in case the slider fails to make contact. By turning the slider all the way to one end of its travel, the circuit will be completed through the jumper and slider to the piece of copper or brass which usually is at the extreme ends of the

resistance element. This might allow keeping the set in operation, even though in an unsatisfactory manner, and it might prevent damage to other parts by overloading them with current that should be taken in part by the defective resistor.

When correct rotation of the slider requires circuit connections as at 6, the jumper wire is connected as at 10, to bridge or to "short circuit" the unused portion of the resistance element. This connection of a jumper would be indicated on a circuit diagram as at 11.

**POWER DISSIPATION.** Adjustable resistors, like fixed resistors, are rated as to total resistance in ohms of the element and in the number of watts of power which may be dissipated without dangerously overheating the unit. The power rating is based on having the total resistance in circuit, or on having the current flowing in the entire re-

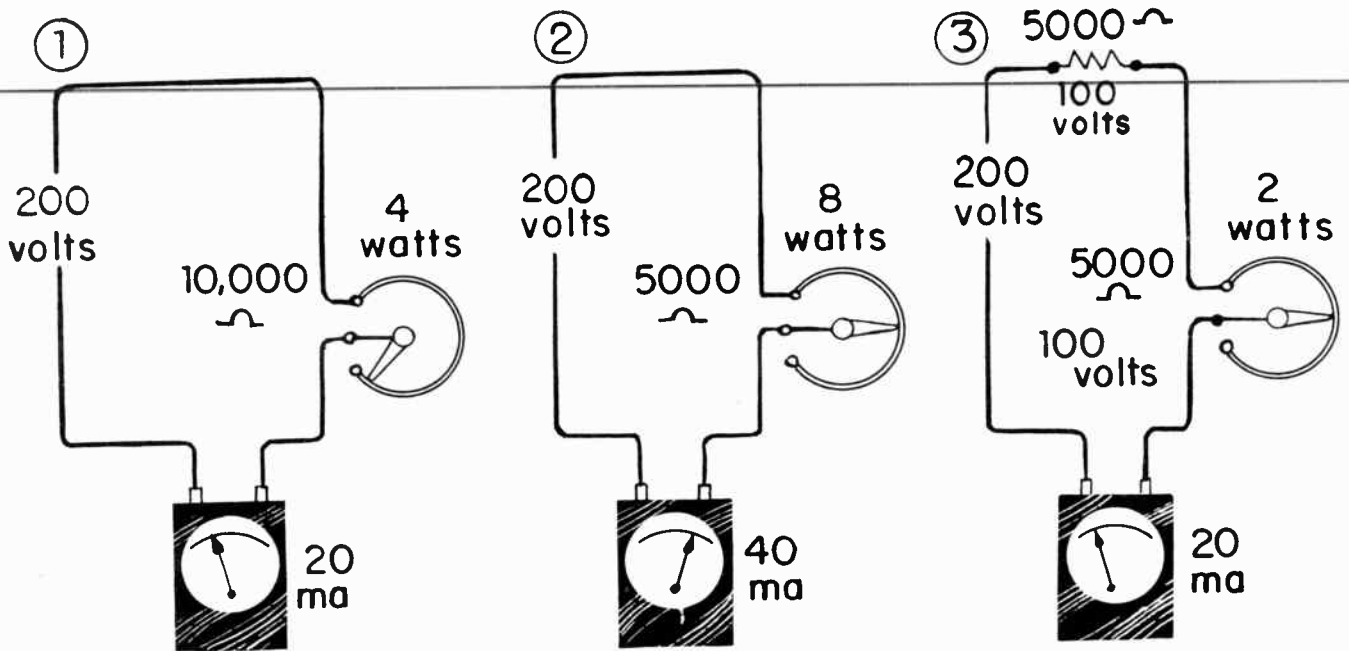

Fig. 4. Potentiometers of certain resistances and power ratings are capable of carrying only a definite maximum current without overheating.

sistance element. This leads to burn-out of many elements, for reasons which we shall examine.

Assume that we have a potentiometer whose total resistance is 10,000 ohms, and, as at 1 in Fig. 4, we apply to this potentiometer a potential difference of 200 volts. A meter would show the current to be 20 milliamperes. Milliamperes is such a long word that nearly always we abbreviate it to "ma", as on the diagram. The slider of the pot is in position to insert the total resistance in the measured circuit. Any of the power formulas used in the preceding lesson will show that the heat dissipation in the resistance element must be 4 watts. Accordingly, we shall assume further that this "pot" is capable of dissipating 4 watts of power without overheating, when all the resistance is in use.

At 2 the slider has been moved to leave only half the total resistance, or 5,000 ohms, in the circuit. Applying the original 200 volts to half the original resistance must double the current, which now reads 40 milliamperes. Again using one of the power formulas, we find that power dissipation has gone up to 8 watts. We are trying to dissipate double the power from only half the resistance element, which means four times the

original load in this portion of the element. Our 4-watt pot will burn out.

In diagram 3 we have added a 5,000-ohm fixed resistor in the same line with the 5,000 ohms of half the pot resistance. This brings the total resistance to 10,000 ohms, just as in diagram 1. With the original resistance and the original applied voltage we will have the original current of 20 milliamperes in the pot resistance element, or in 5,000 ohms. The power formulas now will show that power dissipation in half of the resistance element is 2 watts. If the entire element will safely dissipate 4 watts (from its entire surface) then half the element and half as much surface will safely dissipate half as much power, or 2 watts. Note that with the total circuit resistance equally divided between the fixed resistor and the pot, the total applied voltage must divide equally between these two units, and we have 100 volts potential difference across each one.

The most helpful thing to remember about adjustable resistors is this: A unit of any given resistance and maximum power rating of a certain number of watts will safely carry a maximum current which depends on resistance and wattage rating. In the example of Fig. 4 this maximum current is 20 milliamperes. You may have 20 milliam-

## LESSON 6 – ADJUSTABLE RESISTORS FOR CIRCUIT CONTROL

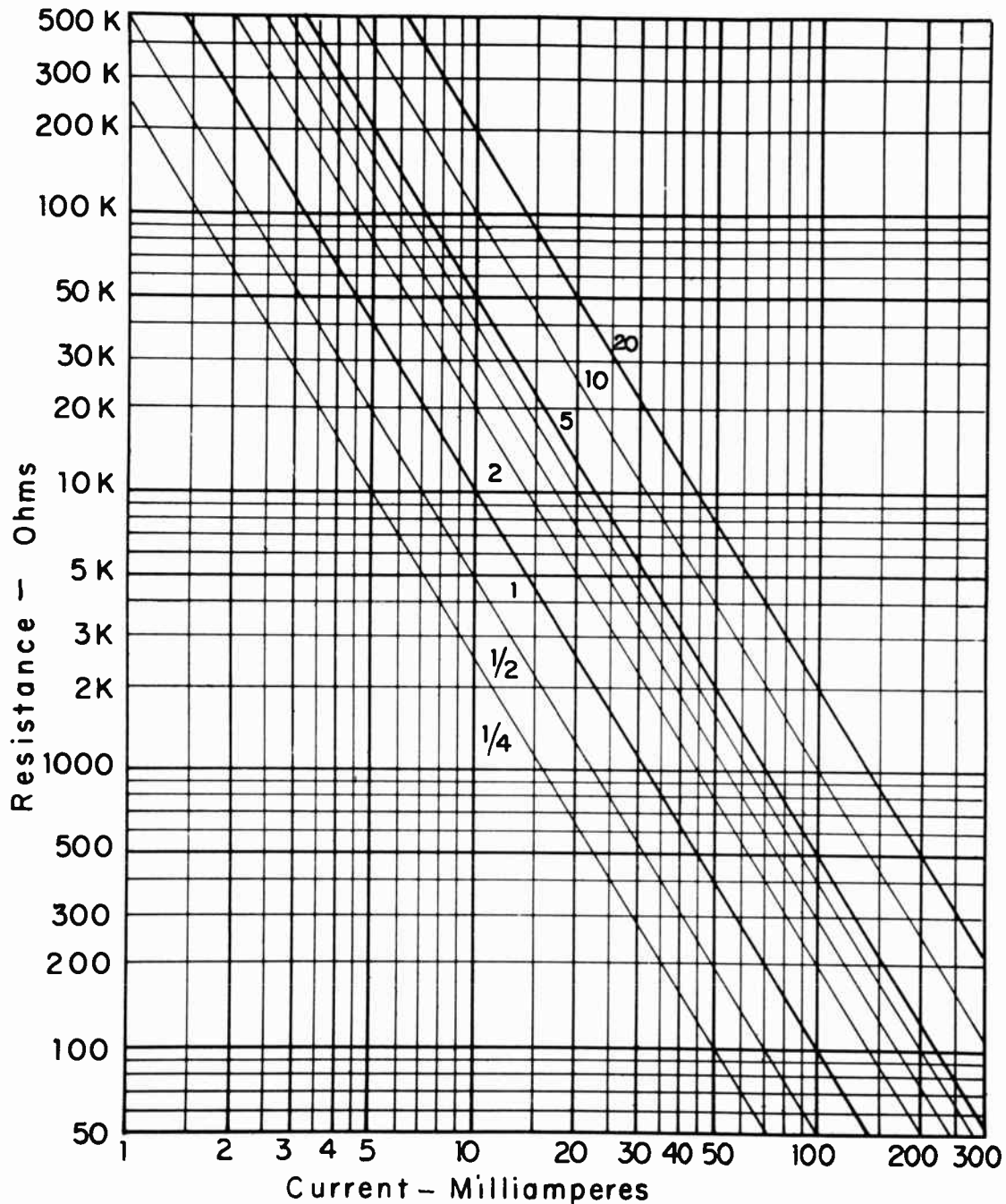

Fig. 5. A service chart which shows relations between resistance, current, and power dissipation in watts.

peres in the entire resistance element or in any smaller part, and so long as this current is not exceeded the pot won't be damaged by overheating. Unfortunately, the rules for determining maximum safe current when we know the ohms of resistance and the allowable watts of power involve finding a square root, which most of us don't like to do. This is the way to do the figuring.

1. Multiply the number of watts by 1,000,000.

2. Divide by the number of ohms.

3. Extract the square root of the number found in step 2. This gives the maximum permissible current in milliamperes.



## COYNE - *television home training*

A much easier way to arrive at answers which are close enough for all practical purposes is to use the chart of Fig. 5. The left-hand vertical scale shows resistances from 50 ohms to 500K (500,000) ohms. The lower horizontal scale gives permissible currents, from 1 to 300 milliamperes. There are diagonal lines for all the power ratings in general use, from 1/4 watt to 20 watts. To use this chart proceed as follows:

1. On the left-hand vertical scale find the number of ohms which is the total resistance of the pot.
2. On the line for ohms trace to the right until coming to the diagonal line for rated watts of the pot.
3. From the intersection follow downward to the scale of milliamperes, and there find the maximum safe current.

This chart may be used also for determining the actual watts of power dissipation when you know the current and the number of ohms resistance in which that current will flow. Find the intersection of a vertical line for current and a horizontal line for resistance in ohms. The dissipation in watts is found from the diagonal lines. You can estimate wattages for intersections which would be between two of the diagonal lines. These wattages are actual power dissipations. Always use a wattage equal to or higher than the actual power when working with adjustable resistors. When using this chart for selecting fixed resistors, select a unit having a rating two to four times the actual dissipation, or even larger, all as discussed in our talks about fixed resistors and their power dissipation.

When replacing an adjustable resistor select a unit of the same resistance as in the original resistor, and of the same or greater wattage rating, whenever the necessary information is available. Manufacturers usually give power ratings in their service parts lists for all adjustable and fixed resistors in a receiver. After we learn quite a bit more about circuits and how they behave it will be possible to make satisfactory replacements even though the original unit is so badly dam-

aged that you cannot measure its resistance.

**CARBON AND COMPOSITION CONTROLS.** Adjustable resistors, like the fixed types, are made with resistance elements of the composition or carbon type and also with wire-wound elements. The flat circular resistance element in one style of carbon pot is the nearly black area which can be seen on the insulating support at the left in Fig. 6.

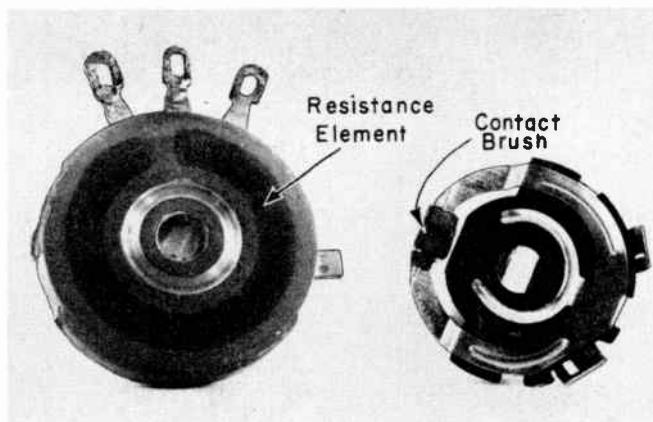

Fig. 6. A carbon or composition adjustable resistor with a flat circular element.

The outer two of the three terminals connect through the support to the ends of the carbon element. The center terminal is connected to the metal ring at the center of the support. At the right is the rotor element of this resistor. On the outer edge of the rotor is a graphite brush that rides on the resistance element. This contact brush connects through metal parts to two springy finger contacts that press onto the center metallic ring of the left-hand picture.

The construction of a different style composition or carbon adjustable resistor is pictured by Fig. 7. Here the resistance element is a ring-shaped member around the inside wall of the housing, with the two ends connected to the two outer terminals. Contact with the resistance element is made by means of a flexible spring bronze band, any one point of which is pressed outward by a brush that is attached to the rotor. The spring band is electrically connected to the center terminal, and remains stationary except as it is pushed outward at one place or another to bring more or less of the resistance element into a connected circuit.

## LESSON 6 – ADJUSTABLE RESISTORS FOR CIRCUIT CONTROL

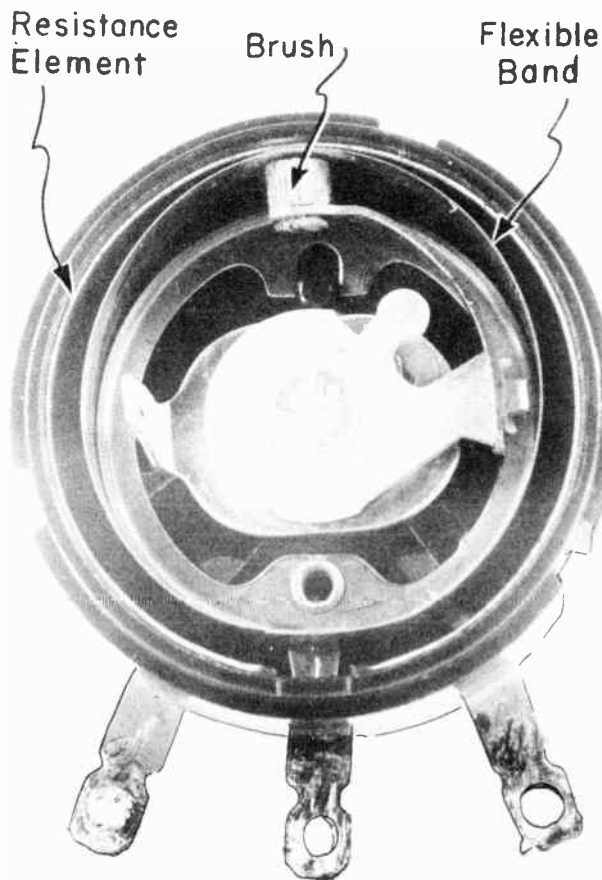

Fig. 7. A composition adjustable resistor with a wall element.

Because small carbon or composition adjustable resistors originally were made for volume control in sound radio receivers, it is rather common practice to call all such units by the name "volume control" no matter what their actual use. Most of these small control units have no regularly listed wattage rating. In this case you may assume a maximum permissible power dissipation of  $1/2$  watt. Some units have power ratings of 1 watt, and a few types are rated as high as 2 watts with composition or carbon elements.

Regularly available resistances range all the way from as little as 50 ohms up to as much as 10 megohms, although relatively few styles come with resistances of less than 500 to 1,000 ohms. As with all resistors, the overall size depends on the wattage rating rather than on the resistance. The  $1/2$ -watt types often have outside diameters of an inch

or even less, while units for dissipating greater power may run up to about  $1\frac{1}{2}$  inches in diameter.

When selecting composition or carbon resistors for replacement purposes you will be asked what "taper" you want. The taper of such units refers to the manner in which the resistance varies as the slider is rotated, whether the change is uniform all the way around the resistance element, or whether it is more or less rapid at some points than at others.

Some examples of tapers are illustrated by Fig. 8. Various percentages of maximum

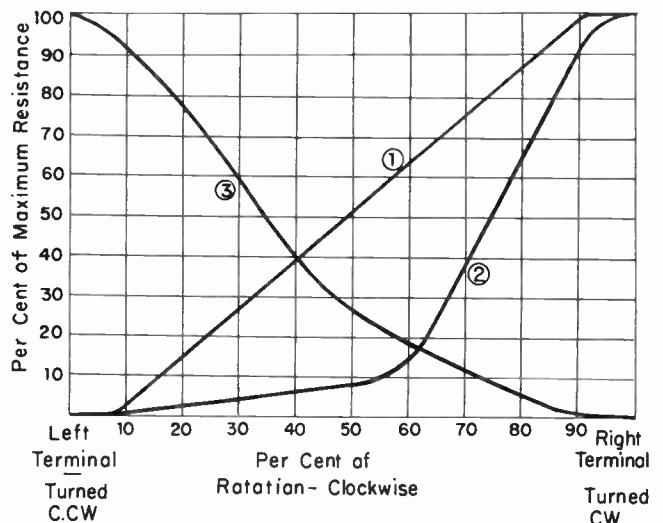

Fig. 8. Typical tapers found in small composition or carbon adjustable resistors.

or total resistance of the unit are marked on the left-hand vertical scale. Rotation of the slider, from all the way counter-clockwise to all the way clockwise, is marked on the bottom scale. The curves show relations between resistance and slider rotation.

Rotation of the slider is assumed to start from the left terminal. The left terminal is the outer terminal at which the slider is making contact when the slider is turned all the way counter-clockwise as you look at the shaft side of the resistor. That is, when you hold the shaft toward you and the resistor housing away from you, then turn the shaft as far as possible counter-clockwise or to the left, the slider has been brought to the left terminal. The outer terminal is, of course, the right terminal.

## COYNE - *television home training*

Curve 1 of Fig. 6-8 illustrates what is called a linear taper or a straight taper. There is zero or minimum resistance with the slider at the left terminal, and there is no change until the slider has been rotated through nearly 10 per cent of its total travel. Then there is a uniform or linear increase of resistance until the slider reaches about 90 per cent of its total travel. Here the resistance is maximum, and so it remains for the balance of the slider travel.

With the taper represented by curve 2 there is a very slow increase of resistance while the slider is rotated from zero, or the left terminal, to between 50 and 60 per cent of its total travel. With further rotation of the slider, resistance increases at a rapid rate to maximum value. Curve 2 shows what may be called a left-hand taper. A left-hand taper is one in which the slower change of resistance is toward the left terminal of the unit.

Curve 3 represents a taper with which maximum resistance exists with the slider turned to the left terminal. Clockwise rotation of the slider decreases the resistance, quite rapidly at first and then more gradually, until there is zero or minimum resistance with the slider at the right terminal. This curve represents a right-hand taper, because the slower change of resistance is toward the right terminal. It may be called also a reversed taper, because resistance decreases rather than increases with clockwise rotation of the slider.

Various other tapers are available in stock potentiometers. The tapers of units made by one manufacturer may or may not be just like those of another manufacturer, although the differences are not very great. Linear tapers, curve 1, are found in the majority of television controls. Non-uniform tapers are used chiefly for volume, tone, and sensitivity controls in sound radio receivers.

**WIRE WOUND CONTROLS.** Adjustable resistors in which power dissipation must be greater than allowable in the carbon or composition types are made with wire-wound resistance elements in most cases. There is some overlapping, in that some composition

units in the larger sizes may have wattage ratings as great or slightly greater than the smallest sizes of wire-wound types. Most wire-wound controls are rated for 2, 3, 4, or 5 watts. Outside diameters for this range of power ratings will run from about 1 inch up to between 1-1/2 and 1-3/4 inches. Total resistance of wire-wound elements may be as little as 1 ohm. Maximum stock resistances of most wire-wound styles are between 10K and 20K ohms, although some have resistances up to 100K ohms with power ratings of 3 to 5 watts.

In general, we find wire-wound adjustable resistors where it is necessary to satisfy either of two special requirements. The first is where power dissipation must be greater than permissible in composition or carbon types. The second is for resistances which must be less than anything available in the composition units. When either a wire-wound or composition type would meet all electrical requirements it would make no difference which kind is used.

The construction of one style of wire-wound potentiometer is illustrated by Fig. 9. At A is the interior of the housing as it appears with the cover cap, the rotor, and the rotor shaft removed. The resistance element may be seen around the inside wall of the housing. The two ends of this element are connected to the two outer terminals. In the bottom of the housing is a metallic ring which is connected to the center terminal. The rotor shaft extends through a brass bushing in the center of the housing.

At B in the picture is the side or end of the rotor as it would appear when looking into the housing with the shaft in its normal position. The slider which makes contact with one edge of the resistance strip may be seen extending toward the right on the rotor. The projection on the opposite side of the rotor is a stop, which comes up against a projection in the housing in order that the shaft and rotor may not be turned too far in either direction, causing the slider to leave the resistance strip.

At C is a side view of the shaft and rotor. The slider extends upward, and the stop



## LESSON 6 — ADJUSTABLE RESISTORS FOR CIRCUIT CONTROL

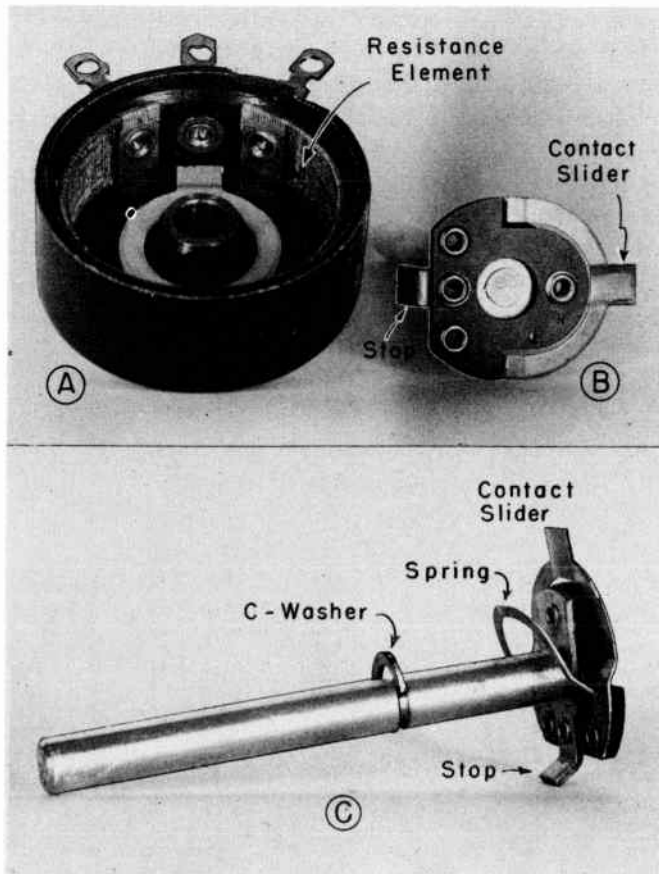

Fig. 9. Construction details of a wire-wound potentiometer.

downward. Underneath the main body of the rotor is a spring that makes contact on the metallic ring in the housing. This spring tends to force the rotor up and out of the housing. The rotor and shaft are held in place, and the spring is kept under tension, by the C-washer that you can see pushed part way into a groove cut around the shaft. With the shaft in its normal position this groove comes just at the outer end of the brass bushing. When the C-washer is pressed all the way into the shaft and is closed into a ring, this washer is of diameter just enough larger than the bushing hole to keep the shaft from slipping out of position.

**TAPPED POTENTIOMETERS.** At the left in Fig. 10 is part of a circuit diagram showing the contrast control for a television receiver, and at the right is part of a diagram showing a volume control in a sound radio receiver. At present we are interested only in the one feature that is common to both diagrams, this being the use of a tapped

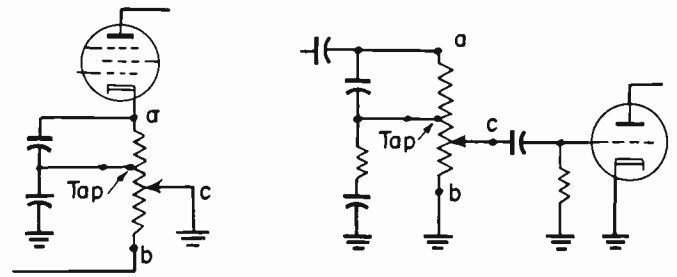

Fig. 10. Two circuits in which tapped potentiometers are required.

potentiometer for control purposes. On each of the potentiometers there are outer terminals indicated at a and b, also a slider terminal indicated at c, but there is also an additional connection on the resistance elements between terminals a and b. These added connections are called taps. They are brought out to a fourth terminal extending from the housing of the potentiometer.

A tap may be almost anywhere between the outer terminals. Many times there is a "center tap" at a midpoint along the total resistance. In other cases the tap may be at a point which is only 3 to 4 per cent of the way from one outer terminal to the other, and still other taps are used at any percentages of the total resistance. Tap connections allow the controlled circuits to perform in certain desirable ways which we shall investigate in due time. Just now we need only know that a fourth terminal means a tapped resistance element. Five terminals would mean that there are two taps, in addition to the usual connections and terminals for the outer ends of the resistance element and for the slider.

**DUAL CONTROLS.** Television receivers always have required more operating controls than sound radios. On the front panels of the early television sets were adjustable controls for channel selection, for fine tuning, for contrast, for brightness, for both vertical and horizontal "hold", for focusing, and sometimes even for centering of the picture. This multiplicity of adjustments appeared highly confusing, and seemed to place the operation of a television receiver in much the same class as operation of a transport airplane.

## COYNE - *television home training*

On more recent television receivers the front panel no longer carries controls for focusing or centering, and in some cases the controls for fine tuning, for brightness, and for holding the picture have been moved to the rear, where they become service adjustments, or have disappeared behind little auxiliary doors which may be opened when adjustments become necessary during a program.

To lessen the apparent number of control knobs which the operator must manipulate some of them are doubled up by using a dual potentiometer operated by two shafts, one within the other, and by one large knob and smaller one attached to these shafts. The most usual pairs are the vertical hold and the horizontal hold controls, which prevent the picture from slipping either up or down or else sideways, also the controls for contrast and for brightness. When there is a tone control for sound it often is combined with the volume control in a dual unit.

One style of dual concentric control is shown by Fig. 11. There are two complete

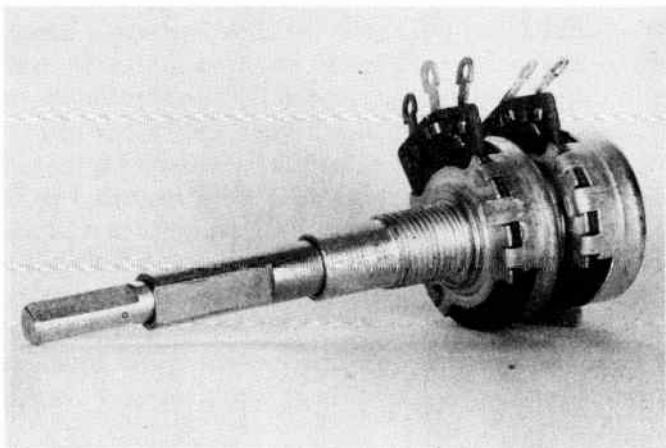

Fig. 11. A dual concentric potentiometer with two units operated independently by one shaft inside another and with two separate knobs.

and independent potentiometers, one for each function, and each with the usual three terminals. The shaft that operates the unit which is closer to the panel, when mounted, is a piece of tubing. Inside this tubing is a relatively small solid shaft that extends through and operates the other potentiometer. As you will see in the picture, the inner shaft

extends out beyond the outer tubing. The knob which goes onto the tubing has an opening all the way through its center, to pass the smaller shaft, and on the end of the shaft is placed a second knob. Either of the potentiometers may be operated quite independently of the other one.

Fig. 12 is a picture of a dual concentric control in which the two potentiometers have

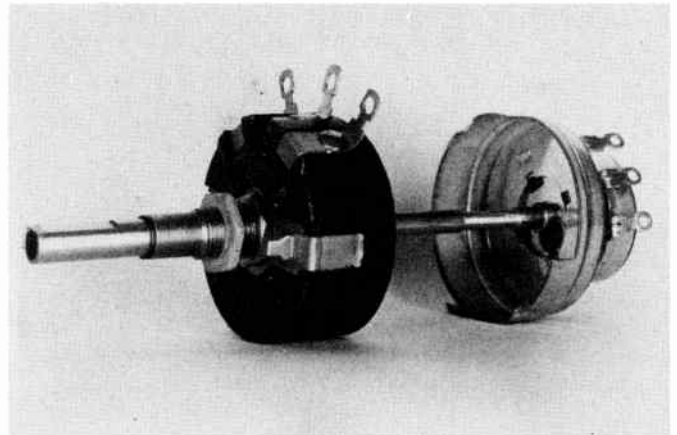

Fig. 12. A dual concentric potentiometer shown with one unit disengaged and moved away from the other to expose the inner control shaft.

been separated to better show the construction. Here it is possible to see the small-diameter shaft which extends right through the larger unit and into the smaller one, where this shaft carries its rotor and slider. The front unit, or the one which would be farther from the panel when mounted, is attached to the cover of the rear unit. It is the rear cover and the front potentiometer which have been moved away from the rear potentiometer in the picture.

The two potentiometers of a dual control may be of different resistances, as usually they are. One may be wire-wound and the other a composition or carbon type, or both may be wire-wound, or both may be composition. Oftentimes one or both units will be tapped.

**MOUNTING OF POTENTIOMETERS.** Practically all potentiometers used in television and radio receivers are designed for mounting in a hole of 3/8-inch diameter that is punched or drilled in the chassis metal.

## LESSON 6 — ADJUSTABLE RESISTORS FOR CIRCUIT CONTROL

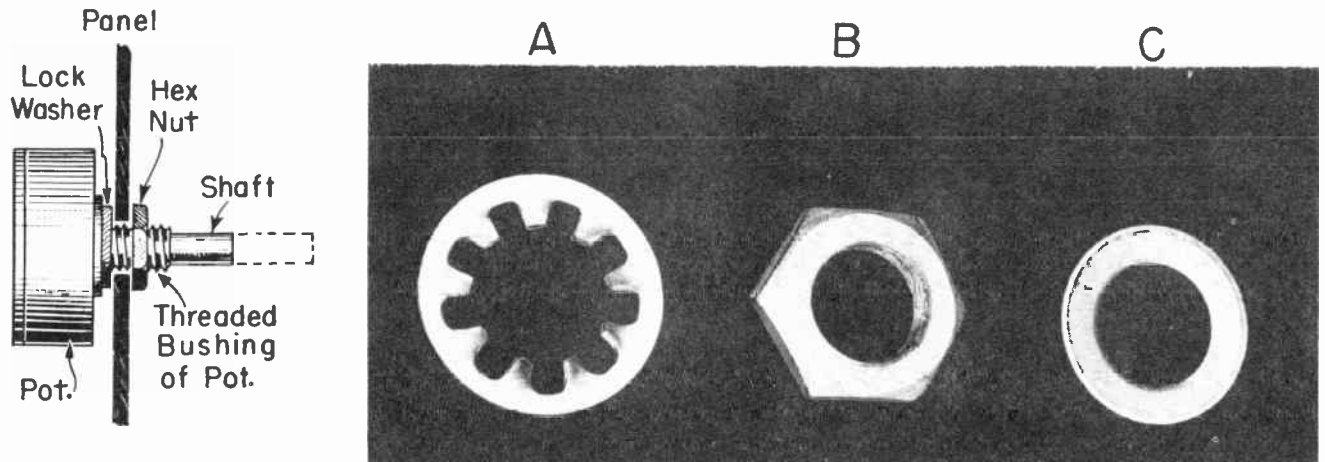

Fig. 13. How a potentiometer with insulated shaft may be mounted on the chassis.

Such a mounting is shown at the left in Fig. 13. Fastened securely in the housing of the potentiometer is a brass or bronze bushing that is threaded on its outside, and which is of such outside diameter as to pass through the 3/8-inch hole in the chassis. Before inserting the potentiometer a lock washer is slipped over the bushing. One of these washers is pictured at A. Then the bushing is put through the chassis hole, the pot is held in the desired position for convenient wiring to its terminals, and a hexagon nut is screwed tightly onto the bushing which extends through the chassis. Such a "hex" nut is shown at B. To allow tightening the hex nut when the chassis hole is rough or burred, a plain washer like the one at C may be used between the chassis surface and the hex nut.

The shafts of stock potentiometers usually are 1-1/2 to 3 inches long outside the threaded bushing. You are to cut the shaft to whatever length is needed to take the control knob. This length varies with different receivers, because sometimes the chassis is close to the front panel of the receiver and again the chassis may be quite a ways back from the panel. The panel is part of the cabinet or is attached to the cabinet. Shafts may be of brass, of aluminum alloy, or of steel. Any of them can be cut by holding the outer end in a vise while using a hacksaw.

For some receivers the shafts of control units may have to be extra long. Stock potentiometers used for replacement in such cases may have the outer end of the regular

shaft threaded or slotted to take and hold an extension shaft. If it is possible to obtain replacement parts made by the receiver manufacturer everything will be of the correct size without any cutting or fitting, and the units will be of correct values and characteristics to perform as they should.

In the great majority of control potentiometers the slider is insulated from the inner end of the shaft, and all the metallic connections between the slider and the center terminal are insulated from the shaft and the threaded bushing. Such construction is illustrated in Figs. 2, 6, 7, and 9. We say that these units have insulated shafts. When using the mounting method of Fig. 13 for a pot of insulated shaft construction there is no metallic or conductive connection between the slider or the center terminal and the chassis. That is, the slider and the center terminal are not grounded to the chassis, even though the bushing is in contact with chassis metal.

In some control potentiometers the slider and center terminal are not insulated from the shaft and the threaded bushing. When using the mounting method of Fig. 13, with the bushing in contact with chassis metal, the slider of the pot is grounded to the chassis. With some circuits this is a desirable or necessary connection, but with other circuits it is necessary to insulate the bushing from the chassis in order to insulate the slider when using a pot having a grounded slider.



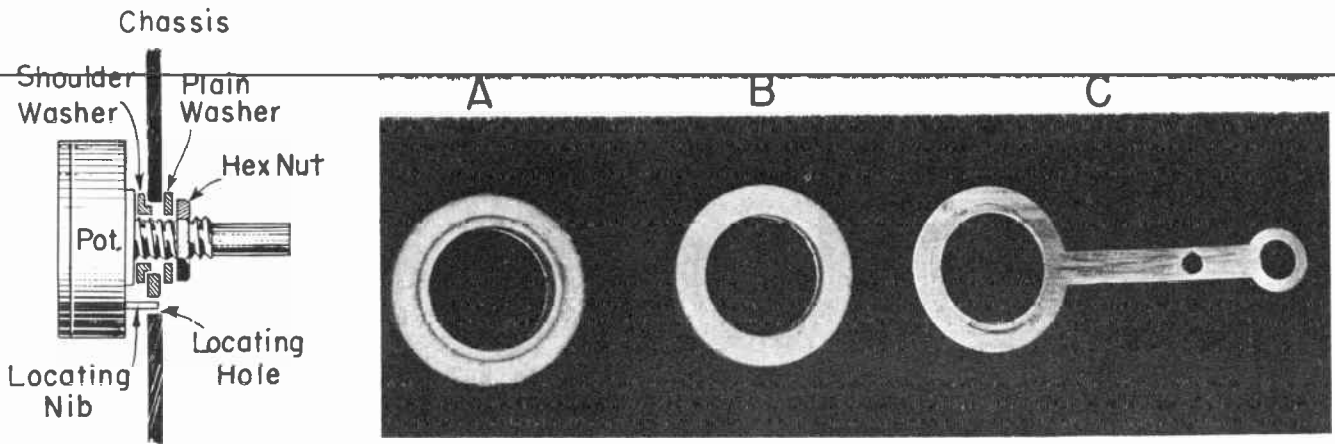

Fig. 14. Mounting a potentiometer having an uninsulated shaft so that all its terminals are insulated from chassis metal.

The bushing and the entire potentiometer may be insulated from chassis metal with the mounting method of Fig. 14. Instead of a lock washer between the pot and chassis metal we use a shoulder washer made of fibre or other insulating material. A shoulder washer has a projecting ring or shoulder, as pictured at A. The hole in the chassis metal now must be made large enough to admit the shoulder, which usually means an opening of 1/2-inch diameter instead of 3/8-inch. On the outside of the chassis is placed a plain insulating washer, or a second shoulder washer if chassis metal is thick enough to take two shoulders without letting them touch each other. A plain insulating washer is shown at B. The hex nut is used outside the outer insulating washer, or a plain metal washer may be used between the nut and the insulating washer.

The two insulating washers isolate the potentiometer from the chassis, but there is not enough friction between these washers and chassis metal to hold the pot firmly in position when someone gives the control knob a hard twist. Consequently, the pot is provided with an extending locating nib which goes through a small extra hole in the chassis, as shown at the left in Fig. 14. This extra hole and the one that takes the bushing usually are 1/2 inch apart, center-to-center.

At C in Fig. 14 is an extension solder lug which may be slipped over the pot bushing to rest on the extension of this bushing on the housing. When used with the mounting

method of Fig. 14 the extension lug allows connecting circuit wires to the bushing and the non-insulated slider of the potentiometer. When used with the mounting method of Fig. 13 the extension lug provides a connection to chassis metal or ground. It is considered good practice to make ground connections to an extension solder lug rather than to chassis metal when a ground connection is needed at or close to a potentiometer.

Fig. 15 is a picture of a potentiometer on the housing of which there is a locating

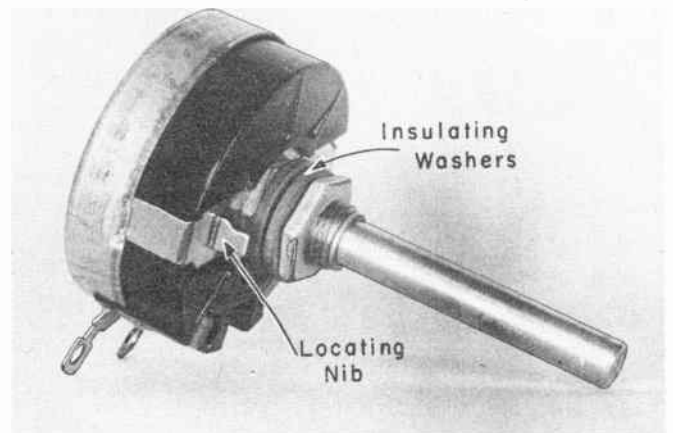

Fig. 15. A control potentiometer with locating nib and insulating washers.

nib. On the bushing of this unit are two insulating washers, with the hex nut outside the washers. A locating nib must itself be insulated from the slider and from the bushing of the pot, since the nib will make direct contact with chassis metal.

## LESSON 6 – ADJUSTABLE RESISTORS FOR CIRCUIT CONTROL

There is a great variety in methods of attaching control knobs to the ends of potentiometer shafts. In the majority of cases the knob is held by spring pressure or friction, and may be pulled straight off the end of the shaft. Sometimes a knob is held onto the shaft by a small set screw which threads through the side of the knob and digs into the shaft. Unless you know from experience with a certain receiver that the control knobs pull off, look carefully for set screws before doing any great amount of pulling. When a set screw, or sometimes two of them, are loosened, the knob will slip off the end of the shaft quite easily.

When two control knobs are used on dual concentric units such as pictured by Figs. 11 and 12 it may be difficult to pull off the front or smaller knob by itself. Usually it is easier to grasp the rear knob or the one nearer the panel and pull both knobs at the same time.

The ends of shafts which take pull-off knobs may be slotted, fluted, flatted on one or more sides, grooved in various ways, and otherwise shaped so that the shaft must rotate when the knob is turned. The opening in the knob then is of a form that fits the end of the shaft. The openings of pull-off knobs often carry flat or curved springs which provide friction for holding the knob on the shaft. On a receiver from which the knobs have not been pulled very many times during previous service jobs the knobs may hang onto the shafts very securely, and require a strong pull to remove them. However, if you are certain that there are no set screws or other special locking devices, don't be afraid to pull - there is no other way of removing the knobs when a chassis is to be taken out of its cabinet.

We have taken quite a bit of time for discussing the mounting of potentiometers, for two reasons. One reason is that there are so many such potentiometers to be handled. The other reason is that the majority of adjustable capacitors, especially those used for service adjustments, are mounted with mechanical arrangements just like those used for pots.

ADJUSTABLE POWER RESISTORS. Still another style of adjustable resistor is illustrated by Fig. 16. These often are called

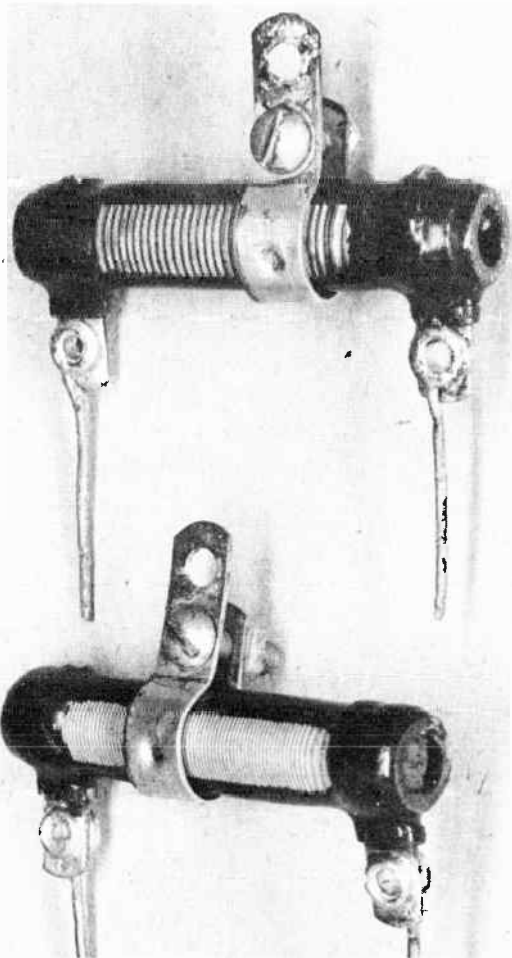

Fig. 16. Power resistors having a movable intermediate contact for adjustment.

power resistors because they seldom are made for dissipations of less than 10 watts, also because they are more common in the power supplies of receivers and other kinds of apparatus than anywhere else.

The construction is practically identical with that of vitreous enameled fixed resistors, except that the enamel or cement coating is absent along one side, to expose the wire winding, and there is a movable slider member which will make contact anywhere along the exposed resistance wire. One cir-

## COYNE - *television home training*

cuit wire is soldered to the extension of the slider, this being the wire that would go to the center terminal and slider of a potentiometer. The other two circuit wires or connections go to solder lugs or pigtail leads at the two ends of the power resistor.

These power resistor units are used only where adjustments seldom if ever require changing, as in some service controls. The slider is held in position, and its small indentation is held securely in contact with the resistance wire, by tightening a screw that extends across the opening of the slider band. Be sure to loosen this screw before attempting to shift the contact. Loosen the screw enough to allow completely free movement of the slider, otherwise you are almost certain to tear and break the resistance wire, or to push turns of wire into contact with one

another where they should remain insulated from turn to turn.

Power resistors usually are available in dissipations of from 10 to 200 watts. We seldom find anything larger than a 25-watt size in receivers. This rating requires a diameter of something like 1/2 inch with a length of 2 to 2-1/2 inches. Maximum total resistance is limited, because very great resistance would require winding with wire so fine and delicate as to be easily damaged. Maximum resistance in thousands of ohms usually is about the same as the number of watts permissible dissipation. That is, the maximum available resistance of a 10-watt unit may be 10K ohms, and of a 25-watt unit it may be 25K ohms. In sizes up to 200 watts it is possible to have resistances up to 100K ohms.





---

---

**LESSON 7—TROUBLE SHOOTING WITH THE OHMMETER**

---

---

***Coyne School***  
*practical home training*

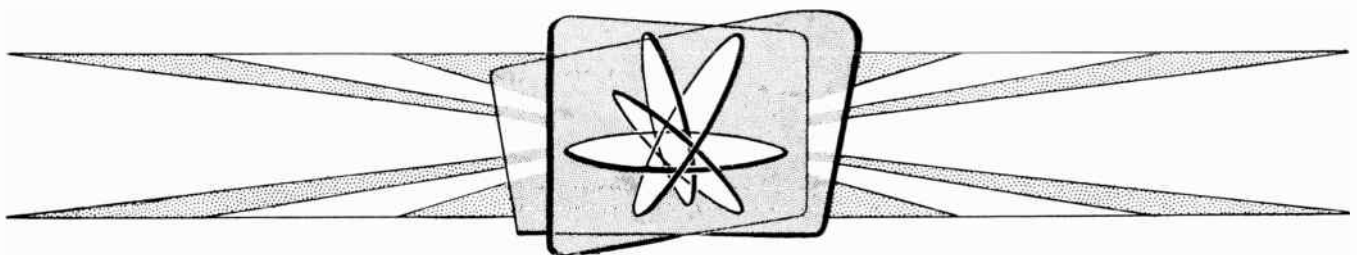

*Chicago, Illinois*

---

*Copyright, 1954 by Coyne Electrical School  
Chicago 12, Illinois  
All rights reserved.*

Litho. in U.S.A

## Lesson 7

### LESSON 7—TROUBLE SHOOTING WITH THE OHMMETER

We have learned about the relations between power dissipation and resistance, about power and current, and about power and voltage. Such information allows you to select and install parts which are of such types and ratings as will stand up in normal use and cause minimum trouble. But in the business of servicing it is just as important to be able to locate troubles when they do occur as it is to avoid trouble -- perhaps even more important.

When it comes to locating the exact point at which a fault exists there is one thing even more useful than a bench full of costly equipment. This thing is a thorough understanding of the relations between voltage, current, and resistance. These three are so closely tied together that when you know any two of them the third can have but one possible value. This simple statement may not sound so very important, as yet, but at least half of all your trouble shooting will depend on it.

Since service procedures depend so vitally on voltages, resistances, and currents, we must have means for measuring these things. An instrument for measuring volts is a voltmeter. One for measuring resistances in ohms is an ohmmeter. And one for measuring currents in milliamperes is a milliammeter. It would be entirely possible to use a voltmeter, an ohmmeter, and a milliammeter for making all manner of measurements. However, it isn't often done that way. The service technician ordinarily uses a combination instrument which will measure either volts, ohms, or milliamperes, depending on how switches or other controls on this instrument are operated.

The combination testing instrument is called a volt-ohm-milliammeter, a name which usually is abbreviated to the three initial letters, "VOM". Volt-ohm-milliammeters are manufactured in a wide variety of styles, and at a wide range of prices. The



Fig. 1. These students in the Coyne School Shops are using various kinds of testing instruments to locate troubles in receivers.



## COYNE - *television home training*

differences between high and low cost are in accuracy, reliability, convenience of operation, and in the ranges or extent of values which may be measured.

Measurements with a volt-ohm-milliammeter or some equivalent instruments are so essential in servicing that many manufacturers of television and radio receivers include in their service manuals either a diagram or a table showing the voltages which should exist between various points when the receiver is working correctly. Some manufacturers list also the resistances which should exist between various points when all the parts are in good order and properly connected. Fig. 2 is a small portion of a diagram on which are represented tube sockets and service controls as these parts appear from underneath the chassis of a television receiver. All voltages shown here are measured with the voltmeter or VOM connected between the chassis and the point at which each voltage reading is marked on the diagram. All the resistances are measured with the ohmmeter or VOM connected from the chassis to the point where the resistance is marked on the diagram.

Let's look at the values shown for tube number 20 on this diagram. At the socket lug for pin 1 of the tube we read 3 V and 10.4 K. This means that here we should find a potential of 3 volts with reference to the chassis. The measured resistance should be 10.4 thousands of ohms, or 10,400 ohms. As is done on this diagram, the letter K often is used to mean thousands of ohms.

Proceeding to lug or pin number 2 we should find 200 volts and 18,000 ohms. At pin 3 there should be 6.4 volts and 1 K or 1,000 ohms. At pin 4 there should be 12 volts, but this voltage should be negative with reference to the chassis. Wherever a voltage should be negative it is marked with a minus sign. Where there is no sign the voltage should be positive with reference to the chassis. At this pin 4 are shown two values of resistance, 330K ohms and 580K ohms. Underneath these resistance values we read (Vert Hold), which means that the measured resistance should vary between the two values when the vertical hold control is adjusted one way or the other.

At pin 5 the readings should be 135 volts and 370K ohms, and at pin 6 we should find 6.4 volts and 1K ohms. At pin 7 there should be no reading, or rather a zero voltage reading, which is indicated by the absence of any marked value at this point. The resistance measurement at pin 7 likewise should indicate zero ohms or no resistance. For pin 8 the marking is 6V AC, meaning 6 volts alternating-current. At this pin there should be an alternating voltage or an a-c voltage, as indicated by the letters AC on the diagram. These letters are used only where the voltage should be alternating. Everywhere else the voltage should be direct, or should be a d-c voltage or a direct-current voltage.

Nowhere on the diagram of Fig. 2, nor on other similar diagrams, will you find any listing of a current value. Everything is voltage or resistance. There are good reasons for omitting current values. First, to measure a current we would have to remove a wire from some one terminal, connect that wire to one side of our current meter, and connect the other side of the meter to the point from which the wire was removed. All this would require a great deal of time, for every test. All voltages, and many resistances, can be measured without disturbing any connections.

There is seldom any real need for direct measurement of current, for this reason. When you know the resistance of any part or circuit, and know also the voltage or potential difference across that part or circuit, it is easy to compute the current which must be flowing. The method is as follows.

1. Multiply the number of volts by 1,000.
2. Divide by the number of ohms. The result is current in milliamperes.

If you correctly measure the voltage and resistance, and make no error in the simple arithmetic, the computed value of current must be correct when using this method.

Because so much of our trouble shooting can be done with measurements of voltages and resistances, without any direct measurements of current, we shall commence this work with a volt-ohmmeter rather than with

# LESSON 7—TROUBLE SHOOTING WITH THE OHMMETER

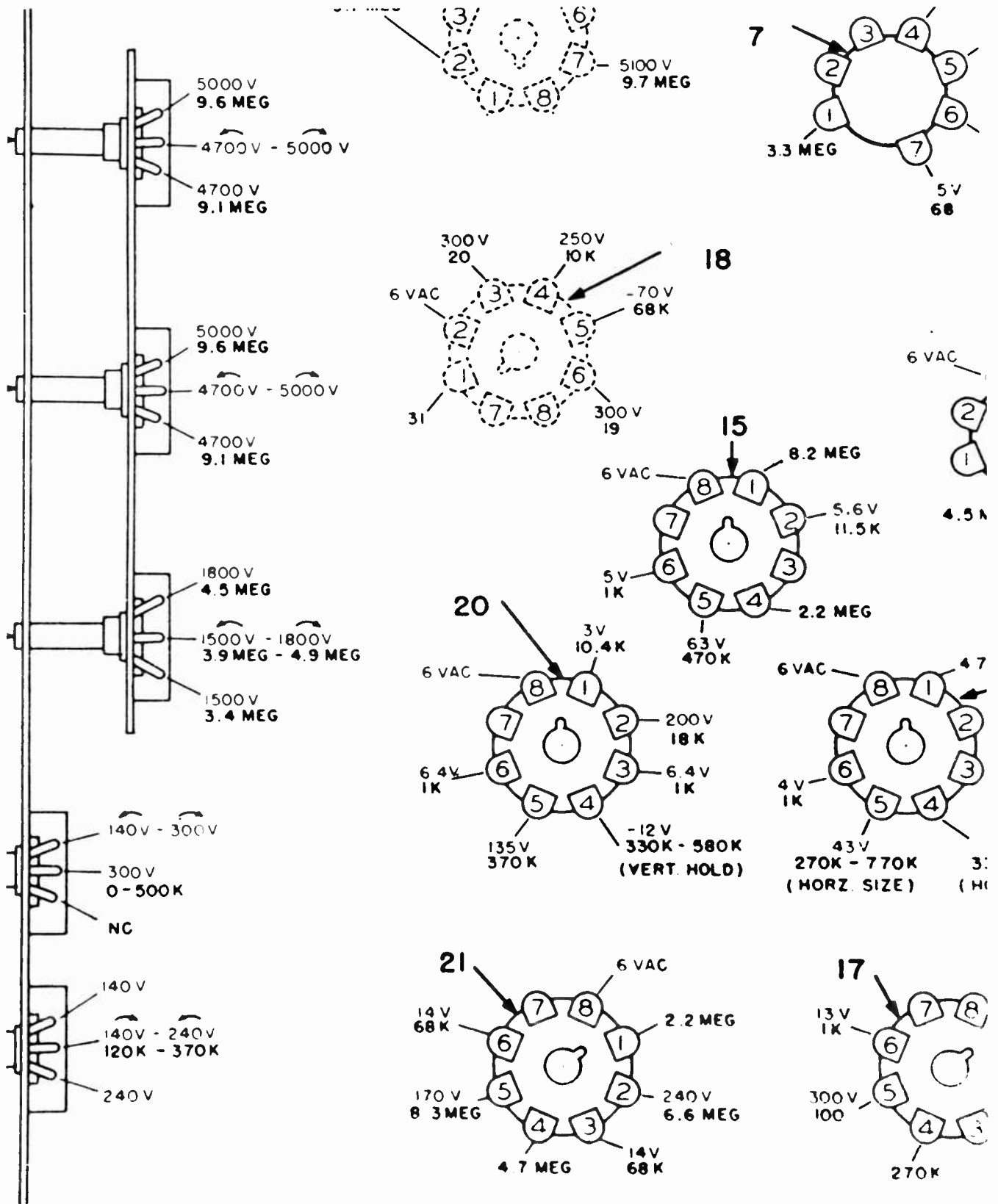

Fig. 2. Part of a service diagram showing resistances and voltages which should exist in a television receiver chassis.

# COYNE - *television home training*

a volt-ohm-milliammeter. A volt-ohmmeter is a combination instrument for measuring either voltage or resistance. Also, since there are only a few places where it is necessary to measure alternating voltages, we shall further simplify our test instrument by designing it to measure only direct or d-c voltages. Such a volt-ohmmeter is pictured by Fig. 3. We shall use this instrument in making a number of tests.

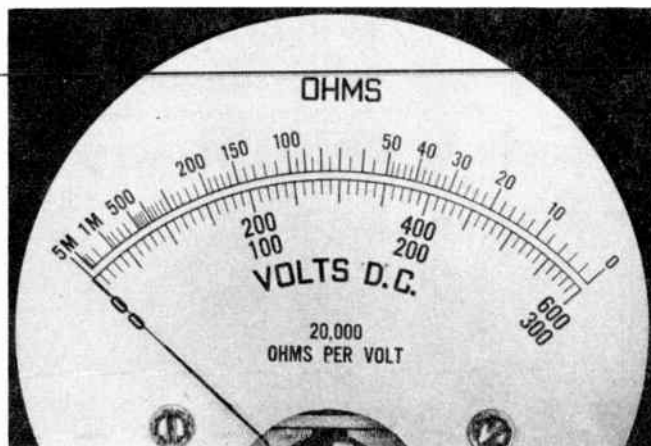

Fig. 4. The dial scales of the volt-ohmmeter to be used for service tests.

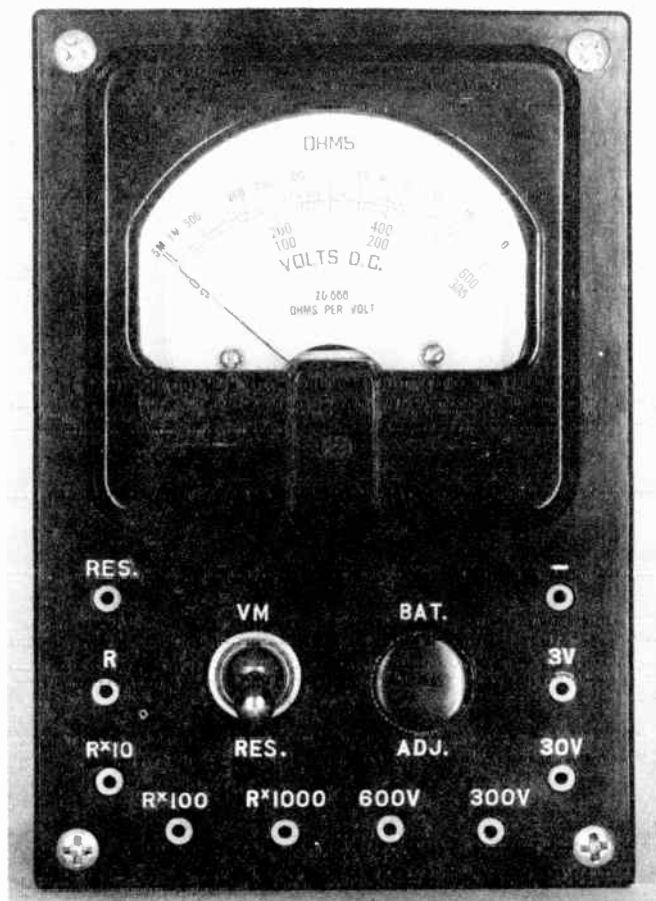

Fig. 3. The volt-ohmmeter which will be used in many examples of circuit testing.

Fig. 4 is an enlarged view of the dial scales of our volt-ohmmeter. Across the top is the ohms scale. This scale is graduated from zero (0) ohms at the right to 5,000 ohms at the left. The number 5,000 is here shown as 5M, and the graduation for 1,000 ohms on this scale is marked 1M. The capital letter M, as used here, is a standard arithmetical symbol for thousand. When designating thousands of ohms in television and radio work we more often use K, the initial letter

of kilo-, but using M to mean thousands is not incorrect. All other resistance graduations on the meter dial are shown without symbols or abbreviations.

Underneath the ohms scale is a scale for volts. The volts scale is provided with two sets of numbers. One set reads 0 - 200 - 400 - 600, which are the markings to be used or read when measuring potential differences up to 600 volts. The other set consists of 0 - 100 - 200 - 300. These markings are used for all measurements of 300 volts or less.

Around the outer edges of the lower panel of the volt-ohmmeter, Figure 5, are ten small openings. These are jacks into which are plugged the two cables or two test leads used for making connections to measured circuits.

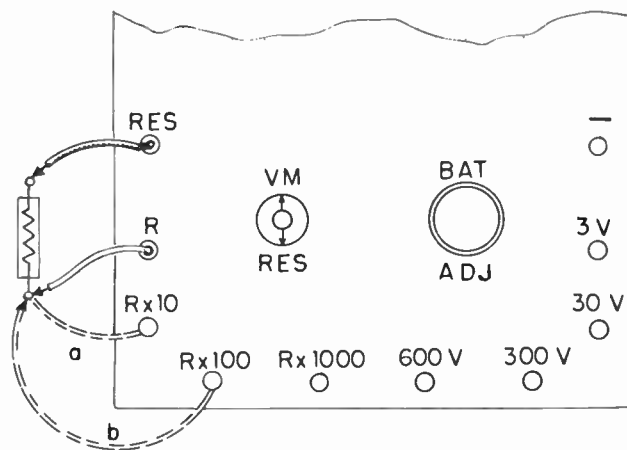

Fig. 5. The range and function markings, also the zero ohms adjustment, on the panel of the volt-ohmmeter.



## LESSON 7—TROUBLE SHOOTING WITH THE OHMMETER

Each test lead consists of an insulated flexible wire having at one end a metallic tip or plug that fits into any of the jacks, and on the other end either a sharply pointed metal prod for touching the points at which measurements are made or else a spring clip for making more solid connections.

Near the center of the instrument panel is a switch marked VM and RES. This switch is moved to the VM position when the instrument is to be used as a voltmeter, and to the RES position when measuring resistances or when using the instrument as an ohmmeter. To the right of this "function switch" is a small knob marked BAT ADJ. This knob operates an internal potentiometer which, when correctly adjusted, brings the meter pointer to zero on the ohms scale.

Inasmuch as the highest marking on the resistance scale of the meter is only 5,000 ohms it might seem impossible to measure greater resistances. Actually, however, we may measure resistances up to 5,000,000 ohms or 5 megohms. This is done by employing various "ranges" of this multi-range instrument. The panel jacks provide for the ranges. The jacks are marked as in Fig. 5. To measure any resistance from one ohm or less up to a maximum of 5,000 ohms we proceed thus.

1. Plug one test lead into the jack marked RES and the other test lead into the jack marked R.
2. Move the panel switch to its RES position.
3. Hold the prods or clips on the free ends of the test leads in contact with each other while turning the BAT ADJ knob to bring the meter pointer exactly to zero on the ohms scale.
4. Separate the ends of the test leads from each other, connect them to any points between which resistance is to be measured, and read the resistance on the ohms scale of the meter.

When we wish to measure greater resistances, between about 100 ohms and 50,000

ohms, one of the test leads is left in the RES jack, but the other lead is plugged into the jack marked  $R \times 10$ , as shown at a in Fig. 5. Then we proceed as before to adjust for zero ohms and make connections to the points between which resistance is to be measured. But now any meter reading is to be multiplied by 10, this being the meaning of  $R \times 10$ .

For measurements up to 500,000 ohms the second test lead is plugged into the jack marked  $R \times 100$ , as at b, and any meter reading is multiplied by 100. For resistances up to 5 megohms the second test lead is plugged into the  $R \times 1000$  jack, and meter readings are multiplied by 1,000. The first test lead remains plugged into the RES jack for all resistance measurements.

Many volt-ohm-milliammeters are provided with a rotary switch and pointer knob for selecting the range in which a measurement is to be made. One such instrument is illustrated by Fig. 6. For all measurements except those in the highest voltage range the test leads are plugged into the two jacks at the left, and the pointer of the switch is turned to the range to be used. Still other instruments select both the kind of measurement and the range with a single rotary switch. Except for the method of selection, all these VOM's are operated as previously explained.

All instruments make resistance measurements by sending current through the resistance and using this current to actuate the meter. The current that flows in the meter is inversely proportional to measured resistance. By marking the meter scale in ohms of the proportional resistance rather than in milliammeters of current we have direct readings of resistance. A little later we shall learn how this is accomplished so simply. The emf which sends current through the measured resistance and the meter comes from a small dry-cell battery that is inside the instrument housing. The battery used for resistance measurements in our volt-ohm-meter may be seen in Fig. 7.

Any battery becomes gradually weaker as it is used. This is compensated for by using the BAT ADJ knob and its potentiometer.

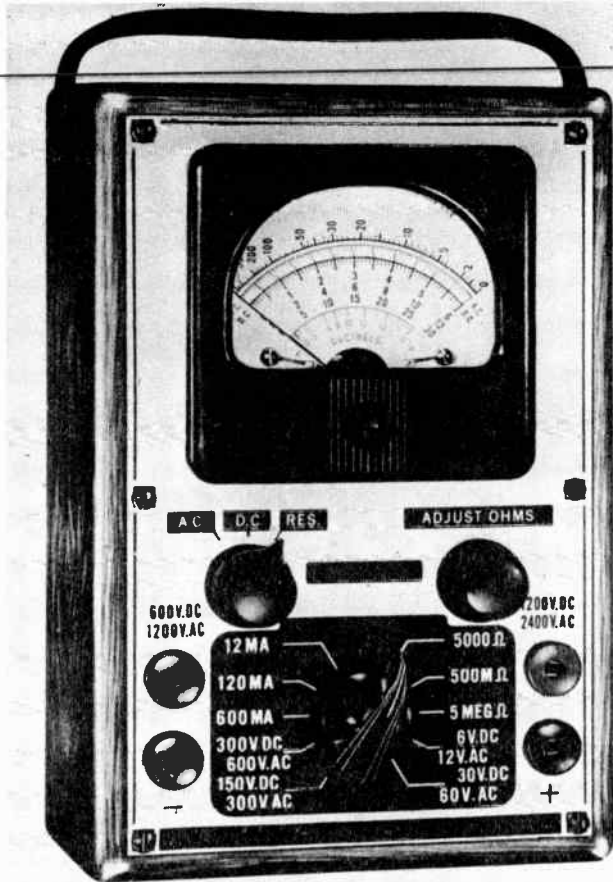

Fig. 6. Volt-ohm-milliammeter with a rotary selector switch for the ranges of current, voltage, and resistance.

meter to make a zero ohms adjustment just prior to each resistance measurement. When the meter pointer no longer can be brought to zero on the ohms scale it is time to replace the battery with a fresh one. Incidentally, Fig. 7 shows some of the many fixed resistors which are required in any kind of multi-range instrument. Also visible here are the inner ends of the range jacks.

Our volt-ohmmeter becomes a multi-range voltmeter when the panel switch is moved to the VM position. For measuring voltages one of the test leads, usually one with black insulation or black fittings, is plugged into the jack marked with a negative sign (-) and remains in this jack for all measurements. The prod or clip on this lead always should be touched to or clipped to the point that is negative with reference to whatever other point is being checked for potential difference. The second test lead, usually

one with red insulation or red fittings, is plugged into one of the other jacks and its prod or clip is used at the point which is positive with reference to the first one.

If the voltage to be measured is between about 50 volts and 600 volts the second test lead is plugged into the jack marked 600 V, and meter indications are read on the upper volts scale, the one that goes from zero to 600. If the measured voltage is no greater than 300 the second test lead is plugged into the 300 V jack, or if no greater than 30 volts this lead is put in the 30V, and for potential differences not exceeding 3 volts this second lead is plugged into the 3V jack.

Always you must remember this most important of all precautions when using any voltmeter. Unless you are certain of the approximate voltage between points being checked, consequently are not sure which range should be used, commence by using the highest range. With the volt-ohmmeter being examined, the highest range is 600 volts. If the meter of this instrument then should indicate less than 300 volts but more than 30 volts, drop down to the 300-volt range. If a reading is less than 30 volts but more than 3 volts use the 30-volt range. Only when another range has shown less than 3 volts should you use the 3-volt range.

The lower the range that can be used the greater is the distance across the scales corresponding to any given change of voltage, and the easier it is to make reasonably accurate readings. Should you make the sad mistake of commencing with a low range, and get the test leads connected across a high voltage, it almost certainly means that you are in for a costly repair job, to be handled by a meter specialist.

Since polarities aren't always known in advance you often will get the test leads reversed, the negative lead to a relatively positive potential and vice versa. No harm will be done if the measured voltage does not exceed the high limit of the range being used. The meter will try to read backward, the pointer will move to the left of zero on the volts scale. It is necessary only to reverse

## LESSON 7—TROUBLE SHOOTING WITH THE OHMMETER

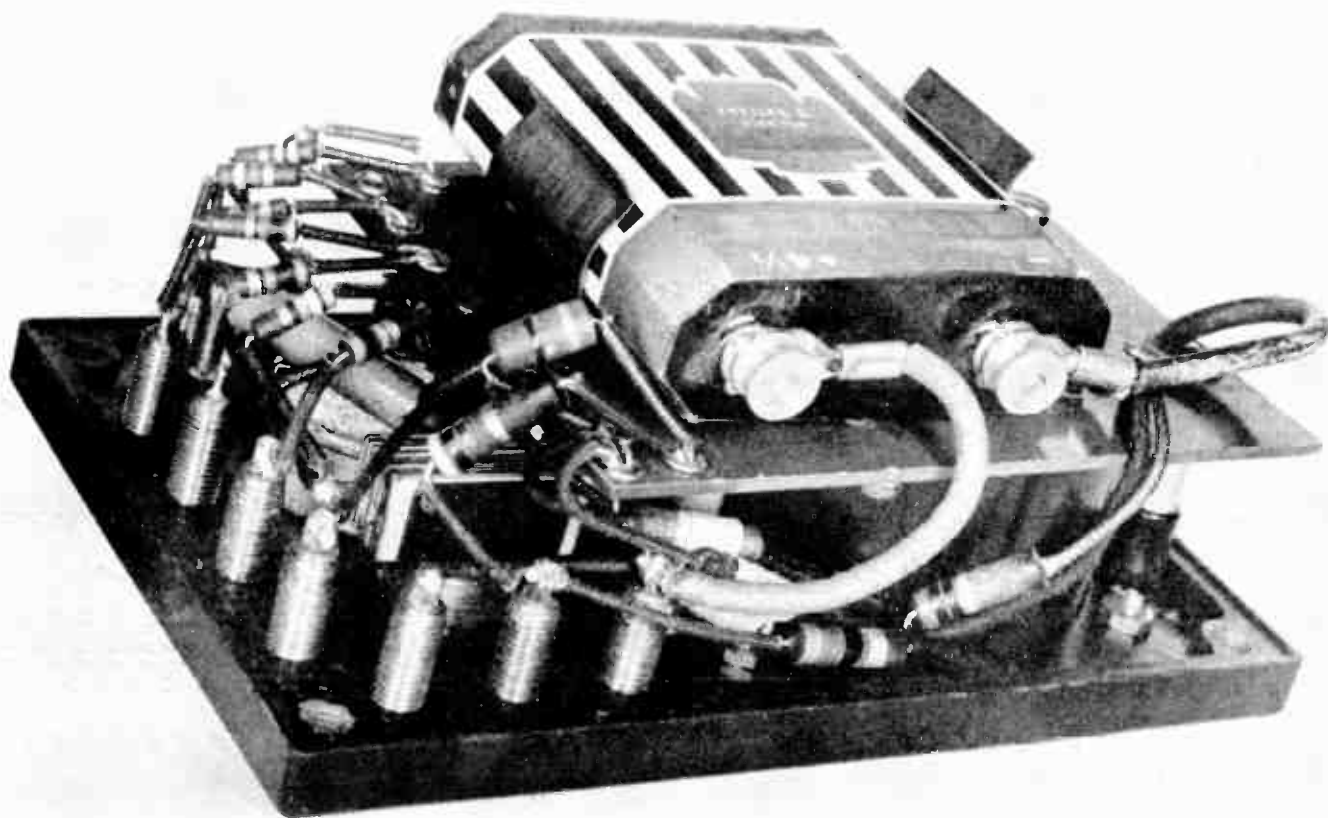

Fig. 7. The inside of the volt-ohmmeter, showing the small dry battery connected into the meter circuit when measuring resistances.

the test leads, at either the instrument or the circuit points, and proceed as usual.

A d-c voltmeter may be used as a polarity indicator as shown by Fig. 8. Employing a high range, connect the two test leads to the two points whose relative polarity is to be determined. If the meter reads "up scale", with the pointer moving to the right of

zero, the negative lead is connected to the point which is relatively negative, and the positive lead is on the point which is relatively positive. Should the meter read off scale to the left of zero volts you have the positive lead on the negative side of the potential difference and have the negative lead on the positive side. This is the method ordinarily employed for checking polarities during service work.

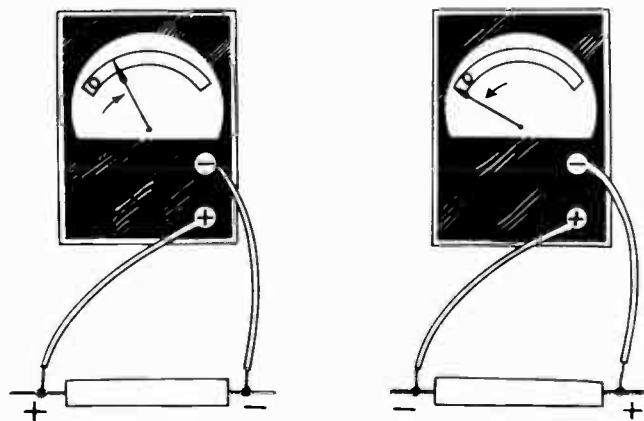

Fig. 8. Using a d-c voltmeter as a polarity indicator on circuits which are carrying direct (one-way) currents.

**CIRCUIT CONNECTIONS.** Now that we know something about the instruments to be used for locating circuit troubles we must learn to describe and recognize the kinds of circuit connections which may be encountered. Any two or more parts or components may be connected together in any of three principal ways; in series, in parallel, or in series-parallel. These three methods of connection are illustrated by Fig. 9.

If all the parts are connected end to end they are in series with one another. There may be any number of parts. All may be resistors, all may be inductors, or all may be



# COYNE - *television home training*

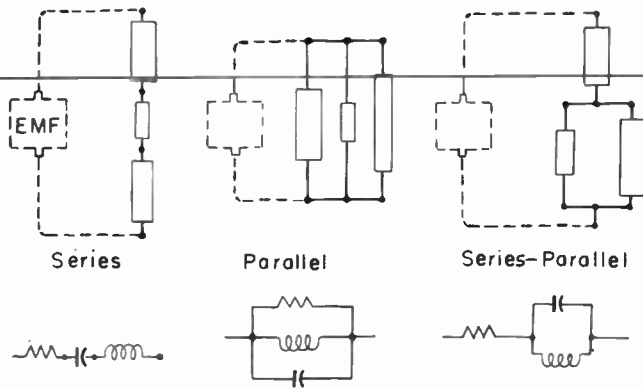

Fig. 9. The three principal types of circuit connections.

capacitors. Some parts may be resistors, others may be inductors, and still others may be capacitors. The kinds of parts, their number, and their values may be anything at all, but so long as all of them are connected together end to end the parts are in series. The word series refers only to the manner of connection.

If current flows in the series-connected parts there must be a source of emf somewhere in the circuit. The strict definition of a circuit says that it is a complete path in which current may flow, and such a complete path would have to include a source of emf. It is common practice, however, to speak of any group of connected parts as a circuit—whether or not a source of emf is included in the group. For instance, any resistors, inductors, and capacitors which may be connected between the plate and cathode of a tube are called the plate circuit.

Should all of the parts be connected in a side by side arrangement, as at the center of Fig. 9, the parts are connected in parallel with one another. Again we may have all resistors, all inductors, or all capacitors, or there may be any possible combination. There may be any number of parts, and they may be of any values. So long as one end or side of every part is connected to one end of every other part, and the opposite ends of all the parts are connected together, they are in parallel with one another. A source of emf may or may not be considered as part of the parallel circuit. The name parallel refers only to the manner of connection.

When some parts are connected together in parallel, and the parallel group is in series with one or more other parts, we have a series-parallel connection, as at the right in Fig. 9. There may be any number of parts in parallel with one another, and any number of parts may be in the series portion of the circuit. Resistors, inductors, and capacitors may be anywhere in either the parallel or series portions of the circuit. Values may be alike or different anywhere. The term series-parallel refers only to the manner of connection.

A series circuit is the simplest of the three general types. We shall learn also that even the most intricate parallel and series-parallel combinations may be "reduced" to equivalent series circuits when it comes to checking performance. Therefore, we shall commence our tests with series circuits.

**CURRENT IN A SERIES CIRCUIT.** Although we seldom make any direct measurements of current, still it is necessary to understand what the currents must be doing. The most essential fact to remember is this: Current, in milliamperes or any other unit, must be the same everywhere in a series circuit.

The fact that current could not be otherwise than the same everywhere in a series circuit may be demonstrated by comparison with the series water circuit of Fig. 10. Here we have pipes and water chambers of various sizes, lengths, and shapes - all connected to-

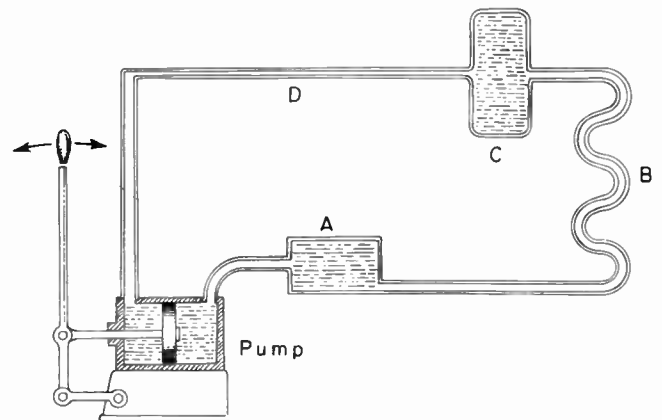

Fig. 10. A series-connected water circuit which behaves in many ways like a series electric circuit.

## LESSON 7—TROUBLE SHOOTING WITH THE OHMMETER

gether in an end-to-end fashion, or in series. This system is full of water, just as the electric circuit is full of free electrons. Water may be moved back and forth in the water circuit by working the handle connected to the piston of a water pump. This pump represents the source of emf in an electric circuit, it moves the water just as emf moves the free electrons. The water is completely enclosed within the pipes and chambers, just as free electrons are enclosed by insulation in the electric circuit. Neither water nor free electrons can escape from their circuits, nor can additional water or free electrons get in.

If you push the pump handle to the right, water is forced into the left-hand end of chamber A, and exactly the same quantity of water is pushed out of the right-hand end of this chamber during exactly the same time. Water is forced into the bottom of pipe coil B, and out of the top in the same quantity and time. Water is forced into and out of chamber C in the same quantity and time, and into and out of the small pipe at D in the same quantity and time. Water comes into the left-hand side of the pump in the same quantity and during the same time that it leaves the right-hand side. Regardless of what the water must pass through, the rate of flow (quantity per unit of time) is the same everywhere. Regardless of the kinds of parts in a series electric circuit, the rate of flow or the current (quantity of free electrons per unit of time) must be the same everywhere.

It so happens that the diagram of Fig. 10 is a good illustration of what happens when the emf is alternating in an electric circuit, and when we have alternating current and alternating voltages. Were you to work the pump handle back and forth the water would flow first one direction and then the opposite direction everywhere in the water circuit. When polarity of a source of emf reverses or alternates back and forth at regular intervals, the free electrons in a connected circuit are forced to move first one direction and then the opposite direction. This is alternating current.

Once more considering the water circuit, with the pump piston moved back and forth

through its entire travel, no particles of water will be moved all the way around the circuit. Yet water is moved everywhere in the circuit. The water-moving force produced at the pump acts everywhere in the water circuit, with the water acting only as a means for transferring the force from the pump to every part of the circuit. When there is alternating emf and alternating current in an electric circuit, only rarely would there be time for any particular free electrons to get all the way around the electric circuit. The electrons merely surge back and forth, sometimes moving only the smallest fraction of an inch during one alternation. The electrons really are a means for carrying energy from the source of emf to all parts of the electric circuit.

There will be some cases in which it is desirable to make a current measurement with a milliammeter. Then, it may be helpful to know that current is the same everywhere in a series circuit, for it may be much easier to insert the current meter at one place than another. Along the bottom of photo in Fig. 11 we have a series circuit consisting, from left to right, of (1) a fixed resistor, (2) a large inductor, (3) a potentiometer, (4) a small inductor, and (5) another fixed resistor. A voltmeter, in a square housing, is connected across the power supply. A milliammeter, in a round housing, is connected between the potentiometer and the small inductor.

The arrangement of parts in the photograph is shown more clearly by the symbols in the diagram below the picture. The current meter reads 40 milliamperes, measured between the potentiometer and one of the inductors. We might be particularly interested in how much current flows in one of the resistors, and would know that it is 40 milliamperes because this is a series circuit with a 40-milliamperere current measured at one place, but present also everywhere else.

The voltmeter of Fig. 11 reads 48 volts. This is the voltage applied by the power supply unit to the entire series circuit. The milliammeter shows that current in this entire circuit is 40 milliamperes. What is the resistance of the entire circuit? We might

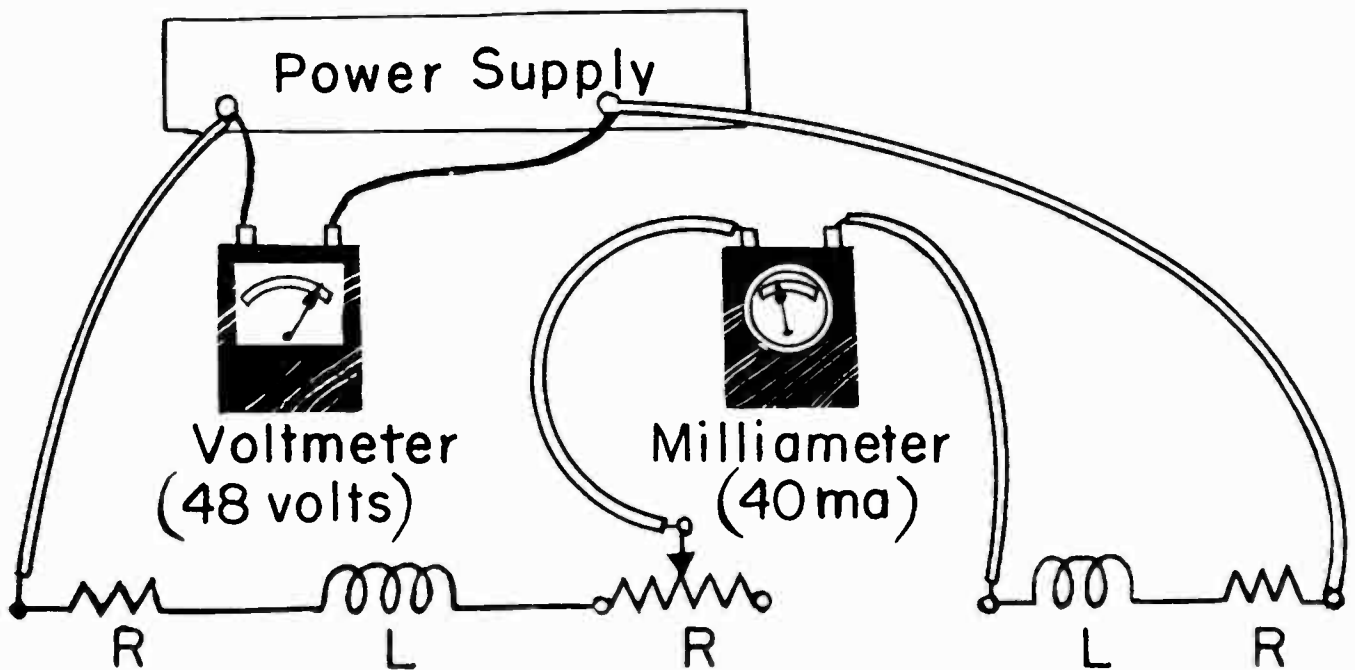
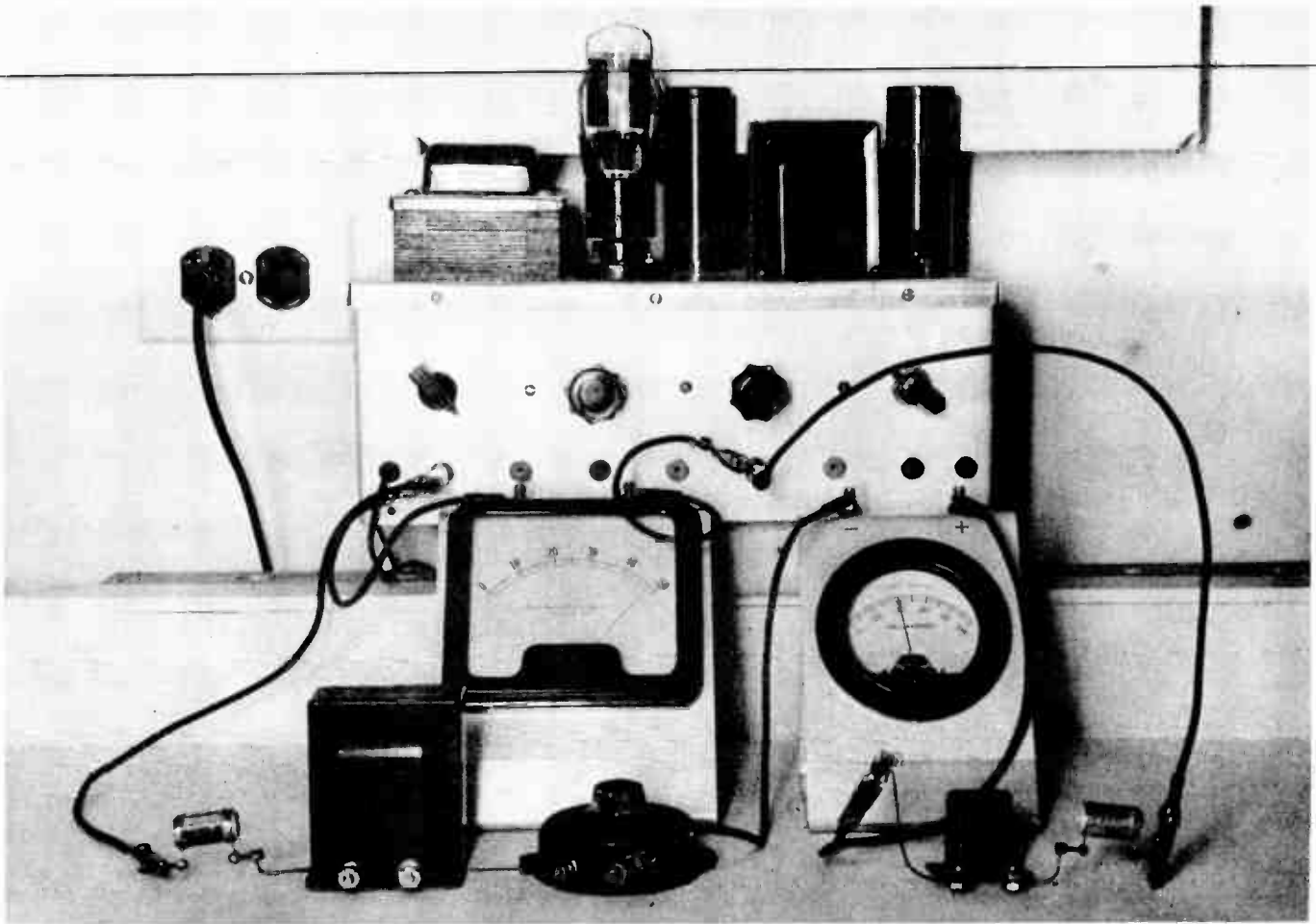

Fig. 11. Current may be measured anywhere in a series circuit, or between any two parts connected in series, and will be the same everywhere else in the same circuit.



## LESSON 7—TROUBLE SHOOTING WITH THE OHMMETER

measure the resistance with an ohmmeter, but since we already know the voltage and current there is an easier way, like this.

1. Multiply the number of volts by 1,000.
2. Divide by the number of milliamperes.

The result is resistance in ohms. Multiplying 48 (volts) by 1,000 gives 48,000. Dividing 48,000 by 40 (milliamperes) gives 1,200, which is the number of ohms resistance of all the parts in the whole circuit when connected in series with one another. It would be a good idea to compare this method of computing resistance with the method given earlier in this lesson for computing current.

Supposing we were to measure the voltage across the entire series circuit, as in Fig. 11, and thus learn that the total potential difference is 48 volts. Then we could use the ohmmeter to measure total resistance, which would be 1,200 ohms. Knowing the voltage and the resistance we could use that earlier method for computing current, as follows.

1.  $48 \text{ (volts)} \times 1000 = 48,000$
2.  $48,000 \div 1200 \text{ (ohms)} = 40 \text{ milliamperes, the current.}$

Obviously, it would be much easier to measure the voltage with a voltmeter, and the resistance with an ohmmeter, then compute the current, rather than breaking the circuit connections to insert a milliammeter.

**RESISTANCE TESTS.** In Fig. 12 we have at A a photographic picture, at B a pictorial diagram, and at C a schematic diagram - all showing the same circuit. In a pictorial diagram the parts are drawn very much as they actually appear, and in the relative positions they occupy in the apparatus. When the circuit is a simple one it is easy to trace paths for current through all the connections of a pictorial diagram. But if the wires have to cross a number of times, or if some parts are partially concealed by others, it may be quite difficult to trace a circuit.

A schematic diagram represents all parts and their connections by means of symbols. Relative positions of the symbols may

be entirely different from relative positions or parts in the actual apparatus. But the schematic diagram shows in the clearest possible manner the electrical connections between parts, and makes it as easy as possible to trace the current paths. Service diagrams nearly always are of the schematic variety. The various parts usually are arranged in the approximate order of their actual positions in the apparatus, but the order may be changed when this will make the diagram easier to follow. It is essential that you become able to trace a circuit through a receiver by referring to a schematic service diagram.

The parts shown by Fig. 12 will be used for making various tests such as required during trouble shooting. This piece of equipment was taken from a television receiver. It consists of a sheet of insulating material on which are mounted four fixed resistors, also a potentiometer with its cover removed, a number of additional unused solder lugs or tie points, and metal supports on opposite sides of the panel. Some of the extra lugs originally carried capacitors and inductors. These units have been removed to simplify the tests which involve only resistances in a series circuit.

The metal support at the left will serve as a ground connection and will represent the receiver chassis. From this ground point two short wire connections lead to resistor number 1. At the following tie lug this resistor is connected to the slider (center) terminal of the potentiometer, which we identify as element number 2. One outer terminal of the pot is connected at another tie lug to resistor 3 which, in turn, is connected at tie lugs to resistors 4 and then 5. The pigtail at the top of resistor 5 is left open. Note that all circuit elements are connected end to end, in series with one another.

Fig. 13 illustrates measurement of resistor number 5, which is the 15K unit at one end of the series string. The volt ohmmeter switch is in its RES position. The two test clips are connected to the top and bottom of the measured resistor. The meter pointer stands at the division or mark next below 150 on the ohms scale. At this portion of the

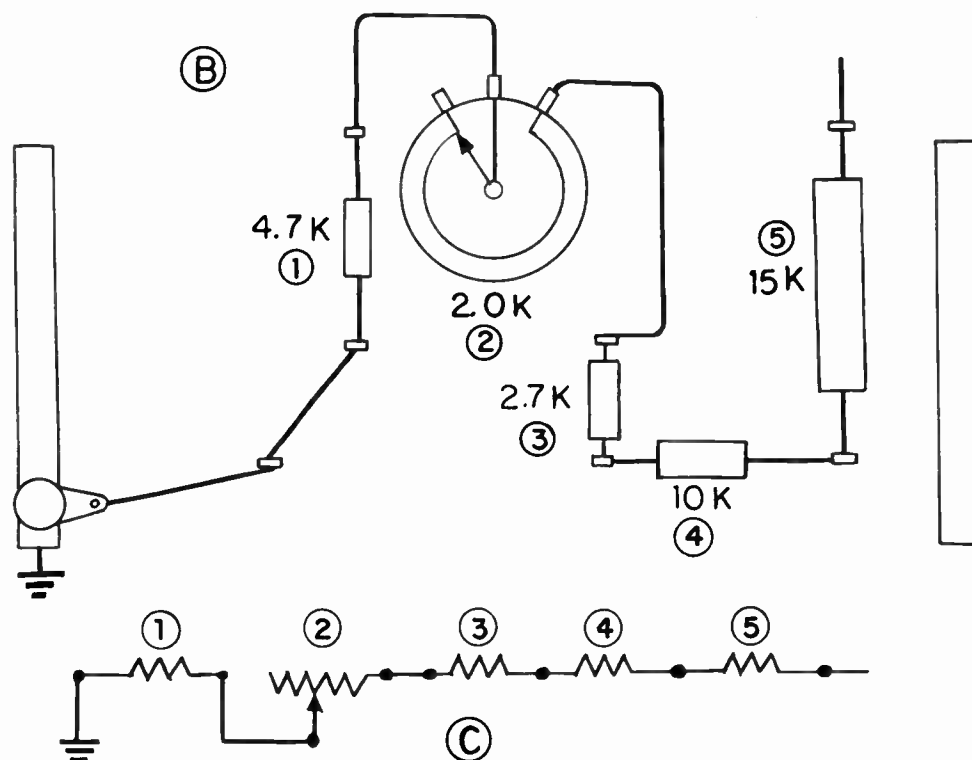
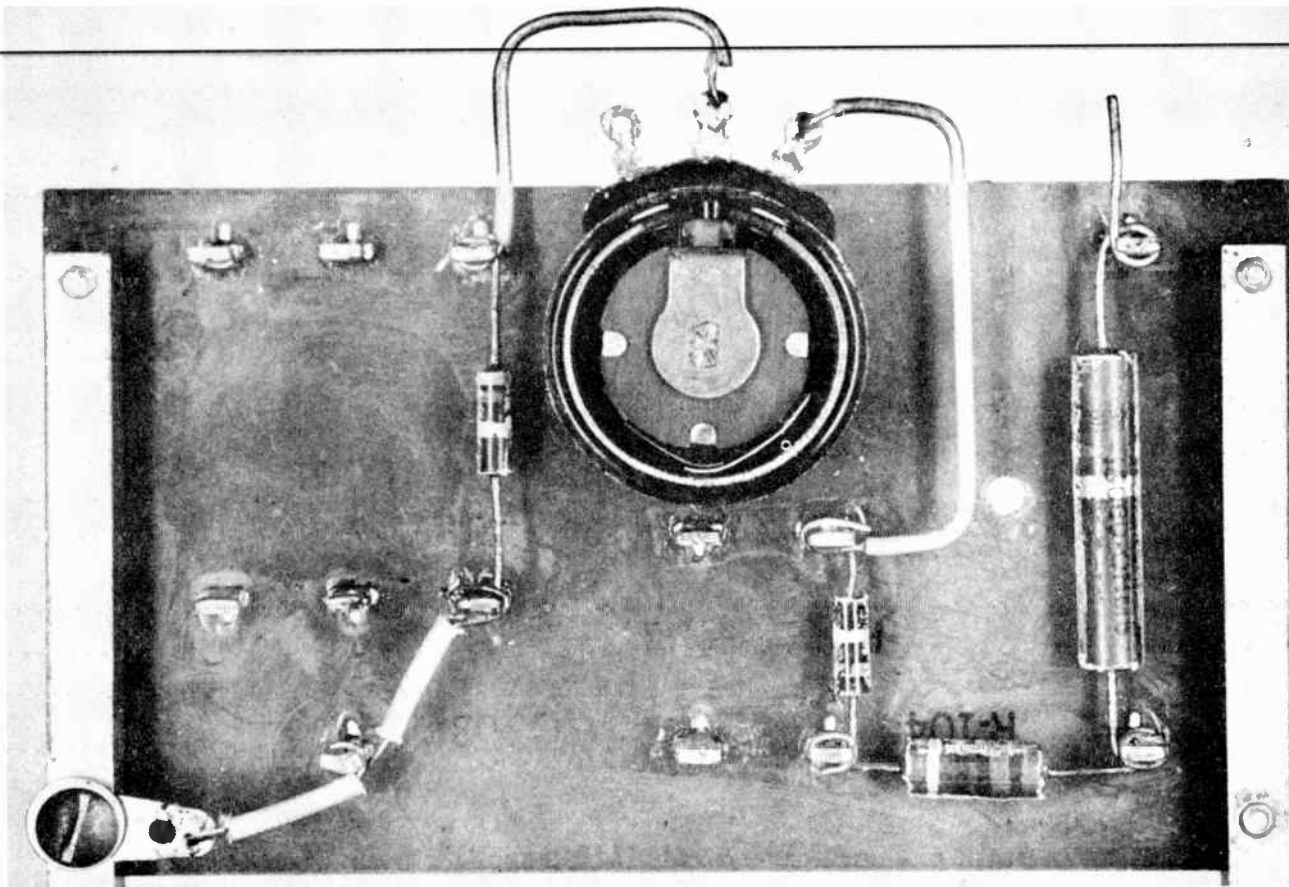

Fig. 12. The series circuit on which will be made various resistance measurements.

## LESSON 7—TROUBLE SHOOTING WITH THE OHMMETER

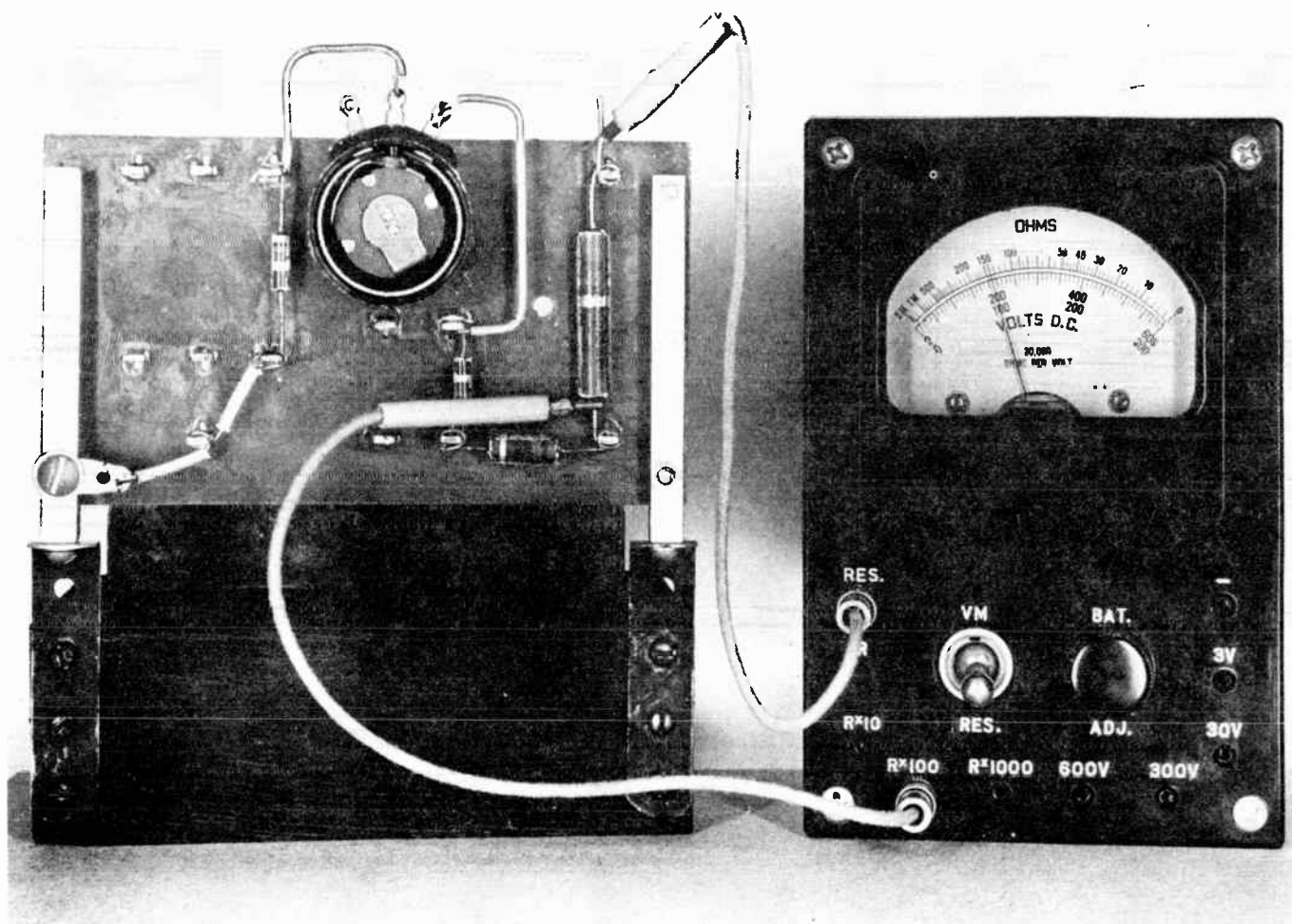

Fig. 13. Measuring the resistance of a single element of the series circuit.

ohms scale each division stands for 10 ohms, so the meter reading is 140 ohms. We are using the  $R \times 100$  range of the ohmmeter, as indicated by the panel jack at which one of the test leads is connected. We must accordingly multiply the dial scale reading by 100, thus arriving at 14,000 ohms as the measured resistance. Note that the slider of the potentiometer is turned to the position giving maximum resistance between its two terminals used for wiring connections.

Resistance of each of the other fixed resistors and of the potentiometer may be

measured in a similar manner, by connecting the test clips to the two terminals of each measured element. It makes no difference which of the clips and leads is connected to which end of any element, the resistance will measure the same in either direction.

The accompanying list gives the resistances according to color coding of resistors and according to a marking on the pot. It gives also the resistance of each separate element as measured with our volt-ohmmeter, and the wattage ratings of the several units.



## COYNE - *television home training*

ELEMENT	CODED OR MARKED RESISTANCE, OHMS	MEASURED RESISTANCE, OHMS	WATTS RATING
1	4.7 K	4.4 K	1/2
2	2.0 K	2.0 K	1/2
3	2.7 K	2.7 K	1/2
4	10 K	9.8 K	1
5	<u>15 K</u>	<u>14.0 K</u>	2
Totals	34.4 K	32.9 K	

The measured resistances are not necessarily the true resistances of the elements, because our ohmmeter is not a precision laboratory instrument. It is, however, a good quality service instrument which is in error by no more than the width of one of the scale lines except in the neighborhood of 5,000 to 6,000 ohms on the R x 100 scale, where the error reaches as much as 2 per cent. Many ohmmeters are less accurate, especially after long use, and possible abuse. Following are some other causes for errors.

A measurement made on one range may differ from measurement of the same resistance on another range.

Accuracy at one point on the dial may be different from that on other points.

When making the initial "zero ohms" adjustment the voltage of the small internal battery may drop slightly lower than when making a resistance measurement. The older the battery the greater is this error, and usually it is greater on low ranges such as R and R x 10 than on higher ranges.

The meter may have been calibrated or adjusted for use when lying flat, or it may have been calibrated for standing upright. When used in the other position the calibration may not hold true.

You may not be looking straight toward the meter dial, with your line of sight at right angles to the dial. If you look from a posi-

tion on the right of the pointer, and look across the pointer toward the dial graduations, you will see a scale marking which is to the left of the actual pointer position. If you look from the left you will see a marking to the right of the pointer position. This effect and the resulting error is called parallax.

For ordinary service work an error of two or three per cent, high or low, is of no importance, and a five per cent error seldom would account for any noticeable change of circuit behavior. An error of 10 per cent may lead to difficulty in critical circuits, while errors of 15 to 20 per cent always are bad.

After measuring the resistance of each separate element we may proceed to measure the total resistance of the entire circuit, as in Fig. 14. Here one test clip is at the metal support which represents ground and the other clip is at the top or free end of the 15K fixed resistor. The meter pointer stands at slightly less than 32 ohms. Because we now are using the R x 1000 range this reading is multiplied by 1,000 to give an indicated resistance of slightly less than 32,000 ohms.

Had this overall measurement been made with the R x 100 range the meter pointer would have stood near 320 ohms on the dial scale, and we would multiply by 100 to again find the resistance as about 32,000 ohms. Scale markings are spread farther apart between 30 and 40 than between 300 and 400 on the ohms scale, and are easier to read. This

## LESSON 7—TROUBLE SHOOTING WITH THE OHMMETER

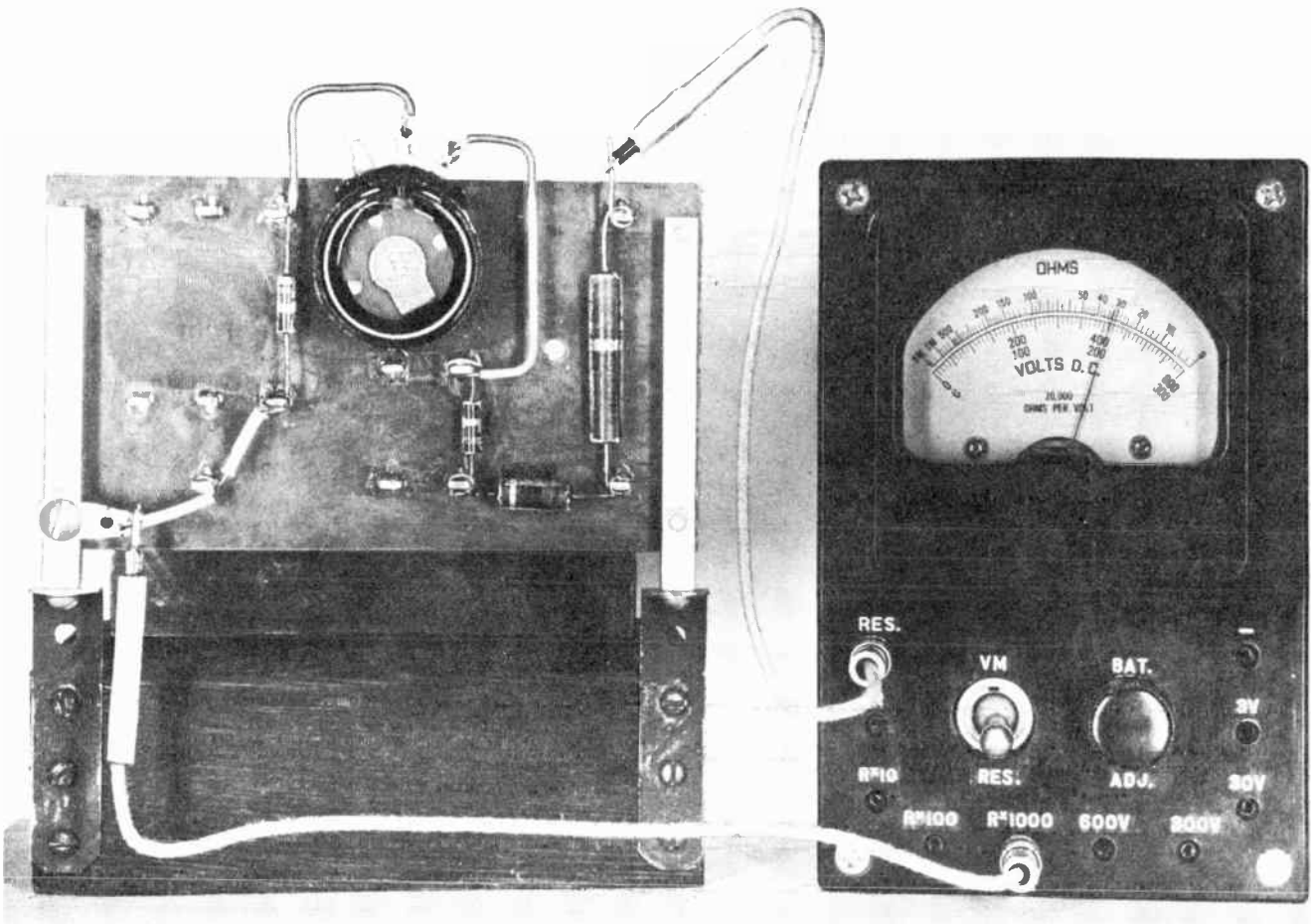

Fig. 14. Measuring the total resistance of the series circuit.

is the reason for using the  $R \times 1000$  range.

Note that the sum of the resistances as measured separately, and given in the preceding list of values, is 32.9K ohms or 32,900 ohms, while the meter measurement across the entire circuit shows about 32,000 ohms. The difference is somewhat less than three per cent, which may be accounted for by any of the errors or any combination of errors previously mentioned. Regardless of any apparent differences between measurements the actual fact is this, and here we have one of the really important laws for series circuits.

Total resistance of any series circuit is equal to the sum of the separate resistances in the same circuit.

When checking through a circuit to locate a fault you often will commence resistance measurements at one end of a series of elements and proceed unit by unit to the other end. For example, in our illustrative circuit you might commence by measuring resistance of the 4.7K unit, number 1. Then you would leave one test clip on the ground side of the 4.7K resistor and connect the other clip on the far side of the potentiometer, thus getting the test clips across both the resistor and the pot. Measured resistance should be approximately the sum of the two separate resistances. The next step would be to shift the clip from the far side of the pot to take in the 2.7K resistor, number 3. Then, as in Fig. 15, this clip would be moved to take in everything from the beginning of the circuit through to the far end of the 10K unit, number 4.

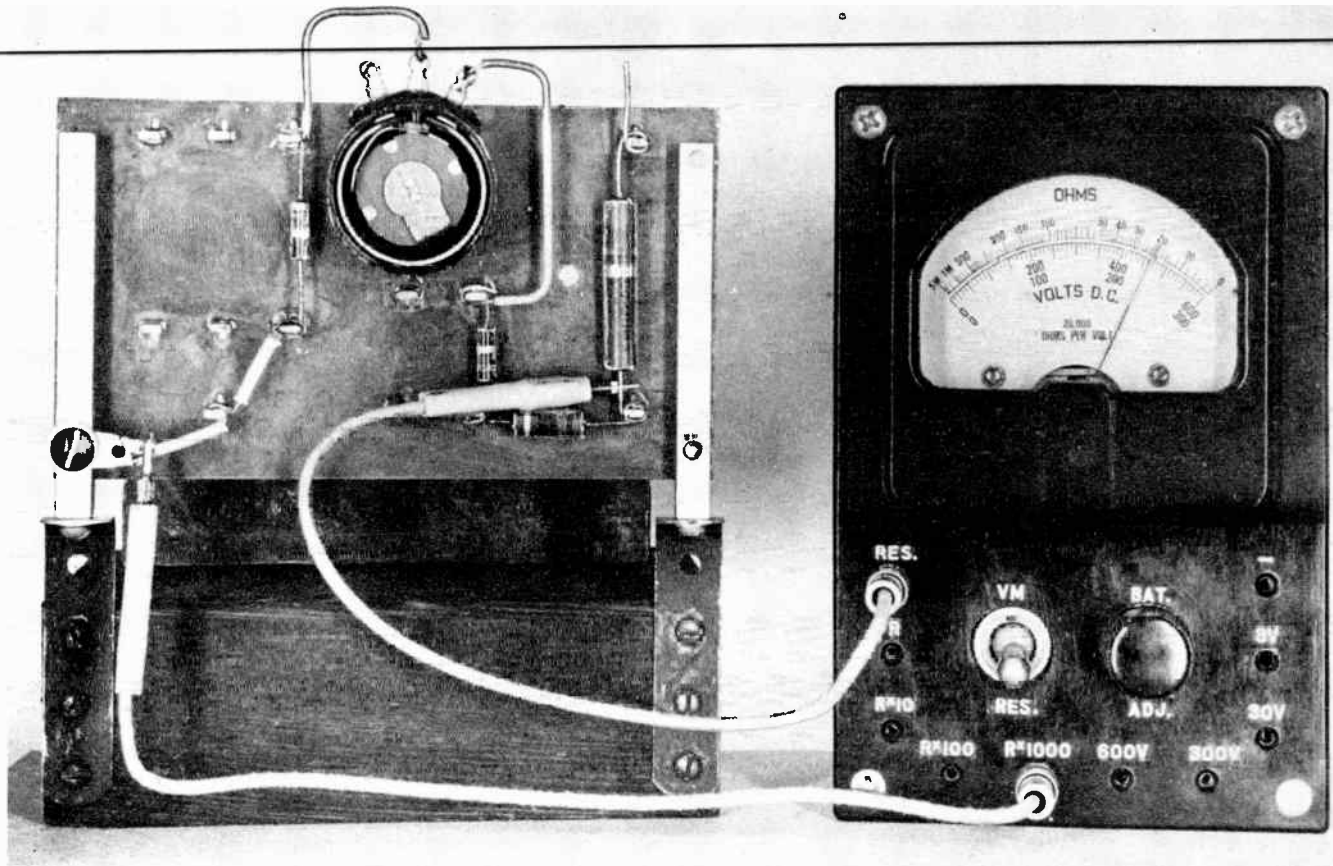

Fig. 15. Measuring the resistance totals in a series circuit by including one additional element at each successive step. Here are included four out of five elements in a typical circuit.

In Fig. 15 the meter pointer stands at slightly less than 21 ohms. Since we are now using the  $R \times 1000$  range this reading is multiplied by 1,000 to give slightly less than 21,000 ohms as the measured resistance. By adding together the separately measured resistances of the four elements now included between the test clips, as these resistances are listed in the earlier table, we have,

Element 1	4.4 K ohms
Element 2	2.0 K ohms
Element 3	2.7 K ohms
Element 4	9.8 K ohms
Total	18.9 K ohms, or 18,900 ohms

The difference between this sum of the separate resistances (18,900 ohms) and their total resistance as measured in Fig. 15 is about 10 per cent. This difference is not too

serious but it is greater than necessary because, had the case of the volt-ohmmeter been tapped lightly with a fingernail before taking the reading, the meter pointer would have moved to indicate 20,000 ohms. Then the difference between this overall reading and the sum of the separate resistances would have been only about five per cent. This would be accounted for by normal errors in measurements.

You should make it an invariable habit to lightly tap every meter before taking a reading. This applies not only to ohmmeters, but also to voltmeters, current meters, and every other kind of meter. It applies to ohmmeters during the zero ohms adjustment as well as when making resistance measurements.

A meter should be tapped for the following reason. Although the pointer is carried



## LESSON 7—TROUBLE SHOOTING WITH THE OHMMETER

by jewel bearings, like those in a fine watch, the bearing friction still puts enough drag on the pointer to keep it from moving quite so far to the right as it would travel with no friction at all. The maximum current that flows in the meter of our volt-ohmmeter is only 50 millionths of an ampere or only 50 microamperes. This exceedingly small current can apply but little force to the pointer. Tapping frees the pointer from the slight drag of the bearings, and allows the pointer to find its correct position.

There are two other precautions which must be observed when measuring resistances. First, no power may be applied to any circuit while using an ohmmeter on that circuit. The meter in an ohmmeter may be safely subjected to no voltage greater than that from its own internal battery. This battery voltage usually is something from 3 to 15 volts. If you apply the leads from an ohmmeter to a "live" circuit the meter might be acted upon by a potential difference of hundreds of volts, with results disastrous to the meter. Always turn off the power from any circuit being checked for resistance. The

only safe way is to pull the power cord plug from the line receptacle.

The second precaution is not necessary so far as safety to the meter is concerned, but is very necessary if you are to obtain correct readings. It is this: The tested circuit must be open at one end, or a tested resistor must be disconnected at one end.

Supposing that this latter precaution has not been observed, and you are trying to measure the resistance of series elements a and b of diagram 1 in Fig. 16. Current from the battery in the ohmmeter, which flows also in the meter of the instrument, will flow in the two resistances as shown by full-line arrows. Were this the only current it would cause the ohmmeter to correctly indicate the sum of the resistances of elements a and b.

But because a and b have not been disconnected from other parts of the apparatus, there is additional current flowing in the other paths, as shown by broken line arrows. Current from the ohmmeter battery, and in the indicating meter, is not only that which

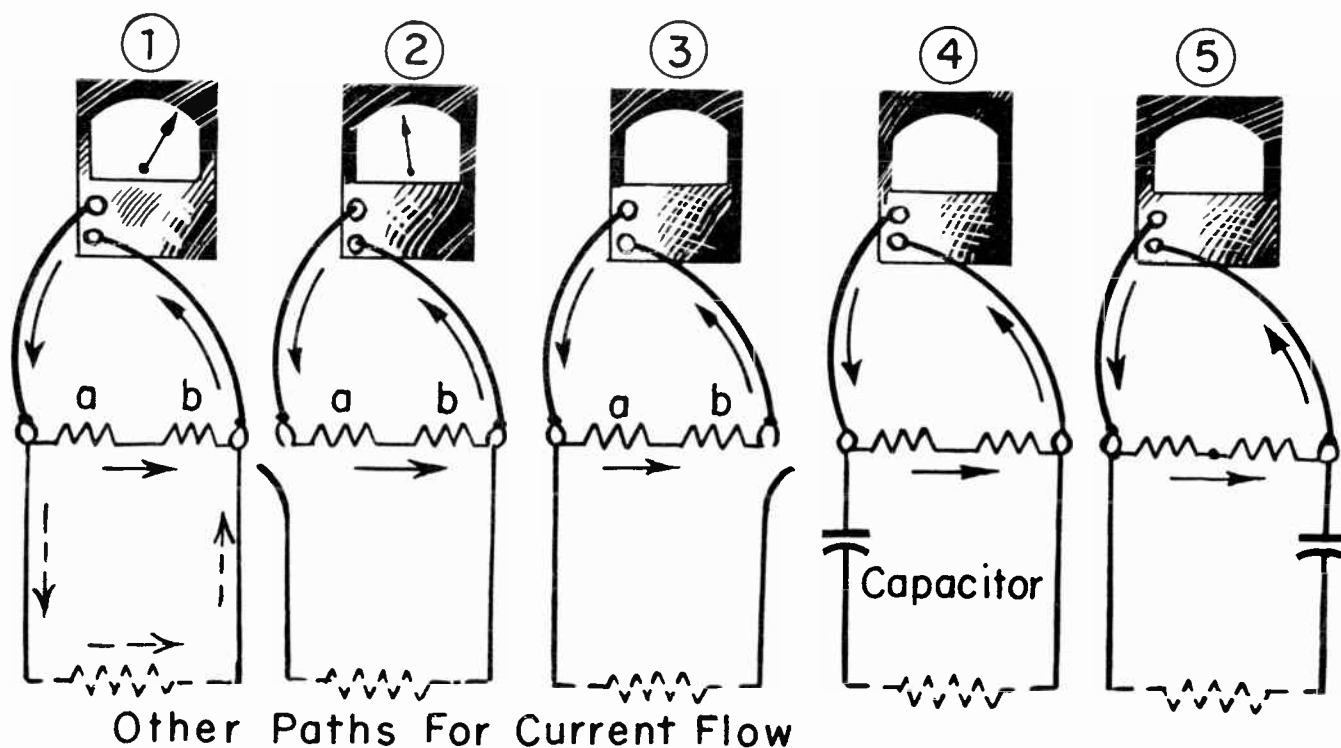

Fig. 16. Elements measured for resistance must be isolated from all other paths in which ohmmeter current might flow.

## COYNE - *television home training*

flows in elements a and b, it is increased by the extra current flowing in other paths. This greater current is the same as would flow in resistance less than at a and b. Consequently, the ohmmeter will indicate a resistance less than that of the elements which you are trying to measure.

Were the measured elements to be disconnected from other paths at a point beyond a (diagram 2) or at a point beyond b (diagram 3) or anywhere else that would isolate these two elements from other current paths, we then could make a true measurement. Then there could be no extra ohmmeter current due to flow in other paths, and the indication would depend only on resistance of a and b.

Fortunately, there is a very common circuit arrangement with which it is not necessary to open any connections when making resistance tests. This is the condition, shown by diagrams 4 and 5 of Fig. 16, wherein there is a capacitor of certain types at either end of the series circuit in which resistance is to be measured.

Certain types of capacitors will not permit current from the ohmmeter battery to flow through them. These capacitors act toward the ohmmeter current exactly as though the circuit were disconnected or open at the point where the capacitor is used. These types of capacitors which do not permit passage of battery current include all varieties except those called electrolytic capacitors.

An ohmmeter battery, and all other batteries, furnish only direct current or only direct (one-way) emf and voltage. An electrolytic capacitor will allow a greater or less flow of direct current through it, and thus will upset any measurements of resistance. No other type of capacitor will permit flow of direct current when the capacitor is in good condition. All capacitors, no matter what their type, will permit flow of alternating current. But since ohmmeters operate only with direct current, any capacitor other than an electrolytic is the equivalent of a disconnected or opened circuit so far as resistance tests are concerned.

Later we shall learn why capacitors be-

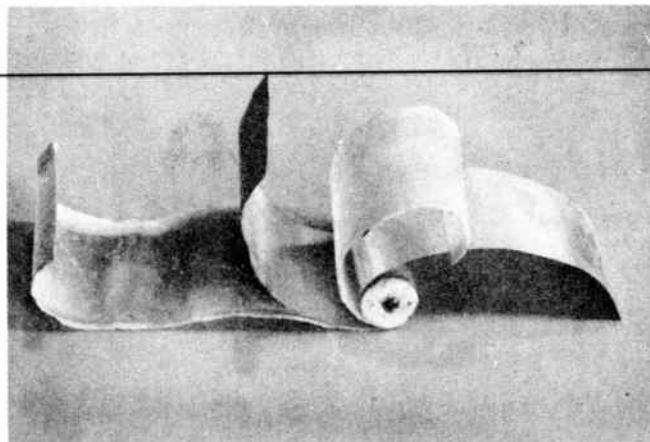

Fig. 17. This electrolytic capacitor consists of metal-foil "plates" separated by porous material saturated with liquid called the electrolyte.

have as they do, why they are necessary in many circuits, and how to recognize the various kinds. For the present we need know only how to detect the presence of an electrolytic capacitor in a circuit being tested for resistance. The inside of an electrolytic, when all opened up, is pictured by Fig. 17. Of course, we cannot open the capacitors to determine their type - there is a more practical way, as follows.

If your ohmmeter indicates any value of resistance at the instant in which you first complete the connection of the test clips, and the meter pointer then moves toward a greater resistance while the test connections remain in place, almost certainly there is an electrolytic capacitor somewhere in the measured circuit. When the ohmmeter acts this way you must open the measured circuit as in diagrams 2 or 3 of Fig. 16.

There is one other case in which we do not have to open a circuit being tested for resistance. This case is illustrated by Fig. 2 of this lesson. When a service diagram gives resistances which should be indicated with the ohmmeter connected between certain points and chassis ground, or between any other specified points, the measurement is to be made without any disconnections. Of course, if there are any special notes or instructions on the service diagram you must observe them, but in general the resistance measurements are made in the ordinary way.

# LESSON 7—TROUBLE SHOOTING WITH THE OHMMETER

## CONDENSED INFORMATION FOR READY REFERENCE

### Series circuit or connection.

All elements connected end to end.

Current is the same everywhere in the circuit, in all the elements.

Total resistance is equal to the sum of the separate resistances.

### Parallel circuit or connection.

All elements connected side by side. Terminal on one side of every element connected to terminal on one side of every other element, and terminals on opposite sides of all elements connected together.

### Series-parallel (or parallel series)

Any combination with which some elements are in series and others in parallel.

$$\text{Current in milliamperes} = \frac{1000 \times \text{volts}}{\text{ohms}}$$

$$\text{Resistance in ohms} = \frac{1000 \times \text{volts}}{\text{milliamperes}}$$

### Measure resistance with ohmmeter.

1. Select the function on multi-purpose instrument, set for resistance.
2. Select the lowest range which includes the probable resistance.
3. Adjust for zero ohms with test clips in contact with each other. Replace internal battery when meter pointer cannot be brought to zero ohms.
4. Connect or touch the test clips across resistance to be measured. It is not necessary to observe meter polarity when measuring resistance. Tested elements must be open at one end, by removing a connection or relying on a capacitor not of the electrolytic type. Remove all power and external voltage from the measured elements or

circuit, disconnect the tested apparatus from the power line.

### Errors when measuring resistance.

1. Failure to lightly tap the instrument before taking a reading.
2. Instrument used in position different from that for which calibrated.
3. Failure to look straight toward the meter dial, parallax error.
4. Differences between measurement of same resistance on different ranges.
5. Meter accidentally on a range other than the one assumed for multiplying.
6. Variation of voltage from internal battery.
7. Percentage accuracy of the instrument.
8. Variations of accuracy at different points on the dial.

### Voltage measurements.

Commence with highest voltage range when any possible doubt of approximate voltage to be measured.

Drop to the range whose high limit is nearest the voltage indicated by the first measurement.

Use the lowest range that includes the voltage actually measured.

Never leave the instrument set for a low range. Upon completion of every test, leave the range selection disconnected or set it for the highest range.

### Polarity test.

Connect voltmeter (on high range) across points whose relative polarity is to be checked.

Meter reads up scale from zero when positive test lead to circuit point which is relatively positive, and off scale to left of zero when positive lead to point which is relatively negative.



# TELEVISION

- RADIO
- ELECTRONICS

---

LESSON 8 – TROUBLE SHOOTING WITH THE VOLT-OHMMETER

---

***Coyne School***

*practical home training*

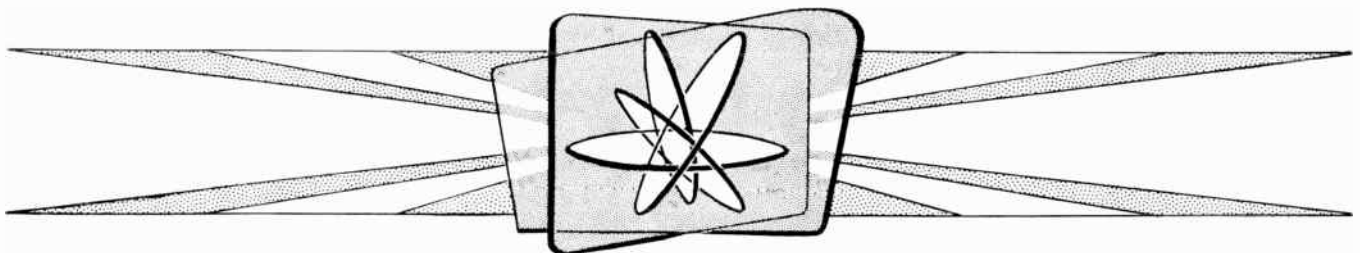

*Chicago, Illinois*

## CONDENSED INFORMATION FOR REFERENCE

---

### Voltage Measurements

$$\frac{\text{Potential difference}}{\text{in volts}} = \frac{\text{milliamperes} \times \text{ohms}}{1000}$$

Potential differences across elements in a series circuit are directly proportional to resistances in the same elements.

Voltage from end to end of a series circuit equals the sum of the voltages across the separate parts of the circuit.

Change of resistance anywhere in a series circuit changes the current everywhere, and the change of current alters all the voltages.

Voltage across any portion of a series circuit is equal to the difference between voltage across the remainder of the circuit and that across the entire circuit.

Standard a-c power line voltage for service measurements is 117 volts.

#### Errors in voltage measurements.

- Failure to lightly tap instrument before taking a reading.
- Instrument used in position different from that for which calibrated.
- Failure to look straight toward meter dial, parallax error.
- Differences between measurements on different ranges.

Meter accidentally on a range other than the one assumed.

Percentage accuracy of instrument.

Variations of accuracy at different points on the dial.

Variations of power line voltage between measurements.

### Short Circuits

A short circuit diverts some or all current away from parts in which the current should flow.

When using an ohmmeter for progressive checks, a short exists ahead of the first point at which there is no increase of resistance, or zero resistance.

#### Symptoms of short circuits and grounds.

Overheating and possible burnout of parts not shorted out of circuit.

Excessive current in the circuit containing the short.

Decreased voltage from the power supply, to all circuits.

Shorts and grounds usually located with ohmmeter while no power applied to tested circuit.

An accidental ground is a short circuit to ground from some circuit point whose potential is normally positive or negative with reference to ground.

## Lesson 8

### TROUBLE SHOOTING WITH THE VOLT-OHMMETER



Fig. 1. These service benches in the Coyne School are equipped with instruments and convenient connections for tracing circuits.

Now we shall use the voltmeter function of our volt-ohmmeter for measurement of potential differences (voltage) in the series circuit previously checked for resistances. The first measurement is pictured by Fig. 2. At the left is the volt-ohmmeter with its function switch in the VM position, for voltage tests. At the right is the circuit panel carrying four fixed resistors and a potentiometer in series with one another. Behind the volt-ohmmeter and circuit panel can be seen the tops of some of the parts on a power supply unit. The power rectifier tube is at the far right. At the left of the rectifier tube appears a power transformer, a filter inductor, and two cylindrical filter capacitors of the electrolytic type.

The negative d-c voltage terminal of the

power supply is connected at a solder lug to the left-hand metallic support of the circuit panel, which is the support representing chassis ground. The positive terminal of the power supply is connected through a panel lug to the top of the right-hand resistor. This is the resistor color-coded for 15K ohms, and measuring 14K ohms. You may refer to the preceding lesson for other information about marked and measured resistances of the several circuit elements. The slider of the potentiometer is in the position for maximum resistance between its center and outer terminal used for wiring connections, this resistance being 2,000 ohms.

The test of Fig. 2 illustrates measurement of voltage applied from the power supply to the ends of the series circuit. The test



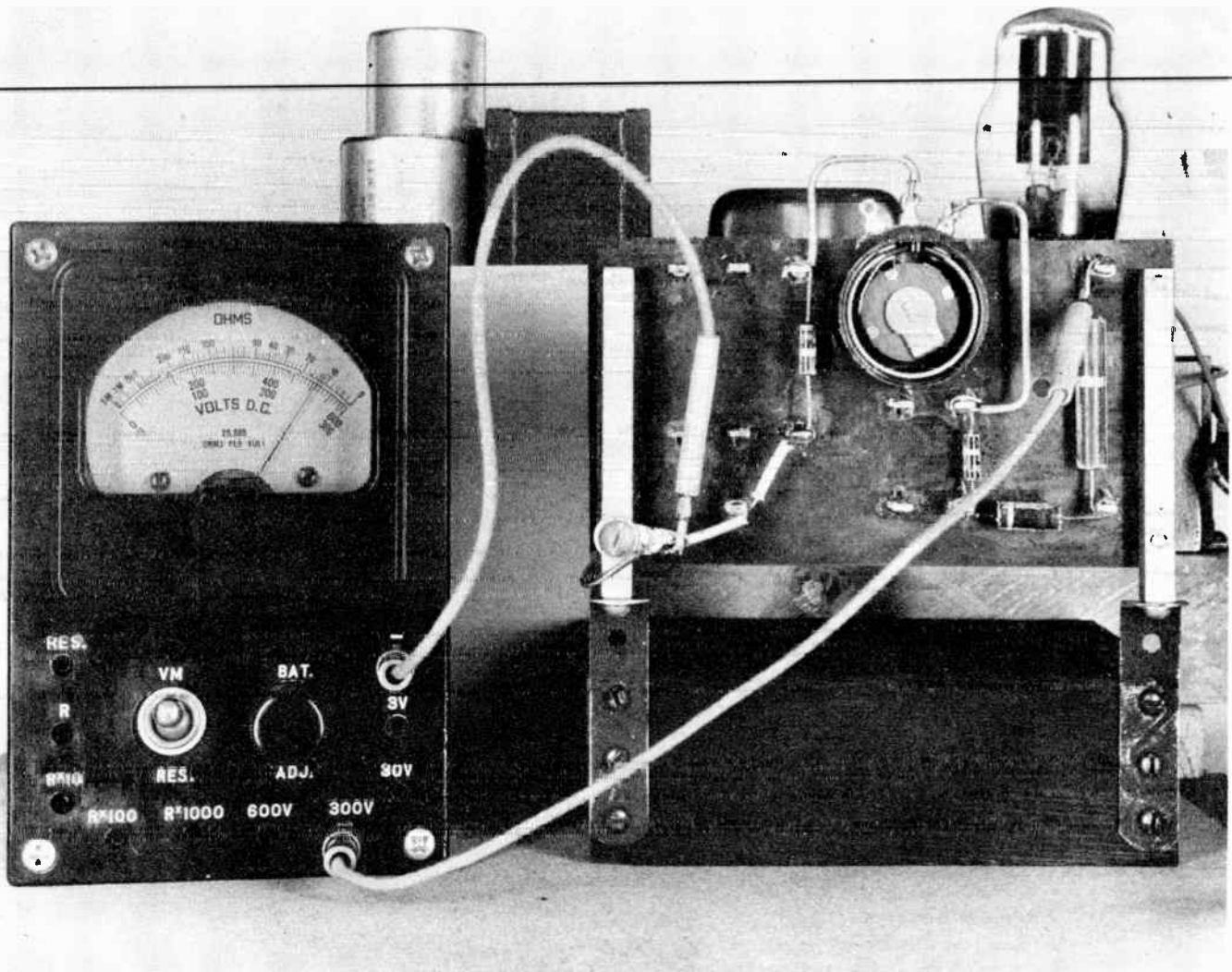

Fig. 2. Measuring the voltage applied by the power supply unit to the ends of the series circuit.

lead from the negative voltmeter terminal is connected to the ground post of the circuit panel. This is the negative end of our series circuit because it is the end connected to the negative side of the power supply. The other test lead is connected to the high side of the 15K resistor. This is the positive end of the series circuit because it is the end connected to the positive side of the power supply. This second test lead is in the 300-volt jack of the volt-ohmmeter, so we read voltage on the 300-volt scale of the meter. This reading is very close to 254 volts.

To begin with we shall compute the current flowing in the series circuit, using the method or formula for current as given in an earlier lesson. One of the values needed for current computation is the 254-volts mea-

sured in Fig. 2. The other value is the sum of the resistances or the total resistance of the series circuit, earlier found to be 32,900 ohms. Here is the computation.

$$\text{Current milliamperes} = \frac{1000 \times \text{volts}}{\text{ohms}} = \frac{1000 \times 254}{32\,900} = \frac{254\,000}{32\,900} = 7.7 \text{ ma, approx.}$$

Thus we learn that current everywhere in the series circuit is approximately 7.7 milliamperes. This is the current in each of the fixed resistors, also in the potentiometer.

**AVOIDING ARITHMETIC.** Just as in the example of determining current from values of volts and ohms, we have continual need for formulas, rules, or some other method for finding the values of milliamperes, volts, or ohms when any two of these values are known to begin with. Although the formulas involve

# LESSON 8 – TROUBLE SHOOTING WITH THE VOLT-OHMMETER

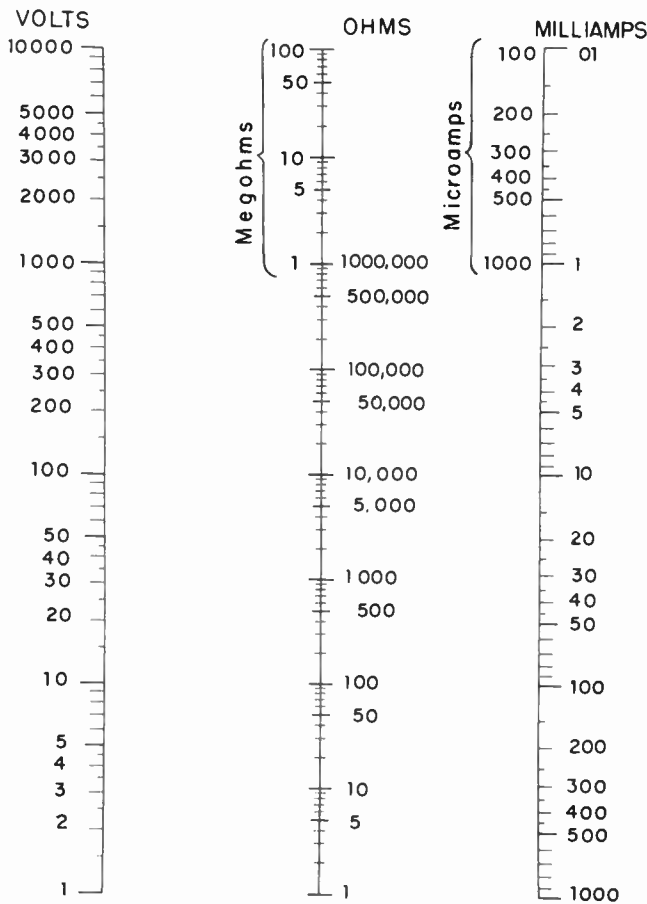

Chart A. Relations between volts, ohms, and milliamperes.

only multiplication and division, it is convenient and often desirable to get along with no figuring at all. This may be done with Chart A, simply by laying any straightedge across the two known values on two of the scales and reading the third unknown value on the third scale.

Chart B shows how to use this method. It is assumed that we have 500 volts across a resistance of 20,000 ohms, and wish to determine the current. The straightedge may be a ruler, a folded piece of paper, or anything else having one straight side. Lay the straight side on the left-hand Volts scale at 500 volts, and at the same time on the center Ohms scale at 20,000 ohms, as shown by the full line drawn on the chart. Then read the current at the point where the straightedge crosses the righthand Ma scale. You will read 25 milliamperes.

The two known values may be on any two of the three scales, and the unknown value

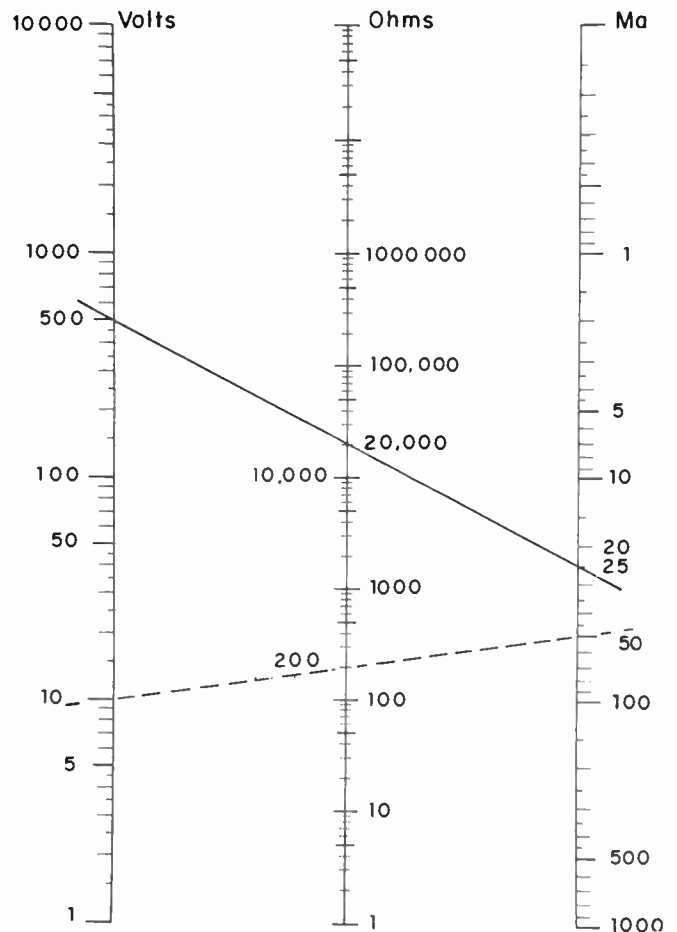

Chart B. How the alignment chart is used for determining an unknown value when the other two values are known.

will be found on the remaining scale. Consider the example illustrated by the broken line on Chart B. We wish to know what resistance will provide 10 volts when current is 50 milliamperes. Laying the straightedge at 10 volts on the left-hand scale, and at 50 milliamperes on the right-hand scale, we read on the center scale that 200 ohms is the required resistance.

This and other charts of the same general style do not allow determining values with such precision as do the formulas. Values determined from the charts are, however, amply accurate for all ordinary service work. This is true because stock resistors, capacitors, and other units seldom are accurate to better than 10 per cent, or at the most to within 5 per cent of their marked or nominal values. It is very easy to read a chart to better than 10 per cent, and not at all difficult to attain 5 per cent accuracy.

## COYNE - television home training

The scales on our charts are "logarithmic" rather than uniform or linear. The spread between 1 and 10 volts is the same as between 10 and 100 volts, and between 100 and 1000 volts. The other scales are similar. This allows reading with the same percentage of accuracy at all values. Each scale provides for a wide range of values, the ratios being 10,000 to one for volts and milliamperes, and one hundred million to one for ohms.

In using these charts you must take care to note how values change at each graduation on the scales, becoming closer and closer as you go toward higher numbers. You must practice also in estimating values which are between two markings. All this takes but a little practice. You can have much such practice in this and following lessons, where we shall use the regular formulas and work out the answers so that you may check them against your own answers as determined from the chart.

### WORKING WITH THE SERIES CIRCUIT.

Now we may go back to the series circuit, for which the relative positions of parts are shown by Fig. 3. The coded or marked re-

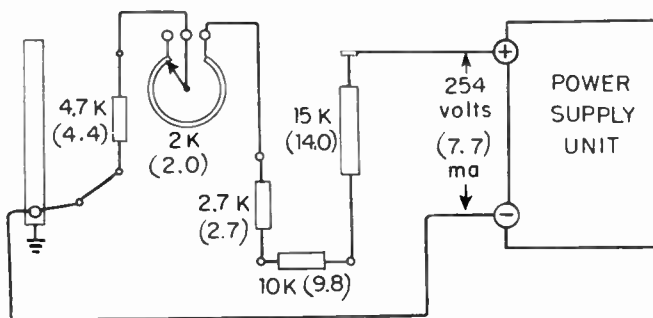

Fig. 3. Coded or marked resistances, and measured resistances, of elements in the series circuit.

sistance of each element is followed by the letter K, for thousands of ohms. The measured resistances are shown in parentheses. At the right is the power supply unit with its terminals marked as to polarity. At the terminals of the power supply, and at the ends of the series circuit there is 254 volts, and everywhere there is current of about 7.7 milliamperes.

Just as we noted a number of possible errors of observation, and also errors in the test instrument when measuring resistances, so we must consider the possible errors when measuring voltages. The first seven of the possible voltage errors are the same or very similar to resistance errors. These will not be explained in detail, because they were covered in the lesson on resistance measurements. The eighth possible error is peculiar to measurements of voltage. Here is the list.

1. Failure to lightly tap the instrument before taking a reading.
2. Instrument used in a position different from that for which calibrated.
3. Failure to look straight toward the meter dial, parallax error.
4. Differences between measurement of same voltage on different ranges.
5. Meter accidentally on a range other than the one assumed for multiplying.
6. Percentage accuracy of the instrument.
7. Variations of accuracy at different points on the meter dial.
8. Power line voltage may vary from time to time.

With reference to the eighth possible cause of error in measuring voltages, the voltage of the a-c power line in the building seldom remains constant. It is this power line voltage that operates the receiver or other apparatus in which you are measuring voltages. In all receivers except the very few which contain means for compensating any line voltage variations, every change of line voltage will cause a percentage change of receiver d-c voltages which is as great, and usually somewhat greater, than the percentage change of line voltage.

Test voltages shown by service diagrams and tables issued by the manufacturers are based on operating the receiver from 117 a-c line volts. If line voltage is higher than this



## LESSON 8 – TROUBLE SHOOTING WITH THE VOLT-OHMMETER

standard value, the voltages measured in the receiver will be proportionately higher. If line voltage is lower than 117 a-c volts the measured voltages will be proportionately lower than normal values.

In many localities the line voltage drops considerably during periods of heavy loads. These periods include times before and just after sunrise in the winter, they include times during which people prepare and eat their meals, and they include the few hours which follow the coming of darkness the year around. In between the periods of heavy loads the line voltage is likely to rise. Line variations usually are greater in suburban and country districts than in the more heavily populated districts of large cities. Variations of five per cent plus or minus are not unusual, and much greater changes occur in some places.

Before proceeding further with voltage measurements on the equipment operated from the line-power supply we shall temporarily use some apparatus in which the effects of common errors have been reduced to a minimum. In this apparatus, shown by Fig. 4, the voltage source is a set of large

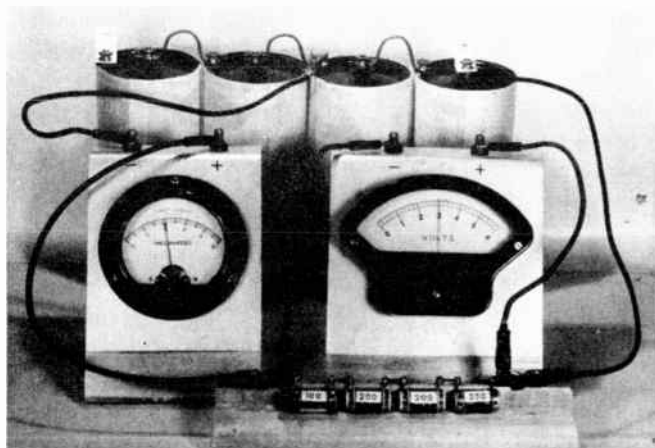

Fig. 4. There are very definite relations between voltage, current, and resistance in the series circuit.

dry cells. Dry cells may be depended upon for constant voltage provided they are not too old and provided their current capacity is not exceeded. Normal capacity of the cells being used is 250 milliamperes, and from them we shall take less than 10 milliamperes.

There are four resistors of the precision type, accurate to better than one per cent of their marked values. The values, from left to right, are 100 ohms, 200 ohms, and another 200 ohms, and 250 ohms, which makes a total series resistance of 750 ohms. The milliammeter in the round case and the voltmeter in the fan-shaped case have been carefully calibrated for accuracy.

Although there are four dry cells in the picture, the resistors and milliammeter are connected in series across only the two cells at the right. Each dry cell provides almost exactly  $1\frac{1}{2}$  volts, and the two being used provide 3 volts.

The voltmeter is connected across the four series resistors. In series between the resistors and one of the dry cells is the milliammeter. Resistance of this meter is only about  $3\frac{1}{2}$  ohms, which is less than one-half of one per cent of the 750 ohms in the resistors. Consequently, so far as our measurements are concerned, the voltmeter may be considered as connected across the two dry cells. This meter is indicating the terminal voltage of the two cells as well as the potential difference across the series resistors.

In Fig. 4 we have a known resistance of 750 ohms, an accurately measured potential difference of 3 volts, and a current of 4 milliamperes indicated by the milliammeter. Let's put these values of volts and ohms into our formula for current, thus.

$$\text{Milliamperes} = \frac{1000 \times \text{volts}}{\text{ohms}} = \frac{1000 \times 3}{750} = \frac{3000}{750} = 4 \text{ ma}$$

Next, let's put the known values of volts and milliamperes into our formula for resistance, like this.

$$\text{Ohms} = \frac{1000 \times \text{volts}}{\text{ma}} = \frac{1000 \times 3}{4} = \frac{3000}{4} = 750 \text{ ohms}$$

With these simple formulas it is easy to compute current in milliamperes when we know the potential difference in volts and the resistance in ohms. It is just as easy to compute the resistance in ohms when knowing volts and milliamperes. All that we lack is simple formula for computing potential difference in volts when we know the current in

## COYNE - *television home training*

milliamperes and the resistance in ohms. Here it is

$$\text{Volts} = \frac{\text{milliamperes} \times \text{ohms}}{1000}$$

Let's check this formula by using the values of current and resistance from Fig. 4.

$$\text{Volts} = \frac{4 \text{ (ma)} \times 750 \text{ (ohms)}}{1000} = \frac{3000}{1000} = 3 \text{ volts.}$$

The formulas for milliamperes, ohms, and volts always work, they always are correct. If discrepancies appear in your measurements, you have made a mistake in the simple arithmetic, or have failed to allow for errors as previously listed, or there are faults in the parts being tested - which is what we are looking for.

Now we come to another of the rules or laws which are exceedingly helpful when checking circuits and looking for trouble. It is this.

The voltages across the elements in a series circuit are directly proportional to the resistances of the same elements.

To check this statement we may go to Fig. 5. Everything is the same as in Fig. 4 except that here the voltmeter is connected across only the 250-ohm resistor instead of across the entire 750 ohms. Current still is

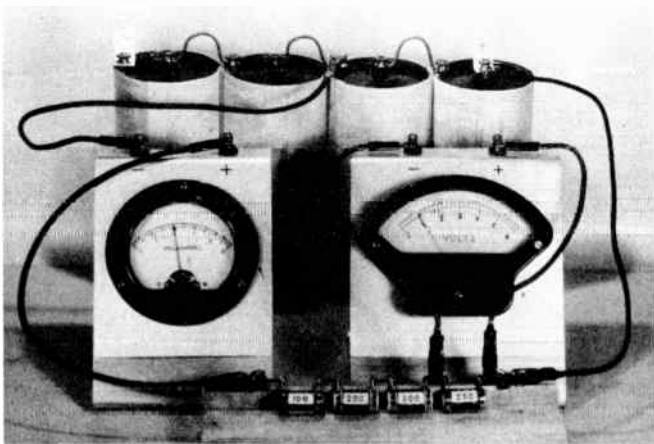

Fig. 5. Potential differences in a series circuit are directly proportional to resistances.

4 milliamperes, because the dry cells have remained connected to the ends of the entire series circuit. The voltmeter now indicates only 1 volt. This is 1/3 of the voltage measured across the total resistance, because 250 ohms is 1/3 of 750 ohms.

For an additional check we may connect the voltmeter across 500 ohms out of the total 750 ohms in the series string of resistors. This has been done in Fig. 6. The

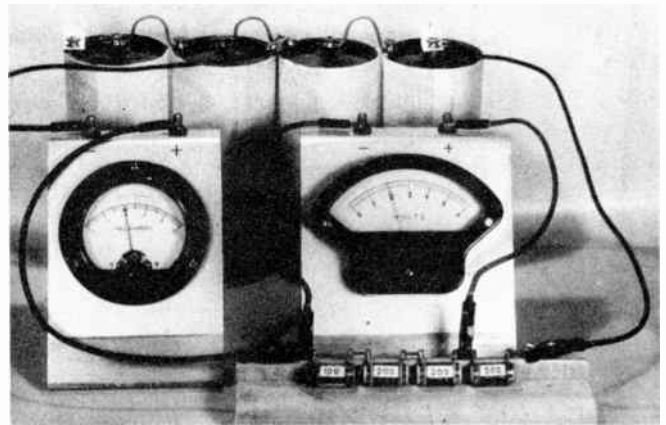

Fig. 6. The sum of the separate voltages in a series circuit equals the voltage across the entire circuit.

voltmeter is connected across three resistors whose values are 100, 200, and 200 ohms, making a sum of 500 ohms. This is 2/3 of the total 750 ohms in the series string. The 2 volts is 2/3 of the overall potential difference of 3 volts.

Supposing that we leave the voltmeter connected across 1/3 of the total resistance (as in Fig. 5) and increase the overall voltage on the entire series circuit to 6 volts. This has been done in Fig. 7. The overall voltage here is 6 volts because the series resistors and milliammeter are connected across all four dry cells. With 1½ volts per cell, four cells in series with one another furnish 6 volts. The voltmeter indicates 2 volts across 1/3 of the total resistance, and 2 volts is 1/3 of the overall 6 volts.

Figs. 4, 5, and 6 illustrate another of those rules or laws which are going to prove so useful in trouble shooting. You can figure this one out for yourself. Look at Fig. 6. Here we have the voltage across one part or

## LESSON 8 – TROUBLE SHOOTING WITH THE VOLT-OHMMETER

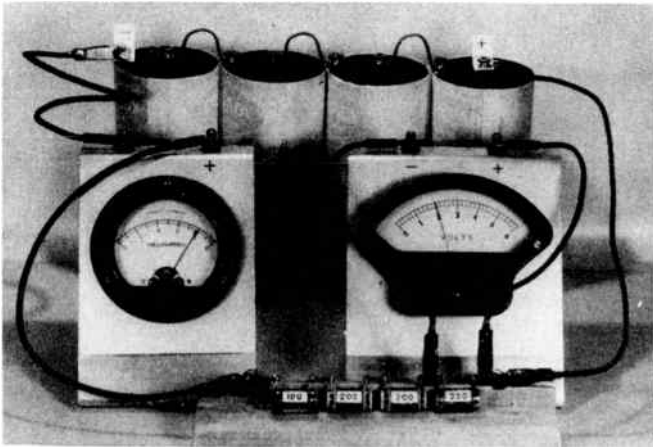

Fig. 7. Doubling the current in any given resistance doubles the potential difference across that resistance.

one section of the series circuit. Next, look at Fig. 5. Here we have the voltage across all the remaining parts of the same circuit. Finally, look at Fig. 4. Here we have the voltage across the entire series circuit. What is the relation of the voltages across the two sections of this circuit to the voltage across the whole circuit?

The overall voltage from end to end of a series circuit is equal to the sum of the voltage across the separate parts of the same circuit.

It is only natural that there should be a direct relation or a direct "proportionality" between resistances and voltages in a series circuit. The greater the opposition to flow of current, or the greater the resistance, the harder the free electrons must work to get through. The harder the electrons work, the more of their energy or working ability will be used up. Electron energy is measured in volts of potential. When electrons start from the negative terminal of the source they have maximum energy and maximum potential. They lose energy, and the potential drops, as the electrons travel toward the positive side of the source. How much energy is used up, and how much the potential changes in any given portion of a circuit? Both of these are directly proportional to resistance in that same portion of the circuit.

When you remember that resistances and voltages are directly proportional to each other in a series circuit it becomes almost

as easy to measure resistance with a voltmeter as with an ohmmeter, provided you know any one resistance and don't mind a little arithmetic. An example follows.

In Fig. 8 we are measuring the voltage across the resistor which is color coded for 10,000 ohms, and whose resistance was measured earlier as 9,800 ohms. The volt-ohmmeter, used as a voltmeter, is indicating about 73 volts. Note, incidentally, that the negative jack of the meter is connected through one of the test leads to the end of the resistor which is toward the negative side of the power supply or toward the negative end of the series string of resistors. The 300-volt jack of the meter, which is a positive jack, is connected through the other test lead to the end of the resistor which is toward the positive end of the series circuit, or toward the positive side of the power supply.

Supposing now that we wish to determine the resistance of the element which is coded for 4.7K ohms. Of course, we could assume that the resistance of this element is approximately 4,700 ohms, but for this illustrative example we shall assume that the resistance is wholly unknown. Our next step is to measure the voltages across this "unknown" resistance with the connections of Fig. 9. We are continuing to use the 300-volt jack; it always is a good idea to keep the same range when making comparative measurements. The reading is about  $32\frac{1}{2}$  volts. Now for the arithmetic.

1. Divide the greater voltage by the lesser voltage. We divide 73 volts (across the 10K element) by  $32\frac{1}{2}$  volts (across the 4.7K element) to find that voltage on the 10K element is about 2.25 or  $2-1/4$  times the voltage on the 4.7K element.

2. Earlier we determined that the resistance of the 10K element is 9,800 ohms. This must be 2.25 or  $2-1/4$  times the resistance of the 4.7K element, so we divide 9,800 ohms by 2.25 to find that the apparent resistance of the 4.7K element is 4,350 ohms.

When measuring resistances in the preceding lesson it was found that the real re-



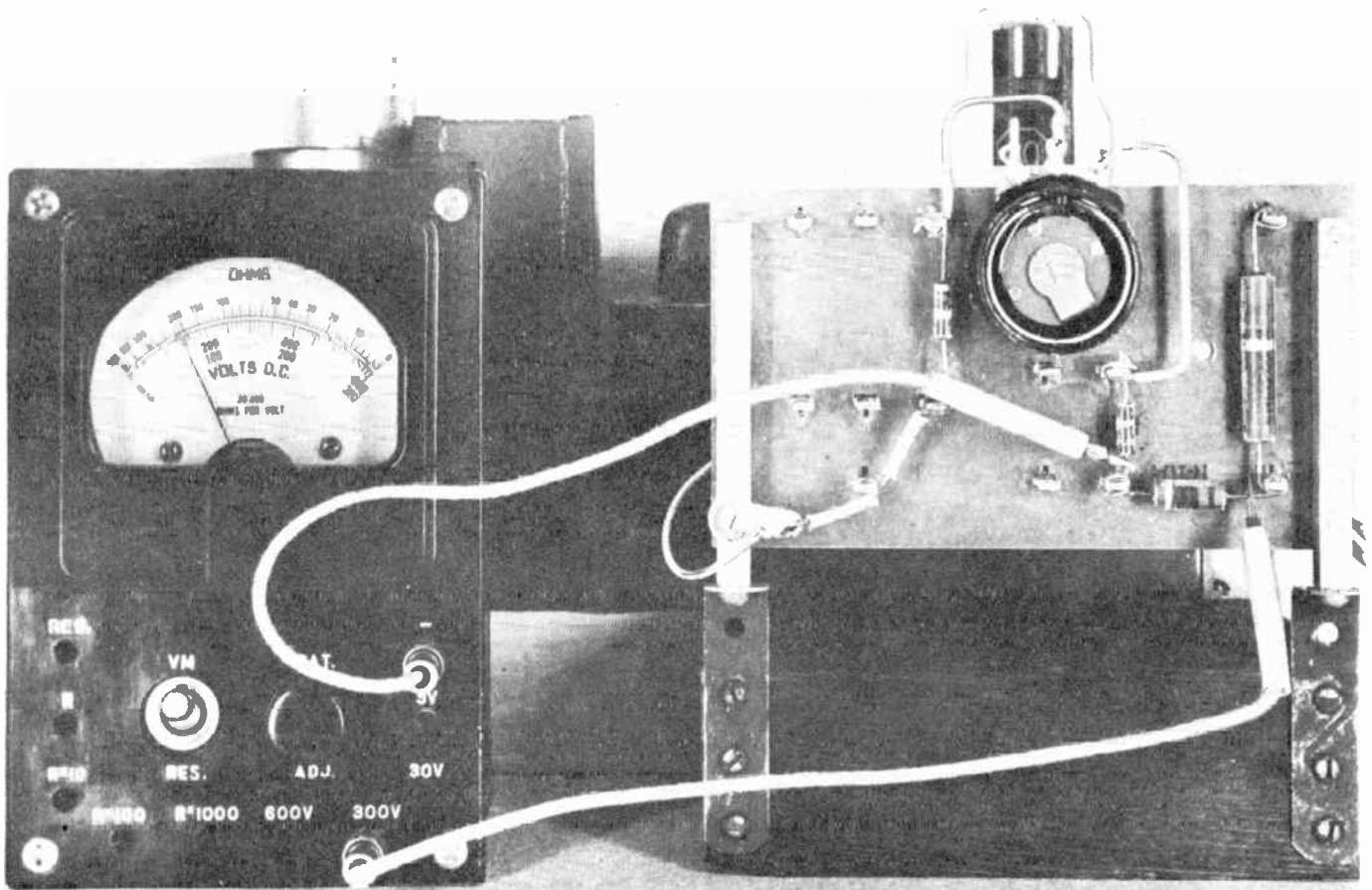

Fig. 8. Measuring the potential differences across one element of a circuit, in preparation for computing the resistance of another element.

sistance of the 4.7K element is 4,400 ohms. Then the value of 4,350 ohms as computed from voltage measurements will be close enough for all practical purposes. You realize, of course, that the resistances must be proportional to the voltages because the same current is flowing in both resistors. This would be true in all series circuits, but might not and probably would not be true in other circuits.

When looking for trouble a common procedure is to commence measuring voltages at either end of a series circuit, leave one terminal of the voltmeter connected to the starting point, and shift the other test lead to take in one additional element at each step.

The measured voltage should increase at each step in proportion to the resistance of the element then added to the group being measured. When you come to a point of serious trouble the voltage at this step may go disproportionately high, or it may drop to zero or nearly so, or may become of any value which is very apparently the wrong value.

We might commence such a process by measuring the voltage across the element nearest the negative end of the series string, as in Fig. 9. Then we would leave the negative lead of the meter on the negative end of the circuit, at the metallic support, and shift the positive lead to the right-hand outer

## LESSON 8 – TROUBLE SHOOTING WITH THE VOLT-OHMMETER

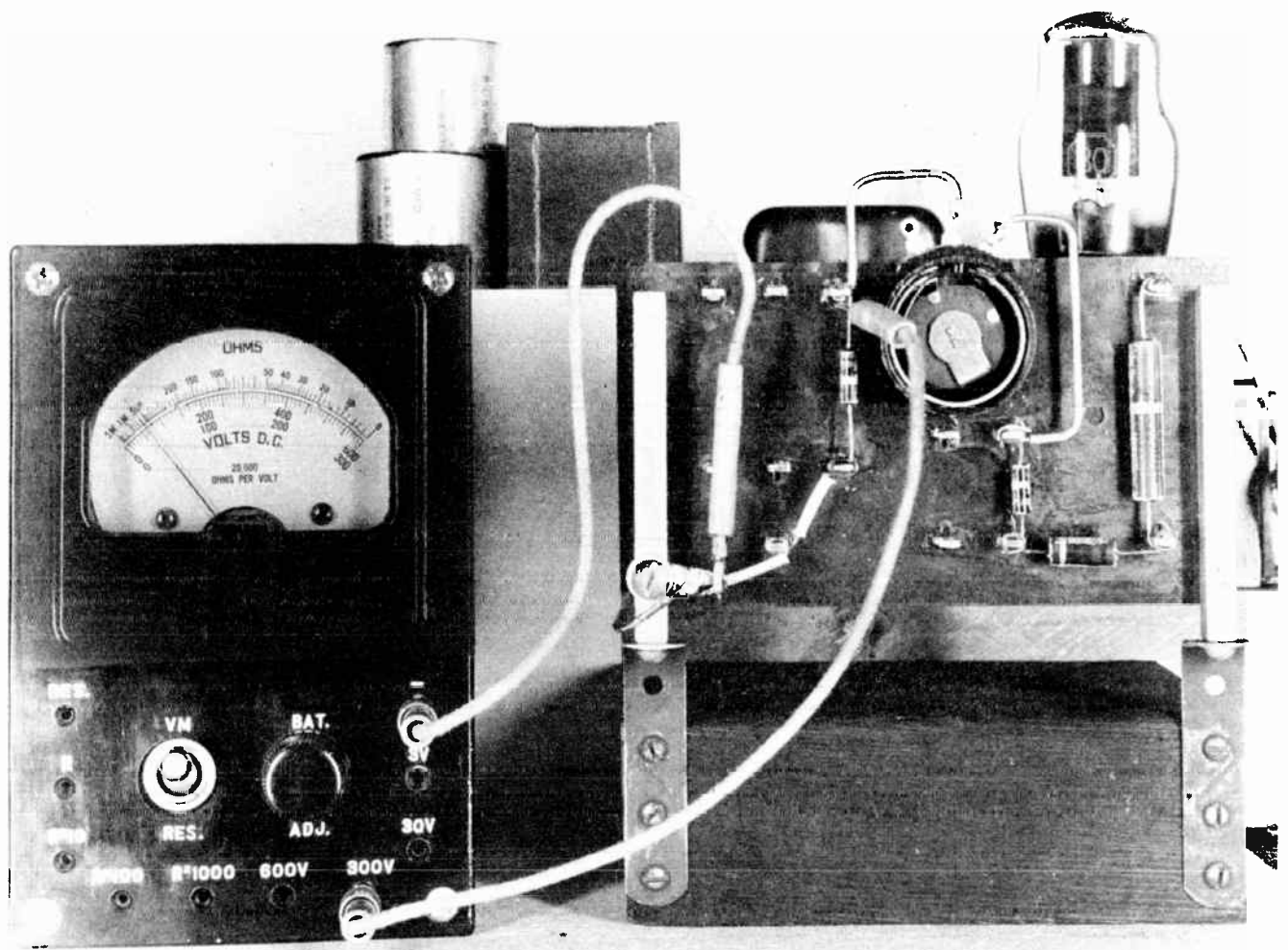

Fig. 9. Measuring potential difference across the circuit element whose resistance is to be computed.

terminal of the potentiometer. Measurement then would be of the voltage across both the 4.7K resistor and the potentiometer. The next connection of the positive test lead would be to the lug between the 2.7K and 10K elements, thus adding the 2.7K element to the portion of the circuit being measured.

The next step, pictured by Fig. 10, would be to shift the positive test lead to the far side of the 10K element. Now the meter is indicating the potential difference across the first 4.7K element, the potentiometer, the 2.7K element, and the 10K element. The measured potential difference is about 151 volts. The final step would be to move the positive test lead to the top of the 15K ele-

ment, which is at the positive end of the series circuit. This final step would be exactly the same as pictured back in Fig. 2 of this lesson. There we measured the potential difference across the entire series circuit as about 254 volts.

Now, if the total potential difference across the whole circuit is 254 volts, and the potential difference across everything except the 15K unit is 151 volts, what should be the measured potential difference across the 15K unit? Obviously, it should be the difference between 254 volts and 151 volts, because the overall voltage on a series circuit must be the sum of the separate voltages across all its parts.



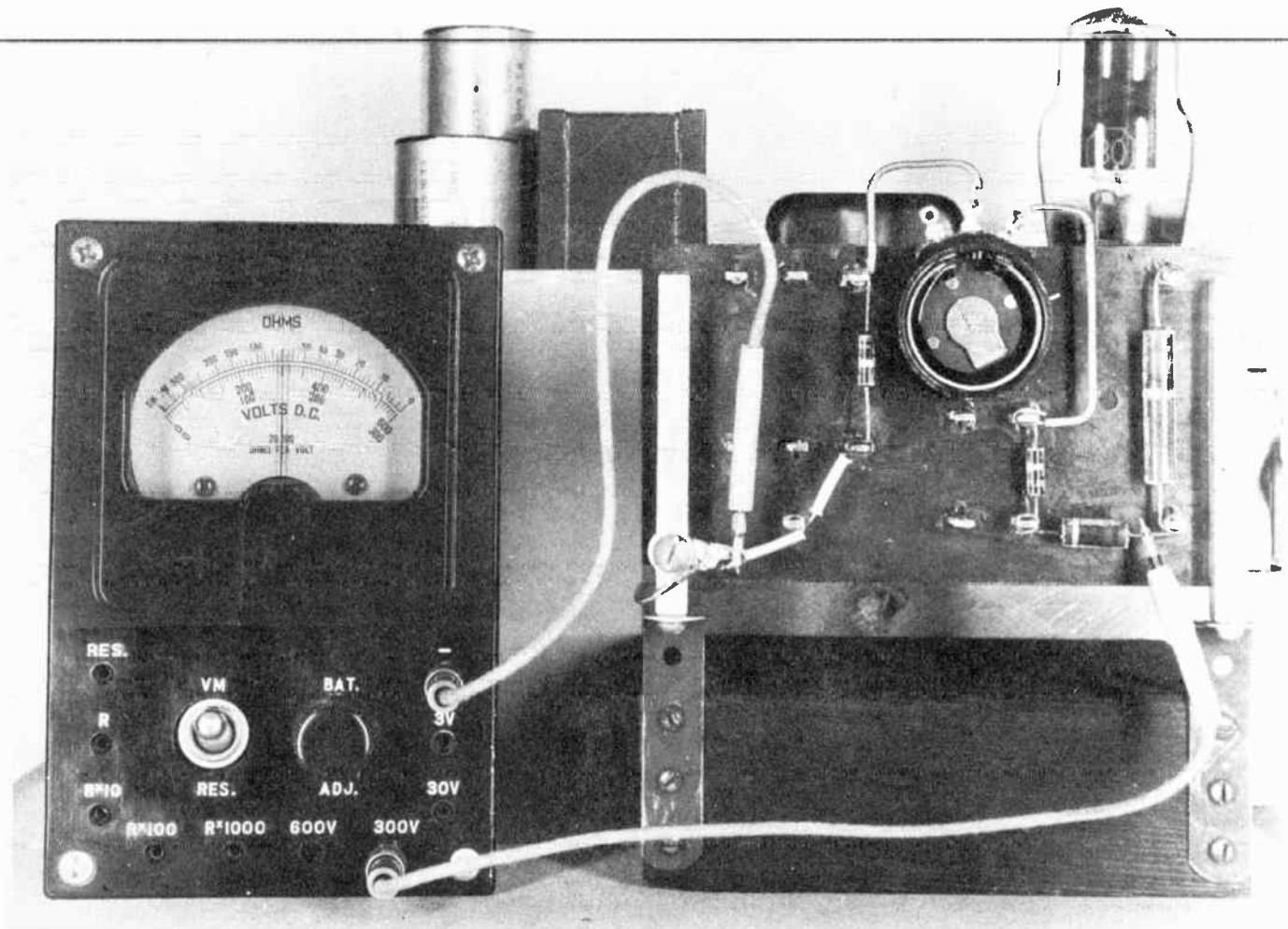

Fig. 10. Measuring the potential difference across all but one element of the series circuit.

How well this works out in practice is illustrated by Fig. 11. Here we are measuring the potential difference across the 15K resistor which is at the positive end of the series string. The reading is about 103 volts, which is precisely the difference between 254 volts on the whole circuit and 151 volts on everything except the 15K unit. That the three voltages check with such exactness is due largely to good luck when making the measurements. It just happened that no errors caused any great effect, or it may have been that certain errors in one direction were balanced by other errors in the opposite direction. Had we come within five per cent or even ten per cent, no serious fault would have been indicated.

By looking back at the many measurements of resistance and voltage which have

been made with various kinds of equipment you will find that definite relations between these two values exist only in the same element or in the same section of a series circuit. That is to say, the voltage and resistance in any one part are directly proportional, but there is not this relation between the voltage across one part and the resistance of some other part, even though both are carrying the same current.

There are, however, many cases in which a change of resistance in one portion of a series circuit will alter the voltages across other parts, but this is only because the change of resistance alters the current in the entire circuit. When there is a change of current there will be proportional changes of voltages everywhere in a series circuit. This



## LESSON 8 — TROUBLE SHOOTING WITH THE VOLT-OHMMETER

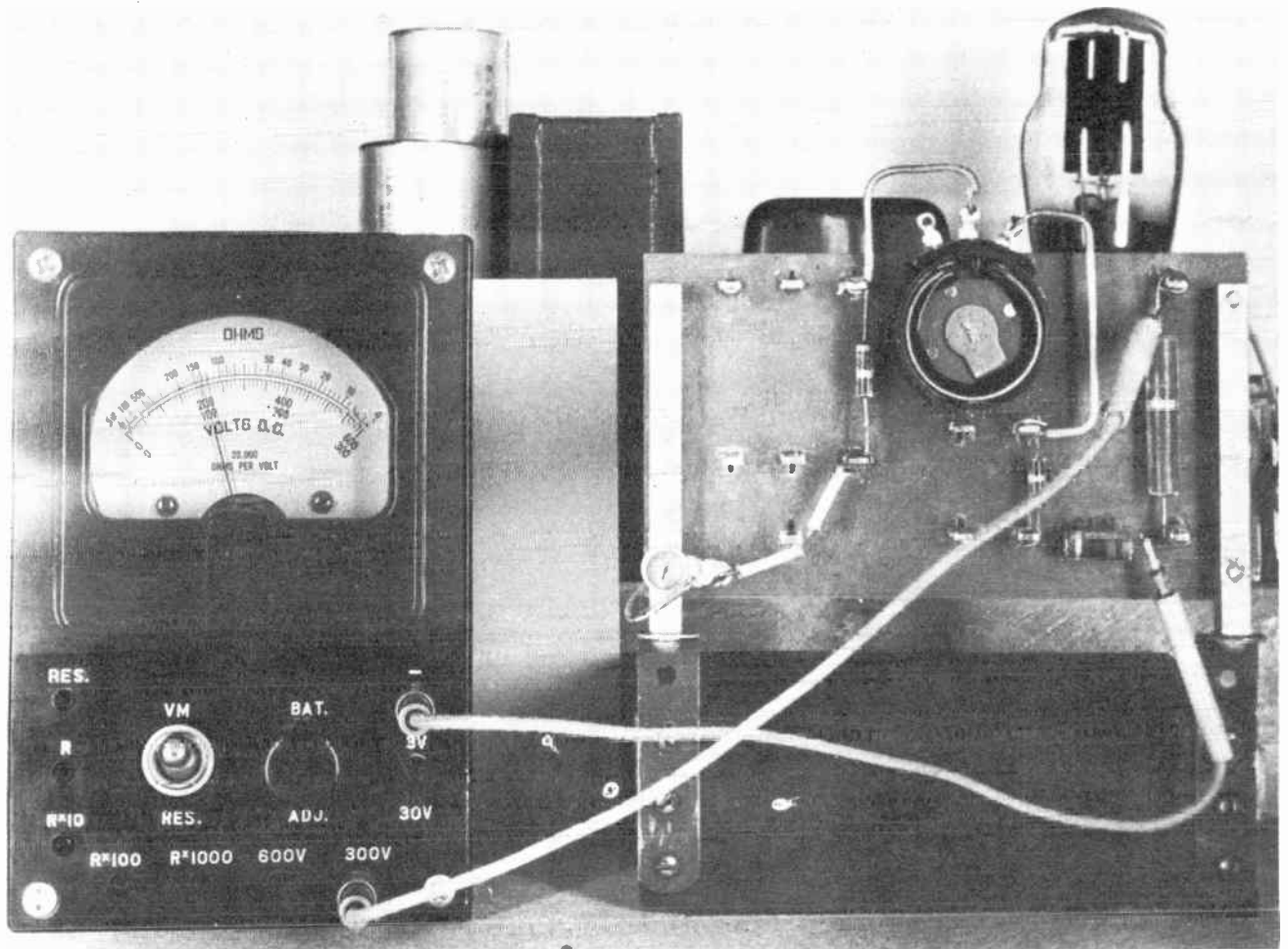

Fig. 11. Voltage across this remaining element is the difference between voltage across the entire circuit and that of the parts checked in Fig. 10.

is true because voltage is directly proportional to current as well as to resistance.

For an illustration of the direct relation between voltage and current look back at Figs. 5 and 7 of this lesson. In both tests we have the same resistance, 250 ohms. In Fig. 5 the current is 4 ma and the potential difference across the resistance is 1 volt. In Fig. 7 the current is 8 ma and the potential difference across the same resistance is 2 volts. Doubling the current doubles the voltage across the same resistance, or halving the current halves the potential difference.

Now compare Fig. 6 with Fig. 12. In both tests the voltmeter is connected across 500 ohms. In Fig. 6 there is current of 4 milliamperes and voltage of 2 volts. In Fig. 12 the current is 8 milliamperes, double the earlier value, and potential difference also

has doubled to become 4 volts. You may check this direct relation between current

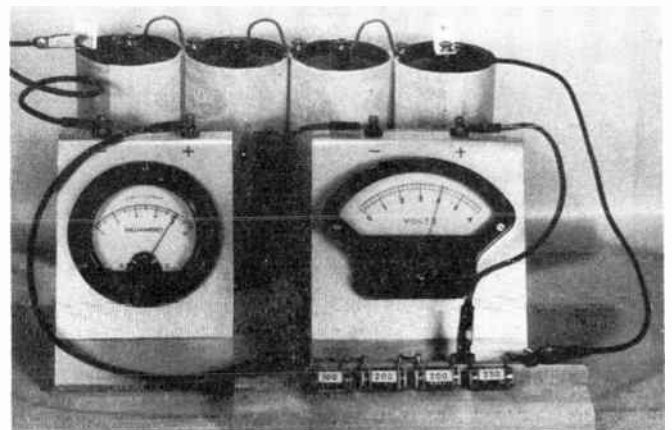

Fig. 12. Potential difference across any portion of a series circuit is directly proportional to current in the same portion

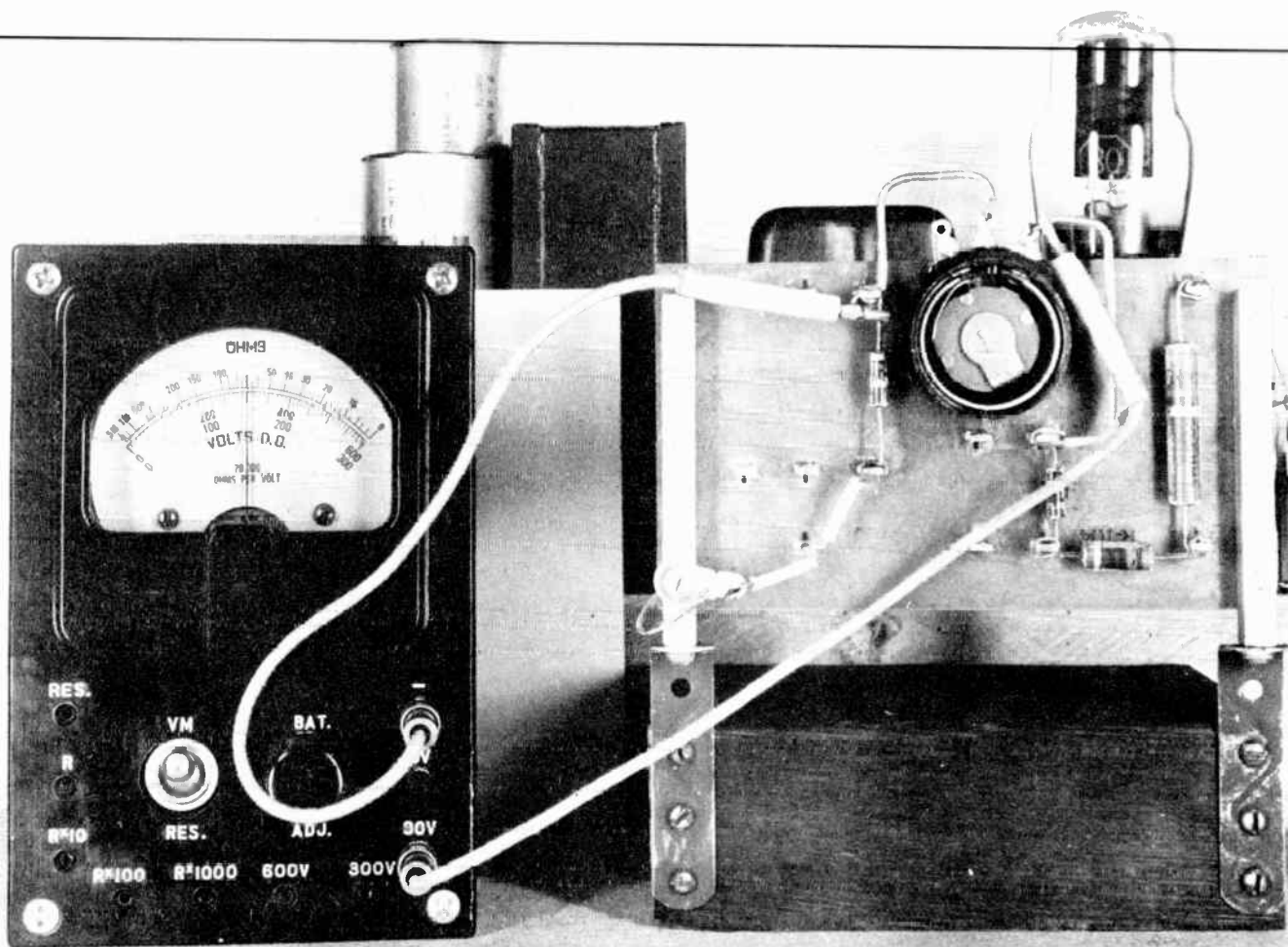

Fig. 13. We measure 15 volts across the potentiometer when its slider is in position for maximum resistance and all other parts of the circuit are operating normally.

and voltage in any given resistance by working out any number of examples with our formula for voltage, using the same resistance in all the examples.

To observe how a change of resistance anywhere in a series circuit alters the voltage everywhere else we may commence with the test illustrated by Fig. 13, where there is measurement of potential difference across the potentiometer. Note that we are using the 30-volt range of the volt-ohmmeter, also that the negative test lead is on the side of the potentiometer toward the negative of the power supply, while the positive lead is on the side toward the positive of the source. The reading is almost exactly 15 volts. From

earlier measurements we know that the resistance of the potentiometer, with the slider in position for maximum resistance, is almost exactly 2,000 ohms. Then how much current is flowing in the potentiometer. The regular formula for current will give a value of 7.5 ma. This, of course, is also the current in all other parts of the series circuit.

Look next at Fig. 14, and before reading further try to locate the trouble which has caused the potential difference across the potentiometer to jump from 15 volts to 20 volts. Doubtless you discovered that the ends of the 10K resistor have been connected together through a piece of wire fitted with two spring clips. The resistance of this wire



## LESSON 8 – TROUBLE SHOOTING WITH THE VOLT-OHMMETER

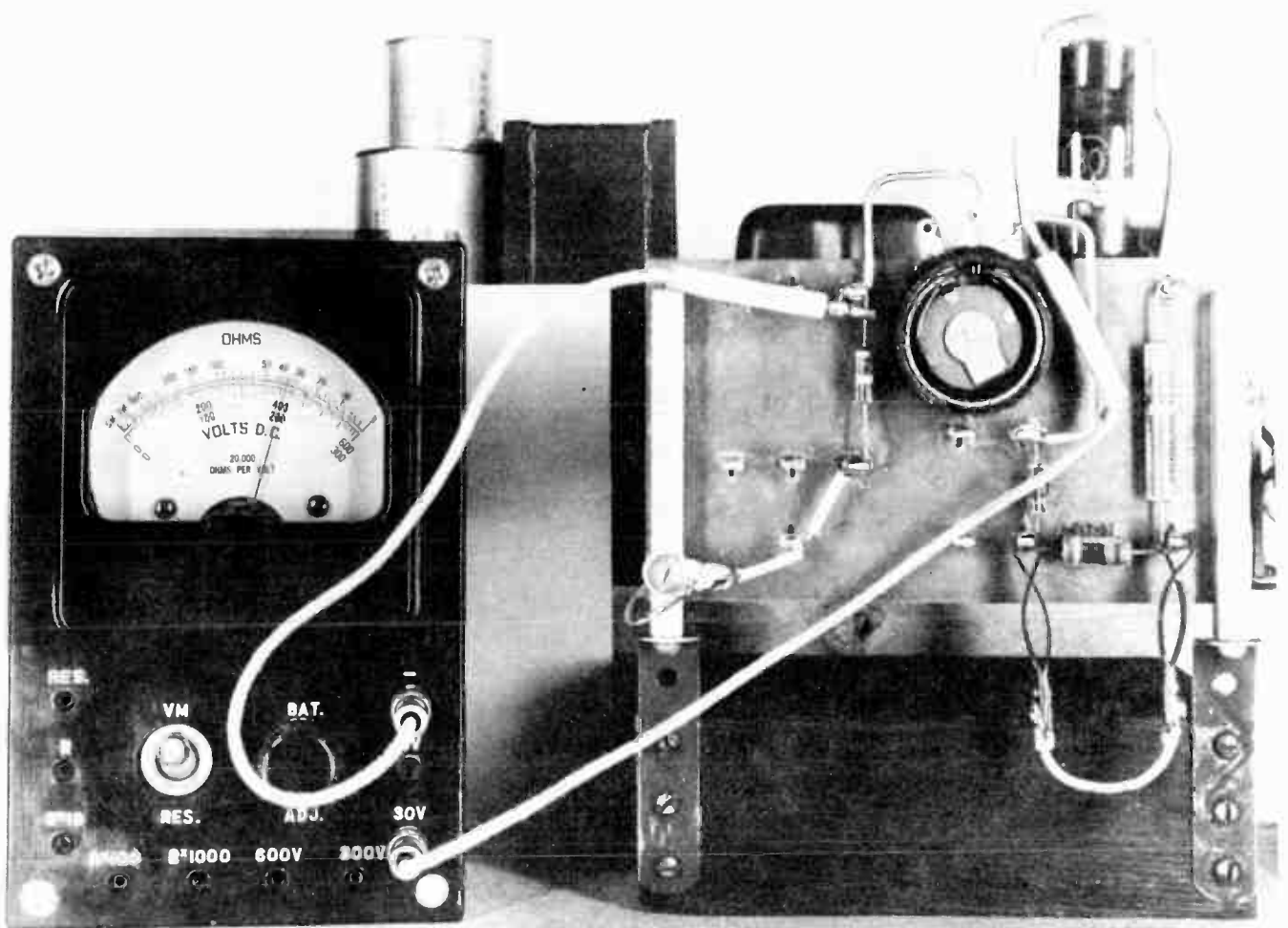

*Fig. 14. A fault in another part of the circuit has changed the voltage across the potentiometer.*

jumper is wholly negligible. It forms a "short circuit" across the 10K resistor, and all current which formerly flowed in the resistor now takes the electrically shorter and easier path through the jumper. It is as though the resistor had been removed from the series circuit and replaced with a short piece of wire.

If you again use our formula for current, and place in that formula the value of resistance in the potentiometer and the new value of voltage across the potentiometer (20 volts) you will find that the current has increased to 10 ma. This greater current flows not only in the potentiometer but also everywhere else in the series circuit. A fault at the 10K re-

sistor has changed both the current and the potential difference at the potentiometer. It has changed also the current and the voltages at every other element in the circuit.

The increase of circuit current is due to the lessened resistance of the circuit. With the 10K resistor "shorted out" by the wire jumper, the circuit resistance has been reduced by 9,800 ohms, which is the measured resistance of the 10K element. The voltage applied from the power supply unit to the series circuit causes greater current in the lessened circuit resistance.

Possibly you will be curious enough to use our formula for voltage and figure out the



## COYNE - *television home training*

voltage from the power supply with the full resistance of the circuit and 7.5 ma (Fig. 13) ~~and with the decreased resistance and 10 ma~~ (Fig. 14). You will discover that the potential difference from the power supply must have dropped by about 16 volts because of the short circuit in Fig. 14. This really did happen; the "terminal voltage" of the power supply dropped when the supply was called upon to deliver the extra current. The lost voltage disappeared in the resistances which are inside the power supply unit.

This business of voltage, current, and resistance seems to be getting rather involved. It seems that way because now we are working with a real power supply such as used in television and radio receivers, and are working with circuit elements and a measuring instrument of the kinds found in everyday practice. We shall find, as we proceed, that everything behaves according to the rules and formulas. Any apparent confusion at this point is due to the fact that we have not yet heard the whole story.

Up to this point we have kept the slider of the potentiometer on our panel board in the position for maximum resistance. This is the position used for the test of Fig. 14 and all the other tests with this particular series circuit. On the rotor of the potentiometer you will see a rather large piece of metal which is circular at the center and extends straight out to the edge of the rotor. This piece of metal is not the slider; it carries the stop. The slider is directly opposite the stop.

In Fig. 15 the slider of the potentiometer has been rotated half way through its travel, as you will see upon comparing the position of the rotor in this picture with its position in the earlier pictures. The short circuit has been removed from the 10K resistor. Note the voltages across the potentiometer as now indicated by the voltmeter. To correctly read this voltage we must consider that the meter is on its 30-volt range, which requires dividing all numbers on the 300-volt dial scale by 10. Making this division, the indicated potential difference is 4 volts.

How does it happen that moving the slider half way through its travel changes the

voltage across the pot from 15 volts (Fig. 13) to 4 volts, when voltage must be proportional to resistance? The answer is that our potentiometer is not a linear unit, it has a tapered resistance element. With the slider in the position shown by Fig. 15 the resistance between the slider, or center terminal, and the outer right-hand terminal is a little greater than 500 ohms, which is 1,500 ohms less than in the position for maximum resistance of 2,000 ohms.

The resistance of the entire series circuit has been reduced by about 1,500 ohms, and the current has increased accordingly. With the increased current throughout the circuit there will be proportionately greater voltages across every element in the circuit. It is a general law that a change of resistance anywhere in a circuit will change the voltages everywhere else in the same circuit - because there is a change of current everywhere in the circuit.

**LOCATING SHORT CIRCUITS.** In Fig. 14 we looked at one kind of short circuit, and noted its effects. There are many other ways in which a short circuit may occur, but all of them may be defined as follows. A short circuit is a fault which diverts some or all of the current away from parts of the circuit in which the current should flow. A short circuit or a "short" is literally a current path which is electrically shorter than it should be, or in which resistance is less than it should be.

A short circuit of any kind will lessen the total resistance of the circuit in which this fault exists. The lessened resistance allows the current to become greater than normal, as we observed in Fig. 14. The excess current nearly always will overheat some or all of the parts which are not shorted out of the circuit. Consequently, overheating usually indicates a short circuit.

The excess current also overloads the power supply. Because there is a good deal of resistance in the parts of the power supply itself, the extra current flowing in this resistance is accompanied by an abnormally great loss of potential within the power supply. The result is a decided decrease of

## LESSON 8 – TROUBLE SHOOTING WITH THE VOLT-OHMMETER

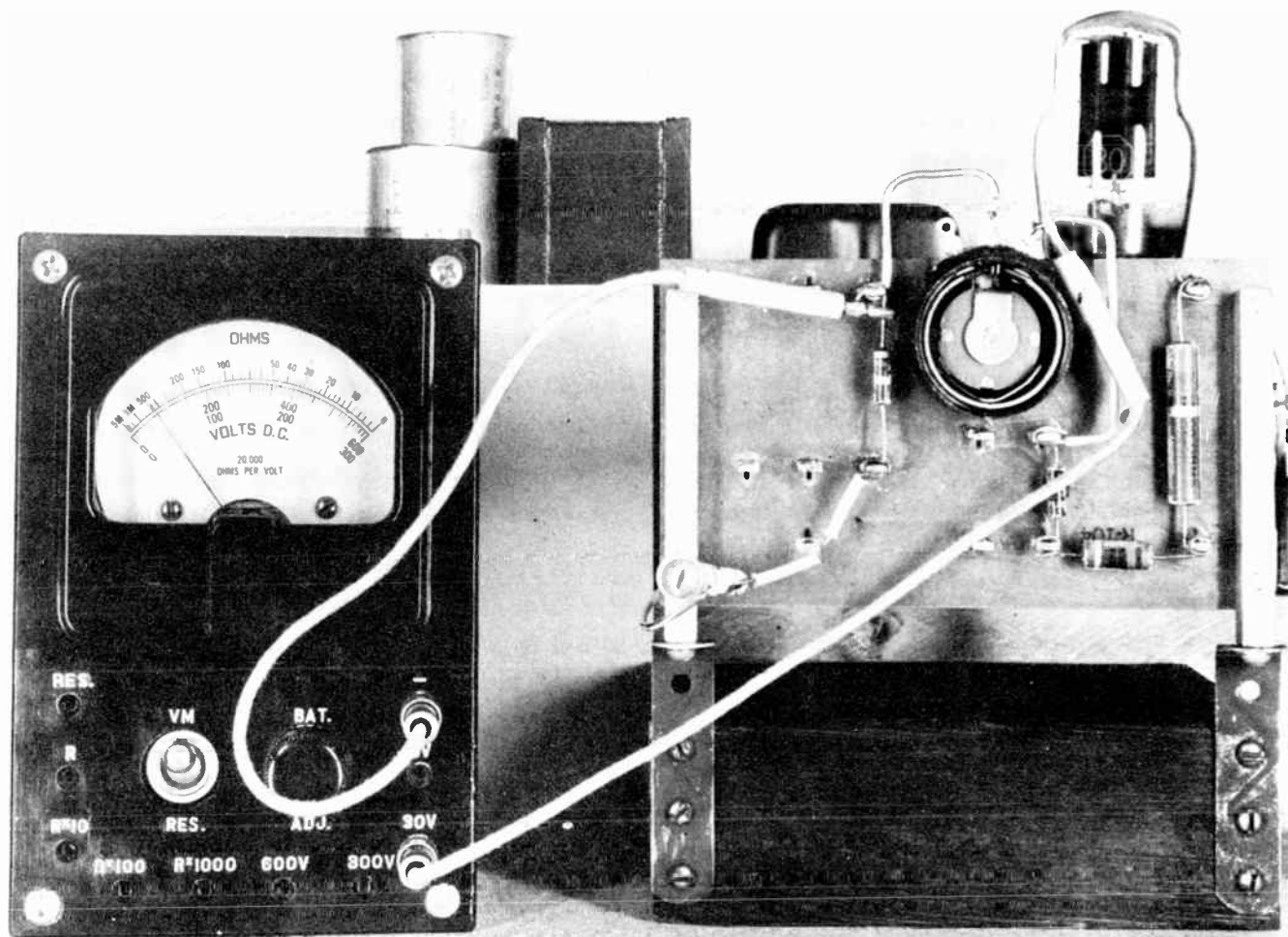

Fig. 15. Moving the slider of the potentiometer changes the resistance of this element, and alters the potential difference.

voltage remaining at the terminals of the power supply section, and a decided decrease of voltage furnished to all circuits of the receiver.

This decreased voltage will cause poor performance, not only in the circuits containing the short, but in every other circuit operated from the power supply. Generally poor performance, and low voltages everywhere, often indicates a short circuit.

Careful inspection of resistors, capacitors, and inductors in a circuit suspected of containing a short may locate the part at which, or near which, the fault exists. This may save a great deal of time, because your search will be narrowed to a comparatively small portion of the receiver.

Fixed resistors which have suffered from overheating will be abnormally dark in appearance, or may be nearly black. Colors on the coding bands may become unrecognizable. Surfaces of overheated resistors may appear blistered, bubbly, or rough. A fixed capacitor of the "paper" type which has been overheated may have the darkened appearance of an overheated resistor, but more often the outer cover of the capacitor will appear blistered. With many capacitors some of the insulating compound will have been forced out at the ends of the unit. Severe overheating of small inductors usually melts some of their insulation. Large, enclosed inductors which have been badly overheated will have the characteristic odor of burnt or charred insulation - an odor easily recognized after you smell it a couple of times.

## COYNE - *television home training*

If visual inspection fails to locate the point of trouble we must resort to the ~~voltmeter or ohmmeter~~. Even though you are almost certain of which part or parts are in trouble, it is highly advisable to confirm your suspicions with one of these testing instruments.

The voltmeter can be used only while power is applied to the receiver or other apparatus being worked upon, for otherwise there will be no voltages to measure. If the short still exists, and has not caused burnout of some part to stop the excess current, application of power is likely to continue the overheating and ruin parts which have not yet been affected. To avoid such additional damage we may search for shorts with the help of an ohmmeter rather than a voltmeter. You will recall that the ohmmeter is used only while no power is applied to apparatus being tested.

One of the best ways to locate short circuits with the ohmmeter is to check resistances, step by step, from one end of the suspected circuit to the other. As in Fig. 16,

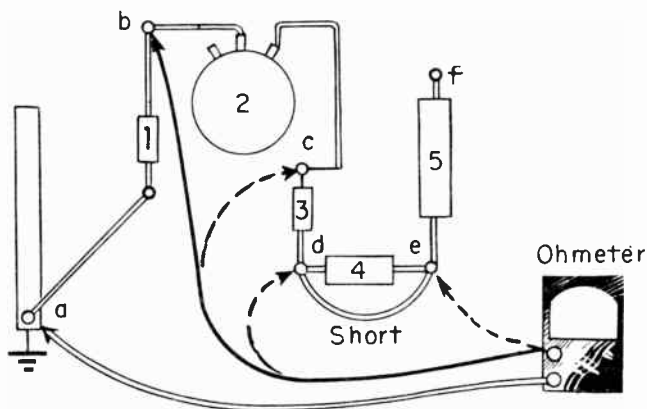

Fig. 16. Locating a single shorted element by using the ohmmeter.

either test lead of the ohmmeter should be connected to one end of the circuit, at a, and should remain there. The other test lead is connected first at point b, just beyond the resistor. If you read the color coding of this resistor it will indicate about how much resistance should be found. But you don't have to read the color coding, because any reasonable or probable resistance shows that this element is not shorted.

Then you shift the test lead to point c, just beyond the next circuit element. The resistance indication should increase. You may or may not wait to determine how great the increase should be, but there should be some increase in comparison with point b. Next you check at point d, just beyond the next circuit element, where again there should be an increase of resistance.

Now the test lead is moved on past one more circuit element, to point e. The short circuit exists between points d and e. Therefore, there will be negligible resistance between these two points, and at e the ohmmeter will indicate the same or practically the same resistance as at d. You know that there should be at least some increase of resistance from d to e, because a resistor is connected between these two points. But actually there is no increase. Then the short must exist between the last point at which there is an increase of resistance and the first point at which there is no increase.

When using this method for locating shorts you may commence at either end of the circuit and check through to the other end. Instead of checking step by step as illustrated, you could measure the resistance across each separate element. There would be zero resistance across the shorted element. This latter method would require shifting both test leads to the two ends of each element, which would take much more time than moving only one test lead for each successive check.

In every test for shorts with the ohmmeter you should continue on to the end of the circuit, or to some open point such as a capacitor, even though a fault has been located. There might be other faults which you would miss by not completing the tests. In the case illustrated by Fig. 16 we would continue on to point f, where resistance once more would increase in relation to point e, because element 5 now is included between the two test leads of the ohmmeter.

The following is a general rule for locating short circuits with the ohmmeter. When, at some certain point of measurement, the resistance does not increase, or possibly



## LESSON 8 – TROUBLE SHOOTING WITH THE VOLT-OHMMETER

drops to zero or near zero, a short exists somewhere between this point and the beginning of the circuit being tested.

The step-by-step or progressive method of checking is better than separate measurements of each element when two or more elements are shorted out at the same time. Fig. 17 is an example. Elements 3 and 4 are

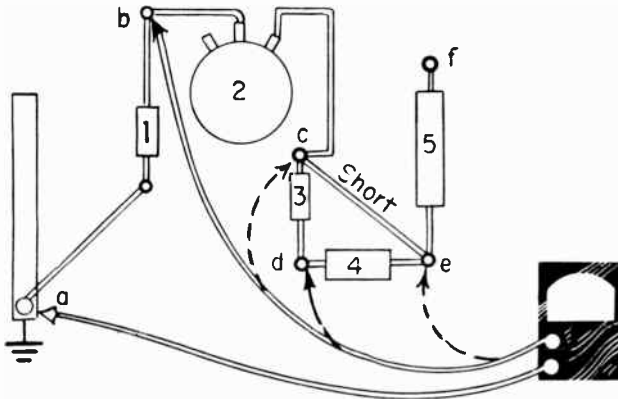

Fig. 17. Using the ohmmeter to locate a short circuit that bridges across more than one element of the circuit.

bridged by a short circuit. We connect one ohmmeter lead to point a and leave it there. The other lead is connected successively to following points b, c, d, and so on.

A check at point b will show resistance, and at c and d there will be increases of resistance. But at e the resistance will not increase. Instead it will drop back to the same value as at c, because c and e are shorted together and, consequently, must be at the same potential. Therefore, our rule holds good. The short is between the point (e) where resistance does not increase, and other points (d, c, etc.) which already have been checked.

Measuring the resistances of separate elements never would locate the kind of short illustrated by Fig. 17. No one element is shorted, and each would check good by itself. It takes a test method which covers more than one element at a time to locate a fault such as this one. As usual, the checks should be continued by going on to the end of the circuit, at f. Here there will be an increase

of resistance because resistor 5 how is included between the ohmmeter test leads.

Still another variety of short is illustrated by Fig. 18. Here there is a short from

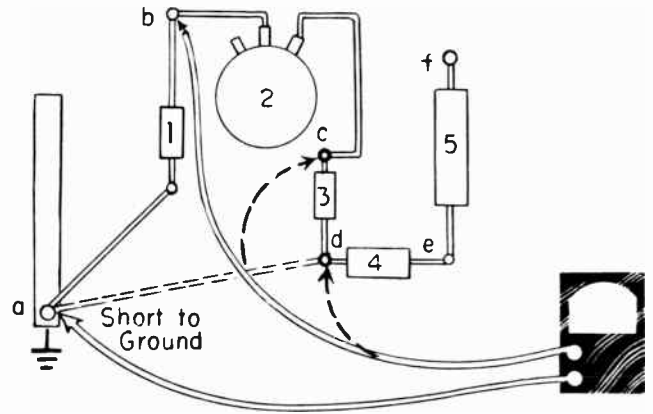

Fig. 18. Locating a "short to ground" by using the ohmmeter.

point d, between elements 3 and 4, to the grounded support at a, the end of the circuit which we assume to be negative. When there is a short from any point to chassis metal or other grounded metal, the fault is called an accidental ground or simply a ground. The fault which we call a ground is merely one variety of short circuit, it is a "short to ground".

Once more we connect one test lead of the ohmmeter to the beginning of the circuit at a, and connect the other lead successively to points following. Resistance will be indicated at b. It will be of a value depending on the combined effects of two paths through which ohmmeter battery current may flow from b to point a. One path is from b through element 1 to point a. The other is from b through element 2, element 3, and the short circuit back to a. At c we again will have a resistance reading. From here also there are two paths for ohmmeter battery current. One is from c through elements 2 and 1 to a. The other is from c through element 3 and the short circuit to a.

Continuing with the tests, we proceed to point d of Fig. 18. Once more there are two

## COYNE - *television home training*

paths for ohmmeter battery current. One path is from d through elements 3, 2, and 1 back to point a, while the other is through the short circuit from d to a. In the short circuit there is no appreciable resistance, and with the ohmmeter leads connected across no resistance the reading will be zero. According to our general rule, a short exists between a point (d) where resistance drops to zero and the beginning of the circuit being tested.

Having located one short, we should proceed, as usual, to the end of the circuit. If the remainder of the circuit contains no shorts, at e the resistance would be greater than zero, due to element 4, and at f the resistance would be still greater because of element 5.

Supposing, however, that element 5 were shorted within itself. This additional short would be discovered, because resistance at f would be the same as at e, whereas it should increase. Resistances at these two points

would read the same because, with element 5 shorted, there would be no resistance between e and f, and their potentials would not be the same. When the tests not completed this short would go undetected.

When you locate an accidental ground the thing to do is get the conductors insulated from each other so that the ground no longer exists. If other parts are not burned out or otherwise damaged, there is nothing more to do. A short involving more than one element, as in Fig. 17, may require only separation and possibly re-insulation of the shorted conductors.

A short circuit in some one element, as represented by Fig. 16, calls for replacement of that element. Then it is essential to determine why that element shorted before installing a new part. Unless you determine the underlying cause, and correct or remove it, a new part will go the way of the original one as soon as the receiver is placed in operation.

# TELEVISION

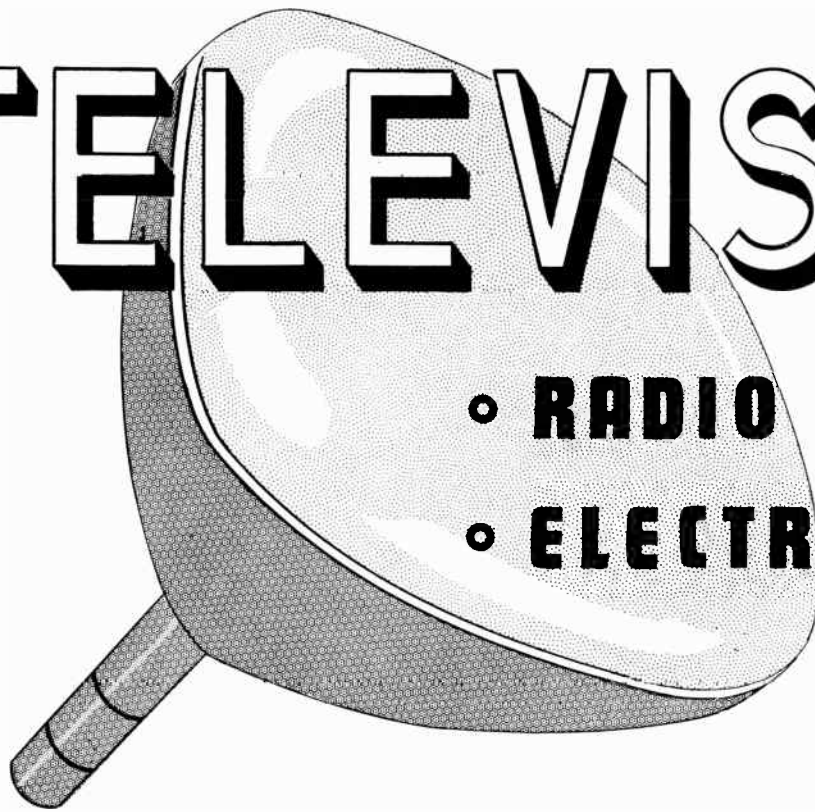

---

---

## LESSON 9 – TROUBLE SHOOTING IN A PLATE CIRCUIT

---

---

***Coyne School***

*practical home training*

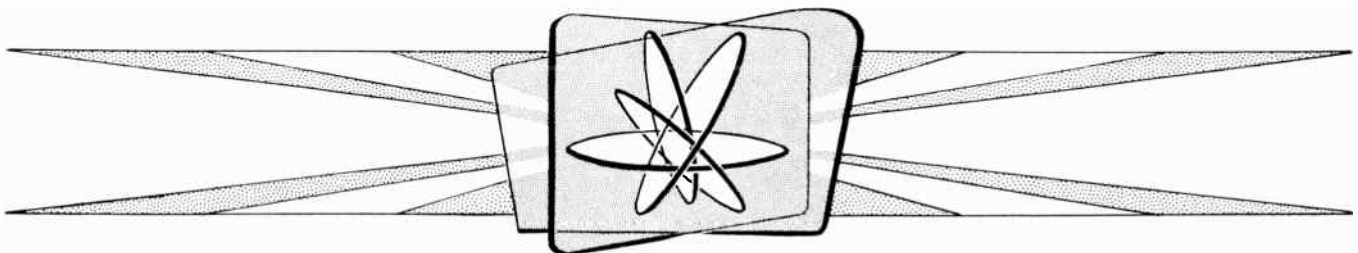

*Chicago, Illinois*



## CONDENSED INFORMATION FOR REFERENCE

### Circuit testing, general procedure.

When an overload or overheating is indicated, turn off power and use the ohmmeter to locate possible shorts. Then use voltmeter, with power on, to locate opens.

### Open circuit.

A point in a normally closed or completely conductive circuit at which there is a break in the conductive path.

#### Common causes for open circuits.

Wires or other conductors broken or disconnected.

Soldered joints poorly made.

Screw terminals loose, or contacting surfaces dirty.

Resistor burned out. Inductor winding burned out or broken.

Tube with heater burned out, or with poor contact between pins and socket.

### Open circuit indications

#### Voltmeter

No voltage across resistors or other elements which are not open.

Voltage greater than normal power supply voltage across the open point.

#### Ohmmeter.

Infinite resistance across the open point.

Resistance less than infinite across any element or section not open.

### Effects of capacitors in series circuits.

#### Voltmeter

Meter pointer jumps away from zero, then drops back.

With electrolytic capacitor the pointer may remain above zero.

#### Ohmmeter

Electrolytic capacitor. Resistance low when connection made, then increases. Resistance goes higher when ohmmeter battery polarity correct for capacitor than when reversed.

Other capacitors. Meter pointer may jump slightly away from infinite resistance at instant of connection, then returns to infinite if capacitor not shorted or leaky.

### Replacements or substitutions of components.

Changing the resistance anywhere in a series circuit changes the current everywhere in that circuit.

Changing the resistance anywhere in a series circuit changes the voltages across all parts in that circuit, since there is a change of current.

Different tubes of the same type may not have equal effective resistances, so tube substitution usually changes circuit current and voltages on all elements.

## Lesson 9

### TROUBLE SHOOTING IN A PLATE CIRCUIT



*Fig. 1. These students in the Coyne Shops are tracing circuits in television and radio apparatus.*

The technician in search of trouble must spend much time in tracing and testing the receiver circuits in which he believes the faults may lie. Preliminary observations and measurements will have determined which circuits must contain the trouble, but the final analysis will depend on work such as we shall do in this lesson. The faster the technician can trace a circuit and check the behavior of its elements the more profitable the job will be. Speed depends largely on ability to see the relations between service

diagrams of the schematic variety and the components or wiring which they represent.

We are going to practice on the portion of a manufacturer's service diagram shown by Fig. 2, which includes the video amplifier section of a typical television receiver. One of the tubes is the video amplifier, which feeds picture signals to the picture tube. Another tube is the sync amplifier, for signals that time or synchronize the movements of the electron beam. This tube also is fed

# COYNE - television home training

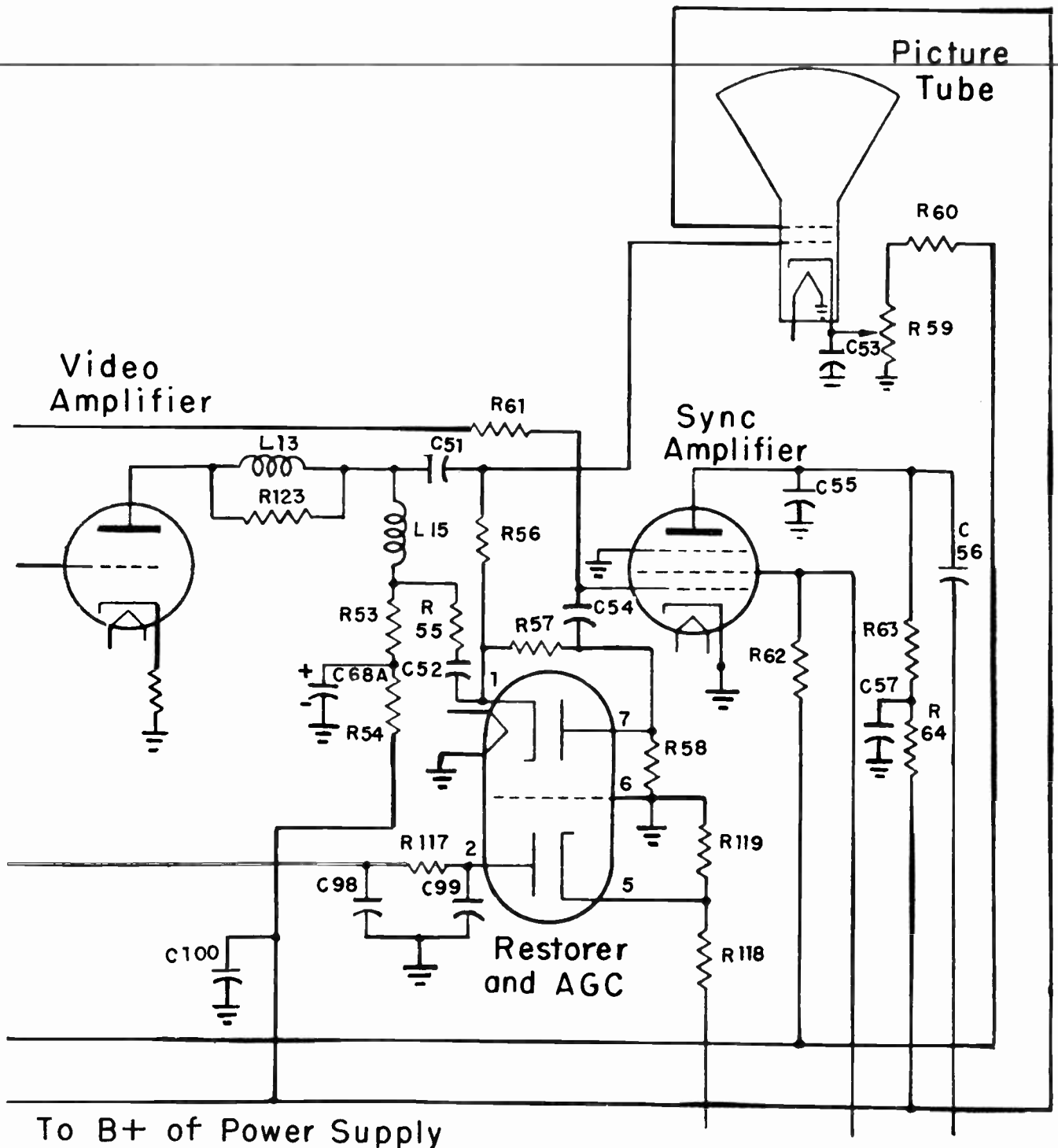

Fig. 2. This portion of a service diagram shows a video amplifier and associated circuits.

from the video amplifier. A third tube, marked "Restorer and AGC", has two complete sets of elements inside its single bulb or envelope. One set of elements helps maintain average brightness of pictures at levels corresponding to brightness in the

scenes being televised. This is the restorer function. The other set of elements compensates for any erratic changes in strength of the signal coming to the receiver. This function is called automatic gain control, abbreviated AGC.



## LESSON 9 – TROUBLE SHOOTING IN A PLATE CIRCUIT

Although we are on our way, we do not as yet know enough about tubes and their behavior to check the performance of all those included on this partial service diagram. Therefore, we shall limit our present investigations to the plate circuit of the principal tube of the group, this being the video amplifier. We will assume that trouble is suspected in this particular circuit and that we wish to check the voltages, the currents, and some of the resistances; then search for open circuits and possible shorts.

In order that the video amplifier tube may do its appointed work, the plate of this tube must be maintained positive with reference to its cathode, or the cathode must be negative with reference to the plate. This, of course, is merely saying the same thing in two different ways.

The plate is made positive by connecting it to the positive side of the d-c power supply, not directly, but through several resistors and inductors. The cathode is made negative by connecting it indirectly to the negative side of the d-c power supply. When the polarities of plate and cathode are thus maintained in correct relation, and when the cathode is heated to a dull red, free electrons from the negative side of the power supply will flow to the cathode of the amplifier tube, thence through this tube to its plate, and from the plate the electrons will go back to the positive of the power supply.

The electron flow or current in the plate circuit of the video amplifier tube is a direct current, because it always is in the same direction. This direct current is varied in accordance with signals handled by the tube, but always the flow will be in only one direction. This is important, because it enables us to test the plate circuit with our d-c voltohmmeter.

**TRACING A PLATE CIRCUIT.** When tracing a plate circuit the first step is to find on the service diagram a path in which direct current may flow between the tube plate and the positive side of the power supply, and another path in which direct current may flow between the negative side of the power supply and the tube cathode. These

two parts of the plate circuit may be traced all the way to the power supply terminals, or they may be traced only as far as wires or other conductors which appear on the service diagram as leading without interruption to both sides of the power supply in the receiver.

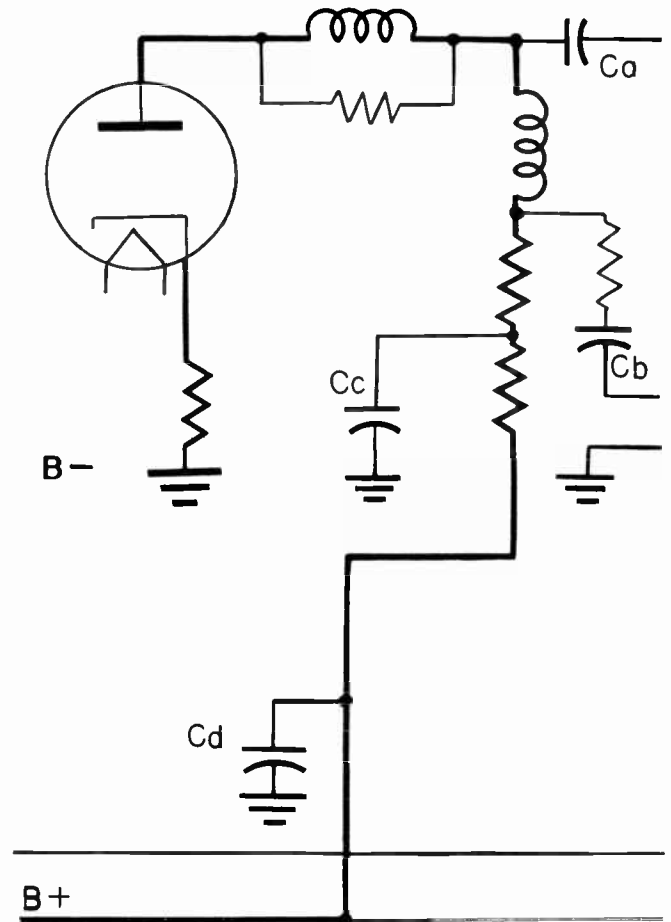

Fig. 3. The positive and negative sides of the plate circuit for the video amplifier tube.

Fig. 3 shows in heavy lines the conductive paths between the video amplifier plate and the main lead which goes to the positive of the power supply, and between the cathode and the negative side of the power supply, through ground. The path between the tube plate and positive of the power supply is the positive side of the plate circuit, sometimes called the "high side". The path between tube cathode and negative of the power supply is the negative side of the plate circuit, or the "low side".

The negative of the d-c power supply in this receiver is connected to chassis metal

## COYNE - *television home training*

or chassis ground. The cathode of the video amplifier tube is connected through a fixed resistor to chassis ground. Thus the negative side of the plate circuit is completed through chassis metal and through the one resistor which is between the tube cathode and chassis metal or ground.

Direct current in the plate circuit of the video amplifier tube passes only through the heavy-line paths of Fig. 3. This diagram is an enlargement of part of Fig. 2, with markings on the parts changed to allow easier reference in discussions to follow. Plate circuit current does not, or at least should not take any other paths, because all other paths contain capacitors.

Commencing at the plate of the video amplifier tube and proceeding toward the main B+positive conductor which goes to the power supply, we find that the first branch goes to capacitor Ca. The next branch goes to capacitor Cb. The third branch goes to capacitor Cc. The fourth and final branch goes to capacitor Cd. Unless some of these capacitors are of the electrolytic type, all will act as "dead ends" so far as direct current is concerned. They will restrict direct current in the plate circuit to the paths which are completed through resistors and inductors.

**TESTING THE PLATE CIRCUIT.** In the actual receiver all the parts and connections represented on service diagrams would be close together, making it difficult to show clearly with photographs the steps to be taken in testing the plate circuit. Therefore, we shall use the same kinds of parts, but mount them on a panel where everything may be spread out, as in Fig. 4. The parts on this test panel include the video amplifier tube, the five fixed resistors and two inductors which are in the plate circuit, and also the "dead end" capacitors which should confine direct current to the heavy-line paths of Fig. 3.

Behind the test panel is a power supply assembly which furnishes direct voltage and current for the plate circuit, also alternating voltage and current for the heater in the amplifier tube. The heater, as you may recall,

serves only to raise the temperature of the cathode. The heater is electrically insulated from the cathode and from all other parts of the plate circuit.

A wire lead from the negative d-c terminal of the power supply comes around the left side of the panel to the shelf that represents the chassis or ground. A lead from the positive d-c terminal of the power supply comes around the panel a little lower down and connects to the junction between a resistor and a capacitor. The heater leads come through the panel to the tube socket lugs, and do not show in the picture.

Wiring connections between all the components on our test panel are exactly the same, electrically, as on the schematic diagrams and in the actual receiver. The relative positions of parts on the test panel are not the same as in either the receiver or the service diagrams, nor would the relative positions be the same on the manufacturer's service diagram and the receiver. This is the situation which always confronts you during service operations - you have to work with diagrams which look one way and a receiver which looks quite different, yet must see that both are essentially the same thing.

On the test panel shelf that represents chassis metal and ground is mounted the amplifier tube and also capacitor Cc. This is an electrolytic capacitor enclosed with an aluminum "can". The side of this capacitor which must be connected to the negative side of the circuit, or to ground, is connected internally to the metal can. With this can attached securely to chassis metal, as in the picture, one side of the capacitor is connected to chassis ground. The terminal of the capacitor that must be connected to the positive side of the circuit is insulated, and protrudes through the bottom of the can and through a hole in the chassis. This is the terminal to which a wire is connected.

**CURRENT IN THE PLATE CIRCUIT.** We shall hereafter refer to parts and connections in the video amplifier plate circuit in accordance with markings and lettering of Fig. 5. Normally our first step would be to measure the voltage across the entire plate

## LESSON 9 -- TROUBLE SHOOTING IN A PLATE CIRCUIT

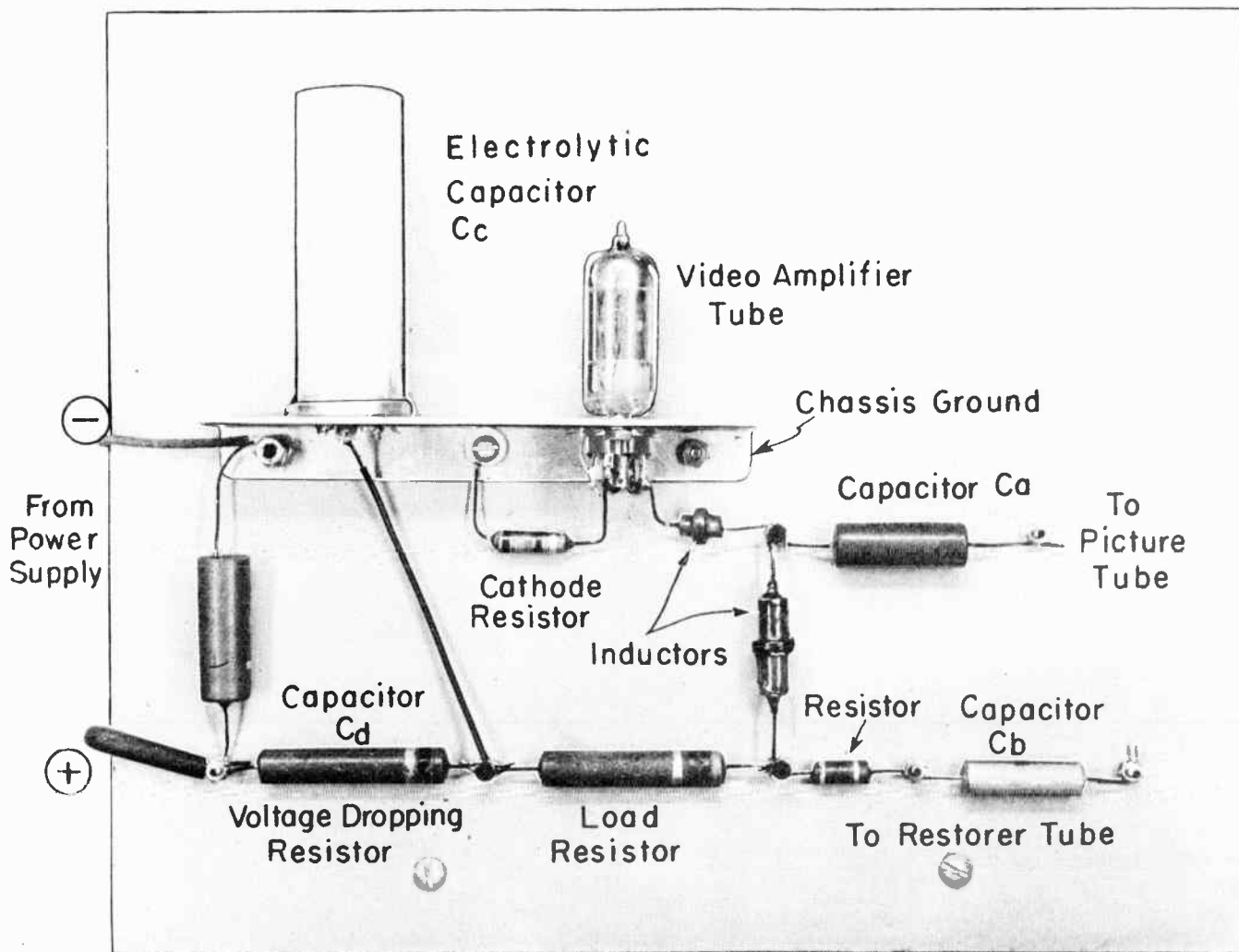

Fig. 4. These are the parts of the plate circuit and its branch connections.

circuit, by connecting the voltmeter to chassis ground and to the B+ positive line going to the power supply, or between terminals 1 and 2 on the test panel. Thus we would make sure that a suitable voltage is being applied to the plate circuit, and that trouble in some other circuit is not preventing power supply voltage from reaching the circuit being checked. Potential difference between terminals 1 and 2 measures 326 volts.

Next we wish to determine how much current is flowing in the plate circuit. This may be done by measuring the voltage across any circuit element of known resistance, then using a formula or chart which gives the value of current when voltage and resistance are known.

Note: In the remainder of this lesson

there will be many occasions for determining currents, voltages, or resistances when any two of the values are known. Although correct answers always will be given, it would be excellent practice for you to figure out every problem for yourself. The easiest and most practical way is to use the alignment chart for volts, ohms, and milliamperes. You may use the formulas if you prefer. This would help to memorize the formulas, after which you won't need ever a chart when working out service problems.

To compute plate circuit current we shall make use of fixed resistor  $R_o$ . This unit is coded green-brown-red, indicating 5,100 ohms. We measure the potential difference as in Fig. 6. The meter shows about 29 volts



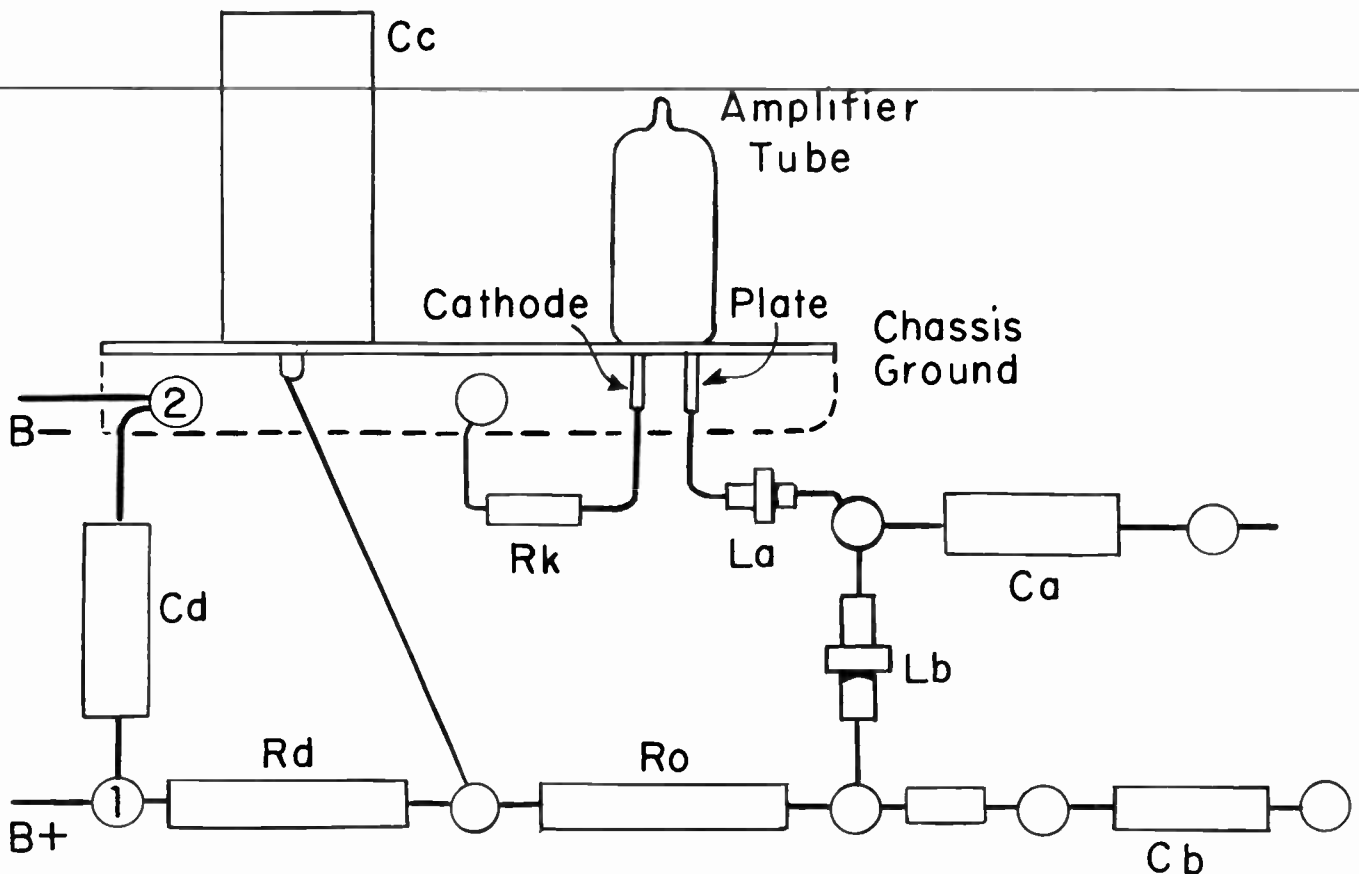

Fig. 5. Letter symbols by which the parts of the plate circuit will be identified.

on the 300-volt scale. The combination of 5,100 ohms resistance and 29 volts indicates a current of about 5.7 milliamperes, which is wrong.

This computed current is wrong, because we should not have accepted a color-code value for resistance, especially in view of the fact that resistor Ro has neither a silver nor a gold band, so may have a tolerance error of as much as 20 per cent either way. Careful measurement of the resistor which actually appears in the picture showed its resistance to be 3,900 ohms, a value nearly 24 per cent lower than the coded value. Resistors of poor quality, and some which are bought as "bargains", may have resistances far different from their coding - even should they carry a silver band.

When we employ the actual resistance of 3,900 ohms, and the measured voltage, the indicated current is about 7.5 milliamperes. This should be the current flowing in all parts of the series circuit.

It happens that the resistance of 3,900 ohms is the correct value for the position in which unit Ro is used, as given in the manufacturer's parts list. When you find an incorrectly coded resistor, but one which is of correct resistance for its work, that unit may have been checked with an ohmmeter before installation. Some service men purchase 20 per cent resistors, which cost less than those of closer tolerance, then measure their true resistances in order to have on hand a wide choice of values for replacement purposes.

**POLARITIES AND POTENTIALS.** You will note in Fig. 6 that the voltmeter leads are crossed in order to make connections which are correct in relation to polarities at the ends of resistor Ro. Polarities at opposite ends of any circuit element depend on which end is connected toward the positive side of the power supply, and which end is toward negative of the power supply. It is power supply polarity which determines also the directions of electron flow in circuit elements.

## LESSON 9 -- TROUBLE SHOOTING IN A PLATE CIRCUIT

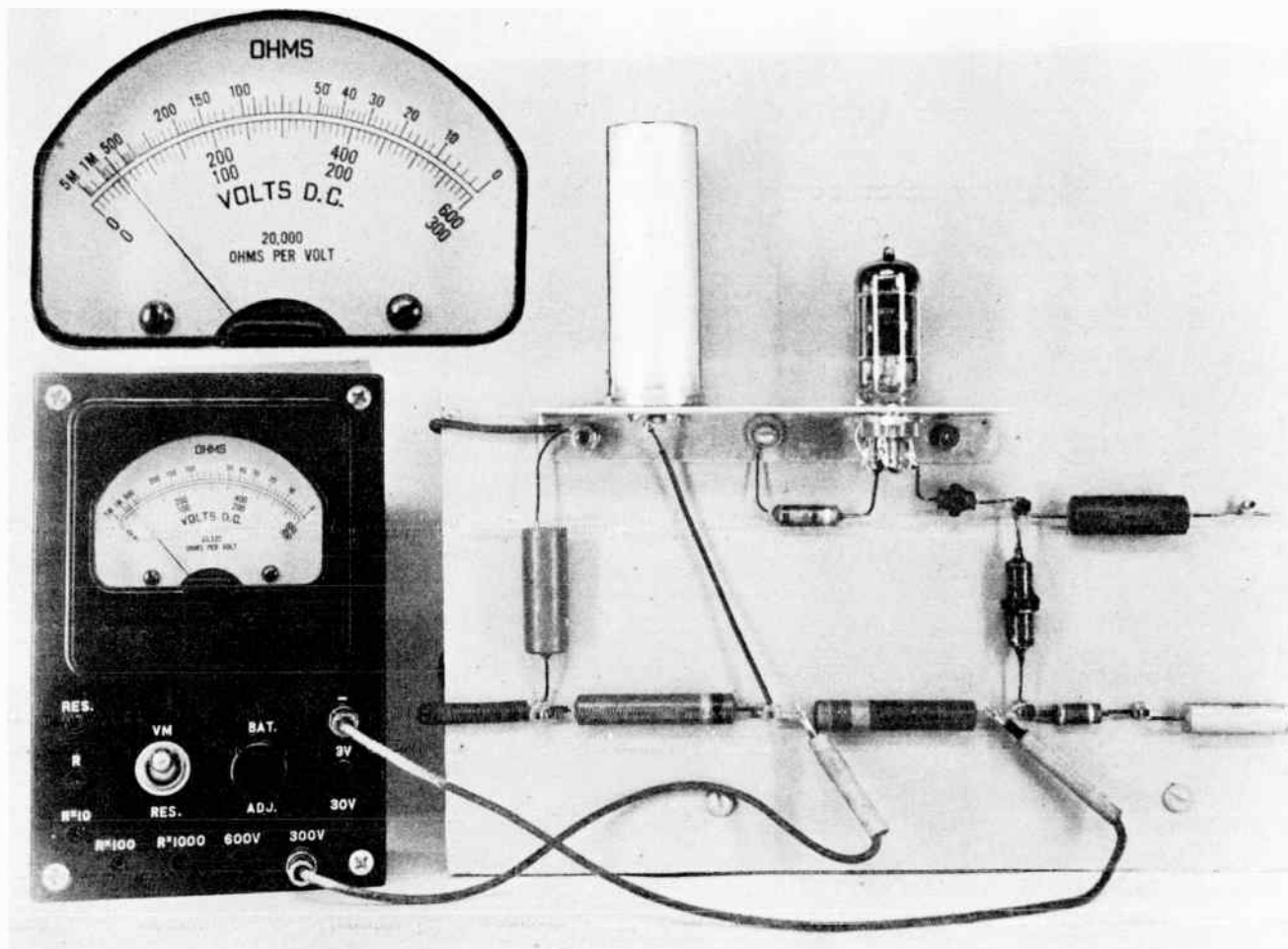

Fig. 6. Measuring voltage across the load resistor as a step in computing current in the plate circuit.

Fig. 7 shows directions of electron flow in the plate circuit elements, also the potentials at various points. When we connect the negative test lead of a voltmeter to the negative side of the power supply, or to chassis ground, all the measured voltages will become progressively greater as the positive lead of the meter is moved to points which are electrically farther and farther from ground. Then, so far as meter indications are concerned, we may consider the negative starting point or chassis ground as of zero potential, and all other points as of various positive potentials indicated by the meter. This common practice has been followed in Fig. 7.

Progressive measurements through the plate circuit will show that the cathode of the video amplifier is nearly 5 volts positive with

reference to ground. The plate of the amplifier tube is about 220 volts positive. Note that we are following the direction of electron flow. The right-hand end of resistor  $R_o$  is also about 220 volts positive, while its left-hand end and the right-hand end of resistor  $R_d$  are about 249 volts positive. The left-hand end of  $R_d$  and the main B-positive line to the power supply are 326 volts positive. All these positive voltages are with reference to chassis ground and to the negative side of the d-c power supply.

**INDUCTOR RESISTANCE.** Now let's consider inductors  $L_a$  and  $L_b$  which are between the plate of the video amplifier and resistor  $R_o$ . Voltmeter tests showed no difference between potentials at opposite ends of the two inductors. Voltage at the end of inductor  $L_a$  nearer the amplifier plate mea-

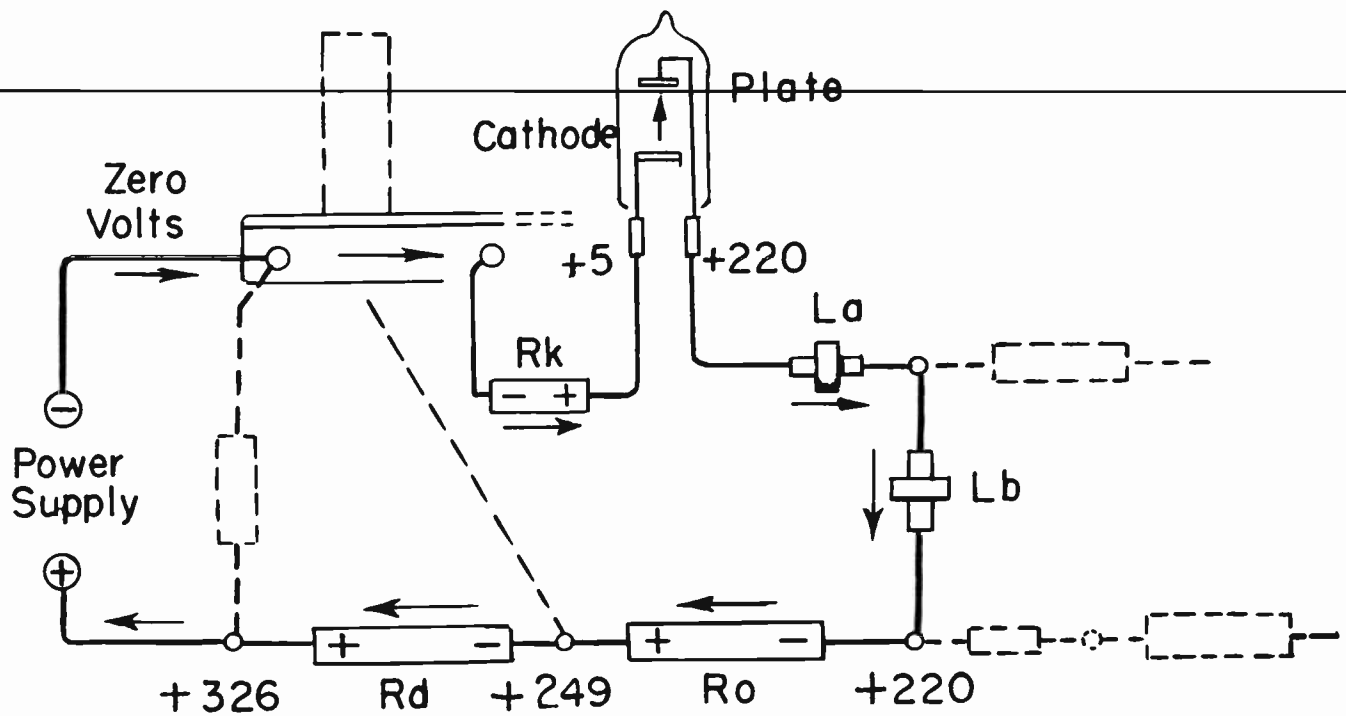

Fig. 7. Electron flow and positive potentials in the plate circuit.

sure the same as at the end of  $L_b$  connected to resistor  $R_o$ . This would indicate that there is no resistance in these inductors.

Actually there is some resistance in the inductors, but their combined series resistance is only about 7 ohms. When this resistance carries the circuit current of 7.5 milliamperes, the potential difference across the two inductors will be about  $1/20$  volt. When the voltmeter is being used on a range suitable for other circuit voltages a difference of  $1/20$  volt cannot be detected so far as movement of the meter pointer is concerned.

Looking back at the circuit diagrams of Figs. 2 and 3 you will see that inductor  $L_a$ , nearer the plate of the amplifier tube, is in parallel with a resistor. The resistance of this paralleled resistor is 39,000 ohms. You may question why such great resistance does not introduce a potential difference which would be indicated by the meter.

The answer is quite simple. Imagine a great quantity of free electrons traveling in the plate circuit and coming to the divided paths through inductor  $L_a$  and the paralleled resistor. Opposition (resistance) of the in-

ductor is about 3 ohms, and of the resistor is 13,000 times as great. Which path would the electrons take? Actually so few free electrons wander through the paralleled resistor that the potential difference across it is negligible, far too small to be indicated by the voltmeter. Consequently, the resistance of the inductor and resistor in parallel appears no greater than that of the inductor alone. The combined or parallel resistance really is even less than that of the inductor, as we shall learn when getting better acquainted with parallel connections.

For convenience in manufacture and assembly any small inductor or coil which is to be paralleled by a fixed resistor may be wound on and supported by the resistor. This construction, illustrated by Fig. 8, is employed for inductor  $L_a$ . The two ends of the insulated wire in the coil winding are bared and soldered to the resistor pigtailed. The coil is held on the resistor by cement or wax. When the resistor pigtailed are soldered to lugs or circuit tie points, the inductor and resistor are in parallel with each other, and in series with the remainder of the circuit.

Inductor  $L_b$ , which is not paralleled with



## LESSON 9 -- TROUBLE SHOOTING IN A PLATE CIRCUIT

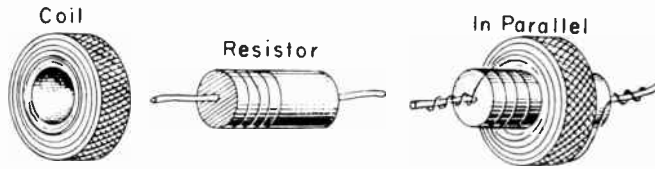

Fig. 8. How a coil or inductor in series with a resistor may be connected in parallel with each other.

a resistor, is mounted on a small piece of cylindrical insulation fitted with pigtail leads. The ends of the coil are soldered to the end leads, and the leads are connected into the main circuit.

**TUBE RESISTANCE.** Now we wish to determine the opposition or resistance offered by the amplifier tube to flow of electrons through it. We shall commence by finding the total resistance of the entire plate circuit, using the overall potential difference of 326 volts and the previously determined circuit current of 7.5 milliamperes. These two values indicate a circuit resistance of about 43,500 ohms. We know that total resistance of any series circuit is equal to the sum of resistances in the separate elements, so we shall add together the resistances of all elements except the amplifier tube.

Cathode resistor, $R_k$	640 ohms
Inductors $L_a$ and $L_b$ (negligible)	
Load resistor, $R_o$	3,900 ohms
Voltage dropping resistor, $R_d$	10,000 ohms
Total	<u>14,540 ohms</u>

The difference between total indicated resistance of the plate circuit (43,500 ohms) and the resistance of all elements except the tube (14,540 ohms) is 28,960 ohms. This must be the resistance effect, or effective resistance, of the amplifier tube.

To verify this tube resistance we may measure the potential difference between cathode and plate of the amplifier with the voltmeter connected as in Fig. 9, then use this measured voltage in combination with the known circuit current to compute the tube resistance. The potential difference from cathode to plate is 215 volts, as you can see. This voltage in combination with the circuit current of 7.5 ma indicates a tube resistance of about 28,700 ohms.

The tube resistances arrived at by two different methods agree within better than one per cent. Such close agreement, when making measurements with ordinary service instruments, comes about only because errors in one direction are partially compensated for by other errors in the opposite direction.

The only practical way to determine the effective series resistance of a tube is to measure its current and potential difference, and make a suitable computation. There are two good reasons why we cannot use an ohmmeter. First, unless the tube cathode is hot, no electrons can flow through the tube unless an applied potential difference is so great as to cause an internal flash. The resistance of a tube with its cathode cold is many, many megohms. Second, strange as it may seem, the effective resistance of a tube varies with applied voltage. Resistance is very great with a small applied voltage, and decreases as the voltage increases. We cannot use a voltage such as employed for normal operation, because this voltage would wreck the ohmmeter.

With d-c voltage from the power supply cut off, while keeping the cathode of the amplifier heated, the ohmmeter which we have been using indicates resistance of two to three megohms between cathode and plate. This meter, with its small internal battery, applies only about  $4\frac{1}{2}$  volts across the tube. When using another ohmmeter having a  $13\frac{1}{2}$ -volt internal battery the indicated resistance is between 300K and 400K ohms. Neither meter, nor any generally similar instrument, gives a useful indication.

All tubes of a given type do not have the same effective resistance. As an experiment, eight tubes of the same type were tried out on our test panel. Measured potential differences between cathodes and plates ranged from 185 to 215 volts. Each different tube caused some change of circuit current, because each one altered the total resistance in the circuit. The measured currents ranged from about 7.4 to nearly 8.3 milliamperes. Effective tube resistances, computed from the measured voltages and currents, ranged from 22,400 to 29,000 ohms. Changing a tube will change the circuit current, and this will

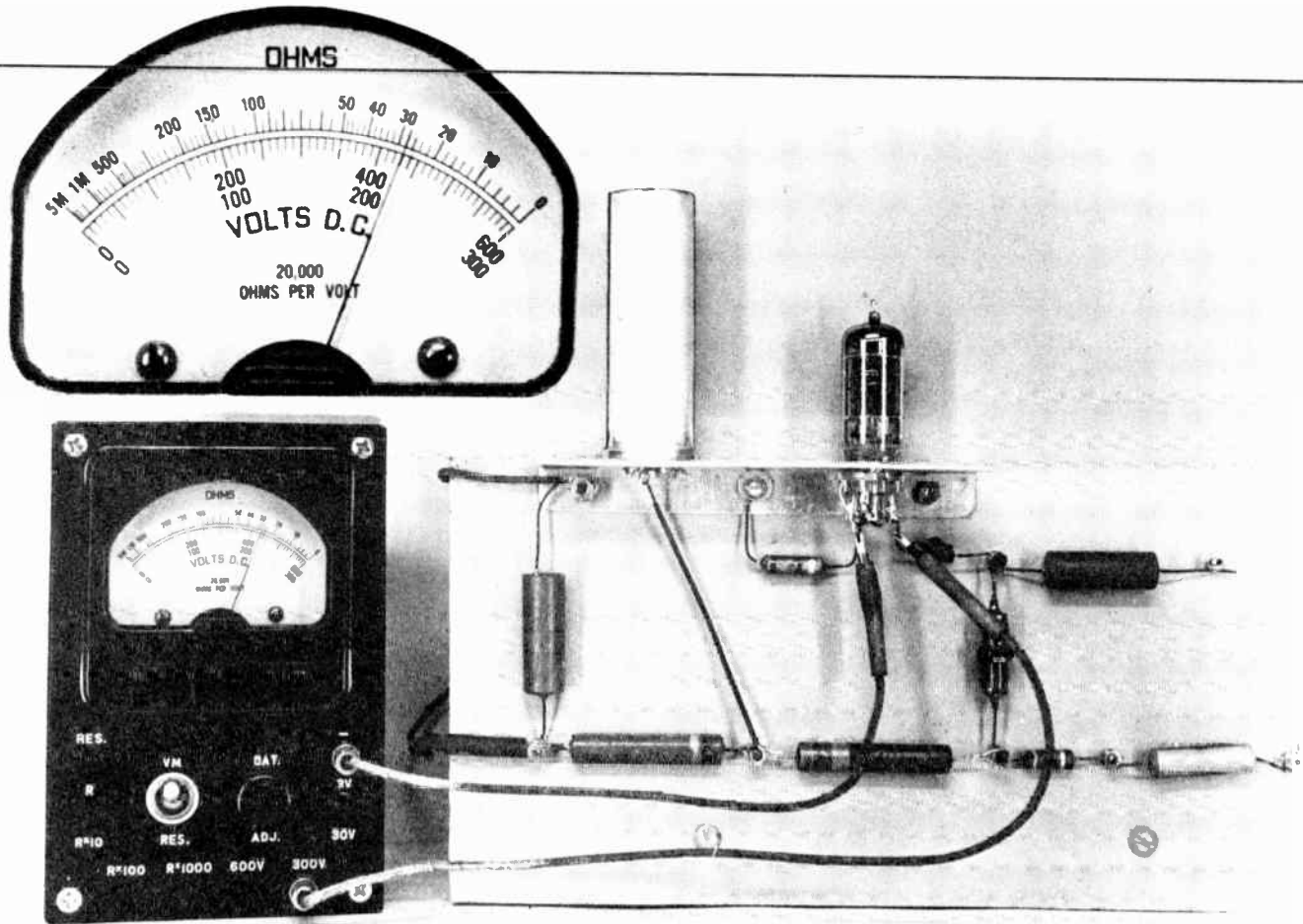

Fig. 9. Voltage across the amplifier tube when it is carrying plate current.

alter the potential difference across every resistor which is in the same circuit.

little resistance to electron flow, and usually will suffer serious and permanent damage.

#### ELECTROLYTIC CAPACITOR EFFECTS

Looking back at Fig. 3 you will see that the terminals of capacitor  $C_c$  are marked with positive and negative signs. Such polarity markings, when used, indicate that the capacitor is an electrolytic type, and that it must be connected into the circuit with due regard to polarity shown on diagrams and marked on the capacitor itself.

The difference between resistances in opposite directions may be observed by connecting the test leads from an ohmmeter first one way and then the opposite way to the capacitor terminals. When the leads are connected to apply voltage from the ohmmeter battery in correct polarity for the capacitor, resistance at the instant of connection will be only a few thousand ohms. But the meter pointer will immediately commence moving toward greater resistance, and within a short time will indicate many hundreds of thousands of ohms or possibly several megohms. With the ohmmeter leads connected for reversed polarity the initial resistance again will be only a few thousand ohms. The resistance will increase but it will not become very great.

When the positive terminal of an electrolytic capacitor is connected to the positive side of a circuit, and the negative of the capacitor is connected to the negative side of the circuit, the capacitor will have high resistance to electron flow in the direction from negative to positive. If the capacitor connections are reversed the unit offers very

## LESSON 9 – TROUBLE SHOOTING IN A PLATE CIRCUIT

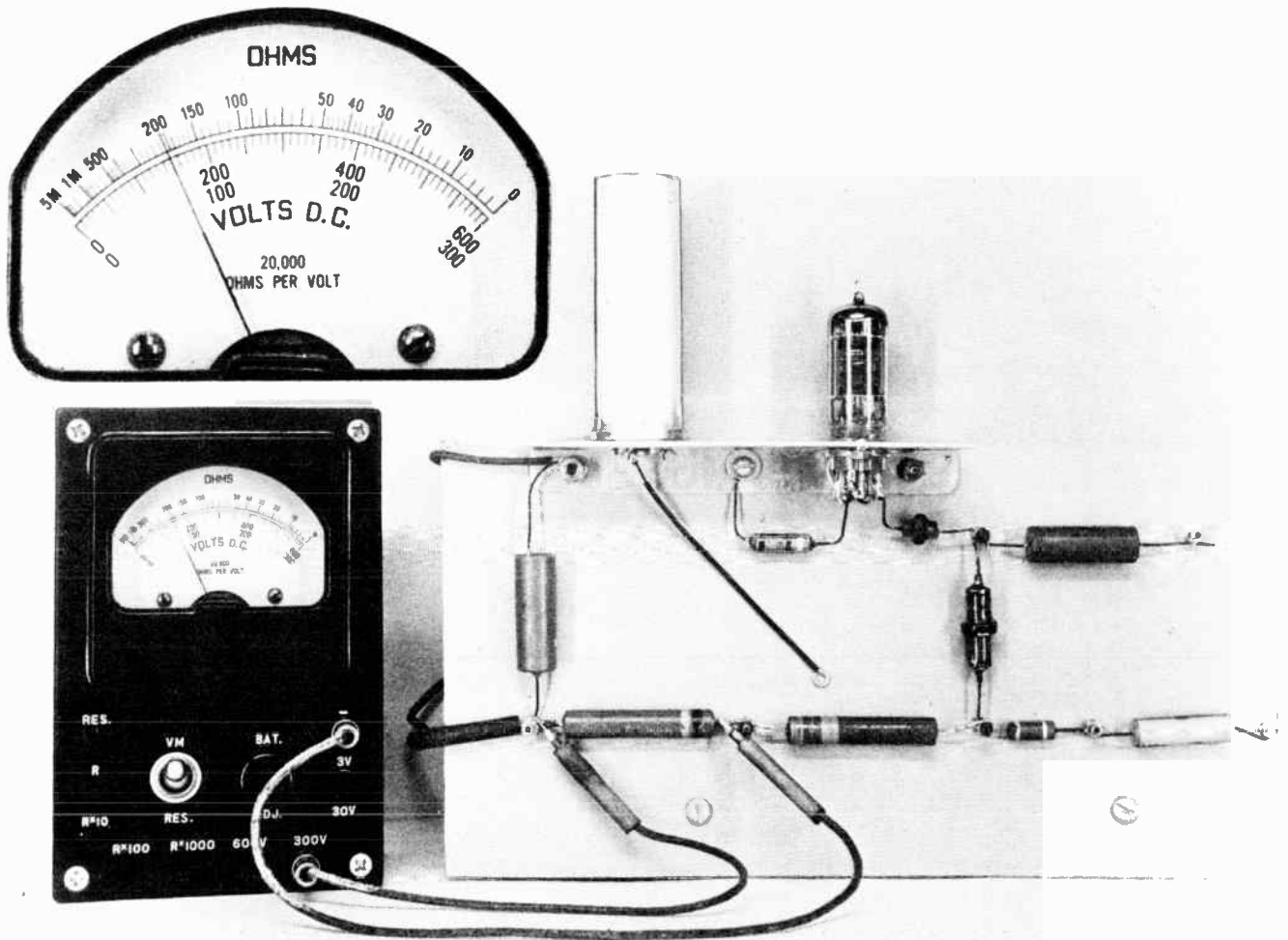

Fig. 10. Voltage across one of the series resistors when the electrolytic capacitor is disconnected.

The electrolytic capacitor  $C_c$  on our test panel is connected in correct polarity. Its insulated terminal goes to the positive side of the circuit at the junction between resistors  $R_o$  and  $R_d$ , and the can of the capacitor is attached to negative ground. We wish to learn whether this capacitor is having any effect on currents and voltages in the plate circuit.

During the first test we shall disconnect the insulated terminal of the capacitor from the positive side of the plate circuit, as in Fig. 10. While the capacitor is disconnected, we measure the potential difference across resistor  $R_d$ , and find it to be 75 volts. With the voltmeter connections unchanged, but

with the capacitor re-connected to the positive side of the plate circuit, the potential difference across resistor  $R_d$  increases to about 83 volts, as shown by Fig. 11.

This increase of voltage across resistor  $R_d$  can mean only that the electrolytic capacitor is allowing additional current to flow in the resistor. This current or electron flow is taking the path shown by full-line arrows on the diagram of Fig. 12. Normal current through other elements and through  $R_d$  is indicated by brokenline arrows. The additional electrons flow from the negative chassis (the metal shelf of our test setup) through the electrolytic capacitor, thence through the



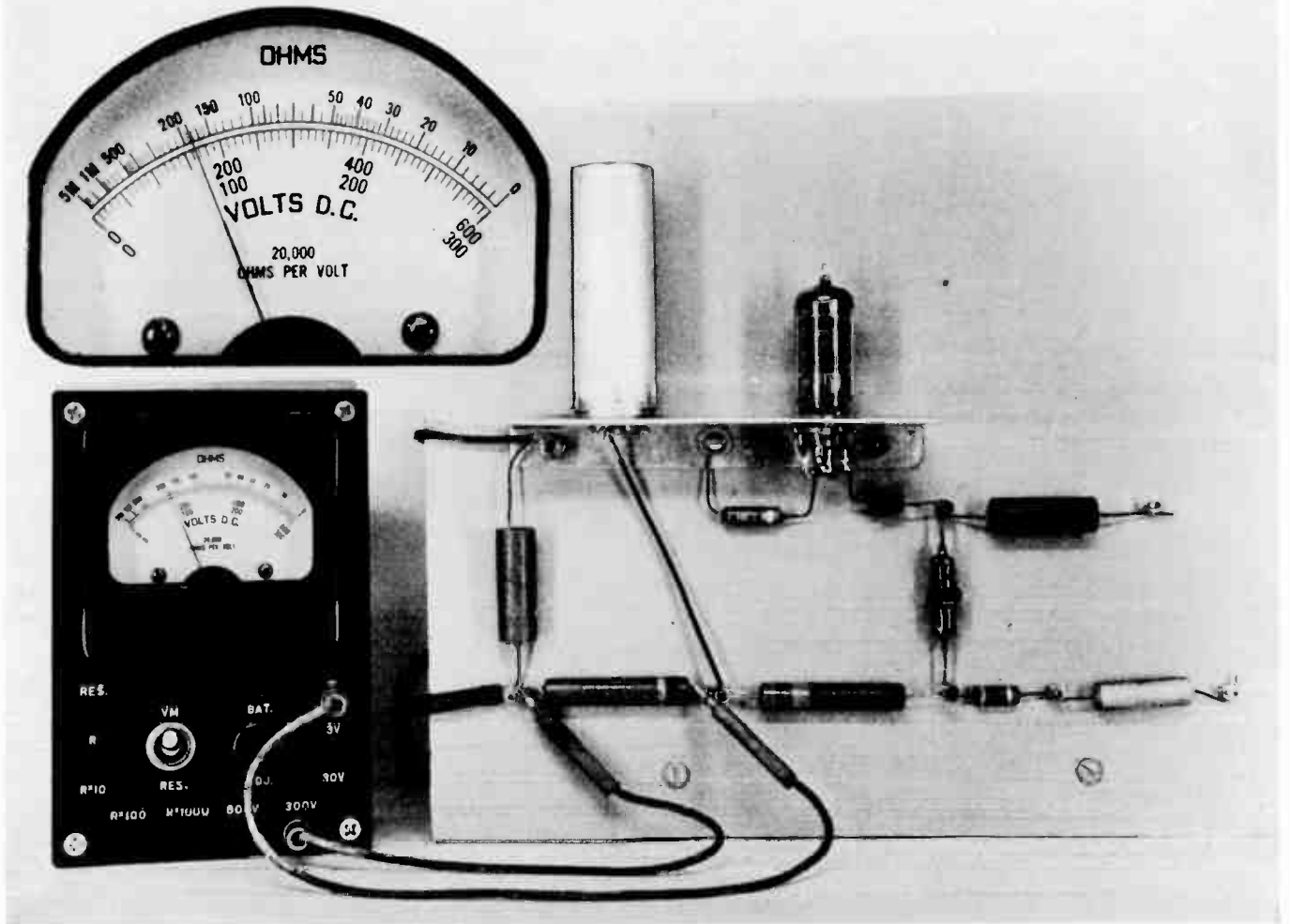

Fig. 11. There is increased voltage across the resistor when the electrolytic capacitor is connected.

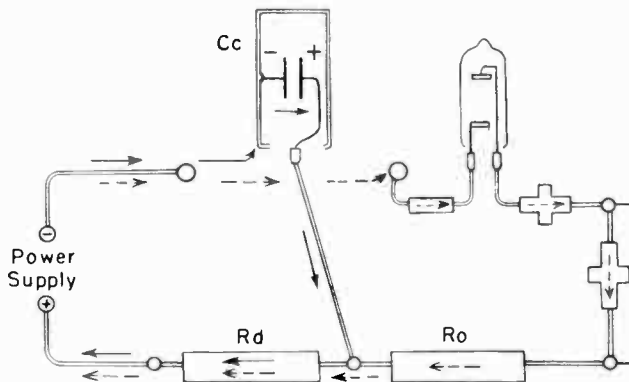

Fig. 12. Normal plate current follows the broken-line arrows. Additional leakage current through the electrolytic capacitor follows the full-line arrows.

wire going to the junction between resistors  $R_o$  and  $R_d$ , and back through resistor  $R_d$  to the positive side of the d-c power supply.

Resistance of  $R_d$  is 10,000 ohms. Connecting and disconnecting the electrolytic capacitor changes the potential difference across  $R_d$  from 83 to 75 volts. The change of potential difference is 8 volts. The change of voltage across  $R_d$  must be due to the additional current coming through capacitor  $C_c$ . The value of this current may be computed by employing the resistance of  $R_d$  and the change of voltage in our regular formula for current, thus.

$$\text{Milliamperes} = \frac{1000 \times 8 \text{ (volts change)}}{10000 \text{ (ohms)}} = \frac{8000}{10000} = 0.8 \text{ ma}$$

## LESSON 9—TROUBLE SHOOTING IN A PLATE CIRCUIT

A moderate electron flow from negative to positive terminals of an electrolytic capacitor does not indicate a fault in the capacitor. It is called leakage current, and is normal for all capacitors of this kind. The value of normal leakage current increases with the electrical size of a capacitor and with the maximum voltage at which it is designed to operate. The leakage current which we have computed is not excessive for the capacitor used in our test setup.

Additional current or electron flow coming through the electrolytic capacitor flows in resistor  $R_d$  but not in resistor  $R_o$ . Earlier we employed resistor  $R_o$  when computing the value of current in the entire plate circuit. Had we measured the potential difference across resistor  $R_d$  with the electrolytic capacitor connected, this potential difference would have been too great because of additional current from the capacitor. Our computation then would have indicated current greater than flowing in any parts of the circuit except resistor  $R_d$ .

Whenever you intend to make voltage or current measurements which should be quite accurate and representative of conditions in an entire series circuit it is advisable to temporarily disconnect any electrolytic capacitor from the measured circuit. By careful analysis you could determine which of the circuit elements would be affected by additional current coming through capacitors, but usually it is quicker and more certain to disconnect the capacitors.

**OPEN CIRCUITS.** An open circuit is a point in a normally closed or complete circuit at which there is a break in the conductive path. A closed circuit, on the other hand, is one consisting entirely of conductors, or of conductors and tubes, through which free electrons will flow when there are normal potential differences to cause such flow.

Resistors are classed as conductors because, although they oppose electron flow, they do allow such flow to pass through them. Inductors or coils are conductors because they are made with copper wire or some other metallic wire. Capacitors other than

the electrolytic kind are not conductors, because they do not permit a steady electron flow to pass through them.

If a wire or any other conductor in a series circuit becomes broken or disconnected is an open circuit at the point of break or disconnection. Poorly made soldered joints may be open circuits, either because the rosin flux gets between the conductors to insulate them, or because the conductors were heavily oxide coated when the joint was made. Screwed terminals may be open circuited because the screws are loose, or because the contacting surfaces of the conductors are not clean.

A resistor which has burned out because of overheating usually becomes an open circuit, although sometimes it will short circuit. Inductors or coils made with small wire may be open circuited due to burnout from overheating, or the small wire may have been accidentally broken.

A tube will act like an open circuit when its heater is burned out after long use. With the heater out the cathode remains cold, and with a cold cathode there can be no electron flow through the tube. If a tube is left out of its socket all the circuits connected to socket lugs are opened. Many a service man has hunted for an open circuit underneath a chassis after forgetting to replace a tube which he has removed while making preliminary tests.

**LOCATING OPEN CIRCUITS.** When a series circuit is open at any point there can be no electron flow across the break. Since electron flow or current is the same everywhere in a series circuit there will be no current anywhere in the circuit. With no current there will be no potential differences across any of the circuit elements.

Absence of potential difference due to an open circuit is illustrated by Fig. 13. To make an open clearly evident in the picture, inductor  $L_b$  has been disconnected. The power supply is turned on. The voltmeter is connected across resistor  $R_o$ , and reads zero voltage because there is no current in this resistor while the series circuit is open at any point.

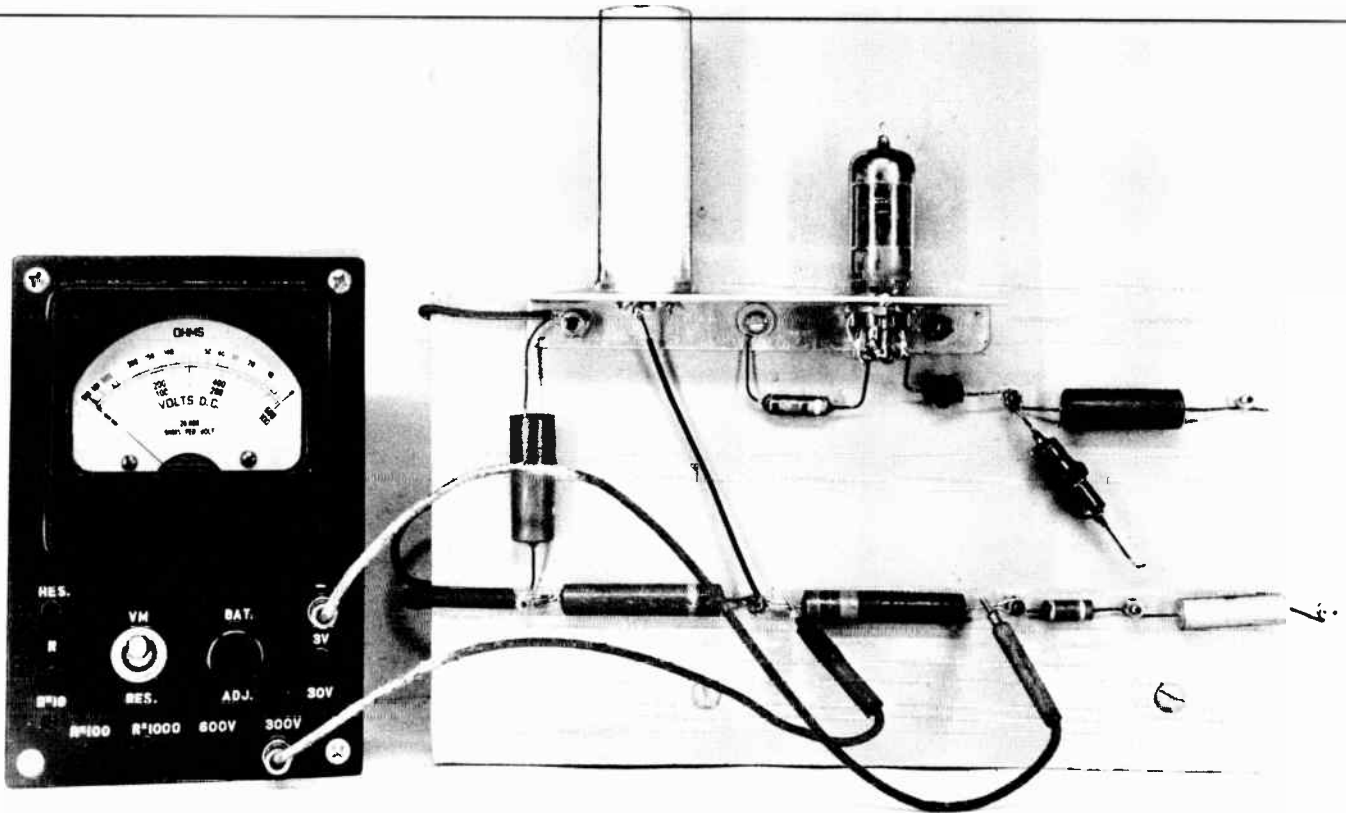

Fig. 13. There is no voltage across any element of a series circuit when there is an open, at some other point in the circuit.

Were the voltmeter connected across resistor  $R_d$  we would have a reading of about 10 volts. This potential difference would be due to leakage current from the electrolytic capacitor flowing in  $R_d$ , as shown by the full-line arrows of Fig. 12. Leakage current through the electrolytic capacitor would be somewhat greater than the previously computed value because power supply voltage increases to some extent when there is reduction of total circuit current with an open at  $L_b$ .

After you have some experience in checking plate circuits you would realize that a potential difference of only about 10 volts across the 10,000 ohms of resistor  $R_d$  means that the circuit is carrying much less than normal current, and you would look for the cause. If, however, you follow the advice of temporarily disconnecting electrolytic capacitors while measuring circuit voltages it won't be necessary to worry about the effects

of capacitor leakage currents. Now we may write this general rule.

When there is zero voltage across any circuit element which has appreciable resistance, and which should be carrying current in a series circuit, there is an open at some other point in the circuit.

To locate any one open circuit we may connect the voltmeter successively across each circuit element while the power supply is turned on. There will be zero voltage across all parts or elements except the one which is open circuited. There the voltage will become practically the same as at the terminals of the power supply. This is illustrated by Fig. 14. The voltmeter is connected between the terminals where inductor  $L_b$  has been disconnected to leave an open. The potential difference is about 370 volts, on the 600-volt range. This is greater than the volt-



# LESSON 9 – TROUBLE SHOOTING IN A PLATE CIRCUIT

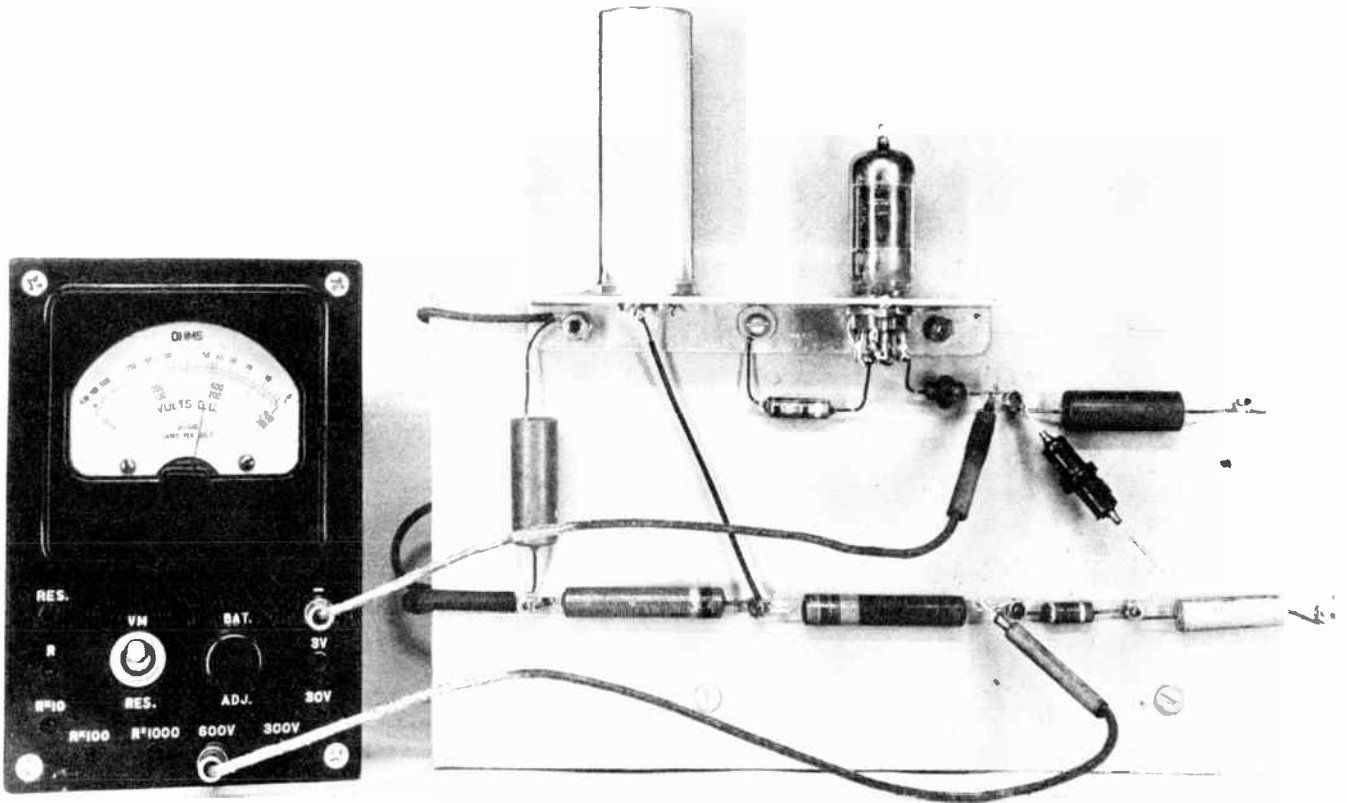

Fig. 14. Voltage across an open point in a series circuit is somewhat in excess of supply voltage normally applied to the circuit.

age previously measured at the ends of the plate circuit when there was no open point.

Power supply voltage increases when there is an open circuit, because less than normal current then is drawn and there is less loss of voltage within the power supply. The only current flowing in the plate circuit with the conditions of Fig. 14 is that which actuates the voltmeter. Resistance of this meter, on the 600-volt range is 12 megohms. This very great resistance allows current of only about 30 microamperes. This small current allows the power supply voltage to increase.

The method just explained will locate an open circuit when there is only one such fault in a series circuit. To illustrate, assume that there is one open at inductor  $L_b$  and another at cathode resistor  $R_k$ , as represented in Fig. 15. With the voltmeter across either fault the other one still prevents all current

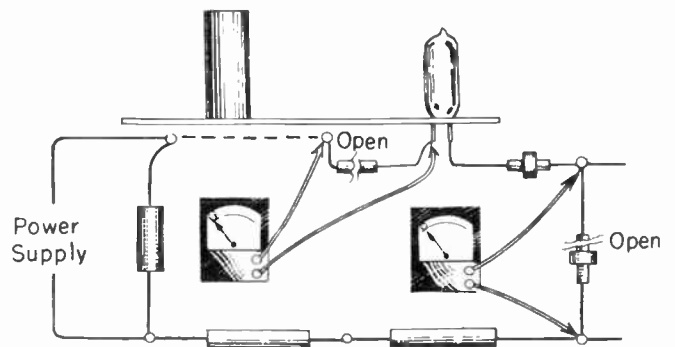

Fig. 15. When there is more than one open in a series circuit, connecting the voltmeter across individual elements will not locate the trouble.

flow, and the meter reads zero. Always it is possible that more than one open exists at the same time. Therefore, the following method of testing is to be preferred.

Connect either test lead of the voltmeter to the appropriate end of the series circuit,

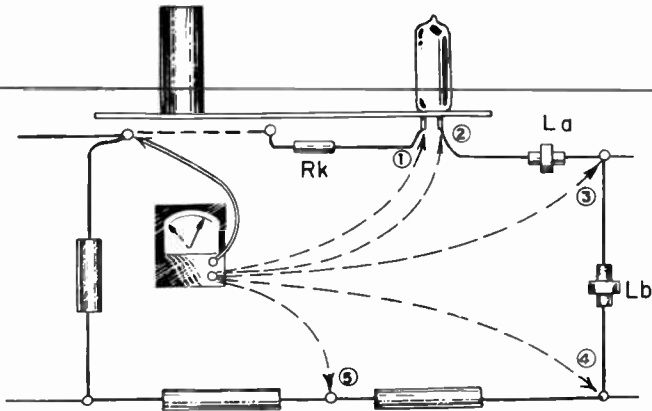

Fig. 16. To locate more than one open in a series circuit the voltmeter lead is applied to successive points along the circuit.

positive or negative as the case may be. Turn on the power supply and, as in Fig. 16, touch the other test lead to the points as successively numbered and which are electrically farther and farther from the connection of the first lead. The meter will read zero until you reach the first test connection after the last open in the circuit, for then the meter is bridging all opens. Were there opens at both Rk and Lb you would get no voltage reading until coming to point 4. This would indicate that one open is between points 3 and 4, for at point 3 there would be zero voltage and at 4 there would be full voltage.

The thing to do next is to turn off the power and make a repair or replacement which corrects the open circuit between points 3 and 4. Then you should turn on the power supply and start all over again at point 1. If the reading is zero volts you have not corrected all the opens. Proceed through the successively numbered test points until the meter reads a high voltage. This means that an uncorrected open circuit is located between the point then being checked and the preceding point at which voltage is zero. This open must be repaired before trying again.

When all open circuit points have been corrected, a voltmeter check such as illustrated by Fig. 16 will give voltage readings which become greater and greater as you proceed around the circuit. This will mean

that the current path is complete all the way around.

When testing for opens, also when making regular voltage measurements with a d.c. voltmeter, the pointer may sometimes move up on the dial and then drop back to zero. When this happens there is a capacitor somewhere in series with the voltmeter. Supposing, for example, you are making tests such as illustrated by Fig. 16, After touching the positive lead of the meter to point 3 in that diagram you might go next to the tie point beyond capacitor Ca, as in Fig. 17. The meter pointer would jump up to something like 40 or 50 volts, then go back to zero and stay there. If you touch the test lead to this same tie point a few moments later the meter pointer hardly will move, it will remain near zero.

This is what happens. The positive side of the voltmeter, through its test lead, is connected through capacitor Ca and inductor La to the plate lug of the tube socket. The tube plate is at a potential 220 volts positive with reference to chassis ground, to which is connected the negative test lead of the meter. Electrons rush into one side of the capacitor and out of the other side through the voltmeter. One side fills up while the other empties to give the internal parts of the capacitor negative and positive charges. There can be no continued electron flow right through the capacitor, for there is insulation between its internal parts. Consequently, after the momentary rush of charging current, the electron flow drops to zero and so does the meter pointer.

The capacitor will retain its charges for quite a long while. When you make the same meter connection a second time the capacitor is already charged, and only a small quantity of additional electrons can flow into and out of the capacitor. This is why the meter pointer hardly rises on the second test, or on any following tests made before the capacitor loses its charges.

The same thing would happen were you to touch the meter lead to the tie point which is beyond capacitor Cb. It will happen whenever the meter is connected in series with any capacitor which is in good condition, and

## LESSON 9 -- TROUBLE SHOOTING IN A PLATE CIRCUIT

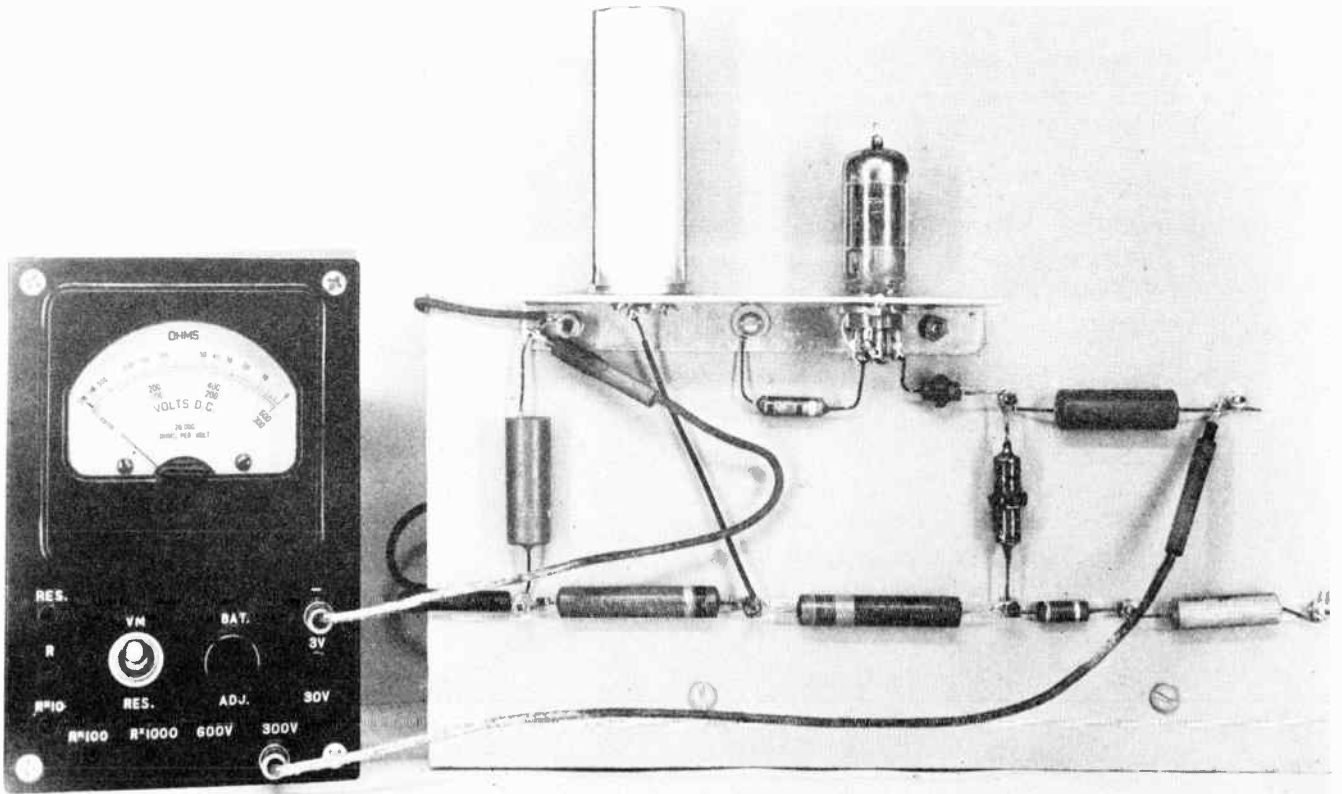

Fig. 17. A capacitor in series with a voltmeter and a source of potential prevents the meter from indicating a steady voltage.

when there is a difference of potential across the meter and capacitor. If the capacitor is an electrolytic type the meter pointer will return toward zero more slowly than with other types, and may not go all the way to zero. By observing the rise and fall of a voltmeter pointer the technician can tell that a capacitor is somewhere in series with the test points, and after a little practice will know whether the capacitor is an electrolytic or some other type.

**LOCATING OPENS WITH THE OHM-METER.** The ohmmeter may be used for locating open points in a series circuit provided the power supply is kept turned off to protect the meter. One end of the series circuit must be disconnected from all other circuits so that resistance measurements will not be confused by conductive paths through the other circuits. These are the same precautions as observed when using the ohmmeter for locating shorts.

The ohmmeter may be connected across individual circuit elements, just as the voltmeter is connected in Fig. 15. The reading will indicate infinitely great resistance when the connections are across an open point. You must remember that a tube with its cathode cold becomes an open circuit, and the cathode will be cold while the power supply is turned off.

It is necessary also to take especial care when electrolytic capacitors remain connected to the tested circuit. Such capacitors sometimes provide a conductive path for current from the ohmmeter battery even when the meter leads are across some element which is open. If resistance increases after connecting the ohmmeter, an electrolytic capacitor is affecting the reading.

Instead of testing individual elements the ohmmeter may be used in the same manner that a voltmeter is employed in Fig. 16. When



## COYNE - *television home training*

there is an open circuit between the points at which the test leads are connected the reading will indicate the sum of the resistances of all the parts which then are between the test leads. As soon as you pass an open point the resistance will increase to an infinitely high value.

As an example, assume that there is an open in inductor Lb of Fig. 16. One ohmmeter lead is connected to chassis ground. When the other lead is applied to point 1 the indicated resistance will be that of resistor Rk. With this other lead on point 2 the ohmmeter will read infinite resistance, indicating an open. This is correct, because the amplifier tube with its cathode cold really is an open circuit. Now you may either connect a piece of wire between the cathode and plate lugs of the tube socket, to bridge the open circuit which is the tube, or else move the first test lead from chassis ground to the plate terminal of the tube socket before proceeding.

Then, with the second test lead on point 3 there would be a reading corresponding to resistance of Rk, because the resistance of La is negligible. With this second lead on point 4 the ohmmeter will read infinite resistance, because the open is between points 3 and 4.

As a general rule it is easier to locate open circuits with the voltmeter than with the ohmmeter. When using the voltmeter you don't have to disconnect one end of the tested circuit. Tubes remain hot and conductive, so that they don't have to be bridged with jumper wires, nor do test leads need shifting to get around tubes. Power is kept turned on to operate all parts under fairly normal conditions, yet, because open-circuit trouble re-

duces direct current nearly to zero, there is little likelihood of causing further damage.

The ohmmeter usually is preferred for locating shorts. This is because a short may allow excessive current and further damage with the power turned on, and with power turned off the voltmeter is useless.

After locating an open circuit by any means it is essential to find why the open occurred, or at least to determine whether it is the result of a burnout in the unit affected. If the open component apparently has been burned out you must find whatever allowed the excessive current that caused the overheating. More than likely the excessive current came through some other part which is short circuited. Every component in the connected circuit should be checked for shorts.

Many times you will discover that a fixed capacitor has shorted, or has allowed abnormally great leakage current. The excessive current usually overheats a resistor in the same circuit, and the resistor burns out to form an open. The open resistor is the final trouble, but the real cause is the shorted capacitor. New resistors will burn out as fast as you install them - until you locate and replace the shorted capacitor.

In this lesson we have employed a particular plate circuit to illustrate the location of opens and shorts, methods of measuring and computing voltages and currents, and of making other service tests. This plate circuit has been employed only to give us something definite on which to practice. The same general procedures are used in checking any and every other kind of circuit in television and radio, so what we have learned here is applicable in every variety of service work.

# TELEVISION

◦ RADIO

◦ ELECTRONICS

---

**LESSON 10 – THE LOW VOLTAGE POWER SUPPLY**

---

***Coyne School***

*practical home training*

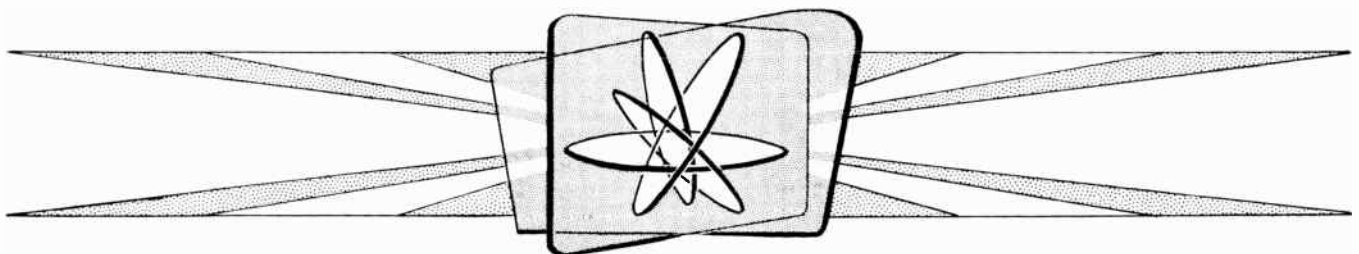

*Chicago, Illinois*

---

*Copyright, 1953 by Coyne Electrical School  
Chicago 12, Illinois  
All rights reserved*

Litho. in U.S.A.



## Lesson 10

# THE LOW VOLTAGE POWER SUPPLY

While locating short circuits and open circuits in various parts we have taken it for granted that the power supply is furnishing all necessary voltages and currents. But the power supply itself may develop trouble. When anything is seriously wrong in this section of the receiver the picture tube remains dark, the speaker is silent, and the set is completely out of commission - for everything depends on the power supply.

We might consider any receiver to consist of apparatus which allows the received signals to control electric power obtained from its power supply. Were signals from the antenna to be applied directly to the picture tube they would be far too weak to produce pictures, and from the speaker they could not produce sounds audible at more than two or three inches.

From the power supply of the receiver we can secure electric power strong enough to vary the screen of the picture tube from the most brilliant white to jet black. But to form these variations into a picture the power must be controlled, by the signal. The power supply could furnish enough power to tear the speaker cone loose from its fastenings. But to have music and speech this power must be controlled.

How much power is needed, and how it is furnished, depend on where the power is to be used. For tube heaters we want power in the form of alternating current at various voltages between 5 and 50. For plates and screens of amplifiers and other small tubes the power must be in the form of smooth direct current at voltages anywhere between 10 and 350 volts. For the heater of the picture tube we again want alternating-current power at low voltage, but for other elements in this tube the power must be smooth direct current at voltages from about 250 up to 15,000 or even more.

So far as the receiver is concerned, the source of energy for all these alternating and

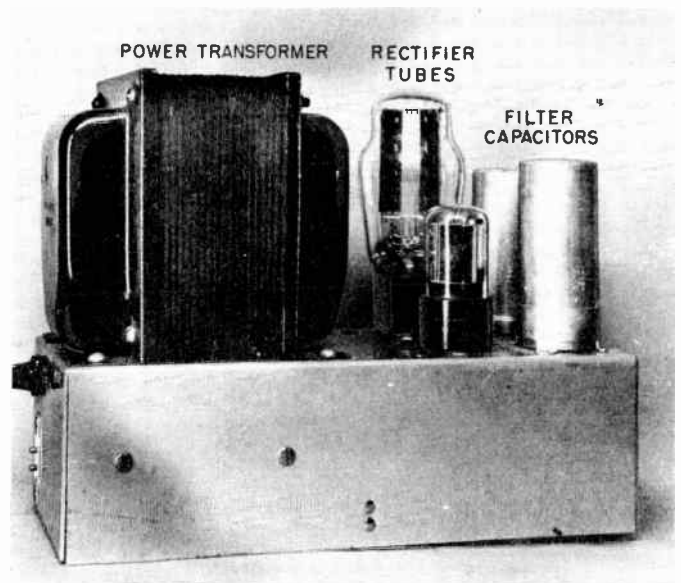

Fig. 1. A television low-voltage power supply section constructed on a separate chassis.

direct currents, with their wide range of voltages, is the electric light and power line in the building where the receiver is used. In this power line there is only alternating current. There is only one voltage, which usually is between 110 and 120 volts.

It is the function of the power supply of the receiver to take line power in the form of alternating current at 110-120 volts, and to turn out all the different alternating and direct currents and all the many voltages which are to be controlled by the received signal. In actual practice this work is divided between two power supply sections. One furnishes all the alternating currents and voltages for tube heaters, also all the smooth direct currents at voltages up to about 350, for all the tubes. This section usually is called the low-voltage power supply. Picture tube voltages higher than about 1,500 are furnished by another section called the high-voltage power supply.

The low-voltage power supply sometimes is on a separate small chassis, and is connected through a multi-conductor cable to the

## COYNE - *television home training*

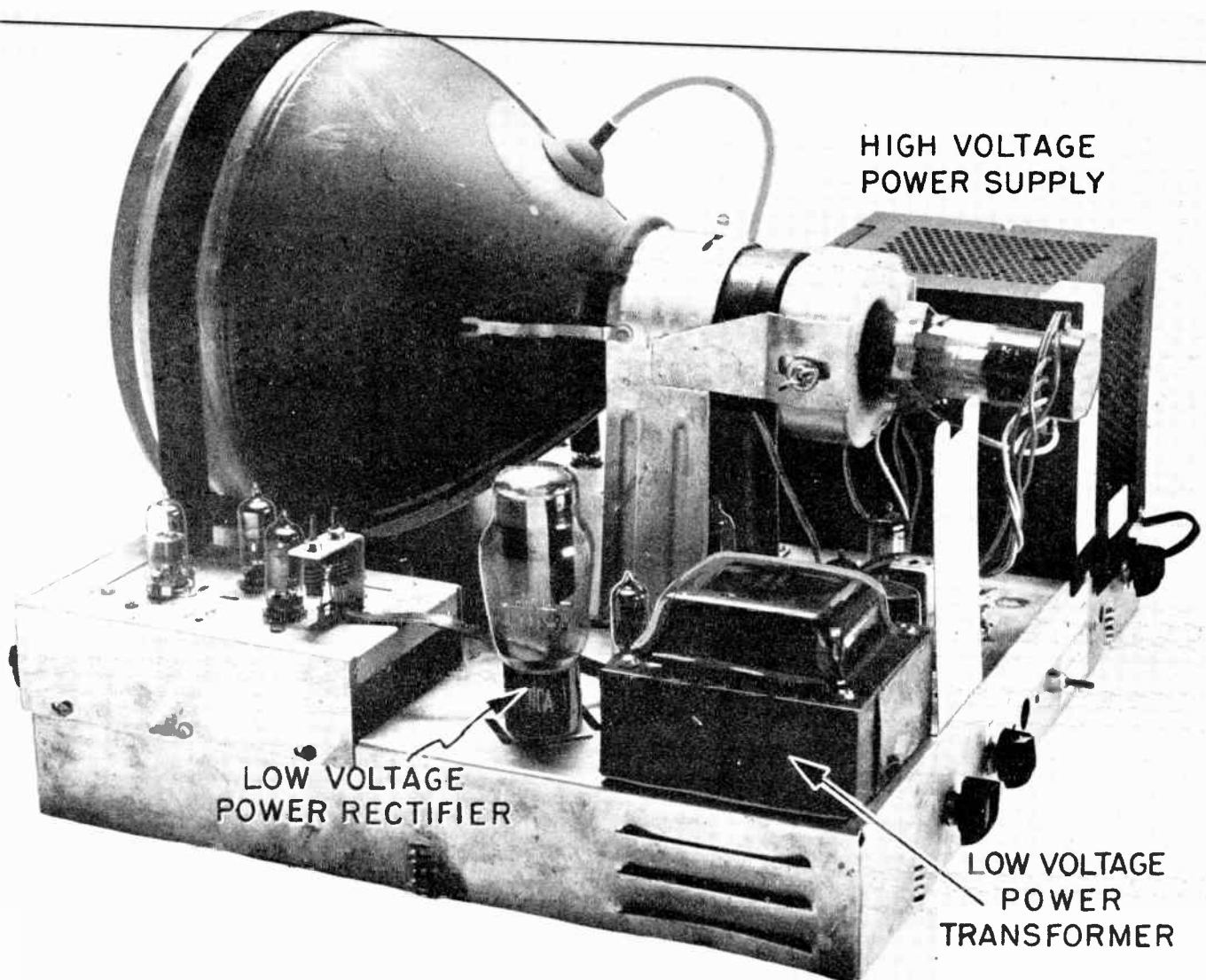

Fig. 2. The power supply sections usually are mounted on the main chassis.

main chassis. Fig. 1 is a picture of such a separate power supply for a large television receiver. More often the power supply parts are mounted on the main chassis. Such construction, on a small television set, is pictured by Fig. 2. Parts of the low voltage power supply are mounted on the corner of the chassis which is nearest to you in the picture. The high-voltage power supply is on the rear corner farther from you. We shall deal first with low-voltage power supplies.

To learn how a low-voltage power supply does its work we shall watch it perform. We shall see the alternating voltage from the

building power line, and see it change to higher or lower voltages. The higher alternating voltage will change to an irregular or "pulsating" direct voltage. Finally this pulsating voltage will change to the smooth or constant direct voltage required by tube elements.

Pictures of all the voltages and their changes will appear on a service instrument called the oscilloscope. Part of the oscilloscope is a cathode-ray tube which is quite like the picture tube of a television receiver. Inside the cathode-ray tube is an electron beam which traces luminous lines on the screen, just as does the electron beam in a picture

# LESSON 10 – THE LOW VOLTAGE POWER SUPPLY

tube. But the oscilloscope is so designed that these traces show any voltages which are applied to the input of the instrument.

First of all we shall look at the alternating voltage furnished by the building light and power line. You can see it in Fig. 3. This is

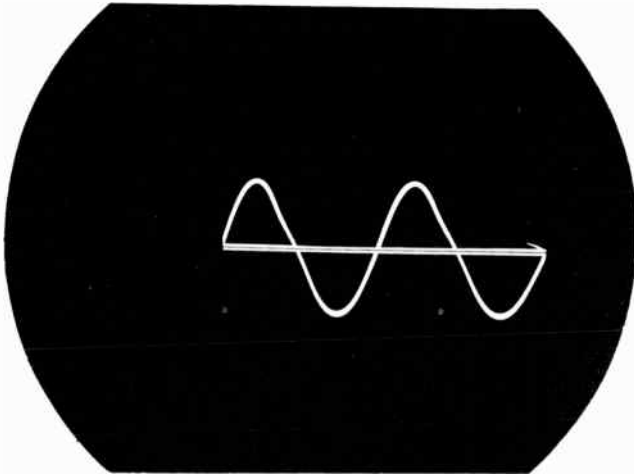

Fig. 3. This is the alternating voltage from the power line, as seen by the oscilloscope.

the voltage that sends electrons first one way and then the opposite way in the line wires and in anything connected to them.

The trace shows how the voltage changes during a certain time. The voltage always is changing in this same manner, but here we are looking at what happens during only a brief interval of time. If you imagine the left-hand end of this trace to commence at some one instant, the right-hand end occurs  $1/30$  second later. We are seeing the changes of voltage which occur during  $1/30$  second, with time increasing from left to right.

Changes of voltages are shown by rise and fall of the trace. It appears that voltage is merely increasing and decreasing. But actually the voltage becomes zero at every instant in which the trace passes across the horizontal line drawn on the picture.

From this zero value the voltage increases in one direction or one polarity when the trace rises above the horizontal line. The voltage increases to its maximum or peak value in this polarity, and drops back to zero. Then the voltage becomes stronger in

the opposite direction or polarity as the trace drops below the horizontal line. The voltage goes to its maximum or peak value in this direction, and again returns to zero. This continues indefinitely.

The voltage in either direction or polarity may be called positive with reference to the zero value, and then in the opposite direction or polarity it would be called negative. Purely as a matter of convenience, we usually think of the upward trace as representing positive voltage and of the downward trace as representing negative voltage, with reference to the central zero value.

Fig. 4 is a drawing showing the variation of voltage from zero to positive to negative

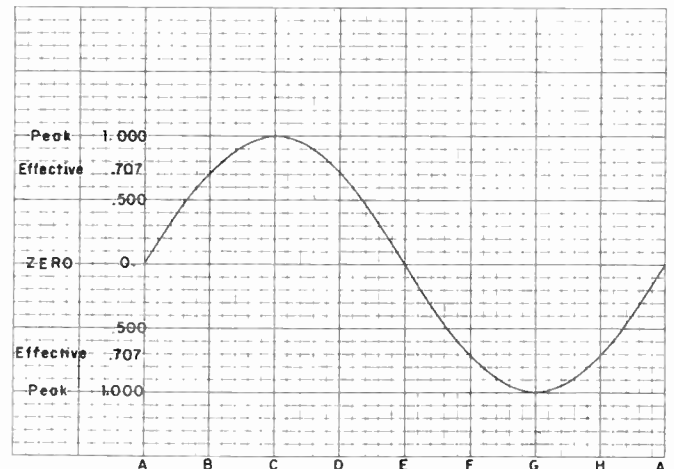

Fig. 4. A sine-wave alternating voltage or current, and its principal values.

and back to zero. When the voltage varies in the manner shown by the drawing it is called a sine-wave voltage. A current varying in this manner is called a sine-wave current. Nearly all our simple rules for behavior of alternating voltages and currents are based on having sine-wave forms or changes. Some people use the word sinusoidal to describe a sine-wave voltage or current. Sinusoidal and sine-wave mean the same thing.

When a sine-wave current has a peak or maximum value of one milliamper, or one of any other unit of current, it will produce heat at some certain rate when flowing in a resistance. Heat would be produced at exactly the same rate by a steady direct current of only 0.707 milliamper, or of only 0.707



# COYNE - television home training

times any other current unit used for measuring the alternating current. Consequently, we say that the effective value of a sine wave current is 0.707 of its peak value, as marked on Fig. 4. The effective value of a sine-wave voltage is likewise 0.707 of its peak value.

Another name for effective value is root-mean-square value. The term root-mean-square often is abbreviated to rms or r-m-s. Any alternating voltage or current which is not specifically stated to be a peak value or some other particular value always is understood to be an effective or rms value. Don't forget this. All a-c voltmeters and a-c current meters commonly used for service tests indicate effective or rms values.

By dividing 1.000 (the peak value) by 0.707 (the effective value) you will find that the peak of a sine-wave is equal to 1.414 times the effective or rms value. When the effective or rms value is 1.000 milliamper, or 1.000 of any other current unit, the peak value is a sine wave will be 1.414 of the same current unit. This same relation holds for peak and effective sine-wave voltages. A meter scale graduated for both kinds of values would appear as in Fig. 5. Each value

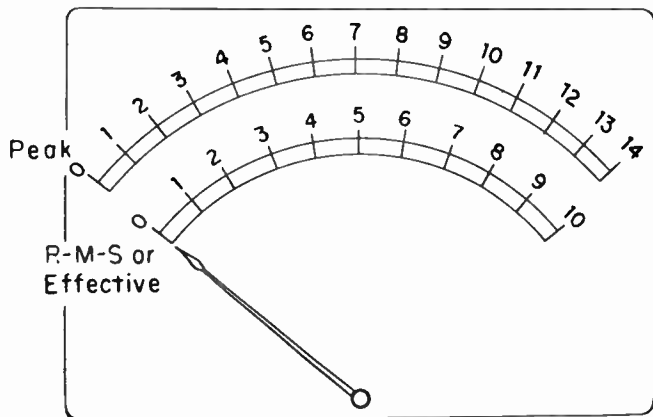

Fig. 5. How peak values of a sine wave compare with effective or rms values.

on the peak scale is 1.414 times the value at which the pointer would stand on the rms or effective scale.

All these relations between effective and peak values hold true only when the voltage or current varies according to the sine-wave form. In many television circuits we have voltages which are not of sine-wave form.

Then it becomes necessary to measure peak values in other ways.

The changes of voltage or current represented by Fig. 4 make up what is called one cycle. A cycle of alternating voltage or current includes all the changes which occur between the instant at which we commence our observation and the following instant at which there are exactly the same conditions.

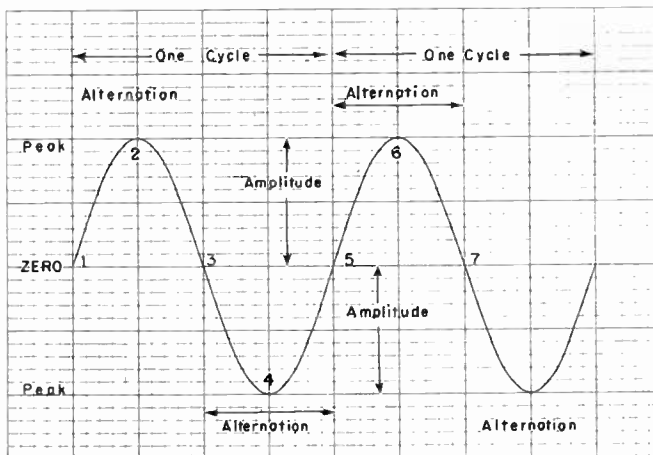

Fig. 6. The meanings of some terms which relate to alternating voltage or current.

Fig. 6 shows two cycles. If we consider the cycle to begin at 1 in Fig. 6, that cycle ends at 5, because at 5 the voltage or current is again at zero and is ready to increase in the same polarity as at 1. If we consider a cycle to begin at 2 it ends at 6, because at both these instants the voltage or current is at its peak value in the same polarity. A cycle might be considered to begin at 3 and end at 7, or it might extend between any other two points provided a complete set of changes is included between the points.

The rise and fall of voltage and current in one polarity, either one, may be called an alternation. There will be two complete alternations in a cycle which begins and ends at zero.

The amplitude of an alternating voltage or current, as shown by Fig. 6, is the maximum or peak value reached in either polarity. With a sine-wave voltage or current, or with any other symmetrical "waveform", the amplitudes are the same in both polarities, and are equal to the maximum or peak values.

## LESSON 10 – THE LOW VOLTAGE POWER SUPPLY

Otherwise the amplitudes in opposite polarities may or may not be equal.

Cycles of alternating voltage and current repeat over and over again. The number of cycles completed during one second of time is the frequency of the voltage or current in cycles per second. The term cycles per second may be abbreviated to c.p.s. or to cps. Power line frequency most often is 60 cycles per second, although in some localities we find 50 cycles per second and in a few cases 25 cycles per second. The frequency of the voltage in Fig. 3 is 60 cycles per second.

**The POWER TRANSFORMER.** Now let's get back to the power supply section of the receiver and see what the power transformer does to the alternating line voltage, which was shown by Fig. 3. Inside the transformer are several coils or windings made of insulated wire. One of these, called the primary winding, is connected to the power line. Another, called the high-voltage secondary, furnishes voltage and current which eventually will deliver power to plates and screens of all the small tubes.

When the oscilloscope is connected to the high-voltage secondary of the power transformer we find the voltage pictured by Fig. 7.

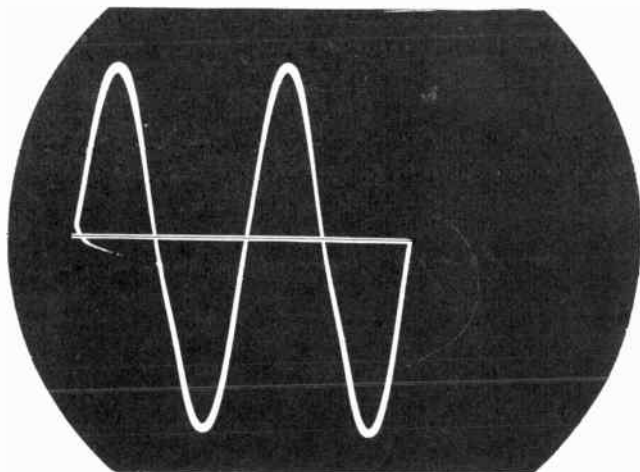

Fig. 7. The power transformer increases the alternating voltage taken from the power line.

A horizontal line has been added to show the point of zero voltage. The voltage still is alternating, and is of the same waveform and same frequency as before. But the trace is

much higher, the amplitude of the voltage is greater. From the line we obtained 120 effective volts. From the high-voltage secondary of the power transformer we have close to 350 effective volts. The transformer has increased the alternating voltage by about 2.9 times, but otherwise has made no change.

In the power transformer is another winding called the heater winding, which furnishes alternating current at 6.3 volts for the heaters of all tubes in the particular receiver whose power supply we are examining. With the oscilloscope connected to this heater winding we can see that the voltage is alternating, but it is of such small value or small amplitude that the height of the trace is difficult to observe or measure.

In the oscilloscope is a "vertical gain control" which acts like the vertical size control or height control of a television receiver. By operating this gain control to make the trace for any applied voltage about 5 times as high as before, we obtain the trace pictured by Fig. 8. Again we find the same

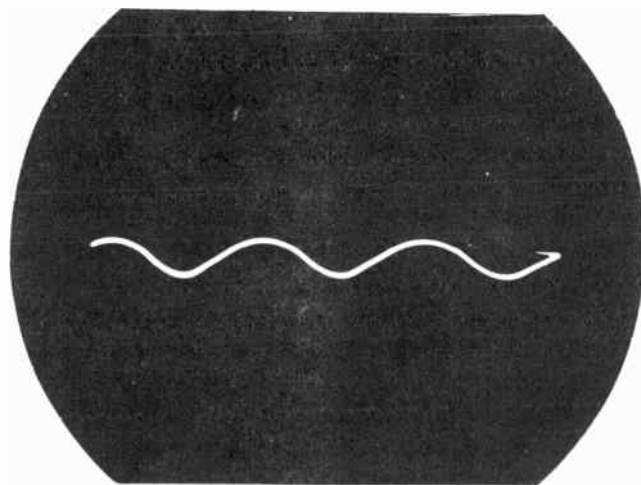

Fig. 8. The alternating heater voltage is much weaker than power line voltage.

waveform and same frequency as from the power line. But the transformer has reduced the alternating voltage to about 1/19 of its value in the power line.

By means of a transformer we may obtain alternating voltages which are either greater or less than the alternating voltage fed into the transformer from a power line.

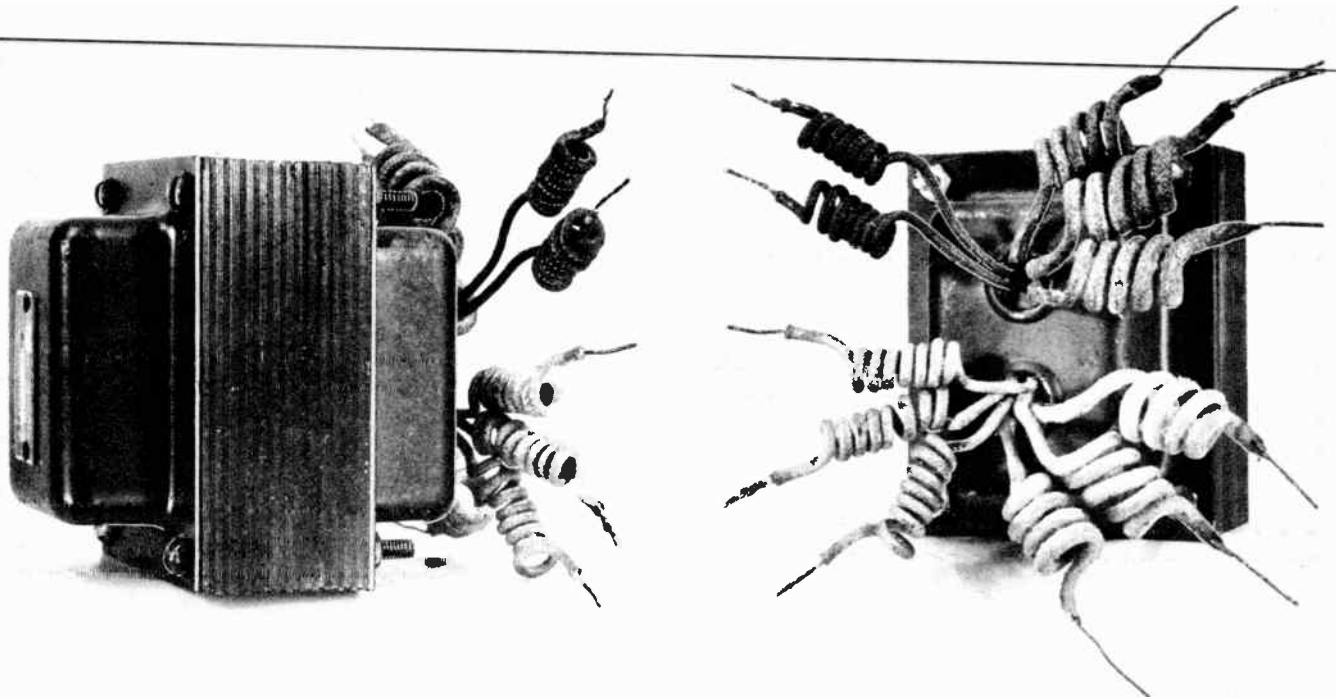

Fig. 9. The insulated leads connect to the internal windings of this transformer.

A transformer which is correctly designed and constructed will not change the form of the applied alternating voltage, nor will it change the frequency, it changes only the value or amplitude of the alternating voltage. It will be interesting to look inside a power transformer, and learn how it does its work.

A typical power transformer of medium size is pictured by Fig. 9. A number of insulated wires extend from the internal windings out through one side of this particular transformer. This side would go through an opening in the chassis to make the leads accessible from underneath.

In Fig. 10 we have removed the two metal shells that enclose and protect the internal parts of the transformer. This exposes an iron core in the center of which are mounted the several windings or coils. The windings are made of correct shape before being assembled into the core. Typical preformed windings are shown by Fig. 11.

The core itself, without any of the windings in place, appears as in Fig.12. The core is made up of many thin sheets of iron called

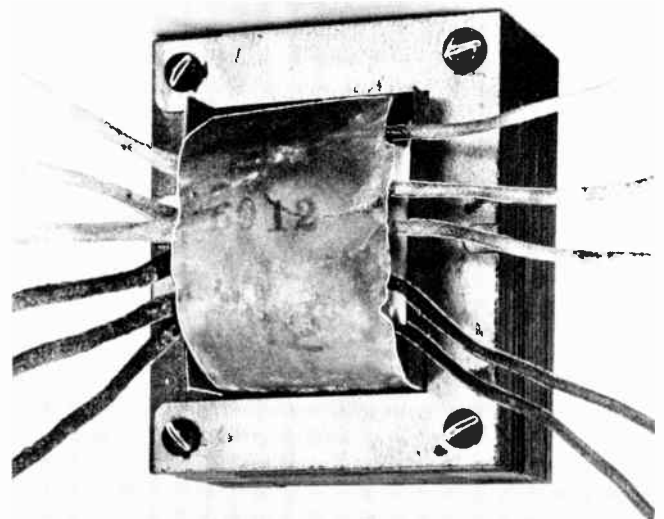

Fig. 10. The core and windings of a power transformer.

laminations. The laminations which we speak of as being made from iron really are of a special grade of steel, called transformer steel. It is, however, common practice to say that the core is of iron.

We may represent the transformer core and one winding in simplified fashion as in



## LESSON 10 – THE LOW VOLTAGE POWER SUPPLY

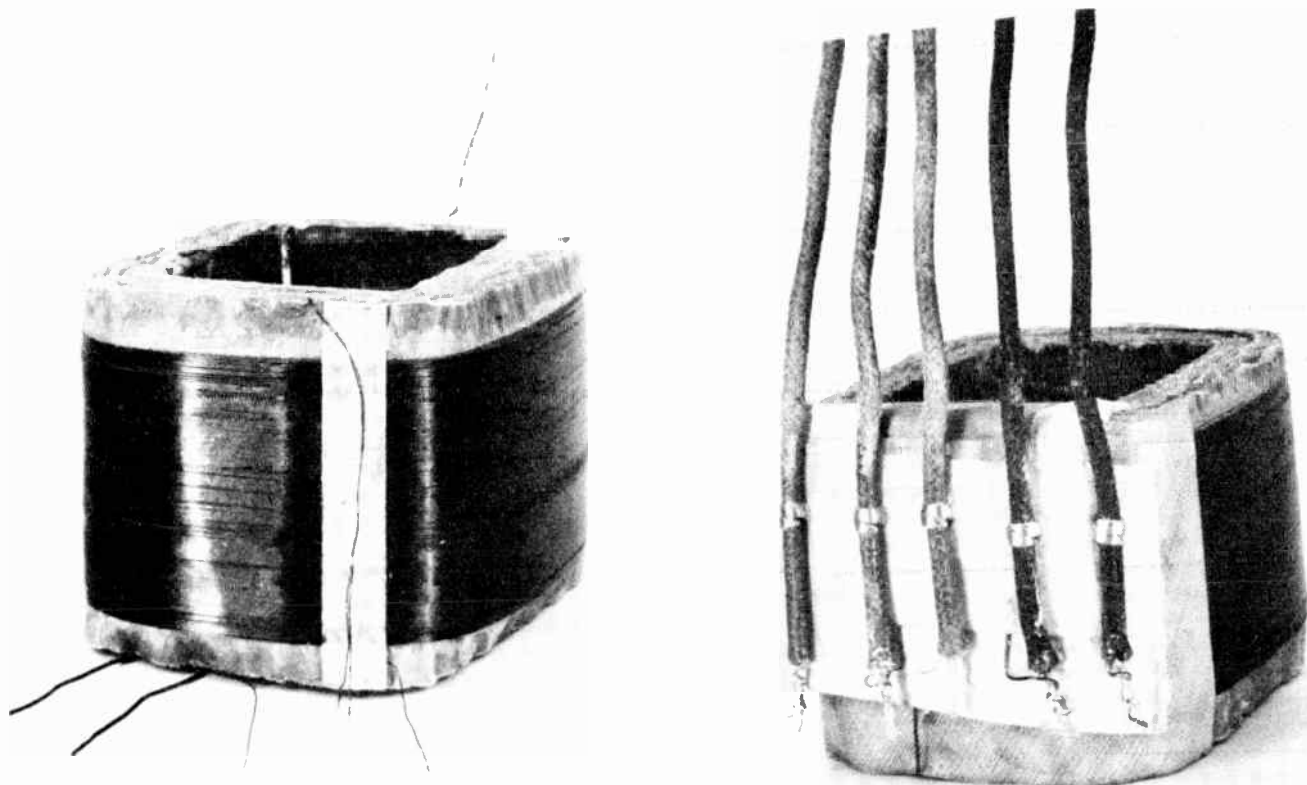

Fig. 11. Several windings may make up a single coil assembly for a power transformer.

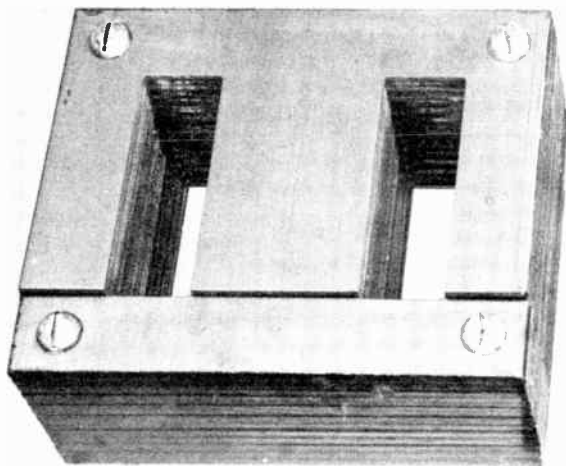

Fig. 12. The transformer core with all windings removed.

Fig. 13. The core laminations are of such shape that when assembled there are openings or windows for the winding. The center legs of the laminations pass through the center opening of the winding. The outer legs of the core form a complete path all the way around

on both sides of the winding. When current flows in the winding the core becomes a magnet, and magnetic lines of force flow within the core iron as shown by broken lines and arrows.

Supposing that a source of alternating voltage, such as the power line, is connected to this winding. This will cause an alternating current to flow in the winding. During any instant in which the voltage is going through zero there will be no current. Then the core is not a magnet, it is just a piece of iron.

As voltage and current increase in either polarity the core is magnetized more and more strongly. In the space surrounding any magnet there is a magnetic force. It is this force that causes a toy magnet to attract a nail or other small pieces of iron or steel. The space in which the force exists is called the magnetic field of the magnet. The greater the voltage and current, the stronger becomes the magnetic force, and the farther it extends from the iron of the core. The force or the magnetic field moves outward from the surfaces of the core iron.

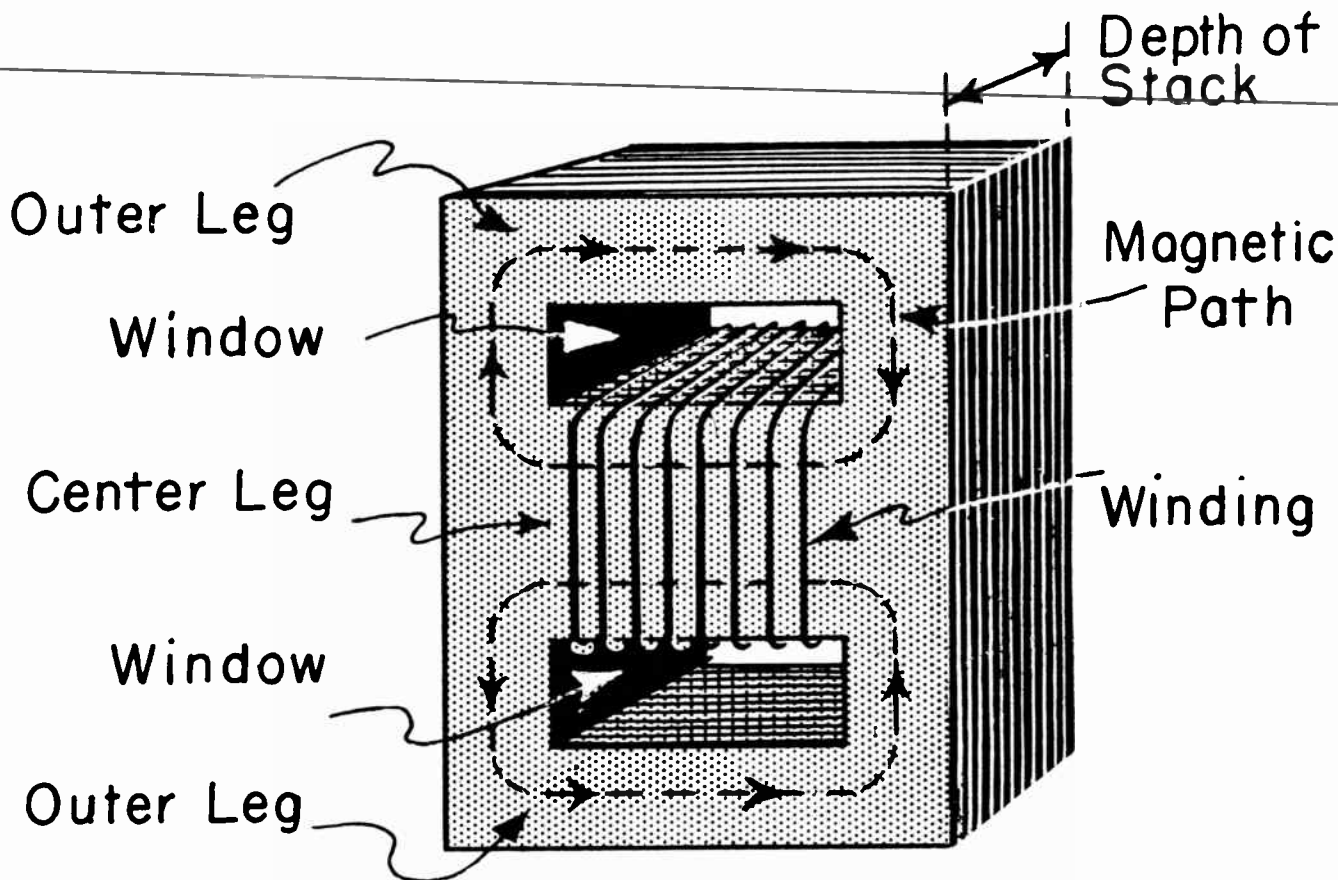

Fig. 13. The path followed by magnetic lines of force in a transformer core.

When voltage and current reach their peak values and commence to decrease, the magnetic field and force become weaker and weaker. In effect, the field shrinks back toward the core and disappears when voltage and current become of zero value. During the next alternation of current the same thing happens, except that the magnetic lines circulate in the opposite direction through the core. Again the field expands and contracts around the core iron. This action continues repeatedly.

Supposing now that we place a second winding closely around the one in which alternating line current is causing the magnetic field to expand and contract. Fig. 14 is a picture of transformer coil assemblies consisting of more than one winding in each. When assembled in a transformer, all the windings are around the center leg of the core, and all are surrounded by the outer legs of the core. The winding which takes voltage from the power line is called the

primary winding. All the others are called secondary windings.

The expanding and contracting magnetic field produced by action of the primary winding must be moving out and back through the turns of all secondary windings, because all windings are so close together on the same core.

Now we encounter one of the most remarkable of all electrical actions. When a magnetic field moves across or through any conductor, an electromotive force or "electron moving force" appears in that conductor. The wires of primary and secondary windings are insulated, and the windings are insulated from each other. Yet the magnetic field produced by one winding will cause electromotive force and voltage to appear in the other winding.

The action just described is called electromagnetic induction. Without it there would

## LESSON 10 – THE LOW VOLTAGE POWER SUPPLY

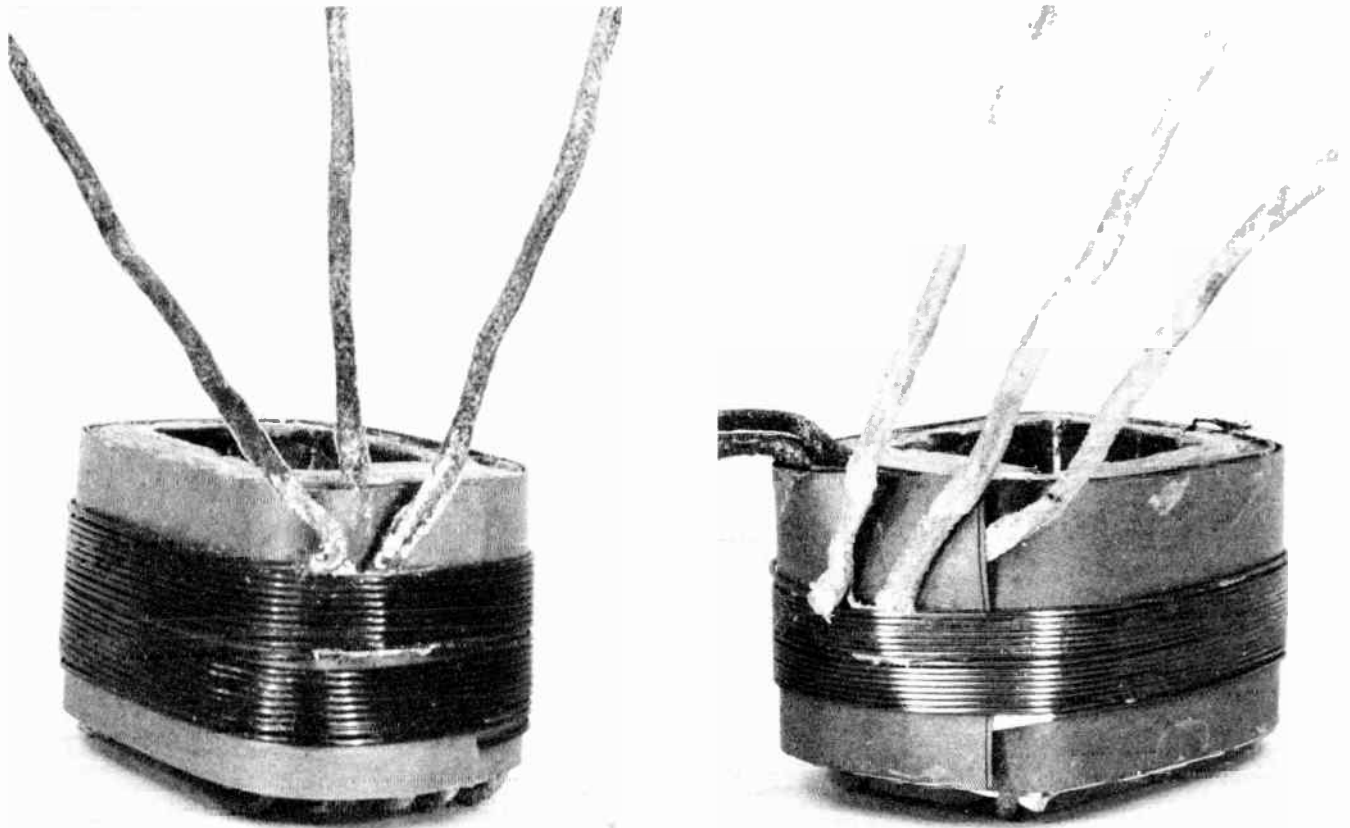

*Fig. 14. Winding assemblies formed to fit the core of a power transformer.*

be no radio and no television as we know them, for you will find this action employed in many places throughout all receivers. An alternating current in a transformer primary winding will induce an alternating voltage in the secondary winding. If the secondary is connected to any complete circuit, the induced alternating voltage will cause flow of alternating current in that circuit and in the secondary winding.

**PRIMARY CURRENT.** The primary winding of a power transformer usually consists of but a few hundred turns at most. The resistance of such a winding may be about 4 ohms. Our alignment chart or a formula for current will show that 120 volts from the power line applied across resistance of 4 ohms should cause current of 30 amperes. Yet if you measure the alternating current in the primary while the secondaries are delivering no current to other circuits, this primary current will be in the neighborhood of 1/4 ampere.

The primary current is limited by a voltage called counter-emf. Counter-emf is induced in the primary winding by the expanding and contracting magnetic field, just as other voltages are induced by this moving field in the secondaries. But at every instant the polarity of the induced counter-emf is opposite to the polarity of the line voltage, and the counter-emf always is opposing and largely balancing the line voltage. It is only the difference between line voltage and the voltage of counter-emf that causes current to flow in the primary winding.

If one or more of the secondary windings are delivering voltage and current to connected circuits, there will be an increase of primary current. There must be an increase of primary current, for this is the only way in which the transformer may take more energy or power from the line. It is the extra power represented by greater primary current that becomes power going out from the secondary windings.



## COYNE - *television home training*

**TURNS RATIOS.** In an earlier example we figured out that alternating voltage from a high-voltage secondary winding is about 2.9 times as great as the line voltage applied to the primary. Should you open this transformer and unwind the secondary and primary, while counting the turns in each, you would find about 2.9 times as many secondary turns as primary turns.

The number of secondary turns divided by the number of primary turns is called the turns ratio of the windings. Dividing the secondary alternating voltage by the primary alternating voltage gives a number called the voltage ratio of the two windings. The two ratios always are very nearly alike.

All that we need do to have secondary output voltage any number of times greater than primary input voltage is to have a turns ratio of approximately the same number of times. This makes what may be called a step-up transformer or a step-up secondary. Should we wish to have secondary voltage smaller than line voltage it is necessary only to have fewer secondary turns than primary turns. Then we have a step-down transformer or a step-down secondary.

From a single transformer we may obtain as many different secondary or output alternating voltages as desired. It takes one secondary winding for each required voltage. The one primary winding serves for all the secondaries, and there is only a single core. Power transformers for television and radio receivers are made this way. The one transformer can be constructed to furnish some alternating voltages which are higher and others which are lower than line voltage, all at the same time.

Power transformers are represented on service diagrams with symbols such as shown by Fig. 15. Windings are shown by series of loops. The core is shown by two or more straight lines. Usually the primary is represented on one side of the core, and all the secondaries on the other side, although all windings sometimes are drawn on the same side of the core lines. The number of loops representing a winding has no particular relation to the number of turns or to the

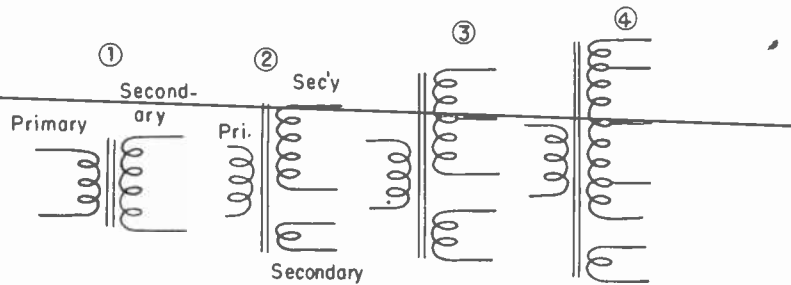

Fig. 15. Symbols which represent power transformers on service diagrams.

turns ratio. The symbol at 1 represents one primary and one secondary winding. Two secondaries are shown at 2. At 3 and 4 are shown tapped secondaries having connections intermediate between the two ends. We shall need tapped secondaries as we proceed with our investigation of power supplies.

**POWER RECTIFIERS.** Back in Fig. 7 we obtained about 335 alternating volts from the high-voltage secondary winding of our power transformer. We wish to make this alternating voltage produce a direct voltage. Then the direct voltage will cause flow of a direct current. All this is accomplished by connecting a rectifier to the secondary winding of the power transformer.

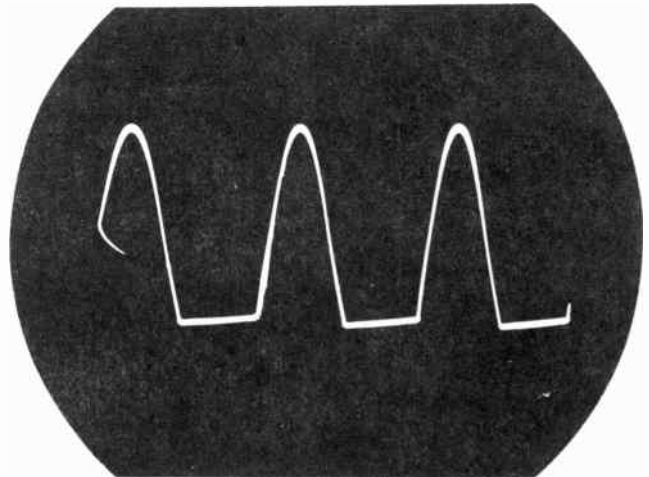

Fig. 16. The rectifier passes alternating voltage pulses of only one polarity, while cutting off those of opposite polarity.

When the oscilloscope is connected to the other side of the rectifier the voltage trace appears as in Fig. 16. If you compare this trace with the one of Fig. 7 it is plainly apparent how the rectifier does its work. The

## LESSON 10 – THE LOW VOLTAGE POWER SUPPLY

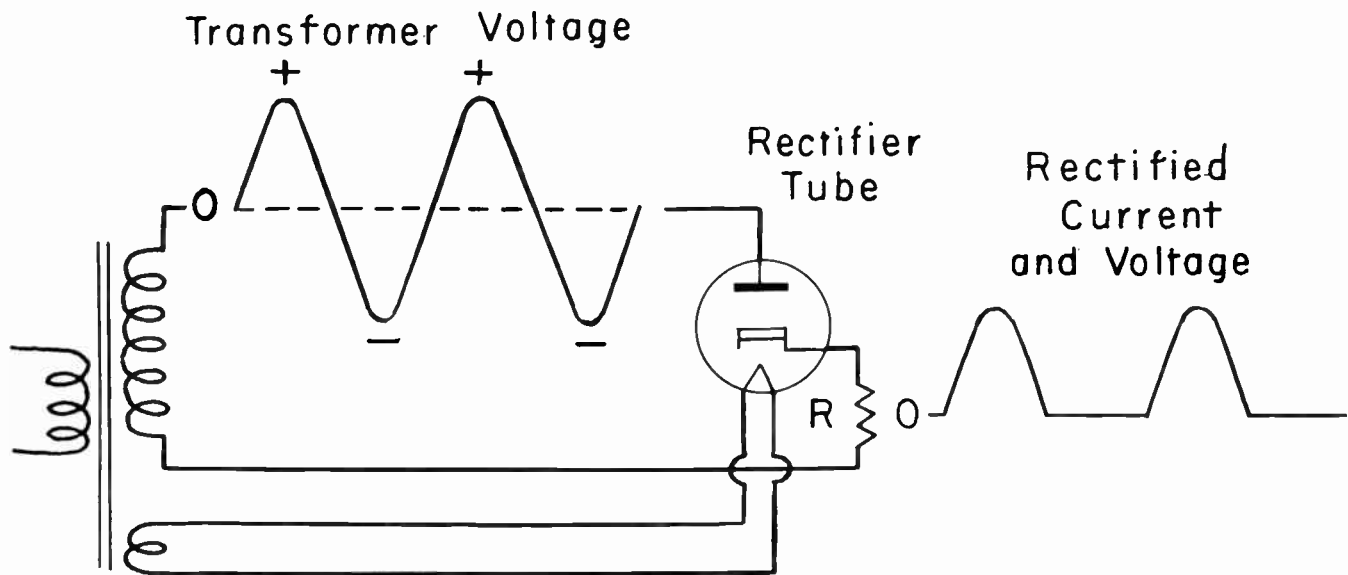

Fig. 17. Voltages at the input and output of a rectifier.

rectifier merely cuts off one polarity from the alternating voltage. The remaining voltage is just like the portion of the alternating voltage that is above the zero line, it consists of pulses which are all of the same polarity.

A voltage which acts always in the same polarity or direction is a direct voltage. The direct voltage need not be continual or steady. It may be intermittent or may occur in separated pulses, but so long as the polarity does not change we have a direct voltage.

The rectifier whose action we are examining is a vacuum tube containing only a plate, cathode, and heater, as shown by the symbol in Fig. 17. The heater takes no part in the rectifying action other than to heat the cathode to a temperature at which the cathode can emit electrons.

The alternating voltage from the secondary winding of the power transformer is applied to the rectifier plate and, by way of resistor R, to the rectifier cathode. During the alternations of transformer voltage which make the rectifier plate positive and its cathode negative, electrons are drawn through the tube from cathode to plate. This electron flow or current passes also through resistor R and the transformer secondary winding.

During the intervening alternations of

transformer voltage the polarity is reversed, and the rectifier plate is made negative while its cathode is positive. No electrons can flow from the cathode to the negative plate. Consequently, there is no electron flow or current through the tube, and none in resistor R or in the transformer secondary winding.

There is current in the rectifier circuit, including resistor R, only during the intervals in which the applied alternating voltage makes the rectifier plate positive, or during only half the alternations. These pulses of rectified current and the intervening periods of zero current, are represented at the right in the diagram, and in Fig. 16. To obtain the picture of Fig. 16 the oscilloscope was connected across resistor R.

Fig. 18 is a picture of a small power rectifier of the vacuum tube type from which the outer glass envelope has been removed to expose the internal elements. The base of the tube has been inserted part way into a socket, so that we still see the base pins through which connections are made from external circuits through the socket to elements inside the tube.

The large flat element, at whose center is a cylindrical vertical passage, is the plate. The extensions on either side of the plate help carry heat away from the central cylin-

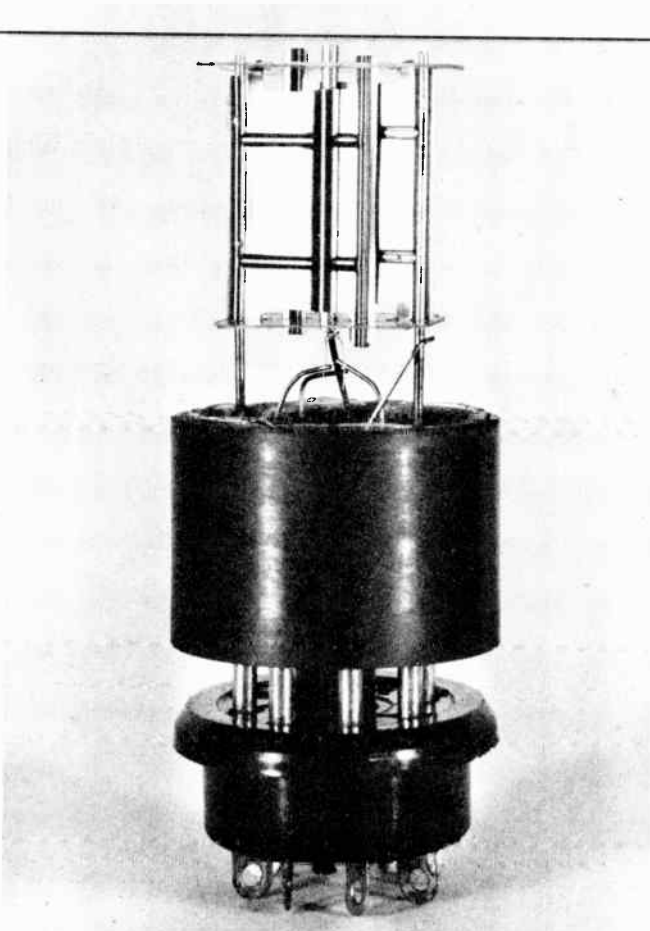

Fig. 18. The plate of a small vacuum-tube power rectifier tube.

dricular part which collects electrons coming to it from the cathode.

In Fig. 19 one side of the plate has been removed to expose the cathode. The cathode is the small white cylinder which would pass vertically through the central opening of the plate were all of the plate in place. There is, of course, some space between the outside of the cathode and the inside of the plate when the tube is completely assembled. The white coating on the cathode consists of a mixture of metallic salts which emit great quantities of free electrons when their temperature is raised to a dull red. This cathode material is coated onto a cylinder of thin metal, inside of which is the heater.

The cathode structure which we are discussing is employed not only in small power rectifiers but also in many tubes used for amplification and other purposes. Fig. 20

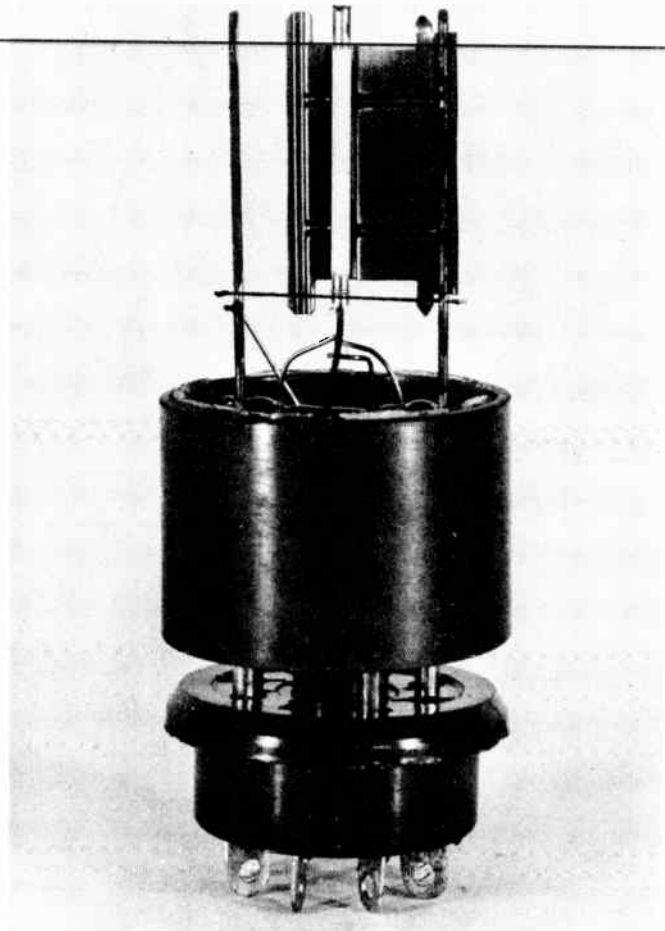

Fig. 19. With part of the rectifier plate removed we see the cathode.

shows heater wires which have been spread apart after a cathode cylinder has been removed from around them. Although this particular heater is from an amplifier tube rather than a rectifier, it illustrates how many heaters are made.

In the great majority of amplifier tubes and in many power rectifiers the heater wires are coated with insulating material and thus are completely insulated from the cathode. There are other rectifiers in which one end of the heater wire is connected inside the tube to the cathode. Whether or not the rectifier heater is insulated from the cathode depends on the design of external circuits.

In many of the larger power rectifiers the cathode and heater are one and the same element. Fig. 21 is a picture of the elements in such a rectifier. In the tube here illustrated there are two plates and two cathodes, but



# LESSON 10 – THE LOW VOLTAGE POWER SUPPLY

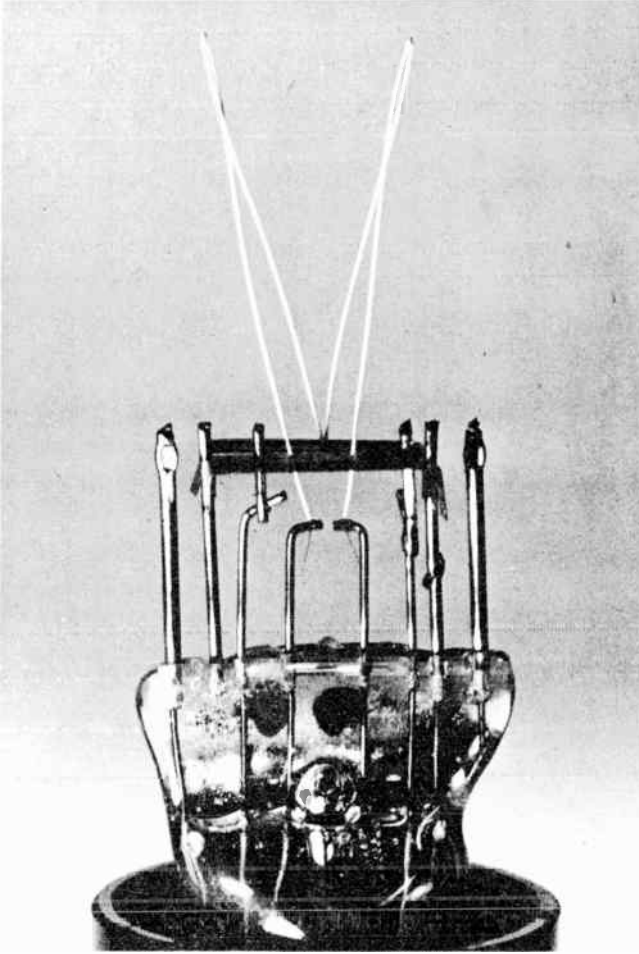

Fig. 20. A heater from which the cathode cylinder has been removed.

both sides are alike. The plate has been removed from around one of the cathodes and laid to one side. A tube constructed in this manner is said to have a filament-cathode. One with separate heater, as in Fig. 18, is said to have a heater-cathode.

Connections to the rectifier with a filament-cathode are made as shown by Fig. 22. A filament secondary winding of the power transformer is connected to the two ends of the filament-cathode in the tube. Alternating current from this secondary winding heats the filament-cathode to a dull red. The filament-cathode, which is in the form of a small, flat ribbon of metal, is coated with the same electron-emitting substances used for all cathodes, and electrons boil out of the surface in the same manner.

The high-voltage secondary of the power transformer is connected at one end to the

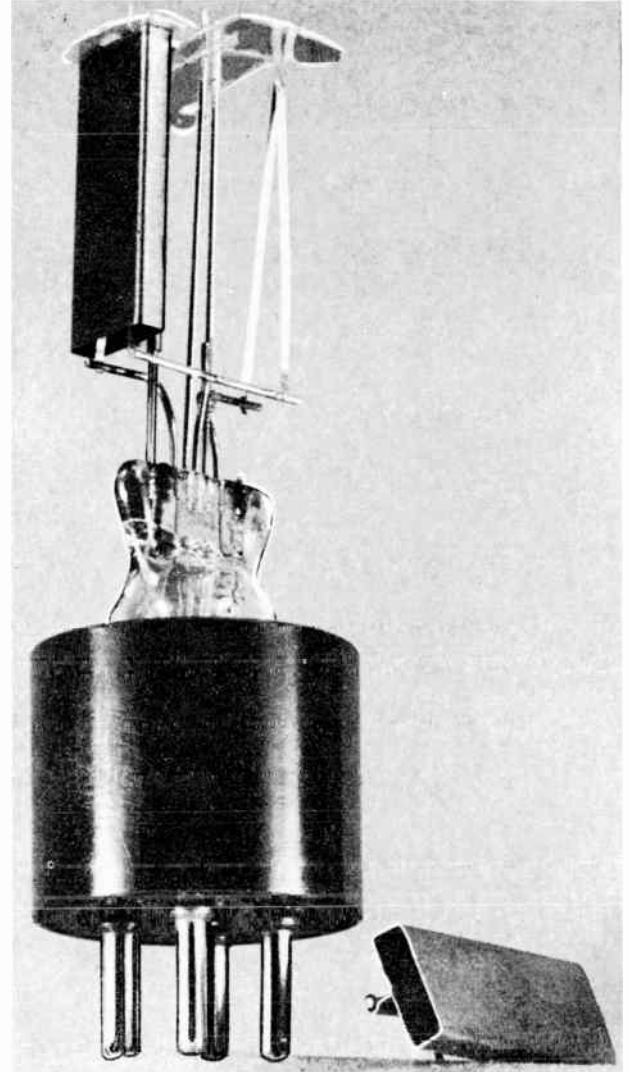

Fig. 21. A power rectifier in which are filament-cathodes.

plate of the rectifier tube and at the other end is connected through resistor R to the filament-cathode of the tube. Electrons flow in this high-voltage circuit as shown by small arrows. This electron flow, which is the rectified current, does not pass into or

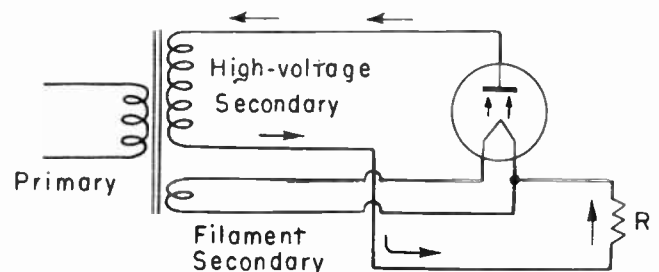

Fig. 22. Direction of electron flow in a rectifier having a filament-cathode.

## COYNE - *television home training*

through the filament secondary of the power transformer, ~~nor does the cathode-heating current~~ from the filament secondary pass through the high-voltage circuit in which there is rectified current. Both currents flow in the filament-cathode, but they are separated everywhere else.

When any kind of cathode has its temperature raised to red heat, even with no potential difference or voltage between it and the plate, the heat gives electrons in the cathode so much extra energy that great quantities pass out through the surface of the cathode substance and into the evacuated space around the cathode. These emitted electrons tend to drop back into the cathode, and they actually do so. But there is continual emission of additional free electrons from the hot cathode. The free electrons which are temporarily in the evacuated space around the cathode surface are called the space charge. Because electrons are negative electricity, the space charge is a negative charge.

The plate does not emit free electrons because it is not coated with the metallic salts from which it is easy for electrons to escape, and also because the plate remains much cooler than the cathode. Plates often are made of nickel or nickel alloys. Such material will not emit electrons unless heated to a bright yellow, and the plate does not even approach red heat.

It should be mentioned that resistors R in Figs. 17 and 22 represent what we call the load on the rectifier tubes and circuits. These load resistors have to be used to complete the rectifier circuit, so that we do not have an open circuit. They are used also to provide resistance across which there may be a voltage or a difference of potential when rectified current flows in the resistors. It is this resistor voltage which is being pictured or traced by the oscilloscope. In actual practice the load would be other parts of the power supply and also the plate circuits and screen circuits of various tubes in the receiver.

Up to this point we have been examining the process called half-wave rectification.

It is given this name because, as you may see in Fig. 17, only half of the alternating input voltage is utilized for production of output current. We utilize only the portions of the input voltage "wave" that are above the zero line, only the alternations that are of one polarity. The other half of the input voltage wave does nothing. A rectifier tube having one plate and one cathode is called a half wave rectifier, because it is suitable for half-wave rectification.

**FULL-WAVE RECTIFICATION.** Now we are going to put both halves of the alternating input voltage to work in producing rectified output current. Then we shall have full-wave rectification. With the oscilloscope connected to the output of a full-wave rectifier the voltage trace appears as in Fig. 23. Compare

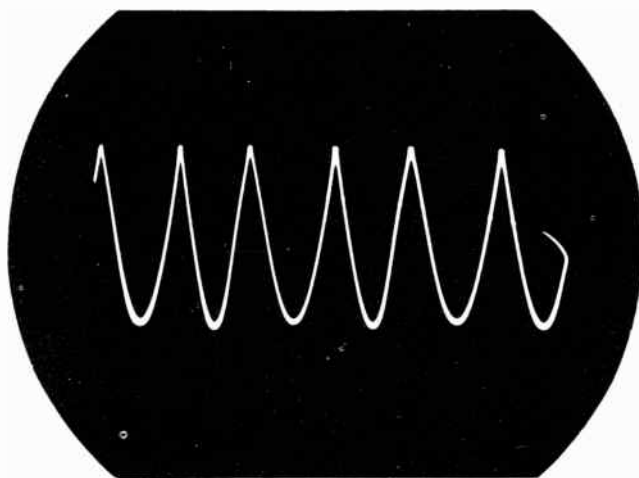

Fig. 23. This is the output voltage from a full-wave rectifier.

this with the output voltage trace of Fig. 16. We still have all the voltage pulses of the earlier method. But in every one of the gaps where voltage formerly dropped to zero we now have a pulse. There are twice as many voltage pulses, and during any given time there would be twice as many current pulses with full-wave rectification as with the half-wave method.

To understand how full-wave rectification is accomplished we should examine the voltage from the power transformer secondary a little more carefully than before. By means of a service instrument called an electronic switch it is possible to apply to the

## LESSON 10 – THE LOW VOLTAGE POWER SUPPLY

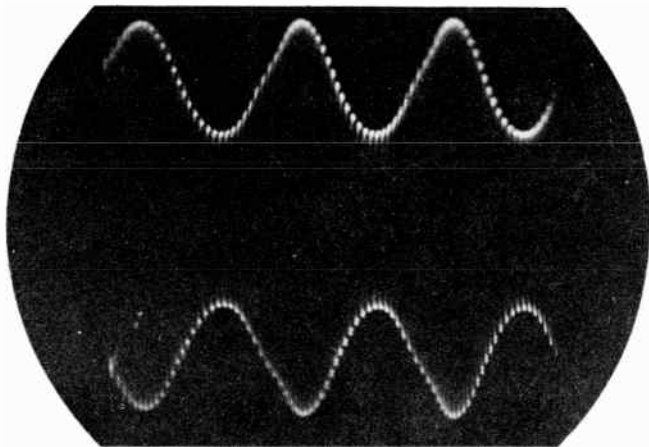

Fig. 24. Voltage changes are in opposite polarities at the two ends of a secondary winding at any given instant.

oscilloscope the voltages from both ends of the secondary winding at the same time.

The two voltages appear as in Fig. 24. Both these voltages are alternating. Both go from zero to positive, then back through zero to negative, and return to zero. But while the voltage at one end of the secondary is going positive, the voltage at the other end is going negative. While voltage at the first end goes negative, voltage at the other end goes positive. Both voltages go through their zero values at the same instants of time.

When you think the matter over it becomes plainly evident that the voltages at opposite ends of the secondary could act in no other way than as shown by the oscilloscope. Supposing the two ends of the secondary were connected to a resistor as in Fig. 25. As alternating voltage reverses its polarity in the secondary, current would flow first in one direction, as at a, and then in the opposite direction, as at b. Electrons always must flow away from the negative terminal of any source, and toward the positive terminal. Therefore, while one end of the transformer winding is positive the other end must be negative. And when the first end becomes negative the opposite end must become positive.

Next, as at c in Fig. 25, we shall divide the secondary winding into two equal parts, and from their junction bring out a center-tap. Our load resistor is connected in the lead from the center tap. When the top of the

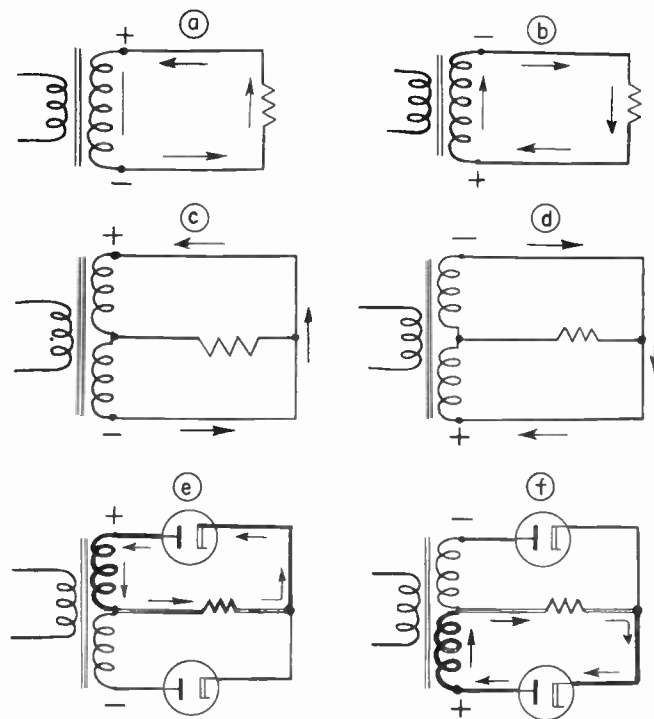

Fig. 25. How the full-wave rectifier circuit does its work.

divided secondary is positive, and the bottom negative, there is electron flow as shown by arrows in diagram c. When the polarities reverse there is electron flow in the direction shown by arrows at d. In neither case is there any electron flow or current in the resistor or in the center-tap connection. We seem to have accomplished nothing other than to establish a short circuit between plus and minus and prevent current from flowing in the resistor, but watch the next steps.

At e we have connected rectifiers to both outer ends of the secondary winding, with the plates of both rectifiers toward the winding. The rectifier cathodes are connected together and to one end of the load resistor which is in the center-tap lead. Remember, a rectifier allows electron flow or current through it only while its plate is positive, and the electron flow then can be only from cathode to plate inside the rectifier and in the corresponding direction through the remainder of the rectifier circuit.

While the upper end of the secondary winding is positive it makes the plate of the upper rectifier positive, and there is electron flow in the direction of the arrows. At this



## COYNE - *television home training*

time there can be no electron flow or current through the bottom rectifier, because its plate is made negative by the negative polarity at the bottom of the secondary. Consequently, there can be no current in the portion of the circuits connected to the bottom rectifier. Current in the upper rectifier must complete its path through the load resistor in the center-tap lead.

In diagram f the polarity of the secondary winding has reversed. Now the plate of the upper rectifier is made negative, and in this rectifier and the portion of the circuit connected to it there can be no current. But the plate of the bottom rectifier now has been made positive. There is electron flow through this bottom rectifier and its connected circuit as shown by arrows. This electron flow of current cannot pass through the upper rectifier, so it has to complete its path through the center tap lead and the load resistor.

Note this fact carefully. Current is in the same direction through the load resistor with both polarities of the transformer secondary. It is from left to right in diagram e of Fig. 25, and is from left to right in diagram f with the secondary polarity reversed.

We have rectified both the positive and the negative alternations of the secondary

alternating voltage. Rectified current and rectified voltage is of the same polarity or direction in the load resistor during both alternations. All this is pictured by the oscilloscope trace of Fig. 23, in the making of which the oscilloscope was connected to a load resistor such as shown by Fig. 25 at e and f.

It is entirely possible to have full-wave rectification with two separate rectifiers connected to a single center-tapped secondary winding. It is far more common to use a single tube of special design. Since the two cathodes of Fig. 25 are connected together, they may be replaced with a single cathode. But because the two plates are connected to two different points we must have two separate plates in a full-wave rectifier tube.

The full-wave rectifier circuit employing a single tube with two plates and one cathode usually is shown on service diagrams somewhat as in Fig. 26. At the left the rectifier tube has a heater-cathode, and at the right a filament-cathode. Otherwise the two diagrams are alike. Connection from the secondary center-tap to one side of the load may be through a wire conductor, or it may be through chassis ground as shown by broken-line ground symbols.

Directions of electron flows during the

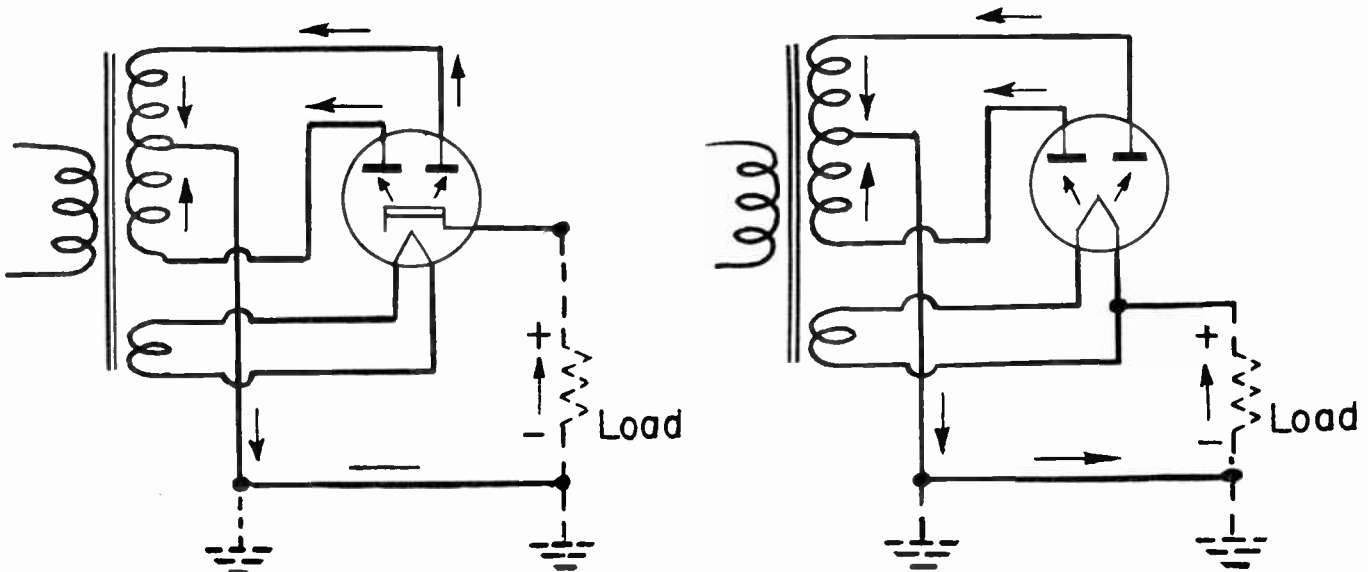

Fig. 26. Full-wave rectifier circuits employing tubes with heaters-cathode and with filament-cathode.

## LESSON 10 – THE LOW VOLTAGE POWER SUPPLY

opposite alternations of secondary alternating voltage are shown by arrows. These directions are the same as at e and f of Fig. 25. Take careful note of the direction of electron flow through the loads. If any load or any resistance the direction of electron flow must be from a potential that is relatively negative to one that is relatively positive. Then, so far as the load is concerned, the cathode of the rectifier is the positive side of the power supply. The secondary center tap is the negative side of the power supply, so far as the load is concerned. It is true that the cathodes are negative with reference to the plates inside the tubes, but the cathodes are positive with reference to the secondary tap outside the tube. Polarities always are considered

to be in accordance with direction of electron flow, which always is from negative to positive no matter where the flow occurs.

So far we have succeeded in obtaining at the output of a rectifier either the pulsating direct (one-way) voltage pictured by Fig. 16 or else the pulsating direct voltage of Fig. 23. Although these are direct voltages, because they act in only one direction, they are far from being the smooth or steady direct voltages required for plate and screen circuits of amplifiers and other tubes in the reviewer. Our problem in the following lesson will be to add a "filter" after the rectifier, and thereby to change the pulsating direct voltages to smooth direct voltages.

-----

Here is a list of new words and terms which have appeared in this lesson. Think about the meaning of each one as you read through the list.

Alternation  
Amplitude  
Center-tap  
Core  
Counter-emf  
Effective value  
Electromagnetic induction  
Filament-cathode  
Full-wave rectification  
Half-wave rectification  
Heater-cathode  
Laminations  
Load  
Low-voltage power supply

Magnetic field  
Magnetic force  
Primary winding  
Pulsating direct voltage  
Rms  
Secondary winding  
Sine wave  
Sinusoidal  
Space charge  
Step-down transformer  
Step-up transformer  
Turns ratio  
Voltage ratio

# TELEVISION

- RADIO
- ELECTRONICS

---

## LESSON 11 – POWER SUPPLY FILTERING

---

***Coyne School***

*practical home training*

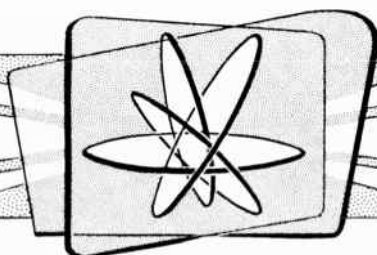

*Chicago, Illinois*



---

Copyright 1953 by Coyne School  
Chicago 12, Illinois  
All rights reserved

Litho. in U.S.A.

## Lesson 11

### POWER SUPPLY FILTERING

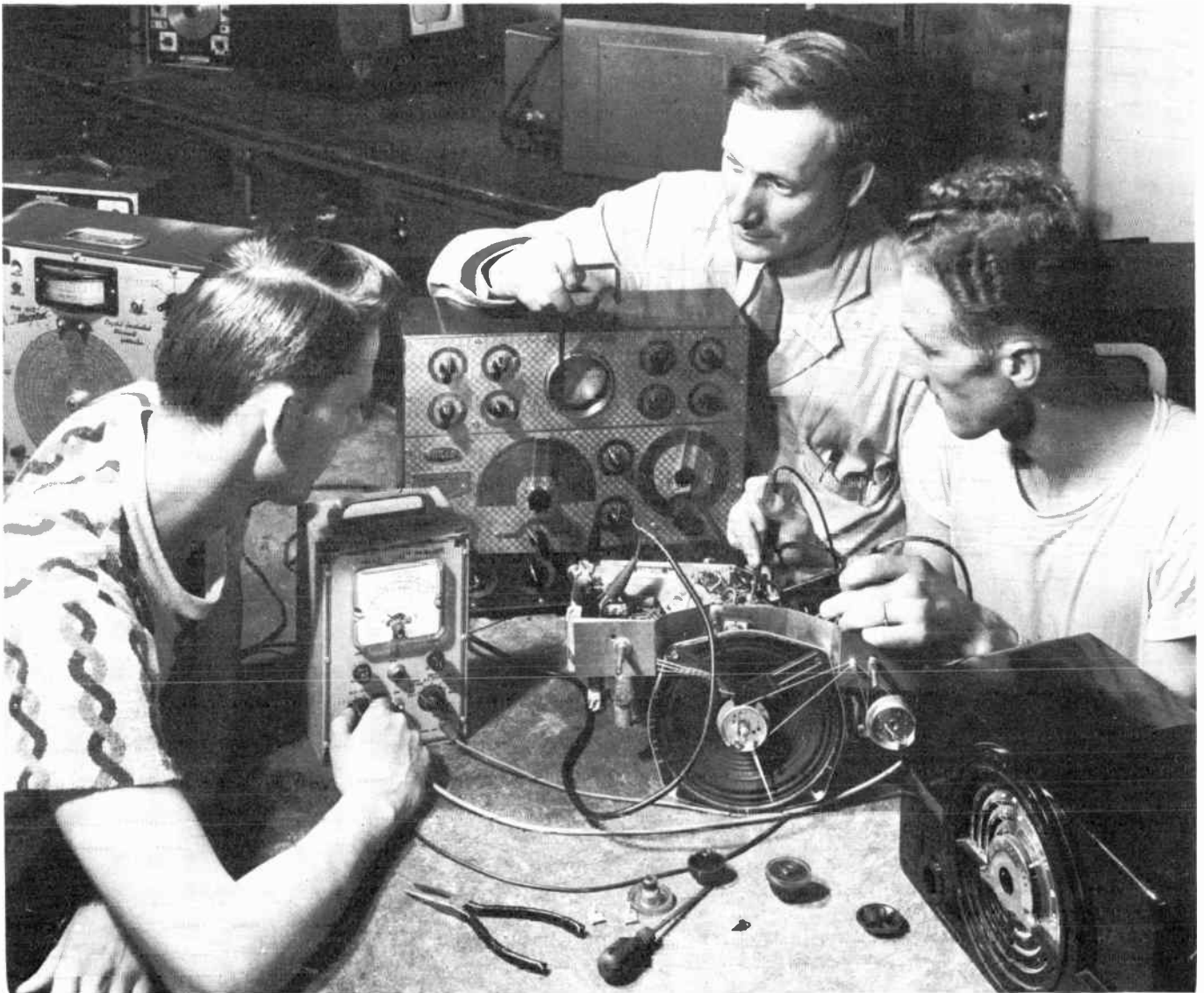

Fig. 1. These students in the Coyne School are watching a voltage trace on the screen of an oscilloscope.

In the preceding lesson we found that the power transformer and rectifier would change the alternating line voltage to a much stronger direct voltage. But this direct voltage is pulsating. As one student said, "It goes steady by jerks." Were this pulsating direct voltage to be applied to the plate and screen circuits of amplifier tubes, the speaker would emit a continual humming or buzzing sound and the screen of the picture tube would be covered with light and dark horizontal bars.

The pulsating voltage must be changed to a smooth or constant direct voltage before it may be passed on to receiver circuits. Then the speaker will be able to reproduce only the sounds of music and speech in the programs, and the picture tube screen can show pictures which are free from annoying bars. The smoothing process is carried out in a portion of the power supply which is called the filter.

All power supply filters make use of

# COYNE - television home training

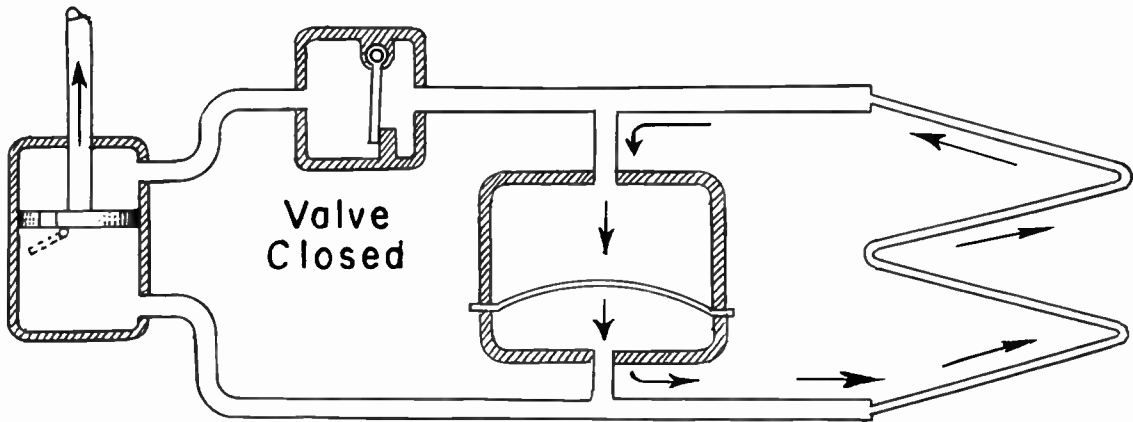
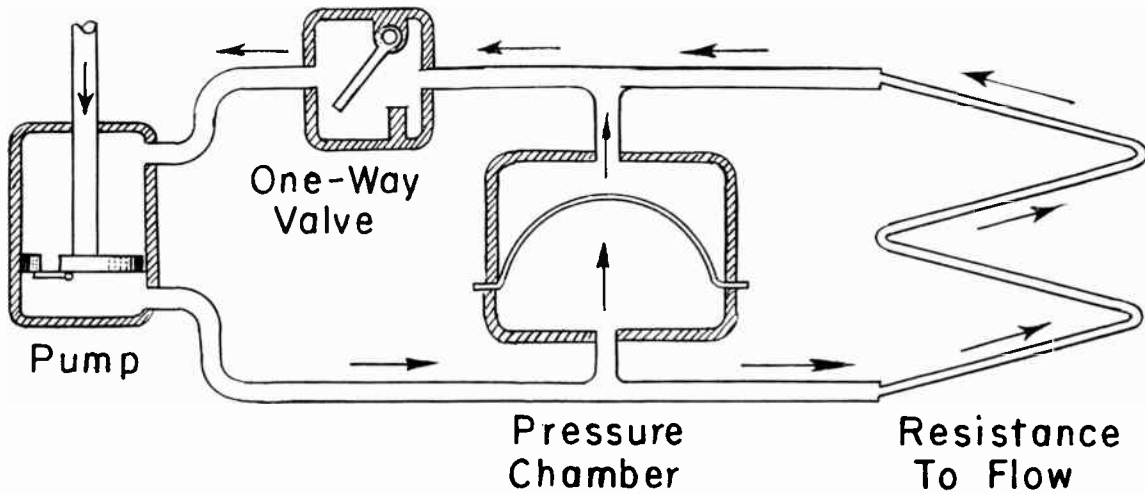
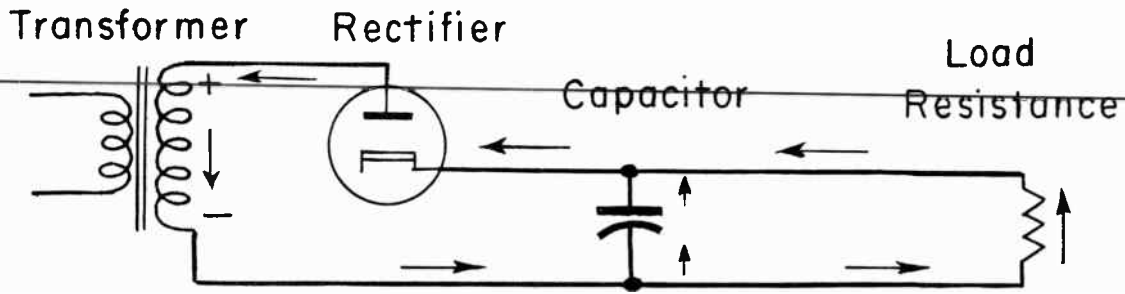

Fig. 2. The filter capacitor is charged from the rectifier, and then discharges through the load.

one or more capacitors. Consequently, in commencing our experiments with the smoothing process we shall connect a capacitor between the rectifier and the load as shown at the top of Fig. 2. It has been said before that a capacitor acts for electricity like a tank for water or air, which will receive and later discharge any quantities of water or air forced into it.

The power supply with its filter capacitor may be compared to the water system

with its pressure chamber or tank shown by the lower diagrams of Fig. 2. The transformer in the electrical system is like the reciprocating pump of the water system. One produces alternating electrical pressure or voltage, the other produces alternating water pressure. The rectifier is like the one-way water valve.

The capacitor of the electrical system is like the pressure chamber in the water system. This pressure chamber consists of



## LESSON 11 – POWER SUPPLY FILTERING

upper and lower compartments, with between them a flexible rubber disc or diaphragm. This diaphragm will stretch, but it won't break unless excessive pressure is applied. When water is forced into one side of the pressure chamber, water is forced out of the other side as the diaphragm stretches. No water can pass all the way through the pressure chamber. When the original force is removed or released, the diaphragm contracts. This contraction pushes water out of the side where water formerly entered, and pulls water back into the side from which water formerly was expelled.

The upper electrical diagram of Fig. 11-2 shows by means of arrows the directions of electron flow during an alternation in which the upper end of the transformer secondary and the plate of the rectifier tube are positive. Note that part of this electron flow goes into the lower side of the capacitor, and that other electrons are flowing out of the upper side. The remainder of the electron flow goes through the load resistor.

In the center diagram, showing water flow, the pump piston is moving downward, with water being forced out of the bottom and pulled into the top of the pump. The one-way valve is opened by this direction of water flow. (The rectifier is allowing electrons to flow through it from cathode to plate). Part of the water flow is going into the lower compartment of the pressure chamber (capacitor) and is stretching the rubber diaphragm upward. This forces water out of the upper compartment.

The remainder of the water flow is passing through the long, small piping at the right. This piping represents the load on the water system. It is so difficult for water to get through this long, small piping that the pump must build up considerable pressure. It is this pressure that forces part of the flow into the pressure chamber.

The bottom diagram shows conditions in the water system during the opposite "alternation", with the pump piston moving upward. Water pressure has forced the one-way valve (rectifier) to close, so that there can be no flow in the portion of the water

system that includes this valve. Now the rubber diaphragm in the pressure chamber is contracting, because energy was stored in the diaphragm when it was forced to stretch.

As the rubber diaphragm contracts, it forces water out of the lower compartment and pulls water into the upper compartment. This flow cannot get through the portion of the piping that includes the one-way valve (rectifier) because the valve is held closed by pump action. So water leaving and entering the pressure chamber (or electrons leaving and entering the two sides of the capacitor) must flow through the load.

Now look at the directions of electron flow through the load piping of the water system during the two alternations of pump pressure. Water flows the same direction through the load during both alternations, and so would electrons flow the same direction through the electrical load during both voltage alternations. During one alternation the flow in the load results from water pump pressure or from positive polarity at the top of the transformer secondary. During the opposite alternation the water flow is continued by discharge action of the pressure chamber, and electron flow is continued by discharge of the capacitor - which was charged during the other alternation of transformer voltage.

Note: Because in the bottom water diagram of Fig. 11-2 the pump piston could not rise and compress the water after the one-way valve was closed, we have to show by broken lines another smaller valve in the piston. In the electrical system there is nothing equivalent to this smaller valve, because we may have electrical pressure or voltage with no electron flow.

This is an illustration of difficulties encountered with all comparisons or analogies between electricity and anything else. The analogies are all right up to some certain point, and then they always fail - because nothing else behaves just like electricity. Never try to follow an analogy too far, and never take comparisons too literally.

## COYNE - *television home training*

FILTER CAPACITORS. Every capacitor consists of two conductors or two groups of conductors separated by insulation. The two separated conductors correspond to the two compartments of the pressure chamber in Fig. 2. The insulation between the conductors corresponds to the rubber diaphragm. When insulation is used between the conductors of a capacitor it is called the dielectric. The material itself might be mica, or anything else. When this material is used merely to prevent electron flow it is called insulation, and when used between capacitor plates it is called a dielectric.

The two conductors of a capacitor receive and give up electrons. That is, they are charged and discharged. The electrical force that opposes charging of the conductors with extra electrons builds up in the dielectric (as in the rubber diaphragm). It is this force built up in the dielectric that drives the extra electrons back out of the capacitor when the charging voltage decreases or becomes zero.

Previously we have looked at some capacitors in which the conductors are metal plates and the dielectric is air between the plates. Air capacitors are not used in power supplies because such capacitors could not take in and discharge enough electrons unless of a size many times larger than any television receiver.

Most filter capacitors are of the electrolytic type, because small units of relatively low cost in this type can charge and discharge tremendous quantities of electrons. In the electrolytic capacitor one of the conductors is made of thin metal foil. The other is a liquid in which chemical salts have been dissolved to make the liquid conductive. The dielectric is an exceedingly thin film of metal oxide or may be an equally thin film of gas.

A filter capacitor of the electrolytic type, partially opened or unrolled, is pictured by Fig. 3. You can see the metal foil on the cylindrical part of this unit. The liquid is held by porous material, some of which has been unrolled and may be seen in front of the cylindrical part of the unit. Later we shall have much more to say about electrolytic

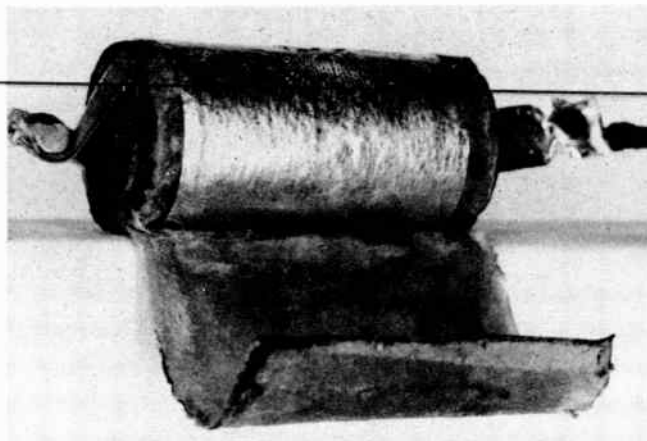

Fig. 3. Internal construction of an electrolytic capacitor.

filter capacitors, for they provide plenty of work for the service technician.

Now let's see what the filter capacitor, connected as at the top of Fig. 2, does to the pulsating direct voltage. With the oscilloscope connected across the load resistance we obtain the trace of Fig. 4. This, remember, is the voltage with a half-wave rectifier.

The voltage still is not smooth. It is increasing and decreasing as shown by the jagged line at the top. Zero voltage is indicated by the straight horizontal line down below. At the high peaks we have about 387 volts, and at the bottoms of the dips we have about 343 direct volts. There is a change between peaks and valleys of about 44 volts, and the average is about 365 volts.

What we have, in effect, is a direct voltage and an alternating voltage at the same time in the same load or circuit. There is an average direct voltage of about 365. At the same time there is an alternating voltage varying, from upper to lower peak, by about 44 volts. We say that there is a direct voltage with an alternating component. What we wish to do is get rid of the alternating component while keeping the direct voltage as high as possible.

Service technicians more often call the alternating component a ripple voltage. By looking at Fig. 4 you can see that the variations of voltage, with reference to the zero line down below, are like ripples of water on

## LESSON 11 – POWER SUPPLY FILTERING

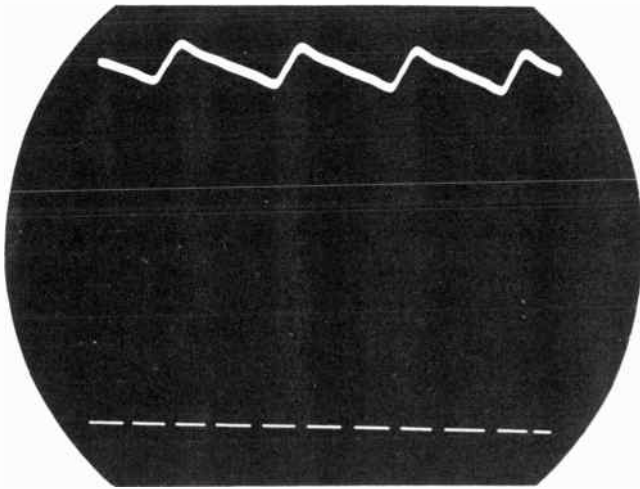

Fig. 4. The "alternating component" of the direct voltage on a filter capacitor.

the surface of a tank or a pond with reference to the bottom. Ripple voltage produces humming or buzzing sounds from speakers, and alternate dark and light bars across a picture.

The sharp rises of ripple voltage occur while the filter capacitor is being charged, while electrons are being forced into one side and out of the other side. The charging periods are brief, because it takes only a very short time for enough electrons to pass into and out of the capacitor to make the difference of potentials between its conductors equal to the difference of potential from the transformer and rectifier. You will recall that the greater the charge or the quantity of electrons put into any conductor, the greater becomes its negative potential. And the greater the quantity of electrons taken out of a conductor the greater becomes its positive potential. When the potential difference or voltage across the capacitor becomes equal to potential difference or voltage from the transformer and rectifier, the charging stops.

Looking back at Fig. 2, you can imagine the rubber diaphragm stretching so far that its tension or pressure becomes equal to pressure from the pump. Then no more water can be forced into and out of the pressure chamber by the pump. In other words, the pressure chamber then is charged with all the water that the maximum pump pressure can force into one of the compartments.

The longer downward slopes of ripple

voltage occur while the filter capacitor is discharging electrons through the load. This discharge through the load continues until transformer voltage again is great enough, and of correct polarity, to recharge the filter capacitor.

The filter capacitor has done quite well in smoothing out the pulsations of voltage obtained with the rectifier working alone, but it has not done nearly enough. Our next step will be to use a full-wave rectifier, with the filter capacitor and everything else in the circuit the same as before. Then the oscilloscope shows us the trace of Fig. 5.

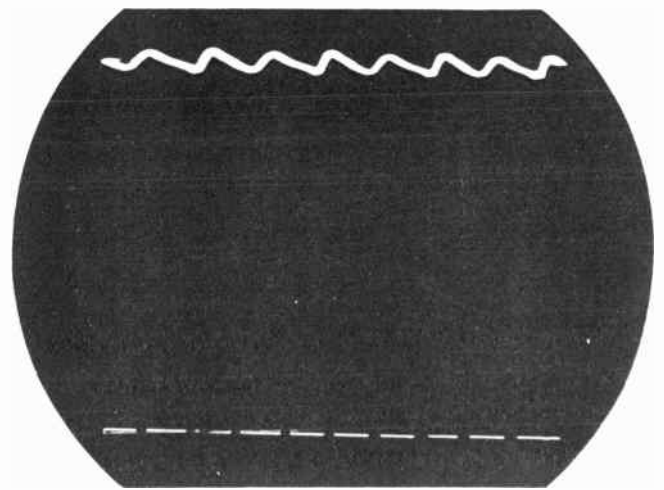

Fig. 5. Ripple voltage from a full-wave rectifier followed by a filter capacitor.

There are twice as many peaks and valleys of ripple voltage as before, because with a full-wave rectifier we obtain twice as many voltage pulses as with a half-wave rectifier during the same time. With a 60-cycle per second line voltage and with a half-wave rectifier we obtain 60 pulses of direct voltage during every second. But with a full-wave rectifier we rectify both alternations of every cycle, and have 120 pulses of direct voltage during every second.

We may think of the alternating component or the ripple voltage as consisting of cycles. These cycles are not of sine-wave form, but they truly are cycles because in each one the voltage goes through a complete series of changes, and these changes repeat over and over again.



## COYNE - *television home training*

With the half-wave rectifier the ripple voltage goes through 60 complete cycles per second. Then the frequency of this ripple voltage with a half-wave rectifier is 60 cycles per second, and is the same as the frequency of the line voltage. With a full-wave rectifier the ripple voltage goes through 120 complete cycles per second, and its frequency is twice that of the line voltage. Don't forget this, because it will have a great effect in some of the filters to be examined.

There is much less difference between peaks and valleys of ripple voltage with the full-wave rectifier than with the half-wave type. In Fig. 5 the peaks are at about 432 volts, the valleys are at about 408 volts, and the average is about 420 volts. The difference between peaks and valleys is now only 24 volts, and we have 24 volts of ripple with the full-wave rectifier where we had 44 volts with the half-wave rectifier.

This great reduction of ripple voltage is obtained at the cost of adding only another plate in the rectifier tube. As you will see, the higher frequency of the full-wave ripple voltage allows using smaller and less costly parts in the filter while obtaining equal smoothing action. For these reasons we nearly always find full-wave rectifiers in receiver power supplies of the low-voltage type. Most of our following work in this lesson will be done with full-wave rectifiers.

FILTER RESISTORS. Now we are

ready to reduce the ripple voltage obtained with the full-wave rectifier and the filter capacitor. This ripple, as seen on the oscilloscope, appears as at the left in Fig. 6. Before we are through it will become so slight, between peaks and valleys, as to become almost invisible. Therefore, going further, we shall magnify the ripple voltage as at the right. This is done by increasing the gain control of the oscilloscope to give a trace about 16 times as high for the same voltage. The ripple at the right is the same as the one at the left, but greatly "blown up" in height.

Our next step will be to split the filter capacitor, not by using an axe, but by substituting two separate capacitors, each equal to half of the original one. The principal property of a capacitor is its ability to receive and hold electrons when a given potential difference or voltage is applied to the two conductors of the capacitor. This ability is called the capacitance of the capacitor.

The basic unit of capacitance is called the farad. You never will see a capacitor so large as to have a capacitance of one farad. Were there to be such a capacitor in existence you would run a current of 82 milliamperes into one side and out of the other for two whole minutes, and the resulting charges would have a potential difference of only 10 volts.

Our largest practical unit of capacitance is the microfarad, which is the one-

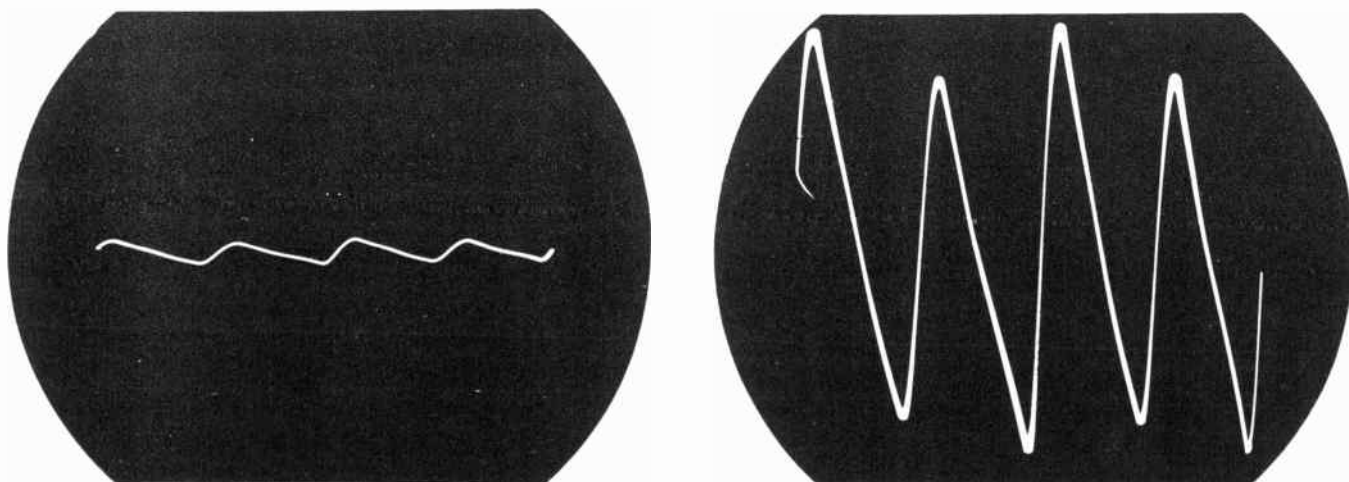

Fig. 6. Three cycles of full-wave ripple voltage as they appear with lower and higher gain in the oscilloscope.

# LESSON 11 – POWER SUPPLY FILTERING

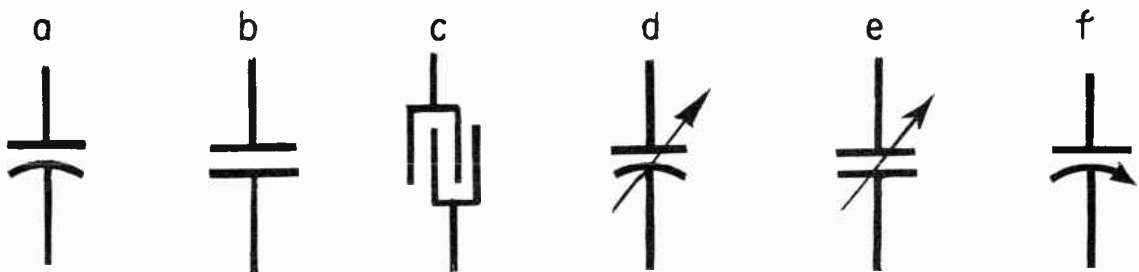

Fig. 7. Symbols used to show capacitors on service diagrams. The same symbols are used no matter how the capacitor is constructed.

millionth part of a farad. Up to this point we have been using a filter capacitance of one microfarad. Small capacitances usually are measured in micro-microfarads, one of which is equal to the one-millionth part of a microfarad. The word microfarad is abbreviated to mf, or sometimes to mfd. Micro-microfarad is abbreviated to mmf, or sometimes to mmfd. The letter symbol for capacitance in any unit is the capital letter C. Capacitors on service diagrams often are identified by the letter C.

Capacitor symbols used on service diagrams are shown by Fig. 7. Fixed capacitors, whose capacitance is not adjustable,

are shown by symbols at a, b, and c. The symbol at a is the standard. The one at b will be found in older diagrams, and some new ones. The symbol at c is used in diagrams of industrial electrical apparatus. Symbols for adjustable or variable capacitors are shown at d, e, and f. The capacitance may be adjusted or varied. The symbol at d is standard, but the others sometimes are found.

Until now we have been using a single 1-mf filter capacitor connected as at a in Fig. 8. At b this capacitor has been replaced with two capacitors of 0.5-mf each. The two capacitors are connected side by side or in parallel. When any parts are connected in

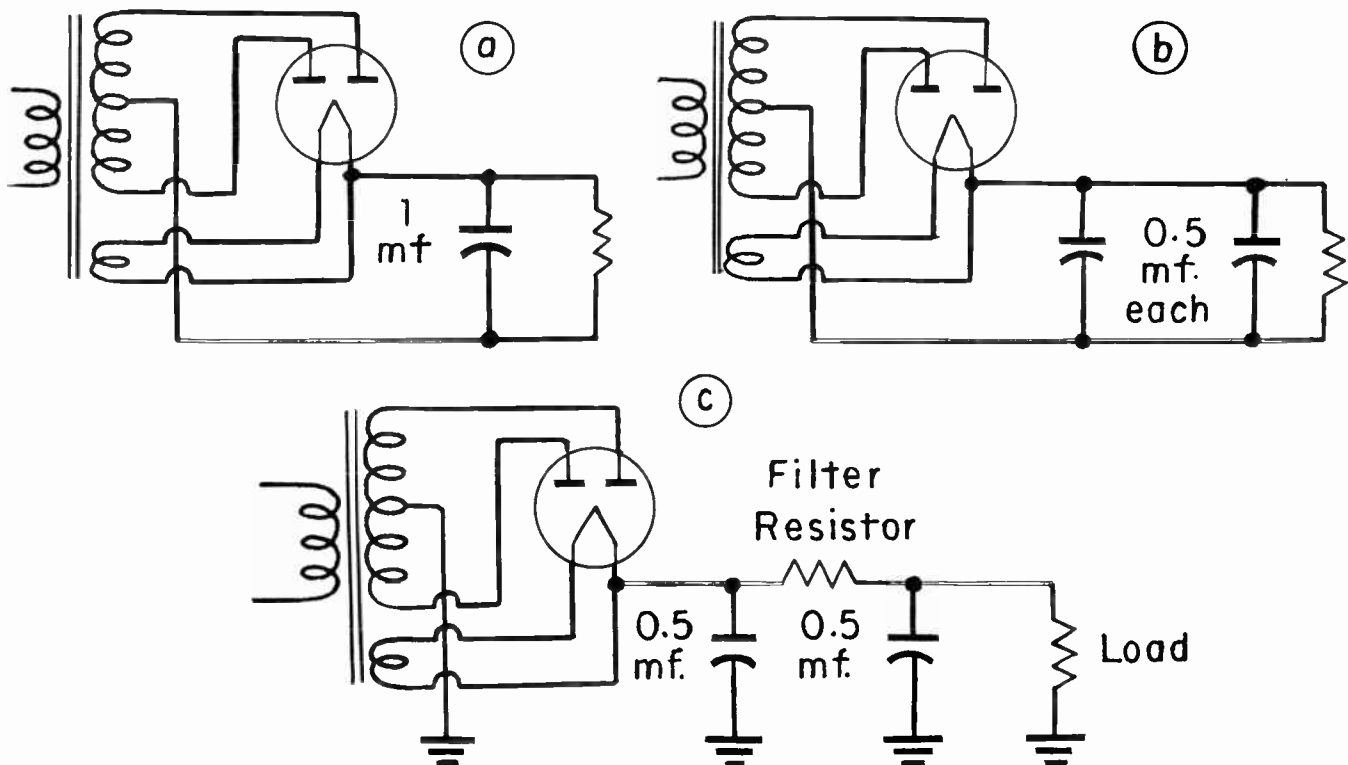

Fig. 8. Connections for two filter capacitors and a filter resistor.

## COYNE - *television home training*

parallel with one another, one end or terminal of each part is connected to one end or terminal of every other paralleled part. The opposite ends or terminals of all the parts are similarly connected to one another. Then the whole assembly has, in effect, only two terminals, one at each end. The assembly or group of paralleled parts may be connected into any circuit just as though they were a single part.

When two capacitors are in parallel their capacitances add together. Our two 0.5-mf capacitors in parallel have a total or combined capacitance of 1.0 mf. As would be expected, they have the same filtering effect as the original 1.0-mf capacitor, and the ripple voltage is the same as in Fig. 6.

Next we proceed to diagram c of Fig. 8. Incidentally, the lower ends of all leads formerly connected together by a wire now are connected to chassis ground, as indicated by the ground symbols. The principal change in this new arrangement is insertion of a resistor between the two capacitors. The capacitors no longer are in parallel, they act independently of each other.

effect of the filter resistor on reduction of ripple voltage depends on its own resistance and on the load resistance. With filter resistance of about 2,000 ohms and load resistance of 40,000 ohms, and with the two 0.5-mf filter capacitors, the output ripple is as shown at the left in Fig. 9. Compared with Fig. 6, where there was no filter resistance, the ripple voltage has been reduced by about 1/8 of its earlier value while using the same total filter capacitance.

When the filter resistor is made 15,000 ohms we have the output ripple voltage shown at the right in Fig. 9. Increasing the filter resistance from 2,000 to 15,000 ohms has reduced the ripple voltage until there is only about one fourth as much with the higher resistance as with the lower resistance. Still more filter resistance would further reduce the ripple.

The principal objection to using a high filter resistance for ripple reduction is that more direct voltage is then used up in the filter resistance and less remains for the load. In our present experiments the d-c voltage across the load measures about 420

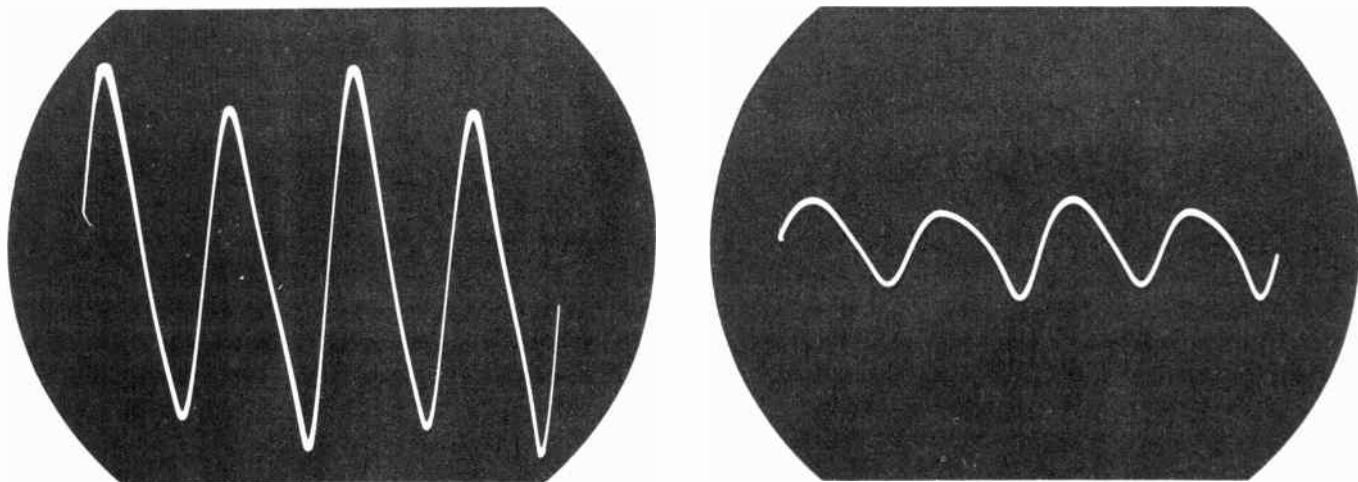

Fig. 9. Ripple voltage at the left is decreased to that at the right by using more filter resistance.

The ripple voltage or alternating component of voltage in the rectifier output acts in the filter capacitors as they charge and discharge. In the filter resistor there is all of the direct current flowing to and through the load, and also the alternating ripple current for the second filter capacitor. The ef-

with no filter resistance, it measures a little more than 400 volts with 2,000 ohms filter resistance, and only a little more than 300 volts with 15,000 ohms in the filter.

Tubes in other parts of the receiver require certain voltages from the power supply, and



## LESSON 11 – POWER SUPPLY FILTERING

if we reduce this voltage those other tubes cannot do their work. To keep the load voltage high while using more filter resistance we would have to have more alternating voltage from the secondary of the power transformer. With greater transformer voltage there would be more original ripple voltage, ahead of the filter. It becomes apparent that there is a limit to the usefulness of filter resistance in reducing the ripple.

**FILTER CAPACITANCE.** Since we are limited in the use of filter resistance for ripple reduction we shall turn next to changes of filter capacitance. We shall go back to the 2,000-ohm filter resistor, which was used with 0.5-mf filter capacitors to obtain the trace of ripple voltage at the left in Fig. 9.

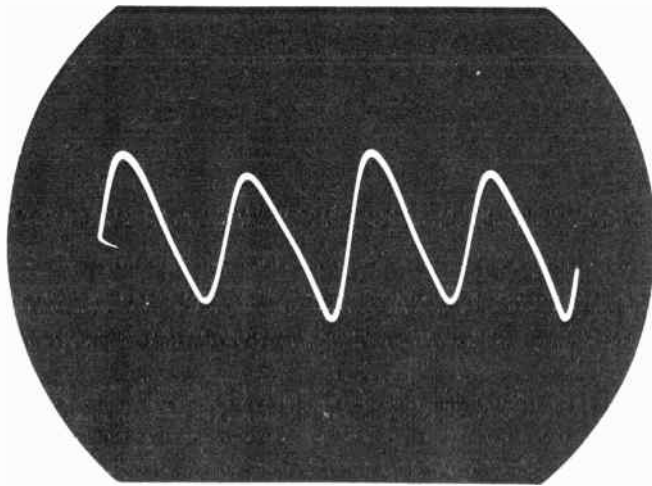

It is becoming quite evident that the most effective way to reduce the ripple is to use greater filter capacitances. Certainly we seem to have made great progress in this direction. Yet at the right in Fig. 10 we still have a ripple of about 3.6 volts, when the ripple alone is considered as an alternating voltage, and the effective value is measured.

This is too much ripple, for the following reason. Supposing that 3.6 alternating volts were to go along with the high direct voltage to an amplifier tube in the receiver. Supposing too that this amplifier were followed by one or two more amplifiers. That 3.6 volts of ripple would be so amplified as to come as a roar from the speaker, and would ruin any picture.

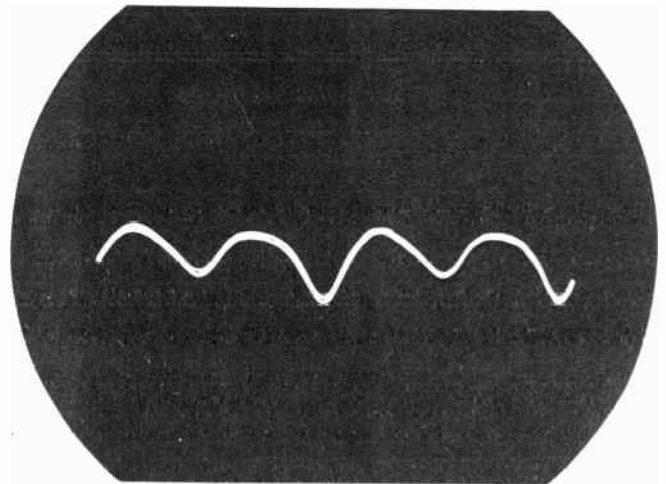

Fig. 10. The effect on ripple voltage of increasing the filter capacitance.

When the capacitance of each capacitor is doubled, and made 1 mf, we obtain the ripple voltage shown at the left in Fig. 10. With the larger capacitors we have only about 43 per cent as much ripple voltage, yet have just as much direct output voltage as before.

Now we shall again double the filter capacitances, making each one 2 mf. This brings the ripple voltage down to the point shown at the right in Fig. 10, on the oscilloscope. Here we have only about 20 per cent of the ripple that existed when using 0.5 mf filter capacitors. Still there has been no loss in direct output voltage, such as occurred when increasing the filter resistance to drop the ripple.

As a final experiment on this particular filter we may boost the values of the two filter capacitors to 10 mf each, while still keeping the 2,000 ohms of filter resistance. The oscilloscope shows the ripple voltage, with the 10-mf capacitors, as at the left in Fig. 11. The waviness now is too slight to be easily measured. To clearly display the small ripple voltage we once more increase the "gain" of the oscilloscope, this time to about 700 times that with which we commenced our measurements of ripple voltage.

This gives the trace of ripple voltage shown at the right in Fig. 11. This ripple is of about 0.1 alternating volt, effective value. This alternating voltage, which is a compo-

## COYNE - *television home training*

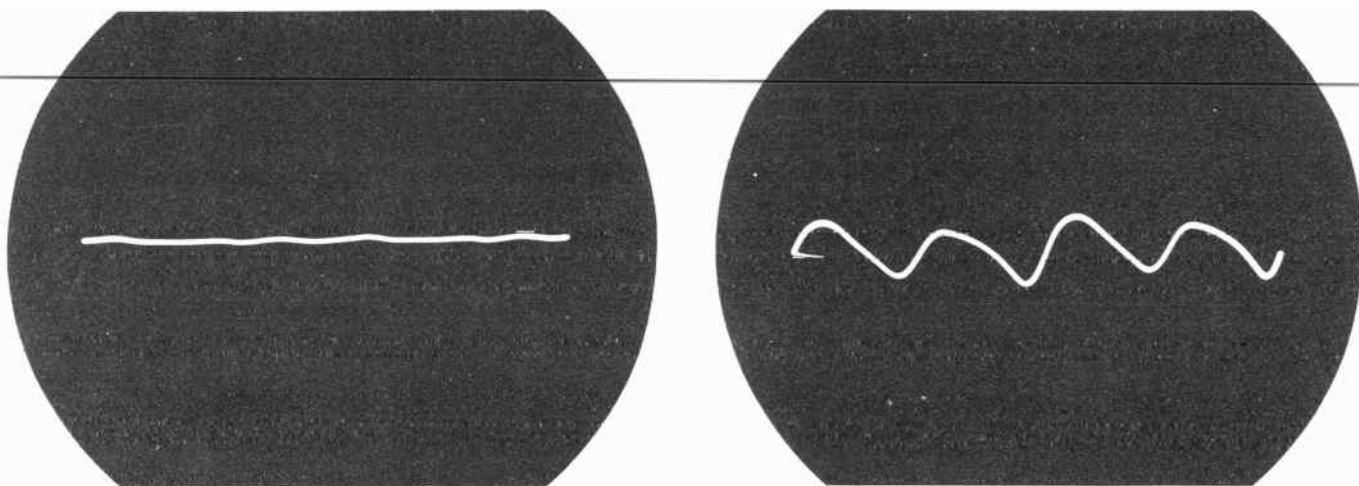

Fig. 11. Still more filter capacitance decreases the ripple as at the left. This voltage is magnified by the oscilloscope, as at the right.

ment of the direct voltage, might not be too objectionable were it to reach an amplifier tube which is not followed by too many other amplifiers, so that the ripple would not be amplified to any great extent.

**POWER SUPPLY VOLTAGES.** The oscilloscope traces of ripple voltages, and all of the direct and alternating voltages mentioned in preceding pages, were made and measured with the line delivering 120 a-c volts to the primary of the power transformer. When the manufacturer of a power supply or of any other television and radio apparatus specifies certain output voltages, ripple voltages, output currents, and other characteristics of such apparatus, these values are based on having 117 a-c volts from the power line.

Designs are based on 117 a-c volts from the line; this is called the design center voltages. As a general rule it is possible to have reasonably satisfactory performance with line voltage no lower than 105 and no higher than 130 a-c volts.

There is no fixed relation between the secondary a-c voltage from the power transformer and the d-c output voltage from the filter. With a correctly designed transformer, large enough to handle its appointed work, the secondary voltage remains nearly constant while the output voltage varies with the load. The greater the direct current taken from the power supply the lower will be the

d-c output voltage. This happens because there is loss of voltage in the rectifier tube, there is loss in the resistance of the secondary winding, and there is loss in resistance of the filter. As you know, the voltage drop or voltage loss across any given resistance will increase with increase of current through the resistance, so more output current must be accompanied by lower output voltage.

In a typical small power supply the output d-c voltage measured 260 with current somewhat less than 7 ma, it measured 228 with current of 11 ma, and measured only 183 volts with current of nearly 19 ma. Yet the transformer secondary delivered very close to 340 a-c volts for all of these changes in d-c output. The effective a-c voltage from the transformer secondary always must be more than the d-c output voltage from the filter, in order to make up for drops of voltage in the rectifier and in transformer and filter resistances.

If you go back and examine the diagrams showing performance of a full-wave rectifier it will be apparent that only half the secondary is working at any one time. The half on one side of the center tap delivers voltage and current to the rectifier during one alternation, and the half on the other side of the center tap delivers voltage and current during the opposite alternation in every cycle.

Whatever secondary a-c voltage is required to furnish d-c output voltage must be

## LESSON 11 – POWER SUPPLY FILTERING

supplied from each half of the secondary. The 340 a-c volts mentioned in the preceding example is the voltage from one-half the secondary. This voltage is measured between the center tap and either end of the secondary. Were a-c voltage to be measured across the entire secondary, from one end to the other, it would be double the voltage of either half, and, in our example, would be 680 volts.

This particular power transformer would be specified in a parts list or catalog as furnishing 680 secondary volts or 680 plate volts. In some cases it might be specified as furnishing 340 volts each side of center-tap. In addition to the voltage rating there would be a specification of direct current in milliamperes. This would be the normal d-c output current or might be the maximum output current or might be the normal or maximum alternating (effective) current in the secondary winding. Methods of specifying performance differ between manufacturers.

Usually there are additional secondary windings for heaters and filament-cathodes. These secondaries are specified as furnishing certain values of alternating voltage and alternating current, as required by the rectifier and other tubes.

When the rectifier is a filament - cathode type the filament is the output point for rectified voltage. Consequently, the filament is at the highest d-c pulsating voltage, which is considerably higher than the d-c output voltage. The secondary winding for this rectifier filament must be separate from all other windings in the transformer, and must be insulated to withstand high voltage.

Secondary windings used exclusively for the heaters of heater-cathode tubes in the receiver are rated for the required alternating voltage and current in the heaters. If the rectifier is a heater-cathode type, and if cathode and heater are not internally connected together, the heater winding used for amplifiers and other tubes may be used also for the rectifier heater provided all the heaters require the same voltage.

RECTIFIER RATINGS. The rectifier

ratings of chief interest in service work include the maximum permissible a-c (effective) volts per plate from the power transformer and the maximum permissible d-c output current per plate. In a full-wave rectifier only one of the plates works at a time, so these ratings would apply to the tube as a whole.

The largest rectifiers used in home receivers include types such as 5U4G, 5X4G, 5Z3, and 5T4. All of these are rated for 450 maximum a-c volts per plate and for maximum current of 225 milliamperes. Smaller rectifiers include types such as 5Y3G, 5Y3GT, 5Y4G, 5Z4, 5Z4GT, and 80. All of these are rated for 350 maximum a-c volts per plate and maximum current of 125 milliamperes. Rectifiers of still lower ratings include the 6X4, which is a miniature type, and the 6X5GT metal type, both with maximum ratings of 325 a-c volts per plate and 70 milliamperes of current. Fig. 12 shows the three sizes of glass bulbs most often used for rectifier tubes.

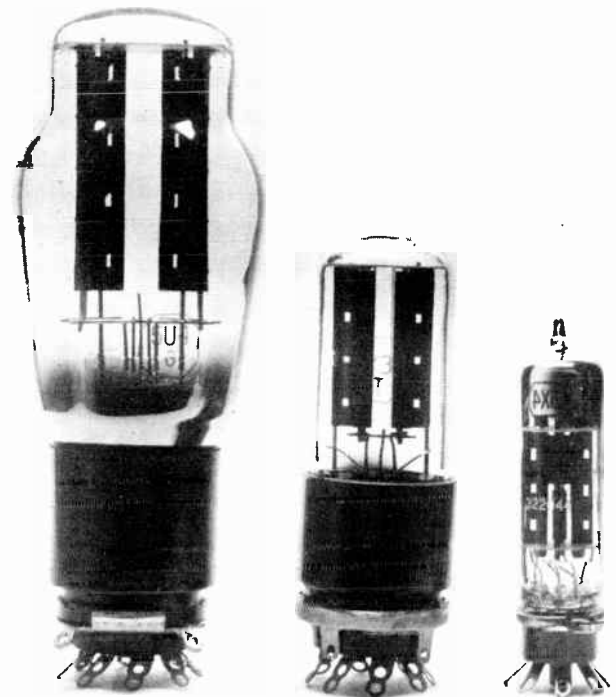

Fig. 12. Full-wave rectifier tubes. From left to right: 5U4G, 5Y3GT, and 6X4.

The following table lists some of the most commonly used full-wave rectifier tubes and gives their principal characteristics.



# COYNE - *television home training*

The ratings for a-c volts per plate and for d-c ma output apply when the tube is followed by a filter capacitor, as in the type of power

supply filter which we have been studying. Fig. 13 shows connections between base pins and internal elements for these rectifiers.

## FULL-WAVE RECTIFIER TUBES

Type	A-c Volts per Plate (maximum)	D-c ma Output (maximum)	Type	CATHODE		BASE		Envelope
				Volts a-c	Amperes a-c	Type	Pins	
5T4	450	225	Filament	5.0	2.0	Octal	5	Metal
5U4G	450	225	Filament	5.0	3.0	Octal	5	Glass
5V4G	375	175	Heater*	5.0	2.0	Octal	5	Glass
5Y3GT	350	125	Filament	5.0	2.0	Octal	5	Glass
5Z4 °	350	125	Heater*	5.0	2.0	Octal	5	Metal
6X4	325	70	Heater	6.3	0.6	Min'tur	7	Glass
7Y4	325	70	Heater	6.3	0.5	Lock-in	8	Glass
7Z4	325	100	Heater	6.3	0.9	Lock-in	8	Glass
80	350	125	Filament	5.0	2.0	Medium	4	Glass

\* Cathode is internally connected to the heater.

° Equivalent tube in glass envelope is 5Z4GT.

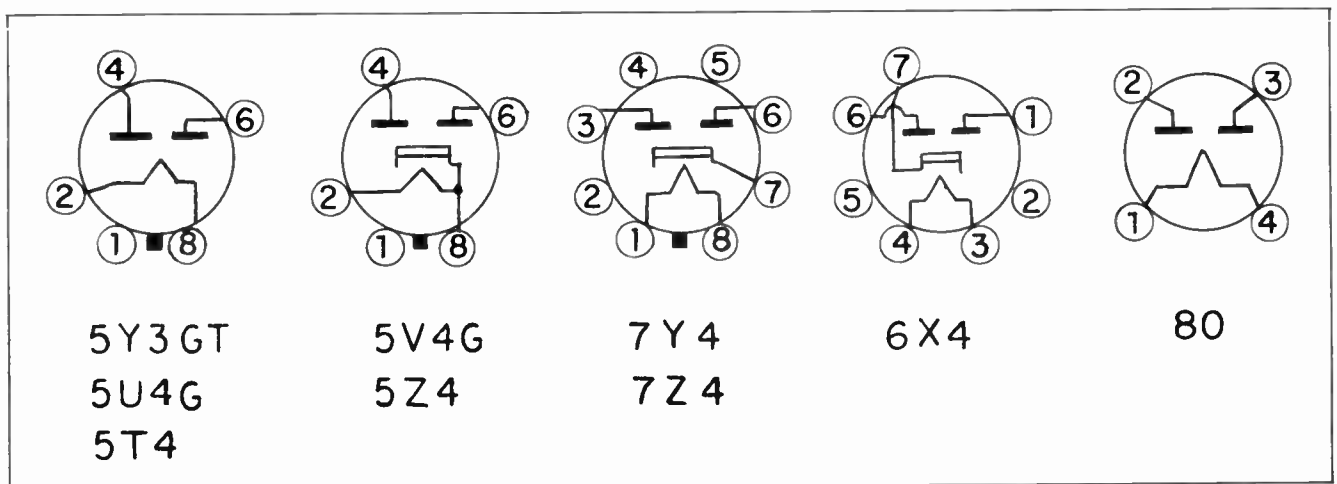

Fig. 13. Base pin positions (from bottom) and internal connections of full-wave rectifier tubes.

The only two of these rectifiers which might be directly interchangeable are the 5Z4 and 5Y3GT. The difference is in the envelopes, and in the fact that the metal shell of the 5Z4 is connected to number 1 base pin. With all the others there are differences between maximum permissible plate voltages and output currents, or in the voltages and currents for cathodes, or in the base and its connections.

An octal base is a base having spaces for eight equally spaced pins. The 5-pin octal base used for many rectifiers has only five pins in five of the eight spaces, with

three spaces vacant. A lock-in base has eight pins of small diameter, and at the center has a metal ball that snaps into and locks into a springy recess in the socket. We shall discuss bases and pin connections in more detail when taking up the matter of tube construction in general.

**CAPACITOR RATINGS.** When two filter capacitors are used, the one toward the rectifier is called the first filter capacitor and the other is the second filter capacitor. The first capacitor acts as illustrated in Fig. 2, maintaining a fairly steady direct current during intervals in which voltage pulses from

## LESSON 11 – POWER SUPPLY FILTERING

the rectifier are of low value or zero. The second capacitor does much the same thing, but it not only helps compensate for changes in rectifier voltage, but also for changes in current demands by the load.

In many circuits of the receiver there are momentary variations of effective resistance, which is load resistance so far as the power supply is concerned. If the direct voltage is to remain constant or nearly so, the power supply must furnish more current when load resistance drops and must furnish less current when load resistance rises. These momentary changes of current for the load are handled by the charge stored in the second filter capacitor. This capacitor acts much like a tank from which the load may draw a varying electron flow without greatly affecting the pressure.

The two capacitors in the filter may be of the same value, which commonly is almost anything from 10 to 40 mf. To have an effective tank action for supplying variations of load current the second capacitor sometimes is of greater capacitance than the first capacitor. If the first filter capacitor is too small it will allow a decrease in direct voltage for the output. In this case the small capacitor cannot hold enough charge to maintain load voltage and current during dips of rectifier voltage, and there is a drop of average output voltage from the filter system.

The greater the capacitance of the first capacitor, the greater will be the charging current it can take. With very large capacitance, say with more than 40 mf, this charging current may be so great as to overheat the rectifier tube through which the current comes to the first capacitor.

Electrolytic capacitors for power supplies in receivers practically always are of the polarized type. This means that a capacitor has a positive terminal and a negative terminal. The positive terminal may be connected only to the side of the circuit that is relatively positive, and the negative terminal only to the side that is relatively negative. The positive terminal of the filter capacitor must go toward the cathode of the rectifier, and the negative terminal to the side of the circuit connected to the center-tap of a full-wave transformer.

If a polarized electrolytic capacitor is connected in the wrong polarity, with terminal connections reversed, the capacitor will offer very little resistance to current flow,

The capacitor itself will be overheated and ruined in a very short time. The excessive current may continue for long enough to seriously damage the cathode of the rectifier.

A small electrolytic capacitor is shown at the top of Fig. 14. The negative side of the internal elements is connected to the outer aluminum shell or "can", and to the far end of this shell is attached a wire lead of the pigtail type. The positive side of the internal elements is connected to a second pigtail lead attached at the center of an insulating disc which closes the end of the shell that is toward you in the picture. Capacitors of this style are enclosed within a cylinder of cardboard or fibre which leaves only the two ends and their connections exposed.

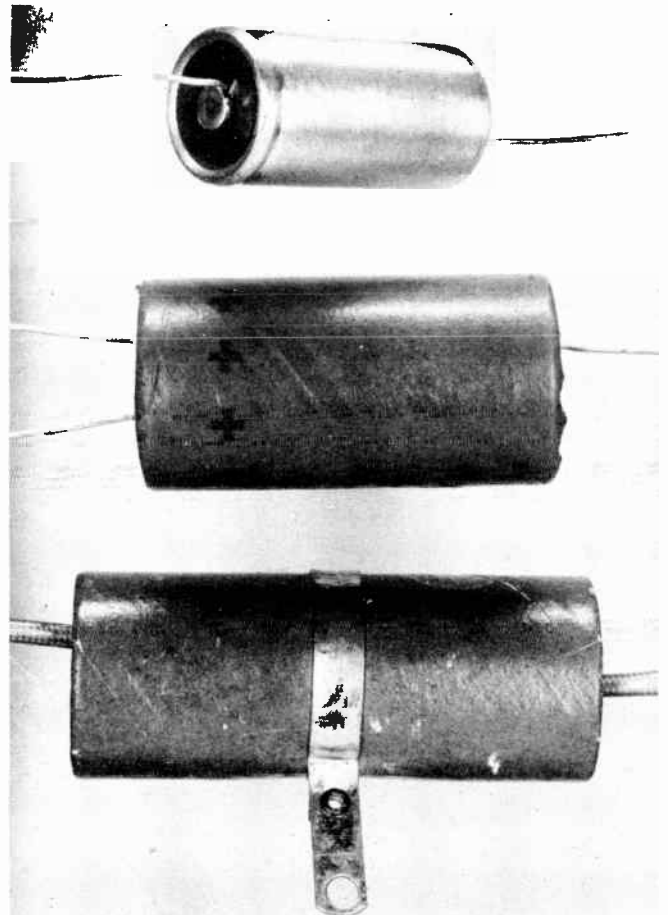

Fig. 14. Electrolytic capacitors with pigtail wire leads for terminals.

At the center of Fig. 11-14 is a cardboard encased electrolytic capacitor containing two sections or what amounts to two capacitors within the one can. Extending

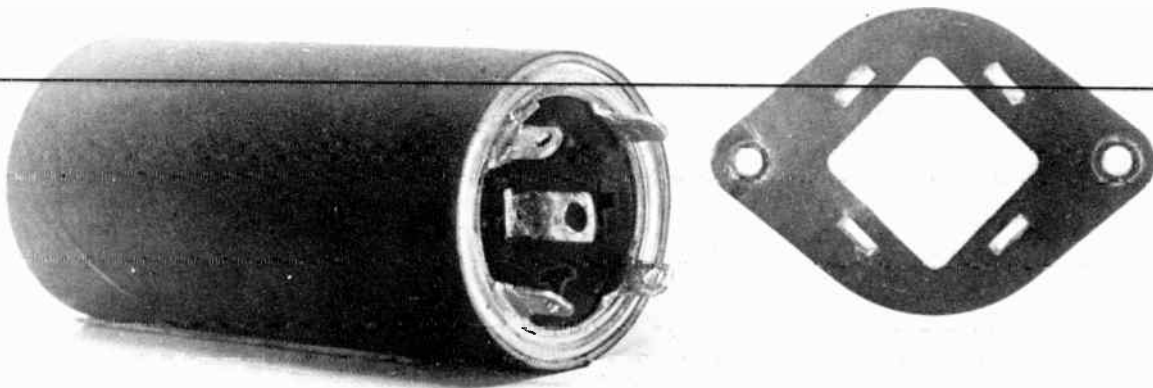

Fig. 15. An electrolytic capacitor designed for prong or twist-lock mounting. An insulating mounting plate or washer is at the right.

from the insulated left-hand end of the unit are two leads. Each is the positive lead for one section. At the other end, connected to the can, is a single negative lead for both sections. Looking back at Fig. 8 you will see that this would make a convenient method of connection. The single negative lead would go to ground or to the transformer center tap, while the positive leads would go on opposite sides of the filter resistor.

Electrolytic capacitors are available with one, two, three or four sections in one housing. The various sections may be of the same or different capacitances. Most often there are separate positive leads for each section, and a common negative lead for all sections. In some instances there is more than one negative lead, with part of the sections connected to one of the negatives and other sections to a different negative.

Small capacitors having pigtail leads may be supported by these leads, as are resistors, or they may be held in place by some of the receiver wiring. As shown at the bottom of Fig. 14, there may be around the outside of the cardboard case a clamping band for attachment to any convenient screw or to a screw inserted for the purpose anywhere in the chassis.

Fig. 15 illustrates a style of mounting often employed for filter capacitors and for larger electrolytic units used for other purposes. Around the outside of the bottom end of the can are four extended lugs. These lugs slip through four slots in the mounting washer that is shown at the right. The mounting washer is held on the chassis by rivets or screws through the holes at opposite ends of the washer. With the lugs inserted and the

capacitor held closely against the mounting, the exposed ends of the lugs are twisted through part of a turn to hold the capacitor securely in place. This may be called a prong mounting or a twist-lock mounting.

The lugs which pass through the mounting are negative terminals for the capacitor, and wires for the negative side of a circuit may be soldered to one or more lugs. The positive terminal, or several terminals for several sections, are in the form of lugs which extend from insulation in the bottom of the capacitor unit, and pass through a large central opening of the mounting washer. The unit illustrated has only one section and only one positive terminal.

Instead of using a mounting washer, as pictured in Fig. 15, the slots for the capacitor lugs and the central opening for positive terminals may be punched right in the chassis metal. This grounds the negative side of the capacitor or capacitors.

The negative side of the power supply does not always connect to chassis metal or chassis ground. There are circuit arrangements with which the transformer center tap, or the most negative point of the power supply, may be more negative than chassis ground. Then the filter capacitors must be insulated from chassis metal. This is done by making the mounting washer of some mechanically strong insulating material. Fig. 16 is a picture of three electrolytic capacitors supported by such insulating washers on a chassis.

Electrolytic capacitors of all styles are specified in parts lists and catalogs according to capacitance in microfarads and



## LESSON 11 – POWER SUPPLY FILTERING

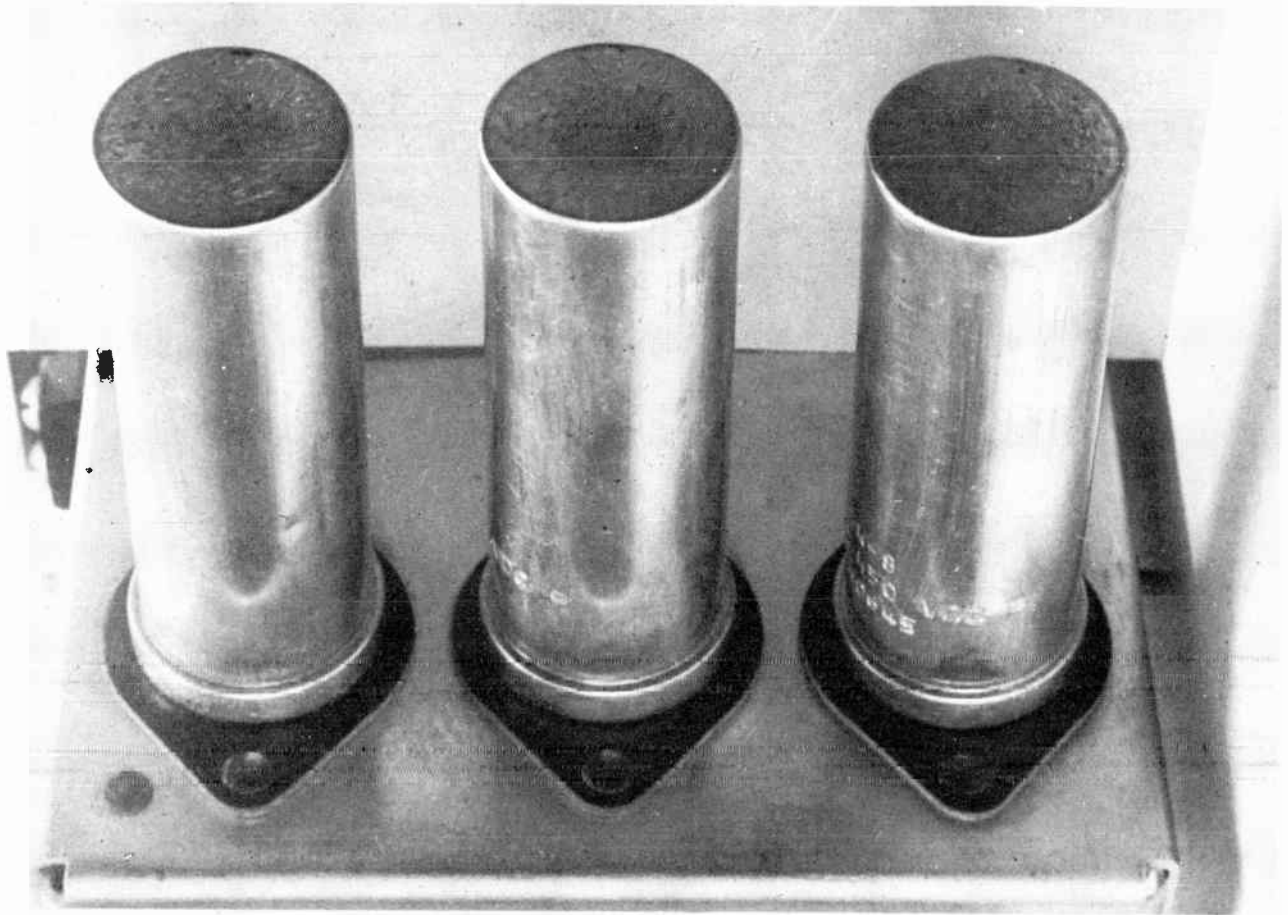

*Fig. 16. Filter capacitors insulated from chassis metal by their mounting washers.*

according to working voltage. This working voltage is the maximum direct voltage that the capacitor can withstand for continual operation. It is all right to use a capacitor having a rated working voltage higher than the actual direct voltage encountered in the filter system, but a capacitor of lower rating cannot be expected to stand up.

Working voltage ratings for stock types of electrolytic filter capacitors range all the way from 3 volts up to 600 volts and sometimes to 700 volts. Capacitances of stock types range all the way from 1 mf to as much as 6,000 mf. But you wouldn't find such a combination as 600 working volts and 6,000 mf capacitance, nor would you be likely to find the combination of 6 working volts and 2 mf of capacitance. The high working voltages are available only in fairly small capacitances, while the very great capacitances are available only with low working voltages.

The first filter capacitor must with-

stand the peaks of pulsating direct voltage coming to it from the rectifier. These peak voltages are very nearly as high as peak voltages in the alternating output from the secondary of the power transformer. There is some small loss of voltage in the rectifier tube, but it is wise to assume that the rectified peaks are equal to the alternating peaks. The alternating peak voltage is equal approximately to 1.414 times the effective alternating voltage from the secondary.

This means that, when selecting a first filter capacitor, you should measure the effective alternating voltage from either half of a full-wave secondary winding, using an a-c voltmeter of sufficiently high range. Then multiply this effective voltage by 1.414 or, roughly by  $1\frac{1}{2}$  times, in arriving at the minimum d-c working voltage of the required filter capacitor.

Normally the second filter capacitor is subjected to a direct voltage only slightly higher

## COYNE - *television home training*

than the output voltage from the power slightly. But were the load removed and no current to flow in the filter circuits, the second capacitor would receive the same peak voltage as the first one. Consequently, it is safe practice to have the same working voltage rating for both capacitors, and to have this rating as high as computed in accordance with the transformer effective and peak voltages.

**WET ELECTROLYTICS.** The electrolytic capacitors which have been illustrated and discussed are of the so-called dry type. This means that the liquid that forms or acts in connection with the dielectric is absorbed into some kind of porous material. Earlier electrolytic capacitors were of the wet type, with which the can contained a liquid free to move about, and not absorbed in any porous substance.

Wet electrolytic capacitors still may be found in some of the older radio sets. When these units fail they are replaced with dry electrolytics of equal or greater capacitance and voltage rating. Fig. 17 shows a dry electrolytic capacitor of a style made especially for replacement of wet types. The upright can looks like that for a wet type. A threaded extension passes down through a round hole in the chassis, and a large nut screwed onto this extension holds the capacitor in place. One of these nuts is shown resting below the capacitor in the picture. Positive and negative leads come out through the bottom extension of the capacitor.

The liquid used in the earlier wet electrolytic capacitors is called the electrolyte, this being the name for any liquid in which

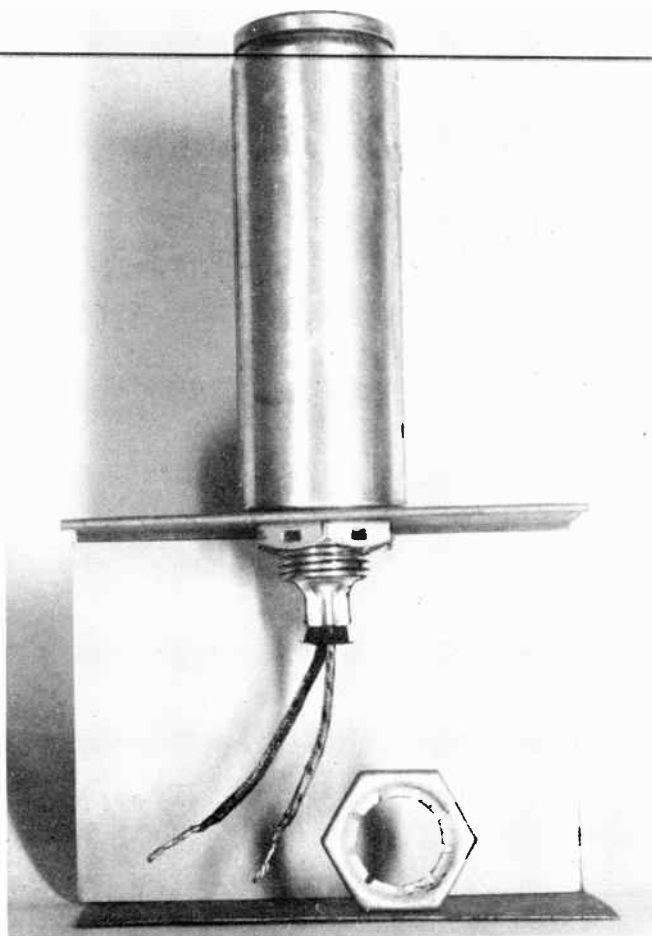

Fig. 17. A dry electrolytic capacitor of a style used for replacing wet electrolytic types.

there is current flow in any electric apparatus or device. The electrolytic capacitor got its name from the use of electrolytic liquid. The liquid still is there, but when absorbed into a porous material we have a "dry electrolytic" capacitor.

---

The following new words and terms have appeared in this lesson. Look them over.

Alternating component  
Capacitance  
Dielectric  
Dry electrolytic  
Electrolyte  
Electrolytic capacitor  
Farad  
Filter  
Mf

Microfarad  
Micro-microfarad  
Mmf  
Parallel  
Polarized capacitor  
Ripple voltage  
Wet electrolytic  
Working voltage, d-c

# LESSON 11 – POWER SUPPLY FILTERING

## REFERENCE INFORMATION

Electrolytic filter capacitors must be connected to the rectifier side of the filter with due regard to their polarity markings. The positive terminal may be marked POS, or with a plus sign (+), or it may have a red lead.

When the rectifier is considered as the source of voltage for the filter and the load, the cathode of the rectifier is the positive terminal. The most negative point in a full-wave rectifier system is the center tap of the transformer secondary.

D-c working voltage of a filter capacitor should be no less than 1.414 times the effective or rms a-c voltage from one half of a full-wave power transformer secondary, as measured with an a-c voltmeter.

Voltage from the entire high-voltage secondary of a power transformer, one outer end to the other outer end, is double the effective voltage applied to each plate of a full-wave rectifier.

Output d-c voltage from the power supply filter decreases when there is more load current, and increases when there is less load current.

Ripple voltage frequency from a full-wave power supply is twice the line frequency. From a half-wave system the ripple is at line frequency.

Any number of capacitors connected in parallel with one another provide a total capacitance equal to the sum of the separate capacitances. Example:  $1.5 \text{ mf} + 2.5 \text{ mf} + 0.5 \text{ mf} = 4.5 \text{ mf}$  combined capacitance.



# TELEVISION

◦ RADIO

◦ ELECTRONICS

---

---

## LESSON 12 – IMPROVING THE POWER SUPPLY

---

---

***Coyne School***

division of

*practical home training*

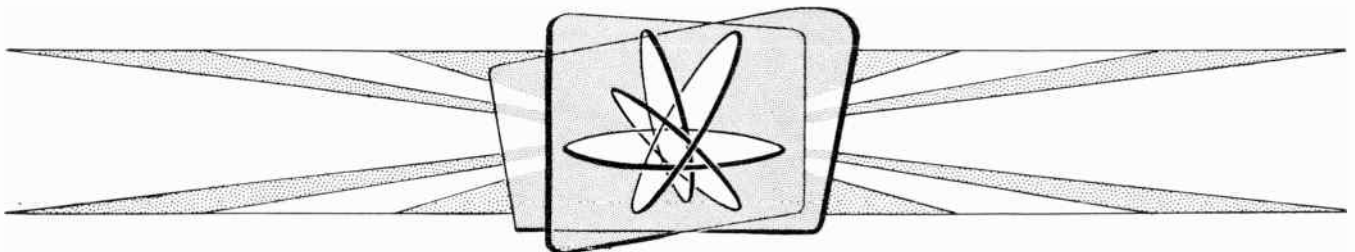

*Chicago, Illinois*

---

Copyright 1953 by Coyne School  
Chicago 12, Illinois  
All rights reserved

## Lesson 12

### IMPROVING THE POWER SUPPLY

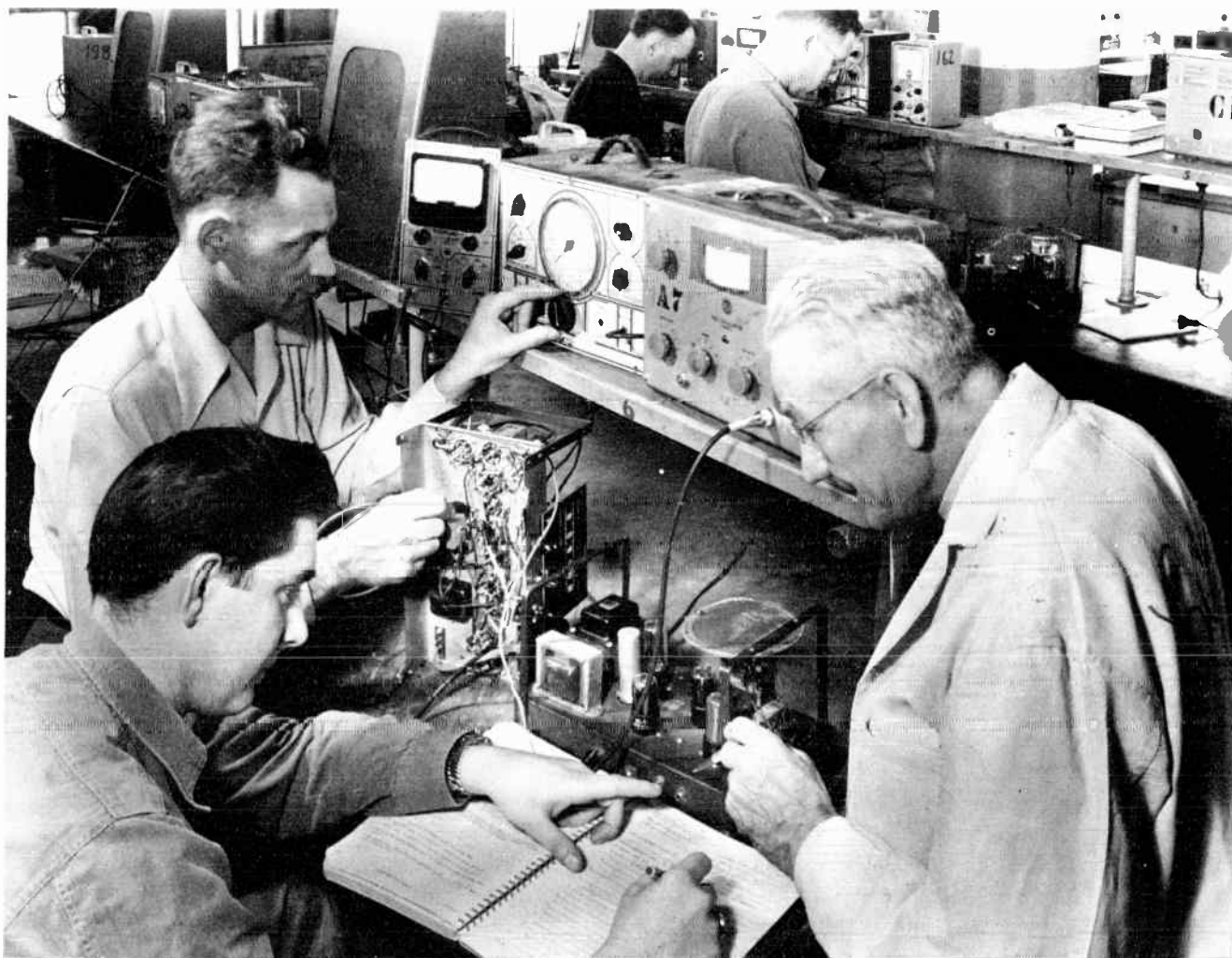

Fig. 1. Checking the voltages of receiver power supplies in the shops of the Coyne School.

The power supply system which we have developed would be quite satisfactory for small receivers of good quality, but for large receivers and for those designed for best possible performance this power supply has two shortcomings. First, there would be too much ripple voltage accompanying the direct voltage at the output. Second, we could not obtain sufficient output power without wasting a great deal of energy or power in the filter resistor.

There is too much ripple voltage be-

cause we have not done enough filtering. We have only a single-section filter. This single section consists of the filter resistor and the second capacitor which follow the first capacitor or the one that is connected directly to the rectifier. Filtering may be increased, and ripple voltage reduced, by adding another section consisting of another resistor and another (third) capacitor.

A power supply with a single-section filter is represented by the diagram at a in Fig. 2. A two-section filter is represented



## COYNE - television home training

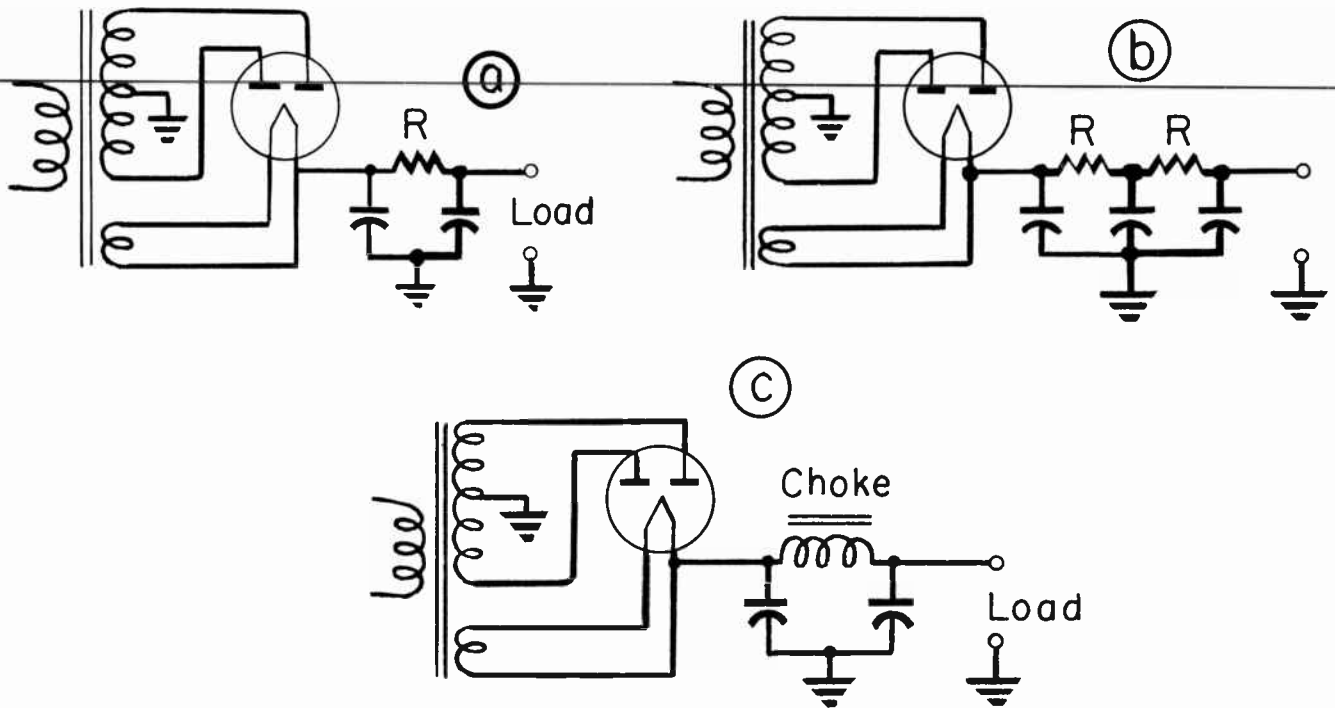

Fig. 2. Single-section and two-section resistance-capacitance (R-C) filters for power supplies at a and b. At c is an inductance-capacitance (L-C) filter.

at b. Both of these are called resistance-capacitance filters, or, using letter symbols, are called R-C filters, because they include resistance and capacitance.

The power output of any R-C filter is of limited value because of the power wasted in production of heat in the filter resistors. All of the direct current for the load must flow from the rectifier through the filter resistors. The watts of power which are used for production of heat are proportional to the resistance and to the square of the current. Consequently, twice the load current means four times the heat, three times the load current means nine times the heat, and so on. When circuits for plates and screens of tubes in the receiver require a large total current, as is true with any large receiver, a lot of power would be wasted in heating of the filter resistors.

To allow handling of large load currents without excessive heating in the filter of the power supply we may substitute filter chokes for the filter resistors, and have the arrangement represented by the diagram at c in Fig. 2. A filter choke is one kind of inductor. It has great opposition to the alternating component of the output, this being the

ripple voltage, yet has very little opposition or very little resistance to the direct voltage and direct current for the output or load.

The opposition to ripple voltage is due to a property of the choke which is called inductance. The letter symbol for inductance is the capital letter L. A filter system employing chokes may be called an inductance-capacitance filter, or, using the letter symbols, may be called an L C filter. In the filter choke we may have a great deal of inductance and very little resistance, which means a great deal of opposition to ripple voltage and little opposition to direct voltage and current. With small opposition or resistance to direct current, the filter can handle large output current with minimum waste of power in heating.

We may have a single-section L-C filter, as at c in Fig. 2, or there may be added sections. Fig. 3 is a picture of the underside of a heavy duty power supply unit in which there is a two-section L-C filter employing the two filter chokes which are marked on the photograph.

A filter choke looks somewhat like a small transformer. Manufacturers often use

## LESSON 12 – IMPROVING THE POWER SUPPLY

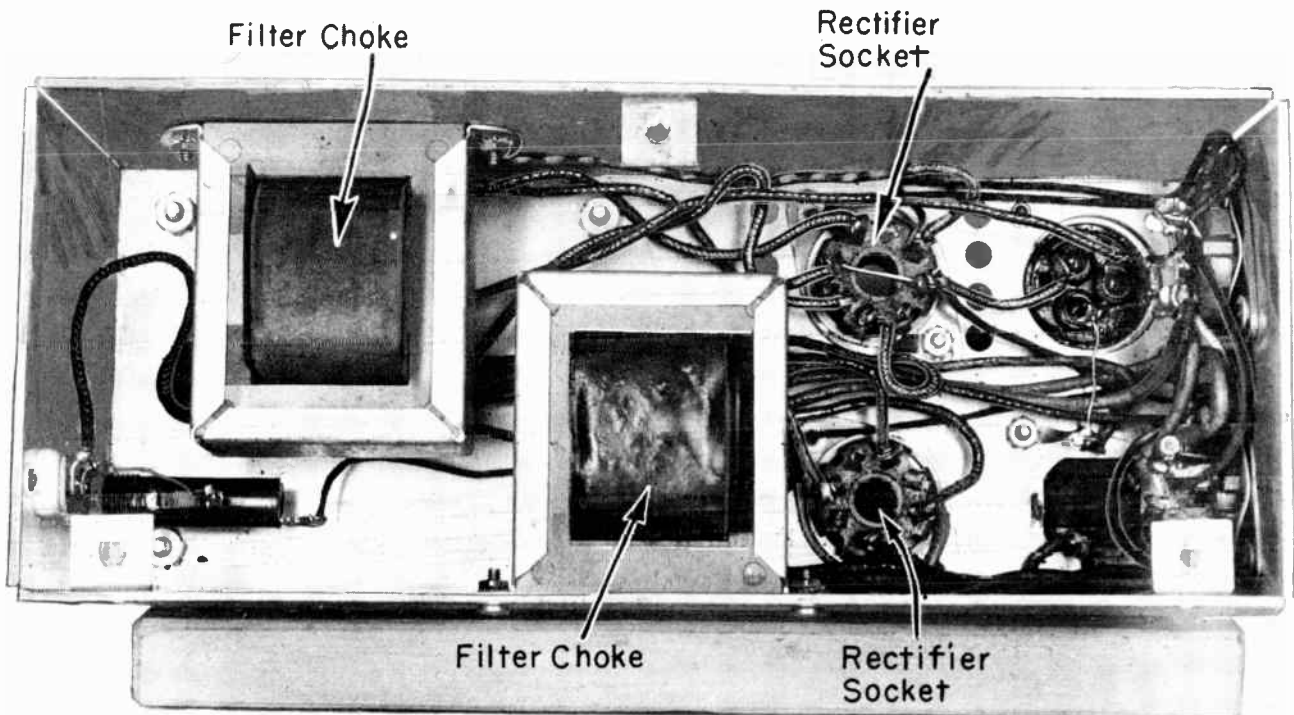

Fig. 3. In this heavy-duty television power supply there are two filter chokes and two rectifier tubes.

the same cores and supporting frames for both chokes and transformers. But a choke has only a single winding or single coil, while transformers have two or more.

**INDUCTANCE AND INDUCTION.** No doubt you recall that excessive alternating current does not flow in the primary winding of a power transformer because of counter-emf induced in the primary. If we left off the secondary windings and retained only the single winding which is used for the primary we no longer would have a transformer, we would have a choke. In the single winding of this choke there would be induction of counter-emf, just as in the primary of the transformer. This counter-emf in the choke winding would oppose the alternating component or the ripple voltage, just as counter-emf in the transformer primary opposes alternating line voltage.

We have been using the words induction and inductance. They don't mean the same thing. Induction is the electrical action which causes an emf or voltage to appear in a winding when a magnetic field moves one way and the other through the turns of that winding.

When the moving (expanding and contracting) magnetic field is caused by changes of current (alternating current) in some other winding the action is called mutual induction. The action in any transformer is due to mutual induction. A current which is changing or alternating in one winding induces a similarly changing or alternating emf or voltage in the other winding.

When the entire action occurs in a single winding, as in the primary of a transformer or in a choke, the action is called self-induction. The changes of current in the one winding induce an emf or voltage in that winding. This self-induced emf or voltage is what we have called counter-emf.

Now for the word inductance. Inductance is the property or ability of a winding which enables it to oppose all changes of current in the winding. If a winding and its associated core are so constructed as to strongly oppose all changes of current we have large inductance, and if there is little opposition to changes of current we have small inductance. The inductance of any winding or any inductor depends on how

## COYNE - *television home training*

the inductor is constructed, just as the resistance of any resistor depends on how the resistor is constructed. This property of inductance which exists in a single winding and enables that winding to oppose changes or alternations of voltage and current is correctly called self-inductance, but when we use the word inductance by itself it generally refers to self-inductance.

Mutual inductance is the property or ability of two windings or coils by which each induces an emf or voltage in the other one of the pair. It happens that we seldom have need to refer to mutual inductance, but will be talking about self-inductance many, many times in future lessons.

Inductance, either self- or mutual, is measured in a unit called the henry. Here is a definition. When current in a winding or coil is changing at the rate of one ampere per second, and the induced emf is one volt, the inductance is one henry. As an example, supposing that current at some instant is 3 amperes, and one second later has increased to 4 amperes. This is a change of one ampere per second. If the induced emf or voltage, or the counter-emf, is maintained at one volt while the current continues to change at this rate, the inductance is one henry.

The inductance possessed by a winding or coil increases with more turns of wire. In general, the inductance increases as the square of the number of turns. Inductance

varies also in accordance with the overall size and the shape and the proportions of the coil. ~~A short, fat winding will have more~~ inductance than a long, thin one when both have the same number of turns. Inductance is greatly affected by the kind of material inside of and around the coil, for it is in this material that the magnetic field must expand and contract.

An inductor such as the filter choke at the left in Fig. 4 has large inductance in proportion to its number of turns, because it is very easy for the magnetic force to act in the iron of the core which is in and around the winding. The inductor or coil at the right has relatively small inductance in proportion to the number of turns, because it is hundreds of times harder for the magnetic force to act in all substances other than iron or steel.

So far as their effect on inductance is concerned, all substances other than iron and steel, act like so much air in and around the coil. This is true of all pure metals such as brass, copper, and aluminum, and it is true also of all kinds of insulating materials which may be used for coil support. Any inductor which does not have a core of iron or steel often is called an air-core inductor or coil, because the core might as well be air in relation to the inductance.

The large inductances of iron-core chokes, as used in filters, are measured in henrys. Such chokes commonly have induc-

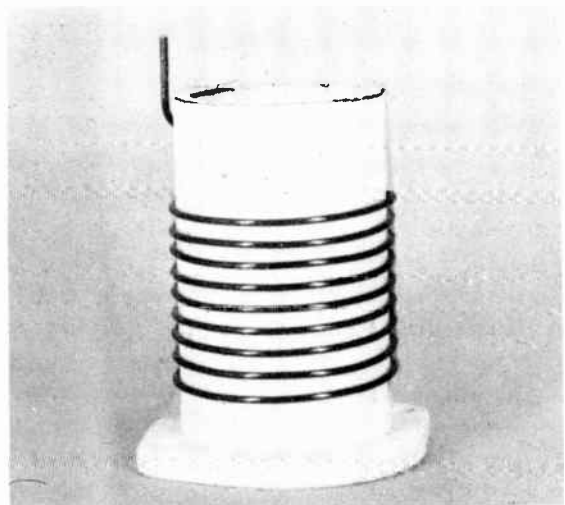
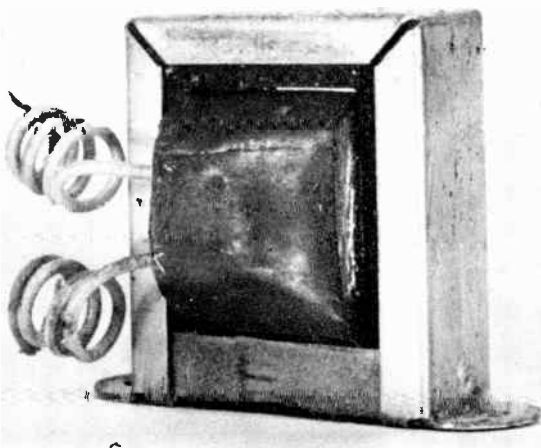

Fig. 4. An iron-core filter choke (left) and an "air-core" inductor or coil (right).



## LESSON 12 – IMPROVING THE POWER SUPPLY

tances of anywhere between 3 and 20 henrys. Smaller inductances, such as found in coils whose iron cores do not extend around the outside of the coil, may be measured in millihenrys. One millihenry is one one-thousandth of one henry of inductance.

Air-core coils, like the one at the right in Fig. 4, have inductances so small as to be measured in microhenrys. One microhenry is one one-millionth of one henry. Some air-core inductors have inductances great enough to be conveniently measured in millihenrys.

REACTANCE. Here is something which you should consider rather carefully. We have said that inductance is a measure of the ability of a winding or coil to oppose changes or alternations of voltage and current. Inductance is a measure of what the coil might do, under certain conditions. Inductance is not a direct measure of how much opposition the coil actually offers in a certain application.

To determine the actual opposition of an inductor to alternating current and voltage we could figure out the number of volts of counter-emf. To compute the counter-emf we would have to multiply the inductance in henrys by 6.28, and then multiply the result by the number of amperes of current and then by the number of cycles per second of frequency. All this is mentioned not because we have any particular need for computing counter-emf, but to bring out the fact that opposition to alternating voltage and current depends on current and on frequency, as well as on inductance.

To simplify our thinking, the whole matter may be boiled down to the statement that opposition to alternating voltage and current offered by any particular inductance depends on the number of times per second that lines of magnetic force cut through the turns of wire in the inductor. The greater the current in amperes, the stronger will be the magnetic field, the greater will be the number of magnetic lines, and the more lines will cut the coil turns in any length of time. The higher the frequency, the more often the whole thing happens every second, the greater

will be the number of magnetic lines cutting the turns every second.

Look at Fig. 5. The curve at 1 represents an alternating voltage or current of low frequency and moderate amplitude (as measured in amperes). A certain length of time is marked off from a to b. During this time the change of current, and movement of magnetic lines, is proportional to the height of the vertical double-headed arrow.

At 2 we have the same amplitude (current in amperes) but have doubled the frequency per second. During the same length of time as before there is a much greater change of current, and in rate of cutting by the magnetic lines.

At 3 we have gone back to the lower frequency, but have increased the amplitude (current). During our constant interval of time there is an even greater change of current and of rate of cutting by magnetic lines.

At 4 we have retained the higher current and have gone to the higher frequency. During the same length of time as in all the other cases there is now a greater change of current than ever before.

When alternating voltage and current are opposed by something other than ordinary resistance the opposition is called reactance. When this opposition is due to inductance it is called inductive reactance. All reactances are measured in ohms, just as all resistances are measured in ohms. You will find, in fact, that every kind of opposition to every kind of voltage and current is measured in ohms.

Resistance opposes all voltages and currents, whether direct or alternating. Reactance opposes only alternating voltage and current, because to have reactance we must have a voltage or current that is changing. Otherwise there won't be any movement of the magnetic lines of force, nor any counter-emf.

Now for a question which should be easy for you to answer. We have two rectifiers, one full-wave and the other half-wave, operated from the same line frequency. Both furnish the same direct current. We want the

# COYNE - *television home training*

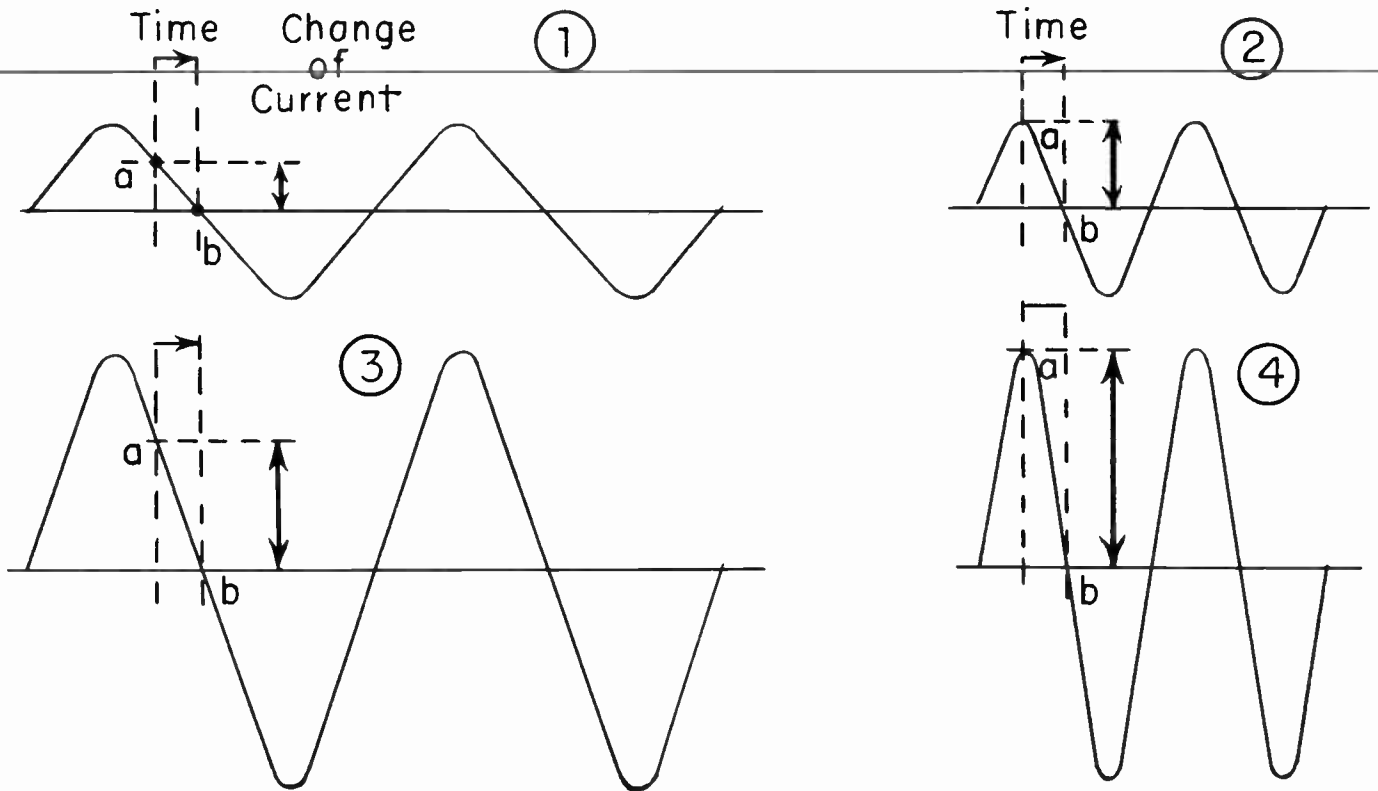

Fig. 5. How the change of current during any given length of time is affected by frequency and by amplitude.

same reactance (opposition to ripple voltage) in both filters. Which must have the greater inductance, the choke for the full-wave rectifier circuit or the choke for the half-wave rectifier circuit?

Your answer is correct. At twice the line frequency, from the full wave rectifier, we can have the same opposition to ripple (same reactance) with half as much inductance in the full-wave choke. This is a real advantage of full-wave over half-wave rectification. A half-wave choke costs 25 to 35 per cent more, and weighs 30 to 50 per cent more than a full-wave choke that does the same work on ripple voltage.

You should remember this about inductance and inductive reactance. Inductance is built into the choke or other inductor by the design; inductance does not change with frequency. Reactance depends on both inductance and frequency, therefore the reactance of any choke varies with frequency.

**FILTER CHOKE RATINGS.** When looking at parts lists and catalogs you will

find three principal ratings for filter chokes. One is the inductance in henrys. Another is the maximum direct current, in milliamperes, that the choke should carry. The third is the resistance of the choke. This resistance, in ohms, is not the same as the inductive reactance in ohms. The resistance is that for direct current. It is the resistance which you would measure with an ordinary ohmmeter. This resistance opposes flow of direct current through the filter to the load circuits. It does not change with line frequency nor with ripple frequency.

The rated direct current for the filter choke should not be exceeded. More current, in moderate amount, won't necessarily burn out the wire in the choke winding, but it will reduce the inductance and thereby will reduce the reactance to ripple voltage.

It is a characteristic of all iron cores that the amount of change in magnetic field strength and in magnetic lines for any given alternating component (ripple voltage) becomes less and less as direct current increases. In many filter chokes you would

## LESSON 12 – IMPROVING THE POWER SUPPLY

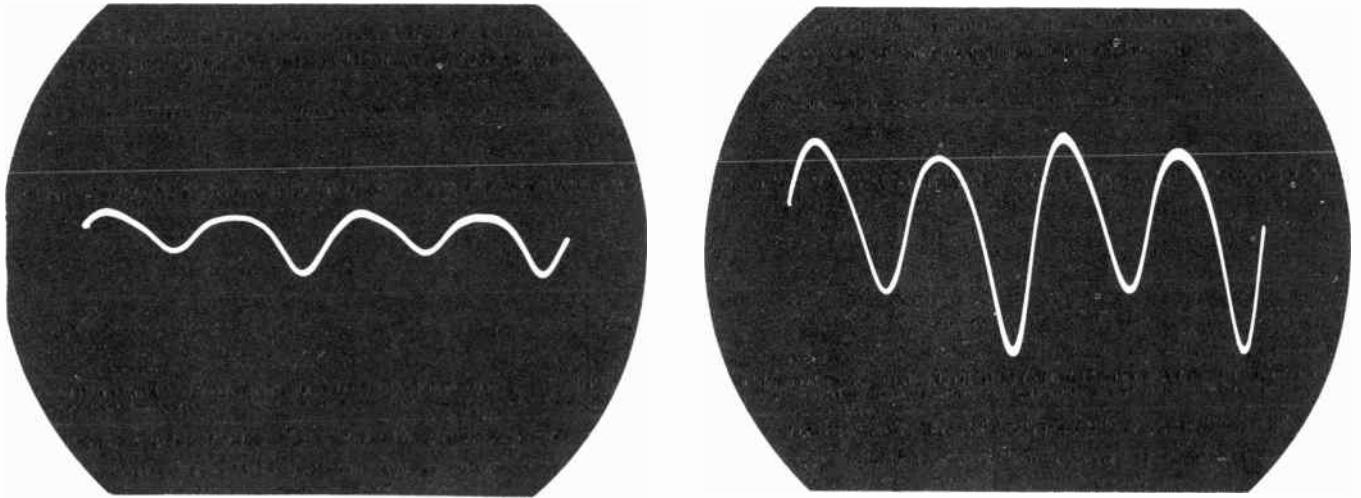

Fig. 6. The effect on ripple of substituting for a filter choke a resistor which allows the same output voltage.

have twice the inductance in henrys and twice the reactance in ohms were all direct current kept out of the winding. With the rated value of direct current the inductance and reactance will be about half as much as with only alternating current. If direct current exceeds the rated value by any great amount, the choke loses practically all its ability to oppose ripple voltage.

Probably you have wondered why, if chokes are so good, we ever use the R-C type of filter. The answer is that a filter choke costs, on the average, about four to five times as much as a generally equivalent filter resistor. And a choke weighs, on the average, about 100 times as much as a filter resistor.

Now that we know something about filter chokes we may watch one in action, by means of the oscilloscope. Using the same power supply employed in earlier tests, a filter choke was substituted for the filter resistor. This particular choke had measured inductance of about 15 henrys with no direct current, and probably would be rated at about half this inductance with flow of direct current in the winding.

With the oscilloscope adjusted for high gain the output ripple voltage appeared as at the left in Fig. 6. D-c output to the load measured 255 volts. Then an adjustable resistor was put in place of the choke, where a filter resistor would be used.

To obtain the same ripple voltage re-

quired filter resistance of 6,500 ohms. This high resistance dropped the d-c output voltage from 255 to less than 210 volts, with the same load resistance as before.

To obtain the same d-c output voltage as with the filter choke, the filter resistance had to be dropped to 2,200 ohms. Then the ripple voltage went up as shown at the right in Fig. 6. The d-c resistance of the filter choke measured 320 ohms, with the ohmmeter. The remainder of its opposition to ripple was due to inductance and to inductive reactance.

**SPEAKER FIELDS AS CHOKES.** All speakers must have as part of their structure a strong magnet. Most of them employ a permanent magnet, and are called PM speakers. There are, however, some speakers in which there is an electromagnet. The electromagnet consists of an iron core around which is a winding or coil of many turns of insulated wire. When direct current flows in this winding the core becomes a strong magnet. This is an electromagnetic or "electrodynamic" speaker. The electromagnet is called the speaker field.

Since the speaker field consists of a single winding on an iron core it may be used as a filter choke, connected as in Fig. 7. Because there is some alternating component or ripple voltage in any filter choke there will be an alternating voltage of small value in a speaker field used as a choke. This could cause a hum from the speaker but for the fact that special types of speaker field



# COYNE - television home training

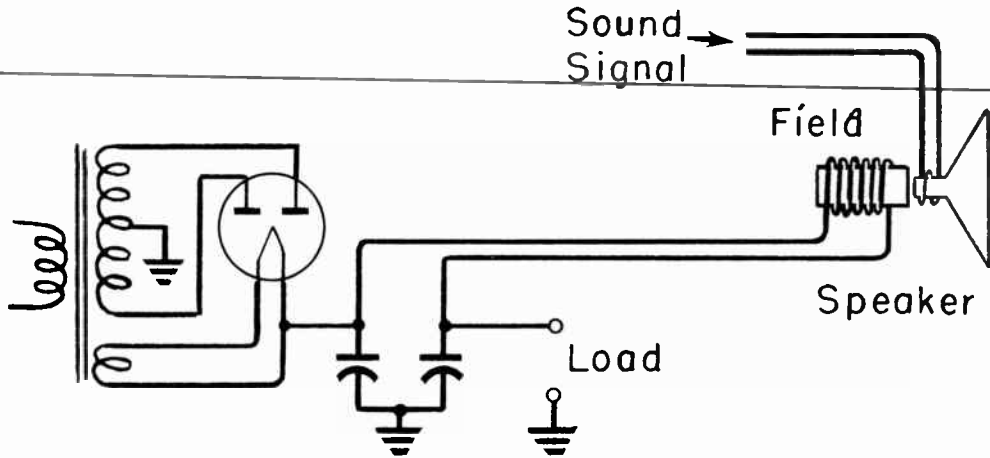

Fig. 7. A speaker field used as a choke for the power supply.

windings are used to counteract the hum voltage. Such designs will be explained when we come to a study of speakers and how they perform.

**MULTI-SECTION FILTERS.** It was mentioned at the beginning of this lesson that ripple may be reduced by adding a second section to the filter. Obviously, if one section reduces the ripple to some fraction of the original pulsations, a second section can reduce the ripple output of the first one to a still smaller fraction.

Although both sections of a two-section filter may employ chokes, or both may employ resistors, it is quite common prac-

tice to use a choke in the first section and a resistor in the second section, as shown by Fig. 8.

Output direct voltage and current are taken from two points on this filter system, one point at a following the choke and the other at b following the resistor. Output from point a goes to the second amplifier tube of a pair or to any tubes requiring relatively large currents for their plates and screens. These large direct currents flow only in the filter choke, not in the following resistor, and because a choke has small resistance to direct current there is but little drop or loss of direct voltage in the choke, even with large currents.

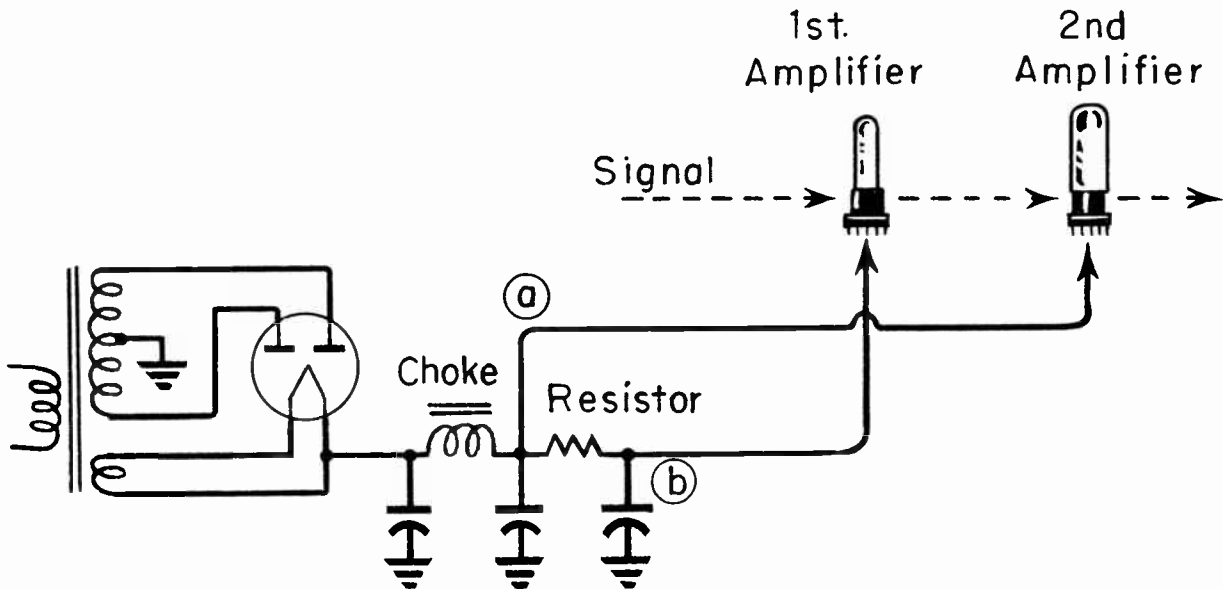

Fig. 8. A power supply filter furnishing two different output voltages and currents.

## LESSON 12 – IMPROVING THE POWER SUPPLY

Output from point b of the filter goes to a first amplifier tube or to any tubes which require relatively small currents for their plate and screen circuits. This smaller current flows in the filter resistor as well as in the choke, but there is not excessive voltage loss in a fairly high resistance, because of the relatively small direct current.

It is plainly apparent that there will be stronger ripple voltage from a on the filter than from b, since the resistor and added capacitor provide additional filtering action. Let's assume, merely for illustration, that we have 1/10 volt of ripple at point b and have 1 volt of ripple at a. We shall assume also that the first amplifier increases the signal voltage and also any ripple voltage by 10 times. Then the 1/10 volt ripple to this amplifier from b will be increased to 1 volt (by the 10 times amplification) in the ripple voltage passed along with the signal from the first to the second amplifier.

Now the ripple voltage reaching the second amplifier from a on the filter is no greater than the ripple voltage coming from the first amplifier, and originating at b on the filter. Direct voltage from a on the filter will be higher than from b. This is desirable because amplifiers operated with large currents usually require proportionately high direct voltages, while amplifiers requiring small currents often need proportionately small direct voltages.

In an actual power supply filter having one L-C section followed by one R-C section, the ripple following the choke was practically identical with that shown by the oscilloscope at the left in Fig. 6. The ripple following the filter resistor was as shown by Fig. 9. Filter choke inductance was 7.5 henrys and filter resistance 5,700 ohms. The capacitor following the rectifier was a 4-mf unit, and the other two of 8 mf each.

**CHOKE INPUT FILTERS.** All of the filter systems which have been examined are of the capacitor-input type. This means that a capacitor immediately follows the rectifier, and that input to the filter is from this capacitor. Now we shall make the rather radical change illustrated by Fig. 10. Here we have

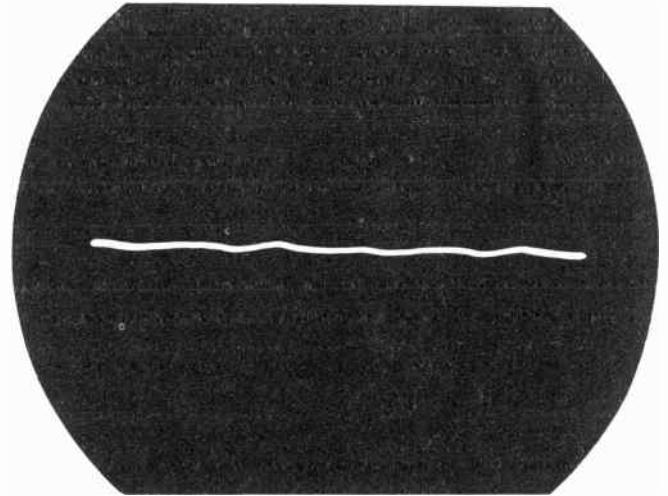

Fig. 9. The second section of a filter reduces the ripple from that shown at the left in Fig. 6 to the value shown here.

a choke-input filter. Immediately following the rectifier is a choke rather than a capacitor, and input to the remainder of the filter is from this choke.

Fig. 11 shows the rectified voltage from the rectifier to the input choke, with the oscilloscope connected to the lead going from the rectifier cathode to the choke. Compare the form of the voltage pulses with the form when there is capacitor input, as shown by earlier pictures of traces. With capacitor input the positive peaks at the tops of the traces are sharply pointed. With choke input these peaks are rounded off. Choke input is easier on the rectifier tube, because it does not allow such high peaks of rectified voltage and current.

With a capacitor-input filter the first capacitor is charged to a voltage nearly equal to voltage of the high, sharp pulses. Because the peaks are rounded off by a choke, the capacitor following the choke is not charged to so high a voltage. The final result is that d-c voltage output is lower with a choke-input filter than with a capacitor-input type when other things are unchanged.

Choke-input filters allow handling large d-c outputs with excellent reduction of ripple voltage. They also maintain a more nearly constant voltage when there are large variations of load resistance and load current. But for the same output power a supply with

## COYNE - *television home training*

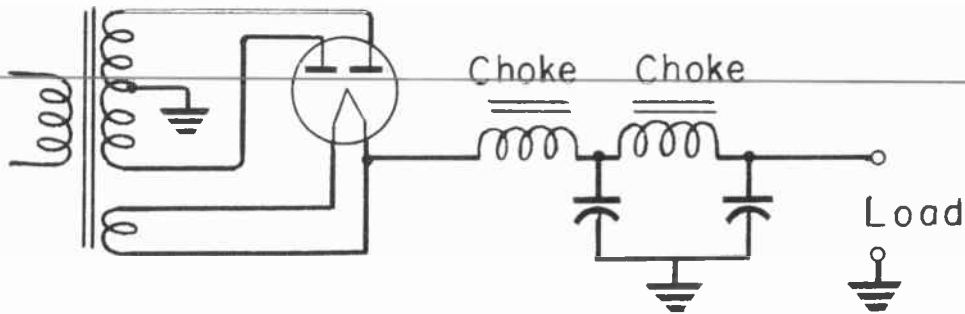

Fig. 10. This filter is of the choke-input type.

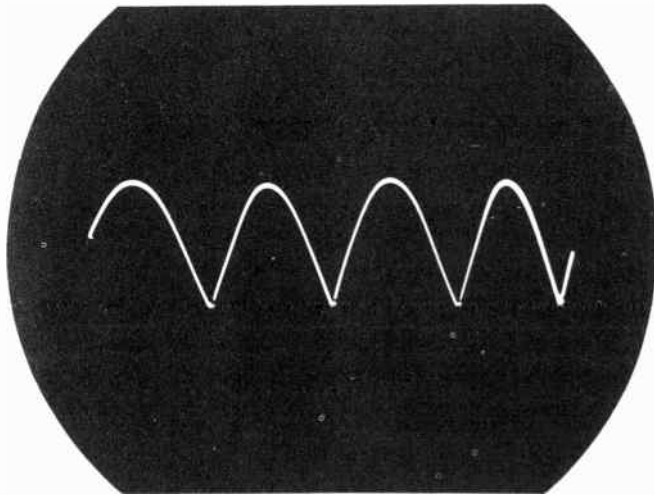

Fig. 11. Output pulses from a full-wave rectifier which is followed by a choke-input filter.

capacitor-input filter costs less than one with choke input. As a consequence, choke-input filters seldom are found in home receivers

for radio and television, but they often are found in public address systems and other applications where high power and the best possible sound quality are required.

HANDLING LARGE OUTPUT CURRENTS. In some television receivers and in many amplifiers used for public address and similar heavy duty applications the total required direct current exceeds the current capacity of even the largest home receiver type rectifier tubes. To avoid going to the more costly transmitter types of heavy duty rectifiers we may connect two of the receiver types in parallel with each other.

Such a connection is shown by Fig. 12. Each rectifier tube is a full-wave type, but its two plates are connected together to make the equivalent of a single plate. The normal maximum current rating for a full-wave rectifier is the current "per plate" and the two plates working together will handle twice as much current as either one alone.

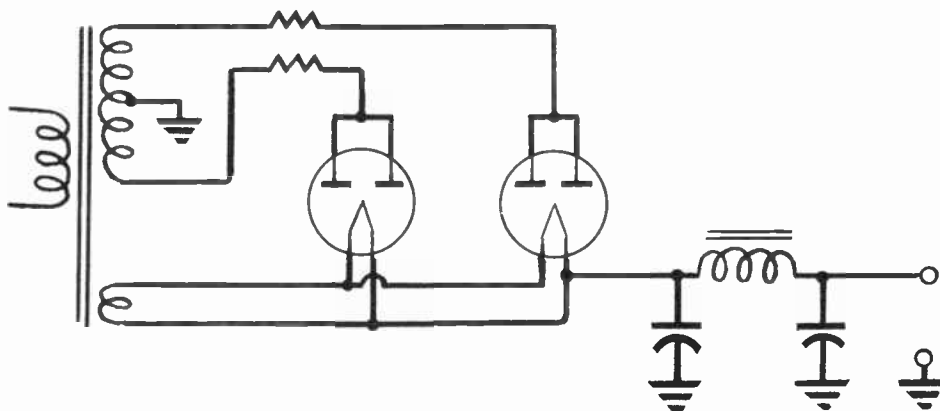

Fig. 12. Full-wave rectifier tubes with the plates of each in parallel. The two tubes give full-wave rectification.



## LESSON 12 – IMPROVING THE POWER SUPPLY

The paralleled plates of each rectifier are connected to the outer ends of the transformer secondary, just as each individual plate of a single full-wave rectifier would be connected. The cathodes of the two rectifiers are connected together, and from them a lead goes to the filter. The two tubes work on alternate alternations of transformer secondary voltage, as would the two plates of a single full-wave rectifier.

Although the rectifiers will handle double or approximately double the current that one plate would handle, the maximum effective voltage recommended for ordinary operation must not be exceeded. The parallel rectifier arrangement thus allows about double the d-c output current of a single similar rectifier, but the output voltage can be only slightly if at all higher than with one rectifier tube.

The two resistors shown in series with the end leads of the transformer secondary may or may not be used. The purpose of these resistors, when included, is to add enough resistance in the circuit for each tube to insure approximately equal currents in both tubes. The d-c resistance of rectifiers is quite small. From the cathode to each plate of a 5U4G, as an example, the resistance may be only about 250 ohms. With the plates

in parallel this resistance is halved. Should resistance of either rectifier differ materially from this average value, one of them might carry more or less current than the other one. Excessive current would overheat the tube. Series resistors of something like 100 to 200 ohms each then help to equalize the resistances in the two sides of the circuit, and thus to equalize the currents.

In some of the preceding oscilloscope traces of ripple voltage you may have noticed that alternate peaks and valleys sometimes are higher or lower than those in between. This may have resulted from slightly different d-c resistances in the two sections of the single full-wave rectifier tube. It could result also from the center-tap of the transformer secondary not being at the true electrical center of the winding, thus making unequal alternating voltages from the two parts of the secondary. These inequalities in ripple cycles are of no great importance, since practically all of the ripple must be filtered out in any case, and if ripple is troublesome it won't be any worse for having slight differences between cycles.

In many television receivers and in some radio sound receivers requiring more direct current than can be furnished from a single rectifier it is more common practice

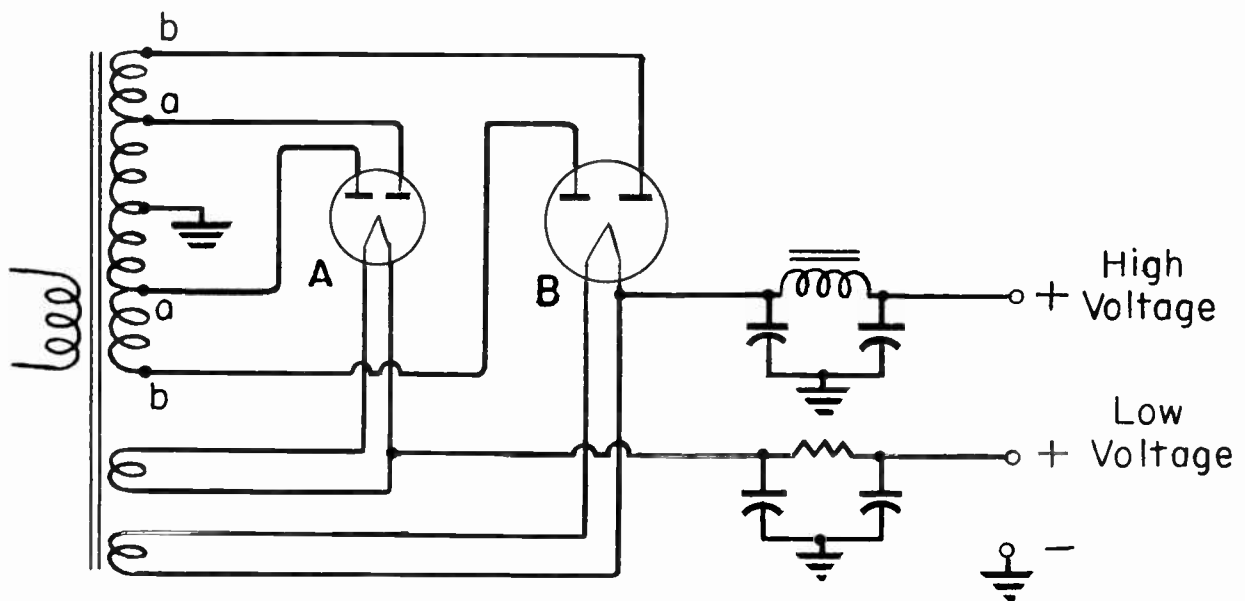

Fig. 13. Two power rectifiers and two filters connected to a single power transformer secondary winding.

# COYNE - *television home training*

to use the arrangement of Fig. 13 than to use paralleled rectifiers. Here we have two full-wave rectifier tubes each working as a full-wave rectifier. Rectifier A ordinarily would be rated for less voltage and current than rectifier B. For instance, A might be a 5Y3GT type and B a 5U4G type of tube.

The power transformer secondary has the usual center tap and two end terminals marked b, and in addition has two other taps, a, which are a little ways in from the ends. There are more secondary winding turns between the center tap and the ends, b, than between the center tap and the intermediate a taps. Therefore, there will be higher secondary voltage at the outer b terminals than at the intermediate a taps.

The lower secondary voltage is applied to the plates of the smaller rectifier, A, while the higher secondary voltage is applied to the plates of the larger rectifier, B. There must be on the transformer a separate filament or heater winding for each rectifier, because the two tubes will operate at different voltages.

There are two separate filters, one connected to the cathode of each rectifier. The filter for the high-current high-voltage output from rectifier B would nearly always include a choke. The filter for the lower voltage and current from rectifier A might

be either a choke (L-C) type or else a resistor (R-C) type. All receiver tubes requiring plate and screen voltages in the range from 200 to 350 volts would be supplied from the filter which is on rectifier B. All tubes requiring lower voltages would be supplied from the filter on rectifier A.

LINE VOLTAGE TAPS. We have just seen one example of how a tapped transformer winding may be useful. Tapped windings are used for many purposes other than for two rectifier tubes. A fairly common use of taps is to allow compensation for line voltages that are abnormally high or low. It has been mentioned that most power supplies will operate on line voltages all the way from about 105 to 130, when 117 a-c volts is the value assumed in designing the apparatus. There are localities in which line voltage is persistently low or high, and in these places it is desirable to make a correction.

Fig. 14 illustrates line voltage compensation by means of power transformer taps. In the left-hand diagram the primary winding has a "common" terminal at the end permanently connected to one side of the power line, and at the other end has three taps, or rather it has an end terminal and two taps. For a normal line voltage of between 115 and 120 volts we would use the "medium" tap marked M. This would give a correct turns ratio and voltage ratio between the primary and the secondaries.

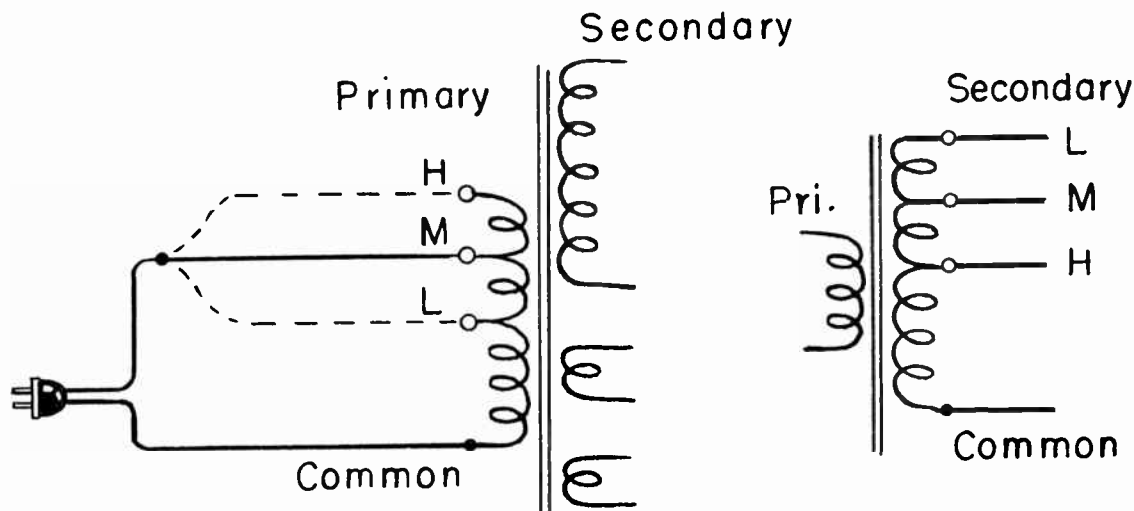

Fig. 14. Transformer windings which are tapped to allow compensation for various line voltages.

## LESSON 12 – IMPROVING THE POWER SUPPLY

If line voltage is too high we would make connection to terminal H. Now there are more active turns in the primary. The secondaries have not been changed. Therefore there are, proportionately, fewer secondary turns in relation to active primary turns than before. Then secondary voltage won't be so high in proportion to primary voltage, and the power supply will operate satisfactorily even with the abnormally high line voltage.

If line voltage is too low we would use tap L. This reduces the number of active primary turns. The ratio of secondary turns to primary turns has been increased, and the secondary voltage will be proportionally higher in relation to primary voltage. Thus we have suitable secondary voltages in spite of an abnormally low line voltage.

Were there only a single secondary, as in the diagram at the right, compensation could be made with taps on the secondary. Note how the ratios of secondary to primary turns are altered by using secondary terminals L for low line voltage, M for normal line voltage, and H for high line voltage. With several secondaries it would be more costly in construction and would mean more work in servicing to change connections on all the secondaries than on the one primary. Consequently, tapped primaries are used for line voltage compensation in the case of power transformers.

POWER SUPPLY REGULATION. As various controls are operated in television receivers, and in some sound radio receivers, the circuit resistances are altered. This may allow taking more or less current from the power supply. When power amplifier tubes and other tubes requiring large currents are handling the varying signal voltages the currents for plate and screen circuits may undergo large variations at the frequency of the signals. Unless voltage from the power supply remains fairly constant with the varying currents, the performance will not be at its best.

The variation of output voltage from the power supply when there are changes of output current is called voltage regulation. Regulation usually is expressed as a per

cent. It is the percentage of the output voltage with no current by which the voltage changes when there is maximum current. Here is an example.

Direct voltage at the output of a power supply filter is 250 when no load current is being taken from the supply. With 13.3 ma to the load the output voltage drops to 200. The change of output voltage is 50. This 50 volts of change is  $1/4$  or is 25 per cent of the "no-load voltage". Therefore, the voltage regulation for a load of 13.3 ma is 25 per cent.

The percentage of voltage regulation always is far greater than variation of output voltage during normal operation of a receiver. Although the load current does vary, it never goes down to zero current. Then the variation of current never is so great as assumed in computing the regulation percentage.

It is well to get acquainted with the manner in which the output voltage from any source, even from a battery, must change when there are variations of current. Many service problems may be cleared up by understanding what is happening, and why. To begin with, every source must contain something which produces emf or voltage. This may be energy in the chemicals inside a battery, or it may be line power or energy in a power transformer, it may be heat in a thermocouple, or anything else than can change into emf.

Next, any path through which the emf can cause electron flow or current inside or through the source must have more or less resistance. There is no such thing as an electrical conductor without resistance. Then whatever current may flow must flow in this internal resistance of the source.

Now we may go to diagram A of Fig. 15. The box at the left represents a source, any imaginable kind of source. We shall assume that the internally produced emf amounts to 100 volts, and that the internal resistance of this particular source is 100 ohms. These two things won't be altered by anything we do outside the source.

In diagram A the external load connected to the source has resistance of 900



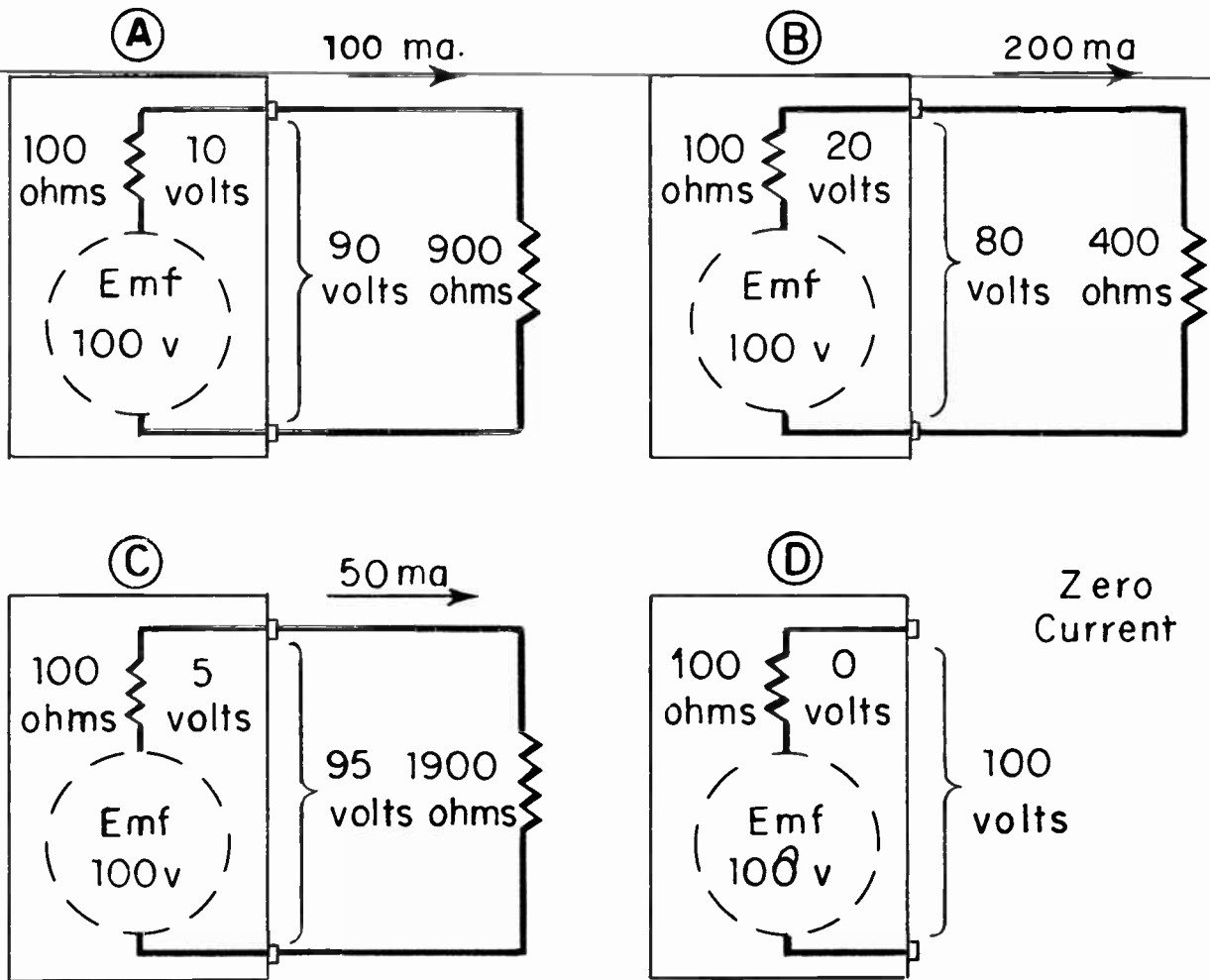

Fig. 15. Why the terminal voltage of any source must vary when there are changes of load resistance and output current.

ohms. Current will flow in the heavy-line path, passing through the 100-ohm resistance of the source and the 900-ohm resistance of the load, for a total resistance of 1,000 ohms. With 100 volts acting on 1,000 ohms the current will be 100 ma. When this 100 ma current flows in the 100-ohm internal resistance of the source there will be 10 volts used up in that resistance. This leaves 90 volts out of the original 100 volts of emf to become "terminal voltage" and to act on the load resistance.

In diagram B the load resistance has been reduced to 400 ohms. Together with 100 ohms inside the source this makes a total of 500 ohms on which will act the emf of 100 volts. Resulting current is 200 ma. When 200 ma flows in the 100-ohm internal resistance of the source, 20 volts out of the 100-volt emf

will be used up inside the source. Only 80 volts will remain at the source terminals and across the load.

Diagram C shows load resistance of 1,900 ohms, making a total external and internal resistance of 2,000 ohms. Going through the same computations as before, we find 95 volts at the terminals of the source.

At D there is no external load resistance. The terminals of the source are open circuited, and we have a no-load condition. There can be no current, and consequently no loss of voltage in the internal resistance of the source. Then the entire emf remains for the source terminals, and the open-circuit voltage is 100 volts, the same as the emf of the source.

## LESSON 12 – IMPROVING THE POWER SUPPLY

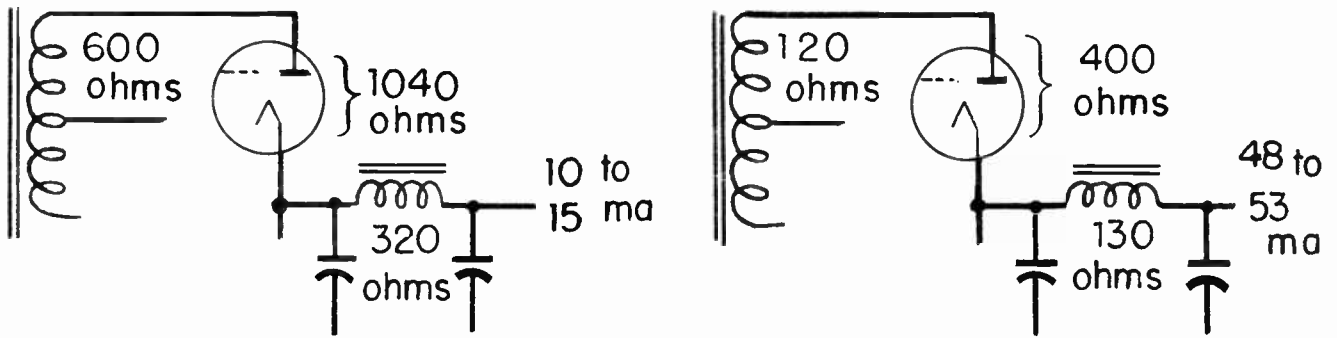

Fig. 16. D-c resistances of the transformer, the rectifier, and the filter choke in two power supplies.

A television or radio power supply contains three internal resistances. They are: 1. Resistance of the filter resistors or filter chokes, or both. 2. Resistance of the rectifier tube to flow of direct current through it. 3. Resistance of the transformer secondary winding. The less the total internal resistance the better will be the voltage regulation.

Fig. 16 shows actual "internal" resistances of two power supplies. Values at the left are for a small unit using a 5Y3GT rectifier. Resistance of half the secondary winding is 600 ohms, effective resistance of the tube is about 1,040 ohms, and d-c resistance of the filter choke is 320 ohms, for a total of 1,960 ohms. When direct current changes from 10 to 15 ma, which is a change of 5 ma, the total internal resistance causes output voltage to change by about 9.8 volts.

Values shown on the right-hand diagram are for a larger power supply using a 5U4G rectifier. Resistance of half the secondary is 120 ohms, effective resistance of the rectifier is about 400 ohms, and d-c resistance of the choke is 130 ohms, making a total of 650 ohms. When direct current changes from 48 to 53 ma, a change of 5 ma, the change of output voltage due to internal d-c resistance is only about 3.25 volts. The transformer and choke in this larger power supply weigh more than twice as much as those in the smaller unit. Heavy-duty power supplies of good design must be built with large and heavy parts.

The effective resistance of rectifiers, and the loss of voltage, becomes less and less

as rectified current decreases. Between 225 and 20 ma the effective resistance of a 5U4G, as computed from voltage drop, increases from about 260 to 550 ohms. Rectifiers with heater-cathodes have less space between cathode and plate and have less voltage drop than filament cathode types. But the closer spacing allows the heater-cathode types to operate only with lower voltages and smaller currents.

Voltage regulation of the power transformer itself is improved by using more turns of larger wire on both windings, while maintaining the same turns ratio. It is improved also by using a larger core, which allows more effective induction of secondary voltage. A transformer big enough for its job costs more, and is worth it.

While a choke-input filter allows lower d-c output voltage than a capacitor-input type, the choke-input filter provides much better voltage regulation. This is true even when the chokes have the same inductance and the same d-c resistance for both designs.

Increasing the capacitance of the first capacitor in a capacitor-input filter improves the voltage regulation to some extent, but not by any important amount. More capacitance in the capacitor at the output end of any filter will greatly improve the voltage regulation during rapid changes of output current. A big capacitor can hold enough charge to supply quick changes of output current without a great decrease of capacitor voltage.

A method of improving voltage regulation by means of bleeder current is illust-

## COYNE - television home training

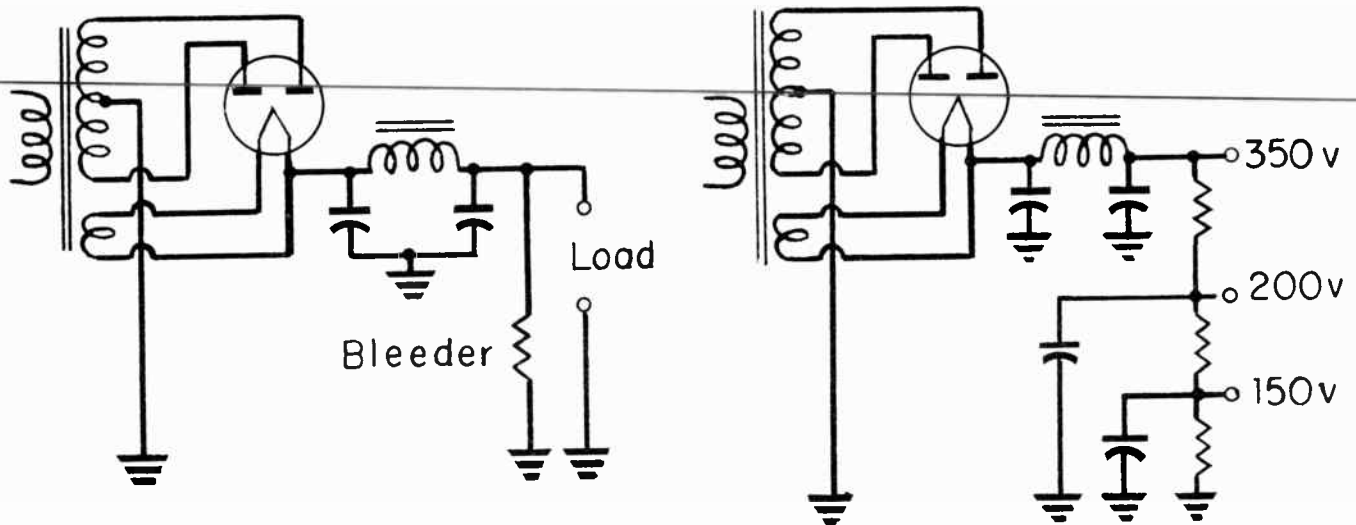

Fig. 17. Resistors connected between the positive output of the filter and negative or ground for the purpose of improving voltage regulation.

rated at the left in Fig. 17. Within the power supply a bleeder resistor is connected from the positive output terminal to negative or ground. Current flows in this resistor at all times, in addition to whatever current goes to the load.

Assume that bleeder resistance is such that it carries average current of 20 ma and that load current changes from 40 ma to 50 ma. Total output current is that for the bleeder and load together. When load current changes as mentioned, total current for bleeder and load will change from 60 to 70 ma. This is a 10-ma change, and it represents an increase of 16.7 per cent above the minimum 60-ma current. Were there no bleeder, and only the load current, the change of current still would be 10 ma. But this is 25 per cent of the minimum 40-ma current. The lesser percentage change with the bleeder improves the voltage regulation. This is a wasteful method, because bleeder current always is producing heat in the resistor.

A better method is shown by the right-

hand diagram. Here the bleeder resistance is divided into several sections. The several sections might have resistances so proportioned as to give three different voltages to ground, as marked. Actually these voltages would be made of whatever values are needed for various receiver circuits.

A certain amount of current flows through all three sections of resistance, as with the bleeder resistance in the left-hand diagram. Additional current for the 200-volt tap flows in the upper section. Current for the 150-volt tap flows in the middle and upper sections.

The resistances in the right-hand diagram would make up what is called a voltage divider. The upper and middle resistances would be called divider resistances, and the bottom one would be the bleeder resistance. In later lessons we shall follow up the matter of voltage division at some length, since you will find that it is of prime importance in a large number of trouble shooting procedures.

These are some of the new words and terms which have appeared in this lesson.

Air-core  
Bleeder current  
Capacitor-input filter  
Choke-input filter  
Filter choke

Henry  
Inductance  
Induction \*  
Inductive reactance \*  
Microhenry



# LESSON 12 – IMPROVING THE POWER SUPPLY

Millihenry  
Mutual inductance \*  
Mutual induction \*  
Reactance \*

Resistance-capacitance filter  
Self-inductance \*  
Self-induction \*  
Voltage regulation

---

## REFERENCE INFORMATION

Compared with an R-C filter, an L-C filter allows handling greater direct current with less loss of output voltage, and with large currents gives greater reduction of ripple.

The inductance of a filter choke, and consequently the opposition to ripple voltage, becomes less and less as more direct current flows in the choke. Never substitute a choke of lower inductance for the original choke, and never exceed the maximum current rating of a choke.

Opposition of a filter choke to ripple (inductive reactance of the choke) depends on both inductance and on frequency of rectified pulses. Less inductance is needed with full-wave than with half-wave rectifiers.

Rectifiers with paralleled plates allow double the rated rectified current, but can

safely handle voltage no greater than for normal operation.

So far as effect on inductance is concerned, any ordinary material other than iron or steel acts like air. Iron or steel for a core causes a great increase of inductance with all else unchanged.

$$\text{Voltage regulation} = \frac{\text{no-load volts} - \text{normal load volts}}{\text{no-load volts}}$$

This formula gives a fraction. Multiply the fraction by 100 to change to a percentage.

\*The meaning and significance of these things will become more apparent as we proceed to make use of them. Any present difficulty in understanding the marked words and terms will disappear when you see the principles applied in many ways during following lessons.

# TELEVISION

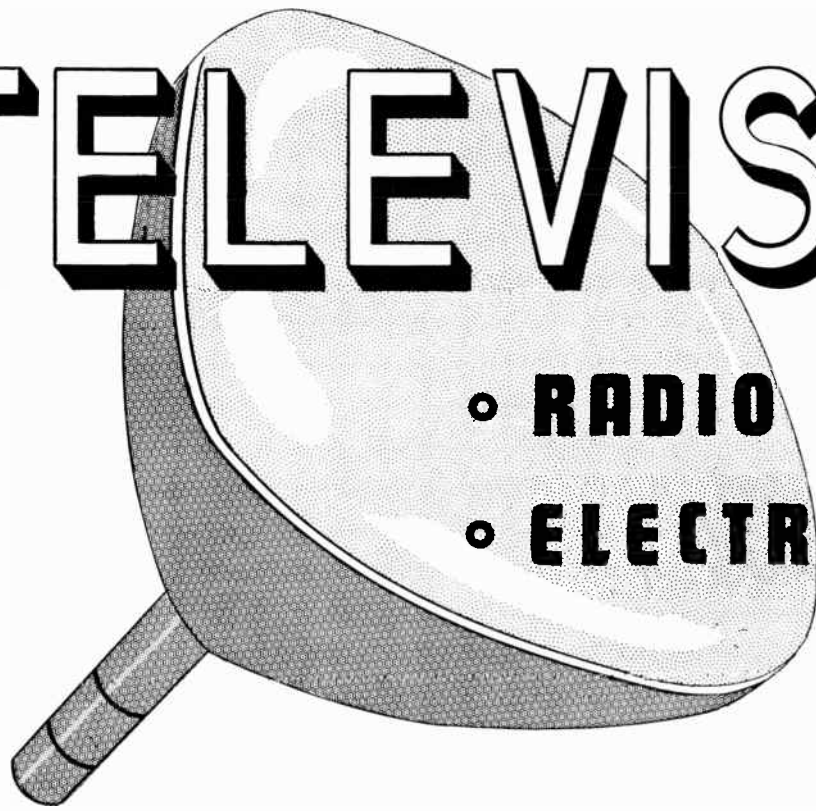

• **RADIO**

• **ELECTRONICS**

---

## LESSON 13 – TRANSFORMERLESS RECEIVERS

---

***Coyne School***

division of

*practical home training*

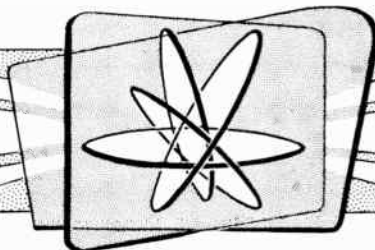

*Chicago, Illinois*

---

Copyright 1953 by Coyne School  
Chicago 12, Illinois  
All rights reserved

Litho. in U.S.A.



## Lesson 13

# TRANSFORMERLESS RECEIVERS

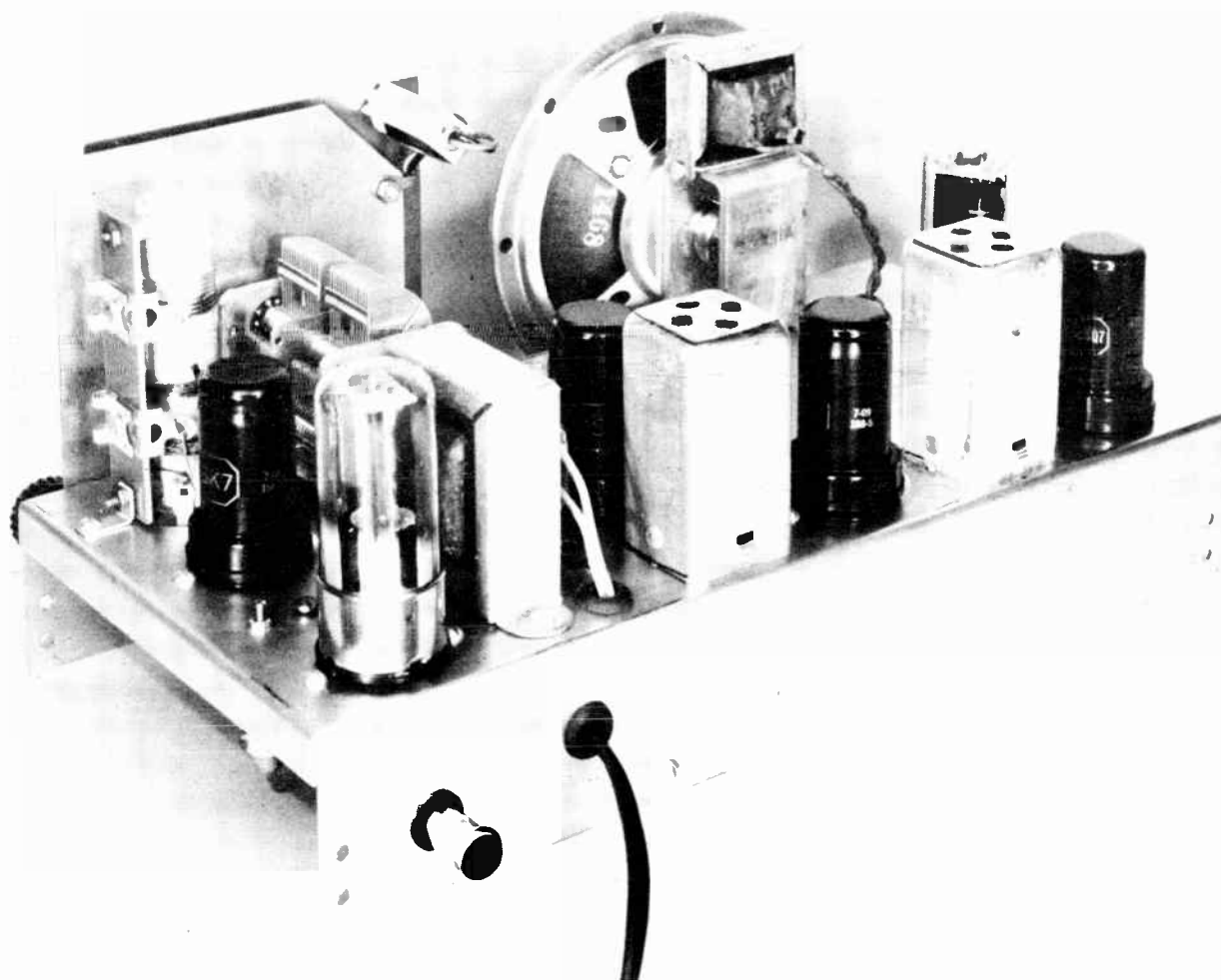

Fig. 1. Transformerless radio receiver in which the tube heaters are connected in series.

After learning how a power transformer gives all the different voltages required by receivers we are going to look at some small radio sets and some of the lower cost television receivers in which there is no power transformer at all. Yet, as a rule, these "transformerless receivers" require more different alternating voltages than the other kinds.

Part of the explanation of how receivers get along without voltage-changing power transformers is found in what we already know about series circuits - in the fact that any overall voltage divides among a number of

resistances proportionately to the values of resistance. It will be easy to see how this works out in practice by examining a small radio set. Later we shall extend the method to television receivers.

The top of a six tube radio chassis is pictured by Fig. 1. The names of most of the tubes are like those of tubes in television receivers. The "converter" tube in a radio set is a combined r-f oscillator and mixer tube. Just now we are not concerned with oscillation and mixing, but only with the heaters of the tubes. The tubes alone are shown at the left in Fig. 2. The underside of

**COYNE - television home training**

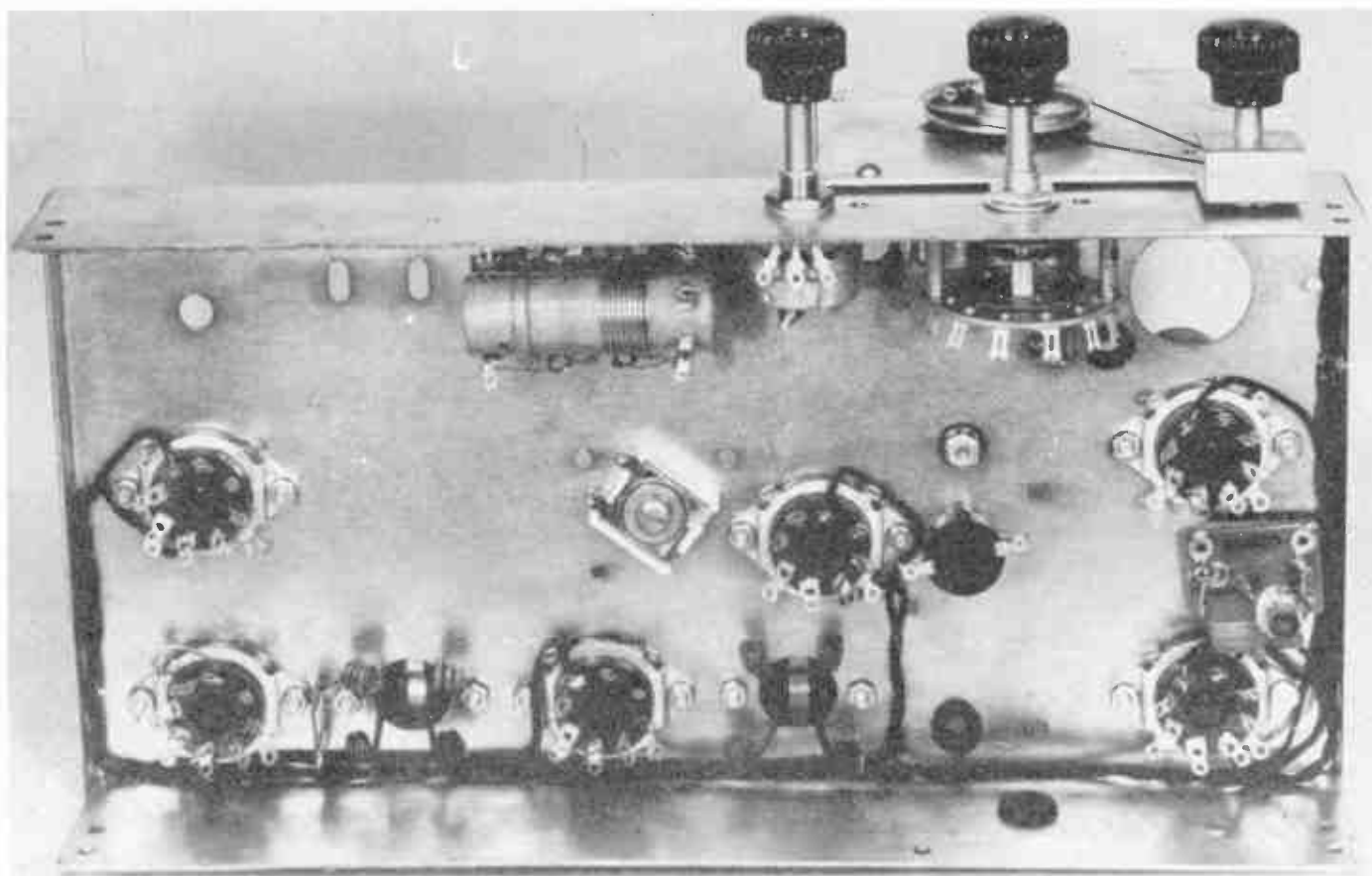
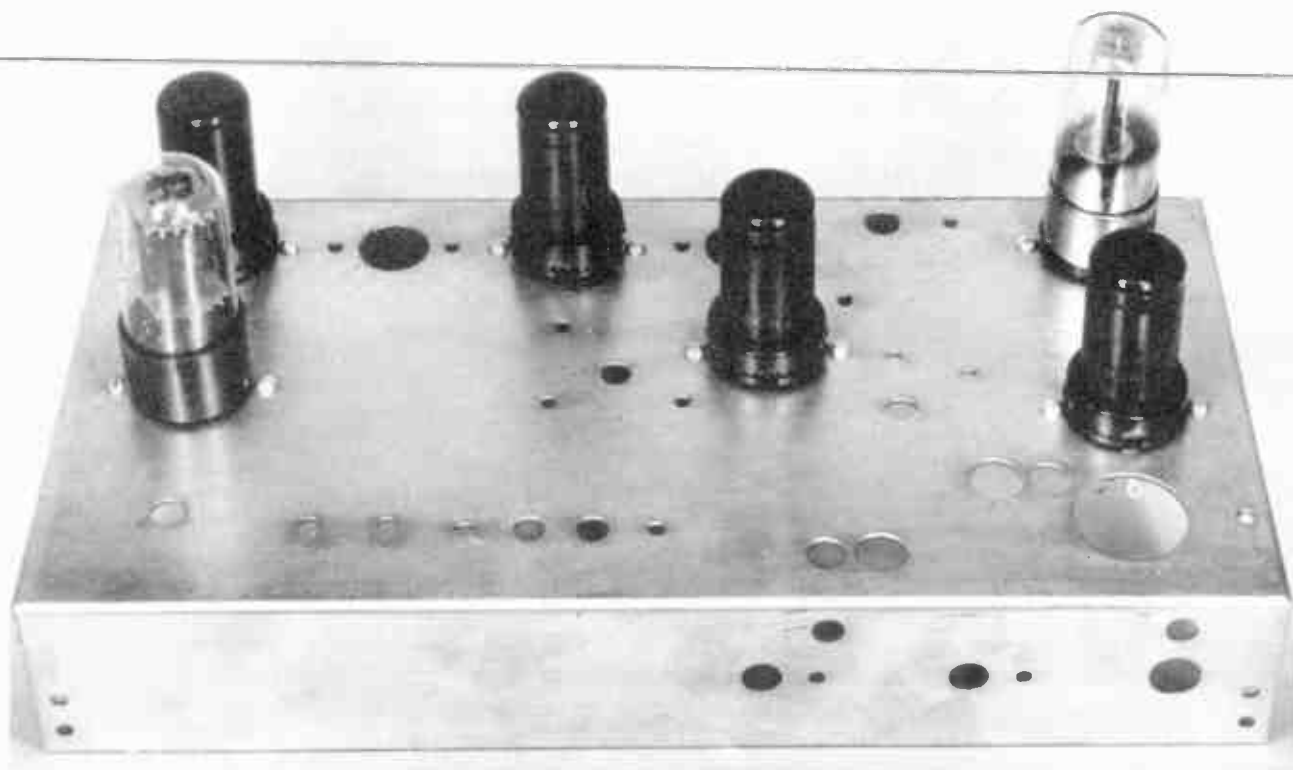

*Fig. 2. Above are the six tubes as they appear above the chassis, and below is the heater wiring underneath.*

## LESSON 13 – TRANSFORMERLESS RECEIVERS

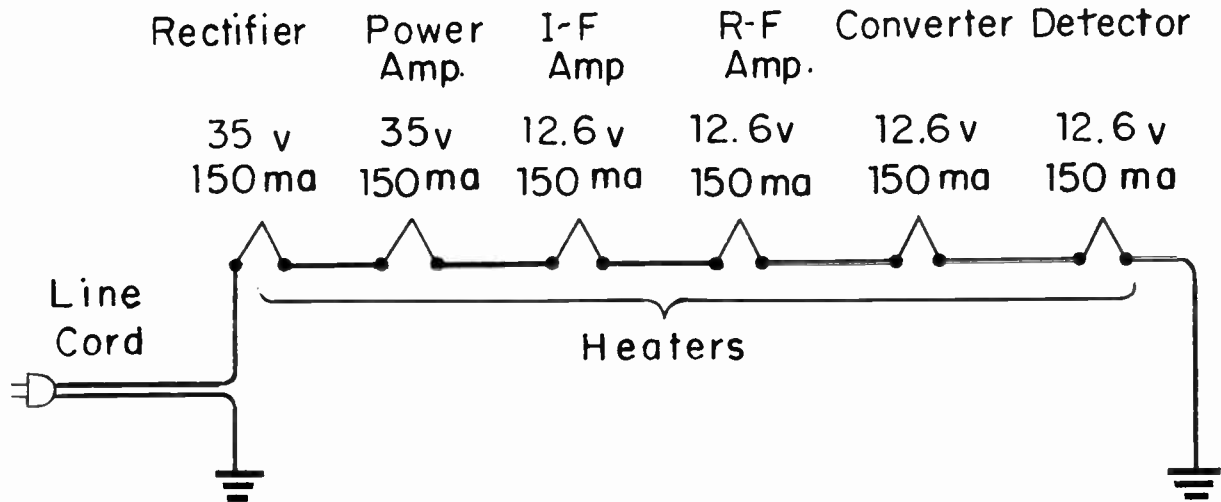

Fig. 3. Voltages and current in each of the six heaters.

the chassis, with only the tube heater wiring in place, is shown at the right.

The heaters of all six tubes are connected in series with one another, as illustrated by the simplified diagram of Fig. 3. This series "string" of heaters is connected across the a-c power line, with connections to chassis ground completing one side of the heater circuit.

The heaters of the rectifier tube and of the power amplifier tube are so designed as to reach correct operating temperature when there is 35 a-c volts across each heater. The heaters of the other four tubes reach correct operating temperature with 12.6 a-c volts across each of them. Now add together the voltages required for all six tubes. The sum is 120.4 volts.

When the line to which this heater string is connected furnishes 120.4 volts we have precisely the correct partial voltage across each heater. Should line voltage drop to 105 a-c volts the heater voltages would be only about  $4\frac{1}{2}$  per cent below normal. Line voltage so high as 130 a-c volts would raise the heater voltages only about 8 per cent above the normal values.

In any series circuit there is the same current in every part. Consequently, all the heaters in the series string of Fig. 3 must be designed to operate with the same current, although the voltages may be different. All

the tubes in this particular receiver have heaters designed for normal operation when carrying current of 150 ma, which is the same as 0.150 ampere.

When the 35-volt heaters reach normal operating temperature, and are carrying 150 ma, the resistance of each heater is 233 ohms. This you can determine from the alignment chart or from a formula for resistance. The 12.6-volt heaters, when carrying 150 ma of current, have resistances of 84 ohms each. Total resistance of the six heaters is 802 ohms, or approximately 800 ohms, because resistances in series add together. If we apply 120 line volts across 800 ohms the current will be 150 ma, as you can determine with the alignment chart or a formula. Everything works out according to rule.

Series heaters work just as well on a direct-current power line as on an alternating-current power line, provided the line voltage is the same in both cases. Later we shall learn that the rectifier section of the receiver will operate from either an a-c or a d-c power line. For this reason, transformerless receivers often are called ac-dc receivers; they work on either kind of power line.

Portable battery-operated radio sets may operate with tube cathodes or filaments in series on a battery. Many such sets are designed so that the series filaments may be



## COYNE - *television home training*

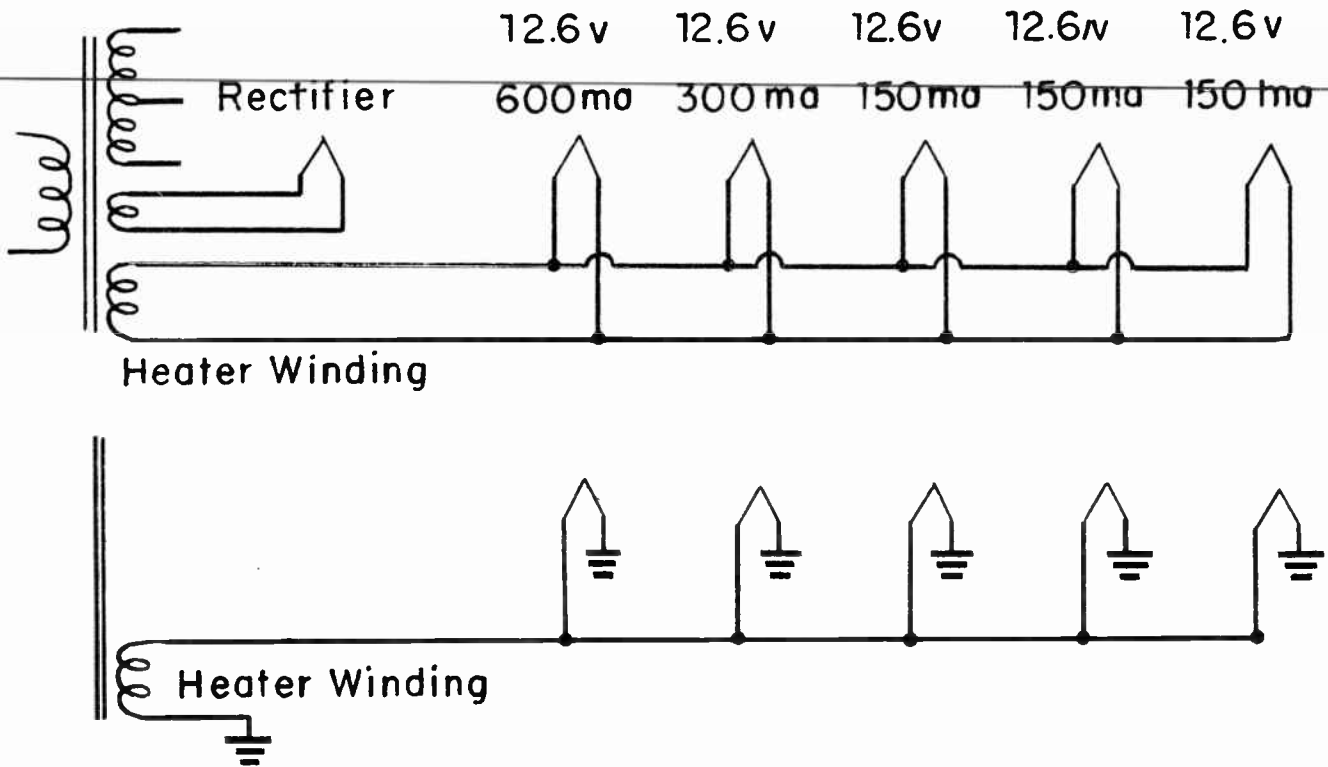

Fig. 4. When heaters are in parallel, each connects directly or through ground to the transformer winding.

operated also from either an a-c or a d-c power line. Then we have what may be called a universal receiver; it operates on either kind of power line or on its self-contained batteries. Still another name is three-way receiver.

By employing series heaters we may do away with a transformer having a step-down ratio to furnish heater voltage lower than power line voltage. But there is the disadvantage that a burned out or otherwise open circuited heater in any one tube of a string puts out all the other tubes, because an open anywhere in a series circuit stops all current everywhere in the circuit.

Were we using for the six-tube radio receiver a transformer with a low-voltage heater winding as one of the secondaries, connections would be made as in Fig. 4. Both sides of every heater, except that for the rectifier, are connected directly to the two terminals of the heater winding. We speak of a direct connection because resistance of the wiring is negligible. Instead of using the two insulated heater lines of the upper diagram it

is more common practice to ground one terminal of the transformer winding and to ground one side of each heater. Then one side of the heater circuit is completed through chassis ground. Operation is the same with grounded and ungrounded circuits.

Since all the heaters are connected across the one transformer winding, and since one winding can furnish only one voltage at a time, all heaters must be designed to operate at the same voltage. This might be 12.6 volts as shown, or any other voltage for which tubes are designed, but it must be the same for all tubes. We say that the heaters are connected in parallel.

The paralleled heaters need not take equal currents. Each can take the current which is determined by the heater resistance, when connected to the transformer voltage. There might be heaters taking three different values of current, as illustrated, or every heater might take a different current, or all might take equal currents. The transformer heater winding is designed to furnish the sum of all the heater currents.

## LESSON 13 – TRANSFORMERLESS RECEIVERS

In any parallel connection the total current for all the parts must be the sum of the separate currents for each part. In our example, enough current must flow from one side of the transformer winding for the heater of the first tube. Enough additional current must flow from this side of the winding for the second tube, and still more for the third tube, and so on. All these currents which go through all the heaters then join together and come back to the other side of the transformer winding. The sum of all the heater currents in Fig. 4 is 1,350 ma, which is the same as 1.35 amperes. The heater winding must furnish 1.35 amperes at 12.6 volts.

With heaters in parallel any one or more tubes may be removed from the circuit without affecting operation of the others. The heater of any one tube might burn out or become otherwise open circuited without affecting other tubes. This is because each heater is connected directly to the transformer winding, without current for that heater having to go through any other heater or any other tube.

### HEATER VOLTAGES AND CURRENTS.

Various types of television and radio tubes are designed with heaters for normal operation on all these different voltages.

6.3 volts	25 volts	50 volts
12.6 volts	35 volts	70 volts
18.9 volts	45 volts	117 volts

When heaters are connected in parallel on a transformer winding we nearly always

find that these heaters are for operation at 6.3 a-c volts. All the heater voltages from 12.6 through 70 volts ordinarily are found in series heater connections. The heaters rated for 117 volts may be connected directly across the common 110-120 volt power line. Any heater will operate equally well on either its rated effective a-c voltage or on the same d-c voltage.

Heater voltage and the appearance of a tube have no relation. The tube at the left in Fig. 5 has a 35-volt heater, the second one has a 50-volt heater, and the other three have 12.6-volt heaters.

The first figure or figures in the type designation of a tube indicate approximate heater or filament voltages of tubes designed during the past 10 to 15 years. These figures, examples of tubes using them, and corresponding voltages, are as follows.

1. (as for 1LG5 tube) 1.4 volts. These are battery operated tubes. The initial numeral 1 has been used for older types operating at 1.25 or at 2.0 volts.
2. (as for 2X2A tube) 2.5 volts for the heater.
3. (as for 3LF4 tube) 2.8 volts for heater. Battery-operated tubes.
5. (as for 5Y3-GT tube) 5.0-volt heater. This heater rating is found most often in rectifier tubes.

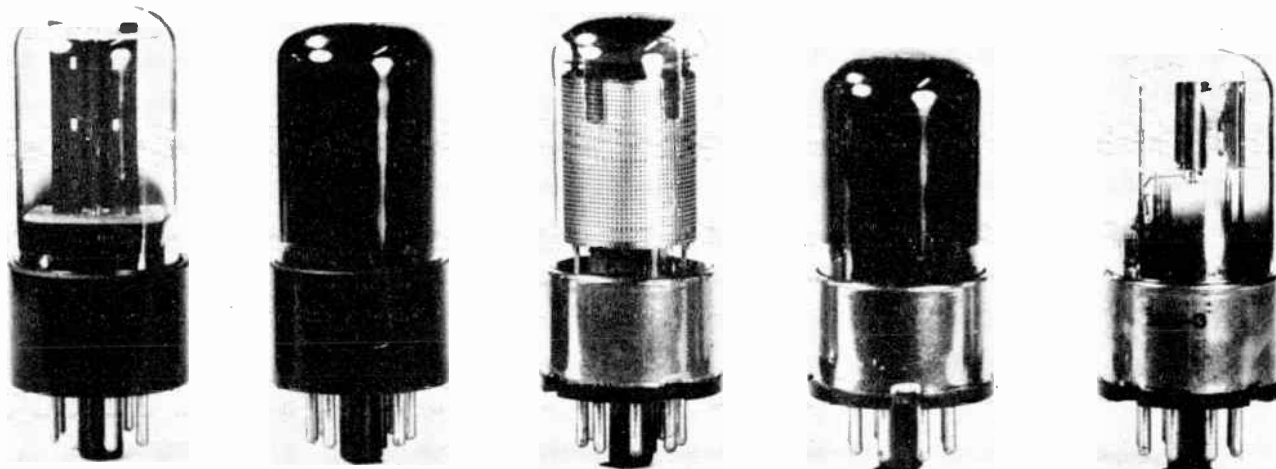

Fig. 5. These five tubes are designed to operate with three different heater voltages.

## COYNE - *television home training*

6. (as for 6CB6 tube) 6.3 volt heater. This is the most common heater voltage.
7. (as for 7AF7 tube) 6.3-volt heater. The initial numeral 7 is used for tubes having the lock-in style of base. Heaters are designed for a "nominal" voltage of 7.0, but practically always are operated on 6.3 volts.
12. (as for 12BA7 tube) 12.6-volt heater.
14. (as for 14AF7 tube) 12.6 volt heater. This is a lock-in base designation for tubes having a nominal heater voltage of 14, but operated at 12.6 volts.
19. (as for 19BG6-G tube) 18.9-volt heater.
25. (as for 25W4-GT tube) 25.0-volt heater.
35. (as for 35W4 tube) 35.0 volt heater.
45. (as for 45Z5-GT tube) 45.0-volt heater.
50. (as for 50L6-GT tube) 50.0-volt heater.
70. (as for 70L7-GT tube) 70.0-volt heater.
117. (as for 117Z3 tube) 117-volt heater. For connection directly across a 110-120-volt power line. These tubes are designed for normal operation on 117 line volts.

Entirely aside from heater voltages, tubes are designed to handle certain values of plate current and screen current. The cathodes must be capable of emitting electrons at a rate great enough to form these plate and screen currents. The greater the electron emission from a cathode the greater must be the heating energy furnished to the cathode. This heating energy for the cathode originates in the heater of the tube.

In order that the heater may furnish heat energy at a certain required rate to the cathode, the heater must use a proportional power in watts. The number of watts depends on heater voltage and current. The number of watts is, in fact, equal to the product of volts and amperes in the heater. For exam-

ple, a heater using 35 volts at 0.150 ampere (or 150 milliamperes) is using power at the rate of 35 times 0.150 ampere, or at the rate of 5.25 watts.

The heater would furnish the same heating energy to the same cathode with any other number of heater volts and amperes whose product is 5.25, or approximately so. Here are some other combinations.

18.9 volts	0.30 ampere (300 ma)	5.67 watts	
12.6 volts	0.45 ampere (450 ma)	5.67 watts	
12.6 volts	0.40 ampere (400 ma)	5.04 watts	
6.3 volts	0.80 ampere (800 ma)	5.04 watts	

Now we may list all the different heater currents which are used in various tubes having 6.3-volt heaters, as rated for normal operation. Here they are.

HEATER CURRENTS, AT 6.3 VOLTS

Amperes	Milliamperes	Amperes	Milliamperes	Amperes	Milliamperes
0.15	150	0.50	500	1.00	1000
.175	175	.60	600	1.20	1200
.25	250	.65	650	1.25	1250
.30	300	.70	700	1.50	1500
.40	400	.75	750	1.60	1600
.45	450	.80	800	2.50	2500
		.90	900		

So far as plate and screen currents, and signal handling ability are concerned, we might have equivalent tubes with two or more ratings of heater voltage and current, provided the combinations of heater voltage and current produced the same wattage. This is true of a great many tubes having 6.3-volt and 12.6-volt heaters, and having heater currents respectively of 0.30 and of 0.15 ampere.

There are several types of tubes used in television receivers, and in radio sound receivers also, which have heaters arranged for operation on either 6.3 volts or 12.6 volts. Among these are the 12AT7 and 12AU7 types. As shown by Fig. 13 6 the heater in such tubes is in two equal parts, with end connections to two base pins and a center-tap connection to a third base pin.

At the left are shown connections for using the tube with its heater in series with other heaters. Only the base pins for the end terminals of the heater are used. The center-tap heater pin is left unconnected. Now, as shown by the small diagram below the tube

# LESSON 13 – TRANSFORMERLESS RECEIVERS

## Series Heater Circuit

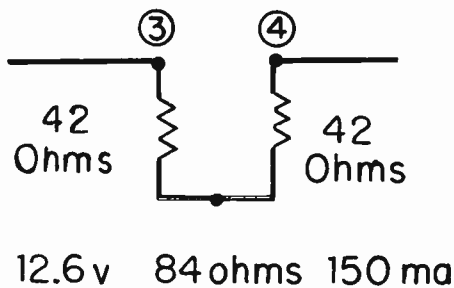
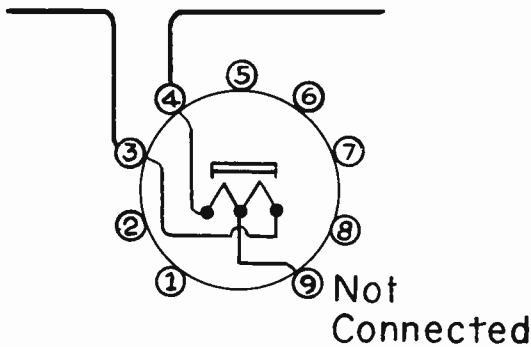

## Paralleled With Other Tubes

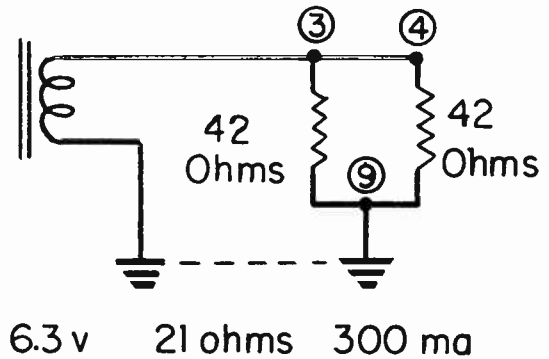
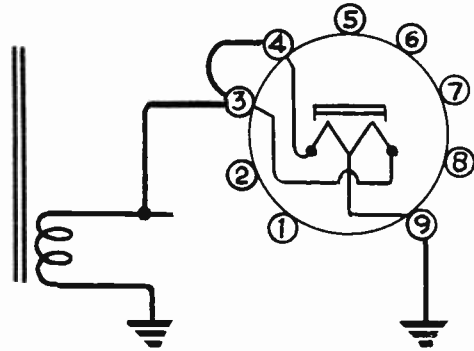

Fig. 6. This heater operates on 12.6 volts with its sections in series, or on 6.3 volts with its sections in parallel.

symbol, the two sections of the heater are in series with each other. Each section has normal working resistance of 42 ohms, and the two sections in series have total resistance of 84 ohms. Heater current of 150 ma flows when 12.6 volts are applied across the entire heater.

At the right are shown heater connections which allow using the same tube with its heater in parallel with other heaters, all taking the same voltage. Now base pins 3 and 4, for the outer ends of the heater, are connected together and to the heater line from one side of the transformer secondary. Pin 9, for the heater center tap, is connected to ground and through chassis metal to the other side of the transformer winding.

Now the two sections of the heater are in parallel with each other, as shown by the small diagram below the tube and transformer symbols. When two equal resistances are connected in parallel their combined or effective resistance is only half that of either resistance alone. Thus the resistances of 42

ohms in each of the heater sections have combined resistance of only 21 ohms. When 6.3 volts are applied to 21 ohms the current is 300 ma, as you can find by using the alignment chart or a formula for resistance.

If you wonder why two equal resistances in parallel with each other act like half the resistance of either part alone, this is an explanation. In the small diagram at the lower right in Fig. 6 it is plain that 6.3 volts from the transformer act on one heater section from pin 3 to pin 9, while the same 6.3 volts act on the other section from pin 4 to pin 9. Each section has resistance of 42 ohms. When 6.3 volts act on 21 ohms the current is 150 ma. The two currents of 150 ma each join together at pins 3 and 4, also at pin 9. Then the total current must be 300 ma.

If we have twice as much current in the two heater sections paralleled as with either alone, and with the same voltage in each case, the effective resistance must have been cut in half by the parallel connection. We are getting into so many applications of parallel



# COYNE - television home training

connections that before long we shall have to take a little time to get together all the rules and laws which allow understanding such connections. The rules are just as simple as those for series connections, and they are of just as much help in solving some of the knotty problems in servicing.

**CURRENT SURGES.** One of the major difficulties with series heater circuits is burnout of heaters which take lower voltages than other heaters in the same string. This happens because all the heaters are subjected to excessive current when the set is first turned on, and because excessive current and voltage continue in the small-voltage heaters longer than the higher-voltage heaters.

Sometimes when you have a good opportunity, connect an a-c voltmeter to the socket terminals of a series heater rated for operation at, for example, 12.6 volts. Then turn on the set while watching the meter. The voltage immediately goes up to around 25, then drops very slowly to the normal operating value for the tube. Turn off the set and let the heaters cool for five to ten minutes at least. Then try the same thing on one of the high-voltage heaters. Voltage will rise to only about 15 or 20 per cent above the normal operating value, not to double that value. The voltage then will fall slowly to normal.

Next you should measure the cold resistance of a heater, by using the ohmmeter. The tube must be out of the set and well cooled. Checking a heater rated for 12.6 volts and 150 ma doubtless will show resistance of about 15 ohms just as you make the ohmmeter connection. Yet computation of the resistance from rated voltage and current shows 84 ohms, which must be the resistance at operating temperature.

When a set with heaters in series is first turned on there is a surge of current in the cold heaters. A short time later the lower-voltage heaters will have reached almost normal temperature, and their resistance will be high. But the high-voltage heaters contain much more heating conductor, and this greater "mass" warms up slowly. The continued low temperature and low resistance of the high-voltage heaters allows continued excessive current, which is forced through the low-voltage heaters whose resistance has increased rapidly. Now, in these low voltage heaters, we have high resistance and abnormally great current, a combination which means excessive watts and overheating. The high-voltage heaters protect themselves against excessive watts.

**BALLASTS.** Current surges may be reduced, but not eliminated, by using a fixed

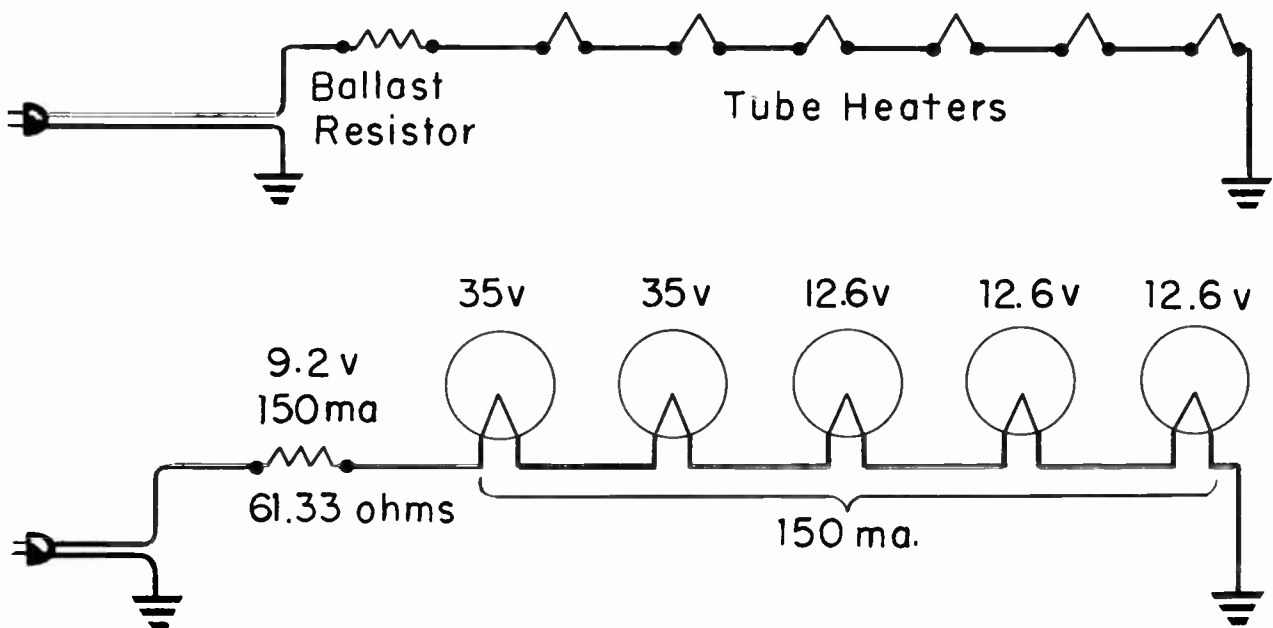

Fig. 7. How ballast resistors are connected in series with heater strings.

## LESSON 13 — TRANSFORMERLESS RECEIVERS

resistor in series with the series heaters, as illustrated by Fig. 7. Even ordinary fixed resistors are of such materials and construction as to change their resistance but little with wide variations of temperatures within safe operating ranges.

Let's assume that cold resistance of a series string is 150 ohms, and hot resistance is 800 ohms. With a 200-ohm fixed series resistor the cold resistance will be increased to 350 ohms, with proportionate reduction of surge current. Hot resistance will be increased to 1,000 ohms. Heater ratings would have to be chosen of such values as to allow the required heater current with total hot resistance of 1,000 ohms.

A fixed series resistor sometimes is used when the total of rated heater voltages is less than line voltage. For example, in the five-tube heater string at the bottom of Fig. 7 it might be desired to use two tubes with 35-volt heaters and three with 12.6-volt heaters, all of types designed for 150 ma heater current. The sum of the tube heater voltages is only 107.8. The difference between this sum and the standard line voltage of 117 is 9.2 volts. Therefore, the added resistor should use up 9.2 volts when carrying current of 150 ma. The alignment chart or a resistance formula shows that the resistor should be of 61.33 ohms. One of the "preferred number" resistances usually found in stock is 62 ohms, which would be close enough.

Still another use for resistors in series with series-heater strings is to compensate for excessive fluctuations of line voltage. Resistor units made especially for this purpose usually are called ballasts or ballast resistors. Any resistance element whose purpose it is to prevent excessive variations or surges of current, and of voltage, may be called a ballast. Therefore, from the name "ballast" alone, you cannot always be sure of just what type of unit is referred to.

A line-voltage ballast usually has iron wire for its resistance element. Iron has the peculiar property of changing its resistance rather slowly with rise of temperature until reaching a dull red heat. At a critical temperature the resistance commences to rise

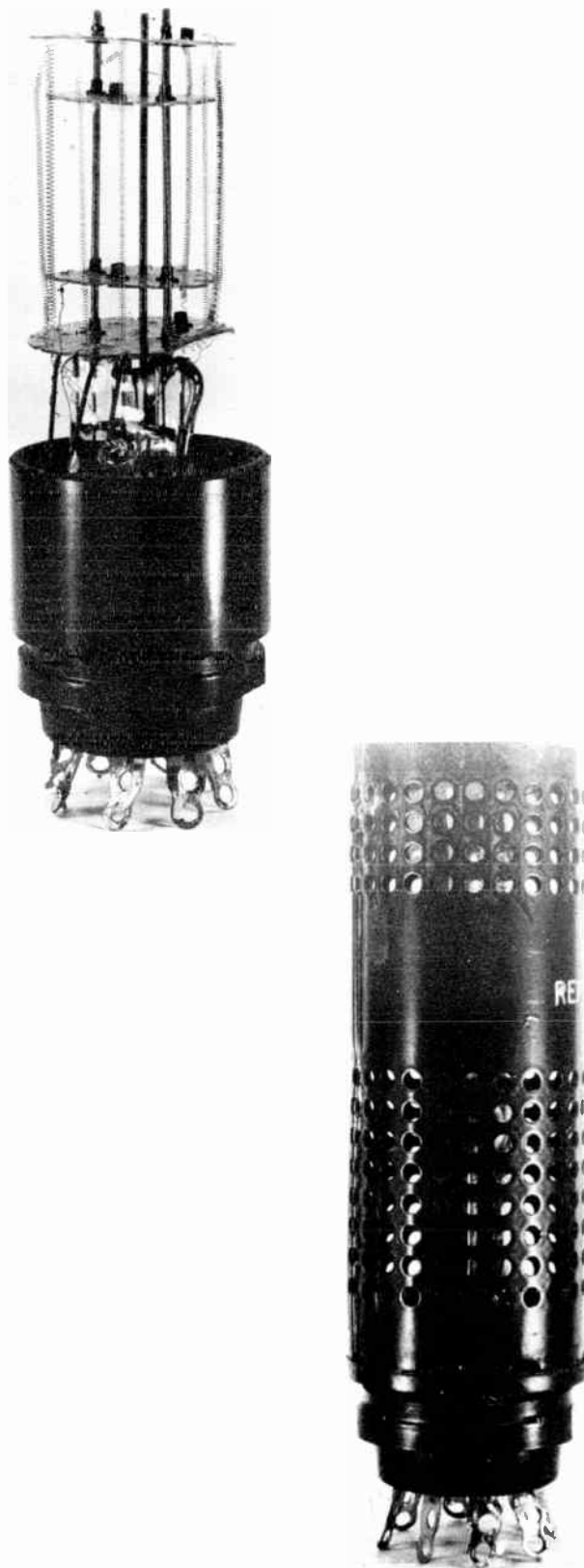

Fig. 8. Resistance wire in a ballast tube (above) and a perforated steel housing for a ballast (below).

## COYNE - *television home training*

quite sharply with increased heating. If the element is operated near this critical temperature the resistance will increase in considerable degree when excessively high line voltage tends to force excessive current through the heater circuit.

Some ballasts are enclosed within a glass envelope, like a tube. At the left in Fig. 8 is such a ballast from which the glass envelope has been removed to more clearly show the resistance wire. The envelope may be filled with hydrogen gas, which is a poor conductor of heat. Then the resistance element does not lose heat rapidly to and through the envelope, with the result that temperature of the wire depends almost entirely on the current it carries. A cracked envelope will admit air which, with the hydrogen, forms an explosive mixture. The mixture will be ignited by the red hot wire and glass will be blown outward.

Ballasts also are enclosed within a perforated steel housing, as at the right in Fig. 8. Sometimes a housing is placed around an inner glass envelope. A receiver having more than one heater string may require more than one ballast resistance, in which case all the resistances may be and usually are inside a single envelope or housing. Oftentimes this envelope or housing will also contain resistors employed in other receiver circuits, possibly for rectifier circuits and plate circuits of amplifier tubes.

Ballasts of all kinds run quite hot. Nearly always they are mounted on top of the chassis, where there is good ventilation for carrying away the heat. A ballast will burn out quite easily in case of severe overload due to a short circuit or any other cause. A burned out ballast must not be replaced until you locate the cause for the burnout, since a replacement unit will go the way of the original. Ballasts of the tube type cost as much or nearly as much as small radio tubes.

### CIRCUIT ELEMENTS IN PARALLEL.

We have seen a few applications of parallel connections, such as paralleled rectifier plates and paralleled sections of a tube heater. Many more applications are to come. Parallel connections allow using heaters of

different current ratings in the same series heater string. They allow using several separate heater strings in large television receivers. With parallel connections you can obtain required resistances and watts dissipation when having on hand no suitable single units. Knowing the rules will explain the limitations of pilot lamps connected in parallel with part of the rectifier heater. These are only a few of the parallel connections encountered in routine service operations.

Any elements may be connected in parallel. As in Fig. 9, we may have paralleled resistors, capacitors, or inductors, or may have any combination of unlike units. When any parts or any sections of circuits are paralleled, one terminal at one end of each is directly connected to one end of each other part or section. Then the remaining terminals or ends of all parts or sections are connected together. The basic rules for all parallel connections will be worked out by using resistors. Applications of these basic rules to capacitor and inductor combinations will be taken up as the need arises.

The first thing to be noted about all parallel connections is this. Voltage is the same across all the parts or circuit sections. Whatever may be the potential at one end of the parallel connection, this same potential must exist at one end of every part, because all these ends are directly connected. Whatever other potential exists at the opposite end of the parallel connections must exist at the remaining terminals of all parts or sections. Then the difference of potential, which is voltage, must be the same across all the parts.

### CURRENT IN PARALLEL CIRCUITS.

To determine the current in any one paralleled part we need consider only the common voltage and the resistance in that one part. As an example, at A in Fig. 10 are paralleled resistors of 3,000 ohms and 6,000 ohms connected across 12 volts. Current in the 3,000-ohm resistor is indicated by broken-line arrows. With 12 volts acting on 3,000 ohms the current must be 4 ma. Current in the 6,000-ohm resistor is indicated by full-line arrows. With 12 volts acting on 6,000 ohms the current must be 2 ma.

## LESSON 13 – TRANSFORMERLESS RECEIVERS

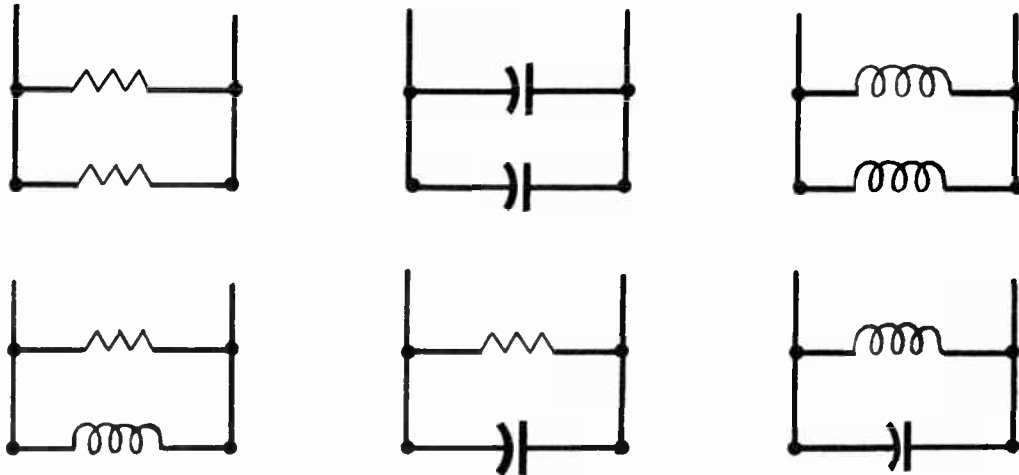

Fig. 9. Any combinations of like or unlike elements may be connected in parallel.

Both resistor currents must combine as a single current in the source of voltage and its direct connections. This combined or total current must be 6 ma. When any parts are paralleled the total current is equal to the sum of the separate currents. Here is something else that is plainly evident from the connection diagram. Total current must be greater than current in any one part or path.

The relative values of voltage, resistance, and total current are easily verified with the test setup of Fig. 11. The two paralleled resistors are down below the meters. The instrument at the left is the volt-ohmmeter that we have used before. Here it is being used as a voltmeter, on its 30-volt scale or range. The voltmeter is connected to two screw terminals just above the resistors. To these screw terminals is connected also a d-c power supply which can be adjusted to maintain a 12-volt output when there are changes of current. The power supply unit is behind the test panel and meters.

If you examine the circuit connections it is apparent that all current going from the power supply to the right-hand ends of the resistors must flow through the milliammeter that is alongside the volt-ohmmeter. Current indicated by the milliammeter is not precisely 6 ma, because the resistors are ordinary stock types having nominal values of 3,000 and 6,200 ohms. The 6,200-ohm value is as close to the desired 6,000 ohms

as we can come with "preferred" values of stock resistors.

Precision resistors would allow a precisely correct current. The indicated current is, however, close enough to 6 ma to prove that our conclusions from the diagram of Fig. 10 are correct so far as practical results are concerned.

In diagram B of Fig. 10 there has been added a third paralleled resistor of 8,000 ohms. This resistor is acted upon by the same voltage that acts on the other two. With 12 volts across 8,000 ohms the current must be 1.5 ma. Currents in the other two resistors are the same as before adding the third one. The new total current must be the sum of 4, 2, and 1.5 ma, or must be 7.5 ma.

In Fig. 12 we have added a third paralleled resistor to the test setup. This resistor is of nominal 8,200 ohms, which is as close to 8,000 ohms as we can come in a "preferred" value of stock resistor. Indicated current is close enough to 7.5 ma to again prove that our computations are satisfactory for all practical purposes.

All the rules previously mentioned hold good with three paralleled resistors. Voltage is the same across all the paralleled units. Total current is the sum of all the separate currents. Total current is greater than current in any one path. There will be quite a few rules relating to current in paral-



# COYNE - television home training

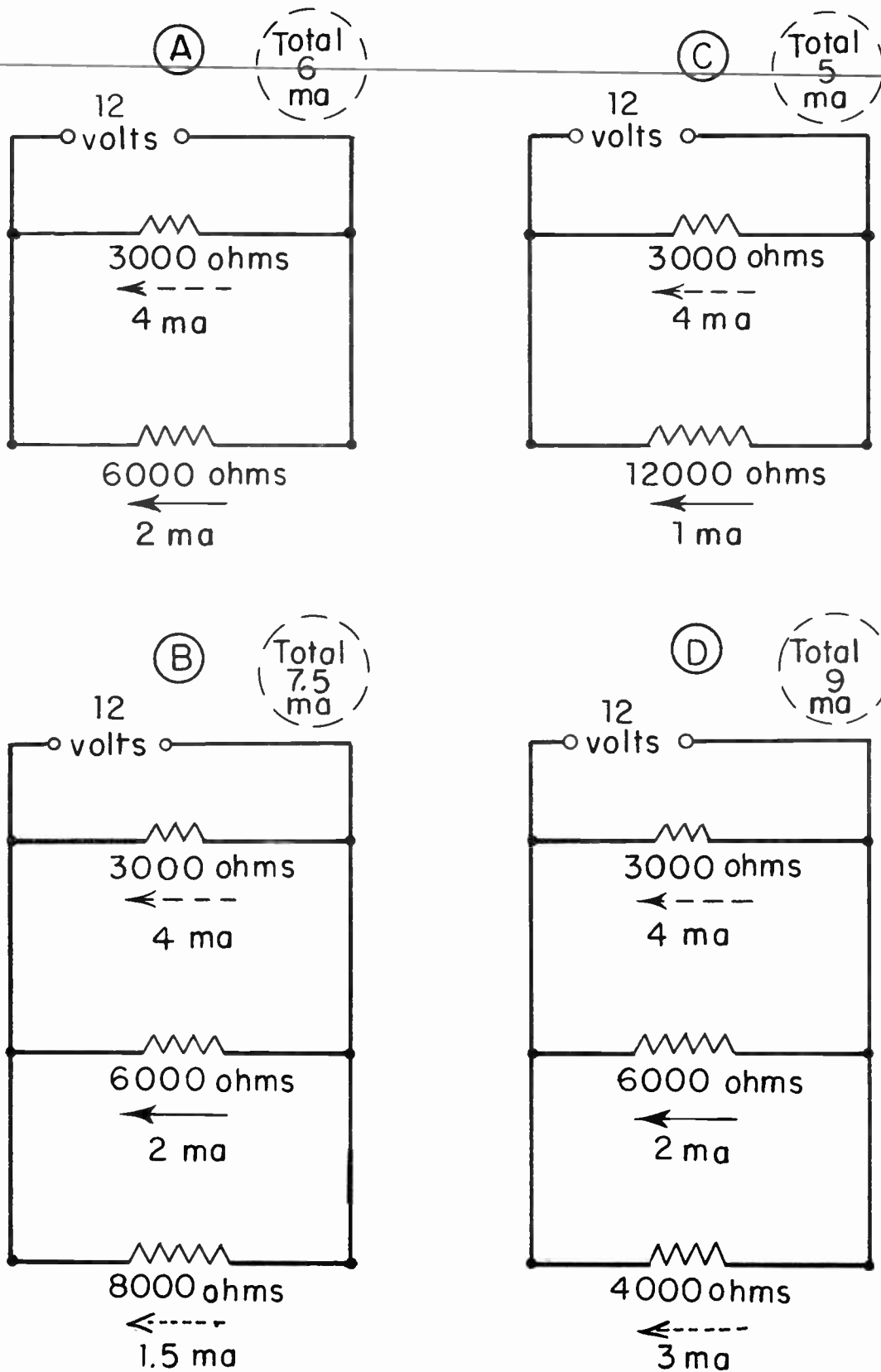

Fig. 10. Relations between voltage, resistance, and current in some combinations of paralleled resistances.

## LESSON 13 – TRANSFORMERLESS RECEIVERS

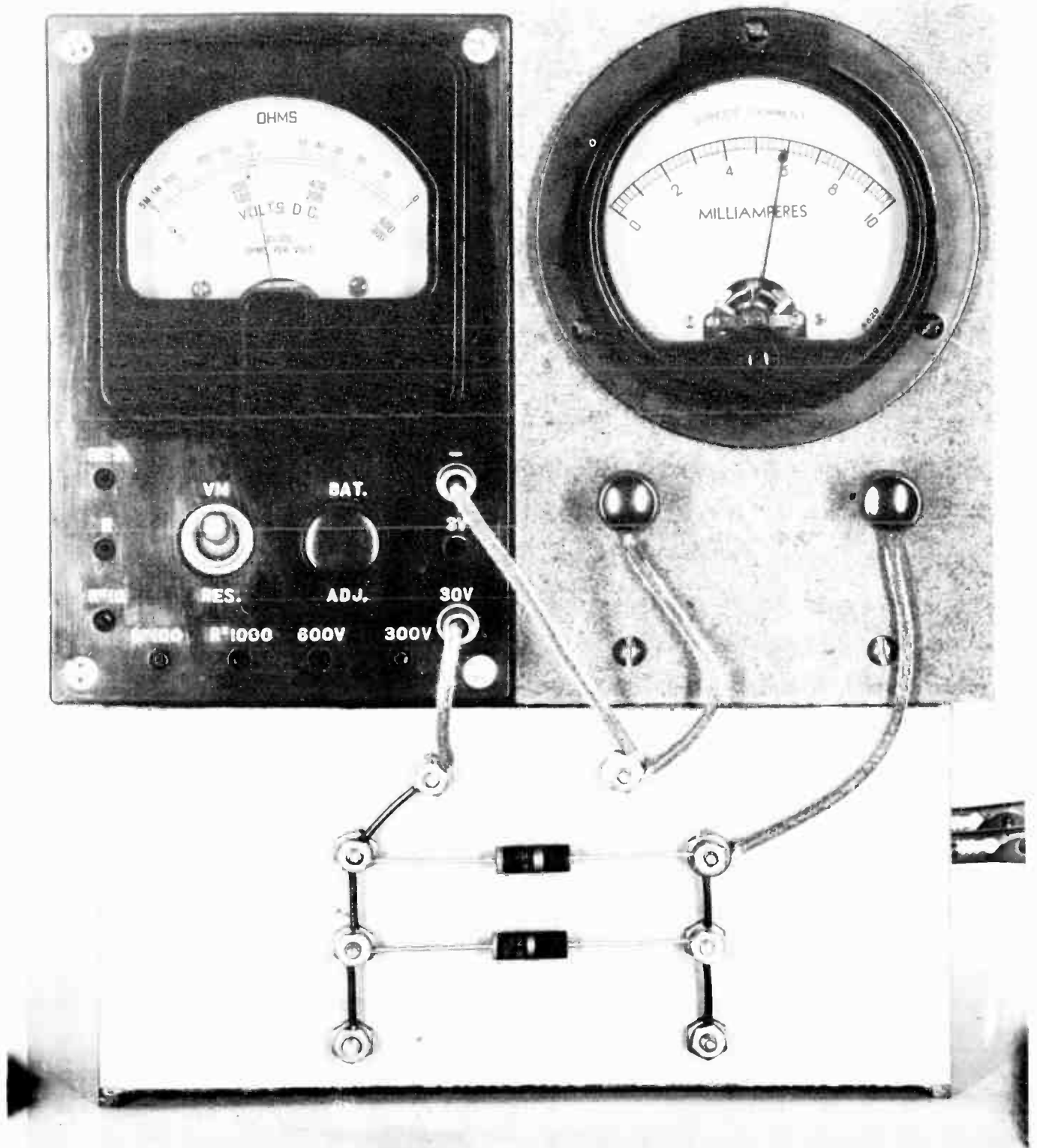

Fig. 11. The test setup for measuring total current flowing in paralleled resistors.

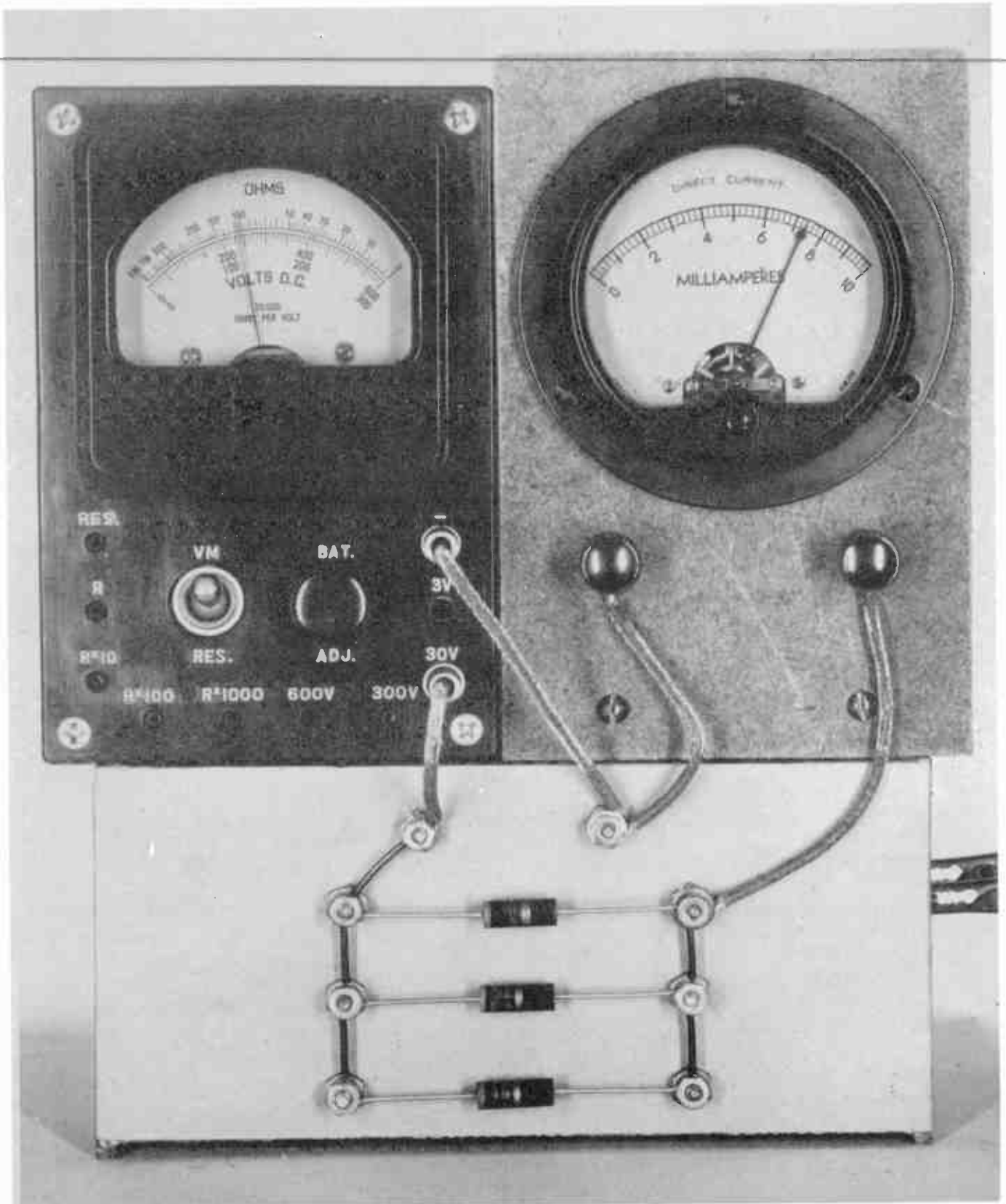

Fig. 12. Adding another paralleled resistor increases the total current.

## LESSON 13 – TRANSFORMERLESS RECEIVERS

leled parts or paths, so let's commence numbering them, thus.

1. Total current is equal to the sum of all separate currents.

2. Total current is greater than current in any one part or path.

From examination of diagrams A and B in Fig. 10 we may arrive at a third current rule for elements connected in parallel.

3. Current is greatest in the least resistance, and is least in the greatest resistance.

Now look at diagram C of Fig. 10. It is like diagram A except that the bottom resistance has been changed from 6,000 to 12,000 ohms. This greater resistance decreases the current in the bottom resistance. Since total current always is the sum of all separate currents, we have changed the total current by altering one of the paralleled resistances. The total current now becomes 5 ma.

To verify our conclusions the third resistor has been removed from the test set up and, in Fig. 13, the former 8,200-ohm resistor has been replaced with one of 12,000 ohms. As in other tests, this new resistor is a commercial type. Current indicated by the milliammeter is so close to the computed value of 5 ma as to prove that precision resistors would give the exact computed current.

Diagram D of Fig. 10 is like diagram B except that the bottom resistance has been changed from 8,000 to 4,000 ohms. This reduction of resistance allows more current in the bottom resistance, and changes the total computed current to 9 ma. In Fig. 14 a third resistor has been connected in parallel with the two used in Fig. 13. This third resistor is of nominal 3,900 ohms, the closest "preferred" value to the desired 4,000 ohms. As in other tests, the indicated current comes as close to the computed 9 ma as could be expected with commercial resistors.

These observations allow writing a fourth rule relating to current in parallel circuits.

4. Changing any one resistance alters the total current.

It is worth noting also that altering the resistance in one parallel path does not change the currents in other paths, provided the applied voltage does not vary. From our earlier discussion of voltage regulation in power supplies we know that normally there would be some variation of supply voltage or terminal voltage, because there are changes of total current.

In Fig. 13 the total current is less than in Fig. 11, and source voltage normally would rise. In Fig. 14 there is more total current than in Fig. 12, and source voltage normally would drop. The voltage has not changed because it has been readjusted to 12 volts each time the resistors were changed. Otherwise the voltage would have increased with less current and would have decreased with more current.

Now we come to the fifth and final rule relating to current in parallel circuits. This rule is illustrated by Fig. 10 when you compare diagram A with B, or compare diagram A with D. Everytime we add a parallel path, no matter what its resistance, there must be some flow of current in this extra path. This must increase the total current. Therefore, we have the rule.

5. Adding parallel paths increases the total current.

PARALLEL RESISTANCE. During many service operations, especially when making replacements and when using parts not designed for the job, we must determine the effective resistance of parts connected in parallel with one another. Obviously, two or more resistances in parallel won't oppose current to just the same degree as either one alone, because total current won't be the same as any one of the separate currents. Opposition offered by two or more paralleled resistances, acting together, may be called effective parallel resistance or simply parallel resistance.

The following fact, which we already know very well, is of help in determining



**COYNE** - *television home training*

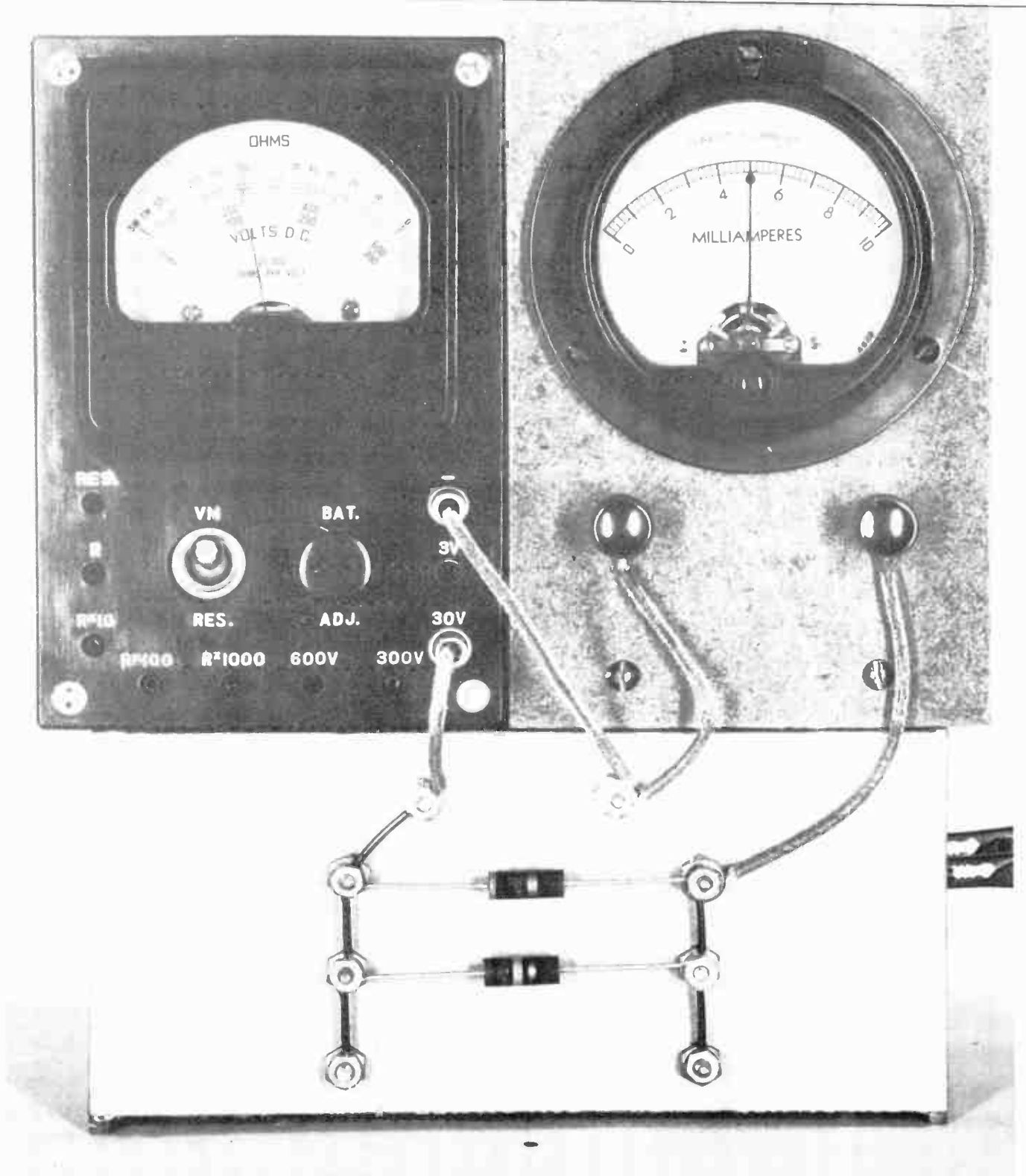

*Fig. 13. Total current is changed by altering any one paralleled resistor.*

# LESSON 13 – TRANSFORMERLESS RECEIVERS

parallel resistances. When voltage remains constant and current increases, the resistance must have decreased. And if current decreases, the resistance must have increased. Based on this "inverse" relation between current and resistance we have for each of the five rules relating to total or combined current a corresponding rule relating to parallel resistance.

Rule 1 for current says, "Total current is equal to the sum of all separate currents". The corresponding rule for parallel resistance is so important as to require rather extended consideration, so we shall postpone talking about this rule until getting the other four out of the way. We shall commence with rule 2 for current and the corresponding rule for parallel resistance. Here they are, side by side.

2. Total current is greater than current in any one path or paths

2. Parallel resistance is less than any one separate resistance.

By going back to the diagrams of Fig. 10 we could prove this rule for parallel resistance by using the alignment chart or a resistance formula with the values of voltage and total current shown on the diagrams. It would be good practice for you to do this. An easier proof is afforded by changing the volt-ohmmeter to its ohmmeter function, and actually measuring some parallel resistances.

Fig. 15 shows the same two resistances represented at A in Fig. 10, and the same actual resistors pictured by Fig. 11. The milliammeter has been removed from the test setup, and a jumper wire connected in place, from one side of the power supply to the right-hand resistor line. The separate resistances are, nominally, 3,000 ohms and 6,200 ohms. But the ohmmeter reads very close to 2,000 ohms. This is less than either one of the separate resistances.

Fig. 16 pictures the three resistances represented at B in Fig. 10 and the actual resistors of Fig. 12. The separate resistances are, nominally, 3,000 ohms, 6,200 ohms, and 8,200 ohms. The ohmmeter shows a little more than 1,600 ohms, which is much less than the smallest separate resistance. Precision resistors would have given a reading of precisely 1,600 ohms.

Now we shall look at the number 3 rules for current and for parallel resistance.

3. Current is greatest in the least resistance, and is least in the greatest resistance.

3. The least resistance carries the most current, and the greatest resistance carries the least current.

The two rules merely say the same thing in two different ways. You may see examples or illustrations of both rules in all four diagrams of Fig. 10.

Next come the number 4 rules for current and for parallel resistance.

4. Changing any one resistance alters the total current.

4. Changing the resistance of any one path alters the parallel resistance.

In Fig. 17 the ohmmeter is proving this rule 4 for resistance. The test setup is like that of Fig. 15, except that the bottom resistor is now 12,000 ohms where formerly it was 6,200 ohms. The ohmmeter formerly showed about 1,600 ohms. Now it shows close to 2,400 ohms. The parallel resistance has been altered by changing only the bottom resistance.

The number 5 rules for current and for parallel resistance read thus.

5. Adding parallel paths increases the total current.

5. Adding parallel paths reduces the parallel resistance.

For proof of rule 5 for parallel resistance look at Fig. 18. The only change from Fig. 15 is the addition of a third resistor. The other two are the same as before, but there is an extra 3,900-ohm unit at the bottom. In Fig. 15 the indicated parallel resistance is about 2,000 ohms. Now, with an added resistor, the indicated parallel resistance is only slightly more than 1,300 ohms.

## COMPUTING PARALLEL RESISTANCE.

Finally we are ready for the number 1 rules relating to parallel current and resistance. You will be glad to know that this rule for resistance never is needed in practical service work, for there are other far easier ways of arriving at the answers. Here are the rules.

1. Total current is equal to the sum of all separate currents.

1. The reciprocal of parallel resistance is equal to the sum of the reciprocals of the separate resistances.

Now for the first of the easier ways for computing parallel resistance. If all resist-

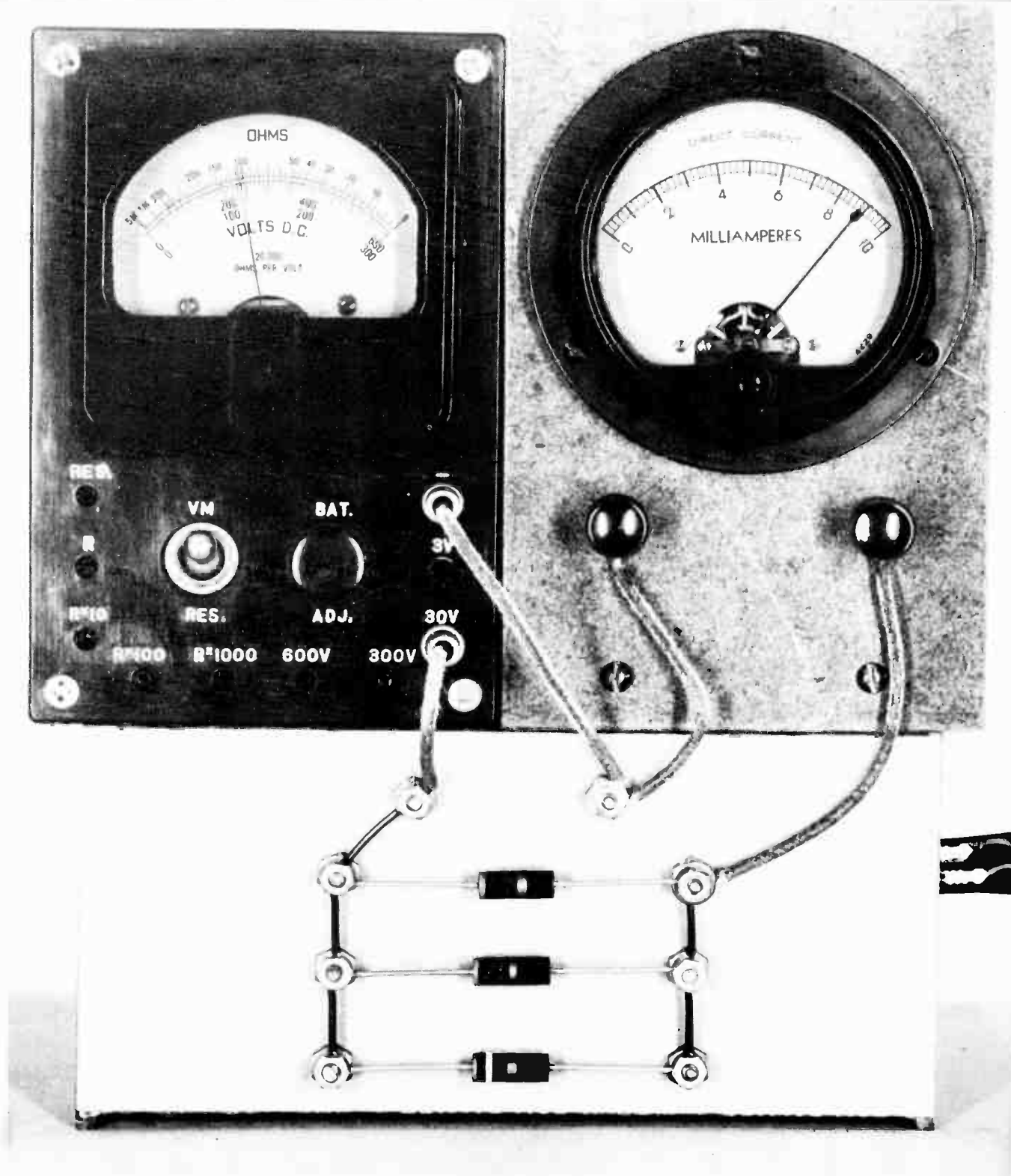

Fig. 14. The effect of adding a resistor in parallel with others.



# LESSON 13 – TRANSFORMERLESS RECEIVERS

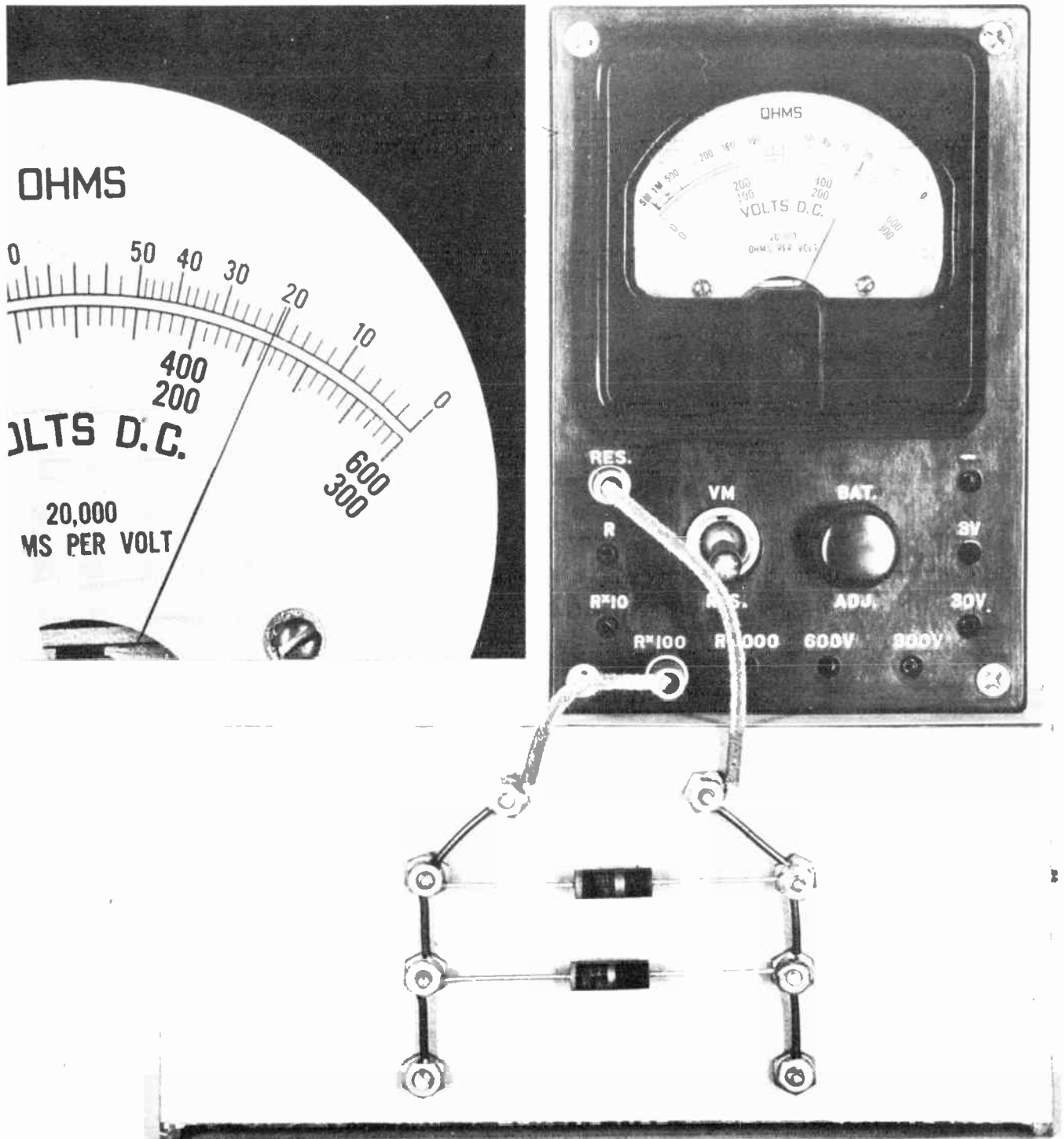

Fig. 15. Parallel resistance is less than any separate resistance.



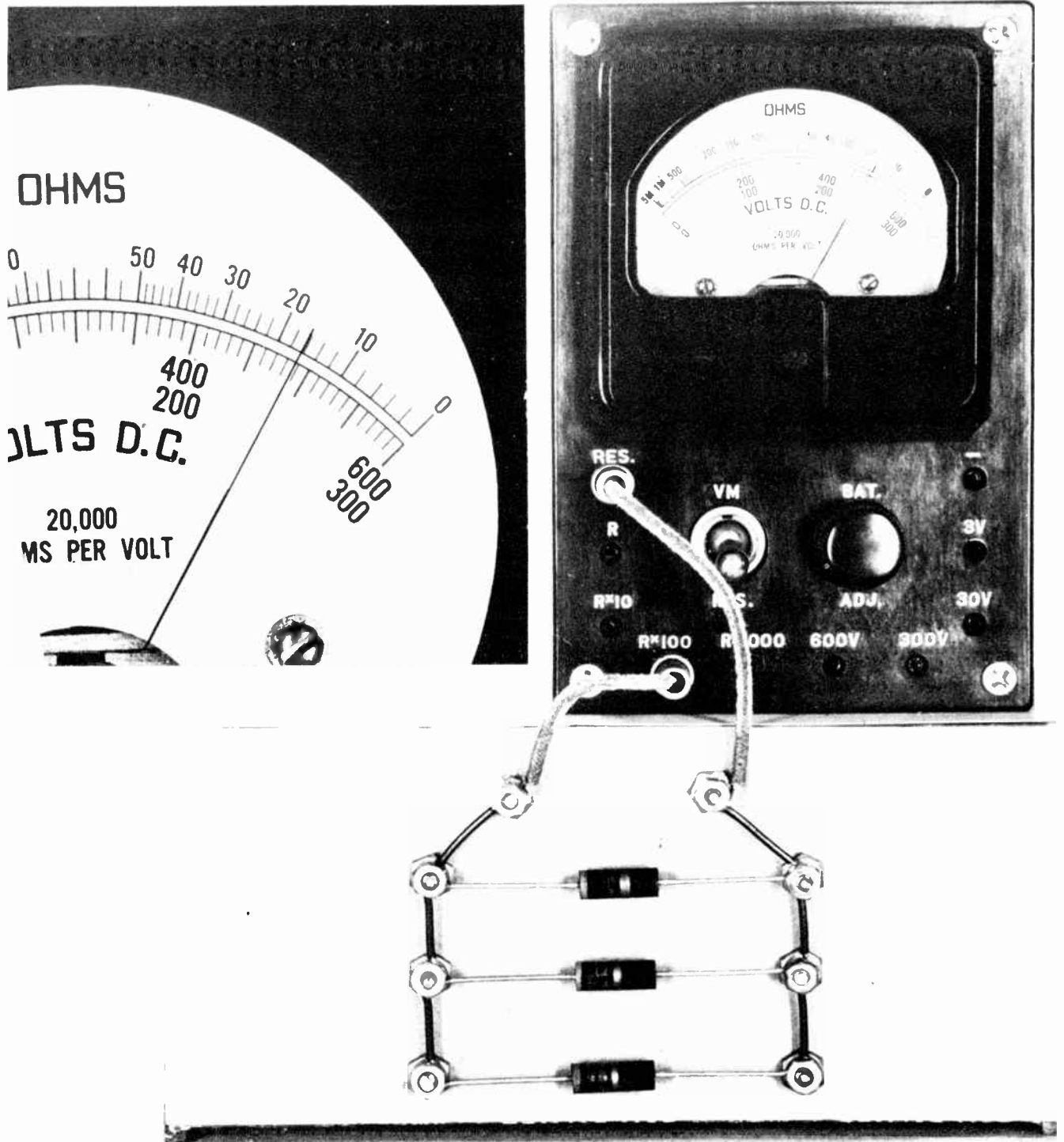

Fig. 16. Adding a paralleled resistor has decreased the parallel resistance.

# LESSON 13 – TRANSFORMERLESS RECEIVERS

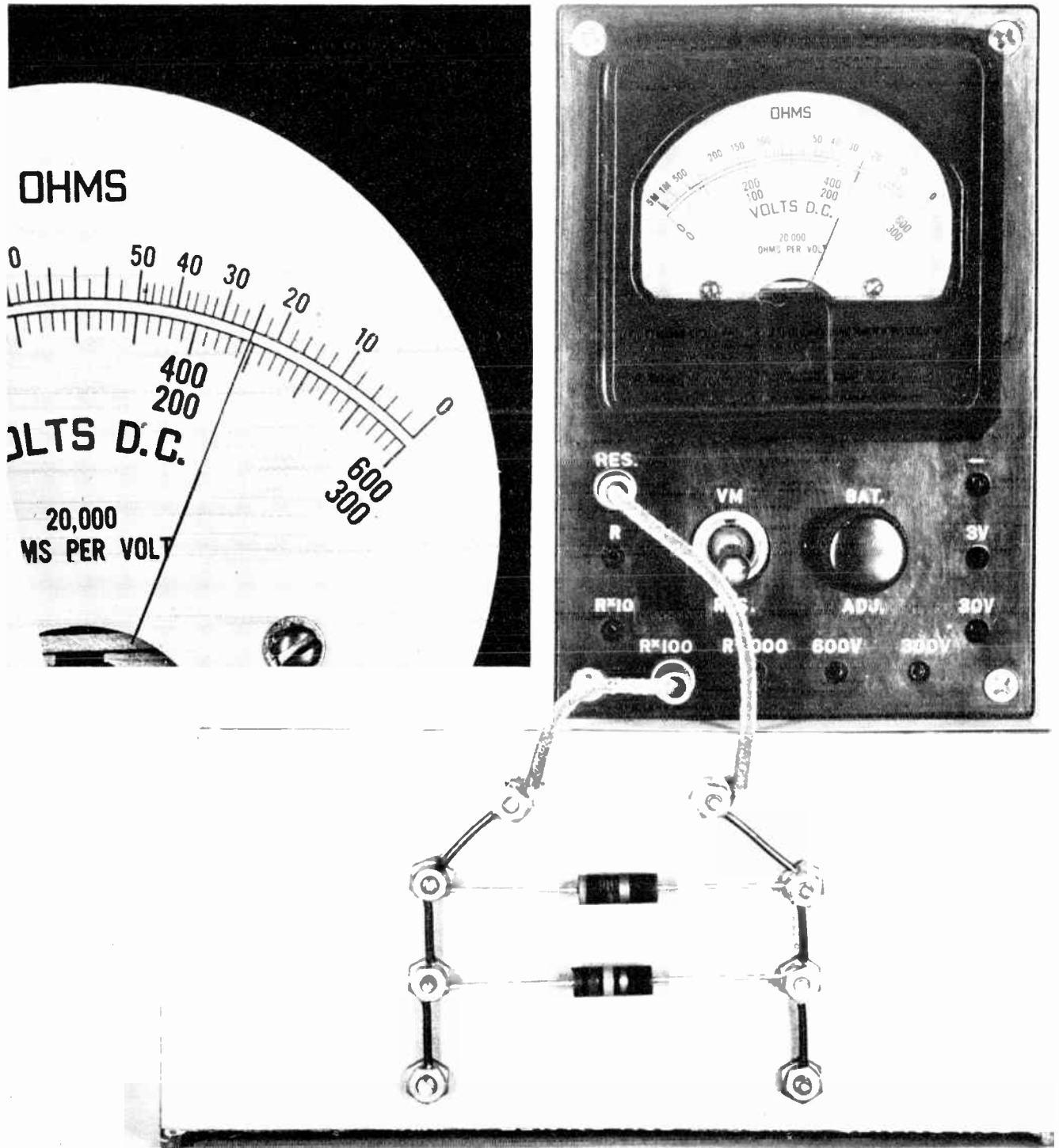

Fig. 17. Changing any one resistor alters the parallel resistance.

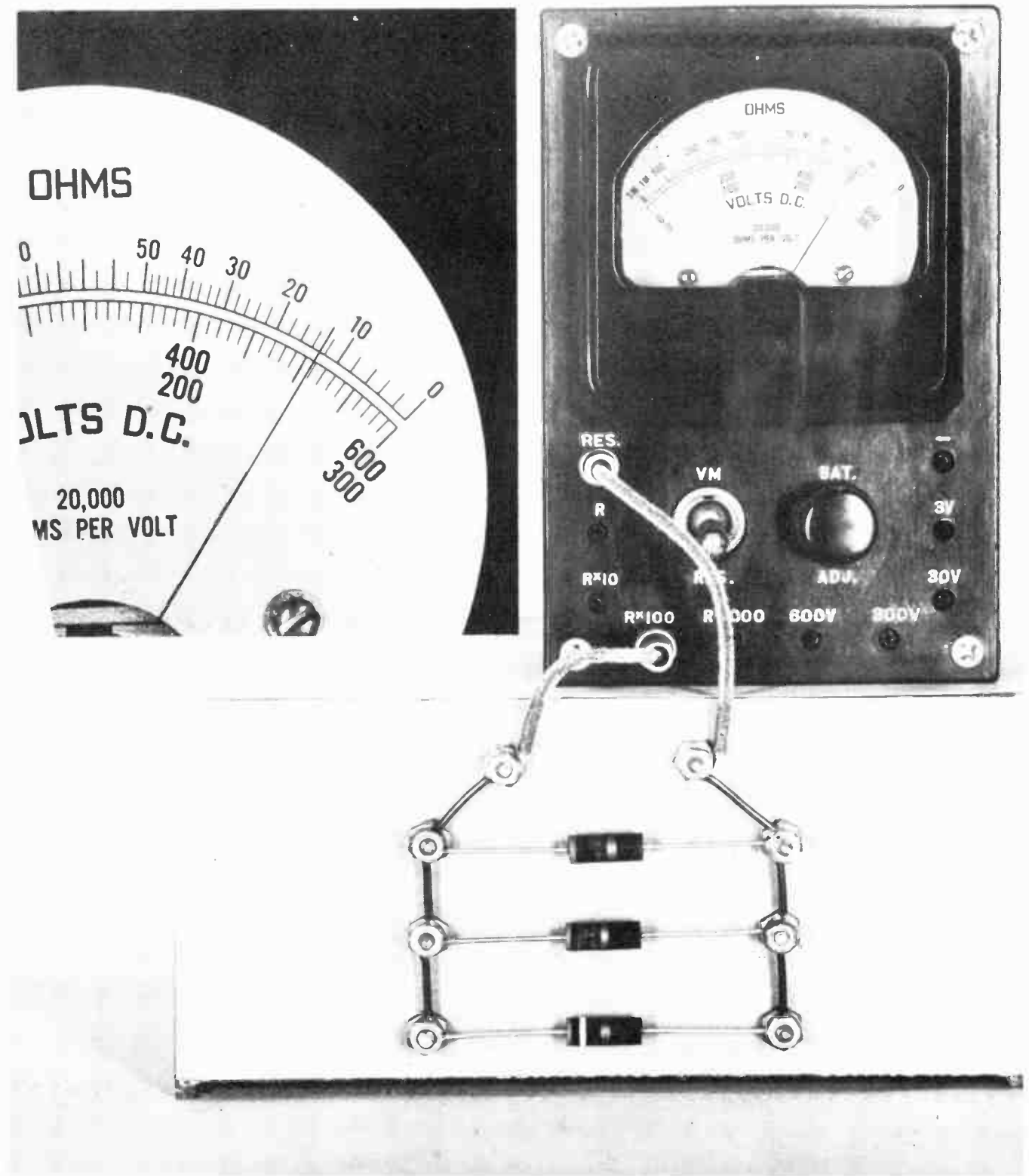

Fig. 18. No matter what the value of an added resistor, it decreases the parallel resistance.

# LESSON 13 – TRANSFORMERLESS RECEIVERS

ances are equal, no matter how many there may be, divide the resistance of one element by the number of elements. For example, the parallel resistance of two 1,200-ohm resistances is 1,200 divided by 2, or is 600-ohms. The parallel resistance of nine 1,800-ohm resistances is 1,800 divided by 9, or is 200 ohms. It is as easy as that.

When two parallel resistances are unequal we do this.

a. Multiply one resistance by the other, which gives their product.

b. Add the two resistances together, which gives their sum.

c. Divide the product by the sum. This gives the parallel resistance.

For an example we may go to diagram A of Fig. 10, where the two resistances are 3,000 ohms and 6,000 ohms. We simplify the process of division by cancelling the same number of ciphers in both quantities.

$$\begin{array}{l} \text{a. Product. } 3000 \times 6000 = 18,000,000 \\ \text{b. Sum. } 3000 + 6000 = 9,000 \\ \text{c. Division. } \frac{18\ 000\ \cancel{000}}{9\ \cancel{000}} = 2000 \text{ ohms parallel resistance.} \end{array}$$

For proof that this method works, look at Fig. 15.

Supposing that we have three resistances in parallel, as at B in Fig. 10. Proceed in this fashion.

a. Compute the parallel resistance of any two separate resistances.

b. Consider this parallel resistance as a unit resistance, and use it with a third resistance to compute the parallel resistance of all three elements.

For an example we may take the three resistances of diagram B in Fig. 10. They are 3,000 ohms, 6,000 ohms, and 8,000 ohms. The steps are as follows.

a. We compute the parallel resistance of 3,000 ohms and 6,000 ohms with the method used for any two resistances. In the preceding example we found the parallel resistance of these two resistances to be 2,000 ohms.

b. Now we use the 2,000 ohms, which represents two of the resistors, in combination with the 8,000 ohms of the third resistor and proceed as with any two resistances.

$$\begin{array}{l} \text{Product. } 2000 \times 8000 = 16,000,000 \\ \text{Sum. } 2000 + 8000 = 10,000 \\ \text{Division. } \frac{16\ 000\ \cancel{000}}{10\ \cancel{000}} = 1600 \text{ ohms parallel resistance of three elements.} \end{array}$$

Were there four or any greater number of paralleled resistances we would commence with any two, then use this parallel resistance with a third separate resistance, next use the resulting parallel resistance with a fourth separate resistance, and so on for any number.

## PARALLEL RESISTANCE CHART

The rules for computing parallel resistance give exact values, which seldom are necessary because ordinarily we use commercial resistors having tolerance of no better than 5 per cent. Values sufficiently accurate for service work may be read directly from the alignment chart of Fig. 19.

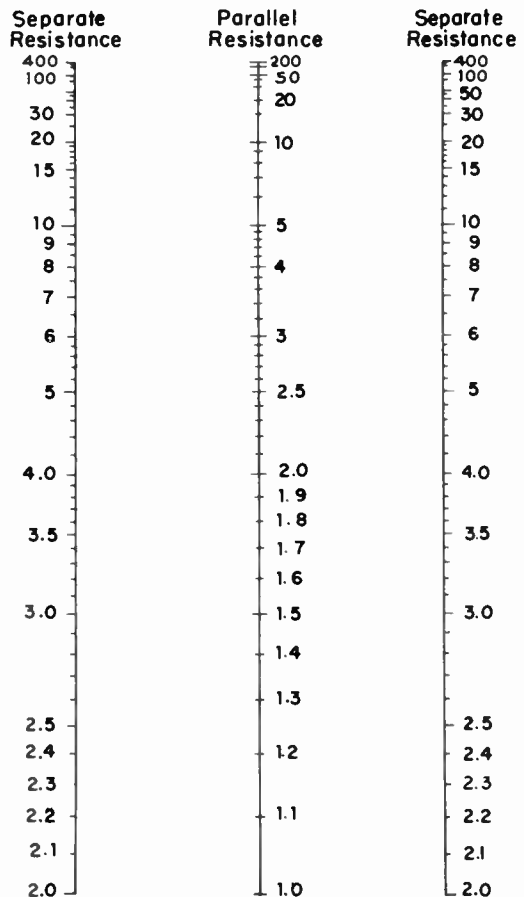

Fig. 19. The chart for parallel resistance.



## COYNE - *television home training*

Lay a straightedge on the two outer scales at the values of the two separate resistances. Read the parallel resistance where the straightedge crosses the center scale.

To increase the range of the chart the values marked on all three scales may be multiplied by the same number, such as 10, 100, or 1,000. Problems used for examples in the latter part of this lesson would be solved by multiplying all three scales by 1,000. Then the two outer scales would read from 2,000 to 400,000 ohms, and the center scale from 1,000 to 200,000 ohms. All three scales may be divided to make values such as 1/10, 1/100, or 1/1000 or those marked.

When you have on hand a certain re-

sistor (call it A) and wish to parallel it with another resistor (B) to provide a lesser resistance (C), proceed as follows.

Lay the straightedge on either outer scale at the value of A, and on the center scale at the value for C. Where the straightedge crosses the other outer scale read the value for the required parallel resistor (B).

Example: You have a 7,500-ohm resistor and want resistance of 2,300 ohms. With the straightedge on the left-hand scale at 7,500 (at 7.5 times 1,000), and on the center scale at 2,300 (at 2.3 times 1,000), read the required resistance as about 3,300 ohms (3.3 times 1,000) on the right-hand scale. This 3,300-ohm value is in error by about 1/3 of one per cent.

# TELEVISION

◦ RADIO

◦ ELECTRONICS

---

**LESSON 14 – TRANSFORMERLESS POWER SUPPLIES**

---

***Coyne School***

*practical home training*

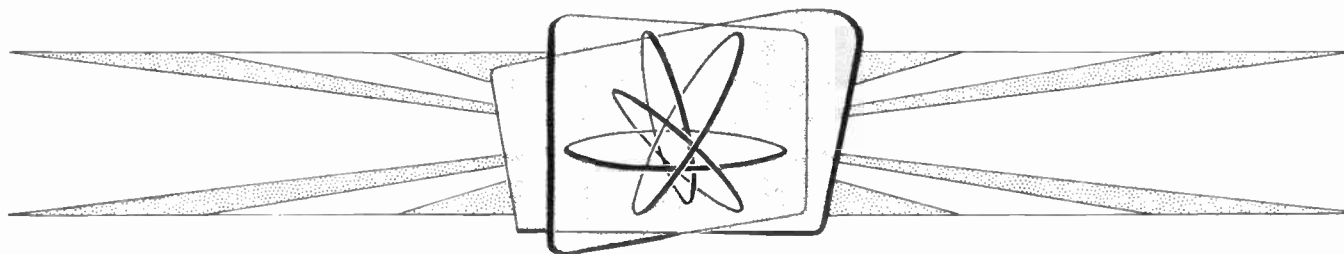

*Chicago, Illinois*

*Copyright, 1953 by Coyne Electrical School  
Chicago 12, Illinois  
All rights reserved*

Litho. in U.S.A.

## Lesson 14

### TRANSFORMERLESS POWER SUPPLIES

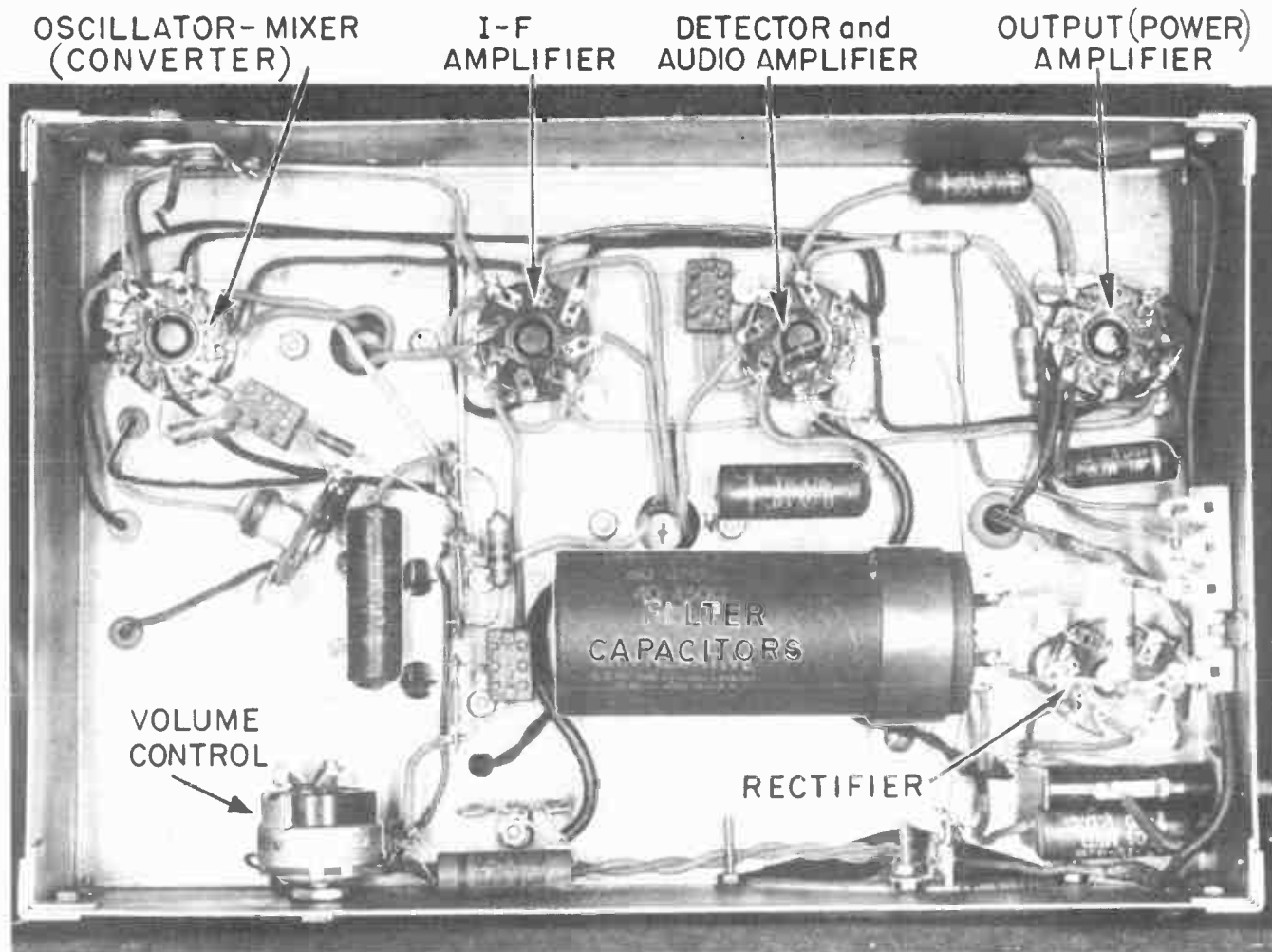

Fig. 1. Chassis wiring of a transformerless radio receiver.

In order to make some actual service measurements on a transformerless receiver we shall commence with the five-tube ac-dc radio broadcast set whose under-chassis wiring is pictured by Fig. 1. There are many different makes and almost innumerable models of small radios using the same general electrical design.

Fig. 2 is a schematic diagram of the d-c power supply section and the series heater wiring. The d-c power supply includes a half-wave rectifier tube of the heater-cathode type whose plate is connected to one side

of the a-c power line. The filter is of the resistance-capacitance type.

The rectifier has a 35-volt heater. One of the other tubes has a 50-volt heater, and the remaining three tubes have 12.6-volt heaters. All the heaters are in one series string, and all are rated for current of 150 ma or 0.15 ampere.

The lower diagram of Fig. 2 shows the heaters alone, with their rated voltages and also actual voltages as measured with an a-c voltmeter while the line furnished the stand-



# COYNE - television home training

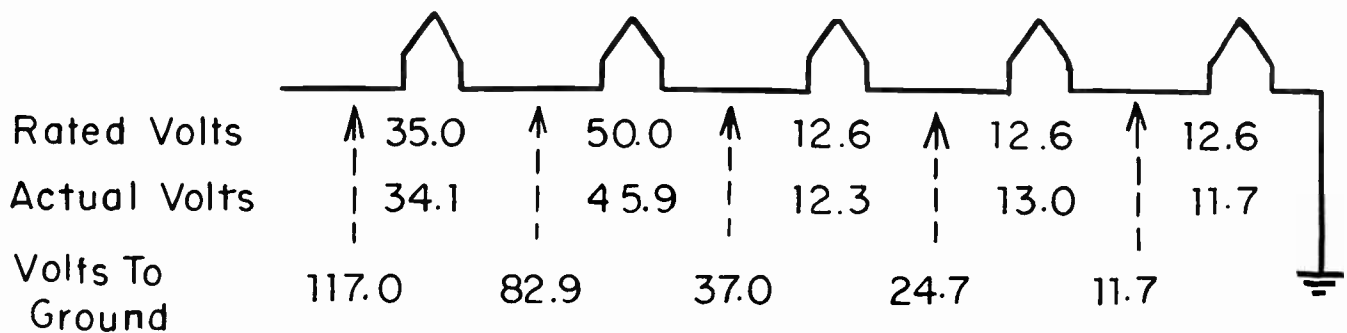
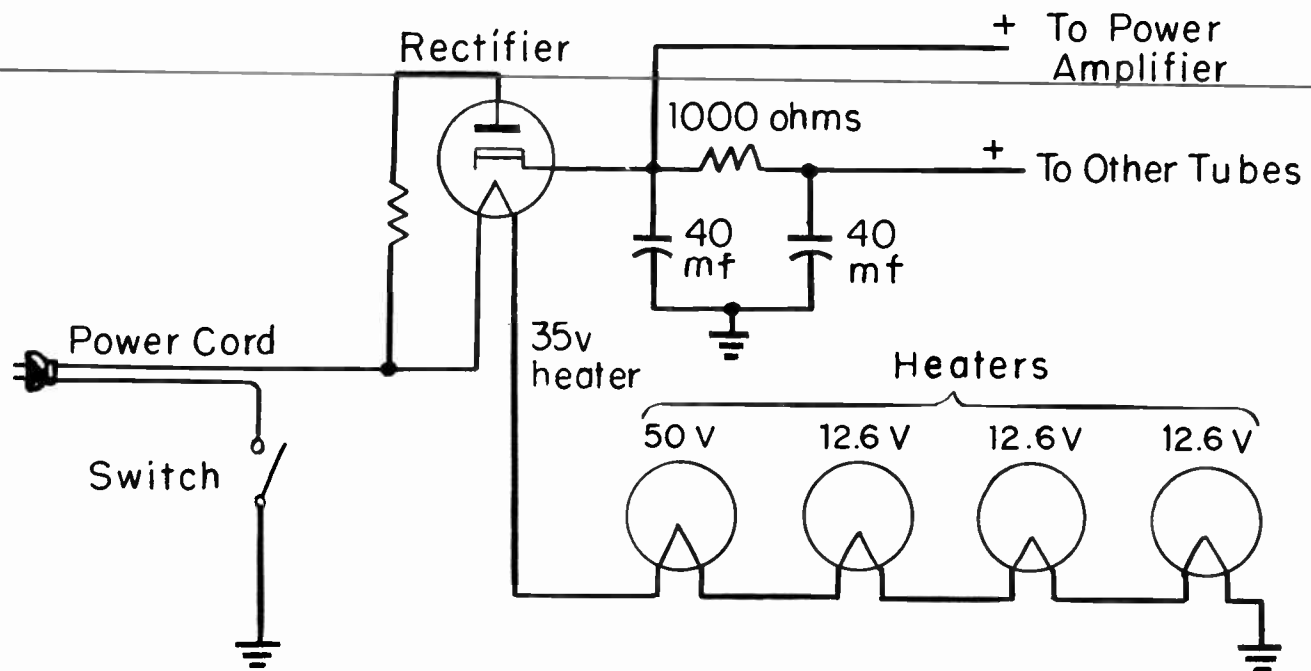

Fig. 2. Circuits for the d-c power supply and for tube heaters in the five-tube receiver.

ard 117 volts.. Not one of the actual voltages measured across the heaters is the same as the rated heater voltage for the tube. This is entirely normal. Very seldom will you find an actual voltage exactly equal to the rated heater voltage for the tube, but the measured voltages should be reasonably close to the ratings. Note that the sum of the measured voltages across all the heaters equals the 117 volts from the line.

Instead of connecting the leads of the a-c voltmeter to the heater pins of each tube by itself, you might connect one meter lead to ground and then connect the other lead progressively to the heater pins as they are connected from the grounded end to the line end of the string. This method of measurement gave the values shown as 'volts to

ground" on the lower diagram. Each of these voltages is higher than the one preceding by the number of volts across each heater.

Both methods of checking the performance of series heater strings are useful. Measuring individual voltages requires shifting of both meter leads for each measurement. Measuring the voltages progressively away from either end of the string requires subtracting each voltage from the one preceding in order to determine whether or not the actual voltage on each heater is at least fairly close to the rated value. Variation should be no more than 10 per cent above or below rated values.

Fig. 3 shows the d-c power supply system of the receiver being examined, and

## LESSON 14 – TRANSFORMERLESS POWER SUPPLIES

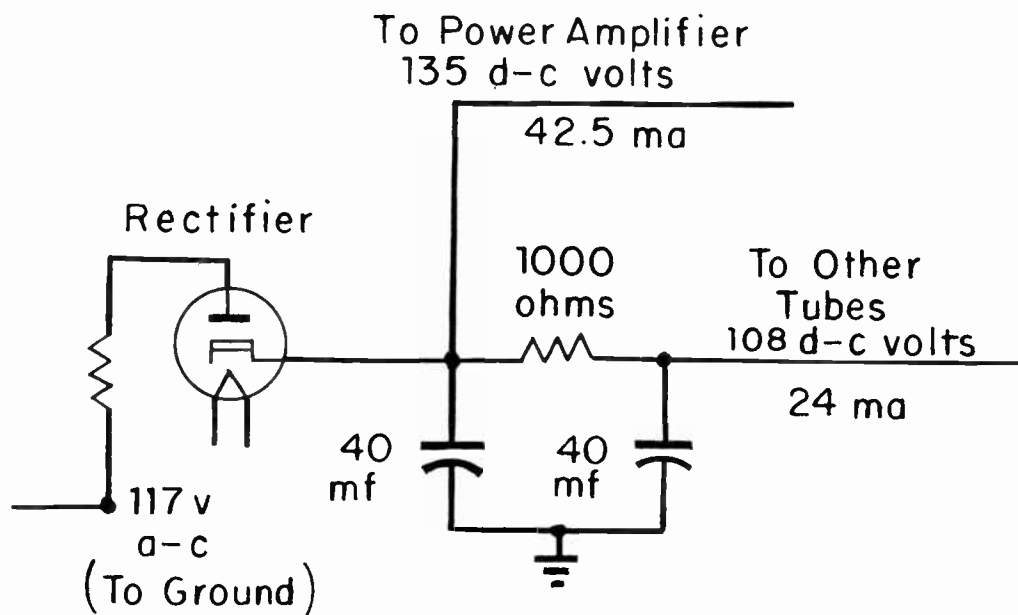

Fig. 3. Voltages and currents in the d-c power supply.

gives some voltages and currents as actually measured between the points specified and ground. On the plate of the rectifier tube we have 117 a-c volts, which is the line voltage. At the cathode of the rectifier the d-c voltage measures 135, which is 18 volts higher than the effective a-c voltage applied to the rectifier.

The d-c voltage output from the rectifier is greater than the effective a-c input voltage because of the difference between effective and peak a-c voltages and because of the first filter capacitor. With 117 effective volts the peak is equal to 1.414 times 117, or to about 165 volts. There is some loss of voltage in the rectifier tube, but even so, the first filter capacitor is charged to a voltage considerably higher than the effective value during each cycle of applied alternating voltage. The first filter capacitor is so large (40 mf) that it retains much of the high charging voltage between applied peaks, and the result is d-c output voltage higher than the effective a-c input voltage.

The full 135 d-c volts from the rectifier cathode is taken to the power tube, which is the audio amplifier tube feeding the speaker. This voltage is filtered to an extent satisfactory for a small radio set by the large first capacitor of the filter. Current

from the rectifier to the power tube is 42.5 ma.

Additional current of 24 ma for other tubes in the receiver flows through the 1,000-ohm filter resistor and is filtered additionally by the second capacitor, also of 40 mf. At the output of the entire filter the d-c voltage is 108, as measured.

Immediately you will note that voltage across the 1,000-ohm filter resistor is the difference between 135 and 108, or is 27 volts. But 24 ma in 1,000 ohms should be accompanied by a drop of only 24 volts. Why the difference? The answer is that the second filter capacitor, which is an electrolytic type, is not a perfect insulator against direct voltage. Some current is flowing through this capacitor, in addition to the 24 ma going to the receiver tubes. The additional "leakage current" for the capacitor is flowing in the filter resistor, and is causing the voltage drop across the resistor to be 27 instead of 24.

A half-wave rectifier is satisfactory in receivers which do not have great enough amplification to strengthen the ripple voltage to an objectionable degree. The ripple is greatly reduced by using filter capacitors of large capacitance. The filter in these small

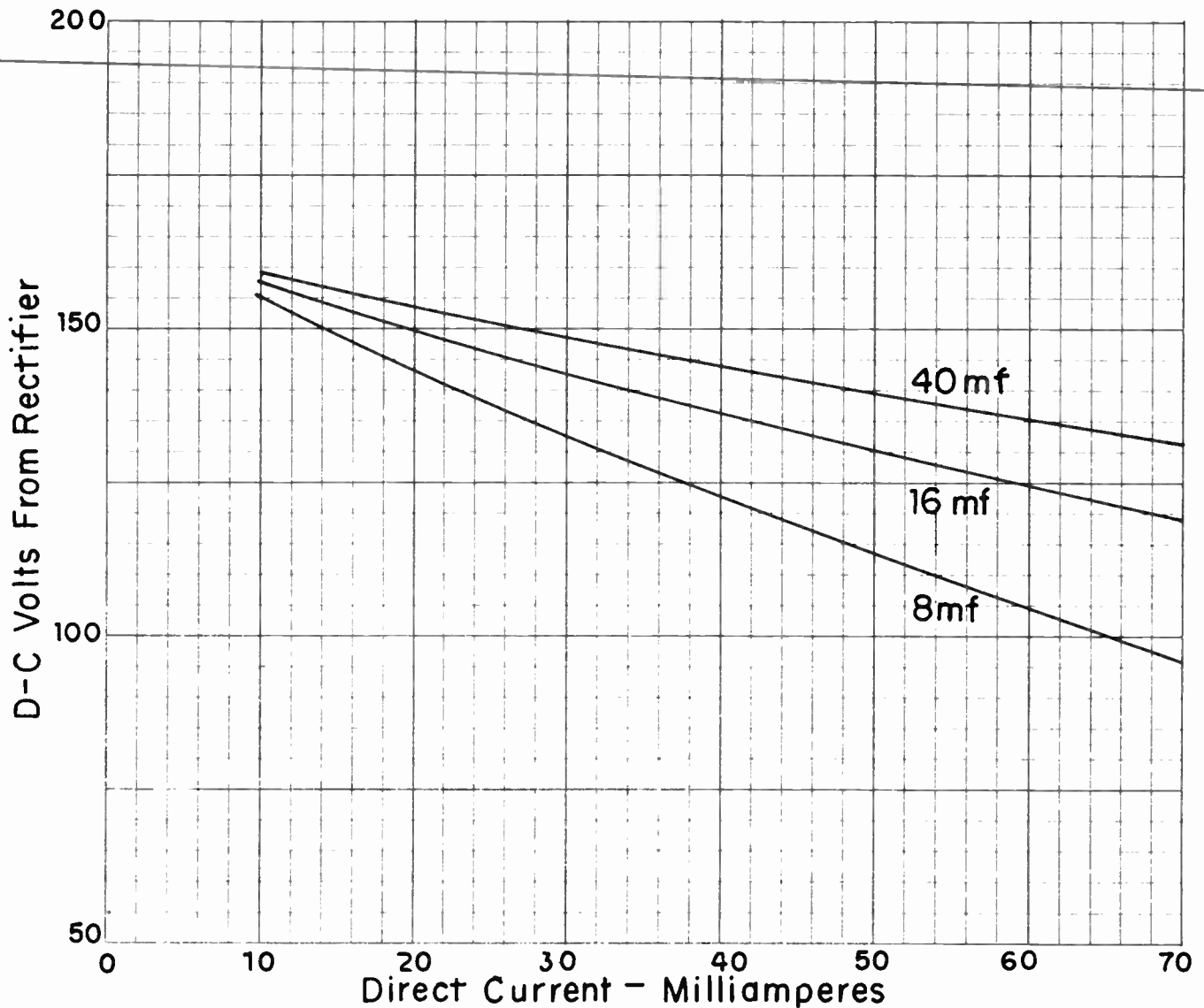

Fig. 4. How voltage regulation is affected by d-c output current and by capacitance of the first filter capacitor.

receivers always is a capacitor-input type, because the first capacitor allows higher d-c output voltage from the rectifier than could be had with a choke-input filter. A filter including a resistor instead of a choke is satisfactory for the rather small direct currents to be handled.

When using filter capacitors of 30 mf or more capacitance, they take such a large charging current on voltage peaks as possibly to overload the rectifier. To reduce the current peaks a resistor of something like 25 to 50 ohms is connected in series with the rectifier plate, as shown in our diagrams. Where line voltage may rise considerably higher

than the standard 117 volts this series resistor on the rectifier may be of 50 to 100 ohms value

Fig. 4 shows, in a general way, how d-c output voltage from the half-wave rectifier is affected by the capacitance of the first filter capacitor and by the direct current for the load or loads. The upper curve shows how output voltage decreases with increase of current when the capacitance is 40 mf. The middle curve shows the effect of using 16 mf, and the lower curve shows "voltage regulation" with only 8 mf for the first filter capacitor. It is quite plain that large capacitance is desirable when the voltage is to be

# LESSON 14 – TRANSFORMERLESS POWER SUPPLIES

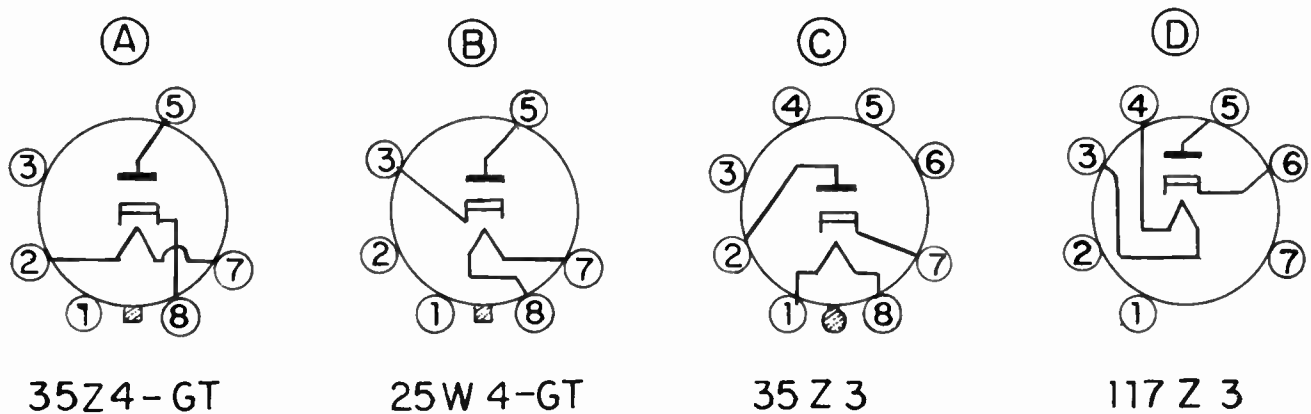

Fig. 5. Basing connections for half-wave heater-cathode rectifier tubes.

held reasonably high with increasing current. The curves do not apply to the particular rectifier used in our receiver, but they do illustrate the performance of all generally similar power supplies.

Fig. 5 shows base pin and internal element connections for commonly used half-wave rectifiers having heater-cathodes. Pin numbering and positioning is as seen from the bottom, or from underneath the chassis. Under each diagram is the type number of a rectifier employing that arrangement of connections.

Diagrams A and B apply to octal base tubes, having eight pin positions, but with which there are actually only the six pins shown. Some pins have no internal connections. Diagram C applies to a tube having a lock-in base, while diagram D is for a 7-pin

miniature tube. The 35Z4-GT and 35Z3 tubes take 150 a-c ma for the heaters and have maximum d-c output of 100 ma. The 25W4-GT takes 300 a-c ma for the heater and has maximum d-c output of 125 ma. The 117Z3, for connection directly across a power line, takes 40 a-c ma for its heater and has maximum d-c output of 90 ma.

PILOT LAMPS. In Fig. 6 a pilot lamp or dial lamp is connected in parallel with part of the heater of the rectifier tube. The entire heater extends from b to c. There is a tap at e, which is brought out to a separate base pin. This tap is externally connected to pilot lamp terminal d, and end b of the heater is externally connected to pilot lamp terminal a. The portion of the heater voltage between b and e is thus applied to the pilot lamp. The rectifier tube is of a type especially designed for this method of connection.

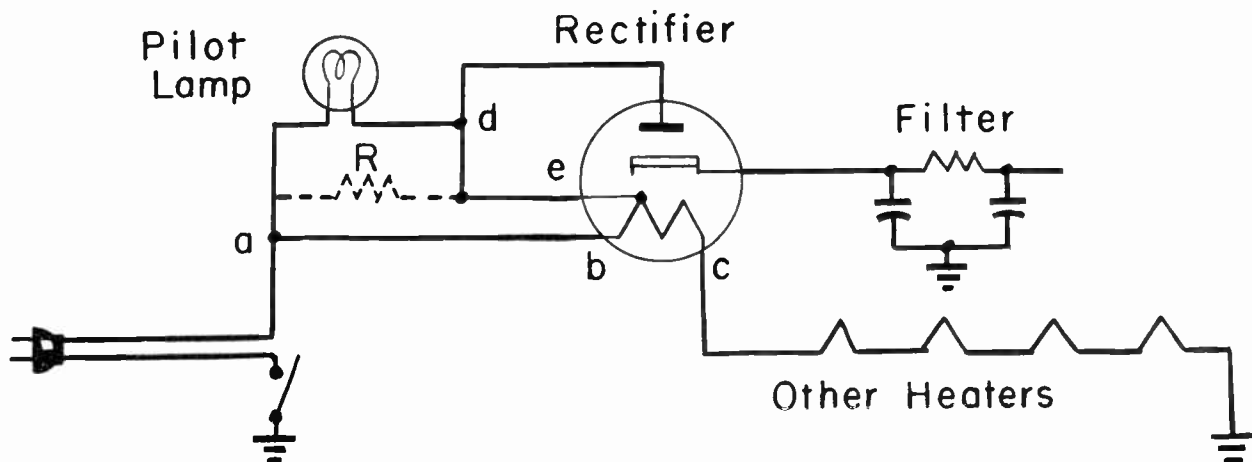

Fig. 6. Pilot lamp connected in parallel with a portion of the heater in the rectifier tube.



## COYNE - *television home training*

Rectified plate current flows in the pilot lamp from d to a and to one side of the line, also through the heater from d to e to b and to the line. The pilot lamp may be a type 40, with screw base, or type 47, with bayonet base. Other than for the style of base these two lamps are identical. Each is designed to operate at 6.3 volts, with which the lamp current is 150 ma or 0.15 ampere.

When one of these pilot lamps is connected as shown by Fig. 6, the voltage across the lamp and across the heater section between b and e is nominally 5.5 volts, but often is less than this value. When no pilot lamp is used, and rectifier terminal e is left open, the a c voltage across the section of the heater between b and e is nominally 7.5. The remainder of the nominal or rated heater voltage is between terminals e and c.

If, in a circuit designed for a pilot lamp (Fig. 6) the lamp burns out or is removed, the entire rectified plate current in addition to normal heater current must flow in the section of the heater between e and b. This extra plate current will cause the voltage across the heater from e to b to increase, and when plate current is more than 30 to 40 ma the tapped portion of the heater may be seriously overloaded, to the extent of burning out within a short time unless the lamp is replaced.

Should the pilot lamp persist in burning out at frequent intervals, as happens with some receivers, it may be replaced with a

type 46 (screw base) or a type 44 (bayonet base). These types are designed for a current of 250 ma or 0.25 ampere with 6.3 volts. They will not light so brilliantly as the regular types, but neither will they burn out so often.

When the d-c output current is more than 60 ma, a resistor shown in broken lines at R in Fig. 6 should be connected in parallel with the pilot lamp to carry part of the load. Resistances which are satisfactory for average conditions are 300 ohms for 70 ma d-c output, 150 ohms for 80 ma output, and 100 ohms for 90 ma output.

With receivers having series heaters, and a ballast resistance in series with the heaters, a pilot lamp may be connected in parallel with part of the ballast. The portion of the ballast resistance paralleled by the lamp is such as to have a voltage drop suitable for the lamp filament. Pilot lamps available for such service include types rated for 2.0, 2.5, 2.9, 3.2, 6.3, 6.5 and 7.5 volts, at currents all the way from 60 to 500 ma in the lamp filament.

Fig. 7 shows base pin positions and connections to internal elements of half-wave rectifier tubes in which the heater is tapped to allow parallel connection of a pilot lamp. The base of diagram A is an octal type with six pins, at B it is a lock-in type, and at C a 7-pin miniature. All the tubes whose type numbers are written below the diagrams take 150 a-c ma for their heaters and have rated

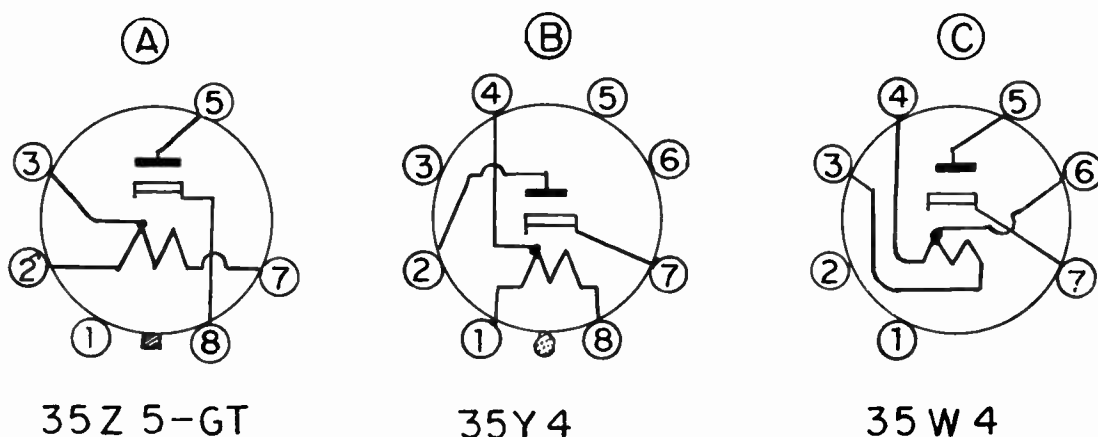

Fig. 7. Basing connections for half-wave heater-cathode rectifier tube having a pilot lamp tap on the heater.

## LESSON 14 – TRANSFORMERLESS POWER SUPPLIES

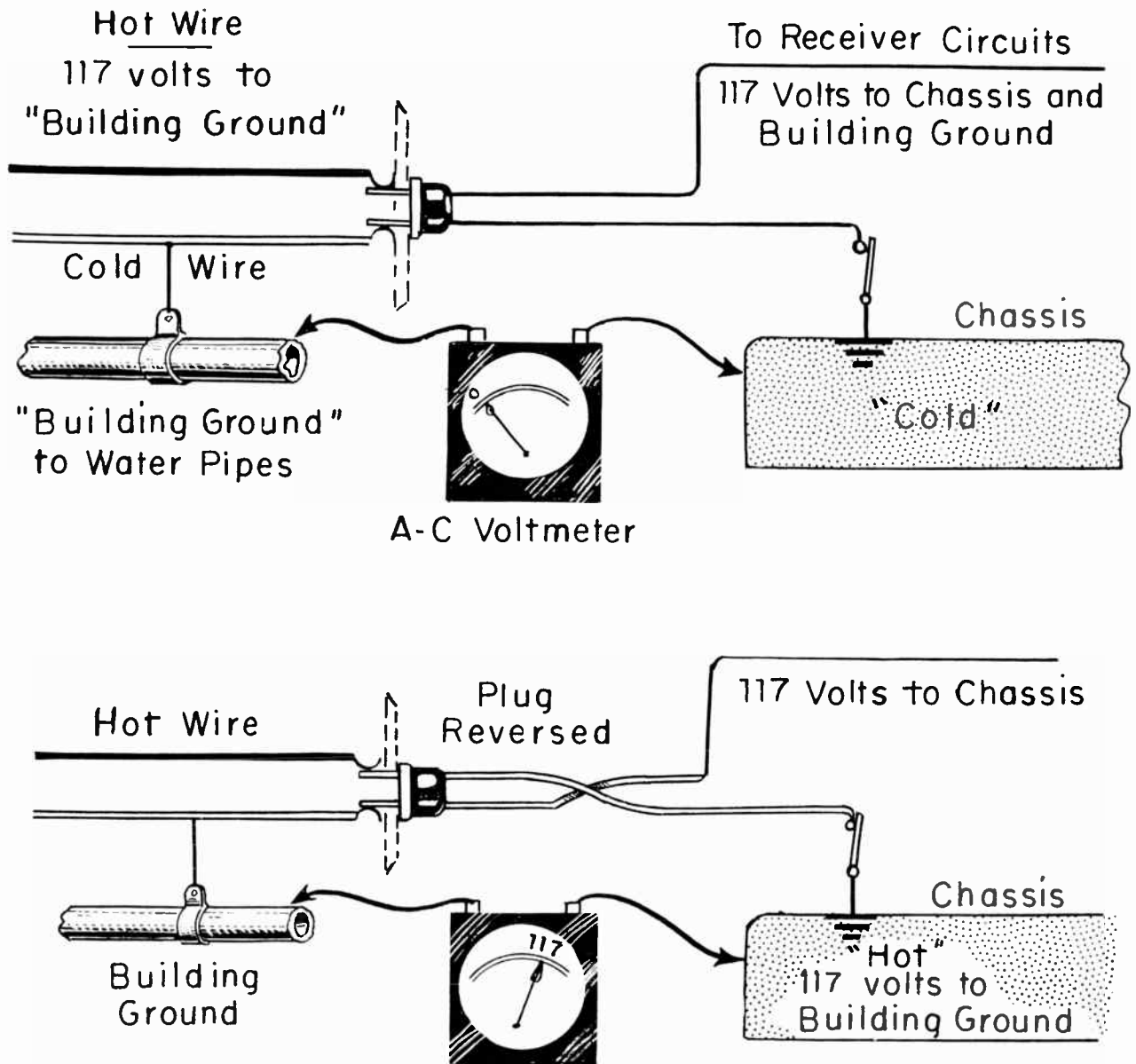

Fig. 8. The chassis metal is "cold" in the upper diagram and is "hot" in the lower diagram.

maximum d-c output currents of 60 to 100 ma.

**HOT CHASSIS.** Rules of the Fire Insurance Underwriters require that one of the two wires of an a-c lighting and power system in a building be connected to a ground, which usually means to a cold water pipe which extends without any insulating breaks into permanently moist earth. Such a building ground is represented at the left in the diagrams of Fig. 8. The grounded wire may be called the cold wire, and the other wire may be called the hot wire.

When the plug on a receiver power cord

is inserted into a receptacle as in the upper diagram the receiver chassis is connected through the power cord and the building wiring to the building ground. Then the chassis is said to be "cold". The other side of the power cord goes to the receiver circuits, and is at 117 volts to the chassis and to the building ground.

The building ground connects conductively not only to all the cold water piping in the building, but also to all the hot water piping, probably to the waste pipes, and to all the metal faucets and other fittings of the entire water system. It may connect conductively to heating systems, air conditioning

## COYNE - *television home training*

systems, ranges, refrigerators, and almost any appliances.

If, with the power cord inserted as in the upper diagram, you connect an a-c voltmeter between the receiver chassis and any metal which connects to the building ground the meter will indicate zero voltage. If you touch the chassis and at the same time touch any grounded metal objects as previously mentioned, you will feel nothing at all.

Supposing now that the plug on the receiver power cord happens to be inserted into the receptacle with prongs reversed, as in the lower diagram of Fig. 8. Now the hot wire of the building wiring is connected to the receiver chassis, while the cold wire goes to the receiver circuits. There is again 117 volts from the receiver wire to the chassis, and the receiver works just as well as before.

But now an a-c voltmeter connected between the chassis and any metal which is conductively connected to the building ground will show 117 volts, or whatever the line voltage may be. The chassis now is "hot". If you touch the chassis and at the same time touch anything connected to the building ground you will get a severe and possibly dangerous shock. This is why people sometimes are killed when listening to a radio while taking a bath. They are well grounded through the mass of water, and happen to grasp the metal of a hot chassis. Radios constructed with chassis grounds such as shown by Figs. 2 and 6 have all grounded

metal parts well protected by the cabinet and covers, but people sometimes get their fingers through the protection.

When any receiver having one side of the power cord grounded to the chassis is out of its cabinet for servicing you must use caution. Do not touch the chassis or any other metal object unless you know that the chassis is cold. Many service men make a check with an a-c voltmeter, as shown by Fig. 8. If the meter reads line voltage, or approximately so, they reverse the plug to get a zero reading before commencing work on the receiver. One side of the meter may be connected to any or all metal objects which might be touched while working, the other side is connected to the chassis.

A still safer method, which is employed in most well equipped service shops, is to use an isolation transformer as in Fig. 9. A simple isolation transformer has a voltage ratio of one-to-one, and applies to the receiver the same a-c voltage supplied by the line. On one side of the transformer is a cord and plug for the building line receptacle. On the other side is a plug receptacle for the receiver power cord. Since the primary and secondary windings of the transformer are well insulated from each other, the receiver chassis cannot be made hot with reference to any other metal.

A transformer having primary taps for line voltage compensation often is used as an isolation transformer. On the primary side,

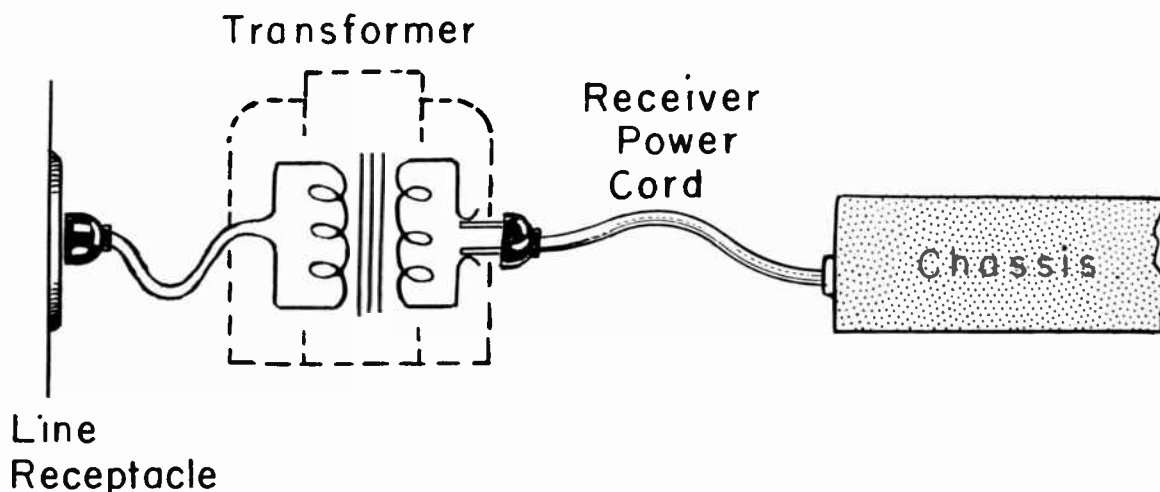

Fig. 9. Using an isolation transformer to avoid possibility of working on a hot chassis.

## LESSON 14 – TRANSFORMERLESS POWER SUPPLIES

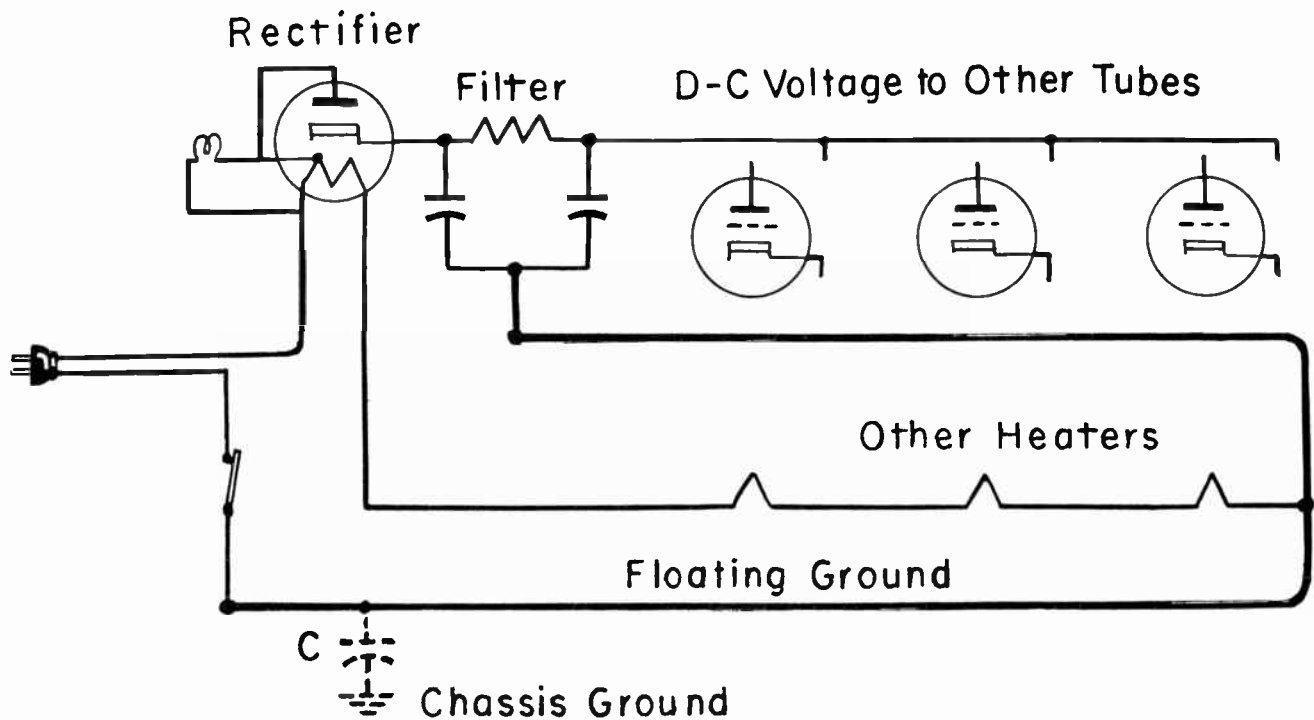

Fig. 10. How a hot chassis is avoided by use of a floating ground conductor.

which connects to the building line, is a switch that allows raising or lowering the a-c voltage to the receiver by altering the effective turns ratio and voltage ratio. Usually the switch allows dropping a high line voltage or raising a low voltage to approximately 117 volts for the receiver. This allows making service measurements with an approximately standard applied voltage.

An isolation transformer must have a high enough power rating, in watts, to handle receivers without overheating of the transformer. A 100-watt or 150-watt size will be satisfactory for all small radios of varieties having up to about 10 tubes. Television receivers require transformers rated at something like 250 to 350 watts.

**FLOATING GROUND.** A method of avoiding a hot chassis in a transformer receiver is illustrated by Fig. 10. Instead of connecting one side of the power line, one end of the heater string, the d-c filter capacitors and other parts to chassis ground, all of them are connected to an insulated wire which extends from place to place throughout the receiver. This wire, which takes the place of chassis metal as a conductor, is called a floating ground. The receiver operates in

exactly the same manner as though chassis metal were used as one of the conductors in all the circuits. But because the power line is not conductively connected to chassis metal, the chassis cannot be hot with respect to metal fittings, fixtures, and appliances in the building or shop.

Due to the mechanical construction of some parts, such as many tuning capacitors, one side of their circuits must connect to chassis metal or chassis ground. The only parts in this classification are those operating at high frequencies. To complete the high-frequency circuits the floating ground conductor may be connected to chassis metal through a capacitor shown in broken lines at C on the diagram.

Opposition (reactance) of a capacitor to flow of alternating currents in it becomes less as frequency increases, this being true for any given capacitance. Oftentimes the grounding capacitance is about 0.05 mf, which has reactance of only about 3 ohms at frequencies in the middle of the standard broadcast band. But reactance of any capacitor increases as repeated frequency decreases, and at a 60-cycle line frequency the 0.05 mf capacitance has reactance of about 53,000 ohms.



## COYNE - *television home training*

With 117 a-c volts from the power line the high reactance of the grounding capacitor at 60 cycles allows line current of only about 2.2 ma between line and chassis. This is too little current to give a noticeable shock.

D-C OPERATION. A transformerless receiver may be operated from a d-c power line furnishing between 105 and 125 volts provided the line polarity is correctly applied to the rectifier. When the plug of the power cord is inserted in the receptacle in such position as to make the rectifier plate positive and its cathode negative, the rectifier will conduct continually. Its d-c output will pass through the filter resistor or choke, and the receiver will operate normally. With the power cord plug reversed, the rectifier plate will be negative and the cathode positive, and the receiver will not operate.

Series heaters will light no matter which way the plug is inserted in the line receptacle. Some ac-dc receivers have a self-contained polarity reversing switch. If the set does not operate from a d-c line with the plug inserted, the polarity switch is moved to its other position. Buildings in which light and power service is direct rather than alternating current may have polarized outlet receptacles which will take only a polarized plug on which the flats of the prongs are at right angles rather than being parallel to each other. An ac-dc set used only in such a building or locality may have a polarized plug fitted to its power cord, whereupon line voltage can be applied to the receiver circuits in only the correct polarity.

No receiver in which all or part of the power must pass through a transformer will operate from a d-c line. A transformer depends for energy transfer on mutual induction. There can be induction only when magnetic fields and conductors have relative motion. With direct current in a transformer primary the magnetic field is of constant value, it does not expand and contract, or move, and no voltage will be continually induced in the secondary. The only result of connecting a transformer type receiver to a d-c line will be to blow the line fuse, or, if the fuse doesn't blow promptly, to burn out the transformer primary winding. The low

d c resistance of a primary, as contrasted with its high reactance to alternating current, allows a very great direct current in the primary until a fuse blows or the winding burns out.

TELEVISION HEATER STRINGS. In television receivers having series heaters there are not too many tubes for arrangement in one string on 117 line volts provided all tubes were to have 6.3-volt heaters and there were no more than 18 of them. But because it often is desirable to use at least a few tubes having higher heater voltages, and also because some of the sections or some classes of tubes should be electrically separated, it is customary to use two or more heater strings.

Fig. 11 shows two heater strings as used in a 19-tube television receiver. The two strings are in parallel with each other, and the two together are in series with the picture tube. Picture tubes of all sizes and types have heaters which operate with 0.6 ampere or 600 ma on 6.3 a-c volts. Therefore, the total current through the two paralleled heater strings must be 0.6 ampere in order to maintain correct current and temperature in the heater of the picture tube.

You will note also that the two paralleled heater strings are in series with a 20-ohm resistor. Since there must be a total of 600 ma for the paralleled strings and the picture tube heater, this must be the current through the resistor. With 600 ma in 20 ohms the voltage across this resistor is 12.0.

We have on one side of the power cord connection a drop of 12.0 volts in the series resistor, and on the other side there is a drop of 6.3 volts in the heater of the picture tube. Subtracting the sum of these two voltages from 117.0 line volts leaves 90.7 volts across each of the heater strings.

Rated heater voltages are marked above each tube. All tubes, in both strings, are rated for heater current of 0.3 ampere or 300 ma. Note that in the upper string there are tubes in the vertical sweep section, the video amplifier, and the tuner having heaters in two sections which may be operated in

# LESSON 14 – TRANSFORMERLESS POWER SUPPLIES

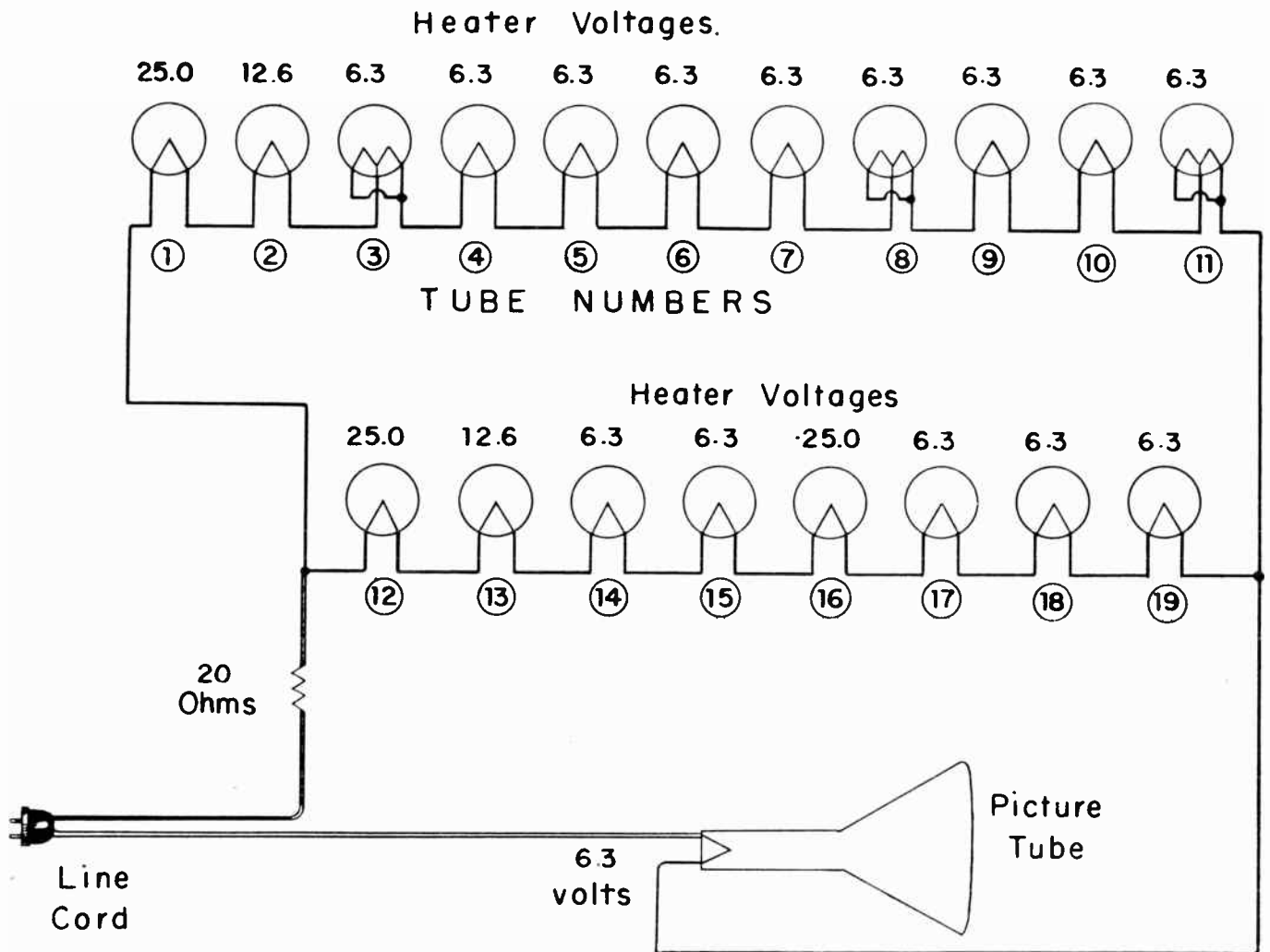

Fig. 11. Two paralleled strings of series heaters used in a 19-tube television receiver.

series with each other on 12.6 volts at 150 ma or on 6.3 volts at 300 ma. The heater sections in all these tubes are paralleled.

If you add together the rated heater voltages for 11 tubes in the upper string the total comes to 94.3 volts instead of our previously assumed 90.7 volts. The sum of all the rated heater voltages for tubes in the lower string is 94.1 volts.

To straighten out the apparent discrepancy in actual and rated voltages we might compute the hot resistances of all the tubes, by using the rated voltages and current with an alignment chart or a formula. Hot resistance of the upper string would turn out to be about 314.3 ohms, and for the lower string about 313.6 ohms. The parallel resistance of the two strings would be almost exactly

157.0 ohms. Now we have across the line a total resistance as follows.

Parallel resistance of two heater strings .....	157.0 ohms
Resistance of fixed series resistor.....	20.0 ohms
Resistance of picture tube heater (hot).....	<u>10.5 ohms</u>
Total .....	187.5 ohms

With 187.5 ohms across 117 line volts, the current will be about 624 ma or 0.624 ampere instead of the 600 ma or 0.6 ampere as based on tube ratings. This 4 per cent of excess current is not objectional nor harmful to the tubes.

In the actual receiver chassis, as in all chasses, the tubes are not arranged in such

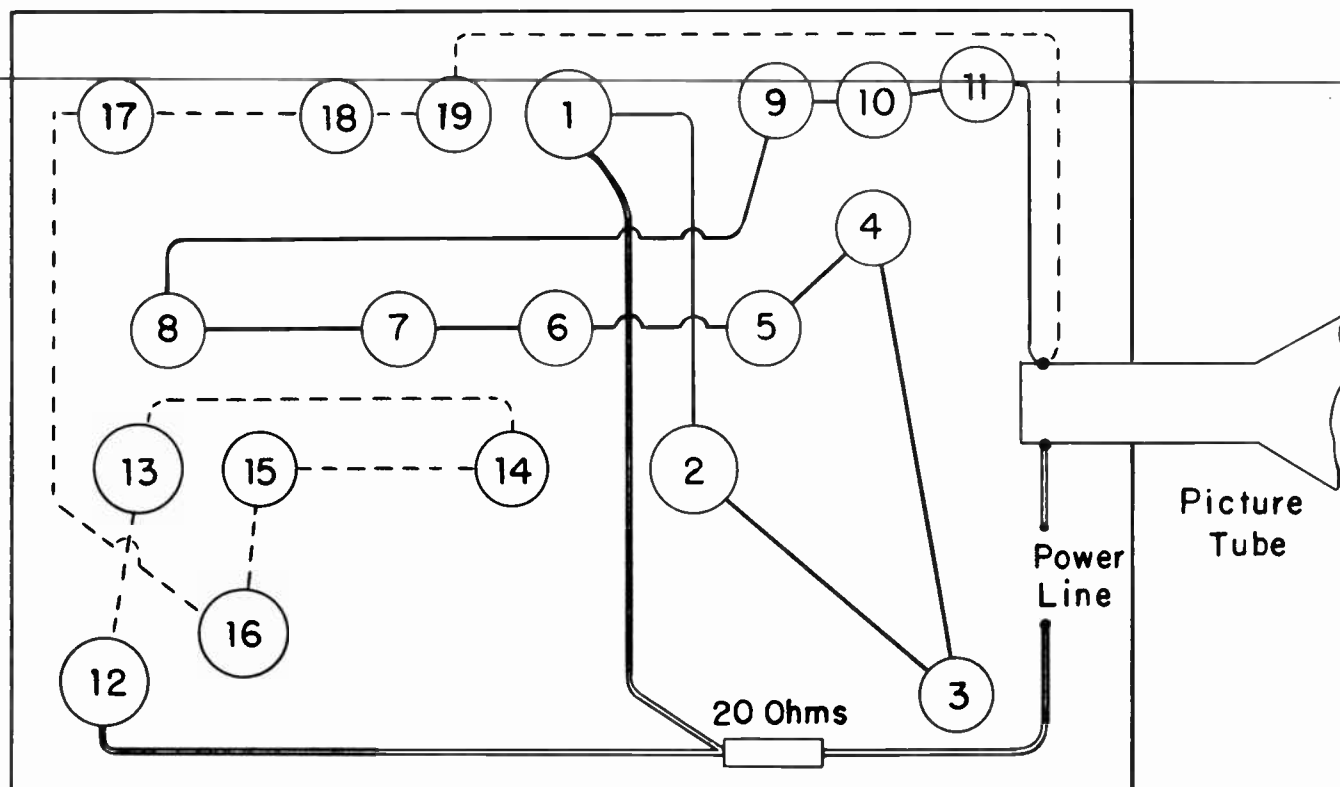

Fig. 12. Relative positions of tubes in the chassis, and how the connections for two heater strings extend from tube to tube.

orderly fashion as shown by Fig. 11, and it is not quite so easy to trace the series heater connections as that diagram might lead you to believe. In the chassis being considered the tube layout is as shown by Fig. 12. The numbers in the circles on the chassis drawing correspond to numbers written below each tube heater symbol of Fig. 11. The solid line on the chassis drawing follows the series connections for one string, the broken line follows the other string, and the double line is the return from the picture tube.

Fig. 13 is a diagram of the heater circuits in a 23 tube television receiver. Again we have a number of separate series-heater strings connected in parallel with one another, but some series combinations are in series with others while at the same time being in parallel with still others. Written above each tube symbol is the rated heater voltage for that tube, and underneath each series string is written the current that must be carried by all the tubes in that string, which is their rated heater current.

For the various tubes there are four different heater voltages; 6.3 volts, 12.6 volts, 35 volts, and 50 volts. There are four different heater currents; 150 ma or 0.15 ampere, 300 ma or 0.3 ampere, 450 ma or 0.45 ampere, and 600 ma or 0.6 ampere. There are three ballast resistors, of 107 ohms, 22 ohms, and 59 ohms. Under the symbol for each ballast is written the total current and also the voltage drop when carrying this current.

We are going to spend a little time getting acquainted with what happens in this combination of series and parallel connections. It is important to be able to analyze such circuits, not only because they are used for tube heaters, but because they occur in nearly all the voltage dividing systems of both television and radio receivers. The voltage dividing system includes all the circuits, connections, and resistances which divide the voltage from the power supply filter among all the tubes in accordance with their needs. When locating troubles in all kinds of

# LESSON 14 – TRANSFORMERLESS POWER SUPPLIES

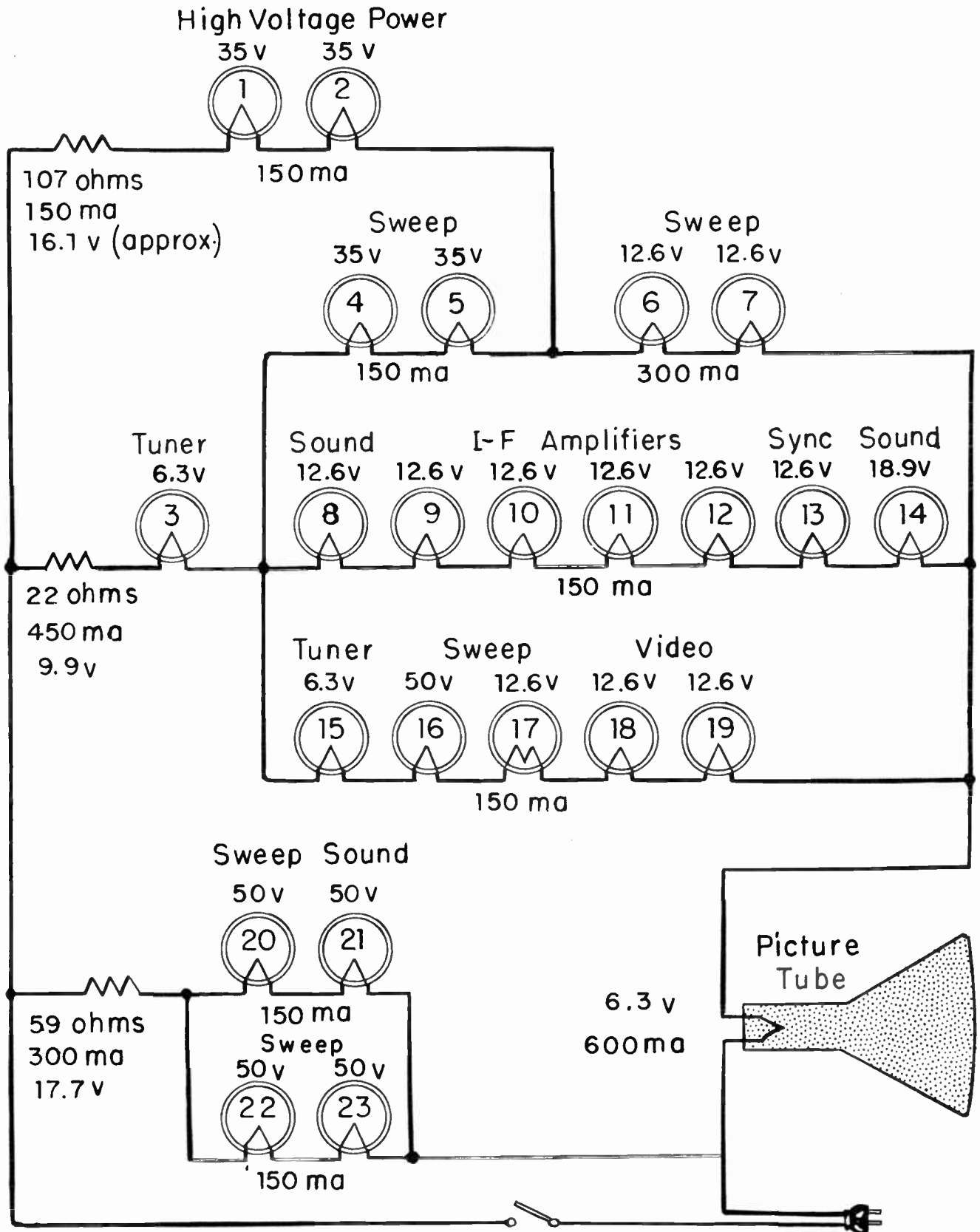

Fig. 13. Six series-heater strings and their parallel connections for a 23-tube television receiver.



# COYNE - television home training

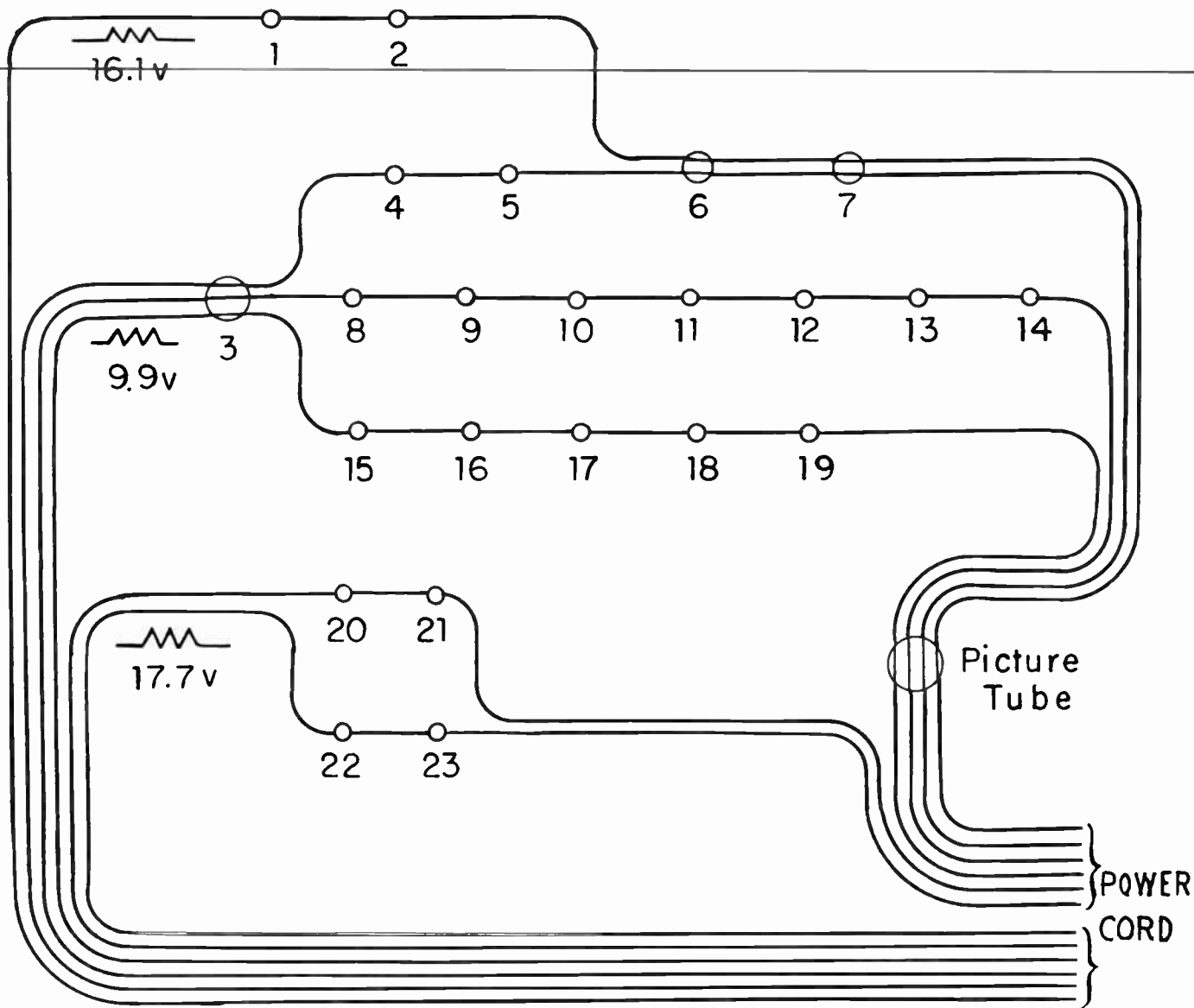

Fig. 14. Paths followed by each 150-ma portion of the total heater current in the 23-tube receiver.

receivers you will have to follow the voltages and currents through these series-parallel connections to determine where things commence to go wrong.

We may think of the actual connection diagram of Fig. 13 as consisting of the current paths shown by the lines of Fig. 14. Each line represents the path followed by 150 ma or 0.15 ampere of heater current. The tube heaters along each line are represented by circles; the smallest circles for 150-ma heaters, larger ones for 300 ma heaters, still larger ones for 450 ma, and the largest for the 600 ma in the heater of the picture tube.

Each current line begins and ends at the power cord for the receiver, the cord connected to the building a-c power supply. The sum of the voltage drops in all the heaters and the ballast resistor included along each current line must equal the voltage from the power cord. Let's look first at the outermost of the six current lines. Here are the rated voltage drops.

Ballast resistor (107 ohms, 150 ma).....	16.1 volts
Tube number 1.....	35
Tube number 2.....	35
Tube number 6.....	12.6
Tube number 7.....	12.6

## LESSON 14 – TRANSFORMERLESS POWER SUPPLIES

Picture tube ..... 6.3  
 Total (rated) voltage drop..... 117.6 volts

Here are the rated voltage drops along the second line from the outside.

Ballast resistor (22 ohms,  
 450 ma) ..... 9.9 volts  
 Tube number 3 ..... 6.3  
 Tube number 4 ..... 35  
 Tube number 5 ..... 35  
 Tube number 6 ..... 12.6  
 Tube number 7 ..... 12.6  
 Picture tube ..... 6.3  
 Total (rated) voltage drop ..... 117.7 volts

Adding together the voltages across each of the other lines gives the following totals. The several lines are here identified by their tube numbers. Each line includes a ballast resistor.

Tubes 3, 8, 9, 10, 11, 12, 13, 14,  
 picture tube.....117.0 volts  
 Tubes 3, 15, 16, 17, 18, 19,  
 picture tube.....116.6 volts  
 Tubes 20, 21. Includes ballast,  
 but not picture tube.....117.7 volts  
 Tubes 22, 23. Includes ballast,  
 but not picture tube.....117.7 volts

Next, let's see where the tubes requiring more than 150 ma heater current get the extra current. Tubes numbered 6 and 7 require 300 ma. They get 150 ma through tubes 1 and 2, and they get another 150 ma through tubes 4 and 5. These two currents of 150 ma each flow together in tubes 6 and 7 to provide the required 300 ma.

Tube number 3 requires 450 ma of heater current. It is carrying 150 ma to tubes 4, 5, 6, and 7. It is carrying another 150 ma to tubes 8 through 14 inclusive. And thus tube number 3 is carrying a third 150 ma current to tubes 15 through 19 inclusive. The three currents of 150 ma each flow through the heater of tube number 3, and make up the required total of 450 ma.

The heater of the picture tube requires 600 ma or 0.6 ampere. This heater is carrying 150 ma from each of four current lines coming to it from up above in Fig. 14. These

four currents combine in the picture tube heater to make up the required 600 ma.

Back to one side of the power cord comes the 600 ma from the heater of the picture tube, also 150 ma from tubes 20 and 21, and another 150 ma from tubes 22 and 23. Thus we have at the power cord the sum of 600 ma, 150 ma, and 150 ma, for a total of 900 ma or 0.9 ampere of alternating current for all the heaters in the entire system.

SERVICE PROBLEMS. There are tubes of different type-numbers whose performances with respect to amplification and related properties are alike or very similar, but which differ in rated heater currents and voltages. During war time emergencies and under other conditions making certain tube types unobtainable, it may be possible to make substitutions in order to keep receivers in operation.

Fig. 15 shows necessary circuit changes. The substitute tube may require the same heater current with more or less voltage. It may require a smaller current with voltage which is the same or more or less than the original. The substitute may require more current with the same or more or less voltage. In each diagram the third tube from the left is assumed to be the substitute. Of course, the substitute might be in any other position without altering the principles. It will be necessary to refer to resistances of ballasts, also to hot resistances of heaters as shown by the accompanying table.

We shall consider each of the cases shown by Fig. 15. You will find that every alteration conforms to our rules for series and parallel resistances. We have here merely some practical applications of the rules.

1. The substitute tube requires the same heater current but more voltage. This means that the new tube will have greater resistance. To maintain the original total series resistance of the heater string, resistance of the ballast must be reduced by the same amount that heater resistance is increased.

# COYNE - television home training

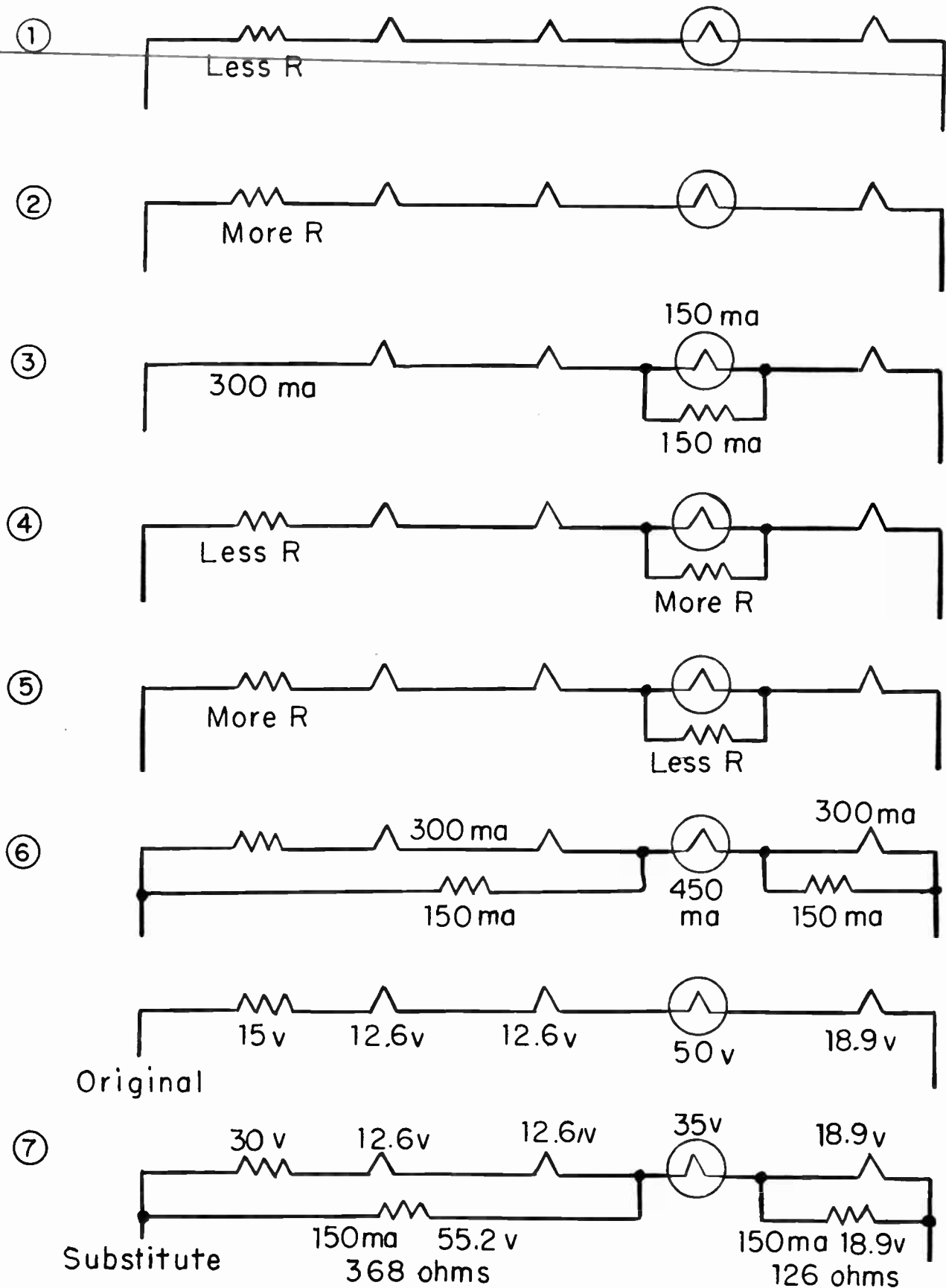

Fig. 15. Using substitute tubes which require either more or less heater current than other tubes in the same string.

# LESSON 14 – TRANSFORMERLESS POWER SUPPLIES

## HEATERS, HOT RESISTANCES, APPROXIMATE OHMS

Amps	Volts		Ma.	Volts			Ma.	Volts								
	5	6.3		6.3	12.6	18.9		25	35	45	50	70	117			
0.9		7	150	42	84	126	40									2930
1.0	5.0	6.3	175	36	72		75			600						1560
1.2		5.3	250	25	50	75	90									1300
1.25	4.0	5.1	300	21	42	63	150	166	233	300	333	467				
1.5	3.3	4.2	400	15.7			300	83	117		167					
1.6		4.0	450	14	28	42										
2.0	2.5	3.2	500	12.6												
2.5		2.6	600	10.5	21											
3.0	1.7	2.1	650	9.7												
			700	9												
			750	8.4												
			800	7.9												

Example: For 25-volt 150-ma tube substitute 35-volt 150-ma tube. The table shows original resistance to be 166 ohms and substitute resistance 233 ohms. Decrease the ballast by the difference, which is 67 ohms.

2. The substitute requires the same heater current but less voltage, which means lower resistance. Ballast resistance must be increased by the same amount that heater resistance is lowered.

3. The substitute requires less current with the original voltage. Part of the heater string current is carried around the new tube by a paralleled resistor.

Example: For 300-ma 12.6-volt tube substitute one requiring 150 ma at 12.6 volts. Of the 300 ma in the heater string only 150 ma may flow in the new tube, with the other 150 ma in the paralleled resistor. Voltage across this resistor must be the same as across the tube, 12.6 volts, when the resistor carries 150 ma. Required resistance is 84 ohms.

4. The substitute requires less current at more than the original voltage. A paralleled resistor carries the portion of the heater string current which must not flow in the new tube. The original voltage drop across the entire heater string must be maintained.

Example: For a 300-ma 6.3-volt tube substitute one requiring 150 ma at 12.6 volts.

Step a. The parallel resistor is selected as in example 3.

Step b. To maintain the same total resistance in the heater string, compare the resistances of the original and substitute heaters, as given in the table. The original resistance is 21 ohms. Parallel resistance of the substitute and its resistor is half that of the tube alone, or is 42 ohms. This is 21 ohms more than the original resistance, so the ballast resistance must be decreased by 21 ohms.

5. The substitute requires less current at less than the original voltage. Again we use a paralleled resistor and change the ballast as needed.

Example: For 300-ma 50-volt tube substitute one taking 150 ma at 35 volts.

Step a. The parallel resistor is selected as in example 3.

Step b. To maintain the total heater string resistance proceed as in example 4. Resistance of the new tube, from the table, is 233 ohms. To carry half the current the paralleled resistor must be of 233 ohms, and parallel resistance of tube and resistor will be 116.5 or about 117 ohms. Resistance of



## COYNE - *television home training*

the original heater is 167 ohms. The new resistance is less than the original. The difference, 50 ohms, must be added to the ballast resistor, or a 50-ohm ballast inserted if there is none to begin with.

6. The substitute requires more current with the original voltage. Additional current is brought to the new tube through resistors which parallel the other tubes. Each resistor is selected to carry the extra current at a voltage equal to the sum of all heater and ballast voltages which are paralleled by that resistor. The diagram shows an extra 150 ma being furnished to the substitute tube.

7. The substitute requires more current at less than the original voltage. As in case 6, the additional current flows in resistors which parallel other tubes.

Example: For a 150-ma 50-volt tube substitute one taking 300 ma at 35 volts. The lesser voltage drop in the new tube must be compensated for by adding to the ballast resistance, or inserting a ballast, to provide additional voltage drop equal to the difference between the original and substitute heaters. The resistor which parallels the ballast and heaters must be selected to carry the extra current at voltage equal to the sum of the paralleled ballast and heaters. Diagrams in Fig. 15 show conditions before and after the substitution of this particular example.

8. The substitute requires more current at more than the original voltage. The general procedure and the diagram is the same as for example 7, except that ballast voltage would be reduced.

Always check the power in watts which must be dissipated by all added resistors, then use units having ratings of at least twice the actual wattage. You will find that methods number 6, 7, and 8 cause considerable power waste, and often require large and rather costly resistors. The added units must be well ventilated.

TUBE REMOVALS. Oftentimes it is convenient or necessary to remove or disconnect a tube in a series heater string while performing various service operations. This

is especially true of the picture tube. In order to keep other series tubes in operation ~~a fixed resistor may be connected between~~ the heater openings or lugs of the socket while the tube is out of place.

The preceding table of hot resistances of heaters gives the number of ohms required in the resistor which replaces any heater. Compute the required wattage rating of the resistor by multiplying together the heater current in ma and the volts, dividing this product by 1,000 to determine actual dissipation, and using rated resistance of two or three times this computed dissipation in watts.

For example, picture tube heaters operate on 600 ma at 6.3 volts, and have hot resistance of 10.5 ohms. A 10-ohm or 12-ohm resistor will be satisfactory. The actual dissipation, as computed, is 3.78 watts. A 5-watt resistor will get very hot. A 10-watt size will be much more satisfactory.

A resistor may be temporarily connected into most tube sockets by bending the ends of the pigtail leads and inserting these ends into the socket holes. Spring clip connections are likely to cause shorts.

### OBTAINING REQUIRED WATTAGES.

When you need some combination of resistance and safe power dissipation for which no available unit is suitable, it usually is possible to handle the job with series or parallel connections of resistors which are on hand. High resistance with moderate current is obtained with resistors in series, while low resistance with large current is obtained with parallel connections.

At A in Fig. 16 are represented two resistors of 1,000 ohms and 1,500 ohms in series. The assumed current, 20 ma, must be the same in both resistors. The 1,000-ohm unit must be dissipating 0.4 watt in heat, and the 1,500-ohm unit must be dissipating 0.6 watt. For any given current, power dissipation is directly proportional to resistance. The first resistor might be of a size rated for 1 watt, which is  $2\frac{1}{2}$  times the actual dissipation. The second resistor could be of the same rating, which here would be only  $1\frac{2}{3}$  the actual dissipation, and would allow

# LESSON 14 — TRANSFORMERLESS POWER SUPPLIES

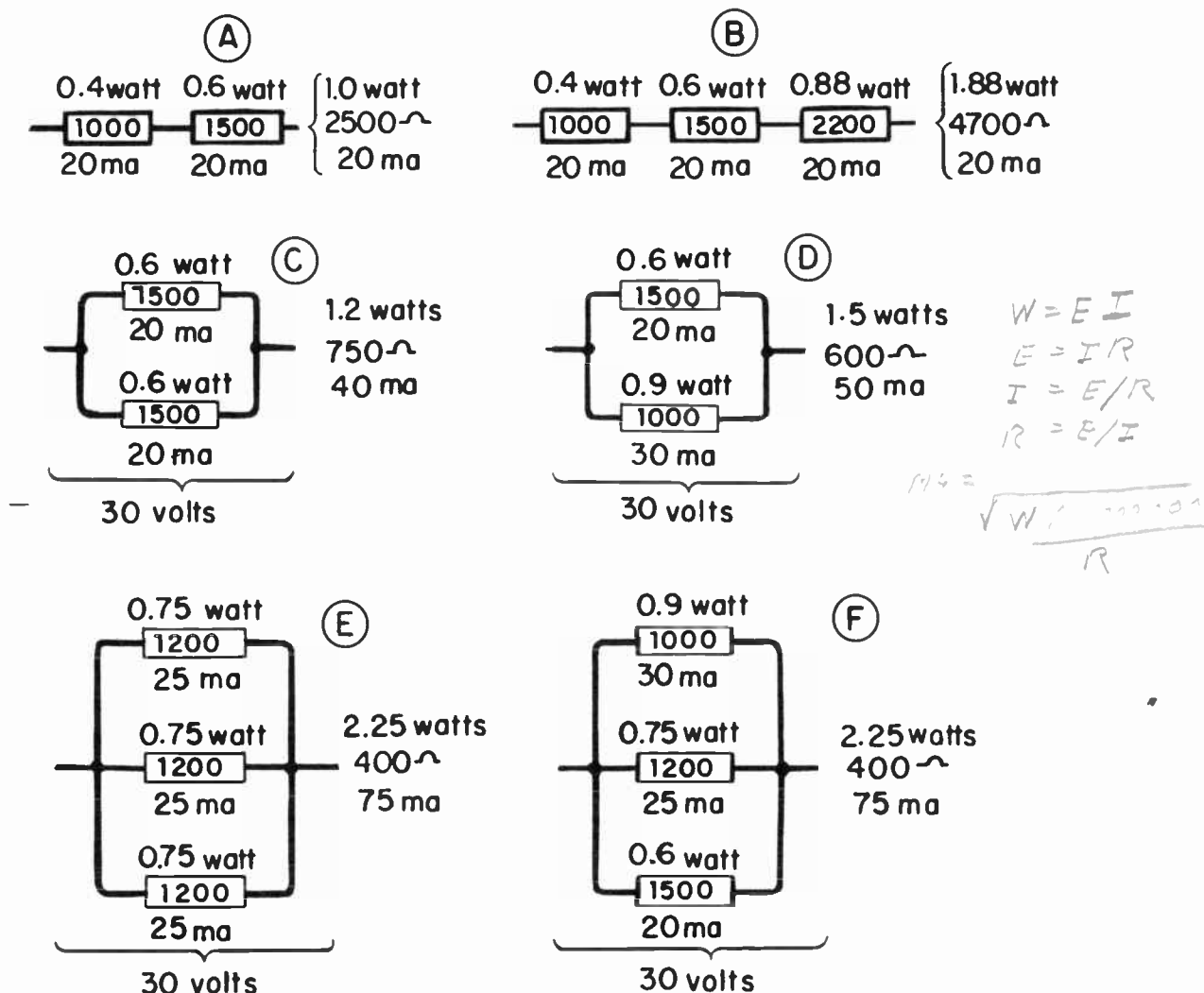

Fig. 16. Power dissipations in watts of resistors connected in series and in parallel.

this unit to run rather hot. The two units together would provide 2,500 ohms, would carry a total of 20 ma, would dissipate 1.0 watt, and would have a rating of 2 watts. The power rating is the sum of the separate ratings.

If a third resistor, shown at B, is connected in series with the other two the total resistance will be the sum of the three separate resistances, which here is 4,700 ohms. Current still is 20 ma. This third unit will dissipate 0.88 watt, due to its higher resistance, and should be rated for not less than 2 watts. Now we have total dissipation of 1.88 watts and total power rating of 4 watts.

Now let's see what happens with resistors in parallel. At C in Fig. 16 there are two 1,500 ohm units. We know that voltage

must be the same across all paralleled resistors, 30 volts being assumed here in order that we may compute some currents and power dissipations. Equal resistances subjected to the same voltage must carry equal currents, with total current equal to the sum. Power dissipation is the same in the equal resistances, and total dissipation equals the sum of the separate watts.

At D we have unequal resistances. Current in the greater resistance will be less than in the smaller resistance, with the same voltage. Power dissipation in paralleled resistors is directly proportional to currents. Because the 1,000 ohm unit carries 50 per cent more current than the 1,500-ohm unit, power in the 1,000-ohm unit is 50 per cent greater than in the 1,500-ohm unit. Parallel resistance is less than either separate re-

# COYNE - *television home training*

sistance. Total current equals the sum of the separate currents. Total power dissipation equals the sum of the separate dissipations.

At E there are three equal resistances in parallel. Rules are the same as for two or any other number of equal resistances in parallel. Parallel resistance, total current, and total power dissipation are shown at the right of the diagram.

Diagram F shows three unequal resistances in parallel. All must be subjected to the same voltage. Current in each unit is computed from its resistance and the common voltage. Power dissipations in watts also may be computed from each resistance and the common voltage. The important thing to note is this: With resistors in parallel, the one with least resistance must dissipate the greatest power. With series resistors the unit with greatest resistance must dissipate the most power.

When selecting resistors for replacement where original equipment has given trouble, and for new applications also, it is essential to consider the power dissipations. Otherwise you will use resistors that literally burn up in operation, or will waste money on resistors too large for the requirements.

You cannot possibly memorize all the rules and applications which have been brought out in this lesson. Simply try hard to understand each of the examples as you study it. Then remember that detailed instructions can be found in this lesson when you come to actual service operations requiring substitutions, additions, and other changes of circuit resistance. In all such work it will be necessary to refer to various alignment charts or, if you prefer, to use formulas for volts, milliamperes, ohms, and watts. This is the way all competent technicians handle their problems.

---

## CONDENSED INFORMATION

Heater voltage should be no more than 10 per cent below nor more than 10 per cent above the rated voltage for the tube.

Pilot lamps in parallel with part of the heater in a rectifier tube usually are types 40 (screw base) or 47 (bayonet base).

Use large capacitance in the first filter capacitor to increase the d-c output current and reduce the ripple.

Isolation transformer ratings. Small radios, 100 to 150 watts. Television sets, 250 to 350 watts. These ratings avoid overheating of the transformer.

Check for hot chassis. Connect an a-c voltmeter, on 150-volt or higher range, between chassis metal and any metal leading to the building ground. Reading of approximate line voltage indicates hot chassis. Zero reading indicates cold chassis.

A receiver using a power transformer will

not operate on a d-c power line. A fuse will blow or the transformer will burn out.

When an ac-dc receiver is operated from a d c power line, the power cord plug or other device must be inserted or polarized to make the rectifier plate positive.

Power rating of resistors in series or in parallel is the sum of the separate power ratings. The separate power ratings may or may not be suitable for the separate resistors.

Power dissipation for any given current is directly proportional to resistance. The greatest resistance must dissipate the greatest power. Watch this when using series resistors.

Power dissipations in paralleled resistors are directly proportional to currents.

Power dissipation with paralleled resistors is greatest in the least resistance.

# TELEVISION

◦ RADIO

◦ ELECTRONICS

---

LESSON 15 – CONTACT RECTIFIERS AND VOLTAGE MULTIPLIERS

---

***Coyne School***

*practical home training*

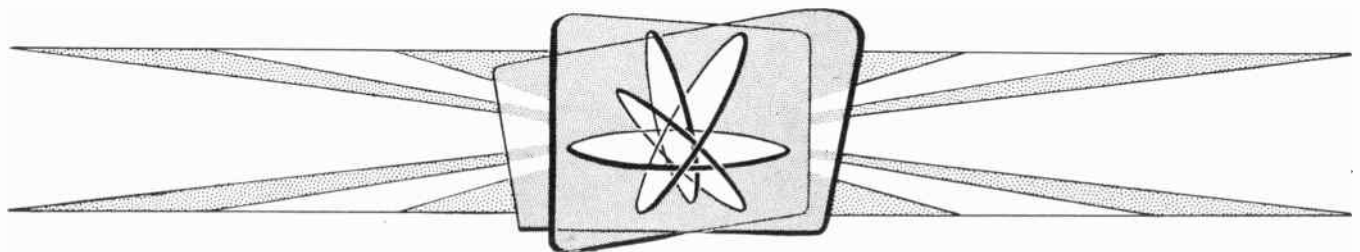

*Chicago, Illinois*



---

*Copyright, 1953 by Coyne Electrical School  
Chicago 12, Illinois  
All Rights reserved*

Litho. in U.S.A.

## Lesson 15

### CONTACT RECTIFIERS AND VOLTAGE MULTIPLIERS

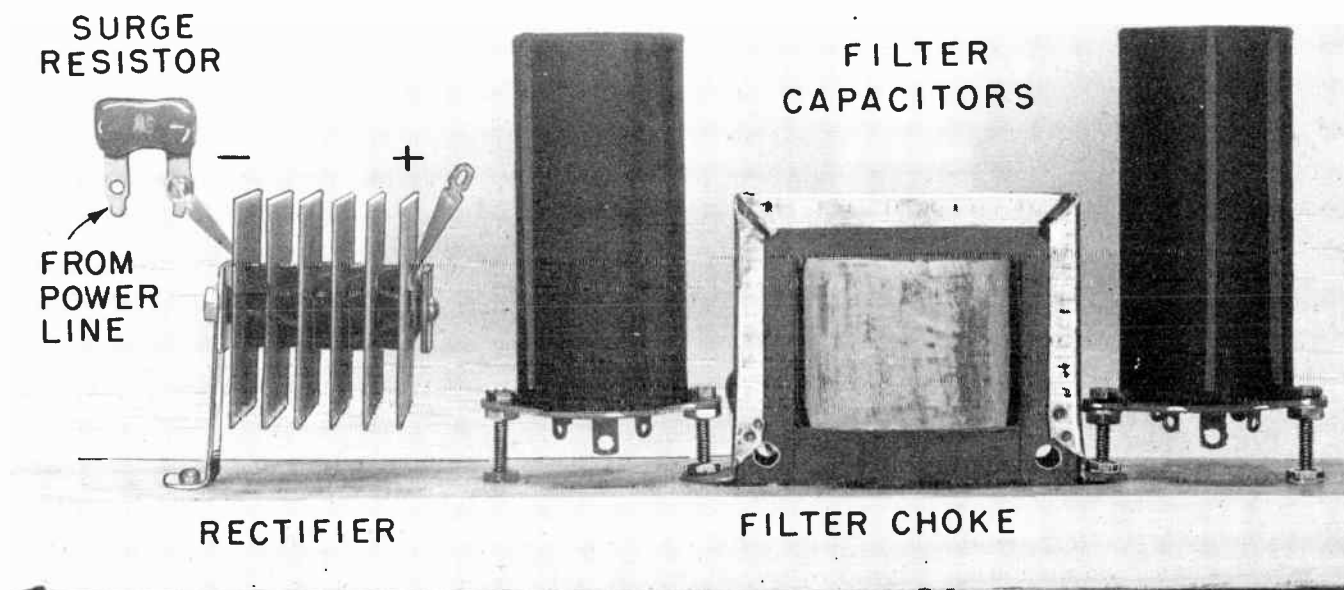

Fig. 1. The parts for a heavy-duty d-c power supply employing a selenium rectifier.

In many transformerless receivers for television and radio there is no rectifier tube. Instead there is a contact rectifier of the selenium type. Fig. 1 shows such a rectifier, together with other parts which might be used to form a complete d-c power supply. The particular rectifier pictured will deliver direct current as great as 450 ma at the output of the power supply.

Unlike a vacuum tube rectifier, the contact type has no heater or filament. It requires no power for a heater, and no heater wiring is needed. The contact rectifier mounts with a screw or stud, and requires no socket. The normal life of a selenium rectifier when not overloaded or overheated should be about 10,000 hours of actual operation. The efficiency actually improves during the first few hundred hours of operation, then remains quite constant until eventual failure.

There are other contact rectifiers than the selenium type. Copper-oxide contact

rectifiers are used for such work as storage battery charging, and small ones are found in meters which measure alternating voltages and currents. There is also a copper-sulphide contact rectifier which has limited uses. The advantage of the selenium rectifier over other contact types is its ability to operate at higher voltages. The result is that only selenium rectifiers are used in power supplies for television and radio receivers.

Although the selenium rectifier will operate at higher a-c and d-c voltages than other contact types, it cannot efficiently handle voltages nearly so high as those applied to vacuum tube rectifiers. Nearly all television and radio power supplies employing selenium rectifiers are for operation at 117 a-c volts from a power line.

A single rectifier unit, such as illustrated by Fig. 1, is a half-wave rectifier. For full-wave rectification we could use two units and a power transformer with center-tapped secondary, just as two sections of a vacuum

## COYNE - *television home training*

tube rectifier are used with a center-tapped secondary for full-wave rectification. It would be possible also to have full-wave rectification without a transformer, by using four rectifier units in what is called a bridge circuit, to be discussed later. The additional rectifier units would make the total cost about three-fourths that of a full-wave vacuum tube rectifier and power transformer, and still we could not have the high-d-c output voltages made possible by a step-up transformer.

The difference in cost of a small selenium rectifier unit and of an equivalent half-wave vacuum tube rectifier with socket is only a few cents, if anything. Large selenium rectifiers cost about twice as much as equivalent vacuum tube types operated as half-wave rectifiers with plates paralleled.

Because in the contact rectifier there is no heater to warm up before electron emission can take place from a cathode, the contact rectifier commences to rectify at the instant power is turned on. This is an advantage in some special applications, but in ordinary receivers it results in applying direct voltage to the tubes before their cathodes can heat, and it is not desirable to thus pull electrons away from a cathode before it is fully heated. However, with the moderate d-c voltages supplied from power systems in most transformerless sets the tubes suffer little if any real harm.

A selenium rectifier of the style used on a-c power lines at 117 rms volts for television and radio d-c power supplies consists of five elements or five cells in series with one another. The cells are in between extended metal flanges which help to carry away the heat produced with the rectifier in action. There are six such flanges, which allows one flange at each end of the group of elements.

Each element consists of an aluminum plate on one side of which is coated a very thin layer of the metal selenium. On the outside of the selenium is a layer of metal which serves to distribute electron flow uniformly over the entire area of the selenium. The rectifying action takes place between this

outer conductive metal and the selenium, in what is called the "barrier layer". This barrier layer allows relatively free electron flow through it in one direction, while strongly opposing flow in the opposite direction.

When the barrier layer is formed between selenium and the outer conductive coating, there is free electron flow from the coating to the selenium, and strong opposition to flow from the selenium to the conductive coating. The aluminum plate of each rectifying element is toward the negative terminal of the rectifier, with the conductive coating on the selenium toward the positive terminal.

Each element will operate without overheating at a maximum of 26 rms or effective a-c volts. Therefore, the five elements in series form a unit which is rated for a maximum of 130 rms volts. This would be the maximum permissible a-c line voltage. Although the maximum applied voltage is not altered, the current carrying capacity is increased by increasing the size and contact areas of the element. Larger cells working at full rated currents produce more heat than small cells, and require larger heat radiating flanges or fins.

At the left in Fig. 2 is a selenium rectifier rated for 75 maximum d-c ma. The fins are about 1 inch square. At the right is a 150-ma rectifier, with fins about 1-3/16 inches square. The unit used in Fig. 1, rated at 450 maximum d-c ma, has fins about 2 inches square.

When you look in parts catalogs for selenium rectifiers suitable for television and radio d-c power supplies you will find listed a number of characteristics, chief among which are the following.

Maximum rms input voltage, which always is 130 volts for the commonly employed five-element units.

Maximum inverse peak voltage, which is the a-c peak voltage of the alternation which is not rectified, or with which input voltage acting on the rectifier is in the opposite polarity from that which causes recti-

## LESSON 15 – CONTACT RECTIFIERS AND VOLTAGE MULTIPLIERS

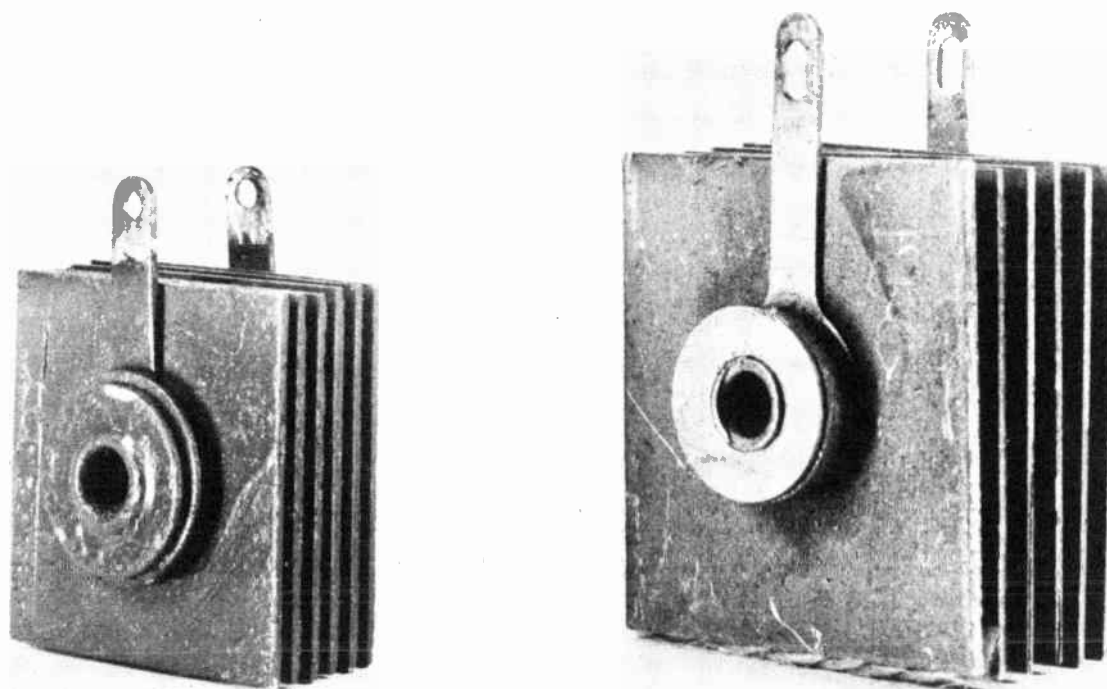

Fig. 2. Selenium rectifiers such as used in transformerless power supplies.

fication. This rating usually is 380 volts when maximum rms input voltage is 130.

### Maximum output d-c milliamperes.

Rectifiers in general use are rated all the way from 65 to 450 ma, with units for such outputs as 65, 75, 100, 150, 200, 250, 300, 350, and 450 ma. Rectifiers for work such as battery charging, at low voltages, may be rated for outputs up to 2,000 ma or 2 amperes.

Maximum peak milliamperes, which is the instantaneous current that the rectifier will carry. This rating usually is about 10 times the maximum output d-c ma.

Maximum rms input milliamperes, which is the maximum unrectified current from the power line. This rating is usually about  $2\frac{1}{2}$  times the maximum output d-c ma.

Whereas a vacuum tube rectifier has no measurable conduction on the a-c alternation which is not rectified, the selenium rectifier and other contact types allow some conduction during the reverse alternation. The ratio of forward (rectified) voltage to

back voltage is, however, so great that the back conduction makes no practical difference in d-c power supply operation.

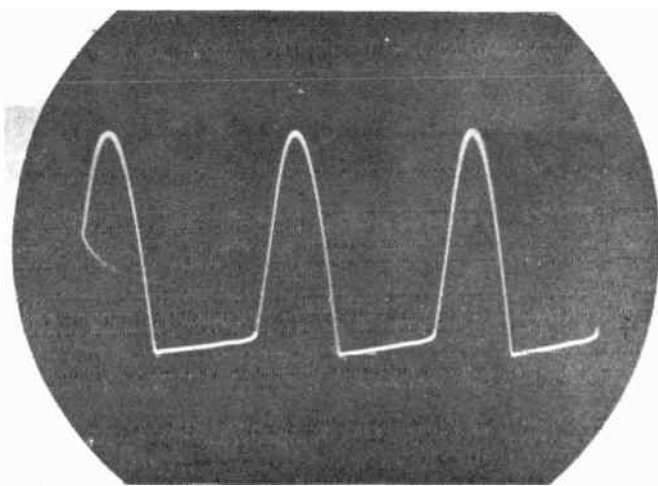

Fig. 3. Voltage pulses from the output of a half-wave selenium rectifier operating without a filter capacitor.

Fig. 3 is an oscilloscope trace of rectified voltage on the output side of a selenium rectifier. If you compare this with similar traces for a half-wave vacuum tube



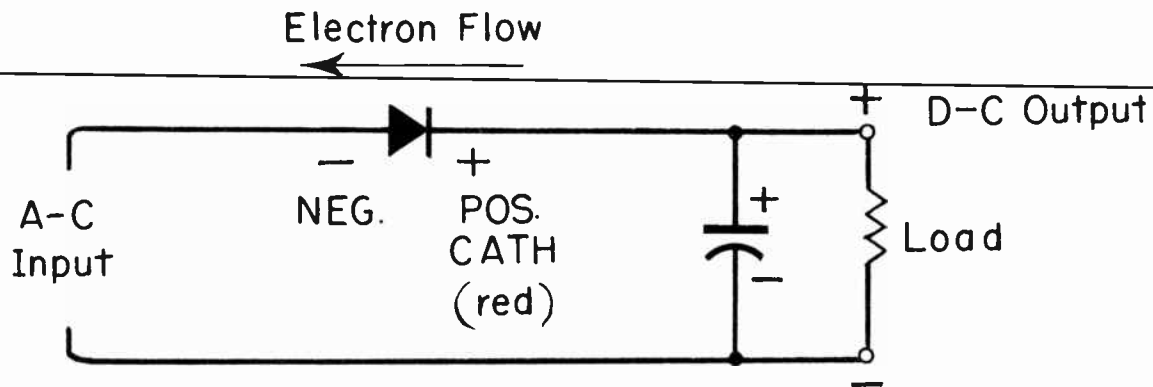

Fig. 4. The standard symbol for a contact rectifier is an arrowhead and a bar.

rectifier it is apparent that the principal difference is a slight lengthening of the downward side of each pulse and slight additional tilting of the trace during periods of cutoff between rectified pulses.

The standard symbol for a contact rectifier is shown in Fig. 4. This symbol consists of an arrowhead with its point against a straight bar. The side with a bar indicates, or should indicate, the terminal at which rectified electron flow enters the unit. On the actual rectifier this terminal may be marked with a plus sign (+), with the letters POS for positive, with letters CATH for cathode, or it may be colored red. The opposite terminal usually is unmarked, although it may have a minus sign (-), may be marked NEG, or may be colored black or yellow. So far as the symbol is concerned, you should note that the direction of electron flow is opposite to the direction in which the arrowhead points.

Selenium rectifiers ordinarily are mounted on the receiver chassis by means of a screw or stud which passes through or into a hole through the center of the unit. This hole and its ends are insulated from the rectifier elements. The bracket or other supporting part on the chassis should be such as allows a strong, rigid mount.

The rectifier unit should have reasonable air space all around it, in order to allow enough air circulation or ventilation to carry away the heat. To allow the freest circulation the rectifier fins should be vertical, not horizontal. The unit should not be close to high wattage resistors, large tubes, or other

parts from which it might absorb heat, nor should it be close to capacitors, small inductors, or wire insulation which might be overheated from the rectifier.

Some selenium rectifiers are rated for operation at temperatures not exceeding 185° F., while with others their temperature must not exceed 167° F. Higher temperatures increase the conduction in both directions, and shorten the useful life of the rectifier.

The extended metal fins or flanges are electrically alive. Those toward the positive terminal are at or near the positive potential, while those toward the opposite terminal are at or near the negative potential. Consequently, it must be impossible for the fins to come in contact with other metal parts or with uninsulated conductors. When the rectifier is on top of the chassis, possibly in a socket mounting, it should be protected with a perforated metal shell or can.

Like any other rectifiers operating at 60 or 120 cycles, the selenium unit should not be mounted near any sound amplifying circuits or parts, in which there might be much pickup of ripple or hum voltage. The rectifier should preferably be placed closer to circuits and parts operating at carrier and intermediate frequencies, which do not respond to nor have much pickup for rectifier frequencies.

Fig. 5 shows how the d-c output voltage changes when there is variation of d-c output current with several selenium rectifiers of different maximum current capacities. Maximum rated current capacities are the

## LESSON 15 – CONTACT RECTIFIERS AND VOLTAGE MULTIPLIERS

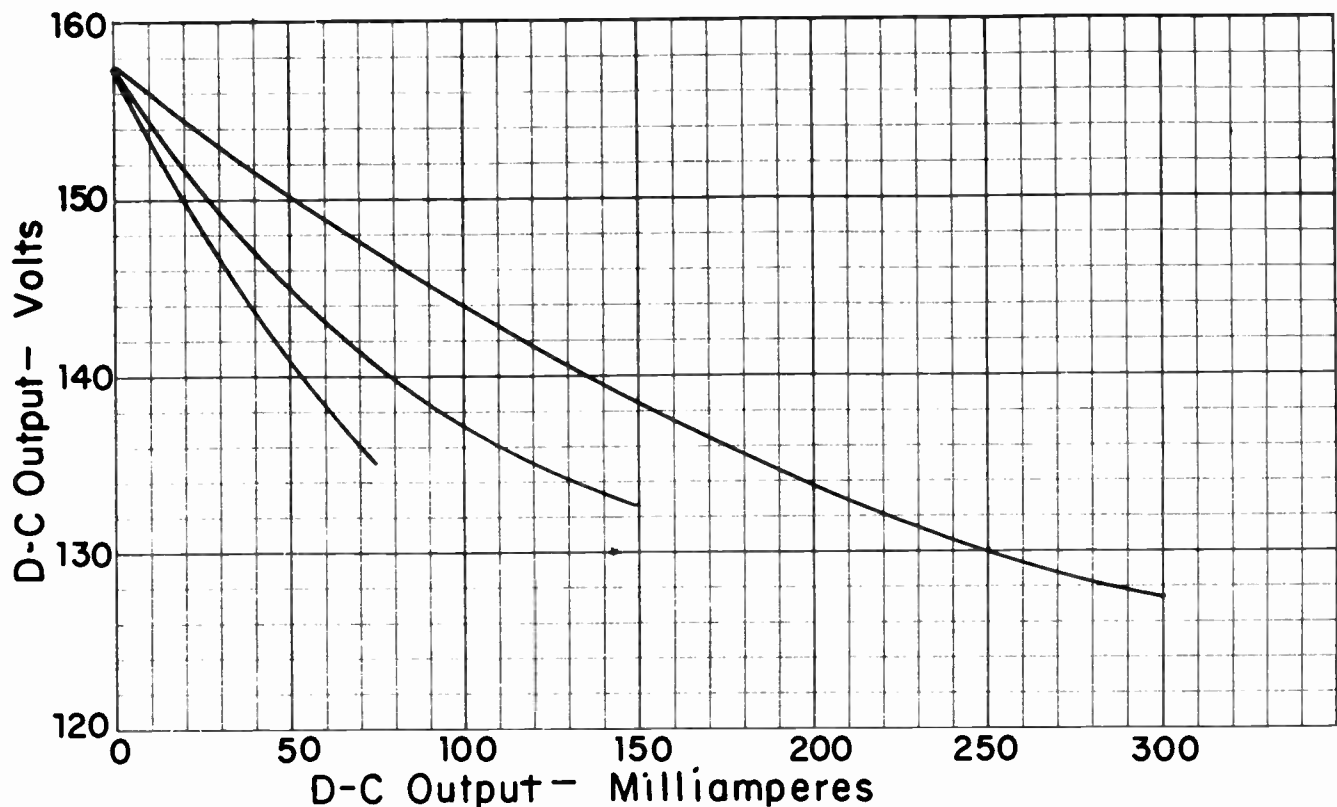

Fig. 5. How d-c output voltage changes when there is variation of output current from selenium rectifiers of various maximum current capacities.

values at the right-hand ends of the curves. It is apparent that voltage regulation is better with the larger sizes of rectifier, since curves for the greater current capacities have less slope than those for smaller sizes. Regulation is somewhat better when the output is at relatively large currents rather than smaller currents, with the same rectifier.

Fig. 6 shows how voltage output and regulation are improved by using larger input filter capacitances. The three curves are for the same rectifier and same load, but with filter capacitances varying from 50 mf to 150 mf. Note especially that large capacitance not only improves the voltage regulation, as indicated by less slope in a curve, but it also causes a material increase of output voltage when line voltage remains unchanged. At 200-ma output a 100-mf capacitor allows about 10 per cent more voltage than a 50-mf size. When changing from 100-mf to 150-mf capacitor size, the additional increase of output voltage is only about 2 per cent.

The chief enemies of selenium rectifiers are high temperatures and current

overloads. As mentioned before, excessive temperature due to incorrect mounting and lack of air circulation will materially shorten the useful life of the rectifier. When rectifiers are attached to chassis metal with mountings of substantial size, and are not too far from the metal, the chassis helps carry away and distribute heat from the rectifier and keeps the temperature down.

Short circuiting or excessive current leakage through the filter capacitors will overload and overheat the rectifier in the same way that such faults would overload a rectifier tube. Contact rectifiers, which are on the verge of failure may cause popping noises after the receiver has operated for a short time. There may also be a disagreeable odor from the rectifier.

When checked with an ohmmeter connected first in one polarity and then in the opposite polarity, a selenium rectifier in good condition will show 10 to 100 times as much resistance one way as the other. A shorted rectifier will have approximately the same resistance in both directions. An ohmmeter test will indicate complete failure of a

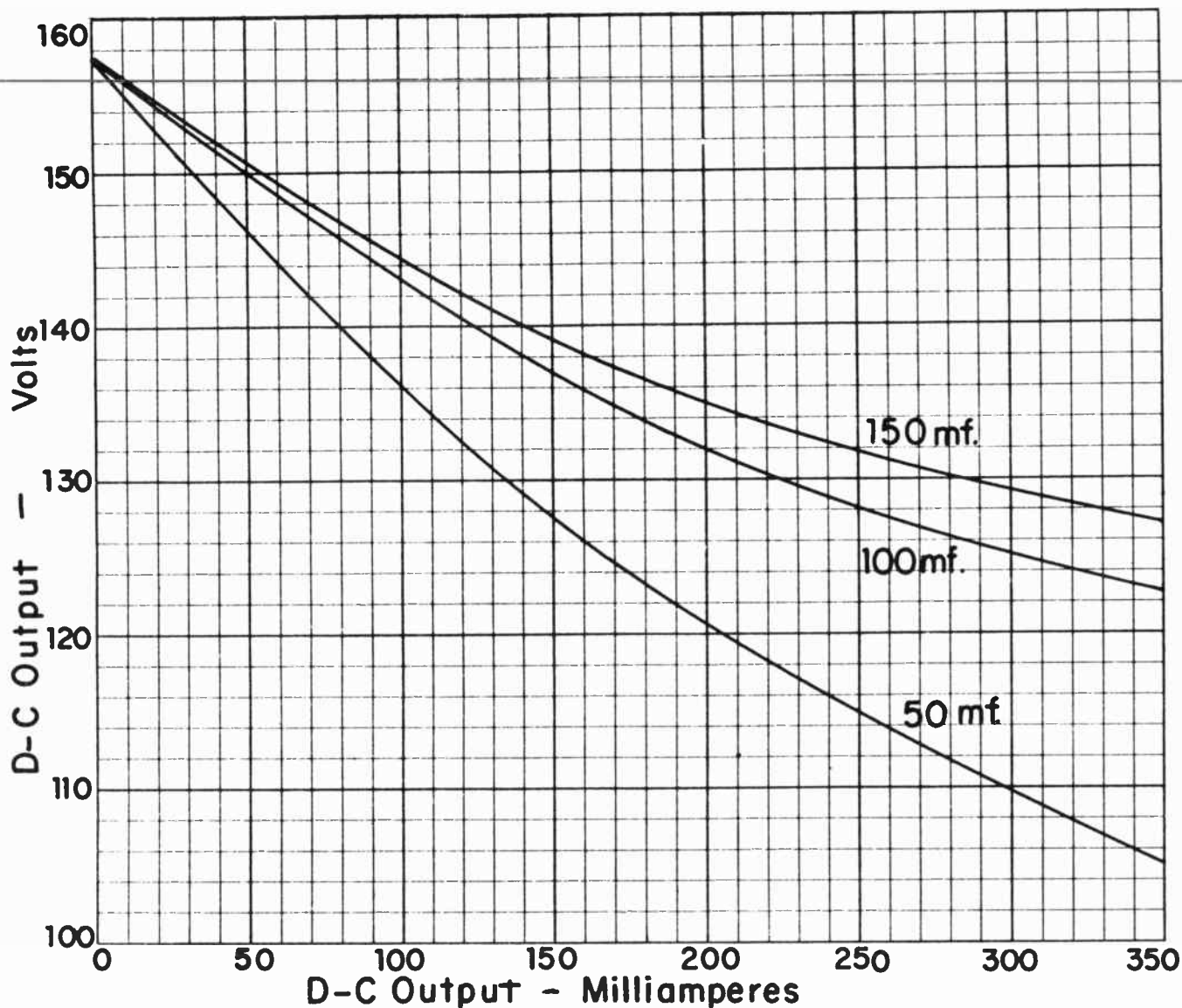

Fig. 6. How the value of a-c output voltage and also the voltage regulation are affected by various values of capacitance at the filter input.

rectifier, but not its ability to operate satisfactorily. This is because there is no current load and only a low voltage on the rectifier.

Tests for rectifying ability usually are made by connecting the rectifier into a circuit such as shown by Fig. 7. Load resistance R and capacitor C are of such values as allow d-c output current equal to or slightly in excess of the d-c current rating of the rectifier tested, assuming a unit in good condition, when d-c output voltage is 125 to 130. If the d-c voltmeter indicates voltage much more than 10 per cent low or high, the rectifier may be considered as defective.

#### SELENIUM RECTIFIER CIRCUITS.

What might be called the basic half-wave circuit for a d-c power supply employing a selenium rectifier is pictured by Fig. 8. The rectifier unit is in exactly the same relative position as a half-wave vacuum tube rectifier in a generally similar circuit. The negative terminal of the rectifier is toward the a-c power line, as would be the plate of a rectifier tube. The positive terminal of the selenium rectifier is toward the filter, as would be the cathode of a vacuum tube rectifier. The filter resistor and capacitors are no different than similar parts used with a tube rectifier.

## LESSON 15 – CONTACT RECTIFIERS AND VOLTAGE MULTIPLIERS

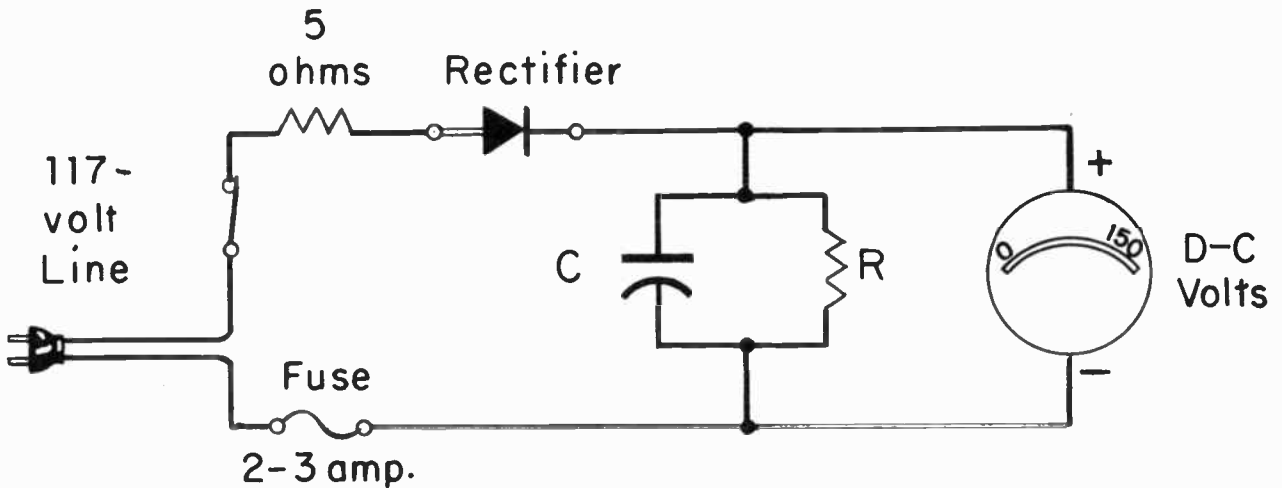

Fig. 7. A circuit used for testing the performance of selenium rectifiers.

It is worth noting that an input filter capacitor of given capacitance will cause the d-c output voltage to be somewhat higher with a selenium rectifier than with a vacuum tube rectifier. This is because the voltage drop in the five-element selenium unit is only about 5 volts rms, or will be somewhere between 4.5 and 6.5 volts in rectifiers commonly employed for receivers. This is less than the drop in a vacuum tube rectifier, and allows the first filter capacitor to charge more nearly to the peak value of a-c line voltage.

The surge resistor shown in series with the selenium rectifier in Fig. 8 and also in Fig. 1 is for the purpose of reducing the peaks of rectified voltage and current, and thus giving protection to both the rectifier and the first filter capacitor. When there is no fuse on the a-c input side of the rectifier circuit this surge resistor may burn out in case of a short in or beyond the filter, and thus will prevent continued excessive current from flowing in the rectifier and the filter. Replacing a surge resistor is much less costly than replacing a rectifier.

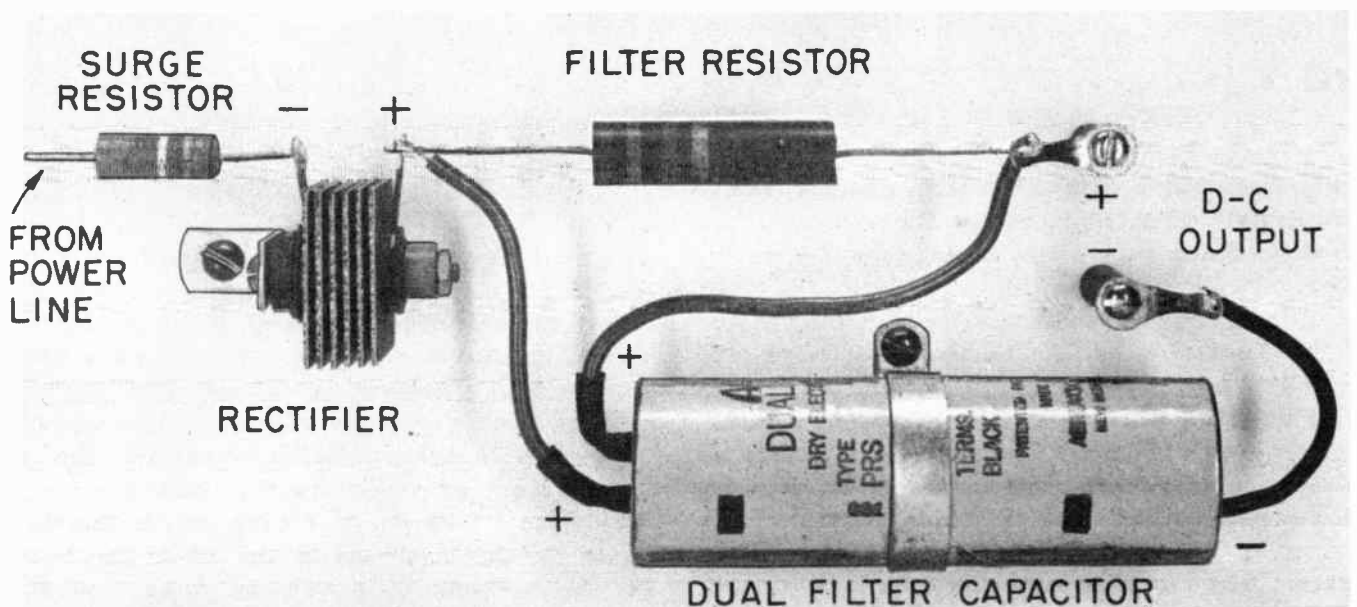

Fig. 8. The principal parts of a d-c power supply using a selenium rectifier.



# COYNE - television home training

The surge resistor ordinarily is of such value, in ohms, that if considered to carry only the maximum rated d-c output current of the rectifier the drop in the resistor would be at least 1.5 to 2.5 volts. That is to say, dividing a number between 1,500 and 2,500 by the rated d-c current in milliamperes will give the approximate minimum ohms for the surge resistor. As an example, consider a rectifier rated for maximum output of 100 ma. Dividing 1,500 by 100 (ma) gives 15, and dividing 2,500 by 100 (ma) gives 25. Then the surge resistance should be at least 15 to 25 ohms, and often is more. Of course, a resistor used for replacement should be of the same number of ohms and of the same wattage rating as the original. Only when the correct resistance is unknown should our rough rule be employed.

Although a surge resistor may burn out and protect other circuit elements in case of severe overload, it is common practice to have a regular fuse in series with one side or other of the a-c power line, as shown by Fig. 7. This is because a shorted contact rectifier may carry current so great as to raise cir-

cuit wiring to temperatures which can cause a fire.

Fig. 9 shows the d-c power supply connections and the series heater string for a transformerless receiver in which the rectifier is a selenium type. The 27-ohm surge resistor is on the positive side of the rectifier instead of on the negative side as in other illustrations. The filter is a two-section R-C type with the high-voltage high-current output from the end of the first section, and the low-voltage low-current output from the second section. Such dual outputs have been explained previously.

When the power rectifier is a selenium type the pilot lamp or lamps may be in various circuit positions, since there is no rectifier heater across part of which a lamp may be connected. In the present diagram the pilot lamp is in parallel with a resistor, with the lamp and its resistor in series with the tube heaters. When the lamp is hot its resistance is about 52.5 ohms, which, in parallel with the 120 ohm resistor, gives a parallel resistance of 36.5 ohms. With 150

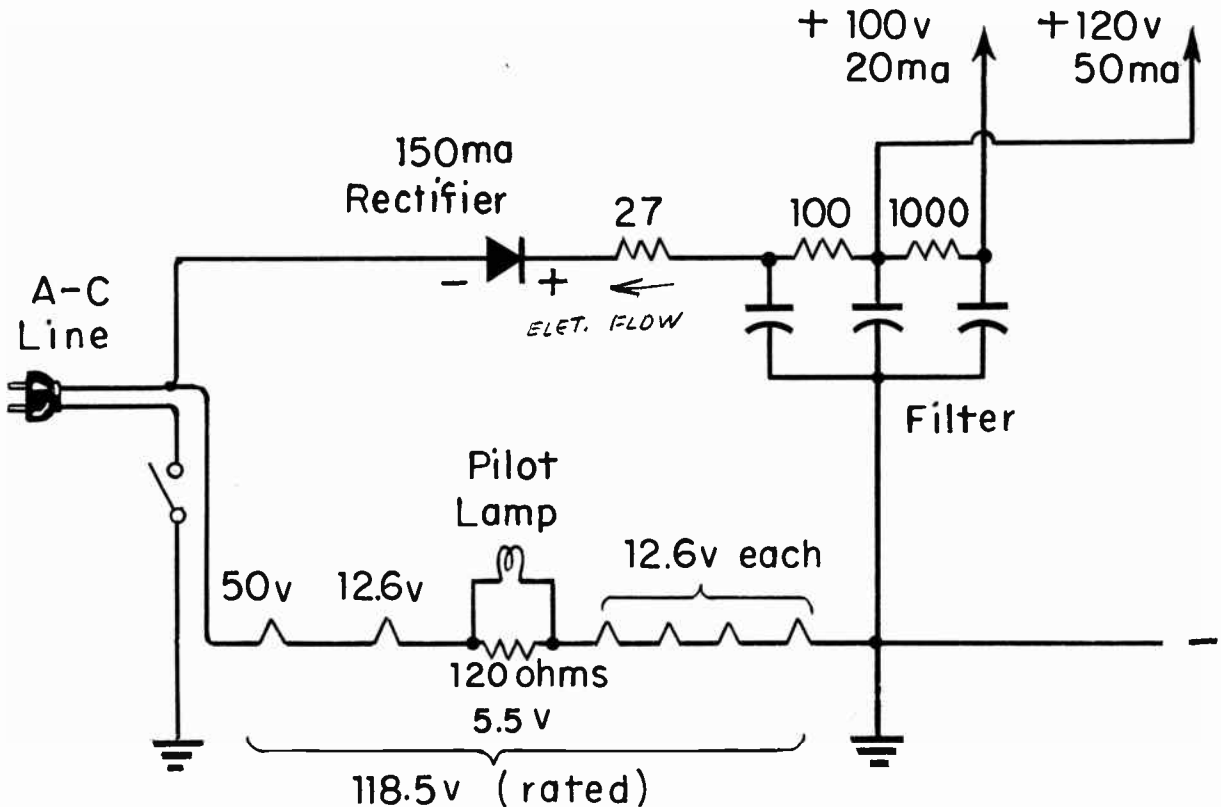

Fig. 9. A pilot lamp connected into the series heater string.

## LESSON 15 — CONTACT RECTIFIERS AND VOLTAGE MULTIPLIERS

ma of heater current in this parallel resistance the drop lamp and resistor is about 5.5 volts. Total across rated voltages drop in the series heaters and the lamp connection is 118.5 volts.

Fig. 10 illustrates another pilot lamp connection which may be used when there is a selenium power rectifier. Here there are two lamps in series with each other and paralleled by a 66-ohm resistor. Lamp resistance is about 105 ohms, and the parallel resistance is about 40.5 ohms. The lamps and resistor carry not only the 150 ma current for the series heaters, but also the current which goes through the rectifier. Total current is about 270 ma, with which there is a drop of about 11 volts across the lamp circuit. This, added to the rated drop of 107.8 volts in the heater string, makes a total of 118.8 rated volts.

**VOLTAGE MULTIPLIERS.** The output voltage from a transformerless power supply using a single rectifier never can be more than the peak value of a-c line voltage, even when no current is being furnished to a load. When direct current to the load is half the rated maximum for the rectifier employed, and power is taken from a 117-volt a-c line,

the d-c output voltage will be in the neighborhood of 130 to 135 at best.

This is not enough d-c voltage for many of the tubes in television receivers and in the larger radio sets. To obtain higher d-c voltage without using a power transformer we may resort to voltage multiplying, by means of two or more rectifiers and two or more capacitors.

With a voltage doubler circuit, employing two half-wave rectifiers and two capacitors, it is possible to obtain d-c output voltage of approximately twice the a-c line voltage. With a voltage tripler, using three rectifiers and three capacitors, the d-c output voltage will be about three times the a-c line voltage. In a few special applications we find voltage quadruplers, giving about four times the line voltage. But when quadrupling, the efficiency and the voltage regulation become quite poor, and when attempting any greater multiplication of line voltage the results are not worth the cost of extra parts.

Either vacuum tube types or selenium rectifiers may be used in voltage multiplying circuits. We shall commence with the selenium circuits because diagrams appear sim-

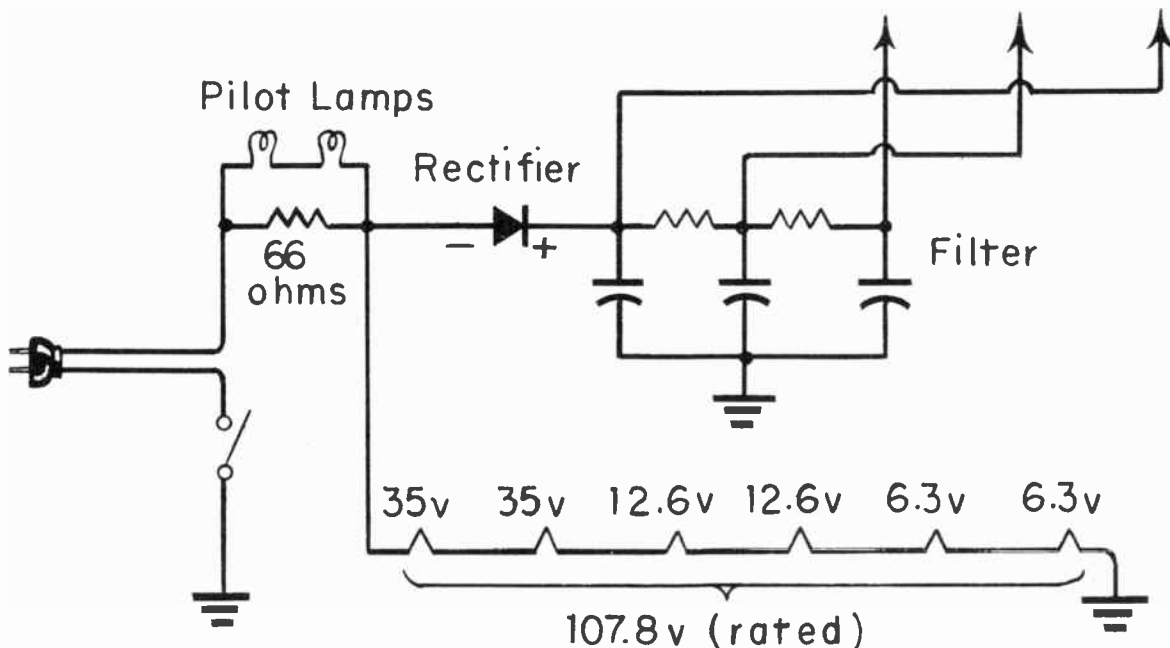

Fig. 10. Pilot lamps paralleled with a resistor, carrying current for both the rectifier-filter system and the series heater string.

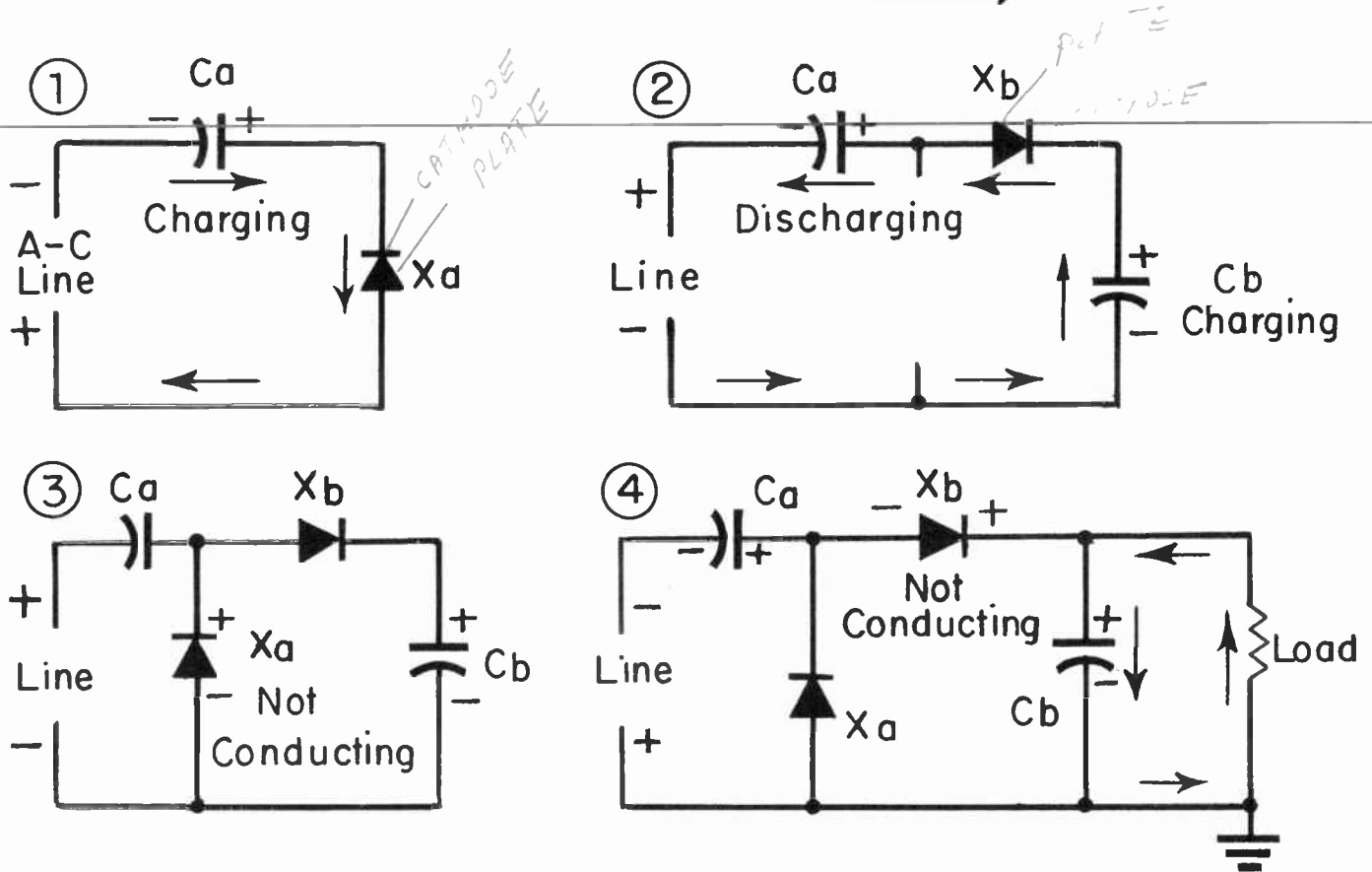

Fig. 11. Action in a half-wave voltage doubler.

pler and are somewhat easier to understand than when showing vacuum tubes.

**VOLTAGE DOUBLERS.** At 1 in Fig. 11 we have in series on the a-c power line a capacitor  $C_a$  and a selenium rectifier  $X_a$ . During half of one a-c cycle the upper end of the a-c line is made negative and the lower end positive. The rectifier is so connected into the circuit that it conducts with this relation of line polarities. Resulting electron flow is in the direction of the arrows. This flow charges capacitor  $C_a$  to a negative potential on the side toward the line, and to a positive potential on the side toward the rectifier. The capacitor will charge to a potential difference or voltage somewhere near the peak value of a-c line voltage.

In diagram 2 we have temporarily removed rectifier  $X_a$  and have connected in series with capacitor  $C_a$  another rectifier  $X_b$  and a second capacitor  $C_b$ . We shall assume that a-c line voltage has gone to a following half-cycle and that the line polarity is re-

versed. Now the upper end of the power line is positive and the lower end negative.

Electron flow with this changed polarity is in the direction of arrows in diagram 2. Rectifier  $X_b$  is conducting, and capacitor  $C_b$  is being charged to make its lower plate negative and its upper plate positive. This capacitor is being charged by line voltage. But it is in series with capacitor  $C_a$ , which already is charged to approximately line voltage. Therefore, the second capacitor,  $C_b$ , is being subjected to line voltage plus the voltage to which  $C_a$  was charged during the preceding half-cycle. The result is that capacitor  $C_b$  is charged to approximately double the value of line voltage.

In diagram 3 we have replaced rectifier  $X_a$  while still having the line polarity of diagram 2. The arrowhead side of rectifier  $X_a$  is made negative. This side of the selenium rectifier corresponds to the plate of a rectifier tube. The bar end of the selenium rectifier is positive. This side of the rectifier

## LESSON 15 – CONTACT RECTIFIERS AND VOLTAGE MULTIPLIERS

corresponds to the cathode of a tube. Consequently, rectifier Xa cannot conduct with the line polarity as shown in diagrams 2 and 3, and it is as though this rectifier were not present.

Now look at diagram 4. We have returned to the line polarity of diagram 1. With this polarity applied to rectifier Xb that rectifier cannot conduct, for the same reason that Xa does not conduct in diagram 3. But capacitor Cb has been charged to nearly double the peak of line voltage, and with Xb nonconductive there is nowhere for this charge to go except through the load. Electron flow from capacitor Cb through the load is as shown by arrows.

The circuit whose performance has been examined is that of a half-wave voltage doubler. The frequency of ripple voltage is the same as the line frequency, as with an ordinary half-wave rectifier. As shown by diagram 4 of Fig. 11, the negative side of the load and one side of the a-c line may be grounded to the chassis. It would be possible

also to use a floating ground. Although surge resistors are not shown in the diagrams, they should be used. A single surge resistor may be connected between one side of the line and capacitor Ca. Two surge resistors may be used, with one of them connected to the negative terminal of one rectifier and the other to the negative terminal of the second rectifier.

It is apparent from the diagrams that the half-wave voltage doubler cannot employ a dual electrolytic capacitor with a single common negative terminal, since the negative sides of the two capacitors are not connected together. The first capacitor, Ca, need withstand only peak voltage from the line, and usually is of 150-volt rating. The second capacitor, Cb, must withstand nearly double the line peak, and commonly has a rating of 250 volts as a minimum.

Fig. 12 illustrates the operating principle and an application of a full-wave voltage doubler. There are two rectifiers and two capacitors, connected to the a-c line as shown by the diagrams. At 1 the upper side

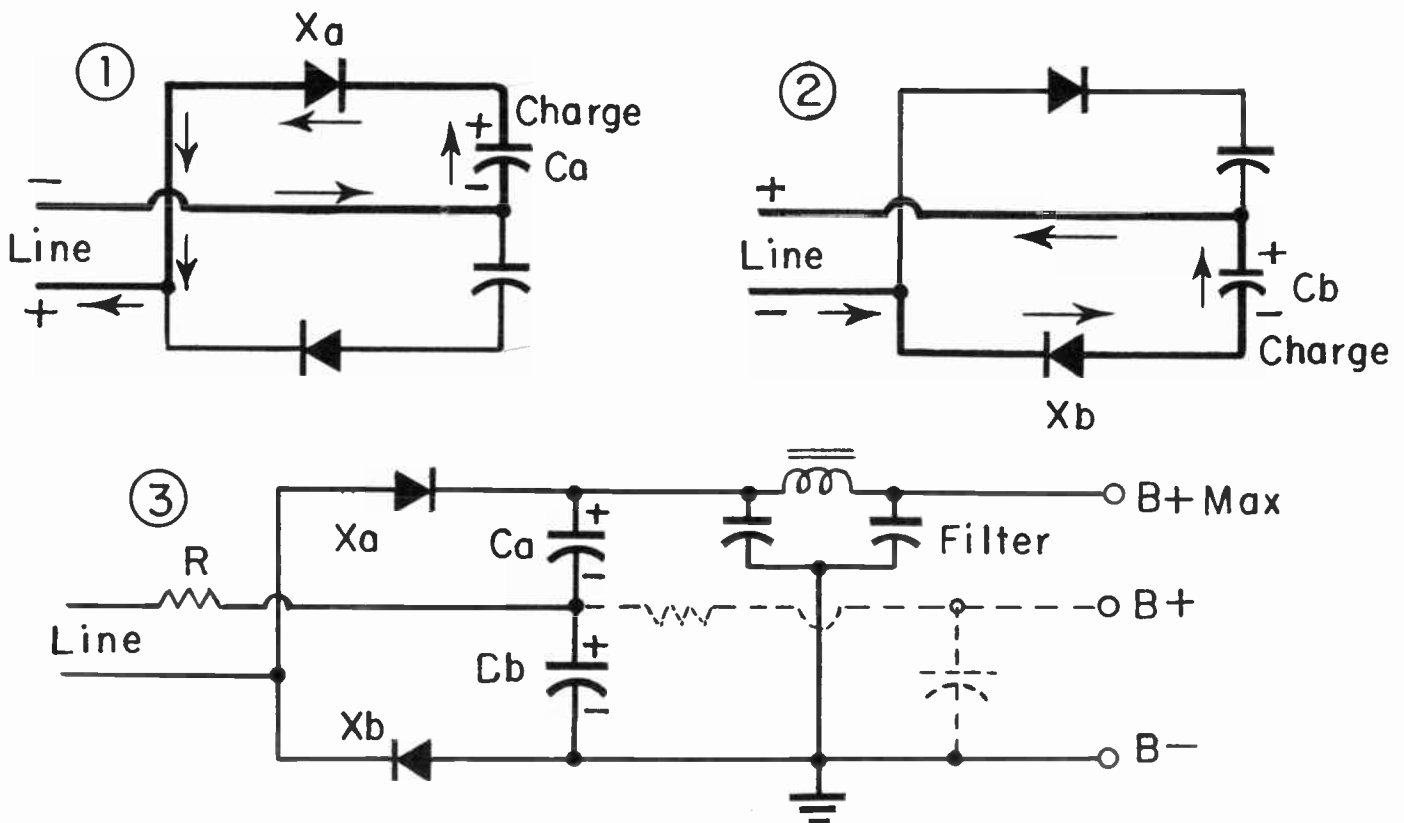

Fig. 12. Action in a full-wave voltage doubler.



# COYNE - *television home training*

of the a-c line is assumed to be negative during half of one cycle. With this polarity on both rectifiers only the one marked Xa can conduct. You will recall that electron flow can be only in a direction opposite to that in which the arrowhead of the symbol is pointing. The electron flow in the direction of the arrows charges capacitor Ca to make its lower plate negative and the upper one positive, as marked.

When line polarity reverses during the other half of a cycle, as shown by diagram 2, only the rectifier marked Xb can conduct. The resulting electron flow, indicated by arrows, charges capacitor Cb to make its lower plate negative and its upper plate positive. The result of all this is to charge one capacitor during one half of each a-c cycle of line voltage, and to charge the other capacitor during the other half of each cycle.

The two capacitors are connected to the output or to the load as shown by diagram 3. So far as the load is concerned the two capacitors are in series with each other. The polarities of the capacitor charges are in the same direction, both positive sides are up and both negative sides are down in the diagrams. Consequently, the capacitor voltages add together, and since each one has been charged to somewhere near the peak value of a-c line voltage the sum is approximately twice the line voltage.

Maximum d-c output voltage of the full-wave doubler is taken from between the terminals marked B+ Max and B- of diagram 3. It is possible also to take another d-c voltage of about half the maximum from a tap between the two capacitors, as shown by the broken-line connections. This intermediate voltage has half-wave characteristics, such as ripple at line frequency rather than at twice line frequency.

Compared with the half-wave doubler the full wave type will have slightly less ripple voltage, better voltage regulation, and will have a ripple at twice the line frequency instead of at line frequency, which makes for easier filtering. These features are common to all full-wave rectifier systems as compared with half-wave types.

With the full-wave doubler neither side of the a-c line may be directly connected to the negative side of the d-c output, although the d-c side may be grounded to the chassis or connected to a floating ground. The two capacitors should have as nearly as possible the same characteristics in order to divide the load equally between the two rectifiers. This is not so important with the half wave doubler. It is usual practice to use only a single surge resistor in the full-wave circuit, as shown at R of diagram 3.

Fig. 13 shows at the left the ripple voltage from a half-wave doubler system, and at the right the ripple from a full-wave doubler system. The two circuits were made up with the same rectifiers, the same capacitors, and the same load, connected first for half-wave operation and then for full-wave operation. The ripple voltage actually is not so great as these photographs indicate, since the oscilloscope was used at rather high gain in order to bring out the features.

VOLTAGE TRIPLER. In diagram 1 of Fig. 14 the full-line connections and parts show the voltage doubler of Fig. 11. The rectifiers and capacitors are lettered alike in both figures. The positive d-c output terminal of the doubler system is at A in Fig. 14, and the negative d-c output is at B. By adding one more rectifier at Xc and one more capacitor at Cc we have a voltage tripler.

Action in the doubler portion of the new circuit is the same as previously explained. Capacitor Cc is charged by conduction through rectifier Xc, and the charge voltage is added to the output of the doubler circuit to provide a d-c output voltage approximately three times the a-c line voltage. The output ripple is at line frequency, so this circuit might be called a half-wave voltage tripler.

The tripler circuit is not usually shown by a diagram similar to 1 in Fig. 14, but more often in some such manner as at 2. Here there have been added surge resistors at R and R. All other parts are similarly lettered in both diagrams, and all connections are electrically alike. It will be good practice to trace the connections and make sure of their similarity, since oftentimes it is

## LESSON 15 – CONTACT RECTIFIERS AND VOLTAGE MULTIPLIERS

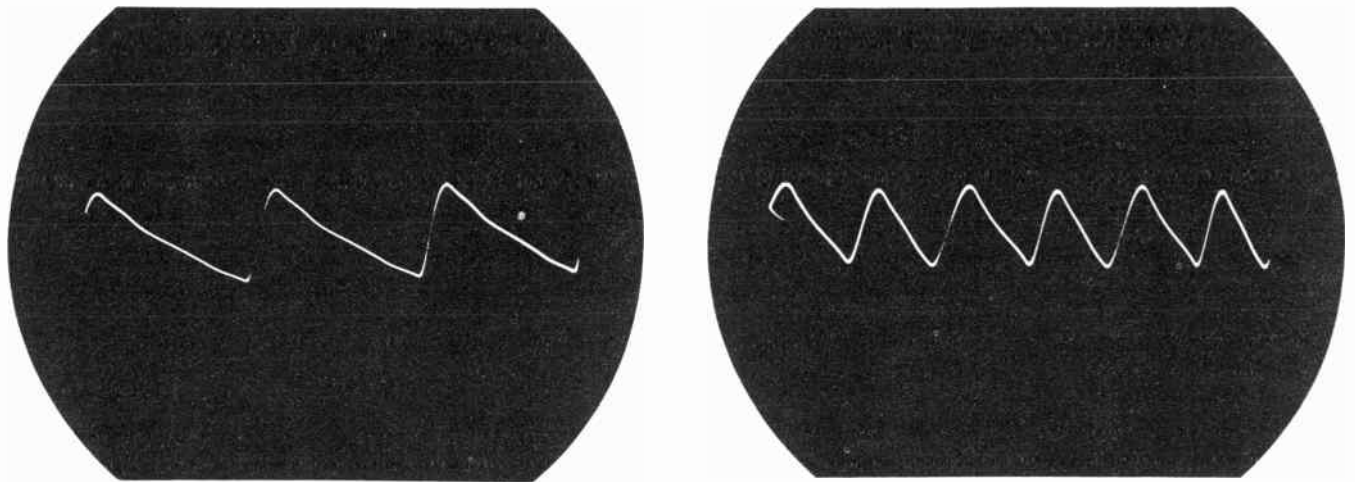

Fig. 13. Ripple voltages from a half-wave doubler (left) and from a full-wave doubler (right) in which the same units are employed.

necessary to recognize various fundamental circuits, no matter how differently they may be shown by service diagrams.

With a tripler system it is possible to obtain three different d-c output voltages. The lowest voltage, equal to that from a single half-wave rectifier, is taken from between rectifiers Xa and Xb. A higher d-c voltage, equal to that from a doubler, may be taken from between rectifiers Xb and Xc. The highest voltage, the actual tripler output, is from a point following rectifier Xc.

To make a voltage quadrupler we might commence with the tripler circuit of Fig. 14 and add still another rectifier and capacitor, as these two units were added to the doubler

circuit in order to make a voltage tripler. Another way is to use two voltage doublers in series with each other, so that their d-c output voltages add together. As mentioned earlier, quadrupler circuits seldom if ever are found in receiver power supplies.

**VOLTAGE MULTIPLIERS WITH TUBE RECTIFIERS.** With two half-wave vacuum rectifiers and two capacitors it is possible to make either a half-wave or a full-wave voltage doubler. The two rectifiers for receiver power supplies are the two sections of a tube in which are two plates and two separate cathodes. Separate sets of elements are required because neither the plates nor the cathodes may be connected together in a doubler circuit.

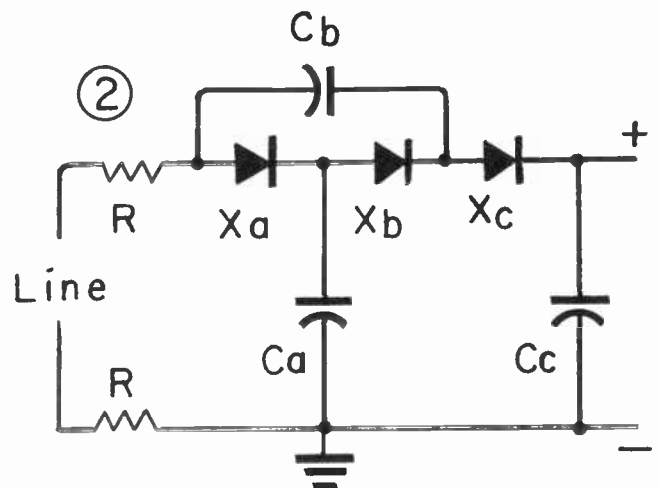
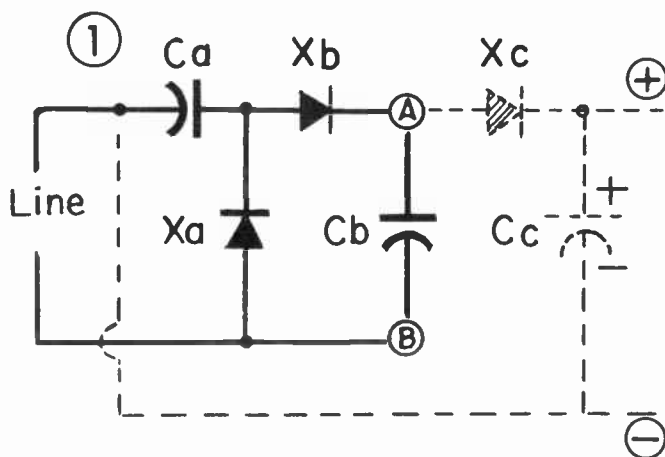

Fig. 14. Connections for a voltage tripler using contact rectifiers.

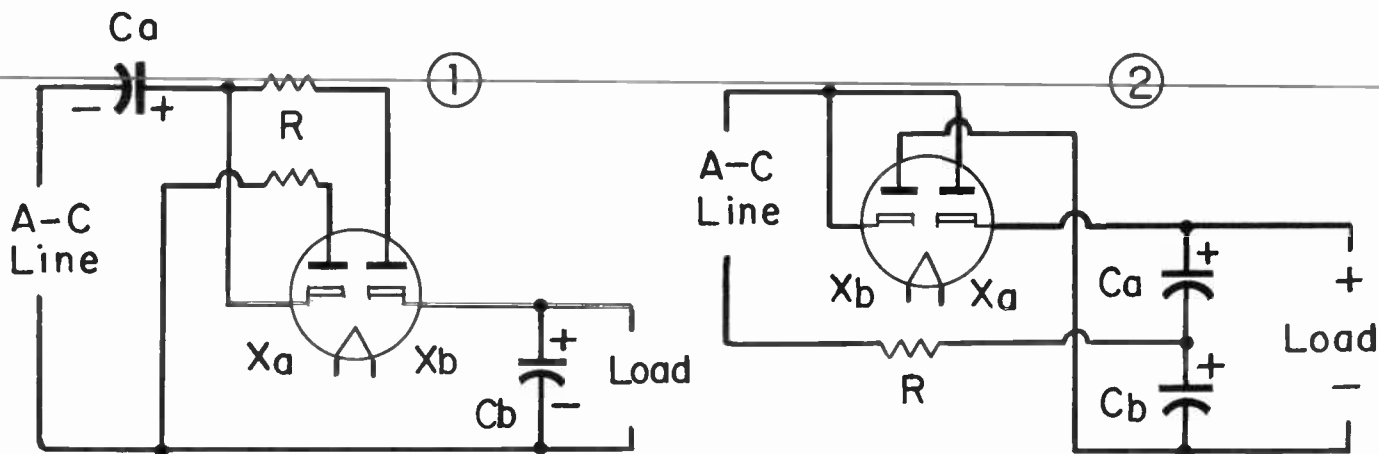

Fig. 15. Vacuum tube rectifiers in a half-wave voltage doubler (1) and in a full-wave doubler (2).

Diagram 1 of Fig. 15 shows connections for a half-wave voltage doubler constructed with a vacuum tube rectifier of a type designed for the purpose. The two sections of the rectifier are lettered to correspond with the two separate rectifiers in the half-wave doubler of Fig. 11. The explanation previously given for the doubler with contact rectifiers applies to the type using the vacuum rectifier tube, in spite of the fact that the two diagrams appear quite dissimilar.

Diagram 2 of Fig. 15 shows connections for a full-wave voltage doubler employing the two sections of a vacuum rectifier. Again the lettering of parts for this style of doubler is like that for the doubler using contact rec-

tifiers as shown in Fig. 12, and the explanation of how the action proceeds applies equally well to both styles of apparatus. The diagrams appear quite unlike, but the principles are unchanged.

Fig. 16 shows a method of connecting a pilot lamp in parallel with part of the heater in a rectifier tube used in a full-wave voltage doubler circuit. Connections for the lamp are practically the same as those used with simple half-wave rectifier circuits, while the voltage doubling features are like those of the circuit in diagram 2 of Fig. 15.

Fig. 17 shows basing connections of tubes which are designed for use as rectifier-

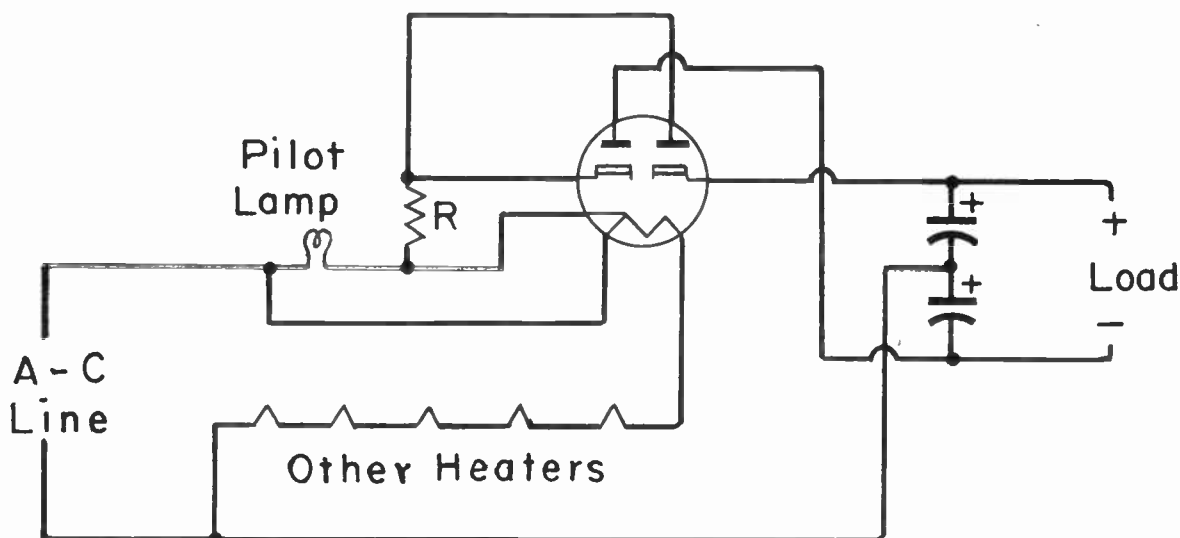

Fig. 16. A pilot lamp in parallel with part of the heater of a rectifier-doubler tube.

## LESSON 15 – CONTACT RECTIFIERS AND VOLTAGE MULTIPLIERS

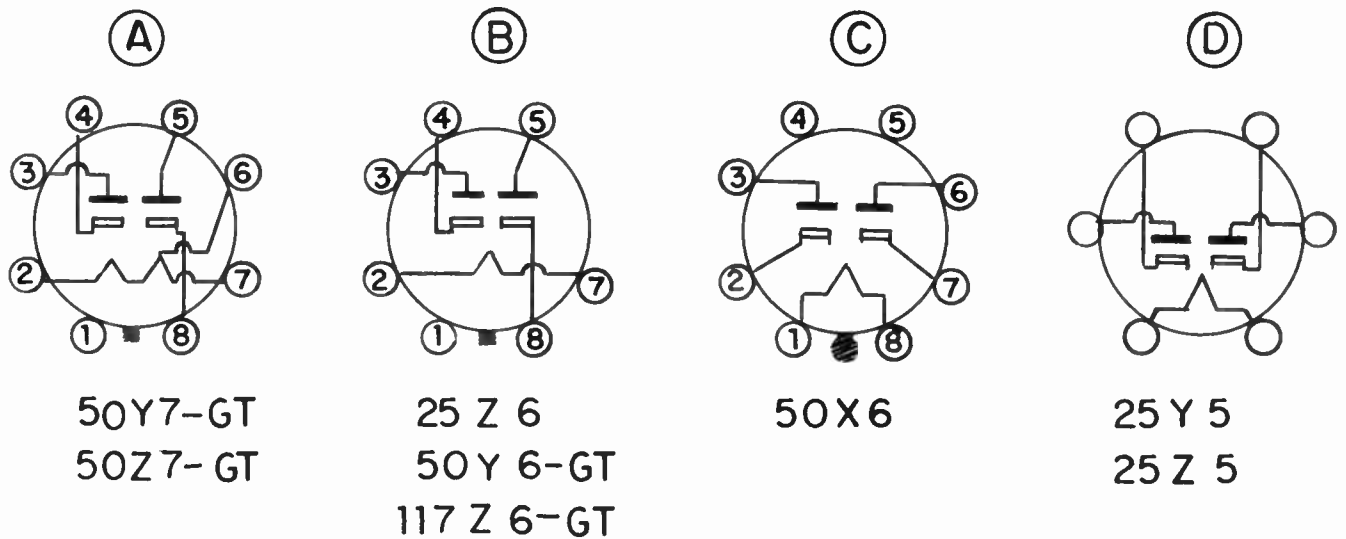

Fig. 17. Basing connections for rectifier-doubler tubes.

doublers. All have two plates and two cathodes, with separate base pins for all four elements. At A is an octal base with pins in all eight positions. At B is an octal base with only seven pins. The base at C is a lock-in type with eight pins, of which two have no internal connections. An older style six-pin base is shown at D. The two heater pins are larger than the other four, which makes it impossible to insert the tube other than in the correct position in the socket. Under each symbol are the type numbers of tubes made with that basing.

These rectifier-doubler tubes have maximum d-c outputs of 60 to 75 ma. All those rated for 25 volts take 300 a-c ma for heaters, those rated for 50 volts take 150 ma for the heater, and the 117 volt tube takes 75 ma for its heater. Any of these tubes may be used not only as voltage doublers, but also as full-wave rectifiers with a center-tapped transformer secondary, or as half-wave rectifiers with the two plates connected together and the two cathodes connected together to form the equivalent of a single rectifier with double the d-c current rating of either section used alone.

In some voltage doubler systems and in quite a few voltage triplers you will find vacuum tubes and selenium rectifiers used together. The selenium units are in the lower voltage positions, closer to the a-c line side, while the vacuum tubes are in the

higher voltage positions toward the d-c output.

**VOLTAGE REGULATION OF MULTIPLIERS.** In Fig. 18 are shown typical voltage regulation curves for a voltage tripler, a voltage doubler, and a single half-wave rectifier. All three curves are made with the same type and size of rectifier in all positions, and with the same values of capacitance. The better the voltage regulation or the less the change of voltage with variation of output current, the less is the degree of slope in a voltage regulation curve. It is apparent that regulation is poorest with the tripler system, is better with the doubler, and is still better with a simple half-wave rectifier.

Voltage regulation is important, because in any receiver using heavy-duty amplifier tubes which handle strong signals there will be very considerable variations of plate current as the signal voltage changes from instant to instant. The effect of poor regulation ordinarily is worse in small receivers than in large ones, since in the small receiver there is likely to be only one amplifier which take much more direct current and voltage than all the other tubes put together. In a large receiver there will be a greater total number of tubes, and variations of current in the heavy-duty amplifiers will have less effect on the total current taken from the d-c power supply.



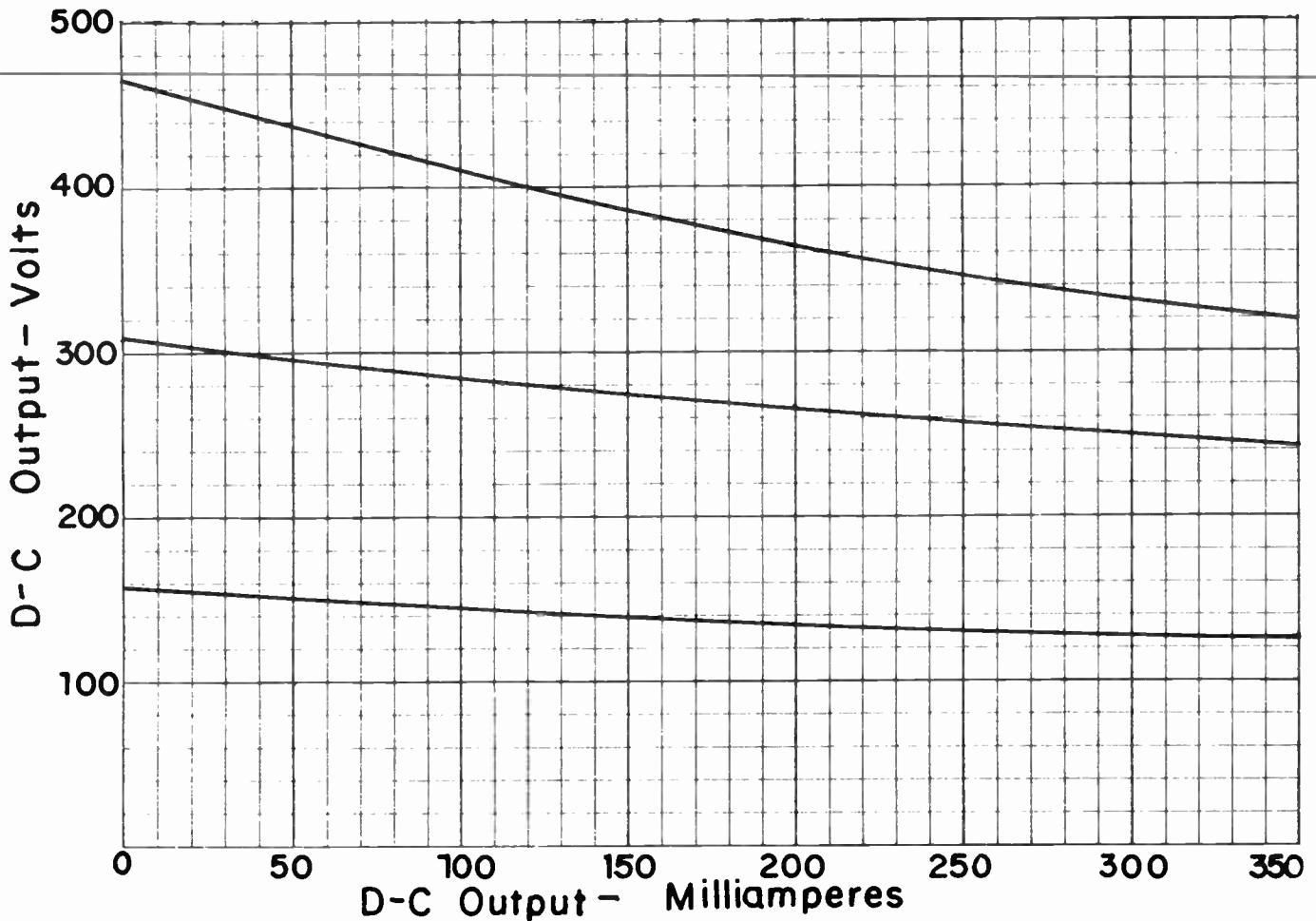

Fig. 18. Voltage regulation curves for a tripler, a doubler, and a single half-wave rectifier, all used with the same filter input capacitance.

When an increase of current to receiver tubes drops the power supply output voltage there is, of course, a similar drop of voltage at the receiver tubes. When tube voltage goes down it means that tube current must decrease. Consequently we have a condition in which an original increase of current to receiver tubes acts on the power supply to cause a decrease of receiver tube current. The real effect is to limit the amount by which signal current can vary in the amplifier tubes, and we do not obtain the full degree of amplification which the tubes should provide.

As we have learned before, voltage regulation of any power supply system is improved by using greater capacitance in the filter capacitors. Where filter capacitance of 40 to 50 mf might give satisfactory regulation with a simple half-wave rectifier system, it often is the practice to use 100 to 200 mf for voltage doublers and up to 300 mf or even more for voltage triplers. In this way we are able to secure satisfactory regulation while obtaining high d-c voltages in a transformerless receiver.

# LESSON 15 – CONTACT RECTIFIERS AND VOLTAGE MULTIPLIERS

## CONDENSED INFORMATION

### Mountings for selenium rectifiers.

Should be strong and rigid.

Allow for air circulation.

Fins to be vertical.

Fins must not have possibility of touching any other conductors.

Rectifier not close to other high-wattage units, nor to capacitors, inductors, or wire insulation.

Rectifier not located close to circuits or parts of the sound system.

### Causes for trouble in contact rectifiers.

Usually a continued current overload, or excessive operating temperature.

### Symbol for contact rectifier.

When symbol is correctly drawn, electron flow is in a direction opposite to that in which the arrowhead points.

### Surge resistor.

Purpose is to decrease the peaks of input voltage and current, especially during the warm up period.

May act as a fuse, burning out on continued current overloads.

Minimum ohms =  $\frac{\text{some number between 1500 and 2500}}{\text{maximum rated rectifier output, d-c milliamperes}}$

Voltage Doubler Characteristics		
	<u>Half-wave</u>	<u>Full-wave</u>
<u>Output</u>	Only one d-c voltage at output:	Two d-c voltages available, one a half-wave type.
<u>Ripple voltage</u>	At line frequency.	At twice line frequency.
<u>Regulation</u>	Fairly good with large filter capacitances.	Better, with same filter capacitances.
<u>Capacitors</u>	Need not be exactly alike.	Should have identical characteristics.
<u>Line connection</u>	May go directly to B- of d-c output, or to chassis ground.	Must not go directly to B-side of output circuit.

# TELEVISION

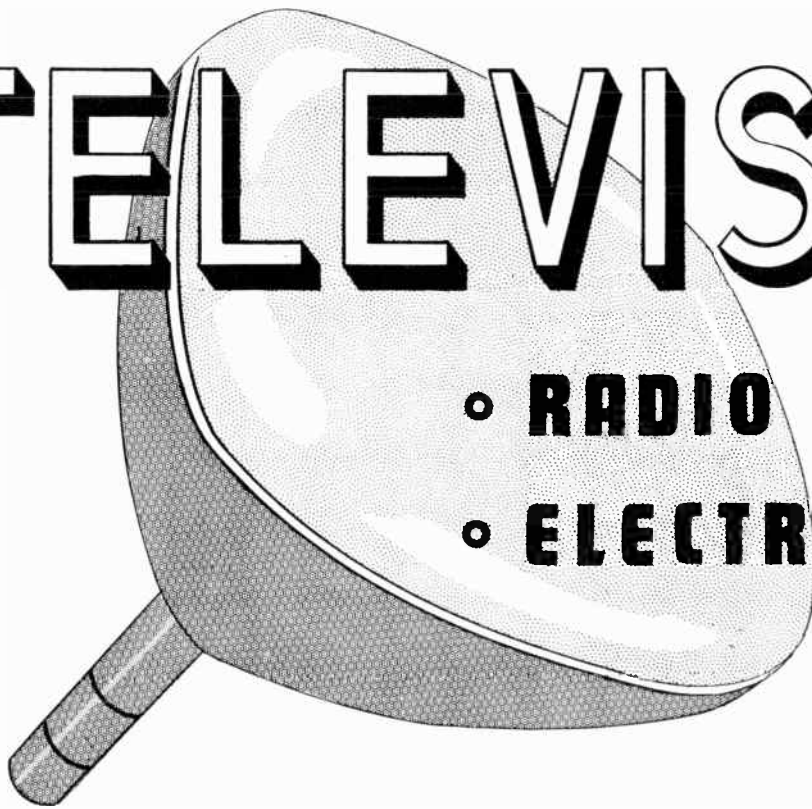

• RADIO

• ELECTRONICS

---

---

## LESSON 16 – ELECTRONIC TUBES

---

---

***Coyne School***

*practical home training*

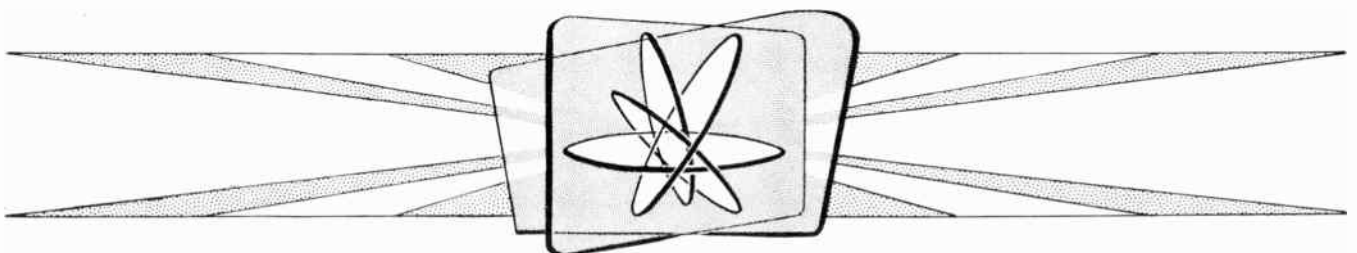

*Chicago, Illinois*

---

Copyright 1953 by Coyne School  
Chicago 12, Illinois  
All rights reserved

Litho. in U.S.A.



*Lesson 16*  
**ELECTRONIC TUBES**

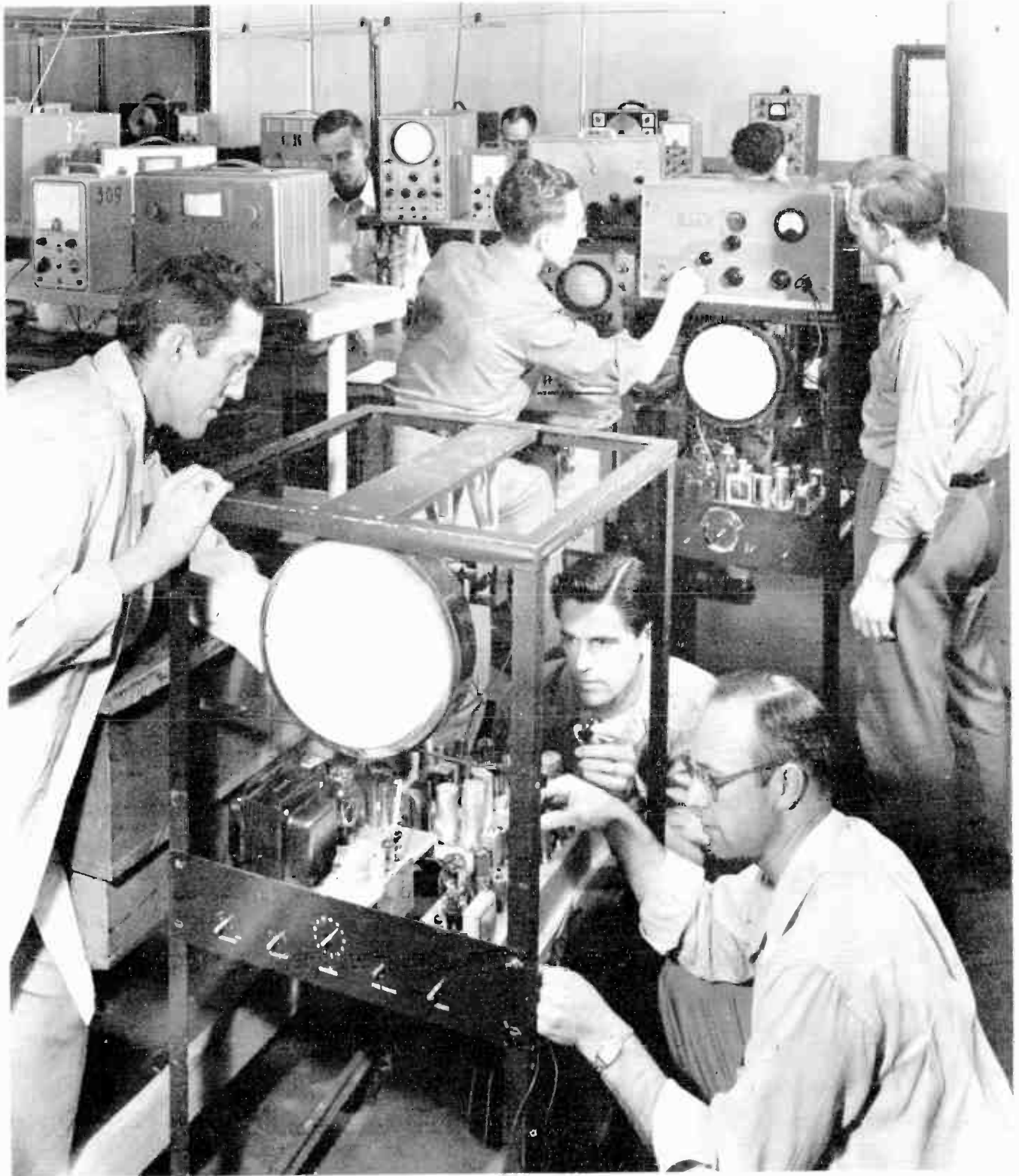

*Fig. 1. These test racks in the Coyne School allow rapid checking of all tubes and circuits in television receivers.*

## COYNE - *television home training*

The speediest camera shutter can start and stop a ray of light within a thousandth of a second. While the shutter is acting once, a television or radio tube can start and stop an electric current a million times. In addition to being the fastest of all known control devices, the tube has other exclusive advantages. It doesn't vibrate. It contains no moving mechanical parts. It neither sparks nor arcs. It consumes no power for its operation. Furthermore, the vacuum tube can not only start and stop an electric current, it can hold the rate of flow at any desired value, or can regulate the flow between any desired limits.

All these things are possible because, inside the tube, electrons emerge from one conductor and move through space to another conductor. It is while the electrons are freed from the conductors that the most remarkable methods of control may be exercised.

The tubes in a receiver do practically all the important jobs that bring forth pictures and sound. There are amplifier tubes which strengthen signals at carrier frequencies, at intermediate frequencies, at video frequencies, at audio frequencies, and at synchronizing frequencies. Other tubes, the limiters and clippers, reduce the signal strength if it is excessive. There are oscillator, mixer, converter, and demodulator tubes which change one frequency to another, without losing the signal.

Inverter tubes can turn a signal upside down, and back again when necessary. Separators split a signal and discard portions not wanted in certain circuits. Restorer tubes match the picture tones with those of the original scenes. Damper tubes keep wriggles and twists out of the pictures. Frequency control tubes prevent pictures from sliding off the screen. Rectifier tubes produce direct currents from alternating voltages. Finally, most remarkable of all, there is the picture tube.

To do these jobs and others which are essential in television and radio reproduction there are about 650 types of receiving tubes from which to choose. Each type is

designed to do some certain kind of work or to fit into some particular circuit or mechanical arrangement better than any other type. Aside from picture tubes, which are in a class by themselves, all the others may be classified most conveniently according to the number of their active elements. An active element is an internal part which emits, collects, or controls electrons which flow through the tube, it is a part which directly affects the electron flow or current in the tube.

The simplest tube contains only two active elements, separated from each other by a space from which air and gases of all kinds have been almost completely removed to leave a high vacuum. One of these elements is called a cathode. It is the element through which electrons enter the tube from external circuits, and from which electrons emerge into the evacuated space. The electrons flow through this space to the other element, which is called the plate.

All tubes contain at least one cathode and one plate. Mounted in the space between cathode and plate may be from one to six other elements. At the left in Fig. 2 is a picture of a tube from which the bulb or envelope has been removed. The outermost element is the plate which, in this particular tube, is an open-ended rectangular structure of thin sheet metal. At the very center can be seen the upper end of the cathode. Other elements are in between.

At the right is a tube in whose outer plate is a sort of window through which may be seen other elements, which are spirals of thin wire. At the center, as always, is the cathode. The outermost active element always is the plate, while the element surrounded by all the others is the cathode. A tube which contains only a cathode and a plate, with no other active elements, is called a diode.

When other elements have been removed from around it, the cathode of a typical tube appears as at the left in Fig. 3. When this cathode is heated, electrons are emitted from its surface into the evacuated space, and are drawn through this space to the plate

## LESSON 16 – ELECTRONIC TUBES

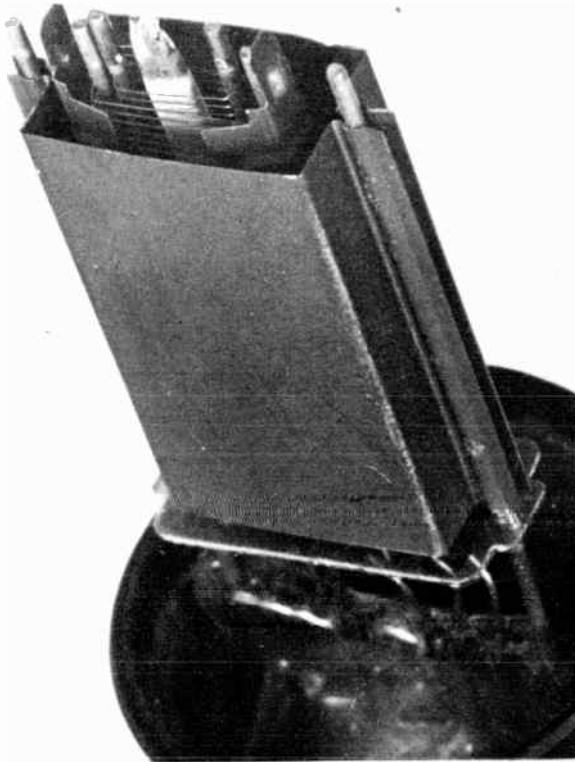
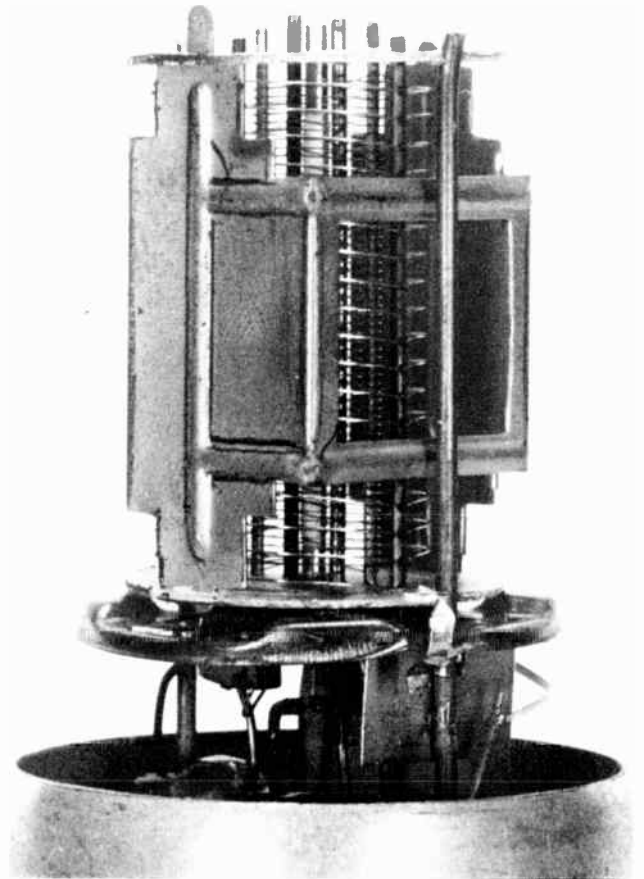

Fig. 2. Plate structures of electronic tubes. Other elements may be seen between the outer plate and the cathode at the center.



Other elements may be seen between the outer

when the plate is positive with reference to the cathode.

The cathode pictured by Fig. 3 consists of a small diameter metallic cylinder coated on the outside with a mixture of oxides or salts of strontium and barium. It is this white coating that shows so clearly in the picture. Great quantities of free electrons "boil" out through the surface when this material is heated to something like  $1,300^{\circ}$  to  $1,500^{\circ}$  F.

The metallic cylinder, and the outer coating which is the active cathode material, are heated from an insulated wire inside the cylinder. This heater wire sticks out a little way above and below the open ends of the cathode cylinder in the picture. The heater wire is made very hot, bright red, by an alternating electric current - just as the filament in a lamp bulb is made very hot by cur-

rent flowing in it. At the right in Fig. 3 is a picture of a heater from around which the cathode cylinder has been removed.

A cathode operated with a separate heater is called a heater-cathode, or sometimes an indirectly heated cathode. Such cathodes are used in the great majority of all tubes in television and radio receivers, including the picture tubes. Since the heater is separated from the electron-emitting cathode material it is possible to use alternating current at power line frequency in the heater without the alternations affecting the flow of electrons from cathode to plate.

Not all tubes are heater-cathode types. Many rectifier tubes, which produce direct currents from alternating voltages, have their cathode and heater as a single unit. Fig. 4 shows a rectifier tube of a type employing two plates and two cathodes, from which one



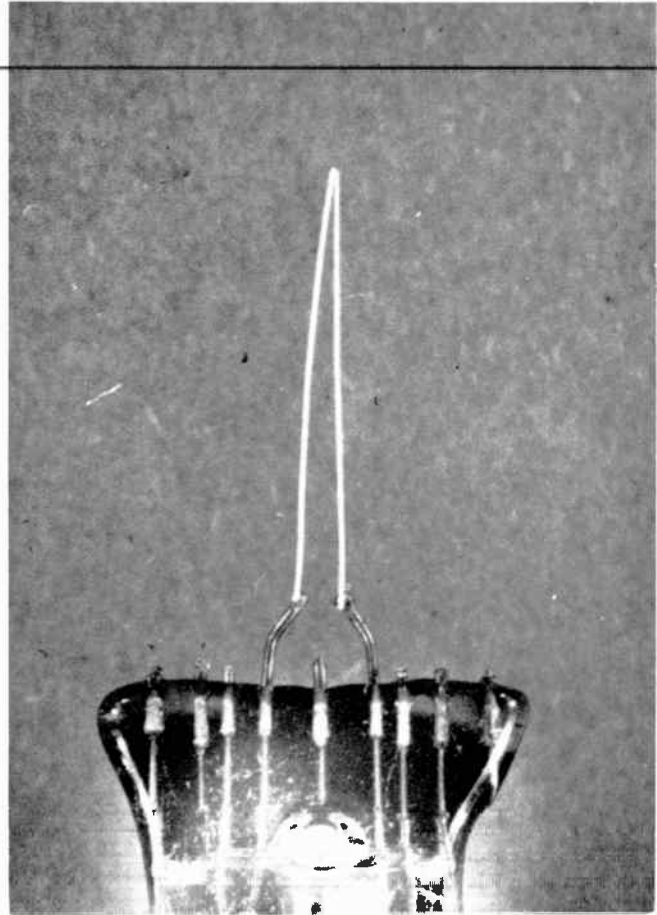
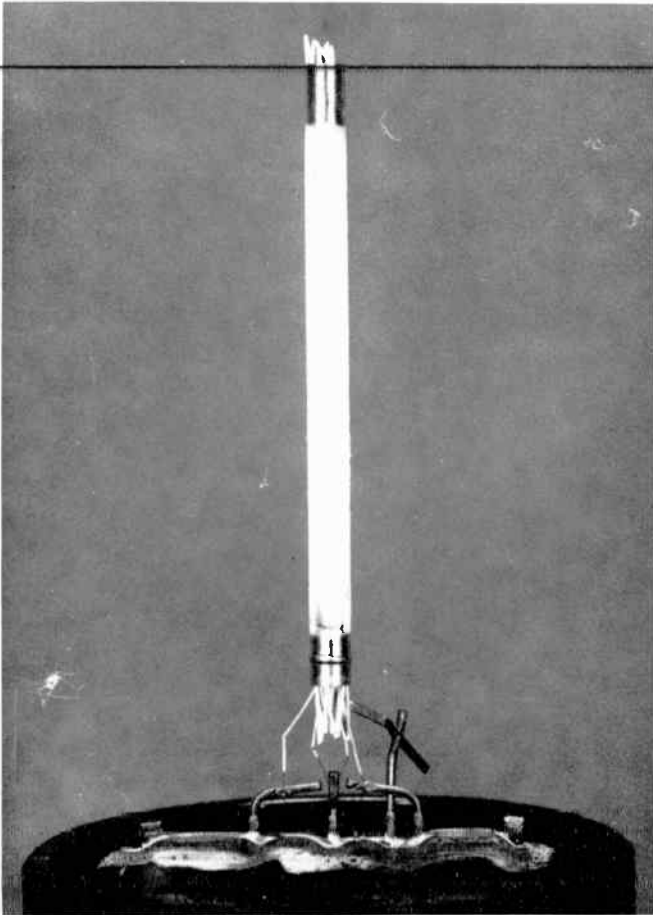

Fig. 3. A cylindrical heater-cathode (left) and a heater wire from which the cathode has been removed (right).

plate has been removed to expose one of the cathodes. The cathode is the white ribbon of inverted V-shape. The white coating is of the same materials used on cylindrical heater-cathodes.

When electric current of suitable value is passed through the V-shaped ribbon that carries the cathode coating, the temperature of ribbon and coating is raised to a point at which electrons are emitted from the surface. Here we have what is called a filament-cathode or a directly heated cathode.

When alternating current is used in a filament-cathode for heating, the temperature fluctuates to some slight extent at the alternating frequency. Then the rate of electron emission and the current between cathode and plate are varied at this frequency. With most tubes this would cause objectionable hum effects in pictures and sound. This

does not happen with a rectifier tube because all current leaving a rectifier is changed to a smooth or steady direct current by filtering before this current goes to other tubes in the receiver.

Filament-cathodes are used in amplifiers and all other tubes designed for operation from batteries in portable radios. A battery furnishes smoother or steadier direct current than any other kind of power source. Consequently, when battery current is used for heating of filament-cathodes there are no hum effects.

VACUUMS. In order that free electrons emitted from the cathode may move freely through the space between elements it is necessary to remove from inside the tube practically all gases and vapors. Otherwise the emitted electrons would collide with billions of the heavier and larger atoms of gases



## LESSON 16 – ELECTRONIC TUBES

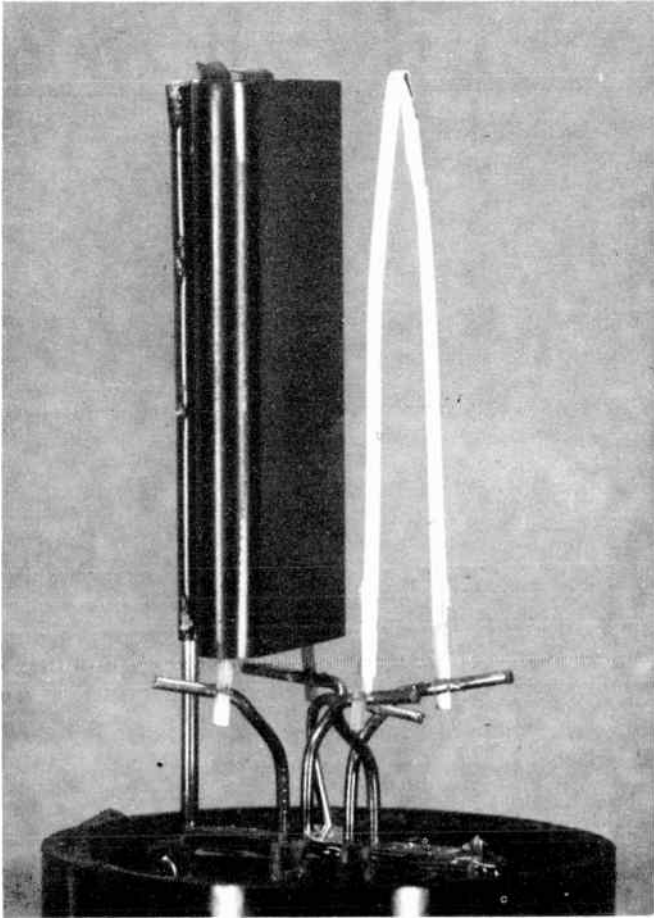

Fig. 4. The filament-cathode has been exposed by removing one of the plates from this tube.

and vapors. In traveling through air at atmospheric pressure an electron would collide with an air molecule every time the electron moved, on the average, about one twenty-millionth of an inch. Even though the electrons could emerge from the cathode surface, they could not get through the tube space to contain any appreciable quantity of gases or vapors.

Before the glass or metal outer envelope of the tube is sealed, it is pumped to a very high vacuum while heated in an oven or electric furnace. Inside the tube is a small piece of "getter" material which flashes during the process to absorb almost all remaining gas atoms. When evacuation is complete, an electron may travel all the way from cathode to plate with only slight chance of hitting a gas atom.

Free electrons are enabled to pass

from the main body of the cathode material through the surface into the evacuated space because of extra velocity or speed imparted to the electrons when the cathode is heated. The heat energy is changed into energy of motion, and the electron escapes through the surface.

SPACE CHARGE. With any given tube structure the rate at which electrons are drawn away from the cathode to and into the plate depends on how positive the plate is made with reference to the cathode. Electron flow from cathode to plate is called plate current, and potential difference between cathode and plate is called plate voltage. Plate current depends on plate voltage.

A properly heated cathode emits electrons at a rate greater than that required for the maximum plate current which should be allowed to flow in that particular tube. Saying this another way, the rate of electron emission is greater than the rate at which electrons are drawn to the plate under the influence of the maximum plate voltage which should be used with the tube in question.

The excess of emitted electrons remains in the region near the cathode surface. Those emitted electrons which are not drawn to the plate quickly drop back into the cathode. The electrons which remain temporarily in the space between cathode and plate, before going to the plate or falling back into the cathode, form what is called the space charge. This is a negative charge, because electrons are negative.

The rate at which electrons are emitted from the cathode surface depends on cathode temperature, increasing as the temperature rises. When the cathode is maintained at a correct operating temperature there is always more or less space charge within the tube. Any increase of plate current causes some reduction of the space charge, and a decrease of plate current allows an increase of space charge.

When the cathode is kept hot enough, and the plate voltage low enough to allow a space charge to remain around the cathode, the operation is said to be space charge

## COYNE - *television home training*

limited. The rate at which free negative electrons are emitted from the hot cathode is being retarded or limited by the negative space charge, because there is repulsion between the two negative masses. This is the normal manner of operation for all receiver tubes.

If cathode temperature gets too low, with no change of plate voltage, the rate of electron emission will drop until there is no space charge, and until electrons are drawn to the plate as fast as they are emitted from the cathode. Then, regardless of plate voltage, the plate current can be no greater than the rate of electron emission. Since the rate of emission depends on cathode temperature, and plate current depends on emission, the current depends on cathode temperature rather than on plate voltage. Such operation is called temperature limited.

In order that a tube may have a long useful life, the cathode temperature must be kept high enough to avoid temperature limited operation. With such operation the emission may be excessive from some spots on the cathode surface. These spots will be overheated by electron activity and the active material will break loose to ruin the tube. When there is a space charge the rate of emission is held practically uniform over the entire cathode surface.

It is just as important that the cathode temperature does not become too high over the entire surface, for this would cause excessive emission and excessive electron activity to damage the cathode material and materially shorten the life of the tube. To avoid these dangers, the voltage for the heating current in either a heater-cathode or a filament-cathode should be kept within 10 per cent of the rated voltage for the tube, or should remain within limits of 90 per cent and 110 per cent of the rated heater or filament voltage.

DIODE BEHAVIOR. When the active elements include only a cathode and a plate the tube is of the general class called diodes. In some tubes there are two diodes within a single envelope. In still other tubes there are one, two, or even three diodes built into

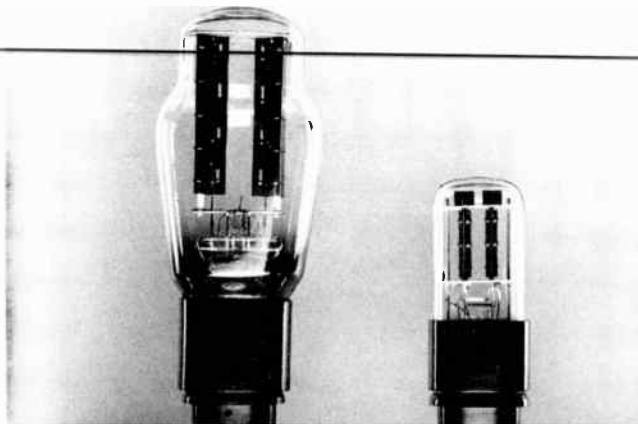

Fig. 5. Twin-diodes (rectifier tubes) having large current-handling ability.

the same envelope with other groups of elements.

Considered according to their current-carrying ability there are those distinct kinds of diodes. The largest are those designed to act as rectifier tubes in power supplies. They are capable of handling direct currents as great as 60 to 225 ma. Two such tubes are pictured by Fig. 5. Although the rectifiers have only cathodes and plates as their elements, and from this standpoint may be classed as diodes, they ordinarily are referred to as rectifiers rather than as diodes.

Another class of diodes includes those capable of handling direct currents up to 8 or 9 ma, but no more. Two examples are the 6AL5 and 6H6 tubes illustrated by Fig. 6. Diodes of the smallest current handling ability are those built in with tubes of other types, as with triodes and pentodes. The small diodes in such combination tubes can safely handle direct currents of only about 1 ma.

Whether a diode is designed to handle 1 ma or 200 ma, the principles of operation or action are the same. Differences are in currents and in permissible applied voltages. We may get acquainted with diode performance by making tests on some 6AL5 tubes, which are in the class designed for maximum direct currents of 9 ma. They are used for a wide variety of purposes in television receivers.

Within the single glass envelope of a 6AL5 tube are two complete diodes, or two

## LESSON 16 – ELECTRONIC TUBES

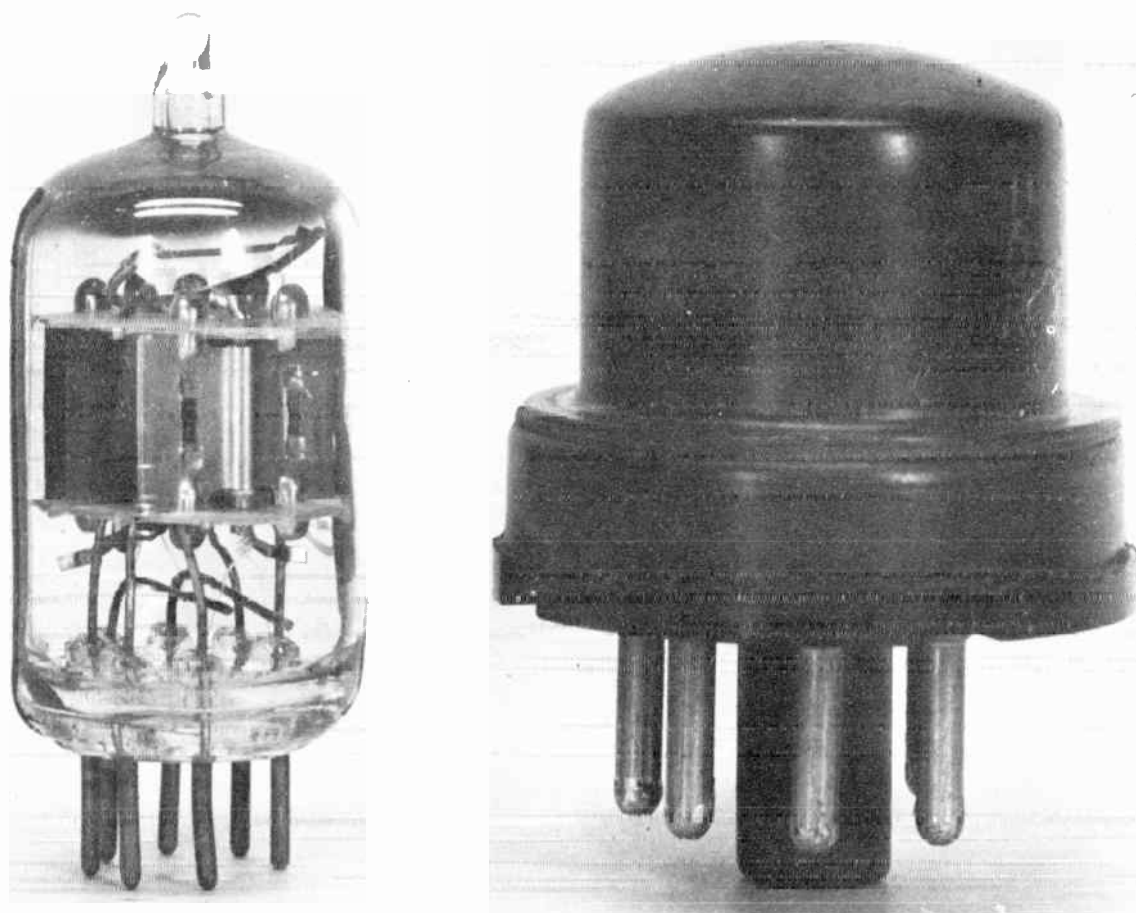

Fig. 6. Twin-diode tubes of moderate current-handling ability.

sections each consisting of a cathode and a plate. Such a tube is called a twin diode or a duodiode. The two sections are alike in construction. One section might be used as a video detector while the other is used as an automatic gain control tube, or any other two functions might be served by the one tube. The two sections may also be used together to form the equivalent of a single diode with greater current handling capacity.

To measure the performance of one of the diode sections we shall use a voltmeter and a current meter connected into the testing circuit shown in layout form at the left in Fig. 7 and in a simplified diagram at the right. In this diagram the tube is shown by the usual symbol for a twin diode.

Testing voltage is furnished from a d-c power supply unit connected to the two term-

inals marked Input Volts. When polarity of this testing voltage is such as to make the diode plate positive and its cathode negative with reference to each other, electron flow through the diode follows the path shown by heavy or black lines on the diagrams. The flow is from one side of the power supply to diode base pin 1 and from this pin to the cathode. Electrons flow from cathode to plate within the tube, thence from base pin 7 through the Plate Current meter and back to the power supply. All electron flow or current in the diode must pass through and be indicated by the current meter.

The voltmeter, marked Input, is connected to the two power supply terminals. Consequently, this meter indicates at all times the power supply voltage applied to plate and cathode of the diode. The voltmeter carries none of the diode current, it merely measures and indicates the applied voltage.



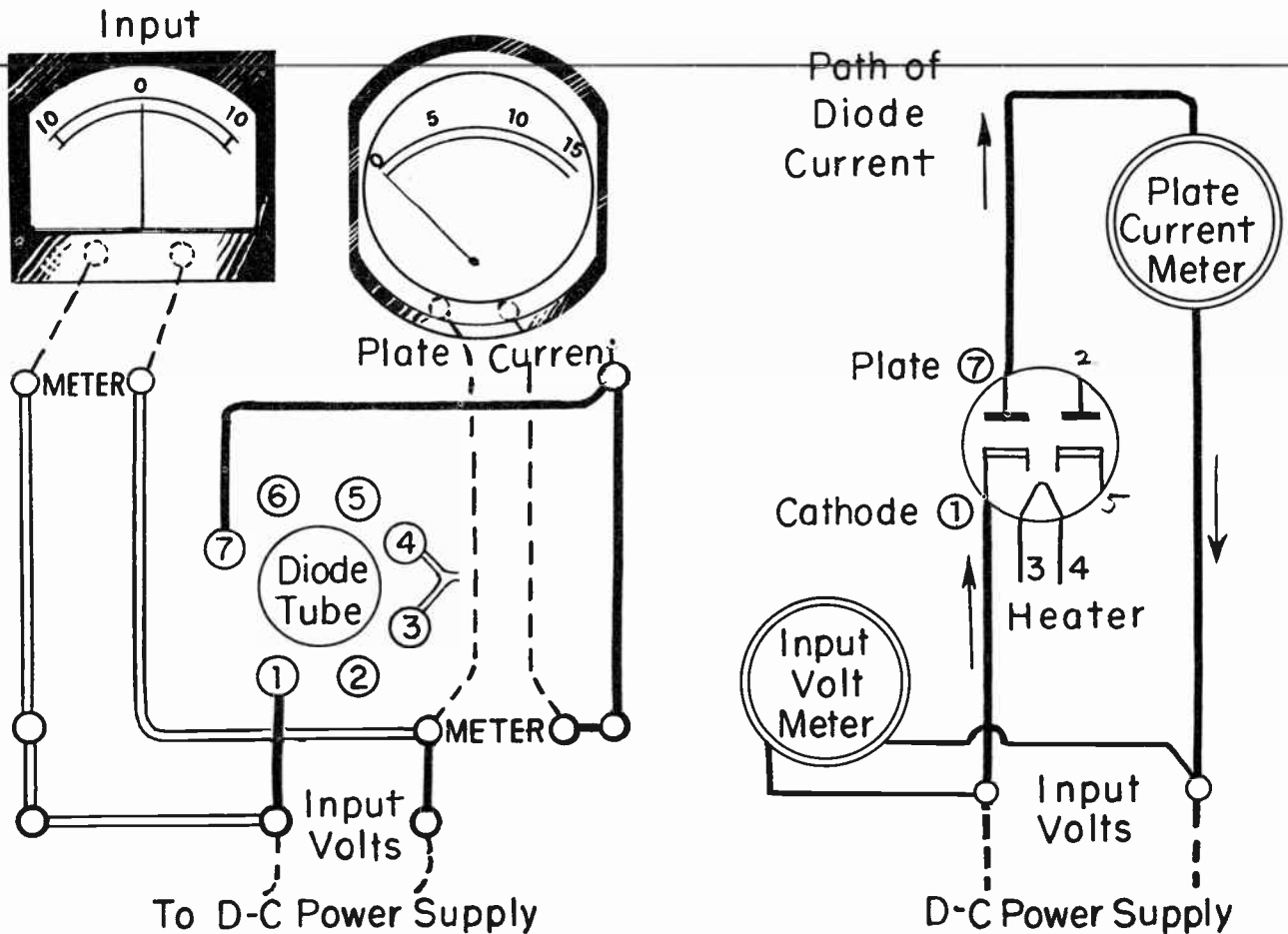

Fig. 7. The circuit used for testing the operation of diode tubes.

The voltmeter is of the zero-center type, in which the pointer moves one way from zero when applied voltage is of one polarity, and the other way from zero when this voltage is reversed. The meter is here connected so that its pointer moves to the right when the plate of the diode is made positive and its cathode negative. The pointer moves to the left when the plate is made negative and the cathode positive.

Although the 6AL5 tube contains two separate heater cathodes, the heater wires which are inside the cathode cylinders are connected together and to base pins 3 and 4. These base pins are connected to a section of the power supply unit that furnishes alternating current at 6.3 volts, the rated heater voltage for this tube.

Our first tests will be made on the diode section whose plate and cathode are internally connected to base pins 7 and 1. The

plate of the unused diode section connects to base pin 2 and its cathode to base pin 5.

**EFFECTS OF PLATE VOLTAGE.** We shall now check the effects of various plate voltages on flow of current through the diode. In Fig. 8 the power supply has been adjusted to apply 3.0 volts between plate and cathode of the diode, as shown by the Input meter. The pointer swings to the right, indicating that the plate is positive with reference to the cathode. Plate current is measured as 4.0 ma.

In Fig. 9 the plate voltage has been increased to about 5.8. The result is an increase of plate current to 7.0 ma. By making a series of tests with plate voltage varied in small steps while noting the resulting plate currents, the relations between voltage and current for the one particular diode being tested were found to be as shown by the full-line curve of Fig. 10.



## LESSON 16 – ELECTRONIC TUBES

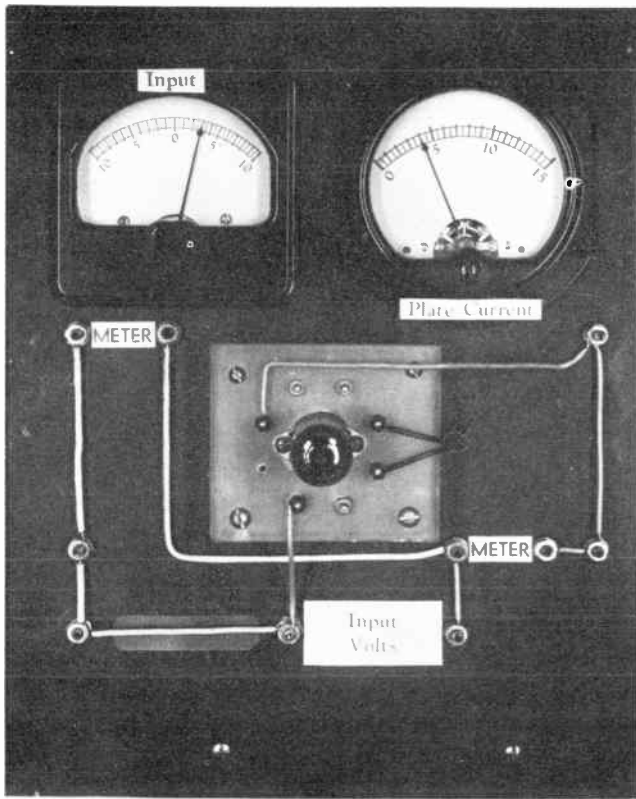

Fig. 8. When the plate is positive with reference to the cathode, current flows through the diode tube.

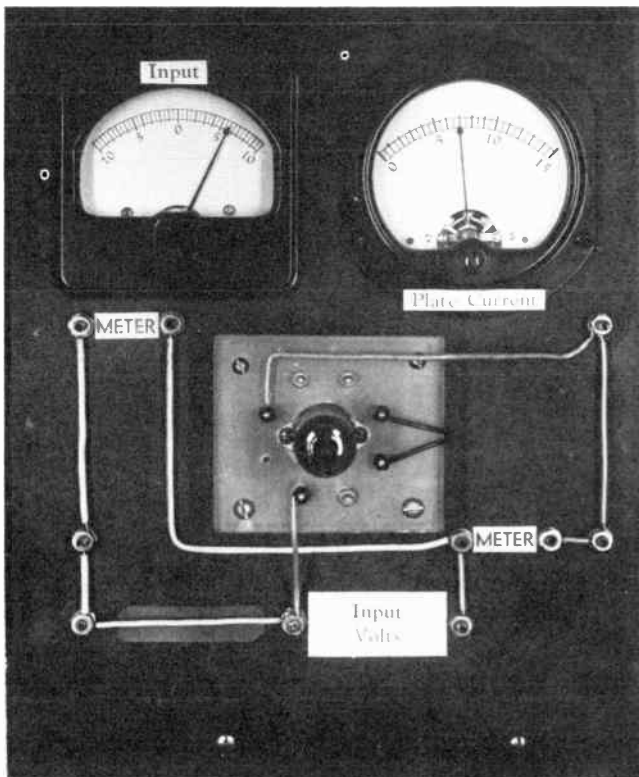

Fig. 9. Increasing the positive plate voltage increases the plate current.

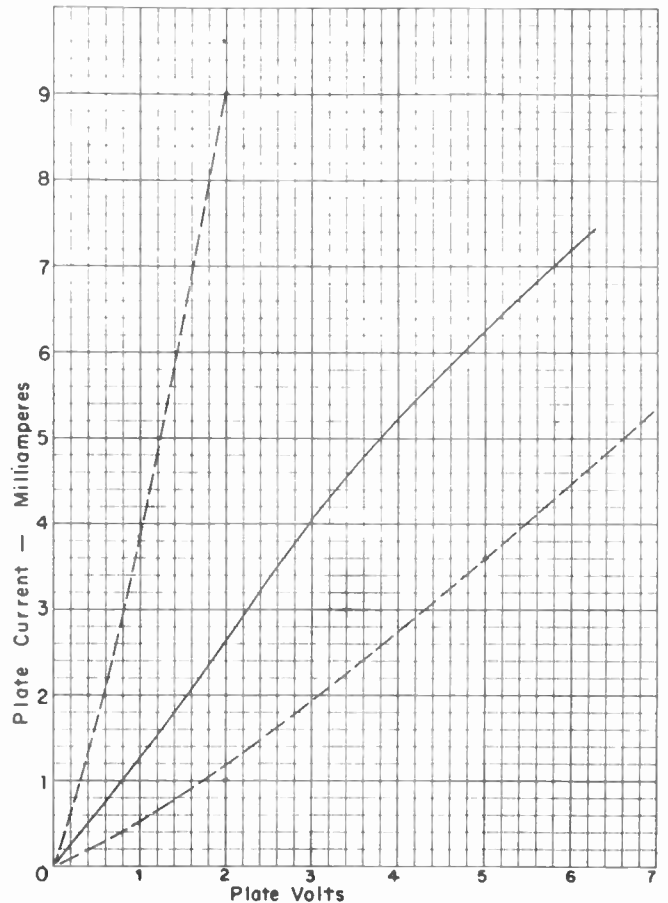

Fig. 10. Relations between plate current and plate voltage in a certain diode tube.

Upon making similar tests with other tubes of the same type, many of them allowed plate currents much greater than the first unit with any given voltage. Current-voltage relations for these tubes were about as shown by the upper broken-line curve. A few of the other diodes allowed much smaller currents for any given voltage, as shown by the lower broken-line curve. All the tubes were new, and all were found capable of operating as a video detector in a television receiver. Greater signal sensitivity was realized with those diodes which allowed greater plate currents.

It may seem strange that tubes with such widely varying performances will operate acceptably in the same position of a receiver. The explanation is that in any such case we must consider not only the tube but also the circuit in which it is used. In the video detector circuit the diode is in series

## COYNE - television home training

with a fixed "load" resistor of 4,700 ohms. The same current must flow in the tube and the load. This circuit current is determined by applied voltage and by the sum of the resistances in the diode and the load.

Now let's check the apparent internal resistances of three diodes represented by the three curves of Fig. 10. The resistances may be computed by using corresponding values of voltage and current in a resistance formula or with an alignment chart. With 2.0 volts on the plates, the corresponding currents and computed resistances are as follows.

Upper broken-line curve	2.0 volts	9.0 ma	222 ohms
Full-line curve	2.0 volts	2.8 ma	714 ohms
Lower broken-line curve	2.0 volts	1.2 ma	1667 ohms

When these diode resistances are in series with 4,700 ohms load resistance the total series resistances with three tubes represented by the three curves are 4,922 ohms, and 6,357 ohms.

Before going further we shall simulate the detector circuit as in Fig. 11. Here a fixed resistor of 4,700 ohms has been connected in series with the diode on the test panel. This resistor is at the right-hand side of the panel where formerly there was a straight wire connection. The diode being used in this test is one of those whose performance approximates the upper broken-line curve of Fig. 10, it is one of the tubes having small internal resistance. The plate current meter now indicates almost exactly 2.0 ma, with the input meter showing 10 volts applied to the diode and resistor in series.

In Fig. 12 the diode has been changed to one of those represented by the lower broken-line curve of Fig. 10, one of the units having high internal resistance. Now the current is about 1.3 ma with 10 volts applied to the diode and the 4,700-ohm load resistor in series.

We may consider the 10 volts applied to the circuits in Figs. 11 and 12 as an input signal to the detector. The signal output is

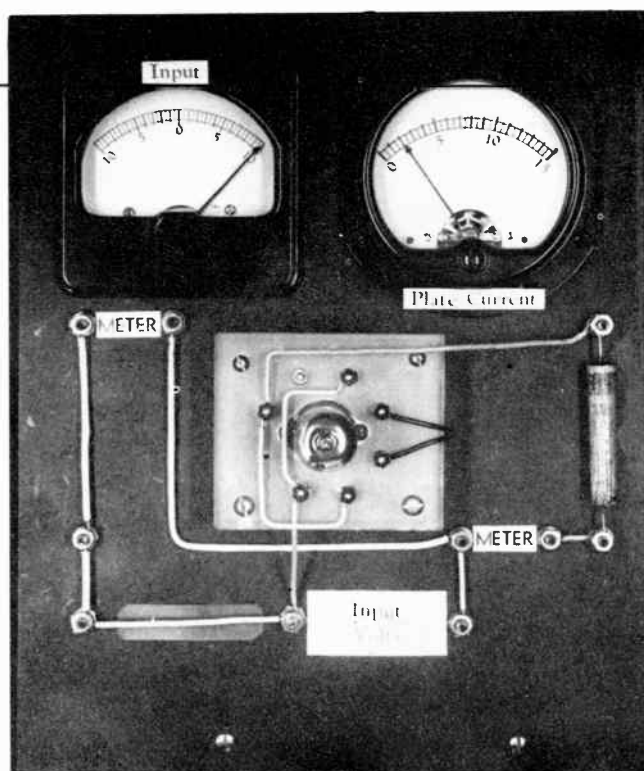

Fig. 11. The diode is being operated with a load resistance in its plate circuit.

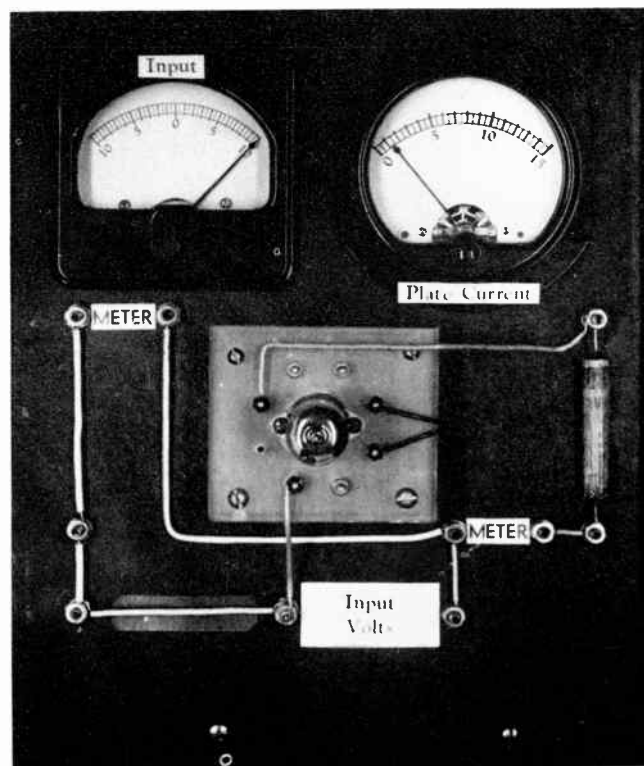

Fig. 12. Plate current is reduced when using a diode of higher internal resistance.

## LESSON 16 – ELECTRONIC TUBES

represented by voltage across the load resistor. This output voltage may be computed from the current and the number of ohms resistance.

With the highly sensitive diode (Fig. 11) the computed output is 9.4 volts, for 2.0 ma in 4,700 ohms. With one of the least sensitive diodes (Fig. 12) the computed output is 6.1 volts. By using the weaker diode, output voltage is dropped by about 35 per cent when the input voltage remains unchanged.

The actual loss of output voltage is far less than we might have assumed from considering only the internal resistances of the diodes, while neglecting the effect of load resistance. The 4,700-ohm load resistance is so much greater than the internal resistance of either diode that the current and the voltage across the load depend chiefly on load resistance rather than on diode resistance. The total input voltage, which represents a signal voltage, divides between the diode and the load in accordance with their relative resistances. The greater the internal resistance of the diode the more of the input voltage is used up in getting current through the tube, and the less remains as output across the load.

ONE-WAY CONDUCTION. In the preceding tests which simulated part of the action in a videodetector circuit we are anxious to have appear across the load resistor as much as possible of the input voltage. This being the case, why use the diode tube, in which there is bound to be some loss of signal voltage no matter how good the tube? The answer is that the signal coming to a detector is an alternating voltage, and before it is possible to have pictures or sound this alternating signal voltage must be changed to a one-way or a direct signal voltage. It is this change that is made by the diode. All the details will come out when we take up the study of detector action.

Diodes serve a wide variety of purposes in television receivers. They are used as detectors or demodulators, as mixers, as limiters, as restorers, and as dampers. You will discover that every one of these applica-

tions depends on the ability of the diode to conduct in one direction or polarity, but not in the other.

When any alternating voltage is applied in series with a diode, the alternations during one half-cycle make the diode plate positive and its cathode negative. Then the diode conducts, and in its output there is a current corresponding to that half-cycle of input voltage. During the opposite half-cycle the diode plate is made negative and its cathode positive. Then the diode refuses to conduct, and for this half-cycle of input voltage there is no output current on the load side of the diode.

The alternating input voltage produces only a series of current pulses during the half-cycles which make the diode plate positive. During every pulse, the current flows the same direction, which is from cathode to plate within the diode and from plate back to cathode in the external circuit. These one-way pulses constitute a direct current, which is a current flowing in only one direction, never reversing.

In all the preceding tests the input voltage from the power supply has been of such polarity as to make the diode plate positive and its cathode negative. In Fig. 13 the polarity of power supply voltage has been reversed, as shown by the pointer of the input voltmeter swinging to the left of zero. Although we have 6.0 volts applied to the diode, current is zero. Even were we to apply as much as 330 volts in this reversed direction the 6AL5 diode would not conduct the smallest fraction of a milliammeter. Beyond that there might be an internal breakdown and the tube would be ruined.

Were it possible for the input voltmeter on our test panel to follow the alternations of an alternating voltage applied to the diode circuit, the pointer of the meter would swing back and forth as between the positions of Figs. 9 and 13. During alternations which would swing the pointer to the right, and make the diode plate positive, electron flow would be shown by the plate current meter. During alternations which would swing the pointer to the left, and make the diode plate negative,



## COYNE - *television home training*

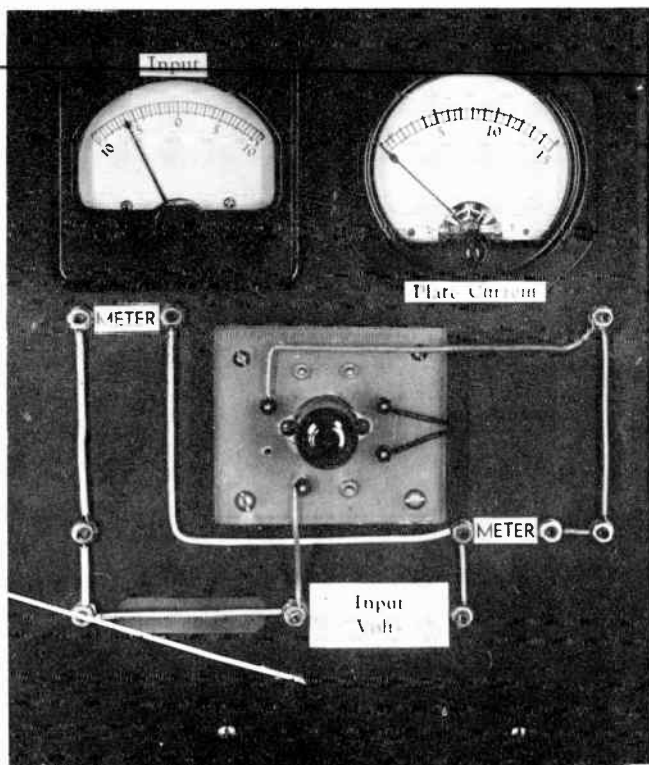

Fig. 13. When the diode plate is negative with reference to its cathode there is no conduction.

the current meter would indicate zero electron flow.

There can be electron flow only from the hot cathode to the plate inside the tube. This is because electrons can be emitted only from the cathode. For the plate to emit electrons its temperature would have to be raised to  $4,000^{\circ}$  F, or more, since the material in the plate is not such as will allow electron emission at any lower temperatures. With no electron emission from the plate there can be no electron flow away from the plate and toward the cathode, no matter how positive the cathode may be made with reference to the plate.

This highly important and useful property of allowing electron flow in only one direction through the tube and a connected circuit is possessed not alone by diodes but also by all other tubes having hot cathodes and relatively cool plates. No matter how many other elements may be added between cathode and plate, electron flow can be only away from the hot cathode. If some of the other elements are positive with reference to

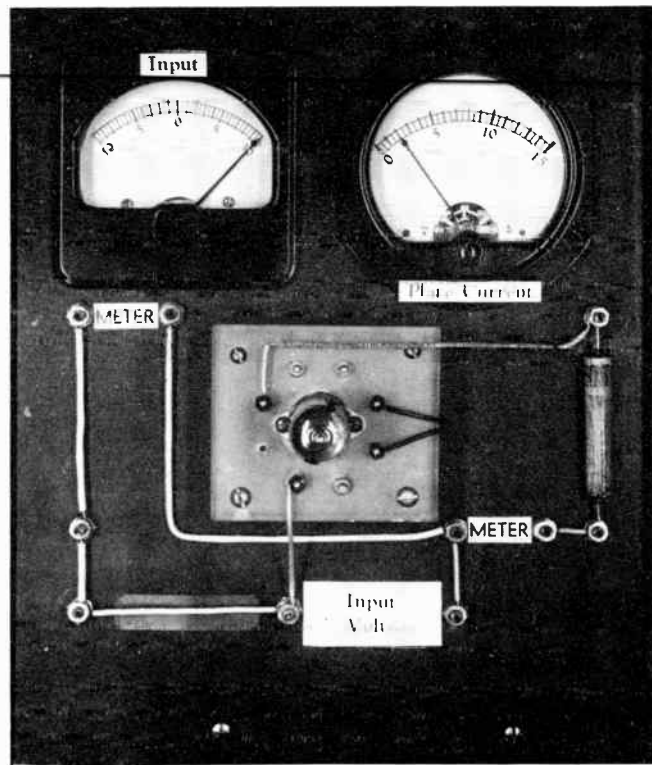

Fig. 14. Wires added on the socket terminals serve to connect the two sections of the twin-diode in parallel with each other.

the cathode, part of the electron flow may go from the cathode to these other elements and part to the plate. But the fact always remains that all the flow, no matter where it goes, can be only in a direction away from the cathode.

DIODES IN PARALLEL. In Fig. 14 the two sections of one of our twin diode tubes have been connected in parallel to operate as a single diode. This means that the two cathodes have been connected together and that the two plates have been connected together. As you can see in the picture, a wire has been run from base pin 1 to base pin 5, these being the pins for the two cathodes. Another wire has been added between base pin 7 and pin 2, the pins for the two plates in this type of tube.

In series with the paralleled diodes is the 4,700-ohm load resistor used in preceding tests. The tube is the one which, in Fig. 12, allowed a current of 1.3 ma with 10 volts applied. But in the present test we are not getting twice the current from the two diodes that we had with one of them. Twice the



## LESSON 16 – ELECTRONIC TUBES

original current would be 2.6 ma, yet actually the combined currents come to only 2.0 ma, as shown by the plate current meter. This is in spite of the fact that the second diode section of this particular tube, when tested by itself, showed much less internal resistance than the 1,667 ohms computed for the first one. Can you tell why the current is not doubled, before reading further?

It is the load resistance, which is much greater than the diode resistances, which limits the combined plate current. Although the effective or paralleled resistance of the two diode sections is less than half that of the section first tested, the total circuit resistance is not changed in any such proportion.

When diodes are operated in parallel the object ordinarily is to allow a greater current that could be handled safely by one diode. Where the direct current capacity of one diode section in this particular type of tube is 9 ma, the two sections in parallel could carry 18 ma provided the total current divided equally between them. In most applications the total circuit resistance is so much greater than internal resistances of the tubes that the reduction of effective tube resistance is not too important in performance.

**TRIODE TUBES.** A diode can control electron flow only to the extent of allowing such flow in one direction while preventing it in the opposite direction. The rate of electron flow cannot be controlled from within the diode unless we resort to temperature limited operation, which tends to damage the cathode. The electron flow rate with any other method of operation depends only on the voltage applied between plate and cathode from some external source.

The earliest radio tubes were diodes. They were used as detectors, to cut off the negative alternations of high-frequency alternating voltages in received signals and allow the positive alternations to produce pulses of direct current. When these pulses of direct current are passed through headphones it becomes possible to hear the sounds of voice, music, or code being sent out from transmitting stations.

The great need during those early days was for some means of strengthening or amplifying the received signal, for even the strongest transmitted signals could cause only weak sounds at the receiving apparatus. Weak signals and those from distant transmitters could be heard only with difficulty, if at all.

Amplification of signals became possible with the introduction of a third element mounted between the original cathode and plate. This third element is called the control grid, or more often is called simply the grid. Any tube having three active elements consisting of a cathode, a grid, and a plate is called a triode. In modern types of television and radio triodes the grid is a spiral of thin wire supported around the outside of the cathode as in Fig. 15.

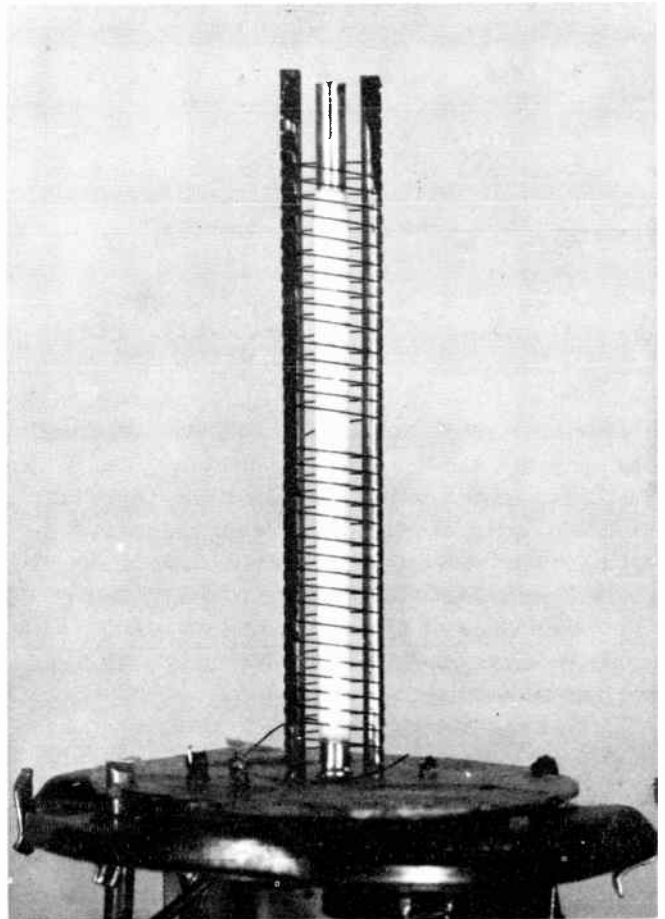

Fig. 15. The grid is spiral of thin wire mounted around the cathode, but not touching the cathode at any point.

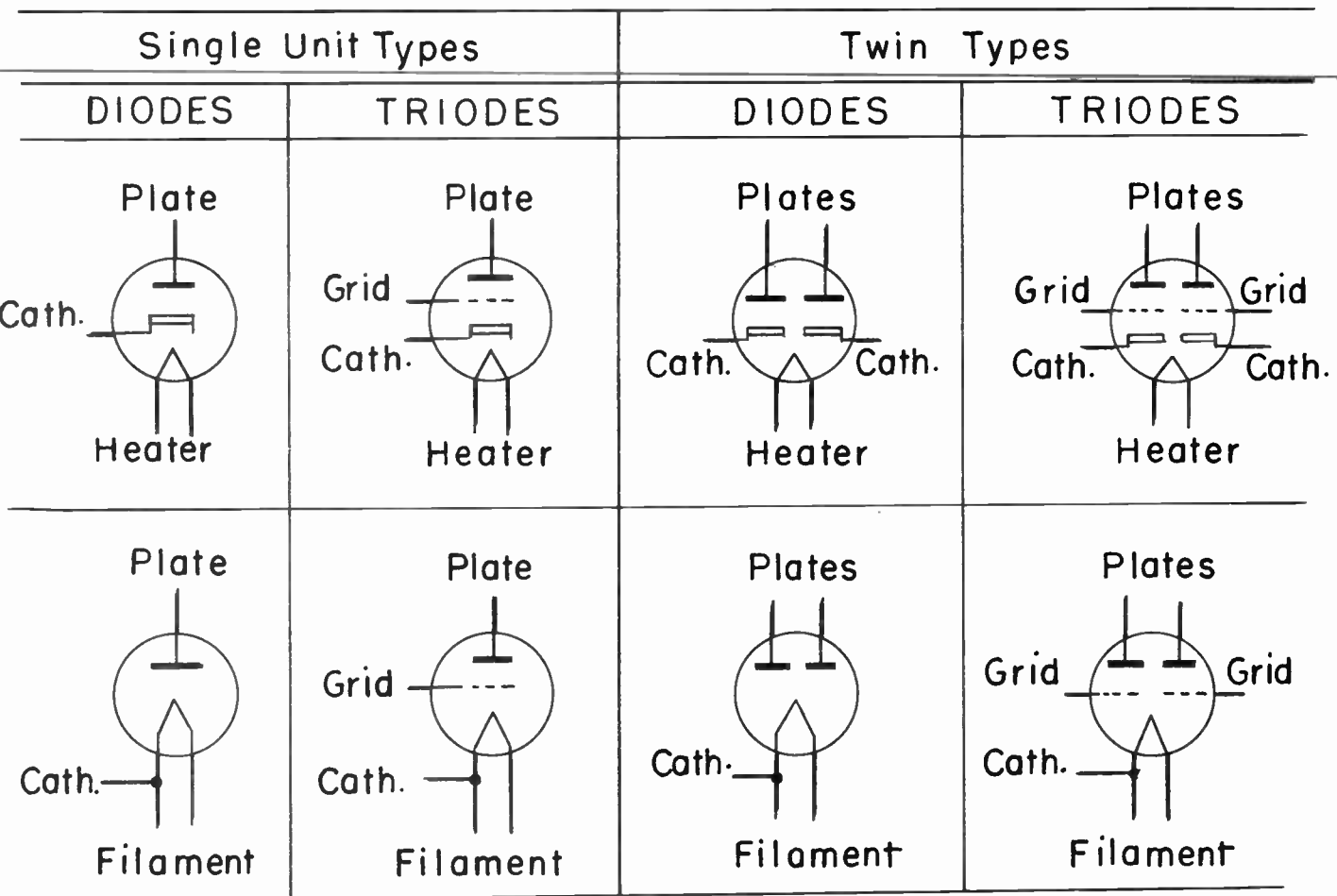

Fig. 16. Symbols used to represent diodes and triodes in service diagrams.

Fig. 16 shows symbols for diodes and triodes in which there are either single or twin sets of elements, and in which there are either heater-cathodes or filament-cathodes.

All the free electrons which flow from cathode to plate in the triode must pass through the grid. These electrons, you should remember, are negatively charged or are particles of negative electricity. If the grid itself is negatively charged it will repel the negative electrons and tend to drive them back toward the cathode, because two negative charges repel each other. This limits the rate at which electrons may leave the vicinity of the cathode and travel to the plate through the grid, and plate current is reduced.

If the grid is positively charged it attracts the negative electrons being emitted from the cathode, just as these electrons are attracted by a positively charged plate. The

rate at which electrons are drawn away from the cathode is increased, and their speed is increased. Some of the negative electrons enter the positively charged grid, but the grid wires are so thin and the spaces between them are relatively so wide that most of the additional electrons pass right on through the grid and enter the positive plate. Thus the plate current is increased.

The grid provides means for varying or controlling the plate current flowing through the triode. The more negative the grid, the less becomes the plate current with any given plate voltage. Making the grid less negative allows plate current to increase. If the grid is made positive there is a still further increase of plate current.

When an alternating signal voltage is applied to the triode grid in such manner as to make the grid alternately negative and positive, the plate current is varied in ac-

## LESSON 16 – ELECTRONIC TUBES

cordance with signal voltage. A small change of grid voltage is capable of causing large changes of plate current. When these large changes of plate current flow in a load resistor which is in the plate circuit there are large changes of voltage across this resistor. Thus a weak signal voltage applied to the grid causes relatively strong voltages across the triode load resistor, and the signal voltages are amplified in the output of the triode.

The charge of the grid is measured by the potential of the grid with reference to the cathode. If the grid is at the same potential as the cathode, or if there is no potential difference between these elements we say that the grid is at zero potential or that we have a zero grid. If the grid is more negative than the cathode or is negatively charged with reference to the cathode we have a negative grid. If the grid is positive with reference to the cathode we have a positive grid.

Instead of speaking of charges on the grid we ordinarily speak of grid voltages, which are potential differences between the grid and the cathode. When, for example, we say that the grid is five volts negative we mean that its potential is five volts more negative than the potential of the cathode. If we say that the grid is five volts positive we mean that its potential is five volts more positive than the potential of the cathode.

It is a general rule that the voltages of all elements in a tube are measured and specified with reference to the cathode. The cathode always is considered to be at zero potential so far as element voltages are concerned. Actually the cathode might be either negative or positive with reference to chassis ground, or with reference to any other point or points in the circuit wiring of the receiver. But so far as elements in the tube are concerned, the cathode potential always is assumed to be zero, or is assumed to be the reference potential for voltages on all other elements.

When we speak of some certain plate voltage it is presumed to be the voltage of the plate with reference to the cathode in the same tube or in the same section of a tube unless there is a specific statement to the contrary. Should we wish to specify the potential difference between a plate and chassis ground it should be called plate voltage to ground, not simply plate voltage. When we specify some certain grid voltage it is presumed to be the voltage of the grid with reference to the cathode of the same tube or section, not with reference to any other point unless there is a statement to that effect.

In order that grid voltage may be fixed in relation to the cathode there must be an external connection between these two elements, as in Fig. 17. At A the grid is con-

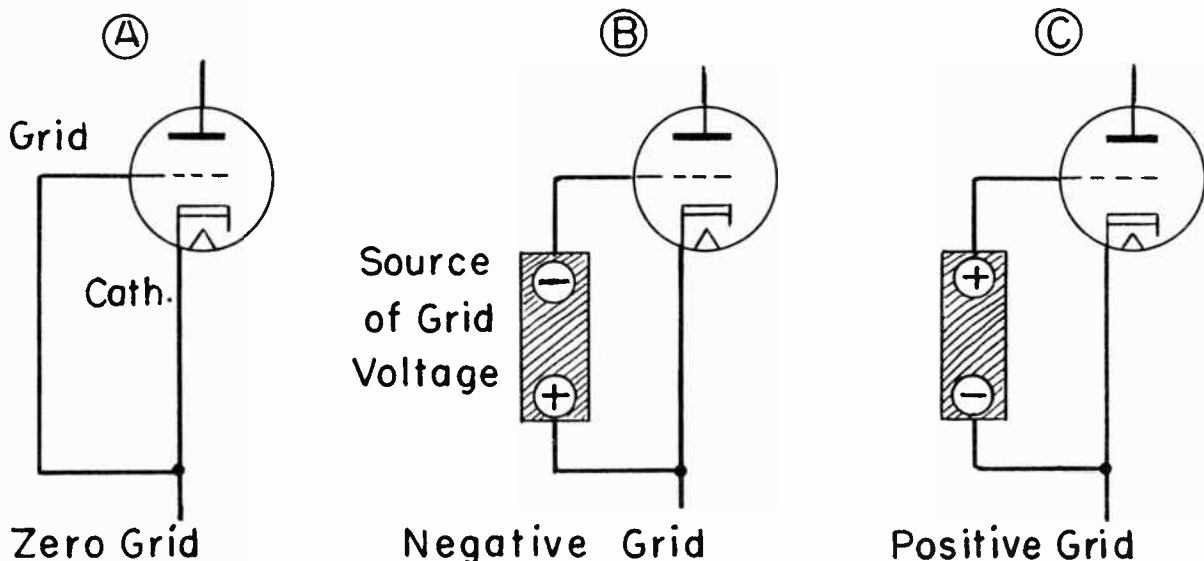

Fig. 17. Voltages of the grid always are considered with reference to the cathode.

# COYNE - *television home training*

nected to the cathode through an external conductor of zero or negligible resistance. Across such a conductor there can be no difference of potential or no voltage. Consequently, the grid must be at the same potential as the cathode, and the grid is at zero voltage or we have a zero grid.

At B a voltage source is connected between grid and cathode with the negative side of this source toward the grid and its positive side toward the cathode. This makes the grid more negative than the cathode, and we have a negative grid. At C the polarity of the source of grid voltage has been reversed, placing its positive side toward the grid and its negative side toward the cathode. Now the grid is more positive than the cathode, and we have a positive grid.

The triode has the property of one-way conduction, just as has the diode. Electrons can flow only from the cathode to the plate within the triode, and current in the connected plate circuit and load can flow only in the corresponding direction. If an alternating

voltage is applied between plate and cathode of a triode, the tube can conduct plate current only during the alternations which make the plate positive with reference to the cathode. During intervening alternations, which make the plate negative with reference to the cathode, there can be no plate current. This is true whether the grid is negative, positive, or zero with reference to the cathode.

At the left in Fig. 18 an alternating plate voltage is represented as a wave that rises above zero when its polarity is such as to make the plate of the triode positive, and which dips below zero when the polarity reverses to make the plate negative. Plate current will flow in the tube and the load only while the plate is positive, as shown by the pulses which represent this current. No matter what is done with the grid voltage, there can be no plate current unless the plate is positive with reference to the cathode.

In order that there may be plate current at all times, the plate must be kept positive with reference to the cathode at all times.

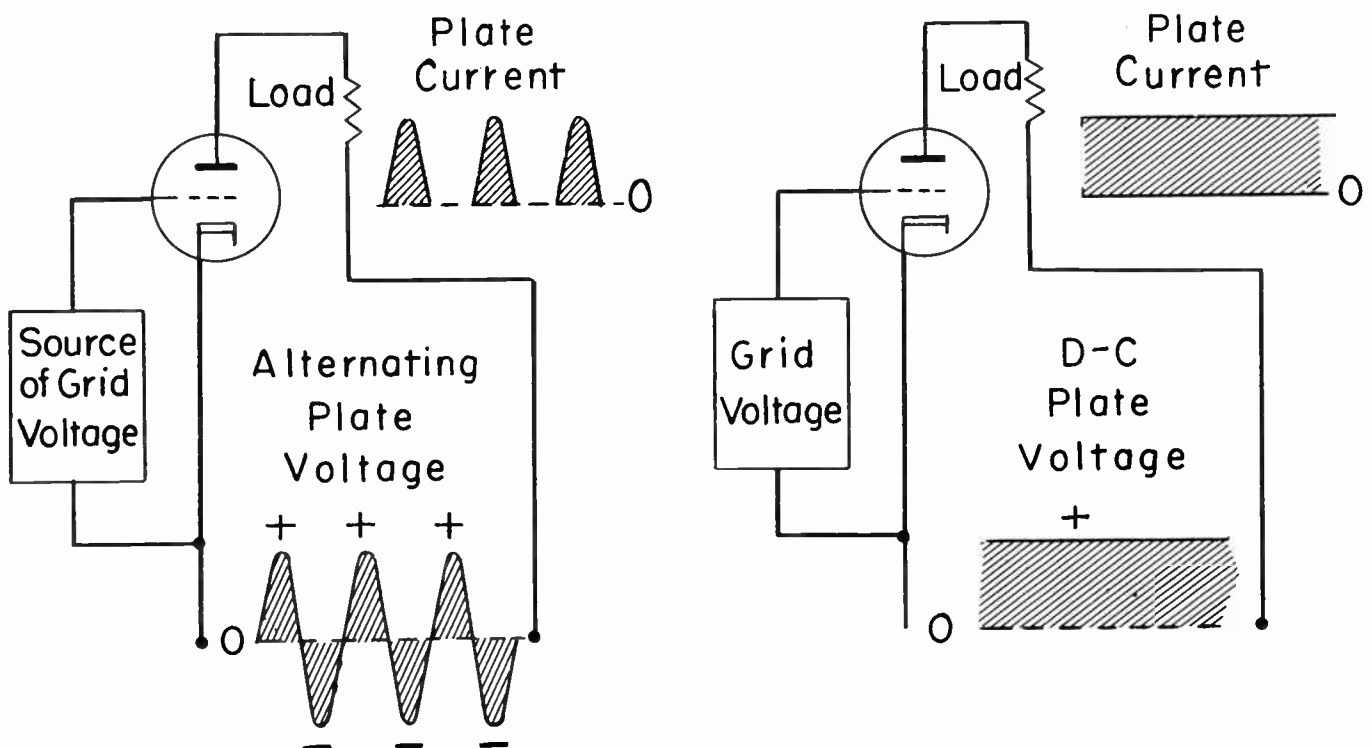

Fig. 18. An alternating plate voltage applied to a triode causes one-way or direct pulses of plate current, while a positive plate voltage causes a continual flow of plate current.



## LESSON 16 – ELECTRONIC TUBES

Between plate and cathode there must be a source of direct voltage, not alternating voltage, and the positive side of this d-c voltage source must be toward the plate of the triode, as shown at the right in Fig. 18.

With the plate remaining positive at all times, plate current may be varied by altering the grid voltage. Making the grid more negative with reference to the cathode will reduce the plate current, while making the

grid less negative will allow the plate current to increase. The grid is a means for varying the plate current, but in order to have any plate current at all it is necessary that the plate be positive with reference to the cathode.

In the following lesson we shall examine the performance of triodes by measuring currents in the plate and load circuit and noting the effects of altering the voltages of the plate, the grid, and the applied signal.

### CONDENSED INFORMATION

**Diode.** A two-element tube or section containing a cathode and a plate.

**Twindiode or duodiode.** A tube containing two diode sections, each consisting of a cathode and a plate.

Diodes are connected in parallel to obtain greater current handling capacity.

**Triode.** A three element tube or section consisting of a cathode, a grid, and a plate.

**Space charge.** Negative electrons which remain temporarily between cathode and plate before going to the plate or falling back into the cathode.

**Space charge limited.** A method of operation with which not all emitted electrons are drawn to the plate. There is a space charge.

**Temperature limited.** A method of operation with which electrons are drawn to the plate at the same rate emitted from the cathode. There is no space charge.

All tubes having heated cathodes, no matter what their type, allow electron flow in only one direction, which is away from the cathode inside the tube.

Voltages of all elements are specified with reference to the cathode in the same tube or section, the cathode being assumed as of zero potential so far as the tube or section is concerned.

**Zero grid.** Grid potential same as cathode potential in same tube or section.

**Negative grid.** Grid potential negative with reference to the cathode.

**Positive grid.** Grid potential positive with reference to the cathode.

Filament-cathodes are used in large rectifiers, in some large general-purpose triodes, and in all battery operated tubes. Heater-cathodes are used in practically all other tubes.

# TELEVISION

◦ RADIO

◦ ELECTRONICS

---

LESSON 17 – SIGNAL AMPLIFICATION

---

***Coyne School***

*practical home training*

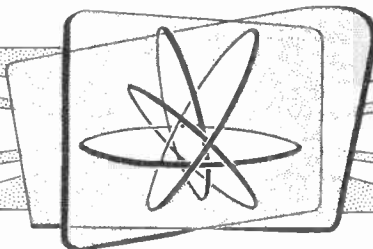

*Chicago, Illinois*

---

Copyright, 1953 by Coyne School  
Chicago 12, Illinois  
All rights reserved

Litho. in U.S.A.

*Lesson 17*

**LESSON 17 – SIGNAL AMPLIFICATION**

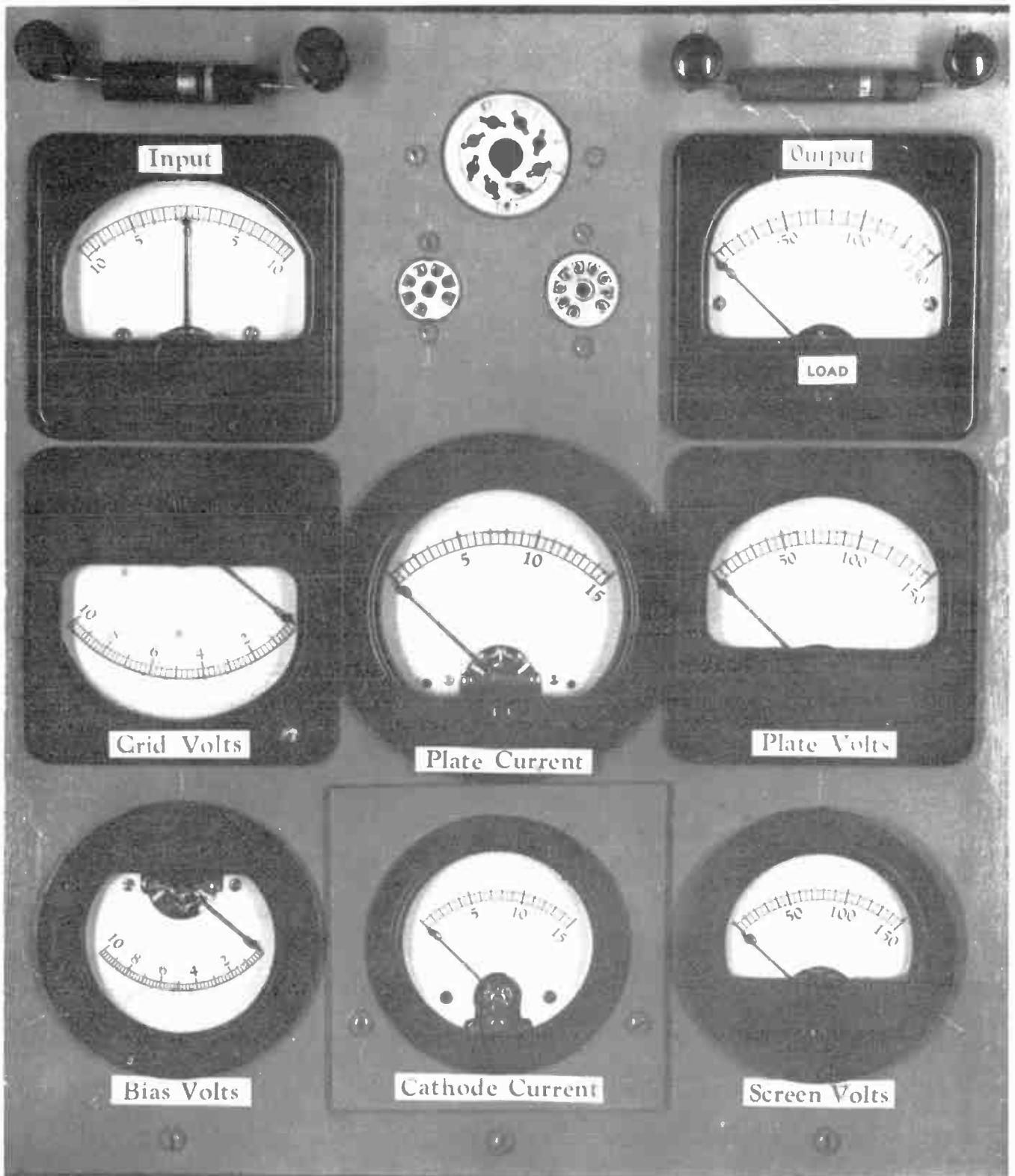

*Fig. 1. The meters for measuring the performance of triode and other tubes.*



## COYNE - *television home training*

To test the performance of three-element triodes and other tubes having four or five active elements it is necessary to measure more voltages and currents than in the case of relatively simple diodes. For these other tubes we shall make use of the apparatus pictured by Fig. 1. At the top center of the panel are sockets for octal base tubes, for 7 pin miniature tubes, and for 9-pin miniature tubes. These three sockets allow testing most of the tubes used in television and radio receivers.

There are eight meters. The three on the left hand side of the panel are voltmeters for making measurements in the grid circuit of any tube having a control grid. The upper meter, marked Input, is a zero-center type reading from zero to 10 volts in either polarity. It measures positive or negative signal voltages applied between grid and cathode of the tube. These voltages are fed to the terminals immediately above the meter. The Grid Volts meter measures the voltage or potential difference between grid and cathode of the tube being tested.

The Bias Volts meter at the lower left measures a voltage which is applied in series with the signal input voltage. The bias voltage always is sufficiently negative to balance or more than balance a positive signal voltage, and thus to keep the grid negative at all times. Keeping the grid negative prevents electrons emitted by the cathode from entering the grid, and insures that all electrons flow to the plate or to elements other than the grid. Since both the biasing voltage and grid voltage always are negative during normal operation, these two meters are arranged to read only negative voltages, from zero at the right-hand ends of their dial scales to a maximum of 10 negative volts at the left-hand ends.

In the center of the panel is a Plate Current meter which measures the number of milliamperes of current leaving the plate of the tube and flowing through the load. Down below is a Cathode Current meter which measures the number of milliamperes flowing into the cathode. With tubes having more than three elements, and with abnormal operation of triodes, the cathode current may be greater than the plate current.

At the upper right on the test panel is the Output meter, which is a voltmeter for ~~measuring the voltage developed across the~~ load resistor in the plate circuit. This load resistor is connected between terminals immediately above the meter. Next below the output meter is a Plate Volts meter which measures the voltage between plate and cathode of the tube being tested. At the lower right is a Screen Volts meter which will be used later on when testing tubes having more than three elements. All the voltmeters on the right-hand side of the panel have dial scales graduated from zero to 150 volts.

When a triode is used for amplifying or strengthening a signal, the circuit, in its simplest form, is as shown by Fig. 2. The input signal, whatever its form, comes from some part or circuit which precedes the triode in the receiver layout. This signal causes current to flow in the grid resistor and across this resistor appears a voltage corresponding to the signal. The grid resistor is connected between the grid and cathode of the amplifier triode, and signal voltage across the resistor is thus applied between grid and cathode.

In series with the grid resistor and the cathode of the tube is a source of bias voltage connected in such polarity as to make the grid negative with reference to the cathode at all times. Since no electron flow can pass from cathode to grid of the tube, and since no electrons can flow away from the cold grid toward any other element in the tube, there can be no current in the wire connection to the grid. Also, since any current in the source of bias voltage would have to pass through the grid and cathode, and since no current can flow in the negative grid, there is no current in the bias source. This source furnishes only a voltage between grid and cathode, it furnishes no current.

Plate current flows in the plate circuit shown by heavy lines, in which is included the load resistor. The plate current varies in accordance with signal voltage applied to the grid and cathode, and across the load resistor appears a voltage that varies according to the input signal voltage. This varying voltage across the load is the output signal voltage of the triode amplifier.

## LESSON 17 – SIGNAL AMPLIFICATION

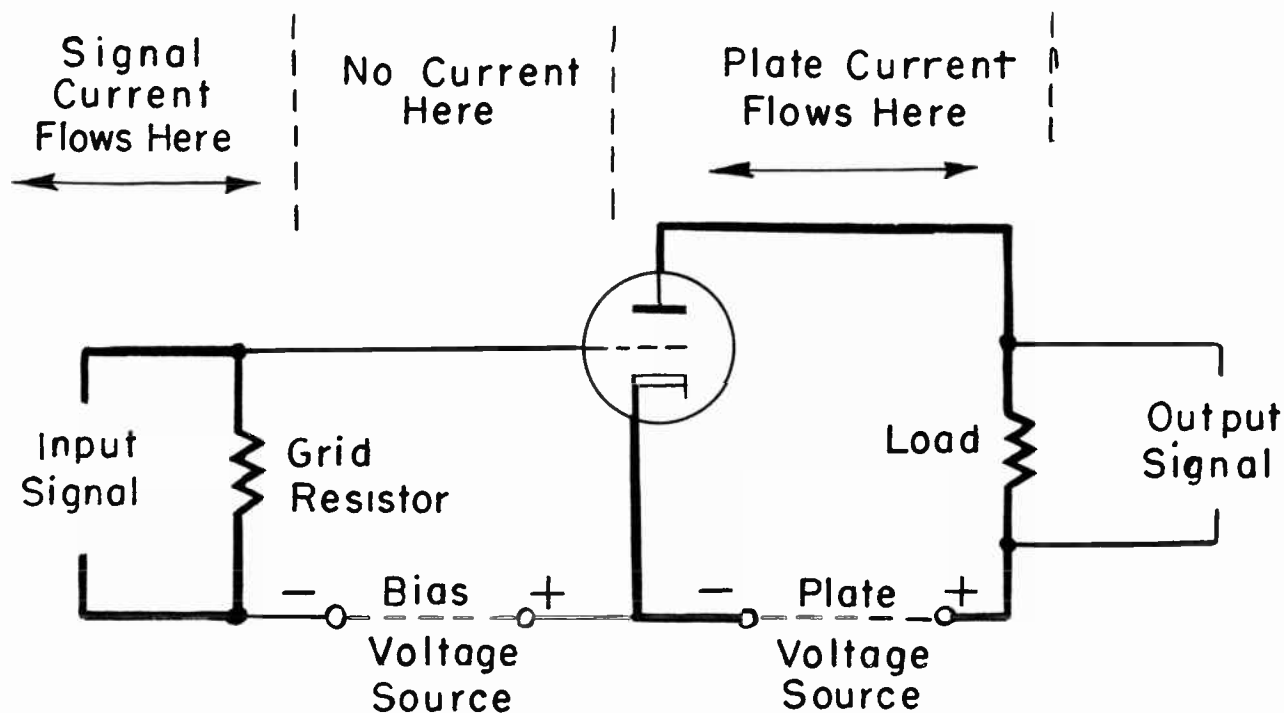

Fig. 2. Elementary circuit connections for a triode amplifier tube.

The same amplifier circuit is shown by Fig. 3, but with connections arranged as on the test panel to include the meters. In examining this layout diagram it is necessary to keep in mind the difference between voltmeters and current meters. The resistance of a voltmeter is very high, so high that the meter carries only negligible current and, so far as the present diagram is concerned, may be regarded as an open circuit. The voltmeter indicates potential differences between points to which it is connected, but should not be considered as forming a current path between these points.

The resistance of a current meter is very low, so low that the meter does not add enough resistance to the circuit with which it is in series to affect the performance of that circuit. The plate current meter is in series with the plate of the tube, and carries all current flowing in the plate. The cathode current meter is in series with the cathode, and carries all current flowing to the cathode. All the voltmeters are connected between points whose voltages we wish to measure.

The input voltmeter reads to the right of zero when signal voltage is of such polarity as would make the grid of the tube positive

were it not for the opposing negative bias voltage. This meter reads to the left of zero when signal voltage polarity is such as to make the grid negative. As mentioned before, the grid volts meter and bias volts meter indicate negative voltages. All the other voltmeters indicate positive voltages.

Wiring on the back of the test panel is not quite so simple as the layout diagram would indicate. It is pictured by Fig. 4. Mounted on the meters are various resistors which compensate for slight inaccuracies and which, in the case of the voltmeters, add the necessary high resistances.

Immediately below the three tube sockets, at the upper center, is a group of terminals which allows making correct socket connections to the testing circuits for whatever type of tube may be tested. There are nine terminals for base pins or socket lugs, and six for the testing circuits. Interconnections are made to suit any particular tube. Testing voltages are furnished from an external adjustable power supply connected to the panel at terminals along the bottom edge.

WHY BIAS VOLTAGE IS NEEDED. Signal voltages applied to the grid circuits of

# COYNE - television home training

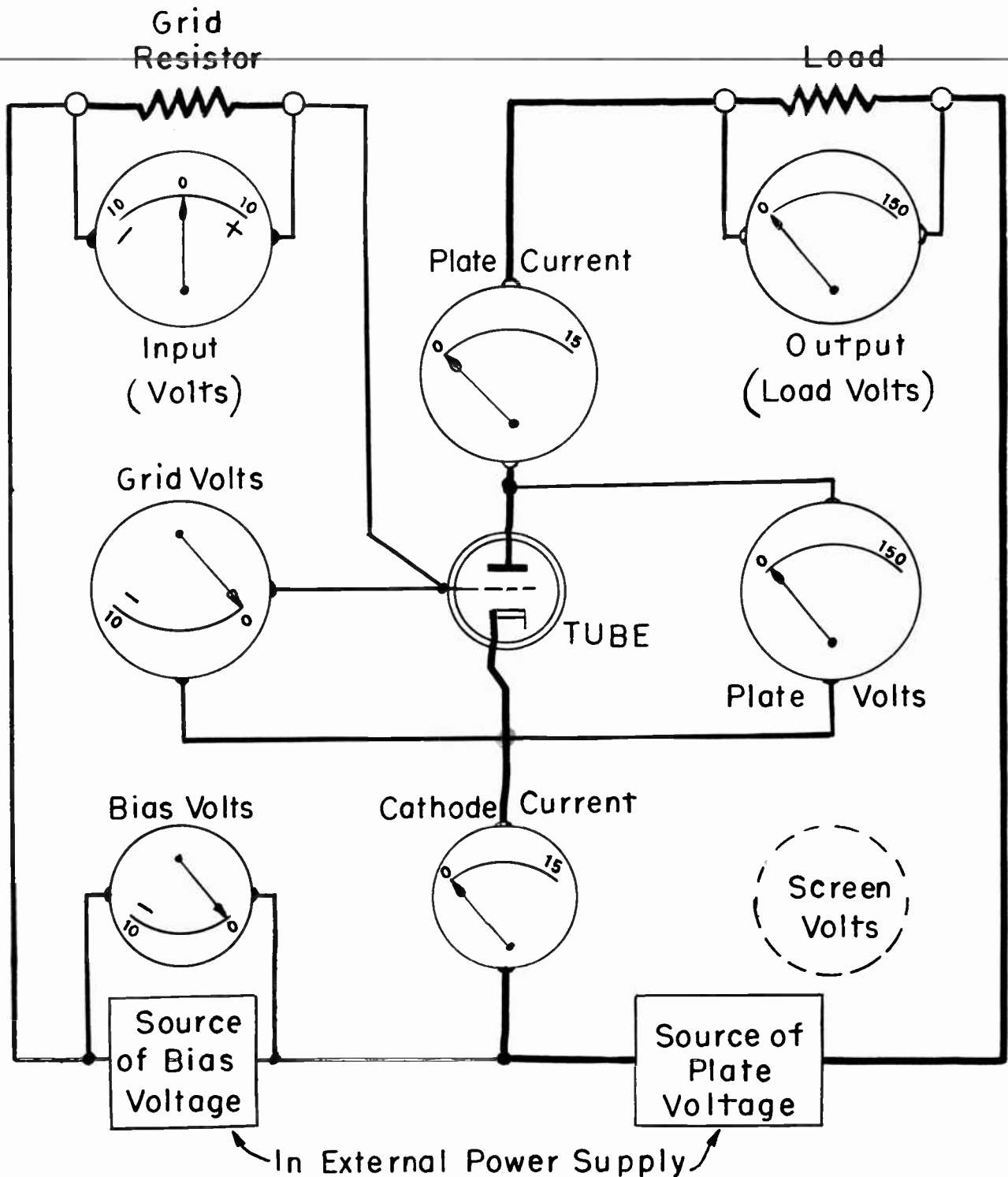

Fig. 3. How the meters of the test panel are connected to the elements of the triode tube and to the power supply voltages.

amplifier tubes nearly always are alternating voltages. In the plate circuit load we wish to have a voltage of the same form as the alternating signal voltage, but of greater strength. Anything which causes changes of

load voltage or output voltage to be of different form than input signal voltage will distort the signal.

If an alternating signal voltage were to

## LESSON 17 – SIGNAL AMPLIFICATION

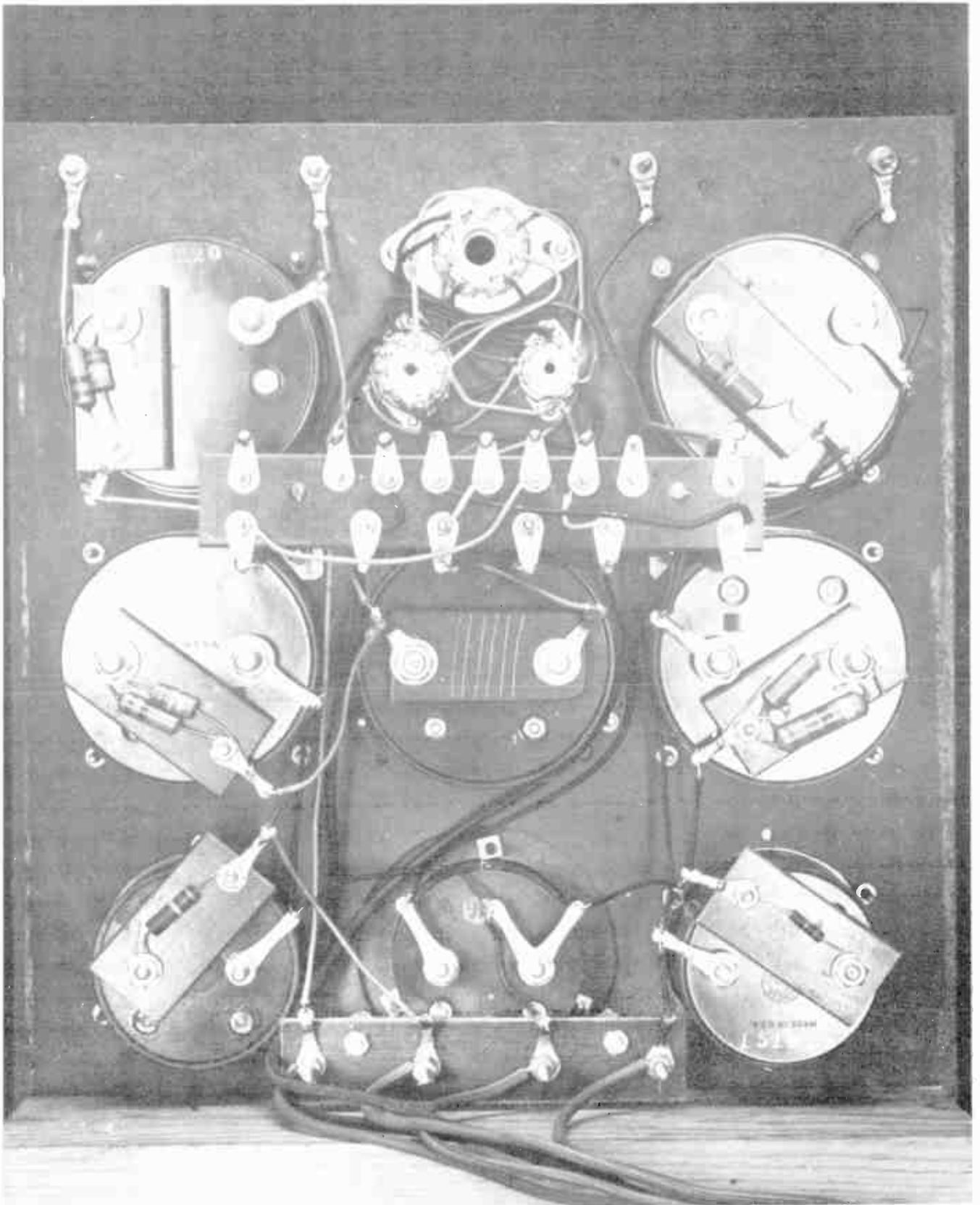

*Fig. 4. Wiring of the meters and the tube socket terminals on the back of the test panel.*



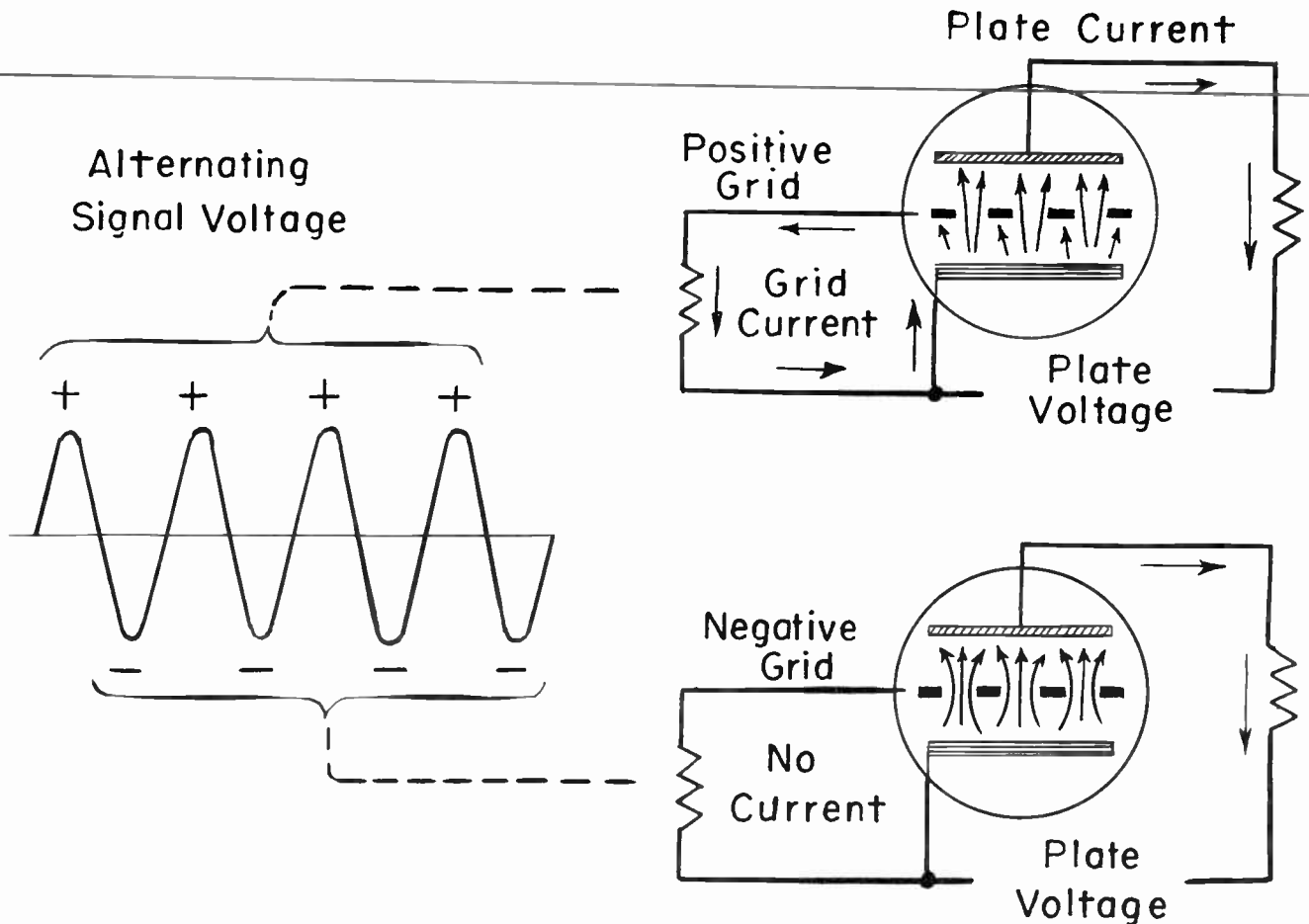

Fig. 5. When the grid is positive some of the electron flow passes through the external grid circuit, while with a negative grid all flow is to the plate of a triode tube.

be applied between grid and cathode of the amplifier tube, unaffected by any other voltage, the results would be as shown by Fig. 5. Signal alternations of one polarity make the grid positive with reference to the cathode, while alternations of the opposite polarity make the grid negative with reference to the cathode.

During those alternations which make the grid positive, some of the electrons emitted by the cathode flow to the grid and through the external grid circuit back to the cathode. This grid current passes through the grid resistor to which the signal voltage is being applied. The grid current causes a voltage or a potential difference to appear across the grid resistor. This voltage due to grid current combines with the signal voltage, and as a consequence the actual voltage be-

tween grid and cathode is no longer that of the signal alone.

During opposite alternations of signal voltage the grid is made negative. No electrons can pass from the cathode into the negative grid, and there is no grid current in the external circuit nor in the grid resistor. Now the voltage across the grid resistor, and between grid and cathode of the tube, is only that of the applied signal. Obviously, this voltage across the grid resistor is not the same as when there is grid current. As a result the grid voltage and plate current during signal alternations of one polarity will not be the same as during signal alternations of the opposite polarity. The output voltage in the load resistor will not be the same during both signal alternations, and there will be distortion.

## LESSON 17 – SIGNAL AMPLIFICATION

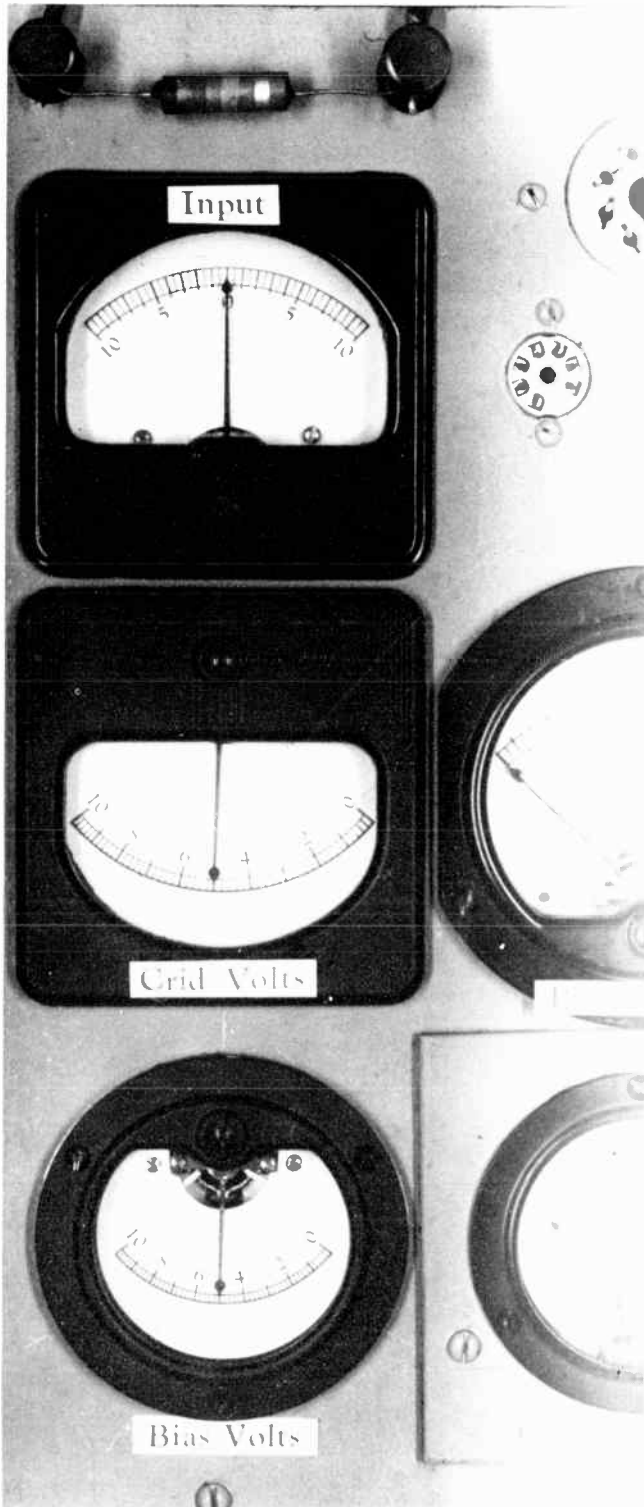

Fig. 6. With no signal, the grid voltage is the same as the bias voltage.

To avoid such distortion of the signal it is necessary to prevent flow of grid current. This can be done by keeping the grid negative even during signal alternations

which tend to make the grid positive. To keep the grid negative we must use a bias voltage between the cathode and grid, as shown by Fig. 2. This bias voltage acts on the grid through the grid resistor. If this bias voltage is as strong, or is stronger than the most positive peaks of signal voltage, it will balance or overbalance those positive peaks, and the grid never will become positive. Alternations of signal voltage will combine with the bias voltage to make the grid less negative when these alternations are positive, and to make the grid more negative when the signal alternations are negatives.

Now let's see what actually happens when a bias voltage and an alternating signal voltage are applied between the grid and cathode of a tube. In Fig. 6 there is a bias of 5 volts negative, as shown by the bottom meter on the left-hand side of the test panel. This voltage is acting through the grid resistor and, as shown by the Grid Volts meter, is making the grid 5 volts negative with reference to the cathode. No signal is being applied, the Input meter stands at zero.

With the grid negative with reference to the cathode there is no grid current in the grid resistor. With no signal there is no signal current in this resistor. With no current there is no difference of potential across the grid resistor, both ends are at the same potential, and thus the negative potential from the bias source is applied to the grid without change.

In Fig. 7 there is a 4-volt negative signal, as shown by the Input meter reading to the left of its zero. This represents signal voltage at an instant when an alternating signal voltage has swung to a maximum negative potential of 4 volts. We cannot show an actual alternating voltage because the meter would not follow the voltage swings, and even though the meter could do this you could not see it in a still picture. Therefore, we are using a direct signal voltage which may be adjusted to the value of an alternating voltage at any point in a cycle.

The 4-volt negative signal combines with the 5-volt negative bias, and the grid is made 9 volts negative with reference to the

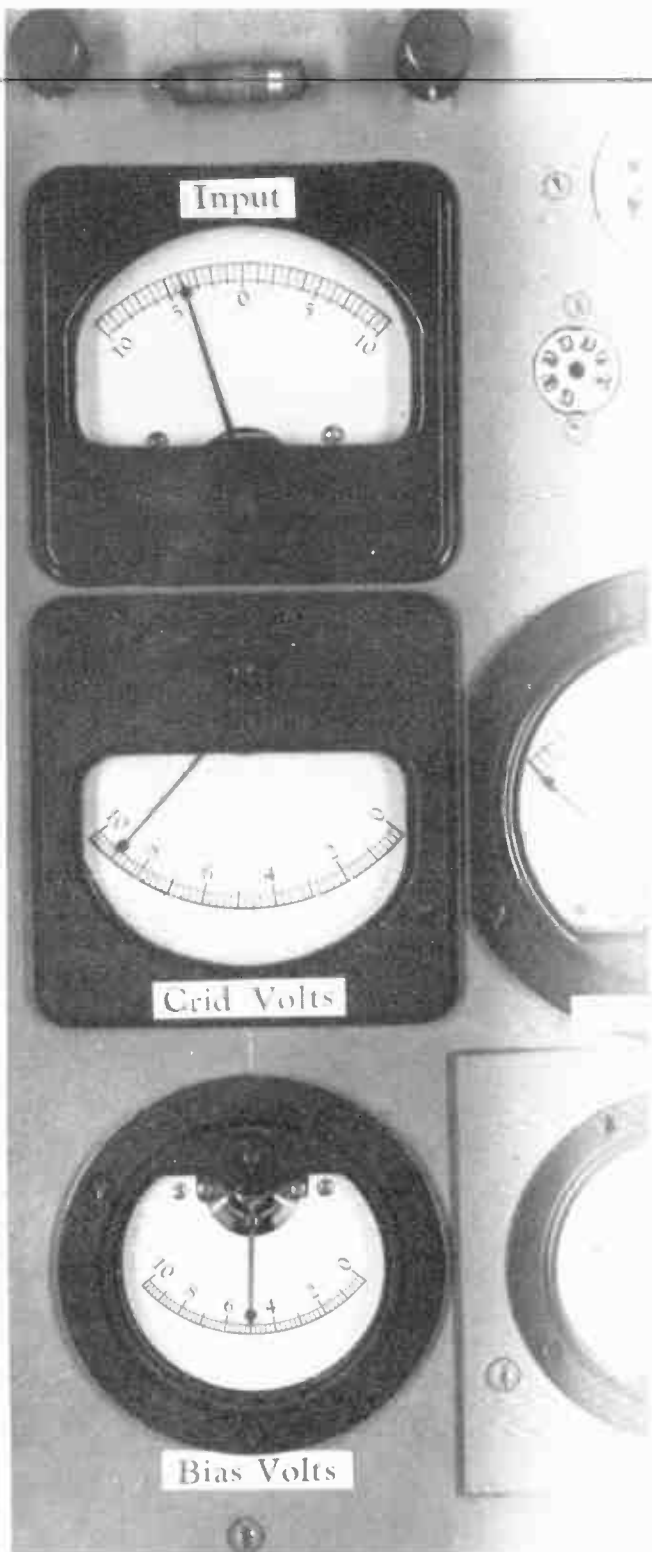

Fig. 7. The 4-volt negative signal combines with the 5-volt negative bias to make the grid 9 volts negative with reference to the cathode.

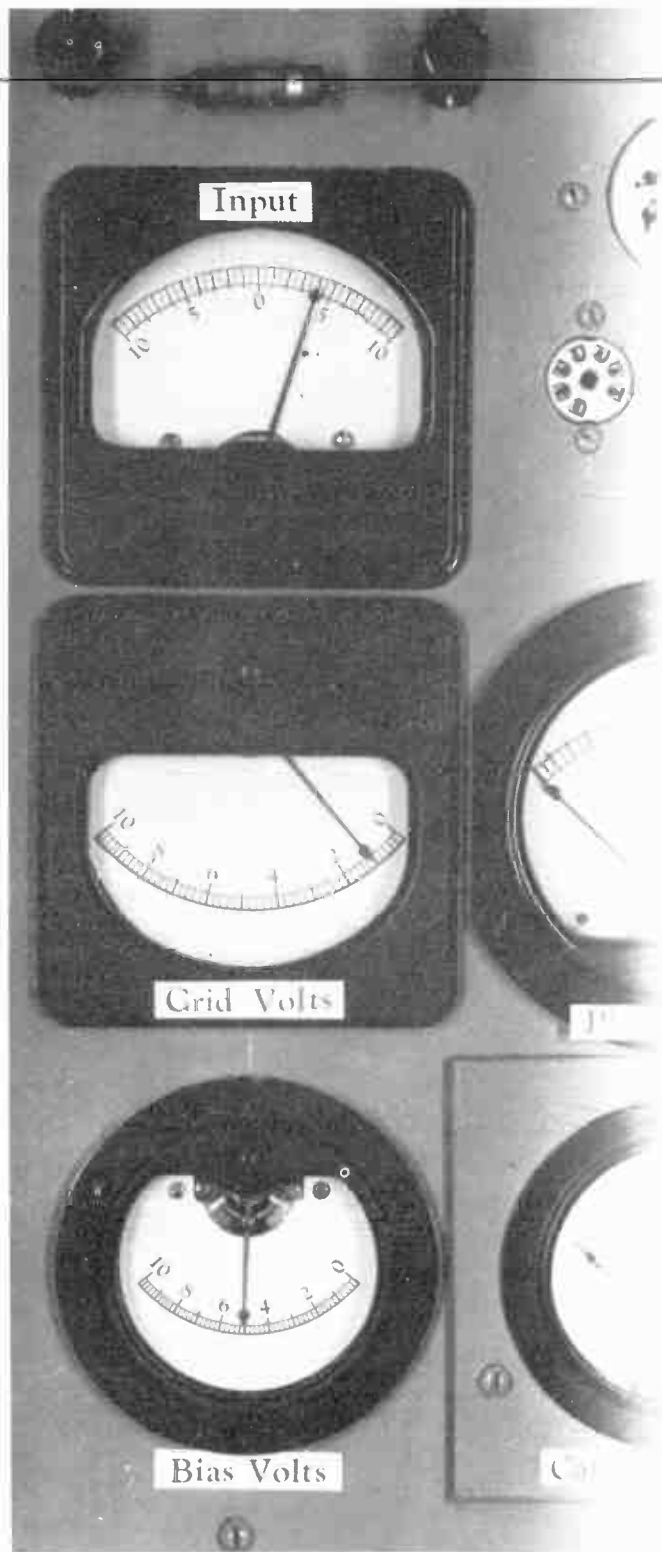

Fig. 8. The 4-volt positive signal counteracts part of the 5-volt negative bias, and the grid becomes 1 volt negative with reference to the cathode.

cathode of the tube. This is shown by the Grid Volts meter.

In Fig. 8 the signal voltage (on the Input meter) has been made 4 volts positive, as



## LESSON 17 – SIGNAL AMPLIFICATION

shown by the pointer swinging toward the right from zero on the dial. Again the signal voltage and bias voltage combine, and the grid is made 1 volt negative with reference to the cathode. The bias voltage is trying to make the grid 5 volts negative while the signal is trying to make the grid 4 volts positive. The 4-volt positive signal counteracts 4 volts of the total 5-volt negative bias, and leaves 1 volt negative as the actual grid voltage, shown by the Grid Volts meter.

The total swing of signal voltage, from maximum negative to maximum positive, is 8 volts. It swings 4 volts in each direction from zero. The total change of grid voltage also is 8 volts, from 9 volts negative to 1 volt negative. The change of grid voltage is exactly the same as the change of signal voltage, yet the grid always remains negative while the signal goes back and forth between negative and positive.

As we have heard before, the maximum swing of signal voltage in either polarity from its zero value is the amplitude of the signal voltage. It is quite evident that the negative bias voltage must be at least equal to the amplitude of signal voltage in its positive polarity if the grid is to remain negative.

In Fig. 9 we again have the 4-volt positive swing or amplitude of signal voltage, on the Input meter. But now the bias voltage, on the Bias Volts meter, is only 3 volts negative. The pointer of the Grid Volts meter has moved off scale to the right, indicating that the grid now is positive with reference to the cathode. The grid actually has been made 1 volt positive, because the 3 volt negative bias is counteracting only 3 volts out of the total 4 volts of positive signal amplitude.

In order that the grid may remain negative at all times the negative bias voltage may be any amount in excess of maximum positive signal amplitude, but the bias must not be less than this maximum positive signal amplitude. With such a negative bias the changes of grid voltage will follow the changes of signal voltage precisely, but the grid cannot become positive and there can be no grid current.

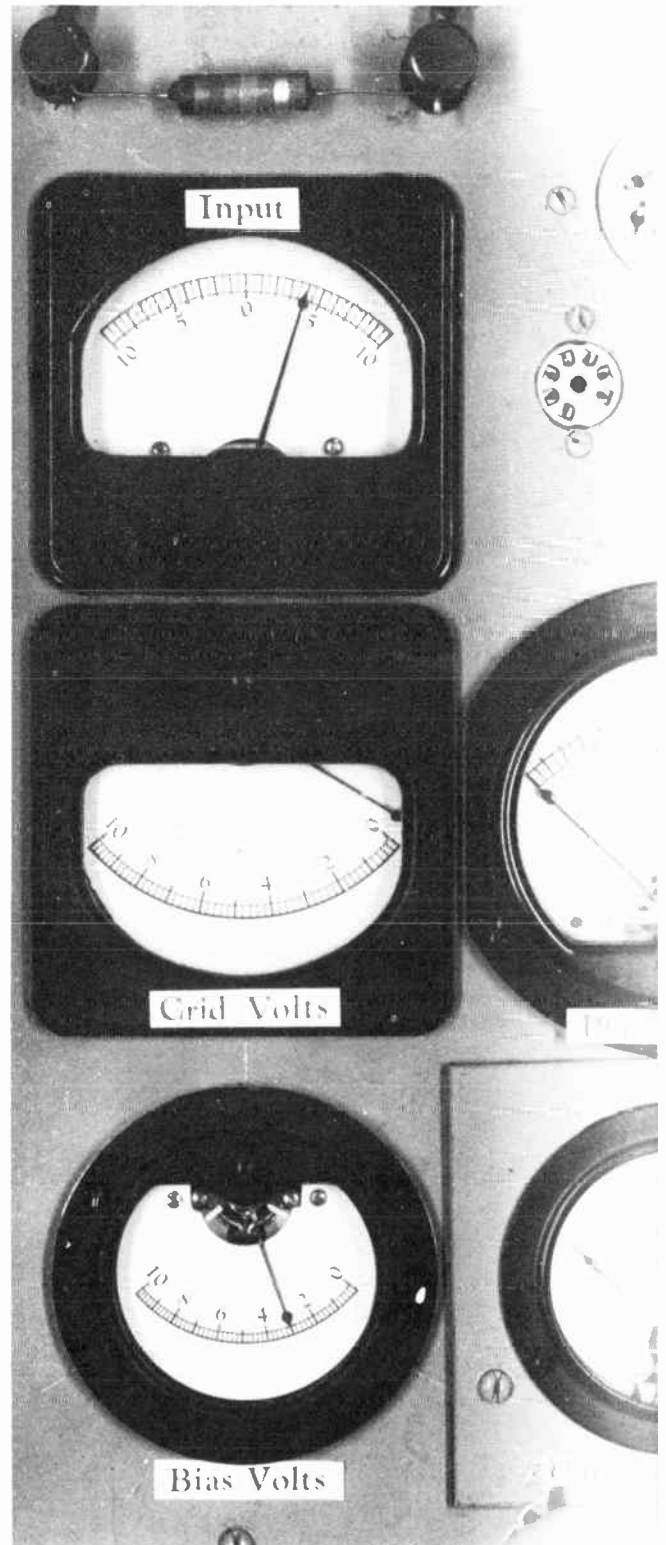

Fig. 9. When the negative bias voltage is less than a positive signal voltage, the grid is made positive with reference to the cathode.

During our experiments with bias and signal voltages there has been no tube in any of the sockets. The grid voltages would not



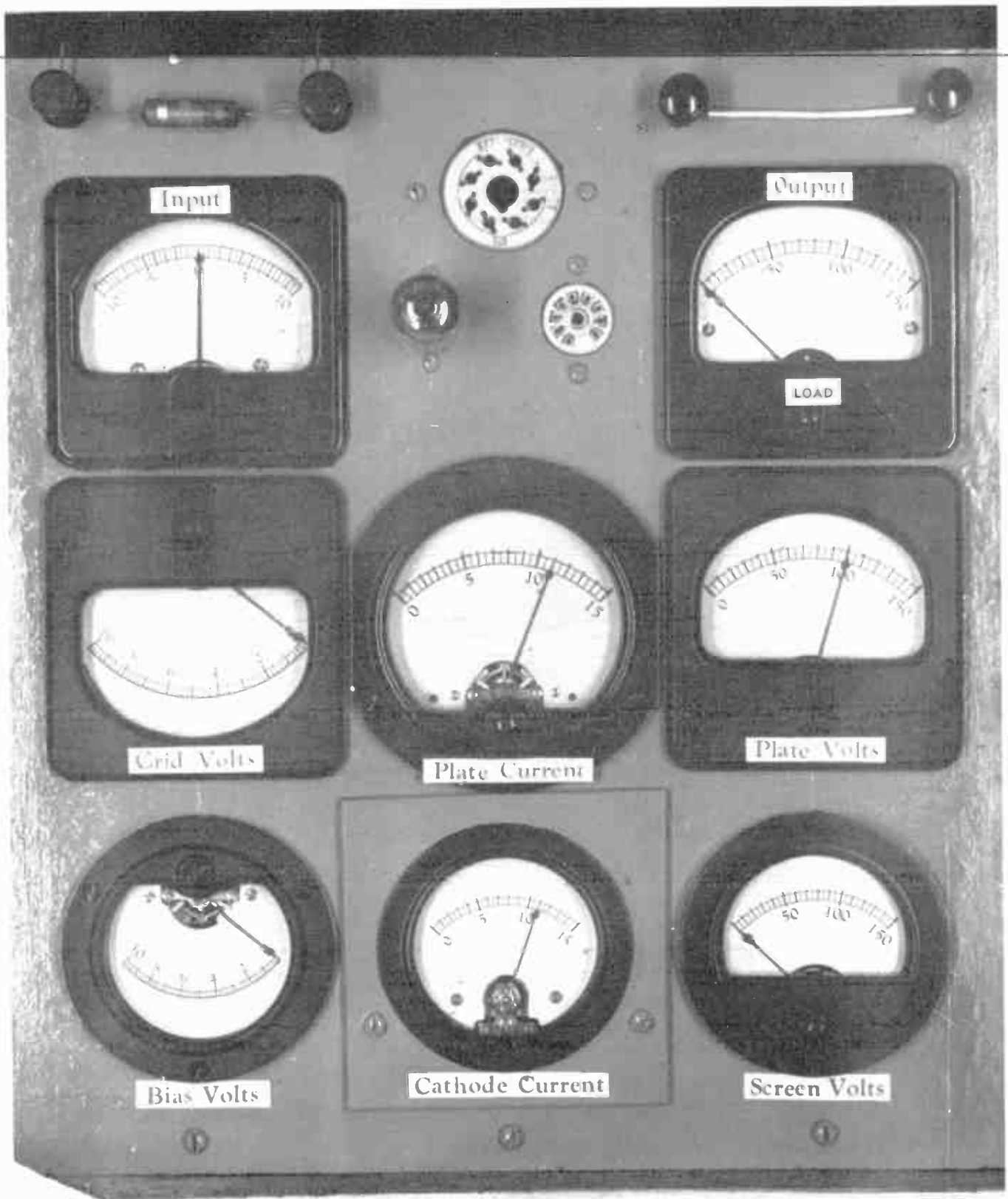

Fig. 10. Plate current of the triode tube when the grid is zero and the plate is 100 volts positive.

## LESSON 17 – SIGNAL AMPLIFICATION

have been affected one way or the other by having a tube in the circuit. Grid voltage depends on the relations between signal voltage and bias voltage, and it is the same whether or not there is a tube in the grid circuit. The grid voltage is applied to a tube when present, but the voltage is there anyway.

PLATE CHARACTERISTICS. Now we are ready to measure the performance of a triode tube. For this purpose we shall use a 6C4 tube, which is a miniature type having a 7-pin base. It is widely employed in high-frequency service testing equipment and in the tuners of some television receivers. This tube is a single unit triode having the same operating characteristics as either section of the 12AU7, which is a twin triode found in a great many television receivers.

In Fig. 10 a 6C4 triode is in the 7-pin socket of our tube testing panel. Bias voltage is zero, there is no input signal, and grid voltage is accordingly zero. Note that there is no load resistor in the plate circuit, this resistor having been replaced with a length of wire between the terminals immediately above the output meter. Consequently, the output meter indicates zero voltage, since it is connected across the wire of practically zero resistance. Plate voltage is 100. Plate current is 11.0 ma. Cathode current also is 11.0 ma, because in a triode with a zero or negative grid all the electron flow from the cathode goes to the plate, none to the grid.

In Fig. 11 the plate voltage still is 100, but instead of zero bias we have a bias of 5 volts negative. With no signal being applied this, of course, makes the grid 5 volts negative. The plate current has been reduced from its former value of 11.0 ma with a zero bias down to 1.5 ma with the grid 5 volts negative. The negative grid is retarding the electron flow to this extent.

After making many measurements of plate currents produced by various plate voltages with different biases or grid voltages we could plot the curves of Fig. 12 showing all the relations between plate current, plate voltage, and grid voltage. On this graph there are curves for grid voltages of zero, of 2.5 volts negative, 5.0 volts negative, 7.5 volts

negative, and 10.0 volts negative. Any number of other and intermediate curves might be drawn after making suitable measurements.

Each of the curves in Fig. 12 is called a plate characteristic. A group of such curves is called a family of plate characteristics. Graphs showing families of plate characteristics are published by tube makers for all of the tubes in general use. The published characteristics are averages for all tubes of a given type. One particular tube may differ in its performance from the average characteristics, but all tubes of good quality, which are in good operating condition and not too old in service will perform very much as shown by the published curves.

PLATE CURRENT CUTOFF. On the characteristic curve for zero grid volts there is zero plate current when plate voltage is zero. Then the current increases at a more or less uniform rate with increasing plate voltage. But the curves for all negative grid voltages come down to the line for zero plate current before plate voltage is dropped to zero. There is plate current cutoff, due to negative grid voltage, while the plate is still positive with reference to the cathode.

This effect is illustrated by Fig. 13. Grid bias and grid voltage are 5 volts negative. Plate voltage is about 58 or 59. Yet plate current, and cathode current, are zero. This is the condition shown at the bottom end of the curve for 5 volts negative grid in Fig. 12, it is the point of plate current cutoff for the particular tube being tested.

Were the plate voltage increased ever so little, plate current would commence to flow and would increase with increase of plate voltage. For all plate voltages less than the cutoff value the current will remain zero. For all grid voltages more negative than 5 volts the plate current will remain zero with 58 or 59 volts on the plate. But were the grid voltage to be made less negative, even by a small amount, plate current would commence to flow and it would increase with the grid made less and less negative.

At plate current cutoff the negative grid voltage is exactly counteracting the positive

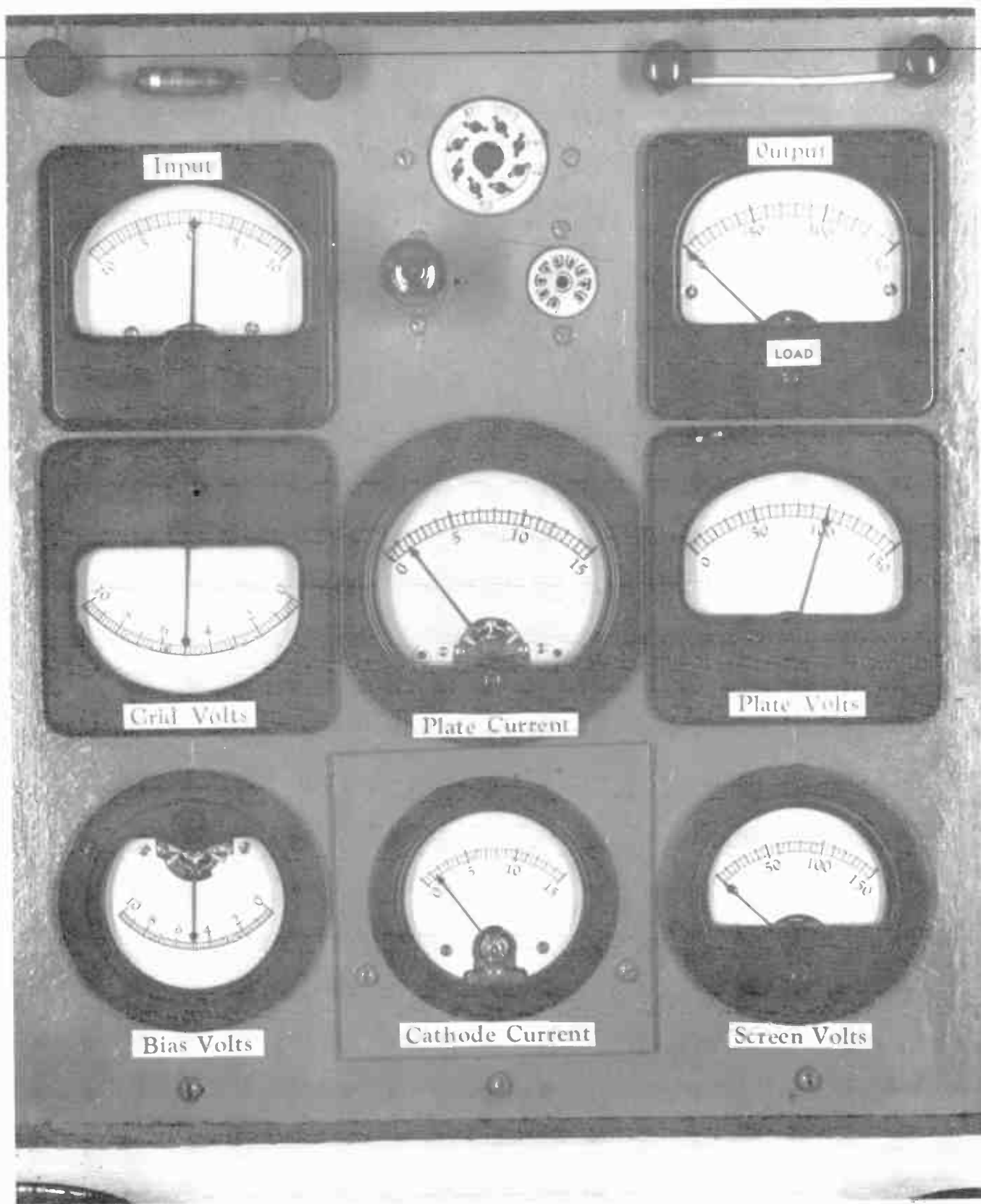

Fig. 11. When the bias and grid voltages are made negative, with plate voltage unchanged, there is a decrease of plate current.



# LESSON 17 – SIGNAL AMPLIFICATION

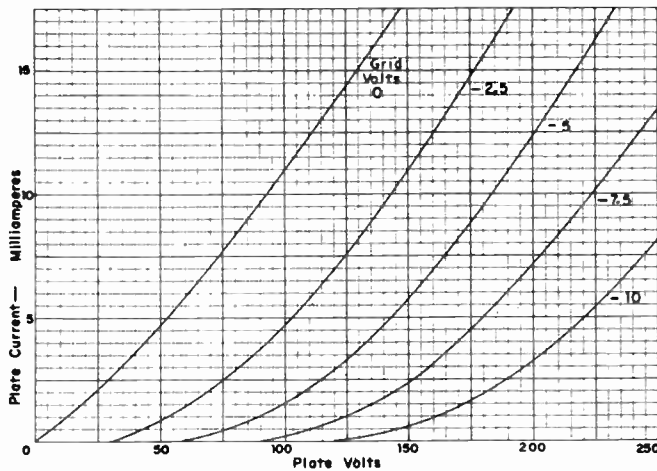

Fig. 12. A family of plate characteristics for the 6C4 triode tube.

plate voltage so far as electron flow is concerned. The negative grid voltage which causes cutoff is much less than the positive plate voltage that no longer is effective in drawing electrons through the grid to the plate. This is because the grid is much closer to the cathode than is the plate, and grid voltage exercises much greater control of electron flow than does plate voltage.

Plate current cutoff is an exceedingly useful property of triodes and of all other tubes containing control grids. You will find this action employed time and again in television circuits which will be examined in later lessons.

**SIGNAL AMPLIFICATION.** Now we shall watch the triode tube amplify a signal voltage. In Fig. 14 the signal, shown by the Input meter reading to the right, is 3.0 volts positive. In order to make sure that no grid current will flow the bias is made 4.0 volts negative. Grid voltage then is the difference between the bias and the signal, and is 1.0 volt negative.

Plate voltage is about 89. This plate voltage, with the grid 1.0 volt negative, causes plate current of 6.5 ma. The cathode current is of the same value as the plate current.

This plate current is flowing through the load resistor which is mounted above the Output meter. This meter shows that the

potential difference or voltage drop across the load is about 111 volts.

The power supply must be furnishing a total of 200 volts, which is the sum of 89 plate volts and 111 load volts. The tube, between cathode and plate, and the load resistor are in series with each other across the power supply voltage, since the negative side of the power supply is connected to the cathode and the positive side to one end of the load resistor. This series circuit shows up clearly in Fig. 2, also in Fig. 3.

The total voltage of the power supply always must divide between the resistance of the tube, cathode to plate, and the resistance of the load. Saying this another way, the power supply must furnish a voltage equal to the sum of the plate voltage and the load voltage.

Now we shall assume that the signal voltage decreases from its positive peak of 3.0 volts to zero. Remember, our slowly changing signal voltage represents an alternating signal voltage that swings continually back and forth between positive and negative peaks, going through zero in between.

The results of the zero signal voltage are shown by Fig. 15. The bias is unchanged, at 4.0 volts negative, and since there is no signal voltage combining with the bias, the grid is 4.0 volts negative. Supply voltage is still 200, this being evident from the fact that plate voltage now is 125 while load voltage is 75. With 125 volts on the plate, and a negative bias of 4.0 volts, plate current has decreased to 4.0 ma.

We may assume that the signal voltage has equal amplitudes in both polarities, and that next it swings to a negative peak of 3.0 volts. What happens is shown by Fig. 16. The negative signal voltage is indicated by the Input meter. Bias is still 4.0 volts negative. The negative signal and the negative bias combine to make the grid 7.0 volts negative. If you look closely at the reading of the Grid Volts meter you will see that it falls a little short of 7.0 volts, the pointer actually standing at approximately 6.9 volts negative. This is due to the fact that we have service grade meters on our test panel, and such meters may be in error by as much as two



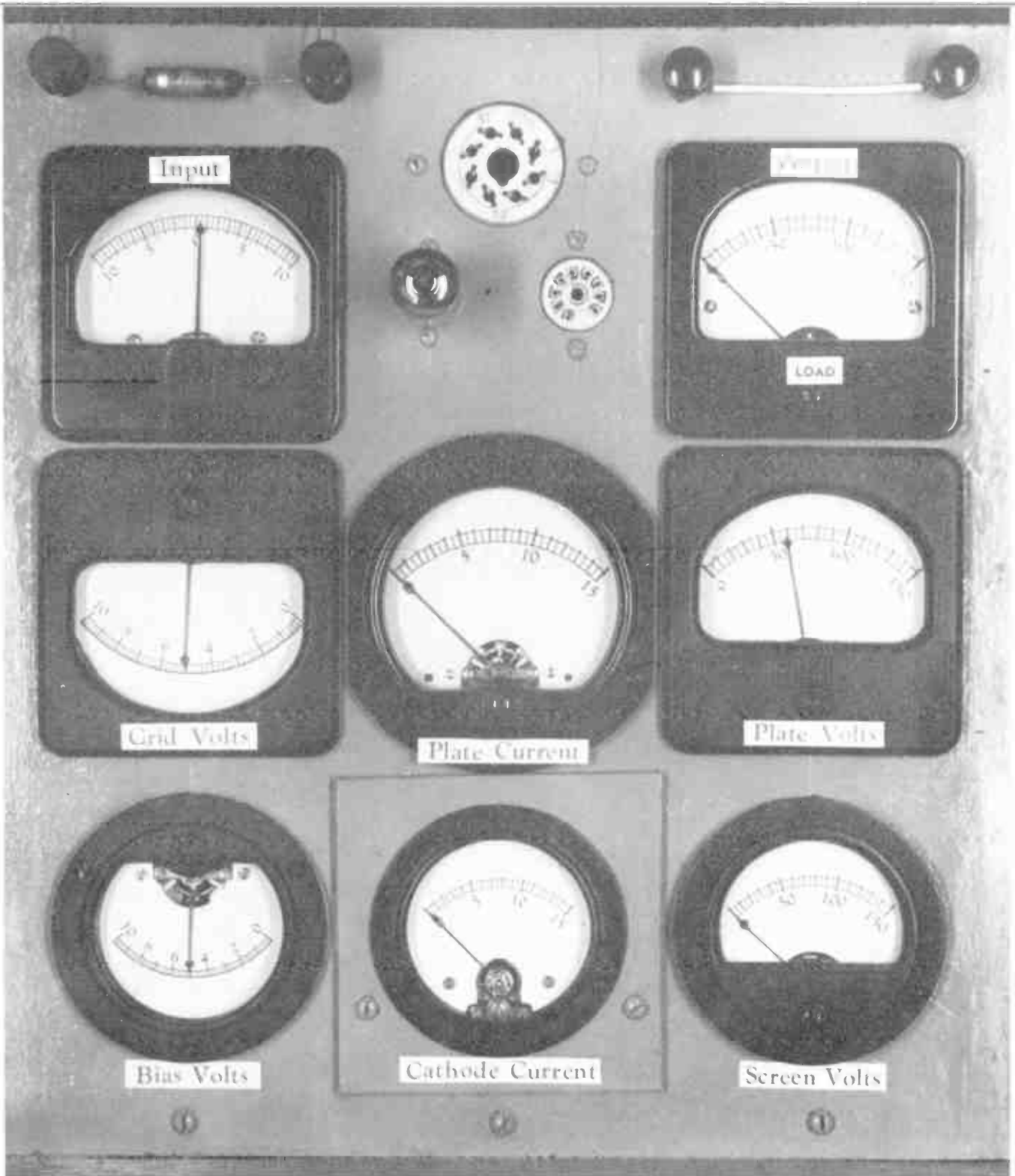

Fig. 13. A grid voltage sufficiently negative causes plate current cutoff, even though the plate is positive.

## LESSON 17 – SIGNAL AMPLIFICATION

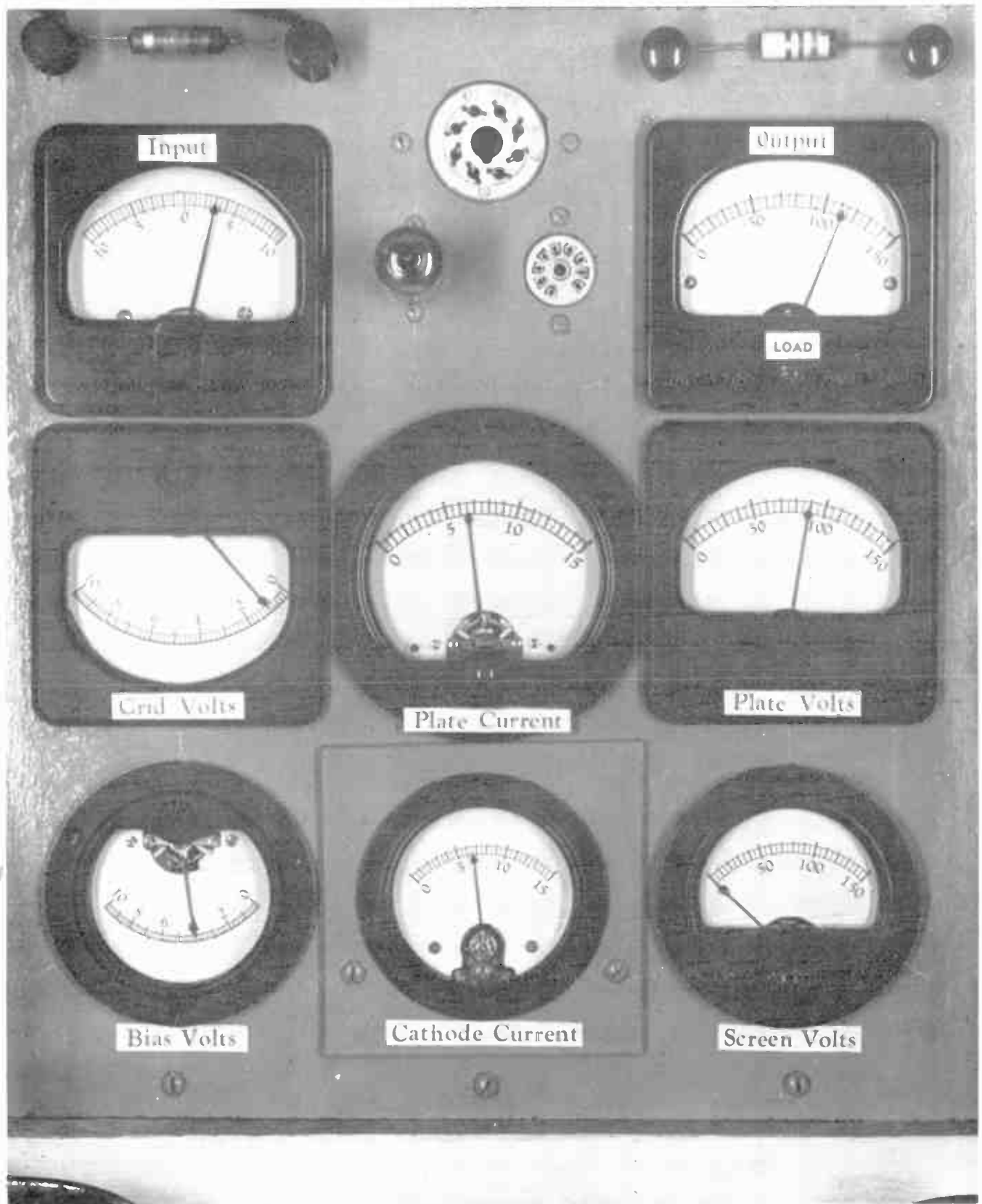

Fig. 14. Here are shown the current and voltages in the plate circuit when the signal swings 3 volts positive while the bias is 4 volts negative.

**COYNE - television home training**

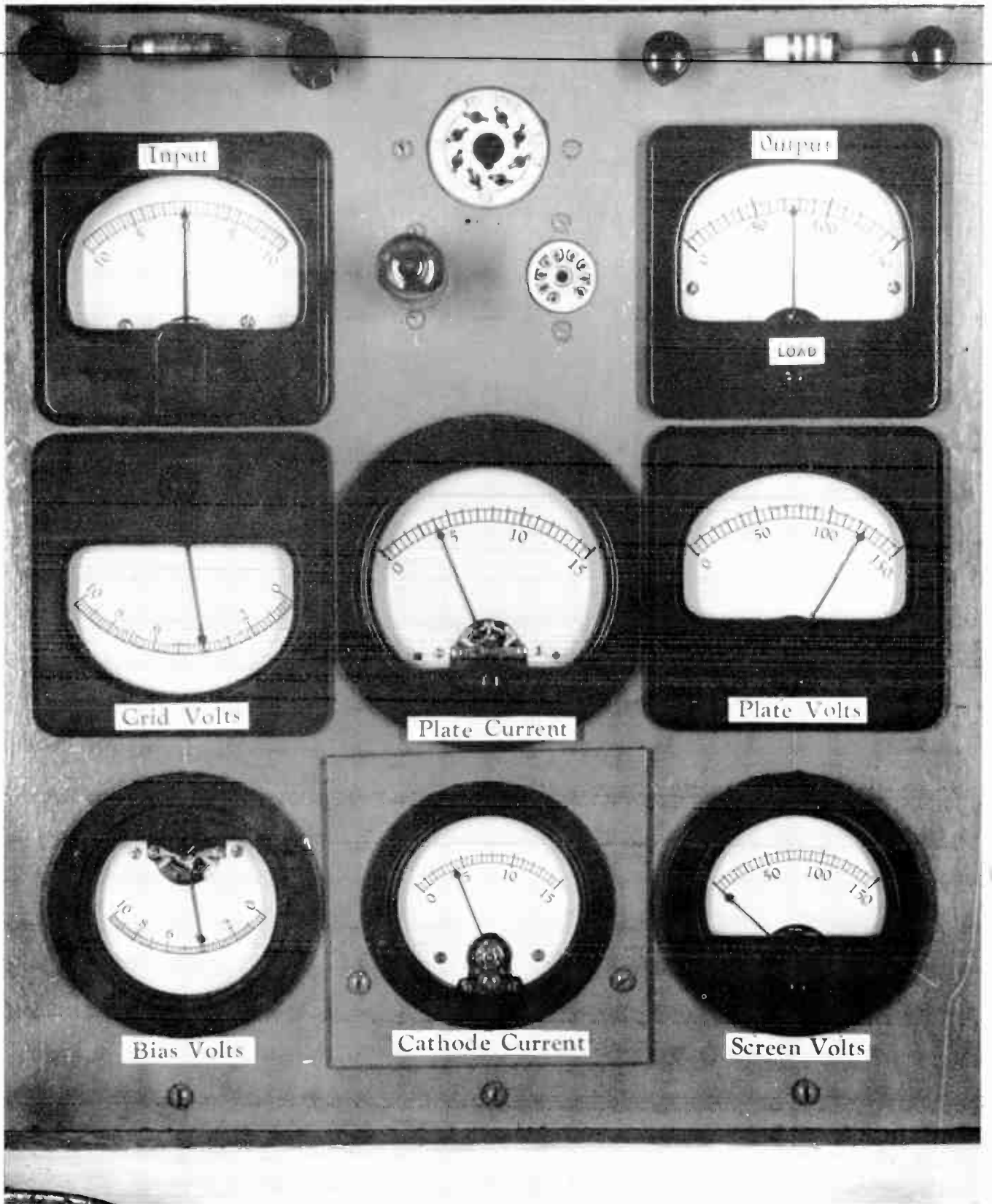

Fig. 15. When signal voltage goes through zero the grid becomes more negative and there is a reduction of plate current in the tube and the load.



## LESSON 17 – SIGNAL AMPLIFICATION

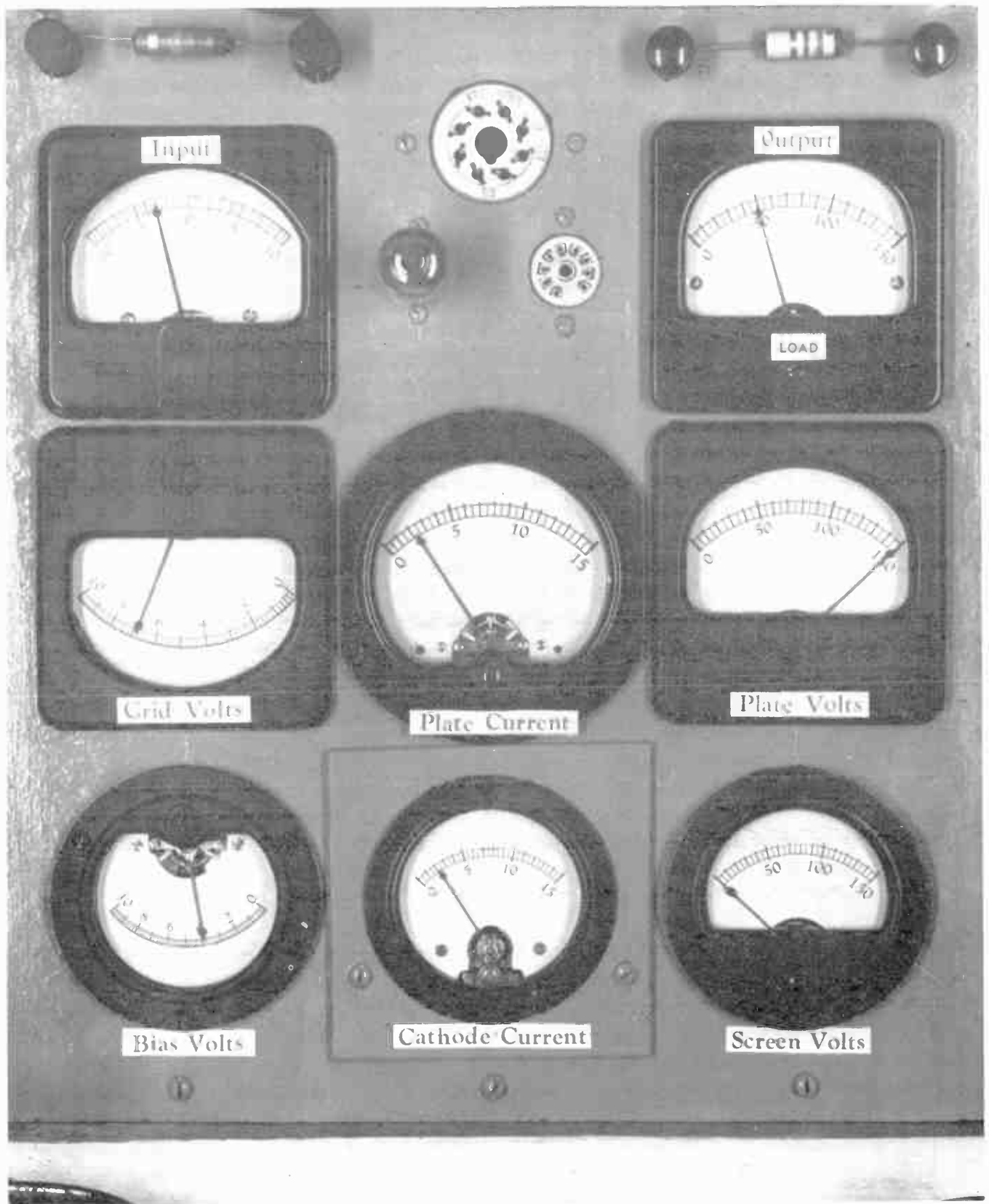

Fig. 16. As the signal goes from zero to negative the grid becomes even more negative than before, and there is further reduction of plate current.



# COYNE - *television home training*

per cent of the voltage or current at full scale. The error of about 0.1 volt, the difference between 7.0 and 6.9 volts, is less than two per cent of the full scale value, which is 10.0 volts.

Returning to the readings with the signal 3.0 volts negative we note that plate current has decreased to about 2.3 ma. This is due primarily to the increased negative grid bias. Plate voltage has increased to 150, while voltage across the load resistor has dropped to 50. The sum of the plate voltage and load voltage remains at 200, which is the voltage being furnished by the power supply for all our tests.

The signal has changed through a total of 6.0 volts, from 3.0 volts positive through zero to 3.0 volts negative. The grid voltage has changed by the same total, from 1.0 volt negative to 7.0 volts negative.

The useful output voltage of the amplifier is that which appears across the load resistor. It is only the change of voltage across this resistor which can be applied to some circuit following the amplifier in a receiver. The total change of load voltage or output voltage has been 61, from 111 volts with the signal 3.0 volts positive to 50 volts with the signal 3.0 volts negative. The 6-volt change in the signal has caused a 61-volt change at the amplifier output. Therefore, the signal voltage has been amplified by a little more than 10 times.

The strengthening of the signal by the process which we have watched on the test panel usually is referred to as voltage gain. With the 6C4 tube operated with the voltages which have been applied in the tests, and with the particular value of load resistor employed, the voltage gain is a little more than 10 times.

AMPLIFICATION FACTOR In lists of typical operating characteristics of triode tubes the manufacturers often list a characteristic called amplification factor. This factor is the ratio of the change in plate voltage which is required to bring plate current back to a former value, to the change of grid voltage that altered the plate current.

The meaning of amplification factor is more easily understood by following an example or a test, as follows. With the 6C4 tube that we have been using, the grid voltage was adjusted to zero. Plate current was adjusted to 8.0 ma, which required 79 volts on the plate of the tube. Then the grid voltage was made 1.0 volt negative. This reduced the plate current, and in order to bring the current back to 8.0 ma it was necessary to increase the plate voltage to 100.

The change of grid voltage was 1.0. The change of plate voltage was 21.0, from 79 to 100. The ratio of 21.0 to 1.0 is 21. Therefore, for this particular value of plate current, the amplification factor of this tube was found to be 21. This is a somewhat greater amplification factor than found with average 6C4's. The amplification factor is greater than any voltage gain which can be realized in practice. Amplification factors do, however, indicate the relative values of tubes as voltage amplifiers. When specified operating conditions are observed, a tube with a greater amplification factor can be made to give a greater voltage gain than one with a lesser amplification factor.

Amplification factor really indicates the relative effectiveness of grid voltage and plate voltage in altering the plate current. If a tube has an amplification factor of 21, for example, grid voltage is 21 times as effective as plate voltage in altering the plate current.

PLATE RESISTANCE. Another operating characteristic usually listed for triodes, as well as for other kinds of tubes, is called plate resistance. Plate resistance is the ratio of a change in plate voltage to the resulting change in plate current when the voltage on the control grid and on any other elements remains unchanged. Except for the fact that we deal with changes of voltage and current rather than with single fixed values, the computation of plate resistance for a tube is no different from computation of any ordinary resistance. You can see that the two computations are very similar by comparing the following formulas, one of which is used for ordinary resistances and the other for plate resistances.

## LESSON 17 – SIGNAL AMPLIFICATION

$$\text{Resistance, ohms} = \frac{1000 \times \text{volts}}{\text{milliamperes}}$$

$$\text{Plate resistance, ohms} = \frac{1000 \times (\text{change of plate voltage})}{(\text{change of milliamperes})}$$

Plate resistance can be computed quite easily from plate characteristic curves such as those of Fig. 12. As an example, consider the curve for zero grid volts. At 85 volts on this curve the plate current is 9.0 ma. At 90 volts the current is about 9.6 milliamperes. The change of plate voltage is 5.0 volts, and the accompanying change of plate current is 0.6 ma. We use the formula thus.

$$\text{Plate resistance, ohms} = \frac{1000 \times 5}{0.6} = \frac{5000.0}{0.6} = 8330 \text{ ohms, approximate}$$

On the curve for 7.5 volts negative grid we may consider the change from 180 to 185 plate volts, with which there is a change from 5.0 to 5.5 ma. The plate voltage changes by 5.0 volts, the current changes by 0.5 ma, and indicated plate resistance is 10,000 ohms. Plate resistance of any tube varies with plate voltage and current for which the resistance is computed. In making any such computations there must be no change of grid voltage. There is no change of grid voltage when all the values are taken from the same plate characteristic curve, as in the preceding examples.

When a tube is operated in a manner to have high plate resistance, relatively high plate voltage is required to produce any given plate current. You can judge approximate plate resistances or their relative values by noting the slope of plate characteristic curves. For example, near the top of the curve for a 5-volt negative grid in Fig. 12, where the curve slopes steeply upward, plate resistance is in the neighborhood of 6,000 ohms. Near the bottom of the same curve, where there is little slope, plate resistance approaches 17,000 ohms. Plate resistances always are least for operating conditions represented by the steeper slopes.

**TRANSCONDUCTANCE.** A third characteristic nearly always listed in tables of tube performance is called transconductance. It refers to the change of plate current that results from a change of grid voltage, with plate voltage remaining constant. As an ex-

ample, supposing that a change of 1 volt on the grid causes the plate current to change by 3 ma. This is a change of 3 ma per volt, current being in the plate circuit and voltage in the grid circuit.

To avoid cumbersome decimal fractions when current change is measured in milliamperes and fractions, the current may be measured in microamperes. Since one milliamper is equal to 1,000 microamperes, a change such as 3 ma would be the same as a change of 3,000 microamperes per volt change on the grid. Such a ratio of microamperes of plate current change to volts of grid potential change is called the number of micromhos of grid-plate transconductance.

During a test of our 6C4 triode the plate current was found to be 11.0 ma with 100 volts on the plate and grid zero. Making the grid 1.0 volt negative while holding the plate voltage at 100 reduced the plate current to 8.3 ma. This was a change of 2.7 ma or 2,700 microamperes for the 1-volt change of grid voltage. Transconductance of this particular tube operating at the specified conditions was thus found to be 2,700 micromhos.

A name formerly in general use, and still applied to grid-plate transconductance of a triode, is mutual conductance. Mutual conductance and grid-plate transconductance of a triode are one and the same thing. As a general rule, when using the name transconductance it is understood to mean grid-plate transconductance, or to mean the effect of grid voltage changes on plate current changes. It is not necessary to use the full name of grid-plate transconductance.

It is necessary that we understand the meanings of the terms transconductance, plate resistance, and amplification factor, because their values are specified in all published listings of tube performance. These values are, however, more useful to the designing engineer than to the service technician. The reason is that in determining any one of the three values there may be a change in only two factors while all others are held constant. That is, with transconductance the plate voltage must not change, with

plate resistance the grid voltage must not change, and with amplification factor the plate current must not change.

In actual operation, especially when there is a load resistor in the plate circuit, every change of grid voltage causes variations of both plate voltage and plate current. None of these three factors remains constant. Consequently, it is rather difficult to determine actual voltage gains from the published characteristics. As a rule we resort to measurements with sensitive voltmeters while changing the grid bias, the plate or supply voltage, and the load resistance to obtain desired performance.

**GRID CHARACTERISTICS.** In addition to plate characteristic curves, such as shown by Fig. 12, you often will find in tube manuals and other published data a set or family of grid characteristic curves of the type shown for our 6C4 tube by Fig. 17. A grid charac-

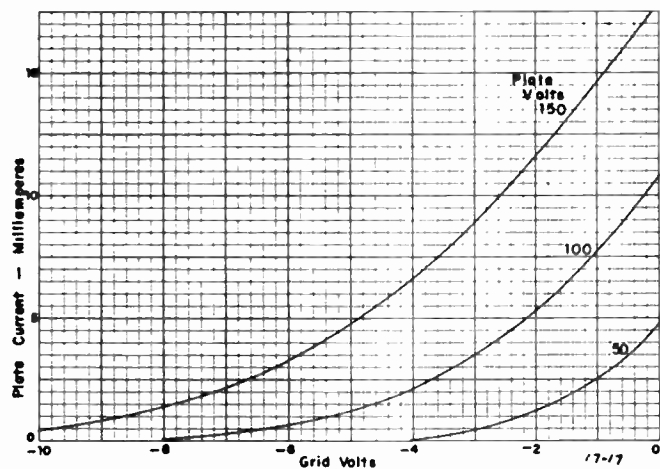

Fig. 17. Grid characteristics of the 5C4 triode with three different plate voltages.

teristic curve shows the relations between plate current and grid voltage for some certain plate voltage. On the graph there are curves for 150 plate volts, for 100 plate volts, and for 50 plate volts. Grid voltages range from zero to 10 volts negative.

Grid characteristics sometimes are called mutual characteristics, indicating their close relation to mutual conductance or transconductance. The curves are useful for

estimating the effect of signal (grid) voltage changes on changes of plate current. They are not directly applicable to service problems because plate voltage is assumed to remain constant along any one curve when the grid voltage varies. As we have seen, every variation of grid voltage or signal voltage causes a change of plate voltage as well as of plate current.

**SIGNAL INVERSION.** In all but a very few television and radio applications a signal voltage applied to the grid of an amplifier tube is an alternating voltage. Such an input signal was represented in Figs. 14 to 16 by a voltage which changed from positive through zero to negative. To complete one alternating cycle the change would continue from negative through zero and back to positive, and there would be a succession of similar changes at the signal frequency.

Amplified changes of voltage appear across the load resistor in the plate circuit. But here the voltage is not alternating, it is the varying plate voltage which always remains positive in order that electrons always may flow from cathode to plate in the tube.

What we need from the amplifier output is not this varying direct voltage, but an alternating voltage which is like the alternating signal voltage, but stronger. By connecting a capacitor as in Fig. 18 it is possible to separate the changes of plate voltage from the average of positive voltage being applied to the plate from the power supply. These changes of voltage will act through the capacitor on any following circuit, such as that of the output resistor in the diagrams.

To see how this works out we may commence by looking back at Fig. 15. Signal voltage is zero. Plate voltage is 125. This is the potential at the plate and at the plate end of the load resistor with reference to the cathode and to the negative side of the d-c power supply. Conditions at this instant of zero signal voltage are shown by diagram 1 of Fig. 18.

Because there is insulation or a dielectric between the two sides of the capacitor the plate voltage can cause no steady current

## LESSON 17 – SIGNAL AMPLIFICATION

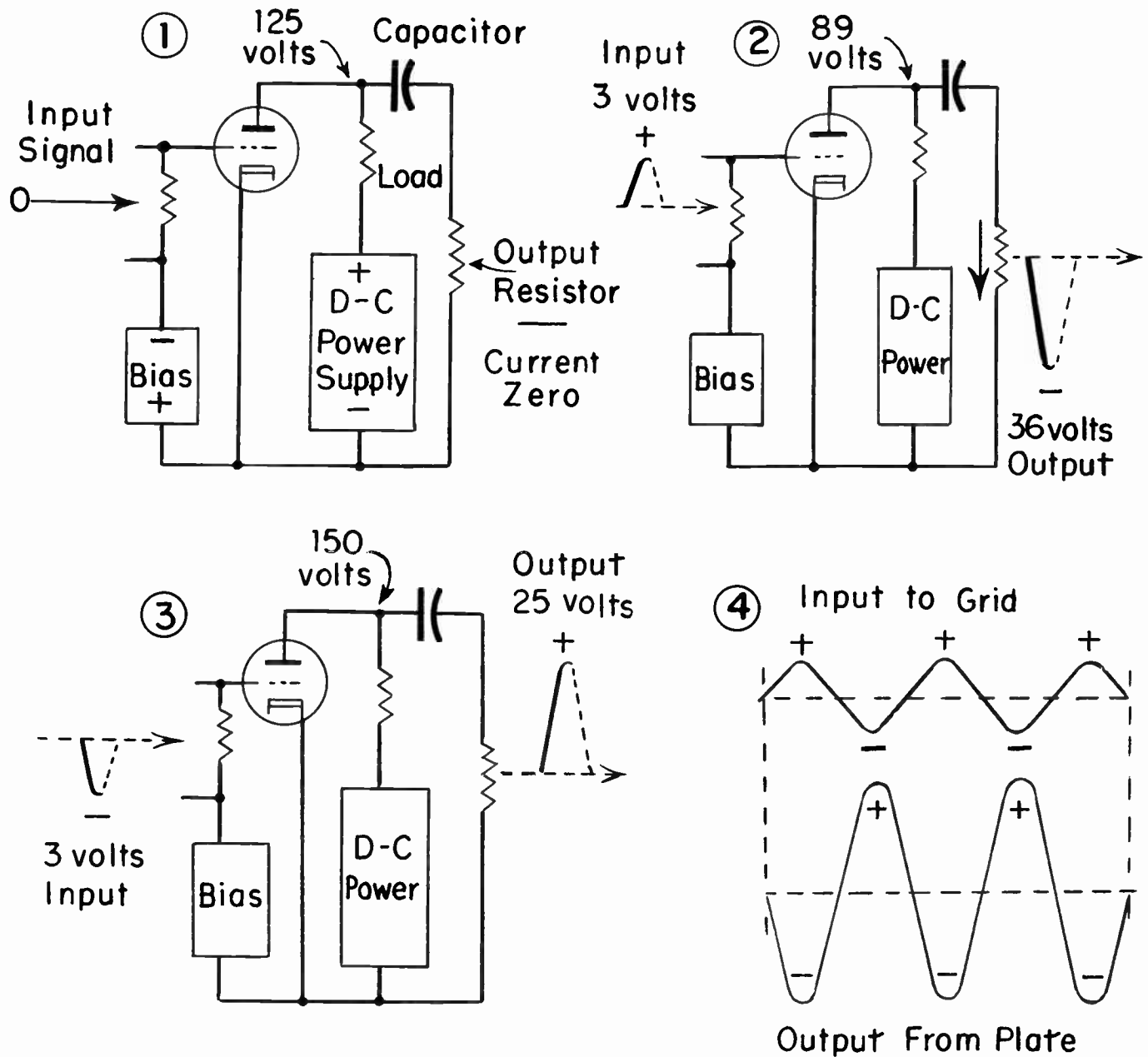

Fig. 18. When the grid becomes more negative the plate becomes more positive, and there is inversion of signal polarity.

to flow through the capacitor from one side to the other. There will be current into and out of the capacitor only until the capacitor becomes charged to an extent depending on voltage in the plate circuit of the amplifier tube. Then, unless there should be a change of plate voltage, there is no further current in the capacitor.

Since the capacitor is in series with the output resistor, there can be no current in this resistor nor in any other circuit element

similarly connected on the output side of the capacitor. With no current in the output resistor there can be no voltage across it, and we find that the output signal is zero when the input signal is zero.

Now look back at Fig. 14 and compare it with Fig. 15. The input (alternating) signal voltage has swung to 3 volts positive. Plate voltage has decreased to 89 volts. These conditions are shown by diagram 2 of Fig. 18. Because voltage on the capacitor is changing



## COYNE - *television home training*

from the former 125 volts down to 89 volts, current flows into one side and out of the other side of the capacitor while this change of voltage is taking place.

Inasmuch as plate voltage has decreased, the charge and the voltage across the capacitor have decreased. Current which flows in the capacitor during this change must flow also in the output resistor which is in series with the capacitor. The flow is in such direction as to make the capacitor end of the output resistor negative with reference to its other end. Thus we find that during the time in which the input signal is swinging positive the output signal voltage is swinging negative, as shown by diagram 2.

Look next at Fig. 16 and compare it with Fig. 15. The input voltage has swung from zero to 3 volts negative. Plate voltage has increased to 150 volts. Conditions are now as shown by diagram 3 of Fig. 18. The increase of plate voltage acts on the capacitor, to cause flow of current into and out of the capacitor in a direction opposite to that of the former flow. This flow of capacitor current passes through the output resistor in a direction that is opposite to the former flow, and the capacitor end of this resistor becomes positive with reference to its other end. Here we find that output signal voltage swings positive while input signal voltage to the grid is swinging negative.

The whole thing is summed up by thinking of plate voltage as changing in a negative polarity whenever grid voltage changes in a positive polarity, and of plate voltage as going positive when grid voltage swings negative. This is shown for alternating voltages by diagram 4 of Fig. 18. We ignore the fact that the grid always is actually negative, and the plate actually positive, and consider only the directions or polarities of the changes of grid voltage and plate voltage. We think of these changes as being the alternations of grid and plate voltages, which are the alternating input and output signals. Plate voltage and output voltage are inverted with reference to grid voltage and input voltage.

In all except a few circuits of some of the larger sound radios the matter of signal

inversion is of no importance, because positive and negative alternations of sound signals are alike or of the same form. But signal inversion is of great importance in television, because positive and negative sides of the television signals are decidedly different from each other. Unless the signal reaching the picture tube is of correct polarity there would be no pictures, only streaks on the screen. Unless synchronizing signals applied to sweep circuits are of correct polarity the deflections of the electron beam would be away out of time with picture signals.

DISTORTION. If you examine Figs. 14 and 16, and check the output signal voltages of Fig. 18, you will note that the changes of output voltages in negative and positive polarities are not equal, although changes of input voltages are equal. When the grid goes 3 volts positive the plate goes 36 volts negative, but when the grid goes 3 volts negative the plate goes only to 25 volts positive, with reference to the zero or average voltage. This means that the input signal is distorted, that the output signal is not of the same "waveform" as the input signal.

This distortion occurs because we are not operating the tube at suitable points on the plate characteristics, or that plate voltage is too low, or signal voltage too great in amplitude. The examples sufficed to illustrate the principles of amplification, but for acceptable operation we would have to avoid distortion of the signal when amplification is our object. Various kinds of distortions, and how they are avoided, will be discussed after we become better acquainted with all types of tubes.

If you watched all the voltages and currents shown by Figs. 14 to 16 with great care, and compared them with what you know about elementary electrical principles, you must have noticed something rather strange. Here is a hint. What is the resistance of the load resistor? Figure it out before reading further.

The voltage across this resistor is indicated by the output voltmeter, and current in this resistor should be the plate current. The voltages or currents may be used with a

## LESSON 17 – SIGNAL AMPLIFICATION

resistance formula or an alignment chart to determine the approximate indicated resistance of the load resistor, like this.

Fig. 14. Voltage = 111 Current = 6.5 ma Resistance = 17,100 ohms

Fig. 15. Voltage = 75 Current = 4.0 ma Resistance = 18,750 ohms

Fig. 16. Voltage = 50 Current = 2.3 ma Resistance = 21,700 ohms

What causes these discrepancies? The load resistor is the same unit in all three figures. The trouble arises because of the various meters connected into the plate circuit. Current from the d-c power supply flows not only through the tube and the load resistor, but also through the meters. Voltmeters require very little current in order that their pointers may be moved. The resistances of voltmeters are high. But the currents flowing in the meters are enough to upset the readings. The smaller the actual plate current the greater is the effect of the added meter currents, and the greater becomes the difference between the actual ef-

fective load resistance, which is 16,000 ohms, and the resistances computed from current and voltage readings.

By considering the meter resistances and their series and parallel connections in the plate circuit, we could compute the reasons for and the values of all errors. It would not be worth the effort, because the discrepancies are due to the testing apparatus and to the methods of testing rather than to anything related to normal operation where no meters would be in use. This is an example of why you must not worry too much about small differences between actual and theoretical results when doing practical service work. In view of usual tolerances in resistors, capacitors, and all other circuit elements, readings which are approximately that they should be are good enough for such operations as shooting trouble. Real trouble will throw the readings so far out of line as to be unmistakable.

# COYNE - *television home training*

## CONDENSED INFORMATION

Signal inversion. Plate voltage changes in a polarity opposite to that in which grid voltage is changing. Polarities of an alternating signal are inverted between grid and plate. This is true not only with triodes, but also with any type of tube when an input signal is applied to the grid and an output signal is taken from the plate.

Grid voltage is equal to the combined voltages of the signal and a bias source.

Negative bias must be equal to or greater than the most positive amplitude of signal voltage in order that the grid may remain negative, or zero, and draw no grid current.

A source of bias voltage furnishes no current, but only a voltage, when the grid is negative or zero.

The d-c plate power supply must furnish a total positive voltage equal to the sum of plate voltage and load voltage.

Voltage gain. The change of output signal voltage divided by the change of input signal voltage. The alternating output voltage divided by the alternating input voltage. Alternating grid voltage divided by alternating plate voltage.

Amplification factor. The ratio of a change of plate voltage to a change of grid voltage with which plate current remains constant. The amplification factor of a tube varies with operating conditions. It is greater

than the voltage gain which may be obtained in practice. A symbol for amplification factor is the Greek letter mu, which is written thus.

Plate resistance is the ratio of a change of plate voltage to the resulting change of plate current when grid voltage remains constant. Plate resistance varies with operating conditions. A symbol for plate resistance is R<sub>p</sub>.

Transconductance is the ratio of a change in plate current to the change of grid voltage with plate voltage remaining constant. Transconductance usually is specified in micromhos, and then is equal to the microamperes change of plate current per volt change of grid potential. A symbol is G<sub>m</sub>.

Following are letter symbols commonly employed for various voltages and currents.

E<sub>p</sub> Plate voltage

E<sub>g</sub> Grid Voltage

E<sub>b</sub> D-c power supply voltage

I<sub>p</sub> Plate current

I<sub>g</sub> Grid current

I<sub>k</sub> Cathode current

B+ (B+plus or B-positive) Any voltage from the positive side of the d-c power supply.

B- (B-minus or B-negative) Any voltage from the negative side of the d-c power supply.

# TELEVISION

• RADIO

• ELECTRONICS

---

---

## LESSON 18 – PENTODE VOLTAGE AMPLIFIERS

---

---

***Coyne School***

division of

*practical home training*

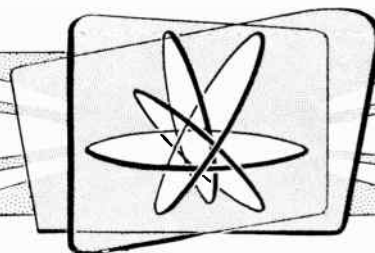

*Chicago, Illinois*



---

Copyright 1953 by Coyne School  
Chicago 12, Illinois  
All rights reserved

## Lesson 18

### PENTODE VOLTAGE AMPLIFIERS

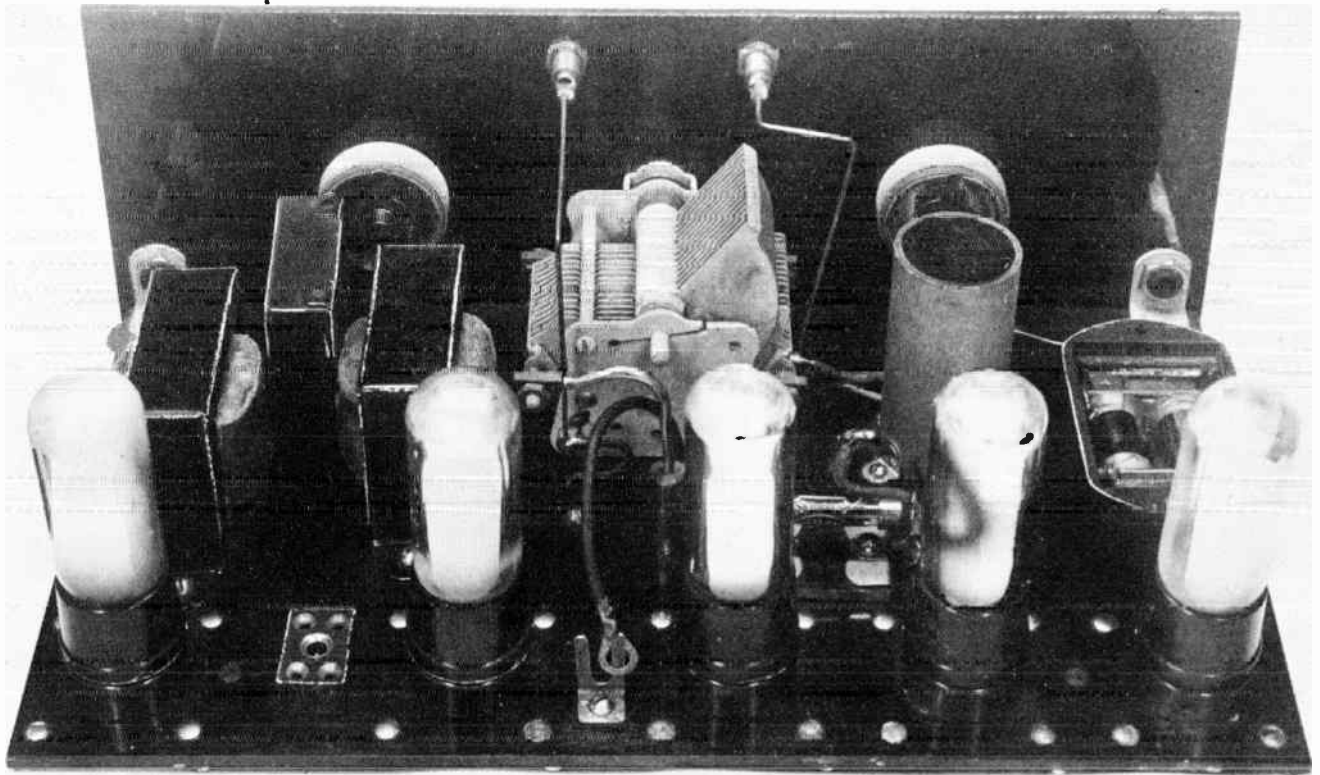

Fig. 1. A "tuned radio frequency" receiver of 1928. There are five type '99 triodes. Two are r-f amplifiers, one is a detector, and two are audio amplifiers.

Had you talked with a radio technician during the year 1924 or 1925 he would have told you about the many "trick circuits" which allowed using triodes as amplifiers for broadcast carrier frequencies as well as for the lower audio frequencies. Only triode amplifiers were available. But in spite of all the circuit kinks which were devised, the voltage gains obtainable from triodes became less and less as carrier frequencies became higher and higher.

A couple of years later the technician would have been enthusiastic about the wonderful new screen grid tube which, he felt sure, would overcome all the difficulties with high-frequency amplification. This tube had an extra element between its grid and plate, making four active elements in all. But soon it became evident that the screen grid amplifier performed its wonders only in those

portions of the receiver where the carrier-frequency signals still were quite weak. Strong signals, with wide swings of grid voltage, could be amplified only to moderate degrees.

Then the tube makers put another element between the screen and the plate, thus producing the five-element pentode tube. The pentode really did a job. It allowed voltage gains which, at that time, seemed almost impossibly great at even the highest broadcast carrier frequencies.

The pentode remained the preferred amplifier for both carrier frequencies and intermediate frequencies, and still is in almost universal use for these frequencies in sound radios. It was only natural to adopt the pentode for amplification of television carrier frequencies as well as for intermediate

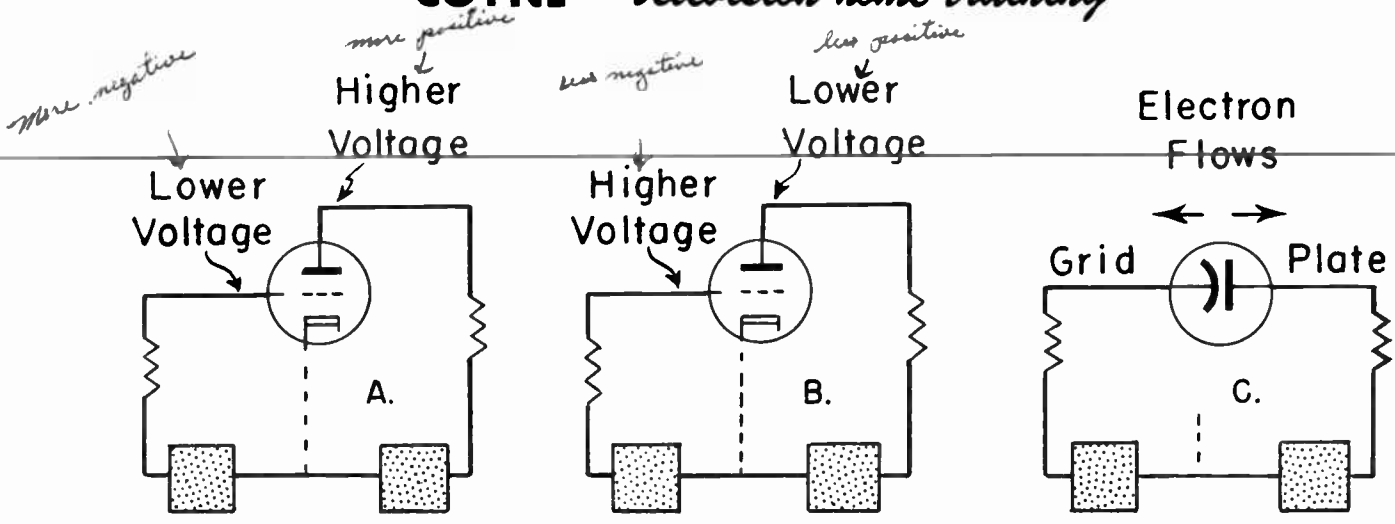

Fig. 2. Signal energy from the plate circuit feeds back through grid-plate capacitance to the grid circuit.

frequencies during the development of television receivers.

But even the pentode suffered from its own kind of faults when receiving the higher channels of the very-high-frequency television band, from 174 to 216 megacycles. At carrier frequencies in the ultra-high frequency television band, above 470 megacycles, these difficulties proved to be really serious. So what do you suppose happened? No, the manufacturers did not put a sixth element into the tube. Instead we have gone back to the triode for amplifying ultra-high frequencies. Triodes are used also for the very-high television carrier frequencies in many of the latest receivers.

**FEEDBACK IN THE TRIODE.** The reason why we get into trouble when using ordinary triodes in ordinary circuits for amplification of high frequencies is illustrated by Fig. 2. As we have learned, and as shown by diagram A, plate voltage increases or goes more positive when grid voltage decreases or goes more negative. And, as shown at B, plate voltage decreases or becomes less positive when grid voltage rises or becomes less negative.

Now look at diagram C. The grid and the plate are really the equivalent of a small capacitor inside the tube, because both elements are made of conductive metal, and between them is the insulating vacuum which acts as the dielectric of the capacitor. In early types of triode amplifiers the capac-

itance between grid and plate was as much as 8 micro-microfarads, and in only a few types was it less than 3.5 mmf. The grid plate capacitance in the 6C4 miniature triode is about 1.6 mmf.

When voltage increases on one side of a capacitor while decreasing on the other side, electrons are going to flow into one side and out of the other. That is, there will be a current in the circuit of which the capacitor is a part. A current means that energy and power are being transferred from one place to another. In the triode it means that power from the relatively strong signal voltages in the plate circuit is being carried back to reinforce the weaker signal voltages in the grid circuit.

What happens is this. While the grid is swinging positive, the feedback of energy or power from the plate circuit acts to make the grid even more positive. And while the grid is swinging negative the feedback acts to make it even more negative. How often there is a pulse of feedback power from plate to grid depends on the operating frequency. As frequency increases, the feedback pulses occur more and more often during every second, and the total feedback power per second increases with frequency.

Unless plate signal voltages are held to rather low values, which means a small voltage gain, the feedback becomes so great that swings of grid voltage get entirely out of hand. They no longer are proportional only

## LESSON 18 – PENTODE VOLTAGE AMPLIFIERS

to the applied signal, but they become so strong as to be self-supporting, and the tube becomes an oscillator. When this happens, as it did on the early receivers, the voice and music of transmitted signals gave way to loud howls and sequels at the frequency of oscillation. High-frequency power, produced by the oscillating amplifier, went out through the antenna of the receiver just as though it were a small transmitter. All the neighbors could hear the howls on their own sets. The radiating receivers were called "bloopers", and other names even less complimentary.

**THE SCREEN.** If a third conductor is mounted between two other conductors which are acting as the plates of a capacitor, and if the third conductor is connected to a point whose potential remains in between that of the capacitor plates, the capacitance is reduced to a very small value. A screen mounted between grid and plate reduces the

grid-plate capacitance to a small fraction of its value without the screen.

A screen mounted around the outside of a grid is pictured at the left in Fig. 3. Around the outside of the screen would be the plate of a screen grid tube. Using a screen reduces the grid-plate capacitance to less than one one-thousandth of its value in triode amplifiers which immediately preceded the screen grid type, and reduces the feedback proportionately.

It might seem logical to connect the screen to the cathode, which remains at a potential in between those of the grid and plate. But such a connection would have been equivalent to making the screen merely a second grid remaining at zero voltage, and it would have been almost impossible to get any plate current through both the grid and the screen.

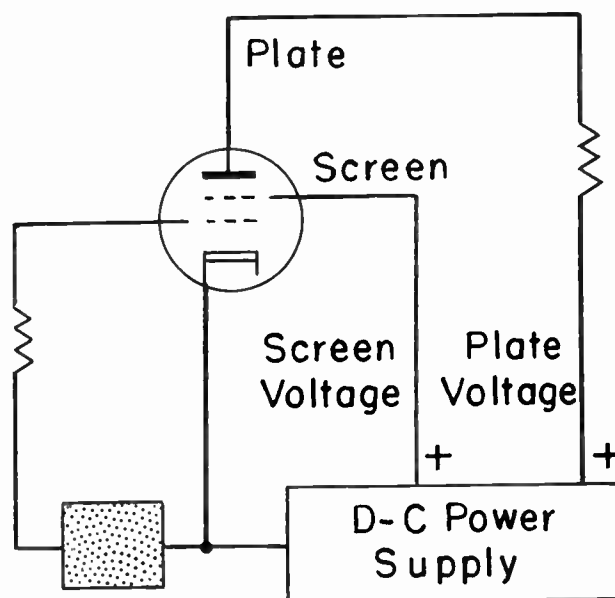
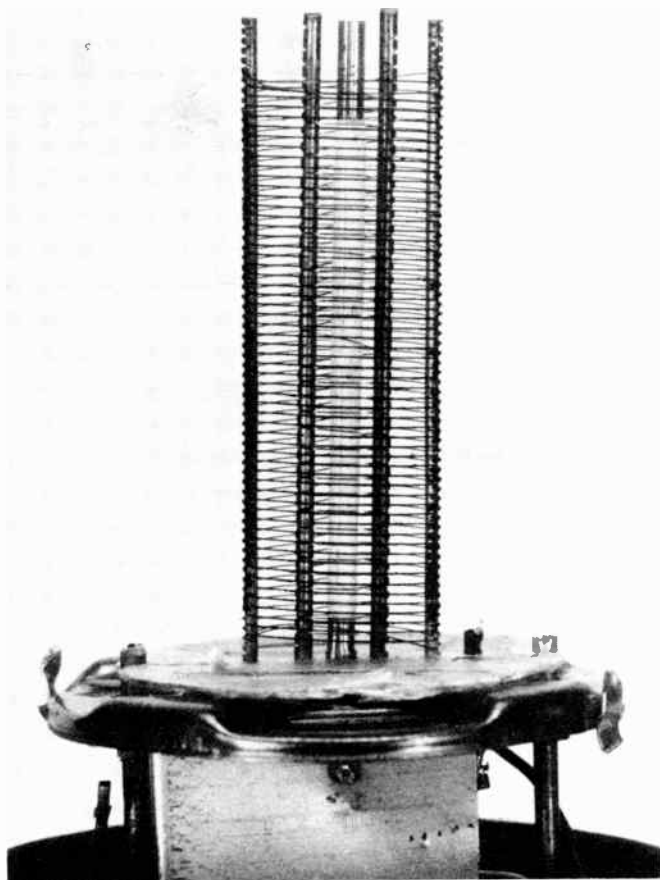

Fig. 3. The screen, mounted around the outside of the grid, is connected to a positive voltage from the d-c power supply.



## COYNE - *television home training*

Actually the screen was connected to a positive voltage point on the d-c supply, as at the right in Fig. 3. Ordinarily the positive screen voltage was made about half as high as the positive plate voltage. So far as high-frequency voltages and feedback were concerned this connection of the screen made a satisfactory reduction of grid plate capacitance and of the feedback.

The positive screen helped to pull negative electrons away from the cathode and through the zero or negative grid. A good many of the electrons would enter the positive screen and flow from the screen through the external connection to the d-c power supply. But, as you can see in the picture of a screen, it is formed of very thin wire with fairly wide spaces or gaps between the turns. By far the greater portion of the emitted electrons would go right on through the screen and into the plate.

Screen grid tubes possessed amplification factors about 50 times greater than the factors of early triode amplifiers. But plate resistances of screen grid tubes were about 40 times higher than in those triodes, and as a result the plate current in the screen grid tube was small and the transconductance not a great deal higher than in the triodes of that period. Probably you have noticed that we talk about what the screen grid tube used to act and what it used to do, not about what it does now. This is because the screen grid

type no longer is used. Within a very short time it was replaced by the five-element pentode.

**SECONDARY EMISSION.** The screen grid tube disappeared because it suffered excessively from an effect called secondary emission. When there is such an effect, electrons coming from the cathode hit the surface of the plate so hard as to knock other electrons right out of the plate and into the space near the plate. If a plate is 150 volts positive with reference to a cathode, electrons are traveling at about 14,000,000 miles an hour when they hit the plate. A body even so nearly weightless as an electron possesses considerable energy when moving at such speed. This energy, imparted to other electrons at the surface of the plate, gives those electrons the ability to jump out of the plate metal, and they do so. These electrons freed from the plate are called secondary electrons, and the action is called secondary emission.

There is secondary emission in all types of tubes. It does no particular harm in a triode because the plate is the only element which is positive with reference to the cathode. The secondary electrons, which are negative, immediately fly back into the highly positive plate, and plate current is not affected by their temporarily leaving the plate.

What happens with a screen grid tube is illustrated by Fig. 4, where are represent-

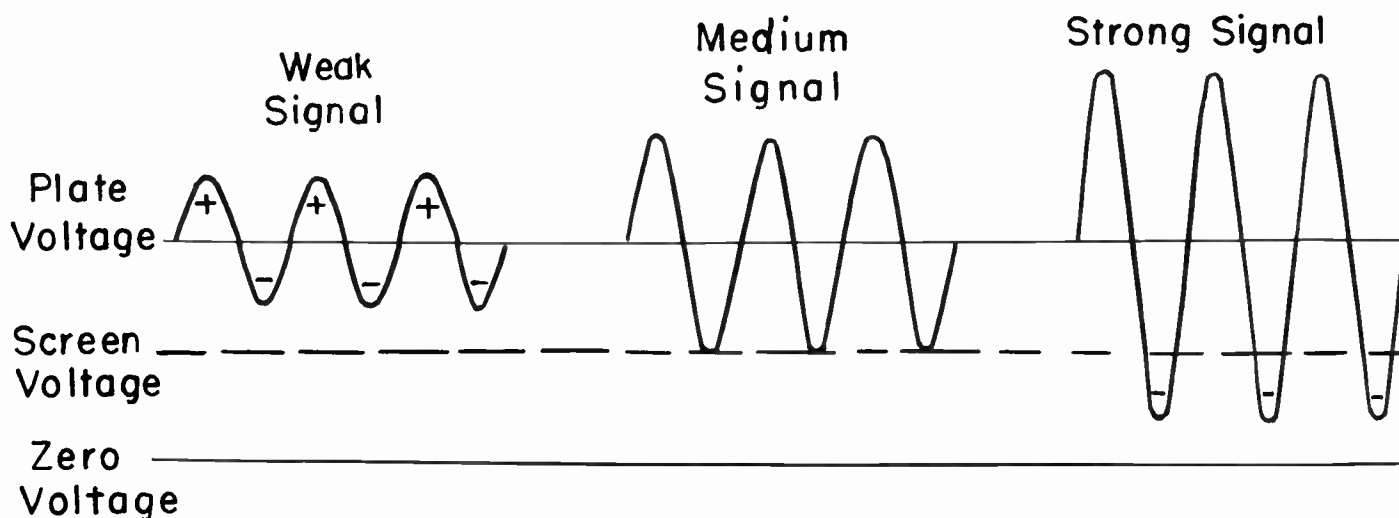

Fig. 4. During negative peaks of strong signals the plate may become less positive than the screen.

## LESSON 18 – PENTODE VOLTAGE AMPLIFIERS

ed the swings or alternations of plate voltage for signals of three different strengths. The straight horizontal lines represent average plate voltage, the constant screen voltage as fixed by connection of the screen to the d-c power supply, and zero d-c voltage. The variations of signal strengths at the plate might be due to an effect such as softer and louder passages in a musical program, or to increased alternating signal voltages at a second or third stage of amplification, or to any other cause.

With the weak signal the plate always is more positive than the screen, even when the plate signal swings negative. Secondary electrons are pulled back into the more positive plate, and do no harm. With the signal of medium strength the plate voltage comes down close to or as low as the screen voltage on negative swings of the signal alternations. At the negative peaks of signal it is just as easy for secondary electrons to go to the positive screen as for them to go back to the equally positive plate, and some of them do go to the screen.

With the strong signal the plate voltage during negative swings becomes less positive than the screen voltage. Then secondary electrons leaving the plate during these periods go to the more positive screen, and never do get back into the plate. These secondary electrons that go to the screen are subtracted from what should be plate current. Plate current changes normally during positive alternations of plate signal voltage, but part of this current is lost during negative alternations.

To make full use of the high amplification possibilities of the screen grid tube it must be allowed to carry strong signals. But strong signals are distorted because plate current alternations become lopsided. If strong signals cannot be amplified without distortion there is no object in using the screen grid tube.

PENTODES. The pentode tube contains a screen, just as did the screen grid tube whose other name was a tetrode. The purpose of the screen in the pentode is to reduce the grid-plate capacitance and thus reduce energy

feedback from the plate circuit to the grid circuit. A fifth element, called a suppressor, is mounted between the screen and the plate. The suppressor does not prevent secondary emission, but it drives secondary electrons back into the plate where they belong, and thus reduces or eliminates the ill effects of secondary emission. Fig. 5 is a picture of a suppressor grid mounted around the outside of a screen grid. The plate, in a complete tube, would be mounted around the suppressor.

As shown at the right in Fig. 5, the suppressor may be connected to the cathode or else to chassis ground. In many pentodes the suppressor is internally connected to the cathode, and there is no separate base pin for the suppressor. With any method of connection, the suppressor is at or very nearly at the potential of the cathode, and with reference to both the plate and the screen the suppressor is highly negative. This is simply a way of saying that both the plate and the screen are highly positive with reference to the suppressor.

When secondary electrons leave the plate these negative electrons cannot pass to the screen, even when the screen is momentarily more positive than the plate. On the way to the plate the negative secondary electrons approach the negative suppressor, and since two negative charges repel each other the secondary electrons are forced back to the plate. Plate current and alternations of plate current are not affected by secondary emission.

The suppressor, like other elements between cathode and plate, is made of thin wire with relatively wide gaps between turns. By the time primary electrons, from the cathode, have been speeded up by the positive screen and are being pulled along by the positive plate, they are going so fast that they fly right through the spaces between turns of the suppressor and reach the plate. Although the suppressor is at much the same potential as the grid, it is so far from the cathode that it does not act on emitted electrons as does the grid.

PENTODE PERFORMANCE. To become acquainted with the operating char-

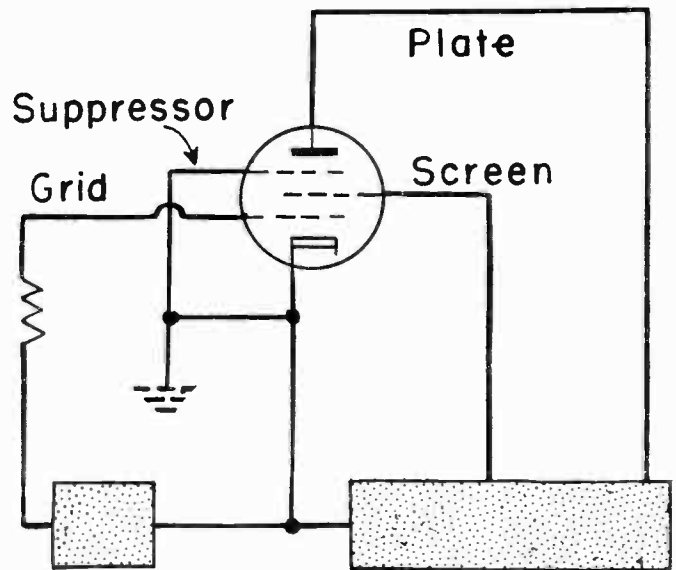
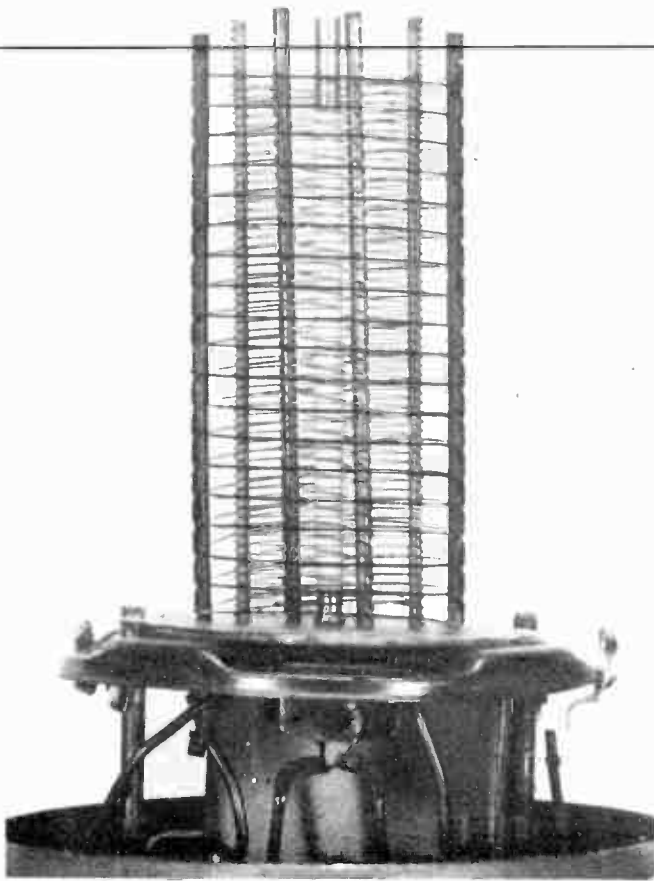

Fig. 5. The suppressor in a pentode is mounted around the outside of the screen, and is between the screen and the plate.

acteristics of pentodes we shall make tests on a type 6BC5, which is fairly representative of many pentodes used in the intermediate frequency amplifiers, video amplifiers, some tuner circuits, and various synchronizing circuits of the majority of television receivers. Other pentodes differ more or less in transconductance, plate resistance, back pin connections, bulb styles, and heater voltages and currents. But in all of them the effects of element voltages on element currents follow the same general pattern, and it is these effects which concern us in service work.

The 6BC5 is a miniature tube with a 7-pin base having transconductance ranging from 4,000 to 6,000 micromhos (microamperes per volt) according to operating voltages and characteristics of parts in its grid and plate circuits. The suppressor is internally connected to the cathode. Plate resistance is about 500,000 ohms or 0.5 megohm for usual operating conditions.

In Fig. 6 the pentode is in the 7-pin socket of our tube testing panel. Since there is a screen in this type of tube, voltage applied to the screen will be indicated by the Screen Volts meter at the lower right. When the screen is positive, as will be indicated by this meter, there will be electron flow from cathode to screen in addition to any flow from the cathode to the plate. The total electron flow or current from the cathode will be indicated by the Cathode Current meter. The portion of this flow going to the plate will be indicated by the Plate Current meter. The difference between cathode current and plate current will be screen current, so long as the grid is zero or positive and drawing no grid current from the cathode.

Screen voltage in Fig. 6 is zero, while the plate is 100 volts positive, as shown by the Plate Volts meter. Cathode current is zero, and, of course, the plate current must be zero when there is no cathode current. Incidentally, the load terminals above the



## LESSON 18 – PENTODE VOLTAGE AMPLIFIERS

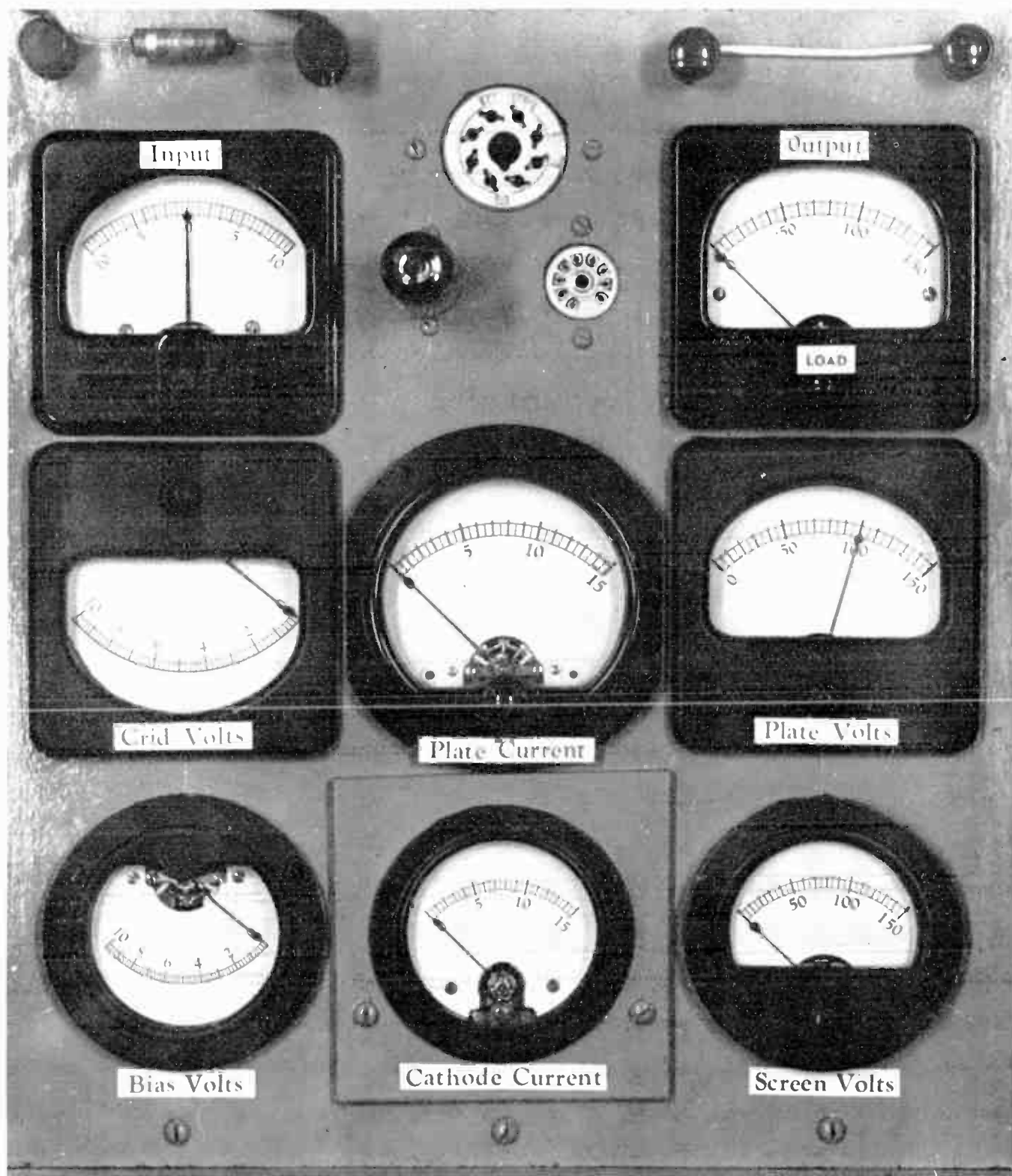

Fig. 6. Unless there is positive voltage on the screen of the pentode, plate current remains zero even with the plate highly positive.

Output meter are shortcircuited with a length of wire, since for our first tests the tube is to work with no resistance in its external plate circuit.

In Fig. 7 the screen has been made 50 volts positive with reference to the cathode. Plate voltage still is 100, and, as before, the grid is zero. Plate current has commenced



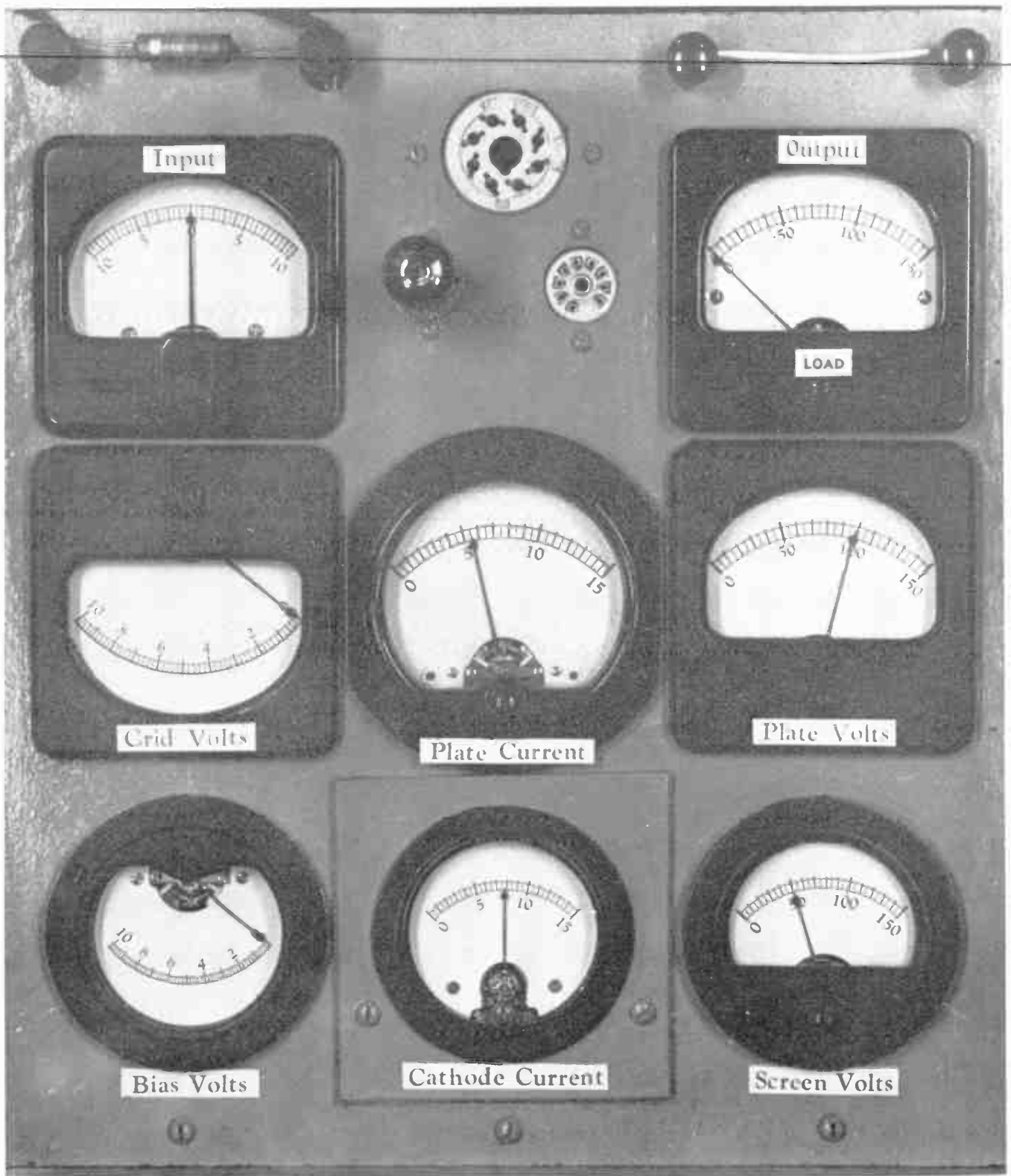

Fig. 7. A positive screen causes plate current to flow through it to the plate.

to flow, and is 5.5 ma. Cathode current is indicated as 7.8 ma. The difference between 7.8 ma of current leaving the cathode and the

5.5 ma leaving the plate must be the current flowing from the cathode to the positive screen. This screen current is 2.3 ma.

## LESSON 18 – PENTODE VOLTAGE AMPLIFIERS

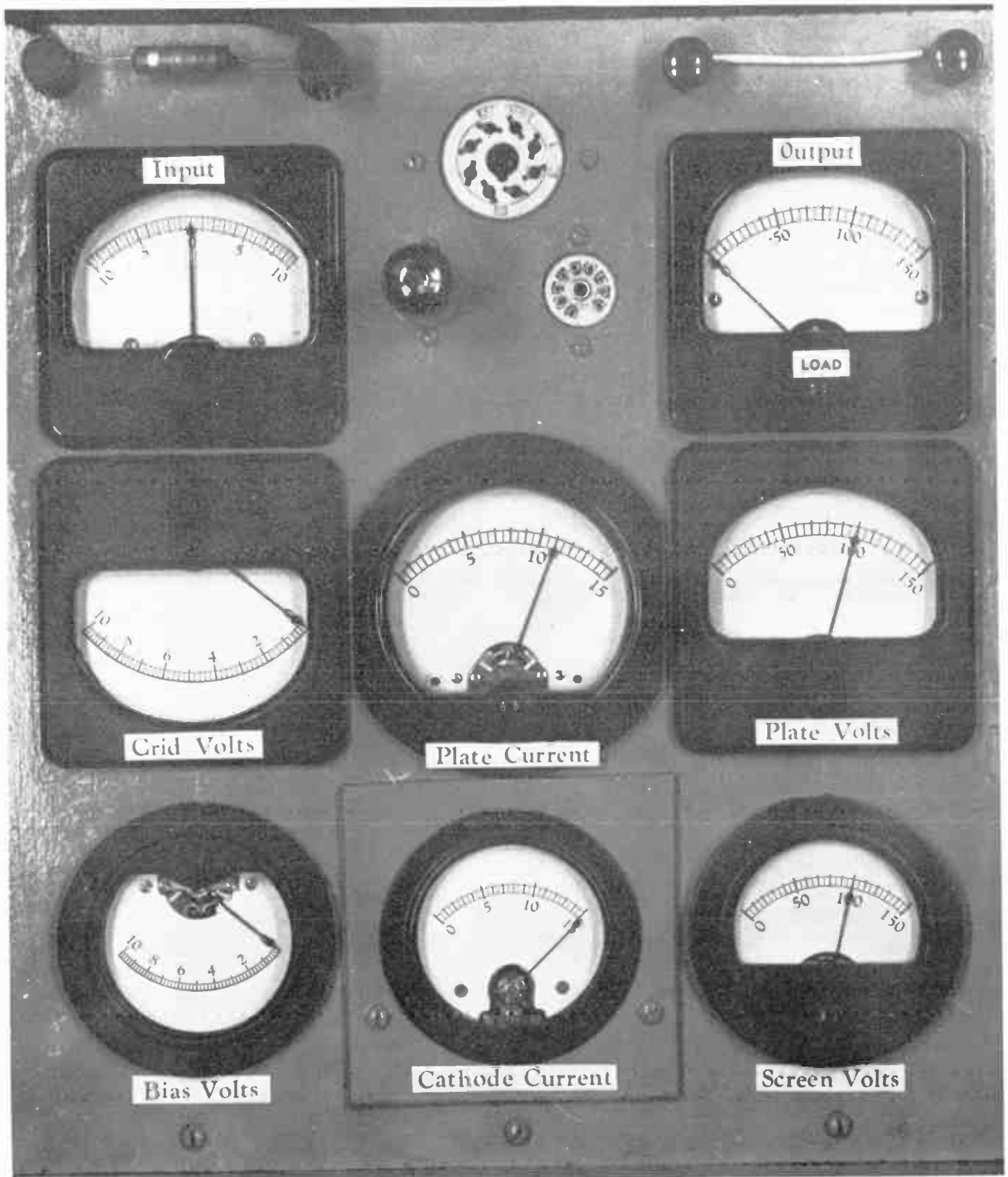

Fig. 8. The more positive the screen, the greater is the plate current for any given voltage on the plate.

In Fig. 8 the screen voltage has been increased to 100, while holding the plate at 100 volts and the grid at zero. Now we have

plate current of 11.0 ma and cathode current of about 15.2 ma, as nearly as can be read where the pointer of the cathode current

meter has gone slightly off scale at the high end. The difference between cathode and plate currents indicates a screen current of about 4.2 ma.

What we are getting at just now is the relation between screen voltage and plate current in the pentode tube. At the same time we are observing the effect of screen voltage on screen current, and on cathode current. It is plate current and changes of plate current that will be used for signal amplification, so it is the plate current that is of major importance.

By taking many readings of voltage and current it is possible to plot the curves of Fig. 9. The solid-line curve at the top shows

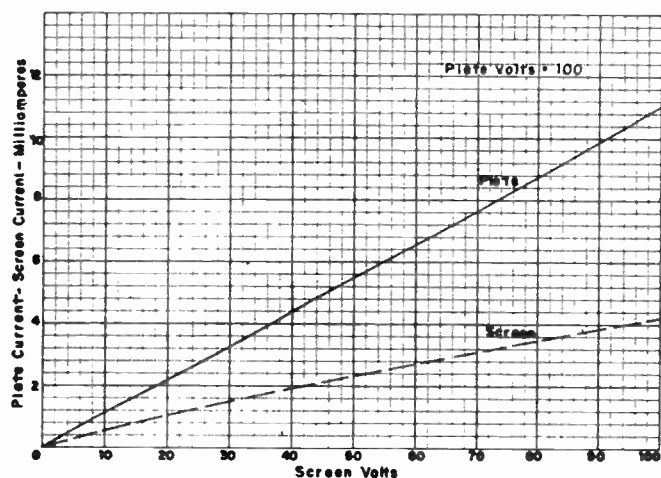

Fig. 9. The manner in which plate and screen currents of the pentode increase as the screen is made more and more positive.

how plate current increases with increase of screen voltage when plate voltage is held constant at 100. The broken-line curve shows how the screen current increases with screen voltage when there is a constant plate voltage. Although these two curves apply exactly only to the particular tube being tested, they show in a general way the effect of screen voltage on plate current in every other pentode.

Having seen what happens to plate current when there are changes of screen voltage in the pentode tube, let's check the effect of plate voltage on plate current. To begin with, in Fig. 10, we have 25 volts on the plate

and 80 volts on the screen. The grid still is zero, and there is no load resistance in the plate circuit. Cathode current is 10.0 ma, while plate current is only about 2.8 ma. The difference between these currents is screen current, which now is 7.2 ma. It is only natural that with screen voltage so much higher than plate voltage we should have screen current greater than plate current.

In Fig. 11 the plate voltage has been raised to 50, while screen voltage still is held at 80 and the grid at zero. Plate current has increased to about 8.4 ma, and cathode current to about 11.4 ma, which means that screen current now is 3.0 ma. The higher plate voltage, with no change of screen voltage, has brought about a large increase of plate current, from 2.8 all the way up to 8.4 ma. But this increase of plate voltage, with constant screen voltage, has caused the screen current to decrease. The screen current has dropped from 7.2 to 3.0 ma.

Now look at Fig. 12. Screen voltage has been held at 80 while plate voltage has been raised to 100. Compare the plate and cathode currents of this figure with those of Fig. 11, keeping in mind that between these two figures the plate voltage has been doubled. Plate current has increased by possibly 0.1 ma, and cathode current has increased by about the same amount. In spite of doubling the plate voltage there has been practically no increase of plate current, and there has been practically no change of screen current.

We have observed something which you must remember when making service tests where pentodes are involved. Plate current increases at a nearly uniform rate with increase of screen voltage, as shown by Figs. 6 to 8. But, as we have seen in Figs. 10 to 12, above a certain value of plate voltage the plate voltage has practically no effect on plate current. Because pentodes seldom if ever are operated with plate voltages below this certain value, we may say that plate current of a pentode is determined almost entirely by screen voltage, and is determined to a nearly negligible extent by plate voltage. In the normal operating ranges for these tubes, plate current is almost independent of plate voltage.



## LESSON 18 – PENTODE VOLTAGE AMPLIFIERS

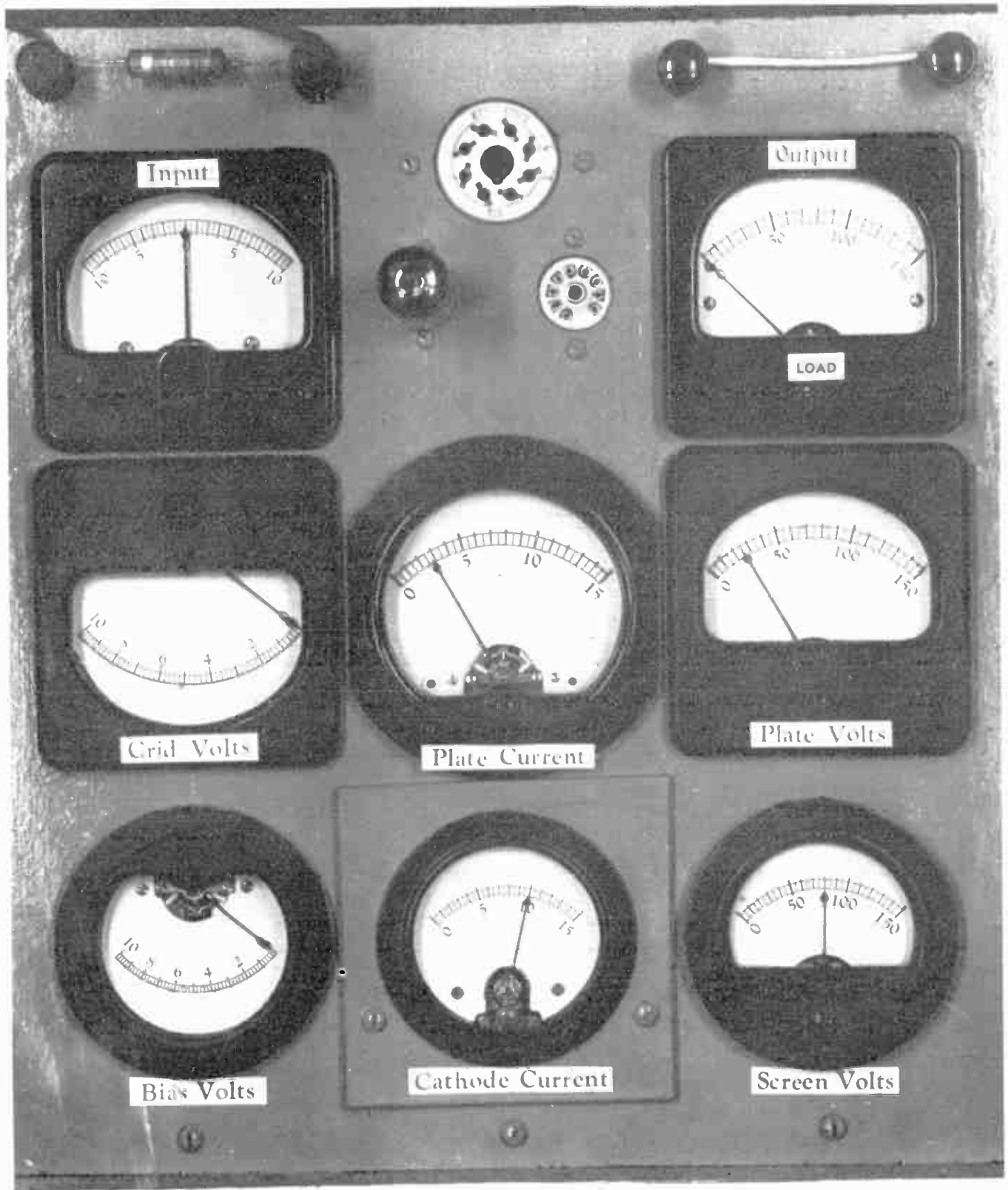

Fig. 10. When the screen is more positive than the plate, more of the cathode current flows to the screen than to the plate.



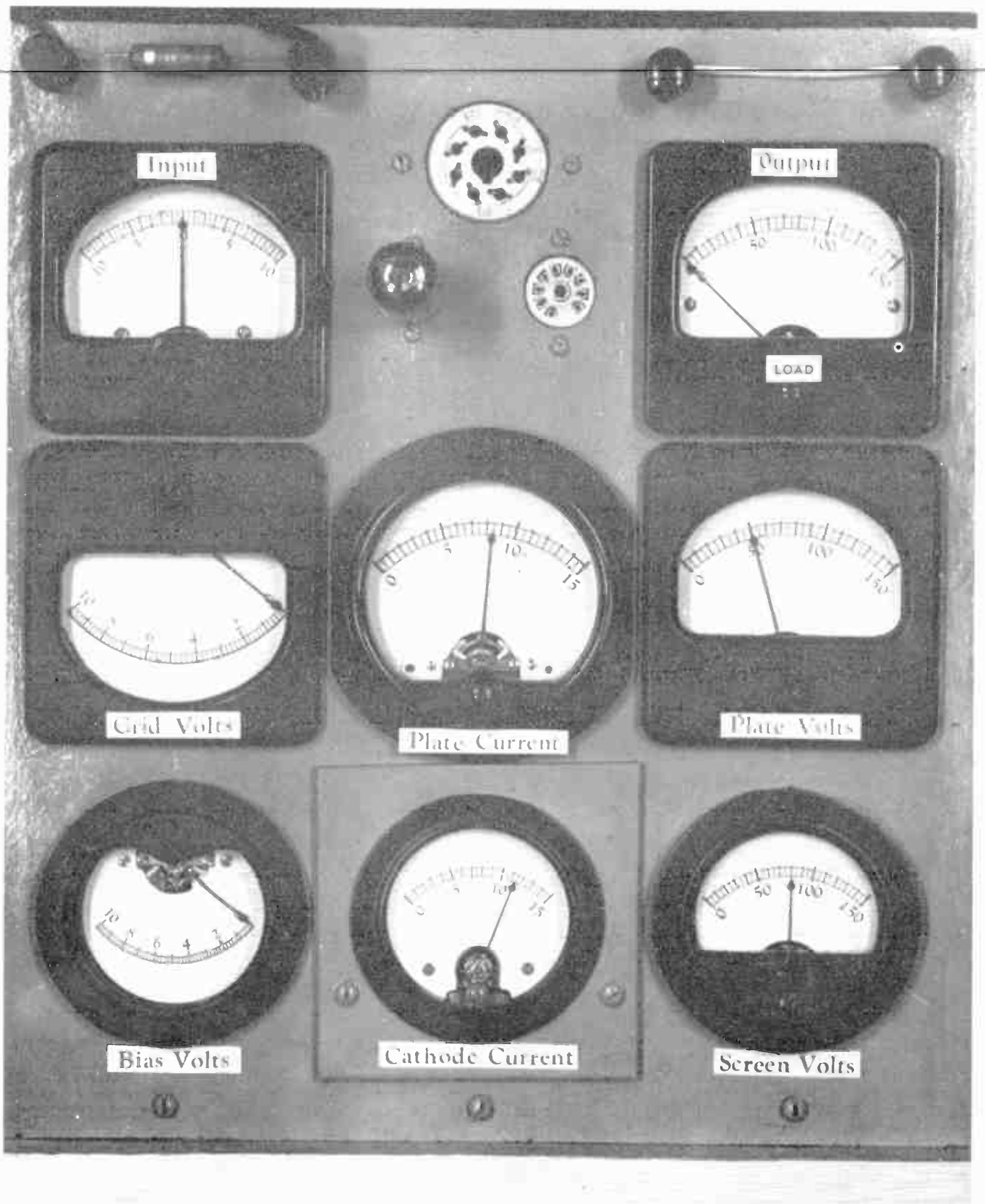

Fig. 11. As the plate is made more positive, with screen voltage constant, plate current increases more rapidly than screen current.

## LESSON 18 – PENTODE VOLTAGE AMPLIFIERS

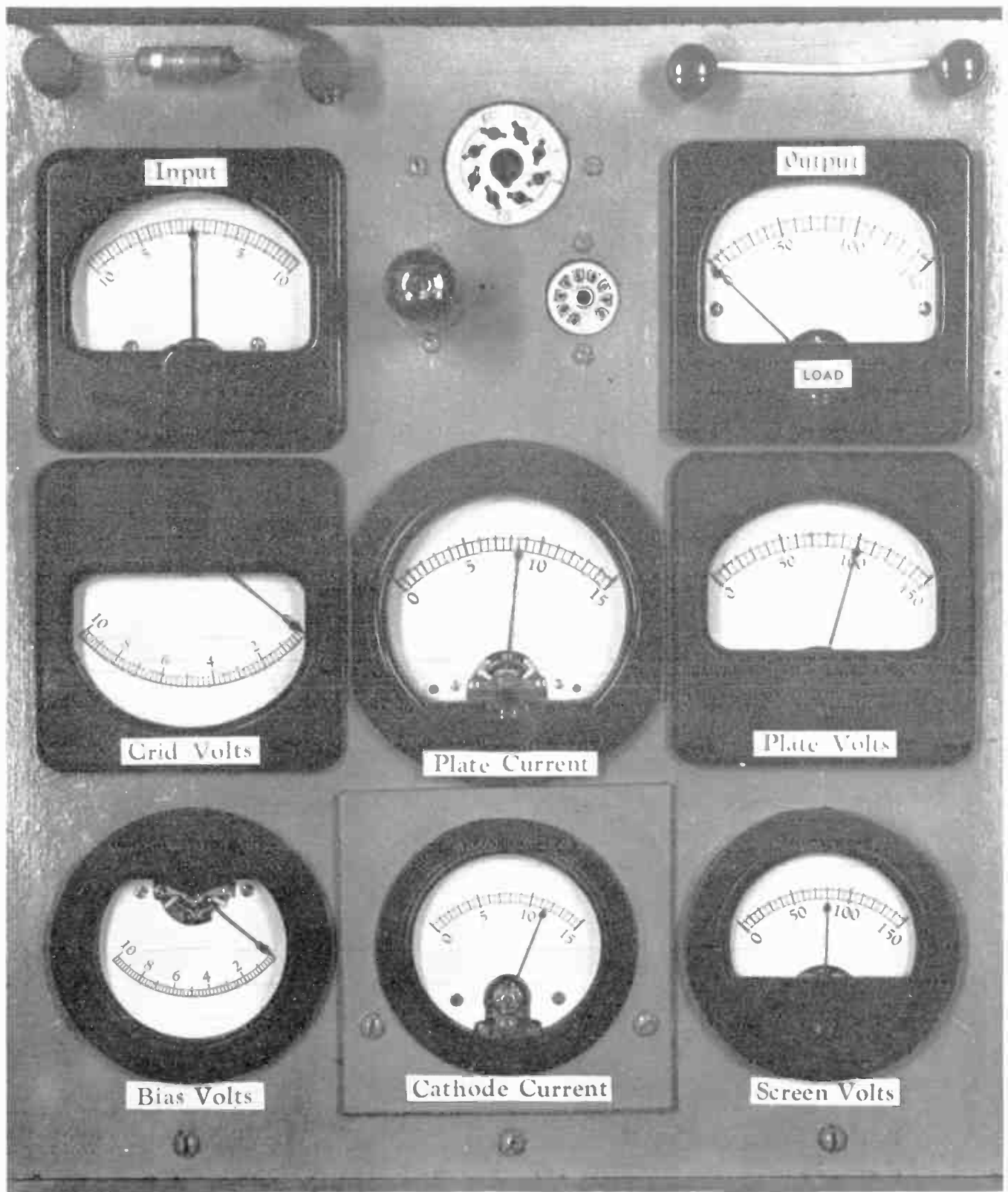

Fig. 12. Increasing the plate voltage of a pentode above some certain value causes very little further increase of plate current.

For the range of plate voltages from zero to 100, the relations between this voltage and currents in the plate and screen of the particular pentode being tested were found to be as shown by Fig. 13. As plate

grid is zero, the plate voltage is 100, and the screen voltage is 80. Note that plate current for these voltages is 8.5 ma. We are not particularly interested in cathode and screen currents, because it is plate current and its changes which will be used in amplification and in most other applications.

In Fig. 14 the grid has been made 1.0 volt negative. This is done by applying a negative bias of 1.0 volt. There is no input signal. The plate is still at 100 volts and the screen at 80 volts. Plate current has been decreased from 8.5 ma, in Fig. 12, to 3.0 ma in the present figure. This drop of plate current is due to the change of grid voltage, to making the grid more negative, inasmuch as neither the plate voltage nor the screen voltage has been altered.

In Fig. 15 the bias and the grid voltage have been made 2.0 volts negative. Plate and screen voltages are unchanged. The increased negative voltage on the grid has dropped the plate current to about 0.5 ma. From these tests we may conclude that changes of grid voltage in the pentode have the same effect on plate current as in a triode. That is, plate current is decreased by making the grid more negative, and would be increased by making the grid less negative when plate and screen voltages are constant. It is apparent that a signal voltage applied to the grid of the pentode will be amplified.

To check the amplification or voltage gain of the pentode it is necessary to have a load in the plate circuit, for it is only from across a load that we can obtain variations of voltage which represent the signal output of a tube. This has been done in Fig. 16. Instead of the short-circuiting wire above the output meter there is a resistor which provides an effective load of about 25,000 ohms.

We are going to find that amplification of the pentode is much greater than that of the triode employed for testing in earlier experiments. Changes of output voltage from the pentode will be so great that, to keep the pointer of the output meter on scale, it will be possible to change the input voltage by only very small amounts. In order to read

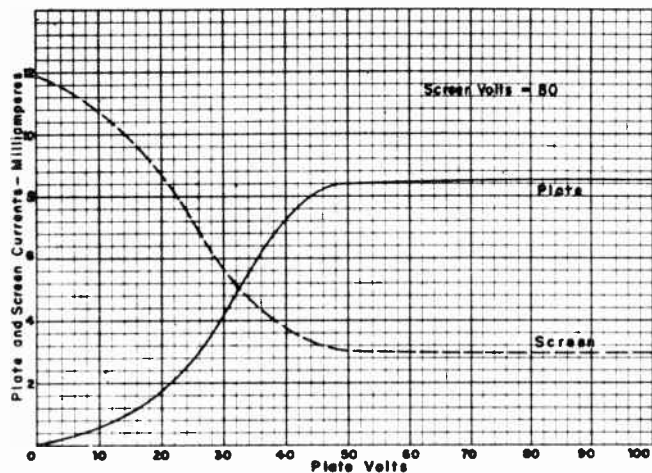

Fig. 13. The manner in which plate and screen currents vary in the pentode when plate voltage is increased while maintaining screen voltage constant.

voltage is increased from zero to 50, with the screen held at 80 volts, the screen current drops as the plate current rises. Above 50 volts the two currents level off, and for higher plate voltages there is very little change in either one.

The tube would not be operated with such voltages and such loads in the plate circuit as to drop the plate voltage to 50 or below. This means that signal voltages must not swing the plate voltage to or below a value at which plate current commences to drop off. Operation should be such that, during alterations of signal voltage and variations of grid voltage, the plate voltage remains on the portion of the plate characteristic curve that is nearly level. The full-line curve of Fig. 13 is a plate characteristic for the pentode being tested. Note that it is of very different form than a plate characteristic for a triode tube.

Now we have checked the effect of screen voltage on plate current and of plate voltage on plate current. It is in order to check the effect of grid voltage on plate current in the pentode. We may commence our grid voltage tests with Fig. 12, where the



## LESSON 18 — PENTODE VOLTAGE AMPLIFIERS

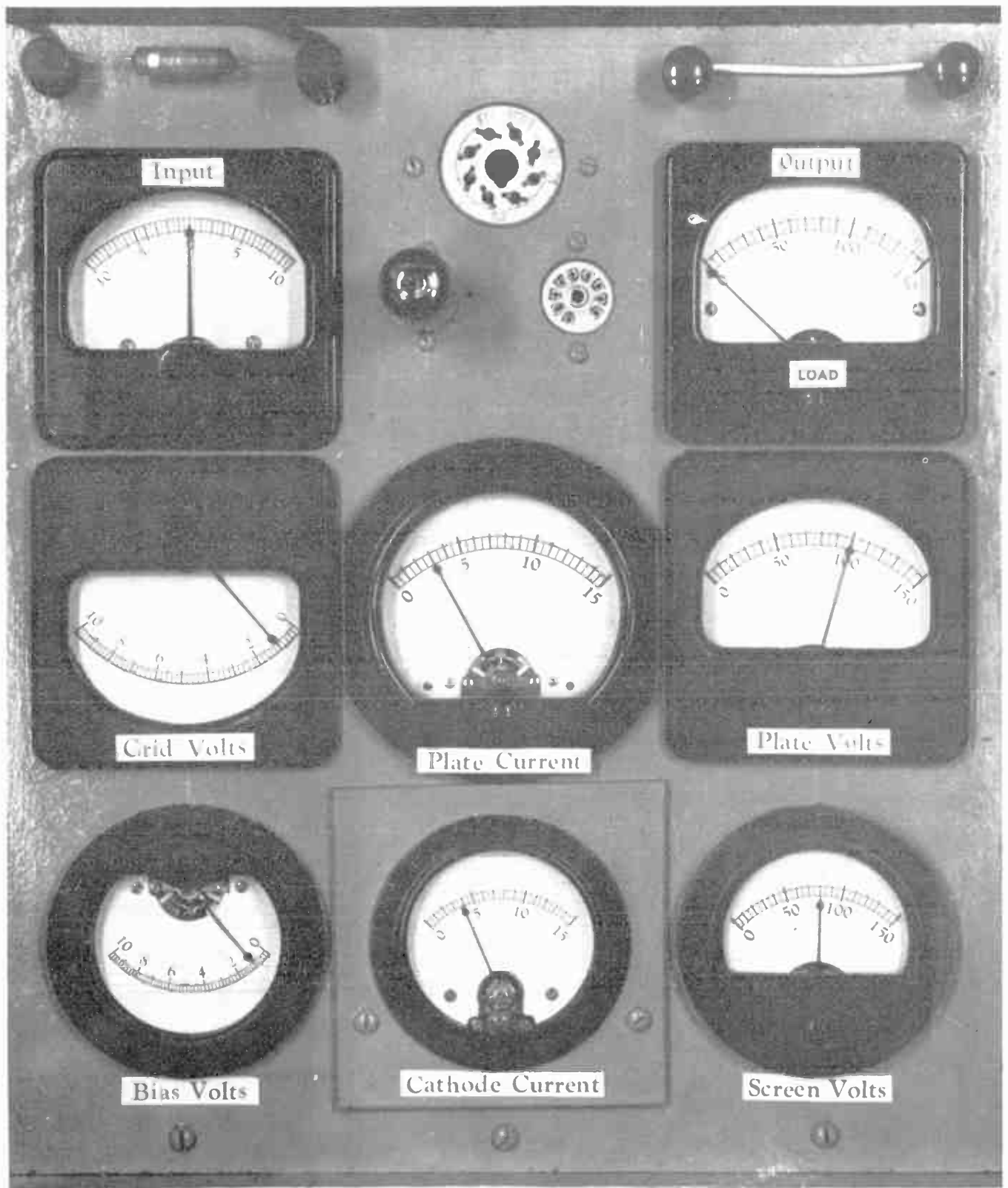

Fig. 14. When plate and screen voltages remain constant, plate current in the pentode is decreased by making the grid negative.





## LESSON 18 – PENTODE VOLTAGE AMPLIFIERS

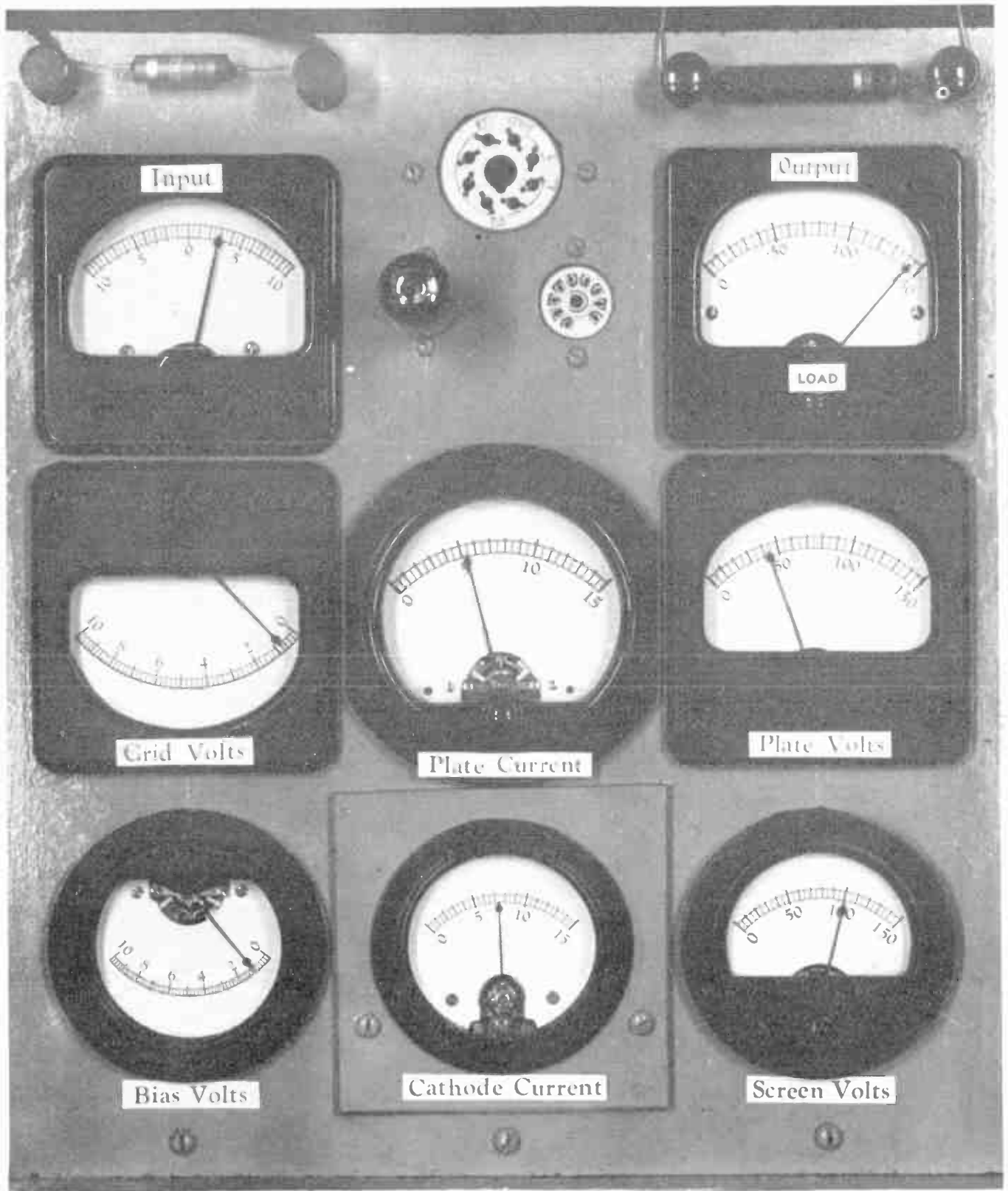

Fig. 16. The first step in testing voltage gain of the pentode amplifier.

## COYNE - *television home training*

the small changes of signal voltage the Input meter is being used on a different range. Its readings now extend from zero to only 1.0 volt in each polarity, so the dial readings must be divided by 10. In Fig. 16 the Input meter is indicating a signal voltage 0.3 volt positive.

Grid bias is 1.0 volt negative, which is a bias often used with the type of pentode being tested. The Grid Volts meter reads, or should read, 0.7 volt negative. Actually, because all service type meters tend to become inaccurate at very low readings, this meter shows about 0.8 volt negative. The screen is at 100 volts, and will be held there during our checks of amplification.

Note that voltage across the load, as shown by the Output meter, is about 143. Plate voltage is about 43. The power supply voltage must be the sum of the load and plate voltages, or about 186. This power supply voltage will remain practically unchanged as we proceed to check the effect of signal voltage.

In Fig. 17 the signal voltage has swung to 0.3 volt negative. Bias remains 1.0 volt negative, the Grid Volts meter reads 1.3 volts negative. The signal has changed through 0.6 volt, from 0.3 volt positive to 0.3 volt negative, and the grid voltage has changed by the same total, from 0.7 to 1.3 volt negative.

Output voltage or voltage across the plate load has dropped to about 95, due to less plate current, resulting from the more negative grid. Plate voltage has gone up to about 92. Supply voltage must be the sum of load and plate voltages, or about 187. By how much has the load voltage changed while the grid swings through 0.6 volt? The change of load voltage has been from 143 to 92, a change of 51 volts. Dividing the change of output voltage, 51, by the change of input voltage, 0.6, shows that we have voltage gain of about 83 times in the pentode tube with the load and the voltages here employed.

By employing a higher screen voltage, to cause more plate current, and by using a bias less negative, to work closer to the zero

grid condition, it would be possible to obtain voltage gains much greater than has been indicated - provided the load resistance were made high enough. The ranges of our test panel meters do not allow checking the very high gains of which a pentode is capable. Instead of employing more screen voltage and more load resistance we shall make some tests with a lesser load.

In Fig. 18 the input voltage, grid bias, and screen voltage are the same as in Fig. 16. But the effective load in the plate circuit has been reduced to about 9,500 ohms. Plate voltage is 123 and output or load voltage is 64, with a sum of 187 volts furnished from the d-c power supply, as in preceding tests of gain.

In Fig. 19 the signal voltage has swung to 0.3 volt negative, just as it did in Fig. 17 while we had the greater load resistance. Screen voltage is being held at 100. Now the plate voltage is about 143 and load voltage is down to 43. The sum of these two voltages is 186, showing that supply voltage has undergone no material change. The change of signal voltage and of grid voltage is the same as before, 0.6 volt total. Load voltage has changed from 64 to 43, a change of 21 volts in the output. When we divide the 21-volt change of output by the 0.6-volt change of input it appears that the voltage gain now is only 35.

Between the two pairs of tests for voltage gain nothing was changed except the load. Signal and screen voltages remained the same. Decreasing the effective load from about 25,000 to 9,500 ohms decreased the voltage gain from 83 to 35. The tests with less load were made for a good reason. In many television amplifier circuits it is possible to use loads of only 2,000 to 5,000 ohms, this being necessary in order that the gain may remain fairly uniform over a wide range of operating frequencies. Why this is true will come out when we study high-frequency amplification, but here we have a preview of what will happen to gains, and why.

PLATE CURRENT CUTOFFS. With a triode tube we found that the grid voltage for cutoff of plate current depends on plate



## LESSON 18 – PENTODE VOLTAGE AMPLIFIERS

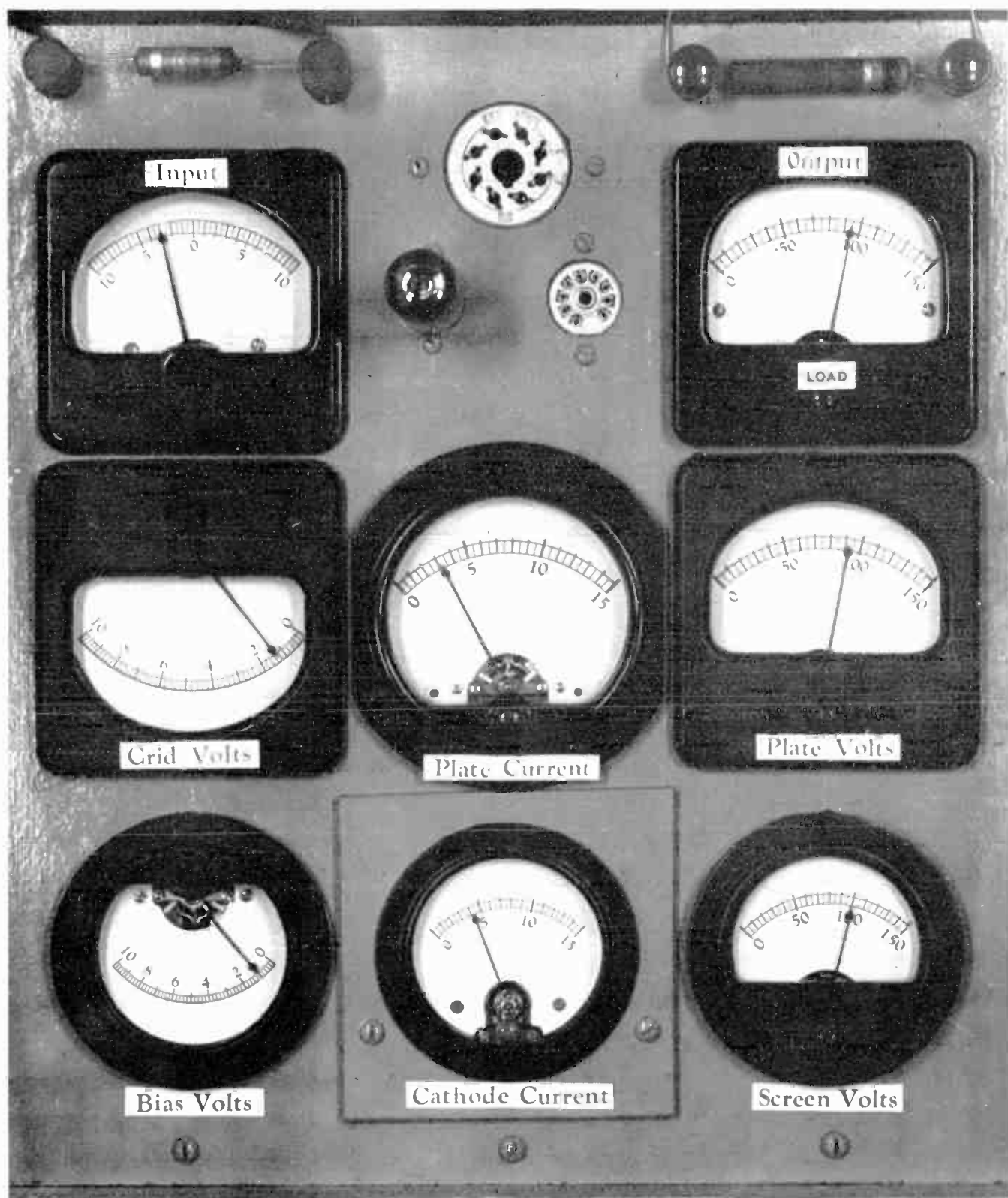

Fig. 17. With a 25,000-ohm load, voltage gain from grid to plate is about 83 times.



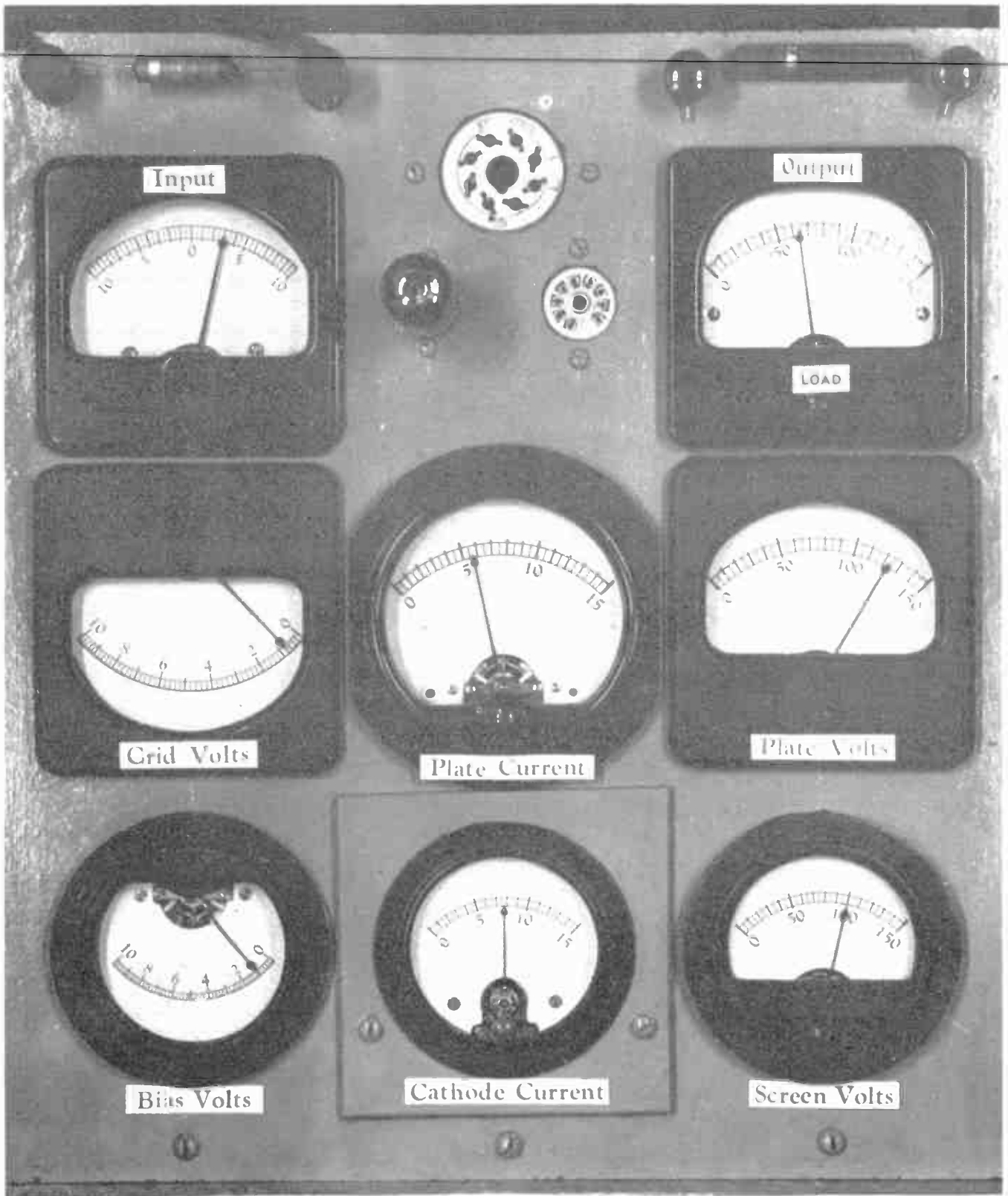

Fig. 18. The effect on output and plate voltages of using less load.

## LESSON 18 – PENTODE VOLTAGE AMPLIFIERS

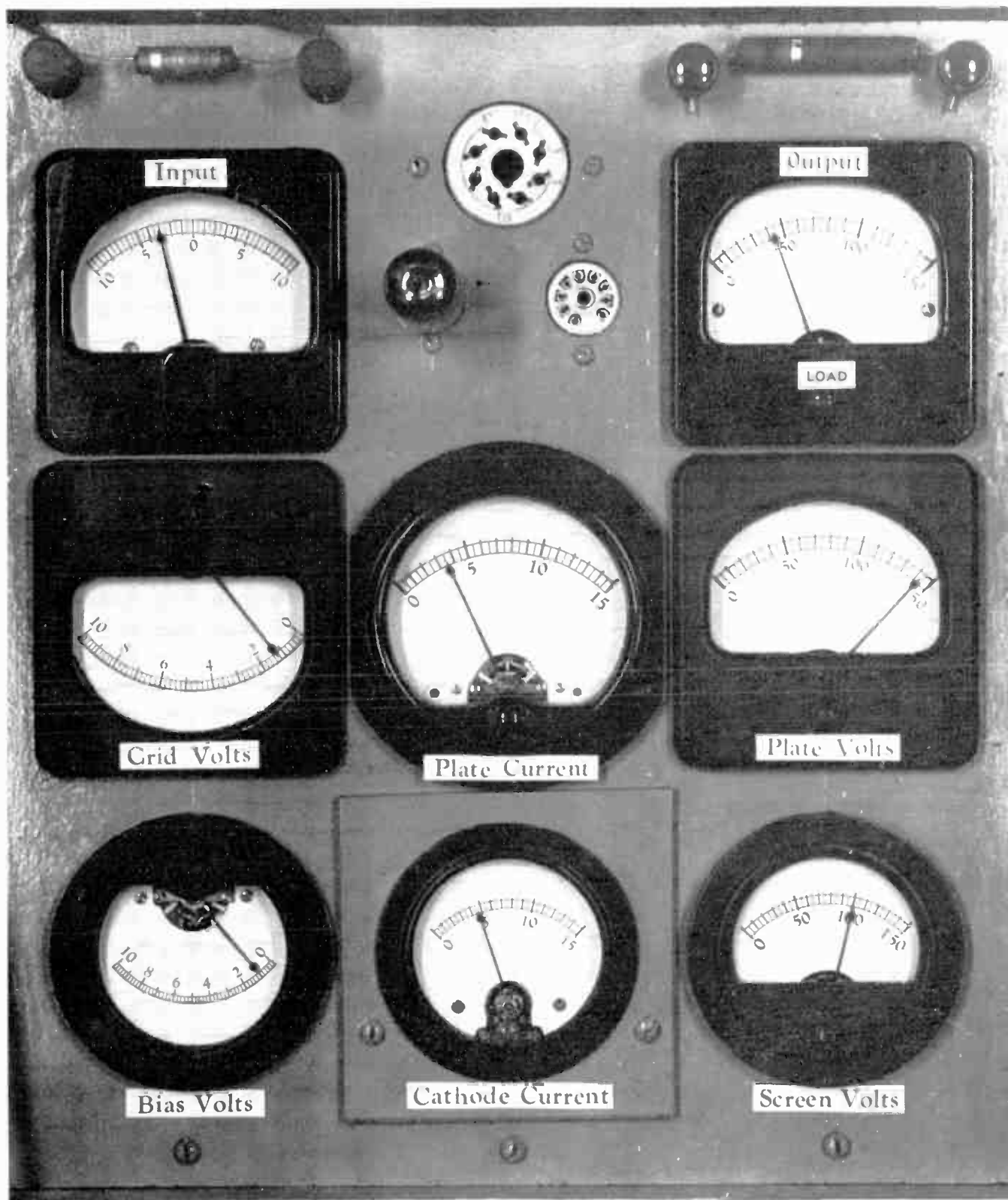

Fig. 19. With less load, and with the same signal and d-c supply voltage, voltage gain decreases to about 35 times.

# COYNE - television home training

voltage, the higher the plate voltage the more negative the grid must be made to reduce the plate current to zero. With a pentode the grid voltage for plate current cutoff depends practically not at all on plate voltage, it depends on screen voltage. With the screen of a pentode held at any given voltage while grid voltage is made just sufficiently negative for cutoff of plate current, the plate current will not resume even though plate voltage is greatly increased.

The tube with which we have been making tests is one of many voltage amplifying pentodes classed as a sharp cutoff type. In all pentodes of this class the plate current decreases sharply as the grid is made more and more negative, and there is complete cutoff of plate current at some fairly small

negative grid voltage. Such performance is illustrated at the left in Fig. 20. One of the curves is made with the screen held at 150 volts and the other curve is made with the screen held at 100 volts, while the grid is made more and more negative as shown by the bottom scale. Both curves show how plate current drops as the grid is made negative. Plate voltage is maintained constant at 150. With 150 screen volts there is cutoff when the grid becomes about 5.0 volts negative, and with 100 screen volts the grid has to be made only about 3.6 volts negative for cutoff.

The curve at the right in Fig. 20 shows negative grid voltages for plate current cutoff when screen voltage is anywhere between zero and 150 volts positive. In plotting this

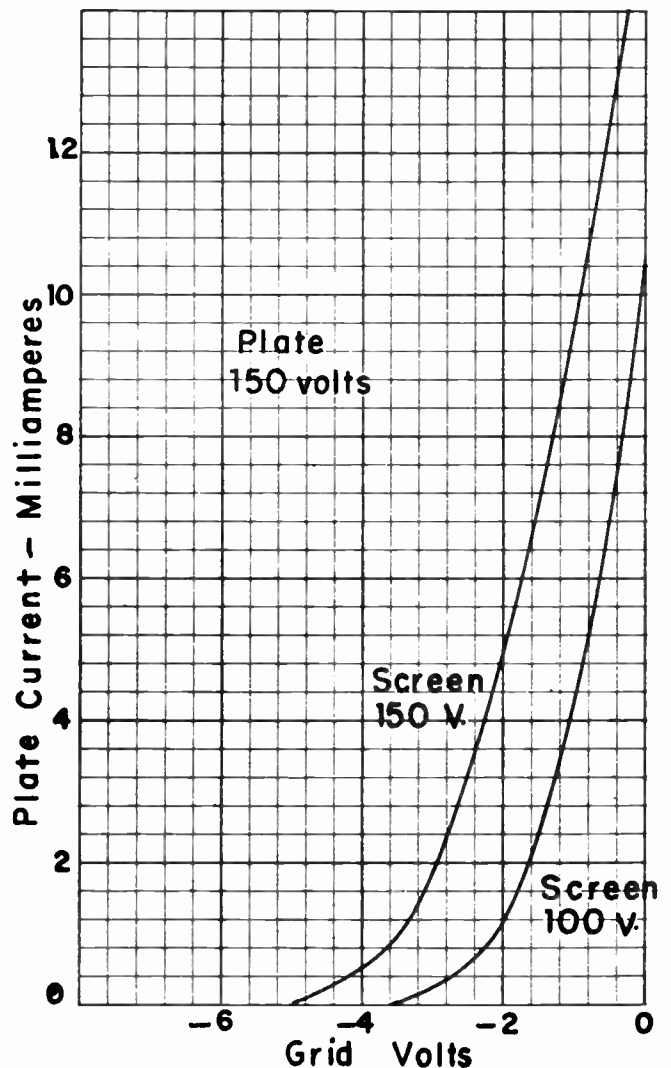
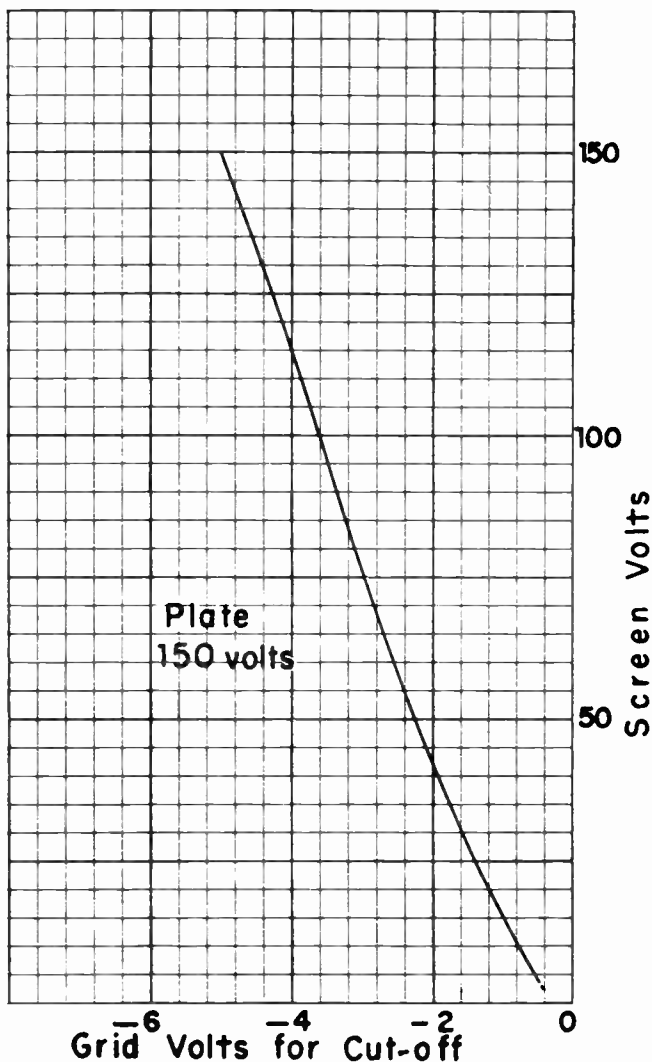

Fig. 20. Performance of a sharp cutoff pentode.



# LESSON 18 – PENTODE VOLTAGE AMPLIFIERS

curve the plate voltage was maintained at 150, although any change of plate voltage within the normal operating range for this tube would have had no noticeable effect on relations between screen and grid voltages for cutoff.

Another class of voltage amplifying pentodes, less used for television but found in many sound radios, includes those having a remote cutoff. Fig. 21 shows the relations between plate current and negative grid voltage when the screen is held at 150 volts in a miniature pentode of the remote cutoff type. As the grid is made negative by a few volts the plate current drops in much the same way as with a sharp cutoff tube. But then the grid has to be made highly negative before plate current is dropped all the way to zero.

Remote cutoff pentodes are used chiefly where there may be large variations of input signal voltage, and where the amplifier must be able to handle both weak and strong signals without plate current cutoff and the distortion which would result from this effect.

When operating the sharp cutoff pentode of Fig. 20 with 150 volts on the screen, the total swing of signal and grid voltages would have to be somewhat less than 4 volts in order to work on the straighter portion of the curve, or in order to avoid cutoff at the negative signal peak. With a remote cutoff tube of Fig. 21 the total swings of signal and

grid voltages might be very great without danger of complete cutoff.

When considering the operation of a tube in relation to grid-voltage plate-current curves we must remember that the average grid voltage or the grid voltage with zero signal is determined by the bias. The signal then shifts the grid voltage less negative and more negative than the bias voltage. Voltage gain with the remote cutoff pentode may be varied by altering the bias voltage. While this is true to some extent with all types of amplifiers, it is a special feature of the remote cutoff tube. How bias affects the gain is illustrated by the following example.

Assume first that there is a strong signal, as when receiving from a nearby transmitter, and that resulting signal voltage at the grid of our amplifier alternates between 2 volts positive and 2 volts negative. If, on the curve of Fig. 21, the bias is 9 volts negative, the grid voltage will shift from 7 to 11 volts negative. This will shift the plate current from 2 to 1 ma, which is a change of 1 ma. There will be a corresponding change of voltage across whatever load is employed.

Next assume that there is a weaker signal, as when receiving from a distant transmitter, and that at the grid of our amplifier this signal causes a voltage alternating between 0.3 volt positive and 0.3 volt negative. For this weaker signal we may make the bias 3.0 volts negative. Grid voltage will shift between 2.7 and 3.3 volts negative on the curve of Fig. 21, and plate current will vary between 6 and 5 ma, which again is a change of 1 ma in the load. Here is a summary of what happens.

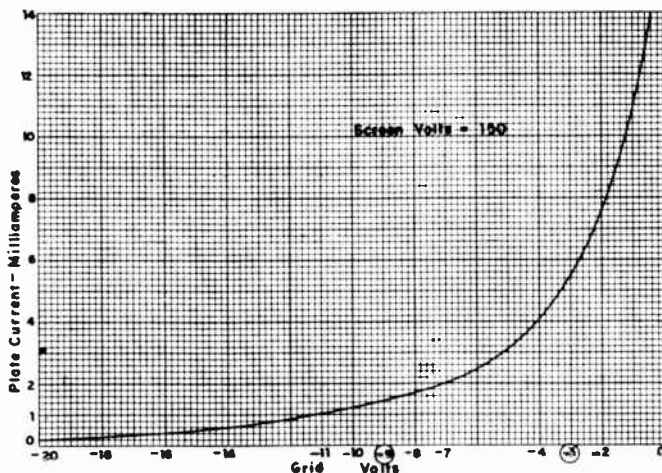

Fig. 21. Grid voltage must be made highly negative to cause plate current cutoff in a remote cutoff type of pentode amplifier.

Signal Alternation	Bias Volts	Grid Volts Change	Plate Current Change	Plate Current Difference
+2.0 to -2.0	-9.0	-7.0 to -11.0	2.0 to 1.0 ma	1.0 ma
+0.3 to -0.3	-3.0	-2.7 to - 3.3	6.0 to 5.0 ma	1.0 ma

These equal changes of plate current or equal differences between plate currents will produce equal output signal voltages across the load resistance. Thus it is apparent that we may have equal outputs from weak and strong input signals by altering the bias of the pentode amplifier having remote



# COYNE - *television home training*

cutoff. Of course, the outputs do not have to be made equal for all inputs, they may be anything desired. The point is that the remote cutoff feature allows handling a wide range of signal strengths by altering the bias on the tube.

---

## CONDENSED INFORMATION

Screen. Lessens grid-plate capacitance and reduces feedback of signal power from plate circuit to grid circuit.

Secondary emission. High velocity electrons from the cathode strike the plate and drive other (secondary) electrons out of the plate. This action is called secondary emission.

Suppressor. When maintained at approximately the potential of the cathode, forces secondary electrons back into the plate and prevents secondary emission from distorting the plate current on strong signals.

### Pentode characteristics.

As a class, have high transconductance, high plate resistance, and allow high gains of signal voltage.

Actual voltage gain depends largely on load in plate circuit, increasing with load resistance up to any reasonable limit of load and operating voltages.

### Pentode performance.

Average plate current, with any given bias and no signal, depends almost entirely on screen voltage and very little on plate voltage.

Increases of plate voltage through the normal range have little effect on plate current.

Changes of grid voltage alter the plate current in the pentode as in a triode.

Bias voltage effects, when plate and screen voltages are unchanged.

BIAS CHANGE	PLATE CURRENT (Average)	PLATE RESISTANCE	TRANSCONDUCTANCE	POSSIBLE GAIN OF VOLTAGE
More negative	Less	Higher	Lower	Less
Less negative	More	Lower	Higher	More

### Sharp and remote cutoffs.

Sharp cutoff pentodes provide high gains, but can be used only where input signals do not vary a great deal in strength.

Remote cutoff types can be used for either weak or strong signals by altering the negative bias.

# TELEVISION

◦ RADIO

◦ ELECTRONICS

---

**LESSON 19 – TUBE TYPES AND STRUCTURES**

---

***Coyne School***

*practical home training*

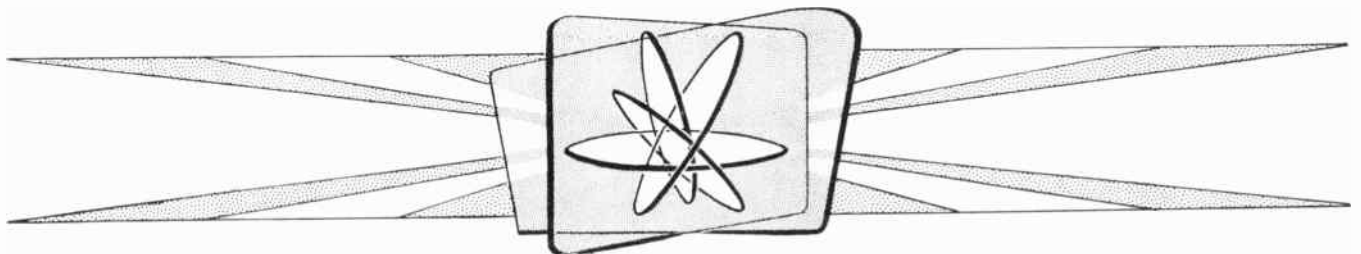

*Chicago, Illinois*

---

Copyright 1953 by Coyne School  
Chicago 12, Illinois  
All rights reserved

Litho. in U.S.A.

## Lesson 19

### TUBE TYPES AND STRUCTURES

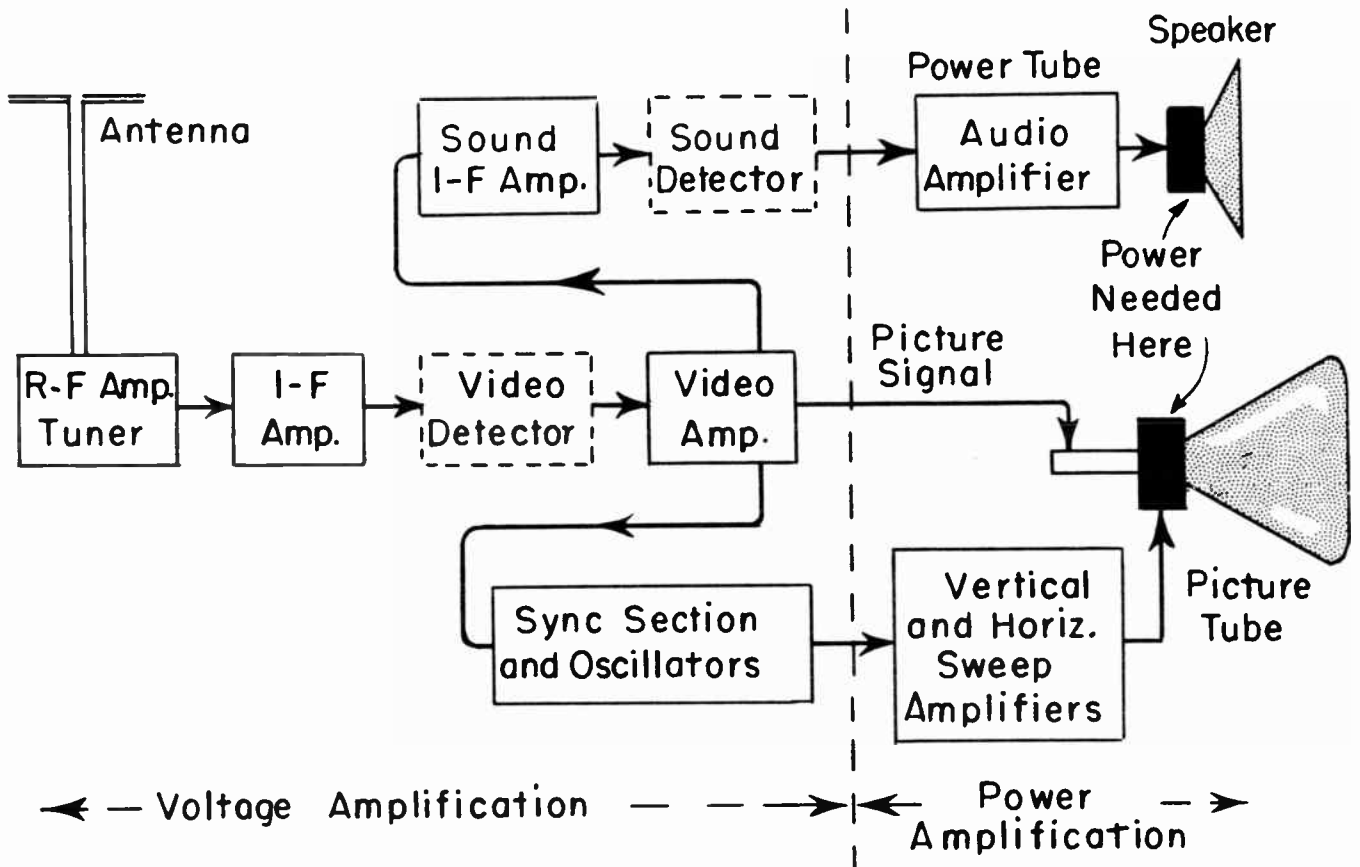

Fig. 1. The sections of a television receiver in which voltage amplification and power amplification are required.

We have examined the process of voltage amplification, with which a signal voltage applied to the grid circuit comes from the plate circuit as a stronger signal voltage. We speak of this as voltage amplification because we are concerned only with obtaining increases of voltage and are making no attempt to obtain large signal currents in the plate circuits.

On the left-hand side of the vertical broken line in Fig. 1 are shown all the sections of a television receiver in which voltage amplification is employed. Between the antenna and the signal grid of the picture tube are the r-f amplifier, the i-f amplifier, and the video amplifier, in all of which the tubes are voltage amplifying types.

The lights and shadows on the screen of the picture tube result from variations of voltage at its signal grid. Like the grid of an amplifier tube, this signal grid must never become positive, it must remain zero or negative with reference to the cathode of the picture tube. The signal grid must not draw current to itself any more than the grid of an amplifier tube should draw current. Consequently, at the signal grid of the picture tube we require only variations of voltage corresponding to lights and shades of pictures. The video amplifier tube feeding the signal grid may be a voltage amplifying tube.

Sound signal voltages taken from the video amplifier are strengthened in the sound i-f amplifier section. In this section we use



## COYNE - *television home training*

voltage amplifying tubes. But in the speaker of either a television receiver or a sound radio we need ~~more than variations of voltage~~. The cone of the speaker and the surrounding air possess weight or mass, and to vibrate them takes power, in watts. It is impossible to cause continued movement of anything having weight without using power.

To have power we must have more than voltage, we must have both voltage and current. Power, as you should remember, is proportional to the product of current in milliamperes times potential difference in volts, divided by 1,000. We may have any given power with high voltage and small current, or with low voltage and large current, but there must be current. Consequently, the audio output amplifier tube or tubes must be of types called power amplifiers.

Tubes which are designed to handle plate currents great enough to produce useful power in the output circuits are classed as power amplifiers. There are triode power amplifiers, pentode power amplifiers, and a modification of the pentode which is called a beam power amplifier.

Power is required also in the process of sweeping the electron beam in picture tubes which operate with magnetic deflection. We need power because magnetic fields that deflect the electron beam result from changes of current in the deflecting coils which are around the neck of the picture tube. In these coils there must be rapid changes of rather large currents. The variations of current are caused by variations of voltage across the coils. Since there must be changes of both voltage and current in the deflecting coils it is necessary to furnish power to these coils, and the output tubes in the vertical and horizontal sweep amplifier sections must be power amplifier types.

In the sync section and sweep oscillators between the video amplifier and sweep amplifiers we need only voltage amplifier types of tubes. Power amplifier tubes sometimes are used as sweep oscillators, but it is not absolutely necessary.

When comparing power amplifiers with voltage amplifiers of similar types it will be

found that the power types are operated with greater plate currents and, accordingly, must have less plate resistance. Accompanying the lesser plate resistance will be lower transconductances. These are the differences between power and voltage amplifying triodes, and between power and voltage amplifying pentodes.

BEAM TUBES. The inside of a beam tube with the outer envelope removed appears no different than the inside of many other tubes, as you can see at A in Fig. 2. But removing the plate, as at B, exposes two beam forming electrodes, one on either side of the remaining elements. These electrodes, which partially surround the cathode and other elements, are internally connected to the cathode. They confine electrons traveling from cathode to plate into two beams.

Through the openings between the opposite beam forming electrodes can be seen turns of the screen. The screen surrounds the grid that is around the cathode, as in any other tube having a grid. There is no suppressor element, yet secondary electrons from the plate are prevented from going to the screen. Suppressor action in the beam tube is obtained as follows.

When dips of plate voltage make the plate less positive than the screen, electrons coming from the cathode and moving through the space between the more positive screen and less positive plate are slowed down. Where these electrons slow down they congregate with considerable density, much as runners on a race course would come closer together were all of them to slow down while passing some certain point.

At this point between screen and plate the massed negative electrons form a negative charge, which is equivalent in action to the charge of a suppressor since a suppressor is negative with reference to the plate and screen. When secondary electrons from the plate try to go to the more positive screen they encounter the concentration of negative electrons and are driven back to the plate in the same manner as by a suppressor. This action occurs only when the plate becomes less positive than the screen, to slow down

## LESSON 19 – TUBE TYPES AND STRUCTURES

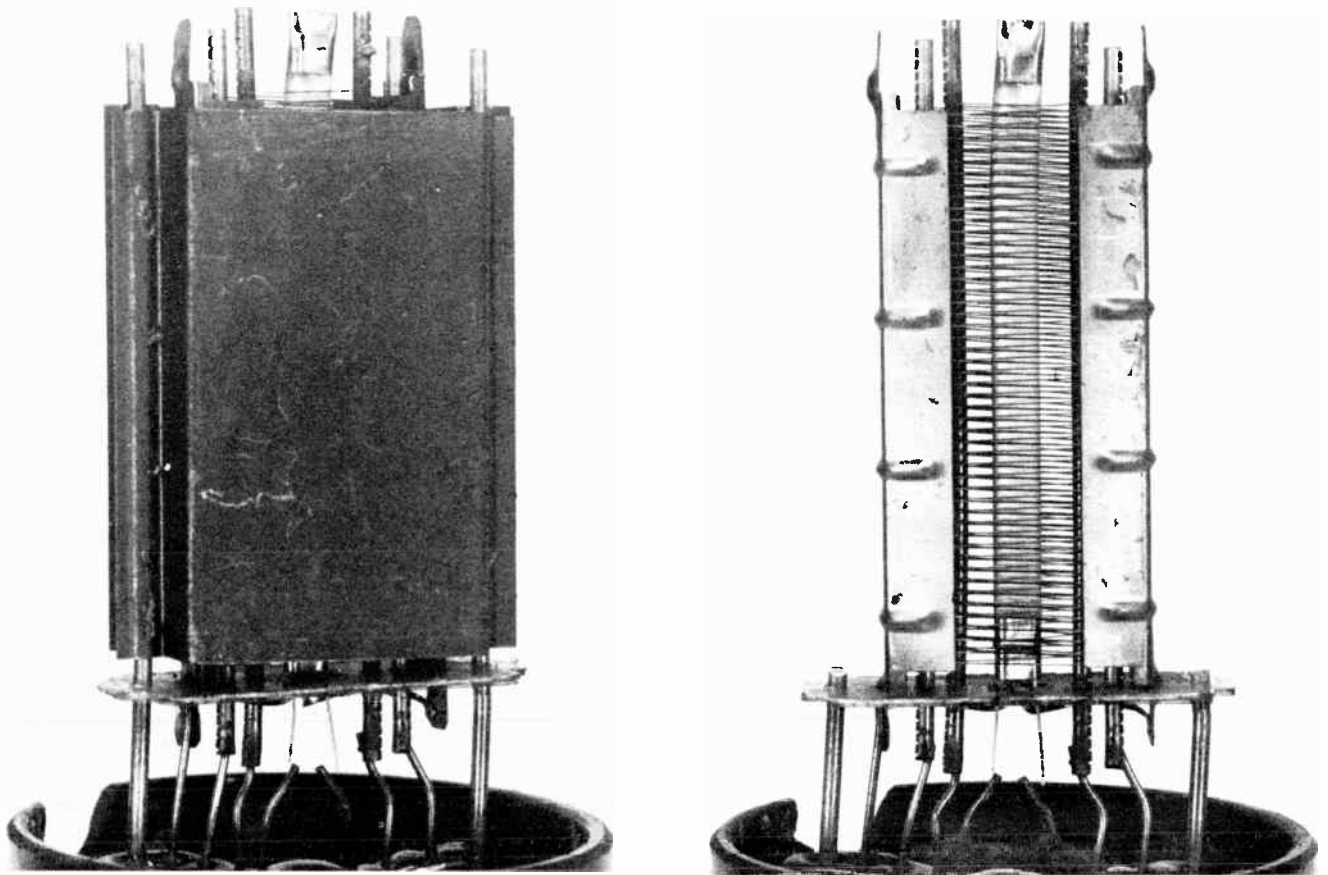

Fig. 2. A beam tube with its plate in place (left) and with the beam forming electrodes exposed (right).

the flying electrons. It is only then that secondary emission would cause trouble.

Each turn of the screen in a beam tube is located directly in line with or directly outside of a turn of the grid. With the grid negative, electrons flow only through gaps between the grid turns. Consequently, in the spaces immediately outside of each grid turn there are few electrons. It is here that the screen turns are located. The result is that few electrons enter the positive screen, and screen current in the beam tube is smaller than might be expected in view of the large plate current.

Most power tubes are of the beam type. Power pentodes, with suppressor elements, were used before development of the beam tube, but now are seldom used. Power triodes are found in many audio amplifiers designed for high quality reproduction, be-

cause triodes are less subject to signal distortion than are beam tubes or power pentodes. Power triodes are used also for sweep amplifiers in the vertical deflection sections of television receivers.

Either voltage amplifier or power amplifier pentodes sometimes are connected to work as triodes. When there are separate base pins for plate, suppressor, and screen, all three are connected together, at the socket, as shown at A in Fig. 3. If the suppressor is connected to the cathode inside the tube, as at B, the plate and screen are tied together at the socket in order to provide triode operation. Beam tubes are not so often operated as triodes, but when this is done the connections are as at C. There are no separate base pins for the beam electrodes, these electrodes always are connected internally to the cathode.

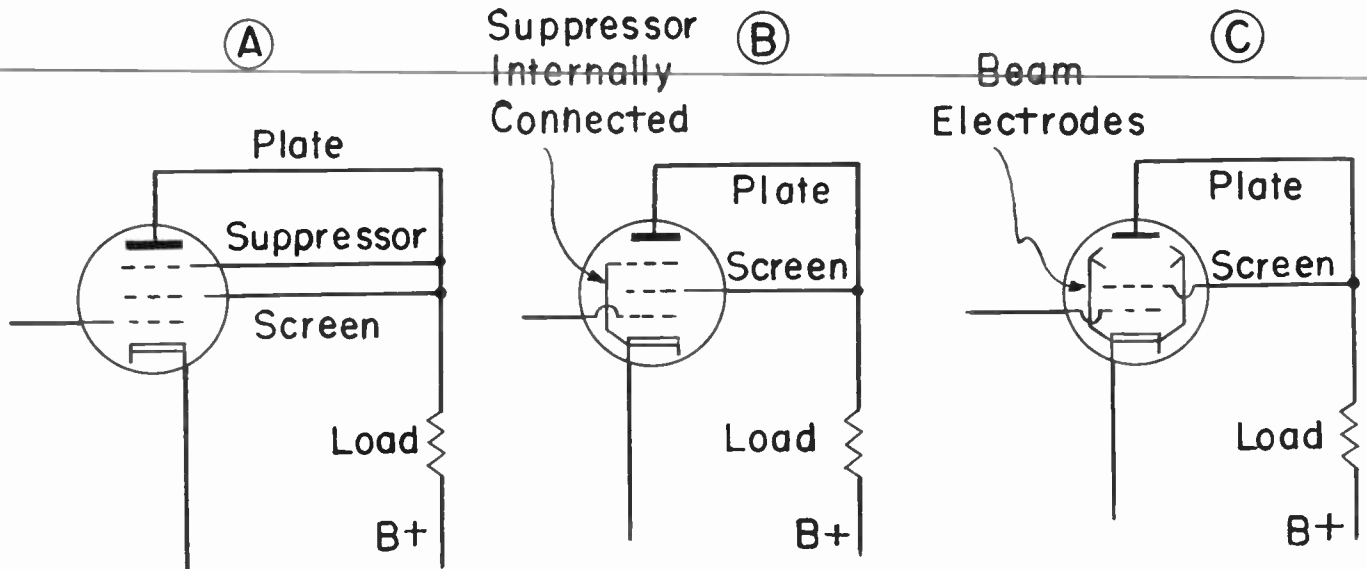

Fig. 3. How pentodes and beam tubes are connected to operate as triodes.

When a pentode or a beam tube is operated as a triode the screen and bias voltages are made such that plate current is no more than the sum of plate and screen currents for pentode operation, and usually the plate current is made somewhat less. Plate resistance of a pentode operated as a triode is, on the average, only about 1/100 of the resistance for pentode operation. Beam tube plate resistance as a triode may be about 1/20 of that for regular beam power operation. Transconductance with triode operation may be something like 20 per cent more or less than as a pentode or beam tube, but is not enough different to cause much change in gain.

**POWER DISSIPATION.** If you touch the bulb or envelope of a tube which has been operating for some time you will find it very hot. The heating results from electric power which is being changed to heat within the tube. A good deal of the heat comes from the cathode, but in many cases a still greater portion comes from the plate. The plate temperature is raised by energy of electrons which are bombarding it.

The amount of heat produced at the plate, or the rate of heat production, may be measured by the watts of power used at the plate. The number of watts of power produced at the plate, and radiated or dissipated from the plate, is equal to the product of

plate volts and plate current <sup>IN</sup> is amperes, or to the product of plate volts and milliamperes divided by 1,000.  $W = (E_p)(I_p)$

If you look at the published ratings for any type of tube, one of the listings will be of maximum allowable plate dissipation in watts. Another may be maximum screen dissipation in watts, for the number of watts of power being changed to heat at the screen is proportional to the product of screen volts and screen current.

As an example, a 6AQ5 beam tube is rated for 12 maximum watts of plate dissipation. If an average tube of this type is operated with 250 volts on the plate, 250 volts on the screen, and negative bias of 12.5 volts, the plate current will be 45 ma when there is no signal. Plate dissipation is figured thus.

$$\frac{250 (E_p \times 45 \text{ ma } (I_p))}{1000} = \frac{11250}{1000} = 11.25 \text{ watts}$$

This is just within the safe plate dissipation for the tube. Were screen voltage to be increased it would be necessary to make the bias more negative. Otherwise the plate current and plate dissipation would rise dangerously high. Were grid bias to be reduced it would be necessary to reduce screen voltage at the same time in order to hold plate current within the limit of safe dissipation. With a power triode instead of a beam

## LESSON 19 – TUBE TYPES AND STRUCTURES

tube, or a pentode, the plate voltage and grid bias would have to be such as to prevent excessive plate current and plate dissipation.

Excessive power dissipation in a pentode or beam tube may cause trouble with secondary emission, it may release gases within the evacuated space, it may warp the elements because of overheating, and doubtless will ruin the tube if allowed to continue. Servicemen sometimes boost the plate voltage or screen voltage, or they reduce the negative bias in an attempt to get greater transconductance and voltage gain. If the tube already is working near its dissipation limit this is bad practice. There may be greater gain for a short time, after which the tube will be finished.

Screen dissipation increases not only with more screen voltage and current, but also with more resistance in the plate load and with stronger signals. Why the load and the signal increase screen dissipation is a rather technical matter, but it is related to the greater swings of plate voltage and current. It seems rather strange, but it is true, that the maximum allowable plate load depends largely on the permissible screen dissipation. Excessive screen dissipation, and the resulting overheating, can ruin a tube just as surely as excessive plate dissipation.

**STYLES OF TUBES.** The fact that there are hundreds of tubes in use is due in part to the fact that equal or equivalent electrical performance from the same kinds of elements may be had in many different types. There are differences in size and materials of the envelopes or bulbs. There are numerous styles of bases and contact pins, and various ways of connecting the same group of elements to the base pins. Element groups or sections of various types may be built together in single envelopes. For example, a 6SN7 is the exact equivalent of two separate 6J5's, and, as mentioned before, a 12AU7 is the equivalent of two separate 6C4's.

The most noticeable difference between tubes is in the material of their envelopes. Some are metal and some are glass. The largest and smallest sizes of metal-envelope receiving tubes are pictured by Fig. 4. In-

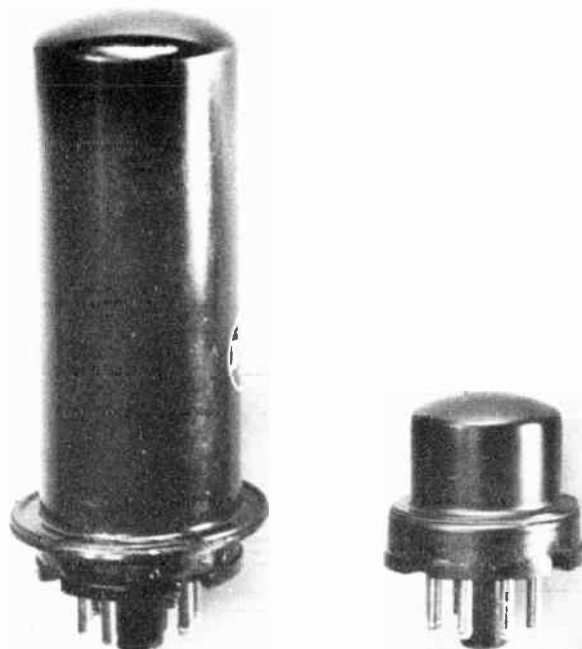

Fig. 4. The largest and smallest home receiver types of metal-envelope tubes.

side the metal tube is a glass "header" through which pass the leads for the various elements. The heater is sealed to a metal ring which is welded to the metal envelope or shell. The bottom of the envelope is crimped onto the base which carries the contact pins.

Fig. 5 shows relative sizes of three commonly used styles of metal tubes. The overall height of the one at the left is  $4 \frac{5}{16}$  inches or may be slightly less. The one at the center is about  $2 \frac{5}{8}$  inches from the top of the envelope to the bottom of the locating pin which is in the center of the base. At the right is the style having an overall height of about  $1 \frac{3}{4}$  inches. Shell diameter of the largest size is about  $1 \frac{1}{4}$  inches and of the smaller sizes is very little more than an inch..

All of the earlier tubes having glass envelopes were of the general form shown by Fig. 6. The overall heights, from left to right, are approximately  $5 \frac{5}{16}$  inches,  $4 \frac{5}{8}$  inches, and  $4 \frac{1}{8}$  inches. The dimensions of all tubes are mentioned as being approximate because there are slight variations which represent manufacturing tolerances.



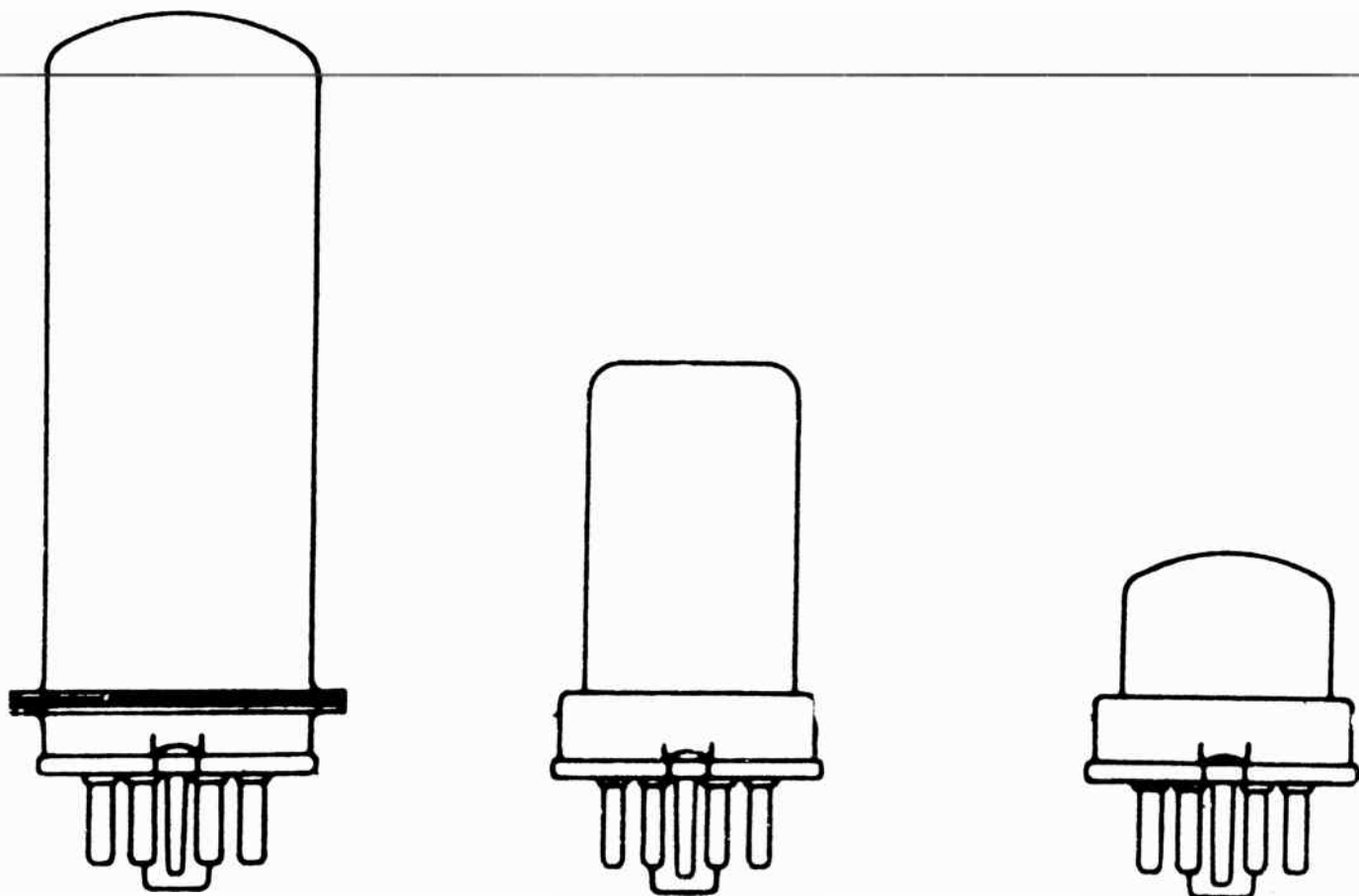

Fig. 5. Relative sizes of metal-envelope tubes. All have octal bases.

The largest of the glass envelopes illustrated still is current in some of the heavy-duty power rectifiers, but for amplifiers and tubes performing other functions these flared envelopes have largely disappeared from current production. These glass envelope tubes were, in many cases, electrical counterparts of still earlier glass tubes having 4-, 5-, 6-, or 7-pin bases. When the same type was made with an octal or 8-pin base, as in the illustration, the capital letter G often was added to the type number. The letter G was used also to designate the glass counterpart of a metal tube. For example, the 6N7 has a metal shell and the 6N7-G has a glass bulb, with the two otherwise identical.

Somewhat later many of the same tubes, electrically, were made with smaller cylindrical glass bulbs instead of with those having flared sides. The two styles are shown side by side in Fig. 7. The smaller tubes are identified by the letters GT at the

end of the type number. In this designation the letter "G" stands for glass and the letter "T" for tubular. The great majority of glass-envelope tubes now in use as amplifiers and general purpose tubes, other than the miniatures, are of the GT style.

When a GT tube was made electrically equivalent to a former G-type, and the G-type was discontinued in manufacture, the new tube often was identified as a GT/G type. This means that the tube is of the GT size and style, but may be used as an exact replacement for a G-type whose type number or type designation is otherwise the same. As an example, a remote cutoff pentode widely used in sound radios has the type designation 6SK7-GT/G, indicating that it replaces a 6SK7-G, which carried the letter G because there is also a 6SK7 with a metal envelope.

Some glass tubes with tubular envelopes are higher than others, as shown by the scale drawings of Fig. 8. Most of the GT types are

## LESSON 19 – TUBE TYPES AND STRUCTURES

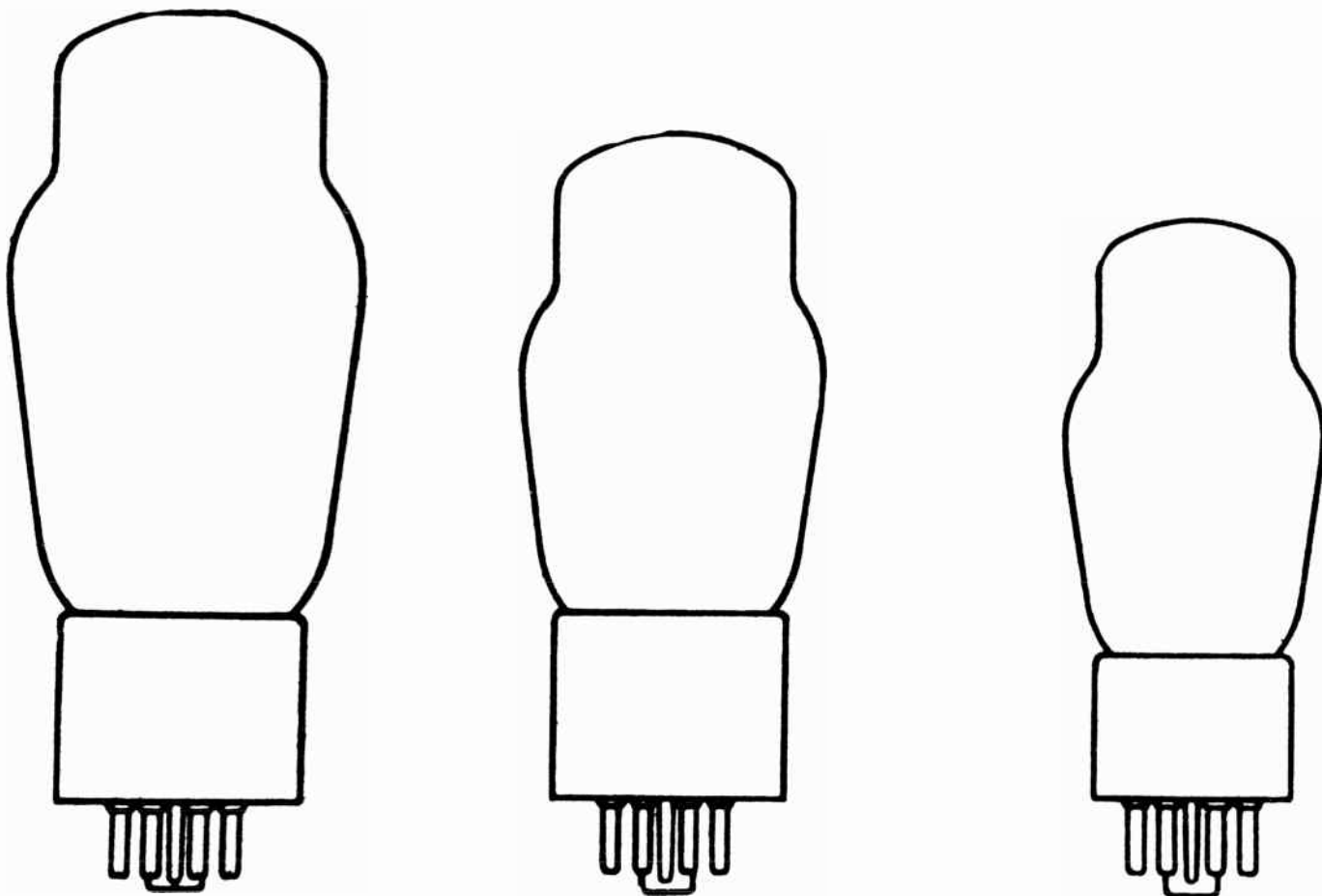

Fig. 6. Relative sizes of some glass-envelope "G" tubes having octal bases.

of the proportions shown at the right, with overall height of about 3-5/16 inches. Tubes of the GT style used as power rectifiers and as power amplifiers usually have bases of Bakelite, as have also most of the audio voltage amplifiers. The GT styles used at radio and intermediate frequencies often have a base consisting of a bakelite wafer carrying the contact pins and a cylindrical metal shell which is cemented to the glass envelope. There is no fixed practice as to which style of base is used for any given tube type.

The base construction of a lock-in type of tube is illustrated by Fig. 9. The base consists of a short cylindrical metal shell which comes down under the tube and carries the metal locating pin extending downward from the center. The end of this central pin is ball-shaped, with a groove which is engaged by springs in the socket. This is the lock-in feature which makes this style of base especially well suited for tubes in automobile

radios, airplane radios, and wherever there is vibration and shock which might eventually loosen other bases in their sockets.

Although the lock-in tube holds securely in place when pressed down into the socket, it is easily removed by a slight preliminary tilting in line with the key on the locating pin. When the tube is in its socket the position of the key may be determined by a small bump or circular protrusion on the side of the metal base that is in line with the key. These bumps on the base and the keys on the central locating pin are clearly shown in Fig. 10. Tilt the tube either toward or away from the bump and it will free itself from the socket springs. This diagram shows also the relative heights of glass envelopes used on various types of lock-in tubes.

The base pins of lock-in tubes are extensions of the element leads which come down through the bottom glass header and

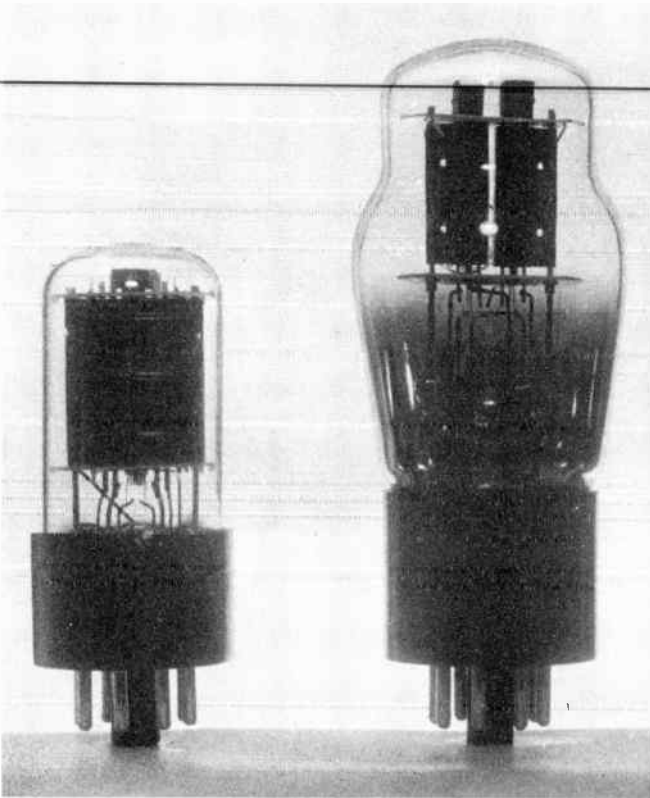

Fig. 7. A "GT" tube at the left and a "G" type at the right. Both have octal bases.

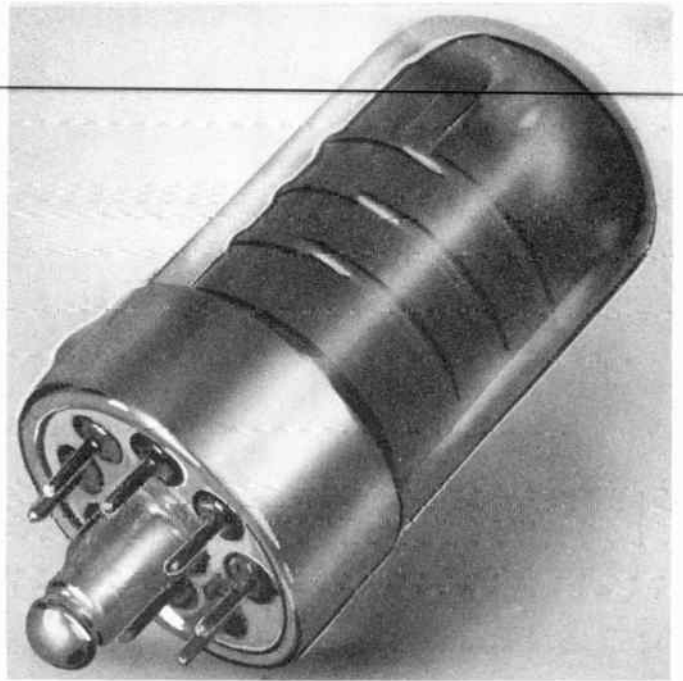

Fig. 9. The construction of a lock-in base.

openings in the metal of the base. The pins are shorter and of much smaller diameter than those on octal base tubes. On all the lock-ins there are eight base pins whether or not all of the pins are connected to internal elements, while on octal bases there may be no pins in some of the eight possible positions.

Lock-in tubes having heater-cathodes designed for 6.3 a-c heater volts have type numbers commencing with 7, while those for 12.6 heater volts have type numbers commencing with 14. Quite a few lock-ins are electrically the same as certain tubes with octal bases and either GT or metal envelopes. For example, a beam type 7C5 lock-in is electrically the same as a beam type 6V6-GT. Because of the short leads to elements, the use of only glass and metal in the base, and other design features, many of the lock-in tubes are well adapted to use at the very-high frequencies in television receivers, and some operate well at ultra high frequencies.

Present tendency in television receivers, in f-m sound receivers, and in many standard broadcast receivers is toward the use of more and more miniature tubes instead of those with octal bases. Fig. 11 is a picture of one of the smallest miniatures alongside

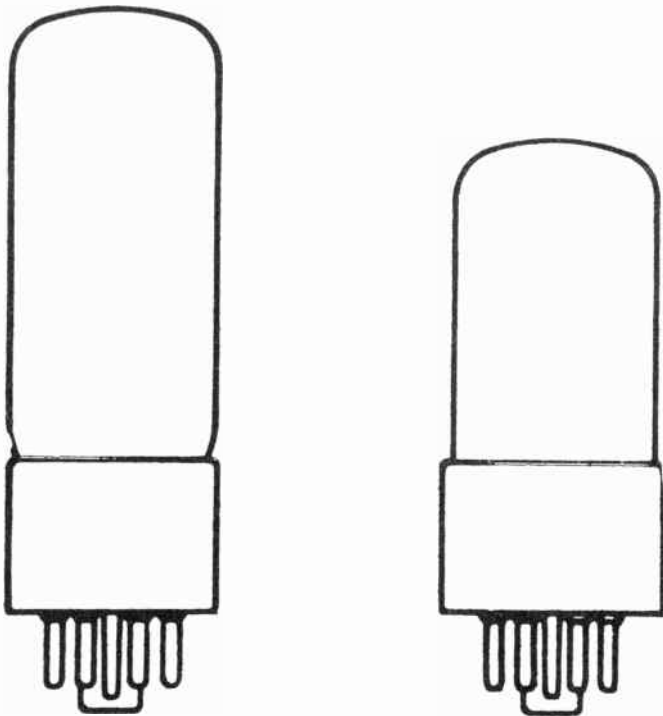
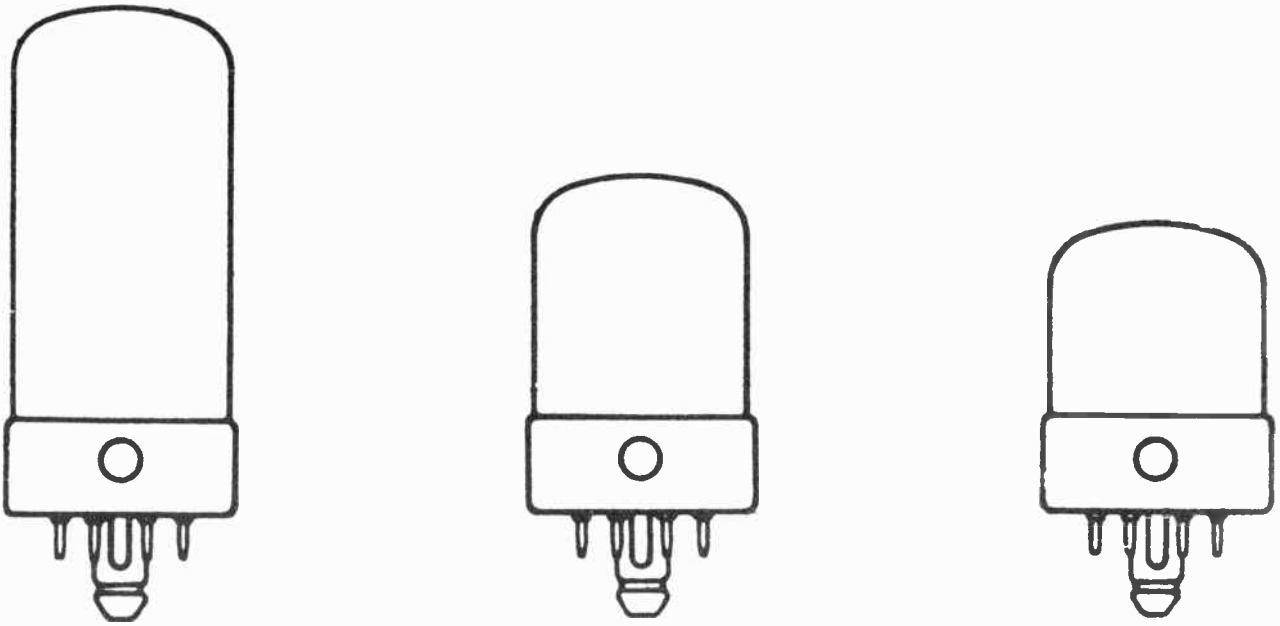
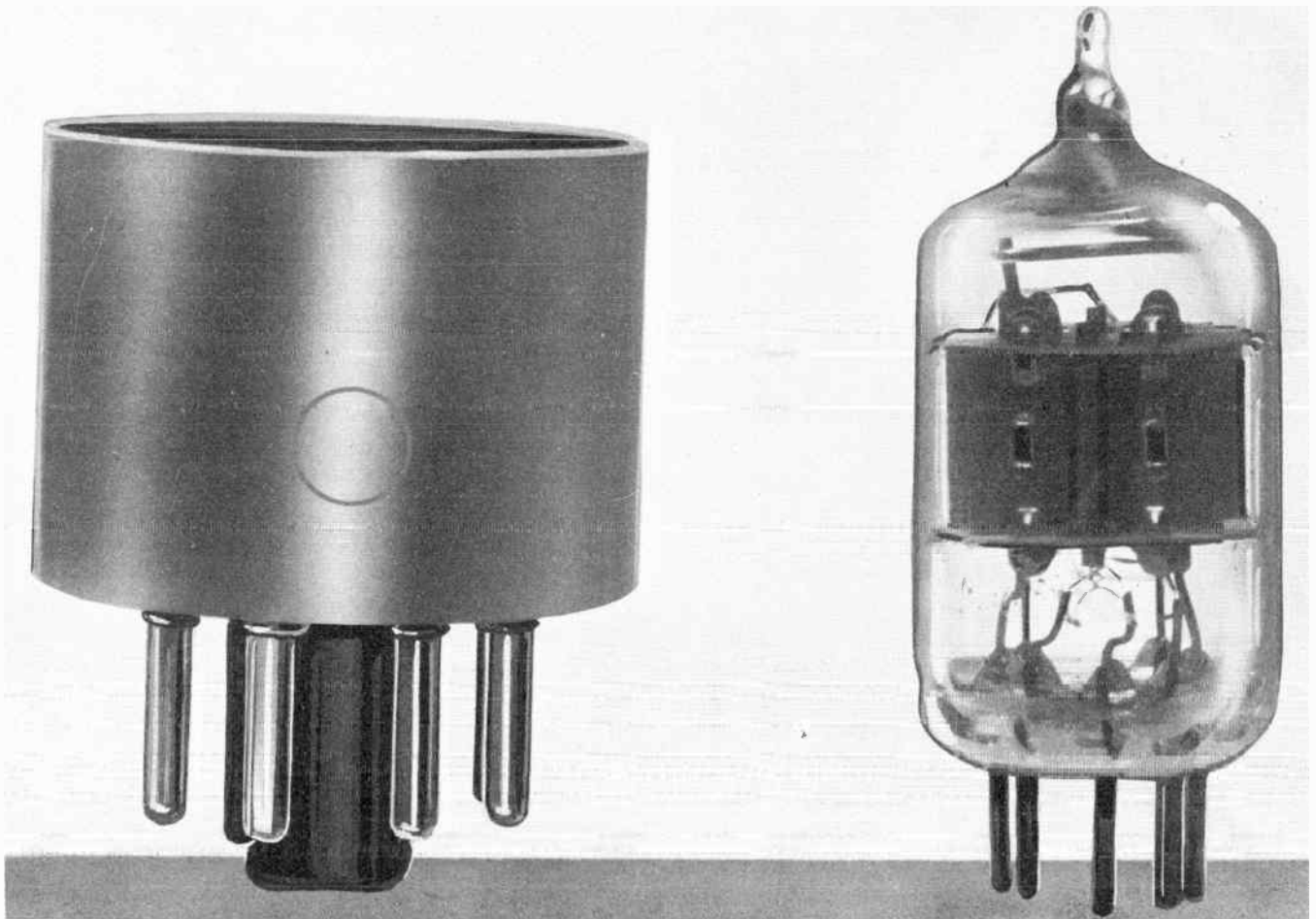

Fig. 8. Relative sizes of two tubes having tubular glass envelopes.

## LESSON 19 – TUBE TYPES AND STRUCTURES



*Fig. 10. Relative dimensions of glass-envelope tubes of the lock-in type.*



*Fig. 11. The smallest miniature tube is not so large as an octal base.*



## COYNE - *television home training*

the Bakelite base of an octal tube. Miniature tubes are especially well suited for high-frequency operation because of their short element leads, small base pins, absence of all insulating materials other than glass and mica, and because of the generally compact construction.

Practically every type of tube, from the electrical standpoint, may be had in miniature styles - other than heavy-duty rectifiers whose heat dissipation is greater than can be handled from a small glass envelope. In all miniature types the base pins are formed by extensions of the element leads coming down through the bottom of the glass envelope.

Most of the miniature tubes have seven pins, with bulb diameter of about  $11/16$  inch and not exceeding  $3/4$  inch. The heights vary, as shown by Fig. 12. At the left is a twin

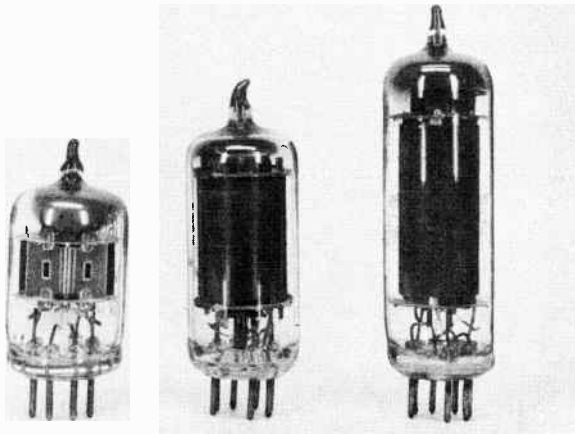

Fig. 12. Three sizes or heights of 7-pin miniature tubes.

diode measuring only a little more than  $1-5/8$  inches in overall height. Next is a voltage amplifier pentode somewhat less than  $2-1/8$  inches high. At the right is a beam tube measuring a little more than  $2-1/2$  inches from the bottom of the pins to the top of the tip on the bulb.

Some miniature tubes which contain more than one section or more than one group of elements within a single bulb have nine pins. These types have bulbs of greater diameter than the seven pin styles, but the diameter does not exceed  $7/8$  inch.

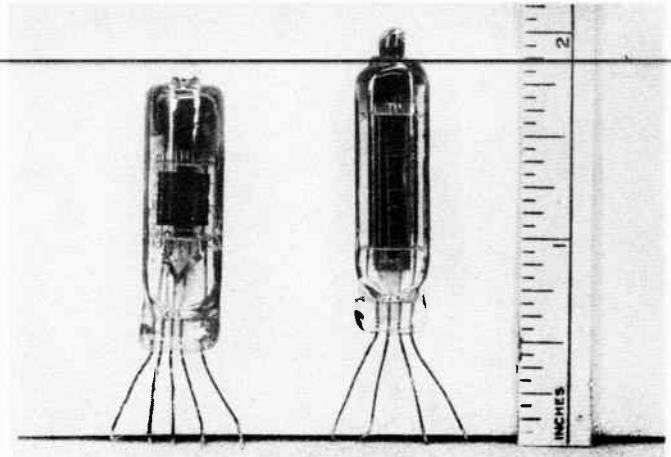

Fig. 13. Subminiature tubes having flexible external leads of solid wire.

Tubes even smaller than the miniatures are called subminiature types, two of which are pictured by Fig. 13. The one at the left has a cylindrical envelope about  $3/8$  inch in diameter, while the one at the right has an envelope about  $3/8$  inch wide and  $1/4$  inch deep from front to back. The overall height of the bulb is somewhat less than  $1-1/2$  inches.

Subminiatures are made in all the usual types of diodes, triodes, pentodes, beam tubes, and rectifiers. They are used chiefly in hearing aids, but are found also in radios attached to weather observation balloons, in radiation counters, and in various scientific and industrial instruments where minimum size, weight, and power consumption are essentials. Most of these tubes have filament-cathodes, but a few have the heater-cathode.

The leads which extend through the glass press at the end of the bulb may be soldered directly to circuit elements, or they may be cut off rather short and inserted into small sockets made especially for the purpose.

**TUBE BASES AND PINS.** Earlier tube designs of all electrical types were fitted with Bakelite or Bakelite and metal bases having four, five, six, or seven contact pins arranged as at A, B, C, and D of Fig. 14. Although these bases are no longer used for home receiver tubes, they still are used for connectors on flexible cables between sec-

## LESSON 19 – TUBE TYPES AND STRUCTURES

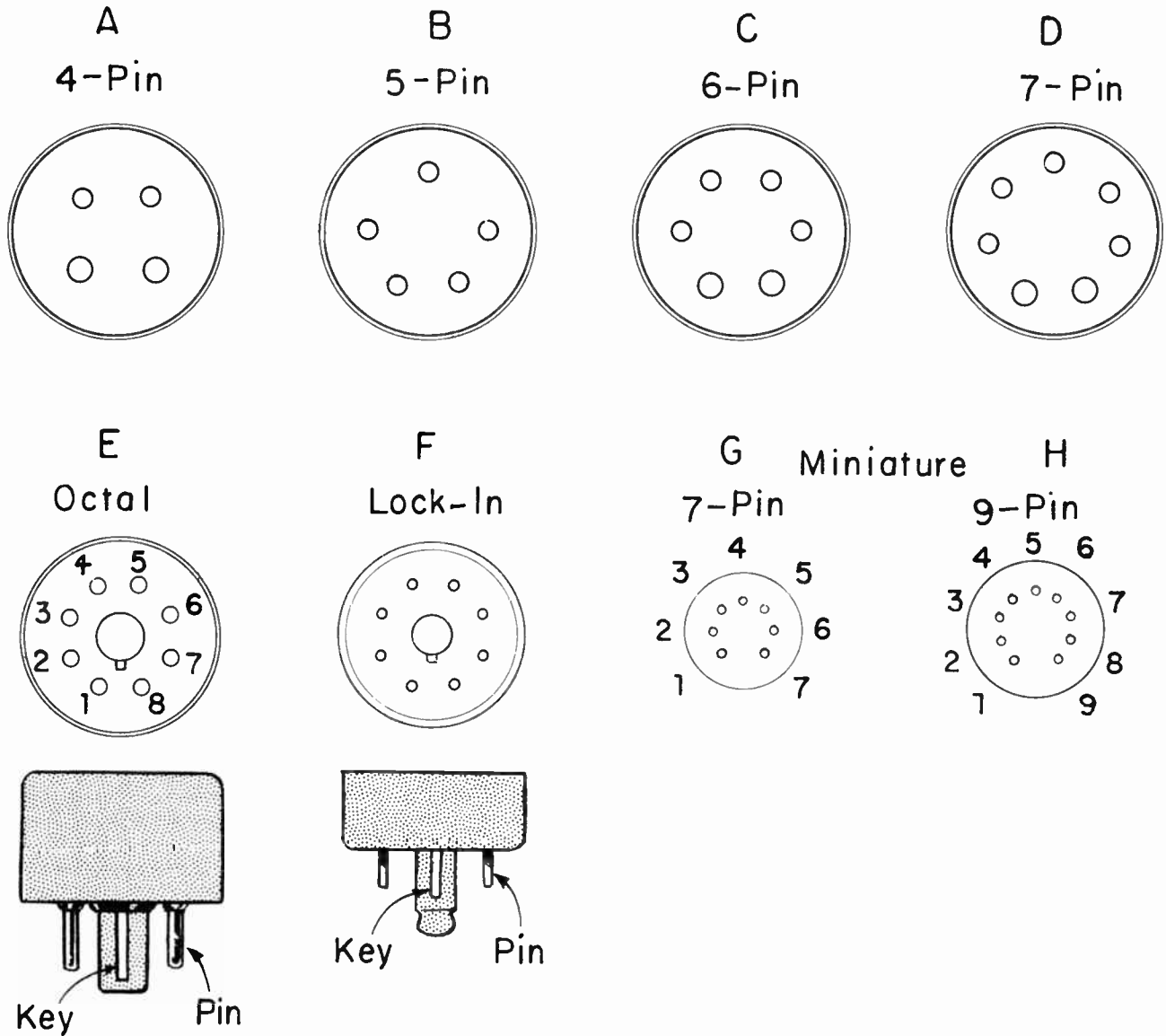

Fig. 14. Relative dimensions of bases and pins used for tubes in the past and present.

tions of apparatus constructed as separate units.

With the 4-pin type at A two of the pins are  $5/32$  inch diameter and the other two are of  $1/8$  inch diameter. As used on tubes, the two larger pins were for the filament-or heater cathode and the two smaller ones for other elements, usually for the grid and plate of a triode or the two plates of a full-wave rectifier. Differences between pin sizes prevents inserting the base pins in the wrong positions in a socket.

With the 5-pin type at B all pins are  $1/8$  inch diameter, but one pin has greater spacing from the others in order to insure

correct insertion in a socket. When used on a tube, the two pins at the bottom of the drawing usually were for the filament-cathode or the heater.

On the 6-pin base at C all pins are equally spaced, but the two at the bottom of the drawing are  $5/32$  inch diameter while the other four are  $1/8$  inch diameter. On a tube the two larger pins usually were used for the filament or the heater. Correct insertion in a socket is insured by the different pin sizes.

With the 7-pin base shown at D there are two  $5/32$  inch diameter pins and five of  $1/8$ -inch diameter, thus preventing wrong inser-

## COYNE - *television home training*

tion in a socket. There is also a smaller 7-pin base on which the pins are around a smaller circle, of the same size as the pin circle of the 4-, 5-, and 6-pin bases, and with which the outside diameter of the Bakelite base is somewhat smaller than that of any of the types illustrated.

On the octal socket at E there are eight equally spaced pins, all of which are slightly less than  $1/10$  inch in diameter, about 0.093 inch to be more exact. On some tubes having octal bases there are fewer than eight pins. That is, there are the usual spaces for eight pins, but not all of them are occupied. What is called a 7-pin octal base may have all pins except number 6. On a 6-pin octal base, pins 4 and 6 may be omitted. On 5 pin octal sockets there may be no pins in positions 3, 5, and 6, or else none in positions 3, 5, and 7.

Extending downward from the center of the octal base is a Bakelite cylinder on one side of which, at a point between pins 1 and 8, is a locating key that comes a little lower than the bottom ends of the pins. When entering an octal based tube in its socket, place the Bakelite extension in the center opening of the socket, then rotate the tube while exerting a little downward pressure until the locating pin slips down into a notch on one side of the socket opening. Then the tube may be pressed all the way down into the socket with assurance that all pins are in the correct socket openings. As has been mentioned before, the pins are numbered in a clockwise direction when looking at the bottom of the tube base, commencing at the position adjacent to the locating key for a pin number 1. Pin numbering is shown on the diagram.

On the lock-in base, at F in Fig. 14, there are eight pins, each  $1/20$  inch in diameter. The pins are equally spaced, and there are pins in all eight positions. Pin numbering is the same as on the octal base, commencing with number 1 adjacent to the locating key, and proceeding clockwise around to pin 8 when looking at the bottom of the base.

At G in Fig. 14 is shown the arrangement of the 7-pin miniature base, and at H

the arrangement of the 9-pin miniature base. The pins on all tubes using these bases are  $1/25$  inch in diameter, and they extend below the glass anywhere from  $3/16$  to  $9/32$  inch. At one point around the pin circle is a space twice as wide as the space between any other two pins. Numbering of the pins commences at this wider space, and proceeds clockwise around the base when looking toward the bottom of the tube.

All of the diagrams in Fig. 14 are drawn to the same scale, so that they show actual relative sizes of base diameters, pin circles, pin spacing and size.

On all bases except the miniature and lock-in types the pins are hollow. During manufacture of the tube, element leads are put down through the pins and extend out through the bottoms of the pins. The leads are cut off flush and soldered at the pin tips. A small amount of solder should enter the end of the pin, around the lead, to insure good electrical connection, but there should be the least possible quantity of solder on the outside of the pin where it would make entering of the pin into a socket more difficult. On lock-in and miniature bases these soldered joints are avoided by making the pins an integral part of the leads which go to the various elements.

Fig. 15 shows connections between elements and base pins for some of the miniature voltage-amplifier pentodes of the 7-pin type which often are used in i-f amplifiers and tuners of television receivers. Underneath each basing diagram are the type numbers of tubes employing these particular connections. Since new types of tubes are appearing continually there might be at any time many others having these particular connections, and some of the types shown on the diagram already are well on the way to obsolescence.

With all of the basing connections illustrated, the heaters connect to pins 3 and 4. Connections have been omitted to simplify the diagrams. Note also that the grids of all tubes connect to pin 1, that all the plates connect to pin 5, and that all the screens connect to pin 6. The differences are in con-

## LESSON 19 – TUBE TYPES AND STRUCTURES

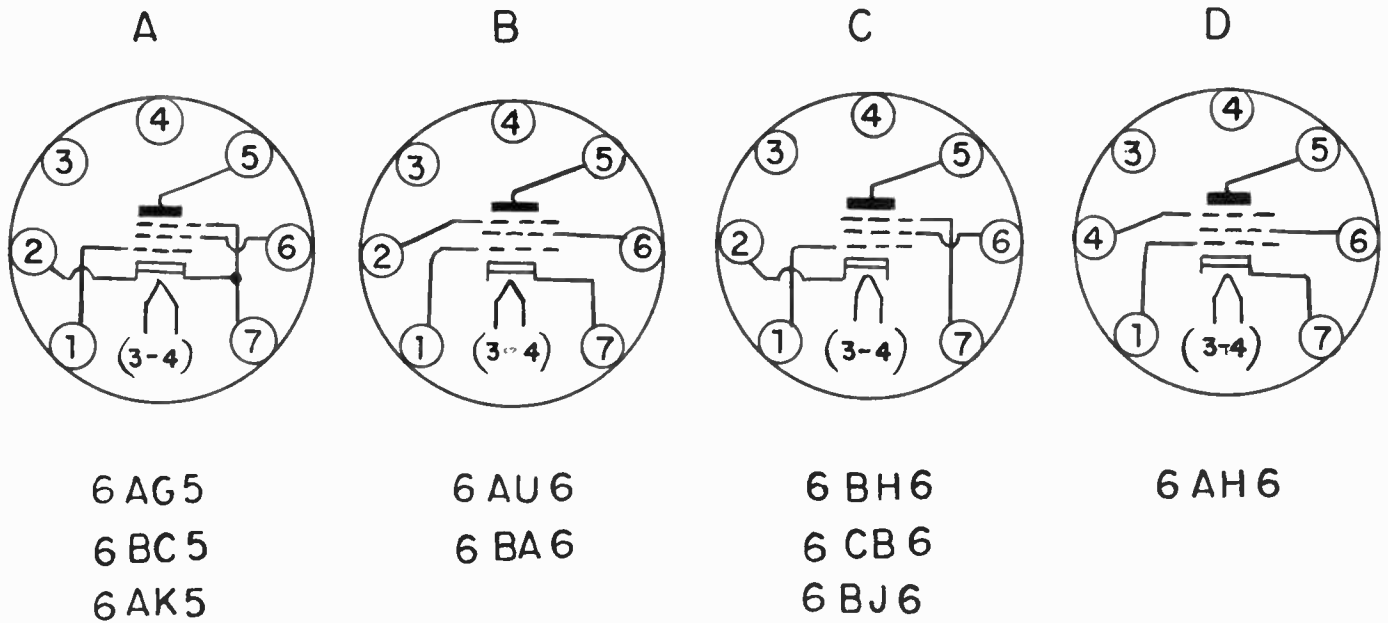

Fig. 15. Element connections to base pins in several types of 7-pin miniature voltage amplifying pentodes used in television receivers.

nections of cathodes and suppressors. In diagram A the suppressor is internally connected to the cathode, and the cathode is connected to both pin 7 and pin 2. In the other diagrams there is a separate base pin for the suppressor, and the cathode is connected either to pin 2 or pin 7.

To show all the internal connections between elements and external terminals in all types of tubes would require a total of more than 400 diagrams of this general style, and listings of tubes made with each basing arrangement never would be complete because they could not include the most recently announced tubes. Service technicians keep themselves up to date on tube basing by means of charts and manuals issued at frequent intervals by the tube makers.

In the early G-type tubes the leads from the elements through the base were so long and so close together that when both grid and plate were connected to pins there was excessive grid-plate capacitance. To lessen this capacitance, and the resulting feedback troubles, many of those tubes had their grid connected to a cap on top of the glass envelope, as in Fig. 16. The grid lead came from the element group up to this cap, while the plate lead went down through the base.

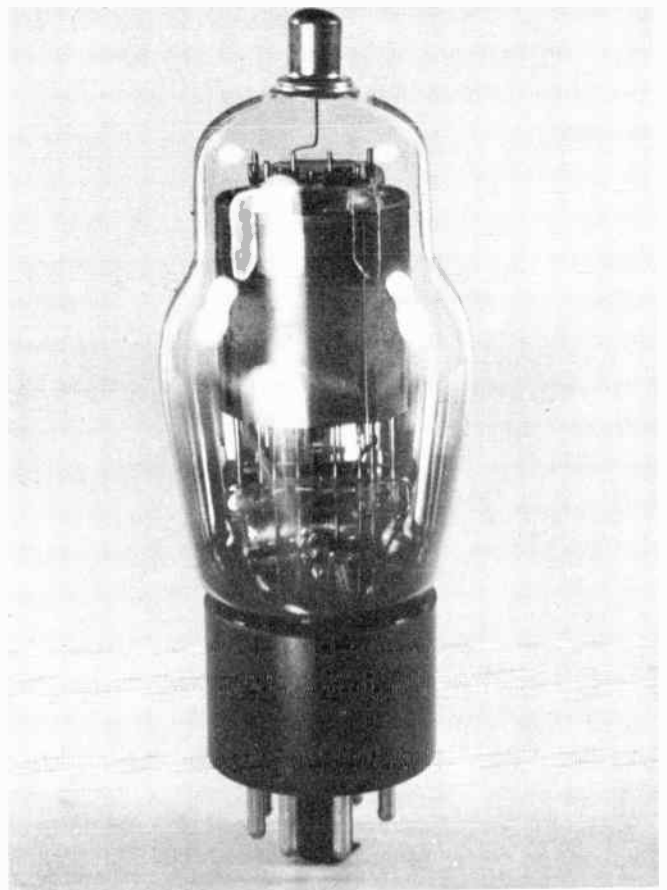

Fig. 16. A "G" type octal-base tube with a top cap connection for the grid.



## COYNE - *television home training*

In later designs the internal leads were so shortened and separated as to make it possible to connect all elements to base pins without undue increase of grid-plate capacitance. These newer tubes were called single ended styles. When a single ended tube was designed to replace an earlier type having a top cap, the type designation of the newer unit often was the same as that of the replaced tube except for including the letter S, meaning single ended. For example, the 6A7 with a top cap for the signal grid was replaced by the 6SA7 with all leads through base pins.

Top caps always have been used and still are used on recent types of high-voltage rectifiers, such as those used in the high-voltage power supply of television receivers which furnish thousands of volts to picture tube anodes. In such rectifiers the top cap is the connection for the plate. The object is to have a long expanse of glass insulation between the plate connection and the cathode connections which, if close together, would suffer from flashover and current leakage.

Top caps are found on many transmitting tubes and on others designed for various special purposes. Fig. 17 is a picture of a triode amplifier used at high frequencies in some instruments and for other applications. There are two caps, one for the grid and the other for the plate. Only the cathode and heater are connected to base pins.

**BATTERY TUBES.** Battery tubes include the types having filament-cathodes designed to be heated at 1.4 volts and most often with current of 50 ma or 0.05 ampere, although some take currents of 100 ma or even 150 ma. These filaments operate satisfactorily from a single dry cell or from several cells connected in parallel to furnish a nominal potential difference of 1.5 volt when fresh. With correct receiver design the tubes will give acceptable performance until battery voltage drops to about 1.2, after which the cell or battery discharges and loses voltage very rapidly.

Battery tubes are made with octal bases and GT envelopes, also in lock-in and 7-pin miniature styles. They are used chiefly in portable sound radios, and in some cases for portable service testing instruments.

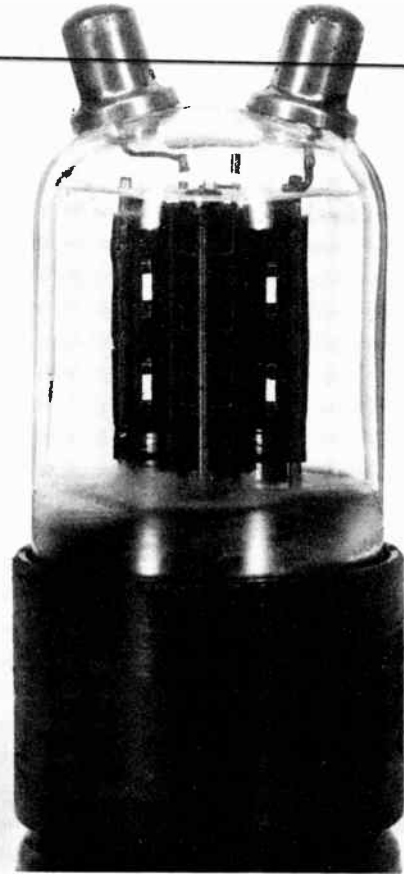

Fig. 17. A high-frequency triode having top caps for both grid and plate.

**MULTI-SECTION TUBES.** The principal combinations of element groups found in single envelopes are as follows.

Twin diodes	Triode and two diodes	Pentode and diode
Twin triodes	Triode and three diodes	Pentode and two diodes
Twin pentodes	Triode and pentode	Pentode and power rectifier
	Triode, pentode, and diode	Beam type and power rectifier

The diode sections in these combination tubes are the small types having current capacities of about one ma, and are used chiefly as detectors.

All of the combinations listed are found in sound radios, and many of them are found in audio amplifiers such as used in connection with phonographs. The two types commonly used in television receivers are twin diodes and twin triodes.

Which sections of a combination tube may be used for independent circuits depends on the number of cathodes. If there is a separate cathode with a separate base pin

## LESSON 19 – TUBE TYPES AND STRUCTURES

for every section, then every section may be used independently of every other section. Fig. 18 shows symbols with base pin numbers for several combination tubes commonly used in television receivers. The 6AL5 twin diode at A has separate cathodes and also an internal shield, connected to pin 6, which lessens the chance of electrical interference between the sections.

The other three diagrams are for twin triodes. At B is a 12AU7 9-pin miniature type having a center-tapped heater allowing its operation on either 6.3 volts (in series) or on 12.6 volts (in parallel). The 6SN7-GT with octal base and eight pins is shown at C. At both B and C we have separate cathodes. At D is the 6J6 in which there are two plates and two grids, but only one cathode. This tube often is used as an r-f oscillator and mixer in television tuners, since these two circuits are closely associated. The single cathode would prevent entirely independent operation of the two sections. No matter how many cathodes there may be, only a single heater is needed. This heater wire extends through all the cathodes.

TYPE NUMBERING. So many different systems of type numbering have been employed during succeeding periods of radio and television development that, except for tubes of fairly recent design, the type designation may have little relation to the construction or operating characteristics. Gradually you will become familiar with the

numbers of the most common tubes in the same way that a person speaking a language becomes familiar with meanings of its words. The following notes apply only to tubes designed since about 1935, and only to types for home receivers. They do not apply to transmitting tubes, to airplane types, to military types, to picture tubes, nor to various kinds designed for special purposes.

Most tubes have a type designation consisting of a first numeral or group of numerals, followed by one or more letters, and usually by additional numerals. For instance, a certain tube may be known as a 6BC6-G, which happens to be a beam tube for horizontal sweep circuits of television receivers. The initial numerals have, in general, the following meanings.

- 0 No external source of heating current for a cathode. These are a special kind of "cold-cathode" rectifier seldom used in present day receivers.
- 1 Filament-cathode battery types, usually for 1.4-volts but for some 2.0-volt power amplifiers.
- 2 Older types taking 2.5 volts for filament or heater.
- 3 Center-tapped filament-cathodes taking 2.8 volts in series or 1.4 volts in parallel. Battery operated.

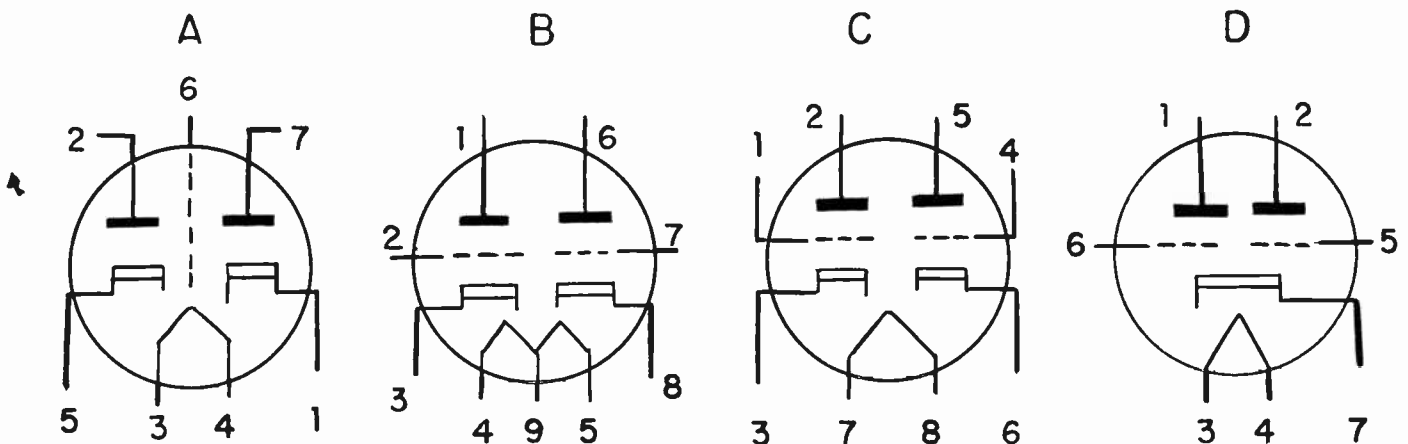

Fig. 18. Symbols for multi-section television tubes having separate and single cathodes.

## COYNE - *television home training*

- 5 Power rectifiers taking 5 volts for filament cathodes, and in a few styles for heater-cathodes.
- 6 For tubes having heater-cathodes taking 6.3 volts. Octal, miniature, etc.
- 7 Lock-in tubes having 6.3-volt heater cathodes.
- 12 For heater-cathodes taking 12.6 volts. Octal, miniature, etc.
- 14 Lock-in tubes having 12.6-volt heaters.
- 19 Heater cathodes taking 18.9 volts. Octal, miniature, etc.
- 25 and up. Actual voltages for heater-cathodes.

The first letter or group of letters may mean nothing more than the order in which

various types were designed or released on the market. The letter L may indicate a battery operated tube with a lock-in base. As already mentioned, the letter S may stand for single-ended, as contrasted with a similar type having a top cap. The letters U, V, W, X, Y, and Z are generally used in type designations of power rectifiers.

The second group of numerals originally was intended to show the number of active elements, as when using the number 5 for a pentode. Because no fixed practices have been followed by all tube manufacturers, these numerals cannot be depended on to indicate the number of elements.

The meanings of a final letter G or of the letters GT and GT/G have been explained. In a few cases a final letter A indicates a type which has improved performance, but is interchangeable with tubes having the same designation without the A.

# TELEVISION

• RADIO

• ELECTRONICS

---

**LESSON 20 – FIXED CAPACITORS AND HOW THEY ACT**

---

***Coyne School***

*practical home training*

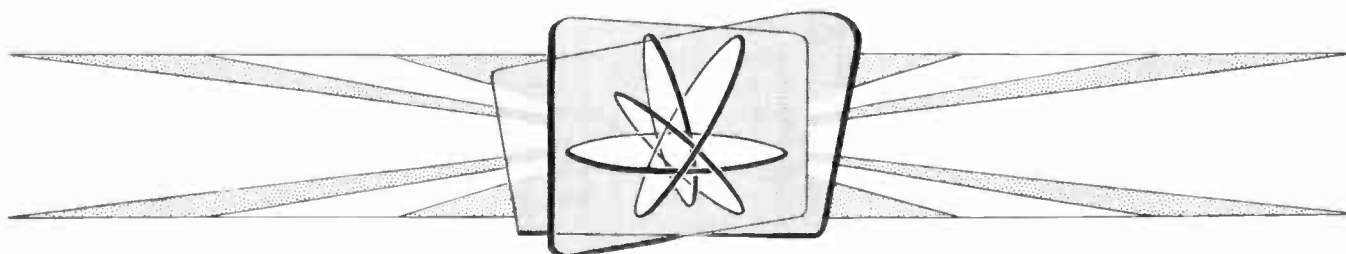

*Chicago, Illinois*



---

*Copyright, 1953 by Coyne Electrical School  
Chicago 12, Illinois  
All rights reserved*

## Lesson 20

### FIXED CAPACITORS AND HOW THEY ACT



*Fig. 1. These Coyne resident students are using service diagrams while examining the circuit layouts in television receiver chassis.*

In a certain television receiver having 19 tubes in addition to the picture tube, five tubes are combination types having two sections, and one has three sections. This makes the equivalent of 27 tubes when we count each section. Of this total, 11 tubes or sections are amplifiers of one kind or another. There are i-f amplifiers and a video amplifier. In the sound section there are i-f, audio voltage, and audio output amplifiers. There is an r-f amplifier for carrier frequencies, a sync pulse amplifier, and vertical and horizontal sweep amplifiers.

It is evident that amplification must be highly important during service work, and that we should become well acquainted with practical details of how alternating voltages are amplified. We have watched the process of

amplification in a sort of "slow motion" way by using fixed direct voltages to represent peaks of an alternating signal voltage. In actual amplifier circuits we must deal with real alternating signal voltages, and must be able to separate these signals from the d-c voltages for plates, screens, and grid biases. The separation can be accomplished only by means of capacitors.

The simplest amplifier, and one which illustrates most of the basic principles, is called a resistance-capacitance coupled amplifier. As you would conclude from the term "resistance-capacitance", essential functions must be carried out by capacitors. These capacitors are not of the electrolytic type which we have examined, they are paper, mica, and ceramic types. Before we proceed

# COYNE - *television home training*

it will be necessary to learn how these capacitors perform.

As soon as we know how to apply capacitors we may study the several methods of biasing which may be employed, for in some of the most widely used biasing systems we need capacitors. After that it will be necessary to study methods of dividing the voltage current output of the power supply section between plate, screen, and grid biasing circuits. Here again we shall find that capacitors are essential. Then it will be a simple matter to apply all of this knowledge to the construction and operation of amplifiers. Now that we know where we are going and how to get there, we shall start out with the subject of capacitors.

FIXED CAPACITORS. The capacitors which we are about to use consist of two sheets or plates of conductive metal separated by insulating material, which, when used in a capacitor, is called the dielectric.

From the standpoint of adjustment there are two general classes of capacitors, fixed types and those which are adjustable or variable. The value of capacitance in a fixed capacitor cannot be altered after the unit is built. It is with fixed capacitors that we shall be concerned in this lesson. With adjustable or variable capacitors the value of capacitance can be altered while the unit is operating. This general class of capacitors will be used later, when we adjust various circuits so that they respond best at certain frequencies.

Fixed capacitors are further classified according to the kind of dielectric material used between their plates. The kinds commonly used in television and radio receivers include those having dielectrics of paper, of mica, and of ceramic materials. They are called, respectively, paper capacitors, mica capacitors, and ceramic capacitors.

PAPER CAPACITORS. Several paper capacitors are pictured by Fig. 2. The in-

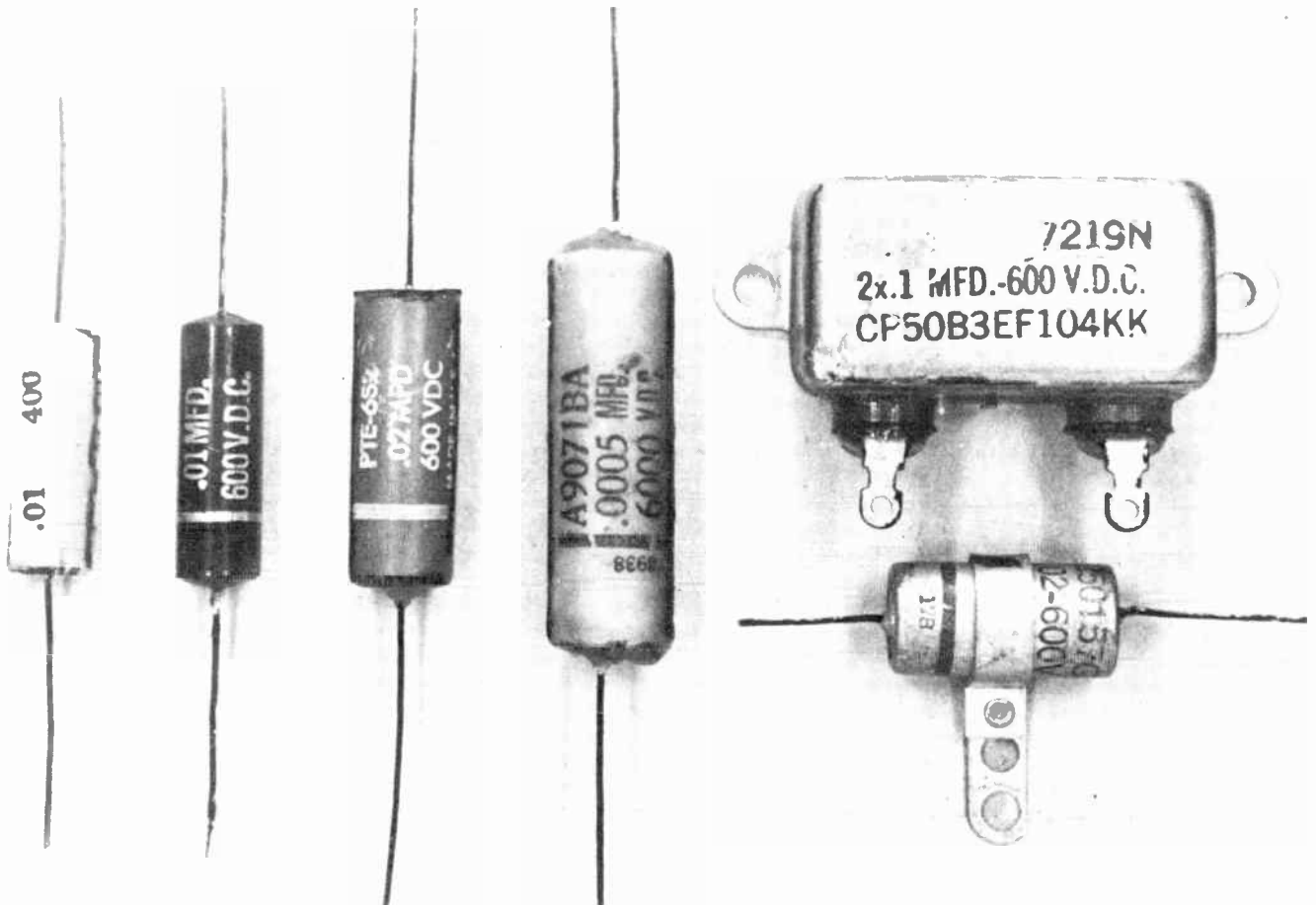

Fig. 2. Paper capacitors with outer casings of plastic, cardboard, and metal.

## LESSON 20 – FIXED CAPACITORS AND HOW THEY ACT

ternal construction of all of them is essentially the same, but there are differences between the outer coverings or cases. The two units at the left are encased in hard plastic. The two at the center have covers of heavy waxed paper or cardboard. The two units at the right are encased within metal shells.

All the paper capacitors illustrated, except one of the metal-shell units, have pigtail wire leads which are used for connections to other circuit elements, and usually also for supporting the capacitor. These leads are used like the pigtails on fixed resistors and on some electrolytic capacitors. On one of the metal-shell capacitors are terminals of the solder lug type. Both metal shell units are arranged for mounting with screws or rivets through extension ears or a metal band. Metal band supports are found also on some of the larger paper capacitors having plastic or paper covers.

On the covers or cases of paper capacitors are marked their capacitance in microfarads (mf) and the maximum d-c voltage at which the capacitor may be operated without danger of breakdown. Capacitances most often used range from 0.0001 mf (100 mmf) to 1.0 mf (1,000,000 mmf), although still greater capacitances are available. Capacitance tolerances may be from 10 to 20 per cent less than marked values up to 20 to 60 per

cent more than the marked values. Tolerances usually are closer, in percentage, for units of large capacitance than for those of smaller capacitance.

D-c working voltages of paper capacitors used in most television and radio circuits are 150, 200, 400, or 600 volts. The d-c working voltage is also the maximum safe peak voltage. Peak a-c voltage, assuming a sine-wave form, is about 1.4 times the effective or rms value, and the effective value is about 0.7 times the peak value. Therefore, the maximum effective or rms a-c voltage for a capacitor is its d-c working voltage multiplied by 0.7. For example, a capacitor rated for 200 d-c volts may be used up to 0.7 times 200, or to 140 effective a-c volts where the voltage is sine wave.

When a paper capacitor is removed from its case and unrolled the parts appear as in Fig. 3. The "plates" are two sheets of very thin aluminum foil. The dielectric consists of two or more layers of very thin paper. After the foil and paper are rolled to form during manufacture, the element is dried and evacuated, then is impregnated with some kind of wax or other high grade water-resistant dielectric material to fill the pores of the paper and add to its insulating value, and also in some cases to affect the capacitance value.

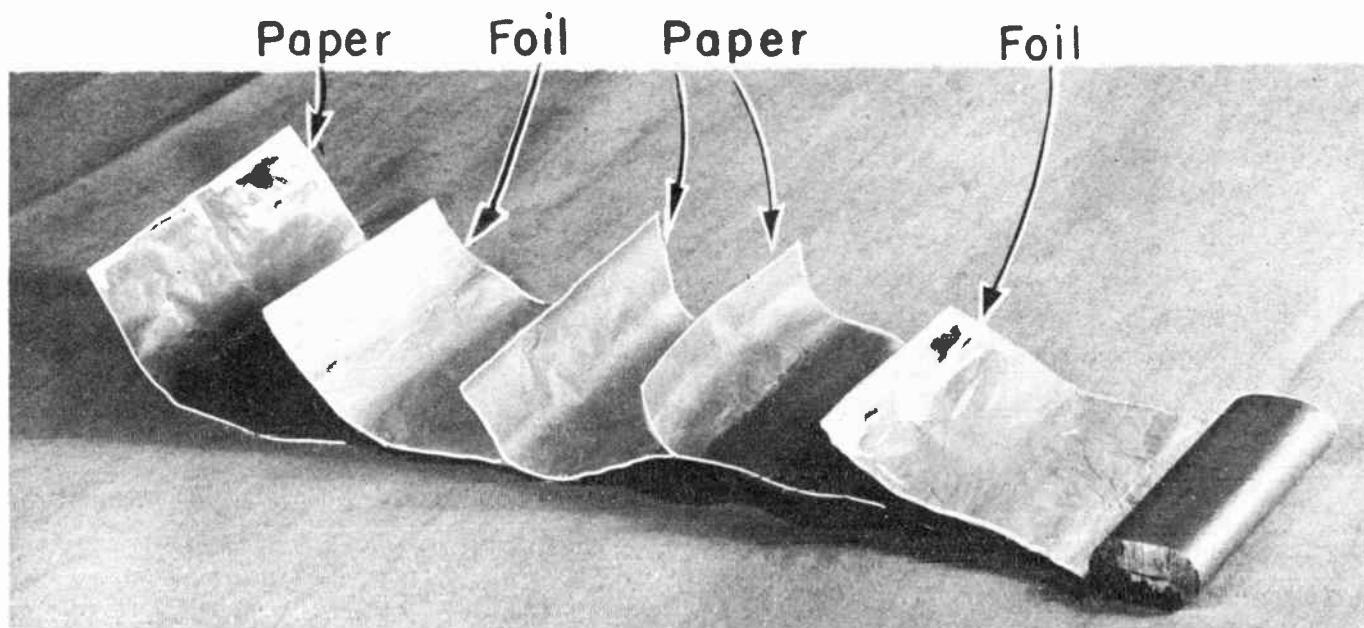

Fig. 3. The internal construction of a paper capacitor.



## COYNE - *television home training*

The conductive plates which are rolled between the insulating layers of dielectric have, to some extent, the properties of a coil. They possess inductance as well as capacitance, and at high frequencies the capacitor acts as both a capacitance and an inductance. In some styles, called non-inductive, the coil effect is lessened by bringing one of the foils beyond the dielectric at one end, and the other foil beyond the dielectric at the other end, then pressing the exposed parts of the foils into practically continuous masses of conductor.

In many cases it is desirable that the capacitor be "shielded" against the effects of electric and magnetic fields in surrounding space. This may be done rather effectively by connecting the outer layer or outer end of the foil to the grounded or the B-minus side of the circuit in which the capacitor is used. With many paper capacitors the pigtail which connects to the outer foil is at the end of the cover on which is a band or ring, usually black or some contrasting color. These bands may be seen on some of the capacitors in Fig. 2. On other capacitors there may be an arrow pointing toward the outer foil terminal, or there may be words "Outside Foil".

In some television sweep circuits, and always in circuits of the high-voltage power supply and the picture tube high-voltage anode, the capacitors must be able to withstand several thousand volts. The paper covered unit nearest the metal-shell types in Fig. 2 is rated at 0.0005 mf and 6,000 d-c working volts. In some television circuits and often in oscilloscopes the high-voltage capacitors are of the oil-filled or oil-impregnated type. These are paper capacitors treated or filled with oils having very high dielectric strength, which is the ability to resist breakdown or puncture due to high voltages. Such a capacitor is shown by Fig. 4. Note the long insulators which are around the terminals.

**MICA CAPACITORS.** Molded mica capacitors such as are used for amplifiers and other circuits have for their dielectric thin sheets of mica. In the more commonly used styles the conductive plates are thin metal foils. The assembly is molded within a pro-

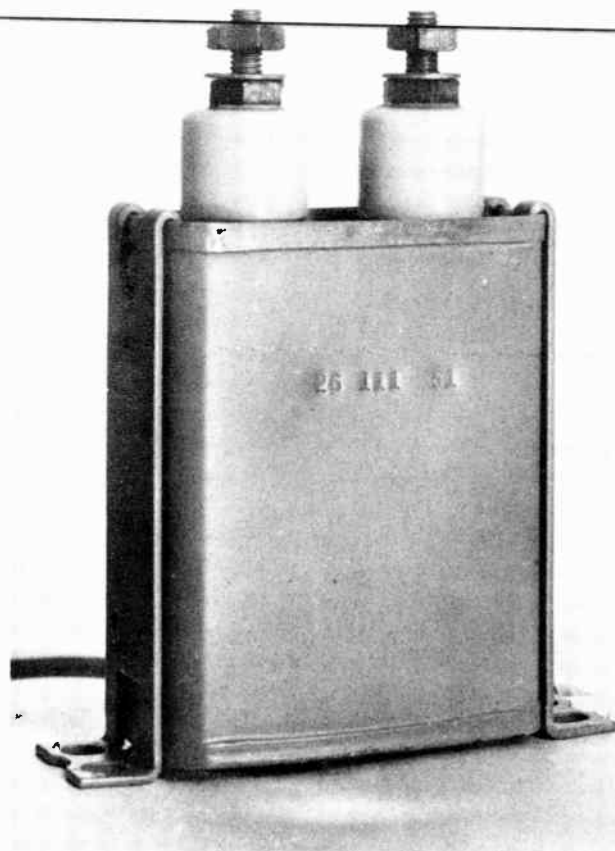

Fig. 4. An oil-filled paper capacitor for use at high voltages.

ductive covering of Bakelite or other hard plastic.

Several molded mica capacitors are shown by Fig. 5. All except the one at the right have pigtail wire leads for making circuit connections and for supporting the capacitors. The right-hand unit is a high-voltage type, 2,500 d-c working volts, with end lugs for support and as terminals for making circuit connections.

The construction of mica capacitors makes them practically non-inductive. The mica provides such excellent insulation that there is negligible current leakage up to the breakdown voltage, in units of good quality. Commonly available capacitances range from 0.000002 mf (2 mmf) to about 0.01 mf (10,000 mmf) in most cases, although greater capacitances sometimes are used. The cost of a mica capacitor of given capacitance is considerably more than that of a rolled or tub-

## LESSON 20 – FIXED CAPACITORS AND HOW THEY ACT

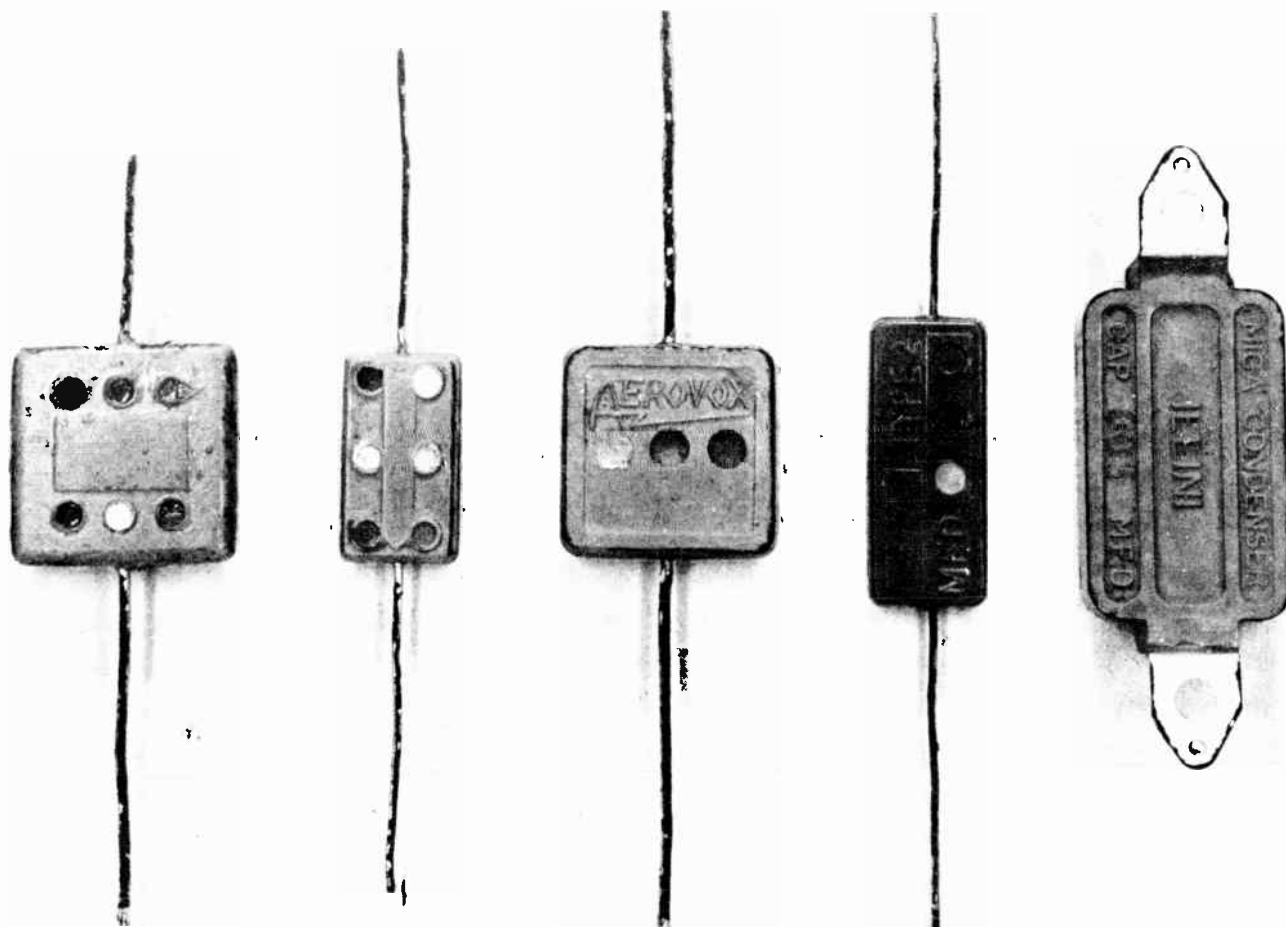

Fig. 5. Mica capacitors.

ular type of the same capacitance. Capacitors such as the four smaller units of Fig. 5 usually have working voltage ratings of 300, 400, or 500 d-c volts. Higher voltage ratings are available when needed. Capacitance tolerance most often is plus or minus 20 per cent of the marked or rated capacitance. Units with tolerances of plus or minus 10 per cent, 5 per cent, 2 per cent, and 1 per cent are used where such precisions are necessary.

Silver micas may be used for high-frequency circuits and where great stability of capacitance is required. In these units the thin sheets of mica are coated with a compound which changes to pure silver when subjected to high temperature during manufacture. The usual capacitance tolerance of silver micas is plus or minus 5 per cent although it may be 10 per cent or as little as 1 per cent. These styles cost more than the foil micas. The capacitor second from the right in Fig. 5 is a silver mica type.

While some mica capacitors are plainly marked with their ratings, most of them are color coded according to systems illustrated by Fig. 6. The coding consists of small colored circles, some of which show quite clearly in Fig. 5. These usually are referred to as dots. The meaning of each color, so far as it refers to significant figures and multipliers, is the same as in the fixed resistor color code.

At A in Fig. 6 are shown the significance of the dots for the six-dot system of the RTMA (Radio-Television Manufacturers Association). While reading the coding, hold the capacitor so that an arrow or anything in the general form of an arrow points toward your right, or so that the name of the manufacturer or any other wording is right side up and reads from left to right. The dots then read in order from left to right across the top, and from right to left across the bottom. The three upper dots indicate the first, second, and third significant figures for capacitance

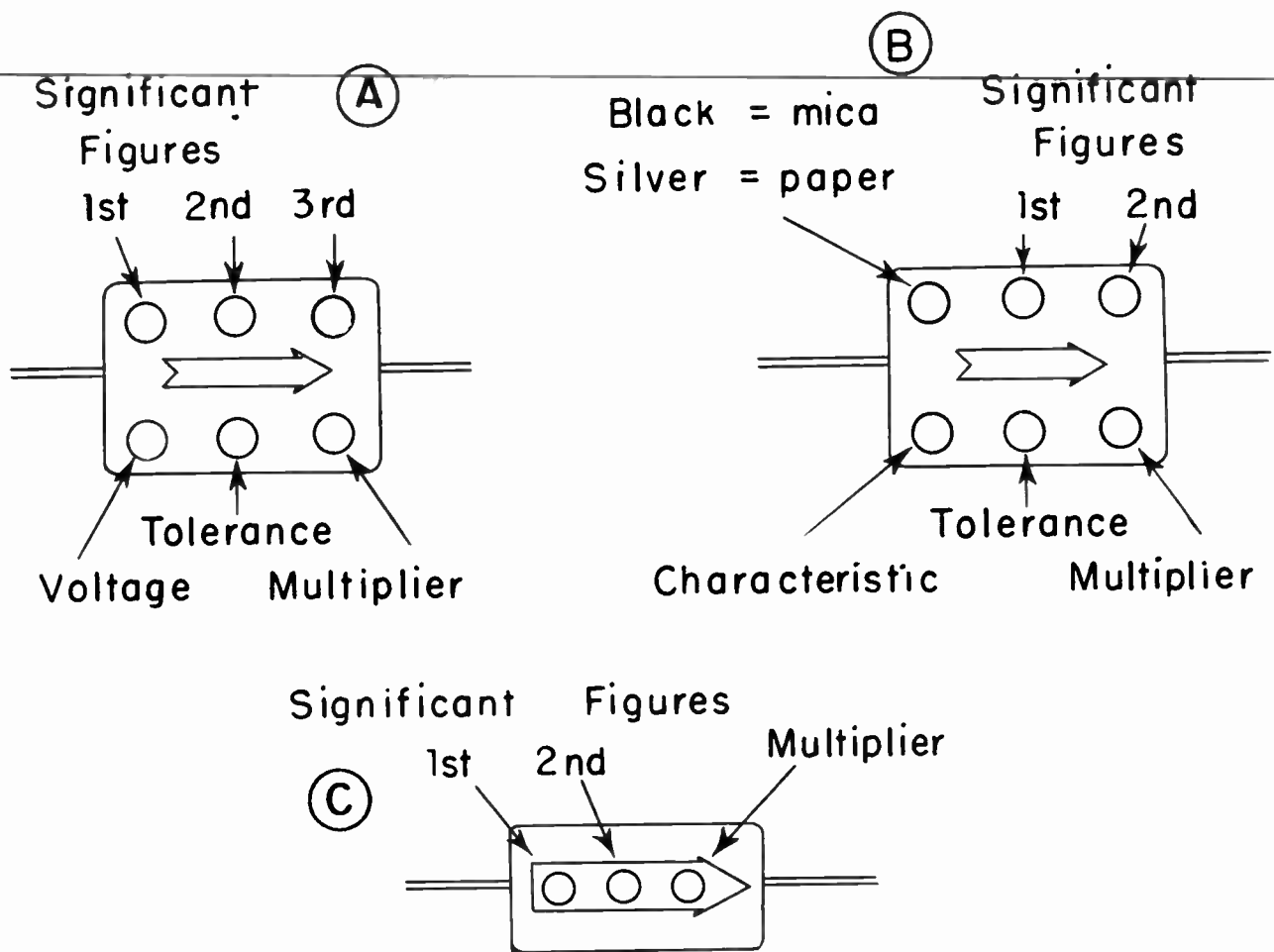

Fig. 6. Positions of dots and their meanings in color coding systems for molded mica capacitors and for some rolled paper types which look like micas.

in micro-microfarads. From right to left across the bottom the dots indicate respectively the multiplier or number of ciphers to be added after the significant figures, then the capacitance tolerance, and finally the voltage rating. Colors and their corresponding numbers are listed in the accompanying table.

Many molded mica capacitors, including nearly all of those sold as surplus items, have color codings based on specifications called Joint Army-Navy, and abbreviated JAN, or American War Standards, abbreviated AWS. The two codes are alike, and are illustrated at B in Fig. 6. When the upper left-hand dot is black it indicates that the capacitor is a mica type. Should this dot be silver, the capacitor is a rolled paper and foil type having the appearance of a mica unit. On some molded mica capacitors which

are not JAN or AWS types this upper left-hand dot is white.

The second and third dots across the top indicate the first and second significant figures for capacitance. From right to left across the bottom the dots indicate the multiplier, the capacitance tolerance, and the "characteristic", which covers voltage, temperature coefficient (change of capacitance with temperature) and other features or properties of the unit.

There is also a three-dot RTMA coding system illustrated at C in Fig. 6. The center capacitor of Fig. 5 has three-dot coding. This system is used only for units rated at 500 d-c working volts and having capacitance tolerance of plus or minus 20 per cent. When holding the capacitor in the correct position, as explained earlier, the dots from left to

# LESSON 20 – FIXED CAPACITORS AND HOW THEY ACT

## MOLDED MICA CAPACITOR COLOR CODE

Color	Significant Figure	Multiplier	Tolerance		Voltage (RTMA)
			(RTMA)	(JAN-AWS)	
Black	0	1		20%	
Brown	1	10	1%		100
Red	2	100	2%	2%	200
Orange	3	1,000	3%		300
Yellow	4	10,000	4%		400
Green	5	100,000	5%		500
Blue	6		6%		600
Violet	7		7%		700
Gray	8		8%		800
White	9		9%		900
Silver		0.01	10%	10%	2,000
Gold		0.1			1,000
No color			20%		500

right indicate the first and second significant figures and the multiplier for the value of capacitance in micro-microfarads.

CERAMIC CAPACITORS. Several styles of ceramic capacitors are illustrated by Fig. 7. The dielectric is ceramic (porcelain-like)

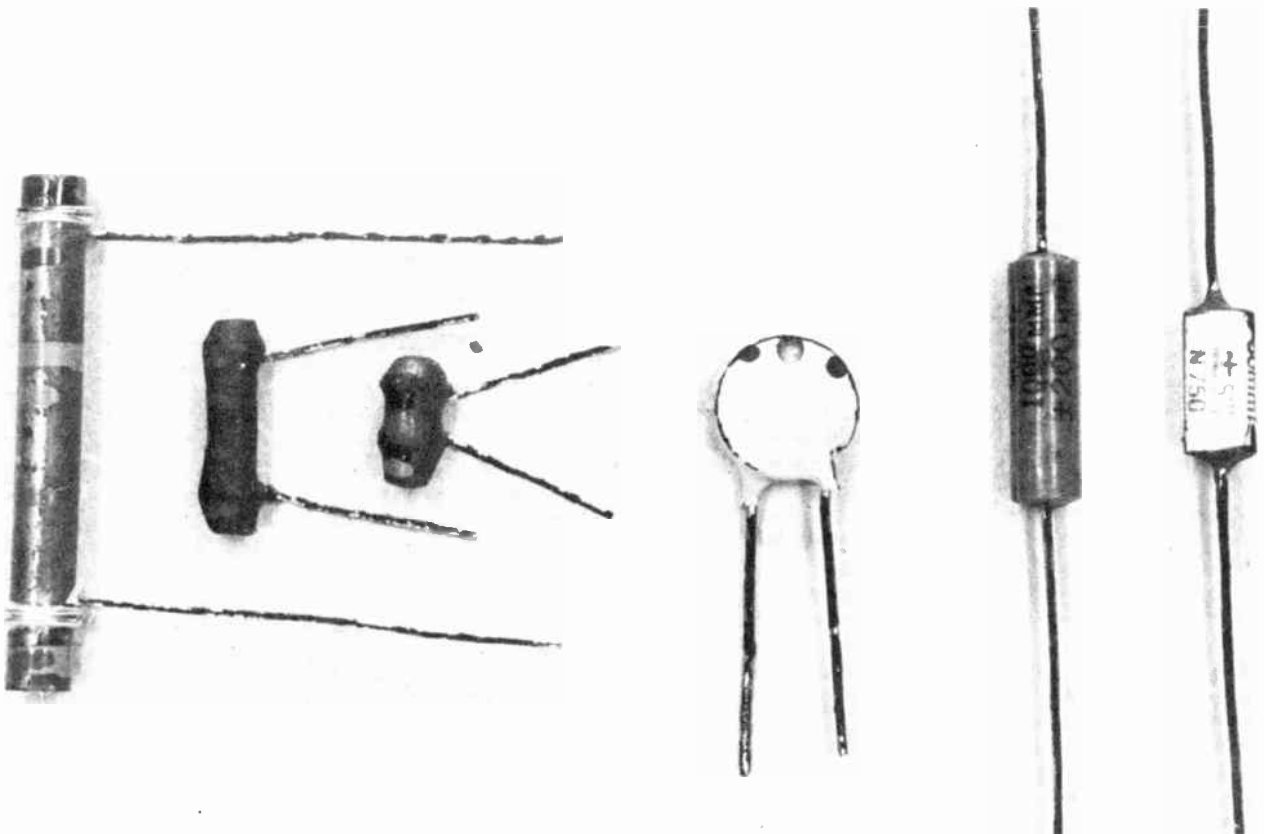

Fig. 7. Ceramic capacitors.



# COYNE - television home training

material with which are mixed substances which allow large values of capacitance in proportion to the overall size of the capacitor. The conductive plates usually are of silver, which is electroplated onto the ceramic dielectric. This active part of the capacitor may be protected with other metallic platings and various kinds of insulating coverings. All of the units illustrated, and nearly all other ceramics used in receivers, are fitted with the familiar wire pigtails for combined electrical connections and support of the capacitor. Pigtails may come out at the ends (axial) or at the sides near the ends (radial).

Ceramics, as a class, are practically non-inductive and most of them are of designs suitable for use in high-frequency circuits. The tubular types may be used in any such circuits. Disc ceramics, one of which is third from the right in Fig. 7, are not used in circuits which determine the operating frequencies of amplifiers and other sections. We shall learn more about these various applications in future work.

Capacitances of ceramic units in general use range from as little as 1/2 micro-micro-

farad up to 0.01 mf (10,000 mmf), with the greater capacitances usually found in disc types. Most ceramics are rated for 500 maximum d-c working volts. Most breakdowns are due to excessive voltage, either because of incorrect application or else because of shorts in other parts or circuit elements.

Many cylindrical capacitors having cases of hard plastic are plainly marked as to rated capacitance, tolerance, and sometimes for voltage. Tubular types, which have open or hollow centers, usually are color coded as shown at A in Fig. 8. When there are radial pigtail leads, extending out from the sides rather than the ends, the colors are read in order from left to right while holding the unit with its pigtails upward. Disc ceramics may be coded as at B. Cylindrical types with closed ends may be coded as at C, with which system the colors are read in order when holding the unit so that the single wide band is to your left.

The meanings of the colors in the various positions are given in the accompanying table. Note that the right-hand column refers to

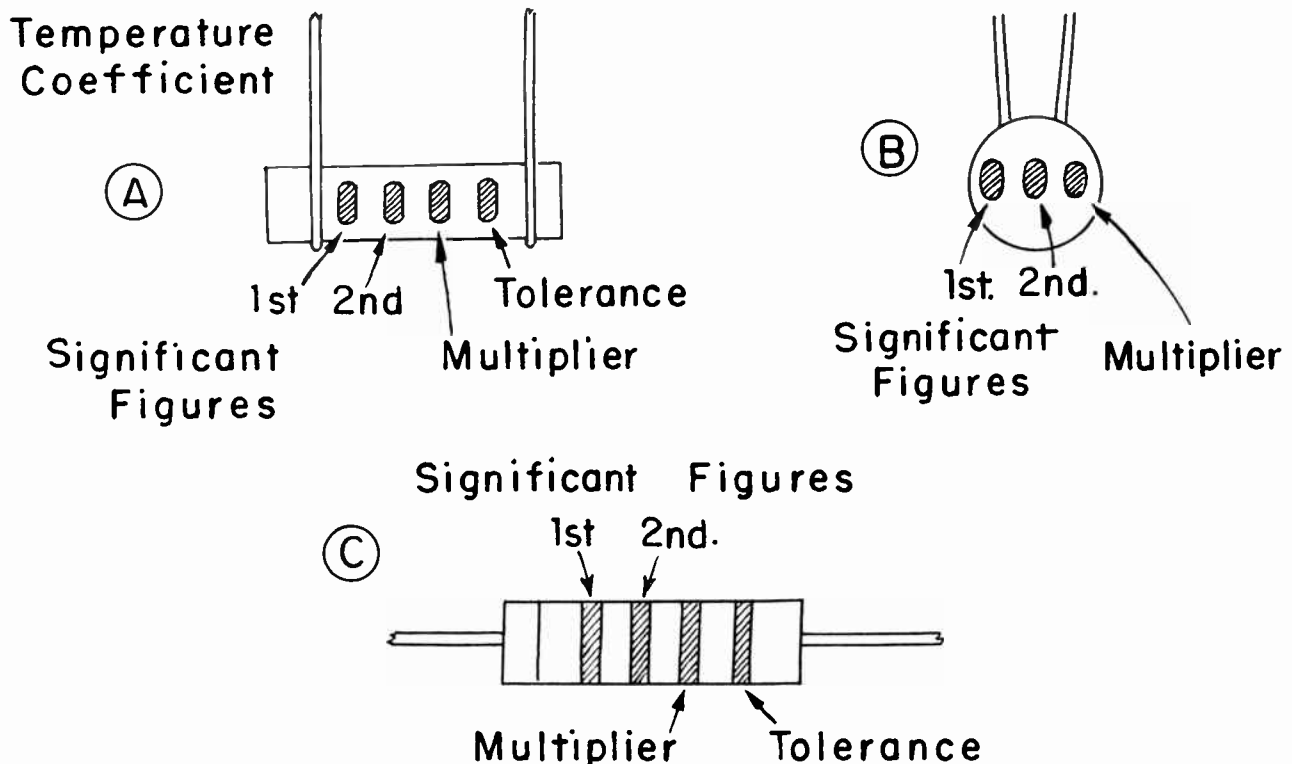

Fig. 8. Color coding systems for ceramic capacitors.

## LESSON 20 — FIXED CAPACITORS AND HOW THEY ACT

temperature coefficient, and that some of the code spots or bands on capacitors are related to this coefficient. The temperature coefficient

of a capacitor tells by how much its capacitance changes when its temperature rises or falls.

### CERAMIC CAPACITOR COLOR CODE

Color	Significant Figure	Multiplier	If C more than 10 mmf	If 10 mf or less	Temperature Coefficient
Black	0	1	20%	2.0 mmf	zero (0)
Brown	1	10	1%	0.1 mmf	-33 or -30
Red	2	100	2%	0.2 mmf	-75 or -80
Orange	3	1000	2½%		- 150
Yellow	4				- 220
Green	5		5%	0.5 mmf	- 330
Blue	6				- 470
Violet	7				- 750
Gray	8	0.01		0.25 mmf	+ 30
White	9	0.1	10%	1.0 mmf	

A capacitor whose capacitance changes by a definitely specified amount when there is a certain change in its temperature is called a temperature compensating capacitor. If capacitance decreases when temperature rises, the unit has a negative temperature coefficient as indicated by the minus sign in the table. If capacitance increases with rise of temperature the coefficient is positive.

Capacitors having negative coefficients are used in circuits which determine operating frequencies, and they are used to compensate for variations in other circuit parts which would tend to change the frequency when there are changes of temperature in the apparatus. If a rise of temperature would cause a frequency variation such as might be brought about by more capacitance, a capacitor having a negative temperature coefficient will reduce its own capacitance and the circuit capacitance. If the capacitor coefficient has been correctly chosen, the operating frequency will remain nearly constant. Later we shall make good use of temperature compensating capacitors in connection with oscillators of television tuners and in many other circuits.

The number which is given as the temperature coefficient is the change of capacitance in micro-microfarads per each microfarad of nominal capacitance when the temperature changes by one degree centigrade. When temperature change is measured in ordinary Fahrenheit degrees, the number of Fahrenheit degrees must be divided by 1.8, or else multiplied by 0.555, to give the change in equivalent centigrade degrees. For example, should temperature increase from 70° F to 160° F the change would be 90° F. Dividing by 1.8 would give the change as 50° C.

Supposing that the capacitor has nominal capacitance of 300 mmf, which is the same as 0.0003 mf or the same as 3/10000. Assume that the capacitor has a negative coefficient of 750 and that temperature rises by 50° C. We multiply together the capacitance, the coefficient, and the degrees, like this.

$$\frac{3}{10000} \times 750 \times 50 = \frac{112,500}{10,000} = 11.25$$

Thus we find that the capacitance of this particular capacitor will decrease by 11.25

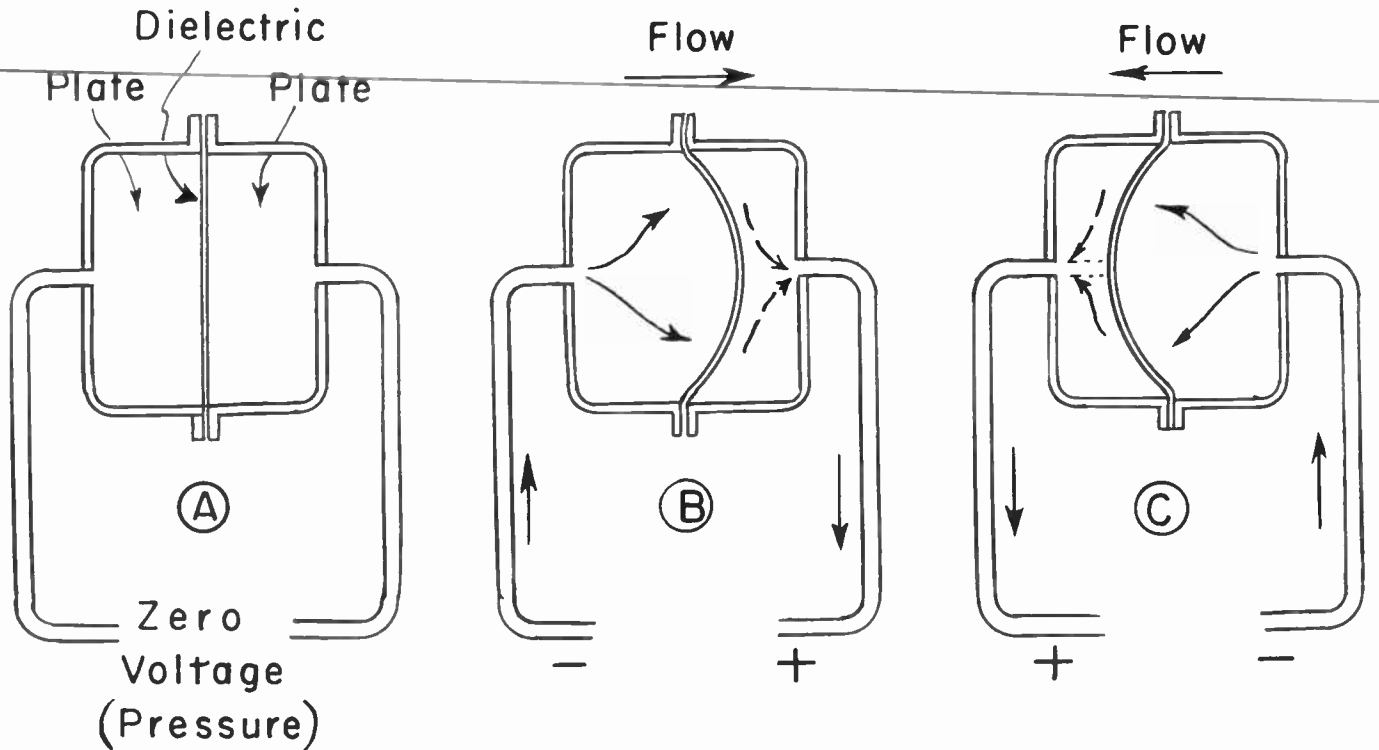

Fig. 9. The electrical action of a capacitor may be compared with the hydraulic action of two water chambers separated by a flexible diaphragm.

mmf when the temperature rises 50° C or 90° F.

**WHAT HAPPENS IN A CAPACITOR?** An easy way to understand what really goes on in a capacitor is to compare it with two water chambers separated by a diaphragm of flexible rubber, as in Fig. 9. The two chambers, which will receive and discharge water, are like the two conductive plates of a capacitor, which will receive and discharge electrons or electricity.

The rubber diaphragm, which will not allow passage of water through it, is like the dielectric of the capacitor, which is insulation and will not allow electrons to pass through it. When the diaphragm is stretched one way or the other it is under mechanical stress, although it should not break. When there are electric charges on the capacitor plates the dielectric is under electrical stress, although it should not puncture.

In diagram A the water chambers are subjected to no pressure difference, which is equivalent to no voltage or no potential difference across the capacitor. There are equal quantities of water in both chambers,

and equal quantities of electrons in both capacitor plates.

In diagram B there is greater water pressure on one chamber than on the other. The diaphragm stretches. Water flows into one chamber and out of the other in exactly equal quantities. When one plate of the capacitor is subjected to negative potential while the other plate is subjected to positive potential, or when there is any difference between potentials, the dielectric is electrically stressed as electrons flow into one plate and out of the other plate in exactly equal quantities.

For all practical purposes, electrons are flowing right through the capacitor, into the plate being negatively charged and out of the plate being positively charged. There is electron flow or current in the circuit of which the capacitor is a part. This flow is from negative to positive in the circuit and capacitor, just as though the capacitor were a conductor of any kind.

In diagram C the water pressure has been reversed, or the polarity of voltage on the capacitor has been reversed. Water

## LESSON 20 – FIXED CAPACITORS AND HOW THEY ACT

leaves one chamber and enters the other. Electrons leave the capacitor plate formerly given a negative charge, and enter the plate formerly given a positive charge. Once again, for all practical purposes, there is electron flow or current right through the capacitor, although no electrons actually go through the dielectric. In the circuit of which the capacitor is a part there is electron flow in a direction which is the reverse of the former direction.

As electron flow which reverses is an alternating current. It is quite apparent that alternating current may flow in a capacitor - not actually through the capacitor, but back and forth in the capacitor and a connected circuit.

Now let's ask what happens when a direct or one-way voltage is applied to a capacitor, or when one-way water pressure is applied to the water chambers? Water will flow into one chamber and out of the other only until the diaphragm is stretched as much as it can be stretched by the applied pressure. Then the flow will cease. Electrons will flow into one capacitor plate and out of the other plate only until the dielectric is stressed as much as it can be stressed by the applied voltage. Then the electron flow or current will cease.

A capacitor subjected to direct voltage will allow electron flow only until the capacitor is charged to an extent determined by applied voltage. Then the flow or current will cease unless the dielectric breaks down. Consequently, direct current cannot flow continually in a capacitor.

Now let's see what factors determine the rate of alternating electron flow in a capacitor. Rate of flow means current, so we are going to inquire into what determines the alternating current in a capacitor and in conductors connected to it. In following this line of investigation we shall look at some variable capacitors having air for the dielectric between plates, because in these open structure types it is easier to see various changes than in fixed capacitors. Rules applying to capacitor action are the same regardless of construction.

First Factor: Alternating current de-

pends on the plate area in contact with the dielectric. This area is comparable to the size of the water chambers and the diaphragm. The larger the water chambers and diaphragm the more water will flow in and out for any given applied pressure. The larger the capacitor plate area and dielectric area the greater will be the alternating current when other things are unchanged.

Greater plate and dielectric area may be had in two ways, by using larger plates or by using a number of plates all connected together to make the equivalent of a single large plate. Both methods are employed in the dual capacitor of Fig. 10, where two capacitors are mounted together. In both units there are many plates connected together to make the equivalent of two large plates for each unit.

The unit on the left has 14 pairs of plates, and one on the right only 10 pairs. Also, each plate in the left-hand unit is larger than each plate in the unit at the right. More alternating current will flow in the unit at the left than in the one at the right when factors other than effective plate areas are unchanged.

Second Factor: Alternating current in a capacitor depends on thickness of the dielectric, or on separation between the plates. The thicker the dielectric and the greater the separation between plates the less will be the alternating current when other factors are unchanged. Were we to use thicker and thinner diaphragms of the same grade of rubber between the water chambers, the thick diagram would be harder to stretch than the thin one. For any given water pressure there would be less flow into and out of the chambers with the thick rubber than with the thin rubber.

In Fig. 11 the alternating current in one section of the capacitor with big plates would be practically the same as in one section of the unit having smaller plates. This is due chiefly to the fact that plates are farther apart and the air dielectric is "thicker" in the big capacitor than in the small one. The change of dielectric thickness just about balances the difference in plate areas.



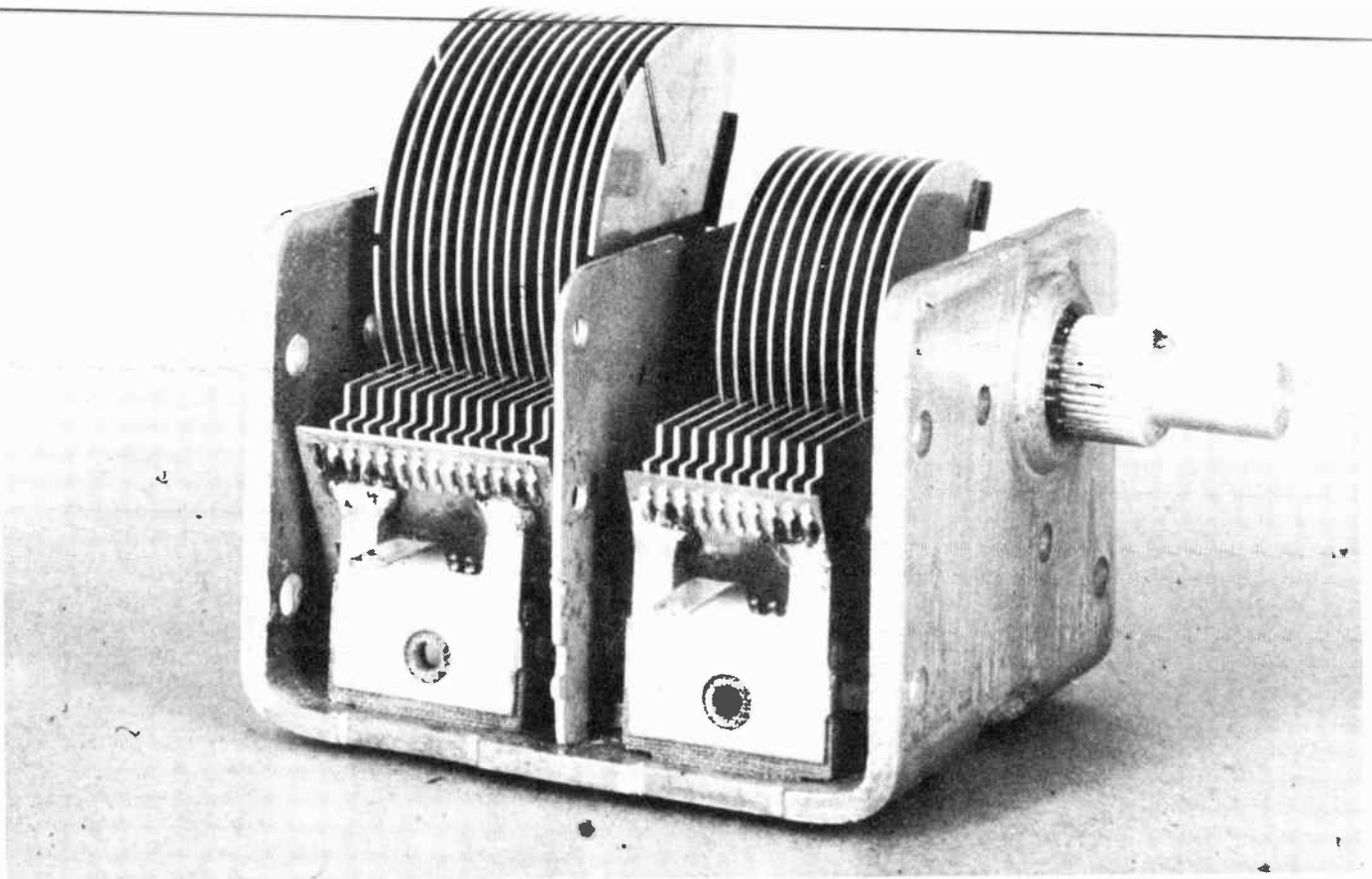

Fig. 10. The rate of alternating current flow and also the capacitance are affected by the number of plates and by their area in any capacitor.

Third Factor: Alternating current in a capacitor depends on the kind or grade of dielectric material. Let's go back to the water system for a moment. If we were to have one diaphragm of soft flexible rubber, such as in the inner tube of an auto tire, and another diaphragm of stiffer rubber, such as used in tire casings, the soft diaphragm would allow greater water flows than the other one - with both diaphragms of the same thickness and size.

At the left in Fig. 12 is a simple two-plate capacitor in which the dielectric is air between the plates. At the right a sheet of glass fills the space between plates. Alternating current with the glass dielectric would be seven to eight times as great as with the air dielectric, although plate separation and dielectric thickness are unchanged.

CAPACITANCE. The three factors which

have been discussed determine the property of a capacitor called capacitance. Capacitance measures the quantity of electrons or electricity which will flow into and out of the capacitor with a given applied voltage. It measures the charge put into a capacitor by a given applied direct voltage. Capacitance is a measure also of alternating current that will flow in a capacitor with a given applied alternating voltage.

If one volt puts a charge of one coulomb of electricity into a capacitor, the capacitance is one farad, which is the fundamental unit of capacitance. As you know, the practical units are the microfarad (mf) which is one millionth of a farad, and the micro-microfarad (mmf) which is one millionth of a microfarad.

The three factors affect capacitance are as follows.

## LESSON 20 – FIXED CAPACITORS AND HOW THEY ACT

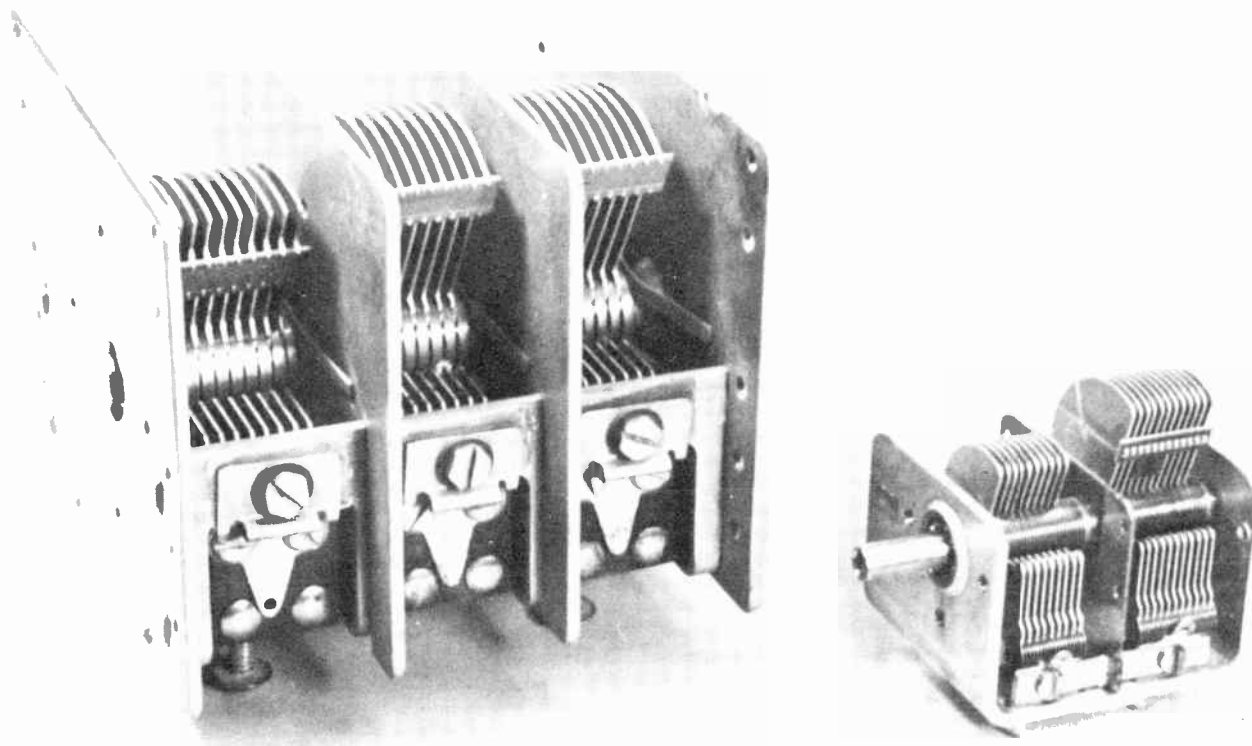

Fig. 11. Because of compensating or balancing differences between plate separations and plate areas, the flow of alternating current (and the capacitance) in these two capacitors is about the same.

1. Capacitance varies directly with plate area in contact with dielectric. Capacitance doubles with twice the area, halves with half the area, and so on.

2. Capacitance varies inversely with thickness of dielectric or separation of the plates. Capacitance doubles when dielectric thickness is halved, and decreases to half the former value when dielectric thickness is doubled.

3. The effect of the kind of dielectric material on capacitance is called the dielectric constant of the material. The dielectric constant is the number of times that capacitance is increased by using the given material instead of air for the dielectric. It was mentioned that substituting ordinary glass for air increases the alternating current by seven to eight times. Current varies directly with capacitance, so seven to eight times the

current means that this glass has a dielectric constant of 7 to 8. The dielectric constant of air is 'unity', or 1. The accompanying table gives dielectric constants of some common dielectric materials.

DIELECTRIC CONSTANTS			
Air	1.0	Porcelain, unglazed	5 to 7
Glass, Pyrex window	4 to 5 7 to 8	Quartz	4.7 to 5.1
Mica	5.4 to 8.0	Steatite	4.8 to 6.5
Paper, plain	2.0 to 2.6	Steatite low loss	4.4
Paper wax impregnated	3.5	Titanium dioxide, used in ceramic compounds.	90 to 170
Phenols, mica filled*	5.0 to 6.0	Waxes	1.9 to 3.2
Phenols low loss	5.3		
Polyethylene	2.3 to 2.4	* Phenols include Bakelite and other materials having a phenolic base.	
Polystyrene	2.4 to 2.8		

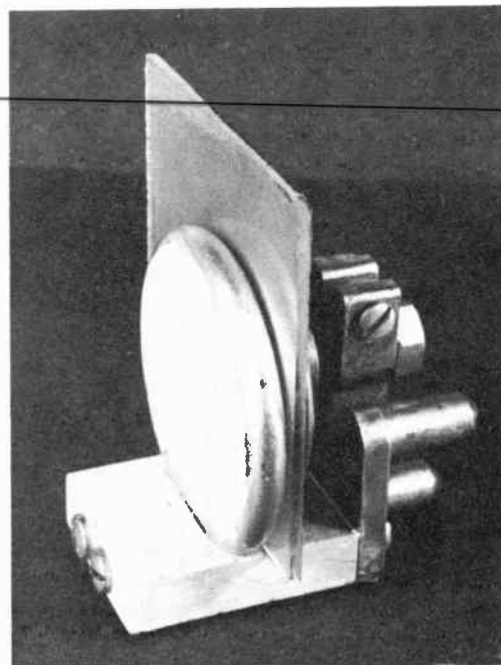
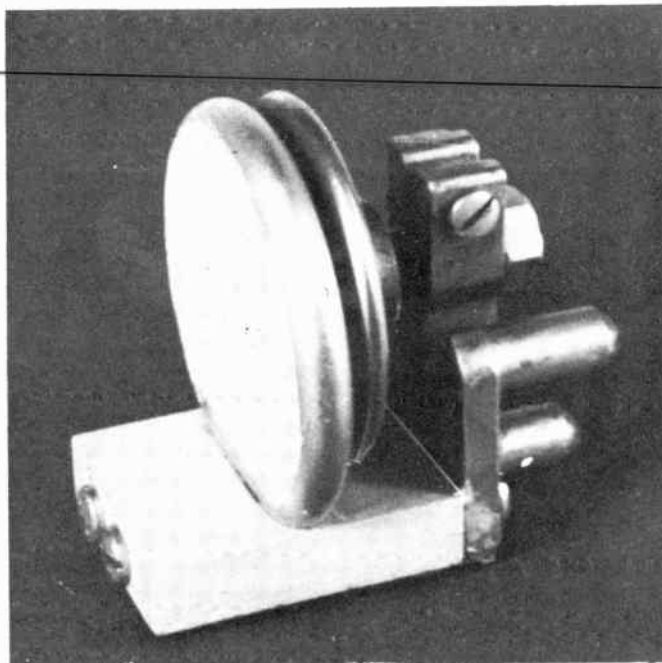

Fig. 12. Current flow and capacitance in a capacitor will vary with the kind of dielectric material.

Dielectric constants are not strictly "constant" for a given substance. They vary to some extent with frequency, with whether current is direct or alternating, with length of time in operation, and with differences between makes and grades of the materials listed. In most materials there is some variation with temperature. In temperature compensating ceramics there is controlled variation with temperature, this being the feature which allows compensating action.

We should not forget that the name dielectric is applied to an insulating material used in a capacitor or in any similar manner where the material takes part in charging and discharging of conductors. All dielectrics are insulators. All insulators can act as dielectrics when they are used in capacitors or in any equivalent application.

CAPACITIVE REACTANCE. At A in Fig. 13 a capacitor of 1.0 mf capacitance is shown connected to an a-c source furnishing 120 volts at a frequency of 60 cycles. In the capacitor there is alternating current of 45.25 or 45-1/4 ma. Forget, for a few moments, that we are working with a capacitor and imagine that it is a resistor. With this voltage and current what would be the resistance in ohms. Knowing the voltage and cur-

rent we could use an alignment chart for resistance, or the regular resistance formula, thus.

$$\text{Ohms} = \frac{1000 \times \text{volts}}{\text{milliamperes}}$$

$$\frac{1000 \times 120 \text{ volts}}{45.25 \text{ ma}} = \frac{100,000}{45.25} = 2,653 \text{ ohms}$$

The 1.0-mf capacitor working at a frequency of 60 cycles opposes flow of alternating current to the same extent as would a resistor of 2,653 ohms. The opposition of the capacitor to alternating current is not called resistance, it is called capacitive reactance.

Capacitive reactance of the 1.0-mf capacitor working at a frequency of 60 cycles is 2,653 ohms. Reactance, like all kinds of opposition to any kind of current, is measured in ohms. The 2,653 ohms of capacitive reactance acts for alternating current like resistance of 2,653 ohms would act for alternating or any other kind of current. Reactance is opposition to alternating current. Resistance is opposition to any kind of current.

Alternating current in a capacitor varies directly with capacitance. Were our capacitance doubled, to make it 2.0 mf as at B in Fig. 13, the current would double with the



## LESSON 20 – FIXED CAPACITORS AND HOW THEY ACT

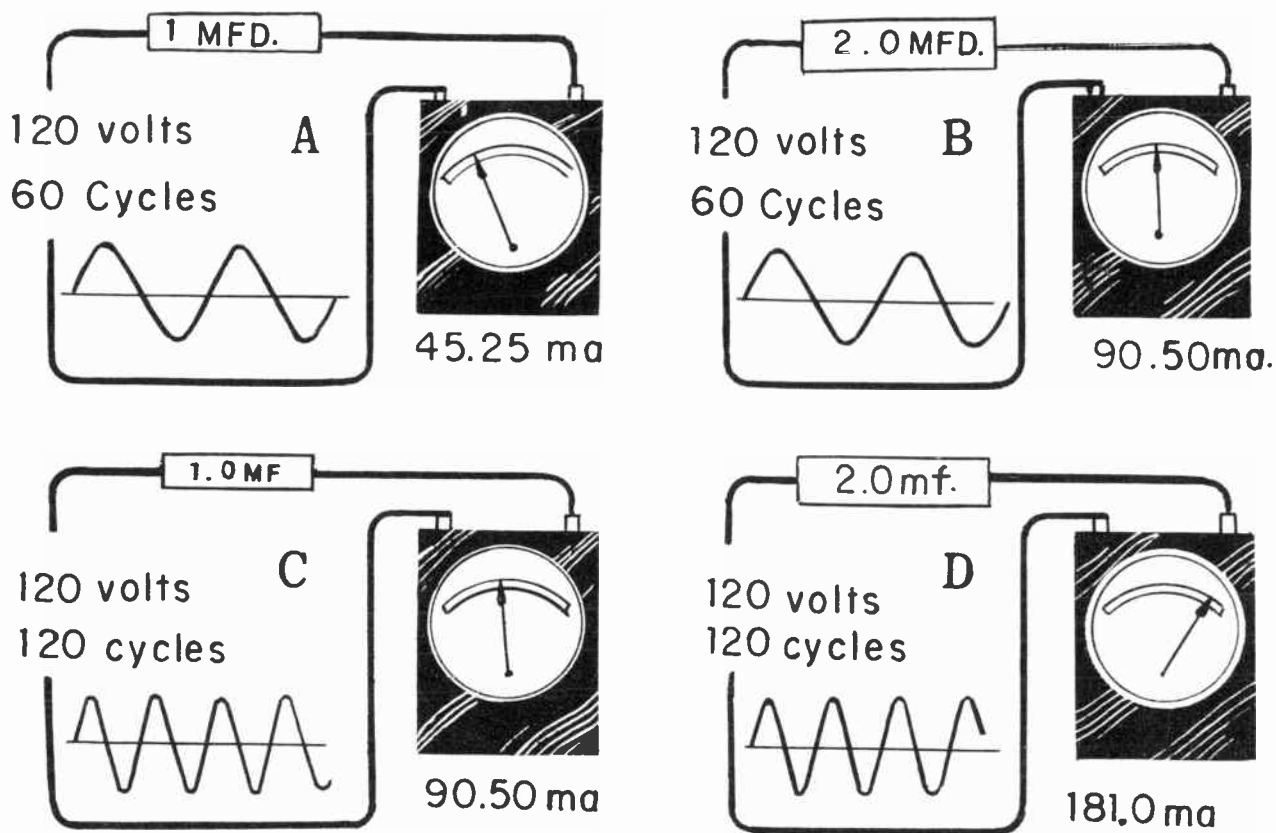

Fig. 13. Alternating current that flows in a capacitor depends on capacitance, on frequency, and, of course, on applied voltage.

same voltage and frequency. Since the current has doubled, the opposition to current must have dropped to half its former value. Therefore, we may say that capacitive reactance varies inversely with capacitance; twice the capacitance has half as much reactance, half the capacitance has twice as much reactance, and so on. It is only natural that more capacitance should allow more current, and have less reactance or opposition to current, because everything that increases the capacitance allows more current to flow into and out of a capacitor.

At C in Fig. 13 we have gone back to 1.0 mf capacitance, but have doubled the frequency, making it 120 cycles instead of 60 cycles. This doubles the current in comparison with current at a 60-cycle frequency and with the same capacitance. Inasmuch as current has doubled, reactance must have been halved. Were we to halve the frequency, in going back from diagram C to A, the current would be halved and the reactance would be doubled.

It is natural that current should double with twice the frequency, because then the capacitor is charged and discharged twice as often during every second. With the same charging current during each alternating cycle, there must be twice the total electron flow per second, and there will be twice as much alternating current.

Were we to go from diagram A to diagram D of Fig. 13, and double both the capacitance and the frequency, each of these factors would double the current and the total would be four times the original current. Of course, this would mean one-fourth of the original reactance.

You can determine capacitive reactance accurately enough for practically all service problems with the help of the alignment chart of Fig. 14. The left-hand scale covers capacitive reactances from 0.5 to 30,000 ohms. The center scale is for frequencies between 30 cycles and 300 megacycles. The right-hand scale is for capacitances from 0.0001 to



# COYNE - television home training

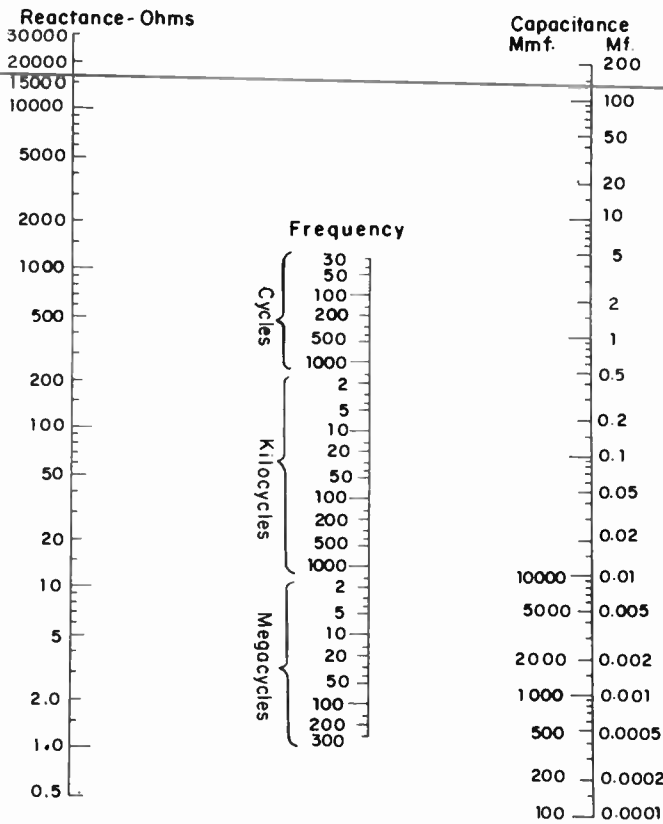

Fig. 14. The alignment chart for capacitive reactance, frequency, and capacitance.

200 mf, with part of this scale marked also for capacitances in mmf. Lay your straightedge on two scales for any two of the values which are known, and read the third unknown value where the straightedge crosses the third scale.

For more precise results than can be read from the chart you may use the following formulas, all of which are for capacitive reactance when frequency and capacitance are known.

$$\text{Reactance,} = \frac{159\ 155}{\text{ohms} \quad \text{cycles} \times \text{mf}}$$

$$\text{Reactance,} = \frac{0.159155}{\text{ohms} \quad \text{megacycles} \times \text{mf}}$$

$$\text{Reactance,} = \frac{159.155}{\text{ohms} \quad \text{kilocycles} \times \text{mf}}$$

$$\text{Reactance,} = \frac{159\ 155}{\text{ohms} \quad \text{megacycles} \times \text{mmf}}$$

$$\text{Reactance,} = \frac{159\ 155\ 000}{\text{ohms} \quad \text{kilocycles} \times \text{mmf}}$$

**CAPACITANCES IN SERIES AND IN PARALLEL.** When two or more capacitors or capacitances are connected together either in series or in parallel we sometimes are

interested in knowing the combined capacitance, and again in knowing the combined capacitive reactance.

Combined capacitive reactances in ohms are determined with exactly the same methods used for combined resistances in ohms. When you are interested in opposition to current, just remember that ohms, are ohms whether they measure reactance or resistance. Reactances of capacitors in series are equal to the sum of the separate reactances. Reactances of capacitors in parallel are equal to the product divided by the sum, of the ohms. All the other rules for series and parallel resistances apply to series and parallel reactances.

If it is combined capacitance, rather than reactance, in which you are interested, do not get capacitance in mf or mmf confused with reactance in ohms. The rules for determining combined series capacitances are like the rules for combined parallel resistances. The rules for combined parallel capacitances are like the rules for combined series resistances.

The problem of combined paralleled capacitances is easy. All the capacitors are subjected to the same voltage, when in parallel. Each capacitor will take charges or will allow currents proportional to its capacitance. Then the combined charges must be equal to the sum of the separate charges, and the combined current must be the sum of the separate currents. The combined current will be greater than current in any one capacitor, so combined capacitance must be greater than capacitance of any one unit. All that you need do is add together all the separate capacitances to find the total or combined capacitance.

The only thing to look out for is that each and every one of the paralleled capacitors has voltage rating high enough for the voltage which is applied to all of them.

Series capacitances are not quite so easy, unless you remember how to apply the rules for resistors in parallel. The two most useful rules are as follows.

## LESSON 20 – FIXED CAPACITORS AND HOW THEY ACT

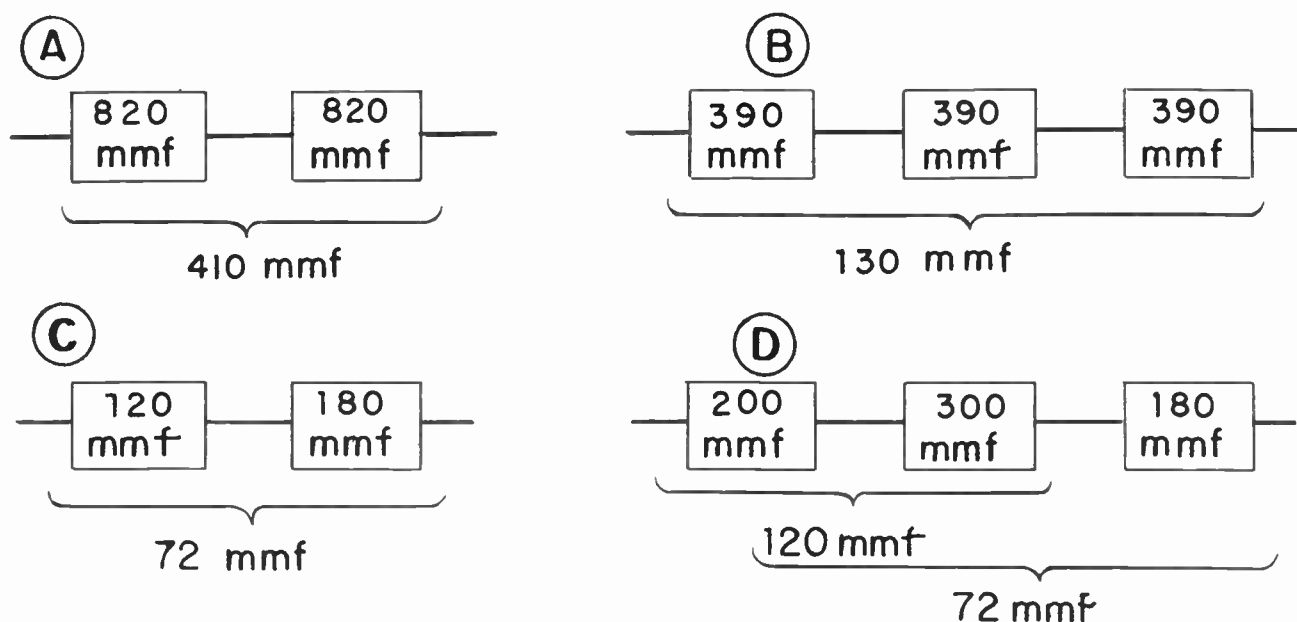

Fig. 15. Some examples showing combined capacitance of capacitances in series.

1. The capacitance of any number of equal capacitances in series is equal to one capacitance divided by the number of capacitances. This is illustrated at A and B of Fig. 15. With two 820-mmfm units, divide 820 by 2 to find that the combined capacitance is 410 mmfm. With three 390-mmfm units, divide 390 by 3. Combined capacitance is 130 mmfm.

2. Capacitance of two unequal capacitances in series is equal to their product divided by their sum. This is illustrated at C in Fig. 15. The separate capacitances are 120 mmfm and 180 mmfm. It works out like this.

$$\frac{120 \times 180}{120 + 180} = \frac{21600}{300} = 72 \text{ mmfm, combined series capacitance.}$$

If there are more than two unequal series capacitances, as at D in Fig. 15, work out the combined capacitance of two of them, by dividing the product by the sum. For 200 and 300 mmfm the product is 60,000 and the sum is 500. Dividing gives the series capacitance as 120 mmfm. Then use this combined capacitance with the capacitance of a third unit, and again divide the product by the sum. In the problem illustrated we would have 120 mmfm for the first two units and 180 mmfm for the third unit. Dividing the product of 120 times 180 by the sum of 120 plus 180 gives 72 mmfm as the series capacitance of the three

units. Any number of unequal capacitances can be handled by continuing to include one more unit at each step.

Fig. 16 is an alignment chart for combined capacitance of two equal or unequal capacitances ranging between 15 and 1,000 mmfm, when connected in series. Lay the straightedge on the outside scales at the values of the separate capacitances. Read the combined capacitance where the straightedge crosses the center scale.

If you wish to determine the value of a capacitor to be connected in series with one you have on hand, in order to give some certain combined series capacitance, proceed thus: Lay the straightedge on either outside scale at the value of the capacitor which is on hand, and on the center scale at the value of combined capacitance which you wish to obtain. On the other outside scale read the value of the required series capacitor.

Fig. 17 is a similar alignment chart for separate capacitances between 0.00015 mf (150 mmfm) and 0.01 mf (10,000 mmfm). Either chart may be extended in usefulness to any greater or lesser capacitances by multiplying the numbers on all three scales by the same number, or else by dividing all three by the same number. Convenient multipliers or divisors are 10, 100, 1,000, and so on.

# COYNE - television home training

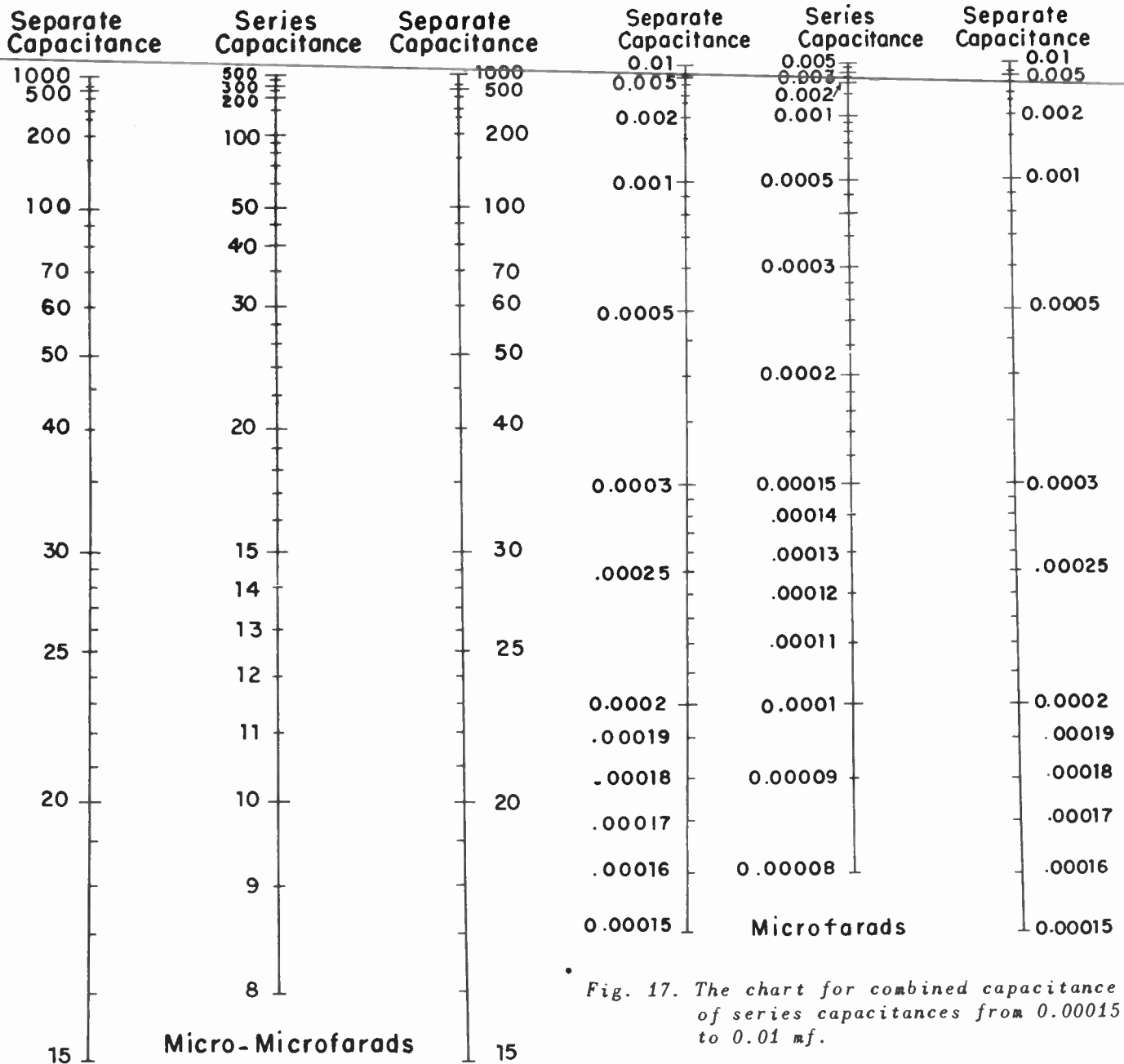

Fig. 16. The chart for combined capacitance of series capacitances from 15 to 1,000 mmf.

Fig. 17. The chart for combined capacitance of series capacitances from 0.00015 to 0.01 mf.

**VOLTAGE RATINGS OF SERIES CAPACITORS.** Probably you recall that with series resistors the wattage ratings of the several units had to be watched carefully, because the greatest resistance could easily be overloaded and burned out. There is a somewhat similar problem with series capacitors, but it is the voltage ratings which must be watched in order to avoid breakdown and

shorting. The smallest capacitance gets the greatest portion of the applied voltage, while the greatest capacitance is subjected to the least voltage.

This happens because the smallest capacitance has the greatest reactance, in ohms. The total voltage applied to the series capacitors divides between them according to their reactances in ohms, just as it would divide between unequal series resistors proportionately to resistances in ohms. It isn't very easy to figure out the exact division of voltage between series capacitors, unless you like arithmetic, and it seldom should be

## LESSON 20 – FIXED CAPACITORS AND HOW THEY ACT

necessary. The one safe way is to have all series capacitors of voltage ratings at least equal to the overall applied voltage.

The advantage is not only that the smallest capacitor won't be broken down, but in case one of the capacitors shorts and becomes of little or zero reactance, the extra voltage on those remaining won't break them down.

By connecting in series two or more capacitors having equal capacitances and equal voltage ratings it is possible to obtain

an increased voltage rating. For example, if two capacitors having ratings of 300 volts are connected in series they will withstand a total of 600 applied volts. Of course, the combined capacitance will be only half the capacitance of each unit. If you use different capacitances in series, the unequal division of overall voltage prevents the total effective voltage rating from equalling the sum of the separate ratings. A mathematical solution of the actual combined effective voltage rating usually would take more time than the job would be worth.



# TELEVISION

• RADIO

• ELECTRONICS

---

---

**LESSON 21 – GRID BIASING**

---

---

***Coyne School***

*practical home training*

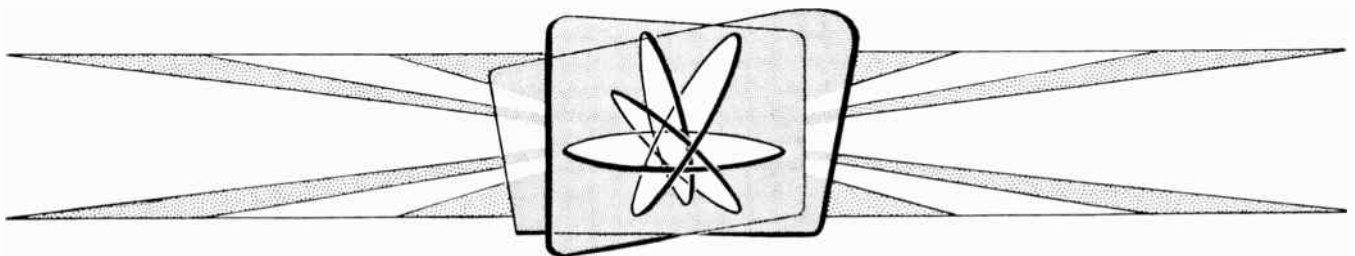

*Chicago, Illinois*

*Copyright, 1953 by Coyne Electrical School  
Chicago 12, Illinois  
All Rights reserved*

Litho. in U.S.A.

# Lesson 21

## GRID BIASING

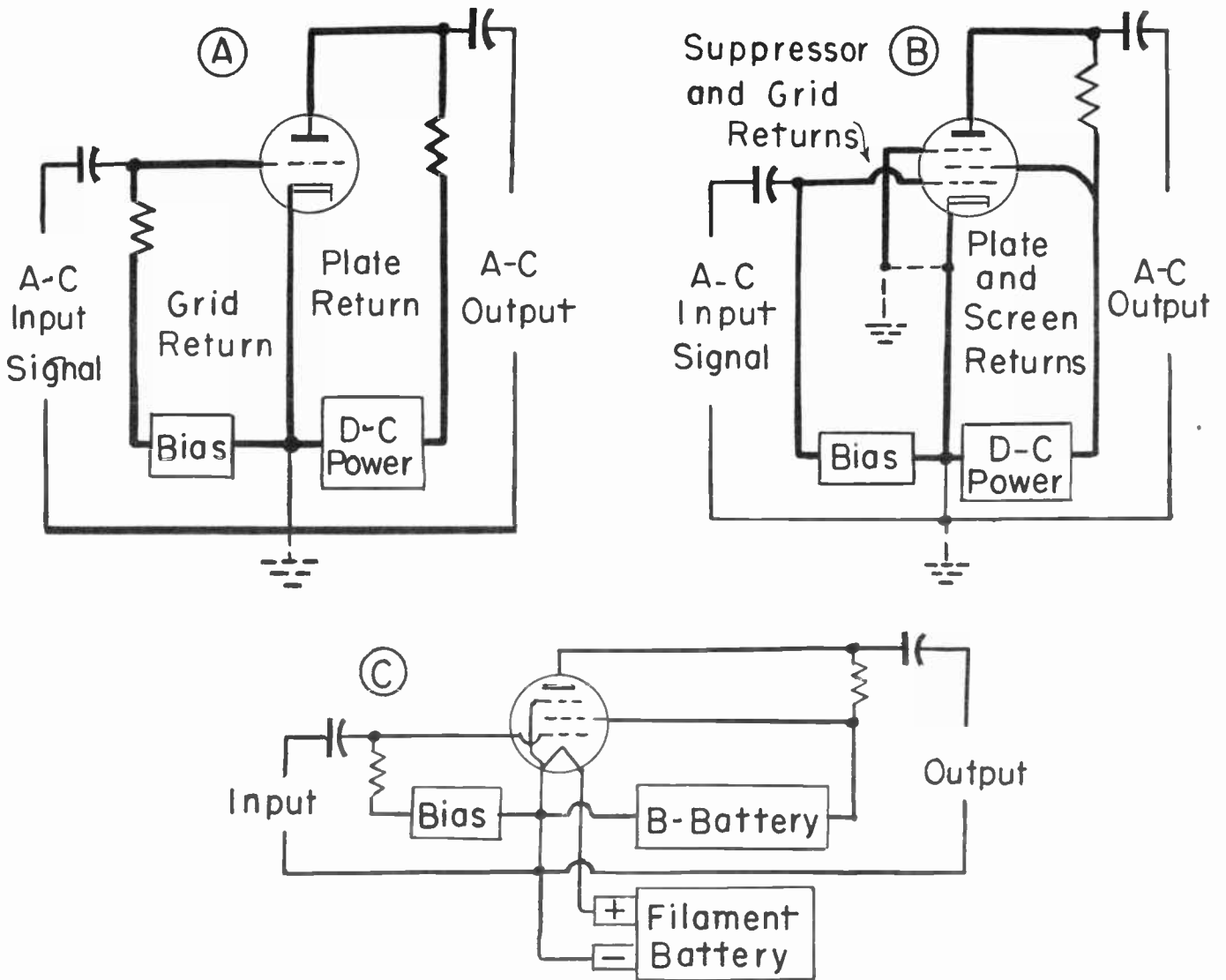

Fig. 1. Cathode returns for triodes and pentodes.

Every active element in any tube must be connected to the cathode of that tube through conductors which can carry direct current. These d-c paths, between other elements and the cathode may be called cathode returns. For a triode there are two returns, as shown by heavy lines at A in Fig. 1. One is the grid return and the other is the plate return.

Any source of bias voltage and any source of d-c plate power may be parts of the

return circuits, because all such sources are capable of carrying direct currents. There must be no capacitors in the cathode returns, for the dielectric in a capacitor is insulation, and could not pass direct current or voltage.

A grid return must be capable of passing direct voltage because grid bias is a direct voltage. The dielectric insulation of a capacitor would be the equivalent of an open circuit so far as direct voltage is concerned, and bias voltage could not act on the grid of

## COYNE - *television home training*

the tube. With no conductive connection between grid and cathode there would be what is called a free grid. A free grid collects electrons from the space charge and retains these electrons because there is no conductive path through which they can get back to the cathode. These retained electrons make the grid negative in an erratic manner, often to the extent of cutting off plate current.

It is necessary that there be a plate return capable of carrying direct current in order that there may be plate current, which is one-way or direct current flowing from cathode to plate inside the tube while being varied by grid voltage. Except when there is intentional cutoff, plate current never should decrease to zero, but should flow continually from the plate through the output load to the positive side of the d-c power supply. A capacitor in the plate return circuit would prevent flow of this direct current.

Cathode returns for a pentode are shown by heavy lines in the diagram at B in Fig. 1. In addition to a grid return and a plate return there must be conductive paths from the screen and from the suppressor to the cathode. A screen return is necessary in order that the screen may be held at a certain average d-c potential with reference to the cathode. The suppressor must be connected directly or through ground to the cathode in order that the suppressor may remain at or near the same potential as the cathode.

If a tube has a filament-cathode the grid return always is to the negative side of the filament or to the side of the filament connected to the negative of the filament voltage supply. This is shown at C in Fig. 1. Plate and screen returns most often are to the negative side of the filament, but sometimes are to the positive side. With these returns to the positive side of the filament, filament voltage is added to d-c power supply voltage. Then plate and screen voltages are somewhat higher than the voltage of the d-c power supply alone.

FIXED BIAS. When voltage for grid bias is obtained from any source that does not permit the bias to be strongly affected by signals we have what is called a fixed bias.

In our earlier experiments with amplification and other properties of tubes we have used fixed biases.

The most common way of obtaining a fixed bias is illustrated by Fig. 2, where are shown a d-c power supply and a single amplifier tube. Additional amplifiers might be connected to this system. Electron flows which are direct currents in the power supply load resistors and in the amplifier plate circuit are indicated by arrows. The ground symbols indicate chassis grounds. All conductors connected to these grounds are effectively connected together through chassis metal.

We are interested only in filtered direct voltages and their accompanying direct currents, since we wish to obtain a bias voltage as free from ripple voltage as possible. There are filtered direct voltages, and any accompanying direct currents, in the power supply resistors between A and B, also in all circuits lying to the right of these points. To the left of A and B are pulsating direct currents in the power supply rectifier, transformer, and filter.

Direct current for the amplifier plate circuit flows from point A through resistor R<sub>a</sub> to a chassis ground at G. This current goes through ground metal to the amplifier cathode, through the amplifier from cathode to plate, from the plate through resistor R<sub>o</sub>, and back to point B on the power supply. We pay no attention to capacitors along this current path, because capacitors do not pass direct current. Additional direct current flows from A through power supply resistors R<sub>a</sub> and R<sub>b</sub> to point B.

All smooth direct current is flowing away from point A. Consequently, this must be the most negative point in all circuits carrying smooth direct voltages and currents. All such currents flow toward point B. Consequently, B must be the most positive point. The ground connection at G is taken from part way between the most negative point (A) and the most positive point (B). This ground must be less negative than A, and it is equally true that A is more negative than the ground at G.



## LESSON 21 – GRID BIASING

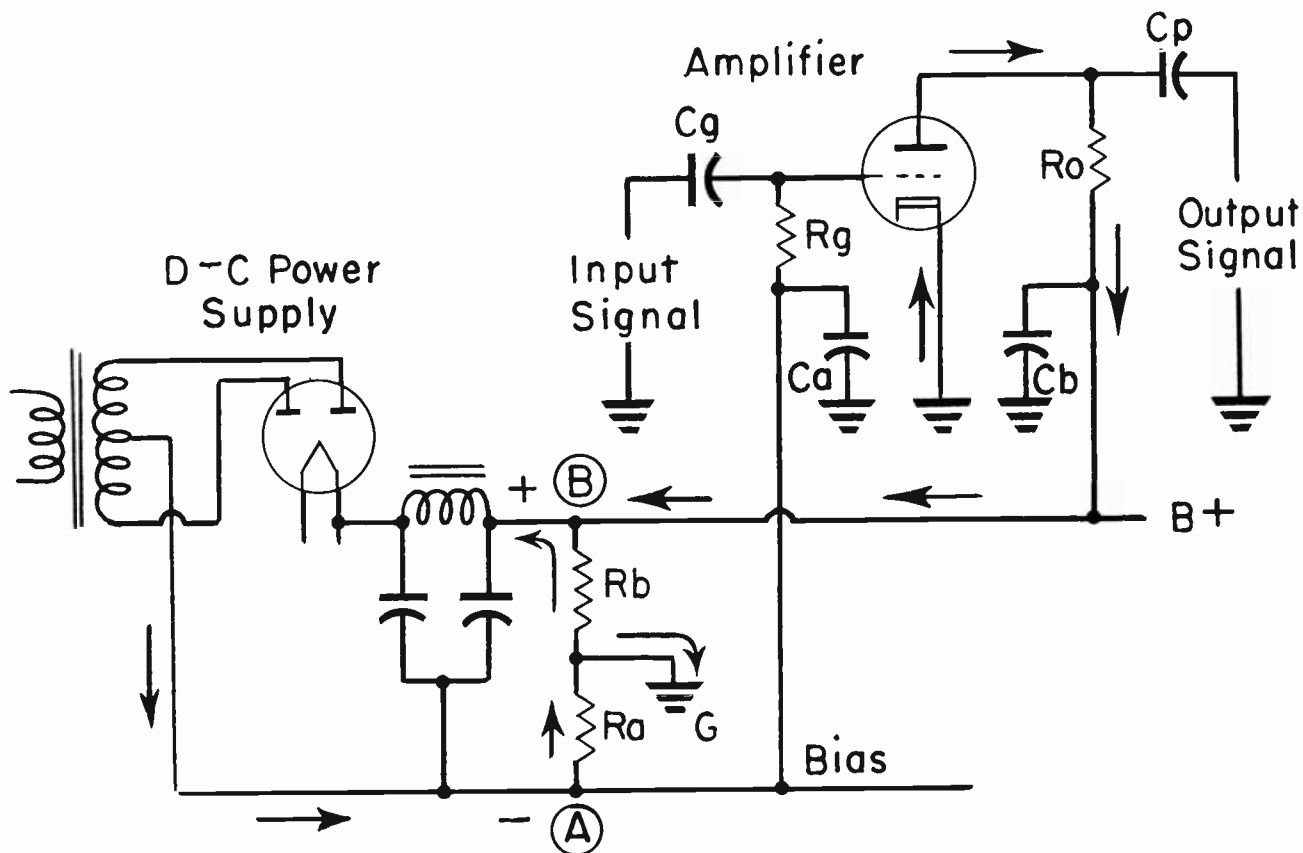

Fig. 2. Fixed bias from a d-c power supply.

Since all grounds are connected together, all of them must be less negative than point A. The cathode of the amplifier is connected to ground, so must be less negative than point A. The amplifier grid, or grid return, is connected through resistor Rg to point A. Then the cathode of the amplifier must be less negative than its grid, or, what amounts to the same thing, the grid must be more negative than the cathode. This constitutes a negative grid bias.

Before continuing with the matter of grid bias let's look at the several capacitors in the amplifier circuits. The alternating input signal voltage is applied to the amplifier grid through capacitor Cg, and to the cathode through ground. There will be some alternating signal voltage in resistor Rg, because the lower end of Rg connects through the power supply and ground to the amplifier cathode. Rather than having some of the signal voltage go into the power supply it is better to keep it between grid and cathode of the amplifier. This is done by connecting at Ca a large capacitance, with low capacitive

reactance, from the lower end of Rg through ground to the cathode.

The alternating output signal voltage from the amplifier plate goes through capacitor Cp to following circuits. The voltage variations which form the output signal are in plate resistor Ro, and, like the grid signal voltage, would go through the power supply and ground to the amplifier cathode. To keep the output signal voltage out of the power supply we connect from the lower end of Ro a capacitor Cb of large capacitance and low reactance, and connect the other side of this capacitor through ground to the amplifier cathode. All the capacitors in the amplifier circuits provide paths for alternating signal voltages, and two of them keep these signal voltages out of the power supply.

Any number of different fixed bias voltages may be obtained from the same power supply. The arrangement for two biases is shown by Fig. 3. Here are shown only the output resistors of the power supply, which now are three instead of the two used in Fig. 2.

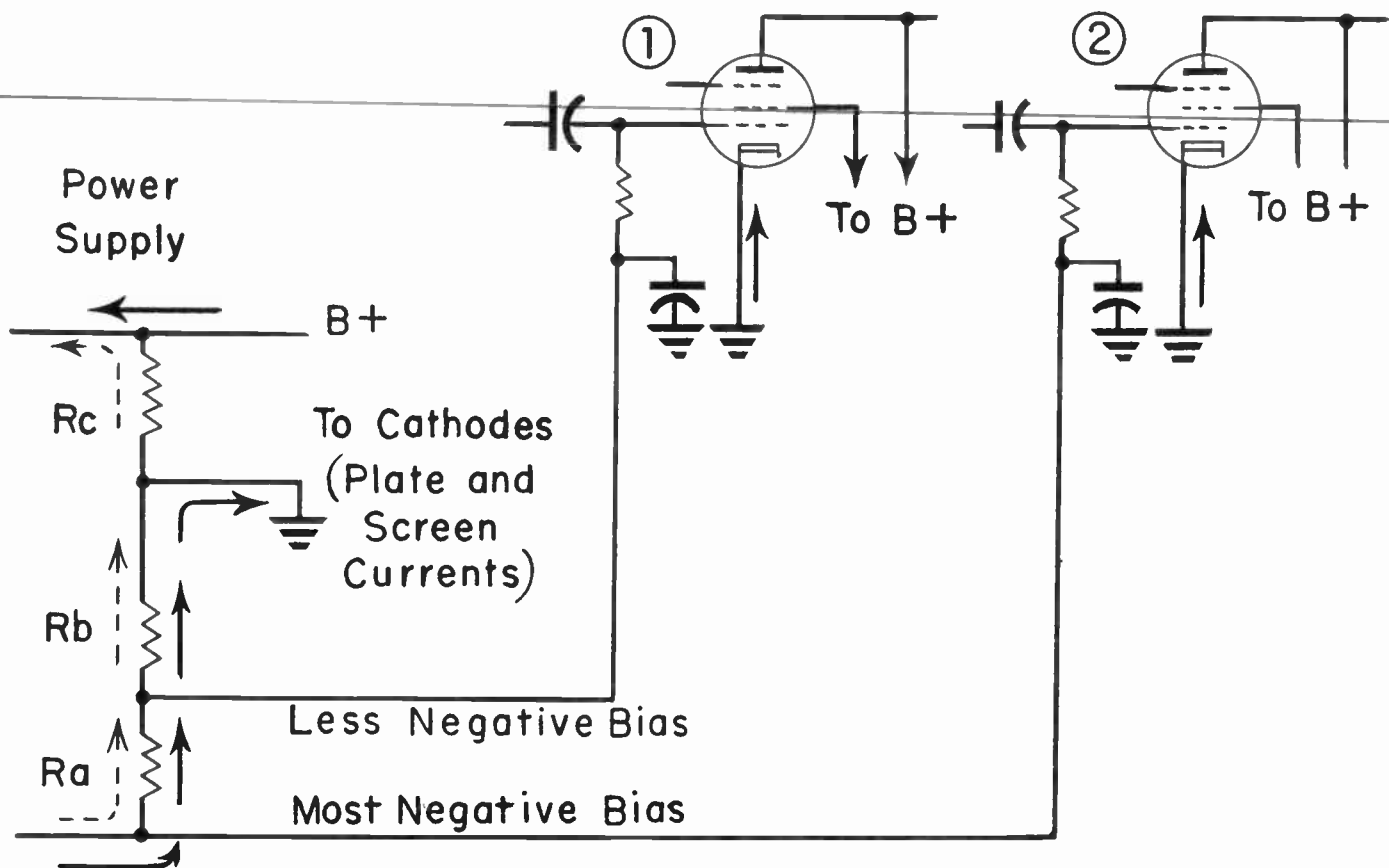

Fig. 3. Two fixed bias voltages from the d-c power supply.

Electron flow or current for plate and screen circuits is shown by full-line arrows. This flow goes through power supply resistors  $R_a$  and  $R_b$  to chassis ground, then through ground to the cathodes of all biased tubes, and from plates and screens back to B+ at the top of the power supply resistors. This plate and screen current flows only in power supply resistors  $R_a$  and  $R_b$ . There is additional direct current, represented by broken-line arrows, flowing from negative to positive through all three power supply resistors.

Grid bias voltage for amplifier 1 is the potential difference or voltage drop across resistor  $R_b$ , because one end of  $R_b$  is connected to the grid of this amplifier and the other end is connected through ground to the amplifier cathode. Voltage across  $R_b$ , and the bias for amplifier 1, are proportional to resistance of  $R_b$  and current flowing in it. Bias for amplifier 2 is the sum of the voltage drops across resistors  $R_b$  and  $R_a$ , since the grid is connected to the bottom of  $R_a$  while the cathode is connected through

ground to the top of  $R_b$ . The sum of the voltage drops, which is bias for amplifier 2, is proportional to the current in  $R_a$  and  $R_b$ , and to the sum of their resistances.

Since the cathodes of both amplifiers are connected through ground to the top of resistor  $R_b$ , bias voltage for amplifier 2 must be more negative than for amplifier 1, for the reason that the grid of amplifier 2 gets the sum of the voltages across  $R_a$  and  $R_b$ , while the grid of amplifier 1 gets only the voltage across  $R_b$ .

Resistor  $R_c$  on the power supply output in Fig. 3 may be omitted, and the bias connections made as in Fig. 4. The purpose of  $R_c$ , when used, is to permit a certain amount of output current in addition to plate and screen currents. Then variations of plate and screen currents have less effect on total output current, and voltage regulation is improved. The resistor which carries extra current,  $R_c$  in these examples, is called a bleeder resistor.

## LESSON 21 – GRID BIASING

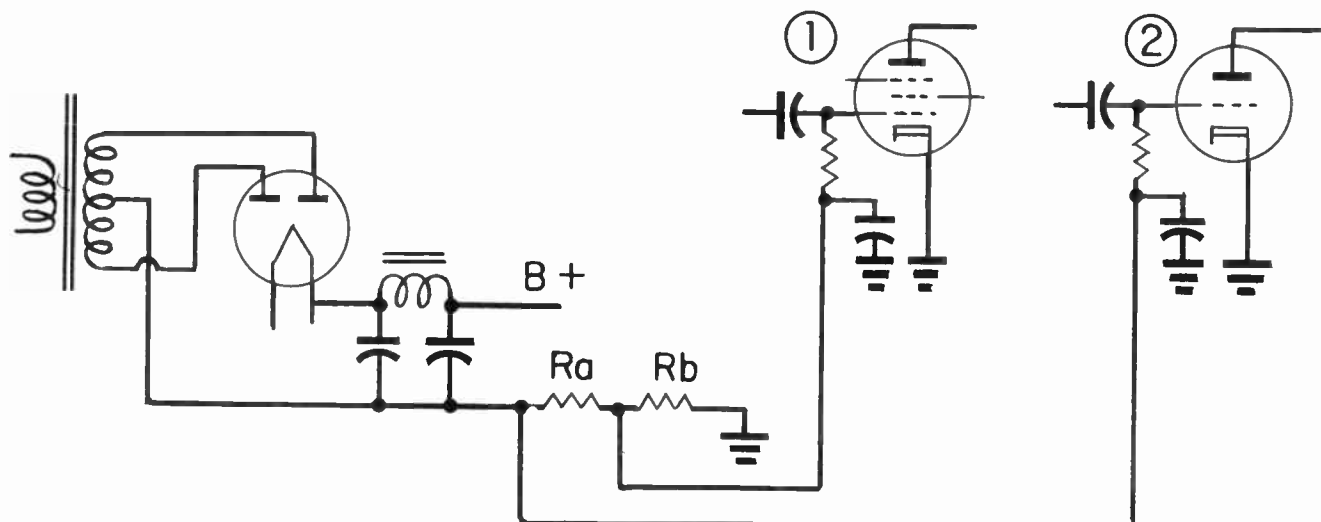

Fig. 4. Two fixed biases, with no bleeder resistor on the d-c power supply.

The total d-c output voltage from the power supply divides between voltages for plates and screens and voltages for grid biases. This is illustrated by Fig. 5. Assuming that cathodes are connected to ground, as in preceding figures, the voltage for plates and screens is that between B+ and ground on the power supply output. Bias voltage is that between ground and B- or the most negative bias line.

When tracing circuits and checking d-c voltages during service work, remember that the wire or other conductor going directly to the secondary center tap of a full-wave power

transformer is the most negative point in the entire d-c system. All points separated from the center tap by resistance are at less negative potentials. The most negative line, and all points directly connected to it usually are designated as B-minus, or B-. Chassis ground would not be at the same potential as B- when fixed bias is employed. Chassis ground would be the same, in potential, as B- when the center tap of the transformer secondary is connected to chassis ground.

As shown by Fig. 6, the power supply filter choke, or a filter resistor, sometimes is in the negative side of the filter instead

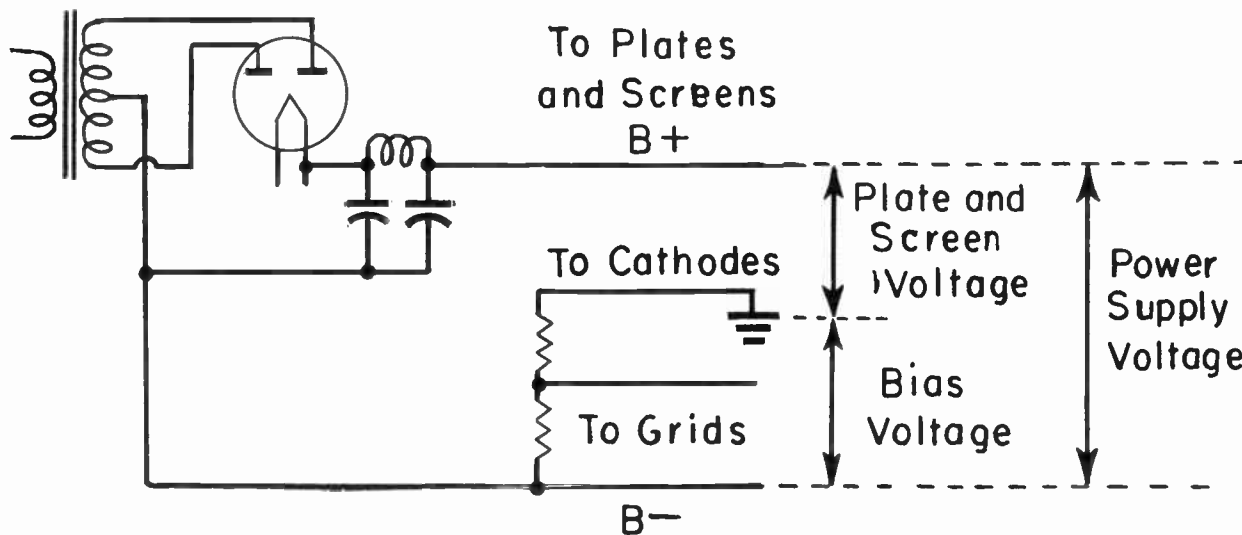

Fig. 5. Power supply d-c output voltage must equal the sum of maximum plate or screen voltage and maximum negative grid bias.

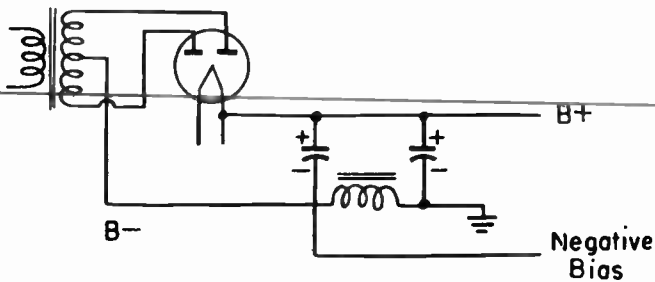
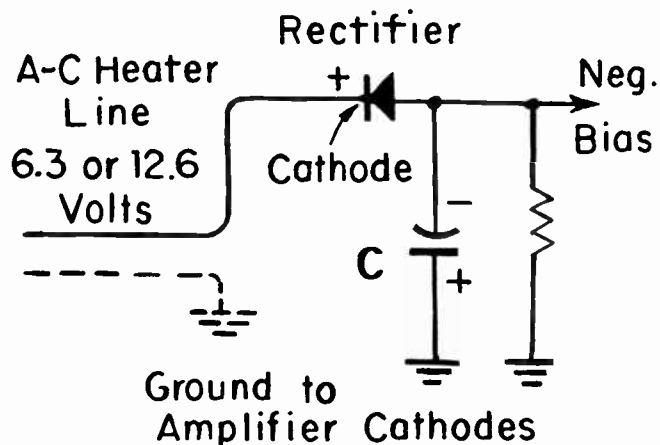

Fig. 6. Voltage drop across a filter choke, or resistor, may be used for negative grid bias voltage.

of in the positive side. Then the d-c voltage drop across the choke or filter resistor may be used as a negative bias voltage, with the bias line connected to B-, and the output side of the choke or filter resistor connected to chassis ground and thereby to tube cathodes.

**BIAS RECTIFIERS.** In quite a few receivers you will find a separate half-wave rectifier providing d-c bias voltages. This bias rectifier usually is a selenium type, but may be a tube or a section of a tube.

Typical circuits are shown by Fig. 7. In the left-hand diagram the a-c voltage to be rectified is taken from an a-c heater line for receiver tubes, at 6.3 volts, 12.6 volts, or whatever the heater voltage may be. The single filter capacitor, C, is an electrolytic type, usually of at least 50 mf capacitance.



With a large capacitance the negative d-c bias voltage will approach the peak a-c voltage, and will be somewhat greater than the effective or rms voltage of the a-c heater line.

In the diagram at the right in Fig. 7 the a-c source is the a-c power line, to which connection usually would be made on the primary side of a power transformer, or directly through the on-off switch in a transformerless receiver. Electrolytic filter capacitors at C may be of capacitances between 10 and 50 mf each. Filter resistor R may be between 1,000 and 50,000 ohms or more. Two or more negative bias voltages may be taken from the output by using suitable resistances across the output of the filter.

**CATHODE BIAS.** The widely used method of grid biasing called cathode bias, or sometimes called self-bias, is illustrated by Fig. 8. Bias voltage is developed across a bias resistor connected in series with the cathode of the biased tube. Through this resistor flows all direct current going to the cathode, which is the plate current of a triode or the sum of plate and screen currents of a pentode or beam tube.

Cathode current flows through the bias resistor in the direction of the arrow. Since current always flows from negative to positive, the upper end of the bias resistor and

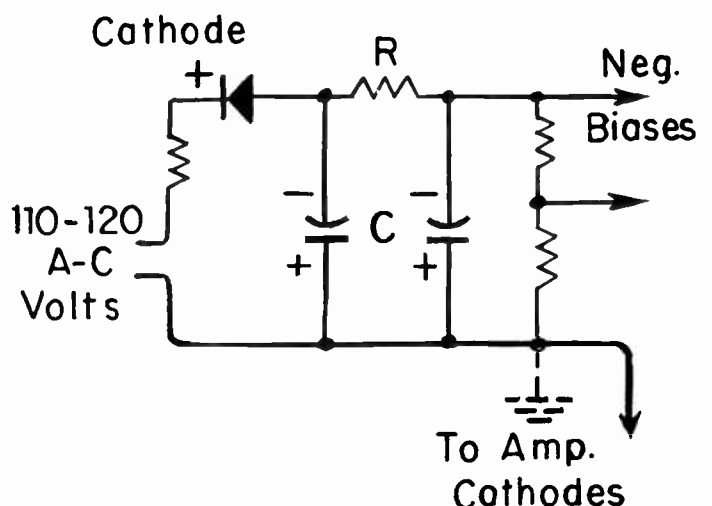

Fig. 7. Selenium rectifiers providing negative grid bias voltages.



## LESSON 21 – GRID BIASING

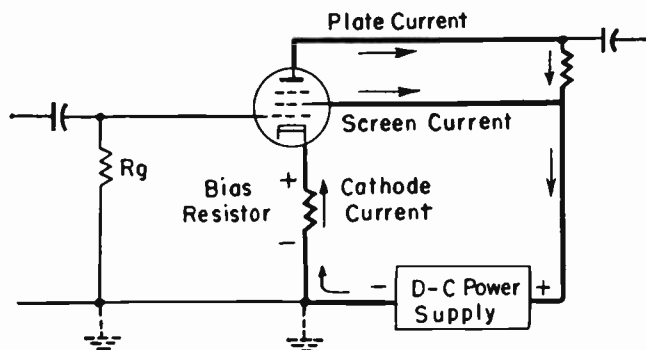

Fig. 8. The elementary circuit for cathode bias.

the cathode to which it connects are positive with reference to the lower end of the resistor, or the lower end is negative with reference to the cathode.

The grid of the tube is connected through grid resistor  $R_g$  to the lower (negative) end of the bias resistor. This connection may be made through chassis ground by connecting the lower ends of the grid resistor and the bias resistor to ground. When there is no current in the grid resistor and no voltage drop across it, potential at the grid end of  $R_g$  and at the connected grid of the tube will be the same as at the lower end. Thus the grid is made negative with reference to the cathode of the tube, or is negatively biased. There is no current and no voltage drop across  $R_g$  with the grid negatively biased.

Bias voltage is the voltage drop across the bias resistor. This voltage is proportional to the resistance of the bias resistor and the cathode current flowing in it. Bias resistance required for any bias voltage may be found thus.

$$\text{Resistance, ohms} = \frac{1000 \times \text{required bias volts}}{\text{cathode current, ma}}$$

For example, assume that specifications of a certain pentode show that it normally carries 6.0 ma plate current and 1.2 ma of screen current when the bias is 2.0 volts negative. Total cathode current is the sum of plate and screen currents, or is 7.2 ma. Putting these values in the formula, we have.

$$\text{Resistance, ohms} = \frac{1000 \times 2}{7.2} = \frac{2000}{7.2} = 278 \text{ ohms, approximately}$$

Stock resistors of the nearest preferred values are 270 ohms and 300 ohms. A 270-ohm resistor would provide bias slightly less than 2 volts negative, while a 300-ohm unit would make the bias somewhat greater than 2 volts.

When using cathode bias, the total d-c output voltage from the power supply divides between the bias voltage and the voltages for the plate, the screen, and any plate load resistance. As you can see from Fig. 8, the d-c power circuit includes the internal resistance of the tube, resistance of the load, and resistance of the bias resistor, all in series on the d-c power supply. The power supply must furnish the sum of the voltage drops in all these resistances.

The grids of several tubes may be cathode biased from a single bias resistor provided all the tubes require the same number of biasing volts. Connections for two tubes are shown by Fig. 9. All the cathodes are

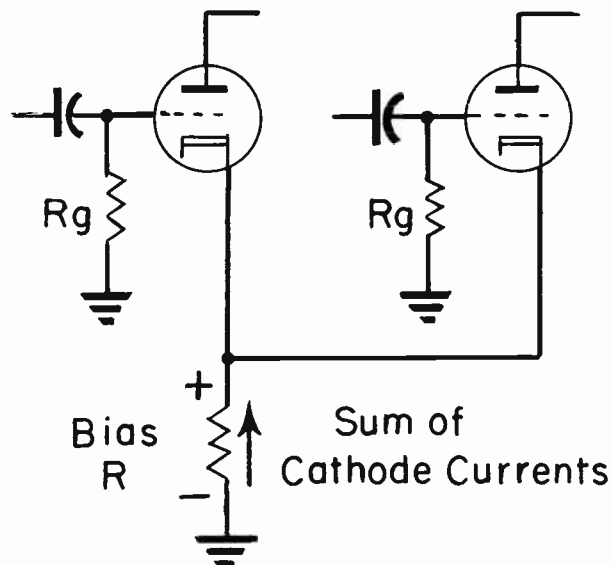

Fig. 9. Two tubes biased from a single cathode resistor.

connected together and to one end of the bias resistor. All the grid returns are connected through ground or otherwise to the opposite end of the bias resistor. Bias voltage is proportional to the ohms of biasing resistance and to the sum of all the cathode currents flowing in this resistance.

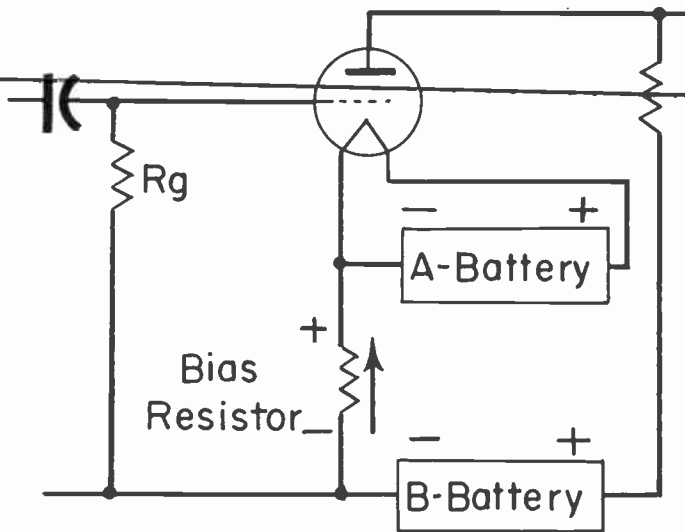

Fig. 10. Cathode-current biasing for a filament-cathode tube.

A form of cathode bias may be used for tubes having filament-cathodes, as shown by Fig. 10. Plate current for a triode, or plate and screen currents for a pentode or beam tube, flow from the negative side of the B-battery through the bias resistor to the negative side of the filament-cathode. This direction of electron flow makes the cathode end of the bias resistor positive with reference to the end which is connected through  $R_g$  to the grid, thus making the grid negative with reference to the cathode. As with other cathode-biases, the biasing voltage is proportional to cathode current and to resistance of the bias resistor.

With any method of cathode biasing the plate current or the combined plate and screen currents flow in the bias resistor. Anything which increases plate current, screen current, or both currents, will increase the total cathode current and will increase the voltage drop across the bias resistor. This means that every increase of plate or screen current will make the grid bias more negative. Since a more negative bias tends to decrease the plate current, it comes about that every increase of plate current acts through the bias resistor in a manner which tends to decrease the plate current.

Every decrease of plate current, screen current, or both, lessens the current in the

bias resistor, decreases the voltage drop across this resistor, and reduces the bias to make the grid less negative than before. So it happens that decreases of plate current act through the bias resistor to limit the decreases.

When plate voltage of a triode is increased, it tends to increase the plate current, and does so. But the amount of current increase is limited because at the same time the greater plate current acts to make the grid more negative. Decreases of triode plate current have opposite effects.

If screen voltage of a pentode is increased, there is an increase of both plate current and screen current, or there is an increase of cathode current. This makes the grid of the pentode more negative, which limits the increase of plate current and has a lesser effect of the increase of screen current. Decreases of screen voltage have, of course, the opposite effects.

#### BYPASSING FOR CATHODE RESISTORS.

We have just learned that variations of plate current or cathode current act through a cathode bias resistor to alter the grid bias. When an a-c signal voltage is applied to the grid-cathode circuit of a tube there are variations of plate current, and these variations are going to affect the bias just as would any others - except that changes of bias voltage will occur at the frequency of the a-c signal voltage.

In Fig. 11 an a-c signal is represented as acting on the grid. Let's consider the instant or time period represented at a, during which the signal reaches its peak positive voltage. On the plate side of the tube is represented the variation of plate and cathode current which is caused by the signal voltage. At instant a there is an increase of current. This increase of current occurs also in the bias resistor.

The increase of bias-resistor current increases the voltage drop across this resistor, and, since this drop is our negative biasing voltage, there occurs at instant a, a more negative bias voltage. This more negative bias voltage is applied to the grid of the tube, along with the signal voltage which, at

## LESSON 21 – GRID BIASING

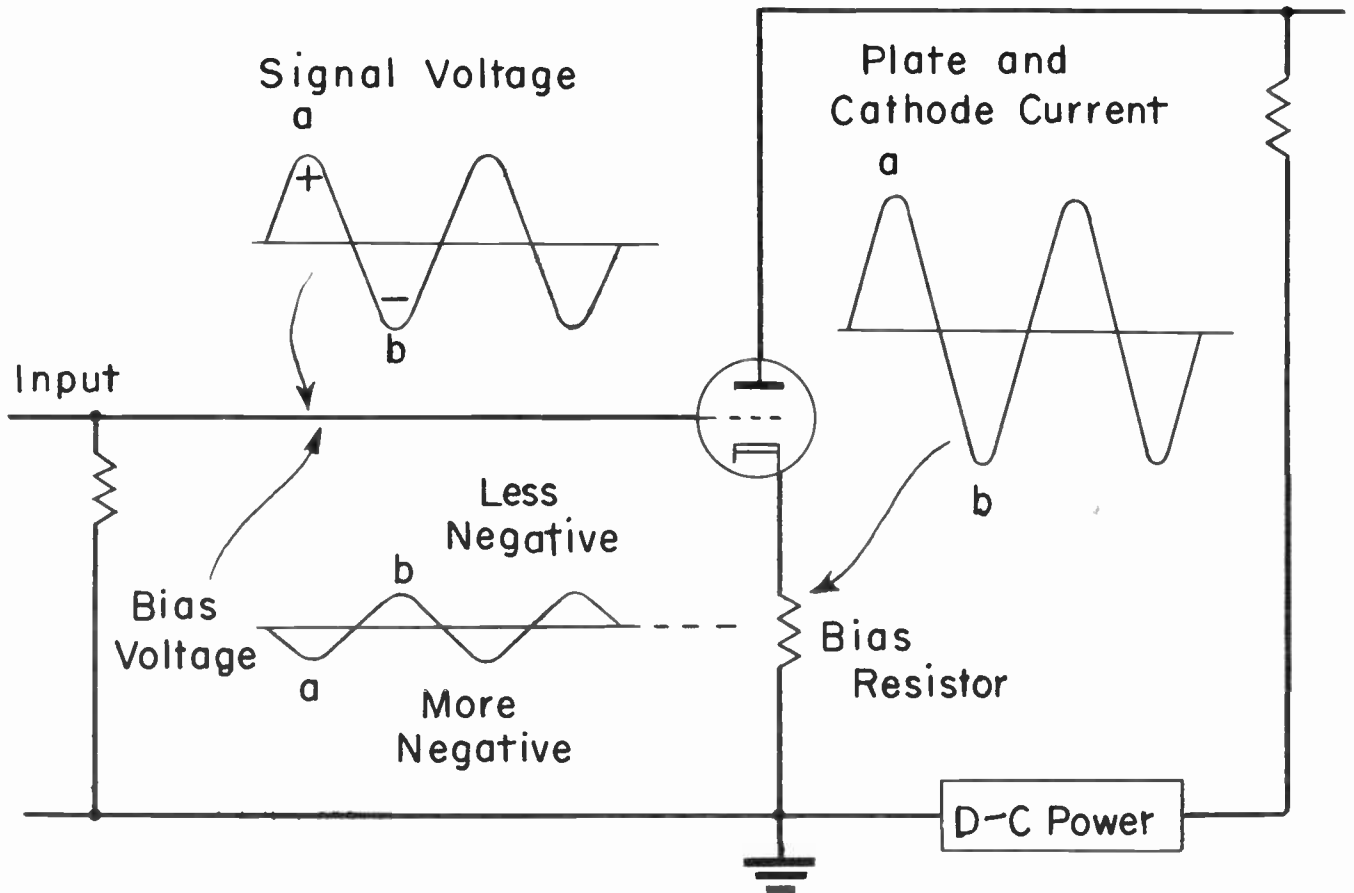

Fig. 11. How cathode bias acts to oppose and weaken the signal voltage applied to the grid.

this instant is positive. Part of the positive signal voltage is balanced out by the increased negative bias, and at the grid we have signal voltage which is less positive than at the input to the amplifier circuits.

We might start all over again with instant *b*, during which the signal voltage swings negative. This decreases the plate and cathode current in the bias resistor, decreases the negative biasing voltage, and the bias becomes less negative. The less negative bias voltage combines with the (more) negative signal voltage, and again weakens the signal voltage going to the grid. The manner in which cathode-bias voltage reacts on grid signal voltage is called degeneration. We shall have much more to do with this action when coming to the matter of signal distortion.

When we wish to lessen or almost completely eliminate the degenerative effects on signal voltages and currents on signal volt-

ages, when using cathode bias, the current variations may be bypassed around the bias resistor by means of a capacitor. The connection is shown by Fig. 12.

The alternating portion or component of plate current which goes to the tube cathode will divide between the bias resistor and bypass capacitor according to their oppositions to alternating current. The a-c component will divide inversely as the oppositions. Opposition of the bias resistor is proportional to its resistance, in ohms. Opposition of the bypass capacitor is proportional to its capacitive reactance, in ohms. The greater the capacitance of the bypass, and the less its reactance, the more of the alternating current will go through the capacitor and the less through the resistance.

The steady or smooth direct current, which is the average value of cathode current, cannot go through the capacitor. All of this steady direct current has to go through

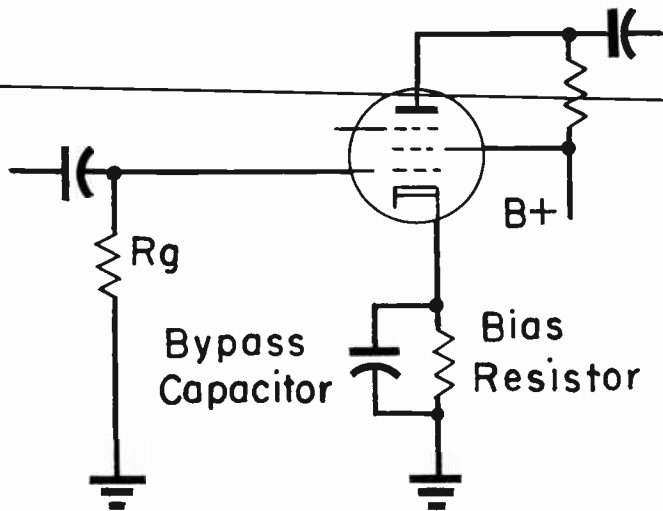

Fig. 12. Bypassing for a cathode-bias resistor.

the bias resistor, in which the accompanying voltage drop is negative grid biasing voltage. As a consequence, the value of negative biasing voltage is not affected one way or the other by the presence of the bypass capacitor. Grid bias still depends on the resistance of the bias resistor and on the value of average or smooth direct current flowing through this resistor to the cathode of the tube.

The bypass capacitor acts only to keep variations of cathode current which are at signal frequency out of the resistor. Then the bias voltage is not altered at the signal frequency, or, at least, is not altered so much as without the bypass capacitor. Actually the capacitor charges when voltage across it and the resistor tends to increase, and discharges when this voltage tends to decrease. The effect is to smooth out the current in the bias resistor.

Bypassing action depends on signal frequency, because capacitive reactance varies with frequency. This reactance decreases as frequency increases, and vice versa. At high signal frequencies we need much less capacitance for the bypass than at lower frequencies, for causing any given smoothing effect.

Here are two examples. First, assume that the lowest audio frequency to be bypassed with fair effectiveness is 100 cycles per second, and that resistance of the bias resistor is 200 ohms. For reasonably effective bypassing, the reactance of the bypass capacitor should be about 1/10 the resistance of the bias resistor. Then we wish to have capacitive reactance of 20 ohms at 100 cycles. From the alignment chart for capacitive reactances we find that the capacitance must be nearly 80 mf.

Supposing next that the lowest frequency to be effectively bypassed is 40 mc, as might be the case with i-f amplifiers in a television receiver, and that bias resistance still is 200 ohms. The alignment chart shows that a capacitive reactance of 20 ohms at 40 mc is provided by capacitance of only 0.0002 mf (200 mmf). This is about 1/400000 as much capacitance as is needed at 100 cycles for equivalent bypassing.

With bypass capacitance equal to 1/10 of the bias resistance, both in ohms, about 91 per cent of the alternating current will flow in the capacitor and 9 per cent in the resistor. This percentage of alternating current remaining in the bias resistor will react on grid signal voltage 9 per cent as much as though no bypass were used. If this much reaction (degeneration) is too much it becomes necessary to use still greater capacitance and thus provide still less capacitive reactance.

Sometimes the cathode bias resistance is in two sections, with only one section bypassed, as in Fig. 13. There is, of course,

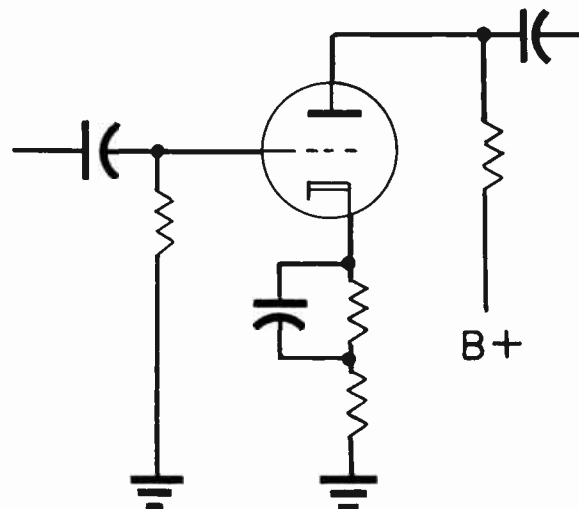

Fig. 13. Only a part of the cathode-bias resistance is bypassed



## LESSON 21 – GRID BIASING

less bypassing effect with a capacitor across only part of the bias resistance than when across all the resistance. In diagrams illustrating biasing circuits, the tubes have been shown as pentodes in some cases and as triodes in other cases. The type of tube does not affect the principles of biasing. The only effect on practical applications is that bias current or cathode current is only plate current for a triode, and is the sum of plate and screen currents for pentodes and beam tubes.

**GRID LEAK BIAS.** A method of grid biasing which is not too important in sound radios, but which is of exceeding importance in television receivers, is called grid leak bias. Bias voltage is provided by combined action of a grid capacitor  $C_g$  and a grid resistor or grid leak  $R_g$  connected as in Fig. 14. These connections appear much like those in several earlier diagrams for fixed bias,

but there are two important differences. Grid resistor  $R_g$  is here connected directly or through ground to the cathode of the biased tube rather than to d-c power supply circuits. Also, this resistor for grid leak bias usually has resistance of a large fraction of a megohm, or even more than a megohm, whereas for fixed bias its resistance usually is on the order of 10,000 to 50,000 ohms.

Now we shall examine the production of bias voltage. Assume, in diagram A, that there is no signal. The tube grid is connected through resistor  $R_g$  to the cathode, and since there is nothing to cause current and voltage drop in  $R_g$ , the grid is at the same potential as the cathode or is at zero bias.

When an alternating signal voltage is applied there will be half-cycles during which signal polarity is such as to act through  $C_g$

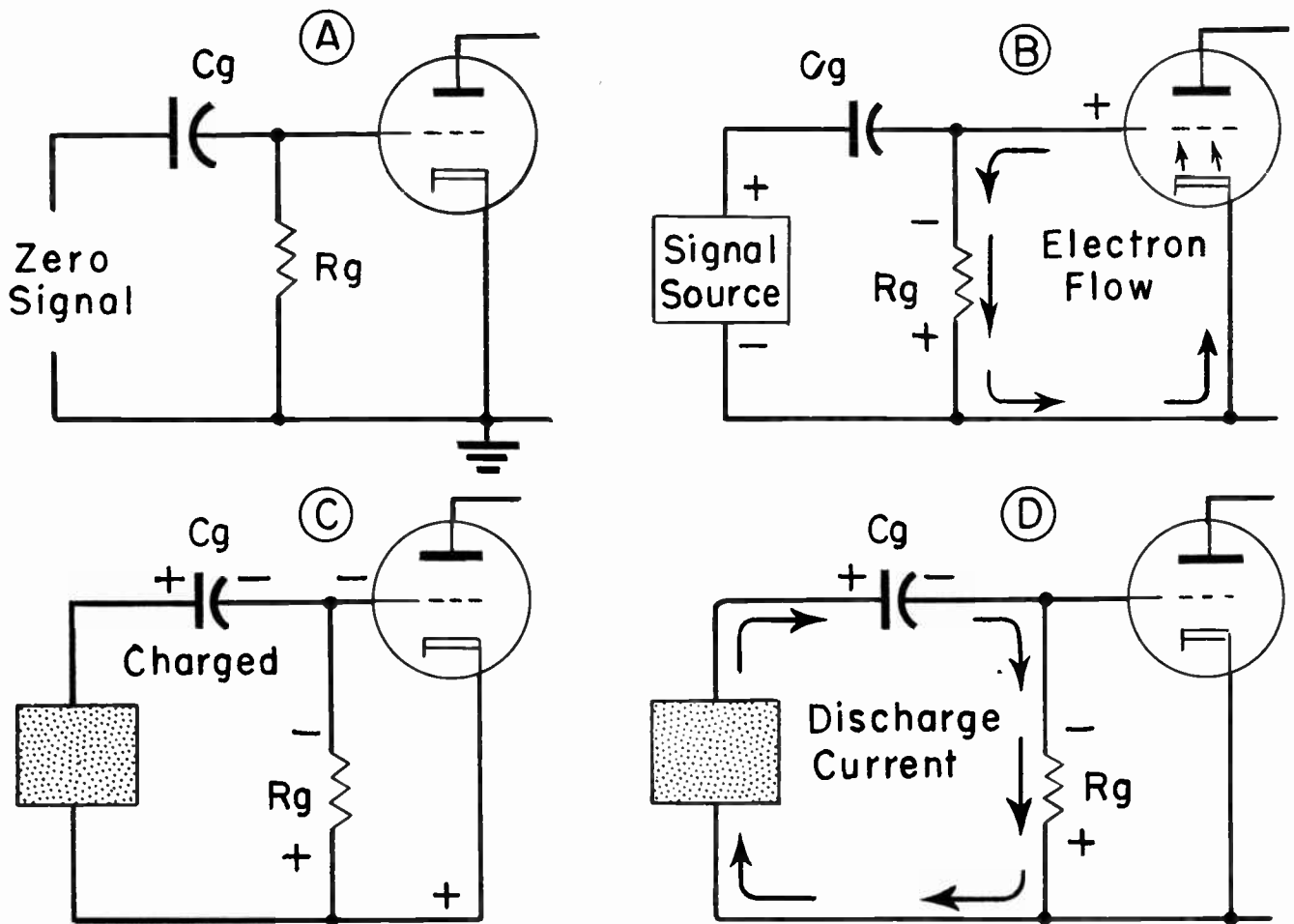

Fig. 14. How grid leak biasing voltage results from positive peaks of signal voltage.

to make the grid positive, and to make the cathode negative. Then we have the conditions represented by diagram B. Electrons flow from cathode to positive grid inside the tube, and follow the external path shown by arrows. This is grid current. The grid current electrons cannot pass through the dielectric of capacitor Cg, but they do flow downward through resistor Rg to the cathode. This direction of flow is such that the upper end of Rg becomes negative with reference to its lower end. Resistance of Rg is so great that even a small grid current means a considerable voltage across this resistor.

As indicated by diagram C, the side of capacitor Cg which is toward the tube grid, and the grid itself, now must be negative with reference to the tube cathode. This comes about because the one side of the capacitor, the tube grid, and the top of Rg are all connected directly together and must be at the same potential - which has to be the negative potential developed at the top of Rg.

Capacitor Cg is charged, in the marked polarity, to the value of voltage developed across Rg. Flow of grid current has been stopped by the change of grid potential from positive (diagram B) to negative (diagram C). Capacitor Cg cannot discharge through the tube, because electrons cannot flow out of and away from the relatively cold grid to the cathode any more than they could flow away from a plate to a cathode. This being the case, the charge electrons commence to flow from the negative side of Cg downward through Rg as shown by diagram D of Fig. 14. Note that the discharge electrons flow through Rg in the same direction as the former grid current. This maintains the upper end of Rg and the grid of the tube at a negative potential with reference to the cathode. The potential difference or voltage across Rg is our negative bias voltage.

Voltage of the charged capacitor actually is only the bias voltage. Resistance of Rg is so great that the bias voltage forces only a small current through Rg. Current means rate of electron flow, and a small current means a small rate of electron flow. So we find that electrons can "leak" away from the charged capacitor only slowly through Rg. Then the charge and a corresponding voltage

on Cg will last for some time, at least with reference to time periods in signal cycles.

Now we may look at this performance in another way, as in Fig. 15, where are shown a few cycles of alternating signal voltage and accompanying changes of grid bias. As soon as a positive alternation of signal voltage makes the tube grid positive, there is grid current and an accompanying voltage across the grid resistor which charges the grid capacitor, at a on the diagram. Almost instantly the grid is made negative, grid current stops, and the capacitor discharges through the grid leak resistor from a to b, which represents an interval of time.

At instant b there occurs another positive peak of signal voltage. There is a brief pulse of grid current and the capacitor is recharged to the voltage represented at c. Again the capacitor discharges through the grid leak resistor until instant d, at which time there is another positive peak of signal voltage, a capacitor recharge to e, and so the action continues as long as the signal lasts.

The negative biasing voltage results primarily from positive peaks of signal voltage and pulses of grid current. The biasing voltage varies between values represented at a, c, and e on the diagram, and lesser values at b, d, and at similar points which would follow. The average value of negative biasing voltage is between the higher and lower values.

Capacitance of the grid capacitor is large enough to have small capacitive reactance at the signal frequency. Although only positive peaks of signal voltage cause grid current and biasing voltage, the entire positive and negative swings of signal voltage act through the grid capacitor on the grid of the tube. So far as grid voltage (not bias voltage) is concerned, the swings of signal voltage make the grid more and less negative than the bias voltage, just as with any other system of negative biasing.

You may have noticed that only the cathode and the grid of the tube take part in development of grid leak bias voltage. The tube may be a triode or a pentode or a beam tube without affecting the bias action. We may

## LESSON 21 – GRID BIASING

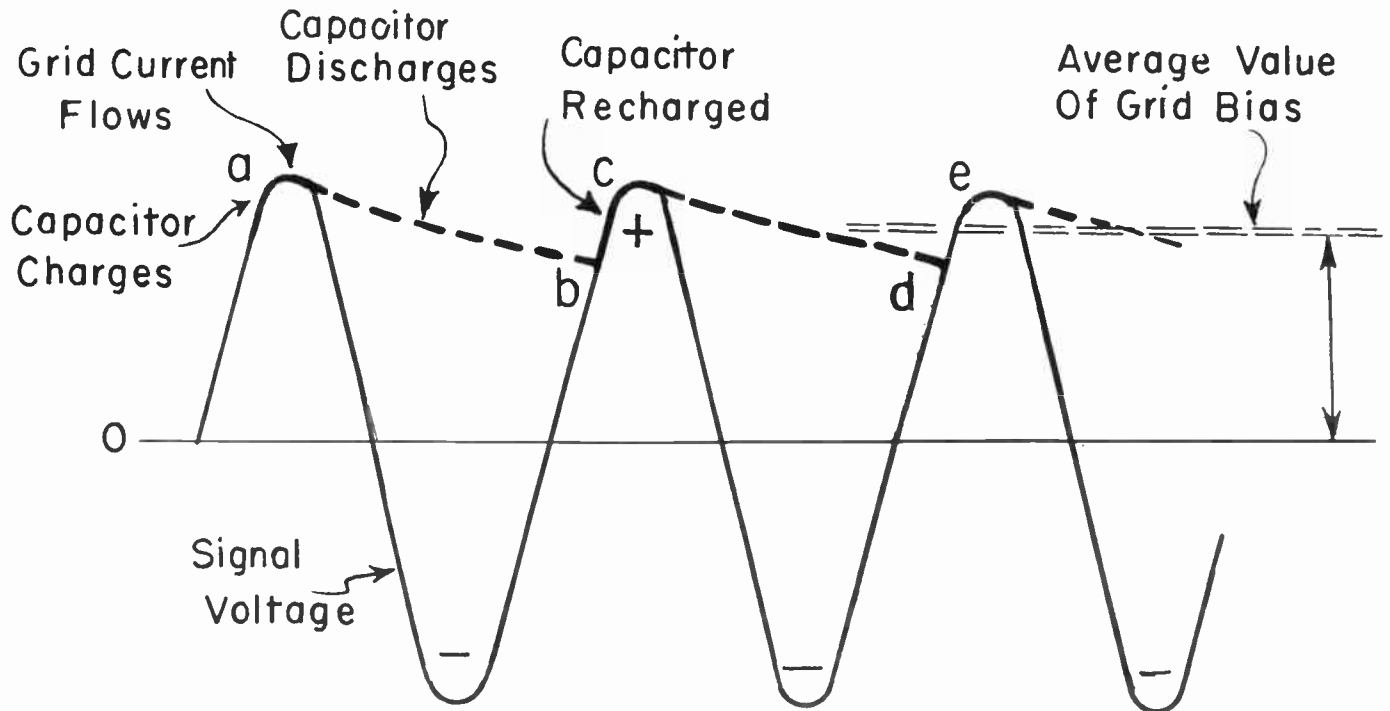

Fig. 15. Signal voltage cycles, charge and discharge of the grid capacitor, and average negative grid bias.

even bias a diode, by letting its plate act like the grid in preceding explanations, and its cathode like the cathode. As a matter of fact we actually shall bias diode tubes in some television circuits.

Grid capacitors and grid leak resistors for biasing may be connected in various ways, some of which are shown by Fig. 16. At A the arrangement is essentially the same as in Fig. 14 except that the circuits are completed through chassis ground. At B the grid capacitor and resistor are in parallel with each other. This connection is quite common where the a-c signal is introduced through a transformer.

At C we have, effectively, the same connections as at B, but the capacitor and resistor are on the low side of the signal transformer, and they are paralleled by connecting one side of each element to ground. The connection at D amounts to the same thing as the one at C. The essential features of all connections are; first, the conductive grid return path to the cathode must include the grid resistor  $R_g$ , and second, the grid capacitor must discharge through the grid resistor.

Negative grid biasing voltage varies with strength or amplitude of the a-c input signal, as is apparent when you look at Fig. 15. The stronger the signal or the greater its amplitude, the more negative is the bias. When the signal strength decreases, the grid capacitor discharges through the leak resistance until capacitor voltage and bias voltage drop to a new average value.

When resistance of the grid resistor is great enough, and capacitance of the grid capacitor is large enough, the negative bias voltage becomes almost as great as the peak value of the a-c signal voltage.

With any given signal amplitude and capacitance, the bias voltage is determined by resistance of the grid leak. The greater this resistance the greater becomes the bias voltage. By reducing the resistance of the grid resistor the bias voltage may be dropped to zero, when there is zero resistance.

If signal voltage is disconnected from the input, or becomes zero for any reason, the bias voltage drops to zero. This is because the grid capacitor discharges through the

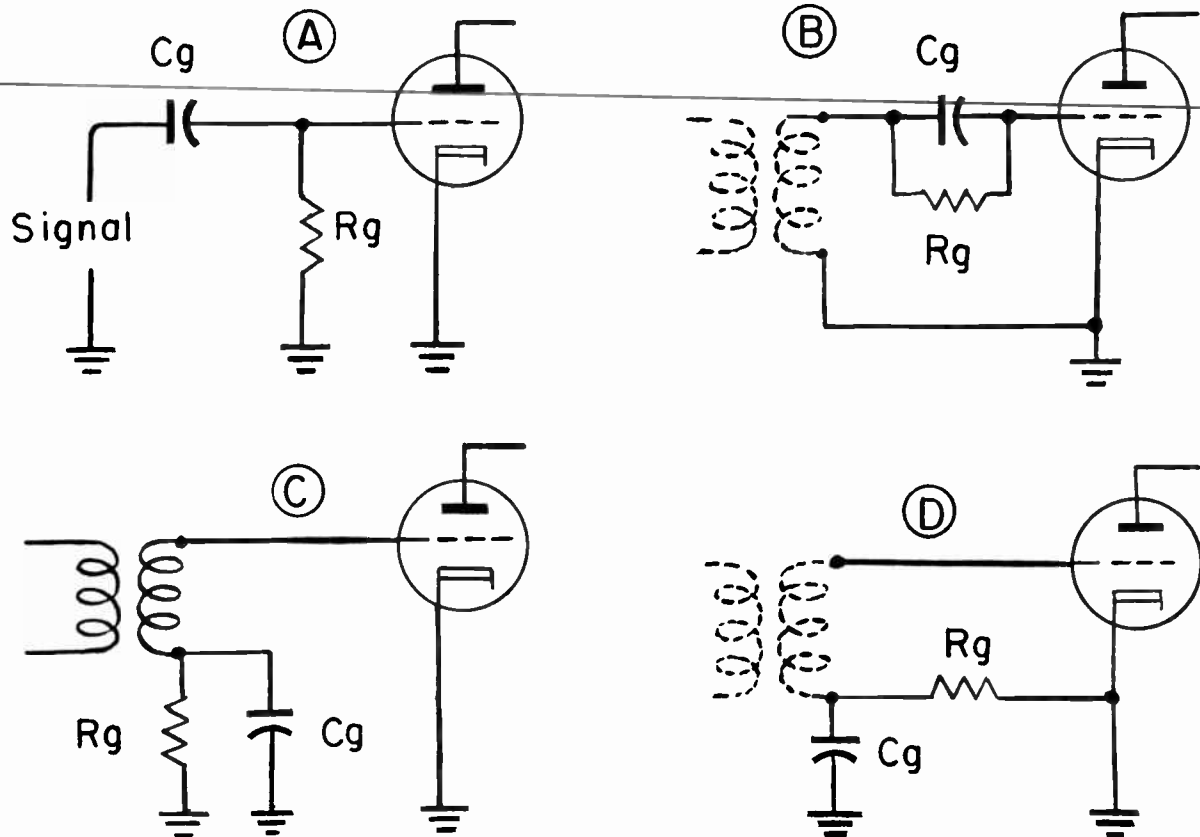

Fig. 16. Various ways in which the grid capacitor and leak resistance may be connected for grid leak bias.

grid leak, and is not recharged. Then plate current in the tube increases to the value for zero bias and the plate voltage on a triode or the screen voltage on a pentode.

**COMBINATION BIASES.** With grid leak bias and no signal voltage, plate current might become great enough to overheat the tube by exceeding the power dissipation rating. In designs where this could happen it is customary to use cathode bias in addition to grid leak bias, as at the left in Fig. 17. Cathode bias voltage becomes more negative with increase of plate current, and would be designed to limit the plate current to a safe value even were the grid leak bias to become zero. The cathode bias would limit the total bias voltage to some minimum safe negative value.

As shown at the right in Fig. 17, cathode bias may be used to insure some minimum negative bias voltage when there is fixed bias or some variable bias voltage. A variable bias is provided by some automatic gain con-

trol systems in television receivers and by some automatic volume control systems in sound radios. The automatic bias voltage becomes more negative when signals are strong, and less negative when signals are weak. The cathode bias insures a minimum negative bias which will prevent excessive plate current no matter what happens to the variable or automatic bias voltage.

**USES OF BIASING SYSTEMS.** Fixed bias is used chiefly for voltage amplifiers. If used for power amplifiers the general rule is that total resistance of the grid return circuit shall not exceed 100,000 ohms. Power amplifiers usually have cathode bias, especially when operated with voltages and loads allowing maximum or near maximum output powers. With such cathode biased power amplifiers the total resistance in the grid return circuit ordinarily should not exceed 500,000 ohms.

When signal input to any amplifier is through a capacitor, excessively high resis-



## LESSON 21 – GRID BIASING

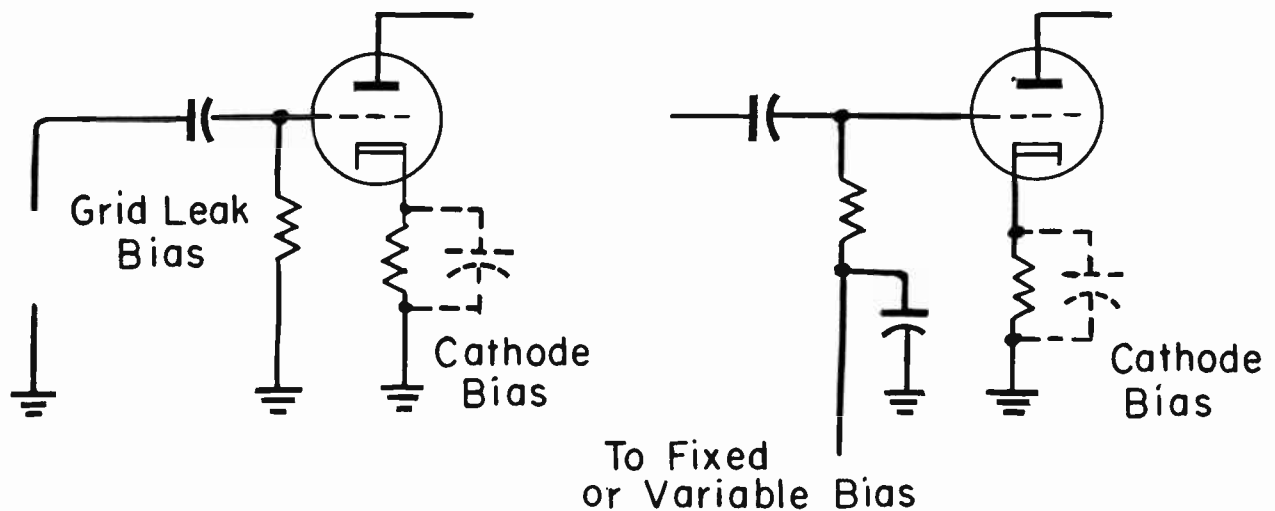

Fig. 17. Cathode bias combined with grid leak bias (left) and with fixed bias (right).

tance in the grid return circuit might act like a grid leak resistor to cause grid current and at least some slight waveform distortion. Such distortion is undesirable in any amplifier where the form of the signal wave is to be preserved, although in many other uses of tubes it does no harm.

Grid leak bias is used chiefly where we are interested in maintaining some frequency while amplifying, inverting, or otherwise modifying the signal, but where some distortion of waveform will cause no trouble. Grid leak bias is used where detector action is wanted, where we are employing plate current cutoff to limit a signal strength, and in certain high power amplifiers where means are provided for cancelling waveform distortion. Grid leak bias is employed also for practically all oscillators. It is these various uses of grid leak bias that make it important in television. All of them will be examined in due time.

### CAPACITOR CHARGE AND DISCHARGE.

A negative bias voltage is maintained with the grid leak method by controlling the rate of capacitor discharge with a suitable resistor. This is but one application of a principle widely employed in television. A few of the many other applications include.

a. Regulating the operating frequency of sweep oscillators.

b. Maintaining correct tone relations between pictures and original scenes.

c. Preventing movements of the electron beam from being affected by interference.

d. Automatic control of voltage gain in r-f and i-f amplifiers.

Before proceeding to any of these applications we must have clear mental pictures of what happens during charging of any and all capacitors. The actions are illustrated by Fig. 18, where diagrams are numbered to correspond with the following paragraphs.

1. While a capacitor is not charged, or is completely discharged, there is no potential difference or voltage between its plates, because both plates contain equal quantities of electrons.

2. There is a potential difference or voltage between terminals or plates of a charged capacitor. Electron quantities are unbalanced. Electrons are trying to flow from the greater quantity the negative charge, to the lesser quantity, the positive charge.

3. While a capacitor is being charged from an external voltage source, electrons flow into one capacitor plate from the negative side of the source, and out of the other

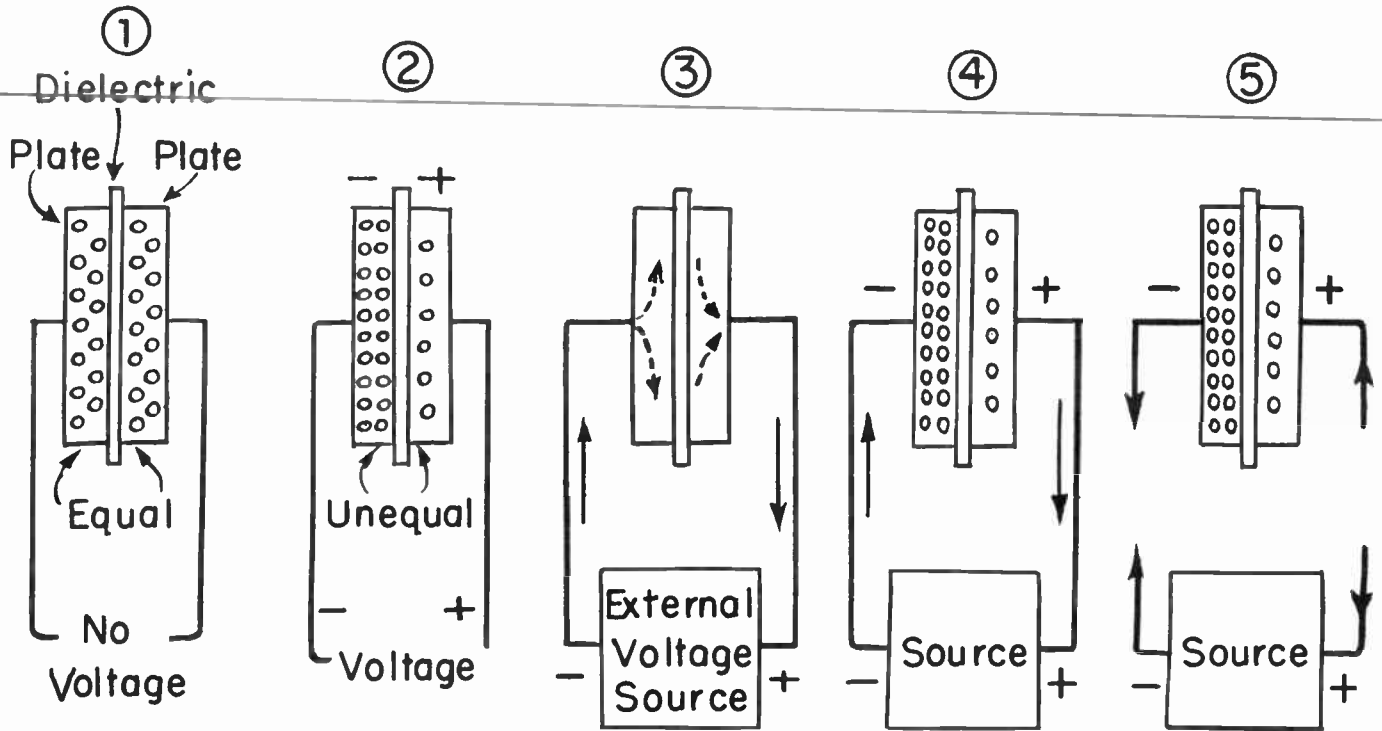

Fig. 18. What happens during charge of a capacitor from an external source of voltage.

capacitor plate back to the positive side of the source. These are the directions of flow with any voltage source.

4. The capacitor plate connected to the negative side of the external source acquires negative electrons, a negative charge. The plate connected to the positive side of the source loses electrons, and acquires a positive charge.

5. If the capacitor, while charged, is disconnected from the external source, the charged capacitor has a voltage of its own as long as its charges are retained. The charged capacitor is the equivalent of a voltage source, until discharged. Considering the charged capacitor as a voltage source, its negative plate is toward the side of the external source from which came the charge, and their positive sides are toward each other. Capacitor voltage opposes external voltage, because the negative plate of the charged capacitor is trying to force its ex-

cess of electrons toward the negative side of the external source, and the negative side of the source is trying to force its own excess of electrons toward the negative side of the capacitor. Force directions are opposed also between the positive plate of the capacitor and the positive side of the source.

Now we shall examine the charging and discharging of a capacitor in series with which is a resistor, once more referring to our familiar capacitor analogy; two water chambers separated by a flexible diaphragm. This time, in Fig. 19, one of the water chambers is connected to a source of water pressure through a pipe of such small diameter as to strongly oppose flow of water through it. This small pipe represents resistance in series with a capacitor.

Comparable actions in the water system and capacitor-resistance combination are explained in following side-by-side paragraphs, which refer to the numbered diagrams of Fig. 19.

## LESSON 21 – GRID BIASING

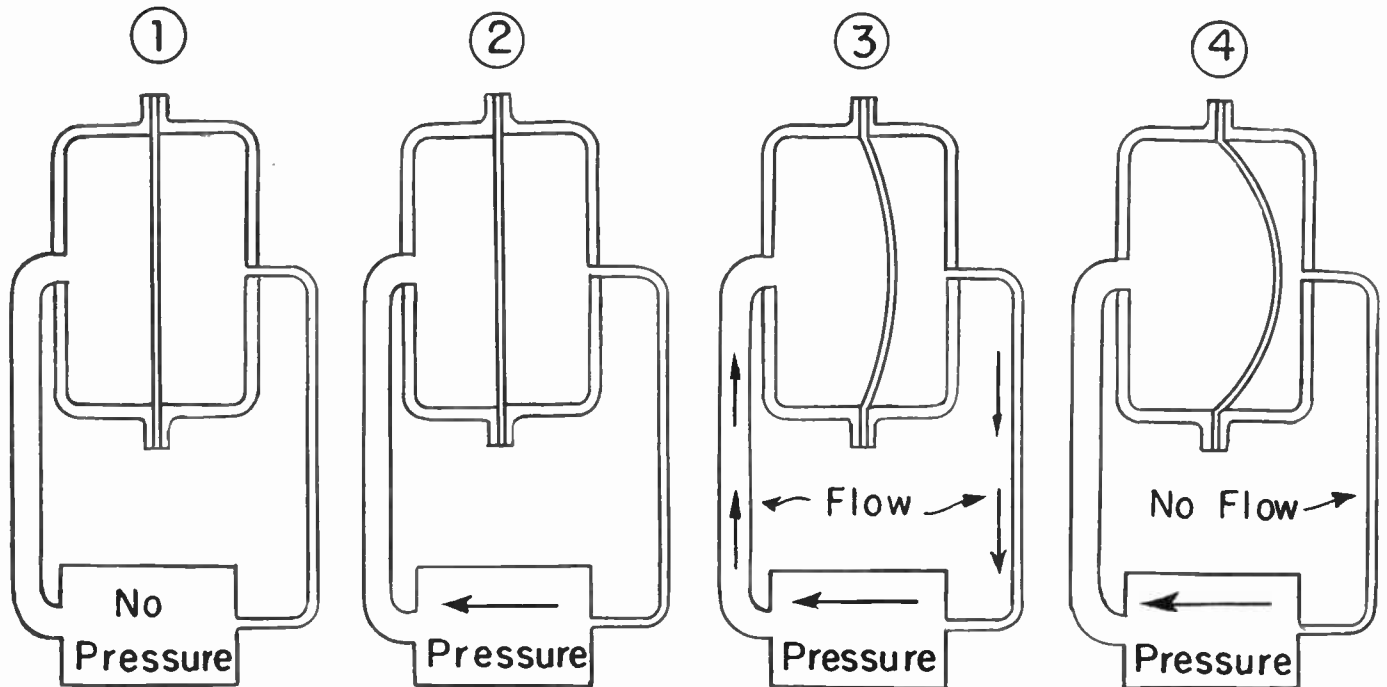

Fig. 19. Water chambers in series with a small pipe illustrate charging of a capacitor which is in series with a resistance.

### WATER SYSTEM

### CAPACITOR-RESISTANCE

#### Diagram 1

Diaphragm is not stretched. Both chambers contain equal quantities of water. There is no pressure from the source.

Capacitor is not charged. Both plates contain equal quantities of electrons. No external voltage is being applied.

#### Diagram 2

Water pressure is applied suddenly. During the first brief instant of time the unstretched diaphragm offers no opposition to water flow. Rate of flow depends only on applied pressure and opposition of the piping.

Voltage is applied suddenly. For the briefest instant the unchanged capacitor has no opposing voltage. Charging current depends only on applied voltage and resistance of the circuit.

#### Diagram 3

Water enters one chamber and leaves the other. The diaphragm is stretched and develops a pressure of its own, which opposes pressure of the source. Water flow is opposed by tension of the diaphragm as well as by opposition of the piping. Pressure acting to cause flow is only the difference between source pressure and diaphragm back pressure. Flow rate decreases.

The capacitor commences to charge. The unbalanced electron quantities produce a potential difference, a capacitor voltage. Current is opposed by capacitor voltage as well as by circuit resistance. Voltage acting to cause electron flow or charging current is only the difference between external applied voltage and capacitor voltage. Charging current decreases because capacitor voltage opposes applied voltage.

# COYNE - *television home training*

Diagram 4

The diaphragm is stretched as far as pressure from source can stretch it. Back pressure or diaphragm tension is equal to source pressure, and counteracts all external pressure. With no pressure difference, water flow stops.

The capacitor is charged as much as applied voltage can charge it. Capacitor voltage equals external applied voltage, and counteracts that voltage completely. No voltage difference remains, and charging current stops.

Next, we shall allow the water chambers to "discharge" through the small pipe, and allow the charged capacitor to discharge through the series resistance. Actions are shown by Fig. 20, where diagram numbering is continued from Fig. 19. The external source of water pressure has been removed,

or pressure reduced to zero, and the water chambers are connected together through the piping. The external voltage source has been disconnected from the capacitor and resistance, or voltage has been reduced to zero, and the two plates of the capacitor are connected together through the resistance.

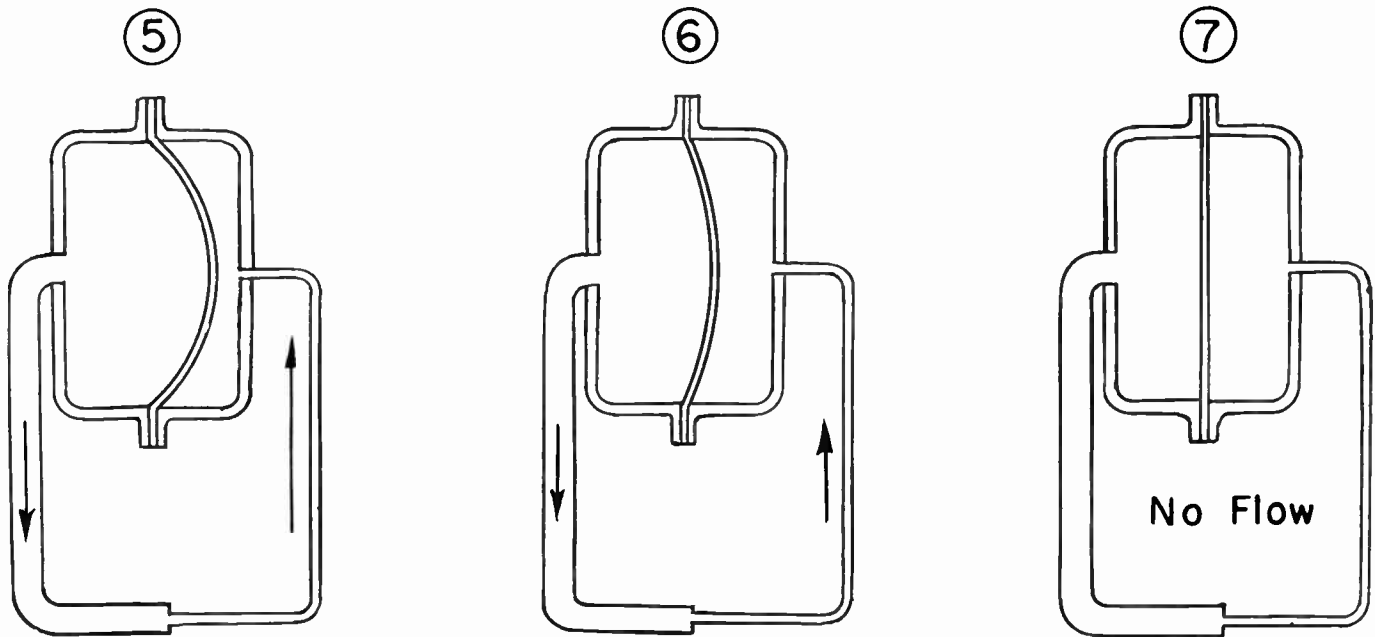

Fig. 20. The water chamber analogy for discharge of a capacitor in series with resistance.

Diagram 5

Diaphragm fully stretched. Initial rate of water flow is high, because maximum tension of diaphragm is acting on opposition of the piping. The diaphragm immediately commences to lose tension. Opposition of the piping is unchanged, so water flow rate decreases.

Capacitor fully charged. Initial discharge current is high, because maximum capacitor voltage is acting on circuit resistance. Capacitor immediately commences to discharge, and its voltage drops. Circuit resistance is unchanged, so discharge current decreases.



# LESSON 21 – GRID BIASING

Diagram 6

Water quantities in chambers becoming equalized. Diaphragm losing tension and exerting less pressure. Water flow rate decreases still more.

Capacitor is partially discharged, and has less voltage of its own. Discharge current decreases still more.

Diagram 7

Water quantities fully equalized in the chambers. Diaphragm is flat, it exerts no pressure on the water. There is no water flow.

Capacitor is fully discharged. It has no voltage of its own because electron quantities and potentials are equal on both plates. There is no current

While examining capacitor charge and discharge the matter of time has not been mentioned. No matter how great might be the opposition of the small water pipe, even though it allowed a mere trickle, the chambers still would be filled and emptied to an extent depending on pressure, were the pressure continued for long enough.

Similarly with the capacitor and resistance. No matter how great the resistance and how small the charge and discharge currents, the capacitor still would be charged to a voltage equal to applied voltage, and later completely discharged, were we to wait long enough.

How long it would take to fully charge the water chambers would depend on how much water they hold. The greater their capacity the longer the charging would take, with any given opposition and rates of water flow. In the case of the capacitor and resistance, time for charging to a voltage equal to applied voltage, and time for complete discharge, would depend on how much electricity the capacitor can hold. In other words, charge and discharge times would depend on capacitance. These times would depend also on circuit resistance, for resistance determines the rates of electron flow or current into and out of the capacitor plates.

Now we come to a fact which, at first, may seem rather strange. Time for charge does not depend on applied voltage, and time for discharge does not depend on capacitor voltage. One might think that the greater these voltages, the more quickly the capacitor

would be charged and discharged, but let's see.

The charges or electron quantities in the plates of any capacitor depend on the voltage to which the capacitor is charged. With any given capacitance, the greater the voltage the greater become the charges. If voltage is increased, the capacitor is forced to take more charge. Even though the increased voltage does increase the current rate, more electrons must be moved into and out of the capacitor plates. Increased current merely makes up for the greater electron quantities or charges.

If a charged capacitor possesses high voltage of its own it means that the capacitor has greater charges. Although the high voltage causes correspondingly high discharge current, there are so many more electrons to be moved that time is unaltered. We must conclude that times for charging and discharging a capacitor depend not on voltages, but only on capacitance and circuit resistance.

TIME CONSTANTS. When reading television service manuals and talking with technicians there will be many references to time constants of circuits containing capacitance and resistance. These usually are references to the time required for charge or discharge of a capacitor in comparison with the time for one or more cycles of voltage or current at the operating frequency.

A time constant is a length of time measured in seconds or fractions of a second. It is not the time for complete charge nor for

# COYNE - television home training

complete discharge of a capacitor. Instead, it is the time required for the capacitor to charge to 63.2 per cent of the maximum possible charge at the existing applied voltage, and it is the time for the capacitor to discharge or lose 63.2 per cent of its initial charge, whatever that charge may be.

One curve of Fig. 21 shows the manner in which capacitor charge and voltage increase from the beginning of charge. Time is shown in numbers of time constants. The other curve shows how charge and voltage decrease after the beginning of discharge. These curves apply to all combinations of capacitance and resistance, because they are based on time constants, and time constants represent the products of any capacitance and any resistance.

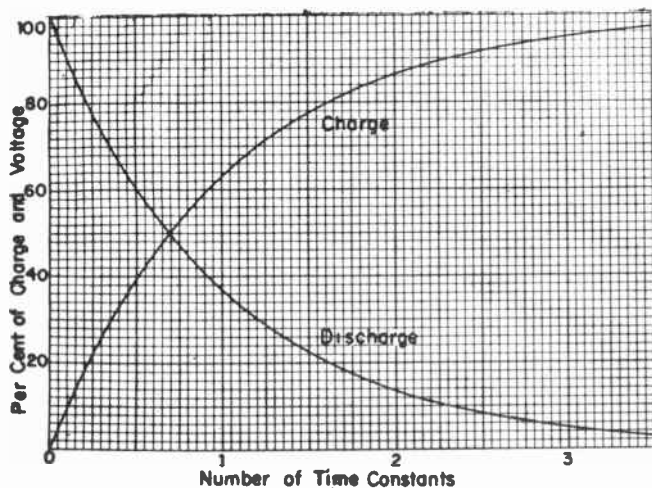

Fig. 21. Changes of capacitor charge and voltage are rapid at the beginning of charge and discharge, but become slower as the actions continue.

When you know capacitance in microfarads and circuit resistance in megohms, time constants are computed thus.

$$\text{Time constant, seconds} = \text{capacitance, microfarads} \times \text{circuit resistance, megohms}$$

A time constant may be the smallest fraction of a second, or it may extend to many seconds or even minutes. Any given time constant may be had with little capacitance and high resistance, or with large capacitance and low resistance. Here are two examples.

1. Small capacitance, 0.0002 mf. High resistance, 500,000 ohms or 0.5 megohm. Time constant =  $0.0002 \times 0.5 = 0.0001$  second.
2. Larger capacitance, 0.01 mf. Less resistance, 10,000 ohms or 0.01 megohm. Time constant =  $0.01 \times 0.01 = 0.0001$  second.

Note that we have considered circuit resistance, not only resistance of a series resistor. There might be several resistors or other circuit elements possessing resistance, all connected in series with the capacitor. Resistance might be anywhere in the series circuit, on either or both sides of the capacitor, or anywhere else - just so that charge and discharge currents have to pass through the resistance. Also, the capacitor or capacitance will charge and discharge through any current leakage path as well as through more easily identified resistances.

In practical problems where we desire some certain time constant, either the capacitance or the resistance often must be chosen to suit some other requirement. Capacitance might be chosen to provide some certain reactance at the operating frequency, or resistance might be chosen to provide some certain voltage gain. Then the other element, resistance or capacitance as the case may be, is selected to provide the desired time constant.

# LESSON 21 — GRID BIASING

## CONDENSED INFORMATION

With fixed bias, also with cathode bias, the total d-c output voltage from the power supply divides between (a) maximum plate or screen voltage and (b) maximum negative grid bias voltage, and must be equal to the sum of these two voltages.

The most negative conductor in any full-wave d-c power supply system is the one connecting directly to the secondary center tap of the power transformer.

Chassis ground is the most negative point only when the secondary center tap is grounded, this being common practice when cathode bias is used. Chassis ground is not the most negative point when fixed bias is taken from the power supply.

### Cathode Bias.

$$\text{Bias resistor, ohms} = \frac{1000 \times \text{required negative grid bias, volts}}{\text{total cathode current, ma}}$$

Cathode bias is degenerative, reduces strength of signal at the grid, to a degree depending on how effective the bypass capacitor may be.

Effectiveness of the bypass capacitor increases with more capacitance (less reactance) and higher signal frequency. Decreases with less capacitance and lower signal frequency.

### Grid Leak Bias.

Bias becomes more negative on strong signals, less negative on weak ones. With

usual designs remains close to peak amplitude (in volts) of the signal.

For any given grid capacitor and signal amplitude, bias voltage is increased by more grid leak resistance, is decreased by less leak resistance.

Capacitance of the grid capacitor usually is great enough to have signal-frequency reactance of only a few hundred ohms at most.

Time constant of grid capacitor-resistor combination must be considerably longer than time of one signal cycle to avoid excessive discharge of the capacitor and fluctuations of bias voltage between signal peaks.

There must be at least some grid current, although usually it is small.

### Capacitor Charge and Discharge.

Time depends only on capacitance and resistance, not on applied voltage or capacitor voltage.

One time constant is the length of time for capacitor to charge to 63.2 per cent of applied voltage, or to discharge 63.2 per cent of initial capacitor voltage and retain 36.8 per cent of this initial voltage. These times for charge and discharge are equal.

$$\text{Time constant, seconds} = \text{total capacitance, microfarads} \times \text{total circuit resistance, megohms}$$

# TELEVISION

◦ RADIO

◦ ELECTRONICS

---

**LESSON 22 – RESISTANCE – COUPLED AMPLIFIERS**

---

***Coyne School***

*practical home training*

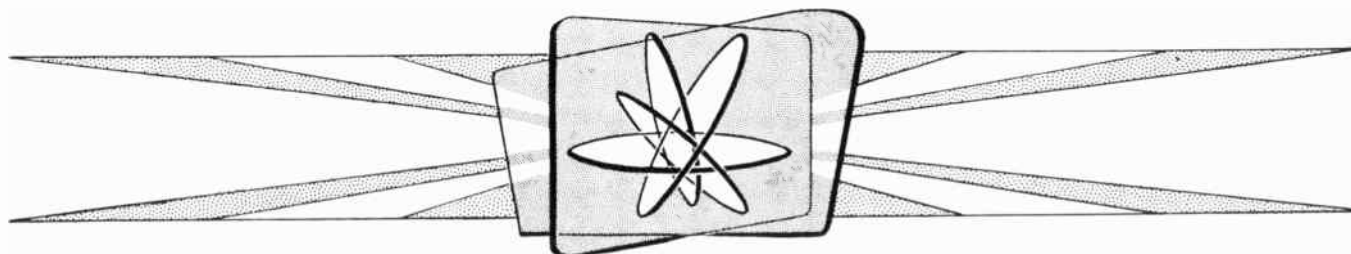

*Chicago, Illinois*



---

*Copyright, 1953 by Coyne Electrical School  
Chicago 12, Illinois  
All rights reserved*

Litho. in U.S.A

## Lesson 22

# RESISTANCE – COUPLED AMPLIFIERS

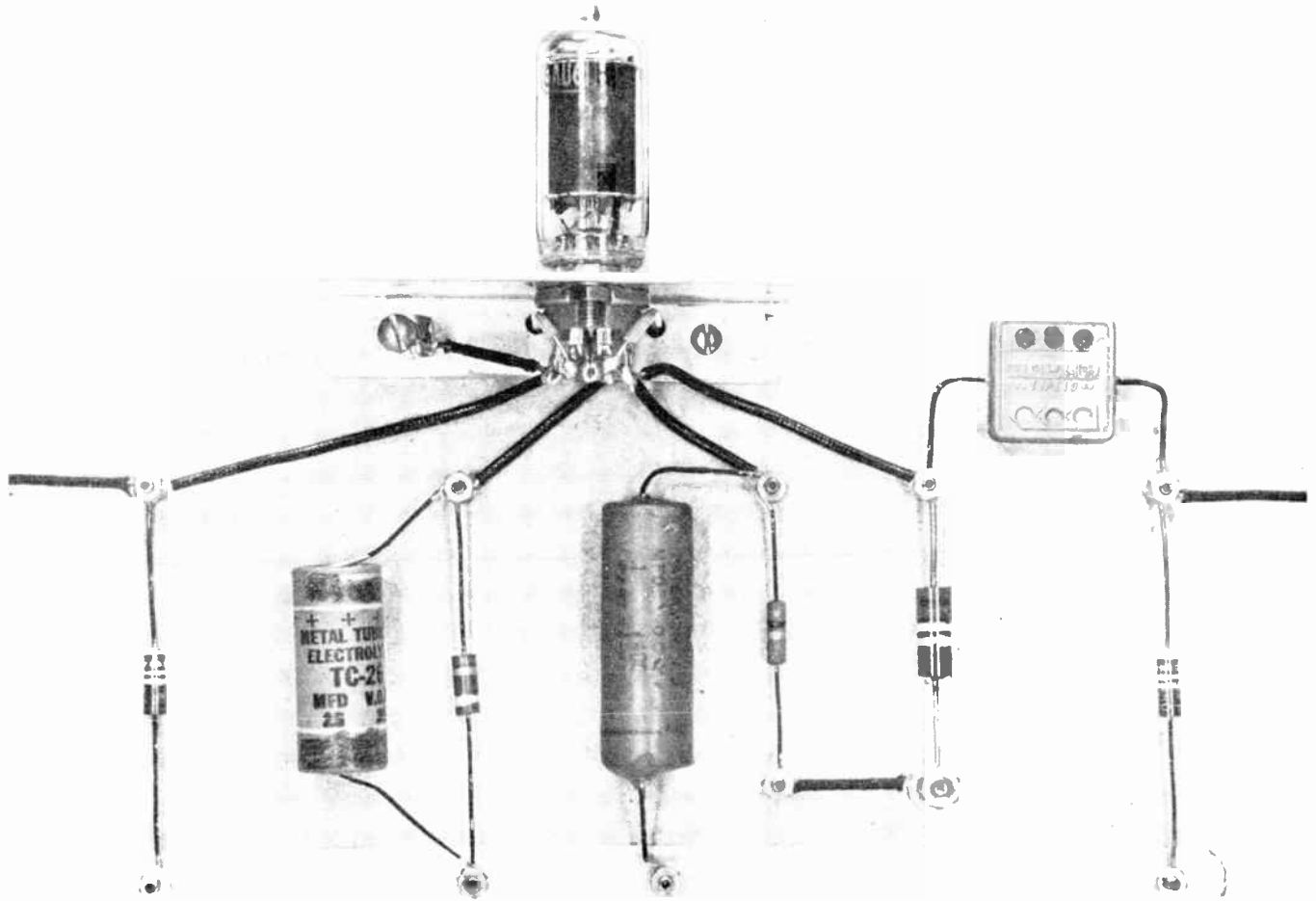

Fig. 1. The parts and connections for one stage of resistance coupled amplification.

When testing the performance of triodes and pentodes as amplifiers we employed a direct voltage to represent signal input and measured the output in accordance with changes of direct voltage in the plate circuit. Input and output voltages in actual practice are alternating signal voltages. We must have capacitors in order to separate these alternating signal voltages from direct voltages in the plate circuit, also for preventing direct voltages in preceding circuits from reaching the amplifier grid while allowing the alternating signal voltages to pass.

Fig. 1 is a picture of all the parts and connections used with a pentode tube in a resistance-coupled amplifier or resistance-capacitance coupled amplifier capable of handling signal voltages. The tube, a 6AU6 voltage amplifying pentode, is on a metal shelf which represents part of the chassis metal or chassis ground. At the bottom is a long strip of metal also representing the chassis. These two pieces of metal are connected together behind the panel, and are connected to B-minus of the d-c power supply.

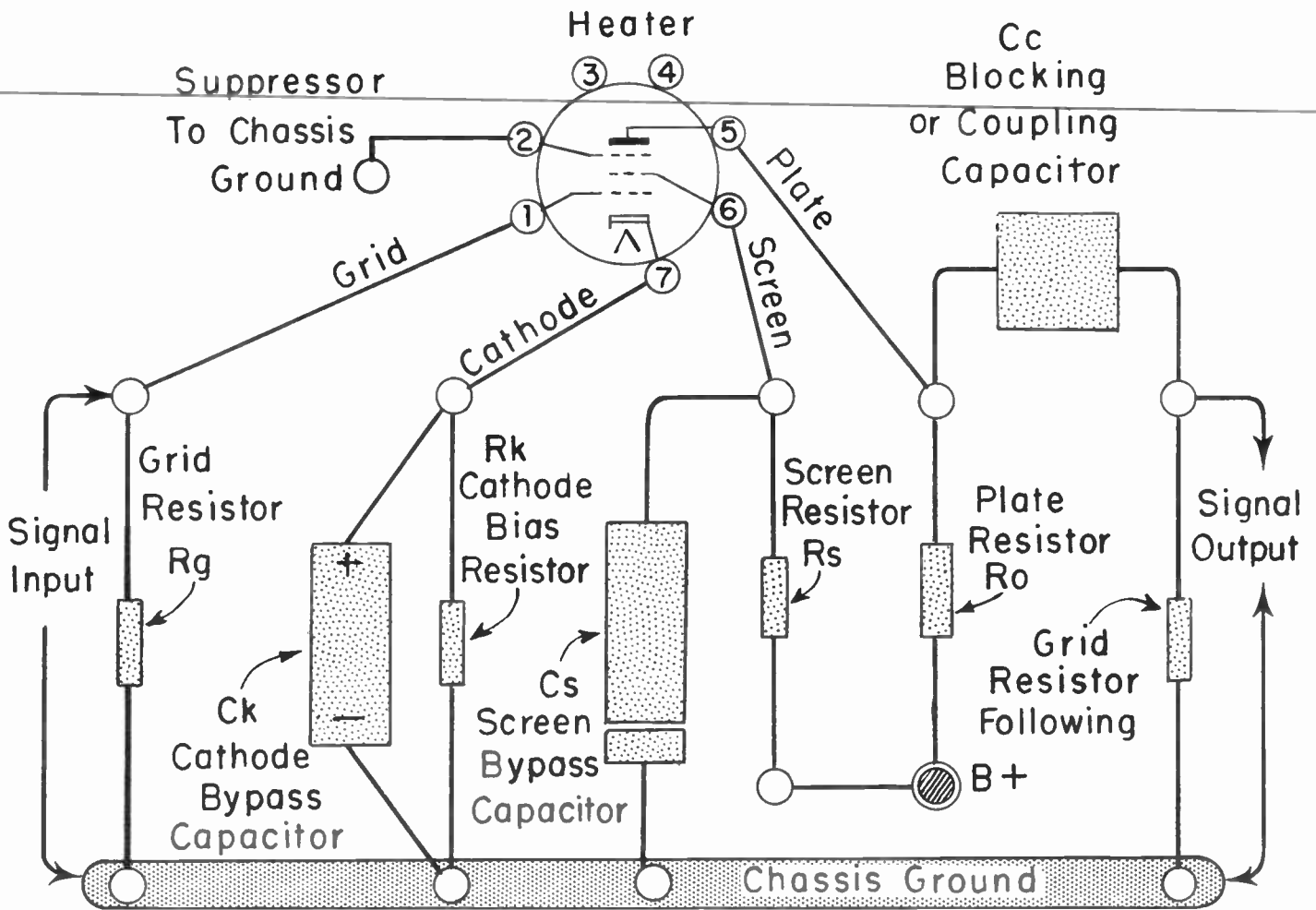

Fig. 2. Connections from the tube elements to capacitors and resistors.

The entire layout, with all parts named, is shown by Fig. 2. Each circuit element is identified on this layout by a letter symbol which we shall use in following discussions. The parts are spread out to allow following the connections and for convenience in making substitutions during tests. In a real receiver everything would be close together near the tube socket, with short connecting leads. A-c signals enter the amplifier system at the left and leave at the right.

We have here what is called one stage of amplification. A single stage includes one tube or one section of a multi-section tube, and extends from the grid input of this tube to the grid input of any following tube. At the extreme left is the grid resistor for the stage with which we are working. At the extreme right is a similar grid resistor for the tube in any following stage. A-c input signal voltage is applied across the left-hand grid re-

sistor, and the amplified output signal voltage appears across the right-hand grid resistor.

Fig. 3 is a schematic diagram or service diagram for the one stage of amplification. Circuit elements here are identified only by the letter symbols used in Fig. 2. We already know the purposes of most of these parts. The only features at all new are the connections for the screen and the connection of both the screen resistor and plate resistor to the same B+ terminal, which goes to the high voltage positive output of the d-c power supply.

Screen resistor Rs is of such value as to drop the power supply voltage to that desired for the screen. Plate load resistor Ro drops the supply voltage to a value desired at the plate of the tube. It is necessary to use screen bypass capacitor Cs to prevent screen voltage from being affected by vari-

## LESSON 22 – RESISTANCE – COUPLED AMPLIFIERS

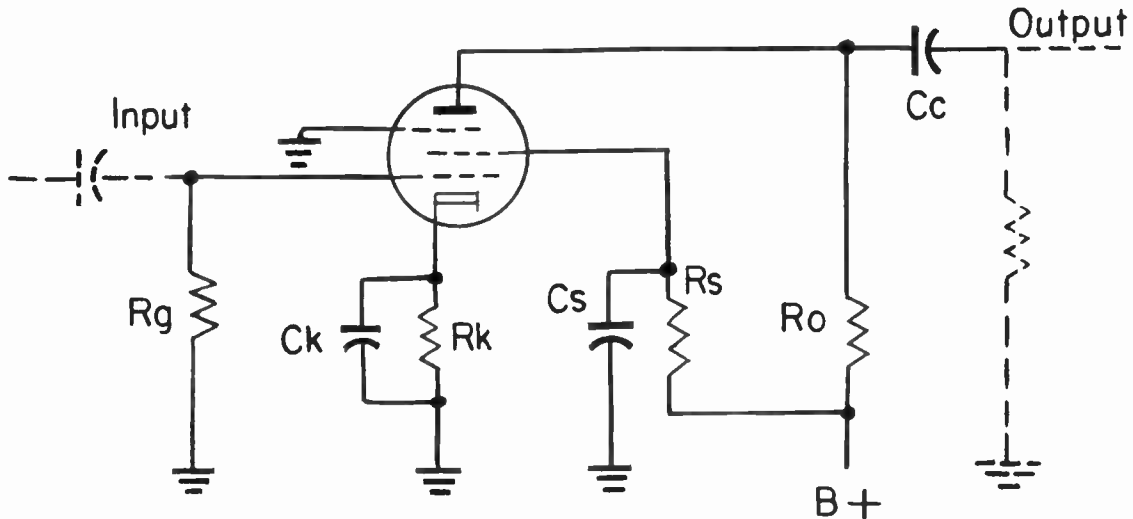

Fig. 3. A schematic circuit diagram for the resistance coupled amplifier.

ations of electron flow in the plate circuit and by any remaining ripple voltage from the power supply. The small reactance of this capacitor is intended to bypass these a-c voltage variations to chassis ground.

We wish to determine the effects on amplification or voltage gain of changes in B-supply voltage and bias voltage, and to determine the effects on gain of altering the values of various resistors and capacitors. No amplifier will provide the same gain at all frequencies. The one with which we are working is designed for operation within the range of frequencies ordinarily reproduced by standard broadcast radios and by the sound sections of most television receivers. This range extends from about 20 cycles to 20,000 cycles per second.

An amplifier having performance suitable for this entire "audio" range of frequencies would be suitable also for the synchronizing sections of television receivers, which handle the 60-cycle vertical deflection frequency and the 15,750-cycle horizontal deflection frequency

The voltage gain of the amplifier pictured by Fig. 1 is shown by the curve of Fig. 4. Such a curve usually is called a frequency response since it shows gains at all frequencies within some certain range. The left-hand vertical scale is for gain, or number of times that the input signal voltage is multiplied at the output.

Frequencies in cycles per second are shown along the bottom horizontal scale. This scale is "logarithmic", as it must be in order to give useful information. Equal distances along a logarithmic scale correspond to equal multiplications of frequency. For instance, the multiplication is 10 times from 20 cycles to 200 cycles, from 200 to 2,000 cycles, and from 2,000 to 20,000 cycles. Each of these pairs of frequencies is separated by equal distances along the frequency scale. It is this way in which your ears hear increases of pitch in sounds. If your ears tell you that there is a certain increase of pitch or shrillness from 400 to 800 cycles, a doubling of frequency, the frequency will again have to be doubled, from 800 to 1,600 cycles, in order that once more it may seem to cause an equal rise in pitch.

Voltage gain shown by the curve is low at 20 cycles, then increases quite uniformly to about 200 cycles. Then, from 200 to about 3,000 cycles we have the astonishingly great gain of better than 160 times, with a single amplifier tube. At 5,000 cycles the response is commencing to drop, and at still higher frequencies there is a rapid falling-off. The general shape of this curve is characteristic of all frequency responses. A considerable portion of your service work with television i-f amplifiers and video amplifiers will have to do with obtaining correct responses.

For reproduction of sound it usually is considered that the useful response of an



## COYNE - *television home training*

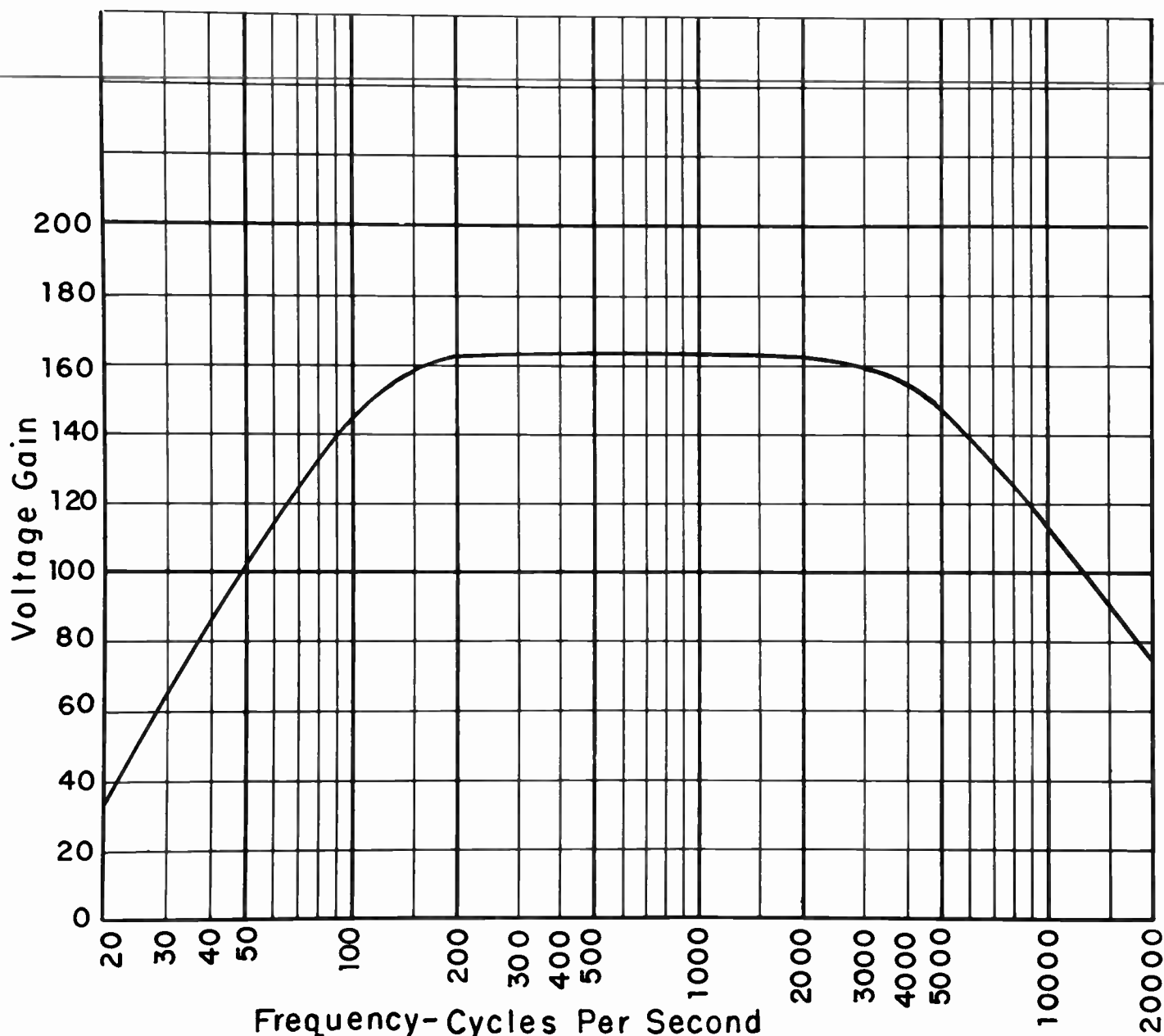

Fig. 4. Frequency response of the resistance coupled amplifier as originally constructed and operated.

amplifier extends between the low and high frequencies where response is 70 to 80 per cent of maximum. Fig. 4, shows maximum gain of about 164 times, of which 80 per cent would be about 131 times. Response or gain rises to 131 times at a low frequency around 80 cycles, and drops back to this figure at a high frequency around 8,000 cycles.

This would be good high-frequency response for a standard broadcast sound radio,

since in the transmissions of most channels there are no audio frequencies exceeding 5,000 cycles. It would be fair, but not too good, at the lower frequencies where you hope to hear the big bass viol and the low notes of the organ. The response would be fair for a 60-cycle vertical deflection frequency, but rather poor at 15,750 cycles for horizontal deflection. The response of a television video amplifier should be quite uniform all the way from 60 cycles to

## LESSON 22 – RESISTANCE – COUPLED AMPLIFIERS

4,000,000 cycles per second. Much will have to be done with our resistance coupled amplifier before it becomes a video amplifier.

Now we shall proceed to check the effects of each circuit element on voltage gain and on uniformity of gain throughout the range of frequencies.

**PLATE LOAD RESISTOR.** With the original setup of the amplifier the plate load resistor  $R_o$  was of 220,000 ohms. D-c power supply voltage was 180, and will be held there while making other changes. Voltage at the plate of the tube was 62. This means that drop across the plate load resistor was 118 volts which, across 220,000 ohms, indicated a current (plate current) of about 0.97 ma. Plate currents always are small in resistance coupled amplifier designed for operation at low frequencies. This is because we use high resistances as the plate load in order to have large changes of signal voltage and high gains.

In general, the greater the plate load resistance the greater is the maximum voltage gain. We are limited in the amount of load resistance because it increases and voltage drop between power supply and tube plate. There must be enough voltage remaining at the plate to cause plate current great enough for some reasonable value of transconductance, and to have such plate voltage with very great load resistances would call for very high d-c voltage from the power supply.

Fig. 5 shows what happens to voltage gain when the plate load resistor is changed. The broken-line curve is our original response obtained with resistance of 220K for plate load. The upper full-time curve shows the response with 470K plate load, and the lower full-line curve shows the response with 100K for the plate load.

The greater the plate load resistance the greater is the gain at all frequencies, although this advantage becomes very slight up around 20,000 cycles. Now let's check the uniformity of frequency response, considering that the useful frequency range extends between points at which the gain drops to 80 per cent of maximum.

Plate Load Resistance	Voltage Gain		Frequencies For 80% Gain	
	Maximum	80 per cent	Low	High
100K	116	93	90	9500
220K	164	131	80	7500
470K	224	179	66	5800

Increasing the plate load resistance has these effects.

Gain: Increased.

Response, low-frequency: Is improved, extended lower.

Response, high-frequency: Is made poorer, cuts off at lower frequencies.

Decreasing the plate load resistance has, of course, the opposite effects.

**SCREEN CIRCUIT.** Screen voltage is made equal to or lower than the average plate voltage or d-c plate voltage unaffected by signals. If screen voltage is too high, it is reduced by using a screen resistor  $R_s$  having more resistance. If screen voltage should be much less than half the value of plate voltage a smaller screen resistance may be used to raise the screen voltage. It must be kept in mind that plate current and transconductance depend largely on screen voltage in a pentode, and if screen voltage is too low there will be a considerable loss of voltage gain.

Screen resistors for resistance coupled voltage amplifiers usually are somewhere between 220K and 2.2 megohms resistance. As a general rule the lower values of screen resistors are found with pentodes having relatively low plate resistances as listed in tables of characteristics. The higher values of screen resistor are found with tubes having higher plate resistances.

When you increase the screen resistance at  $R_s$ , to lower the screen voltage, the plate voltage will go up without making any change in plate load resistor. If you decrease the screen resistance to raise the screen voltage, plate voltage will drop at the same time. In our original setup, with 220K plate load resistance, the screen resistor was of 1.0 megohm. The screen resistor was not changed when going to 100K plate load resistance. But when increasing the plate load resistance to 470K the plate voltage became

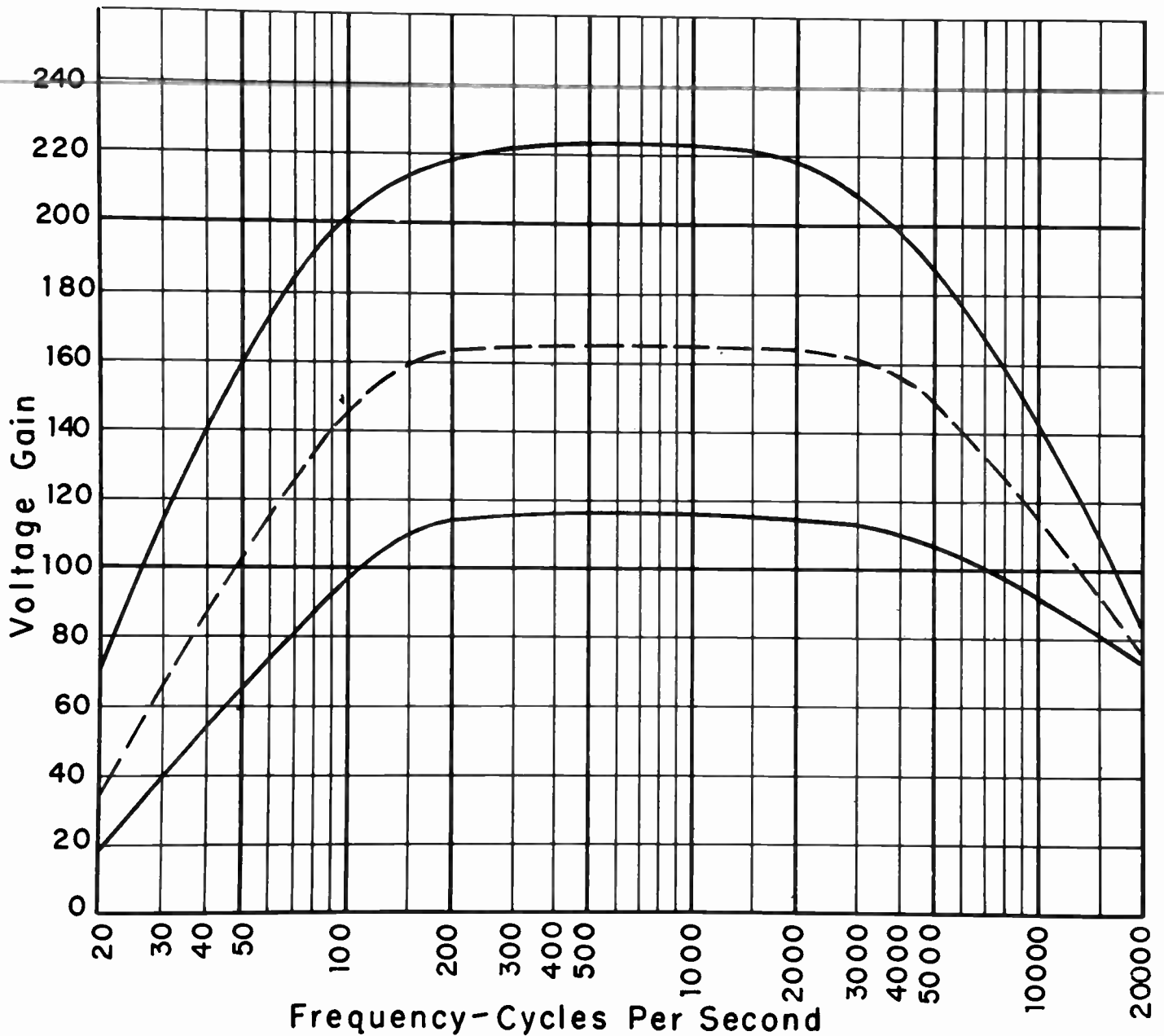

Fig. 5. The effects on gain and frequency response of changing the plate load resistance from a high value (upper curve) to a lower value (lower curve).

less than screen voltage. In order to restore the usual relation between these two voltages the screen resistor was increased to 1.5 megohms, which dropped the screen voltage and at the same time raised the plate voltage.

The screen bypass capacitor  $C_s$  is essential for obtaining low-frequency gain and also for extending the response down into the lower frequencies. Values between 0.05 mf and 0.5 mf are commonly employed in

this position. In our original setup the screen bypass was a paper capacitor of 0.1 mf capacitance.

Fig. 6 illustrates the effects of using various capacitances for the screen bypass. The broken-line curve is the original response, as obtained with a bypass of 0.1 mf and as shown in Fig. 4. The lower broken-line curve shows the response when using a screen bypass of 0.01 mf. The frequency at which the gain drops to about 80 per cent

## LESSON 22 – RESISTANCE – COUPLED AMPLIFIERS

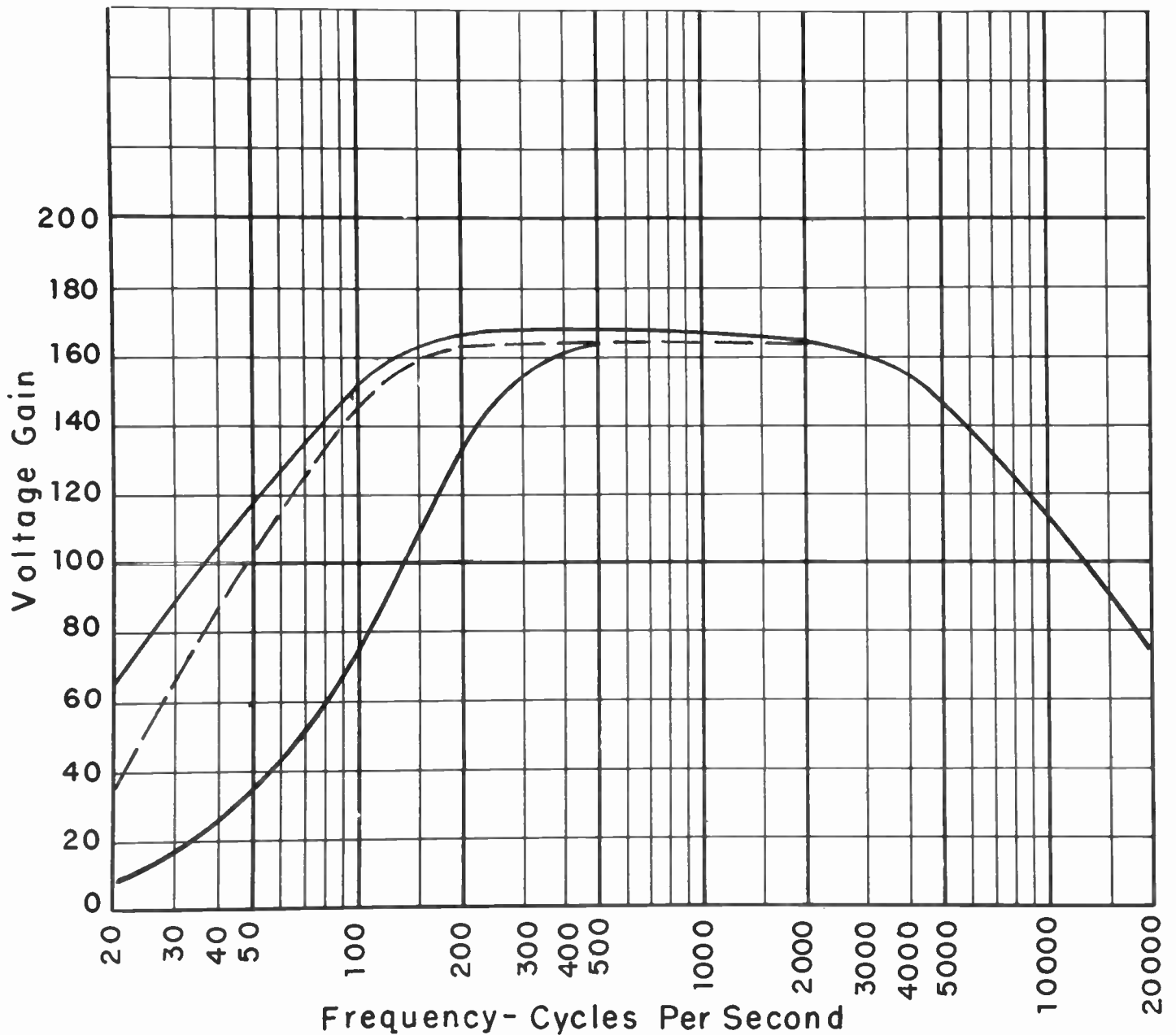

Fig. 6. Effects on gain and response of changing the screen bypass capacitor.

of maximum now is around 200 cycles, and at still lower frequencies the response suffers severely. Where the screen bypass is to be removed completely, maximum gain would be 15 to 20 times and a response curve would run close to the bottom of the graph all the way across.

The upper full-line curve of Fig. 6 is the response when using a screen bypass of 10 mf instead of the original 0.1 mf. Gain is increased at the very low frequencies, but

about 100 cycles the increase is not enough to be of any real advantage. At the higher frequencies, above 1,000 cycles, there is no appreciable change in gain. Results are practically the same with bypasses of 0.01 of 0.1, and of 10 mf.

**GRID BIASING.** The great majority of resistance coupled amplifiers are operated with cathode bias, which may be called self-bias. Fixed bias is seldom employed. Grid leak bias is used with a few battery type



## COYNE - *television home training*

tubes which are so designed that plate current will not become excessive even when bias decreases to zero, also with some seldom used heater-cathode tubes designed to work safely with zero bias. You will recall that grid leak bias becomes zero when there is no signal. For this reason, the system which we call grid leak bias sometimes is designated as zero bias.

The voltage gain at low frequencies and also the uniformity of gain are affected in large measure by capacitance of the cathode bypass capacitor, C<sub>k</sub> in the diagrams. In our original amplifier layout this bypass was an electrolytic type of 25 mf capacitance. The greater the capacitance at this position the less becomes the bypass reactance, the more of the signal current variations are carried around the bias resistor, and the less becomes the degeneration or weakening of signal voltage at the grid of the tube. The reactance of any capacitor decreases as frequency rises. Consequently, at the higher frequencies the reactance of almost any capacitance likely to be used becomes so small that there is almost complete bypassing and almost no degeneration.

The effects of altering the cathode bypass capacitance are illustrated by the curves of Fig. 7. Once again our original frequency response is shown by the broken-line curve, this being the response with a cathode bypass of 25 mf. Just above the low-frequency left-hand end of this original response is a full-line curve, A, going to about 100 cycles. This shows the increase of gain when bypass capacitance is increased from 25 mf to 400 mf. At frequencies about 100 cycles there is no appreciable extra gain. The reactance of 25 mf at 100 cycles is about 64 ohms, and of 400 mf it is about 4 ohms. Either of these reactances is so small in comparison with the approximate 1,800 ohm of bias resistance as to allow almost complete bypassing of signal frequencies.

Curve B shows the effect on gain of decreasing the cathode bypass to 1 mf. The reactance of this much capacitance at 100 cycles is about 1,600 ohms, almost as great in ohms as the cathode bias resistor. Only about half the full strength of signal cur-

rent variations are bypassed at 100 cycles, and resulting degeneration drops the gain materially. With this small bypass capacitance the response becomes quite peaked, with the points for 80 per cent of maximum gain at approximately 300 cycles at the low end and around 7,000 to 8,000 cycles for the high end.

Curve C shows what happens when there is no cathode bypass capacitor, and when, as a result, there is maximum degeneration. Maximum gain is only about 43 times. The points of 80 per cent gain fall at about 80 cycles and 7,500 cycles.

It is evident that good response at low frequencies requires adequate cathode bypassing, with the number of ohms of bypassing reactance no more than 10 per cent of the ohms of cathode bias resistance. Abnormally large bypassing capacitance is not warranted by the slight increase of low-frequency gain, as may be seen from curve A showing the effects of 400 mf bypass capacitance. If, however, the d-c power supply is poorly filtered and puts out a rather high ripple voltage, it may be necessary to use cathode bypass capacitance much greater than needed to insure good frequency response - in order to bypass the ripple voltage which is in the plate circuit.

### SIGNAL CIRCUIT OF THE AMPLIFIER.

The capacitor between the plate and plate load resistor of the amplifier tube and the grid and grid resistor of a following tube may be called the coupling capacitor because it "couples" the signal output of one tube to the signal input of a following tube. This capacitor may be called the blocking capacitor because it prevents or blocks the high positive voltage at the plate of the amplifier tube from acting on the grid of the following tube and destroying its negative grid bias.

The effect of the coupling capacitor on amplifier performance is most easily understood by considering the entire output circuit, which includes not only this coupling capacitor but also the plate load resistor and the grid resistor for the following tube.

An amplifier stage usually is shown on service diagrams as at the left in Fig. 8.

## LESSON 22 – RESISTANCE – COUPLED AMPLIFIERS

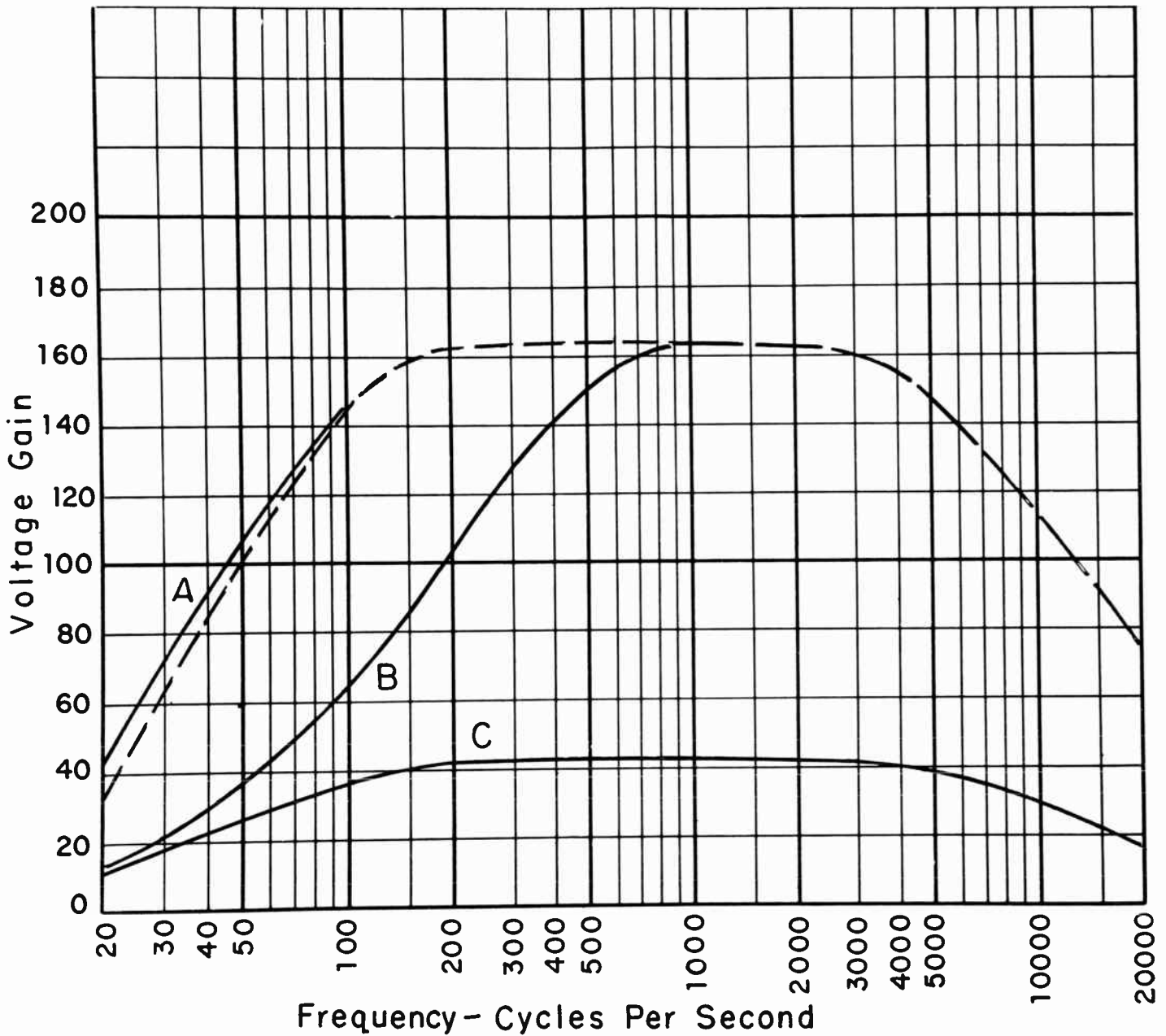

Fig. 7. Changing the cathode bypass capacitance has the effects shown here.

Here we have the circuit for direct current in the plate and cathode as well as the circuit for alternating signal voltage. At present we are interested only in the signal voltage. The d-c circuit serves only to carry direct current for the plate.

If the cathode bias capacitor  $C_k$  is of very small reactance at signal frequencies, as it should be, nearly all of the signal voltage flows in this capacitor between the cathode and ground, and we may neglect the biasing resistor. The reactance of the bypass capacitor is so very small in comparison

with the plate load resistance at  $R_o$  that the reactance has practically no effect on strength of signal voltage. Consequently, we may neglect the bypass capacitor and consider that the cathode is connected directly to ground so far as signal voltages are concerned. Then in the signal circuit diagram at the right, the cathode may be shown connected directly to ground at a.

Returning to the left-hand diagram, we may trace the plate load circuit all the way to the output of the d-c power supply, where we find the filter capacitor  $C_f$ . The reactance

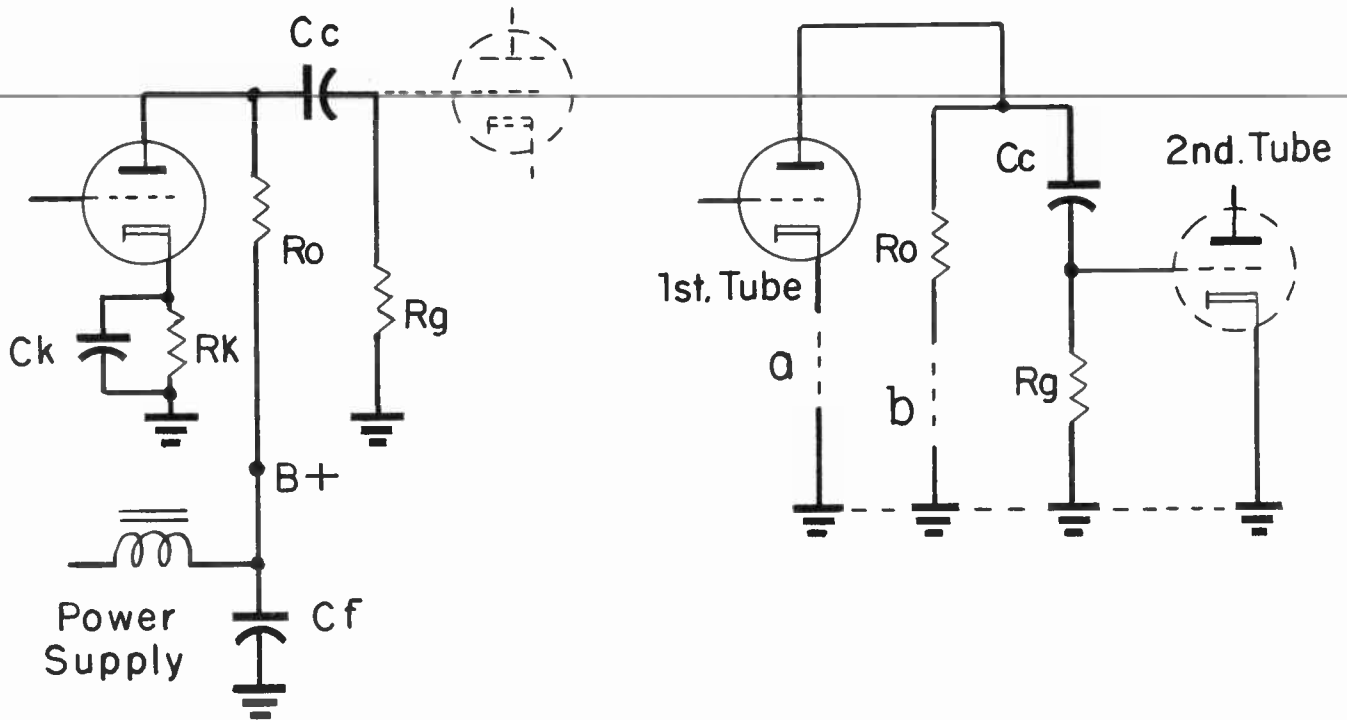

Fig. 8. The actual output circuit of an amplifier (left) and the "equivalent" circuit for signal frequencies (right).

of this capacitor is so exceedingly small that, so far as signal voltages are concerned, the lower end of load resistor  $R_o$  may be considered as connected directly to ground through the capacitor. The equivalent direct ground connection is at b in the signal circuit diagram at the right.

In the signal circuit diagram it is plainly evident that the plate circuit of the first tube is a parallel circuit between the plate and ground. On one side of this parallel connection is output load resistor  $R_o$ . On the other side we have the reactance of capacitor  $C_c$  and the resistance of  $R_g$  in series with each other. The take off point for signal voltage to the grid of the second tube is between  $C_c$  and  $R_g$ .

The full strength of output signal voltage appears across resistor  $R_o$ , between the tube plate and ground. The full strength of signal voltage is also across the reactance of  $C_c$  and the resistance of  $R_g$ , in series with each other. This signal voltage divides between the reactance of  $C_c$  and the resistance  $R_g$ . Only the portion of the signal voltage which is across  $R_g$  is applied to the second tube, because  $R_g$  is connected between grid

and cathode of the second tube. Now let's list some facts relating to the signal circuit.

1. Output signal voltage is increased by using greater resistance at  $R_o$ , as we learned from examining Fig. 5. This is true because greater resistance at  $R_o$  increases total a-c opposition in the amplifier plate circuit, and it is the total of a-c opposition in the plate circuit which affects the voltage gain.

2. Output signal voltage may be increased by using greater a-c opposition at  $C_c$  and at  $R_g$ , for these two elements form the second branch of the parallel circuit, and any increase of opposition in either branch raises the opposition of the entire parallel circuit.

3. We may increase the a-c opposition in the second branch of the parallel circuit by using less capacitance and more reactance at  $C_c$ , by using more resistance at  $R_g$ , or by doing both of these things.

4. If we increase the reactance at  $C_c$ , by using less capacitance, more of the total signal voltage will appear across  $C_c$  and less will remain for  $R_g$  -- and it is signal voltage

## LESSON 22 — RESISTANCE — COUPLED AMPLIFIERS

across  $R_g$  which is the input for the second tube. So it comes about that we want small reactance and large capacitance at  $C_c$ , since signal voltage across  $C_c$  never gets to the tube, and is wasted in  $C_c$ .

5. Increasing the resistance at  $R_g$  causes more of the total signal voltage to appear across this resistor, and less across capacitor  $C_c$ . Increasing the resistance at  $R_g$  thus puts more of the total signal voltage into the grid of the second tube. It is desirable to use the greatest permissible resistance at  $R_g$ .

6. If we use a very large capacitance at  $C_c$  and at the same time use very great resistance at  $R_g$ , the result may be to put a negative grid leak bias on the second tube, in addition to the negative bias which is otherwise and intentionally applied to this second tube. It comes down to a matter of time constants. If the time constant of  $C_c$  and  $R_g$  is long in relation to the time of one cycle of the lowest frequency to be satisfactorily amplified, then there will be small pulses of grid current in the second tube and capacitor  $C_c$  will hold its charge and provide negative grid bias on the second tube. All of this is in accordance with what we learned about grid leak bias. The additional negative bias on the second tube will reduce its amplification and all or most of the advantage of large capacitance at  $C_c$  and of high resistance at  $R_g$  will be lost.

COUPLING OR BLOCKING CAPACITOR. In our original setup of the resistance coupled amplifier the coupling or blocking capacitor at  $C_c$  was a mica unit of 0.005 mf or 5,000 mmf capacitance. The response with this capacitor is shown by the broken-line curve of Fig. 9, which is the same response shown by Fig. 4. When capacitance at  $C_c$  is increased to 0.1 mf (100,000 mmf) the frequency response or voltage gain curve changes ~~at~~ that at A in Fig. 9. There is no change at frequencies above 500 cycles, but at the very low frequencies there is a decided increase of gain. The point at which gain drops to 80 per cent of maximum is down around 28 cycles, whereas the best that we have been able to do with other alterations brought this point around 60 to 70 cycles.

Curve B of Fig. 9 shows what happens to gain and frequency response when the coupling capacitor  $C_c$  is changed to 0.00025 mf (250 mmf). There is hardly any gain at all at frequencies below 50 cycles. Then the gain rises quite gradually to a peak around 3,000 to 4,000 cycles, and drops rapidly through higher frequencies.

It is worth noting that coupling capacitance somewhat smaller than ordinary values may be used where there is excessive ripple voltage from the d-c power supply, usually at 120 cycles for full-wave rectification in the supply. In Fig. 9 we have practically full gain at 120 cycles on the broken-line curve. Decreasing the coupling capacitance to something like 0.003 mf would cause a decided drop in amplification of any 120-cycle ripple voltage, but also would make an equal drop in signal voltages at this frequency.

GRID RESISTOR. In the resistance coupled amplifier as originally constructed, and shown by Fig. 1, the effective grid resistance for the following tube was about 420K. This resistance is specified as "effective" because output signal voltage is being measured with a voltmeter connected across or in parallel with this resistor. Actual opposition to signal voltage then is the paralleled opposition of resistor and meter. In actual practice the grid resistor would be in parallel only with the grid-cathode input of the following tube. With zero grid bias on this tube its input opposition to the a-c signal voltage would be very great, and effective resistance at  $R_g$  would be the resistance of the resistor used in this position.

The original frequency response, with 420K effective resistance at  $R_g$ , is shown by the broken-line curve of Fig. 10. When effective resistance at  $R_g$  is increased to about 2 megohms the voltage gain rises to the values shown by the upper curve. There is a large increase of gain all through the low frequencies, all through the middle frequencies, and even through all the higher frequencies. This is only the second time we have been able to materially increase the gain at high frequencies. The other high frequency improvement is shown by Fig. 5, where plate load resistance at  $R_o$  was increased.



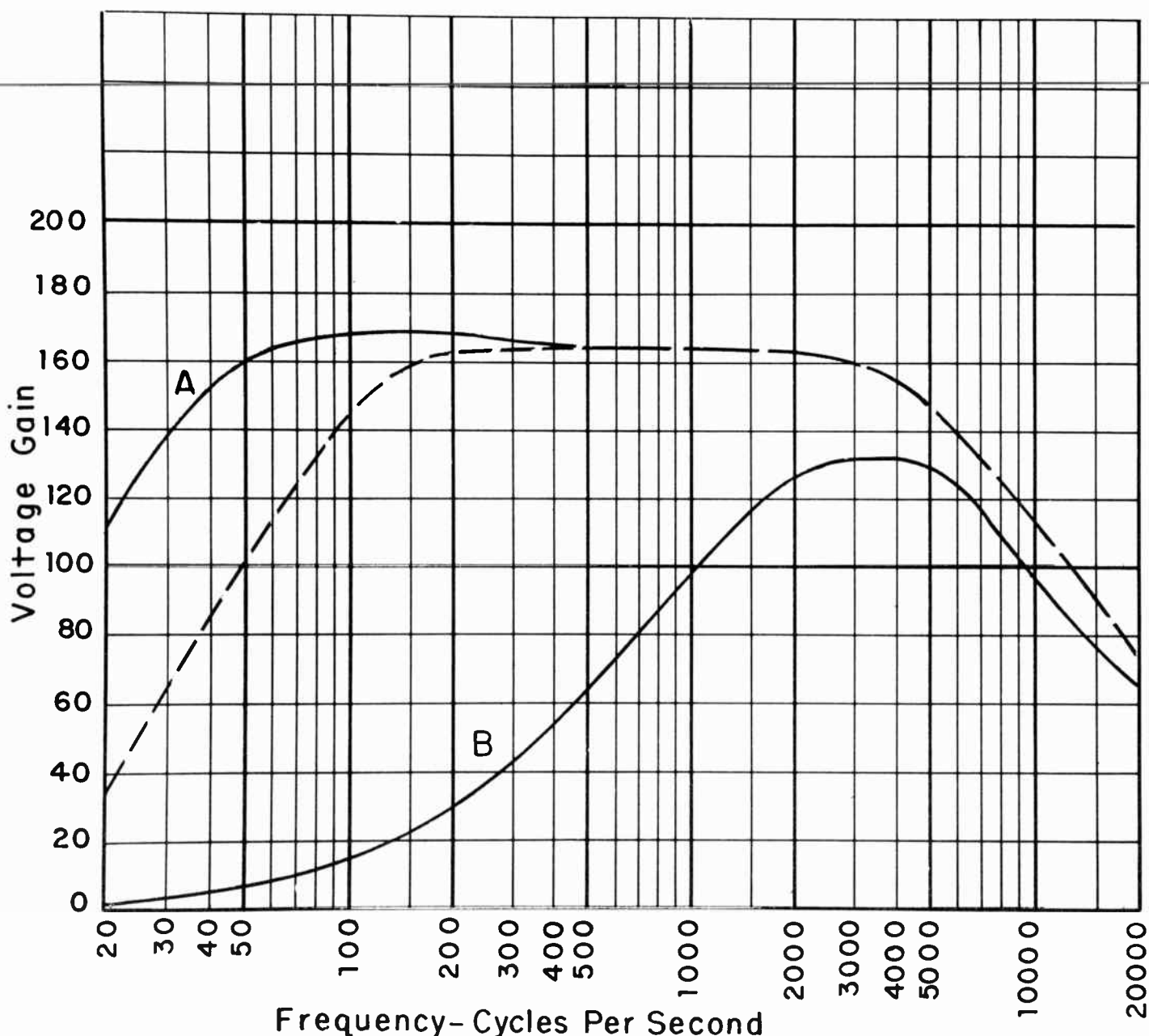

Fig. 9. Effects on gain and response of changing the coupling or blocking capacitance in the amplifier output circuit.

Increasing the plate load resistance,  $R_o$ , increases the combined or parallel resistance of the parallel plate circuit shown at the right in Fig. 8. Increasing the grid resistance,  $R_g$ , does the same thing, for  $R_g$  is in the other side of the parallel plate circuit. Anything which increases the total resistance or total opposition to alternating voltage in the amplifier plate circuit increases the voltage gain at all frequencies.

When resistance at  $R_g$  is decreased to an effective value of about 114K the response becomes as shown by the lower curve of

Fig. 10. There is loss of gain at all frequencies.

We should note also the effects on points of 80 per cent gain of altering the resistances in the amplifier plate circuit. Here is a summary, as taken from Figs. 5 and 10.

Alteration In Circuit	Frequencies For 80% Gain	
	Low	High
Maximum grid resistance	50 cycles	5,200 cycles
Maximum plate load resistance	65 cycles	6,000 cycles
Minimum grid resistance	112 cycles	12,000 cycles
Minimum plate load resistance	90 cycles	10,000 cycles

## LESSON 22 – RESISTANCE – COUPLED AMPLIFIERS

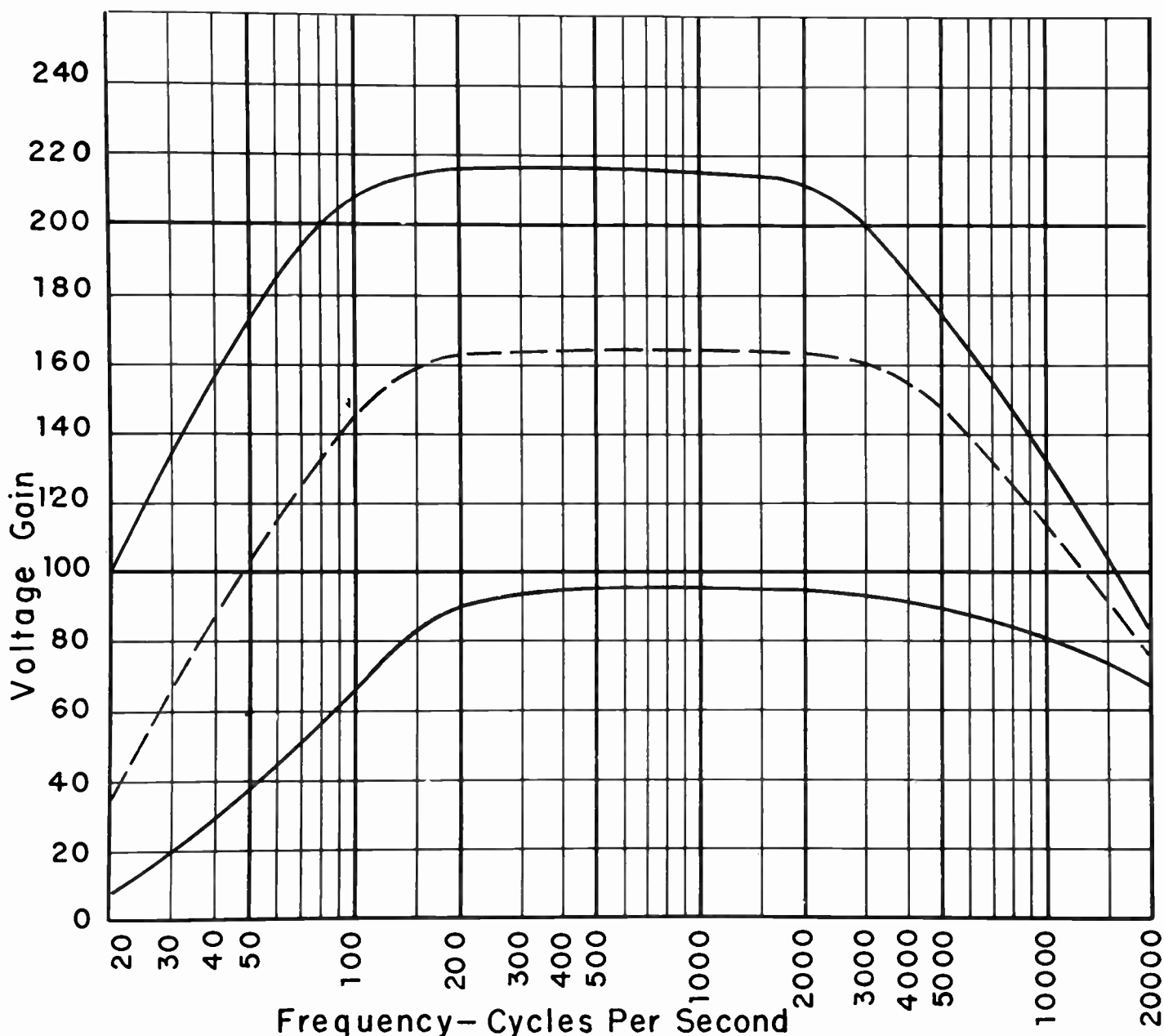

Fig. 10. Changing the following grid resistor has these effects on gain and frequency response.

Here we see that anything which increases the resistance in either side of the amplifier plate circuit or output circuit shifts the response toward lower frequencies, it improves the lows at the expense of the highs. Anything which reduces resistance in the amplifier output circuit shifts the response toward higher frequencies, it improves the highs at the expense of the lows.

With pentode amplifiers the grid resistance, at the following grid, ordinarily is between 100K and 2.2 megohms, and is of

some value between that of the plate load resistance and 5 times that resistance.

With high-mu triodes, having normal amplification factors above 50 and high plate resistances, the plate load resistor usually is from 100K to 500K, and following grid resistors are in this same range but in any given amplifier circuit may be of resistance up to 4 times the plate load resistance.

With medium-mu triodes, having normal amplification factors of less than 50 and

## COYNE - *television home training*

low plate resistances, the plate load resistance usually is between 50K and 300K. The following grid resistance usually is between 100K and 500K, and may be anywhere from 2 to 5 times the plate load resistance in the same amplifier circuit.

RATINGS OF CIRCUIT UNITS. Currents are so small in resistance coupled amplifier that resistors of 1/2-watt nearly always are amply large for the plate load, the screen resistor, the grid resistor, and the bias resistor. Where certain resistance values are specified, a tolerance of plus or minus 10 per cent should make no material difference in performance. This tolerance applies also to capacitors whose values are specified for a certain circuit.

The d-c working voltage of a cathode bypass capacitor need be only slightly in excess of normal grid bias voltage, which allows a rating of 6 to 10 volts. All other capacitors must be capable of withstanding the maximum d-c voltage from the power supply before the tubes warm up. This voltage will be much higher than plate and screen voltages, and it will be higher than the normal B+ voltage coming to plate and screen resistors.

Power supply voltage is initially high because a filament-cathode in a power rectifier tube heats before the heater-cathodes in other receiver tubes. Then the power supply voltage is nearly equal to peak a-c voltage from the power transformer secondary. Only when other tubes commence to draw current, after their cathodes heat, is there enough voltage drop in various circuit resistors to reduce the voltages to normal working values. Precautions relating to voltage overload apply to the coupling or blocking capacitor, to the screen bypass, and to any other capacitors in the plate circuit.

### SUPPLY VOLTAGE AND GRID BIAS.

We have observed the effects on gain of changing nearly everything about the amplifier except the voltage coming from the d-c supply and the grid bias voltage on the amplifier. Variations of d-c supply voltage have much less effect that might be expected. Where we originally had gain of about 164

between 200 and 2,000 cycles when supply voltage was 180, increasing the supply voltage to 250 raises the gain at these frequencies to only about 177. Dropping the supply voltage to 120 decreases the gain in this frequency range to about 150.

Changing the grid bias on the amplifier tube has a very decided effect on gain, because bias effects plate voltage, plate current, and screen voltage, thereby altering the transconductance of the tube. Our earlier tests were made with a bias resistor of 2,000 ohms, which provided a negative bias of about 1.1 volt. The response is shown by the middle curve of Fig. 11.

When substituting a 3,000-ohm bias resistor, making the bias about 1.5 volt negative, the resulting response is as shown by the bottom curve. Substituting a bias resistor of 1,000 ohms, giving a bias slightly more than 0.6 volt negative, brings the response up to the top curve of Fig. 11. Changes of bias voltage raise or lower the gain at all frequencies. Neither the low frequencies, the middle frequencies, nor the high frequencies are affected more than the others. So far as affecting all frequencies equally is concerned, changes of amplifier grid bias have much the same effect as changing the plate load resistor (Fig. 5) or the following grid resistor (Fig. 10).

All of our tests have been made with the same tube, a voltage amplifying pentode. When operated to take full advantage of its characteristics, a pentode will provide higher gains than a triode. It is true also that a high- $\mu$  triode, constructed to have high amplification factor, may be operated to provide greater gains than any medium- $\mu$  triode, which normally has a smaller amplification factor than the high- $\mu$  types. Furthermore, any changes of operating voltages and element currents for any type of tube will increase the voltage gain when these changes are such as to increase the transconductance of the tube.

As we have seen from many of the performance curves in this lesson, high gains often are associated with rather narrow frequency response, by which is meant a limited

## LESSON 22 – RESISTANCE – COUPLED AMPLIFIERS

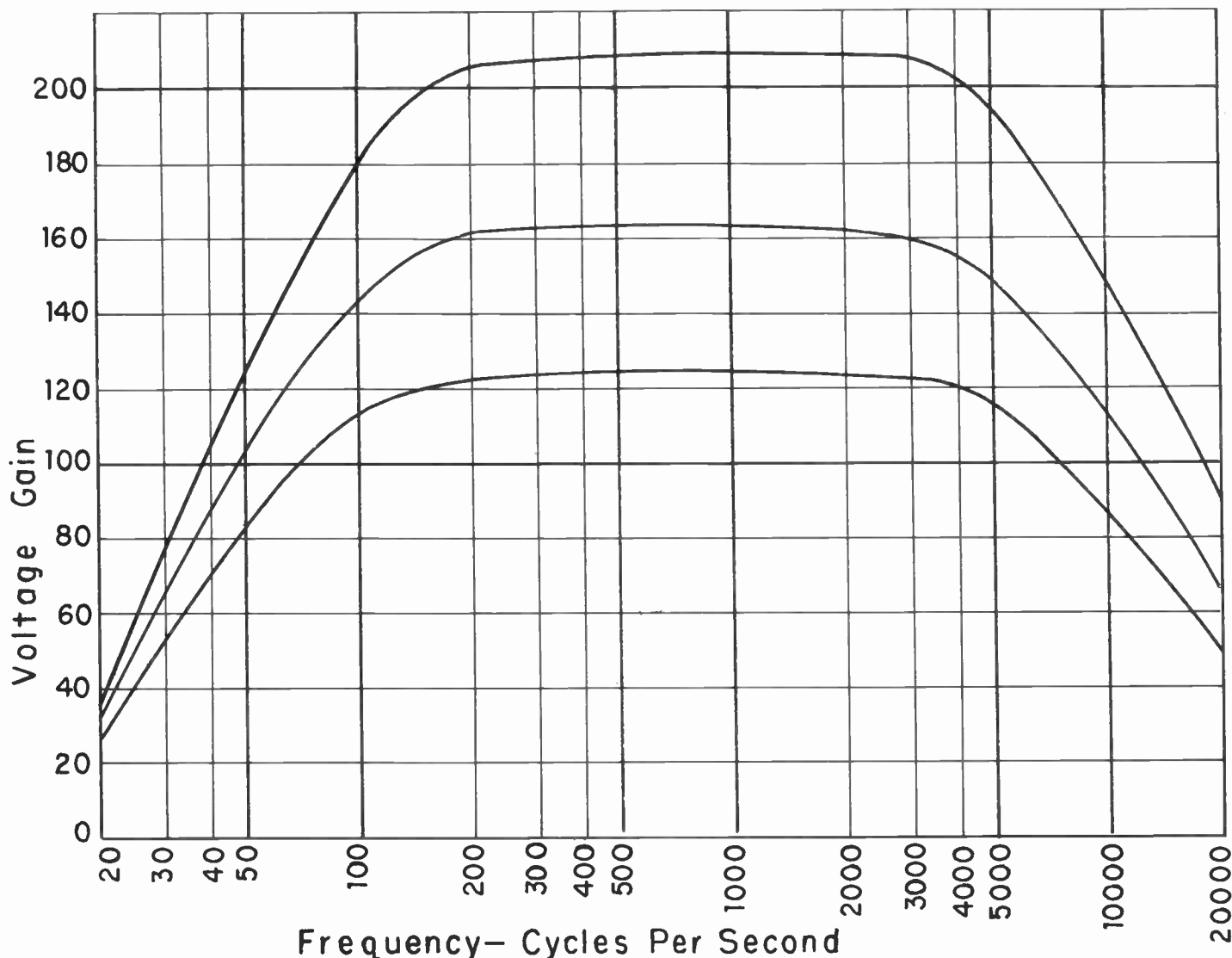

Fig. 11. Grid bias voltage on the amplifier tube affects gain and response as shown here.

range of frequencies between those where gain drops by some specified percentage. Conversely, a lesser gain usually allows somewhat wider frequency response. We have been taking the limits of response as the low and high frequencies at which voltage gain drops to 80 per cent of maximum. Oftentimes it is considered that these limiting frequencies are those at which the gain drops to 70 per cent of maximum. It is quite common practice to speak of the band width of a resistance coupled amplifier as being the range of frequencies between the points of drop to 70 per cent of maximum gain.

**CASCADED AMPLIFIER STAGES.** In Fig. 12 the signal output of one stage of amp-

lification feeds to the signal input of a second stage. Signal input for the entire system is applied at A, to the grid-cathode circuit of the first amplifier. The output of this first amplifier appears at B, and this is the signal input point for the second amplifier, between its grid and cathode. The output of the second amplifier, which is the output of the entire amplifying system, appears at C. The two amplifiers are said to be in cascade, or connected in cascade.

If the two amplifiers are of identical construction and are operated so that each has the same voltage gain as the other at every frequency, the overall gain of the cascade system will be the square of the gain



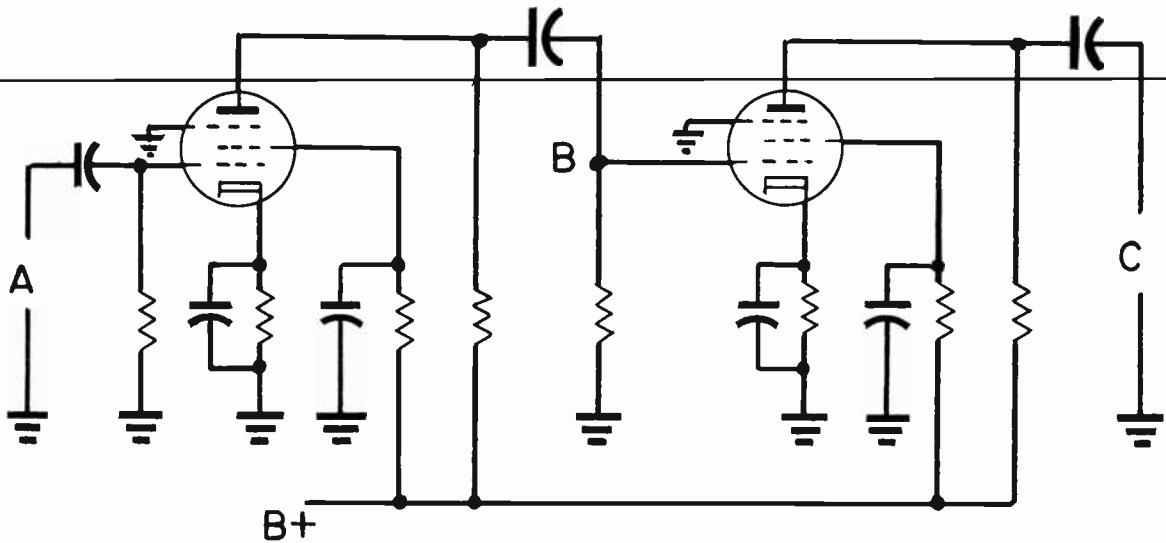

Fig. 12. Two resistance coupled amplifying stages in cascade.

of one amplifier at each frequency. Supposing that the gain of each amplifier at some certain frequency is 100, and that the input signal at A in Fig. 12 to 1/10 volt. The first amplifier will multiply this input by 100, and at its output the signal will be 10 volts. This is the input signal voltage for the second amplifier, which provides another amplification of 10 times. Then the final output signal at C will be 100 volts.

It would be possible to add more stages, and multiply the signal by the voltage gains of these other stages. Our original amplifier is a single-stage amplifier. With two stages in cascade we have a two-stage amplifier, and three cascaded stages would make a three-stage amplifier. The number of stages, is the same as the number of amplifying tubes or sections of amplifying tubes.

The overall gain of any multi-stage amplifier at any frequency is equal to the product of the gains of the several stages at that frequency. That is, the separate stage gains are multiplied together to find the overall gains.

For an example in overall gain we may assume that each of two stages is just like our amplifier whose frequency response is shown by Fig. 4. The overall response is shown by Fig. 13, where the frequency scale is the same as for other gain curves, but the gain scale has been extended to 30,000. The

gain of one stage at 50 cycles (Fig. 4) is a little more than 100. For two stages the overall gain will be 100 multiplied by 100, which makes 10,000. In Fig. 13 the overall gain at 50 cycles is a little more than 10,000. At other frequencies the overall gain is equal to the single-stage gain multiplied by itself, or to the square of the single-stage gain.

The steeply sloped portions of gain curves, at low and at high frequencies, often are called the skirts of the curves. Note that with a single stage (Fig. 4) the skirts flare slightly outward, but that with two stages (Fig. 13) the skirts slope inward. Adding more stages always pulls in the skirts of a frequency response.

Now let's see what we obtain in overall response when the two stages of a cascade amplifier have different responses. We shall assume that one stage has the frequency response shown by curves B of Fig. 7, where low-frequency gain is lacking because of using a small bypass capacitance on the cathode resistor. The other stage is assumed to have the response of curve A in Fig. 9, where low-frequency response is raised by using a coupling capacitor of greater capacitance.

The overall response of two such stages is shown by Fig. 14. The values at various frequencies on this response are found by multiplying together the gains at the same frequencies on the curves for the two stages.

## LESSON 22 – RESISTANCE – COUPLED AMPLIFIERS

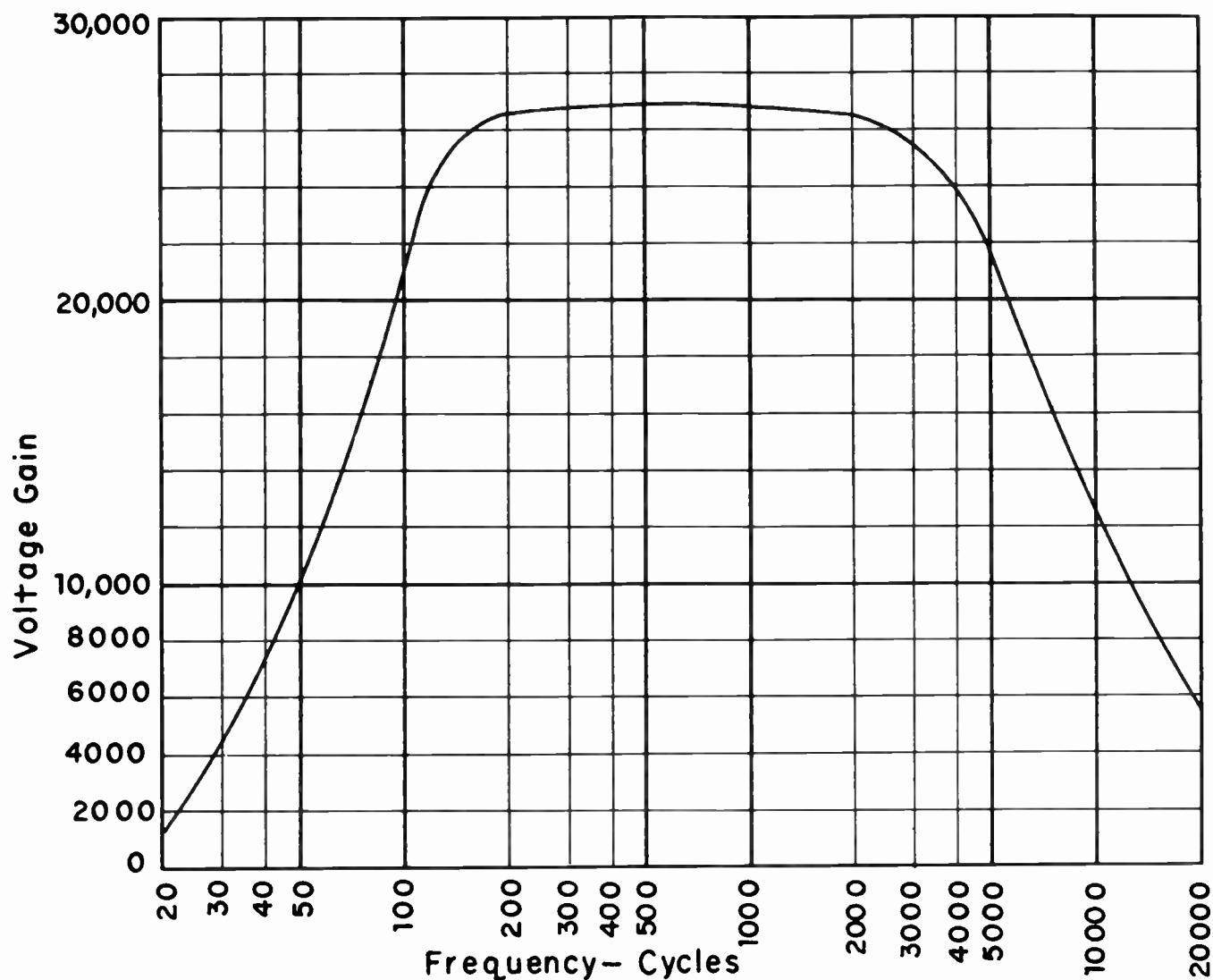

Fig. 13. Voltage gain and frequency response of two amplifier stages in cascade, when the two stages are exactly alike.

Which stage comes first and which second in the cascade amplifier makes no difference. The products of the gains are the same either way, just as the product of 2 times 3 is the same as of 3 times 2.

Cascaded amplifier stages having decidedly different individual frequency responses are used in television i-f amplifier sections to provide an overall response of desired shape. An important part of your service work will be in aligning the separate stages to obtain the correct overall frequency response, while watching that response change its shape as traced on the screen of an oscilloscope.

**SIGNAL OVERLOADING.** All of our preceding tests have been made with an input signal of 0.1 rms volt applied to the grid-cathode circuit of the amplifier tube. This input signal has been provided by an audio-frequency signal generator whose alternating voltage waveform appears on the oscilloscope as at the left in Fig. 15. This is very nearly a true sine wave. With the input signal adjusted to 0.1 volt at a frequency of 2,000 cycles per second, the output signal from our resistance coupled amplifier appears as at the right. Of course, the gain of the oscilloscope had to be greatly reduced to bring the height of the amplified output wave as low as pictured here. In this output there is very

# COYNE - *television home training*

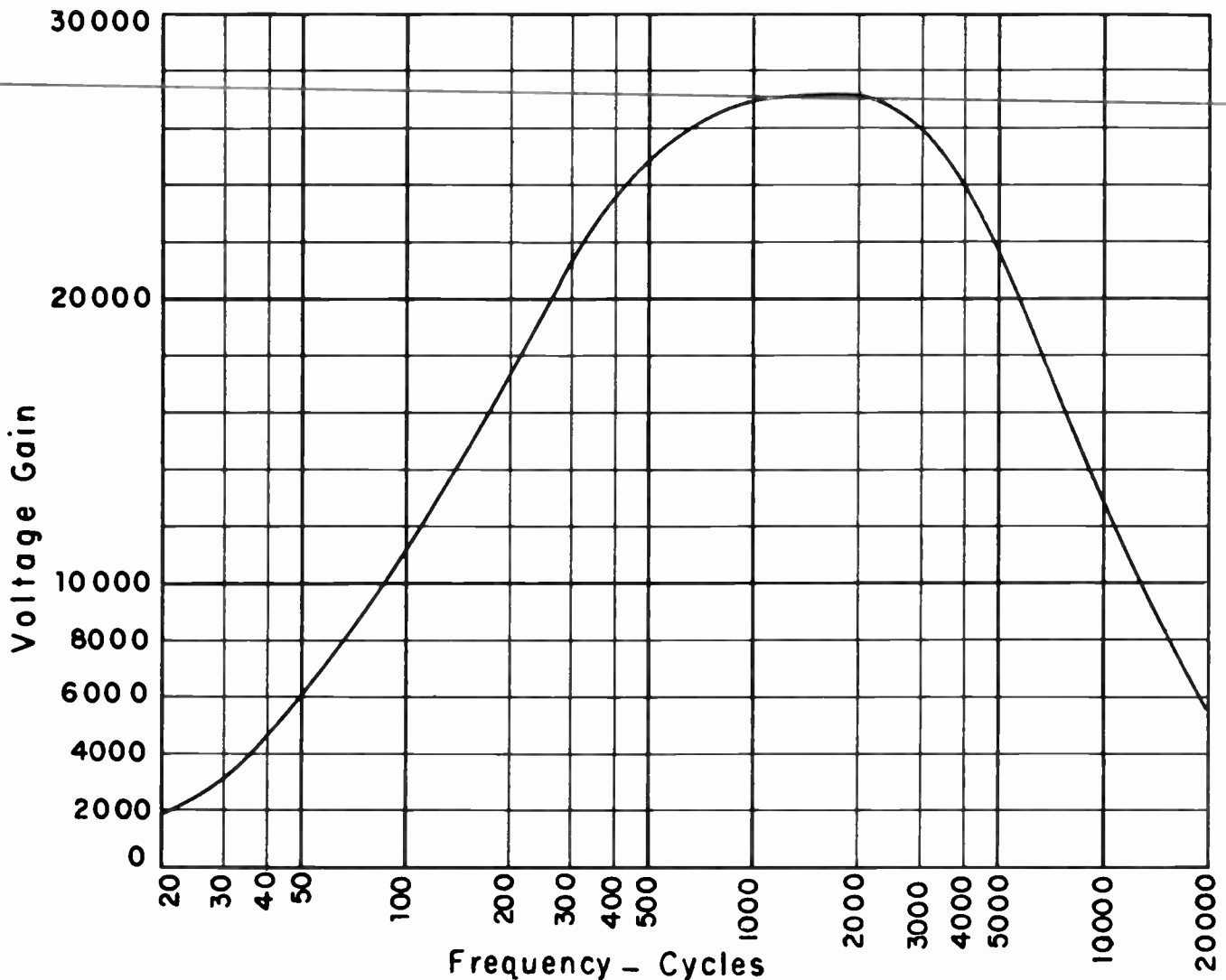

Fig. 14. Overall gain and frequency response of two stages which have different characteristics.

little distortion of the signal waveform, we still have an approximate sine wave.

Upon increasing the input signal to about 0.25 volt, at the same frequency, the output commences to show slight distortion of waveform. The distortion grows worse with increase of input signal voltage, and by the time this input is made 0.6 volt the output waveform appears as at the left in Fig. 16. There is bad distortion at the top or positive side of the wave. This distortion is due to grid current in the amplifier tube. Were there no distortion, the output signal would remain of the same waveform as the input signal, and swings of output signal voltage would continue upward about as shown by

broken-line extensions in the drawing at the right.

With inputs of up to about 0.25 volt there is no grid current in this particular amplifier, and no visible distortion in the output as traced on the oscilloscope. With greater input voltages there is grid current, which increases quite steadily with increase of input signal voltage. As grid current increases, more and more is cut off at the tops of the output voltage waves, and the greater becomes the distortion of waveform.

At the higher input signal voltages so much is cut off the output wave, which really represents the swing of output alternating

## LESSON 22 – RESISTANCE – COUPLED AMPLIFIERS

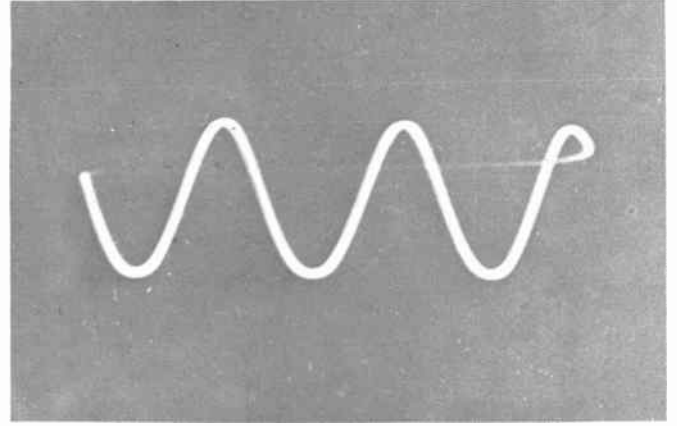
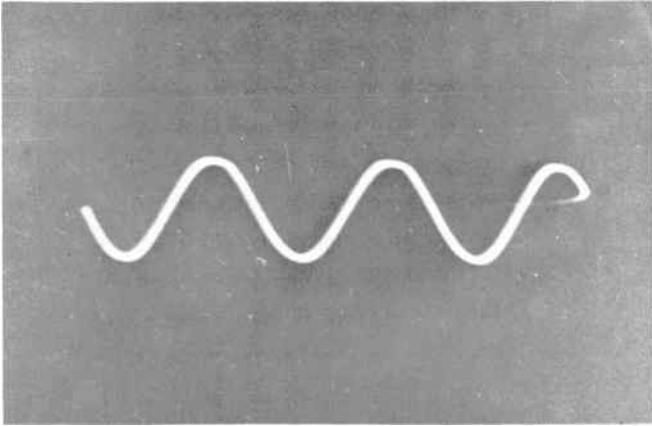

Fig. 15. The input signal (left) and the output signal (right) of the amplifier when input signal voltage is below the value at which grid current flows.

voltage, that the output is no longer proportional to input voltage. In other words, there is loss of gain in addition to severe distortion.

Fig. 17 shows relations between input signal voltage, grid current, and gain, as the signal is increased from zero to 1 volt. Gain comes down as grid current goes up. As soon as gain commences to drop there is distortion, and the greater the drop of gain the greater is the distortion. The thing to be

learned from all this is that a voltage amplifier must not be overloaded with too strong an input signal. High gains of such amplifiers are useful for strengthening weak signals, but the strength of the final output signal is limited by distortion.

Performances illustrated and described in this lesson have been those of only one certain amplifier stage, but they are typical of all resistance coupled amplifiers. Most of the conclusions which have been drawn

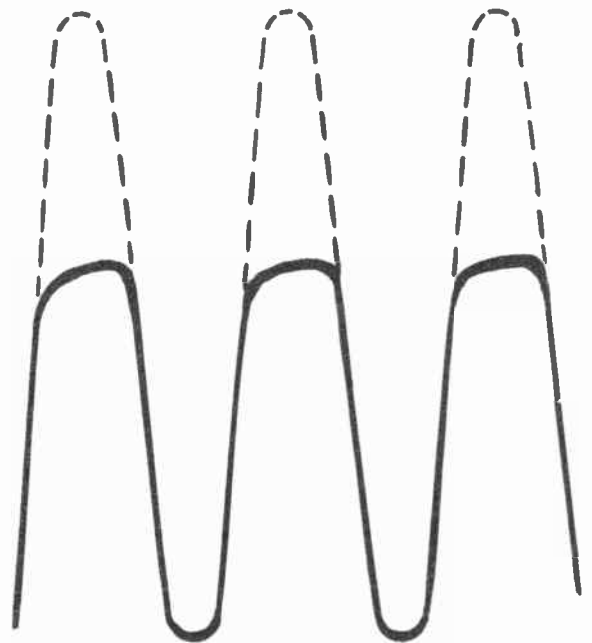
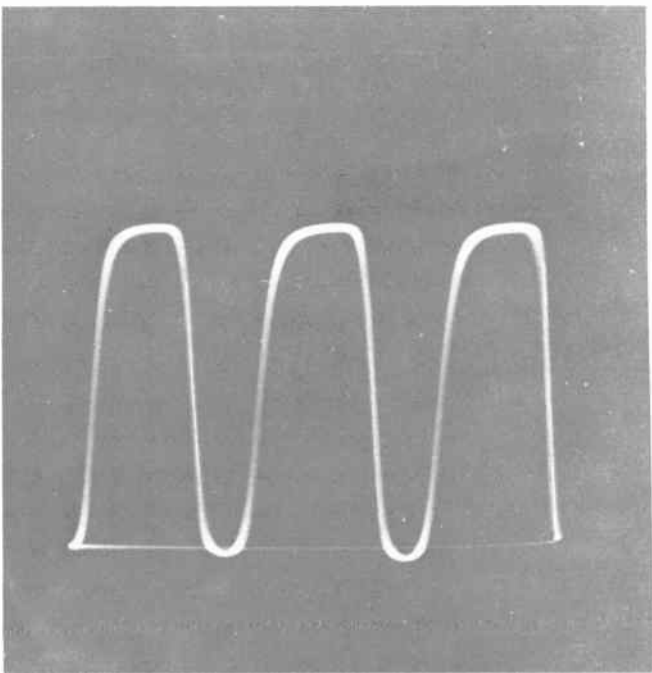

Fig. 16. The distorted output signal caused by excessive input signal voltage and resulting grid current.



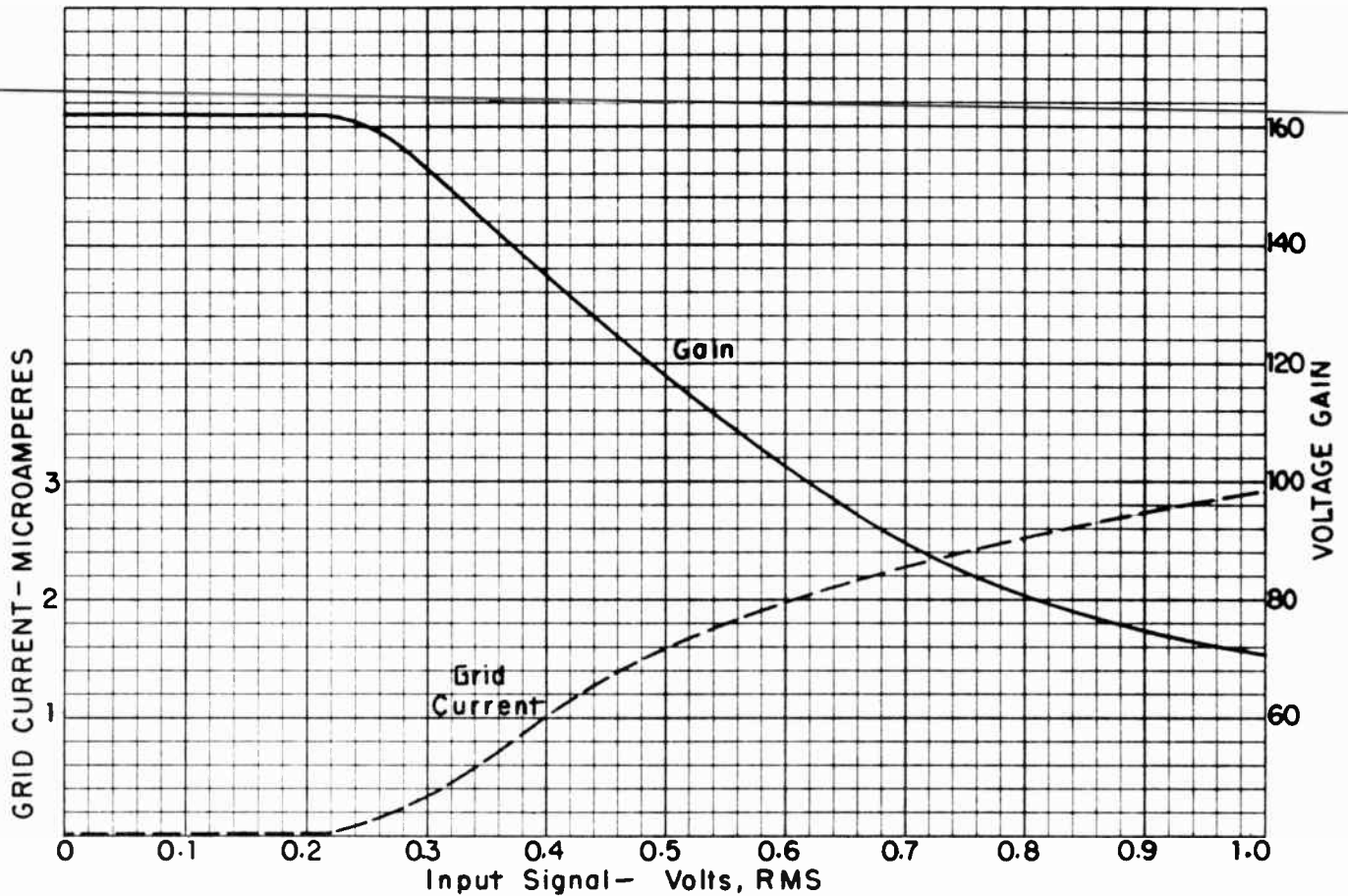

Fig. 17. As signal input voltage exceeds some certain value there is increasing grid current and waveform distortion, also decreasing voltage gain.

apply to all other types of amplifiers as well. You should keep in mind that examples illustrated are those in which only one resistance or capacitance is changed at one time. Two or more changes might be made to accomplish some desired result.

The following summary of the effects of various changes will be helpful in locating

and correcting performance faults. You will see that no single change will improve all operating characteristics at the same time. Improvement in one respect usually brings less desirable performance in other respects. What to do in any given case depends on the most noticeable fault, and on how much deterioration in other characteristics can be tolerated when correcting that fault.

FACTORS IN PERFORMANCE OF RESISTANCE COUPLED AMPLIFIERS					
ITEM TO BE CHANGED	CHANGE TO BE MADE	EFFECTS ON PERFORMANCE			
		Maximum Gain	Response		Band Width
			Lows	Highs	
Plate load resistance	More Less	More Less	Better Poorer	Poorer Better	Narrower Wider
Following grid resistance	More Less	More Less	Better Poorer	Poorer Better	Narrower Wider
Coupling capacitance	More Less	More Less	Better Poorer	Poorer Poorer	Wider Narrower
Cathode bypass capacitance	More Less	Little effect	Better Poorer	Better Poorer	Wider Narrower
Screen bypass capacitance	More Less	Little effect	Better Poorer	Same Same	Wider Narrower
Negative bias voltage	More Less	Less More	Poorer Better	Poorer Better	Little effect

# TELEVISION

• RADIO

• ELECTRONICS

---

---

**LESSON 23 – INDUCTORS FOR TELEVISION AND RADIO**

---

---

***Coyne School***

*practical home training*

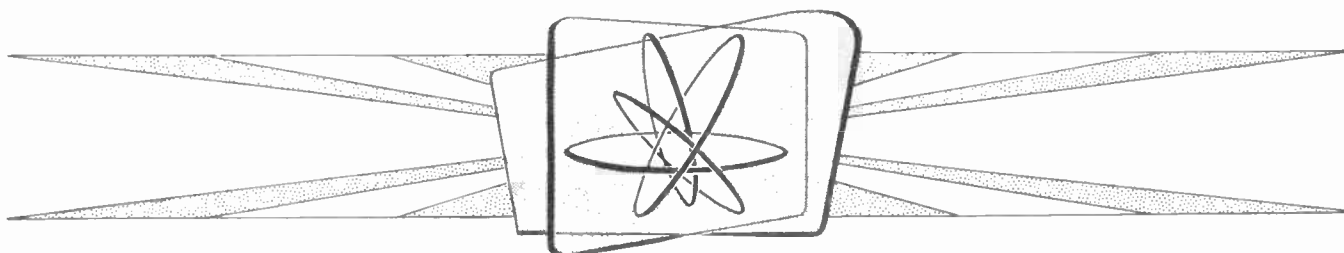

*Chicago, Illinois*

---

*Copyright, 1953 by Coyne Electrical School  
Chicago 12, Illinois  
All rights reserved*

Litho. in U.S.A.

## Lesson 23

# INDUCTORS FOR TELEVISION AND RADIO

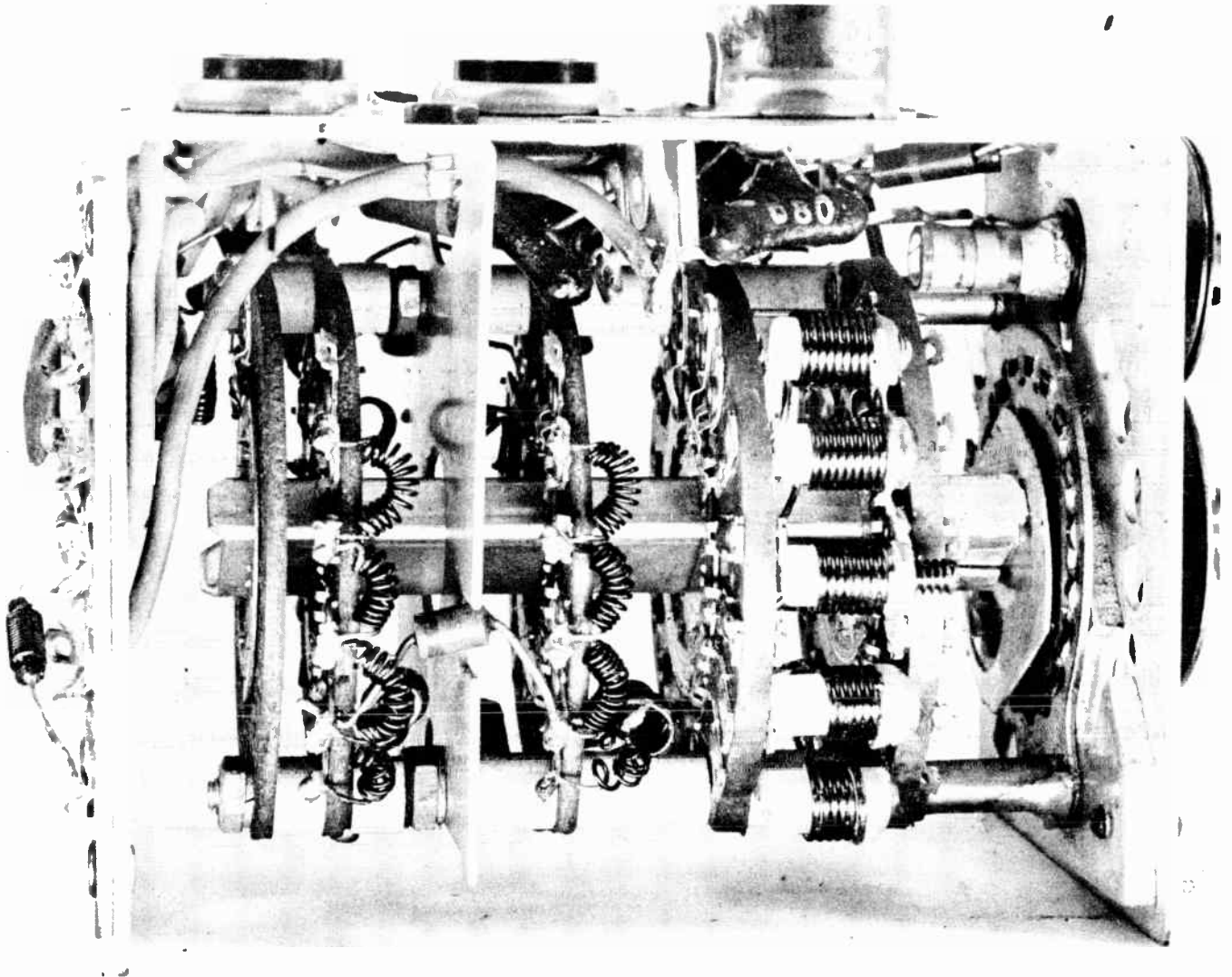

*Fig. 1. Most television tuners contain many inductors, with relatively few capacitors and resistors.*

We have amplified signals at frequencies as high as 20,000 cycles per second by using only resistors and capacitors in connection with a tube. To extend the useful response very far above this frequency we must add inductors. But even though we do add inductors, and build a video amplifier with satisfactory response all the way to four megacycles, we still could not receive a program. To receive a program we must be able to select one transmitted signal from all the others which are on the air at the

same time. No possible combination of resistors and capacitors will allow signal selection, we must have inductors.

In the very earliest radio broadcast receivers you would have looked in vain for a resistor, and the only capacitor would have been a bypass around the headphone. But there would have been an inductor or "tuning coil" two to three inches in diameter and possibly ten inches in length. That entire receiver consisted of this big inductor, a



**COYNE - television home training**

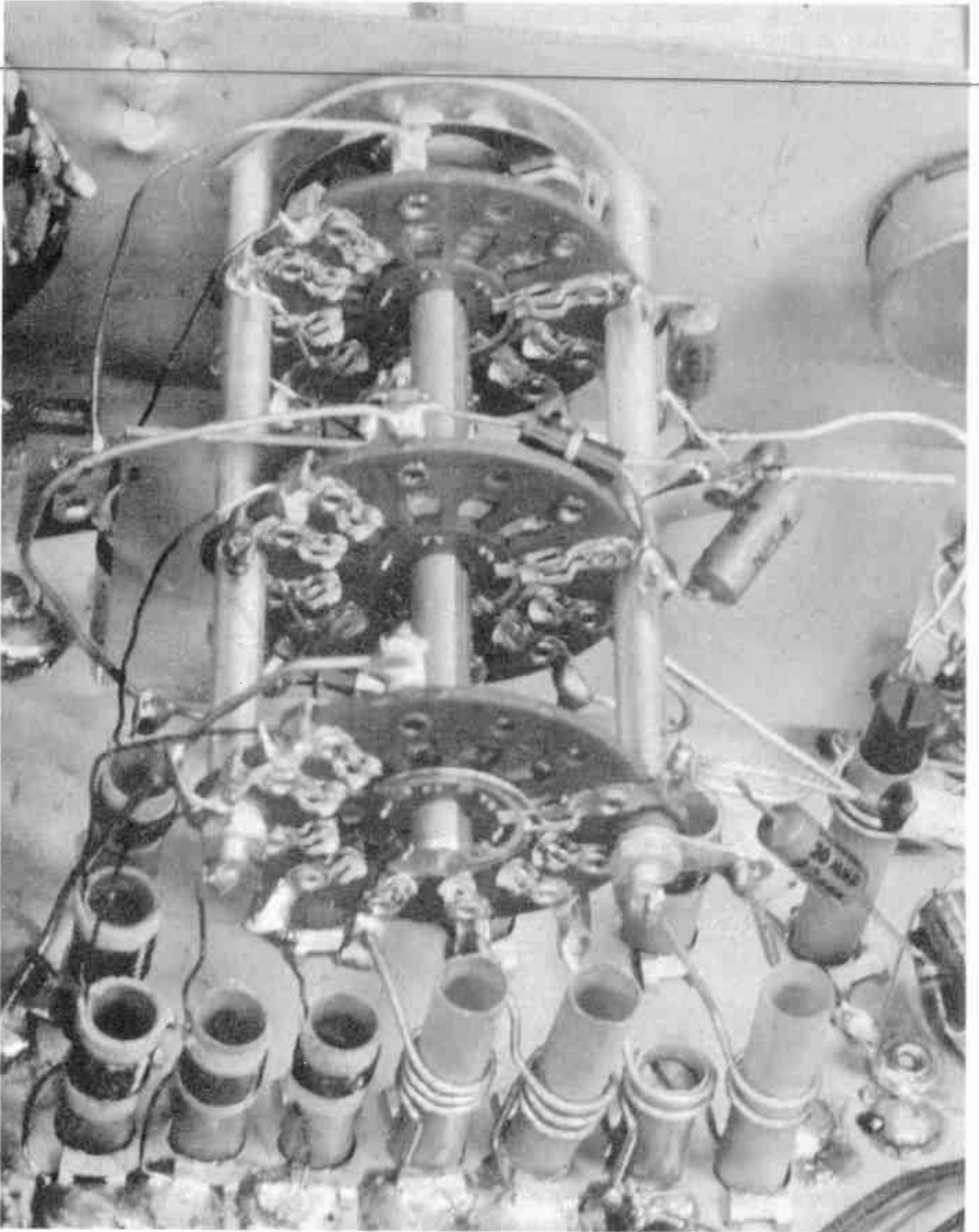

*Fig. 2. The inductors seen in the foreground of this picture are connected into the tuning circuits by the channel selector switch.*

# LESSON 23 – INDUCTORS FOR TELEVISION AND RADIO

crystal detector, the headphone and its by-pass, and an outdoor antenna. There wasn't even a tube.

One of the most interesting things about

inductors is that, in any given situation, they nearly always act in a way which is the exact opposite of what a capacitor will do under the same circumstances. A few comparisons are shown by the accompanying table.

## INDUCTORS VERSUS CAPACITORS

Conditions	Inductor Action	Capacitor Action
When connected to a direct voltage.	Opposition to current is very small, it is only the resistance of wire in the inductor winding.	Opposition to current is infinitely high. Will not pass steady direct current unless the dielectric breaks down.
When applied voltage is of low frequency.	Little opposition to the alternating current.	Strong opposition to the alternating current.
When applied voltage is of high frequency.	Strong opposition to the alternating current.	Little opposition to the alternating current.
As frequency is increased.	Increasing opposition to the alternating current.	Decreasing opposition to the alternating current.
Effect on timing of current alternations.	Retards the timing of current with reference to applied voltage.	Advances the timing of current with reference to applied voltage.
When keeping a receiver tuned to any given carrier frequency.	If a larger inductor is used,	a smaller capacitor must be used with it.
	If a smaller inductor is used,	a larger capacitor must be used with it.

**INDUCTORS.** An inductor might be any piece of metal, although most of them are lengths of wire. In many cases a short length of straight wire forms an inductor which is satisfactory at very-high and at ultra-high frequencies. But to be useful at lower frequencies there must be a greater length of wire, and it must not extend through very much space. Therefore, most inductors consist of wire coiled into a greater or less number of turns to make it compact.

For operation at lower frequencies the inductors have more turns, and may be of fairly large diameter.

Even though many pages were to be filled with pictures, they would not show all the varieties in shape, size, and structural details of inductors used in very-high frequency television and in broadcast radio. The essential part of all these inductors would, however, be a coil of wire.

An inductor operating at carrier frequencies in television tuners may consist of only a few turns coiled to a diameter of something like a quarter inch, like many of the inductors in the television tuner of Fig. 1.

Coiled inductors used for short-wave radio broadcast reception are shown at the left in Fig. 3. There is a minimum of supporting material, with nearly all the space within and around the turns filled with noth-

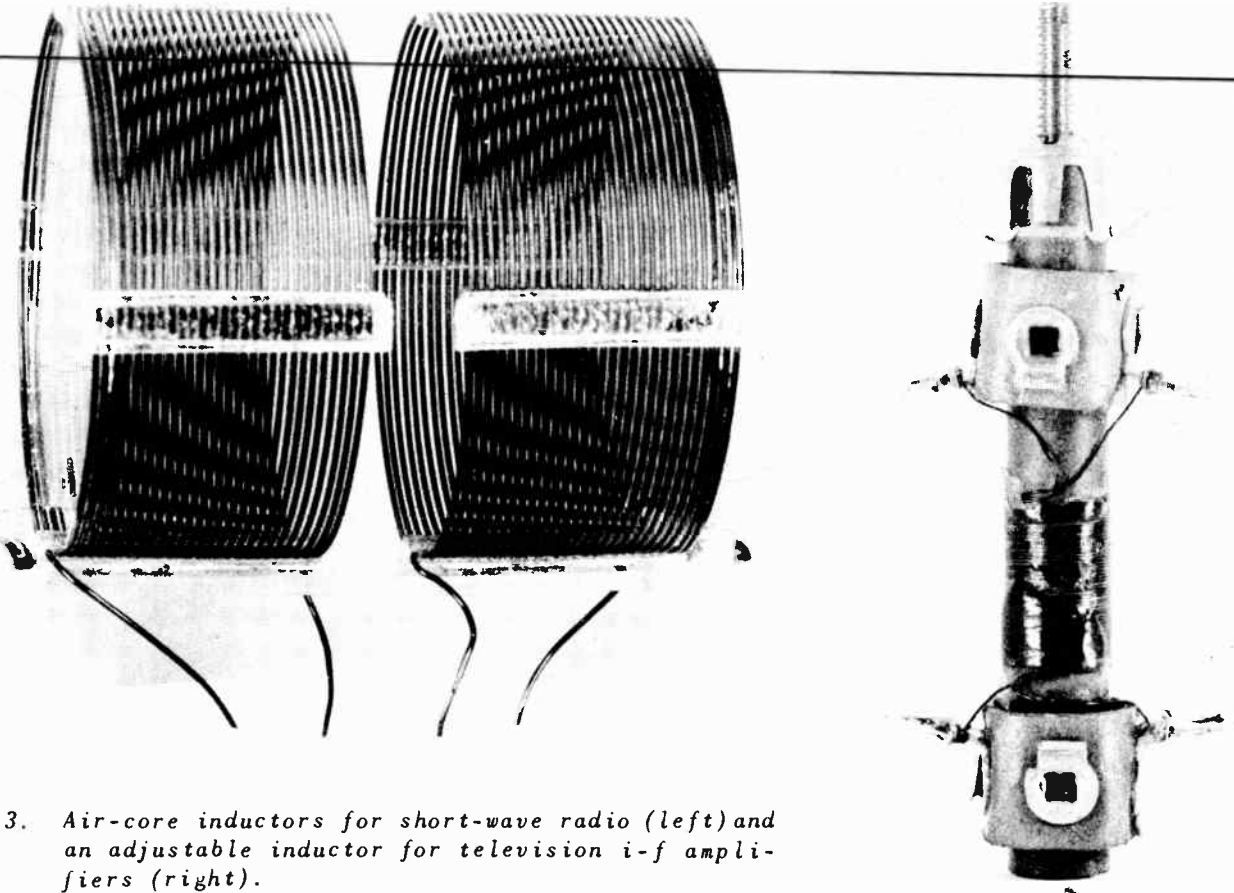

Fig. 3. Air-core inductors for short-wave radio (left) and an adjustable inductor for television i-f amplifiers (right).

ing but air. At the right is an inductor used in television i-f amplifiers, with the coil wound on an insulating and supporting form inside of which is an iron "core".

The usefulness of inductors is due to two properties. First, they oppose alternating currents to a degree depending on frequency, the higher the frequency the greater the opposition. Second, inductors have the ability to store energy in the form of magnetic fields.

OPPOSITION TO ALTERNATING CURRENT. The reason why an inductor opposes alternating current was discussed in lessons dealing with filters for d-c power supplies. That was quite a while ago, so it will do no harm to review the subject in the light of our present need for inductors to be used at frequencies higher than those found in a power supply filter.

To begin with, when current flows in

any conductor, even in a straight wire, a magnetic field is produced around the conductor. This field consists of lines of magnetic force. The lines of force are not there before the current flows, but the instant there is the smallest current the magnetic lines commence to form inside the conductor. As current increases, it produces more and more lines of force, and these lines push outward through the metal of the conductor and into the space around it.

If the conductor is coiled to occupy less space, there are just as many magnetic lines as before, but they are crowded together into the smaller space and thus form a more concentrated and a stronger magnetic field. This is the reason for using coiled inductors.

In Fig. 4 we may see the effect of magnetic field lines around a coiled inductor that is carrying current. This picture was made by passing a sheet of stiff paper through and around the coil, then sprinkling iron filings



## LESSON 23 – INDUCTORS FOR TELEVISION AND RADIO

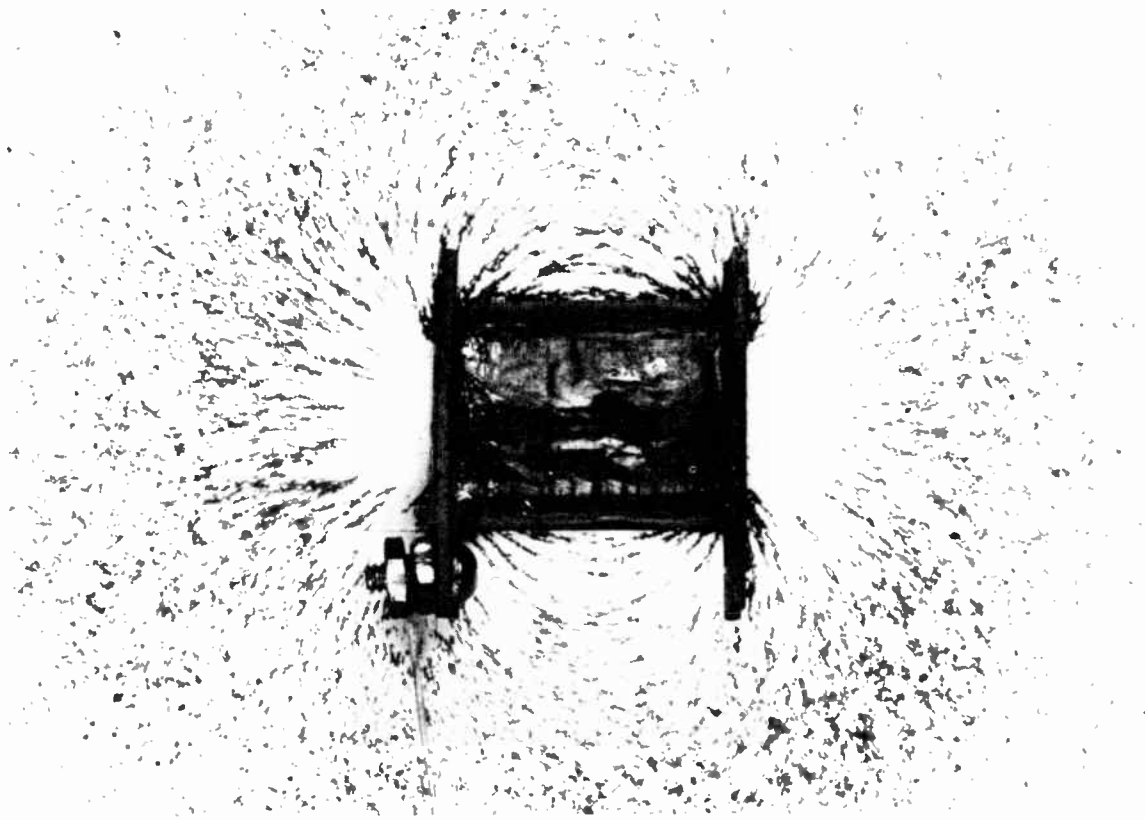

*Fig. 4. This picture shows the curved paths followed by magnetic lines of force in the magnetic field around an inductor which is carrying current.*

onto the paper. The filings arrange themselves along the paths of magnetic lines in the field of the coil.

When an increasing current causes the lines of magnetic force to move outward from the center of the inductor wire these lines cut through or move through the metal of the wire in which they originate. As the field continues to expand, its lines cut also through those portions of the coiled inductor forming all other turns.

Whenever lines of magnetic force cut through any conductor they induce an electromotive force in that conductor. Consequently, as current increases and the field expands, the outwardly moving magnetic lines induce an emf in the originating turns and in all other turns. The magnetic lines from every turn act in this manner on every other turn in the inductor, Were the wire not coiled, the expanding lines would move out

only through the portion of the wire where they originate, and would not cut through other portions of the wire. The effect of coiling the wire is to greatly increase the total number of cuttings, and the total of induced emf.

This emf which is induced while current is increasing acts in the same direction or polarity in every turn. This polarity is opposite to that of the externally applied voltage that is causing current to flow in the inductor. The induced emf opposes and partially counteracts the applied voltage. Then the voltage actually effective in causing current to flow is only the difference between the externally applied voltage and the opposite emf induced in the inductor.

Because the net effective voltage is reduced, the result is equivalent to opposing any increase of current in the inductor. Of course, as long as the external voltage con-



## COYNE - *television home training*

tinues to increase, there must be a continued increase of inductor current. But the rate of increase is slowed down by the self-induced emf.

Now, should current commence to decrease for any reason, usually because of less applied voltage, all the magnetic lines shrink back toward and into their originating turns. In doing so the lines cut back through all the turns in which they formerly moved outward. The direction of cutting is reversed when current is decreasing.

Again there is an emf induced in all the turns, but because the magnetic lines now are moving inward rather than outward the polarity of the induced emf is reversed. Since the polarity of applied voltage has not reversed, even though the voltage has weakened, the reversed emf is now of the same polarity as the applied voltage. The induced emf helps the applied voltage, and thus tries to prevent the decrease of current in the inductor.

The self-induced emf opposes every change of current. While inductor current is increasing, the induced emf opposes the increase. While current is decreasing, the induced emf opposes the decrease.

If the externally applied voltage is alternating, the resulting inductor current is alternating. Such current consists of nothing but changes, of alternating increases and decreases. Every increase and every decrease is opposed by the self-induced emf, which is the same as saying that the entire alternating current is opposed in the inductor. It is opposed to an extent greatly exceeding the opposition due to resistance of the conductor.

Supposing now that a smooth direct voltage is applied to the inductor. Then there is a smooth direct current which does not change its value. When this current first commences and is increasing from zero it produces a magnetic field. There is an induced emf which opposes this increase of current. But once the current has reached a value proportional to applied direct voltage, and the field lines have moved out to a proportional distance, there is no further change

of current nor movement of the lines. Then there is no further cutting, and the induced emf dies away to zero. Thereafter the direct current is opposed only by resistance of the wire in the inductor.

INDUCTANCE. The ability of an inductor to oppose alternating current is called self-inductance. Usually we omit the "self-" portion of this name, and speak of inductance.

Inductance is measured in a unit called the henry. The henry may be defined thus: When current changing at the rate of one ampere per second causes an induced emf of one volt, the inductance is one henry. A change of one ampere per second might mean an increase from zero to one ampere, or from one to two amperes, or from three to four amperes, or any other equal increase during one second. The same rate of change would occur with current decreasing from three to two amperes, or with any other equal decrease in one second.

One henry is a lot of inductance. Inductances so large as to be measured in henrys usually are found only in power supply filter chokes or in transformers and chokes used in audio-frequency amplifiers of some types. In a few television and radio circuits we find inductances which are measured in millihenrys. One millihenry is one one-thousandth of a henry. The majority of inductors used at carrier and intermediate frequencies have inductances so small as to be measured in microhenrys. One microhenry is the one one-millionth part of a henry.

The letter symbol for inductance, in any unit, is the capital letter L. The symbol for henrys is the capital letter H. For millihenrys the symbol is mH. A symbol for microhenrys consists of the Greek letter "mu" ahead of the H, thus:  $\mu\text{H}$

As illustrated by Fig. 5, inductance is affected by four features of inductor design. You will recall that capacitance is affected by four design features of capacitors. It is interesting to compare inductors and capacitors on this basis, as in the accompanying table.

# LESSON 23 – INDUCTORS FOR TELEVISION AND RADIO

	Diameter	Number Of Turns	Length Or Spacing	Core Materials
Less Inductance				 Anything Except Iron
More Inductance				 Iron

Fig. 5. Factors which affect the inductance of a coiled inductor.

## FACTORS AFFECTING INDUCTANCE AND CAPACITANCE

### Inductance Affected By

1. Diameter of turns.
2. Number of turns.
3. Separation between turns or spacing of turns.
4. Kind of material inside of and around the coil, or material of the "core".

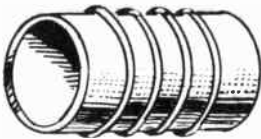
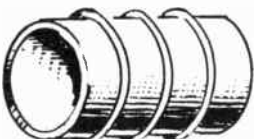
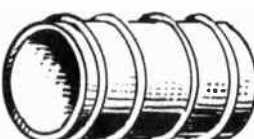
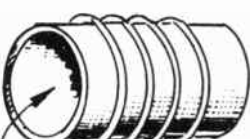
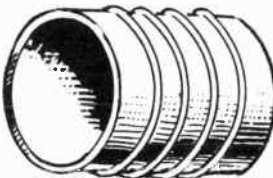
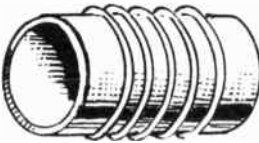
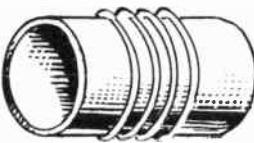
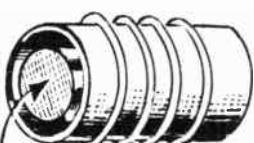
### Capacitance Affected By

1. Area of plates.
2. Number of plates.
3. Separation of plates or thickness of dielectric.
4. Kind of material in the dielectric between the plates.

Each of the four features affects inductance as follows:

1. Diameter of turns. Inductance varies as the square of the coil diameter when everything else remains unchanged. That is twice the diameter means four times as much inductance, because the square of two is four. Half as much diameter means one-fourth as much inductance, because the square of one-half is one-fourth.

2. Number of turns. Inductance varies also as the square of the number of turns. Doubling the number of turns increases the inductance by four times, half as many turns drops inductance to one-fourth, and so on. This assumes that nothing else is altered.

3. Spacing of turns. When altering the spacing between turns it is impossible to leave everything else unchanged, for with any given number of turns more spacing lengthens

pletely it fills the space inside of and around the coil.

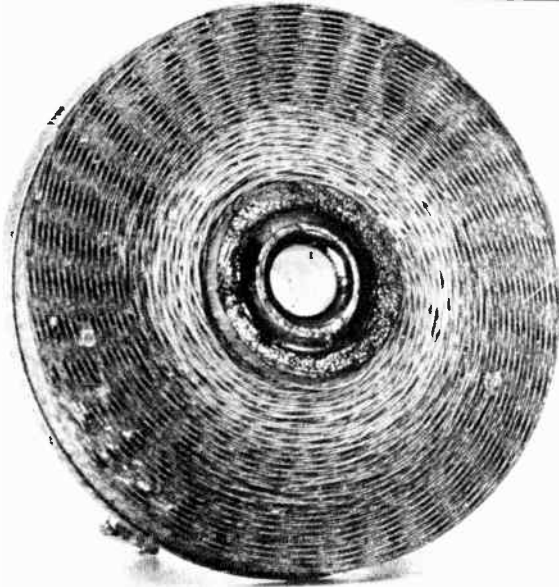

Fig. 6. Many turns, with fairly large diameter, give this inductor a self-inductance of about 1,000 microhenrys, or 1 millihenry.

the coil, while less spacing shortens the coil. Rather than considering the spacing between turns it is more convenient to consider the overall length from the turn at one end to the turn at the other end of the coil. On this basis, inductance varies inversely with overall length when the number of turns is unchanged. That is, doubling the length (and thus increasing the spacing) reduces the inductance to one half. Halving the overall length (decreasing the spacing) doubles the inductance.

**4. Core material.** There is least inductance when only air is inside of and around the inductor turns, just as there is least capacitance when air is the dielectric of a capacitor. But while every dielectric material other than air will increase the capacitance of a capacitor, only iron in one form or another will increase the inductance of an inductor. So far as inductance is concerned, all metals except iron, also all insulators and everything else, are like so much air inside of and around an inductor. What the increase amounts to, in microhenrys or other units, depends on the kind of iron and on how com-

Note: In certain television controls the inductors have brass cores for reducing the inductance. These cores do not alter the true inductance, they introduce energy losses which decrease the "apparent inductance". Such matters will be taken up a little later.

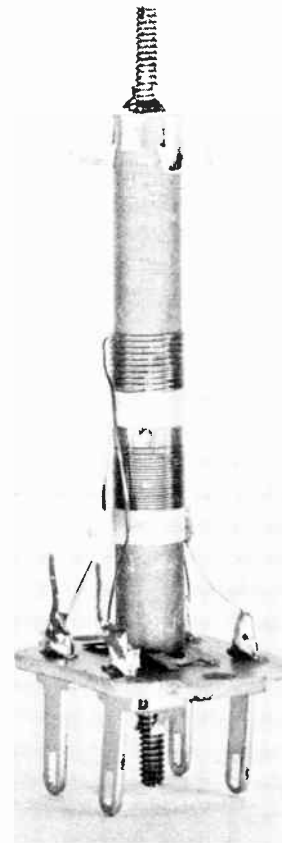

Fig. 7. Inductances of the coil windings are altered by moving an internal iron core.

Fig. 7 is a picture of a certain television inductor. The coils are wound on an insulating and supporting tube inside of which is a cylindrical core of iron. This core can be moved farther into or out of the coil position by turning the adjusting screw at the top. Moving the core farther into the coils increases their inductance, while moving it farther out lessens the inductance.

## LESSON 23 – INDUCTORS FOR TELEVISION AND RADIO

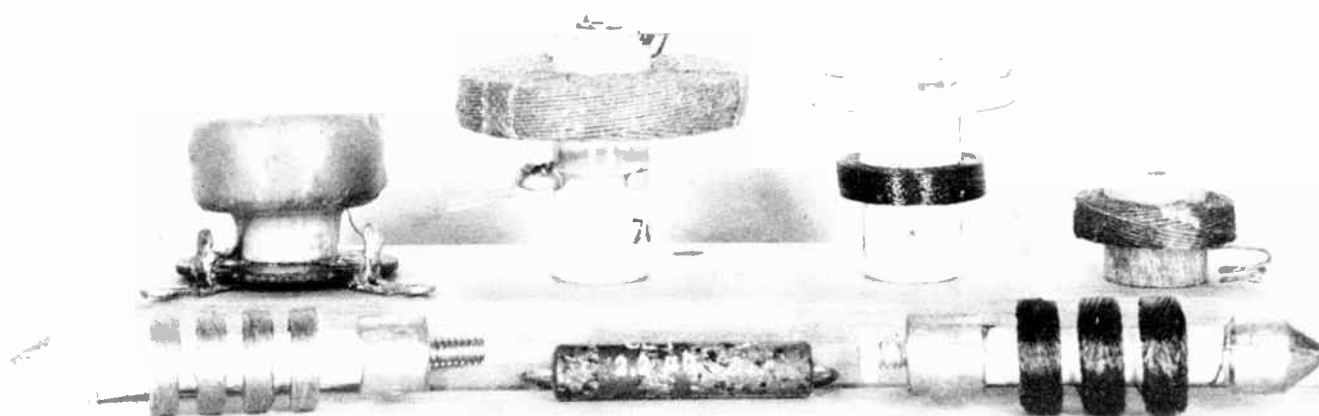

Fig. 8. Radio-frequency chokes, whose inductive reactance opposes flow of high-frequency alternating currents.

**INDUCTIVE REACTANCE.** The opposition of an inductor to flow of alternating current is called inductive reactance. Thus we distinguish this kind of opposition from that of a capacitor, which is called capacitive reactance. Inductive reactance is measured in ohms, just as all other oppositions to all kinds of currents are measured in ohms.

Fig. 8 shows a number of inductors which are used for their ability to oppose flow of alternating currents at radio frequencies, including all carrier and intermediate frequencies in the radio broadcast bands and in the very-high frequency television bands. These are called radio-frequency chokes, a name usually abbreviated to "r-f chokes". They are called chokes because they have the effect of choking back the high-frequency currents while allowing relatively free flow of direct currents through them.

Inductive reactance depends on both inductance and frequency. In fact, this kind of reactance is directly proportional to inductance and is directly proportional to frequency. Twice as much inductance means twice the inductive reactance, and half the inductance means half the reactance, at any frequency. Doubling the applied frequency doubles the inductive reactance, while half the frequency halves the reactance of any given inductance. Inductive reactance increases with frequency because the higher the frequency the greater are the number of

current changes (alternations per second) and the greater becomes the self-induced emf in the inductor.

Since inductive reactance varies directly with inductance, everything which increases the inductance will increase the reactance, and anything which lessens the inductance will lessen the reactance at any frequency. Earlier we listed four factors of inductor construction which affect inductance. By adding the factor of frequency we may make a list of the factors which affect inductive reactance, as in the accompanying table.

### FACTORS IN INDUCTIVE REACTANCE

<u>Reactance Is Increased By</u>	<u>Reactance Is Decreased By</u>
Greater diameter.	Smaller diameter.
more turns.	Fewer turns.
Less overall length, or less spacing between turns.	Greater overall length, or more spacing between turns.
Iron in the core.	No iron in the core.
Higher frequency.	Lower frequency.

The symbol for reactance of any kind is the capital letter X. To indicate that the reactance results from inductance we add the subscript letter L (for inductance) and form the symbol X<sub>L</sub>. If the reactance is due to capacitance we add the subscript letter C (for capacitance) and form the symbol X<sub>C</sub> for capacitive reactance.



## COYNE - *television home training*

When you know the inductance and the frequency, inductive reactance in ohms may be computed from any of the following formulas.

$$\begin{aligned} X_L, \text{ ohms} &= 6.2832 \quad x \text{ henrys} \quad x \text{ cycles} \\ &= 6283.2 \quad x \text{ henrys} \quad x \text{ kilocycles} \\ &= 0.0062832 \quad x \text{ millihenrys} \quad x \text{ cycles} \\ &= 6.2832 \quad x \text{ millihenrys} \quad x \text{ kilocycles} \\ &= 6283.2 \quad x \text{ millihenrys} \quad x \text{ megacycles} \\ &= 0.0062832 \quad x \text{ microhenrys} \quad x \text{ kilocycles} \\ &= 6.2832 \quad x \text{ microhenrys} \quad x \text{ megacycles} \end{aligned}$$

Fig. 9 is an alignment chart which allows avoiding the arithmetic involved when using formulas to determine inductive reactances. As with our other alignment charts, you merely lay a straightedge on any two values which are known, and read the unknown value where the straightedge intersects the third scale.

The left-hand scale covers inductive reactances from 50 ohms to 500,000 ohms. The center scale is for inductances from 0.1 microhenry to 50 millihenrys, the range of values in inductors commonly used at carrier and intermediate frequencies. At the right is the frequency scale, from 50 kilocycles at the top to 300 megacycles at the bottom. This covers carrier and intermediate frequencies for broadcast radio and for the very-high frequency television bands.

Inductive reactances for greater inductances and lower frequencies may be determined from the alignment chart of Fig. 10, which is used in the same way as the first one. The two charts together cover inductances from 0.1 microhenry to 50 henrys, and frequencies from 50 cycles to 300 megacycles. There is some overlapping of the scales, so that a problem which cannot be solved with one chart usually can be handled with the other chart.

TERMS USED WITH INDUCTORS. In connection with inductors there are three

terms which should not be confused with one another. They are (a) inductance, (b) inductive reactance, and (3) induction. The differences between the terms are explained as follows.

a. Inductance. This is the ability or the property of an inductor to oppose alternating currents, and to store energy in the form of a magnetic field. Inductance depends on construction of the inductor - on diameter, number of turns, spacing or overall length, and kind of core material. Inductance does not depend on frequency.

b. Inductive reactance. This is the actual amount of opposition to alternating current, as measured in ohms. This reactance depends on both inductance and frequency.

c. Induction. This is the action or process by which movement of magnetic lines of force, or an expanding and contracting magnetic field, induces an emf in the turns of an inductor. The full name of this action is electromagnetic induction, but nearly always we use the shortened name of induction.

We might employ the three terms in one sentence thus: The action called induction, which occurs in an inductor possessing the property of inductance, accounts for the opposition to alternating current which is called inductive reactance.

INDUCTANCES IN SERIES AND IN PARALLEL. Inductances connected in series with one another add together to make a total inductance equal to the sum of all the separate inductances. An example is illustrated by Fig. 11, where there are three inductors having individual inductances of 10, 6, and 19 microhenrys. The total inductance is the sum of 10, 6 and 19, or is 35 microhenrys. This rule holds good no matter how many separate inductances are connected in series, and no matter what their values may be. Were you to connect an inductor of 10 henrys in series with another of 20 microhenrys the total inductance would be 10,000,020 microhenrys, or 10.00002 henrys.

To conform to the general rule for series inductances the individual coils must

# LESSON 23 – INDUCTORS FOR TELEVISION AND RADIO

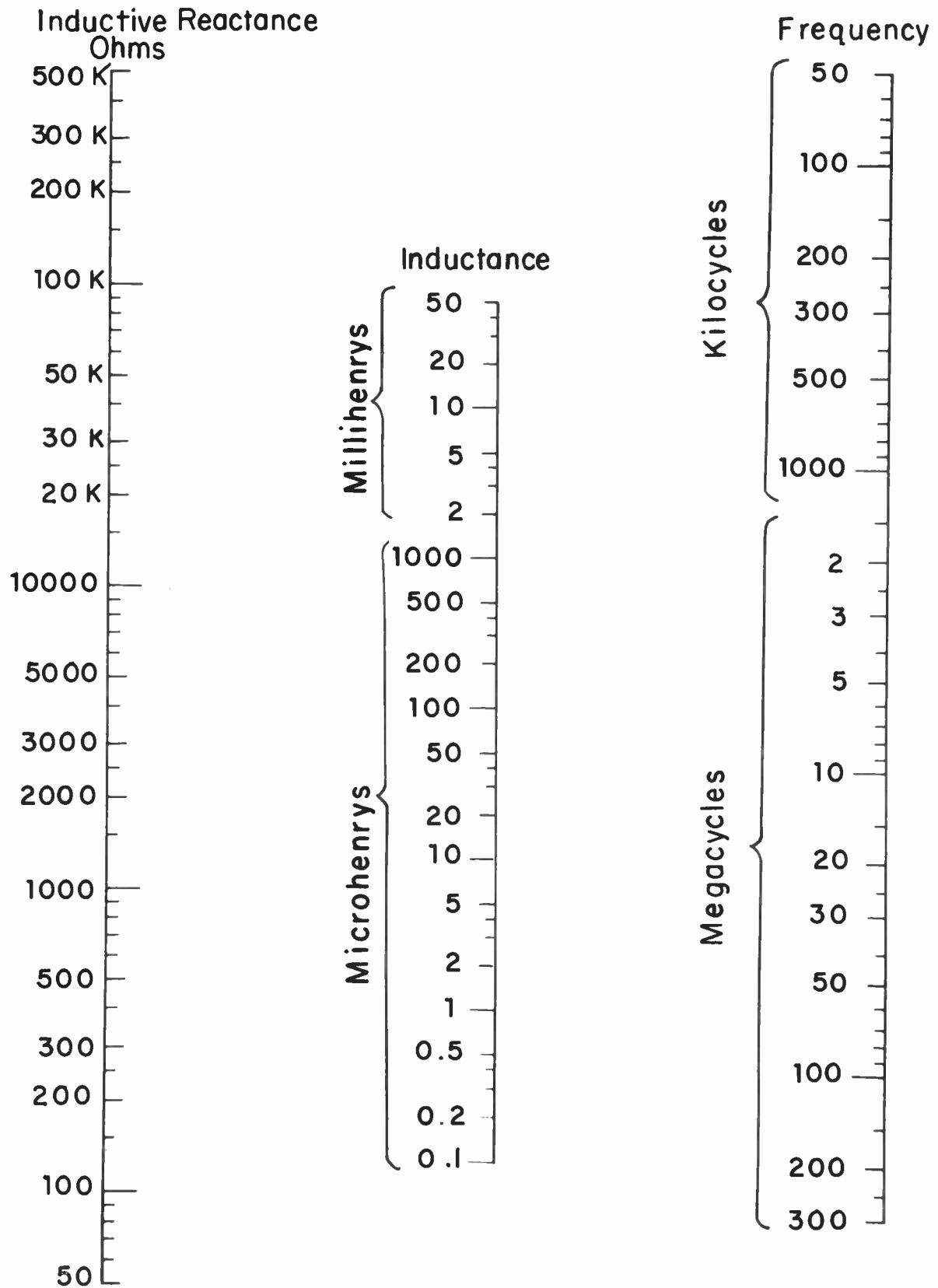

Fig. 9. Chart for inductive reactances at high frequencies.

# COYNE - *television home training*

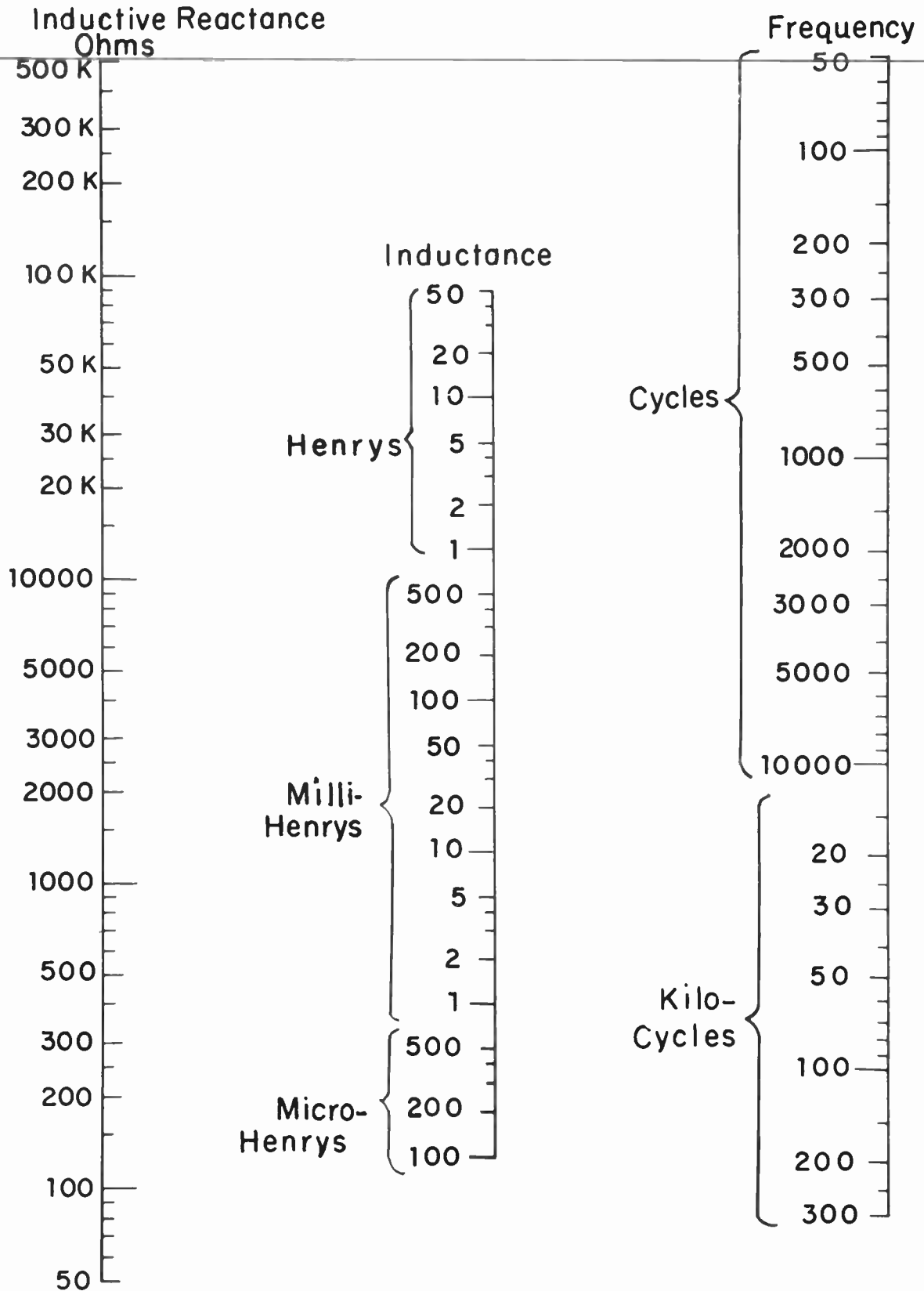

Fig. 10. Chart for inductive reactances at low frequencies.

## LESSON 23 – INDUCTORS FOR TELEVISION AND RADIO

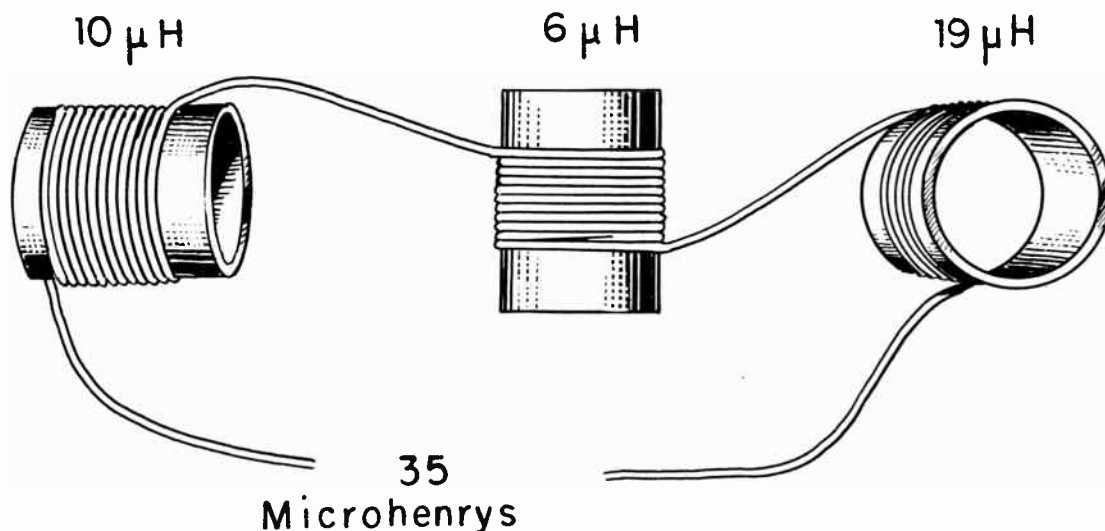

Fig. 11. When inductances are connected in series they add together in forming the total circuit inductance.

be so positioned with reference to one another that the field lines from each can cut through the turns of none of the others. This is the reason why the three coils of Fig. 11 are arranged so that the center line or axis of each is at right angles to the axis of each of the others. Then the magnetic lines from each inductor move parallel to turns on the other inductors rather than cutting across the turns.

If the magnetic field of one series inductor cuts through the turns of another series inductor, the extra cuttings in the second inductor add to or subtract from the sum of the separate inductances. If magnetic lines from one inductor move through a second inductor in such direction that induced emf's are of the same polarity in both inductors there will be additional inductance over and above the separate inductances. If the lines move through the turns of the second inductor to induce an emf whose polarity is opposite to that in the first inductor the total inductance will be less than the sum of the individual inductances.

Interaction between individual inductors may be prevented by placing them so far apart that the field from one is exceedingly weak or zero at the position of the second unit. Another way is to enclose one or more inductors in metallic "shields". The exceptions to the general rule of adding inductances in series will be dealt with at greater

length when we consider the subject of coupling. Until then, don't let it concern you too much - just remember the general rule.

In that inductances in series add together they behave just like resistances in series, for the total resistance of any number of series resistances is equal to the sum of the individual resistances. It is true also that inductances connected together in parallel have total or paralleled inductance which conforms to the rules for resistances in parallel with one another.

The most useful rules, as written so that they apply to inductances in parallel, are as follows.

1. Parallel inductance of any number of equal paralleled inductances is equal to the value of one inductance, in any unit, divided by the number of inductances.

2. Parallel inductance of any two paralleled inductances is the quotient of dividing the product by the sum of the two inductances, both measured in the same unit - in henrys, millihenrys, or microhenrys.

3. Parallel inductance (total) is less than any of the separate inductances.

4. Adding inductances in parallel lessens the total or parallel inductance.



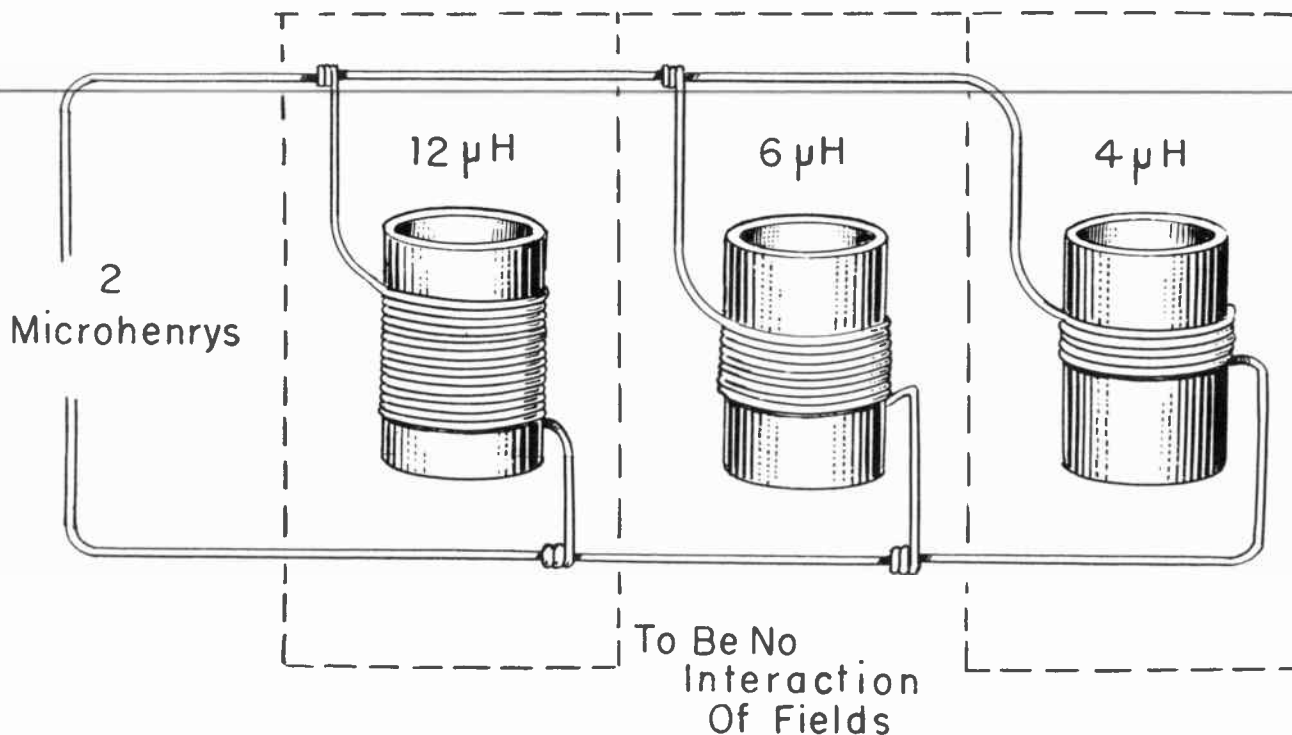

Fig. 12. Combined inductance of inductors in parallel conforms to the same rules as combined resistance of resistors in parallel.

5. Changing any one paralleled inductance alters the total inductance. The total is increased when the change is to a larger inductance, and is reduced when the change is to a smaller inductance.

An example of the application of rules 1 and 2 is illustrated by Fig. 12, where there are paralleled inductances of 12, 6, and 4 microhenrys. The combined inductance of 12 and 6 microhenrys is found with rule 2, thus.

$$\frac{12 \times 6}{12 + 6} = \frac{72}{18} = 4 \text{ microfarads}$$

Now we work with two equal inductances, with 4 microfarads for the first two units and with 4 microfarads for the one at the right. Rule 1 says that the combined inductance is equal to one inductance (4) divided by the number of inductances (2), and 4 divided by 2 gives 2 microfarads as the combined inductance of all three units. Had the third inductance been different from the combined value of the other two we could have used rule 2 a second time, just as when there are three unequal paralleled resistances.

In order that the rules for inductances in parallel may hold good there must be no interaction between the fields of the individual inductors, any more than in the case of series inductances. That is, the magnetic field lines from none of the separate inductors may cut through the turns of another unit and thus induce emf's in the other unit.

REACTANCES IN SERIES AND IN PARALLEL. All of the rules for two or more inductive reactances connected in parallel are the same as for two or more resistances connected in parallel. This fact is easy to remember, because both inductive reactance and resistance are measured in the same unit, the ohm.

All of the rules for two or more inductive reactances in series are the same as for resistances in series.

All of the rules for two or more capacitive reactances in parallel are the same as for resistances in parallel, and all of the rules for capacitive reactances in series are the same as for resistances in series.

# LESSON 23 – INDUCTORS FOR TELEVISION AND RADIO

These simple statements about the two kinds of reactances in parallel and in series are correct, but you may have read into the statements something more than they really say. They do not say that parallel and series reactances follow the same rules as parallel and series resistances. In order that those rules may apply you may connect together only inductive reactances (inductors) or you may connect together only capacitive reactances (capacitors).

When you connect inductors and capacitors together in a series circuit or in a parallel circuit all the similarities to series and parallel resistors go overboard. When an inductor and a capacitor are connected in series, and alternating voltage at one certain frequency is applied, there won't be any reactance at all. When an inductor and capacitor are in parallel, and a certain frequency is applied, the combined reactance will be infinitely greater than either separate reactance or any mathematical combination of the separate reactances. Then you would have series resonance and parallel resonance, which we are ready to consider very shortly.

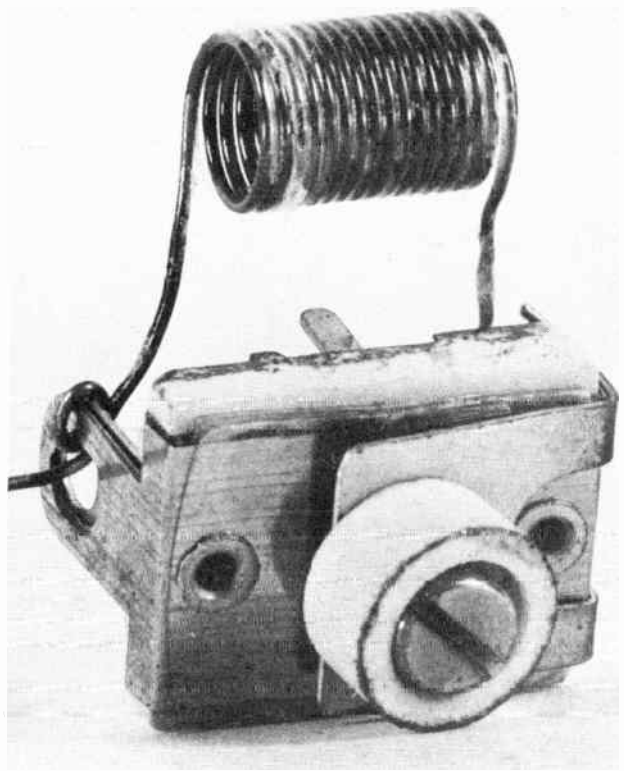

Fig. 13. An inductor and capacitor connected to provide great opposition to a certain frequency.

Fig. 13 shows a small inductor in parallel with an adjustable capacitor having mica dielectric. When the capacitor is suitably adjusted this combination will offer exceedingly great opposition to signal currents of one certain frequency, an opposition far greater than the reactance of either element at the same frequency.

**IMPEDANCE.** Many times in preceding pages we have used the term "opposition to alternating current" when you might have thought that the words reactance or resistance would have expressed the idea much better. We had to talk about opposition to alternating current because a better name, impedance, was not then part of our vocabulary.

The opposition to alternating currents which is offered by reactances and resistances in series or in parallel is called impedance. Because impedance is one kind of opposition to flow of current it is measured in ohms. In d-c circuits, where reactances

become zero or where there are no reactances, we need consider only resistance. But in a-c circuits containing inductors, capacitors, or both, there are reactances in addition to resistances. Then we must consider impedance, which is the opposition to alternating currents which results from the combined effects of resistance and either or both kinds of reactance.

Seldom if ever is it necessary to determine the exact value of an impedance during service operations, although a few important facts should be understood and kept in mind. To compute the impedance of a reactance (either kind) and a resistance in series with each other we proceed thus.

1. Find the square of the reactance, in ohms, by multiplying it by itself.

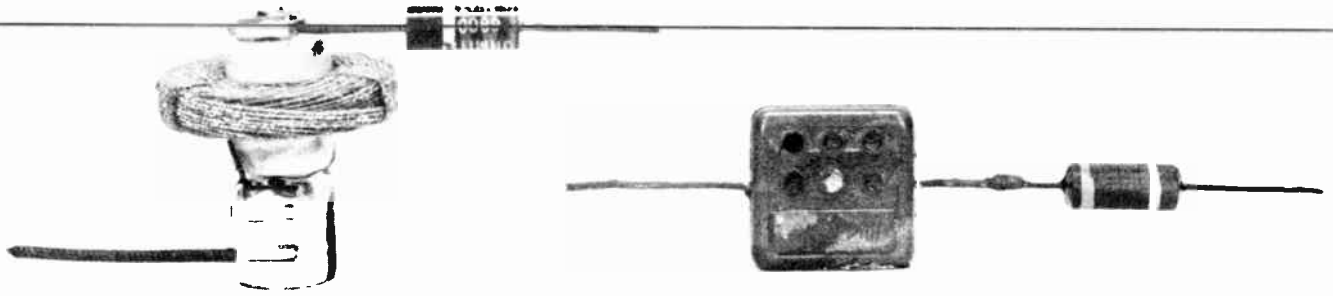

Fig. 14. Impedance is greater than either the reactance or the resistance when these elements are in series.

2. Find the square of the resistance, in ohms.

3. Add together the two squares.

4. Compute the square root of the sum of the squares.

If you work out a number of examples and examine the results, the following facts will become apparent.

The impedance always is greater than either the resistance or the reactance.

The impedance never exceeds the greater separate value, either resistance or reactance, by more than 41.4 per cent. For example if either separate value is 100 ohms, and the other is as much as 99.99 ohms, the

impedance will be very slightly less than 141.4 ohms.

In order that the impedance may be as much as  $1/8$  more than the value of the greater separate element, in ohms, the smaller one must be at least half as great as the larger one. In other words, unless the resistance and reactance are somewhere near equal, in ohms, the impedance won't be much greater than the value of whichever element is the greater, in ohms.

If the reactance and resistance are in parallel, the impedance may be found thus.

1. Multiply together the numbers of ohms of reactance and resistance.

2. Determine the series impedance of

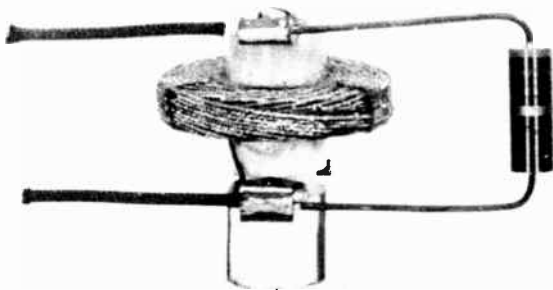

Fig. 15. Impedance is less than either the reactance or the resistance when these elements are in parallel.

## LESSON 23 – INDUCTORS FOR TELEVISION AND RADIO

the two elements according to the earlier rules.

3. Divide the number of ohms found in step 1 above by the number of ohms found in step 2 above.

The following facts apply to a reactance and a resistance in parallel.

Impedance is less than either the reactance or the resistance, in ohms.

Impedance never is less than 70.7 per cent of the smaller separate value, either

reactance or resistance, in ohms. Unless the larger value, either reactance or resistance, is less than two times the smaller one, the impedance will be 90 per cent or more of the smaller value, in ohms.

Considering all the rather involved facts relating to impedances of reactances and resistances in series and in parallel, and the methods of computing exact values, it is fortunate that we don't have to figure impedances on service jobs. The chief purpose of giving the preceding information is so that you will have a good general idea of what impedance means, when we have to talk about it later on.



# TELEVISION

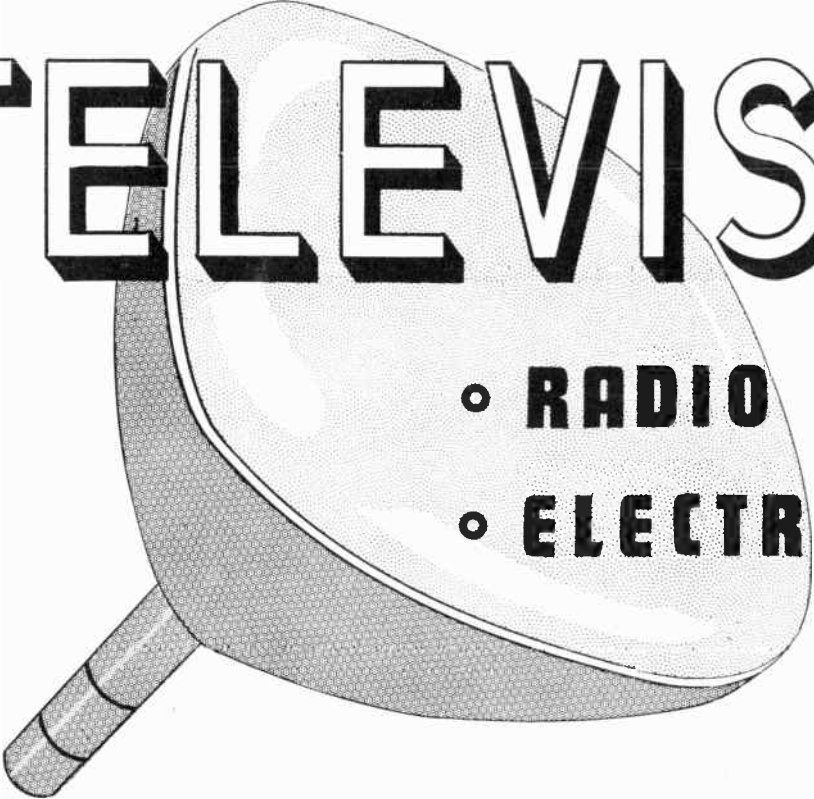

- RADIO
- ELECTRONICS

---

**LESSON 24 – RESONANCE AND SIGNAL SELECTION**

---

***Coyne School***  
*practical home training*

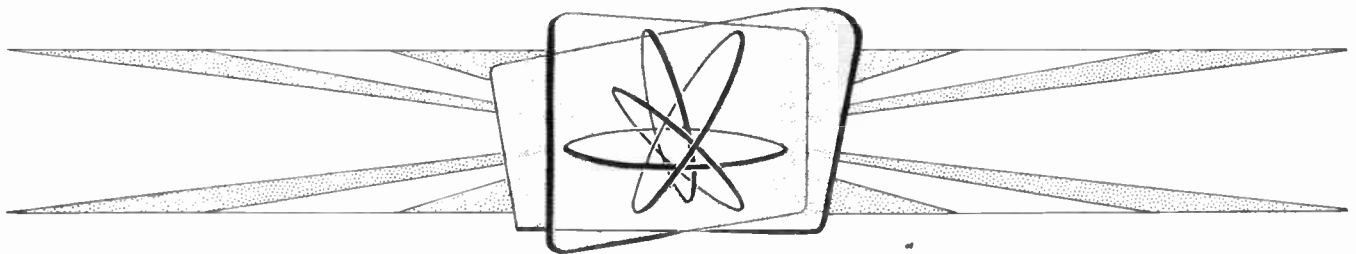

*Chicago, Illinois*

---

*Copyright, 1953 by Coyne Electrical School  
Chicago 12, Illinois  
All rights reserved*

Litho. in U.S.A.

## Lesson 24

# RESONANCE AND SIGNAL SELECTION



*Fig. 1. Signals are selected by adjusting various circuits to resonance at the desired frequencies. This is a view in the Coyne School.*

One of the first things that everyone learns about television and radio is that they must "tune" to the channel or station before any program appears. Were you to tell the set user that he is adjusting either the inductive or capacitive reactances to produce the condition of resonance at the frequency of the channel or station he probably would wonder what you are talking about.

When any circuit of any receiver is adjusted for resonance at the frequency of a desired signal there is maximum gain at that frequency and the signal comes through with

maximum possible strength. Signals at other frequencies receive relatively little amplification, and, if the receiver is satisfactorily "selective", programs other than the one wanted will not be seen or heard.

The explanation of resonance commences with three facts. First, when a capacitor is subjected to an alternating voltage whose frequency is increasing, the reactance of the capacitor decreases as frequency goes up. Second, when an inductor is subjected to an increase of frequency, the reactance increases as the frequency goes

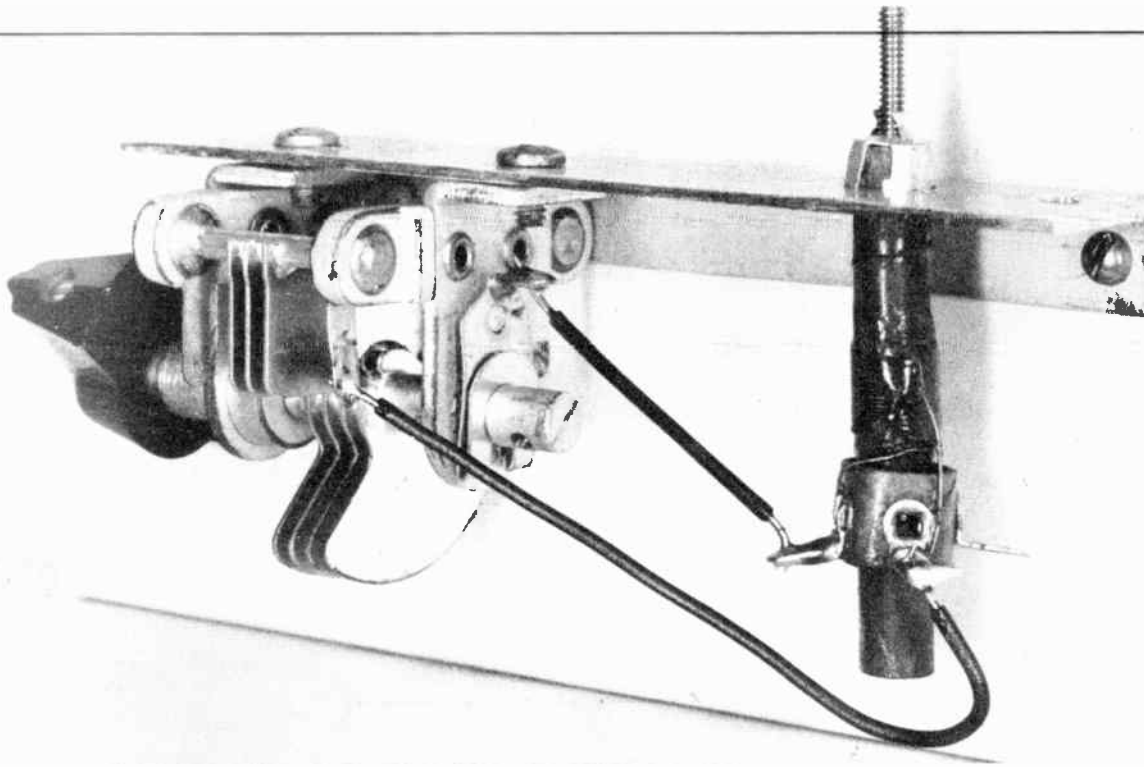

Fig. 2. *The inductor and capacitor used for testing resonant conditions.*

up. Third, no matter what may be the values of capacitance and inductance, there is some one frequency at which the reactances become equal, in ohms.

To check these statements we shall make some tests with the adjustable inductor and adjustable capacitor of Fig. 2. The inductor is a type used in many television i-f amplifiers. It consists of 21 turns of insulated wire closely spaced on a tube 0.3 inch in outside diameter. Inside is an iron core which may be moved up and down by the adjusting screw that sticks out at the top of the support. Moving the core will change the inductance between about 2.25 and 5.75 microhenrys. For our first experiments the inductance will be adjusted to 4.00 microhenrys.

Ordinarily there would be no adjustable capacitor used with such an inductor. Capacitance would be in other parts of the circuit, and would result from effects which we shall examine very shortly. To represent this capacitance in the test setup we are using the

adjustable capacitor, which may be set for any value of capacitance between about 6.5 and 50.0 mmf. The capacitance is adjusted to 16 mmf for our first tests.

The inductor and capacitor are connected in parallel with each other, so that the same voltage and frequency may be applied to both elements. When the frequency of applied voltage is varied between 10 and 30 mc, the inductive reactance of the inductor and the capacitive reactance of the capacitor change as shown by Fig. 3. Capacitive reactance decreases from about 1,000 ohms to 330 ohms, while inductive reactance increases from less than 300 ohms to about 750 ohms.

At a frequency just less than 20 mc the two reactances are equal, each having a value of about 500 ohms. The only reason for commencing with the inductor and capacitor in parallel was to allow simultaneous application of the same voltage of varying frequency to both units. Reactance depends on frequency. Regardless of voltage and regardless of how the inductor and capacitor are con-



## LESSON 24 – RESONANCE AND SIGNAL SELECTION

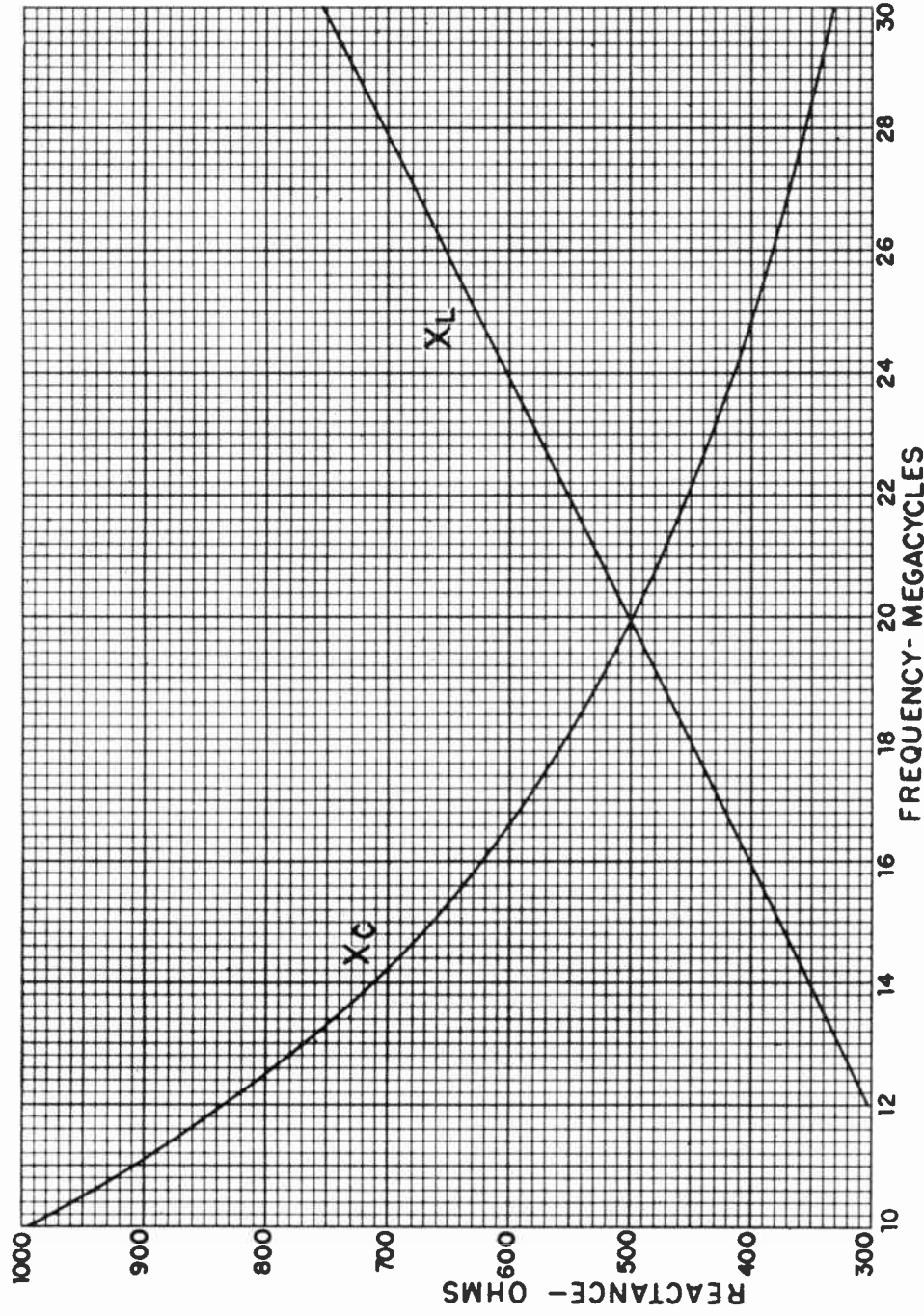

Fig. 3. . How the reactances of the inductor and capacitor change when frequency is varied.

ected together, and even when they are not connected together, the reactances would change with frequency just as shown by Fig. 3.

**SERIES RESONANCE.** In Fig. 4 the inductor and capacitor have been connected in series. No other change has been made. In this series circuit, current must be the same in the inductor, the capacitor, and in whatever resistance is possessed by the conductors.

Now let's see what will happen in the series circuit at a frequency well below that at which the reactances are equal, say at 14 mc. We note from Fig. 3 that, at 14 mc, the capacitive reactance is about 712 ohms and the inductive reactance is about 350 ohms. The capacitor has much the greater reactance and it furnishes most of the opposition to alternating current in the series

circuit. The inductor supplies relatively little opposition.

Next we may go to a frequency of 26 mc, well above  $f_r$  that for equal reactances. Here it is the inductive reactance that is the greater, with a value of about 652 ohms, while the capacitive reactance is only about 382 ohms. At this frequency the inductor is furnishing most of the opposition to current, and the capacitor is furnishing relatively little opposition.

What about the voltage drops across the capacitor and the inductor at the several frequencies that have been considered? Just to give a basis for figuring, we shall hold the alternating current at 4 ma for all frequencies. Were we dealing with direct current, the voltage drops would be computed in accordance with current and resistance. Since

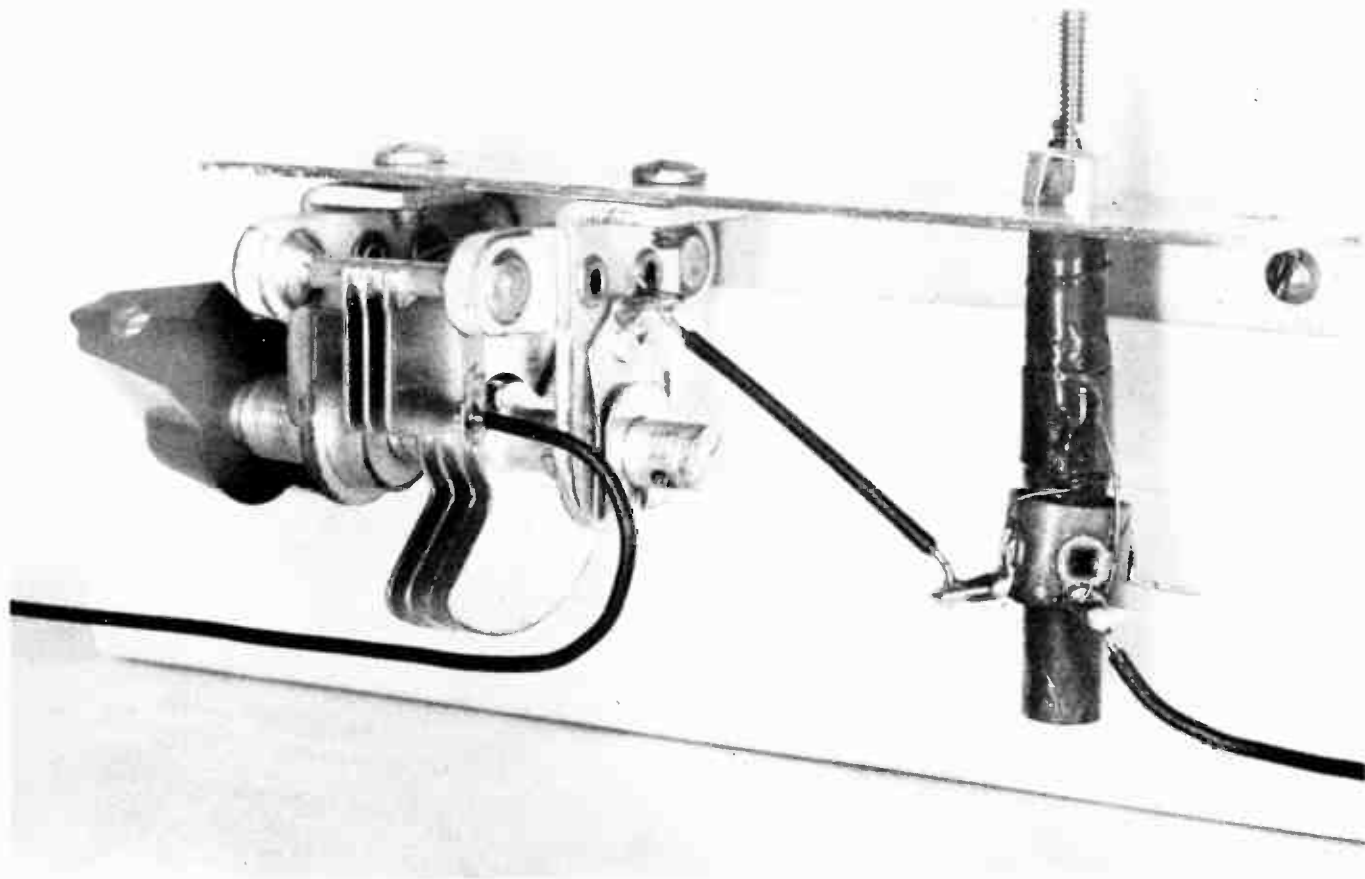

Fig. 4. The inductor and capacitor connected as a series resonant circuit.

we now have alternating current, the voltage drops may be computed from current and impedance, treating ohms of impedance just as we would treat ohms of resistance in a d-c circuit. There is negligible resistance in the inductor, the capacitor, and their connections. Therefore, we may assume that impedances are equal to reactances, and that voltage drops are equal to the product of milliamperes and "reactive" ohms divided by 1,000.

Since the current is constant in all circuit elements and at all frequencies, the voltage drops across the elements must be proportional to reactances. We find the rather peculiar combinations of voltages illustrated by Fig. 5. As we should expect, the voltage across the inductor increases with frequency, because inductive reactance increases with frequency. The voltage across the capacitor decreases with rising frequency

because capacitive reactance decreases with rising frequency.

The strange thing is that the sum of the voltage drops across inductor and capacitor always is much greater than the drop across the two of them in series. In nearly every case the voltage drops across each element are greater than across the entire series circuit. Most noteworthy of all is the fact that at the frequency for which the two reactances are equal, 20 mc, there is hardly any voltage required across the entire circuit, yet there is a drop of 2 volts across each separate element. Do not lose sight of the condition of constant current at all frequencies.

The question is, how can we explain why voltages across either the inductor, the capacitor, or both, are greater than voltages

# LESSON 24 – RESONANCE AND SIGNAL SELECTION

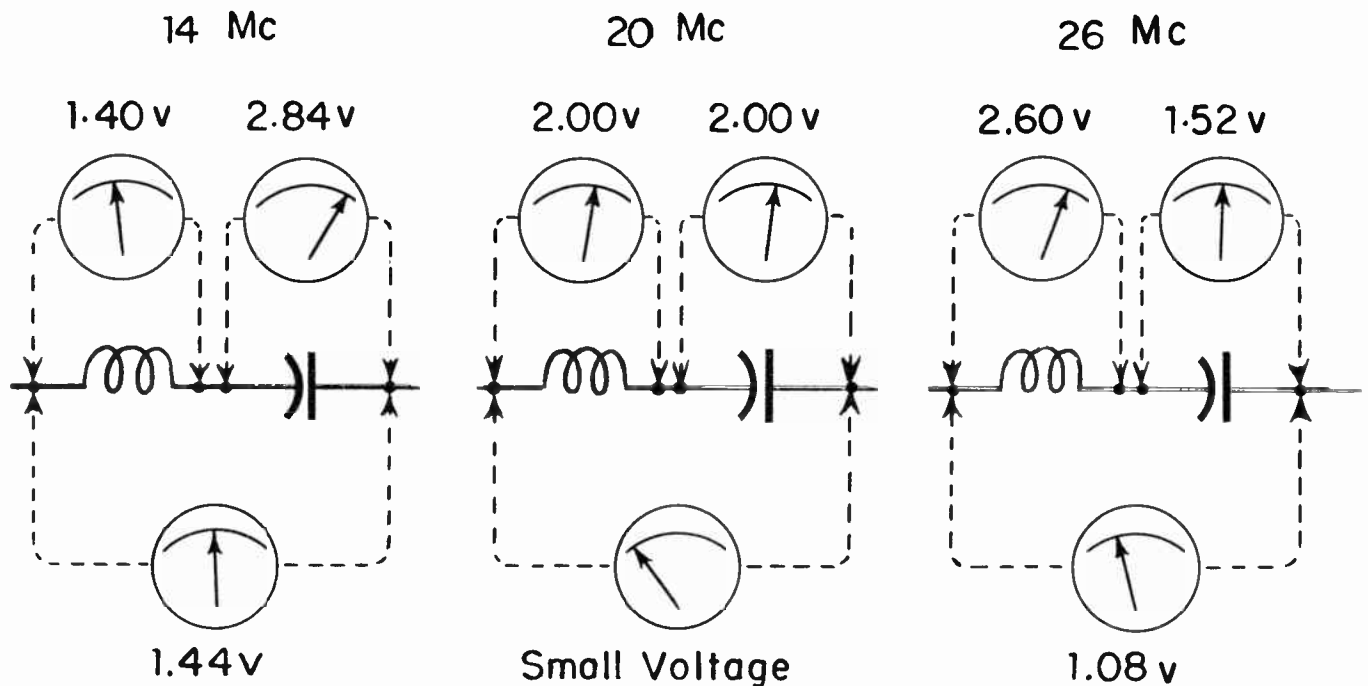

Fig. 5. The sum of the voltages across the inductor and capacitor is not the same as the voltage applied to the series circuit.

across the series connection? The answer is that voltages across the inductor and capacitor are of opposite polarity and one partially cancels the other. If you subtract one separate voltage from the other one at each frequency in Fig. 5 the difference will be the voltage across the series circuit.

For the frequency of equal reactances, 20 mc, the voltages across inductor and capacitor would not be absolutely equal. The voltages due to reactances would be equal and would cancel. But there would be very small voltages due to resistances of the two elements, and across the whole series circuit would be just enough voltage to overcome this resistance and cause the current of 4 ma to flow.

At every frequency except the one for which reactances become equal, the current is opposed by a net reactance equal to the difference between inductive and capacitive reactances, combined with the circuit resistance. In other words, the current is opposed by impedance. But at 20 mc, where the opposite reactances are equal, there is no remaining net reactance and the only opposition to current flow is that due to circuit

resistance. This is the frequency of resonance for inductance of 4 microhenrys and capacitance of 16 mmf.

The chief characteristics of a series resonant circuit are that at the frequency of resonance: 1. Impedance becomes minimum, it is equal only to circuit resistance. 2. For any given alternating voltage applied at the resonant frequency the current through the circuit will be maximum.

The oscilloscope shows how current varies in the series circuit when frequency is altered through the point of resonance. The trace at the left in Fig. 6 is a frequency response for current. Current is maximum at the top of the curve, and minimum at the bottom. We have maximum current, at the peak of the curve, when the frequency is 20 megacycles. At the outer ends of the curve the frequencies are somewhat less at 16 mc, and approximately 26 mc.

While frequency is increasing, current increases very slowly until about 18 mc, then increases rapidly, peaks, and drops back to a small value around 22 mc. At still higher



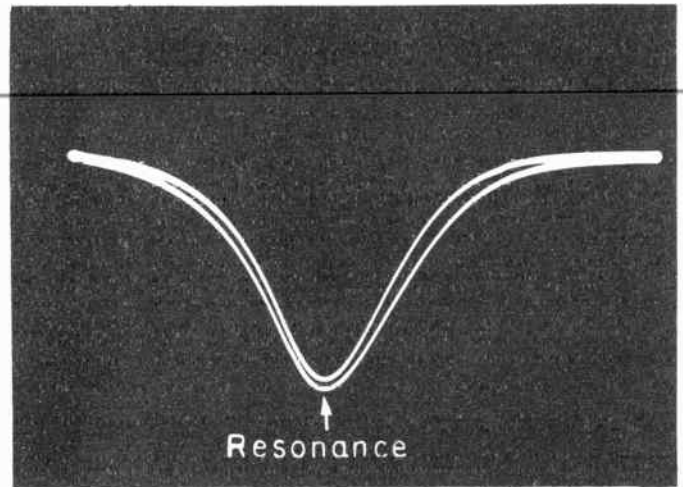
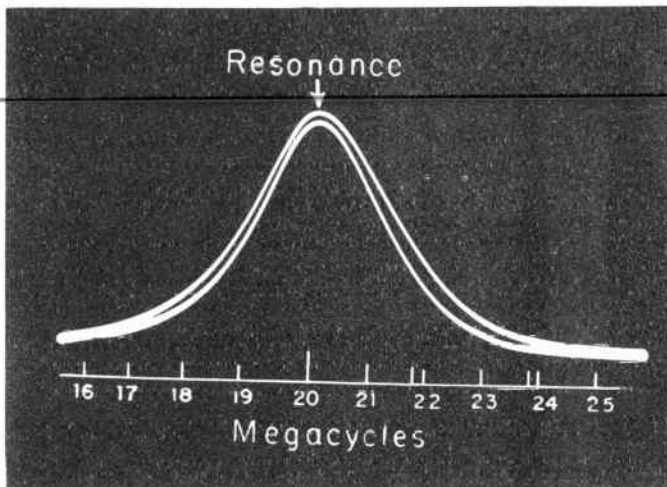

Fig. 6. How current varies in the series circuit at a range of frequencies including that of resonance (left) and how the varying impedance may be approximated by inverting the resonance curve (right).

frequencies there is a continued slow drop of current.

By turning the current curve upside down, as at the right in Fig. 6, we obtain a general idea of how impedance varies as frequency is altered. A true impedance curve would not be exactly like an upside-down current curve, but since current varies inversely as impedance we get a good approximation.

You may have noticed that there are two slightly separated trace lines on the current response. One of these represents changes of current while frequency is increasing. The other shows changes of current while frequency is decreasing. Our source of alternating voltage for these tests with the oscilloscope is a signal generator whose frequency varies continually between the lowest and highest frequencies. This is a "sweep generator", a type commonly used during television servicing for observing either current or voltage-gain responses.

Series resonant circuits are used when, all frequencies except one, or a narrow band are to be strongly opposed while the chosen frequency or band is allowed to pass quite freely. This is the same as saying that a series resonant circuit is used when impedance is to be minimum at a frequency or

narrow band of frequencies, and is to be relatively great at all other frequencies.

Looking back at Fig. 3, we may draw two rather important conclusions with reference to the series circuit. First, at frequencies lower than resonance most of the reactance is capacitive. Therefore, the entire series circuit acts very much like a circuit containing capacitance and circuit resistance. Second, at frequencies higher than resonance most of the reactance is inductive. Therefore the circuit acts much like one containing inductance and circuit resistance. Quite often you will hear it mentioned that a series resonant circuit is capacitive at frequencies below resonance, and inductive at frequencies above resonance.

**PARALLEL RESONANCE.** Now we shall change the connections of the inductor and capacitor to a parallel arrangement, as first pictured by Fig. 2. The change is illustrated by Fig. 7. With the series circuit, diagrams 1 and 2, the a-c source is connected to one side of the inductor at a and to one side of the capacitor at b, with the inductor and capacitor connected together at c.

Earlier we learned that voltages across an inductor and capacitor are of opposite polarity at every instant, and that the voltages oppose each other. Still earlier we learned



# LESSON 24 – RESONANCE AND SIGNAL SELECTION

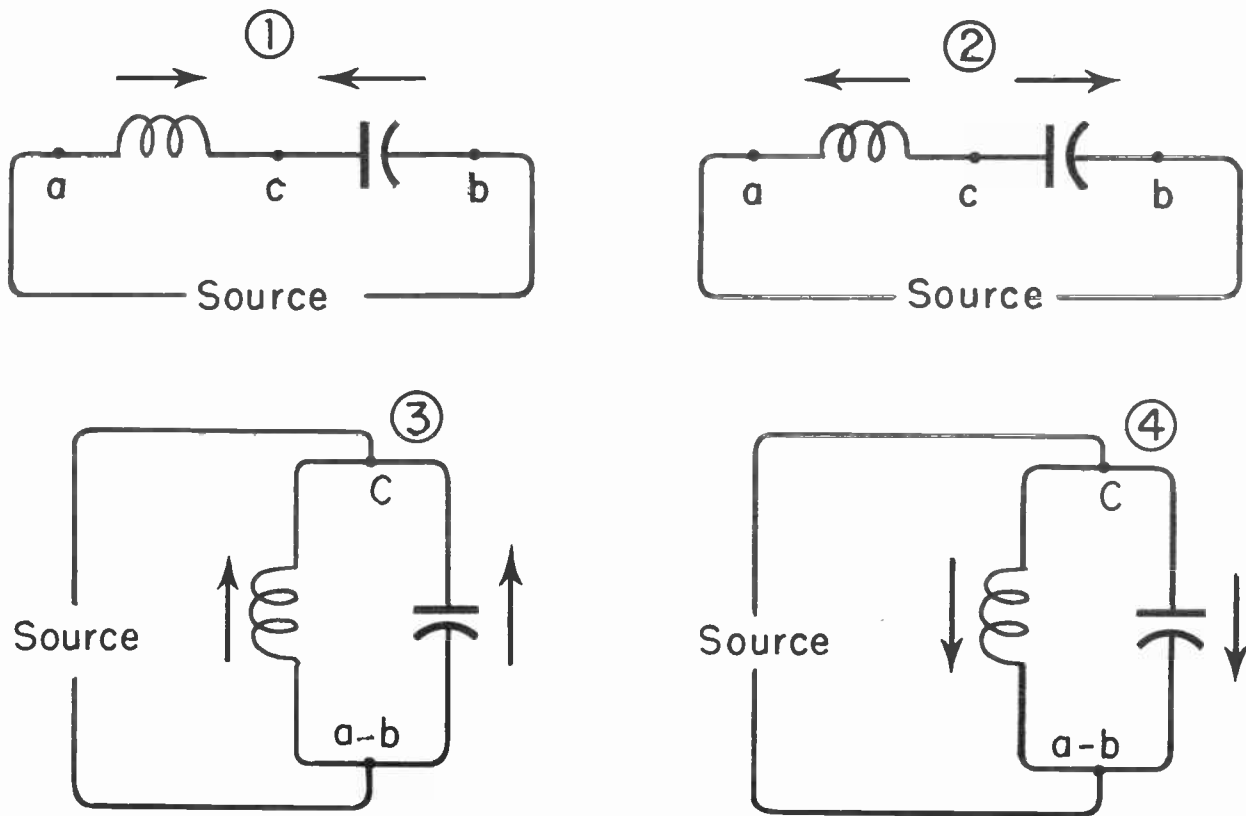

Fig. 7. By folding the series circuit on itself we obtain a parallel resonant circuit.

that self-induced emf in an inductor and the voltages built up in a capacitor during charge and discharge oppose the voltage from the external source. Then it must be true that the internal voltages induced and produced in inductor and capacitor are of such polarity as to oppose the externally applied voltage at every instant during every alternating cycle.

During one half-cycle the polarities of emf and voltage appearing in the inductor and capacitor are as shown by arrows on diagram 1 of Fig. 7, and during opposite half-cycles these polarities are as shown by arrows on diagram 2.

The polarities of internally produced emf's or voltages in the inductor and capacitor are not changed when going from series to parallel, because they depend not on the kind of circuit connections but on the fact that one element is an inductor and the other a capacitor. Then these polarities will be as shown by arrows on diagrams 3 and 4. During the half cycle represented by diagram 1

both of the polarity arrows point toward point c, and both point toward c in diagram 3. In series diagram 2 both polarity arrows point away from c, and this is the way they point in the parallel diagram 4.

The internally produced emf's and voltages in the inductor and capacitor connected in series act oppositely to each other, and at resonance they cancel. With the parallel connection these emf's and voltages are acting in the same direction with reference to the source; both are up or both down at the same times. There is no cancellation at resonance, rather there is a combining of the two forces that are opposing voltage from the external source.

We should remember that the self-induced emf in an inductor is what causes the effect called inductive reactance, and that the opposing voltage built up in a capacitor accounts for the effect called capacitive reactance. Therefore, instead of talking about internally produced emf's and voltages we may talk about reactances.

# COYNE - *television home training*

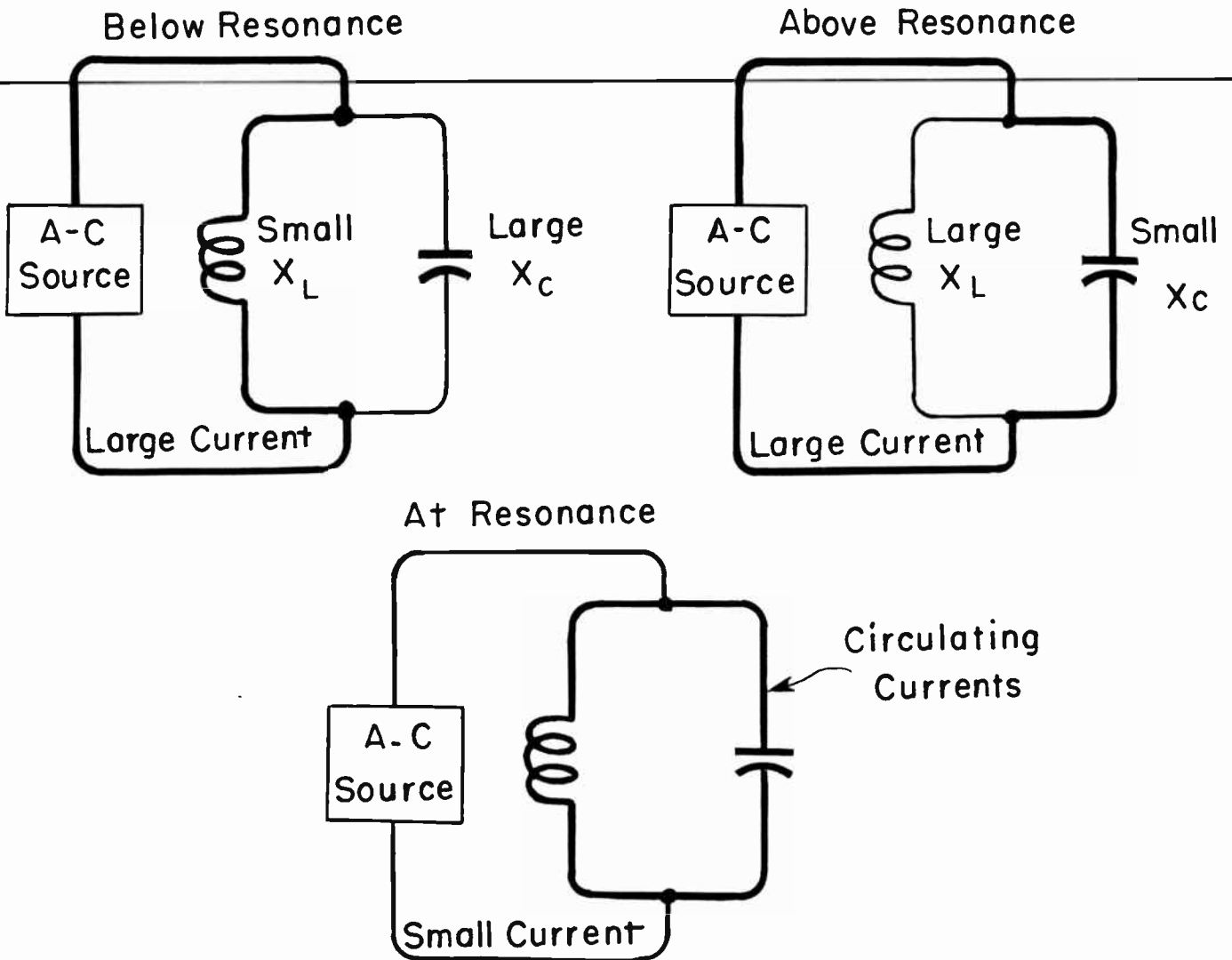

Fig. 8. Currents at various frequencies in the inductor and capacitor connected in parallel.

The conclusion to be drawn is this. At the frequency of resonance the reactances with inductor and capacitor in parallel act together to oppose voltage from the source. Were it not for circuit resistance, the impedance of the parallel circuit at resonance would be infinitely great. This may be proven by working with formulas for impedance and getting rid of the resistance term.

Now let's look at this whole performance from another standpoint, as illustrated by Fig. 8. At frequencies below resonance the inductive reactance of the inductor is much less than the capacitive reactance of the capacitor. Most of the current from the source will flow in the smaller reactance, in

the inductor, and relatively little will flow in the capacitor. The current from the source will depend on how small is the inductive reactance, and because this reactance decreases as frequency decreases, the current will increase as frequency drops.

At frequencies above resonance the capacitive reactance is less than the inductive reactance. Consequently, most of the current from the source will flow in the capacitor, and relatively little in the inductor. Source current, and current through the parallel circuit, will depend on how small is the capacitive reactance. Since this reactance decreases as frequency rises, the current will increase with rising frequency.

## LESSON 24 – RESONANCE AND SIGNAL SELECTION

At the frequency of resonance the two reactances are equal. Because this is a parallel circuit the voltage across the inductor is the same as across the capacitor. With equal reactances and equal voltages the currents must be equal in the two elements which are in parallel. But we know that, at resonance, the parallel circuit has exceedingly great impedance with reference to the source. As a result, there can be very little current from the source. Currents in the inductor and capacitor are much greater than current from the source.

This seemingly strange condition comes about because currents in the resonant circuit, at resonance, circulate back and forth between inductor and capacitor. The explanation goes away back to the time when we said that capacitance is a measure of how much electric energy a capacitor is capable of storing in the form of an electric field which is produced between the plates and in the dielectric.

When capacitor plates are charged with differing quantities of electrons there is a potential difference between them. Between any conductors which are at different potentials there is an electric field. It really is an electric field which is built up when a capacitor is charged, and which disappears when the capacitor is discharged. Energy remains in or is stored in the field so long as the field exists.

We said also that inductance is a measure of how much magnetic energy an inductor is capable of storing in the form of a magnetic field which is formed in and around the wire of which the inductor is made. When current flows in any conductor there are magnetic lines of force and a magnetic field around the conductor. Part of the work done by the current overcomes conductor resistance. Another part produces and maintains the magnetic lines or magnetic field.

After the current has done the work of establishing a magnetic field whose strength and extent are proportional to the current, no more work is needed to maintain the field - although the current must continue to flow. If current increases still more, it does additional work in making a still stronger and

larger magnetic field. All of the work which has been done in forming any given magnetic field remains in the form of magnetic energy until the current changes.

If current tends to decrease for any reason, usually because of less voltage on the conductor, the field lines shrink back toward and into the conductor. This continues until the field again is proportional to the value of current. As the field shrinks, it returns part of its energy to the conductor and thence to the source. If current drops to zero all of the energy goes back into the conductor. Strange as it may seem, no energy is consumed in the process of forming, expanding, and contracting a magnetic field, provided only that the magnetic lines are called on to do no work and impart none of their energy to other parts which may be near the conductor. All of the energy put into the magnetic field is returned when the field disappears.

It is true also that no energy is consumed during the process of charging and discharging a capacitance. Every bit of energy put into the electric field during charge will be returned to the source during discharge, other than the small portion needed for overcoming resistance.

How all this works out in the parallel resonant circuit, at resonance, is shown by Fig. 9. We commence, at 1, with an instant during which all the energy is in the magnetic field of the inductor, with the north magnetic pole of the inductor at the top and its south magnetic pole at the bottom. The capacitor is uncharged.

At 2 the magnetic field is collapsing and returning energy to the inductor. This energy induces an emf, since field lines are cutting the inductor turns, and the emf causes current to flow as shown by arrows. This current is charging the capacitor in the marked polarity.

At 3 all of the energy has left the inductor, its magnetic field is gone, and the energy is in the electric field of the capacitor. The capacitor is fully charged. Flow of current has ceased for the moment.

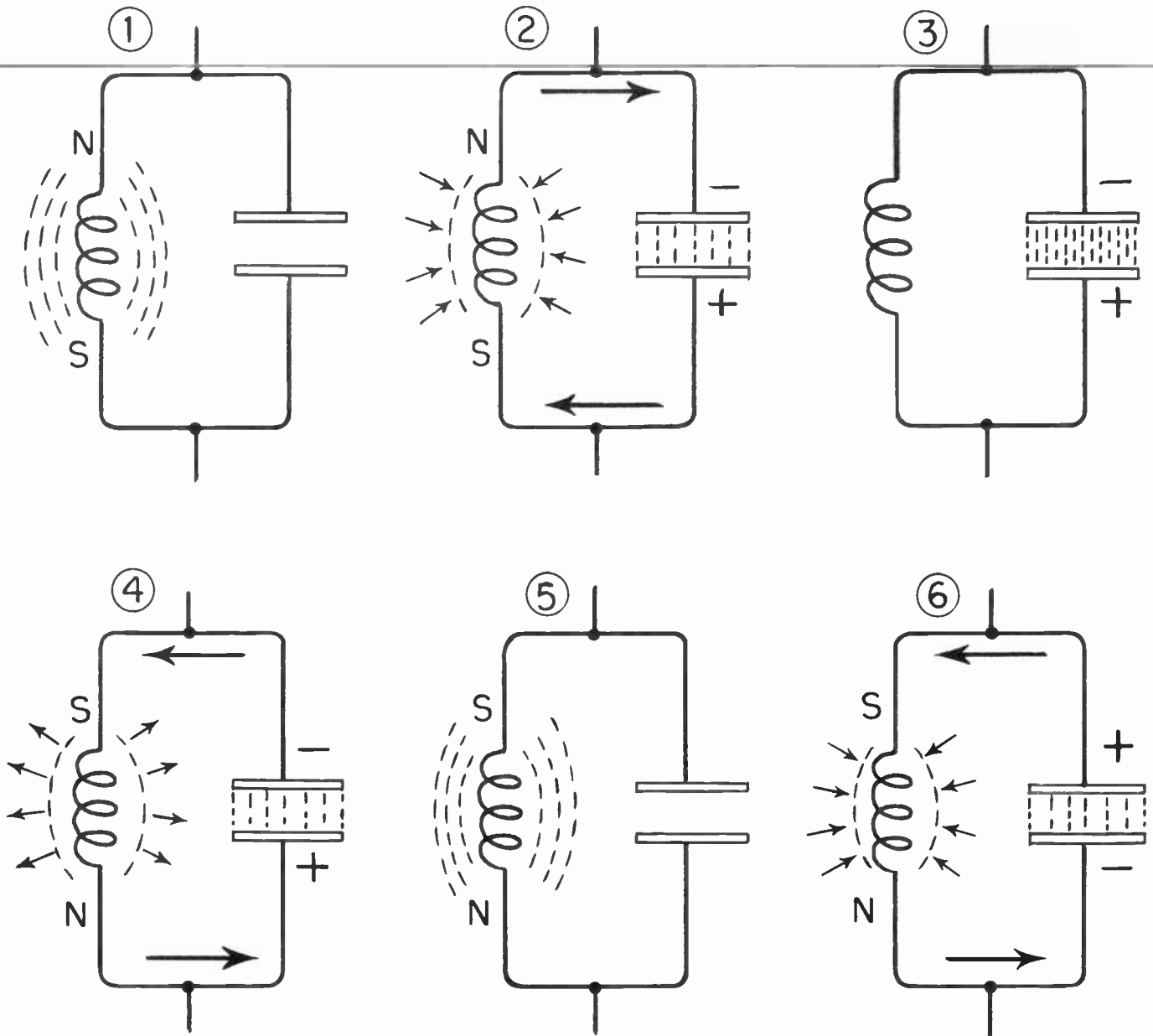

Fig. 9. At resonance there are strong currents circulating between the paralleled inductor and capacitor.

At 4 the capacitor is discharging. As shown by arrows, electrons leaving the negative plate flow to and through the inductor, returning to the positive plate of the capacitor. This electron flow is a current which is building up a new magnetic field around the inductor. The current has reversed with respect to diagram 2, and the magnetic field is of opposite polarity.

At 5 all of the energy has gone back into a magnetic field around the inductor. There is no current.

At 6 the magnetic field is once more collapsing, which induces an emf in the inductor and causes current to flow between inductor and capacitor as shown by arrows. The capacitor is being charged in a polarity the reverse of that in preceding diagram, because the direction of current has reversed.

We might continue by showing that the capacitor becomes fully charged in this reversed polarity. Then the capacitor would discharge and send its energy over into the inductor. When all of the energy returned to



## LESSON 24 – RESONANCE AND SIGNAL SELECTION

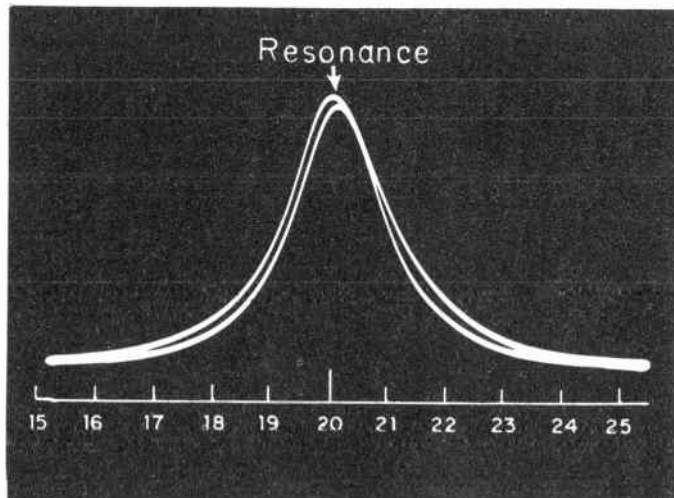

Fig.10. Frequency response for voltage across the parallel resonant circuit.

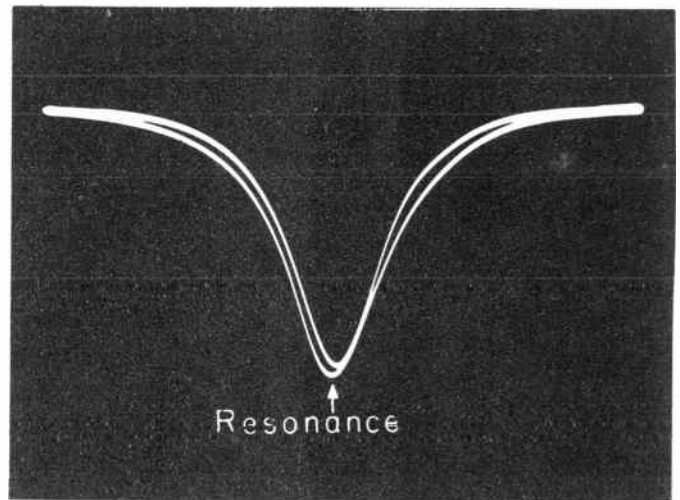

Fig.11. Inverting the voltage curve shows how current varies with frequency in the parallel circuit.

the magnetic field of the inductor we would be right back at the condition of diagram 1.

Currents circulate back and forth between inductor and capacitor at the frequency of resonance. No energy is consumed, or none is lost, in buildup and collapse of the magnetic or electric fields. Other than for energy lost as heat in the conductors the current would circulate forever. To continue these circulating or oscillating currents it is necessary that the source furnish only enough energy to overcome circuit resistance, and this is why current from the source is so very small at resonance.

As is usual when we wish to have visible evidence of what is happening in television circuits we turn to the oscilloscope. Fig. 10 is a trace showing frequency response of the parallel resonant circuit at resonance. This is a voltage trace, not a current trace as in the case of Fig. 6 for the series resonant circuit. The change of voltage with frequency is that occurring across the inductor and capacitor.

At frequencies well below resonance there is very little parallel reactance and impedance, and across this small impedance there is a relatively small drop of voltage - just as there would be relatively small voltage drop across a small resistance.

At the resonant frequency, 20 mc, there is high impedance and the voltage across this impedance is proportionately high. As the frequency goes above resonance there is a decrease of parallel impedance, and the voltage drops proportionately. This voltage response for the parallel circuit is shaped much like the current response for the series circuit, except that the resonant peak is somewhat sharper.

Since voltage drop is proportional to impedance, the curve of Fig. 10 may be considered as a fairly accurate picture of the manner in which the impedance of a parallel circuit changes as the frequency is varied from below resonance to and above resonance.

When we invert the voltage curve, as in Fig. 11, it gives a good idea of how current from the source will vary with frequency applied to a parallel resonant circuit.

The most valuable characteristics of a parallel resonant circuit at resonance are: First, impedance is maximum. Second, current from a source is minimum. Third, when used as the load in the plate circuit of a tube, the impedance can be made maximum for any given frequency or narrow band of frequencies, and there will be maximum voltage gain at this frequency or band.

## COYNE - *television home training*

As may be seen by looking again at Fig. 8, at frequencies below resonance most of the source current flows in the inductor. Therefore, so far as the source is concerned, the parallel circuit acts like an inductance or like an inductive circuit. The opposite is true at frequencies above resonance. Then most of the source current flows in the capacitor. So far as the source is concerned, the parallel circuit acts like a capacitance or like a capacitive circuit at frequencies higher than the resonant frequency. These inductive and capacitive actions of the parallel circuit are just the opposite of the actions of a series circuit at frequencies below and above resonance.

### COMPUTATIONS FOR RESONANCE.

At the end of this lesson are given a number of formulas for computing resonant frequencies of various combinations of capacitance and inductance. There are formulas also for computing the capacitance required with a given inductance for resonance at some certain frequency, and formulas for computing the required inductance when frequency and capacitance are known.

The frequency of resonance depends only on the capacitance and inductance in a circuit. This frequency is not affected one way or the other by circuit resistance. It is possible to have resonance at any frequency by using a relatively large capacitance and small inductance, or by using a relatively small capacitance and large inductance.

You will recall that we obtained resonance at approximately 20 mc with capacitance of about 16 mmf and inductance of about 4 microhenrys. The product of 16 times 4 is 64. We would obtain resonance at the same frequency with any other combination of capacitance and inductance whose product is 64. We might use 64 mmf and 1 microhenry, or 8 mmf and 8 microhenrys, or 1 mmf and 64 microhenrys, and all these combinations would be resonant at the same frequency.

For every frequency there is one certain product of capacitance and inductance which will produce the condition of resonance. This product is called the oscillation constant, because it relates to the frequency at

which currents circulate or oscillate back and forth between capacitance and inductance, as in Fig. 9. Another name sometimes used is L-C constant, using the letter symbols for inductance and capacitance.

The oscillation constant depends on the units in which frequency, capacitance, and inductance are measured. When these units are, respectively, megacycles, micro-microfarads, and microhenrys, the constant is found by dividing 25,330 by the square of the number of megacycles. As an example, supposing that we wish to determine the oscillation constant for a frequency of 20 mc. The square of 20 is 400. Dividing 25,330 by 400 gives 63.325 as the oscillation constant for 20 mc when capacitance is in number of mmf and inductance is in number of microhenrys.

In one of the preceding paragraphs it was noted that resonance at about 20 mc was secured with 16 mmf and 4 microhenrys, whose product is 64. This product is very close to the oscillation constant for 20 mc, which we have just computed as 63.325.

If frequency is measured in kilocycles, capacitance in microfarads, and inductance in microhenrys, we still may find the oscillation constant from dividing 25,330 by the square of the frequency, which now is in kilocycles. Using kilocycles instead of megacycles just compensates for using microfarads instead of micro-microfarads.

Fig. 12 is an alignment chart from which may be read the combinations of capacitance and inductance which are resonant at various frequencies. Most of the inductance scale is graduated in microhenrys, with only the upper end in millihenrys. R-f chokes often have inductances within the millihenry range here shown. The capacitance scale is graduated in microfarads at the top and in micro-microfarads at the bottom. To change any number of mmf to the equivalent number of mf, move the decimal point six places to the left. To change mf to mmf, move the decimal point six places to the right. This chart covers all values of inductance and capacitance usually found in resonant circuits for radio and for very-high frequency television.

# LESSON 24 – RESONANCE AND SIGNAL SELECTION

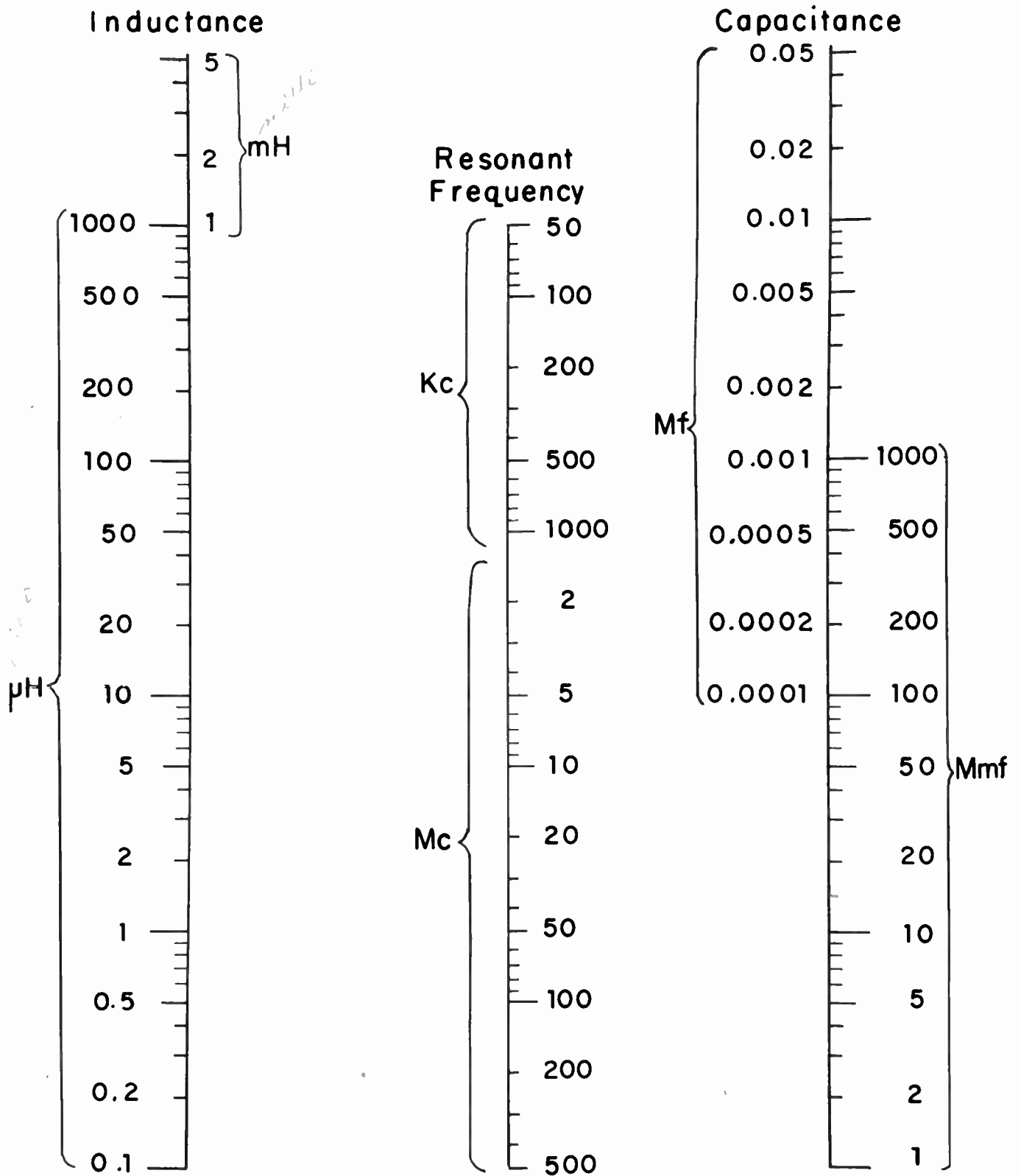

Fig. 12. Alignment chart for inductance, capacitance, and frequency of resonance.

By laying the straightedge on known values of inductance and capacitance you can read their resonant frequency. With the straightedge on a known inductance and a de-

sired resonant frequency it is possible to determine the capacitance required. When the straightedge is on a known capacitance and a desired frequency you can read the

## COYNE - *television home training*

inductance required for this frequency of resonance.

It is interesting to hold the straightedge at any one frequency on the center scale while moving the outer ends up and down on the outer scales. This will give a good idea of the almost limitless combinations of inductance and capacitance which would be resonant at that one frequency.

The chart illustrates many important facts relating to resonance. You should practice with the chart and a straightedge until you are sure that each of the following statements is true.

1. To maintain the same resonant frequency when using more inductance, it is necessary to use less capacitance. Also, more capacitance requires less inductance.

2. To maintain the same resonant frequency when using more capacitance, it is necessary to have less inductance. And less capacitance requires more inductances.

3. When using the same capacitance, more inductance will lower the resonant frequency, while using less inductance will raise the frequency.

4. When using the same inductance, more capacitance will lower the resonant frequency, while less capacitance will raise the frequency.

5. If you reduce both the inductance and the capacitance, frequency goes up.

6. If you increase both the inductance and the capacitance, frequency of resonance goes down.

7. Inductance and capacitance act alike with respect to resonant frequency. An increase of either or both will lower the frequency. A decrease of either or both will raise the frequency.

PHASE. Often we have talked about two alternating voltages or currents as being of the same or opposite polarity at given instants of time. Even more often there will

be two alternating voltages or currents of the same polarity during only parts of the cycles followed by one of them, and of different polarities during other parts of every cycle. Simple statements about polarity will not describe such conditions, we must talk about phase relations.

Phase describes the time at which one alternating voltage or current goes through the changes of each cycle with reference to the times at which another voltage or current goes through similar changes in its own cycles. An understanding of phase is especially important in television. To mention only a few cases, almost every method of holding deflection systems in synchronization with signals depends on phase relations; there are phase detectors in many sync sections; f-m sections, f-m sound detectors depend on phase relations; sweep generators used in service work require phasing controls.

The simplest and easiest way to get acquainted with phase relations will be to look at them with the help of an oscilloscope and an electronic switch. The latter is a service instrument that allows viewing two voltages or currents at the same time. The quantities compared may be two voltages, or two currents, or a voltage and a current. To simplify matters we shall hereafter refer to either an alternating voltage or an alternating current as an alternating quantity.

Fig. 13 shows two alternating quantities that are in phase. This means that both go through their positive peaks, their negative peaks, and the intervening zero values at the same instants of time.

Fig. 14 shows two alternating quantities that are of opposite phase. The positive peaks of one occur at the same instants as the negative peaks of the other quantity, and negative peaks of the first quantity occur at the same instants as positive peaks of the other one. Note that both quantities go through their zero values at the same instants.

Fig. 15 illustrates a condition described as out of phase. Neither the peaks or the zeros of either quantity occur at the same



# COYNE - television home training

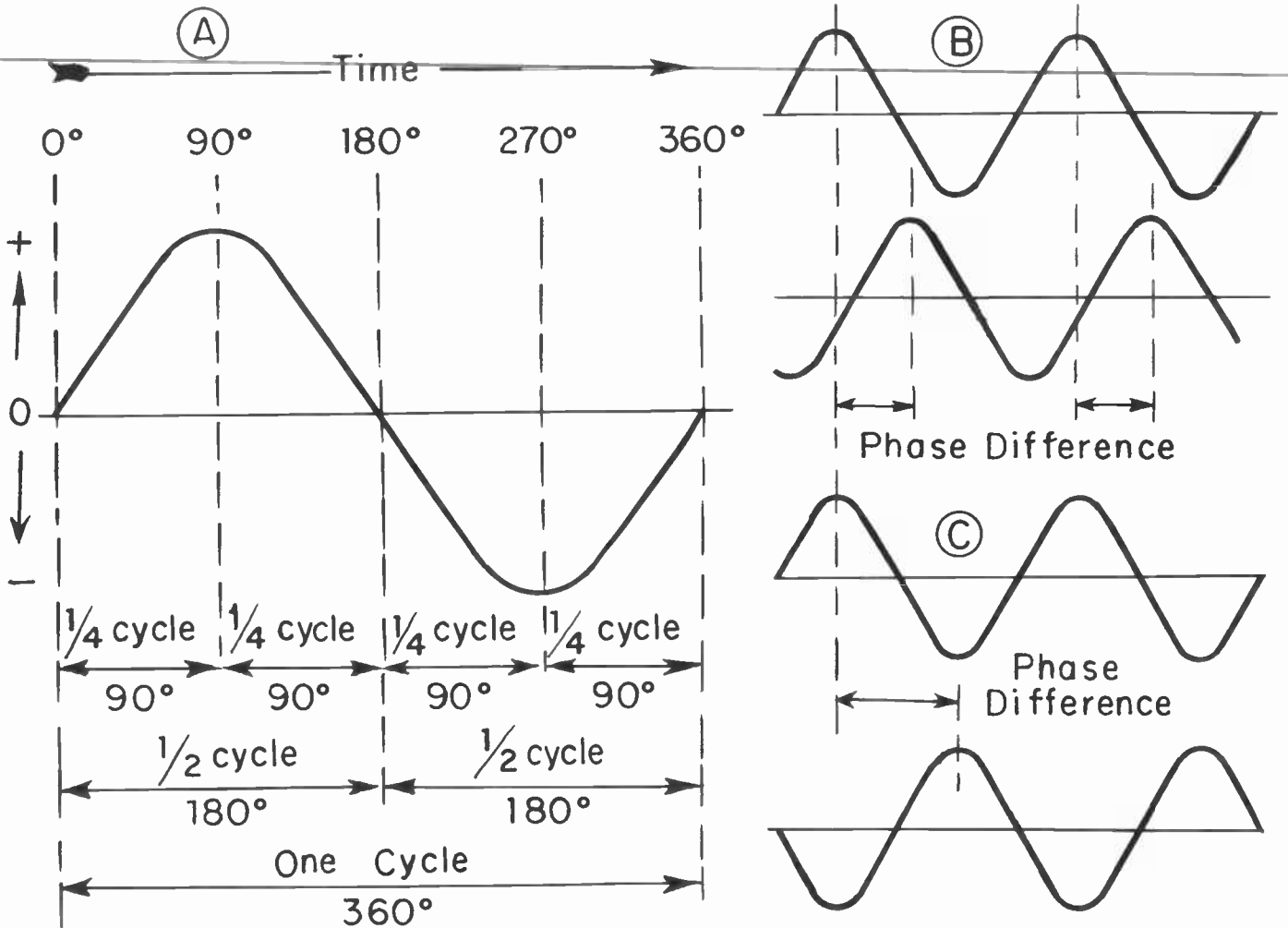

Fig. 16. An illustration of some of the terms used when describing phase relations.

difference. It is the difference between the instants of positive peaks or of negative peaks in the two quantities. Phase difference may be measured and expressed as so many degrees, or, if it is a simple fraction of the time for one cycle, the difference may be given as a quarter-cycle or some other fraction.

At C in Fig. 16 we have the condition of opposite phase, just as in Fig. 14. Here the phase difference is a half-cycle or is 180 degrees. When phase differences are expressed in electrical degrees they may be called phase angles.

In preceding figures the two electrical quantities are shown on separate horizontal lines for their zero values. In Fig. 17 the two quantities are shown on the same line for their zero values. There is a phase dif-

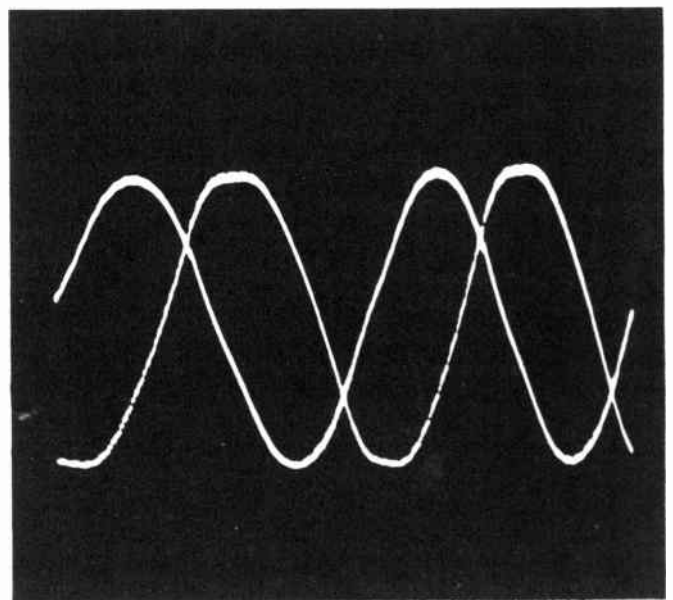

Fig. 17. A phase difference of more than 90 degrees.

## LESSON 24 – RESONANCE AND SIGNAL SELECTION

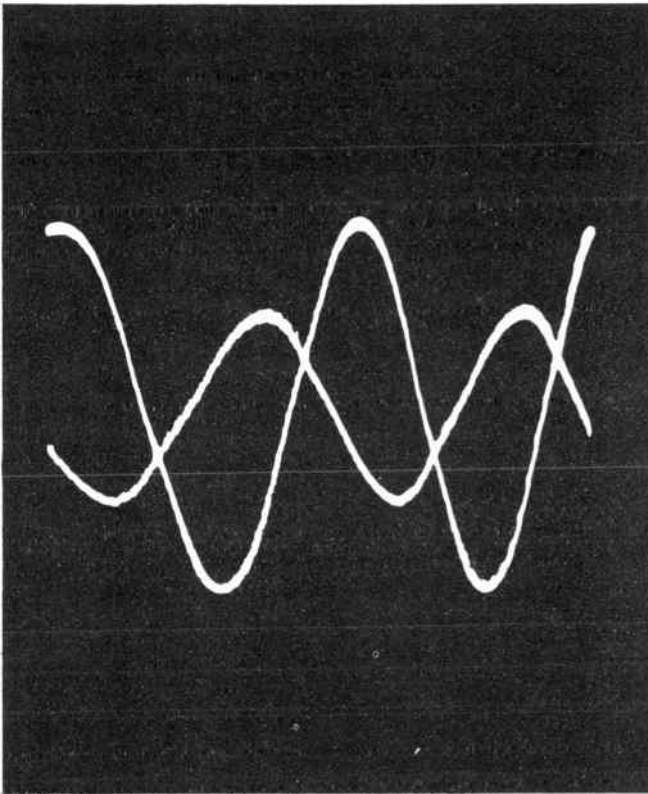

Fig. 18. Another phase difference of more than 90 degrees.

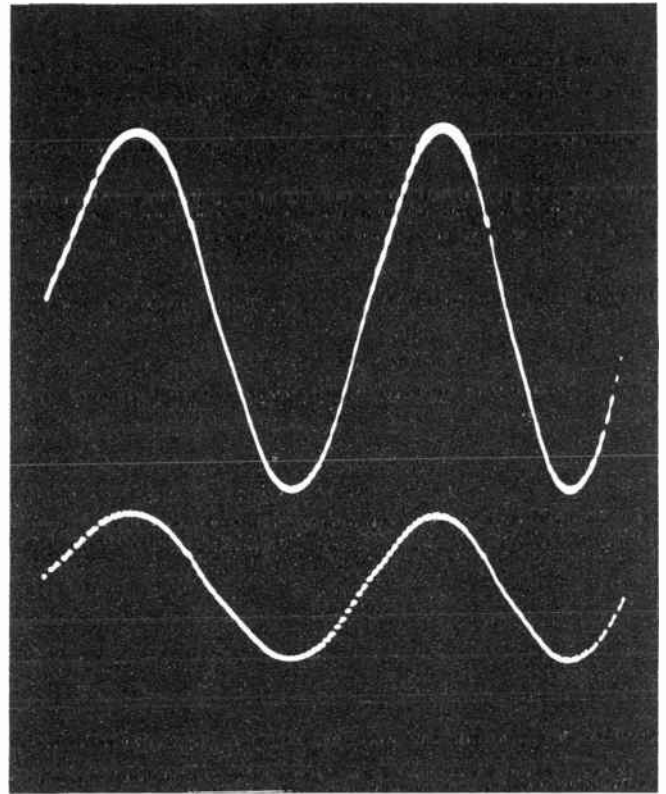

Fig. 20. We may speak of phase relations regardless of frequencies.

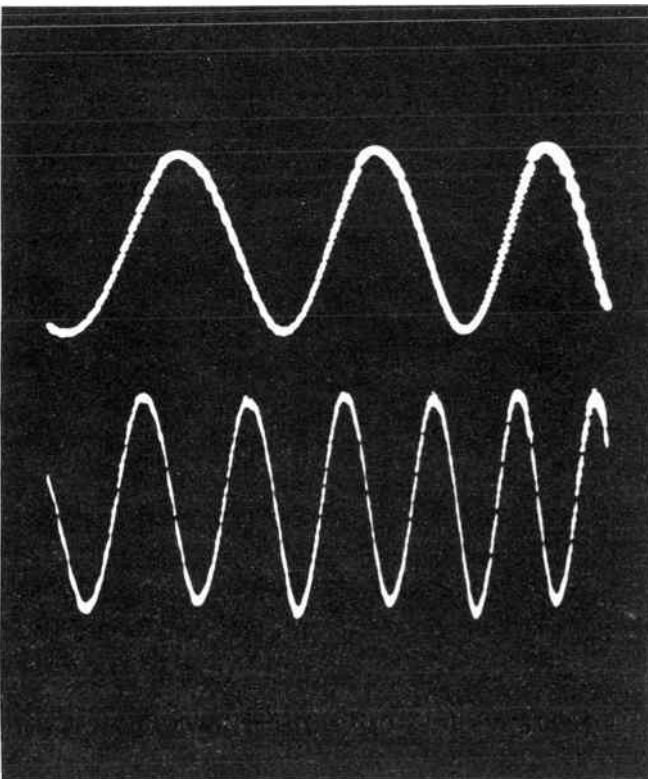

Fig. 19. Amplitude is not considered in discussing phase relations.

ference of more than 90 degrees, something which often occurs in television systems of various kinds where two different voltages are put into the same circuit. Fig. 18 is another example of two alternating quantities shown on the same line for zero values. Again we have an out of phase relation with a difference or a phase angle or more than 90 degrees.

Phase relations are not affected by amplitudes of the two quantities. Amplitudes are larger and smaller in Fig. 18 where the quantities are out of phase. There are different amplitudes again in Fig. 19, where the two quantities are in phase.

Phase is not necessarily related to frequency, although as a general rule the two quantities are of the same frequency. In Fig. 20 the quantity shown by the bottom trace is at twice the frequency of the one shown by the top trace.

It is not necessary that the two quantities be of the same waveform. In Fig. 21 the

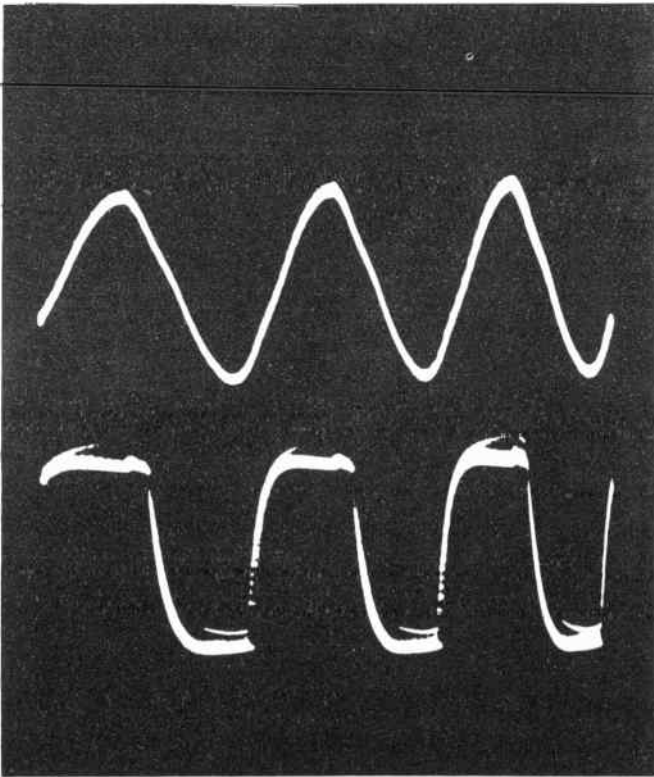

Fig. 21. The sine wave and the square wave are very nearly in phase, both commence to rise and fall at about the same time.

quantity shown by the top trace is a somewhat distorted sine wave, while the one shown by the bottom trace is a distorted square wave. Combinations of different waveforms are common in television control systems. We may find a sine wave combined with the square wave of a sync pulse, or there may be a combination of two square waves from two different sources.

The distortions of the waves in Fig. 21 would not necessarily be present in television or radio circuits. They are due largely to the fact that the two quantities have to come together at the input circuit to the oscilloscope.

EFFECTS OF CAPACITANCE, INDUCTANCE, AND RESISTANCE. When positive and negative peaks of one alternating quantity occur earlier in time than similar peaks of the other quantity, the first one is said to lead the second, or to be in leading phase. Also, the quantity whose peaks occur later in time than similar peaks of the other quantity

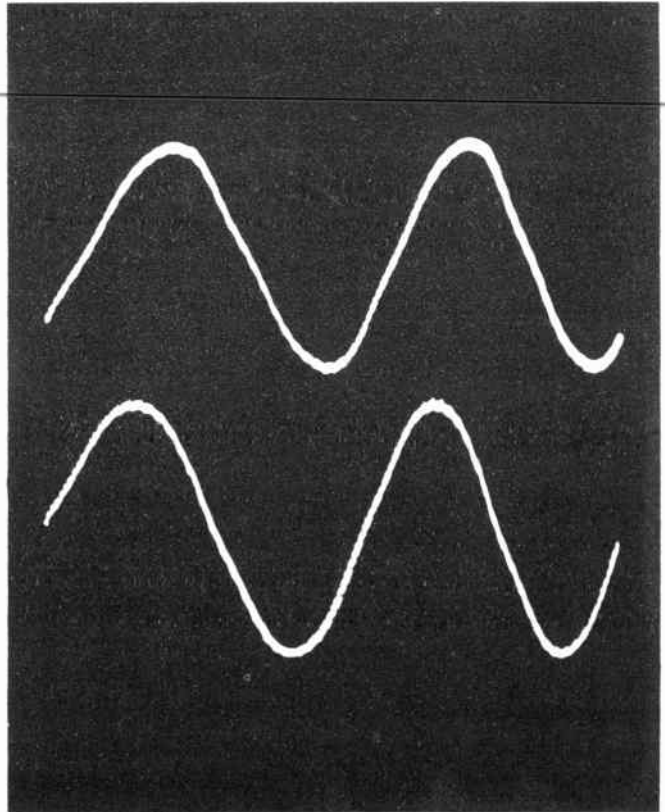

Fig. 22. Current (below) is leading the voltage (above).

is said to lag that other quantity, or to be in lagging phase. Either quantity may lead or lag the other one.

If a circuit contains more capacitive reactance than inductive reactance the current in that circuit will lead the applied voltage. Such a condition is shown by Fig. 22, where the upper trace shows cycles of applied voltage and the lower trace shows cycles of current in the capacitive circuit.

It seems rather strange that positive and negative peaks of a current could occur before the positive and negative peaks of the voltage that is causing the current to flow. This would not happen were we to consider only the first cycle of applied voltage, but it does happen just as soon as the capacitor commences to charge and discharge regularly. The technical explanation is quite long and involved. It depends in part on the fact that a large positive charging current flows into the capacitor the instant the applied voltage commences to go positive. It is not



## LESSON 24 – RESONANCE AND SIGNAL SELECTION

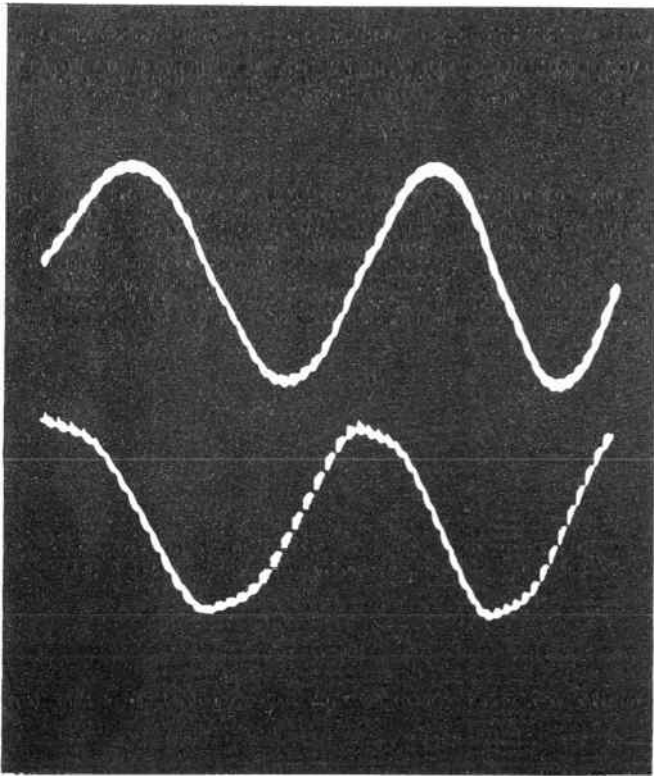

Fig. 23. Current (below) leads voltage (above) by nearly 90 degrees.

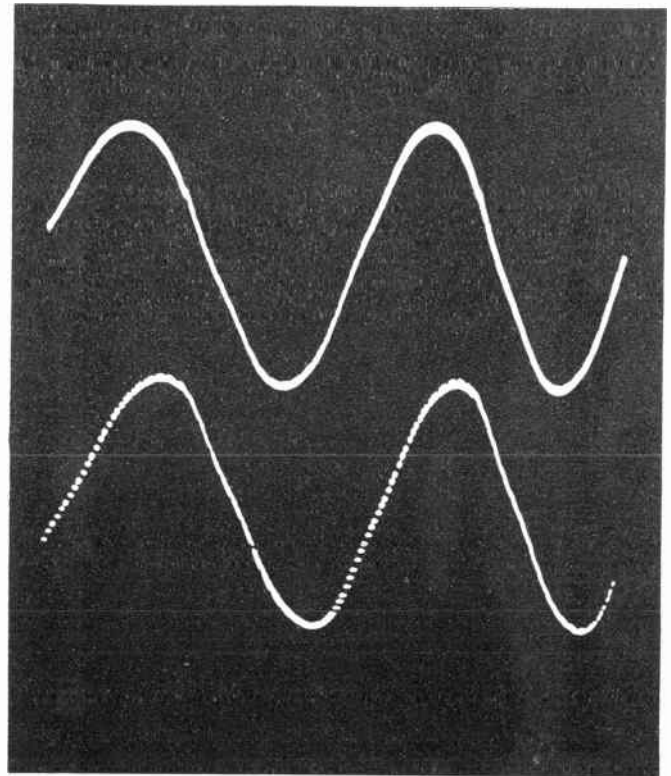

Fig. 24. Current (below) lags the voltage (above) by about 35 degrees.

at all necessary to discuss or to remember the so-called theory, but it is exceedingly important to remember the fact - current leads the applied voltage in a capacitive circuit. This fact will come up many times in future work.

Were it possible to construct a circuit with only capacitance, and with neither inductance nor resistance, the current would lead the applied voltage by 90 degrees. It is impossible to build a circuit without at least some resistance, because we must have conductors. Therefore, the actual lead never can be quite as much as 90 degrees

Fig. 23 shows a 90-degree lead as nearly as it can be caused in a practical circuit. The upper curve is for applied voltage and the lower one is for current. Note that the lead of the lower curve ahead of the upper one is much greater than in Fig. 22.

When a circuit contains more inductive reactance than capacitive reactance the current will lag the applied voltage. A lagging current, shown by the lower trace, is illus-

trated by Fig. 24. The applied voltage is shown by the upper trace. This is what happens in an inductive circuit. Again it is not nearly so important to understand the reason why as it is to remember that current lags the applied voltage in an inductive circuit.

The lag of current behind applied voltage would become 90 degrees only in a circuit containing nothing but inductance, with no capacitance and no resistance. Since such an ideal circuit cannot be built in practice, the actual lag never is quite so much as 90 degrees, but it may come very close. The lower curve of Fig. 25 shows current in a circuit containing large inductive reactance with negligible capacitive reactance and resistance. Current is shown by the lower trace, and applied voltage by the upper trace. No lag is practically 90 degrees.

Were a circuit to consist wholly and only of resistance, with neither capacitance nor inductance, the current would be exactly in phase with the applied voltage. Such a condition or such a phase relation is shown by Fig. 26, where the trace of greater am-



plitude is for applied voltage and the one of smaller amplitude is for resulting current. The circuit has high resistance.

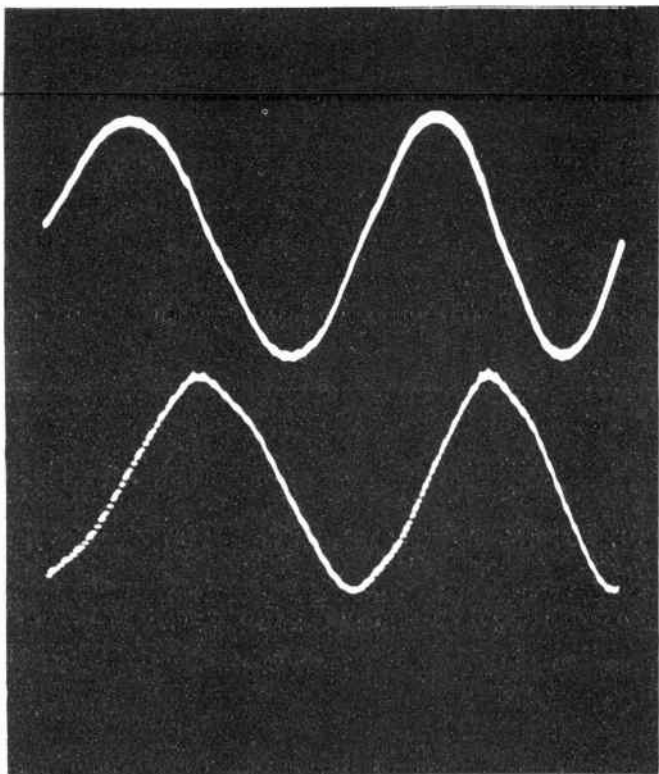

Fig. 25. Current (below) lags voltage (above) by nearly 90 degrees.

It is far easier to build a circuit consisting almost entirely of resistance than to build one containing only inductance or only capacitance. This is especially true at low frequencies, where inductive reactance of the circuit conductors is very small, and where capacitive reactance may be avoided by suitable spacing and positioning of circuit elements.

If we have a circuit in which capacitive reactance is far greater than either inductive reactance or resistance the current will have a large lead over the voltage. Or, if we have a circuit whose opposition to current flow is almost entirely in the form of inductive reactance the current will have a large lag behind the applied voltage.

Now, if we add more and more resistance to these circuits, without making any change in their capacitance or inductance, the current will be brought more and more nearly into phase with the applied voltage. The effect of adding resistance is shown by Fig. 27. The lagging quantity happens to be current, although the traces would look much the same were the voltage lagging (with current leading). The circuit originally contained a great excess of inductive reactance. Adding resistance pulled the current cycles farther ahead and closer to the voltage cycles. By adding enough resistance to a circuit, the current may be brought very nearly into phase with applied voltage.

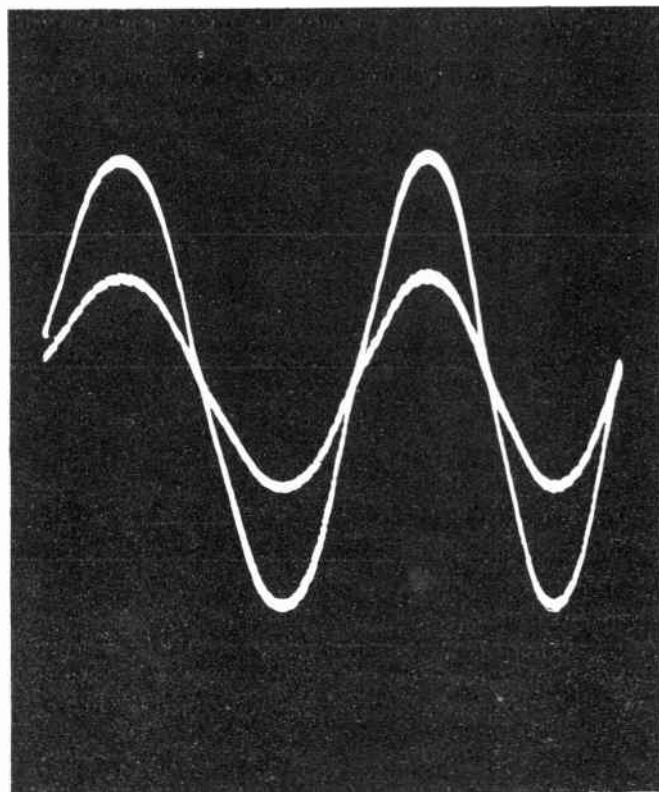

Fig. 26. With only resistance, current and voltage are in phase.

Had we studied phase relations before resonance it would have been possible to explain what happens in a capacitor and inductor at resonance and at frequencies below and above resonance by talking about relative phases of voltages and currents. As an example, the traces of Fig. 28 might illustrate the voltage built up in the capacitor and the induced emf in the inductor of a series resonant circuit at the resonant frequency. The two quantities are in opposite phase and of equal amplitudes, consequently they would cancel to leave only the effect of resistance.

## LESSON 24 – RESONANCE AND SIGNAL SELECTION

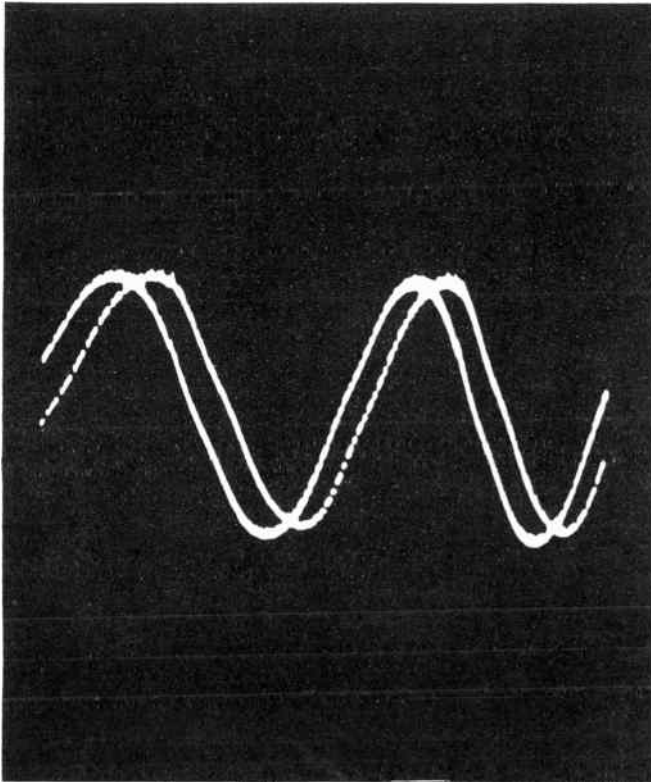

Fig. 27. Adding resistance brings current and voltage more nearly into phase.

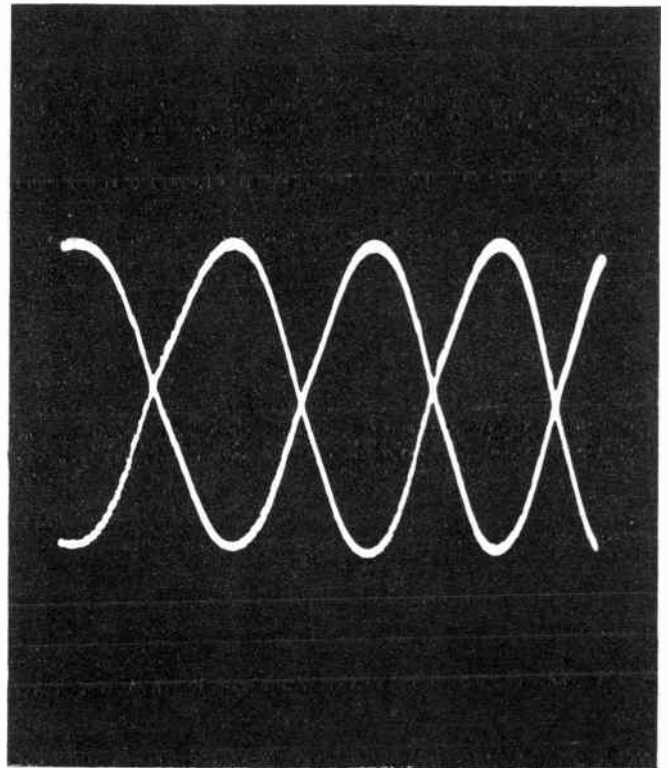

Fig. 28. Voltages across a series inductor and capacitor are equal and of opposite phase at the resonant frequency.

It could be shown also that at frequencies below resonance the current in the series circuit leads the applied voltage, because reactance is mostly capacitive. At frequencies above resonance the current would lag the applied voltage, because reactance is mostly inductive.

In leaving the subject of phase relations it should be mentioned that the term phase shift does not mean, or should not be used as

meaning, just the same thing as a phase difference. A phase shift usually is considered as meaning a change of phase between voltage (or current) at the input of some system, and voltage (or current) at the output. As an example, in high-frequency amplifiers it is quite difficult to keep input signal voltages reasonably in phase with output signal voltages. In resistance coupled amplifiers the losses of gain at both lowest and highest frequencies are due largely to phase shifts.

### RESONANT FREQUENCIES, CAPACITANCES, AND INDUCTANCES

$$\text{Cycles} = \frac{159.155}{\sqrt{\text{mf} \times \text{henrys}}} \quad \text{or} \quad \frac{5032.5}{\sqrt{\text{mf} \times \text{millihenrys}}}$$

$$\text{Kilocycles} = \frac{5.0325}{\sqrt{\text{mf} \times \text{millihenrys}}} \quad \text{or} \quad \frac{159.155}{\sqrt{\text{mf} \times \text{microhenrys}}}$$

$$= \frac{5032.5}{\sqrt{\text{mmf} \times \text{millihenrys}}} \quad \text{or} \quad \frac{159.155}{\sqrt{\text{mmf} \times \text{microhenrys}}}$$

## COYNE - *television home training*

$$\begin{aligned} \text{Megacycles} &= \frac{0.159\ 155}{\sqrt{\text{mf} \times \text{microhenrys}}} \quad \text{or} \quad \frac{5.0325}{\sqrt{\text{mmf} \times \text{millihenrys}}} \\ &= \frac{159.155}{\sqrt{\text{mmf} \times \text{microhenrys}}} \end{aligned}$$

Capacitance for resonance, when frequency and inductance are known.

$$\begin{aligned} \text{Mf} &= \frac{25330}{\text{cycles}^2 \times \text{henrys}} \quad \text{or} \quad \frac{25\ 330\ 000}{\text{cycles}^2 \times \text{millihenrys}} \\ &= \frac{25.33}{\text{kilocycles}^2 \times \text{millihenrys}} \quad \text{or} \quad \frac{25330}{\text{kilocycles}^2 \times \text{microhenrys}} \end{aligned}$$

$$\begin{aligned} \text{Mmf} &= \frac{25\ 330\ 000}{\text{kilocycles}^2 \times \text{millihenrys}} \quad \text{or} \quad \frac{25\ 330\ 000\ 000}{\text{kilocycles}^2 \times \text{microhenrys}} \\ &= \frac{25.33}{\text{megacycles}^2 \times \text{millihenrys}} \quad \text{or} \quad \frac{25330}{\text{megacycles}^2 \times \text{microhenry}} \end{aligned}$$

Inductance for resonance, when frequency and capacitance are known.

$$\text{Henrys} = \frac{25330}{\text{cycles}^2 \times \text{mf}}$$

$$\begin{aligned} \text{Millihenrys} &= \frac{25\ 330\ 000}{\text{cycles}^2 \times \text{mf}} \quad \text{or} \quad \frac{25.33}{\text{kilocycles}^2 \times \text{mf}} \\ &= \frac{0.00002533}{\text{megacycles}^2 \times \text{mf}} \quad \text{or} \quad \frac{25.33}{\text{megacycles}^2 \times \text{mmf}} \end{aligned}$$

$$\begin{aligned} \text{Microhenrys} &= \frac{25330}{\text{kilocycles}^2 \times \text{mf}} \quad \text{or} \quad \frac{25\ 330\ 000\ 000}{\text{kilocycles}^2 \times \text{mmf}} \\ &= \frac{0.02533}{\text{megacycles}^2 \times \text{mf}} \quad \text{or} \quad \frac{25330}{\text{megacycles}^2 \times \text{mmf}} \end{aligned}$$

# TELEVISION

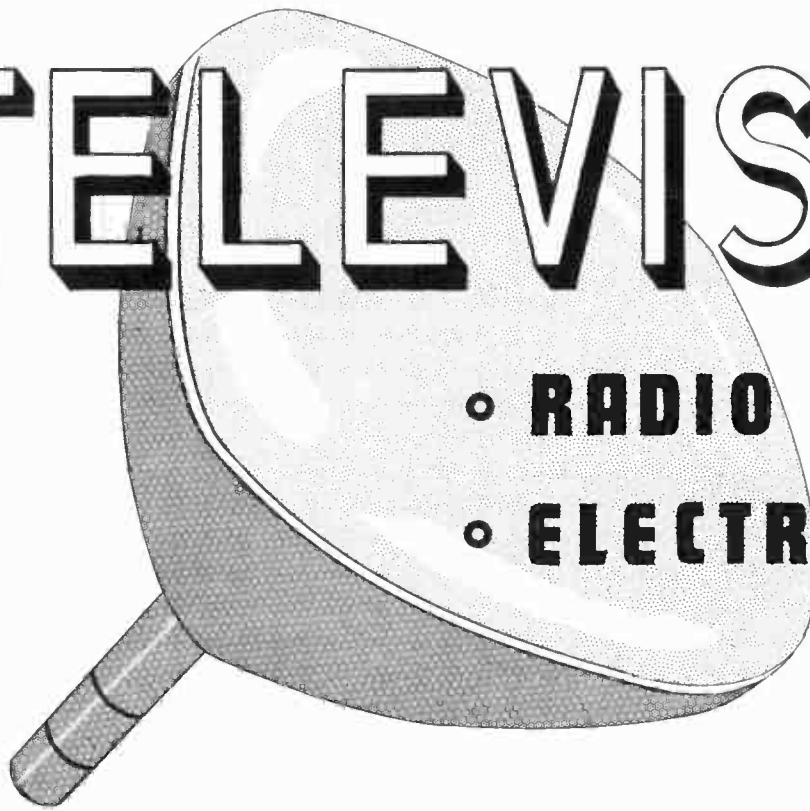

• **RADIO**

• **ELECTRONICS**

---

## LESSON 25 – CAPACITANCE TUNING

---

***Coyne School***

*practical home training*

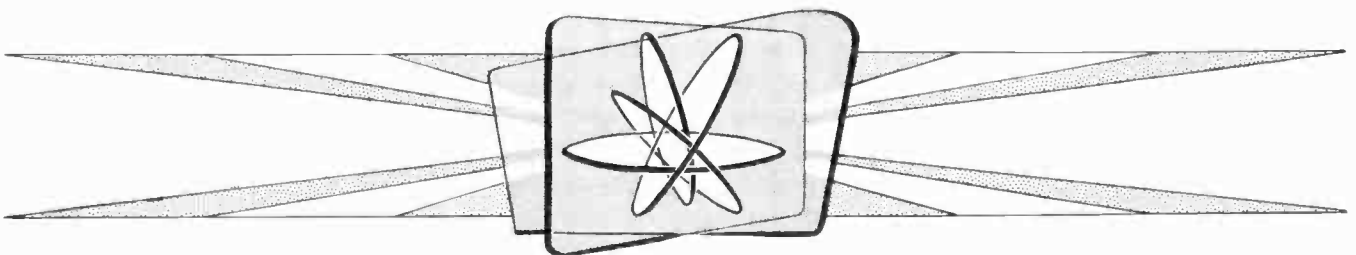

*Chicago, Illinois*



---

*Copyright, 1953 by Coyne Electrical School  
Chicago 12, Illinois  
All rights reserved*

Litho. in U.S.A.

## Lesson 25

# CAPACITANCE TUNING

Variable Tuning Capacitor

Adjustable  
Tuning Inductor

Movable  
Core For  
Inductor

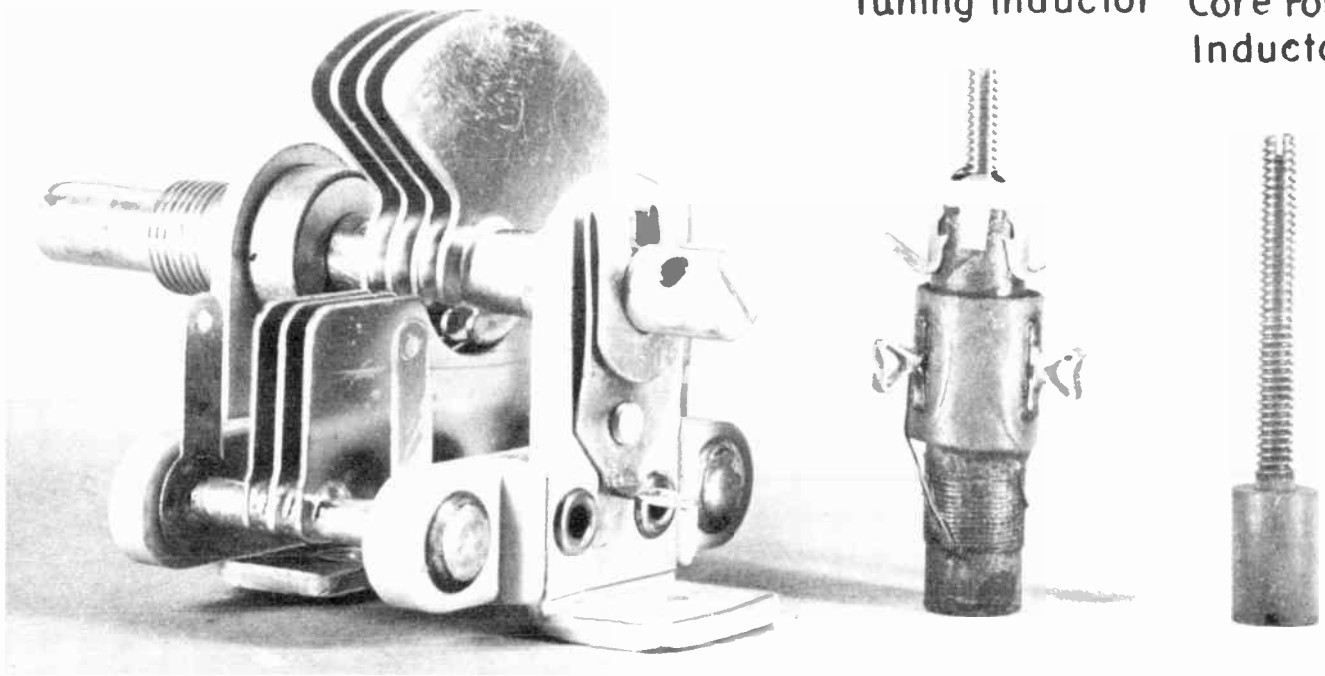

Fig. 1. Tuning may be accomplished by adjusting the capacitance, as with the variable capacitor at the left, or by adjusting the inductance by some means such as the variable inductor at the right.

The only difference between a desired program and all the others on the air at the same time is in the different frequencies at which these programs are transmitted. At least, this is the way the receiver looks at it. If we are to see and hear one program while excluding all the others, the receiving circuits must be made highly responsive to the frequency or narrow band of frequencies at which that one program is transmitted, while having very weak or zero response to all other frequencies.

The problem is solved by tuning the receiver circuits to resonance at frequencies of signals which are wanted. Tuning may be defined as the process of adjusting the inductance or capacitance of a circuit to cause resonance at one certain frequency or band,

which is called the tuned frequency or frequency band.

A circuit which may be tuned must include inductance and capacitance. Either of these elements may be varied during the process of tuning. For capacitance tuning we use a fixed inductance, of unvarying value, and any of various kinds of adjustable or variable capacitors, one of which is shown in Fig. 1. As the movable rotor plates are turned farther into mesh with the stationary stator plates, the capacitance increases and resonant frequency drops. As the plates are moved farther out of mesh, the capacitance is reduced and resonant frequency rises.

For inductance tuning we use fixed capacitance and adjustable inductance. In

# COYNE - television home training

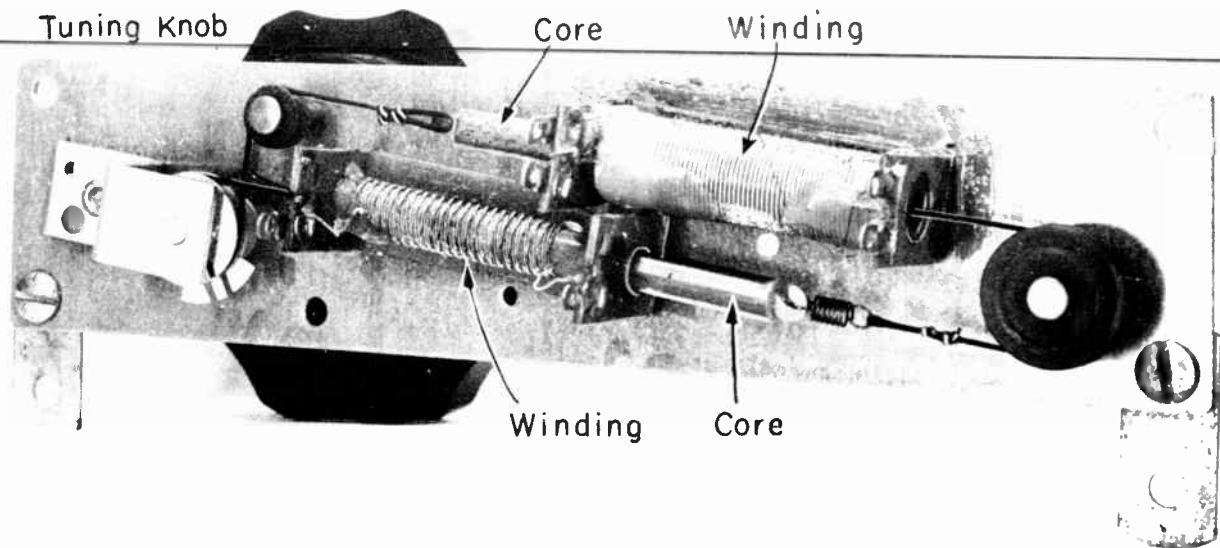

Fig. 2. An inductance tuner for producing the condition of resonance in two circuits at the same time.

circuits which are to be tuned to one certain frequency and left there, as is the case for i-f amplifiers, the inductor usually is of the general type pictured in Fig. 1. Inductance is varied by the movable iron core. A core with its attached adjusting screw is shown separately at the extreme right. A similar core is inside the complete inductor.

When inductance tuning is to cover a continually variable range of frequencies it is usual practice to move the iron core inside of one or more inductor coils by means of a knob or dial used for selecting the station or channel to be received. Fig. 2 is a picture of a tuning unit on which are two inductor coils, each with a movable core. The cores, shown about half way out of their coils, are moved by a pulley and cord arrangement operated by the tuning knob.

## FREQUENCY BANDS AND RANGES.

Since we are going to talk about tuning to various frequencies it will be well to know something about the range of such frequencies. In receivers designed for reception of broadcast programs of various kinds we shall encounter a great variety of frequencies, principal among which are those listed in the accompanying table.

### TUNED FREQUENCIES

Class of Broadcast Service	Carrier Frequencies	Intermediate Frequencies
Standard Radio	540 to 1600 kc	455 or 456 kc
Shortwave radio	6 to 26 mc	Various
F-m radio	88 to 108 mc	10.7 mc
Television		
Very-high frequency, low band	54 to 88 mc	20 to 27 mc or 40 to 47 mc, either band.
Very-high frequency, high band	174 to 216 mc	47 mc, either band.
Ultra-high frequency	470 to 890 mc	Various
Sound sections, all bands		4.5 mc

When we consider every kind of radio service the transmission frequencies extend from below 30 kilocycles to about 3,000 megacycles. This whole extent of transmission frequencies may be divided, for convenience of description, into a number of classes. Names generally applied to these classes are as follows.

### RADIO TRANSMISSION FREQUENCIES

Name	Abbreviation	Range
Very-low	v-l-f or vlf	Less than 30 kc
Low	l-f or lf	30 kc to 300 kc
Medium	m-f or mf	300 kc to 3000 kc
High	h-f or hf	3000 kc to 30 mc
Very-high	v-h-f or vhf	30 mc to 300 mc
Ultra-high	u-h-f or uhf	300 mc to 3000 mc
Super-high	s-h-f or shf	More than 3000 mc

## WAVELENGTH AND FREQUENCY.

The characteristics of a transmitted signal

## LESSON 25 – CAPACITANCE TUNING

which we usually describe as its frequency may be described also as its wavelength. All radio signals pass through space in the form of electromagnetic waves. An electromagnetic wave is a combination of electric and magnetic forces or fields acting together and dependent on each other for their ability to travel in space. The distance between similar forces in two successive waves is the wavelength of the signal.

Regardless of wavelength, all radiated waves pass through space at the same speed, which is approximately the speed of light. This speed is 186,000 miles per second or, in the metric unit of length it is 300,000,000 meters per second. One meter is a length of 39.37 inches.

If a wave starts from a transmitting antenna at a certain instant, that wave will be 300,000,000 meters away at the end of one second. If, during that second, there have been emitted from the transmitting antenna a total of 1,000,000 waves at equal intervals of time all of these waves will be between the antenna and the first one, now 300,000,000 meters distant. Since the intervening waves are equally spaced, the distance between every two successive waves must be the one-millionth part of 300,000,000 meters, or must

be 300 meters. Then the wavelength of this signal is 300 meters.

Conversions between wavelength and equivalent frequency are made as follows:

$$\text{Wavelength, meters} = \frac{300}{\text{frequency, mc}} \quad \text{Frequency, megacycles} = \frac{300}{\text{wavelength, meters}}$$

**TUNING CAPACITORS.** The stators (stationary plates) of any variable capacitor always are connected to the more sensitive side of any circuit in which such a capacitor is used, and the rotors (movable plates) are connected to the less sensitive side of the circuit.

Fig. 3 illustrates an application of this rule where capacitors are used for tuning the grid circuit and also the plate circuit of a tube. The grid of the tube is more sensitive to all electrical influences than is ground, so the stator of the capacitor is connected to the grid and the rotor is connected to ground. The stator of the tuning capacitor in the plate circuit is connected to the plate of the tube, with the rotor connected to the B+ or power supply side of the circuit. This is the ground side of the circuit for signal currents, because of the low reactance connection to ground through bypass capacitor Cb.

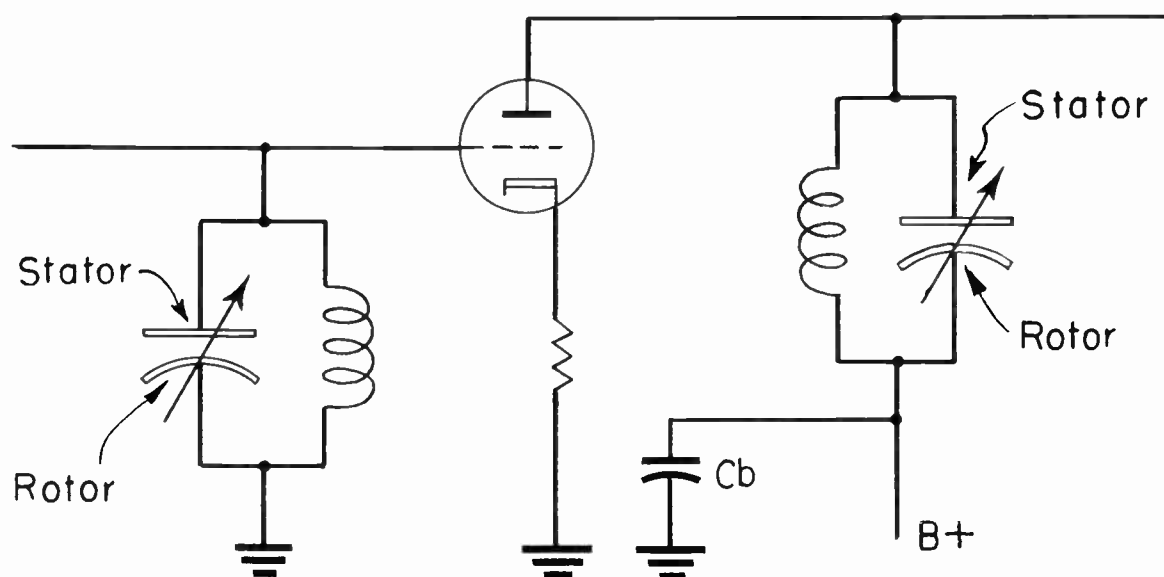

Fig. 3. Stators are connected to the more sensitive sides of tuned circuits, rotors to the less sensitive sides.



## COYNE - *television home training*

The rotor of a tuning capacitor is connected to the less sensitive side or the "low side" of its circuit because the hand of anyone adjusting the tuning comes closer electrically, to the rotor than to the stator - since the rotor plates are attached to the shaft that carries the adjusting mechanism. The effect called hand capacitance or body capacitance will not greatly upset the tuning when brought into the low side of a tuned circuit, but will cause large changes of resonant frequency when brought into the high side, which would be the side connected to a grid, a plate, an antenna, or other such signal carrying element.

Among the characteristics of tuning capacitors which affect their usefulness are four of especial importance, as follows:

a. Relation between minimum and maximum capacitance.

b. Manner in which capacitance varies when turning the rotor plates.

c. Relation between change of capacitance and resulting resonant frequencies.

d. Quality of materials and construction.

The minimum capacitance, with plates turned as far as possible out of mesh, is far from being zero. We will have the metal stator and rotor plates separated by the dielectric, and this means that we still have capacitance. In large tuning capacitors, such as those having maximum capacitances of 250 to 500 mmf, the minimum capacitances may be as little as 4 to 5 per cent of the maximums, or may be on the order of 15 to 20 mmf in good designs, or much greater with poorer designs. When maximum capacitance is small, say around 20 to 50 mmf, the minimum usually is 15 to 30 per cent of the maximum or is something like 6 to 7 mmf.

The manner in which capacitance varies as the rotors are turned in and out of mesh with the stators depends largely on the shape of the plates, usually on the shape of the rotors. When the rotor plates are shaped like a half circle, the capacitance varies at a uniform rate with rotation of the rotors and

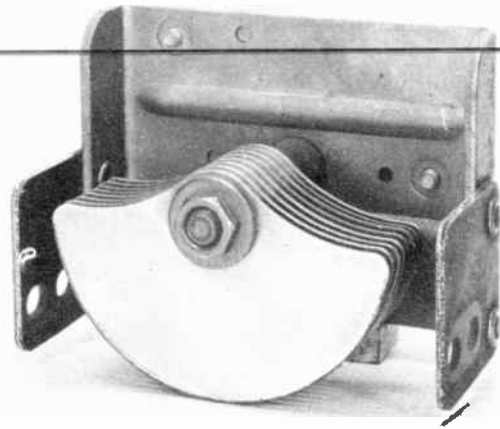

Fig. 4. Semi-circular plates giving straight line capacitance tuning.

the shaft which carries them. Rotor plates of this shape are illustrated by Fig. 4, where the stators have been temporarily removed from the assembly. Such semi-circular rotor plates are shown also by the capacitor in Fig. 1.

When rotating the shaft or tuning dial of a capacitor having semi-circular rotors, the capacitance changes as shown by the broken-line curve of Fig. 5. With the plates all the way out of mesh there is the minimum capacitance, shown here as a little more than 30 mmf. During the first few degrees of shaft rotation the rotors have not yet entered the spaces between stator plates, and there is little change of capacitance. Thereafter the capacitance increases uniformly. The curve becomes a straight line. It is for this reason that capacitors with such plates are called straight line capacitance types.

Let's assume that we wish to have reception in the standard broadcast range with the straight line capacitance tuning capacitor whose capacitance characteristic is shown by the broken-line curve of Fig. 5. Minimum capacitance is 31 mmf and maximum is 380 mmf. When using an inductor of 220 microhenrys the resonant frequency will be about 1930 kilocycles at the minimum capacitance and about 550 kilocycles at the maximum capacitance.

This range of resonant frequencies isn't so bad, but their distribution on a tuning

# LESSON 25 – CAPACITANCE TUNING

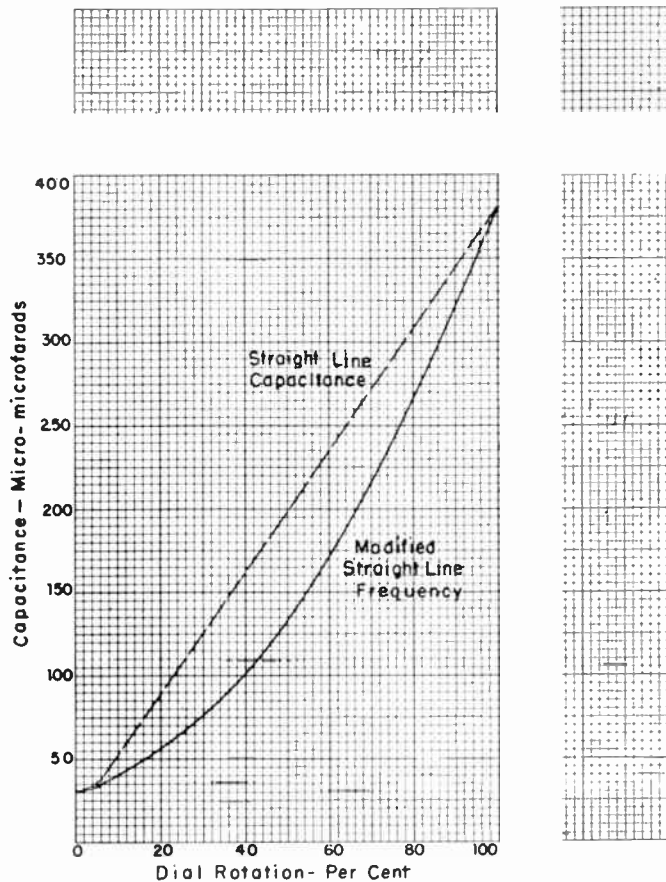

Fig. 5. Variations of capacitance with rotation of the tuning dial or shaft for two types of capacitor plates.

dial is very bad. This distribution is shown by Fig. 6. In covering frequencies from 550 to 800 kc, a spread of only 250 kc, you would have to tune through more than half of the dial scale. All the remaining frequencies, a spread of 1100 kc, would be on less than half

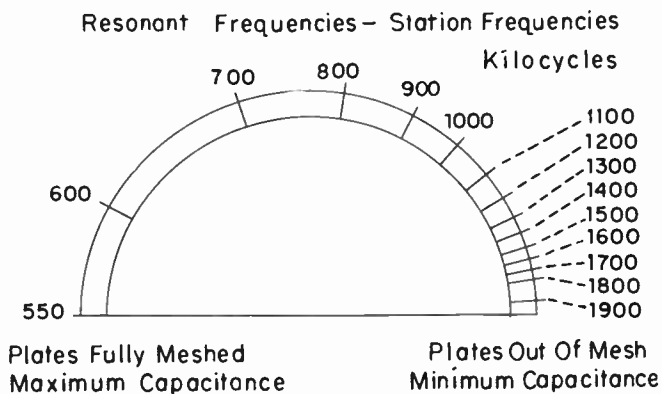

Fig. 6. With straight line capacitance tuning the low frequencies are widely spread on the tuning dial, while the high frequencies are compressed.

of the dial scale. There is extreme crowding at the highest resonant frequencies.

The ideal distribution of resonant frequencies on a tuning dial would provide uniform spacings for equal changes of frequency. This can be accomplished, but it requires a tuning capacitor whose rotor plates have a long taper, and which extend far out from the shaft in one direction. Such a capacitor is called a straight line frequency type.

It is not necessary to have straight line frequency tuning, but it is desirable to lessen the spread between the lower resonant frequencies and to lessen the crowding at the higher frequencies. This is accomplished in a practical way by using a modified straight line frequency tuning capacitor. The shapes of the plates for one such capacitor are shown by Fig. 7. The rotors are tapered,

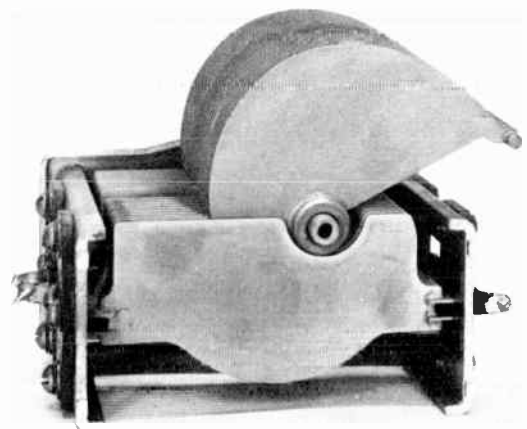

Fig. 7. How the capacitor plates are shaped for modified straight line frequency tuning.

and they extend much farther from the shaft on one side than on the other, but only about half as far as they would extend in a true straight line frequency capacitor.

Change of capacitance with shaft or dial rotation for the capacitor of Fig. 7 is shown by the full-line curve of Fig. 4. Capacitance increases only slowly at first, then more and more rapidly as the shaft is turned at a constant rate. This capacitor has the same minimum and maximum capacitances as the straight line capacitance type represented by the broken-line curve. Therefore, minimum

# COYNE - *television home training*

and maximum resonant frequencies of both types will be the same when we use the same inductor, of 220 microhenrys.

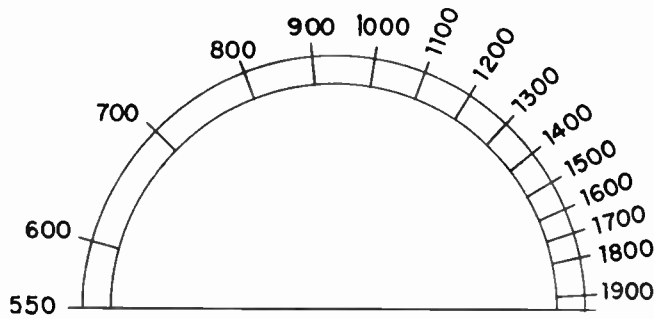

Fig. 8. With modified straight line frequency tuning there is reasonably uniform distribution of frequencies on the tuning dial.

Fig. 8 shows the distribution of resonant frequencies on a tuning dial when using our modified straight line frequency capacitor and the 220-microhenry inductor. The lower frequencies have been brought somewhat closer together, while the high frequencies have been spread enough for convenient tuning. Frequency distribution generally similar to this is found on the tuning dials of most standard broadcast radio receivers, which means that these receivers usually employ modified straight line frequency tuning capacitors.

Capacitors of the straight line capacitance type are found in many test and measuring instruments where frequency is one of the factors, also in some-high-frequency receiver operating through a rather narrow range of frequencies, and for adjustment of various tuned circuits wherever the frequency response is to be changed only at long intervals or only during service operations.

When two or more circuits are to be tuned to resonance at the same time by the same dial or other tuning control we use a multi-section tuning capacitor consisting of several capacitors having the rotor plates of all on the same shaft. A three-section capacitor of this kind is pictured by Fig. 9. The sections usually are referred to as "gangs". The unit of Fig. 9 would be called a three-gang capacitor.

In ganged capacitors the rotors of all sections are electrically together and all of them are consequently connected to the same point, which usually is ground or B minus. All the stator sections are electrically separate, they are individually insulated. The stators may be connected to the high sides of the separate tuning circuits, as to the grids or plates of separate tubes.

An important fact relating to tuning capacitors used with fixed inductances is this: Capacitance must change in a ratio which is the square of the ratio of frequency change. For an example, look back at Fig. 4 where capacitance changes from 31 to 380 mmf and frequency changes from 550 to 1928 kc. Here are the figures.

Frequency      Maximum = 1928 kc.    Minimum = 550 kc.

$$\text{Ratio} = \frac{1928}{550} = 3.5 \text{ approx.}$$

$$\text{Square of ratio} = 3.5^2 = 12.25$$

Capacitance    Maximum = 380 mmf.    Minimum = 31 mmf.

$$\text{Ratio} = \frac{380}{31} = 12.25$$

The ratio of change of capacitance (12.25) is the same as the square of the ratio of change of frequency (12.25).

If the highest tuned frequency in any given case is to be 3 times the lowest frequency, then the maximum capacitance must be 9 times the minimum capacitance, because the square of 3 is 9. If the frequency ratio from highest to lowest is to be only 2 times, then the capacitance ratio need be only 4 times, because the square of 2 is 4.

This rule holds good regardless of the value of inductance used in the tuned circuit. Using less inductance would raise the entire range of tunable frequencies, while more inductance would lower the entire range. But the ratio of capacitances (maximum to minimum) still would have to be the square of the ratio of frequencies, no matter what the frequencies may be in kilocycles or megacycles.

Fig. 10 is a picture of a high-frequency two-gang variable tuning capacitor. The



## LESSON 25 – CAPACITANCE TUNING

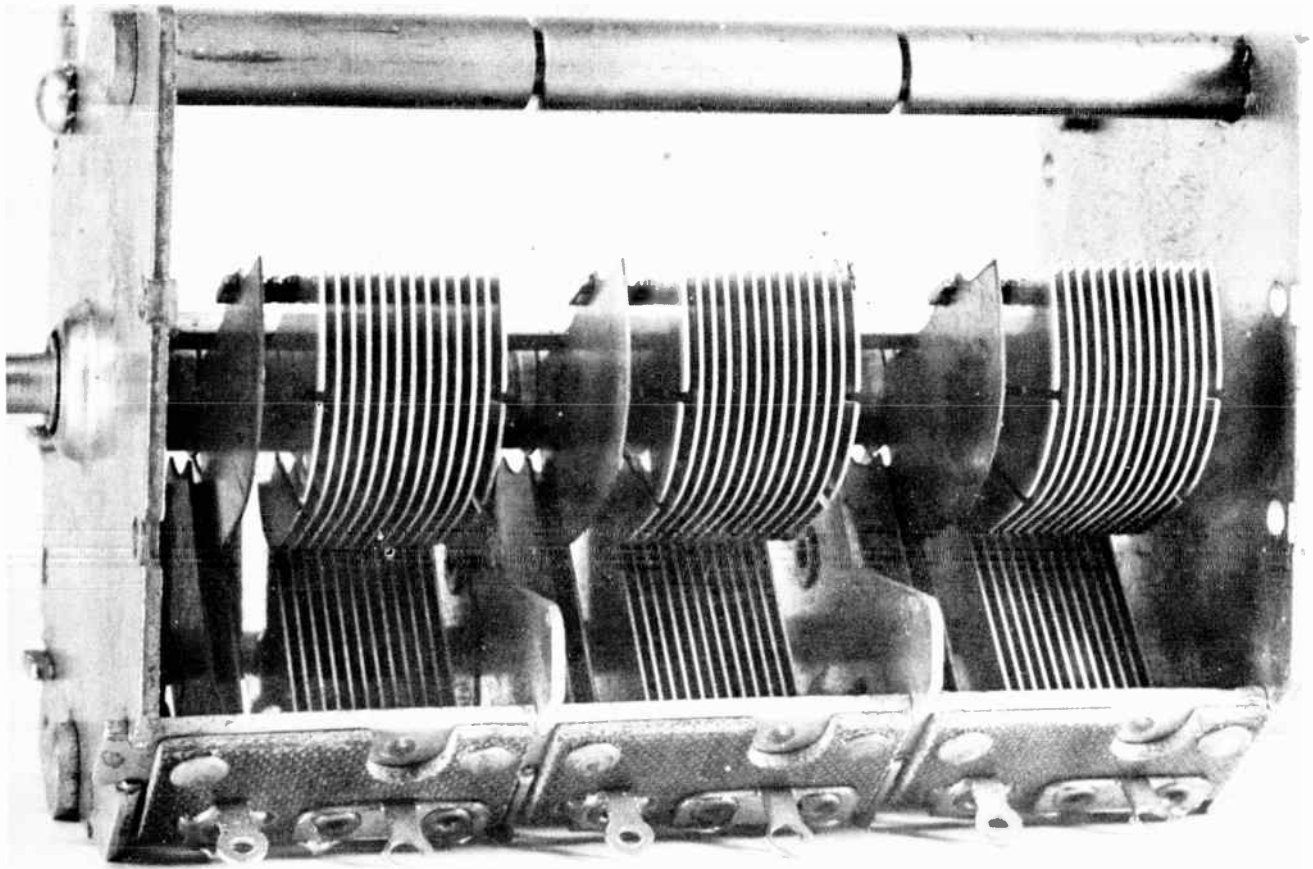

*Fig. 9. A three-gang tuning capacitor.*

maximum capacitance per section is 16.0 mmf and the minimum is 3.8 mmf. The ratio of maximum to minimum capacitances is about 4.21. This figure, 4.21, is the square of the ratio of frequencies which may be tuned by one section. We may determine the frequency ratio by taking the square root of 4.21, which is about 2.05 or approximately 2. Then the highest tuned frequency can be no more than about 2 times the lowest tuned frequency. Were the lowest frequency to be 20 mc, the highest could not be much more than 40 mc, and so on. The actual frequencies would depend on the inductance used with the capacitor.

TRIMMER AND PADDER CAPACITORS. Oftentimes the resonant frequency is not quite what is desired when the plates of the tuning capacitor are nearly all the way out of mesh and capacitance of this unit is minimum. Small changes of capacitance and

fairly large changes of frequency may be made with a trimmer capacitor connected in parallel with the main tuning capacitor, as at the left in Fig. 11. The trimmer is an adjustable capacitor whose maximum capacitance is but a small fraction of the maximum in the main tuning capacitor.

Capacitance of the trimmer adds to capacitance of the main capacitor, because the two are in parallel. When the tuning capacitor plates are all the way or nearly all the way out of mesh with the stators the capacitance is small, possibly of about the same value as that of the trimmer. Then adjustment of the trimmer makes a large change in total capacitance, because the trimmer capacitance is such a large fraction of the total. For example, were trimmer capacitance adjustable from 10 to 50 mmf, and were the tuning capacitor set for 30 mmf, the total capacitance would be adjustable



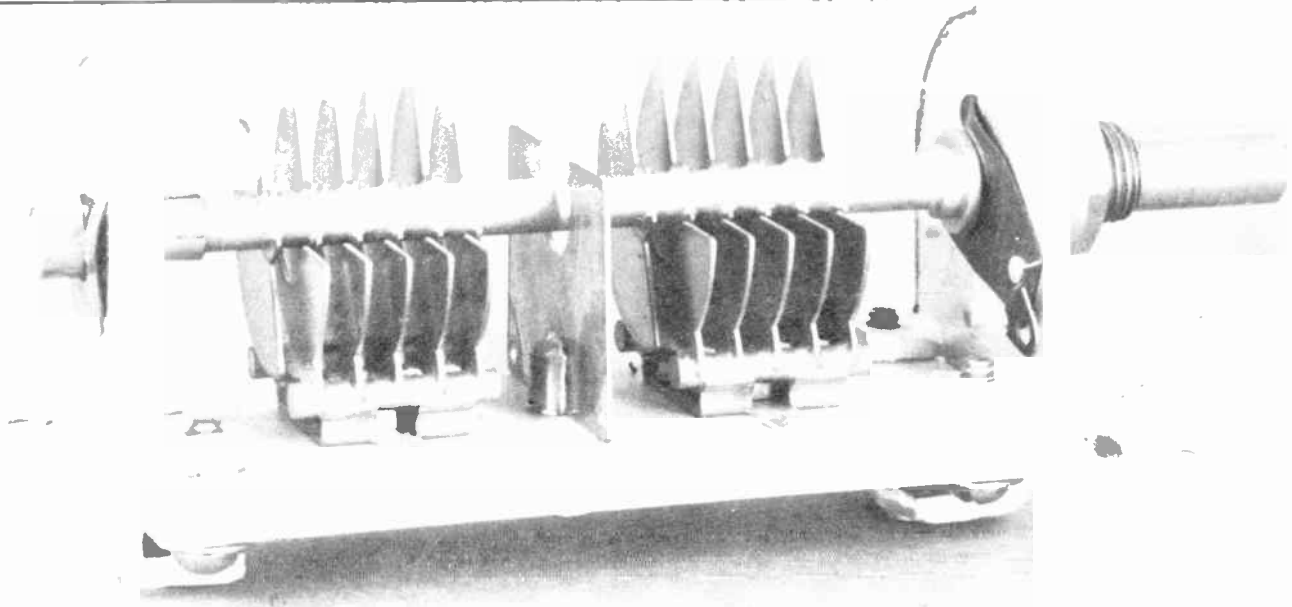

Fig. 10. A two-gang tuning capacitor designed for efficient operation at very-high frequencies.

from 40 mmf (30 plus 10) up to 80 mmf (30 plus 50). This is a change of 100 per cent.

Trimmers are used for adjustment at the high-frequency end of a tuned range of frequencies. They have little effect at the low-frequency end. Supposing, for an example, that the tuning capacitor referred to

in the preceding paragraph has maximum capacitance of 300 mmf and that the same trimmer is used. Total capacitance could be changed only from 310 to 350 mmf, an increase of only about 13 per cent.

For adjustments at the low-frequency end of a tuning range an additional capacitor

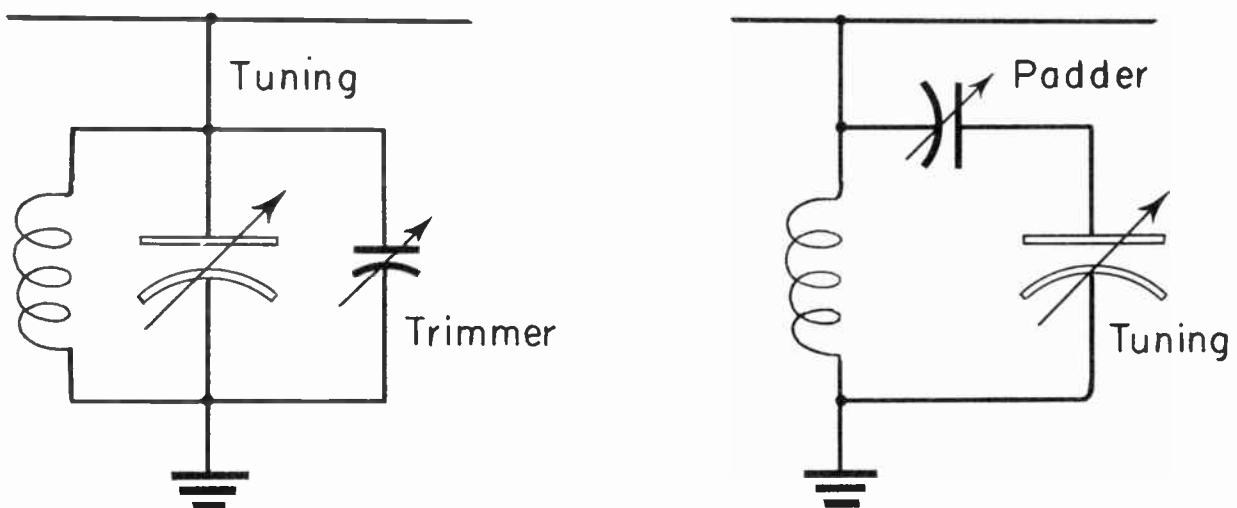

Fig. 11. A trimmer capacitor in parallel with a tuning capacitor (left) and a padder capacitor in series (right).

## LESSON 25 – CAPACITANCE TUNING

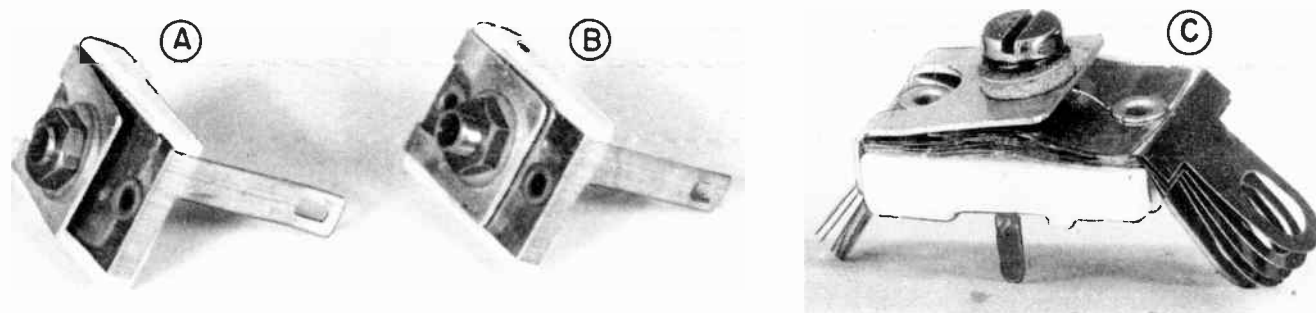

Fig. 12. Mica-dielectric capacitors of the compression type used for trimmers and padders.

may be connected in series with the main tuning capacitor, as at the right in Fig. 11. The added unit, in this position, usually is called a padder capacitor. The capacitance of the padder nearly always is greater than that of the main tuning capacitor. The combined capacitance follows the rules for capacitances in series, always being less than either of the separate capacitances and being equal to their product divided by their sum.

Supposing we have a padder whose capacitance is adjustable from 100 to 500 mmf, and use it without tuning capacitor set for its maximum capacitance of 300 mmf. Padder adjustment will vary the combined series capacitance from 75 to 187.5 mmf, an increase of 250 per cent. What will be the effect of this padder at the high-frequency end of the tuning range, with the main tuning capacitor adjusted for its minimum of 30 mmf? Adjustment of the padder can change the series capacitance only from about 23.1 to 28.3 mmf, an increase of about 12-1/4 per cent.

In some circuits you will find both a trimmer and a padder. The trimmer is used for adjusting the tuned frequency to correspond with a given dial setting at the high end of the tuning range. The padder adjusts the resonant frequency to agree with a given dial setting at the low-frequency end of the tuning range.

Trimmers and padders may be of the mica compression type illustrated by Fig. 12. The dielectric consists of air spaces and of thin sheets of mica held between thin metal plates. The plates are springy. When they

are compressed by the adjusting screw the dielectric spaces are reduced. This does not change the mica but it does lessen the air space between the plates, and bringing the plates closer together increases the capacitance.

At A is a mica trimmer with its plates opened up for minimum capacitance of about 10 mmf, and at B is the same unit with its plates fully compressed for maximum capacitance of about 125 mmf. At C is a mica padder in which are seven thin plates giving a capacitance range from 100 to 500 mmf between the open and compressed positions.

Fig. 13 is a picture of a two-gang tuning capacitor having mica compression trimmers on each section. The trimmers are adjusted by the large-headed screws located near the bottom of the unit.

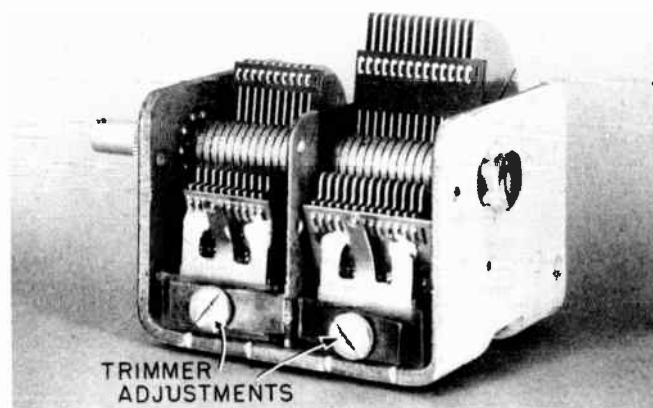

Fig. 13. A two-gang tuning capacitor with mica trimmers mounted on each section.

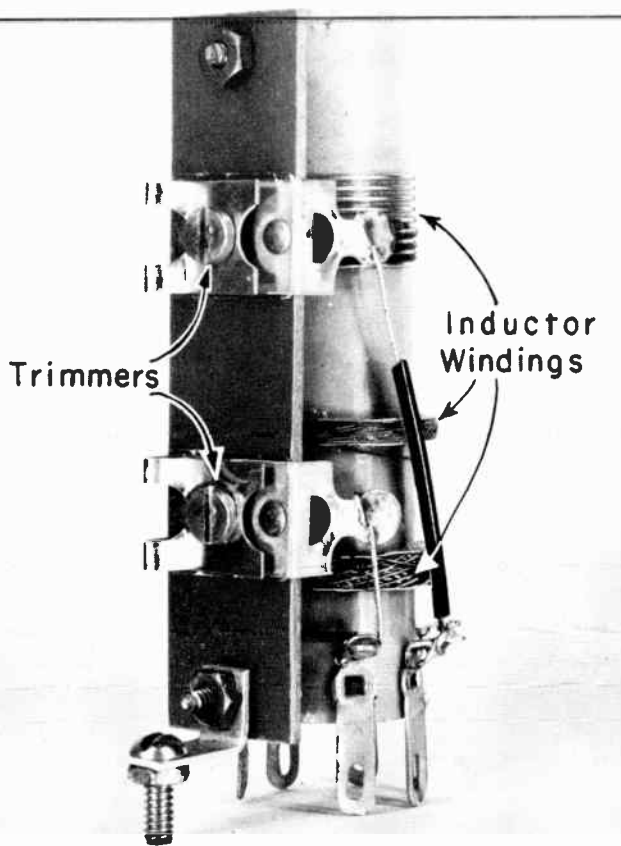

Fig. 14. A tuning inductor on which are mounted mica trimmers.

Trimmers and padders need not be mounted on the tuning capacitors now even close to these capacitors. Fig. 14 shows a tuning inductor whose windings are connected in parallel with a ganged tuning capacitor to form parallel resonant circuits. The mica compression trimmers for the resonant circuits are mounted on the coil form and connected in parallel with the windings. Then these windings, the trimmers, and the main tuning capacitors all are in parallel with one another, just as though the trimmers were on or at the capacitors.

Another method of making small changes of tuning capacitance is illustrated by Fig. 15. The outside plates of the rotor or rotors are slotted so that, from the edges almost to the center or shaft hub, the plates consist of fan shaped sections. To lessen the capacitance one or more of the fan shaped sections are bent slightly farther out, so that they come farther from the end stator plates

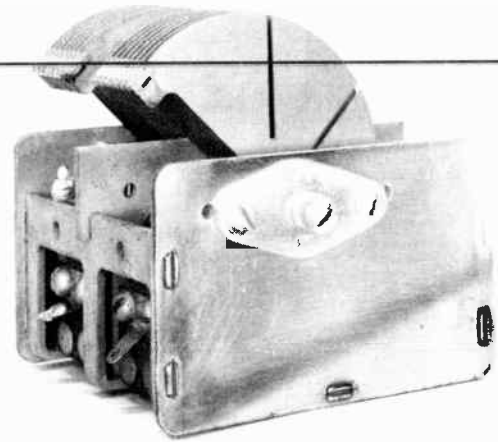

Fig. 15. Slotted rotor plates, for making small changes of capacitance at various points in the tuning range.

when the rotor is turned into mesh. Capacitance can be increased by bending the rotor sections closer to the stators, but there is danger that the two sets of plates then may touch when in some positions and destroy the tuning effect of the capacitor at these positions.

The plates to be bent when making any correction are those which have just been fully or almost fully meshed when the circuit is tuned to the frequency where more or less capacitance is needed to correct the tuning. Capacitance then will be changed at all positions where the bent plates are meshed with the stators, but not at any positions where they are out of mesh. Greatest changes may be made at the high-frequency end of the tuning range. The lower the tuned frequency the less is the effect of bending the slotted rotor plates.

Mica trimmers and padders, also slotted rotor plates, are used chiefly in tuned circuits for standard broadcast and short-wave broadcast radio, where all tuning capacitances are fairly large. For television and f-m radio tuned circuits the capacitances are relatively small, and usually the trimmers, and padders if used, are of various tubular styles.

Fig. 16 is a picture of three tubular trimmers used in high-frequency circuits. All of them mount through holes punched in

## LESSON 25 – CAPACITANCE TUNING

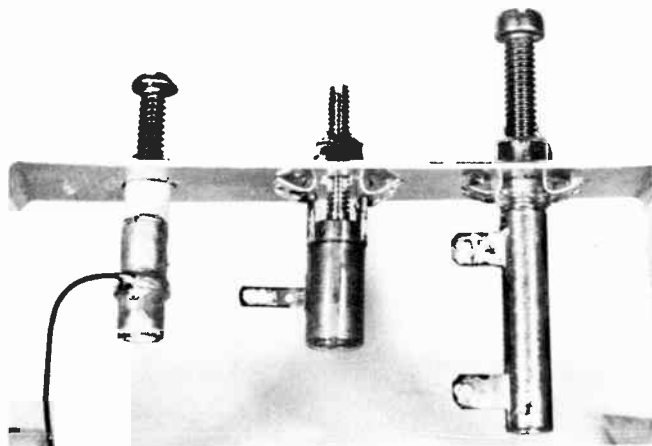

Fig. 16. Tubular trimmer capacitors used in television and f-m radio circuits.

the chassis metal. The capacitance is adjusted by means of screws that extend up from the tops of the capacitors and are accessible from above the chassis. Turning the screws farther into the tubular portions of the units increases the capacitance, turning them out decreases the capacitance.

The unit at the left has a small ceramic cylinder for its dielectric. One plate is the screw, which grounds to chassis metal through the mounting and extends to adjustable distances into the dielectric cylinder. The other plate is a coating of metal around part of the outside of the ceramic tube. To this metal is fastened a pigtail lead for making connections to the high side of a tuned circuit. Capacitance is adjustable from 1 to  $7\frac{1}{2}$  mmf in this particular trimmer. Various lower and higher ranges of capacitance are available.

In the trimmer at the center of Fig. 16 the dielectric is a thin-walled cylinder of plastic material having small energy losses at high frequencies, such as polystyrene. One plate is a cylinder of thin brass around part of the length of the dielectric tubing. A solder lug is attached to the brass cylinder for making connections to the high side of the tuned circuit. The other plate is a small cylinder of solid brass attached to the adjusting screw that extends from the top of the capacitor. This inner plate (usually called a slug) is grounded to chassis metal through the screw and mounting. Capacitance is from 1 to 8 mmf in the unit shown.

At the right is another trimmer having for its dielectric a tube of low-loss plastic material. The outside plate is again a metal cylinder, this time with two solder lugs for high-side circuit connections. The inner plate is the adjusting screw which, as you can see, is of an outside diameter nearly as great as the inside diameter of the outer cylindrical plate. This screw threads into the plastic dielectric tube.

Tubular trimmers of various types may have capacitance ranges as low as from 0.5 to 5 mmf or as high as 20 to 125 mmf, with many ranges in between.

Fig. 17 shows two ceramic trimmer capacitors of the rotary plate style. The unit at the left is pictured from the back, or from its side which would be away from the chassis or other metal on which mounted. The three arms are on the end of an adjusting screw; they rotate the plate on the back of the capacitor when the screw is turned. The unit at the right, not of exactly the same size and design as the other one, is shown from its side on which the adjusting screw is exposed.

The base or body of these trimmers is made of white steatite, with the back surface ground perfectly flat. Pure silver deposited on this flat surface forms the stationary plate of the capacitor. The rotor, of darker tone than the base, is ceramic material of high dielectric constant. The side of the rotor which contacts the stationary plate is ground perfectly flat. On approximately half of the outer exposed surface of the rotor is a deposit of silver which forms the other plate of the capacitor.

When the rotor is turned to bring its silvered area in line with the silvered area of the stationary plate the capacitance is maximum, and when turned half way around the capacitance is minimum. The full range of adjustment requires only a half turn of the rotor, just as with an air dielectric tuning capacitor. These rotary ceramics, and in fact all high-quality ceramic capacitors, give excellent performance at very-high frequencies and also, for most purposes, at ultra-high frequencies. Ranges of the two units illustrated are 20 to 125 mmf for the larger



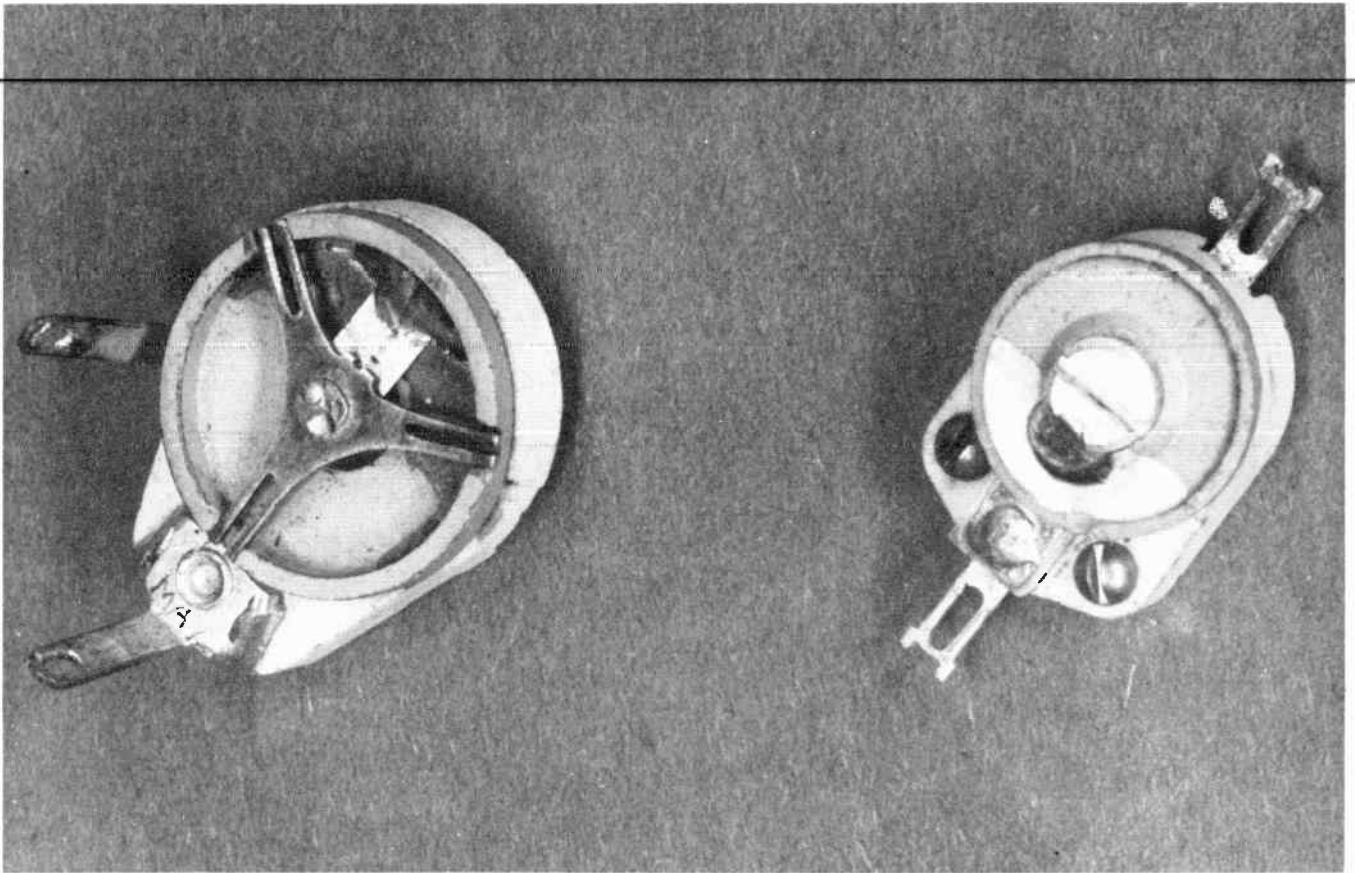

Fig. 17. Ceramic trimmer capacitors of the rotary type.

one and 5 to 50 mmf for the smaller one. Other available ranges go as low as 2 to 6 mmf.

Ceramic trimmer and padder capacitors are available in temperature compensating types, whose capacitance decreases by definitely specified amounts when their temperature rises. These, as mentioned before, are used for maintaining a nearly constant resonant frequency in apparatus where other elements tend to change the resonant frequency during the warm up period.

Midget sizes of air dielectric capacitors often are used as trimmers for high-frequency circuits, and for that matter, at any lower frequencies. Two such units are pictured by Fig. 18. The one at the left has three plates, two rotors and one stator, giving maximum capacitance of about  $7\frac{1}{2}$  mmf and minimum of about 3 mmf. The unit at the right has three rotors and four stators, with maximum and minimum capacitances of 23 mmf and 4 mmf. Ranges with maximums

of around 150 mmf are found in trimmers of this general style. Adjustment is by means of a screw slot on the end of the rotor shaft or sometimes by a hexagon shaped extension on the shaft end.

DISTRIBUTED CAPACITANCE. It is unfortunate that the capacitance which determines resonant frequency is not only that of a tuning capacitor and trimmer or padder, but includes also many other capacitances found in other parts of the tuned circuit. These other capacitances are not so easily controlled in value, and their values seldom are known with any great exactness.

Some of the most troublesome effects result from distributed capacitance of inductors, which is explained as follows. When there is a difference of potential between one end and the other of an inductor winding this difference is divided between or distributed between the adjacent turns. For instance, if there are 10 spaces between turns, and the overall potential difference is 10 volts,

## LESSON 25 – CAPACITANCE TUNING

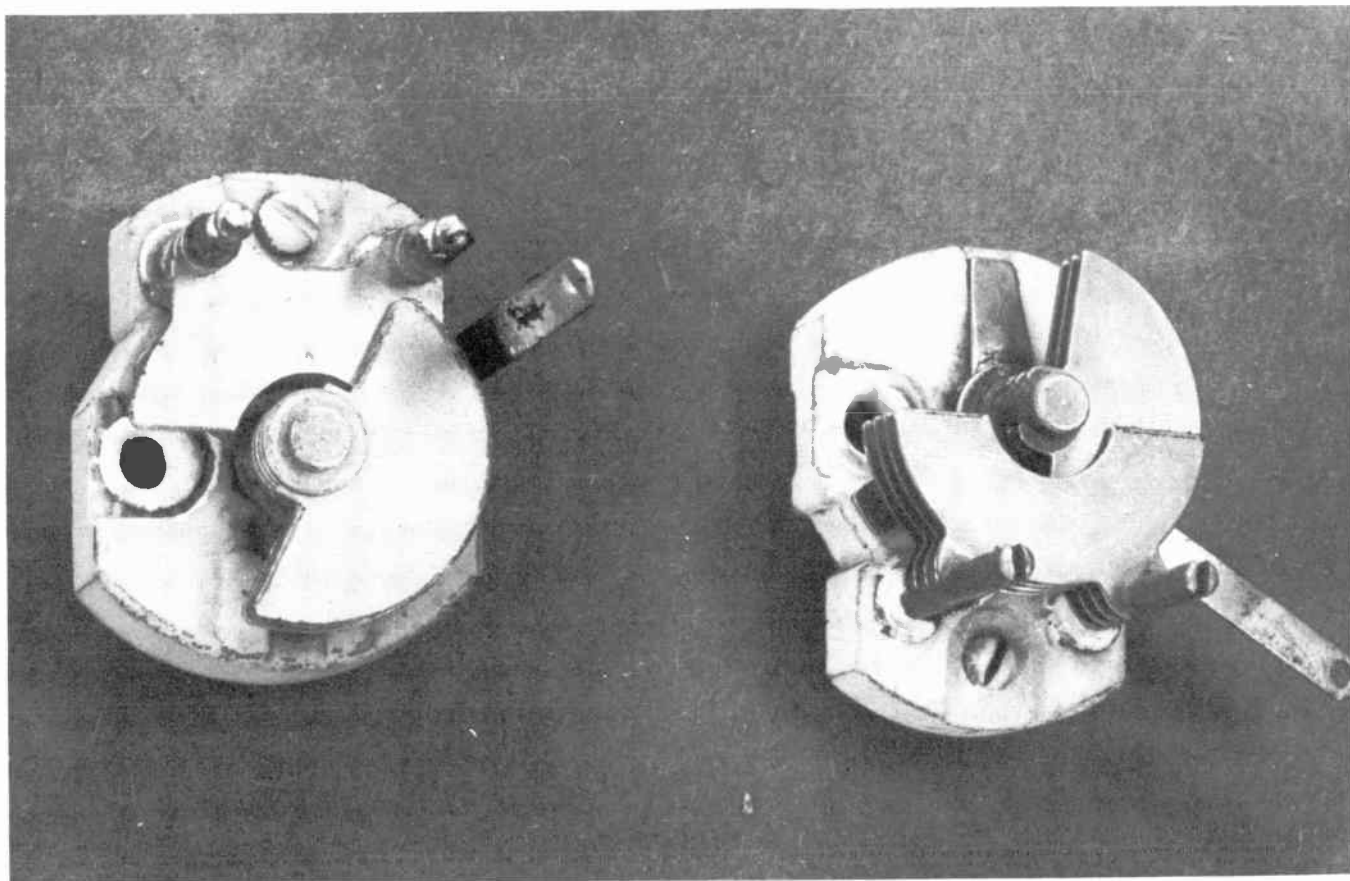

Fig. 18. Midget trimmer capacitors of the air dielectric type.

the difference between pairs of adjacent turns is 1 volt.

Where there is a potential difference between any conductors there is an electric field, and where there is an electric field there is capacitance. Therefore, there is capacitance between every turn and the adjacent turns, also between every turn and every other turn of the winding. All these capacitances together form the distributed capacitance of the inductor.

If an emf is induced in the turns of the inductor, the distributed capacitance acts as though it were in series with the inductance. If an applied voltage comes from outside the inductor and acts across the inductor, the distributed capacitance acts as though it were in parallel with the inductance. When this happens in a parallel resonant circuit we have in parallel with the inductance not only the capacitance of a tuning capacitor and possibly a trimmer, but also the distributed capacitance of the inductor. Total capacitance

then is greater than the sum of adjustable capacitances, and the resonant frequency will be lower than computed from the value of adjustable capacitance.

We have learned that adding capacitance to any tuned circuit has the same effect on resonant frequency as adding inductance. Consequently, so far as tuning is concerned, the distributed capacitance of the inductor acts like additional inductance. The apparent inductance of the inductor is greater than its actual inductance. Reactance of the distributed capacitance varies with frequency, and since it is this capacitance that affects the apparent or effective inductance, the effective inductance of the inductor varies with frequency.

This is the principal reason why formulas for computing the turns required for any given inductance are of little use when working at high frequencies, they cannot take into consideration the effect of distributed capacitance. When it becomes necessary to wind

## COYNE - *television home training*

a small high-frequency inductor for replacements or tests, the practical method is to put on plenty of turns, try the inductor in the circuit where it is to be used, then take off turns or fractions of a turn until the results are as required.

The distributed capacitance of an inductor may act with its inductance to form a circuit which is resonant at some high frequency, without any external capacitor. An inductor suitable for tuning at standard broadcast frequencies may be resonant within itself around 30 to 40 megacycles, and one for tuning at television intermediate frequencies may be self-resonant at some frequency in the ultra-high frequency band. The frequency of self-resonance may be called the natural frequency of the inductor. Distributed capacitance may be called self-capacitance of the inductor.

It is possible for a tube connected to an inductor to oscillate at the self-resonant frequency of the inductor while acting as an amplifier or in some other function at the regular tuned frequency. The result is a waste of high-frequency energy, which must be taken from the signal circuits.

When an inductor is wound on a supporting form of any kind, the smaller the dielectric constant of material in the form the less will be the distributed capacitance of the inductor. If the winding wire is insulated, the smaller the dielectric constant of the insulation the less will be the distributed capacitance. When considering the material of a form and of the wire insulation, the least distributed capacitance is had with wire large enough to be self-supporting (without any form) and having no insulating covering. Then the turns must be spaced away from one another to avoid short circuits between turns.

There is less distributed or self-capacitance for a given inductance when the winding is relatively long and of small diameter rather than being shorter and of greater diameter. This is because the end turns, between which there is maximum potential difference, and farther apart on the longer winding.

The smaller the diameter of the wire with which an inductor is wound the less will be the self-capacitance for any given length, diameter, and number of turns. This is because the smaller wire, acting as plates of the many effective capacitors, has less surface area than larger wire. The smaller the plate area of any capacitor the less is its capacitance. Windings supported by forms may be of wire in gage sizes numbers 22, 24, or 26. Self supporting windings usually are made with wire of gage sizes no smaller than 18, and the size often is as large as number 12.

Inductor windings often are moisture-proofed by impregnating or coating with paraffin or ceresin wax, or a mixture of the two. Beeswax sometimes is added to stiffen the coating. This practice adds to the distributed capacitance, although all these waxes have small dielectric constants, between 2 and 3. The advantage of moisture-proofing outweighs the disadvantage of more capacitance.

Windings are held in place, strengthened, and moisture-proofed by various kinds of coil cements or dopes. Almost any of these materials sold for the purpose are satisfactory at frequencies below about 10 megacycles. If a cement is used for high-frequency inductors it should be of polystyrene or other material having small dielectric constant and low energy losses at such frequencies.

Inductor windings may be made in various ways which lessen distributed capacitance. At the left in Fig. 19 is a spaced self-supporting winding made with bare wire. This, as mentioned before, gives maximum reduction of capacitance. At the right is an example of pie winding. The total inductance is furnished by several separate windings spaced apart on a single supporting form. Total self-capacitance is much less than in one larger winding having the same inductance as the total in the several pies.

At the left in Fig. 20 is an example of duolateral winding. Each turn slopes one direction with reference to the axis for half way around the circumference, then slopes



## LESSON 25 – CAPACITANCE TUNING

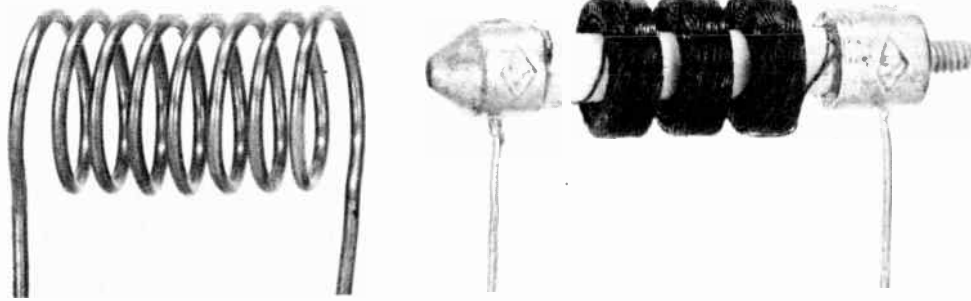

*Fig. 19. A self-supported winding of bare wire (left) and a winding consisting of three pies in series (right).*

the other direction for the remainder of the distance. This places the turns of each layer at an angle to turns of layers inside of and outside of the first one. This crossing of the layer turns at an angle, rather than having them parallel with turns of all other layers, lessens the self capacitance of the winding.

At the right in Fig. 20 are coils made with honeycomb windings. Here the turns in successive turns are at angle with each other rather than being parallel, and, in addition, the turns of each layer are spaced from one another. The resulting openwork pattern of winding accounts for the name honeycomb.

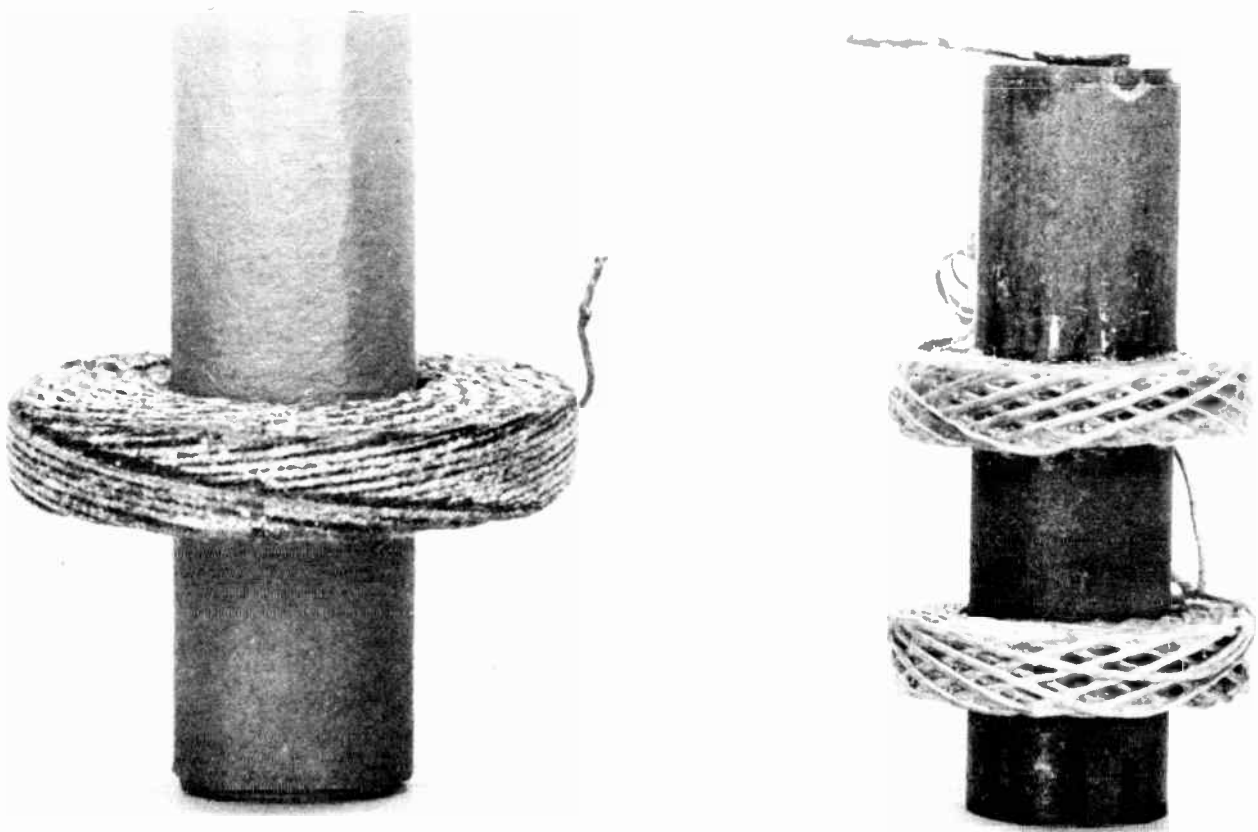

*Fig. 20. A duolateral winding (left) and two honeycomb windings (right).*



# COYNE - *television home training*

This method of winding gives less capacitance than the duolateral method, but also gives considerably less inductance in proportion to the overall size or bulk of the inductor.

STRAY CAPACITANCES. In addition to capacitances of capacitors and of inductors there are numerous other capacitances which have their effect on resonant frequencies. These other capacitances exist between all parts and all wires or other conductors between which there are differences of potential and resulting electric fields. Of course, the capacitances are there regardless of potentials, but it is the voltage differences which cause capacitance currents and which cause the electric fields to interact between the various parts. The capacitances of wiring and of miscellaneous circuit elements are classed as stray capacitances or "strays".

Stray capacitance may be reduced in many ways. Wires and other circuit conductors should be as short as possible. Using wire of small diameter lessens stray capacitance. Keeping wires fairly well separated from one another, and running them in random directions rather than parallel is of help. These precautions apply especially to connections in the grid circuits and plate circuits of all tubes.

The smaller the physical dimensions of coupling capacitors, bypass capacitors, and resistors the less will be the stray capacitances between these parts. The farther these various circuit elements can be separated from chassis metal the less will be the kind of stray capacitance called capacitance to ground. Here again it is the parts which are in grid circuits and plate circuits which should be given most careful attention.

There are stray capacitances in tube sockets, because tube pins and lugs are of metal and they are separated by socket insulation acting as a dielectric. There are similar capacitances in tube bases. This latter effect is relatively small in miniature tubes and in lock-in types whose base pins are short and of small diameter. Where

stray capacitance may be troublesome, as in all very-high frequency circuits, the tube sockets often are made from materials of low dielectric constants.

TUBE CAPACITANCES. Still we are not through with capacitances which affect resonant frequencies and tuning. There are capacitances between all the elements inside of any tube to which our tuned circuits may be connected. The metal elements act as plates and the vacuum space acts as dielectric. All of these interelectrode capacitances act together to form what is called the input capacitance, between the grid and cathode, and the output capacitance, between plate and cathode. The input capacitance will be across any circuit connected to the grid, and the output capacitance will be across any circuit connected to the plate

In miniature pentodes commonly used as amplifiers in television receivers the input capacitances range from about 4 to 10 mmf, with an average of about 6 mmf. Output capacitances of these tubes are from about 2 to 5 mmf. There is no definite relationship between the two capacitances in any given tube.

Octal pentodes in standard broadcast receivers have input capacitances ranging from 5 to 10 mmf and output capacitances usually of 6 to 8 mmf. Triodes of any given structural type, as miniature, octal, lock-in, and so on, have smaller input capacitances than pentodes of similar structure, and may have either smaller or greater output capacitances.

Now we have four kinds of capacitance which add together to determine the resonant frequency when using any certain inductance. The capacitances are (1) That of any capacitors which may be used. (2) Distributed or self-capacitance of inductors. (3) Stray capacitances of circuit parts and conductors. (4) Interelectrode capacitances of tubes, which together form the input and output capacitances.

# TELEVISION



• RADIO

• ELECTRONICS

---

---

**LESSON 26 – INDUCTANCE TUNING**

---

---

***Coyne School***

*practical home training*

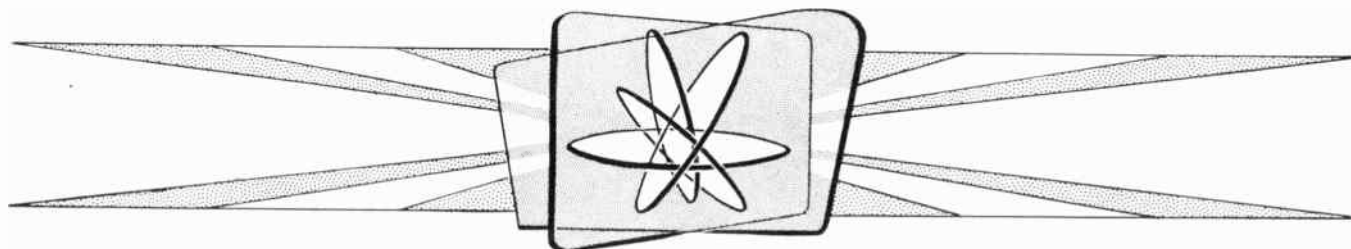

*Chicago, Illinois*

---

*Copyright, 1953 by Coyne Electrical School  
Chicago 12, Illinois  
All rights reserved*

Litho. in U.S.A.

*Lesson 26*  
**INDUCTANCE TUNING**

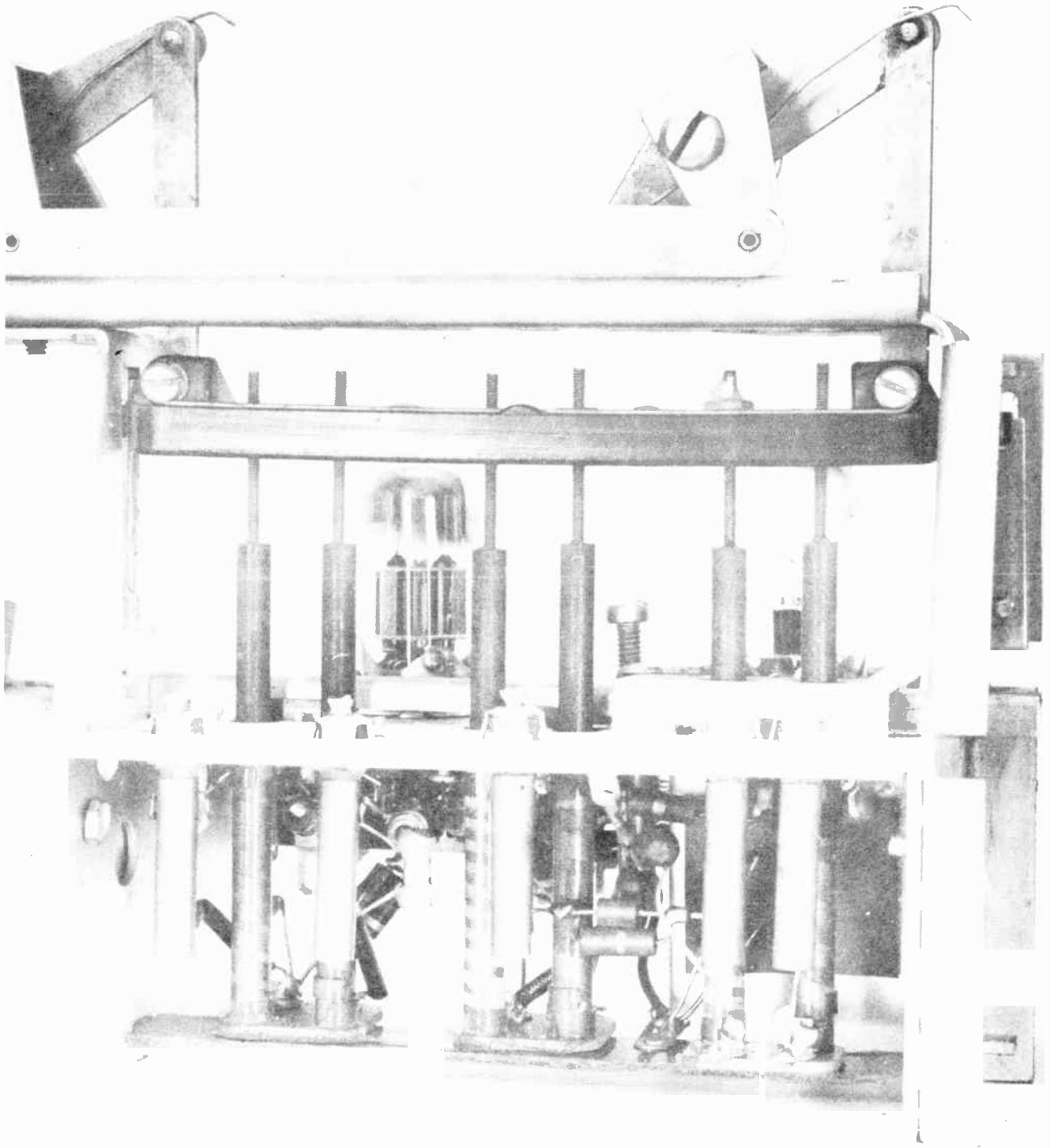

*Fig. 1. A television tuner which employs variable inductors with movable iron cores.*



## COYNE - *television home training*

Even when all the parts of a resonant circuit and all parts connected to the circuit are carefully selected and well arranged there will be capacitance of 15 mmf or more without the addition of a tuning capacitor. This 15 mmf will be the sum of tube capacitance, inductor distributed capacitance, and stray capacitances. It is a fixed capacitance, and cannot be varied during tuning. To tune to frequencies in excess of 20 mc with this fixed capacitance requires inductance of 5 microhenrys and less. Adding any capacitor other than a small trimmer would so increase the total capacitance as to require inductance of one microhenry or less at the lowest frequencies. Consequently, for tuning in television and f-m receivers it is quite common to use variable inductances and omit variable tuning capacitors.

Fig. 1 is a picture of a television tuner which selects channel frequencies by means of three pairs of variable inductors. The six movable iron cores extend above the tube shelf. The windings are in the compartment down below. One of each pair of inductors is switched in for channels 2 through 6, and the other for channels 7 through 13. The cores are raised and lowered for tuning by means of the long black bar to which all of them are attached. This bar is moved up and down by a cam and lever system operated by the channel selector knob.

A close-up view of part of a generally similar tuner may be seen in Fig. 2. The sliding cores of the inductors are above the shelf and the windings are below. On either side of the inductors are two tubular ceramic trimmer capacitors. These are the only capacitors used in the tuned circuits. There are trimmers also on the tuner of Fig. 1, but they do not show up so clearly. Because of small inductances required at the very-high frequencies the inductor windings have only three to ten turns, of widely spaced ribbon made from thin copper strips.

Fig. 3 shows the manner in which inductance changes as an iron core is moved from a position all the way out of an inductor to a position all the way into the winding. This curve is marked Inductance. The other curve, marked Frequency, shows how the

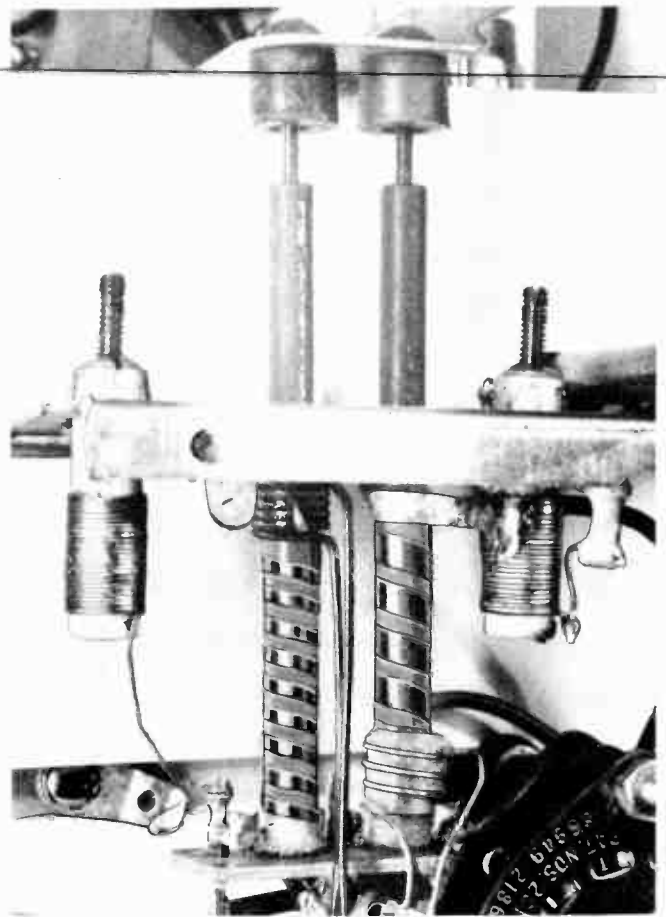

Fig. 2. Tuning inductors with movable iron cores and windings of spiral ribbon conductor.

resonant frequency varies at the same time. Although these curves are made from tests on a certain inductor working through a particular range of frequencies, the general shape of the curves is characteristic of all tuning by means of a movable iron core in an inductor winding.

We learned earlier that, when tuning with variable capacitance, the ratio of maximum to minimum capacitance must be equal to the square of the ratio of maximum to minimum frequency. Now let's see what happens with variable inductance tuning, taking our figures from Fig. 3.

Thus it is demonstrated that the same rule applies to inductance tuning. When frequency is to be changed in the ratio of 2 to 1, inductance must change in the ratio of 4 to 1, because the square of 2 is 4. If frequency

# LESSON 26 – INDUCTANCE TUNING

must change by 3 to 1, inductance must change by the square of 3, or in the ratio of 9 to 1.

Frequency. Maximum = 4.20 mc Minimum = 2.24 mc

$$\text{Ratio} = \frac{4.20}{2.24} = 1.88$$

$$\text{Square of ratio} = 1.88^2 = 3.53$$

Inductance. Maximum = 33.1 microhenrys. Minimum = 9.3 microhenrys.

$$\text{Ratio} = \frac{33.1}{9.3} = 3.56$$

The exposed ends of the threaded rods usually have slots which take a small screw driver.

With the tuning mechanism set for a frequency near the lower end of the range, the threaded rod is adjusted to move the core into its position of resonance for that frequency. Then the tuning dial is set for a frequency near the high end of the range, and a trimmer capacitor is adjusted for resonance at that frequency. The trimmer is connected in parallel with the inductor winding. Exact details of how these steps are carried out will be explained when we come to the subject of receiver alignment.

**TUNING ADJUSTMENTS.** Looking back at Figs. 1 and 2 you will see that the inductor cores are fastened to the movable members of the tuning assembly by slender rods extending upward from the end of the core. These rods have very fine threads which screw into or through the supports.

Although variable or adjustable inductance tuning is employed in the majority of television and f-m receivers, it is not confined only to these high-frequency applications. Exactly the same principles are em-

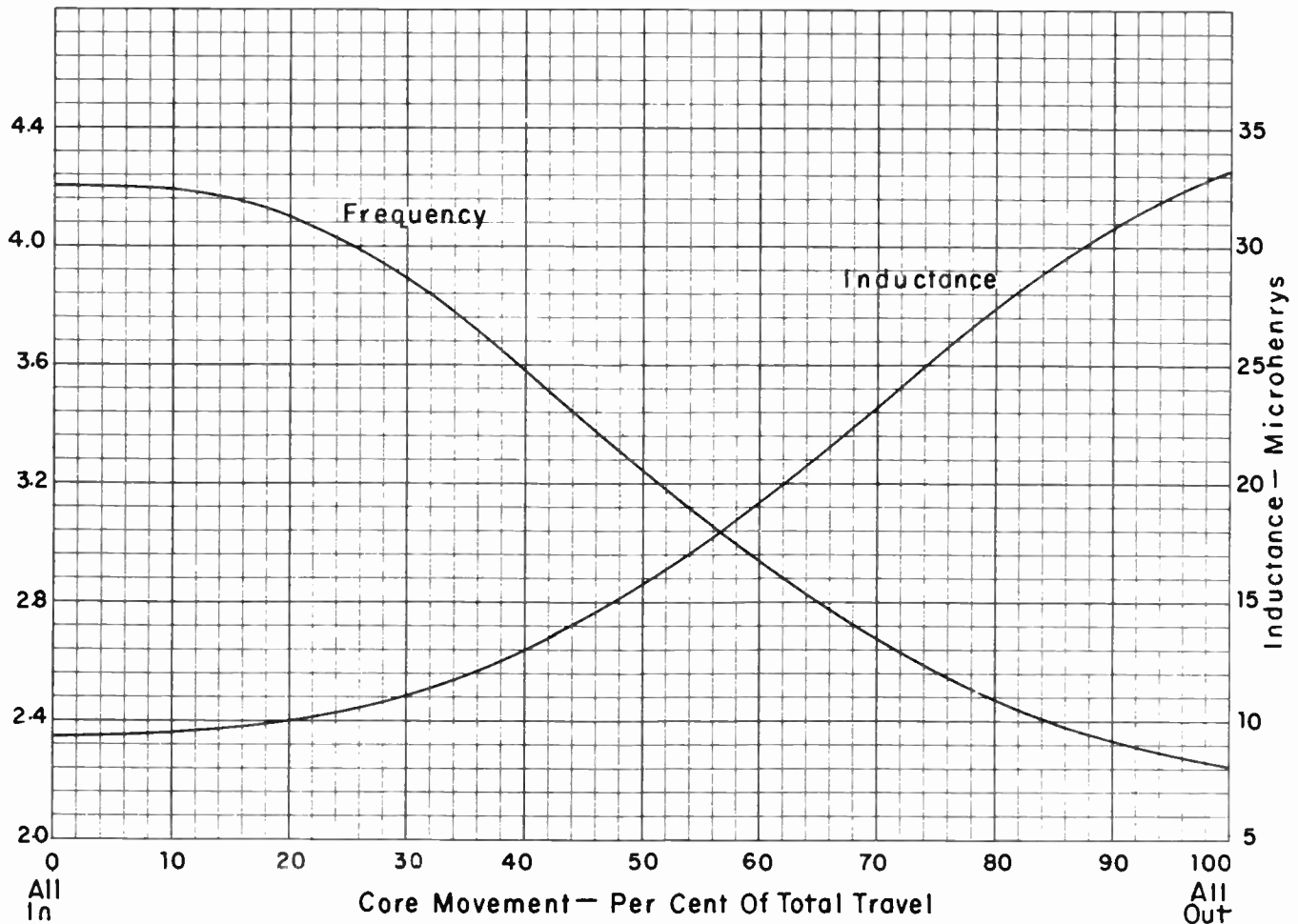
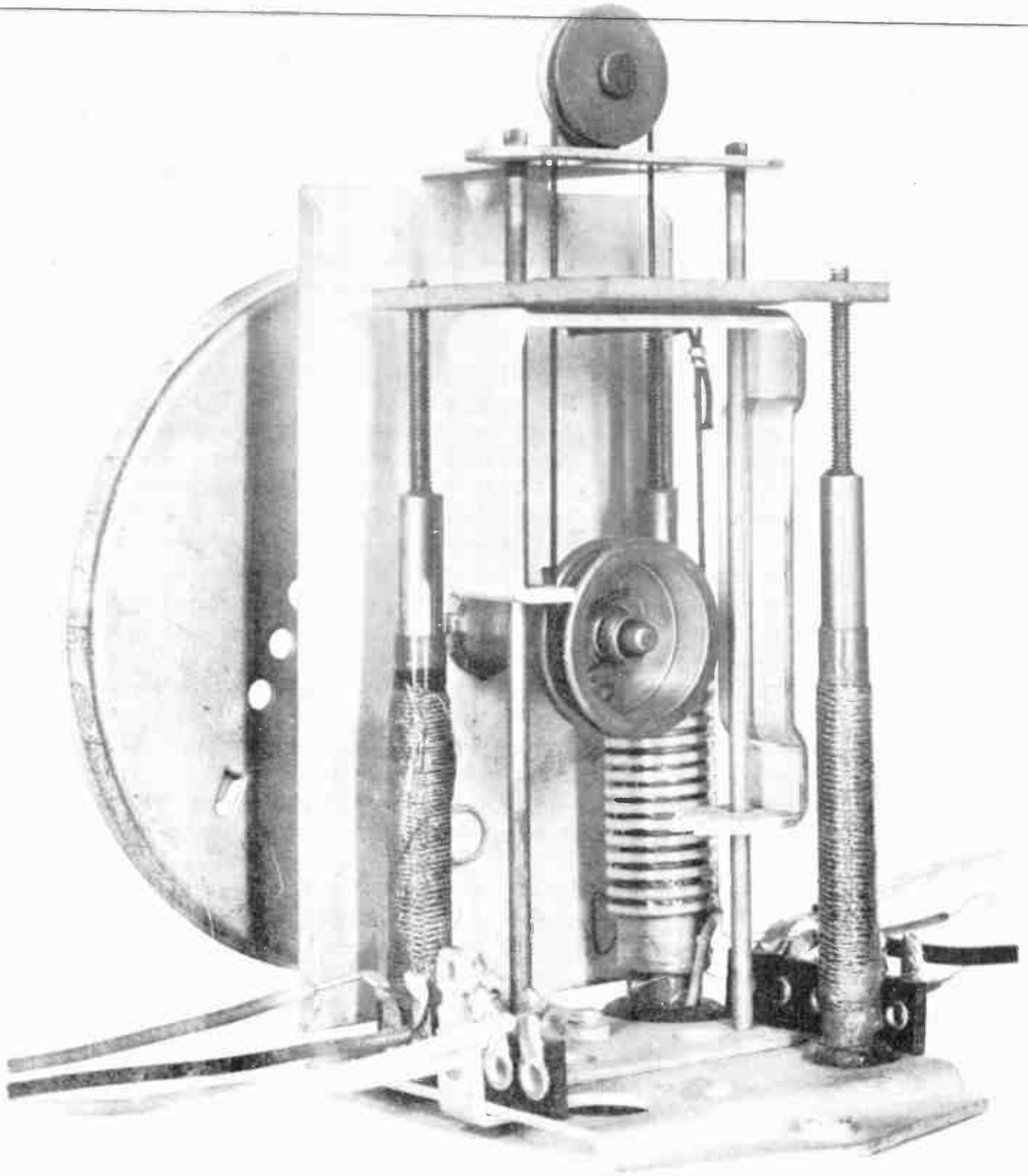

Fig. 3. Changes of inductance and of tuned frequency as an iron core is moved into and out of an inductor winding.



*Fig. 4. An inductance tuner designed for operation at standard broadcast frequencies. This unit may be called a permeability tuner*

## LESSON 26 – INDUCTANCE TUNING

ployed for tuning a number of standard radio broadcast receivers. An inductance tuner for this band of frequencies is illustrated by Fig. 4. There are three inductors whose movable cores are operated through pulleys and cords which raise and lower the bracket into which the threaded core rods are screwed. One inductor tunes the grid circuit of an r-f amplifier tube, a second tunes the plate circuit, and the third tunes an oscillator tube.

TUNING A SINGLE FREQUENCY. In earlier lessons we have looked at a number of inductors whose inductance may be varied by means of a movable iron core. Another is shown by Fig. 5. This and generally

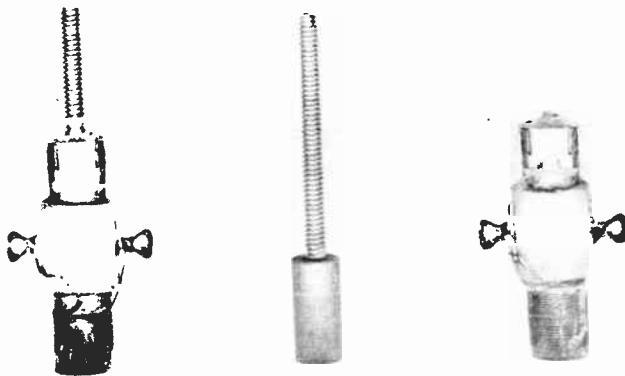

Fig. 5. Adjustable inductors for tuning to some fixed or constant frequency during service operations.

similar types are used in the i-f amplifiers of television receivers and in some f-m receivers, also in any other circuits which are to be tuned to high frequencies during service operations, but whose resonant frequencies are altered only during service operations, not when tuning from channel to channel.

The core is moved with reference to the winding by a screw which extends upward through the mounting clip which passes through a hole in the chassis or other supporting metal. The changes of inductance and of resulting resonant frequency follow the pattern illustrated by Fig. 3. There is very little change for a considerable travel of the

core when it is almost all the way out of the winding, and there is the greatest change for a given travel when the core is approximately centered in the winding.

Trimmer capacitors sometimes are used in connection with these adjustable inductors, but as a general rule the tuning capacitance consists only of distributed capacitance of the inductor, tube capacitance, and stray capacitances in the circuits.

Adjustable inductors tuned with movable cores often are used to provide great impedance at certain frequencies or else to freely pass certain frequencies while offering high impedance at all other frequencies. That is, the inductors are used as parts of parallel resonant circuits or of series resonant circuits. In this case we usually find a fixed capacitor connected in parallel or in series with the inductor. Such a combination is pictured by Fig. 6.

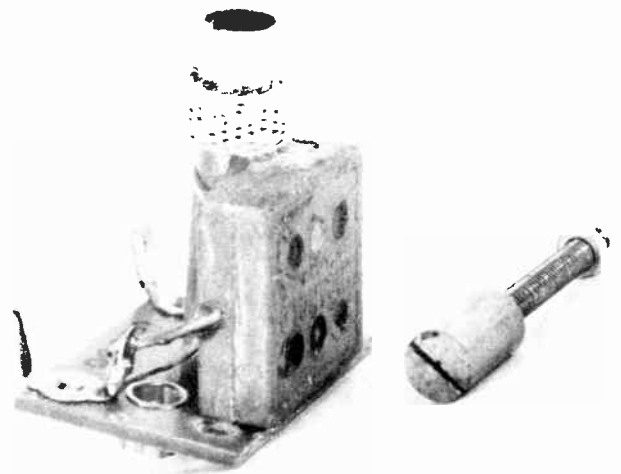

Fig. 6. An inductor and capacitor whose frequency of parallel resonance is adjusted by the movable core shown removed from the unit. This is a "wave trap".

When resonant circuits are employed to provide either maximum or minimum impedance at selected frequencies they are called traps. The full name, or original name, is wave trap. The resonant frequency is adjusted entirely by movement of the inductor core. The fixed capacitor brings the



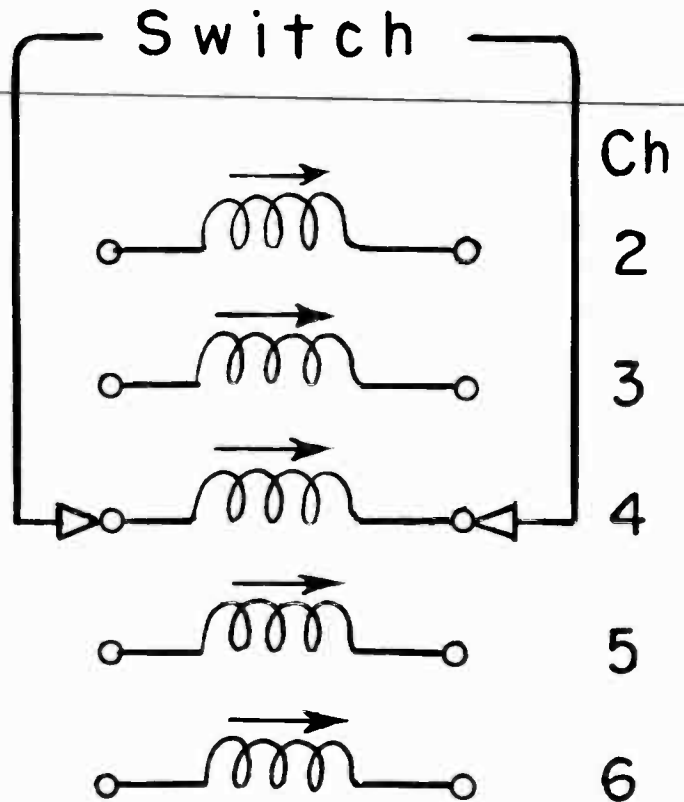
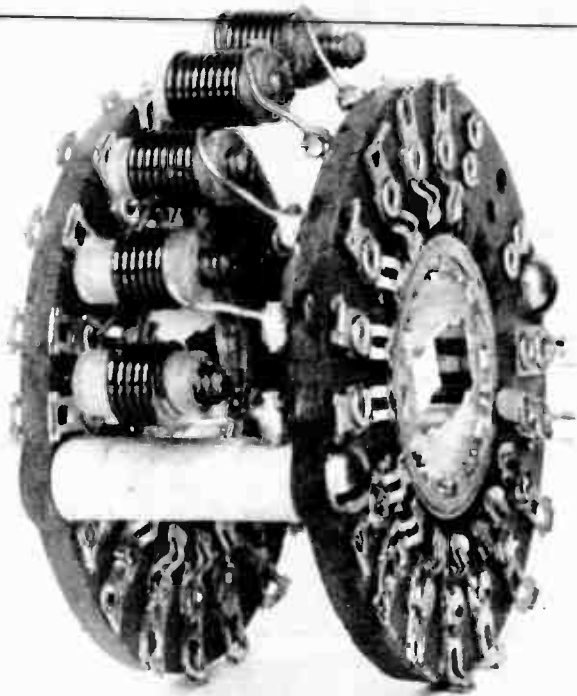

Fig. 7. A television tuner switch section having separate inductors for each channel.

tuning range within the band of frequencies to be weakened or allowed to pass.

#### TUNING TO INDIVIDUAL CHANNELS.

As you may have noticed, relatively few television receivers tune without breaks throughout the frequency bands, rather they tune in steps from channel to channel. For each channel there is a definite position of the selector knob or dial, and upon turning the selector away from one channel there is no tuning effect until reaching the position for an adjacent channel.

One method of tuning in this manner is illustrated by Fig. 7. A number of inductors, one for each channel, are connected between the contact lugs of two rotary switch sections. As the switch is turned from one position to another the rotor contacts of the switch connect the various inductors into the tuned circuit. The number of turns, length, and diameter of each inductor winding are suited to the desired resonant frequency. In addition there is a small screw, acting as an adjustable core, passing into the insulating

form on which is the winding. These cores allow precise frequency adjustments.

Inductors of this general type may be shown on service diagrams as in the sketch at the right. The arrows near each winding indicate the adjustable cores. The tuned channels may be marked on the diagram or they may be evident from the layout of other connections.

Fig. 8 shows another tuner switch section on the left-hand side of which are several small self-supporting inductors. With this construction the inductance and resonant frequency are adjusted by squeezing the turns of an inductor closer together or by spreading them farther apart. Closing the turns increases the inductance and lowers the resonant frequency, while spreading the turns lessens the inductance and raises the resonant frequency.

If inductor windings are to be lengthened or shortened while the receiver is in operation, work only with screw drivers or other

## LESSON 26 – INDUCTANCE TUNING

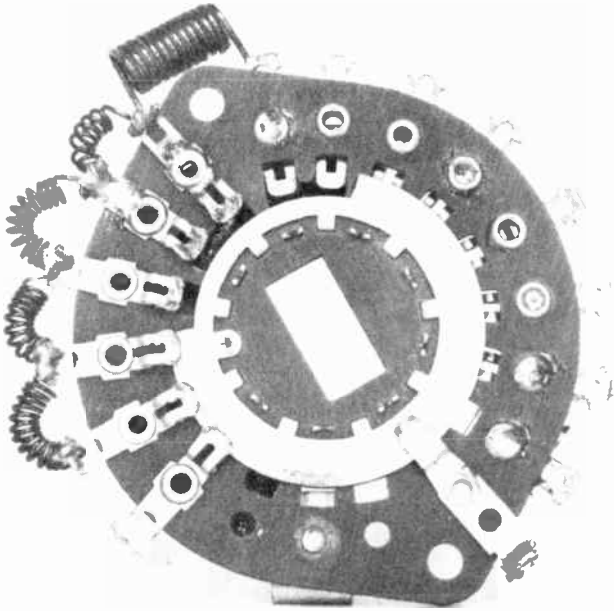

Fig. 8. A section of television tuner switch whose inductances are varied by spreading or squeezing the turns of the small coils.

tools having blades and tips made entirely of fibre or other insulating material. Any tool, even one made of insulating material, will affect the resonant frequency while the tool is near the inductor. You should make a tentative adjustment, then take away the tool while measuring or observing the effect, continuing thus until the desired results are obtained.

When inductors wound on forms and fitted with movable cores cannot be adjusted to resonance by means of the cores, it often is possible to alter the inductance by spreading or squeezing the turns. As a rule this can be done only with the two turns at the ends of the windings, the inner turns will be held securely in place by some kind of cement.

Inductors with so many turns as those of Figs. 7 and 8 have inductances suitable for tuning the low-band channels numbers 2 through 6 of the very-high frequency television range, but they have too much inductance for the high-band channels 7 through 13.

The small inductances needed for tuning the high-band channels may be provided as illustrated by Fig. 9. Here we have between

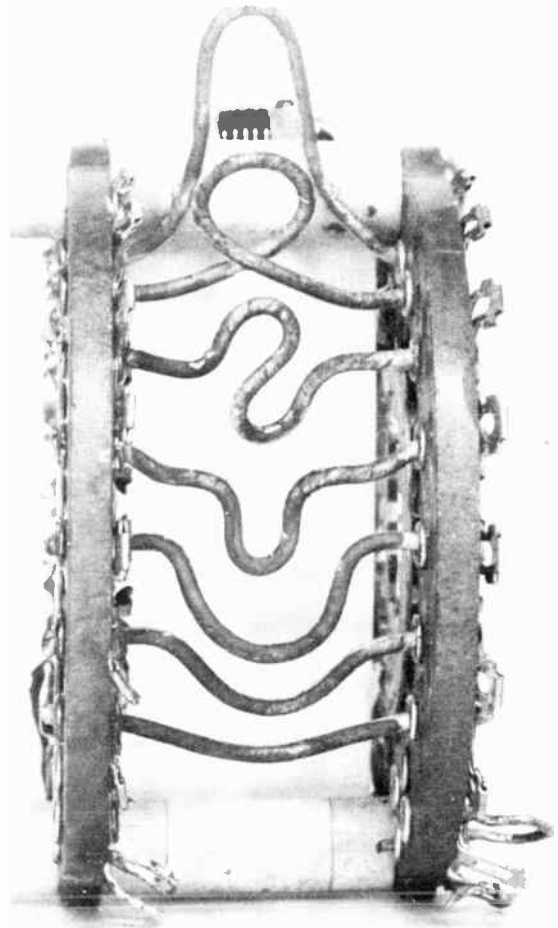

Fig. 9. Inductances for tuning the high-band channels of the very-high frequency television range may consist of short lengths of wire.

the two rotary switch sections a number of wires which are formed into a single turn coil, a nearly closed loop, a letter-S shape, and some open loops consisting of little more than a bend in the conductor. All of these conductor forms have been mounted together to show the variety which may be expected. It would be more usual to find all the inductors of generally similar shape.

When inductors are formed into "hairpins", open loops, zig-zag figures, and such shapes their inductance depends partly on the total length of wire and partly on the area enclosed or covered by the inductor. The greater the length of wire the greater is its inductance. The length cannot be changed by service adjustments.

# COYNE - *television home training*

In general, the greater the area enclosed within the form of an inductor or the greater the area over which the inductor extends, the higher is its inductance and the lower will be the resonant frequency to which it tunes. If you spread the sides of a hairpin or open the sides of any loop while preserving the original form so far as possible, the inductance will be increased and the frequency lowered. Bringing the sides closer together, to lessen the area covered, will reduce the inductance and raise the resonant frequency. The greatest inductance and lowest frequency would be obtained with the inductor wire formed as nearly as possible into a circle, since this would enclose the greatest possible area. Least inductance and highest frequency would be obtained with the wire formed into a loop with its sides almost touching, since this would enclose the least area.

On some channel selector switches are inductance loops of the type illustrated by Fig. 10. A short-circuiting bar or band of

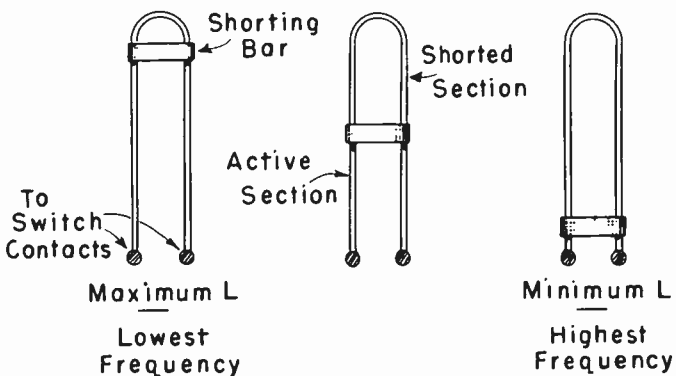

Fig. 10. Inductor loops having adjustable sliders.

thin metal may be moved from one end to the other of the loop. When the shorting bar is farthest from the end of the loop attached to the switch contacts there is maximum inductance and the lowest resonant frequency. At the other end of its travel the shorting bar causes minimum inductance and highest resonant frequency. The shorting bar is held in place on the loop by solder. By touching the soldering iron to the bar, the solder may be softened while the bar is moved from place to place during tests of resonant frequency and circuit performance.

The inductance of any looped inductor may be lessened, and the resonant frequency raised, by filling all or part of the enclosed area with a film of solder. This method might be used with loops of the form shown in Fig. 10. It could be used also for some of the loops of Fig. 9, and with other small loops to be shown later in this lesson. The addition of solder reduces inductance in two ways; it fills part of the area formerly enclosed by the loop, and at the same time increases the diameter or cross sectional area of the conductor, which is one way of lessening the inductance of a conductor which is straight or nearly straight.

**NON-MAGNETIC CORES.** Many adjustable inductors for use at television carrier and intermediate frequencies have cores of brass, bronze, aluminum, or some alloy of metals which is not magnetic. These non-magnetic cores are of about the same sizes as iron (magnetic) cores, and they are moved into or out of the winding position by adjusting screws, just as are iron cores. But the effect of a non-magnetic core is exactly the opposite of a magnetic (iron) core.

The farther the non-magnetic core is moved into the winding the less becomes the effective inductance and the higher becomes the frequency of resonance. Moving the non-magnetic core farther out of the winding allows the effective inductance to increase.

Fig. 11 shows the behavior of an inductor having an adjustable brass core. This particular inductor has three turns of 0.46-inch diameter in a length of 0.15 inch. The brass core, 0.3 inch in diameter and 0.2 inch long, exclusive of the adjusting screw, travels a total distance of about 0.25 inch. Parallel capacitance in the circuit from which the curves were derived measured about 21.5 mmf.

Compare these curves with those of Fig. 3, which show behavior of an iron-core inductor. The curves are of generally similar form in both cases, but the frequency and inductance curves are inverted with reference to core travel. Inductors with non-magnetic cores are common in television tuners. The small screws in the inductors of Fig. 7 are of brass. In some cases there are brass



# LESSON 26 – INDUCTANCE TUNING

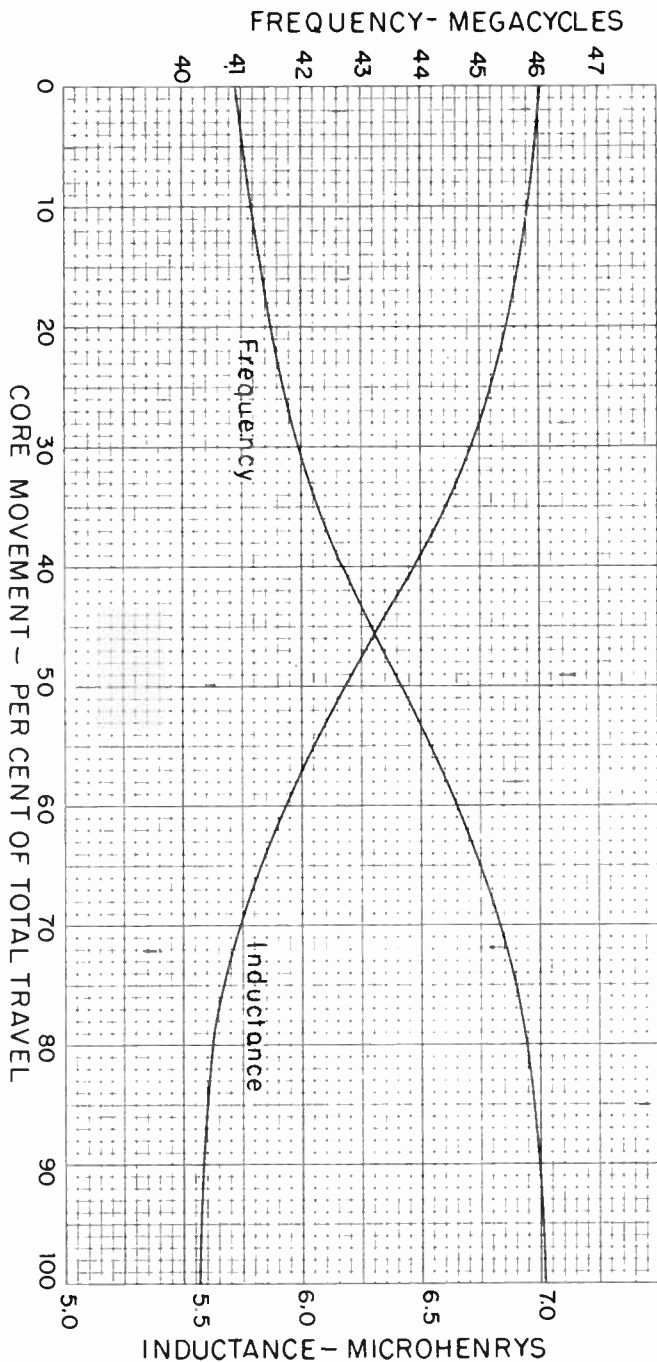

Fig. 11. Change of inductance and of resonant frequency as a non-magnetic core is moved into and out of an inductor winding.

screws located outside the inductors, parallel to and close to the windings. The effects of turning the external adjusting screws are the same as with non-magnetic cores which are inside the windings.

In a few receivers the inductance and frequency of some high-frequency circuits are altered by changing the spacing between

leads or conductors going to the two ends of an inductor. Moving the leads closer together increases their capacitance and lowers the resonant frequency. Moving the leads farther apart lessens the capacitance and raises the frequency.

**INCREMENTAL TUNING.** In many television tuners there are no separated inductors for tuning to each channel. Instead there is a single tapped inductor or a string of inductors connected in series with one another. The total series inductance is suitable for tuning to the lowest channel frequency. A channel selector switch short-circuits more or less of the total inductance to leave amounts required for tuning to each channel. This method may be called incremental tuning, because, commencing with the least inductance for the highest frequency, inductance is added in "increments" for tuning each lower frequency.

Fig. 12 is a picture of a switch section designed for incremental tuning. The short-circuiting portion of the switch rotor is here set for tuning to channel 13 in the high band of the very-high frequency television range. Before examining the mechanical and electrical action of this switch it will be well to get acquainted with the changes of inductance required for tuning through all the very-high frequency channels.

In Fig. 13 the lengths of the vertical lines are proportional to inductances in microhenrys; the greater the length of line between any two points the greater being the change of inductance between these points. The entire diagram is based on using total inductance of 0.6500 microhenry with circuit capacitance of about 12 mmf. This total inductance will tune to the lowest-frequency channel, number 2. Frequencies marked on the diagram are center frequencies of the various channels. For instance, channel 10 extends from 192 to 198 mc. Its center frequency is midway between these limits, and is 195 mc, as marked on the diagram.

Changes of inductance for tuning the high-band channels, 13 down to 7, are illustrated at the left. Commencing with zero inductance at the top of the vertical line it is



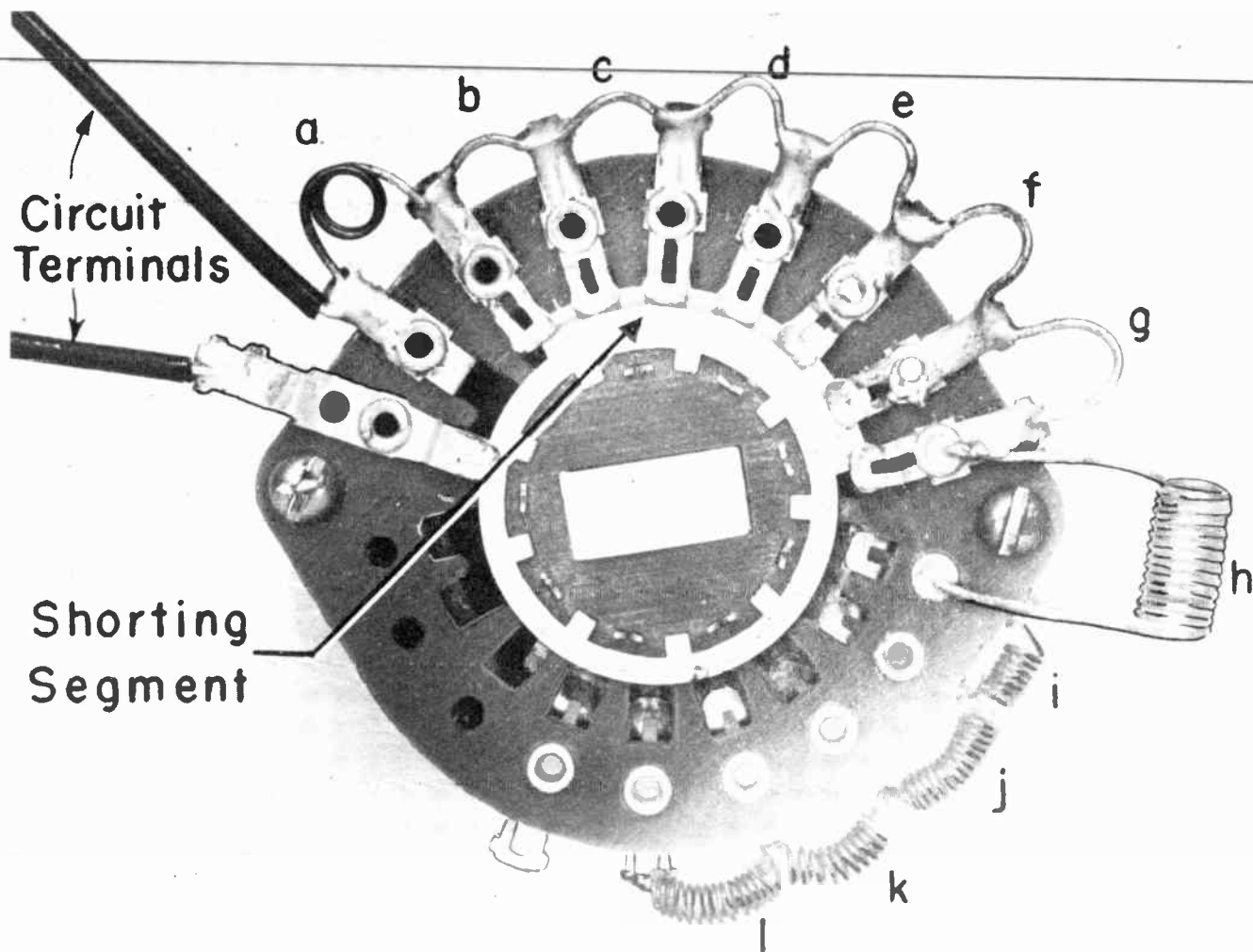

Fig. 12. A switch section of a television tuner designed for incremental tuning.

necessary, for tuning to channel 13, to add 0.0465 microhenry of inductance, as represented by the length of line marked a.

For tuning to channel 12 the total inductance must be made 0.0493 microhenry. This inductance is obtained by adding 0.0028 microhenry to that used for channel 13, as represented by the length of vertical line marked b. For tuning to successively lower channels we add amounts of inductance represented by line lengths c, d, e, and so on, until arriving at channel 7, which requires total inductance of 0.0674 microhenry. This completes the high-band tuning.

To change from channel 7 at the bottom of the high band to channel 6 at the top of the

low band the center frequency must change all the way from 177 mc down to 85 mc. Tuning inductance must be increased from 0.0674 microhenry all the way to 0.2920 microhenry. This is too much change to be shown on a vertical line scaled as at the left in Fig. 13, so we adopt a shorter inductance scale and go to the right-hand side of the diagram. Change of inductance for any given length on the right-hand vertical line is ten times the change represented by an equal length on the scale at the left.

On the right-hand vertical line the change of inductance from zero to 0.0465 microhenry required for channel 13 is represented at a. The total change of inductance for tuning through the entire high band

# LESSON 26 – INDUCTANCE TUNING

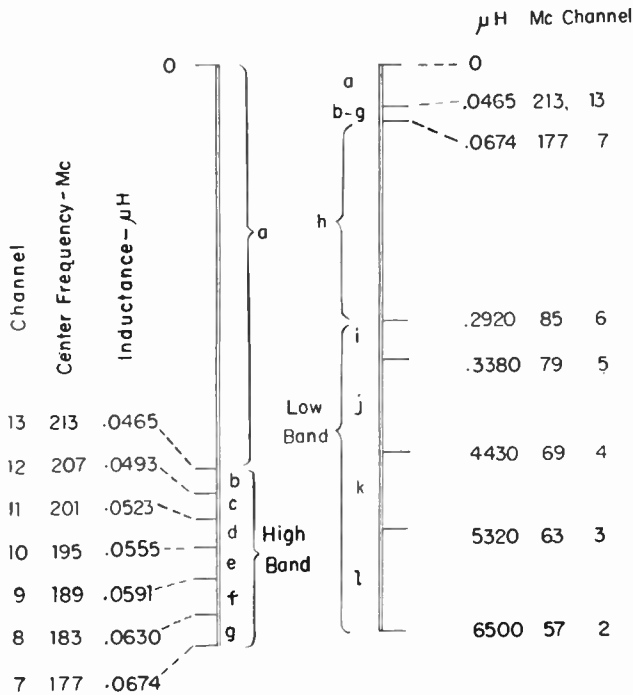

Fig. 13. Inductances and changes of inductance required for tuning through the very-high frequency television band by the incremental method.

is represented at b-g. This means that the entire inductance scale at the left is included at a and b-g on the right.

The large change of inductance required in going from channel 7 in the high band down to channel 6 in the low band is represented at h on the right-hand vertical scale. Added inductance for tuning from channel 6 to channel

5 is represented at i. Much more inductance must be added when tuning from channel 5 to channel 4, as shown at j. Note that center frequencies of channels 5 and 4 are 10 mc apart, while center frequencies of other low-band channels are only 6 mc apart.

Next we add inductance represented at k to reach channel 3, and add still more at l to tune channel 2. Here, at channel 2, we are using the total series inductance of 0.6500 microhenry for tuning to the lowest channel frequency.

Fig. 14 is a schematic circuit diagram of the channel selector switch whose operation is illustrated by Fig. 13 and which is pictured by Fig. 12. Inductances or sections of inductor are similarly lettered on all three figures. Points between the sections are connected to switch contacts. The shorting segment of the switch rotor, actually part of the circular metallic rotor as you can see in Fig. 12, is shown as a straight bar in Fig. 14. The straight bar would be considered as moving right and left as the rotor segment is turned around.

In Fig. 14 the shorting segment is positioned for tuning to channel 10. Inductor sections a, b, c, and d are not shorted, and together they provide 0.0555 microhenry inductance as required for tuning channel 10. Moving the shorting segment to the left on the schematic diagram would short out more in-

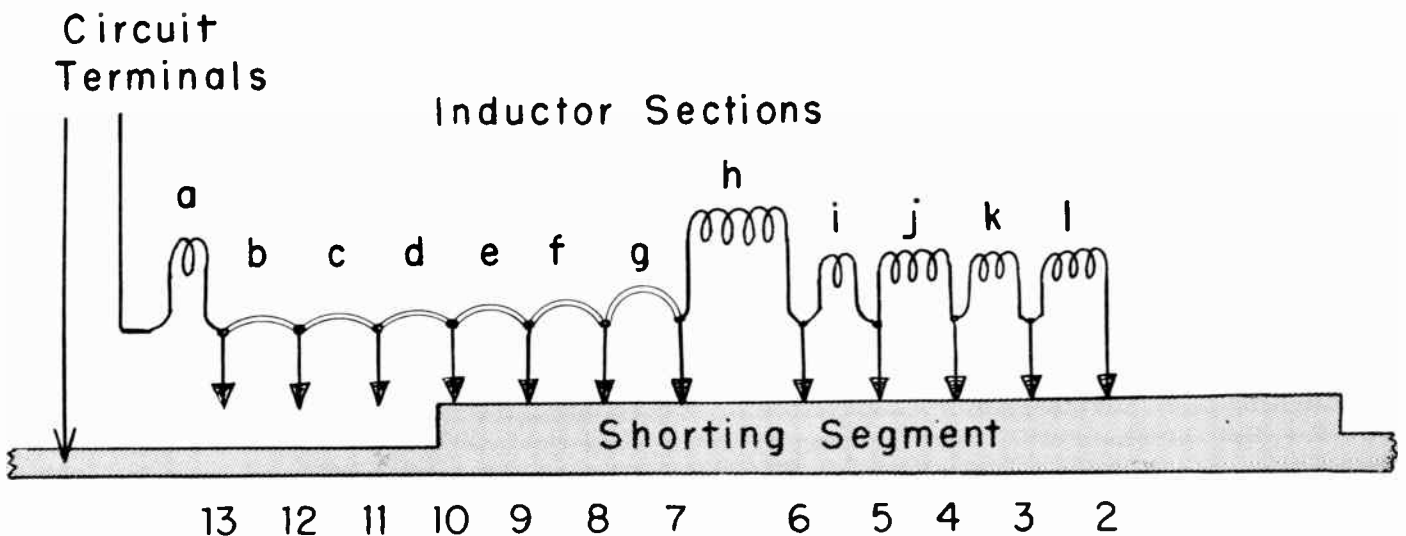

Fig. 14. A schematic circuit diagram representing the switch section of Fig. 12 and the inductance changes of Fig. 13.

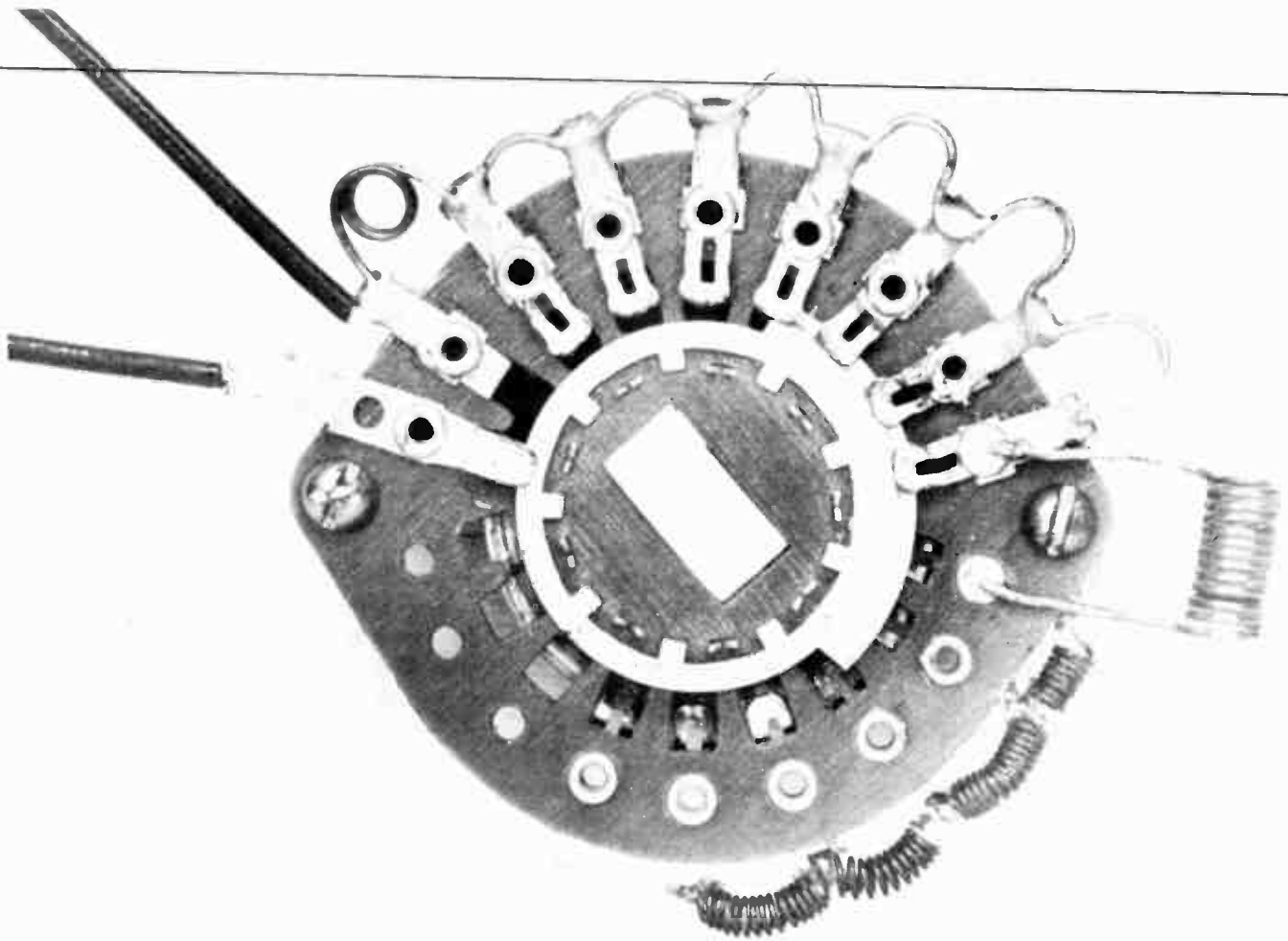

Fig. 15. At the left the shorting segment of the switch rotor is set for channel 10, and at the right it is set for channel 7.

ductor sections, would lessen the active inductance, and would tune to higher channels. Moving the shorting segment to the right would remove the short circuit from more and more inductor sections, would increase the active series inductance, and would tune to lower channels.

Above in Fig. 15 the shorting segment of the switch rotor is turned for tuning channel 10. Below the segment is turned for tuning channel 7. The short has been removed from all the high-band inductor sections. The portion of the shorting segment that acts on the low-band inductors is on the reverse side of the switch rotor, as you can see on Fig. 8, but is conductively connected to the front segment. It is necessary to place the low-band shorting segment on the other

side of the rotor in order that it may not come around and short out part of the high-band inductance when tuning to the lowest channels of the low-band. The low band inductors are, as you can see, made up of small self-supporting coils. It is necessary to use these coiled inductors to provide the relatively large inductances for tuning in the low band.

Any one or more of the inductor sections for incremental tuning may be altered by changing the spacing between turns, by bending to enclose more or less area, by partially filling with solder, or in other appropriate ways. When making any such changes it is important to keep this in mind: Altering any one section will change the tuning not only for the channel connected im-

## LESSON 26 – INDUCTANCE TUNING

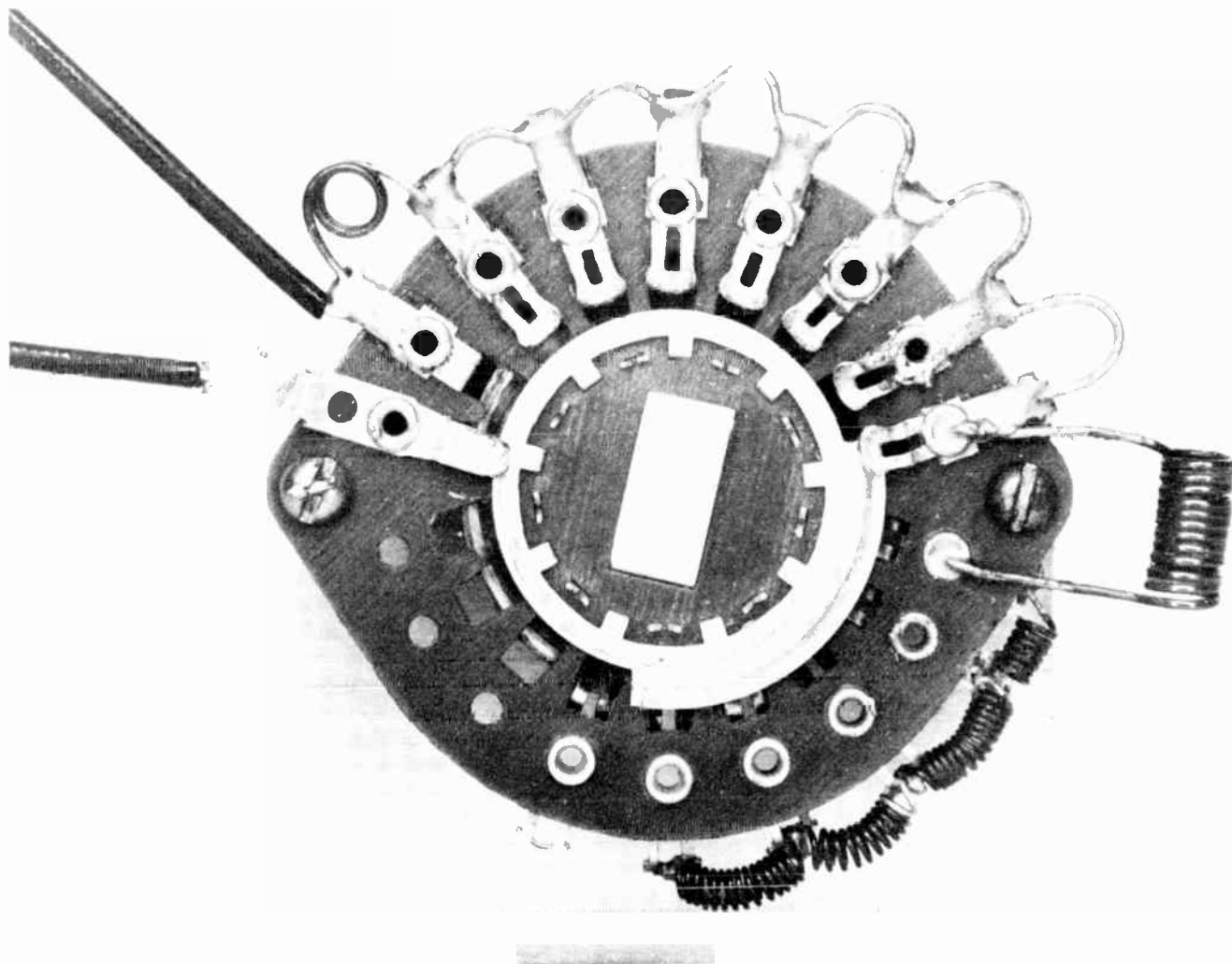

Fig. 15. Right

mediately below that section, but also for every lower channel.

To see why this is true, imagine that there is a change of inductance in section d of Fig. 26-14. This will affect the tuning for channel 10, because section d is active or is not shorted on this channel. If the selector is changed to tune channel 9, section d still be active because it remains not shorted. Then tuning of channel 9 is affected. The same reasoning holds for all lower channels, for section d remains unshorted. If the selector is moved to tune channel 11, section d of the inductance will be shorted and will be inactive. This is true also when tuning channels 12 and 13, section d remains shorted and inactive.

Altering the inductance at a of Fig. 14

will affect tuning of all the high-band channels, because all of the other inductance sections for the high band are below point a.

Changing the inductance of any one or more of the high-band sections, a to g inclusive, will have no noticeable effect on tuning any low-band channel. The reason is that the high-band inductances are so exceedingly small compared to those for the low band. The average value of inductance sections b through g is only 0.0035 microhenry. Adding this entire inductance to that for any of the low-band channels would alter that low-band inductance by something like one per cent at most.

Changing the inductance at h of Fig. 14 will affect tuning of all the low-band channels, because this section is not shorted and is ac-



## COYNE - *television home training*

tive on all the low-band channels. Changing the inductance at *i* will affect tuning of channels ~~5, 4, 3, and 2~~. Changing the inductance at *j* will affect channels 4, 3, and 2, while a change at *k* will affect channels 3 and 2, and a change at *l* will affect only channel 2.

WIRE LENGTH AND DIAMETER. If you look at the changes of inductance for tuning from channel to channel in the high band, as shown by Fig. 13, they are found to be very small - only three or four thousandths of a microhenry. Even in the low band the changes are only about one-tenth to one-twentieth of a microhenry. This is proof of how great could be the upsets in tuning were there even the slightest alterations of inductances as originally fixed by the manufacturer.

If you look at the pictures of tuning inductors in Figs. 12 and 15 you will see how very short are the inductor sections for tuning from channel to channel in the high band. It is evident that a very slight change in the length of a wire might so alter the inductances as to make tuning to particular channels quite impossible.

You must realize and remember that short lengths of straight or slightly curved wire have enough inductance to bring about great variations of resonant frequencies when working at television carrier frequencies, and in many cases when working at intermediate frequencies. Here is something else of importance. The diameter of a wire has a decided effect on inductance. Should you substitute a length of 30 gage wire where 20 gage had been used, the inductance could go up by 20 to 40 per cent.

The self-inductance of only one inch of number 30 wire (1/100 inch diameter) is about 0.025 microhenry. Four inches of this wire has inductance of about 0.150 microhenry. The four inches of wire, used with capacitance of 15 mmf, would make a circuit which would be resonant at about 106 mc. This is near the upper end of the f-m broadcast carrier band.

Inductance of a straight wire increases with length of the wire, but at a greater rate

than the length. Doubling of lengths which originally are around a fraction of an inch up to four or five inches will increase the self-inductance about two and one-half times.

Inductance of straight wires decreases as the diameter of the wire is increased. Increasing the diameter by about three times will drop the inductance to something like three-fourths of its first value. By increasing the diameter six times the inductance will drop to about half its first value. Conversely, decreasing the diameter of a straight wire to one sixth will double the inductance. These are not exact figures, for there are no direct relations between inductance and either length or diameter, but the examples do illustrate what to expect when alterations are made.

Earlier we learned that the combined inductance of inductors in parallel follows the rules for resistances in parallel. The combined inductance is less than that of any of the separate inductances, and, if all inductances are equal, the combined inductance is equal to the value of one unit divided by the number of units.

Often it becomes necessary to reduce an inductance below any value which can be obtained with wires of length and diameter suitable for use in some piece of apparatus. Then the engineer resorts to paralleled inductors; he connects two or more short, straight wires in parallel. The greater the spacing between the paralleled wires, within reasonable limits, the greater is the drop of inductance resulting from the parallel connection. This is because the magnetic fields of well separated wires do not cut through the other wires in the group.

To anyone not acquainted with high-frequency practice it probably would appear rather useless to have two or more short, straight wires between the same two terminals. They might substitute a single wire, with results which would be astonishing when it came to tuning.

Inductance is not confined to coiled inductors, it is present in every wire and every other kind of conductor. At low frequencies the circuit inductances are of little import-

## LESSON 26 – INDUCTANCE TUNING

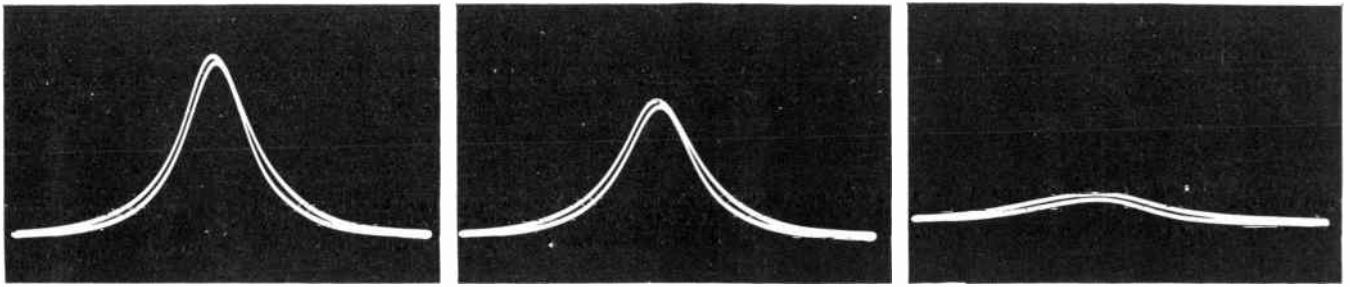

Fig. 16. The greater the resistance or the greater the energy loss in any tuned circuit the less is the voltage at resonance, and the less is the difference between voltages at resonance and either side of resonance.

ance, they are not great enough to affect resonant frequencies to any appreciable extent. But at very-high frequencies the circuit inductances are highly important. In one experiment, cutting one inch from the leads to a coil of 1-1/3 turns raised the range of tuned frequencies by 15 per cent.

LOSSES OF SIGNAL ENERGY. Some time ago we looked at an oscilloscope trace showing frequency response of a resonant circuit. This trace is shown again at A in Fig. 16. The voltage peak at resonance is high and sharp, and falls off decidedly at lower and higher frequencies. Adding 1,200 ohms of resistance to this circuit changes the response to that at B. We still have resonance and a resonant peak, but the peak voltage is materially less and there is much less difference between voltage at resonance and at lower and higher frequencies. Adding 12,000 ohms of resistance produces the response shown at C. The resonant peak has all but disappeared. Now the circuit would be of little use for signal selection.

Signal energy is wasted as heat produced by signal currents in resistance added to the resonant circuit. Anything which wastes signal energy in heating would have the same effects on resonant voltage as does ordinary resistance added when making the response traces of Fig. 16. Many electrical actions and effects can waste signal energy. All of them are classed as high-frequency resistance because the losses become progressively greater as frequency rises. As an example, energy loss in an inductor operating at very-high frequencies may be 100 times that due to ordinary ohmic resistance with direct current. We shall briefly discuss

some of the principal causes for high-frequency resistance.

Distributed Capacitance. Waste of signal energy may result from distributed capacitance when this capacitance and circuit inductance are resonant at some frequency other than the tuned frequency at which the circuit is supposed to operate. Currents at this other frequency cause additional heating, which means energy loss.

If only part of an inductor is active, and the remainder is not short circuited, the inactive portion is almost certain to be resonant at a frequency corresponding to its distributed capacitance and inductance.

Skin Effect. The magnetic lines induced by current in a conductor are most concentrated and the field is strongest at the center of the conductor or along the axis of the conductor. Consequently, induced emf's and resulting inductive reactance are maximum at the conductor center and least at the surface. This action becomes more pronounced as frequency rises, because any kind of inductive reactance increases with frequency. Alternating signal currents at the center of the conductor are strongly opposed, and the greater portion of these currents is thus forced to flow at the surface or at the "skin" of the conductor. This action is called skin effect.

With nearly all of the signal current flowing at the conductor surface, only this outer portion is acting as an effective conductor. We have the equivalent of a conductor of smaller cross sectional area, which means higher resistance, more heating, and

## COYNE - *television home training*

more energy loss. Skin effect commences to have ill effects at frequencies as low as three megacycles, and becomes progressively worse as frequency rises.

If some conductor connected to a tuned circuit has more surface area than the wire, most of the signal current may leave the conductor where it should flow and go to this other larger surface. The other surface might be on the plates of a tuning capacitor. Conductors in high-frequency transmitting apparatus often are made of thin copper tubing, since the interior of these conductors would be nearly useless. High-frequency inductors, coiled or straight, often are made of bare wire silver plated. Silver has least resistance of any metal and does a better job of carrying signal currents forced to the surface by skin effect.

When wires or other conductors carrying high-frequency currents run side by side and close together there may be an action somewhat similar to skin effect. Maximum current will flow on the side of each conductor which is toward the other conductor. Thus part of each conductor carries excess current, and there is additional heating of this part.

Eddy Currents. When the lines of a magnetic field pass into or through any conductor they induce emf's and currents in that conductor. These induced currents circulate around the direction of field lines. For example, if the field lines extend in a vertical direction, the induced currents will travel around in horizontal circles. These currents are called eddy currents because they whirl around and around like water in an eddy or whirlpool in a river.

The eddy currents cause heating of the conductor wherein they are induced. The effect is most troublesome in magnetic cores made of iron or steel, because these metals have fairly high resistance and considerable power is used in forcing eddy currents to flow. Eddy current losses are lessened by using thinly divided sections of iron for magnetic cores, for then the currents can flow only in limited paths. This is the reason for making transformer cores of thin laminations rather than of solid iron or steel.

The movable or adjustable cores of high-frequency inductors are not made of ordinary iron, they are made of finely divided or powdered iron whose particles are coated with very thin coatings of insulating cement. The cores are formed to the desired dimensions, then compacted by heating at high pressure. Such cores maintain their good magnetic properties and have acceptably small energy loss at high and very-high frequencies, where iron in sheets or in solid form would have prohibitive energy loss.

Dielectric Losses. When any insulating material is in an alternating electric field the electrons within the atoms are pulled first one direction and then in the opposite direction. This heats the insulation or dielectric material in the same way that movement of electrons as current heats a conductor. Movements of the electrons do not follow changes of field direction and strength instantaneously. The electron movements lag somewhat behind the changes of field strength. When the field is reduced to zero the electrons do not immediately return to their normal positions in the atoms.

Were the dielectric a perfect one, according to theory, all of the energy used for moving the electrons one direction would be returned to the circuit when the electrons return to their original positions. Actually this does not occur; some of the signal power disappears in heat and is lost to the circuit. The percentage of signal power thus wasted is the dielectric power factor of the material. Dielectric power factor is small in high grade ceramic and steatite insulation and in polystyrene. The factor is slightly greater in low-loss yellow Bakelite and in some electrical glasses. It is high in ordinary molded insulation and supporting materials and in fibres.

Losses are proportional to strength of the electric field. This field strength is proportional to the dielectric constant of the material. Therefore, if two different materials have the same or nearly the same dielectric power factors, the one of lower dielectric constant will have the lower total energy loss. It is for this reason that materials of low dielectric constants are favored

## LESSON 26 – INDUCTANCE TUNING

for insulation subjected to high-frequency electric fields. All of the signal energy losses that occur in insulating and dielectric materials are classed as dielectric losses, whether the materials are used for capacitor dielectric, coil forms, wire insulation, supports, or what not.

### Losses in Inductors And Capacitor.

The principal causes of signal energy loss of high-frequency resistance in inductors are skin effect and distributed capacitance. There may be serious loss also in wire insulation, in the material of a form that supports the winding, and in many of the cements and binders used for holding the turns in

place. A further loss may result from eddy currents induced in any metal parts which are near the inductor. Energy for all these losses must be supplied by signal currents, and it is subtracted from available signal energy.

Capacitors suffer from skin effect loss in their plates. Eddy current losses may be rather large if there is any iron or steel within the field space of the capacitor or close to the edges of the plates. Dielectric losses occur when any kind of dielectric material is in the field space or very close to the edges of the plates, especially when this material has high power factor or large dielectric constant.



# TELEVISION

◦ RADIO

◦ ELECTRONICS

---

**LESSON 27 – TRANSFER OF SIGNAL VOLTAGES**

---

***Coyne School***

*practical home training*

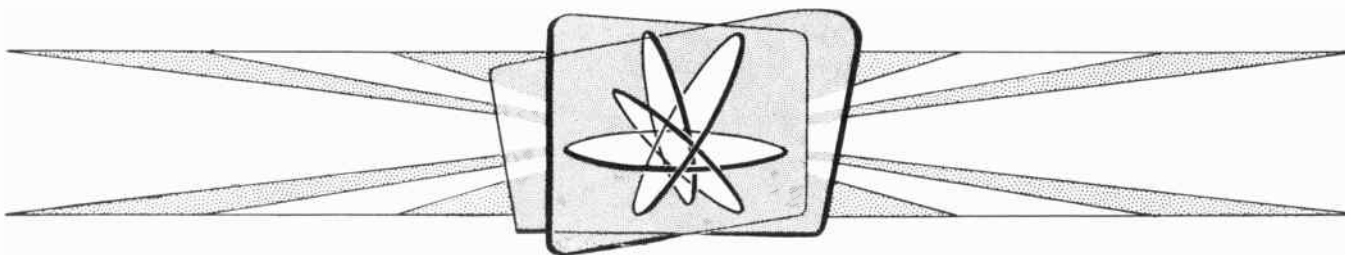

*Chicago, Illinois*

---

*Copyright, 1953 by Coyne Electrical School  
Chicago 12, Illinois  
All rights reserved*

## *Lesson 27*

### **TRANSFER OF SIGNAL VOLTAGES**



*Fig. 1. This student in the Coyne School is aligning a television receiver. He is adjusting the i-f coupling transformers to their correct resonant frequencies.*

# COYNE - *television home training*

The first circuit through which the signal passes upon entering a television receiver is the "coupling" between antenna and the r-f amplifier of the tuner. Thereafter, all the way from the output of the r-f amplifier to the picture tube and speaker, the signal voltages are transferred from tube to tube through interstage couplings, perhaps as many as twenty or thirty times.

The tubes increase signal strength, and some of them may change the form of the signal in various ways required for reproduction of pictures and sound. But it is the couplings between the tubes that select the frequencies to which the circuits are responsive, that determine which frequencies are passed and which are stopped, and determine to a great extent the portions of the signal which are to be fed into the various sections of the receiver.

As a service technician you can do relatively little to change the performance of a tube. Of course, varying the operating voltages will affect the gain and such things as plate current cutoff. Otherwise, however,

the action of tubes on the signal cannot be altered to any great extent.

The couplings between tubes or stages can, in the majority of cases, be so adjusted as to make great variations in the form of the signals, in signal strengths, and in the portions of signals to be utilized at various points in a receiver. Most television service adjustments, and those for sound radios too, are in the interstage couplings.

Couplings may be defined as follows. Circuits are coupled when a reactance or an impedance is common to both or is part of both circuits, and when changes of voltage or current in one circuit cause changes of voltage or current in the other. This definition is entirely correct, but it is too simple and brief to give us much idea about coupling until we look at a few applications.

At 1 in Fig. 2 is represented any source of a-c voltage, in series with which is resistor Rs. Alternating current will flow in this resistor, and across it will be alternating voltage. At 2 is a resistor, Ri, in parallel

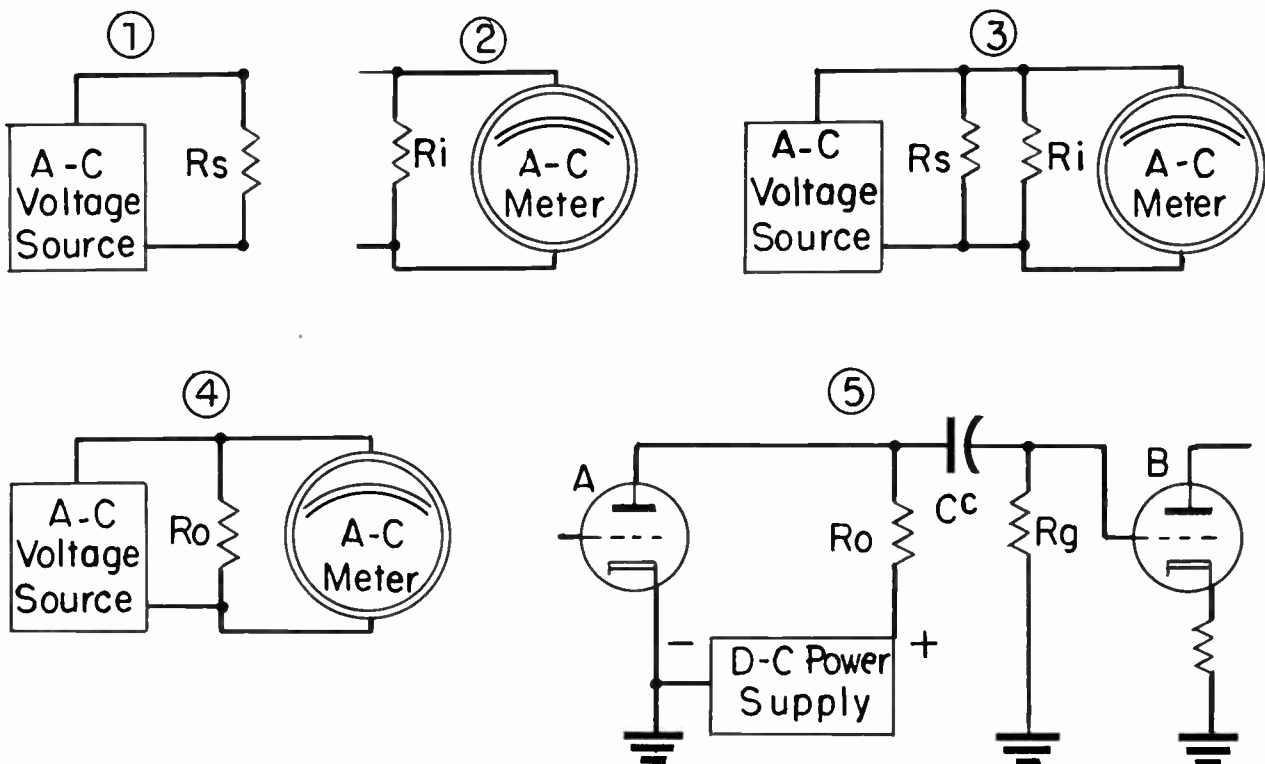

Fig. 2. Two circuits are coupled when an impedance is common to both circuits or is part of both circuits.



## LESSON 27 – TRANSFER OF SIGNAL VOLTAGES

with an a-c voltmeter. If we cause alternating voltage to appear across this resistor, the voltage will be indicated by the meter. At 3 the two circuits have been combined. Alternating current and voltage in resistor R<sub>s</sub> cause alternating current and voltage in resistor R<sub>i</sub>.

At 4 the paralleled resistors are replaced with one resistor, R<sub>o</sub>, and results are the same as in diagram 3. The source and meter are coupled through the resistance of R<sub>o</sub>, which is in the source circuit and also in the meter circuit.

At 5 is a simplified diagram of the resistance coupled amplifier with which we became well acquainted in other lessons. Here the a-c source is tube A and its plate circuit, while the voltage sensitive element is tube B and its grid circuit. As you will recall, the purpose of capacitor C<sub>c</sub> is to keep positive direct voltage of the plate circuit out of the grid circuit. If we neglect the small reactance of C<sub>c</sub> at the signal frequency, resistors R<sub>o</sub> and R<sub>g</sub> are effectively a single load resistance. This single effective load resistance is in the plate circuit of tube A and also in the grid circuit of tube B. Therefore, these two circuits are coupled through the

load resistance which is common to both circuits.

Any kind of reactance or impedance may be substituted for the coupling resistance. As an example, at 1 in Fig. 3 there is an inductor in the plate circuit and another inductor in the grid circuit. The two circuits are coupled through inductive reactance. Alternating signal voltages produced across the reactance by the first tube appear in the grid circuit of the second tube.

At 2 in Fig. 3 there is an inductor in the plate circuit and a resistor in the following grid circuit. Alternating voltages across the inductor reactance appear across the grid circuit resistance. At 3 the positions of the inductor and resistor have been interchanged. Alternating voltages produced across the resistance appear also across the reactance of the inductor.

In diagrams 2 and 3 we have the necessary conductive connections from the plate to the d-c power supply, for carrying direct plate current, and we have a conductive connection from the grid through ground to the cathode for a grid return. So far as coupling action is concerned we might employ the

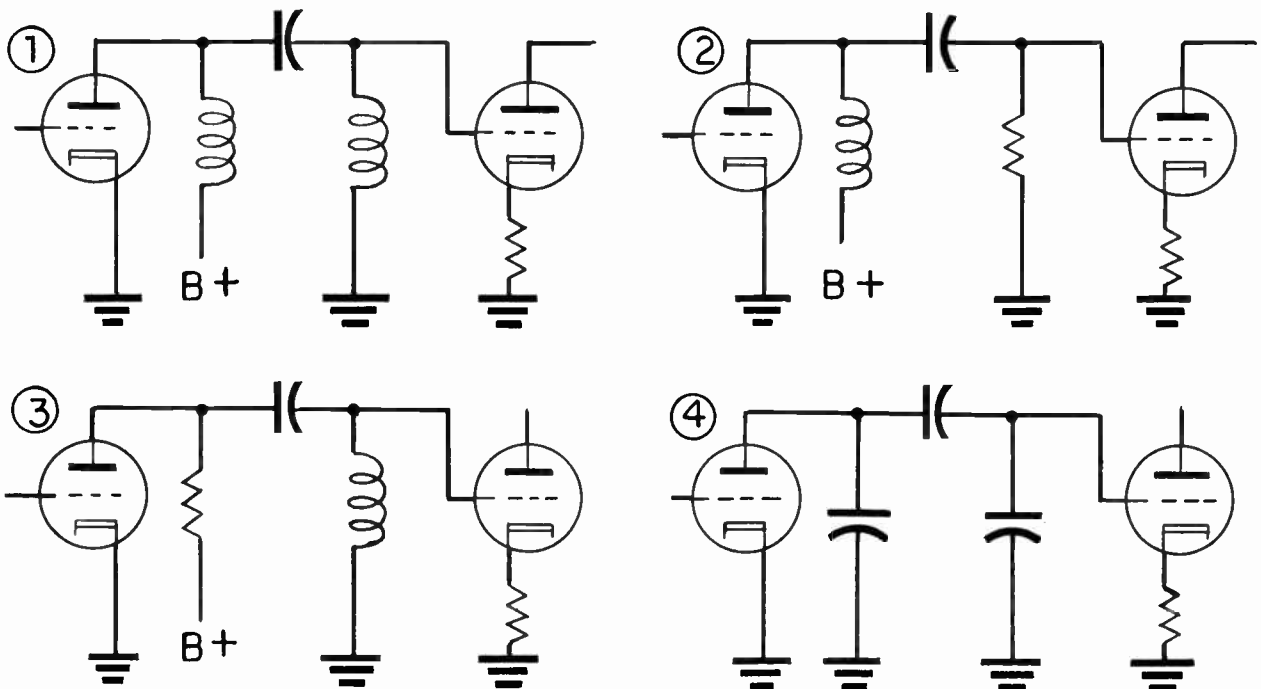

Fig. 3. The impedance which couples two tubes may consist of inductance or capacitance or resistance, of various combinations.

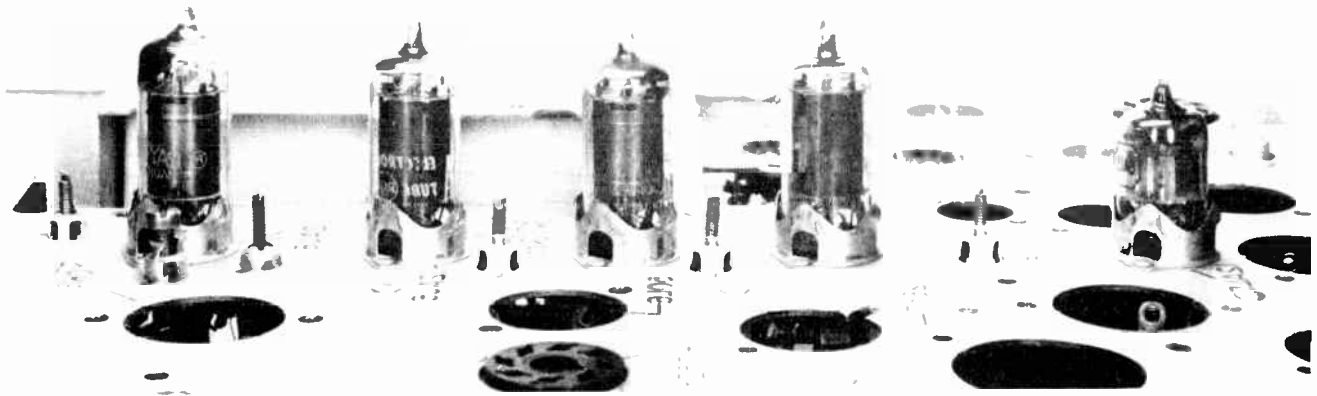

Fig. 4. The four larger tubes toward the left and the first, second, third, and fourth i-f amplifiers for a television receiver. The smaller tube at the right is the video detector.

capacitive reactances of capacitors, as at 4 of Fig. 3. But with the arrangement illustrated there would be no path for direct plate current and there would be no conductive grid return. Later we shall see some capacitive couplings in which the d-c paths are provided, but it adds somewhat to the complication of connections.

**TUNED COUPLINGS.** The simple couplings which have been shown are suitable for audio and other low-frequency interstage couplings where maximum amplified frequency is to be several hundred times as great as the lowest frequency. For r-f and i-f television amplifiers we wish to have response only for a relatively narrow range of frequencies. In tuner circuits the frequency response need cover only a little more than six magacycles, the extent of any one channel. In i-f amplifiers for picture signals the response usually is somewhat narrower.

To limit the amplification or frequency response to these narrow bands we almost always use tuned resonant couplings, with either adjustable inductance or adjustable capacitance. Such couplings are used in the i-f amplifier of Fig. 4. This picture shows the top of a television chassis from which have been removed all parts except those related to the five tubes, which are, from left to right, the first, second, third, and fourth i-f amplifiers and the video detector.

Fig. 5 is a view of the i-f amplifier parts as seen from the underside of the chassis. In the maze of resistors, capacitors, inductors, and their connections the tuned inductors which couple the stages are not too noticeable. They are of the type having an adjustable iron core, the type which we have seen in many earlier pictures. The tuning adjustment screws that move the cores may be seen in between and on either side of the tubes in Fig. 4.

Fig. 6 is a schematic service diagram of the i-f amplifier shown by the pictures. The tuning inductors are drawn in heavy lines. Near each is an arrow, indicating an adjustable core. Tuning capacitance for each inductor is the sum of the tube capacitance, the small distributed capacitance of the inductor winding, and the stray capacitances of connections and other parts.

The first adjustable inductor is in the plate circuit of the last tube in the tuner, not shown on the diagram. The next three adjustable inductors are in the plate circuits of the first, second, and third i-f amplifier tubes. These plate circuit inductors are connected through blocking capacitors to following grids and grid resistors in each case. The principal difference between the stages of this amplifier and the resistance-coupled type studied earlier is in substitution of

## LESSON 27 – TRANSFER OF SIGNAL VOLTAGES

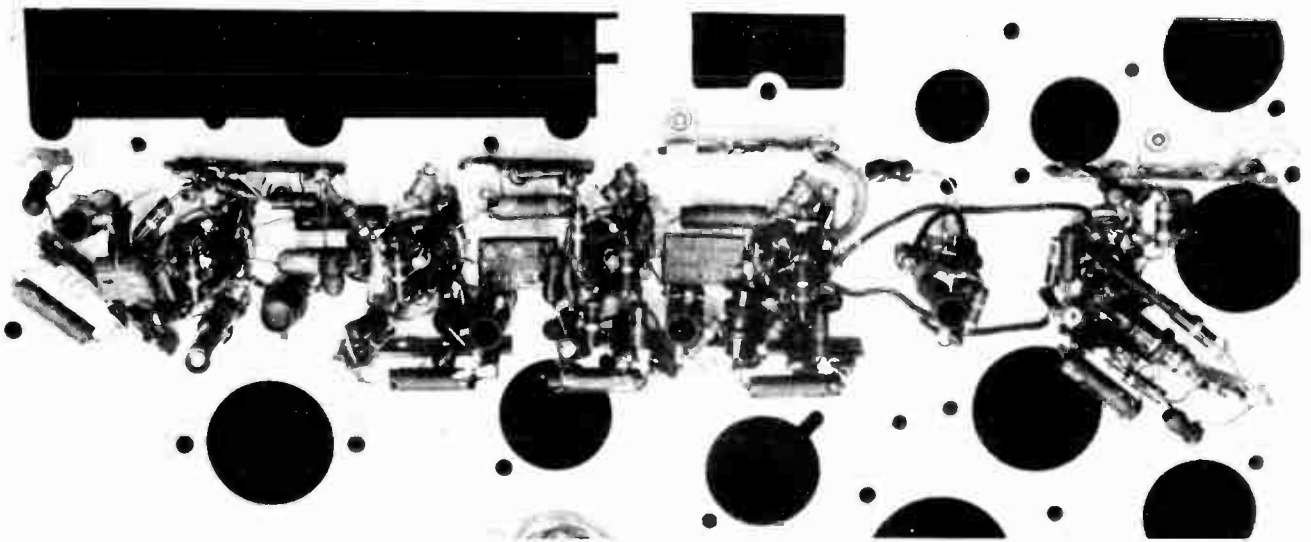

Fig. 5. From the under side of the chassis we see these parts which couple and also help control voltages applied to the tubes of Fig. 4.

tuned inductors for resistors in the plate circuits.

The last of the tuning inductors is not in the plate circuit of the fourth i-f amplifier, but is on the detector side of the coupling. In the plate circuit is a radio-frequency choke having high inductive reactance for all frequencies in the i-f range of the receiver.

All amplifier cathodes are connected

to B- minus through biasing resistors and r-f chokes. The high reactance and impedance of these chokes helps to prevent signal voltages and currents in one stage from passing to other stages. Plate circuit tuning inductors and the r-f choke in the plate circuit of the fourth amplifier are connected through voltage dropping resistors to the B-plus line. The grids of the first, second, and third i-f amplifiers are bypassed through capacitors to the cathode circuits and are conduc-

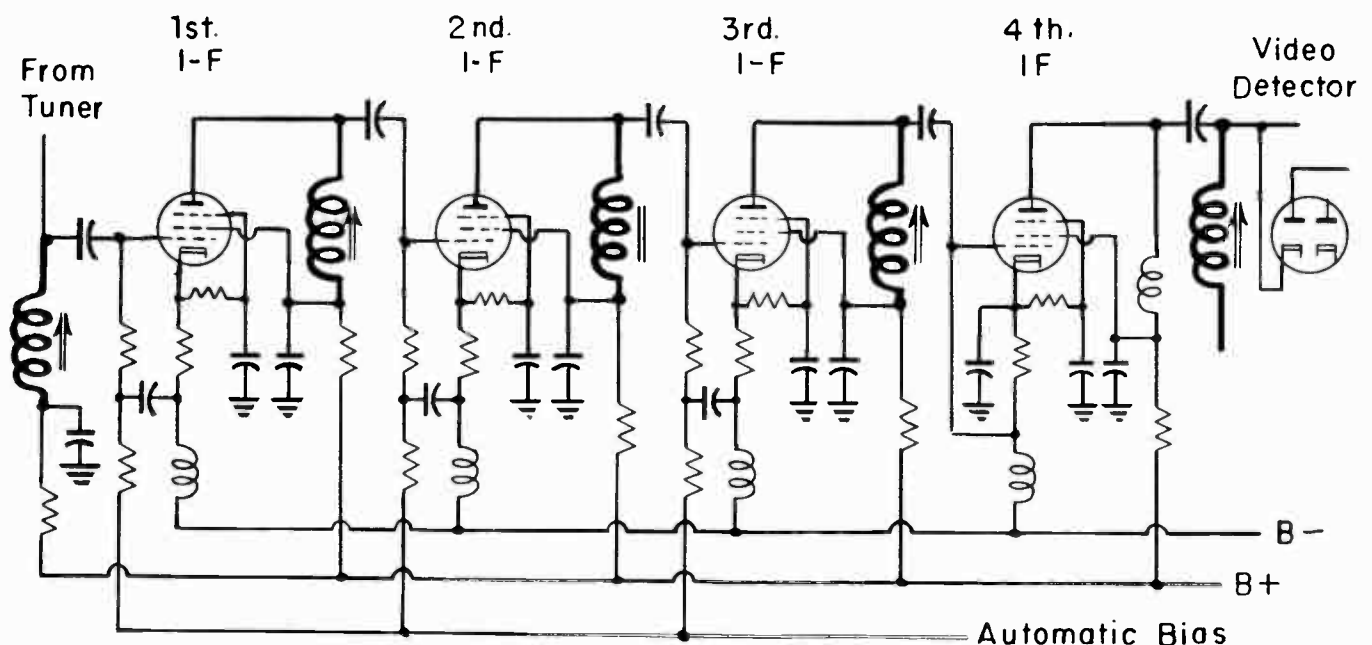

Fig. 6. This is the circuit diagram for the tubes and other parts illustrated by Figs. 4 and 5.

# COYNE - *television home training*

tively connected through resistors to a line for automatic bias. The automatic bias voltage controls amplifier gain in relation to strength of the received signal, increasing the gain on weak signals and lessening it for strong signals.

## COUPLING WITH TRANSFORMERS.

While studying power supplies we learned that a-c power is transferred from the line to receiver circuits by means of induction in the power transformer. Power transformers and others similarly constructed are highly efficient at low frequencies. However, at frequencies above about 30 kc most of the input power to such transformers would be wasted in eddy current losses and other losses in the laminated iron core, and in dielectric losses, leaving very little output power.

If we construct a transformer in a manner to have minimum energy losses at high frequencies it may be used for transfer of r-f signal power from tube to tube and from circuit to circuit. Such a transformer may be used for interstage coupling. The basic action is the same as in a power transformer. That is, magnetic lines of force produced by alternating signal current in the primary cut through the turns of the secondary and induce emf's in the secondary. When the secondary is connected into a closed circuit its alternating emf's cause alternating signal currents and voltages in that circuit.

The amount of signal power transferred from primary to secondary is, of course, proportional to the strength of signal emf's induced in the secondary. Induced secondary voltage depends on two prime factors: (1) on the number of magnetic lines produced by the primary, and (2) on how many of these lines cut through the turns of the secondary.

When a large portion of signal power put into the primary is transferred to the secondary, the two windings are said to have tight coupling or close coupling. If only a small portion of the signal power is transferred, there is loose coupling. When we have tight coupling a great many of the magnetic lines from the primary cut through the secondary. When we have loose coupling,

relatively few of the primary lines cut the secondary turns.

The number of magnetic lines produced by any given alternating current in the primary winding depends on the self-inductance of this winding. The greater the self inductance the greater will be the number of lines and the tighter will be the coupling when everything else remains unchanged. On this basis we have the following four factors affecting coupling.

### Tighter Coupling and More Power Transfer

Greater winding diameter.

More turns in winding.

Less length of winding.

Iron core.

### Looser Coupling and Less Power Transfer

Smaller winding diameter.

Fewer turns in winding.

Greater length of winding.

Air or other non-magnetic core.

How many of the magnetic lines from the primary cut through the secondary turns depends on the relative positions of the center lines or axes of the two windings and on spacing between the windings. Couplings with which the two axes lie on the same straight line are illustrated by Fig. 7. These couplings have the following effects on signal transfer.

When the two windings are far apart, as at 1, the coupling is reduced or made looser, and signal transfer is reduced. When the windings are closer together, as at 2, there is greater coupling or tighter coupling, and greater transfer of signal power.

If one winding will slip over the other, as at 3, there is less coupling with the windings separated, more coupling when one is part way inside the other, as at 4, and maximum coupling with one winding all the way inside the other, as at 5. Transfer of signal power increases as the coupling is increased.

There would be theoretical maximum possible coupling and power transfer were both windings of the same kind of wire, of the same diameter, same number of turns, and could both occupy the same space at the same time. The nearest practicable approach to this condition is in the bifilar



## LESSON 27 – TRANSFER OF SIGNAL VOLTAGES

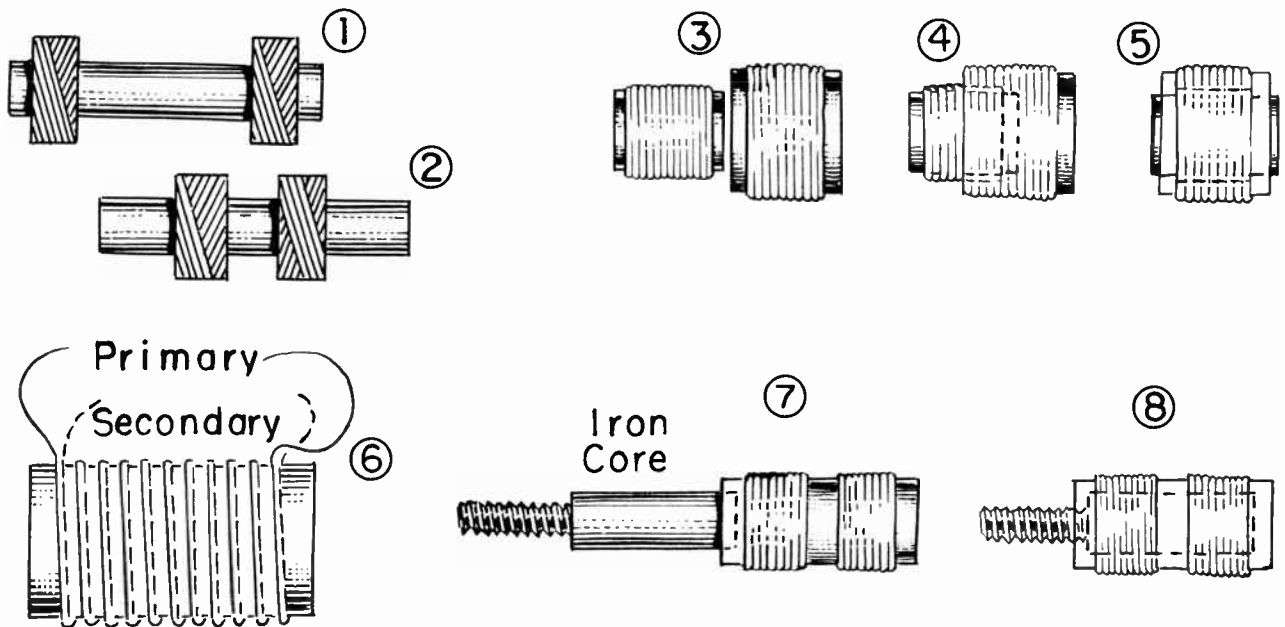

Fig. 7. The coupling of two windings is varied by changing the separation of the windings.

winding represented at 6 in Fig. 7. Primary and secondary wires are side by side, separated only by their insulation, and both are wound together around the supporting form.

If there is an adjustable iron core, as at 7, there is looser coupling and less signal power transfer with the core out of the windings as far as possible. There is closest coupling and maximum power transfer with the core centered in the winding space, as at 8.

Fig. 8 shows how coupling and signal energy transfer may be varied by separating the axes of the primary and secondary, and by changing the angle between the two axes. At 1 the two axes are at right angles to each other, with their inter-section lying on the axis of one winding. This gives minimum or loosest coupling and least transfer of signal power for the separation existing between the windings. As the two axes are turned more nearly into line, as at 2, the coupling and power transfer increase. When both axes are on the same line, as at 3, there is maximum coupling and maximum transfer of signal energy for the existing separation between windings.

If, as at 4 and 5, the two axes are kept parallel but are moved sideways from each

other, the coupling is loosened and signal transfer is reduced in comparison with diagram 3. If one winding is moved around to the side of the other one as at 6, there is tighter coupling than at 4 or 5, but not such a tight coupling as at 3.

When dealing with power transformers we found that secondary voltage may be stepped up or down in relation to primary voltage by varying the relative numbers of turns on the two windings. In high-frequency transformers, such as being considered now, the secondary voltage cannot be affected appreciably by the turns ratio of the windings. Secondary voltage is affected, for all practical purposes, only by inductances, by relative spacings and positions of the windings, and by the factor to be considered next, which is tuning to resonance at the signal frequency.

**TUNED TRANSFORMERS.** Either the primary, the secondary, or both windings of a coupling transformer may be tuned to resonance at or near the frequencies of signals to be transferred. The tuned circuit may consist of fixed inductance in the winding and of a variable capacitor in combination with the various circuit capacitances, or the tuned circuit may consist of an inductor with a movable core in combination with tube

# COYNE - *television home training*

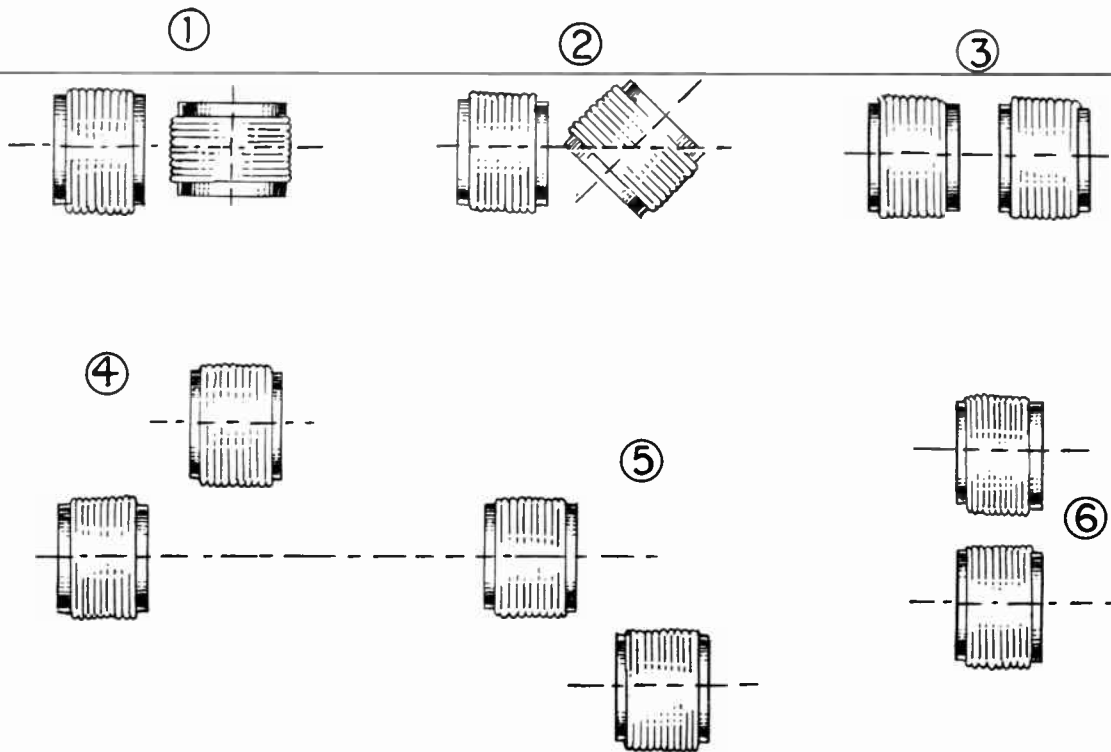

Fig. 8. Coupling is varied by relative positions and angles of the two windings.

capacitance, distributed capacitance, and stray capacitances.

Regardless of actual relative positions of the two windings of a transformer they usually are shown on service diagrams by symbols such as illustrated in Fig. 9. Along the top row are windings tuned by variable capacitors. At 1 there is a tuned plate or tuned primary winding, at 2 there is a tuned grid or tuned secondary winding, and at 3 both of the windings are tuned.

Along the bottom row are shown windings adjusted to resonance or tuned by means of movable cores. Any arrow or arrowhead near a winding indicates that that winding is adjustably tuned. As in diagrams 4 or 5, there may be small fixed capacitors across any of the windings. When one arrow is above and the other below the symbol, as at 6, it indicates that one winding is adjusted by a screw protruding from above, while the other winding is adjusted by a screw extending downward and accessible from underneath the chassis.

The frequency response of a simple tuned transformer is, in general, of about the

same form as that of a tuned impedance coupler having a single winding. The trace at the left in Fig. 10 is the frequency response of a single-winding coupler and the one at the right is the response of a transformer with a bifilar winding. Both units were connected to the same amplifier tube in the same circuit. Both are designed for use in television i-f amplifier sections, and, for making the traces, both were tuned to exactly the same center frequency.

Any change of inductance or capacitance in either the primary or secondary circuit of a transformer effects not only the resonant frequency of the winding where the change is made, but also the resonant frequency of the other circuit. More inductance or more capacitance on either side lowers the resonant frequency of the transformer as a whole, and less on either side raises the transformer frequency.

Any loss of energy or high-frequency resistance in a circuit containing an untuned primary of a transformer will lower the resonant voltage and broaden the frequency response of a tuned secondary winding. A 10,000-ohm resistor was connected in par-

# LESSON 27 – TRANSFER OF SIGNAL VOLTAGES

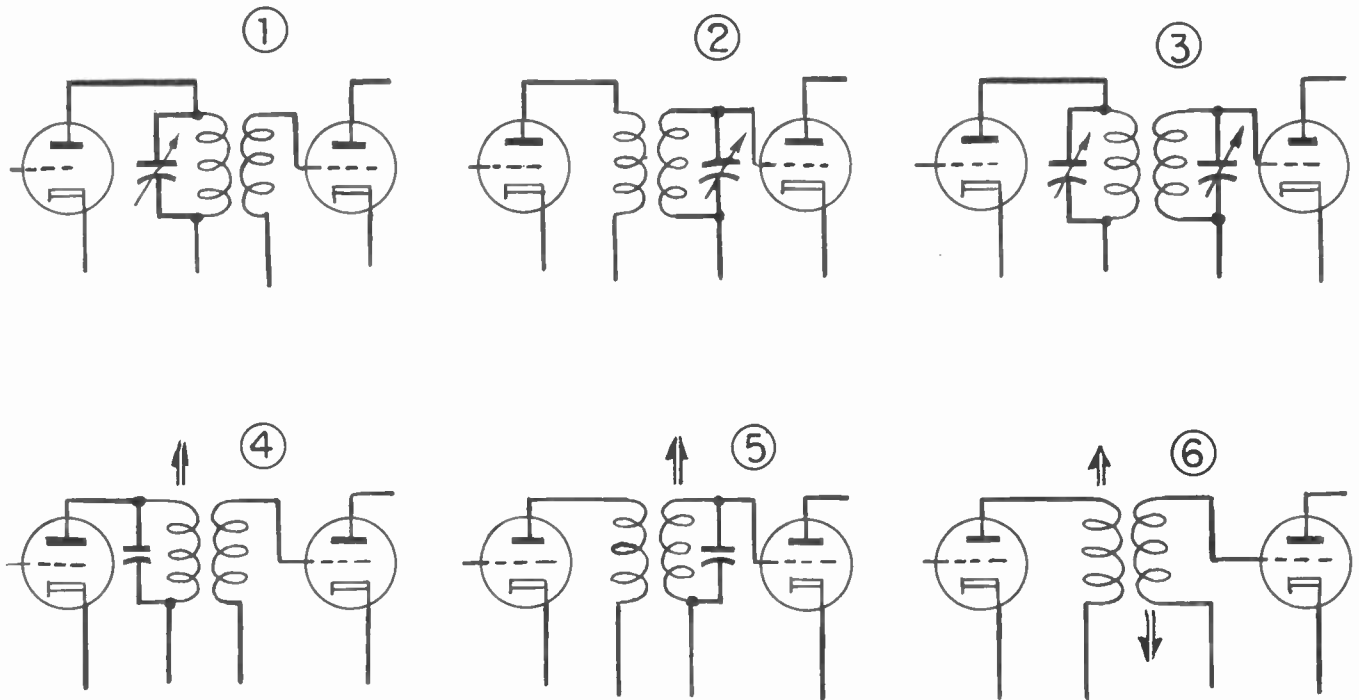

Fig. 9. Symbols which represent coupling transformers having one or both windings tuned.

allel with the primary of the transformer whose original response is shown at the right in Fig. 10. The frequency response became as shown at the left in Fig. 11. Voltage at the resonant peak is less than half of its original value.

Connecting the same 10,000-ohm resistor in parallel with the secondary winding caused the same drop of voltage at resonance. An equal drop of voltage at the peak was brought about by connecting a 95-ohm

resistor in series with the primary winding. But with the same 95-ohm resistor in series with the secondary the response became as shown at the right in Fig. 11, where the peak voltage is but a small fraction of its value with no added resistance on either side of the transformer.

The effects on resonant voltage of adding resistors would be the same as with equivalent energy losses due to any kinds of high-frequency resistance in either circuit.

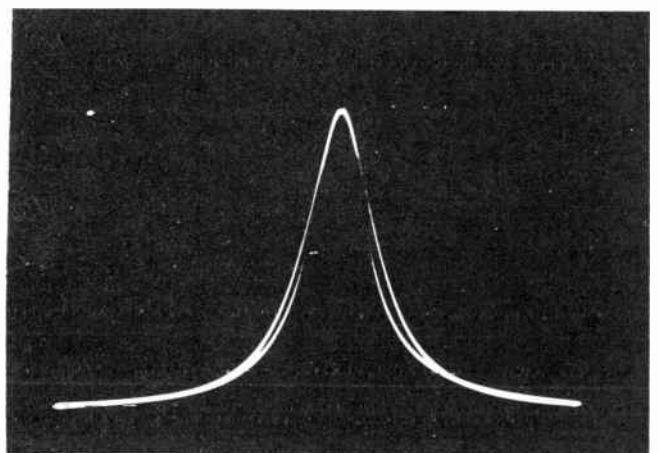
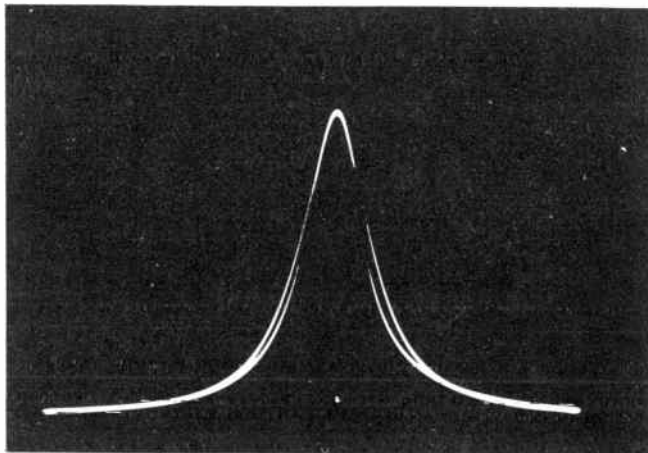

Fig. 10. Frequency response of an impedance coupler with a single winding (left) and of a two-winding transformer (right).

## COYNE - *television home training*

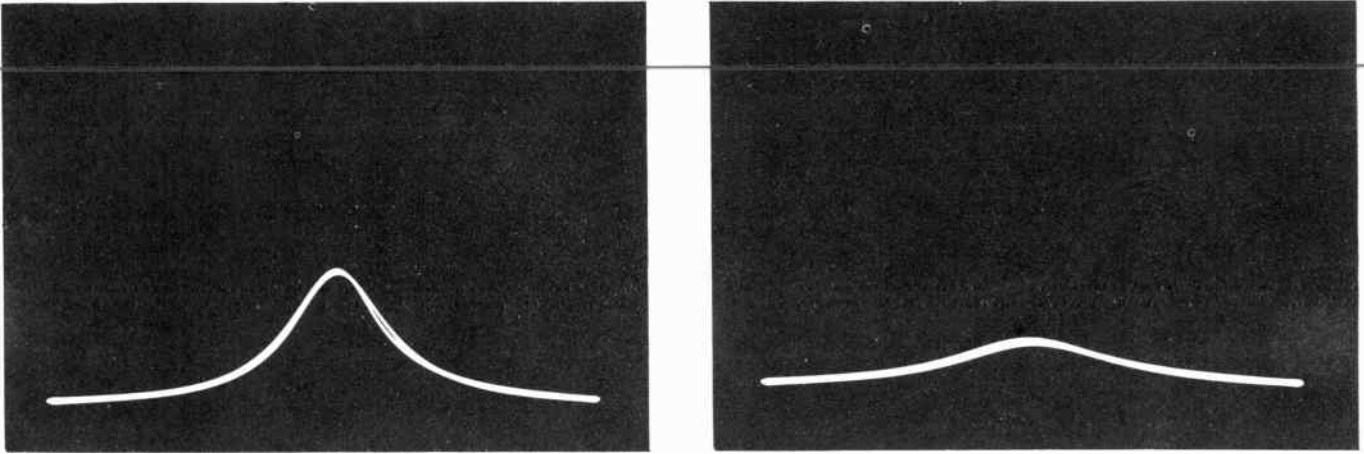

Fig. 11. Effect of connecting 10,000 ohms in parallel with either the primary or secondary winding (left) and of connecting 95 ohms in series with the secondary (right).

Such high-frequency resistance could be the result of any energy losses which were mentioned when discussing this class of equivalent resistances.

In some cases a resistor of something like 8,000 to 30,000 ohms or more is connected in parallel with a tuned winding to broaden the frequency response or to make the response fairly uniform throughout a wider range of frequencies. The frequency response of Fig. 12 was secured from the bifilar transformer with 10,000 ohms in parallel with the primary. The gain was increased to make the peak voltage about the same as at the right in Fig. 10, where no re-

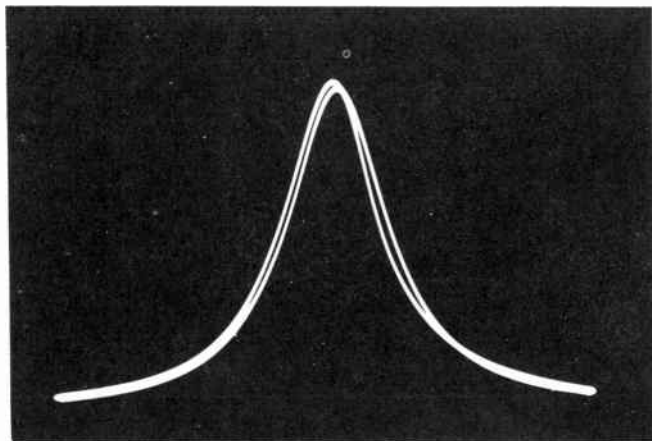

Fig. 12. This frequency response resulted from connecting resistance across the primary of the transformer considered in Fig. 10, and increasing the circuit gain to obtain the same peak voltage.

sistor was used. It may be seen that the response maintains fairly high voltages over a greater range of frequencies, from left to right, with the resistor in use. When resorting to this method of obtaining broader response, the reduction of stage gain due to the resistor may be made up in various ways.

PASS BANDS. Maximum possible voltage at the peak of a frequency response is necessary if we are to make full use of the amplification of tubes and are to have a strong signal at the output of an amplifier section. But high voltage is not the only thing of importance; it is necessary also that there be approximately uniform voltage throughout the range of frequencies in whatever signal is being handled. The range of frequencies for which the response is fairly uniform is called the pass band of the transformer or of any other type of coupling. Another name often used is band pass.

In the sound i-f amplifiers of television receivers it is necessary to have a pass band of at least 0.2 mc (200 kc), and in most cases this pass band is made 0.3 to 0.5 mc (300 to 500 kc). These pass bands are suitable also for the i-f amplifiers of f-m broadcast sound receivers.

In the i-f amplifier section which carries the picture signals of a television receiver the pass band should be at least 3.5 mc and preferably is 4.0 mc. This wide pass band is required because the frequencies in



## LESSON 27 – TRANSFER OF SIGNAL VOLTAGES

picture signals extend up to 4.0 mc or slightly higher, and all these frequencies should be amplified as uniformly as practicable. With some wire line transmissions the picture frequencies may extend only to somewhat less than 3.0 mc, but a receiver designed for this limit would not give the best possible picture reproduction on programs where picture frequencies go higher. The fine details which result from the highest frequencies would be lacking.

We shall look first at the production of a frequency response wide enough for sound i-f amplifiers, using the transformer of Fig. 13. The shield for this transformer has been removed and placed to one side. The primary winding is toward the top of the supporting form, with the secondary down below. In parallel with each winding is a small ceramic capacitor which fixes the tuning range. There are separate adjustable iron cores inside of each winding. The screw adjustment for the primary extends upward from the top, while the secondary adjustment extends down through the bottom of the transformer.

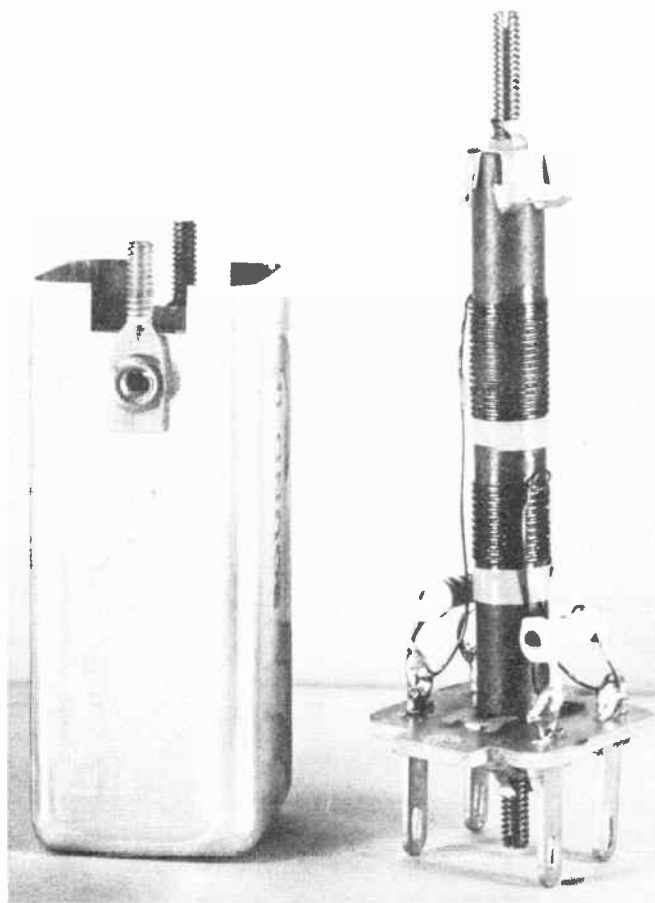

Fig. 13. A television sound i-f transformer.

When both windings are tuned by their separate cores to be resonant at the same frequency the response is as shown at the left in Fig. 14. The peak is sharp. There is uniform voltage over an exceedingly narrow range of frequencies, with rapid drops of voltage at frequencies only a little lower and higher. The pass band does not become 0.4 mc wide until going down the sides of the re-

sponse to points about 75 per cent of the maximum height.

By tuning either winding to a frequency slightly different from the other the response

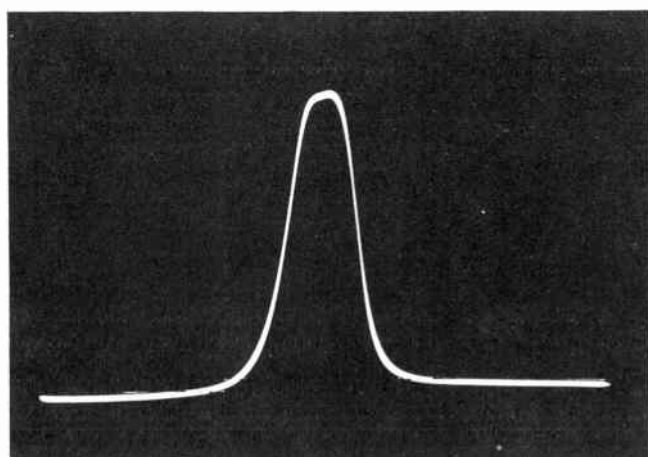
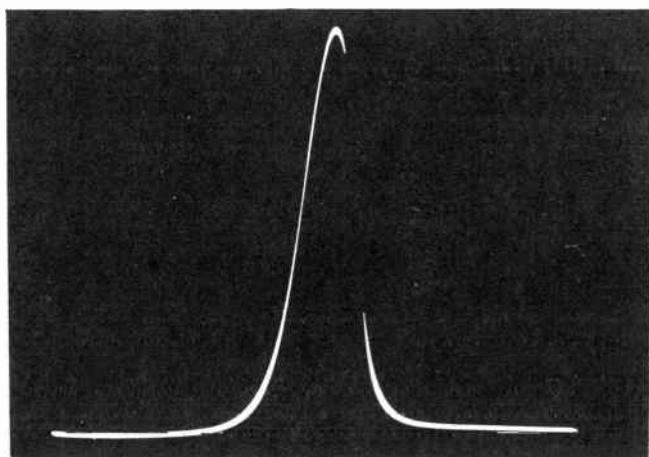

Fig. 14. Frequency response of the transformer with both windings tuned to the same frequency (left) and when tuned to slightly different frequencies (right).

## COYNE - *television home training*

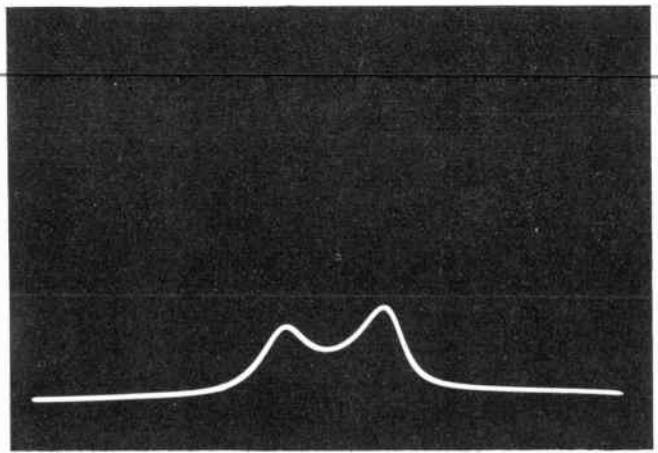
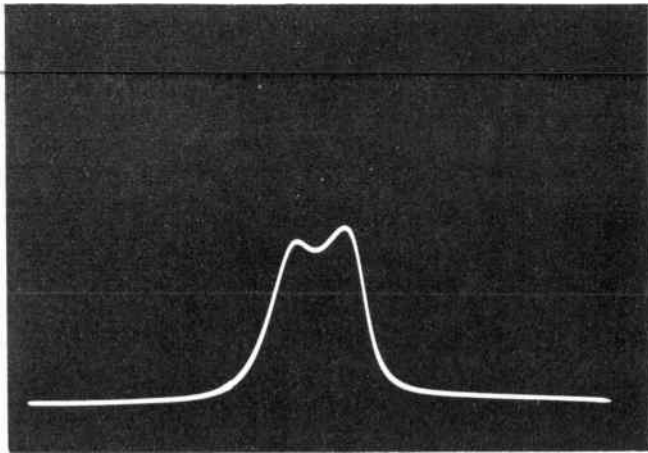

Fig. 15. When resonant frequencies of the two windings are made further apart the result is two peaks (left) and with still greater frequency difference the peaks move apart (right).

is changed as shown at the right. Maximum voltage is lower than before, because there is maximum signal power transfer only when both windings are tuned to work at the same frequency. But the peak of the response now is fairly flat over a range of 0.4 mc. That is, there is a frequency difference of about 0.4 mc from corner to corner of the top of the curve. The effect is much as though the sharp peak were cut off the original response at a point where the pass band is 0.4 mc. This flatter response would allow amplification of a sound signal with very little distortion.

If either winding is tuned to a frequency which differs still more from that of the other winding the frequency response of the transformer becomes as shown at the left in Fig. 15. Now there are two distinct peaks on the response, separated by about 0.7 mc. One peak is due to resonance in the primary winding, and the other is due to resonance in the secondary. In between the peak is a drop of voltage, usually called a valley in the response. The valley is only about 10 per cent lower than the higher peak. This response would be sufficiently uniform or sufficiently "flat" for most purposes.

Tuning either winding to a frequency still further removed from that of the other winding causes the response to appear as at the right. The two separated peaks are clearly defined, with a deep valley between them. Peak separation now is about 1.4 mc. Volt-

age in the valley is but little more than 50 per cent of that of the higher peak. Peak voltages are far less than with any of the other responses for this transformer. This response with its widely separated peaks would be decidedly unsatisfactory from the standpoint of maximum voltage and also because of non-uniform voltage across the top.

Any of the responses shown by Figs. 14 and 15 could be shifted bodily to higher or lower frequencies, within certain limits, without changing the general form of the curves. This would be done by changing the tuning of both windings. If both windings are tuned to lower frequencies the entire pass band will go to lower frequencies, and if both are tuned to higher frequencies the pass band will go to higher frequencies.

OVERCOUPLING. When the two windings of a transformer are coupled more and more closely while tuned to have resonance at the same frequency there is a continual increase of power transfer. The frequency response will show an increasingly higher peak of voltage. The highest possible single peak occurs when the coupling is of a value called critical coupling.

If the coupling between windings can be made still closer than the critical value the voltage peak will increase no more in height, but will separate into two peaks. One of the new peaks is at a frequency lower than that of the former single peak, while the other new

## LESSON 27 – TRANSFER OF SIGNAL VOLTAGES

peak is at a higher frequency. This effect commences when coupling is increased beyond the critical value. With any greater degree of coupling the windings are said to be over-coupled. With any coupling less than the critical value the windings are undercoupled.

The greater the overcoupling the greater is the frequency difference between the two peaks. With an overcoupled transformer the separation between peaks may be made much greater than with an undercoupled transformer without having an excessively deep valley between the peaks. Overcoupled transformers are used in some television tuners and picture i-f amplifier sections to obtain a pass band possibly as wide as 3.5 mc.

Unfortunately it is practically impossible to obtain overcoupling in a simple two-winding transformer which will operate at high frequencies. There would have to be a nearly complete path of iron all the way around the windings as well as inside of them. This would lead to excessive energy losses at television and f-m broadcast frequencies.

Overcoupling to provide a broad pass band with high-frequency transformers usually is secured with one of the arrangements shown by Fig. 16, or something generally

equivalent. The essential feature is to have a single reactance included in both the primary and secondary circuits. In the diagram at the left this single or common reactance is an inductor in which must flow signal currents of the plate circuit and also signal currents of the grid circuit. At the right the common reactance is a capacitor, which is included in the plate circuit and the grid circuit for high-frequency signal currents. Any or all of the coupling elements may be adjustable. It is necessary to have a blocking capacitor in the grid circuit to keep positive B-voltage from affecting bias of the second grid.

In the majority of television receivers the broad pass band required for picture signals is secured by an ingenious scheme which employs only single-peaked transformers or impedance couplers with one winding. The couplings between the several amplifier tubes in the i-f section are tuned to resonance at different frequencies, all, however, within or very close to the range of frequencies to be passed. In the final output of the i-f section is the required band of picture frequencies, resulting from amplification in the several stages of different parts of the band. We shall look into this method in detail when studying television i-f amplifiers.

**SHUNT FEED.** A method of coupling called shunt feed or parallel feed is illus-

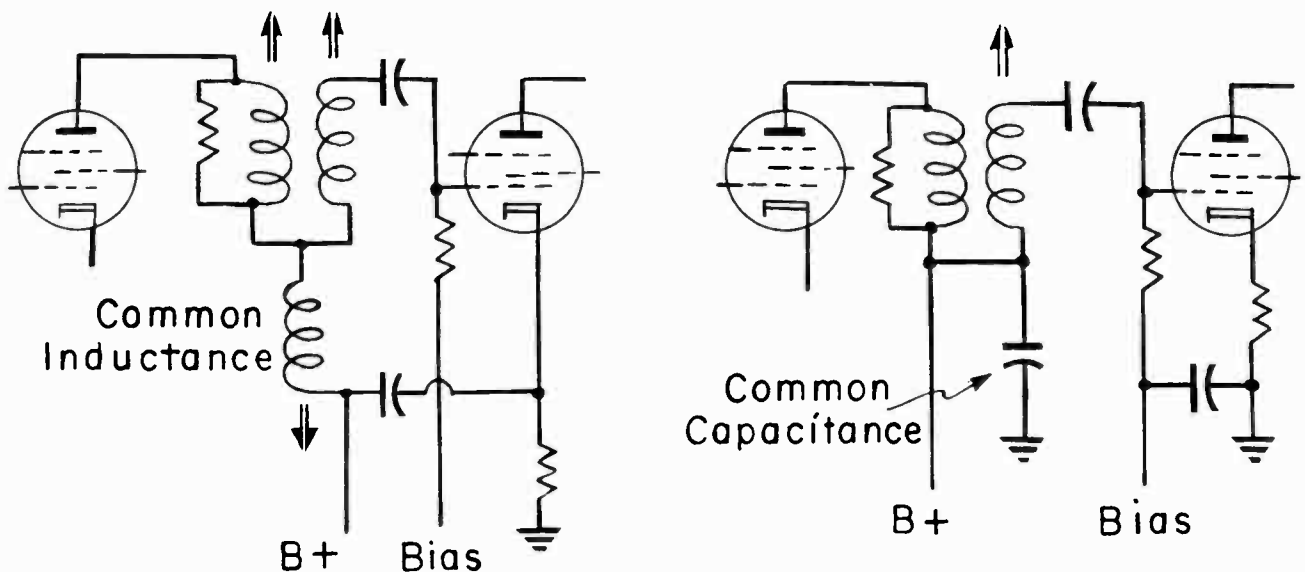

Fig. 16. Circuits for obtaining overcoupling and wide pass bands.

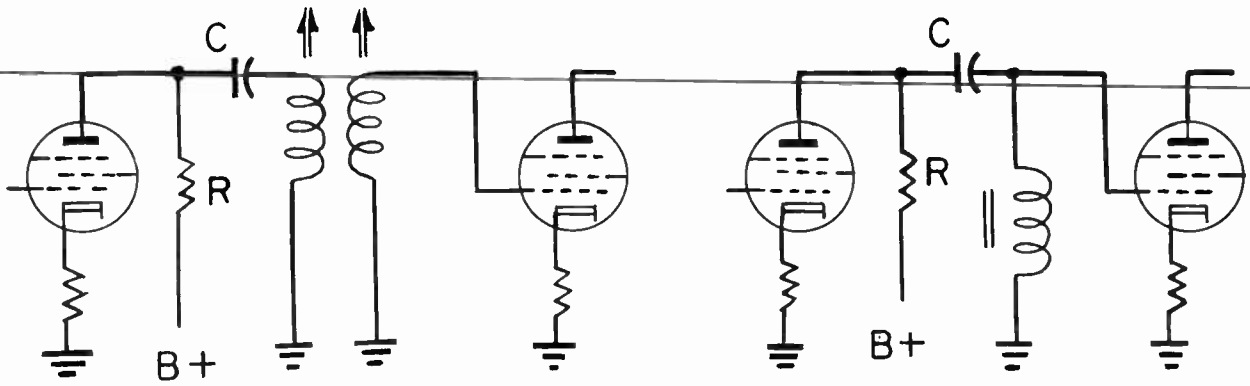

Fig. 17. Circuits of the shunt feed or parallel feed type.

trated by Fig. 17. The left-hand diagram shows a shunt fed transformer, while at the right is a shunt fed single-winding coupler. The feature which distinguishes this method from series feeds is that d-c plate current does not flow in the coupling device.

D-c plate current flows in resistor R, but is kept from the coupler by blocking capacitor C. Alternating signal currents are opposed by resistor R, but pass through capacitor C with comparative freedom. If R cannot be made of great enough resistance to strongly oppose signal voltages without excessive d-c voltage drop this unit is replaced by an r-f choke having high inductive reactance to signals, but very little d-c resistance. Sometimes a resistor and r-f choke are used in series with each other between the tube plate and the B+ connection.

LINK COUPLING. When two circuits are too far apart to be coupled conveniently by a transformer or an impedance coupler we may resort to the link coupling shown by Fig. 18. At each end of the link circuit conductors are coils which, for high-frequency

applications, have no more than eight to ten turns each, and oftentimes fewer turns. The link coils are placed in such positions relative to the main circuit inductors as to have coupling with the inductors. Provided the conductors between the link coils are kept away from parts which might cause undue energy losses, these conductors may be several feet in length.

AUTOTRANSFORMERS. An autotransformer has a single continuous winding or several winding sections in series. The one winding or the several sections are positioned to have but a single magnetic field. At 1 in Fig. 19 is a picture of an autotransformer designed for signal input to the sound section of a television receiver.

The unit illustrated has three coils or three winding sections connected in series as shown at 2. One of the three terminals connects to the end of one outer coil, another to the end of the other coil, and the third terminal connects to a point between two of the coils. The transformer is tuned to resonance by a movable core, the adjusting screw

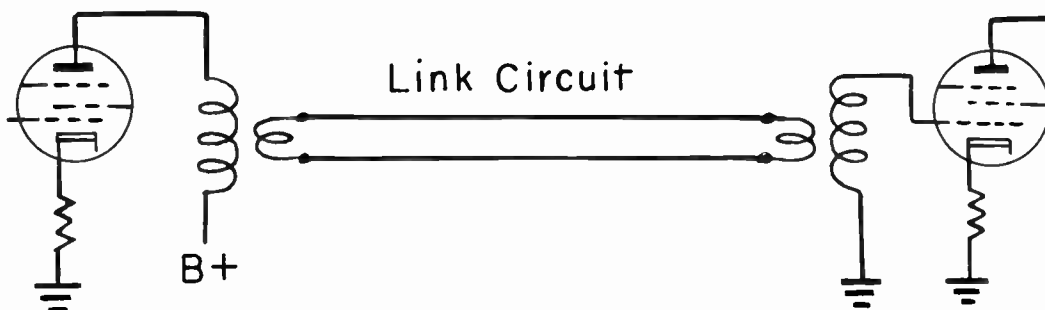

Fig. 18. Coupling by means of an untuned link circuit.



## LESSON 27 – TRANSFER OF SIGNAL VOLTAGES

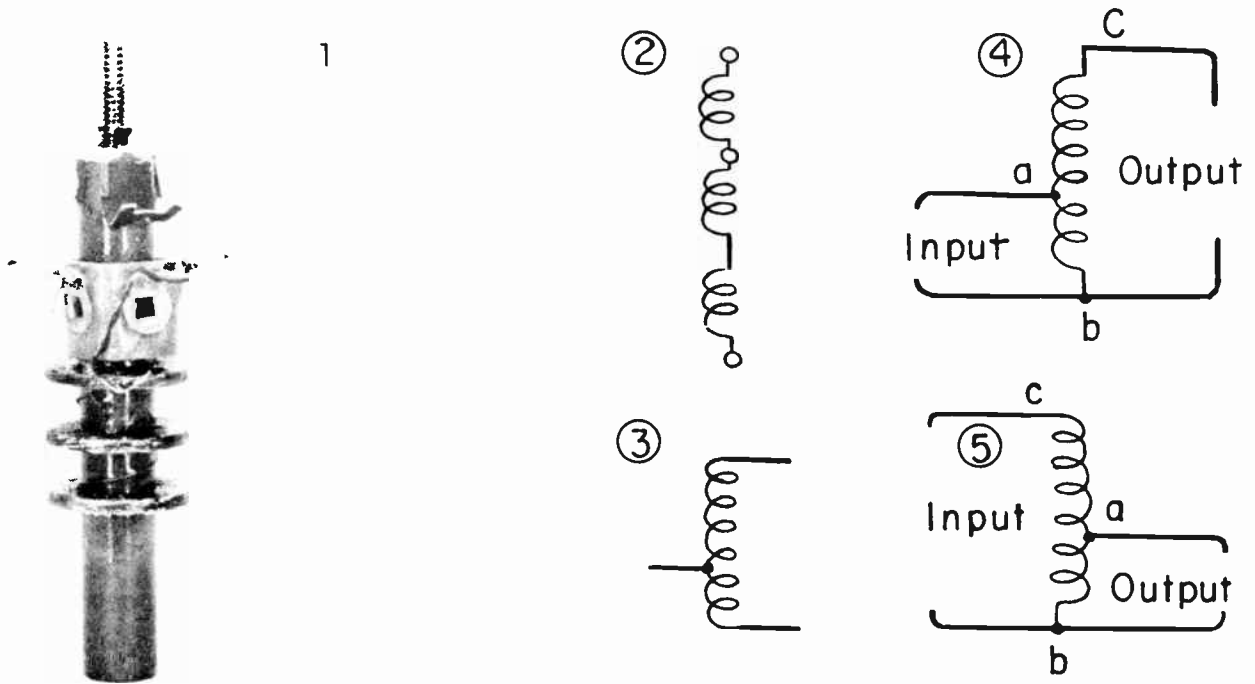

Fig. 19. An autotransformer used in television receivers, and winding connections which may be used with transformers of this general type.

for which may have been seen protruding from the top of the form. This or any autotransformer usually would be represented on service diagrams by a symbol such as the one at 3.

As in diagram 4, signal input to an autotransformer may be between the tap connection, a, and one of the ends, b. Then signal output would be from the entire winding, between b and c. It would be possible also, as in diagram 5, to apply the incoming signal across the entire winding, between terminals b and c, while taking the output signal from part of the winding, between a and b.

The tap connection, marked a on the diagrams, may be at any point between the outer ends as required for the particular circuit in which the autotransformer is to be used. This allows providing different reactances or impedances in the input and output circuits. There is the greater impedance between the two end terminals, and a lesser impedance between the tap and either end.

Were an autotransformer employed for interstage coupling, as at 1 in Fig. 20, using

the entire winding in the plate circuit would provide maximum load on the plate side. Using only part of the winding in the plate circuit, as at 2, would provide less load. The tube preceding the autotransformer would develop greater output power and signal voltage with the greater impedance or load in its plate circuit. As a result, there would ordinarily be greater output voltage, on the grid side of the autotransformer, with connections at 1 than with those at 2.

Large autotransformers with laminated cores like those of power transformers are sometimes employed as power transformers. Then the ratio between input and output voltages is approximately the same as the ratio between input turns and output turns, just as with a two-winding power transformer.

If, as in diagram 3 of Fig. 20, the power line were connected between the tap and one end of the autotransformer, with the entire winding used for output, there would be a step-up turns ratio and voltage ratio. With input and output connections reversed, as in diagram 4, there would be more turns in the input circuit than in the output circuit. Then there would be a step-down ratio of turns and of voltage between input and output.

# COYNE - television home training

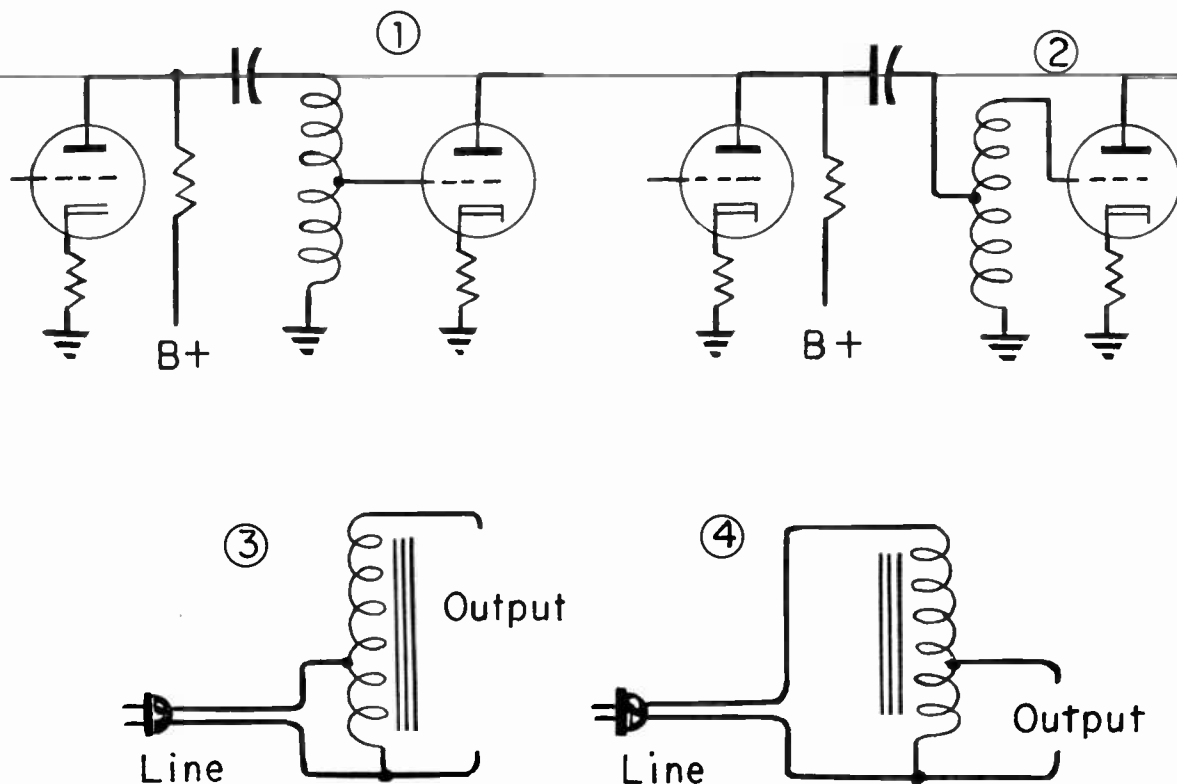

Fig. 20. Autotransformers used as interstage couplings and as power transformers.

The chief disadvantage of the autotransformer in comparison with a two-winding power transformer is that primary and secondary are not insulated from each other. Any circuits connected to the output of the autotransformer are conductively connected to the power line. This would make a chassis hot with respect to one side of the line unless some means, such as a floating ground, were employed to prevent it.

**CATHODE FOLLOWER.** Occasionally it is necessary to transfer signals having a wide range of frequencies from a circuit of high impedance to another circuit of low impedance. As one example, a video signal produced across a high impedance in the plate circuit of an amplifier may be applied to a following circuit through a low-resistance potentiometer for varying the signal strength. Many other examples will appear as we study various sections of television receivers, also in some types of service instruments.

It might seem possible to use a transformer, with high impedance in its primary

and low impedance in the secondary. But inductance and distributed capacitance of a transformer would cause trouble when handling a wide range of high frequencies. Impedances would vary with frequency. There would be phase shift of current in relation to voltage. The form of signals which are not sine waves would be altered.

To avoid these difficulties it is common practice to employ a cathode follower as the signal transfer device. The cathode follower is a triode or pentode tube of any type which might be used as an amplifier, but it is employed in a different manner. In an amplifier circuit the tube is connected as at the left in Fig. 21. Signal input is between grid and cathode. Output is from a plate circuit load connected between the plate and  $B_f$ .

Connections for the tube used as a cathode follower are shown at the right. Signal input is between grid and cathode, the same as before. At this input there is high impedance when the tube is negatively biased. There is no load impedance between the plate and  $B_f$  of the power supply. Instead, the

## LESSON 27 – TRANSFER OF SIGNAL VOLTAGES

plate is connected to ground and to the cathode circuit through a capacitor having small reactance at all signal frequencies.

Signal output is taken from across the resistor in the cathode circuit of the follower. There is low output impedance across this resistor, while there is high input impedance in the grid circuit. Compared with a transformer, the cathode follower has negligible inductance and capacitance, and there is minimum distortion of the signal.

The cathode follower does not amplify the signal voltage, it reduces the signal voltage. Depending chiefly on transconductance of the tube and on the value of the cathode resistor, output signal voltage usually is between two-thirds and nine-tenths of the input signal voltage. On the other hand, signal current is greatly increased for in the cathode resistor there is plate circuit signal current.

At the input we have small signal current in a high impedance. At the output there is large signal current in a low impedance. As a result, there is almost as much signal power at the output as at the input, in spite of the fact that signal voltage is decreased.

As we learned when studying amplifier tubes, there is inversion of signal polarity between the grid and the plate. Portions of a signal which are positive at the grid be-

come negative at the plate, and vice versa. In the cathode follower there is no inversion of signal polarity. Portions of the signal wave which are of one polarity at the grid are of the same polarity at the cathode. This feature alone makes the follower useful in certain television video and sync circuits where signal polarity must be one certain way at the output of a section.

With the simple follower circuit at the right in Fig. 21 the cathode resistor not only acts as the output load resistor, but also as a grid bias resistor. Sometimes the value of resistance providing a required output impedance does not provide the necessary grid bias voltage. Then it is necessary to use an additional resistor.

If the signal output resistor would produce too much negative biasing voltage, the scheme shown at the left in Fig. 22 may be employed. A resistor giving the correct bias voltage is connected at  $R_b$  between the cathode and the output resistor  $R_o$ . The grid return is connected to the bottom of  $R_b$ , so that bias voltage is only the drop across  $R_b$ .

If the output resistor would provide too little negative biasing voltage we may use the arrangement at the right in Fig. 22. The grid return here is through ground to the bottom of both cathode resistors, which are

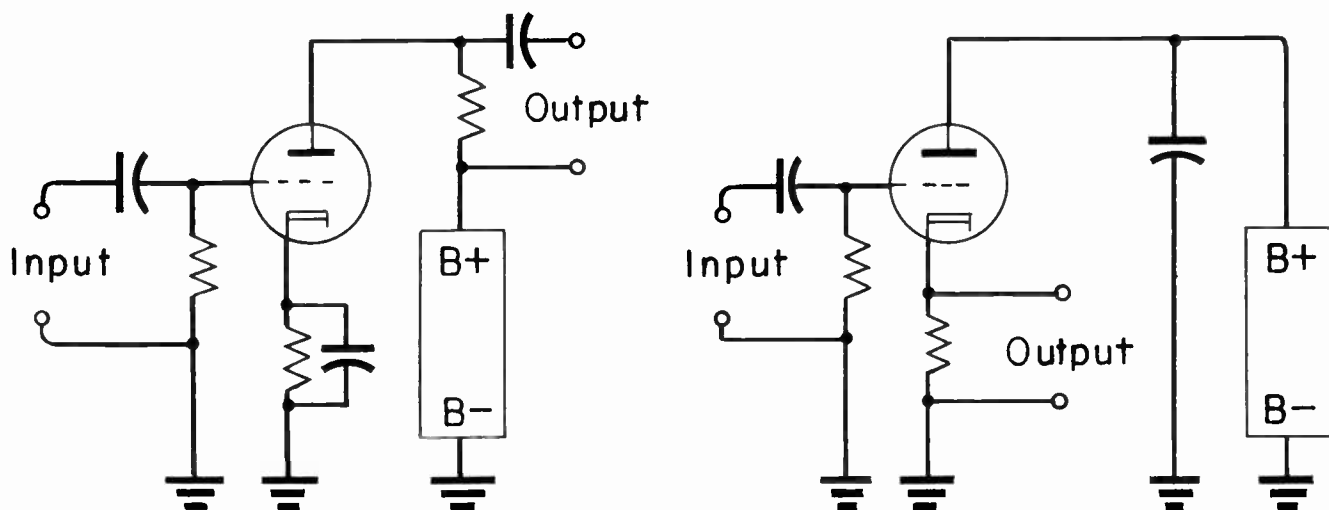

Fig. 21. A tube used as an amplifier (left) and as a cathode follower (right).

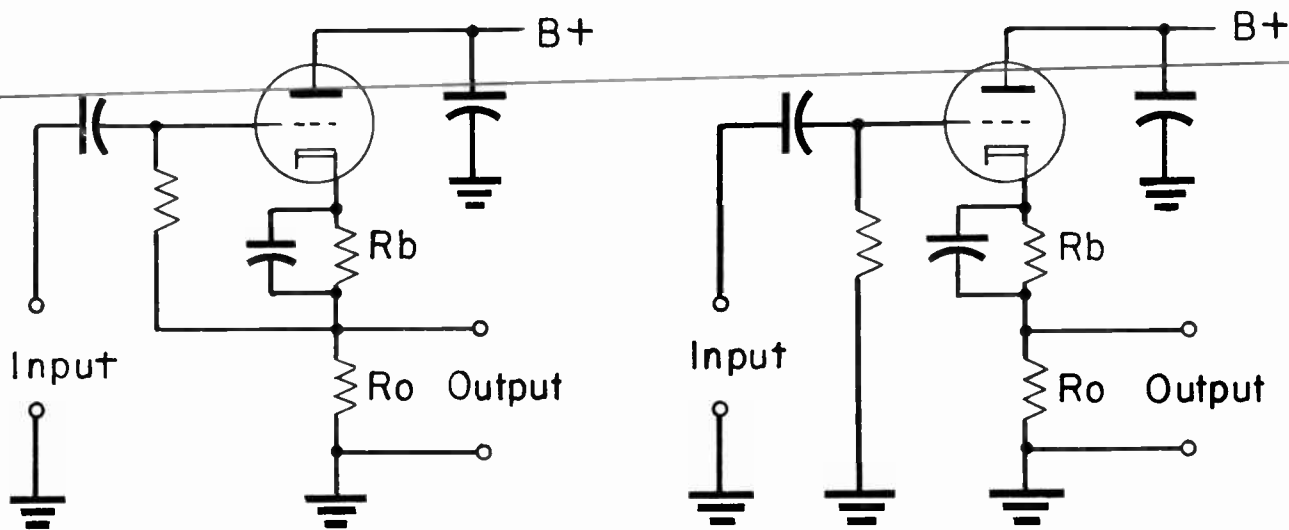

Fig. 22. How negative biasing voltage for the grid of a cathode follower may be decreased (left) or increased (right).

in series. Voltage drop across resistor  $R_b$  now adds to the drop across  $R_o$ , and the bias is made more negative than with  $R_o$  alone.

Any added biasing resistor is bypassed with a capacitor having very little reactance at the lowest signal frequency, because we do not want to lose any a-c signal voltage across this resistor. The output resistor never is bypassed, for then the alternating output signal voltage would be bypassed and would

not go to the output circuit.

We may note that the a-c output impedance across the output resistor always is less, in ohms, than the resistance of this unit. Output impedance does not consist only of the cathode load resistance. So far as any circuit connected to the output is concerned, the impedance consists of the load resistance in parallel with the effective plate resistance or plate impedance of the tube.



# TELEVISION

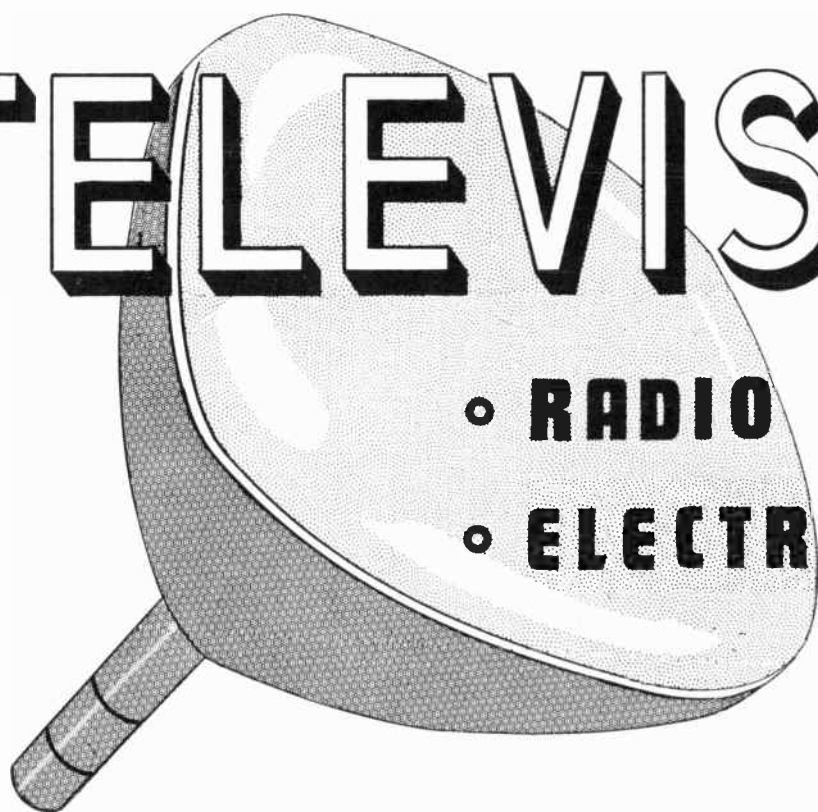

◦ RADIO

◦ ELECTRONICS

---

**LESSON 28 – THE SUPERHETERODYNE**

---

***Coyne School***

*practical home training*

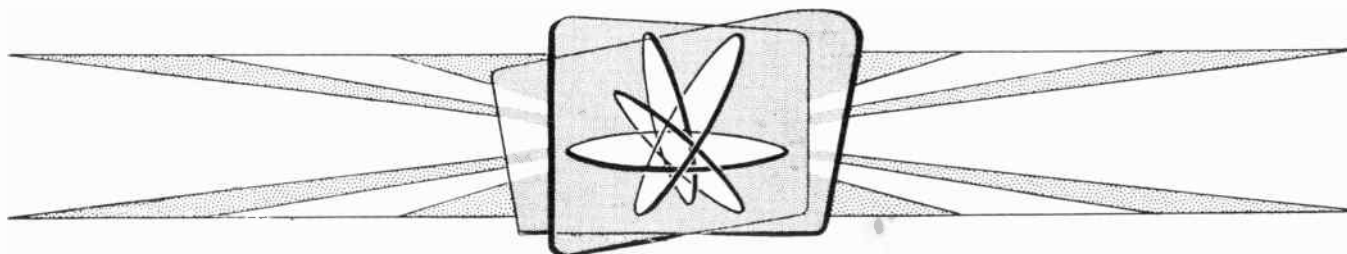

*Chicago, Illinois*

---

*Copyright, 1953 by Coyne Electrical School  
Chicago 12, Illinois  
All rights reserved*

Litho. in U.S.A.

## Lesson 28

# THE SUPERHETERODYNE

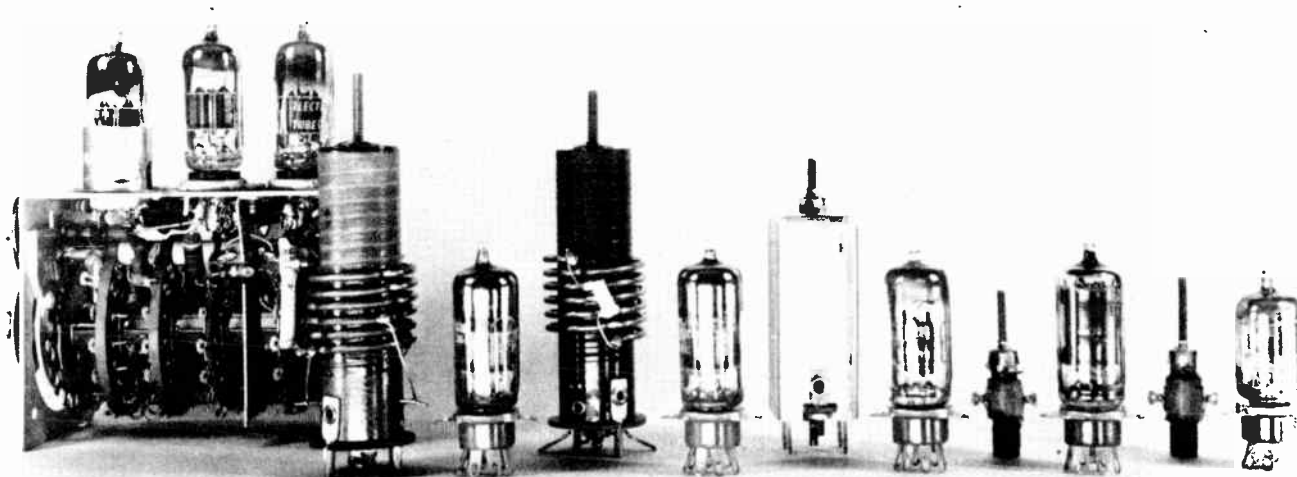

Fig. 1. At the left is a television tuner. Toward the right are interstage couplers, i-f amplifier tubes, and the video detector tube.

In the days when screen grid tubes first made it possible to amplify the higher radio broadcast frequencies without excessive feedback there was one type of receiver that could use triodes and still avoid trouble. This was the superheterodyne. The inventors of the superheterodyne knew that feedback would not be so troublesome and that all kinds of signal losses would be reduced if amplification could be at lower frequencies. So they designed a circuit which changed all the many carrier frequencies into a single frequency only about one-tenth as high as the average carrier.

Nowadays all television receivers use the superheterodyne circuit. So do all f-m broadcast receivers, the great majority of standard broadcast receivers, and a large percentage of short-wave broadcast receivers. The single frequency to which all carriers are changed is called the intermediate frequency.

As an example of how this works out, consider the twelve channels of the v-h-f television broadcast band. Picture carrier frequencies in the various channels range all the way from 55.25 mc up to 211.25 mc.

Every one of these carrier frequencies is changed to a single picture intermediate frequency. This intermediate frequency may be 41.25 mc, or 21.25 mc, or of some other value, depending on the make and model of receiver. But in any one receiver all the carrier frequencies for all the channels are changed to the same intermediate frequency.

It is fairly easy to design and construct an efficient amplifier system for the single intermediate frequency. We may use as many amplifier stages as needed to provide satisfactory overall voltage gain. Every stage is tuned once and for all at the intermediate frequency used by the particular receiver. No matter what channel is being received there is no need to change this tuning, for all carriers will have been changed to the one intermediate frequency. The portions of the carrier signals which represent pictures and sounds are transferred onto the intermediate frequency without being altered in the least.

By using an intermediate frequency low enough we could employ triodes in all the i-f (intermediate - frequency) amplifier stages and still avoid feedback trouble. However, for reasons which will appear later, it is de-

## COYNE - *television home training*

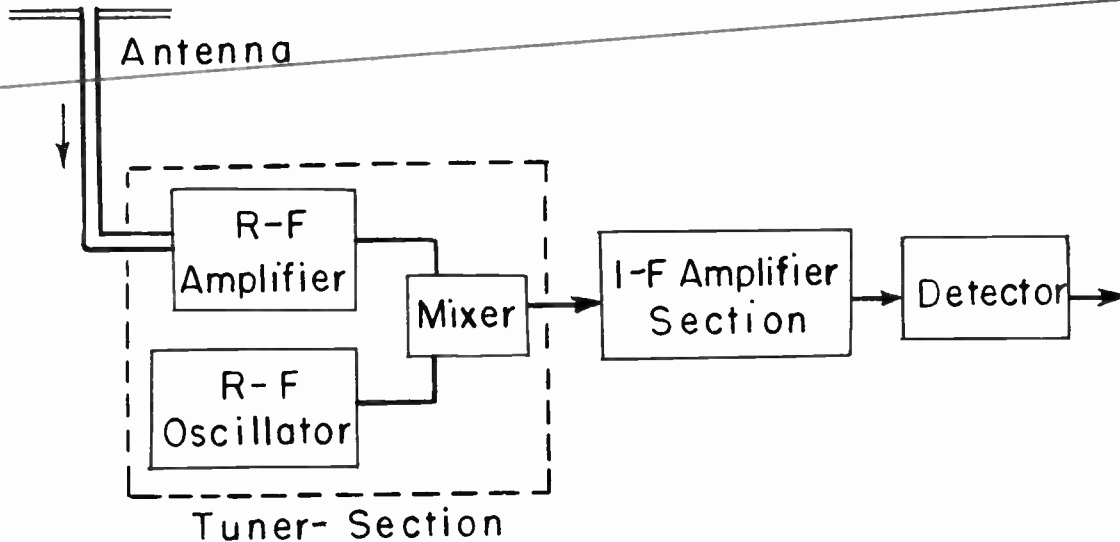

Fig. 2. The path of television signals from antenna through the tuner to the i-f amplifier and detector.

sirable to use an intermediate not too much lower than the lowest carrier frequency. To amplify such intermediates with minimum feedback and good voltage gain the amplifier tubes nearly always are pentodes.

The essential parts of the superheterodyne are shown by the block diagram of Fig. 2. Carrier waves which bring pictures and sound cause antenna voltages which go to the r-f amplifier in the tuner of the receiver. This r-f amplifier increases the strength of the carrier signals but does not change their form or frequency. The amplified carrier signals go to the mixer.

An r-f oscillator which is part of the tuner produces a voltage whose frequency is higher than that of whatever carrier is being received, in almost all television receivers. This oscillator voltage goes to the mixer, where it combined with the carrier voltage. In the output of the mixer the combination produces a frequency equal to the difference between oscillator and carrier frequencies. This is the intermediate frequency. It is strengthened to any desired extent in going through the i-f (intermediate - frequency) amplifier section.

During all this progress of the signals the frequencies which represent pictures or sound have been riding along, first on the carrier frequencies and then on the inter-

mediate frequency. In the detector which follows the i-f amplifier in a television receiver the picture frequencies are separated from the intermediate and passed along through other parts which lead to the picture tube.

In a standard broadcast sound receiver the detector separates the sound frequencies and they pass through other parts which lead to the speaker. Television sound is separated from the intermediate frequency by an additional detector of different type.

An easy way to learn how carrier frequencies are changed to an intermediate frequency without altering picture or sound signals will be to watch the process on the screen of an oscilloscope. Before proceeding to do this it will be well to understand how different periods of time may be shown by the oscilloscope, and how it is possible to observe details of changing signal voltages.

At A in Fig. 3 the oscilloscope trace shows about 100 cycles of an alternating voltage. The total time, from left to right, is about 1/18 second. On this basis there would be 1,800 of these cycles during a whole second of time, or the frequency would be 1,800 cycles per second. The separate cycles and alternations are so close together as hardly to be distinguishable one from another. When taking in so much time as on this trace it



## LESSON 28 – THE SUPERHETERODYNE

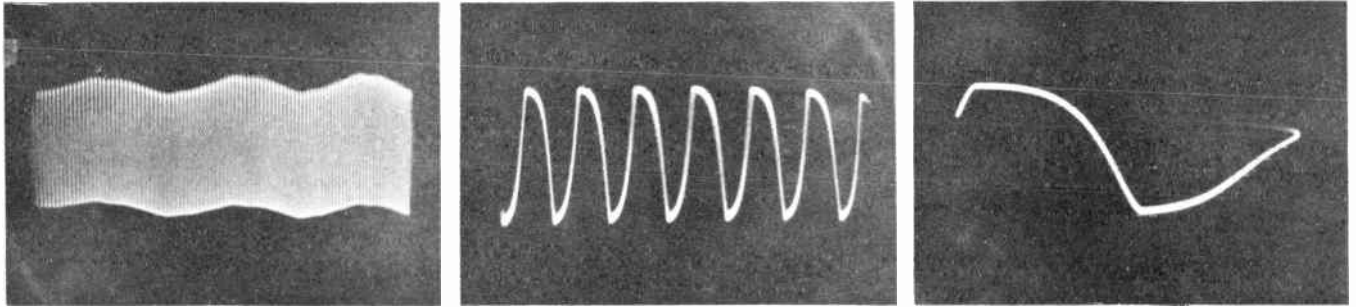

Fig. 3. The oscilloscope makes it possible to examine alternating waveforms occurring during various time periods.

may be seen that the entire signal is swinging up and down at a rather slow rate, at about 60 times per second.

At B the oscilloscope has been readjusted to show what happens during only about 1/300 second, but the space used for this shorter time is the same from left to right as that formerly used for a much longer time. Although we see fewer cycles, each one shows up more plainly. It is possible to examine the waveform.

Supposing now that we wish to examine the waveform of one cycle more closely. Again the oscilloscope is readjusted, this time so that the entire space from left to right covers only about 1/1800 second. Then we see the trace at C, where a single cycle is spread all the way across the screen.

Most service oscilloscopes allow examining changes of alternating voltage which occur during time periods all the way from about 1/10 second to 1/30000 second. Some go as low as 1/4 second and as high as 1/60000 second. Now we shall proceed to

use the oscilloscope for examination of what happens in a superheterodyne.

AMPLITUDE MODULATION. To begin with we should understand how picture signals or sound signals are added to the original carrier frequencies. The process which we are about to examine is used for transmission of all television picture signals and sync pulses, also for sound signals in standard radio broadcasting. Television sound signals, also signals for f-m sound radio, are handled by a somewhat different process to be examined later.

Let's assume that the low-frequency wave at A in Fig. 4 is to be transmitted. This wave could be part of a television picture signal. The wave might be of any other form, as, for example, at B, and it could be transmitted just as well. In following experiments we shall use the wave at A and call it the low-frequency signal. Frequencies so low as those for sound, for some parts of television pictures, and for television sync pulses cannot by themselves, be radiated and transmitted as electromagnetic waves in space.

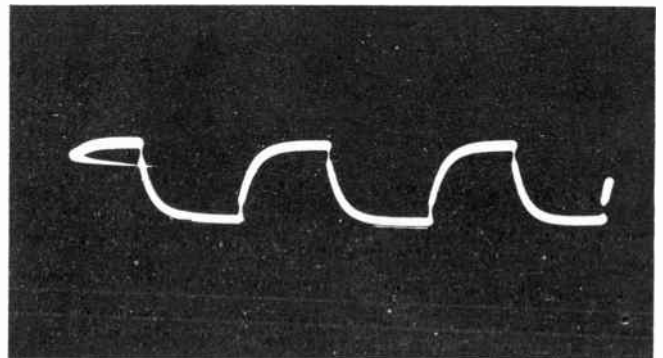
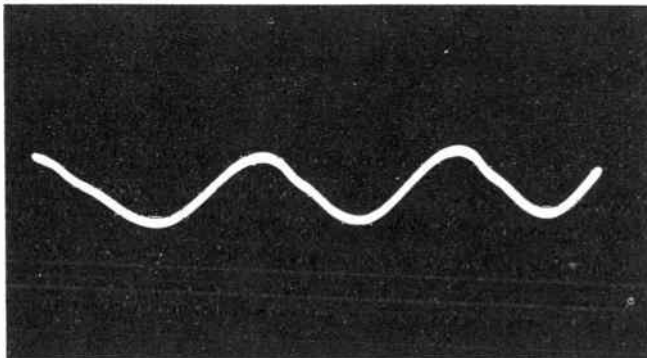

Fig. 4. The low-frequency voltage wave at A will be transmitted. The wave at B could be transmitted just as easily.

## COYNE - *television home training*

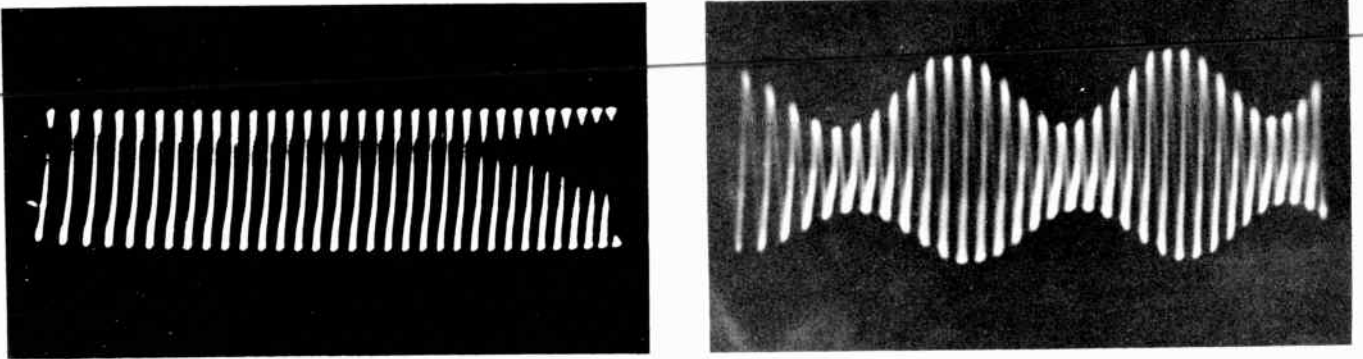

Fig. 5. The unmodulated carrier wave (A) and the same wave modulated with the low-frequency signal (B).

For efficient transmission through space we must have a frequency of at least 30 kilocycles, and preferably one much higher. That is, the carrier waves must be at these higher frequencies. We shall use the alternating voltage at A in Fig. 5 to represent a carrier wave which will "carry" the low-frequency signals through space. Note that our carrier frequency is higher than that of the low-frequency signal to be transmitted.

The low frequency signal is combined with the carrier at the transmitter by the process called amplitude modulation. The combination is shown at B. There are many carrier waves or cycles occurring during each cycle of low-frequency modulation.

When the carrier is modulated by the low-frequency signal the amplitude of the carrier waves is varied at the low frequency. When the low-frequency signal is positive it increases the carrier amplitude, and when the low-frequency signal is negative it decreases the carrier amplitude. It is because carrier amplitude is varied that the particular kind of modulation now being examined is called amplitude modulation. A common abbreviation for amplitude-modulation or amplitude-modulated is a-m.

The high-frequency modulated carrier can be radiated, and the electromagnetic waves will reach the antennas of receivers. Then the a-m signal entering the receiver will be of the form shown at B in Fig. 5. Although the carrier is modulated, its individual waves still are alternating at the carrier frequency. Therefore, the frequency of the modulated signal is the carrier fre-

quency. Any frequency so high as this is quite difficult to amplify efficiently.

In the superheterodyne receiver the high-frequency carrier alternations are changed to alternations at the lower intermediate frequency, where amplification is not so difficult. The i-f alternations retain the amplitude modulation of the carrier. That is, the low-frequency signal will be present as amplitude modulation of the intermediate frequency, just as it is present as amplitude modulation of the carrier frequency.

Do not fail to note that the modulated carrier at B in Fig. 5 varies in amplitude on both top and bottom, on both positive and negative sides of the waves. The form of the low-frequency signal, the modulation, appears on both sides of the carrier. Polarities of these two low-frequency signal variations are opposite; where the top one rises the bottom one falls, and vice versa. The two low-frequency variations of opposite polarities will prove to be highly important later on. They will be present on the modulated intermediate frequency as well as on the modulated carrier.

There are certain relations between carriers and low-frequency modulation which should be examined before following the signals through the superheterodyne. We may commence with the unmodulated carrier represented by the oscilloscope trace at A in Fig. 6. This frequency is so high that separate cycles cannot be distinguished. This would be a normal condition since, in the v-h f television carriers, the lowest frequency is 54 mc or 54,000,000 cycles per second

## LESSON 28 – THE SUPERHETERODYNE

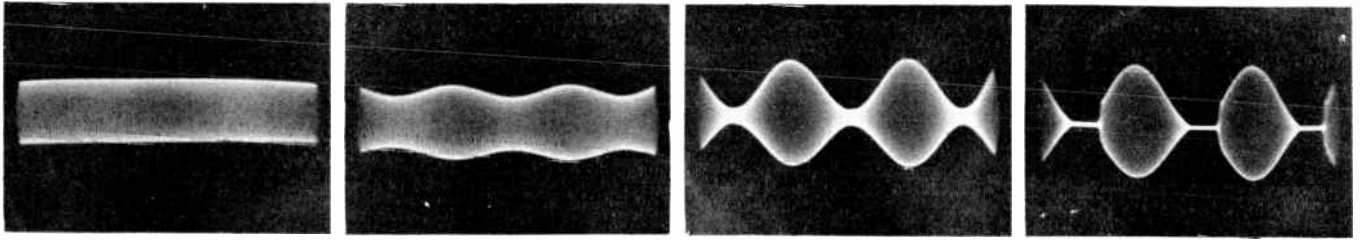

Fig. 6. Various amounts or percentages of low-frequency modulation on the same high-frequency carrier.

When modulated with a low frequency such as a sync signal at 15,750 cycles per second there would be about 3,500 carrier cycles during the time of one modulation cycle.

If the carrier is modulated with a low-frequency of small strength and amplitude the result will be as at B. Were this modulation a sound signal it would be of low audio volume. A loud sound signal would have greater amplitude, and might appear on the carrier as at C. This is very nearly the practical limit of modulation.

Should the sound signal become too loud, or should any other modulation signal become too strong and of too great amplitude, there would be overmodulation. The effect is shown at D in Fig. 6. During periods in which the low-frequency signal approaches and passes through its negative peak the carrier is reduced to zero. Excessive negative amplitude of the modulation completely overcomes the carrier amplitude. At the receiver there would be severe distortion.

In all four traces of Fig. 6 the carrier itself remains of the same average strength. To prove this you may draw on the traces at B and C a horizontal line through the zero points of the upper modulation wave and a second horizontal line through the zero points of the lower modulation. If you do this correctly the two horizontal lines will be the same distance apart on both traces, and the separation will be the overall height (amplitude) of the carrier at A.

Now look at Fig. 7. At A is represented a strong carrier, one of great average amplitude, which is modulated by a strong low-frequency signal. At B the strength of modulation was not changed, but the carrier was made much weaker. Instead of saying that the strength of modulation has not changed we might say that the percentage of modulation has not changed, meaning that relations between average modulation strength and average carrier strength have not changed.

Of course, we may have modulation

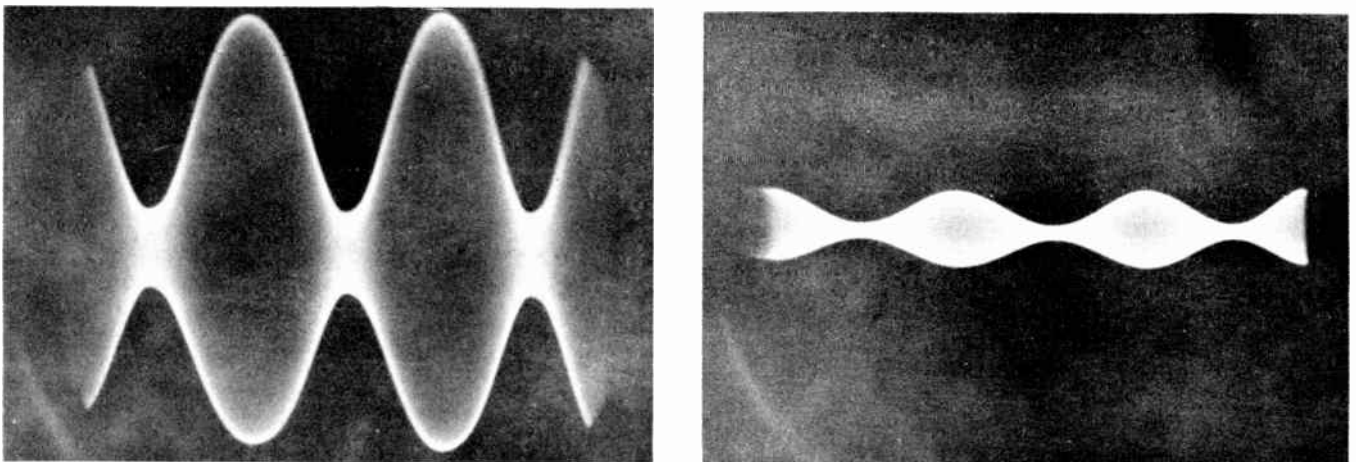

Fig. 7. At A and B the strength of modulation is the same, but carrier strength or amplitude is changed.



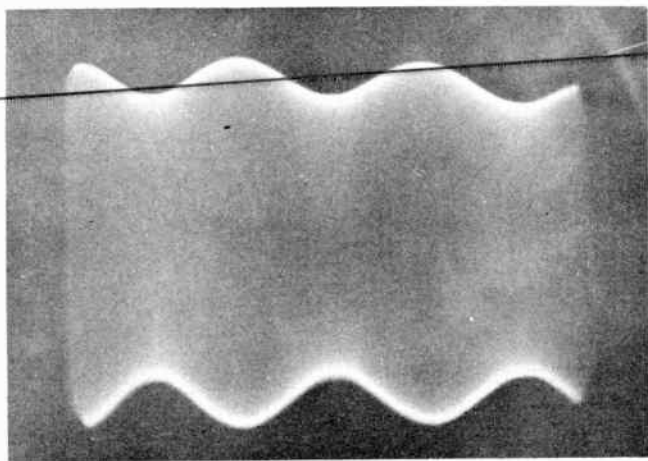

Fig. 7C. At C there is weak modulation on a strong carrier.

voltage of small amplitude on a strong carrier, as at C of Fig. 7. Here the percentage of modulation is much less than in the other cases illustrated. If modulation is of too great strength and amplitude the result will be as at D in Fig. 6, regardless of carrier strength.

**INTERMEDIATE FREQUENCY.** The modulated carrier is changed to a modulated intermediate frequency by adding a third frequency secured from the oscillator which is part of the tuner. In nearly all television receivers the oscillator furnishes a frequency higher than that of the carrier. Because it operates at such high frequency we call this part of the tuner the r-f oscillator. Another name in general use is local oscillator.

The carrier frequency and the r-f oscillator frequency are applied together to the grid of the mixer tube. The mixer may be a triode or a pentode. It is operated at only moderately high plate and screen voltages, but with a bias considerably more negative than would be employed for amplification. As a result, the mixer works at a point low down on its mutual characteristic, at a point where the curve bends rather sharply toward plate current cutoff. Such operation is illustrated by Fig. 8.

Because of operating on the bend of its characteristic the mixer amplifies positive alternations of alternating grid voltage more than negative alternations. Such action would not be suitable for ordinary amplification,

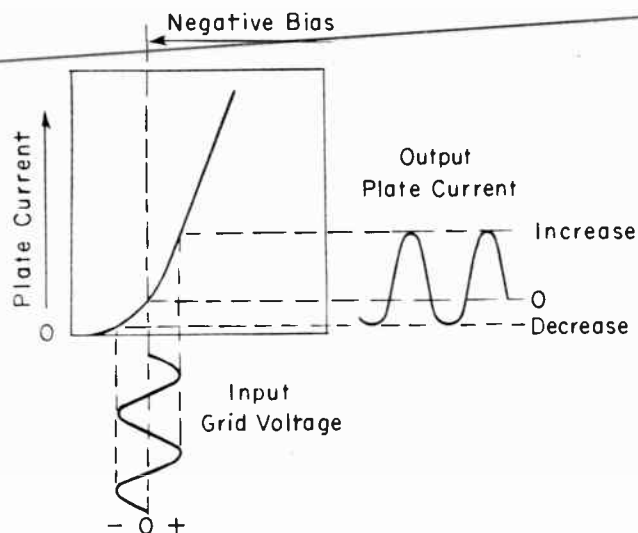

Fig. 8. Grid bias on the mixer is so negative as to intentionally distort the plate current in relation to grid voltage.

where we want no distortion, but it is necessary in the mixer if we are to produce an intermediate frequency.

When any two frequencies, such as those of the carrier and oscillator, are applied to the grid of a tube which does not equally amplify both polarities there is a peculiar result. In the output or plate circuit of that tube there is a new frequency equal to the difference between the two frequencies applied to the grid. This "difference frequency" is called the beat frequency.

Now we may watch the formation of a beat frequency from two higher frequencies. At A in Fig. 9 is an oscilloscope trace which will represent the carrier frequency. Because at present we are interested only in the formation of a beat frequency, not in modulation, the carrier is not modulated. Furthermore, in order to see the individual waves more clearly, the trace is spread out to cover a short period of time. During the time between the two short lines drawn above the trace there are eight complete cycles of this carrier frequency.

At B is a trace showing the r-f oscillator frequency. Above the trace are two short lines separated by the same distance from left to right as the two on the carrier trace, consequently including the same time



## LESSON 28 – THE SUPERHETERODYNE

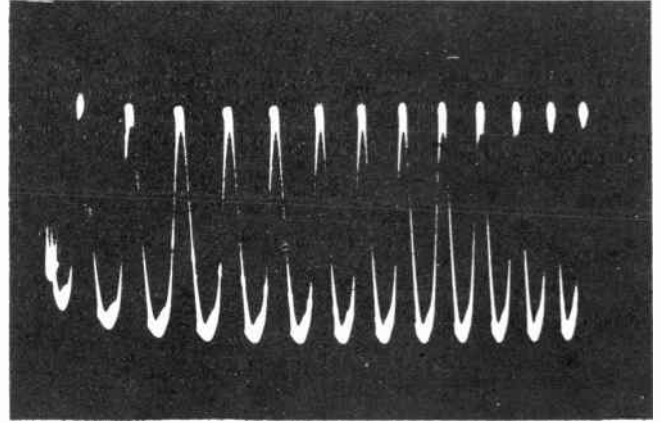
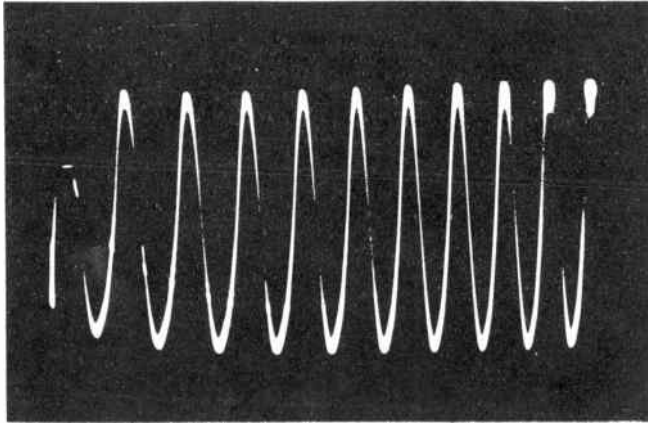

Fig. 9. The carrier frequency (A) and the r-f oscillator frequency (B)

period. Between these two lines are ten complete cycles of oscillator frequency.

At A in Fig. 10 is the waveform of voltage at the output of the mixer tube. This output wave alternately increases and decreases in amplitude, but not in the same way as with modulation. With modulation the positive and negative alternations remained of practically equal amplitudes at any given instant. Now, when using a mixer tube, the positive or upward alternations are considerably greater in amplitude than the negative or downward alternations. This is because the mixer is operated to amplify positive alternations of grid voltage more than negative alternations.

There are some instants during which both the oscillator and carrier alternations go through their positive peaks together, or

very nearly so. Midway between are instants during which these two waves are of opposite polarity. When both alternations at the grid are positive there is a high positive peak in the mixer output. When the input alternations are of opposite polarities there are low amplitudes in the mixer output.

Above the trace showing mixer output are two short lines the same distance apart as those above the carrier and oscillator traces, consequently including the same time period as on those other traces. During this time the amplitude of the mixer output goes from high through low and back to high, then to low again and back to high. That is to say, the change of average output voltage from the mixer goes through two complete cycles during the marked time period. The difference between 10 cycles of oscillator frequency and 8 cycles of carrier frequency is 2 cycles,

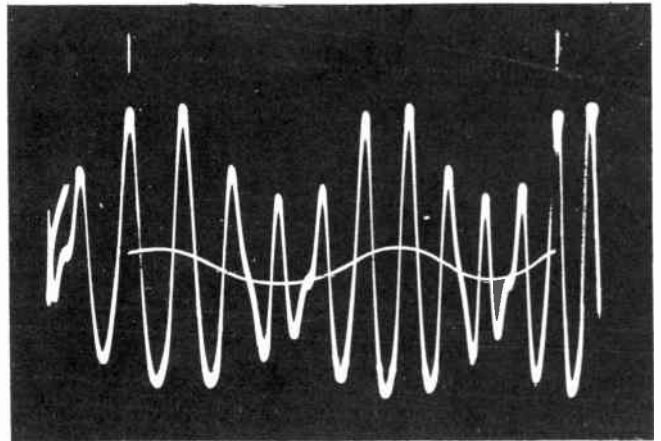
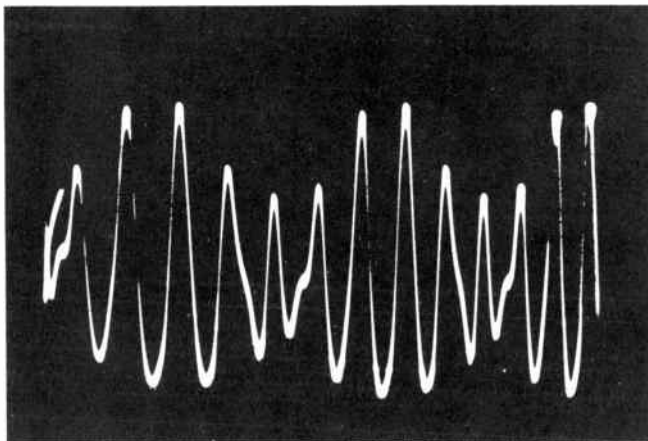

Fig. 10. Voltage in the plate circuit of the mixer tube. The wavy line at B represents the average of the alternations.

# COYNE - television home training

and these two cycles in the mixer output represent the beat frequency.

At B in Fig. 10 a wavy line has been drawn through the average of voltage swings in the mixer output. This voltage rises and falls at the frequency of beats in the mixer output, which is the intermediate frequency. Since this voltage really is voltage across the load in the plate circuit of the mixer it is a varying direct voltage. But by taking the output through a capacitor, as we have done in many amplifier circuits, the variations will pass through and leave the direct voltage behind. Then the variations will be an alternating voltage at the beat frequency or at the intermediate frequency.

The relation between oscillator frequency, carrier frequency, and resulting beat or intermediate frequency would hold good for any actual frequencies. Supposing that oscillator frequency were 246.50 mc and that carrier frequency were 205.25 mc. The beat frequency or intermediate frequency would be the difference, which is 41.25 mc. The fre-

quency of 205.25 mc is the video carrier frequency for television channel 12, and 41.25 mc is the intermediate frequency used in many receivers. To produce this intermediate for reception of channel 12 the r-f oscillator of the receiver would be tuned to operate at 246.50 mc.

It will be interesting to look at the fairly typical circuit connections of Fig. 11. Here we have a mixer, an r-f oscillator, and a first i-f amplifier tube. The modulated carrier signal will be brought into coil A of a group of three coils, A, B, and C. Coil A, with its carrier frequency, is coupled to coil B in the grid circuit of the mixer. Thus the modulated carrier frequency is applied to the mixer grid.

Down below the mixer is the circuit of the r-f oscillator. Do not concern yourself at present with how this oscillator operates, it will be examined later. Just now the important point is that oscillator frequency appears in coil C. This coil is coupled to B, in the mixer grid circuit. Thus the oscillator fre-

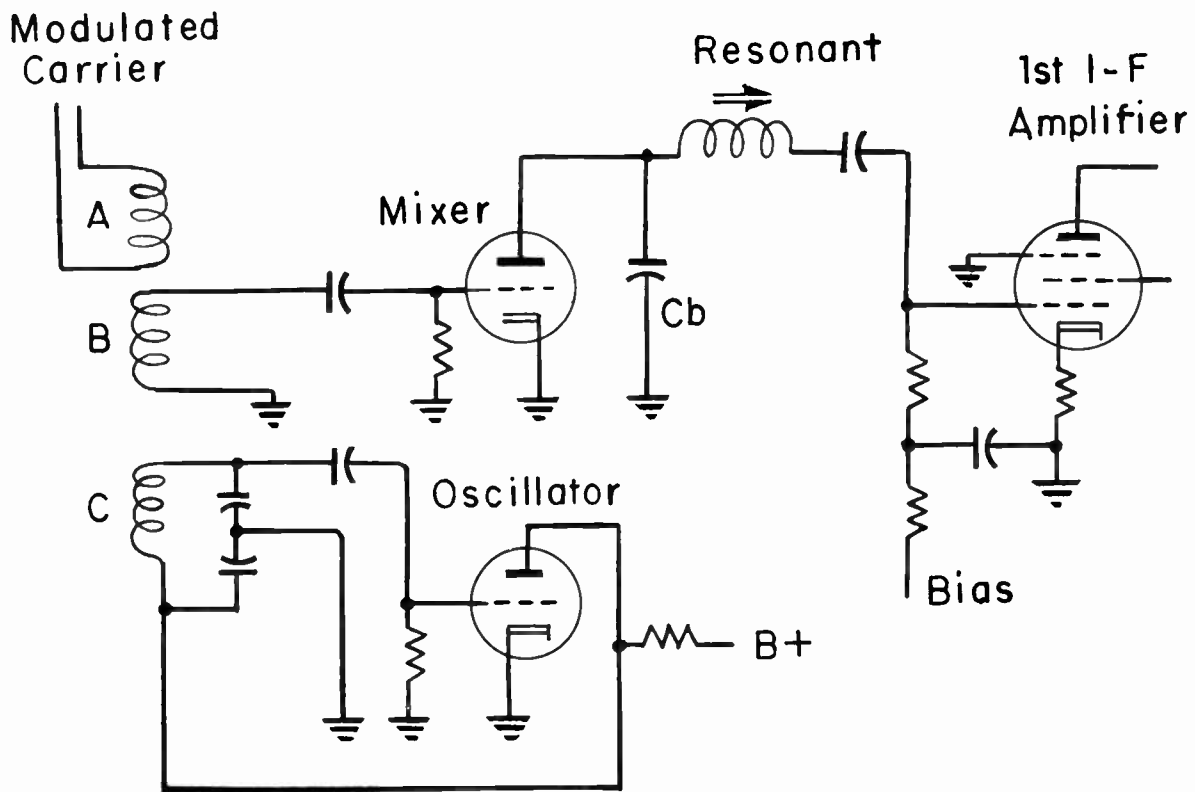

Fig. 11. A television tuner circuit in which carrier and r-f oscillator frequencies are coupled into the mixer grid circuit.

## LESSON 28 — THE SUPERHETERODYNE

quency is applied to the mixer grid along with the carrier frequency.

If we get rid of the high-frequency carrier and oscillator alternations in the mixer output, and leave only the rising and falling average voltage, we shall have the intermediate frequency all by itself. This is easy. As a start we connect a small capacitor at Cb in Fig. 11 from the mixer plate to its cathode or to ground. The capacitor is of a value having small reactance at carrier and oscillator frequencies, but greater reactance at the lower intermediate frequency. Much of the strength of the carrier and oscillator alternations is bypassed to ground or the cathode through this capacitor.

The capacitor alone won't do a complete job, so we put into the plate circuit of the mixer a tuned circuit resonant at the intermediate frequency. If this circuit is series resonant, as in Fig. 11, it will freely pass the intermediate frequency while strongly opposing the higher frequencies. Were the circuit parallel resonant, and connected from mixer plate to the cathode through a bypass capacitor, it would provide high impedance at the intermediate frequency and little impedance at the higher frequencies. Then there would be maximum voltage gain at the intermediate and little gain at other frequencies.

Now what about the low-frequency modulation, which must be carried all the way to the detector? To show this modula-

tion we must change the oscilloscope adjustments to cover more time. The screen of the oscilloscope wouldn't be wide enough and neither would this page be wide enough, to show the high-frequency waves and also the low-frequency modulation.

The i-f signal from the mixer grid is shown at A in Fig. 12. This trace was made without eliminating any of the frequencies; it contains the carrier frequency, the oscillator frequency, and the beat frequency which is the intermediate frequency. But, as you can see, the whole thing is modulated by the low-frequency signal. It is possible to distinguish eight or nine beats. Some are higher than others, which was not true when forming beats from an unmodulated carrier at A in Fig. 10. The present variations of height in the beats is due to low-frequency modulation.

With carrier and oscillator frequencies removed, leaving only the intermediate or beat frequency with low-frequency modulation, we would have the effect shown at B in Fig. 12. This trace covers still more time, taking in about ten beats and two cycles of low-frequency modulation. No doubt you notice that beat amplitudes increase more in an upward than in a downward direction. This is because the voltage from which the trace was photographed had not been put through a capacitor to leave only an alternating voltage, it is still a direct voltage with an alternating component.

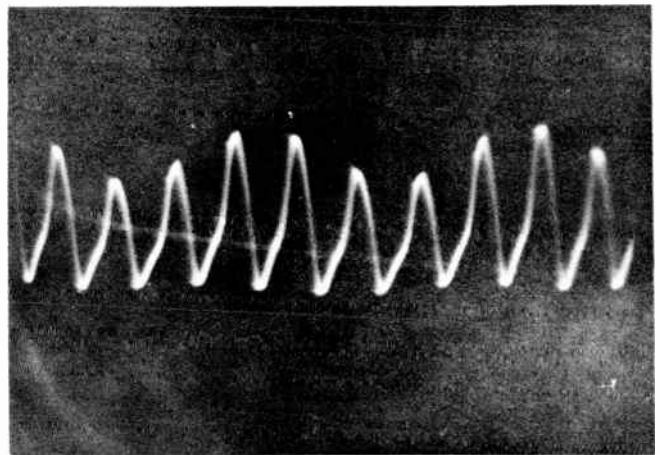
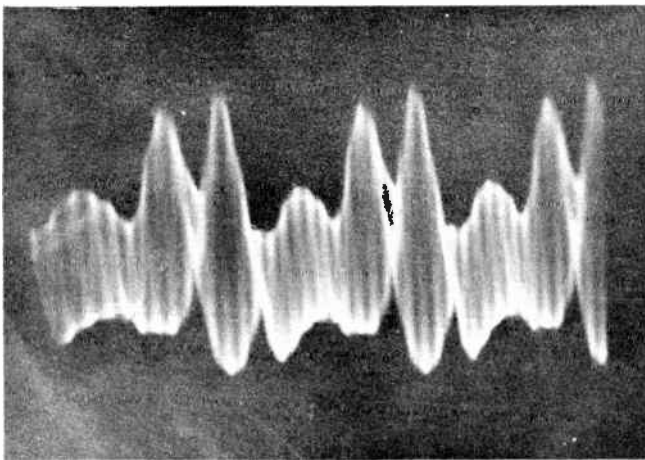

Fig. 12. At A the beats still show the separate frequencies from which they are formed, while at B the alternations of intermediate frequency are modulated by the low-frequency signal.



## COYNE - *television home training*

Between the output of the mixer and the input to the detector the modulated i-f signal will be ~~strengthened in going through the i-f amplifier section of the receiver.~~ The first tube of this section is shown in Fig. 11. At the output of the detector will be only the waves which earlier were low-frequency modulation, first on the carriers and then on the intermediate frequency voltages.

The process which we have watched occurs in all superheterodyne receivers, whether television, f-m broadcast, standard radio broadcast, or short-wave broadcast. The differences are in the values of carrier frequencies, oscillator frequencies, and intermediate frequencies employed in the various services. The principles remain unchanged.

Now that we have watched what happens between the antenna of the superheterodyne and the input to the first i-f amplifier we may discuss certain details which are important in practice.

First, it is desirable to have as much amplification as possible in the mixer while at the same time forming the intermediate frequency. When talking of amplification in the mixer stage we do not speak of voltage gain, but of conversion gain. Conversion gain is the ratio of i-f signal voltage to carrier signal voltage. The carrier voltage usually is measured at the mixer grid, and the i-f voltage at the grid of the first i-f amplifier tube.

You may hear technicians speak of conversion transconductance of a tube used for mixer service. This is similar to ordinary transconductance except that we consider the relation between i-f plate current out of the mixer and carrier voltage into the mixer. Ordinary transconductance, in micromhos, is equal to the micro-amperes of signal plate current per volt of signal at the grid of an amplifier. Conversion transconductance is equal to the number of microamperes of i-f signal current at the mixer plate for each volt of carrier signal on the mixer grid. Conversion transconductance of any tube used as a mixer always is much less than ordinary transconductance of the same tube used as an amplifier.

To obtain best possible conversion gain, mixer tubes are of types ~~having fairly high transconductance or amplification factor,~~ capable of operating with a sharp plate cutoff, and having low internal capacitances on both the input and output sides. The rather large grid-plate capacitance in triodes is not troublesome in mixer service. This is because the difference between intermediate frequencies and carrier or oscillator frequencies is so great, and the circuits are so different, that plate voltages do not greatly affect grid voltages even when there is feedback.

Negative grid bias on a mixer should exceed the sum of maximum modulated carrier voltage plus the r-f oscillator voltage. Provided mixer bias remains sufficiently negative, moderate increases of r-f oscillator output will raise the conversion gain. Mixer bias usually is provided by the grid-leak method, with which bias automatically becomes more negative as input signal voltages increase.

We have seen that in the mixer output there are carrier and oscillator frequencies as well as the beat frequency which is the intermediate. In addition there is a rather weak "sum frequency" which is equal to the carrier frequency plus the oscillator frequency.

The mixer sometimes is called a first detector. Then the regular detector which follows the i-f amplifier section is called the second detector. Still another name sometimes applied to the mixer is converter or frequency converter, because it converts the modulated carrier frequencies to a modulated intermediate frequency.

HOW AN OSCILLATOR WORKS. An oscillator uses power from the d-c supply system of the receiver for producing alternating currents and voltages. One of the many methods in common use is illustrated by Fig. 13. There is a resonant circuit consisting of tuning capacitance Ct and of inductance in windings Lg and Lp. This resonant circuit is tuned to the frequency at which the oscillator is to operate, or to the required frequency of oscillator voltage. It may be called the tank circuit.



## LESSON 28 – THE SUPERHETERODYNE

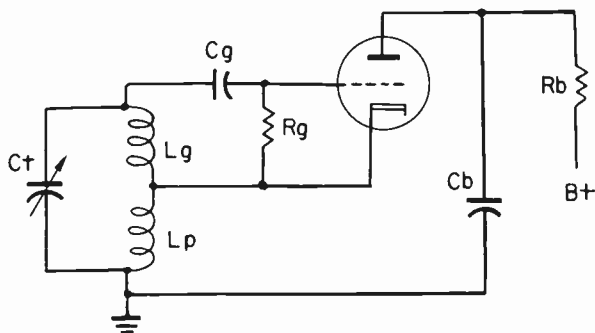

Fig. 13. The elementary circuit for a Hartley oscillator.

Winding  $L_g$  is in the grid circuit of the oscillator tube, being connected between grid and cathode. Capacitor  $C_g$  and resistor  $R_g$  provide bias by the grid-leak method. No other biasing voltage is applied to the oscillator tube. Consequently, when there are no currents in the tube, also during times when the grid is not positive with reference to the cathode, the bias is zero.

Winding  $L_p$  is in the plate circuit of the oscillator. The bottom of this winding is connected to the tube plate through low-reactance capacitor  $C_b$ , which permits free passage of alternating currents and voltages between plate and winding. The upper end of  $L_p$  is connected to the tube cathode. Direct current and voltage for the plate are furnished from  $B+$  of the power supply through resistor  $R_b$ , whose opposition to alternating currents and voltages is much greater than the reactance of capacitor  $C_b$ . There is no direct current in plate winding  $L_p$ .

Windings  $L_p$  and  $L_g$  are inductively coupled. Consequently, alternating voltages in the plate circuit are fed back into the grid circuit through this coupling. Feedback is necessary in an oscillator, although not desired in an amplifier. The only alternating voltage applied to the grid of the oscillator tube is that fed back from the plate circuit. No external signal voltage of any kind is applied to the oscillator grid.

Alternating current and voltage are produced in the resonant circuit as follows. The process is called oscillation. Numbered paragraphs correspond to numbers at various points along the curves for plate current and grid voltage on Fig. 14.

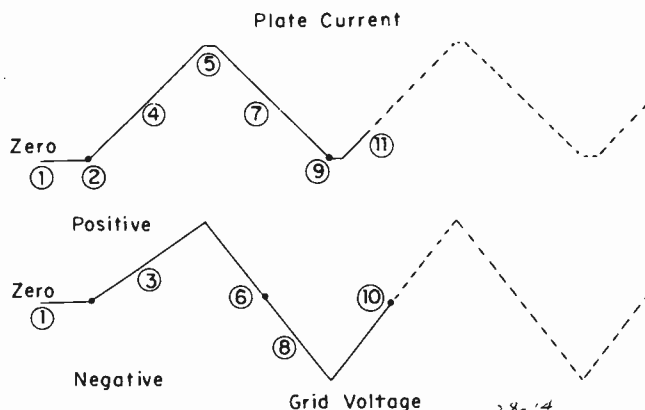

Fig. 14. Changes of plate current and of grid voltage during oscillation.

1. Before d-c power is turned on, plate current and grid voltage are zero.

2. When power is first turned on, plate current commences to flow, and increases. This is a changing current, the equivalent of part of a cycle of alternating current, so it acts through capacitor  $C_b$  and winding  $L_p$  of Fig. 13. Rise of current in  $L_p$  produces outwardly moving magnetic lines around this winding.

3. Magnetic lines moving outward from  $L_p$  cut the turns of winding  $L_g$ , and in  $L_g$  they induce an emf of such polarity as to swing the grid positive.

4. The positive grid causes plate current to increase. While plate current is increasing, more and more of the power supply voltage is used up in resistance or impedance of the plate circuit, and less voltage remains at the plate.

5. There comes a time when voltage remaining at the plate is too low to draw additional current through the tube, and plate current levels off at a momentarily steady value.

6. With steady plate current there is no movement of magnetic lines around  $L_p$ , no induction of emf in  $L_g$ , and grid voltage goes back to zero.

7. The change of grid voltage from positive to zero reduces the plate current. This decreasing current allows the magnetic

## COYNE - television home training

lines around  $L_p$  to move inward, which is a reversal of their former outward movement.

8. The reversed direction of cutting of magnetic lines through  $L_g$  induces in this winding an emf of reversed polarity, of polarity which swings the grid negative.

9. The grid goes so far negative as to cause plate current cutoff.

10. At cutoff there is no plate current, no current in winding  $L_p$ , no magnetic field, no cutting of turns in  $L_g$ , no induced emf, and grid voltage goes from cutoff value back to zero.

11. As grid voltage becomes less negative, in going from cutoff value to zero, plate current again commences to flow and to increase as the grid becomes less negative. This is where we began the process, with plate current increasing from zero.

The whole performance repeats over and over again, as shown by the continued broken line curves of Fig. 14. Plate current, accompanying plate voltage, and voltages in winding  $L_p$  and  $L_g$  are alternating. The frequency of these alternations is determined by tuning of the resonant tank circuit. Voltage changes illustrated by Fig. 14 do not take into account the biasing effect of the grid capacitor and leak. This negative bias would bring all the curves farther down or farther negative in voltage values, but feedback and oscillation would be essentially as shown. Grid voltage has to go momentarily positive during each cycle in order to draw the grid current for biasing voltage in the grid-leak resistor.

The circuit of Fig. 13 is that of a Hartley oscillator. The name Hartley does not refer to any particular manufacturer or to any particular receiver, it designates a type of oscillator circuit. Hartley oscillators are widely used in all branches of radio and television. There is great variety in arrangement of parts and in circuit details, but whenever there is a divided or tapped inductor in the resonant circuit, with the tap connected to the tube cathode, the oscillator is a Hartley type.

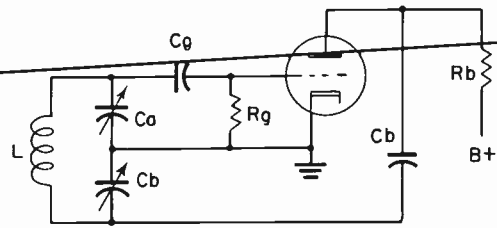

Fig. 15. The elementary circuit for a Colpitts oscillator.

The other widely used oscillator for television and radio is the Colpitts type, whose fundamental circuit is shown by Fig. 15. Here the resonant circuit consists of the single untapped inductor  $L$ , across which are two tuning capacitors  $C_a$  and  $C_b$ . These capacitors are in series with each other, and in parallel with the inductor. From between the two capacitors there is a connection to the tube cathode. Grid bias is provided by the grid-leak method, as is the case with nearly all feedback oscillators, here employing grid capacitor  $C_g$  and grid resistor  $R_g$ .

Capacitor  $C_a$  is in the grid circuit of the oscillator tube while capacitor  $C_b$  is in the plate circuit. The plate circuit is completed for alternating or oscillating currents and voltages through low-reactance capacitor  $C_b$ . These currents and voltages are strongly opposed by resistance at  $R_b$ , thus being kept from the d-c power supply circuits and forced to flow through  $C_b$  and the a-c plate circuit.

The same oscillating or circulating currents flow in capacitors  $C_a$  and  $C_b$ , and in inductor  $L$ . Power to maintain the oscillating currents is brought into the tank circuit from the plate circuit across the capacitive reactance of  $C_b$ . Power from the tank circuit is fed into the grid circuit of the tube from across the reactance of  $C_a$ .

Frequency of oscillation depends on inductance at  $L$  and on the combined capacitance of  $C_a$  and  $C_b$ . Since the two capacitors are in series, their combined capacitance will be less than that of either one alone. To maintain oscillation at any given frequency the combined capacitance of  $C_a$  and  $C_b$  must remain the same. When either capacitance is increased the other must be decreased.

## LESSON 28 – THE SUPERHETERODYNE

The amount of feedback from the plate circuit to the grid circuit depends on the relative capacitive reactances of  $C_a$  and  $C_b$ . Reducing the capacitance at  $C_b$  increases the capacitive reactance. Then there is more plate circuit voltage across the increased reactance, and an increase of feedback power. Increasing the capacitance at  $C_a$  would also increase the feedback, for this would lessen the reactance at  $C_a$ , and leave a greater proportional reactance at  $C_b$ . Opposite changes of these capacitances would reduce the feedback.

Changing either capacitance by itself will alter the oscillating frequency. If frequency is to be unchanged, the two capacitances must be altered in opposite ways to increase or decrease the feedback. If frequency is to be changed without altering the feedback, both capacitances must be increased or decreased together to maintain the same ratio of reactances.

Actual design and construction of Colpitts oscillators may be varied in many ways while retaining the fundamental principle. No matter what may be the modifications, an oscillator utilizing a single resonant inductor paralleled by two resonating capacitances in series with each other is a Colpitts oscillator. The television r-f oscillator of Fig. 11 is a Colpitts type.

Just as the strength of feedback in the Colpitts oscillator depends on the ratio of capacitive reactances in the resonant circuit, so the feedback in the Hartley oscillator depends on the ratio of inductive reactances in the resonant circuit. In the Hartley circuit of Fig. 13 the feedback is increased by more inductance and more inductive reactance at  $L_p$ , or by relatively less inductance and inductive reactance at  $L_g$ . Changing either inductance by itself will alter the oscillating frequency, just as changing either capacitance by itself will alter the frequency in the Colpitts circuit.

With either type of oscillator, using too little reactance in the plate circuit will so reduce the impedance load in the plate circuit as to make the tube operate with little output. If grid circuit reactance is reduced exces-

sively, when attempting to have high relative reactance in the plate circuit, the feedback actually will be reduced. This is because the grid circuit reactance is made so small that very little alternating voltage appears across it and in the grid circuit. As a general rule, oscillation will be most active and dependable with approximately equal capacitances in the resonant circuit of the Hartley oscillator, and with approximately equal capacitances in the resonant circuit of the Colpitts oscillator.

It is interesting to note that there would be effective feedback in the Hartley oscillator even though the two inductances were not coupled by means of a common magnetic field. There would be feedback because both windings are in the same resonant circuit or tank circuit, and the same circulating or oscillatory currents must flow in both. Then the same currents are in the grid circuit and the plate circuit, with power supplied from the plate circuit and put into the grid circuit.

The same reasoning applies to the Colpitts oscillator. Capacitors  $C_a$  and  $C_b$  are both in the tank circuit and in both of them must be the same oscillatory currents. Then the same currents, and their voltages, are in both the plate circuit and the grid circuit, with power from the plate circuit put into the grid circuit.

So long as winding turns on the tank inductor are all in the same direction around the form it is impossible to have feedback grid voltage in a polarity that won't maintain oscillation. The reasons follow. In any tube having a grid and a plate, grid voltage and plate voltage change in opposite polarities at every instant. When the plate goes positive the grid must go negative, and vice versa.

Now, with the single inductor in the Colpitts tank circuit or the two series inductors of the Hartley circuit, one end is connected to the grid and the other to the plate of the tube. When a changing or alternating current flows in any winding, one end is going more negative while the other is going more positive. This effect is produced and strengthened by the feedback. A positive-going plate voltage applied to the plate end of the inductor causes a negative going voltage

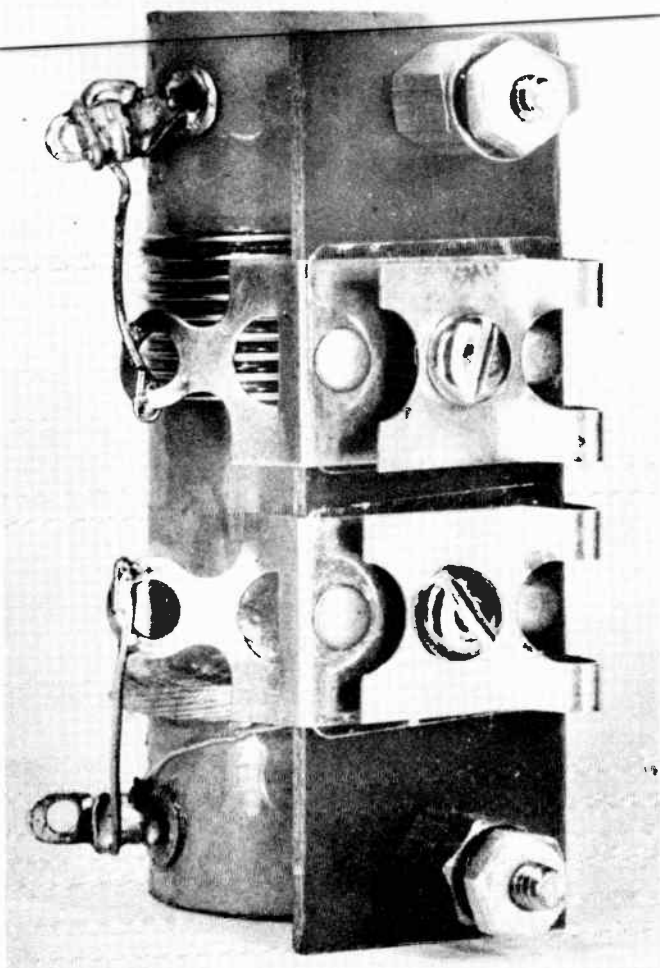

Fig. 16. On this form are oscillator inductor windings for the standard broadcast band and for short-wave carrier frequencies to about 20 megacycles.

at the grid end, the very effect needed to maintain oscillation. This does not conflict with Fig. 14, for there we are dealing with plate current and here with plate voltage.

Oscillators are negatively biased by the grid-leak method for two good reasons. First, the bias adjusts its value to operating conditions and always allows just enough grid current to keep the grid capacitor charged. Second, there is zero bias before oscillation begins, which is necessary in order that the grid may go positive during the first cycle of Fig. 14.

You will find that the strength of alternating or oscillating output voltage, as to a mixer or other circuit, is closely proportional to oscillator bias. The more negative the bias, the stronger is the output.

Because of the high frequency and small power from the oscillator it is difficult to measure the output voltage without taking so much power as to drop the very voltage being measured. But the output voltage may be judged closely enough for service work by measuring the negative bias voltage across the oscillator grid leak. This can be done with any good quality d-c service voltmeter of high sensitivity or high resistance in itself.

Bias voltages thus measured will range from as low as two or three volts up to 20 volts and even more. They vary in different receivers, but practically always are much greater than for the same tube used as an amplifier. If changing any tuning adjustment drops the oscillator bias to zero or very nearly to zero, something is wrong in the oscillator circuit or tube or else the change of adjustment has overloaded the oscillator and caused oscillation to cease. Any other changes which stop oscillation are causing some kind of trouble. This measurement of d-c bias voltage across the oscillator grid leak resistor is a highly useful service test.



# TELEVISION

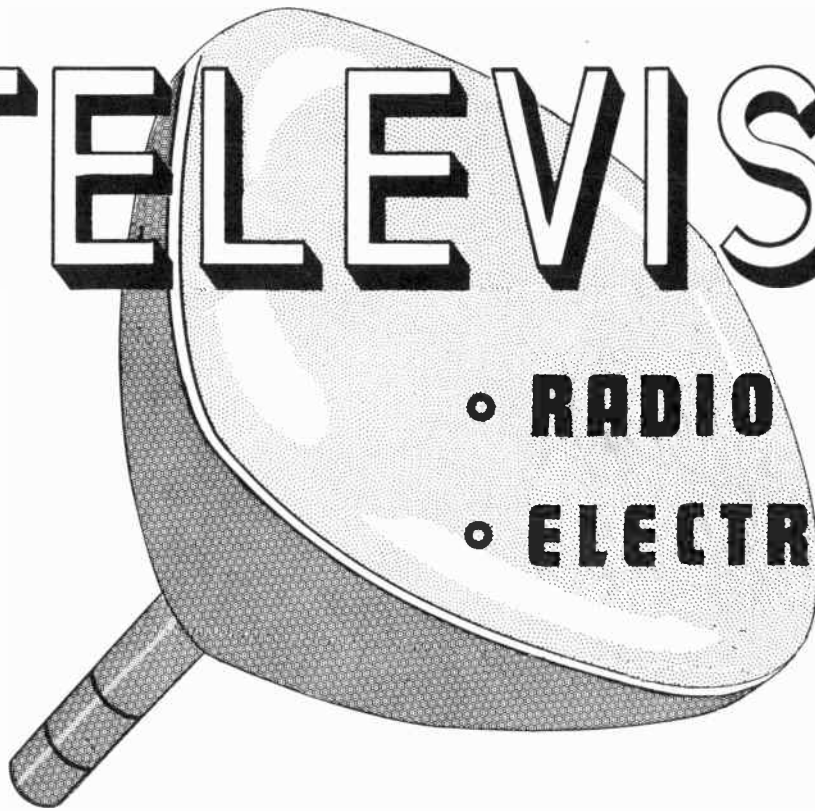

• **RADIO**

• **ELECTRONICS**

---

**LESSON 29 – BROADCAST RECEIVERS**

---

***Coyne School***

*practical home training*

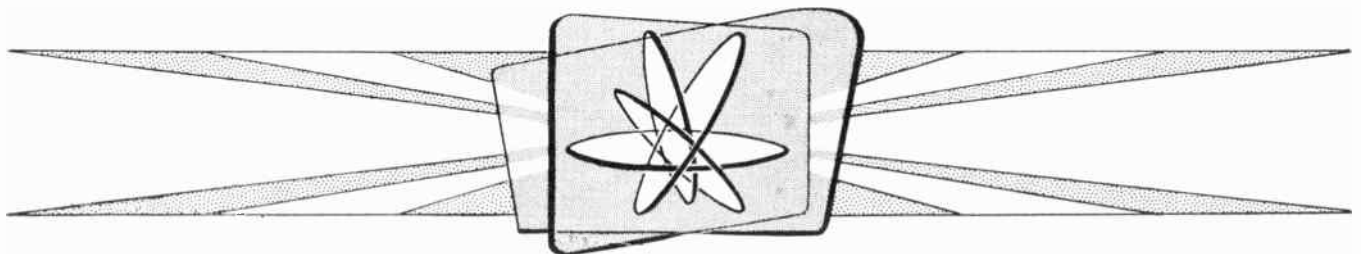

*Chicago, Illinois*

---

*Copyright, 1953 by Coyne Electrical School  
Chicago 12, Illinois  
All rights reserved*

Litho. in U.S.A

## Lesson 29

# BROADCAST RECEIVERS

Although practically all the receivers which you will service are of the superheterodyne type, there are quite a few varieties whose differences depend on the band or bands of carrier frequencies to be handled. In this lesson we shall examine some of the practices followed in broadcast receivers for sound, and compare them with what is done in equivalent sections of television receivers.

In the tuner of a television receiver the mixer and r-f oscillator always are separate tubes or separate sections of a twin tube. This practice is common also in receivers for f-m sound broadcast, where carrier frequencies are in the same general range as for the v-h-f television bands. But in most standard broadcast sets, also in many used for both standard broadcast and short-wave

reception, the functions of mixer and r-f oscillator are served by a single tube having a single set of internal elements. Such a tube is called a converter.

In i-f amplifiers for television and f-m sound the gain per stage is not very great, because of the rather high intermediate frequencies employed in these services. It is necessary to use two, three, or more than three i-f stages to have sufficient overall gain. But with the relatively low intermediate frequencies employed in standard broadcast sets there is high gain, and a single i-f amplifier stage usually is sufficient.

Carrier frequencies for the several broadcast services are as follows:

Carrier frequencies for the several broadcast services are as follows.

Standard radio broadcast.	0.540 to 1.600 mc (540 to 1600 kc)
International short-wave broadcast.	Up to 20 mc.
F-m (frequency-modulation) broadcast.	88 to 108 mc.
Television v-h-f broadcast	54 to 88 mc, and 174 to 216 mc.
Television u-h-f broadcast	470 to 890 mc.

In receivers for television, in many for f-m broadcast, and in most of those for shortwave broadcast reception there is an r-f amplifier stage or two such stages between the antenna input and the mixer or converter. The purpose of this r-f stage is to strengthen and help select the modulated carrier signals before these signals go to the mixer or converter. In many standard broadcast receivers, probably in the majority, there is no r-f amplifier stage; modulated carrier signals from the antenna pass through a tuned coupling directed to a converter tube.

Broadcast receivers need not be designed to handle only a single frequency band or only a single class of service. By means of band switching it is possible to receive either standard broadcast or f-m broadcast

with the one receiver, or to receive standard or else short-wave broadcast. Many television receivers will operate in the f-m broadcast band as well as for the v-h-f television bands. It is possible, and quite common practice, to have one receiver for television, for f-m broadcast, and for standard broadcast.

Fig. 1 is a picture of a receiver which operates only in the standard broadcast band, from 540 to 1,600 kilocycles. Fig. 2 shows the layout of the principal parts as seen from the top of the chassis, and, in broken lines, shows the path of the signals through this receiver.

There are five tubes. One is a power rectifier which takes no direct part in amplification or in conversion of signal frequen-

## COYNE - *television home training*

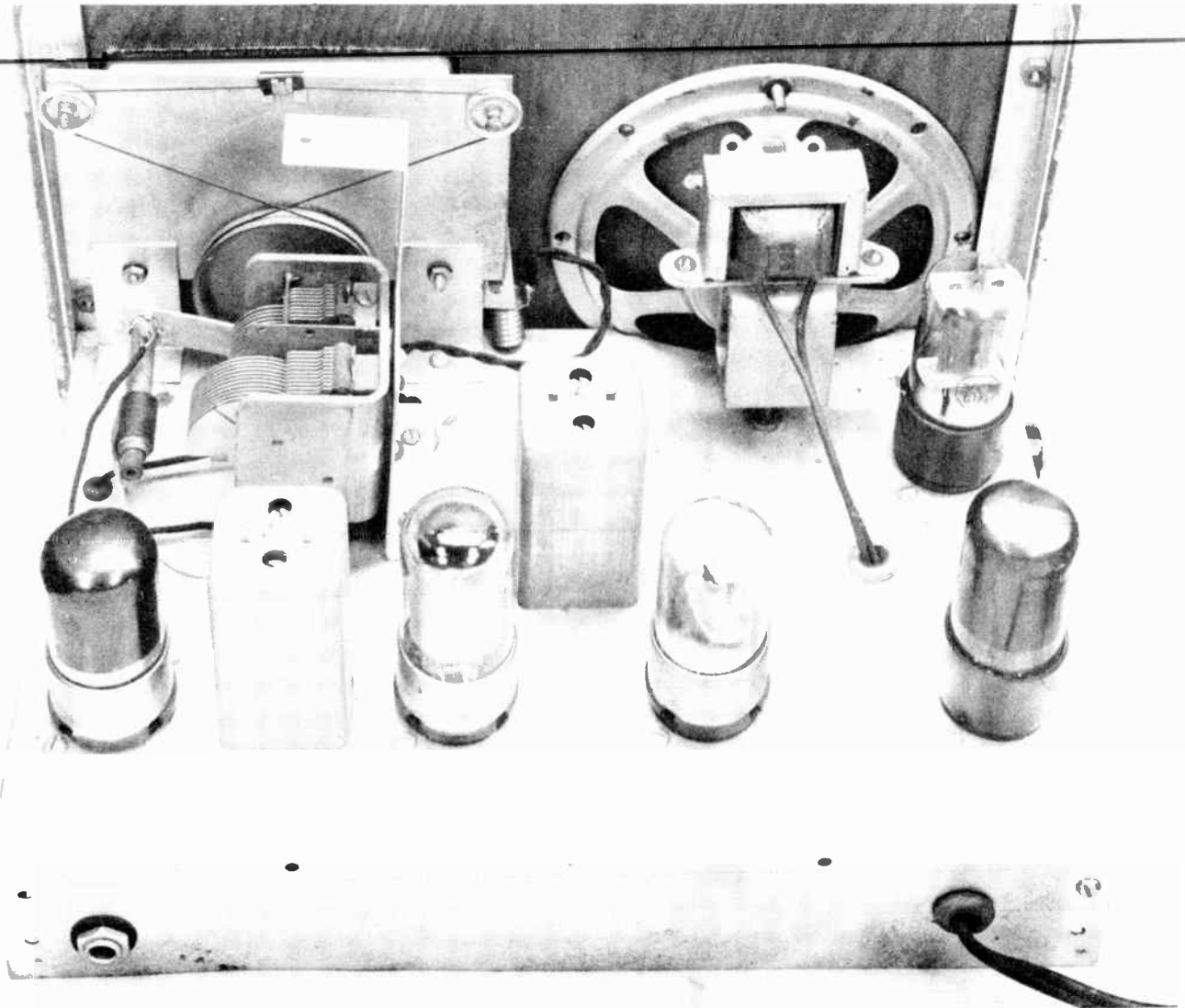

Fig. 1. Parts which are on top of the chassis of a receiver which operates only in the standard broadcast band.

cies. There is no r-f stage. The antenna is connected to the antenna coupler which, with one of the two tuning capacitors, is made resonant at the frequency of a carrier to be received. From this tuned coupling the modulated carrier signals go to the converter which acts not only as a mixer but also as an r-f oscillator. The output of the converter is the intermediate frequency, modulated with the low-frequency sound signals.

The modulated intermediate frequency goes from the converter through an i-f transformer to the i-f amplifier tube. This transformer is tuned to resonance at the intermediate frequency employed in the receiver. The amplified and still modulated intermedi-

ate frequency goes through a second i-f transformer which is tuned to the intermediate frequency.

From the second i-f transformer the i-f signal goes to a single tube in which one section acts as a detector and the other section as a voltage amplifier for audio or sound frequencies. In the detector section of this tube the low-frequency sound signals are separated from the intermediate frequency which, up to this point, has carried the sound signals as modulation.

Between the detector and audio amplifier sections of the combination tube is a resistance coupling circuit such as we ex-



## LESSON 29 – BROADCAST RECEIVERS

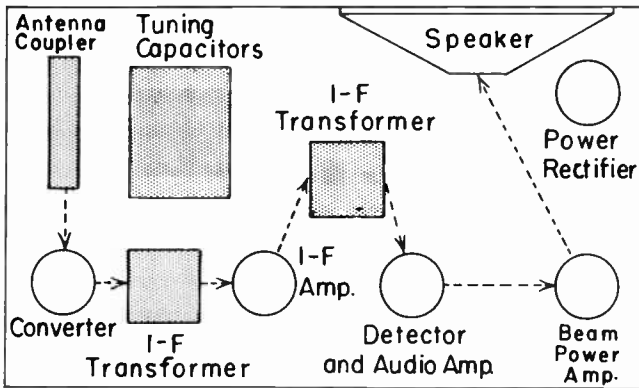

Fig. 2. Layout of the parts and path of the signal in the standard broadcast receiver.

amined in other lessons. The output of the audio amplifier section of the tube goes through another resistance coupling to the beam power amplifier tube. The output of the beam power tube goes through a small iron-cored transformer to the speaker.

Fig. 3 is a photograph of a receiver designed to operate at standard broadcast frequencies and also at international short-wave broadcast frequencies. Fig. 4 shows the layout of the principal parts and, in broken lines, the path of the signals. In this set there are six tubes. One is a power rectifier. The first tube in the signal path now is an r-f amplifier, to which come modulated carrier signals from the antenna coupler. The

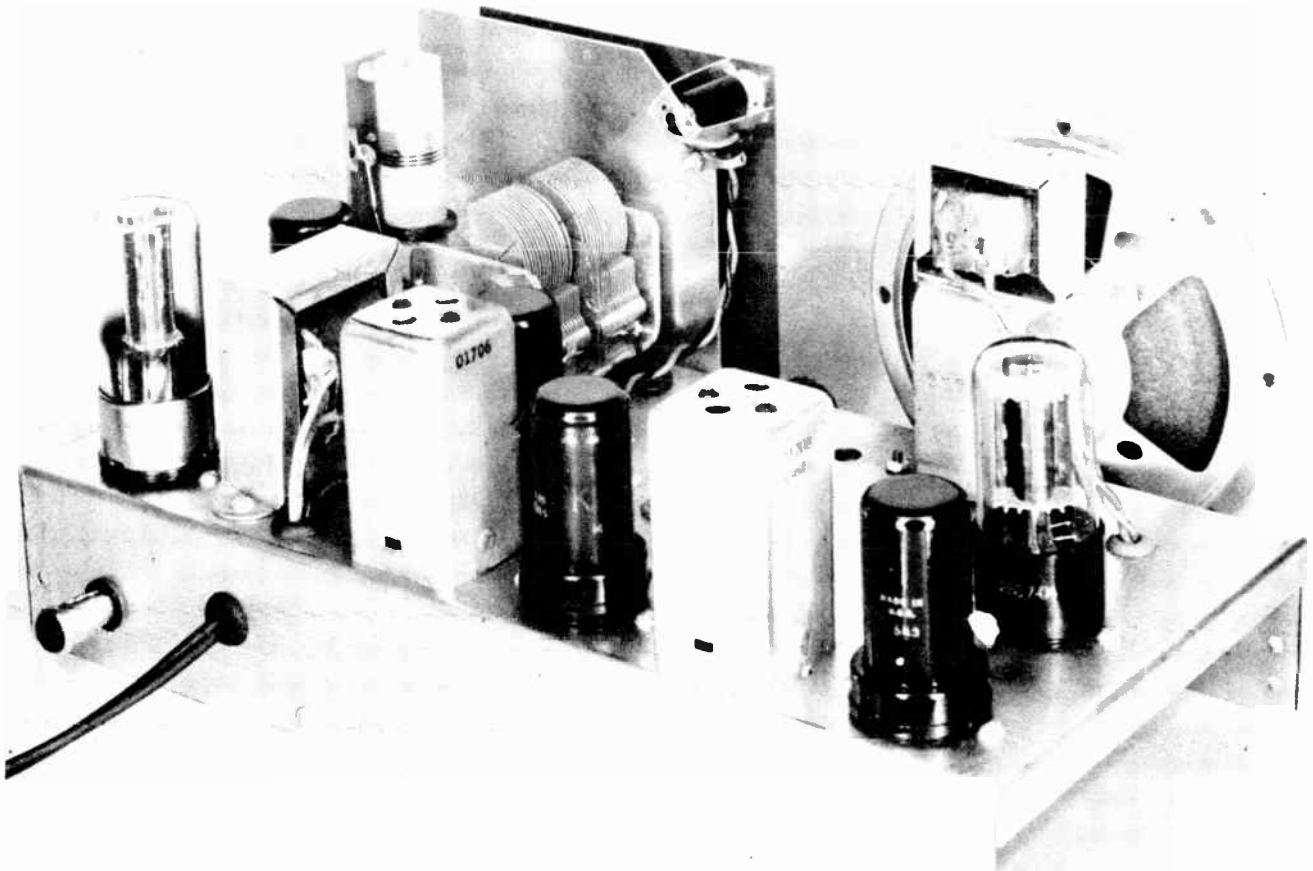

Fig. 3. This receiver operates in the standard broadcast band and also in several short-wave bands.

# COYNE - television home training

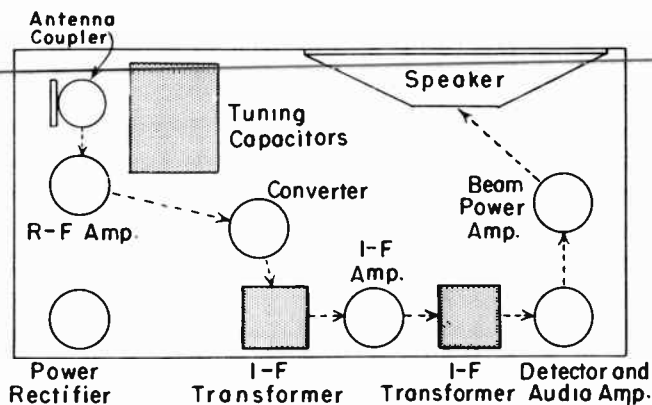

Fig. 4. Parts layout and signal path in the combination standard broadcast and short-wave receiver.

coupler is tuned to resonance at carrier frequencies by one of the two variable capacitors.

In this receiver, and also in the five-tube standard broadcast type of Fig. 1, tuning capacitors are of the two-gang type. One section is used for tuning the antenna coupler. The other section tunes the r-f oscillator circuit. The tuning of antenna and oscillator circuits must be changed together in order that the difference between their frequencies always may remain the same intermediate frequency.

The output of the r-f amplifier tube in Fig. 4 goes through an untuned resistance-coupled circuit to the input of the converter. This untuned coupling operates with reasonable effectiveness and uniformity at all frequencies in the standard broadcast band and in the short-wave bands up to 18 mc, which is the high limit of tuning and reception in this particular set.

Between the converter input and speaker of the six-tube receiver the parts and the path of the signals are the same as in the five-tube set. There is one i-f amplifier tube, two i-f transformers, a combined detector and audio voltage amplifier, and a beam power amplifier.

Fig. 5 is a picture of a receiver designed to operate on either standard broadcast or f-m broadcast frequencies. The layout of parts on top of the chassis is shown by Fig. 6. There are nine tubes in all. One, as usual, is a power rectifier. In this set there is an

r-f amplifier stage which operates for both reception bands. Instead of a converter there are separate mixer and r-f oscillator tubes. As mentioned before, separate mixer and oscillator tubes or separate sections of a twin tube represents common practice in receivers designed for the f-m band. There are however, many f-m sets which employ a converter or a combined mixer and oscillator tube.

In this particular receiver the standard broadcast carrier frequencies are tuned by means of variable capacitors in a three-gang unit. The f-m carrier frequencies are tuned by variable inductors. The iron cores of the inductors are moved into and out of the windings by the same tuning knob and mechanism that operate the variable capacitors for the standard broadcast band. Incidentally, when a set operates in either the standard broadcast or the f-m band it is quite common to refer to standard broadcast as the a-m (amplitude-modulation) band.

Signal paths in the combination a-m and f-m receiver are shown by arrows in Fig. 7. There are two antennas, one for the a-m (standard broadcast) band and a different one for the f-m band. Signals from both bands go through the tuning or frequency selecting system to the r-f amplifier, which is fed also from the r-f oscillator.

Between the r-f amplifier and the mixer is one section of the tuning system, indicated on the signal path diagram by a square in broken lines. Then, of the three sections in the tuning mechanism, one tunes the antenna coupling, a second tunes the r-f oscillator, and the third tunes the coupling between r-f amplifier and mixer.

Both a-m and f-m signals go from the output of the mixer through three i-f transformers and two i-f amplifier tubes. In each of these transformers are two sections, one tuned to the intermediate frequency used for a-m signals and the other tuned to a different intermediate frequency used for f-m signals. The same tubes handle signals and intermediate frequencies for both bands.

From the f-m section of the third i-f transformer the modulated intermediate fre-

# LESSON 29 – BROADCAST RECEIVERS

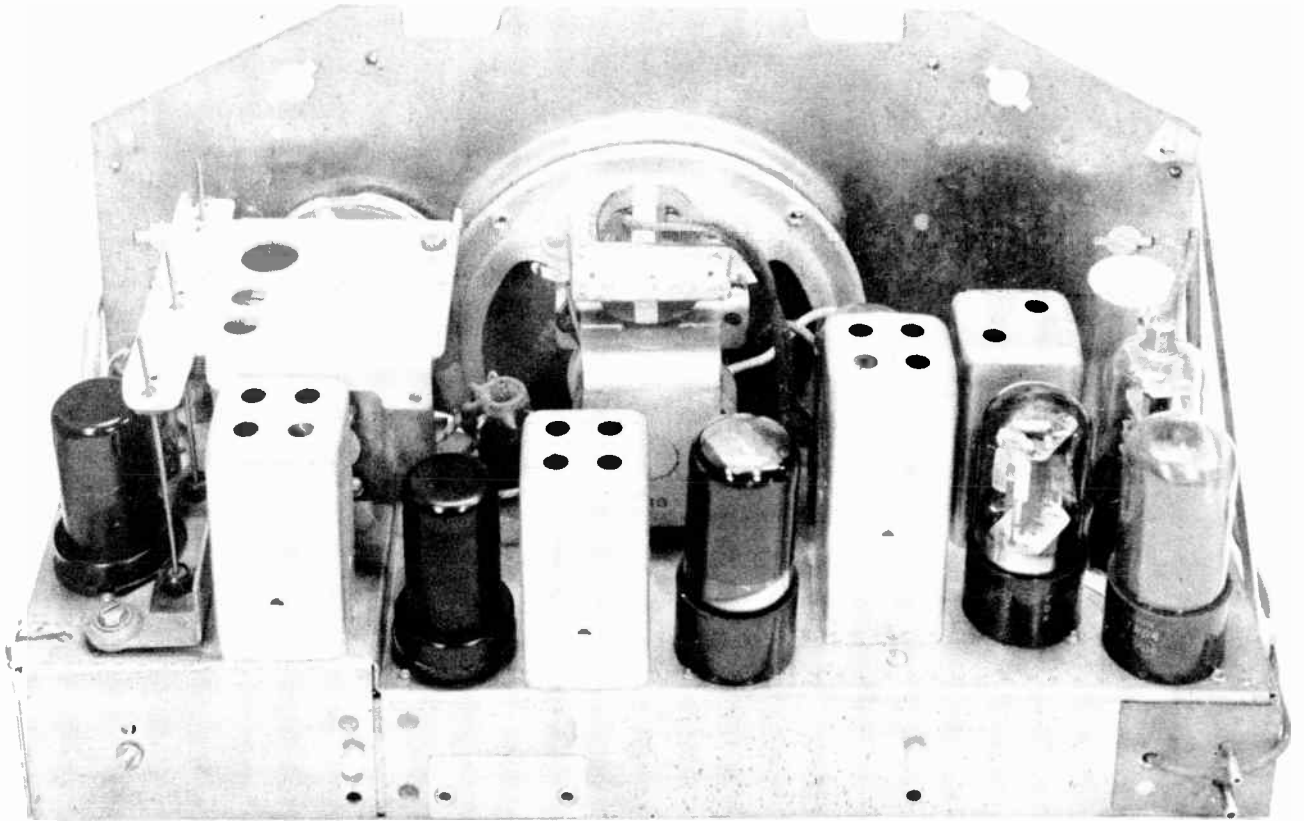

Fig. 5. This is a combination AM-FM receiver which operates in the standard broadcast band and also in the f-m broadcast band.

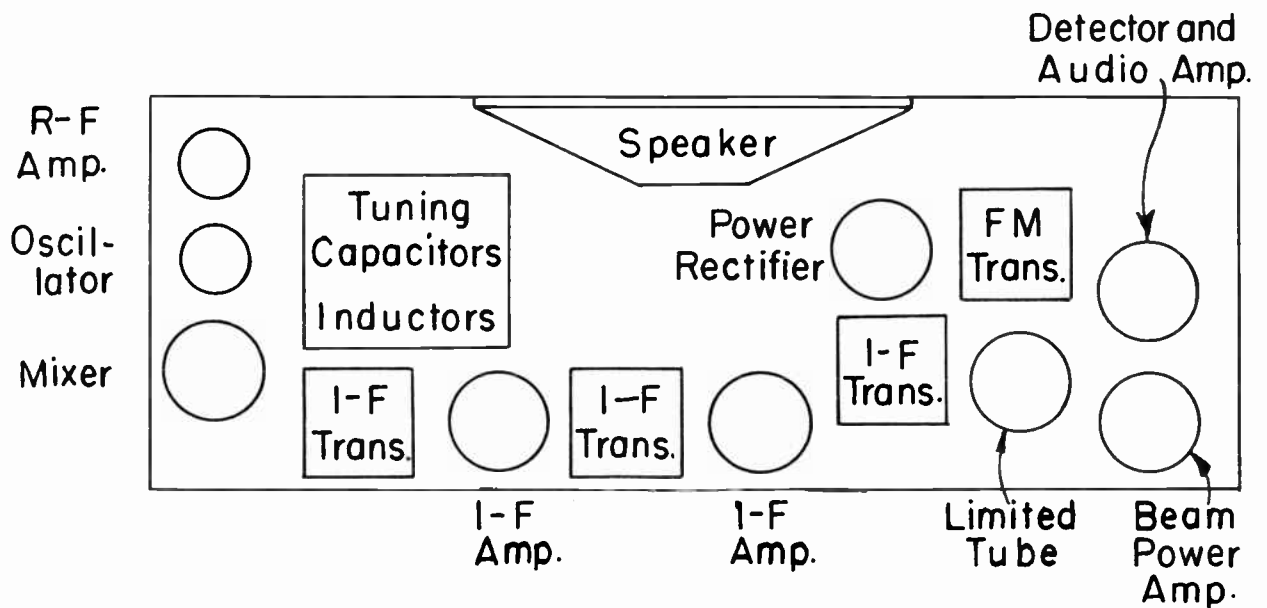

Fig. 6. Parts layout as seen from the top of the chassis of the combination AM-FM receiver.

## COYNE - *television home training*

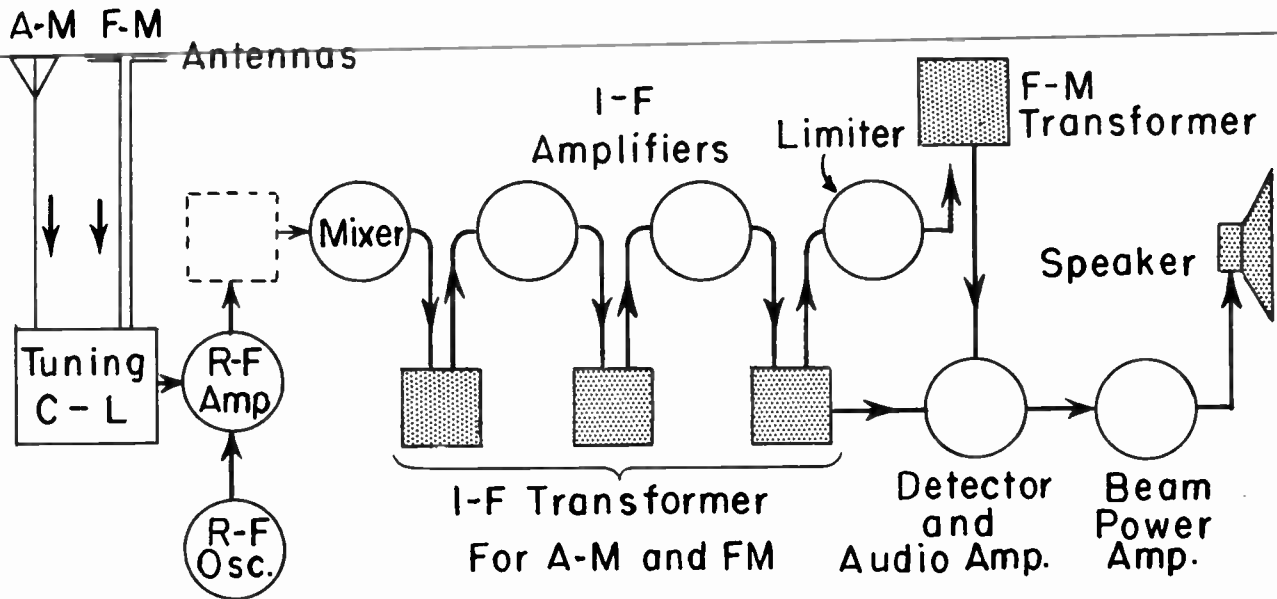

Fig. 7. Paths followed by signals in the combination AM-FM receiver.

frequency for this band goes to a limiter tube. The purpose of this tube is to limit or prevent passage of noise impulses which may have become associated with the f-m sound signals. Following the limiter tube is an additional coupling transformer used only for f-m signals. The output side of this transformer is connected to the combined detector and audio amplifier tube.

From the a-m section of the third and last combination i-f transformer the a-m intermediate-frequency signals go directly to the combined detector and audio amplifier tube, without passing through the limiter and additional f-m transformer. Between the output of the detector and the audio amplifier section of the combination tube is the usual resistance coupling. There is another resistance coupling between the audio amplifier section of this tube and the beam power amplifier. This power amplifier feeds into an iron-cored transformer whose secondary goes to the speaker.

A separate oscillator tube for the standard broadcast band and for the lower frequencies in the short-wave bands might be a pentode, but triode oscillators are favored for all frequencies above a few megacycles. Often the separate oscillator is one section of a twin triode tube, with the second section

used as a mixer or for various other functions. Satisfactory triode oscillators have fairly high trans-conductances, small internal capacitances, and usually are of the miniature style. There are also a number of lock-in triodes which make very satisfactory oscillators.

High-frequency alternating voltage may be taken from a separate oscillator to a mixer grid in various ways. One of the most common methods employs a fixed capacitor of small capacitance connected from either the plate circuit or the grid circuit of the oscillator to the grid of the mixer. At the oscillator end this connection is made at one end or the other of the tank inductor. Another way is by inductive coupling, with the oscillator tank inductor near enough the inductor in the mixer grid circuit to couple through a magnetic field.

For f-m and television service a twin triode having a single cathode with separate grids and plates often is used as the r-f oscillator and mixer. Another combination tube consists of a triode section used as the r-f oscillator and of a pentode section used as the mixer. In this triode-pentode there is a single cathode for both sections, with separate grid and plate for the triode, and with separate grid, screen, suppressor, and plate



## LESSON 29 – BROADCAST RECEIVERS

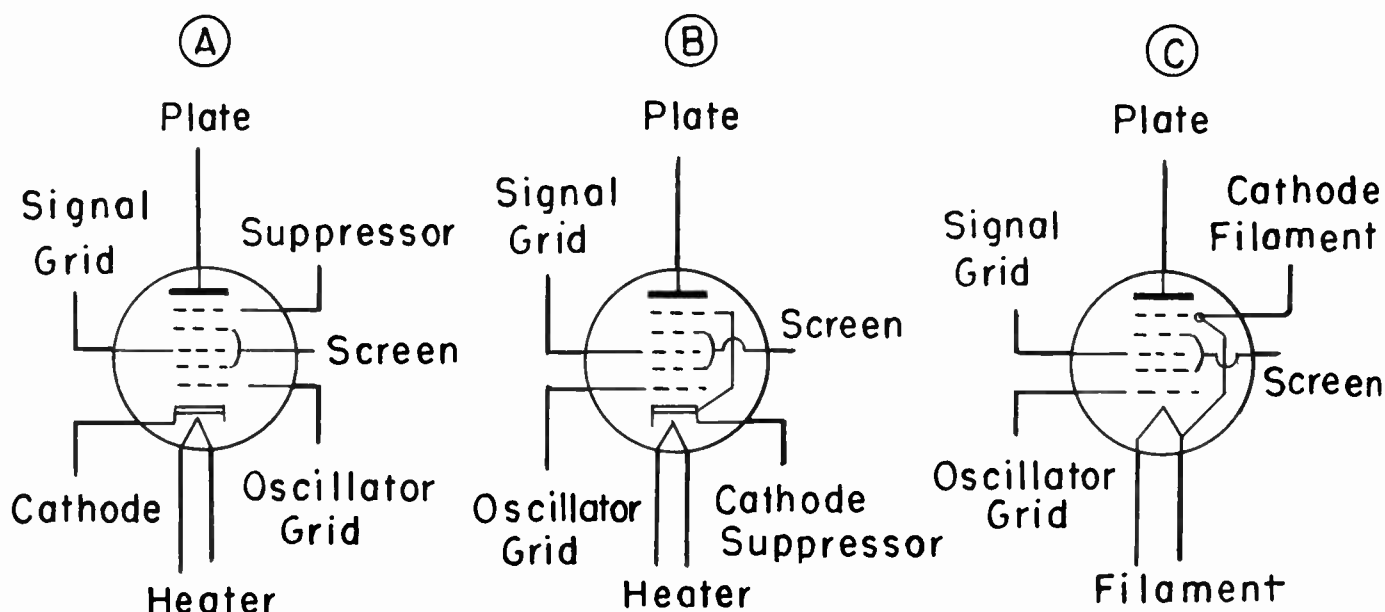

Fig. 8. Arrangements of the elements in pentagrid converter tubes which are in general use.

for the pentode section. The twin triode used for this service is a 7-pin miniature, and the triode-pentode is a 9-pin miniature type.

**CONVERTERS.** The order in which the elements of converter tubes are arranged is illustrated by Fig. 8. These are called pentagrid converters because, between cathode and plate there are five grids, and penta-is a Greek word meaning five. Another name is heptode converter, which means that there is a total of seven elements. Heptode comes from hepta, a Greek word meaning seven.

The difference between the element

arrangements at A and B is in the connection of the suppressor or suppressor grid. At A the suppressor is connected to a separate base pin, while at B it is internally connected to the cathode. The type of tube represented at C has a filament-cathode, while the others have heater-cathodes. The tube with a filament-cathode is designed for battery operation.

The accompanying table lists the type numbers of pentagrid converters at present in general use, and gives the basing-arrangements or the numbers of the base pins to which the various elements are connected.

### PENTAGRID CONVERTERS

TYPE	STYLE	Base Pin Numbers								
		1	2	3	4	5	6	7	8	9
1R5	Miniature 7-pin	F-Su	P	Sc	Go	F-Su	Gs	F		
6BA7	Miniature 9-pin	Sc	Go	K	H	H	Su	Gs		P
6BE6	Miniature 7-pin	Go	K-Su	H	H	P	Sc	Gs		
6SA7	Metal octal	Su	H	P	Sc	Go	K	H	Gs	
6SA7-GT	Glass octal		H	P	Sc	Go	K-Su	H	Gs	
6SB7-Y	Metal octal	Su	H	P	Sc	Go	K	H	Gs	
7Q7	Lock-in 8-pin	H	P	Sc	Go	Su	Gs	K	H	

Abbreviations for elements: F, filament  
 Go, oscillator grid  
 Gs, signal grid  
 H, heater  
 K, cathode  
 P, plate  
 Sc, screen  
 Su, suppressor

## COYNE - *television home training*

In these converter tubes there is only a single electron stream from the cathode to the plate. When electrons in this stream leave the cathode the first element they encounter is the oscillator grid. To this grid comes the alternating voltage from the oscillator circuit, and electron flow is varied at the oscillator frequency just as the flow would be varied by an alternating voltage applied to the grid of any kind of amplifier tube.

To the screen of the converter is applied a moderately high positive d-c voltage, so that the screen draws electrons from the cathode through the oscillator grid and accelerates the electrons toward the plate. The screen is in two parts, one inside and the other outside of the signal grid. It is the signal grid to which is applied the modulated carrier signal. The screen is externally connected through a bypass capacitor to the cathode or chassis ground, so that, so far as high frequencies are concerned, the screen is at cathode or ground potential. Thus the screen reduces or prevents capacitance effects and coupling between the signal grid and the other elements.

When electrons come through the section of the screen which is between the oscillator and signal grids the flow is varying at the oscillator frequency. Now the signal grid further varies the electron flow at the carrier frequency. The oscillator section and the mixer section (the signal grid) of the pentode are "electron coupled", because it is through the electron stream that the oscillator and carrier frequencies are brought together and allowed to combine in the formation of a beat frequency. This beat frequency is the difference between oscillator and carrier frequencies, as in any mixer, and it becomes the intermediate frequency.

The section of the screen which is between the signal grid and the suppressor acts to continue the acceleration or the speeding of electrons toward the plate. The suppressor acts to reduce or prevent the effects of secondary emission when d-c voltages on the plate and screen are equal or approximately so, and, in any event, acts to increase the internal plate resistance of the tube, which is desirable in converter service.

The electron stream which is being varied at both the oscillator frequency and at the carrier frequency enters the plate of the converter and passes through whatever load may be in the external plate circuit. In the plate output of the converter are the oscillator frequency, the modulated carrier frequency, the difference frequency (which is the beat and intermediate frequency) and also the frequency equal to the sum of oscillator and carrier frequencies. That is, the output of the converter is no different from that of a separate mixer.

Typical connections to a pentagrid converter are shown by Fig. 9. Between the receiver antenna and the signal grid of the converter are tuned circuits and possibly an r-f amplifier stage. In the circuit illustrated, the signal grid is negatively biased from a separate biasing voltage. Otherwise it would be possible to use grid-leak bias or self-bias. We must keep in mind that the signal grid of the converter is equivalent to the grid of any mixer tube, and the bias must be sufficiently negative to cause operation on the bend of the characteristic curve while signals are being received.

As you can tell by the tapped tuning inductor, the oscillator circuit is a Hartley type. Connected across the oscillator inductor is a main tuning capacitor C, also a trimmer capacitor C<sub>t</sub> for making adjustments at the high-frequency end of the tuning range. In series with the oscillator inductor is a padder capacitor C<sub>p</sub> for making adjustments at the low end of the tuning range.

Between the oscillator tank circuit and the oscillator grid of the converter is grid capacitor C<sub>g</sub>. This capacitor, in connection with grid resistor R<sub>g</sub> provides grid-leak bias for the oscillator. This, as you will recall, is the kind of bias employed for nearly all r-f oscillators.

The screen grid of the converter tube acts as a plate for the oscillator action. That is, so far as the oscillator is concerned, the cathode is the cathode, the oscillator grid is the grid, and the screen is the plate. The oscillator "plate circuit" is completed through capacitor C<sub>b</sub> to ground and through ground to

## LESSON 29 – BROADCAST RECEIVERS

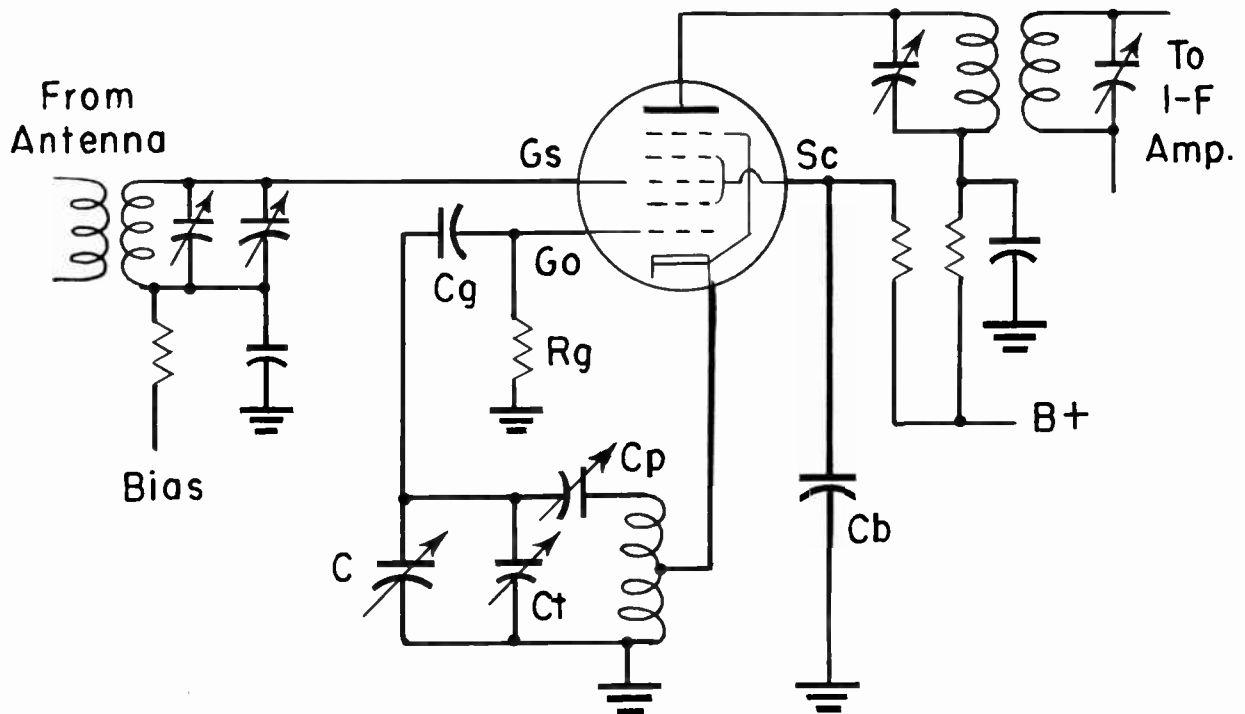

Fig. 9. Circuit connections to a converter tube.

the lower end of the oscillator inductor, just as with any other Hartley circuit.

The modulated beat frequency or intermediate frequency appears at the regular plate of the converter. This plate is coupled through the first i-f transformer to the grid of a following i-f amplifier tube. This latter tube is not included in the diagram of Fig. 9.

In Fig. 10 the signal grid of a converter is coupled to the antenna without any r-f amplifier stage in between. In the antenna circuit is inductor La tuned to carrier frequencies by variable tuning capacitor Ca and trimmer capacitor Ct. The high side of this antenna circuit goes to the converter signal grid. The grid is biased from a separate source. You can trace the conductive grid return from the converter signal grid through inductor La to the bias source.

Again the oscillator circuit is a Hartley type. The grid is biased by Cg and Rg. To the oscillator tank circuit is a connection through capacitor Cb from the screen of the tube. The tank inductor is tuned to the required oscillator frequency by variable tuning capacitor Co and the trimmer Ct.

The antenna tuning capacitor Ca and the oscillator tuning capacitor Co are two sections of a ganged variable capacitor such as used in the receiver pictured back in Fig. 1. The fact that both capacitors are operated together is indicated by the broken line between their arrows in the symbols of Fig. 10.

Converter output goes from its plate to the primary of a double tuned i-f transformer. The secondary of this i-f transformer is connected to the grid of the first i-f amplifier tube.

In Fig. 11 we have a pentode r-f amplifier for modulated carrier signals, a converter acting as combined mixer and r-f oscillator, and a pentode i-f amplifier. There are three tuned circuits between antenna and converter. At A is a tuned circuit between antenna and r-f amplifier. At B is the tuned circuit for the oscillator action of the converter. At C is a tuned circuit between the plate of the r-f amplifier and the signal grid of the converter.

All three circuits are tuned by movable iron cores in the inductor windings. An arrangement similar to this is used for tuning

# COYNE - television home training

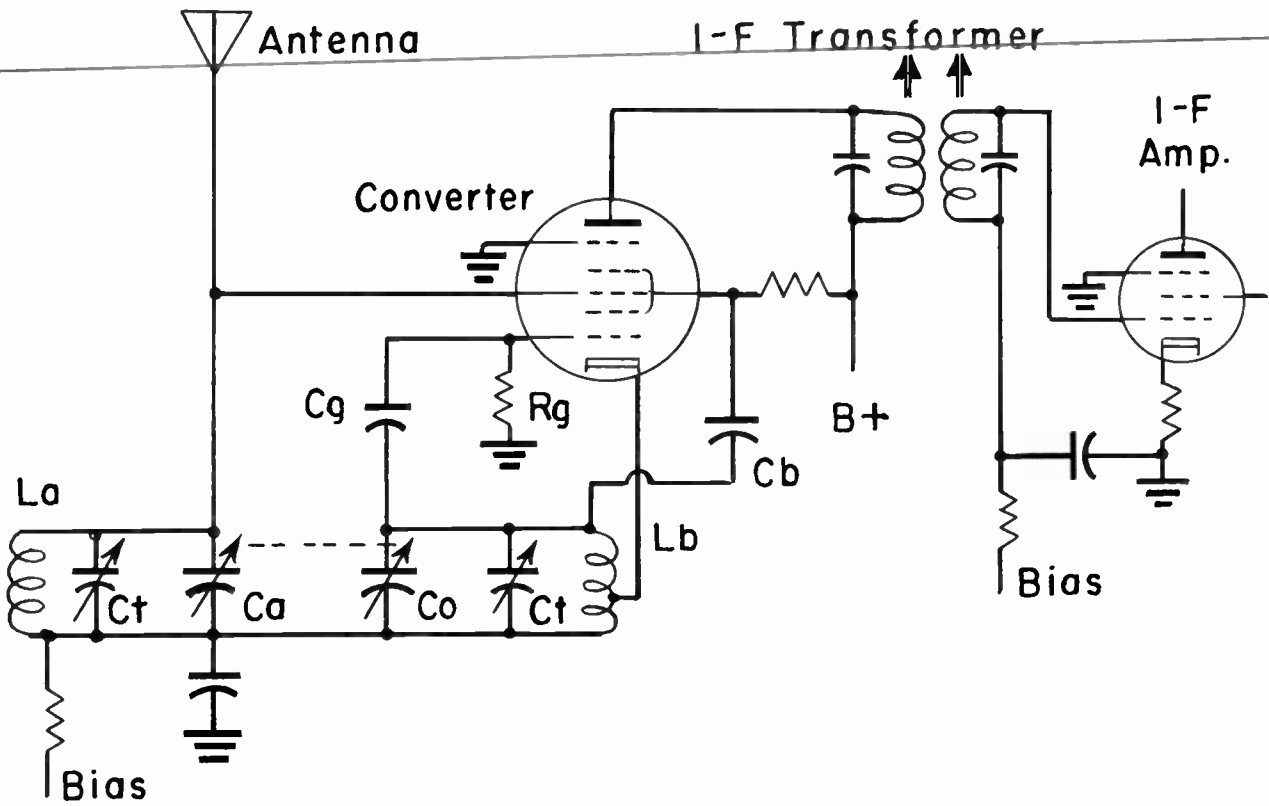

Fig. 10. A tuned antenna circuit connected directly to the signal grid of a converter.

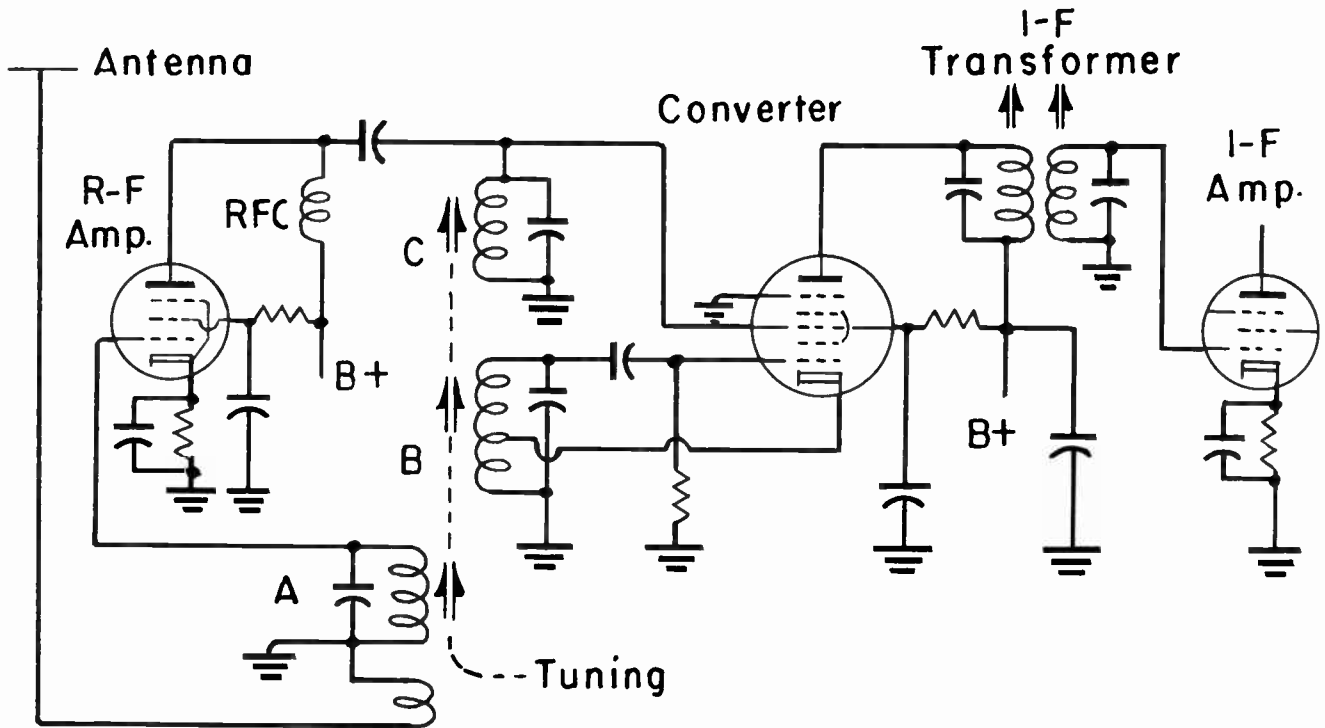

Fig. 11. An r-f amplifier and converter system employing three tuned circuits at A, B, and C.



## LESSON 29 – BROADCAST RECEIVERS

the f-m band in the combination set pictured by Fig. 5. The three movable cores are raised and lowered together by the mechanism operated by the tuning dial of the receiver. Circuits A and C are made resonant at the carrier frequency of a signal to be received. Circuit B is made resonant at a higher oscillator frequency, so that the difference between this oscillator frequency and the carrier frequency always will be the intermediate frequency.

The i-f-transformer between the converter plate and the grid of the i-f amplifier tube is tuned to the intermediate frequency. This transformer tuning is a service adjustment, and remains the same for all received signals. Tuning of all three circuits between antenna and converter must be changed for every different carrier frequency.

Converters of all the types listed in a preceding table are entirely satisfactory at received frequencies up to around 6 mc and all of them will do very fair work up to perhaps 15 mc. The 1R5, 6BA7, and 6BE6 work very well at carrier frequencies up through the f-m broadcast band, which extends to 108 mc. These types will, of course, prove equally satisfactory for reception in the low-band of the v-h f television frequencies, extending from 54 to 88 mc. The 6SB7-Y is designed especially for operation in the f-m broadcast band, and is good also for all lower frequencies. This particular converter has not been widely used. No presently available converters perform satisfactorily in the high-band of v-h-f television frequencies, from 174 to 216 mc, and none of them are useful for the u-h-f band.

It is difficult to maintain oscillation at necessary strengths in the higher frequencies. Also, because there is only a single electron stream to be varied by oscillator and carrier frequencies, there is a tendency for "pulling" of one frequency toward the value of the other, and for consequent varying of the intermediate frequency. Another disadvantage for high-frequency operation is high internal capacitances. R-f input capacitance of converters runs around 10 mmf, and i-f output capacitance is nearly as high, on the average. Oscillator input capacitance is around 6 to 7 mmf. These are greater capa-

citances than is readily available in separate mixers and oscillators.

There are a number of converters which are obsolete, but still found in a few old receivers. You can distinguish them by the fact that all have top caps. In this class is the 6A8 pentagrid converter and its glass counterparts. There is also the 6J8 triode-heptode converter with a triode section and a pentagrid section. Another obsolete type is the 6K8 with a triode section and a tetrode section. The 6L7 pentagrid mixer was used with a separate oscillator tube.

TRACKING. As we have seen, the frequency of the r-f oscillator must be changed in such manner that it always differs from the received carrier frequency by the same amount, which is the intermediate frequency. When different carriers or different programs are selected by varying the carrier tuning systems, the accompanying variation of oscillator frequency is called tracking. If the oscillator tracks correctly the intermediate frequency will remain nearly enough at a constant value to allow satisfactory operation of the i-f amplifier throughout the entire range of received frequencies.

The intermediate frequency for standard broadcast reception is fairly well standardized at 455 kilocycles, although you will find 456 kilocycles used in some sets. For short-wave reception with the same receiver used for standard broadcast the intermediate frequency ordinarily remains the same. For reception in the f-m broadcast band, on carriers between 88 and 108 mc, the intermediate frequency is 10.7 megacycles. Television intermediate frequencies are not standardized, or, even though there are recommended standards, there is wide variety of intermediates in various makes and models of receivers.

Satisfactory tracking is a more difficult problem in the standard broadcast band than in any other single band of frequencies. For this reason we shall take the standard broadcast band as an example of what is required.

In a typical receiver for the standard broadcast band the tuning inductor in the os-

## COYNE - *television home training*

cillator circuit has an apparent inductance of 200 microhenrys when measured at a frequency near the center of the band. Apparent inductance is that due to true inductance and to the effects of distributed and stray capacitances. The tuning inductor in the antenna circuit measured about 5 per cent greater inductance. For simplicity we shall assume that each inductance is 200 microhenrys.

On the basis of the assumed inductance in each circuit we may compute the capacitances required throughout the standard broadcast band for (1) tuning the antenna circuit to carrier frequencies, and (2) tuning the oscillator circuit to maintain an intermediate frequency of 455 kilocycles. This means that at every setting of the tuning capacitors the oscillator frequency must be 455 kilocycles higher than the carrier frequency.

The results of the computations are shown by Fig. 12, for carrier frequencies be-

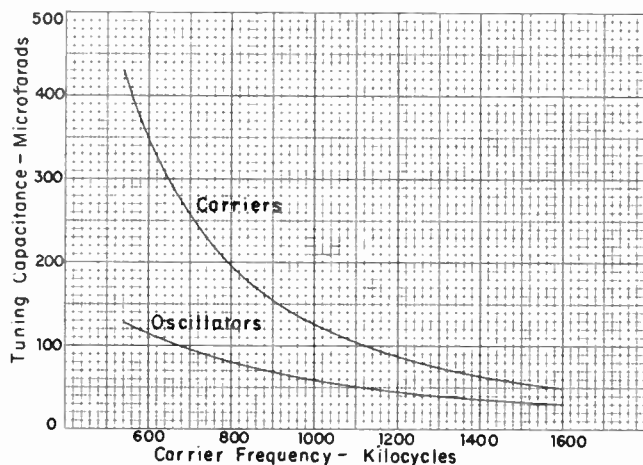

Fig. 12. The simultaneous variations of carrier and oscillator tuning capacitance in the standard broadcast band.

tween 540 and 1,600 kilocycles. Capacitance for tuning the carrier frequencies must change from about 435 mmf at 540 kilocycles down to about 49.5 mmf at 1,600 kilocycles. But capacitance for oscillator tuning must change from only about 128 mmf at 540 kilocycles down to 30 mmf at 1,600 kilocycles. The total change of carrier tuning capacitance is 385.5 mmf and the total change of oscillator tuning capacitance is 98 mmf. Were the tuning to be handled with variable inductances instead of variable capacitances,

the relative changes in the carrier and oscillator tuning circuits would be on the same order.

There are two distinctly different methods of obtaining the widely different changes of capacitance required in carrier and oscillator circuits when rotors of the tuning capacitors are turned together. One method employs a "cut plate" capacitor for the oscillator circuit and the other method employs a paddler capacitor.

We looked at a cut plate tuning capacitor once before, but a picture is shown again in Fig. 13. The section for tuning the carrier

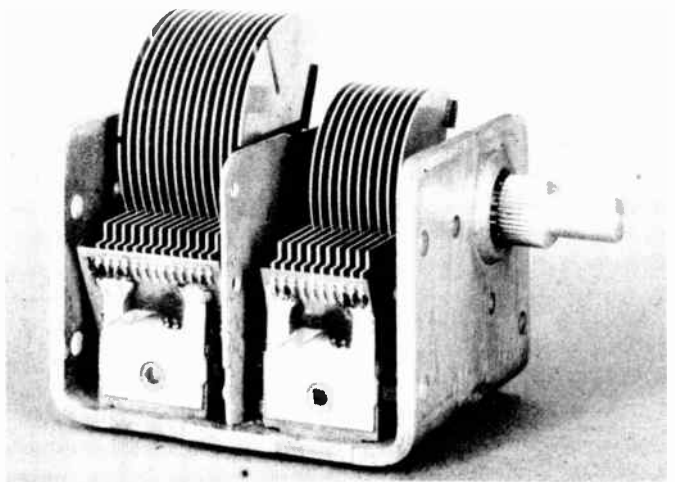
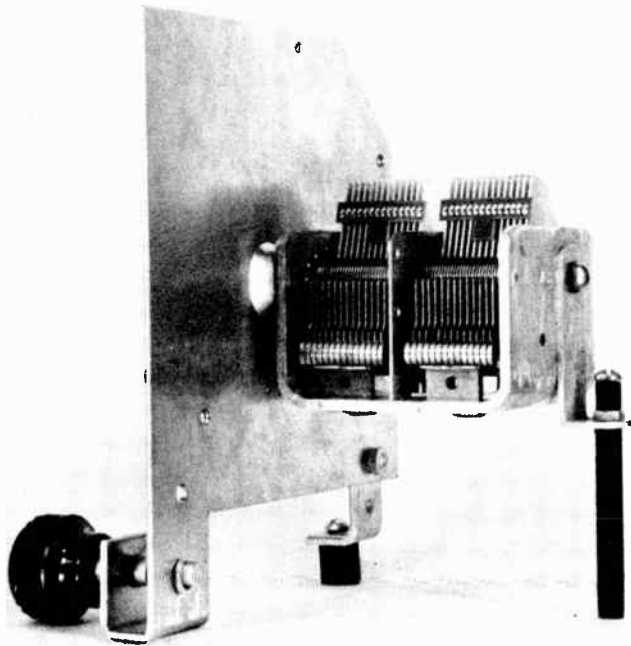

Fig. 13. The smaller unit of this ganged capacitor tunes the oscillator circuit while the larger unit tunes to the carrier frequencies.

frequencies is at the left and the section for tuning oscillator frequencies is at the right. The oscillator section has much the smaller plates, as required by the smaller capacitance it is to furnish. The rotors of both sections of the capacitor are shaped to give correct simultaneous changes of capacitance in the two circuits.

We have seen a number of paddler circuits, some when studying tuning capacitances and others in this lesson. The capacitor is an adjustable capacitor in series with the tuning inductance and is effectively in series with both the inductance and the variable tuning capacitor of the resonant circuit. When using a paddler, the two vari-

## LESSON 29 – BROADCAST RECEIVERS



*Fig. 14. When capacitors for tuning carrier and oscillator frequencies are alike, a padder capacitor is used in the oscillator tank circuit.*

able tuning capacitors for the carrier and oscillator circuits may be and usually are alike. An example is illustrated by Fig. 14.

The padder reduces the effective tuning capacitance, because two capacitors in series have less combined capacitance than either one alone. This satisfies one of the requirements illustrated by the curves of Fig. 12. The requirement that oscillator tuning capacitance must be much less than capacitance for tuning the carriers.

When two capacitors are in series a change of capacitance of either one causes much less change of combined capacitance than as though both were changed together. This allows the series padder to meet a second requirement, that the rate of change of oscillator tuning capacitance be slower than the rate of change of carrier tuning capacitance.

If the padder capacitor is adjusted to the correct value, a service operation, and if it is used with a suitable tuning inductor there will be exact tracking at three places

in the frequency range. These three are (1) close to the highest tuned frequency, (2) close to the lowest tuned frequency, and (3) at a frequency about midway between highest and lowest. Variations at other frequencies will be too small to cause trouble. As doubtless you remember, the padder is adjusted while the set is tuned close to the low-frequency end of the band, while a trimmer in parallel with the inductor or the main tuning capacitor is adjusted at the high-frequency end of the band or near this end.

When the padder system is employed, a different range of frequencies may be tuned with the same variable tuning capacitors by using a different inductor and a different padder or padder setting for each range. This allows a receiver of fairly simple construction to receive standard broadcast and also a number of short-wave bands. For each higher range of frequencies the padding capacitance is made greater and the tuning inductance is made smaller, with the same variable tuning capacitor used for all ranges or bands.

A cut plate tuning capacitor as one section of a ganged unit can be used only for a single band. This because in any other band the ratio of highest to lowest tuned frequency will be different, and the rate of change of capacitances would not meet the different ratio.

It should be mentioned that the omission of an r-f amplifier stage makes for easier tracking. This is because the energy losses in the antenna system "load" the first tuned circuit and make it tune quite broadly. When there is an r-f stage, with a tuned coupling between the r-f amplifier and the mixer or converter, the tuning is sharper at all frequencies, and tracking is more difficult.

Fig. 15 shows the required changes of capacitances for tuning carriers and oscillator through the f-m broadcast band from 88 to 108 mc. The curves are based on the use of 1/10 microhenry tuning inductance in both circuits and on an intermediate frequency of 10.7 mc. Then the oscillator always must tune to a frequency 10.7 mc higher than whatever carrier is being received.



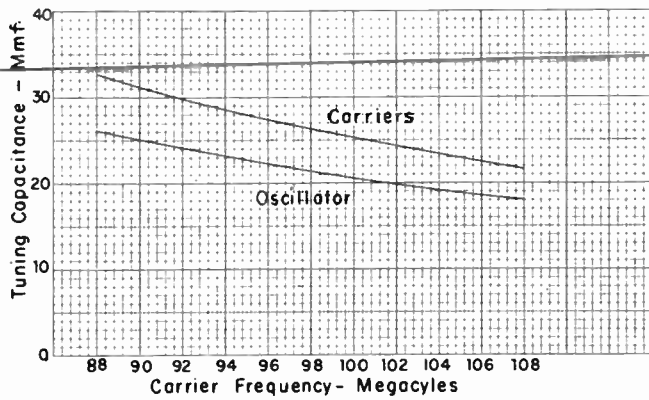

Fig. 15. Variations of tuning capacitances for carriers and r-f oscillator in the f-m broadcast band.

When comparing these two curves with the carrier and oscillator curves of Fig. 12, for the standard broadcast band, it appears that the two frequencies for the f-m band change at very nearly the same rate, and that by using somewhat less inductance in the oscillator circuit a plain two-gang variable tuning capacitor with trimmers should be satisfactory. In practice it actually does work out this way, even though when such small capacitances are involved we must consider the distributed and stray capacitances, which are fixed.

In any event it will turn out that the ratio of highest to lowest tuning capacitance in the f-m band is far smaller than this ratio in the standard broadcast band. This results from the fact that the ratio of highest to lowest carrier frequencies is much less in the f-m band than in the standard broadcast band. Any time that the ratio of highest to lowest carrier frequencies is relatively small there will be little trouble with tracking.

With television tuners which tune in steps from channel to channel all the inductors and capacitors can be individually designed or adjusted for frequencies in each channel, and there is no tracking problem so far as servicing is concerned. With television tuners having continuously variable tuning inductors or capacitors the ratio of high to low frequencies in the high-band of the v-h-f range is about the same as in the f-m broadcast band, and in the television low

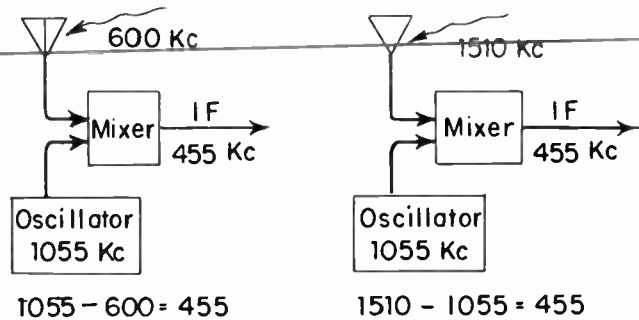

Fig. 16. A carrier at an image frequency produces the same intermediate frequency as the carrier for which a receiver is tuned.

band, channels 2 through 6, the ratio is only a little greater. Therefore, television tracking problems are not very serious.

**IMAGE FREQUENCIES.** At the left in Fig. 16 it is assumed that a carrier at 600 kc is reaching the antenna of a receiver and that the receiver is tuned to this carrier. Since the intermediate frequency is 455 kc, the oscillator frequency must be this amount higher than the received carrier frequency, or must be 1055 kc. Then the difference between 1055 kc of the oscillator and 600 kc of the desired carrier will be the intermediate frequency of 455 kc.

At the right in Fig. 16 is represented a carrier frequency of 1510 kc reaching the antenna of the receiver that is tuned to receive a carrier at 600 kc. The oscillator frequency still is 1055 kc. The higher carrier frequency beats with the oscillator frequency in the mixer, or it would beat with the oscillator frequency in the mixer portion of a converter. The difference between the higher carrier frequency of 1510 kc and the oscillator frequency of 1055 kc is 455 kc. This 455-kc frequency is the intermediate frequency to which the i-f amplifier of the receiver is tuned, and, if nothing is done to prevent it, the signals of both carriers will go to and through the i-f amplifier at the same time.

The frequency of 1510 kc is the image frequency of 600 kc when the intermediate frequency is 455 kc. When the oscillator frequencies are maintained higher than frequencies of received carriers, as nearly always



## LESSON 29 – BROADCAST RECEIVERS

is the case, an image frequency is equal to the sum of the regularly received carrier plus twice the intermediate frequency. In our present example, the frequency of the carrier which is received and desired is 600 kc. Twice the intermediate frequency of 455 kc is 910 mc. And the sum of 600 kc and 910 kc is 1510 kc, which is the frequency of the carrier which is the image.

The higher the intermediate frequency the farther above any tuned signal will be the image frequency, for the difference between the regularly tuned frequency and the image always is twice the intermediate frequency. This is the reason for using intermediate frequencies as high as can be employed without getting too close to the low end of the frequency band in which the receiver is to operate.

As an example, were the intermediate frequency to be 200 kc, there would be images at all carrier frequency which are 400 kc ( $2 \times 200$  kc) above any tuned carrier. Then, in the standard broadcast band, with the receiver tuned from 540 to 1200 kc there would be images from all carriers between 940 and 1600 kc. Only in the tuning range above 1200 kc would there be no image frequencies from other carriers in the standard broadcast band.

For another example, consider the f-m broadcast band. The standard intermediate

frequency for f-m broadcast reception is 10.7 mc. Then any image frequency must be of a value equal to twice 10.7, which is 21.4 mc, plus the regularly tuned carrier frequency. The lowest carrier in the f-m broadcast band is at 88 mc. This frequency plus 21.4 mc equals 109.4 mc, at which there would be the image of 88 mc. But the f-m broadcast band extends only to 108 mc, so nowhere in this band would there be image frequencies - the lowest possible image (109.4 mc) would be 1.4 mc higher than the top of the band in which the receiver operates. This explains why the standard f-m intermediate frequency is 10.7 mc.

Later we shall find that intermediate frequencies used in television receivers prevent any television carrier from being an image of any other carrier frequency in any of the television bands. In receivers which use the standard broadcast intermediate frequency for short-wave reception there can be trouble with image frequencies for the following reason. The intermediate of 455 kilocycles amounts to only 0.455 megacycle. Twice this intermediate is 0.91 mc. Then, if a shortwave band extends to more than 0.91 mc above the lowest regularly tuned frequencies there will be images in all the higher-frequency carriers of the band or of other bands.

Image response is lessened by a tuned

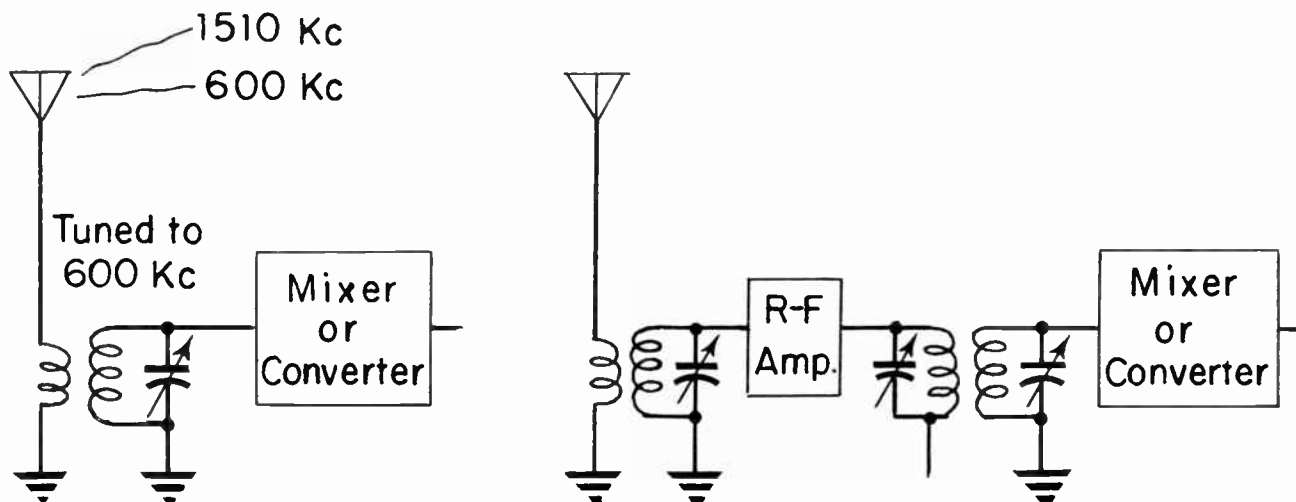

Fig. 17. Response to image frequencies is lessened by tuned circuits which precede the mixer or converter.

## COYNE - *television home training*

circuit or by tuned circuits between the antenna and the mixer or the signal grid of a converter. At the left in Fig. 17, with a desired frequency and its image reaching the antenna, there is minimum impedance to the desired carrier in the tuned coupling and higher impedance to the image. But because antenna circuits tend to tune broadly, there may still be fairly strong response at the image frequency.

An r-f amplifier stage preceded and followed by tuned couplings, as at the right, reduces the response at image frequencies to a low value. Whatever image signal gets through the first tuned circuit is almost completely rejected by the second tuned circuit. In well designed receivers the response to image frequencies may be only a small fraction of one per cent of the response to tuned carrier frequencies.

# TELEVISION

• RADIO

• ELECTRONICS

---

**LESSON 30 – THE I-F AMPLIFIER AND THE DETECTOR**

---

***Coyne School***

*practical home training*

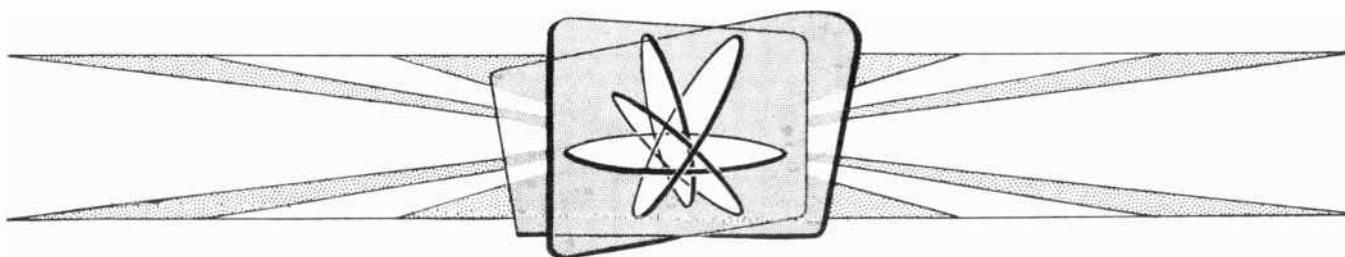

*Chicago, Illinois*

---

*Copyright, 1953 by Coyne Electrical School  
Chicago 12, Illinois  
All rights reserved*

Litho. in U.S.A.



## Lesson 30

### THE I-F AMPLIFIER AND THE DETECTOR

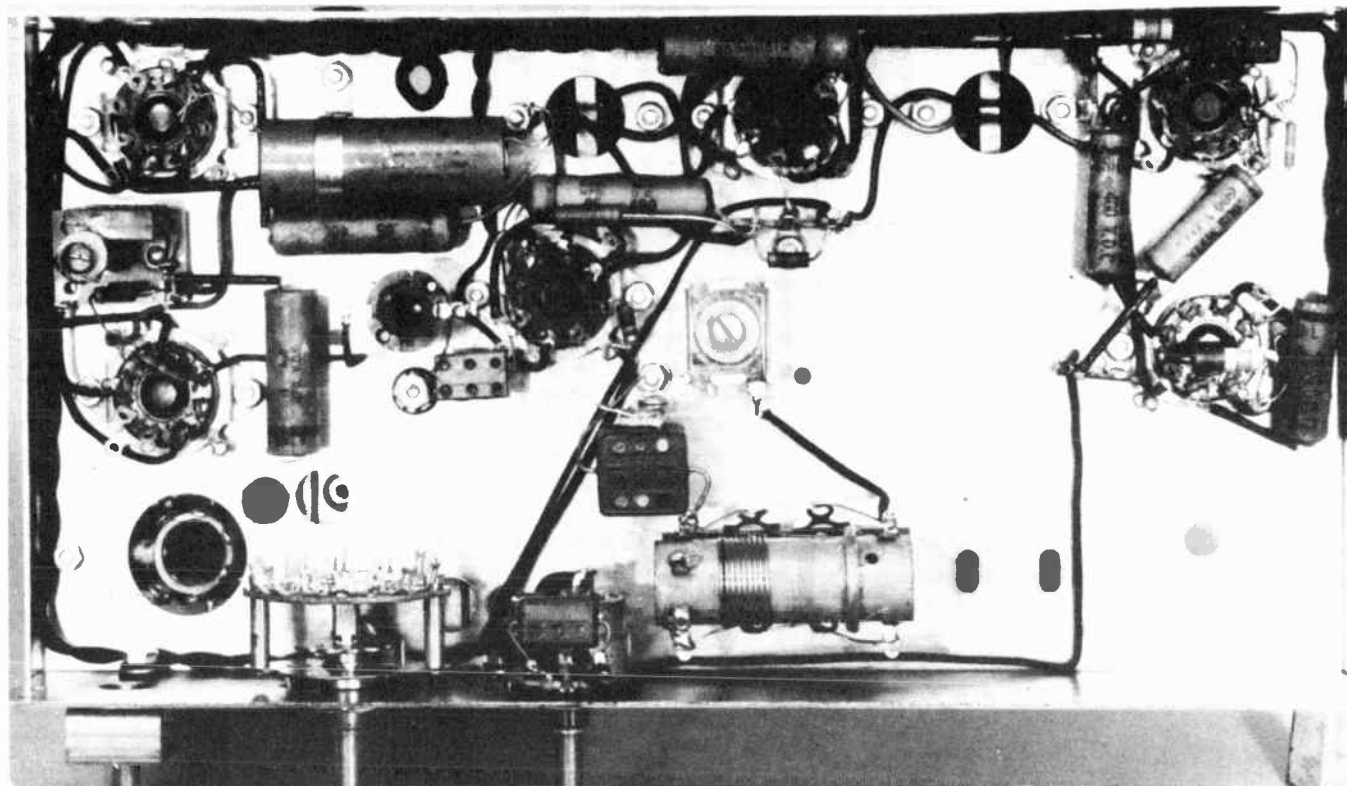

Fig. 1. Wiring of a standard broadcast receiver is simple, and circuits are easily followed.

The under-chassis wiring for a small standard broadcast receiver is pictured by Fig. 1, and that for a typical television receiver by Fig. 2. In the sound receiver there is a single i-f amplifier tube and two i-f transformers. In the television set there are three i-f amplifier tubes and four i-f transformers. The sound receiver has one detector and the television set has two. And for television there are many tubes and circuits not needed at all for reception of sound. Yet both sets are fundamentally superheterodynes, although one is exceedingly simple and the other is quite complex.

An easy introduction to some of the more intricate television circuits will be to look first at their elementary forms as found in sound receivers. This will be profitable too, for there are literally millions of stand-

ard broadcast sets to be serviced, and you won't wish to ignore this source of revenue.

We have followed the signal from the antenna coupling through the mixer or converter, and have seen the signal change from a modulated carrier to a modulated intermediate frequency. Now, in the circuits shown by Fig. 3, we shall follow through the parts lying between a converter and a beam power tube which actuates a speaker.

In the output circuit of the converter is the first i-f transformer, whose secondary feeds the grid of the i-f amplifier tube. From this tube the modulated i-f signal goes through the second i-f transformer to the detector. The detector is the diode section of a combination tube. The other section is a triode acting as an audio voltage amplifier. The

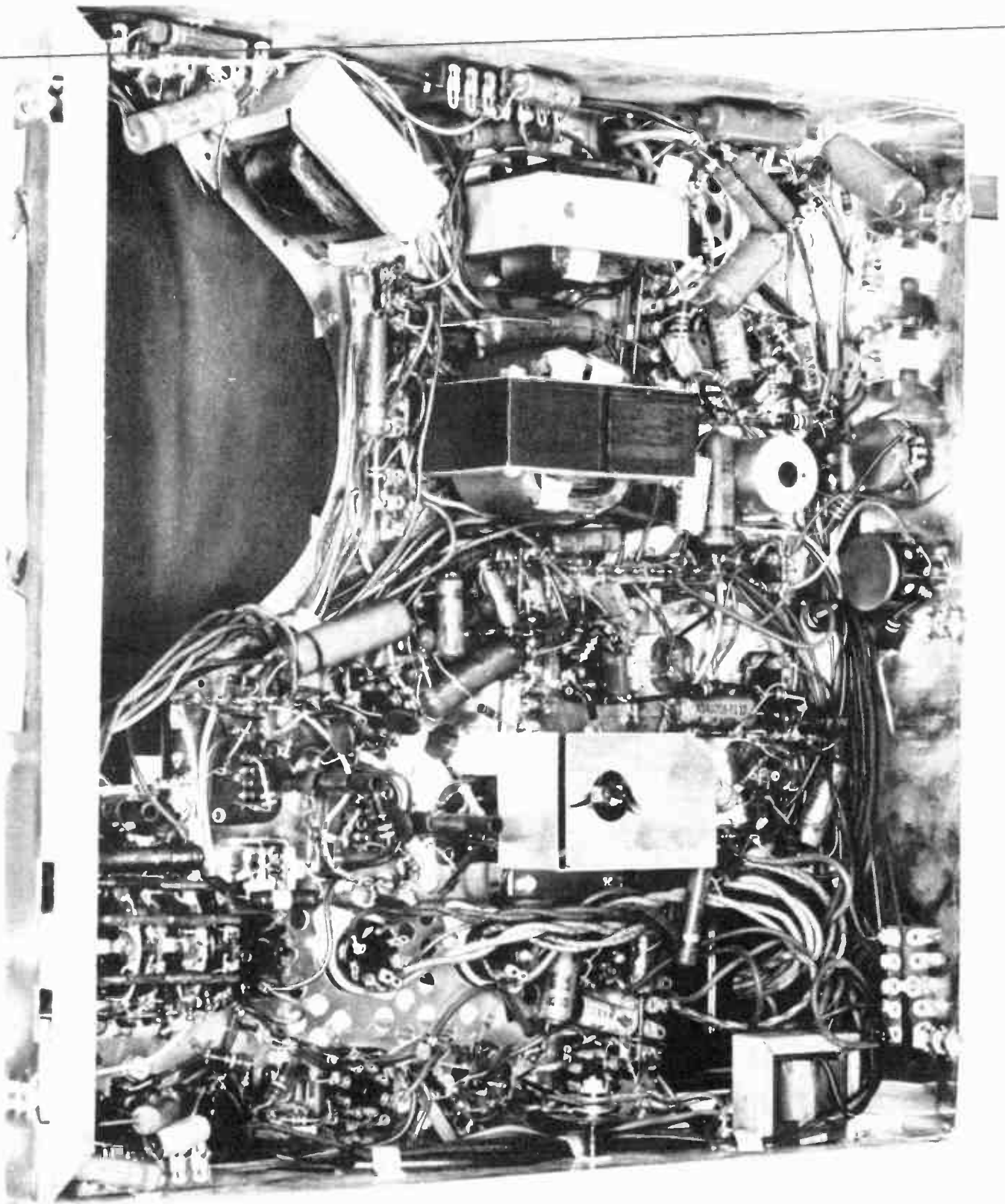

Fig. 2. *The television receiver has many additional parts and circuits.*

## LESSON 30 – THE I-F AMPLIFIER AND THE DETECTOR

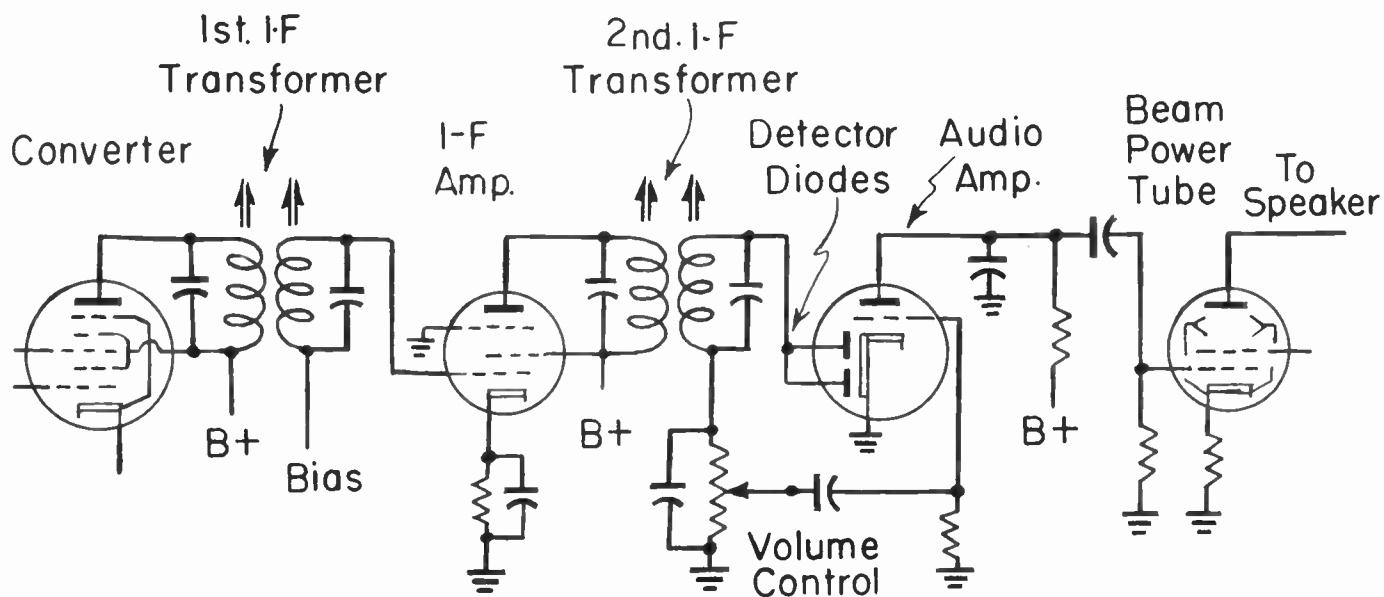

Fig. 3. Circuits between the output of the converter and the input to the beam power tube of a superheterodyne receiver.

grid of the triode is connected through a volume control to the detector side of the tube, by way of the transformer secondary. From the triode plate the audio signals go through a resistance coupling to the grid of the beam power tube.

An i-f transformer for sound broadcast receivers is illustrated by Fig. 4. At the left the unit is removed from its shield, which is shown separately at the center. At the right the transformer is inserted part way into the shield. These transformers have primaries and secondaries individually or separately tuned. The primary is in the plate circuit of one tube and the secondary is in the grid circuit of a following tube or in the detector circuit. Tuning may be with movable cores, as indicated in Fig. 3, or with adjustable capacitors, as on the unit of Fig. 4.

Both i-f transformers are tuned for the same constant intermediate frequency, although primary and secondary tuning may be for slightly different peak frequencies in order to obtain the desired pass band. As mentioned before, most standard broadcast sets employ an intermediate frequency of 455 kc, with 456 kc found in some cases. These intermediates are satisfactory with carrier frequencies up to at least five or six

megacycles when the antenna coupling connects directly to the signal grid of a converter. They are satisfactory up to 20 mc or somewhat higher in the carrier frequencies when there is a tuned r-f stage between antenna and converter.

The i-f amplifier tube practically always is a pentode. It may be of the variable- $\mu$  type so that grid bias may be varied to change the amplification in compensating for varying strengths of received signals. Television i-f amplifier tube are pentodes in nearly all cases, but almost always they are of the sharp cutoff type.

**SELECTIVITY.** An amplifying tube and the coupling which transfers the signal to a following tube is spoken of as a stage of amplification. But there must be more than amplification; there should also be selection of the desired frequency or frequencies and rejection or weakening of all other frequencies. The degree to which the coupling elements weaken or reject undesired frequencies is called selectivity. Selectivity sometimes is called sharpness of resonance, because the more sharply peaked is the frequency response at and near resonance the less is the gain at frequencies both lower and higher than resonance.



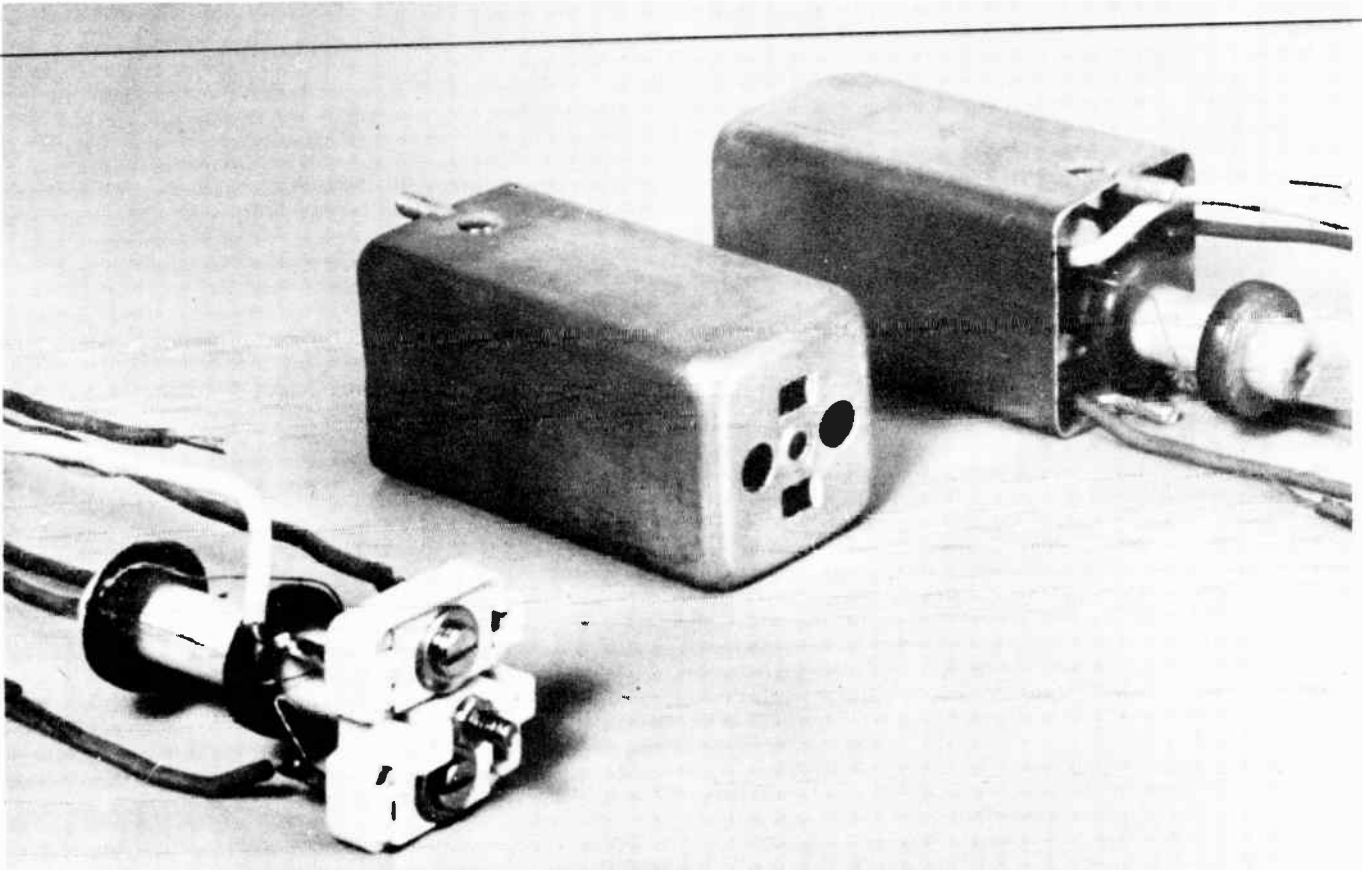

Fig. 4. An i-f transformer for a standard broadcast receiver.

To illustrate selectivity or sharpness of resonance we may examine the frequency responses at several points in an amplifying system. The oscilloscope trace at A in Fig. 5 shows the response at the output of the r-f amplifier in a standard broadcast receiver. The curve is not sharply peaked; there is not much selectivity, and frequencies either side of the peak are not greatly reduced. Neither is there a great deal of amplification or gain. There is little gain and little selectivity because the r-f stage is heavily loaded by energy losses in the antenna, which is coupled to the grid of the r-f amplifier tube.

The trace at B shows frequency response at the output of the r-f amplifier tube. This tube so greatly increases signal voltage that, in obtaining this trace, the gain of the oscilloscope itself has to be reduced to a fraction of that employed for the trace at A. Otherwise the height of the screw would have

far exceeded the size of the oscilloscope screen. The sides of this new curve are much steeper than on the response from the r-f amplifier, a change brought about by the coupling transformers which weaken or "attenuate" frequencies below and above resonance.

The reason why we want steeply sloped sides on response curves is found in certain characteristics of transmitted frequencies and in the limits of transmission channels.

To illustrate what happens we may consider a standard broadcast program transmitted on the channel whose carrier frequency is 1000 kc. This carrier frequency is being transmitted at all times, although it may vary in amplitude. At some certain instant the program may contain a musical tone whose principal audio frequency is 3000 cycles per second or 3 kc. At this instant



## LESSON 30 – THE I-F AMPLIFIER AND THE DETECTOR

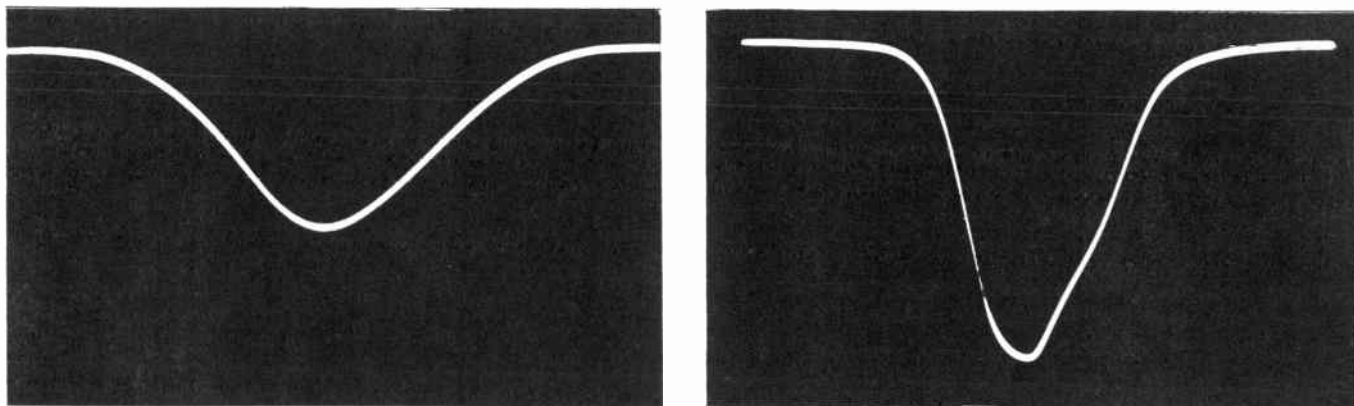

Fig. 5. At the output of the r-f amplifier (A) there is only moderate gain and little selectivity, but both characteristics are improved at the output of the i-f amplifier (B).

there will be transmitted, in addition to the carrier, two other frequencies.

One of the other frequencies is equal to the carrier plus the modulation frequency, 1000 kc plus 3 kc, which makes 1003 kc. The second additional frequency is equal to the carrier minus the modulation frequency, which makes 997 kc. These additional frequencies which are above and below the carrier are called side frequencies. Their values change from moment to moment with every change of modulating frequency.

In order to accommodate the side frequencies, each transmission channel must provide not only for the carrier but also for a certain range above and below the carrier. In the standard broadcast band each channel has a total frequency width of 10 kc, going to 5 kc above and to 5 kc below the carrier frequency. These 5-kc ranges are called the upper side band and the lower side band.

The side frequencies must not extend outside their channel, in order that the programs transmitted on one channel shall not interfere with those being transmitted in adjacent channels. Since side frequencies are the result of modulation frequencies, and side frequencies cannot go more than 5 kc from the carrier frequency modulation frequencies must not exceed 5 kc. In other words, sound or audio frequencies of programs transmitted on a 10-kc channel cannot go higher than 5 kc or 5000 cycles per second.

In the channel whose carrier frequency is 1000 kc the upper side band extends from 1000 kc up to 1005 kc, and the lower side band goes from 1000 kc down to 995 kc. The next lower channel centers at 990 kc, and with its side bands takes in all frequencies from 985 to 995 kc. Next above is the channel with a carrier at 1010 kc and side bands extending from 1005 to 1015 kc. When considering the 1000-kc channel, the others immediately below and above are called adjacent channels.

The entire standard broadcast band is made up of similar channels, each covering 10 kc. In the f-m broadcast band each channel takes in 200 kc. In the television broadcast bands each channel is 6 mc wide, which means 6,000 kc. In the frequencies for one television channel it would be possible to accommodate 30 f-m channels or 600 standard broadcast channels.

The response traces now being examined were made with the receiver tuned to a broadcast carrier of 1000 kc, or, more correctly, to the channel centering at 1000 kc and extending from 995 to 1005 kc. At A in Fig. 6 the channel limiting frequencies are marked on the response trace taken at the output of the i-f amplifier. At the lower edge of the tuned channel, at 995 kc, the signal voltage is down to approximately 70 per cent of the peak value. At the top of this channel, 1005 kc, the signal voltage is about 60 per cent of the peak value.

## COYNE - television home training

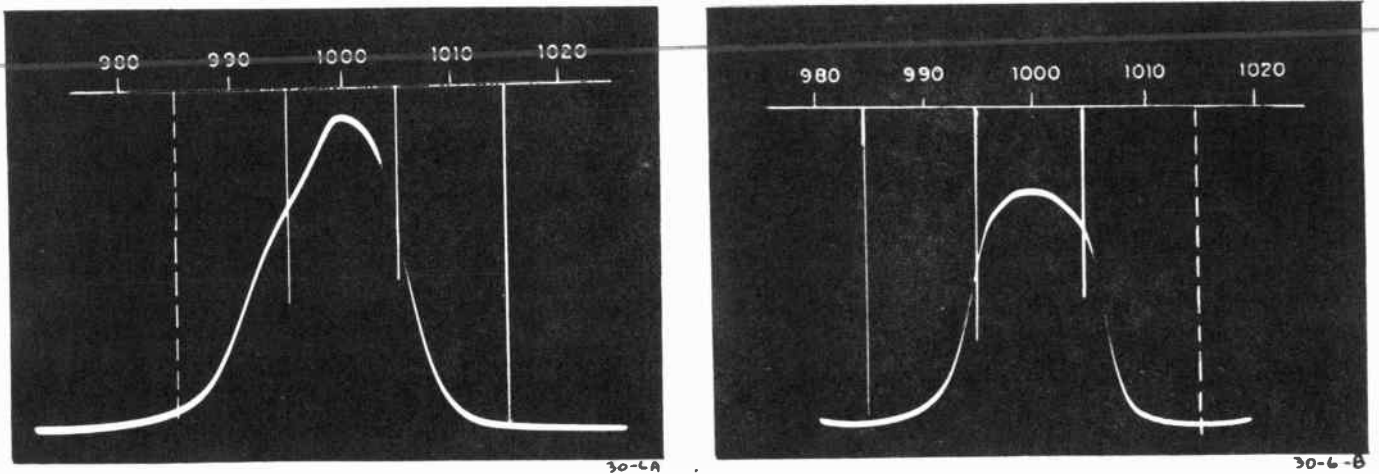

Fig. 6. Frequency responses for the tuned channel and for adjacent channels at the i-f amplifier (A) and at the detector (B).

At B in Fig. 6 is the response at the output of the second i-f transformer, which is the same as the input to the detector. Compared with the trace at A we now have less peaking and more uniform signal voltage throughout all the frequencies in the 1000-kc channel, as evidenced by the flatter top of the curve. Gains at the lowest and highest frequencies in this channel are somewhat greater percentages of the peak gain than at the output of the i-f amplifier.

A major advantage of the response at B over that at A is in the more steeply sloped sides or skirts of the curve. There is much better cutoff action between the 1000-kc

channel and the adjacent channels. At 990 kc in the next lower channel the response at A is about 28 per cent of the peak, while at B it is down to 6 per cent. At 1010 kc in the higher channel the response at A is only about 7 per cent of the peak value, and at B it is still lower.

The response at B of Fig. 6 is the overall response of the r-f and i-f amplifying systems. It shows greater selectivity than the response at A because one additional i-f transformer is being used. The greater the number of tuned couplings, when all are tuned for the same frequency or frequencies, the steeper will be the skirts of the response and

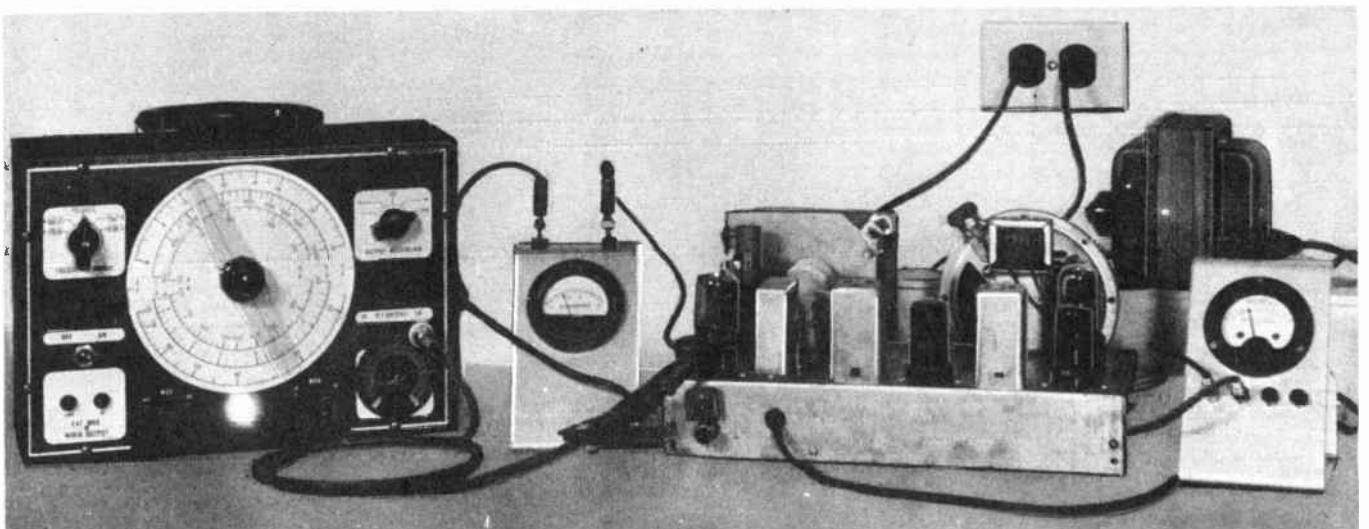

Fig. 7. The receiver in the copper shielding box at the left is being tested for selectivity by using the r-f signal generator at the right.

## LESSON 30 – THE I-F AMPLIFIER AND THE DETECTOR

the better will be the selectivity against channels other than the one tuned. Of course, overall selectivity depends also on sharpness of resonance or lack of it in each coupling.

In any receiver, whether standard broadcast, f-m broadcast, or television, the r-f amplifier stage does not contribute very much to adjacent channel selectivity. The r-f response always is quite high well beyond the limits of the channel to be received. It is the i-f amplifying system that is depended on to provide necessary adjacent channel selectivity and by far the greater portion of total voltage gain.

An r-f amplifier stage is selective against carrier frequencies far removed from that of the tuned channel. For example, an r-f stage may be of great help in reducing the response at image frequencies, which differ from the tuned channel frequency by two times the intermediate frequencies.

**SENSITIVITY.** Sensitivity is a measure of how weak may be a signal from the antenna which will produce some certain output from the speaker, the picture tube, or both. The input signal at the antenna is measured in microvolts at carrier frequencies. Sound output is measured as power at audio fre-

quencies. An audio power output often taken as standard for small receivers is 0.05 watt, and for larger receivers is 0.5 watt of audio power. Sensitivity then would be specified as the number of microvolts of antenna signal required to produce the standard output.

Sensitivity of television receivers, for pictures and sync pulses, often is specified as the number of microvolts of antenna signal required to produce one volt of signal at the output of the video detector. As a general rule, when the picture is satisfactory there is ample signal strength for television sound. In fact, oftentimes it is possible to hear the sound portion of a television program when the picture is barely recognizable or is entirely absent.

Although sensitivity is measured as the relation between input and output signal voltages or powers, it really depends on voltage gain. The greater the total voltage gain or the sum of all the voltage gains the greater will be the sensitivity, and the less the overall voltage gain the less will be the sensitivity of the receiver.

**Q-FACTOR.** When a technician speaks of a "low-loss" design or construction in a tuned circuit or its parts he could use the



Fig. 8. The receiver is being tested for sensitivity by measuring strengths of signals at the antenna input and at the speaker output.



## COYNE - *television home training*

term "high-Q" and mean the same thing. The Q of an inductor, capacitor, or entire circuit means Quality, not quality of materials and workmanship, but quality of electrical performance. Measurement of this kind of quality is based on reactances and on energy losses.

The greater the inductive reactance of an inductor in relation to its high-frequency energy losses the higher is the Q of that inductor. A capacitor having large capacitive reactance in proportion to its energy losses possesses high Q. In an entire circuit the greater the effects of reactances as compared with total losses of energy the higher is the Q of that circuit.

The inductor in the tuned circuit of Fig. 9 is of high-Q or low-loss design and construction. The winding is of bare wire, with spaced turns, on a form made of steatite. There is ample separation between the inductor and surrounding parts which are of

metal or of insulating and dielectric materials. The tuning capacitor also is of high-Q construction and is well suited for operation at very-high frequencies.

We have learned that losses of energy which occur at high frequencies are the equivalent of high-frequency resistance, which may be measured in ohms. Reactances also are measured in ohms. Q is equal to the ratio of ohms of reactance to ohms of high-frequency resistance at some specified operating frequency, thus:

$$Q = \frac{\text{reactance, ohms}}{\text{high-frequency resistance, ohms}}$$

Most of the energy loss or high-frequency resistance of a tuned circuit occurs in the inductor or inductors, and only relatively little in capacitors, provided the capacitors are of high-grade types. Consequently, the Q of any ordinary tuned circuit is almost the same as the Q of the inductor or inductors in that circuit.

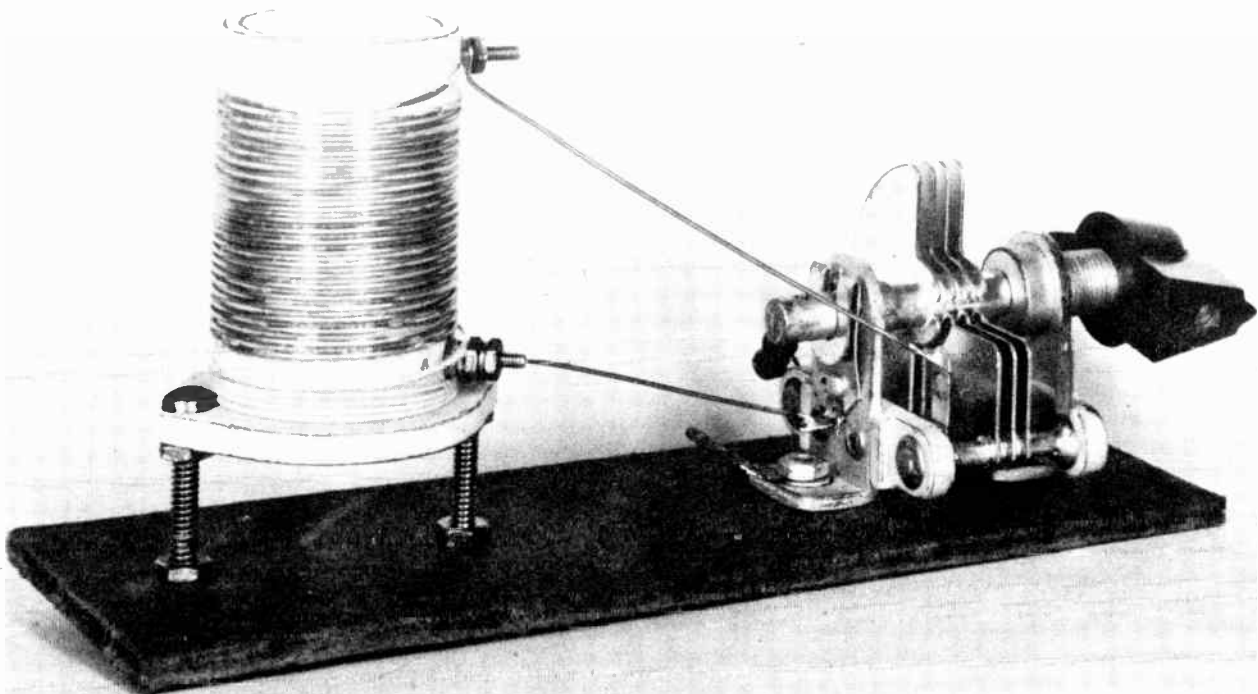

Fig. 9. The inductor and tuning capacitor are of high-Q design and construction.



## LESSON 30 — THE I-F AMPLIFIER AND THE DETECTOR

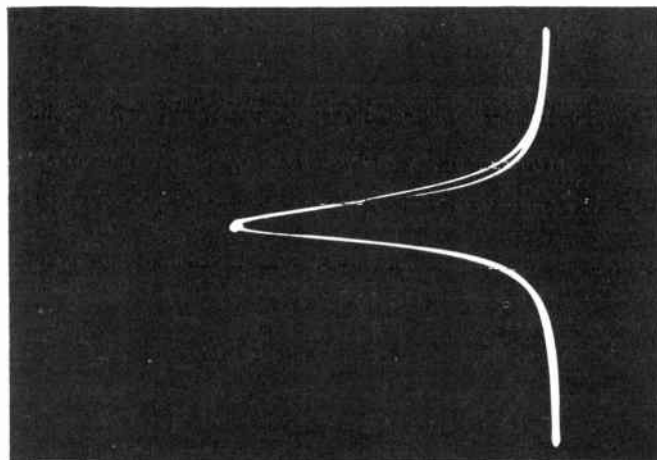
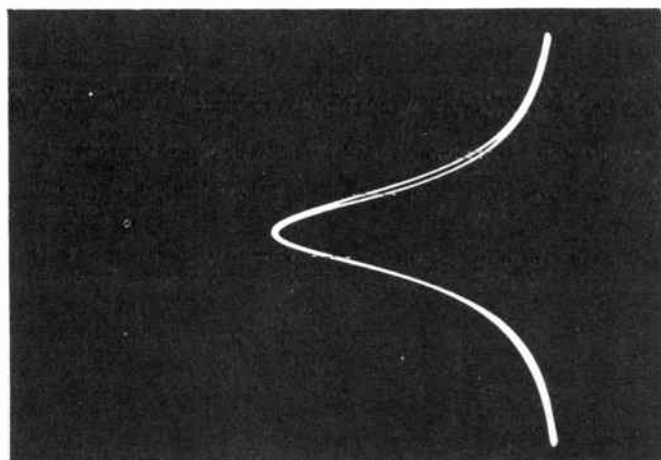

Fig. 10. Selectivity improves at lower frequencies in a circuit tuned by variable capacitance.

Inasmuch as inductance and inductive reactance increase as frequency increases, it might seem that the  $Q$  of an inductor should increase with frequency. But energy losses usually increase at about the same rate as does inductive reactance throughout the medium frequency range. In this range the ratio of reactance to losses remains fairly constant, and the  $Q$  of an inductor is little affected by change of frequency. In the high, very-high, and ultra-high ranges of frequency the energy losses increase more rapidly than inductive reactance, and  $Q$  decreases in spite of the fact that reactance is increasing.

Resonant circuits may be tuned to the same frequency with large inductance and small capacitance or with small inductance and large capacitance, so long as the product of inductance and capacitance remains unchanged. The circuit with large inductance and small capacitance will have greater  $Q$  than the other circuit, provided the general design and construction are similar in both circuits. The circuit with greater  $Q$  will be more selective and also will allow more voltage gain than the circuit with smaller  $Q$ .

The statements in the preceding paragraph are likely to be misleading unless you keep in mind that there we are speaking of two distinct circuits, each having different inductance and different capacitance than the other. When we deal with a single resonant circuit which may be tuned to various frequencies by varying the capacitance or inductance, but not both, selectivity changes with frequency.

Change of selectivity with frequency is illustrated by Fig. 10. These traces were taken with the circuit pictured by Fig. 9, where there is fixed inductance and variable tuning capacitance. At A is the resonance curve with the capacitor plates all the way out of mesh, for minimum capacitance. Peak frequency is about 9.2 mc. With the capacitor plates all the way in mesh, for maximum capacitance, the curve changes as at B. Here the peak frequency is about 5.8 mc. It is plain that sharpness of resonance and selectivity are improved at B, where frequency is lower.

Fig. 11 shows how selectivity changes with resonant frequency in a circuit having fixed capacitance, with tuning by variable inductance, a movable iron core in the inductor. The curve at A results when the core is nearly all the way out of the winding, for minimum inductance. The peak frequency is 16 mc. At B is the curve produced by moving the core far enough into the winding to make the peak frequency 8.0 mc, this lower frequency resulting from increase of inductance. Again we find sharper resonance and greater selectivity at the lower frequency, just as with variable capacitance tuning.

Doubtless you have noticed that the resonance curves of Fig. 11 are lower than those of Fig. 10, indicating a reduction of gain. Gain is reduced because the inductor of the capacitance-tuned circuit has higher  $Q$  than the inductor of the inductance-tuned circuit. The inductor for this latter circuit

## COYNE - *television home training*

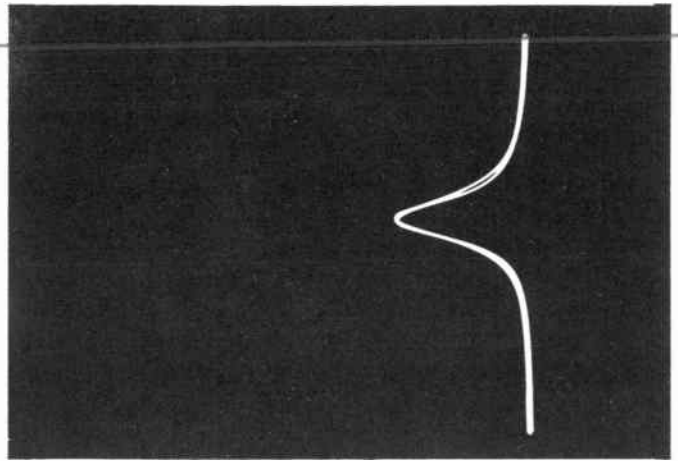
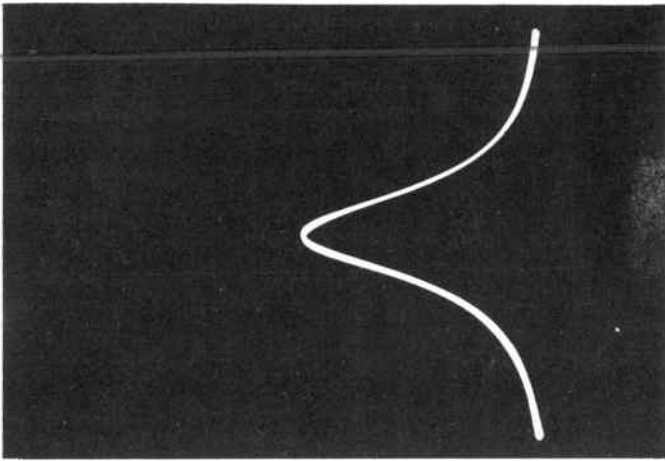

Fig. 11. There is some improvement of selectivity at lower frequencies when tuning is by variable inductance.

is made with enameled wire instead of bare wire. Turns are close together instead of being spaced. The supporting form is a tube of plastic material instead of steatite.  $Q$  is further reduced because test frequencies for Fig. 11 are higher than those for Fig. 10, and  $Q$  decreases as frequency increases in the ranges used for the tests.

The reactance of a capacitor drops as frequency rises, and even though energy losses could remain unchanged there would be less  $Q$  at higher frequencies. However, because most of the energy losses occur in the inductors and connections, with relatively little loss in high grade capacitors, the reduction of capacitor  $Q$  with rising frequency does not greatly affect the  $Q$  of the entire circuit.

It is entirely possible to construct a resonant circuit of such high  $Q$  as to be too selective for some purposes. For example, the resonant peak might be so sharp and narrow as to cut off most of the response at side frequencies in a transmission channel. This would be called side band cutting. You will encounter many tuned circuits in which the  $Q$  is intentionally reduced, as with a resistor connected across the primary or secondary winding of a transformer. Without thus adding to energy loss the circuit might not allow satisfactory gain throughout the required range of signal frequencies.

THE DETECTOR. Now we have taken the signal from the antenna through the r-f

stage, the converter, and the i-f amplifying system. Next we shall carry on through the detector and the audio amplifier, observing the forms taken by the signal as it passes progressively from one point to another as numbered on the circuit diagram of Fig. 12.

At the output of the i-f amplifier tube, point 1 on the diagram, we have the intermediate frequency modulated with an audio frequency as shown by Fig. 13. The intermediate frequency is 456 kilocycles and the modulation frequency is 500 cycles per second. During each cycle of modulation frequency there occur nearly 1000 cycles of intermediate frequency. Consequently in showing the modulation cycles the i-f cycles are too close together to be separately identified on the oscilloscope trace.

Note that both top and bottom of the modulated intermediate frequency wave show the 500-cycle waveform. What we wish to do is cut this doubly modulated signal straight across on a horizontal line through the zero value, which is midway between top and bottom. This has been accomplished quite well at point 2 on the circuit diagram, where the form of the signal shows up as in Fig. 14. This change has been made by the detector.

The detector is one section of the combination detector and a-f amplifier tube. The detector section is a diode. There are two diode plates. In some applications which will be explained later the diodes plates would be used separately, but here they are tied to-

## LESSON 30 – THE I-F AMPLIFIER AND THE DETECTOR

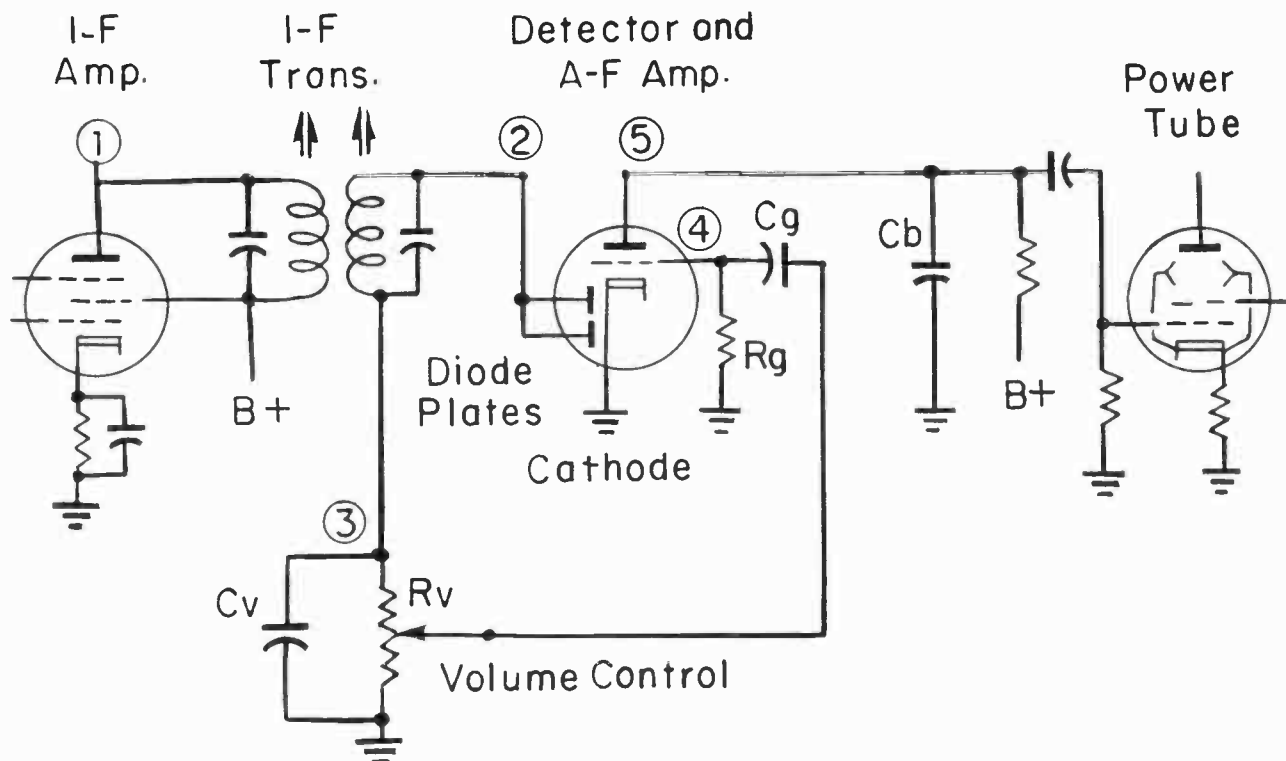

Fig. 12. The signals will be observed as they pass successively through the points numbered on this circuit diagram.

gether to act like a single plate. These diode plates are close to the single cathode, which serves for both the detector and the audio amplifier sections.

Every diode is a rectifier, it conducts when its plate or plates are positive with reference to the cathode, and does not con-

duct when the polarity reverses. Our diode detector conducts during the positive alternations of the modulated i-f wave of Fig. 13, and does not conduct during the negative alternations. Therefore, only positive alternations cause current to flow in the detector circuit, and during negative alternations there is no current. This is why the bottom of the doubly modulated i-f signal has been cut off, it consists of negative alternations. Only the positive alternations cause current in the detector circuit, as shown by Fig. 14.

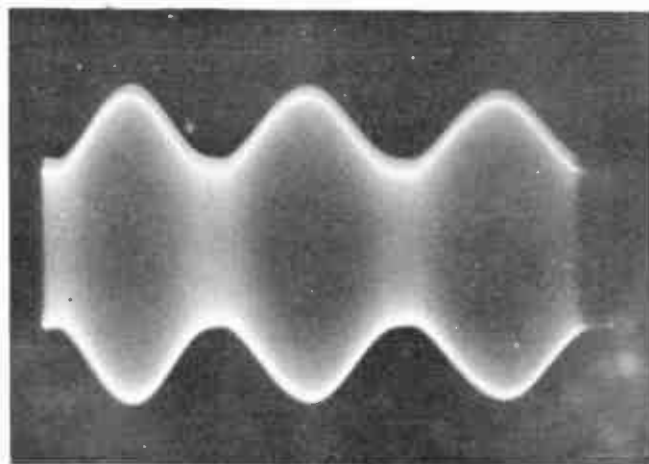

Fig. 13. At the i-f output there is the intermediate frequency modulated on both the positive and the negative amplitudes.

Fig. 14 shows signal voltage at the plates of the diode detector. Signal current corresponding to this voltage flows in the detector circuit. The detector circuit is as follows: Commencing at the tube cathode, electrons flow to the diode plates, thence through the secondary of the i-f transformer and volume control resistor  $R_v$  to ground. Through ground the electron flow goes back to the tube cathode.

The volume control resistor  $R_v$  is the load for the detector circuit. This load resistance may be almost anything between 100,000 ohms and 2 megohms. A value of 500,000 ohms is quite common.



## COYNE - *television home training*

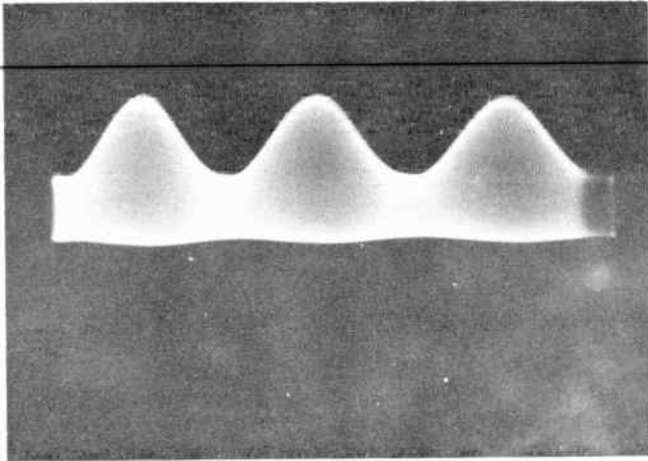

Fig. 14. The detector cuts off the negative amplitudes of the i-f signal.

In parallel with the load resistor is a capacitor  $C_v$ , which commonly is of some value between 100 and 500 mmf, with 250 mmf quite generally used. Signal voltages in the detector circuit charge this capacitor, and the charge continually leaks away through the load resistor. The time constant of the load resistor and capacitor is short in relation to the time of each audio modulation cycle. Consequently, the capacitor charge, and voltage at the top of the capacitor and top of the resistor, rise and fall at the frequency of modulation.

This voltage at the top of the load resistor and capacitor, point 3 of Fig. 12, appears as in Fig. 15. This waveform is that of the 500-cycle modulation. It is the aver-

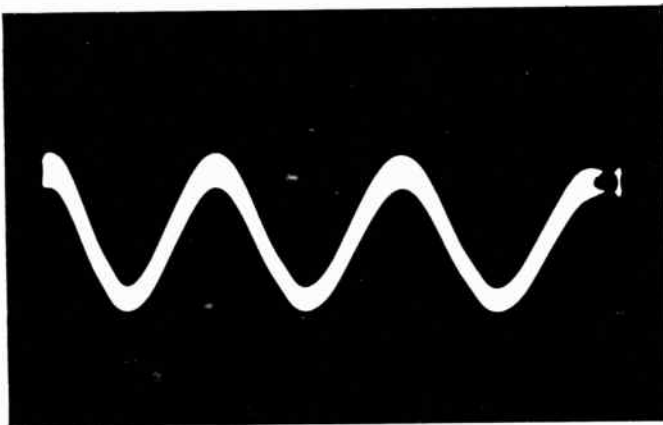

Fig. 15. Low-frequency modulation voltage appears at the high side of the detector load resistor.

age of the alternations occurring in Fig. 14. We saw an effect quite similar when examining the action of a mixer or converter.

Although the voltage wave at the top of the volume control or load resistor is that of the audio modulation, the trace appears rather thick or "fuzzy" because, along with the audio frequency, we still have some remaining intermediate-frequency voltage. Most of the i-f voltage and current have been bypassed to ground through capacitor  $C_v$ , because at the intermediate frequency of 455 kc the reactance of a 250-mmf capacitor is only about 1,400 ohms. The audio voltage is not bypassed to any great extent because at a medium audio frequency of 2,500 cycles per second the reactance of 250 mmf is about  $1/4$  megohm.

Increasing the load resistance in a diode detector circuit, or increasing the volume control resistance in the case being examined, will cause a moderate increase of receiver sensitivity, and this increases the apparent selectivity. For example, increasing the load resistance from 100,000 ohms to 2 megohms will raise the detector output voltage by something like 25 to 40 per cent when input signal voltage remains the same.

The detector load resistor of Fig. 12, which is the volume control, consists of a potentiometer with one end connected to the i-f transformer secondary, the other end to ground, and the slider to the grid circuit of the audio amplifier. Audio voltage from the detector load which goes to the a-f grid circuit is that portion of the total load voltage which appears between the slider and the grounded end of the potentiometer. Moving the slider away from the grounded end picks off more of the total detector output voltage for the a-f grid, and moving the slider toward the grounded end takes off less of the total voltage. Thus we vary the audio voltage applied to the grid of the a-f amplifier, and control sound intensity or volume from the speaker which is at the far end of the a-f amplifying system.

The audio signal from the slider of the volume control potentiometer goes to the grid of the a-f amplifier through blocking capaci-



## LESSON 30 – THE I-F AMPLIFIER AND THE DETECTOR

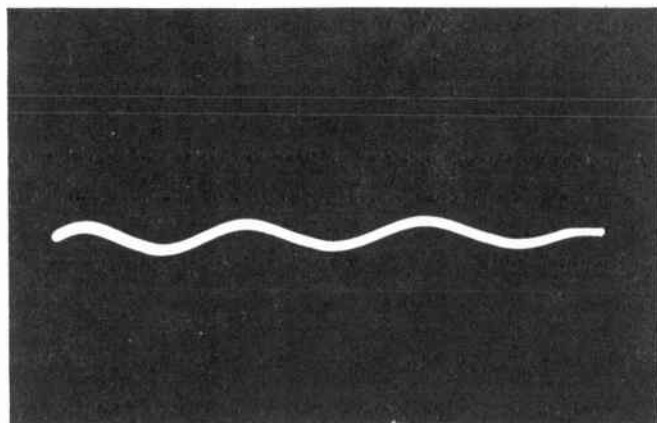
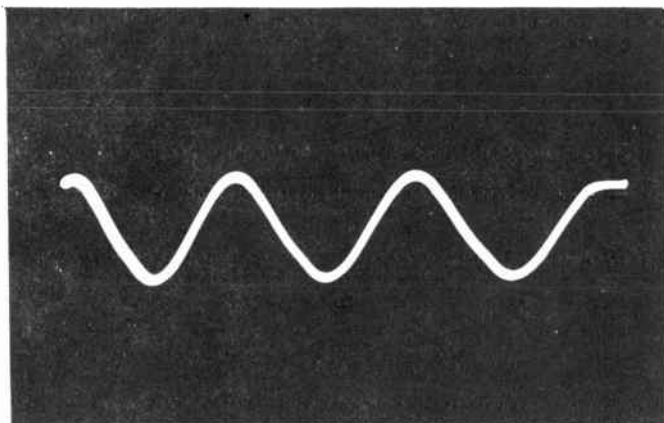

Fig. 16. Voltage at the audio amplifier grid with the volume control turned up (A) and down (B).

tor  $C_g$ . Capacitance here should be about 0.01 mf to pass the lower audio frequencies, although the value often is much less to prevent passing low-frequency ripple voltage from a poorly filtered d-c power supply. Between the a-f grid and ground, and through ground to the cathode, is grid resistor  $R_g$ . Resistance here usually is between 5 and 15 megohms. Capacitor  $C_g$  and resistor  $R_g$  maintain a negative bias on the a-f grid.

The audio signal at the a-f grid is shown by Fig. 16 at A. This oscilloscope trace is taken at point 4 on the diagram of Fig. 12. A large portion of the i-f voltage which we found at the top of the volume control now has disappeared, leaving a "cleaner" audio signal.

The signal shown by the trace at A is obtained with the slider of the volume control turned well away from the grounded end of this control, thus taking to the audio grid a large part of the detector output voltage. When the volume is turned down, by rotating the slider of the control toward the grounded end of the resistance, the signal at the audio grid decreases in amplitude, as at B.

Our final check point on the diagram of Fig. 12 is at point 5, the plate of the a-f amplifier. Here the signal appears as shown by Fig. 17. Practically all of the i-f voltage now has disappeared from the audio wave. This is due to the bypassing action of capacitor  $C_b$ , whose capacitance usually is 250 mmf or thereabouts. The reactance of this capacitor at intermediate frequencies is very

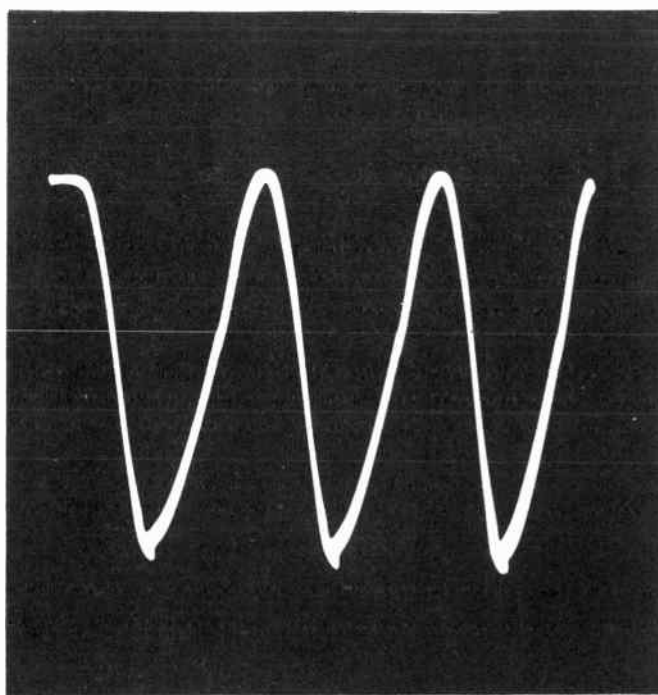

Fig. 17. The audio-frequency waveform at the plate of the a-f amplifier.

small, and they are bypassed to ground, but the reactance at audio frequencies is very high, and these frequencies go through the resistance coupling to the grid of the power tube.

In connection with diode detectors you sometimes hear the word perveance, which refers to the ability of a diode to detect or rectify high-frequency signal voltages without great loss of signal voltage in the diode itself. A diode having high perveance will

## COYNE - *television home training*

have little voltage drop and also will have small internal capacitances.

The diode detector which has been examined is essentially a half-wave rectifier, since it employs only one plate or two plates tied together to act as one. The two plates may be used separately in a full-wave rectifying circuit similar in principle to that of a full-wave power rectifier. A half-wave diode detector gives greater output signal voltage than a full-wave type for the same applied signal, but does not give as much audio power. Since we wish to have high signal voltage rather than power for application to the grid of the a-f amplifier, nearly all diode detectors are of the half-wave type rather than of the full-wave type.

**BIASED DETECTORS.** The diode detector is universally used for the video detector of television receivers and for practically all standard broadcast detectors. Other types of detectors have been used in the past. All of them depend on partial rectification of the doubly modulated i-f or r-f signal. As we observed in Fig. 13, the diode does a nearly complete job of rectification, cutting off just about all of the alternations in one polarity. Other detectors do a less complete job, by passing alternations of one polarity more freely than those of the opposite polarity.

Many of the very early broadcast receivers employed for their detector a triode having grid-leak bias. As with any other application of such biasing, the grid becomes more negative as the applied signal swings to stronger positive amplitudes, and is maintained negative so long as there is any applied signal. Then, when a signal voltage such as that of Fig. 13 is applied to the grid-lead detector, the bias varies with the low-frequency modulation. This varying grid bias causes plate current of the triode to change at the frequency of modulation, and we have an audio voltage in the plate circuit.

Another early form is called the plate detector. It employs a triode with strong negative grid bias, causing operation down near the bend of the mutual characteristic curve. We noted the result of such operation when studying mixers and converters; posi-

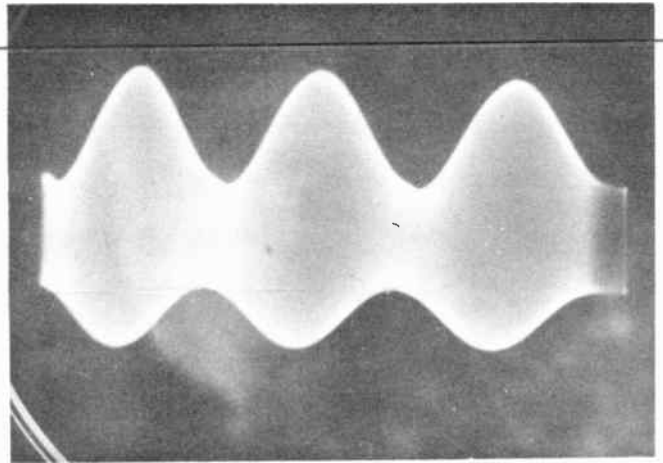

Fig. 18. Some detectors only partially rectify the modulated i-f signal.

tive alternations of the i-f signal voltage are amplified to a much greater extent than the negative alternations. The effect, in the detector output, is shown by Fig. 18. The average of the i-f alternations rises and falls at the frequency of modulation.

The diode detector causes less distortion of audio signals than either of the other detectors, but it is less sensitive to weak received signals. The lack of sensitivity is easily overcome, because with modern pentode amplifier tubes and improved circuit designs the gain ahead of the detector may be raised as required.

Diode detectors can be used only when there is amplitude modulation of received signals. F-m or frequency-modulation detectors for the sound section of television sets and for f-m sound receivers operate on entirely different principles, as will be explained in due time. It might be mentioned that any process of detection may be called demodulation, and the detector may be called a demodulator.

**OTHER VOLUME CONTROLS.** The method of volume control shown in Fig. 12 is employed in most of the standard broadcast sets of small and medium size. It is possible, however, to use various other methods.

Fig. 19 shows how volume is controlled by variable cathode bias on an i-f amplifier tube of the variable-mu type. In the cathode lead of this tube are two biasing resistors in

## LESSON 30 – THE I-F AMPLIFIER AND THE DETECTOR

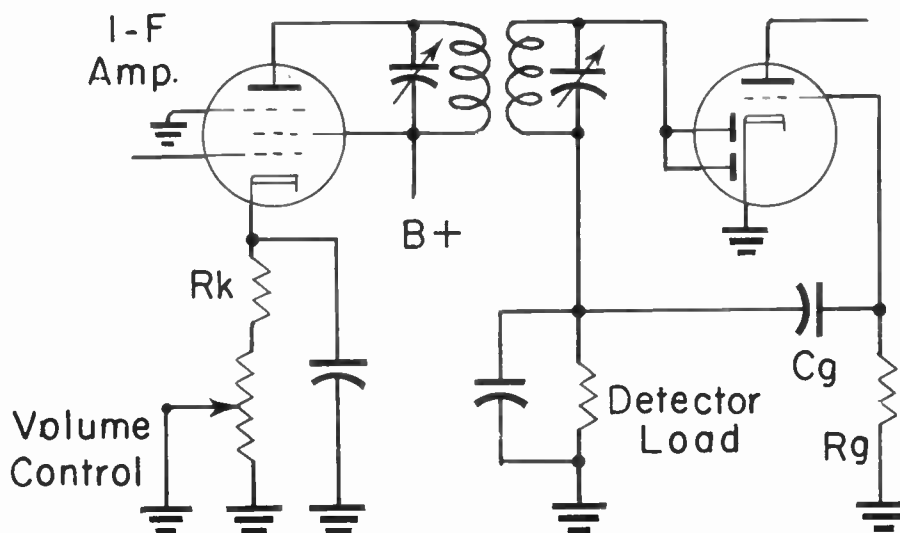

Fig. 19. Volume control with adjustable cathode bias on an i-f amplifier.

series. One,  $R_k$ , is of such value as to maintain some minimum value of negative grid bias regardless of volume control setting. This minimum bias might be something between 1 and 3 volts negative, depending on the type of tube and on the plate and screen voltages being used.

The other cathode resistor, which is the adjustable volume control, consists of a potentiometer capable of increasing the bias to possibly 20 volts negative or even more, depending on what bias is required to sufficiently reduce the amplification of the type of tube used as i-f amplifier. The total resistance of the potentiometer may be 50,000 to 100,000 ohms. The resistance element usually is tapered to cause slow change of resistance at the end toward the cathode and rapid change at the end toward ground.

When there is more than one i-f amplifier tube the cathodes of all of them may be connected together and to ground or B-minus through a fixed minimum-bias resistor and as adjustable volume-control potentiometer. With all cathode currents through the same biasing resistors these resistances are of such values as will give required negative biasing voltages in relation to the total current.

If there is an r-f amplifier in addition to the i-f amplifier tube, and if both these tubes are of the variable- $\mu$  type, their

cathodes may be connected together and to ground or B-minus through a single biasing and volume control system. Here again the fixed bias resistor and also the volume control potentiometer will have resistances giving necessary bias voltage with the total cathode current.

Still another volume control method employs a negative grid biasing voltage taken from the d-c power supply. The principle was explained when we studied what is called a fixed bias, with which the grid returns of one or more amplifying tubes go to the negative side of the power supply, between ground and the center tap of the secondary on a power transformer. This biasing voltage may be made adjustable by bringing the grid returns to the slider of a potentiometer connected into the negative side of the power supply, whereupon the potentiometer becomes an adjustable volume control acting to make the amplifier grids more or less negative.

### AUTOMATIC VOLUME CONTROL.

Several times we have spoken of an automatic biasing system which varies the grid bias and amplification of various tubes to compensate for changes of strength in received signals. Such a biasing control, as used in sound receivers, is called an automatic volume control.

One of the simplest automatic volume controls is illustrated by Fig. 20. Note that

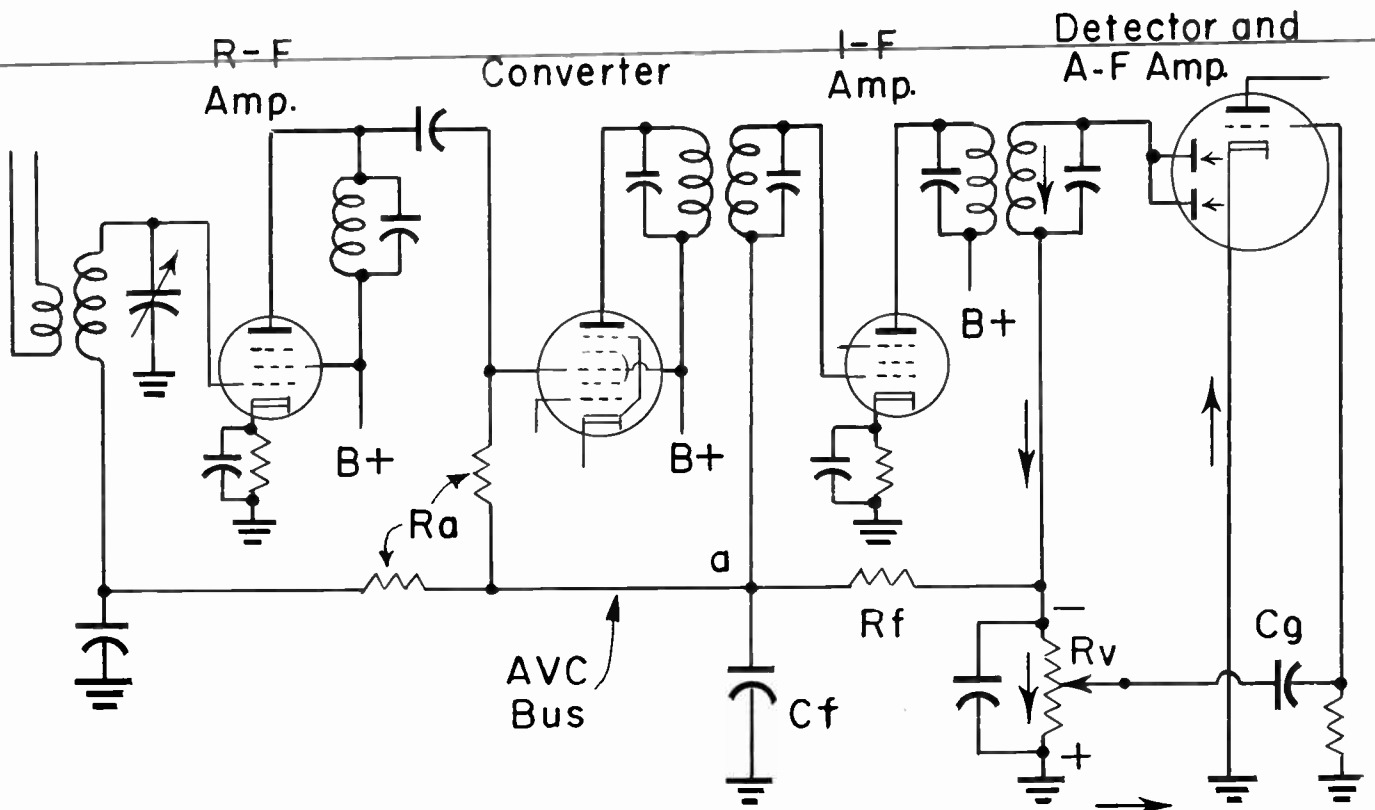

Fig. 20. A simple type of automatic volume control

the combination detector and a-f amplifier tube, also the volume control potentiometer, are exactly the same as discussed in preceding pages of this lesson. This potentiometer might be called a manual (hand operated) volume control to distinguish it from the automatic volume control system.

To understand how the automatic volume control operates we should first follow the path of electron flow in the diode detector circuit, as shown by arrows on the diagram. Starting from the tube cathode, this flow is to the diode plates, through the secondary of the i-f transformer, and downward through the manual volume control resistor to ground. The electron flow goes through ground back to the cathode.

Although this electron flow is varying at the modulation frequency or at an audio frequency, it really is a direct or one-way current because of the rectifying action of the diode detector. The audio voltage does not become a pure alternating voltage until it goes through capacitor  $C_g$  and to the grid of the a-f amplifier. Since electron flow is

downward through the manual volume control resistor  $R_v$ , the top of this resistor is negative with reference to its lower end and to ground.

At the top of resistor  $R_v$  we now have a direct (one-way) current varying at audio frequency. The average value of this current increases when stronger signal voltages come into the detector circuit, for then there is greater amplitude of the a-c signal and greater electron flow in the detector diode and its circuit.

Connected to the top of resistor  $R_v$  is a filter resistor  $R_f$ , whose value may be somewhere between 1/2 megohm and 2 megohms or more. Following the filter resistor, toward the left, is a filter capacitor  $C_f$ , whose value usually is between 0.01 and 0.10 mf. The filter resistor and capacitor act like any resistance-capacitance filter system, such as examined when we studied power supply systems. At the output of the filter, point  $a$  on the diagram, nearly all of the a-f variations have been removed and there remains a nearly constant direct voltage. This voltage



## LESSON 30 — THE I-F AMPLIFIER AND THE DETECTOR

is negative with respect to ground, because it comes from the top of resistor Rv.

At point a on the diagram of Fig. 20 is connected a line called the avc bus. The letters avc are an abbreviation for automatic volume control. To the avc bus are connected the grid returns of the r-f amplifier tube of the signal or mixer section of the converter, and of the i-f amplifier tube. Consequently, the grids of these tubes are at a potential which is negative with reference to ground, and since all the cathodes are connected more or less directly to ground all the grids are at a negative bias.

If the strength of a received signal becomes greater at the antenna there is a resulting increase of i-f voltage reaching the detector. This causes greater electron flow in resistor Rv, and voltage at the top of Rv and in the avc bus becomes more negative with reference to ground. This, of course, makes the grids of all the controlled tubes more negative with reference to ground and their cathodes, and amplification and gain are reduced proportionately to the increased strength of antenna signal. Should the received signal decrease in strength there is a weaker i-f voltage at the detector, less current in the detector circuit, and voltage in the avc bus and at the tube grids is made less negative. This allows amplification and gain to increase proportionately to the decrease of received signal strength.

The automatic control of amplification is entirely independent of the setting of the manual volume control. The manual control fixes the sound output from the speaker at some desirable level for a given program or transmission. Then, as the signal from the tuned station varies in strength, the automatic volume control action tends to compensate for the variations and to maintain a fairly constant sound output from the speaker.

There are numerous minor modifications of this basic avc circuit. For example, only one of the diode plates may be used for detection or demodulation, and the other may be connected to a separate avc filter circuit. Between the top of resistor Rv and the bottom of the i-f transformer secondary may be an

additional resistor and a small bypass capacitor to ground. This helps to get rid of i-f voltages in the avc and manual volume control circuits, but also reduces the automatic biasing voltage. In transformerless sets having a floating ground the connections shown grounded in Fig. 20 should be made to the B-minus line.

Resistors Ra in the grid returns of the several tubes are isolating resistors whose purpose is to prevent signal voltages in one stage from reaching other stages. These resistors usually are of about 100,000 ohms, but may be of greater resistance so long as the value is not much more than one-third that of filter resistor Rf. There is no voltage drop in the isolating resistors, and they do not affect the automatic biasing voltage, for in the grid returns of negatively biased tubes there is no appreciable current to cause voltage drop.

The diagram of Fig. 20 is intentionally drawn to show various types of couplings between tubes, and the manner in which each kind of grid return is connected to the avc bus.

Not all the tubes shown by Fig. 20 need be automatically biased, although the greater the number of stages thus controlled the more effective is the action in compensating for antenna signal variations. Avc action is most effective on the r-f amplifier, less so on the converter, and still less on i-f amplifiers as we go toward the detector. Either variable-mu or sharp cutoff pentode amplifiers may be automatically controlled.

Automatic volume control cannot fully compensate for variations of antenna signal strength. There still will be some change in speaker output, although it will be only a fraction of what would occur without automatic control. Amplifiers usually are operated with some fixed minimum negative bias to prevent the occurrence of zero grid action. The limit of amplification on weak received signals is fixed by this minimum bias, even should avc voltage drop to zero.

When the antenna signal increases in strength the avc bias becomes more negative.

## COYNE - *television home training*

But it cannot become so negative as to bring ~~amplification down to the value with a weaker~~ antenna signal, for that would leave no increase of i-f voltage at the detector diodes and there would be no increase of detector current to make the automatic bias more negative than with the weaker signal.

There are ways of overcoming to a

greater or less extent the shortcomings of the avc system as just mentioned. We shall look at the more important of these modifications when coming to the subject of automatic gain control for television sets. The elementary principles of automatic gain control are the same as these for automatic volume control, and many of the modifications are essentially the same in both applications.

# TELEVISION

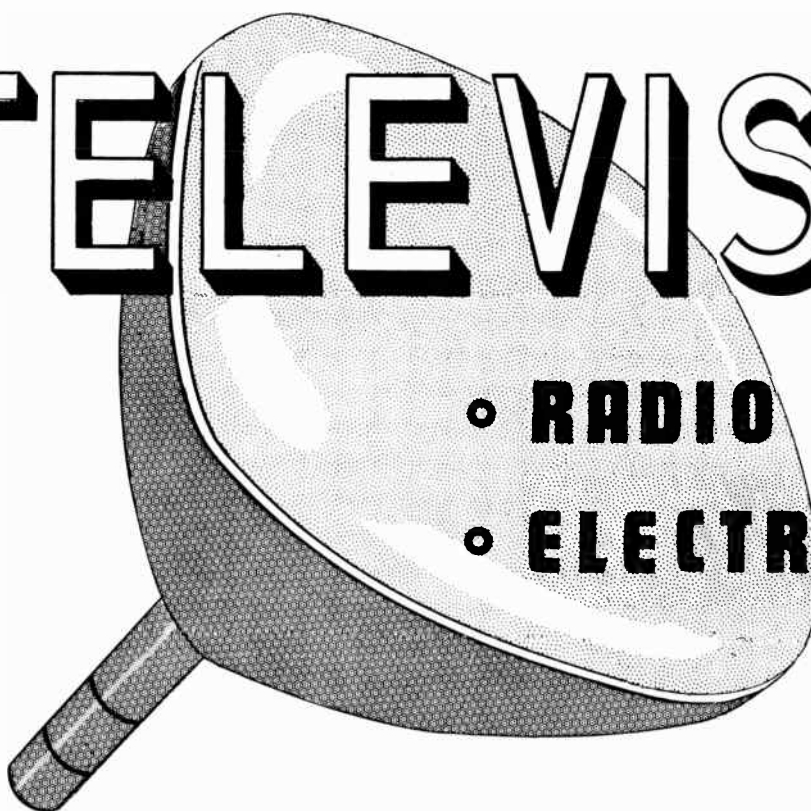

• **RADIO**

• **ELECTRONICS**

---

---

**LESSON 31 – METERS AND INSTRUMENTS**

---

---

***Coyne School***

*practical home training*

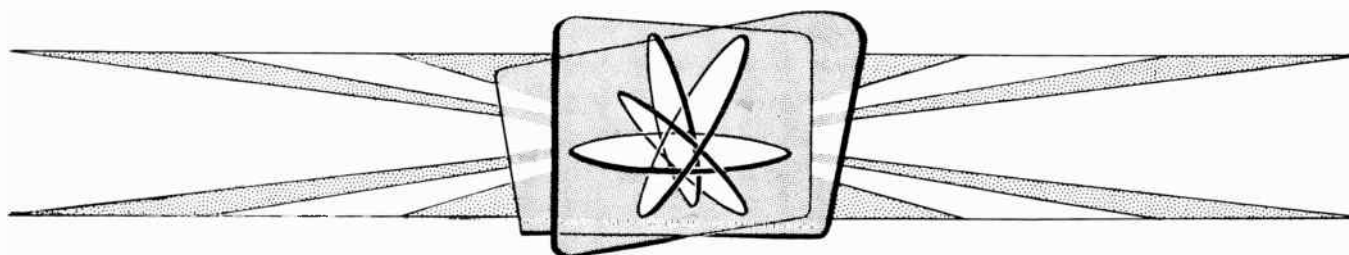

*Chicago, Illinois*

---

*Copyright, 1953 by Coyne Electrical School  
Chicago 12, Illinois  
All rights reserved*

Litho. in U.S.A.



## Lesson 31

# METERS AND INSTRUMENTS

We wish now to perform the service operation of aligning the superheterodyne receiver. Experienced and expert technicians can do a fairly good job of alignment with no elaborate instruments, working only with an insulated screw driver while listening to broadcast programs. But they, and everyone else, can do a better job with suitable service instruments, and that is the way we shall work.

For alignment we need two instruments. One of a source of modulated r-f signal voltage, which is an r-f signal generator. In addition we need a meter which will measure and indicate when maximum signal output is obtained, which means correct alignment. We shall commence with the meter, or, rather, with meters in general. There are certain features of current meters and voltmeters which make them suitable or unsuitable for various service operations, and these features should be understood.

**CURRENT METERS AND VOLT-METERS.** With very few exceptions the mechanism which is the heart of every meter used in service work is of the general type illustrated by Fig. 1. This picture shows the meter as it appears when removed from the case or housing that protects the delicate parts against dust, moisture, and mechanical damage.

The large member of generally circular shape is a permanent magnet. Such a magnet, by itself, is pictured by Fig. 2. In the space between the ends or poles of the magnet is an opening within which is a cylinder of soft iron. The magnetic lines of force or magnetic field between the poles is in the small gaps around the soft iron cylinder. This cylinder provides an easy path for magnetic lines between the poles, helps to keep the field concentrated within the gaps, and to make it more uniform.

Mounted so that it may rotate through part of a turn in the field gaps is a coil of

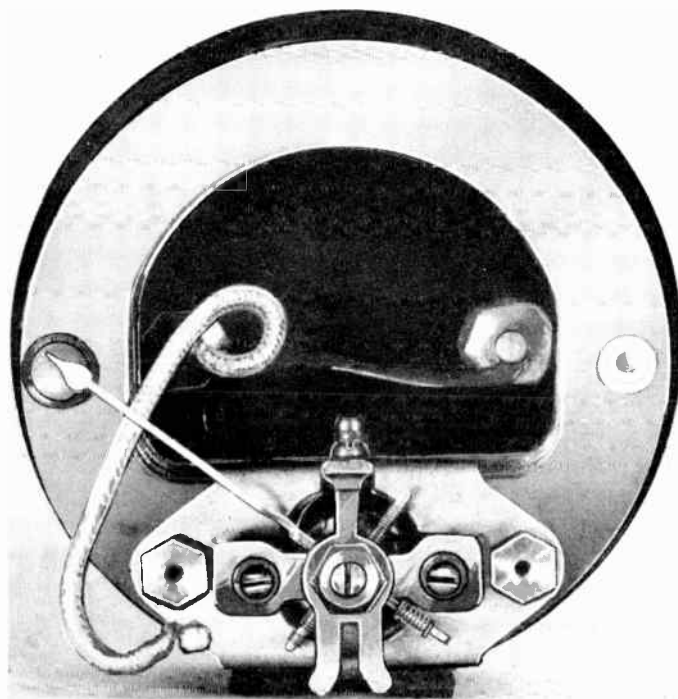

Fig. 1. The movement of a permanent magnet moving coil meter.

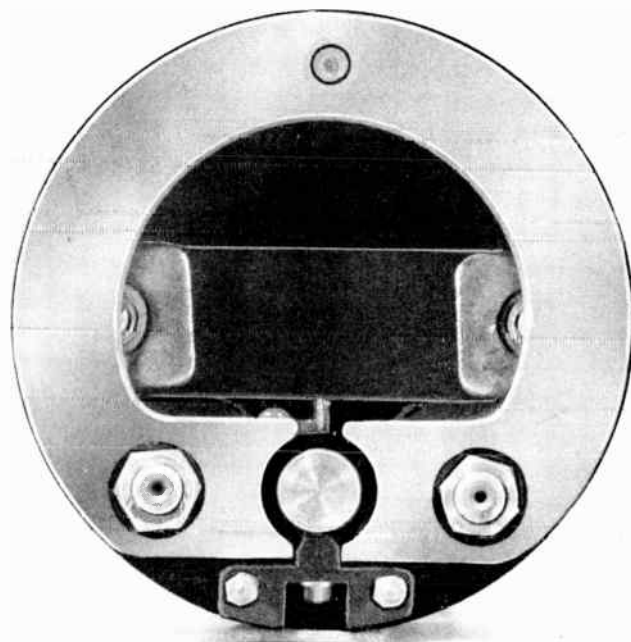

Fig. 2. The permanent magnet and the soft iron armature core of the meter.

## COYNE - *television home training*

wire called the armature. The armature cannot be seen clearly in Fig. 1, but by taking away the large permanent magnet the armature could be seen around the soft iron core, as in Fig. 3. The armature winding is supported on a bobbin made of aluminum or other non-magnetic material.

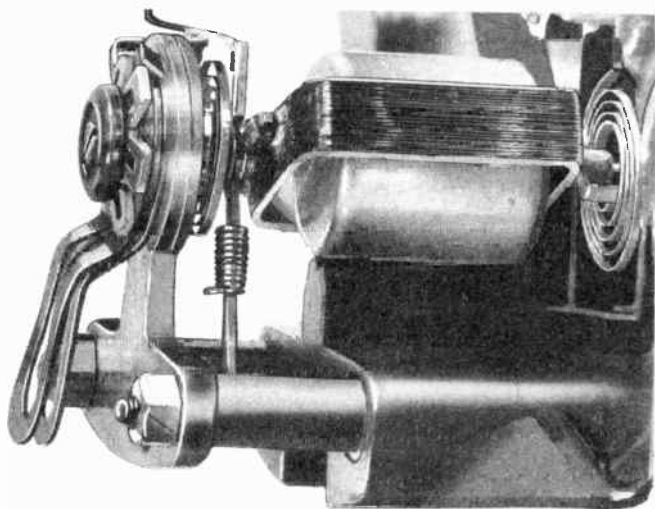

Fig. 3. The armature may rotate through part of a turn around the core.

Attached to the front and back of the bobbin are pointed steel pivots that extend into recesses in jewels, often of sapphire, which act as bearings for the pivots, the bobbin, and the armature winding. This portion of the construction may be seen in Fig. 4.

Fastened to the ends of the bobbin, at the pivots, are the inner ends of two small spirally coiled springs. These are the hairsprings. Each is quite similar to the hairspring on the balance wheel of a watch or clock. As you can see in Fig. 3, the outer ends of the hairsprings are fastened to stationary parts of the meter.

The hairsprings tend to keep the armature in one certain position within the air gaps, but the springs are sufficiently elastic to allow rotation of the armature through part of a turn on its pivot bearings. The armature rotates against tension of the springs, and the springs always tend to bring the armature back to its original position.

Attached to one end of the bobbin that carries the armature is the pointer which

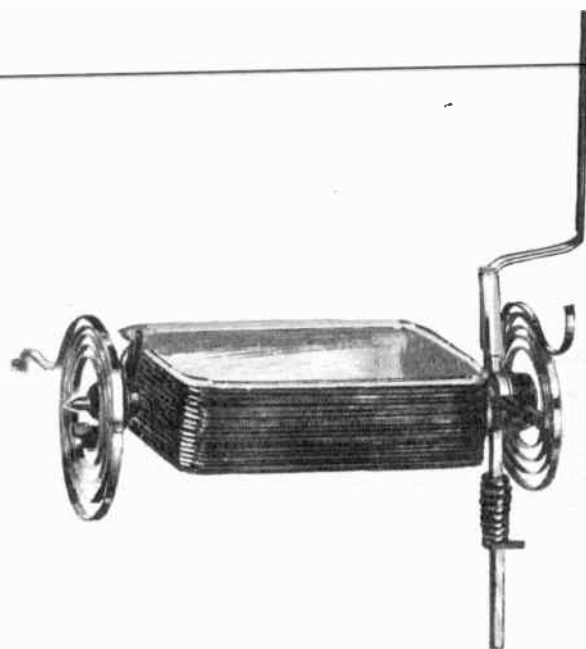

Fig. 4. The armature and the two hairsprings, with the pointer attached to the bobbin.

swings across the dial scale of the meter. You can see the pointer swung to the left in Fig. 1, and in Fig. 4 can see the inner end of the pointer where it is attached to the bobbin.

The parts which have been shown and described make up what is called the movement of the meter. The movement illustrated is called a permanent magnet moving coil type. Another name is d'Arsonval movement, after the man who originally devised this kind of measuring instrument. A permanent magnet moving coil meter will operate only on direct current or voltage. To measure alternating current or voltage we shall later employ a rectifier in connection with the d-c movement.

When the meter is in use, direct current from the circuit in which measurements are made, or from a rectifier, flows through the terminals on the housing and through the hairsprings to and through the armature winding. This current produces around the armature a magnetic field whose strength is proportional to the current.

The magnetic field of the armature reacts with the field of the permanent magnet, and the armature tries to rotate into

# LESSON 31 – METERS AND INSTRUMENTS

such position that opposite poles of the two magnetic fields come together. Armature rotation is opposed by tension of the hair-springs, and the armature with its attached pointer comes to rest where the magnetic turning force is balanced by spring tension. At this position of the pointer on the dial scale may be marked the value of current flowing in the armature, if the instrument is being used as a current meter.

The greater the field strength of the permanent magnet the stronger is the reaction between this field and that of the armature, and the farther the armature and pointer will move for any given current in the armature winding. Should the permanent magnet become weakened, due to age or abuse, the pointer will not swing as far as it should. Then dial readings will be less than actual value of current in the meter.

## SHUNTS FOR CURRENT METERS.

Service instruments may have meters whose pointers will swing to full-scale, all the way across the dial scale, with as little as 10 microamperes flowing in the armature. In most meters used for television and radio

service instruments the armature current for full scale reading is something between 50 microamperes and one milliampere.

For measurements of currents greater than those which may flow in the armature of the meter we connect in parallel with the armature a resistor called a shunt. Then a large portion of the measured current will flow in the shunt, and only a relatively small portion in the armature.

A shunt is connected across the armature as shown in Fig. 5. The shunt resistor may be mounted inside the meter housing, or it may be connected externally between the terminals which are on the housing or case. You can increase the range of dial readings for any current meter by using an external shunt.

To determine the shunting resistance required for any increase of current measuring range it is necessary to know the internal resistance of the meter. This is the resistance of the armature or of the armature and all internal conductors across which the shunt will be connected in parallel.

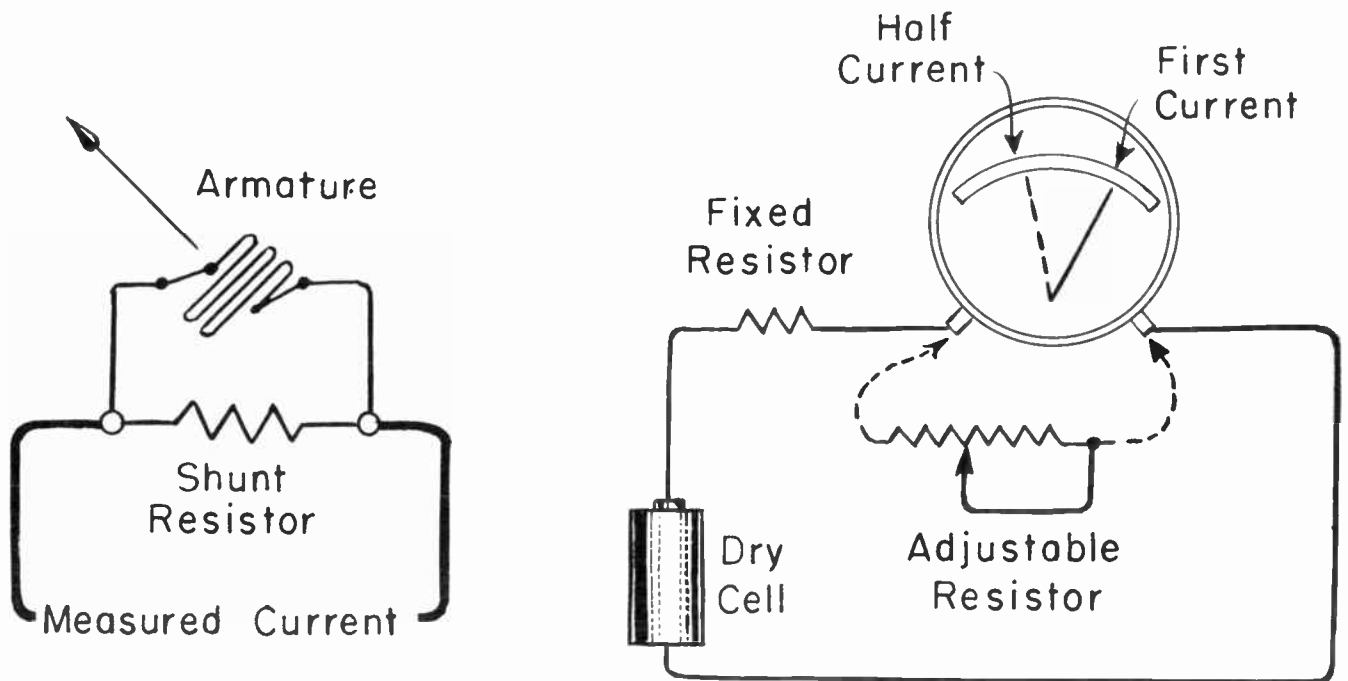

Fig. 5. Connection of a current meter shunt (left) and a method of measuring internal resistance of a meter (right).

## COYNE - *television home training*

Unless the internal resistance is marked on the meter or is otherwise known it will be necessary to measure this resistance. If you try to measure meter resistance by using an ohmmeter across the armature or across the meter terminals the chances are that you will burn out the armature. For measuring resistances so low as those of current meters nearly all ohmmeters apply a current much in excess of the maximum which may be carried by the measured meter.

You may safely measure the internal resistance of any current meter by the method illustrated in Fig. 5 at the right, proceeding as follows.

1. Note the full scale current reading of the meter, and connect in series with the meter and a single dry cell a fixed resistor which will limit the current to something less than the full scale value. Determine the fixed resistance by dividing 1500 by the full-scale milliamperes, or by dividing 1,500,000 by the full-scale microamperes, then using about 10 per cent more resistance.

2. Make a record of the exact current indicated by the meter with the preceding connections completed.

3. Connect across the meter or armature terminals a low-resistance adjustable resistor, such as a potentiometer. Adjust this resistor to bring the meter reading down to exactly half of the original current indication.

4. Without disturbing the setting of the adjustable resistor, disconnect it from the meter and read the adjusted resistance by means of an accurate ohmmeter. The ohmmeter reading is equal to the internal resistance of the meter.

This scheme works out for the following reasons. When the adjustable resistor is set for half current in the meter, the other half must be flowing in the adjusted resistor. With equal currents in paralleled resistances to which the same voltage is applied, the two resistances must be equal.

Having determined the internal resis-

~~tance of the meter, the required shunt resistance is computed in the following manner.~~

1. Divide the desired higher full-scale reading of the meter by the original full-scale reading, both in the same unit of current. This gives the number of times that the reading is to be increased.

2. From the number arrived at in step 1 subtract 1.

3. Divide the meter internal resistance, in ohms, by the number determined in preceding step 2. This gives the ohms required for the shunt resistor.

Example: Assume that the internal resistance of the meter is 50 ohms, that its original full-scale reading is 1 milliampere, and that the desired full-scale reading is 10 milliamperes. Using these assumed figures in the three steps for determining shunt resistance, we have.

1.  $10 \text{ (ma)} \div 1 \text{ (ma)} = 10$

2.  $10 - 1 = 9$

3.  $50 \text{ (ohms)} \div 9 = 5.555 \text{ ohms}$

A shunt resistance so small, and of such an odd fractional value, would have to be a wire-wound type. Ordinarily you would commence with something like 6 to 10 ohms and cut off the wire until the desired full-scale reading is secured. You might connect the shunted meter in series with another meter reading to 10 ma or more. Then using an adjustable resistor in series with both meters and a dry cell, the current would be controlled to give a 10-ma reading on the "standard" meter when the shunt resistance is of such value as to bring the shunted instrument to its full scale reading.

With the assumed increase of 10 times for the full scale reading, all lower readings of the shunted meter would be multiplied by 10 in determining the measured current with connections as at the left in Fig. 5.

### MULTIPLIERS FOR VOLTMETERS.

All voltmeters of the d'Arsonval type are



## LESSON 31 – METERS AND INSTRUMENTS

fundamentally current meters, with enough resistance in series to limit the current when measured voltages are applied. The series resistance is connected between either end of the armature and an external terminal as at the left in Fig. 6. A current meter may be used as a voltmeter by connecting a series resistor outside the meter case, so that this resistor comes between the meter and the source of measured voltage.

The value of the series resistor, whether it is inside or outside of the current meter, depends on the full-scale current reading of the meter movement and on the desired full-scale voltage reading, as a voltmeter. Computation is made with either of the following formulas, according to whether full-scale current is measured in milliamperes or in microamperes.

$$\text{Ohms of series resistance} = \frac{1000 \times \text{desired full-scale volts}}{\text{full-scale milliamperes}} - \text{ohms of meter resistance}$$

$$\text{Ohms of series resistance} = \frac{1,000,000 \times \text{desired full-scale volts}}{\text{full-scale microamperes}} - \text{ohms of meter resistance}$$

The steps are as follows:

1. Multiply the number of full-scale volts desired by 1,000 or by 1,000,000, according to whether current is measured in milliamperes or microamperes.

2. Divide by the number of full-scale milliamperes or micramperes.

3. Subtract the number of ohms of meter or armature resistance.

It is necessary to perform the third step only when meter resistance is more than about 1/200 of the resistance computed from steps one and two. Otherwise the meter resistance is such a small fraction of the total resistance as to make little difference in accuracy of voltage readings whether or not this resistance is considered. The armature resistance or internal resistance of the current meter may be measured as explained in connection with Fig. 5.

The full-scale range of a meter which already is a voltmeter may be increased by using an external resistor in series, as at the right in Fig. 6. This added resistor is called a multiplier. There already is a series resistor inside the case of the voltmeter, and the external multiplier adds enough series resistance to raise the voltage range of the meter. Multiplier resistance is computed thus:

1. Divide the desired full-scale volts by the original full-scale volts of the voltmeter. This gives the number of times that the range is to be increased.

2. Subtract 1.

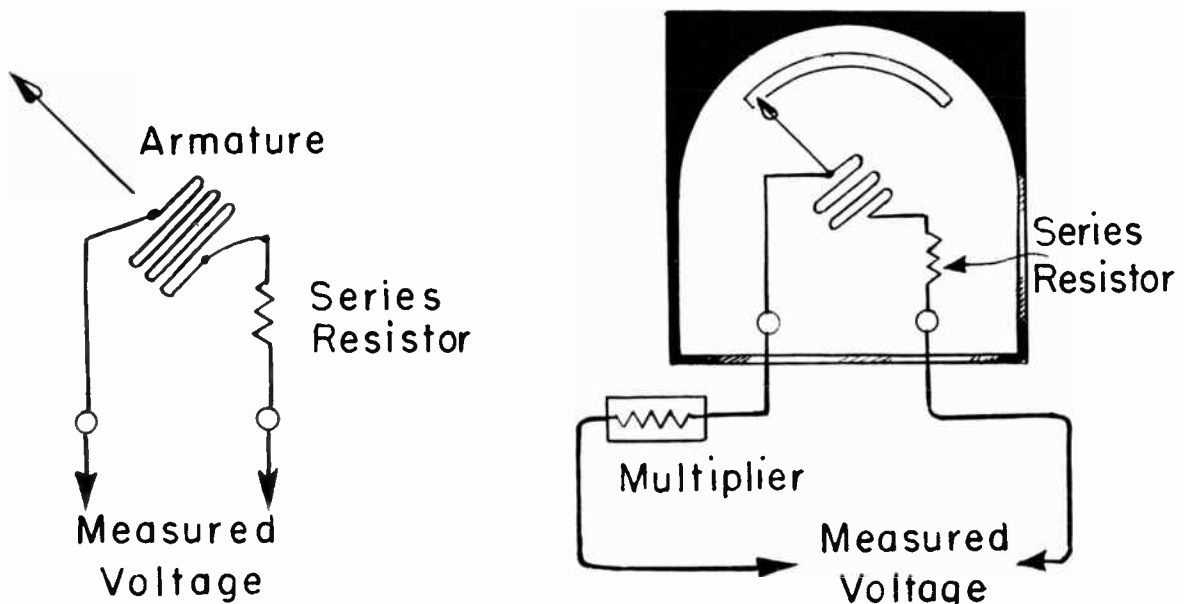

Fig. 6. Connection of a series resistor in a voltmeter (left) and an external multiplier for the voltmeter (right).

# COYNE - *television home training*

3. Multiply by the originally resistance of the voltmeter, which will be the sum of resistances of the armature and of the internal series resistor.

Example: We have a meter originally reading 100 volts at full-scale and wish to increase the full-scale reading to 500 volts. The internal resistance of the voltmeter is 100,000 ohms. The three steps of computation are as follows:

1.  $500 \text{ (volts)} \div 100 \text{ (volts)} = 5$
2.  $5 - 1 = 4$
3.  $100,000 \text{ (ohms)} \times 4 = 400,000 \text{ ohms, multiplier resistance.}$

External multipliers for voltmeters should have a wattage rating great enough to avoid all possibility of overheating, since this would change the resistance and the voltage indications. Actual power dissipation may be computed thus.

1. From the new and higher number of full-scale volts subtract the original full-scale volts.

2. Square the number which is the difference between new and original readings.

3. Divide by the number of ohms in the multiplier resistor.

In the case where we raised the full-scale reading from 100 to 500 volts the power dissipation would be found by following the three steps like this.

1.  $500 \text{ (volts)} - 100 \text{ (volts)} = 400$
2.  $400^2 = 160\,000$
3.  $160\,000 \div 400\,000 \text{ (multiplier ohms)} = 16/40 \text{ or } 0.4 \text{ watt.}$

To insure that the resistor remains cool, the rated power dissipation should be at least 4 or 5 times the actual dissipation. In the present example this would call for a multiplier resistor rated at 2 watts or even more.

Multiplier resistors, also shunts for current meters, should have resistance tolerance or accuracy of one per cent or better for use with service type meters. Carbon resistors of this accuracy are satisfactory, but it is more usual practice to use wire-

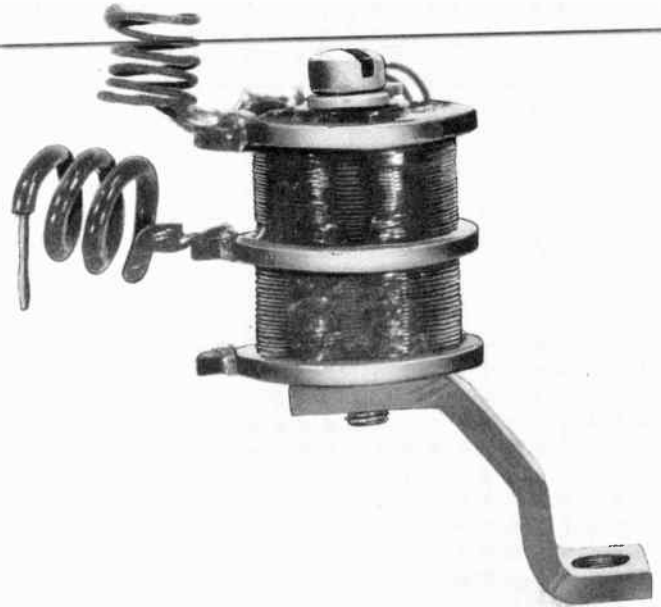

Fig. 7. A wire wound resistor such as used for shunts or multipliers.

wound types. Fig. 7 shows a wire-wound resistor such as used for shunts or multipliers.

ACCURACY OF METERS. The accuracy of current meters and voltmeters usually is expressed as some certain percentage, plus or minus. This means that the reading may be higher or lower than the actual current or voltage by the stated percentage. Most d-c meters of service types are accurate to within 2%, and some to within 1%. Closer accuracies are found in meters for laboratories, for checking production standards, and for scientific work in general. Here the accuracy may be as good as 1/10 of one per cent.

An important point in relation to rated accuracy is that it applies only at full-scale readings. As an example of what this means, consider the dial scale of Fig. 8 which is divided into 100 equal parts, with each division representing one per cent of the total range. If the meter has accuracy of plus or minus 2% the pointer may stand anywhere between the two broken lines at the top of the scale when the measured current or voltage has a value of 100 in any unit. One of the lines is two divisions (2%) below 100 and the other is the same distance above 100.

At any point lower on the scale the pointer may stand below or above the correct

## LESSON 31 -- METERS AND INSTRUMENTS

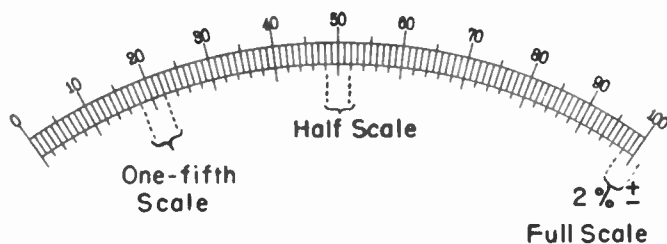

Fig. 8. Possible variations of pointer position on the dial scale of a meter having 2 per cent accuracy at full scale.

indication by the same distances as at the top of the scale or at full-scale. At half-scale these distances would allow readings anywhere between 48 and 52 units when actual current or voltage has a value of 50 units. This would be a variation of 2 units either way in a total of 50 units, which is an accuracy of 4% plus or minus. At one-fifth scale, for another example, the same distances by which the pointer may vary from a true reading would extend from 18 to 22 units when the true reading should be 20 units. This is an accuracy of 10% plus or minus.

The rated accuracy refers to the maximum error. Instrument makers aim to make the readings better than the rated accuracy, but this cannot be depended upon. The real accuracy varies at different places across the dial - it might be better at one-fifth scale than at half-scale.

To obtain reasonably true indications of current and voltage you should try to use a meter, or the range of a meter, which brings the pointer to half-scale or above for the currents or voltages being measured. Readings taken at the low end of a meter scale are likely to be highly inaccurate.

**SENSITIVITY OF VOLTMETERS.** The sensitivity of a voltmeter is a measure of how much current must flow through the meter for full-scale deflection of the pointer. The smaller this current, the more sensitive is the voltmeter. For example, a voltmeter with a 10-microampere movement (10 microamperes in the armature for full-scale deflection) is twice as sensitive as one with a 20-microampere movement, and is 100 times as sensitive as a meter with a 1-milliamperere movement.

Although voltmeter sensitivity really is based on current, it is not specified in terms of current. Instead, the sensitivity is designated as some certain number of ohms per volt. The number of ohms per volt is equal to the resistance of the meter, in ohms, divided by the number of volts at full-scale reading. Supposing, for example, that the resistance of a voltmeter is 2,000,000 ohms and that the full-scale reading is 100 volts. Dividing 2,000,000 by 100 gives 20,000, so the sensitivity of the voltmeter is 20,000 ohms per volt. Another meter with full-scale reading of 100 volts might have resistance of 100,000 ohms. Dividing 100,000 by 100 gives 1,000, so the sensitivity of this other meter is 1,000 ohms per volt.

Any sensitivity in ohms per volt is easily translated into the value of current taken through the meter at full-scale. Consider the instrument with sensitivity of 1,000 ohms per volt. If you apply a potential difference of 1 volt across a resistance of 1,000 ohms what current will flow? Our regular formula for current is this,

$$\text{Milliamperes} = \frac{1000 \times \text{volts}}{\text{ohms}}$$

Using the assumed values in this formula gives,

$$\text{Milliamperes} = \frac{1000 \times 1}{1000} = 1 \text{ milliampere, current at full scale.}$$

In the case of the meter with sensitivity of 20,000 ohms per volt, determine the current with 1 volt across 20,000 ohms. The answer is 1/20 milliampere, which is the same as 50 microamperes, and the meter draws 50 microamperes at full scale. The meter whose sensitivity is 1,000 ohms per volt must have a 1-milliamperere movement, and the one with sensitivity of 20,000 ohms per volt must have a 50-microampere movement.

Knowing the sensitivity of any voltmeter, in ohms per volt, you can quickly determine the resistance of the instrument on any voltage range. Simply multiply the ohms per volt by the full scale volts for that range. The product is meter resistance in ohms.

On the voltmeter dial of Fig. 9 the sensitivity is shown as 20,000 ohms per volt. There are two ranges, one for full-scale

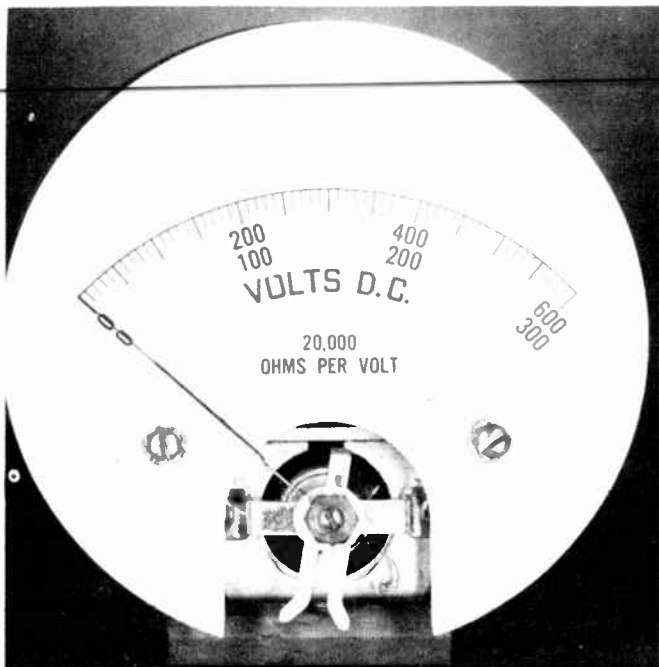

Fig. 9. The scale of a two-range voltmeter having sensitivity of 20,000 ohms per volt.

reading of 600 volts and the other for full-scale at 300 volts. What are the meter resistances when operating on each range? For the 600-volt range we multiply 20,000 by

600, which gives the meter resistance as 12,000,000 ohms or 12 megohms. A similar calculation for the 300-volt range gives the meter resistance as 6,000,000 ohms or 6 megohms on this range.

Although voltmeter resistance is computed in accordance with the full-scale reading for any range, the resistance remains of this full value for all measurements on that particular range. If resistance is 6 megohms on a 300-volt range, resistance remains 6 megohms no matter what voltage actually is measured on that range of the meter. This general rule holds good for any range and any resistance.

**SENSITIVITY EFFECTS.** Now we shall make some voltage measurements on the tube circuit of Fig. 10, using first a meter of 20,000 ohms per volt sensitivity and then one having sensitivity of 1,000 ohms per volt.

Voltages and currents marked on the diagram are those with no meter connected at any point. They are normal operating voltages and currents. The voltmeters will be connected at points 1, 2, 3, and 4, as indicated. Within the meter symbol at each po-

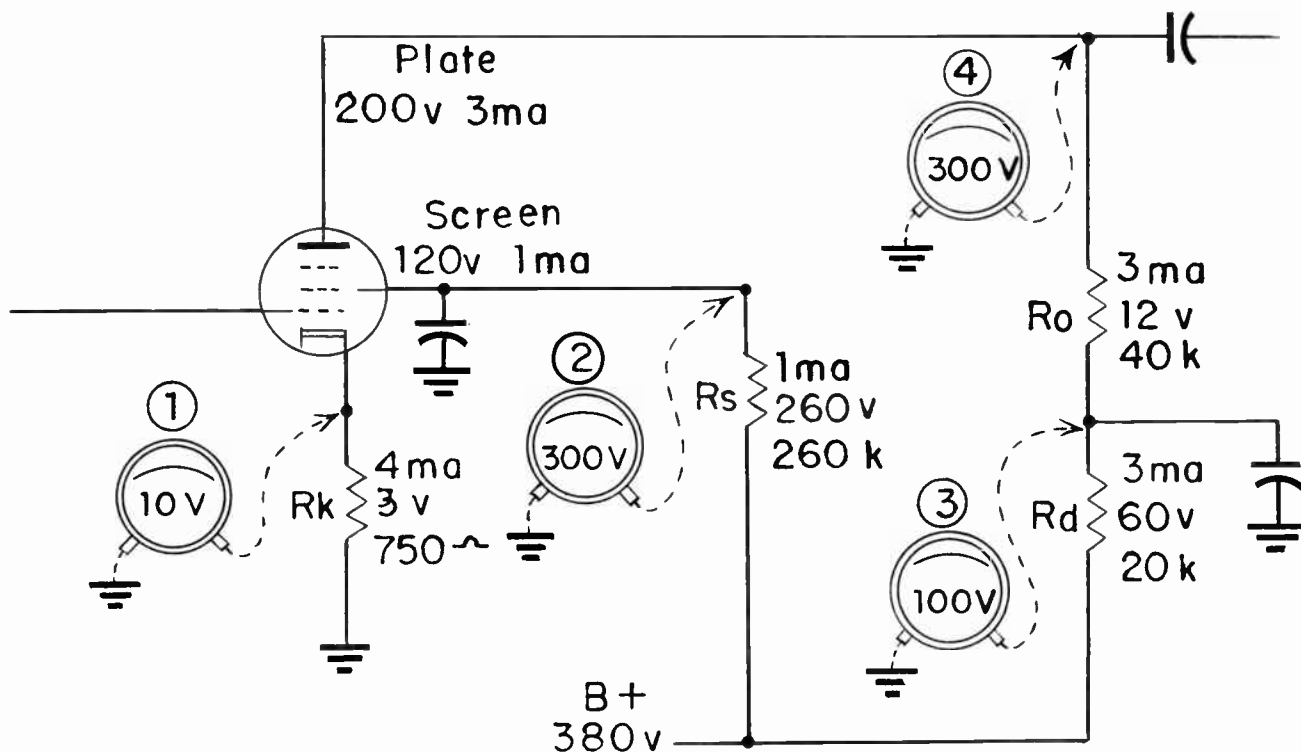

Fig. 10. Voltage measurement points in the plate and cathode circuits of a tube.



# LESSON 31 – METERS AND INSTRUMENTS

sition is marked the voltage range used for that measurement. The range determines the meter resistance.

During each test the meter and its resistance are in parallel with one of the circuit resistors. For instance, in test number 1 the meter parallels cathode bias resistor R<sub>k</sub>, which is of 750 ohms. In test number 2 the meter parallels the screen resistor R<sub>s</sub>, of 260,000 ohms. Resistances of the paralleled resistor are marked at each test position. Voltage drop in each resistor is marked on the diagram.

When any resistance, such as that of a voltmeter, is placed in parallel with any circuit resistance the combined or parallel resistance is less than that of the circuit resistance. Therefore, every time you make

a voltage measurement the circuit resistance is decreased and, normally, the current will increase. The current will increase because the circuit or the power supply must furnish current that flows in the meter as well as current through the circuit resistor.

For each of the numbered measurements we wish to determine and compare the results with the two different voltmeters. The results which are of interest include, first, the parallel or effective resistance, second, the change of resistance from the normal circuit value, and, third, the voltage error or the difference between true voltage and voltage indicated by the meter. To avoid the need for long explanations, results of measurements with the 20,000 ohms-per-volt meter are shown by the accompanying table.

TESTS WITH 20,000 OHMS PER VOLT METER (Fig. 10)

Point of Test	Meter Ohms	Resistor Paralleled	Resistor Ohms	Parallel Resistance (approx.)	Change of Resistance	Voltage Error
1	200,000	R <sub>k</sub>	750	747.2	- 0.4%	negligible
2	6,000,000	R <sub>s</sub>	260,000	249,000	- 4.2%	3.0%
3	2,000,000	R <sub>d</sub>	20,000	19,800	- 1.0%	0.5%
4	6,000,000	R <sub>o</sub> -R <sub>d</sub>	60,000	59,400	- 1.0%	1.7%

The voltmeter always causes a reduction of effective or parallel resistance. The less the resistance of the meter and the greater the paralleled circuit resistance the greater is the reduction as a percentage.

Voltage errors as listed in the last column were measured, not computed. They were measured by comparison with a meter having resistance of about 25 megohms on all ranges. Whether the error in indicated voltage is greater or less than the change of resistance depends on many circuit factors, since the tube is assumed to be in operation and every change of voltage on one element changes currents and voltages on all other elements.

The next table gives the results of making the same four tests with the meter of less sensitivity.

The smaller resistance of the less sensitive meter causes relatively large changes of effective resistance and greatly increased voltage errors. When the resistance paralleled approaches the meter resistance, voltage measurements give indications having little relation to actual operating voltages with no meter in use. This shows up in the test at point 2, where the voltage error is 38%. The reading should be 120 volts, but the meter would indicate only about 74 or 75 volts. With the more sensitive meter the reading would be about 116 volts.

# COYNE - *television home training*

TESTS WITH 1,000 OHMS PER VOLT METER (Fig. 10)

Point of Test	Meter Ohms	Resistor Paralleled	Resistor Ohms	Parallel Resistance (approx.)	Change of Resistance	Voltage Error
1	10,000	R <sub>k</sub>	750	698	- 6.9%	- 5.7%
2	300,000	R <sub>s</sub>	260,000	139,300	- 46.4%	- 38.0%
3	100,000	R <sub>d</sub>	20,000	16,670	- 16.7%	- 10.0%
4	300,000	R <sub>o</sub> -R <sub>d</sub>	60,000	50,000	- 16.7%	- 21.5%

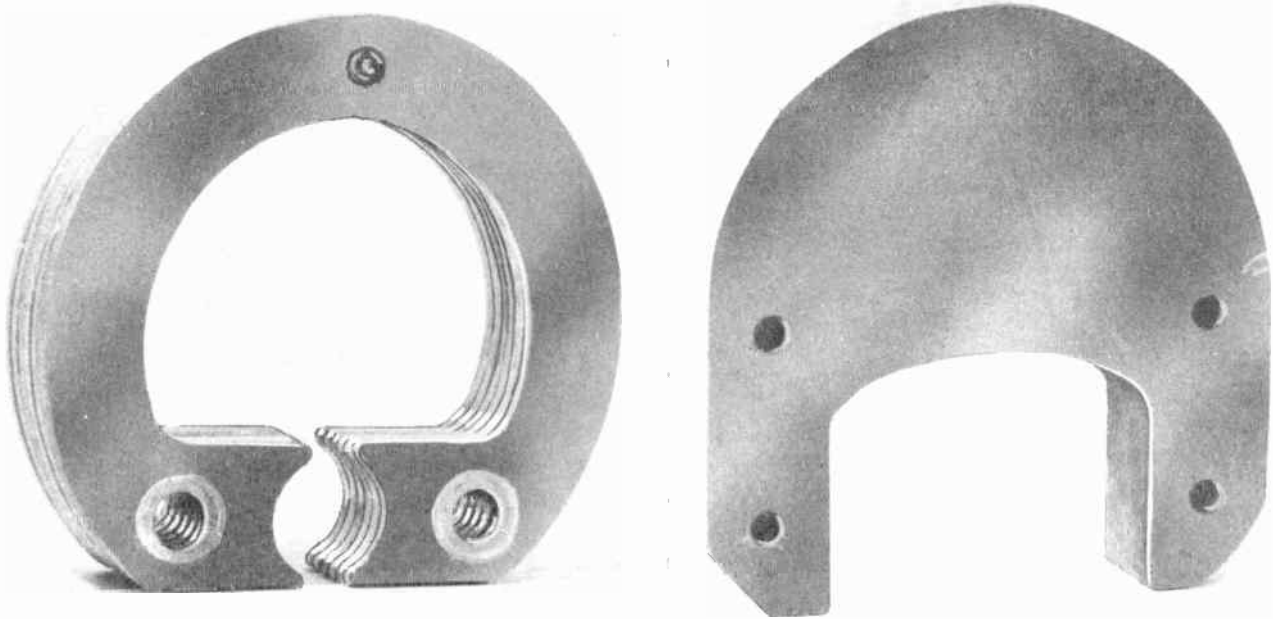

Fig. 11. Permanent magnets for meters. A type made up of thin laminations (left) and an Alnico solid magnet (right).

**RECTIFIER METERS.** For measurement of alternating currents and voltages from power lines there are several types of a-c voltmeters and current meters which operate on principles entirely different from those of the d'Arsonval movement. In most of these power type a-c meters the pointer is attached to a pivoted vane of soft iron that moves in a magnetic field produced by the measured current. All such instruments draw currents far greater than should be taken from audio

circuits and other a-c circuits which are beyond the power line connections in television and radio receivers. This is to say that the sensitivities of the a-c power meters is very low.

To have satisfactory sensitivity for measurements up to around 30,000 cycles or a little higher in receiver circuits we employ a rectifier between the source of alternating current or voltage and a d'Arsonval move-

## LESSON 31 — METERS AND INSTRUMENTS

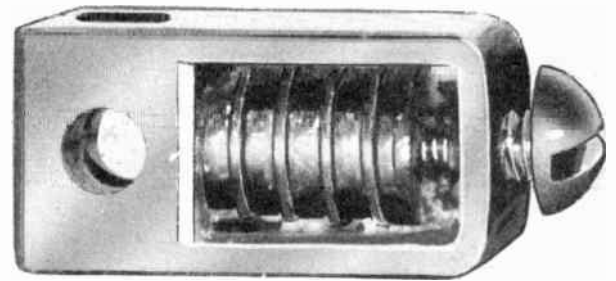
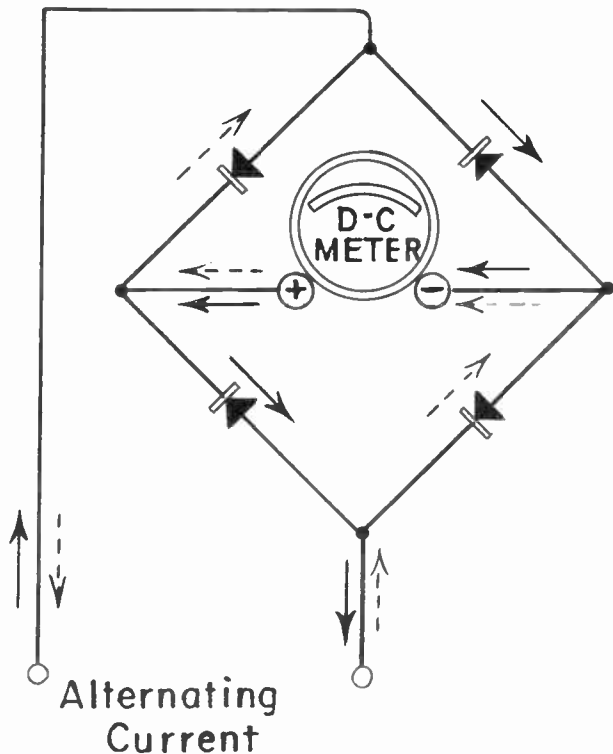

Fig. 12. A bridge rectifier circuit for meters (left) and one style of meter rectifier assembly (right).

ment. The meter movement then is operated by rectified direct current. The combination of rectifier and d-c movement is called a rectifier meter.

A circuit commonly employed for meter rectifiers is shown at the left in Fig. 12. This is a full-wave bridge rectifier circuit. It consists of four small contact rectifier elements connected as in the diagram but mounted together in a supporting frame as pictured at the right.

The rectifier discs are only about  $3/16$  inch square, or of this diameter when round. Actual overall height of the assembly illustrated is about a half inch. This unit may be mounted inside the case of the meter as shown by Fig. 13. Otherwise the rectifier unit may be external to the movement case and mounted within the housing of any instrument which utilizes a rectifier meter.

During one polarity of measured alternating voltage or current the electron flow is as shown by full-line arrows on the diagram of Fig. 12. During the opposite polarity the flow takes the path shown by broken line arrows.

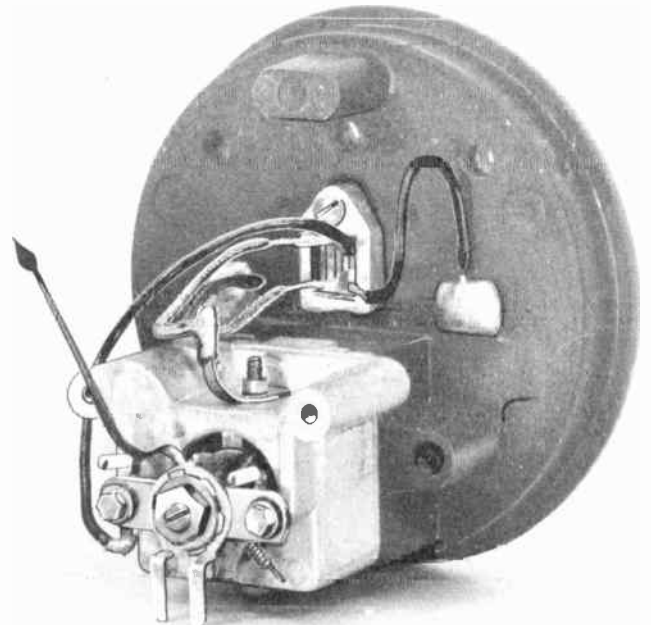

Fig. 13. A meter rectifier mounted on the back of the instrument case, above the movement.

The rectifier elements are so arranged that both polarities or both alternations cause rectified current to flow in the same direction through the d-c movement of the meter.

## COYNE - *television home training*

Rectifier elements commonly are of the copper-oxide type, although small selenium elements also are used. A copper-oxide rectifier element consists of a copper disc or plate on one side of which has been formed a film of copper oxide. There is little opposition to electron flow from copper to oxide, but relatively great opposition to flow in the other direction. Thus we have rectification.

When a shunt is used with a rectifier meter for measurement of currents greater than can safely be carried by the d-c movement, the shunt resistor must be connected between the a-c input terminals, not in the arms of the bridge nor in the leads from the bridge to the d-c movement. A multiplier or a series resistor for making the rectifier meter into a voltmeter must be in series with either of the a-c terminals, between these terminals and the bridge, not in the bridge arms nor in leads to the d-c movement. Otherwise the rectifier elements will be overloaded and destroyed.

Resistors used for shunts and multipliers must be non-inductive, they must have only negligible inductive reactance at all measured frequencies. These resistors also must have very small capacitance effects, to avoid bypassing part of the measured voltage and current. Carbon resistors meet these two requirements. Special types of non-inductive low-capacitance wire wound resistors may be used. These wound resistors are less subject to change of resistance with variation of temperature than are ordinary carbon types.

### SENSITIVITY OF RECTIFIER METERS.

Current meters of the rectifier type are available with full-scale pointer deflection as low as 100 microamperes. Other common ranges include 200 and 500 microamperes, also 1, 2, 3 and 5 milliamperes for full-scale deflection.

Sensitivity of rectifier type voltmeters depends on the current which causes full-scale deflection of the d-c movement and on the total resistance or impedance of the movement, the rectifiers, and any multiplier which may be used. The majority of rectifier type service voltmeters have sensitivity of 1,000 ohms per volt, although some of them

have sensitivities as high as 2,000, 5,000, or even 10,000 ohms per volt.

The impedance of a meter rectifier is quite small when the current is large, but increases rapidly when the current becomes small. The impedance might be something like 500 ohms when current is 1 milliampere. It might rise to 1,000 ohms at 1/2 milliampere, and to about 4,000 ohms at 1/10 milliampere.

This variation of impedance with current causes the low end of a voltage or current scale to be crowded. This effect is illustrated by the a-c voltmeter scale of Fig. 14. Above 0.5 volt the scale is quite uniform,

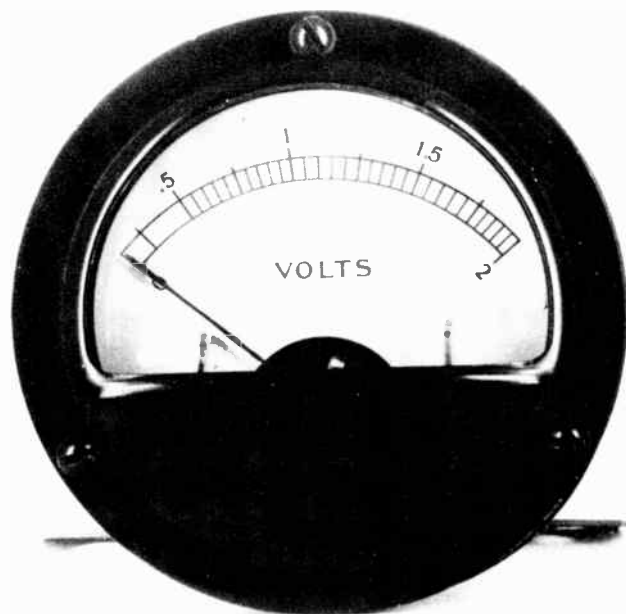

Fig. 14. The dial scale of a rectifier meter would be crowded at low readings, and usually has no graduations at the low end.

but it is not graduated at the low end because markings would come very close together and the accuracy would not be entirely satisfactory.

The less the voltage for full-scale deflection the greater is the relative crowding at the low end. For full-scale deflections at 10 volts or higher the graduations remain fairly uniform nearly to the bottom. On meters having one range of 3 volts or less, and other higher ranges, the low range usually is



# LESSON 31 -- METERS AND INSTRUMENTS

used with a scale different from that for the higher ranges.

## ACCURACY OF RECTIFIER METERS.

The accuracy of rectifier meters is affected by temperature. When such meters are stored and used where room temperature remains between 60° to 90° Fahrenheit the accuracy of service type instruments usually is about 5 per cent plus or minus. At either lower or higher temperatures the readings will be somewhat lower than actual values of measured voltages and currents, the error sometimes going to as much as 15 or even 20 per cent.

Another cause for inaccuracy is waveform of measured voltages or currents. Rectifier meters actually respond to the average amplitude of a-c voltage or current, but they are calibrated and the dials are graduated to read effective or r-m-s values. The calibration is made for sine-wave form, and best accuracy is obtained when measuring sine waves. If peaks of voltage or current are flatter than those of a sine wave the readings will be too high, and if peaks are sharper than those of a sine wave the readings will be too low. A rectifier meter used on direct voltage or current will read 10 to 11 per cent high.

Still another cause for inaccuracy of rectifier meters is high frequency of the measured voltage or current. Greatest accuracy is obtained at frequencies around 500 cycles and lower. For every successive rise of about 1,000 cycles in frequency the error may increase by 1/2 to 1 per cent. As an example, at a frequency of 10,000 cycles the error due to frequency may be something between 5 and 10 per cent, with readings lower than actual values of measured voltage or current.

Frequency error is due chiefly to capacitance of the discs or plates in the rectifier unit. The smaller the unit the less may be its capacitance, and the less the frequency error. At frequencies greater than about 30,000 cycles the bypassing effect of rectifier capacitance becomes so great as to make this type of meter nearly useless.

**THE OHMMETER.** An ohmmeter, as we learned in earlier lessons, is an instrument for directly measuring and indicating the value of a resistance connected between two terminals of the ohmmeter. Fig. 15 illustrates the action of an ohmmeter circuit generally employed for service work. A d'Arsonval type movement is connected in series with resistor  $R_c$ , a dry cell or bat-

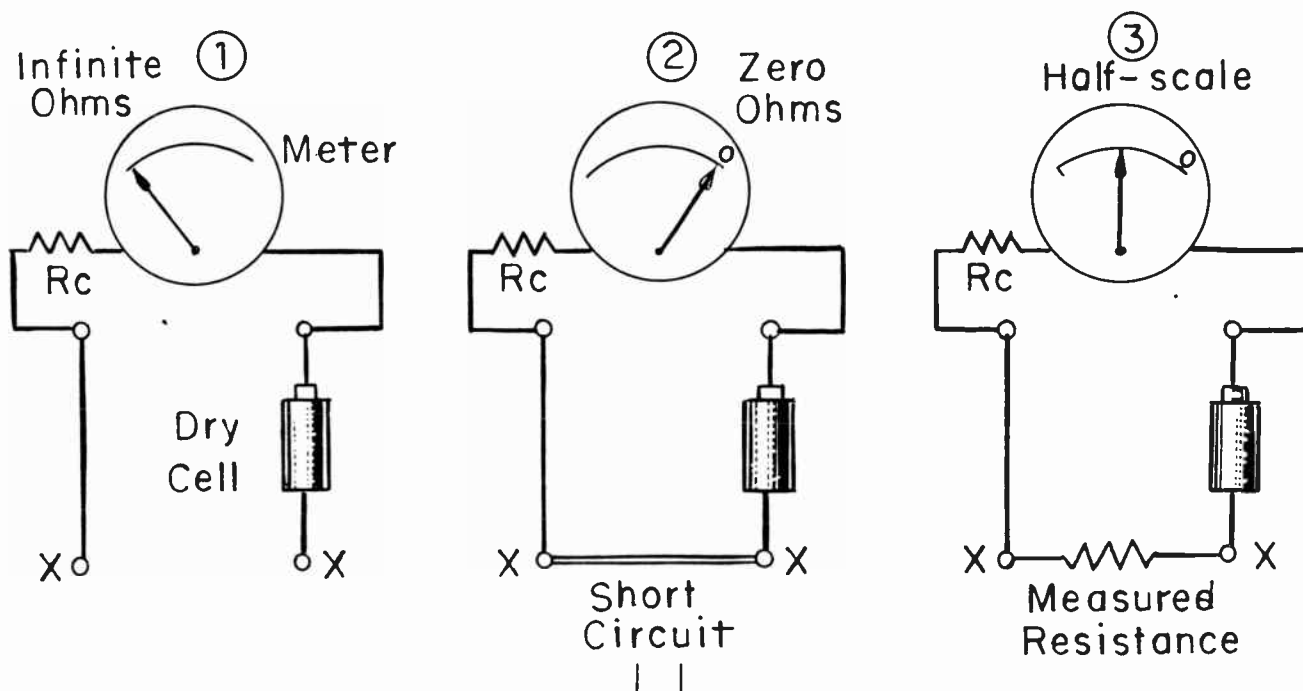

Fig. 15. The elementary circuit for an ohmmeter.

# COYNE - *television home training*

tery, and the two terminals X and X between which will be connected any resistance to be measured.

In diagram 1 nothing is connected between terminals X - X. The meter circuit is open, and no current can flow. The pointer of the meter stands at the left-hand end of its dial, which is the normal position for zero current. But this position of the pointer corresponds to infinitely great resistance (an open circuit) between terminals X-X and it indicates an open circuit when using the ohmmeter for testing.

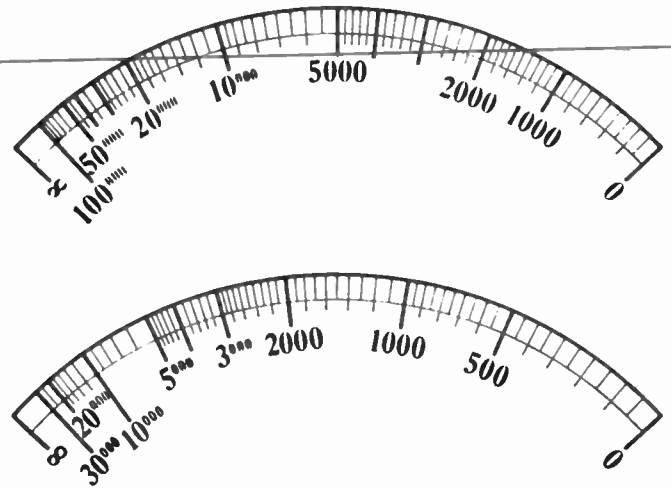

Fig. 16. Resistance values indicated on ohmmeter scales vary with the type of ohmmeter or with the range being used.

In diagram 2 terminals X-X have been short circuited with a conductor of negligible resistance. Current flows through the dry cell, the meter movement, resistor Rc, and the short-circuiting conductor. Resistor Rc is of such value as to limit the current to a value causing full-scale deflection of the meter pointer. The required value of Rc depends on the voltage from the dry cell battery, on the resistance of the meter movement, and on the current which causes full-scale deflection. This position of the pointer indicates zero resistance between terminals X-X when the instrument is used as an ohmmeter.

ations are widely spread in the lower portion of the ranges, and become very crowded at the high-resistance end.

In diagram 3 the measured resistance, between terminals X-X, is exactly equal to the sum of the resistance of the meter movement and resistor Rc. Now the total resistance of the circuit is twice as much as in diagram 2, and, accordingly, the meter pointer stands at half-scale. This point on the ohmmeter dial will be marked as a resistance value equal to the combined resistance of the movement and Rc. The half-scale resistance depends on the characteristics of the movement and on the voltage of the battery, and varies in different ohmmeters.

The wide variety of resistances to be measured during service operations makes it necessary to use a multi-range ohmmeter, one having three or more ranges of measured values. With the simple design of Fig. 15 different ranges could be had only by changing the current range of the meter, by changing the battery voltage, or by doing both. Additional ranges usually are provided in practice by using several different shunt resistors across the meter thus, in effect, changing the full-scale current values. This principle is illustrated by Fig. 17.

Diagram 1 is similar to diagram 1 of Fig. 15 except for having a shunt resistor connected across the meter movement and series resistor Rc. There is no resistance between terminals X-X. This opens the meter circuit and allows the pointer to stand at the position for infinite resistance.

Either by measuring a large number of known resistances or else by computation, the entire dial scale may be graduated in values of measured resistance. Two ohmmeter scales are shown by Fig. 16. The one at the top reads 5,000 ohms at half-scale and the one below reads 1,250 ohms at half-scale. For equal changes of resistance, the gradu-

In diagram 2 terminals X-X are shorted, as in the similarly numbered diagram of Fig. 15. The pointer swings to the position for zero resistance because, as in the earlier diagram, one side of the battery is directly connected to one side of the meter movement and the other side of the battery to resistor Rc.

## LESSON 31 – METERS AND INSTRUMENTS

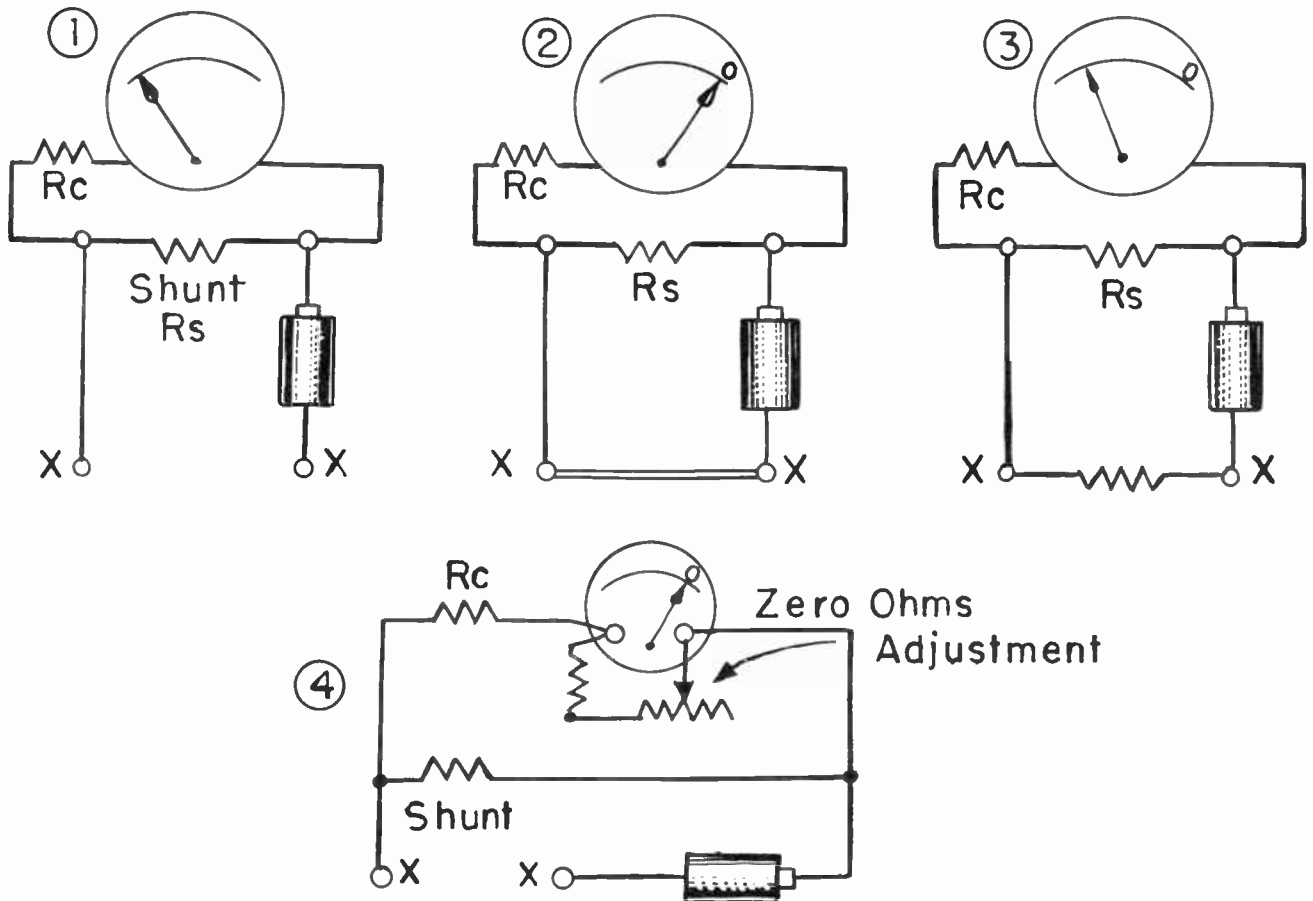

Fig. 17. The addition of a shunting resistor at  $R_s$  will change the range of the ohmmeter. Any of several shunting resistors may be used to make a multi-range ohmmeter.

In diagram 3 a measured resistance is connected between terminals  $X$ - $X$ . Now part of the battery current flows in the shunt resistor and only the remainder in the meter and resistor  $R_c$ . The pointer now does not go as far as half-scale. To bring it there the measured resistance would have to be reduced, allowing more current to flow to the meter through the measured resistance and the meter movement. Any resistance in the shunt position lowers the measurement range from that with no shunt resistance. The less the shunt resistance the lower becomes the range of measured resistances. By switching more or less resistance into the shunt position it is possible to provide a number of ranges for measured resistance.

As the ohmmeter battery voltage decreases with age and use the meter pointer will not be deflected so far with any given measured resistance between terminals  $X$ - $X$ .

This weakening of the battery may be compensated for in various ways, one of which is shown at 4 in Fig. 17. Across the meter movement is a continuously adjustable shunt resistor. When the ohmmeter battery is fresh and strong the adjustable shunt is set for fairly low resistance, to take a fair amount of current away from the movement. As the battery weakens, the adjustable shunt resistance is increased, to force more of the total current through the movement.

The adjustable shunt resistance is called a zero ohms adjustment and always is controlled by a knob or pointer on the front panel of the ohmmeter. Each time the ohmmeter is to be used, test terminals  $X$ - $X$  are shorted together while the zero ohms adjustment is set to bring the pointer to the zero ohms position on the dial. Then the short is removed and the ohmmeter is ready to make measurements of resistance.

# TELEVISION

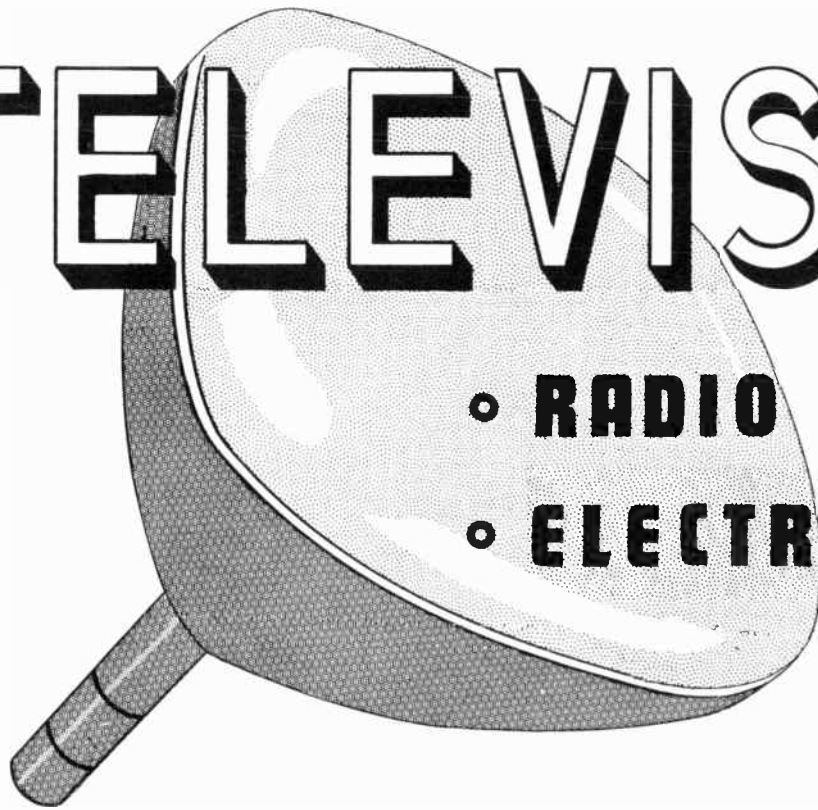

◦ **RADIO**

◦ **ELECTRONICS**

---

---

## LESSON 32 – SIGNAL GENERATORS

---

---

***Coyne School***

*practical home training*

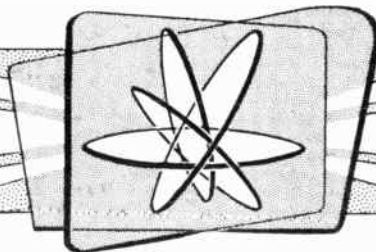

*Chicago, Illinois*



---

*Copyright, 1953 by Coyne Electrical School  
Chicago 12, Illinois  
All Rights reserved*

Litho. in U.S.A

## Lesson 32

# SIGNAL GENERATORS

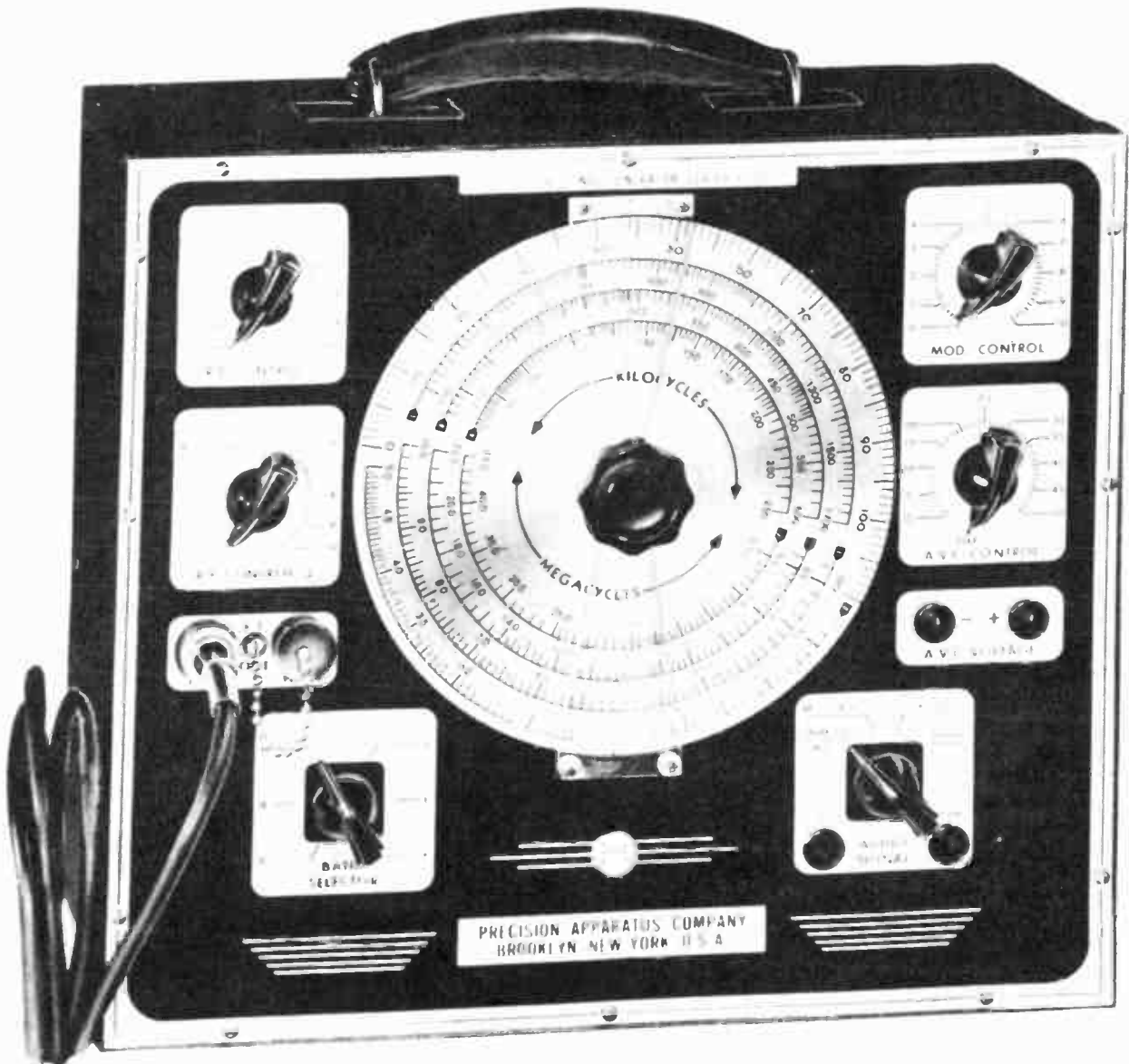

Fig. 1. A signal generator.

A signal generator consists essentially of a radio-frequency oscillator whose frequency and output voltage may be varied throughout wide ranges, and whose r-f output may be modulated with an audio frequency. The generator provides the equivalent of a transmitted radio signal which may be varied in frequency, strength, and modulation as re-

quired for testing and adjusting receiver circuits, all the way from the antenna coupler to the loud speaker.

R-f signal generators to be now considered are of types designed particularly for servicing of standard broadcast and short-wave broadcast receivers, although they may

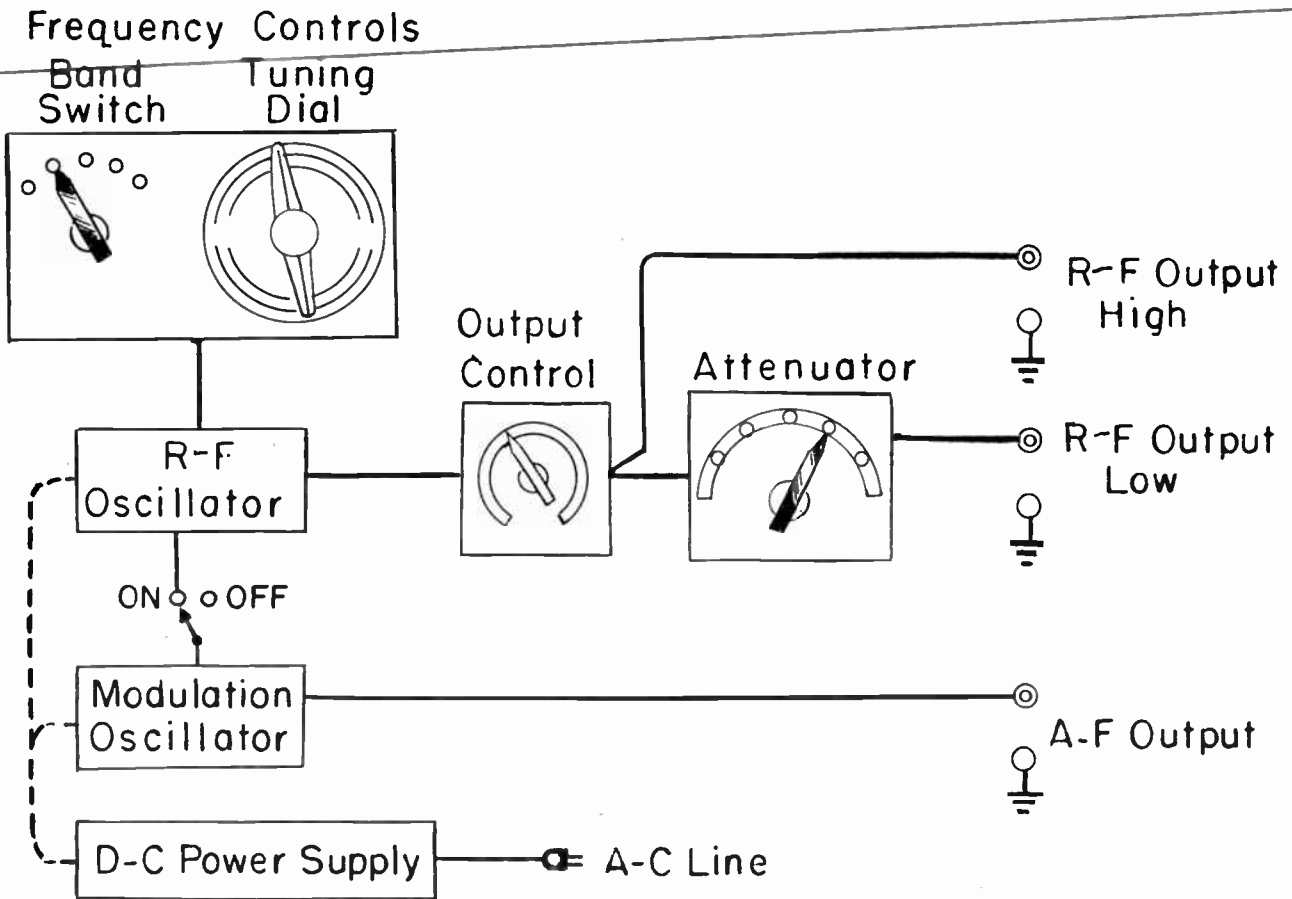

Fig. 2. The principal sections of a typical signal generator.

be used also for many common service operations on television sets. Such a signal generator is pictured by Fig. 1.

Fig. 2 shows in block form the principal sections of a signal generator and their relations to one another. The heart of the instrument is the r-f oscillator. This usually is a Hartley type, although other kinds of feedback oscillators are fairly common. The frequency of this oscillator may be varied from a low value of something like 75 to 150 kilocycles up to a high value of 30 to 60 megacycles.

The total range of radio frequencies is divided into several bands, any one of which may be selected by means of a multiple-position band switch. The highest frequency in each band is equal to two or three times the lowest frequency. In each band the frequency may be varied from lowest to highest by the tuning dial. In the majority of signal genera-

tors this dial operates a variable tuning capacitor, although a variable inductor may be used.

The output of the r-f oscillator may or may not be modulated with a low-frequency furnished from a separate modulation oscillator built into the signal generator. When a modulated r-f signal is needed the modulation switch is turned on. For a pure r-f signal, unmodulated, this switch is turned off.

The high-frequency voltage from the r-f oscillator, with or without modulation, goes to the output control. This control usually is a potentiometer, but may be of some special construction adapted to the requirements of high-frequency voltage control. By means of this adjustment the high-frequency voltage going to following sections may be varied from practically zero to the maximum which the r-f oscillator can furnish.

## LESSON 32 – SIGNAL GENERATORS

Immediately following the output control may be a lead to one of the external terminals of the signal generator. This terminal would be marked "R-F Output, High", or something equivalent in meaning. Here may be secured the strongest r-f voltage, for use with receivers or circuits which are not sensitive or which are badly out of adjustment when you commence work. This high r-f voltage may or may not be modulated, depending on the position of the modulation switch.

From the adjustable output control another lead goes to the attenuator. This section consists of a rather elaborate network of resistors capable of reducing the r-f voltage in steps. Any of the voltage steps may be selected by means of a multiple-position switch. From the attenuator a lead goes to an external terminal marked "R-F Output, Low", or something generally equivalent. Any signal voltage taken from the attenuator may or may not be modulated, according to the setting of the modulation switch.

There may be still another external terminal to which runs a lead from the modulation oscillator. From this terminal may be taken a voltage at the modulation frequency, which is an audio frequency. This output is used for servicing audio amplifier or other low-frequency circuits of receivers.

The standard modulation frequency is 400 cycles per second. Most signal generators furnish approximately this frequency both to the r-f oscillator circuit for modulation and to an external terminal for other purposes. Percentage of modulation may be adjustable. Otherwise it usually is fixed at about 30 per cent, which is standard for routine service operations.

Voltages for plates and screen of tubes in the generator are furnished by a self-contained d-c power supply. The power supply most often includes a full-wave rectifier tube operated from a power transformer with center-tapped secondary. Half-wave selenium rectifiers sometimes are used. The power supply filter may be either a choke-capacitor type or a resistor-capacitor type.

HARMONIC FREQUENCIES. Many signal generators which tune to only moder-

ately high frequencies, even on their highest bands, still may be used for tests at frequencies two or three times as high. This is because an r-f oscillator may be designed and operated to produce not only the frequency for which it is tuned, but also several multiples of this frequency.

The frequency for which the resonant circuits of the oscillator are tuned is called the fundamental frequency. At the same time there is produced a harmonic frequency twice as high, which is called the second harmonic. For example, when an oscillator is tuned to a fundamental frequency of 20 mc it produces at the same time a second harmonic frequency of 40 mc. For every other fundamental frequency to which the oscillator is tuned it will produce simultaneously a second harmonic twice as high.

When the r-f oscillator is operated with such voltages on the plate, screen, and grid as to drive plate current to the high limit allowed by plate voltage, and also to plate current cutoff on every cycle, there will be many harmonic frequencies. During a check of a service type signal generator tuned to a fundamental frequency of 10 mc, harmonics could be detected up to and including the sixteenth. That is, in addition to the fundamental of 10 mc there was a second harmonic of 20 mc, a third harmonic of 30 mc, and so on at intervals of 10 mc all the way to the sixteenth harmonic, at 160 mc.

A similar check of a different signal generator showed no readily measurable harmonics beyond the third, which was very weak. The difference in number of harmonics results from the types of oscillator tubes, the voltages at which they are operated, and the kind of oscillating circuits. There are fewer and weaker harmonic frequencies with a high-Q tank circuit than with one of lower Q.

Between the oscillator and part or all of the output control sections may be an amplifier stage, often called a buffer amplifier. Then the oscillator may be operated to have weaker output voltage and fewer harmonics. The oscillator voltage is stepped up by the buffer amplifier. This amplifier circuit is untuned, usually having resistance coupling,



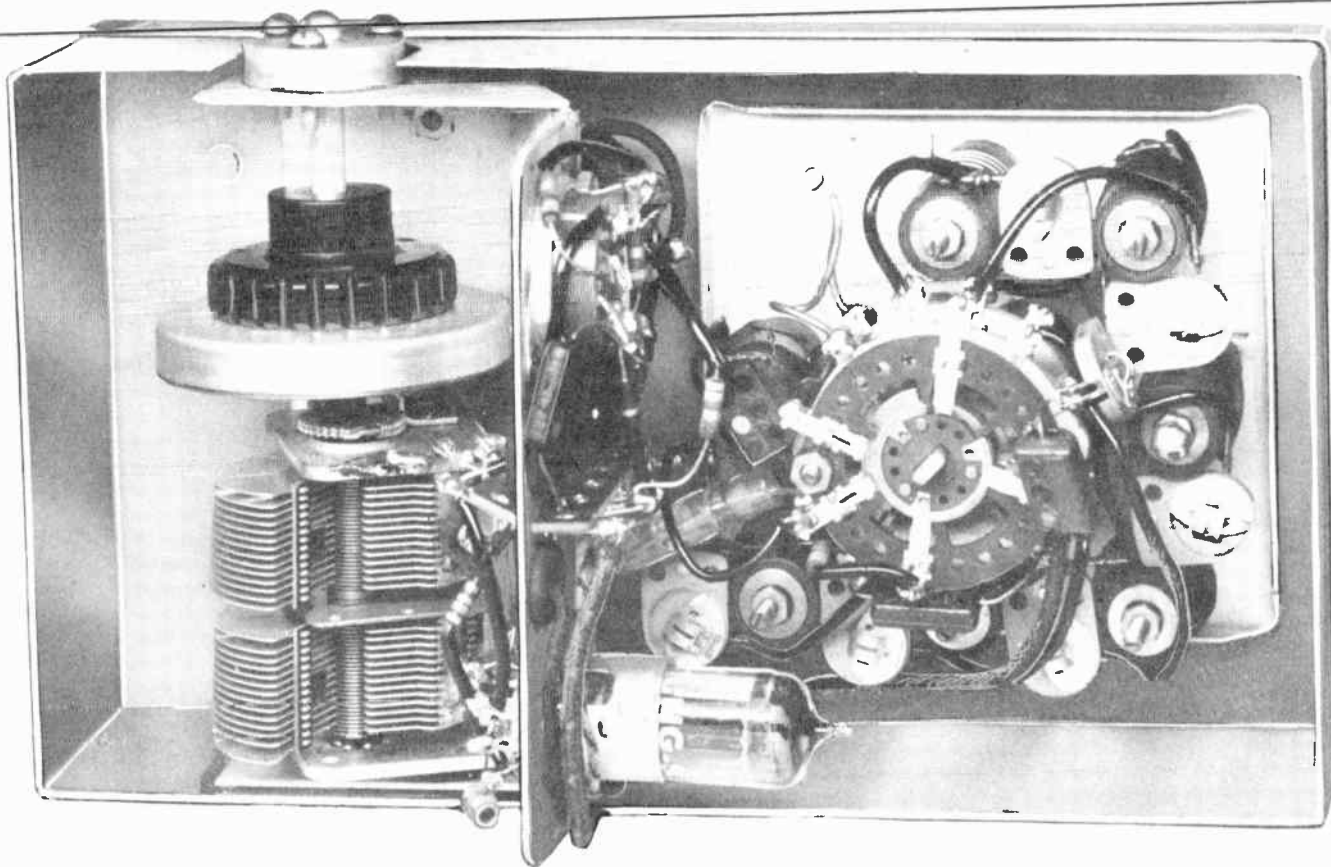

Fig. 3. An oscillator tuning capacitor and inductors which are selected for the various frequency bands covered by a signal generator.

so that it may operate in the entire range of frequencies furnished by the r-f oscillator.

Signal generators which tune to fundamentals no higher than something like 60 mc usually are designed to furnish second and third harmonic frequencies, and sometimes a fourth, of strength sufficient for many service operations. For instance, a generator whose highest fundamental frequency is 50 mc might supply second harmonics up to 100 mc, third harmonics to 150 mc, and possibly fourth harmonics to a limit of 200 mc. Generators which tune to higher fundamentals usually are designed to have fewer and weaker harmonic frequencies.

The strength or the r-f voltage of the second harmonic is much less than that of the fundamental. The third harmonic usually is quite a bit weaker than the second, and a fourth is decidedly weaker than the third. It is the decreasing strength of successively

higher harmonic voltages that limits their use, or limits the frequency to which their use may be extended.

#### COUPLING TO THE OSCILLATOR.

Any changes of load impedance in the output circuit of the r-f oscillator affect the frequency. For this reason it is desirable to isolate the oscillator elements from the output load so far as is practicable. The load consists principally of the output voltage control and the attenuator. One method of load isolation employs an electron coupled oscillator, with which the only transfer of signal voltage from oscillator to load is through the electron stream within a pentode tube.

Fig. 5 shows circuits for an electron coupled Hartley oscillator. Other types of oscillator circuits may have electron coupling. The tube elements used for oscillation include the cathode, the grid, and the screen. The screen acts as the oscillator plate. If

## LESSON 32 – SIGNAL GENERATORS

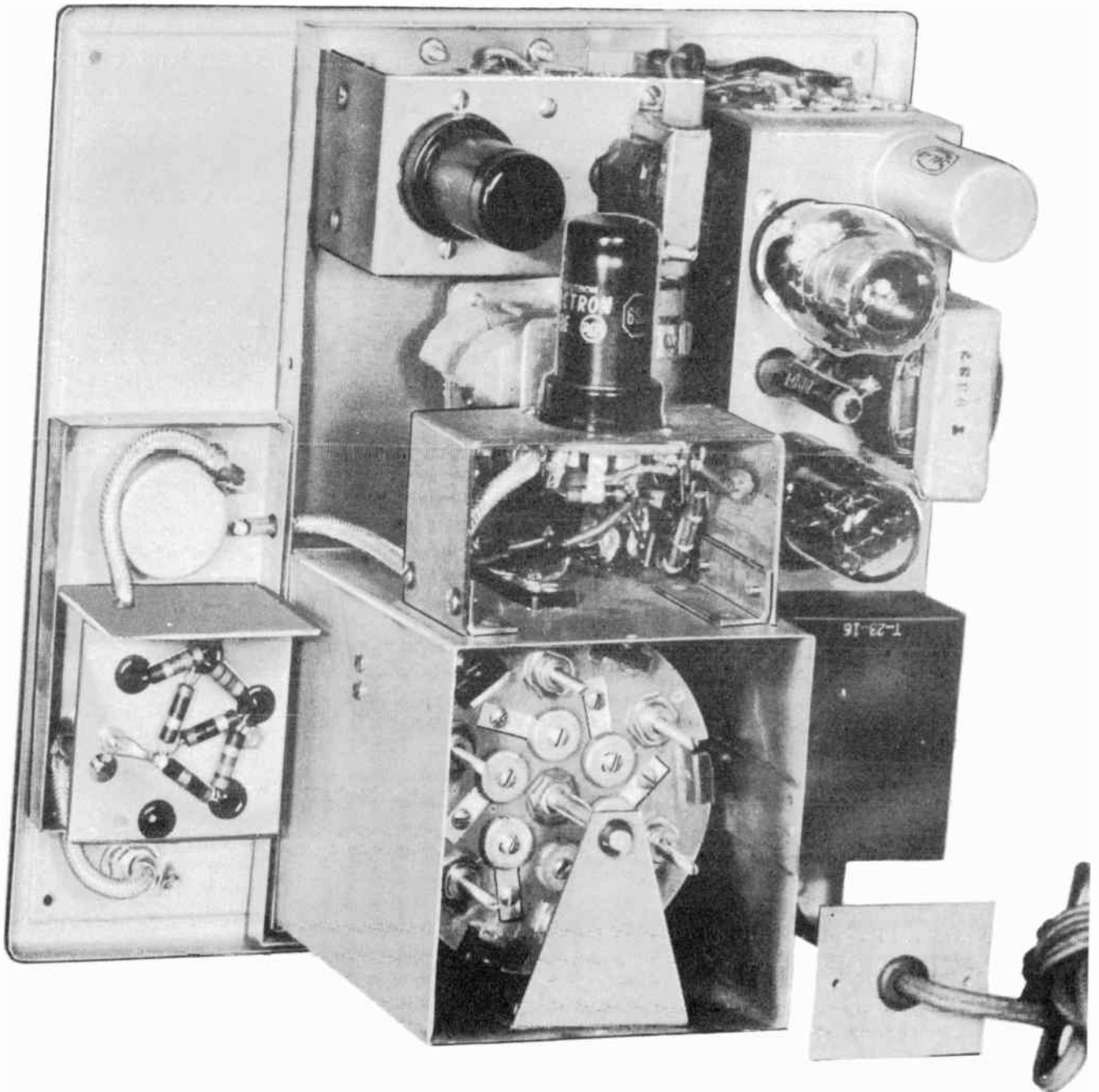

Fig. 4. Tubes and other parts which are inside a signal generator. Covers have been removed from the various shields.

you imagine the screen to be the plate of a triode, the oscillator circuit is seen to be an ordinary Hartley type. The pentode plate is maintained at a d-c voltage higher than that on the screen. Then most of the electron stream, varying at the oscillation frequency, goes through the suppressor to the pentode plate.

Oscillating voltage is taken from across plate resistor  $R_o$  through blocking capacitor  $C_c$  to the output control. The triode oscillator section of the tube is isolated from resistor  $R_o$  and the output control by the suppressor, which is at cathode potential. The only coupling between the oscillator section of the tube and the load is through

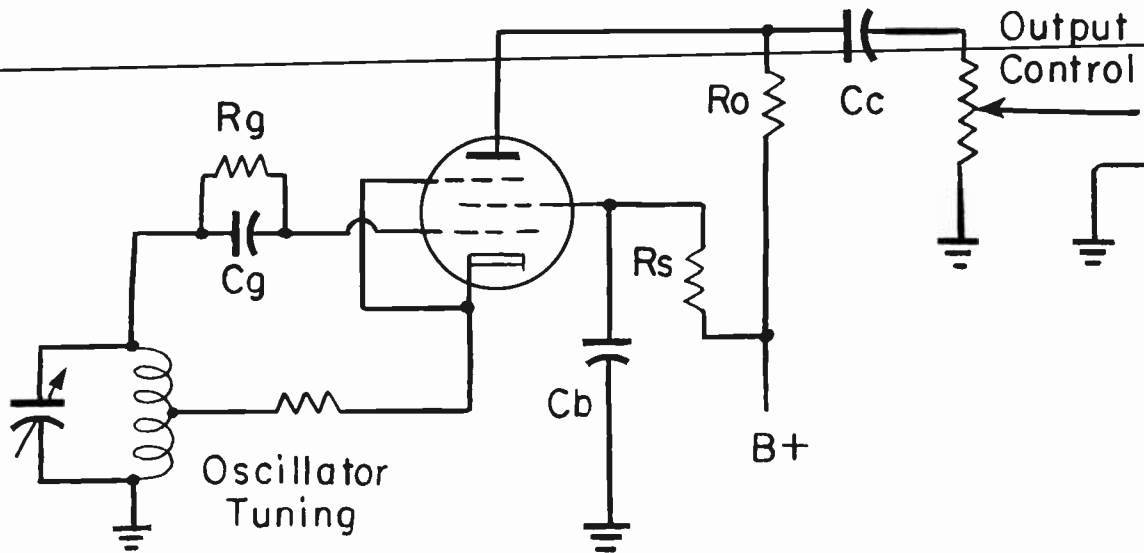

Fig. 5. The circuit connections for an electron coupled oscillator of the Hartley type.

the electron stream passing through the suppressor. A common abbreviation for electron coupled oscillator consists of the letters ECO.

MODULATION. With the modulation oscillator operating at a fixed frequency of about 400 cycles it is possible to employ various simple oscillator circuits which include iron-core feedback transformers. Sometimes the low-frequency oscillator circuits are designed with resistor-capacitor combinations whose time constants determine the operating frequency.

Output voltage from the low-frequency oscillator may be fixed at such value as gives approximately 30 per cent modulation of the r-f voltage. More often the strength of amplitude of modulating voltage is adjustable, so that actual percentage of modulation may be set anywhere between zero and 80 to 100 per cent. This allows using modulation strong enough to send a good audio signal into the a-f amplifier and speaker while the average r-f amplitude is kept relatively low. If the r-f voltage is made too strong the automatic volume control may act to cause misleading test indications.

Modulating voltage may be coupled into the output of the r-f oscillator in various ways. It may be applied to the suppressor of an electron coupled oscillator as in Fig. 6.

Here the modulating voltage is secured from a winding on the feedback transformer of the low-frequency or a-f oscillator. When using an electron coupled r-f oscillator such as that of Fig. 5 the modulating voltage might be applied through a large capacitance to the screen of the tube, at the junction between Rs and Cb of that figure.

If a buffer amplifier follows the r-f oscillator, modulating voltage may be coupled into the plate circuit of the buffer. Sometimes a buffer amplifier follows the low-frequency oscillator, with the a-f output from this buffer going to the d-c plate supply line of the r-f oscillator.

When modulating voltage is secured from a low-frequency oscillator which is part of the signal generator we have internal modulation. Many generators have provision also for applying as modulation on the r-f output an alternating voltage obtained from an external source. Then we have external modulation. The external modulating voltage may be of any frequency up to about one-tenth of that at which the r-f oscillator is operating.

One method of switching from internal to external modulation is illustrated by Fig. 7. The r-f oscillator is shown as an electron coupled type, with modulating voltage applied to either the suppressor or the screen. At

## LESSON 32 – SIGNAL GENERATORS

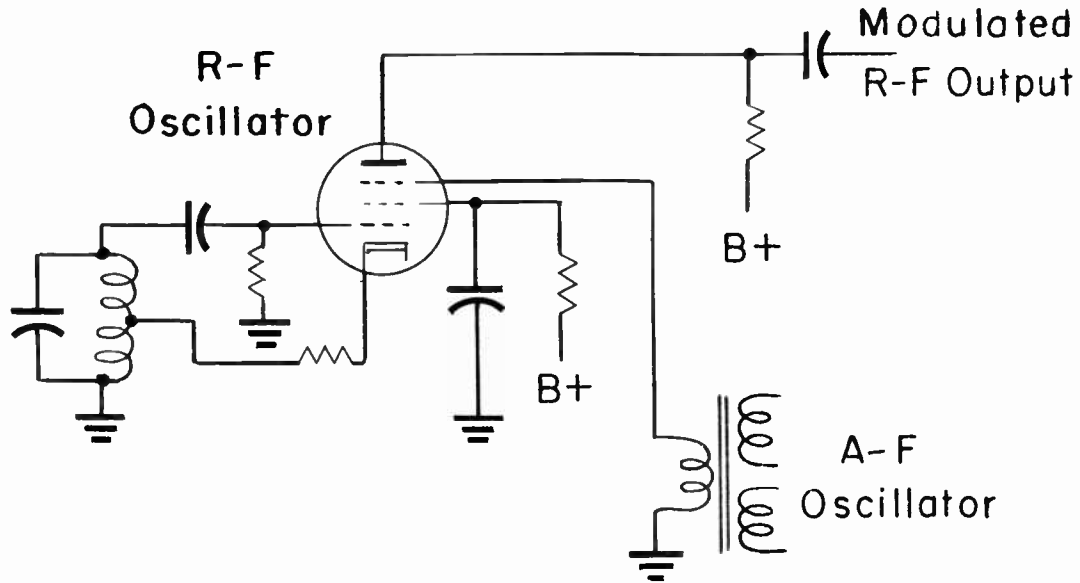

Fig. 6. Audio modulation applied to the suppressor of an electron coupled oscillator.

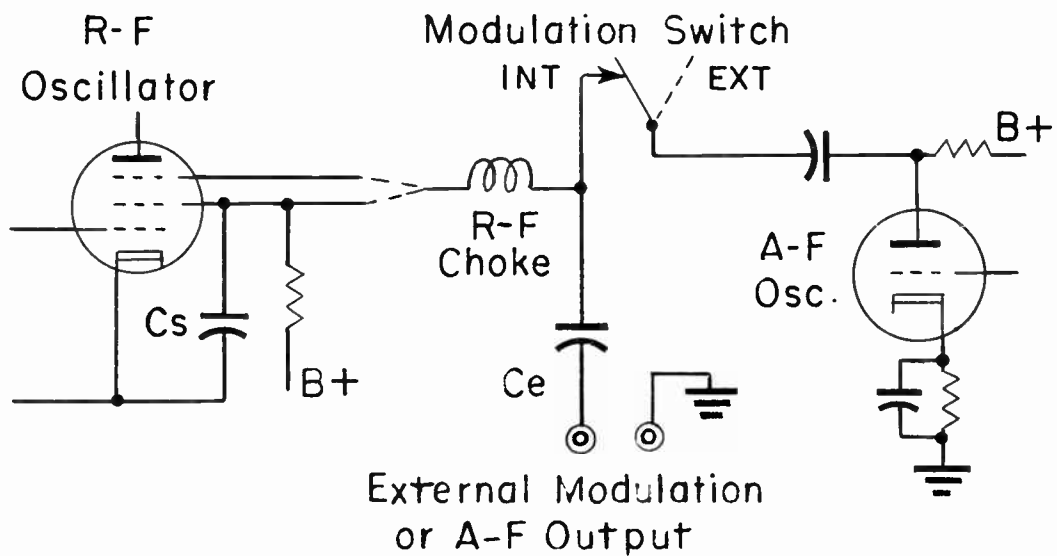

Fig. 7. A control for selecting either internal or external modulation.

the right is represented any kind of low-frequency oscillator. The modulation switch is a simple single-pole single-throw type which is closed for internal modulation and opened for external modulation. Down below are terminals to which a source of external modulating voltage may be connected.

With the modulation switch closed, low-frequency voltage from the a-f oscillator goes through the r-f choke to the a-f oscillator. The high impedance of this choke at radio frequencies isolates the r-f oscillating circuits from the a-f oscillator, while the r-f

circuits are completed through capacitor Cs. With the switch in this position it is possible also to take the a-f voltage from the external terminals, for use in checking the audio sections of receivers.

When the modulation switch is open the a-f oscillator is disconnected from the r-f oscillator. Then the r-f oscillator will furnish unmodulated high-frequency voltage to and through the attenuator. While the switch is open any alternating voltage to be used for modulation may be connected to the external terminals. Then this external modu-



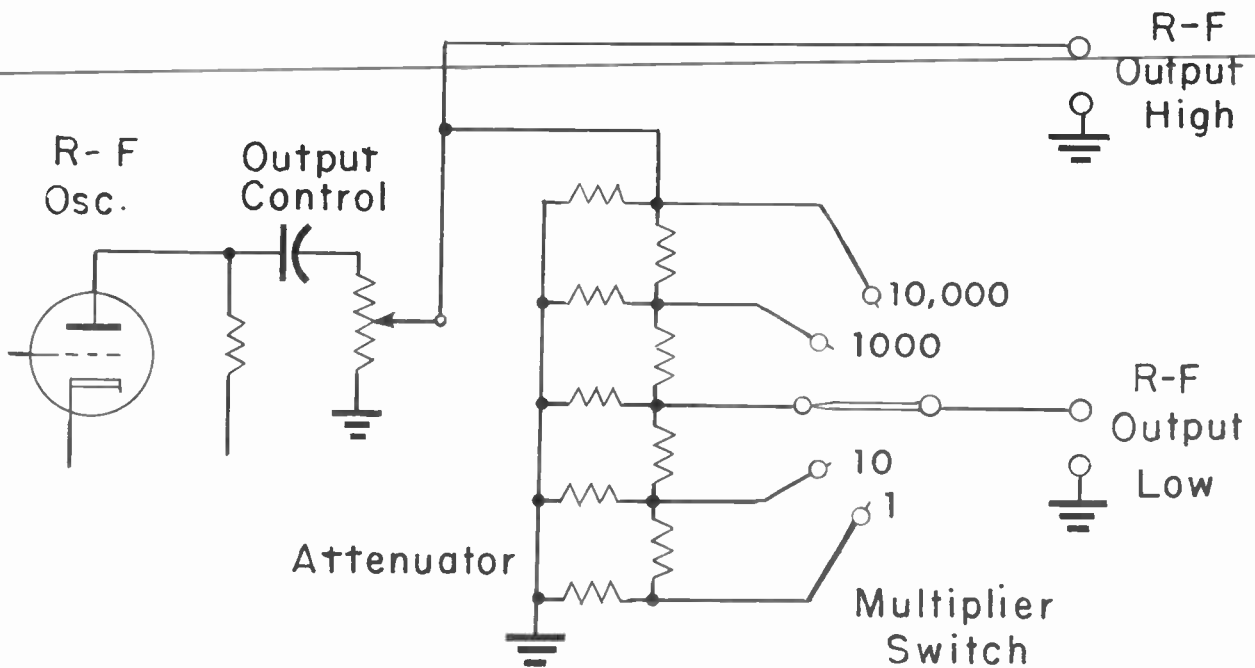

Fig. 8. An r-f output control and a ladder attenuator.

lating voltage goes through capacitor  $C_e$  and the r-f choke to modulate the r-f oscillator.

**ATTENUATORS.** The majority of service type signal generators have output controls and attenuators of the general type shown by Fig. 8. The attenuator is of the so-called ladder type, consisting of a number of resistors in series, with other resistors from the junctions to ground. From the junctions are connections also to a selector switch that may be called a multiplier switch.

With the r-f oscillator voltage applied to one end of the attenuator, certain fractions of this voltage appear at the switch connections and go through the switch rotor to the r-f output terminals. The least r-f voltage appears at the attenuator connection farthest from the oscillator input, at the switch connection marked 1 on the diagram. Here we might obtain 1 microvolt when the output control potentiometer is set at some certain position. Then the next higher switch position might give 10 microvolts, the following one 100 microvolts, and so on.

With the output control potentiometer kept at one position, resistance or impedance across the r-f oscillator plate circuit re-

mains constant with the multiplier switch at any position from 1 through 1000. Using any one of these switch positions then affects oscillator frequency little or not at all. At the same time the resistance of the attenuator network across the r-f output terminals does not change when the switch is moved through positions 1 to 1000, and performance of receiver circuits connected to this output will not be affected by changes of multiplier setting.

Altering the adjustment of the output control potentiometer does alter the resistance or impedance across the plate circuit of the oscillator, regardless of multiplier switch setting, and usually has some effect on oscillator frequency. The greatest effect is with the multiplier switch at its highest position, at 10,000 on the diagram of Fig. 8. Also, with the multiplier switch at this highest position, resistance across the r-f output terminals is materially different than resistance with any other switch setting unless the output control potentiometer is adjusted to or close to the high end, farthest from the ground connection.

In order to have the most nearly constant oscillator frequency, also the most nearly constant resistance across the r-f

## LESSON 32 – SIGNAL GENERATORS

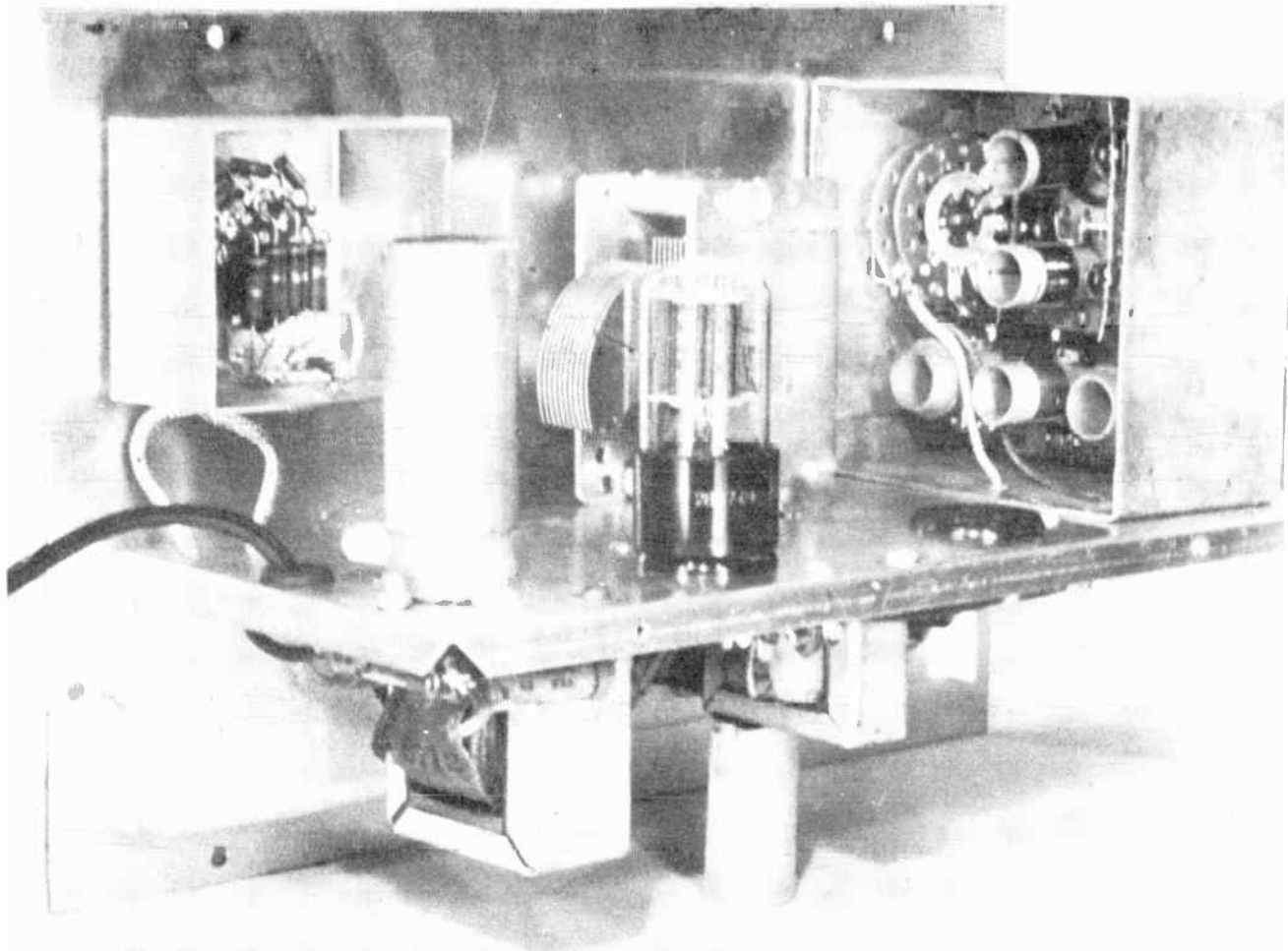

*Fig. 9. The attenuator of this signal generator is at the upper left. The resistors have been exposed by opening the shield.*

output, it is desirable to work with the output control potentiometer set high and to avoid using the highest setting of the attenuator.

**OUTPUT INDICATORS.** The r-f output voltage from an oscillator varies with frequency. As a general rule this voltage will be greatest on the lowest frequency band or on the band next to the lowest, and will be smallest on the highest frequency band. R-f voltage varies also within each band, often peaking somewhere around the middle of the band and decreasing toward either end.

It is fortunate that most service operations may be completed while the signal

generator furnishes one unvarying frequency, or with frequency and output controls at the same setting throughout the job. In some cases, however, it is desirable to have the same r-f voltage at two or more different frequencies. This cannot be accomplished with any certainty by using output control and attenuator systems of the simple types shown by Fig. 8; there are too many variable factors affecting the voltage.

To maintain a constant r-f output voltage, or to obtain some known output voltage at different oscillator frequencies it is necessary to meter the output. Then it is possible to maintain or to obtain a desired voltage

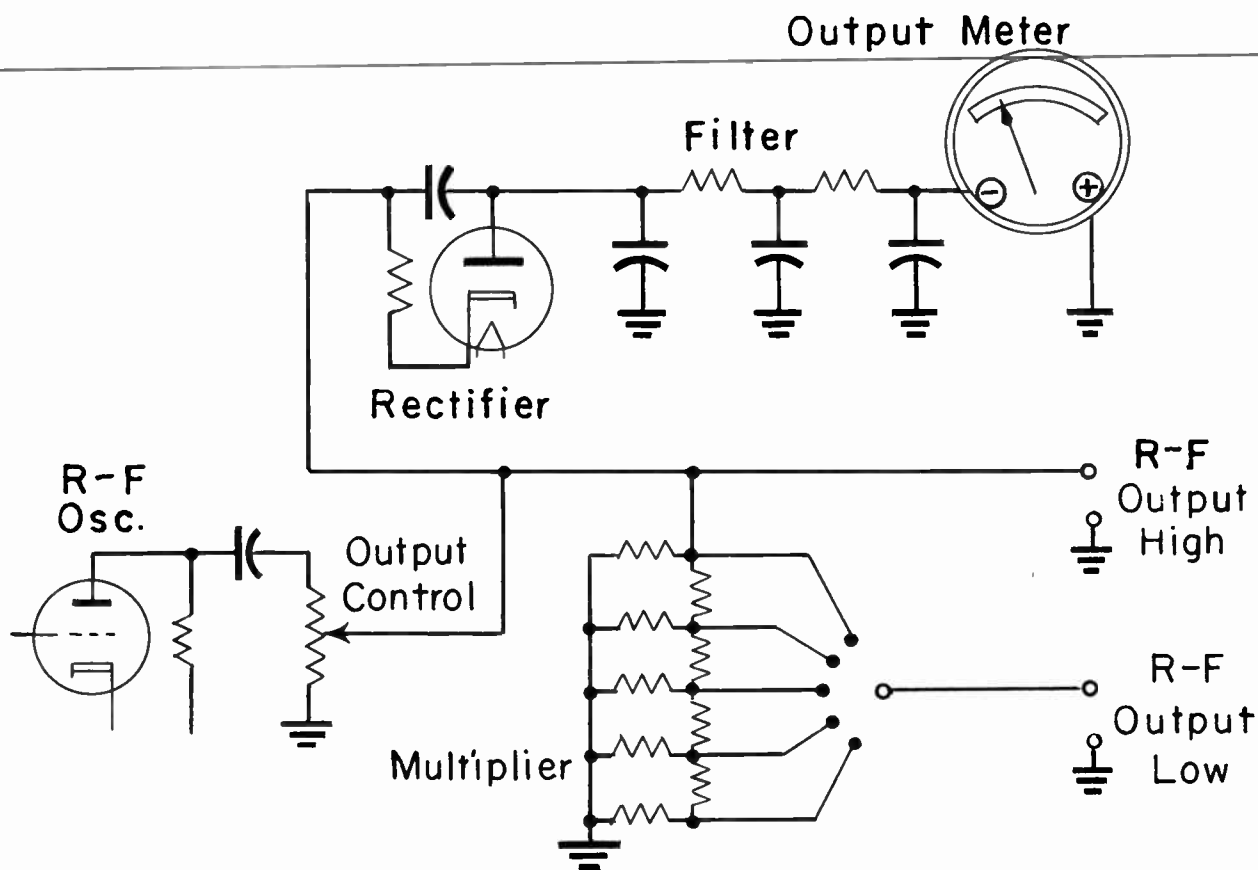

Fig. 10. Connections of a meter used for determining r-f output voltage at various settings of output control and attenuator.

as frequency is changed by adjusting the band switch and the tuning dial. The attenuator and output control may be readjusted as frequency is varied.

One method of measuring the r-f output is shown by Fig. 10. The output meter is a d-c type having full-scale current range of something like 50-to 100 microamperes. To this meter is brought rectified direct current taken from the high r-f output and brought through a rectifier and filter circuit. The meter is calibrated and graduated to read r-f voltage, which is proportional to the rectified current.

R-f voltage applied to the metering system is that which goes also to the high side of the attenuator. With the connections shown, this voltage is adjusted by means of the output control potentiometer. So long as the output control is adjusted or readjusted to maintain some certain reading of the meter, r-f voltage at the top of the attenuator will be of the same value regardless of frequency.

If oscillator frequency is varied, the output control may be readjusted to bring the meter reading back to the desired value.

For any given reading of the output meter the positions of the multiplier switch may be marked for certain numbers of microvolts of r-f output. With the output control varied to double the indication of the meter, the numbers of microvolts at each position of the multiplier switch will be doubled. If the meter is made to read 10 times as high, all the output voltages will likewise be multiplied by 10. Thus the signal generator controls may be adjusted for desired microvolts at the output terminals connected to the multiplier switch.

Other meter circuits may be used, such, for example, as a full-wave bridge rectifier arrangement. There may be modifications also in the attenuator and in other controls for output voltage. But always it is possible to adjust the r-f output voltage to definite values. Accuracy of indicated output

## LESSON 32 – SIGNAL GENERATORS

voltages may be on the order of 10 per cent at the lower frequencies, but often becomes no better than 20 to 25 per cent at the highest oscillator frequencies.

CALIBRATION OF SIGNAL GENERATORS. The calibration of a signal generator refers to the relations between frequencies as marked on the tuning dial and frequencies actually furnished at each dial setting. The difference between actual and marked frequencies usually is expressed as a percentage of the marked frequency. For example, if calibration is accurate to within 1 per cent, actual frequencies will be within one per cent, plus or minus, of dial readings.

Although calibration of a signal generator may be of some certain accuracy when the instrument is new, the accuracy usually becomes gradually less as tubes and other circuit elements age in normal use. It is not difficult to check the accuracy of a generator. A record may be made of errors at various frequencies, or variations may be plotted on a graph which is referred to when highly accurate values of frequency are required.

Errors may be corrected by adjusting the resonant circuits within the signal generator. Adjustable trimmer capacitors, padding capacitors, and movable cores in inductors are used for this purpose, which is called recalibration. It is decidedly inadvisable to attempt recalibration until you thoroughly understand, and have practice with, the methods and precautions observed in bringing generator frequencies into agreement with standard frequencies obtained from outside sources.

Frequency errors are checked by "beating" the actual generator frequency with carrier frequencies from broadcast stations operating in the ranges to be checked. This consists of combining the two frequencies to produce a difference frequency, which is the beat frequency. Broadcast carrier frequencies are highly accurate, and make satisfactory standards.

The radio frequencies from the signal generator and the broadcast transmitter are

far above the limits of audibility. But when these two radio frequencies come close together the resulting beat frequency is low enough to be heard from the speaker of a receiver. As an illustration, when the two radio frequencies are within 5,000 cycles of each other a 5,000-cycle beat note will be heard as a high-pitched whistle.

As the two radio frequencies are brought still closer into agreement the beat frequency will become lower, and the resulting sound will change to a low-pitched growl. Finally, when the radio frequencies are equal there will be no beat frequency and no sound. This condition is called zero beat.

The broadcast signal and r-f voltage from the generator are fed together to the antenna circuit of any standard broadcast receiver which is in reasonably good operating condition. Whether or not frequency markings are accurate on the tuning dial of the receiver makes no difference in the work of checking calibration. The receiver is used merely as a sort of mixer of the two radio frequencies, and for producing beat frequencies which can be heard from the speaker. The procedure is as follows:

1. Couple the low r-f output of the signal generator to the antenna input of the receiver.

- a. When the receiver has terminals for an external antenna, connect to these terminals the cable from the r-f output of the signal generator. If one receiver terminal is marked Antenna or Ant. and the other is marked Ground or Gnd., connect the high side of the generator output cable to the antenna terminal and the ground clip of the cable to ground on the receiver. Make the high-side connection through a mica or ceramic capacitor of about 1,000 mmf (0.001 mf) in series with the cable clip. For transformerless receivers make the ground connection through a paper capacitor of about 0.01 mf of greater capacitance, having a d-c voltage rating of 200 volts or greater. Never take the chance of making a direct ground connection from the signal generator to a transformerless receiver, the attenuator system of the generator may be ruined.



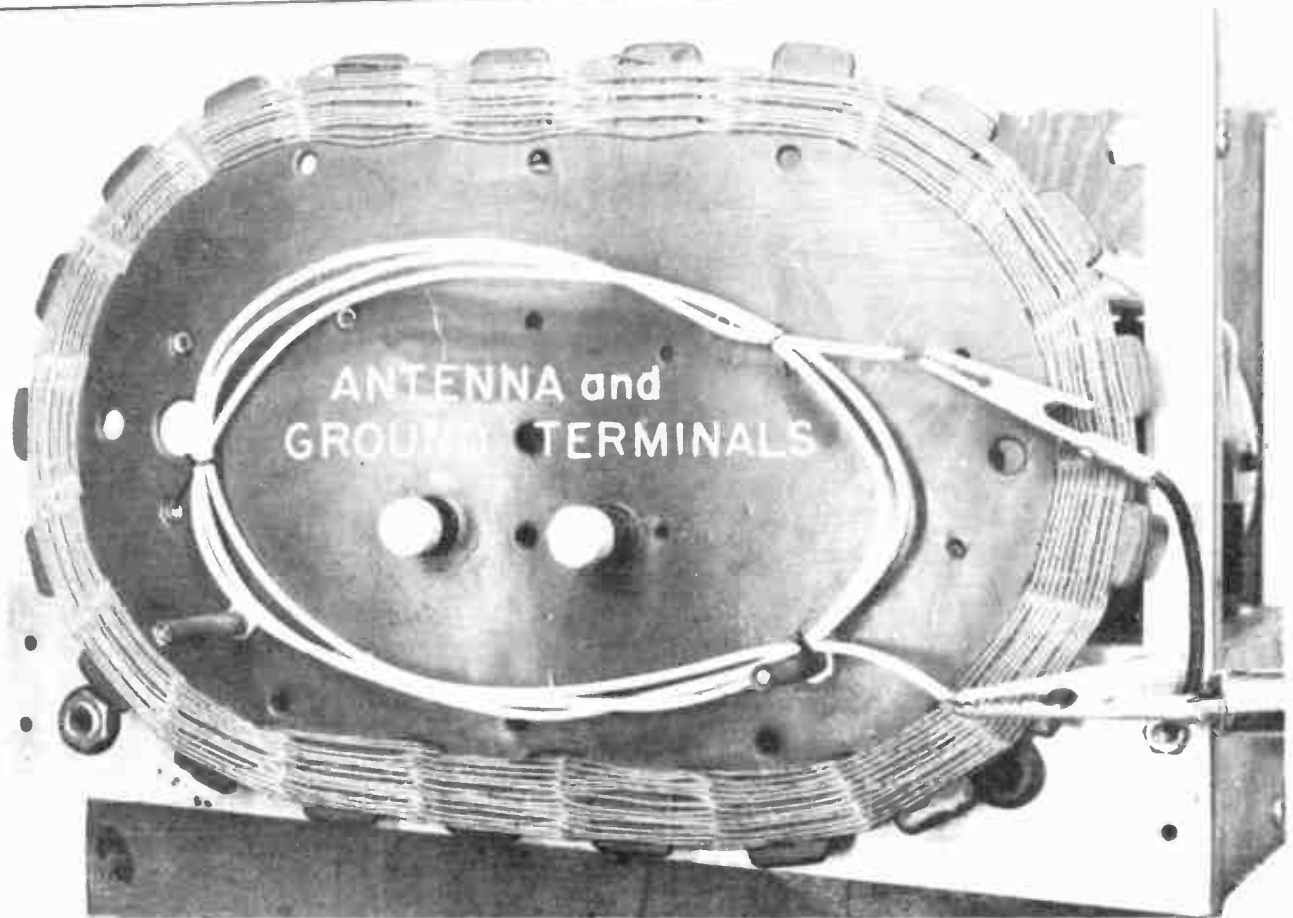

Fig. 11. A loop antenna and a coil for coupling the signal generator output to the antenna circuit of the receiver.

b. If the receiver has a built-in loop antenna of the general style pictured by Fig. 11, usually there will be terminals on the loop support for connection of an outside antenna. Connect the generator output cable to these antenna terminals as explained in preceding paragraph a.

c. If the loop antenna carries no terminals for an external antenna, make up a coil of three or four turns of any kind of insulated wire, as illustrated in Fig. 11, and support this coupling coil near the loop antenna. Clip the r-f output cable of the generator to the two ends of the coupling coil. The two cable clips may be seen in the picture, with the cable coming from the right.

2. Set the modulation switch of the signal general for unmodulated output.

3. Turn on the generator and let it warm up for at least 15 minutes, or for as long as 30 minutes, before proceeding with the tests.

4. Turn on the receiver and tune it to a station of known carrier frequency. If necessary, wait for an announcement of station call letters, from which you can positively identify the carrier frequency from listings in newspapers or other sources of program schedules.

5. Adjust the receiver volume control only high enough to hear the program clearly, but not very loud. Do not again alter the tuning of the receiver until after the first carrier frequency has been checked on the tuning dial of the signal generator.

## LESSON 32 – SIGNAL GENERATORS

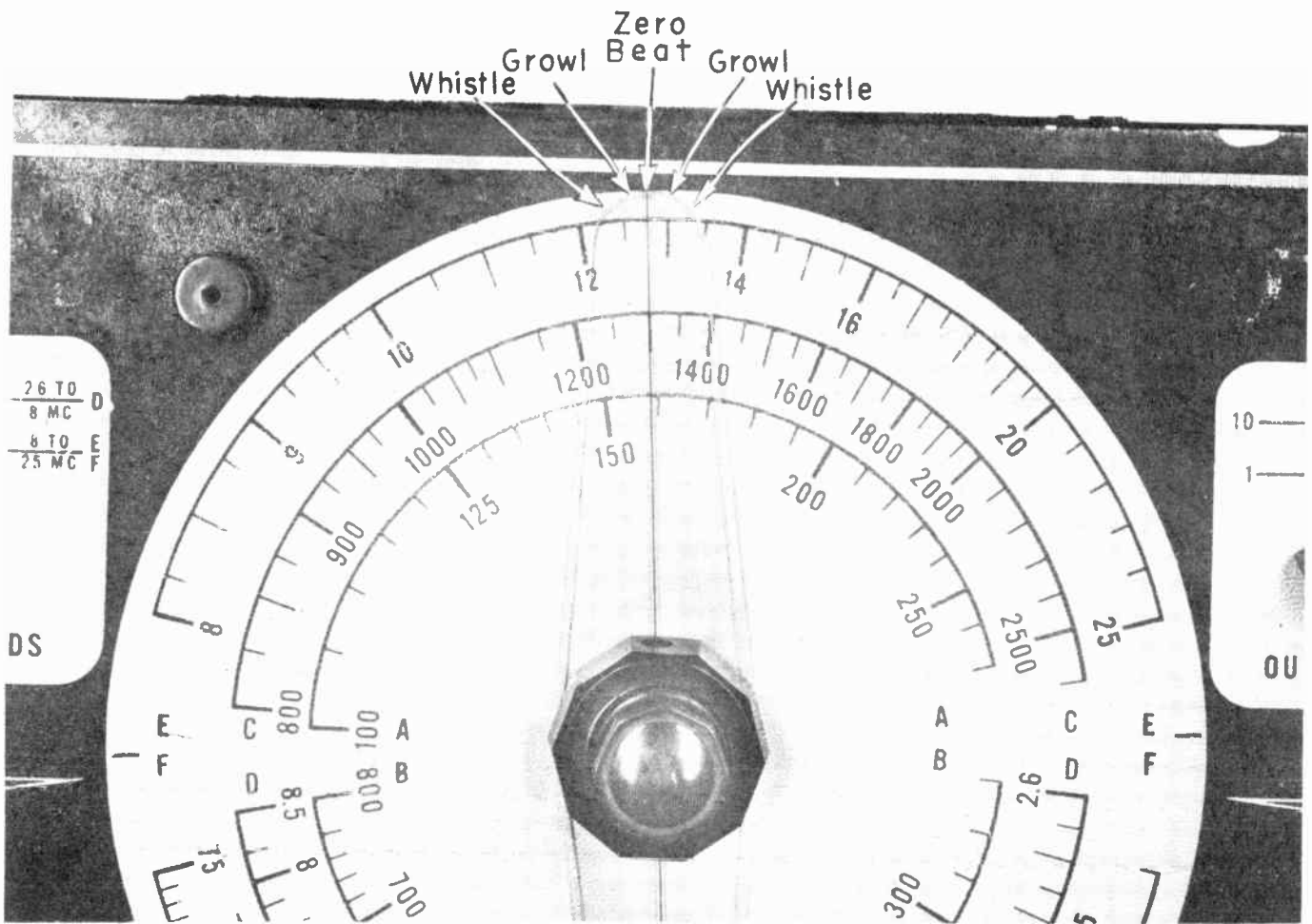

Fig. 12. As signal generator frequency is varied through a carrier frequency, the point for zero beat will be found between low-pitched growls.

6. Adjust the generator attenuator and output control high to begin with. As you proceed with the tests, reduce the output as much as possible while still being able to identify beat whistles and the condition of zero beat.

7. Tune the signal generator slowly back and forth across the carrier frequency of the station being received. As illustrated by Fig. 12, find the dial positions at which there are two high-pitched whistles, with between them regions of lower pitch or a growling sound. Between the two growls locate the point where there is minimum sound or no sound. This is the point of zero beat. The tuning dial of the generator now is set for the carrier frequency of the received station. Compare the dial reading with the carrier frequency, and note any error.

8. Check the calibration of the signal generator at other carrier frequencies by tuning in other broadcast stations and setting the generator tuning dial for zero beat on each carrier.

If there are whistles of varying intensities at two or more settings of the signal generator tuning dial the receiver is so far out of alignment that it cannot be used for calibrating. Realignment will be our subject for the following lesson. If it is impossible to secure audible whistles you might try using the high-r-f output of the signal generator. Calibration with high r-f output probably will be slightly different than on the low r-f output, for reasons explained during our discussion of attenuator systems.

It is possible also to check generator

## COYNE - *television home training*

dial frequencies lower than those of broadcast carriers by utilizing a combination of zero beat and generator harmonics, as follows.

1. Proceed as in steps numbered 1 through 6 for checking broadcast carrier frequencies. Leave the receiver tuned for any carrier frequency.

2. Tune the signal generator back and forth through a frequency marking which is one-half of the receiver tuned frequency. Proceed as instructed in step 7 of the earlier process to find the generator tuning for zero beat. The generator dial now is set for a frequency just half that of the carrier tuned on the receiver dial. Note the error, if any, in dial reading.

3. The signal generator may be tuned successively to frequencies equal to one-third, one-fourth, and even smaller simple fractions of any previously identified carrier frequency. The generator then will be producing third, fourth, and higher harmonics, which will be equal to the carrier frequency. The zero beat method may be used for checking generator dial markings at each fractional frequency.

Here is an example. Assume that the receiver is left tuned for 910 kc. Half this frequency is 455 kc. When the signal generator is tuned to precisely 455 kc the instrument is furnishing a fundamental of 455 kc and a second harmonic of 910 kc. This second harmonic is beating with the 910 kc broadcast carrier.

Do not expect laboratory standards of accuracy from service types of signal generators; there is no real need for such accuracy. Take the case of aligning an i-f amplifier having two or more i-f transformers. So long as all transformers are aligned for the same frequency, there would be no noticeable difference in reception whether this frequency were 455 kc, or 450 kc, or 400 kc, or anything in between. There is a similar situation when working in the carrier-frequency range. If you adjust the r-f and mixer tuning for something like 1010 kc when you think you are working at 1000 kc, the

user of the receiver will still tune for the station he wants to hear, regardless of receiver tuning dial readings.

VOLT - OHM - MILLIAMMETERS. For alignment of a standard broadcast receiver it is necessary to have only a signal generator and an a-c voltmeter which will measure audio-frequency voltage going from the a-f amplifier to the speaker. A-c voltmeters intended for this particular purpose may be called output meters. But in servicing it is necessary to have more than an output meter. Consequently, we usually employ for all purposes a combination instrument called a volt-ohm-milliammeter, a name abbreviated to VOM.

The VOM will measure a-c voltages, including audio frequencies, also d-c voltages, d-c currents, and ohms of resistance. For each of these "functions" there are many ranges, so that all of the quantities mentioned may be measured in the smallest to the largest values ordinarily encountered in broadcast receivers, including f-m and television types. Such an instrument is shown by Fig. 13.

Only a single meter movement of the d'Arsonval type is needed. By means of a selector switch or switches the connections to this movement are changed so it may act as either a permanent-magnet moving-coil voltmeter, a rectifier a-c voltmeter, a d-c milliammeter, or an ohmmeter. For each function the connections are essentially the same as for a separate meter serving the the same purpose.

The meter dial carries a number of scales suited to the several functions and ranges. An example is illustrated by Fig. 14. At the top is an ohmmeter scale. Next below is a scale for d-c volts and d-c milliamperes, with three ranges of values marked. Then comes a scale for a-c volts, also with three ranges of values. Still lower is a scale for a-c volts in the lowest range, up to 2.5 volts at full scale. At the bottom of the dial is a decibel scale for making measurements of a-f voltages in terms of apparent intensities of sound which they produce.



## LESSON 32 – SIGNAL GENERATORS

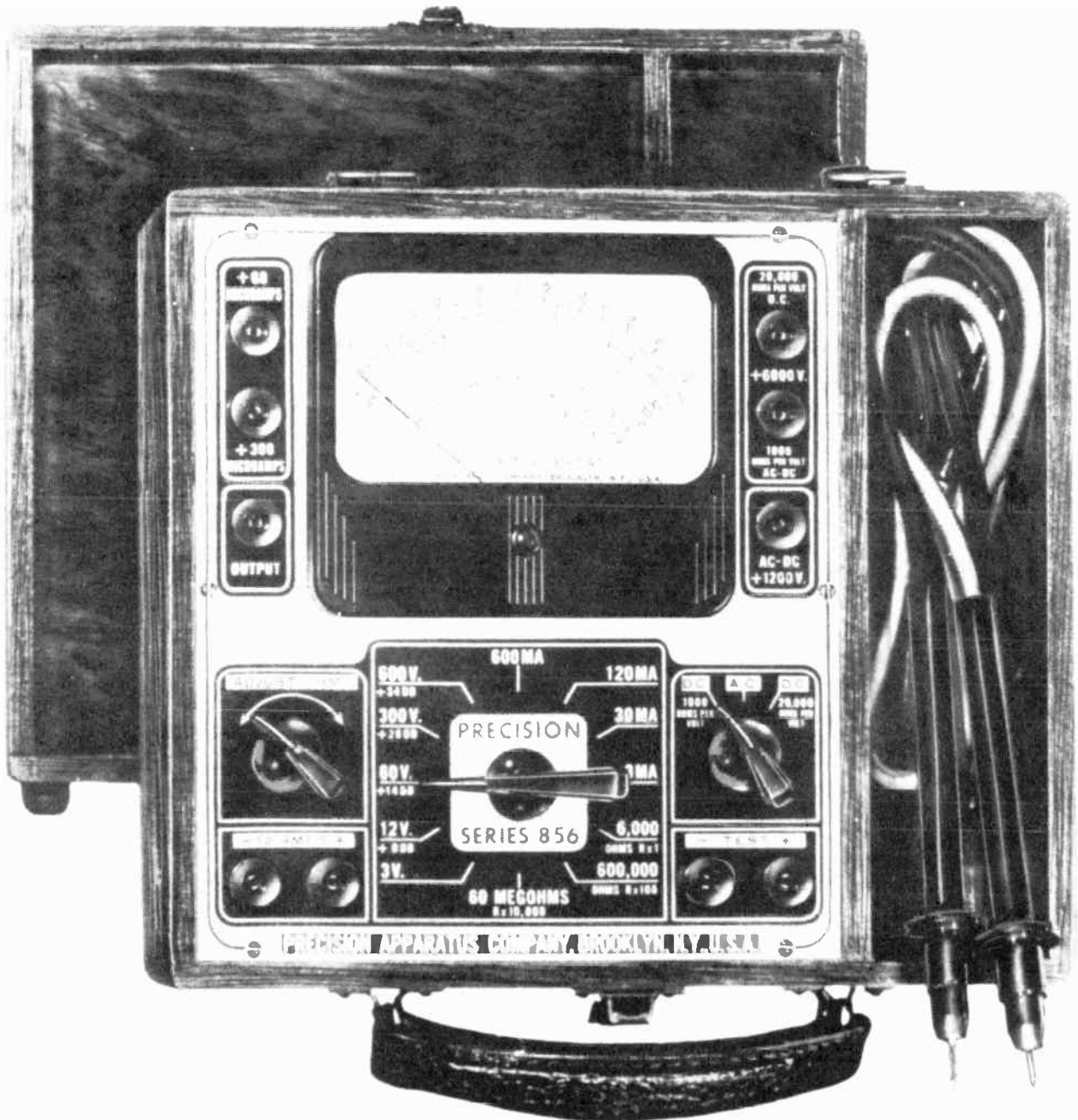

Fig. 13. A multi-range volt-ohm-milliammeter.

Meter movements may give full-scale readings with various values of current in the armature of moving coil. This armature current for full-scale readings determines the sensitivity of the VOM when used as either a d-c voltmeter or an a-c voltmeter. If full-scale armature current is one milliamperes the sensitivity is 1,000 ohms per volt for d-c measurements. If this current

is 20 microamperes the d-c volt sensitivity is 20,000 ohms per volt, and so on. This matter of voltmeter sensitivity works out the same for the VOM as for a separate d-c voltmeter, all as previously explained.

The following instructions on connecting and using the VOM apply specifically to this instrument. However, any instructions



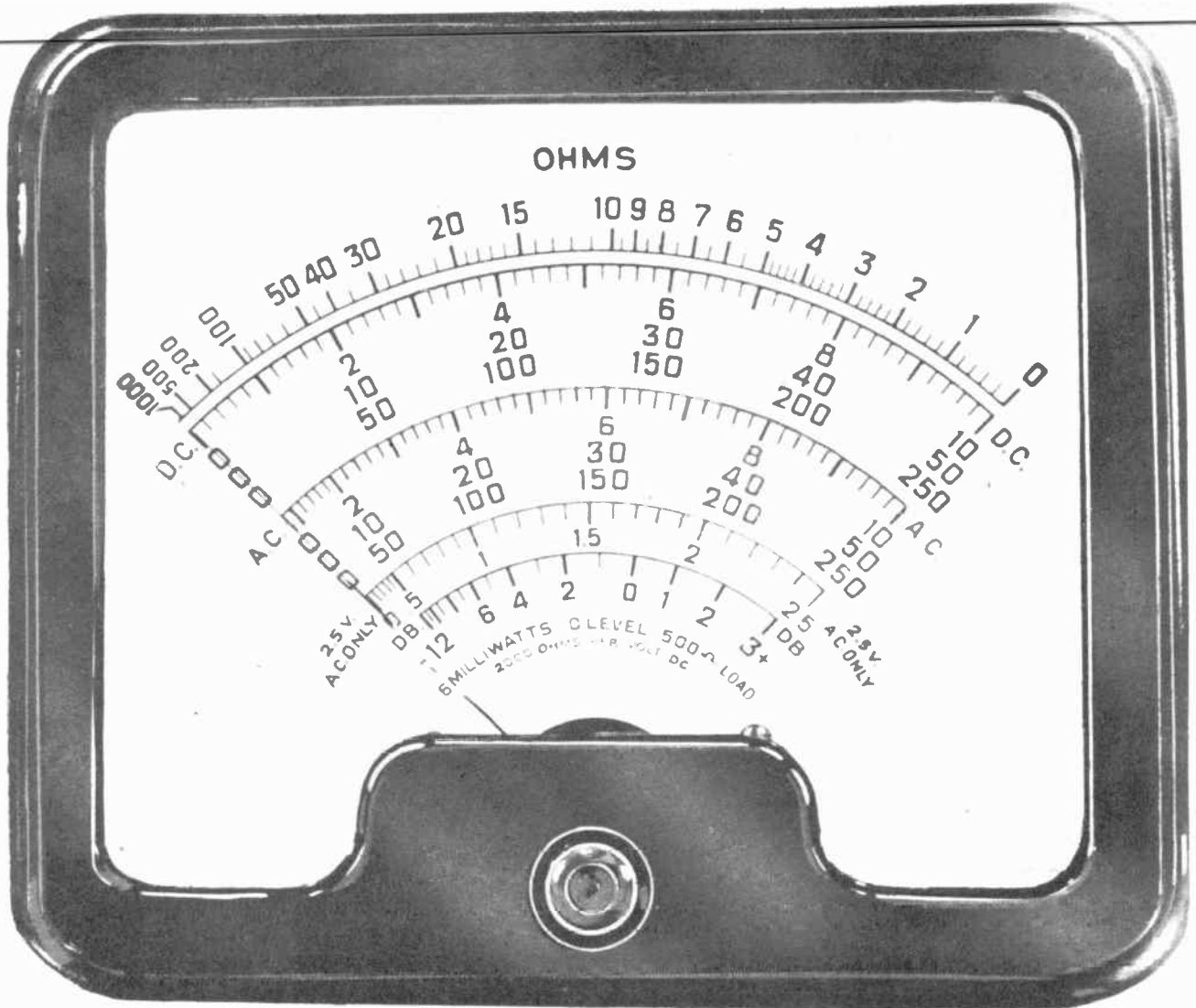

Fig. 14. Dial scales on the meter of a volt-ohm-milliammeter.

for using the VOM as a voltmeter apply equally well when using a separate voltmeter, instructions for using the VOM as a current meter apply also to using any separate current meter, and the notes relating to the VOM as an ohmmeter should be observed for any separate ohmmeter.

Terminals used for measurements of d-c voltage and current are marked as to correct polarity, positive and negative, Sometimes only the positive terminals are thus identified, and a terminal marked "Common" is the negative terminal for all d-c functions.

If you connect the d-c terminals in the wrong polarity to a circuit tested, the meter

pointer will move off scale beyond the zero mark. Unless the measured voltage or current is in excess of that which might be applied safely in the correct polarity the meter will not be damaged. It is necessary only to reverse the connections.

Should alternating voltage or current be applied to the VOM when the function switch is set for d-c measurements the meter pointer may vibrate, but will remain at or near zero. Excessive alternating current or voltage will burn out the meter movement, even though the pointer does remain at zero.

If the same VOM terminals are used for both d-c and a-c measurements, as often

## LESSON 32 – SIGNAL GENERATORS

is the case, polarity markings need not be considered for a-c measurements. The meter will or should read the same with connections either way.

When measuring voltages, either d-c or a-c, do not open or disconnect the tested circuit between points whose potential difference is to be measured. The voltmeter or the VOM as a voltmeter is to be connected across or in parallel with the parts in which voltage drop is to be ascertained.

When measuring current with the VOM as a milliammeter it is necessary to open the tested circuit and connect the meter in series between the opened points. The receiver or other device always should be turned off before this connection is made. The resistance of the instrument as a current meter is low, and if the test leads are connected to points between which there is appreciable voltage (as for a voltage measurement) the meter movement doubtless will be burned out.

Before commencing any measurements, and before the VOM test leads are connected to any circuit to be checked, note whether the meter pointer is exactly on zero. Otherwise set the pointer by carefully turning the zero adjuster by means of the small slotted head, which looks like a screw head, on the case of every meter. Fig. 15 shows a zero adjuster on the case of a milliammeter, whose pointer is badly misadjusted with reference to zero on the dial.

On the inner end of the zero adjuster is a small offset tip that engages a slot in the internal arm shown by Fig. 16. To this arm is attached one of the small spiral springs that holds the armature and pointer in position. Turning the screwhead adjuster swings the slotted arm one way or the other, and moves the pointer accordingly. If the pointer appears to have been bent by an overload, as you look at it through the meter glass, there is little object in using the adjuster to bring the pointer to zero. There will be large errors in all readings until the meter is repaired.

Some meters are calibrated for use in

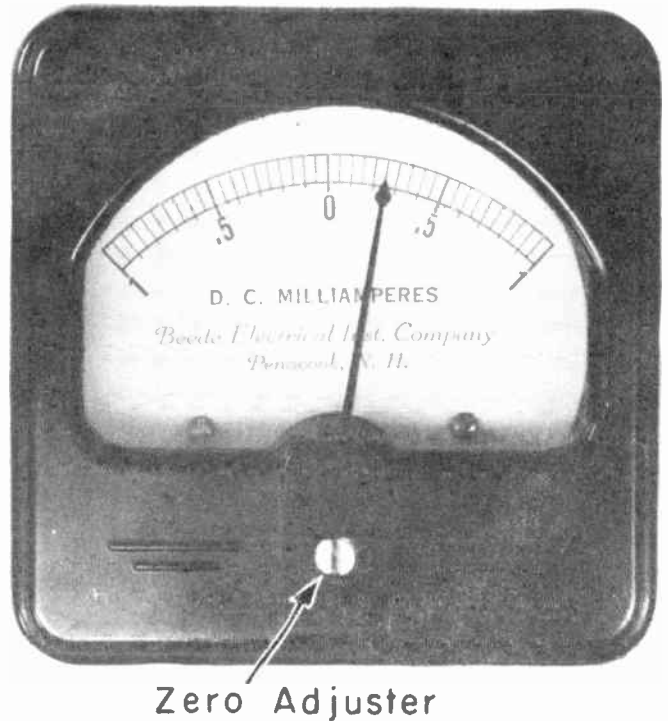

Fig. 15. The zero adjuster should be used to bring the pointer exactly to zero while no current or voltage is applied to the meter.

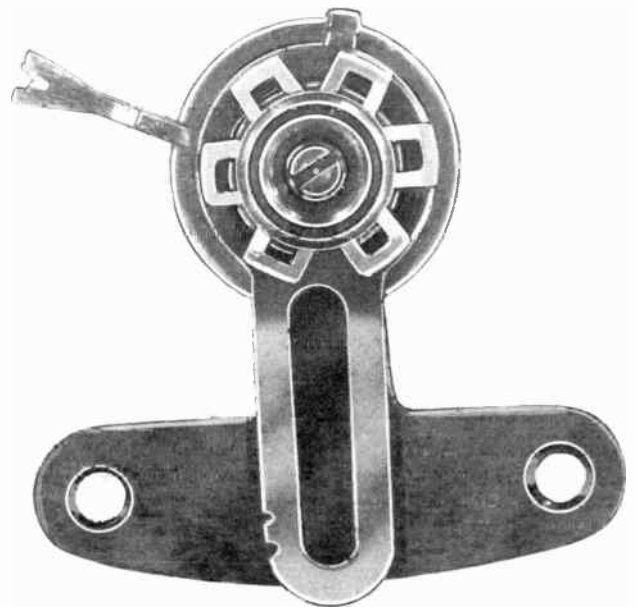

Fig. 16. The parts of a zero adjuster which are inside the meter case.

a horizontal position, some for a vertical position, and still others for use at a slant. A few will retain calibration and make correct measurements in any of several posi-

## COYNE - *television home training*

tions. The correct position will be specified by instructions which come with the instrument. For a check, place the meter either horizontally or vertically and adjust the pointer to exact zero. Then change the position. If the pointer moves off zero the instrument will give correct indications only when used in one specified position. Attempting a correction with the zero adjuster for some other positions will cause erroneous readings.

Do not use a cloth or paper to wipe the meter glass just before taking readings. This usually places an electric charge on the glass, the charge attracts the pointer, and readings will be incorrect. If you do wipe the glass use a moist cloth, or breathe on the glass after wiping with dry cloth or paper. This dispels the charge.

When using the VOM as a voltmeter or as an ohmmeter, keep your fingers off the metal tips or clips at the free ends of the test leads. This is advisable in avoiding possible shocks, but it is absolutely necessary when trying to obtain correct readings with a sensitive voltmeter or when measuring high resistances. The resistance through your body is only a few thousand ohms, and will be in parallel with the meter if you touch both leads at once.

For using the VOM as an ohmmeter there is a "zero ohms" adjustment, just as on a separate ohmmeter. Before attempting to measure any resistance clip the ends of the two test leads together to short circuit the instrument. While shorted, turn the zero ohms adjuster to bring the meter pointer to zero on the ohms scale. Then separate the leads and proceed with the measurement. When measuring several resistances on the same ohms range during a single service operation it is not necessary to reset the zero ohms between tests. The zero must be readjusted or the adjustment checked when the range is changed.

Never leave the VOM function switch on any position for resistance measurement when you are through with a job. The lead tips might become shorted, and the ohmmeter battery would be discharged. If there

is no "Off" position of the switch, always leave it set for the highest d-c voltage range, at which there is little possibility of damage to the instrument. As instructed in other lessons, never attempt a resistance measurement on a live circuit; either shut off the line power or disconnect one end of the circuit in which a measurement is to be made.

Eventually it will become impossible to bring the meter pointer to zero on the ohms scale by turning the zero ohms adjustment. This indicates that the internal battery is weak from age and use or from accidental discharge. Open the instrument and replace the battery with one like the original, or, at least of the same voltage. Carefully note how the battery leads are connected before removing them from the old battery, then replace the leads in the same polarity or polarities.

Resistance readings will be of best obtainable accuracy when they can be taken fairly near the center of the ohms scale, or somewhere between one-fourth and three-fourths of the distance in inches, not ohms, across the scale. Use a range allowing such measurements when possible. A separate ohmmeter, or the VOM as an ohmmeter, should have ranges varying in multiples of 10 in order to make all readings at favorable points on the ohms scale. If one range is 100 times, or is 1/100 of, an adjacent range it will be difficult to measure some resistance values without getting too close to the ends of the scale.

Most VOM's have a single selector switch for setting to all ranges of voltage, current, and resistance, with maximum values or full-scale values for all the functions marked at each position of the switch pointer. Some of the smaller and less costly instruments may have pin jacks instead of a selector switch for the various ranges, as on the unit pictured by Fig. 18. The jacks are marked with the function and the range. The center knob seen in the picture is a zero ohms adjustment.

The selector switch or pin jacks may cover more ranges than are marked on the dial scales. A typical meter dial is shown by



## LESSON 32 – SIGNAL GENERATORS

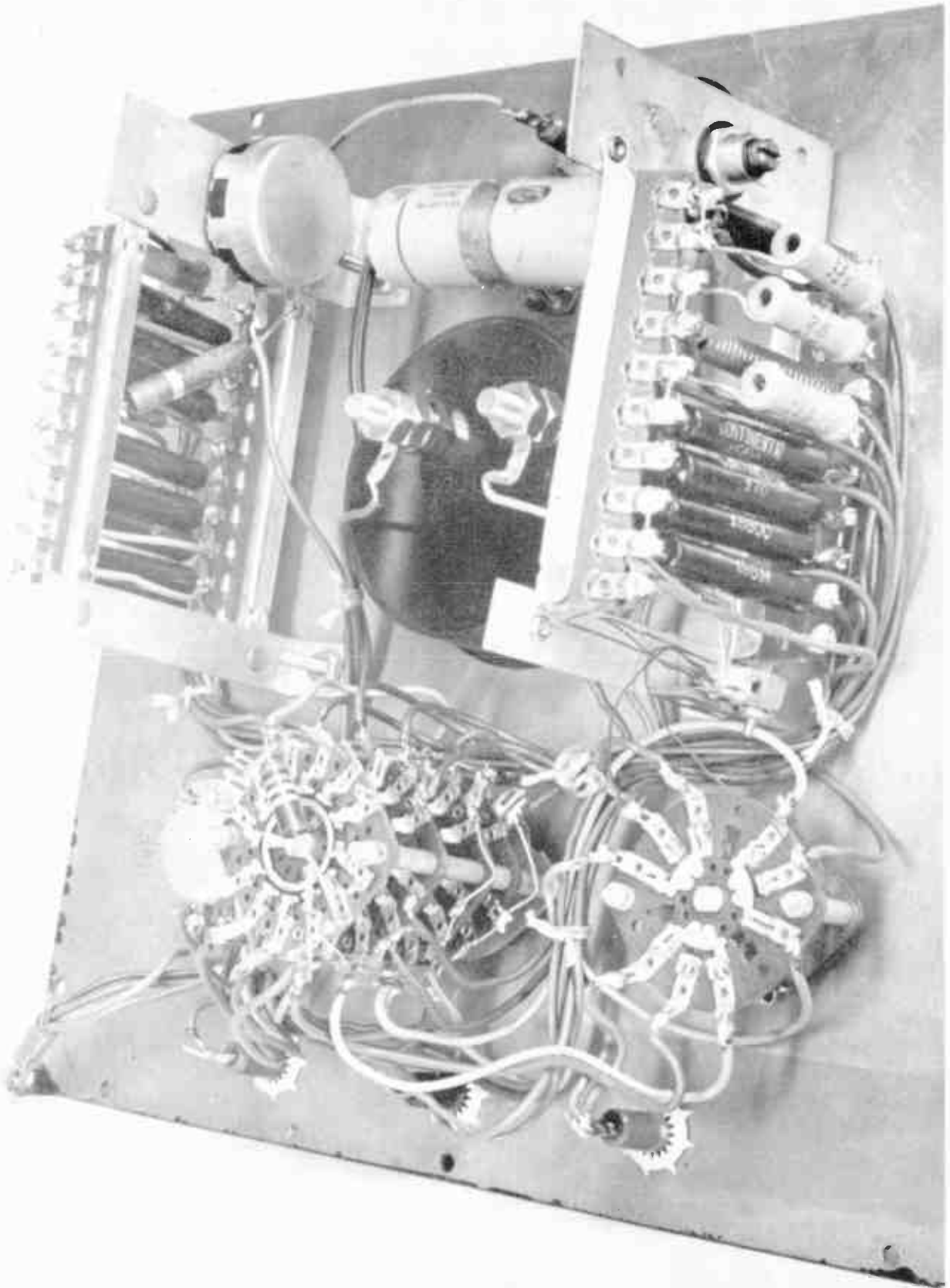

Fig. 17. Function and range switches are at the bottom. Multiplier and shunt resistors are in two banks on either side of the meter.





Fig. 18. A volt-ohm-milliammeter with pin jacks instead of a selector switch.

Fig. 19. There is only one ohms scale, but the instrument has five resistance ranges. For the lowest range the scale is read directly. For the higher ranges the scale readings are multiplied respectively by 10, by 100, by 1,000, and by 10,000, with the selector switch at the corresponding positions. There are only three scales for d-c volts and three for a-c volts, but the VOM has five ranges for each function. Some of the ranges are used by multiplying the dial scale readings by factors marked at the positions of the selector switch.

When making measurements with a multi-range measurement on a circuit whose voltage or current is unknown, always commence by using the highest range or the one

with highest full-scale reading. If the measured quantity would be indicated and read more easily on a lower range, drop down to an appropriate range to complete the work.

D-c voltage ranges may be extended on the VOM by using external multipliers, just as with a separate voltmeter. Current ranges may be extended with external shunts whose values are computed as explained in connection with current meters.

When reading any meter try to look squarely toward the dial. That is, try to have your line of sight at right angles to the dial face. If you look from either side across the pointer at the dial graduations you will see a value which is really at one side or the other of the pointer, and such readings will be inaccurate. If you look from "down scale" with reference to the pointer your observed readings will be too high, and if you look from "upscale" they will be too low. This is called the parallax error.

To check the accuracy of any voltmeter connect it in parallel with another voltmeter of known accuracy and use both meters at the same time for measuring the same voltage. The measured voltage must, of course, be within the ranges of both meters. This voltage, no matter what its value, must be the same on both meters. Both should read the same, regardless of their sensitivities. Either d-c or a-c voltmeters may be checked in this manner. A rectifier voltmeter may be compared with a moving vane type a-c meter. Good quality moving vane meters usually are more accurate than rectifier meters, although not so sensitive.

A current meter is checked for accuracy by connecting it in series with another current meter of known accuracy. Then the same measured current must flow in both meters at the same time, and both should read the same. The measured current must be limited by a series resistor to a value within the ranges of both meters. Otherwise there will be no object in checking accuracy, for both instruments will be burned out.

## LESSON 32 – SIGNAL GENERATORS

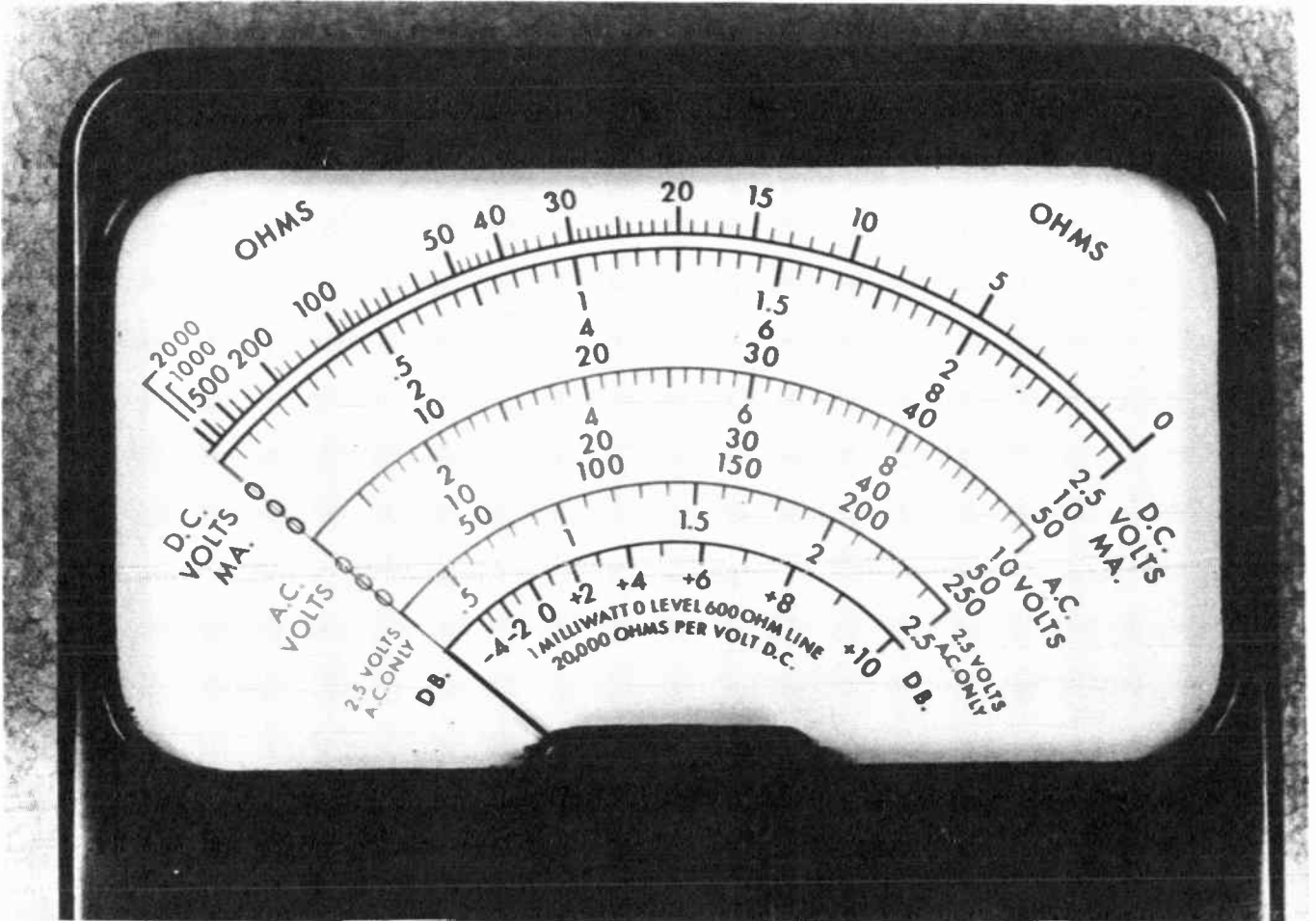
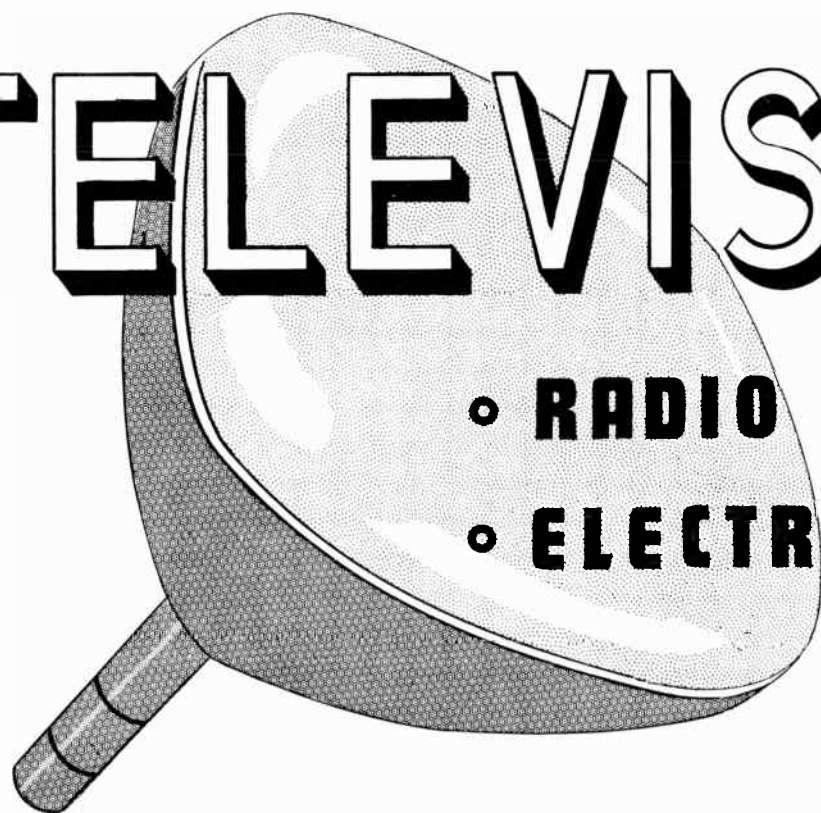

Fig. 19. All the ranges of an instrument need not be shown on the meter dial, some ranges may be used by multiplying the dial readings.

# TELEVISION



• RADIO

• ELECTRONICS

---

---

**LESSON 33 – RECEIVER ALIGNMENT**

---

---

***Coyne School***

*practical home training*

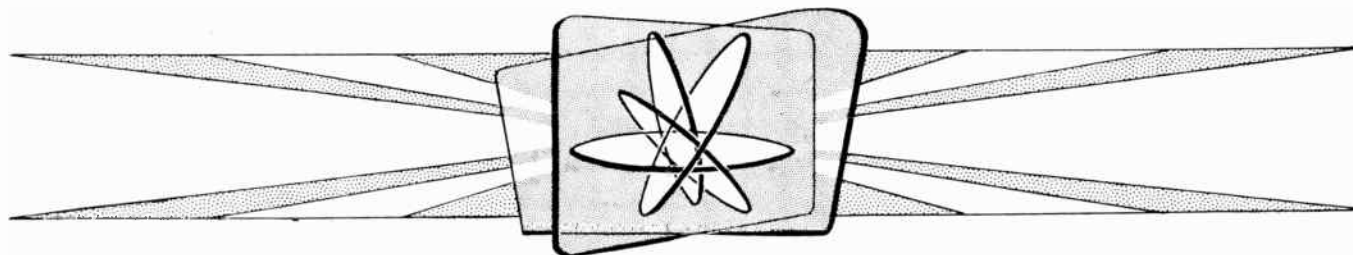

*Chicago, Illinois*

*Copyright, 1953 by Coyne Electrical School  
Chicago 12, Illinois  
All rights reserved*

Litho. in U.S.A.



## Lesson 33

# RECEIVER ALIGNMENT

A setup for alignment of a broadcast receiver is pictured by Fig. 1. At the left is a signal generator, down below is the receiver, and at the right is a VOM used as an a-c voltmeter or output meter. The generator feeds a modulated r-f signal to the antenna terminals of the receiver. The VOM measures the output of the receiver audio amplifier. Alignment will be correct when we obtain maximum audio output with minimum r-f input.

The process of alignment consists of adjusting the resonant circuits of a receiver for desired frequency response and maximum gain. Circuits to be aligned include those of the antenna coupling, the r-f oscillator, the r-f stage if such a stage is present, and the i-f amplifier section. Procedures to be followed in this lesson apply specifically to a standard broadcast receiver, but they are an introduction to alignment of f-m broadcast sets and of television receivers.

If a receiver actually is misaligned, correct adjustments will do wonders in improving the performance. Realignment, however, won't correct for defective tubes, resistors, capacitors, or inductors, nor for shorts, grounds, and other circuit troubles. You should not attempt to realign any receiver until all other possible faults have been looked for, and corrected when found.

This lesson deals with methods for aligning any and all standard broadcast receivers. After studying it you will be able to follow the condensed instructions issued by manufacturers for particular models of their sets. When such instructions are available they should be followed to the letter.

PREPARING THE RECEIVER. A transformerless receiver, whose chassis may be "hot", should be connected to the a-c power line through an isolation transformer. If you do not have one of these transformers, insert the power cord plug into the line re-

ceptacle in the position that makes the chassis cold with respect to grounded pipes and other metal in the building. This was explained when studying power supplies.

If the receiver is provided with metal shields for tubes, coils, or other parts, all of these shields should be in place during alignment.

The receiver will have at least some of the following controls, but rarely would have all those listed. For controls which are present make the settings thus:

1. Volume control at position for maximum volume. This allows using a weak signal from the generator, avoiding overload of receiver tubes while obtaining better frequency stability from the signal generator.

2. A tone control should be set in the position marked for speech, for treble, or any position which allows reproduction of the full range of audio frequencies.

3. A phonograph-radio switch must be in its "Radio" position.

4. Combination receivers have a switch marked BC or AM for standard broadcast reception, marked FM for f-m broadcast, and TV or Television. There may be a position marked SW for short-wave reception, or marked with short-wave band limits. Place this switch for standard broadcast reception when aligning the standard broadcast sections of the receiver.

5. If there is push-button tuning set the control for manual tuning or hand tuning, not for push-button operation.

6. A selectivity control should be in the position for maximum selectivity.

7. Some sets have a switch for local-distance reception, or for sensitivity, Turn

**COYNE - television home training**

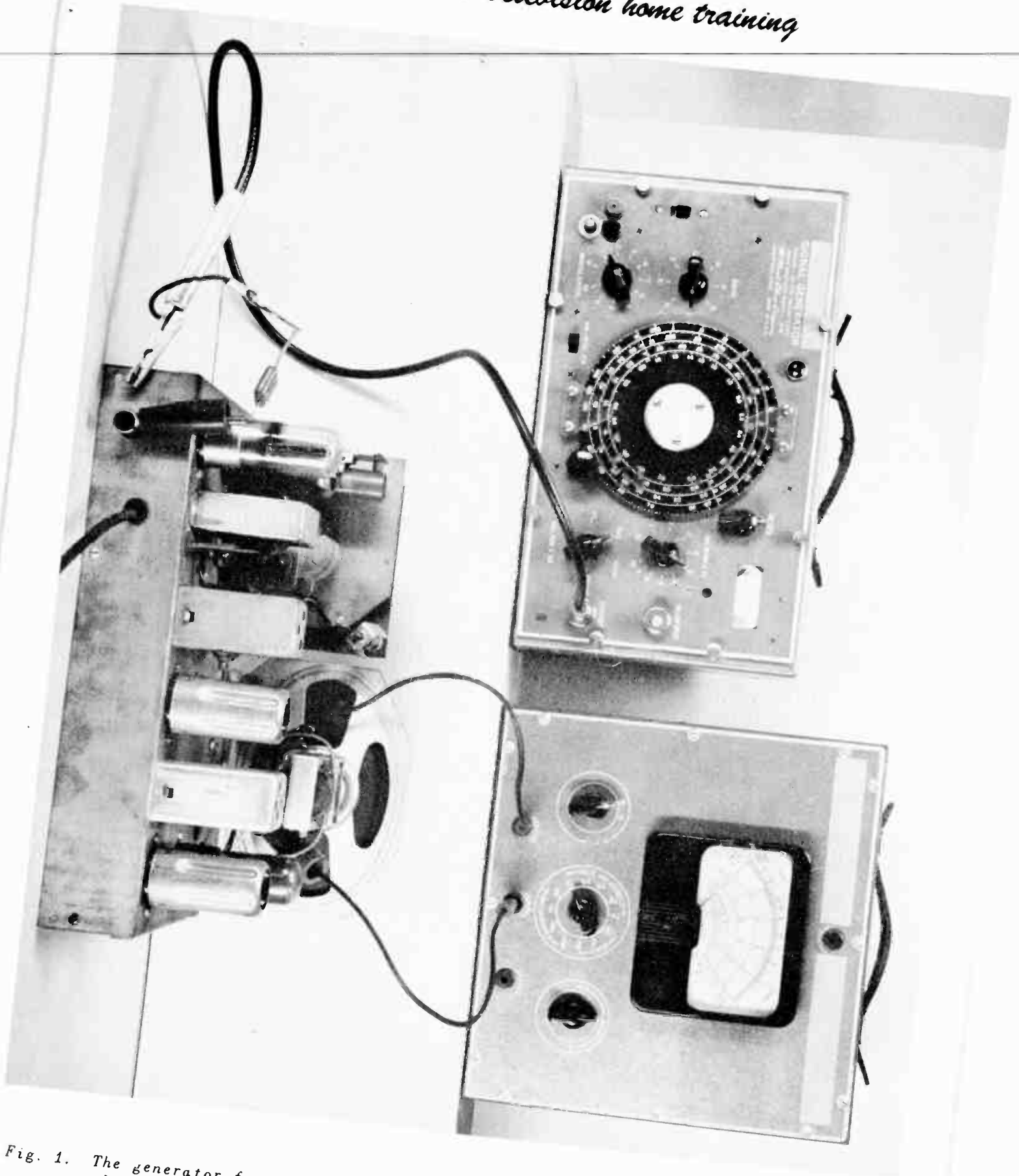

*Fig. 1. The generator furnishes signals and the VOM measures the receiver output during alignment.*

## LESSON 33 – RECEIVER ALIGNMENT

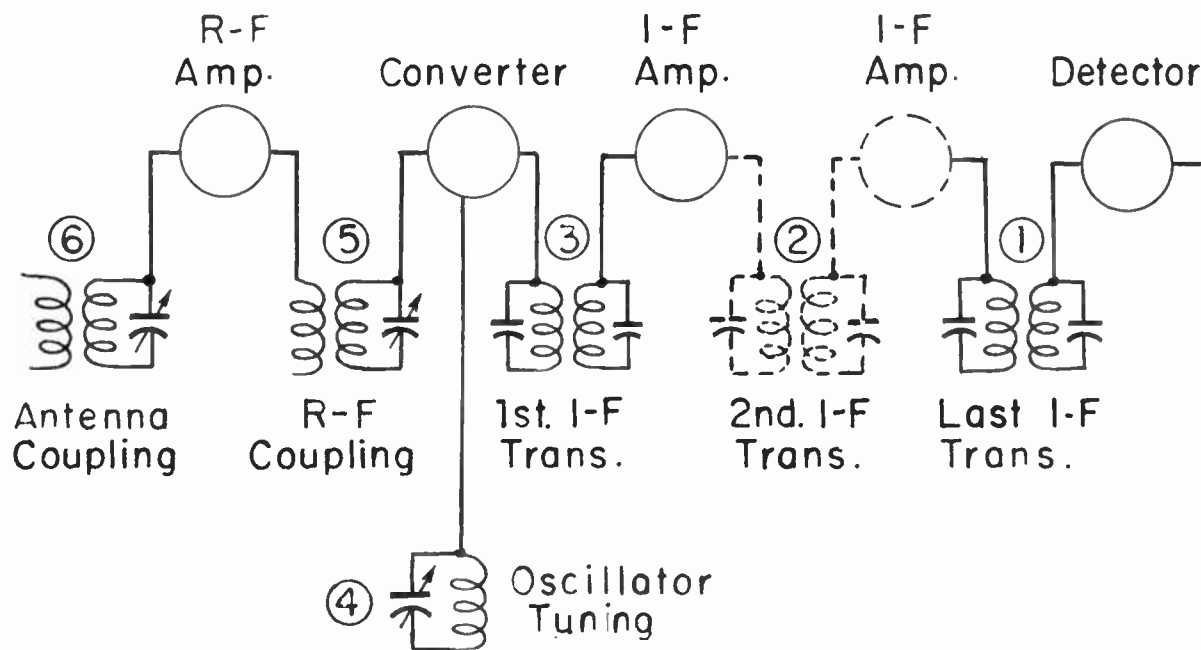

Fig. 2. The usual order or sequence of alignment for a broadcast receiver.

this switch for distance reception, for maximum sensitivity.

The resonant circuits and the order in which they are aligned are shown by Fig. 2. We commence with the last i-f transformer, the one just ahead of the detector, and work back to the antenna coupling. If there are two i-f stages, the second is aligned before the first. There may or may not be an r-f amplifier stage. If not, the antenna coupling is aligned after the oscillator section of the converter. You will find this same order used for television alignment, except that there we work from the video detector back through the tuner to the antenna coupling.

You should make it a rule, after completing all the adjustments, to commence all over and check every one the second time.

Trimmer and padder capacitors, also movable iron cores or slugs, are adjusted only by using non-metallic screw drivers, wrenches, or whatever form of tool is required. These tools usually are made of fibre or plastic. Several alignment screw drivers are illustrated by Fig. 4. The same types are used when working on television alignment. Tools made with metal blades or sockets would alter the effective inductance of wind-

ings and make correct adjustment impossible. Screw drivers with very small metal tips set into non-metallic blades may be used for i-f adjustments, but they may give trouble when aligning r-f and oscillator circuits.

Adjustable cores of inductors often have screw driver slots or specially shaped openings right in one end of the iron core rather than on an extension stud. In this case the alignment tool must fit the core correctly or there is great danger of breaking out the sides of the iron. Sometimes the core itself is threaded, which means that only moderate pressure may be used if threads are not to be stripped.

The signal generator and receiver are to be turned on and allowed to warm up for at least 15 minutes, and preferably for as much as a half-hour, before commencing alignment adjustments. Many technicians occupy themselves during the warm-up period by making the necessary test connections.

**ANTENNAS.** The manner in which the signal generator is connected to or coupled to the receiver varies with the type of receiving antenna. Most standard broadcast sets have a built-in loop antenna of the general style pictured by Fig. 5. The loop is a large in-

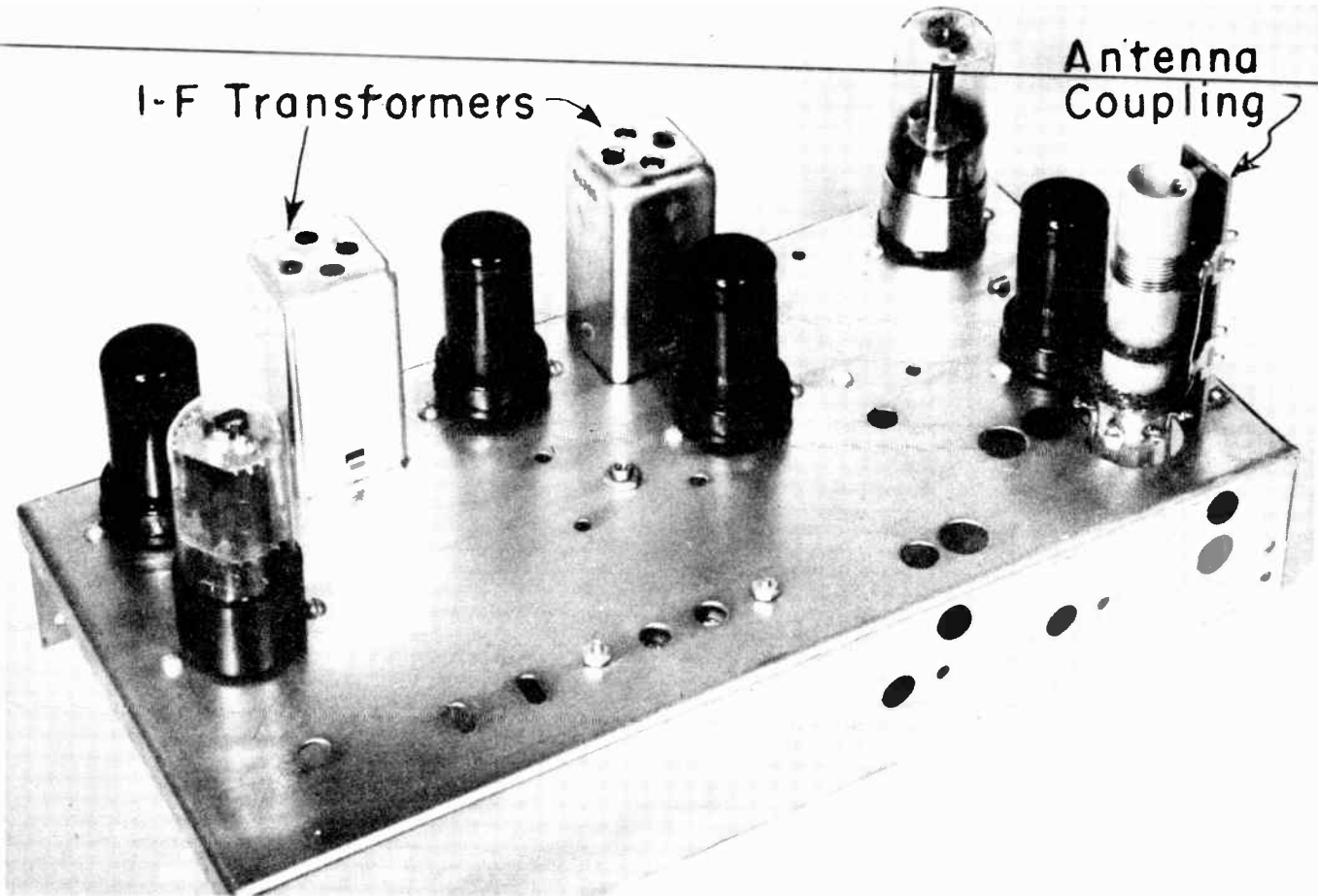

Fig. 3. *Some of the parts which are adjusted during alignment.*

ductor of outside dimensions and proportions that fit conveniently into the receiver cabinet.

When the electromagnetic waves of radiated signals pass through the turns of the loop antenna the magnetic fields of the waves induce emf's in the turns of the loop winding—just as any magnetic field induces emf's in conductors through which it cuts. When the plane or flat dimension of the loop is in line with the direction of signal travel a given signal wave induces emf in the side of the loop which is toward the transmitter a fraction of a second earlier than in the other side. As a consequence, the emf's in the two sides of the loop winding are slightly out of phase. The two emf's combine to produce a single signal voltage which appears across the ends of the winding.

The wider and higher the loop, and the more turns in the winding, the greater are

the induced emf's and the stronger is the signal thus brought into the receiver. When the loop is turned edgewise toward the transmitter whose signal is to be received there is maximum possible phase difference between emf's in opposite sides of the winding, and the signal from the loop is of maximum strength. If the plane of the loop is at right angles with a line toward the transmitter the radiated waves cut both sides of the winding at the same instant. Then there is no phase difference and, theoretically, there is no signal pickup. Actually there always is some signal pickup because the loop is affected to some extent by the electric fields of the transmitted waves. All this explains why the reception is better with the loop and the receiver turned in some positions than in other positions.

Typical symbols for loop antennas, as shown on service diagrams, are shown by



## LESSON 33 – RECEIVER ALIGNMENT

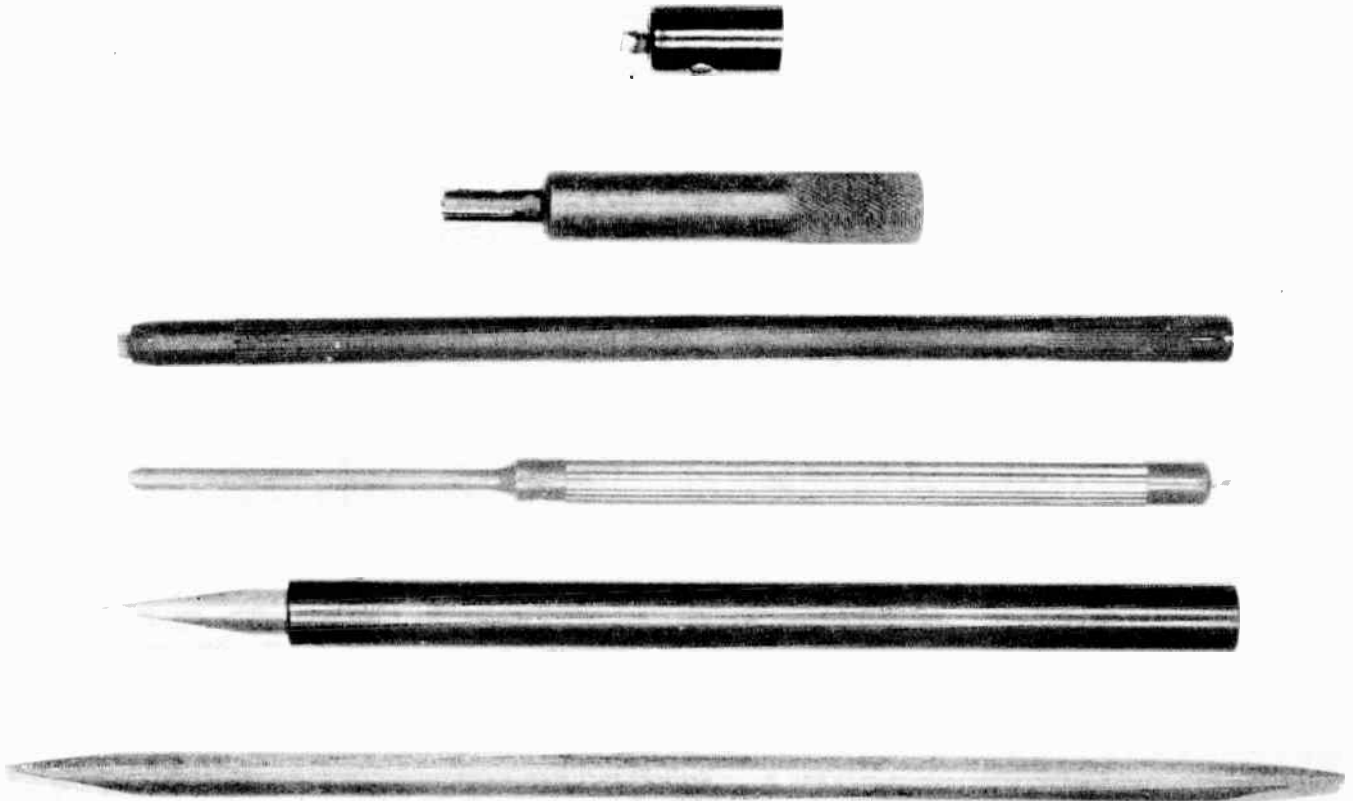

*Fig. 4. Alignment tools used for television and radio servicing.*

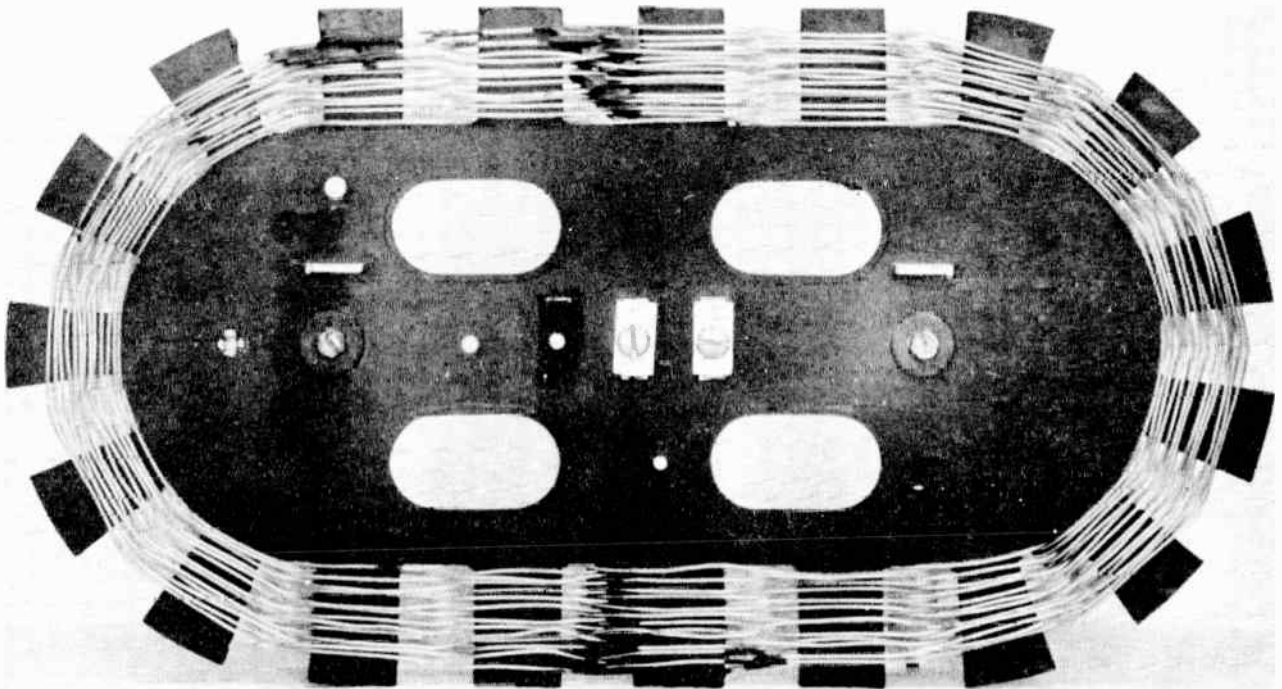

*Fig. 5. The loop antenna is really a large inductor.*

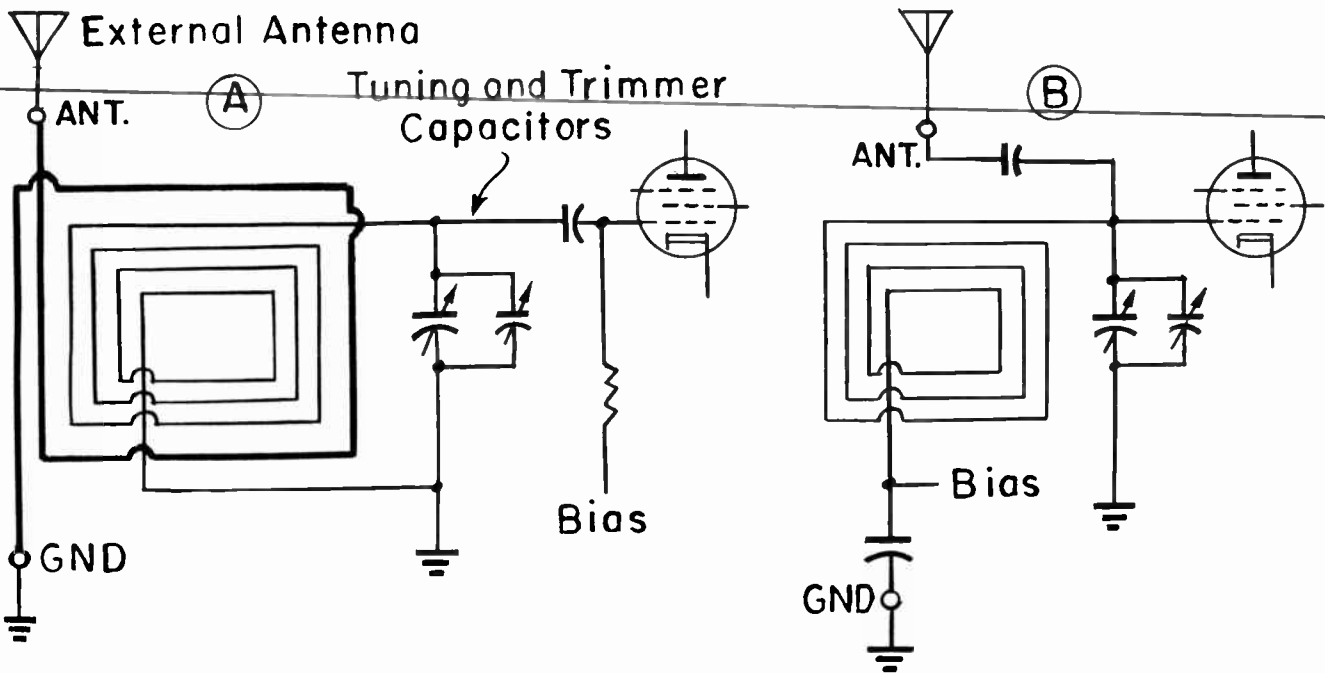

Fig. 6. How loop antennas may be shown on schematic service diagrams.

Fig. 6. At A the inner turns represent the loop winding, whose inductance is tuned to resonance at the signal frequency by a tuning capacitor and a trimmer which complete the grid circuit of the r-f amplifier or for the signal grid of a converter tube when no r-f amplifier is used. Around the outside of the loop winding are two or three additional turns. The terminals of these added turns may be connected to an external antenna and to ground, whereupon the external antenna turns act as the primary of a transformer whose tuned secondary consists of the loop winding and the capacitors.

In diagram B the loop winding is similar, but there are no additional turns for the external antenna circuit. Instead, the external antenna is connected to the loop-capacitor circuit through a small series capacitor. The low end of the loop winding is connected to ground through another series capacitor. Here the loop and its paralleled capacitors act as a tuned impedance in the external antenna circuit.

External antennas, supported either outdoors or indoors, are necessary only in localities where desired radio signals are very weak. All early radio receivers re-

quired outdoor antennas, but modern amplifier tubes have such high transconductances, and improved construction has so lessened losses of signal energy that a loop antenna or merely the connection to a power line usually provides good reception. It still is true that an external antenna will allow receiving more stations, and those at greater distances, than will a loop or only a power line pickup.

**SIGNAL INPUT CONNECTIONS.** When the receiver has terminals marked for antenna and ground, either on the chassis or on the loop framework, the r-f output cable from the signal generator will be connected to these two terminals. In series with the high side of the cable, the conductor carrying the r-f signal, place a fixed mica or ceramic capacitor of 200 to 500 mmf, or even greater capacitance. The principal object of this series capacitor is to safeguard the attenuator of the generator in case the antenna circuit of the receiver might possibly go conductively to a hot chassis on a transformerless set.

If the receiver is a transformerless type, with a chassis which may be hot under some conditions, and if it is not connected to the a-c power line through an isolation transformer, further precautions must be ob-

## LESSON 33 – RECEIVER ALIGNMENT

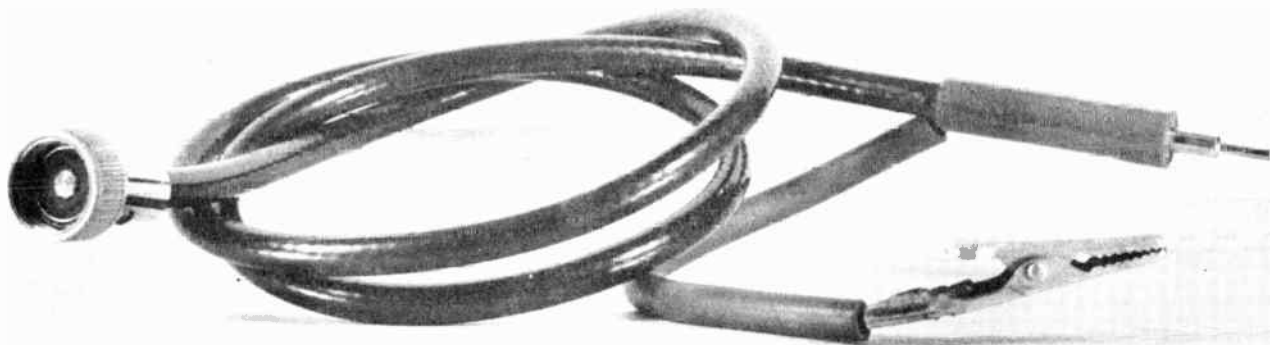

*Fig. 7. A shielded cable with a prod and a clip, for connecting the signal generator to the receiver terminals or circuits.*

served. Then the ground side of the generator output cable should be connected to chassis ground only through a fixed paper capacitor of 0.01 mf or greater capacitance, with d-c working voltage not less than 200.

For a transformerless receiver having a floating ground, connected to the chassis through an internal capacitor, the ground lead from the signal generator may be connected to any point on the floating ground conductor without a series capacitor. With receivers having transformer types of power supplies the ground lead of the generator may be directly connected to chassis ground without danger.

Fig. 7 is a picture of a cable such as used for the r-f output of a signal generator.

The end that attaches to the generator is at the left. This is a microphone connector which screws onto a terminal fitting. The cable is a shielded type, with the shield connected to the screw fitting at the generator end, and at the other end connected to the spring clip which may be seen at the right in the picture. The inner conductor of the cable is connected to an insulated central contact at the generator end, and at the other end to an insulated tip that shows at the right in the photograph.

For making high side connections to tuned circuits through small mica or ceramic capacitors it is convenient to use the method illustrated by Fig. 8. To one pigtail lead of the capacitor is attached any small sized spring clip. This clip will fasten to any ac-

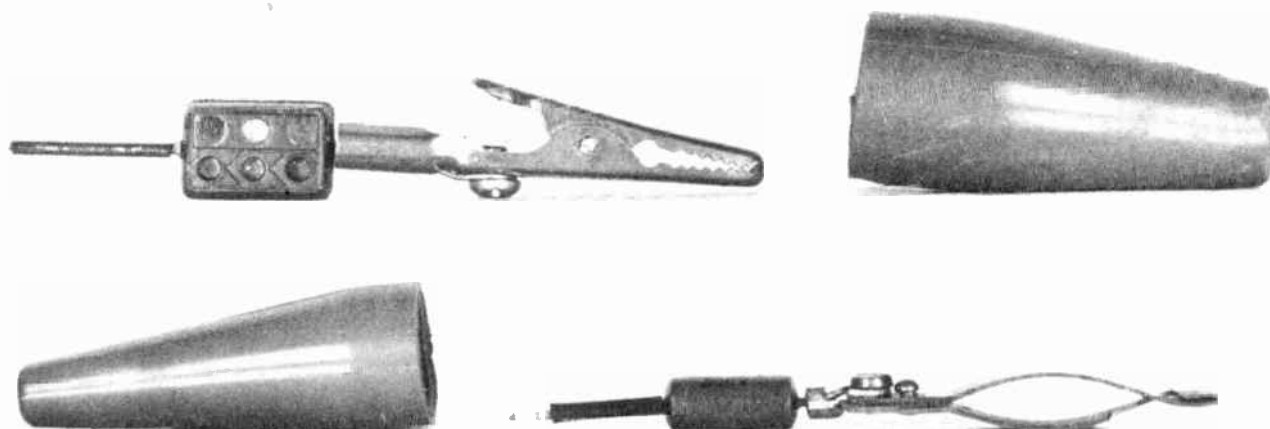

*Fig. 8. Clips to which are attached small capacitors, as used for making high side connections from generator to receiver.*

## COYNE - *television home training*

cessible point on the side of a tuned circuit to which the signal is applied. The other pig-tail of the capacitor is attached to the high side of the generator cable. To prevent accidental short circuits it is advisable to slip over the spring clip one of the rubber sleeves illustrated.

If the receiver has a loop antenna, and is not badly out of alignment, ample transfer of signal from generator to receiver often is had by merely laying the free end of the generator output cable near the loop. Clip the ground side of the cable to the high-side to complete the attenuator circuit of the generator.

Should the cable alone fail to provide enough signal, connect between the high side and ground clip of the cable a coil made of insulated wire, such as pictured in the preceding lesson in connection with signal generator calibration. This coil should have only two to four turns. Coupling and signal transfer from coil to loop are regulated by moving these two farther apart or closer together.

Always use the loosest coupling between generator and loop that will cause easily recognizable indications from whatever kind of output meter is being used. After this coupling is determined, do not alter it during the process of alignment. Changes of signal input should be made by varying the settings of attenuator and output control on the signal generator as alignment proceeds.

No matter how the generator signal is brought into the receiver, the r-f output of the generator always must be kept as low as will give distinct indications of signal strength at the audio amplifier end of the set. When you commence making alignment adjustments the generator output may have to be rather high, because the circuits to be adjusted will not respond as they should. But if generator output is not reduced as the work proceeds there is certain to be overloading of amplifier tubes, which then will fail to perform as for normal reception.

MEASURING RECEIVER OUTPUT. Fig. 9 shows connections of any type of a-c volt-

meter for measuring the audio output from the receiver during alignment. At A the meter is connected between the plate of the audio output tube (beam power tube) and either chassis ground, B-minus when there is a floating ground, or the cathode of the power tube.

Audio output power in the plate circuit results from rather high a-f voltage and current. The plate circuit power is coupled to the speaker through an output transformer of the voltage step-down type. The secondary of this transformer is connected to the "voice coil" of the speaker. This coil is attached to the speaker cone. Instead of connecting the a-c voltmeter to the plate of the output tube it may be connected across the voice coil, as at B. Here the a-f voltage will be much lower than at the plate.

Fig. 10 is a picture of a typical speaker with an output transformer mounted on the rear extension of the speaker frame. The two coiled leads extending to the right are the ends of the primary winding of the transformer, which connect into the plate circuit of the audio output tube. From the other side of the transformer may be seen one of the secondary leads going to a terminal on the framework back of the cone. This lead goes to one end of the voice coil. On the far side, where it does not show in the picture, is the other voice coil lead. With connections as at B of Fig. 9 the meter leads would be clipped to the voice coil terminals on the cone framework.

VOM's which will measure a-c voltage, also separate a-c voltmeters of the rectifier type, usually are designed to measure pure alternating current with which there is no d-c component. If direct current and voltage are present in the measured circuit the meter readings are affected by both d-c and a-c voltages. Furthermore, the d-c voltage usually will be high enough to cause burnout of the meter when the meter is used on a range low enough to measure the a-c voltage.

With the connections at A of Fig. 9 the meter is connected across a d-c voltage drop in the plate circuit, and to protect the meter while allowing it to measure audio voltage



## LESSON 33 – RECEIVER ALIGNMENT

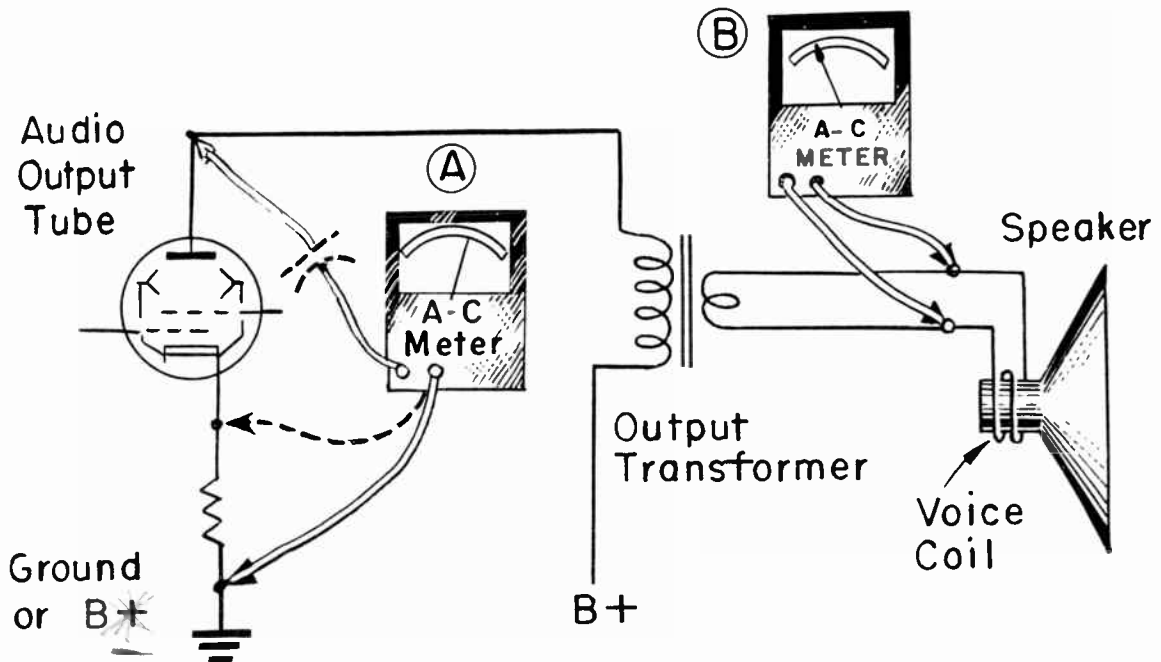

Fig. 9. An a-c voltmeter or output meter may be connected to the power tube plate or to the voice coil of the speaker.

there must be a fixed capacitor in series with one or the other of the meter leads.

Unless you are certain that such a series capacitor is inside the meter, one must be connected externally. Use a paper capacitor of at least 0.1 mf, and preferably one of 0.25 to 0.50 mf capacitance. The d-c working voltage of this capacitor must be higher than any d-c voltage drop across which the meter is connected. With connection to a plate circuit the rating must be greater than maximum d-c voltage from the power supply, which may be higher than the plate voltage. It seldom is safe to use a capacitor rated at less than 400 volts on sets with transformer power supplies.

Some VOM's have an external terminal marked "Output", or otherwise identified for use when the instrument is used as an output meter where d-c voltage may be present. There is an internal blocking capacitor in series with this terminal. One of the meter leads is to be connected to the output terminal and the other to the common terminal used when measuring pure a-c voltages.



Fig. 10. Wire connections on an output transformer for the speaker.

When using this general method of measuring audio output the volume control of

## COYNE - *television home training*

the receiver should be set for maximum volume. The r-f output of the signal generator ~~must be modulated with an audio frequency~~, because you will be making measurements beyond the detector, where r-f voltages have disappeared and only audio voltages remain. A-c voltmeters will not respond to voltages at radio or intermediate frequencies.

The a-c voltmeter used as an output meter will respond to ripple voltage or hum voltage as well as to the modulation voltage. Consequently, the meter reading will never drop all the way to zero unless there is absolutely no hum voltage - something not likely.

There are few, if any, modern receivers which do not have automatic volume control. When r-f voltage from the signal generator exceeds some very low value the avc system will hold down the amplification. Then, you can shift the generator frequency back and forth through quite a range with hardly any change in reading of the output meter. There will be no sharp peaks of frequency response by which you can identify correct alignment adjustments. After the adjustments are changed to an extent that increases the gain, the avc action will prevent this possible gain from showing clearly on the output meter, and you cannot tell whether the adjustment is correct or only approximately so.

One way to avoid avc action is to keep the r-f output of the signal generator very low. If you cannot obtain a rather sharp rise and fall of the meter pointer when turning an alignment adjustment the generator voltage is too high. If turning the generator tuning dial a very little off the frequency being employed does not cause sharp rise or fall of the meter pointer the r-f voltage is too high.

A surer method is to override the avc voltage with two or more dry cells connected as in Fig. 11. The negative side of the dry cells or battery is clipped to the avc bus, and the positive side to ground or B-minus. Be sure to get the cells or battery connected on the grid return side of avc filter resistor  $R_f$ , which usually has a value of several megohms. Then the dry-cell fixed biasing voltage will affect only the grids of controlled tubes and will not interfere with operation of the detector and audio amplifier.

This fixes the negative bias on controlled tubes at  $1\frac{1}{2}$  volts per cell of the battery being used. The avc system has no further control of grid bias, regardless of how strong or how weak may be the r-f voltage from the signal generator. It is best to commence with a biasing battery of two or three cells, giving 3 or  $4\frac{1}{2}$  negative volts. If signal indications on the output meter are not strong enough, change temporarily to one cell and  $1\frac{1}{2}$

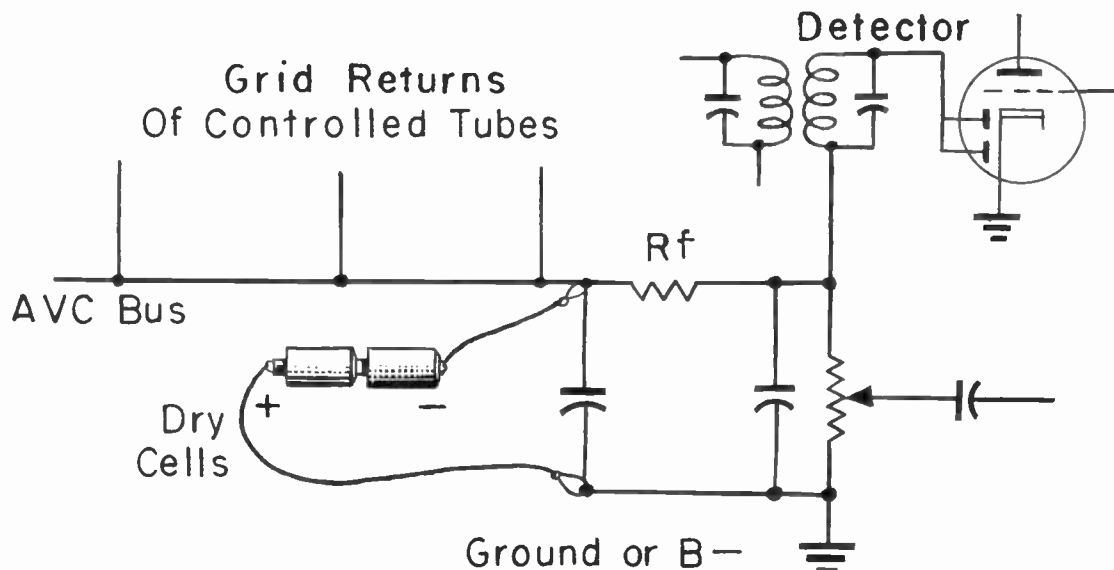

Fig. 11. Connections for overriding the automatic volume control voltage with voltage from dry cells.

## LESSON 33 – RECEIVER ALIGNMENT

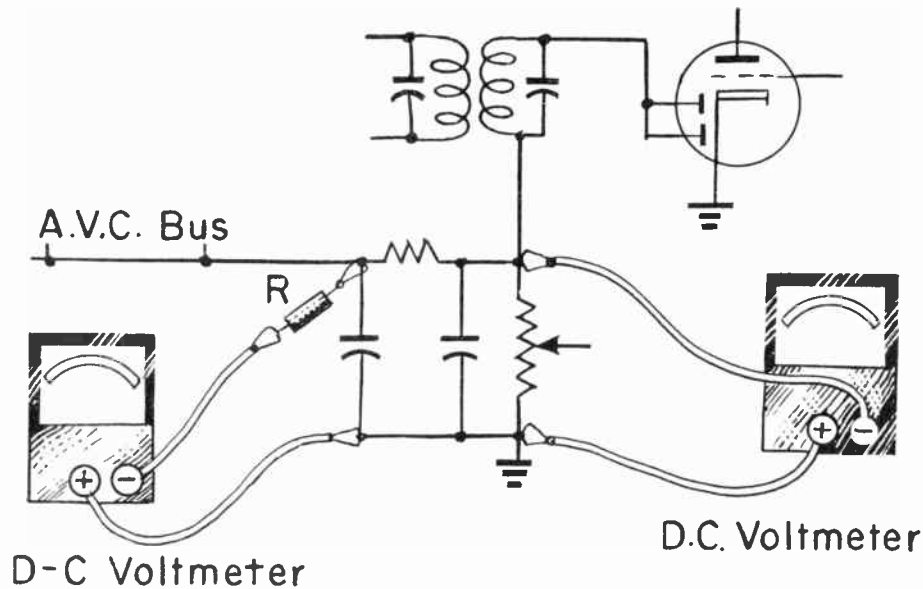

Fig. 12. Using a d-c voltmeter as an output indicator during alignment.

volts bias. Then go back to a higher bias after the output meter readings become high as alignment proceeds.

When overriding the avc voltage with a biasing battery it is not necessary to disconnect or otherwise disturb the avc bus, simply connect the battery between the bus and ground or B-minus.

Fig. 12 illustrates an entirely different method of measuring receiver output during alignment of i-f, r-f, and oscillator circuits. Here we are using a d-c voltmeter connected to either the avc bus or else to the detector load resistor, which usually is the manual volume control resistor or potentiometer.

At the avc bus there is a practically pure direct voltage, and at the top of the detector load there is a direct voltage varying at audio frequency during normal operation, but of steady value during the test to be explained. At both of these points the potential is negative with reference to ground or B-minus. Therefore, the negative lead of the meter is connected to the avc bus or the load resistor while the positive lead is connected to ground or B-minus. At either of these points the voltage applied to the d-c voltmeter increases with increase of r-f and i-f signal voltage coming to the detector circuit, and increases as the tuned circuits are

brought more and more nearly into correct alignment.

The d-c voltmeter or the VOM used as a voltmeter should have sensitivity of at least 20,000 ohms per volt. When making measurements at the avc bus use a fixed resistor of one megohm in series with the lead to the bus, and as close as possible to the bus, as shown at R on the diagram. Usually it will be necessary to use the lowest voltage range of the meter. The series resistor increases the total resistance between the avc bus and ground or B-minus. It is better to use a low-voltage range and a series resistor than a higher range where meter resistance would be greater, because, without the series resistor, you would effectively extend the avc bus and tube grid return circuits all the way to the meter through a low-resistance lead. This could cause difficulties.

With this method of measuring receiver response the r-f output of the signal generator should not be modulated, it should be steady r-f voltage. Do not override the avc voltage with a biasing battery. The receiver volume control may be set anywhere. There will be no sound from the speaker because there is no modulation. Keep the r-f output of the signal generator as low as will allow distinct indications on the meter. When measuring at the avc bus you will, at the same

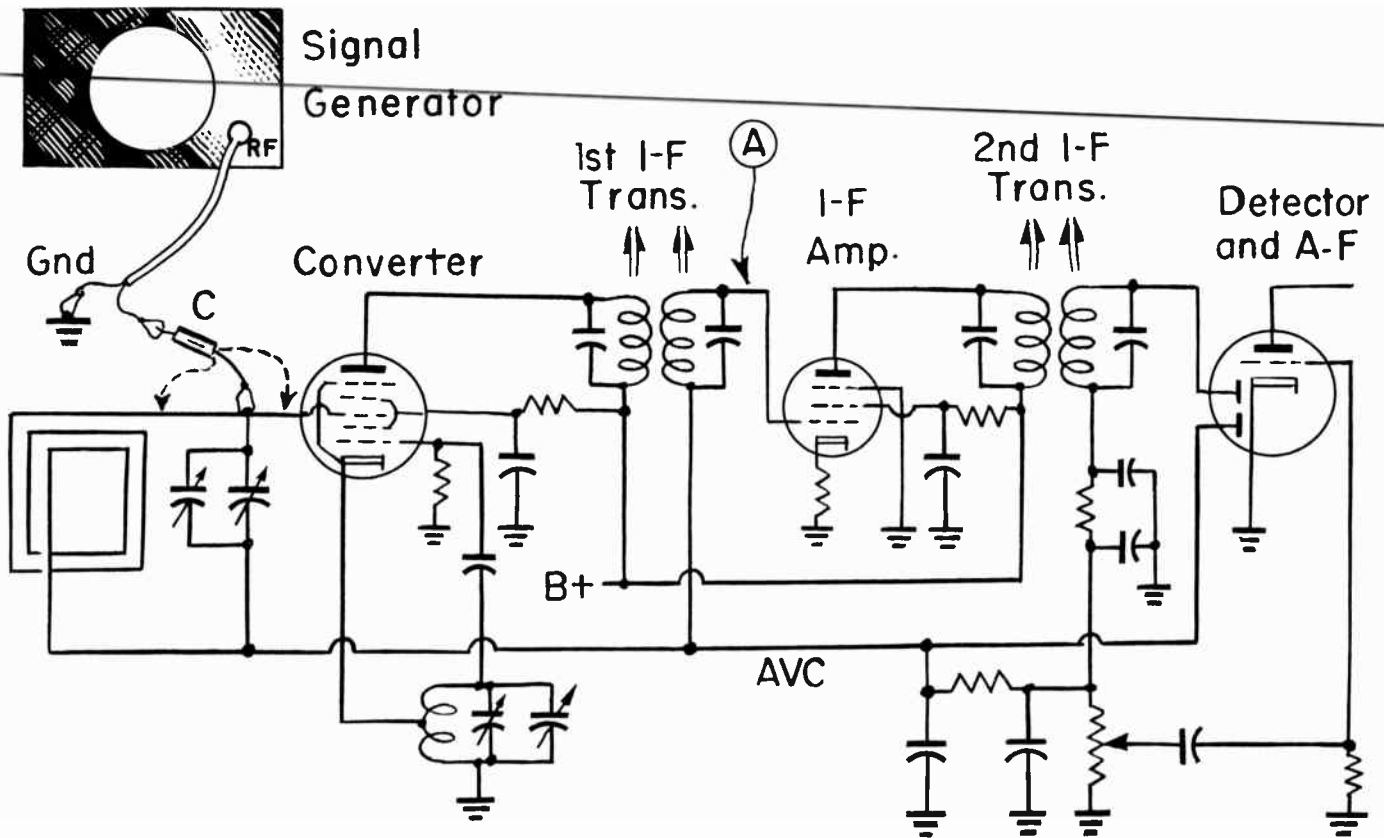

Fig. 13. How a signal generator is connected to the signal grid of the converter for i-f alignment.

time, be checking the action of the avc system. With correct avc action the negative voltage on the bus will change with changes of r-f signal strength.

**I-F ALIGNMENT.** Fig. 13 shows connections for the signal generator during alignment of the i-f transformers. The ground side of the r-f output cable is connected to chassis ground or to B-minus, possibly through a series capacitor as previously explained. The high side of the cable is connected through a blocking capacitor, C, to the signal grid of the converter tube. The blocking capacitor, of 200 mmf or greater capacitance, must be used to prevent short circuiting of the grid bias voltage through the attenuator of the signal generator.

The high side of the cable may be connected to any point from which an unbroken conductor leads to the grid. The connection might be at the grid lug on the converter socket, or at the stator of the tuning capacitor for the loop, or at the high side terminal of

the loop - whichever is most convenient. This general rule applies to all test connections. When something is to be connected to a grid, a plate, a screen, or a cathode, the connection may be to any conductor which goes without break to the specified element.

Tune the signal generator to 455 kc or to any other intermediate frequency employed in the receiver. Do not forget the warmup period. Once the generator frequency is adjusted, do not alter the position of the tuning until the i-f alignment is completed. The important thing is to align all the transformers to the same frequency, even though this frequency is slightly different from the one which should be used.

Adjust the r-f output voltage of the generator to obtain a reading somewhat below half-scale on the output meter. Keep the meter reading in this neighborhood by reducing the generator output as the work proceeds.



## LESSON 33 – RECEIVER ALIGNMENT

The tuning dial of the receiver may be in any position where no broadcast station can be heard, even with the volume control at maximum. It is usual practice to pick a spot on the high-frequency end of the tuning range, although this is not important.

Proceed now to adjust the secondary and primary sides of each i-f transformer for maximum reading of the output meter. When you think that the correct adjustment has been reached, turn the adjuster back and forth through this position several times, until you feel certain that the meter is at the highest possible reading. The adjustment of either secondary or primary affects the operating frequency of the other. It is necessary to work back and forth between the two adjustments on each transformer to be sure of a peak reading on the meter. As the meter reads higher and higher, keep reducing the r-f output from the generator.

Transformer adjustments usually are reached through openings in the tops of the shielding cans. Sometimes the adjusting slots or recesses extend out of the shield. The adjustment for one winding may be at the top of the can, with the other winding adjusted from below. The general procedure is exactly the same whether the windings are tuned by adjustable capacitors or by movable iron cores.

Should the receiver have an r-f amplifier stage, with a tuned coupling between this amplifier plate and the signal grid of the converter, this coupling is tuned to carrier frequencies, not to the intermediate frequency. Because the carrier frequency is far above the intermediate the interstage coupling will have low impedance at the intermediate frequency and it may practically short circuit the i-f voltage coming from the signal generator.

When there is a tuned coupling between r-f amplifier and converter, and you cannot obtain satisfactory readings on the output meter, first try tuning the receiver dial to the low end of its frequency range - to increase the coupling impedance near the intermediate frequency. If this scheme does not work out it will be necessary to tempo-

rarily disconnect the tuned coupling from the converter signal grid. Grid biasing voltage must not be lost, so the converter grid may have to be connected temporarily to the avc bus.

The i-f transformers may be so far out of alignment that no satisfactory reading on output meter can be obtained with the signal generator connected to the grid of the converter. Then the alignment must commence with the high side of the generator connected through the blocking capacitor to the grid of the i-f amplifier, to point A on Fig. 13. Now adjust the secondary and then the primary of the second i-f transformer for maximum meter reading, working back and forth until both windings are correctly tuned.

After completing alignment of the second transformer, move the generator high-side connection back to the converter grid while adjusting the secondary and primary of the first i-f transformer. Should the receiver have two i-f amplifiers and three i-f transformers, commence by adjusting the last transformer. Then shift the generator connection to the grid of the first i-f amplifier tube while adjusting the second transformer. Finally connect the generator to the converter grid while adjusting the first transformer.

ANTENNA, R - F, AND OSCILLATOR-ALIGNMENT. Before commencing alignment of the "front end" of the receiver it is advisable to check the tuning range and the readings of the tuning dial with reference to actual frequencies. Couple or connect the signal generator to the loop antenna or to antenna and ground terminals, as instructed earlier. Modulate the r-f output of the generator. Adjust the receiver tuning dial to its low-frequency limit, then tune the signal generator to hear the modulation tone from the speaker. Make a note of the frequency shown on the generator tuning dial. Check similarly the actual frequency with the receiver tuning dial at its high-frequency limit, and note the actual frequency.

The frequency range should cover the standard broadcast band, 540 to 1,600 kc, or any short-wave range that is being checked.

## COYNE - *television home training*

If the range is sufficiently wide but does not extend to one end of the band, while going beyond the other end, ~~this will be corrected~~ during alignment.

If the receiver tuning dial does not indicate reasonably close to actual tuned frequencies, the condition should be corrected. On nearly all modern sets the drive between tuning knob, indicating pointer, and variable tuning capacitors or inductors is by means of a cord or cords running over or around pulleys. The drive may be as simple as illustrated by Fig. 14 or it may be very elaborate.

drive cord. In any case, the adjustment is a mechanical problem and will require careful inspection before changes are attempted.

Tuning inductors for external antennas, also tuning inductors for an r-f stage when such a stage is present, usually are on top of the chassis. Oscillator inductors usually are underneath the chassis, although trimmer or slug adjustments for the oscillator may be accessible from above the chassis. With one set of inductors above and the other set below, chassis metal provides effective shielding between them.

There may be only trimmer capacitors for alignment. There may be a padder capacitor in the oscillator circuit, but seldom in the antenna or r-f tuning circuits. There may be adjustable iron cores in some or all of the tuning inductors, and in many cases there will be both a trimmer and an adjustable slug for the same inductor. Trimmers may be mounted on the tuning capacitor sections, or they may be mounted on the inductors. Adjustment of all the capacitors and cores may be called "tracking", because the intention is to allow oscillator and mixer or converter tuning to remain in correct relation throughout the tuning range.

The standard carrier or signal generator frequencies for front and alignment are 600 kc, 1000 kc, and 1400 kc for the standard broadcast band. Unless manufacturer's instructions specify other frequencies, all your alignment work may be carried out at the three mentioned. With the signal generator tuned to one of these alignment frequencies, the tuning dial of the receiver should be set at about the same frequency, or where the output readings are highest.

If the only alignment adjusters are trimmer capacitors you will work only at 1,400 kc, or possibly around 1,200 to 1,300 kc. It is assumed that tuned circuits are so designed as to track correctly at the lower frequencies.

When a single inductor has both a trimmer capacitor and an adjustable slug, the trimmer is used for alignment at 1,400 kc and the slug for alignment at 600 kc. If there

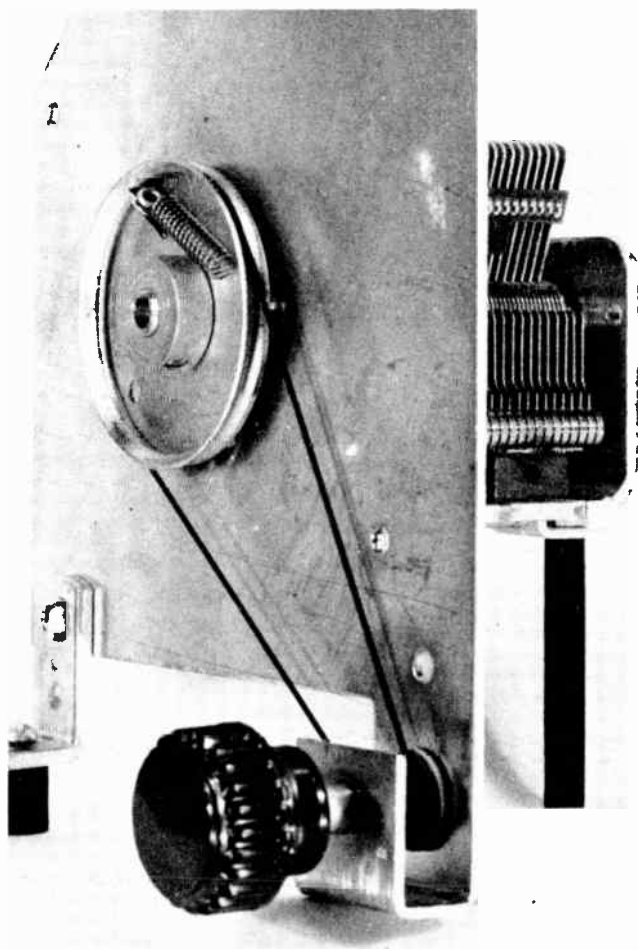

Fig. 14. Drive cord and pulleys for a variable tuning capacitor.

As a general rule it is possible to shift the position of the dial pointer with reference to the tuning capacitors or inductors. The pointer may be held in place with a set screw in a pulley hub. With the so called "slide rule dials" the pointer may be clipped to the

## LESSON 33 – RECEIVER ALIGNMENT

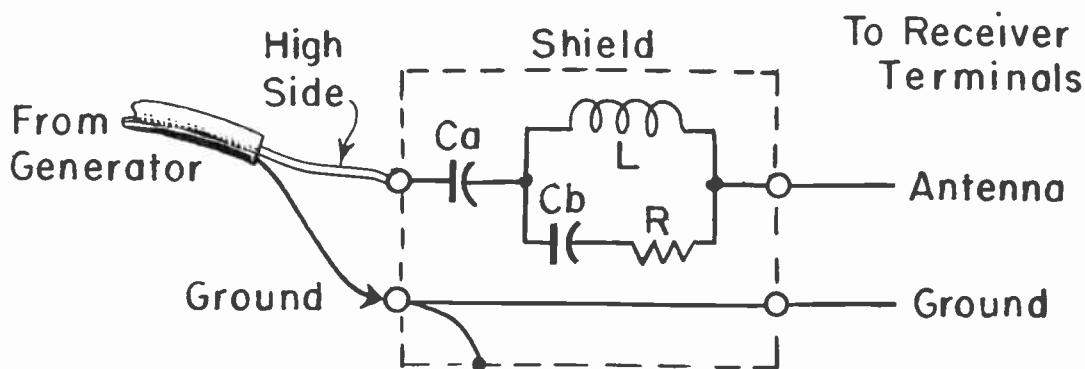

Fig. 15. A dummy antenna which may be used between signal generator and antenna terminals during alignment.

are no trimmers, but only slugs, the slugs may be adjusted for alignment at 1,000 kc. Padder capacitors in the oscillator circuit are aligned with the signal generator and receiver tuning dial set for 600 kc.

As a general rule the oscillator circuit is aligned before the antenna tuning, and before the r-f interstage tuning if present. If there is a tuned r-f stage it is aligned after the oscillator. The antenna coupling is aligned last.

Some manufacturers specify the use of a "dummy antenna" between the high side of the signal generator and the receiver for front end alignment. The circuit for a dummy antenna, and how it is connected, are shown by Fig. 15. Capacitors are ceramic or mica, 200 mmf at Ca and 400 mmf at Cb. At R is a fixed carbon resistor of 400 ohms. Inductor L is of 20 microhenrys inductance. It may be made with 59 turns of number 38 enameled wire close wound on tubing 3/8 inch in diameter.

The dummy antenna is presumed to affect receiver alignment in the same manner as an external or outdoor antenna, so that alignment will not be upset when the signal generator is removed and the regular antenna re-connected to the receiver. The regular antenna is, of course, disconnected while making alignment adjustments with the dummy antenna.

**OSCILLATOR ALIGNMENT.** While aligning the oscillator it is advisable to override the avc voltage as in Fig. 11. The sig-

nal generator may be tuned to 1,400 kc, although a frequency of or close to 1,600 kc is recommended in manufacturers' instructions more often than the lower frequency for adjustment of the oscillator trimmer capacitor. If there is an adjustable slug in addition to the trimmer, or if there is only a slug, it usually is adjusted with the generator tuned to 1,400 kc, or this adjustment may be carried out at a frequency as low as 1,000 kc. Check back and forth between trimmer and slug adjustments if both are present.

It is almost universal practice to have the oscillator frequency remain higher than the carrier frequency in producing the intermediate frequency. In some sets the oscillator trimmer adjustments may have such a wide range that oscillator frequency may mistakenly be made lower than the carrier or lower than the r-f voltage from the signal generator.

If you suspect that this has happened, commence by tightening the trimmer adjustment all the way, for maximum capacitance and lowest frequency. Gradually loosen the trimmer to raise the oscillator frequency. If the meter shows two peaks of voltage, the first peak is with the oscillator frequency below the generator (and carrier) frequency, while the second peak is above, where it should be. It is possible, also, to commence by loosening the trimmer, then gradually tightening it. Then the first of two voltage peaks is at an oscillator frequency above the generator frequency, as should be the case, while the second peak is below the generator frequency.

## COYNE - *television home training*

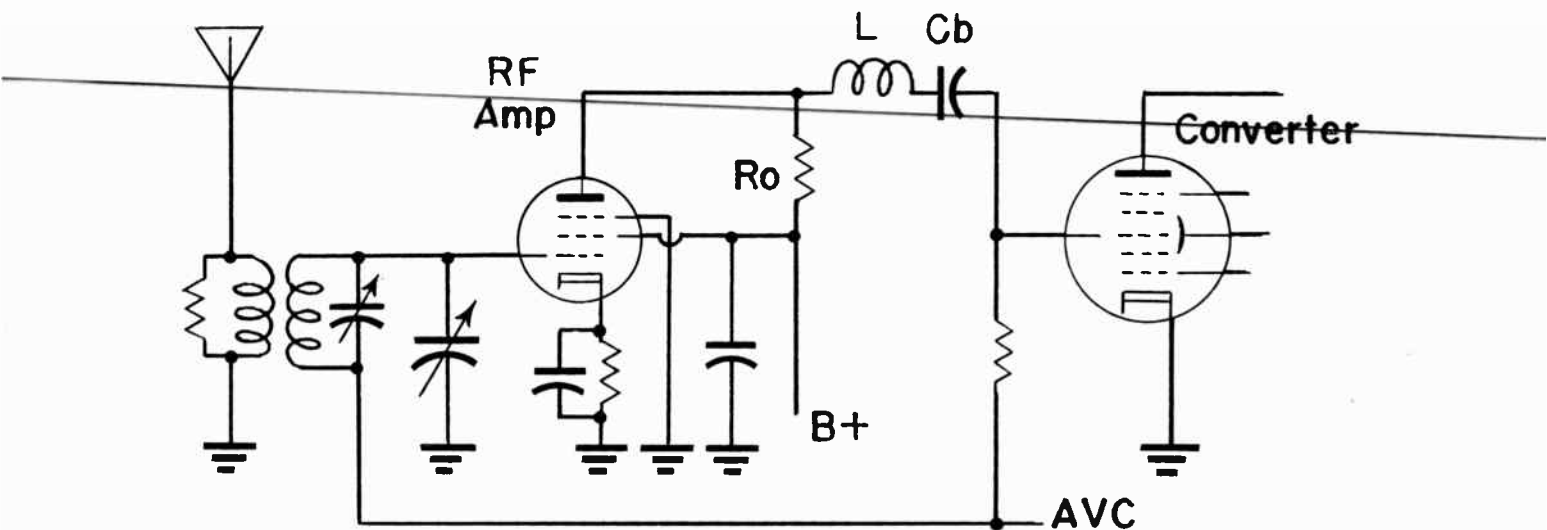

Fig. 16. An untuned coupling between r-f amplifier and converter.

As mentioned before, an oscillator pad-der capacitor is adjusted with the signal generator tuned for 600 kc and with the receiver tuning dial near this frequency. While adjusting the padder, turn the receiver tuning back and forth around 600 kc until finding the combination of receiver tuning and padder adjustment giving the highest reading on the output meter. This is called "rocking" the receiver dial. With the final adjustment of the padder the receiver dial may not indicate 600 kc, but the reading should be reasonably close to this value. Recheck a trimmer adjustment after completing work on the padder.

**ANTENNA AND R-F ALIGNMENT.** In some receivers having an r-f amplifier stage the coupling between plate of the r-f amplifier tube and signal grid of the converter is untuned, it is a resistance coupling. A circuit of this type is shown by Fig. 16. Since an untuned coupling requires no alignment, you would proceed to adjustment of the antenna coupling after completing work on the oscillator.

The particular resistance coupling of Fig. 16 includes an inductor  $L$  in series with the usual blocking capacitor  $C_b$ . This inductor and capacitor are series resonant at a frequency around 1,800 to 2,000 kc, which is somewhat above the high end of the standard broadcast band. Impedance of the series inductor-capacitor combination is high at the

low-frequency end of the band and decreases toward the high frequency end. This effect tends to cause more uniform gain throughout the entire band, since gain normally is greater at low frequencies than at high ones.

If there is a tuned coupling between r-f amplifier and converter, and if the only adjustment is a trimmer capacitor, tune the signal generator to 1,600 kc, and tune the receiver to pick up the signal on the output meter. Then adjust the trimmer for maximum meter reading. When the only adjustment is a movable core, make the setting with the signal generator tuned to 1,400 kc. Should there be both a trimmer and a movable core, adjust the trimmer at 1,600 kc and the core at 1,400 kc, then recheck the trimmer setting.

The tuned coupling between antenna and r-f amplifier, or between antenna and converter when there is no r-f amplifier, is aligned in essentially the same manner as just described for a tuned r-f coupling. It is a good idea to rock the receiver tuning dial while aligning the antenna coupling, to find the combination of settings at which the meter reads peak output. If the tuning dial or pointer of the receiver then is far from the frequency of the signal generator, the receiver dial should be adjusted.

**WAVE TRAPS.** A tuned coupling between an r-f amplifier and a converter adds greatly to selectivity against all unwanted



## LESSON 33 – RECEIVER ALIGNMENT

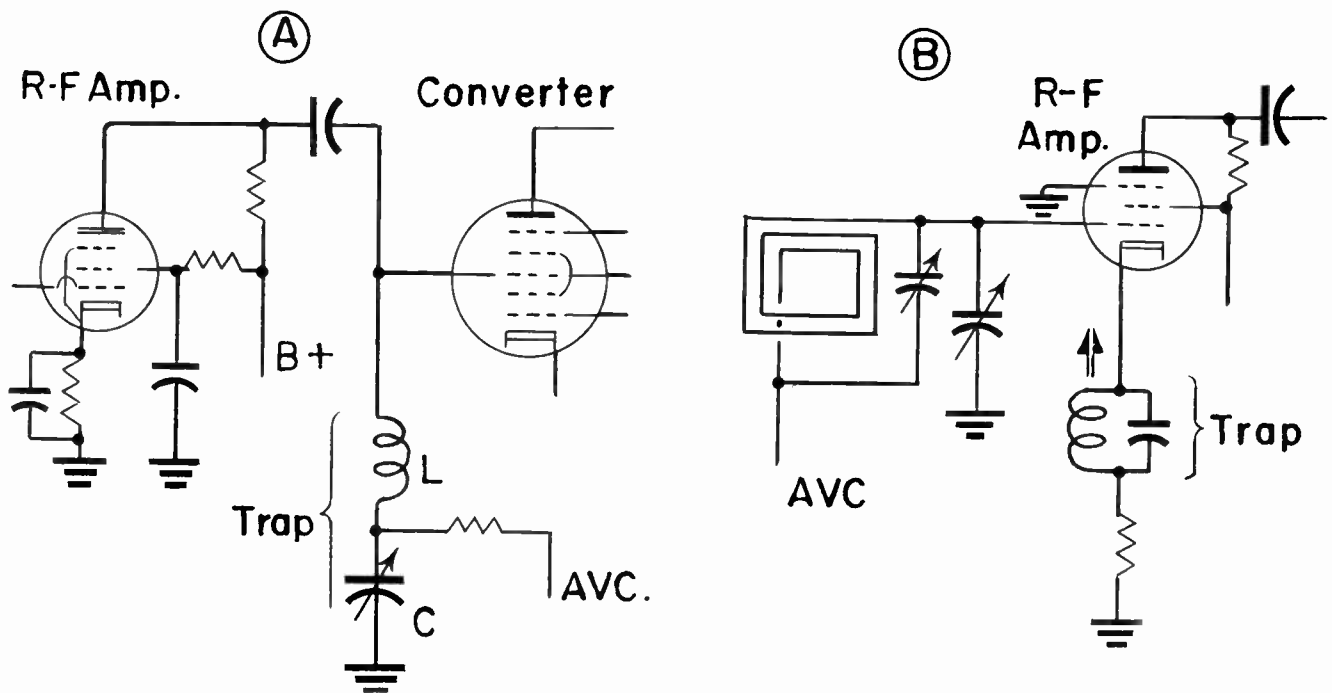

Fig. 17. Wave traps which lessen the possibility of interference at the intermediate frequency.

carriers and other interference frequencies. When this coupling is untuned there is some danger of interference from frequencies in the neighborhood of the intermediate frequency of the receiver. Such interference may be guarded against by a wave trap which either bypasses the interference frequency to ground or else offers high impedance at this frequency.

Two common types of wave traps are shown by Fig. 17. At A the trap consists of inductor L and adjustable capacitor C which are made series resonant at the intermediate frequency of the receiver. This series resonant circuit is between the signal grid of the converter and ground. Signals at and near the intermediate frequency which may come through the r-f amplifier are bypassed by the trap and kept out of the converter, which would pass them on to following i-f stages to be amplified.

At B the trap is a parallel resonant circuit in the cathode lead of the r-f amplifier. This lead, as you know, is part of the grid circuit and also part of the plate circuit of the amplifier. When the trap is tuned to resonance at the intermediate frequency, this frequency is strongly opposed in both the

grid circuit and the plate circuit of the r-f amplifier.

An i-f wave trap, if present, usually is aligned immediately after the i-f transformers while the signal generator still is tuned to the intermediate frequency. Later it may be difficult to re-tune the generator to precisely the same frequency. Any kind of i-f wave trap is aligned as follows:

1. Couple the signal generator to a loop antenna or connect it to the antenna-ground terminals of the receiver in the manner explained earlier.
2. Tune the generator to the intermediate frequency, if not already there.
3. Adjust the r-f output to obtain a meter reading of one-third to half scale.
4. Adjust the trap capacitor or inductor for minimum reading of the meter.
5. Increase the r-f output from the signal generator as you continue to adjust the trap circuit until obtaining a low meter reading with high signal output.

# COYNE - *television home training*

## ALIGNMENT WITHOUT INSTRUMENTS.

Should you have to make an approximate alignment without a signal generator and output meter, take these steps.

1. Tune the receiver to the weakest signal or weakest broadcast station that you can hear with the volume control set high. If the receiver has a loop antenna turn the receiver to the position giving best reception of a weak station.

2. Adjust each of the i-f transformers, secondary and primary, for loudest reception. Repeat these adjustments at least once.

3. As reception from the station first selected becomes louder, tune the receiver to a still weaker signal.

4. Adjust the oscillator circuit to obtain loudest reception. Try for stations weaker still.

5. Adjust the r-f and antenna couplers for loudest reception. A wave trap cannot be correctly adjusted without a signal generator.

If you have neither an a-c voltmeter, nor a high-sensitivity d-c voltmeter for use

as an output meter, it may be possible with some receivers to use a low-sensitivity d-c voltmeter. It is possible when i-f amplifier tubes, converters, and r-f amplifiers are operated with a cathode bias resistor, in addition to avc.

Connect the low-sensitivity d-c voltmeter across the cathode bias resistor of a tube preceding the i-f transformer or transformers to be adjusted, except for the antenna coupling, for which any bias resistor may be used. The bias resistor must be on a tube controlled by the avc system.

Use the lowest range of the meter which allows the pointer to remain on scale. Make the alignment adjustments for minimum reading on the voltmeter. Actually you are measuring the effect of the avc system, but are doing so with a low-resistance meter across the low resistance of the biasing resistor, instead of with a high-resistance meter directly on the avc bus. As avc voltage becomes more negative with better alignment, the plate current and cathode current of the tube become smaller. You are measuring voltage drop due to cathode current in the biasing resistor, and for this reason you make adjustments for minimum voltage drop.

# TELEVISION

◦ RADIO

◦ ELECTRONICS

---

**LESSON 34 – THE VACUUM TUBE VOLTMETER**

---

***Coyne School***

*practical home training*

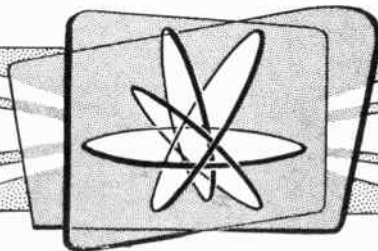

*Chicago, Illinois*

---

*Copyright, 1953 by Coyne Electrical\_School  
Chicago 12, Illinois  
All rights reserved*

Litho. in U.S.



## Lesson 34

# THE VACUUM TUBE VOLTMETER

Earlier we learned that a sensitive voltmeter, having high internal resistance, possesses important advantages over types having relatively low internal resistance. We learned also that sensitivity, in ohms per volt, determines the internal resistance of the meter, and that this resistance varies with full-scale volts of the range employed. For instance, with sensitivity of 20,000 ohms per volt, resistance on a 100-volt range is 2 megohms, on a 300-volt range it is 6 megohms, but on a 10-volt range the internal resistance will be only 200,000 ohms or 0.2 megohm.

Vacuum tube voltmeters, such as the one pictured by Fig. 1, have internal resistances of 10 to 15 megohms on all ranges. If one of these instruments has resistance of 15 megohms, for an example, its sensitivity on a 10-volt range is 1,500,000 ohms per volt on that range. This is seventy-five times the sensitivity of a 20,000 ohms per volt meter, and on this range the vacuum tube voltmeter will take away from the measured circuit only  $1/75$  as much current as the ordinary voltmeter.

Since the resistance of the vacuum tube voltmeter remains constant, its sensitivity in ohms per volt decreases at the higher ranges. On ranges of 500 to 600 volts the sensitivity may be about the same as that of a 20,000 ohms per volt meter, and on still higher ranges the sensitive voltmeter will have greater internal resistance than many vacuum tube voltmeters.

The name vacuum tube voltmeter is so long that usually we write the abbreviation VTVM. This instrument may be called also an electronic voltmeter. Some manufacturers use trade names, such as Voltohmyst and Polymeter. Practically all of these instruments are not only d-c voltmeters, they are volt-ohmmeters measuring d-c volts, a-c and a-f volts, and ohms of resistance. Some will measure direct currents, and there may be provision for measuring capacitances.

All are multi-range instruments, providing about the same ranges on all functions as VOM's which are not of the electronic or vacuum tube type.

The VTVM attains its high sensitivity through the amplification ability of one or more tubes, or twin tubes, built into the instrument. In all except a few VTVM's there is a built-in d-c power supply operated from the a-c line. Like other line-power operated instruments, the VTVM must be allowed to warm up before used for testing. For this reason it is less convenient than the ordinary VOM. In many busy shops the VTVM's are turned on at the beginning of the working day and left on until closing time.

The VTVM is probably the oldest type of instrument designed specifically for making measurements on radio circuits. Textbooks of twenty years ago devoted much space to electronic measurements of voltages. Most of the early designs have disappeared, at least from the service field, and in late years we have settled on what may be called the bridge type of VTVM.

BRIDGE VOLTMETERS. One style of bridge circuit for a VTVM is shown in simplified form by Fig. 3. There two triodes. The grid circuit of triode 1 is connected through the external leads of the instrument to points whose potential difference is to be measured. The high-side lead of the instrument is here shown connected to the positive measured voltage, so that the grid of triode 1 will be made more positive, or less negative, during the measurement. The grid of triode 2 is connected to ground.

Between the plates of the two diodes is connected the indicating meter. This meter is a permanent-magnet moving-coil type giving full-scale reading when its armature carries 100 to 500 microamperes, depending on the design of the VTVM. In the plate circuits of the triodes are load resistors or voltage dropping resistors R1 and R2. These

COYNE - television home training

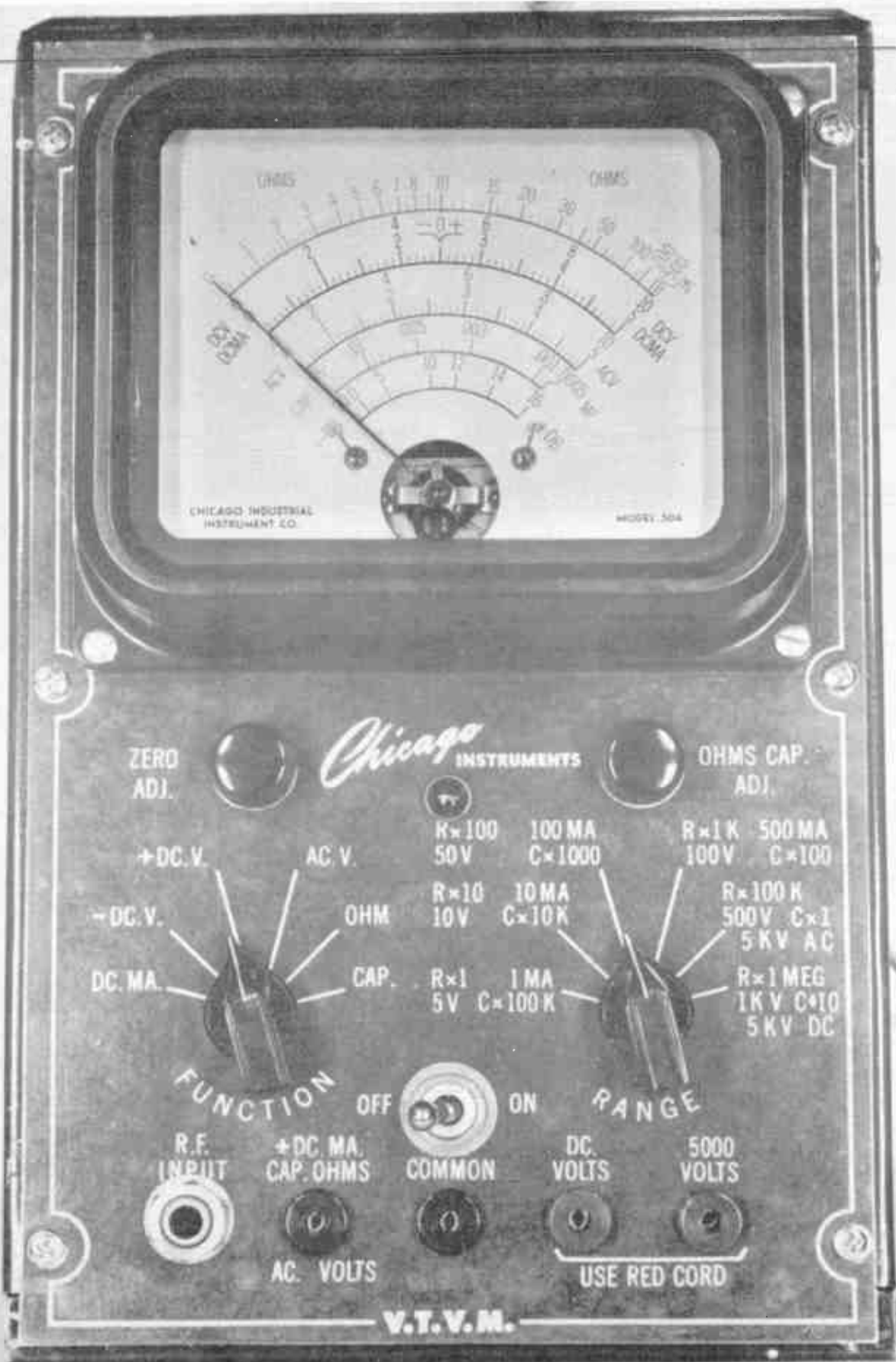
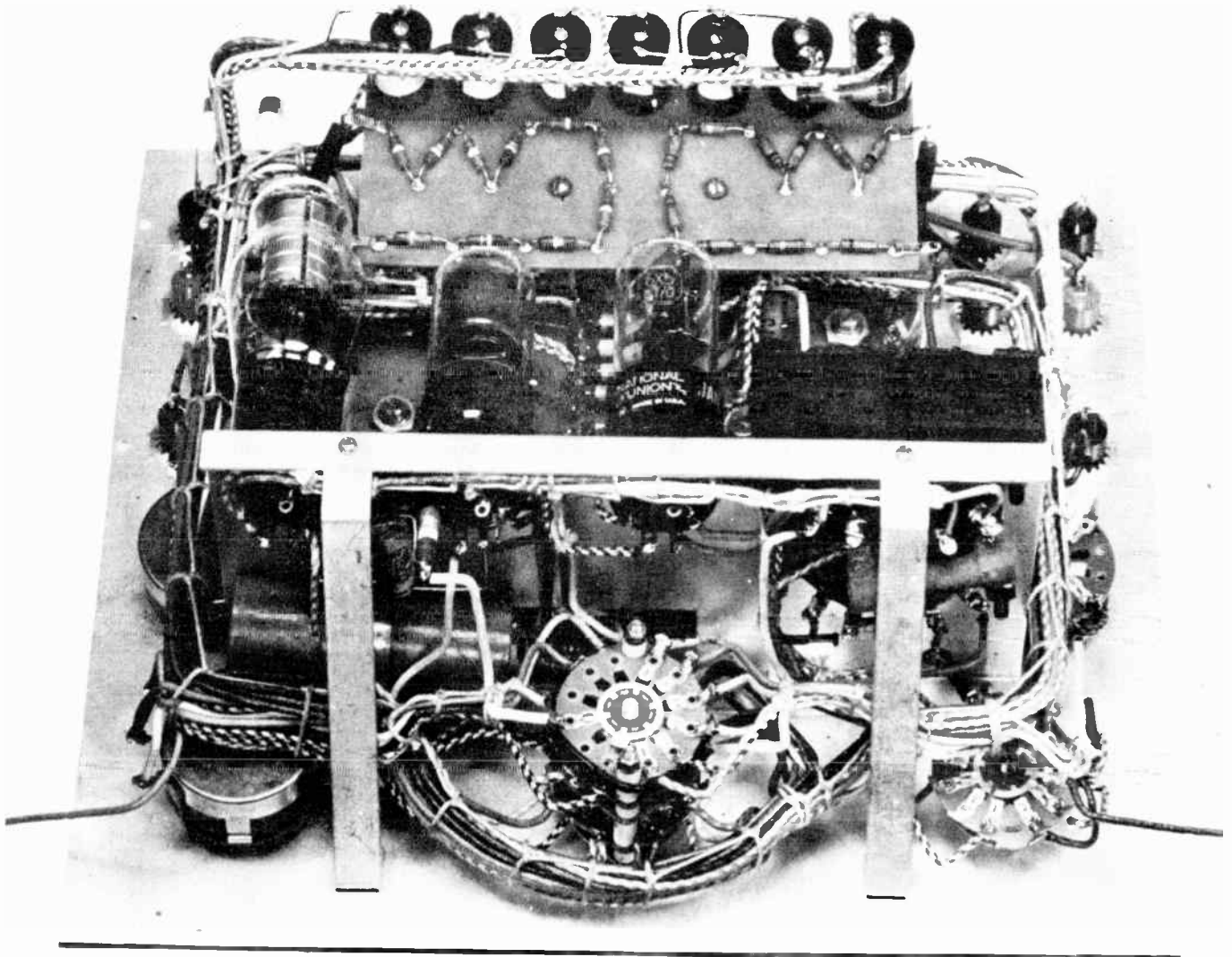

Fig. 1. A vacuum tube voltmeter with multiple functions and ranges.

# LESSON 34 – THE VACUUM TUBE VOLTMETER



*Fig. 2. The interior of a vacuum tube voltmeter.*

two resistors are connected to the ends of a potentiometer which is the zero adjuster. The slider of the potentiometer goes to B-plus.

In the cathode circuits of the triodes are resistors  $R_a$  and  $R_a$  whose purpose is to prevent too much interaction between the two tubes. The common cathode return is through resistor  $R_k$ . This latter resistor, together with units  $R_a$  and  $R_a$ , provides part of the biasing voltage. Total biasing voltage is affected also by the potential to which the B-minus line is connected on the d-c power supply system.

Assume now that the test leads, at the left, are not applied to points whose voltage

is to be measured, but are connected together, to ground the grid of triode 1. The zero adjuster now may be set to apply such voltages at the tops of  $R_1$  and  $R_2$  as to make plate voltages equal at the plates of the two tubes. Adjusting the plate voltages in this manner allows compensating for differences of performance in the triodes and for minor differences in values of circuit elements.

Since plate voltages going to the two terminals of the meter now are equal there is no potential difference across the meter and it reads zero. When the test leads are connected to the measured voltage, as shown on the diagram, the grid of triode 1 becomes less negative, and its plate current increases.



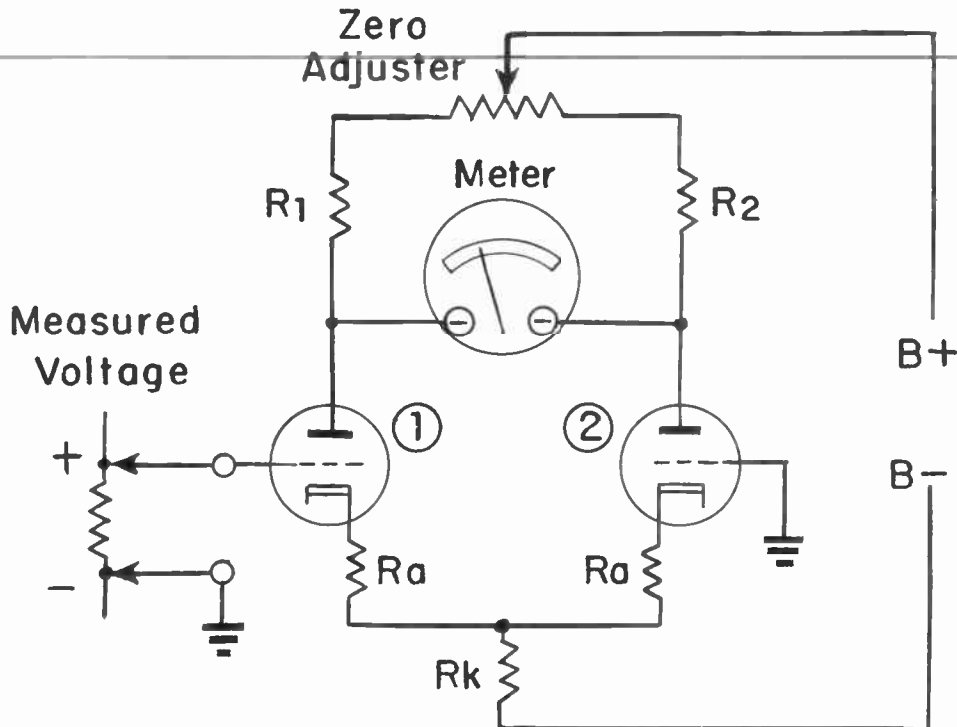

Fig. 3. Bridge circuit of a VTVM.

Plate voltage decreases, because of greater voltage drop in R1. Now the plate potential at the negative of the meter is less positive than before, or is relatively negative. This causes the meter pointer to move up scale.

Something else has happened at the same time. The increased plate current in triode 1 flows as cathode current through resistor Rk. There is greater voltage drop across Rk, and since this is a biasing voltage the grid of triode 2 becomes more negative with reference to its cathode. This change of grid voltage decreases the plate current in triode 2. The smaller plate current flowing in resistor R2 decreases the voltage drop in this resistor, and there is an increase of plate voltage on triode 2 and at the positive terminal of the meter.

Applying a positive measured voltage at the grid of triode 1 has caused potential at the negative terminal of the meter to become less positive while, at the same time, potential at the positive terminal has become more positive. So we have both effects acting together to move the meter pointer up scale. Because triode grid bias remains negative the tube draws no grid current, and so far as

the circuit of Fig. 3 is concerned no current would be taken from the measured circuit. The meter is operated by plate current or by current from the d-c power supply, not by current from the measured circuit.

**POLARITY REVERSAL.** The polarity of voltage in a measured circuit is not always known in advance, and it would be inconvenient to reverse the test leads during tests. Furthermore, during certain service adjustments the polarity may reverse during the operations. For this reason VTVM's have two positions of the function switch for measurements of d-c voltages. One is marked for negative (-) d-c volts, and is used when the high-side test lead goes to a point which is negative with reference to the ground lead. The other function switch position is marked for positive (+) d-c volts, and is used when the high-side lead goes to a positive potential. You can see the two positions for the function switch of Fig. 4.

Reversal within the VTVM may be made in various ways. One method interchanges the connections to the grids of the bridge tubes. That is, the grid of triode 1 (Fig. 3) would be grounded and the grid of triode 2



# LESSON 34 – THE VACUUM TUBE VOLTMETER

would be connected to the test lead were the measured potential negative at the test lead. With another method the connections to the two meter terminals are interchanged.

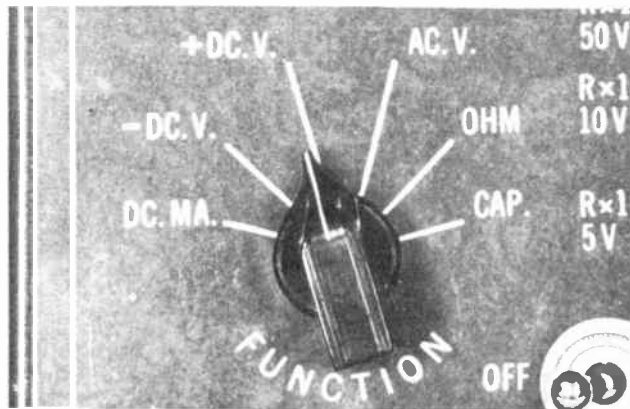

Fig. 4. The function switch has positions for connection of the high-side lead to a positive d-c voltage, and for connection to a negative d-c voltage.

During some of the adjustments on detector circuits of f-m receivers and on the sound detectors of television receivers the check point is a change of potential from positive to negative. To make such tests more convenient some VTVM's have provision for bringing the meter pointer to a zero marking at or near the center of the dial scale. Such a center zero point may be seen on the dial of Fig. 5, just below the ohms scale. This is a picture of the meter dial on the instrument pictured by Fig. 1.

The pointer is brought to a center zero by increasing the resistor in series with the plate of one bridge tube. On the diagram of Fig. 3, adding resistance between  $R_1$  and the regular zero adjuster will make plate voltage less positive (effectively more negative) at the plate of triode 1 and at the negative terminal of the meter. This will cause the meter pointer to move up scale to the center zero.

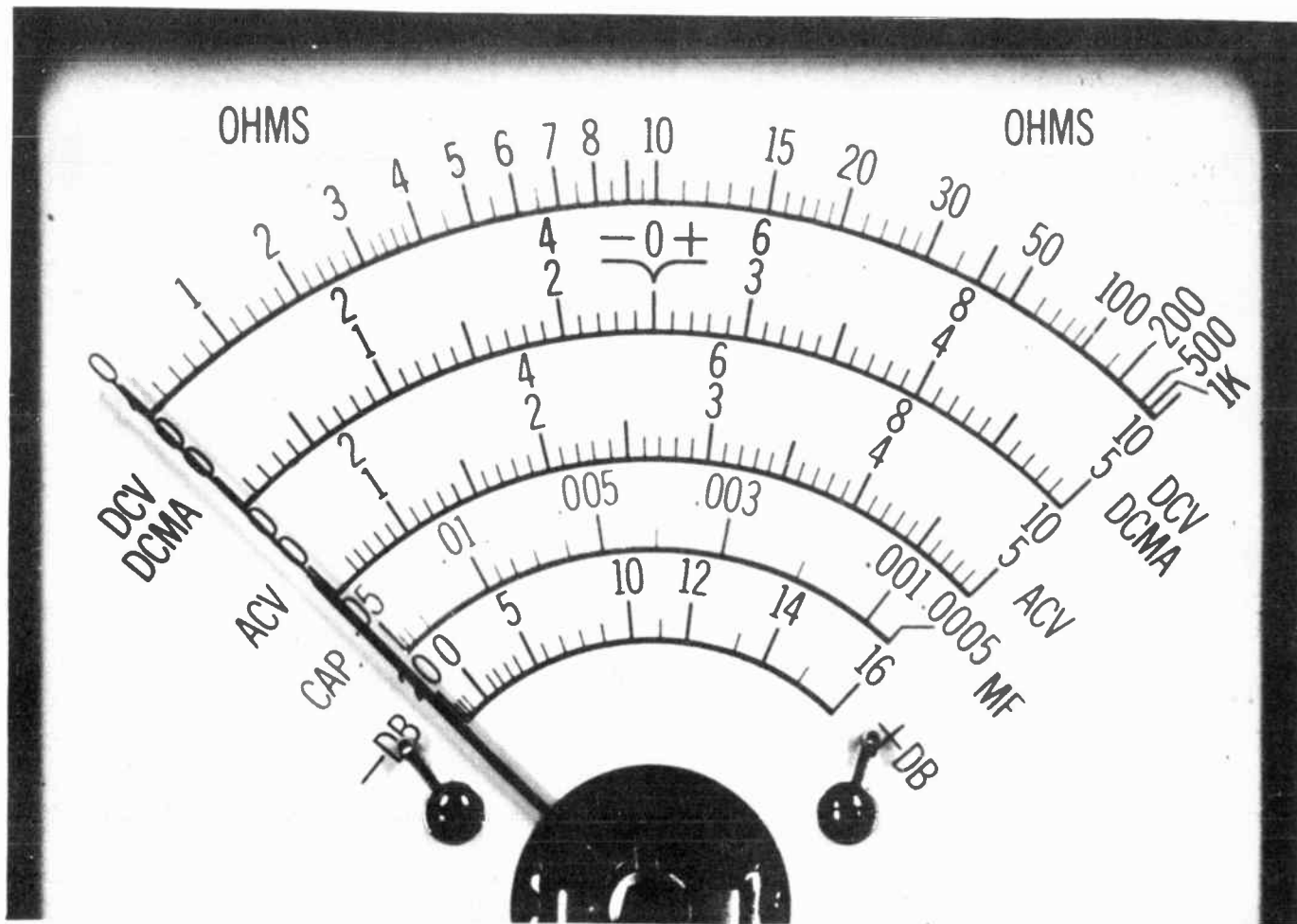

Fig. 5. Dial scales of a VTVM.

# COYNE - *television home training*

The extra resistance may be cut in or out of the circuit by a special switch, or on one position of the regular function switch.

OTHER BRIDGE CIRCUITS. There are numerous variations of the bridge circuit shown by Fig. 3, but all perform basically in the same manner. With one modification the indicating meter is connected between the cathodes of the two bridge tubes. Then the meter is actuated by differences in cathode voltages or by differences at the cathode ends of resistors in the cathode circuit.

The bridge tubes may be two separate triodes, but more often a single twin triode is used for both sides of the circuit. In some instruments the tubes are pentodes, but their plates and screens are connected together for operation as triodes.

With most VTVM's there is little or no likelihood that excessive applied voltage will damage the indicating meter. Plate voltages may be so low that changes of grid voltage cannot increase plate current and alter plate voltage much beyond values that cause full-scale deflection of the pointer. Initial grid voltages or biasing voltages may be of values which prevent excessive changes of plate voltage.

A-F and A-C MEASUREMENTS. To use the VTVM for measurement of audio-frequency voltages or any other a-c voltages of moderate frequency it is necessary only to connect a rectifier ahead of the bridge circuit that measures direct voltages. This gives the equivalent of a rectifier meter such as studied earlier. The rectifier is cut onto the circuit when the function switch is turned to the position marked A-c Volts, or with any marking of similar meaning.

There may or may not be a blocking capacitor internally in series with the test lead connection used for a-f and a-c measurements. Should there be no such capacitor within the instrument, one must be connected externally according to the instructions for using a VOM as an a-f or a-c voltmeter.

CONTACT POTENTIAL. A rather peculiar effect which occurs in all tubes, and which may cause difficulties with rectifiers

in VTVM's and other test instruments, is called contact potential. Contact potential is a small voltage that appears between cathode and plate of a diode or between cathode and grid of other tubes. It is explained as follows.

If a plate or grid is so close to the cathode as to be in a dense region of the space charge the plate or grid will collect negative electrons from the space charge. If these negative electrons cannot flow quite freely through an external circuit back to the cathode, as when there is high resistance in the external circuit, the element will become negatively charged to an extent causing a negative voltage as great as one volt or even more with respect to the cathode.

In the case of a grid the contact potential will affect the grid bias, making it more negative. As the electrons flow back to the cathode as a current they cause a voltage drop in any resistance between the grid (or a diode plate) and the cathode. When the external resistance is high the voltage across it will approach the value mentioned for contact potential. The effects of contact potential appear as soon as the cathode is heated, to emit electrons, and it is not related to the positive voltages normally applied to the plate or the screen. The higher the cathode temperature and the greater the electron emission, the higher becomes the contact potential.

In instruction literature issued by manufacturers you occasionally find the statement that some amplifier is biased by contact potential. Usually it is the a-f voltage amplifier. Then you will find that the grid return of this amplifier is through a resistor of possibly 10 to 15 megohms. The circuit looks as though there were grid leak bias, but negative bias actually is the result of contact potential on the grid, and it is maintained because electrons can leave the grid only at a very slow rate through the high resistance of the grid return.

When a tube is used as the rectifier for a-c and a-f voltages in a VTVM, contact potential can cause current to flow in the range resistors. On high-voltage ranges, where the multiplying resistance is high, the result is a deflection of the meter pointer while no ex-

## LESSON 34 – THE VACUUM TUBE VOLTMETER

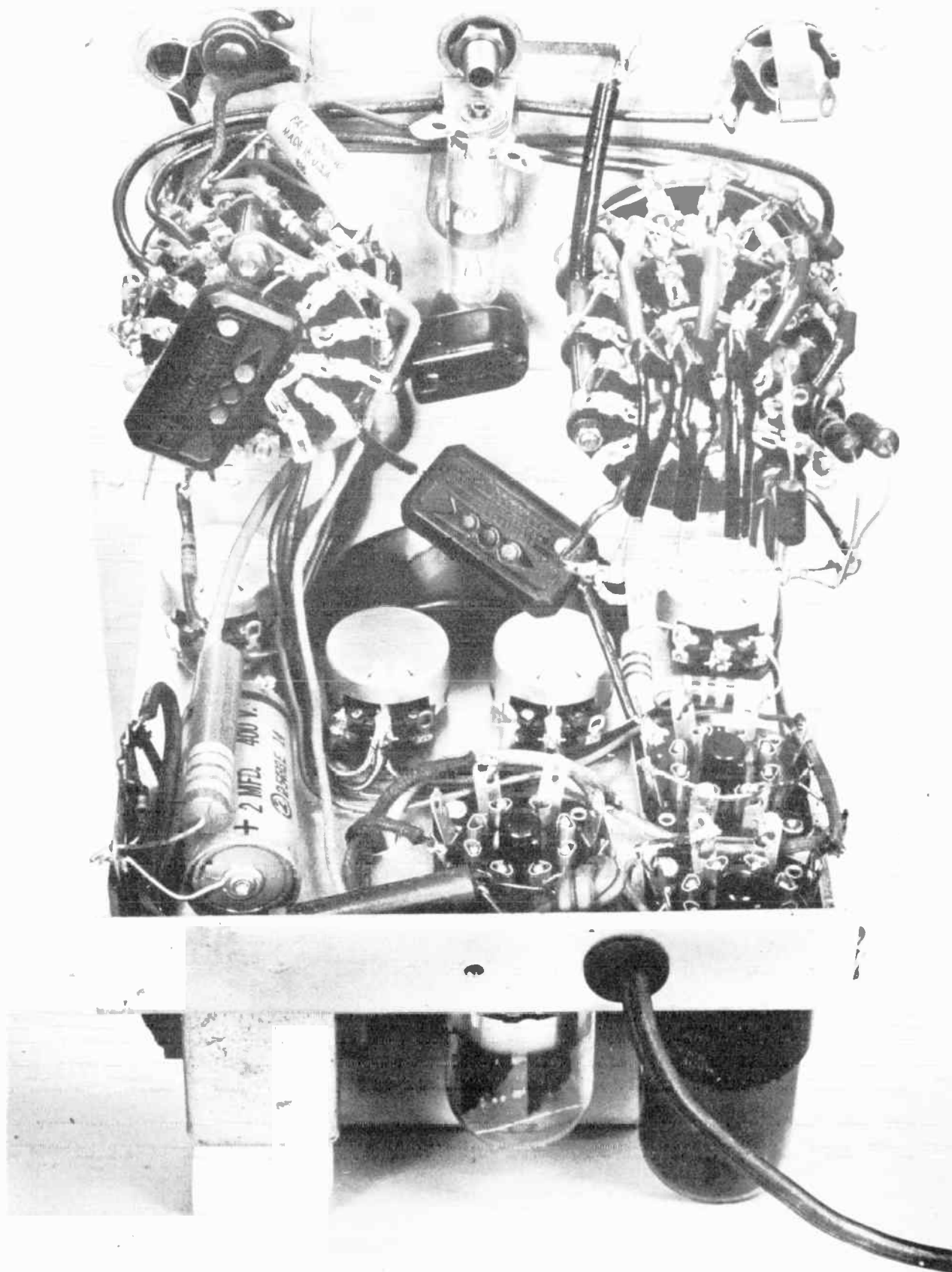

Fig. 6. A view from underneath the tube shelf of a VTVM, with the instrument upside down. Function and range switches are at the top of the picture.



ternal voltage is being measured. A voltage of opposite polarity is required for balancing the contact potential effect.

Compensation usually is provided by using a twin diode for the a-c and a-f rectifier. One section acts as a half-wave rectifier for voltage which is to be measured. The contact potential which develops in the second section balances the presumably equal contact potential of the rectifier section.

One style of circuit for balancing contact potential is shown by Fig. 7. Diode A is the rectifier connected to terminals for test leads through range resistors. Rectified voltage from the plate side of this diode goes through various resistors to the grid of one of the bridge tubes. Most of the resistors, and all of the capacitors to ground along this line help to filter the rectifier output and leave smooth d-c voltage at the grid of the bridge tube.

Contact potential which develops in diode B is used for balancing. The cathode of this balancing diode is connected to one end of the a-c balance potentiometer. The plate of diode A is connected to the other end

of this potentiometer. Thus the contact potentials are of opposite polarity at the two ends. The slider of the balance potentiometer may be moved to a position where the opposite contact potentials are equal at the line going to the d-c bridge. Then the indicating meter pointer may be brought to zero with the same setting of the regular zero adjuster that is correct for d-c voltage measurements.

### INPUT RESISTANCE AND IMPEDANCE.

The resistance of the VTVM for d-c voltage measurements may be made very high by connecting the high side of the test lead to one end of a series of range resistors, then taking voltage to the bridge from various points along the series of resistors.

In addition there always is a resistor in a probe handle at the free end of the test lead used for d-c voltage measurements. This resistor may be of one megohm or greater resistance. Its principal purpose is to isolate the test prod or clip from the cable and from the body of the VTVM, thus preventing the test connection from greatly affecting the measured circuit. Because of containing the probe resistor, the test lead or cable used for d-c voltages must be used for this work,

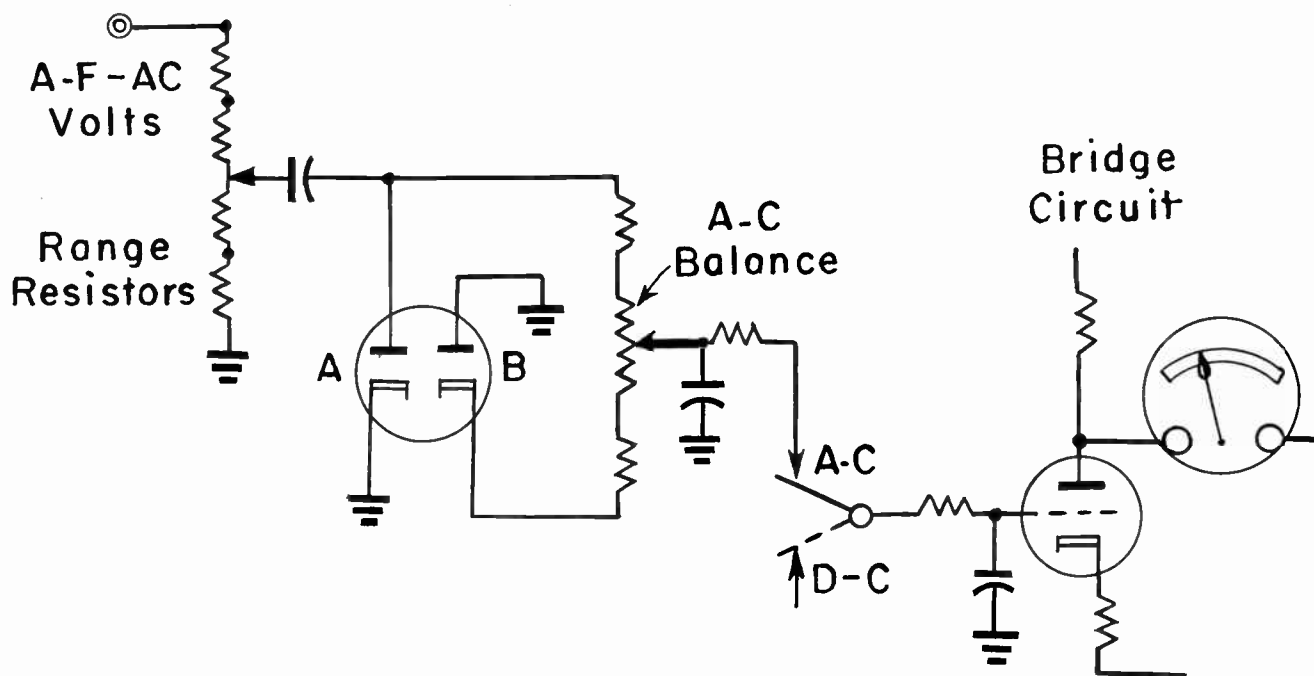

Fig. 7. A circuit for measuring a-c voltages with the VTVM.



# LESSON 34 – THE VACUUM TUBE VOLTMETER

and seldom may be used for measurements of a-c voltages or resistances.

When measuring audio frequencies or radio frequencies we are concerned not with ohmic resistance at the test leads of the VTVM, but with impedance. Impedance becomes less and less as frequency rises. The circuit loading effect of a VTVM may be specified as a combination of resistance and equivalent paralleled capacitance. As a fair example for high quality instruments we may assume for the a-c input a resistance of 1.5 megohms shunted by 60 mmf of capacitance.

Capacitance effects commence with the test lead, which usually is a shielded cable. High grade coaxial or microphone cable may have capacitance of about 20 to 25 mmf per foot of length. From this we may observe that a test cable should be as short as can be used conveniently. There is capacitance also at the instrument terminals, in the range multiplier, in the rectifier, and so on. Consequently, assuming a total capacitance of 60 mmf is quite conservative.

The computed impedance of 1.5 megohms resistance paralleled or shunted by the capacitive reactance of 60 mmf at a few frequencies is as follows. The values are approximate.

60 cycles	1,450,000 ohms	5,000 cycles	390,000 ohms
120 cycles	1,400,000 ohms	10,000 cycles	225,000 ohms
400 cycles	1,220,000 ohms	1000 kc	2,650 ohms
1000 cycles	960,000 ohms	45 megacycles	59 ohms

Through the range of audio frequencies up to 5,000 cycles and even to 10,000 cycles the impedance is high enough for accuracy in voltage measurements. In the standard broadcast carrier range the impedance becomes very small, and in attempting measurements in the i-f amplifier of a television set the instrument would act as a near short circuit. For measurements at standard broadcast and short-wave carrier frequencies, and at both i-f and carrier frequencies of television, we need an accessory called a detector probe. Such probes will be considered as we progress.

D-c input resistance, and input impedance at audio frequencies, may be increased

by various features of circuit design. The method of Fig. 8 utilizes cathode followers ahead of the bridge tubes. The cathode followers, shown as a twin triode, may be operated with highly negative grid bias, and with their low-resistance output, from the cathodes, going to the grids of the bridge tubes. This is but one example of the many uses of cathode follower circuits in test and measuring equipment.

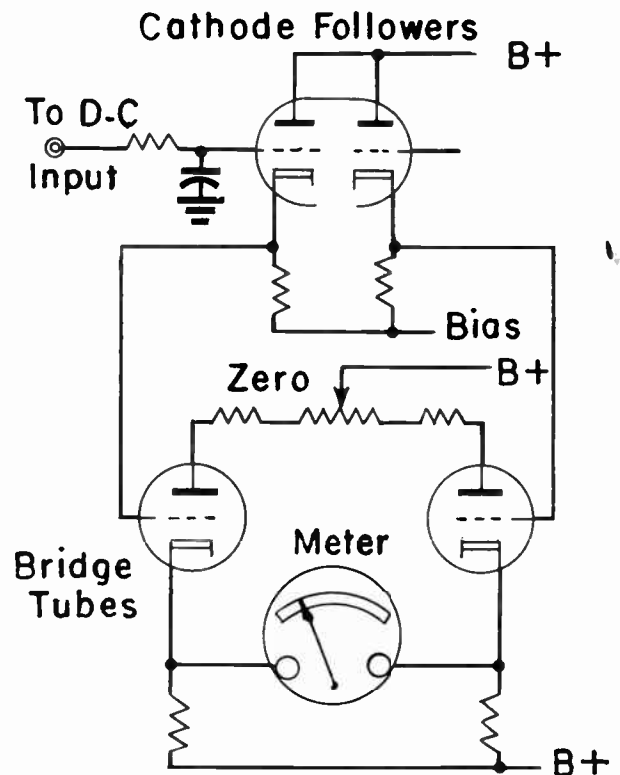

Fig. 8. Cathode followers connected between the d-c input and bridge circuit of a VTVM.

The accuracy of a VTVM of any given quality, good or poor, is inherently less than that of a VOM of equal quality, because circuits inside the VTVM are so intricate as to give many more chances for loss of accuracy. With high-grade service type instruments the accuracy may be 3 to 5 per cent on d-c voltages, and 3 to 7 per cent on a-c and a-f voltages. For a-c and a-f measurements the accuracy normally decreases on the higher voltage ranges and at higher frequencies. Accuracy of resistance measurements may be 5 to 10 per cent near the middle of the ohms scale. All these accuracies are "plus or minus".

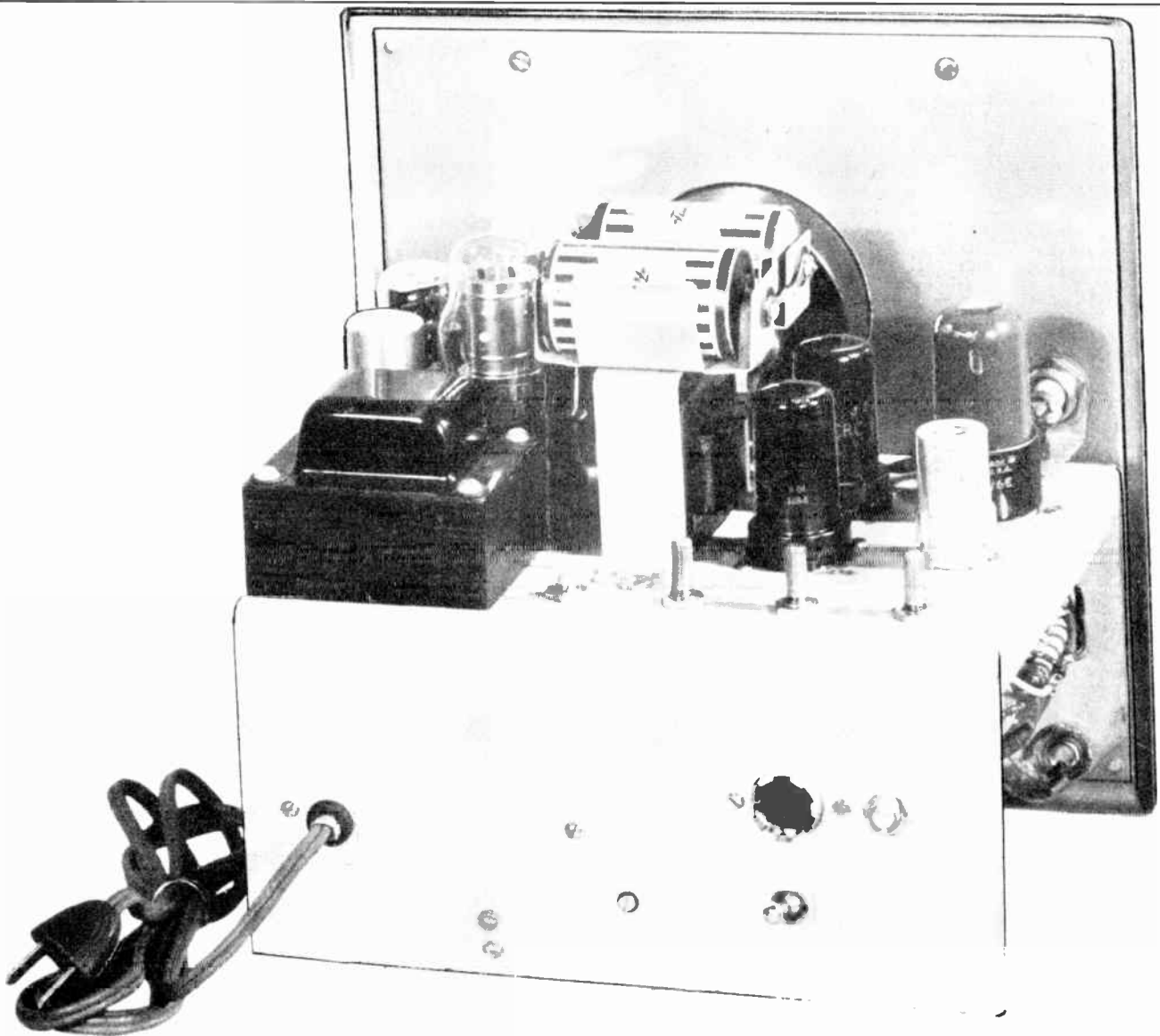

Fig. 9. Dry cells for the ohmmeter function of this VTVM are mounted above the center of the tube shelf.

**RESISTANCE MEASUREMENT.** VTVM's usually employ a battery of one or more dry cells, mounted within the instrument, for measurement of resistance in the lower ranges. Battery current is allowed to flow through the measured resistance while resulting voltage drop across the resistance is applied to the bridge circuit. The indicating meter then is read on its ohms scale. On the higher resistance ranges the current flowing through the measured resistance may be obtained from the a-c rectifier of the VTVM, avoiding all drain on the self-contained bat-

tery. The function switch makes the necessary changes of internal connections. In Fig. 9 the dry cells for the ohmmeter function may be seen mounted above the tube shelf of a VTVM.

**CALIBRATION.** VTVM's are provided with various calibrating adjustments for obtaining correct indications of measured voltages, currents, and resistances, and sometimes for preventing shift of the meter pointer away from zero when changing functions. Along the rear edge of the tube shelf

## LESSON 34 – THE VACUUM TUBE VOLTMETER

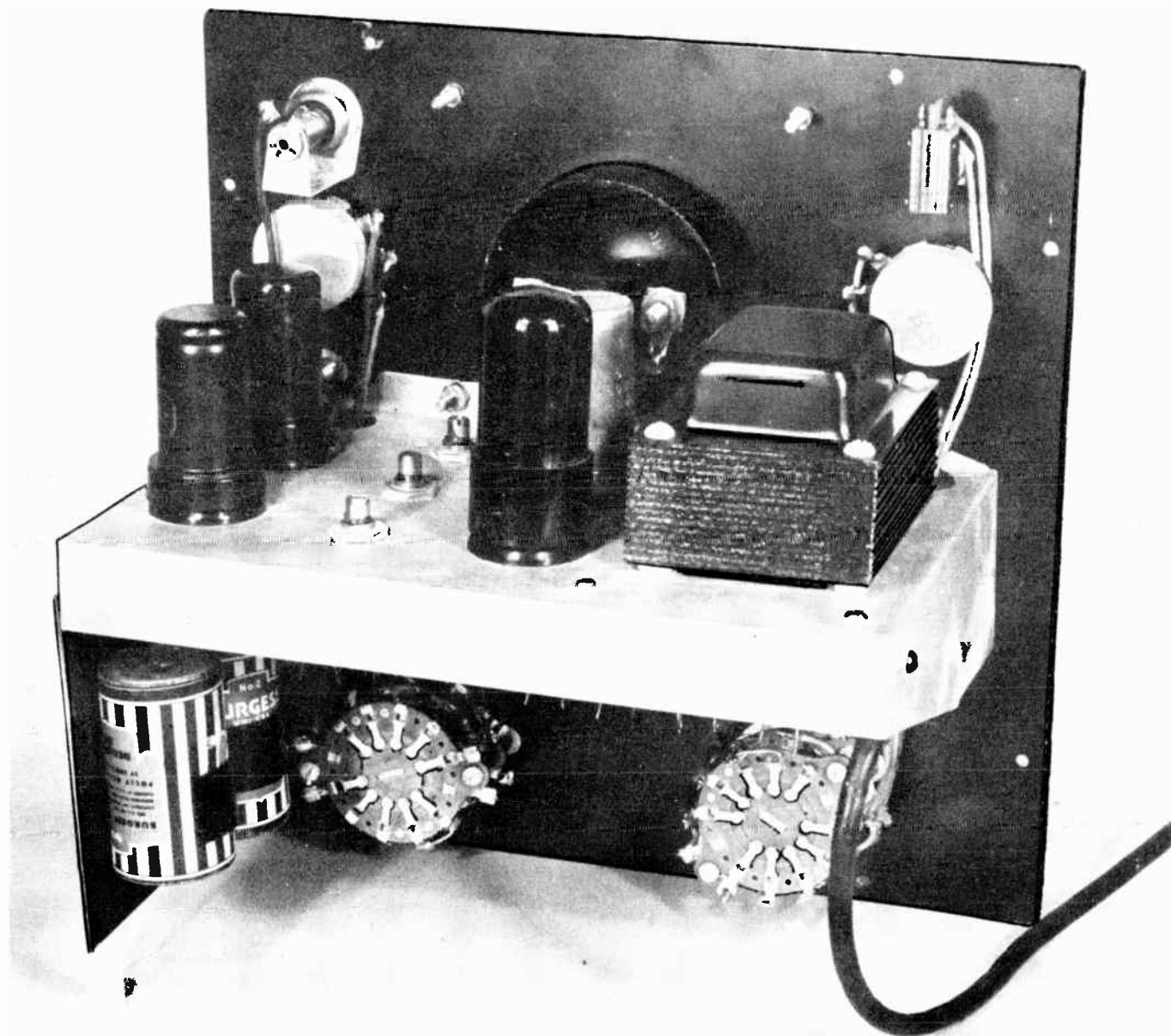

*Fig. 10. Shafts of calibrating potentiometers are on the top of the tube shelf, in between the tubes.*

in Fig. 9, toward the right side, may be seen the shafts of three calibrating potentiometers. A fourth, closer to the power transformer, does not show up quite so clearly. On the tube shelf of the instrument pictured by Fig. 10 may be seen the shafts of three calibration potentiometers, in between the tubes.

Calibration for d-c and a-c voltages is carried out by measuring known voltages with the regular test leads while adjusting the calibration potentiometers for correct read-

ings on the dial scales. Current calibration is made while measuring a current of known value, and resistance calibration while measuring one or more precision resistors, of 1 per cent or better accuracy. If the instrument manufacturer furnishes details of calibration methods these instructions should be followed exactly.

The very first step is to bring the pointer of the indicating meter to zero, by using the zero adjuster on the case of the meter, be-



## COYNE - *television home training*

fore turning on the power. The next step is to let the VTVM warm up thoroughly, usually for at least a half hour, after turning on the power.

As a rule there are calibration adjustments only for the several functions, not for the different ranges on each function. Therefore, calibration may be carried out on any range for which voltage, current, or resistance of known value is available. It must be assumed that the range resistors will allow correct readings on all the ranges for one function when correct readings are obtained on any one range.

After the instrument is well warmed up, check for zero readings on all functions. Use the test leads and prods which are intended for the function checked. Clip the free ends together to make a short circuit, and try operating the zero adjustment knob that is on the housing of the VTVM, not the one on the case of the indicating meter. If the meter pointer cannot be brought to zero for all functions it is possible that the bridge tube or tubes are not matched or have deteriorated in use to an extent that their plate voltages cannot be made equal. This is the purpose of the zero adjuster, as we observed in examining Fig. 3. The remedy is to change the bridge tube or tubes.

Some VTVM's have an internal zero adjustment in addition to the one operated by a knob on the housing. When the external zero adjuster operates a potentiometer in the plate circuits, as in Fig. 3, the internal adjuster might be another potentiometer in the cathode circuit.

The calibrating adjusters for volts, ohms, and possibly for current, usually are adjustable resistors in series with one side of the indicating meter. There will be one adjuster for each function, connected into the meter circuit when the function switch is changed.

A convenient source of d-c voltage for calibration consists of one or more small dry cells, reasonably fresh. With the exceedingly small current taken by the VTVM, each dry cell furnishes 1.55 or 1.56 volts, two in series will furnish 3.10 or 3.12 volts,

and so on for any number. Connect the dry cell or cells to the d-c test leads, first with the negative of the battery to the high-side test lead while setting the negative d-c volts calibration adjuster, then with the battery reversed while setting the positive d-c volts adjuster. Bring the pointer of the meter to the voltage being furnished by the battery. Tap the instrument lightly while making the adjustments, to make certain that indications are accurate.

A standard for a-c voltage calibration is not so easily obtained. If you live in a large city or in any community where the electric utility maintains a nearly constant line voltage, and if you know or can learn this voltage, and if there are no overloads on your power line, the line voltage may be used for calibration on a suitable range. Heater voltages of receivers vary too much between one set and another to be used for a-c calibration.

A-c calibration may be carried out with the VTVM and an a-c voltmeter connected across any a-c voltage within a range on both meters. A good quality moving vane a-c voltmeter is accurate enough for calibration in service work. Then both instruments may be connected to the a-c line, to any heater voltage, or to any other convenient source of alternating voltage while the a-c calibrator of the VTVM is adjusted to make the reading the same as that of the "standard" meter. Be sure to measure a pure a-c voltage, not one with which there is a d-c component. A-c voltage is calibrated after d-c voltage for the reason that the d-c bridge is used also for a-c measurements.

If there is an a-c balance potentiometer, as shown by Fig. 7, adjust it while turning the function switch back and forth between the positions for a-c and one of the d-c voltage positions. The object of this adjustment is to keep the pointer of the indicating meter at zero when changing between a-c and d-c voltage measurements.

A new VTVM is likely to require recalibration after it has been in normal use for a week or more; it takes this long for the tubes and other circuit elements to reach an "aged" condition where performance will re-



## LESSON 34 – THE VACUUM TUBE VOLTMETER

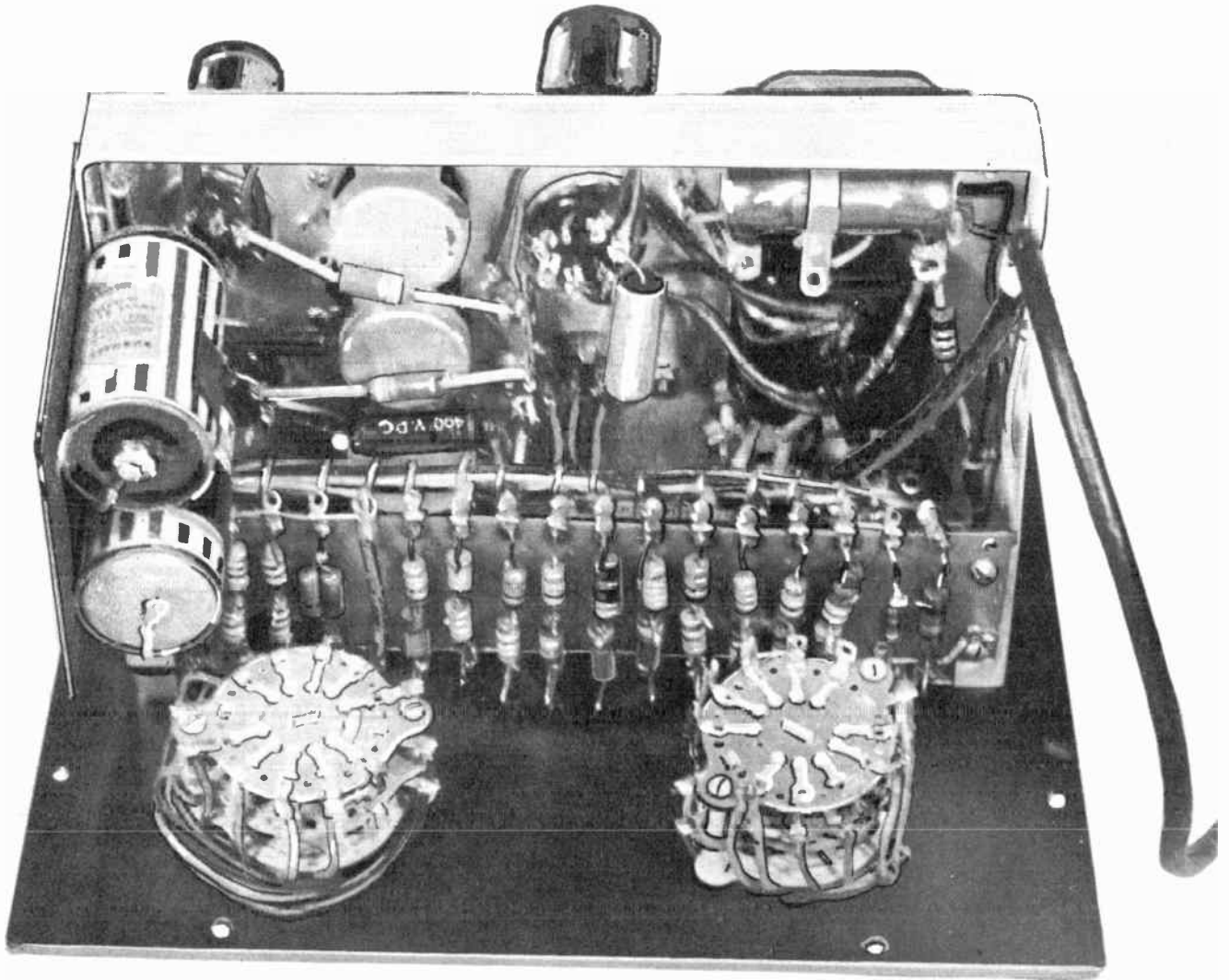

Fig. 11. The range resistors are on the insulating panel just above the function and range switches.

main almost unchanged for long periods. Re-calibration always is necessary when a tube is replaced, whether it is a bridge tube affecting all functions, or a rectifier affecting only a-c voltage.

There is little satisfaction in making resistance calibration on resistors of usual tolerances. If you have several resistors of 5 per cent tolerance they may serve for an approximate check. Resistors of 1 per cent tolerance are satisfactory standards for service purposes.

Many difficulties with VTVM calibration or readings are due to dirty contacts on the function or range switches, or on both. Wash

the contacts with carbon tetrachloride, "carbon tet", applied with a small brush. Operate the switch and repeat the washing several times. Zero adjusting potentiometers may be of kinds which develop contact resistance between the slider and the resistance element. This trouble usually may be cleared by rapidly rotating the adjusting shafts or knobs back and forth through their range of travel several times.

USING THE VTVM. The vacuum tube voltmeter is capable of making all measurements which can be made with a volt-ohm-milliammeter. Some measurements can be made better with the VTVM, and a few which are easily handled by the VTVM can be made



## LESSON 34 – THE VACUUM TUBE VOLTMETER

VOLTAGE MEASUREMENTS. The test lead or cord intended for d-c voltage measurements contains a resistor of one megohm or more at the free end or in the prod handle. Be sure to use this lead for all d-c voltages, but do not use it for measurement of a-c voltage, ohms, or current unless instructions for the particular instrument say to do so. This high-side lead is used on one of the points where voltage is to be measured, and the common or ground lead of the VTVM is used at the other point.

Plate, screen, and other d-c voltages are preferably measured with respect to chassis ground or B-minus, while the common or ground lead of the VTVM is clipped to chassis ground or to a conductor on the B-minus side of the measured circuit. If the ground lead of the VTVM is connected to a point which is not at chassis ground or B-minus potential in the receiver this point will then be connected to ground in the VTVM, and readings will be difficult to make or will be erroneous when made.

To measure voltage between two points, neither of which is at ground or B-minus potential, measure the voltage from each point to ground or B-minus of the receiver, then subtract the lower voltage reading from the higher one. This gives the potential difference or voltage between the two points.

There are some cases, as when measuring voltage across certain cathode resistors, that require connection of the two test leads to two points which are not at ground potential. For such measurements connect in series with the ground or common lead of the VTVM a fixed resistor of about 100,000 ohms. This resistor will isolate the instrument from the receiver circuit, but will cause no appreciable error in voltage indications because 100,000 ohms is small in comparison with the input resistance of the VTVM on d-c functions.

The polarity reversing feature of the VTVM allows the high-side test lead, the one with resistance at the prod, to be connected to points not at ground potential whether these points are positive or negative with reference to ground. This allows the common or ground test lead always to remain con-

nected to chassis ground or to B-minus. Should the meter read backward, off scale to the left, move the function switch from positive to negative d-c volts, or vice versa, to make the meter read up scale. Reversing the polarity in this manner allows correct indications only provided there is no shift of the pointer when changing polarities while no voltage is being measured and with the test leads shorted on each other. Should the pointer shift, it will be necessary to readjust for a zero reading every time the polarity is changed.

Before you measure alternating voltages in circuits where d-c voltage may also be present, make sure that there is an internal blocking capacitor in series with the lead used for a-c measurements, or use an external capacitor just as when making such measurements with the VOM. As a check try measuring the voltage of one or two dry cells on the a-c volts function of the VTVM. No reading indicates that there is a series blocking capacitor within the instrument. Also, if the meter pointer jumps up, then returns to zero and remains there, a blocking capacitor is built into the VTVM. If there is a steady reading use an external series capacitor.

When preparing to measure a-c voltages make the zero adjustment with the function switch set for a-c volts and with the test leads shorted on each other. When you separate the leads before connecting them to the measured voltage the pointer probably will move away from zero. Pay no attention to this movement, and do not readjust the zero while the leads are separated.

WAVEFORM ERRORS. On the a-c volts or a-f volts function the VTVM is designed to read correctly when the measured voltage is of sine-wave form or approximately so. Readings then indicate effective or r-m-s voltages. Other waveforms cause errors of greater or less magnitude.

The voltage represented at A of Fig. 13 is not sinusoidal (of sine-wave form) but alternations are equal above and below zero. We say that the waveform is symmetrical. A voltage reading on the VTVM would not be very far from the effective value. The wave at B is not symmetrical; positive and negative



## COYNE - *television home training*

alternations are not equal or alike. Voltage readings would have little relation to the effective value or to the peak amplitude of either polarity. At C is represented voltage consisting of a series of brief pulses. The VTVM would read very nearly zero.

If a measured alternating or audio voltage is not of equal average values in both polarities the reading of the VTVM will change when the test leads are reversed on the points of measurement. This is one way of identifying an unsymmetrical a-c voltage; there will be a higher reading with the leads connected one way than when reversed.

Some VTVM's have a position of the function switch at which peak values of an a-c voltage are indicated by the meter, or there may be a position for measuring the peak-to-peak voltage of any a-c wave. Such readings are of great usefulness when trouble shooting in the sync and sweep sections of television receivers.

CURRENT MEASUREMENTS. Some VTVM's have a position of the function switch at which it is possible to measure direct currents, in milliamperes. Usually this measurement is not electronic, it does not employ the bridge circuit of the VTVM but connects the d'Arsonval meter movement to the test leads. Shunt resistors are connected across the meter for the various ranges of measured current.

If there is no provision for current measurement the high sensitivity of the VTVM allows such measurements with the method illustrated by Fig. 14. The circuit whose current is to be measured is opened at any convenient point and between the opened ends is connected a carbon resistor. The inserted resistance should be only two or three ohms, and hardly ever more than 10 ohms, so that it will not have any great effect on total resistance of the measured circuit.

The test leads of the VTVM are connected to the inserted resistor. The function switch is set for d-c volts when direct current is to be measured, and for a-c volts when alternating or audio current is to be measured. Use a voltage range low enough to allow distinct meter readings. From the

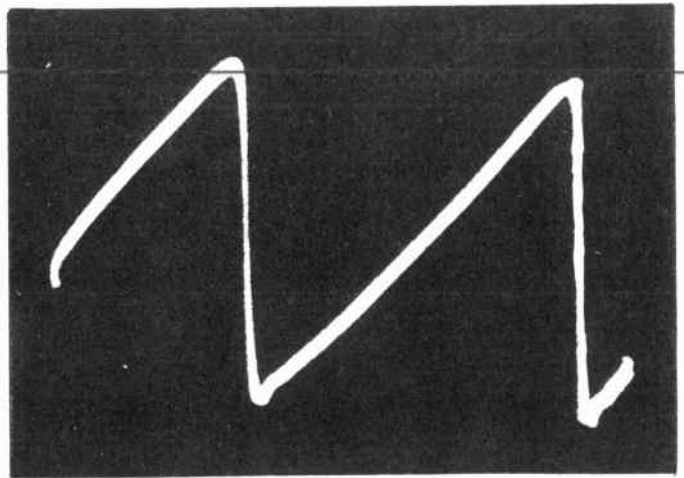

Fig. 13A

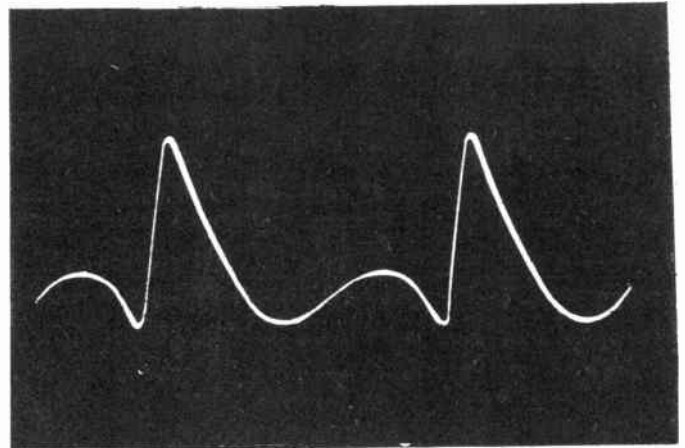

Fig. 13B

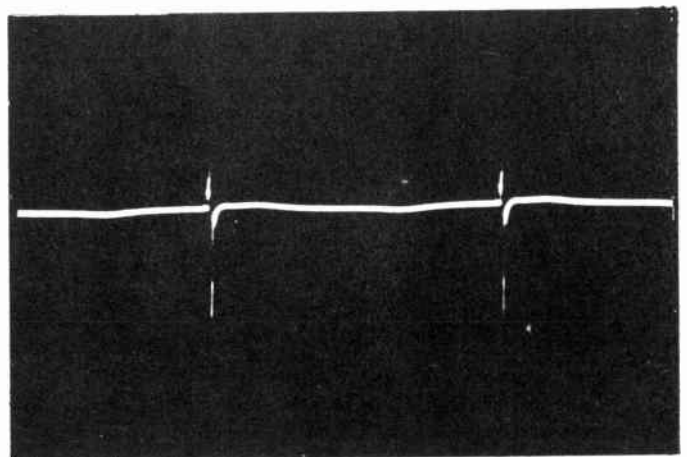

Fig. 13C

Fig. 13. A-c voltage indications of the VTVM are affected by the waveform of a measured voltage.



# LESSON 34 – THE VACUUM TUBE VOLTMETER

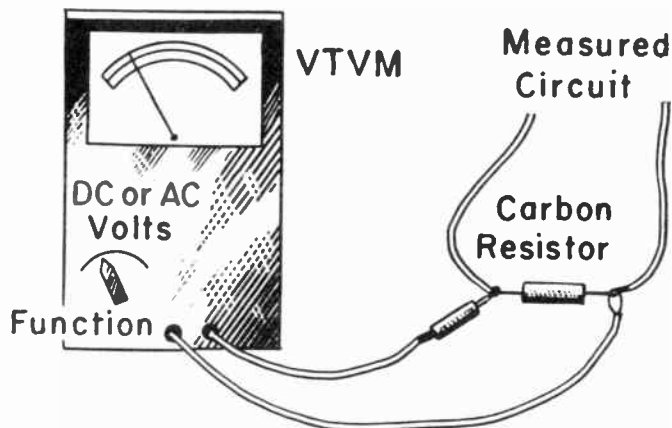

Fig. 14. Measuring direct or alternating current with a VTVM which has no provision for such measurements.

known value of inserted resistance and the measured voltage you can compute the circuit current by using our regular formula for current. That is, multiply the measured volts by 1,000 and divide by the number of ohms of inserted resistance. The result is the number of milliamperes of direct or alternating current in the measured circuit. The computed current value will be as accurate as the tolerance or accuracy of the resistor, and of the VTVM.

## VOLTAGES AT HIGH FREQUENCIES.

On the a-c or a-f functions few service types of VTVM's will give reasonably true readings for voltages at frequencies as high as 30,000 cycles per second, and not many will reach this figure. Results of tests on two instruments are shown by Fig. 15. Both were about equally accurate up to 2,000 cycles. Readings of instrument A fell rapidly through higher frequencies. Instrument B still would read about 90 per cent of the actual voltage at 10,000 cycles, and somewhat better than 70 per cent at 20,000 cycles per second.

For measurement of voltages in the radio-frequency ranges it is necessary to use in connection with the VTVM a detector probe. Such a probe is illustrated by Fig. 16. On one end of a shielded cable is a plug or other connector fitting either the d-c voltage terminal of the VTVM or else a jack or terminal used exclusively for high-frequency or r-f measurements. At the other end of the cable is a shield of metal tubing or there may be a metal lined tube of insulating material. At the end of this "probe" is a tip, or maybe a small clip, for making connection to the high side of the measured circuit. There is also a clip that connects to the prod shield, the

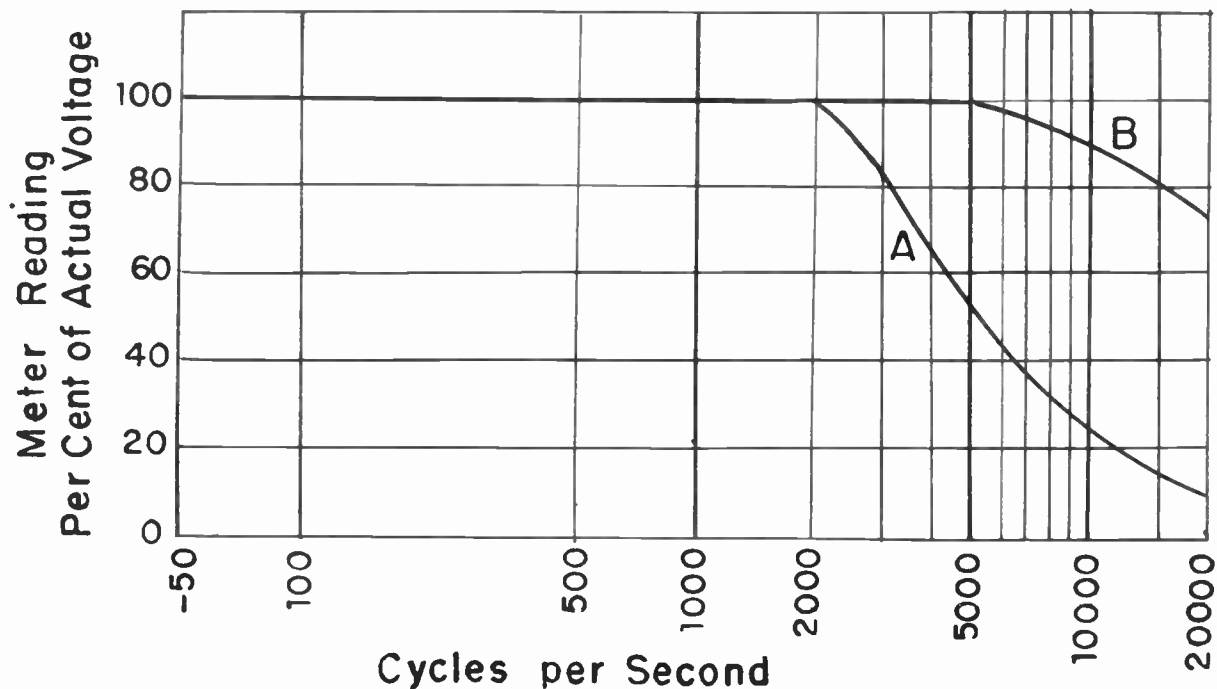

Fig. 15. Voltage readings of many VTVM's drop rapidly with increase of frequency through the audio range.

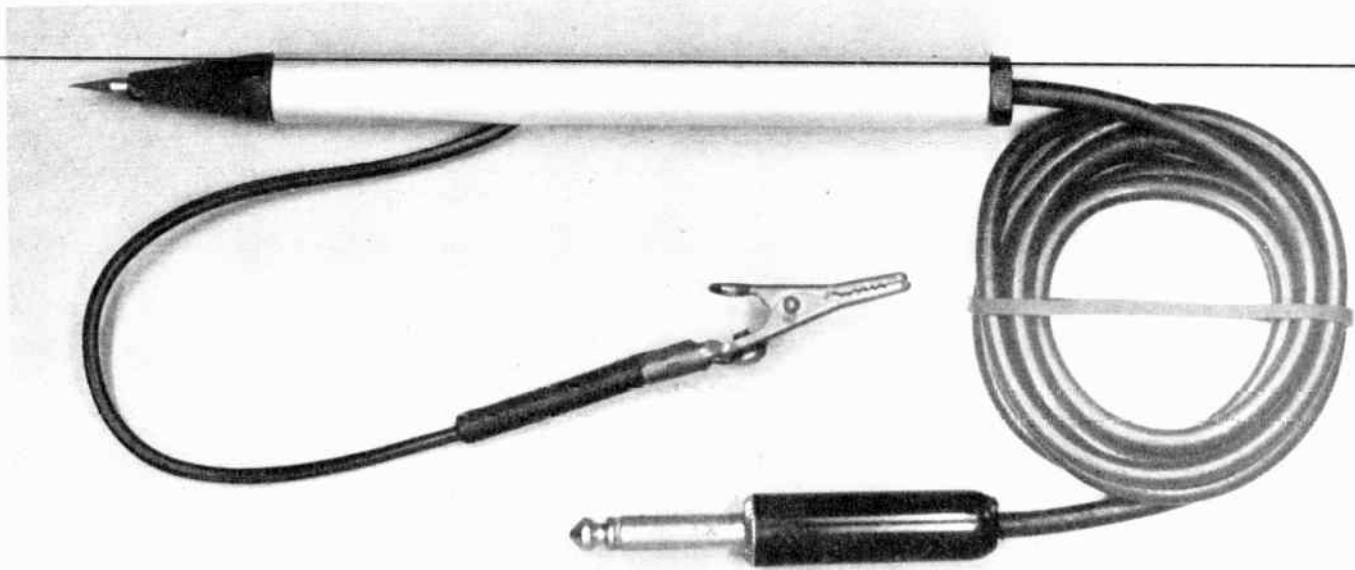

Fig. 16. A detector probe and its shielded cable used for measuring r-f voltages.

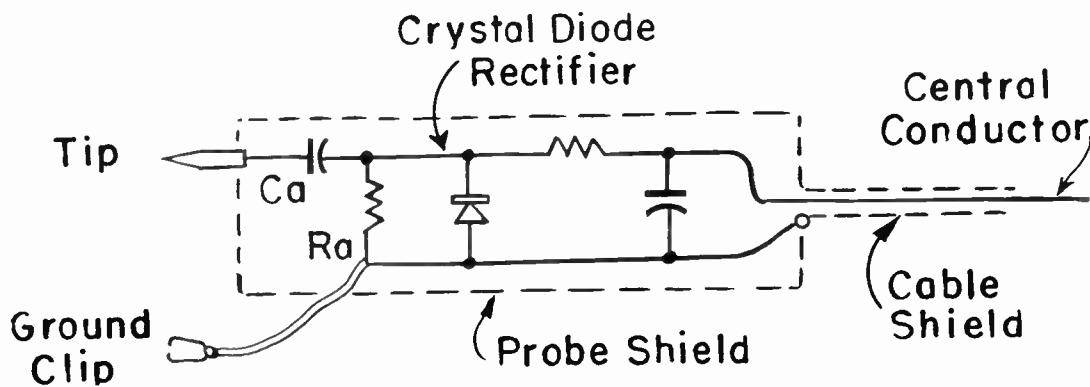

Fig. 17. Circuit of one style of detector probe in which is a crystal diode rectifier.

shield of the cable, and thereby to the ground side of internal circuits of the VTVM.

Within the shielded probe is a small rectifier, most often of the crystal diode type but sometimes a miniature diode tube. Built in with the rectifier is a filter circuit including one or more small sized capacitors and resistors. One of the more common probe circuits is shown by Fig. 17. The crystal diode is a form of contact rectifier that operates very well at frequencies up to and somewhat beyond 100 megacycles when used in suitable circuits and constructions.

ground clip connected to the low side of the same circuit, high-frequency voltages are rectified by the crystal to produce pulsating direct current at the same frequency. Pulsations are smoothed out by the filter capacitors and resistors of the probe and by capacitance of the shielded cable. Resulting direct voltage acts through the cable and conductor and shield, and is applied to the d-c voltage measuring circuits of the VTVM. For indicating r-f voltages taken through the probe there may be a special dial scale or readings of the scales may be multiplied or divided by some factor.

When the probe tip is placed on the high side of a high-frequency circuit, and the

High-frequency voltage and current from the measured circuit act only through the

## LESSON 34 – THE VACUUM TUBE VOLTMETER

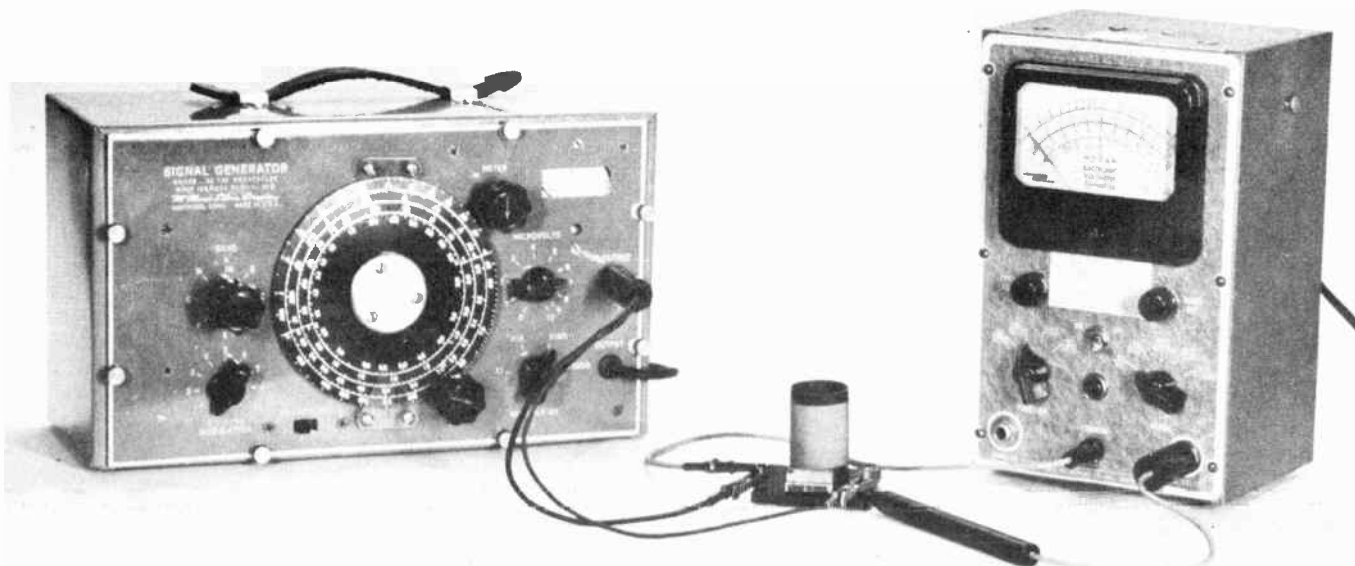

Fig. 18. Measuring resonant frequency of a coil and capacitor by means of the signal generator and a VTVM.

probe tip, capacitor  $C_a$ , resistor  $R_a$ , and the ground connection. The output from the probe through the cable to the VTVM is direct voltage and current, independent of frequency in the measured circuit. The probe usually is called a detector probe, because it acts somewhat like a detector in obtaining direct voltage from an alternating voltage.

The addition of a detector probe extends the usefulness of the VTVM to the measurement of high-frequency voltages, but even with the probe there is a frequency limit. Good quality probes will work well at all standard broadcast and international short-wave frequencies, also at television intermediate frequencies, television carrier frequencies in the low band of the v-h-f range, and usually at f-m broadcast carrier frequencies. Very few will give useful measurements on carrier frequencies in the high band of v-h-f television, and none are useful at ultra-high frequencies.

The probe is not essential for most routine service work, even in television. Methods have been devised for completing most service operations with the VTVM as a d-c voltmeter. The detector probe makes it possible to carry out many rather specialized tests. As examples, two such tests will be explained.

In Fig. 18 a VTVM and detector probe are being used in connection with a signal generator to determine the resonant frequency of a circuit consisting of a coil and fixed mica capacitor. Any other tunable circuit may be similarly tested. Connections are shown more clearly by the diagram of Fig. 19.

Connect the high r-f output of the signal generator and the detector probe of the VTVM to one side of the tested circuit. Connect the ground leads of both instruments to the other side of the tested circuit. Use the generator without modulation. Set the VTVM for its lowest voltage range. Commence by tuning the generator to a frequency higher than any at which you think the tested circuit may be resonant. Reduce the frequency until a peak reading is obtained on the VTVM. This method of tuning from high to low frequencies prevents assuming that a harmonic frequency is a resonant frequency. The frequency at which a peak reading is first secured is that of resonance.

The capacitance of the detector probe and of connections to the signal generator are added to capacitance of the tested circuit. This may cause little error at frequencies up to something like three megacycles, but at television intermediate and carrier fre-

## COYNE - television home training

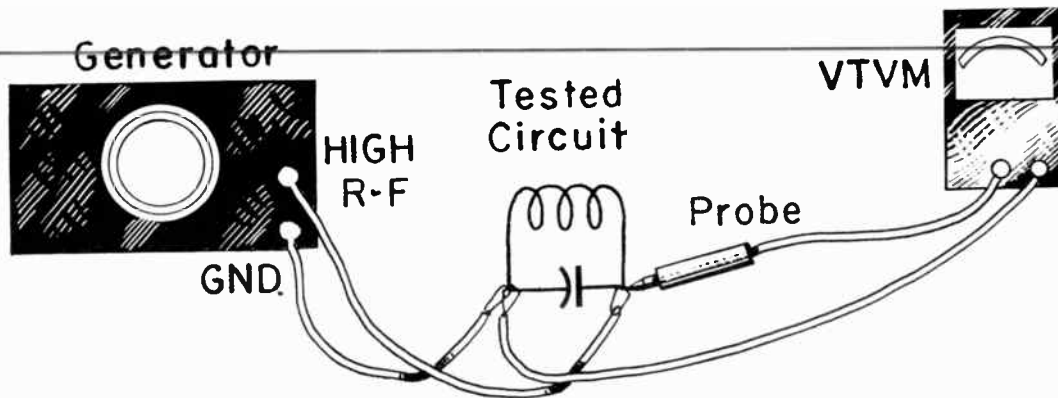

Fig. 19. Connections for measuring resonant frequency, also for measuring the Q-factor of a resonant circuit.

quencies the indicated frequency would be far below that of the circuit alone.

If the tested circuit is series resonant, connect the capacitor and inductor for parallel resonance during the test. If the capacitance of the tested circuit is of known value, inductance of the coil may be computed from the known capacitance and measured frequency. Use the formulas or alignment chart given in lessons dealing with resonance. An unknown capacitance may be similarly determined from the measured frequency and a known value of inductance. Should the tested circuit tune too broadly for identification of the resonant peak, tune the signal generator to one frequency below resonance and to another above resonance at which voltage indications are exactly the same. The resonant frequency is approximately midway between the two generator frequencies for equal voltages.

Q-factor may be measured with the same setup as shown by Figs. 18 and 19. The steps are as follows.

1. Make adjustments for peak frequency of resonance, as explained by preceding paragraphs. Read VTVM voltage and generator

frequency as accurately as possible and make note of the values.

2. Tune the signal generator to a frequency far enough above resonance to bring the meter reading down to 0.707 times the peak voltage of step 1. Make a note of this frequency.

3. Tune the generator to a frequency below resonance at which voltage again comes down to 0.707 times the peak value. Note this lower frequency.

4. Subtract from the higher frequency (step 2) the lower frequency (step 3).

5. Divide the peak frequency (step 1) by the difference between frequencies (step 4). This gives the Q of the entire circuit.

The computed Q is affected by energy losses in the detector probe and in the connections to the generator, and will be less to a greater or less extent that Q of the tested circuit. To reduce losses to the generator try using inductive coupling to the tested circuit. Connect a coil of a few turns of insulated wire to the generator leads and bring this coil close enough to the tested circuit to obtain readable voltages.



# TELEVISION

• RADIO

• ELECTRONICS

---

---

**LESSON 35 – TELEVISION SIGNAL**

---

---

***Coyne School***

*practical home training*

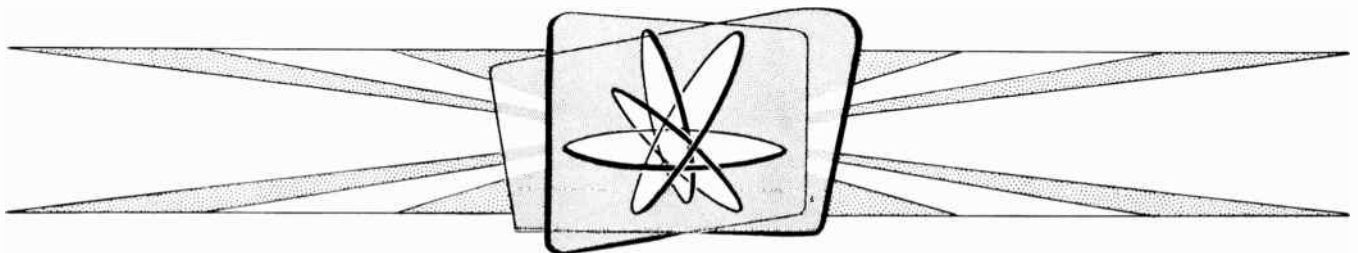

*Chicago, Illinois*

---

*Copyright, 1953 by Coyne Electrical School  
Chicago 12, Illinois  
All rights reserved*

Litho. in U.S.A

## Lesson 35

### TELEVISION SIGNAL

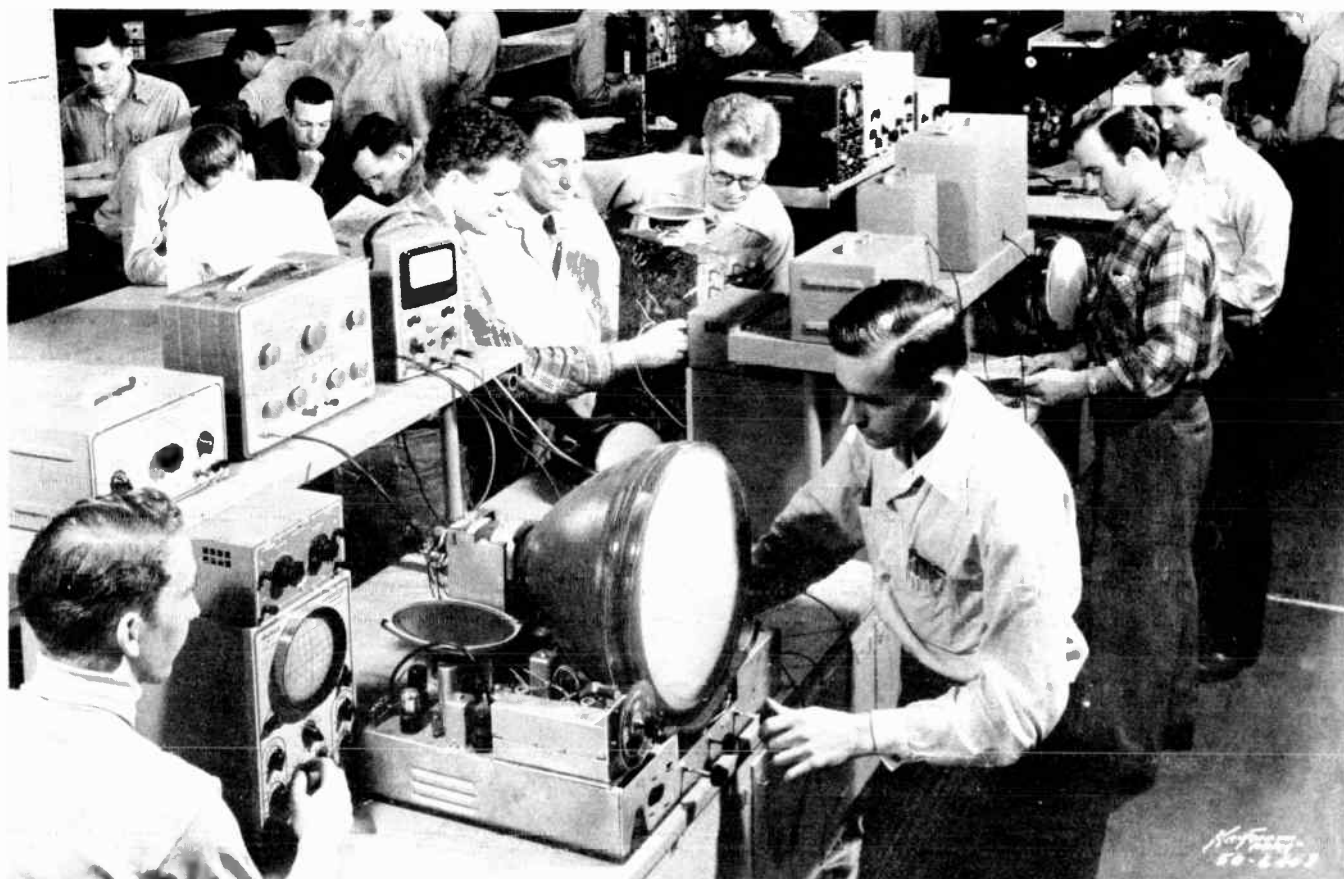

Fig. 1. Students in the Coyne School are observing and measuring the effects of television signals.

It is the television signal that produces pictures and controls their timing or synchronization to make them look like pictures instead of confused lights and shadows. If anything goes wrong with the signal, from the instant when it enters the tuner until its effects reach the picture tube, the picture will be wrong. To determine the cause we must follow the signal as it divides and subdivides along the way. Any point at which the signal first varies from its correct form must be near the seat of trouble. In order to locate trouble with least loss of time we should be well acquainted with every part of the television signal, and with what each part is supposed to accomplish.

THE TELEVISION CHANNEL. To begin with we should look at a channel in which are

transmitted the picture carrier and sideband frequencies, the sync pulses, and the sound signals. Each television broadcast channel extends through a total frequency range of six megacycles. Fig. 2 at A shows the distribution of frequencies in relation to the video carrier or picture carrier. Immediately we note that the carrier is not at the center of the channel; sideband frequencies go about five times as far above the carrier as below. The reason for this rather peculiar arrangement is that video frequencies for transmitting clear pictures won't fit into a six-megacycle channel with the carrier at the center. The explanation follows.

In the earliest lessons we learned that each complete picture or each frame is formed by tracing about 490 horizontal lines

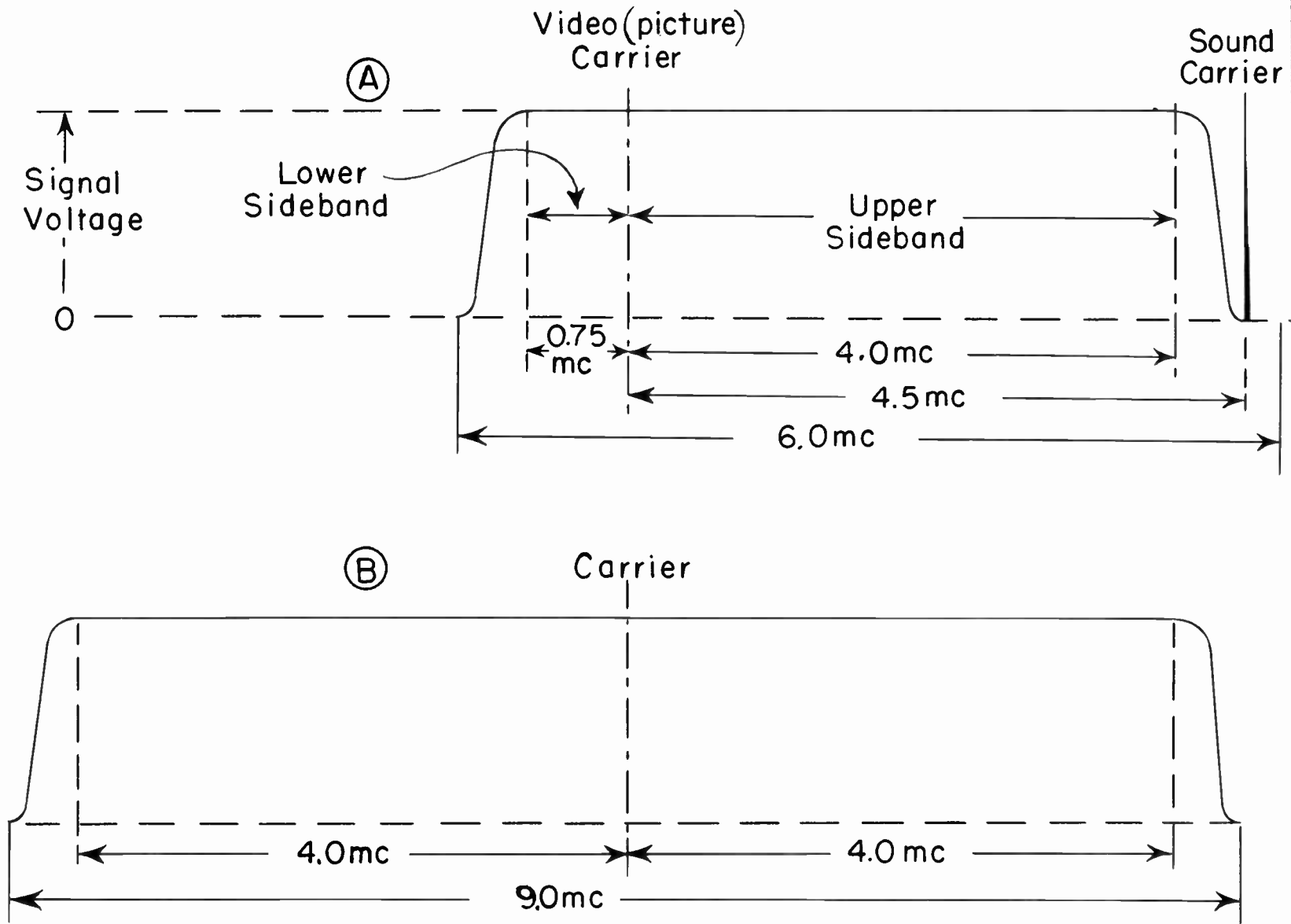

Fig. 2. Vestigial sideband transmission allows a wide range of picture frequencies in a relatively narrow channel



## LESSON 35 – TELEVISION SIGNAL

on the screen of the picture tube. Each frame consists of two fields. The periods for vertical retrace between fields take up about as much extra time as would 35 extra lines. Thus there would be time for a total of 525 lines, were all of them used for pictures. Each frame is completed in  $1/30$  second, which means that during every whole second there are 30 complete frames of 525 line periods each. Multiplying 525 (lines) by 30 (frames) shows that during each second of time there could be 15,750 line periods.

Were a picture to show a great many objects, such as spectators in the stands at a ball game, or were there to be many small details along each line, there might be as many as 250 changes from dark to light and back again. During the one second of time for 15,750 line periods there could be almost 4,000,000 changes. Every complete change requires that signal voltage controlling intensity of the electron beam go through one cycle. The frequency of the picture signal then might be as great as 4,000,000 cycles or 4 megacycles per second.

Were the carrier at the center, with equal 4-mc sidebands above and below, the frequency distribution for picture signals would have to be as at B in Fig. 2. Each channel would have to be at least 9 mc wide, which is 50 per cent more than allowed for television transmission.

### VESTIGIAL SIDEBAND TRANSMISSION.

With the actual arrangement at A of Fig. 2 the upper sideband extends in full signal strength to 4.0 mc above the video carrier, thus accomodating the full range of picture frequencies for fine details. The lower sideband extends in full strength only 0.75 mc below the video carrier; it is called a vestigial sideband, only a vestige of a full sideband.

This method of transmission is entirely practicable because, as you know, all of the side frequencies exist in each sideband when the two sidebands are alike - as in standard radio broadcast transmission. Even though we eliminated one sideband completely, all the frequencies still would be present in the remaining sideband. Such a method would be called single sideband transmission.

There are a few features of the channel for vestigial sideband transmission which should be noted. First, the sound signal is in the same channel with the video signals. The sound carrier always and invariably is precisely 4.5 mc above the video carrier, and is 0.25 mc below the high-frequency limit of the channel. It is desirable but not necessary that video signals or video frequency response extend to 0.75 mc below and to 4.0 mc above the video carrier at full strength, but it is absolutely necessary that this response come down to zero at the low limit of the channel and at somewhat below the sound carrier near the upper end.

The transmitted video signal is shown again by diagram 1 of Fig. 3. Here it is made plain that all frequencies are transmitted doubly or in double strength in a range from 0.75 mc below the carrier to 0.75 mc above the carrier, for all these frequencies occur in both the lower vestigial sideband and in the complete upper sideband. These are the side frequencies between the carrier and a of the lower sideband and between the carrier and b of the upper sideband. All the higher video frequencies, from b to c in the upper sideband, are transmitted only in this band and in single strength.

At the receiver all the side frequencies which arrive in double strength must be reduced or attenuated to make them equal in strength to all the rest. Otherwise the reproduced pictures will lack fine detail, and lines which should be sharp will be broadened or blurred. This could be accomplished were it possible to adjust frequency response of the receiver as shown at 2. Here the gain is only 50% of maximum for all frequencies within 0.75 mc of the video carrier, and is 100% for all higher video frequencies. A response of this kind would require elaborate filtering.

A simpler method, the one actually employed, is shown at 3. The receiver response is made equal to 50% of maximum at the video carrier frequency, to 100% at 0.75 mc above the carrier, to zero at 0.75 mc below the carrier, and of uniform slope. Consider now a frequency which falls at the point of 25% gain on this slope. The same frequency will occur also in the upper side band, and

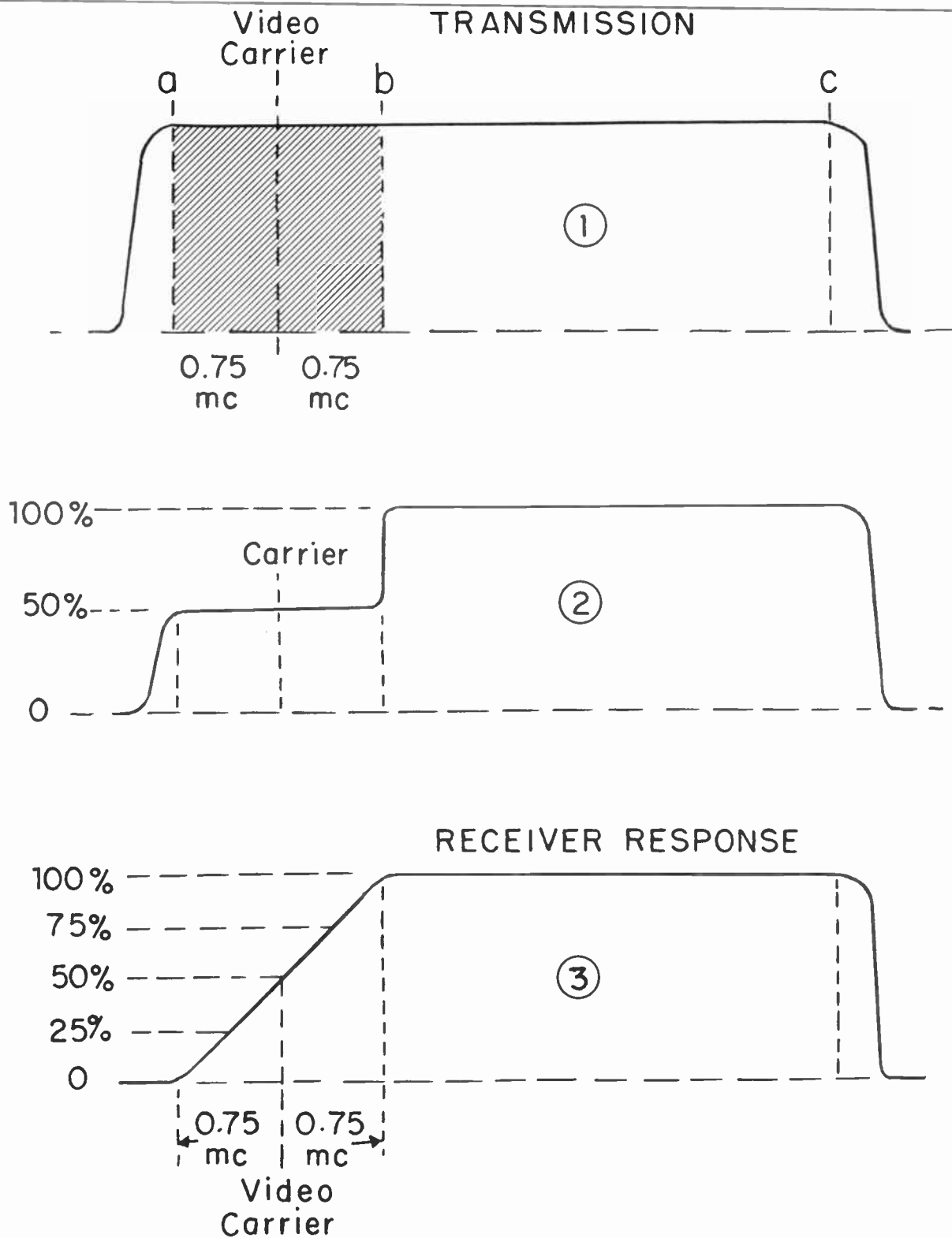

Fig. 3. The receiver response must compensate for the doubly transmitted frequencies.

## LESSON 35 – TELEVISION SIGNAL

there will be at the point of 75% gain. This particular frequency is subjected to combined gains of 25% and of 75%, or to a total gain of 100%. Every other frequency which falls on the slope of the response similarly is subjected to gains whose total equals 100%. Thus all the video frequencies which are received in double strength are brought to the same total gain as those which are received only in single strength.

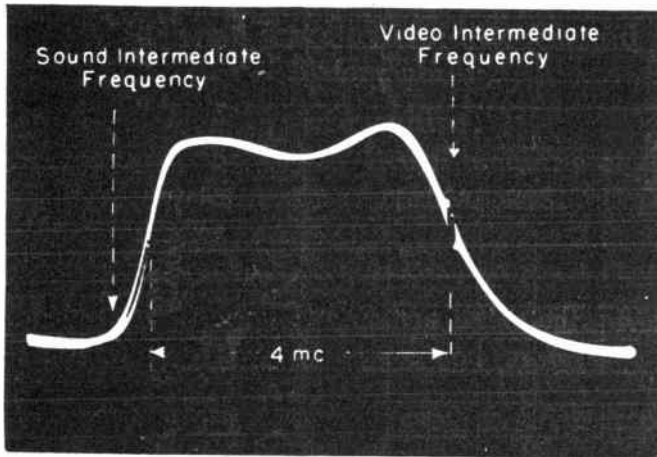

Fig. 4. Frequency response of a television i-f section. In passing through the mixer, the video intermediate frequency becomes higher than the sound carrier.

The ideal receiver response shown at 3 of Fig. 3 cannot be attained in practice. It can, however, be approximated by your alignment of the i-f amplifier stages of television receivers. The result of i-f alignment adjustments, as seen on the oscilloscope, is illustrated for one particular receiver by Fig. 4. The "pip" which appears on the right-hand slope is at the video carrier frequency, which here has become the video intermediate frequency. The pip is put there by a "marker generator" tuned to this frequency. All these matters will be dealt with at length when we work on television i-f alignment. Just now we are learning why such alignment is necessary.

**SIGNAL WAVEFORMS.** Now that we have discussed frequencies, frequency limits, and frequency responses related to the television signal we are ready to take up the waveforms which are required for timing or synchronizing the pictures. The entire television signal

which is transmitted in any one channel includes portions for picture lights and shadows, other portions for synchronizing the pictures, and also signals for the accompanying sound. The portions which produce pictures and those consisting of synchronizing pulses make up the video signal, as distinguished from the sound signal.

The video signal, (pictures and sync pulses) consists of amplitude modulation of the carrier and of the same amplitude modulation carried through onto the intermediate frequency. The principles are the same as for the amplitude modulation examined in connection with standard broadcast reception.

The video signal really is a combination of several signals, each of which is responsible for one of the following actions.

1. Variation of beam intensity. This is the function of the picture portion of the signal. All remaining actions are the functions of the sync pulses and their associated signal voltages.

2. Blanking the beam at the end of every horizontal line, when the beam reaches the right-hand side of the picture tube screen.

3. Bringing the beam back to the left, where it must be for starting the trace of another horizontal line.

4. Blanking at the bottom of every field, after the beam has traced alternate horizontal lines all the way to the bottom of the picture area.

5. Bringing the beam to the top of the picture area, where it must be for starting another field.

6. Starting alternate fields at the upper left-hand corner of the picture area, and intervening fields at the center. This is necessary in order to have interlaced scanning.

7. Keeping the horizontal sweep oscillator correctly timed or synchronized while the beam is blanked between successive fields. Were this not done, the oscillator might not be ready to start each horizontal line at the correct instant, and the left-hand side of the picture would be irregular.

## COYNE - *television home training*

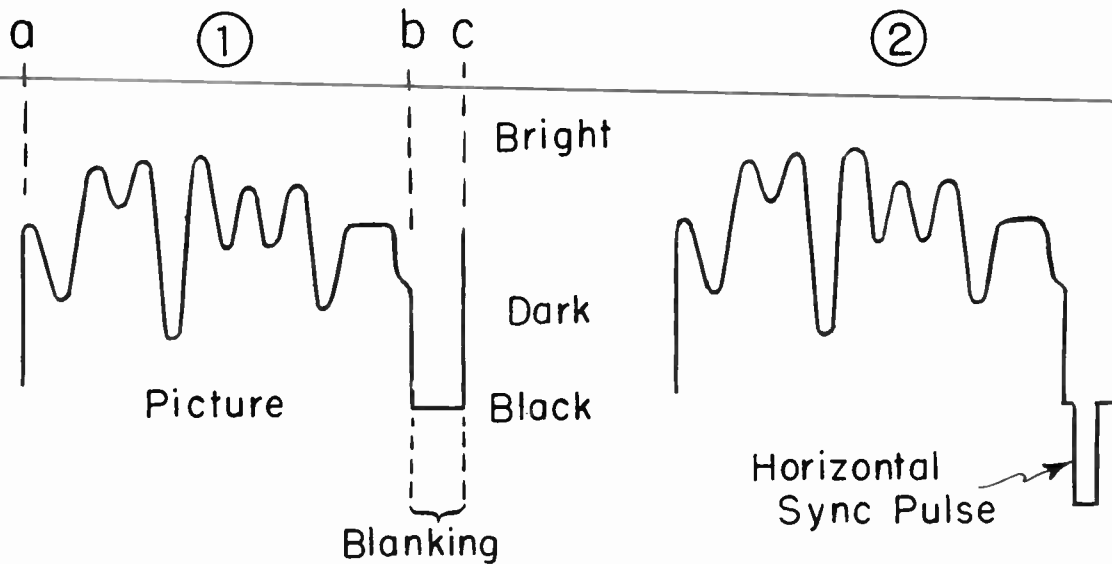

Fig. 5. Signals or signal voltages during one horizontal line period.

We shall examine these actions one by one, commencing with a single horizontal line period during which the electron beam traces a line of light and shade from left to right across the screen of the picture tube. The signal voltage that varies the intensity of the electron beam may be represented as from a to b on diagram 1 of Fig. 5. This is the signal voltage that carries out the action numbered 1 in the preceding list.

At the end of this horizontal line the beam must be blanked, and kept blanked until the beginning of the next picture line. Therefore, at instant b the signal voltage must change to a value which shuts off the beam and keeps it shut off until time to start the next line, at c. This is the action numbered 2 in our list.

While the beam is being varied in intensity by the video signal voltage it is deflected from left to right by another voltage or current produced in the horizontal sweep section of the receiver. At the end of each horizontal line this sweep voltage or current is of the polarity and strength which brought the beam to the right-hand side of the screen. Now the sweep voltage or current must be momentarily reversed, in order that it may be ready to start the next horizontal line at the left-hand side of the screen. The reversal is brought about by the horizontal sweep oscillator.

To carry out action number 3 of our preceding list the horizontal sweep oscillator must be "triggered" at the instant in which the sweep is to be reversed. The triggering is controlled by a pulse of voltage added to the video signal. This is a horizontal sync pulse. Triggering of the horizontal sweep oscillator should occur while the beam is blanked between lines, so we add the sync pulse as in diagram 2 of Fig. 5.

Polarity of the sync pulse is opposite to that of the picture signal. Otherwise the pulse voltage would act just like picture voltage and could produce a bright streak at the end of every picture line. Since the beam is blanked when signal voltage comes down to the value marked "Black" on the diagram, carrying the voltage still further in the same polarity will keep the beam blanked. Thus the sync pulse cannot get into the picture, but it can be used for triggering the horizontal sweep oscillator.

**NEGATIVE TRANSMISSION.** In Fig. 5 maximum positive signal voltage produces bright tones in the picture, while less voltage produces darker tones or black. This signal polarity is correct for the grid of the picture tube, since making the grid more positive or less negative increases intensity of the electron beam and makes a brighter trace on the screen. The least positive voltage is used for sync pulses.



## LESSON 35 – TELEVISION SIGNAL

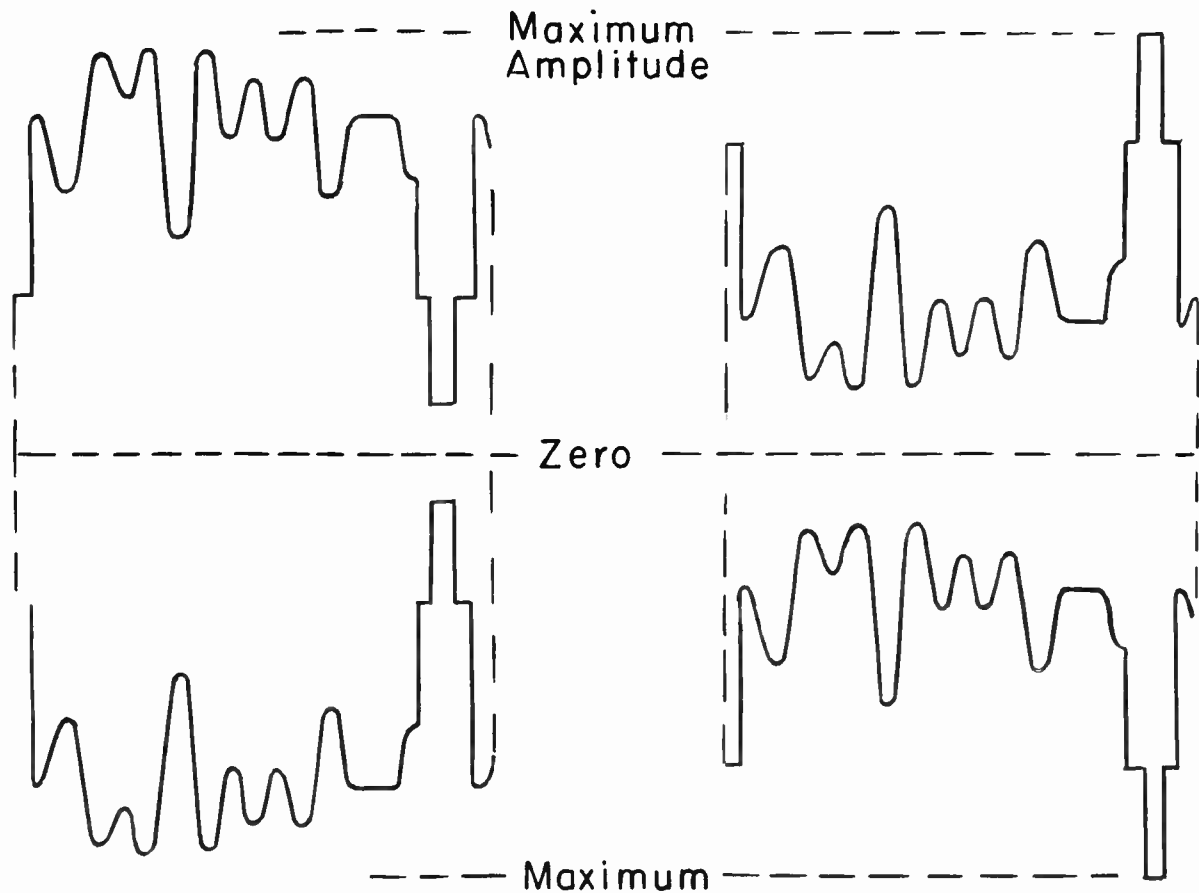

Fig. 6. Positive transmission (left) and negative transmission (right).

Were picture and sync signals of this polarity used for amplitude modulation of the transmitted carrier, the modulated carrier wave would have the form shown at the left in Fig. 6. Picture signals would extend out toward maximum positive and negative amplitudes, while sync pulses would come down toward zero amplitude. The strongest portion of the transmitted signal would be used for picture lights and shadows, while the weakest portion is used for synchronizing.

This signal polarity at the left in Fig. 6 is undesirable, because with weak sync pulses there is danger of losing synchronization. Then pictures would slip or jump sideways on the screen. There is no great need for extra strong picture signals, for no great harm would result from losing a few picture lines from one field - probably it would not even be noticed.

In actual practice the polarity of carrier modulation is reversed, as at the right in

Fig. 6. Now the tips of sync pulses are at maximum signal amplitude, and the entire pulse is within the strongest amplitudes. This helps insure that synchronization shall be effective at all times, for sync pulses form the strongest portion of transmitted signals. The system illustrated at the right is called negative transmission. The system at the left would be called positive transmission.

There is no difficulty in obtaining positive picture signals from negative transmission. All that we need do is design the video detector circuit to cut off the upper modulation of the negative transmission at the right in Fig. 6, and retain the lower modulation. This lower side of the negative transmission wave has modulation exactly the same as shown by Fig. 5, where picture signals are positive.

SIGNAL LEVELS. When referring to relative strengths of various parts of video signal modulation of the carrier we do not

# COYNE - *television home training*

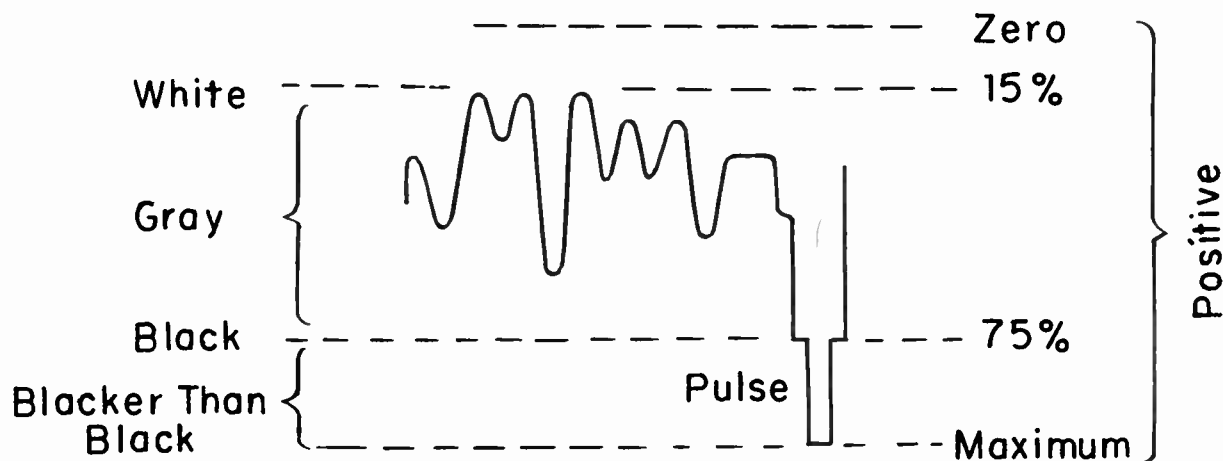
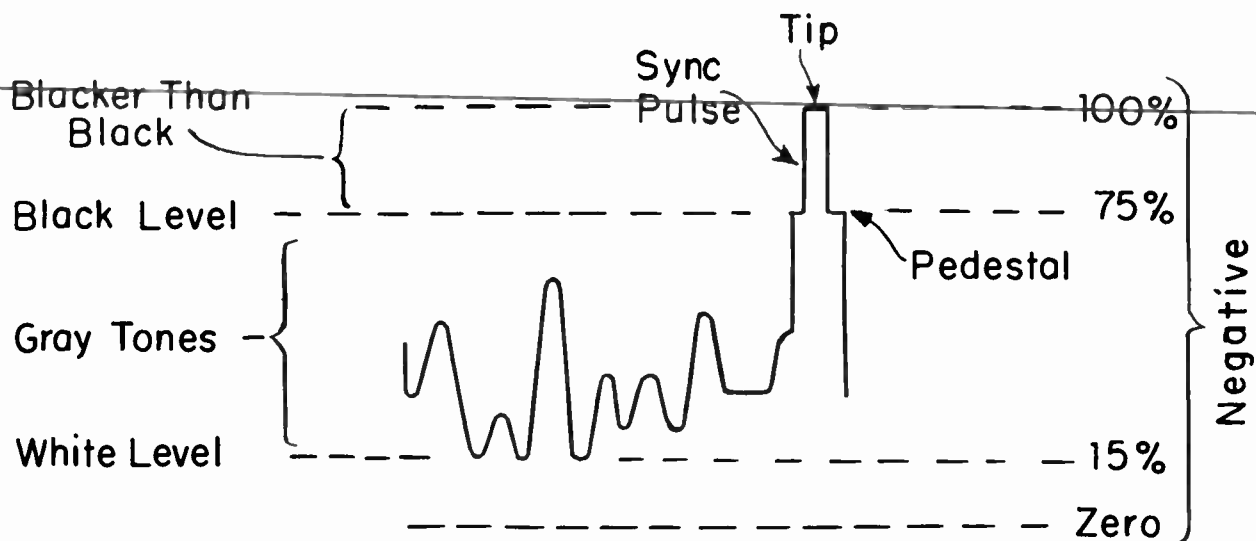

Fig. 7. The various voltage levels and percentages in a video signal of the negative transmission type (top) and the same levels when inverted as for application to the picture tube grid (bottom).

speak of certain amplitudes or voltages but rather of certain levels and percentages, as shown by Fig. 7. Maximum amplitude or signal voltage is 100%, at the tip of the sync pulse. Pulse voltage extends from 100% down to 75%, approximately, or within  $2\frac{1}{2}\%$  either way from 75%. The pulse may be thought of as standing on a pedestal formed by the horizontal blanking period.

The brightest parts of the picture are produced by signal voltage at the white level, which is 15% above zero voltage or amplitude. As 75% of maximum voltage the beam is cut off and the screen is unilluminated. This

voltage is called the black level or sometimes the pedestal voltage. At all greater voltages the beam remains cut off in the picture tube. These voltages, from 75% to 100% often are called 'blacker than black'. Gray tones in the pictures result from signal voltages of values between the black level and the white level. The signal never should go to zero, because then there would be danger of overmodulation.

The black level voltage or amplitude is transmitted during all intervals in which the beam is to be blanked. This voltage is interrupted by sync pulses, which are blacker

## LESSON 35 – TELEVISION SIGNAL

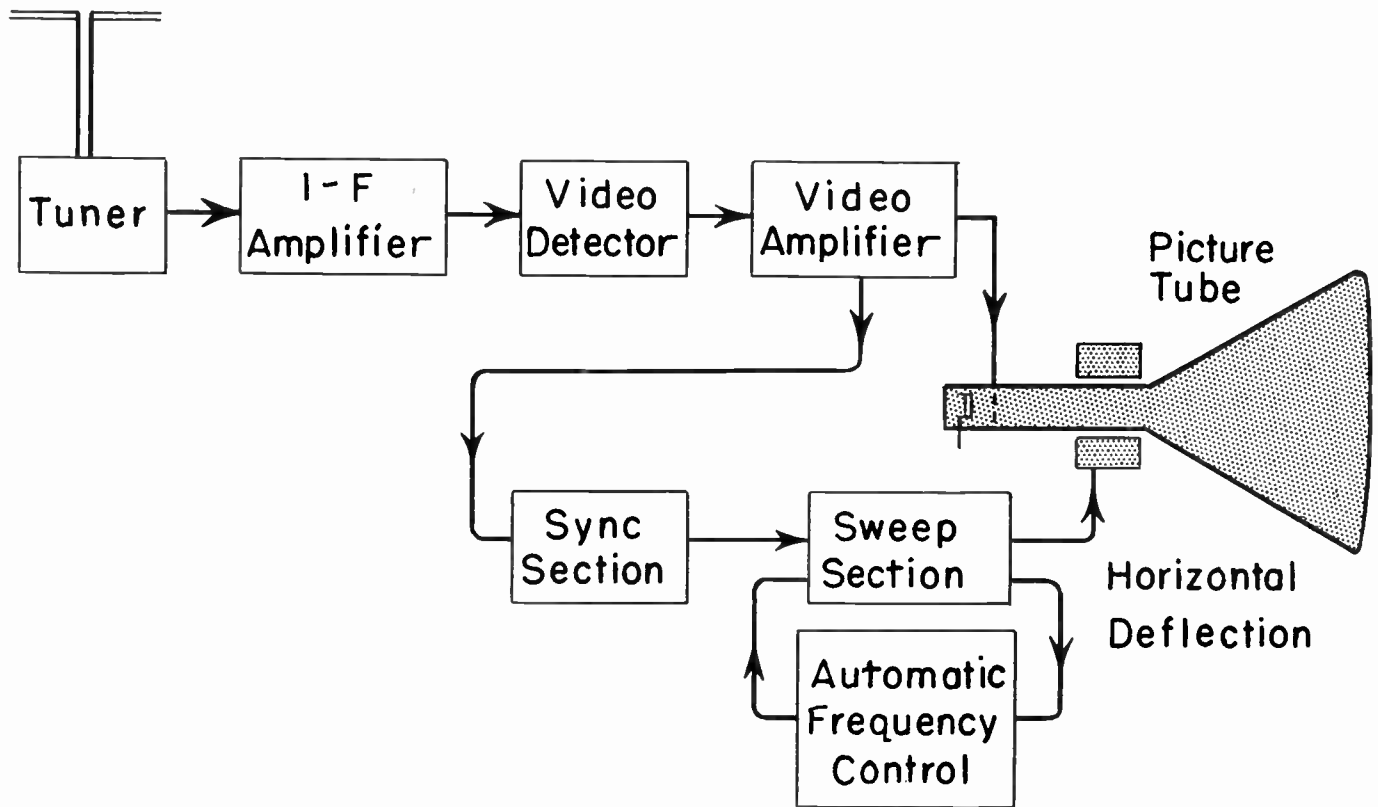

Fig. 8. The paths followed by picture signals and by horizontal sync pulses.

than black. The black level is a definite amplitude or voltage of the signal, and does not refer to tone or shade of the pictures. Even though the signal voltage were to reach the black level, the picture tube screen would not become absolutely black because of external light reflected from the screen material.

When the picture tube is operated with correct relative potentials on grid and cathode, or when grid bias is correct for the applied signal, grid voltage will become sufficiently negative to cut off the beam at the black level of the signal. Voltages blacker than black then will make the grid more negative than for cutoff. As signal voltage becomes less than that for the black level, the grid will be made less and less negative, intensity of the beam will increase and a brighter line will be traced. This is shown on the lower diagram of Fig. 7.

**UTILIZING THE HORIZONTAL SYNC PULSES.** It will be interesting to follow one or more of the horizontal sync pulses and associated picture lines part way through a receiver. The entire video signal which is

selected by the tuner passes from the mixer through the i-f amplifier section to the video detector. The detector rectifies one side or the other of the modulated wave and cuts off the other side. The modulation which is retained goes through the video amplifier section to the picture tube grid-cathode circuit, and through the sync and sweep sections to the deflection systems for the picture tube. This path is shown by Fig. 8.

The rectified signal or the modulation as it comes from the video detector is seen on the oscilloscope as in Fig. 9. Here we have one complete horizontal line of picture lights and shades in between two horizontal blanking intervals and sync pulses, with parts of other picture signals before and after the blanking intervals. Note that the sync pulses and pedestals appear very much as they were drawn in Figs. 5 and 6. The part of the flat pedestal which occurs before the pulse is called the front porch. It is somewhat shorter than the part following the pulse, this part being called the back porch. The picture signal is somewhat blurred, because neither the oscilloscope nor the camera is fast

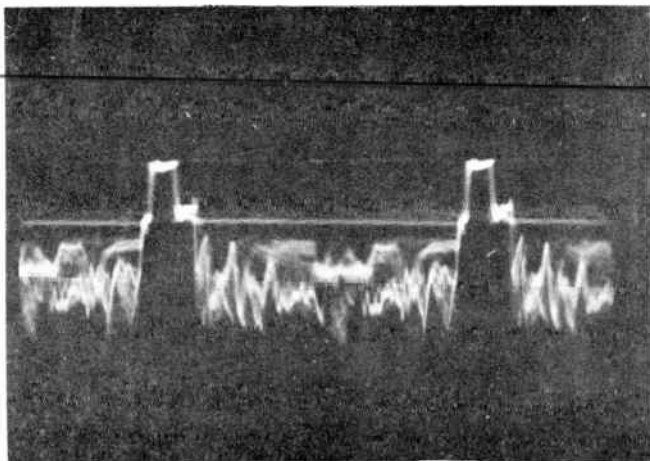

Fig. 9. The signal which comes from the mixer tube of the tuner section. Only one polarity of the modulation is reproduced in this picture.

enough to catch the variations which are occurring at the rate of millions of times per second.

In the output of the video detector the sync pulses are shown as positive and the picture signals negative. In the video amplifier this polarity is inverted, so that we come to the grid of the picture tube with a signal such as that of Fig. 10, where the picture is

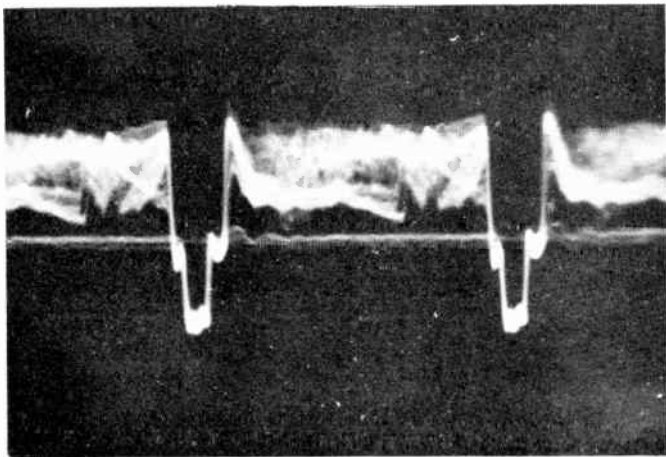

Fig. 10. The video signal which is applied to the picture tube grid.

positive and the pulses negative. This will produce pictures with correct relations between light and shade.

In Fig. 10 we have one complete picture line, with two blanking intervals and two sync

pulses. Figs 9 and 10 were not taken from the same receiver. Comparison will show slight differences between pedestals, pulse tips, and lengths of front and back porches. Such discrepancies may be due to differences in receiver circuits and in their alignments. There are slight differences between signal waveforms from one station and another. Frequency compensation of the oscilloscope may not be as good in one case as in others, which will affect the waveform of the observed signal. It is, however, always possible to determine whether the signal is coming through with approximately the correct waveform.

The complete signal, including pictures and sync, goes through the sync section. In this section the picture signal variations are removed and the sync pulses are strengthened, so that we have a synchronizing signal of the general form shown by Fig. 11. The

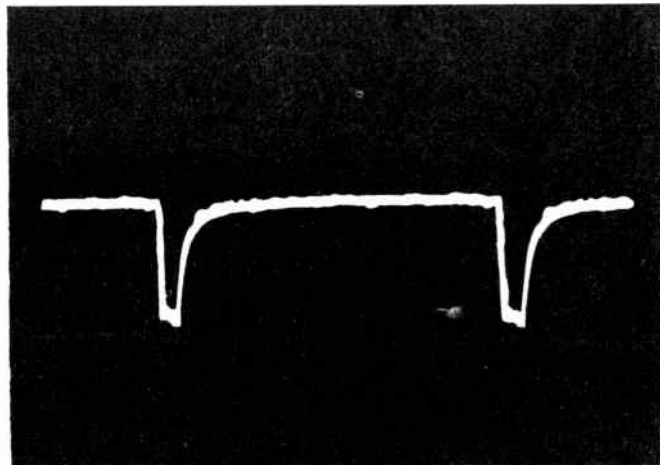

Fig. 11. The sync section removes practically all of the picture signals and retains the sync pulses.

pulses may be of the polarity shown or of the opposite polarity. The inversion, if required, is secured by putting the signal into the grid and taking it out at the plate of a tube used for inverter service.

Connected to the horizontal sweep section, or built as a part of that section, is an automatic frequency control. The purpose of this control is to insure that the sweep voltage or current remains strictly in time with the synchronizing pulses. A small portion of the actual sweep voltage, shown at A in Fig.



## LESSON 35 – TELEVISION SIGNAL

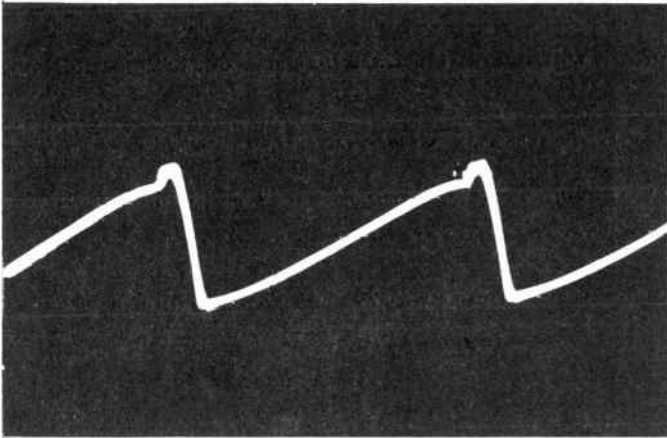

Fig. 12A

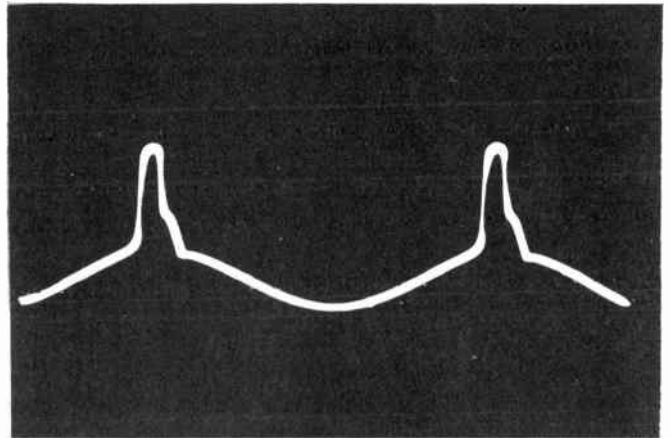

Fig. 13A

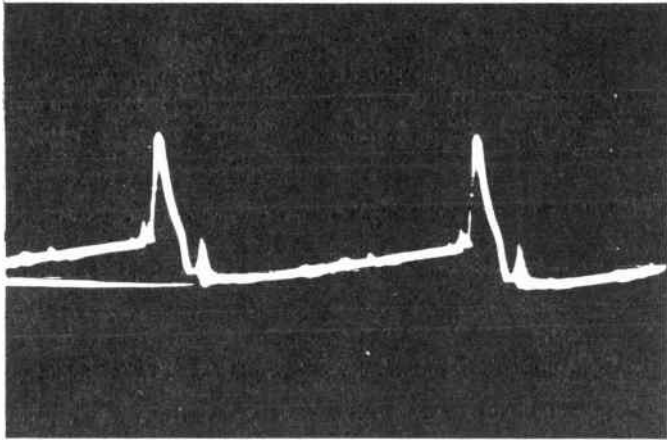

Fig. 12. The actual sweep voltage (A) is combined with sync pulses (B) to provide voltage that corrects any variations in horizontal timing.

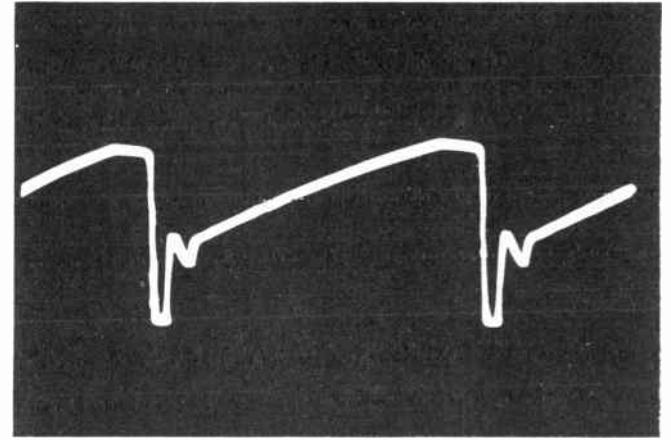

Fig. 13. The corrected sync pulses (A) trigger the horizontal oscillator to produce an output voltage (B) which will be used for horizontal deflection of the electron beam.

12, is taken from the output of the sweep section and combined with the incoming sync pulses to obtain a waveform such as at B. Later we shall go into details of what happens, but the essential feature is formation of a correction voltage that automatically brings the actual sweep back into time with the sync pulses whenever the sweep tends to vary.

For triggering the horizontal oscillator, which is part of the sweep section, we now have voltage pulses such as illustrated at A in Fig. 13. These pulses are completely under control of the horizontal sync pulses of the received video signal.

At the output of the horizontal sweep oscillator appears a voltage wave of the general style shown at B of Fig. 13. At the instants in which this voltage drops sharply downward it acts to bring the electron beam to the left-

hand side of the picture area in readiness for starting a horizontal line. The gradual rise in oscillator voltages acts to deflect the beam from left to right across the picture tube screen during tracing of a horizontal line.

What we have seen in Figs. 9 through 13, with the help of the oscilloscope, is merely a preview of what happens to various parts of the video signal in going through a receiver. There are many methods of obtaining essentially equivalent results at the picture tube, all of which will be examined as we progress.

VERTICAL BLANKING AND SYNCHRONIZATION. Now we are ready to examine the many things which must be done between the end of one field and the beginning of a following field. The vertical blanking interval,

which takes the same time as  $17\frac{1}{2}$  horizontal line periods, may be represented as at A in Fig. 14. Line periods are marked along the top of the diagram. We commence at the left with three complete picture lines. The variations which form picture light and shade have to be greatly compressed to get all that is to be shown within the confines of the diagram. These picture lines and accompanying horizontal sync pulses represent the three lines at the bottom of a field which ends with a complete line all the way across the picture area. Then begins the vertical blanking period, with signal voltage at the black level.

After an interval equal to three line periods comes the beginning of the vertical sync pulse, during which signal voltage goes blacker than black. The vertical sync pulse continues for a time equal to three horizontal line periods. Using this very long pulse for vertical synchronization, and short pulses for horizontal synchronization, makes it possible to separate the two kinds of pulses in the sync section of the receiver. The short pulses, or their effects, then go from the sync section to the horizontal sweep oscillator and trigger this oscillator. The effect of the longer vertical pulse goes from the sync section to the vertical sweep oscillator, and triggers that oscillator.

Following the end of the vertical sync pulse, blanking is continued to make up a total of  $17\frac{1}{2}$  horizontal line periods. The half-line period at the completion of vertical blanking is necessary in order that the following field may commence with a line started from half way across the picture area. The last picture line at the left on the diagram is a full line, and the beginning of the following field at the right on the diagram is a half line.

The signal at A in Fig. 14 would fail to maintain horizontal synchronization during the vertical blanking interval. Preceding the vertical sync pulse are three line periods with no horizontal sync pulses. There are no horizontal pulses during the long vertical pulse. And there are no horizontal sync pulses during the  $11\frac{1}{2}$  line periods following the vertical pulse. With no triggering of the horizontal sweep oscillator during all this time that oscillator would be likely to get quite out of time with horizontal synchronization of the received signal, and when horizontal pulses resume after vertical blanking it would be difficult to pick up correct timing until several picture lines had been completed.

To avoid the chance of losing horizontal synchronization we could add horizontal sync

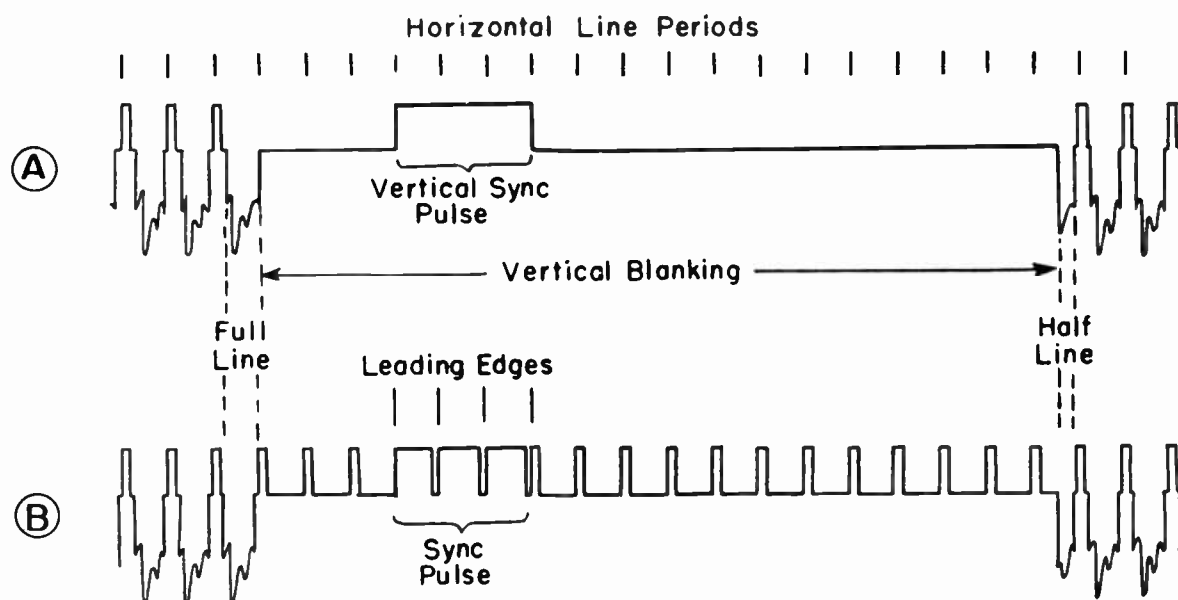

Fig. 14. How horizontal synchronization is maintained during the vertical blanking interval.

# LESSON 35 – TELEVISION SIGNAL

pulses during the vertical blanking interval as shown by diagram B of Fig. 14. This would be satisfactory so far as concerns the vertical blanking interval being considered, which is the interval beginning after a full line and ending at a half line. We are due for further difficulties when coming to the vertical blanking interval that begins after a half line and ends before a full line, but first let's examine the method of carrying horizontal synchronization through the long vertical sync pulse.

The explanation depends on the fact that sweep oscillators are triggered by the "leading edge" of a sync pulse. The leading edge of any pulse is the one that occurs first in time, it is the start of the pulse. Leading edges of all the pulses of Fig. 14 are the ones toward the left, since time is assumed to increase from left to right. The long vertical pulse has been broken up into sections such that a leading edge occurs at every instant in which the horizontal sweep oscillator should be triggered. The sections are called serrations, and so we now have a serrated vertical sync pulse.

The leading edges in the serrated vertical pulse will trigger the horizontal sweep oscillator. This is because at every one of these instants the horizontal oscillator is almost ready to go through one of its cycles, and needs only a little extra push from the sync pulse to start the cycle. The vertical sweep oscillator won't be triggered by the leading edges of the serrations, because at these instants the vertical oscillator is not sensitive and would require a pulse voltage far stronger than anything available in order to start a vertical oscillation cycle.

EQUALIZING PULSES. Now we come to the problem of starting every alternate field with a full line and all the intervening fields with half lines while maintaining horizontal synchronization throughout the entire time that the program continues. In Fig. 15 the vertical blanking interval begins after a half line, whereas in Fig. 14 this blanking interval begins after a full line. In diagram A of Fig. 15 the leading edges of sync pulses for horizontal synchronization have been carried all through the vertical blanking interval just as at B of Fig. 14. That is, we

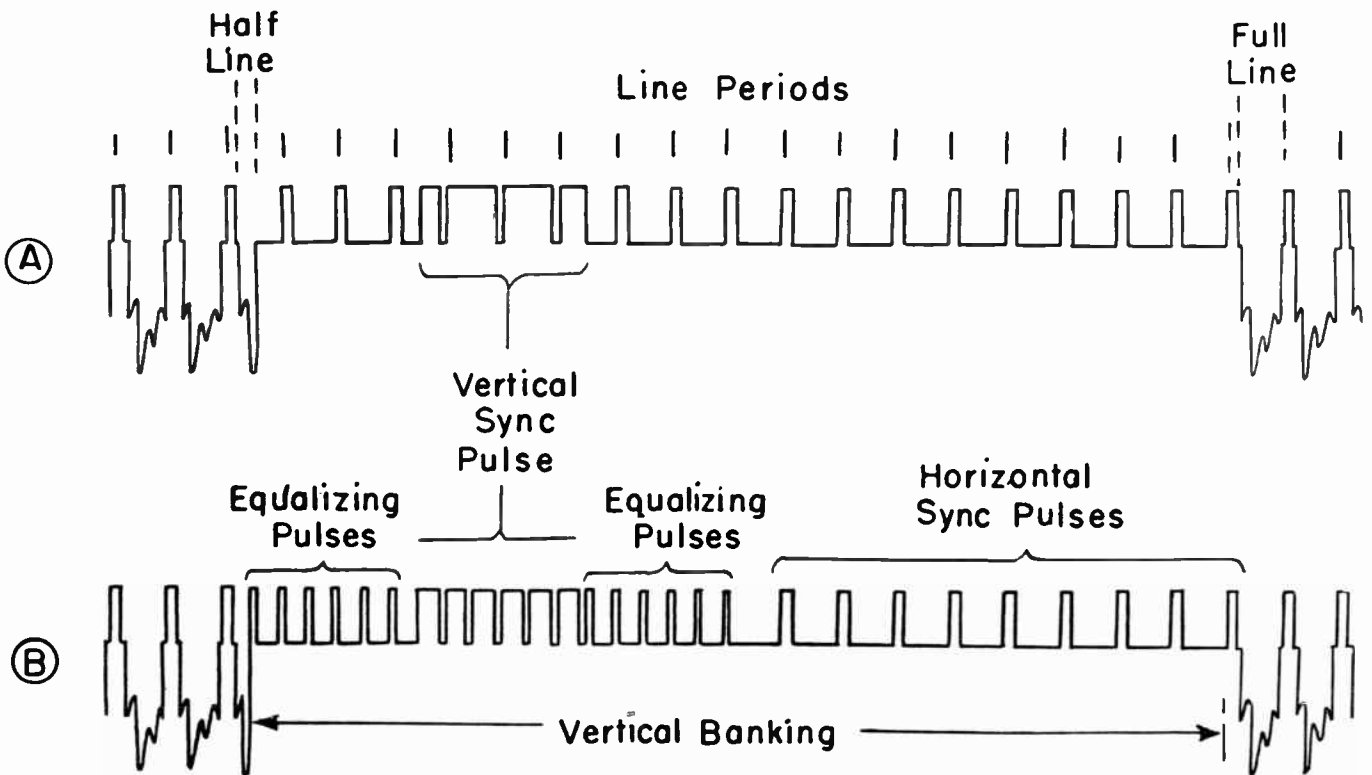

Fig. 15. Equalizing pulses allow maintaining horizontal sync with interlaced scanning, with alternate fields beginning with a full line and a half line.



have worked out a horizontal synchronization system which is satisfactory for vertical blanking that begins with a half line, just as formerly, we worked out a system satisfactory for vertical blanking beginning with a full line.

The two methods are not alike, as you can see by comparing the divisions or sections of the vertical sync pulses, and the positions of horizontal sync pulses occurring before and after the vertical pulses. At B in Fig. 15 the two methods have been combined. During the three line periods preceding the vertical pulse have been placed six very brief pulses, equally spaced at half-line intervals. Another series of similar brief pulses have been placed in three line periods following the vertical pulse. These are called equalizing pulses.

The serrations into which the vertical sync pulse is divided now are only a half-line in duration and all of them are equal. Now there is a leading edge of one kind or another at every instant in which the horizontal sweep oscillator is to be triggered. Before and after the vertical sync pulse, and during this pulse, there are leading edges twice as often as needed during this particular blanking interval. The extra leading edges cause no difficulty, because the horizontal oscillator is in condition to be triggered only by pulses occurring at the correct instants, and is quite insensitive to the extra ones.

When we go back to the other vertical blanking interval, the one commencing after a full line, these extra equalizing pulses and serration pulses take over the timing or triggering of the horizontal sweep oscillator. The result is continual and steady horizontal synchronization right through both vertical blanking intervals.

The diagram at B of Fig. 15 represents a complete video signal for the time of a vertical blanking interval and for two or more picture lines before and after this interval. Everything shown by this diagram occurs within a time of about  $1/700$  second. Were there a total of 244 line periods, with their picture signals and horizontal sync pulses, either before or after the vertical blanking interval, the result would be the

video signal during one complete field and one vertical blanking interval, or it would show the video signal during  $1/60$  second of time.

FOLLOWING THE VERTICAL SYNC PULSE. Since the vertical sync pulse and other synchronizing pulses associated with the vertical blanking interval are part of the video signal, all of them come through the tuner, the i-f amplifier, the video detector, and the video amplifier as shown by Fig. 8. At the output of the video detector the modulated i-f signal has been rectified, to leave one side of the modulation. Here the signal is seen on the oscilloscope screen as in Fig. 16.

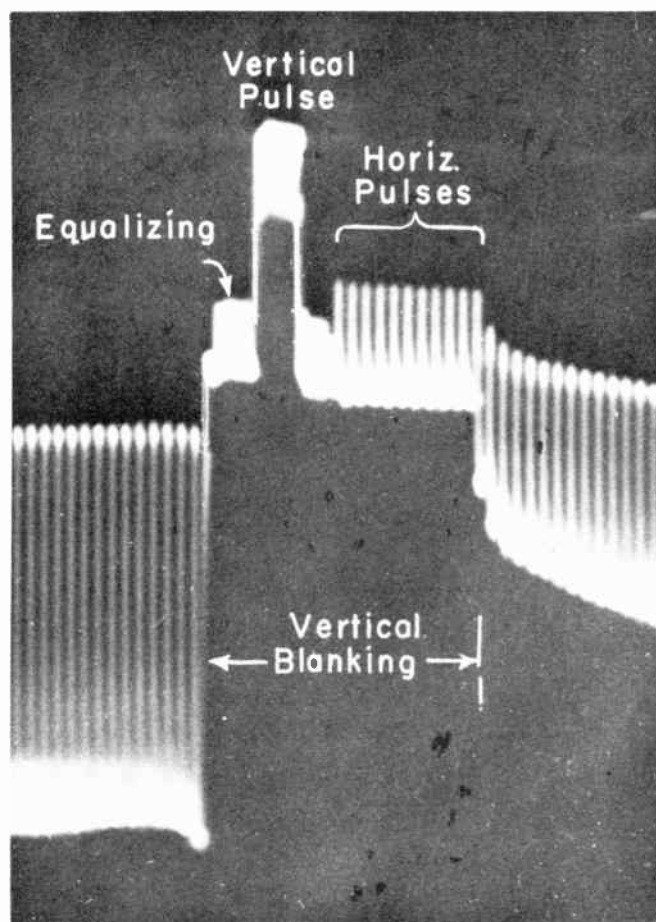

Fig. 16. How the oscilloscope sees the pulses occurring during one vertical blanking interval, also some of the horizontal lines before and after blanking.

Here we have several horizontal lines preceding and following the vertical blanking interval. The interval appears shorter than in the detailed diagrams which have been



## LESSON 35 – TELEVISION SIGNAL

used for explanation of the various features. It is possible, however, to distinguish the various kinds of pulses which occur during vertical blanking. These pulses are of varying heights on the oscilloscope trace. The oscilloscope responds to voltages; the greater the voltage the higher the trace.

Immediately following the last horizontal line at the left is the voltage resulting from six very brief equalizing pulses. These pulses are too close together to be distinguished one from another. Then comes a high voltage which is due to the serrated vertical sync pulse. There is high voltage because this pulse is continuous for three line periods except for the brief gaps between serrations. Following the vertical sync pulse we observe the effect of six more equalizing pulses. Then the remainder of the blanking interval is filled with horizontal sync pulses. These horizontal sync pulses can be individually distinguished because they are separated by full line periods and because each pulse lasts long enough to produce appreciable rise of voltage.

In the sync section of the receiver the pulses which occur during vertical blanking cause variations of voltage as shown by Fig. 17. The horizontal lines before and after vertical blanking have been greatly weakened. After the last horizontal line preceding vertical blanking there is a small rise of voltage due to the equalizing pulses. Then the six strong pulses which are serrations of the vertical sync pulse cause the voltage to climb in successive steps until reaching the highest value. This is the increase of voltage that will be used to trigger the vertical sweep oscillator. Following the peak, voltage drops rapidly during the time of equalizing pulses, then levels off through the horizontal sync pulses which continue until the end of vertical blanking. Then another field begins with the following horizontal line signals.

After further treatment in the sync section the synchronizing voltage is applied to the vertical sweep oscillator. Part way up on the voltage climb of Fig. 17 this voltage becomes strong enough to trigger the vertical oscillator. Then, at the input of the oscillator, occur the very sharp downward spikes of voltage shown by Fig. 18. These spikes occur

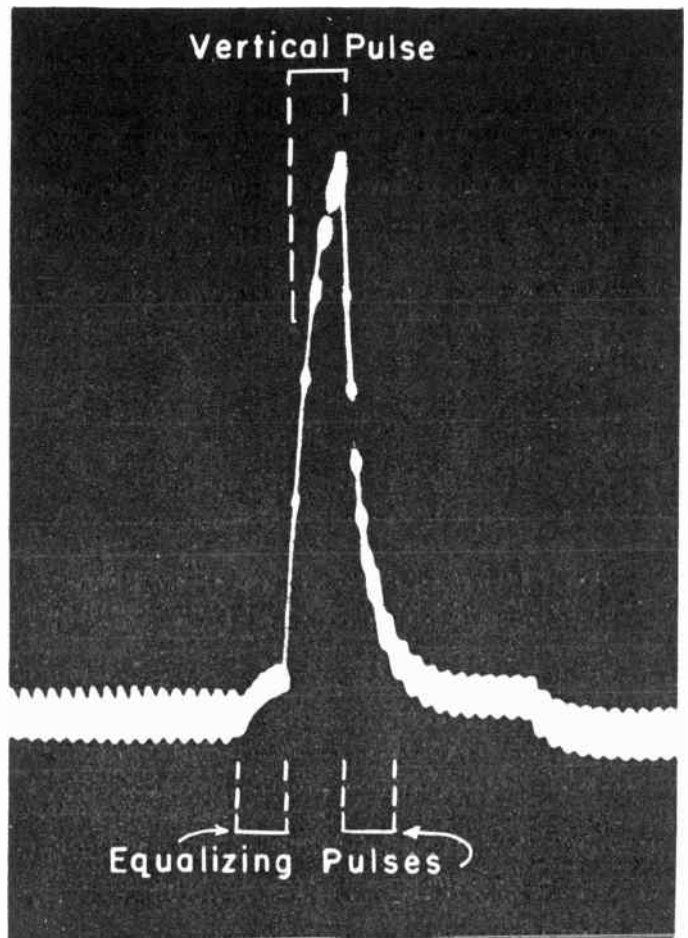

Fig. 17. Appearance of the vertical pulse at a point near the end of the sync section.

every  $1/60$  second, just after the end of every field. Each spike causes the vertical oscillator to go through one of its cycles, which brings the deflection voltage to the value which will start the following field at the top of the picture area. The elapsed time

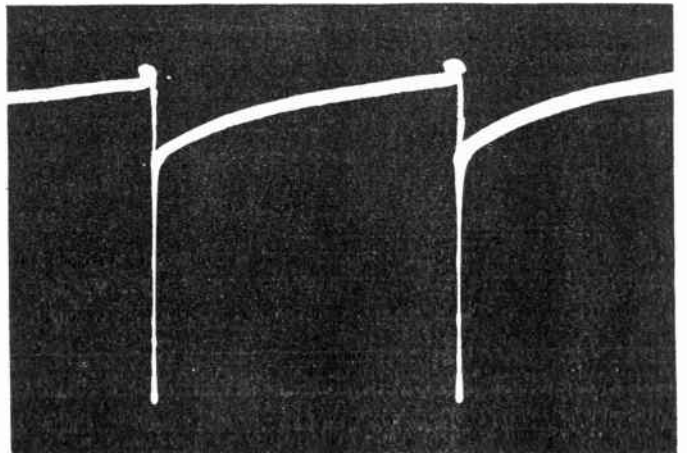

Fig. 18. These sharp voltage spikes trigger the vertical sweep oscillator.

between the two voltage spikes of Fig. 18 is  $1/60$  second. The entire time from left to right in Fig. 17 is about  $1/400$  second, including the vertical blanking interval and the horizontal line periods before and after vertical blanking.

On the output side of the vertical oscillator we find a voltage going through the changes shown by Fig. 19. The form is quite

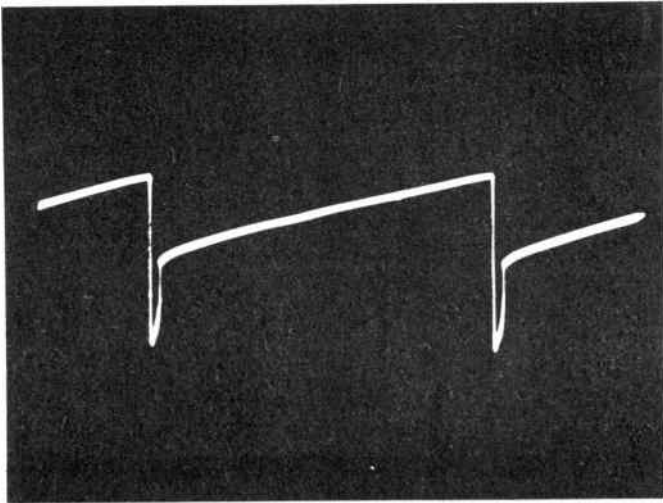

Fig. 19. Voltage at the output of the vertical oscillator.

similar to that shown at B of Fig. 13 on the output side of the horizontal sweep oscillator. But now, in the vertical sweep section, the sharp drop of voltage brings the electron beam to the top of the picture area in readiness for starting a new field. The gradual rise of voltage acts to deflect the beam from top to bottom of the picture area during one field.

It was mentioned in connection with horizontal synchronization and deflection that there are many ways of securing essentially the same final results at the picture tube. This is true also of vertical synchronization and deflection. When following either horizontal or vertical synchronization through the sections of receivers you quickly learn to recognize whether or not the successive actions are such as will finally sweep the beam horizontally and vertically in a satisfactory manner.

TELEVISION CONTROLS AND ADJUSTMENTS. Except for rate instances in which

there is trouble at the transmitter or in wire lines which bring programs to the transmitter, the signals sent out are of nearly perfect quality. These signals will allow reproduction of good quality pictures by a receiver which is correctly adjusted and in which there are no seriously defective parts. Any ordinary television receiver has more than twenty controls and adjustments whose purpose is to insure good reproduction of a desired program. Only a few of these controls and adjustments are for use by the operator, most of them are employed only during service operations.

Controls which are to be used by the operator are accessible from the front of the receiver. Any of these operating controls which should require adjustment only occasionally may be concealed back of a small cover plate which is easily opened or removed when necessary. Most service adjustments are on the rear or on top of the chassis. A few may be underneath the chassis. Some service adjustments may be accessible from the front of the cabinet upon removal of a cover plate.

With the earliest television receivers it was necessary for the operator to manipulate a great many controls which nowadays are used only as service adjustments. This led to much dissatisfaction, because the tendency of many people, when anything appears wrong with the pictures, is to twist any control which may be within reach. Usually this ruins the reproduction quite completely. Then they try turning all remaining accessible controls, making pictures steadily worse. All this is spite of the fact that each control is plainly marked with its purpose.

Improvements in design have steadily lessened the number of operating controls, and the chances for difficulty on the part of users. Nowadays there are only four controls which always are within instant reach of the operator. These four include (1) an off-on switch, (2) the channel selector for tuning to a desired program, (3) a control for sound volume, and (4) a control for picture contrast.

The contrast control sometimes is called a picture control, or it may be called a sen-



## LESSON 35 – TELEVISION SIGNAL

sitivity control. This control varies the voltage gain of the video amplifier which is between the video detector and picture tube, or the gain of the i-f amplifier, or possibly the gain of both these amplifier sections at once. The contrast control is a gain control for pictures, just as the volume control is a gain control for sound.

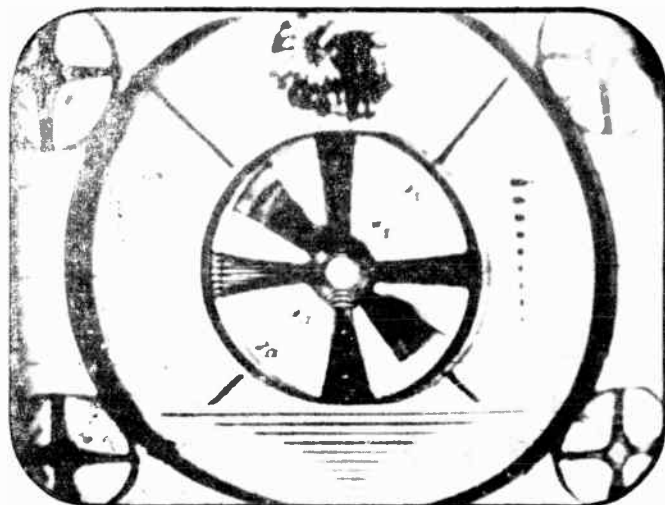

Fig. 20. The effect of excessive contrast.

Fig. 20 shows the effect of setting the contrast control too high. Dark tones are made pure black or nearly so, while light tones are made pure white. This is what a photographer would call a "soot and white-wash" effect. When the contrast control is adjusted correctly the pictures will have a full range of shading from very dark to very light. Only the portions which should appear nearly white will look that way, and only those which should appear black will look that way. In between will be a full range of gray tones, allowing everything to appear as natural as in a high quality photograph.

On the majority of receivers there is a fifth control which may be used by the operator, this being the fine tuning control. Fine tuning varies the frequency of the r-f oscillator in the tuner, to compensate for any slight differences between responses of antenna and mixer circuits at the different frequencies of various channels.

What the fine tuning control does in practice is move the video carrier frequency or the video intermediate frequency one way

or the other on the receiver frequency response shown at the bottom of Fig. 3. With correct adjustment, this frequency is brought to or close to the 50% point on the sloping side of the response. If you watch an i-f frequency response on the oscilloscope while adjusting the fine tuning, the marker shown on the curve of Fig. 4 will move above or below the 50% point. Best possible picture quality is obtained only with correct adjustment of the fine tuning control.

Another control which nowadays usually is a service adjustment is that for brightness, called also the brilliancy, background, or intensity control. On some receivers this is an operating control, either completely accessible or concealed until needed. The brightness control varies the negative bias voltage on the grid of the picture tube, and thus varies average intensity of the electron beam. This changes the average or overall brightness of pictures, or their apparent overall illumination. Fig. 21 shows the effect

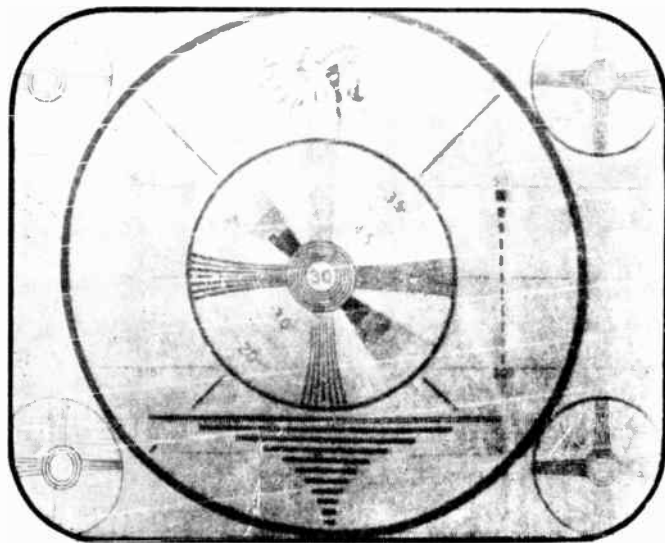

Fig. 21. The brightness control is set too high.

of turning a brightness control too high, making the picture tube grid bias insufficiently negative.

There is a vertical hold control and also a horizontal hold control which formerly were operating controls on all receivers, but now are either service adjustments or else are accessible to the operator only by opening some kind of cover plate. The hold controls vary the frequencies of the vertical and

## COYNE - *television home training*

horizontal sweep oscillators to bring them close enough to synchronizing frequencies that the sync pulses can trigger these oscillators at the correct instants. Were oscillator frequencies allowed to differ too greatly from synchronizing frequencies, the sync pulse would not be strong enough for effectual triggering.

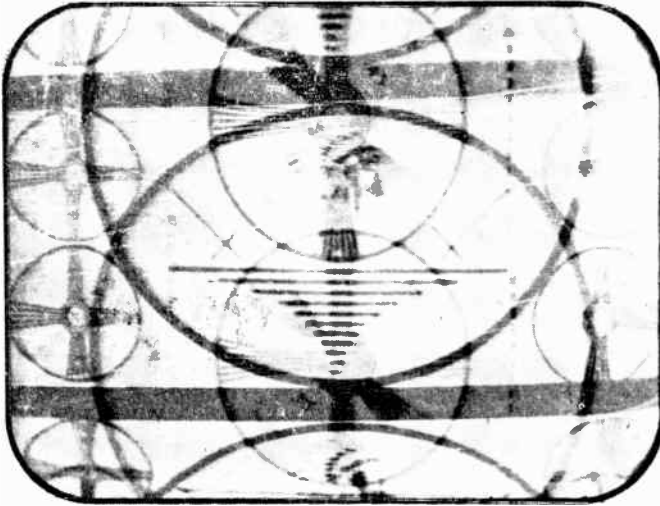

Fig. 22. With the vertical hold incorrectly adjusted, pictures move up or down.

Fig. 22 shows what happens when the vertical hold control is misadjusted. Pictures shift continually upward or downward on the screen of the picture tube. Pictures are said to "roll". If the horizontal hold control is wrongly adjusted we have the effect shown by Fig. 23. Pictures are compressed into diagonal areas which shift more or less continually.

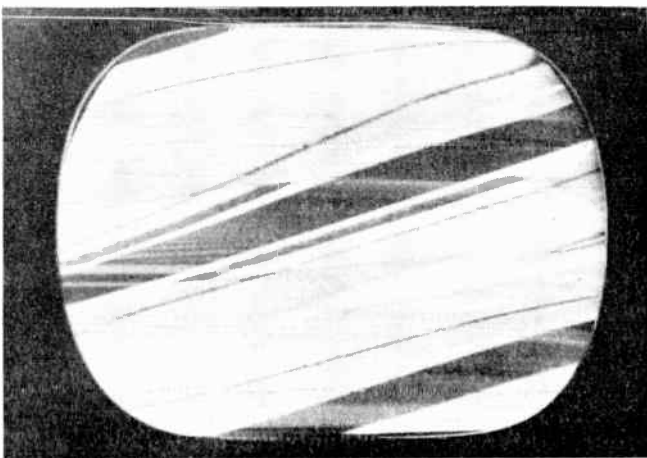

Fig. 23. Wrong adjustment of the horizontal hold control.

The focusing control is a service adjustment on practically every receiver of modern manufacture, although once it was an operating control. Focusing brings the electron beam down to a very small spot where it strikes the screen of the picture tube, somewhat as a magnifying glass will focus a beam of light onto a small spot. When focusing is correct you can distinguish each separate horizontal line all the way across or nearly all the way across the picture area. Incorrect focusing blurs the picture details, as illustrated by Fig. 24.

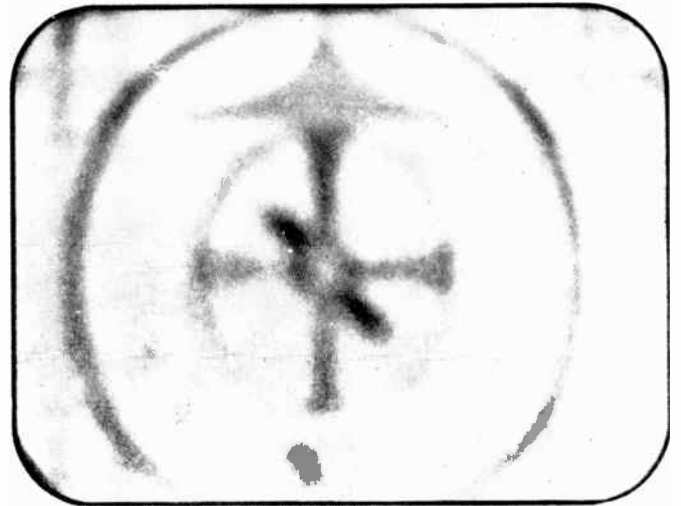

Fig. 24. Incorrect adjustment of the focusing control.

Controls for vertical centering and for horizontal centering are service adjustments. They bring the center of reproduced pictures to the center of the picture tube screen or to the center of the opening in a cabinet mask mounted in front of the screen. The vertical centering control moves the picture up or down. The horizontal centering control moves the picture to the left or right. Other names are position controls, or framing controls.

There are service controls for height and for width of the reproduced pictures. A height control may be called a vertical size control, and a width control a horizontal size control. These controls vary the distance through which the electron beam is deflected vertically to make pictures higher or lower in overall dimensions, and they vary the horizontal deflection distance to make pictures wider or narrower. With correct size adjustments the pictures extend just beyond the top, bottom, and sides of the mask open-



## LESSON 35 – TELEVISION SIGNAL

ing, so that practically the entire picture is visible without exposing dark areas of screen which are out beyond the picture edges.

Controls for horizontal linearity and for vertical linearity make objects in the pictures appear of correct relative proportions when the objects are to the left or right of center or are above or below center. That is, a given object will appear to have the same proportions and dimensions no matter where it is located in the picture, instead of appearing compressed one way or the other when in some positions, and expanded when in another position.

A typical effect of incorrect horizontal linearity is illustrated by Fig. 25. There is

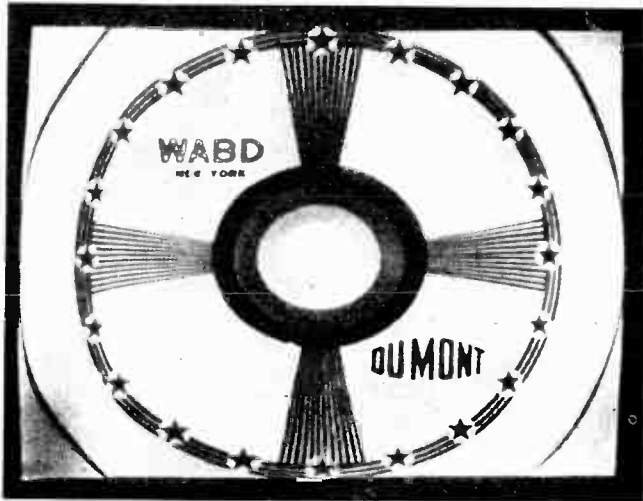

Fig. 25. Misadjustment of horizontal linearity allows sidewise compression or expansion.

severe cramping at the left of center and the center is elongated horizontally. There might also be stretching sideways in the right-hand of the picture. Misadjustment of vertical linearity affects the top of the pictures. In Fig. 26 the top is cramped. Incorrect ad-

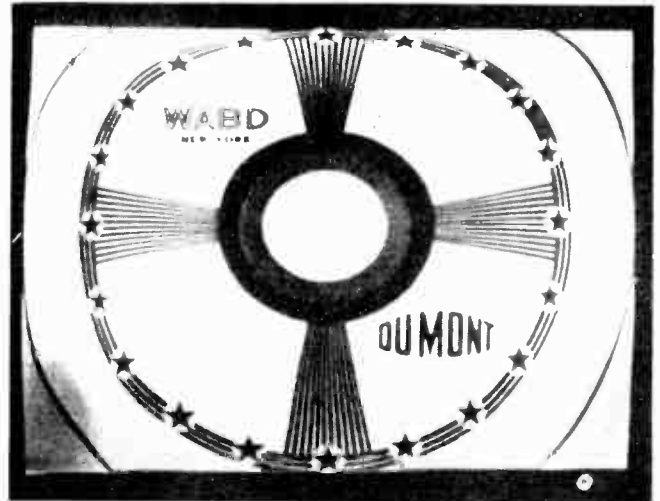

Fig. 26. Incorrect vertical linearity compresses or expands the upper part of pictures or patterns.

justment may cause elongation or vertical stretching of all objects in the upper half of the picture.

Another important service control is one marked drive or peaking. This control affects the width of the picture, also the relative proportions or apparent dimensions of objects either side of center. Later we shall learn that controls for horizontal linearity, for width, and for drive must be adjusted together, since each of them will affect the results produced by both the others.

Details of how all the service adjustments are made will have to wait until we learn more about the electrical principles and actions involved. When we know not only what a control should accomplish, but also how it works, adjustments become quite easy. Otherwise they are merely hit or miss experiments, and when you get into adjustments which affect one another there is little chance of hitting one if you miss another.

# TELEVISION

• RADIO

• ELECTRONICS

---

**LESSON 36 – TELEVISION IF AMPLIFIER**

---

***Coyne School***

*practical home training*

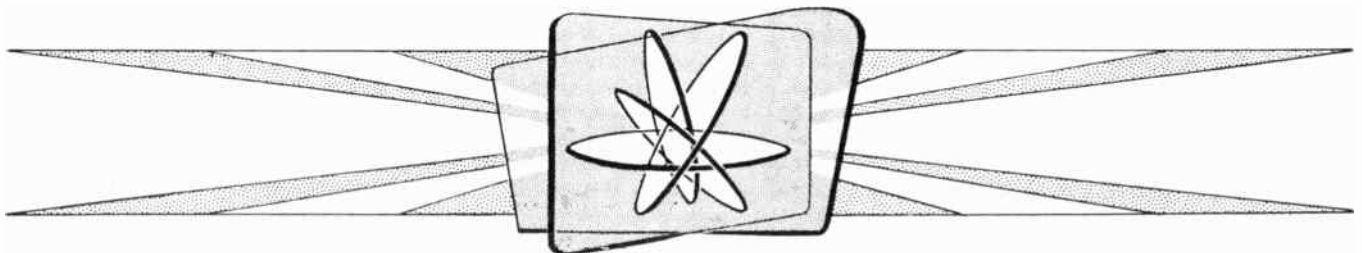

*Chicago, Illinois*

---

*Copyright, 1953 by Coyne Electrical School  
Chicago 12, Illinois  
All rights reserved*

Litho. in U.S.A.

## Lesson 36

### TELEVISION IF AMPLIFIER

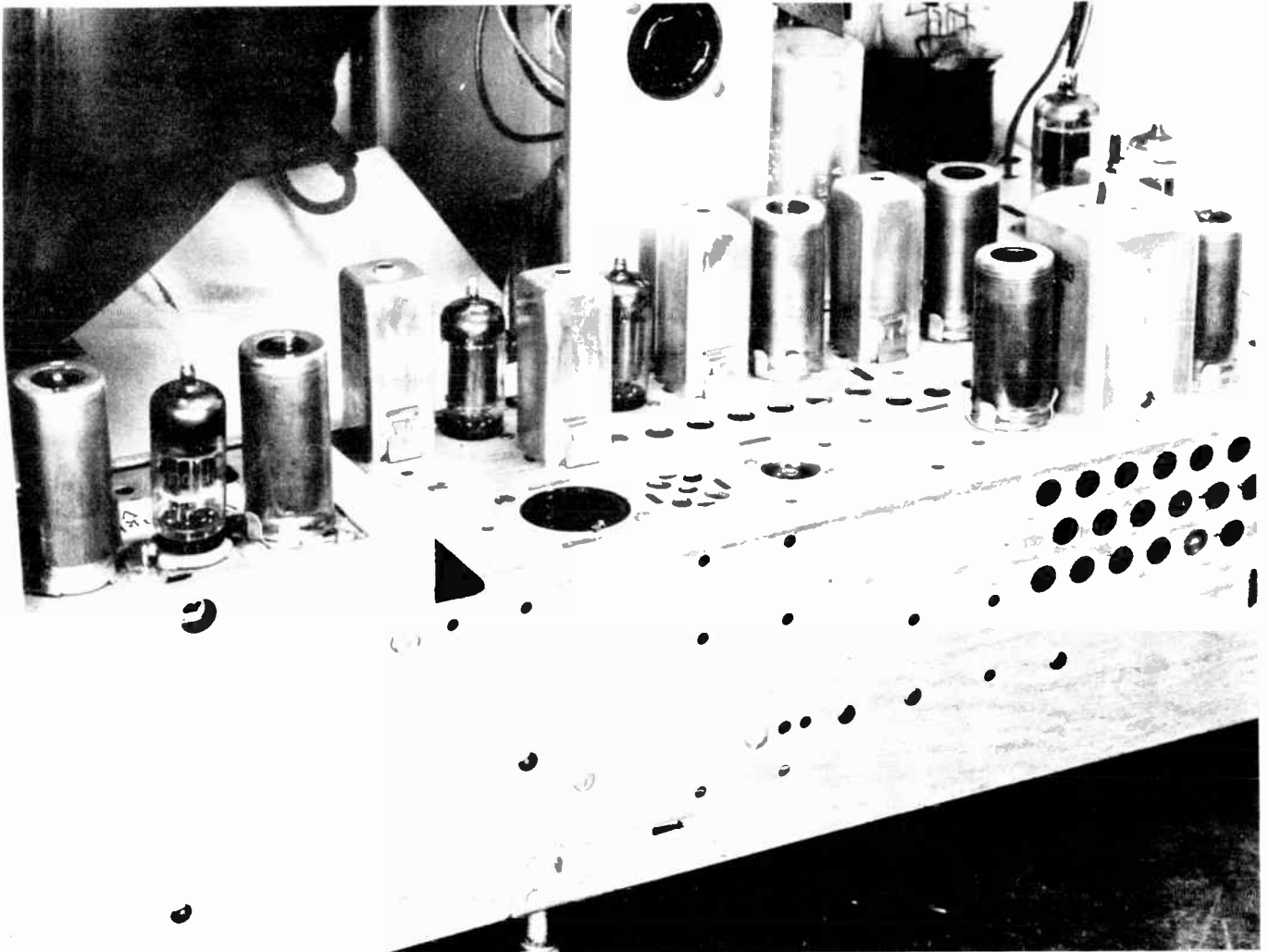

*Fig. 1. The tuner, at the extreme left, is followed by the i-f amplifier section toward the right.*

Some of the principal differences between a standard broadcast radio and a typical television receiver are illustrated by the two block diagrams of Fig. 2. When the radio set has an r-f amplifier there are tuned or untuned couplings between antenna and amplifier and converter tubes. The converter combines the functions of mixer and r-f oscillator by means of a single electron stream within the tube. There is a single i-f amplifier tube, preceded and followed by transformer couplings tuned to the intermediate frequency. The last coupling or transformer feeds the detector, whose output goes to the audio amplifier.

In the television receiver we have comparable parts, but there are more of them. Always there is an r-f amplifier tube, and often more than one. The r-f amplifiers are fed through a tuned coupling from the antenna, and they feed through another tuned coupling to the mixer. These two couplings are tuned to frequencies of the channel to be received. To the mixer comes also the output of the r-f oscillator. Mixer and oscillator always are separate tubes or sections of a twin or combination tube in which there are separate electron streams for the two functions. The r-f amplifier or amplifiers, the mixer, and the r-f oscillator, together with couplings



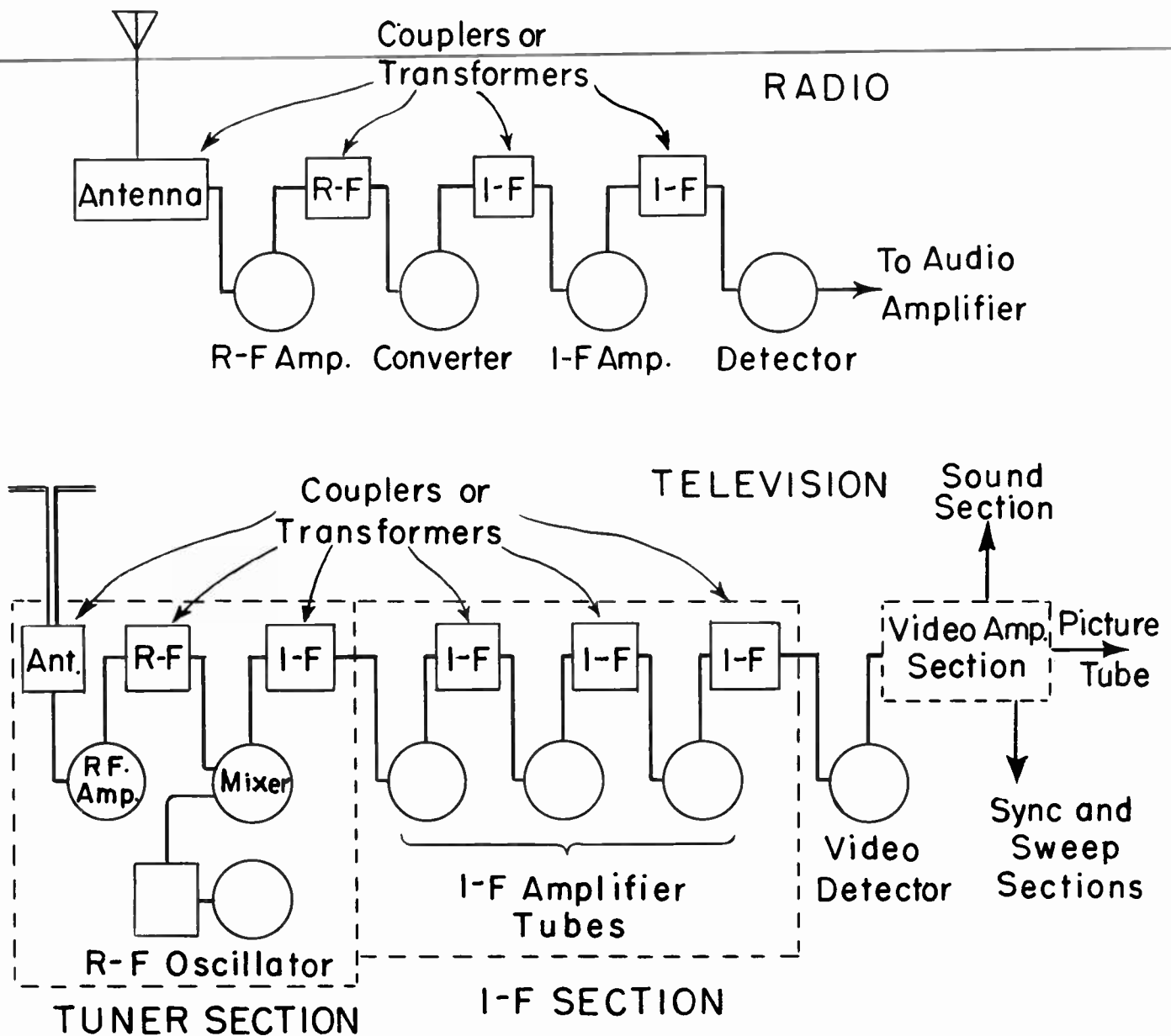

Fig. 2. There are more types of parts, and more of each type, for television than for sound radio.

between them, make up the tuner section of the television receiver.

The mixer produces two beat frequencies or two intermediate frequencies. One is the video intermediate frequency, equal to the difference between frequencies of the r-f oscillator and those of received video carriers. The other is the sound intermediate frequency, equal to the difference between frequencies of the r-f oscillator and of received sound carriers.

The two intermediate frequencies and their modulations go from the plate of the mixer to an i-f coupler or transformer which is tuned to a band of frequencies including both intermediates. This first i-f coupler often is mounted on or in the tuner, although electrically it is part of the i-f section because of being tuned to the intermediate frequencies.

In the i-f section represented by Fig. 2 there are three i-f amplifier tubes. Numer-

# LESSON 36 — TELEVISION IF AMPLIFIER

ous receivers have four i-f amplifier tubes, a few have been built with only two i-f amplifiers, but in the majority we find three i-f amplifiers or three i-f stages. Preceding and following each i-f amplifier tube is a transformer or coupler tuned within the band of intermediate frequencies used for the receiver. With three amplifier tubes there are four i-f couplers, with four tubes there would be five couplers, and with only two i-f amplifiers there would be only three i-f couplers or transformers.

Most of the voltage gain as well as the selectivity for any television receiver is secured in the i-f section. This also is the section whose frequency response is shaped to provide only 50 per cent of maximum gain at the video carrier or video intermediate frequency, as required with vestigial side-band transmission.

INTERMEDIATE FREQUENCIES. A wide variety of video and sound intermediate frequencies have been used and still are used in receivers old and new. Following are some of the more common intermediate frequencies.

## INTERMEDIATE FREQUENCIES, MEGACYCLES

Video	Sound	Video	Sound	Video	Sound
25.75	21.25	26.25	21.75	36.0	31.5
25.8	21.3	26.4	21.9	36.125	31.625
26.1	21.6	26.5	22.0	37.3	32.8
26.2	21.7	26.6	22.1	45.75	41.25
		26.75	22.25		

The great number of intermediates in the range between 21 and 27 mc is accounted for by the fact that a former television standard provided for video intermediates between 25.75 and 26.40 mc, and for sound intermediates 4.5 mc lower, or between 21.25 and 21.90 mc. A more recent standard specifies the video intermediate frequency as 45.75 mc and the sound intermediate as 41.25 mc.

The standard intermediates at higher frequencies are intended to lessen the effects of various interferences, including that from amateur and other short-wave transmitters, from television channels other than the one tuned, from image frequencies of f-m broad-

cast transmissions, and from some types of medical apparatus. There also is less likelihood that the receiver will radiate its own r-f oscillator frequency, to interfere with other nearby sets.

The higher intermediates bring difficulties of their own, chiefly in the way of energy feedbacks such as always become more troublesome as frequency rises. There may be difficulties in the mixer circuits when receiving channel 2, where the video carrier is less than 10 mc from the video intermediate. Extra precautions must be taken also in the design of i-f amplifier circuits to prevent back coupling from stage to stage.

Certain important facts related to intermediate frequencies are most easily explained by means of a few practical examples. For the first example we shall consider the frequencies involved during reception of channel 6 by a receiver whose video intermediate frequency is 45.75 mc and whose sound intermediate is 41.25 mc.

R-f oscillator		129.00 mc		129.00 mc
Carriers, Ch. 6	Video	<u>83.25 mc</u>	Sound	<u>87.75 mc</u>
Intermediates (differences)	Video	45.75 mc	Sound	41.25 mc

As another example assume that the same receiver is tuned for channel 10. This would require changing the r-f oscillator frequency as well as the resonant frequency of antenna and mixer circuits. Then we have,

R-f oscillator		239.00 mc		239.00 mc
Carriers, Ch. 10	Video	<u>193.25 mc</u>	Sound	<u>197.75 mc</u>
Intermediates (differences)	Video	45.75 mc	Sound	41.25 mc

These two sets of figures illustrate, first, that the intermediate frequencies for any given receiver remain unchanged no matter what channel is received. And second, although the video carrier frequency is lower than the sound carrier, the video intermediate frequency is higher than the sound intermediate.

For a third example we may consider a receiver operating with intermediate frequencies of 25.75 mc for video and of 21.25 mc for sound, and tuned for reception of channel 6.

# COYNE - *television home training*

R-f oscillator		109.00 mc		109.00 mc
Carriers, Ch. 6	Video	83.25 mc	Sound	87.75 mc
Intermediates (differences)	Video	25.75 mc	Sound	21.25 mc

Again we find that the video intermediate frequency is higher than the sound intermediate. This always is true of all intermediates, regardless of the receiver or the channel to which tuned. In all three examples we observe that the separation between the two intermediate frequencies always is exactly 4.50 mc, just as the separation between video and sound carriers always is exactly 4.50 mc.

**SOUND SIGNALS.** In the great majority of recently designed television receivers the video signals and also the sound signals are carried from the tuner all the way through the i-f section to the video detector, as at A in Fig. 3. The two signals beat together in this detector to produce at its output a difference frequency which carries the modulation of the sound signals. This difference frequency always is 4.5 mc, because the difference between the video and sound intermediates always is 4.5 mc. The 4.5-mc beat frequency, modulated by the sound signals, is taken from some point beyond the video de-

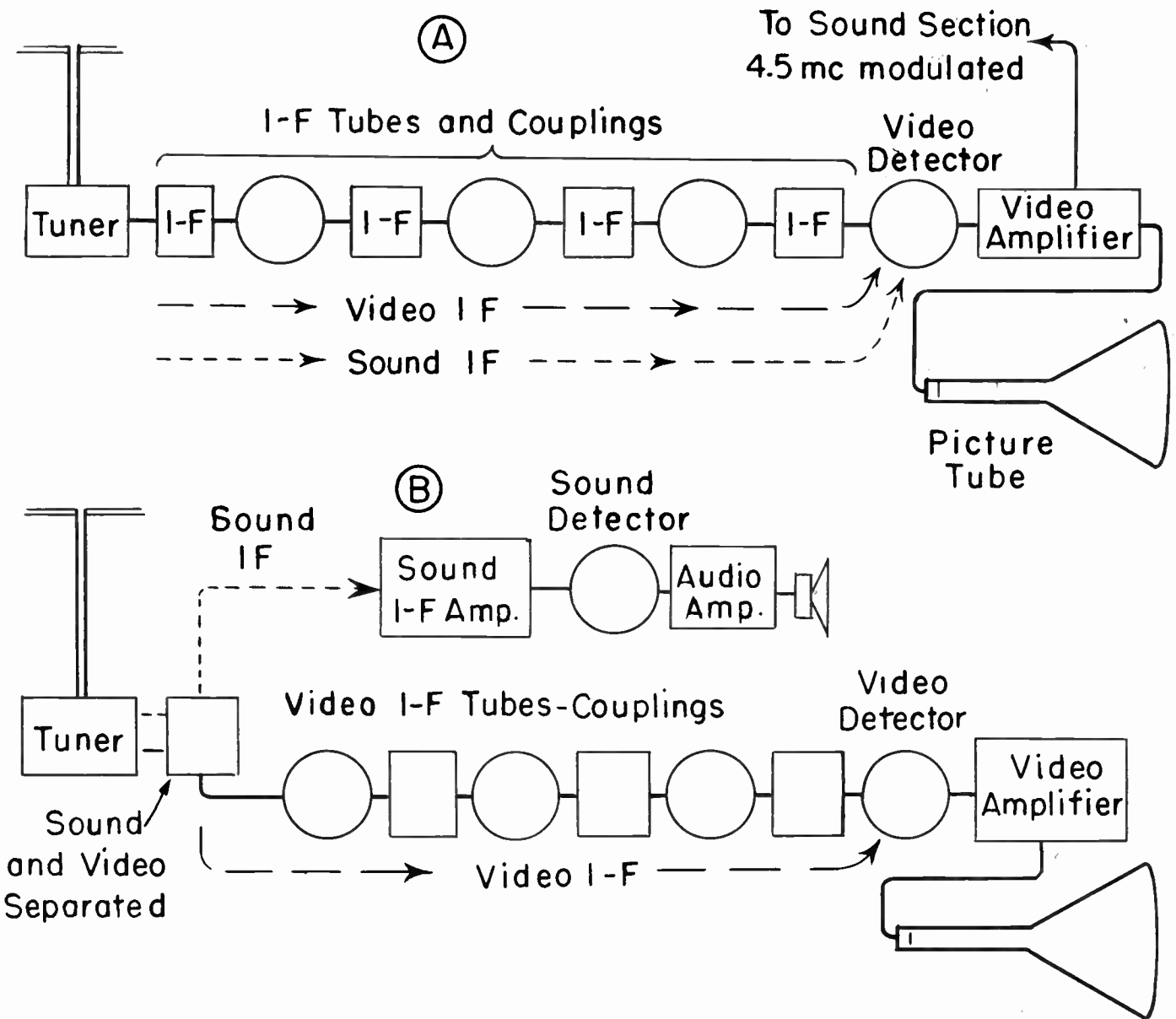

Fig. 3. Video and sound signal paths for intercarrier sound (A) and for dual sound (B).

# LESSON 36 – TELEVISION IF AMPLIFIER

detector to the sound section of the receiver. This method of carrying both video and sound all the way through the i-f amplifier goes by the name of intercarrier sound system.

In all of the early television receivers and in great numbers of fairly recent manufacture we find dual sound systems, as at B of Fig. 3. With a dual sound system the video and sound intermediates are separated immediately after the tuner, or in the output coupling for the mixer. Then the video i-f signals go through what is called the video i-f amplifier section to the video detector. The sound i-f signals go to a separate sound section which includes its own i-f amplifier. The change from dual to intercarrier sound has come about because the intercarrier method is simpler, requires fewer tubes, is easier to align correctly, and gives satisfactory performance.

**FREQUENCY RESPONSE.** The frequency to which the r-f oscillator is tuned beats with the modulated carrier frequencies for video and sound to produce the desired intermediate frequencies. The oscillator frequency will beat also with any other modulated carrier frequencies which come through the antenna circuit and r-f amplifier to the mixer input. This actually may happen, because the frequency response of most tuners is rather wide, often being 10 mc or even more. This wide frequency response may allow passage of modulated carriers from "adjacent" channels above and below the one for which the receiver is tuned.

What may happen in any three channels which adjoin one another in frequency may be illustrated by assuming that a receiver is tuned for channel 3, in between channels 4

and 2, and that the intermediate frequencies are 45.75 for video and 41.25 mc for sound. All of the beat frequencies or difference frequencies to be considered are listed in the following tabulation. The r-f oscillator frequency remains unchanged because it is fixed when the receiver is tuned for channel 3. This same oscillator frequency will beat with any carrier frequencies reaching the mixer, and will allow production of various difference or beat frequencies.

The carrier frequency limits of channel 3 are 66.00 and 60.00 mc. Were frequencies at these limits to beat with the r-f oscillator frequency the resulting frequencies at the mixer output would be 41.00 and 47.00 mc. Consequently, we may take these latter two frequencies as the channel limits so far as the i-f amplifier section is concerned.

We may assume that the frequency response of the tuner is 10 mc wide, and that it extends from 2 mc below to 2 mc above the channel limits. Resulting beat frequencies then would be 2 mc below 41 mc and 2 mc above 47 mc, and it would be possible for beat frequencies anywhere between 39 and 49 mc to reach the i-f amplifier section.

Within this range of 39 to 49 mc we find in the preceding tabulation the adjacent channel video frequency of 39.75 mc and also the adjacent channel sound frequency of 47.25 mc. The i-f amplifier section should not be responsive to either of these adjacent channel frequencies, for certainly we do not wish to have them interfering with the selected program. To meet this requirement the frequency response of the i-f section should be such as will have no gain at these adjacent

FREQUENCIES	CHANNEL 4 (Adjacent)			CHANNEL 3 Tuned			CHANNEL 2 (Adjacent)	
	Sound	Video	Channel Limit	Sound	Video	Channel Limit	Sound	Video
R-f Oscillator	107.00	107.00	107.00	107.00	107.00	107.00	107.00	107.00
Carriers	71.75	67.25		65.75	61.25		59.75	55.25
Channel Limits	<hr/>		66.00	<hr/>		60.00	<hr/>	
Differences Or Beats	35.25	39.75	41.00	41.25	45.75	47.00	47.25	51.75



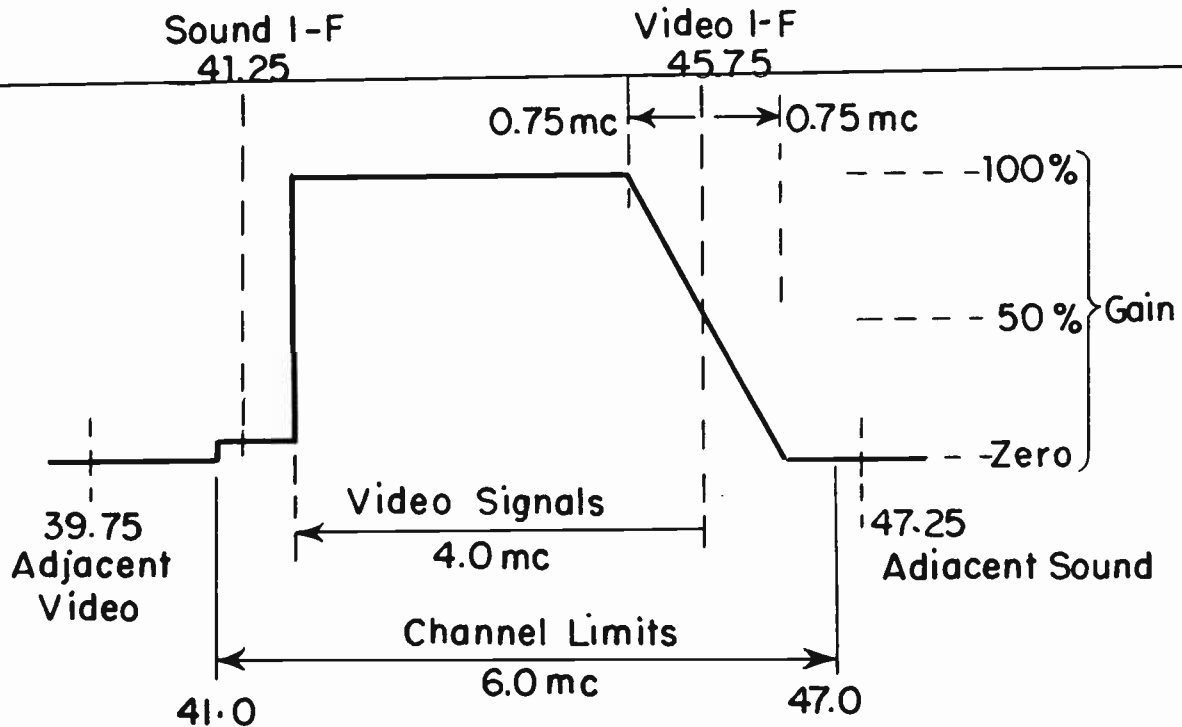

Fig. 4. The ideal frequency response for an i-f section.

channel frequencies, while correctly amplifying the modulated video and sound intermediate frequencies for the tuned or selected channel.

Such an ideal frequency response for the i-f section is shown by Fig. 4. The gain is zero for all frequencies outside the limits of the tuned channel, thus rejecting the unwanted adjacent channel frequencies. At the video intermediate frequency the response is 50% of maximum. At 0.75 mc below the video intermediate the response is up to 100%, and at 0.75 mc above the video intermediate the response is down to zero. This takes care of the requirements for vestigial sideband transmission.

From the video intermediate frequency across to the sharp drop somewhat above the sound intermediate the range is shown as 4 mc. There would be little object in having the video response much wider, because in few if any transmissions do the video or picture signals extend to a frequency of more than 4 mc. Even though we did extend the response a little more, it would have to come down to a low value at the sound intermediate

and to zero at the channel limit. The added video response could not be enough to make an appreciable improvement in picture quality.

With the intercarrier sound system we must not lose the sound intermediate frequency in the i-f section, for at the video detector the sound and video intermediates are to beat together in forming the sound-modulated 4.5 mc signal for the sound section. However, the sound intermediate signals must reach the video detector at very low gain, or at a gain just sufficient to allow the 4.5-mc beat. Were the sound intermediate too strong at the video detector the sound signals or the 4.5-mc beat would go to the picture tube and cause "sound bars" running horizontally across the pictures as shown by Fig. 5.

**STAGGERED TUNING.** It is impossible or at least impracticable to have changes of gain so sharp as those of Fig. 4 at certain frequencies. Were corners of that ideal response are square or at definite angles the actual changes will be more gradual and the response will show curves.

## LESSON 36 — TELEVISION IF AMPLIFIER



Fig. 5. Sound bars may result from sound signals reaching the grid-cathode circuit of the picture tube.

An entirely satisfactory frequency response for an i-f amplifier section is shown by Fig. 6, as seen on the oscilloscope. The point at which the video intermediate frequency falls on this curve is indicated by a marker, placed there by a marker generator operating at this frequency.

It would be impossible to have a frequency response as wide as that of Fig. 6, and with a top so nearly flat, with any tuned coupling other than one sufficiently over-coupled to produce two separated peaks. Overcoupled circuits were used for i-f couplers in all stages of many of the earlier re-

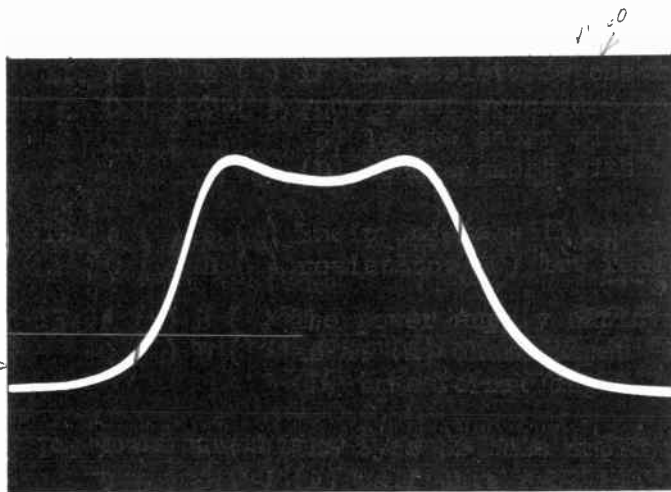

Fig. 6. Actual i-f response of a television receiver. The video intermediate frequency is indicated by a marker.

ceivers. They still are used in one or another of the several i-f stages in many present-day receivers. Unfortunately, over-coupled transformers are difficult to align correctly without rather elaborate service instruments.

In nearly all recent television i-f sections the methods of obtaining a broad and fairly flat-topped frequency response is much simpler. It is called staggered tuning. With staggered tuning the successive stages are tuned to different frequencies in the range between video and sound intermediate frequencies. Usually there is undercoupling in all stages, with each coupler peaked at its own frequency. All of the stages contribute to the overall response. By suitable choice of the various stage frequencies in relation to the stage gains, the total or overall frequency response will be such as meets the requirements which have been outlined.

We shall examine the action of staggered tuning by watching the performance of an i-f section whose circuit connections are shown by Fig. 7. There are four pentode i-f amplifier tubes between the mixer and video detector. The five interstage couplers are shown as the tuned impedance type, which you have seen in many pictures of earlier lessons.

The five couplers are individually tuned to resonance at the frequencies marked on the diagram. The video intermediate frequency is 26.1 mc, and the sound intermediate is 21.6 mc. All of the coupler frequencies lie within the range between the two intermediates. This is not always the case; sometimes there will be one coupler tuned to a frequency slightly higher than the video intermediate.

With a signal voltage applied to the mixer grid and the amplified voltage taken from the grid of the first i-f amplifier to the oscilloscope the frequency response appears as in Fig. 8. The peak is at 24.8 mc. This is the response of the coupler located between the mixer and the first i-f amplifier tube, which is tuned to 24.8 mc.

The responses of the other four couplers are of practically the same shape, with each curve peaking at the frequency to which the

# COYNE - *television home training*

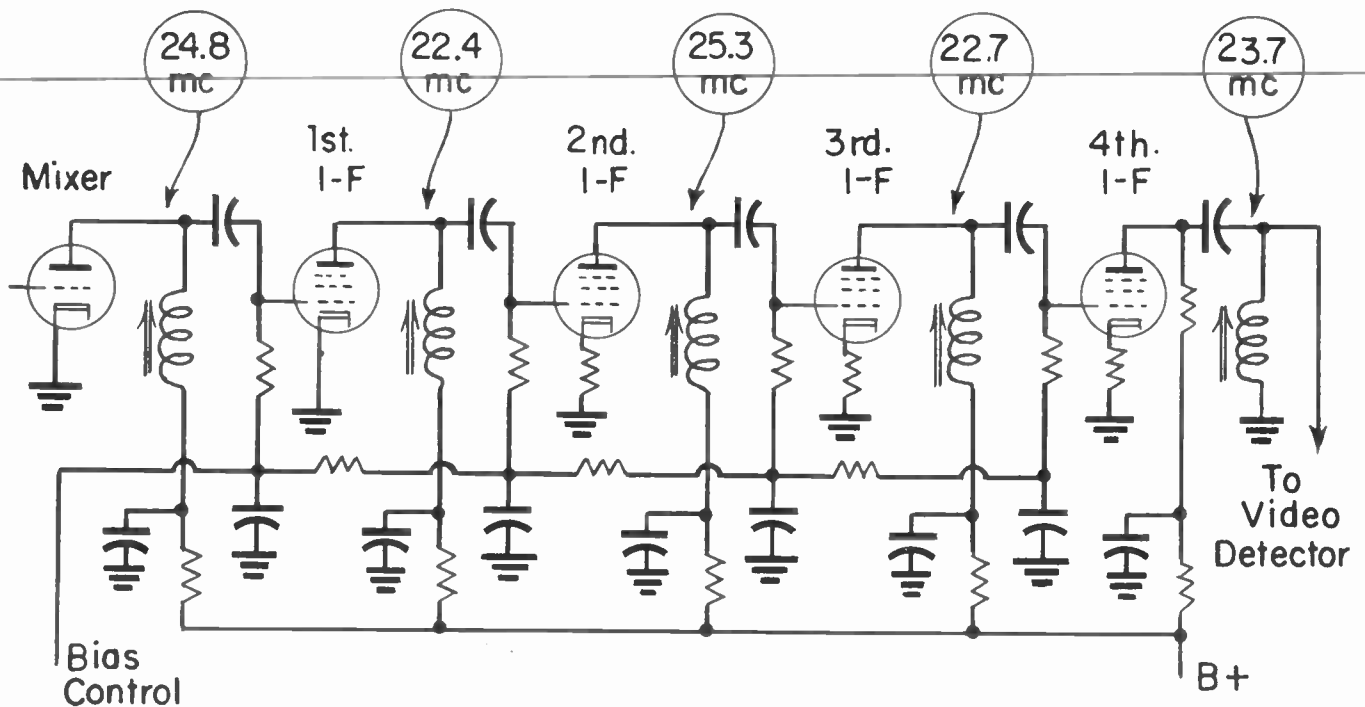

Fig. 7. An i-f section employing four amplifier tubes and five couplings tuned to different frequencies.

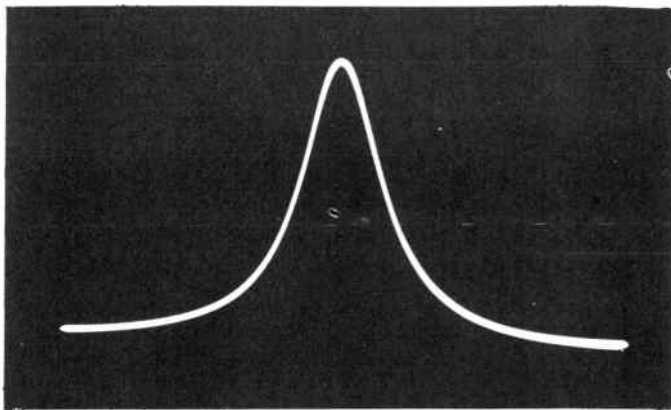

Fig. 8. Individual frequency responses in each stagger tuned stage are of this general form.

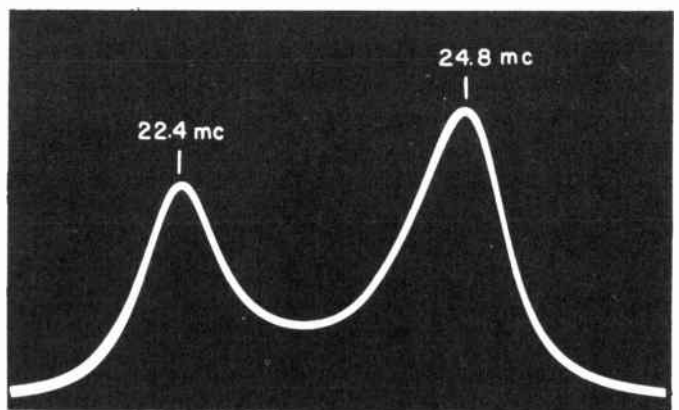

Fig. 9. Frequency response of two stages, with each of the peak frequencies plainly evident.

coupler is tuned. The last coupler, between the fourth i-f amplifier and the video detector, shows a response somewhat lower and wider (less selective) because of the additional loading effect of the diode detector.

When we keep the input voltage at the mixer grid and connect the oscilloscope to the grid of the second i-f amplifier the response appears as in Fig. 9. This trace shows the effect of the first two couplers. The peak toward the left is at 22.4 mc, the frequency to which is tuned the coupler be-

tween the first and second i-f amplifiers. The right-hand peak is at 24.8 mc, the tuned frequency of the first coupler.

Before proceeding to examine the responses with additional stages of amplification included we should understand just what is happening. Each stage is amplifying the voltages fed to it by the preceding stage. The voltages do not merely add together, they multiply. As an example, if one stage delivers a 2-volt signal at a certain frequency, and if the following stage has voltage ampli-

# LESSON 36 – TELEVISION IF AMPLIFIER

fication of 10 times at the same frequency, the output from the second stage at this particular frequency will be 10 times 2 volts, or will be 20 volts.

Actually the second stage will not be peaked at the same frequency as the first stage. Consequently, the peak voltage from the first stage will not be multiplied by the peak amplification of the second stage, because the two resonant peaks are not at the same frequency.

The response shown by Fig. 9 results from the following conditions. At the peak frequency of the second stage (22.4 mc) the voltage coming from the first stage is quite weak, because it is far from the resonant frequency of the first stage. This weak voltage from the first stage is amplified at the peak frequency of the second stage (22.4 mc) to produce the left-hand peak.

The high peak of resonant voltage from the first stage (Fig. 8) comes to the gain curve of the second stage at a frequency where the amplification of the second stage is quite small, because it is far from the resonant frequency of the second stage. Then the peak voltage from the first stage gets only small amplification in the second stage, and at this frequency the output from the second stage is little stronger than from the first stage.

By assuming voltages far higher than actually exist in an i-f section it is possible to give the following simple explanation of what takes place.

Frequency	1st Stage Output	2nd Stage Amplification	Overall Response
24.8 mc	10 volts	2 times	20 volts
22.4 mc	1½ volts	10 times	15 volts

The high peak output from the first stage receives small amplification in the second stage. The low off-resonance output from the first stage receives high amplification in the second stage. The overall result or response is just about as shown by Fig. 9 so far

as relative strengths of the two peaks are concerned.

Now we may bring in the effect of an additional stage by keeping the signal input at the mixer grid while moving the oscilloscope connection to the grid of the third i-f amplifier tube. The response now is as shown by Fig. 10. We have added the effect of the third coupler, tuned to peak at 25.3 mc. This is a frequency higher than that of either of the preceding couplers and it boosts the entire right-hand side of the curve, which is the high-frequency side. This leaves us with a high peak well up toward the highest frequencies.

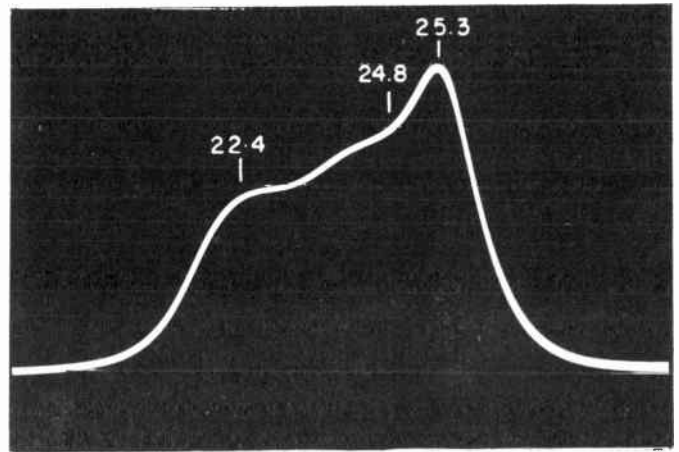

Fig. 10. The response of three stages working together. Separate peaks commence to disappear, although their effects still may be discerned.

The gain throughout the entire response of Fig. 10 is much greater than that of the entire response of Fig. 9. To keep the trace low enough to remain on the screen of the oscilloscope the amplification of the oscilloscope has been reduced. This makes the peaks on the left-hand side of the curve appear to have been reduced in voltage. This is not really true. These left-hand peaks represent even greater voltage than in Fig. 9, but the new peak at the right represents such a high voltage that the curve as a whole has been lowered to keep this peak in view. As we proceed to bring still more stages and more total amplification into the response the voltages will go still higher and the traces will have to be lowered by still further lessening the amplification in the oscilloscope, which is being used as a measuring



and indicating instrument. It is much the same as changing the range of a voltmeter when greater voltages are to be measured - in order to keep the meter pointer on the scale.

Our next step will be to bring in a fourth coupler by connecting the oscilloscope to the grid of the fourth i-f amplifier tube. The resulting change in the response is shown by Fig. 11. This fourth coupler is tuned to peak at 22.7 mc. As a result we now have the higher gain or the higher peak on the response near the low-frequency end. Although the right-hand (higher-frequency) peak now appears lower, this is due to the necessity of reducing amplification of the oscilloscope. Voltage represented by the right-hand peak is even greater than before, but the voltage of the left-hand peak is still greater.

In Fig. 11 there is a considerable difference between voltages of the two peaks

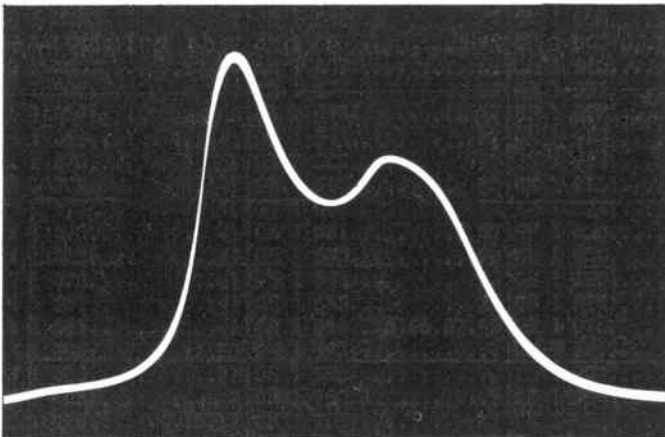

Fig. 11. The mixer and three amplifiers, together with four tuned couplings, are working together to produce this response.

in the response, and in between them the voltage dips to a value undesirably low. We can get rid of the greater portion of the dip or valley and at the same time make the two peaks more nearly equal by means of the fifth interstage coupler. This fifth coupler is tuned at 23.7 mc, a frequency just about midway between the video and sound intermediate frequencies. The result is shown by Fig. 12. Now the peak at the left is only slightly higher than the one at the right and the dip has been brought up until it is almost equal to the right-hand peak. Here we have the

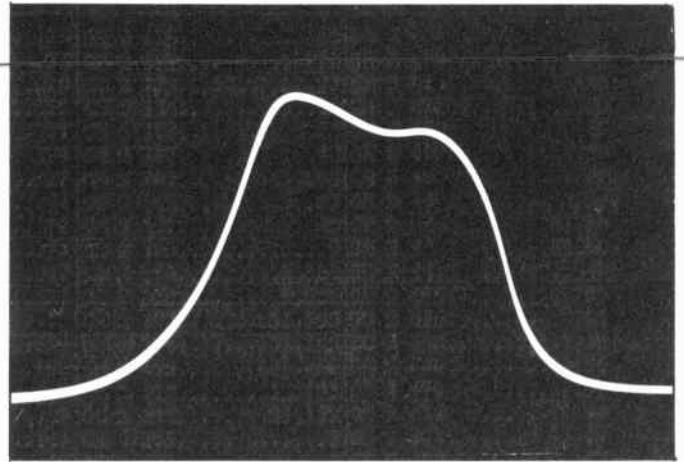

Fig. 12. The fourth coupler lessens the dip or valley while making the peaks more nearly of equal gain.

voltages or the range of the frequency response applied to the video detector. The form is generally similar to that of the response in Fig. 6.

For the i-f section whose performance has been examined we might represent the relations of coupling frequencies to the intermediate frequencies as at A in Fig. 13. All the frequencies are spaced at their relative positions along the scale extending from 20 to 27 megacycles.

As mentioned before, the i-f sections of many receivers have three amplifier tubes and four interstage couplers instead of the four tubes and five couplers which have been checked. The distribution of coupling frequencies in the i-f section of one such receiver is shown at B. The intermediates are 41.25 mc for sound and 45.75 mc for video signals. One coupling is tuned quite close to the sound intermediate. Another is tuned about midway between the intermediate frequencies. The remaining two are tuned up toward the video intermediate frequency, with one of them peaked exactly at this frequency.

At C is shown the coupling frequency distribution in one example of a method often called "staggered pairs". Two of the couplings are tuned to the same frequency somewhat above the sound intermediate. The other two are tuned to the same frequency somewhat below the video intermediate. The low and high coupling frequencies always al-

# LESSON 36 – TELEVISION IF AMPLIFIER

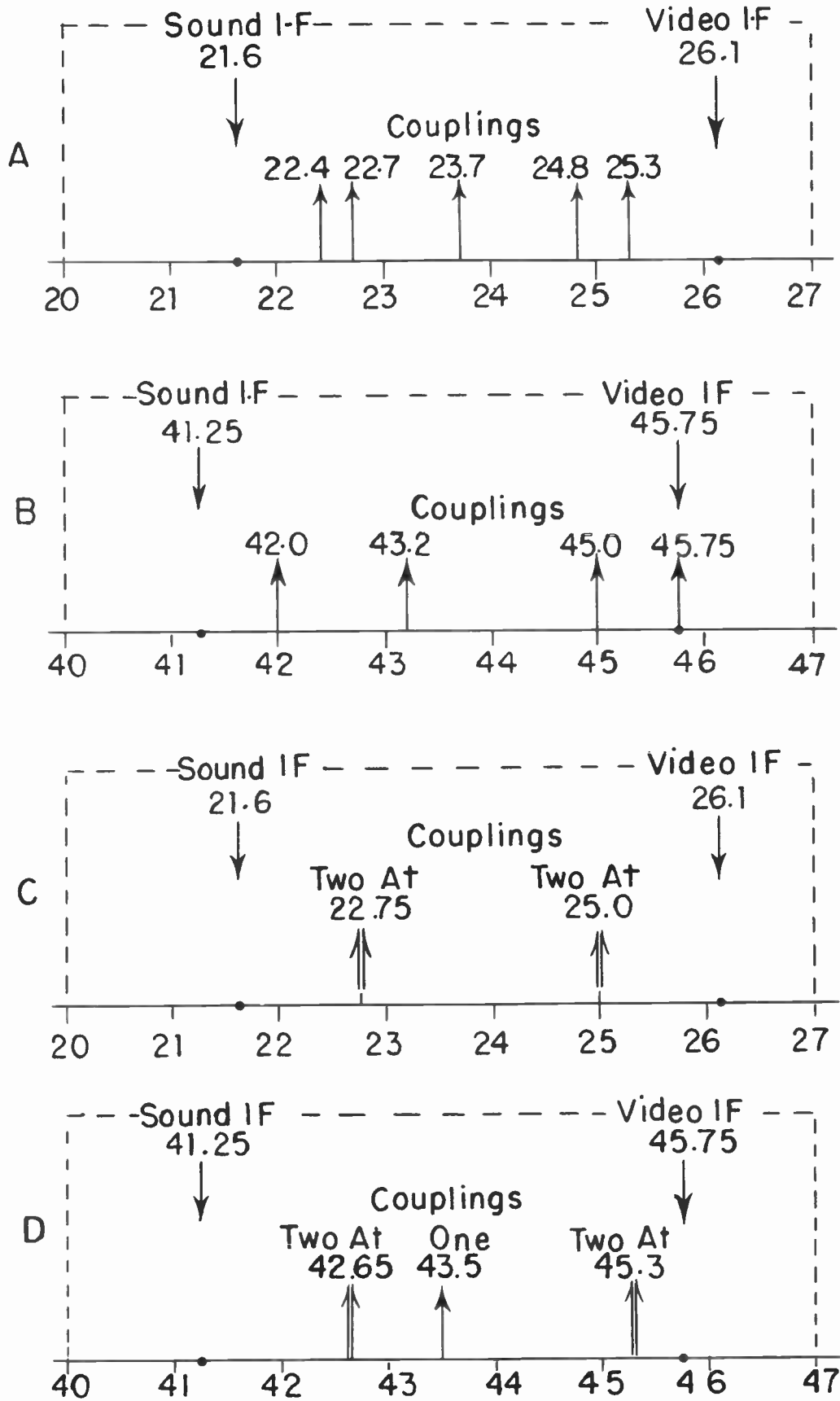

Fig. 13. Some relations of coupling peak frequencies to sound and video intermediate frequencies for staggered tuning in various receivers.

## COYNE - *television home training*

ternate. Those illustrated might be arranged in either of the following orders, from mixer to video detector.

1st Coupling	2nd Coupling	3rd Coupling	4th Coupling
22.75 mc	25.0 mc	22.75 mc	25.0 mc
25.0 mc	22.75 mc	25.0 mc	22.75 mc

Couplings tuned to the same frequency or to frequencies very nearly alike must be separated to avoid not only the possibility but almost certain feedback of energy in sufficient strength to cause regeneration and probable oscillation.

At D of Fig. 13 is shown one example of coupling frequency distribution in which there are two staggered pairs at 42.65 mc and 45.3 mc, with a single additional coupling tuned approximately midway between the intermediate frequencies, at 43.5 mc.

When a fifth coupling is used and is tuned about midway between the sound and video intermediates this coupling and its associated tube add amplification or gain to the entire response. In addition, the fifth coupling when so tuned raises the dip or valley between the lower and higher peaks, or may completely remove the valley and provide a practically flat top for the response. This we observed when bringing in a fifth coupler for the response shown by Fig. 12.

When using only four couplings tuned as staggered pairs it is quite easy to obtain satisfactory gain at the lower and upper ends of the intermediate frequency band, because two of the couplings are working together at each end. There is, however, a tendency to have a rather pronounced dip between the peaks, somewhat as shown at A in Fig. 14. This is because there is insufficient total amplification for the mid-frequencies. The amount of dip in this response, compared with the peak voltages, is slightly greater than usually specified as a maximum. Maximum permissible dip often is specified as 30 per cent of maximum peak voltage, or voltage at the bottom of the valley should be at least 70 per cent of the highest peak voltage.

The valley is reduced when the pairs of coupling frequencies are brought closer together, for a response such as shown at B. This narrows the range of frequencies at

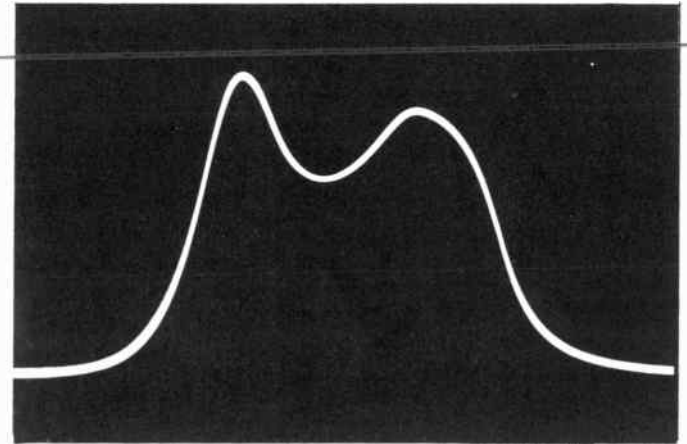

Fig. 14A

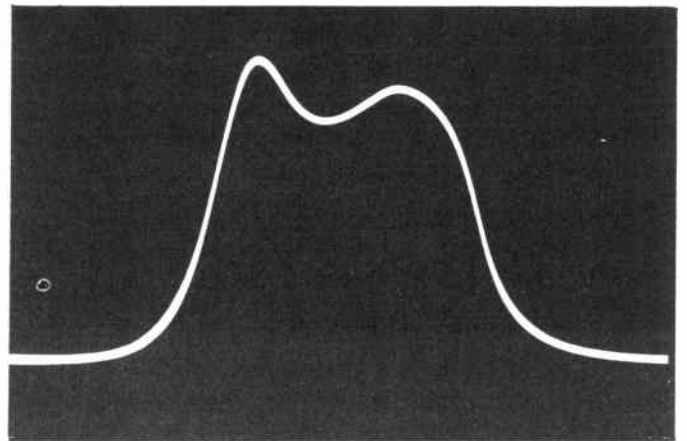

Fig. 14B.

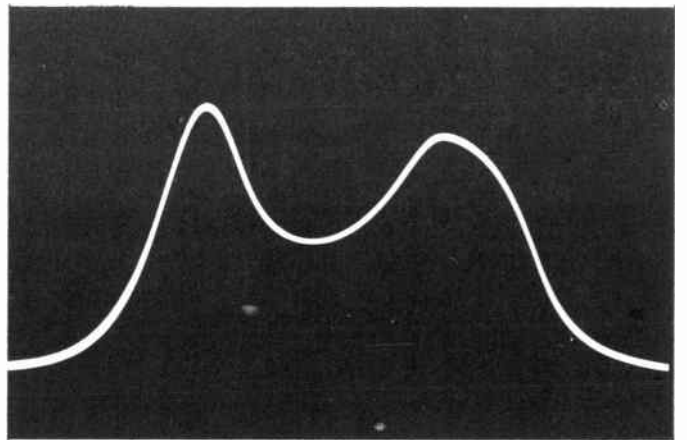

Fig. 14C.

Fig. 14. Examples of frequency responses obtained with staggered pairs.

which there is good gain. Inasmuch as the video intermediate frequency must remain close to 50 per cent of maximum gain, the narrowing must be done at the low-frequency

## LESSON 36 — TELEVISION IF AMPLIFIER

end of the response. When the response becomes too narrow, the higher video frequencies are not well amplified and pictures will lack sharp detail.

When we attempt to widen the frequency response, by extending it toward the low-frequency or sound intermediate side, the valley is likely to become excessively deep, as at C in Fig. 14. Here the voltage at the point of maximum dip is only about 50 per cent of that at the higher peak, and the middle range of video or picture frequencies will receive too little amplification.

The most important single requirement for any i-f response is that of maintaining the video intermediate frequency where it belongs. Theoretically this frequency should be at exactly half or at 50 per cent of maximum gain. In practice the video intermediate may be as low as 45 per cent. Very often it is at 55 to 60 per cent of maximum, and sometimes may be up to 70 per cent of maximum gain.

Part of the troubles resulting from wrong placement of the video intermediate on the response are due to the simultaneous displacement of the sound intermediate. For an example of what happens look first at trace A of Fig. 15. The positions of the video and sound intermediate frequencies are indicated by two markers. The video marker is approximately 50 per cent down on the high-frequency side of the response. The sound marker is far down on the low-frequency side, at a point where the gain is only enough to provide a low-voltage sound signal at the video detector.

The video and sound markers are separated in frequency by 4.5 mc. During actual reception the video and sound intermediate frequencies always will be separated by 4.5 mc, for reasons that have been explained previously. The markers on the oscilloscope trace merely show where the two intermediates will fall during reception.

At B the video intermediate frequency, indicated by a marker, has been brought very nearly to the highest peak of the response. The marker has moved toward the left, to a lower frequency. Since the separation between video and sound intermediates cannot

change, but must remain 4.5 mc, the sound marker has moved to the left through the same distance as the video marker. This brings the sound intermediate to a point of very little gain on the response, quite possibly to a point of practically zero gain.

There now will be greatly increased gain for video frequencies close to the video intermediate. These are the high video frequencies from which are reproduced the heavier lines and coarser details of pictures. These features will be over-emphasized in the reproduction. There will be strong synchronizing pulses, whose frequencies are close to the video intermediate. The response now extends to a lesser distance than before toward the low-frequency side, as measured from the video intermediate point. Therefore, the range of reproduced video frequencies will be restricted. Fine lines and sharp details will not be reproduced in the pictures.

If the sound system is of the intercarrier type the sound signals going from video detector to the sound section will be weak, and quite likely cannot be amplified to satisfactory volume. With a dual sound system the sound will disappear completely. This is because the sound i-f amplifier of a dual system is tuned to accept and amplify only a very narrow range of frequencies centering at the sound intermediate frequency. This particular trouble will be more easily understood after we have learned more about the peculiarities of television sound.

At C in Fig. 15 the video intermediate frequency, again indicated by a marker, has been moved far below the point of 50 per cent gain on the response. Accordingly, the sound intermediate frequency, indicated by the other marker, has moved proportionately high. Now our troubles will be of kinds opposite to those occurring with excessive gain at the video intermediate.

There is insufficient gain at video frequencies near the intermediate. The stronger lines and contrasts will disappear from reproduced pictures, there will be lack of "snap", everything will appear dull. Since the sync pulse frequencies are close to the video intermediate, these pulses will be weak and pictures will tend to drop out of



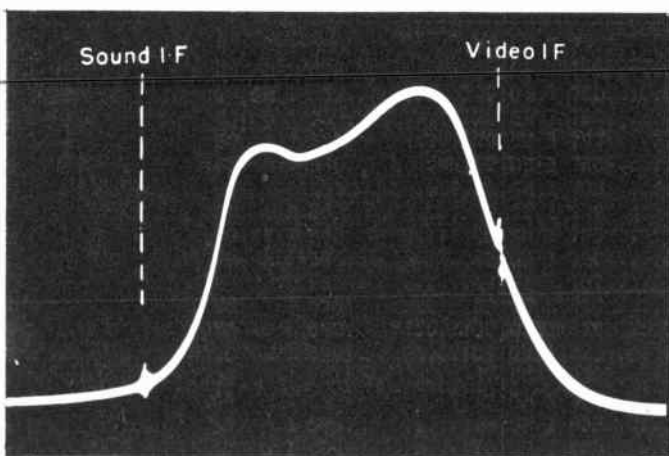

Fig. 15A

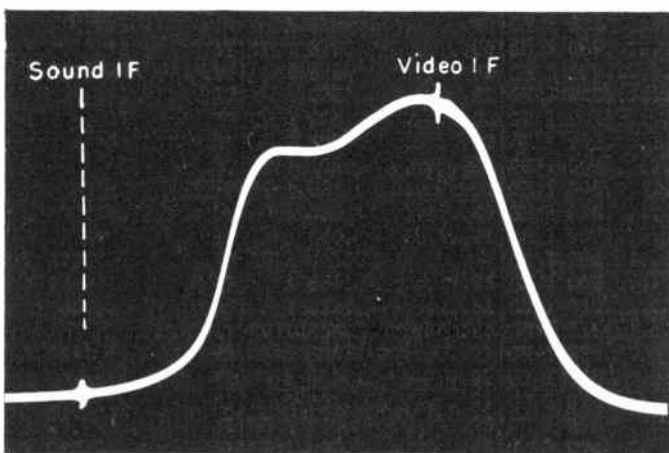

Fig. 15B

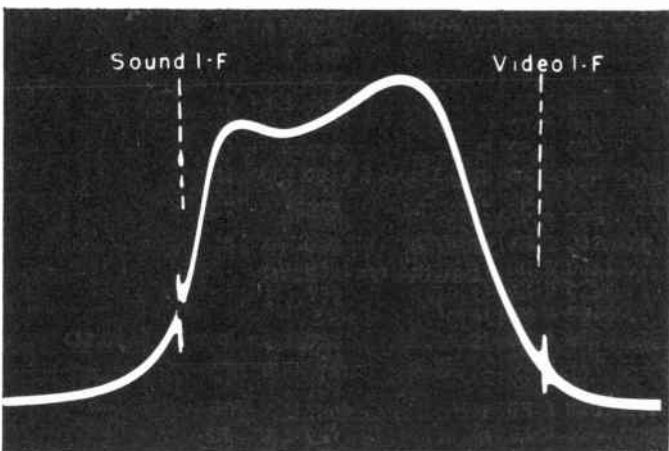

Fig. 15C

Fig. 15. When the video intermediate moves either direction on a frequency response, the sound intermediate must move the same direction and to the same extent.

synchronization both horizontally and vertically. It may be quite impossible to hold pictures stationary on the screen of the picture tube.

With the sound intermediate brought too high on the response there will be excessive gain or amplification for sound signals. With an intercarrier sound system the sound signals almost certainly will get through to the grid-cathode circuit of the picture tube and there they will produce horizontal sound bars on all pictures. With many receivers, especially the first ones which used the intercarrier system, there will be loud buzzing from the speaker. With a dual sound system the normal sound program will disappear, for again the sound intermediate will have been moved far from the point where it can be picked up for the sound i-f section.

I-F TUBES AND TUBE CIRCUITS. The i-f amplifier tubes almost always are miniature pentodes. The chief reason for using pentodes is that their internal capacitance between plate and grid is so small as to minimize the chance of energy feedback, which could cause regeneration and oscillation in the amplifiers. Pentodes have also the desirable property of high transconductance, which allows high voltage gains. There are triode voltage amplifiers having transconductances as high as any of the pentodes used for i-f amplifiers, but the triodes have relatively large plate-to-grid capacitances.

It has been mentioned before that interstage coupling inductors used at high frequencies seldom are tuned to resonance by means of capacitors, rather they are tuned by the sum of a number of circuit capacitances. Changes of resonant frequency then are made by varying the inductance, usually with a movable core.

What this means in television i-f amplifier circuits may be explained with the help of Fig. 16. At 1 are shown all the circuit elements used between the plate of one tube and the grid of a following tube. The tunable inductor is L, the following grid-return resistor is R<sub>g</sub>, and signal voltages pass through blocking capacitor C<sub>b</sub>. Capacitor C<sub>b</sub>, also

## LESSON 36 – TELEVISION IF AMPLIFIER

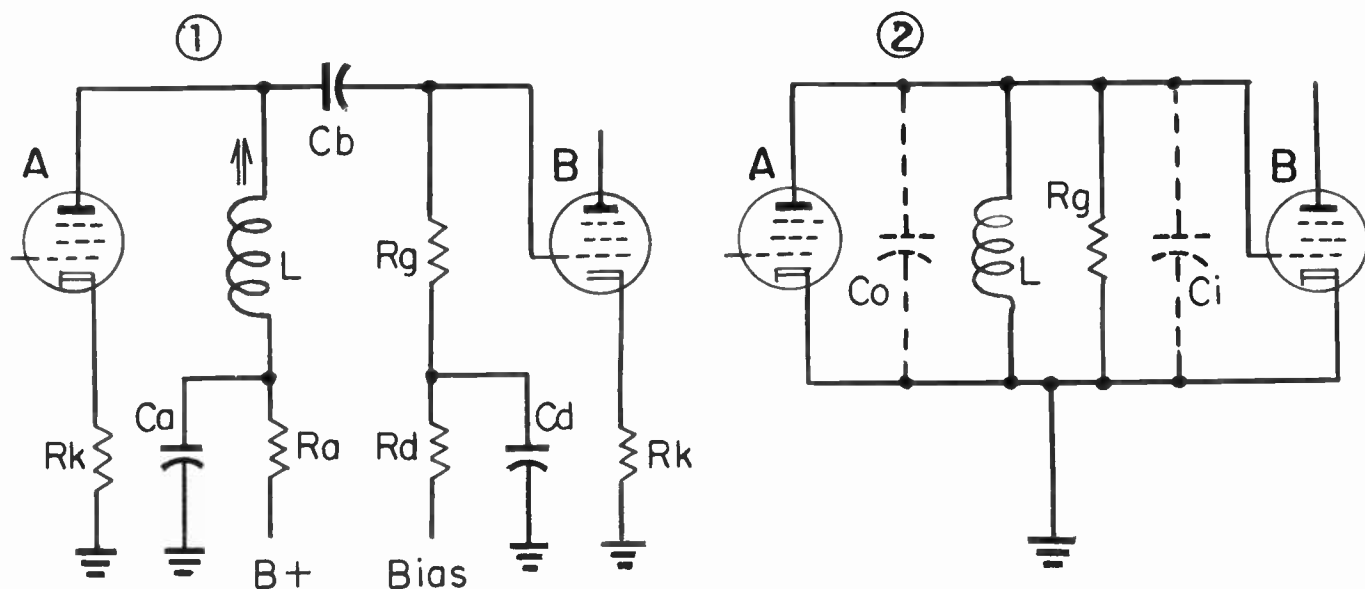

Fig. 16. The actual i-f coupling circuit and its equivalent for high frequencies.

the remaining circuit elements, are required because we must have paths for direct currents and voltages as well as for signal currents and voltages. So far as the signals are concerned, we could omit all these parts except L and Rg, as shown by diagram 2.

Let's see why all the other parts could be omitted. Cathode resistors Rk-Rk provide a minimum d-c bias for the grids. These resistances are of much less than 100 ohms, when used, and for signal voltages the cathodes could be connected directly to ground. Blocking capacitor Cb is of such small reactance at signal frequencies that we might as well have a direct connection, assuming that no direct voltage is to be blocked from the grid circuit.

Bypass capacitor Ca completes the plate circuit through ground to the first cathode for signal voltages and currents. Bypass capacitor Cd does the same thing for the following grid circuit. Both capacitors have very small reactance at signal frequencies, and for these frequencies the inductor and the grid resistor are effectively connected to ground and the cathodes. With plate and grid circuits completed to the cathodes for signal voltages and currents, voltage dropping resistor Ra and grid isolating resistor Rd need no longer be considered.

Now we have the "equivalent" signal circuit of diagram 2 in Fig. 16. Invisible to the eye, but of great importance electrically, are capacitances Co and Ci shown by broken-line symbols. These symbols represent internal capacitances of the tubes. Output capacitance of tube A is the sum of all the capacitances between the plate and other electrodes operating at the same signal potential as the cathode. Input capacitance of tube B is the sum of all the internal capacitances between the grid and all electrodes at the same signal potential as the cathode. Output capacitances of pentodes commonly used as i-f amplifiers range from about 2 mmf to 5 mmf, depending on the type of tube. Input capacitances of these tubes range from 4 to 7 mmf.

The output and input capacitances are effectively in parallel with each other, and they add together for a total of 6 to 12 mmf. There are stray capacitances in the plate and grid wiring, and between wiring or circuit parts and ground. There is a small distributed capacitance in the inductor. The total of all these capacitances, which are effectively across the tuning inductor, seldom can be less than 15 mmf, and often is much more. Capacitances to ground are lessened by keeping plate and grid leads, and blocking capacitors, away from chassis metal. When a tube is enclosed by a tight fitting metal

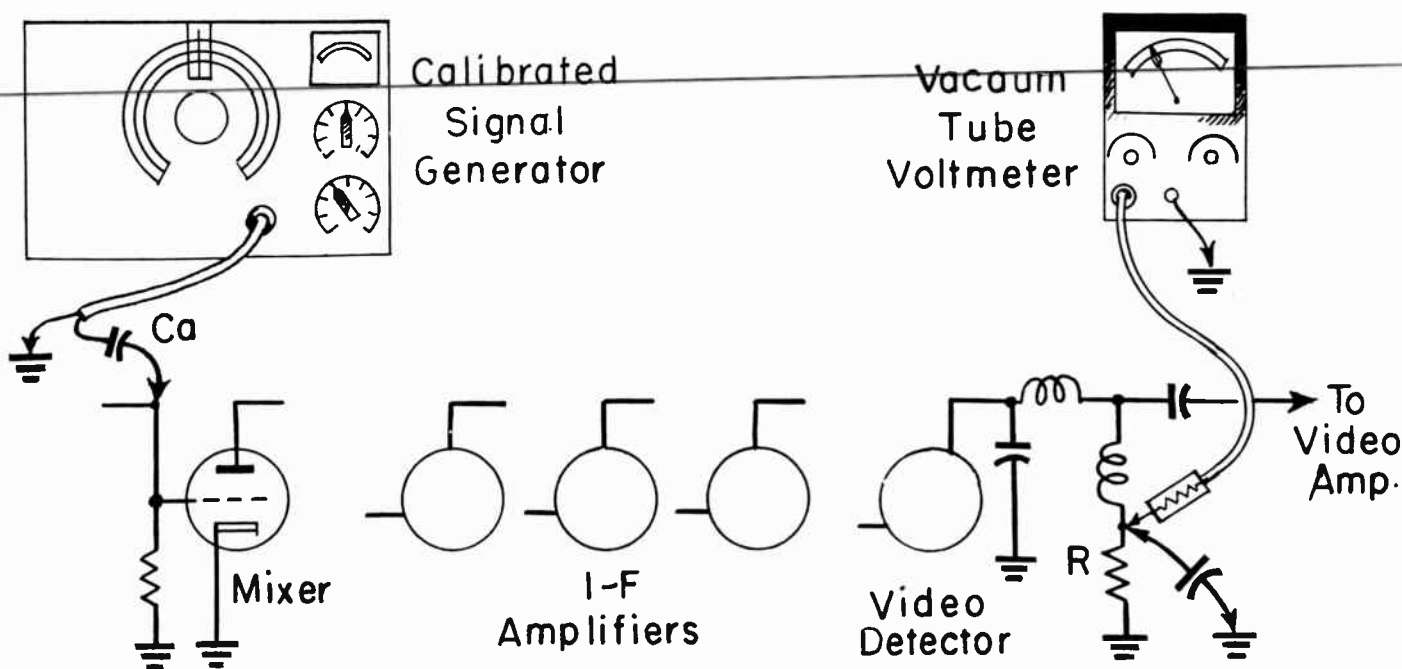

Fig. 17. Connections of signal generator and vacuum tube voltmeter for plotting a frequency response.

shield grounded, there is a small increase of input capacitance, but output capacitance may be doubled.

Grid resistor  $R_g$  is in parallel with the tuning inductor and the resonant circuit. It acts like any parallel resistance, reducing the maximum or peak gain while broadening the frequency response. Grid resistors may be of various values from about 3,000 to 10,000 ohms, depending on the make and model of receiver and on the stage in which used. They have important effects on individual stage responses and, consequently, on the overall response of the i-f section. Grid resistor values should not be altered unless you have accurate and reliable testing apparatus with which the results can be observed and measured.

Curves showing the frequency response of i-f sections may be plotted and drawn on ruled graph paper, without using an oscilloscope, by using the instrument setup of Fig. 17. The signal generator is a calibrated type, for it is necessary to maintain signal voltage of constant value to the receiver at all frequencies. The range should cover the intermediate frequencies on fundamentals. The generator is used unmodulated, with its r-f

output connected to the grid of the mixer tube through a fixed capacitor  $C_a$  of 10 to 20 mmf. The low side is connected to chassis ground or to B-minus.

Grid bias for some or all of the i-f amplifier tubes is determined by an automatic gain control whose basic principles are like those of automatic volume controls in sound receivers. Grid returns of all controlled tubes are connected to a control bus which, in Fig. 7, is marked Bias Control. The automatic gain control voltage must be overridden by a fixed bias voltage. A 3-volt bias should be satisfactory, as furnished by two dry cells in series with each other. The positive side of the dry-cell battery is connected to chassis ground or to B-minus, and the negative side to the control bus, just as a similar connection is made for overriding the automatic volume control voltage is a sound receiver.

Signal output from the i-f section of the receiver is measured by a vacuum tube voltmeter with its controls set for reading d-c voltages on the lowest voltage range. The VTVM probe is connected to the top of the video detector load resistor,  $R$ . This load resistance, associated with one or more small inductors, is in the circuits between the



## LESSON 36 – TELEVISION IF AMPLIFIER

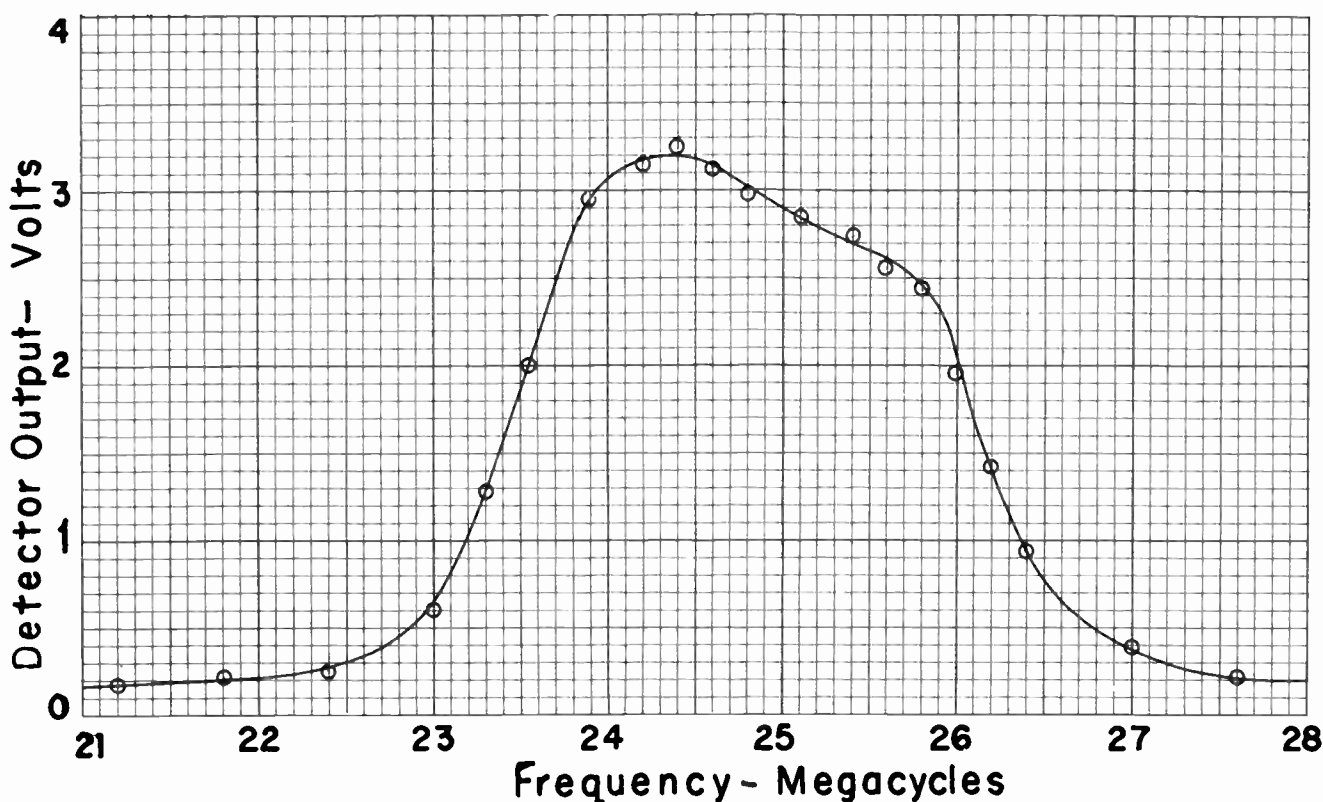

Fig. 18. A response plotted from voltage readings.

detector output and the grid of a video amplifier tube. From the top of the load resistor to ground should be connected also a fixed capacitor of not less than 1,000 mmf, to bypass any intermediate-frequency voltage which may reach the load resistor.

With the attenuator of the signal generator adjusted for a low output voltage the generator tuning control is varied through the full range of intermediate frequencies to be measured, while watching the VTVM readings. The attenuator of the generator is set so that the maximum VTVM reading will be no more than three to four volts when generator frequency is that giving the highest reading.

Now the signal generator is tuned by small steps throughout the entire range of intermediate frequencies. Generator output voltage must be kept constant, by varying the attenuation controls. The reading of the VTVM is noted at each frequency step. These readings are plotted on graph paper as shown, for one example, by the small circles of Fig. 18. Readings should be close together in fre-

quency where VTVM readings are undergoing small changes, and may be further apart in frequency where the readings appear to be changing at a fairly constant rate. The voltages thus plotted on the graph may be slightly irregular, due to small errors in measurement, but a smooth curve is drawn to pass through as many of the points as possible. This curve is the frequency response of the i-f section.

When pictures are weak, as in so-called "fringe areas" of reception, there are various ways of making them more acceptable. Sometimes the overall gain of the i-f section is increased by substituting amplifier tubes of greater transconductance. This may or may not require changes of socket wiring, depending on the connections of base pins to the internal elements of the new tubes. Complete realignment always will be necessary.

In other cases the plate and screen voltages on the original amplifier tubes are raised by changing some of the voltage dropping resistors. Maximum permissible element voltages and power dissipations must not be exceeded. Such alterations should not be



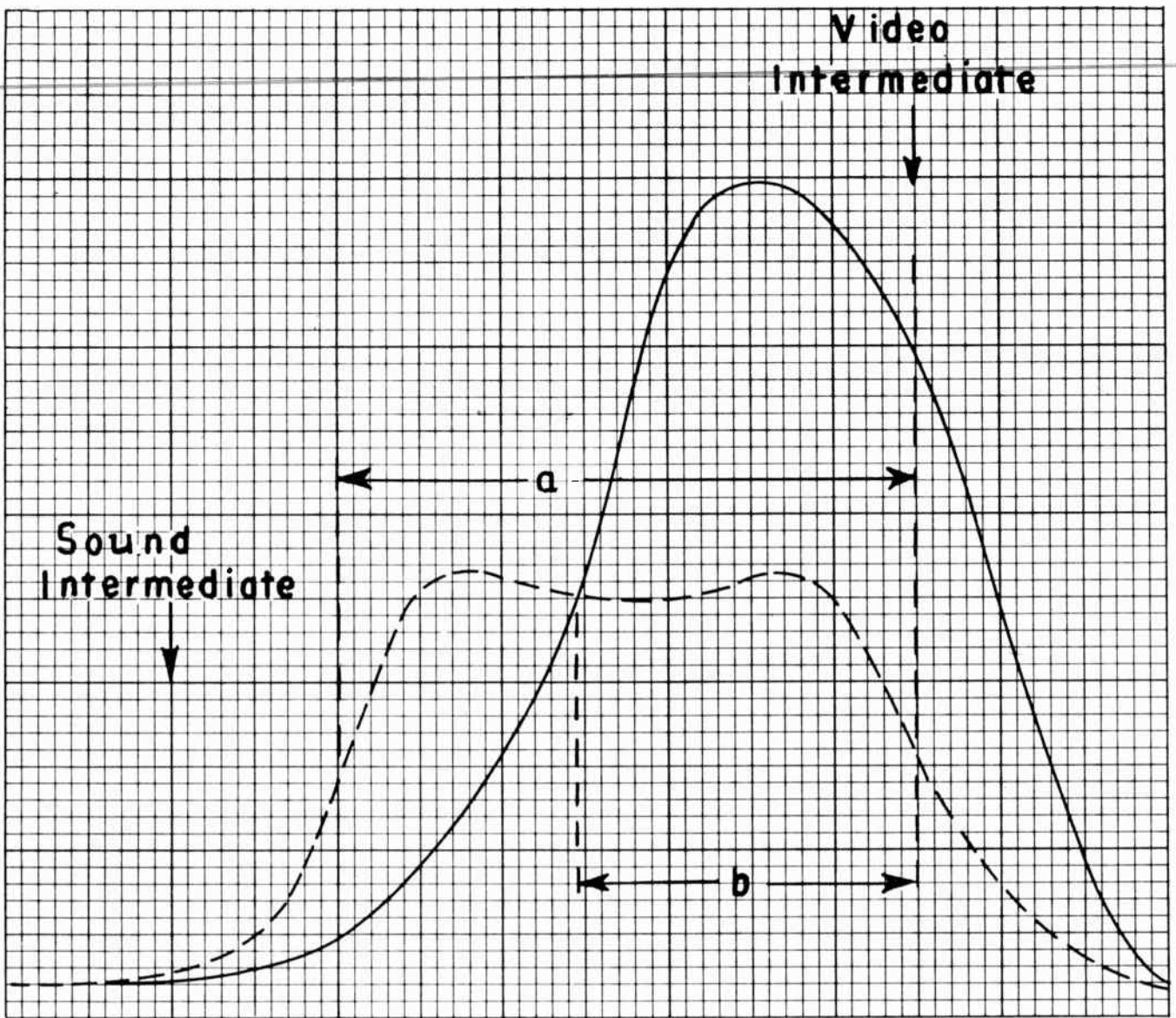

Fig. 19. When the gains for all staggered stages are concentrated within a limited range of frequencies the response allows fair reception with very weak signals.

undertaken until you have had experience in service operations.

A more common method of improving weak pictures consists of changing the alignment to give a frequency response of higher gain at and near the video intermediate frequency, with a sacrifice of gain toward the lower intermediate frequencies. As an example, the frequency response might originally be as shown by the broken-line curve of Fig. 19. The range of video frequencies here extends from the intermediate to a limit of about  $3\frac{1}{2}$  mc at the point of half-gain in the lower frequencies, as shown by arrow a. This response would allow pictures of excel-

lent quality where received signals are of fair or better strength.

For very weak received signals the response might be changed to a form such as shown by the full-line curve. Here there is practically a single peak, near the video intermediate frequency. The video intermediate is brought up to about 80 per cent of maximum gain instead of being near 50 per cent of maximum. As shown by arrow b, the video response now extends from the video intermediate only about 2 mc to the point of half-gain on the lower-frequency side of the curve. Pictures will lack fine detail, but the principal lines and shadings will be relatively

## LESSON 36 – TELEVISION IF AMPLIFIER

strong, and for fringe area reception the pictures will be greatly improved over those obtained with a more normal frequency response. Sync pulses will be strong enough to hold pictures horizontally and vertically on the screen. Sound will be weakened, but in most cases can be made loud enough by turning up the volume control.

After learning a little more about certain features of interstage couplings, and after examining the effects of various kinds of "traps", we will be ready to take up practical methods of aligning and realigning the i-f sections of television receivers. Then it will be possible to obtain the results which have been shown and explained.

# TELEVISION

◦ RADIO

◦ ELECTRONICS

---

**LESSON 37 – IF TRAPS AND VIDEO DETECTORS**

---

***Coyne School***

*practical home training*

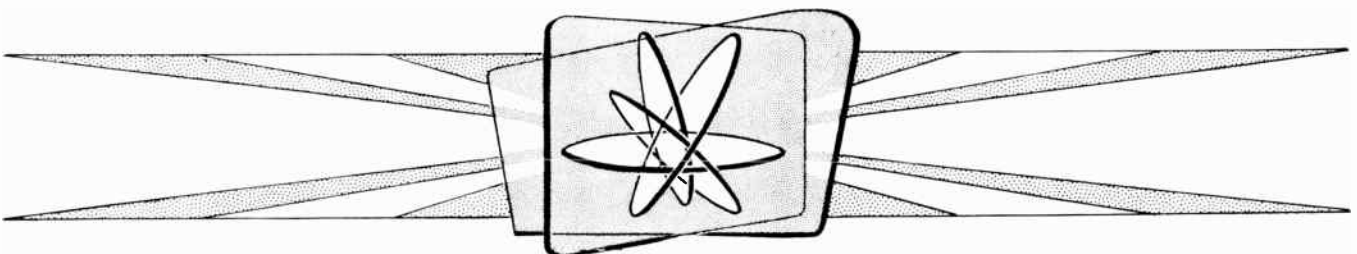

*Chicago, Illinois*

---

*Copyright, 1953 by Coyne Electrical School  
Chicago 12, Illinois  
All Rights reserved*

Litho. in U.S.A



## Lesson 37

### IF TRAPS AND VIDEO DETECTORS

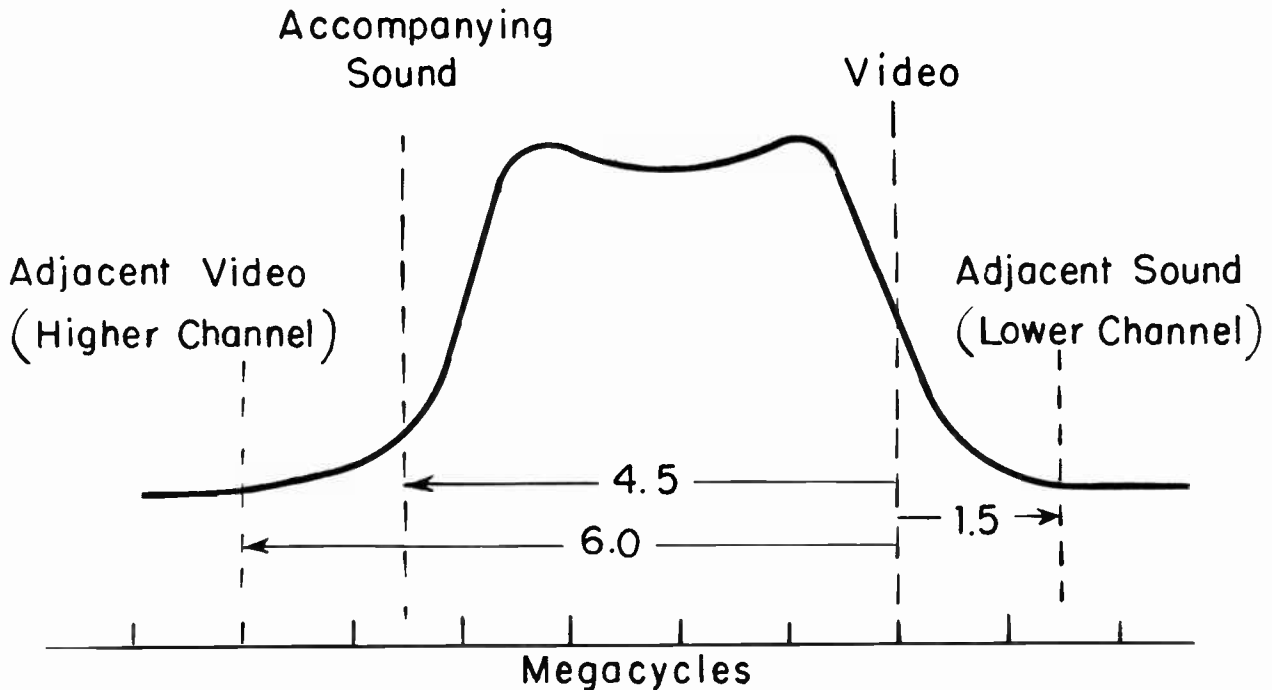

Fig. 1. Relations between the video intermediate frequency and frequencies to be attenuated.

When first studying frequency responses of i-f amplifier sections we learned that beat frequencies from video and sound carriers in adjacent channels should fall at points of zero gain. We learned also that the sound intermediate frequency for the selected channel should fall at a point of very low gain in receivers employing the intercarrier sound system, and should be kept out of the video i-f amplifier when using a dual sound system.

Fig. 1 shows the relations of these several frequencies to the video intermediate frequency. The sound signal for the selected channel may be called accompanying sound or associated sound. It always is 4.5 mc below the video intermediate. The adjacent sound signal from a lower channel is 1.5 mc higher in intermediate frequency than the video intermediate. The adjacent video signal from a higher channel is 6.0 mc below the video intermediate.

It is accompanying sound that ordinarily causes the greatest difficulty, as will become

evident from examination of Fig. 2. At A we have a fairly typical i-f response. One of the markers shows the position of the video intermediate on the high-frequency slope, at approximately 50 per cent of maximum gain. The other marker, on the low-frequency side, also is at a point of approximately 50 per cent gain. The range of video frequencies between the two markers is about 3.75 mc, which means that video or picture frequencies all the way up to 3.75 mc would receive at least 50 per cent of maximum amplification. This would allow reproduction of high quality pictures with plenty of detail.

Difficulty arises because, with such a response, the accompanying sound is almost certain to come up so high on the low-frequency side of the curve as to have too much gain, this being especially true when the response results from using three i-f amplifier tubes and four tuned couplings. The result will be sound bars in the pictures. One cure would be to reduce the width of the response. A more desirable remedy is to maintain the wide response for video signals while re-

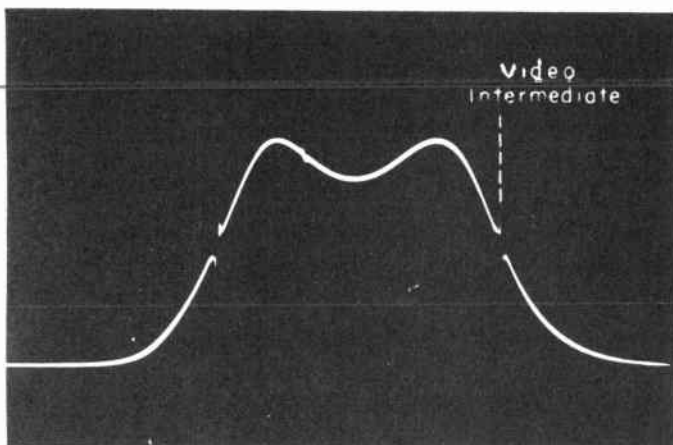

Fig. 2A

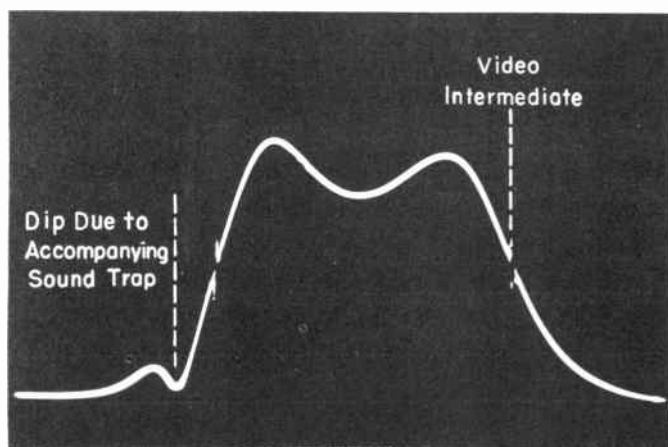

Fig. 2B

Fig. 2. How a trap attenuates the accompanying sound frequency.

ducing the gain for accompanying sound to a low value.

The more desirable remedy has been applied in producing the curve at B of Fig. 2. Now the response dips almost to zero at the sound intermediate frequency. The low-frequency slope of the response has been made much steeper than before, and at the point of half gain on this side the frequency is a full 4.0 mc from the video intermediate. This would allow good reproduction over nearly the full range of transmitted video frequencies, for high quality pictures.

The improvement in the frequency response is the result of adding a "trap" for accompanying sound on one of the i-f couplings. At A in Fig. 3 is a picture of one particular

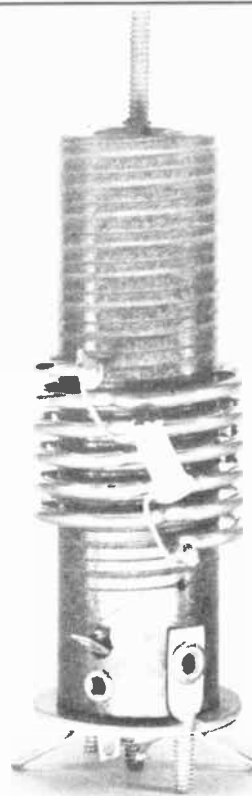

Fig. 3A

style of i-f coupler with which is combined a trap. At B the combination has been disassembled. The coupler, an ordinary impedance type with single winding and adjustable core, is shown at the left. On the base of the coupler fits the large cylinder at the center. Around the outside of the cylinder is a spaced winding of a few turns, across which is connected a fixed capacitor which is visible at A. This outer winding and the capacitor are tuned to resonance at the trapped frequency by means of the adjustable slug at the right. Normally this slug is supported by its threaded screw inside the trap winding.

Figs. 4 through 7 show a variety of trap circuits. All traps are resonant circuits made up of a coil and a capacitor which may be tuned to the trapped frequency. The connections provide either parallel or series resonance, depending on how the trap is to be used. Parallel resonant traps are used in either of two ways. First, the trap circuit

## LESSON 37 — IF TRAPS AND VIDEO DETECTORS

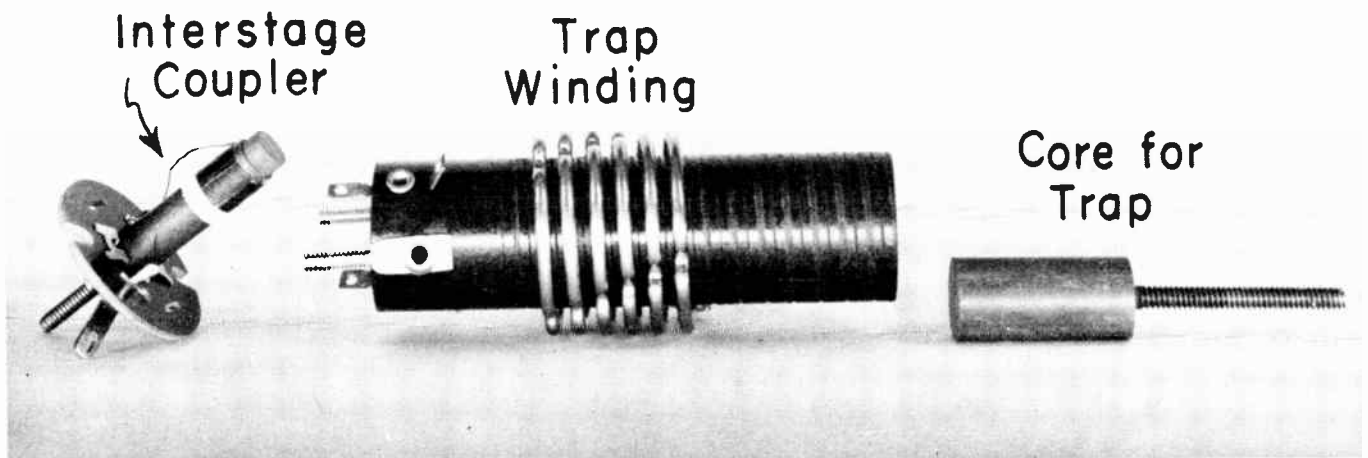

Fig. 3B

Fig. 3. A trap combined with an interstage coupling.

may absorb and dissipate signal energy at the trapped frequency. Second, it may provide very high impedance for signals at the trapped frequency. Series resonant traps ordinarily provide what amounts to a short circuit to ground for signals at the trapped frequency.

At 1 in Fig. 4 a series resonant trap is coupled to the tuning inductor in the grid circuit. The trap circuit sometimes is grounded, as shown by broken lines, or it may not be grounded. The trap and the coupling inductor are each tuned by their own adjustable slug. Traps sometimes are tuned by an adjustable capacitor, with the inductor a fixed type.

At 2 a series resonant trap is coupled to a tuning inductor in the plate circuit. In diagram 1 and 2 the tuning inductors are impedance types, with a single winding. At 3 the interstage coupling is a transformer with a bifilar winding which is tuned by a slug that affects both transformer windings. A series resonant trap circuit is coupled to the transformer.

All of the series resonant trap circuits of Fig. 4 act to absorb signal energy from the coupling element at the frequency for which the trap is tuned. This energy sets up circulating currents in the winding and capacitor of the trap, and high-frequency losses dissipate energy in these trap elements.

Series resonant traps shown by Fig. 5 are connected or coupled to the signal transfer circuits through small capacitors C<sub>c</sub> rather than through the inductive couplings employed for the circuits of Fig. 4. As a rule the coupling capacitors are of values between 2 and 10 mmf. Diagram 1 shows the coupling inductor on the grid side of the signal transfer circuit, while at 2 the coupling inductor is on the plate side. In both cases the trap is coupled to the grid circuit.

At 1 in Fig. 6 is shown a series resonant trap circuit consisting of adjustable inductor L and fixed capacitor C which are tuned for the frequency to be trapped out of the signal transfer circuit between the two tubes. At this frequency the series resonant trap circuit has minimum impedance, and carries signal energy to chassis ground. At all other frequencies the trap circuit has high impedance. Series resonant traps may be used anywhere in the i-f amplifier section. Two such traps, tuned to two different unwanted frequencies, may be connected to the same coupling circuit rather than being used in different stages.

At 2 in Fig. 6 the inductor of a series resonant trap is inductively coupled to a coil in series with the cathode of an amplifier tube. The low impedance of the trap, at its tuned frequency, absorbs energy from the cathode coil at this frequency from both the

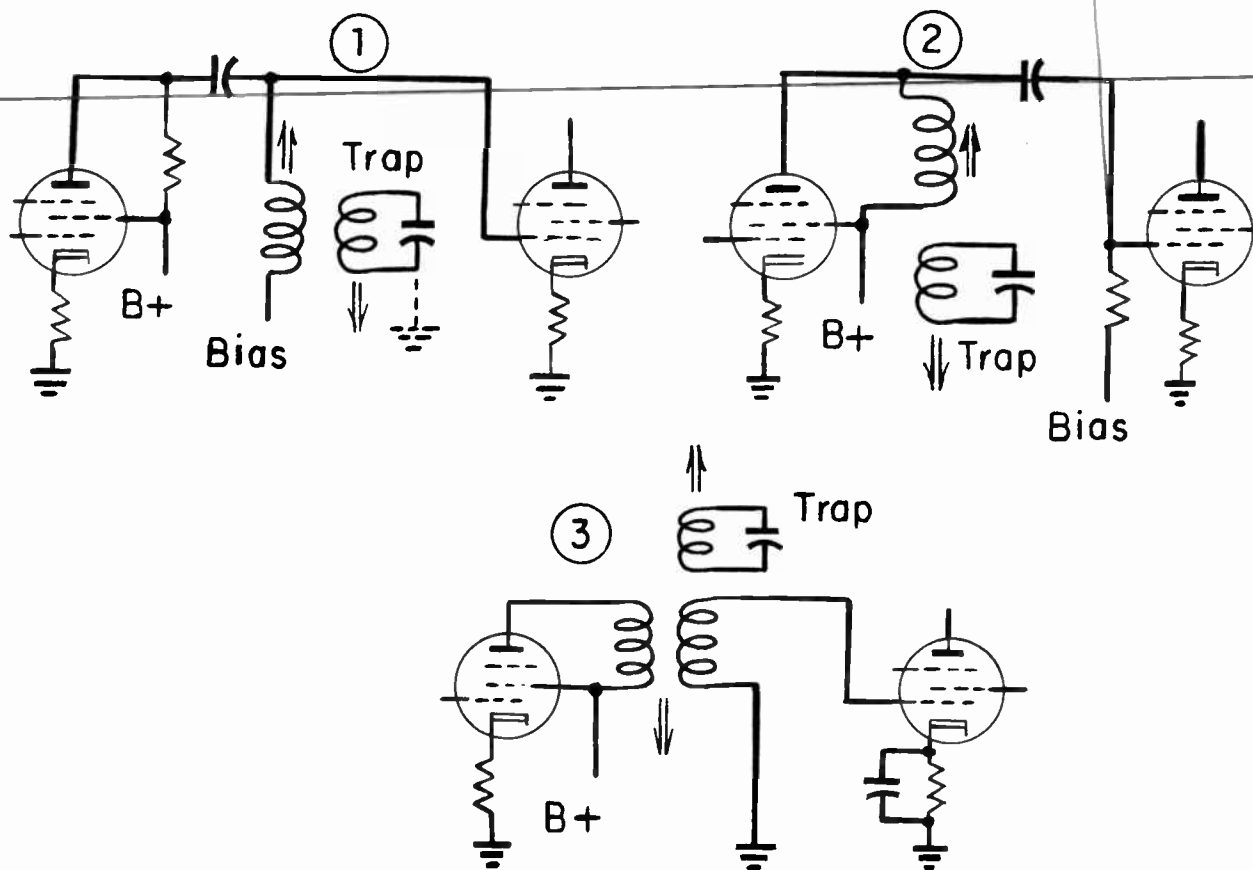

Fig. 4. Parallel resonant traps inductively coupled to interstage transformers and impedance couplers.

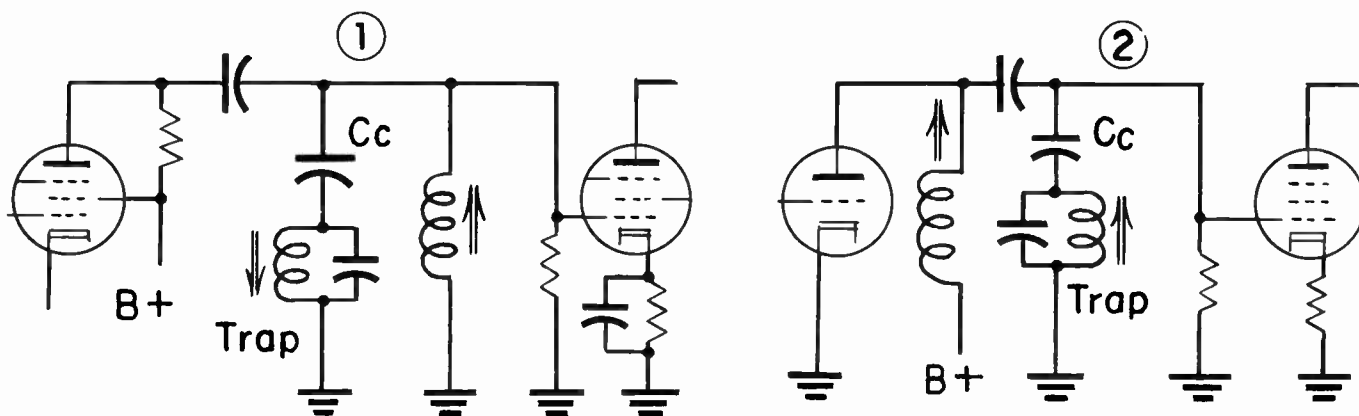

Fig. 5. Parallel resonant traps coupled through small capacitors.

grid circuit and plate circuit of the tube, since the cathode is a part of both these circuits.

Fig. 7 shows how a parallel resonant trap may be used in series with the signal transfer circuit to provide high impedance at the frequency to be rejected or highly attenuated. When a trap is used in this general manner

there usually will be two separate inductors  $L_a$  and  $L_b$  tuned for the frequency band to be passed through the i-f amplifier section. One of these inductors will be in the plate circuit and the other in the grid circuit. The combination forms one type of wide-band coupling which may be tuned at two slightly different frequencies for a double peaked response. Other modifications of coupling em-



## LESSON 37 – IF TRAPS AND VIDEO DETECTORS

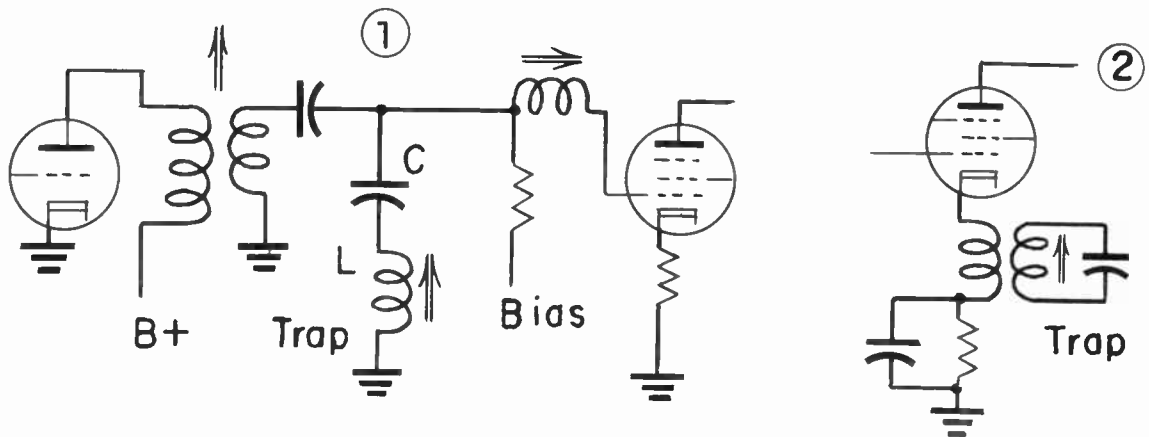

Fig. 6. A series resonant trap at 1 and a cathode trap at 2.

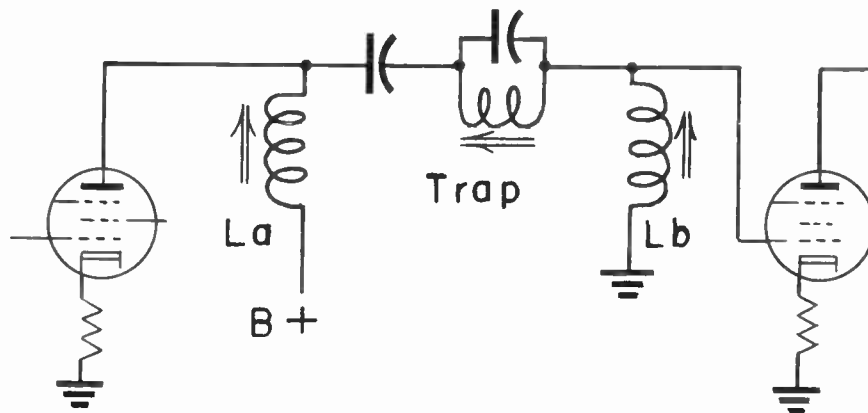

Fig. 7. The parallel resonant trap provides high impedance at its tuned frequency.

ployed with series traps of the parallel resonant type allow sufficient overcoupling to provide a double peaked response having a fairly wide frequency range.

Any of the trap circuits shown may be used for accompanying sound, for adjacent sound, or for adjacent video. The values of these three frequencies, in megacycles, will depend on the intermediate frequencies of the receiver in which the traps are used. This you can see by looking back at Fig. 1. Knowing the video intermediate frequency it is easy to determine any trapped frequency by subtracting or adding the appropriate numbers of megacycles as shown by that figure.

In the i-f sections of many receivers there are no traps of any kind, but in the majority of models there will be at least one trap for accompanying sound. When there are two traps it is common practice to tune one for accompanying sound and the other

for adjacent sound. As you can see from Fig. 1, aligning the high-frequency side of the curve to bring the video intermediate to the half-gain point is quite likely to extend the bottom of this slope far enough to have appreciable gain for adjacent sound, which then may be trapped out.

If the response is as low as it should be at the accompanying sound frequency it is most unlikely that there will be any measurable gain at the still lower intermediate frequency corresponding to adjacent video signals. Consequently, adjacent video traps are rarely used.

Many receivers have three traps on the i-f stages. Then there may be two for accompanying sound and one for adjacent sound, or else two for adjacent and one for accompanying sound. It would be most unusual to have a trap or traps for adjacent sound and none for accompanying sound, or, saying this the other way around, there always will be

one or more traps for accompanying sound when there are any traps at all, and there may or may not be traps for adjacent sound.

Trap circuits are of the high-Q variety in nearly every case, designed to have a resonant peak sharp enough to attenuate only a narrow band of frequencies centered at the one to be attenuated. As a general rule a trap is coupled or connected to an i-f coupler which is peaked at a frequency within about two megacycles of the trap frequency. This means that traps for accompanying sound usually are on couplers peaked toward the lower frequencies in the i-f pass band, while traps for adjacent sound will be on couplers which are peaked up toward the video intermediate frequency. There are exceptions to this rule in i-f sections having several traps.

The primary purpose of traps for accompanying and adjacent sound is to attenuate or to remove these frequencies from the response, and the traps should be tuned accordingly. A trap will alter the shape of the response at points near the trapped frequency, as we observed at B in Fig. 2, where the low-frequency side of the response has a much sharper cutoff than without an accompanying sound trap. Altering the shape of the response is not, however, the real purpose of traps. If you tune a trap to obtain some certain form of response curve instead of tuning for the unwanted frequency the trap will fail to do its work of keeping sound out of the pictures.

In a few receivers there are traps whose purpose is to shape the response rather than to attenuate one of the sound frequencies. Such traps have been used where tuning of the i-f couplings is such as might produce an undesirably high peak or high gain at some frequency within the i-f pass band. Such a peak is shown at A of Fig. 8. A broadly tuned trap, not a high-Q type, used in a stage peaked at a frequency quite a ways from the trap frequency, will change the response to the form shown at B.

There are receivers using a dual sound system in which the signals at the sound intermediate frequency are not taken off immediately after the mixer tube, but after having passed through one or more of the i-f

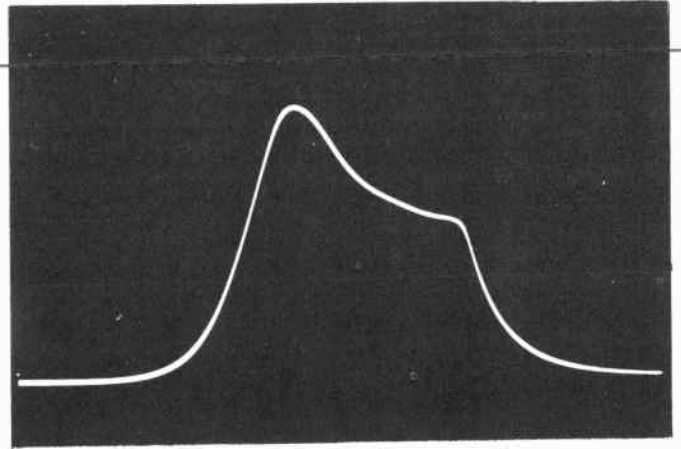

Fig. 8A

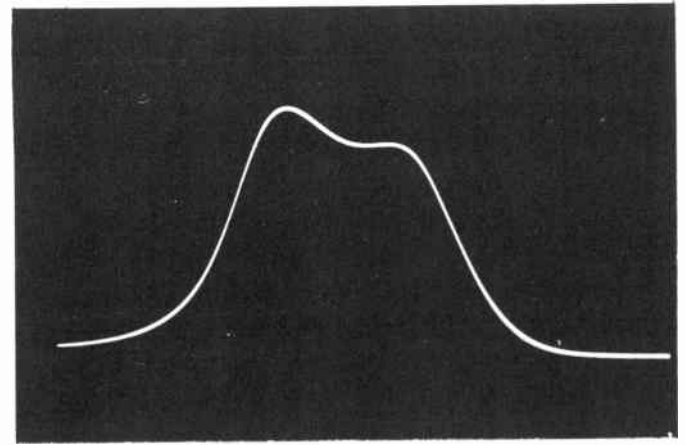

Fig. 8B

Fig. 8. The peak at A may be lowered as at B by means of a trap tuned to the peak frequency.

amplifier stages. In such receivers there will be no traps for accompanying sound in any of the i-f stages which carry both sound and video intermediate frequencies. Accompanying sound traps will be in any of the following stages.

Traps of one kind or another may be found in any i-f stages of receivers using the intercarrier sound system, and with dual sound the traps may be in any stages except those mentioned in the preceding paragraph. No traps are used in sound sections. The frequency response of sound sections is so narrow as to exclude video or picture frequencies without the need for traps.

I-F INTERSTAGE COUPLINGS. Either a single winding impedance coupler or a

## LESSON 37 — IF TRAPS AND VIDEO DETECTORS

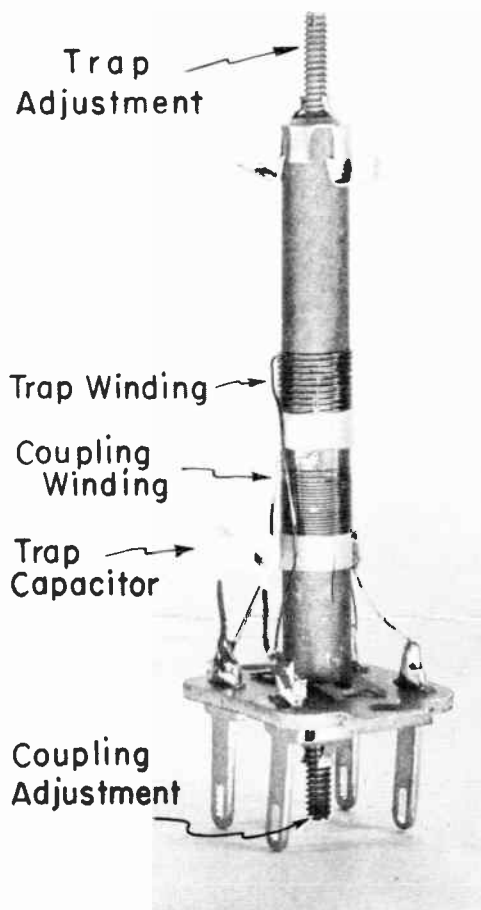

Fig. 9. Inductors for an interstage coupling and for a trap wound on the same supporting form.

double winding bifilar transformer ordinarily may be adjusted throughout a range of inductance having a ratio of about 3 to 1. For example, if the maximum inductance with the core centered in the winding is about 6 microhenrys, the minimum inductance with the core all the way out of the winding may be about 2 microhenrys. With fixed capacitance for tuning this allows frequency variation in a ratio between 1.5 and 1.7 to 1.

Were such a coupler designed for tuning at an intermediate frequency such as 22.5 mc it probably could be tuned to any frequency between 18 and 27 mc without any change of circuit capacitances, or could be tuned still lower or higher were the circuit capacitances altered accordingly. A coupling unit designed for this general range of frequencies could not, however, be returned to the i-f range between 40 and 47 mc. Neither

could a unit designed for the higher i-f range be returned to operate in the lower range.

Interstage couplings designed for use in certain receivers are made to suit the peak frequencies of the several stages of a particular receiver. They have enough range of adjustment to compensate for such changes of circuit capacitances as occur when replacing tubes, and sometimes for the change of input or output capacitance when substituting other types of tubes. But in general the coupling units are not directly interchangeable between stages which are to peak at different frequencies which are widely separated. Were a certain coupling unit designed for tuning near the low-frequency end of the i-f pass band there would be difficulty in using it for a frequency near the high end of the band, and tuning might be impossible.

Bifilar transformers are being used to an increasing extent in receivers of recent design. These are the transformers having plate and grid windings with turns side by side for their entire length, both starting together at one end of the supporting form and both ending together at the other end. There is a single adjustable core which changes the resonant frequency but does not alter the degree of coupling to an appreciable extent. In most of these transformers both windings have practically the same inductance and distributed capacitance, and both tune to the same frequency when circuit capacitances associated with each circuit are about equal.

No blocking capacitor is needed between plate and grid circuits when using a bifilar transformer, since the two windings are insulated from each other. Because the two windings are so close together throughout their length there is rather large capacitance between them, just as there is capacitance between any two conductors separated by insulation acting as the dielectric.

When the grid return of the second amplifier tube is through one of the windings of the bifilar transformer there is much less d-c resistance in the grid circuit than when the return is through a resistor on the grid. This small resistance, in connection with grid circuit capacitances, keeps the time constant of this combination so short that

# COYNE - television home training

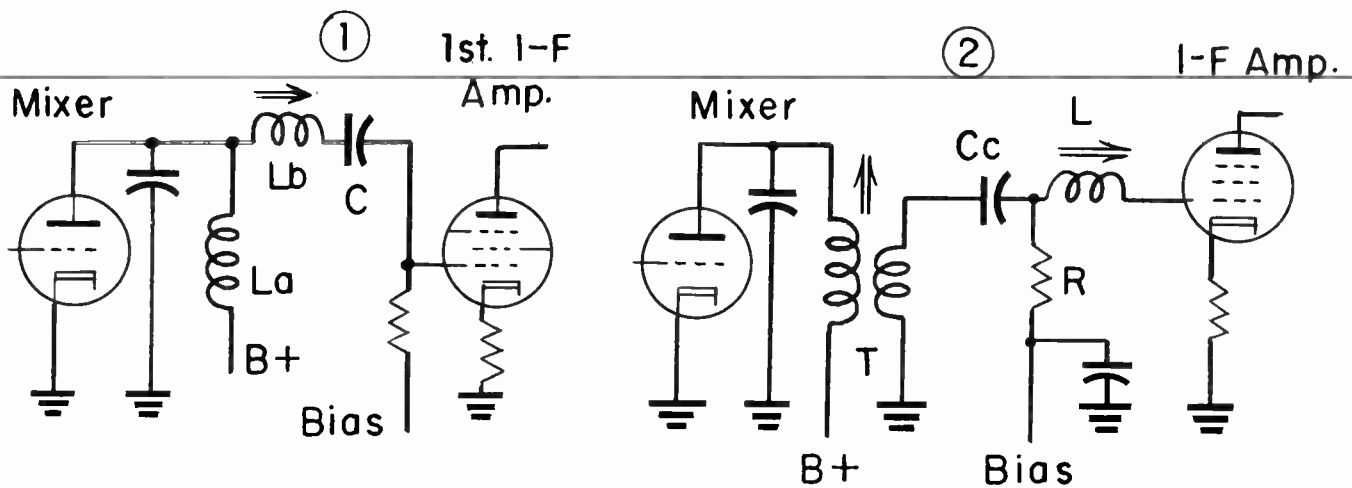

Fig. 10. Tuned couplings between mixer tubes and first i-f amplifier tubes.

voltage pulses due to electrical "noise" have little tendency to momentarily vary the grid bias. In a grid circuit having a resistor for the return, bias might be varied by momentarily charging of the circuit capacitance, with the charge held for an instant by resistance of the grid return path.

Some interstage couplings consist of circuits which cannot be classified as either impedance or transformer types of any simple form. Such, for example, is the coupling at 1 of Fig. 10. At  $L_a$  is an untuned inductor having high impedance at all frequencies within the i-f pass band. Tunable inductor  $L_b$  and fixed capacitor  $C$  form a series resonant circuit which is adjusted for a peak response near the high-frequency end of the pass band, but which has response at moderate gains for all the desired intermediate frequencies. The series resonant circuit has high impedance at the carrier frequencies, r-f oscillator frequencies, and sum frequencies which are in the output of the mixer, and thus prevents these frequencies from reaching the first i-f amplifier tube.

In diagram 2 there is a tuned transformer  $T$  in the plate circuit of the mixer. The secondary of this transformer furnishes signal voltages to the grid of the i-f amplifier through capacitor  $C_c$ . The grid circuit is tuned by adjustable inductor  $L$ , which is adjusted to peak at the same frequency as transformer  $T$ . Coupling between the mixer plate (secondary of transformer  $T$ ) and the grid of the i-f amplifier is determined by the

value of resistance at  $R$ . This resistance is common to both the plate circuit and the grid circuit.

Some i-f couplings consist of a two-winding transformer with one winding in the plate circuit, the other in the following grid circuit, and with each winding individually tuned by its own adjustable core. We examined the performance of such transformers in another lesson, and found that their frequency response may have a single fairly broad peak or may have two peaks slightly separated in frequency. With separate tuning for the windings, one may be resonated with the output capacitance of one tube while the other is resonated with the input capacitance of the following tube.

Earlier we learned that an overcoupled transformer has a frequency response with a broad top or with two peaks whose separation increases with the degree of coupling, but that sufficient overcoupling cannot be obtained with ordinary transformers having only inductive coupling between primary and secondary. Overcoupling which is to be effective at high frequencies requires some kind of impedance which is in both the plate circuit and the grid circuit or which is common to both circuits.

Two methods of obtaining overcoupling and broad frequency response are illustrated by Fig. 11. At 1 the common impedance is inductor  $L_a$ , which is in the plate circuit and also in the grid circuit for signal voltages



## LESSON 37 – IF TRAPS AND VIDEO DETECTORS

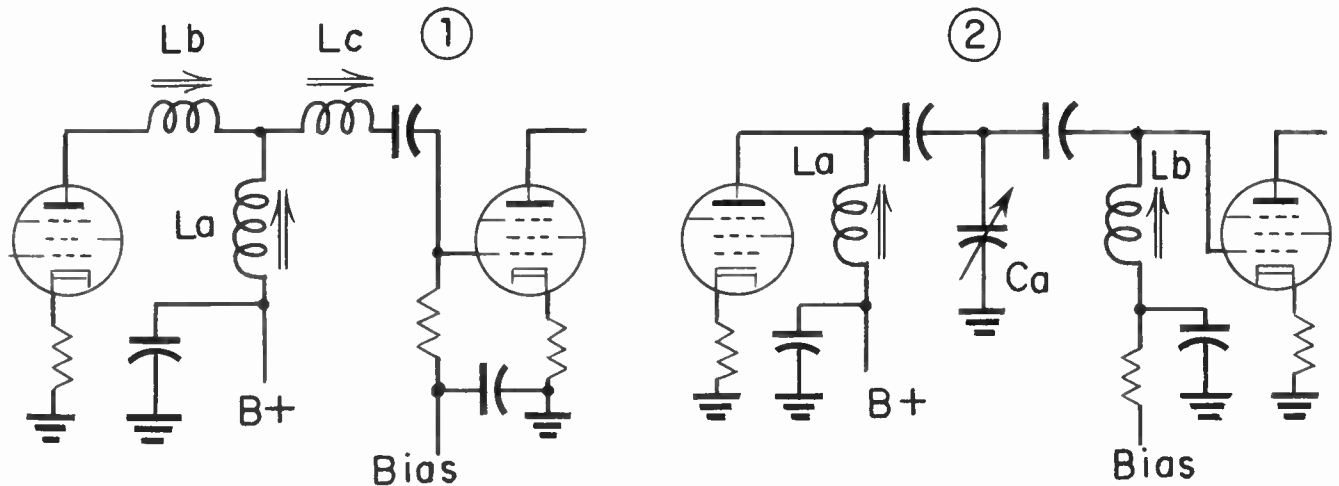

Fig. 11. Overcoupling for a wide-peaked response obtained by means of reactances common to both the plate circuit and the grid circuit.

and currents. Inductors  $L_b$  and  $L_c$  are tuned for the band of frequencies to be amplified, while inductance of  $L_a$  is adjusted for the desired separation of the resonant peaks and for consequent width of the pass band.

In diagram 2 the common impedance consists of adjustable capacitor  $C_a$ , which is varied to obtain the desired peak separation and pass band. Inductor  $L_a$  in the plate circuit and inductor  $L_b$  in the grid circuit are tuned for the band of frequencies to be amplified. The capacitors in the direct line from plate to grid are for blocking and for transfer of signal voltages and currents through the coupling system.

The closer the coupling or the greater the common impedance of any overcoupled transformer the wider will be the pass band and the greater will be separation between resonant peaks, but the deeper will become the valley between peaks. To prevent excessive dip in the valley, the same i-f section may contain one or more impedance couplers or bifilar transformers peaked at frequencies which will raise the response where the overcoupled unit alone would leave it too low.

Overcoupled transformers, by themselves, tend to have long outward sweeps of the frequency response where it comes down toward zero gain. These sweeps ordinarily would extend through the frequencies of accompanying sound and of adjacent video. The difficulty may be overcome by using two or

more similarly tuned overcoupled units in cascade, in successive stages. This allows maintaining the wide top of the response while narrowing the skirts. It is possible also to use traps for the frequencies which are to be attenuated or removed from the response.

**VIDEO DETECTORS.** The amplitude-modulated video intermediate frequencies which have been amplified in the i-f section go to the video detector, where they are rectified or demodulated. This detector might be of any kind which could be used for amplitude-modulated standard broadcast signals, but for the same reasons which make it the nearly universal choice for sound receivers, the television video detector is a diode type in all but a few cases. The diode, as you may recall, causes minimum distortion and is capable of handling signals of widely varying strengths.

When the video detector is a diode tube it usually is one section of a twin diode, employed as a half-wave detector. The other section may be used for various purposes, often in the automatic gain control system, or for some function in the sync section. Sometimes the second section is not used at all, its elements are grounded.

There is a considerable reduction of signal strength in any diode detector. The "detection efficiency" of a half-wave diode detector of the tube type is about 35 per cent,

# COYNE - television home training

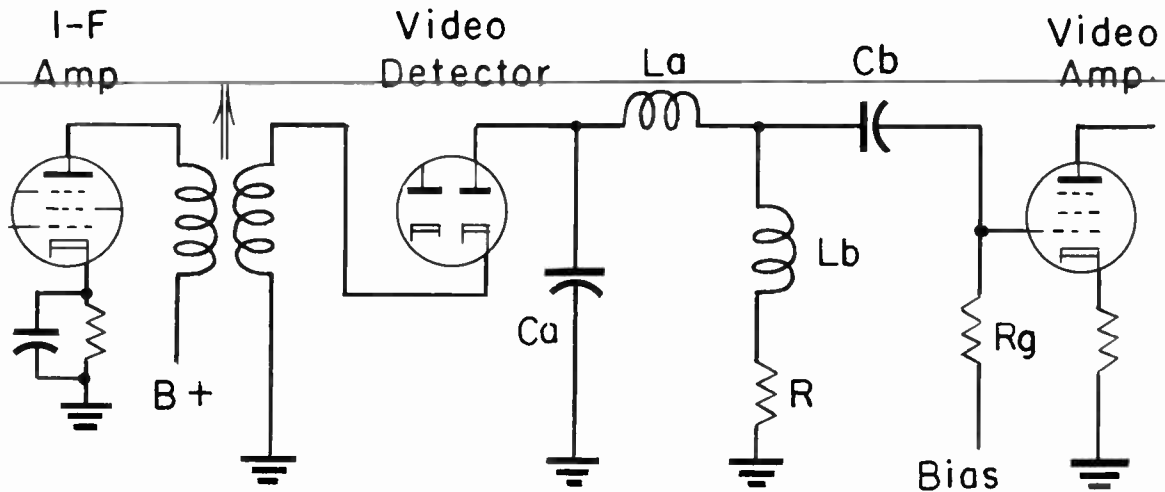

Fig. 12. A video detector output coupling having compensating inductors which permit a wide frequency response.

the meaning of which may be illustrated by an example. Assume that the i-f signal coming to the detector has a peak to peak value of 3 volts from the positive tips to the negative tips of the sync pulses on the top and bottom of the modulated wave. In the demodulated output of the detector the peak-to-peak voltage will be about 35 per cent of 3 volts, or will be in the neighborhood of 1 volt. This will be the voltage or the potential difference between the tips of the sync pulses and the white level.

In the demodulated signal going from video detector to video amplifier will be all the sync pulse frequencies in addition at all the picture frequencies. Vertical sync frequency is 60 cycles per second, while picture frequencies go as high as 4,000,000 cycles or 4 megacycles per second. This is a tremendously great ratio of low to high frequencies, and highly specialized design is needed in the coupling between detector and video amplifier in order that the entire range may be passed through with reasonable uniformity.

There is no such thing as a standardized coupling for the video detector output, but what probably is the closest approach is the circuit of Fig. 12. At least, this circuit has been used more commonly than others, and it illustrates most of the principles which are of importance in the many modifications.

The coupling between the final i-f ampli-

fier and the video detector is shown as a bifilar transformer, although it might be any other type of transformer or might be a single-winding impedance coupler. The secondary of this coupling transformer connects to the cathode of the detector diode and to chassis ground. The rectified output of the detector is taken from the diode plate. The essential features of the detector circuit would not be changed by applying the i-f signal to the diode plate and taking the detector output from the cathode. Then we would be rectifying the opposite polarity of the modulated i-f signals.

Capacitor Ca is a bypass for the intermediate frequencies coming through the detector, so that these frequencies will be kept from the following video amplifier. Capacitance at this point usually is about 10 mmf when intermediate frequencies are in the 20-30 mc range, and about 5 mmf for intermediates in the 40-50 mc range. In any case the capacitive reactance is relatively low for the intermediate frequencies, but is high for the video and sync frequencies of modulation. These lower video frequencies thus are forced to continue on toward the video amplifier.

Inductor La has high inductive reactance for the intermediate frequencies coming through the detector, but has comparatively small reactance for the lower frequencies of the video signals. The result is to strongly oppose the intermediate frequencies, and

## LESSON 37 – IF TRAPS AND VIDEO DETECTORS

force them to ground through Ca, while passing the video frequencies on toward the video amplifier with relative freedom. The value of La may be between 50 and 200 microhenrys, with the lower values used where intermediate frequencies are in the high range, 40-50 mc, and higher values of inductance where intermediates are in the low range, 20-30 mc. It is the inductive reactance that is important, and the reactance depends on frequencies as well as on inductance.

Blocking capacitor Cb is of large capacitance and correspondingly small capacitive reactance, in order to pass the lower video frequencies, without too much opposition. Values commonly are between 0.05 and 0.10 mf, but may be greater or smaller. Resistor Rg provides a d-c grid return path for biasing the video amplifier.

The load circuit of the video detector, across which the video signal voltages appear, consists of inductor Lb and resistor R in series with each other. The impedance of this combination is in the output circuit of the detector and also in the grid circuit of the video amplifier, just as a coupling resistor is in the plate and grid circuits of successive amplifier tubes for other applications.

Inductor Lb increases its inductive reactance with rising frequency of video signals, thus tending to provide greater reactance and greater gain at the higher frequencies. This is necessary because, not visible as such, there are capacitances in parallel with the load impedance. These capacitances are the input capacitance of the video amplifier, capacitance to ground of the video detector, and the usual stray and distributed capacitances with which we always have to contend in high-frequency circuits. The reactances of these various parallel or shunt capacitances decrease with rising video frequencies. This lessens the effective load impedance and tends to decrease the gain. The increasing reactance of Lb is intended to compensate for the decreasing capacitive reactances, and thus to maintain fairly uniform gain throughout the whole range of video frequencies.

To assist in having fairly uniform gain the detector load resistance at R has to be

quite small. Values commonly are between 2700 and 8200 ohms, with an average of about 4000 ohms. Using a small load resistance maintains reasonably uniform gain throughout a wide range of frequencies for reasons which were investigated when studying the performance of resistance coupled amplifiers. The coupling between video detector and video amplifier actually is a resistance coupling, with such additions as are necessary due to the great range of frequencies to be handled.

The video detector, like any other rectifier, produces a varying direct current from an alternating voltage. The alternating voltage is the modulated i-f signal. The varying direct current is the demodulated video signal. These signal variations do not become an alternating signal current until they pass through blocking capacitor Cb of Fig. 12 to leave the average d-c component behind.

Since detector action depends on production of direct current, there must be a path for such current through the a-c voltage source, the detector elements, and the load impedance or resistance. In Fig. 12 the source of a-c voltage for the detector circuit is the secondary of the transformer on the i-f amplifier. The d-c circuit then goes from cathode to plate in the detector, through inductors La and Lb, and through resistor R to ground. The d-c circuit is completed through ground back to the transformer secondary.

Now we shall look at some of the many modifications found in video detector circuits. Fig. 13 shows a single-winding impedance coupler in the plate circuit of the final i-f amplifier tube, with the modulated i-f signals going from the top of this coupler to the video detector through a blocking capacitor. The d-c circuit for the detector is completed to chassis ground through RFC (radio-frequency choke) which has high impedance for the i-f signal voltages. The parts of the detector circuit marked Ca, Cb, Lb, R, and Rg are the same as those similarly marked in the preceding diagram.

Instead of filter inductor La of the preceding diagram there is now the primary winding of a transformer, T, from whose secondary the 4.5-mc sound-modulated signal goes to an amplifier tube in the sound section.

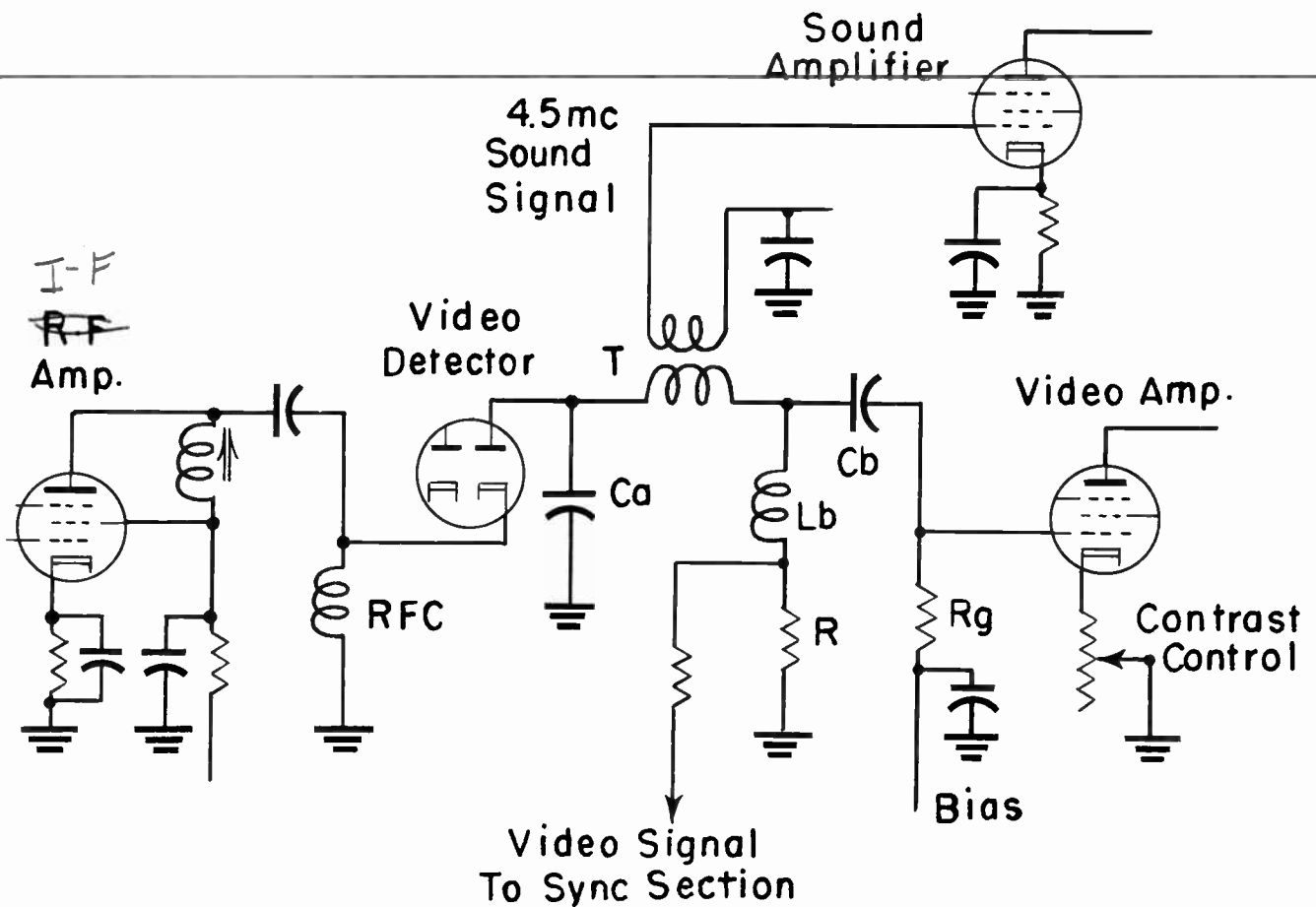

Fig. 13. Takeoffs in the video detector circuit for sound signals and for sync pulse signals.

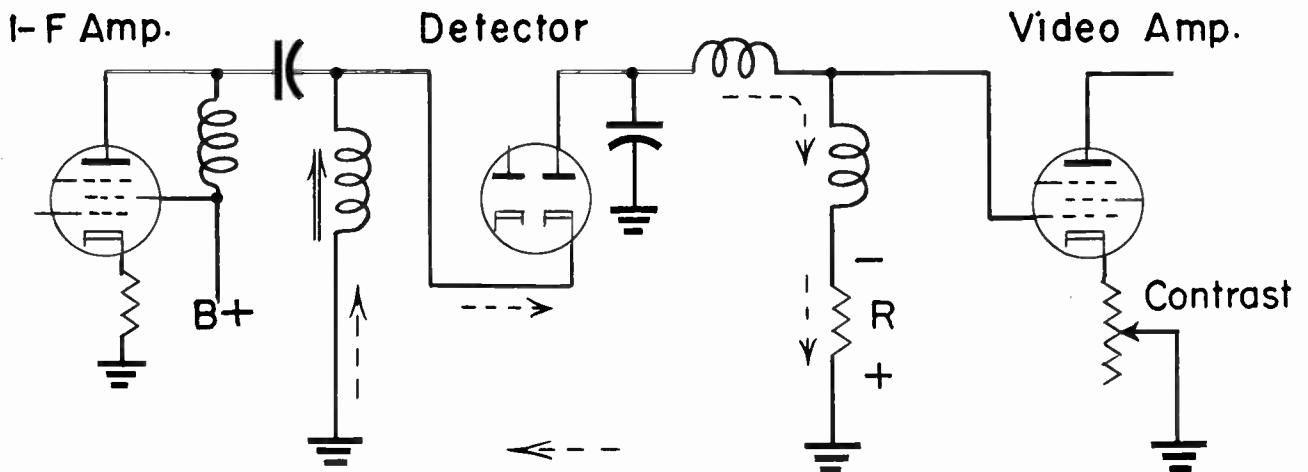

Fig. 14. One of the many common modifications of the video detector circuit. Here there is a direct conductive connection to the video amplifier grid.

From the top of detector load resistor R the video signal is taken through a resistor to the sync section, where the sync pulses will be separated from the picture variations. The video amplifier tube is provided with an adjustable cathode bias, which varies the bias

and amplification of this tube and forms the contrast control for pictures.

In Fig. 14 there is an untuned inductor providing high impedance in the plate circuit of the final i-f amplifier tube. I-f signals go



## LESSON 37 – I-F TRAPS AND VIDEO DETECTORS

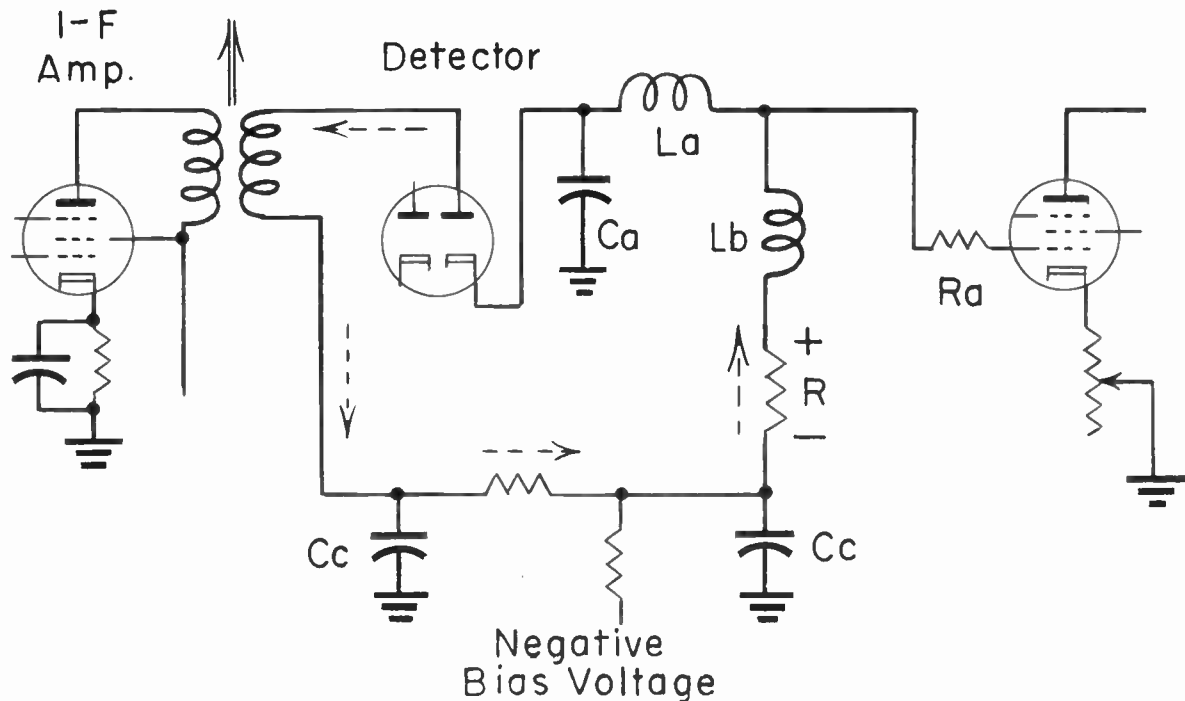

Fig. 15. A circuit in which i-f signals are applied to the plate of the video detector diode.

through a blocking capacitor to the tuned impedance coupler in the detector circuit. The path followed by the varying d-c signal currents is shown by broken-line arrows. The varying electron flow is downward through detector load resistor  $R$ , making the top of this resistor negative with reference to the bottom.

The negative end of resistor  $R$  is conductively connected to the grid of the video amplifier tube, there is no blocking capacitor in the grid circuit of this tube. Therefore, the video signals in the form of a varying negative voltage are applied from the top of the load resistor directly to the grid of the video amplifier.

In Fig. 15 the signal output from the last i-f amplifier is applied to the plate rather than to the cathode of the video detector diode. Now the d-c electron flow is reversed in direction from that with the i-f signal to the detector cathode, as shown by the broken line arrows. This makes the top of load resistor  $R$  positive with reference to the lower end. To overcome this average positive voltage of the rectified video signals, the entire d-c circuit of the detector is made negative with reference to chassis ground and to the cathode of the video amplifier by a nega-

tive d-c biasing voltage introduced as shown by the diagram.

The variations of video signal voltage, or the a-c component of the voltage, still go through chassis ground and to the cathode of the video amplifier through bypass capacitors  $C_b$  and  $C_c$ . The d-c circuit for the detector is completed through all the conductors shown along the path followed by broken-line arrows.

Another method of applying the i-f signals to the plate of the video detector is illustrated by Fig. 16. Here the d-c circuit of the detector is isolated from the grid of the video amplifier by blocking capacitor  $C_b$ . The amplifier grid is negatively biased by a d-c voltage brought through resistor  $R_g$ . Relative positions of the compensating inductors  $L_a$  and  $L_b$ , and load resistor  $R$ , are not the same as preceding diagrams. The positions may vary in any detector circuit so long as these elements are electrically in places where they can do their appointed tasks.

In all the preceding diagrams for video detector circuits the cathode and plate of the detector are in series between the i-f amplifier plate and the video amplifier grid so far as signal voltages are concerned. In Fig. 17 the detector elements are in parallel with the

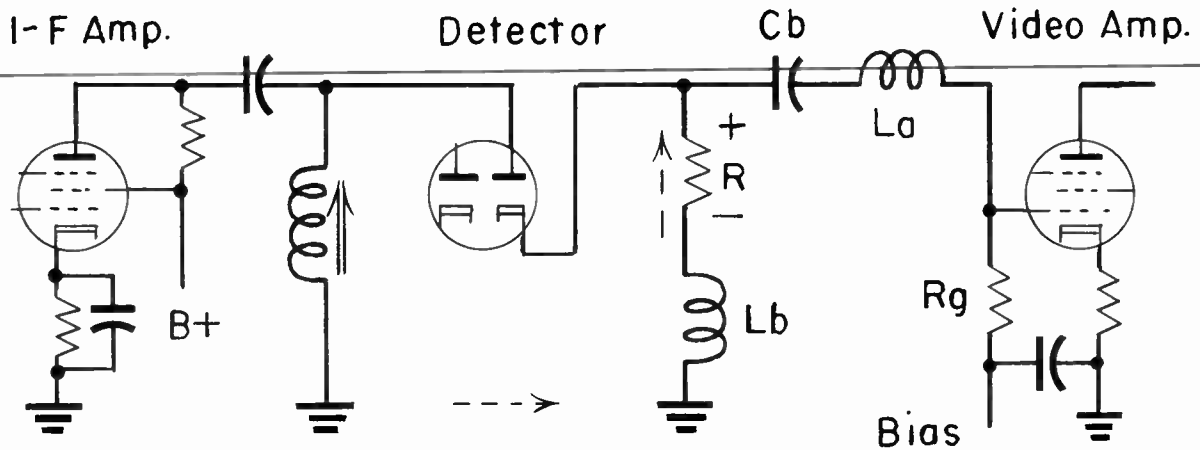

Fig. 16. The average positive voltage in the detector output is isolated from the video amplifier grid by a blocking capacitor.

plate and grid circuits, or are shunted across these circuits. During i-f signal alternations of polarity which make the detector plate positive, the detector conducts and passes these alternations to ground. During opposite i-f alternations the detector plate is negative, there is no conduction, and these alternations are passed along to the video amplifier.

The d-c circuit for the shunt detector is marked by broken-line arrows. Electron flow is in such direction as to make the top of load resistor  $R$  negative with reference to the lower end. Compare this polarity of the rectified signal with the polarity when using a series detector with input to the plate, as in Figs. 15 and 16.

In Fig. 17 there is an overcoupled transformer between the i-f amplifier and detec-

tor. The video amplifier grid is biased by the grid leak method, by the combined action of grid capacitor  $C_g$  and grid resistor  $R_g$ . These features, and others shown by the several detector diagrams, have no direct bearing on action of the detector. They have been shown merely to illustrate the many modifications which may be found in circuits associated with the detector.

**CRYSTAL DIODES.** Not all video detectors are diodes of the electron tube type. Many are crystal diodes. Fig. 18 is a picture of a crystal diode alongside one of the smallest miniature diode tubes mounted in a socket. The crystal diode most commonly employed in television receivers consists of an insulating cylindrical housing inside of which is a very small piece of slightly impure germanium, one of the metallic ele-

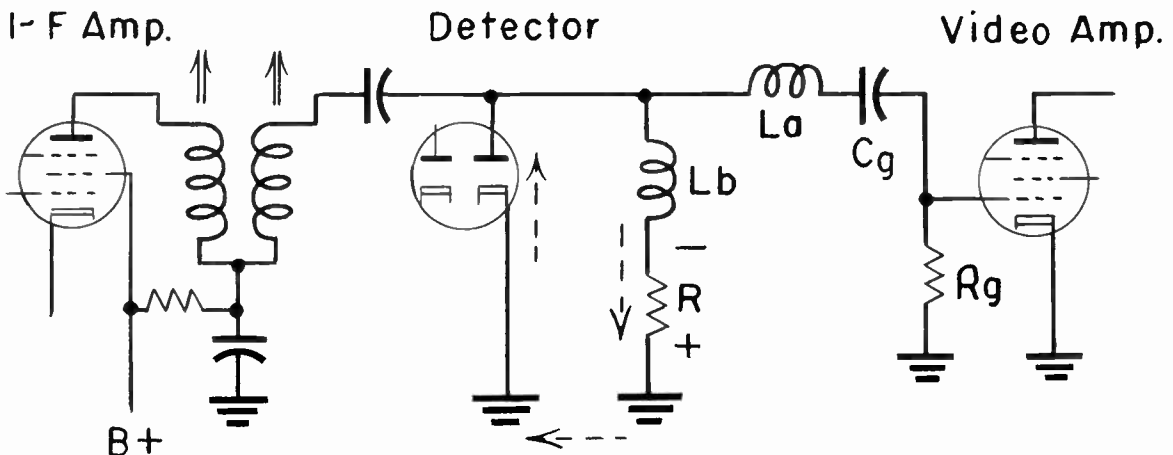

Fig. 17. A shunt-connected video detector.

## LESSON 37 – IF TRAPS AND VIDEO DETECTORS

tures after the relations have been upset in video amplifier circuits. Crystal diodes may be used also in the sync section, and for automatic control of sweep oscillator frequency. They are used for furnishing d-c bias voltages. Many kinds of service instruments use crystal diodes. Mixers in ultra-high frequency television receivers nearly always are crystal diodes.

Crystal diodes are small in size. Diameters of various types range from slightly more than 1/8 inch to a little over 1/4 inch, and lengths are from 1/2 to 7/8 inch. Many types have pigtail leads like the leads on small fixed resistors and capacitors. The diodes may be supported and connected into their circuits by means of the pigtails. Other styles may be supported by an end cap. Still others, as shown by Fig. 19, have end pins which fit into spring clips. This picture again compares a crystal diode with one of the smallest miniature tubes for size.

The germanium element of a crystal diode is the cathode, and corresponds to the cathode of a diode tube. The pointed wire is the "anode", and corresponds to the plate of a diode tube. Various markings are used to indicate which of the pigtails, caps, or pins is connected internally to the cathode, and which to the anode. Sometimes one end is marked CATH, for cathode, or the cathode end may be marked with a negative sign (-), or with a green band, or with a heavy black bar. On other styles the anode end is marked with a positive sign (+), or there may be a positive sign at the anode end and a negative sign at the cathode end.

ments. Against the polished surface of the germanium presses the point of a wire made of tungsten or of a platinum alloy. Electrons will flow from the germanium to the pointed wire far more readily than in the opposite direction. Consequently, the combination may be used as a rectifier.

Crystal diodes are employed not only as video detectors but almost anywhere else that a rectifier is needed. In television receivers we find these units in automatic gain control circuits, as detectors for sound signals, and for restoration of correct shadings in pic-

The standard symbol for a crystal diode is the same as for a contact rectifier of the power type, as shown by Fig. 20. It consists of an arrowhead with its point against a straight bar or line. The straight bar or line represents the cathode of the crystal diode, and the arrowhead represents the anode which corresponds to the plate of a diode tube. It is well to remember that electrons flow more freely against the arrowhead.

There are a great many different types of germanium diodes designed for different applications. Safe inverse voltages, which

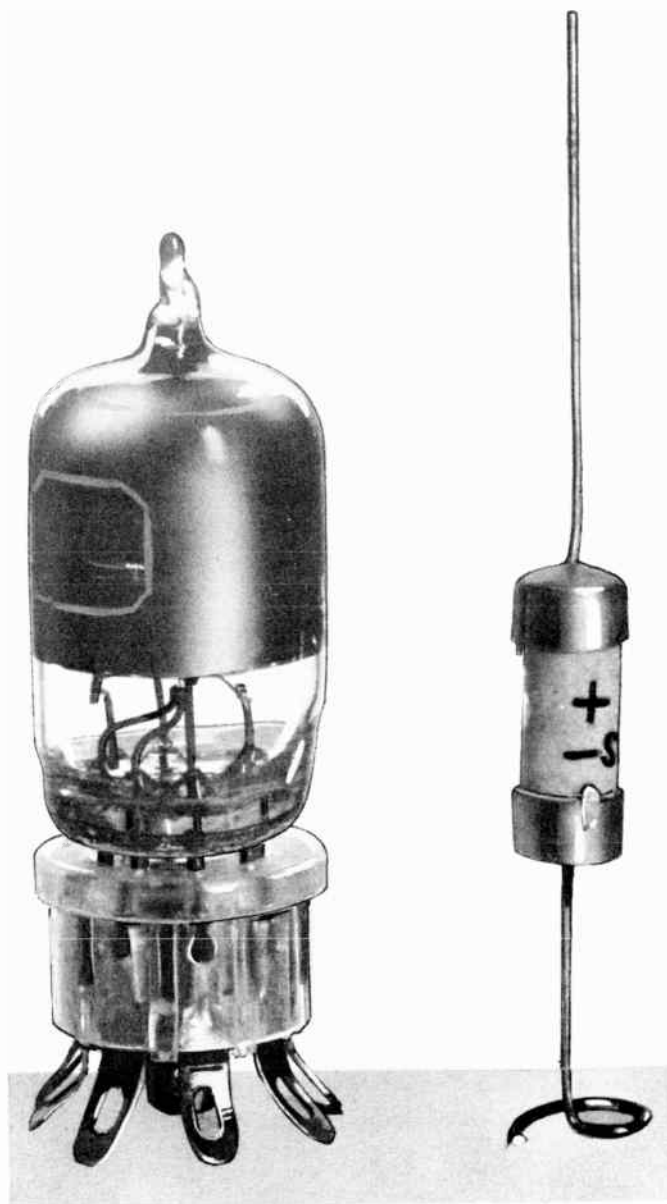

Fig. 18. A crystal diode compared for size with the smallest type of diode tube commonly used in receivers.

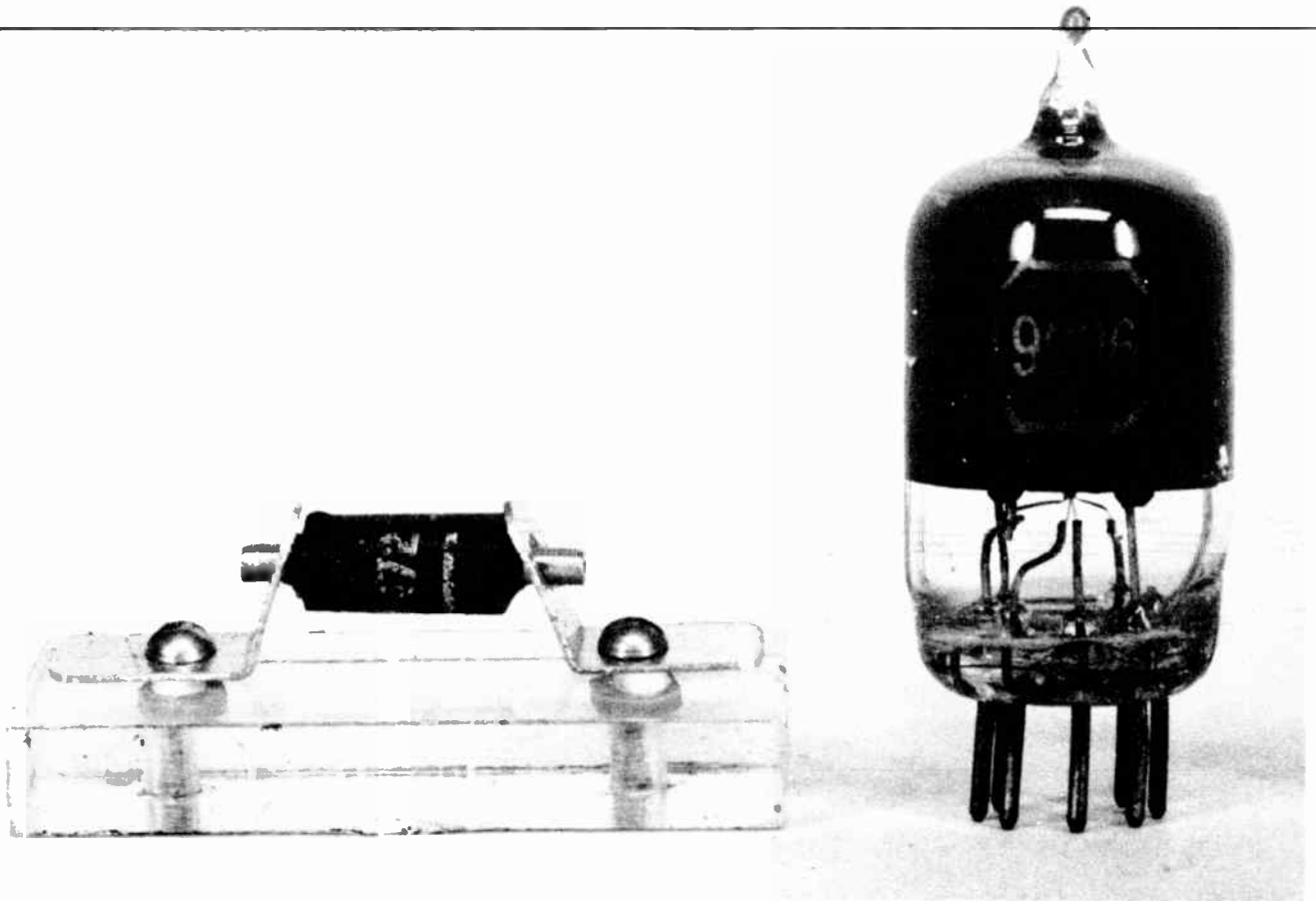

Fig. 19. A crystal diode designed for mounting in spring clips of the kind illustrated or of other forms.

make the cathode positive, may be anything from 5 to 200 volts. Maximum continual rectified currents usually are between 25 and 50 milliamperes, while peak values in a signal wave may go from 60 to 200 ma, and instantaneous "surge" currents may be as high as 100 to 1,000 ma in various types of diodes.

Resistance of a crystal diode to electron flow from anode (plate) to cathode is not nearly so high as in a diode tube, and this "back resistance" varies with value of applied voltage. At normal maximum inverse voltages, which range from 3 to 150 volts in various types, the back resistance may be between 100,000 ohms and nearly  $1\frac{1}{2}$  megohms, but the back resistances bear no direct relation to inverse voltages.

Crystal diode resistance in the forward direction, with electron flow from cathode to anode, may be as low as 60 odd ohms for

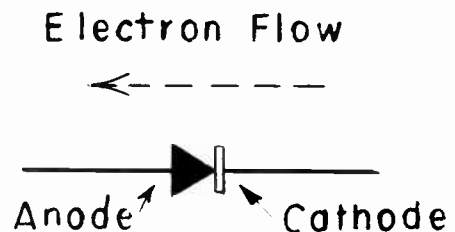

Fig. 20. The symbol used in service diagrams to indicate a crystal diode.

units of high-conduction types, and almost 700 ohms in some types designed for high inverse voltages. Back resistance decreases as inverse voltage rises. This may spell danger, for the higher the inverse voltage the less is the diode resistance opposing the flow of current, which easily may become great enough to destroy the germanium surface.

The ratio of back resistance to forward resistance may be on the order of 500 times



## LESSON 37 – IF TRAPS AND VIDEO DETECTORS

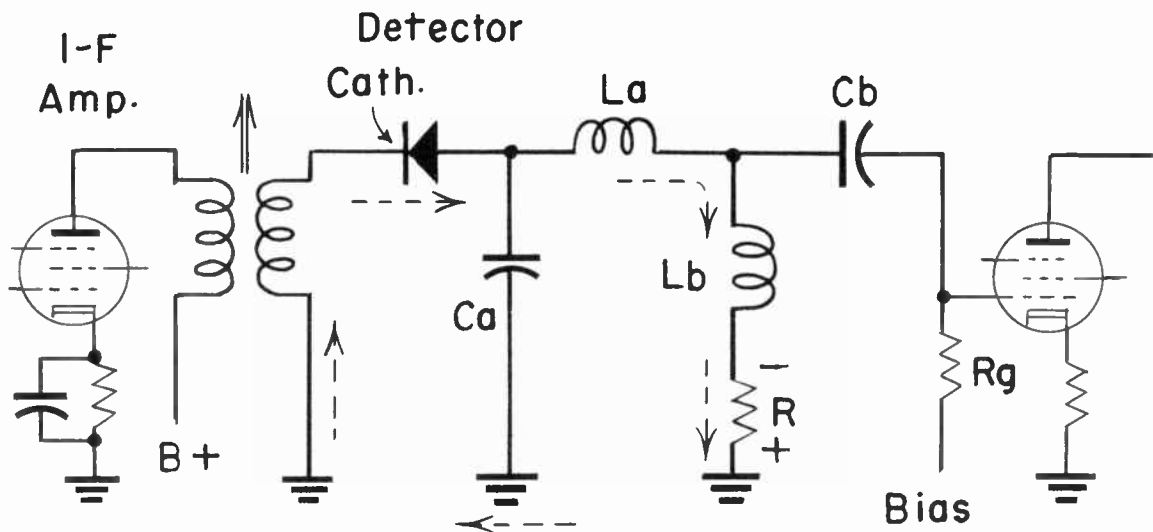

Fig. 21. The circuit for a crystal diode video detector may be quite similar to the circuit for a diode tube.

in some of the high-voltage diodes. It may be from 1,000 to 1,500 times in general purpose types, and in diodes designed for high back resistance this ratio may be up to 5,000 or 7,500.

Some of the advantages of crystal diodes in any application are: No heater current is needed. Pigtail types need no socket or other special mounting. Forward resistance normally is less than in diode tubes. Internal capacitance is exceedingly small, being about 1 mmf. When used as a video detector the crystal diode is capable of preserving good linearity at very small signal voltages, it may improve the rendition of gray tones and very light tones in pictures, and distortion is quite easily avoided by suitable circuit design.

Among the precautions to be observed with crystal diodes are the following.

Mount the units as far as possible from hot parts, such as tubes and power transformers, and where there won't be excessive vibration, as too close to a speaker.

Do not drop the crystal diode, nor tap on it, nor subject it to any unnecessary mechanical shocks.

When soldering a unit in place by means of its pigtailed avoid overheating the elements.

Do a quick job with a hot iron. If possible, grasp the pigtail with flat-noise pliers between the unit and the point of soldering, thus carrying away or absorbing excess heat. Do not cut the pigtailed so short as to impose possible stress on the unit itself.

Make certain that the crystal diode is connected in correct polarity.

Do not substitute one type of crystal diode for another original type without express instructions from the manufacturer or unless you can measure all working conditions accurately enough to avoid excessive voltages or currents.

**CRYSTAL DIODE DETECTORS.** Circuits for crystal diode video detectors are generally similar to circuits for diode tube detectors. An example is shown by Fig. 21, which you should compare with the diode tube detector circuit of Fig. 12. In this new diagram the direction of electron flow is indicated by broken-line arrows. As you will recognize, the crystal diode detector is in series with the signal path from i-f amplifier plate to video amplifier grid.

In Fig. 22 we have a shunt detector of the crystal diode type. Connections are essentially like those of Fig. 17 for a shunt detector of the diode tube type. Some of the circuit

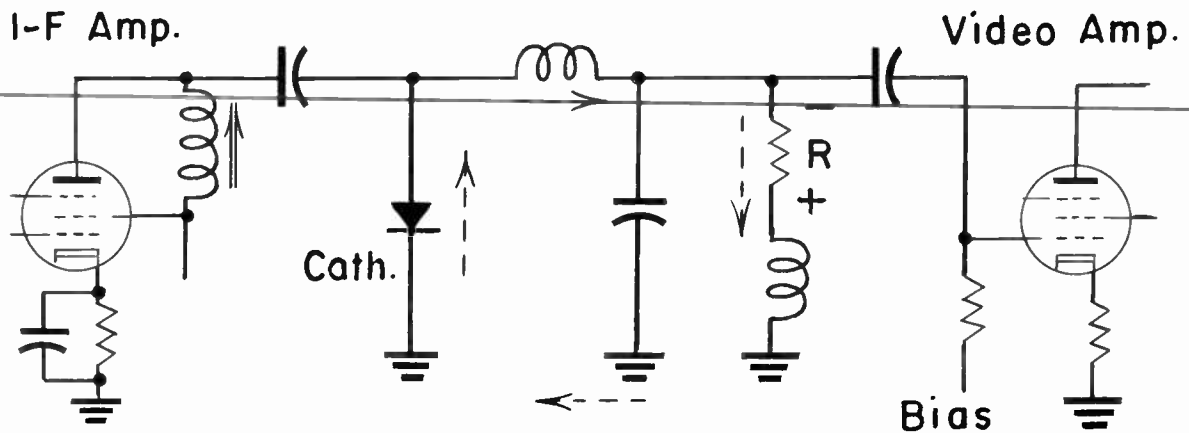

Fig. 22. A crystal diode connected as a shunt detector.

elements are in different relative positions, but so far as detector action is concerned there is little change.

Crystal diodes used as video detectors in receivers of recent design are of types which have been especially developed for such service, and which have been tested in operating circuits at the factory. Replacements should be made with these types, for they have more uniform characteristics than the general purpose crystal diodes and usually will allow satisfactory performance without extensive adjustments.

Video detectors of the crystal type nearly always are mounted within shielding enclosures which are grounded to chassis metal.

Often there is a shield within which is the crystal and some of the associated inductors. In some receivers the crystal detector is mounted inside the shielding can that encloses also the output coupler or transformer for the last i-f amplifier, which feeds to the detector. At first glance it appears as though there were no video detector.

In spite of the general similarity between circuit diagrams for diode tubes and crystal diodes as video detectors, it is not possible to make a direct substitution of the crystal for a tube. Although connections may be the same or nearly so, the values of inductors, capacitors, and resistors are not the same for the two kinds of detectors, and results would be decidedly disappointing in most cases.

# TELEVISION

• RADIO

• ELECTRONICS

---

## LESSON 38 – TELEVISION ALIGNMENT

---

***Coyne School***

*practical home training*

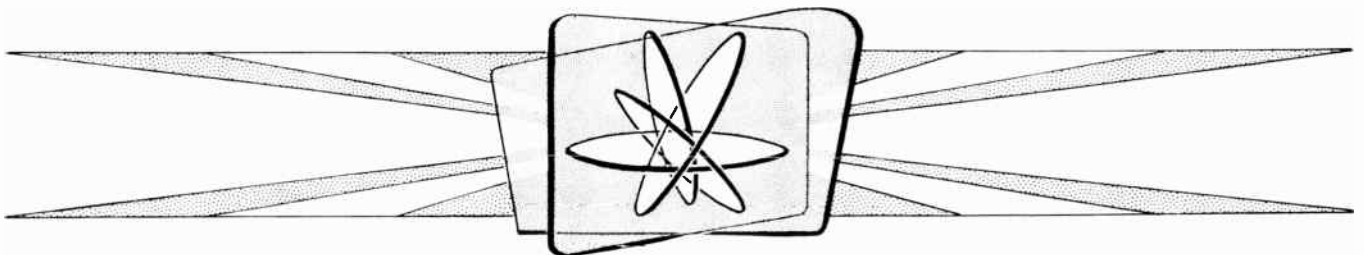

*Chicago, Illinois*

---

*Copyright, 1953 by Coyne Electrical School  
Chicago 12, Illinois  
All rights reserved*

Litho. in U.S.A.



## Lesson 38

# TELEVISION ALIGNMENT

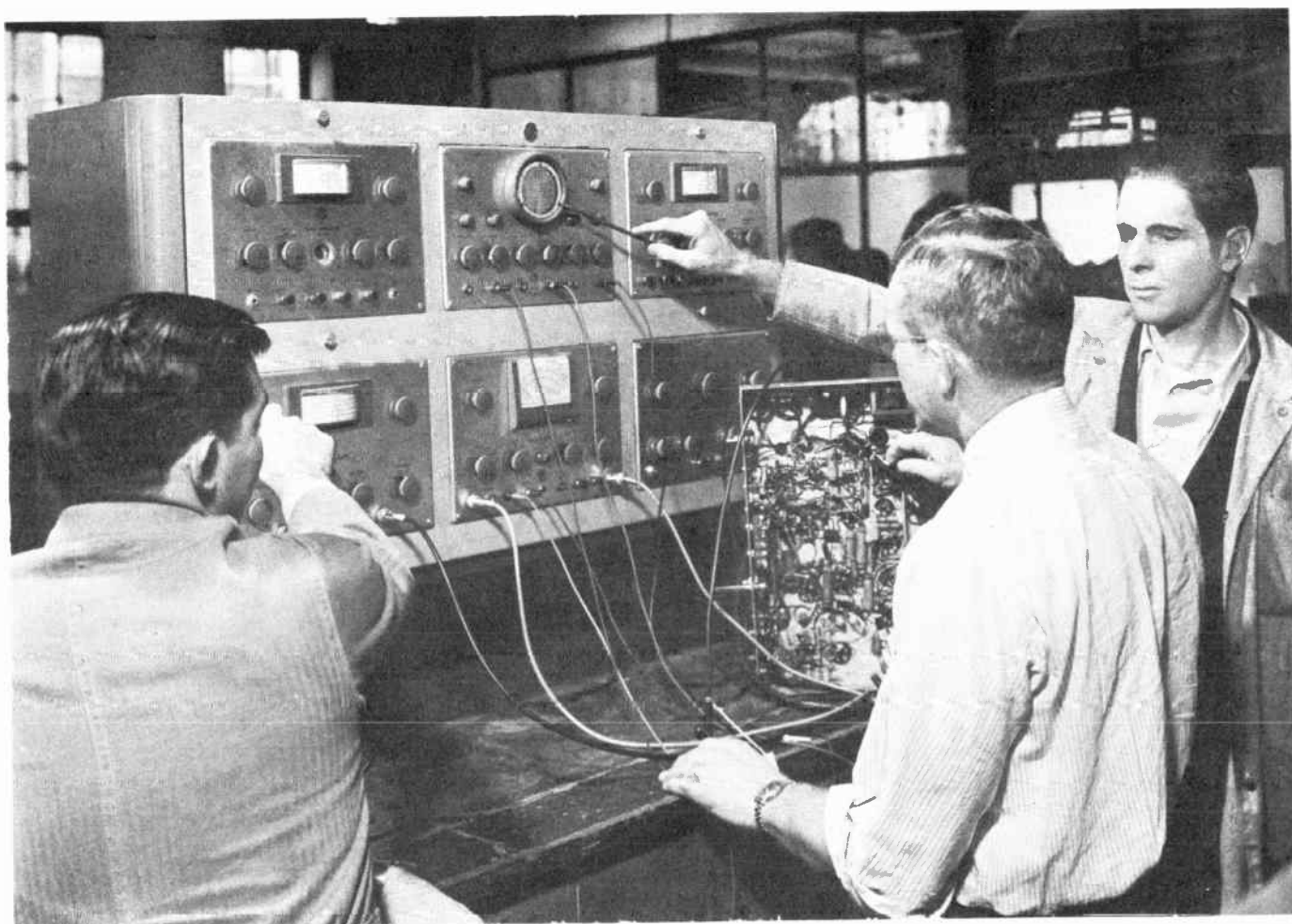

*Fig. 1. Students in the Coyne School are being shown how to align a television receiver.*

If a television receiver has a long history of fuzzy pictures, unsatisfactory sound, and generally poor performance the cause is likely to be misalignment. But if operation has been satisfactory until something suddenly goes wrong, the trouble won't be corrected by realignment once in a thousand times. Then you should look for failure of a tube, a capacitor, or some other circuit element.

Even when faulty performance has existed for a long time you should check other possible causes before undertaking realignment. The operator may not know how to manipulate the controls in a way which allows good reception. Some or all of the

tubes, including the picture tube, may have become weak due to long use. If you have them available it is a good plan to substitute new tubes for the video amplifier or amplifiers, the video detector, the r-f oscillator in the tuner, and always the rectifier or rectifiers in the d-c power supply.

It is quite possible that something has gone wrong with an outdoor antenna, or with a built-in antenna when the receiver operates with that kind. The transmission line from antenna to receiver may have sagged against metal parts of the building, or developed corrosion or looseness at some of the outdoor connections.

# COYNE - *television home training*

Realignment is a shop operation unless you have rather elaborate testing equipment which may be taken out. Everything that can be done to locate trouble should be tried in the home of the set owner before taking the receiver to the shop. How much can be done depends on your knowledge and experience in servicing, on whether you have detailed service information on the make and model of receiver in trouble, and on what portable service instruments you can take along.

Either in the home of the set owner or in the shop you should measure d-c voltages for all plates, screens and grids - except in the high-voltage power supply for the picture tube anode. Even though you do not know the correct average operating voltages for a particular receiver, you do know that practically all plates and screens should be supplied with 50 or more d-c volts, and that amplifier grids should not be positive with reference to cathodes of the same tubes.

Wiring connections underneath the chassis should be examined with care while looking for defective fixed resistors and capacitors. Joints made with large "blobs" of solder, with rough solder and with wire ends remaining unconnected indicated that circuit parts have been snipped out and replaced with others. The parts connected at such joints are those whose originals have given trouble. New parts may be of wrong types or wrong values, or wrongly connected, or their connections may be loose or of high resistance.

Only after making all these preliminary checks, is it in order to undertake realignment, which means adjustment of tuning inductors and possibly capacitors in the i-f amplifier section, in the sound section, and in the tuner for the purpose of improving the frequency responses. Adjustments always are made while applying a suitable signal voltage to the input of the section being aligned, while measuring the voltages or currents from the output of this section.

ALIGNMENT PRINCIPLES. Diagram 1 of Fig. 2 illustrates the basic principle of i-f alignment. The signal generator is coupled to the grid circuit of the mixer tube. The resulting output signal is measured at the video detector load resistor or load resistor

and inductor, or at the grid circuit of the first or only video amplifier.

For alignment of an intercarrier sound section, represented by diagram 2, the signal generator is coupled to the grid of the last video amplifier tube which carries the sound-modulated 4.5-mc signal from the video detector, and output is measured at the detector of the sound section.

For tuner alignment, diagram 3, the signal generator is connected to the antenna terminals of the receiver while output is measured either at the grid or the plate side of the mixer.

An overall video alignment, diagram 4, is carried out with the signal generator connected to the antenna terminals while output is measured in the load circuit of the video detector, or possibly farther along in the video amplifier.

Should the receiver have a dual sound system, diagram 5, the sound is aligned with the signal generator coupled to the mixer grid circuit, while output is measured at the detector in the sound section. If sound i-f signals go through some video i-f stages the generator is coupled to a grid just ahead of the sound takeoff.

There are two general methods of aligning any of the receiver sections. With one method the input signal is supplied by a generator which furnishes a frequency that remains constant at the value to which the generator is tuned. Output is measured by a vacuum tube voltmeter, or, for some operations, output may be measured by a high-sensitivity moving coil d-c voltmeter.

With the other general method we measure or observe the output frequency response on the screen of an oscilloscope. The input signal then is provided by a sweep generator which furnishes frequencies that vary or sweep rapidly back and forth throughout the entire operating range of the section being aligned. Then the oscilloscope will display the frequency response or the relative gains for all these frequencies on a trace similar to many of those which have been pictured in other lessons. Frequencies at various points

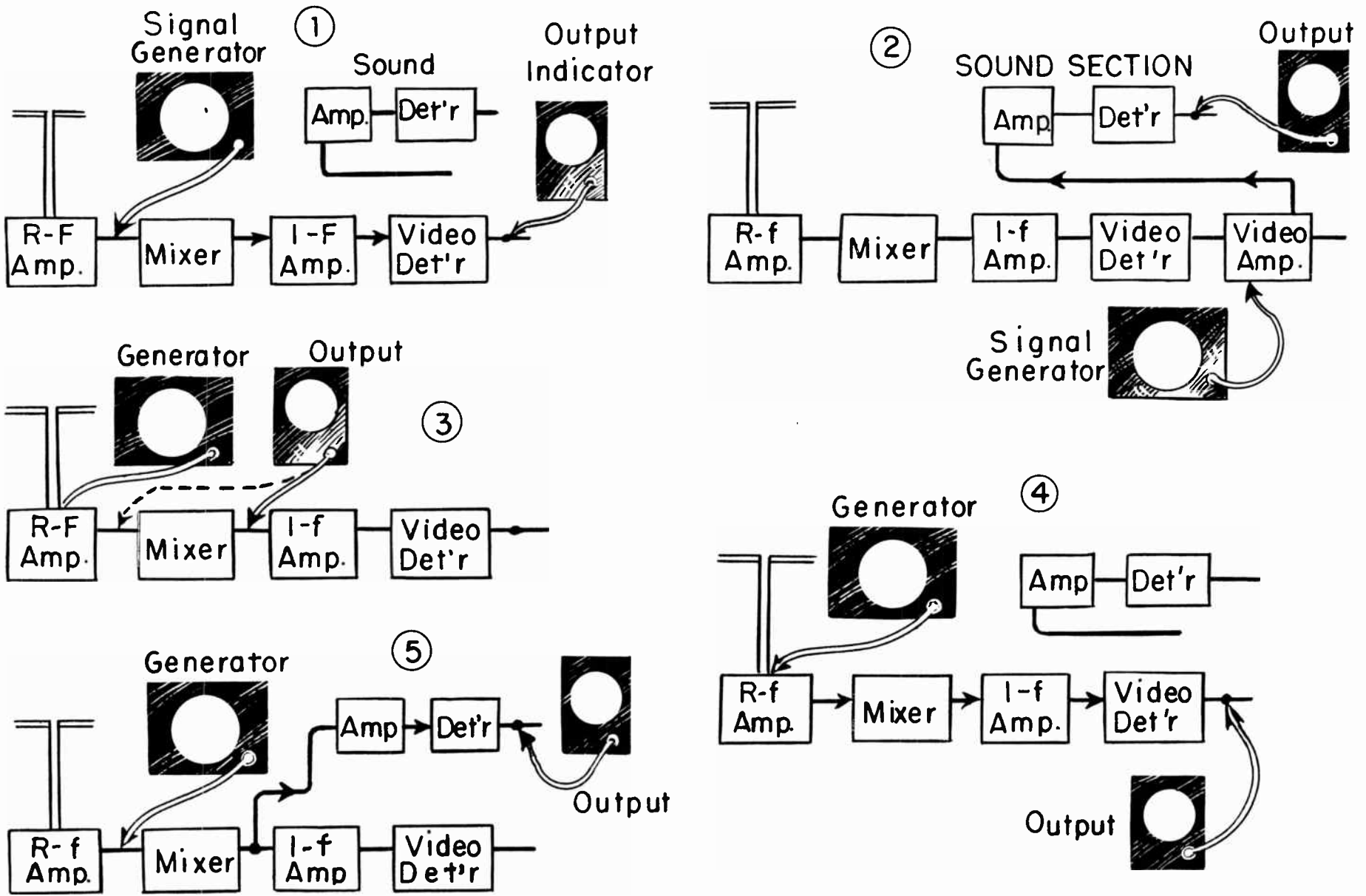

Fig. 2. How the signal generator and output indicator are connected or coupled during alignment of various sections in receivers.



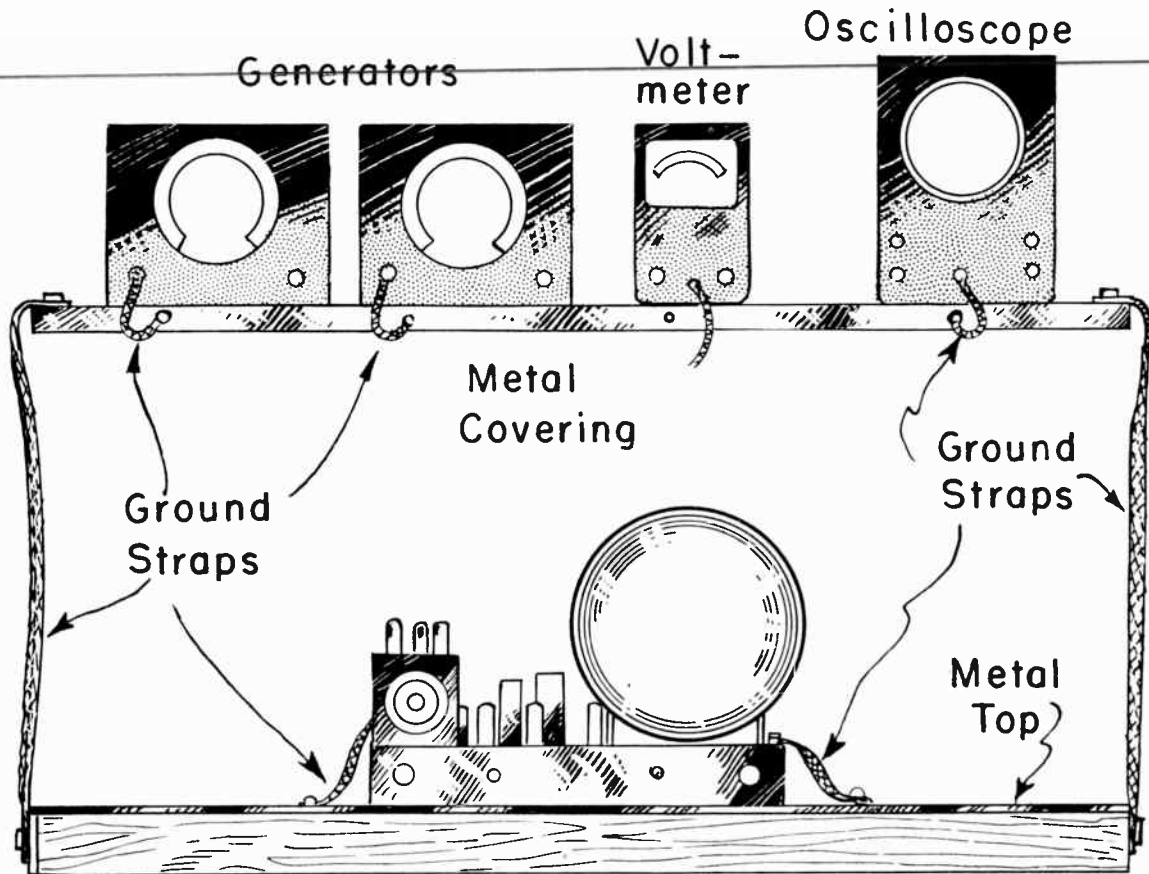

Fig. 3. The chassis, the test instruments, and the metal tops of working surfaces should be maintained at the same r-f potential.

along the oscilloscope trace are identified by means of a marker generator.

A complete realignment of a receiver having an intercarrier sound system begins with the i-f section, not with the tuner, as might reasonably be expected. There are several reasons for this. Misalignment of the i-f section usually causes more trouble than misalignment of the tuner. Video and sound intermediate frequencies which together form the intercarrier sound signal must pass first through the i-f section to the video detector, and the i-f section must be suitably aligned if there is to be satisfactory reproduction of sound. Fortunately, test equipment for i-f alignment is simpler, less costly, and easier to use than that needed for tuner alignment.

After attending to a few preliminaries we shall commence by aligning the i-f section with a constant-frequency signal generator and vacuum tube voltmeter. Later the oscilloscope, sweep generator, and marker gen-

erator will be used for the same kind of work. In due time we shall employ both general methods for aligning other sections of the receiver.

**THE TEST BENCH.** When working with frequencies so high as those used for i-f amplifiers, and even more so at carrier frequencies, it is essential that chassis metal of the receiver, metal housings of all test instruments, and ground or B-minus connections be at the same r-f potential. This can be insured only by providing adequate low-resistance connections between all these parts, so that no appreciable differences can develop between their r-f potentials. Connections of instrument low-side or ground leads to the receiver chassis help in this respect, but they cannot be depended on for the entire job.

The usual method of insuring good interconnections is illustrated by Fig. 3. The top of the work bench, on which will rest the receiver chassis, is covered with a sheet of



## LESSON 38 – TELEVISION ALIGNMENT

aluminum, copper, or steel. Provisions are made for connecting this bench top to the chassis at one or more points through straps of flexible braided copper.

The instrument shelf above the bench also is covered with sheet metal, and provisions are made for connecting instrument cases to the shelf covering through flexible straps. The metal coverings of bench and shelf are connected together at their ends and sometimes at intermediate points by other flexible straps, or possibly with metal shelf supports that make good electrical contact with the bench top.

During some tests the cable connections from a vacuum tube voltmeter or from an oscilloscope are to receiver circuits which are not at chassis ground potential, but are either positive or negative with reference to the chassis. If the cases of the instruments are internally connected to their low-side or grounding leads, as usually they are, the cases must not be in electrical contact with the metal of the instrument shelf. That would short circuit the connections in the receiver. Contact with the shelf covering may be prevented by resting the VTVM or oscilloscope on a piece of fibre or any other insulating material.

So long as the instrument shelf and bench top are effectually bonded together it is not necessary to connect them to any actual earth ground, such as a cold water pipe. In fact, such an earth connection might cause trouble when working on transformerless receivers. The idea is to have the bench top, the shelf covering, the receiver chassis, and all instrument cases at the same r-f potential, not necessarily at actual ground potential.

When using the VTVM as an output indicator during alignment you should touch the receiver chassis and the instrument cases with your fingers while all the equipment is alive. Should this alter the reading of the meter by more than about one per cent the interconnections are not as effective as they should be. Try using an additional connection from the bench top to the receiver chassis or move one of the existing connections to a different place on the chassis. Difficulty may be avoided also by connecting the low-sides

of instrument cables to points on the chassis or on B-minus leads as close as possible to where the high-side connections are made.

CHASSIS REMOVAL. Removal of the chassis from its cabinet will necessitate disconnecting the power cord, which usually is attached to the cabinet back or to some other cover which must be taken off to expose the chassis. Line power then will be applied to the chassis by using a service type power cord, otherwise called an interlock cord or a "cheater" cord.

Principal parts of a service power cord are shown by Fig. 4. On one end (A) is a regular two-prong plug that fits into any line receptacle or wall receptacle. On the other end is a molded female connector (B) which slips onto a recessed male connector (C) attached to the chassis and connected internally to the low-voltage power supply. The service cord is a duplicate of the regular power cord, but is not fastened to the cabinet or a cover.

With the majority of receivers the chassis is removed from the cabinet as follows.

1. Remove the cabinet back and the regular power cord previously mentioned.

2. With a flash lamp or extension lamp examine the inside of the cabinet to determine what parts will remain in the cabinet and, consequently, must be disconnected from the chassis. These parts usually include at least the speaker and any builtin antenna attached to the cabinet. In addition, it will be necessary to disconnect a transmission line coming from an external antenna. Other parts which have to be disconnected from the main chassis may include the low-voltage power supply and sometimes a separate smaller chassis for a-m and f-m sound broadcast reception. There are a number of receivers in which the picture tube is mounted in the cabinet, not on the chassis.

Leads or cables from parts which remain in the cabinet attach to the main television chassis with plug and socket connectors, with ordinary screw terminals, or in some way easily recognized upon examination. All these parts must be disconnected and their cords or cables placed where they

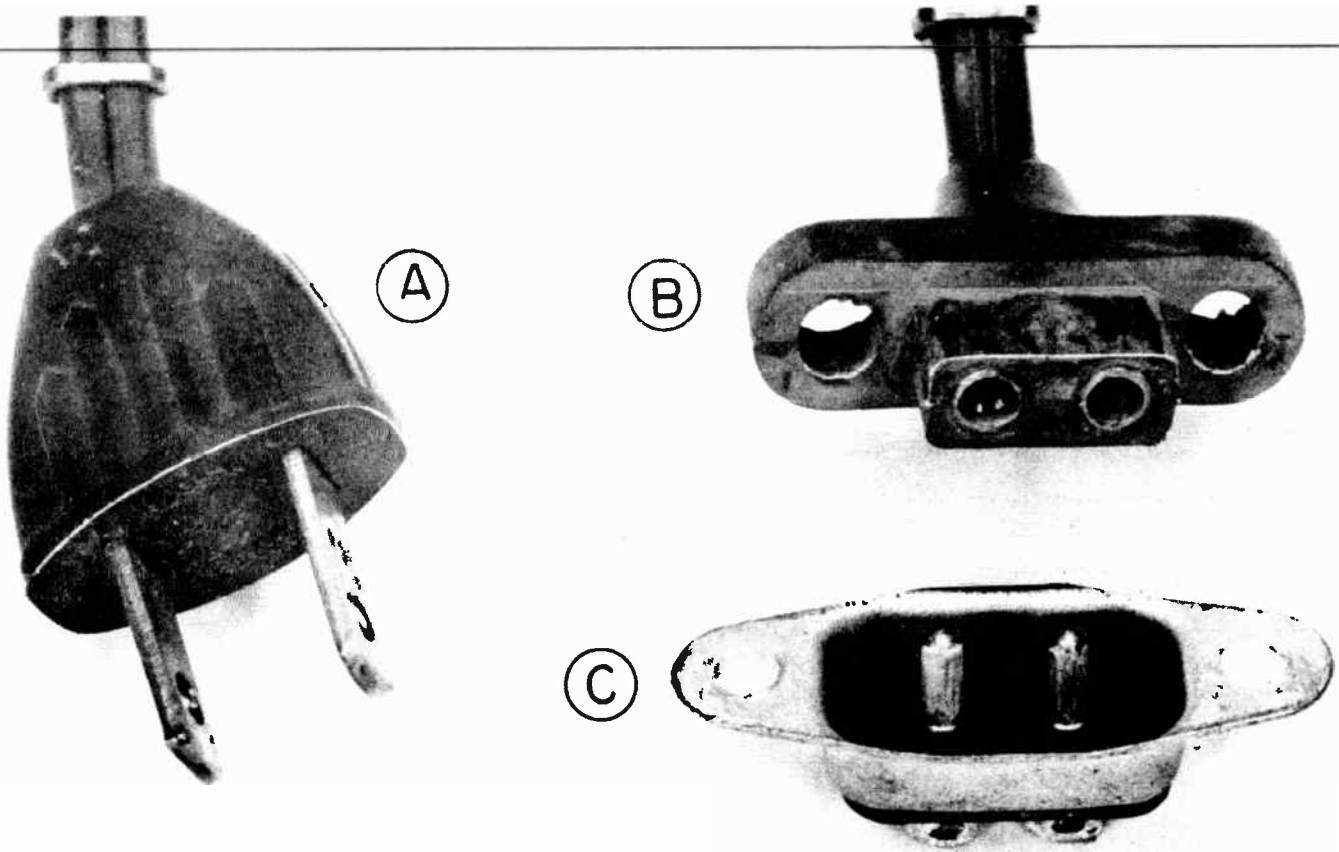

Fig. 4. These are the terminal connections for a service type power cord.

won't interfere with chassis withdrawal.

3. From in front of the cabinet remove all control knobs and channel selector knobs which examination shows cannot pass through sufficiently large openings while remaining with the chassis. Be sure to look inside of any panel or plate which conceals some of the auxiliary operating controls. Unless you can see the heads of set screws or other fastenings on the sides or hubs of knobs, they are designed to pull off the control shafts.

It should not be necessary to pry behind any knob; such a practice may bend and cause binding of the control shaft. Simply grasp each knob and pull in line with the shaft. A dual control with a large knob behind a smaller one is illustrated by Fig. 5. The small knob may be pulled first, then the larger one. Knobs may be difficult to remove from new receivers, but they come off quite

easily on sets which have seen many service operations. On such sets it may be easy to grasp only the larger knob and pull both together. Keep track of which knobs go on certain control shafts.

4. Chasses are held in their cabinets by machine screws, cap screws, or with special screws having threads similar to those of an ordinary wood screw. Bolts with nuts are found only in rare cases. Heads of screws are of hexagon shape, slotted, or may be both hexagon and slotted. The screws pass through openings in the cabinet, usually through the bottom or through a shelf in a console. Locate and remove all the screws or bolts while the cabinet is in a position where the chassis won't slide as it is freed from the fastenings.

5. Make a final examination to see that the chassis can be withdrawn without striking any part of the cabinet or anything which re-

## LESSON 38 – TELEVISION ALIGNMENT

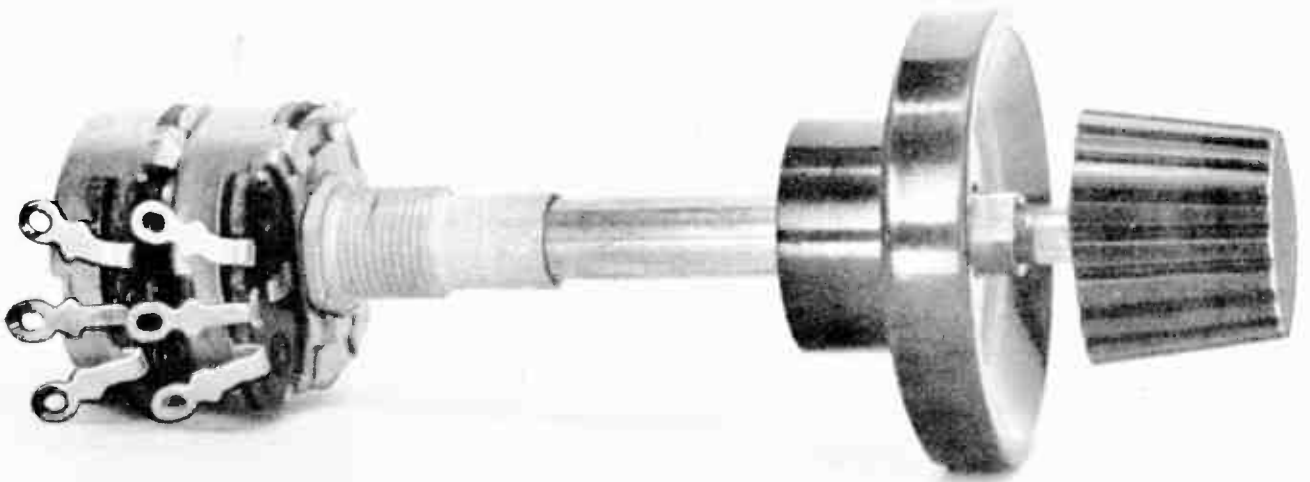

*Fig. 5. The two knobs which operate dual controls may be pulled straight off the shafts in most cases.*

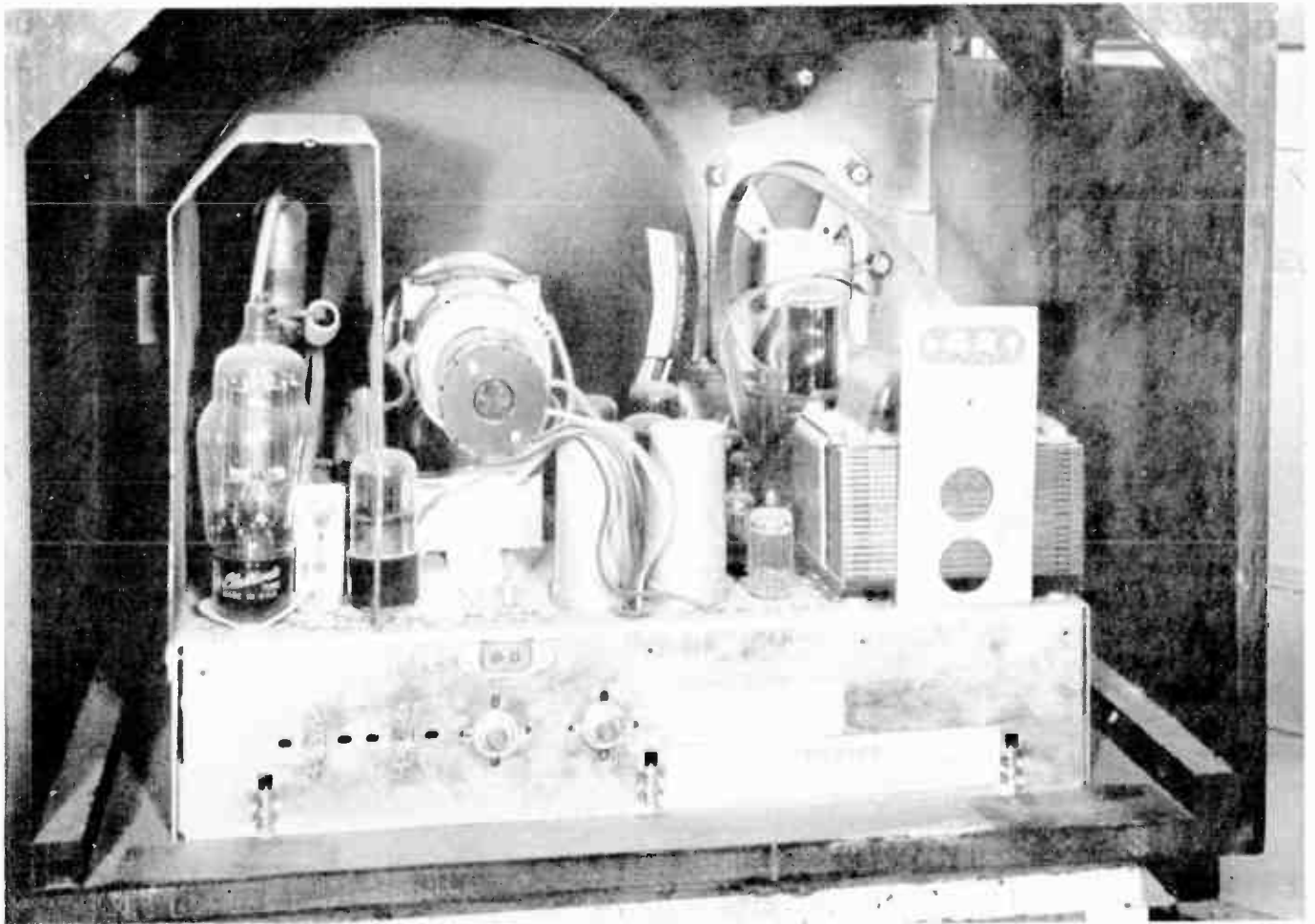

*Fig. 6. Carefully examine everything inside the cabinet to make sure that the chassis will clear all obstructions while being withdrawn.*



mains fastened in the cabinet. With some sets it is necessary to remove the speaker, a built-in antenna, or other parts.

6. Carefully slide the chassis out of its cabinet. Whether the picture tube remains in the cabinet or comes along with the chassis, use all care that nothing solid or hard strikes any part of the tube. On every square inch of tube surface there is atmospheric pressure of about 14.7 pounds in excess of internal pressure. On a typical 16-inch tube the total pressure difference may be more than  $3\frac{1}{2}$  tons.

A cracked tube may implode, meaning that the external pressure drives particles of glass inward with great force. Instantly the particles rebound outward and may cause severe injury to you and anyone else in the way, not to mention loss of the picture tube itself and damage to other parts of the receiver.

The safe way is to wear shatterproof goggles, also cotton or canvas work gloves, keep your sleeves rolled down and your collar turned up. Many technicians grow careless and neglect these precautions, but sooner or later they may suffer. Eyesight is not easily replaceable. While the chassis is out of the cabinet it is a good idea to keep a piece of heavy cloth over all glass parts of picture tubes, including the neck.

If your negligence with picture tubes allows personal injury to someone not an employee of the same shop, you can be held responsible. Financial loss might be great. Make it a rule to insist that other people remain at safe distances while you are handling unprotected picture tubes.

Many late model receivers and some of the older types provide for making all instrument connections at points on top of the chassis during alignment. These test points usually lead to the grid circuit of the mixer tube, to the load circuit of the video detector, to any of various circuits of the sound section, and to any other circuits at which signal voltages are to be introduced or measured. On top of these chassis are also the adjusters, or most of them, for alignment of the various sections. Such sets need only be

rested on the bench top in their normal upright position during alignment.

Most of the older receivers, as well as some not so old, do not have readily accessible test points. Instrument connections must be made underneath the chassis. Alignment adjusters sometimes may be reached from under the chassis, or all of them may be on top. When both top and bottom of the chassis must be reached, the obvious solution is to rest it on one side, on the side which seems to allow connections being made most easily while also being able to reach the top adjusters.

A chassis on its side must be so firmly supported as to preclude the possibility of falling. Cradles are made which have clamps for the chassis and trunnion supports which allow tilting and locking in various positions. Merely blocking with loose pieces of wood and miscellaneous objects is not safe, especially when the picture tube remains on the chassis. It is better to bolt or screw one or more pieces of wood or flat metal to some of the regular mounting holes or to any available openings, using corner irons or other fastenings as needed. Then the chassis may be moved and turned with safety.

### TRANSFORMERLESS RECEIVERS.

Transformerless receivers having series heaters and possibly hot chassis require special precautions during alignment. When connected directly to the a-c line through the power cord and plug there is danger of shock, as explained when we studied power supplies. There is even greater danger of damaging the attenuator system of the signal generator.

Surest protection is provided by an isolation transformer having separate primary and secondary windings for connection to the power line and to the receiver. Thus the chassis of the receiver cannot possibly have a direct conductive connection to either the hot side or the grounded side of the power line.

A plain isolation transformer having a turns ratio of 1-to-1 is shown at the left in Fig. 7. The primary leads for the power line and the secondary leads for the receiver may be connected in any manner you find conven-



## LESSON 38 – TELEVISION ALIGNMENT

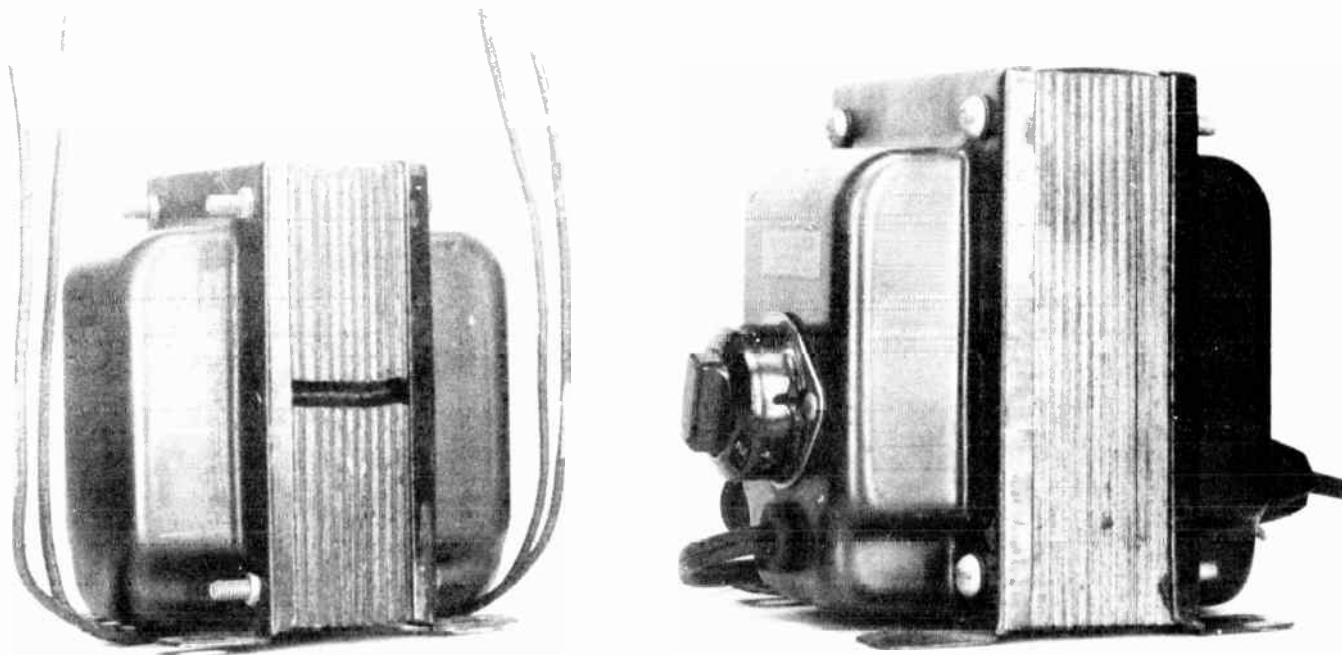

Fig. 7. An isolation transformer (left) and a combined isolation and voltage adjusting transformer (right).

ient for shop use. The unit mentioned is 4 inches high and has power handling capacity of 80 watts. This is enough for small radio sets, but not for many television receivers. Capacities up to 300 watts or more are available in transformers of this type.

The transformer at the right is a combination isolating and voltage compensating type of 150-watt rating. On the side which carries a power cord and plug for the a-c line in the building there is a rotary switch connected to a tapped primary winding. On the opposite side is a socket receptacle for the plug on the receiver power cord. At various positions of the switch, a-c line voltages anywhere between 90 and 135 volts are transformed to 110 to 120 volts for the receiver. One switch position provides a turns ratio of 1-to-1.

Much of the electrical interference which may come from a building power line is stopped if the isolation transformer has an electrostatic shield between its primary and secondary windings. Such a shield, illustrated by Figs 8, consists of a thin copper

band wrapped around the primary and having its two ends insulated from each other. Attached to one end is a lead which is in contact with the core iron and sometimes also with an external grounding terminal. When the shield is grounded through the core or a separate connection it reduces capacitance between primary and secondary and thus lessens or prevents transfer of interference voltages through the capacitance to the secondary and the connected receiver.

If you have no isolation transformer, connect an a-c voltmeter with a range of 150 or more volts from the receiver chassis to a water pipe or other good ground to earth. Insert the receiver power cord plug first one way and then reversed in the a-c line receptacle. Use the position giving zero or a very low reading on the voltmeter, which is the position for a cold chassis. Make sure that the plug remains in this position during all tests.

In addition to insuring a cold chassis it is essential to connect the low side or ground lead of the signal generator to the receiver

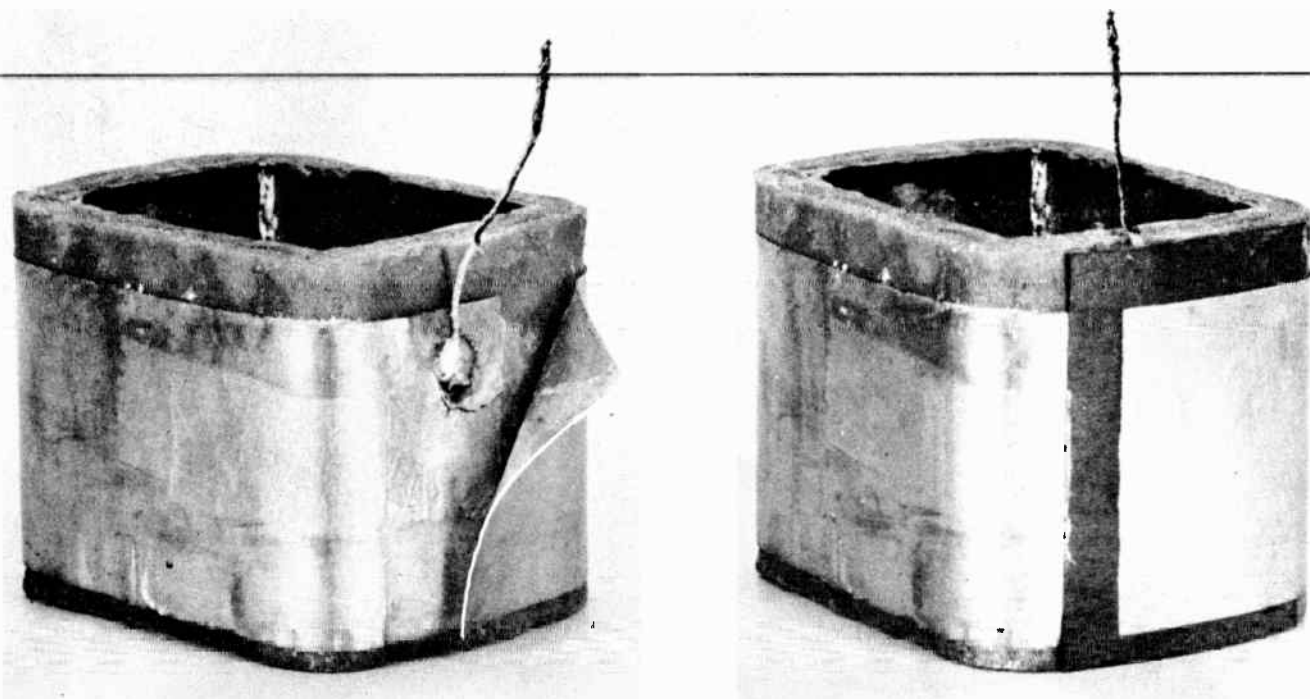

Fig. 8. The electrostatic shield is a single open turn of thin copper between primary and secondary windings.

only through a fixed capacitor of 0.1 mf or greater capacitance, and of d-c voltage rating not less than 150 volts when line voltage is 110-120. A direct conductive connection could result in burnout of the attenuator in the signal generator.

**SPEAKER CONNECTIONS.** With most receivers the speaker will have been disconnected when removing the chassis from the cabinet. If there are only two leads to the speaker it is a permanent magnet type, and may be left disconnected during alignment. In this event it may be well to remove the audio output amplifier or power tube from its socket, to protect the speaker coupling transformer from excessive voltages. This tube must not be removed unless tube heaters are in parallel, not series. Also, in quite a few receivers all or part of the voltages and currents for plates and screens of i-f amplifiers come through the audio section, and if the audio output tube is removed it will cut off or greatly reduce these i-f voltages.

When there are more than two leads or conductors from the chassis to the speaker that unit is of the kind whose field winding is used as a filter choke in the low-voltage d-c

power supply. Fig. 9 is a picture of such a speaker. The large coil immediately above the cone is the field winding. At the right, mounted on the frame of the speaker, is the audio output or speaker coupling transformer.

A speaker of this type must be reconnected during alignment, for without it there will be no B-voltages. The connection may be made with a long multi-conductor cable running from the chassis to a speaker that remains in the cabinet. Nearly always it is more convenient to take the speaker out of the cabinet, lay it near the chassis, and replace the regular connections during alignment. Be sure to protect the fibre or paper cone of the speaker from anything which might strike it. The cone is easily dented or punctured, and then is ruined.

**HIGH VOLTAGE CONNECTIONS.** There is no objection to leaving the picture tube on the chassis and allowing the high-voltage supply to operate during alignment, provided you keep clear of everything carrying the high voltage. With picture tubes having metal cones or flares these metal parts, during operation, are at potentials of thousands of volts positive with respect to chassis metal.

## LESSON 38 – TELEVISION ALIGNMENT

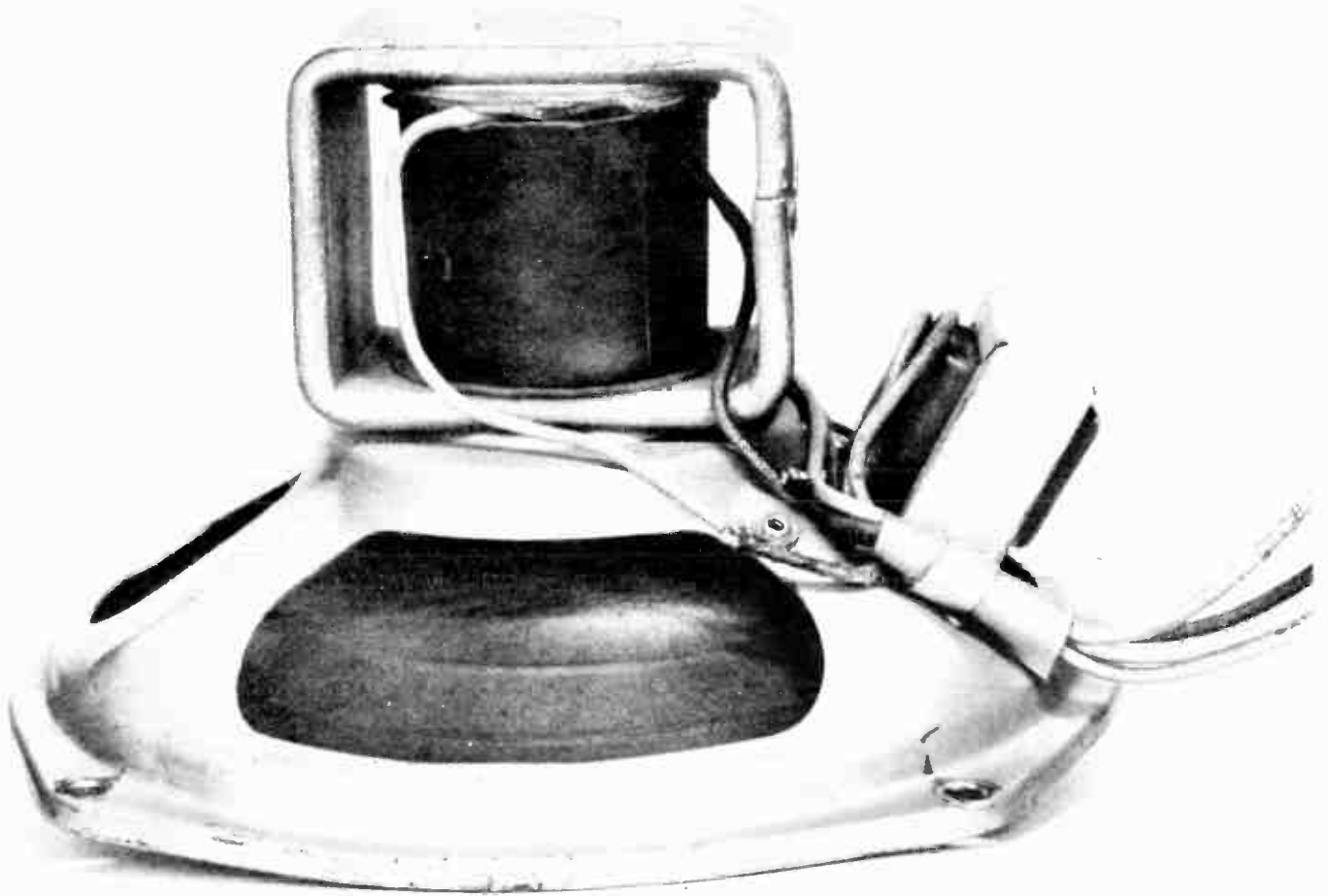

*Fig. 9. The field winding of this speaker is used as a filter choke in the low-voltage d-c power supply.*

Unless the cones or flares are encased by a fibre cover it may be well to disconnect the high-voltage lead, often called the anode lead, or to make the high-voltage power supply inoperative.

The high-voltage lead for metal picture tubes may clip onto the metal rim or lip around the front face of the tube, or a metal tip on the lead may be pushed in between the lip of the tube and surrounding insulation. The clip or tip may be detached, covered with a rubber sleeve, and temporarily fastened where it cannot touch other parts or be touched by any part of your body.

Fig. 10 is a picture of the parts of a fly-back type high-voltage power supply, the type used in most television receivers. Normally everything is enclosed within a perforated or otherwise ventilated metal

housing, part of which has been removed in the picture.

In this particular design the tubes carrying high voltages are the two having top caps that connect internally to the plates. At the cap of the larger tube, the horizontal sweep amplifier, there are 4,000 to 6,000 pulsating volts, and at the cap of the smaller high-voltage rectifier the potential is anywhere from about 8,000 to 12,000 volts or more, depending on the size and type of picture tube.

Removing the clip from the top cap of the horizontal sweep amplifier shuts off production of high voltage, but may affect some of the voltages to the other sections of the receiver. Taking the clip from the cap of the high-voltage rectifier prevents production of high-voltage and does not affect other voltages. Naturally, you will remove either clip





Fig. 10. Caps on the sweep amplifier and rectifier of a high-voltage power supply, also some of the other connections, will give painful shocks if touched.



# LESSON 38 – TELEVISION ALIGNMENT

only while the receiver is disconnected from the power line. When a clip is removed it should be supported where it cannot come close to chassis metal and should be covered with a rubber sleeve.

There is little or no danger from high voltage at an all-glass picture tube unless you expose the connector on the lead that attaches to a terminal on the flare of the tube. Such a connector is shown in place on the flare of a tube at A in Fig. 11. The connector itself, shown at B consists of small springs in the form of a ball that snaps into a recessed metal cavity on the flare. Around the metal of the connector is a soft rubber cup whose edges press against the glass of the tube to form protective insulation all around the terminal.

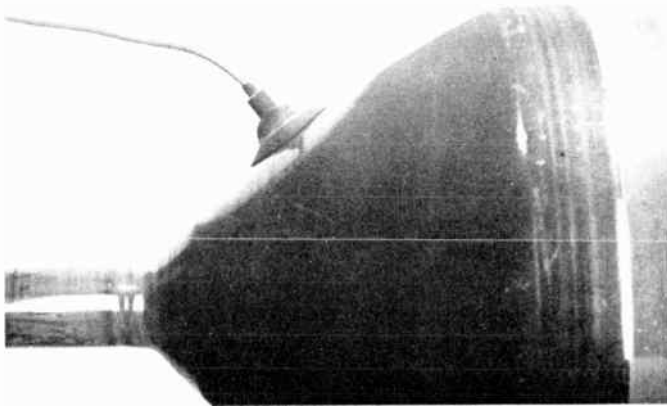

Fig. 11A



Fig. 11B

Fig. 11. A high-voltage or anode connector on the flare of an all-glass picture tube (A) and the construction of such a connector (B).

To disconnect the high-voltage lead fit one side of the rubber, which acts like a suction cup, then pull the spring out of the cavity. If the spring or ball happens to make a fit not too tight it can be pulled free without first lifting the rubber.

When the high-voltage or anode lead is disconnected for any reason, or when the picture tube does not remain on the chassis, the exposed metal tip or ball should be well covered and placed out of the way. If the connector comes in contact with any part of your body you will receive a severe and painful shock, and possibly a small burn, but modern high-voltage power supplies cannot deliver enough current to make the shock dangerous to anyone in normal health.

CONTROLS AND CONNECTIONS. The steps illustrated by Fig. 12 apply to i-f alignment and to sound alignment for receivers using intercarrier sound. Not all of these operations are necessary on all receivers, but they do no harm in any case, and possible omissions will have to be learned by trial on models with which you do a great deal of work. Exceptions for tuner alignment and for alignment when there is a dual sound section will be noted when we come to these operations.

The transmission line coming from either an external or built-in antenna will have been disconnected from the antenna terminals on the chassis when removing the chassis from its cabinet. Do not replace the transmission line, but ground both antenna terminals to chassis metal.

A channel selector having step-by-step positions should be set to the channel of highest number not allocated to any television station in your locality. On some receivers the channel selector has one or more positions where there is no channel number, and should be placed at any such position. A continuously adjustable tuner, not a stepped type, should be adjusted to a frequency not used for television, or to a frequency between the low and high bands of the very-high frequency range.

To further prevent possible pickup of transmitted signals, the first or only r-f

## COYNE - television home training

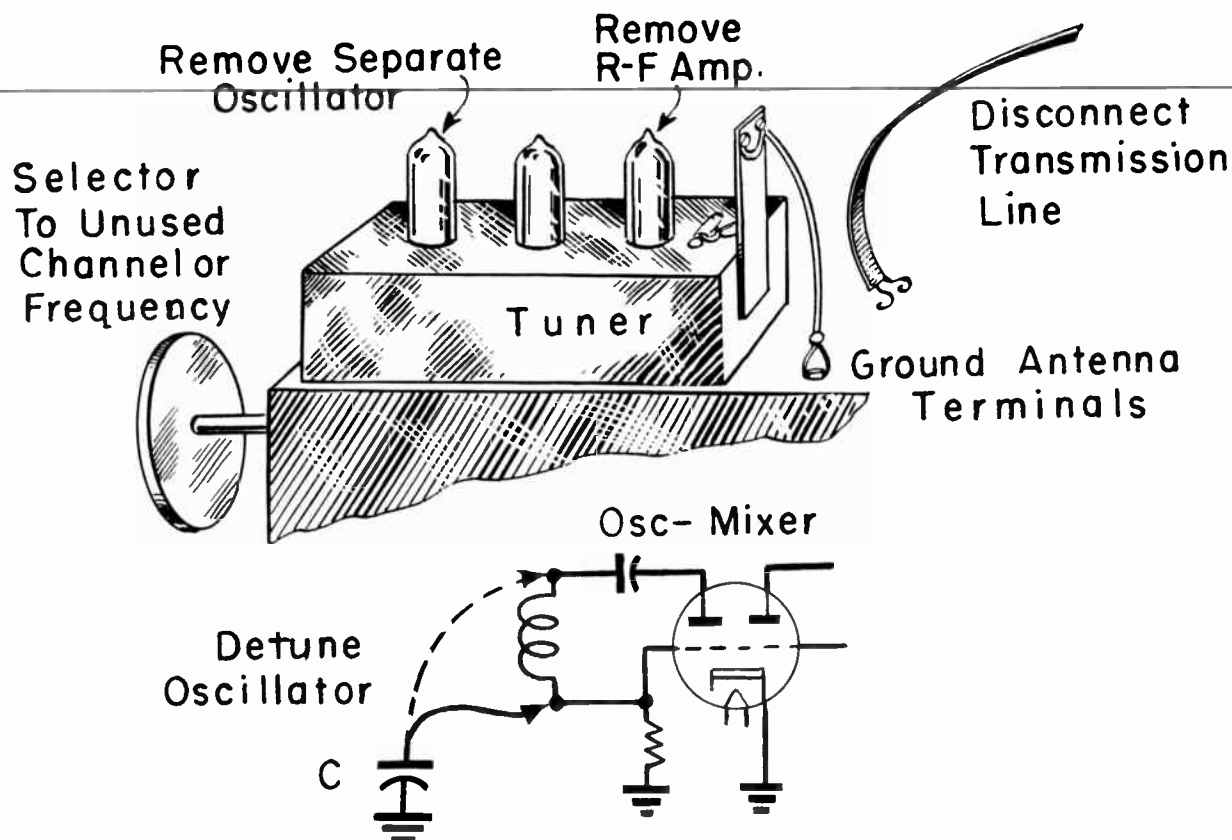

Fig. 12. Some of the steps which precede alignment of i-f and sound sections.

amplifier tube may be removed from the tuner provided tube heaters are connected in parallel, not in series with one another.

Make the r-f oscillator inoperative. When the oscillator is a separate tube, and tube heaters are in parallel, the oscillator tube may be removed from its socket. Otherwise ground either the plate or grid side of the oscillator tuned circuit through a fixed capacitor of 1,000 mmf or greater capacitance to chassis metal or B-minus. A combined oscillator-mixer tube must not be removed, because the mixer will be needed during alignment.

If any tubes which will be connected between the signal generator and output indicator during alignment are provided with shields, these shields must be in place during alignment. Were adjustments made without the shields in place and grounded to chassis metal the peaking would be changed upon replacement of the shields. Later we shall come to a possible exception to this rule, when the input signal is applied through the shield of a mixer tube.

Coupling transformers and coils which are provided with shielding cans always have provision for making adjustments without removing the shields. That is, the adjuster screws or nuts extend through the shield or are reached through holes in the shield. It is a general rule that all regular shielding should remain in place during all alignment operations, whether work is being done on the i-f section, the tuner, or the sound section.

**- OVERRIDING THE AUTOMATIC GAIN CONTROL.** The automatic gain control for a television receiver acts similarly to the automatic volume control for a sound receiver, it maintains fairly constant gain or amplification when received signals vary in strength. The television automatic gain control, abbreviated agc or AGC, acts on some or all of the i-f amplifier tubes and usually on the r-f amplifier in the tuner.

Unless the automatic gain control is overridden by a fixed bias it will vary the amplification to hold the output signals quite constant even when there is tendency for out-

## LESSON 38 — TELEVISION ALIGNMENT

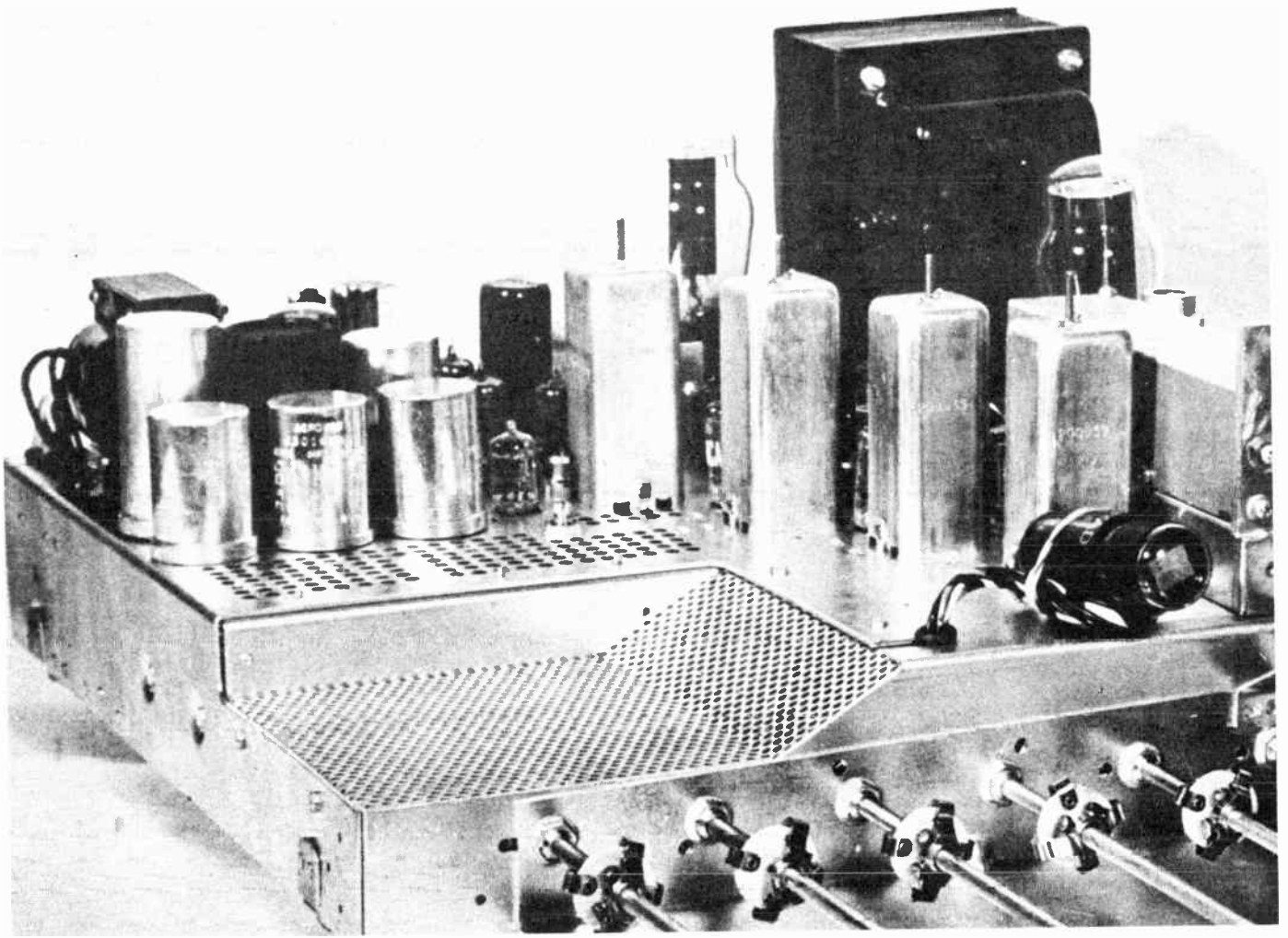

*Fig. 13. On most television chassis there are numerous shields.*

put to increase in strength. It increases of output signal as shown by the VTVM that are depended upon to indicate correct peaking of the various couplings during alignment, and if signal output is leveled off by agc action it will be impossible to make adjustments with any great accuracy.

In theory it is possible to keep signal voltage from the generator so low that there is no agc action. In practice it is difficult to do this with any certainty, especially when using the VTVM as output indicator. For this reason it is accepted practice to override the automatic gain control.

Some typical examples of agc systems are shown by Fig. 14. At 1 the d-c control voltage is taken from the video detector load resistor and applied to the agc bus. At 2 there is an agc amplifier tube between the de-

tector load resistor and the agc bus. At 3 the two sections of a twin diode are used as video detector and agc rectifier. The agc rectifier section produces a d-c control voltage from the i-f signal voltages.

Later we shall examine various agc systems in detail, but for the present we need only know that, regardless of how the agc voltage is obtained, it may be over ridden by connecting a dry cell battery between the agc bus and chassis ground or B-minus, just as when overriding the automatic volume control during alignment of a broadcast sound receiver. You can locate the agc bus by tracing connections from grids of i-f amplifier tubes. When you find two or more of these grid returns completed through resistors to a common line along which are fixed capacitors to ground, that line is the agc bus.

# COYNE - television home training

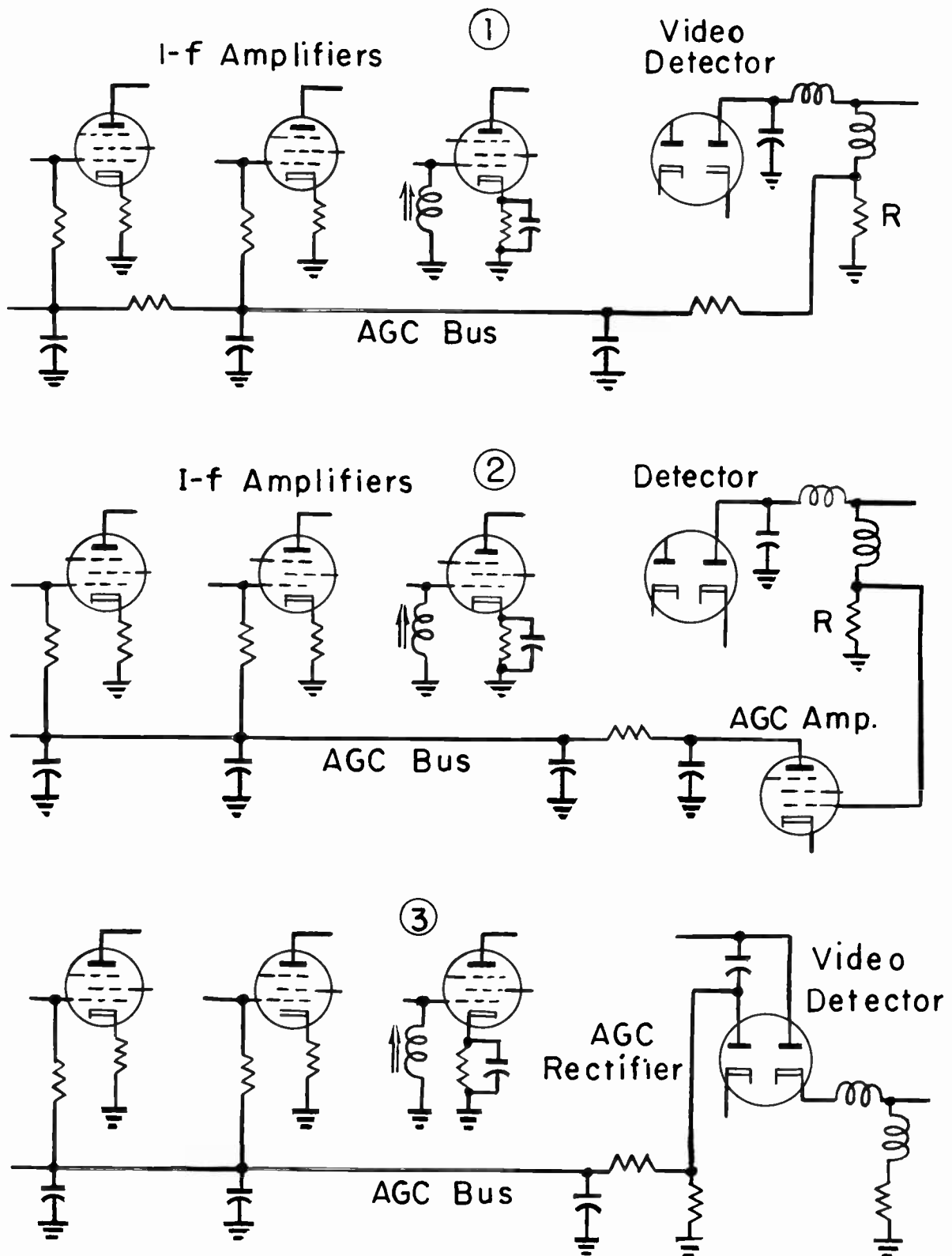

Fig. 14. Connections to the agc bus with several simple types of automatic gain control.



## LESSON 38 — TELEVISION ALIGNMENT

Should there be any doubt, place the receiver in operation and measure the d-c voltage to chassis ground or B-minus from the line you think is the agc bus. Use either a VTVM on a low d-c range or else a sensitive d-c moving coil voltmeter. If this voltage is negative at the line and if it varies with strength of input signal voltage you are on the agc bus. Signal strength may be varied for checking by tuning to different stations or by altering the setting of a line tuning control when signals are those transmitted from broadcasters. With the signal generator connected, altering the attenuator settings of the generator should vary the agc voltage until it is overridden.

Having located the agc bus, connect the negative side of the biasing battery to the bus and the positive side to chassis ground or B-minus. Make this connection at or near one of the grid returns, not directly at the detector load, nor at an agc rectifier, nor an agc amplifier tube. A negative bias of 3 volts, from two dry cells in series, will be satisfactory in nearly all cases. Bias voltage may be dropped to  $1\frac{1}{2}$  or increased to  $4\frac{1}{2}$  volts, with one or three dry cells, should output signals be too weak or too strong with a 3-volt bias.

**INSTRUMENT CABLES.** The cable which carries signal voltages between the signal generator and receiver circuits must be of the shielded type. The cable shield is connected at one end to the low side or ground side of the generator, and at the other end to chassis ground. B-minus, or other specified point on the receiver. The high-side lead is the central insulated conductor of the cable. The low-side lead is the braided shield of the cable. Shielded cables are necessary also for oscilloscope connections, and they are desirable but not essential for d-c connections of the vacuum tube voltmeter.

Fig. 15 shows two shielded cables connected to a test instrument. At the left the cable is carried by a phone plug which pushes into a jack mounted in the instrument case. At the right is a so-called microphone connector which screws onto a fitting mounted in the instrument case. Connectors of this latter type first were used on microphone

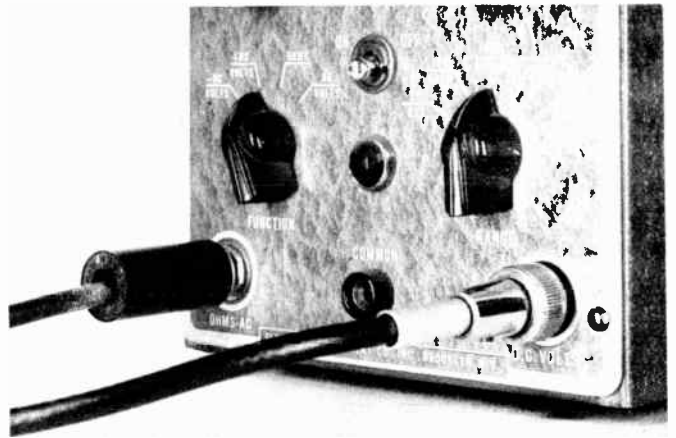

Fig. 15. A shielded cable may be connected to a test instrument by a phone plug and jack (left) or by a microphone connector (right).

cables, but now are found on many kinds of service instruments.

The parts of a phone plug and jack are shown by Fig. 16. At A is a hollow plastic sleeve internally threaded at one end so that it may be screwed onto the plug body to protect the cable terminals. The body of the plug, at B, carries at its righthand end an extension consisting of a metal sleeve about  $1/4$  inch in diameter within which is an insulating tube that encloses a small metal rod extending through to a ball-shaped tip. This extension sleeve is electrically a part of the body of the plug and of the terminal that takes the shield of the cable. The tip connects through the central rod to the other terminal, which takes the high-side insulated conductor of the cable.

At C is a phone jack. The body of this jack, which fastens into the instrument case, will be contacted by the sleeve of the plug and thus connected to the shield of the cable. The extension spring of the jack is insulated from the body and may be connected to any internal circuit of the test instrument. This spring will be contacted by the tip of the jack, and thus connects internal circuits of the instrument to the central conductor of the cable. At D a phone plug is shown inserted in a jack. Here may be seen the manner in which the tip of the plug makes contact with the end of the jack spring.

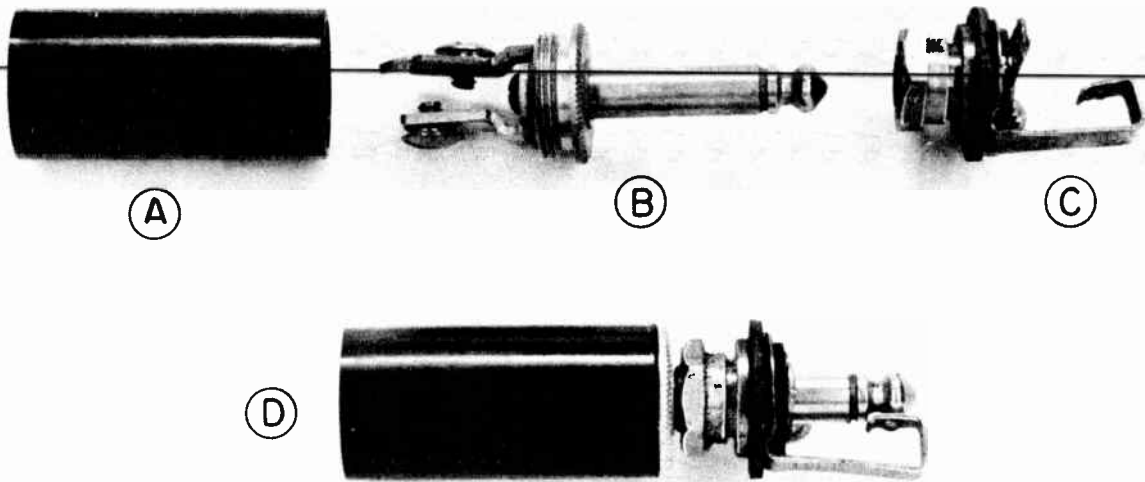

Fig. 16. Construction of a phone plug and jack.

Fig. 17 shows the parts of a microphone connector. At A the end of a shielded cable has been passed through a coiled spring whose purpose is to make connection with the cable shield while preventing a sharp bend of the cable where it enters the connector. The cable shield is bared of its outer covering for a short distance, is pushed through the coiled spring, and part of the shielding braid is turned back over the end of the spring. The turned-back braid may be joined to the spring with a thin layer of solder. Beyond the braid and spring is a short length of exposed cable insulation that surrounds the central conductor. This conductor extends

for a fraction of an inch beyond the insulation.

The spring and cable end are pushed into the hollow sleeve of the female connector shown at B, and are held securely by a small set screw in the sleeve. On the right-hand end of this female connector is an internally threaded cup which turns freely on the sleeve but cannot be detached from the end of the sleeve.

At C is an end view of the threaded cup, showing also the end of the sleeve within the cup. When the cable conductor is pushed into the sleeve, the end of the conductor comes

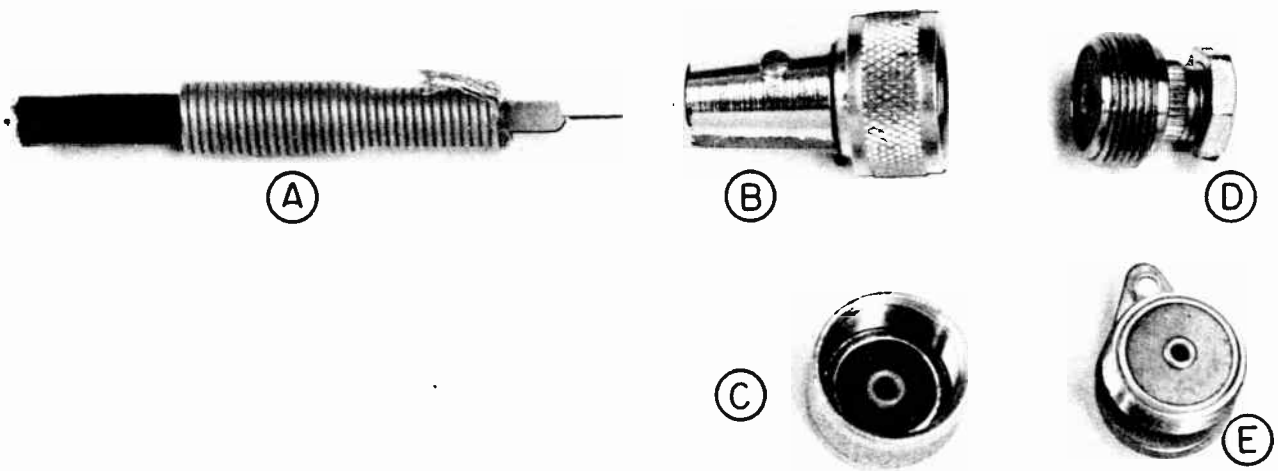

Fig. 17. Construction of a microphone connector.

## LESSON 38 – TELEVISION ALIGNMENT

through a small metal-lined opening at the center of an insulating plug carried by the sleeve. The end of the conductor is held in this opening by a drop of solder.

At D is the male microphone connector which is drawn tightly into a suitable hole in the instrument case and held there securely by tightening the hexagon nut. The outside of this male connector is threaded to take the internal threads of the cup on the female connector. At E is an end view of the male connector. There is an insulating plug at whose center is a metal-lined hole. Any conductor from internal circuits of the test instrument may be passed into this hole and held there by a drop of solder.

When the female connector and cable are screwed onto the male connector, the center soldered points are pressed together, and in this way the high-side conductor of the cable is electrically connected to the conductor leading into the instrument circuits. At the same time the cable shield is connected through the screw coupling to the metal case of the instrument.

Instrument cables should be as short as can be used conveniently. The reason is that usual types of shielded cable have capacitance between the inner conductor and the braided shield of about 20 mmf per foot of length. This much capacitance has rather low reactance at television intermediate and carrier frequencies, and bypasses much signal strength to the grounded side. More important, much of the cable capacitance may be added to circuits tested, and then will have a decided detuning effect where the circuits are resonant types. Instructions in order lessons will specify the use of small fixed capacitors and high-value resistors at the receiver end of high-side cable conductors. Part of the reason for the capacitors and resistors is to lessen the detuning effect of cable capacitance.

In order to have uniform transfer of signal power from generator to receiver without certain peculiar effects quite similar to resonances in the shielded cable, this cable should be correctly "terminated" at the receiver end. A terminated cable has between

its high-side and low-side conductors, at the receiver end, a resistor whose value is equal to or very close to the effective resistance of the attenuator system in the signal generator. Such resistances most often are between 50 and 75 ohms, but may be as low as 30 ohms or as high as 200 ohms. Signal power from the generator appears across this terminating resistance or impedance, and from it is delivered to the receiver circuits.

ALIGNMENT TOOLS. Tools needed for adjustment of inductors and capacitors during television alignment are much like those used for alignment of sound receivers. For adjustments in i-f and sound sections it usually is sufficient to have one or more screw drivers with thin, narrow points and shanks or blades four to five inches long.

Except for use on adjusting screws which are mounted in or pass through chassis metal only the tips of i-f alignment screw drivers should be of metal, with shanks and handles of plastic or other non-metallic material. Tuner alignment operations involving adjusters which are not directly in contact with chassis metal should be performed with tools made entirely of fibre, plastic, or other non-metals. Alignment of r-f oscillators often calls for non-metallic screw drivers or wrenches with long, thin blades. Special tools, possibly with hexagon shaped tips or sockets, or of various special shapes, are needed for a few receivers.

Fig. 18 illustrates several wrenches and screw drivers which may be useful for alignment and other adjustments. The tool at the top has socket wrenches of different sizes on opposite ends. Next below is a tool having a screw driver tip at one end and a socket wrench at the other end. Third from the top is an alligator wrench, which fits any of many sizes of nuts, combined with a socket wrench. At the bottom is a screw driver with a rather long, thin blade at one end, combined with what looks like a socket wrench at the other end, but really is a screw driver tip within a recessed opening which helps hold the tip in place on a screw slot. Various other alignment tools were illustrated in lessons dealing with this class of work on standard broadcast receivers.

**COYNE - television home training**

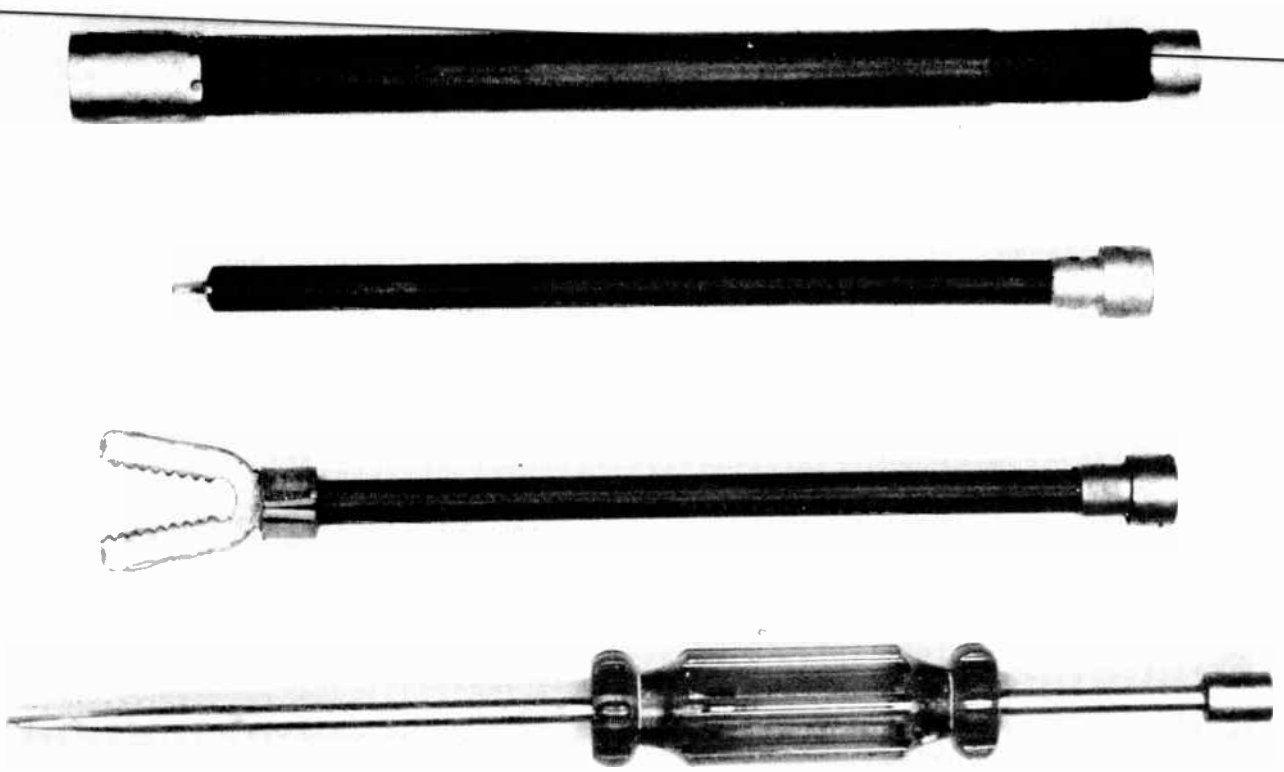

*Fig. 18. Tools sometimes used for making adjustments on television receivers.*



# TELEVISION

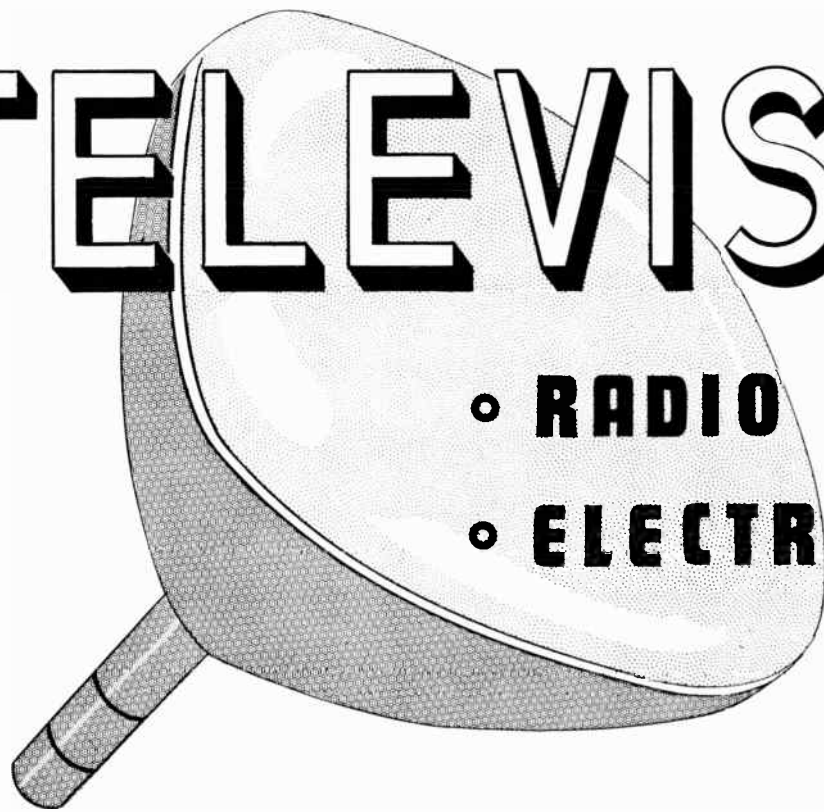

◦ **RADIO**

◦ **ELECTRONICS**

---

**LESSON 39 – ALIGNMENT WITH THE VACUUM TUBE VOLTMETER**

---

***Coyne School***

*practical home training*

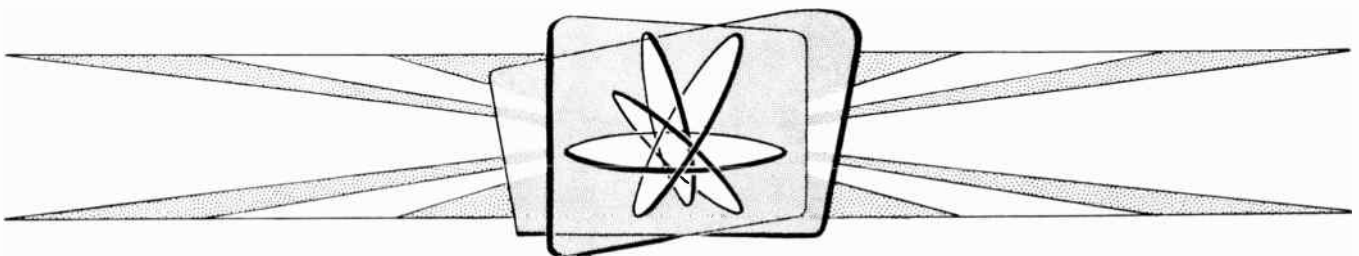

*Chicago, Illinois*

---

*Copyright, 1953 by Coyne Electrical School  
Chicago 12, Illinois  
All rights reserved*

Litho. in U.S.A.

## Lesson 39

### ALIGNMENT WITH THE VACUUM TUBE VOLTMETER

In order to align an i-f amplifier section by using a vacuum tube voltmeter as output indicator it is necessary to know the frequency at which each of the interstage couplings should be peaked. These frequencies may be learned from manufacturer's instruction manuals or from publications giving this and other service information. If such data is not available for a particular receiver it is, of course, possible to make a complete new alignment in accordance with frequencies for some other receiver designed for the same video and sound intermediates and having the same number of i-f stages. But such complete realignment should not be undertaken until you have fairly wide experience in service work.

Assuming that preliminary steps outlined in an earlier lesson have been carried out, it is in order to continue by making suitable connections between test instruments and receiver, and by making the actual adjustments on interstage couplings and traps.

#### SIGNAL GENERATOR CONNECTIONS.

The signal generator may be of any type which can be tuned to the intermediate frequencies of the set to be aligned. The high side of the generator output cable ordinarily is connected first to the grid circuit of the mixer tube. The low side of this cable is connected to chassis ground or B-minus at a point as close as convenient to the socket for the mixer tube.

The high side connection must not provide a conductive path from the tube grid to ground or B-minus through the attenuator of the generator, for that would short circuit the mixer grid bias voltage. A capacitor must be somewhere between the attenuator which is inside the signal generator and the mixer grid circuit. Such a capacitor might be in the generator, although this is unlikely for the reason that in certain other operations a capacitive connection is not wanted. Sometimes a series capacitor is built into the outer end or probe end of a generator cable

to be used only when a capacitive connection is needed.

Unless you know that there is a capacitor in the generator or cable, one must be connected in series between the high-side of the cable and the mixer grid circuit. This capacitor may be of 20 to 100 mmf, or more. The value is not critical, since any capacitance in this range has reactance of less than 500 ohms at any intermediate frequency.

If the set manufacturer has provided test points on top of the chassis the setup would be generally similar to that of Fig. 1. The input connection, on the tuner, usually leads to a tap on the mixer grid return resistor. This is the connection to which a cable comes down from the signal generator, at the upper left. The VTVM, at the upper right, is connected to the load circuit of the video detector which, in the picture, is made accessible through a second test point on top of the chassis.

When there are no readily accessible test points it still is possible to make top chassis input connections in any of several ways. A simple connection or, rather, a coupling, may be made if a separate mixer tube or a combined oscillator-mixer tube has a close fitting metal shield. Lift the shield just high enough to clear the grounding clamps that normally hold it on the chassis and, if necessary, support the shield in this position. Clip the high side of the generator output cable directly to the shield, at the top opening. Do not use a series capacitor, since there is now a capacitive coupling between the shield and the internal elements of the tube, with the glass envelope and internal vacuum space acting as dielectric.

If no shield is regularly fitted on a separate mixer tube, as commonly is the case, do not use a shield from your own stock to make a coupling. Such a shield contains enough metal surface to materially affect the grid circuit capacitance, and alignment might

COYNE - *television home training*

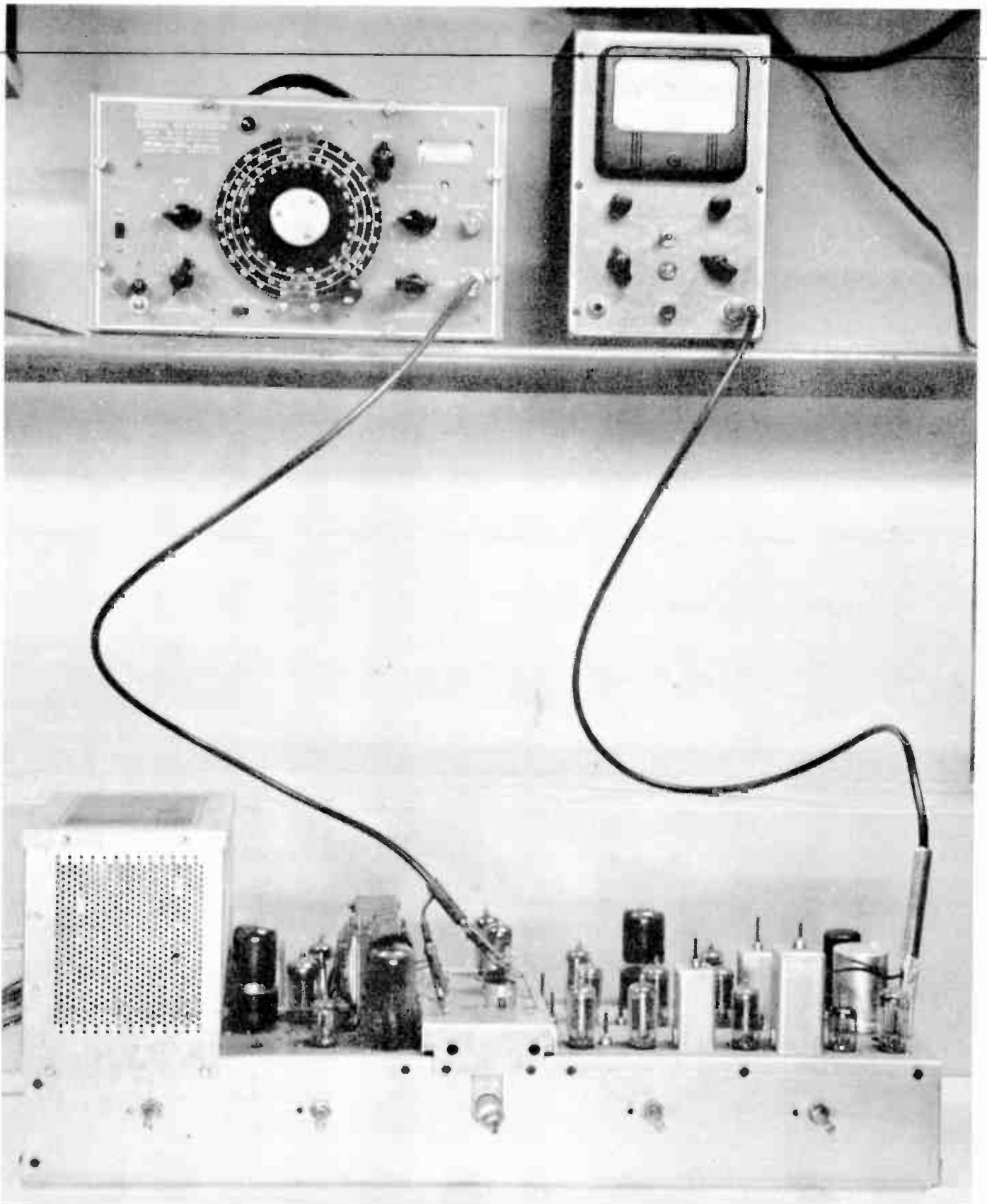

Fig. 1. On some receivers the signal generator and vacuum tube voltmeter may be connected to test points on top of the chassis.



## LESSON 39 — ALIGNMENT WITH THE VACUUM TUBE VOLTMETER

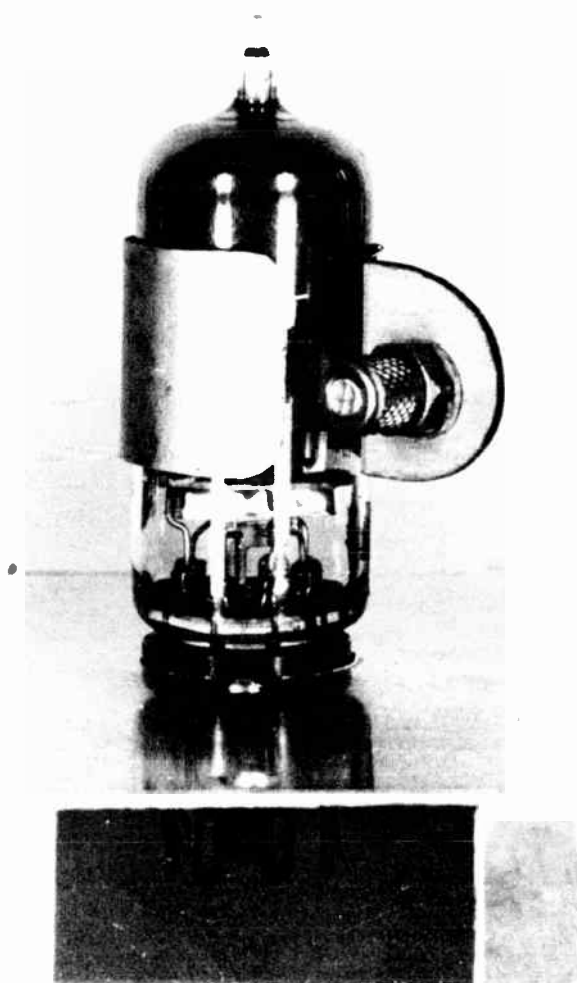

Fig. 2. With the signal generator connected to an open ring, like this one, there is a capacitive connection to the tube elements.

be upset upon removal of the temporary shield.

A capacitive coupling to any tube may be made with an open ring of any nonmagnetic metal, shaped to slide down over the tube envelope. Such a ring is shown in place on a tube by Fig. 2. Such a gadget may be formed very easily from sheet aluminum, copper, or brass by bending a strip of the metal to fit miniature tubes used for tuners. Clip the high side lead from the signal generator directly to the metal ring, without a series capacitor. The degree of coupling or the effective coupling capacitance may be varied by sliding the ring up or down, closer to or farther from the internal elements of the tube.

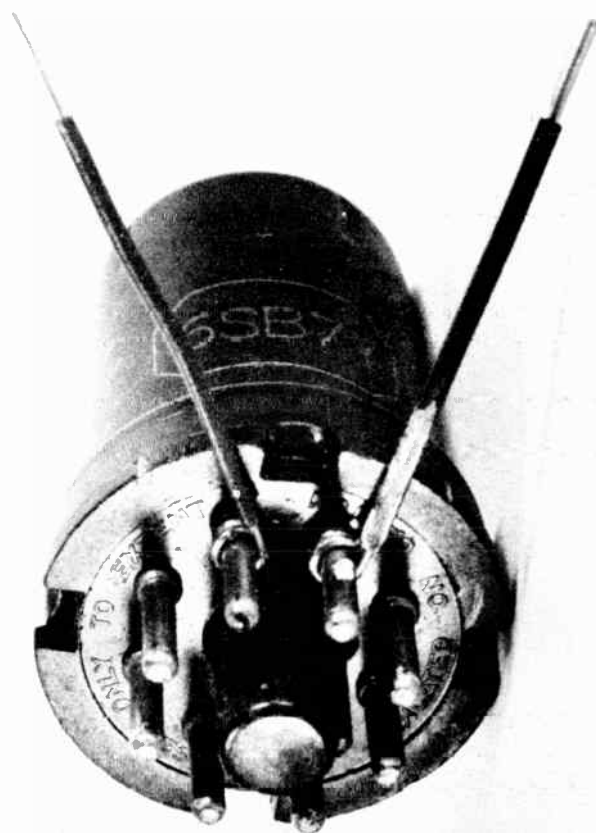

Fig. 3A

An input connection may be made also by winding the bared end of a piece of wire around the grid pin on the base of the mixer tube. The method is illustrated at A in Fig. 3, where connections have been made to two of the base pins on an octal type metal tube. Use the smallest solid-conductor hookup wire on hand, preferably of the kind with plastic insulation. Bare only enough conductor at one end to make a single tight turn around the tube pin, with the remaining insulation coming right to the pin so that this conductor will be insulated from the chassis when the tube is put back into its socket. Cut the wire as short as will allow a series capacitor to be attached to the free end, also bared. The capacitor must be used to prevent a conductive connection to the grid.

At B in Fig. 3 is shown a wire test lead on the base pin of a miniature tube which has been replaced in its socket. Always examine the connection after the tube is in place to make sure that the bare conductor does not touch metal of the chassis or the tube socket.

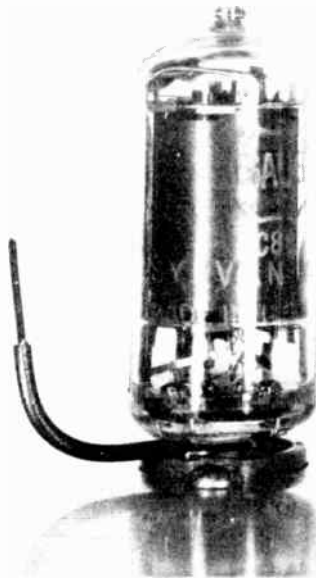

Fig. 3B

Fig. 3. Wire ends may be twisted around tube base pins for connection of the signal generator or other instruments to various tube elements.

A top-chassis connection may be made to any element of any tube by using a test adapter as pictured by Fig. 4. The adapter by itself is shown at the left, and at the right is shown in use. This device consists of a tube socket at the top and the equivalent of a tube base with pins at the bottom, with small metal tips brought out around the sides of the socket member at positions opposite each base pin. The adapter is inserted in the regular socket on the chassis and the tube is inserted into the top of the adapter, as illustrated. Test connections of any kind, with or without a series capacitor, then may be made to the appropriate tip on the adapter.

An objection sometimes made to test adapters is that their connecting leads add excessively to the capacitances between internal elements of tubes. In actual practice,

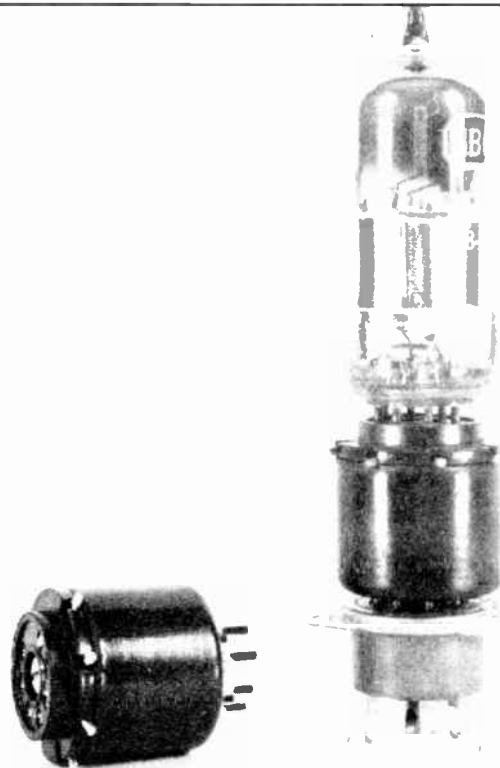

Fig. 4. A test adapter and how it is used between a tube and socket to allow test connections at any element.

however, the adapters seem to work out quite well. They are especially useful also for measuring plate voltages, screen voltages, and cathode bias voltages where socket leads underneath the chassis may be rather difficult to reach.

An advantage sometimes claimed for any of the above-chassis connections from signal generator to grid is that the generator output then is shielded by chassis metal. There is, of course, a certain amount of signal radiation from the cable clips and other connections exposed beyond the cable shield. With under-chassis test connections it may be possible for such radiation to reach circuits in which it is undesirable.

When there are no signal input test points on top of the chassis, and when none of the other top-chassis connection methods are used, it always is possible to turn the re-

## LESSON 39 — ALIGNMENT WITH THE VACUUM TUBE VOLTMETER

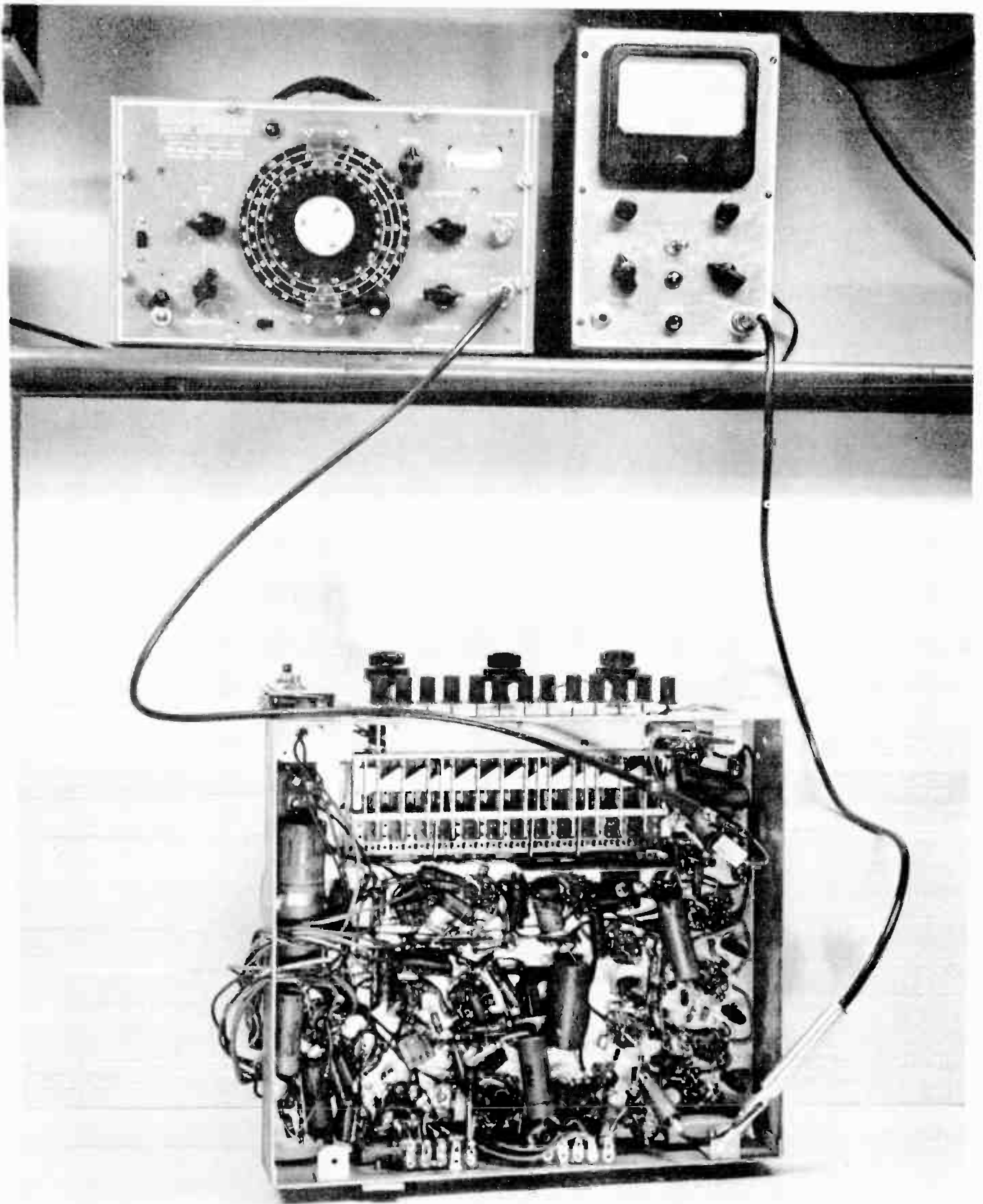

*Fig. 5. When no test points are on top of the chassis the instrument connections may be made underneath.*



# COYNE - television home training

ceiver on its side and make the connections underneath. Such a method is illustrated by Fig. 5.

The high side of the generator output cable is connected through a series capacitor to the socket lug for the mixer grid or to a bare wire attached to this lug. The connection should be as close as possible to the socket, if not directly on the socket. The low side or ground side of the generator cable should be clipped to chassis metal or B-minus as close as possible to the mixer socket. Incidentally, the small chassis pictured is of a kind used with a separately mounted picture tube and separate power supply unit, all connected together by multi-conductor cables when in their cabinet.

As a general rule the i-f amplifier section may be aligned by connecting the output cable of the signal generator to the antenna terminals of the receiver instead of to the mixer grid circuit. Sufficient signal energy at intermediate frequencies usually will come through to the mixer and i f amplifiers unless there is an antenna-circuit trap tuned in the i-f range of the receiver. The high and low sides of the generator cable may be connected directly to the two antenna terminals or to either antenna terminal and chassis ground, whichever way gives better results. Do not use a series capacitor on the high side lead.

The signal generator is to be used unmodulated, with pure r-f output. The generator is tuned to the peaking frequency for the interstage coupler or couples to the first aligned. Two couplers often are aligned for the same peak frequency when stagger tuning is used in the i-f amplifier.

**VTVM CONNECTIONS.** If there is an output test point on top of the chassis the connection may lead to the high side of the video detector load resistor, A in Fig. 6, or to the top of the inductor which is in series with the load resistance, at B. If there is no such test point on the receiver, the high side lead from the VTVM may be clipped directly to either of these points in the detector load circuit underneath the chassis. No series capacitor is used on the VTVM lead, because here you will be measuring a direct voltage.

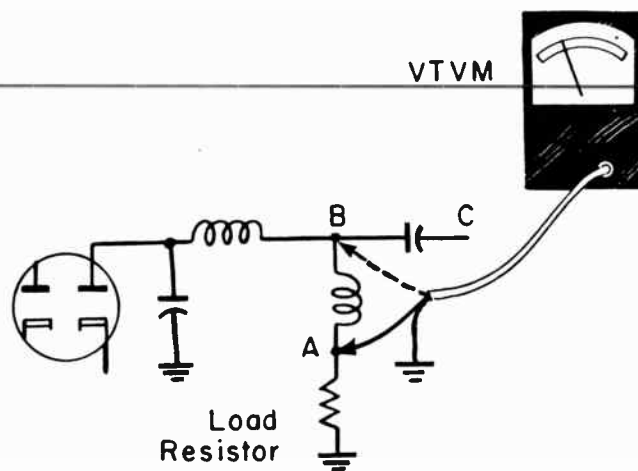

Fig. 6. Points in the video detector load circuit at which the vacuum tube voltmeter may be connected.

Do not connect the VTVM to any point beyond a blocking or coupling capacitor which follows the detector load circuit, not to any point beyond C of Fig. 6. The capacitor would block the direct voltage which is to be measured. Connect the low side or ground side of the VTVM to chassis ground or to B-minus. It is not particularly necessary that this connection be made close to the high side lead, make it wherever convenient.

Set the range selector of the VTVM for the lowest voltage range, usually 5 volts or less. The output of the signal generator will be reduced as alignment proceeds, in order to keep the meter reading within this voltage range. Set the function selector of the meter for d-c voltage, either positive or negative to begin with. Should the meter read down or off scale on the down side during your first tests, change the function selector to the opposite d-c polarity. The correct polarity varies with design of the video detector and video amplifier circuits.

VTVM connections to the load circuit of a crystal diode video detector are the same as shown to the load circuit of a diode tube detector.

The VTVM may indicate voltage when the instruments and receiver are turned on, but with no signal applied to the receiver circuits. This reading may be due to a d-c bias voltage for the video amplifier that fol-



## LESSON 39 — ALIGNMENT WITH THE VACUUM TUBE VOLTMETER

lows the detector, or possibly to a bias for a crystal diode detector. The initial no-signal indication of voltage may be due also to contact potential in a diode tube used as video detector. There is no contact potential from a crystal diode detector.

When voltage is indicated by the VTVM with the signal generator temporarily disconnected, to insure that signal voltage really is absent from the mixer, the meter pointer should be brought to zero by means of the zero adjuster. If the voltage is too great for compensation by the zero adjuster, the pointer may be brought to any convenient reference point on the scale, such as to exactly 1.0 volt. Then this reference point will thereafter indicate actual zero signal output from the video detector.

**COUPLING ADJUSTMENTS.** Before adjusting the interstage couplers set the contrast or "picture" control to a usual operating position or slightly lower, and set the brightness control for minimum brightness. The setting of hold controls has no bearing on i-f alignment adjustments. If the receiver has anything in the nature of a sensitivity control it should be set for maximum sensitivity.

Now the receiver, the signal generator, and the vacuum tube voltmeter should be turned on and allowed to warm up for at least 15 minutes, or preferably for a longer time, up to 30 minutes. Frequencies will not be stable until all parts reach their normal operating temperatures.

Interstage couplers which are to be peaked at the frequency for which the signal generator is tuned now are adjusted for maximum reading of the VTVM. As the voltage increases with the adjustments brought more and more nearly to the correct points, reduce the output of the signal generator to keep the reading of the VTVM from going above one or two volts at most. When you believe that an adjustment is correct, vary it back and forth several times to make certain that the final setting actually is that for highest voltage.

If other couplings are to be peaked at the same frequency it usually is advisable to make those other adjustments before changing the tuning of the signal generator. If you

change to some other frequency and later try to come back to the original one it is unlikely that the second tuning will give precisely the original frequency, even though the dial readings apparently are alike. Careful measurements might show different results when tuning from a lower frequency to the one wanted and when tuning from a higher frequency downward to the one wanted.

**ORDER OF ALIGNMENT.** When aligning an i-f amplifier section we always commence with the transformer or coupler immediately preceding the video detector and work back to the one which follows the mixer. The general idea is illustrated by the upper diagram of Fig. 7. As previously explained, the signal generator is connected through a blocking capacitor C to the mixer grid circuit, and the VTVM is directly connected to the video detector load circuit. Then the couplers are adjusted in either of the numbered orders, from 1 to 4, always commencing with the coupler just ahead of the detector.

If all the couplers are to be peaked at different frequencies the adjustments are made consecutively from detector back to mixer, retuning the signal generator for each step. If two out of four couplers were to be peaked at the same frequency, the second adjustment would be of the one whose peak frequency is to be the same as that of the coupler preceding the detector. Then the generator would be retuned for the second frequency, and the two remaining couplers would be adjusted. The diagram illustrates three i-f amplifier tubes and four interstage couplings or transformers. The same principle would apply with four amplifiers and five couplings, always commencing just ahead of the video detector and ending with the unit that follows the mixer.

This method with which the signal generator remains connected at the mixer grid during all adjustments is suitable when there is no great misalignment to begin with, in which case the realignment often is referred to as a "touch-up" job.

If the i-f amplifier section is badly out of alignment it usually is necessary to follow the method illustrated by the lower diagram of Fig. 7. Here the VTVM is connected, as

# COYNE - television home training

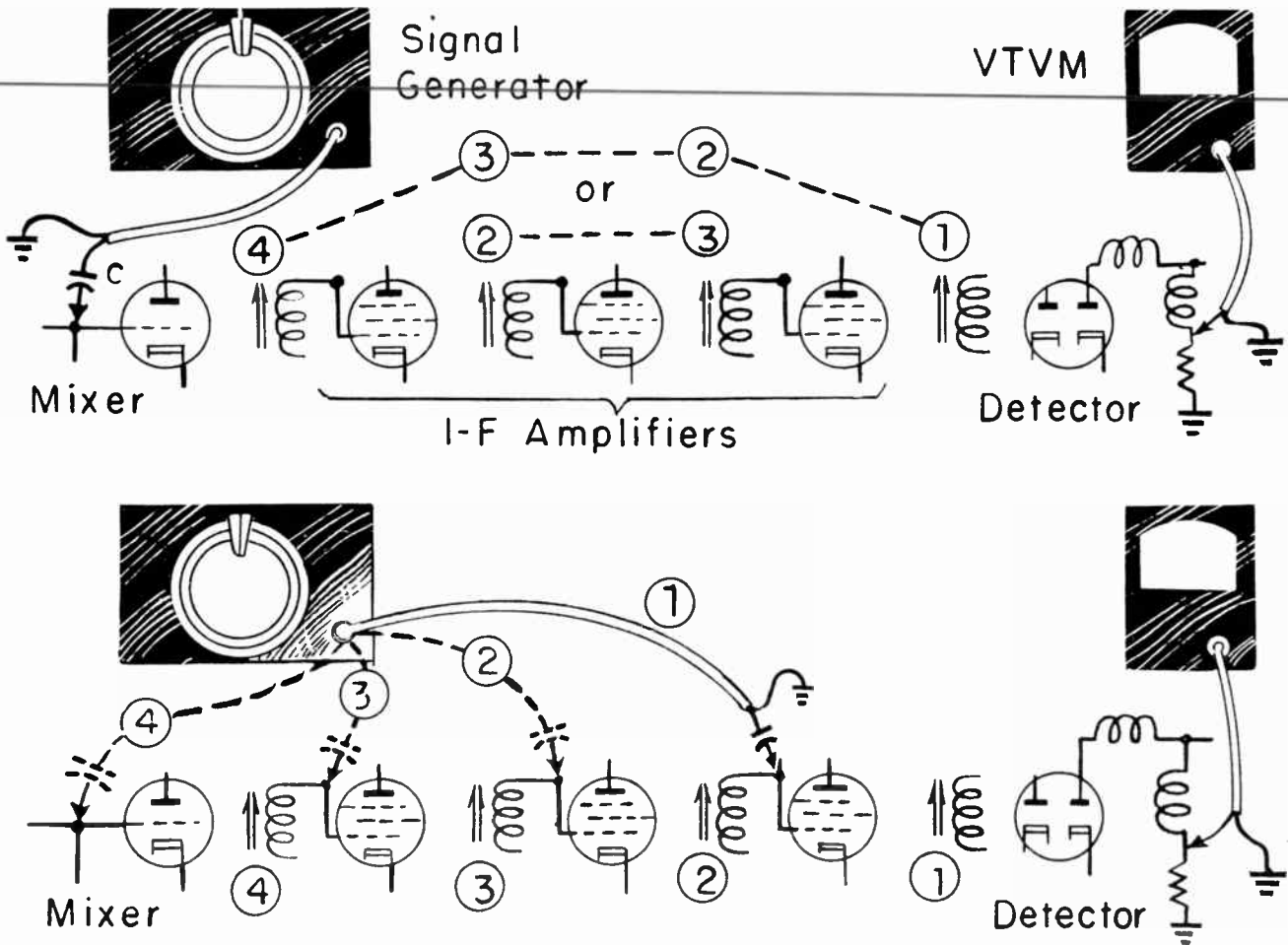

Fig. 7. Orders or sequences in which interstage transformers or other couplings may be aligned.

before, to the video detector load circuit and left there during the entire job. But instead of connecting the signal generator to the mixer grid circuit the generator is connected first to the grid of the amplifier tube immediately preceding the last transformer or coupling unit. This connection is numbered 1 on the diagram. With the generator thus connected, proceed to adjust the last coupler, also numbered 1.

Then the generator cable connection is moved back to the grid of the next amplifier tube toward the mixer, as at 2, while the coupler numbered 2 is adjusted. It will be necessary to retune the signal generator to the peaking frequency for this second coupler. The connection of the VTVM is not altered. For the third step the generator connection is moved to the grid of the next tube, as at 3, is tuned to the peak frequency for coupler numbered 3, and this coupler is ad-

justed. Proceeding in similar fashion, the generator connections is moved back one stage at a time, is retuned for each shift, and adjustment is carried out on the coupler that follows the generator connection. The final connection of the generator is to the grid of the mixer.

With either of the methods described, the reading of the VTVM will increase as more and more couplings are brought into correct alignment. The output of the signal generator must be reduced to bring the VTVM reading down to one or two volts as a maximum.

After all stages have been aligned by either of these methods, leave the generator and VTVM connected as in the upper diagram while making slight readjustments of every transformer or coupler. Remember to retune the generator for the peaking frequency

## LESSON 39 — ALIGNMENT WITH THE VACUUM TUBE VOLTMETER

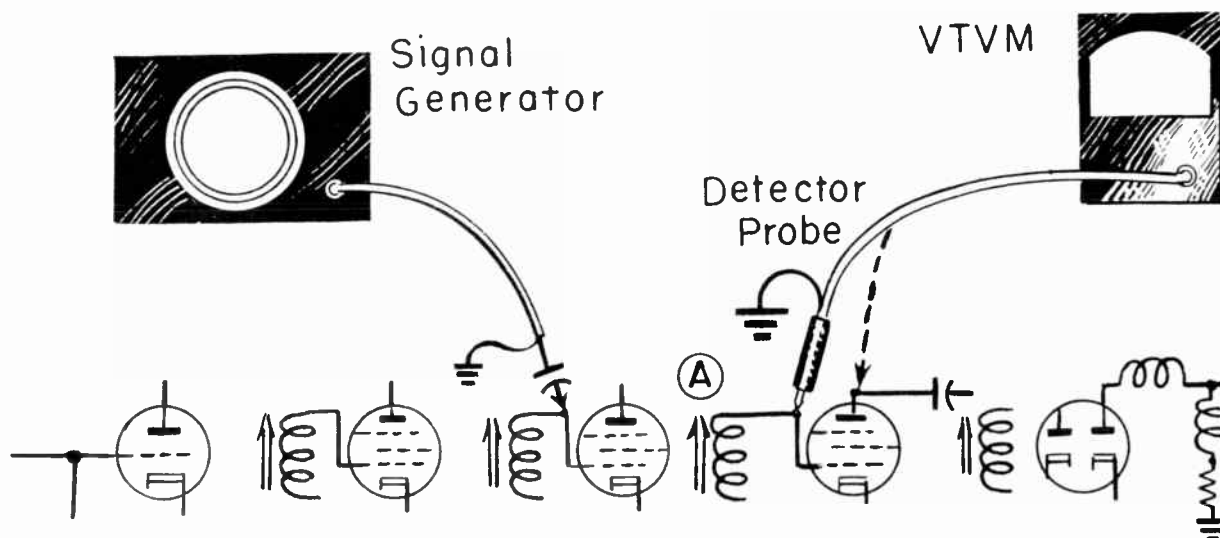

Fig. 8. Instrument connections for aligning a single stage without the signals passing through other stages.

of whichever coupling is being adjusted. If you forget to do this, and forgetting is very easy, the whole section will be farther out of alignment when you finish that it was to begin with.

It is possible to align any one stage or any one coupling as illustrated by Fig. 8. The signal generator is connected through the usual blocking capacitor to the grid of the amplifier preceding the coupling to be aligned, here marked A. The VTVM is connected through a detector probe to the grid of the following tube. The detector probe is necessary because voltage at this following grid is at video frequency, and will not give a correct indication on the VTVM until the voltage is rectified. With earlier connections the video detector does the rectifying.

If the detector probe offers high impedance, the reading of the VTVM may be too low for positively identifying a peak. Then the probe may be applied to the plate of the amplifier following the aligned coupling, as shown by broken lines in the diagram. Were generator output signal voltage to be made great enough to overcome high impedance of a detector probe, the signal probably would so overload the first tube as to cause severe distortion, and would make measurement of a peak voltage quite unreliable.

In case the detector probe possesses impedance low enough to allow a good reading

on the VTVM, the probe capacitance is more than likely to strongly affect the resonant frequency of the aligned coupler when connected to the grid circuit. Using the probe on the plate instead of the grid reduces this detuning effect. When badly misaligned stages are adjusted singly, as in Fig. 8, a final adjustment always should be made with the method illustrated at the top of Fig. 7, with which both test instruments are isolated from the interstage couplings.

The detector probe is not used for alignment of the coupling which immediately precedes the video detector. For adjustment of this one stage, use the connection numbered 1 on the lower diagram of Fig. 7.

**TRAP ALIGNMENT.** The principal difference between alignment of a trap and of an interstage coupler is that the trap is adjusted for minimum amplifier output at a certain frequency, whereas the coupler is adjusted for maximum output. Traps nearly always are adjusted as part of the general process of aligning the interstage couplings of the i-f amplifier section.

Trap adjustment, were it carried out separately, would require the same preliminary steps as general alignment. The signal generator is connected in the same manner, and is used without modulation. The VTVM is connected as usual to the load circuit of the video detector. That is, the connections

## COYNE - *television home training*

for trap alignment are the same as shown by Fig. 7. If a trap on any one coupler were to be aligned by itself, the connections would be as shown by Fig. 8.

The signal generator is tuned to the frequency at which each trap is to be aligned, and the trap is adjusted for minimum reading on the VTVM. As the trap is brought more and more nearly into correct alignment, keep increasing the output of the signal generator until the adjustment shows the lowest possible VTVM reading with a fairly high signal voltage from the generator. Because trap circuits usually are of high-Q design, the dips of voltage at the trapped frequency ordinarily are sharper than the peaks of voltage when aligning interstage couplings.

When more than one trap is to be aligned for the same frequency, possibly that for accompanying sound, all these traps should be aligned without altering the tuning of the signal generator if this does not interfere with the correct order for general alignment.

Should your signal generator have calibrated output or an output meter, it is possible to measure the effectiveness of a trap. With the trap correctly aligned, apply enough signal voltage to give some readily identified reading on the VTVM, and note this signal voltage. Next, detune the trap as far as possible from the generator frequency, or possibly disconnect the trap, and reduce the generator output to that which gives the same VTVM reading as before. Divide the first output voltage by the second output voltage from the generator. The fraction indicates the attenuation provided by the trap at the adjusted frequency. This fraction ordinarily should be no larger than 0.02 or 1/50.

As a final check on trap alignment tune the signal generator very slowly through the entire range of frequencies covering those for which the traps have been adjusted. Watch the VTVM reading closely while the generator tuning is changed. At each sharp dip of voltage note the generator frequency. These should be the frequencies at which the trap or traps have been adjusted.

There are various orders or sequences in which the various adjustments may be

made in an i-f amplifier section containing traps as well as interstage transformers or impedance couplings. First, as each coupling is aligned, any trap associated with this coupling may be adjusted. Second, all traps may be aligned before any of the interstage couplings. Third, all interstage couplings may be aligned before any of the traps. Difficulties which arise with any of these methods are due chiefly to the interaction between couplings and trap circuits; any change of resonant frequency of either element makes some change in resonant frequency of the other.

The first method, aligning couplings and traps for any given stage at the same operation, requires many changes of generator frequency. However, by working back and forth between adjustments for coupler and trap, the effects of each on the resonant frequency of the other may be compensated for quite easily.

When traps are aligned before couplings, or couplings before traps, fewer changes of generator tuning are required. But whichever group of elements is aligned last will affect the resonant frequencies of the group aligned first, and there will have to be a final rechecking. In any case of aligning all traps at one time, either before or after all the interstage couplings, the order of alignment should be from the trap preceding the video detector back to the one nearest the mixer.

In receivers having a dual or split sound system, the i-f signal for the sound section is taken from the video i-f section at some coupling or transformer located between the mixer output and the input to the video detector. The signal going to the sound section is at the sound intermediate frequency. The takeoff for this signal is treated like a trap during i-f alignment, it is aligned or adjusted for minimum voltage at the video detector output, just as though the takeoff were a trap for accompanying sound. This will keep accompanying sound signals from the video amplifier, but will deliver them in good strength to the sound section.

TUNING WANDS. Most transformers and other interstage couplings in television amplifier sections consist of windings on in-



## LESSON 39 — ALIGNMENT WITH THE VACUUM TUBE VOLTMETER



Fig. 9. Tuning wands.

sulating tubing within which is a movable core of powdered iron. Moving the core farther into the winding space increases inductance and lowers the resonant frequency, while moving the core farther out decreases inductance and raises the frequency. A device which shows the effect obtainable by moving the core either way, but without actually making any change in core position, is called a tuning wand.

Two tuning wands are pictured by Fig. 9. Each is a length of spaghetti tubing with a small piece of powdered iron, like a tuning slug, at one end. At the other end is a piece of non-magnetic metal, brass, copper, or aluminum. The diameter is small enough that either end will slip freely into the winding form of most interstage couplings where the end of the form is exposed underneath the chassis.

When you insert the iron end of a wand into a coupler form it adds iron in the core space, and the effect is the same as though you had turned the regular core farther into the winding. Inserting the non-magnetic end of the wand has the same effect as turning the regular iron core farther out of the winding.

With a VTVM for output indicator and the signal generator tuned to the peaking frequency, insert the iron end of the wand into the coupler to be adjusted. If this increases the output voltage, remove the wand and turn the regular core farther into the winding. If voltage does not increase, try the non-mag-

netic end of the wand. Should this end cause the voltage to increase, remove the wand and turn the regular core farther out of the winding. When the regular core is adjusted for maximum possible output voltage, or the desired peak, either the iron end or the non-magnetic end of the wand will cause the indicated voltage to decrease.

The tuning wand is just as useful for checking alignment of circuits tuned by adjustable capacitors as for those tuned by adjustable inductance. If output is improved by the iron end of the wand, it indicates that more inductance is needed. So far as tuning is concerned, more capacitance has the same effect as more inductance, so you should adjust the variable capacitor for more capacitance. If improvement results from using the non-magnetic end of the wand, adjust the variable capacitor for less capacitance. When the capacitor is correctly adjusted for peak voltage, the voltage will drop when using either end of the wand.

SEALED ADJUSTMENTS. You will find many alignment adjusting screws and nuts sealed in position by various kinds of cements or waxes. This is done to prevent the adjustments from changing due to vibration or other mechanical causes.

Some cements may be easily chipped away with the tip of a penknife blade to allow changing the adjustment. Others may be dissolved by lacquer thinner, or by amyl acetate (banana oil), or by cement solvents prepared and sold for this purpose. Most service

## COYNE - *television home training*

shops keep on hand a variety of solvent liquids. If one of them fails to soften or remove the cement, another kind may.

Waxes usually may be softened enough to allow removal or change of adjustment by warming them. Heat the tip of a small screwdriver or other small piece of metal by holding it on a hot soldering iron, then use the heated metal on the cement. If you get the metal too hot, or try using the soldering iron tip directly, it is quite likely that the winding form will be damaged.

Cement or wax seals may or may not be replaced after you complete the alignment. Adjustment screws usually are fitted snugly enough to remain fixed without any sealing, and since it is almost certain that every adjustment will require altering during future service operations, the principal effect of sealing is to make matters more difficult for the next technician, who might be you.

### REGENERATION AND OSCILLATION.

During alignment of an i-f amplifier section there is some danger of energy feedbacks which may cause generation, possibly developing into oscillation, and of excessively sharp peaking which distorts pictures. Regeneration and also peaking at some one frequency may cause reproduced pictures to be filled with short, black horizontal streaks about one picture line in height.

If conditions are favorable for oscillation in an amplifier tube, and feedback is strong enough to start the action, the pointer of the VTVM will swing hard off scale at the high end, denoting very high output voltage. If the picture tube is connected, the screen will become brilliantly white all over its area. Oscillation is self-sustaining so long as cathodes remain hot and B-power is applied. Reducing the generator signal to zero will not stop oscillation; the receiver must be turned off at once to prevent ruining the picture tube screen.

Some of the causes for regeneration, oscillation, and peaking which will be discussed are marked on the diagram of Fig. 10. Your alignment procedure may be faulty. There may be very bad misalignment when the receiver comes to you for attention.

Earlier service operations may have been incorrectly performed. It is possible, but not probable, that the circuit design is poor. This might happen in some of the older sets, or in those assembled and wired by individuals rather than in the factories.

Your alignment procedure should be checked against the abbreviated instructions at the end of this lesson. If everything mentioned there as "Preliminary Steps" and as "Control Settings" has been cared for, the feedback may be due to instrument cables that are too long, carried too close to some of the tuned circuits, of unshielded wire, or used without grounding the cable shield.

The signal voltage from the generator may be too strong, even with the attenuator adjusted to zero. This difficulty may be overcome by using very small capacitance at the high-side connection to grid circuits. Capacitance as small as 2 mmf may be necessary to hold down the signal input to receiver circuits.

Feedback due to reactances of the VTVM cable may be prevented by connecting a fixed capacitor of 1,000 mmf or more from the high-side connection to ground, at the receiver end of the cable.

Feedback or oscillation may be due to incorrect alignment of interstage couplings or traps. If adjacent couplings have been tuned to the same or very nearly the same frequency, the amplifier tube between them may act as a "tuned-plate tuned-grid" oscillator. Your object then will be to prevent the feedback while bringing the couplings into correct alignment. Try any of the following methods.

Override the automatic gain control with a greater negative voltage, up to  $4\frac{1}{2}$  or 6 volts by using three or four dry cells in series. When this allows alignment without oscillation, return to the smaller bias of  $1\frac{1}{2}$  or 3 volts for the final touchup of all the adjustments.

Temporarily detune all the couplings well away from their normal peaking frequencies, turning some of the adjustments farther out and others farther in. Then pro-

## LESSON 39 — ALIGNMENT WITH THE VACUUM TUBE VOLTMETER

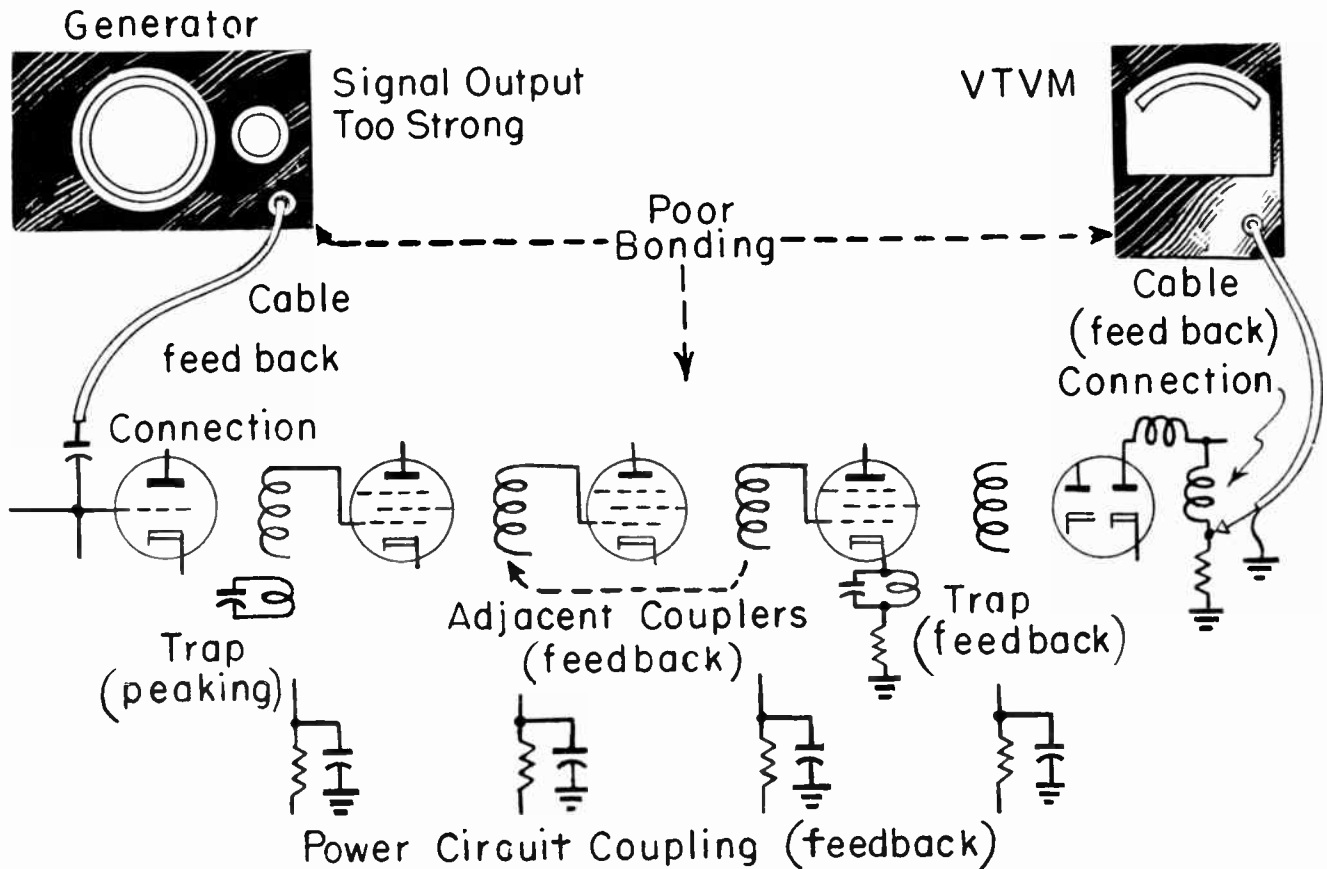

Fig. 10. Locations of various faults which may allow feedbacks and either regeneration or oscillation.

ceed in the usual manner to align the couplings from the video detector back toward the mixer.

Ground the grids of all i-f amplifier tubes except the one just back of the video detector by connecting a 1,000 mmf fixed capacitor or else a fixed resistor of about 300 ohms from the grids to chassis ground. Then try aligning the coupling nearest the detector. Remove the shorts, one at a time, as you align the other couplers in working back toward the mixer. Should the shorting connections prevent getting enough signal voltage through to the last stage, connect the signal generator to the grid of each tube preceding the coupling being aligned, as in the lower diagram of Fig. 7.

In a few receivers there is a trap whose purpose is to prevent excessive peaking at some frequency between the video and sound intermediates. It may be necessary to adjust this trap before adjusting any of the interstage couplers. The correct trapped fre-

quency must be learned from service data applying to the receiver.

Cathode traps sometimes cause feedback because the trap impedance is part of both the plate circuit and the grid circuit of the tube in whose cathode circuit the trap is connected. Try shorting the trap inductor with a wire fitted with clips. Remove this short after all the interstage couplings and other traps have been adjusted, then adjust the cathode trap. Make sure that the shorting connection does not include a cathode bias resistor for the tube. If the cathode trap is intended to attenuate the same frequency as some other trap farther toward the mixer, such as the frequency of accompanying sound, aligning that other trap early in the process of adjustment may prevent feedback due to the cathode trap.

Feedback and oscillation may be the result of faulty servicing methods. Blocking or interstage coupling capacitors, or peaking inductors in the video detector load circuit

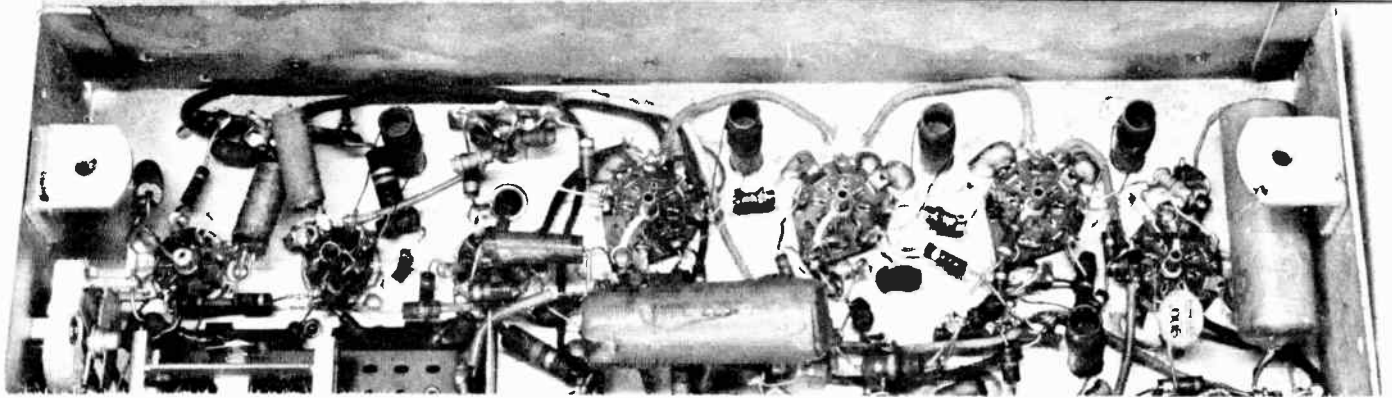

Fig. 11. An i-f amplifier with widely spaced parts and connections which are not likely to cause feedbacks of signal energy.

may have been pushed too close to other parts in plate, screen, or grid circuits. Leads and connections for plate, screen, and grid circuits may have been shifted around and brought too close together or too close to capacitors and inductors of such circuits.

In general, grid connections and inter-stage coupling capacitors are to be kept away from chassis metal and plate connections, while plate connections and parts of the plate circuits may be closer to chassis metal. Screen and cathode connections ordinarily should be run close to chassis metal. Correct positioning of circuit parts and connections is called "dressing". This subject will be considered at greater length in other lessons.

When the elements and conductors of an i-f amplifier section are well spaced and carefully laid out, as in Fig. 11, troublesome feedbacks are unlikely. When all the circuit parts are crowded together, as in Fig. 12, they may have been pushed around during earlier service operations, and excessive feedbacks may result.

Feedbacks may occur because of open or disconnected bypass capacitors in plate, screen, grid, or heater circuits. The positions of such capacitors are shown in Fig. 13. At A is an interstage coupling circuit, which might be of the style illustrated or of any other kind commonly used for i-f amplifiers. Capacitor Cd is a bypass for voltage

dropping resistor Rd, whose resistance would allow resistance coupling and feedback to and from other stages connected to the same B-supply were it not for the small reactance of capacitor Cd. Capacitor Cb is a bypass for isolating resistor Rb, which would provide resistance coupling to other stages on the same agc bus were it not for capacitor Cb furnishing a low reactance to ground.

At B in Fig. 13 is a heater circuit for an i-f amplifier section, with heaters in parallel between the source and ground. Each heater is bypassed to ground through one of the capacitors Ch. R-f chokes are shown at two of the heaters in this diagram. Such chokes may be used at all heaters, or at none, or at any particular heaters. Were it not for the bypass capacitors, and chokes when necessary, there could be feedback couplings through the heater connections and the capacitances between heaters and cathodes inside the tubes.

Series heater circuits usually have more bypass capacitors than used with parallel heaters, and nearly always have more r-f chokes.

If you have reason to believe that the i-f amplifier has been arranged and wired by a novice, or that values of circuit parts have been altered, some of the alterations of Fig. 14 may serve as preventatives of oscillation or of excessive peaking.



## LESSON 39 — ALIGNMENT WITH THE VACUUM TUBE VOLTMETER

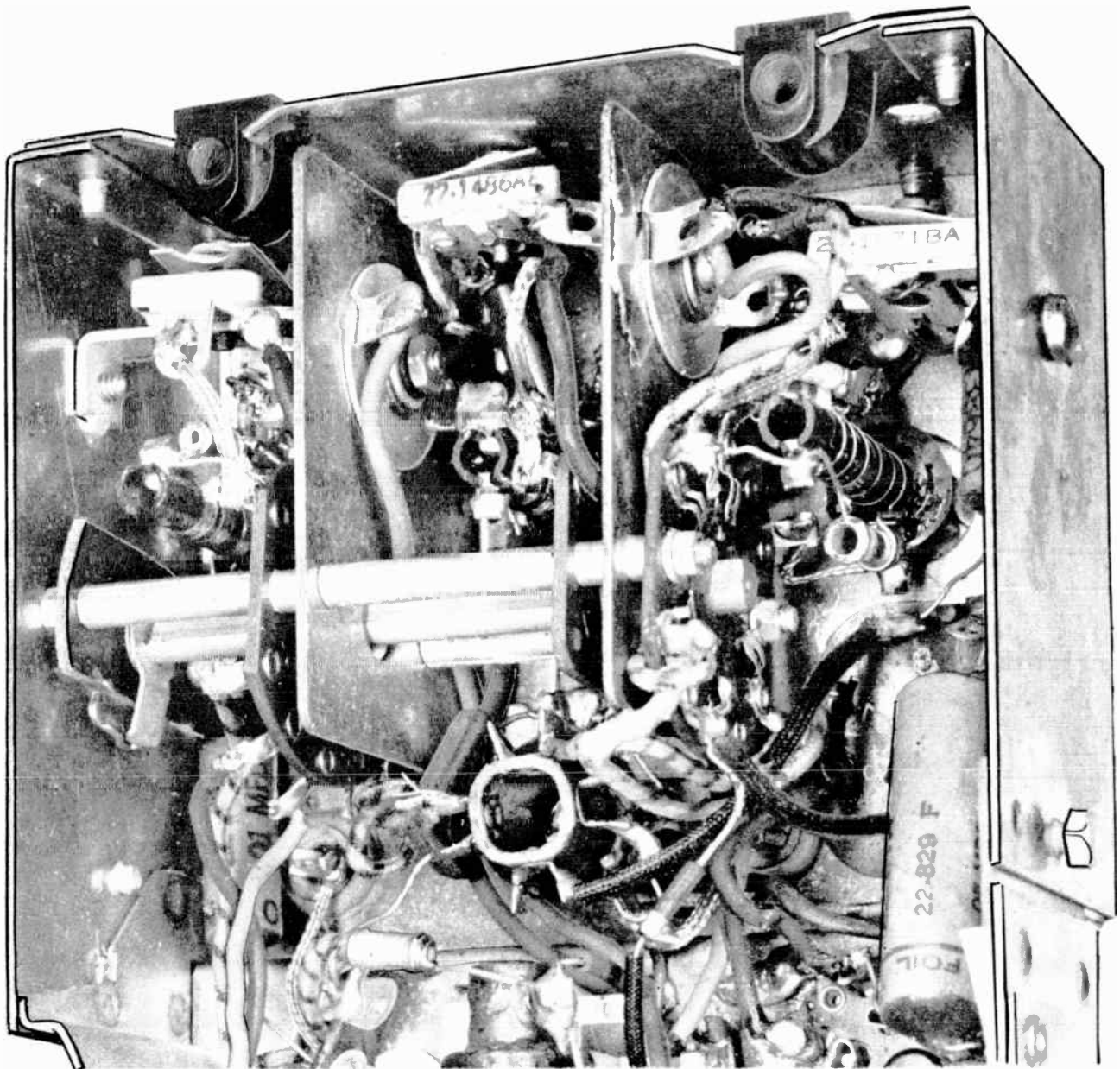

Fig. 12. Crowded parts and connections may be displaced during service operations.

Less resistance for one or more grid returns between grids and bypasses, going as low as 3,000 ohms if necessary. This will reduce the gain.

Less bypass capacitance across one or more cathode bias resistors, or possibly the bypass may be removed entirely. This allows degeneration, and decreases the gain.

Connect "broadening" resistors across one or more interstage coupler windings, if

such resistors are not already used, or decrease the resistance of such units when originally employed. With two-winding transformers work first on the plate side, and if this is not effective, try the grid side. Use the greatest resistance which prevents trouble, commencing with about 40,000 ohms and gradually decreasing the value.

Tightly fitting shields, grounded to the chassis by clips or clamps, may be added on one or more tubes. Shields may be applied

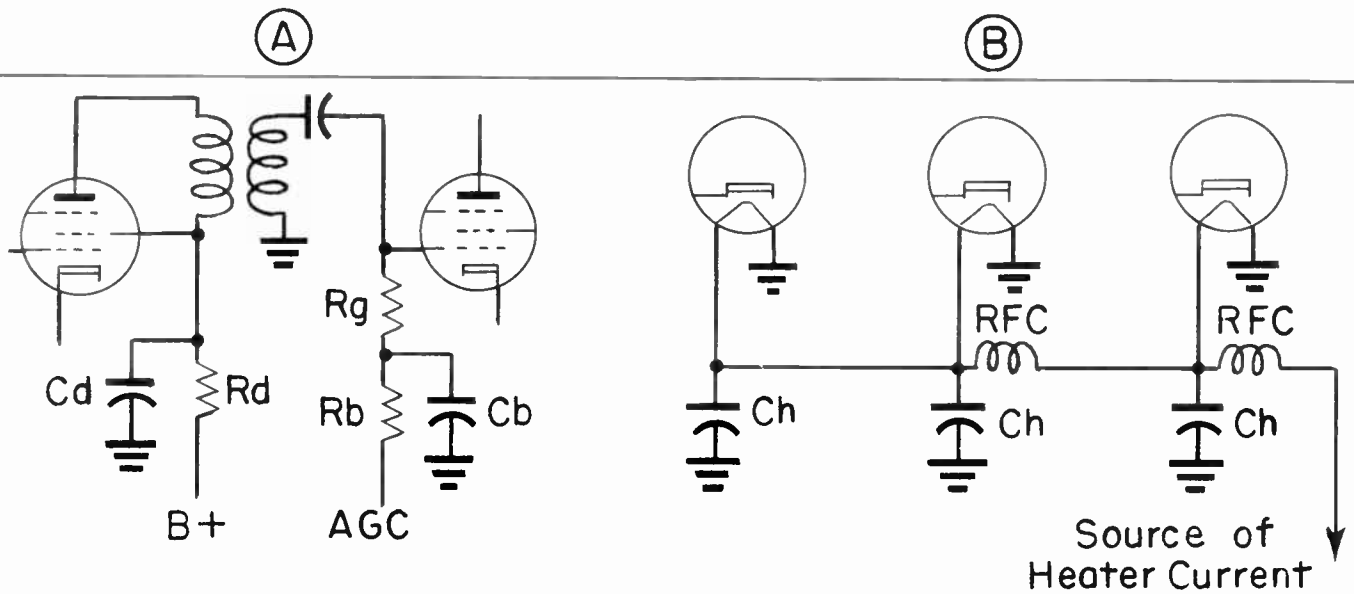

Fig. 13. Bypass capacitors prevent unwanted interstage couplings in circuits for plates, screens, grids, and heaters.

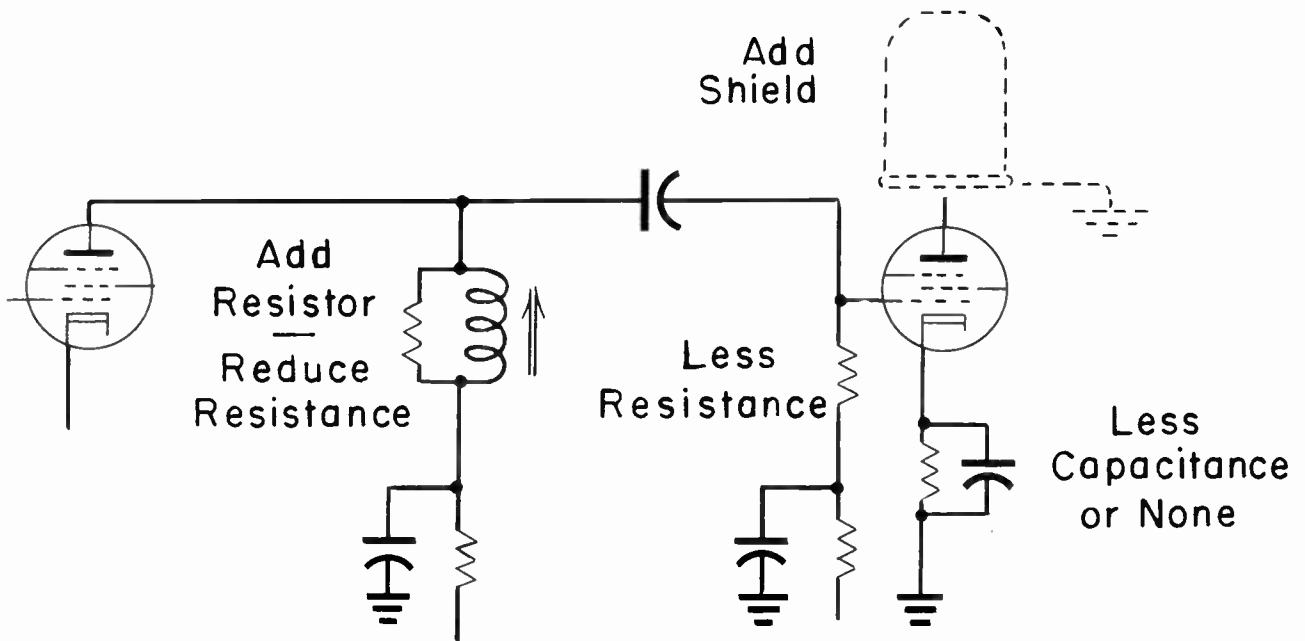

Fig. 14. Changes of circuit design which may prevent excessive feedback and oscillation.

to alternate amplifier tubes, whose associated couplers are tuned to the same frequency in stagger tuned arrangements.

The design changes mentioned should be made only when oscillation or excessive peaking persists after all other remedies have failed.

**PARASITIC OSCILLATION.** Parasitic oscillations are due to the formation of re-

sonant circuits by stray, distributed, and tube capacitances, while inductance is provided by wire and lead connections and sometimes by inductances of r-f chokes. The oscillation frequency has no relation to the regularly tuned frequency, and usually is much higher. At such oscillation frequencies the reactance of tuning inductors may be so great as to act like an open circuit, or these inductors may act like r-f chokes. The equivalent of a Hartley oscillator sometimes is formed by

# LESSON 39 — ALIGNMENT WITH THE VACUUM TUBE VOLTMETER

plate and grid circuit inductances and internal plate-to-grid capacitance of the tube, with the inductance tap formed at the grid and plate bypasses to ground or the cathode.

Low-frequency parasitic oscillation may exist in resonant circuits formed by inductance in r-f chokes combined with almost any circuit capacitances. The frequency then may be less than 100 kilocycles.

Parasitic oscillation is not particularly common in i-f amplifiers, but it may occur here or practically anywhere else in the receiver provided circuit values are suitable for this effect. When you find fixed resistors of possibly 50 to 100 ohms directly in series with a grid, at the socket terminal, the purpose is to suppress this type of oscillation. Any tubes having grids and plates in parallel usually have such suppressor resistors.

The effect of parasitic oscillation may be irregular dark or light streaks of small size on the picture tube screen, or there may be narrow, dark bands at some places. When the trouble is in the sound section, the reproduction of music and voice may be distorted and rough.

## SYSTEMATIC ALIGNMENT METHODS.

In this and the preceding lesson have been given extensive explanations of all the many steps in the process of i-f alignment. The essential points, in the logical order of performance, are summarized in a form convenient for reference by the following instructions.

## I-F AMPLIFIER ALIGNMENT WITH VACUUM TUBE VOLTMETER.

For receivers having stagger tuned i-f stages, intercarrier sound systems, and tube heaters in parallel. Notes applying to transformerless receivers with series heaters are at the end of these instructions.

### A. PRELIMINARY STEPS.

1. Picture tube. Remaining on chassis.

Metal cone or metal flare type. If metal not protected by insulating cover, disconnect and cover the clip

terminal of the high-voltage lead, or make the high-voltage power supply inoperative.

All-glass type. Make sure that no conductors of the high-voltage circuit can be touched during alignment.

2. Bonding. Adequate connections and contacts between signal generator housing, receiver chassis, metal bench top, and top of instrument shelf. Bond to VTVM housing only when cathode returns are to chassis ground or B-minus.
3. Transmission line, or line from built-in antenna. Disconnect from antenna terminals, and ground both antenna terminals to chassis.
4. R-f amplifier tube. May be removed from its socket.
5. R-f oscillator.

Separate from mixer. May be removed from its socket.

Combined with mixer. The oscillator grid may be grounded through a fixed capacitor of 1,000 mmf or greater capacitance.

6. Shields. All shielding must remain in place. This includes tube shields except when used for signal input coupling.
7. Speaker. If of type in which the field coil used as power supply filter choke, reconnect the speaker leads to chassis circuits.
8. Automatic gain control. Override with dry-cell battery, negative to agc bus, positive to ground or B-minus. Three-volts, two cells, usually give satisfactory fixed bias.

### B. WARMUP PERIOD

Turn on receiver, signal generator, and VTVM. Let them warm up at least 15 minutes, preferably more. During this period

# COYNE - *television home training*

the receiver controls may be adjusted and instrument connections completed.

5. Voltage indicated before signal generator connected, or when generator temporarily disconnected. Set pointer at zero or other easily identified point by means of the zero adjuster.

## C. CONTROL SETTINGS

1. Channel selector. To any channel not locally allocated. To any setting that does not tune to a television channel.
2. Contrast or picture control. If acts on i-f amplifier or mixer circuits, set at position for normal reception or slightly lower.
3. Brightness control. If picture tube remains connected, set this control for minimum brightness.
4. Sensitivity control, or any equivalent name. Set for maximum sensitivity.
5. Other controls. Their settings do not affect i-f alignment.

## D. VACUUM TUBE VOLTMETER.

1. High side of cable. Connect directly to video detector test point on top of chassis, if provided. Otherwise directly to high side of video detector load resistor, or to high side of inductor in series with this resistor. Not to any point following a blocking capacitor that comes after the detector load.
2. Low side of cable. To chassis ground <sup>OR</sup> ~~of~~ B-minus when detector load resistor connects to ground or B-minus. Otherwise connect to low <sup>END</sup> ~~and~~ of the load resistor.
3. Range selector to d-c volts, positive negative. Should meter read below scale during alignment adjustments, reverse the d-c polarity.
4. Range selector for lowest d-c volts range during alignment adjustments. May be set to a higher range until all connections complete, in order to avoid slamming of the meter pointer.

## E. SIGNAL GENERATOR.

1. High side of cable. To mixer test point or tuner, if provided. Otherwise to grid of mixer or to grid <sup>of</sup> ~~or~~ an i-f amplifier, according to order and method of alignment being employed. Always have a fixed mica or ceramic capacitor in series with the high-side lead.
2. High side of cable. Signal input sometimes satisfactory with high-side lead directly to either antenna terminal, without a series capacitor.
3. Low side of cable. To chassis ground or B-minus, close as convenient to the high-side connection.
4. Modulation. Generator unmodulated, pure r-f output signal.
5. Tuning. To peaking frequency for transformer, impedance coupler, or trap to be first aligned. Be sure to change this tuned frequency when going to another coupling or trap to be peaked at a different frequency.

## F. ADJUSTMENTS.

1. Coupling transformers or impedances. Adjust for maximum voltage reading on VTVM. Reduce generator output as required to keep reading no higher than 2 volts on meter.
2. Traps, on i-f couplings. Adjust for minimum reading of VTVM. Increase the generator output as trap adjustment proceeds.
3. Order of alignment.

Interstage couplings and connected traps may be aligned together, stage <sup>be</sup> ~~by~~ aligned before the other.



## LESSON 39 — ALIGNMENT WITH THE VACUUM TUBE VOLTMETER

Always begin with the coupler or trap immediately preceding the video detector, and finish with the one immediately following the mixer.

Two or more couplings or traps to be peaked at the same frequency may be aligned without altering the generator tuning.

Sound takeoff for dual or split sound is aligned like a trap for accompanying sound.

### G. RECHECK ADJUSTMENTS.

After all interstage couplings and traps have been adjusted, begin all over with the coupling or trap nearest the video detector and check the adjustment of each unit by the same methods employed for initial adjustment.

After alignment has been completed and rechecked, disconnect the generator and VTVM, remove the agc override, replace any tubes removed or made inactive, reconnect the transmission line or antenna, and recon-

nect the picture tube or high-voltage supply. Observe a regularly transmitted test pattern or picture. If reproduction is unsatisfactory, all alignment adjustments must be made again. Pay careful attention to the preliminary steps mentioned at the beginning of these instructions.

### H. SERIES HEATERS, TRANSFORMERLESS RECEIVERS.

Receiver power cord. Insert only in the output side of an isolation transformer, or directly in a-c receptacle in the position that makes the chassis cold.

Signal generator ground lead. Connect to receiver chassis or B-minus only through series fixed capacitor of 0.1 mf or greater capacitance, and at least 150 d-c working voltage when a-c line voltage is 110-120.

No tubes, including the picture tube, may be removed or disconnected unless socket lugs for heaters are jumped by fixed resistor of value equal to hot resistance of tube, and of sufficient power rating, which never is less than 5 watts and preferably is 10 watts.

# TELEVISION

- RADIO
- ELECTRONICS

---

---

## LESSON 40 – TELEVISION CONTROLS

---

---

***Coyne School***

*practical home training*

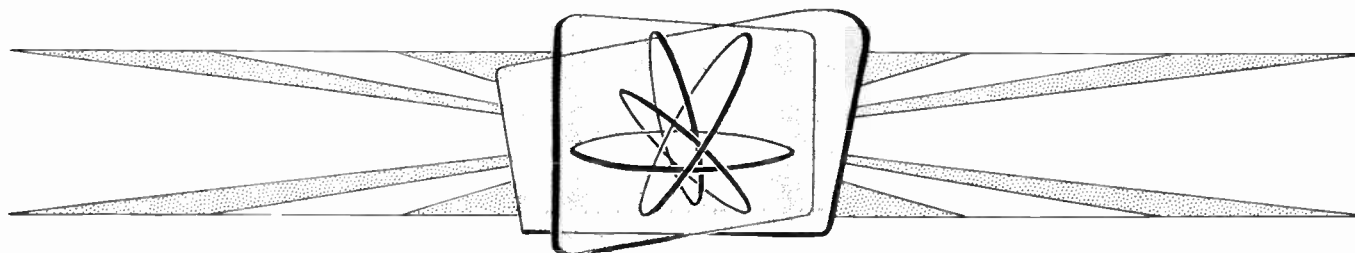

*Chicago, Illinois*

---

*Copyright, 1953 by Coyne Electrical School  
Chicago 12, Illinois  
All rights reserved*

Litho. in U.S.A.

# Lesson 40

## TELEVISION CONTROLS

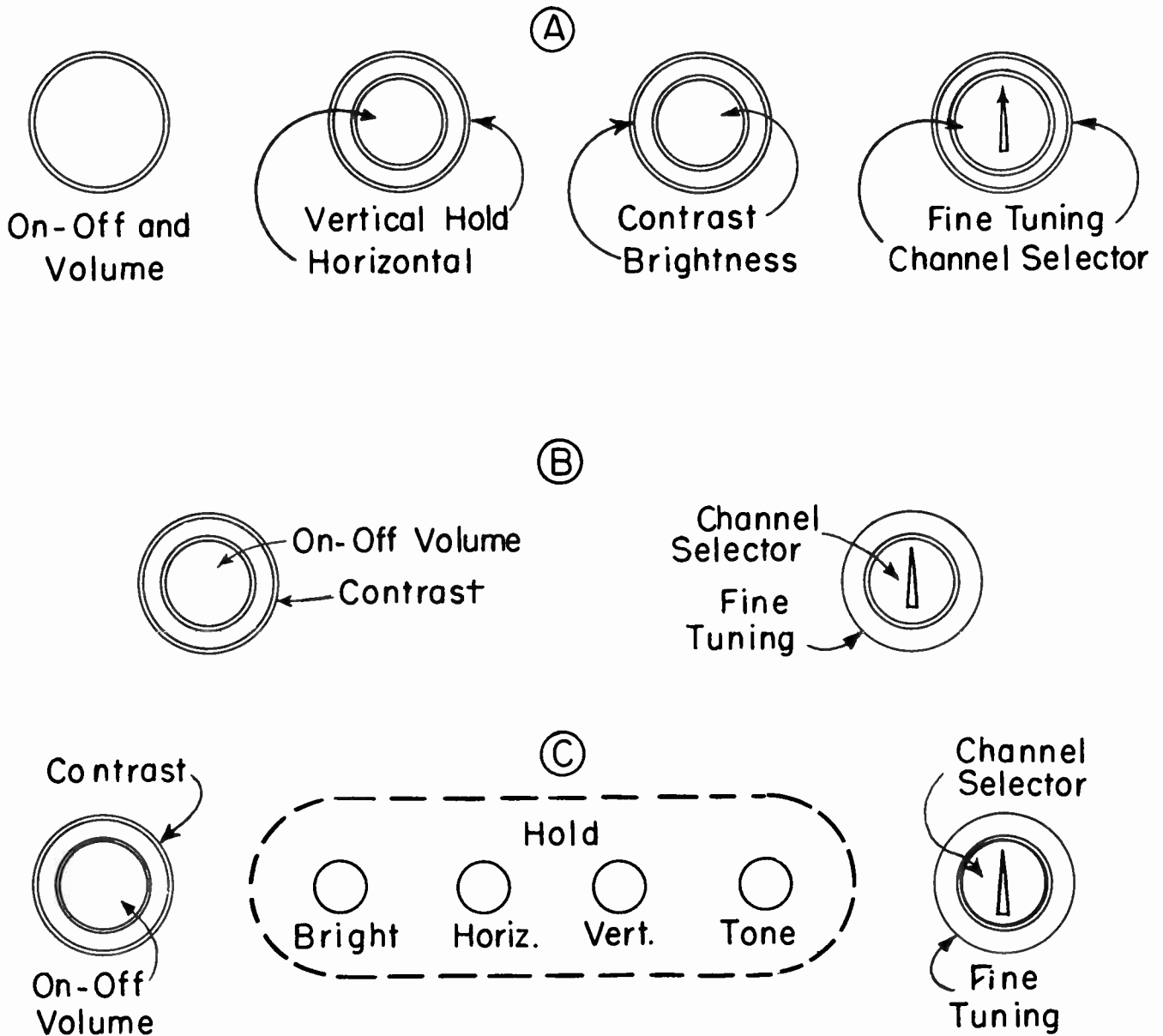

Fig. 1. Typical arrangements of operator's controls on front panels of television receivers.

Among the many advantages of new television receivers over older ones are easier tuning and the ability to switch from station to station without the need for readjusting a multiplicity of controls in order to retain satisfactory picture quality. Much of this improvement has been due to better tuners and to more effective automatic gain controls.

Another advantage of the newer receivers is their ability to hold pictures steady in spite of interference from electrical devices operating nearby. Such interference reaches most receivers, because most people live in closely built up districts, and that is where we find the greatest concentration of electrical devices. Steadier pictures are the result of improved automatic gain controls, and



## COYNE - *television home training*

of better automatic controls for frequency of sweep oscillators.

As a result of all these advances in receiver circuit design it has become possible to change programs with little or no manipulation of controls, other than shifting the channel selector and possibly making a slight readjustment of the contrast control. This is comparable to tuning a radio set by varying only the tuning dial and the volume control.

On nearly all the earlier television receivers the exposed operating controls included those shown at A in Fig. 1. The on-off switch and sound volume control usually are combined, as they are on most sound radio receivers. The other controls were arranged in pairs, with two concentric knobs for each pair. The grouping might be as illustrated, or in any other combination which the designer felt would be convenient.

With all these controls readily accessible it is possible for a careful operator to bring out the best pictures of which the receiver is capable. But the vast majority of operators don't want to be careful, or they don't know what the controls are intended to accomplish. The average set owner wishes only to see and hear acceptable pictures and sound, and to change to other programs with least possible inconvenience.

To satisfy the desires of set owners many of the newer receivers have only two dual controls for operator's use, possibly arranged as at B of Fig. 1. Quite often other controls are concealed behind a cover which is hinged or otherwise made easily removable, as at C. The concealed controls usually are for brightness, and for vertical and horizontal hold. Often they include also controls for focus, tone, and for switching to television, broadcast radio, or phonograph in combination sets. These concealed controls need only occasional readjustment.

Instruction manuals for older receivers emphasize the importance of adjusting contrast and brightness controls together. With too much contrast in proportion to brightness the pictures are mostly black and white, as in Fig. 2, with absence of intermediate grays that bring out the shadings and appearance of

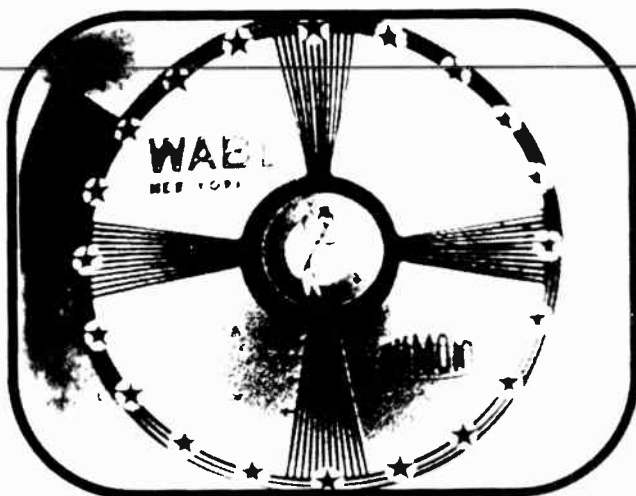

Fig. 2. The result of advancing the contrast control too far, which causes excessive gain or overloading of amplifiers.

solidity in pictured objects. Too much brightness in proportion to contrast results in washed out pictures lacking detail, and in narrow, diagonal white lines across the screen, as in Fig. 3.

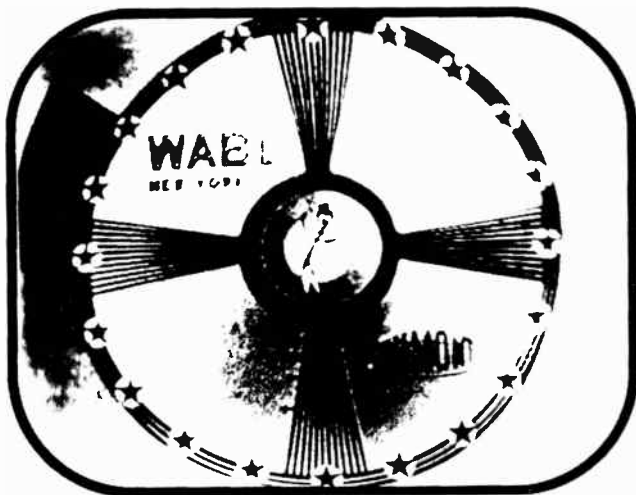

Fig. 3. Brightness control advanced too far in relation to setting of contrast control.

Improved designs all the way from antenna input to picture tube have made it possible nowadays to make only an initial adjustment of brightness which satisfies the viewers, and thereafter to have acceptable picture quality with manipulation of only the contrast or "picture" control.

# LESSON 40 – TELEVISION CONTROLS

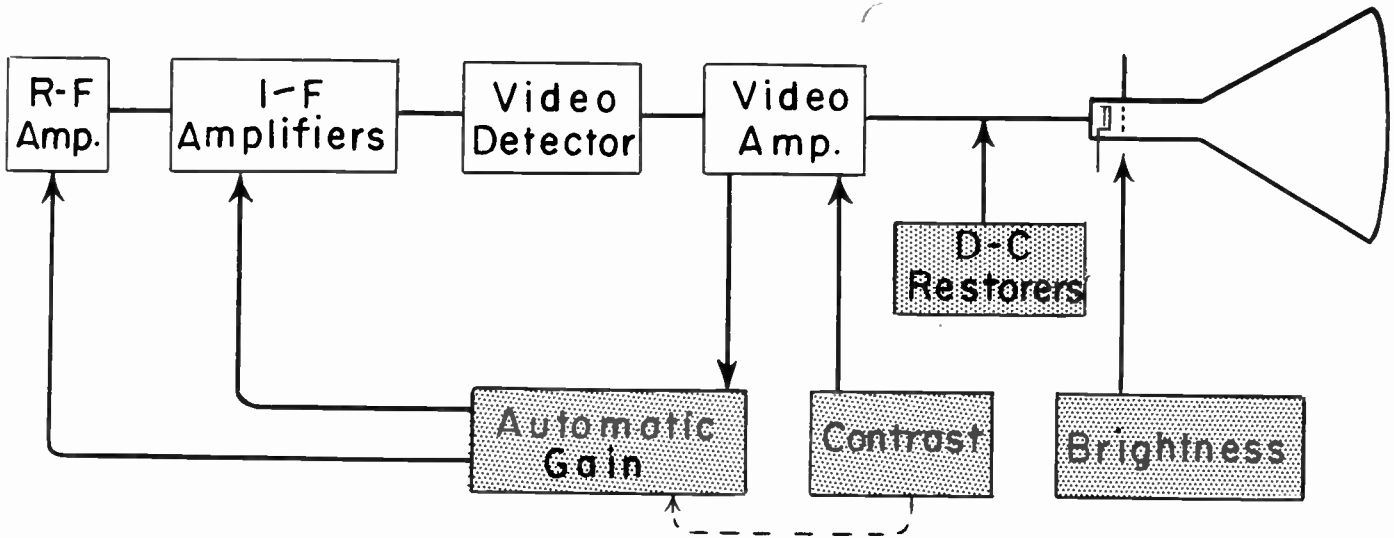

Fig. 4. Relations of some adjustable and automatic controls to various sections of a television receiver.

Manual controls for contrast and brightness, and automatic controls for gain and d-c restoration are related to one another and to various receiver sections as shown in a general way by Fig. 4. Because these controls are closely related we shall examine

With some designs of video amplifier sections it is desirable to have another automatic control that helps maintain correct shading of pictures. This control is called the d-c restorer circuit. It is located between the final or only video amplifier tube and the grid-cathode circuit of the picture tube.

them one after another, commencing with the brightness control.

**BRIGHTNESS CONTROLS.** A brightness control is merely an adjustment for picture tube grid bias. It fixes the average negative potential of the grid with reference to the picture tube cathode.

The elementary principle of brightness control is illustrated by Fig. 5. Here the picture signals pass from the plate of the final video amplifier through blocking capacitor  $C_b$  to the grid of the picture tube, just

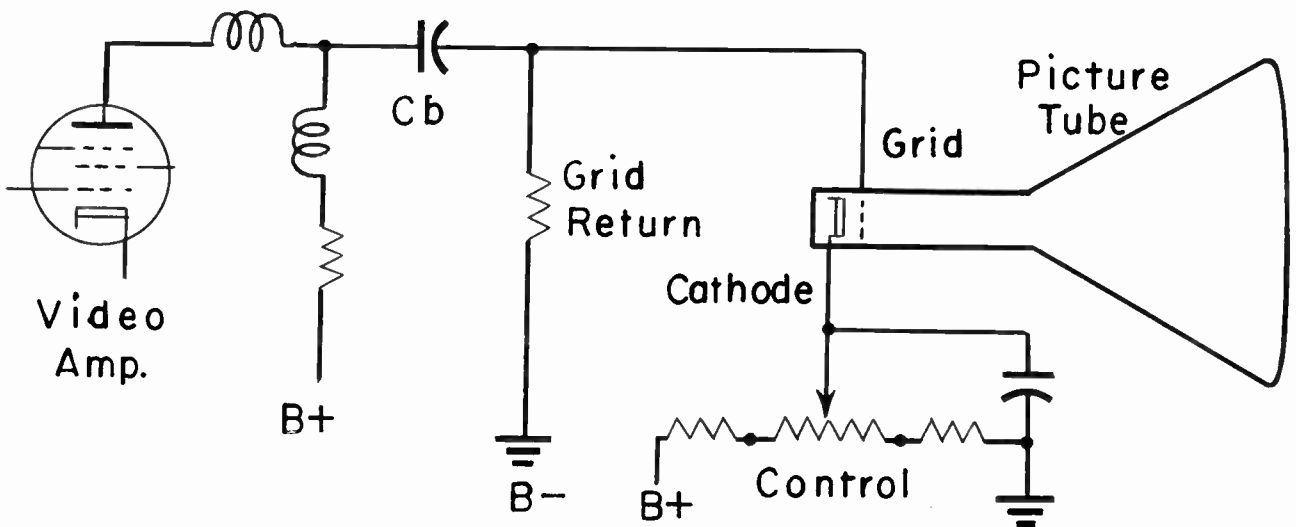

Fig. 5. A type of brightness control in common use.

## COYNE - *television home training*

as they might pass from the plate of any amplifier to the grid of a following amplifier in a resistance coupled arrangement. The inductors and resistor between the amplifier plate and B-positive are for the purpose of maintaining fairly uniform response throughout the range of video frequencies, and have nothing to do with brightness control.

The grid return of the picture tube is shown as through a resistor to ground, which is at B-minus potential. When a d-c restoration circuit is necessary, it is in the position of the grid return resistor. The picture tube cathode is connected to the slider of a brightness control potentiometer in a line of resistors between B-positive and ground. Therefore, the cathode always is more or less positive with reference to the grid, which is connected to ground. This is equivalent to making the grid more or less negative with reference to the cathode, or to providing a negative bias for the grid.

Moving the slider of the brightness control potentiometer makes the grid more or less negative with reference to the cathode. When this negative bias is increased there is less electron flow in the picture tube electron beam just as a more negative bias on an amplifier decreases the rate of electron flow within the amplifier tube. Less electron flow in the picture tube beam allows less illumination of the screen, and pictures are darker or less bright.

When the picture tube grid is made less negative with reference to the cathode there is increased electron flow in the beam, there is greater illumination of the screen, and pictures become brighter. The brightness control setting determines the average illumination of the entire picture, it adds or takes away a certain amount of light or illumination at every part of the screen and at every part of reproduced pictures. What we are calling the brightness control may be called a brilliancy control, an intensity control, or a background control.

You can measure the picture tube grid bias voltage by using the vacuum tube voltmeter as a d-c meter, with the high-side connection to the grid and the low-side connection to the picture tube cathode. Use a

100-volt range of the VTVM, because grid bias voltage will vary from somewhere near zero up to 50 or more volts negative as the brightness control is operated throughout its range. In the brightness control circuit of Fig. 5 the biasing voltage is taken from a resistor string on the low-voltage d-c power supply system. This is true also of most practical brightness controls. A reduction of B-voltage, as might occur from weakening of the power rectifier, will reduce picture tube grid bias. Then the brightness control cannot make pictures dark enough for good reproduction, they will be too light all over, even with the control turned to minimum.

As shown by diagram 1 of Fig. 6 the brightness control may be on the grid return path instead of on the cathode return. The picture signal from the final video amplifier plate again passes through blocking capacitor C<sub>b</sub> to the grid of the picture tube. The grid is connected through resistor R<sub>1</sub> representing the d-c restorer circuit, to the slider of the brightness control potentiometer. The cathode is connected to chassis ground. Chassis ground is not here the same as B-minus, it is at a potential positive with reference to B-minus. We examined such ground potentials when studying low-voltage d-c power supplies.

The brightness potentiometer now is in a resistor string between B-minus, the most negative potential in the receiver, and ground. Consequently, the picture tube grid always is connected through R<sub>1</sub> to a potential more negative than ground potential, to which the cathode is connected. This arrangement provides a variable negative bias for the grid, and a variable brightness control.

Just as it is possible to apply the input signal voltage to the cathode of an amplifier tube, instead of to the grid, so it is possible to apply the picture signal to the cathode of the picture tube instead of to the grid. This is done in diagram 2 of Fig. 6. The grid is connected to chassis ground. Now we find the brightness control in the cathode return circuit, with the control potentiometer in a resistor string between B-positive and ground. As a consequence, the cathode always is positive with reference to the grounded grid, and the grid always is negative with reference

## LESSON 40 – TELEVISION CONTROLS

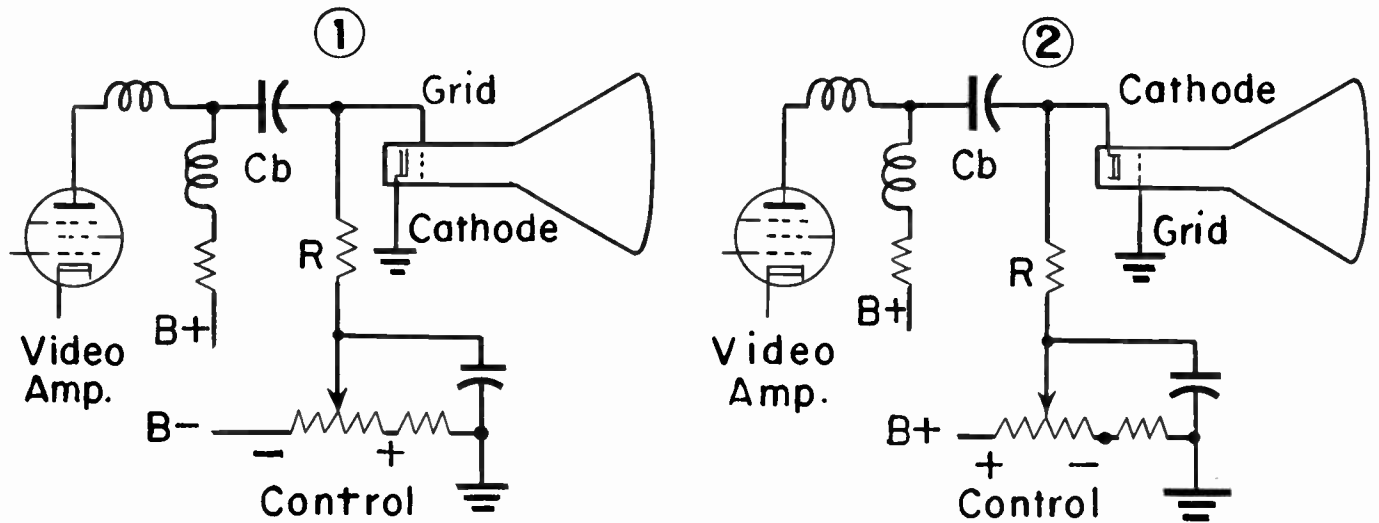

Fig. 6. Brightness controls on a grid return (1) and on a cathode to which video signals are applied in a picture tube (2).

to the cathode - which means negative grid bias.

In many receivers the plate of the final video amplifier tube is conductively connected to the grid of the picture tube, as in diagram 1 of Fig. 7. This means that the amplifier plate and picture tube grid always remain at the same d-c potential. The picture tube cathode is connected to the slider of the brightness control potentiometer, which is in a resistor string between B-positive and ground.

Since the plate load of the video amplifier is connected closer to the source of B-positive voltage than is the brightness control, it might seem that the amplifier plate and picture tube grid would be more positive than the picture tube cathode, connected to the volume control. But by using resistances which provide suitable voltage drops from the B-voltage source to the amplifier plate and the brightness control, it becomes possible to maintain the picture tube grid negative with reference to the picture tube cathode.

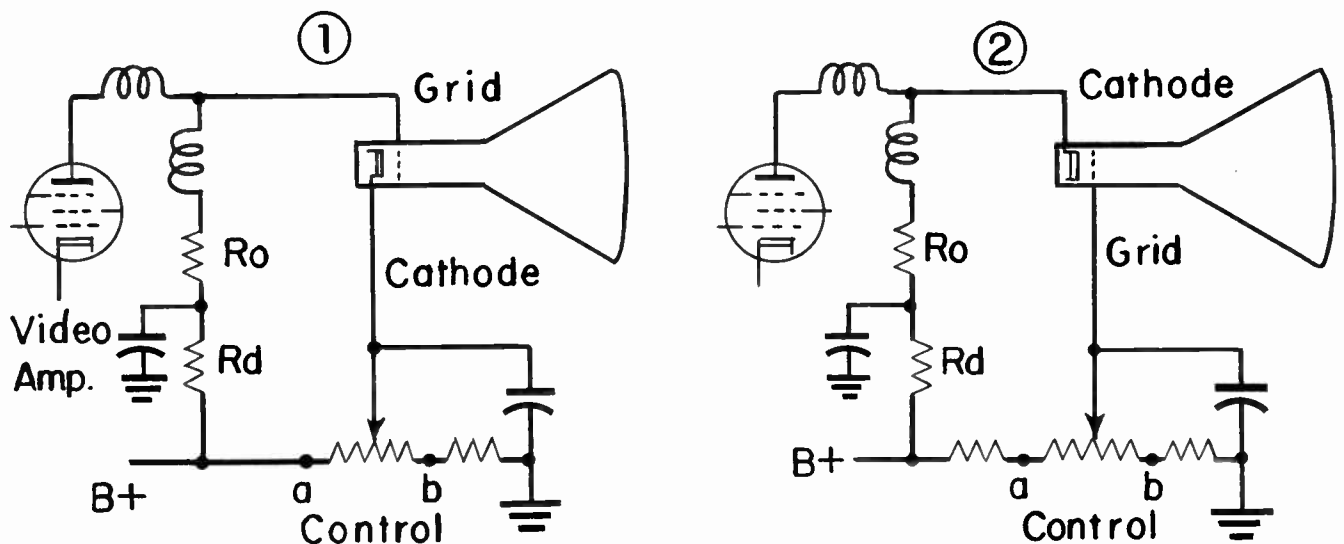

Fig. 7. Brightness control circuits used when the plate of the video amplifier is conductively connected to the grid or cathode of the picture tube.



## COYNE - *television home training*

There are voltage drops in resistors  $R_d$  and  $R_o$  leading to the amplifier plate and picture tube grid. Because of the voltage drops the positive potential at this plate and grid must be less than at the supply point,  $B+$ . But the brightness control potentiometer is connected at a directly to the supply point, and this end of the potentiometer must be more positive than the amplifier plate and picture tube grid. If the control potentiometer is of such resistance that voltage drop through it, from a to b, cannot exceed the drop through resistors  $R_d$  and  $R_o$ , then end b of the potentiometer always will remain more positive than the picture tube grid. In other words, there is more decrease of positive potential in the path to the picture tube grid than in the path through the control to the picture tube cathode, and the grid always will remain less positive (more negative) than the cathode, no matter how the brightness control is adjusted.

In diagram 2 of Fig. 7 there is a direct or conductive connection from the video amplifier plate to the picture tube cathode, with signal input to the cathode instead of to the grid of the picture tube. The grid is connected to the slider of the volume control. To insure that the grid always remains less positive (more negative) than the cathode there must be a greater voltage drop from  $B+$  to a of the control than from  $B+$  to the amplifier plate and picture tube cathode. This will leave the picture tube cathode more positive than the grid, or the grid more negative than the cathode, no matter where the slider of the brightness control may be adjusted.

All brightness controls vary the picture tube grid bias, and thereby vary the current or rate of electron flow in the beam. There is a tendency for pictures to become slightly larger with increase of beam current, at high brightness levels. However, when adjustments for width and height have been made correctly, pictures will not become smaller than the mask opening even with minimum brightness, and slight changes in size will not be noticeable to viewers.

**VERTICAL RETRACE BLANKING.** When brightness is made excessive in proportion to contrast, or when the contrast control is not turned high enough to suit the adjusted

level of brightness, vertical retrace lines may appear in pictures. These are the sloping white lines which show plainly in Fig. 8. As in Fig. 8, such lines usually show on the raster when there is no picture or pattern. Vertical retrace lines may be seen when pictures are momentarily cut off at the transmitter, also when changing from one program or one station to another. This comes about because of differences between cameras, between types of pictures, or variations in transmission characteristics.

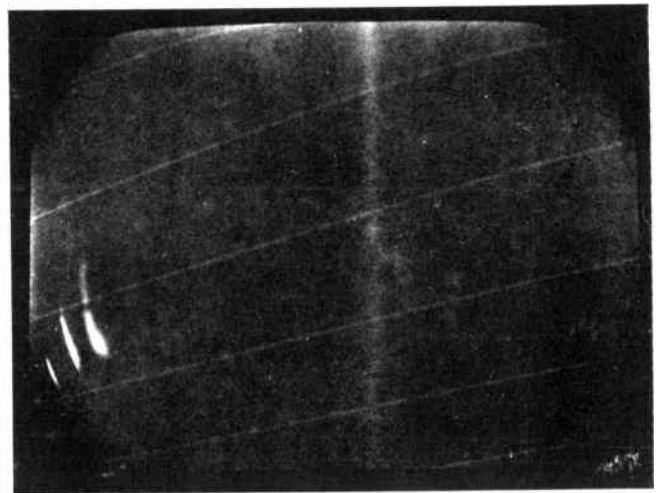

Fig. 8. Vertical retrace lines are sloping white lines on a raster or picture.

Vertical retrace lines are eliminated in many receivers by a blanking circuit which makes the picture tube cathode highly positive, or the grid highly negative, during vertical retrace or blanking periods of the composite television signal. This cuts off the electron beam in the picture tube or reduces it to very low intensity during intervals when retrace lines might appear.

Connections for retrace blanking are shown by Fig. 9. Diagram 1 shows signal input to the grid of the picture tube, with the brightness control on the cathode line. To the cathode are applied pulses of positive voltage brought through capacitor C from the vertical sweep circuit. In addition to capacitor C there may be various other resistors and capacitors on the blanking circuit, the number and arrangement varying in different receivers. The vertical output transformer in the plate circuit of the vertical sweep amplifier is shown as a two-winding type. Equivalent blanking connections may be made

# LESSON 40 – TELEVISION CONTROLS

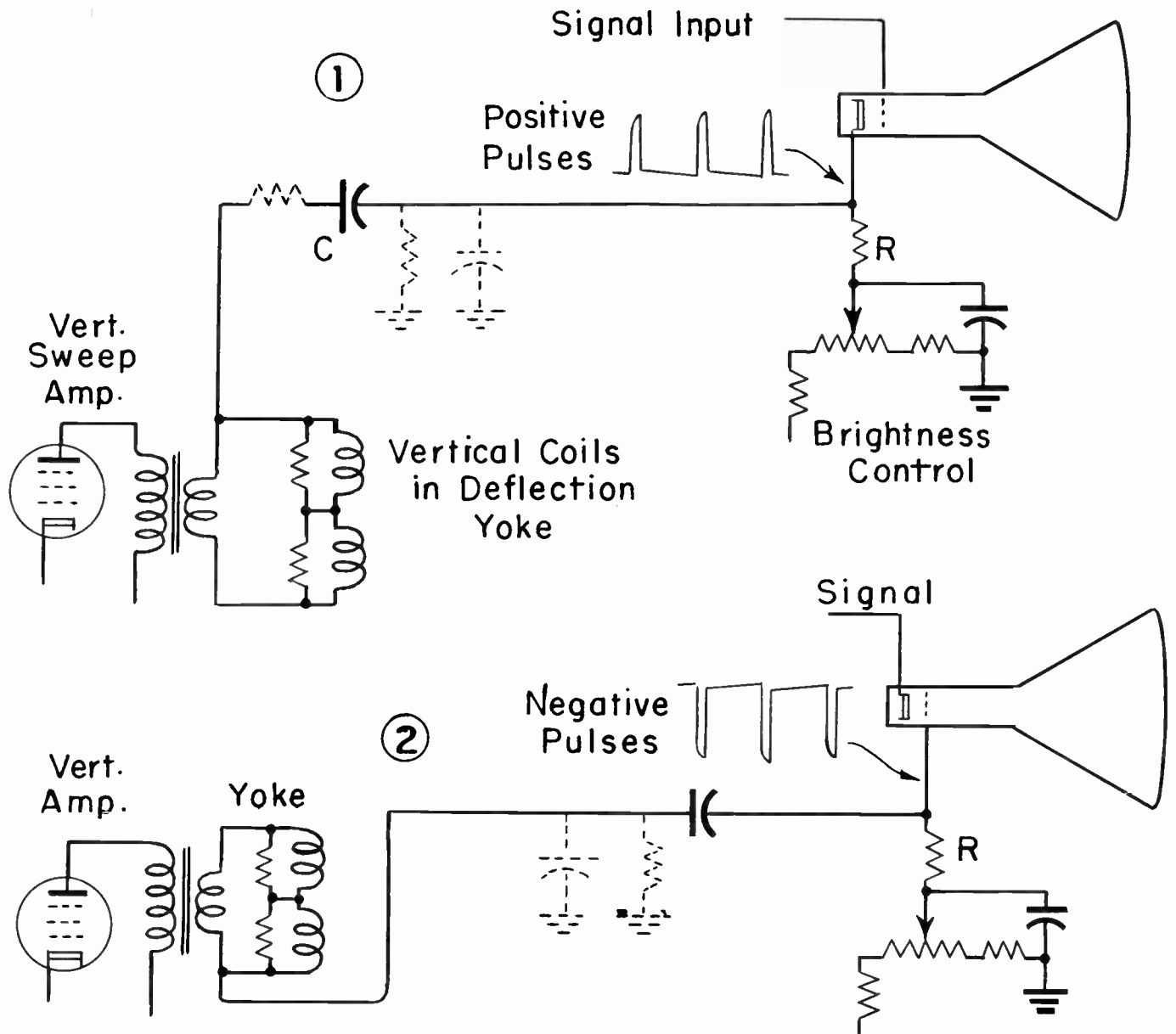

Fig. 9. How positive or negative pulses for retrace blanking may be secured from vertical deflection circuits.

when this unit is an auto-transformer such as found in many receivers.

In vertical deflection coils which are part of the yoke on the picture tube neck, and in the secondary of an output transformer feeding these coils, the changes of current are of sawtooth waveform, as required for deflecting the electron beam in the picture tube. But changes of voltage have the form of sharp peaks or pulses. This seemingly strange combination of current and voltage waveforms will be explained when we come to deflection systems. The voltage peaks occur during the vertical blanking or retrace

intervals, in between downward travels of the electron beam. Consequently, the voltage pulses are just what is needed for blanking the retrace lines.

Diagram 2 of Fig. 9 shows blanking connections when the composite video signal is applied to the picture tube cathode, with the brightness control in the grid return. Connections to the vertical deflection circuit are such that blanking pulses are of negative polarity. These pulses are applied to the grid, making it strongly negative at instants during which vertical retrace lines might be formed. Note that a resistor,  $R$ , is between

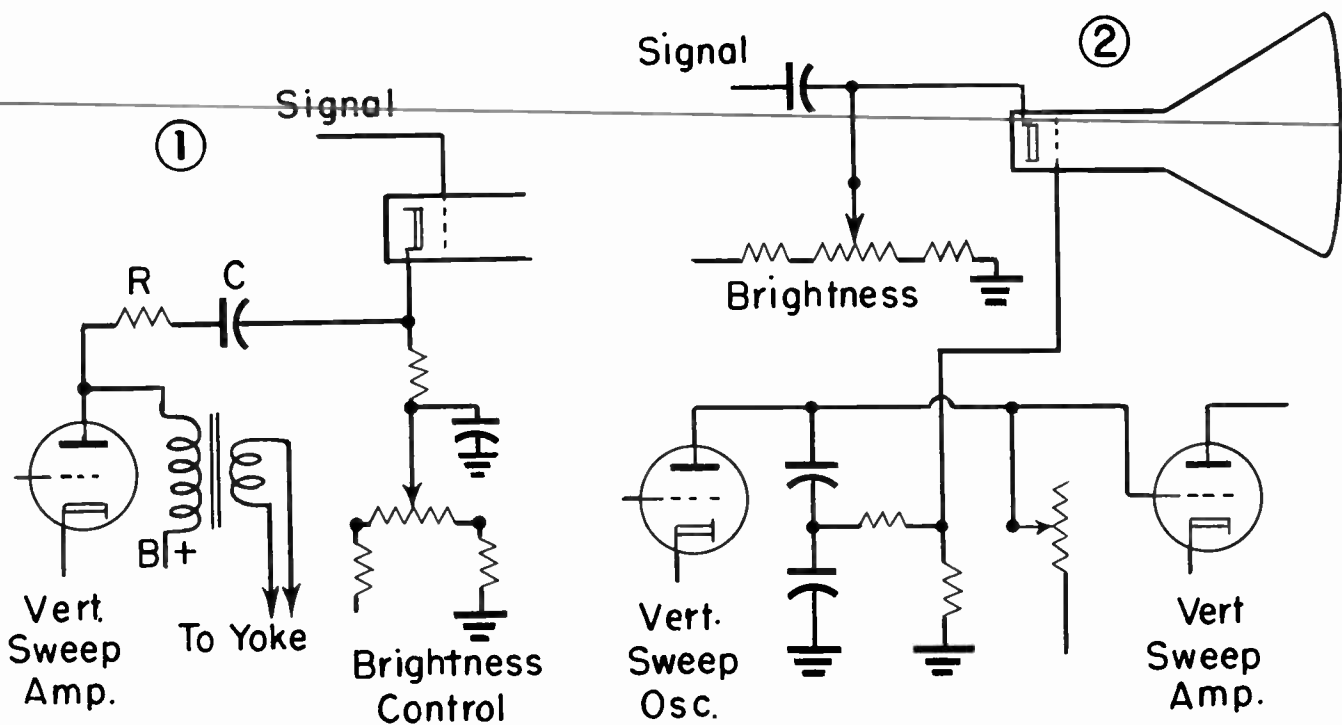

Fig. 10. Pulses for retrace blanking may be secured from various points in the vertical sweep section of a receiver.

the blanking connection at cathode or grid and the brightness control. This resistor prevents grounding the blanking voltage pulses through the bypass capacitor from brightness control slider to ground.

A number of other circuits for blanking of vertical retrace lines are in more or less general use. Two of them are shown by Fig. 10. In diagram 1 the positive blanking pulses are taken from the plate of the vertical sweep amplifier through resistor R and capacitor C to the cathode of the picture tube, to which is connected also the brightness control. Video signal input is to the grid of the picture tube.

In diagram 2 negative blanking pulses are taken from between the vertical sweep oscillator and vertical sweep amplifier, and applied to the grid of the picture tube. Signal input and brightness control are on the picture tube cathode. Output voltage from the oscillator plate is essentially of sawtooth waveform, but at the completion of each gradual rise in the sawtooth there is a strong and very brief negative pulse occurring just before the following gradual rise in the sawtooth wave. The effect of resistance and capacitance in the blanking circuit is to leave only strong negative pulses of voltage for the picture tube grid.

There are still other blanking arrangements which secure pulses from the grid circuit of the vertical sweep amplifier. In some receivers there is an additional tube or a section of a twin tube which changes a voltage waveform from the vertical sweep amplifier into pulses of voltage suitable for blanking.

Pulses applied to the picture tube for blanking ordinarily are of about 80 volts peak value. This value insures that the grid will be made sufficiently negative with reference to the cathode, or that the cathode will be sufficiently positive with reference to the grid, for cutoff of picture tube beam current during retrace periods.

Pulse or peak voltages in the vertical sweep circuits always are much greater than wanted at the picture tube. Part of the purpose of any resistors and capacitors between sweep circuits and picture tube is to reduce the voltage. But the resistance and capacitance must be so related in values as to provide a time constant allowing pulses that are neither too brief nor too long at the picture tube. It is for this reason that values of capacitance must not be changed without compensating changes of resistance, for the time constant must suit the characteristics of pic-

## LESSON 40 – TELEVISION CONTROLS

ture tube and sweep circuits of each particular receiver.

A time constant which is too long, because of too much capacitance or too much resistance, either or both, will keep the picture tube electron beam blanked for too long. Then there will be a dark area to the top of pictures, because the beam cannot resume its normal intensity until the first part of each field has been completed. An excessively short time constant may cause a pulse waveform in which there are both positive and negative peaks. Then the electron beam is made too intense for a brief instant, and there will be an excessively bright area at the top of pictures.

The parts and connections in a retrace blanking circuit should not be moved about nor placed in different positions than originally found. Pulse voltages tend to radiate pulsating electric fields, the voltages induced in other circuits may be troublesome. As a general rule the voltage reducing resistors and capacitors are located close to their connection points at the sweep circuits, thus keeping at minimum length those conductors in which there are relatively high pulse voltages.

**SPOT SUPPRESSION.** A small circle of light or possibly a brilliant spot may linger

near the center of the picture tube screen after the receiver is turned off. The spot results from an undeflected electron beam maintained by slowly discharging filter capacitances in the high-voltage power supply system that furnishes several thousands of volts to the picture tube anode. The spot may continue so long as the cathode remains hot, and connected to ground or B-minus to complete the path for electron flow in the beam. If the spot is large, rather well diffused, and of short life, it does little or no harm. But a concentrated spot, intensely bright, may eventually discolor and permanently damage a small area of the picture tube screen.

A method of cutting off the spot is shown by diagram 1 of Fig. 11. Between the slider of the brightness control potentiometer and the picture tube element to which the slider connects is a single-pole single-throw switch. This switch is operated with, and actually is a part of the on-off switch for the receiver. When the receiver is turned off, the switch at the brightness control is opened. This leaves the picture tube cathode connected to ground or B-minus only through the brightness control bypass capacitor, which is not conductive for direct current. Thus the cathode return circuit is opened, cathode emission cannot continue, and the bright spot cannot remain.

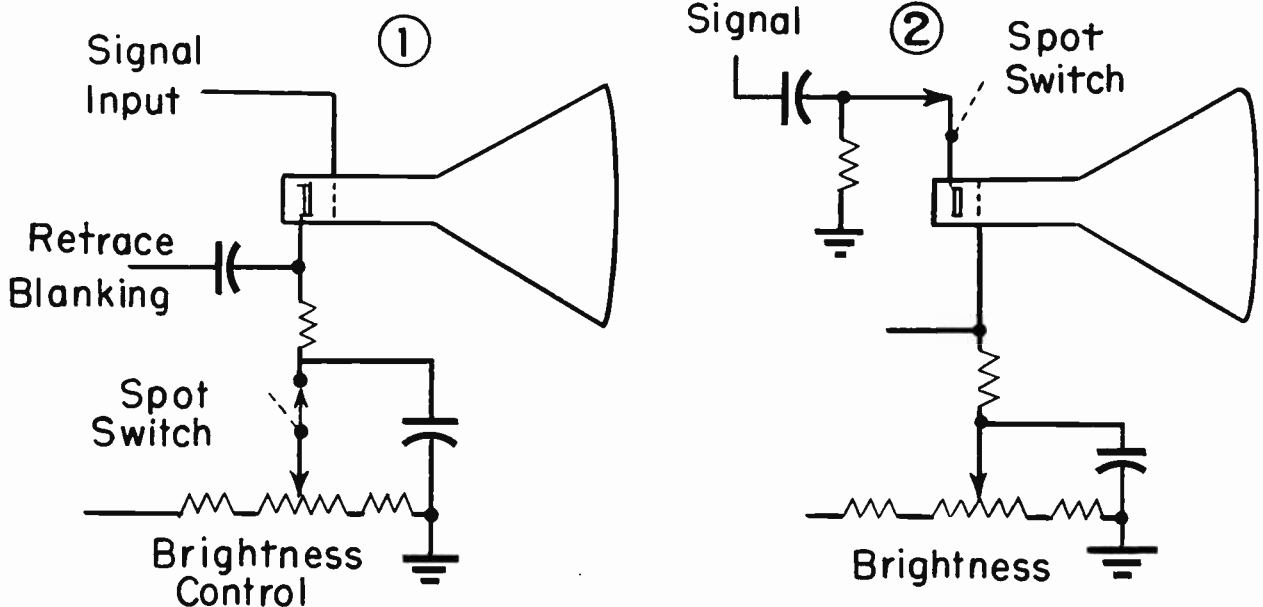

Fig. 11. Methods of preventing a bright spot on the picture tube screen after the receiver is turned off.



## COYNE - television home training

The same general method may be used, as in diagram 2, when signal input is to the picture tube cathode, with the brightness control in the grid return. When the cathode is cut off from all conductive paths to ground or B-minus, electron flow from the cathode cannot continue and a spot of light cannot remain on the picture tube screen.

**CONTRAST AND BRIGHTNESS,** A contrast control, often called a picture control, is a manually operated adjustment for varying the gain or amplification for the video signal applied to the grid-cathode circuit of the picture tube. Most often the contrast control varies the voltage gain of a video amplifier tube, but sometimes it varies the gain in the i-f amplifier section, or may simultaneously regulate gain in both the i-f amplifier and video amplifier sections. In still other cases this control may act to take more or less of the total output of the video amplifier section, and apply that portion to the picture tube,

Should the contrast control be advanced too far in proportion to average brightness of pictures, but not far enough to cause severe signal distortion, the result will be about as illustrated by Fig. 12. The blacks are too intensely black, tones which should be light gray become very nearly white, and where there should be intermediate grays the tone is either black or white. Setting the contrast control very much too high, when received signals are fairly strong, severely overloads

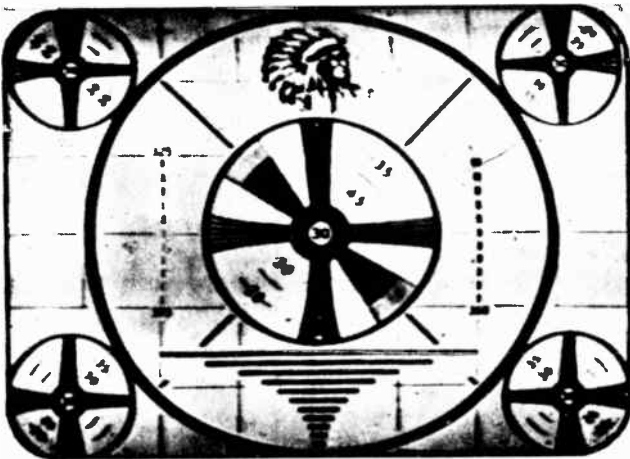

Fig. 12. There is too much contrast in proportion to brightness, but no distortion.

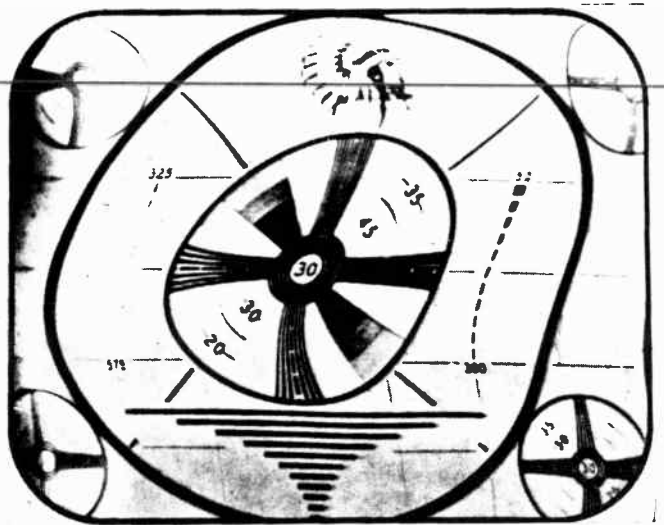

Fig. 13. The contrast control has been advanced so far as to overload some of the amplifiers, and cause picture distortion.

some of the amplifiers. A typical result is illustrated by Fig. 13.

Fig. 14 shows what happens when there are changes of gain due to varying a contrast control while picture tube grid bias as regulated by the brightness control remains constant. The sloping lines or curves are "transfer characteristic" curves of the picture tube. They show relations between changes of grid voltage caused by the input signal and resulting changes of beam current which produce variations of light and shade on the picture tube screen.

Grid signal voltages shown below the curves represent the video signal during one horizontal line and during preceding and following horizontal blanking intervals, with the horizontal sync pulses in these intervals. Assuming that this input signal is an alternating voltage, its positive and negative amplitudes center at the grid bias voltage of the picture tube, just as they would center at the bias voltage for an amplifier tube.

In diagram 1 the picture tube grid bias (brightness control setting) and the strength of the input signal (contrast control setting) are correctly related. The black level of the input signal is brought exactly to the point of beam current cutoff. Now, on the picture tube screen, all the sync pulses are completely out off, as at a and a, and they have no effect on picture reproduction. All of the

# LESSON 40 – TELEVISION CONTROLS

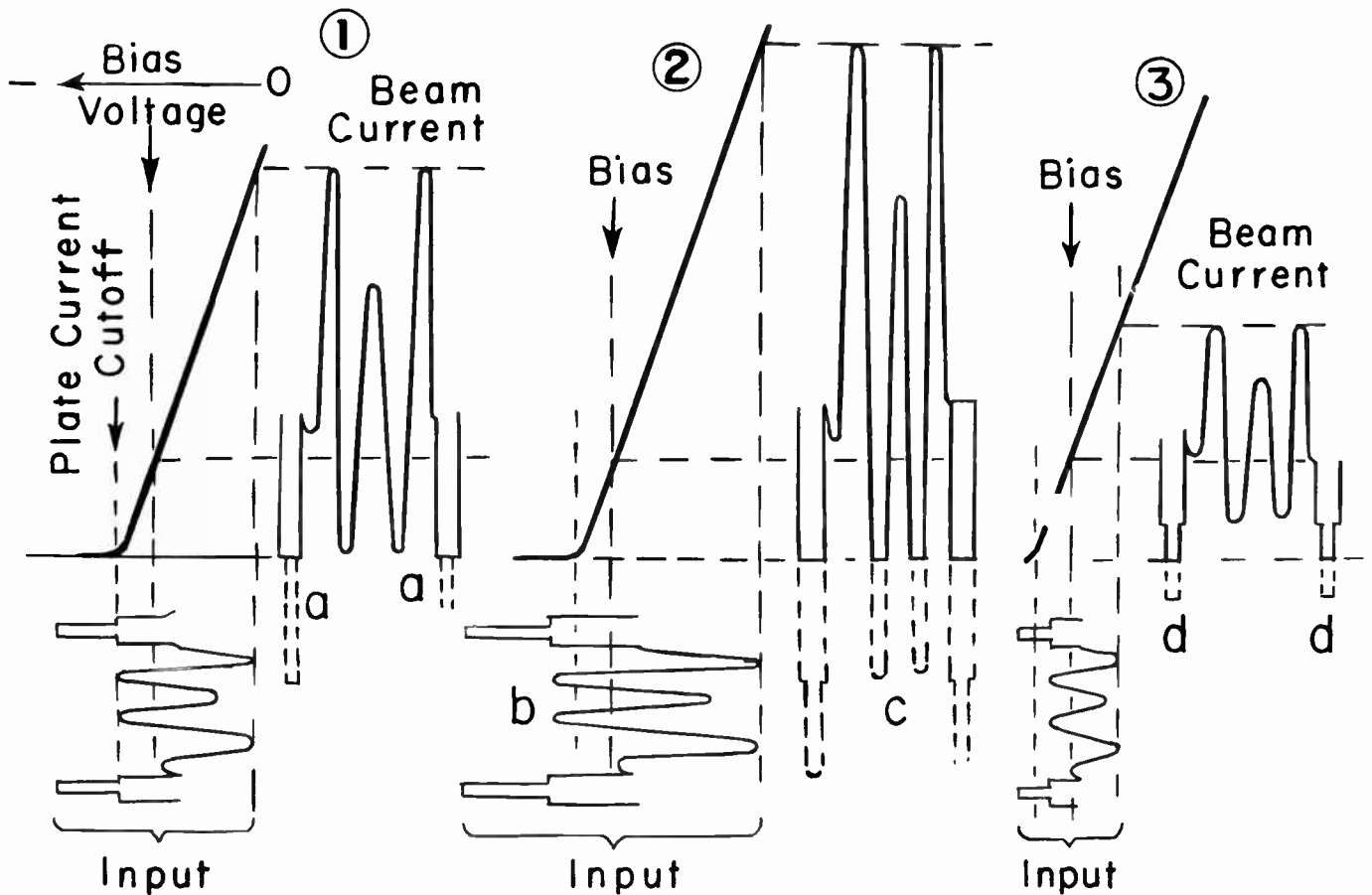

Fig. 14. How picture tube beam current is affected by changing the strength of input signals while grid bias (brightness setting) remains unchanged.

picture signal variations, from darkest to lightest, are fully reproduced. This is evident from the fact that all picture signal variations are in the beam current.

In diagram 2 the input signal voltage is much stronger than before. This could be the result of advancing the contrast control, or it might be the result of a stronger received signal not correctly regulated by the automatic gain control. The amplitudes of this stronger input signal still must center at the grid bias voltage of the picture tube, which has not been changed.

Now we find that increased amplitude of the input signal has made the sync pulses more negative, thus pushing them still farther below the voltage for beam current cutoff. But portions of the picture variations of signal voltage also have been made more negative than the beam current cutoff voltage. This is shown at b on the input signal. How

these portions of the picture variations are cut off in the beam current is shown at c.

This means that some parts of reproduced pictures which should be dark gray appear black, because during these parts the electron beam is completely cut off. Portions of the pictures which should be light gray have gone so high on the beam current curve that they become white. This is why excessive contrast, too much gain, causes pictures to appear black and white, as in Fig. 12, with poor rendition of intermediate grays when viewed in conjunction with the blacks and whites.

In diagram 3 the input signal voltage is weaker than in either of the preceding cases. This might be due to adjusting the contrast control too low, or to a weak received signal without compensating action by the automatic volume control. The picture tube grid bias, or setting of the brightness control, has not been altered.

# COYNE - *television home training*

Only the tips of the sync pulses now are more negative than the grid voltage for beam current cutoff, and it is only these tips that do not appear in the beam current. The partial cutoffs of sync pulses are shown at c and d. Beam current variations are lower down on the beam current curve than in either of the preceding cases. As a result the entire picture appears too dark.

Because we are examining the picture signal and sync pulses associated with only one horizontal line and the beginning of another line, the diagram at 3 of Fig. 14 does not show why vertical retrace streaks appear when setting of the contrast control is too low for the existing level of brightness control. If, however, you imagine a relatively long vertical blanking interval occurring with

bias and gain as in diagram 3, the reason becomes apparent. During that vertical blanking interval, while there are no picture signals, there are a number of horizontal sync pulses. Since these pulses are not cut off, they cause variations of beam current which result in the vertical retrace lines.

Fig. 15 shows what happens when there are changes of picture tube grid bias due to varying a brightness control while gain or amplification, as regulated by a contrast control, remains constant and while the strength of the input signal remains constant.

To begin with, look back at diagram 1 of Fig. 14, where contrast and brightness settings are correct. Only the sync pulses are cut off, and all of the picture variations remain.

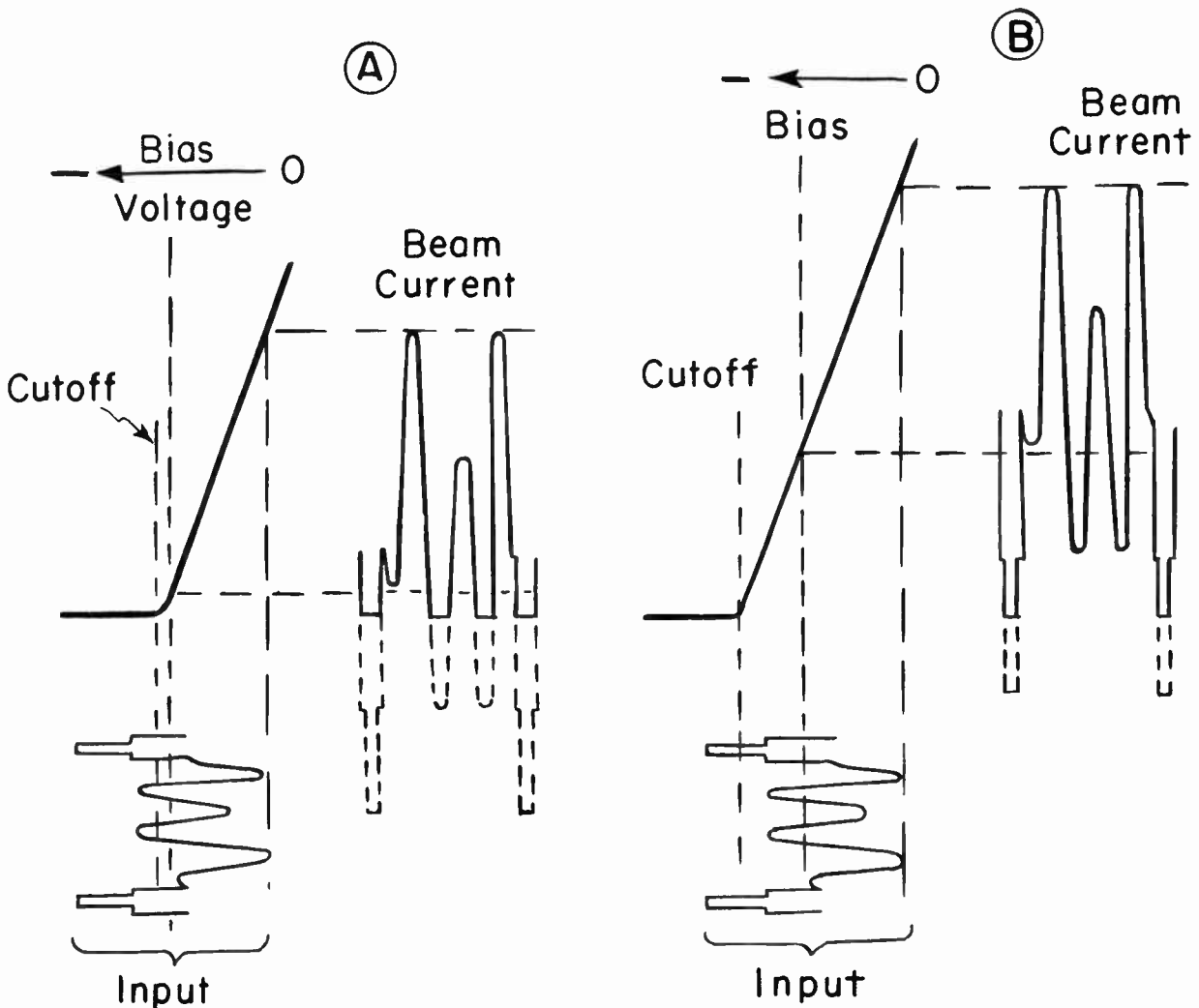

Fig. 15. How picture tube beam current is affected by varying the grid bias (brightness setting) while input signal strength remains unchanged.

## LESSON 40 – TELEVISION CONTROLS

In diagram A of Fig. 15 we have exactly the same input signal strength, since gain or the setting of the contrast control has not been altered. But picture tube grid bias has here been made more negative, it is almost at the point of electron beam cutoff. This change of bias shifts the entire video signal downward on the beam current curve. This cuts off not only the sync pulses, but also the portions of the picture signals which should produce dark gray tones.

By comparing the portions of the video signal which are cut off in diagram A of Fig. 15 with those cut off in diagram 2 of Fig. 14 it is apparent that the general effect on picture quality is much the same. That is, excessive gain or setting the contrast control too high has the same effect on darker parts of pictures as setting the brightness control too low, which means an excessively negative grid bias.

In diagram B of Fig. 15 the picture tube grid bias has been made much less negative. The input signal strength is exactly the same as in diagram A. This entire video signal, as it appears in the reproduction, has been shifted upward on the beam current curve to such an extent that only the tips of the sync pulses are cut off. This effect on sync pulse cutoff, or lack of cutoff, is the same as observed in diagram 3 of Fig. 14. Setting the brightness control too high, in Fig. 15, has the same effect on sync pulse cutoff as setting the contrast control too low, in Fig. 14. Either of these settings will allow vertical retrace lines to appear in pictures.

All of the faulty picture reproductions shown by Figs. 14 and 15 would be corrected by bringing the black level of the video signal to the grid voltage for electron beam cutoff, as shown at 1 of Fig. 14. This could be done either by readjusting the contrast to suit the brightness, or by readjusting the brightness to suit the contrast. Only then would all picture variations remain on the screen, with all sync pulses and their effects eliminated from picture reproduction.

CONTROLS FOR CONTRAST. One of the most widely used types of contrast control is an adjustable cathode bias resistor on a video amplifier tube. If there are two stages of

video amplification the contrast control most often is on the second tube, the one whose output or plate circuit goes to the picture tube.

Several contrast controls of this general type are illustrated by Fig. 16. At A the video amplifier tube is biased not only by the adjustable cathode resistor but also by the negative charge developed on capacitor C<sub>g</sub> and held there by grid resistor R<sub>g</sub>. In diagram B the grid resistor, R<sub>g</sub>, connects to a source of fixed bias voltage instead of to chassis ground. Minimum bias, regardless of contrast control setting, is provided by an extra cathode resistor, R<sub>a</sub>, in series with the control resistor R<sub>k</sub>.

Diagram C shows the output of a video detector directly or conductively connected to the grid of a video amplifier. The detector load circuit is the grid return for the amplifier, and is connected to a source of fixed negative bias for the amplifier. To avoid biasing the video detector, as well as the amplifier, both sides of the detector circuit, both plate and cathode, are connected to the amplifier bias source. Thus the entire detector circuit is at this bias potential, but there is no difference of potential or no bias across the detector itself.

In Fig. 17 the adjustable contrast control resistors on the amplifier cathodes are paralleled by other resistors, R<sub>a</sub>. The effect is to alter the rate of resistance change, or the "taper" of the contrast control as the slider of the control potentiometer is moved. When the contrast control by itself is designed to have a uniform or constant change of resistance with slider rotation, the paralleled resistor allows very rapid change as the slider is moved away from its top position (in the diagrams). The rate of resistance change becomes slower and slower with a steady movement of the slider until, at the lower end of the travel there is little variation of resistance and bias for a considerable movement of the slider.

In diagram A of Fig. 17 there is direct coupling from the video detector to the video amplifier. Electron flow in the detector load circuit is as shown by the arrow, making the end of the load which is toward the amplifier



# COYNE - television home training

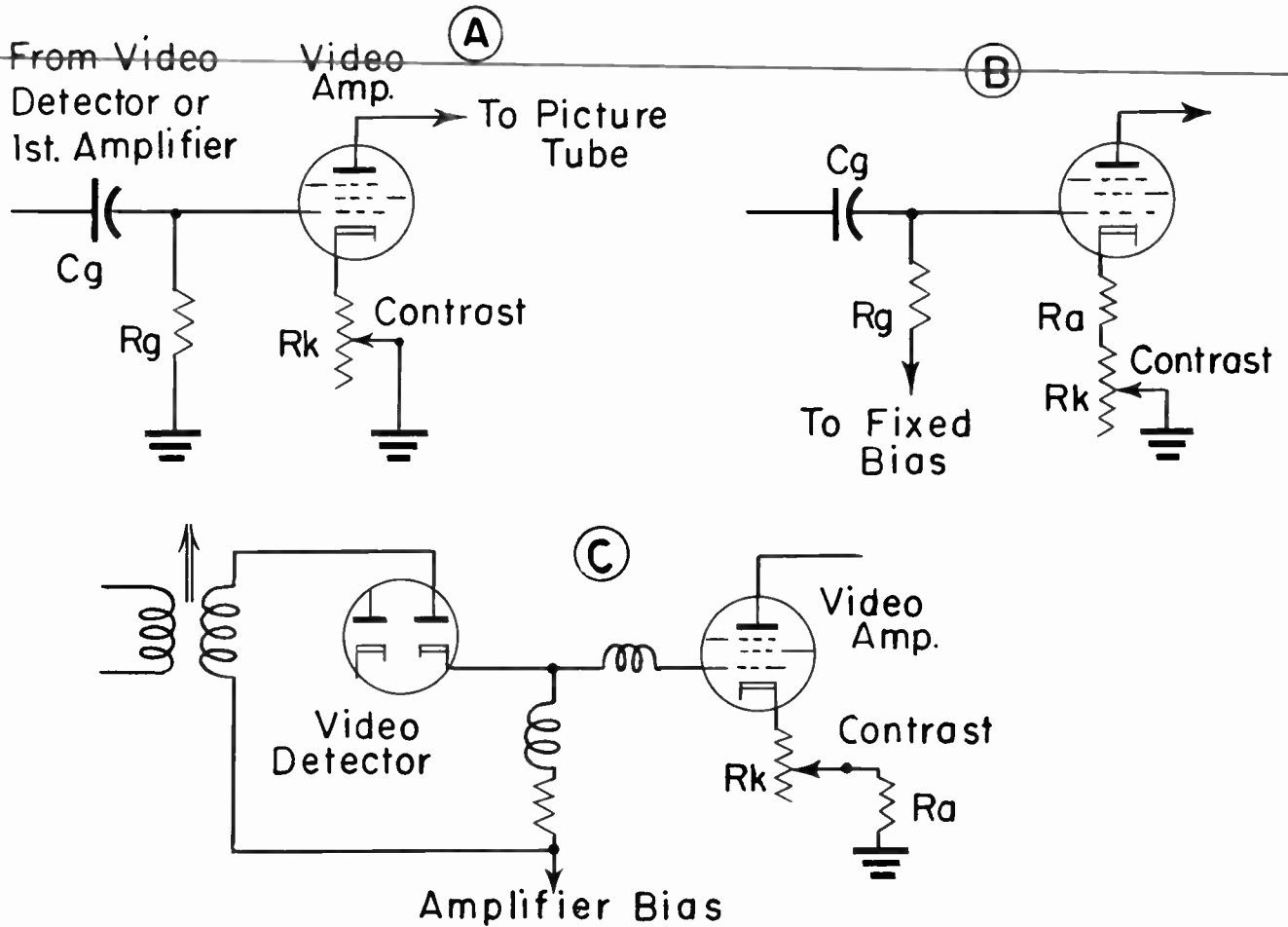

Fig. 16. Contrast control by variable cathode bias on video amplifiers.

grid of negative polarity with reference to the grounded end, which connects to the amplifier cathode circuit. The average d-c voltage across the detector load provides a minimum

negative bias for the amplifier grid.

In diagram B the fixed bias voltage for the amplifier is taken from a resistance volt-

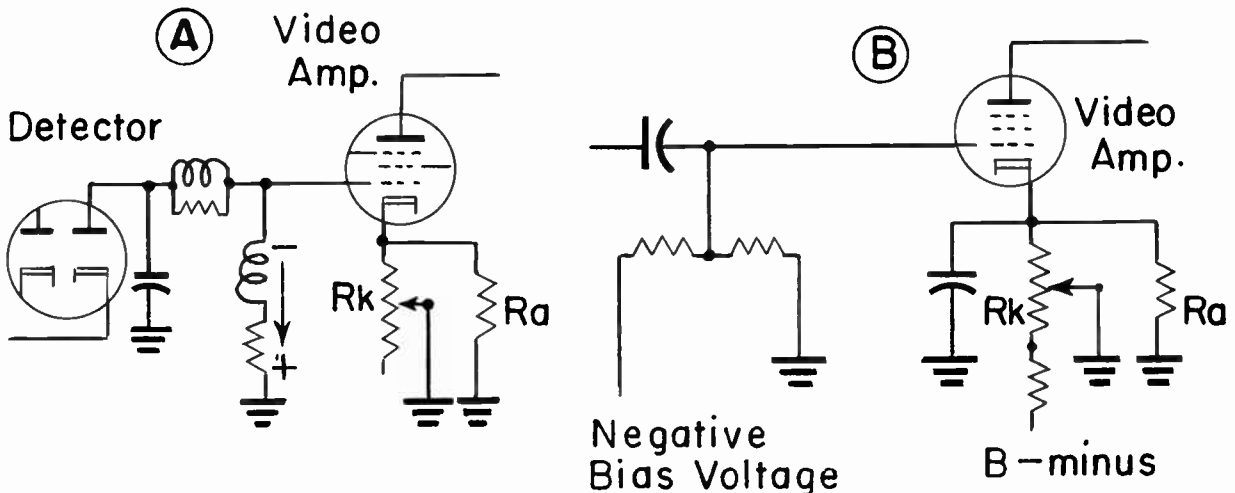

Fig. 17. Video amplifier grid biases from adjustable cathode resistors and from additional sources of negative voltage.

## LESSON 40 – TELEVISION CONTROLS

age divider connected between chassis ground and a fixed voltage that is negative with reference to ground.

Fig. 18 illustrates two more modifications of contrast controls which are in cathode lines of video amplifiers. Amplifier grid biases are somewhat greater than provided by the contrast control resistances because of extra series resistors at  $R_a$ . These added resistors are bypassed by capacitors  $C_b$ , but the adjustable contrast controls are not bypassed.

When any cathode resistor is not bypassed by capacitance having very small reactance at the lowest signal frequencies, signal voltages or currents in both the plate and grid circuits return to the cathode through the unbypassed cathode resistor. This we learned when studying grid biasing in general. In any tube having signal input to the grid and signal output from the plate, plate signal voltages are of polarity or phase opposite to signal voltages on the grid. Consequently, plate signal voltages in an unbypassed cathode resistor oppose signal voltages applied to the grid and weaken the signal voltages at the grid. This is one form of the action called degeneration.

The amount of degeneration or the strength of opposing feedback voltage depends on the amount of unbypassed resistance in the cathode line. The greater this resistance the stronger is the feedback, the weaker becomes the signal remaining at the grid, and

the less becomes the gain or amplification of the video amplifier. When a contrast control consisting of an unbypassed cathode resistor is adjusted for more resistance the effect is to make the grid bias more negative and at the same time to increase the degenerative feedback. Both these actions decrease the gain or amplification, and the overall result is a highly effective contrast control.

Quite often you will find bypasses whose capacitance is less than will provide small reactance at the lowest video frequencies, yet will have small reactance at the higher video frequencies. Then there will be little feedback and little degeneration at the higher frequencies, for which capacitive reactance is small, but there will be more degeneration at the lower frequencies. Because bypass capacitance thus affects degeneration and video amplification, you should not alter the capacitance values in making replacements.

In addition to cathode bias and degeneration adjustable for contrast control there is wide variety in other contrast controls employed now and in the past. A few of these methods are illustrated by Fig. 19. In diagram A the inductor and resistor in the plate load of the first video amplifier are paralleled by an adjustable resistor  $R$  which is the contrast control. More resistance at  $R$  increases the effective plate load of the first amplifier, and increases its gain. Less resistance in the contrast control reduces the plate load and the gain.

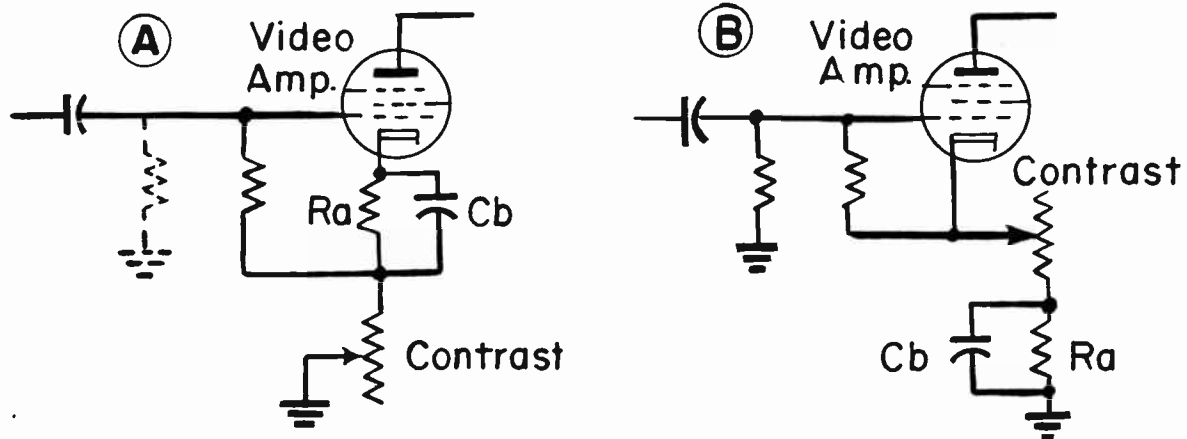

Fig. 18. Minimum negative grid bias for video amplifiers provided by cathode resistances in series with contrast controls.

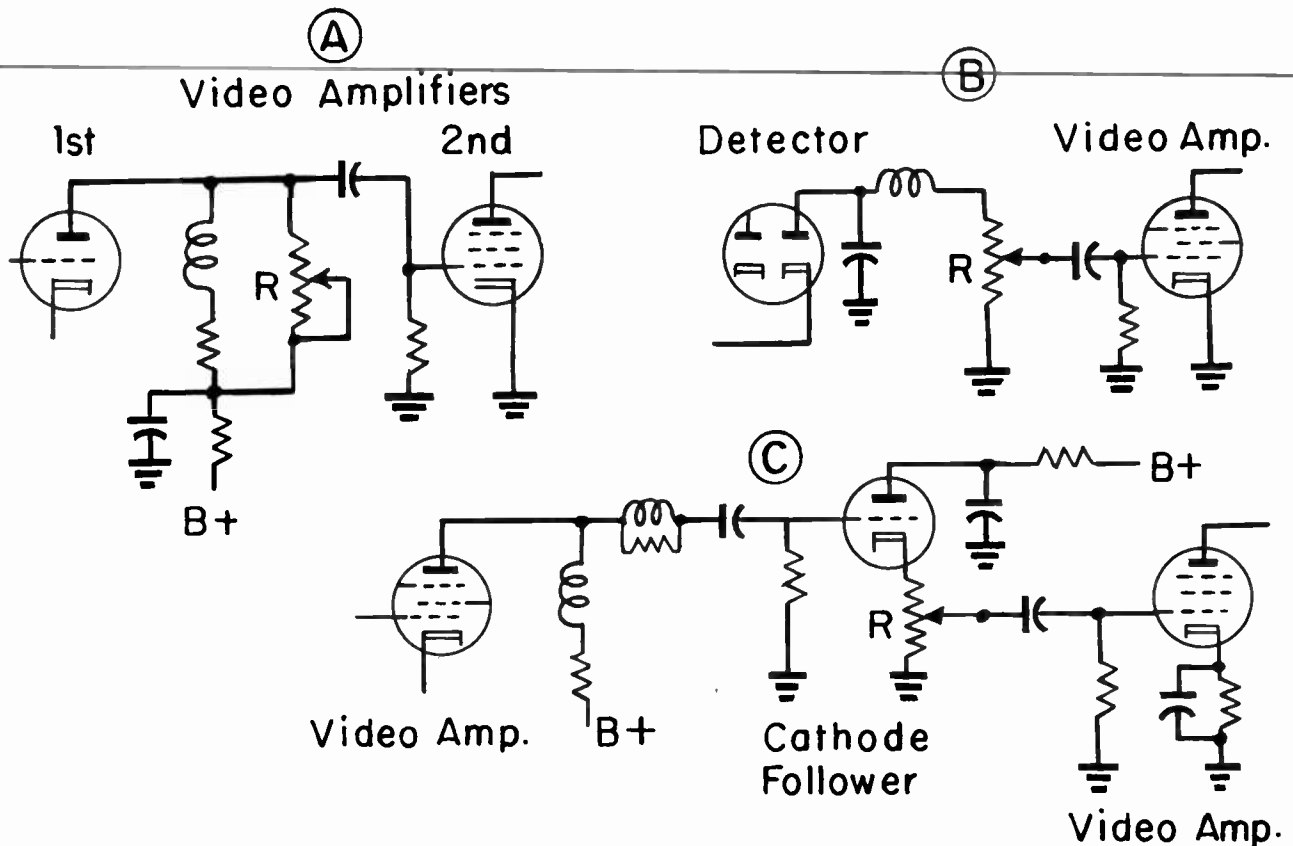

Fig. 19. Contrast controls which do not alter the grid bias of video amplifiers.

Diagram B shows a potentiometer as the video detector load resistor. The slider of this potentiometer, which is the contrast control, goes to the grid of the video amplifier. The higher the slider is moved on the control resistance, the stronger is the signal voltage transferred from detector to amplifier.

In diagram C there is a cathode follower tube between two video amplifier tubes. The grid of the follower tube is fed from the plate load circuit of the first amplifier. The cathode output resistor of the follower is a potentiometer, which forms the contrast control. The slider of the control feeds the grid of the second amplifier. The cathode follower contributes no gain, but it helps maintain a high impedance output load and high gain for the first video amplifier, while providing low impedance grid circuit input for the second amplifier.

In a number of television receivers of earlier design there was no automatic gain control. Instead, the grid returns of i-f and

amplifiers might be connected to a contrast control which furnished an adjustable negative bias for these tubes. In service diagrams for these sets you will find the common grid return line, which nowadays usually is the agc bus, going to the contrast control. Examples of contrast controls which regulate the gain of r-f and i-f amplifiers are shown by Fig. 20.

In diagram A the video detector is one section of a twin diode, whose other section is used as a rectifier for bias voltage. The cathode of this rectifier is connected to the 6.3-volt a-c heater circuit, whose other side is grounded. The rectifier plate is connected to ground through the contrast control potentiometer and a series resistor. Rectified electron flow, in the direction of the arrow, makes the high side of the control potentiometer negative with reference to ground. To the slider of the contrast control are connected the grid returns of those tubes whose gain is to be varied. Gain is reduced by moving the control slider toward negative, and is increased by moving the slider toward positive.

# LESSON 40 – TELEVISION CONTROLS

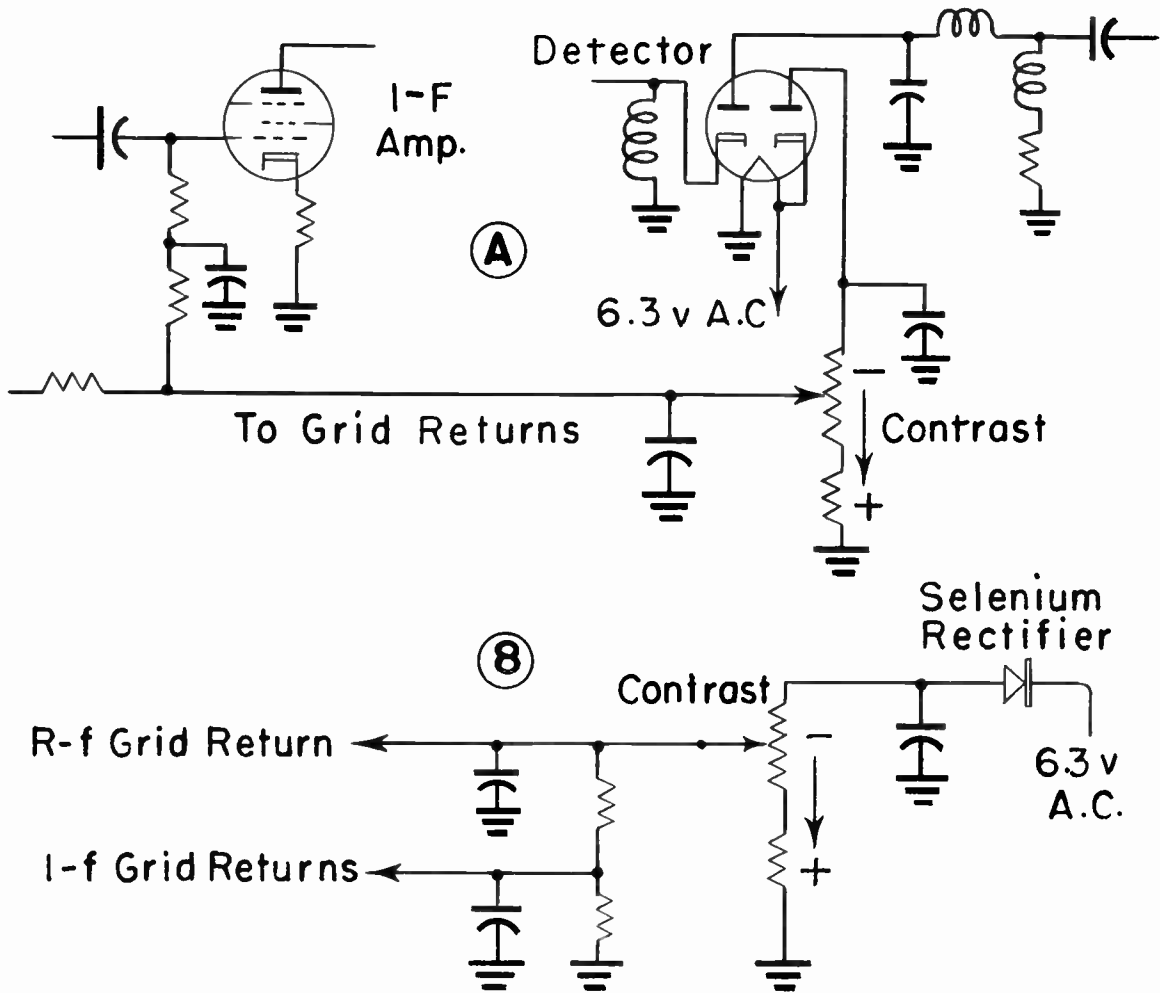

Fig. 20. Contrast controls which vary the gain of r-f and i-f amplifiers.

The controlled tubes usually have auxiliary cathode bias.

In diagram B the bias rectifier is a selenium type such as used in many d-c power supplies, but of small current-handling capacity. The grid return of the r-f amplifier is

connected directly to the slider of the contrast control, while grid returns of i-f amplifiers are connected through a resistor. This allows a greater range of bias control for the r-f than the i-f amplifiers, and thus helps prevent overloading of i-f stages on exceptionally strong received signals.



# TELEVISION



◦ **RADIO**

◦ **ELECTRONICS**

---

---

**LESSON 41 – AUTOMATIC GAIN CONTROLS**

---

---

***Coyne School***

*practical home training*

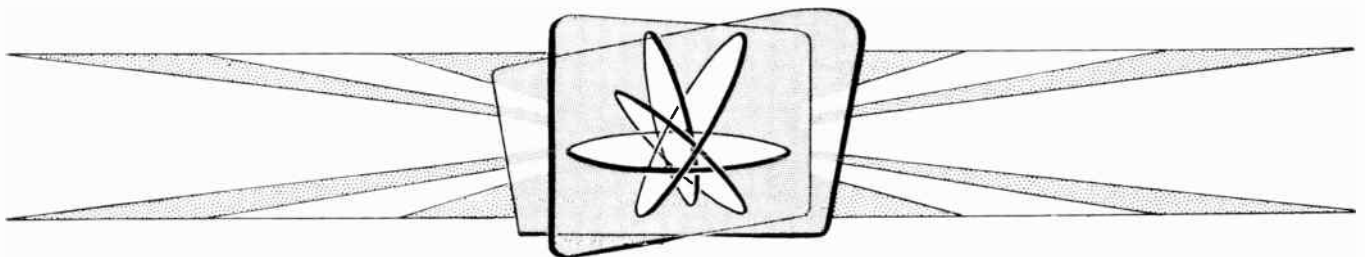

*Chicago, Illinois*

---

*Copyright, 1953 by Coyne Electrical School  
Chicago 12, Illinois  
All rights reserved*

Litho. in U.S.A.

## Lesson 41

# AUTOMATIC GAIN CONTROLS

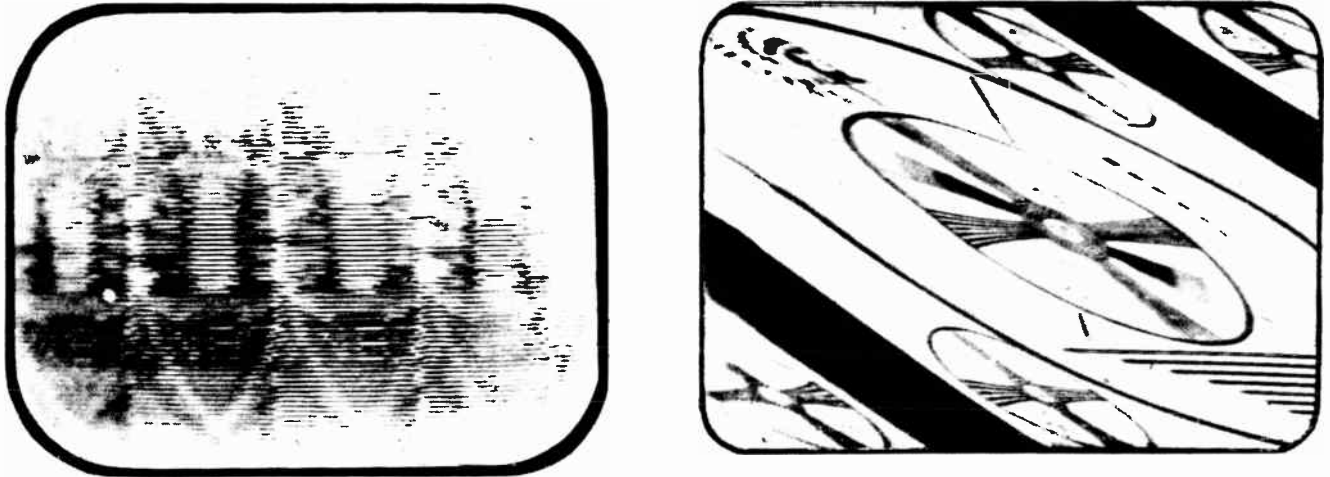

Fig. 1. Faults which may be attributed to other causes sometimes result from trouble in automatic gain controls.

Automatic gain control in a television receiver is even more necessary than automatic sound control in a sound receiver. In both types of receivers the control is intended to maintain fairly uniform performance after a program is tuned in, either uniform level of sound from a broadcast sound receiver or of picture brightness and contrast for television.

Automatic gain control in television helps in other ways when the control really is effective. It helps to allow channel switching without readjustment of contrast and brightness controls. It lessens fluctuations of brightness such as may result from variations of power line voltage, from slight swaying of antennas and transmission lines, and from signal reflections off low-flying aircraft. Finally, a good automatic gain control helps to hold pictures steady on the screen. Effects such as illustrated by Fig. 1 most often are caused by faults in hold controls or their adjustment, but may be caused also by failures in automatic gain control systems.

The simplest automatic gain control for television is quite similar in principle to the simplest automatic volume control for sound reception. At A in Fig. 2 is an automatic volume control circuit, and at B a circuit for

automatic gain control. The biasing voltage for controlled tubes is taken from the high side of the load on the diode sound detector, and from the high side of the load on the video detector for television.

Although many television sets have automatic gain controls of the kind illustrated by Fig. 2, there are certain disadvantages or shortcomings which may be wholly or partially overcome by modifications of the elementary circuit. These changes always require more parts and added complication, which may give trouble in themselves yet be well worth while for reception under adverse conditions. We shall examine modifications which are intended to overcome these faults.

1. Signal strength at input to picture tube varied by changes of shading or tone in the pictures being reproduced.
2. Insufficient amplification of weak signals, such as those in fringe areas.
3. Pictures become momentarily dark, then return to normal brightness.
4. Excessive "snow" in pictures received in closely built up localities.

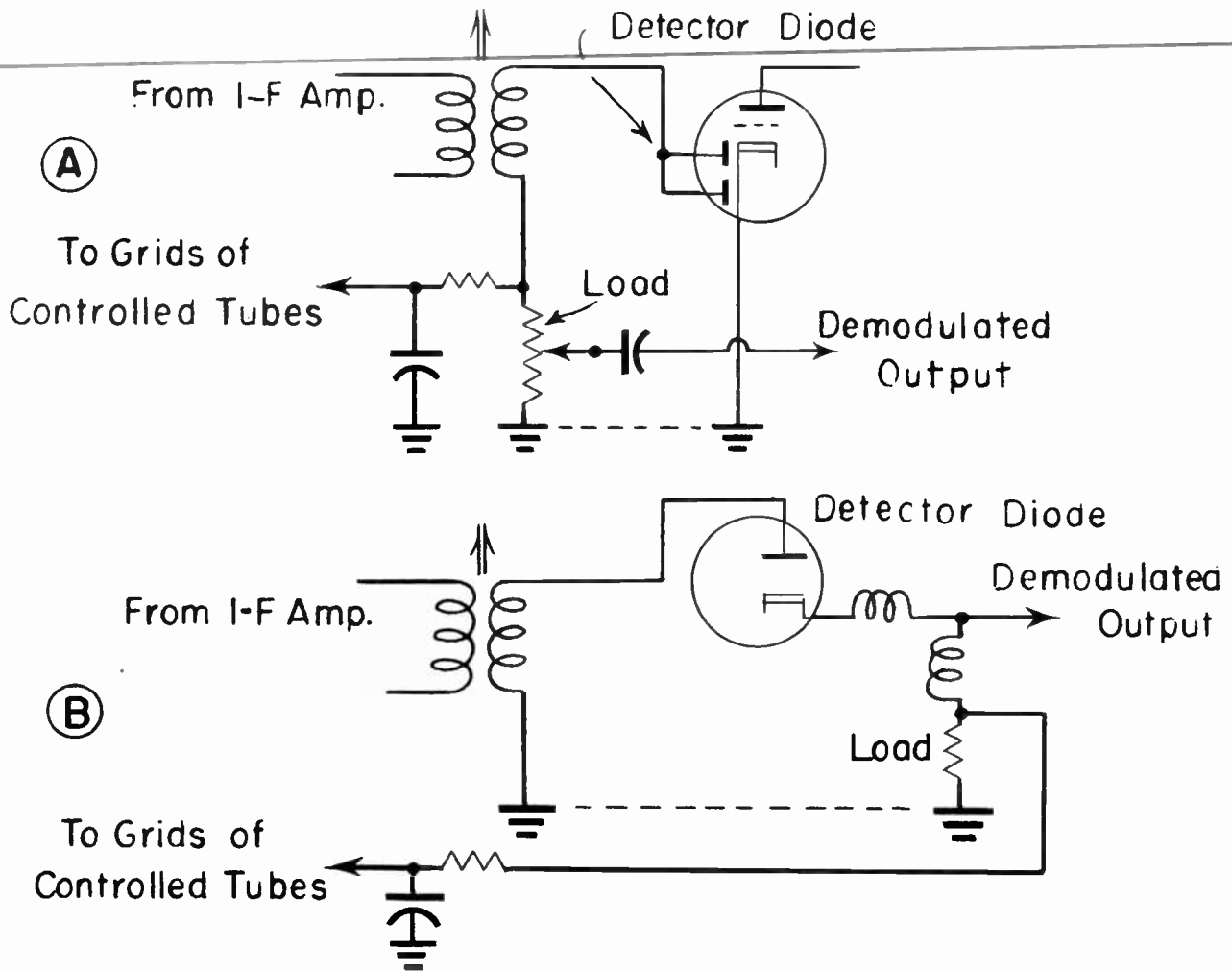

Fig. 2. A simple automatic volume control (A) and a simple automatic gain control (B).

5. Temporary loss of vertical or horizontal synchronization, or both.

**SOURCES OF AGC VOLTAGE.** Fig. 3 represents an audio signal used as the source of avc voltage in a sound receiver. At A is the doubly modulated signal voltage fed from the i-f amplifier to the audio detector. Demodulation by the detector may leave either the upper or lower side of the modulation envelope. The lower side is shown at B. When the received signal becomes stronger there will be greater amplitude on both sides of the i-f signal (A) and the detector output, at C, will have greater variations. A weaker signal would, of course, cause smaller variations in the detector output.

The demodulated or rectified voltage from the sound detector is a varying direct voltage. The average value of this voltage

changes proportionately to strength of the received signal, and this average value is satisfactory as an automatic biasing voltage for volume control in a sound receiver.

Fig. 4 illustrates, at the left, a television i-f signal voltage which we shall assume is of average strength. At the center is a relatively weak signal, and at the right a much stronger signal. When these signals are demodulated by the video detector we recover either the upper or lower side of the modulation envelope. The average of the varying d-c voltage from the detector varies proportionately to strength of received signal. This average is marked A in the diagrams. When this average negative voltage is applied to grid returns of controlled tubes, the bias and gain will vary with signal strength and there will be automatic gain control.



# LESSON 41 – AUTOMATIC GAIN CONTROLS

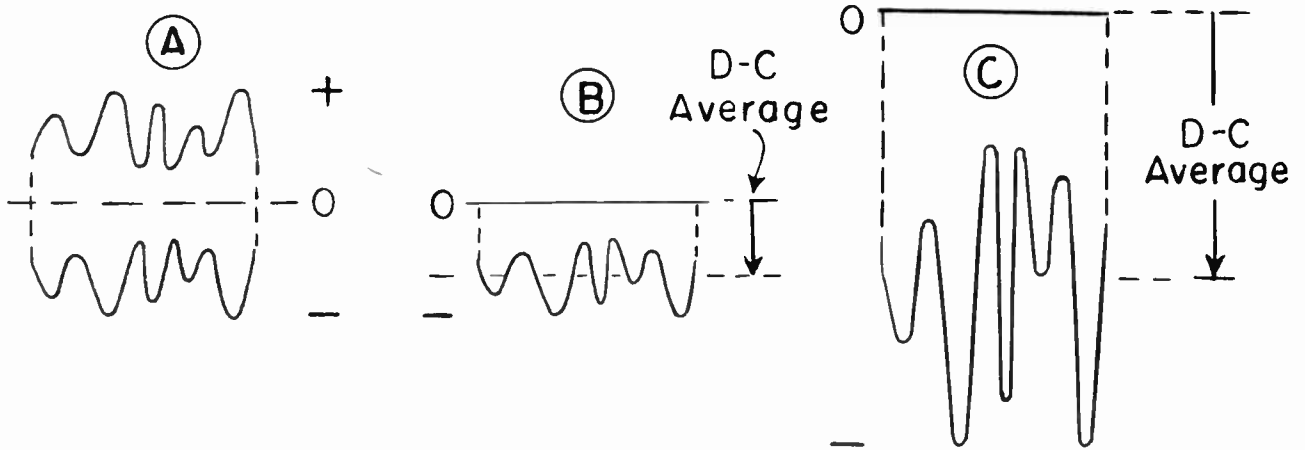

Fig. 3. Average d-c voltage at the detector output is satisfactory for automatic volume control.

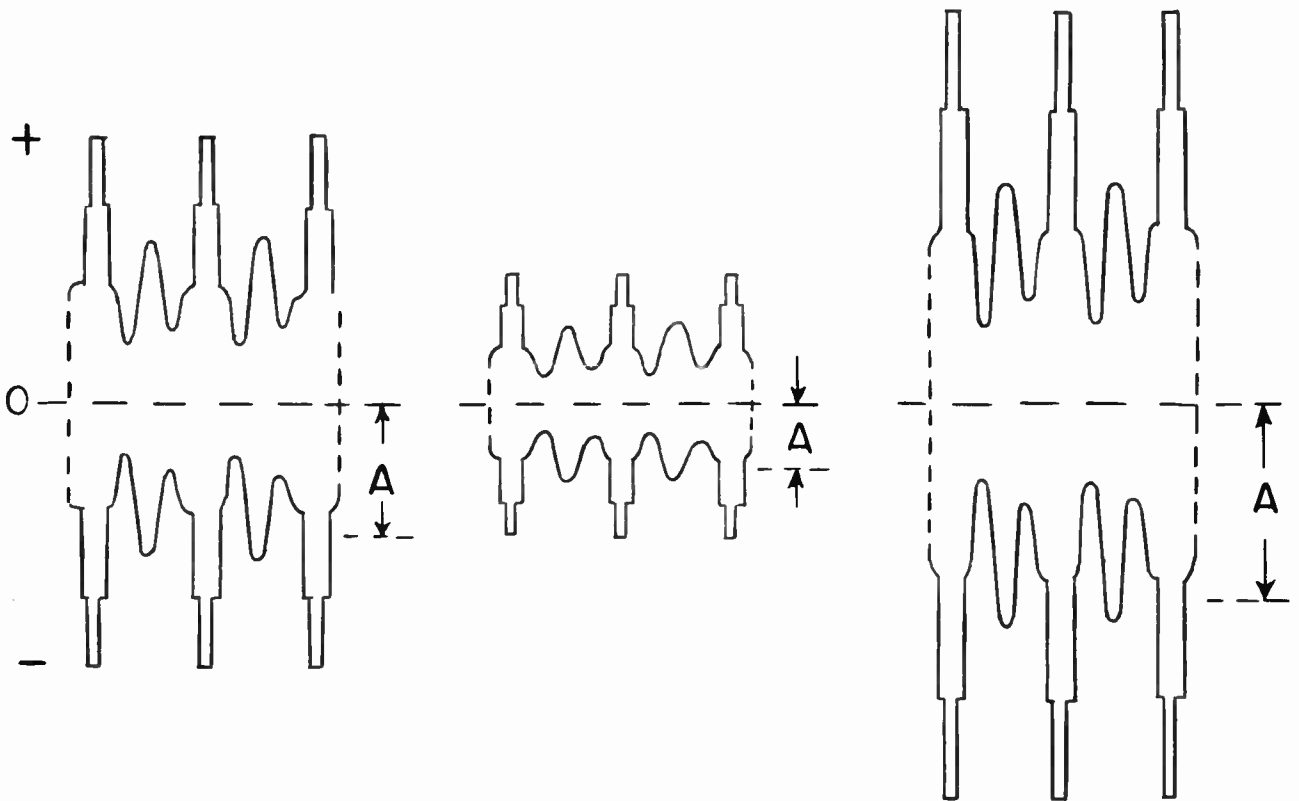

Fig. 4. Average a-c voltage at the video detector output varies with signal strength.

So far so good, but let's look now at Fig. 5. A, B, and C show three i-f signal voltages of equal strengths. The signal strengths are exactly alike because the amplitudes are equal above and below zero, and from peak to peak of the sync pulses.

Picture variations of the signal at A do not extend all the way to either the black or the white levels, but range about midway be-

tween. This might be an average or normal picture. We shall assume that the video detector cuts off the positive side of the i-f signal and retains the lower or negative side, as at the right. Note carefully the average d-c value of the demodulated signal voltage, as measured by the length of the arrow.

Picture variations of the video signal at B in Fig. 5 are near the black level. This

# COYNE - *television home training*

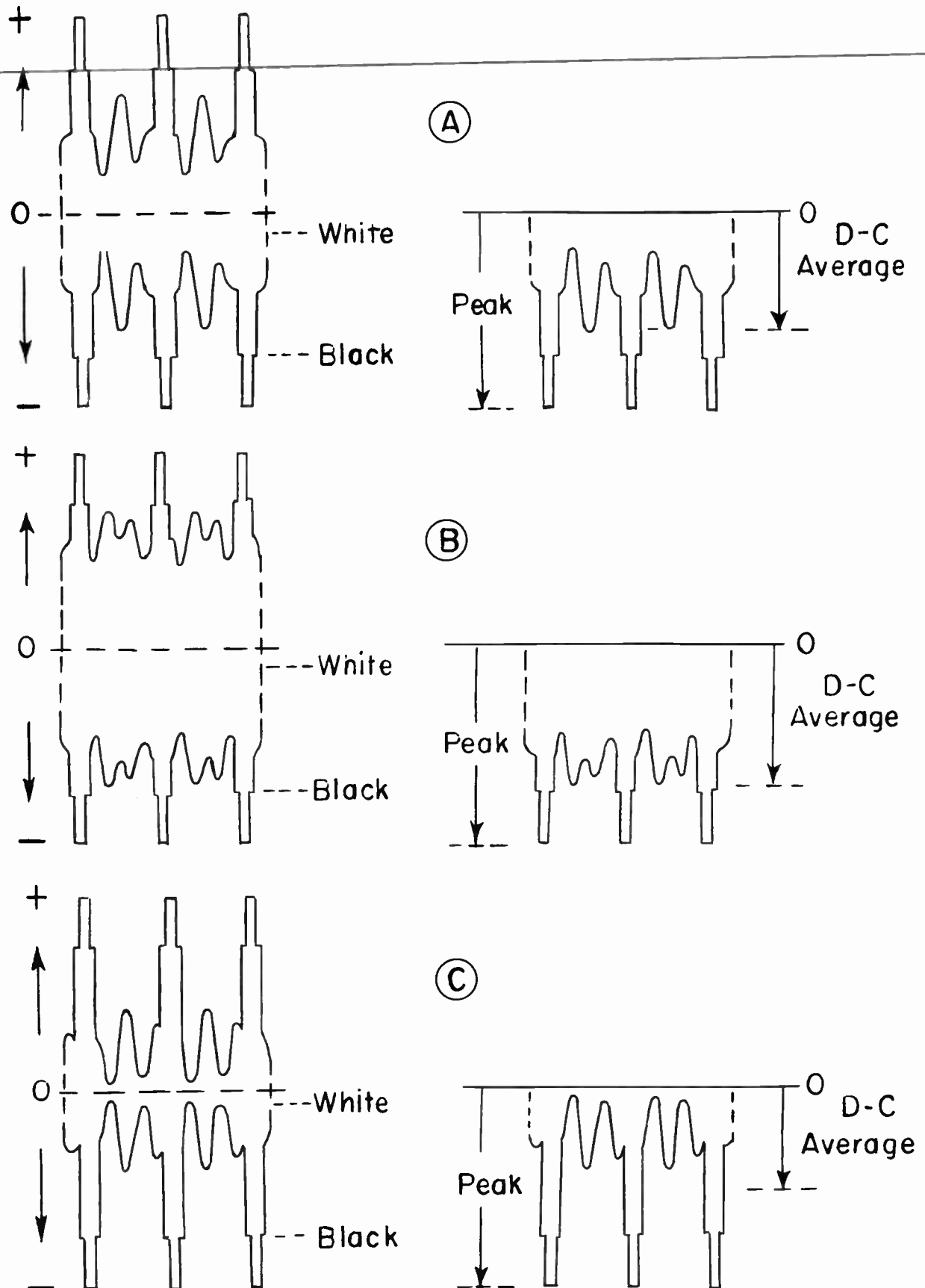

Fig. 5. How the general tone or average brightness of pictures affects the average d-c voltage at the output of the video detector.

## LESSON 41 – AUTOMATIC GAIN CONTROLS

might be part of a night scene in a mystery story. The demodulated signal as it appears at the load of the video detector is shown at the right. The average value of this varying d-c voltage is greater than at A. Were this greater average negative voltage applied as grid bias to controlled amplifier tubes, their gain would be reduced. This would reduce the video signal input to the picture tube, not because of a weaker received signal, but only because of a change toward darker shadings in pictures, even while received signal strength remains unchanged.

In the received signal at C the tone of the picture has become lighter. Picture variations now extend all the way to the white level and none come close to the black level. Demodulated d-c signal voltage again is shown at the right, with average value measured by an arrow. This average is less than in either of the preceding cases. Were this average d-c voltage used for biasing controlled amplifiers, the bias would be less negative than before. There would be greater gain and stronger signal input to the picture tube, as a sole result of change in picture tone, not from any change of strength in received signals.

Variations of gain due to changes of picture tone would alter the strength of signals at the picture tube somewhat as in Fig. 4, but hardly to such an extent. We have learned, however, that any material change of signal input to the picture tube requires readjustment of brightness control, contrast control, or of both controls in order to retain all picture signal variations in the reproduction while keeping all sync pulse effects out.

Looking again at Fig. 5, we note that sync pulse peaks of demodulated signal voltage remain of constant value with all changes of picture shading, so long as received signals are of constant strength. Fig. 4 shows that amplitude of these sync pulse peaks varies proportionately to strength of received signals. Obviously then, voltage of sync peaks in received signals is more nearly proportional to signal strength than is the average value of demodulated signal voltage at the output or the load of the video detector.

AGC RECTIFIERS. The way to utilize the voltage of sync pulse peaks for automatic gain control is to apply the i-f signal voltage to what may be called a peak rectifier system. Such a system is illustrated by Fig. 6. The agc (peak) rectifier is a diode, usually one section of a twin diode whose other section is used as the video detector. The video detector, however, has no direct relation to the agc system, and the two might utilize separate tubes.

The modulated signal voltage from the final i-f amplifier is applied through the agc capacitor to the plate of the rectifier diode. To the plate is connected also the rectifier load resistor. The agc voltage, negative with respect to ground or B-minus, appears at the top of the load resistor, and is taken from there through the usual resistance-capacitance filter to the grid returns of controlled tubes.

The positive side of the i-f signal voltage, coming from the i-f amplifier coupling, makes the plate of the agc rectifier diode positive, and there is conduction through the diode from cathode to plate. Electron flow, as shown by full-line arrows, is from the plate to one side of the agc capacitor, making this side negative by addition of excess electrons. From the other side of the capacitor the flow is through the i-f coupling to ground, and through ground back to the rectifier cathode.

The capacitor cannot discharge through the agc rectifier, for that would require electron flow from plate to cathode. But the capacitor does discharge more or less slowly through the rectifier load resistor. This flow, shown by broken-line arrows, continues from the bottom of the load resistor through ground and the i-f coupling to the positive side of the capacitor. The direction of discharge flow through the load resistor makes the top of this resistor negative with reference to ground. This is the negative agc voltage.

By making the agc capacitor and the rectifier load resistor of such values as to have a fairly long time constant, the capacitor discharges only a small amount between

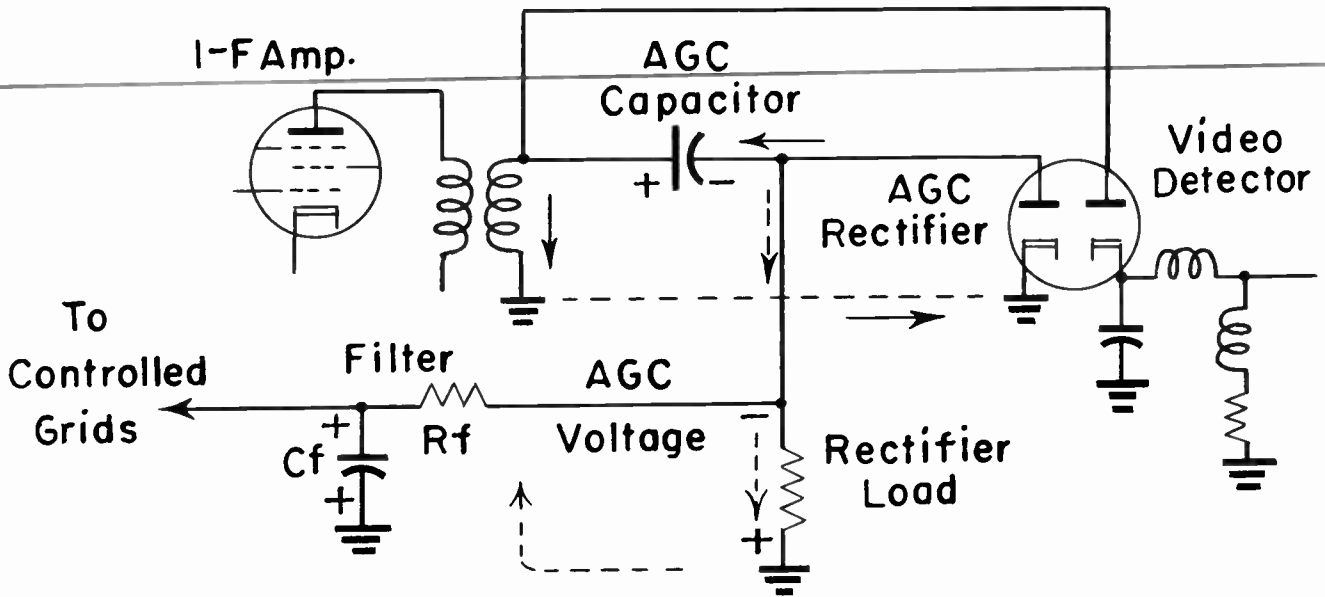

Fig. 6. Obtaining agc voltage from a peak rectifier.

successive positive sync pulses of the signal. Then the charge voltage rises to a value almost equal to the voltage at the peaks of sync pulses, and is held there by the slow rate of discharge. This negative voltage on one side of the capacitor is the voltage at the top of the rectifier load resistor, and the agc voltage to controlled tubes. Thus we obtain an agc voltage proportional to the sync pulse

peaks of the i-f signal, not to the average value of a rectified signal.

There are many variations in employment of rectifiers for obtaining negative agc voltages. An example is shown by Fig. 7. One section of a twin triode is used as a video detector and agc rectifier. The cathode and grid act similarly to the cathode and plate

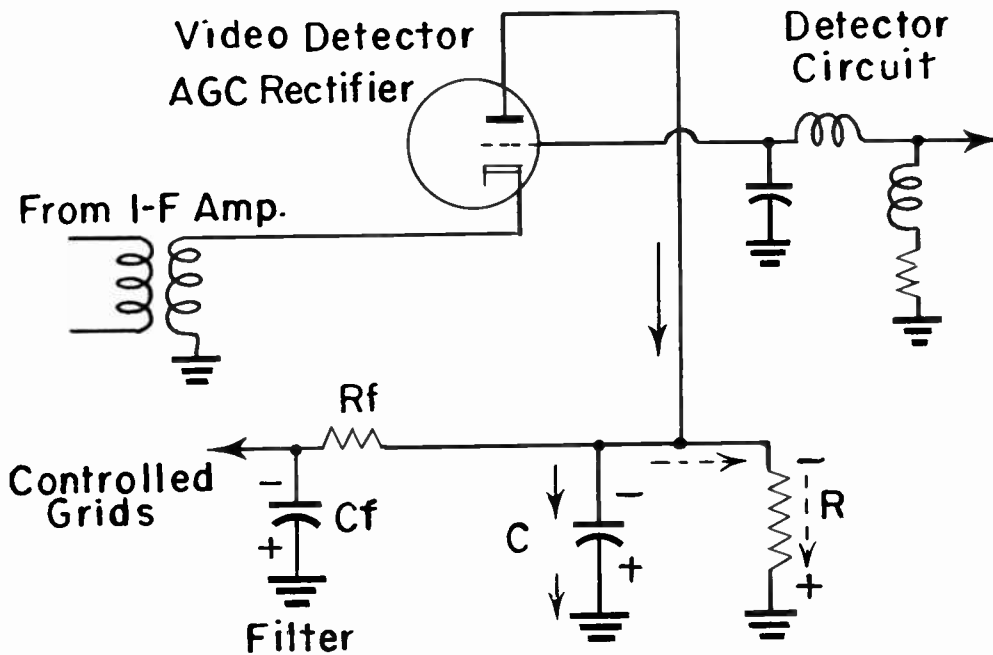

Fig. 7. Using a triode as combined video detector and agc rectifier.



# LESSON 41 – AUTOMATIC GAIN CONTROLS

of a diode video detector. The cathode and plate of the triode act as the rectifier in the agc system.

Signal voltage from the i-f amplifier is applied to the cathode of the detector-rectifier triode. The negative side of the applied signal causes conduction in the triode. Resulting electron flow, shown by full-line arrows, charges agc capacitor G in the marked polarity. The charge escapes only through rectifier load resistor R, as shown by broken-line arrows. The capacitor charges to nearly the peak voltage of the sync pulses. The negative charge voltage at the top of the capacitor and the top of the load resistor becomes the negative agc voltage for biasing the grids of controlled tubes.

Rectifiers are employed in automatic volume control of sound receivers in much the same way as in automatic gain control for television. An avc circuit such as used in many radio receivers is shown by Fig. 8. The tube is the usual duodiode triode found in circuits for sound detectors and first audio amplifiers. The plate of the lower diode here is connected into the detector circuit, which is generally the same as other a-m detector circuits.

The upper diode plate and the common cathode are used as the avc rectifier. The

agc capacitor, C, takes the i-f signal voltage from the secondary of the i-f transformer to the diode plate. The rectifier load resistor, R, is connected from the diode plate to ground, and through ground to the rectifier cathode. The capacitor is charged in the marked polarities, and discharges slowly through the load resistor.

The negative voltage on the side of the capacitor toward the rectifier plate, and at the top of the load resistor, is the negative agc voltage. Electrical action in this avc system is exactly the same as in the television agc system of Fig. 6. Either of the diode plates in the duodiode triode tube may be used for the avc function, with the other plate in the detector circuit.

Crystal diodes instead of tubes may be found in detector and gain control circuits for both sound radio and television receivers. Fig. 9 shows connections for crystal diodes for a sound detector and an avc rectifier. Electron flow in the rectifier diode circuit is shown by full-line arrows. This flow charges the avc capacitor C in the marked polarity. The capacitor discharges through rectifier load resistor R as shown by broken-line arrows. The bottom of the capacitor and top of the resistor became negative with reference to ground at a value approximately equal to peak voltage of the i-f signal, this

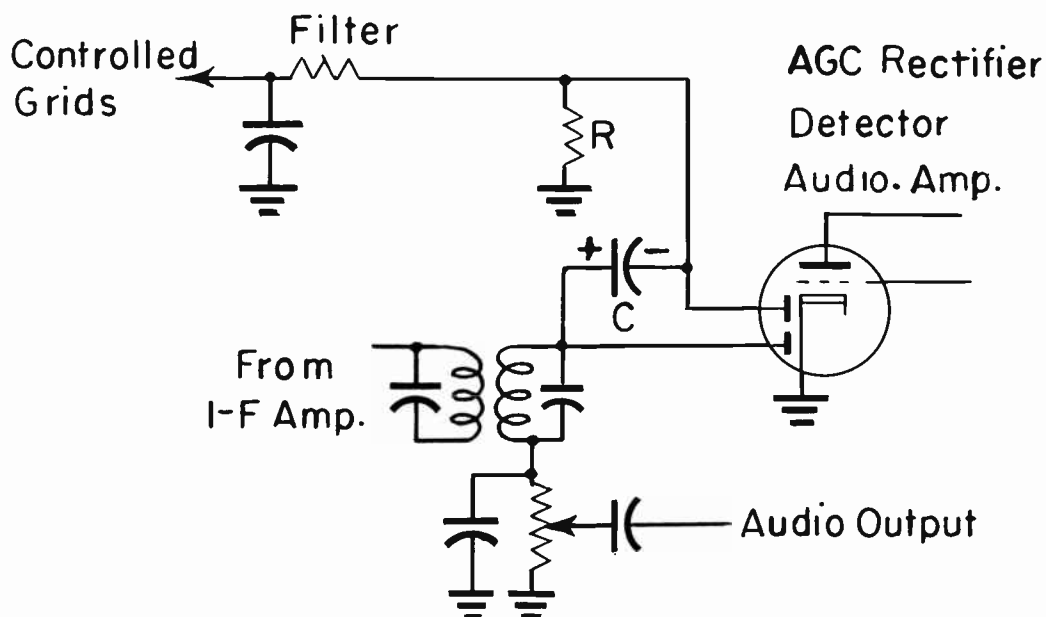

Fig. 8. A peak rectifier in an automatic volume control for sound receivers.

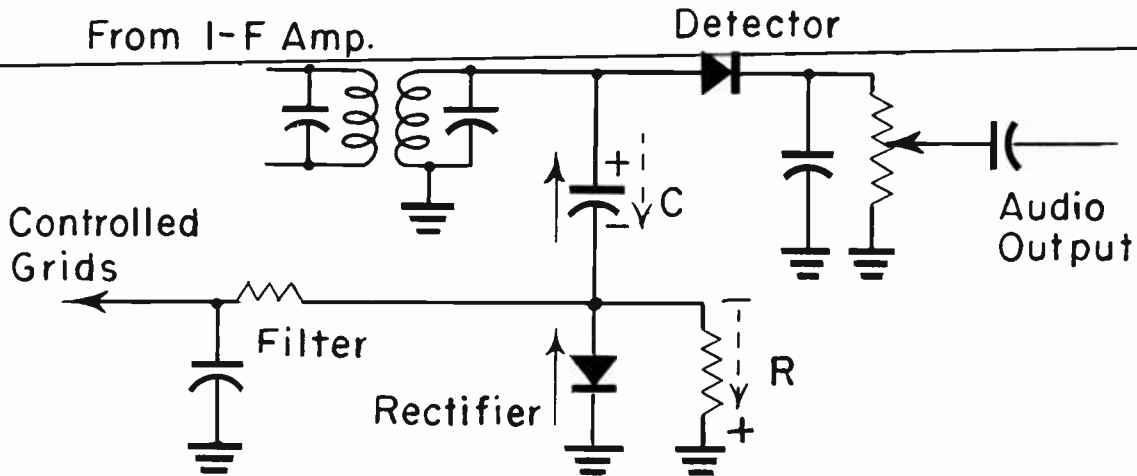

Fig. 9. Crystal diodes for video detector and avc rectifier.

being the negative avc voltage for grids of controlled tubes.

**TIME CONSTANTS.** Looking back at Figs. 6 and 7 you will see that the agc capacitor discharges through the rectifier load resistor. The time constant of this capacitance-resistance combination must be long enough to prevent much discharge of the capacitor between successive horizontal sync pulses. It is only by preventing any great discharge between charges contributed by the sync pulses that the capacitor voltage and negative agc voltage are held very nearly at the peak voltage of the sync pulses.

The time constant usually is made somewhat longer than the period of one horizontal line, which is the interval between successive horizontal sync pulses. The line period, as you will recall, is about 63.5 microseconds. The R-C time constant in the agc rectifier system often is something between 70 and 100 microseconds, but may be a little shorter or quite a bit longer. The time constant, in microseconds, is equal to the product of capacitance in mmf times resistance in megohms.

To prevent taking too much of the i-f signal voltage away from the video detector circuit, the reactance of the agc capacitor must be fairly small at the intermediate frequency. Capacitances most often are between 50 and 120 mmf. To provide the desired time constant with such capacitances, the rectifier load resistance usually is something between

0.5 and 1.0 megohm. This high series resistance helps prevent taking too much signal voltage from the i-f input, and away from the video detector.

Again looking back at Figs. 6 and 7 you will note that between the agc rectifier circuit and the agc bus to controlled grids there is a filter consisting of a series resistor and a capacitor to ground. The filter capacitor,  $C_f$ , is charged from the agc rectifier circuit through filter resistor  $R_f$ . This capacitor discharges slowly through the filter resistor and the rectifier load resistor,  $R$ , since these two resistors are in series between the filter capacitor and ground. Consequently, the charging time constant for the filter capacitor is shorter than the discharge time constant. This difference is not of much concern, except possibly to designing engineers, because the average of both time constants ranges from about 1/10 to 4/5 second, not microseconds. Filter capacitances may be between 0.1 and 1.0 mf, and filter resistors between 0.1 and 1.5 megohms in most cases.

A relatively short time constant for the agc filter allows the gain control voltage to follow rapid variations of received signal strength. The control voltage also may follow vertical sync pulse voltages which come through the rectifier circuit where the time constant is very short. When these sync pulses increase the charge on the filter capacitor and make the control voltage momentarily more negative. The effect is to lessen the gain at these instants. Then the

## LESSON 41 – AUTOMATIC GAIN CONTROLS

strength of vertical sync pulses is reduced, and there may be loss of vertical hold or vertical synchronization in pictures.

A relatively long time constant in the agc filter tends to hold capacitor and control voltage steady, and the control cannot follow very rapid changes of strength in received signals. However, since changes of signal strength most often are quite gradual, the long time constant causes no great difficulty on this score. The long time constant also allows the filter to absorb the effect of the 60-cycle vertical sync pulse voltages without material change of capacitor charge and of agc voltage to the controlled grids.

The greatest problem to be overcome by automatic gain controls is that of noise pulses. These are electrical impulses radiated from all manner of electrically operated devices. These impulses do not occur at any particular frequency; they themselves may be at very low or very high frequencies, or anywhere in between, and the range extends all the way from audio to the high carrier frequencies. Noise pulses often cause peaks of voltage in the i-f signal which are stronger than any of the television sync pulse voltages. Then the agc voltage may be determined by the noise pulse voltages instead of by either sync peaks or average rectified voltage of the television signal.

A relatively short time constant in the agc filter allows quick discharge of the filter capacitor and quick return to normal control voltage after the passage of a strong noise pulse. With a long time constant the strong charge on the filter capacitor may leak away so slowly as to hold the control voltage highly negative, and thus darken the picture for an appreciable time. If a noise pulse is exceedingly brief, the large capacitor in a filter of long time constant can absorb the small added charge without any great change of total charge and of agc voltage.

No matter what the length of the agc filter time constant there are advantages and disadvantages. Designers have tried all kinds of time constants, and have combined two or more time constants in different filter sections, but these expedients have provided no complete solution for noise troubles. All

this applies to automatic volume control systems in sound radios as well as to automatic gain controls for television.

DELAYED AUTOMATIC GAIN CONTROLS. Amplifiers in the r-f and i-f sections of any receiver are operated with some minimum value of negative grid bias. This may be a cathode bias or a fixed bias. When the amplifier grid returns are connected to any of the automatic gain control circuits so far examined, the minimum bias remains so long as no signals are received. Just as soon as a signal voltage reaches the video detector or an agc rectifier from whose load resistance an agc voltage is obtained, the automatic control action makes the amplifier grids more negative than the minimum negative bias existing with no signal.

The result is a reduction of gain on even the weakest received signals. When it is desired to allow maximum possible amplification of very weak signals, while having automatic gain control for all signals above some predetermined strength, we resort to a system called delayed automatic gain control in a television receiver or delayed automatic volume control in a sound receiver.

A simple circuit for obtaining delayed agc in a television receiver is shown by Fig. 10. This circuit is exactly the same as that of Fig. 6 except for the addition of parts drawn with heavy lines. Instead of connecting the cathode of the agc rectifier directly to ground it now is connected to a resistance type voltage divider consisting of resistor R<sub>a</sub> and R<sub>b</sub>. One end of this voltage divider is connected to a source of positive B-voltage and the other end to ground. Capacitor C<sub>a</sub> is only for the purpose of completing the high-frequency circuit of the rectifier to ground and back to the grounded end of the i-f coupling.

Assume, for an example, that the B+ end of the voltage divider is connected to 100 d-c volts, as measured from this point to ground. Assume also that resistor R<sub>a</sub> is of 100,000 ohms and R<sub>b</sub> of 1,000 ohms. Voltage at their junction then will be about 1/100 of the voltage at B+, or will be approximately 1 volt with reference to ground. This makes the cathode of the agc rectifier 1 volt positive.

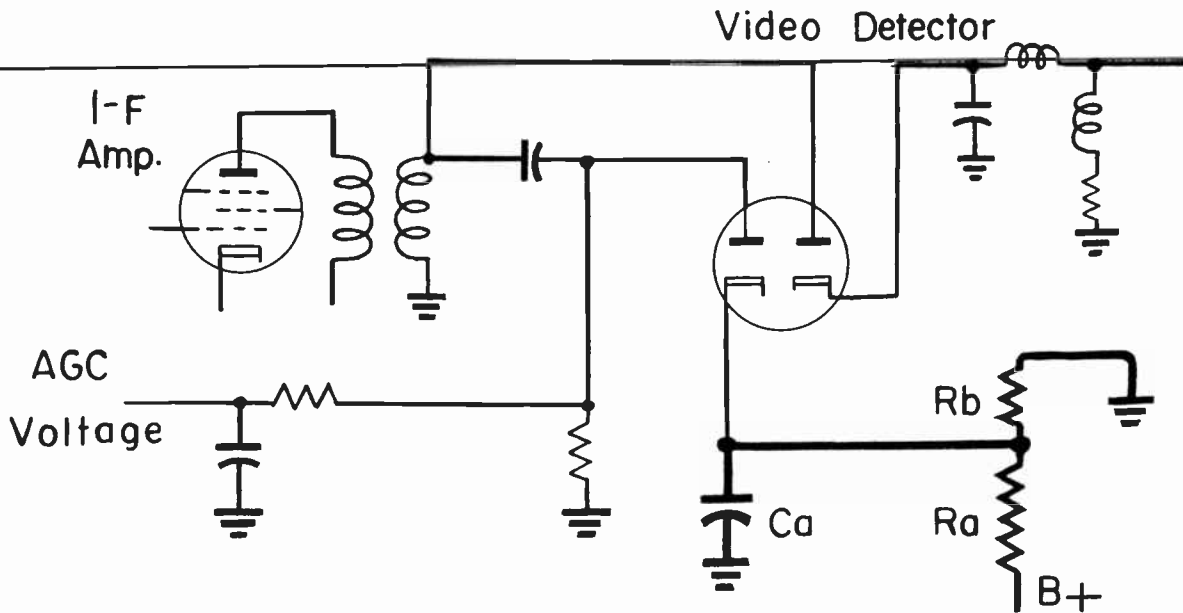

Fig. 10. One type of delayed automatic gain control.

There can be no conduction until i-f signal voltage applied to the rectifier circuit is strong enough to make the rectifier plate more positive than its cathode. For this to happen, the signal at the rectifier must rise to more than 1 volt at the sync peaks. Then, at these peaks, the rectifier plate will be more positive than its cathode, and conduction will occur.

With no conduction in the agc rectifier there is no charging of the agc capacitor, and no negative biasing voltage is developed in the rectifier load resistor. In other words, there is no automatic negative control voltage on the agc bus, and the controlled amplifiers operate at full gain. Only when received signals become strong enough to overcome the delay voltage from the cathode voltage divider on the rectifier will there be automatic gain control. The delay voltage may be made of any desired value by suitable choice of voltage divider resistors in relation to the positive d-c B-voltage applied to the divider.

The effect of delayed agc is shown in a general way by Fig. 11. With no gain control or limiting of any kind, signal output at the detector would increase uniformly with strength of signals from the antenna. With simple agc, limiting of the gain and of the output commences when the input rises from zero. With delayed agc there is no limiting

action until input signals reach some selected strength, as at point a. With lesser strengths of input signal the output increases just as though there were no control, along the straight sloping line. With the delay voltage exceeded, the output increases with greater inputs in much the same way as with simple agc.

The basic principle of delayed automatic volume control for sound receivers is the same as for delayed automatic gain control in television, it is the application of a positive delay voltage to the cathode of the avc rectifier. The positive avc delay voltage may be taken from the B-voltage supply, but more often is furnished by cathode bias for the avc rectifier.

Fig. 12 shows a delayed avc circuit of this type. Connections are almost identical to those of Fig. 8, but instead of connecting the bottom of the volume control and the cathode of the tube together through ground, they are connected together by an insulated wire, and to ground through biasing resistor Rk.

Electron flow in the avc rectifier circuit is from the upper diode plate through rectifier load resistor R to ground, making the upper end of the load resistor and the avc bus negative to ground. The electron flow goes through ground to the bottom of biasing resistor Rk, thence upward through this resistor to the tube cathode. This direction of flow



# LESSON 41 – AUTOMATIC GAIN CONTROLS

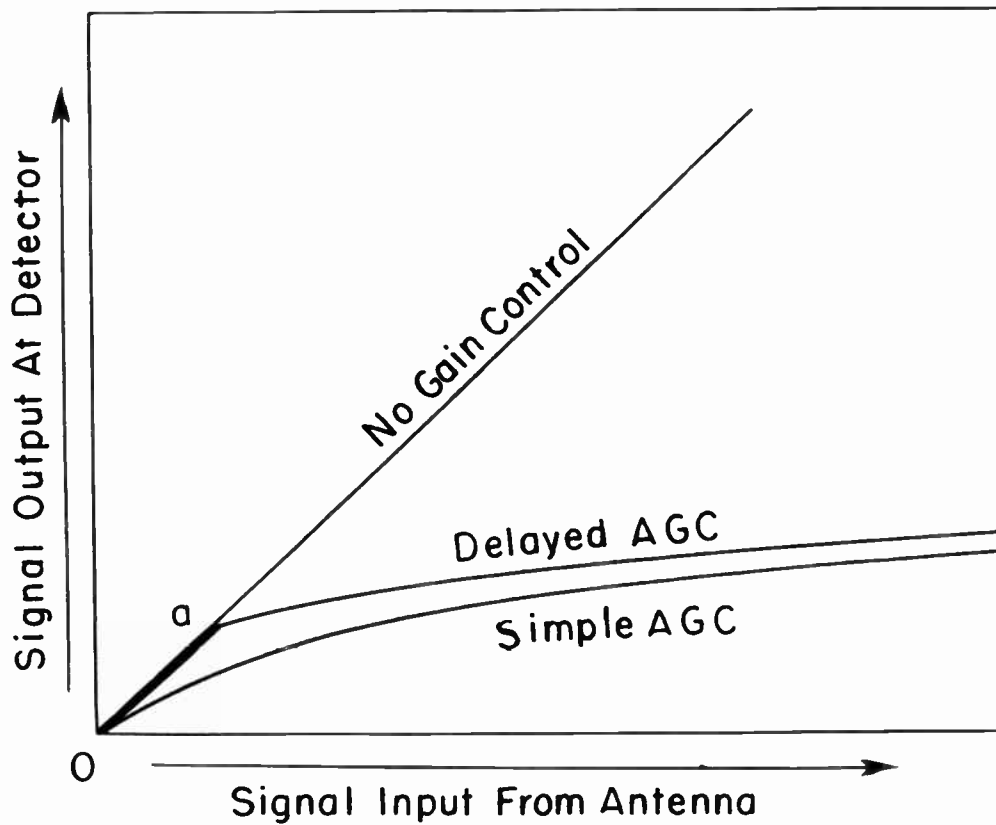

Fig. 11. With delayed agc, controlled amplifiers, operate at full gain on weak signals and with automatic control for stronger signals.

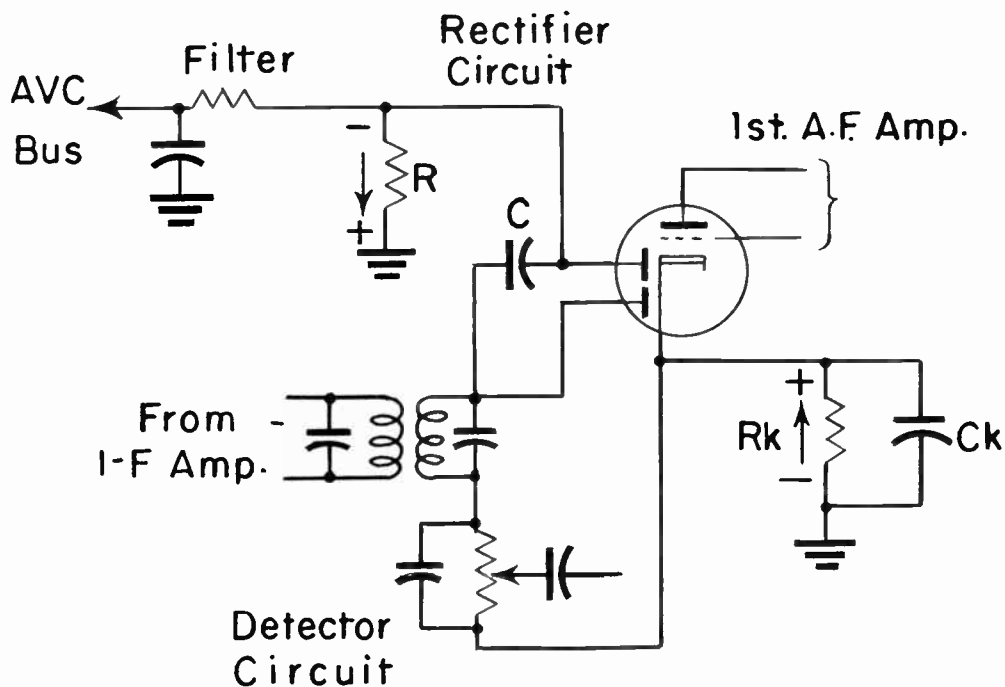

Fig. 12. Delay voltage for automatic volume control taken from a cathode resistor.

## COYNE - *television home training*

makes the upper end of  $R_k$ , and the cathode of the tube, positive with reference to ground.

The cathode of the tube is thus kept positive with reference to the plate of the rectifier diode, and until strength of received signals becomes great enough to overcome this positive voltage there will be no negative avc voltage in the rectifier circuit and the received signals will be fully amplified. This is essentially the same action that we found with delayed agc for television.

The avc delay voltage is the voltage drop across resistor  $R_k$ , which usually is 1 to 2 volts. The delay voltage is proportional to resistance of  $R_k$  and cathode current for the a-f amplifier triode section of the tube as well as for the agc rectifier diode section. Note that the delay voltage is not applied to the detector circuit. The return connection for the detector diode is through the secondary of the i-f transformer and the volume control resistor directly to the tube cathode, not to ground and through resistor  $R_k$  to the cathode.

The use of a cathode resistor on a separate agc rectifier diode would not work out in practice. With very weak signals, for which the delay is needed, there would be little or no conduction in the agc rectifier diode, and no appreciable positive delay voltage would be developed in a cathode resistor.

It is possible to obtain a positive delay voltage for a separate agc rectifier diode by connecting the diode cathode to the cathode of

some other tube on which there is cathode bias. Such an arrangement is illustrated by Fig. 13. The cathode of the agc rectifier is connected to the top of a cathode bias resistor on the i-f amplifier tube. The top of this resistor is made positive with reference to ground by flow of cathode current in the amplifier, and this positive voltage is used for delay on the agc rectifier. Cathode voltage for the agc rectifier must, of course, be taken from the cathode of a tube whose bias is of suitable value for delay purposes.

**AGC WITH VARIABLE DELAY.** A delayed agc circuit that has been used and is being used in many television receivers is shown by Fig. 14. By comparing this diagram with the one of Fig. 10 it is apparent that the only changes are in connections to the cathode of the agc rectifier. In the new circuit the rectifier cathode still is connected to a positive d-c delay voltage through resistor  $R_a$  and to ground through resistor  $R_b$ , with these two resistors acting as a voltage divider which determines the value of delay voltage on the agc system.

But, whereas resistor  $R_b$  formerly was of fixed value to give a fixed delay voltage, it now is adjustable to give a variable delay voltage. Resistor  $R_b$  is combined with the cathode bias resistance on a video amplifier tube, with the ground connection made through the slider of the contrast control. When the control slider is moved upward in Fig. 14 there is additional resistance in the portion below the ground connection, the portion marked  $R_b$  in the diagram. The added re-

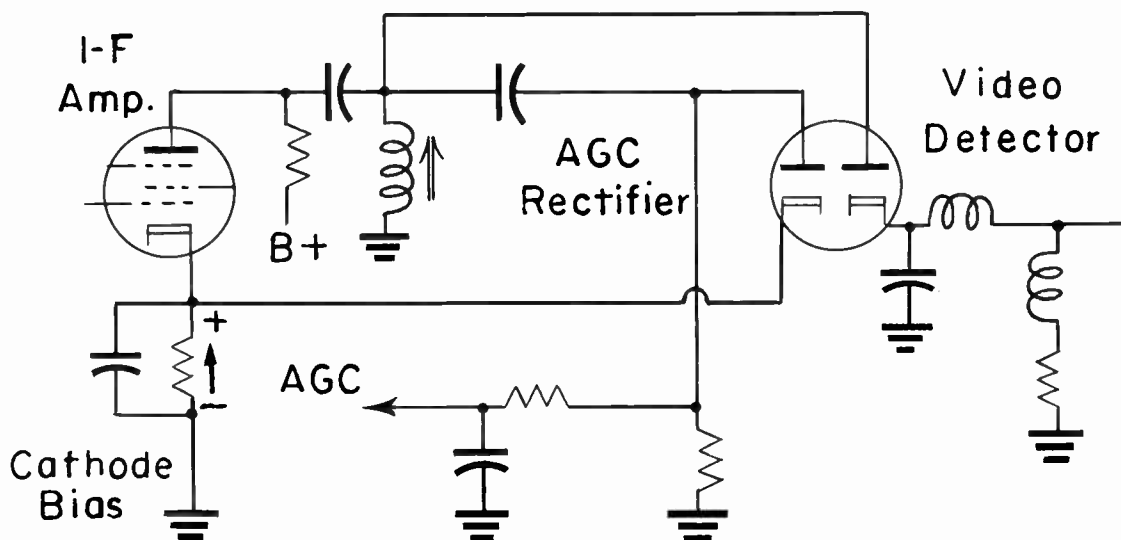

Fig. 13. Delay voltage for television agc obtained from the cathode bias resistor on an amplifier tube.

## LESSON 41 – AUTOMATIC GAIN CONTROLS

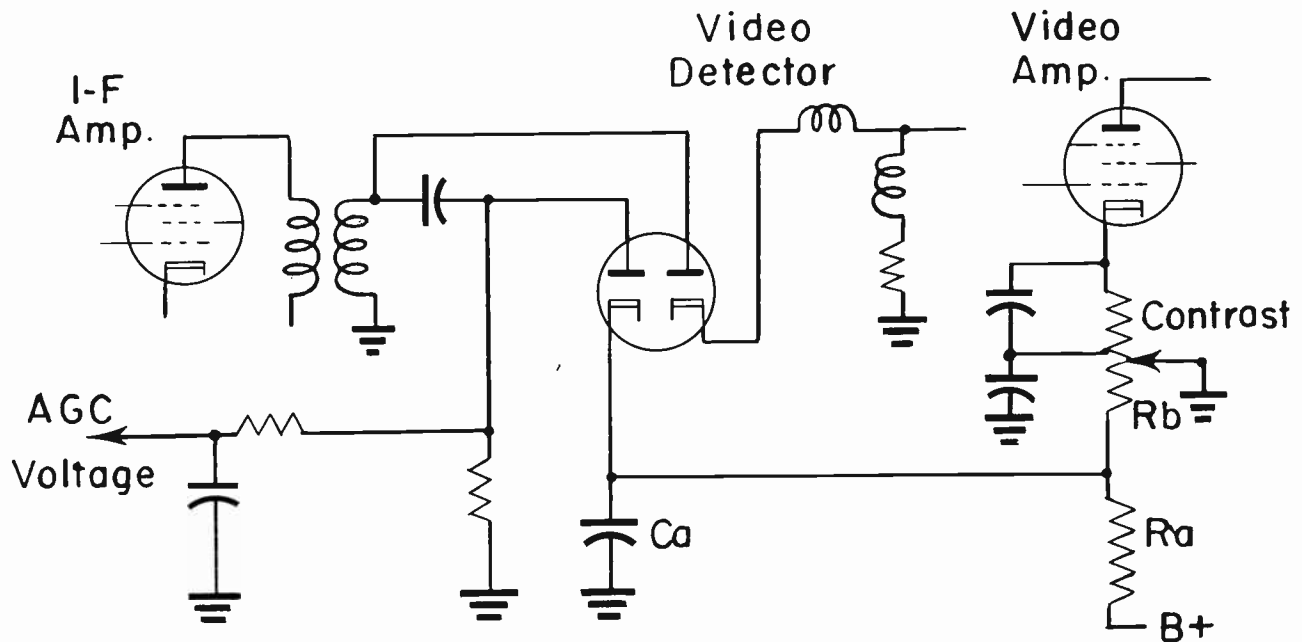

Fig. 14. Variable delay voltage regulated by adjustment of the contrast control on a video amplifier.

sistance means a greater voltage drop across section Rb, since current from the B-supply flows from ground through Rb and Ra to the B+ connection. This increased voltage drop across Rb is an increased positive delay voltage at the cathode of the agc rectifier, and amplifier tubes controlled by the negative agc voltage operate at full gain until received signals become quite strong.

When the slider of the contrast control is moved downward, in the diagram, there is less resistance in section Rb, a smaller voltage drop, less delay voltage on the agc rectifier, and automatic control of amplifier bias and gain commences with weaker signals.

When received signals are weak for any reason, the operator of the receiver advances the contrast control in order to make pictures brighter and of better contrast. When the contrast control is advanced, the slider is moved upward, because this decreases the cathode bias voltage and increases the gain of the video amplifier tube to improve picture reproduction. But this movement of the control slider simultaneously increases the delay voltage on the agc system, and r-f and i-f amplifiers are allowed to run at full gain on the weak signals.

If received signals are strong, the operator retards the contrast control to obtain satisfactory contrast and brightness. This means moving the slider downward to

increase the cathode bias voltage and decrease the gain of the video amplifier. This same movement of the control slider reduces the delay voltage on the agc system, and r-f and i-f amplifiers are subjected to greater negative bias. This lessens the gain in r-f and i-f amplifiers at the same time gain is reduced in the video amplifier.

There are many variations and modifications of this general principle of interconnecting an agc delay system with the contrast control, so that operators unconsciously make a desirable change of delay voltage while adjusting the contrast control. Fig. 15 shows how the principle may be applied when a triode is used as a combined agc rectifier and video detector. This is a modification of or an addition to the triode circuit of Fig. 7. The video detector circuit is no longer completed through ground from the bottom of the detector load resistor to the bottom of the i-f coupler, but is completed through an insulated wire connection. This prevents the positive delay voltage from biasing the detector, but does apply the d-c delay voltage through the i-f coupler to the cathode of the triode, which acts also as a cathode for the agc rectifier circuit which is completed through resistor R to ground.

The insulated conductor which completes the detector circuit, and leads to the cathode of the triode so far as d-c voltage is concerned, is connected to the delay voltage.

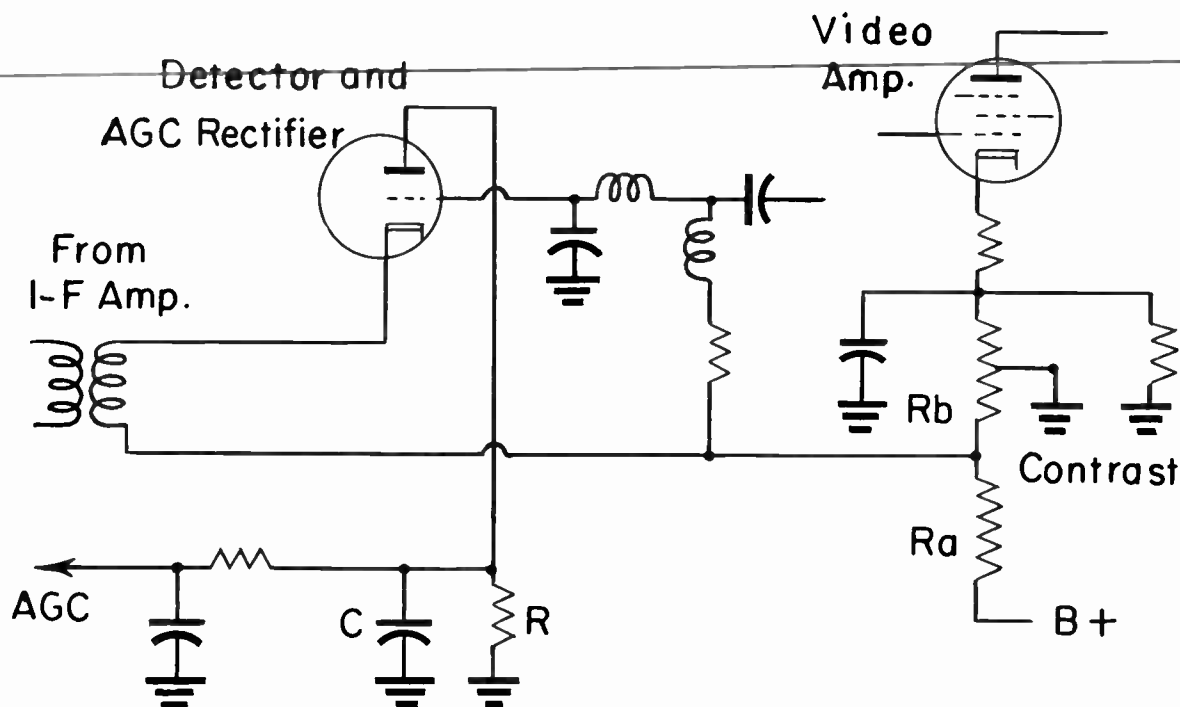

Fig. 15. Contrast control variation of agc delay when a triode is used as combined video detector and agc rectifier.

The delay voltage, obtained from the B-supply, is taken from between resistors  $R_a$  and  $R_b$ , as in Fig. 14. Resistor  $R_b$  is the contrast control in the cathode circuit of a video amplifier. The interaction of the contrast control and the agc delay system is the same as previously explained.

**SENSITIVITY CONTROLS.** Many television receivers have a service adjustment which may be altered to suit the receiver for most satisfactory performance on weak or strong signals, or in localities where there is much or little noise. All of these adjustments act in one way or another on the automatic gain control, the contrast control or both. Although a general name for all of them is sensitivity control, these adjustments go by many names referring to distances from which signals may be received.

Settings usually are made after a receiver is installed, and while tuned in on transmitted program signals. The sensitivity control should be placed in any position that does not cause picture distortion on strongest available signals with the contrast control advanced almost as far as possible. If the control is set while receiving a very weak signal, with the contrast control well advanced, there is likely to be severe picture distortion on strong received signals.

In Fig. 16 the sensitivity control switch is placed in position 1 for reception of normal or high signal strengths. Agc voltage for all controlled amplifiers then comes from the agc rectifier, to which is applied a positive delay voltage. For reception of weaker signals the sensitivity switch is placed in position 2, whereupon the agc voltage is secured from the high side of the video detector load resistor. The two sources of agc voltage would be so designed as to provide negative control voltages of values suited to the two strengths of signals.

In Fig. 17 the sensitivity switch is a three-pole double-throw type set in the position shown by full line arrows for reception of signals having normal strength, and in the position shown by broken-line arrows for weaker signals. In the normal position (full-line arrows) switch section a connects the grid returns of controlled tubes to an agc voltage furnished by the agc rectifier. Delay is provided by connecting the cathode of this rectifier to the top of the cathode bias resistor on an i-f amplifier. Switch section b connects the cathode of the video amplifier to the adjustable contrast control resistor, thus providing the widely used type of contrast control by means of variable bias on this amplifier. Switch section c remains open.



# LESSON 41 – AUTOMATIC GAIN CONTROLS

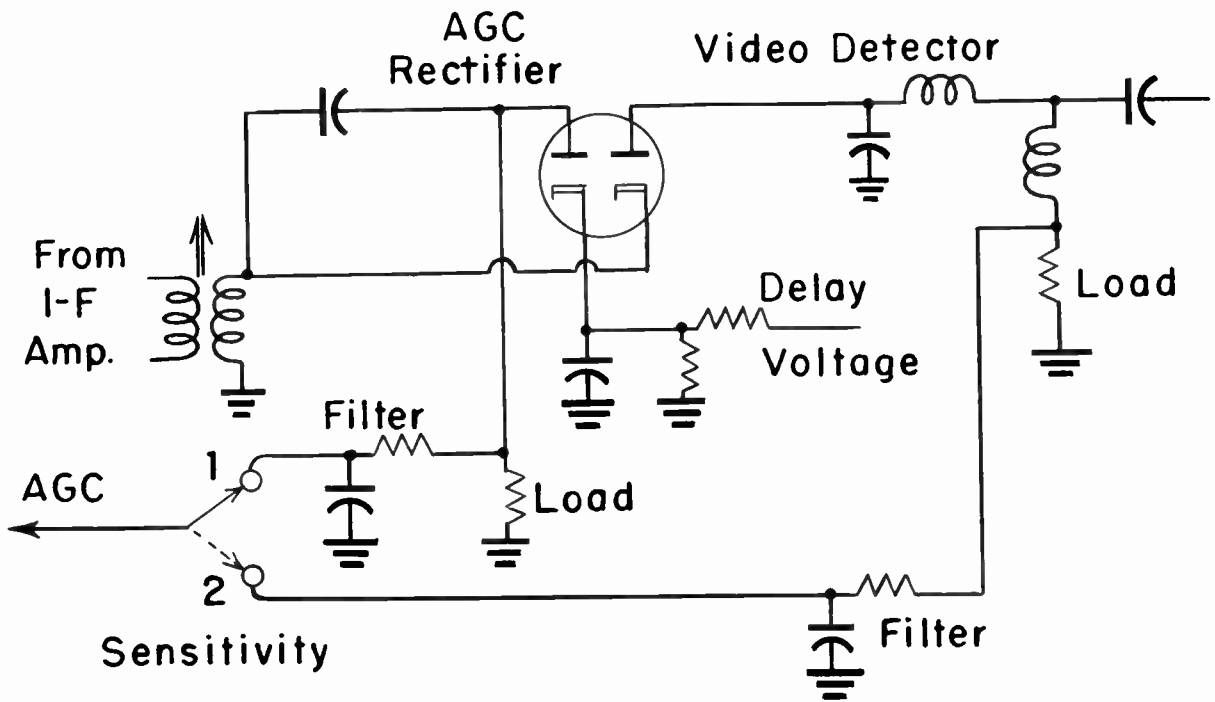

Fig. 16. A sensitivity control taking agc voltage from either an agc rectifier or else from the video detector load.

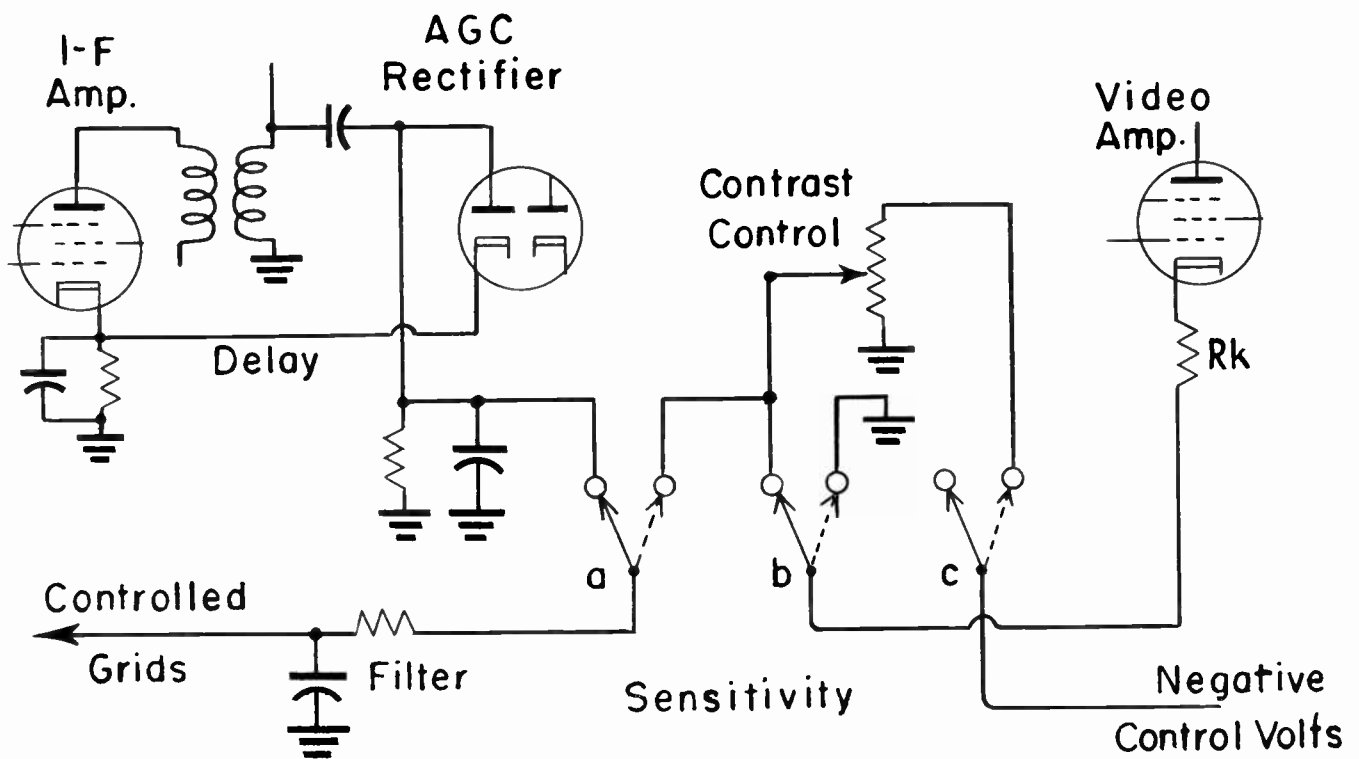

Fig. 17. A sensitivity control that substitutes manually adjustable bias for agc voltage on controlled amplifiers.

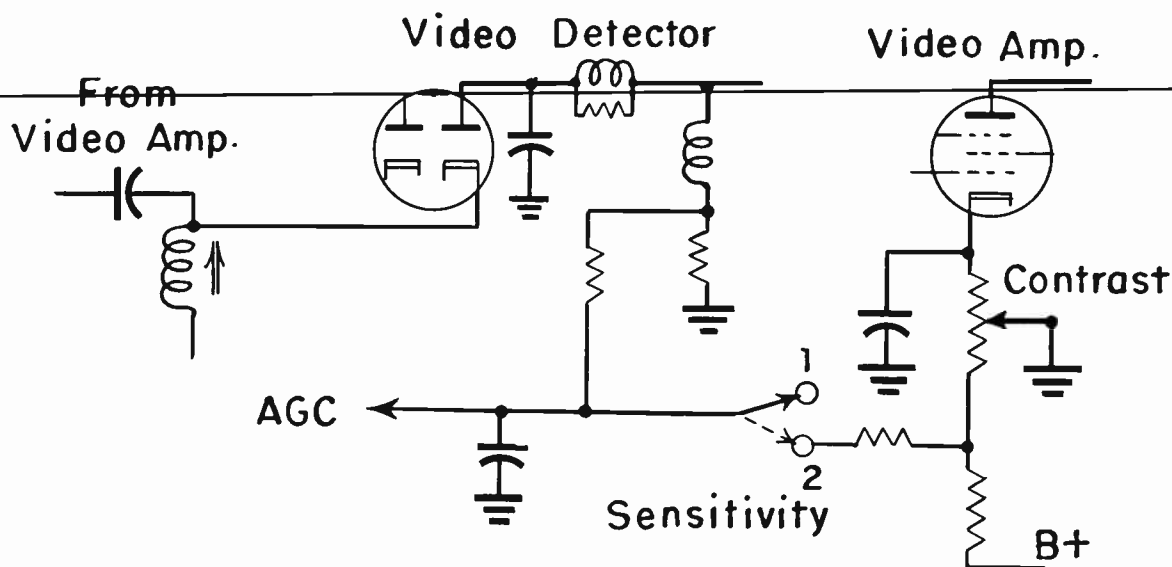

Fig. 18. Sensitivity control providing either delayed or undelayed agc voltage.

With the switch sections in positions shown by broken-line arrows, section a disconnects the controlled grids from the agc voltage and connects them to the slider of the contrast control. Section b connects the cathode of the video amplifier, through biasing resistor R<sub>k</sub>, to ground. This allows the video amplifier to operate at high gain. Switch section c connects the ungrounded end of the contrast control to a source of negative d-c voltage. Operating the contrast control now applies a variable negative bias to the controlled grids, and allows this bias to be made whatever is required for best possible reception of weak signals.

In Fig. 18 the normal setting of the sensitivity switch is at position 1, with the switch open. Agc voltage for controlled amplifiers now is taken from the high side of the video detector load resistor. For weaker signals the switch is moved to position 2, which applies a positive delay voltage varied by operation of the contrast control. This variable delay system operates in general as explained in connection with Figs. 10 and 14, but instead of the positive voltage being applied to the cathode of an agc rectifier, it now opposes the negative agc voltage being taken from the video detector load resistor.

It is the practice in many television receivers to operate the r-f amplifier at high gain on weak signals while at the same time applying agc voltage to the i-f amplifiers. Relatively high gain in the r-f amplifier allows acceptable pictures from weak signals, but output from the r-f amplifier and mixer may become strong enough to overload the

first i-f amplifier were this i-f amplifier operated with little or no automatic control for its grid bias and gain. Desired results sometimes are secured by applying delayed agc voltage to the r-f amplifier, possibly from an agc rectifier system, and taking undelayed agc voltage for the i-f amplifiers from the high side of the video detector load.

A different method is illustrated by Fig. 19, where the sensitivity switch has three positions. For fairly strong or strong signal areas the switch is placed in position 1. The same agc voltage, from the video detector load, is applied to both the r-f and i-f amplifiers. Agc voltage is the same to both sections because there is no current and no voltage drop in resistor R<sub>a</sub> which is between the two agc buses.

In switch position 2 resistors R<sub>a</sub> and R<sub>b</sub> are in series between the source of agc voltage and ground. Therefore, there are electron flows and voltage drops in both resistors, and they act as a voltage divider. With R<sub>a</sub> and R<sub>b</sub> equal in resistance and in voltage drops, the r-f agc bus from the mid-connection will have only half as much agc voltage as the i-f agc bus. In position 3 a relatively small resistance at R<sub>c</sub> forms the lower part of the voltage divider, with high resistance at R<sub>a</sub> as the upper part. Then the r-f agc bus receives only the relatively small agc voltage that remains across the small resistance at R<sub>c</sub>. This position 3 provides maximum sensitivity.

Still another method of providing different agc voltages for r-f and i-f amplifiers

## LESSON 41 – AUTOMATIC GAIN CONTROLS

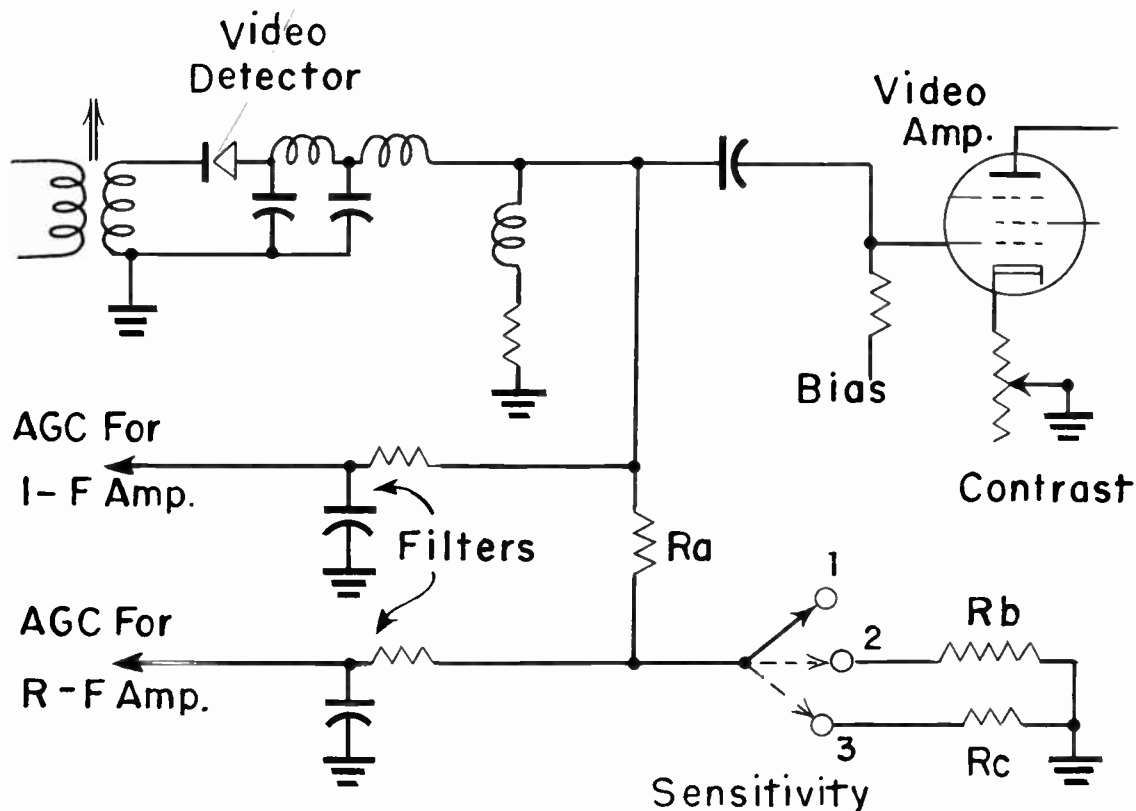

Fig. 19. Sensitivity control furnishing different values of agc voltage to r-f and i-f amplifiers.

is shown by Fig. 20. The sensitivity switch is shown in two sections, each with three positions. Agc voltage is taken from the video detector load resistor. For signals of good strength the switch sections are placed at position 1. The same agc voltage is applied to the i-f and r-f buses, because there is no current and no voltage drop in resistor R<sub>a</sub>, which is between the two buses.

With the switches in position 2 the r-f agc bus is grounded by switch section B. This removes all agc voltage from the r-f amplifiers and lets them operate with only minimum negative grid bias provided from some other source, and, accordingly, at full gain. There is no change in agc voltage applied from the detector load to the i-f agc bus.

In position 3 the r-f agc bus remains grounded, with r-f amplifiers operating at full gain. At the same time, the lower end of resistor R<sub>b</sub> is grounded through switch section A. Resistors R<sub>a</sub> and R<sub>b</sub> now act as a voltage divider, because there is electron flow and voltage drop in both of them. These two resistors are of equal values. Consequently, the agc voltage at their mid-connec-

tion and from there to the i-f agc bus is only half as great as in other switch positions. This position 3 provides maximum sensitivity.

Switches in the schematic diagrams of sensitivity controls are shown by conventional symbols. Actually these switches may be of any structural type, often of the rotary selector style with rotor segments suitably shaped for the control functions. The video detector of Fig. 19 is shown as a crystal diode, while others are represented as tube diodes. Either crystals or tubes might be used as detectors or agc rectifiers in any circuit, since gain control does not depend so much on the kind of rectifying element as on the manner in which it is connected and used.

**AMPLIFIED AUTOMATIC GAIN CONTROL.** In some types of agc systems the control voltage from the source does not vary sufficiently with changes of signal strength to provide biasing voltage suitable for controlled tubes. The varying voltage from the source then may be amplified by applying it to the grid of an agc amplifier tube and using the accompanying larger changes of plate voltage for agc voltage. In this method the plate voltage must become more negative, or

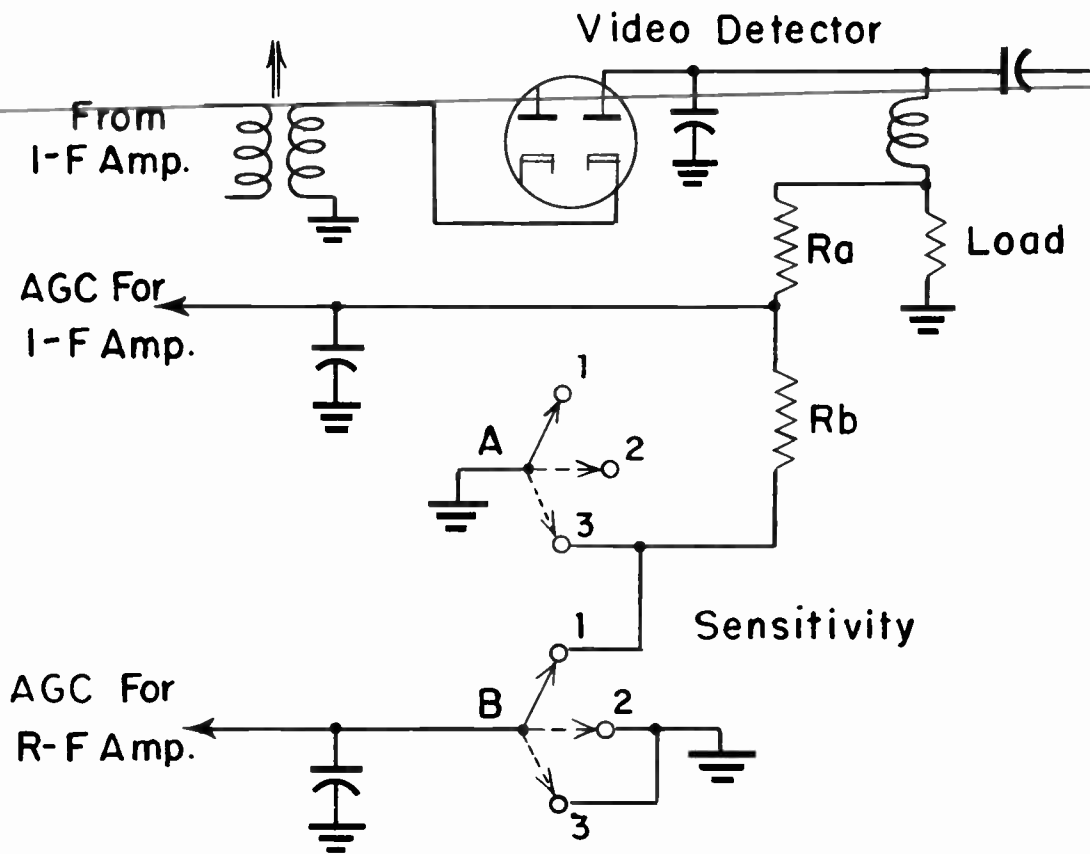

Fig. 20. Sensitivity control which removes agc voltage from r-f amplifiers at one step and reduces the agc in i-f amplifiers as the final step.

less positive, with increase of signal strength. Since there is polarity inversion between plate and grid, the control voltage applied to the grid must become more positive with increase of signal strength. The source of control voltage must be chosen to have this polarity.

Fig. 21 illustrates an amplified agc system which has been used in this form and with various modifications in many television receivers. Control voltage is derived from the complete composite video signal, with sync pulses positive, taken from the plate of a video amplifier to the grid of the agc rectifier. This triode rectifier is biased sufficiently negative to almost completely cut off the picture variations of the composite signal, and leave the sync pulses. Although not directly related to agc action, it may be mentioned that sync pulse voltages that appear in the rectifier plate circuit are taken from there to the sync section of the receiver.

The final negative agc voltage for controlled grids is secured at the plate of the agc amplifier. Consequently, plate voltage on this amplifier must be negative with re-

spect to ground. But to make the amplifier operate as an amplifier, its plate must be positive with reference to its cathode. This is accomplished by making the cathode about 50 volts negative with reference to ground, and by making the plate much less negative, and relatively positive, by voltage drop through resistor  $R_c$ . The voltage drop across  $R_c$  is proportional to electron flow, and to resistances at  $R_c$ ,  $R_d$ , and  $R_e$ , which are in series along a line to a positive B-voltage.

The grid of the agc amplifier is connected through resistor  $R_b$  and the adjustable agc control resistor to a source of approximately 100 negative volts. Voltage drop across the agc control resistor and  $R_b$  brings the amplifier grid to an average of about 55 negative volts. This results in a negative grid bias with reference to the amplifier cathode, which is only 50 volts negative. Any variations from this average grid voltage will vary the plate voltage of the amplifier, and provide changes of agc voltages for controlled r-f and i-f amplifiers. Agc amplifier grid voltage is caused to vary with changes of signal strength in the following manner.



## LESSON 41 – AUTOMATIC GAIN CONTROLS

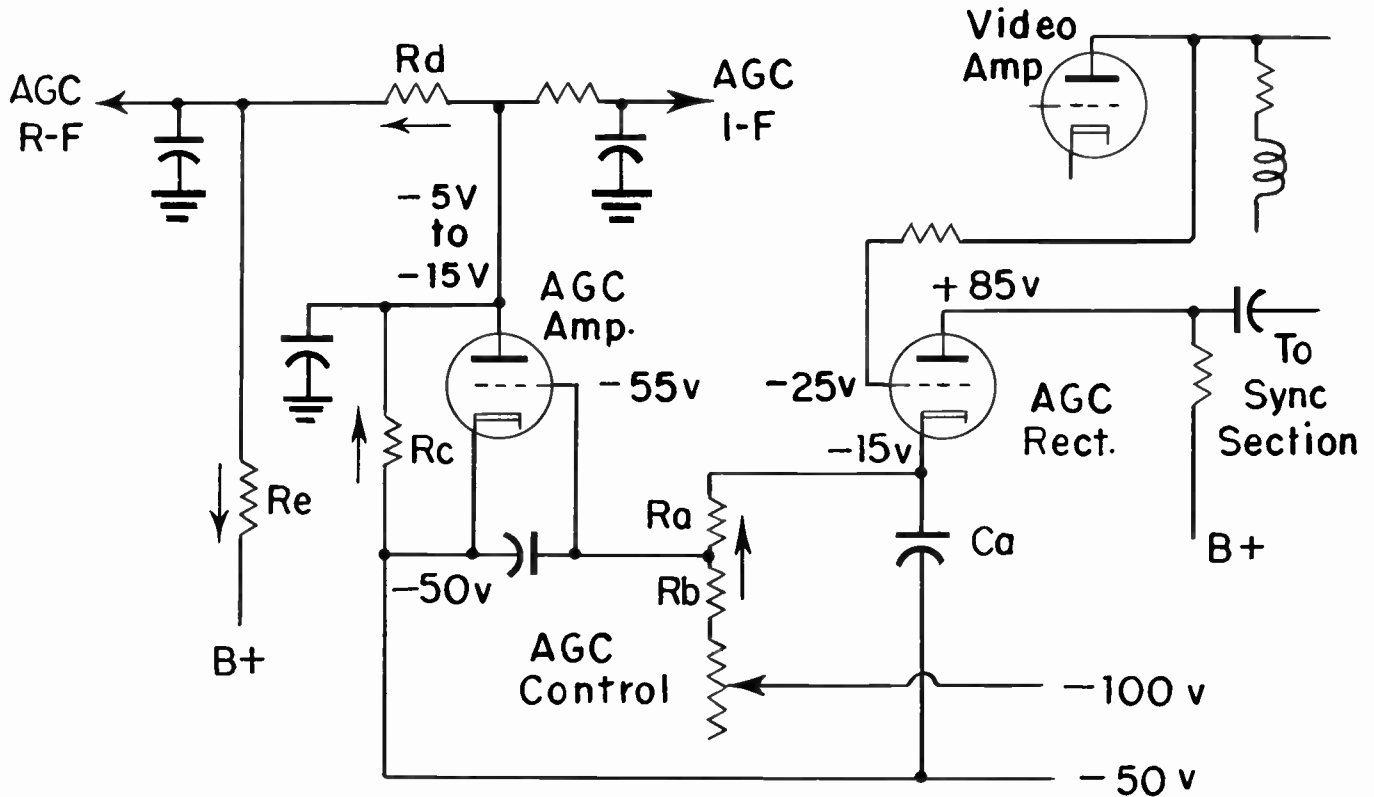

Fig. 21. Circuit connections for one style of amplified automatic gain control.

At the cathode of the agc rectifier there is pulsating rectified voltage having peaks proportional to strength of sync pulses which have been separated from the composite signal taken from the video amplifier. The rectifier is acting somewhat like a cathode follower when we consider its output to be the pulsating voltage at its cathode. The pulsating voltage charges capacitor Ca. The charge can escape only slowly through resistances at Ra, Rb, and the agc control resistor. As a consequence, charge voltage in capacitor Ca varies proportionately to the strength of sync pulses and strength of received signals. This voltage from Ca, varying with changes of received signal strength, is applied through resistor Ra to the grid of the agc amplifier.

When signal strength increases, the change of voltage on capacitor Ca makes the grid of the agc amplifier less negative, effectively more positive. Inversion of polarity between grid and plate of this amplifier

causes its plate voltage, and agc voltage, to become more negative with increase of signal strength, as is required for automatic gain control.

The adjustable agc control in the grid circuit of the agc amplifier usually is called a threshold control. It is a service adjustment, set to make the agc voltage just sufficiently negative to prevent overloading of receiver amplifiers while receiving a strong signal with the contrast control advanced to somewhat more than half of its full travel.

Overloading may be detected most accurately, when it first commences to occur, by watching for change in waveform of the composite video signal with an oscilloscope, while varying the setting of the agc control. In some receivers, overloading causes bending of vertical lines in pictures. The agc control should be adjusted to just prevent such bending on strong signals with the contrast control advanced nearly all the way.

# TELEVISION



- RADIO
- ELECTRONICS

---

**LESSON 42 – KEYED AGC AND VIDEO SIGNAL POLARITIES**

---

***Coyne School***  
*practical home training*

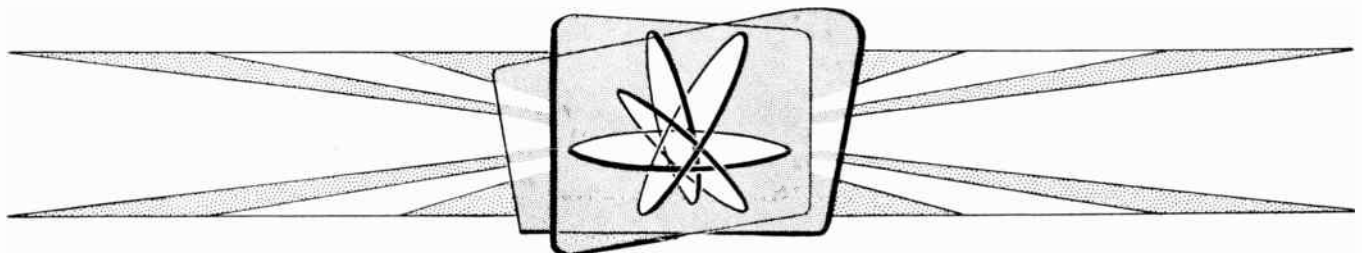

*Chicago, Illinois*

---

*Copyright, 1953 by Coyne Electrical School  
Chicago 12, Illinois  
All rights reserved*

Litho. in U.S.A.

## KEYED AGC AND VIDEO SIGNAL POLARITIES

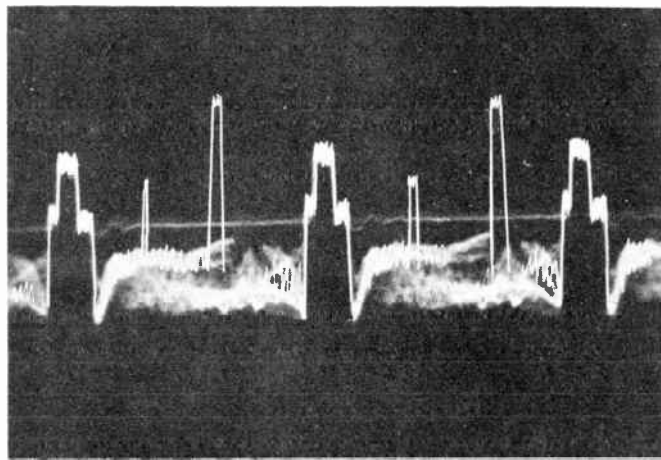
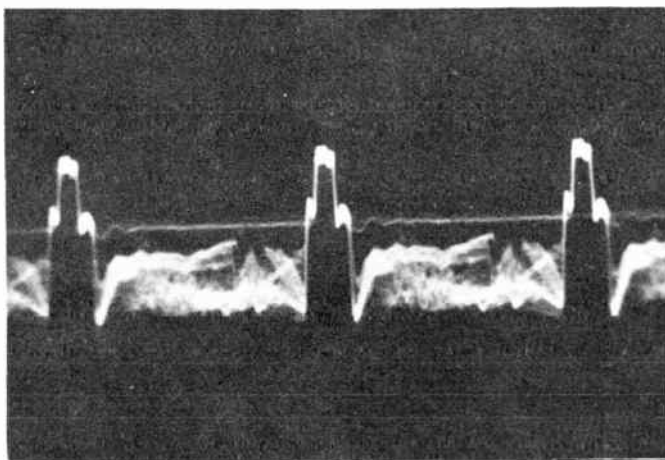

Fig. 1. The composite signal may arrive at the video amplifier accompanied by noise pulses.

A system of gain control more widely used than any other single method in television receivers designed during recent years is called keyed automatic gain control or gated automatic gain control. The chief object of keyed or gated agc is to make the gain of controlled amplifiers more nearly independent of noise voltages. The basic principle, which is simple, is explained as follows.

The composite television signal appearing in the video amplifier section should contain, as at A in Fig. 1, only sync pulses, blanking intervals, and picture variations. But the signal may have picked up a great deal of "noise", causing additional voltage pulses somewhat as represented at B. Actually, these are not oscilloscope traces of noise pulses, they have been added to the waveform merely to show what may happen.

Even though most of the noise pulses are no stronger than regular sync pulses, many are sure to occur at instants between sync pulses, or they may overlap the sync pulses. Then the pulses of noise voltage add to the charge on filter capacitors in an agc circuit. The charge voltage becomes greater than it should be, and the agc voltage becomes more negative than with no noise, while varying with change of noise in received signals.

A first step in eliminating the effects of noise on agc voltage is shown by Fig. 2. Instead of an agc rectifier diode there is a pentode, with the noisy composite signal applied to its grid. This signal is taken from the plate load of a video amplifier tube. The pentode may be called the agc amplifier, the keyer, the gate, or simply the agc tube. It is from variations of plate current in this agc tube that we shall eventually obtain the negative agc voltage for grids of controlled tubes.

The grid of the agc amplifier is biased sufficiently negative that only the positive sync pulses of the composite signal can cause conduction. The picture variations of this signal drives the agc grid more negative than the point of plate current cutoff.

Plate voltage for the agc amplifier is not a steady voltage, rather it consists only of intermittent positive pulses, separated in time by intervals during which the voltage drops practically to zero. Since this or any amplifier can conduct only while its plate is positive, and since the grid bias holds the amplifier beyond plate current cutoff except during instants of positive sync pulses on the grid, it is apparent that conduction can occur only when plate voltage pulses and sync pulses occur together.



# COYNE - *television home training*

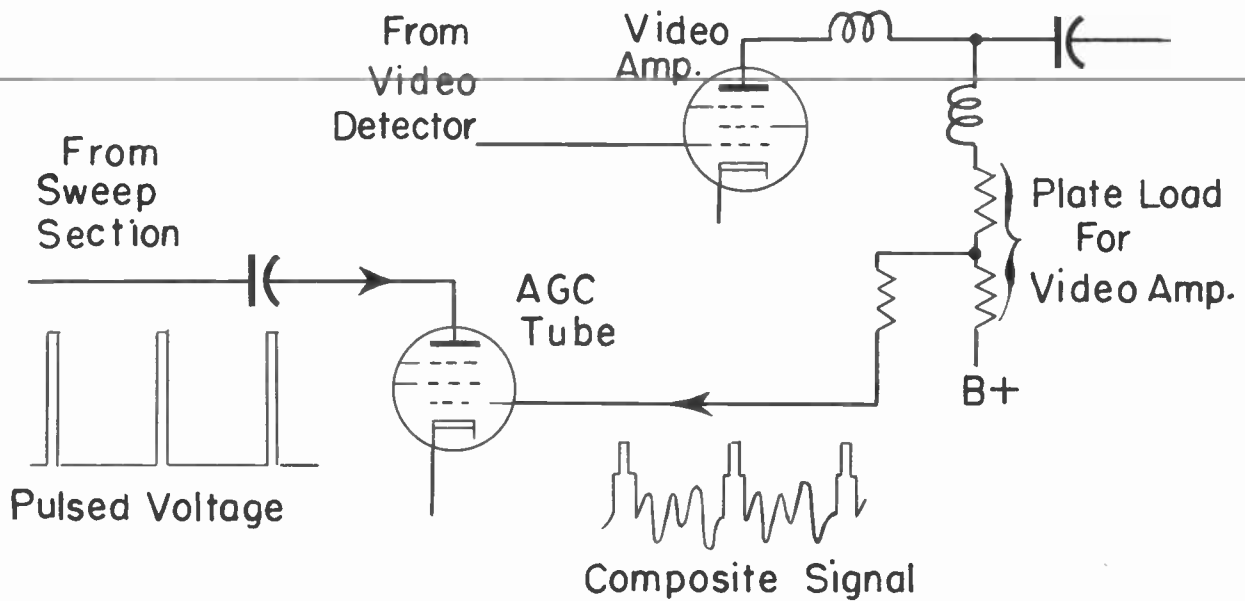

Fig. 2. The agc tube is keyed by pulsed voltage applied to its plate.

Pulses of plate voltage for the agc amplifier may be obtained from any of several points in the horizontal sweep circuits of the receiver, and in any case will have waveforms generally similar to those of Fig. 3. Any voltage pulses taken from the sweep circuits will have precisely the same timing as horizontal sync pulses in the composite video signal, because the sweep oscillator producing the voltage pulses is synchronized by the horizontal sync pulses. Therefore, when synchronization is correct, horizontal sync pulses and pulses of plate voltage will occur together and there will be pulses of plate current in the agc tube.

Peak values of voltage pulses on the plate of the agc tube remain constant regard-

less of changes in received signal strength. This is because voltages in sweep circuits result from changes of current in sweep oscillators. Although these oscillators are synchronized or timed by received signals, oscillation currents and voltages are self-sustaining and of unvarying strength, in no way affected by strength of received signals.

Noise pulse voltages occurring at times between successive sync pulses and simultaneous pulses of plate voltage cannot cause conduction in the agc tube, because at all such times the plate of this tube is at approximately zero voltage and the grid is biased beyond plate current cutoff. Conduction is possible during only about 8 per cent of the total time. Only the noise which oc-

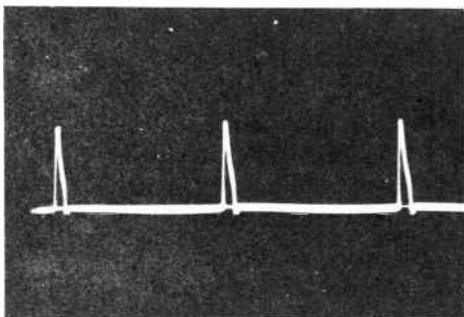

Fig. 3A

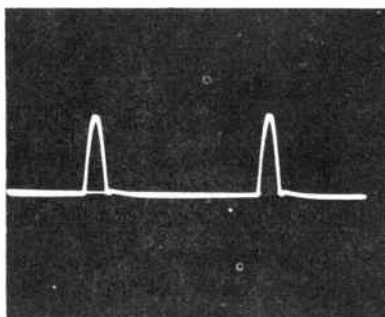

Fig. 3B

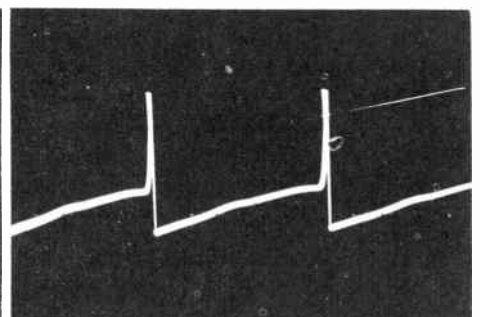

Fig. 3C

Fig. 3. The source of pulsed plate voltage for the agc tube may be any of these waveforms, taken from various points in the horizontal sweep section.

## LESSON 42 – KEYED AGC AND VIDEO SIGNAL POLARITIES

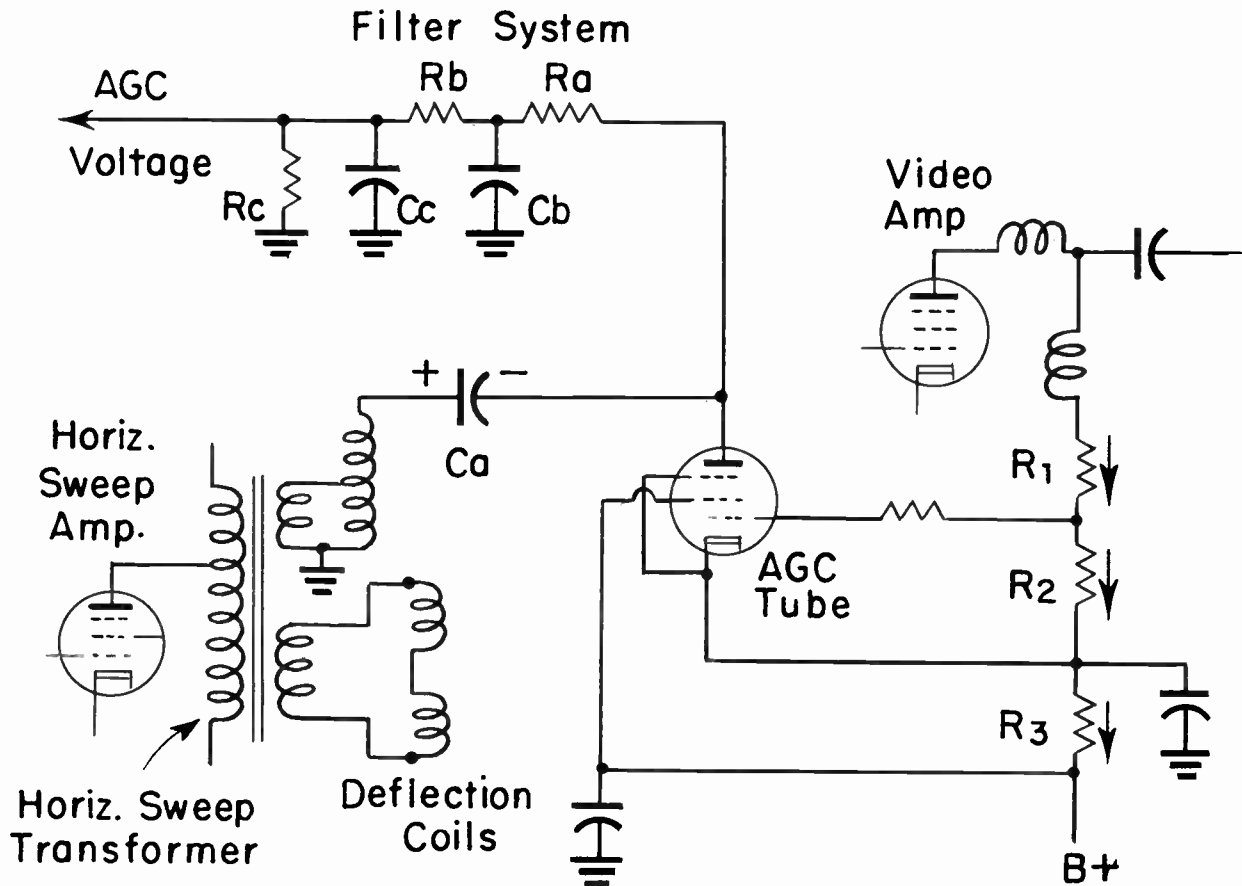

Fig. 4. One type of keyed agc circuit.

curs during this small fraction of the total reception time can affect agc action.

How much conduction occurs in the agc tube, or how much plate current flows during each pulse of voltage, depends on pulsed voltages at the plate and the grid. But, since plate voltage pulses always have the same peak value we have the equivalent of a constant plate voltage, and conduction current varies only with changes of strength in sync pulses at the grid. These sync pulses become stronger when received signals increase in strength, and become weaker with less strength of received signals. Therefore, the plate current during each pulse is strictly proportional to changes in strength of received signals.

The keyed agc circuit is shown in one of its completed forms by Fig. 4. Negative agc voltage for grids of controlled i-f and r-f amplifiers is taken from the plate of the agc tube through a filter system consisting of re-

sistors and capacitors. A charge is built up on capacitor  $C_a$  by pulses of plate current through the agc tube, in the same manner that a charge is placed on the agc capacitor when using a diode rectifier. This charge is negative on the side of the capacitor which is toward the agc tube plate and the filter system leading to the agc bus.

The charge on capacitor  $C_a$  escapes slowly through filter resistors  $R_a$ ,  $R_b$ , and  $R_c$  to ground. Capacitors  $C_b$  and  $C_c$  help absorb the pulses of voltage, to leave a smooth negative direct voltage at the agc bus. Average value of agc voltage is suited to the needs of controlled tubes by selection of filter units correctly related to the current and voltage pulses which charge capacitor  $C_a$ . Because plate current pulses increase and decrease with increase and decrease of signal strength, agc voltage becomes more negative for stronger signals and less negative for weaker signals, thus providing automatic gain control.

## COYNE - *television home training*

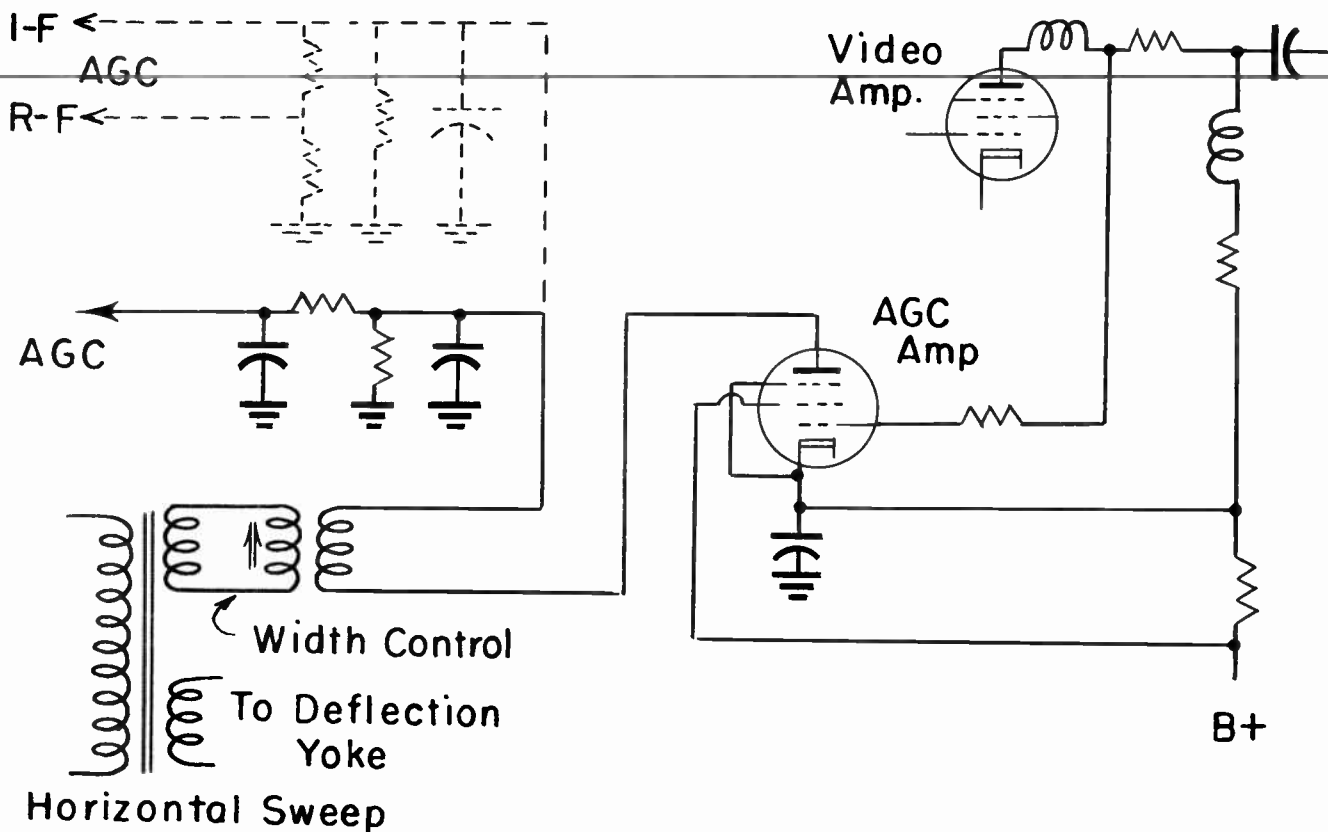

Fig. 5. Pulsed plate voltage is obtained by coupling to a width control winding on the horizontal output transformer.

In Fig. 4 the pulses of plate voltage for the agc tube are secured from a winding on the horizontal sweep transformer. This is the transformer that couples the plate circuit of the horizontal sweep amplifier to the horizontal deflecting coils in the yoke on the neck of the picture tube. It is common practice to take plate voltage pulses from a winding on this transformer, although other connections to the horizontal sweep circuit may be used.

Fig. 4 shows also a method of applying suitable voltages to the several elements of the agc tube. Plate current from the video amplifier flows through resistors R1, R2, and R3 to B-plus, at which there is maximum d-c B-voltage so far as this diagram is concerned. This maximum voltage is applied directly to the screen of the agc tube.

The cathode of the agc tube is at a voltage less positive than on the screen, because of voltage drop in resistor R3. This makes the screen effectively positive with reference

to the cathode. Average voltage or bias voltage on the grid of the agc tube is less positive than at the cathode because of voltage drop in resistor R2, thus giving the grid an effective negative bias. Voltage remaining at the top of resistor R1 is suitable for the plate of the video amplifier.

Grid bias, screen voltage, and voltage of pulses on the plate of the agc tube are so related that this tube can pass pulses of plate current while there are sync pulse voltages of the composite signal on the grid. When there is no video signal the negative grid bias on the agc tube prevents conduction, even during instants of positive pulses on the plate.

Fig. 5 shows some modifications of the keyed agc circuit. Plate voltage pulses for the agc tube are obtained from a winding inductively coupled to a width control winding on the horizontal sweep transformer. The width control is an adjustable inductor on one of the secondary windings of the transformer.

## LESSON 42 – KEYED AGC AND VIDEO SIGNAL POLARITIES

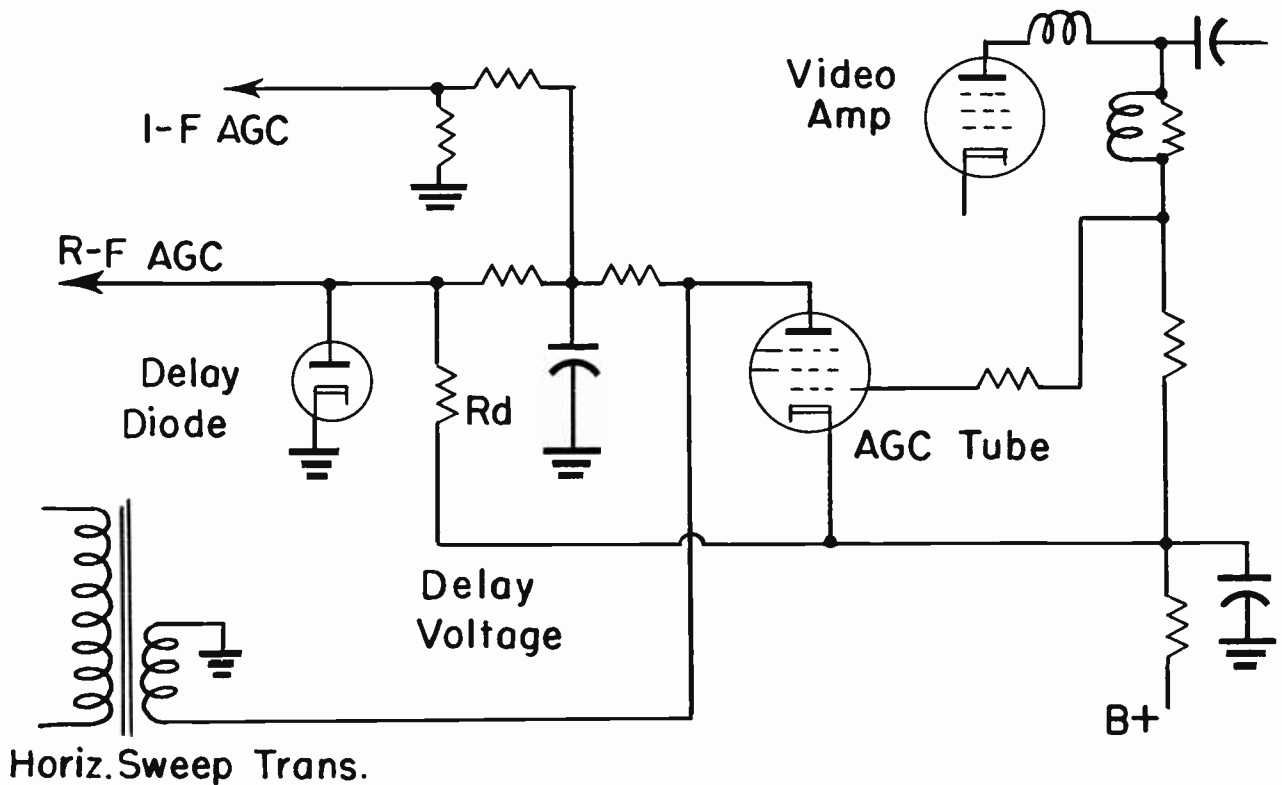

Fig. 6. One type of keyed and delayed agc circuit.

The purpose of this control is to alter the width or horizontal size of pictures. Since the width control winding carries current varying at the horizontal sync frequency, the coupled winding for the plate of the agc tube carries suitable induced pulses of voltage.

Two types of agc filter systems are shown. Both are connected to the end of the transformer winding opposite the plate end. The upper filter circuit, drawn with broken lines, contains a voltage divider that furnishes less agc voltage to r-f amplifiers than to i-f amplifiers.

Fig. 6 shows a keyed agc system with delayed action on the bus for grid returns of r-f amplifiers. Other than in connections to the r-f agc bus this diagram is essentially like others which have illustrated keyed agc systems. A positive delay voltage is applied through high resistance at  $R_d$  from a B-plus point to the r-f bus. To this bus is connected also the plate of a delay diode, whose cathode goes to ground. This delay diode often is called an agc clamp or a clamper.

On very weak signals or when no signals

are received and there is no negative agc voltage from the agc tube, the r-f bus and grids of controlled r-f amplifiers could be made positive by the delay voltage were it not for the delay diode. As we learned earlier, when there is high resistance in a diode circuit the diode plate collects negative electrons from the space charge within the tube because of contact potential effect. Then the diode plate becomes negative with reference to its cathode (and ground in the diagram) by a fraction of a volt.

Positive delay voltage on the r-f agc bus and on the plate of the diode is opposed by the negative contact potential at the diode plate during reception of weak signals. When strength of received signals rises to some predetermined value, negative agc voltage from the agc tube equals the delay voltage, and for all greater signal strengths there is an increasingly negative agc voltage on the r-f bus.

In Fig. 7 we have some further modifications of the keyed agc circuit. Again there is a delay diode on the r-f bus, but now this diode is one of the two in a duodiode triode



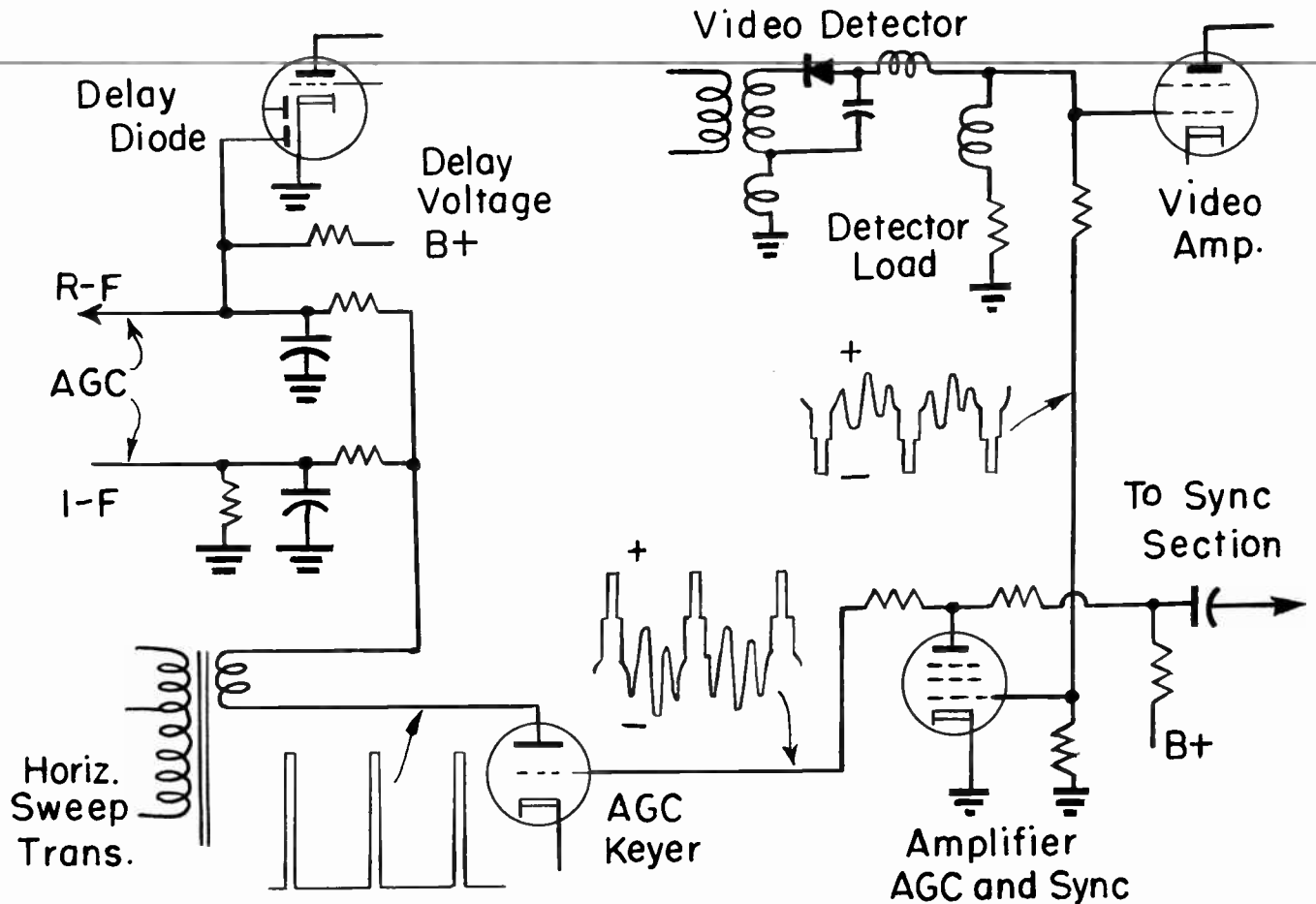

Fig. 7. A keyed delayed agc system employing an amplifier tube for signals on the grid of the agc keyer tube.

whose other diode plate is used as an a-m detector. This method of obtaining an agc delay diode is quite common in combination receivers which have provision for receiving standard radio broadcast as well as television programs. In still other cases you will find both diode plates of a duodiode triode tied together for the agc delay, while the triode section of the tube is used as an a-f amplifier. Delay diodes may be used also in agc systems which are not of the keyed or gated type.

Fig. 7 shows also how a composite video signal may be taken from the output of a video detector through an amplifier to the grid of the agc keyer tube. In the detector output the sync pulses are negative. Signal polarity is inverted between grid and plate of the amplifier, and the sync pulses are of the required positive polarity at the grid of the keyer tube. The keyer tube is shown as a

triode merely to bring out the fact that this tube is not necessarily a pentode, although in the majority of keyed agc systems it is a pentode.

The pentode amplifier shown between video detector and agc keyer is used for amplification and inversion of composite video signals for the sync section of the receiver as well as for the agc keyer. There are a number of keyed agc systems in which the composite video signal is put through some amplifier in the sync section before going to the agc keyer. This may be done only to invert the polarity of sync pulses, or it may be done to strengthen the composite signal when taken from some point where this signal is not strong enough for the keyer grid. Sometimes the tube between the keyer grid and source of the composite signal is biased to partially cut off signal variations while strengthening the sync pulses, thus perform-

## LESSON 42 — KEYED AGC AND VIDEO SIGNAL POLARITIES

ing one of the functions handled by agc tubes in other systems.

As you will have realized by now, the many features found in agc systems, keyed or not, may be combined in a seemingly endless number of combinations. When it comes to trouble shooting it is necessary to recognize the features by themselves, so that essential actions may be checked or measured. For example, at the grid of a keyed agc tube there must be a composite video signal with sync pulses positive, while the picture variations may or may not be compressed or subdued. At the plate there must be simultaneous positive peaks of voltage, synchronized with the sync pulses.

There may be many variations in details without altering the fundamental principles. As an example, in some systems of keyed or gated agc the voltage at the plate of the agc tube may be of sine-wave form or it may be a sawtooth wave, taken from some point in the horizontal sweep section other than from the secondary side of the horizontal sweep transformer. But the peaks of any of these plate voltages occur in synchronism with sync pulses of the composite signal on the grid.

Here is another example. If you examine again the diagrams of Figs. 6 and 7, it is apparent that positive delay voltage reaches through various resistors to the i-f agc bus as well as to the r-f agc bus. The resistors act as voltage dividers applying less delay to the i-f bus than to the r-f bus, so that i-f amplifiers are acted upon by negative agc voltage before r-f amplifiers, and do not overload when there is increased output from the r-f and mixer tubes to i-f amplifiers.

There are keyed agc systems in which the cathode of the agc tube is connected to one end of the contrast control potentiometer on the cathode of a video amplifier, with this end of the contrast control and the cathode of the agc tube connected to a positive B-voltage. Then operation of the contrast control alters the cathode voltage of the agc tube, thus alters the effective grid bias on this tube, and makes the agc voltage less negative as the contrast control is advanced. This particular feature was examined in con-

nection with non-keyed agc systems having a diode type agc rectifier.

In television service manuals you will read about many circuit features which are important from the design standpoint and from the standpoint of performance, yet do not directly affect service operations unless you feel competent to alter the original designs. For instance, when examining non-keyed agc systems we learned that a long time constant in the agc filter allowed absorbing the effects of severe or extended noise pulses, which might cause trouble with a short time constant that allows agc voltage to follow rapid changes of signal strength.

With keyed or gated agc, the extended noise pulses are cut off because agc conduction is possible during only about 8 per cent of each line period, or for only about 5 microseconds during each pulse. This makes it possible to use short time constants in agc filters for keyed systems, and thus to allow agc voltage to follow very rapid changes of signal strength. But in ordinary service work you should make no changes in capacitances or resistances without specific instructions or until you become a truly advanced technician capable of designing circuits on your own.

MILLER EFFECT. When talking about automatic gain controls, or about any of the contrast controls which vary the grid bias on i-f and r-f amplifiers, technicians sometimes mention the "Miller effect". They are referring to a change of input capacitance which occurs in amplifier tubes when the grid bias is altered. This change of capacitance may be important, because the input capacitance of the tube is an i-f or r-f amplifier stage forms a large part of the capacitance that tunes any inductor connected to the grid. The result, then, is to change the tuning and the frequency response of the stage.

With automatic gain control, or with any other control which varies the grid bias, the detuning effect increases on strong signals, for it is on such signals that either an agc system or a manual control will operate or be operated to cause the greatest change of amplifier grid bias. Fortunately, when an i-f or r-f amplifier section is correctly

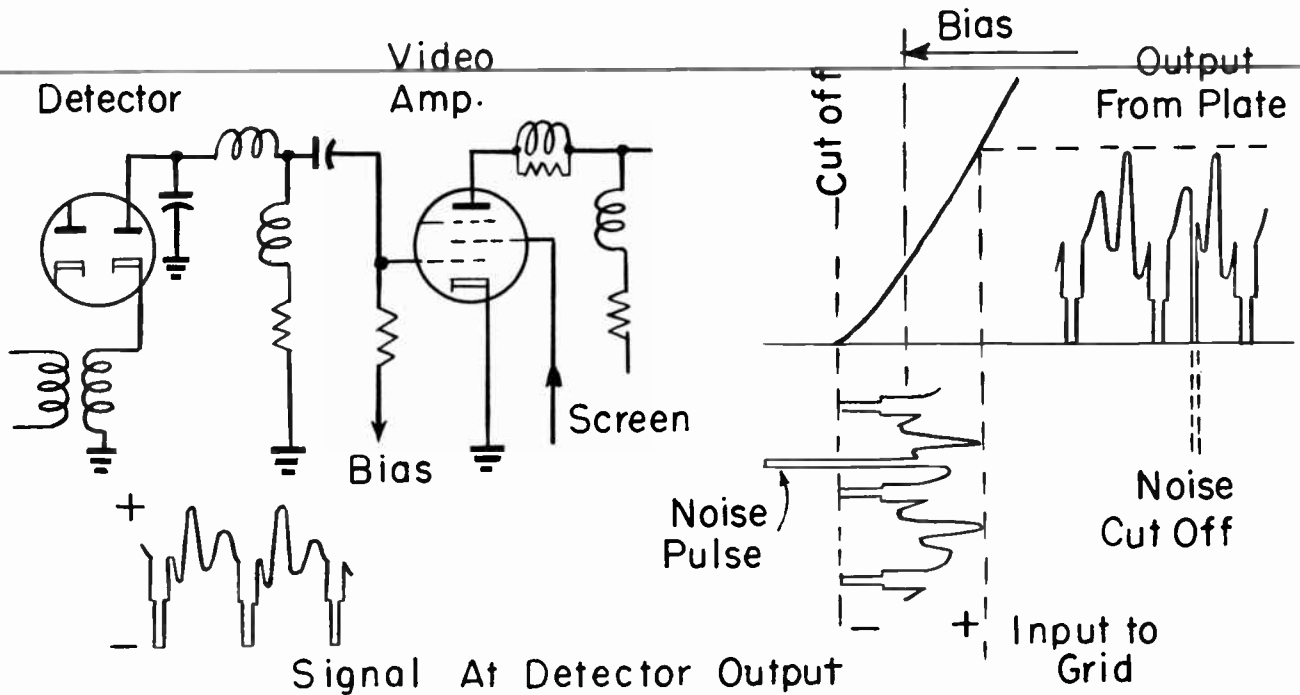

Fig. 8. The action in a video amplifier tube operated as a noise limiter.

aligned the detuning will not be enough to cause serious trouble in well designed receivers. A common method of lessening the detuning is to use unbypassed cathode bias resistors on the amplifiers. This causes a degenerative feedback from plate to grid.

**NOISE CLIPPING OR LIMITING.** A method of limiting the strength of noise pulses which pass through a video amplifier is illustrated by Fig. 8. The diagram at the left shows connections from the output of a video detector to the grid of a video amplifier. The input to the amplifier grid might be from the plate of a preceding amplifier as well as from the detector. The essential feature is that sync pulses in the video signal shall be negative with reference to picture signals at the grid of the amplifier.

When the amplifier is a pentode it is operated with a rather low screen voltage, and when a triode with low plate voltage. The negative grid bias is of such value that the tips of sync pulses, which are negative, bring the grid voltage just to the value of plate current cutoff. Any noise voltages which, at the amplifier grid, are more strongly negative than the tips of the sync pulses will drive the grid more negative than cutoff.

In the diagram at the right a video signal accompanied by a strong noise pulse is applied to the grid-voltage plate-current characteristic of an amplifier. Tips of sync pulses just reach the point of plate current cutoff. The stronger noise pulse is clipped at the voltage level of the sync pulse tips. In the amplifier output, at its plate, the noise pulse still is present but is far weaker than it would have been without the clipping action.

Were the composite video signal from the plate of the video amplifier of Fig. 8 applied to the grid of the keyer tube in a keyed agc system, a noise pulse occurring at the instant shown would be entirely eliminated, because the keyer is not conductive during intervals between sync pulses. Were a noise pulse to occur at the same instant as a sync pulse, the cutoff action in the video amplifier would clip the combined pulses at the level of the sync tips. Then there would be no additional grid voltage on the keyer tube, due to noise, and the noise pulse would not affect agc action.

Although the sync and noise pulses are shown as negative in the output of the video amplifier in Fig. 8, it must be remembered

## LESSON 42 – KEYED AGC AND VIDEO SIGNAL POLARITIES

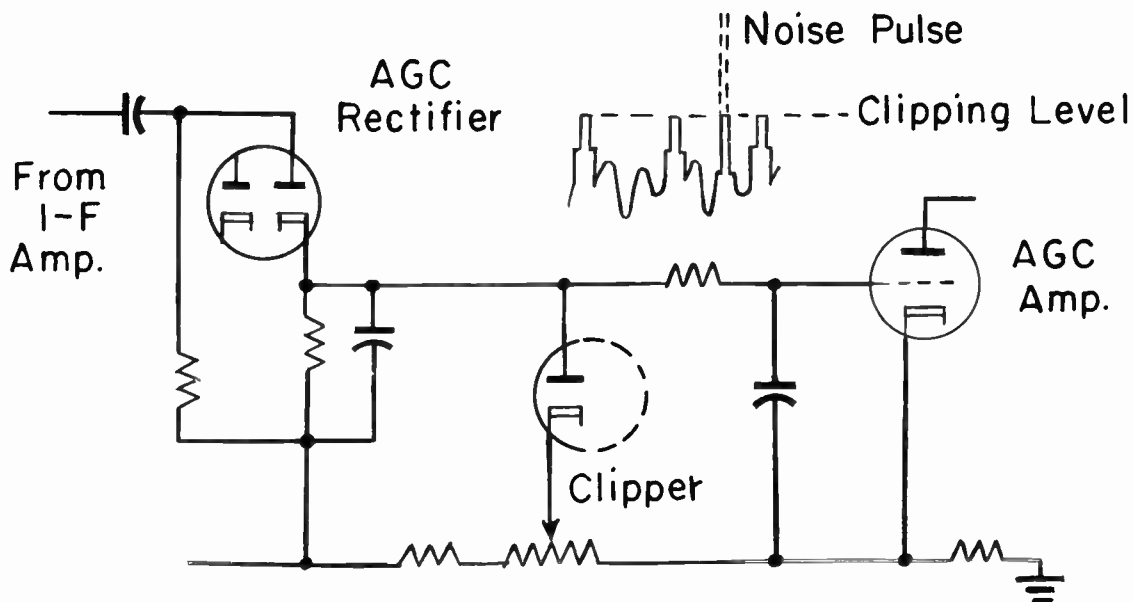

Fig. 9. A noise clipper diode on the input to an agc amplifier tube.

that this is output plate current, not output plate voltage. Changes of plate voltage are in opposite polarities to changes of plate current. Signal voltages would be inverted between grid and plate of the video amplifier, and sync pulse voltages would be positive - suitable for application to the grid of a keyer tube.

There are many other ways of limiting sync pulses and clipping noise pulses. In Fig. 9 a clipper diode is between an agc rectifier and an agc amplifier. The agc rectifier rectifies the positive side of the i-f video signal. Then sync pulses and noise pulses are positive at the plate of the clipper diode. The clipper cathode is connected to a potentiometer slider which is adjusted to make the cathode positive, and the clipper non-conductive, at diode plate voltages up to but no stronger than sync pulse peak voltage. Stronger noise pulses then make the clipper conductive, and its current so loads the agc line as to remove most or all of the noise effect at the grid of the following agc amplifier.

In Fig. 10 the clipper is connected to the plate of the first of two video amplifiers. Sync pulses are positive in the video signal output of this first amplifier. These pulses act through capacitor  $C_c$  to make the clipper plate momentarily positive, and there is con-

duction through the clipper as shown by brokenline arrows. Electrons of this conduction current charge capacitor  $C_c$  in the marked polarity. This capacitor discharges very slowly through resistor  $R_c$ , and the charge thus held on the capacitor maintains the clipper plate at a negative potential very nearly equal to the positive potential of the sync pulses. This charging of capacitor  $C_c$ , and holding the top of resistor  $R_c$  negative, is just like the action occurring in the circuit of an agc rectifier.

If noise pulses are stronger than the sync pulses of the video signal, the stronger positive noise pulses act through capacitor  $C_c$  to overcome the negative potential on the clipper plate, which is approximately equal to sync pulse voltage. Then the clipper conducts during the positive noise pulses, and so loads the circuit as to remove the effect of the noise pulses at the grid of the second video amplifier.

Fig. 11 shows connections for a noise limiter diode between the output of a video detector and the high side of a cathode resistor on an agc keyer tube. The cathode of the noise limiter is positive with reference to ground by the amount of voltage drop in cathode resistor  $R_k$ , wherein electron flow is upward to the cathode of the keyer tube.



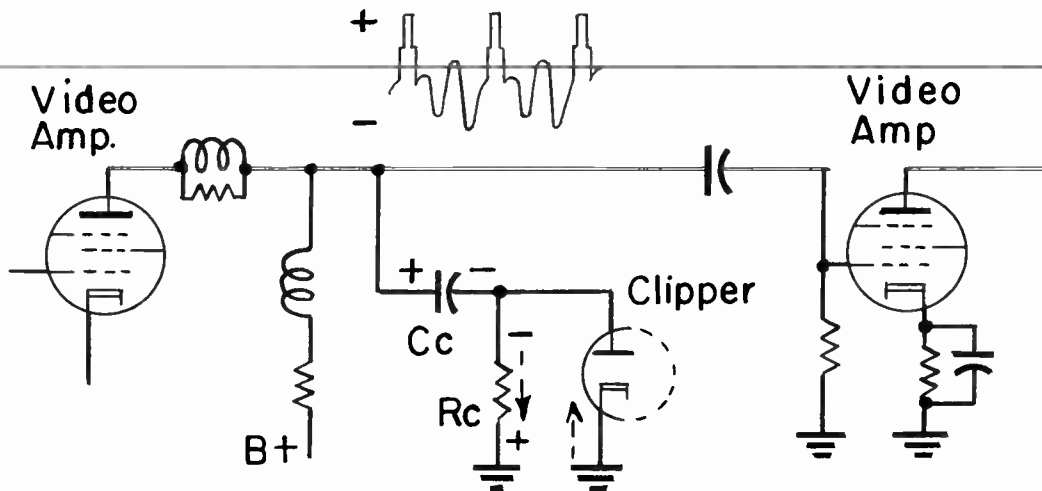

Fig. 10. A noise clipper which acts somewhat similarly to an agc rectifier.

The composite signal at the plate of the limiter diode has sync pulses positive. So long as peak potentials of these sync pulses do not exceed the positive bias on the limiter cathode, the cathode will remain positive to the plate, or the plate negative to the cathode, and the limiter cannot conduct. Should there be noise pulses stronger or more positive than the sync pulses, the noise on the limiter plate will make this tube conduct and limit the effect of noise at the video amplifier which follows the detector. At the same time,

the pulse of electron flow to the limiter passes through resistor  $R_k$  to make the keyer cathode more positive and the keyer grid relatively more negative during the noise. This reduces agc voltage from the keyer and limits the effect of noise on the agc voltage when noise occurs during sync pulses, while the keyer is conductive.

THE VIDEO AMPLIFIER. Up to this point we have dealt with i-f amplifiers and video detectors, and with controls for automatic gain and for contrast, which are associated with i-f amplifiers and video detec-

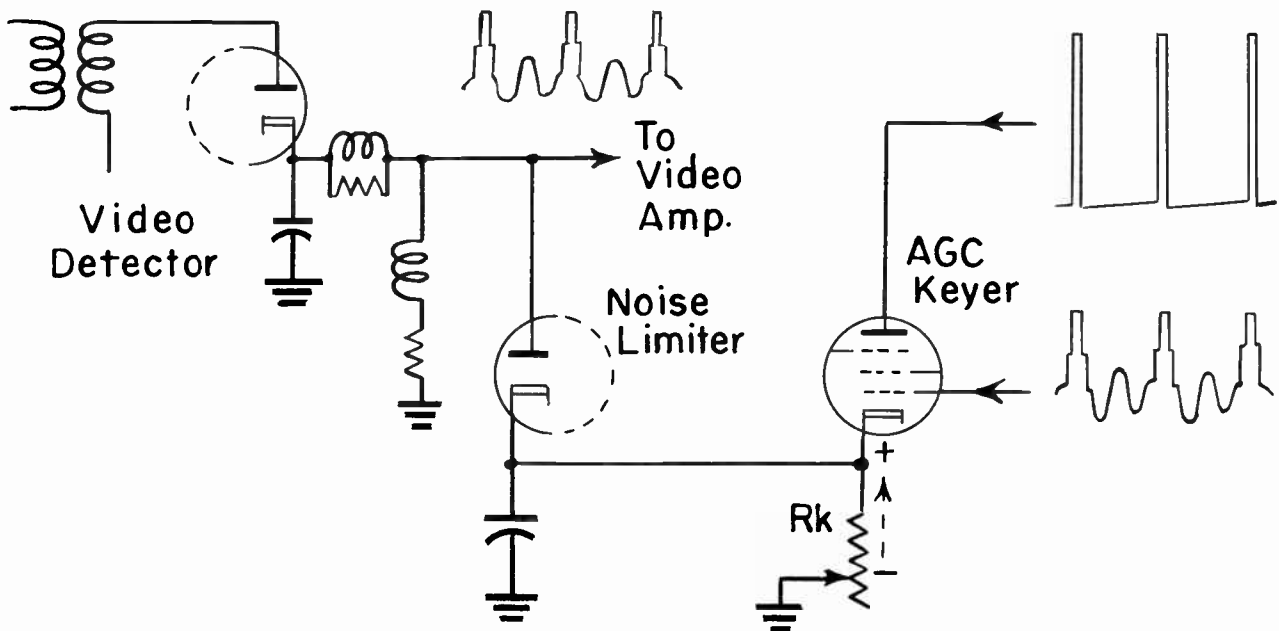

Fig. 11. A noise limiter diode connected to the cathode of an agc keyer tube.

## LESSON 42 – KEYED AGC AND VIDEO SIGNAL POLARITIES

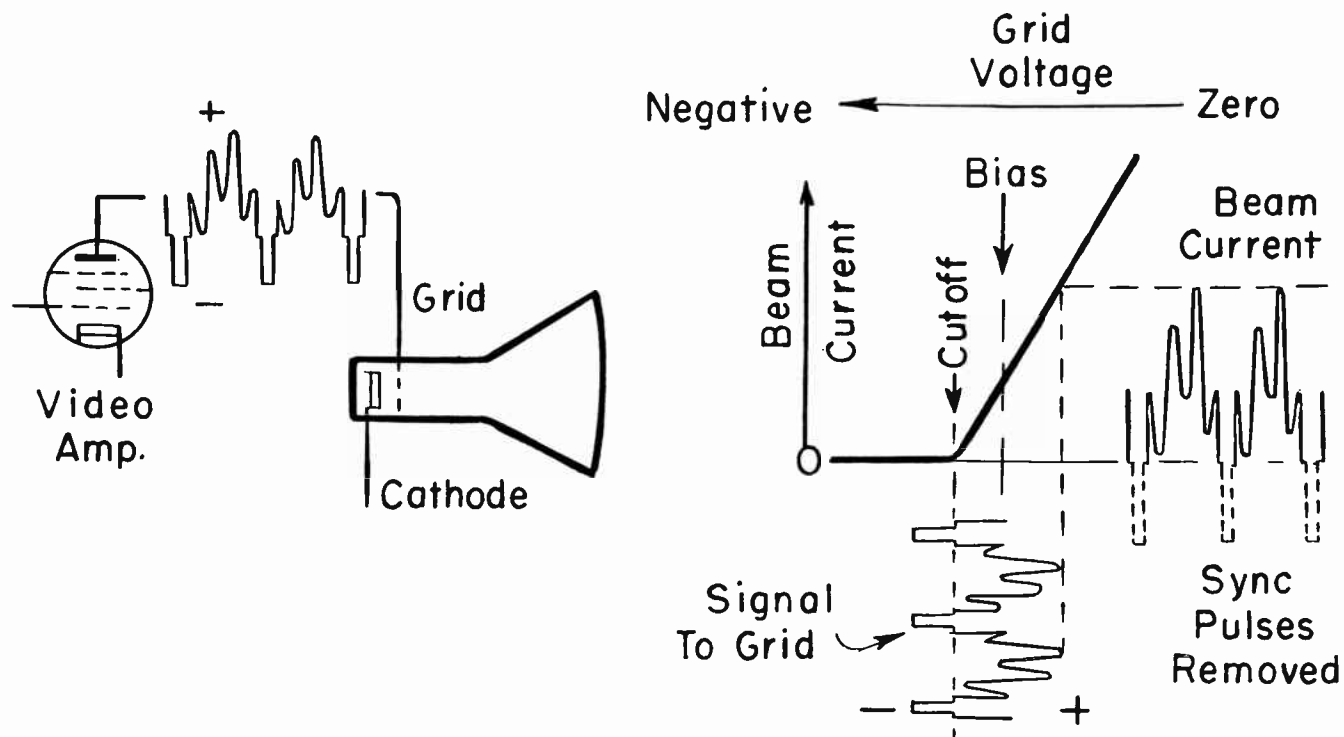

Fig. 12. In a signal applied to the grid of a picture tube, sync pulses must be negative.

tors. D-c restoration, which is one of the automatic controls on our list for investigation, is associated with the video amplifier section of the receiver and with the grid-cathode circuit of the picture tube. Therefore, before taking up the matter of d-c restoration, it will be advisable to become better acquainted with video amplifiers.

The video amplifier amplifies the composite video signals which appear at the output or load of the video detector, and delivers the amplified signals to the picture tube. The composite signal may be applied either to the grid or to the cathode of the picture tube. The video amplifier section, between video detector and picture tube, may comprise one stage or two stages. The number of stages and the element of the picture tube to which the composite signal is applied determine whether sync pulses in the composite signal must be negative or positive at the output of the video detector. It all comes out as explained in following paragraphs, wherein we shall commence at the picture tube and work back to the video detector.

In Fig. 12 the composite video signal is applied to the grid of the picture tube. Pic-

ture variations in this applied signal are positive with reference to sync pulses. The graph at the right shows a beam-current grid-voltage curve for a picture tube. Here we have relations between grid voltage and beam current. The more negative the grid, with reference to the cathode, the less becomes the beam current and the darker the picture areas. A less negative grid increases the beam current and brightens the picture areas. With a certain negative voltage on the grid the beam current is brought to zero, or is cut off. Then the screen of the picture tube is not illuminated by the beam.

Picture variations which extend toward the white level of the composite signal make the picture tube grid more positive, or actually less negative, which amounts to the same thing. This increases the beam current and produces brighter areas on the screen of the picture tube. Picture variations which extend toward the black level of the signal make the grid less positive (or more negative). They lessen the beam current and produce darker areas in pictures.

The picture tube grid is negatively biased with reference to the cathode by means of the

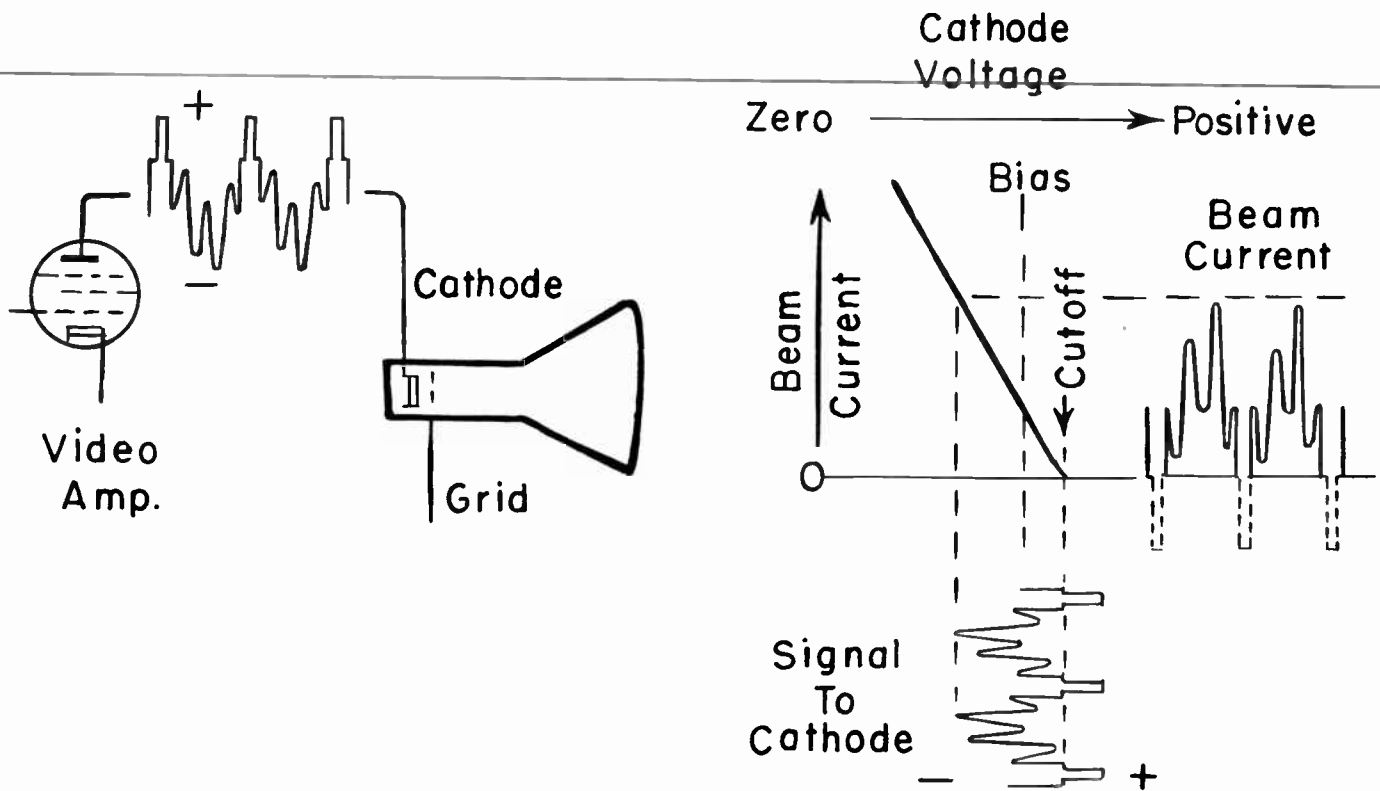

Fig. 13. When the composite signal is applied to the cathode of a picture tube, sync pulses must be positive.

brightness control. The negative sync pulses, in the signal applied to the grid, make the grid more negative than the voltage for beam current cutoff. Then sync pulses do not affect reproduced pictures. The black level voltage of the signal is supposed to be exactly the grid voltage for beam current cutoff. Then everything in the signal which is positive with reference to the black level appears in beam current variations and in reproduced pictures.

The important point is this: When the signal from the plate of a final video amplifier tube is applied to the grid of a picture tube, the signal must be of such polarity that sync pulses are negative with reference to picture variations. Then, provided the picture tube grid is correctly biased, sync pulses will be cut off but everything else will show in reproduced pictures.

In Fig. 13 the composite video signal from the final video amplifier is applied to the cathode of the picture tube. Now, for reasons illustrated by the graph at the right,

sync pulses of the composite signal must be positive with reference to picture variations.

In arriving at the reasons for this change of signal polarity we must keep in mind that grid bias voltage for the picture tube is the potential difference between grid and cathode. Biasing voltage, from the brightness control circuit, must be of polarity that makes the grid negative with reference to the cathode. We may state the same thing by saying that bias voltage makes the cathode positive with reference to the grid.

The transfer characteristic curve at the right in Fig. 13 shows relations between picture tube beam current and cathode voltage with reference to the grid. Making the cathode more positive lessens the beam current, because this is equivalent to making the grid more negative. Making the cathode less positive is equivalent to making the grid less negative. When the cathode is brought to a certain positive voltage, with reference to the grid, there is beam current cutoff. The cathode transfer curve is sloped in a direc-

## LESSON 42 – KEYED AGC AND VIDEO SIGNAL POLARITIES

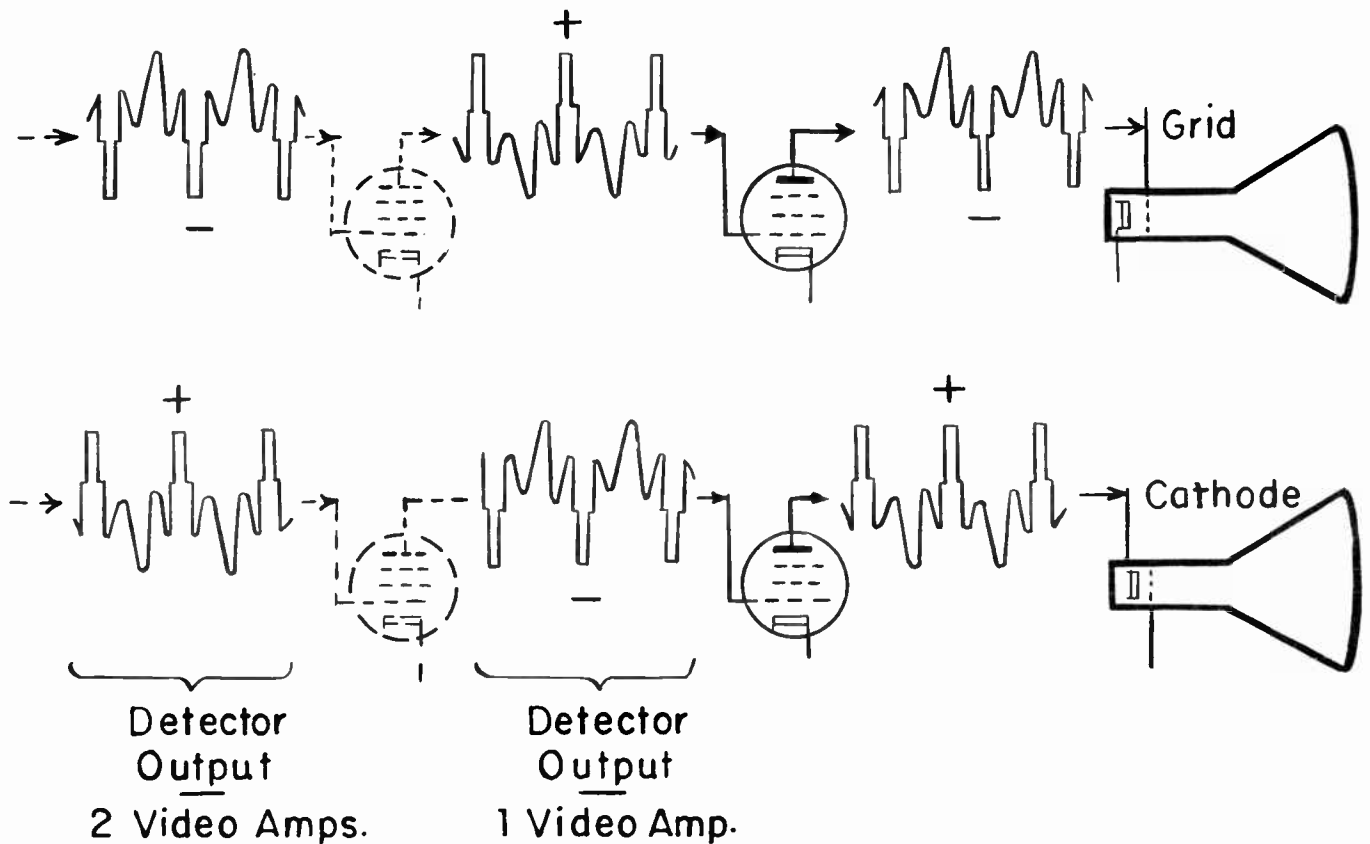

Fig. 14. Signal polarities between video detector outputs and picture tube inputs.

tion opposite to the slope of the grid transfer curve (Fig. 12) in order to illustrate the effects of cathode voltage on beam current.

In Fig. 13 the positive sync pulses of the composite signal applied to the cathode make the cathode more positive than the voltage for beam current cutoff. Beam current becomes zero and the picture tube screen is dark during pulse intervals. But the negative going picture variations of the applied signal make the cathode less positive than the cutoff voltage. Beam current flows, and is proportional to picture variations of the positive cathode voltage.

Beam current variations and picture reproduction are exactly the same whether the composite signal is applied to the grid or to the cathode of the picture tube, provided the applied signal is of correct polarity for each case. We must note this: When the signal from the final video amplifier is applied to the cathode of the picture tube, the signal polarity must be such that sync pulses are positive with reference to picture variations.

Although we have learned about the signal polarities required at picture tube grids and cathodes this does not tell us how the signal must be polarized at the output of the video detector. The reason is that signal polarity will be inverted between grid and plate of each video amplifier tube used between the video detector and the picture tube.

Fig. 14 illustrates signal polarity inversions in video amplifier stages between detectors and picture tubes. On the upper line the composite video signal is applied to the grid of the picture tube, with sync pulses negative. Then sync pulses must be negative at the grid of the video amplifier which feeds the picture tube, because signal polarity will be inverted between grid and plate of this video amplifier. If there is only one video amplifier, whose grid is coupled to the output of the video detector, sync pulses must be positive at the detector output.

If there is an additional video amplifier, as represented by the broken-line symbol, there will be inversion between its grid and



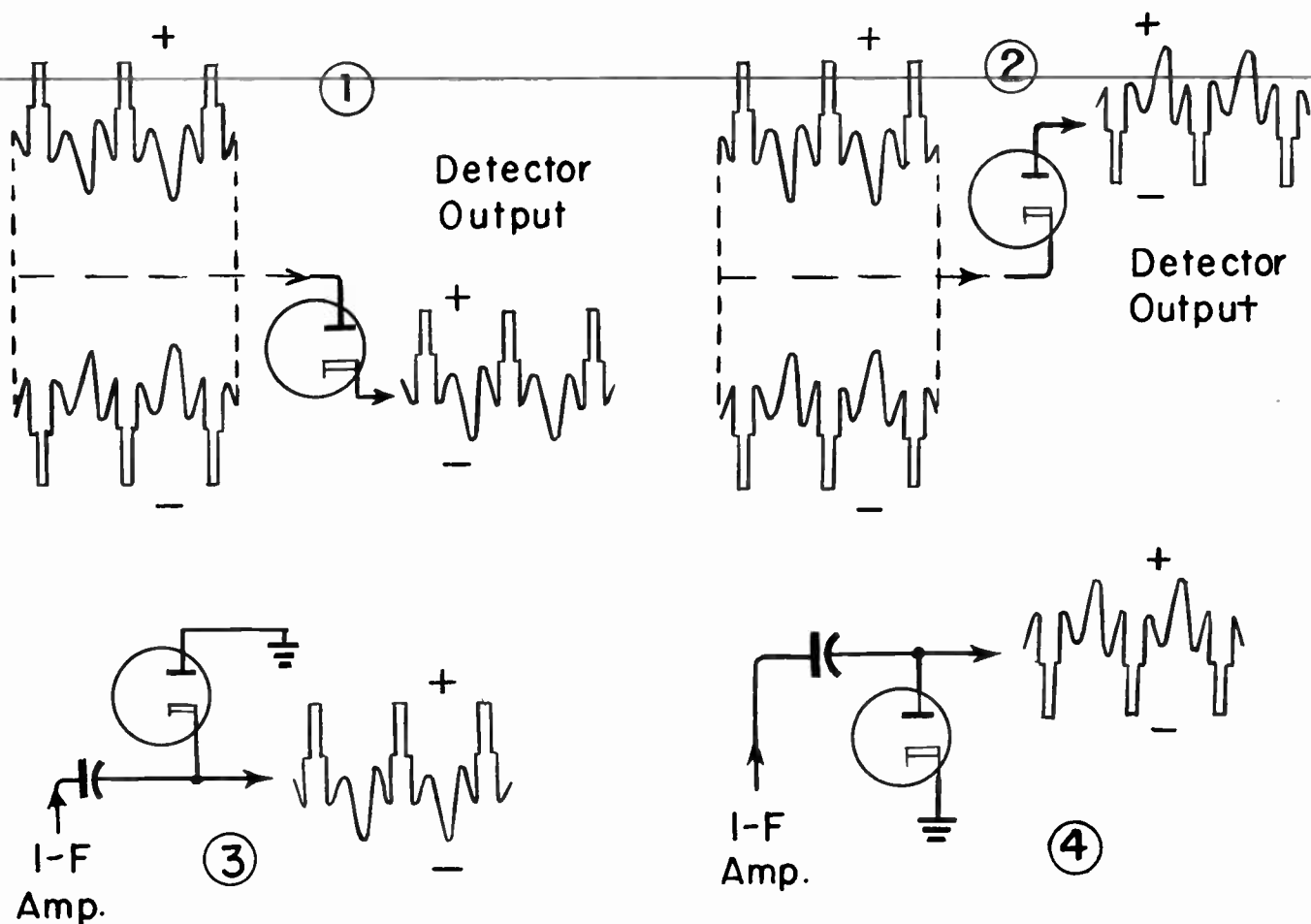

Fig. 15. Signal polarity at the video detector output depends on whether the i-f signal is applied to the plate or cathode of the detector, and on whether the detector is connected for series or shunt operation.

plate. Then, of course, the signal at the grid of this added amplifier must have sync pulses negative. With the grid of this added amplifier coupled to the video detector, sync pulses must be negative in the detector output.

On the bottom line of Fig. 14 the composite video signal is applied to the cathode of the picture tube, with sync pulses positive. Again there will be signal inversion between grid and plate of each video amplifier tube. Consequently, with one video amplifier, sync pulses must be negative at its grid. If there are two video amplifiers, sync pulses must be positive at the grid of the added one. These considerations determine the sync pulse polarity required at the outputs of video detectors followed by either one or two video amplifier tubes.

Fig. 15 shows various connections of video detectors, and polarities of composite signal outputs with each connection. In diagram 1 the doubly modulated signal from the final i-f amplifier is applied to the plate of a diode detector. This detector will rectify, and pass signal currents and voltages, when its plate is made positive with reference to its cathode. Therefore, the upper side or positive side of the i-f signal will be passed, and at the detector output, from its cathode, the signal will have sync pulses positive.

In diagram 2 the i-f signal is applied to the cathode of the detector diode. The detector will rectify and pass the signal when the detector cathode becomes negative with reference to its plate. Then there will be rectification or detection of the lower side or negative side of the i-f signal, and at the out-

## LESSON 42 – KEYED AGC AND VIDEO SIGNAL POLARITIES

put of this detector we have a composite signal with sync pulses negative.

The detectors of diagrams 1 and 2 may be called series detectors, because their plates and cathodes are in series for signal currents flowing between the i-f amplifier and the detector load. The signals appearing at the outputs of these detectors have passed from plate to cathode or from cathode to plate through the detectors.

In a few receivers you will find shunt detectors, connected as shown at 2 and 3 of Fig. 15. In diagram 3 the detector diode is shunted between ground and a line running from the i-f amplifier to the detector load and video amplifier grid. This detector will conduct when its cathode is made negative. This means that there will be conduction on the negative side of the i-f signal, and this side of the i-f signal will be short-circuited to ground. The detector will not conduct on the positive side of the i-f signal. Consequently, the positive side of the i-f signal will not be grounded, but will pass along to the output of the detector. Then, in the detector output, we have a composite signal with sync pulses positive or have the modulation from the positive side of the i-f signal.

In diagram 4 of Fig. 15 the plate of a shunt detector is connected to the line between i-f amplifier and video amplifier grid or detector load. The cathode of this detector is connected to ground. Now the detector conducts when its plate is made positive, and grounds or short-circuits the positive side of the i-f signal. The negative side of the i-f signal makes the detector plate negative. There is no conduction, and the negative side of the i-f signal passes along to the detector load and the video amplifier. Sync pulses are negative in the output of the shunt detector connected in this manner.

Sync pulses are positive in the outputs of the series detector at 1 and of the shunt detector at 3, although the i-f signal is applied to the plate of the series detector and to the cathode of the shunt detector. Sync pulses are negative at 2 and 4, where i-f signals are applied to the cathode of the series detector and to the plate of the shunt detector.

You may match any of the detector outputs of Fig. 15 with any of the video amplifier inputs of Fig. 14, and thus form complete video amplifier sections having the required signal polarities all the way from detector load to picture tube input. Any of the detector outputs with sync pulses positive could go to any video amplifier input where sync pulses are shown as positive. Any detector output with sync pulses negative could go to any video amplifier input where sync pulses are negative. All of the combinations will be found in various receivers.

You will see the various signal polarities and inversions when using an oscilloscope during service operations. At A in Fig. 16 is a trace taken at the output of a final video amplifier. This signal is applied to the grid of a picture tube and, accordingly, has sync pulses negative and picture variations positive. At B is the signal at the grid of the video amplifier, which is also the signal at the output of the video detector which, in this case, feeds to the one and only video amplifier. Here the sync pulses are positive. The signal is inverted between grid and plate of the video amplifier tube.

We have seen that there must be certain relations between signal polarities and inversions between the video detector and the input to the picture tube. It is necessary also that sync pulses be of certain polarities when they reach the sweep sections of television receivers. Some types of sweep oscillators must be triggered by positive sync pulses, while others must be triggered by negative sync pulses.

The pulses which eventually trigger the sweep oscillators are taken originally from video detector or video amplifier circuits. The signals and pulses are carried through the sync section, where the pulses are shaped, amplified, and clipped or limited as may be required, and where necessary inversions of polarity may be applied.

Fig. 17 illustrates a few of the ways in which sync pulses may be taken from circuits between a video detector and a picture tube for application to sync sections. In the video amplifier section, sync pulses are negative

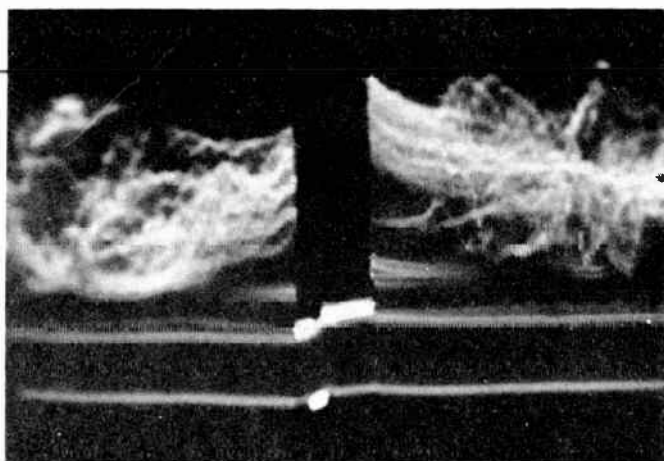

Fig. 16A

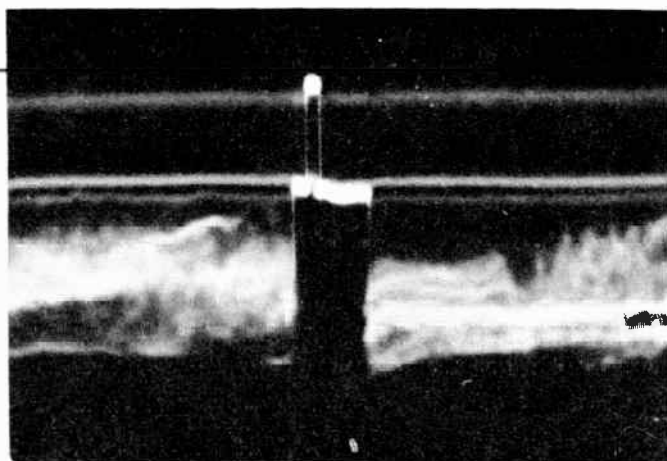

Fig. 16B

Fig. 16. The oscilloscope will show signal polarity inversions between grid and plate of amplifier tubes.

at the detector output, are positive at the output of the first video amplifier, and are negative at the output of the second video amplifier and at the grid of the picture tube. These relative polarities are used only as a means for showing the principles of sync takeoff. The same principles might be used with any other order of signal polarities in the video amplifier section.

At the lower left a composite video signal is taken from the video detector load and applied to a sync amplifier tube. There is inversion in this sync amplifier, so sync pulses which were negative in the detector output are positive at the plate of the sync amplifier. This amplifier might be biased in such manner as to reduce the strength of picture variations while strengthening the sync pulses. Such matters as amplification and limiting will be considered at length when we study sync sections. Now we are considering only how the sync signals may be taken from the video amplifier section.

At the lower center of Fig. 17 a composite video signal is taken from the plate load of the first video amplifier. This signal, delivered to the sync section, is of the same polarity as at the amplifier output, with sync pulses positive.

Should it be necessary to have sync pulses negative at the input to the sync section of the receiver a composite video signal might be taken from the plate load of the second video amplifier, as at the lower right.

Composite signals taken from a detector output would be relatively weak, and would require considerable amplification in the sync section, before being applied to the sweep oscillators. Composite signals from the output of a first video amplifier would be much stronger, and would need less amplification in the sync section. Signals from the output of a second video amplifier, or from a single video amplifier feeding the picture tube, would be the strongest obtainable from the video amplifier section of the receiver.

## LESSON 42 – KEYED AGC AND VIDEO SIGNAL POLARITIES

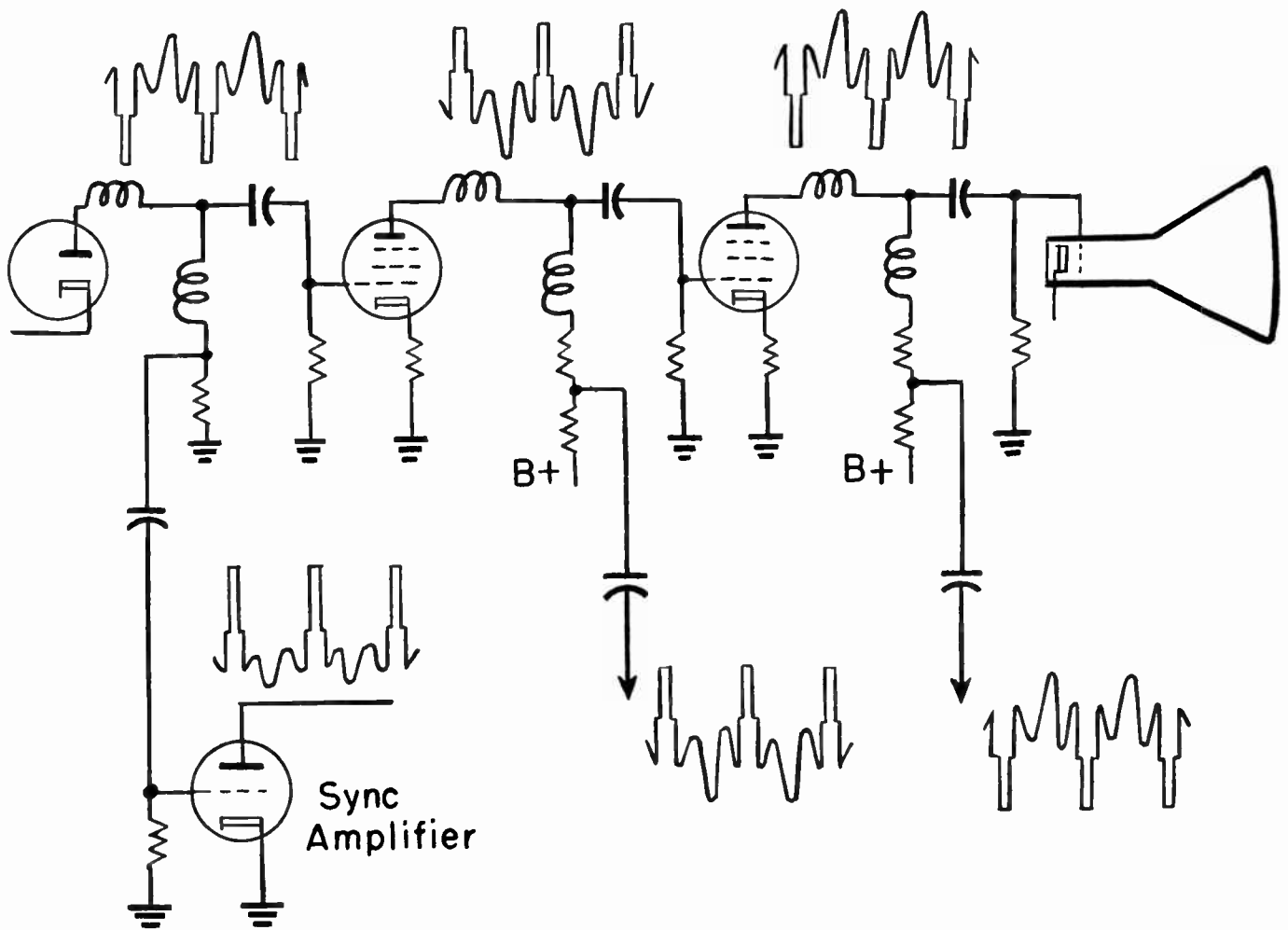
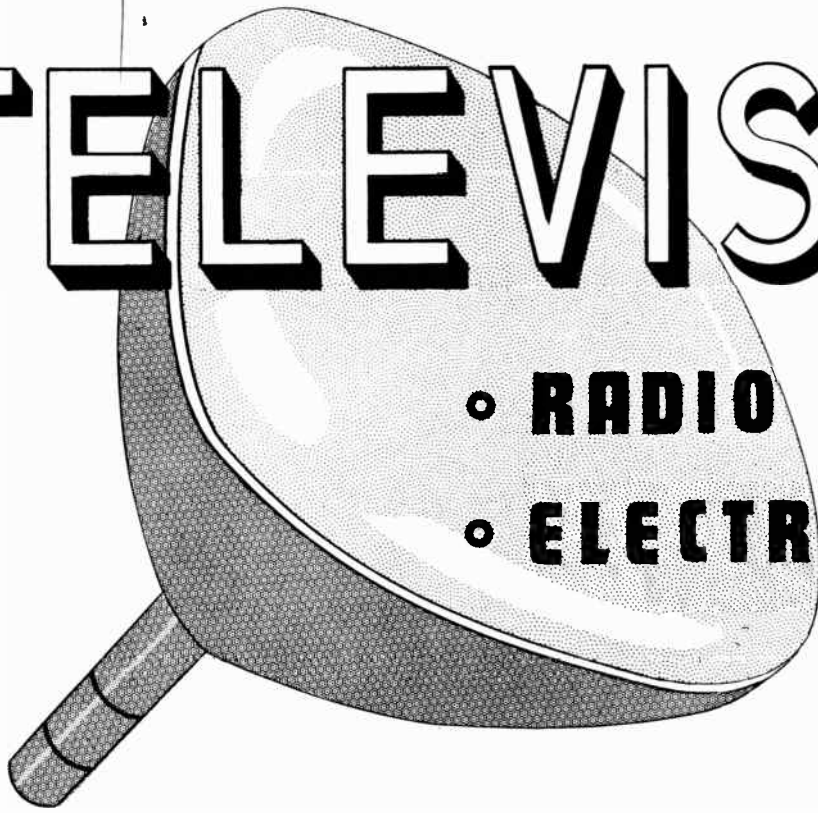

Fig. 17. Composite signals for the sync section of a receiver may be obtained from the output of a video detector or a video amplifier.



# TELEVISION



• RADIO

• ELECTRONICS

---

## LESSON 43 – THE VIDEO AMPLIFIER

---

***Coyne School***

*practical home training*

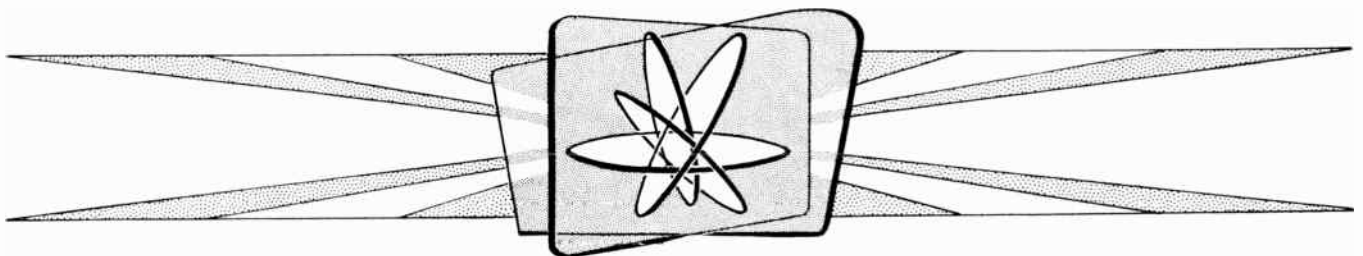

*Chicago, Illinois*

---

*Copyright, 1953 by Coyne Electrical School  
Chicago 12, Illinois  
All rights reserved*

Litho. in U.S.A.

## Lesson 43

### THE VIDEO AMPLIFIER

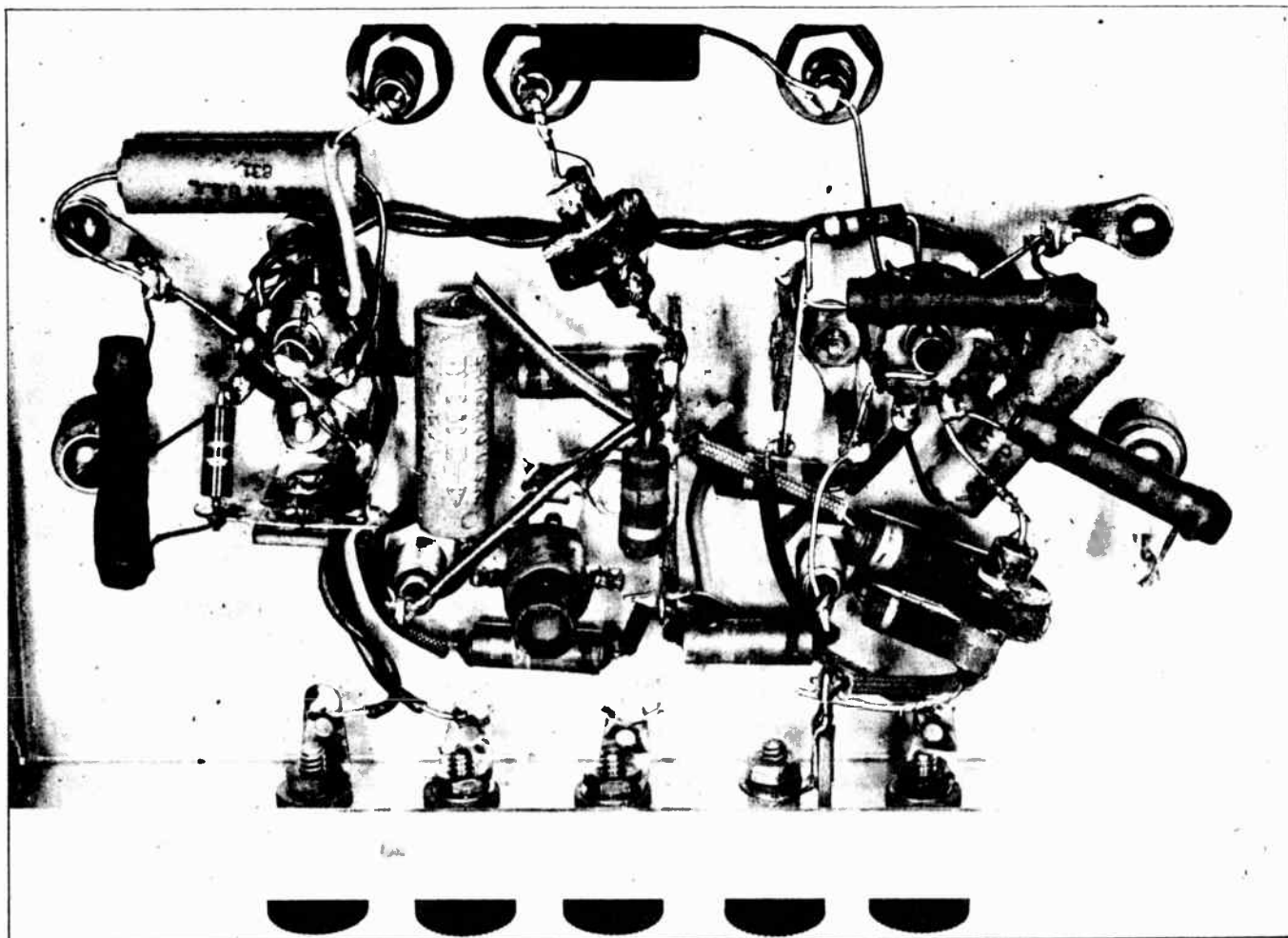

Fig. 1. The parts of a video amplifier, from video detector output to picture tube input.

All the parts required in a complete video amplifier, from detector output to picture tube input, appear from underneath the chassis as in Fig. 1. In addition to the tube sockets there are only fixed resistors, capacitors, and inductors. Only rarely are there any adjustments in this section of the receiver. Servicing consists chiefly of replacements and substitutions, and of care with wiring arrangements. The simplicity of video amplifiers, as they appear in service diagrams, gives little indication of how greatly this section of the receiver affects picture quality.

**VOLTAGE GAIN.** Amplification in the video amplifier section must increase the

video detector output signal to whatever may be required to vary the picture tube beam current between cutoff and the value giving maximum desirable brightness in the lightest picture areas.

In order to reduce beam current to a value which leaves no visible illumination on the screen, it may be necessary to make the grid negative with reference to the cathode by something between 33 and 77 volts, depending largely on voltages applied to other elements of the picture tube. In the following discussion we shall assume that the picture tube is so operated that beam current is cut off with the grid 50 volts negative. Then this will be the grid voltage corresponding to

# COYNE - *television home training*

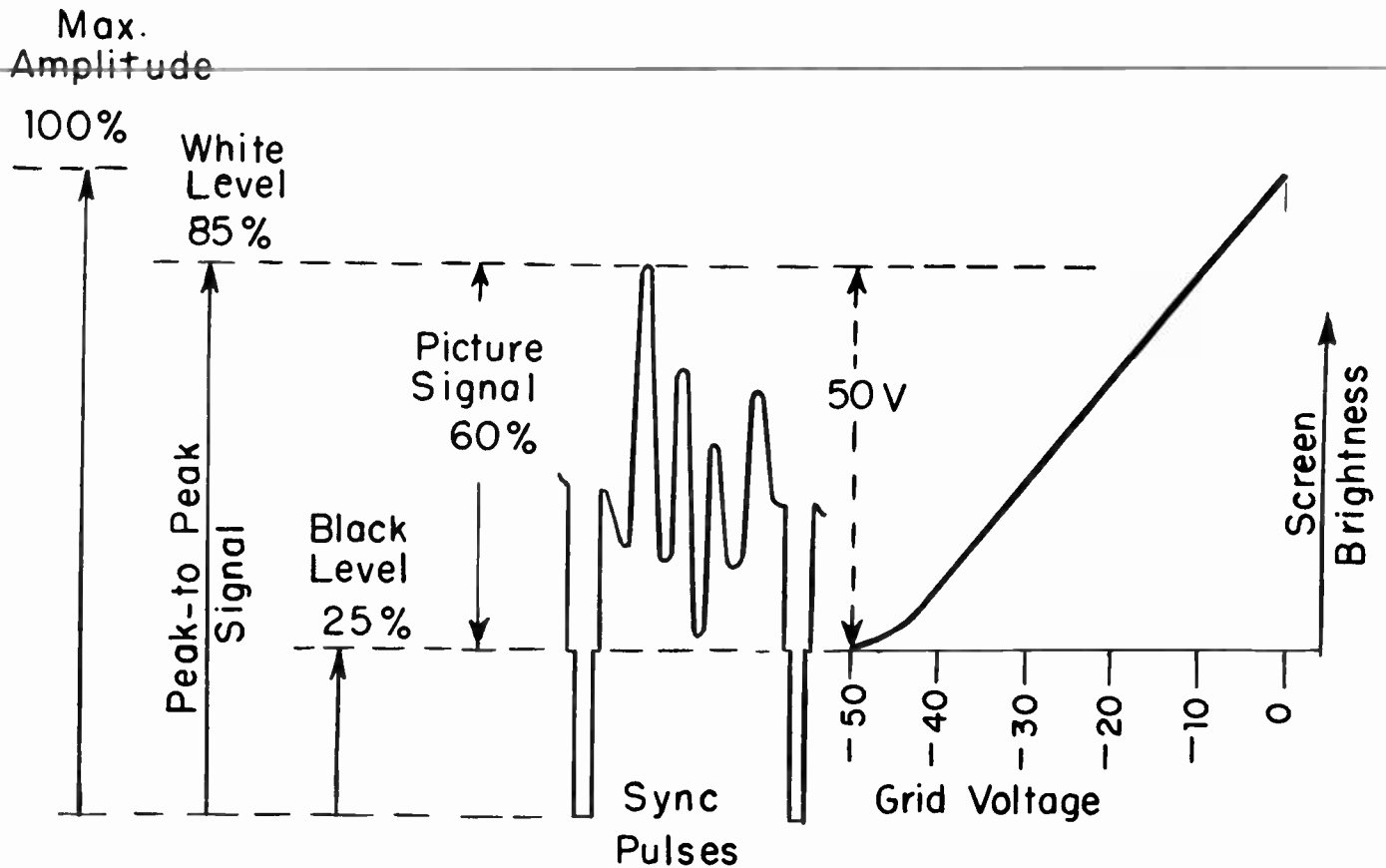

Fig. 2. Composite signal voltage applied to a picture tube having beam-current cutoff with its grid 50 volts negative.

the black level of the applied composite signal.

Certain relations between voltages or levels in a composite signal are shown by Fig. 2. When first studying details of the television signal we considered the maximum carrier or i-f amplitude, from zero to positive and negative sync pulse tips, as 100 per cent of signal strength. This 100 per cent value is shown by an arrow on the diagram.

The white level, or signal voltage for producing the brightest parts of pictures, is at 85 per cent of maximum amplitude. This 85 per cent includes all the changes of video signal voltage from maximum white clear down to the tips of the sync pulses. Since this is the total variation of signal voltage, from sync pulse peaks to peaks for maximum brightness, it is called peak-to-peak signal voltage. The sync pulses, from the black level or pedestal voltage down to the tips, utilize 25 per cent of the original 100 per cent amplitude.

We have assumed that the grid of the picture tube must be 50 volts negative at the black level of the signal. Because the grid should not be driven positive, the total swing of grid voltage from black to maximum white may not exceed 50 volts in this particular example. This will not be peak-to-peak signal voltage, for we have not included the sync pulses.

From Fig. 2 it is plain that the picture portion of the video signal takes in 60 per cent of the original amplitude, because this picture portion extends from 85 per cent at the white level to 25 per cent at the black level, a difference of 60 per cent. The ratio between this picture voltage and peak-to-peak signal voltage is 60 to 85. Consequently, if we are to have a 50-volt swing for picture signals there must be a peak-to-peak total of nearly 71 volts at the input to the picture tube.

Actual peak-to-peak signal voltages at picture tube grids or cathodes in typical re-



## LESSON 43 — THE VIDEO AMPLIFIER

ceivers range from about 55 to 120 volts. These are the signal voltages with the contrast control fully advanced, or advanced as far as possible without causing picture distortion. It is the signal voltage also when there is what might be called a normal signal voltage at the output of the video detector.

The detector output signal voltage depends, of course, on the strength of received signals and on the action of an agc system. Various receivers are designed for average or normal detector outputs ranging from 2 to 7 volts. Gain in the video amplifier section is equal to the quotient of dividing the signal volts at the picture tube input by signal volts at the video detector output, using peak-to-peak values at both points. Actual gains in video amplifiers range from about 10 up to 50, or even somewhat more in some cases. A fair average of voltage gains might be 15 to 20 times.

It is common practice to use only a single stage of video amplification, including a pentode or power pentode tube. Quite often there are two stages utilizing the two sections of a twin triode, or one stage may be a section of a twin triode with a second stage having a power pentode. Video amplifier tubes are types having high transconductance, commonly between 6,000 and 11,000 micromhos. For reasons which will appear later, it is necessary to use small load impedances. To obtain high output signal voltage across the small loads, video amplifiers are of types which handle large plate currents at moderate values of plate voltage. Another requirement is small input and output capacitances, which enable the amplifier to maintain satisfactory gain at the higher video frequencies.

Among the more widely used video amplifiers is the 6CB6 miniature pentode, which is used also as an i-f amplifier in many receivers. There are many miniature 6AH6 pentodes, which are the equivalent of the 6AC7 metal tube. The 6AC7 was one of the first few tubes designed especially for television, and still it is not obsolete. There is also the 6CL6 miniature pentode, which is the equivalent of the 6AG7 metal tube. Of course, there are also many video amplifier tubes other than the few mentioned.

The most serious problem to be overcome in design and operation of video amplifiers is that of maintaining fairly uniform gain throughout an exceedingly great range of frequencies. In the rare instances where a single variation from light to dark and back again takes up the time of an entire frame or even more than one frame, the uniform response of the video amplifier would have to extend as low as 30 cycles per second, the frame frequency.

The high limit of video frequencies depends on the desired detail or sharpness of resolution in pictures having many variations of shading. Better resolution is needed for large screen picture tubes than for smaller ones. The high limit of good or uniform gain may be close to 4 mc in some receivers. Resolution in reproduced pictures cannot be better than allowed by received signals. Signals which have come through some types of wire lines, and those originating from motion picture film not prepared especially for television, may have maximum picture frequencies of only 2.5 mc or even less. Fig. 3 shows poor high-frequency response.

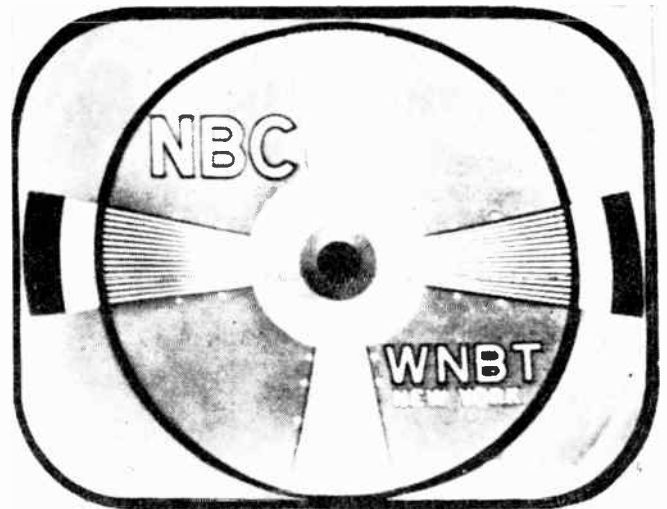

Fig. 3. Lack of gain at the higher video frequencies causes vertical lines to become blurred and indistinct.

Failure to maintain uniform gain may cause picture faults other than poor detail. It may cause effects such as illustrated by Fig. 4, where there are white trailers following dark areas, or it may cause the effect called smearing. The requirements for video amplifiers, and how they are satisfied, are best explained by first reducing these ampli-

## COYNE - television home training

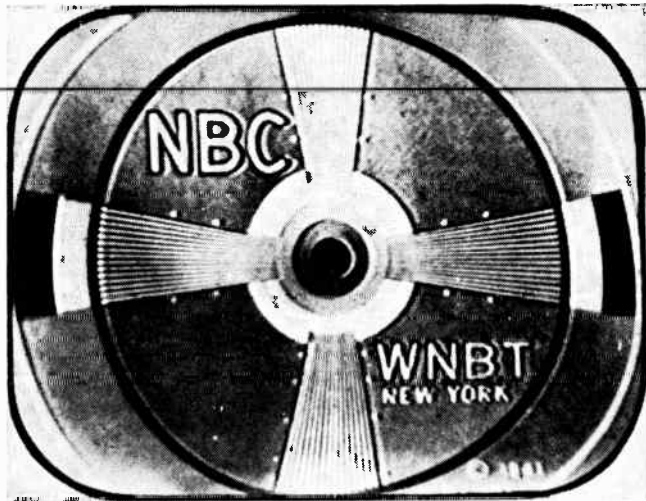

Fig. 4. White trailers may be seen at the right of the wider black areas, while dark or black trailers follow areas which are white.

fiers to their simplest components, then making changes and additions as needed to extend the band width.

Connections which are typical of video amplifiers, from video detector to picture tube, are shown at the left in Fig. 5. If we remove the inductors from the plate circuits, also any resistors which are shunted across these inductors, the remainder will be as shown at the right. Here we have an ordinary resistance coupled amplifier such as studied in other lessons. One of the big differences between video amplifiers and ordinary resistance coupled amplifiers is in these inductors.

Several inductors such as you will find in video amplifier and video detector circuits are pictured by Fig. 6. The inductors wind-

ings are of duolateral or honeycomb types. When one of these windings is to be paralleled or shunted by resistance, the winding is on the outside of a fixed resistor of desired value, on the ends of which are the usual pigtail leads. When there is to be no shunting resistance the winding usually is mounted on a small cylinder of insulating material having pigtail leads at both ends.

The ends of the winding wire are soldered to the pigtail leads in either case. Then the inductor assembly may be supported and connected into its circuit by the pigtail leads, in the same manner as ordinary fixed resistors. For reasons which will appear later these inductors often are called "peakers". You will learn to identify video detector and amplifier circuits underneath receiver chassis by looking for the peakers.

A plain resistance coupled amplifier may have satisfactory gain or frequency response from around 100 cycles up to 5,000 cycles per second or somewhat higher. The video amplifier must have nearly uniform gain from about 50 cycles up to at least  $2\frac{1}{2}$  megacycles, and preferably to  $3\frac{1}{2}$  megacycles or more. It is the peakers, in combination with suitable values of resistance and capacitance, that make the video amplifier a broad band type, while an ordinary resistance coupled amplifier is a narrow band type.

As doubtless you recall, gain of a narrow band resistance coupled amplifier tends to fall off rapidly at frequencies lower than 100 or 200 cycles per second unless special means are used to prevent it. At the high

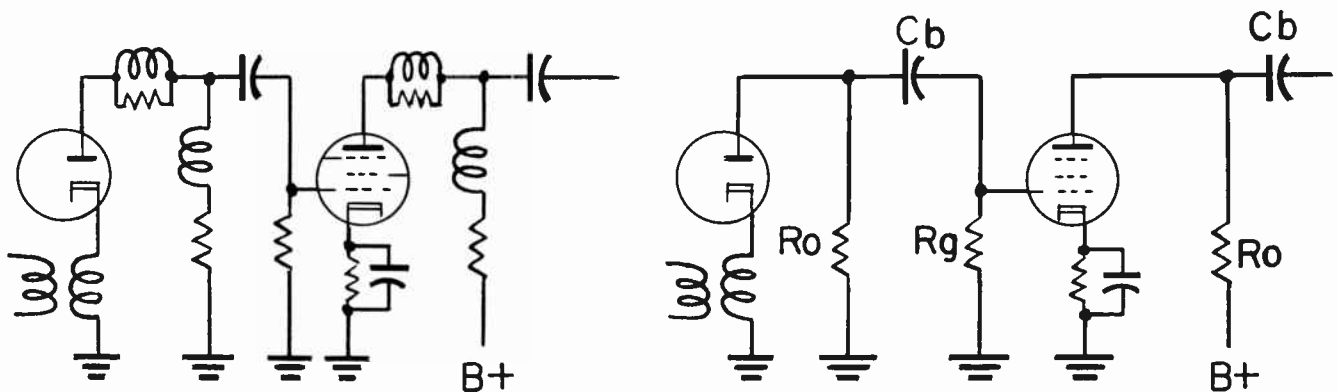

Fig. 5. When peaking inductors are removed from the video amplifier at the left we have the ordinary resistance coupled amplifier at the right.

## LESSON 43 — THE VIDEO AMPLIFIER

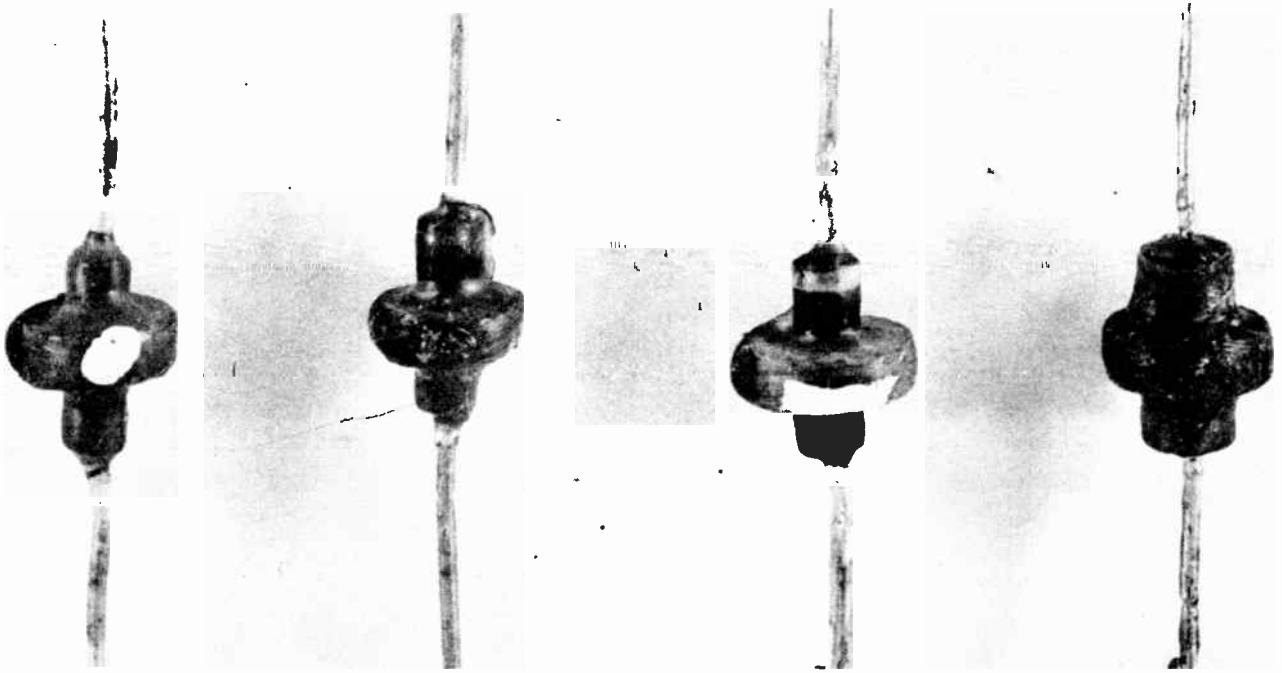

Fig. 6. Peaking inductors such as used in video amplifier circuits.

end of the frequency range the gain of such amplifiers always commences to fall off between 5,000 and 10,000 cycles, and is away down at 20,000 cycles. Response or gain must be improved at the low-frequency end, and extended far above the high-frequency end of this range in order to handle video signals. It will be well to review a few of the more important features relating to frequency response of these narrow band amplifiers.

So far as low-frequency gain is concerned it is desirable to have large capacitance in the blocking or coupling capacitors at  $C_b$  of Fig. 5. This means small capacitive reactance opposing transfer of low-frequency signals through this capacitor.

Signal voltage developed in the amplifier plate circuits appears across load resistors  $R_o$ . In parallel across each load resistor is the reactance of capacitor  $C_b$  in series with resistance of grid resistor  $R_g$ . Signal voltage divides between reactance at  $C_b$  and resistance at  $R_g$ , with only the portion across the grid resistor being applied between grid and cathode of the second tube.

The greater the capacitance and smaller the reactance at  $C_b$ , and the greater the resistance at  $R_g$ , the greater will be the per-

centage of total signal voltage applied to the second amplifier and the less will be the loss of signal voltage in reactance at  $C_b$ . Capacitive reactance of  $C_b$  goes up as frequency goes down, so the value of capacitance at this point has a major effect on low-frequency gain.

When examining the plate circuits of ordinary resistance coupled amplifiers you will find resistors and capacitors such as shown by Fig. 7. These units will be present also in broad band amplifiers, accompanied by peakers. The plate load is resistor  $R_o$ . In series between the load and the B-supply is resistor  $R_d$ . To prevent  $R_d$  from acting as part of the load resistance and carrying signal voltages there is a bypass capacitor  $C_d$  from the bottom of  $R_o$  to ground. The small reactance of this bypass completes the signal circuit from the lower end of  $R_o$  through ground to the cathode, or through another bypass capacitor around a cathode resistor to the tube cathode. It may be necessary to follow a circuit diagram all the way to the power supply in locating  $R_d$ , and sometimes  $C_d$ , but they will be there.

Capacitor  $C_d$  may play an important part in improving low-frequency response. Consider first the fact that reactance of this capacitor is negligible at high and medium



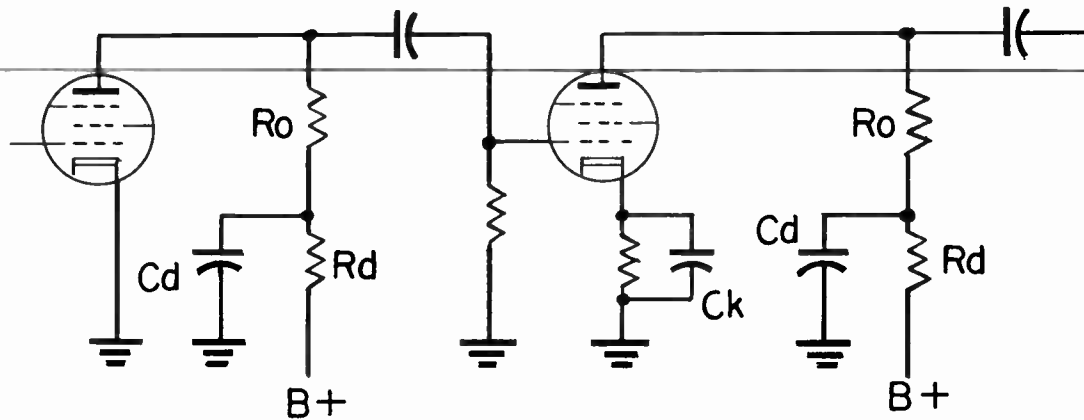

Fig. 7. Low-frequency gain is affected by bypass and blocking capacitances and by resistances used for plate loads and grid returns.

frequencies, but as signal frequencies go lower the reactance increases. The increasing reactance at Cd is in series with load resistor Ro. We assume that resistance at Rd is far greater than resistance at Ro or reactance at Cd, and thus effectively isolates the signal portion of this plate circuit from other circuits in the receiver.

Now the plate load of the amplifier becomes the sum of resistance at Ro and the rising reactance at Cd. The effect is to increase the plate load as frequency drops. As we know, increasing the plate load increases the gain. The less the resistance at Ro and the greater the reactance (smaller the capacitance) at Cd, the greater will be the rate at which load impedance increases with drop of frequency.

Wide band amplifiers may suffer from "phase shift". The term phase shift, used in this connection, refers to differences between times required for signals at different frequencies to get through an amplifier. Video or picture signals of one frequency may take more time or less time to go from input to output of an amplifier than signals at other frequencies.

This is not so strange as it might seem, for phase shift results from differences in time constants of capacitance-resistance and inductance-resistance combinations in the amplifier circuits. The capacitive and inductive reactances change with frequency; so do the time constants, and there are different delays for different frequencies.

Phase shift is not too important in sound reproduction. But because television picture lines and details are reproduced by variations of video frequencies, getting the frequencies for various parts of the picture out of time with one another may cause poor reproduction. Excessive phase shift is prevented in large measure by suitable choice of resistance at Ro and capacitance at Cd of Fig. 7, and by making the time constants of these combinations equal approximately to time constants of blocking capacitors and grid resistors in the same interstage coupling.

### HIGH FREQUENCY COMPENSATION.

So far we have been talking chiefly about low-frequency compensation, about maintaining good gain in the amplifier as frequency drops. Means for improving low-frequency gain are much the same for narrow band and broad band amplifiers. No peakers have been called for in low-frequency compensation, but they will be needed when compensating for medium and high video frequencies, which we may consider as ranging from less than one megacycle to about four megacycles per second.

Let's look first at what really happens, electrically, in the resistance coupled amplifier when signal frequencies go up into the megacycle ranges. At the left in Fig. 8 is shown how the amplifier looks to signals of low frequencies, and at the right how it looks to signals of high frequencies.

At high frequencies the reactances of capacitors Cd, Cb, and Ck become so small



## LESSON 43 – THE VIDEO AMPLIFIER

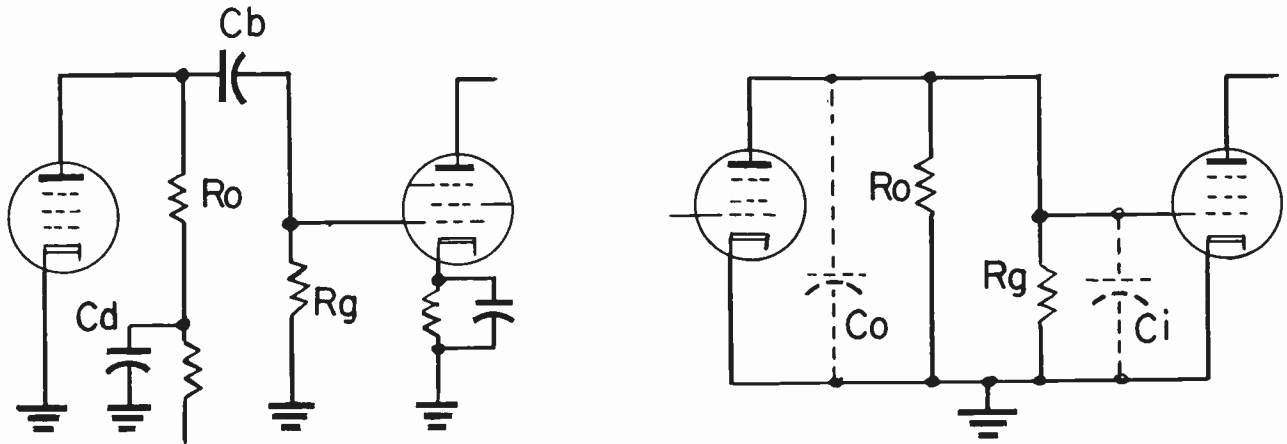

Fig. 8. The elements used in a resistance coupling (left) and how this coupling looks to signals of high video frequencies (right).

that these units are equivalent to short circuits or conductors. For example, at a frequency of one megacycle the reactance of 10 mf at Cd or Ck is about 16/1000 of one ohm, and the reactance of 0.10 mf at Cb is no more than 1.6 ohm. This means that the lower ends of load resistors Ro are effectively grounded for signals, and thereby connected directly or through negligible reactance of a bypass at Ck to the tube cathodes. Because of the very small reactance at Cb the plate of the first amplifier is effectively connected directly to the grid of the second amplifier. Since all grounds are conductively connected together we may show them as a continuous conductor along the bottom of the right-hand diagram.

The real difficulties in maintaining gain at high frequencies arise at Co and Ci in this right-hand diagram. The capacitor symbol at Co represents the output capacitance of the first amplifier and stray capacitances on this side of the circuit. The symbol at Ci represents the input capacitance of the second amplifier tube and stray capacitances on this side of the circuit.

Now you must keep in mind that the diagram at the right in Fig. 8 shows merely how the interstage coupling circuit appears to high-frequency signals. We are not here concerned with any d-c effects, such as furnishing a positive d-c voltage to the plate of the first amplifier, and a negative d-c biasing voltage to the grid of the second amplifier, and a positive d-c voltage to screens. All these d-c voltages and their currents

would be present in the actual circuits, but we are neglecting them in order to bring out more clearly the features which affect only high-frequency signal voltages and currents.

Let's see what has happened to the plate load and, consequently, to the gain of the first amplifier tube. In the load circuit between plate and cathode of this tube we now have resistances Ro and Rg and capacitances Co and Ci. These four elements are in parallel with one another. Therefore, according to the rules for all parallel circuits, the total or parallel impedance of the entire load circuit never can be greater than the least of the paralleled resistances or reactances.

In order to deal with capacitances and resistances such as actually found in video amplifiers we shall assume that the sum of tube output capacitance on one side and tube input capacitance on the other side of the circuit is 14 mmf. This is the average of the sums of these capacitances for tubes commonly used as video amplifiers.

To lessen the stray capacitance as much as possible we shall assume the use of low-loss sockets, short leads, careful layout, and insulation having small dielectric constant. Even then the stray capacitance hardly can be less than 8 mmf, so we shall assume this value. The total of tube capacitances and stray capacitances will be 22 mmf. The change of capacitive reactance in 22 mmf at frequencies between 0.1 mc (100,000 cycles) and 4.0 mc is shown by Fig. 9. The reactance drops very rapidly through the lower fre-

# COYNE - television home training

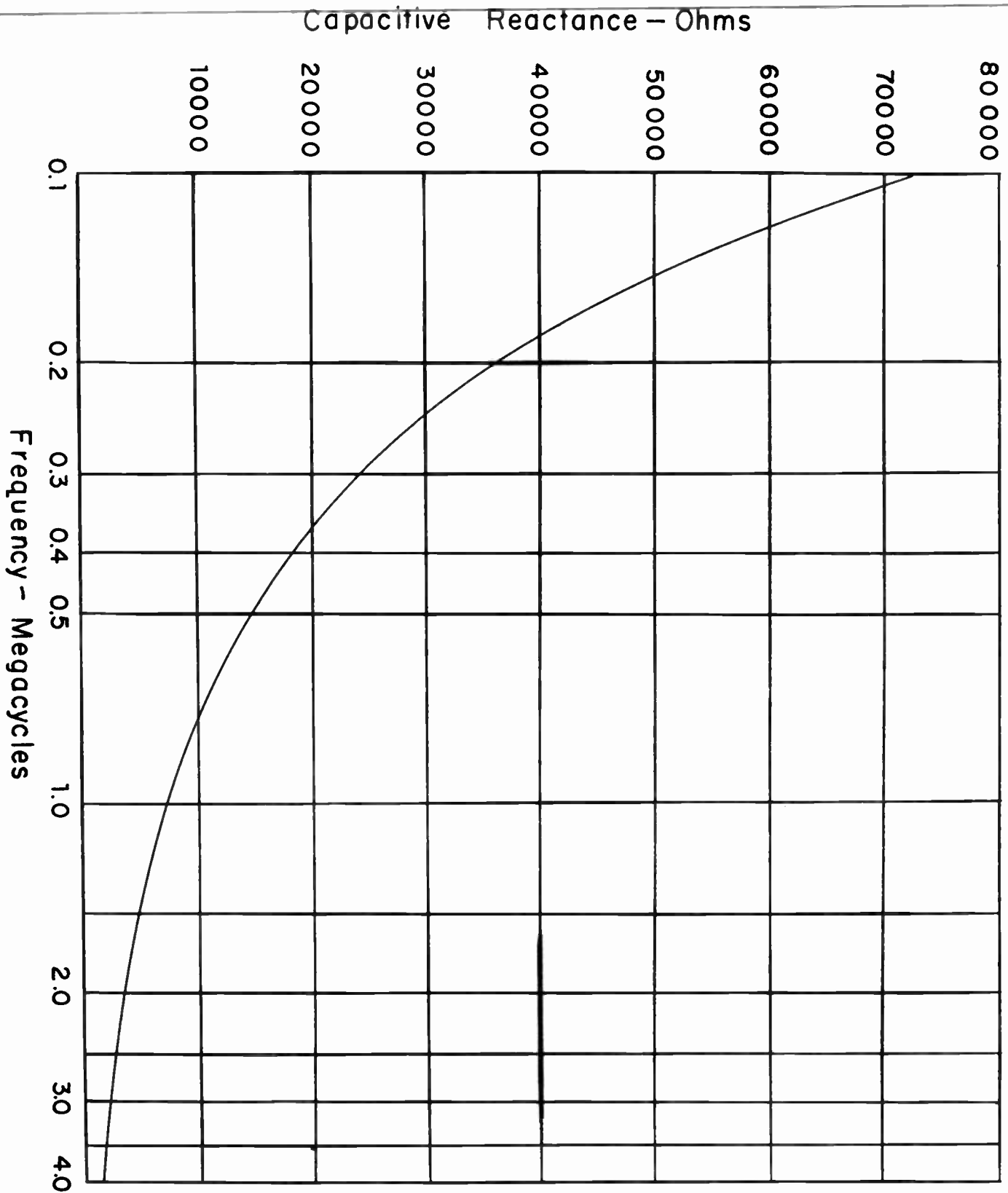

Fig. 9. Capacitive reactance of 22 mmf. at medium and high video frequencies.

# LESSON 43 – THE VIDEO AMPLIFIER

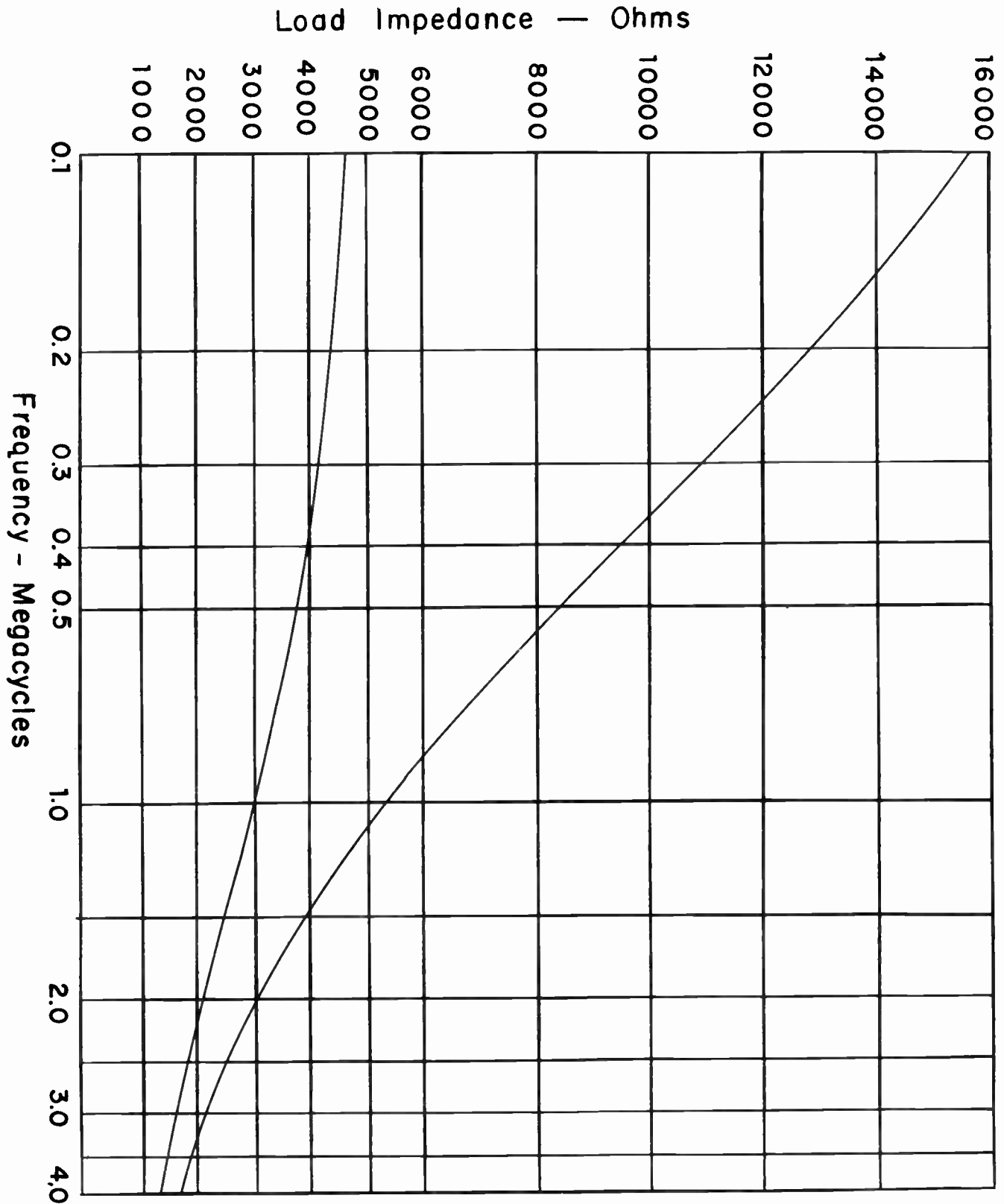

Fig. 10. The upper curve shows plate load impedance for 22 mmf. and 5,000 ohms resistance. The lower curve shows impedance when load resistance is changed to 5,000 ohms.

# COYNE - *television home training*

quencies, then at a lesser rate at the higher frequencies.

One of the paralleled elements is the grid resistor, which may be of 10,000 ohms to 1 megohm. In any case, this resistance will be large in comparison with the small capacitive reactance at highest frequencies. It follows that the actual value of the grid resistor will have little effect on total parallel impedance, and it may be large or small, as required for grid biasing.

Now we may compute the parallel impedance, throughout our selected frequency range, of the 22 mmf capacitive reactance with two different load resistances. The parallel impedance, with 20,000 ohms of load resistance, will vary as shown by the upper curve of Fig. 10. With only 5,000 ohms of load resistance the impedance will vary along the lower curve. These two curves show effective load impedance at frequencies from 0.1 mc to 4.0 mc.

With the greater load resistance there is high impedance and proportionately high gain at the lower frequencies, but gain is not much better than with 5,000 ohms resistance when we come to the highest video frequencies. The gain is far from uniform throughout the range of frequencies, and it is uniform or reasonably uniform gain that we must have in a video amplifier.

With the smaller load resistance the gain at the lower frequencies is little more than one fourth of that for the larger load resistance. But at the highest frequency the gain with the smaller load resistance is slightly more than 80 per cent of that with the higher resistance. We have reasonably uniform gain. This has been accomplished merely by using less load resistance, and sacrificing gain at lower frequencies. Now you know why such small load resistances are used in video amplifiers.

**SERIES COMPENSATION.** Now we shall further improve the high-frequency response by using an inductor to "split the capacitances". This has been done in Fig. 11, which again is a circuit diagram showing paths for signal voltages and currents at high frequencies, while neglecting low-frequency performance and d-c voltages and currents.

The inductor or peaker is in series between the plate of the first tube and the grid of the second tube. It may be called a series peaker, and its effects are referred to as series compensation. The inductive reactance of this peaker increases directly with frequency. Inductances of series peakers usually are between 100 and 250 microhenrys. Their inductive reactances will increase 40 times between frequencies of 0.1 and 4.0 mc, possibly from something like 125 ohms to 5,000 ohms.

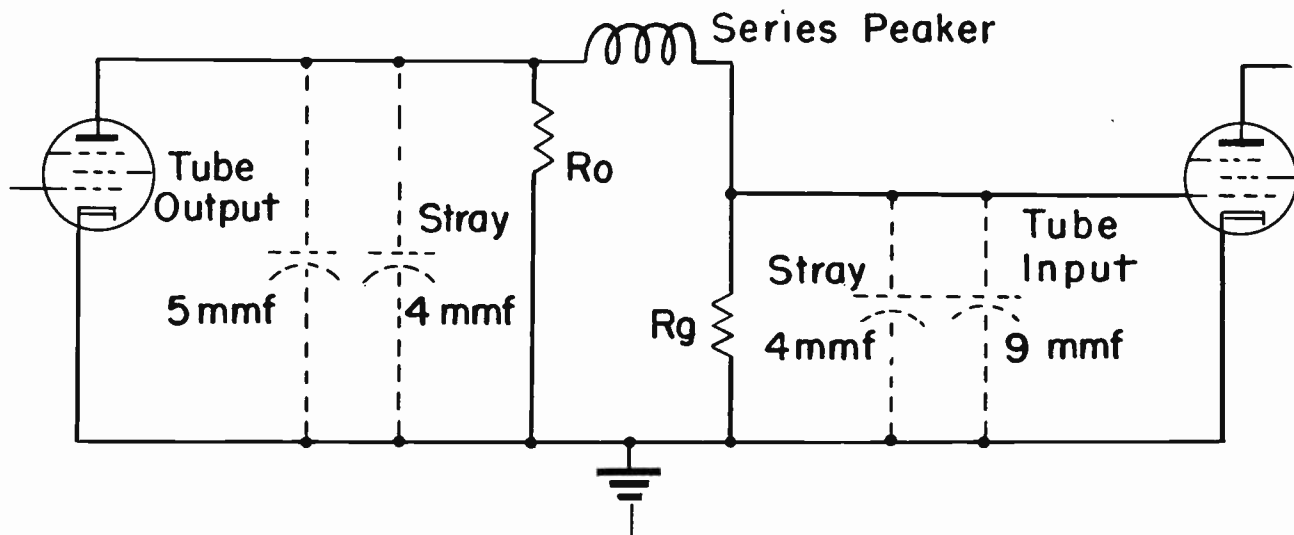

Fig. 11. Inductive reactance of the series peaker effectively "splits" the capacitances at high video frequencies.



## LESSON 43 – THE VIDEO AMPLIFIER

This inductive reactance is interposed between the plate circuit of the first tube and the grid circuit of the second tube, separating the capacitances about as shown by Fig. 11. The 8 mmf of stray capacitance which we have assumed may be split equally, with 4 mmf on each side. The average output capacitance of tubes commonly used as video amplifiers is 5 mmf. Thus we have in parallel with plate load resistor  $R_o$  a total of only 9 mmf capacitance, whereas without the series peaker there was paralleled capacitance of 22 mmf.

This reduced capacitance across the plate load allows doing either of two things. First, we may use a greater load resistance to increase the gain. Second, we may keep the same load resistance, which will result in extension of the uniform gain much farther toward the higher video frequencies. Incidentally, the series peaker lessens the degree of phase shift at the various video frequencies.

Let's look now at what is happening on the other side of the series peaker, on the side toward the grid of the second tube. In Fig. 12 the plate circuit of the first tube has been simplified by considering the load resistor, tube output capacitance, and stray capacitances as forming a load impedance represented by the box. Input capacitance of the second tube and stray capacitances on

this side of the circuit are in parallel, they add together, and are represented at  $C_i$ .

Inductance  $L$  of the series peaker is in series with capacitance  $C_i$  and these two will be series resonant at some frequency determined by the inductance and capacitance. Looking back at Fig. 11 we find that the stray capacitance and tube input capacitance which have been assumed in our examples make up a total capacitance of 13 mmf at  $C_i$  in Fig. 12.

Supposing that we use inductance of 120 microhenrys in the series peaker. The resonant frequency of 120 microhenrys and 13 mmf is about 3.95 mc, or practically 4 mc. Then  $L$  and  $C_i$  will peak at about 4 mc, which is the high end of our video range. At this frequency there will be minimum impedance and maximum signal current in  $L$  and  $C_i$ , and maximum signal voltage appearing across  $C_i$ , will be applied between grid and cathode of the second tube - at the high end of the frequency range. The high resistance of grid resistor  $R_g$  is across capacitance  $C_i$ , but this resistance will merely broaden the resonant peak without affecting the peak frequency.

In actual practice the inductance of the series peaker would be chosen for series resonance and peaking of the video response at whatever frequency the set designer believed to be most desirable. This inductance would depend on the input capacitance of the second tube, which might be a picture tube.

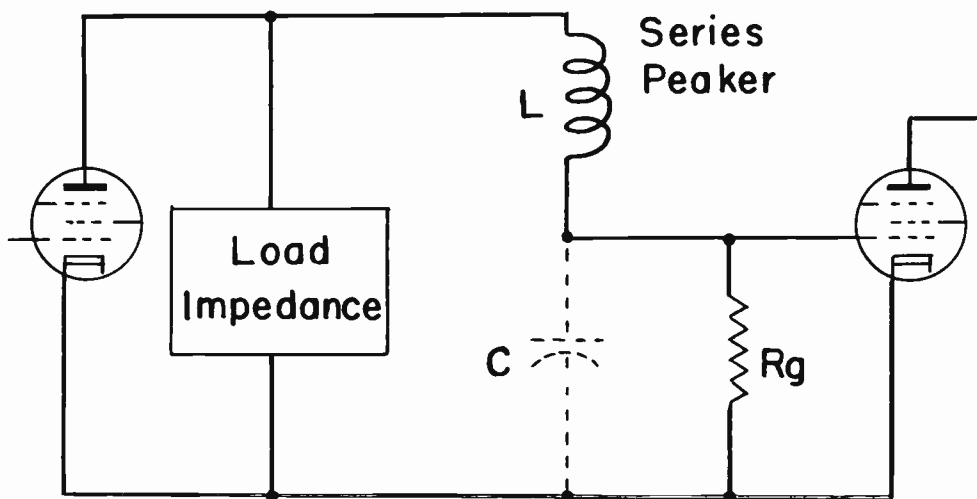

Fig. 12. When a series peaker follows the plate load, this peaker may resonate with capacitances on the grid side of the coupling circuit.

## COYNE - *television home training*

and on the stray capacitances in the circuits as actually constructed for each model of receiver. It is for this reason that you will find series peaker inductances all the way from something like 50 microhenrys up to possibly 250 microhenrys or more in various receivers. Obviously, these series peakers are not interchangeable and have not been selected at random. Do not alter the peaker inductances unless you have instructions for such alteration on a particular receiver, or have the instruments and experience which allow making suitable changes.

What we have accomplished by splitting the capacitances with the series peaker is shown in the upper part of Fig. 13. The broken-line curve, sloping gradually downward toward the higher frequencies, is the same as the bottom curve of Fig. 10, with frequencies extended to a high limit of 7 mc. This curve shows the effective load impedance for the video amplifier without the series peaker, it is the impedance resulting from the parallel combination of load resistance and of output and input capacitances of the two tubes together with stray capacitances.

When the tube and stray capacitances are divided, the smaller capacitances have greater capacitive reactances at all frequencies. These greater reactances, in parallel with the same load resistance of 5,000 ohms, have impedance at various frequencies as shown by the full-line curve in the upper part of Fig. 13. At the lowest frequency on this graph, 0.4 mc, the new impedance curve is only a little more than 10 per cent higher than the one which does not include the peaker effect.

At higher and higher frequencies the additional impedance due to splitting the capacitances becomes steadily greater. At 2 mc there is an improvement of about 50 per cent, and at 5 mc the impedance with the series peaker in use is nearly twice as great as without the peaker. As you know, the amplification or gain is very nearly proportional to load impedance, and so it appears that the series peaker has brought about a great improvement of gain at the high video frequencies.

The curve in the lower part of Fig. 13 illustrates the effect of choosing the series peaker inductance for resonance with tube and stray capacitance at a frequency of about 3 mc. The tendency now is to have maximum signal transfer to the grid of the second tube at this frequency. Because load impedance still falls off at higher frequencies, as shown in the upper part of the graph, the gain tends to decrease at the higher frequencies. But resonance of the peaker and circuit capacitances makes the gain at 3 mc slightly greater than around 1 mc, and very nearly as great as at still lower frequencies.

Above 3 mc the gain falls rather rapidly in spite of the peaking effect, but still is amply high at 4 mc, which is the highest video frequency that we expect to be useful in picture reproduction. How well the gain is maintained and the peak frequency on the gain curve depend on the frequency at which the peaker and circuit capacitances are resonant.

When you examine service diagrams for video amplifiers, such as the one of Fig. 14, the series peakers on the outputs of detectors and amplifiers usually are connected in parallel with resistors. This is the construction in which the inductor winding is around the outside of the resistor. The purpose of the paralleled resistor is to broaden the resonance peak. The duolateral or honeycomb winding, by itself, is of rather high-Q type and would tend to cause a sharp peak rather than the broad one illustrated at the bottom of Fig. 13.

The broadening resistor usually is of some value between 20,000 and 50,000 ohms, while resistance of the peaker winding seldom is more than 10 or 15 ohms. Practically all of the plate current flows in the winding, and because of the small resistance of the winding there is very little voltage drop. Should the winding become open circuited for any reason, whatever, the remaining high resistance of the broadening resistor will decrease the plate current and thus drop the gain.

With an open peaker winding the shunt resistor may carry enough plate current for pictures to continue when the contrast control is advanced nearly all the way, but everything

# LESSON 43 – THE VIDEO AMPLIFIER

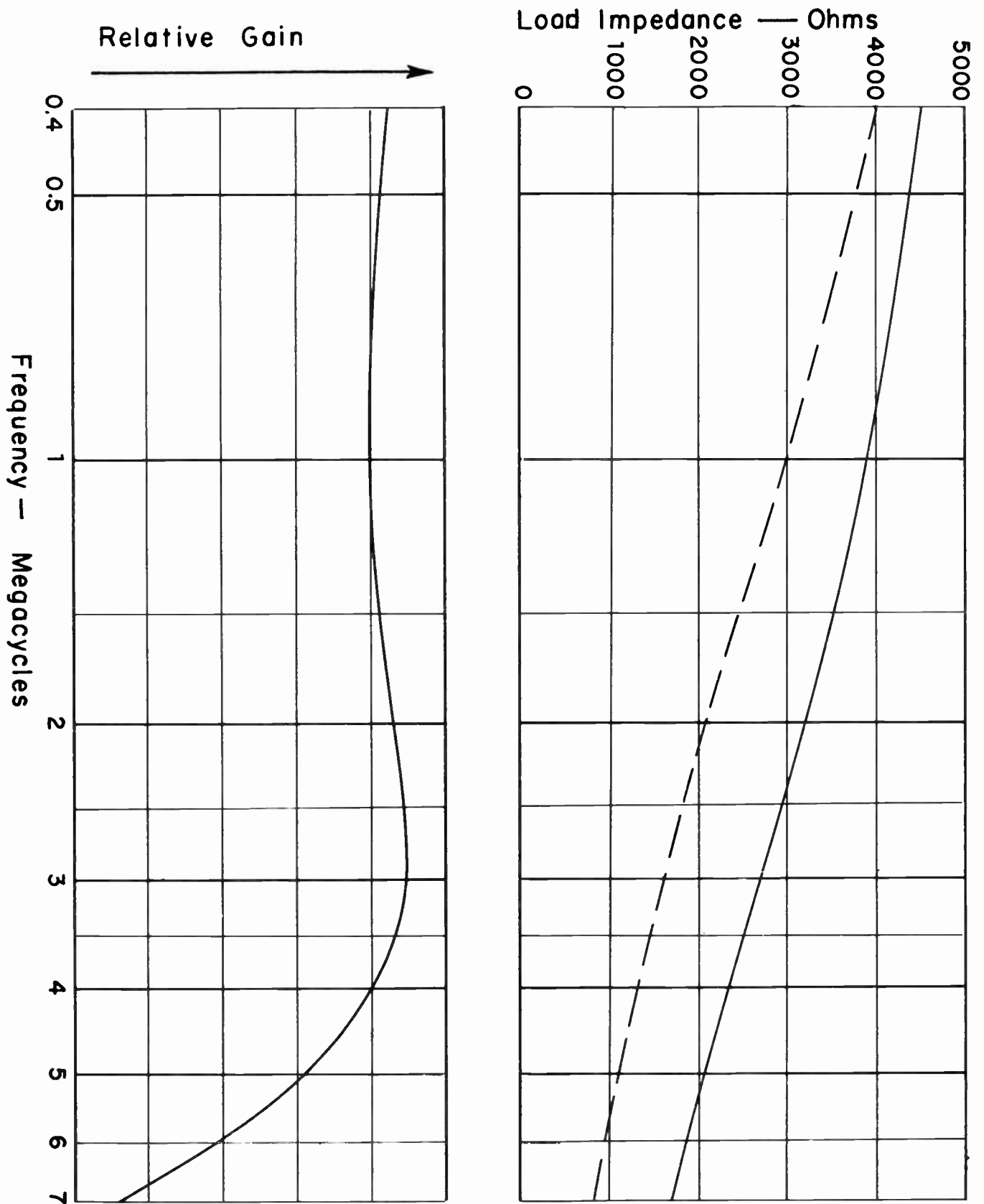

Fig. 13. Splitting the capacitances increases the plate load impedance (upper graph) while resonating the peaker improves the gain at highest video frequencies (lower graph).

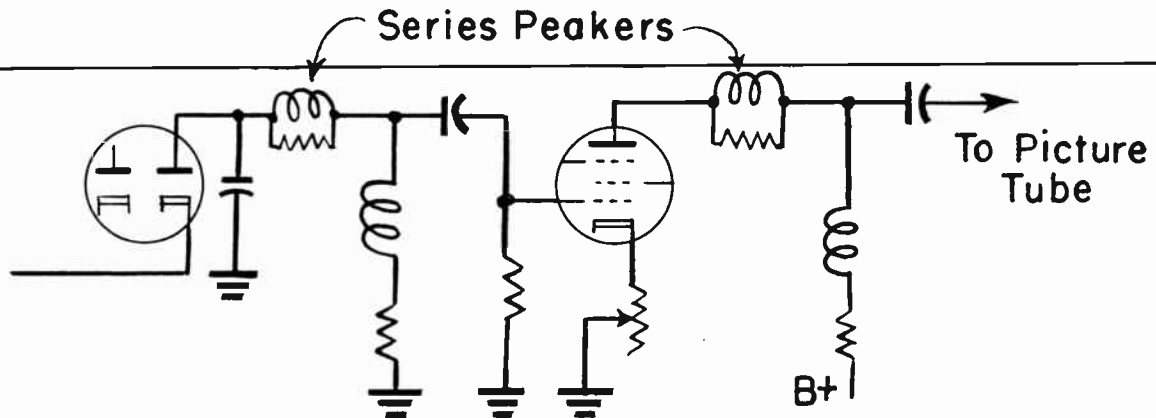

Fig. 14. Typical connections between a video detector and input to a picture tube.

will have a washed out appearance. Shunt resistors on which peaker windings are mounted usually are of one-watt size. Such a resistor will overheat, will melt or burn the wax with which the winding is impregnated, and ordinarily there will be some smoke.

It is highly improbable that a shunt resistor on a peaker will cause trouble so long as the paralleled low-resistance winding remains continuous and connected, because then the resistor carries negligible current. An open resistor would be practically impossible to locate with ordinary tests, and lack of broadening resistance probably would not affect picture quality to an extent noticeable to the average viewer.

**SHUNT COMPENSATION.** In nearly all video amplifier sections you will find, in addition to the peakers which are between the plate of one tube and the grid of a following tube, other peakers connected directly in series with plate load resistors as in Fig. 14. These other units are called shunt peakers because they are in shunt or parallel with the tube and stray capacitances which cause reduced gain at high video frequencies.

In the simplified circuit at A of Fig. 15 there is a shunt peaker Lo in series with load resistor Ro. The series peaker, up above, is separating the tube output capacitance and part of the stray capacitance, represented by Ca, from tube input capacitance and remaining stray capacitance represented at Cb. This leaves Lo and Ro shunted by capacitance Ca. Inductance Lo and capacitance Ca will be parallel resonant at a frequency determined

by values of inductance and capacitance. The inductance at Lo most often is something between 100 and 200 microhenrys. The only effect of load resistance Ro is to broaden the resonant peak, it does not affect the frequency of resonance.

The parallel resonant circuit that includes Lo and Ca now becomes the plate load for the first tube. As compared with a non-resonant load, such as resistance Ro by itself, the impedance of this parallel resonant load will be decidedly increased at the peak frequency, also at frequencies extending somewhat below and above the peak value. The greater load impedance will increase the gain, to cause a response about as shown at B.

In diagram C of Fig. 15 the shunt peaker Lo and load resistor Ro are connected after the series peaker. The series peaker still splits the capacitances and provides the improvement of high-frequency gain illustrated by the upper curves of Fig. 13. Inductance of the shunt peaker Lo now resonates with capacitance at Cb, which is the input capacitance of the second tube plus stray capacitances on this side of the circuit. The effect of added gain at and near the resonant peak is again about as shown at B.

The Q-factor of the resonant circuit that includes the shunt peaker is reduced by the presence of resistance Ro in this circuit. The resistance helps prevent an excessively sharp resonant peak and helps in maintaining more uniform response at the various video frequencies. Because of the load resistance



## LESSON 43 – THE VIDEO AMPLIFIER

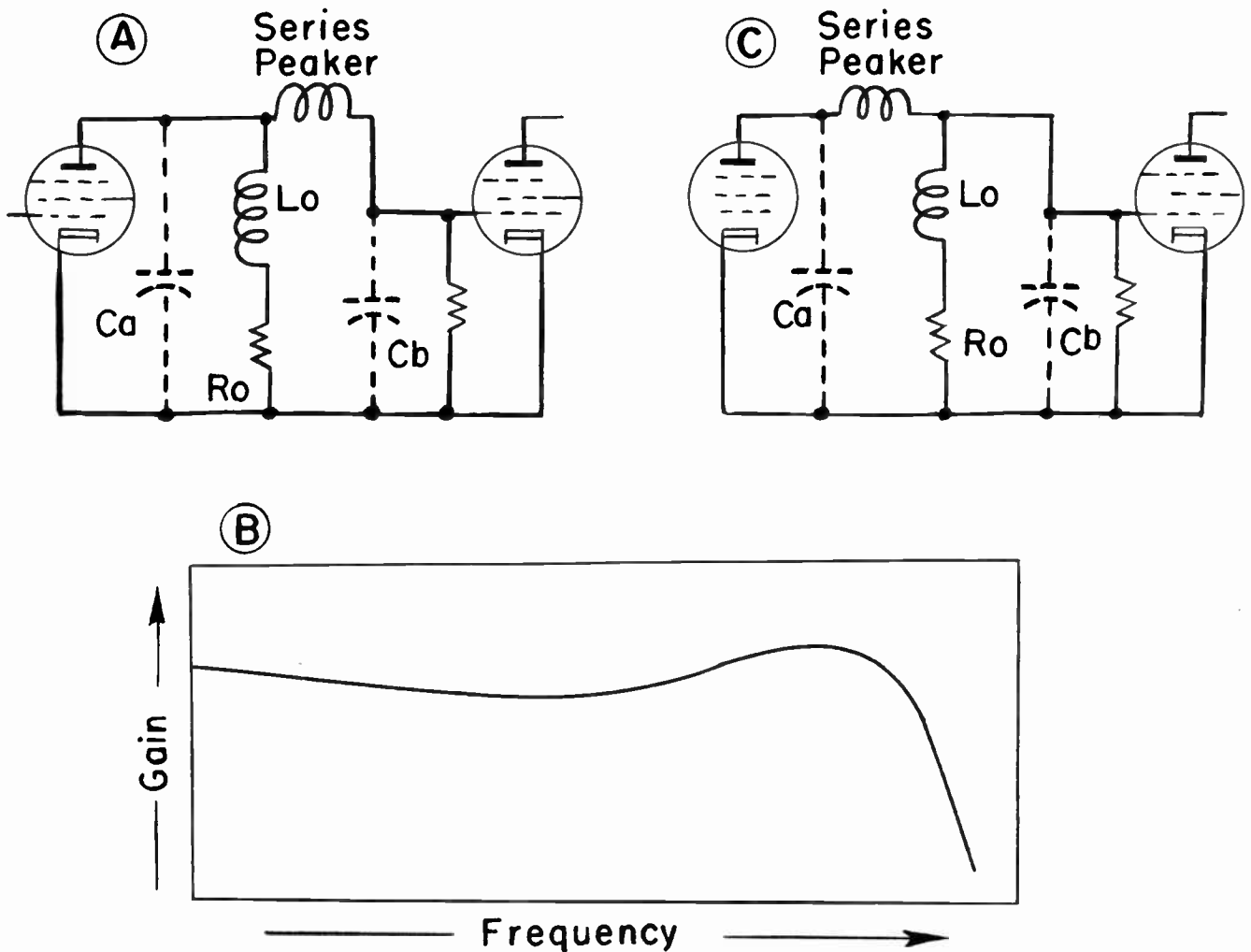

Fig. 15. Relative positions of shunt and series peakers, and how shunt peaking affects the gain curve.

being part of the resonant circuit it seldom is necessary to connect an additional broadening resistor across peaker winding  $L_o$ .

In a few cases you may find the shunt peaker winding mounted on a fixed resistor of some high value, such as one megohm, and connected across the resistor. Resistance so great as this has no appreciable effect on broadness of resonance, and usually it is there only because fixed resistors are more readily available than insulating forms fitted with pigtailed.

Shunt peaking used alone tends to give response peaks somewhat less broad than those obtained with series peaking alone. It is general practice to use both series and shunt peaking in the same amplifier coupling circuit. The connection at C of Fig. 15 is

more common than the one at A, although you may find either of them, or sometimes the two kinds in different stages of the same video amplifier section.

Series and shunt peakers are used in the couplings between detectors and video amplifiers in the same way as in couplings between two video amplifiers or between a final video amplifier and the picture tube.

In diagram 1 of Fig. 16 there is a series peaker  $L_s$  between detector output and amplifier grid, with a broadening resistor across the peaking inductance. The shunt detector  $L_o$ , in series with detector load resistor  $R_o$ , follow the series peaker and thus are placed in parallel with tube input capacitance and stray capacitances on the amplifier side of the coupling.

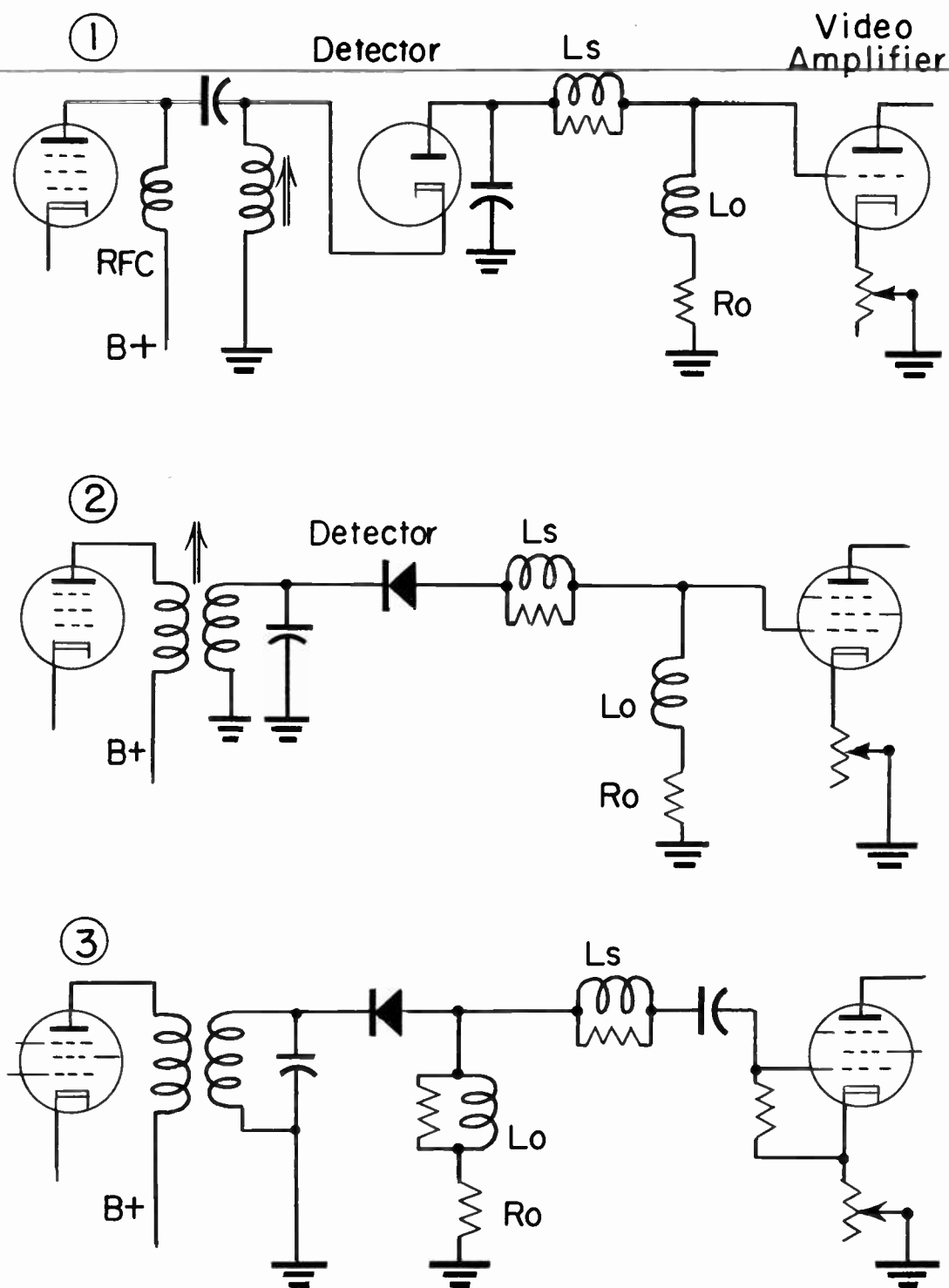

Fig. 16. Shunt and series peakers in couplings between video detectors and amplifiers.

Diagram 2 shows exactly the same arrangement of series and shunt peakers, but here the detector is a crystal diode instead of the tube diode. The type of detector, and the kind of coupling from the final i-f amplifier to detector, have no direct bearing on

arrangement of the peakers between detector and video amplifier.

Diagram 3 of Fig. 16 shows the shunt peaker  $L_o$  connected on the detector side of the series peaker  $L_s$ . Inductance of the shunt

## LESSON 43 – THE VIDEO AMPLIFIER

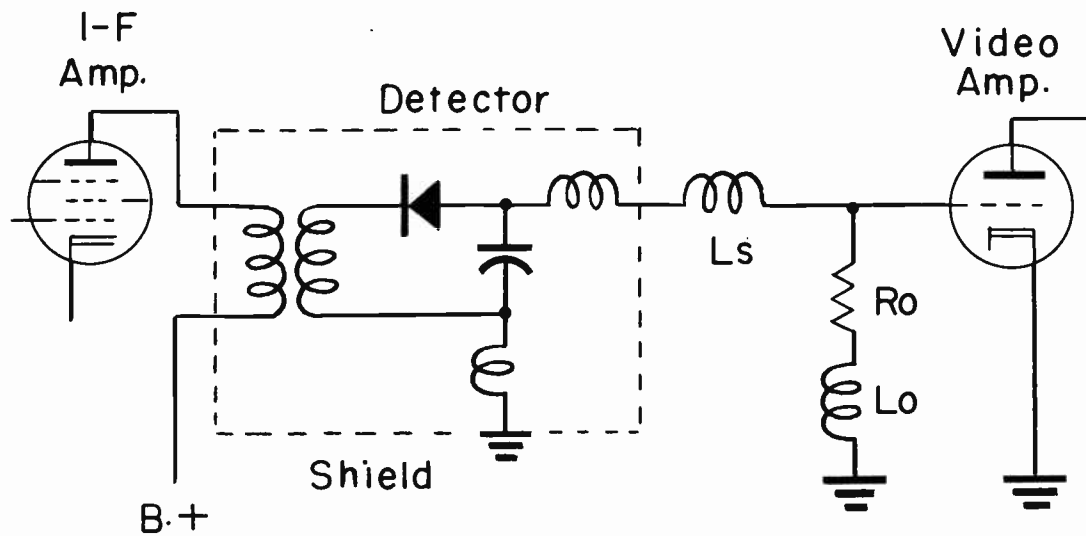

Fig. 17. A shielded crystal diode detector with isolating inductors inside the shield.

peaker now will resonate with capacitances on the output side of the detector.

Crystal diode video detectors often are mounted within a shield of their own, or may be inside the shield that encloses the coupling transformer or impedance between the last i-f amplifier and the detector. A diagram of this latter arrangement is shown by Fig. 17. A series peaker  $L_s$  and a shunt peaker  $L_o$  are in their usual positions outside the shield can. Inside the shield is another inductor in series with the series peaker. The two inductances add their effects so far as peaking is concerned. Between the low side of the crystal detector circuit and ground is still another inductor. The two inductors which are inside the shield help to isolate the higher-frequency i-f currents in the detector circuit, thus adding to the isolating effect of the grounded metal shield.

**VIDEO AMPLIFIER TROUBLES.** The principal picture defects which may be due to faults in the video amplifier section include weak reproduction, poor definition, and trailers or smears. Weak reproduction, with pictures generally dim or dark, or filled with "snow" when brightness and contrast are advanced, may result from defective amplifier tubes or incorrect tube voltages. Replacing a single amplifier tube, or both tubes when there are two stages, may be all that is needed to bring back normal reproduction.

If new tubes make only slight improvement, it is in order to check the voltages at

all tube elements. As little as 100 volts at plates and screens may be entirely normal; it all depends on how the receiver is designed. If you have a vacuum tube voltmeter, measure grid bias (d-c volts) with the meter connected between grid and cathode. When the contrast control acts on a video amplifier tube, rotate the control knob while observing accompanying changes of amplifier grid bias. There might be trouble in the contrast control or its connections.

If the video amplifier is biased by any form of resistance from cathode to ground or B-minus, and in no other way at the same time, grid bias voltage may be measured with any d-c voltmeter connected between cathode and ground. Voltage across the cathode resistor is grid bias voltage. Quite a few video amplifiers are biased by the grid leak method, whereupon the bias voltage can be measured only with a VTVM.

Trouble in the video amplifier section may cause faults not ordinarily associated with this section. For example, signals for the sync section usually are taken from some point in the video amplifier section. Lack of amplification then may cause poor synchronization, with effects at the picture tube screen such as pictured by Fig. 18, or by rolling of the picture upward or downward on the screen. This may happen even when pictures are fairly good, while they can be held synced on the screen.



Fig. 18. Failure to hold picture synchronization might result from faults in a video amplifier section.

With intercarrier sound the sound signals usually are taken from the output of a first or second video amplifier. There is enough amplification in the sound section itself that audio reproduction may be satisfactory even when gain in the video amplifier is so small as to make pictures completely unsatisfactory.

When speaking of poor definition we are referring to what usually is described as "fuzzy" reproduction. Vertical lines which should be distinct and sharply defined become indistinct and blurred. This is due to insufficient amplification of the higher video frequencies. Poor definition may be due also to incorrect focusing, so the focusing control, when there is one, should be carefully adjusted before blaming the trouble on a video amplifier. Poor amplification of high video frequencies may be caused also by incorrect alignment of the i-f amplifier section. If the i-f response does not extend far enough toward the high-frequency or sound side, there cannot be sufficient amplification of the highs. Finally, incorrect adjustment of a fine tuning control may blur the pictures when everything else is normal.

Only after checking the settings of a fine tuning control and of a focusing control, and after making sure that there is best possible alignment of the i-f amplifier, should peakers in the video amplifier be suspected of causing

poor definition. Then it may be that inductance of either series or shunt peakers is too small. A peaker which is short circuited will cause the same effect, for then there is no peaking inductance. While looking at the peakers, any and all blocking capacitors between plates and grids of adjacent tubes should be checked for leakage. It takes only very slight leakage to positively bias the grid of the second tube, and make pictures exceedingly fuzzy.

Trailers were illustrated by Fig. 4, where white areas appear on the right-hand side of every fairly wide dark area. Dark trailers appear also on the right-hand side of large white areas, but usually are not so noticeable. When trailers extend for long distances horizontally, sometimes appearing to pass right on through areas of opposite shading, they may be called smears. A moderate amount of trailing seems to emphasize dark areas, especially those which are rather wide, and may seem to give pictures more "snap". But closer examination will show the trailer affect, and prove that the reproduction really is unnatural.

Trailing will result when there is too much inductance in either series or shunt peakers, for then the peakers resonate at rather low video frequencies and strengthen these frequencies at the expense of the highs.

Trailing usually results from faults other than too much peaker inductance. A plate load resistor may be too great in value, which will increase low-frequency gain while decreasing gain at high frequencies. Resistance in a grid return may be too small. A bypass capacitor to ground or B-minus from the low side of a load resistor may be open or of too small capacitance, thus increasing the effective plate load resistance by including some of the voltage dropping resistance in the load circuit. Blocking capacitors, and peakers too, may be so close to chassis metal as to greatly increase the stray capacitances to ground and thus decrease high-frequency gain so far as to leave the lows predominant.

When there are both series and shunt peakers, both affect picture reproduction in



## LESSON 43 – THE VIDEO AMPLIFIER

the same general manner. That is, too little inductance tends to cause fuzzy pictures, and too much causes trailers, whether the incorrect inductance is in a series peaker or in a shunt peaker.

Peaker inductances are not too critical as to values in microhenrys; they have to be far from the ideal values to cause serious picture defects so far as the average viewer

is concerned. When all other parts of a receiver are designed and operated for highest quality pictures, peaker inductances become important. Even so, the effects of peaker inductances are apparent only when receiving programs of excellent picture quality. With many programs based on old theatre-type movies, you could short circuit all of the peakers without any great effect on reproduced pictures.

# TELEVISION

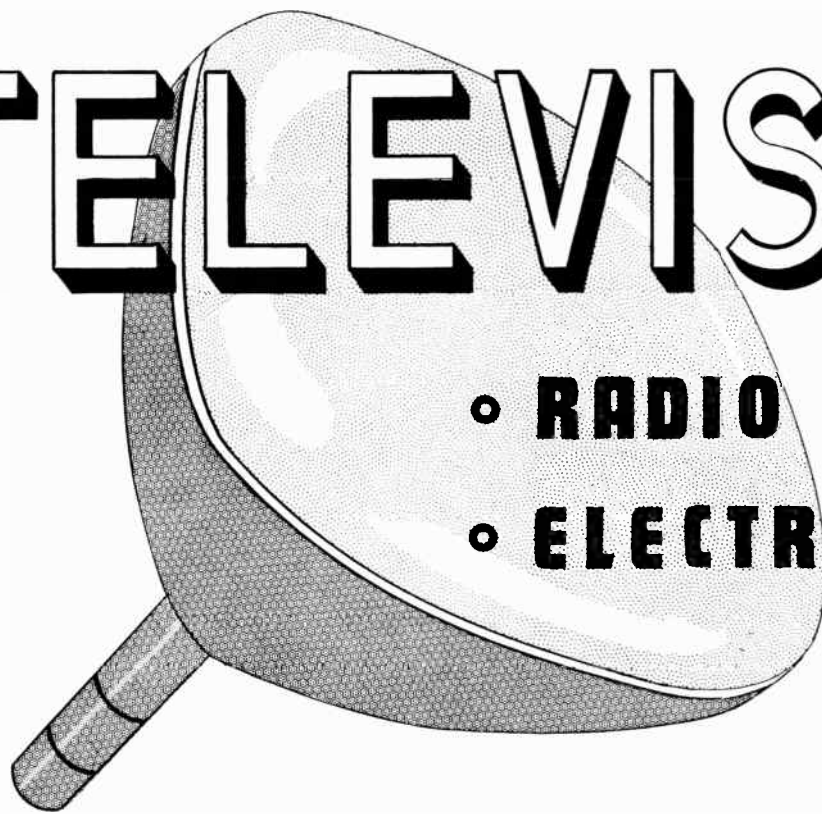

• **RADIO**

• **ELECTRONICS**

---

## LESSON 44 – D-C RESTORATION

---

***Coyne School***

*practical home training*

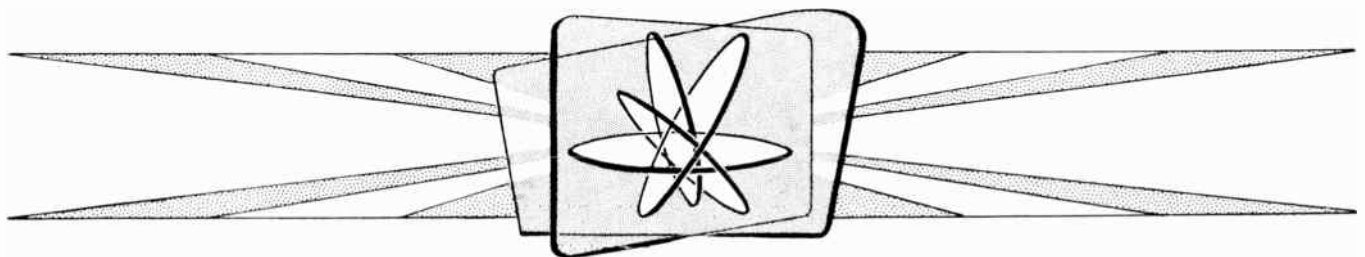

*Chicago, Illinois*

---

*Copyright, 1953 by Coyne Electrical School  
Chicago 12, Illinois  
All Rights reserved*

Litho. in U.S.A.

## Lesson 44

### D-C RESTORATION

In all television receivers of earlier designs, and in many present models, you will find a tube or section of a tube called the d-c restorer. The restorer tube may be connected into any of a great variety of circuits consisting of resistors and capacitors, but always it is somewhere along the line from the plate of the final video amplifier to the grid or cathode of the picture tube, whichever of these elements receives the video signal.

In a great many sets of recent and fairly recent design you will find no d-c restorer. In its place, between video amplifier output and picture tube input, may be a more or less intricate resistance-capacitor circuit. In other cases there is nothing more than a simple resistor completing a d-c return path from the picture tube grid to ground or B-minus.

The purpose of d-c restorers is to insure that brightness of reproduced pictures remains proportional to changes of brightness at the original scene being televised by the camera. However, were a receiver having a d-c restorer altered to make the restorer temporarily inoperative, while completing a grid return for the picture tube, the average viewer would not detect the difference. But were it possible to switch quickly from restoration to lack of it, on the same picture, the viewer undoubtedly would notice a difference in picture quality.

In spite of the fact that d-c restoration or the lack of it may seem to make little difference in performance, it is well to become familiar with methods and circuits employed. If such circuits and tubes are in a receiver, and anything goes wrong with these parts, there will be trouble. Then you must trace the circuits, and you should know how the parts are supposed to perform. To begin with, we shall look into the reasons why d-c restoration is called by this name.

At A in Fig. 1 is represented a doubly modulated video signal for a picture of

generally light tone, with picture variations near the white level. At B is a signal for a picture of generally dark tone, with most of the variations near the black level.

In the output of the video detector these signals become varying direct voltages, or direct voltages with an alternating component. The demodulated signal for the light tone picture is shown at C, and for the dark tone picture at D. The average values of direct voltage are marked by arrows. Note that in these d-c signals the sync pulse tips and also the black levels are at the same d-c voltage for both pictures. This in spite of the fact that average d-c voltage is less for bright pictures (C) than for dark pictures (D).

Supposing now that the d-c signal voltages at C and D are applied to one side of a coupling or blocking capacitor, from whose other side the signal goes to a following tube. The signal path might be from one amplifier tube to another, or from the plate of the final video amplifier to the picture tube grid or cathode.

Only the alternations of the signal would pass through the capacitor. No longer would there be a varying d-c signal, but, as in Fig. 2, there would be only the a-c signal voltages C and D. The d-c portion of the signals has been lost. As a result, sync pulse tips and black levels are not of equal amplitudes in the light and dark tone signals. To bring them back to equal amplitudes or voltages it would be necessary to restore the d-c components of the signals, or do something having equivalent effect.

Our next step is to apply the a-c signals for light and dark tone pictures to the grid of the picture tube, assuming that these signals have come through a capacitor. What happens is illustrated by Fig. 3, where the two signals, still identified as C and D, have their a-c zero values centered on the grid bias voltage. This bias has been adjusted, by operating the brightness control, to bring



# COYNE - *television home training*

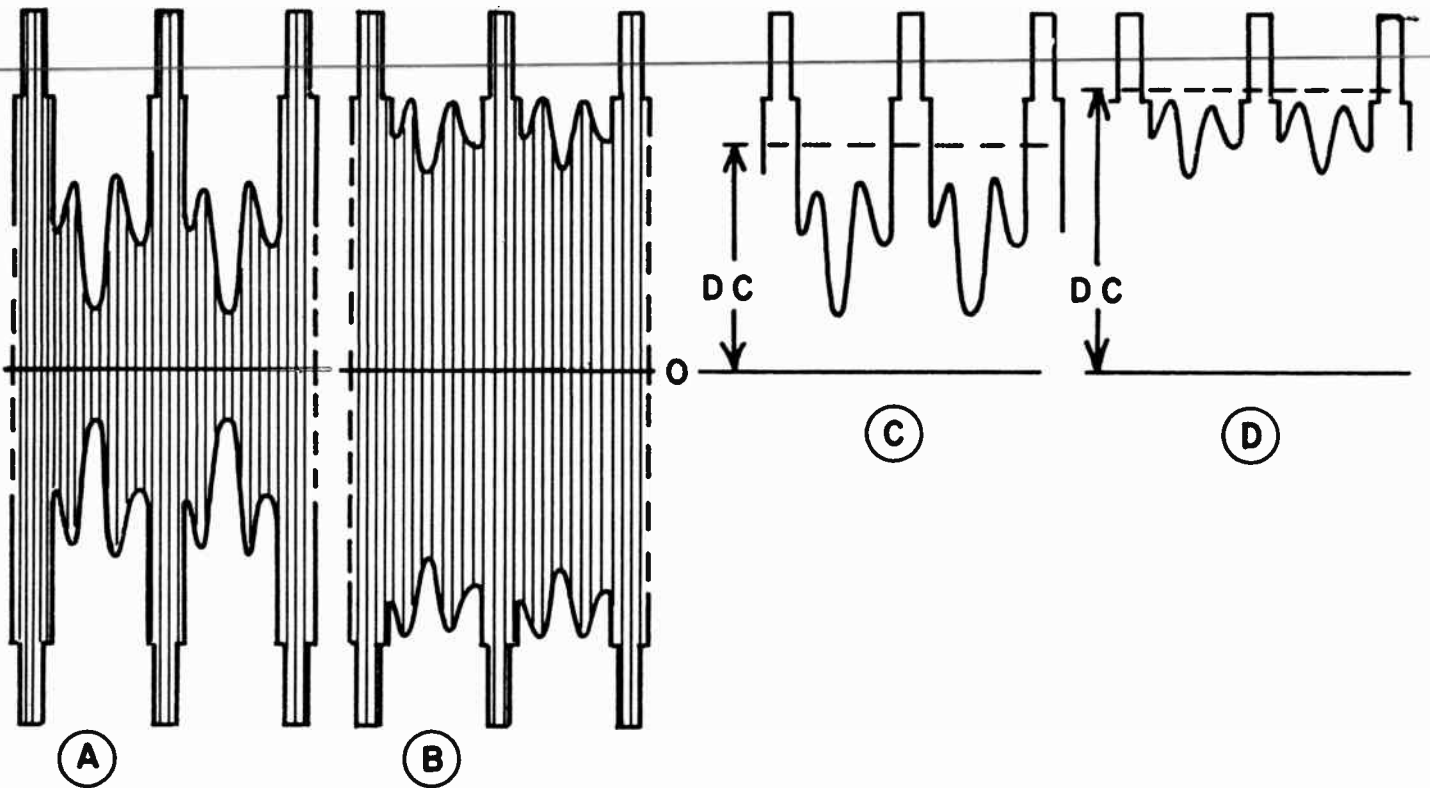

Fig. 1. Signals for pictures of light tone and of dark tone, before and after passing through the video detector.

the black level of the light-tone signal to the voltage of beam current cutoff. This light-tone signal is correctly reproduced, as at the right, with all picture variations but with no sync pulse effects on the picture tube screen.

The signal for the dark picture is not correctly reproduced, but, as shown at the right, the sync pulses are up in the picture. The black level is too high on the beam current curve, and the entire picture will be lighter than it should be. Were the brightness

control altered to make the picture tube grid bias correct for the dark-tone signal, the result would be to bring the light-tone signal too far down on the beam current curve. Then the picture would be darker than it should be, and possibly some of the darker picture variations would be cut off, making them black.

The overall result of losing the d-c portion of the demodulated signals is to make dark pictures too light and light pictures too

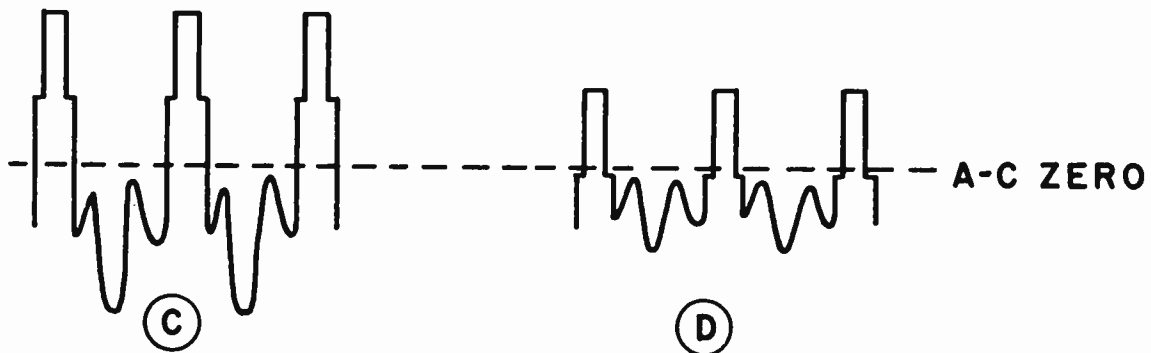

Fig. 2. When demodulated signals pass through a capacitor they become alternating currents and voltages.

# LESSON 44 – D-C RESTORATION

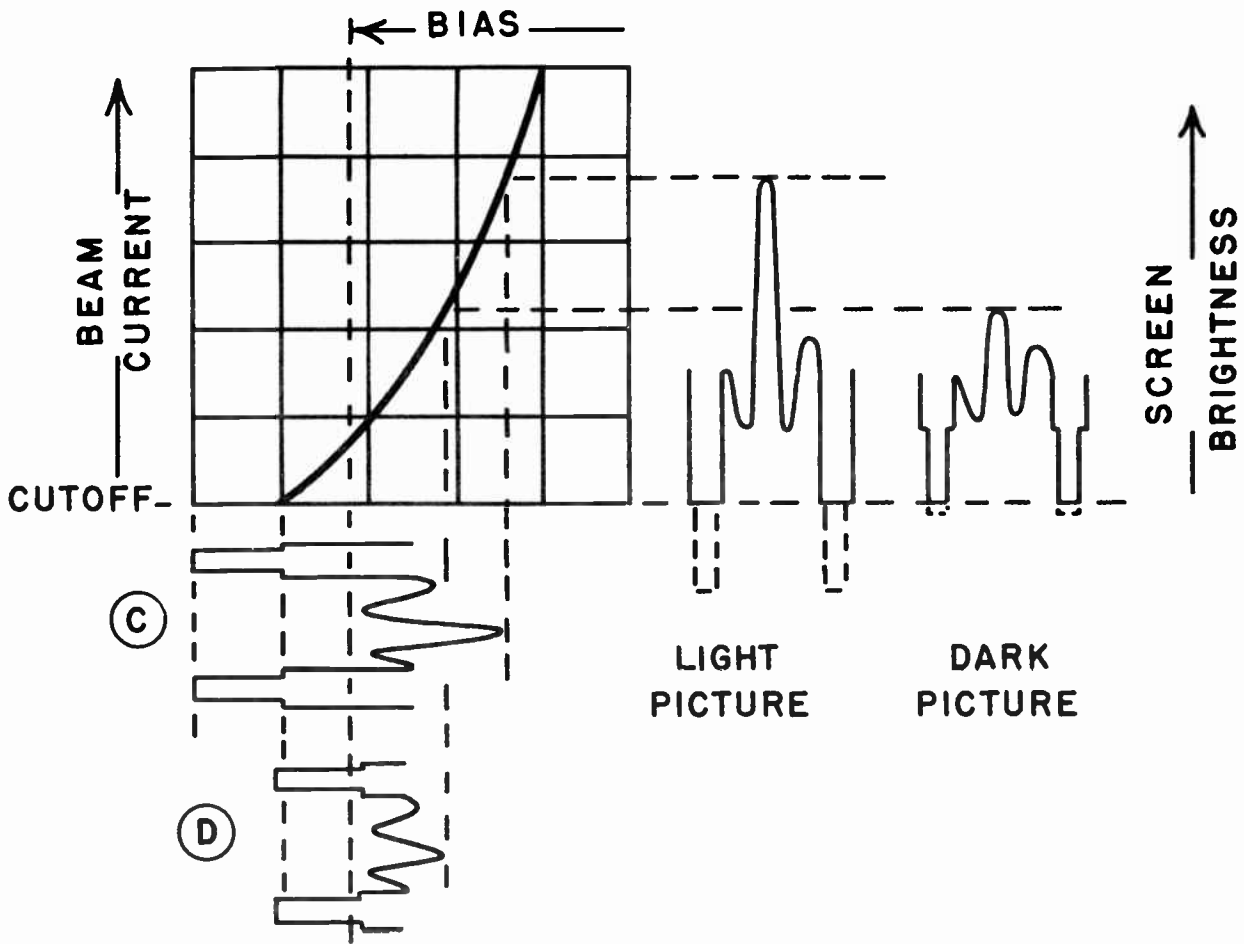

Fig. 3. If grid bias remains constant, signals for dark toned pictures will ride too high on the beam current curve.

dark. This lessens the range of gray tones and of contrasts in the reproduction. Faulty reproduction of this nature could be avoided were it possible to alter the brightness control and picture tube grid bias for every change of tone in pictures. It would, of course, be out of the question to do thus manually, because changes of tone occur too quickly and at unexpected times. But it can be done automatically by d-c restoration systems.

Now look at Fig. 4. Here we have two signals of different strengths but of approximately the same tone. In Fig. 1 the two signals were of equal strengths (tip to tip of sync pulses) but of different tones. Supposing that the signals at A and B of Fig. 4 are demodulated and passed through a capacitor to remove the d-c voltages. Remaining a-c signals will be as at C and D, with their a-c

zero values at the solid horizontal lines and their black levels at the broken lines.

When these a-c signals of unequal strengths are applied to the picture tube, results will be much the same as in Fig. 3. Because the black levels and sync pulse tips again will be at different voltages in relation to cutoff, the weaker signal will become too light in tone, or the stronger one too dark, depending on whether the brightness control is adjusted for one or the other. Both signals would be brought to nearly equal strengths by a highly effective agc system, and this particular difficulty would be avoided unless one of the signals happened to be too weak for satisfactory reproduction, even with full gain in amplifiers.

The action in d-c restoration systems is to automatically vary the picture tube grid

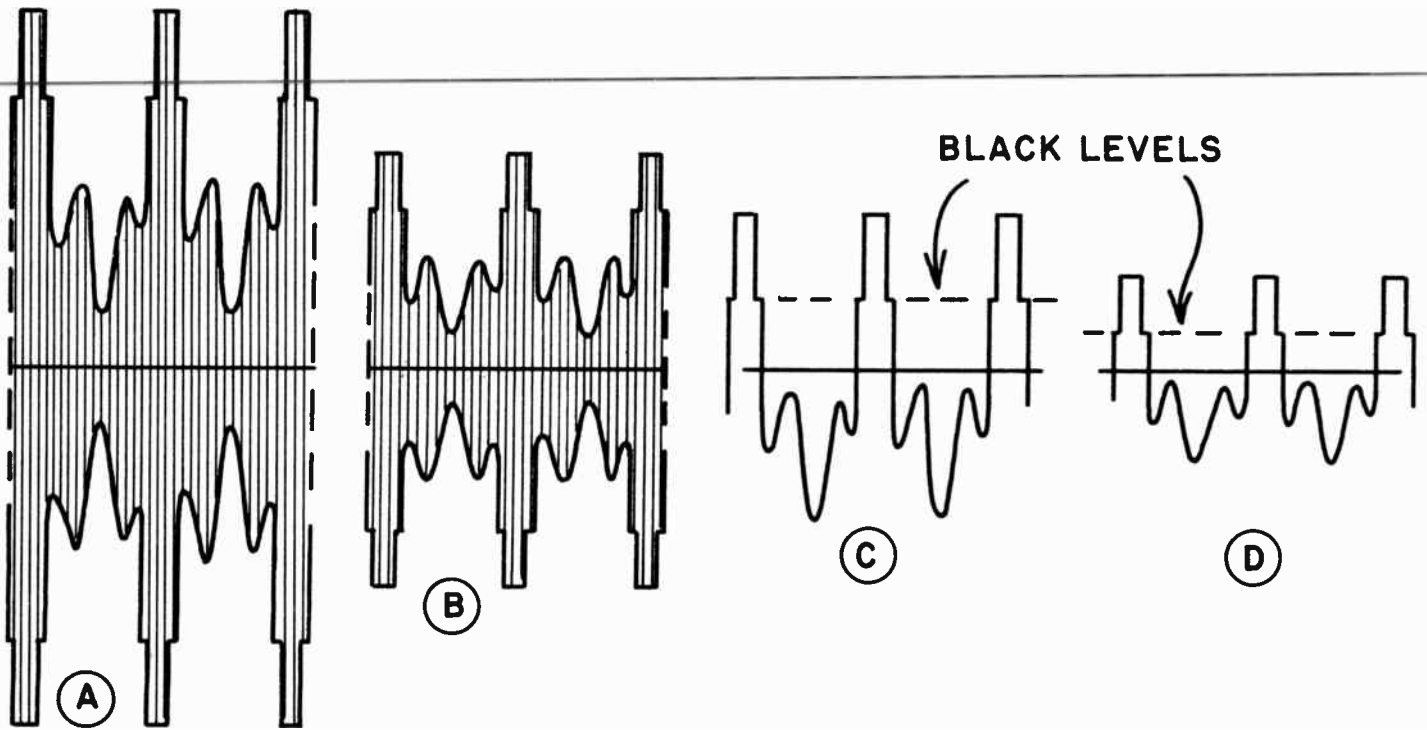

Fig. 4. Black level voltages in demodulated signals are of different values for different tones after the signals go through a capacitor.

bias to compensate for intermittent changes in tone and strength of signals. When signals are of dark tone or weak, the bias should be made more negative, thus moving the average or zero of a-c signal inputs lower on the beam current curve. For lighter tones or stronger signals the bias should be made less negative, which would move the a-c zero of input signal voltage higher on the beam current curve.

A d-c restoration system does not do away with the need for a manually adjustable brightness control. Setting of the brightness control always determines the average brightness of all pictures, and determines the average d-c grid bias for the picture tube. Action of a d-c restoration system merely varies the picture tube grid bias, intermittently one way or the other, with reference to the average bias voltage which is fixed by the brightness control.

When employing d-c restoration we do not take the d-c component of the signal at the detector output and put the same direct current or voltage into the grid or cathode circuit of the picture tube. What we actually

do is vary the d-c grid bias at the picture tube so that it has the same effect on tones of reproduced pictures as though the varying d-c signal at the detector were applied directly to the grid-cathode circuit of the picture tube.

CONDUCTIVE INTERSTAGE COUPLINGS. When d-c restoration is needed, the need arises from the fact that the video signal has been passed through one or more capacitors between the video detector and the picture tube, and at these capacitors has lost the d-c component. If interstage couplings or connections all the way from detector to picture tube can be made with no capacitors, or with conductive couplings between each tube and the one following, the d-c component of the signal will not be lost and won't have to be restored.

Fig. 5 shows one way in which this scheme of direct conductive connections may be carried out. The high side of the detector load circuit is directly connected to the grid of the first video amplifier. The plate of this first video amplifier is conductively connected through a contrast control potentiometer to the grid of the second video ampli-

# LESSON 44 – D-C RESTORATION

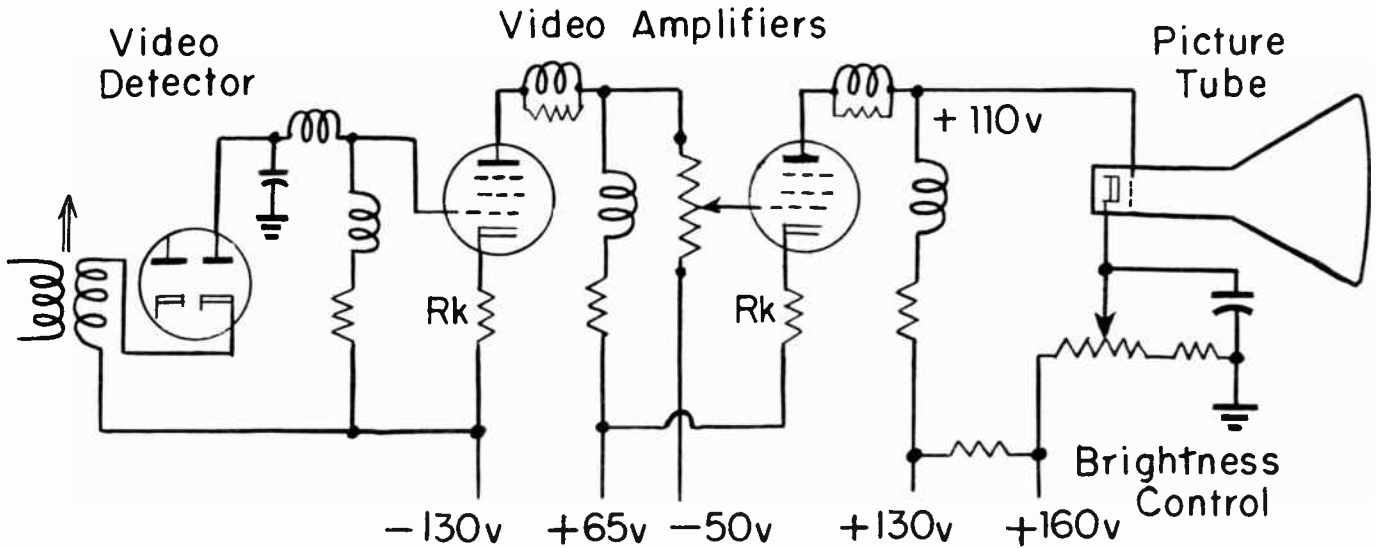

Fig. 5. Direct conductive interstage couplings in the video amplifier make d-c restoration unnecessary.

fier. The plate of the second video amplifier is conductively connected to the grid of the picture tube.

Fig. 6 illustrates the manner in which the d-c component of the signal is carried through the video amplifier section. The detector rectifies the negative side of the doubly modulated i-f signal. At the output of the detector the signal variations are negative with reference to the zero d-c voltage. The average negative voltage of signal variations is at the broken line, and is measured by the arrow extending downward or in a negative direction from the zero line. This negative signal is applied to the grid of the first video amplifier.

At the plate of the first video amplifier the signal polarity has been inverted. Signal variations now are variations of the average positive plate voltage applied to the amplifier plate from the B-supply, which is a d-c voltage. The average of the signal variations is on the broken line, and is at a positive voltage measured by the arrow extending upward from the zero voltage line. This signal is applied to the grid of the second video amplifier.

At the plate of the second video amplifier we have substantially the same relations of zero d-c plate voltage and average voltage of the signal variations as at the plate of the first amplifier. Now, of course, the polarity

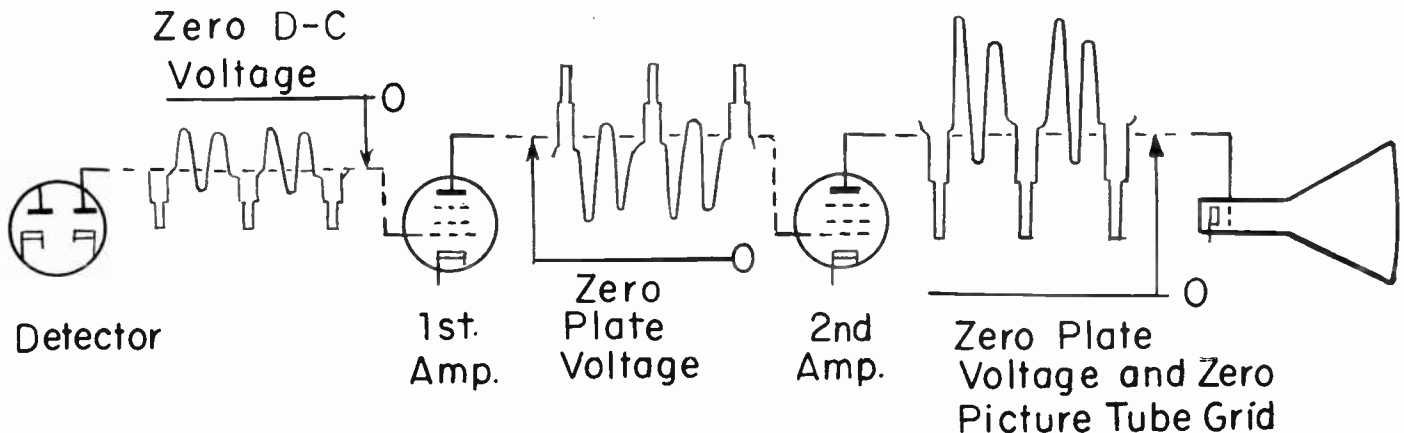

Fig. 6. Signal transfers with direct conductive couplings.



## COYNE - *television home training*

of the signal voltage changes has again been inverted, because the signal has passed from grid to plate of the second amplifier.

The signal from the plate of the second amplifier is applied to the grid of the picture tube. Since the amplifier plate is conductively connected to the picture tube grid, the relations of signal variations to the zero d-c voltage must be the same at both elements. At the grid of the picture tube we have, relatively, the same d-c component of the signal as at the detector output. Although the signal voltage at the picture tube grid actually is positive, the cathode of the picture tube is made so much more positive that the grid in this tube is negative with respect to its cathode.

This general method of retaining the d-c component of the video signal requires the application at various points of B-voltages having some such relations as those marked on the diagram of Fig. 5. The entire video detector circuit, and the grid of the first video amplifier, are at an average of 130 volts negative. This first amplifier is biased by cathode resistor  $R_k$ . The plate of the first video amplifier, the contrast control, and the grid of the second amplifier, are connected to 65 and 50 volts negative. The amplifier is cathode biased by resistor  $R_k$ . The plate circuit of the second video amplifier and the grid of the picture tube are connected to 130 volts positive, with 110 volts positive re-

maining at these two elements. The brightness control is connected to 160 volts positive, which makes the picture tube grid less positive, and relatively negative to the cathode.

In both amplifier tubes the plates are less negative or more positive than the cathodes, which amounts to the same thing. The amplifier grids are made negative with reference to the cathodes by using cathode bias resistors. A generally similar method may be used when signal input at the picture tube is at the cathode instead of the grid. B-voltages applied to the various circuits and tube elements must be of such relative negative and positive values as to provide correct relations between potentials on plates, cathodes, and grids.

Fig. 7 shows how the need for d-c restoration may be avoided while operating the video amplifier with a high plate voltage. There is direct or conductive coupling from the video detector load to the grid of the video amplifier, with the detector circuit completed through ground, and the cathode of the video amplifier to ground through a biasing resistor. There is no loss of the d-c component of the video signal in these connections.

The plate of the video amplifier is connected to the picture tube cathode through capacitor  $C_c$ , which freely passes the al-

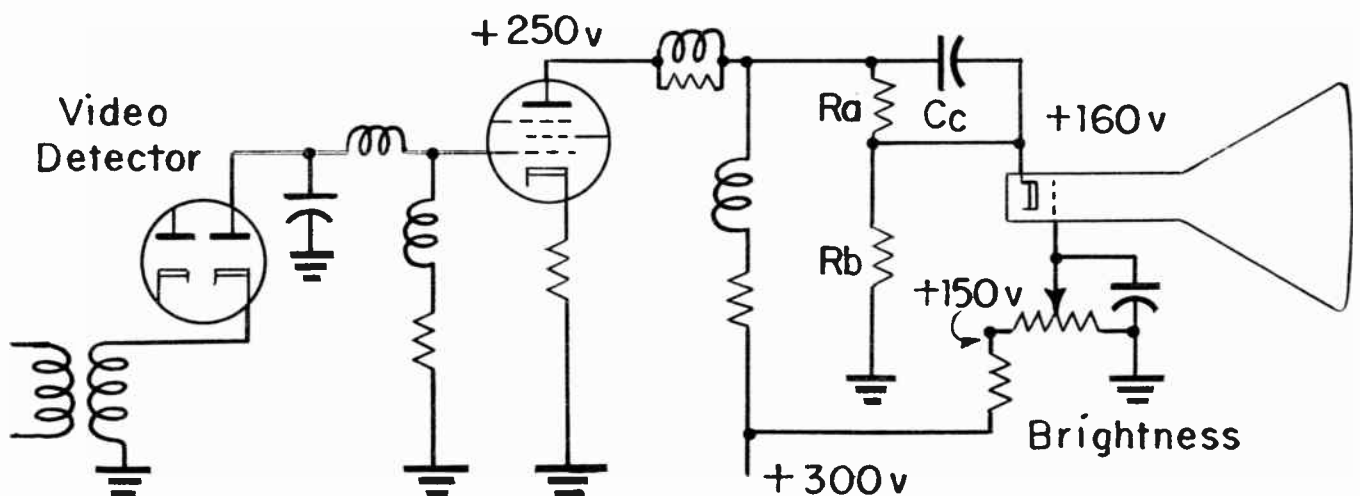

Fig. 7. Video amplifier plate voltage higher than picture tube cathode voltage with a conductive connection.

## LESSON 44 – D-C RESTORATION

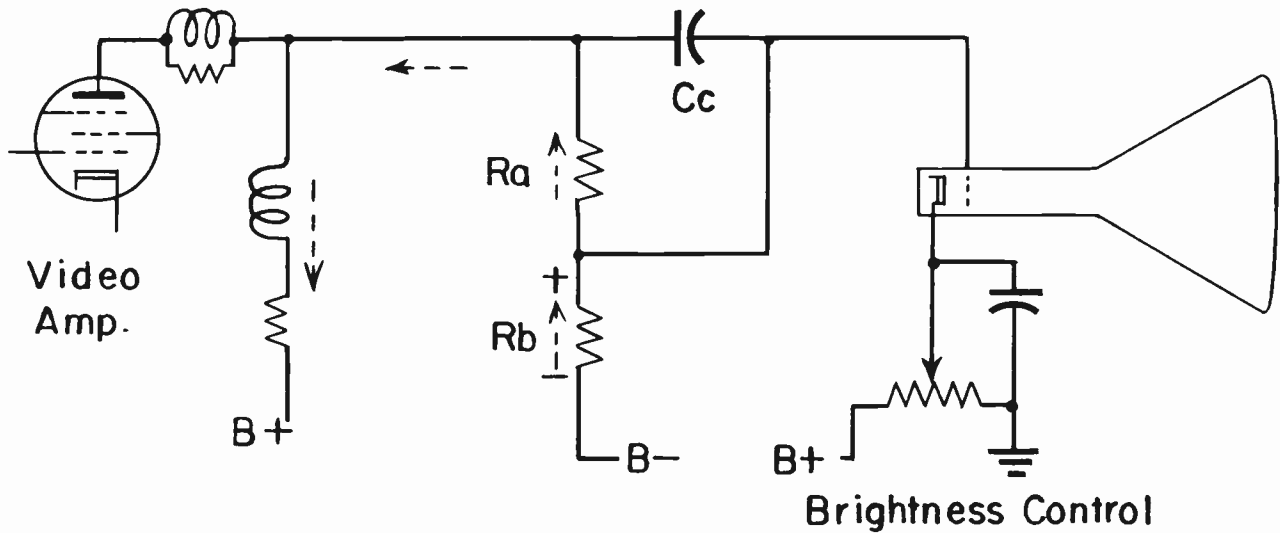

Fig. 8. A conductive connection from video amplifier plate to picture tube grid.

ternating component of the signal from amplifier to picture tube. This capacitance usually is 0.05 or 0.10 mf. The d-c component of the signal goes to the picture tube through resistor Ra, which usually has some value between 0.5 and 1.0 megohm. It is this high resistance that allows having a greater positive voltage at the amplifier plate than at the picture tube cathode.

The picture tube grid-cathode circuit is completed from the picture tube grid through the brightness control to ground, through ground to the bottom of resistor Rb, and through this resistor to the cathode. Fairly typical voltages are shown on the diagram. Note that the brightness control is so connected that the grid of the picture tube cannot be made more positive than 150 volts, and since the cathode is at 160 volts, the grid always will be at least 10 volts negative with reference to the cathode.

A somewhat similar method of transferring the d-c component of the video signal from video amplifier plate to picture tube is illustrated by Fig. 8. Here the signal input is to the grid instead of the cathode at the picture tube. Again the a-c component of the video signal passes quite freely through capacitor Cc, while the d-c component goes through resistor Ra.

The picture tube grid-cathode circuit is completed through resistor Rb, whose low

end usually is connected to a source of negative d-c voltage. This connection may be to ground provided other applied voltages are of such values that the picture tube grid always is less positive or relatively negative in relation to the cathode.

In the circuit of Fig. 8 there is a certain amount of d-c restoration action, and it sometimes is used when there is capacitor coupling somewhere between the video detector and the grid of the video amplifier which feeds the picture tube. This explanation is as follows.

Electron flow is upward in resistors Ra and Rb, as shown by broken-line arrows. Then the top of Rb, connected to the picture tube grid, is more positive than the bottom, which is indirectly connected to the cathode. This polarity of voltage across Rb opposes the negative bias voltage applied to the picture tube grid from the brightness control circuit.

A signal of lighter tone or a stronger signal reaching the video amplifier causes an increase of current and of voltage in resistor Rb. The increased positive potential at the top of Rb makes the grid of the picture tube less negative. A dark-tone or weaker signal reduces current and voltage in resistor Rb, and allows the picture tube grid to become more negative. These are the changes of

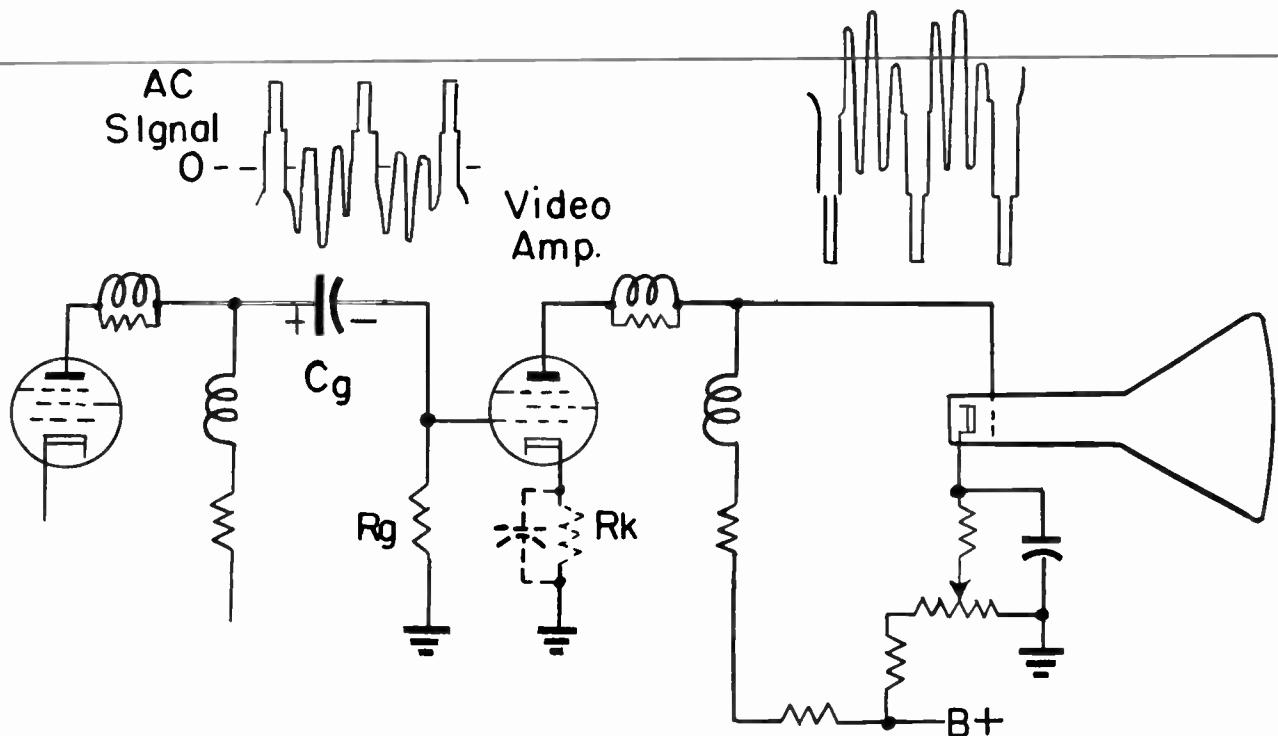

Fig. 9. D-c restoration in the grid circuit of the video amplifier.

picture tube grid bias required for d-c restoration action.

In Figs. 7 and 8 the resistors at Ra and Rb usually, but not necessarily, are of approximately equal values. These values often are between 300,000 ohms and 1 megohm for the circuit of Fig. 7 and between 1 and 2½ megohms for the circuit of Fig. 8. Capacitance at Cc, for either of these circuits, usually is 0.05 or 0.10 mf. The difference between voltage at the plate of the video amplifier and at the grid of the picture tube is the voltage drop across resistor Ra.

**RESTORATION BY AMPLIFIER GRID BIAS.** When there is a conductive connection from video amplifier plate to picture tube, d-c restoration may be effected in the grid circuit of this amplifier, even though the signal on the amplifier grid is alternating. Connections are shown by Fig. 9.

The grid of the video amplifier preceding the picture tube is coupled to the plate of another video amplifier, or possibly to the load of a video detector, through capacitor Cg, which passes only the a-c component of the video signal. The amplitude of this a-c signal

will increase with brighter pictures or with a stronger signal, and will decrease on dark or weak signals.

Capacitor Cg and grid resistor Rg are of such values that the amplifier is biased by grid leak action. There may or may not be a cathode resistor at Rk to provide some minimum negative bias. Grid leak bias action charges capacitor Cg to a voltage equal approximately to the amplitude of the sync pulse tips. This charge will increase and the amplifier grid bias will become more negative on bright or strong signals, and less negative on darker or weaker signals.

Changes of plate current and voltage in the plate load circuit of the video amplifier vary the effective grid bias of the picture tube, because the plate load is in the picture tube grid return to its cathode. A brighter or stronger signal on the amplifier makes its grid more negative and its plate more positive. This greater positive voltage acts also at the grid of the picture tube, and since it opposes the negative bias provided by the brightness control, the picture tube grid is made less negative. A darker or weaker signal has opposite effects, and the picture.

## LESSON 44 – D-C RESTORATION

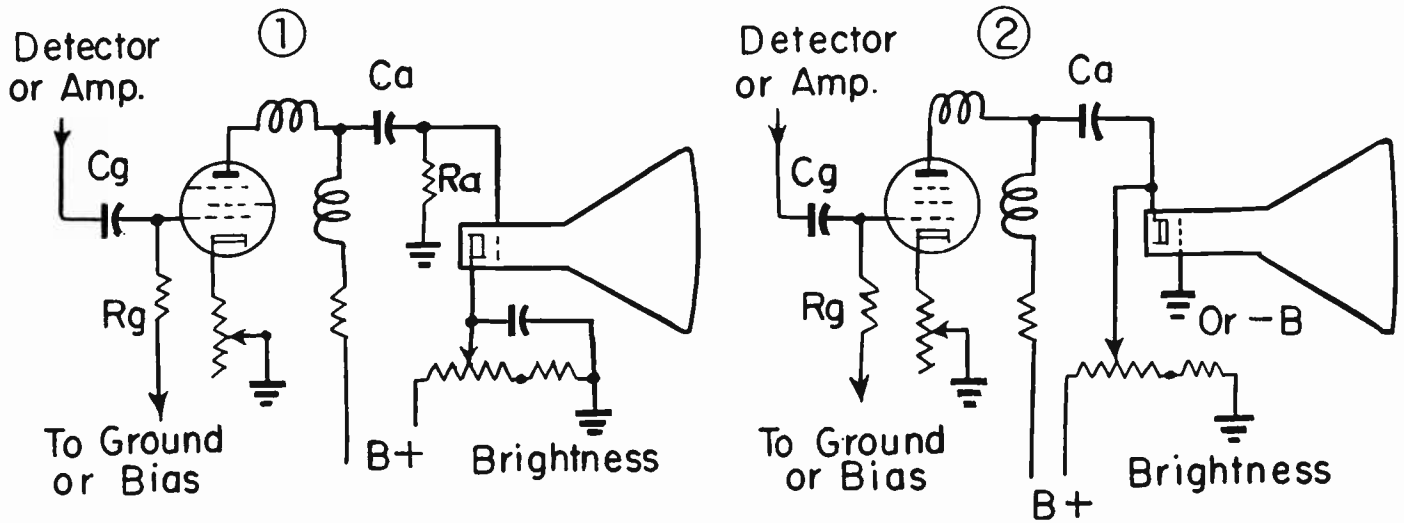

Fig. 10. Capacitor connections from video amplifier to picture tube, with no d-c restoration.

tube grid becomes more negative. These are the changes of picture tube grid bias required for d-c restoration.

Fig. 10 illustrates two circuits with which the plate of the final or only video amplifier is connected to the picture tube input through only a capacitor, with no conductive connection. As mentioned earlier, when the agc system and other features of circuit design between the antenna and video detector are such as to provide strong, steady video signals at the detector, the reproduction may be excellent even with no special means for d-c restoration.

Diagram 1 shows signal input to the picture tube grid, and diagram 2 shows input to the picture tube cathode. Brightness controls are on the cathode lines in both cases. The following values of capacitors and resistors apply to both circuits. Blocking capacitor  $C_g$  for the amplifier grid and  $C_a$  for the picture tube grid or cathode usually are of either 0.05 or 0.10 mf capacitance. Grid resistors  $R_g$  at the video amplifier and  $R_a$  to the grid of the picture tube in diagram 1 usually are of some value around 1 megohm.

**RESTORATION WITH DIODES.** Either a diode tube or a crystal diode may be used for automatically varying the picture tube grid bias in accordance with video signal amplitude. While examining the action of

restoration diodes it must be kept in mind that signal voltages passing through a capacitor lose their d-c component and become alternating voltages whose amplitudes change with picture tone. Signals for light-tone pictures have greater amplitudes than those for dark-tone pictures. An increase of signal amplitude, for a light-tone picture, must make the grid of the picture tube less negative with reference to the cathode, or must make the cathode less positive with reference to the grid. It must be remembered also that a diode will conduct only while its cathode is negative with reference to the plate, or while the plate is positive with reference to the cathode.

Diagram 1 of Fig. 11 shows how a diode produces a voltage which varies with signal amplitude, and which may be employed to change the picture tube grid bias. The cathode of the diode is connected on one side of a capacitor that couples the plate of a video amplifier to the grid of a picture tube. The diode plate is grounded, and connects through ground to the cathode of the video amplifier. This connection of the diode completes a series circuit for alternating signal voltages. Electrons in this circuit may flow from cathode to plate inside the amplifier tube, into one side and out of the other side of the capacitor, thence from cathode to plate inside the diode, and from the diode plate through ground back to the amplifier cathode.



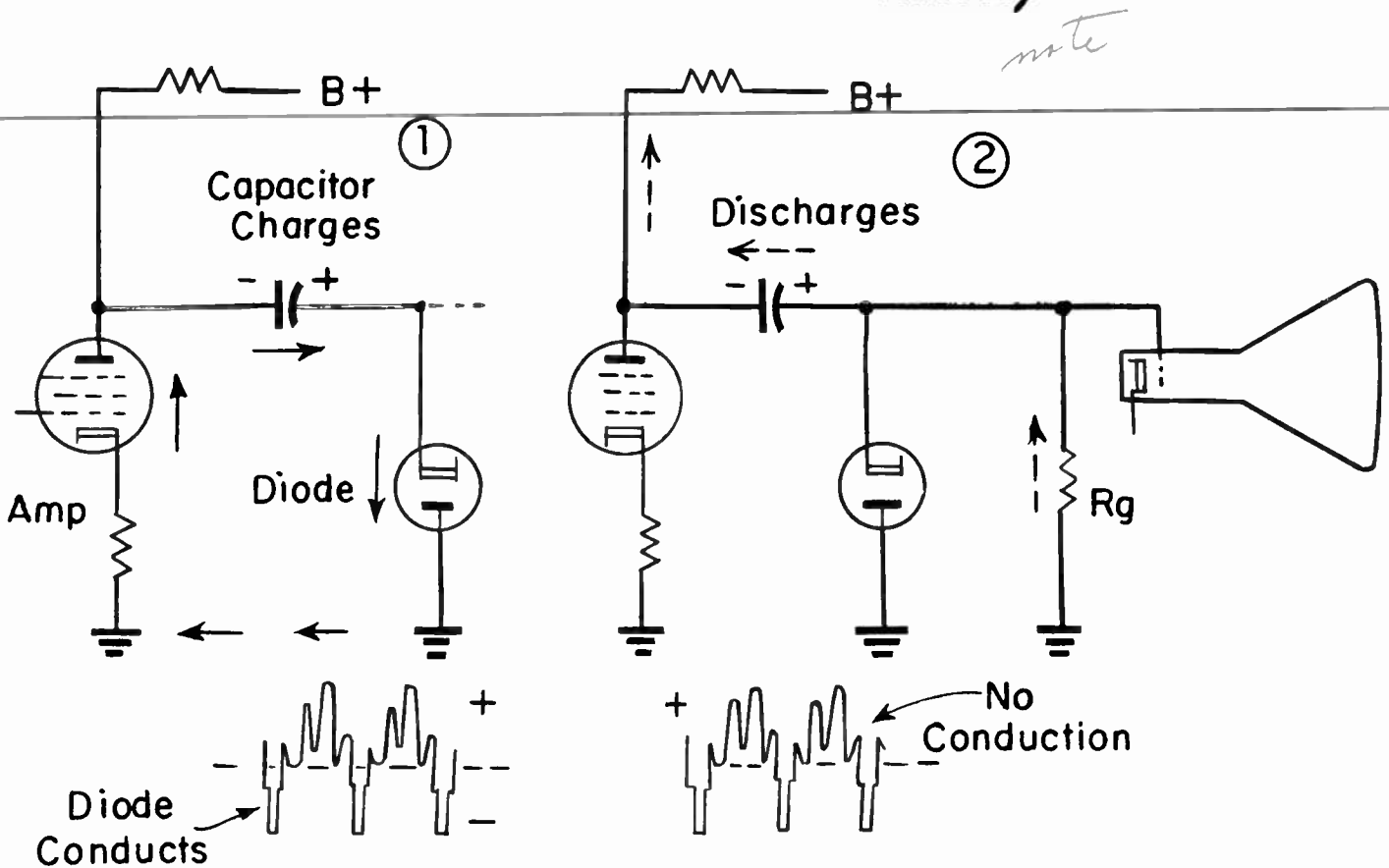

Fig. 11. How voltage for a-c restoration is developed by rectifying action of a diode.

Electrons in the diode circuit will flow as described only when the cathode of the diode is made negative with reference to its plate. This will occur during negative alternations of the video signal at the plate of the amplifier tube, because, as the amplifier plate becomes less positive and relatively negative, the negative-going plate potential acts through the capacitor on the cathode of the diode.

Since electrons cannot flow through the capacitor, but only into and out of its plates, the side of the capacitor toward the amplifier plate becomes negatively charged while the side toward the cathode of the diode becomes positively charged. With only the parts shown by diagram 1 the capacitor cannot lose its charge, because there can be no reverse flow in the diode. Consequently, the capacitor will be charged to a voltage equal to the peak amplitude of the negative sync pulses in the video signal.

In diagram 2 of Fig. 11 a resistor  $R_g$  has been added in parallel with the diode, and

the grid of the picture tube has been connected to the junction of resistor  $R_g$ , the diode cathode, and the side of the capacitor that has accumulated a positive charge.

During positive alternations of the video signal the cathode of the diode is made positive with reference to its plate, and there can be no conduction. But during the periods of positive alternations the capacitor may discharge through the path marked with broken-line arrows. Now the capacitor will be charged by all the negative sync pulses of the signal, and between times the capacitor will discharge through resistor  $R_g$ .

The time constant of resistor  $R_g$  and the capacitor usually is about 0.050 second. As an example, with the capacitor of the commonly used value of 0.1 mf, resistor  $R_g$  may be of  $\frac{1}{2}$  megohm value, whereupon the product of capacitance in microfarads and resistance in megohms gives 0.050 second as the time constant. This time is somewhat longer than that for one picture frame, which is 0.033 second. Therefore, the capacitor will main-

## LESSON 44 – D-C RESTORATION

tain its voltage approximately equal to amplitude of sync pulse peaks during at least one frame in spite of rapid alternations in the picture signal. But capacitor voltage may change during the time of two or more frames, provided there are changes in the amplitudes of sync pulses.

The positive voltage on one side of the charged capacitor is the same as the potential at the top of resistor R<sub>g</sub> and at the grid of the picture tube. The bottom of R<sub>g</sub> is connected through ground and the brightness control (not shown) to the picture tube cathode. Then the voltage across R<sub>g</sub>, and the voltage of the capacitor, is applied between grid and cathode of the picture tube.

A stronger video signal, for a picture of lighter tone, will have greater amplitude at the sync pulse peaks and will increase the charge voltage on the capacitor. This will make the grid of the picture tube more positive with reference to the cathode of the picture tube. Of course, what actually happens is that the increased positive voltage on the capacitor counteracts more of the negative grid bias applied to the picture tube by the brightness control, and the grid becomes less negative with reference to the cathode of the picture tube. This is the action required for d-c restoration.

When the picture changes to a darker tone the video signal will have less amplitude. Then part of the capacitor charge will escape through resistor R<sub>g</sub> and the remainder of the discharge circuit. The lessened capacitor voltage will counteract less of the negative grid bias from the brightness control, and the grid of the picture tube will become more negative - as required for dark-tone signals.

The action of this d-c restoration system has no effect whatever on passage of video signals from the plate of the video amplifier through the capacitor to the grid of the picture tube. The video signal, and especially the picture portions, are alternating or varying at rates far faster than the capacitor-resistor time constant. Therefore, so far as picture signals are concerned, the restoration action is holding the average capacitor voltage at some certain value over considerable periods of time. The picture signals

simply vary the capacitor voltage above and below this average, and pass through to the picture tube grid. We may think of the average capacitor voltage, maintained through one or more frame periods, as the d-c component of the video signal. Then the video signal alternations are variations of this d-c voltage, just as at the output of the video detector.

In Fig. 11 the restoration diode is in parallel with grid return resistor R<sub>g</sub>. An arrangement more often employed in actual practice is shown by Fig. 12. Here the grid return resistor is in two parts, R<sub>a</sub> and R<sub>b</sub>. The restoration diode is connected across only R<sub>b</sub>. Resistance at R<sub>a</sub> is quite small, maybe 10,000 to 25,000 ohms, but at R<sub>b</sub> it is between  $\frac{1}{2}$  and 1 megohm. While the diode is conductive, on negative sync pulses, it practically short circuits R<sub>b</sub>. Then capacitor C<sub>c</sub> can charge rapidly through the diode and the small resistance at R<sub>a</sub>. While the diode is non-conductive it leaves the high resistance at R<sub>b</sub> in series with the capacitor, and there can be only slow discharge.

Fig. 13 shows how this same principle of d-c restoration may be employed when video signal input is to the cathode of the picture tube instead of to the grid. The essential change is a reversal of cathode and plate connections of the diode, with the diode plate toward capacitor C<sub>c</sub>. Now the diode conducts during the positive sync pulses. The sync pulses must be positive, and picture signals negative, when signal input is to the picture tube cathode.

Capacitor C<sub>c</sub> now is charged in opposite polarity with reference to the amplifier plate, and the negative side of the capacitor is toward the picture tube cathode. A stronger (light-tone) video signal increases the capacitor charge voltage. This makes the picture tube cathode more negative, or actually less positive with reference to the picture tube grid. The result is equivalent to making the grid less negative with reference to the cathode, since there is a reduction of potential difference between grid and cathode. Weaker (dark-tone) signals cause opposite actions, and the picture tube grid is made effectively more negative with reference to the cathode.

# COYNE - television home training

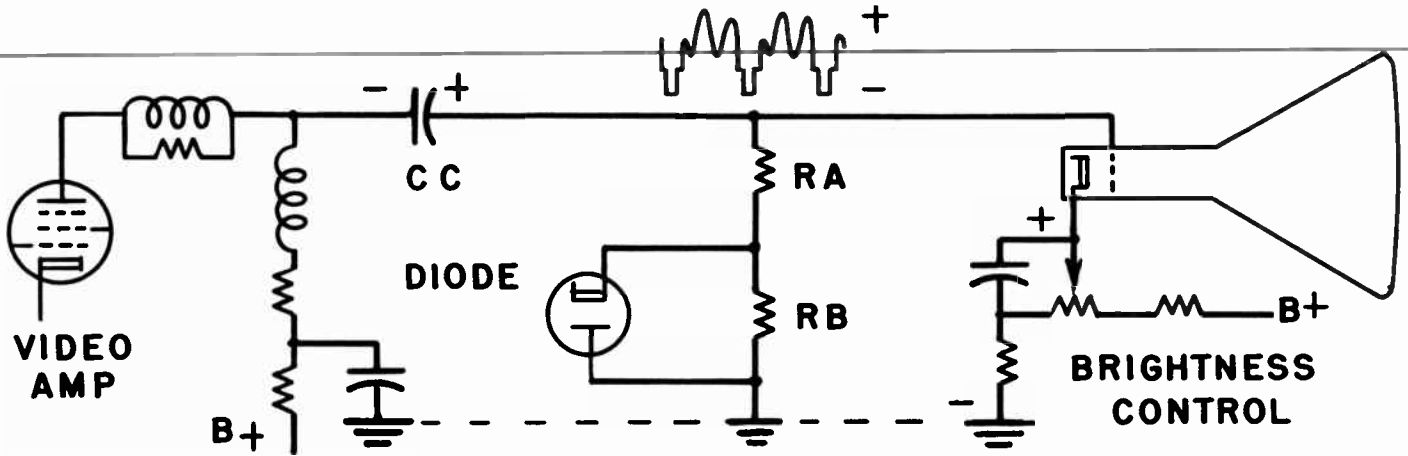

Fig. 12. A diode restoration system with signals applied to the grid of the picture tube.

Thus we have the action required for d-c restoration.

In many d-c restoration systems a separate capacitor is used for the restoration voltage, instead of using the same capacitor that carries video signals from the video amplifier to the picture tube. The essential features of such a system are illustrated by Fig. 14. The signal transfer capacitor is  $C_c$ . The second capacitor,  $C_r$ , is used only for development of restoration voltage. Capacitor  $C_c$  now may be of any value best suited for signal transfer, while the value of capacitor  $C_r$  may be chosen to have such a time constant, in connection with resistor  $R_b$ , as

to provide suitable duration of the restoration voltage. The low resistance at  $R_a$  allows applying the positive restoration voltage to the picture tube grid, and completes the grid return circuit.

You will find a great variety of modifications in d-c restoration systems using a separate capacitor for the restoration voltage. One which has been widely used, especially in some of the older receivers, is illustrated by Fig. 15. There is an additional resistor between the diode plate and ground, and another added resistor in series with the restoration capacitor  $C_r$ . Additions and other variations of the restoration circuit have to

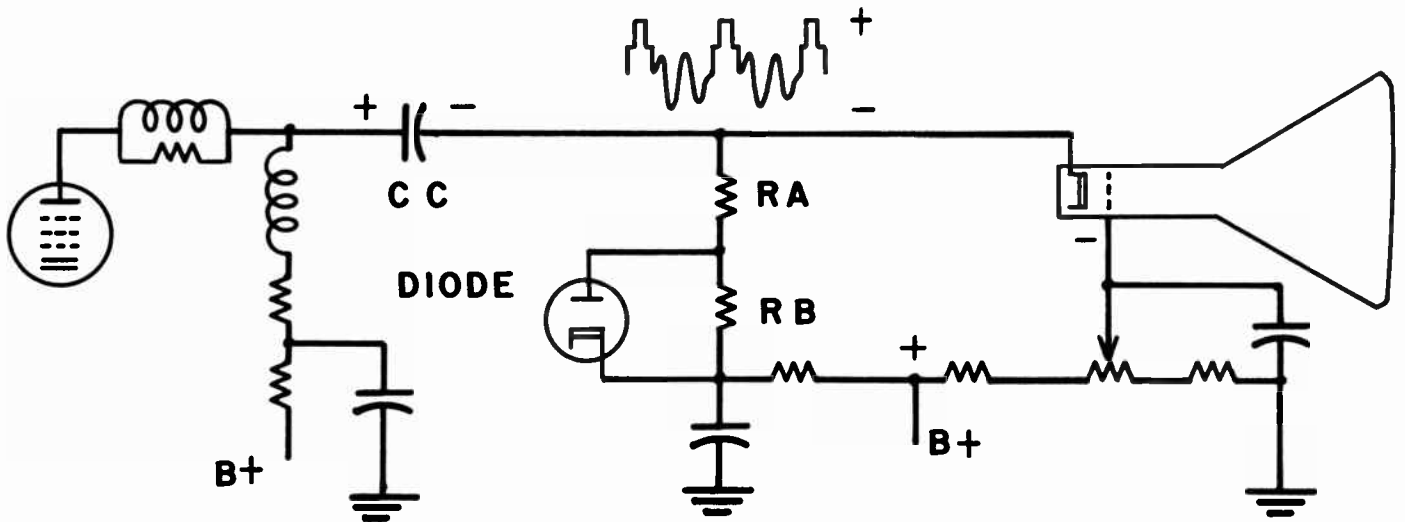

Fig. 13. A diode restoration system arranged for application of signals to the cathode of the picture tube.

# LESSON 44 – D-C RESTORATION

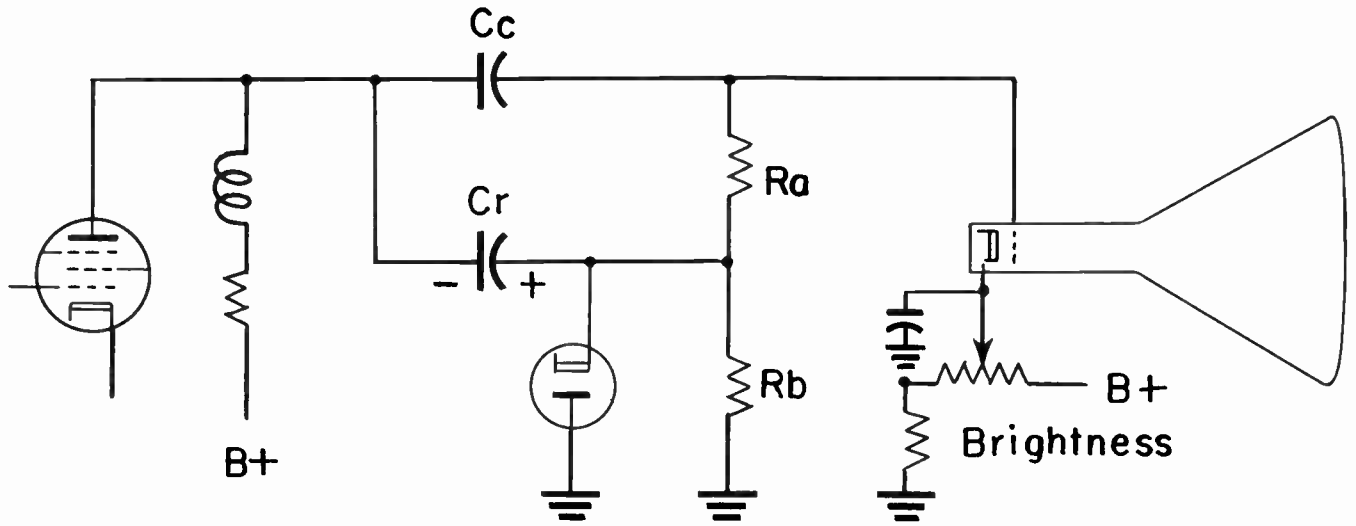

Fig. 14. Employing a separate capacitor for the d-c restoration voltage.

do chiefly with obtaining desired time constants and with isolation of the restoration circuit from the video transfer circuit. They do not alter the basic principles of operation.

is a triode, nearly always one section of a twin triode whose other section is employed as the first tube in the sync section of the receiver.

**RESTORERS AND SYNC SIGNALS.** Fig. 16 shows a d-c restoration circuit used in a large number of receivers, either in the exact form illustrated or with minor modifications. Instead of a diode, the restorer tube

The grid of the restorer triode is grounded, and acts exactly like the diode plate of Fig. 12. That is, the grounded grid of the triode acts in relation to the cathode of this tube just as the grounded plate of a diode

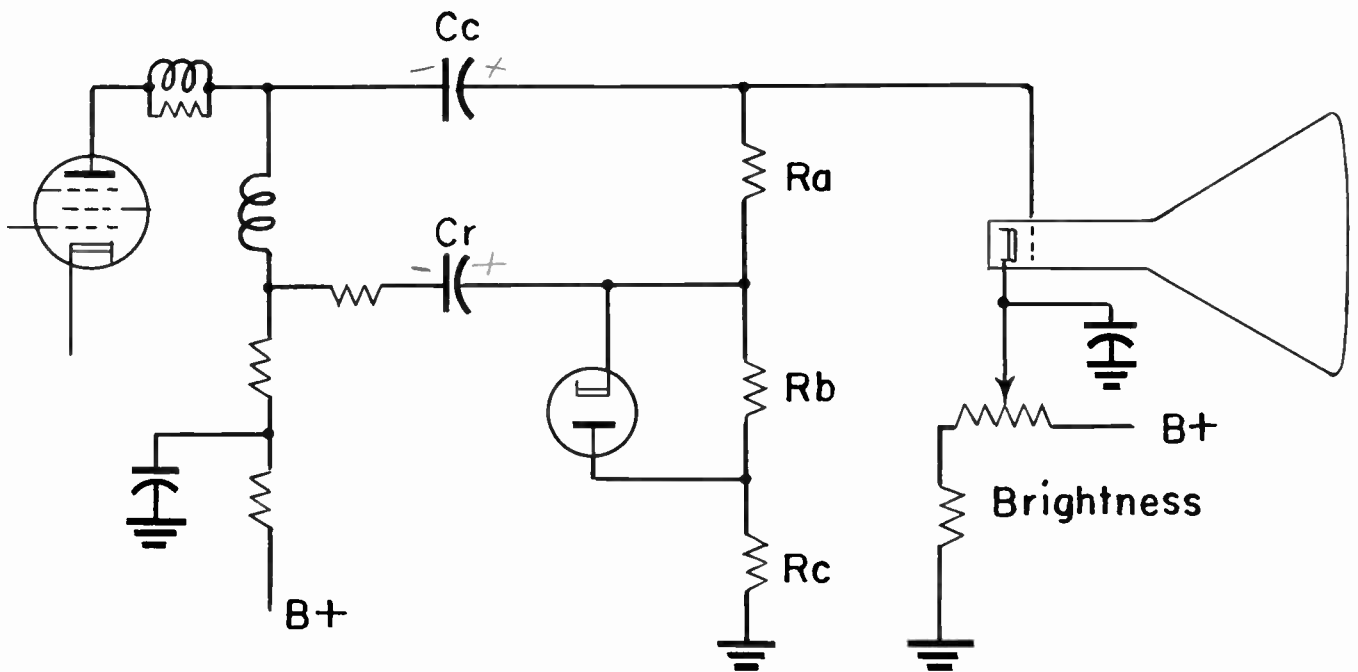

Fig. 15. One modification of the circuit employing a separate capacitor for d-c restoration voltage.



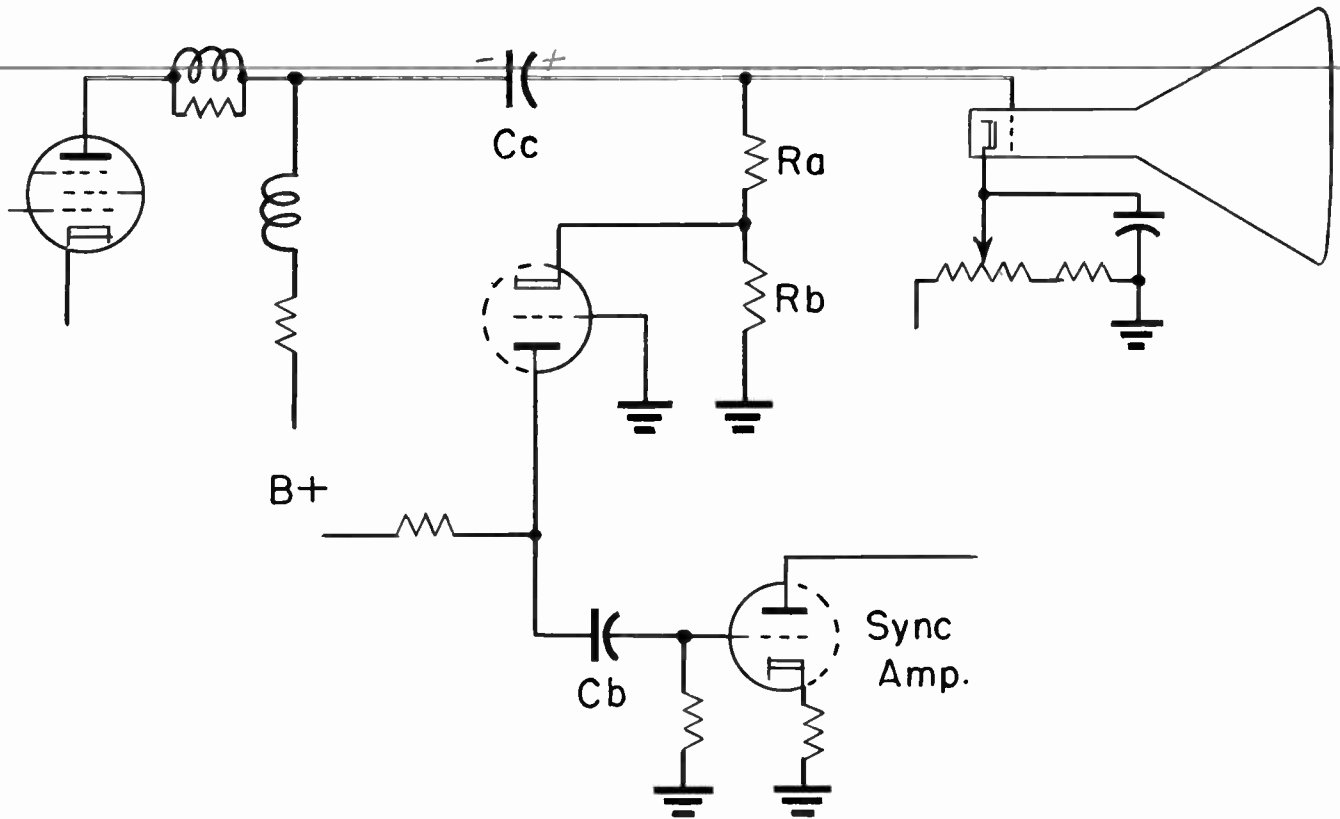

Fig. 16. How two triodes or a twin triode may be employed for d-c restoration and a take off for pulses going to the sync section of the receiver.

acts in relation to the cathode of the diode. Connections of capacitor Cc and of resistors Ra and Rb are the same as of similarly lettered parts in Fig. 12, and, in connection with the grounded triode grid acting as a diode plate, the restoration action is the same as previously described.

A positive B-voltage is applied to the plate of the restorer triode. Then, when the triode becomes conductive during negative (sync pulse) alternations of the video signal, the voltage pulses appear at the triode plate. An oscilloscope trace of the video signal voltage at the cathode of the restorer cathode is shown at A in Fig. 17. The cathode and grounded grid are acting as a rectifier to cut off nearly all of the positive picture alternations of the video signal, and at the plate of the restorer triode we have the voltage pulses shown at B.

The negative voltage pulses from the plate of the restorer triode are applied through blocking capacitor Cb to the grid of

the sync amplifier tube. This tube inverts and amplifies the pulses, and delivers them to other tubes farther along in the sync section. The sync amplifier triode ordinarily is the second section of the twin triode, whose first section is the restorer triode.

In Fig. 18 we again have the first tube of the sync section fed from the plate of a restorer triode. The restorer circuit has separate capacitors for signal transfer (Cc) and for development of restoration voltage (Ct), as in Fig. 15. There is a somewhat different arrangement of resistors Ra, Rb, and Rc. Such variations and modifications do not alter the basic principles of d-c restoration.

Fig. 19 illustrates a d-c restoration system employed in a number of makes and models of receivers. The video signal is applied to the cathode of the picture tube, to which is connected the brightness control. The grid-cathode circuit of the picture tube is completed, from the grid, through resistors Ra and Rb to ground, thence through

## LESSON 44 – D-C RESTORATION

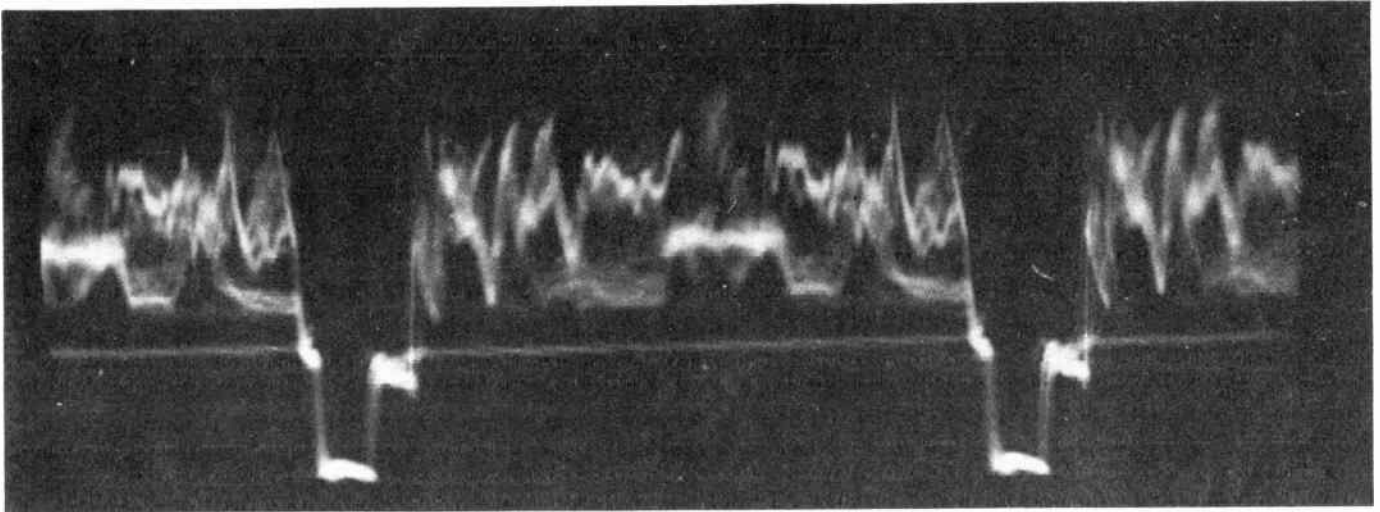

Fig. 17A.

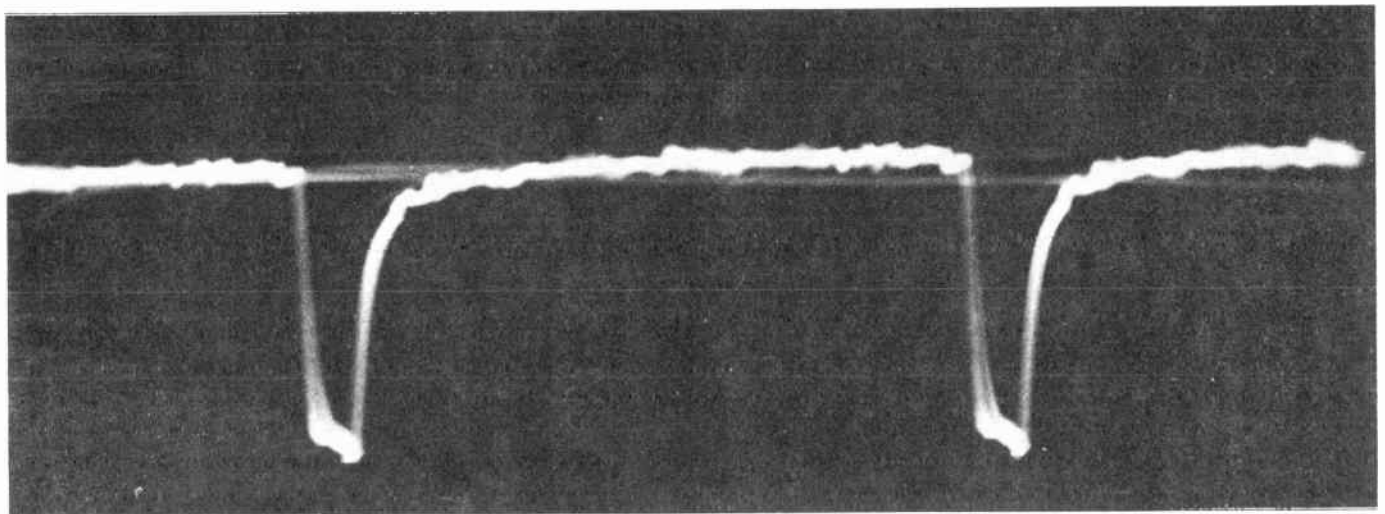

Fig. 17B.

Fig. 17. Signal voltage at the cathode of a restorer triode (A) and at the plate of the same tube (B).

ground and the brightness control to the cathode. Any voltage across resistors Ra and Rb will act as grid biasing voltage for the picture tube.

Resistors Ra and Rb are in the cathode lead of a pentode tube which acts as the d-c restorer and at the same time as the first tube in the sync section of the receiver. To the grid of this tube is applied the video signal taken from the load circuit of the video amplifier. Sync pulses are positive in this signal.

The restorer pentode is cathode-biased by voltage drop across resistor Ra, with the

grid return through resistor Rg. The reason for connecting the grid return in this manner is that total voltage drop across both Ra and Rb would be too great for the required grid bias. This bias is sufficiently negative that the restorer tube operates close to plate current cutoff when there is no video signal on the grid. Because of the strong negative bias, the restorer tube conducts only on the positive sync pulses of the video signal, and cuts off the negative picture variations.

Current pulses in the restorer pentode cause voltage pulses across Ra and Rb that charge capacitor Ck to a voltage equal approximately to the black level voltage of the

# COYNE - television home training

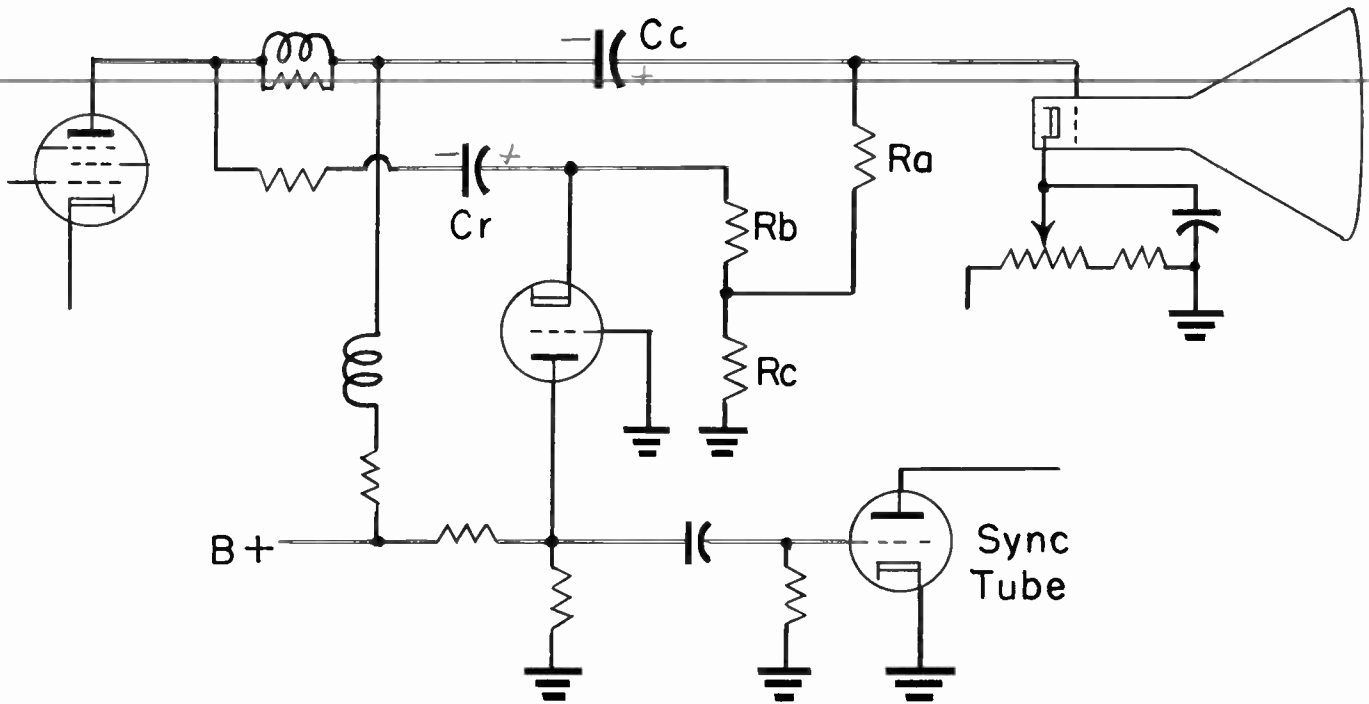

Fig. 18. A restorer triode in a circuit having a separate capacitor for restoration voltage.

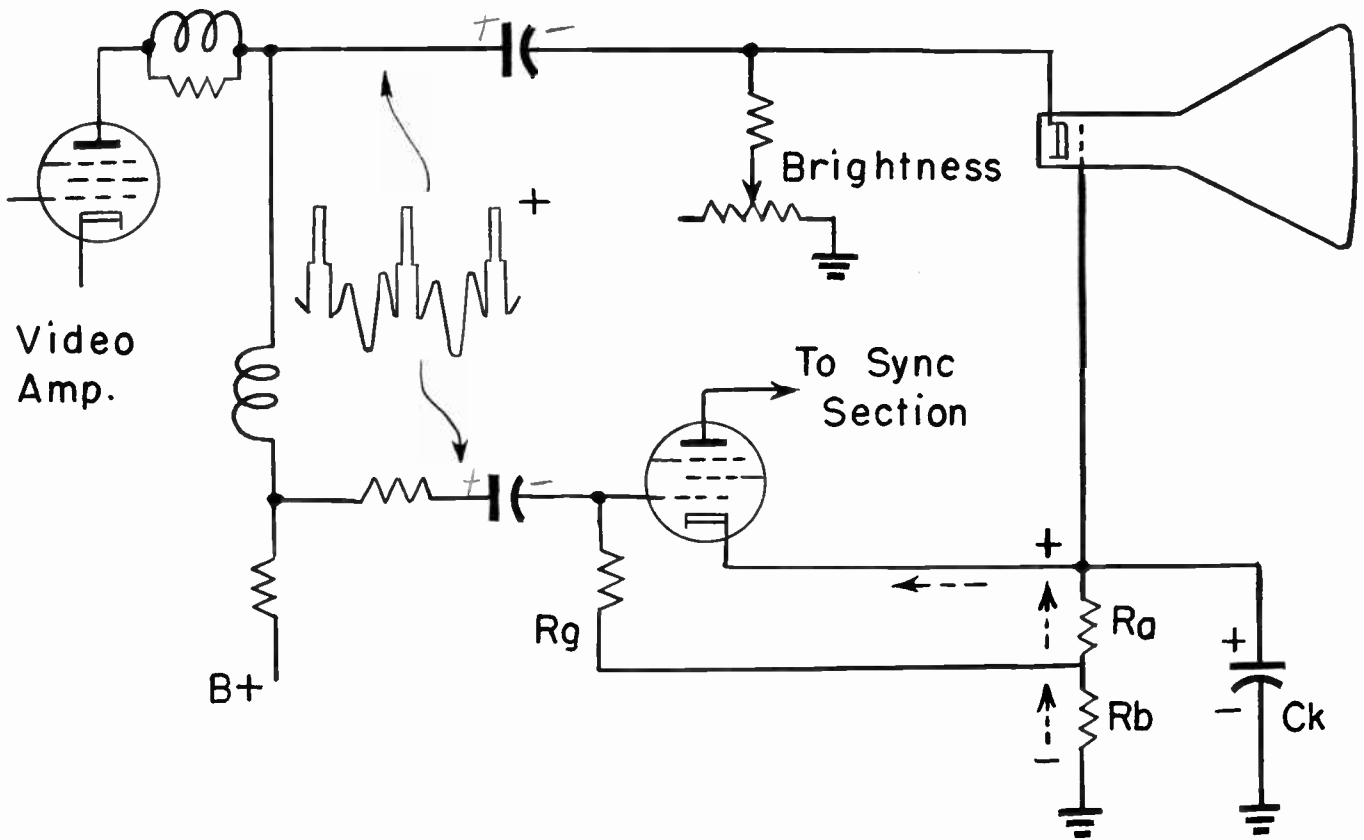

Fig. 19. D-c restoration voltage obtained from the cathode circuit of a tube in the sync section.

## LESSON 44 – D-C RESTORATION

video signal on the grid. Since the positive side of capacitor Ck is connected to the grid of the picture tube, and the negative side through ground to the picture tube cathode, the voltage across Ck makes the picture tube grid more positive, or actually less negative, than the negative voltage from the brightness control.

Stronger video signals for pictures of lighter tone cause increased conduction in the restorer pentode, because such signals are of increased amplitude. The increased conduction increases the voltage across capacitor Ck, thus making the grid of the picture tube less negative with reference to the cathode. This is the change of grid bias required for d-c restoration. Weaker video signals for pictures of darker tone reduce conduction in the restorer tube, allow voltage across capacitor Ck to decrease, and the grid of the picture tube is made more negative.

The restoration time constant is proportional to values of capacitance at Ck and of the sum of the resistances at Ra and Rb, since the charge on Ck leaks away through the two resistors during intervals between sync pulses. Total resistance is suitable for this time constant, while resistance across Ra alone is suitable for biasing the grid of the restorer tube.

In d-c restoration systems which employ diodes or triodes we have seen that a capacitor is charged to voltages which vary with momentary changes of picture tone. A portion of this voltage, presumed to be the required restoration voltage, is put into the grid-cathode circuit of the picture tube, where it varies the grid voltage. The object is to maintain the black level of video signals at the picture tube grid voltage that causes beam cutoff. When this is accomplished, all picture signals will be reproduced on the screen, and all effects of sync pulses will be excluded.

The process is illustrated by Fig. 20. The restoration capacitor is charged to a voltage equal approximately to the amplitude of sync pulse peaks, as represented by the length of the arrow at the left in diagram 1.

We shall assume, for purposes of illustration, that about one-third of this capacitor voltage is used to change the grid voltage of the picture tube, as shown by the arrow at the right. This change of grid voltage brings the black level of the video signal to the grid voltage for beam cutoff, as in diagram 2. Here we have correct restoration for a signal of average tone, as brought about by suitable values of resistances, capacitances, and time constants in the restoration circuit.

In diagram 3 is shown a signal for a picture of lighter tone, with greater amplitude of sync pulse peaks. The resulting voltage of capacitor charge is represented by the length of an arrow at the left in this diagram. This charge voltage is somewhat greater than in diagram 1, due to greater sync pulse amplitude. The fraction of capacitor voltage used for changing picture tube grid voltage is the same as before, approximately one-third, and is represented by an arrow at the right in diagram 3. This change of grid voltage is, of course, somewhat greater than in diagram 1.

The change of grid voltage that accompanies the picture of lighter tone shifts the video signal with reference to beam cutoff voltage as in diagram 4. The black level of the signal has not been brought quite to the cutoff voltage. Were the picture to have changed to darker tone, the charge of the capacitor and the change of grid voltage would have been decreased, but the black level of the signal would not be brought exactly to the grid voltage for beam cutoff.

When d-c restoration voltage is derived from peak amplitudes of sync pulses the results are not perfect, but are so nearly so that imperfections are not noticed by the average viewer. To come still closer to exact restoration it would be necessary to base the restoration voltage on the black level of video signals, rather than on sync pulse amplitude. Several systems have been devised to do just this. The theories are rather involved, and they have no particular bearing on methods of servicing when trouble develops.

**SERVICE TROUBLES.** A d-c restorer makes picture tube grid voltage less negative



PICTURE OF AVERAGE TONE

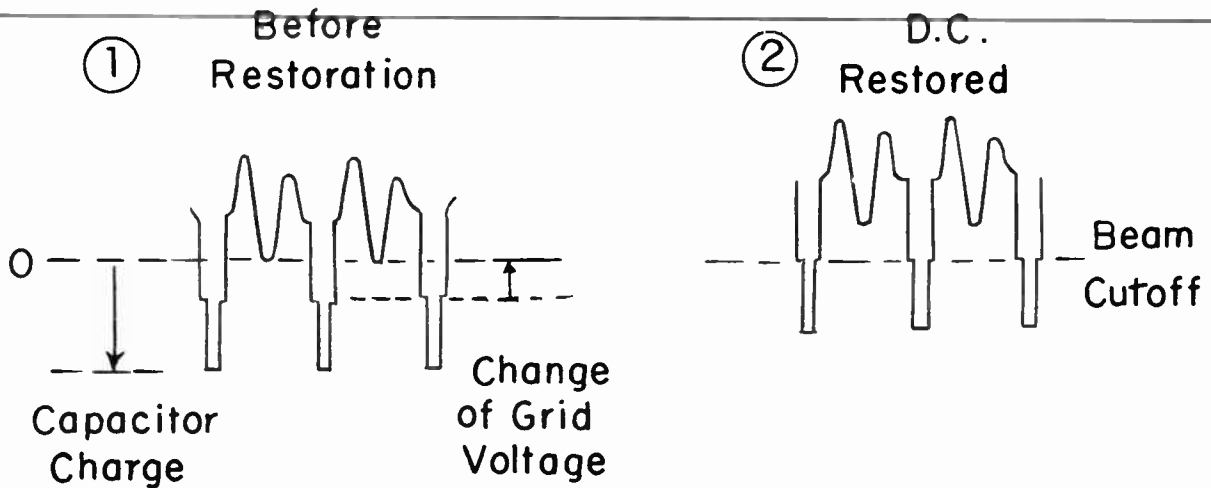

LIGHT-TONE PICTURE

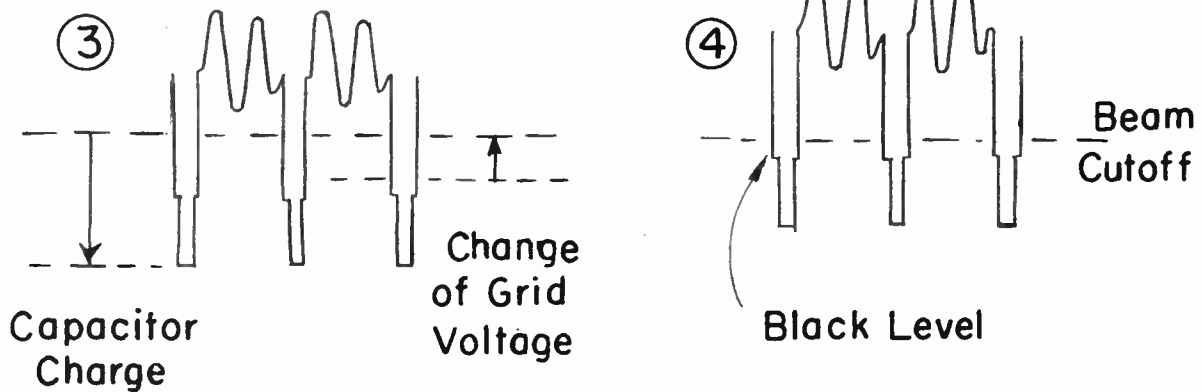

Fig. 20. Restoration voltage derived from peak amplitudes of sync pulses does not always bring the signal black level to beam current cutoff.

than the bias from the brightness control. This increases the beam current and makes pictures somewhat brighter for any given setting of the brightness control. Any irregular action of the restorer thus may cause brightness to vary in an irregular manner. Observation of a high-resistance voltmeter connected between grid and cathode of the picture tube will show that average grid voltage is varying with changes of brightness. Trouble of this kind may originate in the restorer tube, which should be replaced.

Lack of picture contrast and poor rendering of fine details in pictures may indicate faults with the resistor connected between the restorer cathode and the grounded plate or grid. The trouble may be a partial

short circuit, or a short across one of several resistors in series. If the resistor connecting the picture tube grid to the restorer circuit is open or disconnected, pictures are likely to become brighter and brighter after the set is turned on, with no change in setting of the brightness control.

When there is current leakage between cathode and heater of a restorer tube, 60-cycle alternating current and voltage get into the restorer circuit and act on the grid of the picture tube. Then pictures may have a wide dark band extending from side to side, with an excessively light band above or below the dark one. The 60-cycle line voltage in the heater is modulating the picture tube grid voltage.

## LESSON 44 – D-C RESTORATION

If sync signals are taken from the plate of a restorer triode, or if any restorer tube is also a part of the sync section, trouble in the restorer circuit or tube will cause sync failure which is much more noticeable than

any restoration fault. Trouble of this kind will affect both vertical and horizontal synchronization, and it may be difficult or impossible to hold pictures against movement up, down, and side ways.

# TELEVISION

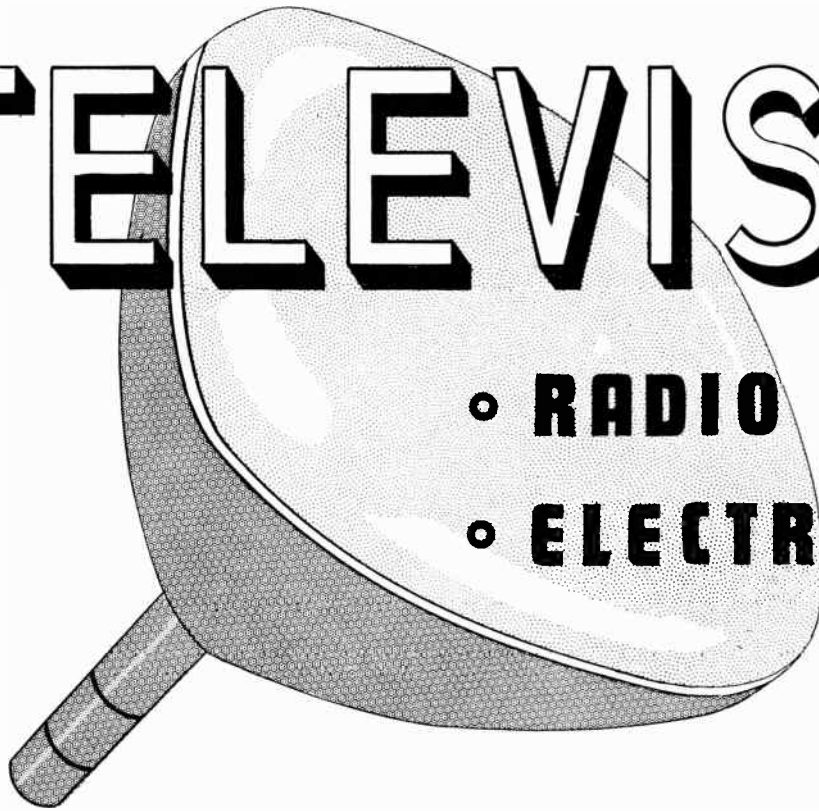

- RADIO
- ELECTRONICS

---

---

## LESSON 45 – PICTURE TUBES

---

---

***Coyne School***

*practical home training*

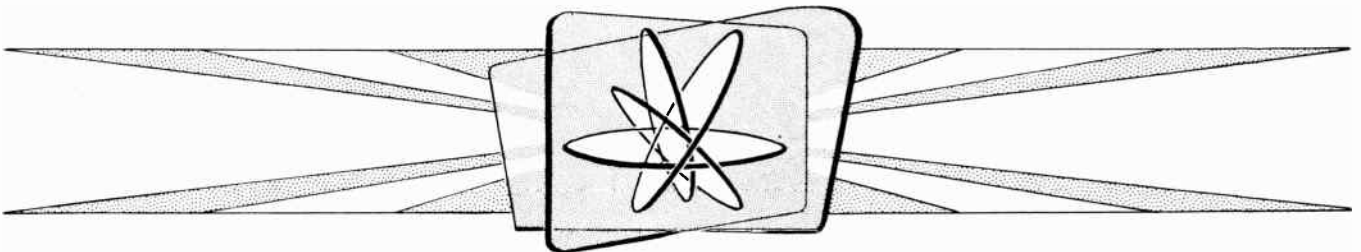

*Chicago, Illinois*

---

*Copyright, 1953 by Coyne Electrical School  
Chicago 12, Illinois  
All rights reserved*

Litho. in U.S.A.



## Lesson 45

### PICTURE TUBES

Were you to take a television receiver from its cabinet and ask any non-technical person to guess which is the most important single part of that receiver, what would be the answer? It could be only the picture tube, for not only is this the biggest and most costly part, but on its screen appears the ultimate object of all the intricate apparatus extending from the television camera to the transmitting antenna, and from the receiving antenna all the way through the receiver.

We have followed video signals as far as the grid-cathode circuit of the picture tube. Now it is time to learn what happens inside this tube. But before looking inside suppose we ask an experienced service technician to name features of picture tubes which are his chief concern when ordering a replacement. His list would read something like this.

1. Type number.
2. Envelope. All glass or metal-glass.
3. Face shape. Rectangular or round.
4. Nominal size. Of the face, anything from 10 to 30 inches. The length, front to back.
5. Face plate. Clear, tinted, frosted, metal backed, cylindrical.
6. Deflection and focusing. Whether both magnetic, or magnetic deflection and electrostatic focusing.

To perform the actual work of removing the original tube and installing a new one the technician would have to understand,

1. How picture tubes are supported or mounted.
2. Safe methods of removal, handling, and re-installation.
3. Correct mounting of various accessories on the neck of the tube.

Before ordering a new tube the technician should have determined the actual need by making certain observations, tests, and measurements. He would look for four general classes of trouble, and in order to interpret the results he would have to understand how picture tubes are supposed to operate. Here are the four general classes of trouble for which the technician would have to "know the answers".

1. The electron beam may lack intensity, or it might be too intense. This calls for answers to the question, what determines beam intensity other than relations between voltages on grid and cathode?

2. The beam may not produce a small, sharply defined spot or line of light on the screen. That is, the beam is not being correctly shaped. Why?

3. There may be insufficient deflection, horizontally, vertically, or in both directions. There might be too much deflection. Why?

4. The raster may not extend over the desired area of the screen, it may be displaced or deformed. Why?

Now, it happens that these troubles may or may not indicate defects in the picture tube itself. However, for the time being, we shall assume that various tests have proved the need for replacement of the tube, and shall check through the features which relate to selection of a new tube.

TYPE NUMBERING. Type numbers by which picture tubes are designated always consist of numbers accompanied by letters, arranged in this general way, 21FP4-A. Such a designation is to be considered in four parts; a number, a letter, a letter and number, and often but not always a final letter, thus: 21 - F - P4 - A.

The significance of the four parts of the type designation is illustrated by Fig. 2. The first number, 21 is our example, tells to the

**COYNE** - *television home training*



*Fig. 1. Students in the Coyne School are examining the electron gun from a television picture tube.*

## LESSON 45 – PICTURE TUBES

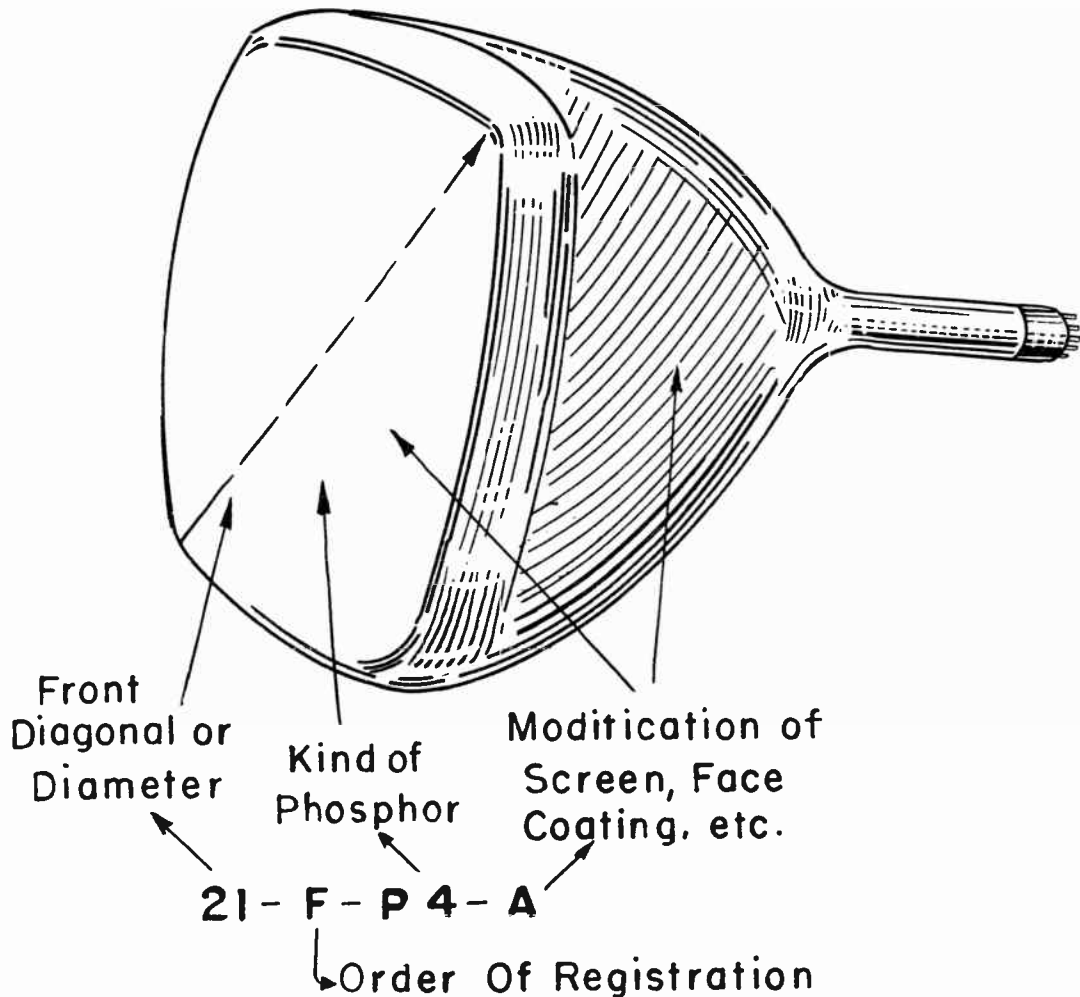

Fig. 2. The meanings of the several parts in the type number of a picture tube.

nearest inch the maximum front dimension. This would be the diagonal distance across a rectangular tube, or the diameter of a round tube.

The letter following the first number indicates merely the order in which this particular design was registered with the RTMA. The first tube of some new general type has the letter "A" in this position. The next one registered by any maker gets the letter "B", and so on through the alphabet. There is a tube designated as type 16AP4, and following the first number are other letters for succeeding registrations all the way to type 16ZP4. After reaching the end of the alphabet, the designations start over again with two letters in this position. You will find type 16-AB-P4 and type 16-AC-P4, and so on.

Next we find a combination of a letter and a number which, for television picture tubes, always is "P4". This means phosphor number 4. A phosphor is the substance or combination of substances mixed into the internal coating of the screen to produce light of the desired color. Phosphor number 4 produces the kind of white light you see from television tubes.

Traces on the cathode-ray tubes of nearly all service type oscilloscopes are green in color, because these tubes are made with phosphor number 1, which produces green light. Accordingly, you will find oscilloscope tubes with type numbers such as 7VP1, indicating a 7-inch tube, registered in the order of the letter V, and having phosphor number 1, indicated by P1 at the end of the type designation.

# COYNE - *television home training*

There are many other phosphors for various special purposes. Phosphors P5 or P11 may be used where it is desired to photograph oscilloscope traces. Phosphors P7, P12, P14, and others are used for radar observation. Number P15 is used for "flying spot scanning" in production of television patterns. Some phosphors are obsolete, such as yellow-green P3 in the earliest television tubes, and a white P6 used for a few pre-war television tubes.

The broken-line curve of Fig. 3 shows relative strengths of light emission from phosphor number 4 at various wavelengths of radiation which causes the impression of light in our eyes. The solid-line curve shows

the relative sensitivity of the average human eye to radiation at these wavelengths. Wavelengths are given in a unit called the Angstrom, equal to approximately one two-hundred-fifty-millionth of an inch. Color sensations usually associated with the wavelengths are shown along the top of the graph. At the middle of the green range the radiation frequency corresponding to wavelength is about 560 million megacycles per second.

Returning now to type designations of picture tubes, the final letter or a letter following a hyphen, identifies types which have some modification of the original design. For example, the 16GP4 has a gray face plate, the 16GP4-A has a clear glass face plate, and

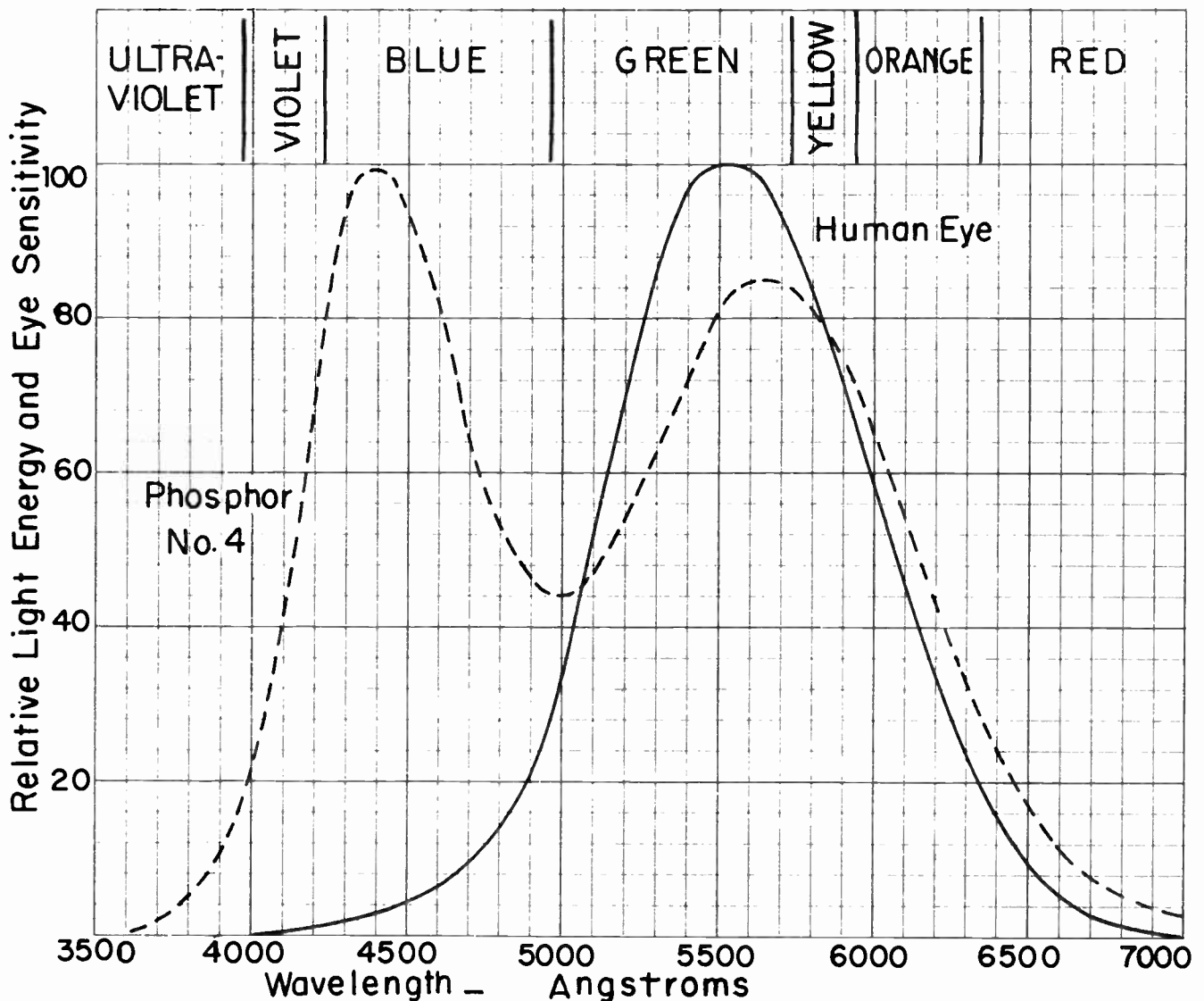

Fig. 3. "Spectral energy emission" of phosphor number 4 (broken line curve) and relative sensitivity of the average human eye for various colors.



## LESSON 45 – PICTURE TUBES

the 16GP4-B has a gray frosted face plate. Modifications such as these call for no circuit alterations when a tube with one suffix letter is substituted for one with a different suffix or none. A final letter may show whether or not there is a conductive coating on the outside of a glass picture tube. As we shall learn later, such a coating acts as part of a high-voltage filter capacitance, and its presence or absence would call for certain changes in filtering the high-voltage power supply. There is no orderly relation between suffix letters and their meanings, you have to refer to specifications of each individual tube.

**GLASS AND METAL ENVELOPES.** The envelopes of some picture tubes are made entirely of glass. Such construction is pictured by Fig. 4. The face, the flare, and the neck are one continuous piece of glass.

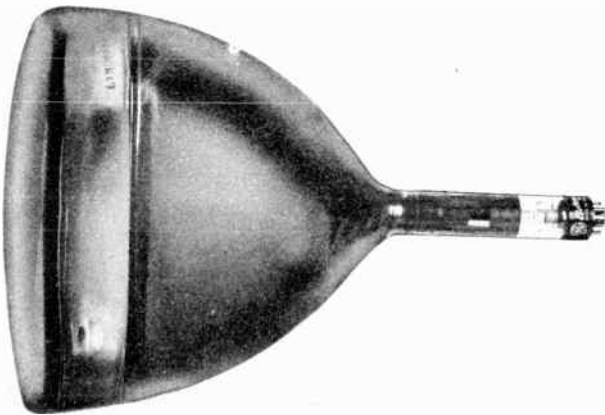

Fig. 4. This is one style of all-glass picture tube.

Other tubes are partly of metal and partly of glass. One example of this construction is shown by Fig. 5. The large flare is of thin, but strong metal. The front edge of the flare is flanged to hold and unite with the glass face in a vacuum tight bond. This edge, which is called the lip of the tube, forms the connection for the highest positive voltage applied from the high-voltage power supply. Since the lip and the flare are a single piece of metal, the entire flare is at this same high voltage.

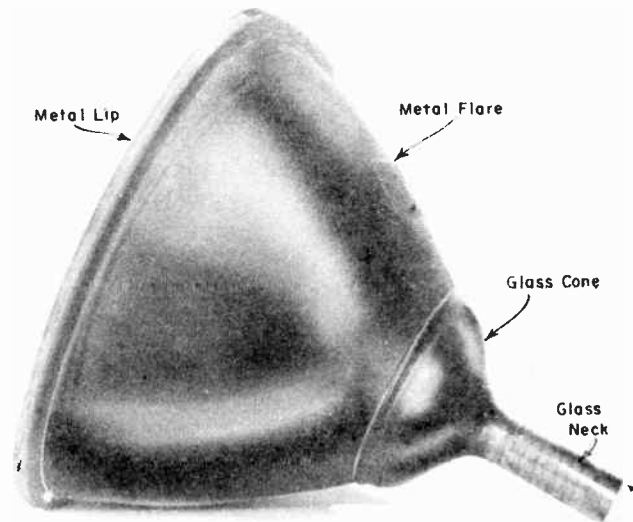

Fig. 5. This is a metal-glass picture tube, commonly called a metal tube.

The small end or the rear of the metal flare is joined to a glass cone which is an extension of the neck. This glass cone, covered with an external insulating coating, forms an insulating barrier between the highly charged metal flare and the deflecting yoke which fits around the neck close against the cone. The coating of the glass cone must be carefully protected against dirt of all kinds. Do not handle this portion of the tube, since your fingerprints might form a current-leakage path of relatively low resistance.

In an earlier lesson dealing with alignment we examined a typical high-voltage terminal connection for all-glass picture tubes, the kind that snaps into a small cavity on one side of the glass flare. Connections to the lips of metal-glass tubes are made with various forms of spring clips which snap into place, or by contact plates held in place by insulation, usually plastic, which encloses and supports the lip.

### RECTANGULAR AND ROUND TUBES.

All of the earlier television picture tubes had round or circular faces. A few years ago there appeared the first tubes with a rectangular face, which is the shape now used for the great majority of new types having either glass or metal envelopes.

Fig. 6 shows some relations between dimensions at the front of a rectangular tube

## COYNE - television home training

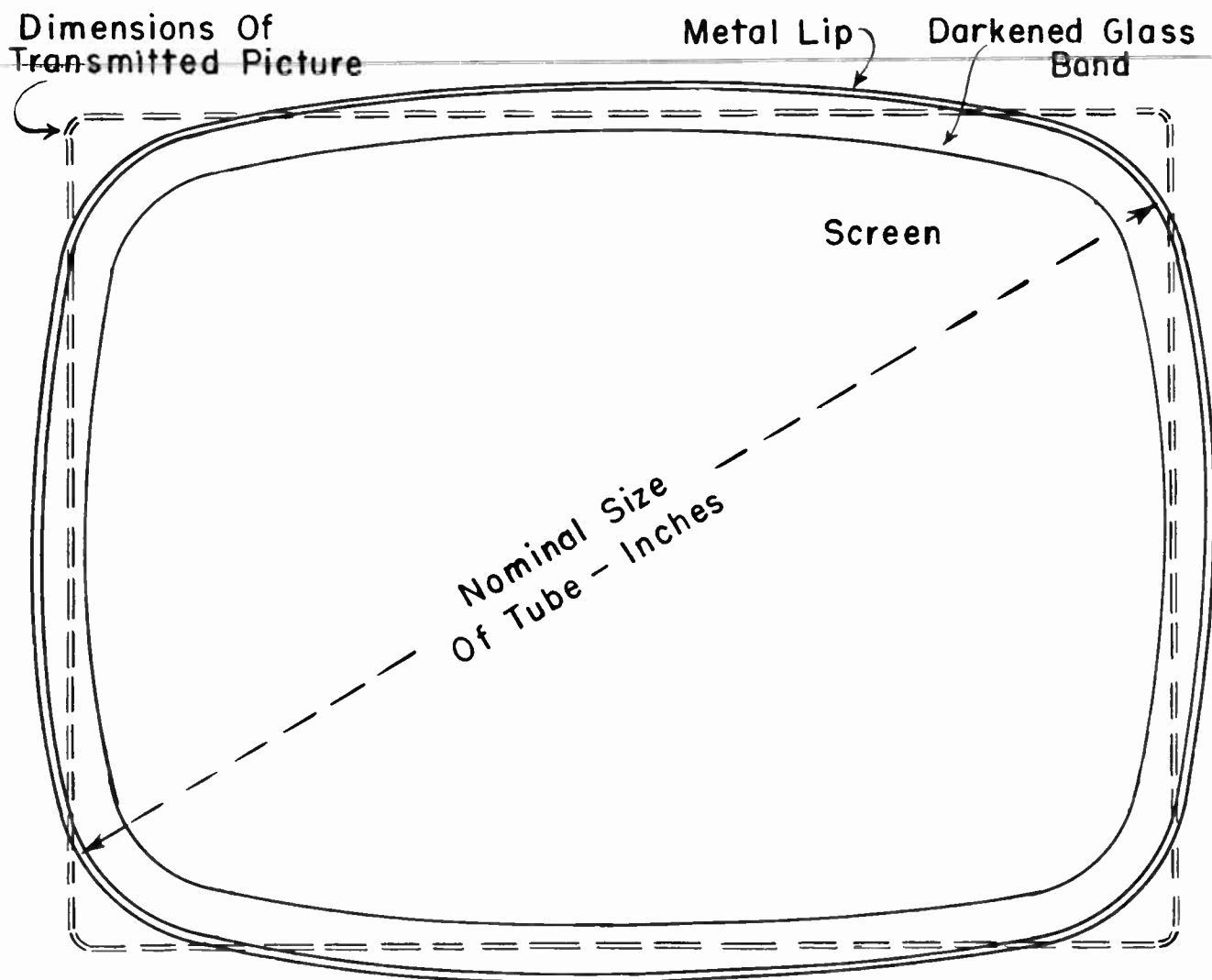

Fig. 6. Face and screen areas of a rectangular picture tube compared with the proportions of a picture having the standard aspect ratio.

and of transmitted pictures. The nominal size of the tube is the distance across a diagonal. For a tube having the number "21" as the first part of its type designation this diagonal distance would be approximately 21 inches. This diagonal is measured on the outside of the lip of a metal shell tube or outside the face of a glass tube. Between the outside limits of the tube and the screen is a band of blackened or darkened glass, usually something like  $1/2$  to  $3/4$  inch in width. Within this darkened band is the screen which may be made luminous for reproduction of pictures. The diagonal distance across the screen always must be less than the nominal size of the tube.

The ratio of width to height on the screen of a rectangular tube is very close to  $4/3$ , to

conform with the standard aspect ratio of transmitted pictures, which always is exactly  $4/3$ . Controls for width and height of reproduced pictures must be such that the edges of all pictures are somewhat outside the limits of the screen, because the edges may be brighter or darker than the main body of pictures, or the edges may be slightly ragged and they must not be visible in the reproduction.

With very careful and close adjustment of the service controls for width and height, a transmitted picture with standard aspect ratio might be related to the screen area as shown by the broken-line rectangle of Fig. 6. Ordinarily an adjustment giving such close relations as shown would cause trouble, because pictures from one station may be

## LESSON 45 – PICTURE TUBES

slightly larger or smaller than from other stations, and there is a tendency for pictures to become slightly smaller with aging of tubes other than the picture tube. In any case, however, a rectangular picture tube allows showing very nearly complete transmitted pictures except for small areas at the four corners.

In front of the picture tube when mounted in a cabinet there always is a sheet of protective glass or plastic surrounded by some kind of frame called the mask. Some masks expose the entire screen area of the picture tube and part of the darkened glass band around the screen. Other masks may conceal the darkened band while exposing very nearly the entire screen area. In this latter case, service controls for width and height are ad-

justed with reference to the limits of the mask.

Fig. 7 is a picture of a television receiver fitted with a round-face all-glass tube of 10-inch nominal size, a size which once was the largest available, but now is obsolete. Round tubes, both glass and metal, are made in all common sizes up to 30-inch nominal diameter for television receivers. The picture shows quite clearly the high-voltage connection on the glass flare. This general method of connection is typical of all glass picture tubes.

Fig. 8 shows relations between some of the dimensions at the front of a round picture tube and the size of a transmitted picture. The nominal size of a round metal tube is the

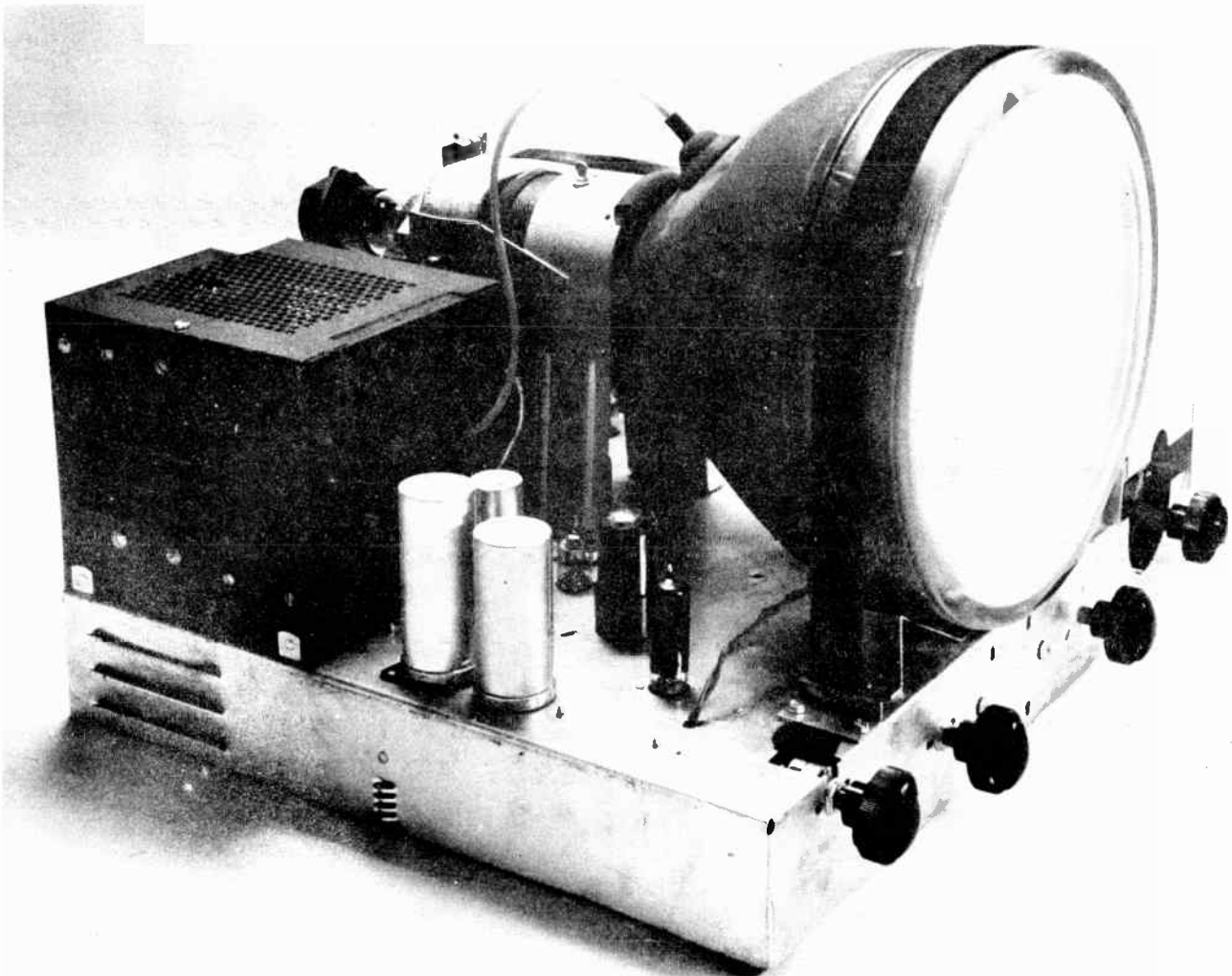

*Fig. 7. A round all-glass picture tube mounted on a television chassis.*

## COYNE - *television home training*

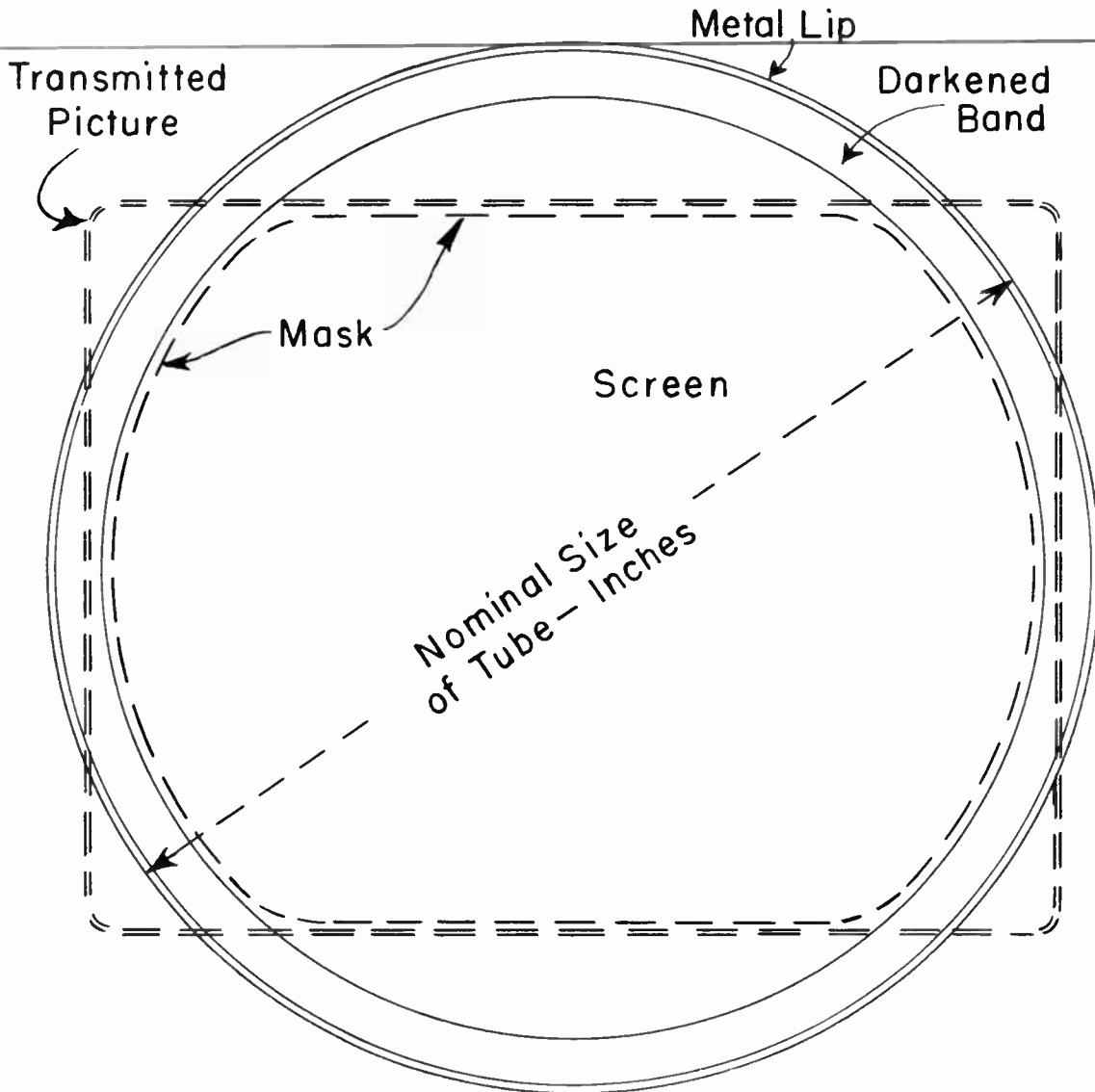

Fig. 8. Relations between front dimensions of a round tube and the outline of a picture having standard aspect ratio.

diameter across the outside of the lip, and of a round glass tube is the diameter on the outside of the face. There is a darkened band of about the same proportional width as on rectangular tubes, and inside this band is the screen.

The outer limits of a transmitted picture having the standard  $4/3$  aspect ratio are shown by the broken-line rectangle, with sufficient overlap beyond the screen to allow the largest possible reproduction. To prevent exposing irregularly shaped sections of the darkened band, there is a mask (on the cabinet) which conceals this band while leaving as much as possible of the screen area in view.

The mask for the round tube cuts off somewhat more at the corners of the transmitted picture than is the case with a rectangular tube. This is no real disadvantage, because little if anything of importance happens in these corner areas. The chief disadvantage of the round tube, compared with the rectangular type, is in the unused portion of the screen and face at top and bottom. For a picture of given size, this necessitates a higher cabinet than needed for a rectangular tube.

**FACE PLATES.** If you have access to a television receiver whose picture tube has a white screen and a face plate of clear glass, an instructive experiment may be performed,



## LESSON 45 – PICTURE TUBES

First, view a picture in a darkened room, adjusting the contrast or contrast and brightness for most pleasing results. Then turn on some fairly bright room lights. The picture will appear to have lost contrast, and to be, comparatively, washed out and of an all-over gray tone.

The external light has added a certain amount of illumination to every portion of the picture. This added illumination forms a large percentage of the illumination originally existing in darker parts of the picture, and makes these parts appear decidedly lighter. The added illumination is only a small percentage of the original "highlight brightness" in the picture, and the brighter portions are not greatly altered in tone.

The external illumination may be called "ambient light", because it comes from the surrounding space, or it may be called "incident light" because it falls on the face of the picture tube. Ambient or incident light passes through a face plate of clear glass with little loss, it is reflected from the white phosphor, and comes back through the face plate to your eyes, along with picture illumination originating from the screen.

One of the more successful means for reducing loss of contrast consists of using in the face plate a kind of glass which absorbs part of the light passing through it. Such glass, which appears gray, may be called a neutral density filter, because it has equal absorption for light energy at all wavelengths. External light passes through the face plate twice, once on its way to the screen and again coming out, and thus is subjected to greater absorption than light from pictures, which passes through the face plate only once.

The gray glass face plate has the further effect of reducing the reflections which occur between the polished outer surface and the reflecting screen on the inside of the face plate. Light thus reflected is that originating from the screen as the electron beam produces a brilliant moving spot, and is reflected back onto the screen. This causes loss of definition or sharpness, as well as of contrast.

Light from lamps, windows, and other luminous objects in a room may be reflected from the outer surface of a smooth face plate, as from a mirror. Then bright areas or spots appear at various places on the pictures. It may be difficult or impossible to avoid such reflections, because the face plate is curved and, to some extent, acts like a polished ball which will reflect light coming from any and all directions.

The sharply defined spots or areas of reflected light are referred to as specular reflection, a term derived from the ancient Roman name for a smooth mirror, a speculum. Some face plates have an outer surface very finely etched or frosted, somewhat like the frosted inner surface of certain electric lamp bulbs, but of finer grain.

These frosted or etched face plates change the specular (sharply defined) reflections into diffuse reflections having no definite form, and much less objectionable. Other face plates are externally coated with some kind of anti-glare material to produce somewhat the same effect. Many picture tubes have face plates of gray glass with external frosting, to combine the advantages of both treatments.

Another means for lessening the objectionable effects of reflections from external light sources makes use of what is called a cylindrical face plate. The difference between a cylindrical face plate and the more familiar spherical type is shown by Fig. 9.

When looking straight across the front surface of a spherical face plate there is the same curvature whether you look down from above or look from either side. That is, the face is shaped like part of the surface of a very large ball or sphere. When looking down at the front of a cylindrical face plate there is the same degree of curvature as on the spherical type, but this curvature extends only crosswise of the plate, from left to right. When you look from either side across a cylindrical face plate the surface is seen to be straight up and down, there is no curvature from top to bottom. The cylindrical face plate is shaped like part of the surface of a large cylinder, whose axis is vertical.

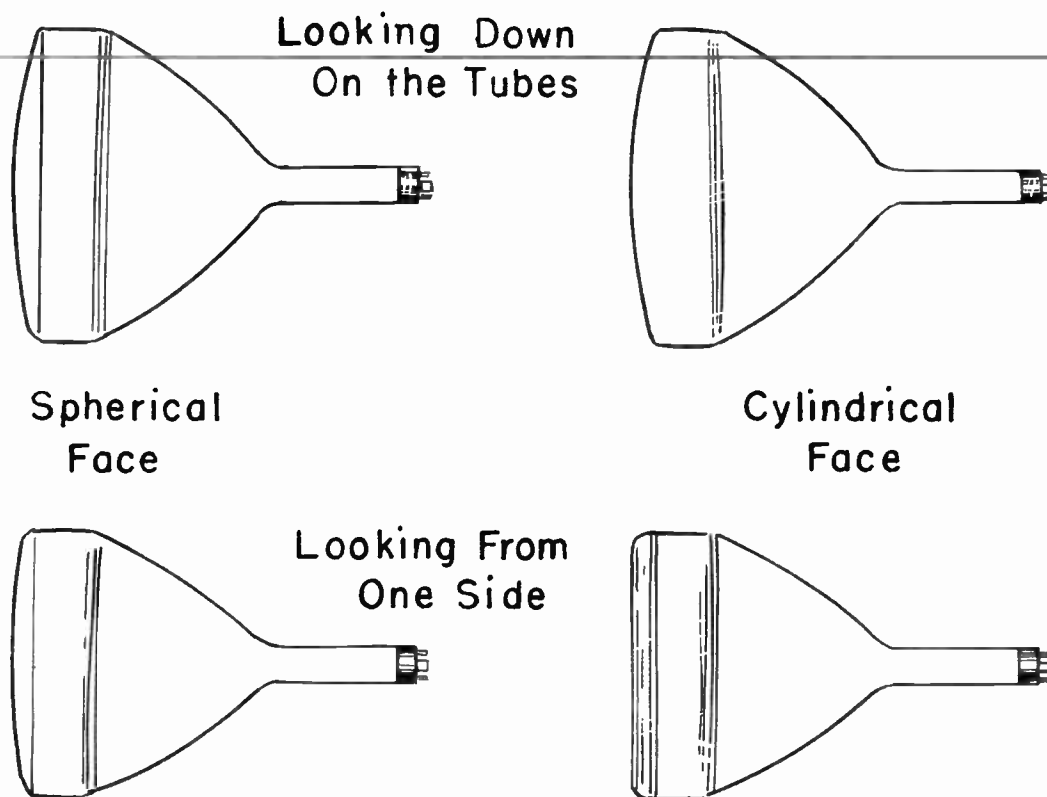

Fig. 9. A spherical face plate curves in all directions, like a ball, but a cylindrical face plate curves only from left to right.

External light reflected from the cylindrical face plate does not reach your eyes unless the light source is at the same level as your eyes and the picture tube, or unless your eyes and the light source are at equal angles above and below the picture tube. To say this more technically, we make use of the optical law that the angle of specular reflection always is equal to the angle of incidence at the reflecting surface.

DEFLECTION AND FOCUSING. Within a television picture tube are elements which perform somewhat similarly to some of those in ordinary amplifier tubes. We already know that in both kinds of tubes there is a cathode which emits electrons when heated, and a control grid which regulates the rate at which emitted electrons may leave the cathode. Beyond the control grid in a pentode amplifier is a screen grid. In a picture tube the element comparable to the screen grid of an amplifier is called the second grid or the first anode. The purpose of the screen grid in an amplifier and of the second grid in a picture tube is to pull electrons away from the cathode and to help accelerate them on

their way to the plate in the amplifier or to the picture screen in the picture tube.

The final element in an amplifier is the plate, which collects electrons and returns them to an external circuit. In a picture tube the final element is called the second anode, or it may be called the ultor. This element eventually collects electrons which have been emitted from the cathode. But before reaching the second anode of the picture tube the electrons strike the screen. After the negative electrons have expended much of their energy ~~in~~ causing illumination of the phosphor or screen they are drawn away from the screen by the high positive potential maintained on the second anode, they travel to and enter this anode, and from it return to the external circuits.

The various elements in a picture tube do not look at all like those in an amplifier. Instead they appear as in Fig. 10, which shows one style of element assembly called the electron gun of a picture tube. As you can see, there are three cylindrical sections. The one nearest the base is the control grid.

## LESSON 45 – PICTURE TUBES

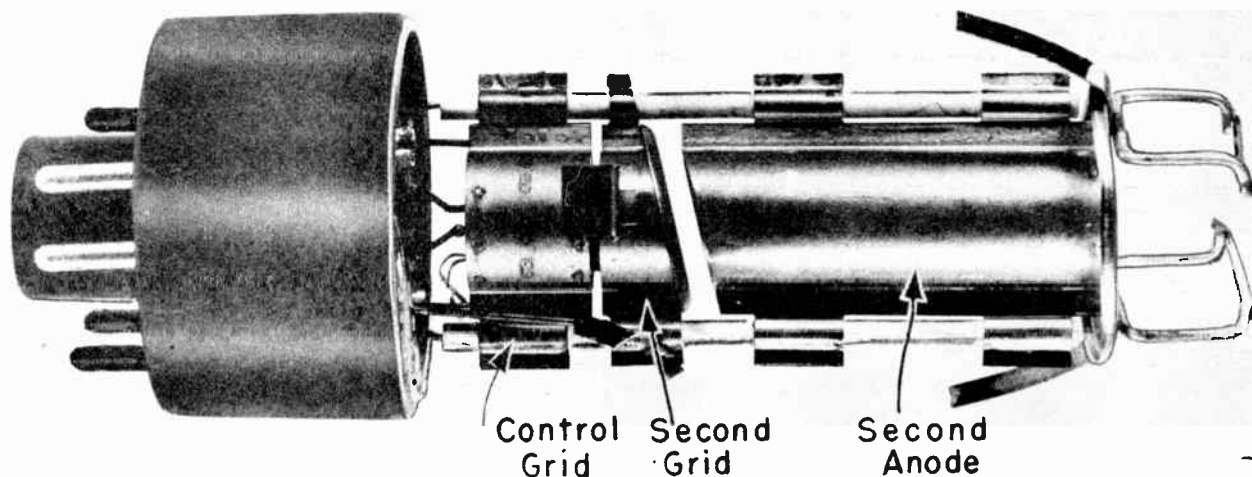

Fig. 10. One style of electron gun used in television picture tubes.

This grid completely surrounds the cathode, which does not show in the picture. The cathode is a still smaller cylinder. Inside the cathode is the heater.

The element next beyond the control grid is the second grid or first anode. The longest of the three cylinders in the electron gun is one part of the second anode or ultor. The remainder of the second anode is a conductive coating on the inside of glass tubes, or is a combination of conductive coating and the metal shell of metal-glass tubes.

Fig. 11 shows the inner conductive coating which forms part of the second anode. This is a simplified diagram applying in particular to glass tubes, and in general to all picture tubes. Electrons enter at the cathode pin on the base and flow to the heated cathode, from which they are emitted. The emitted electrons are drawn through an opening in the control grid by positive voltage on the second grid.

The second anode or ultor element begins with the metal cylinder which forms the front of the electron gun. Flat, flexible springs on the forward end of this cylinder make contact with a conductive coating which comes back along the inside of the glass neck. This conductive inner coating extends forward inside the neck and over all of the inner surface of the glass flare, almost to the screen. Thus the second anode consists of the for-

ward cylinder of the electron gun and all of the inner conductive coating.

In the case of a tube having a metal shell, the conductive coating on the inside of the glass neck extends over the inside of the small glass cone at the front of the neck (Fig. 5) and connects conductively to the metal shell. Thus the metal shell becomes part of the second anode.

With either an all-glass tube or a metal-glass type the entire second anode, including the forward cylinder of the electron gun, is maintained at a positive potential of thousands of volts with reference to the cathode. This exceedingly strong positive charge at the front end of the electron gun accelerates the electrons to tremendous velocity as they pass through and emerge from the gun. This velocity represents energy, and when the flying electrons strike the screen a large part of this energy is expended in producing light for pictures.

After the negative electrons have done their work at the screen, they are drawn to the highly positive inner coating of an all-glass tube or to the shell of a metal tube. Conductively connected to the inner coating of the glass tube is the terminal to which attaches the conductor from the high-voltage power supply. On the lip of the metal tube is the clip or other contact attached to the high-voltage conductor. Electrons which have been

## COYNE - *television home training*

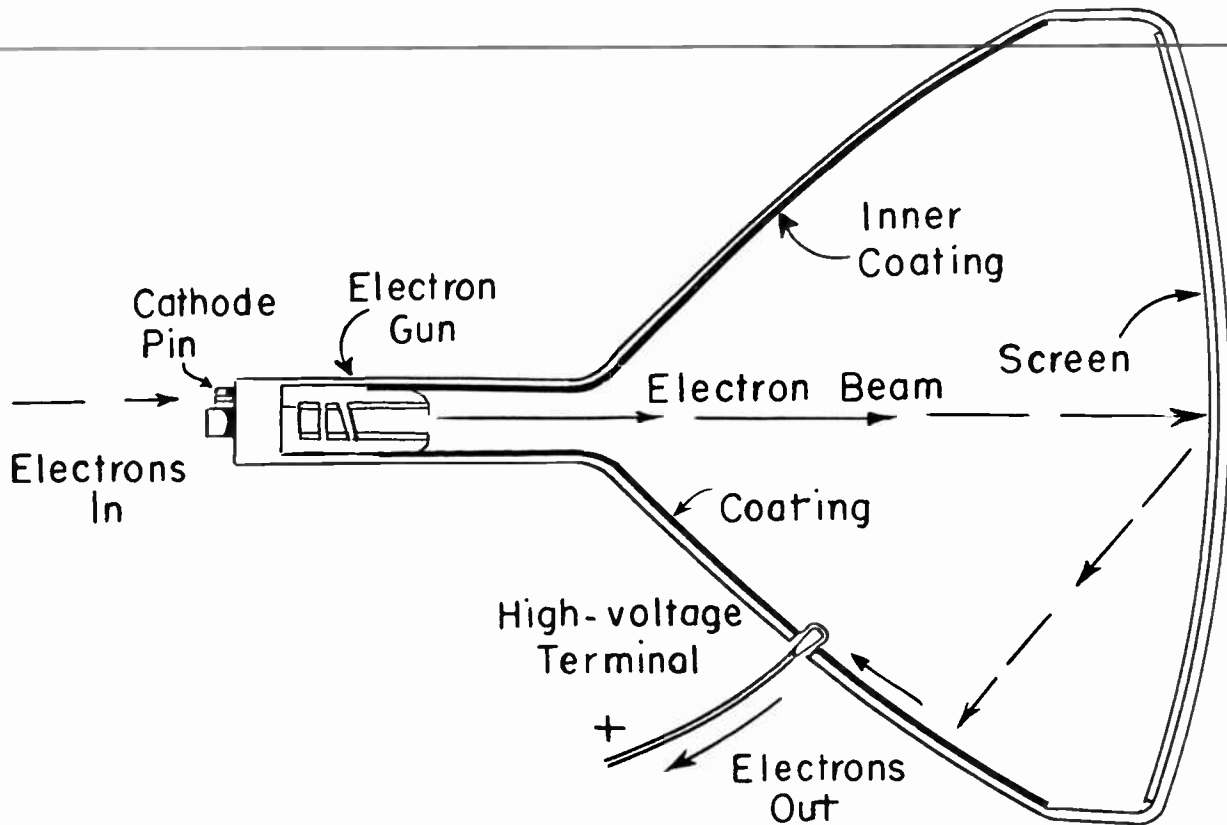

Fig. 11. The inner conductive coating of a glass picture tube, and the connection of this coating to the second anode portion of the electron gun.

collected by the inner conductive coating or by the metal shell flow out through the high-voltage conductor and return through it to the power supply.

With the parts of the picture tube which have been described there would be illumination of the screen. But this illumination would be so widely diffused over the screen surface as to be dim. To obtain a small, bright spot capable of tracing fine lines across the screen the electrons must be concentrated so that all of them come together at one place on the screen. The electrons must be focused, much as a diffuse beam of light is focused by a glass lens into a small, intense spot. We shall do our electron focusing with electron lenses.

Were we to do no more than focus the electrons into a thin and concentrated beam, there would be a stationary spot of light near the center of the screen, and soon it would destroy that small part of the screen surface. To avoid this, and to produce pictures, the

focused beam must be deflected both horizontally and vertically.

With the focused beam deflected horizontally and vertically, the pictures or a raster might be too high, too low, or too far to the right or left. Consequently, we must have means for centering the raster or pictures on the screen.

Even then, with the kind of screen most commonly used, something highly objectionable would happen after using the picture tube for a few weeks or months. Near the center of the screen would appear a brown spot, which would become darker and darker until it spoiled all pictures. Such a spot is an ion burn. The screen material is being damaged by gas ions which come along with the electrons from the cathode. These ions are relatively heavy, compared with electrons. They are not deflected as are the electrons, but always bombard the same small area of the screen. This must be prevented by using an ion trap, which keeps the heavy ions from reaching the screen.



## LESSON 45 – PICTURE TUBES

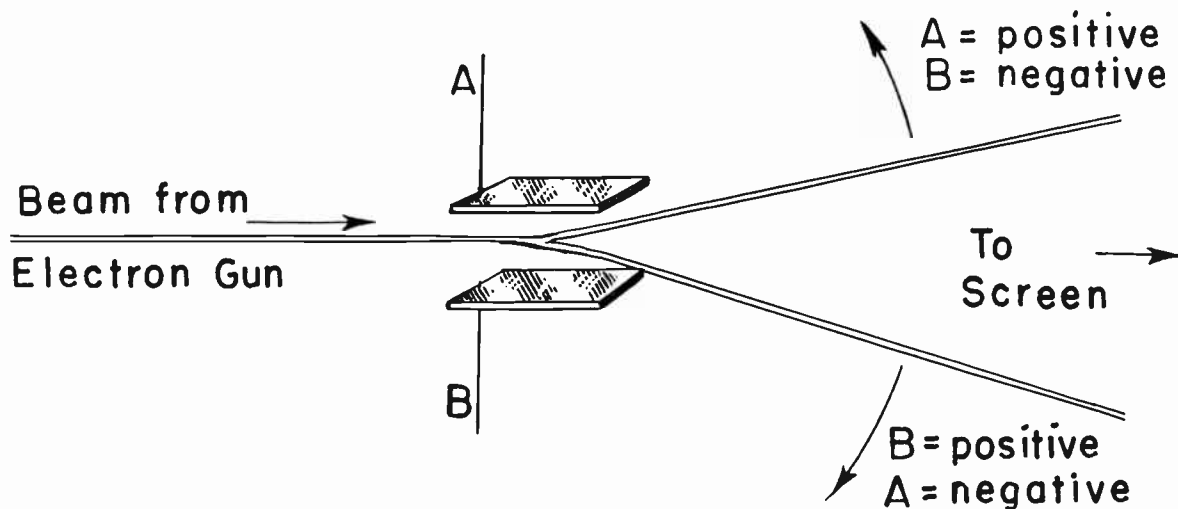

Fig. 12. The principle of electrostatic deflection.

Now let's take stock of some of these items which must be considered in selecting a picture tube for replacement or substitution. They include (1) the method of focusing, (2) the method of deflecting the electron beam, (3) the method of centering and (4) the type of ion trap to use when one is needed.

We speak of a choice between methods because focusing, deflecting, and centering may be carried out in either of two principal ways. One is by means of electric or electrostatic fields between oppositely charged conductors. The other is by means of magnetic fields produced by electromagnets or by permanent magnets. The trapping of gas ions requires both kinds of fields, the electrostatic kind inside the tube and a magnetic field on the outside.

The subjects of deflecting and focusing are big ones, and we shall only touch upon them during this preliminary examination of picture tubes. Centering is closely tied in with focusing and deflecting. The trapping of heavy ions may be considered to best advantage after we study the other things which must be done to the electrons and the beam.

**ELECTRON BEAMS AND ELECTRIC FIELDS.** The principle of electrostatic deflection is simplicity itself. As shown by Fig. 12 the focused electron beam passes between two metal plates, one of which is made positive while the other is negative, and

then their polarities are reversed. When the upper plate, A in the diagram, is positive it attracts the negative electrons in the beam and the beam is deflected upward. At the same time the lower plate, B, is negative, and it repels the negative electrons to add to the upward deflecting effect. When plate polarities reverse, the upper plate repels electrons in the beam while the lower plate attracts them, and the beam is deflected downward. Electrons passing between the two plates are going so fast that they are not pulled into the positive plate, but merely bent away from their original straight path.

In practice there are two sets of deflecting plates, as in Fig. 13. Both sets follow the electron gun. Plates of one set lie in vertical planes, and they deflect the beam horizontally. Plates of the other set are in horizontal planes, and they cause vertical deflection. With both sets of plates working on the beam it is deflected horizontally and vertically, as indicated at the right in this figure.

The elementary principle of electrostatic focusing is illustrated by Fig. 14. The second anode of the electron gun is in two sections which are electrically connected by a conductor so that both sections are at the same high potential. Between the two parts of the second anode is another cylinder, slightly larger, which is the focusing anode. The focusing anode is maintained at a positive

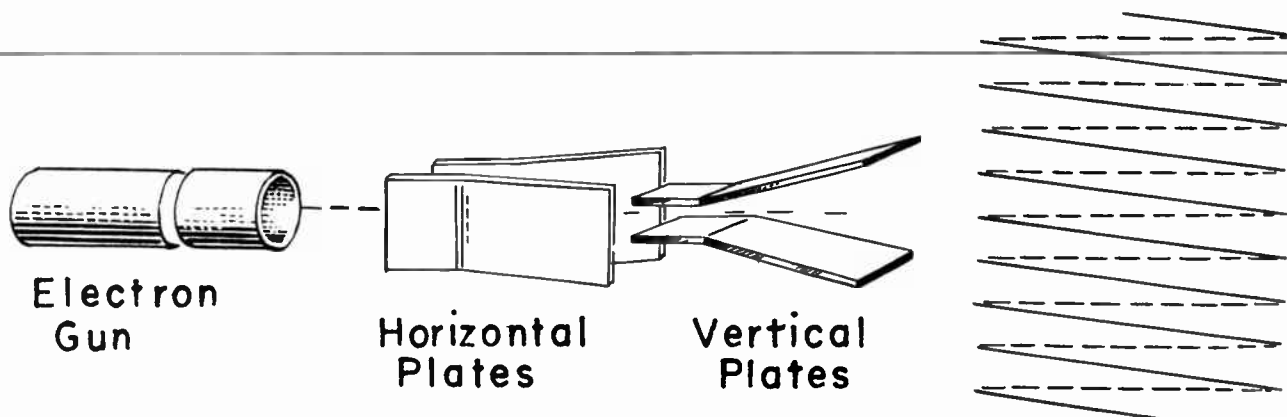

Fig. 13. Two sets of plates for horizontal and vertical electrostatic deflection.

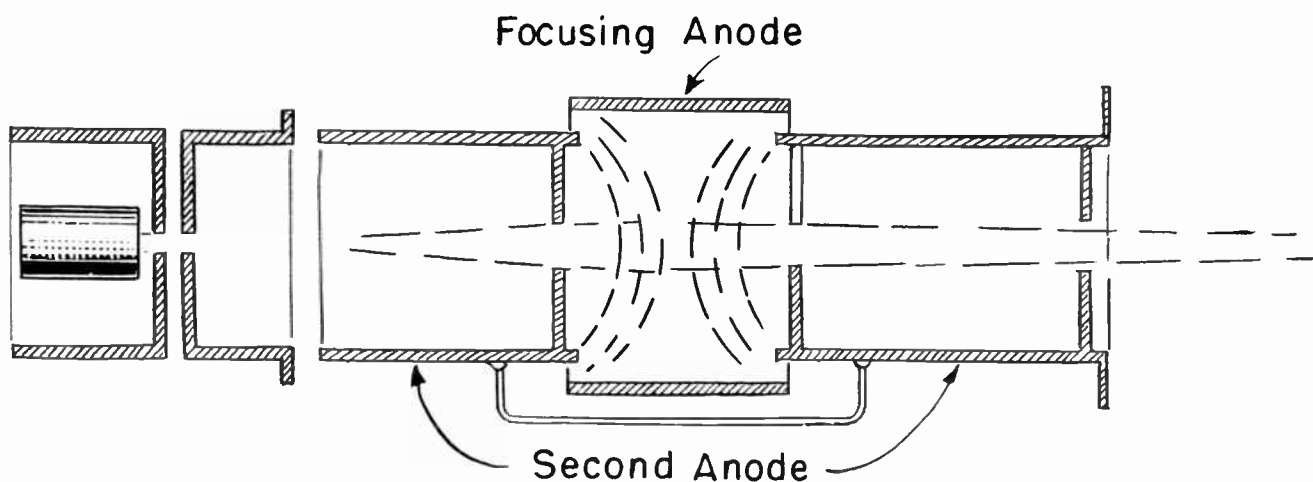

Fig. 14. The beam is focused by electron lenses consisting of electrostatic lines and potentials between the anodes.

potential which, in systems most commonly employed, is no more than 300 volts.

There is, of course, a strong electric field between the rear section of the second anode and the focusing anode, and another strong field between the focusing anode and the front section of the second anode. Within the field spaces are points along imaginary lines at which potentials are equal. It is the tendency of moving electrons to change their direction so that it is at right angles to the equal potential lines of the electric fields. The electrons which are spreading apart from the time they leave the cathode are turned back toward a common point in the electric fields. When second anode and focusing anode potentials are correctly related to each other and to the gun design, the common point at which the electrons come together will be at the picture screen.

**ELECTRON BEAMS AND MAGNETIC FIELDS.** Deflection of the electron beam by means of magnetic fields depends on this fact; lines of magnetic force tend to turn the electrons at a right angle to the direction of the magnetic lines and also at a right angle to the original direction of the electrons. It may be rather difficult to visualize just how the magnetic field acts on the electrons, but what really happens is illustrated by Fig. 15.

At the left in this figure are represented two magnets whose center lines or axes extend away from you along a horizontal line. The field lines between the inner poles of the two magnets then are horizontal, as shown. The focused electron beam is coming from the left, and it will be bent upward or downward according to the magnetic polarities or according to the direction of the magnetic lines of force. Were the two magnets mounted

## LESSON 45 – PICTURE TUBES

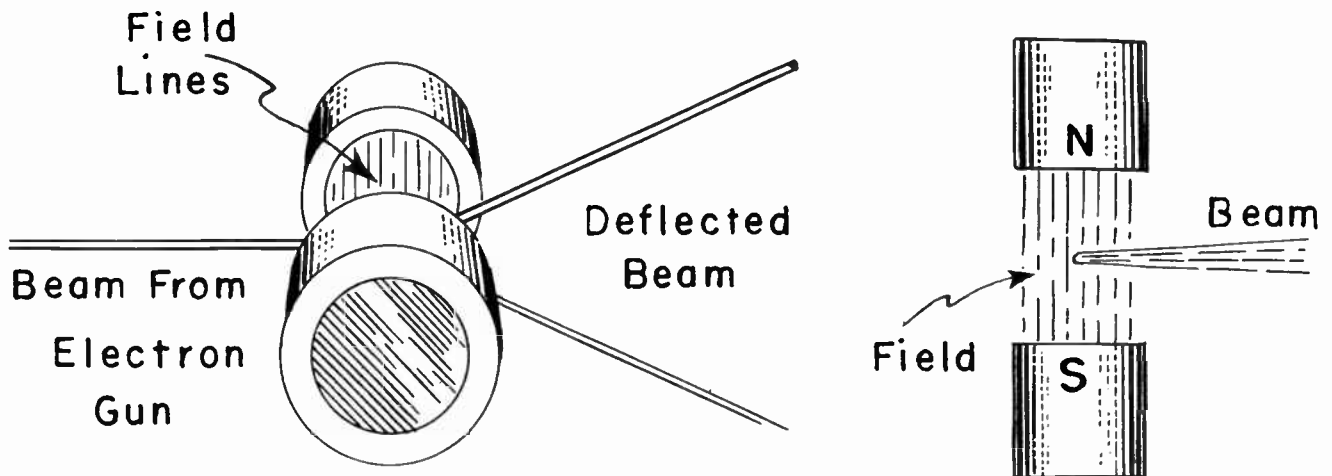

Fig. 15. How an electron beam is deflected when passing through a magnetic field.

vertically, one above the other, with the field lines vertical, the beam would be deflected horizontally.

In the diagram at the right the two magnets are mounted vertically. The electron beam is coming toward you. When a magnetic south pole below, the beam will be deflected to the right, as shown. Were the magnetic polarities reversed, the beam would be deflected toward the left in this diagram.

In the practical application of magnetic deflection, four electromagnets consisting of four coils on a suitable core structure are mounted in what is called a deflecting yoke. The yoke, with its two coils for horizontal deflection and two others for vertical deflec-

tion, is mounted as shown by Fig. 16. The yoke always is close against the beginning of the flare or cone, at the forward part of the glass neck.

The principle of magnetic focusing is shown by Fig. 17. Around the neck of the picture tube, just back of the deflecting yoke, is a cylindrical magnet whose center opening fits over the neck of the tube. This cylindrical magnet may be a coil, an electromagnet as shown, or it may be a permanent magnet. Magnetic field lines pass through the center of the focusing magnet and through the space within the tube neck as indicated by broken lines.

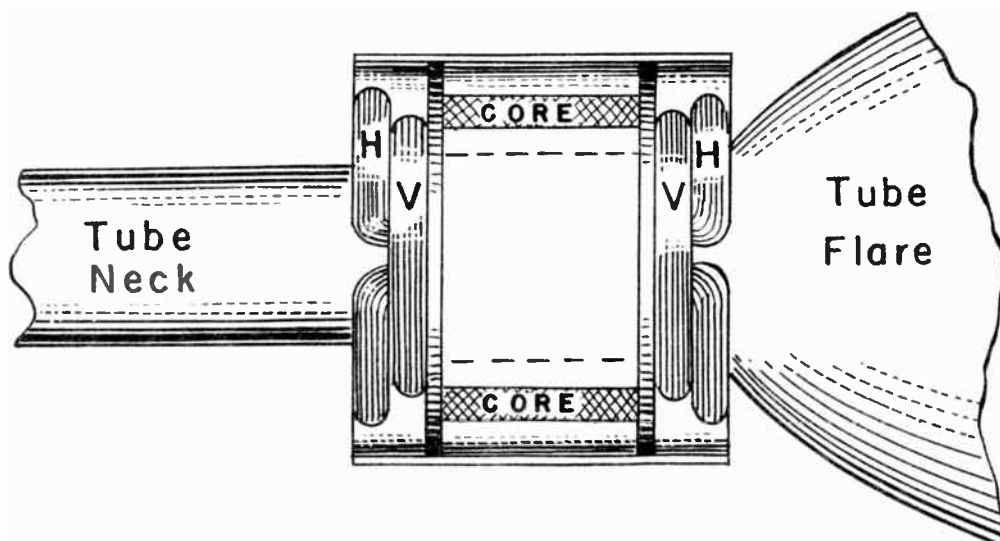

Fig. 16. The deflecting yoke with its four coils is mounted at the rear of the flare or cone on the picture tube neck.

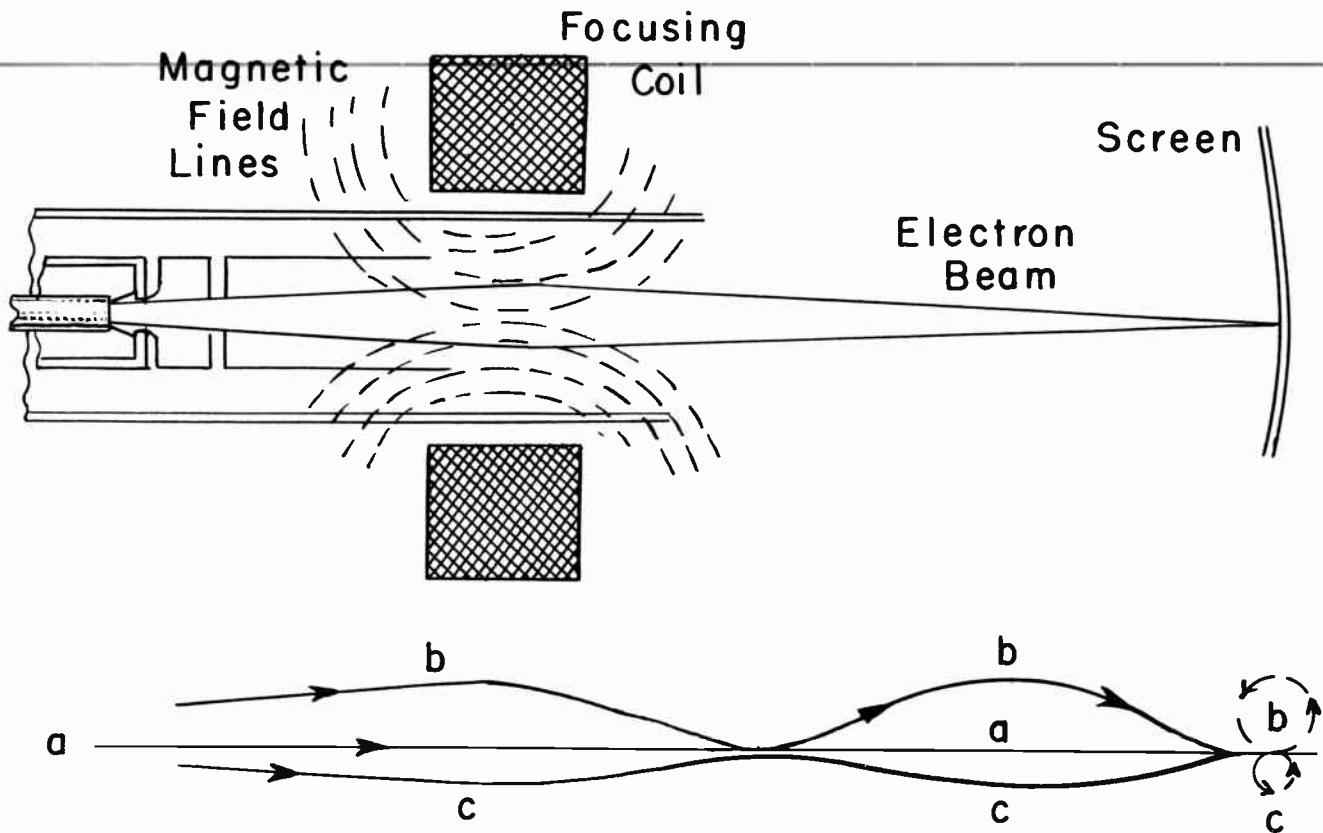

Fig. 17. The principle of magnetic or electromagnetic focusing.

Electrons coming straight through the center of the electron gun, and already aimed along the axis of the tube neck, are not affected by the magnetic field. Such electrons would travel along the line marked a-a of the bottom diagram. But electrons entering the magnetic field along any diverging path, as at b or c of the bottom diagram, are caused to whirl on a spiral path. Every so far, these spiral paths pass through the center axis of the tube neck. When the magnetic field is of correct strength, all the spiral paths being followed by all the electrons come together at the screen of the picture tube, and there the beam is focused to a small spot.

In order to center the electron beam or, rather, to center pictures or a raster on the picture tube screen, it is necessary only to tilt the focusing magnet one way or the other. Tilting the magnet changes the direction of the magnetic field lines which are affecting the electron beam, and, in effect, will direct the beam higher or lower or toward the left or right. Although tilting of the focusing magnet is a practical way of center-

ing the pictures, there are other means for changing the direction of the magnetic lines to cause the same effects.

When the electron beam is electrostatically focused, the focusing anode is part of the electron gun and there is no external focusing magnet. Centering then is obtained in most receivers by providing some relatively small permanent magnet or magnets for the sole purpose of centering the pictures. Another method of centering makes use of direct currents added to the alternating currents in the deflecting coils of the yoke. All methods of centering will be examined in detail a little later on.

**TUBE STRUCTURES.** As you may well imagine, the several methods of deflecting and focusing the electron beam may be combined to make a rather wide variety of picture tube structures. That is, for any given size, screen shape, envelope material, and kind of face plate, there may be different combinations of deflecting and focusing methods. This is one reason why every fairly



## LESSON 45 – PICTURE TUBES

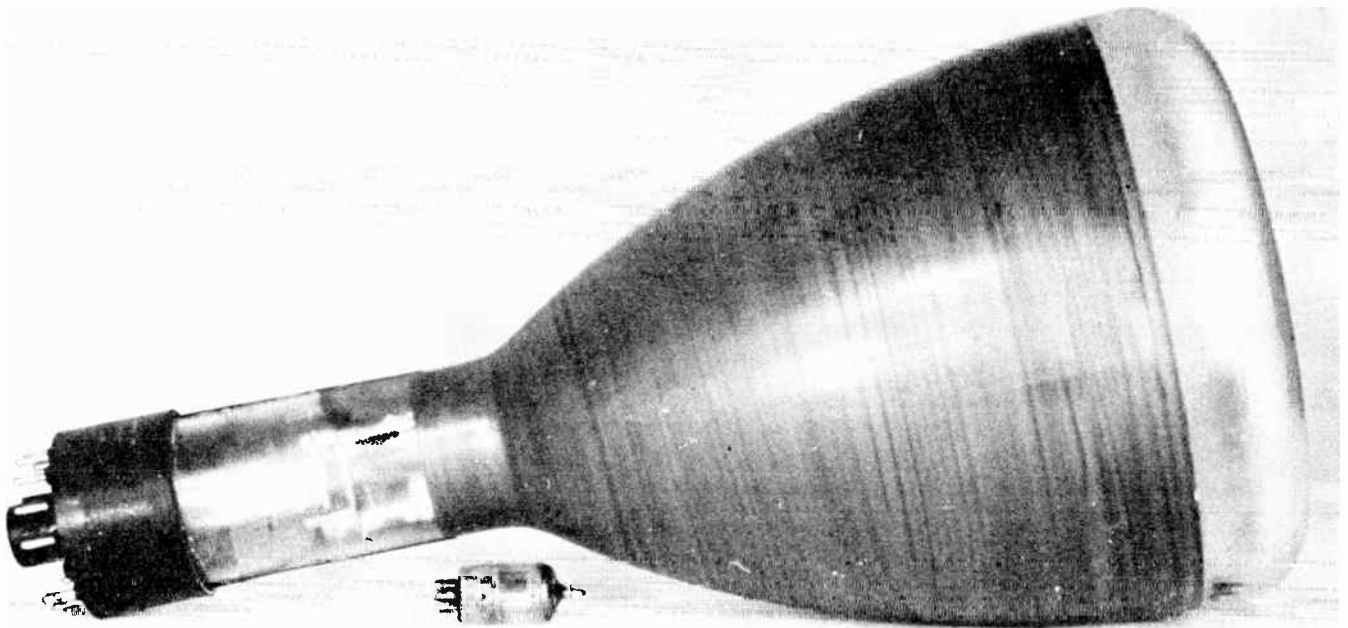

*Fig. 18. A round seven-inch picture tube employing electrostatic deflection and focus.*

complete listing of picture tubes includes at least 150 type numbers, no two of which are exactly alike.

All of the earliest picture tubes used electrostatic deflection and electrostatic focusing. Pre-war tubes of this kind were made in diameters of 3 to 20 inches. Nearly all of the more recently popular small-screen receivers used round tubes of 7-inch diameter with electrostatic deflection and focusing. The most common of these tubes is pictured by Fig. 18, with underneath it a miniature amplifier for comparison.

Tubes with electrostatic deflection and focusing have all but disappeared from new television receivers, but they are universally used in service-type oscilloscopes. This is accounted for by the fact that electrostatic deflection structures will operate satisfactorily throughout a very wide range of sweep frequencies, as required during oscilloscope operations. The frequency range of magnetic deflection is limited by

changes of inductive reactance in the deflecting coils at different frequencies. The reactance effects cause no difficulties in television because the vertical and horizontal sweep frequencies never vary.

With very few exceptions, all post-war television receivers employed picture tubes with magnetic deflection and magnetic focusing until about the year 1951. Focusing, at first, was electromagnetic, with a focusing coil around the neck of the tube. For this combination we find parts arranged as in Fig. 19.

Close against the beginning of the flare, at the forward end of the neck, is the deflecting yoke containing the coils for horizontal and vertical deflection. Just a little distance back of the yoke is the focusing coil, enclosed within a steel housing. On a receiver the yoke and the focusing coil would be supported or mounted in some suitable form of brackets and clamps to hold them firmly in fixed positions while enabling the yoke struc-

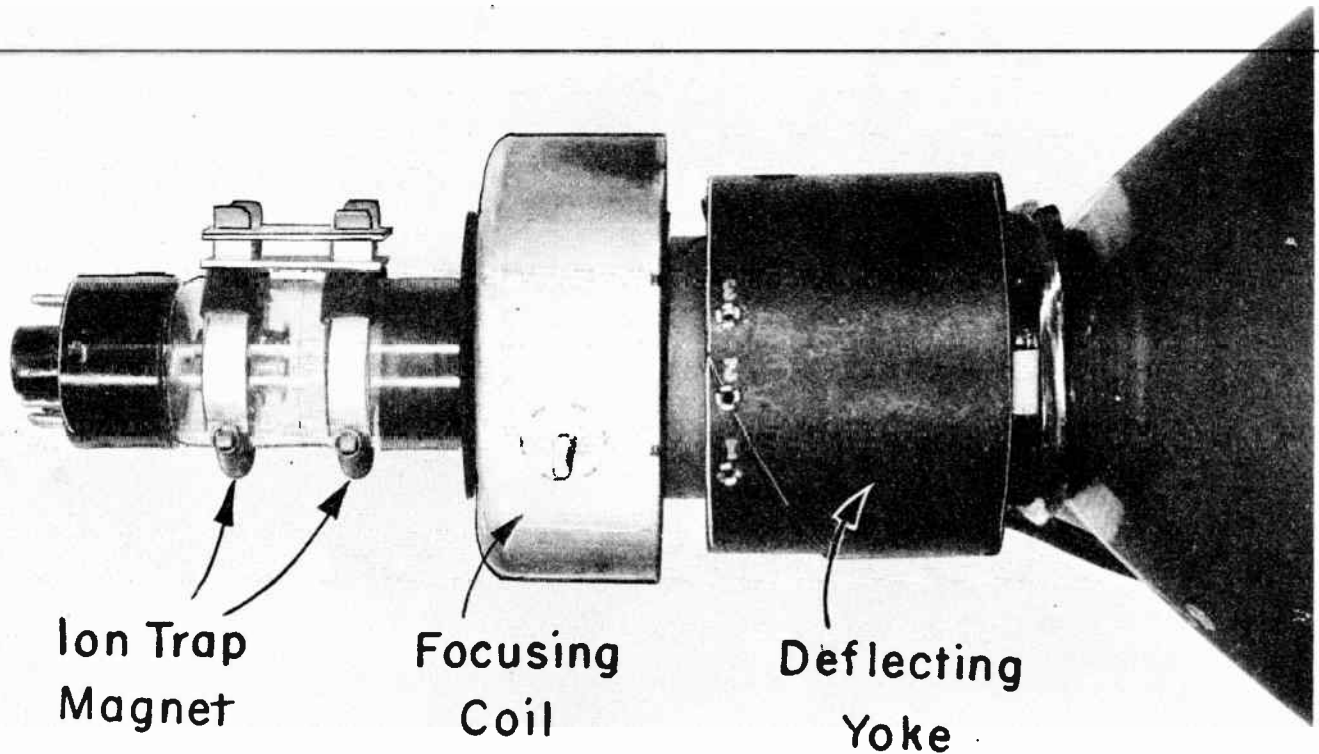

Fig. 19. Here we have magnetic deflection combined with an electromagnet for focusing.

ture to provide most of the support for the neck end of the picture tube. The yoke and focusing coil are here shown by themselves to more clearly illustrate their positions relative to each other and to the tube.

The yoke itself is enclosed within an insulating cover of cardboard, fibre, or plastic, which shows in the picture. Into this cover come four wires; two for bringing deflecting currents to the horizontal coils and two for current to the vertical coils. With some yoke structures there is a fifth wire for grounding the yoke structure to external circuits. Into the steel housing around the focusing coil come the two wires that bring direct current for focusing to the ends of the coil.

A short distance back of the focusing coil, and quite close to the socket of the picture tube, is an ion trap magnet. The magnet pictured really is a double magnet, it consists of two small permanent magnets held by

a support that slides over the socket and onto the tube neck. This double magnet provides the external magnetic fields for trapping the heavy ions, while the internal electric fields are between parts of the electron gun inside the neck.

In some receivers the electromagnetic focusing coil is replaced by a permanent magnet structure. Fig. 20 shows one style of "PM" focusing device replacing the focusing coil. The yoke is unchanged, and the position of the permanent magnet focusing device is the same as that of a focusing coil in relation to the yoke. There are service adjustments that change the strength of the magnetic field for focusing, and others that shift the position of the field for centering. There are no wires connected to the PM focuser.

Fig. 20 shows a single magnet for the ion trap instead of the double magnet. Although a double magnet was shown with

## LESSON 45 – PICTURE TUBES

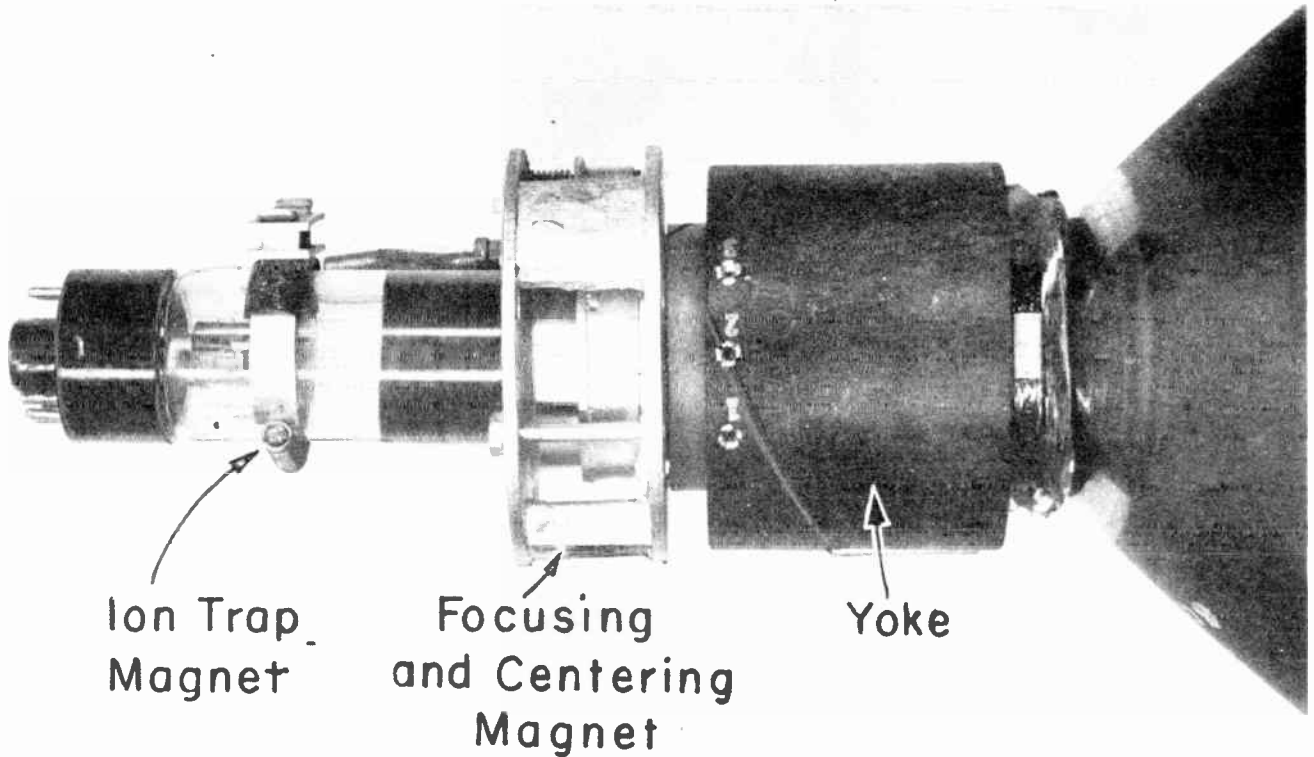

Fig. 20. Magnetic deflection combined with permanent-magnet focusing and centering.

electromagnetic focusing, and a single magnet with permanent-magnet focusing, there is no relation between the method of focusing and the kind of ion trap magnet. Whether the ion trap magnet must be double or single depends entirely on the design of the electron gun inside the tube neck. Some guns require a double magnet. Most of the more recent designs require only a single magnet, for reasons which we shall learn when studying ion traps in detail.

There are two types of picture tubes that require no ion traps and no trap magnets. One of these is the tube employing electrostatic deflection. It happens that the heavy ions are deflected to almost the same extent as electrons by an electrostatic field, and when the ions are distributed over the screen they do no harm. Ions are deflected hardly at all by magnetic fields, therefore all tubes employing magnetic deflection, with one ex-

ception, require an ion trap and either a single or double trap magnet.

The one exception is a type of picture tube in which the inner surface of the screen is coated with an exceedingly thin layer of aluminum, to form what is called an aluminized screen or a metal-backed screen. The aluminum does not interfere in any way with production of light by electrons, whose energy passes through the thin layer of metal to act on the screen. The aluminum does protect the screen from ill effects of heavy ions bombarding one small central area.

Many picture tubes designed and produced in recent years employ magnetic deflection combined with electrostatic focusing. The original reason for using tubes of this kind was to save the copper wire required in a focusing coil and the critical materials needed for making high quality permanent



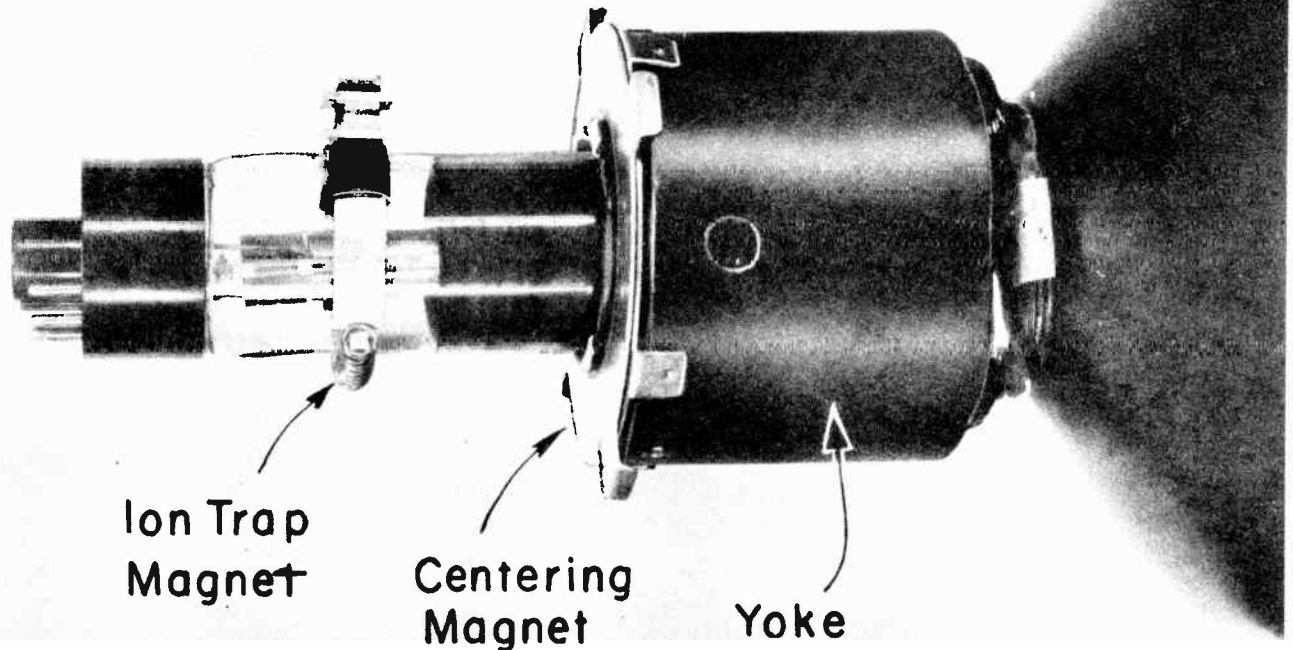

Fig. 21. Magnetic deflection, electrostatic focusing, and permanent-magnet centering.

magnet for focusing. With improvements which have been made in the design and construction of electrostatic focusing elements these tubes give performance and picture quality comparable to that obtained with magnetic focusing.

As shown by Fig. 21, a picture tube designed for magnetic deflection and electrostatic focusing requires the usual deflecting yoke which, as always, is close against the flare or cone of the tube. There is no focusing coil nor is there a large permanent magnet structure for focusing. There is, however, a very small permanent magnet or two or more such magnets, mounted immediately back of the yoke to allow centering of pictures. One such centering magnet assembly may be seen in the photograph.

In a few receivers equipped with picture tubes using magnetic deflection and electrostatic focusing, centering is accomplished by

allowing small direct currents to flow in one direction or the other through the deflecting coils, these direct currents being in addition to the varying currents for deflection. Then there is no need for a permanent magnet centering device.

There are three principal varieties of electrostatically focused picture tubes. In the type first introduced, the focusing anode is maintained at a potential of 2,000 to 3,000 volts with reference to the cathode. This is the high-voltage focus type of tube. The method most widely used at present maintains the focusing anode at a potential of something like 200 to 300 volts with reference to the cathode, or an even lower positive voltage may be used. This is the low-voltage focus tube. In a third type of tube the focusing anode is maintained at the same potential as the cathode. This may be called a self-focusing tube. All of these types require single magnets for their ion traps.



# LESSON 45 – PICTURE TUBES

Now we may make a revised listing of the items to be specified in a complete description of a television picture tube. Of course, if you specify the correct type number it would permit exact replacement of the original tube, but unless you know all the features of that particular tube, the number would tell nothing more than the approximate face size and the kind of phosphor. Here is our list.

- |                        |   |
|------------------------|---|
| 1. Envelope.           | All-glass<br>Metal-glass  |
| 2. Face shape.         | Rectangular<br>Round  |
| 3. Face plate glass.   | Clear<br>Gray or tinted<br>Frosted or etched<br>Combinations of these features. |
| 4. Face plate contour. | Spherical<br>Cylindrical  |
| 5. Deflection.         | Magnetic, electro-magnetic.   |

## 6. Focus

## 7. Center

## 8. Ion trap.

Electrostatic

Electromagnet  
Permanent magnet  
Combined permanent and electromagnet.  
Low-voltage electrostatic  
High-voltage electrostatic  
Self-focus electrostatic

Tilting of focusing coil  
Altering the field of a focusing permanent magnet.  
Small permanent magnets for centering only  
Direct currents in yoke coils

Single magnet  
Double magnet  
No trap, no magnet

# TELEVISION

- RADIO
- ELECTRONICS

---

---

## LESSON 46 – PICTURE TUBE OPERATION

---

---

***Coyne School***

*practical home training*

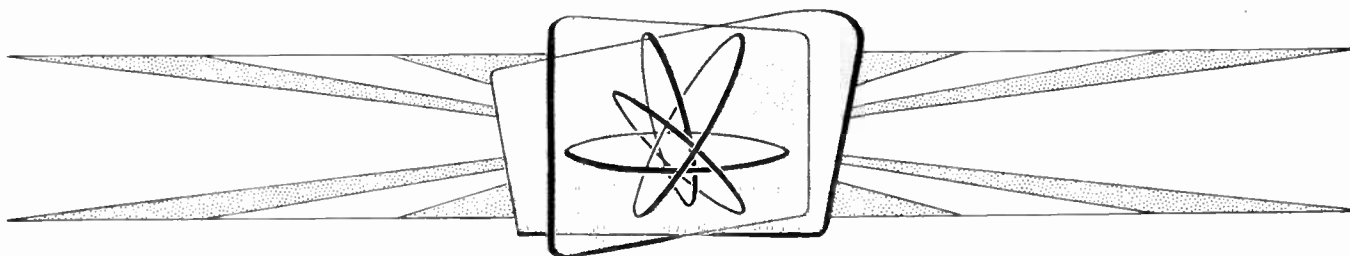

*Chicago, Illinois*

---

*Copyright, 1953 by Coyne Electrical School  
Chicago 12, Illinois  
All rights reserved*

Litho. in U.S.A



## Lesson 46

# PICTURE TUBE OPERATION

Potential on the second anode or ultor element of television picture tubes may be between 8,000 and 16,000 volts, with reference to the cathode, when pictures are of high brightness and sharp definition. These high voltages are necessary in order that electrons striking the screen may have sufficient velocity, and energy, to excite the phosphor material to a high degree of luminescence.

There are no fixed relations between second anode voltage and tube size or shape. Neither is this voltage directly related to envelope material nor to whether the focusing method is magnetic or electrostatic. However, in a very general way, the larger tubes usually are operated at higher anode voltages than smaller tubes. Tubes of 10-inch and 12-inch sizes ordinarily are operated with second anode voltages between 8,000 and 11,000. The 14-inch and 16-inch sizes most often are worked at 9,000 to 12,000 anode volts, while sizes 17-inch and larger commonly are operated at 12,000 to 16,000 volts on their second anodes.

Maximum permissible second anode voltage for any given type of tube always is somewhat greater than voltages regularly employed in receivers. For example, a 20HP4 tube usually is operated with no more than 14,000 volts on its second anode, but the maximum rating for this type is 16,000 volts.

The greater the voltage on the second anode of a picture tube, within safe limits, the more brilliant will be reproduced pictures, and the more sharply the details will appear on the screen. If some particular tube will produce excellent pictures with, for instance, 11,000 volts on its second anode, and this voltage is dropped to 9,000, not many people would notice the difference - unless the change occurred suddenly. But were the anode voltage on this tube dropped to 8,000, or 7,000, or possibly as low as 6,000 volts, there would be greater and greater deterioration of picture quality as the voltage decreases.

When a video signal of ample strength and good waveform is reaching the grid-cathode circuit, and when pictures persist in appearing rather dim and poorly defined, or generally fuzzy when brightness is turned up, the experienced technician measures the second anode voltage and checks it against ratings for the picture tube.

In practically all recently designed home receivers having "direct view" picture tubes, the high voltage for the second anode is obtained as illustrated in Fig. 2. Here we are having a preview of one portion of what is called a flyback or kickback type of high-voltage power supply.

The plate of the horizontal sweep amplifier is connected to the primary winding of the horizontal output transformer. In this winding are produced current variations at the horizontal line frequency, 15,750 cycles per second. These primary currents induce emf's and currents in the deflection secondary winding, which is connected to the horizontal deflecting coils in the yoke on the neck of the picture tube. Actually, the yoke circuit is not nearly so simple as shown here, but details will come later.

During periods of horizontal retrace there are very sudden changes of current in the horizontal deflection circuit. These changes of current in the deflection secondary react on the primary to induce in the primary a series of voltage pulses whose strength is proportional to the rate of current change. Because of the very quick change of secondary current, primary pulses reach a peak value of 4,000 volts or even more. Connected to the high end of the primary winding, and on the same core, is an extension which forms, with the primary, an auto-transformer. By using a suitable number of turns in the extension, the pulses of primary voltage are stepped up to a value suitable of the second anode of the picture tube.





Fig. 1. Coyne students are examining a metal-cone picture tube fitted with a protective cover and an insulating ring around the lip.

**COYNE** - *television home training*

## LESSON 46 – PICTURE TUBE OPERATION

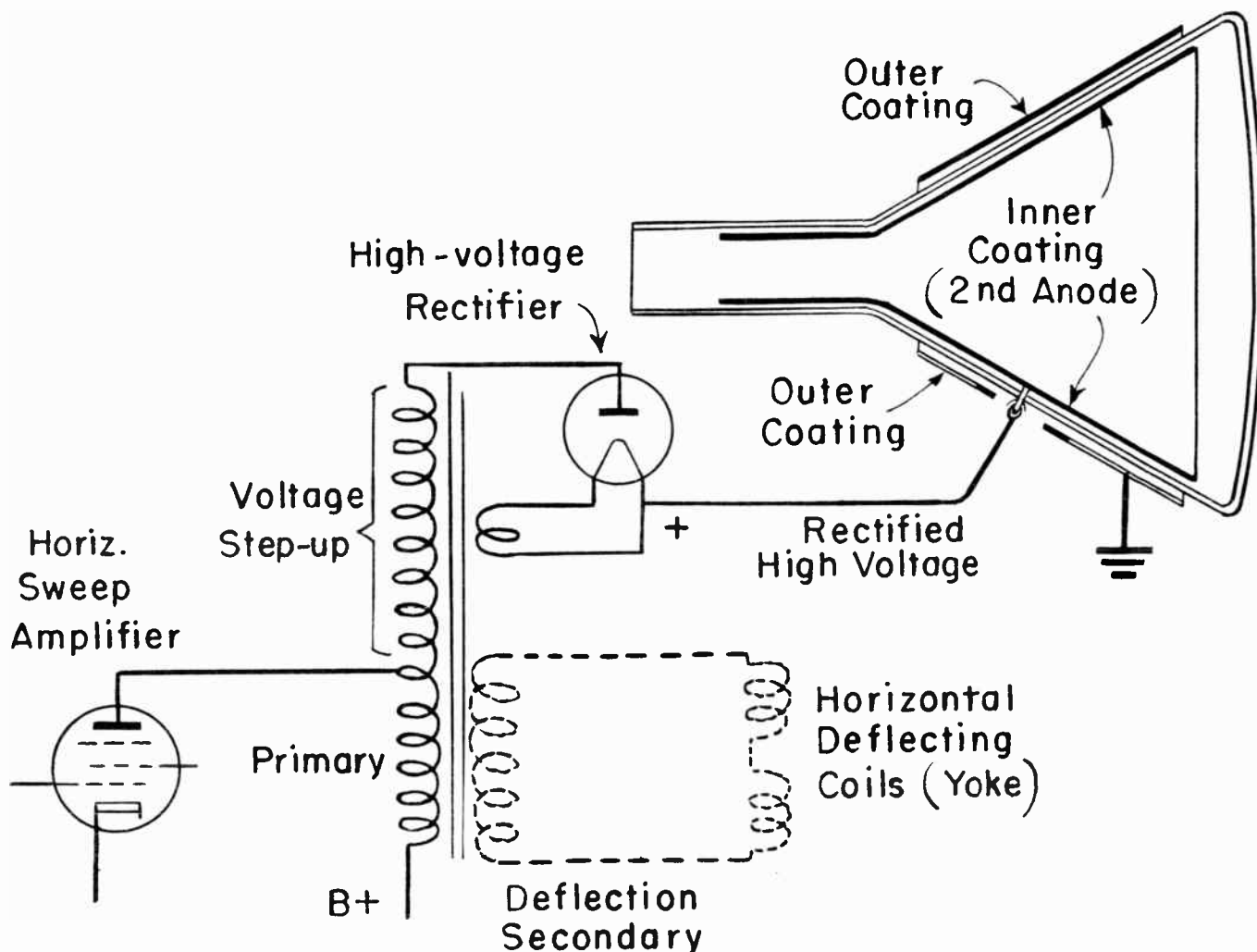

Fig. 2. The high-voltage power supply system for the second anode of a picture tube.

The top of the auto-transformer winding is connected to the plate of a half-wave high-voltage rectifier tube. The cathode of this rectifier, a filament type, is heated by pulsating voltage and current taken from a winding of one or two turns on the core of the horizontal output transformer. Rectified high voltage is positive at the rectifier filament, from which a connection is made to the second anode terminal on the picture tube.

With high voltage taken from the rectifier directly to the anode terminal of the picture tube it might appear that this voltage is not filtered, and that it would consist of successive pulses. Actually, however, there is filter capacitance of at least 500 mmf and sometimes as much as 2,500 mmf in the rectifier output circuit. This capacitance is provided by adding an outer conductive coat-

ing on the glass picture tube. This outer coating may be seen on the tube of Fig. 3, where it appears dull black, with portions of the envelope not coated retaining their shiny appearance. This external coating covers most of the flare except for a fairly large circular area around the high-voltage terminal and a space near the neck where the yoke will be placed.

Filtering capacitance results from the outer conductive coating acting as one plate of a capacitor, with the glass of the envelope acting as dielectric, and with the inner conductive coating as the other capacitor plate. The outer coating always is grounded, usually by some kind of spring contact member that presses against the coating when the picture tube is mounted in its regular operating position. Capacitance thus connected between

# COYNE - *television home training*

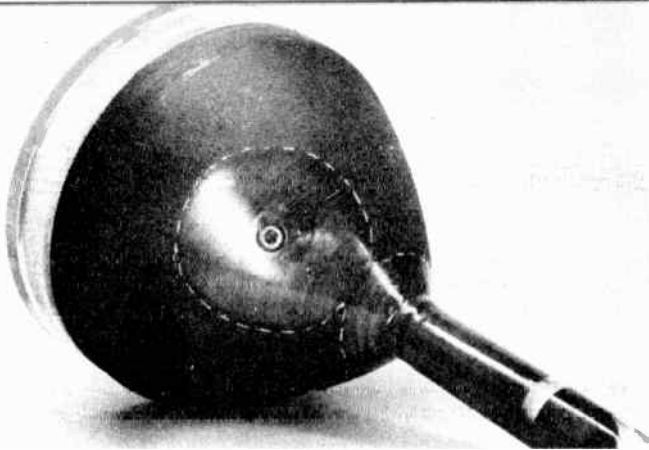

Fig. 3. The outer coating on a glass picture tube acts as one plate of a filter capacitor. Areas not coated are within the broken white lines.

rectifier cathode and ground acts similarly to a filter capacitance in any power supply, it smooths the rectified voltage.

The electrical equivalent of capacitance in the picture tube coatings is shown with conventional symbols at 1 in Fig. 4. Additional capacitance is provided in some receivers by connecting an external capacitor as at C in diagram 2. In nearly all cases this external capacitor has a value of 500 mmf, a d-c voltage rating of 10,000 to 20,000 volts, depending on the second anode voltage employed.

In many high-voltage filter circuits there may be either or both of the resistors shown by diagram 1 of Fig. 5. Resistor R<sub>a</sub>, in series with the rectifier filament, is for the purpose of limiting the filament current. Resistance here usually is of some value between 2.7 and 5.1 ohms. These odd numbers of ohms mean only that the resistors are of "preferred values", not that the values are critical to within one-tenth ohm.

Resistor R<sub>b</sub> is a filter resistor, usually of some value between 0.1 and 1.0 megohm. When this resistance follows an external filter capacitor, C, it is effectively between two filter capacitances, with the second one provided by tube coatings. Then we have the same general type of low-pass filter employed in low-voltage power supplies.

Quite often you will find the external high-voltage filter capacitor connected to the deflection circuit that includes the horizontal deflecting coils or a deflection secondary of the horizontal output transformer, as at 2 in Fig. 5. Such a connection adds to the voltage on the second anode of the picture tube the voltage in the deflection circuit, which ordinarily is between 250 and 350 volts. When the filter capacitor is connected to chassis ground, the second anode voltage is only that secured through the high-voltage rectifier from the auto-transformer winding of the horizontal output transformer.

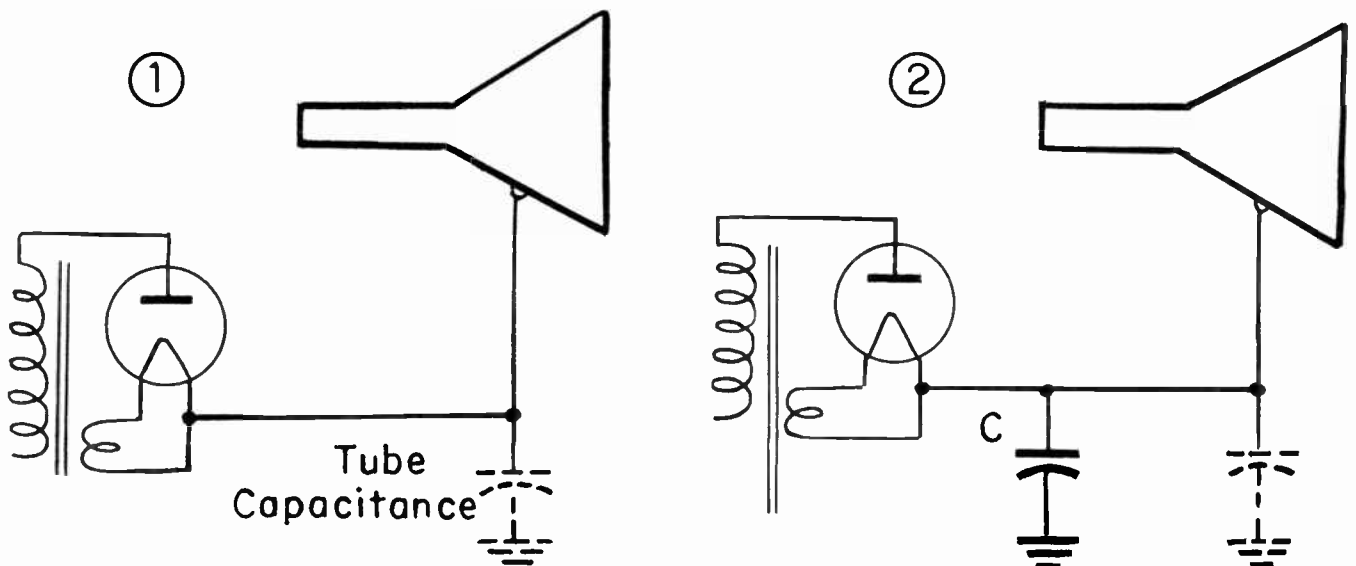

Fig. 4. Filter capacitances in the second anode circuits for picture tubes.

## LESSON 46 – PICTURE TUBE OPERATION

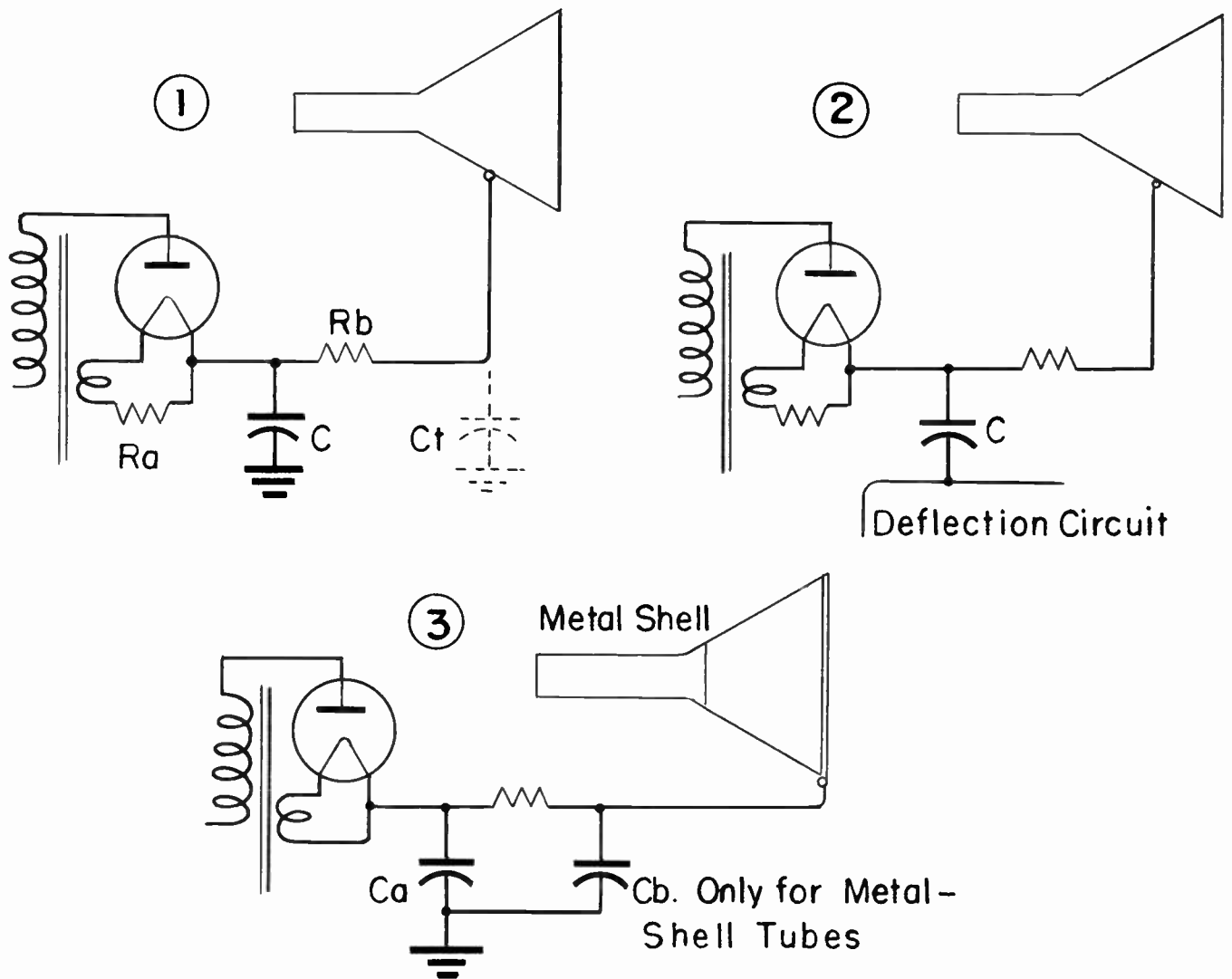

Fig. 5. Filter resistors and capacitors for second anode circuits.

There are a few glass tubes having no external conductive coating. These types provide no capacitance for filtering, and when they are used it is necessary to provide a filter capacitor as shown by diagram 2 of Fig. 4 and by both diagrams of Fig. 5. That is, with no external coating on the glass picture tube, the circuit at 1 of Fig. 4 cannot be used.

Picture tubes with metal shells have no external coating, since the entire shell is of conductive metal, and neither have they an internal conductive coating. As a consequence, metal-shell tubes can provide no high-voltage filter capacitance, and an external capacitor must be used. To make up for lack of capacitance in tube coatings you might expect the external filter capacitance

to be increased for a metal tube. This very seldom is done; in nearly all cases there is a single capacitor of 500-mmf value. There may or may not be a current-limiting resistor in series with the high-voltage rectifier filament, and there may or may not be filter resistance in series with the lead to the second anode of the picture tube.

A given type of chassis may be used with a glass picture tube in some receiver models and with a metal-shell tube in other models. As shown by diagram 3 of Fig. 5, a single filter capacitor,  $C_a$ , may be used for models with glass picture tubes and an additional capacitor,  $C_b$ , for models with metal-shell tubes. Both capacitors usually are of the same type and ratings. The same plan has been employed for chassis using glass tubes



# COYNE - *television home training*

with external coatings for some receiver models and glass tubes with no coatings for other models. The extra capacitor is used with the tubes having no external coatings.

small-shell duodecal 6-pin, and as small-shell duodecal 7-pin.

Fig. 6 shows some symbols for tubes designed for magnetic deflection and magnetic focus, and having 5-pin bases. Looking at the bottom of the base, toward the neck-end of the tube, the pin positions are numbered in a clockwise direction, starting from the locating key. This, as you recognize, is the pin numbering method for all tubes on whose base there is a locating key for engaging a slot or keyway in the socket.

In Diagram A there are pins at positions 1, 2, 10, 11, and 12, but nowhere else. For every socket having pins in these five positions, whether or not there are other pins at other positions, the internal elements connected to each of the five pins will be as shown by this diagram. It will be only a short time until you remember that the heater always connects to pins 1 and 12, that the control grid always connects to pin 2, the cathode to pin 11, and the second grid to pin 10.

Were a metal tube to replace an externally coated glass type it would be necessary to remove the contact which grounded the external coating; otherwise the high voltage would go to ground rather than to the second anode. It would be necessary also to add a filter capacitor, and to change the terminal connector on the high-voltage cable from a ball type to a clip for the lip of the metal-shell tube.

**BASES AND SOCKETS.** All picture tubes designed for magnetic deflection have what is called a small-shell duodecal base. The word duodecal means that on the base there are spaces or positions for 12 pins spaced 30° apart all the way around. Actually there are pins in only five, six, or seven of the twelve possible positions, so we have bases designated as small-shell duodecal 5-pin, as

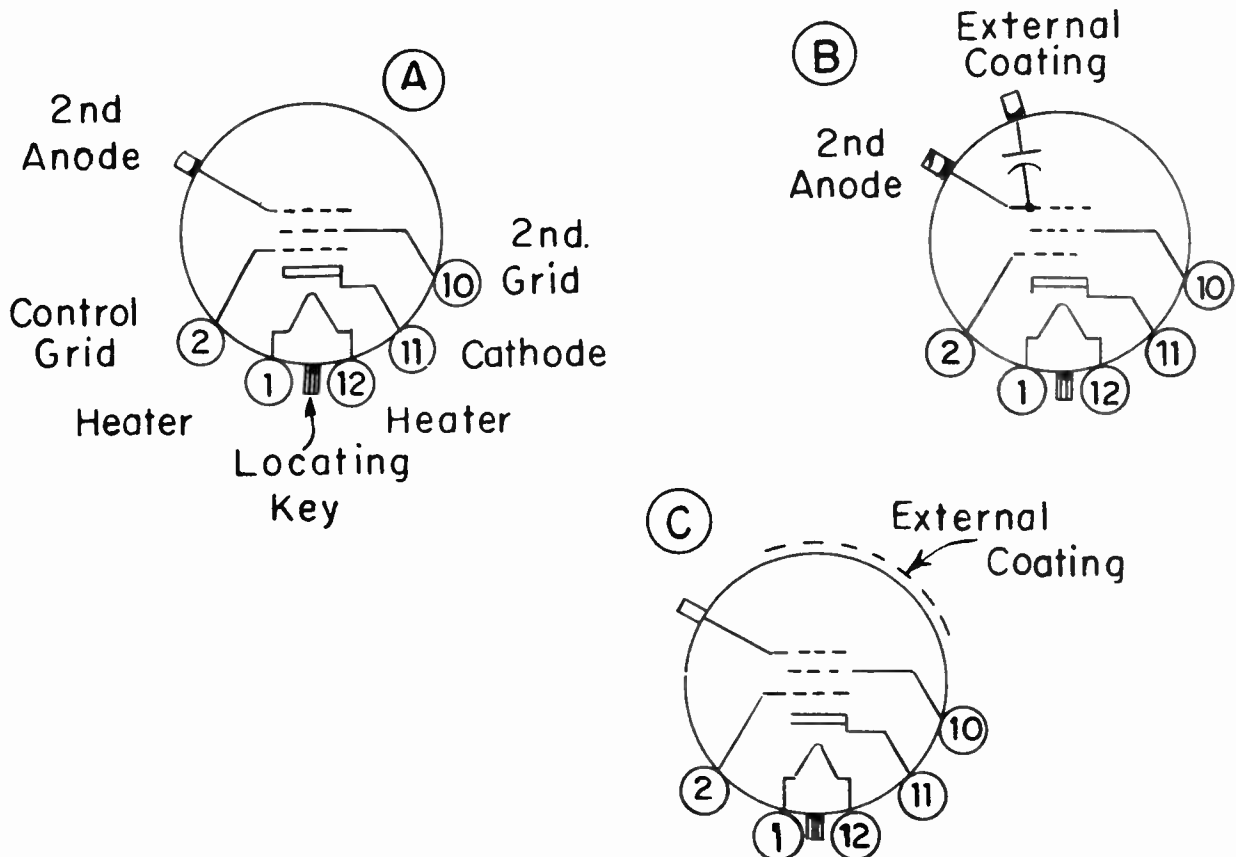

Fig. 6. Symbols and element connections for picture tubes with five base pins.

# LESSON 46 – PICTURE TUBE OPERATION

The symbol of diagram A may represent a metal-shell tube, or a glass tube with no external coating, and sometimes it is used for glass tubes having external coatings. The second anode or high-voltage connection is represented by what looks like a cap; it stands for a ball or cap connection on a glass tube, and for the lip connection on a metal-shell tube.

The fact that a glass tube has an external conductive coating may be shown by the symbol at B of Fig. 6. The connection to the coating is shown by what looks like a second cap, although it is some form of spring contact and is not a part of the tube. The small symbol for a capacitor indicates that the external and internal coatings, with the glass envelope, form a capacitance which may be used for filtering. In some symbols the presence of an external conductive coating is shown as at C, by a broken-line part circle outside the full circle representing the envelope. The capacitor symbol may be used in connection with the broken line.

For tubes designed for magnetic deflection and having an internal electrostatic focusing anode there must be an additional base pin for this focusing element. The pin is invariably in the number 6 position, as shown by Fig. 7. The other five pins are in the same positions, and are connected to the same internal elements, as on tubes designed for magnetic focusing. The symbol at A may

represent a metal-shell tube having electrostatic focusing, or it might represent an electrostatically focused glass tube having no external conductive coating.

The symbol at B of Fig. 7 can represent only an electrostatically focused glass tube having an external conductive coating. Here, as also at B of Fig. 6, the external coating and its connection are represented by an additional cap-shaped terminal, with the capacitance indicated by a small symbol for a capacitor.

Some electrostatic focus tubes have an additional base pin in the number 7 position, as shown at A of Fig. 8. This pin may be connected to internal parts used during manufacture, or it may have no connection. On a number of the earlier structural designs of tubes for magnetic deflection and focusing there are pins in positions 6 and 7, as shown at B, but there are no internal connections from these pins. They were used only to assist in positioning the socket on the base. There have been a few 10-inch and 12-inch tubes having no second grid as part of the electron gun. The basing arrangement and element connections are shown at C. There is a pin in the number 10 position, but it is not internally connected.

Symbols such as used in Figs. 6, 7, and 8 are used in service information and reference material issued by tube manufacturers,

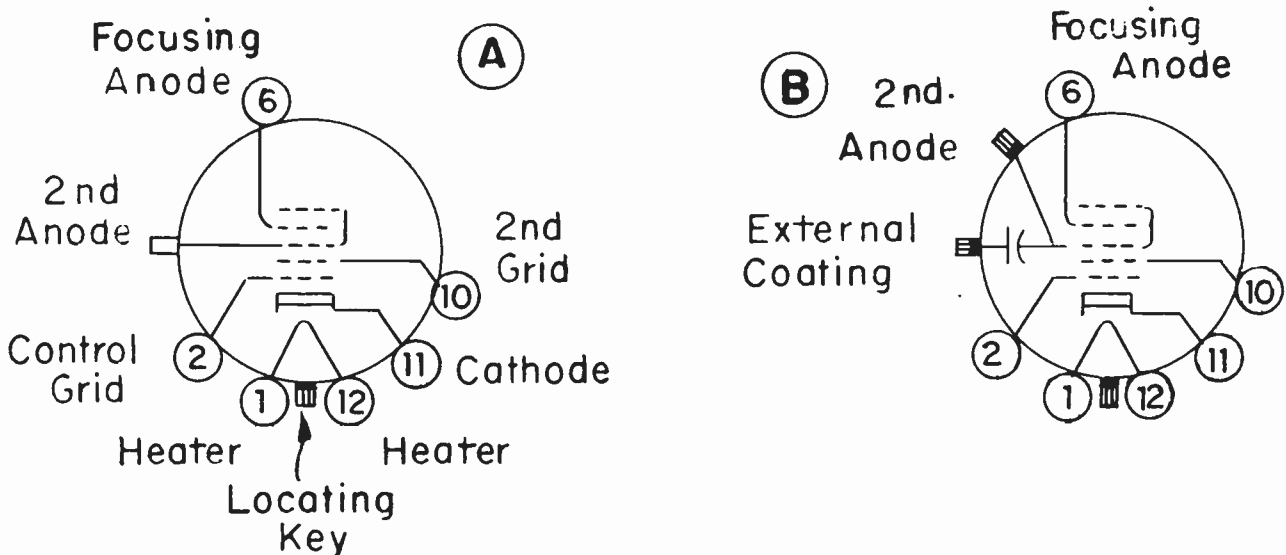

Fig. 7. Symbols and connections for electrostatically focused tubes having six base pins.

# COYNE - television home training

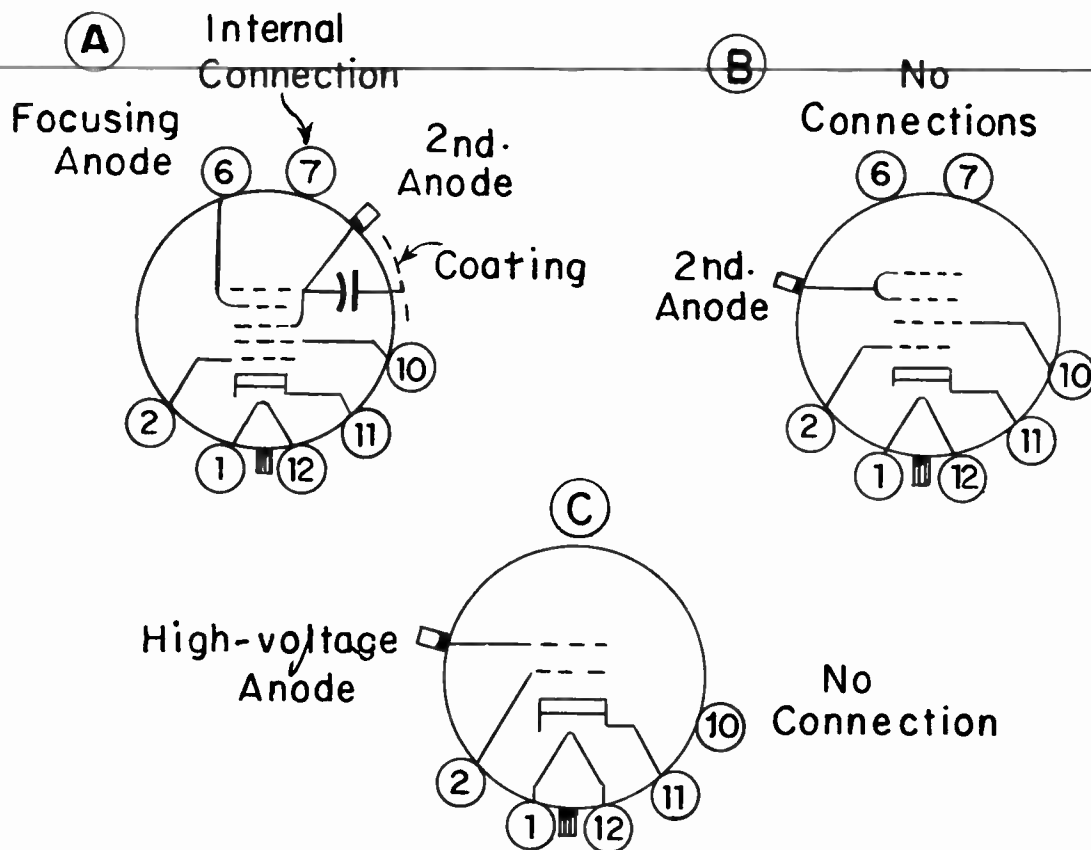

Fig. 8. Symbols and connections for tubes having seven base pins, and for a type having no second grid.

and in some receiver service diagrams issued by set makers. In the majority of receiver service diagrams the picture tube is shown by an outline somewhat similar to the shape of an actual tube. A few samples of such symbols are shown by Fig. 9.

The service symbol at 1 might stand for the tubes at A of Fig. 6 or at B of Fig. 8.

The symbol at 2 might show the same tubes as at B or C of Fig. 6.

The symbol at 3 would show the same tube as at A of Fig. 7.

The symbol at 4 might represent the tubes at B of Fig. 7 or at A of Fig. 8.

Sometimes the service symbols are more complete or elaborate, as at 5 of Fig. 9, where the tube would be the same as at A of Fig. 7.

All of the service symbols for picture tubes are nearly self-explanatory, because

pin numbers are marked near the respective leads, and, as a general rule, the type number of the tube is shown near the symbol.

The relatively few picture tubes with electrostatic deflection and focus which still are in use have medium-shell diheptal bases, meaning that the base has positions for 14 pins equally spaced around a circle. Pins are placed at 12 of these positions, as shown by Fig. 10. Positions 6 and 13 are vacant. There are pins at positions 4 and 12, but they are not connected internally to elements which are active in picture production.

The heater is connected to pins 1 and 14, on opposite sides of the locating key. The cathode, control grid, focusing anode, and second (high-voltage) anode are connected respectively to pins 2, 3, 5 and 9, as shown by the base diagram. The two horizontal deflecting plates, connected to base pins 7 and 8, are those farthest from the tube face and nearest the electron gun. The vertical deflecting plates, connected to pins 10 and 11, are the pair toward the face of the tube

# LESSON 46 – PICTURE TUBE OPERATION

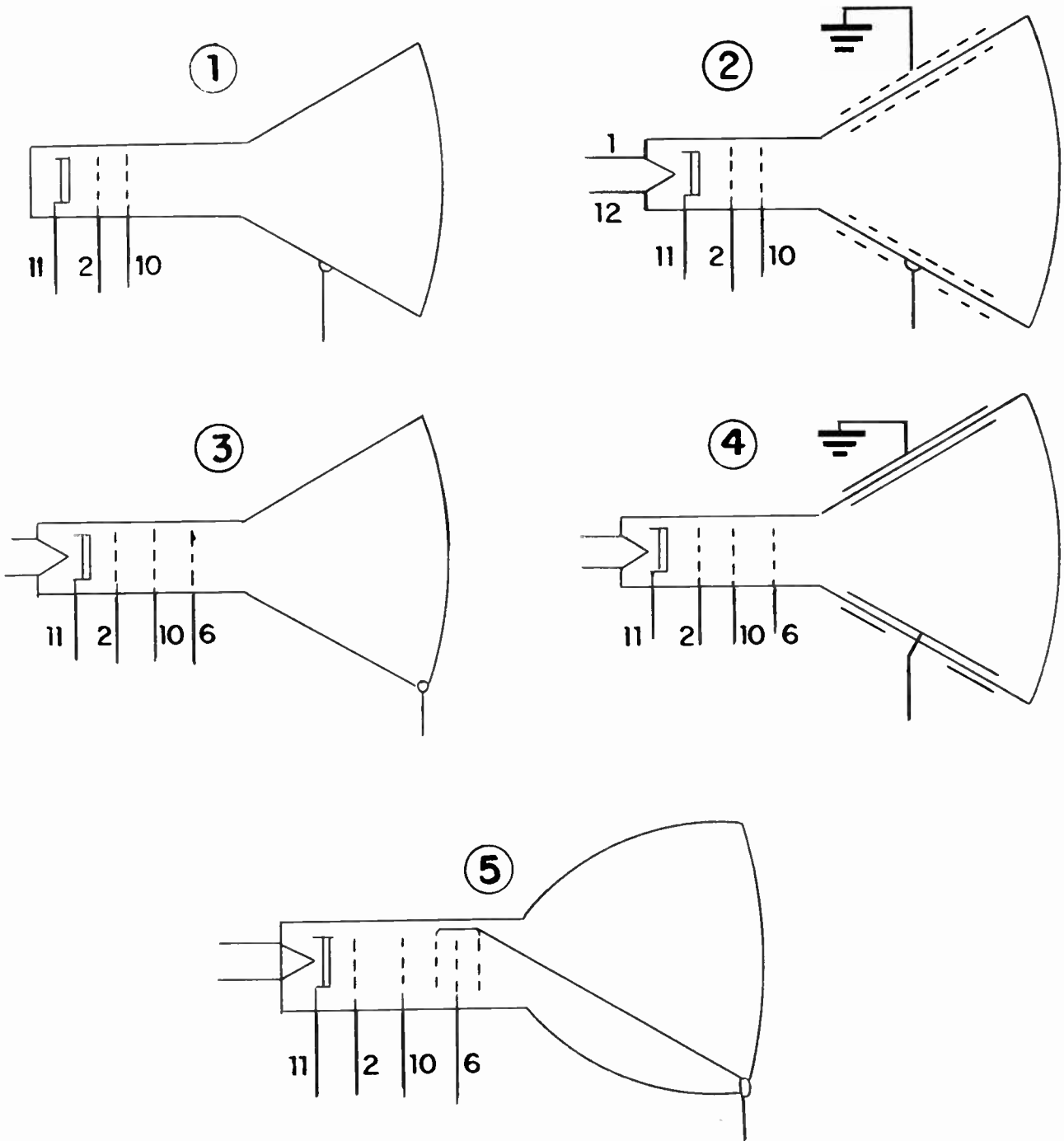

Fig. 9. Picture tube symbols such as used in receiver service diagrams.

and farthest from the electron gun. Since all internal elements are connected to base pins, there is no need for any ball or cap connection on the envelope.

The commonly used electrostatic tubes have glass envelopes. There is an internal conductive coating which, electrically, is part of the second anode. There is no external conductive coating, and no external grounding

spring is required. These electrostatic tubes require a large socket, in which are openings for 14 pins. It is called a diheptal 14-pin socket, and is about 2-1/4 inches in outside diameter.

All tubes, except the picture tube, on a television chassis are supported by their sockets. The picture tube socket is supported by the base of the picture tube. Con-



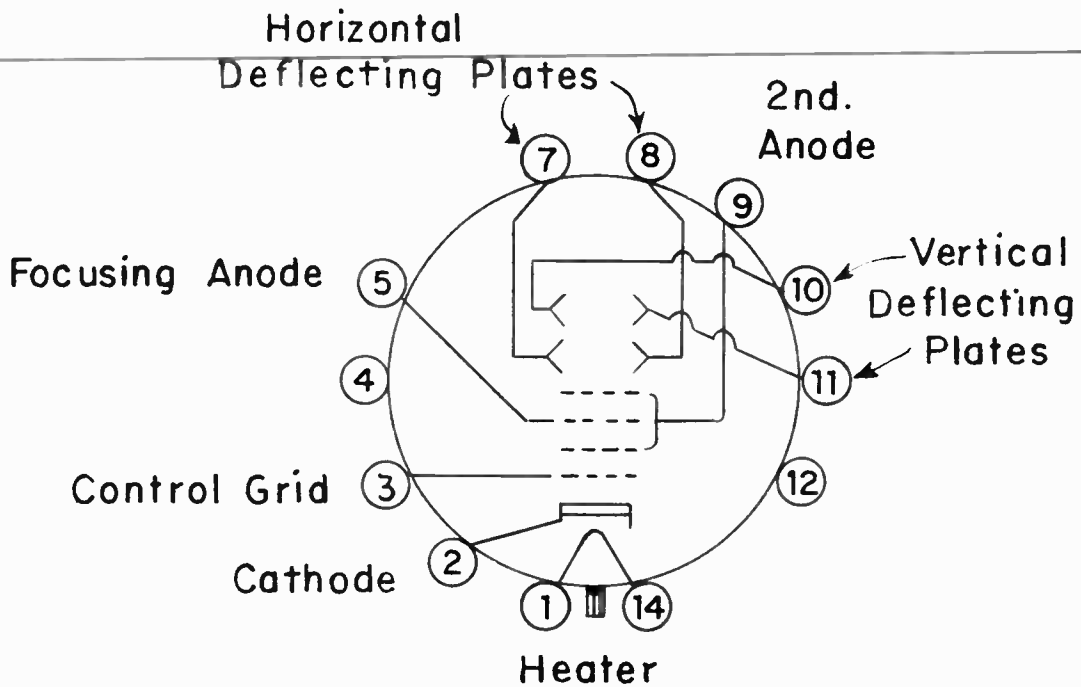

Fig. 10. Base pin connections for a picture tube having electrostatic deflection and electrostatic focus.

nections from the base pins through the socket lugs to receiver circuits are made with flexible wires, which never are drawn tightly enough to place any stress on the base and neck of the tube.

For all magnetic deflection direct view picture tubes the socket is a duodecal type. Three such sockets are pictured by Fig. 11. The one at the left usually is called a full round socket. It has openings and contacts for 12 base pins, and may be used with any

type of magnetic deflection tube when suitably wired. The picture shows five flexible wires entering this full round socket. They are for base pins 1, 2, 10, 11, and 12.

The photograph shows also two styles of what are called half-sockets. They also have five wires for the same five base pins, numbers 1, 2, 10, 11, and 12. But on these half sockets are only five openings or lugs, and they can be used only on tubes having only five base pins in these numbered positions,

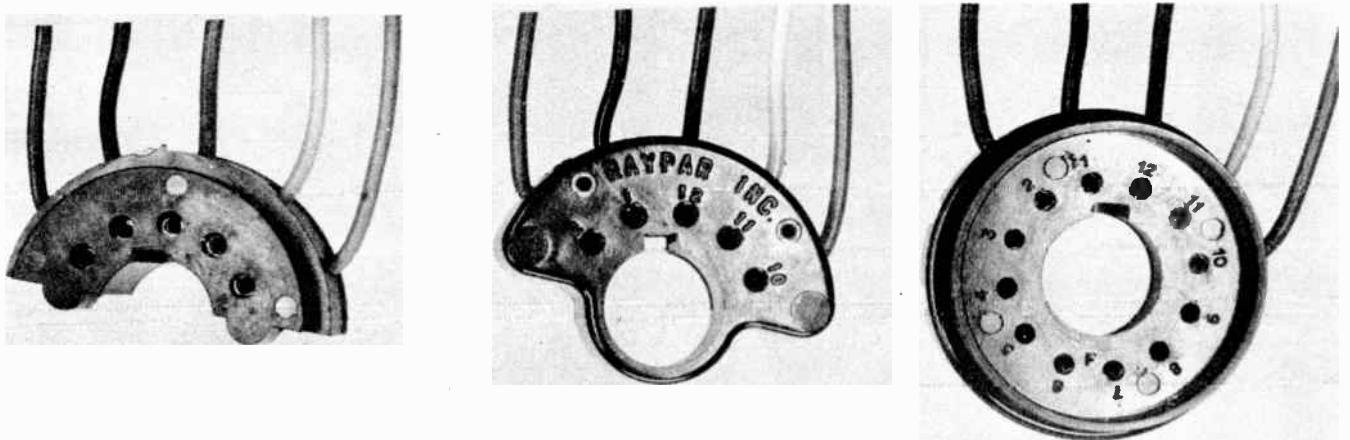

Fig. 11. Duodecal sockets for picture tubes. A full round socket is at the left. The other two are half-sockets.

# LESSON 46 – PICTURE TUBE OPERATION

or having only pins of these numbers connected to active elements within the tube. Accordingly, these half-sockets might be used on any of the tubes whose symbols are shown by Fig. 6 and on the tubes whose symbols are shown at B and C of Fig. 8.

Half-sockets cannot be used on any tube having electrostatic focusing, because there is no way of making a circuit connection to pin 6, which always is for the focusing anode. For the tubes whose symbols are shown in Fig. 7 and also at A in Fig. 8, it is necessary to use a full round socket or, at least, some type which provides a connection to pin 6 in addition to the other five pins. When a socket is used for tubes having electrostatic focusing, there will be a sixth wire for the focusing connection, instead of only the five wires on the sockets of Fig. 11.

It is general practice, but not an absolutely universal rule, to use a green wire for the control grid connection, pin number 2. There is no agreement among colors for the other socket wires. A rather common combination is as follows:

Pin 1	Heater	Black
Pin 2	Control grid	Green
Pin 6	Focusing anode	Blue
Pin 10	Second grid	Red
Pin 11	Cathode	Yellow
Pin 12	Heater	Brown

You cannot depend on this or any other color coding for wiring of picture tube sockets. It is necessary to check on the receiver itself, or on a service diagram for each particular receiver.

TEST CONNECTIONS. The solder lug connections at picture tube sockets are not exposed, as are the lugs of sockets which mount in the chassis. Connections at the picture tube socket always are protected and concealed by part of the plastic structure of the socket itself, and are difficult or impossible to reach. Service tests requiring measurement and observation of voltages and waveforms are made at the chassis end of the picture tube wires, or sometimes at the partially exposed base pins with the socket pulled off the base just enough to get test prods on the pins. Tests at the contacts

of a socket completely removed from the tube base pins ordinarily would have little meaning, for they would not be representative of conditions with the picture tube in operation.

Meter connections for voltage measurements at the picture tube socket or the wire leads connected to the socket are illustrated by Fig. 12. At 1 the vacuum tube voltmeter is adjusted for d-c volts, positive, on a range for 500 volts to begin with. The range may be lowered should measured voltages prove to be within the scale of a lower range. The common lead of the VTVM is shown connected to the cathode of the picture tube. This connection would be used when comparing measured voltages with those given in tube specifications. When voltages are specified on receiver service diagrams or in service lists of voltages, they usually are with reference to chassis ground or B-minus. Then the common lead of the VTVM would be connected to ground or to B-minus.

With the high-side lead of the VTVM connected to number 10 lug or lead wire the measured voltage will be that on the second grid of the picture tube. The reason for using the VTVM instead of a high-resistance or low-resistance moving coil volt-meter is that there may be a high resistance in receiver circuits supplying voltage to the second grid. Any meter other than a VTVM type then would indicate a voltage far lower than actually applied to the second grid, and you might commence looking for trouble that does not exist.

If the picture tube operates with electrostatic focusing the high-side lead of the VTVM may be shifted to the connection for base pin 6 for measurement of focusing voltage, but only after making certain of the focusing method employed in the receiver being worked on. If there is high-voltage electrostatic focusing, potential on the focusing anode may exceed 2,000 volts. The VTVM might or might not be damaged were it set for a 1,000-volt range, but voltage could not be measured. It is necessary to use a special type of high-voltage probe that extends the range of the VTVM to between 10,000 and 30,000 volts. The use of such probes, and other methods for measuring voltages in

# COYNE - television home training

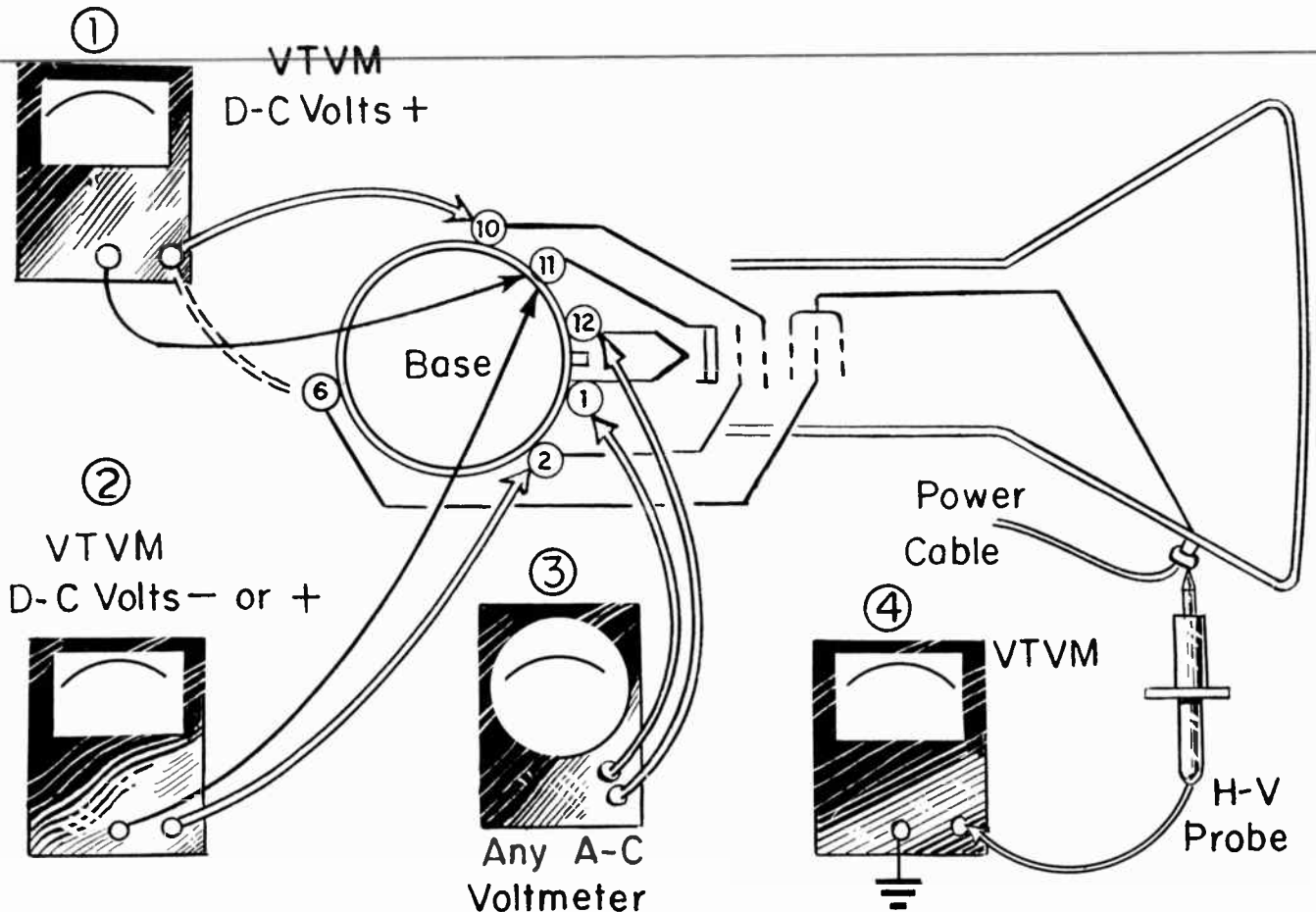

Fig. 12: Connections for measurements of voltages on the elements and heater of picture tube.

excess of 1,000 will be explained when we come to the subject of high-voltage power supplies.

In nearly all recently designed receivers, electrostatic focusing is of the low-voltage or self-focus type. With self-focusing there will be no pin 6. With low-voltage focusing the voltage on the focusing anode will not exceed 500, and measurements may commence on the 500-volt or 1,000-volt range of the VTVM. When making tests on either low-voltage or high-voltage focusing anodes, try operating the focus control while the meter is connected. If the control is working correctly, it will alter the measured voltage.

As a general rule there is not a great deal of receiver circuit resistance in series with the focusing anode connection for the low-voltage system, and measurements of satisfactory accuracy could be made with a high-resistance d-c voltmeter as well as with the VTVM. Only the VTVM, with a high-

voltage probe, should be used on high-voltage electrostatic focus systems, since there always is very great resistance in the control circuits for such systems.

At 2 in Fig. 12 the VTVM is connected for measurement of control grid bias. The actual bias voltage is the potential difference between control grid and cathode, and the VTVM leads should be connected to the control grid and the cathode, as shown. If video signal input is to the grid of the picture tube, connect the high-side lead of the meter to the grid, and the common or low-side lead to the cathode. If signal input is to the picture tube cathode, connect the high-side lead to the cathode, and the common lead to the control grid. Set the VTVM for negative d-c volts when the high-side lead goes to the control grid, and for positive d-c volts when this lead goes to the cathode. Use the 100-volt range of the meter, or a range higher than 100 volts. Receiver service data may

# LESSON 46 – PICTURE TUBE OPERATION

specify control grid voltage with reference to ground or B-minus, to which the common lead of the VTVM would be connected.

With the VTVM connected for measurement of control grid bias, try operating the brightness control. If this control is working correctly it will cause large variations of bias voltage and meter indications. Only a VTVM with internal and probe resistance in excess of 10 megohms can be used for measuring control grid bias. The internal resistance of any high-resistance moving coil voltmeter used on a range of 100 to 200 volts would be so low as to cause measurements to be meaningless.

At 3 in Fig. 12 is shown the connection of any kind of a-c voltmeter to pins 1 and 12 for measurement of heater voltage. This measurement will be accurate when using the a-c function of a VTVM, or when using any high- or low-resistance service VOM on its a-c function. All post-war picture tubes, no matter what their size or type, have heaters designed for 6.3 a-c volts and 0.6 a-c ampere of current. This, of course, is no guarantee that heaters will not be designed for other voltages and currents.

At 4 in Fig. 12 is represented a VTVM fitted with a high-voltage probe for measurement of voltage at the second anode or ultor

element. Do not attempt such measurements until after we study high-voltage power supplies. It is dangerous to work with potentials reaching many thousands of volts until you know how to avoid the dangers with certainty.

## BRIGHTNESS AND GRID VOLTAGE.

Although we are familiar in a general way with the effects of control grid voltage on picture brightness it will be well now to consider some actual voltages such as may be measured in service work. The voltages mentioned in examples to follow apply particularly to picture tubes of 17-inch to 24-inch sizes, but their effects are similar in both smaller and larger tubes in spite of actual values which may be somewhat lower or higher.

Consider first the portion of a video signal that produces pictures. This is the portion that varies the screen brightness between black and maximum white, as shown at the left in Fig. 13. Approximate relations between control grid voltage and picture brightness are shown by the curve at the right. When grid voltage is zero with reference to the cathode, the brightest parts of pictures will be brilliant white. Brightness decreases as the grid becomes more negative and reduces intensity of the electron beam. At some certain negative voltage there is beam cutoff and a black screen.

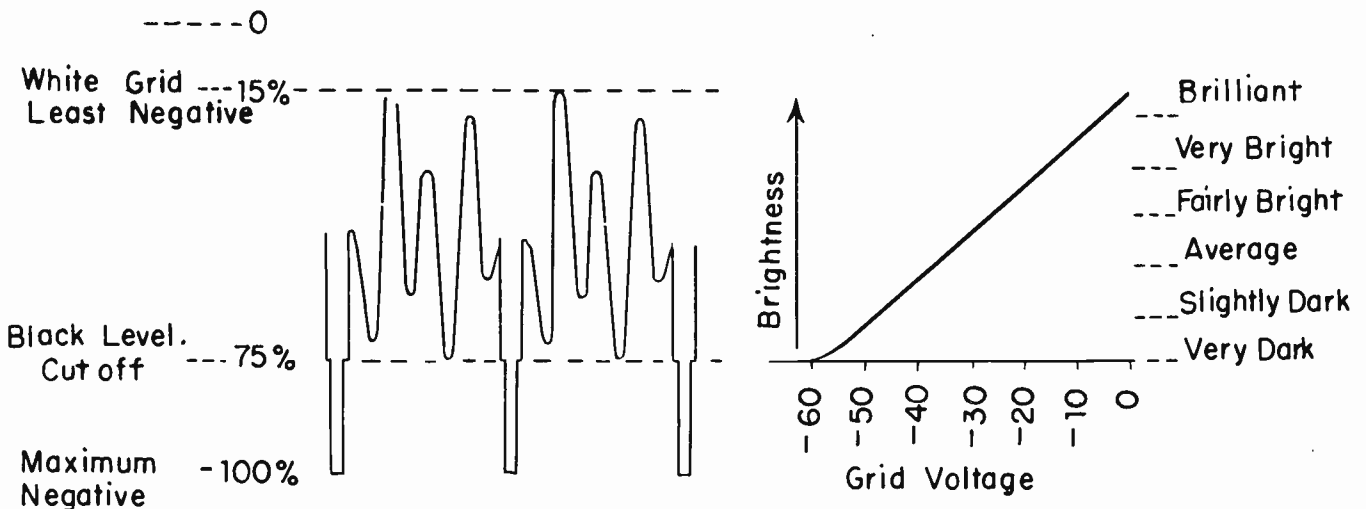

Fig. 13. Relations between voltages in the video signal and screen brightness.



## COYNE - *television home training*

Strictly speaking, the beam cutoff voltage would be the value which just extinguishes the last trace of a visible spot when the electron beam has been sharply focused but is not being deflected either horizontally or vertically. When there is deflection, a raster will disappear when the grid is about 5 volts less negative than for complete beam cutoff. This is because light from the deflected spot is widely distributed over the entire raster area, and appears less bright than from a stationary spot.

Assuming that voltage on the second anode or ultor element is high enough to produce brilliant pictures with sharp detail, the negative grid voltage required for extinction of a raster depends largely on voltage applied to the second grid of the picture tube. The higher the voltage on the second grid, the more negative must be the control grid to extinguish the raster. Here are some voltage values for a typical tube.

Second grid, positive	Control grid, negative. For raster extinction
200 volts	42.3 volts.
300 volts	56.5 volts
400 volts	67.8 volts
500 volts	84.7 volts

The black level of applied video signals should bring the control grid to these negative voltages. The positive limit of control grid voltage, with reference to the cathode, usually is considered to be zero. Actually it is not uncommon to have instantaneous white peaks of the picture signal drive the control grid one or two volts positive with reference to the cathode. Any greater instantaneous positive voltage, or any continued positive voltage, would cause appreciable grid current. Such current is as undesirable in a picture tube as in an amplifier which is to work without distortion.

As you will recall, and as shown again by Fig. 13, the picture portion of the video signals extends from 15 per cent (the white level) to 75 per cent (the black level) of the entire video signal. Sync pulses take up the remaining 25 per cent of the total peak-to-peak video signal voltage. Based on these

percentages, the total swing of control grid voltage from white level to sync pulse tips should be approximately as follows, assuming that cutoff voltages are those previously mentioned. These peak-to-peak grid swings are typical of those found in television receivers of recent design.

Control grid volts. Cutoff. Black level.	Entire video signal. Peak- to-peak volts.	Second grid voltage.
- 42.3	60	+ 200
- 56.5	72	+ 300
- 67.8	90	+ 400
- 84.7	120	+ 500

Peak-to-peak volts, or any lesser portion of the video signal voltage, cannot be measured with any ordinary voltmeter. This is because such voltmeters are calibrated to read correctly only on sine-wave alternating voltages when an a-c function is used. The composite video signal is of complex waveform. Voltage across any portion of any complex wave may be measured with the help of an oscilloscope, as we shall learn later. Peak-to-peak voltage may be measured also by using a special type of probe on a vacuum tube voltmeter.

SECOND GRID OR FIRST ANODE. Voltage on the second grid, often called the first anode, has a decided effect on picture brightness. With all operating and service controls remaining unchanged, increasing the second grid voltage will increase the overall brightness of pictures. Decreasing this voltage will lessen the brightness. If there is no voltage on the second grid, or, in most cases, if there is something less than about 20 volts, the screen will remain dark and there will be neither raster nor pictures. This will be true no matter how far the brightness control is advanced.

Since voltage on the second grid affects brightness, it must affect beam current and also cathode current in the picture tube. If measure cathode current while varying the second grid voltage, cathode current will decrease as this voltage is lowered.

If you happen to be measuring voltage on the second anode at the same time, this

# LESSON 46 – PICTURE TUBE OPERATION

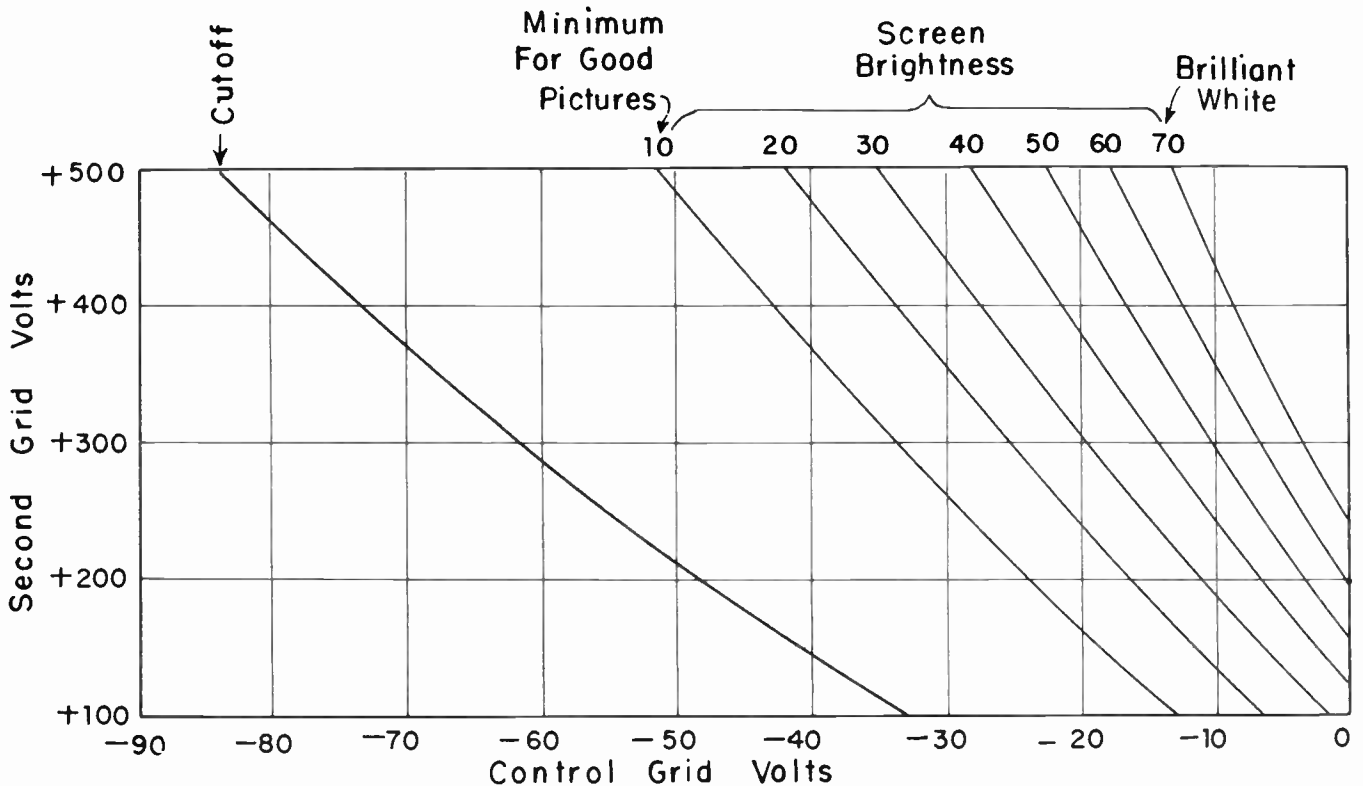

Fig. 14. Control grid voltages for beam cutoff and for various degrees of screen brightness when employing different voltages on the second grid.

second anode voltage will show a moderate increase as cathode current becomes less. The change of second anode voltage is not a direct effect of changing the second grid voltage, rather it results from the decrease of cathode and beam current. The smaller current flowing in resistances of the high-voltage power supply causes less voltage drop in these resistances. This leaves more voltage at the second anode.

Under normal operating conditions the second grid carries no measurable current in itself. If there is current it should be no more than 10 to 15 microamperes. The small current or no current in the second grid, even with several hundred volts applied, is due to the fact that the very high voltage on the second anode pulls electrons from the cathode through the second grid so fast that they do not enter this grid.

Voltage on the second grid affects cutoff of the electron beam. The more positive the second grid, the more negative must be the control grid to cause cutoff. This is shown, for a particular tube, by the left-hand curve

in Fig. 14. Note that the vertical scale on this graph extends through second grid voltages from 100 up to 500. The scale across the bottom shows control grid voltages from zero, at the right, to 90 volts negative at the left. The curve for beam cutoff shows the following relations between positive voltages on the second grid and approximate negative voltages on the control grid for the condition of beam cutoff. These cutoff voltages are not the same as listed earlier, because they were taken from a different tube. Such variations exist even in tubes of the same type.

Second Grid Volts	Control Grid Volts
+ 500	- 84
+ 400	- 73
+ 300	- 62
+ 200	- 48
+ 100	- 33

Fig. 14 may be used to determine strengths of picture signals which will cause various values of screen brightness when there are certain voltages on the second grid.

## COYNE - *television home training*

Several values or levels of brightness are indicated by curves numbered from 10 to 70 at the right. Each curve stands for a definite brightness, which is the same at all points along any given curve. Minimum brightness for good reproduction of pictures is that of curve 10. Brightness increases proportionately to curve numbers. For instance, brightness on curve 20 is twice that on curve 10, and on curve 40 it is twice as great as on curve 20.

Here is an example of how this graph may be used. Assume that the second grid is operating at 300 volts, with which there is cutoff when the control grid is 62 volts negative. Following toward the right on the line for 300 volts for the second grid, we come to brightness curve 10 at a point where the control grid is about 34 volts negative.

Thus we determine that the picture portion of the signal must swing the control grid from 62 volts negative to 34 volts negative in order to produce pictures with a full range of tones and with a brightness corresponding to curve 10. The difference between 62 volts and 34 volts is 28 volts, which is the strength required in the picture portion of the video signal. This signal is indicated by arrow a of Fig. 15.

Supposing now that we have the same 28-volt picture signal, with the brightness control and grid bias remaining unchanged, but with voltage on the second grid increased to 400. The signal still will swing the grid from 62 to 34 volts negative, because control grid bias has not been changed, but, as shown by arrow b, the signal now must be shown on the line for 400 volts on the second grid.

When the signal goes to 62 volts negative it does not bring screen brightness to cutoff, because, with 400 volts on the second grid, cutoff cannot occur until the control grid is 73 volts negative. The black level of the video signal will be at a control grid voltage well above cutoff. Parts of pictures which should appear black will be gray instead.

When the picture signal swings the control grid to 34 volts negative, on arrow b, brightness reaches curve 20. Higher voltage on the second grid, with everything else un-

changed, has made the lightest parts of the picture ~~twice as bright as they were before~~ changing this second grid voltage. The entire picture is too light in tone. It could be darkened by readjusting the brightness control, provided this control has sufficient range of action.

Another example is illustrated by Fig. 16. To begin with, there is a potential of 400 volts on the second grid, and, as shown by arrow a, the applied picture signal is strong enough to bring maximum brightness to curve 40 while the black level is at cutoff. At cutoff the control grid is 73 volts negative, and it is about 21 volts negative for maximum brightness, on curve 40. This means a grid swing of 52 volts (73 to 21) for picture signals.

With the same signal strength of 52 volts, and with no change of brightness control and grid bias, voltage on the second grid now will be dropped to 200. The picture signal still extends from 73 to 21 volts negative, as shown by arrow b, but it must be shown on the line for 200 volts on the second grid.

Fully half the picture signal is at the left of the cutoff curve, indicating that this much of the signal voltage drives the control grid more negative than cutoff. Most of the tones which should be gray will become black. Also, the brightest part of the picture signal now reaches only a little beyond curve 10, so even the lightest parts of pictures will be only about one-fourth as bright as before.

In Fig. 17 we still have the 52-volt picture signal, and second grid voltage still is 200. The brightness control has been changed to make the control grid bias less negative. This has brought the darkest parts of the signal, the black level, to cutoff. But now the lightest parts of the picture signal make the control grid positive, as shown by the arrow extending to the right beyond zero grid voltage. These brightest parts of the signal will be very bright, for they go beyond curve 60, whereas at a in Fig. 16 the brightest portions of pictures reach only to curve 40.

You will find it interesting to work out other examples of your own on the graph of Fig. 14, using various signal strengths and

# LESSON 46 – PICTURE TUBE OPERATION

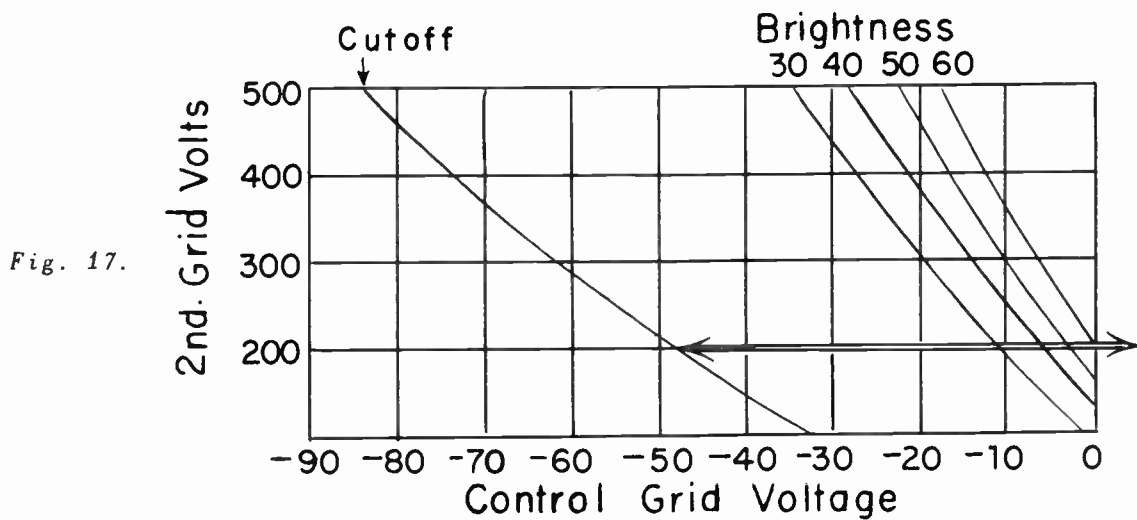
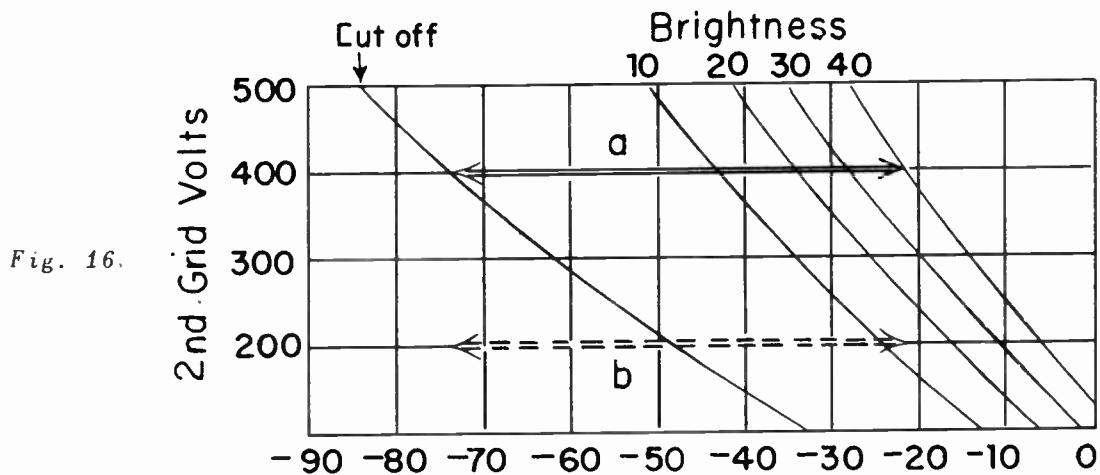
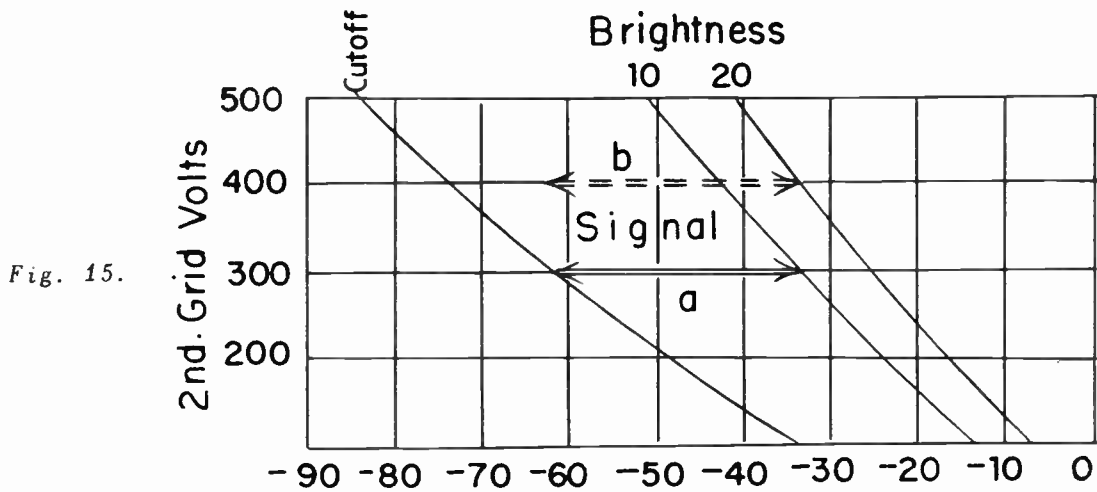

Figs. 15, 16, and 17, top to bottom. These graphs show relations between picture signals of various strengths, different voltages on the second grid, and resulting variations or ranges of screen brightness.



# COYNE - television home training

second grid voltages. All such examples will make it evident that second grid voltage should suit the strength of picture signals available at the control grid-cathode input to the picture tube. If preceding i-f and video amplifiers are capable of delivering strong signals to the picture tube, voltage on the second grid should be proportionately high.

**SECOND ANODE CURRENT.** It is not practicable to make direct measurements of current in the second anode circuit of a picture tube with ordinary service instruments, because of the dangerously high voltage in this circuit. But it is easy and safe to measure total cathode current. If receiver circuits are in good condition and operating normally, cathode current will be very nearly the same as second anode or beam current.

When using a d-c current meter it is necessary only to open a wire connection for the cathode terminal, number 11, of the picture tube socket and to insert the meter in series with the cathode lead. Second anode current may become as great as 2 or more milliamperes under some conditions, so it is advisable to commence work with a meter or a range covering this much current. The

range may be decreased if the current is small enough. Connect the positive terminal of the meter toward the tube cathode, and the negative side to the terminal from which the cathode lead has been removed.

If it is inconvenient to use a current meter, cathode current may be measured with the vacuum tube voltmeter as shown by Fig. 18. The lead from pin 11 of the picture tube and its socket usually goes to a terminal on a tie strip underneath the chassis. Locate this terminal, unsolder the cathode lead wire, and connect a fixed resistor of any wattage rating in series between the wire end and the terminal from which it has been removed, as shown.

Connect the high-side lead of the VTVM to the side of the resistor toward the picture tube socket, and the common lead to the other side of the resistor. The meter will read voltage drop across the resistor, and since this drop is directly proportional to current it is easy to translate voltage readings into equivalent cathode currents.

The resistor may be a non-inductive type of 10,000 ohms. This much resistance added

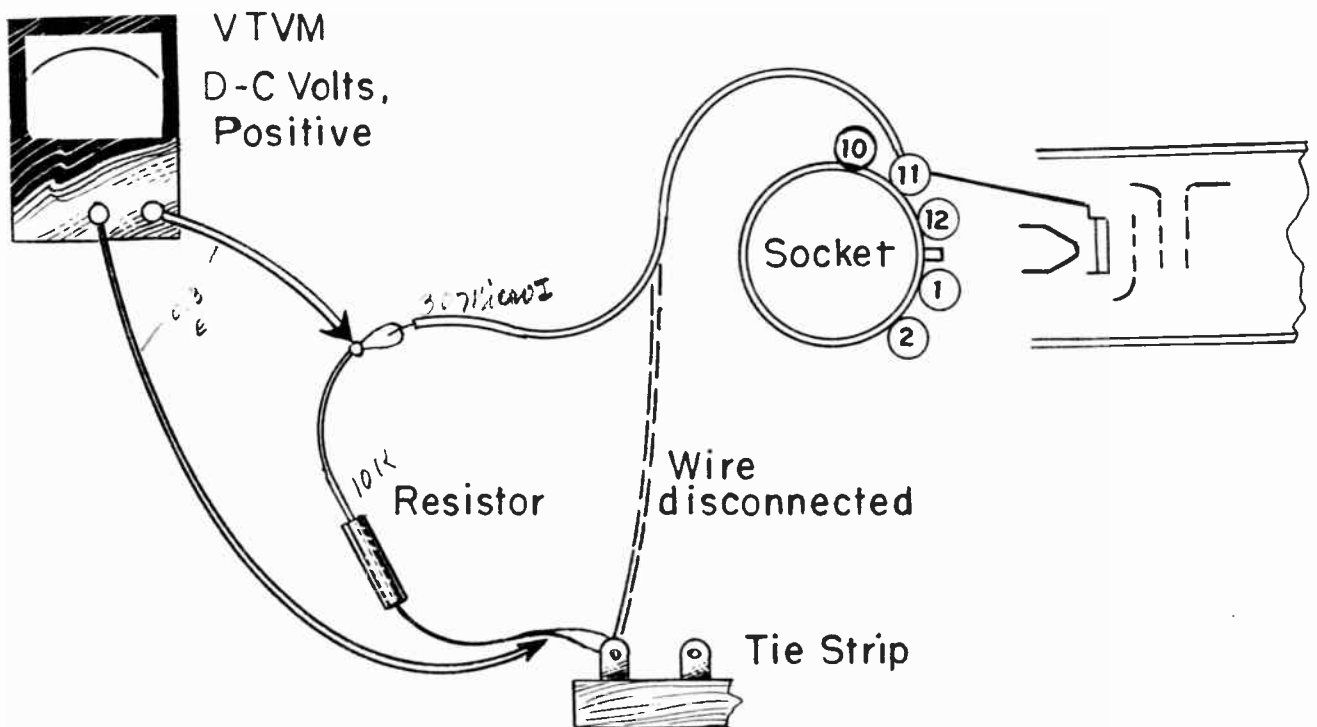

Fig. 18. Measuring picture tube cathode current with a vacuum tube voltmeter.

## LESSON 46 – PICTURE TUBE OPERATION

in the cathode circuit will not affect operation of the picture tube to any appreciable extent. The meter will indicate 1/10 or 0.1 volt for each 10 micro-amperes of cathode current. Most VTVM's have low range scales on which tenths of a volt are easily read. Commence with a range extending to at least 3 volts, in case there is large cathode current. Then drop to a range which covers the actual current, or the corresponding voltage.

With some of the smaller picture tubes the cathode current for satisfactory pictures may be as little as 10 microamperes. Corresponding voltage drop may be difficult to read when using the 10,000-ohm resistor. Deflection of the meter pointer may be increased by using a fixed resistor of 100,000 ohms. This will reduce beam current enough

to noticeably darken the screen, and performance will not be strictly normal, but changes of meter voltage and cathode current will be proportional to those with the lesser resistance or no resistance at all. Meter readings will be in the ratio of 1 volt per 10 microamperes of cathode current, or 1/10 volt per microampere.

If measurements such as these accomplish nothing more, they will make very evident the relations between cathode or beam current and picture brightness. Operating the brightness control will cause large deflections of the meter pointer, because this alters beam current while varying the screen brightness. If a picture program is received with the meter connected, the meter pointer will swing back and forth with every change of average brightness in reproduced pictures.

# TELEVISION

- RADIO
- ELECTRONICS

---

**LESSON 47 – ELECTROMAGNETIC FOCUSING AND CENTERING**

---

***Coyne School***

*practical home training*

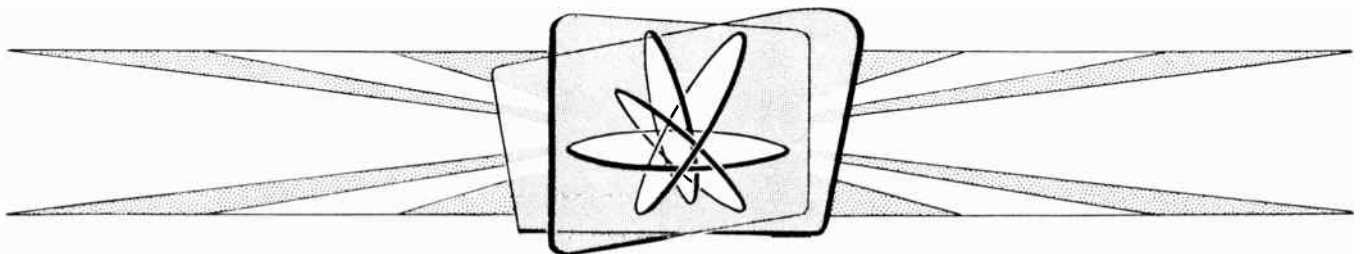

*Chicago, Illinois*

---

*Copyright, 1953 by Coyne Electrical School  
Chicago 12, Illinois  
All rights reserved*

Litho. in U.S.A.



## Lesson 47

### ELECTROMAGNETIC FOCUSING AND CENTERING

Many things must be done to the electron stream between cathode and screen of a picture tube. Heavy ions are trapped out within a half inch of the cathode. Before they get two inches from the cathode the spreading electrons are made to converge toward a focused spot. Almost immediately thereafter the beam is centered with reference to the tube axis. At the end of five inches of travel the focused and centered beam is deflected horizontally and vertically. In a twenty-inch picture tube operating with 15,000 volts on its second anode, all this happens within four billionths of a second.

Everything done during the first five inches of electron travel either shapes or directs the electron stream. This is true of even the ion trap. Although the primary purpose of this trap is to get ions out of the electron stream, its adjustment determines also whether all or only part of the electron beam will reach the screen, whether pictures will be bright or dim, and well formed or misshapen. Incorrect adjustment of the ion trap magnet may cause corner shadowing and partial cutoff of patterns and pictures, as at A in Fig. 1.

Adjustment of focusing determines whether pictures will be sharp or blurred. Bad focusing adjustment has the effect shown at B of Fig. 1. The centering adjustment determines whether all or only part of pictures will appear within the frame of the cabinet mask. At C a wrong centering adjustment has moved the pattern or picture down and to the right. Adjustment of the deflecting yoke determines whether the pictures will be straight or tilted. At D the pattern or picture is tilted because the deflecting yoke is not correctly adjusted.

The four adjustments act on the electron

stream in the order shown by Fig. 2. Nearest the cathode is the ion trap magnet. Next comes the focusing device, followed closely by centering. Finally the beam is deflected horizontally and vertically. Servicing would be greatly simplified were all four of these adjustments to act independently of one another, but they don't. Each adjustment affects those which follow it, and some can react on preceding adjustments.

Unless the ion trap magnet is correctly placed you are certain to have more or less trouble with focusing and centering, and possibly with deflecting the beam. A poor adjustment of some types of focusing devices can make centering difficult or impossible. Wrong centering makes it impossible for the electron beam to put pictures where they belong on the screen.

Although we shall discuss each of the four functions by itself, you should keep in mind that each may affect the others to a greater or less extent. During actual servicing, the adjustment for the ion trap, focusing, and centering ordinarily are performed as parts of a single operation, and nearly always you will check the position of the deflecting yoke at the same time.

Interactions between adjustments would cause no great difficulty were there only one possible method of carrying out each of the operations on the electron stream, but for most of them there are several ways. Each different method requires some modification of your servicing procedures. It will be helpful, here in the beginning, to list and classify the methods commonly used for performing each operation on the electron stream. These classifications will serve as a guide to what we intend to study in detail.

# COYNE - television home training

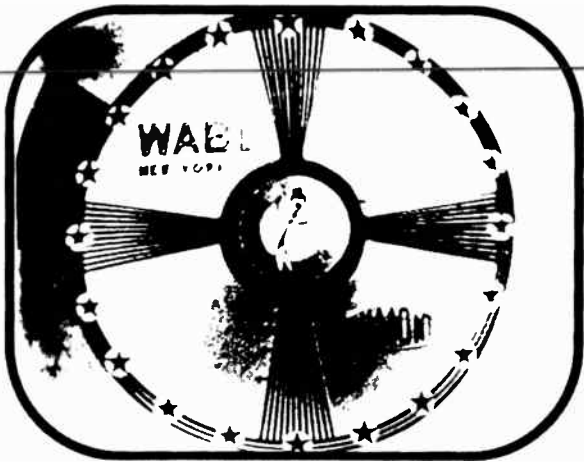

Fig. 1A.

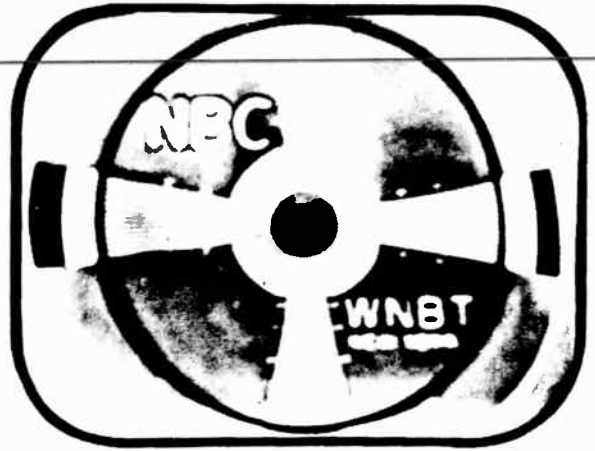

Fig. 1B,

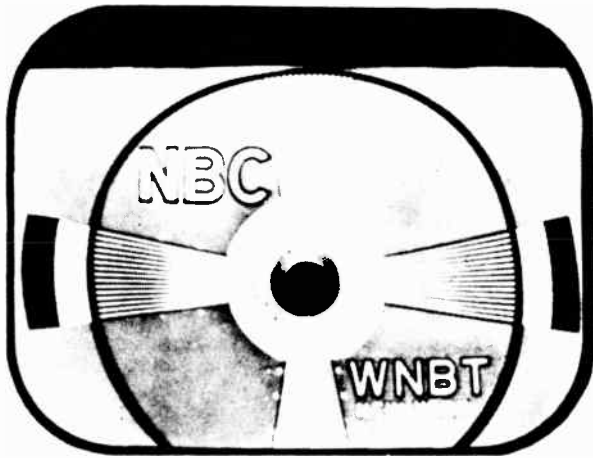

Fig. 1C.

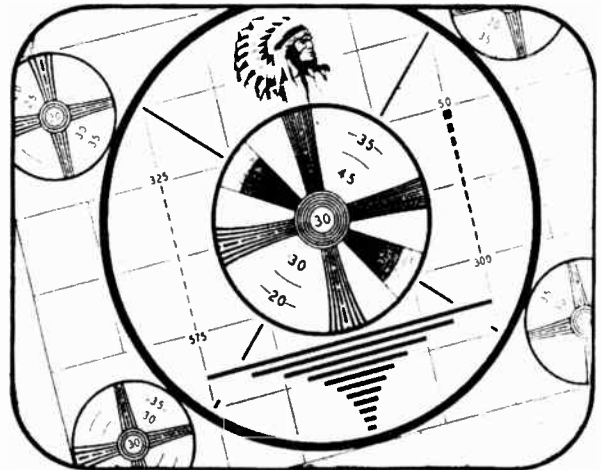

Fig. 1D.

Fig. 1. Some of the effects on pictures or patterns when service adjustments affecting the electron beam are incorrect.

Focus	Magnetic	Electromagnetic coil Permanent magnets Combined permanent magnet and coil	Deflect	Magnetic	Electromagnetic coils. On nearly all recent television sets.
	Electrostatic	Low-voltage Self-focus or zero-voltage High voltage		Electrostatic	Internal deflecting plates. Chiefly in oscilloscopes
Center	Electrical	Direct currents in deflecting coils	Ion trap	Two magnets	With straight electron gun
	Magnetic	Tilting of focusing coil		One magnet	With inclined electron gun With bent electron gun
		Ring-shaped permanent magnets Iron disc on focusing permanent magnet		No magnet	With straight electron gun Metal-backed screen

## LESSON 47 – ELECTROMAGNETIC FOCUSING AND CENTERING

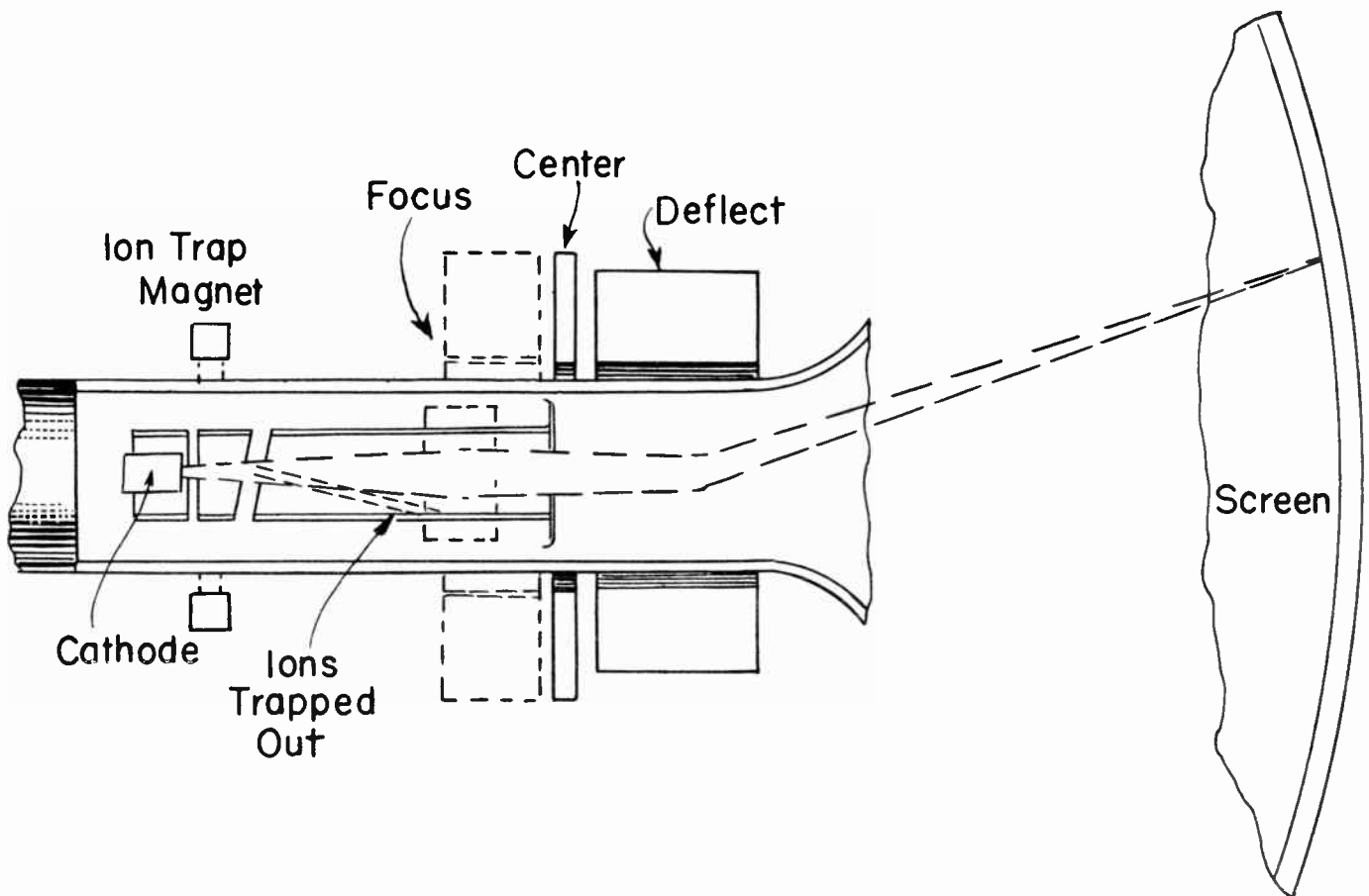

Fig. 2. The electron beam is acted upon by many forces between the cathode and screen of the picture tube.

**FOCUSING AND RESOLUTION.** Before talking about focusing methods and adjustments we should understand the difference between poor focus and lack of resolution or definition in television pictures. To begin with, imagine that you are viewing the television reproduction of a movie film on which the original pictures are out of focus. Maybe the camera was out of focus; you may have taken out-of-focus pictures with a camera of your own. Nothing can be done at the television receiver, by focusing adjustment or otherwise, to make those originally blurred pictures appear sharp. They lack definition.

Take another case. Supposing the received signal is capable of forming excellent pictures, but the i-f or video amplifier, or both amplifiers in your television receiver have weak response or gain at high video frequencies. It is the higher video frequencies that cause fine details and sharp lines to ap-

pear in reproduced pictures. With poor high-frequency response there is nothing in the signal applied at the picture tube which can produce sharp details, and no possible adjustment of a focusing control can put in such details.

Focusing at the picture tube cannot make pictures appear sharp when there is lack of definition or resolution in original pictures or in video signals. Fig. 3 is a photograph of a pattern showing the effects of poor response at high video frequencies in receiver amplifiers. Compare this photograph with the one at **B** in Fig. 1, which shows the effect of poor focusing at the picture tube. Unless the two photographs were labeled, you couldn't tell which one shows poor focusing and which shows lack of gain at high video frequencies. This is because the printed pictures are too small to allow identifying the real cause of fuzziness.

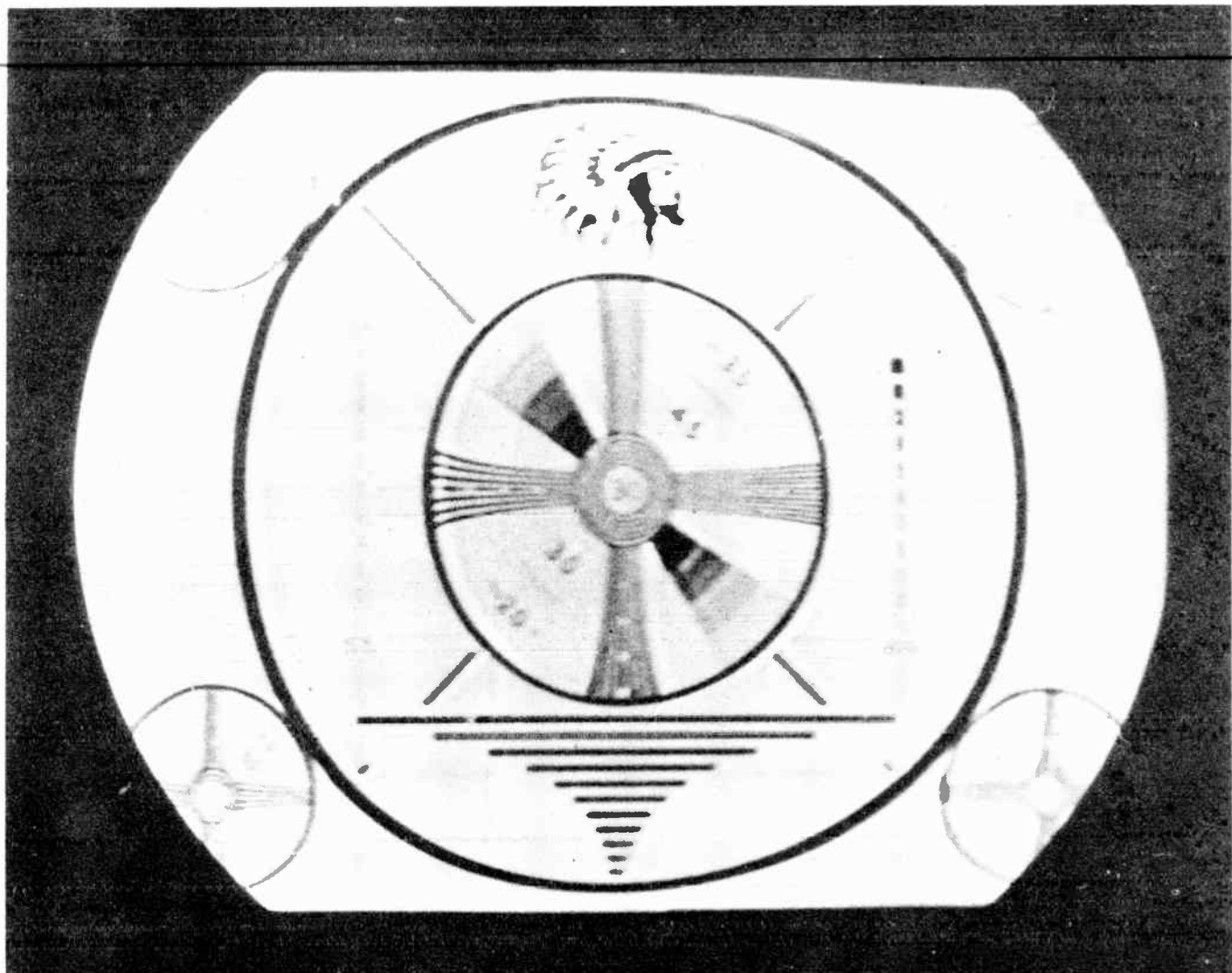

Fig. 3. When there is poor resolution or definition the effect on pictures is similar to that with poor focusing.

Were you to stand far enough from a television receiver to make the screen appear fairly small, it would be impossible to say whether visible blurring is caused by lack of focusing or by lack of high-frequency response. But if you get real close it is easy to tell the difference. Focusing is good when you can see separate horizontal lines which form pictures, as these lines appear in Fig. 4. Then the fuzzy reproduction is due to something other than lack of focusing.

The only thing which can be accomplished by focusing the electron beam in a picture tube is to form the smallest possible spot of light at the screen. A correctly focused electron beam is represented at A of Fig. 5. Focusing adjustment is such that all elec-

trons in the beam come together just as they reach the surface of the screen, and at this point on the screen is produced the smallest possible spot of light. This spot will be of intense brightness, because the combined energy of all the electrons is acting on one minute area of the phosphor material. Were it possible for beam electrons to go right on through the screen and emerge outside the face, the electrons would spread apart as at a.

At B the focusing field has been made so strong that all electrons come together at a point in side the tube, back of the screen surface. Beyond this point of focus the electrons spread apart, and by the time they reach the screen the electrons are distribu-



## LESSON 47 – ELECTROMAGNETIC FOCUSING AND CENTERING



Fig. 4. Separated horizontal lines may be seen when focusing is good.

ted over a circle of fair size and of only moderate brilliance. Could the electrons pass through the screen they would continue to spread, as at b.

At C of Fig. 5 the focusing field is so weak that electrons reaching the screen have not yet come together at a point of focus. This point would be beyond the screen and outside the tube face, could electrons go through the screen. The result is a small circle of light on the screen, but not a fine pinpoint of light.

When a correctly focused electron beam is deflected horizontally, the exceedingly small spot traces a narrow line of light from side to side. When the focusing adjustment is changed in either direction, the former spot enlarges to a small circle. This circle would trace a fairly wide band of light across the screen. But you cannot see these bands, because they overlap as a result of moving the beam horizontally about 490 times from top to bottom of the screen. It becomes im-

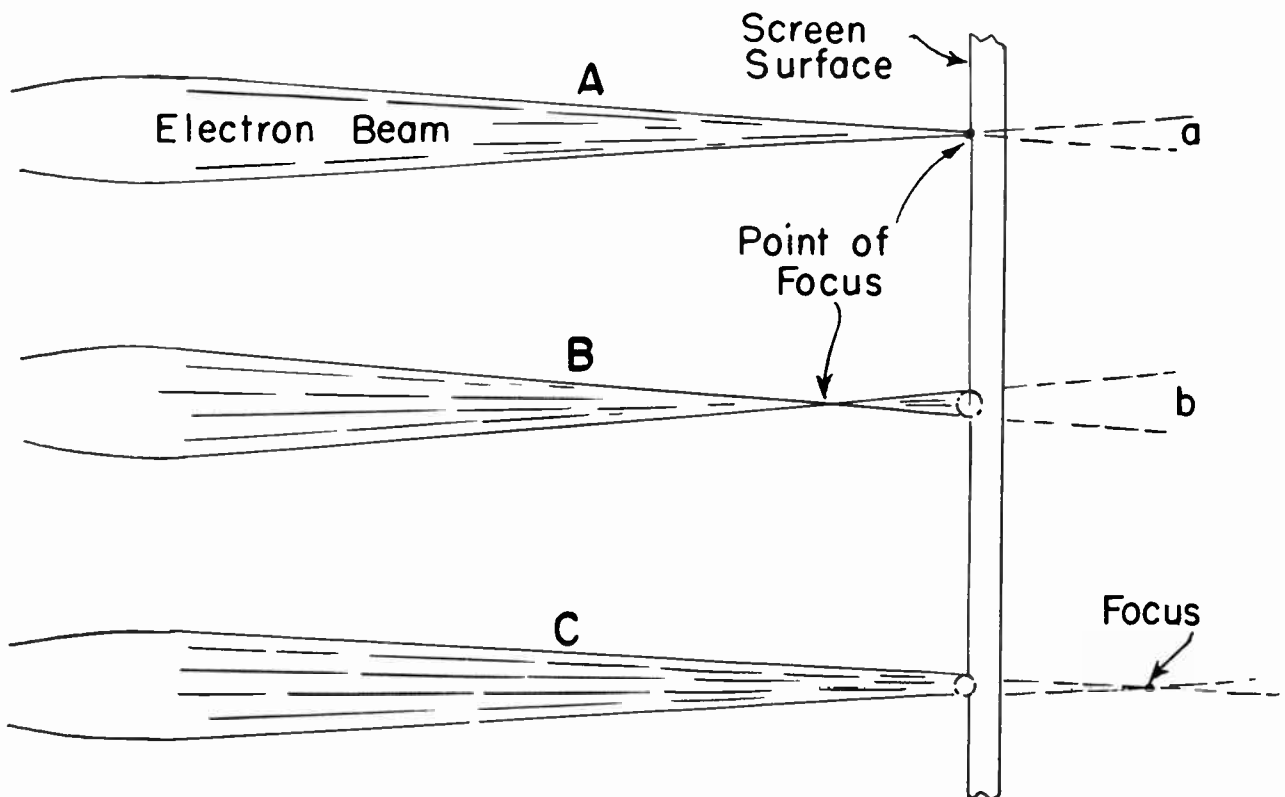

Fig. 5. The point of focus should be at the screen, but may be back of or ahead of the screen.

## COYNE - *television home training*

possible to distinguish separated horizontal traces or lines on the screen.

**ELECTROMAGNETIC FOCUSING.** A typical electromagnetic focusing coil is pictured by Fig. 6. The coil is enclosed within

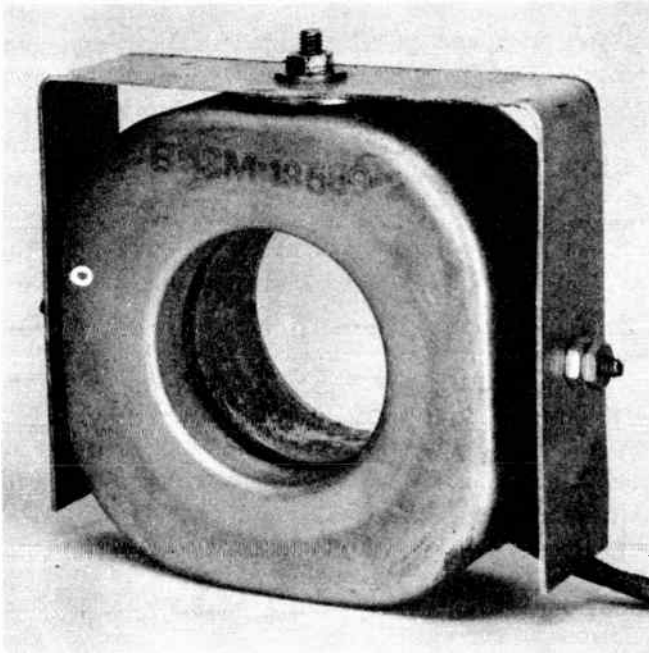

Fig. 6. An electromagnetic focusing coil.

a steel housing which completely covers the winding except for a small circular gap around the inside, where the coil surrounds the neck of the picture tube. While providing protection against mechanical damage to the winding, the housing confines and concentrates the magnetic field and lessens the coil current required for a given focusing effect. Two insulated lead wires that bring direct current to and from the coil may be seen at the lower right in the picture.

Attached to the coil illustrated is part of its supporting framework. With this coil in its operating position, this framework is mounted on a bracket in such manner that the axis of the coil may be tilted up, down, or sideways for centering of pictures.

Focus coils of this general type are mounted on the picture tube neck back of the deflecting yoke, at the end of the yoke that is toward the base of the tube. Between the

rear face of the yoke housing and the front of the focus coil housing the correct spacing will be about 1/4 to 3/8 inch. If the focusing coil is too far back of the yoke, it may be difficult to obtain narrow, clearly defined horizontal lines by means of the focusing adjustment. With the focusing coil too close to the yoke the magnetic field for focusing may act on the deflecting magnetic fields to tilt the picture.

In order that adjustments for focusing and centering may act as they should, it is essential that the axis through the center of the focusing coil be on the axis through the center of the tube neck when the coil is not tilted one way or the other for centering. Then, when the focusing coil is tilted, its center point should remain on the center axis of the neck. This is a point that has been neglected in a few receivers, and the neglect may cause you a good deal of trouble.

There are two standard types of focusing coils, one being designated as number 106, with nominal d-c resistance of 265 ohms, and the other as number 109, with d-c resistance of 470 ohms. Coils of other resistances are used in some sets.

Direct currents in the 265-ohm coils range from 110 to 135 milliamperes in most receivers. This means a drop across the focusing coil of 30 to 36 volts. Direct currents in the 470-ohm coils range from 90 to 115 milliamperes in most cases, which means a drop of 42 to 54 volts across the coils. Actual current required for an individual tube of a given type may be 10 to 15 per cent below or above the average current for this type of tube. Service adjustments always have a range more than sufficient to care for all normal variations of focusing current when receiver circuits, and especially the low-voltage power supply, are operating correctly.

Focusing coils of the 265-ohm type, or of some resistance on this order, are found on 10-inch and 12-inch picture tubes, and on some of the older tubes of larger diameters. The 470-ohm focusing coils, or coils of about this resistance, are commonly used on picture tubes of 14-inch and all larger sizes.

## LESSON 47 – ELECTROMAGNETIC FOCUSING AND CENTERING

For any one type of picture tube and electrical size of focusing coil, current required for focusing varies approximately as the square root of the second anode voltage. Second anode voltage seldom varies by more than 15 to 20 per cent on the same type of tube in different receivers, and required focusing current will not vary by more than about 10 per cent, regardless of second anode voltage.

The d-c resistance and current in focusing coils are important because these coils nearly always are used as chokes for filtering in the low-voltage power supply as well as for focusing. Voltage drops resulting from resistance and current will be subtracted from voltage otherwise available for plate and screen circuits.

D-c resistance of a focusing coil has no direct relation to formation of the magnetic field that focuses the electron beam. The strength of this field, and its focusing effect, depend on the current and the number of turns in the focusing coil - in other words on the number of ampere-turns. There might be any number of turns in a winding of almost any resistance, because resistance would depend on the size or diameter or gage number of the wire. There is no convenient way of measuring the number of coil turns, so the d-c resistance is used as a means for specifying the type of focusing coil employed.

The currents required in focusing coils are as large as the sum of plate and screen currents taken by ten or more amplifier tubes. It would be exceedingly wasteful of power to use this much current and the accompanying wattage merely to focus the electron beam. Consequently, current for focusing coils always is the same current used in plate and screen supplies for various receiver tubes. Several ways of doing this are shown by Fig. 7.

In diagram 1 of Fig. 7 the focus coil takes the place of a choke in the low-voltage power supply filter system. The electrical and magnetic characteristics of focus coils are quite similar to those of ordinary filter chokes, so the coil makes a good substitute for a choke. In parallel with the focus coil are a fixed and an adjustable resistor, with

the adjustable unit forming a focus adjustment.

With the adjustable unit set for zero resistance there remains across the focus coil the 470-ohm resistance of the fixed parallel resistor. D-c resistance of the coil is 470 ohms. Then resistance in series with the low B+ line to tube plates and screens is half of 470 ohms, or is 135 ohms. With the adjustable unit set for its maximum resistance of 2,500 ohms the total resistance across the focus coil is the sum of 2,500 and 470 ohms, or is 2,970 ohms. This much resistance in parallel with 470 ohms d-c resistance in the coil forms effective parallel resistance of about 406 ohms.

Effective resistance in series with the low B+ line thus is varied between 135 ohms and 406 ohms at the extremes of focusing adjustment. If this low B+ line feeds plates, screens, and other circuit elements taking 128 ma of current, the voltage drop across the focus coil and its paralleled resistors will vary between 17.3 and 52.0 volts at the extremes of focusing adjustment. This might vary the B+ line voltage from a maximum of something like 234.7 volts down to a minimum of 200.0 volts.

This same change of the focus adjustment resistor would vary the current in the focus coil from about 63.8 ma, with minimum adjusted resistance, up to about 110 ma with maximum adjusted focus resistance. A variation of coil current so great as this never is needed to maintain correct focusing adjustment. Consequently, the focus adjustment resistor never would be varied over its entire range, and the change of voltage at the B+ line would be nowhere near so great as the approximate 35 volts mentioned in the preceding paragraph.

Diagram 2 of Fig. 7 shows connections for another focus adjuster with which the focus coil is tapped. The adjustable resistor then is connected across only part of the coil.

Diagram 3 shows a low-voltage power supply in which the focus coil acts as a choke in the second section of the filter. In the first section of the filter there is an ordinary

# COYNE - television home training

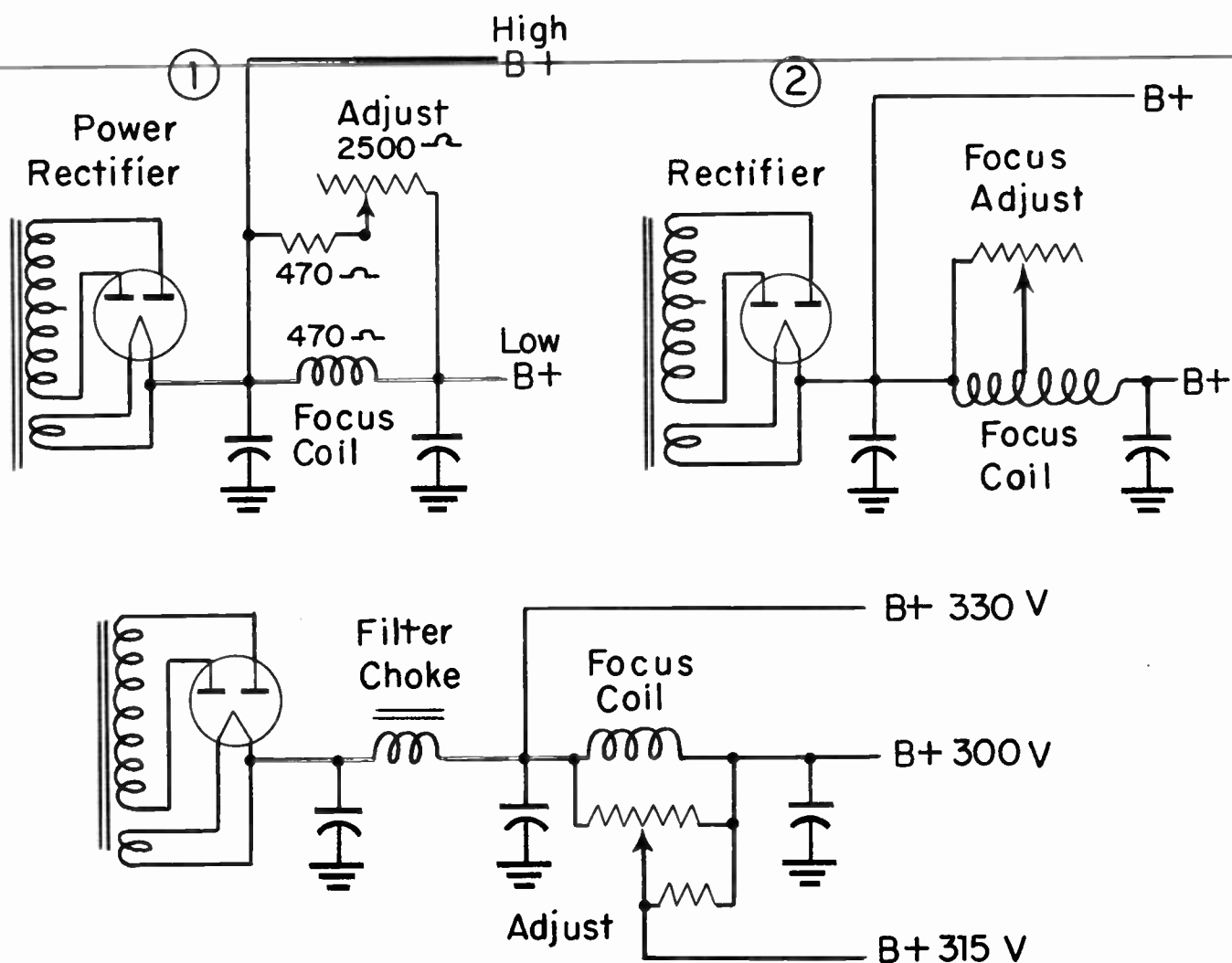

Fig. 7. How focus coils are connected to serve as chokes in low-voltage power supply filters.

filter choke. Current in the focus coil is varied by an adjustable resistor and a fixed resistor in parallel with the coil.

In nearly every case where an electromagnetic focus coil is employed, this coil will be found somewhere in the filter system of the low-voltage power supply. The focus coil connection is most easily found on service diagrams by starting at the filament or cathode of a low-voltage power rectifier and following along the B+ line to the coil.

In the actual wiring on a receiver the focus coil will not be close to the low-voltage power supply, because the coil is on the neck of the picture tube and the power supply rectifier is on the chassis.

When receiver service diagrams show the approximate relative positions of circuit elements, and wiring connections between them, it may require quite a bit of tracing to identify the focusing connections. At the top of Fig. 8 is an example, taken from a service diagram. As shown at the upper right, the deflecting yoke and focus coil are connected through a flexible cable to a plug marked P. This plug is like the base of a tube, with pins into which the leads are soldered.

Mounted on the chassis is a socket, S in the diagram, into which fits the plug. From lugs on the bottom of this socket, wires extend to various places underneath the chassis for completing the yoke and focus coil cir-



# LESSON 47 – ELECTROMAGNETIC FOCUSING AND CENTERING

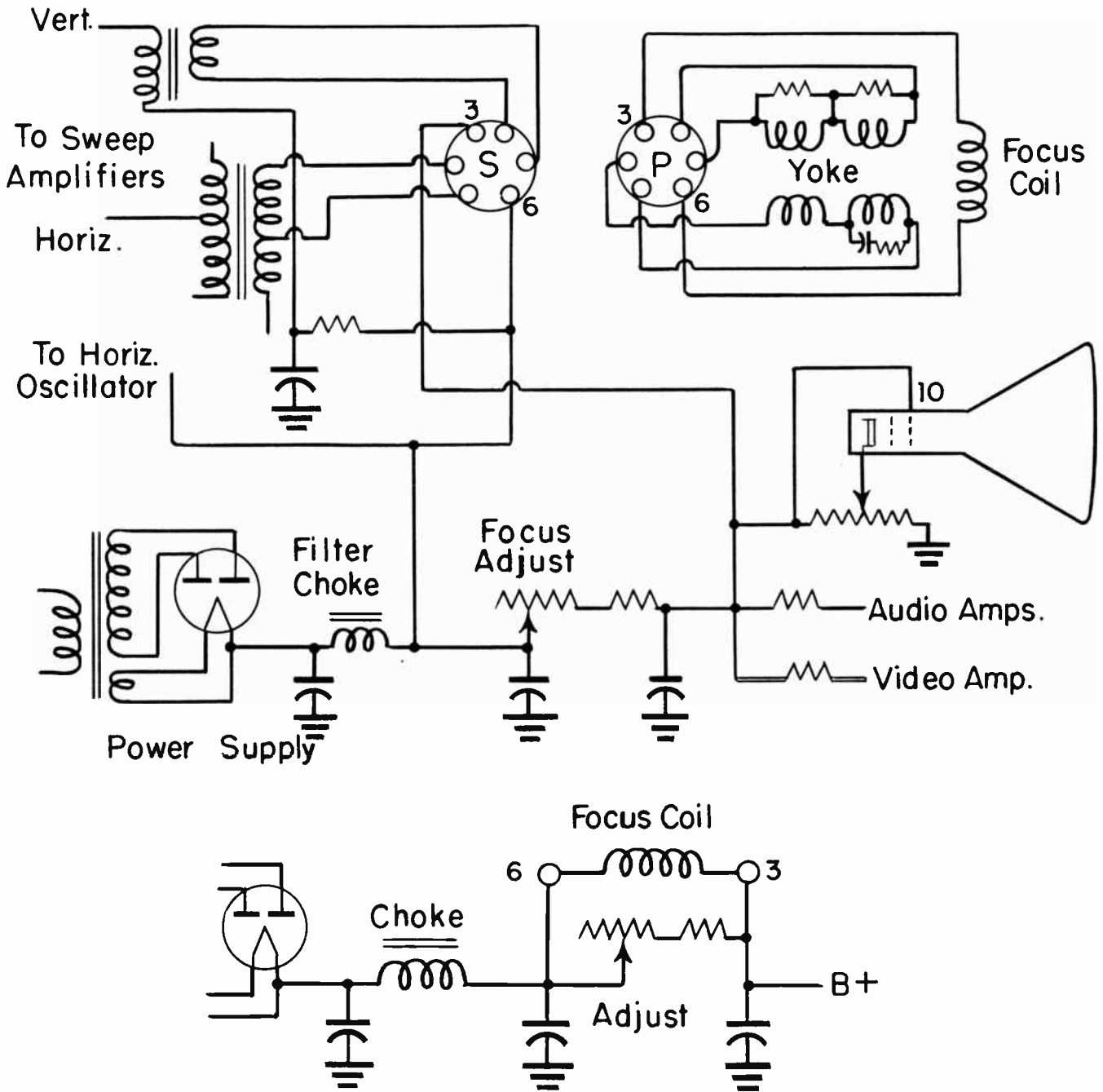

Fig. 8. How the same connections for a focus coil may be shown on a service diagram (above) and on a simplified schematic diagram (below).

uits. One end of the focus coil is connected to pin 3 and lug 3 of the plug and socket. You can follow from socket terminal 3 to the right-hand side of the focus adjust resistors. The other end of the focus coil is connected to pin 6 and socket lug 6, from where you can follow to the left-hand side of the focus adjust resistors. Thus the adjusting resistance

is electrically in parallel with the focus coil.

At the bottom of Fig. 8 is a simplified diagram in which the focus coil and its adjustable resistance are shown close together. This simplified diagram is somewhat similar in the arrangement of parts to the diagrams

## COYNE - *television home training*

of Fig. 7. It is easier to visualize the electrical functions of parts with the help of a simplified diagram, but it is easier to do service work on a receiver when you have a diagram similar to the one at the top of Fig. 8.

When any focusing adjustment is varied from one end to the other of its range, horizontal line focus on the screen of the picture tube should change from fuzzy to sharp and back to fuzzy. That is, the point of actual focus should vary as shown in Fig. 5, from B to A to C, or from C to A to B, always going through the best focus to a poorer focus on either side of the adjustment range.

Sometimes you will find that the best possible focus is obtained with the adjustment at one extreme or the other of its range. Possibly the focus could be improved were it possible to turn the adjustment still farther in one direction. This indicates one of two troubles. First, something may be preventing sufficient voltage and current from the low-voltage power supply. Usually the power rectifier needs replacing, but there may be open or shorted resistances on some B+ circuit. Second, the arrangement of focus control resistors is wrong, or these resistors are not of values suited to the type of picture tube in use. This latter difficulty would arise when a replacement picture tube is of a decidedly different type than the tube originally used on the receiver.

If the leads to a focus coil are interchanged, thus reversing the polarity of its magnetic field, the ability to focus pictures will not be impaired. But pictures which were level or upright with the original connections will be tilted when the leads are reversed. The amount of tilt ordinarily will be no more than can be corrected by adjusting the deflecting yoke. In addition to tilting, the pictures will be decidedly off center. It may or may not be possible to bring pictures into correct position by means of the centering control.

Earlier it was mentioned that the air gap on the inside of the coil housing should be toward the face of the tube, away from the base. If the coil is turned around, front and back, a much greater current will be needed

for good focusing. The increase usually will be 15 to 25 per cent. This is a greater increase of current than allowed by most focusing adjustments, so the coil would have to be turned to its correct position to allow good focusing. Were the air gap centered lengthwise of the coil axis, so that the gap would be in the same position along the neck of the tube with the coil turned around, focusing effect and current required would not be altered.

### CENTERING WITH THE FOCUS COIL.

The picture or raster should be centered, at least approximately, before making focusing adjustments. Therefore, we shall take up the matter of centering and then explain methods of focusing. During actual servicing, you would adjust the ion trap magnet before either centering or focusing is taken care of. Furthermore, before making centering adjustments, you should make sure that the horizontal hold control is in its normal operating position, for this control may shift pictures to the right or left while they still remain in synchronism. The order in which all these adjustments should be made will be reviewed later, after we understand how they are handled individually.

When the spot formed by the electron beam is sharply focused on the screen, but is not being deflected either horizontally or vertically, the spot will not necessarily be at the exact center of the screen. It will be somewhere within a central area measuring about an inch in diameter. If this spot is deflected equal distances horizontally and vertically, the resulting raster and pictures may be off center, and usually would be. This may be corrected by tilting or inclining the focus coil to center the area covered by the raster on the picture tube screen.

The varying intensity of the electron beam which forms pictures on the screen, may be imagined as forming similar but smaller images anywhere between the focus coil and the screen, within the tube. Fig. 9 shows such an image and also the final picture area on the screen. The image rotates as it passes from focus coil to screen within the tube. If the axis of the focus coil is correctly positioned in relation to the axis of the tube neck and the center of the screen, the

## LESSON 47 – ELECTROMAGNETIC FOCUSING AND CENTERING

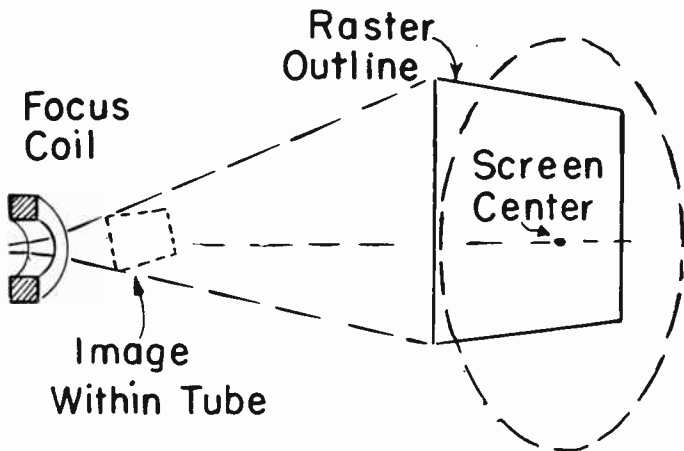

Fig. 9. The electron image rotates in passing from focus coil to screen.

sides of the pictures will be vertical and their tops and bottoms horizontal when the image reaches the screen.

Because of image rotation within the picture tube, tilting the axis of the focus coil straight up will not move the picture straight up. The picture will move diagonally on the screen. Tilting the focus coil to one side or

Fig. 10A.

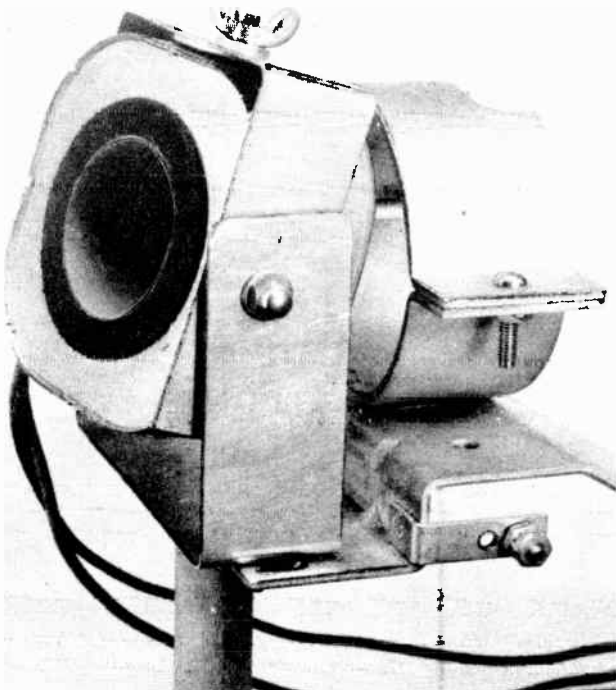

Fig. 10. A focus coil in a gimbal mounting which allows inclining the coil axis in any direction.

the other will not shift the picture horizontally across the screen, it will shift the picture diagonally. To center the picture on the screen it must be possible to incline the focus coil in any combination of vertical and horizontal directions at one time.

It should not be necessary to rotate the picture tube as a whole to make a perfect centering adjustment. There are, however, rare cases in which rotation of the tube may help in cases where centering proves to be very difficult. This indicates that the picture tube is not up to specifications, or that centering adjustments have insufficient range.

There are many methods of inclining the focus coil. All of them are mechanical, not electrical, and careful inspection should allow determining how adjustments can be made. One method is illustrated by Fig. 10, where the coil axis is inclined at one angle in picture A, and at a different angle in picture B. The photographs show greater inclinations than ever are needed in practice, simply to illustrate how adjustments are used. The deflecting yoke has been removed from the

Fig. 10B.

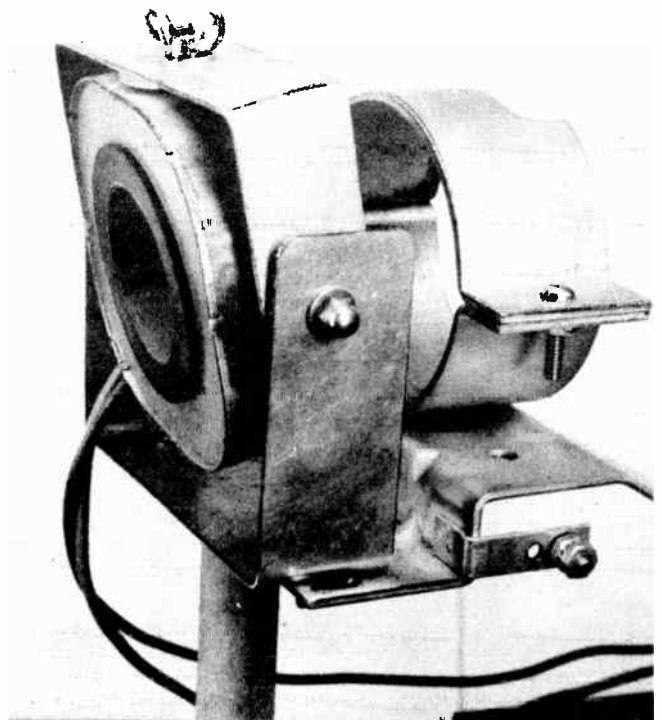



## COYNE - *television home training*

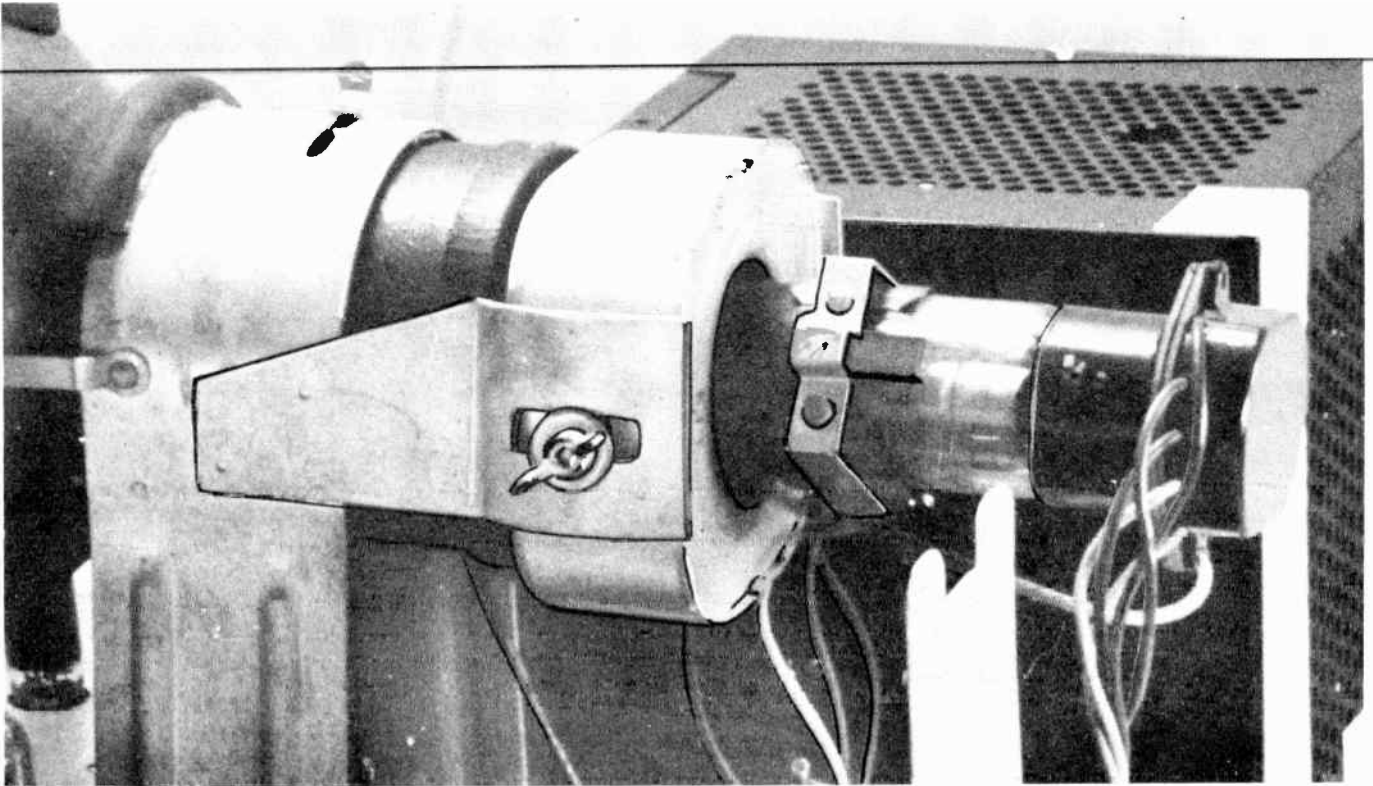

Fig. 11. A focus coil supported by pivot bearings in lengthwise slots of bracket arms.

circular bracket which may be seen just ahead of the coil mounting.

The focus coil is here mounted in what may be called a gimbal. The housing of the coil is supported by an open rectangular frame with a pivot bearing at the top. This bearing allows the coil to turn around a vertical line, so that inclination may be to the right or left. The bearing is locked in any position by means of a wing nut.

The coil frame is in a bracket having pivot bearings on opposite sides, one of which shows in the pictures. On these bearings the coil may turn around a horizontal line, and thus be inclined up or down. With vertical and horizontal bearings just free enough to allow moving the coil, it may be inclined in any degree to the left or right and at the same time in any degree up or down. When the picture is centered on the screen, all bearing nuts are tightened securely.

With another construction, Fig. 11, there are supporting pivots on both sides of the focus coil housing. These pivots pass through

lengthwise slots in arms which extend back from the yoke bracket. With the pivot wing nuts loosened, the focus coil may be moved forward or back on either or both sides, or may be moved forward on one side and back on the opposite side. This allows inclining the coil axis to the left or right. At the same time, the focus coil may be rotated on its two opposite pivots to tip the coil axis up or down.

Still another adjustment mechanism is shown by Fig. 12. By means of small "ears" on the housing, the focus coil is supported by three threaded studs carried by a vertical plate just back of the deflecting yoke. Between this plate and the ears on the coil housing are coiled springs which keep the coil in position along the studs and maintain tension on slotted adjusting nuts which are screwed onto the rear ends of the threaded supporting studs.

Turning the adjusting nuts on the two studs which are on opposite sides of the coil housing will move the picture one direction. Turning the remaining adjusting nut will



## LESSON 47 – ELECTROMAGNETIC FOCUSING AND CENTERING

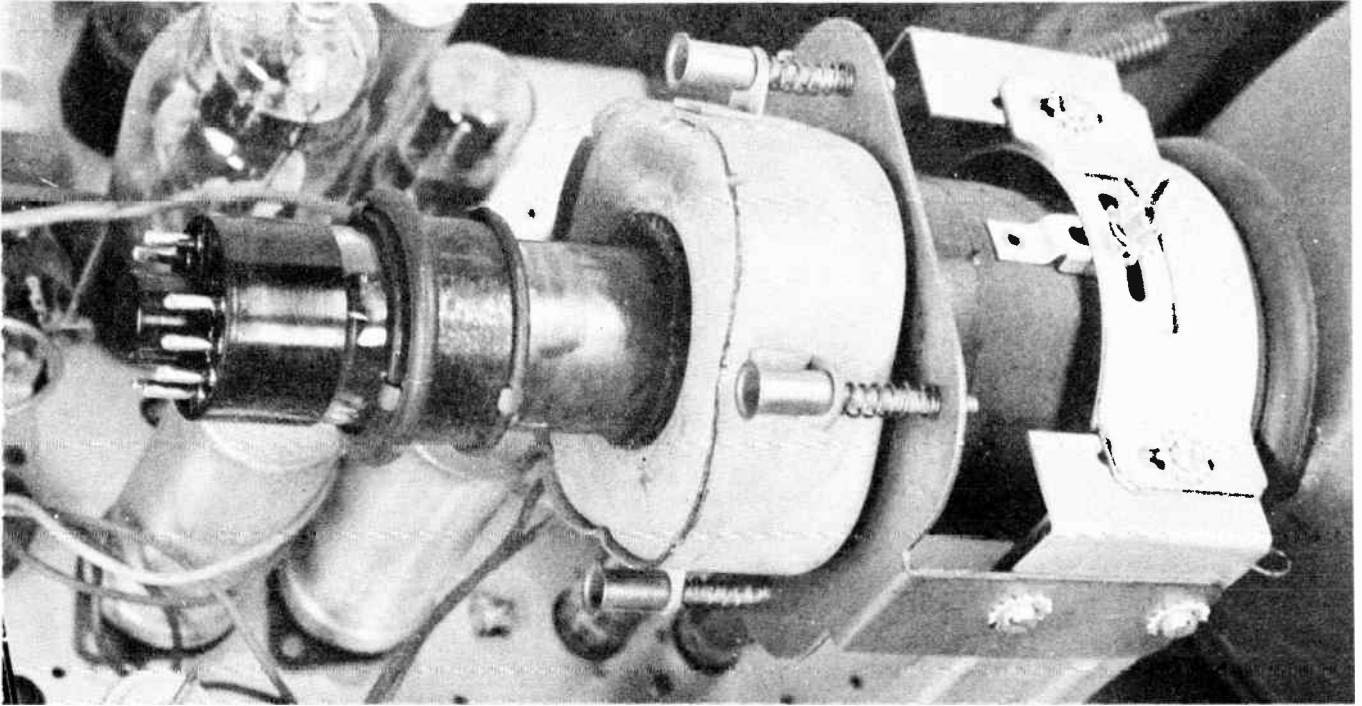

Fig. 12. Any one or more sides of the focus coil housing may be moved forward or back on the supporting studs by turning the adjusting nuts.

move the picture in a direction approximately at right angles to the first one.

Centering and focusing may be difficult, and results unsatisfactory, unless certain matters are checked in advance. First, unless the deflecting yoke is as far forward as it can be moved on the neck of the picture tube there certainly will be difficulties. The front opening of the yoke should be as close as possible to the flare or cone of the tube. Adjustments which allow correct positioning of the yoke will be shown when we come to the subject of deflection in general.

Second, as indicated in Fig. 13, the center axis of the focus coil should lie on the center axis of the tube neck when the coil points straight forward. This is the same as saying that the coil and the tube neck should be concentric. When the focus coil is inclined, its center should remain on the neck axis. The opening through the center of the focus coil always is of diameter enough larger than the outside of the tube neck to allow all the inclination or tilting that may be necessary for centering. The opening through the focus coil should be lined with felt, soft rubber, cardboard, or some ma-

terial which will prevent metal of the coil housing from striking the tube neck should the coil be turned too far. The picture tube

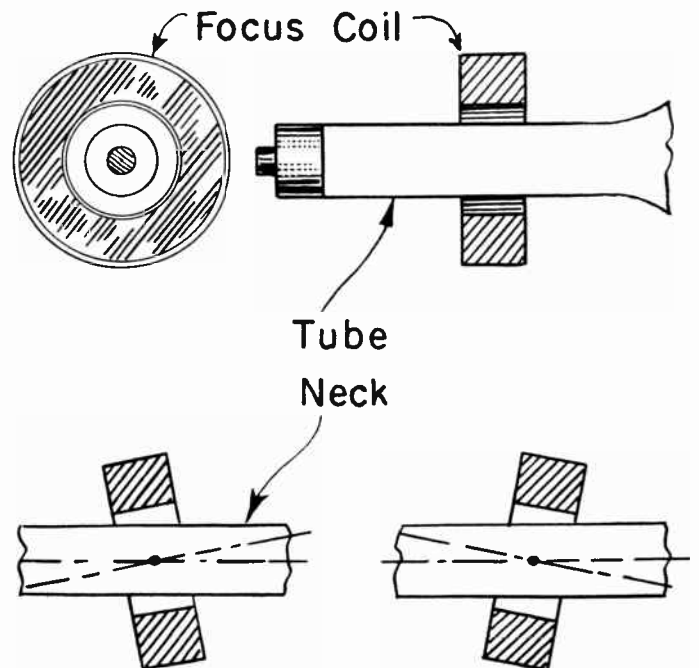

Fig. 13. The center of the focus coil should remain on or very close to the axis of the picture tube neck when the coil is inclined for centering.

## COYNE - *television home training*

neck is fragile, and might be broken. A soft rubber liner is inside the focus coil of Fig. 10.

With some designs the mounting for the focus coil is so constructed that the coil may be moved bodily up or down, and sometimes sideways, to align the axes of the coil and tube neck. With other constructions the focus coil position is fixed, vertically and laterally, but the support for the deflecting yoke may be moved enough to align the coil and neck axes.

The alignment may be checked by pushing some small object, such as a strip of cardboard, into the space between coil and tube neck, working from the rear of the coil. A better check is made by sliding the picture tube out of the yoke and focus coil, or else by removing these elements from the tube, then sighting through the openings - but don't do this until you learn how to handle picture tubes with safety.

Pictures may be centered approximately with the picture tube on a chassis which is removed from the receiver cabinet, but final centering must be done with the tube in its regular position behind the cabinet mask. Centering adjustments are handled from the rear end or socket end of the picture tube. To see the effects of adjustment, it is convenient to place a large mirror in front of the receiver, facing the mirror toward the mask or picture tube screen. By looking into the mirror you can watch the picture shift within the mask as centering adjustments are altered.

Glass mirrors are heavy, awkward to handle, and easily broken. A mirror which is light and unbreakable consists of a chrome plated "ferrotype" plate such as used by photographers to finish glossy prints. These plates, in any desired size, may be had from any photographic supply store, at a cost less than that of an equally good glass mirror.

A picture or raster in position A of Fig. 14 is off center diagonally; it should be moved down and to the left. The correction might require turning the focus coil axis in a horizontal plane to the left or right. At B the diagonally off-center picture might be

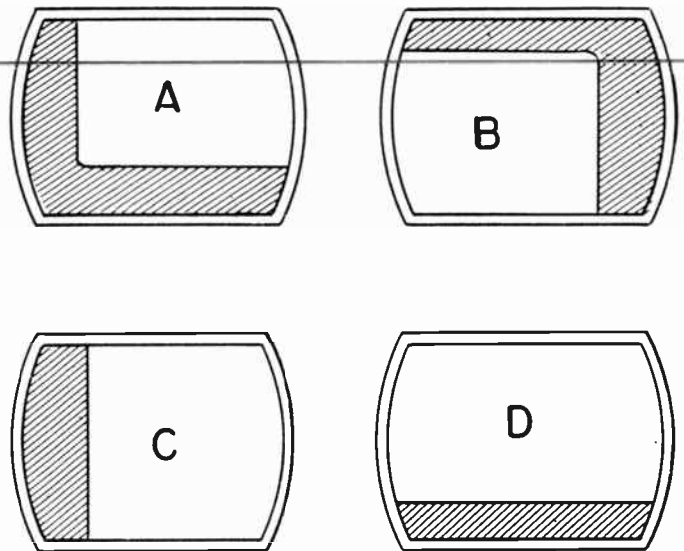

Fig. 14. A picture or raster may be off center diagonally, horizontally, or vertically.

corrected by vertical inclination of the focus coil. At C the picture should be shifted straight toward the left, which would require diagonal tilting of the focus coil, and again a diagonal tilting would be needed to move the picture straight up on the screen.

While attempting to center a picture or raster on the screen you may encounter the effect illustrated by Fig. 15. Dark shadows appear at one corner, or sometimes across the sides or the top or bottom of the illuminated area. These are called neck shadows, because they are caused by the electron beam striking the glass neck of the picture tube where the neck joins the flare or cone. It is the circular form of the neck opening that causes the inner sides or edges of the shadows to be curved.

Neck shadows result from failure to keep the front of the deflecting yoke close to the flare or cone of the tube. Then deflection or bending of the electron beam occurs so far back from the front end of the neck that the beam strikes the glass and cannot continue on to the screen.

Another possible cause of neck shadowing is misalignment of the axes of focus coil and picture tube neck. When the center of the coil is far from the center of the neck there is permanent offsetting of the beam,





## COYNE - *television home training*

rection for least contrast. The brightness control should be adjusted for medium illumination of the screen.

Now the focusing control should be adjusted for clearest horizontal lines when you look closely at the screen. With good focusing the lines should appear as in Fig. 16.

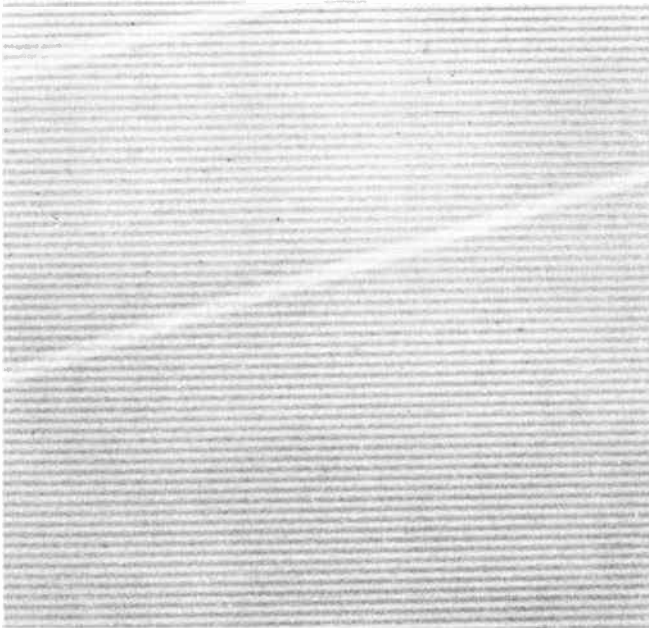

Fig. 16. When focusing is correct it is easy to distinguish separate horizontal lines on a raster,

With some types of deflecting yokes the horizontal lines may be made almost equally distinct all the way across the screen. Otherwise you will find that making the lines sharpest at the center of the screen puts them slightly out of focus at one or both sides, while maximum sharpness at the sides is accompanied by a slight defocusing at the center.

When equally good focus cannot be obtained all over the screen it is advisable to favor the central area, where most of the action takes place in reproduced pictures. Commence by getting the sharpest possible focus at the center, then move the control so that maximum line sharpness moves out a little ways toward the sides. Turn the focusing control back and forth several times, to make sure of obtaining the best all-over result.

Good focusing adjustments may be made with a test pattern on the screen, a pattern such as transmitted by many stations before the beginning of a regular program schedule. Such patterns contain wedge-shaped sections of lines which become narrower toward the center of the pattern, as shown by Fig. 17. Watch the lines on the two wedges that extend

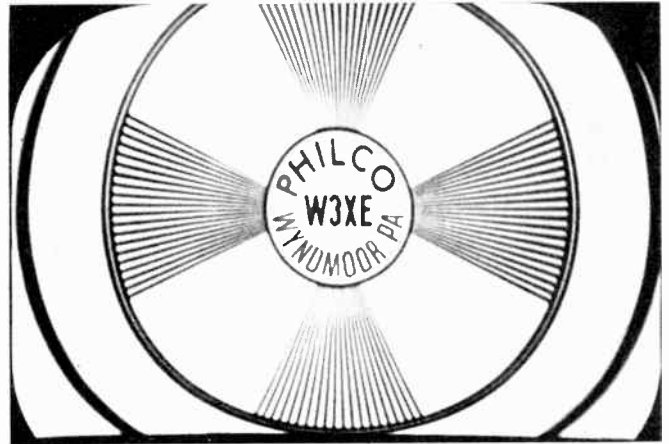

Fig. 17. When focusing on a test pattern, adjust for sharpest lines in the vertical wedges.

from the central circle toward top and bottom of the pattern. Adjust the focusing control so that these vertical wedge lines are most distinct.

It is more difficult to make a good focusing adjustment while watching pictures, in which there is continual movement, than on either a raster or a test pattern. If you do make the adjustment while watching pictures, get the best possible horizontal trace lines to begin with. Then watch any narrow vertical lines in the pictures, such as vertical parts of doorways or furniture, and try to make an adjustment that shows these details most clearly.

No matter what screen subjects are used during focusing, always watch regularly transmitted pictures before assuming that the job is complete. Set contrast and brightness controls for normal reception and try slight readjustments of the focusing control in attempting to obtain any possible improvements.



## LESSON 47 – ELECTROMAGNETIC FOCUSING AND CENTERING

It may prove difficult to obtain satisfactory focus over a reasonably wide area of the screen; focus may be very good at the center and very poor at the sides, or vice versa. Then it will be worth while to try moving the focus coil a little farther forward or back along the tube neck while maintaining the best possible adjustment at all times. Sometimes it is possible to locate a position that will allow spreading the area of sharp focus over more of the screen than with the coil in its original position.

Focusing may be done with the picture tube in or out of the cabinet. If the tube is mounted on the chassis, and the chassis is out of the cabinet, it usually is possible to watch the screen while reaching the focusing adjustments. This comes about because your eyes should be quite close to the screen while watching line focus. If focusing must be done with the picture tube in the cabinet it may be helpful to use a mirror such as mentioned for centering adjustment, but it will be rather difficult to see the focused lines.

**MAGNETIC SHUNTS.** When examining circuits for controlling the current in focus coils, and thereby adjusting the focus, it was mentioned that sometimes the best focus can be obtained only with the control at one end or the other of its range. In a few receivers using electromagnetic focusing there is provision for altering the strength of the magnetic focusing field independently of, or in addition to, the adjustment made by varying the coil current.

This additional adjustment, called a magnetic shunt, is usually in the form of an iron cylinder or ring either around the outside of the coil or else inside the coil opening. Moving the shunt one way or the other, lengthwise of the coil axis, diverts more or less of the magnetic lines of force from the space within the tube neck. With the shunt adjusted for less diversion of the focusing field, the effect is equivalent to increasing the coil current, while opposite adjustment of the shunt is magnetically equivalent to lessening the coil current.

When the control for coil current does not cause best focusing before reaching the

limit of adjustment range in one direction or the other, the magnetic shunt may be moved for compensation. Procedure is to set the focus current control at the center of its range, then adjust the magnetic shunt in the direction and by the amount which gives good focusing. A final close adjustment is made by means of the current control. We shall get better acquainted with the principles of magnetic shunting when studying the subject of focusing with permanent magnets.

### FOCUSING

#### With Electromagnetic Focus Coil

##### Coil Position:

Gap between front of focus coil housing and rear of yoke housing to be  $1/4$  to  $3/8$  inch. To have good focus over the widest possible portion of the screen, it may be necessary to shift the focus coil within these limits or even a little closer to the yoke.

Air gap on inside of coil housing toward the yoke, not toward the base of the picture tube.

##### Adjustment:

Observing a raster.

Contrast control minimum. Brightness control for moderate illumination. If focus cannot be made equally good all across the screen, adjust for sharp focus at and near the central area rather than at sides.

Observing a test pattern.

Adjust for clearest and sharpest tapered lines in vertical wedges.

Observing pictures.

Adjust for clearest vertical outlines of objects which remain stationary in the pictures.

Final check.

Observe regularly transmitted picture programs while making touch-

# COYNE - *television home training*

up adjustment of focus control for possible improvement of clarity.

Coil currents and voltage drops, approximate.  
No. 109 coil. 470 ohms. 90 to 115 ma.  
42 to 54 volts.

No. 106 coil. 265 ohms. 110 to 135 ma.  
30 to 36 volts.

Required current varies as the square root of second anode voltage.

Coil No. 109 used on tubes of 14-inch and larger sizes. Coil No. 106 on 10-inch and 12-inch tubes, with some exceptions.

Best focus only with adjustment all the way in either direction.

Insufficient voltage and current for focus coil. Check low-voltage power rectifier and voltage output from power supply filter section.

Wrong values or defective focus control resistors.

Focus coil turned around, front and back, on tube neck.

Magnetic shunt not adjusted, if a shunt used.

Picture tube has been replaced with type taking more or less focus field strength than original tube.

Order of adjustments which act on electron beam.

1. Ion trap magnet.

2. Horizontal hold, in normal operating position.
3. Centering, approximate adjustment.
4. Focusing.
5. Centering, final adjustment (tube in cabinet).
6. Focusing, final touchup on transmitted pictures.

## CENTERING

### With Electromagnetic Focus Coil

#### Adjustments:

Deflecting yoke must be close as possible to flare or cone of picture tube.

Focus coil axis and center point to be on the axis of tube neck.

In rare cases, may be necessary to rotate picture tube around its axis if this can be done with the second anode connector remaining in suitable position for the high-voltage lead wire.

Make sure that metal housing of focus coil cannot strike glass of tube neck. A soft liner should be inside the opening of the coil housing.

Final centering only with picture tube in cabinet, behind the mask.

#### Neck Shadows.

Deflecting yoke not close to flare or cone of picture tube.

Focus coil not centered around neck of picture tube.

# TELEVISION

• RADIO

• ELECTRONICS

---

**LESSON 48 – ELECTROSTATIC AND PM FOCUSING – CENTERING**

---

***Coyne School***

*practical home training*

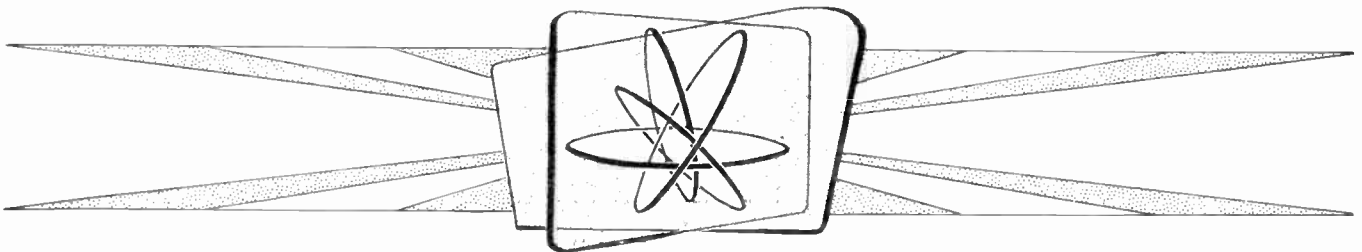

*Chicago, Illinois*

---

*Copyright, 1953 by Coyne Electrical School  
Chicago 12, Illinois  
All rights reserved*

Litho. in U.S.A.



## Lesson 48

### ELECTROSTATIC AND PM FOCUSING — CENTERING

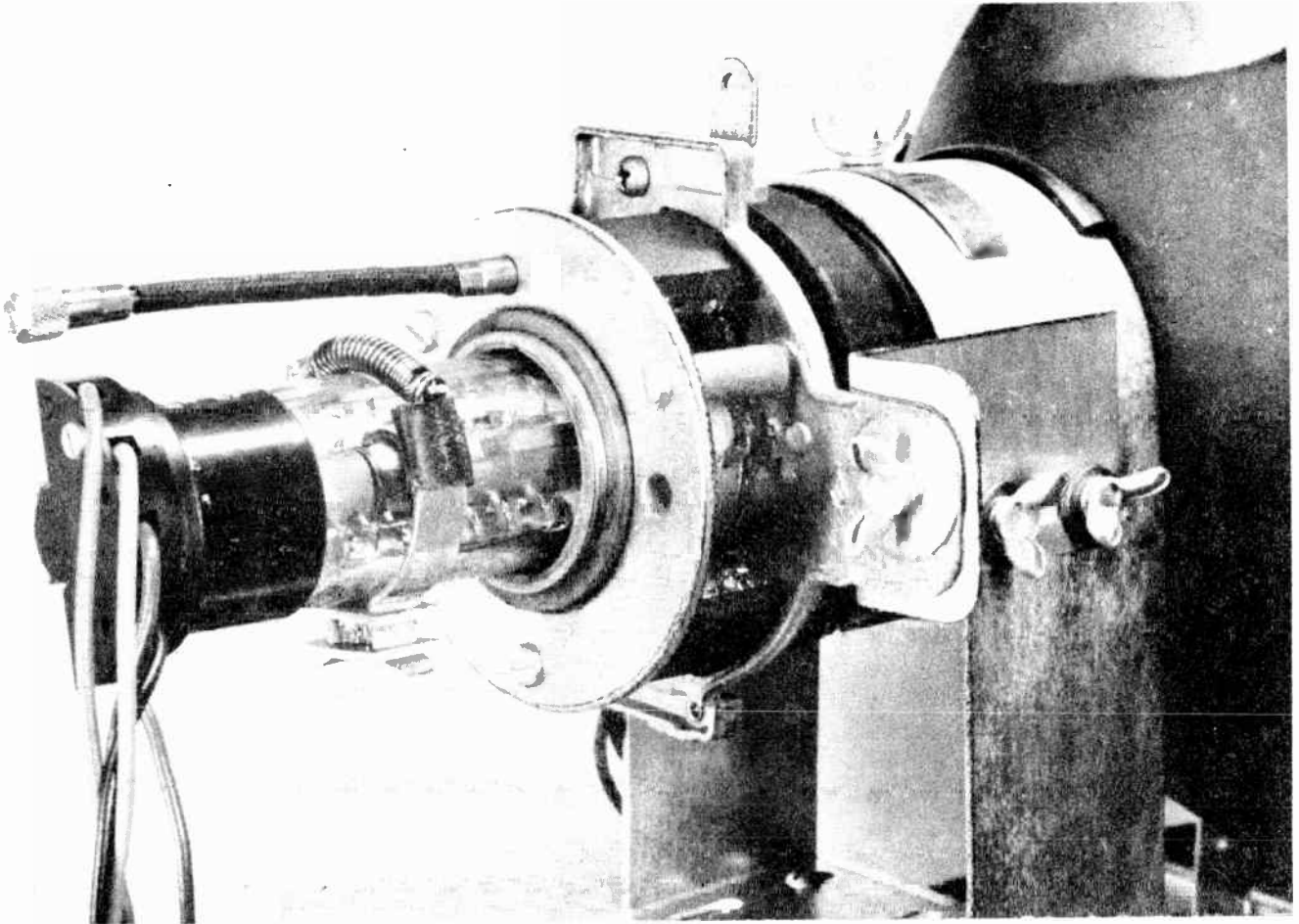

*Fig. 1. A permanent magnet focusing and centering device on the neck of a picture tube employing magnetic deflection.*

The electron beam is brought to a focus at the picture tube screen by action of a magnetic field. Focusing effects are due to strength and direction of magnetic lines of force in the field, and if these two factors are suitable for focusing, it makes no difference whether the field is produced by an electromagnet or by a permanent magnet. Consequently, you will find a great many magnetically focused picture tubes fitted with permanent magnet or PM focusers rather than with focusing coils.

Fig. 1 shows one style of PM focuser. The magnet structure is supported around the neck of the picture tube just back of the deflecting yoke, in the same position as a

focus coil. The focuser is mounted with brackets which allow moving the unit closer to or farther from the yoke, and that allow aligning the axes of the focuser and tube neck in much the same manner that these axes are aligned when using a focus coil.

There is wide variety in mechanical design and construction of PM focusers, but most of them make use of the principle illustrated by Fig. 2. Note first, at the left, the cross section through a focus coil and its housing. In effect, the coil magnetizes the steel housing and causes magnetic poles to appear on opposite sides of the internal gap. The strength of the magnetic field between the poles and in the picture tube neck is

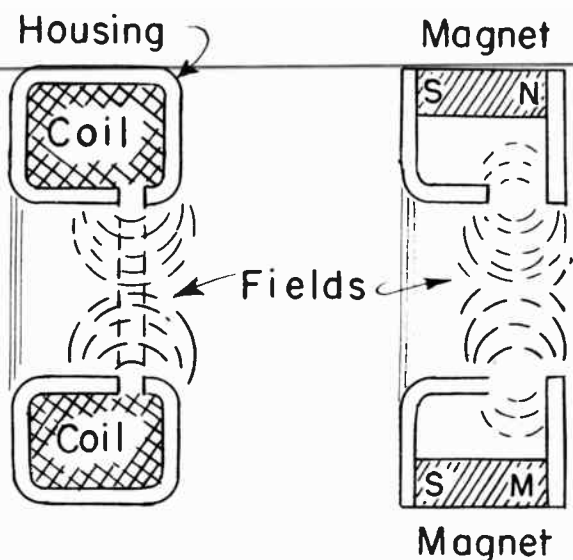

Fig. 2. Magnetic fields are formed at the gaps in focus coil housings or in PM focuser pole pieces.

varied by adjusting the direct current which flows in the coil winding.

At the right in Fig. 2 is a cross section through the principal elements of a PM focuser. Fig. 3 shows actual construction of these elements in one style of focuser. There are two circular plates of soft steel, one at the front and the other at the back. The front plate is flat, with a circular opening at the center. The rear plate has an internal flange extending forward in the form of a cylinder to leave a gap between its front edge and the opening in the front plate.

Three very strong Alnico permanent magnets are held between the two plates, equally spaced around the circumference. In the photograph, one of these magnets may be seen near the bottom of the structure, a second at the top, and a third almost concealed behind the central extension. The two plates act as pole pieces for the permanent magnets, and in the gap appears a magnetic field similar in form to the field in the gap of the focus coil housing.

Fig. 4 shows a method commonly employed for varying the strength and extent of the neck of the picture tube for focusing. Around the cylindrical extension of the rear plate is a ring of soft steel, which may be moved toward or away from the front plate.

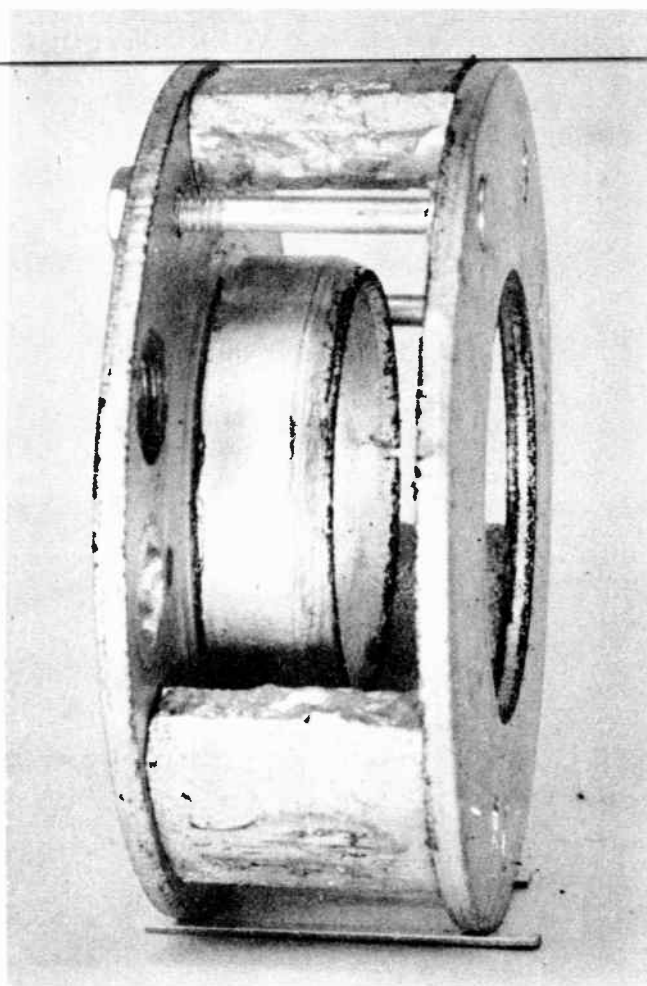

Fig. 3. Permanent magnets and pole pieces of a PM focuser.

As this ring is moved closer to the front plate the magnetic gap is narrowed. This allows the field in the gap to be more intense than before, but less of the total field strength extends into the neck of the picture tube. The result is weakening of the field in the region where focusing is accomplished. Moving the adjustable ring farther from the front plate widens the gap. Then the magnetic field spreads out, and more of the total magnetic strength acts within the tube neck, where focusing takes place.

At the right in Fig. 4 is shown an adjustable ring at the top of which is an extension acting as a support for the ring. Fastened into this supporting extension, but free to turn, is a screw plug that threads into an opening in the rear plate. The exposed end of the plug is slotted, and when turned by a screw driver or equivalent tool the plug and

## LESSON 48 – ELECTROSTATIC AND PM FOCUSING – CENTERING

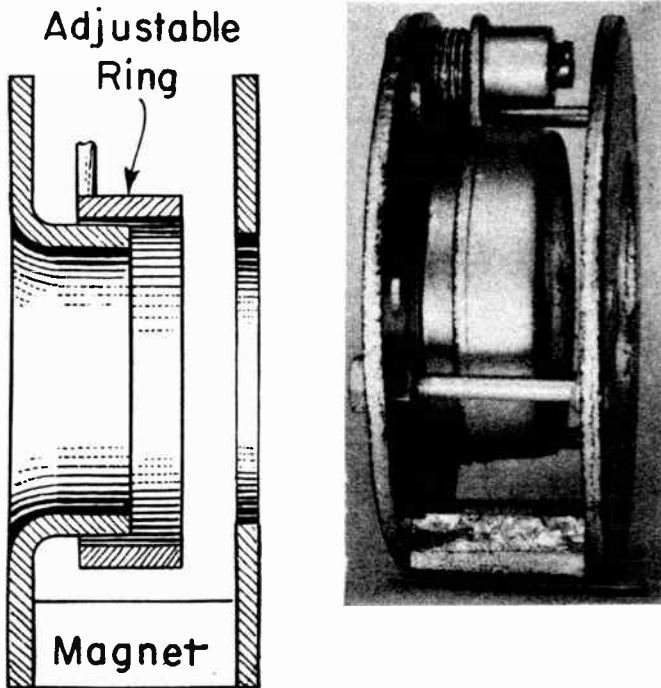

Fig. 4. A movable ring for adjusting the gap in a PM focuser.

magnetic ring move one way or the other to vary the width of the gap. This slotted plug is the adjustment for focusing the electron beam.

It would be possible to center pictures on the screen by inclining the PM focuser in much the same way that a focus coil is inclined, but centering seldom is handled this way in practice. Instead a movable "wobble plate" is mounted on the front pole piece in such manner that the magnetic field may be inclined while the focusing magnet structure remains in a fixed position

Action of a centering mechanism of this kind is illustrated by Fig. 5, which is a view looking at the inside of the front pole-piece plate. The wobble plate is here a flat ring of soft steel whose inner opening is of about the same diameter as the opening through the pole-piece plate. On one edge of the wobble plate is an extension or arm containing a rather long slot through which passes a pivot to form a loose bearing and support. On the opposite edge of the wobble plate is a second arm having a hole into which will fit the end of a centering lever.

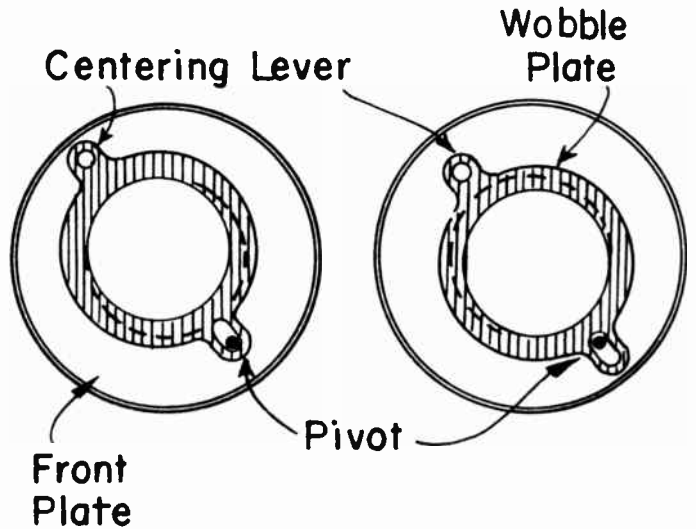

Fig. 5. A wobble plate mounted to allow moving its central opening in any direction.

When the centering lever is shifted one way and another, the wobble plate swings on its pivot bearing. Because of the slot around the pivot the wobble plate with its central opening may be moved lengthwise of the slot, swung to either side, or moved in any combination of these directions. Since the wobble plate is magnetically a part of the front pole piece, shifting the wobble plate shifts the opening of the pole piece with reference to the neck axis of the picture tube.

The forward end of the magnetic field remains approximately centered in the opening of the wobble plate, so shifting this opening will incline the field in any direction required for centering of pictures. From the standpoint of magnetic field direction, shifting the wobble plate has the same effects as inclining a focus coil.

Fig. 6 is a picture of a wobble plate mechanism. The pivot bearing and slot are down below. The centering lever passes through an opening in the rear pole-piece plate, and extends forward to enter the hole in the wobble plate arm. This lever is held securely into the opening of the wobble plate arm by a coiled spring. This spring also presses the wobble plate against the front pole piece to maintain any adjusted position. In the picture the centering lever is inclined in a direction that moves the forward end of the magnetic field down and to the right.



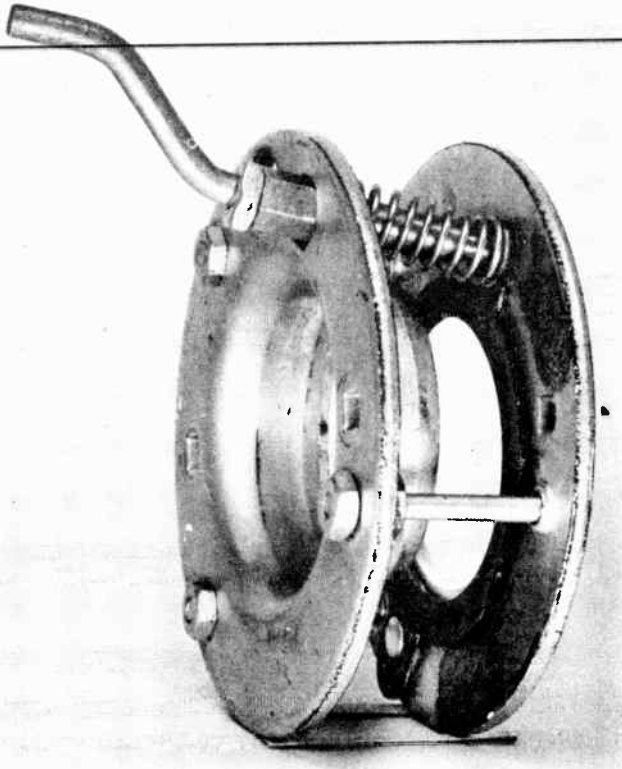

Fig. 6. The centering lever and wobble plate for one style of PM focuser.

Fig. 7 shows the complete assembly of the PM focuser that has been described in some detail. In somewhat similar types there may be two focusing screws. The centering lever may be short and bent, as illustrated, or it may be straight, or it may be long enough to pass through the rear cover of the cabinet to allow centering adjustment from outside the cabinet.

Fig. 8 is a close-up view of part of the focusing-centering mechanism shown in its operating position by Fig. 1. There are front and rear pole-piece plates with three strong Alnico permanent magnets between them. Focusing is by means of a ring of soft steel which slides forward or back to vary the width of the magnetic gap. This focusing ring is moved by a small brass screw that threads through an extension on one side of the ring. The screw is turned by the flexible shaft that extends out through the rear plate. On the end of the flexible shaft is a small knurled part that you can rotate between thumb and finger for accurate focusing.

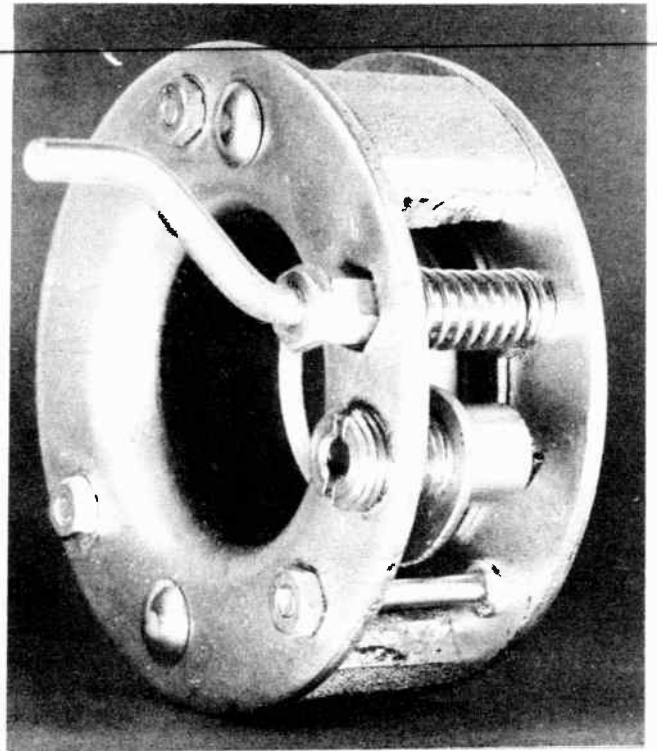

Fig. 7. A complete PM focusing and centering unit.

Some details of this particular design are shown by Fig. 9. The entire structure is built on and supported by a die casting of non-magnetic metal. So far as magnetic fields are concerned this non-magnetic supporting frame acts like so much air. There are the usual Alnico permanent magnets between front and back pole-piece plates. The movable ring that is adjusted for focusing makes a smooth sliding fit on the outside of a central non-magnetic cylinder that goes around the neck of the picture tube. Although there is metal of the support in the gap between this ring and the front pole piece, this metal has no effect on field strength or on the distribution of the field.

The wobble plate used for centering is supported at the bottom by a sliding tongue-shaped extension held between pivot pins. This allows movement of the plate in any direction. The centering adjustment is an upward extending arm shown clearly in Fig. 8. This arm may be moved up, down, and to either side for shifting the opening of the wobble plate and the inclination of the focusing field in relation to the picture tube neck



## LESSON 48 – ELECTROSTATIC AND PM FOCUSING – CENTERING

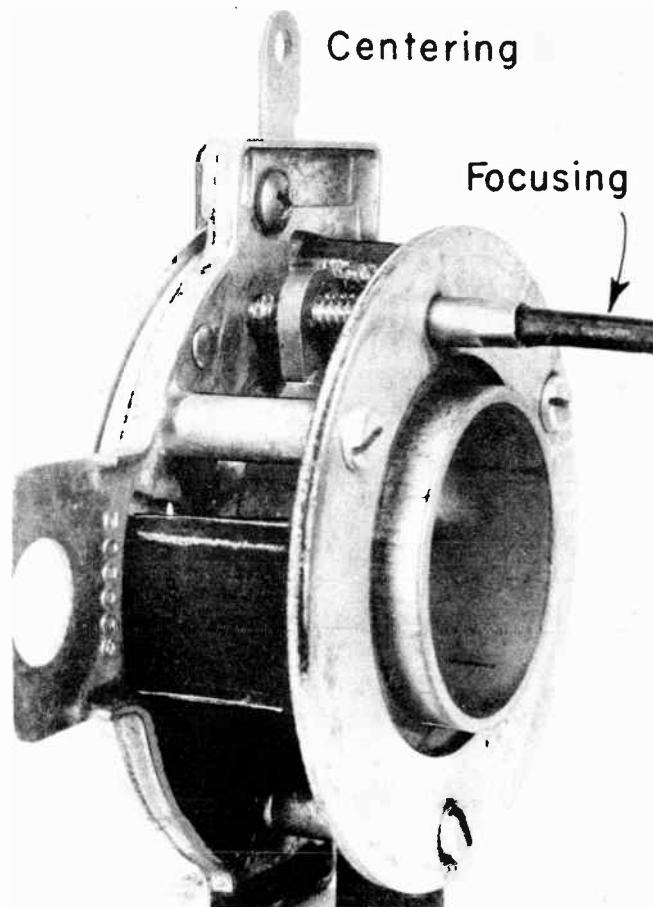

Fig. 8. The focus adjusting shaft and the extended arm for centering with one style of PM focuser.

axis. The adjusting arm and centering plate are locked in position, after adjustment, by tightening the screw shown in Fig. 8. This screw must, of course, be loosened slightly before commencing the centering adjustment.

A somewhat different focuser is pictured by Fig. 10. In the center is a ring-shaped permanent magnet, instead of previously examined separate magnets between pole-piece plates. The rear plate of this focuser is moved toward or away from the ring-shaped magnet by means of a screw attached to a short shaft extending back from the plate. Rotating this shaft with your thumb and finger, or with a screw driver in the slot, adjusts the focus.

There is no centering device in the focuser of Fig. 10. Centering is handled by shifting the focuser structure with reference to the tube axis, or by means of adjustable

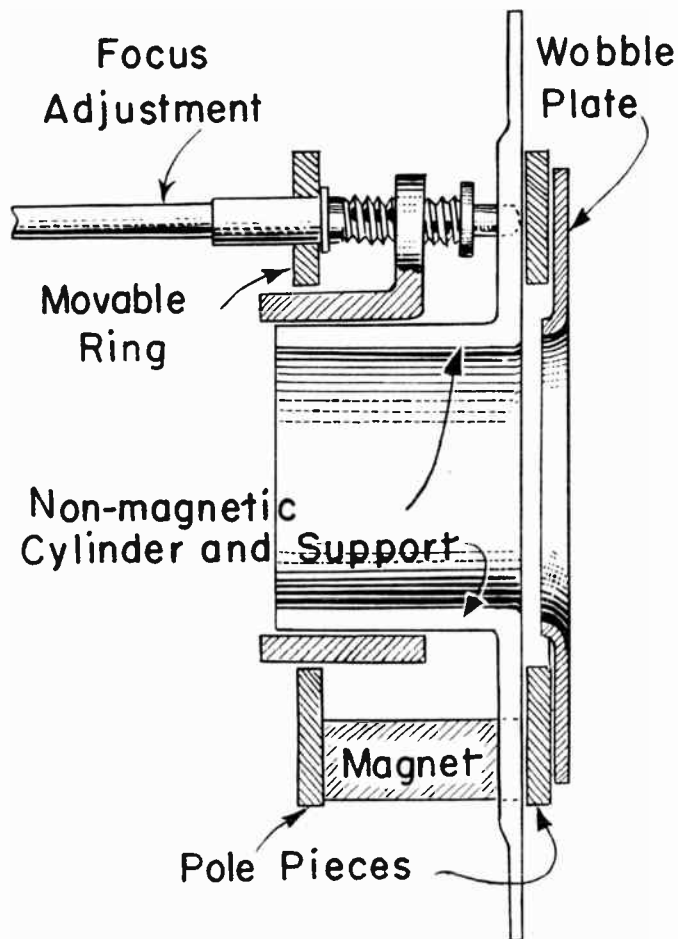

Fig. 9. Details of focusing and centering mechanisms in a PM focuser.

direct currents caused to flow one way or the other in the deflecting coils. These centering currents are in addition to those for deflection. This method will be examined in connection with the subject of deflection in general.

Some other methods of adjusting permanent magnet fields for focusing are shown in principle by Fig. 11. In the design at the left the magnetic gap is made wider or narrower by turning an adjusting sleeve that threads through the rear pole-piece plate. This sleeve is of soft steel. Turning it farther into the focuser narrows the gap and weakens the field within the picture tube neck, while turning the sleeve farther out has opposite effects.

At the right there is an external adjusting sleeve which threads onto the outer circumference of the rear pole piece. There

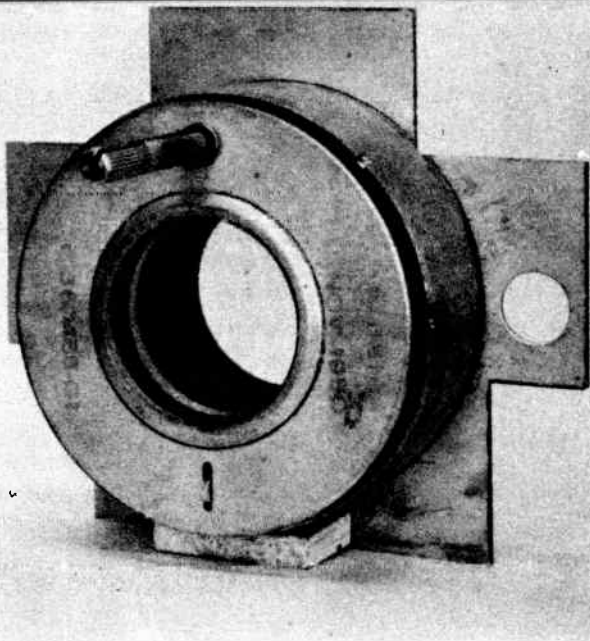

Fig. 10. A PM focuser on which there is no centering adjustment.

is the usual gap between the pole-piece openings which are close around the neck of the picture tube. In this gap appears the focusing field. There is a second magnetic gap between the adjusting sleeve and the front pole piece. The sleeve may be rotated to bring its forward edge toward or away from the outer edge of the front pole-piece, thus changing the width of the second gap. Narrowing this outer gap allows more of the total field lines to concentrate in it, with fewer lines remaining for the focusing gap. Widening the outer gap increases the field strength at the inner focusing gap.

Most PM focusers, with or without adjustable centering plates, are supported by extensions on the two sides of the unit. Such a mounting may be seen in Fig. 1, where wing screws hold the focuser on brackets which extend back from the support for the deflecting yoke.

Openings in the side extensions of the focuser are of large diameter, like the opening visible on one side of the unit pictured by Fig. 10. The fastening screw or bolt which passes through the large opening is of small diameter, as indicated in the diagrams of

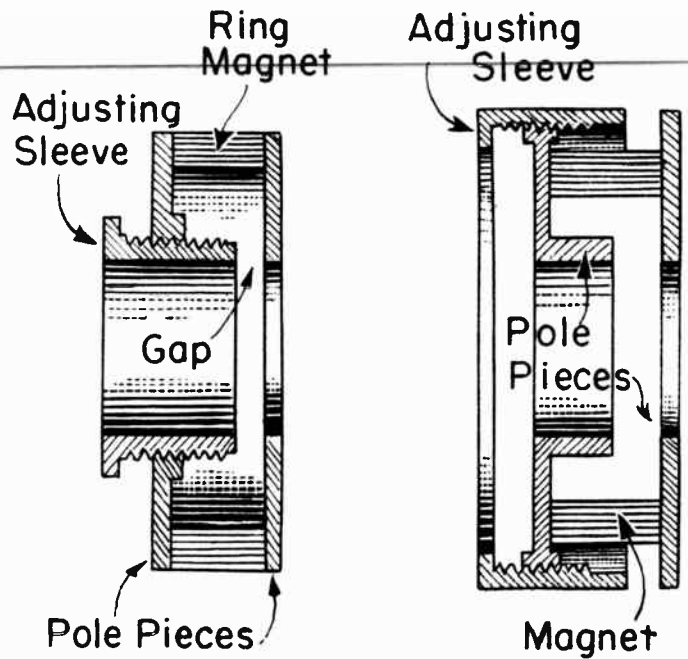

Fig. 11. Focusing adjustments by means of threaded rings of magnetic metal.

Fig. 12. Under the head of the screw or bolt is a washer whose outside diameter is even greater than that of the large opening. With the fastening screw or bolt loosened, it is possible to move the main body of the focuser to various positions in relation to the neck of the picture tube.

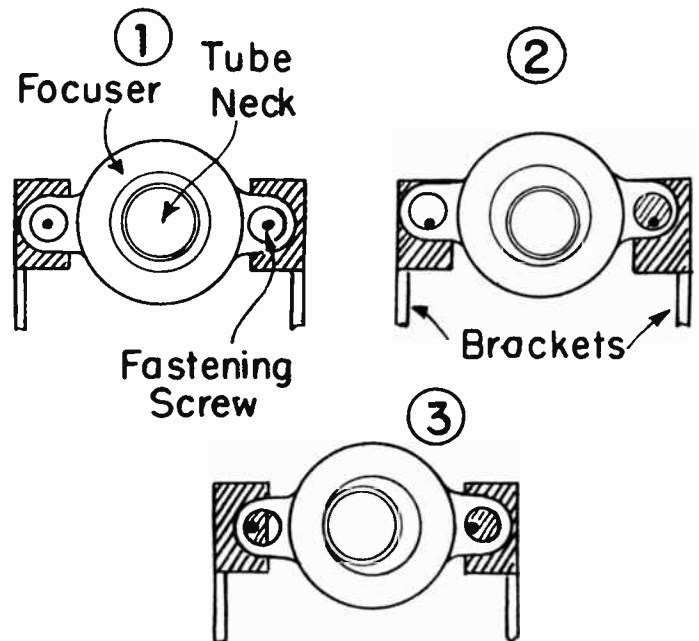

Fig. 12. Vertical and horizontal adjustments for PM focusers.

## LESSON 48 – ELECTROSTATIC AND PM FOCUSING – CENTERING

At 1 in Fig. 12 the opening through the focuser is concentric with the tube neck. At 2 the focuser has been moved up on the supporting brackets. At 3 the focuser has been moved to one side. These vertical and horizontal movements may be combined in any way required for centering. The adjustment described allows aligning the focuser axis with the axis of the picture tube neck. It may be used also to eliminate neck shadows if they appear. On some receivers having no separately adjustable centering device, centering is handled by moving the PM focuser with reference to the tube neck, in the manner just explained.

ADJUSTMENT OF PM FOCUSERS. It would be almost impossible to illustrate and describe all the types of PM focusers and their mountings, but the examples shown will give you a good idea of what to expect. How to adjust those with which you are not familiar often will be a matter of cut and try. Provided you are very careful not to let metal parts strike the glass neck of the picture tube, no harm will result from trying out anything which appears adjustable or movable. When a change effects focusing or centering, for either better or worse, you usually are on the right track.

Clearance between the front of a PM focuser and the back of the deflecting yoke cover may be almost anything from less than 1/8 inch to 1/2 inch, depending on the type of unit. As a general rule, moving the focuser rather close to the yoke allows sharper focus, more uniform focusing all across the screen, and there is less chance for neck shadows.

There are several focusers having adjustment screws in the rear plate, as with the type shown by Fig. 7. These screws should be turned with a non-magnetic tool. The slots ordinarily are wide enough to allow using a dime or a cent as a screw driver. If you do use a screw driver with a steel blade, the focus will change to some extent when the blade is taken away from the adjuster. When there is an extended shaft, as in Fig. 10, any kind of screw driver may be used.

There is no danger of getting PM focusers turned front for back on the picture tube neck, because adjusters for focusing or centering then would strike the deflecting yoke or would be inaccessible. Rotating the focuser around the tube neck does not affect focusing action, but does affect centering. The supporting arms of most focusers may be placed in either of two positions 180 degrees apart around the tube neck, which might be called right side up and upside down. Centering adjustments usually have enough range to allow using the focuser in either of the two possible positions.

The field strength of PM focusers is adjustable within only rather narrow limits. Consequently, the average strength must be suited to the requirements of picture tubes with which the unit is to be used. This is similar to the requirement that focus coils must be of a type suited to their picture tube. A PM focuser which will work with 10-inch and 12-inch tubes may not be strong enough for larger tubes, and a focuser designed for large tubes may not have enough adjustment range to allow its use on small tubes.

Field strength of both permanent magnets and electromagnets often is specified in a unit called the gauss. Another common unit is the number of magnetic lines of force per square inch or per square centimeter of cross section in the field. One gauss is equal to 6.45 magnetic lines per square inch, or to 1 line per square centimeter.

When a magnetic field is specified in these units it is better to speak of field density or field intensity than of field strength. The field density of an electromagnetic focus coil is varied by changing the direct current in the winding. Field density of a PM focuser is altered by changing the width of magnetic gap or by diverting part of the magnetic lines to other paths.

PM focusers are mounted or should be mounted on brackets and supports of non-magnetic materials, usually aluminum or some non-magnetic alloy metal. Were steel brackets used they could provide easy paths for magnetic lines of force, and most of the field strength might be diverted or shunted through the supports rather than being con-



centrated within the neck of the picture tube where it is needed.

PM focusers should not be too close to deflecting yoke brackets or clamps, which usually are of steel and could act as magnetic shunts for the focusing field. Screws or bolts which hold together the front and rear pole-piece plates of a PM focuser must be of non-magnetic material such as brass, bronze, or aluminum alloy, to prevent part of the field lines from going through these fastenings instead of through the useful magnetic gaps.

The chief trouble with PM focusers and centering devices, as with everything else which operates with permanent magnets, is weakening of these magnets. Magnets are weakened by any severe shock, as by dropping on a hard surface. There is loss of magnetic strength when two or more permanent magnets are allowed to remain close together. Consequently, PM focusing and centering devices should be kept away from all similar parts and from permanent magnets of any kind unless the units are so packaged as to maintain adequate separation.

Permanent magnets become weaker when kept in contact with or in close proximity to any steel or iron. Therefore, unless there is suitable packaging or spacing, do not store PM devices on steel benches or shelves, nor in steel bins or drawers. Permanent magnets of high-quality, especially the Alnico variety, will retain their strength almost indefinitely when not mistreated.

**COMBINED EM-PM FOCUSERS.** Fig. 13 is a picture of a focuser consisting of both a permanent magnet and an electromagnet, usually called an EM-PM type. On the outside is a ring-shaped permanent magnet. This magnet encloses a coil, whose connecting leads can be seen extending from the bottom of the unit.

Coil windings in EM-PM focusers usually have d-c resistance of 1,000 to 2,000 ohms, and are designed to operate with average focusing current of 20 to 30 ma. To care for picture tubes requiring different strengths of focusing field, the permanent magnet portion of the focuser is made stronger for tubes or

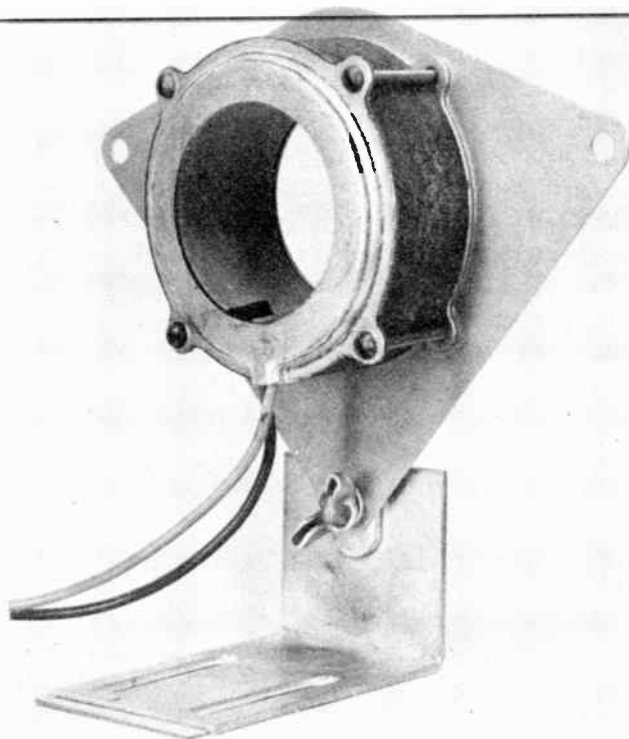

Fig. 13. An EM-PM (electromagnet and permanent magnet) focusing unit.

the larger sizes and for those having deflection angles in excess of 60 degrees.

The permanent-magnet and electromagnet fields act together, and must be of the same polarities at front and back. Reversing or interchanging the coil connections and current direction will cause the two fields to oppose, and the focuser will be useless. Centering is accomplished in most cases by inclining the axis of the focuser with reference to the neck axis of the picture tube, although separate small permanent magnets sometimes are used for centering. Mountings are of non-magnetic materials. EM-PM units must be given the same care when handling as given to any other parts containing permanent magnets.

### ELECTROSTATIC FOCUSING

**LOW VOLTAGE FOCUSING.** Electrostatic focusing is performed entirely by electrostatic fields between elements which are parts of the electron gun within the neck



## LESSON 48 – ELECTROSTATIC AND PM FOCUSING – CENTERING

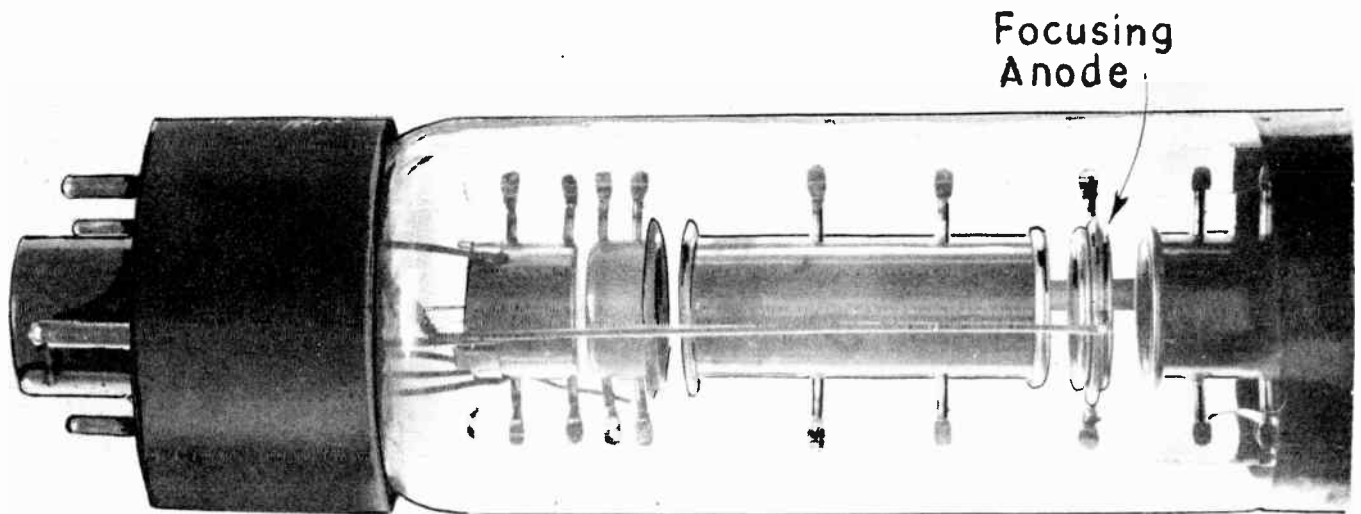

Fig. 14. The electron gun may be seen through the neck of the electrostatically focused picture tube.

of picture tubes. Consequently, picture tubes designed for such focusing require no external focusing device, neither a focus coil nor a PM focuser.

Fig. 14 shows the electron gun in one style of electrostatically focused tube employing what is called the low-voltage method of focusing. The parts of the gun are, from left to right, as follows:

1. The control grid, which encloses the cathode and heater.
2. The second grid, which has the same function as in other picture tubes.
3. One section of the second anode or ultor element.
4. The focusing anode, which here is a small ring.
5. Another section of the second anode. The remainder of the second anode is the internal conductive coating of an all-glass tube or the flare or cone of a metal-shell tube.

Between the focusing anode and adjacent sections of the second anode are potential differences of 12,000 to 16,000 volts. The result is intense electrostatic fields in the gaps on either side of the focusing anode.

These fields focus the electron beam. The focusing anode is connected only to pin 6 on the tube base. It is not internally connected directly or indirectly to any other element. Electrostatically focused tubes are made in 16-inch and larger sizes, both glass and metal types, and with all the usual types of face plates.

With low-voltage focusing the focusing anode most often is operated at a potential 150 to 300 volts positive with reference to the cathode. Since the cathode itself ordinarily is positive to ground by about 50 volts, the focusing anode will be positive with reference to ground by something like 200 to 350 volts.

Focusing anode voltage which gives sharpest and most uniform focus depends on potentials applied to the second anode or ultor element and to a lesser extent on the potential applied to the second grid. Voltage for best focus increases with higher voltages on these other elements. In some receivers the focusing voltage is fixed. This fixed voltage is of a value suited to the type of picture tube and to potentials applied to its second anode and second grid in the particular receiver.

Voltages on all elements in a picture tube are derived in one way or another from

## COYNE - *television home training*

the low-voltage B-power supply system. Therefore, when this power supply voltage rises or falls, all the picture tube element voltages rise or fall at the same time and approximately in proportion. As a result, electrostatic focus tends to remain satisfactory even when there are variations of power line voltage, when there is deterioration of power rectifiers, and with other changes which affect B-power voltage.

In the majority of receivers having electrostatically focused picture tubes the voltage on the focusing anode may be varied by a service adjustment. Fig. 12 shows the typical circuit for this adjustment. A potentiometer is connected from a source of 400 to 500 d-c volts to ground, with the slider connected to pin 6 and thereby to the focusing anode of the picture tube.

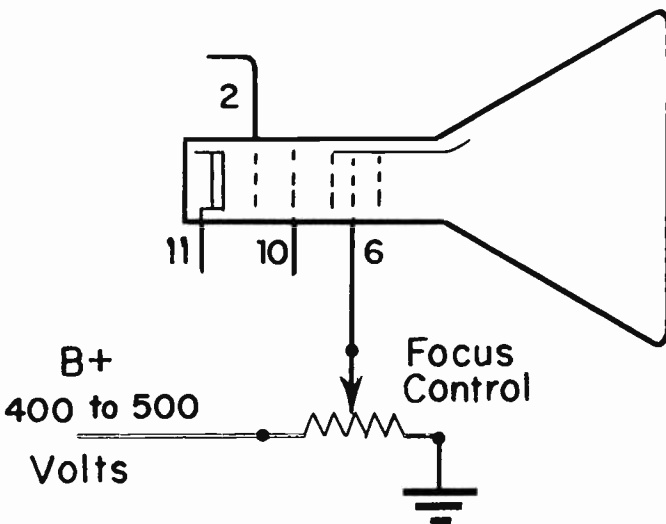

Fig. 15. Typical circuit for adjustment of low-voltage electrostatic focus.

Voltages of 400 to 500 are higher than any directly obtainable from the low voltage B power supply in most receivers. Fortunately, wherever there is a flyback high-voltage power supply for the second anode of the picture tube there is a readily available higher voltage suitable for focusing. This is called the boosted B-voltage. It comes from the circuit of a "damper" tube which is connected into the horizontal deflection circuit, between the horizontal deflecting coils and the secondary of the horizontal output transformer. How this boosted B-voltage is

formed will be explained in connection with the subject of deflection circuits.

Total resistance of the focusing potentiometer is from 1.0 to 2.5 megohms in most receivers. Current in this high resistance, from d-c source to ground, never will be more than 0.5 ampere, and power dissipation due to this current will not exceed 0.25 watt. In actual practice the combinations of supply voltage and potentiometer resistance are such that power dissipation seldom is more than 0.15 watt.

Current to or from the focusing anode will not exceed 25 microamperes, and usually is near zero. This anode current is too small to have appreciable effect on power dissipation in the control potentiometer. Potentiometers having power ratings of 1/2 watt, or 1 watt at most, are amply large for this service. Maximum voltage is not high enough to require more insulation than found in ordinary constructions.

Electrostatic focus obtained in any manner is approximately fixed for best results by design of elements in the electron gun, requiring only adjustment of focusing anode voltage to compensate for manufacturing tolerances. For this reason you will find that setting of the control potentiometer is not very critical, other than for obtaining the widest distribution of sharp focus between center and sides of the screen. Moving a focus adjustment through its entire range may seem to cause only small changes in picture sharpness. If, however, you work with a raster and watch various areas of the screen, you will find that one particular setting gives the most satisfactory overall result.

As with other methods of focusing, there will be difficulty in case of low voltage on the second anode, if voltage on the second grid is not suited to that on the second anode, and if the ion trap magnet is not correctly adjusted.

Because the focusing anode carries negligible or zero current, and because there is such high resistance in the potentiometer, anode voltage may be measured with reasonable accuracy only by a vacuum tube volt-

## LESSON 48 – ELECTROSTATIC AND PM FOCUSING – CENTERING

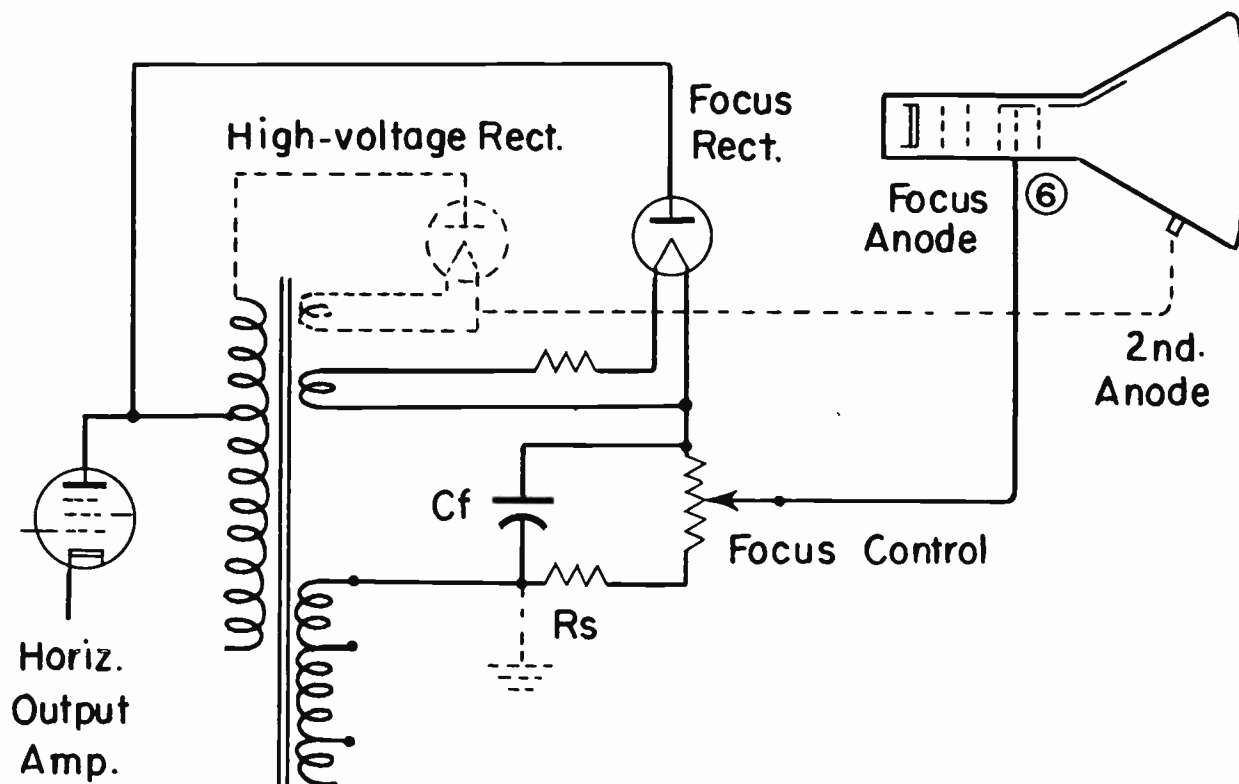

Fig. 16. A circuit for high-voltage electrostatic focusing.

meter. The relatively low resistance of other voltmeters allows so much current through the potentiometer that indicated voltages are not those existing with no meter connected.

**HIGH-VOLTAGE FOCUSING.** There are a number of electrostatically focused picture tubes in sizes from 14-inch to 24-inch designed for operation with 2,200 to 4,000 volts on the focusing anode. This is called high-voltage electrostatic focusing. Voltage on the focusing anode should be roughly proportional to second anode voltage in any given size of picture tube, and is somewhat greater for larger tubes than for smaller ones. As one example, anode voltage for best results with 17-inch picture tubes will be about 20 to 25 per cent of the second anode voltage.

High voltage for the focusing anode is obtained from a separate rectifier and filter system fed from the output transformer of flyback horizontal deflection systems. Typical connections are shown by Fig. 16. The rectifier tube for the focusing circuit is a half-wave type, usually a miniature such as the 1V2 or 1X2. The rectifier plate is con-

nected to the same tap on the transformer primary as the plate of the horizontal output amplifier tube, at which point there is a pulsating direct potential of about 4,000 volts with reference to ground.

The filament-cathode of the focus rectifier is heated from a small winding on the output transformer, similar to the winding that heats the filament of the high-voltage rectifier for the second anode circuit. Connected to the cathode of the focus rectifier, where rectified voltage is positive, is a resistance-capacitance filter consisting of a focus control potentiometer in series with resistor  $R_s$ . These two are paralleled by filter capacitor  $C_f$ . The low side of this filter circuit may go to one of the secondary taps on the flyback transformer or to ground.

Total resistance of the control potentiometer and its series resistor is between 25 and 45 megohms in most receivers, with about 40 per cent of this total in the potentiometer and the remaining 60 per cent in the series resistor. The slider of the potentiometer is connected through pin 6 to the focusing anode in the picture tube.

## COYNE - television home training

Were there 3,500 volts at the high end of the potentiometer, as might be the case in some certain receiver, voltage across the potentiometer, available for focusing by slider adjustment, would be from about 3,500 maximum to about 2,100 minimum volts.

The entire control potentiometer is at high voltage with reference to chassis ground. Across its end terminals may be as much as 1,800 volts. For these reasons this unit must be of special construction, insulated to withstand high voltages. The potentiometer usually has a molded plastic housing of rather large diameter, and the rotor shaft is insulated for safety while making adjustments.

The focus control potentiometer and its connections, as well as the focus rectifier, are mounted within the same shielded enclosure that houses the high-voltage power supply for the second anode. The rotor shaft of the focus control is accessible through an opening in this enclosure, or may extend to the outside. The wire from the potentiometer rotor terminal to the lug for pin 6 on the picture tube socket should be insulated for at least 5,000 volts. Focus anode voltages can be measured only with a vacuum tube voltmeter fitted with a high-voltage multiplier probe.

High-voltage electrostatic focusing was introduced before the low-voltage method, but has largely given way to the low-voltage system. This is because high-voltage focusing requires an added rectifier tube and socket, an extra heater winding on the fly-back transformer, a rather costly control potentiometer, and added resistors and filter capacitor. Low-voltage focusing requires only a low-cost control potentiometer and a few wiring connections.

**AUTOMATIC FOCUS OR SELF-FOCUS.** There is another principal variety of electrostatically focused picture tube in which the focusing electrode is internally connected through a fixed resistor to the cathode. This principle is illustrated by Fig. 17. Since the focusing anode has no connections other than to the cathode, this anode remains at zero potential with reference to the cathode.

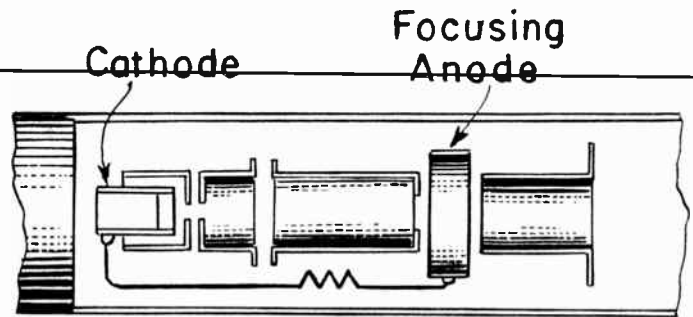

Fig. 17. For automatic focus or self-focus the focusing anode is internally connected to the cathode of the picture tube.

On the base of these picture tubes there is no pin in the number 6 position. The base is a standard 5-pin duodecal type as used on magnetically focused picture tubes. Either a half-socket or a full round socket may be used. There is, of course, no focusing adjustment of any kind. There may be some difficulty in maintaining satisfactory focus if voltages on other elements in the picture tube are not suited to one another, as, for example, when voltage on the second grid is not within a range suitable for second anode voltage. Self-focus picture tubes are made in 16-inch sizes and larger.

**CENTERING WITH ELECTROSTATIC FOCUS.** No variation of voltage or current in any elements within an electrostatically focused picture tube have any effect on centering of pictures. Neither is there an external focus coil to be inclined for centering, nor an external PM focuser whose field direction may be changed by a wobble plate. Consequently, it is necessary to provide some added external means for centering.

Two principal methods are employed. One makes use of small permanent magnets mounted around the tube neck just back of the deflecting yoke. The other employs small direct currents in the deflecting coils, in addition to the alternating currents that deflect the electron beam. We shall examine first the systems using permanent magnets.

Fig. 18 shows a PM (permanent magnet) centering device on the neck of an electrostatically focused picture tube. Two magnetized rings on an aluminum framework may be rotated around the tube neck. This particular centering device is held on the



## LESSON 48 – ELECTROSTATIC AND PM FOCUSING – CENTERING

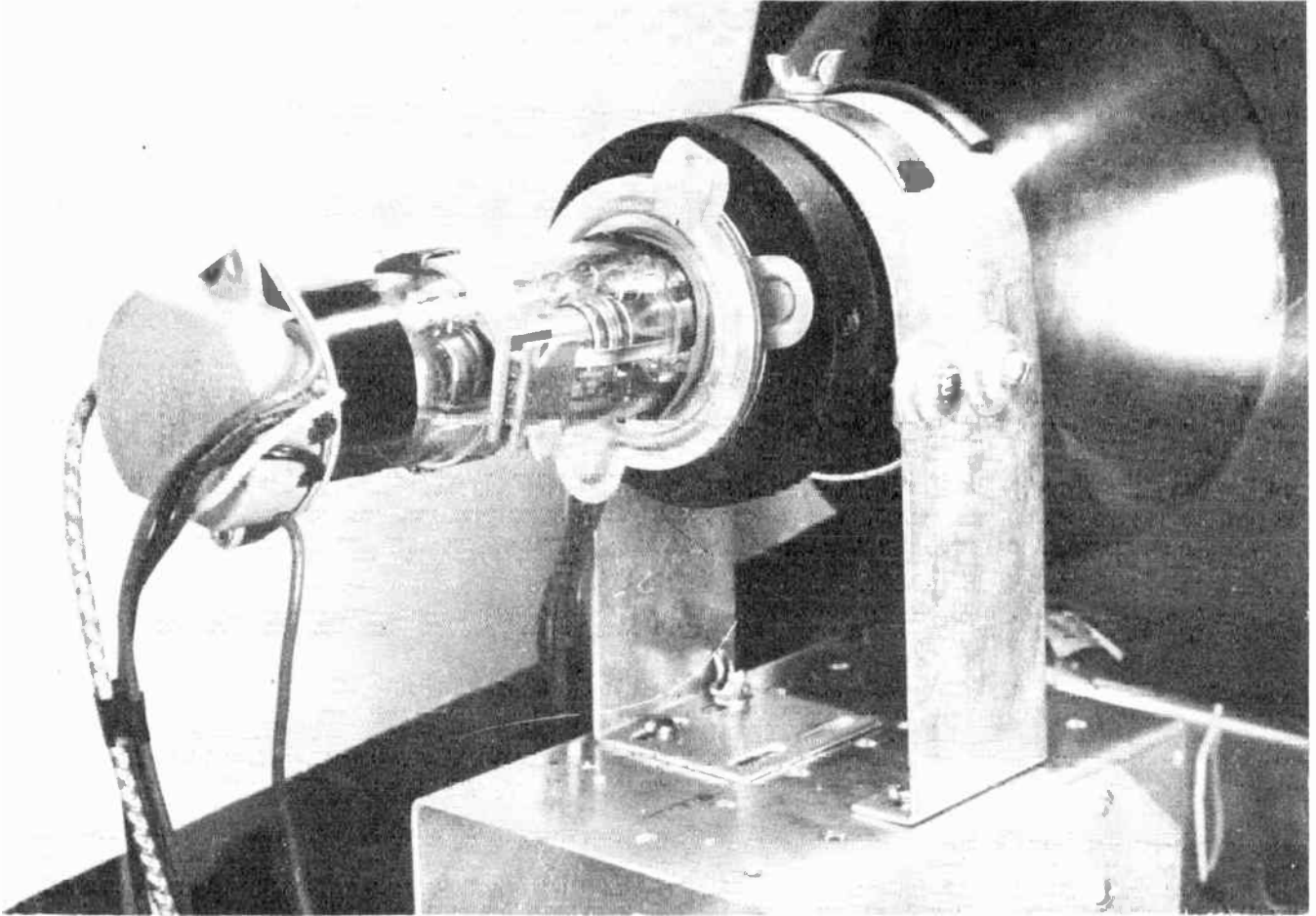

*Fig. 18. A PM centering device on the neck of an electrostatically focused picture tube.*

tube neck by friction of three flat bronze springs which allow sliding the unit over the tube socket for removal and replacement. Other centering mechanisms mount on brackets generally similar to those which carry focus coils or PM focusers.

The ring magnets in many centering devices are of a rather special type. We are used to thinking of a permanent magnet as having a north pole at one end and a south pole at the other end, as at 1 in Fig. 19. But, as at 2, a piece of steel may be magnetized to have north poles at both ends, or with south poles at both ends as at 3. Midway between the ends will be an opposite pole, as marked. This is called a consequent pole.

A ring-shaped magnet such as commonly used in centering devices is made as in diagram 4. At the gap where the two ends come nearly together are two poles of the same

kind, shown here as south. This forms the equivalent of a single south pole. Midway between, at the other side of the ring, is the opposite kind of pole, which here would be a north pole.

Magnetic lines of force between north and south poles of the ring magnet are as shown by diagrams 5 through 8. The field lines pass through the neck of a picture tube and bend the electron beam away from its straight course in a direction at right angles to the field lines. At 5 the beam would be bent to the right as you look at the face of the picture tube, and the raster or picture would be displaced to the right. Were the magnet turned half way around, as at 6, the direction of field lines would be reversed, displacing the beam and raster to the left. With the gap on the left, diagram 7, the picture would be shifted downward, and with the gap at the right the shift would be upward, as at 8.

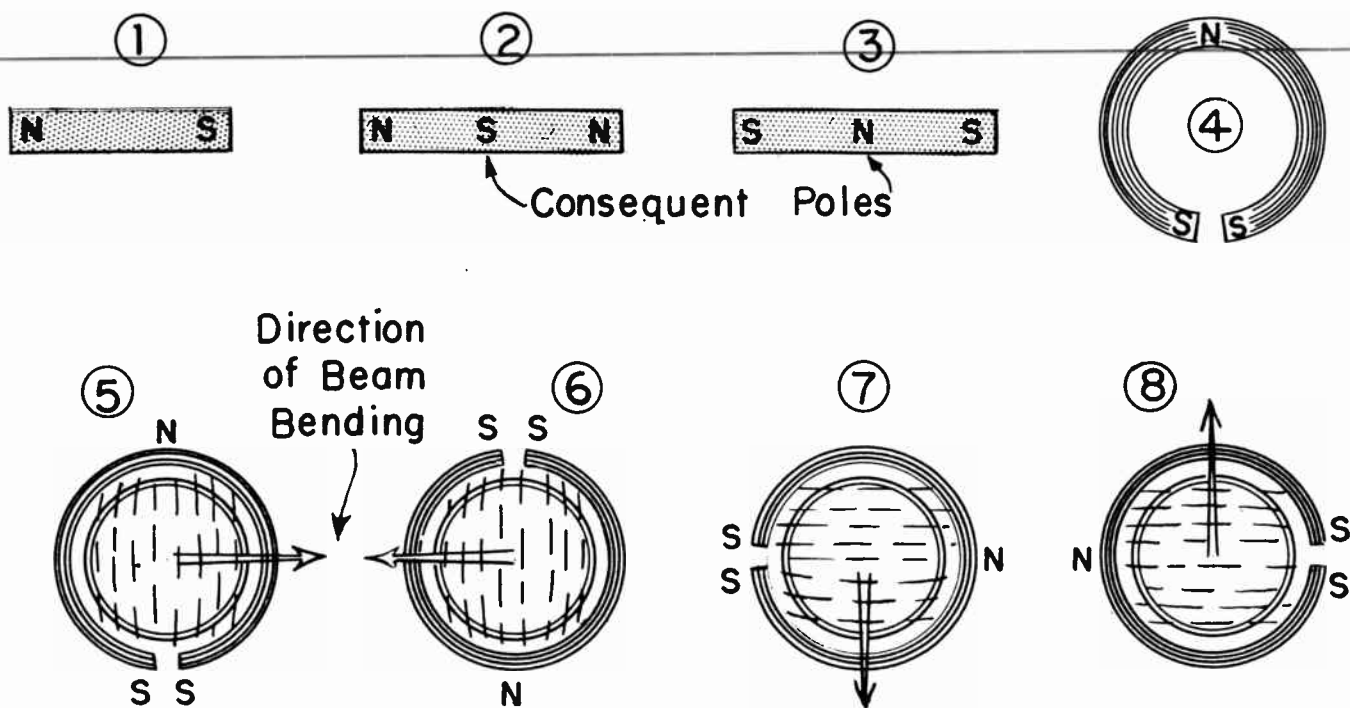

Fig. 19. Directions in which the electron beam is bent by a ring-shaped magnet having a consequent pole.

Rotating the magnetized ring on the neck of the picture tube would cause the center of a raster or picture to move around a circular path on the screen, somewhat as shown at 1 in Fig. 20. Only by chance would any point around this path coincide with the center of the mask and allow accurate centering of the picture. One way of securing accurate centering is to weaken the field of the ring magnet and thus reduce the diameter of the adjustment circle until it does pass through the center of the mask, as at 2.

There are centering adjusters whose magnetized ring may be rotated to any position around the tube neck, and on which is some form of adjustable magnetic shunt for altering the strength of the centering field. Approximate centering is had by rotating the magnet, and closer adjustment by varying its field strength.

With another design of centering mechanism, pictured by Fig. 21, an aluminum plate with a large center opening is attached by clips in a fixed position on the cover of the deflecting yoke. On this plate is mounted another which may be rotated by means of extended tabs. The ring magnet is fastened

to this second plate. The diameter of the magnet is great enough to allow moving its plate up, down or to either side by a little distance.

When the magnet originally is concentric with the tube neck, and then is moved vertically or horizontally at right angles to the direction of its field lines, the picture will be shifted in the same general direction as the magnet, but with some diagonal movement. When the center of the magnet has thus been displaced with reference to the axis of the tube neck, moving the magnet in the same direction as its field lines will shift the picture. As you will realize, it is quicker to make trial adjustments of single ring magnets a little at a time than to figure out the magnetic polarities, field line directions, and directions in which the picture will be shifted. The process often becomes highly confusing.

The type of centering mechanism shown in working position by Fig. 18 has two separately adjustable ring magnets which may be rotated independently or together. The two rings may be set at any positions in relation to each other, then the entire unit may be

# LESSON 48 – ELECTROSTATIC AND PM FOCUSING – CENTERING

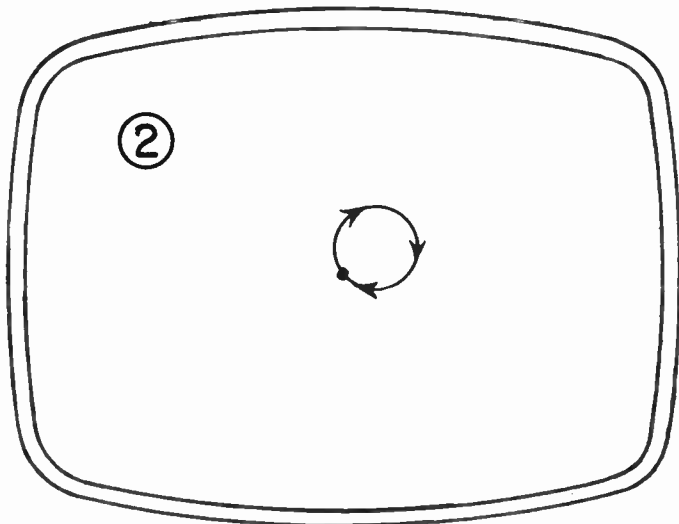
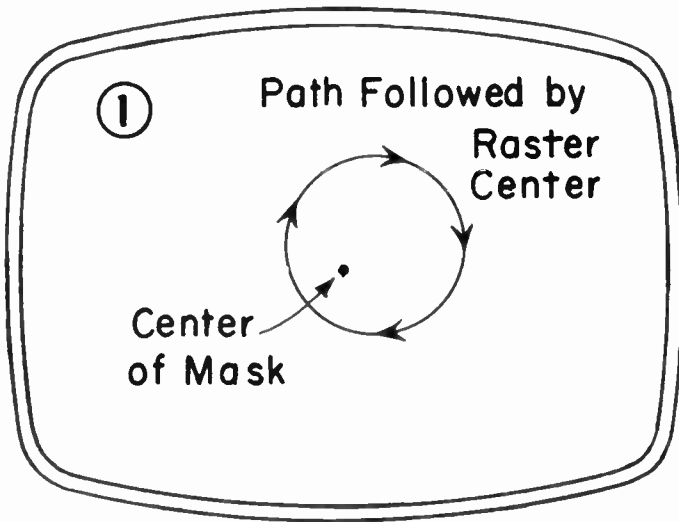

Fig. 20. Rotation of a ring-shaped centering magnet causes the center of the raster or picture to move around a circular path.

rotated without altering this relation between the rings. Both magnets remain concentric with the tube neck, they cannot be moved vertically or horizontally.

When the gaps of the two magnets are together, the two fields act together as a single strong field. Rotation of the entire unit then moves a raster or picture around a rather large circular path on the screen, as at 1 in Fig. 20. If the two gaps are placed diametrically opposite each other, the two fields oppose and very nearly cancel. Then the picture is moved around a very small

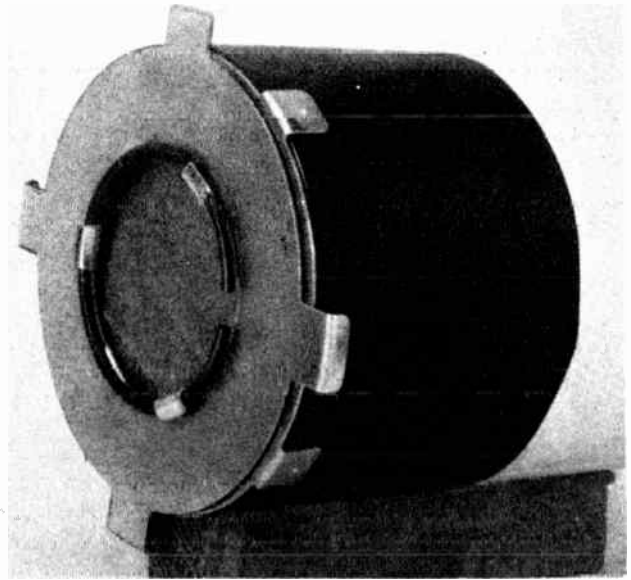

Fig. 21. A centering device whose single magnet may be rotated or moved at right angles to the neck axis of the picture tube.

circle as the unit is rotated. With the two gaps at intermediate position in relation to each other, neither together nor opposite, combined rotation of the unit and relative rotations of the two magnets allows shifting the picture almost anywhere on the screen.

Fig. 22 shows directions of picture shift resulting from adjustment of the two rings. The inner and outer circles of the diagrams represent the front and back rings, which actually are of equal diameters. With the gap of either ring at the top of the tube neck, and the gap of the other ring at the bottom (diagram 1), moving both gaps equal distances to the left (2) will shift the picture straight up, while moving both to the right (3) shifts the picture straight down. Commencing with the gaps on opposite sides of the neck (4), moving both gaps upward equal distances (5) shifts the picture straight to the right, while moving both gaps down (6) makes the shift straight to the left. It is assumed that both gaps are south magnetic poles.

Fig. 23 shows effects of keeping one gap fixed while moving the other. In diagrams 1 through 4 the gaps were initially above and below the tube neck. One gap remains fixed while the other is moved to positions indi-



# COYNE - television home training

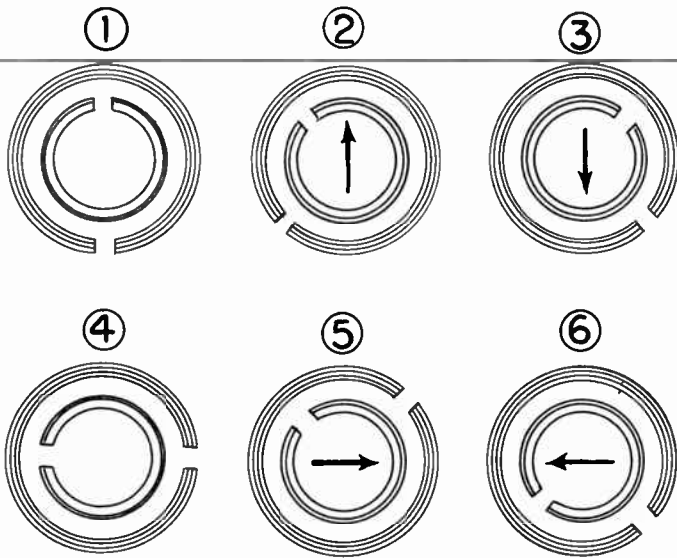

Fig. 22. Directions of picture shift when two ring-shaped centering magnets are rotated during one operation.

cated, with picture shift along the paths shown by arrows. For diagrams 5 through 8 the gaps were initially on opposite sides of the tube neck. One gap remains in its initial position while the other is rotated as indicated. Picture shift paths are again shown by arrows.

It is not at all necessary to use ring magnets with gaps and consequent poles for centering devices. The same effects may be had with straight magnets on mounts which allow rotation or any other movement which changes the slope and directions of field lines passing through the tube neck. U-shaped magnets may be used, mounted in such ways that field lines between the poles pass through the tube neck. The electron beam always is bent at right angles to magnetic field lines, and in directions corresponding to magnetic polarities, no matter what kind of magnets may be used.

Centering devices of any kinds which have been described may be used in connection with focus coils or with combination EM-PM focusers on magnetically focused picture tubes. This avoids the need for inclining a focus coil, or the coil may be inclined only when adjustment of the centering magnets will not bring pictures to the correct position. Centering magnets seldom are used with PM focusers, because the very strong magnets for focusing tend to prevent the weaker fields of small centering magnets from affecting picture position to the required extent.

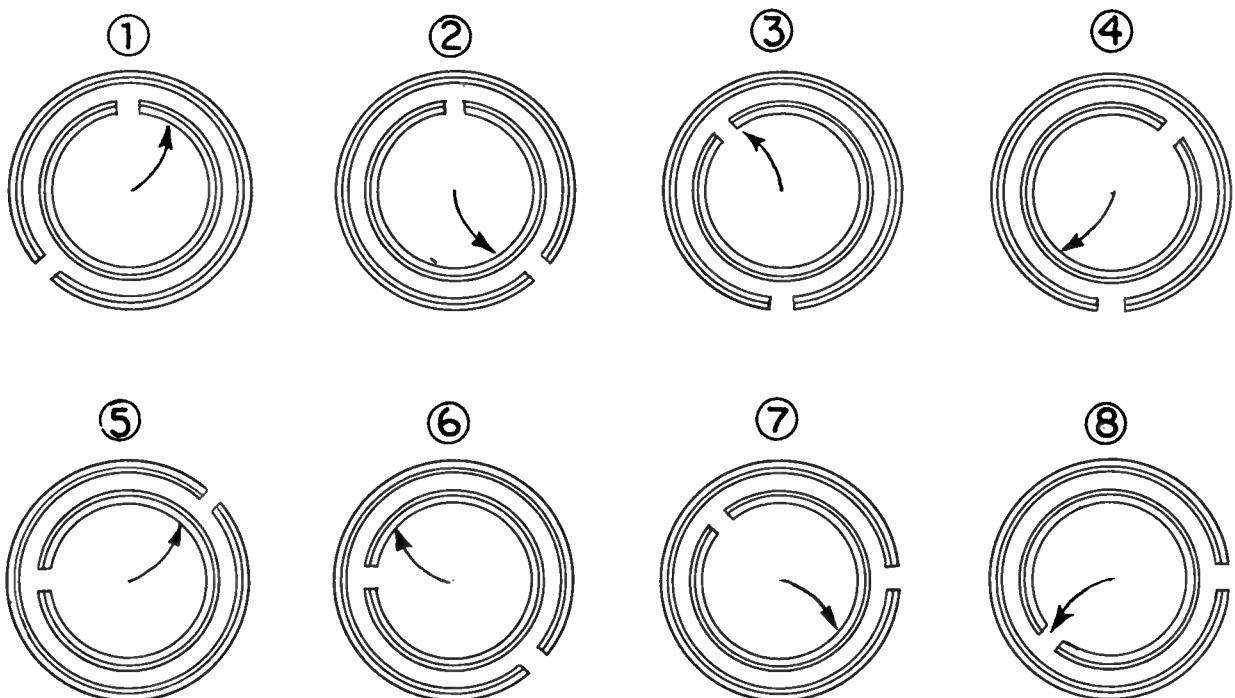

Fig. 23. How pictures are shifted when one magnet remains in its original position while the second magnet is rotated one way or the other.



# LESSON 48 – ELECTROSTATIC AND PM FOCUSING – CENTERING

## FOCUSING

### Electrostatic Focus Picture Tube

#### Adjustment:

##### Observing a raster.

Contrast control minimum. Brightness somewhat less than for normal pictures. Adjust for best distribution of sharp focus between center and sides of screen. Check position of ion trap magnet.

##### Observing a test pattern.

Contrast and brightness as for normal pictures. Adjust for clearest and sharpest lines in vertical wedges.

#### Voltages:

Incorrect voltage on second grid may cause difficulty.

Voltage from base pin 6 to ground often is about 300 volts, measured with VTVM on low-voltage focus tubes.

### PM Focusers

#### Position of unit:

Too far back from deflecting yoke may cause neck shadows, lack of brightness, difficulty in obtaining sharp focus. Too close to yoke may cause eventual weakening of focuser magnets, making sharp focus impossible.

Move slightly forward or back on tube neck in obtaining best average focusing at center and sides of screen.

Move up, down, or sideways on bracket if necessary for elimination of neck shadows, or for centering.

#### Adjustment:

Similar to adjustment with other focusing methods. For best average focusing

at center and sides while observing raster. For clearest vertical lines on test pattern, or clearest stationary vertical lines in pictures. Check position of ion trap magnet.

Make sure that cushion liner prevents wobble plate from striking tube neck.

## CENTERING

### With PM Centering Devices.

Two separately adjustable ring magnets.

Place unit so magnets are about  $3/8$  to  $1/2$  inch back of yoke.

Check position of ion trap magnet.

Rotate the ring magnets to bring gaps of both rings together.

Note whether picture is off center chiefly in vertical or horizontal direction. If greater shift is vertical, set one gap above and other below tube neck (Fig. 22-1), then rotate both gaps equally to one side or other until picture centers vertically.

If greater shift is horizontal, set gaps on opposite sides of neck (Fig. 22-4) then rotate both gaps equally upward or downward until picture centers horizontally.

To complete the centering, do not alter relative positions of the two gaps, but rotate entire structure one way or the other. Make final close adjustment, if needed, by rotating either of the rings while the other remains unchanged (Fig. 23).

Single ring magnet with adjustable shunt.

Rotate entire structure for approximate centering.

Adjust magnetic shunt for final close centering.

## COYNE - *television home training*

If this does not center the picture, rotate the entire structure to a different position at which adjustment of the shunt will bring the picture to the desired position.

---

Single ring magnet with vertical and horizontal movement.

Rotate magnet plate for approximate centering.

Move magnet plate up, down, or to either side for final close centering.

If this does not allow centering, turn the magnet plate to other positions and try readjusting it vertically or horizontally.

# TELEVISION

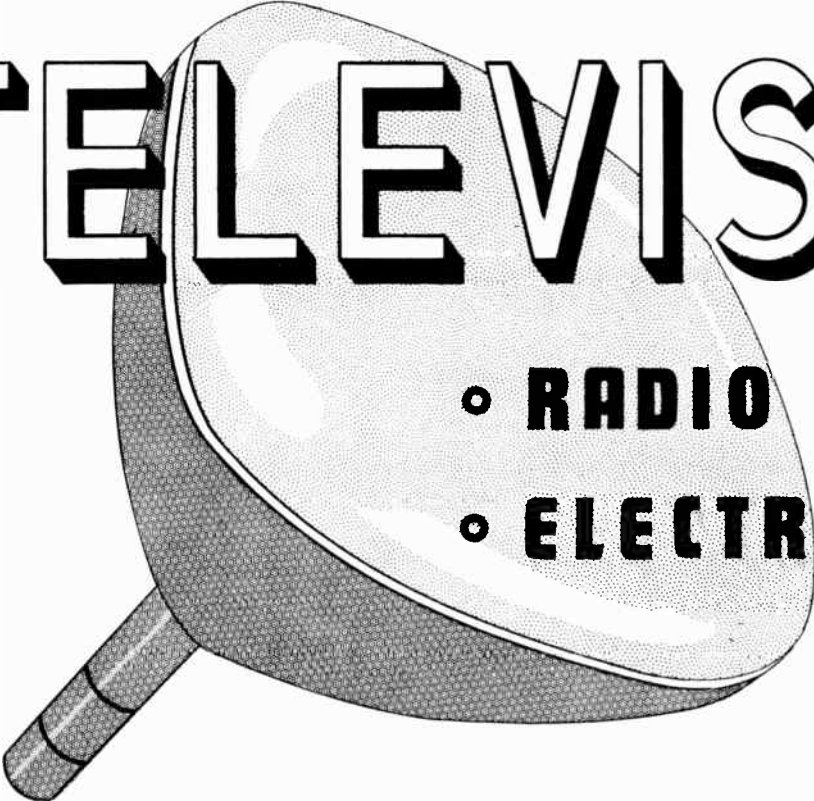

- RADIO
- ELECTRONICS

---

## LESSON 49 – ION TRAPS

---

***Coyne School***  
*practical home training*

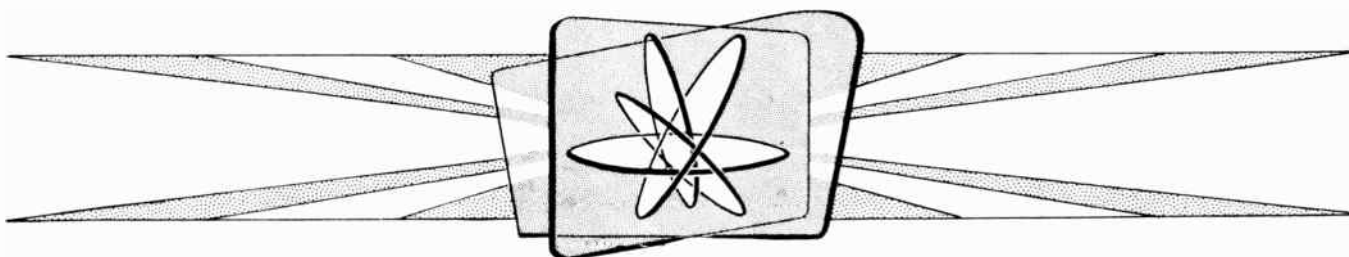

*Chicago, Illinois*

---

*Copyright, 1953 by Coyne Electrical School  
Chicago 12, Illinois  
All rights reserved*

Litho. in U.S.A



## Lesson 49

### ION TRAPS

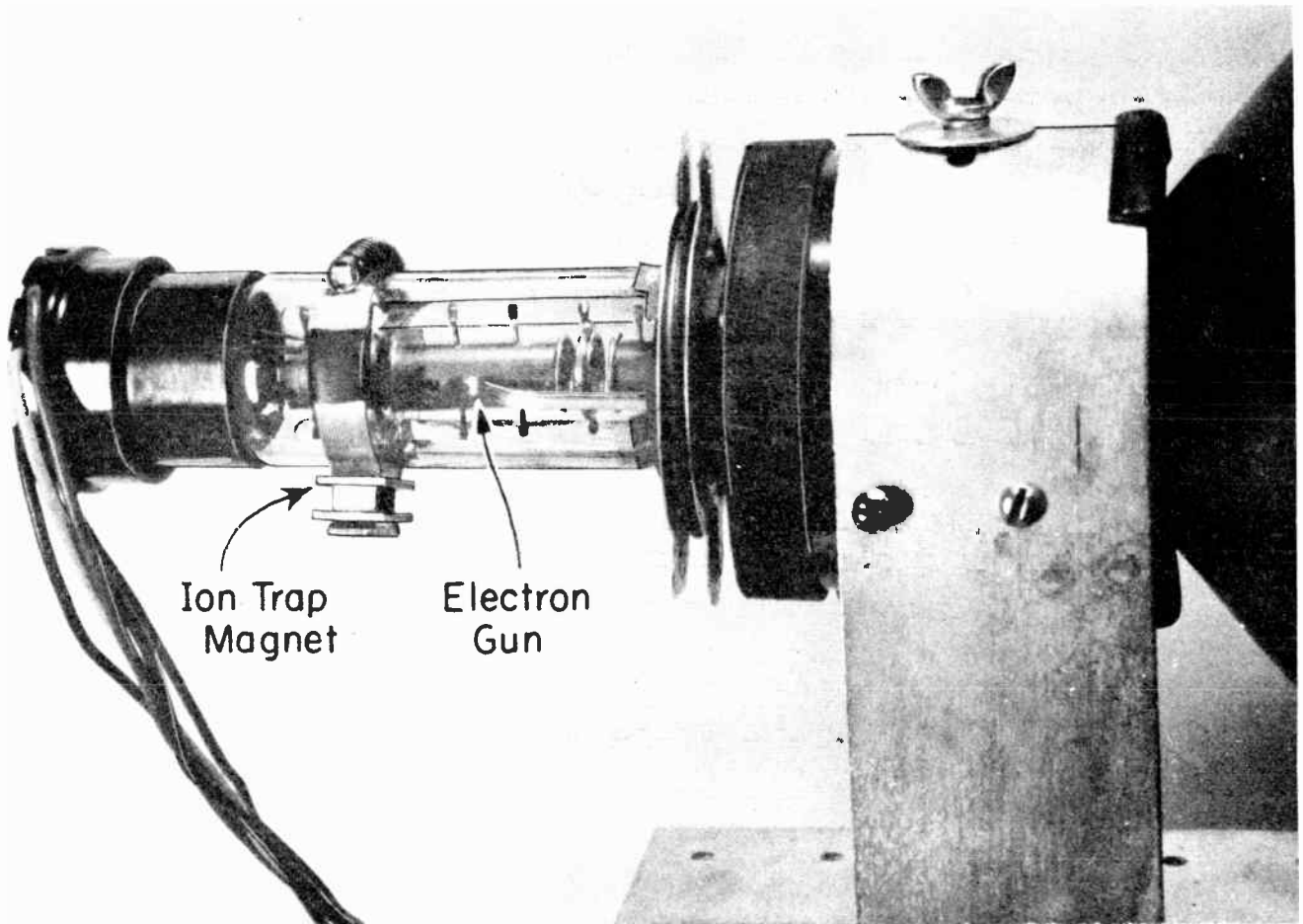

Fig. 1. The ion trap magnet is mounted on the outside of the neck of the picture tube.

A picture tube won't be harmed by wrong adjustment of a focuser or focusing control, or of a centering device, or of the deflecting yoke. But if an ion trap magnet is rotated too far in either direction, or moved too far forward or back, the picture tube can be permanently damaged in a matter of seconds. This adjustable magnet is part of a trap which removes ions from the electron beam. The remainder of the trap is built into the electron gun of the picture tube.

The things called ions, which are to be removed from the electron stream, are atoms of gases or other substances which have picked up one or more extra electrons, and thus have acquired a negative charge.

Many ions are emitted from the hot cathode, along with electrons. Others are formed when emitted electrons collide with gas atoms which remain inside the tube after evacuation. The lightest ion weighs about 1,800 times as much as an electron, and is about 50,000 times bigger than an electron.

If these big, heavy ions would go along with the electrons and allow themselves to be distributed all over the raster during deflection they would cause no serious trouble. The only harm would be gradual loss of brightness over a long period of operation, because substances deposited on the screen in the form of ions or atoms would form a coating through which the electrons could

## COYNE - *television home training*

penetrate and excite the phosphor only with increasing difficulty.

Trouble with ions is due to the fact that the heavier the particle to be deflected the harder it is for a magnetic field to do the deflecting. Therefore, while the magnetic fields in the yoke easily deflect the almost weightless electrons all over the raster area, these fields can turn the heavy ions through only small angles.

Were the ions not removed by a trap, all of them would strike near the center of the screen in a round tube, or possibly in a pattern shaped somewhat like the letter "X" in a rectangular tube. After only a few hours of operation there would be thick coatings of ion material at these places on the screen, and these coatings would show as relatively dark spots or patterns in all pictures. Darkened spots or X-patterns, if they do appear on a screen, are called ion burns. When the burns are bad enough to affect picture appearance, the spots can be seen even while the set is turned off, especially when the picture tube has a clear face plate, not a gray or tinted face plate.

Ion burns are more likely to occur when second anode voltage is normal or somewhat high than when it is lower than should be used for the particular picture tube. This is because high accelerating voltage in the tube gives the ions enough speed to carry them along nearly straight lines to the screen.

Relatively low second anode voltage gives the ions less speed. Then they can be turned through somewhat greater angles by the magnetic deflecting fields in the yoke, and thus distributed over more of the screen area.

**DOUBLE-MAGNET ION TRAP.** Now we shall see how ions are removed from the electron stream leaving the cathode in a picture tube. Fig. 2 shows an electron gun which still remains on the tube base after the glass neck and the envelope have been removed. Nearest the base is the control grid. Then, following a very narrow gap, comes the second grid. At the right is the gun portion of the second anode. Between the second grid and second anode is a fairly wide gap at an angle of about 75 degrees to the axis of the gun.

Potential on the second anode will be between 8,000 and 15,000 volts in most tubes, while potential on the second grid seldom is more than 450 volts. The great difference of potential across the angular gap causes a strong electrostatic or electric field to appear in this gap. The lines of force in this field are at right angles to the edges of the gap, and thus are inclined to the gun axis as shown at A in Fig. 3.

This inclined electric field, or any other electric field, is capable of turning or deflecting either electrons or heavy ions with equal ease. Strange as it might seem, the

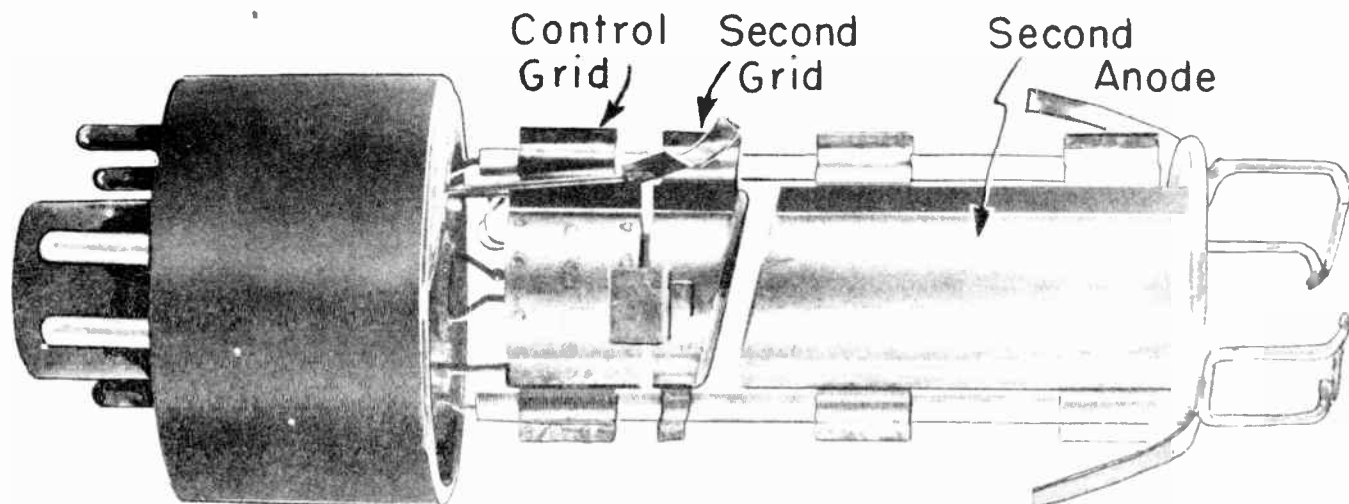

Fig. 2. Part of the ion trap, in some tubes, is an angular gap between second grid and second anode in the electron gun.

## LESSON 49 – ION TRAPS

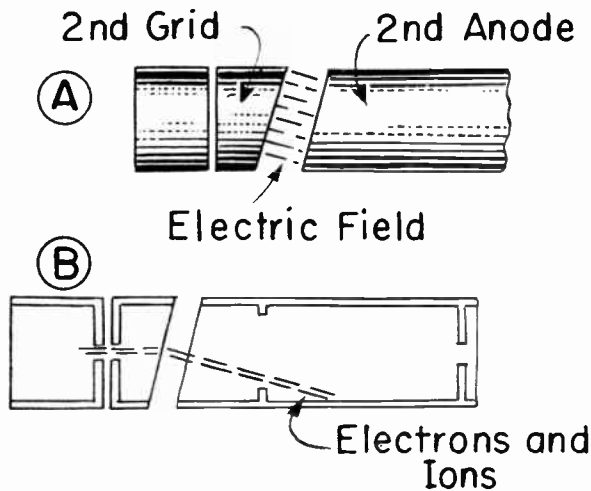

Fig. 3. The electric field in the angular gap acts to deflect electrons and ions.

deflecting ability of an electric or electrostatic field is not dependent on the weight or mass of particles to be deflected. Furthermore, the deflecting force is in the same direction as the field lines, not at right angles to the lines as in the case of a magnetic field.

Were the stream of mixed electrons and ions passing through the second grid to enter the inclined electric field, as at B of Fig. 3, both kinds of particles would be turned in the direction of the field lines. Were nothing further done, both electrons and ions would strike the inside of the second anode, and, since both kinds of particles are negatively charged, both would remain on or enter the highly positive second anode. Here we have succeeded in trapping the ions so that they cannot pass on through the gun to the screen of the picture tube, but we have also trapped the electrons.

To prevent trapping the electrons we make use of the fact that a magnetic field deflects electrons with ease, but has little deflecting ability on ions. This is where the external magnet comes in. As a matter of fact, with the gun illustrated by Fig. 2, we shall need two external magnets.

One style of double external magnet is shown at A in Fig. 4. At the bottom, held between plates of non-magnetic metal, are two small permanent magnets. Extending upward from opposite ends or poles of both magnets

are pole pieces which are curved to fit the neck of a picture tube. The tube neck is protected from scratching by sleeves of soft rubber in each pole piece. This magnet structure is clamped securely in any adjusted position on the tube neck by tightening the nuts on non-magnetic screws passing through the tops of the pole pieces.

Magnetic field lines between opposite pole pieces of either of the bar magnets follow the paths shown at B. When the magnet structure is on the neck of the picture tube, these field lines pass almost straight across through the neck and the electron gun. The gun is made of non-magnetic metal which does not interfere with magnetic fields passing through it. A further important factor in the action of ion traps is that magnetic fields from external magnets act independently of the electric field in the diagonal gap. Each kind of field acts as though the other were not present.

By looking closely at the picture of an electron gun in Fig. 2 you will see that part of the narrow gap between control grid and second anode is hidden by a small rectangular piece of metal. By rotating the gun about a quarter-turn, as has been done in Fig. 5, we observe that this small piece of metal is duplicated by a similar piece on the opposite side of the gun. These two pieces are called "flags". They are attached to the second grid, just ahead of the gap between this element and the control grid.

The flags are of magnetic metal, which provides an easy path for magnetic lines of force. When one of the external magnets is placed so that its extended pole pieces are just outside the two flags, or nearly in this position, the magnetic metal of the flags picks up the field lines from the external magnet and concentrates these lines. Then between the inner ends of the flags and through the center of the second grid there is a concentrated and strong magnetic field.

This magnetic field between the flags crosses through the second grid at the point marked A in Fig. 6. With reference to this drawing, magnetic field lines would pass straight into or out of the paper at this point. The polarity of the external magnet and the



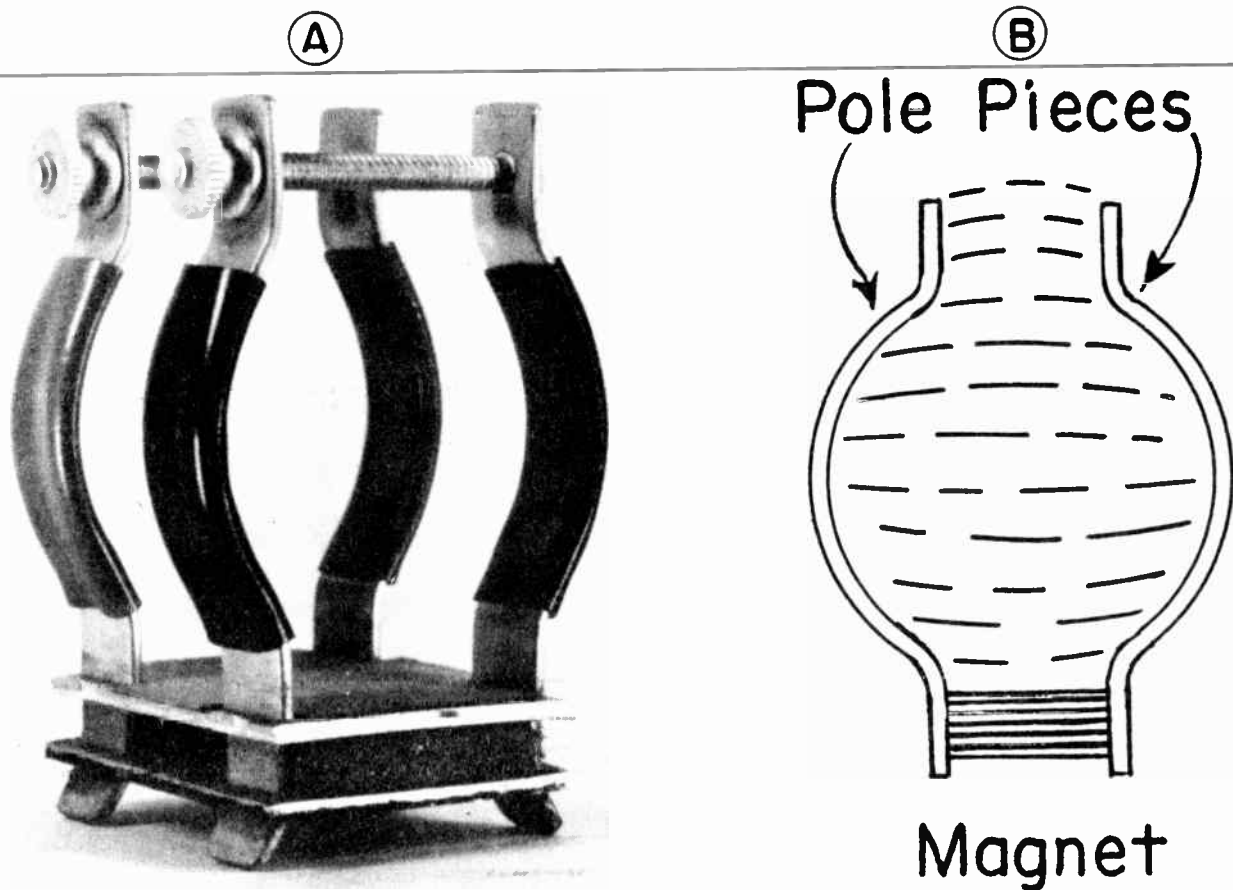

Fig. 4. One style of ion trap magnet, and the direction of magnetic field lines between pole pieces.

direction of its field lines are such that electrons are deflected upward at this point. The magnetic field has negligible effect on ions, which continue straight on to the electric field in the diagonal gap. There the ions are deflected downward to strike the inside

of the second anode, as previously explained.

When the upwardly deflected electrons reach the electric field in the diagonal gap they are turned in the general direction of the electric field lines and continue on be-

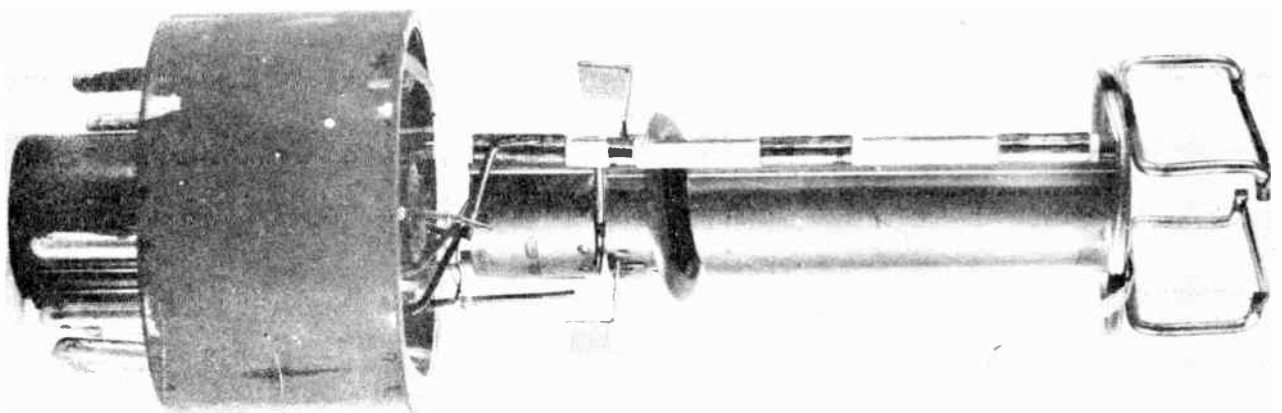

Fig. 5. The two "flags" which guide a magnetic field for the ion trap may be seen on this electron gun.



## LESSON 49 – ION TRAPS

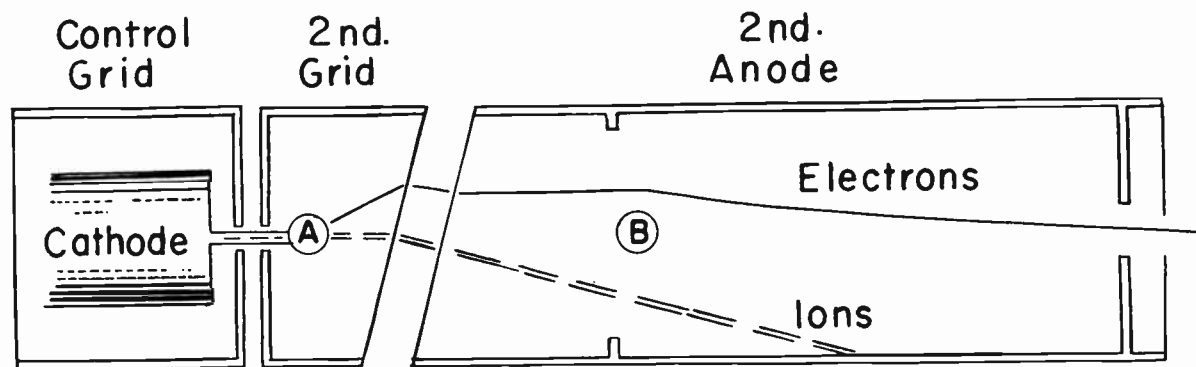

Fig. 6. Approximate paths of electrons and ions when deflected by electric and magnetic fields of the ion trap.

yond the field in this direction. The central highly concentrated part of the electron stream must pass through the center of a rather small opening in the front of the electron gun, without striking the metal around this opening.

As the electrons emerge from the electric field in the diagonal gap they are on a path somewhat too high to pass through the opening at the front of the gun. To aim the electron stream through the opening we use the second of the external magnets. This magnet is mounted so that its polarity is opposite to that of the first one, and the direction of its magnetic field is opposite to that of the first magnetic field. This opposite field deflects the electron stream downward, whereas the first field deflected it upward. The second magnetic field is placed approximately at point **B** of Fig. 6.

To aim the electron stream through the front opening of the gun, the second or forward magnet may have to be moved a little ways forward or back along the neck of the picture tube, and at the same time it may have to be rotated slightly one way or the other around the tube neck. These things are done by moving the entire magnet structure, carrying both magnets. Moving both magnets short distances does not alter the position of the concentrated magnetic field through point **A**, because this field is between the inner ends of the magnetic flags, and the flags remain fixed on the gun.

The external magnet which is closer to the tube base, and which furnishes a mag-

netic field to the flags at point **A** of Fig. 6, always must be much stronger than the magnet farther from the base, which brings the electrons down again. The first magnet has to be strong, for it must deflect the electrons upward in spite of the immediately following electric field which is tending to turn them downward. The second or forward magnet need turn the electrons only slightly downward, because they are already aimed very nearly toward the opening at the front of the electron gun.

We have been talking about deflections as being upward or downward with reference to photographs and diagrams used to show what happens. Were the picture tube and its electron gun, also the ion trap magnets, to be turned half way around, all these directions would be reversed - but the trapping of ions and freeing of electrons would not be affected. The tube may be rotated to any position, provided the trap magnets are rotated with it. The structure carrying the ion trap magnets, their pole pieces and supports, often is called a "beam bender", because its function is to bend the electron beam.

There are and have been so many designs of double magnets for ion traps that it would be difficult to count them. One widely used style is shown by Fig. 7. Two magnetized rings are around the outside of a cylinder made from non-magnetic metal. Inside the cylinder are three thin, flat spring leaves which press firmly enough on the picture tube neck to hold the trap magnets wherever placed. The ring magnets are similar to those used in some centering devices. On



Fig. 7. This ion trap magnet has two magnetized rings with gaps and consequent poles.

one side of each ring is a gap where like magnetic poles, either north or south, come together to form the equivalent of a single pole. At the opposite side of the ring is a consequent opposite pole.

One of the ring magnets is much larger and stronger than the other. The stronger magnet, larger ring, must be placed toward the picture tube base, with the smaller ring toward the face end of the tube. The gaps in the two rings are diametrically opposite or are 180 degrees apart around the supporting cylinder. This causes the direction of field lines across one ring to be opposite to the direction across the other ring. When the structure is rotated on the tube neck to bring one field into the correct direction, the other field automatically is in its correct direction.

On an earlier design employing two ring magnets the front or smaller ring could be independently rotated without turning the the support or the larger ring. The smaller ring was rotated to eliminate screenshadows.

Fig. 8 shows a double-magnet structure with which two small bar magnets are supported on opposite sides of the picture tube neck and in line with the neck axis. The pole at the exposed end of one magnet is north, and the pole at the exposed end of the other magnet is south. Poles at the ends held in the rectangular frame are opposite for each

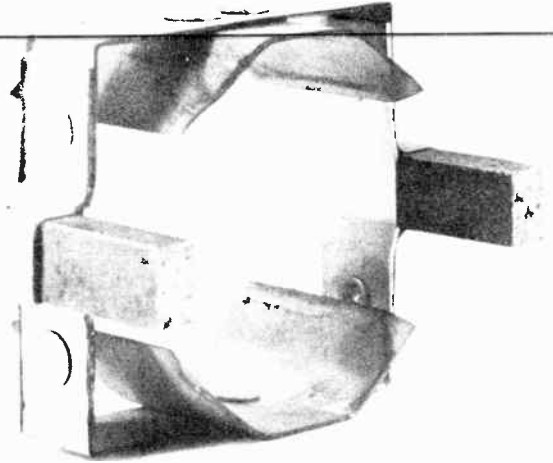

Fig. 8. The stronger magnetic field is between the exposed ends of the magnets in this design.

magnet. This rectangular frame is of magnetic metal. It provides a fairly easy path for the field at its end of the magnets, and weakens the remaining field through the electron gun. The field between the exposed ends of the magnets is relatively strong, consequently it is placed toward the tube base. The supporting frame, and the weaker field, are placed toward the face end of the picture tube.

A great many double magnets for ion traps are generally similar in design to the one pictured by Fig. 4. Such a style is shown by Fig. 9. The chief difference between this and the other design is in the use of two small coiled springs to hold the pole pieces firmly on the tube neck, instead of the clamp screws shown by the earlier picture.

All ion trap magnets or beam benders slide on and off over the base of the picture tube. Maximum standard diameter of a small shell duodecal base such as used on magnetically deflected picture tubes for home receivers is  $1\frac{1}{2}$  inches, and the smallest diameter is only 0.005 inch less. Maximum standard diameter of picture tube necks is  $1\frac{1}{2}$  inches, and the minimum is  $1\frac{3}{8}$  inches. Therefore, anything which can be passed over the base will fit around the neck without difficulty.

The earliest ion trap magnets were electromagnets or coils instead of permanent magnets. The larger of two coils is placed

## LESSON 49 – ION TRAPS

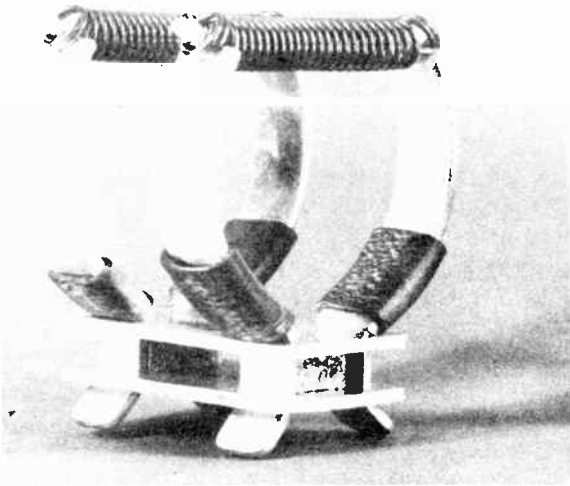

Fig. 9. This ion trap magnet is held in position on the picture tube neck by tension of two coiled springs.

the tube. Often there is an arrow somewhere on the magnet support. The head or point of such an arrow should be forward or toward the face, and away from the base of the picture tube. There is an arrow on the supporting cylinder for the magnets of Fig. 7, on one of the flat tension springs of Fig. 8, on the bottom plate of the structure in Fig. 9, and an arrow may be at any of various places on other magnet assemblies.

The protective sleeves on the pole pieces of one magnet in Fig. 4 are black, and on the pole pieces of the other magnet they are blue. The black sleeves are to be placed toward the base of the picture tube, with the blue sleeves forward. On other double-magnet assemblies there are black sleeves and red sleeves. Again the black sleeves go toward the tube base, while the red sleeves go forward.

When there are no markings to indicate correct positioning, one of two permanent magnets may be visibly larger than the other. The larger magnet should go toward the base of the picture tube. Many times, however, it is impossible to detect any difference in magnet sizes, although one will be stronger than the other. It would seem possible to determine which magnet is stronger by observing their relative pulls on a small magnetic compass such as made for determining geographical directions. The difficulty here is that the stronger magnet is so very much stronger than the other one that the compass needle responds to the stronger magnet in all positions.

As a last resort you can try the magnet assembly with one of its sides forward, and if correct adjustment is impossible, turn it around. How this method would allow correct positioning will become clear when we come to the rules for adjustment.

TILTED GUN ION TRAPS. By tilting or inclining the entire electron gun within the neck of the picture tube it becomes possible to separate ions from the electron stream and to direct the electrons through the gun with only a single external magnet. The more recently designed picture tubes employ this general method, which often is specified as a single-magnet ion trap without particular

toward the base of the picture tube, with the smaller coil forward. The coil windings are connected to the low-voltage power supply system in much the same way that focus coils are connected. Trap adjustment is by variation of coil current and by moving the magnet structure on the tube neck.

Nearly all of the electromagnetic ion traps have been replaced with permanent magnet types. Should you come across one of the old wound-coil types that needs servicing, the simplest and least costly solution for the problem is to remove the old unit from the picture tube without breaking its circuit connections, which would upset operation of the low-voltage B-power system. Fasten the old unit somewhere on the chassis or in the cabinet where it will be out of the way. Install a new double-magnet trap unit on the picture tube. All tubes designed for operation with electromagnetic traps will work as well or better with a double permanent magnet style as a replacement. You may encounter older receivers where such a replacement has been made. Do not disconnect the old unit if it has remained in the power circuit.

POSITIONS OF DOUBLE MAGNETS. It is essential that the stronger field for a double-field or double-magnet ion trap be toward the base of the picture tube, with the weaker field forward or toward the face of



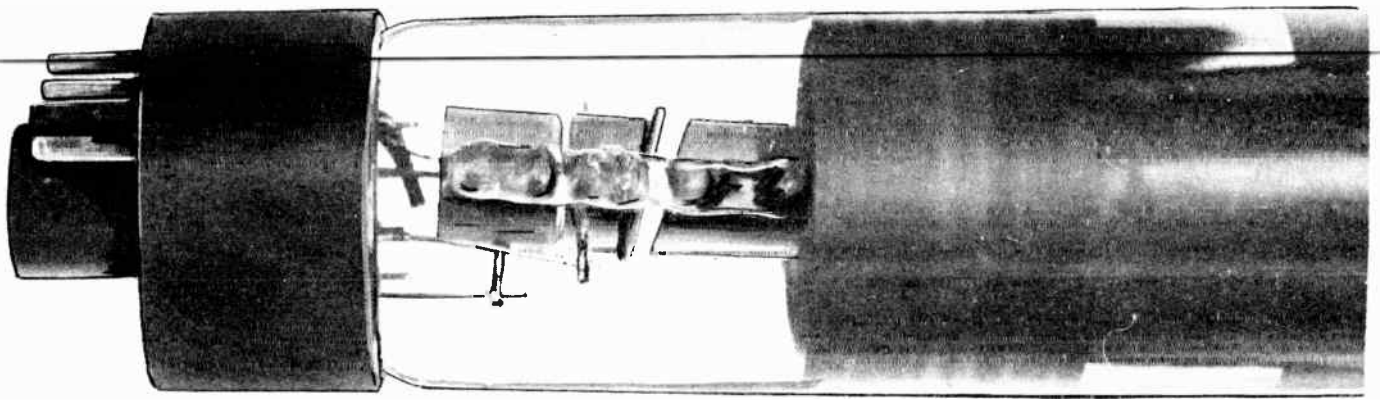

Fig. 10. The electron gun in this tube is tilted for ion trap action with only a single external magnet.

reference to the shape or inclination of the electron gun. The correct name is a single-field ion trap, since it is the number of magnetic fields and not the number of magnets which really counts.

One style of tilted gun, as it appears inside the neck of a tube, is illustrated by Fig. 10. Fig. 11 shows a similar gun removed from the tube, but still attached to the base, so that all of the parts may be seen more clearly. With the tube and the gun in the positions with which these photographs were made, the axis of the gun at the base end or left-hand end is higher than the center of the tube neck. The entire gun is inclined down-

ward at such an angle that the opening through the front end is centered within the tube neck.

This tilting of the electron gun directs both electrons and ions slightly downward as they leave the cathode, pass through the control grid, and enter the second grid. Between second grid and second anode is a diagonal gap in which is a strong electric field. This field tends to turn both electrons and ions still farther downward. But at this point along the gun, outside the tube neck, is placed the single external magnet.

The south pole of the external magnet would be toward you when looking at the pic-

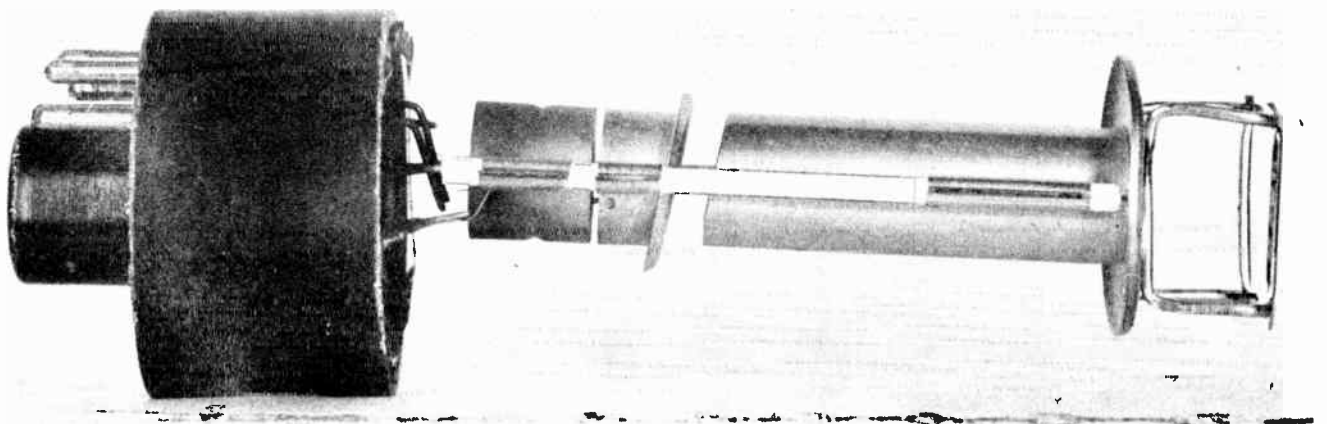

Fig. 11. A tilted electron gun as it appears when removed from the picture tube.



## LESSON 49 – ION TRAPS

tures. The north pole would be on the opposite, concealed, side of the gun. The resulting direction of magnetic field lines through the gun tends to bend the electrons upward. At this point the upward-bending force of the magnetic field is stronger than the downward force of the electric field in the gap, and the electrons are deflected upward.

Since ions are strongly deflected by the electric field, but hardly at all by the magnetic field, the ions continue along a downward sloping path to strike the inside of the second anode, where they are trapped. The magnetic field pulls the electrons up just enough to aim them through the opening in the front end of the gun.

Single-field external magnets used with tilted gun picture tubes are generally similar to one section of many double-magnet assemblies. Two styles of single magnet structures are shown by Fig. 12. The unit at the left is similar to one section of the double-magnet assembly of Fig. 9.

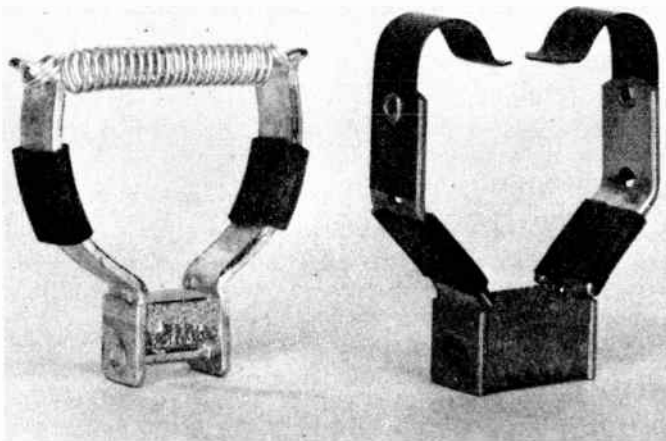

Fig. 12. Single-field ion trap magnets.

The north pole of a single permanent magnet, and its extended pole piece, will be on one side of the tube neck, with the south pole and its pole piece on the opposite side. Magnetic field lines follow the path shown at B in Fig. 4. Single-magnet structures slip over the base of picture tubes in the same way as double-magnet assemblies.

It might be confusing to encounter a single-magnet arrangement on a picture tube

designed for a double magnet or double field. There is such a device in which the one magnet is supported lengthwise of the tube neck. At each end of this magnet are two opposite poles on opposite corners, a north pole at one side and a south pole at the other side. There are two poles also at the two corners of the other end, with positions of north and south poles reversed. The single piece of steel which is the magnet thus has four poles arranged like the four poles of a double-magnet structure, and it is the equivalent of two magnets furnishing two fields.

BENT GUN ION TRAP. In a number of picture tubes the electron gun actually is bent part way along its length, as shown by Fig. 13. The rear end of the gun is at an angle to the neck axis. The forward end is parallel with and concentric with the neck. The cathode, control grid, and second grid are in the bent portion of the gun.

Electrons and ions are directed downward through the bent portion of the gun, in the same direction as electric field lines between the second grid and second anode. A single external magnet is so placed that its field lines cross through the electron gun near the rear or base end of the second anode. This magnetic field is of polarity or direction which turns electrons along the axis of the tube neck and through the opening at the front of the second anode. Ions are not deflected to any extent by this magnetic field, and continue along the downward sloping path to be trapped inside the second anode.

Any single-magnet or single-field magnet structure may be used on bent gun picture tubes. Of course, the magnet or the magnetic field must be of strength suited to the type of picture tube, as is true with all kinds of ion traps.

POSITION OF SINGLE MAGNETS. A single magnet or single-field magnet for any picture tube requiring this style may be used with either side of the magnet structure toward the base of the tube. If placing one side toward the base causes magnetic field lines to pass through the neck and electron gun in the wrong direction, rotating the magnet structure half way around on the neck will reverse the field direction, and it will be

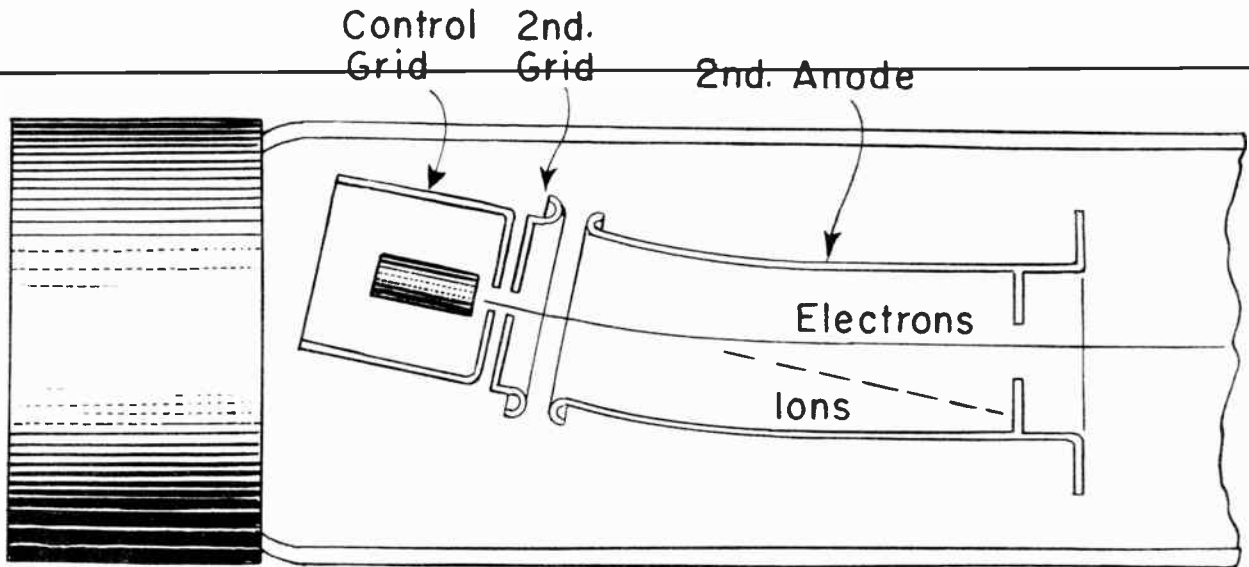

Fig. 13. Paths of electrons and ions in a bent electron gun when a single-field magnet is on the outside of the tube neck.

correct. Consequently, it makes no difference which way you slip the magnet onto the tube neck.

You will find that the correct position of a single magnet lengthwise of the tube neck is approximately in line with the forward end of the second grid or the rear end (base end) of the second anode. This is a good position with which to commence final adjustment. If there are flags on the electron gun, place the single magnet poles approximately in line with the flags when commencing final adjustment.

On picture tubes having tilted electron guns of the general type illustrated by Figs. 10 and 11, the south pole of the single magnet should be directly ahead of and inline with pin number 2 of the base when commencing adjustment. That is, the south pole should be on the same side of the tube as pin 2. Then the north pole of the magnet will be in line with vacant position number 8 of the base. On tubes with bent electron guns the south pole of the single magnet should be approximately in line with pin position 6 on the tube base, which will bring the north pole in line with pin 12.

Single magnets for ion traps sometimes are coded for position by arrows, by sleeves of different colors on opposite poles, by col-

ored dots on one or both sides, and in other ways. These codings, and how they are to be interpreted, apply to particular makes and models of magnet structures, or to certain positions of the picture tube. There are special rules for each kind of magnet structure, or for each receiver, but there are no general rules applying to all single magnets and all picture tubes and receivers.

#### ADJUSTMENT OF ION TRAP MAGNETS.

It takes but a few moments to correctly adjust an ion trap magnet, but to do it right you must observe quite a few precautions. So far as the adjustment itself is concerned, it amounts only to this: Rotate the trap magnet a few degrees one way and the other around the tube neck, and at the same time move it a little ways toward and away from the base, until there is the brightest possible raster for a given setting of the brightness control. However, if you neglect the necessary precautions, the picture tube may be permanently damaged before you get half way through the adjustment process.

The damage happens when the central and most concentrated portion of the high-velocity electron stream strikes the edge of the opening at the front of the second anode section of the gun instead of passing through the center of this opening. The first result is to literally tear particles of metal from

## LESSON 49 – ION TRAPS

around the opening. These particles, and vaporized metal, are driven onto the screen, where they soon cause a dark spot similar in appearance to an ion burn.

The second damaging result is to make the opening in the electron gun of irregular shape rather than a true circle. The usual name for this opening is "limiting aperture". It limits the diameter of the electron stream passing through it by cutting off the less concentrated outer portion of the stream where electrons are not traveling quite so fast. The electron stream passing on through the limiting aperture to the focusing field then is truly cylindrical.

But when part of the metal around the limiting aperture has been torn away by a misdirected stream of high-velocity high-energy electrons, the stream through the opening no longer is cylindrical. Thereafter it becomes difficult or impossible to obtain sharply focused horizontal lines.

Should there be any possibility that an ion trap magnet is out of adjustment, do not turn on the receiver unless the brightness control is retarded as far as it will go. This should make the control grid-cathode voltage of a value which causes beam cutoff, and which prevents electrons from getting past the control grid in the gun.

When an ion trap magnet is far out of adjustment there will be no raster or pictures no matter how far the brightness and contrast controls are advanced, although misdirected high-velocity electrons may be ruining the gun. If the trap magnet is only a little out of adjustment there will be low brilliance even with the brightness and contrast controls advanced, focus usually will be fuzzy, and there may be screen shadows somewhat like neck shadows.

In case you have taken the trap magnet off the tube for any reason, and have forgotten to put it back, there will be no raster or pictures, but there is little chance of damaging the electron gun. This is because electrons as well as ions will be deflected only by the electric field between second grid and second anode, or only by the tilt or the bend of the electron gun. Then electrons will

be trapped inside the second anode, along with ions.

Now we may proceed with a step-by-step procedure for adjustment of ion trap magnets. It will take much longer to read the rules than to make an actual adjustment after once you know all the things to be considered.

1. Check the position of the trap magnet on the tube neck in accordance with instructions given earlier in this lesson. Try to place the magnet approximately where it should be lengthwise of the neck and in relation to rotation around the neck of the picture tube.

2. See that the deflecting yoke is as far forward on the tube neck as it will go, with the yoke against the flare or cone of the picture tube.

3. Make sure that the center of the opening through a PM focuser or focus coil is centered or very nearly centered, around the tube neck.

4. Set the brightness control at minimum, for reasons explained earlier. Also set the contrast control at minimum, and leave it there during the remaining steps.

5. Turn on the receiver and let it warm up for a minute or more while the brightness control remains at minimum.

6. Slowly advance the brightness control while watching the screen for the first appearance of illumination. Keep moving the trap magnet back and forth on the tube neck through a total distance of no more than a half inch, and at the same time keep rotating the magnet a little ways each direction around the neck. Combine these two movements.

If no illumination appears by the time the brightness control is advanced about half way, or to a position ordinarily suitable for viewing pictures, retard this control while rechecking the magnet position as in Step 1. Again try for illumination by slowly advancing the brightness control. Should the screen still remain dark, turn the trap magnet half way around on the tube neck, and try again.

## COYNE - *television home training*

7. After obtaining screen illumination, rotate the trap magnet while moving it forward and backward to the position giving maximum brightness. As screen brightness increases with shifting of the magnet, retard the brightness control enough to keep screen brightness at about the level for viewing pictures, or somewhat lower.

With single-field trap magnets there may be two positions along the neck of the picture tube at which brightness increases to a maximum. Always leave the magnet at the position closer to the tube base. In the forward position, electrons are deflected toward the limiting aperture of the gun after they are well past the electric field in the gap. The beam then passes through the aperture at a decided slant. The beam can be straightened out by the focusing field, but focusing and centering will be made difficult, and there is likelihood of damaging the electron gun as well.

If the trap magnet has to be moved in obtaining maximum brightness more than a quarter inch farther from the tube base than approximately correct positions described earlier, the magnet may have been weakened and should be replaced. The magnet may not be of a type strong enough for the picture tube with which you are working. The stronger a trap magnet, the closer to the tube base it may be placed for maximum brightness. When the rear edge of the magnet pole piece has to be almost at the tube base or within a quarter inch or less of the base, the magnet is stronger than needed for the particular picture tube.

Should shadows appear on the raster with the trap magnet positioned for maximum brightness, do not readjust the magnet position to eliminate the shadows. This is important. Get rid of shadows by correct positioning of a PM focuser, of a focus coil, or of a deflecting yoke in relation to the tube neck, or by correct adjustment of a centering control.

Shadows may be due to wrong positioning of the ion trap magnet, but then the magnet will not be in the position for maximum brightness. Ordinarily, shadows due to setting of the ion trap magnet mean that this

magnet is much too far forward on the tube neck. Move it back to the position for maximum brightness, and if shadowing remains, eliminate it as explained in the preceding paragraph. Shadows due to position of the trap magnet mean that the concentrated electron stream is being partially cut off by the edge of the limiting aperture of the gun.

8. Adjust the focus control for sharpest horizontal lines on the raster while the brightness control is set for normal picture-viewing illumination or somewhat lower. Traps and trap magnets, and methods of adjustment, are the same for electrostatically focused tubes as for those with magnetic focusing. Fig. 14 is a picture through the neck of an electrostatically focused tube in which is a tilted and offset electron gun. A single-field magnet would be or should be placed close to the gap between second grid and second anode, as with other tubes requiring a single-field magnet.

Trap adjustment is somewhat more critical with electrostatic focusing than with magnetic focusing. Never attempt to improve sharpness of focus by moving the trap magnet away from its position for maximum brightness. When all other tube accessory adjustments and all tube voltages are correct, there should be sharpest focus and maximum brightness with the same positioning of the ion trap magnet. That is, when the magnet is placed for maximum brightness, adjustment of the focus control should produce sharply defined horizontal lines.

9. Once more move the trap magnet slightly forward and back while rotating it a little ways around the tube neck to bring about any possible increase of screen brightness.

10. Advance the brightness control as far as possible while retaining sharp line focus, but not beyond a point at which the raster begins to expand in all directions. This expansion is called "blooming".

11. For the last time, try moving the trap magnet lengthwise and around the tube neck for maximum brightness while the brightness control is advanced. This is the final adjustment for the trap magnet.



## LESSON 49 – ION TRAPS

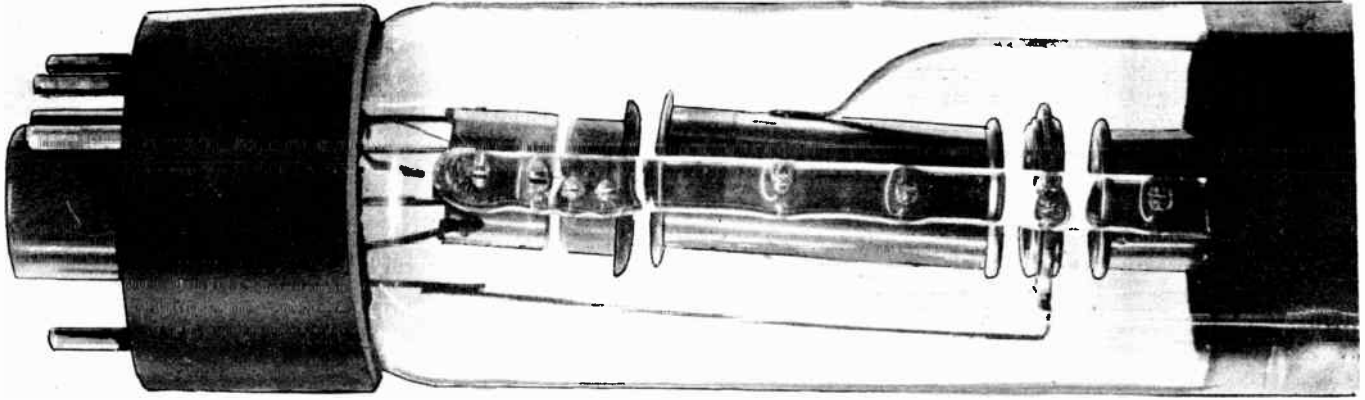

*Fig. 14. A tilted offset electron gun which requires using a single-field external magnet for the ion trap.*

Adjustment of the ion trap magnet should be carefully checked whenever you have made any adjustment on a PM focuser or focus coil, on a centering device, or of deflecting yoke position. Trap magnet setting should be checked also when a chassis has been removed from its cabinet for any kind of servicing. The magnet is easily shifted, and only a little shift may cause poor picture reproduction even though no harm comes to the electron gun.

**TYPES OF TRAP MAGNETS.** The flux density required from ion trap magnets varies from 30 to 50 gauss, or slightly more, for various types of picture tubes and various second anode voltages. The gauss is a unit for measurement of magnetic field density or intensity, or, as we usually say, of magnetic field strength. In a very general way, larger tube screens require stronger ion trap magnets, while smaller screens require weaker magnets. Required strength increases also, to a small extent, with increase of second anode voltage on any tube. If you have on hand some magnets rated at 30 to 35 gauss, and others rated at 40 to 45 gauss, one or the other will work under practically all normal conditions.

As a general rule, a double-field magnet should be replaced when necessary with another double-field magnet, and a single-field type with another providing a single field. A few types of picture tubes originally designed for double-field trap magnets have been redesigned in the most recent versions to

operate with either a double-field or a single-field trap magnet. Among these tubes, of only certain makes or brand names, are the 10BP4, 12LP4, 16AP4, 16JP4, 16WP4, and 16ZP4, usually with a suffix letter following these type numbers. When substituting a single-field for a double-field magnet there may be centering difficulty in some cases, depending on the kind of centering device or centering method employed.

Ion trap magnets must be given the same care as any other devices containing permanent magnets. Do not subject them to severe mechanical shock. Do not let them come in direct contact with one another. Do not leave them on steel shelves, nor stored in steel drawers or bins unless the units are in their original cartons.

**TUBES REQUIRING NO ION TRAPS.** Before design engineers realized the extent to which ions would cause burns on the screens of picture tubes, tubes were made in face sizes up to 20-inch diameter with no provision for ion trapping. In such a tube the electron gun is straight, it is not tilted with reference to the neck axis, and the gap between second grid and second anode is at right angles to the gun. You can see these features in the electron gun of Fig. 15.

Fig. 15 is not a picture of an old time electron gun, rather it shows the gun of a tube having an aluminized screen. An aluminized screen, called also a metal-backed screen, is one onto the inner surface of which

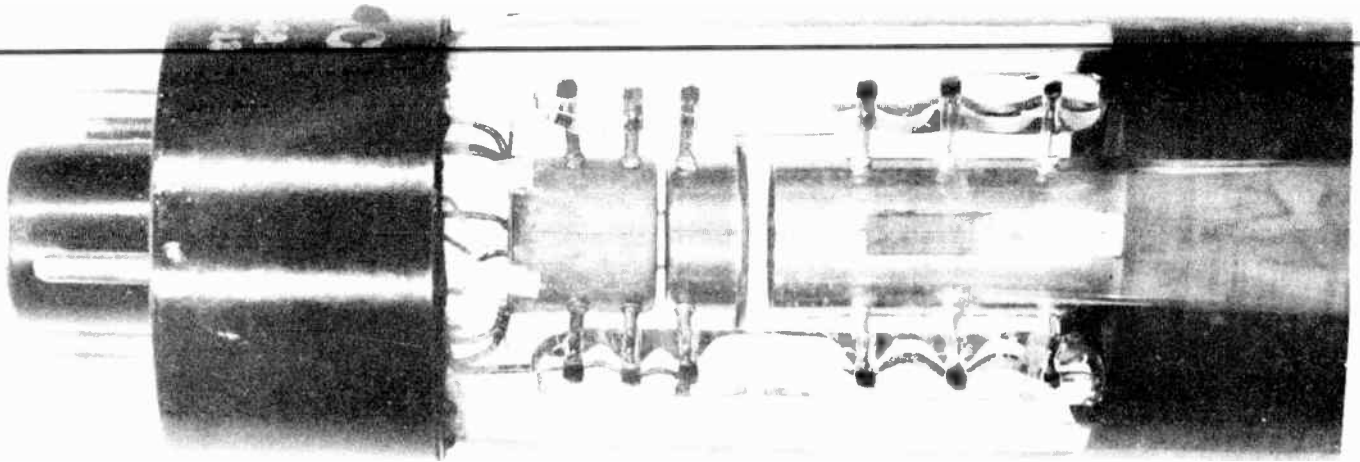

*Fig. 15. This is the electron gun in a type of picture tube which requires no ion trap.*

has been evaporated an exceedingly thin layer of metallic aluminum. High velocity electrons penetrate this metallic layer with ease, and excite the phosphor as in other tubes. But the layer of aluminum is not penetrated by the heavier and more slowly moving ions, and they do not cause burns. The aluminum layer possesses a high degree of reflection ability, which increases the brilliance or apparent brightness of reproduced pictures and improves the contrast or the range of lights and shadows.

No ion trap magnet is required, and none may be used, with picture tubes having metal backed screens. Should you put any type of trap magnet on one of these tubes, it could deflect only the electrons and prevent forma-

tion of a raster or pictures. Ions still would continue through to the screen, but would cause no illumination. The deflected electron stream could damage the limiting aperture of the gun.

The only other present types of picture tube requiring no ion trap magnet are those designed for electrostatic deflection of the electron beam. A few of these tubes, chiefly in a 7-inch diameter type, are still found in some small television receivers. The principal present use of electrostatically deflected tubes is in oscilloscopes. As we already know, an electrostatic field deflects both electrons and ions. Consequently, electrostatic deflecting fields distribute the ions over the entire active screen area, and there is no need for a trap.



---

**LESSON 50 – MAGNETIC DEFLECTION**

---

***Coyne School***

*practical home training*

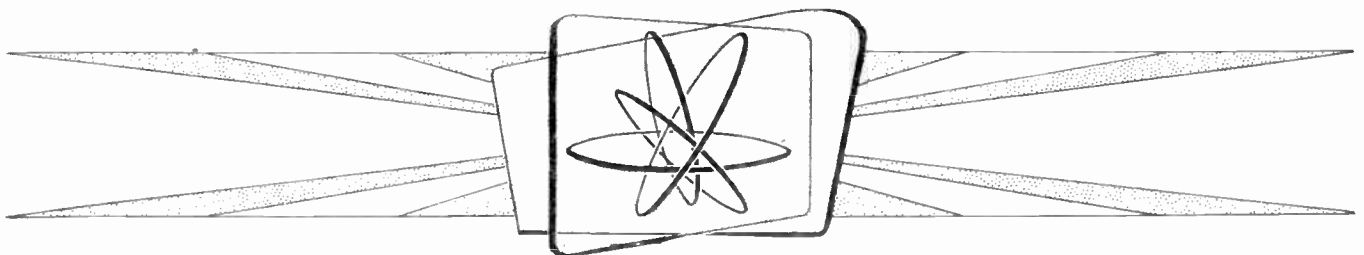

*Chicago, Illinois*

---

*Copyright, 1953 by Coyne Electrical School  
Chicago 12, Illinois  
All rights reserved*

Litho. in U.S.A.



## Lesson 50

### MAGNETIC DEFLECTION

Fig. 1 is a picture of a typical yoke containing horizontal and vertical deflecting coils. The central opening fits quite closely around the neck of a picture tube. When alternating currents of suitable waveform flow in the coils of this yoke, the resulting mag-

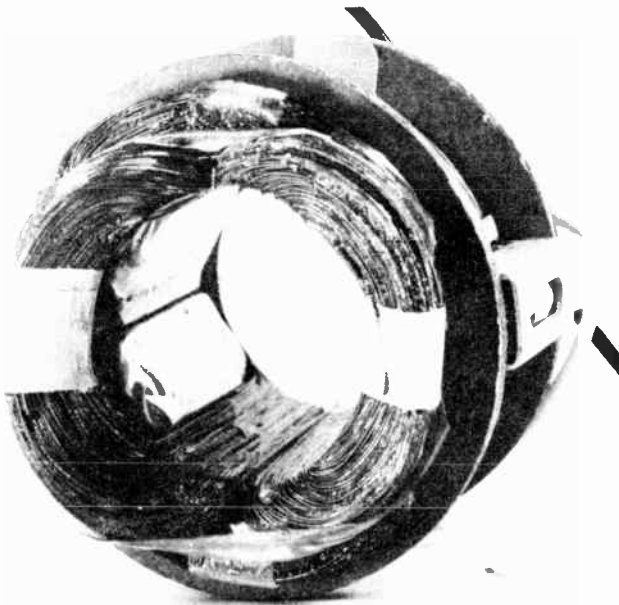

Fig. 1. A yoke for magnetic deflection of the electron beam.

netic fields deflect the electron beam horizontally at a rate of 15,750 times per second and vertically at 60 times per second.

Fig. 2 illustrates, by means of a model, the principle of magnetic deflection. There are two coils vertically in line, one above the other. The coils are electrically connected together to act as a continuous winding and as an electromagnet. When current flows in this winding there will be a magnetic field whose lines of force are vertical, and most concentrated in the central opening which extends downward through the coils.

An electron beam, represented as coming from the left, passes horizontally through the space between upper and lower coils. When electrons move through a magnetic field they are turned from their original straight path. The magnetic turning force always acts to divert the electrons out of the magnetic field and at right angles to the field lines. Diverting to one side would be in a direction at right angles to the field lines, and to get out of the field the electrons must turn horizontally.

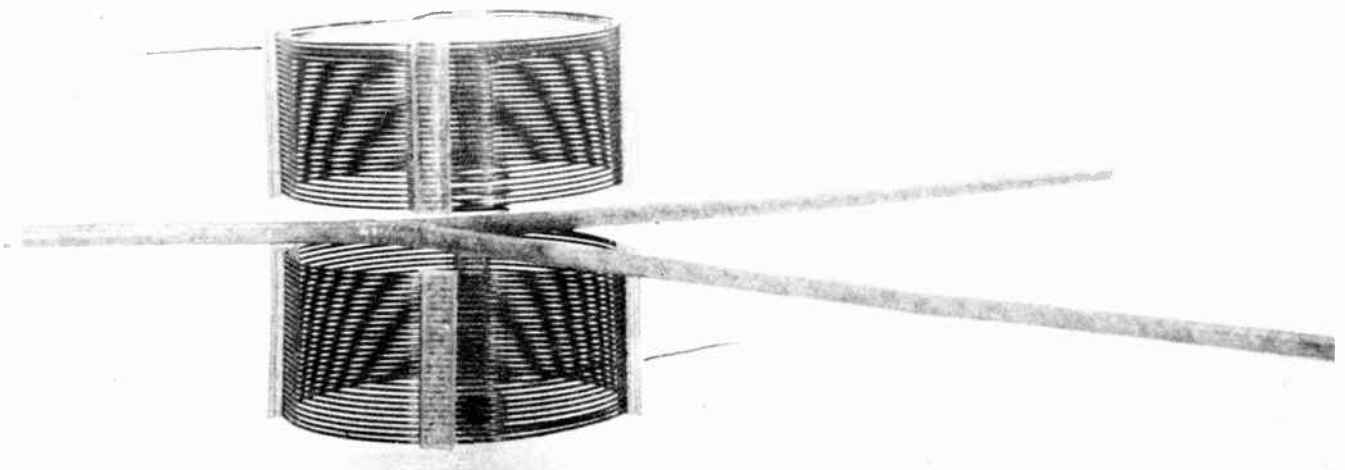

Fig. 2. When deflecting coil axes and their field lines are vertical, the beam is deflected horizontally.

## COYNE - *television home training*

A magnetic field in this model would deflect the electron beam horizontally, either toward or away from you, as the beam passes through and emerges from the magnetic field to travel onward toward the right. Whether actual deflection is toward or away from you depends on the polarity of the magnetic field. When there is alternating current in the winding, field polarity alternates and the beam is deflected alternately toward and away from you. This is horizontal deflection.

Were the axes of the two coils to be horizontal, instead of vertical as in the picture, the direction of field lines would be horizontal. Alternating current in the winding then would cause the electron beam to be deflected alternately up and down. This would be vertical deflection.

For simultaneous horizontal and vertical deflection, as required for pictures, there must be two sets of coils with their axes at right angles to each other. The coils for horizontal deflection are above and below the neck of the picture tube, while those for vertical deflection are on opposite sides of the neck.

Deflecting currents in both sets of coils are of sawtooth waveform, as shown by the oscilloscope trace of Fig. 3. Frequency of

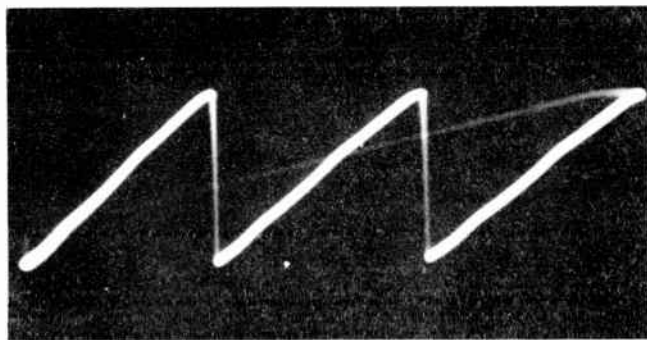

Fig. 3. An oscilloscope trace showing a sawtooth deflecting current.

the horizontal deflecting current is 15,750 cycles per second, and of the vertical deflecting current is 60 cycles per second. The longer slopes of the trace show how current increases at a uniform rate to deflect the beam horizontally from left to right, or vertically from top to bottom. The steeply

sloped returns show how deflecting currents suddenly reverse for horizontal or vertical retraces.

In order that the rate of beam travel during deflection may be proportional to the rate of change of deflecting currents, the magnetic field must be of uniform density all the way through the neck of the picture tube. This requires special kinds of coils and cores.

At A in Fig. 4 is a pair of horizontal deflecting coils taken from a yoke such as pictured by Fig. 1. Openings through which pass the field lines are above and below, so the direction of field lines is vertical. The curved fronts of these horizontal deflecting coils which show clearly in this picture may be seen also at the exposed end of the yoke in the earlier picture. At B is a pair of vertical deflecting coils. Openings through these coils are at the sides, so field lines extend crosswise.

The sides of the vertical coils, which are at top and bottom in the picture, fit into the openings which are at the top and bottom of the horizontal coils. The sides of the horizontal coils fit into the openings which you can see on opposite sides of the vertical coils. When all the coils are assembled they appear as in Fig. 5, where there is an approximately cylindrical central opening which fits around the neck of the picture tube.

To increase the coil inductances the yoke contains a core of magnetic material. This core sometimes consists of many turns of soft steel wire wound around the assembled coils, in the space between the outwardly turned front and back ends of the coils. Other cores are made of molded powdered iron or of ferrite such as used for adjustable cores in coupling inductors and transformers. The core is provided with connections or contacts which allow grounding it through the yoke brackets or supports.

Changes of current in these horizontal and vertical deflecting coils induce what we have called counter-emf's in the coils. You will recall that the strength of counter-emf's depends on the rate of current change. The voltage of counter-emf is not very great dur-

## LESSON 50 – MAGNETIC DEFLECTION

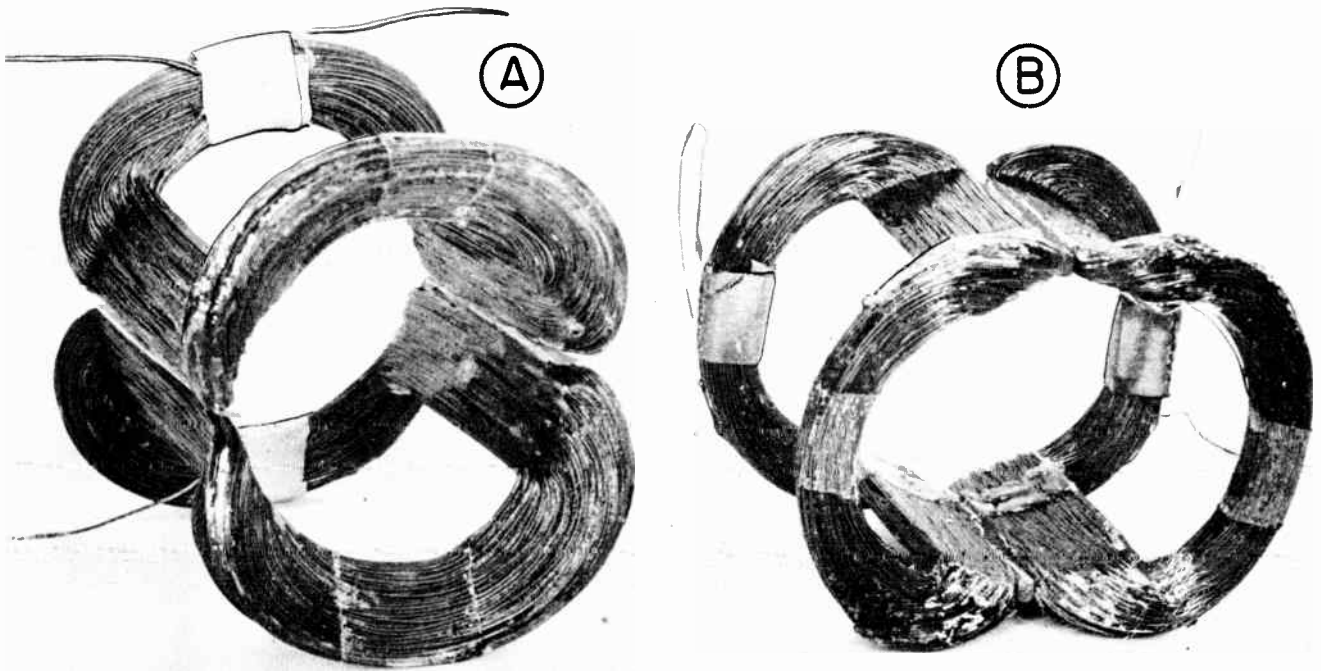

Fig. 4. Horizontal and vertical deflecting coils for a yoke.

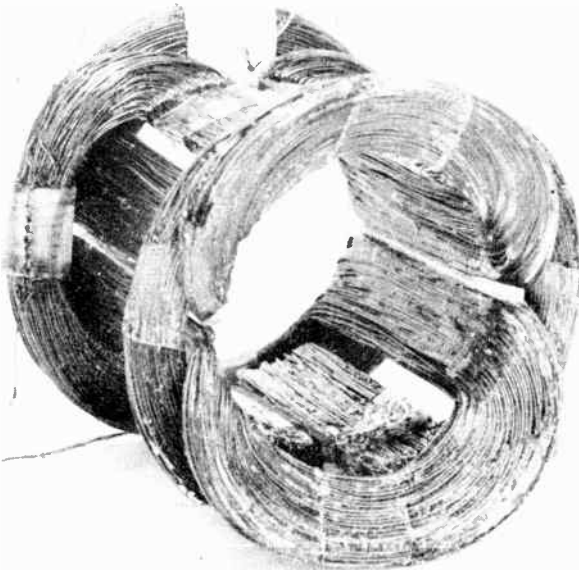

Fig. 5. How the two sets of deflecting coils fit together in the yoke.

ing the gradual changes for deflection, but is many times greater during the very quick changes of current during retraces. For this reason the deflecting coils must be well insulated from the core and from each other.

**DEFLECTION ANGLES.** The amount by which the electron beam must be turned from its original straight path is measured as the deflection angle, illustrated by Fig. 6. The horizontal deflection angle, in which we are chiefly interested, is measured from side to side of the screen, with the apex of the angle at the center of the deflecting yoke.

The horizontal deflection angle in any picture tube depends on the width of the screen and on distance from the center of the yoke to the screen. At 1 in Fig. 6 is a horizontal cross section through a typical picture tube having horizontal deflection angle of 60 degrees. At 2 the width of the screen is practically unchanged, but the tube has a much shorter flare, which increases the deflection angle to 68 degrees. At 3 the screen width still is about the same as before, but

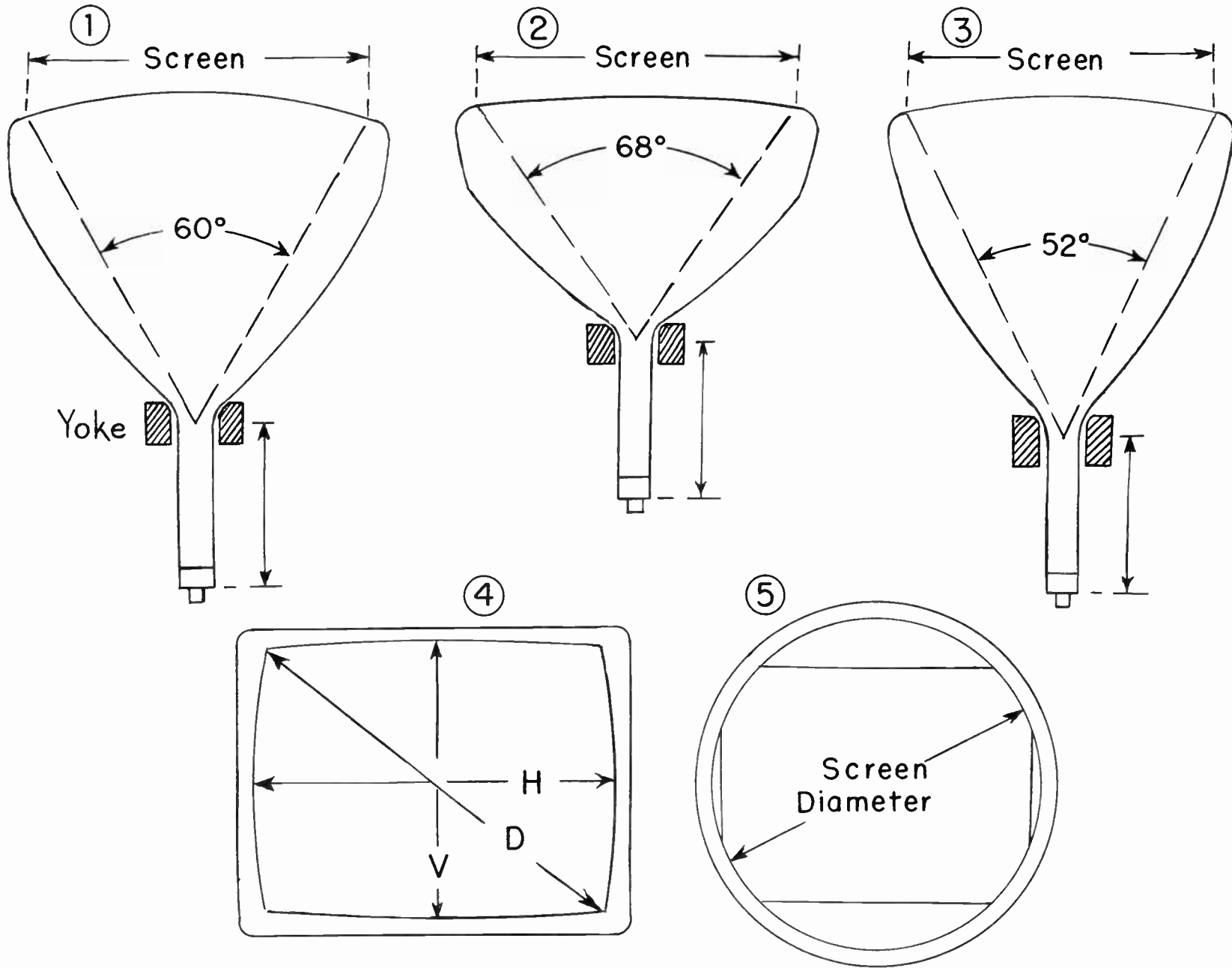

Fig. 6. How picture tube deflection angles are determined and measured.



# LESSON 50 – MAGNETIC DEFLECTION

there is a longer flare and greater distance from yoke to screen. This reduces the deflection angle to 52 degrees. Note that the length of the neck, from yoke to base, is the same for all three tubes.

For any given width of pictures or of screen, the shorter the tube from face to base the greater must be the deflection angle. For any given length of tube, the wider the screen or the pictures the greater must be the deflection angle.

The distance the electron beam is deflected is directly proportional to the amplitude of deflecting current or directly proportional to peak-to-peak value of the saw tooth current such as shown by Fig. 3. Therefore, a wider screen or a shorter tube calls for stronger deflecting current than a narrower screen or longer tube. This is the same as saying that the greater the deflection angle the stronger must be the deflecting current in any given yoke.

In a yoke designed for tubes having relatively narrow deflection angles it would be difficult or impossible to use deflecting current strong enough to provide a much wider deflection angle. It is desirable or necessary to use a yoke designed for wide deflection angles. In general, the same deflecting yoke may be used for any and all picture tubes having deflection angles no greater than about 62 degrees. For tubes having deflection angles greater than about 62 degrees a wide-angle yoke should be used.

In diagram 4 of Fig. 6 the distance from side to side on the screen of a rectangular picture tube is marked H. This is the distance which would determine the horizontal deflection angle for a tube of given length. This angle is 65 or 66 degrees in the great majority of rectangular picture tubes. Sometimes the deflection angle is specified with reference to diagonally opposite corners of the screen, across the dimension marked D. This would be called the diagonal deflection angle. It is 70 degrees in nearly all rectangular picture tubes. The vertical deflection angle for a rectangular picture tube would be measured across line V from top to bottom of the screen. In practically every case this angle is 50 degrees.

As shown at 5 in Fig. 6 the deflection angle for a round picture tube is measured across the diameter of the screen. Since the diameter of a round screen is the same whether measured horizontally, diagonally, or vertically, there is only one deflection angle for any given round tube. This deflection angle ranges from 50 degrees in 10-inch tubes up to 90 degrees in 30 inch round tubes, but is not directly proportional to screen diameter, because tubes are of different lengths. For example, 16-inch round tubes may have deflection angles of 52, 53, 60, 62 or 70 degrees in various types.

DEFLECTION AND SECOND ANODE VOLTAGE. The higher the voltage on the second anode or ultor element of the picture tube the greater is the tendency to pull the electron beam straight toward the center of the screen. The greater the deflecting current in any given yoke the stronger are the forces tending to turn the beam horizontally or vertically. Therefore, second anode voltage opposes deflection. If this voltage is increased, with no change in strength of deflecting currents, the horizontal and vertical distances of deflection will be lessened. Pictures will be made narrower and of less height. Less voltage on the second anode allows greater deflection for any given deflecting currents, and pictures will be wider and higher.

To maintain any given width and height of pictures when second anode voltage is increased, the deflecting currents must be increased proportionately to the square root of second anode voltage. Here is an example: Second anode voltage is increased from 8,100 to 10,000. The square roots of 8,100 and 10,000 are respectively 90 and 100. Then the deflecting current must be increased in the ratio of 90 to 100, or increased by 1/9 of its original value.

In addition to changing the size of pictures, or the deflecting current to maintain some given size, change of second anode voltage has other important effects. More voltage on the second anode causes a smaller illuminated spot and narrower horizontal trace lines of greater brilliance. Any considerable increase of second anode voltage, within the rated maximum for the picture

# COYNE - *television home training*

tube, causes a decided improvement in picture quality.

**DEFLECTING YOKE CHARACTERISTICS.** D-c resistances of the two horizontal coils in series ordinarily ranges from about 12 to 18 ohms for narrow-angle yokes and from 20 to 35 or more ohms for wide-angle yokes. D-c resistances of the two vertical coils in series usually ranges from around 40 to 65 ohms in either type of yoke. Exact values of resistances are important to the designer, and when attempting to make an exact replacement. But in all service work it is important to remember that resistance of the vertical coils always is more than that of the horizontal coils in any one yoke. This allows determining which connections go to the horizontal coils and which to the vertical coils when tracing circuits.

Inductances of horizontal windings in deflecting yokes may be as little as 6 millihenrys and as great as 80 millihenrys, with the more common values in the range of 15 to 30 millihenrys for wide-angle units, and lesser values in narrow-angle yokes. Inductances of vertical windings are greater than those of the horizontal windings in the great majority of deflecting yokes.

You will recall that, during our discussion of focusing, it was mentioned that adjustment should provide best distribution of sharp focus between the center and sides of the screen area. Difficulty in obtaining equally sharp focus all the way across the screen is due largely to variations of focusing field intensity ~~and form~~ from one side to the other of the horizontal coils and the picture tube neck.

There are yokes in which this difficulty is largely or wholly overcome by highly specialized shapes of cores and distribution of coil windings. These often are called cosine yokes. Another name is anastigmatic yokes, because the difficulty they overcome is called astigmatism. Astigmatism is a name given to deformation of the beam spot at the far ends of its travel or near the center, depending on how focusing adjustments are made.

When cosine yokes are used on picture tubes having wide screens there may be out-

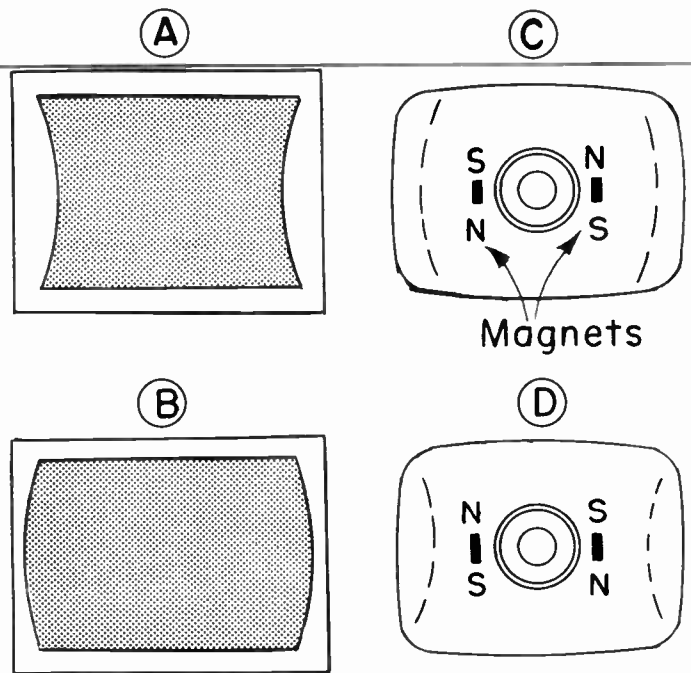

Fig. 7. Pincushion effects and how they are prevented.

ward bulging or inward contraction on the vertical sides or outer edges of pictures and rasters. These are called pincushion effects because, as shown at A and B of Fig. 7, pictures have somewhat the outline of old fashioned pincushions.

Pincushioning is corrected by mounting two small bar magnets just outside the forward end of the yoke, where the flare of the picture tube commences, as shown at C and D. These are views looking straight toward the base end of the tube, from the rear of a chassis or receiver. When the magnet poles are in the relative positions shown at C their fields tend to bulge the picture sides outward as shown by broken lines. This counteracts the pincushion effect at A. With both magnets turned end for end they tend to pull the sides of pictures inward, which corrects the pincushioning effect at B.

Correction magnets are adjustably mounted, usually from the yoke bracket, in such a way that either or both magnets may be moved toward or away from the picture tube. Sometimes the mountings allow the magnets to be moved short distances up or down, or to be slightly tilted. Adjustment consists of moving the two magnets to such positions that

## LESSON 50 – MAGNETIC DEFLECTION

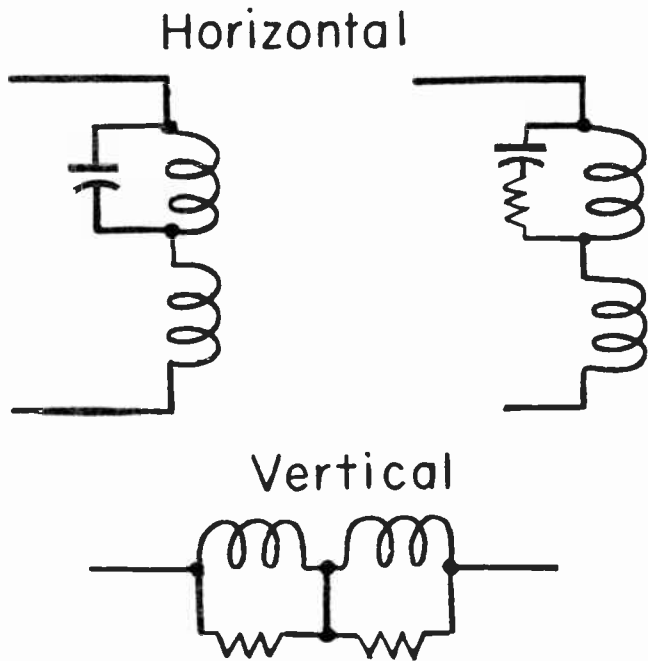

Fig. 8. Symbols for coils in deflecting yokes.

both sides of a raster or pictures are made vertically straight.

Coils or windings of deflecting yokes often are shown on service diagrams by symbols like those of Fig. 8. In parallel with the horizontal deflecting coil on the high side of the circuit or farthest from a ground connection will be a capacitor or a capacitor and resistor in series. Across each of the vertical coils will be a resistor.

Fig. 9 shows the end of a deflecting yoke on which the two resistors for the vertical coils may be seen on opposite sides of the coil assembly. Down below is a capacitor connected across one of the horizontal deflecting coils. Around the outside of the coil assembly, on a ring of insulating material, are eight terminal lugs to which come the eight ends of the four coils, and to which are soldered the leads from horizontal and vertical deflecting circuits of the receiver.

Capacitors connected to deflecting coils must withstand the high counter-emf's induced during retrace periods. These units usually have mica or ceramic dielectric, and are rated for 1,500 d-c working volts. Capacitances are small, usually in the range between 33 and 68 mmf, and are suited to the

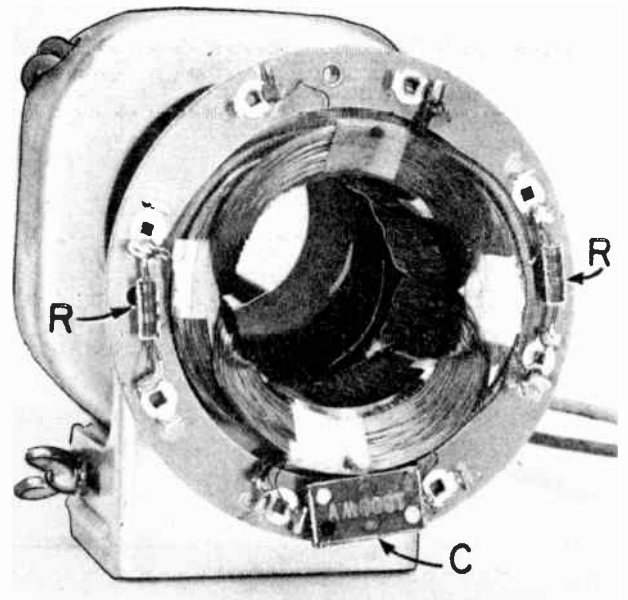

Fig. 9. A yoke with resistors (R-R) across the vertical coils and with a capacitor (C) across one horizontal coil.

characteristics of the particular coil or yoke with which used.

The purpose of yoke capacitors or of capacitors and resistors in series across a horizontal coil is to make this high-side coil electrically similar to the coil on the low side of the circuit. We speak of balancing the coils with respect to ground.

Resistors connected across the vertical deflecting coils are for the purpose of damping or preventing oscillating currents and voltages which might occur because of inductance and distributed capacitance of the coils. The coils would be self-resonant at a frequency far higher than the 60 cycle vertical field frequency at which they should operate, and pictures would be badly distorted. Oscillation at the self-resonant frequency is started by some of the many harmonic frequencies which exist in any sawtooth waveform. Energy of the high-frequency oscillating currents is rapidly dissipated in the paralleled resistors.

A deflecting yoke must be of wide-angle or narrow-angle type, as required by the picture tube with which the yoke is used. In



## COYNE - *television home training*

addition, the inductances of both pairs of coils in the yoke must suit the inductances of the secondary windings of deflection output transformers to which the coils are connected. Unless there is reasonably good matching of inductances in yokes and transformers only a relatively small portion of the deflecting power will be transferred to the yoke, and it will be impossible to obtain pictures of full size.

Many horizontal output transformers have a number of taps on their secondary windings. This allows connecting the horizontal coils of the yoke across a portion of the secondary wherein the inductance is a good match for that of the coils. Transformers designed for making replacements in any of a wide variety of receivers always have tapped windings. Transformers used for original equipment may have no taps allowing a choice of inductances, whereupon it is necessary to use exactly the same type of yoke as originally employed. The matter of matching inductances will be treated in detail when we come to the general subject of sweep circuits.

**YOKE ADJUSTMENTS.** As mentioned many times before, a deflecting yoke must be as far forward as it will go on the neck of the picture tube, bringing the front end of the yoke opening against or very close to the flare or cone of the tube. Furthermore, the central opening through the yoke should be concentric with the neck of the tube. If the yoke is not positioned in this manner, you will have trouble with centering, focusing, and neck shadowing.

In a receiver designed for one certain type of picture tube, supports for the tube and yoke will be in such relative positions that the yoke is concentric with the tube neck, or so nearly concentric that pushing the yoke forward against the flare or cone will insure centering. When more than one kind of picture tube may be used on a chassis, and when yoke and tube are mounted on the chassis, will be provision for raising or lowering the yoke on the tube as required.

An adjustable support such as found on many yokes is illustrated by Fig. 10. Fastened into the yoke structure is a piece of metal in which is a slot extending lengthwise

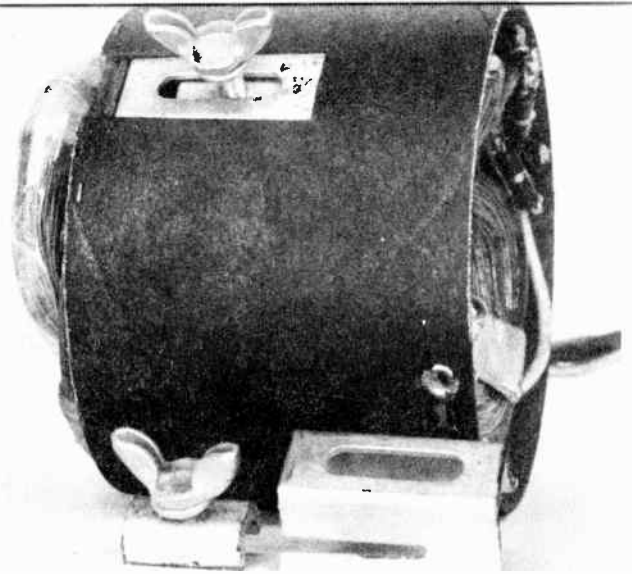

Fig. 10. A type of support which allows moving the yoke forward or backward on its bracket.

of the yoke and tube neck. This slotted piece protrudes through the cover or housing of the yoke. It is shown by itself at the lower right, in front of the yoke. Inside the slotted member, and making a loose fit, is a long nut which you can see by itself at the lower left. A wing screw passes with a free fit through the slotted member and threads into the long nut. The wing screw and nut can be moved the length of the slot, and, because the nut cannot turn, they may be held in any position by tightening the screw.

The wing screw that threads into the nut on the yoke forms the support for the yoke when this screw is passed through a crosswise slot in the bracket for mounting the yoke on a chassis. Such a bracket, with a yoke in place, is shown by Fig. 11. At the top of the bracket you can see the long crosswise slot with the wing screw passing through this slot and into the yoke attachment shown by the preceding picture.

When the wing screw is loosened, the yoke can be shifted lengthwise of the picture tube neck because of the lengthwise slot in the piece of metal fastened into the yoke. This



## LESSON 50 – MAGNETIC DEFLECTION

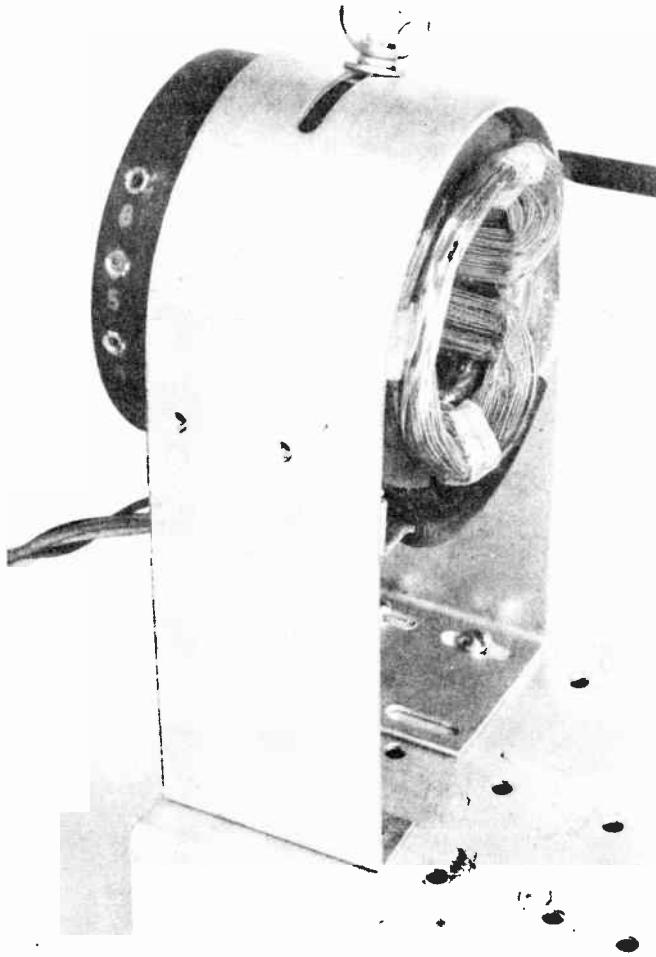

Fig. 11. A crosswise slot in the bracket allows rotating the yoke to a limited extent around the neck of the picture tube.

allows pushing the yoke against the flare or cone of the tube, where it will be held by tightening the wing screw. While the wing screw is loosened it is possible also to rotate the yoke to a limited extent around the neck of the picture tube, because the wing screw that carries the yoke will slide one way and the other in the crosswise slot at the top of the bracket.

The majority of adjustments which allow shifting the position of a yoke in any direction consist of slots along the length of which some mounting screw or bolt may be moved. Although they do not show so very clearly in the photograph of Fig. 11, there are slots in the bottom legs of the yoke bracket where this bracket fastens to the chassis. Were it impossible to shift the yoke far enough length-

wise of the tube neck by means of the adjustment in the yoke itself, the entire supporting bracket could be moved forward or back on the chassis by making use of these slots at the bottom of the bracket.

There are many adjustments for yoke position other than those which have been illustrated. All of them are simple mechanical arrangements, and it is easy to determine by inspection how they are supposed to work.

Some yokes have no position adjustments built into themselves, but are built into a plain cylindrical housing of metal, fibre, or plastic material. Such yokes are supported in a bracket of generally cylindrical form having means for clamping the yoke in any position to which it may be moved. With the clamping device loosened, the yoke may be moved lengthwise of the tube neck and may be rotated on the neck, then held securely in any position by tightening the clamp or clamps.

**PICTURE TILT.** A yoke must be mounted so that it can be rotated a little ways one way or the other around the picture tube neck in order to correct tilting of pictures in the mask. In a picture tube designed for magnetic deflection there is nothing whatever in the electron gun or any other internal part which affects tipping or tilting of pictures on the screen. Directions of horizontal and vertical deflection depend entirely on directions of magnetic field lines in the yoke.

Rotation of the deflecting yoke around the neck of the picture tube will rotate pictures in the same direction that the yoke is turned. When looking toward the face of a tube, rotating the yoke clockwise will rotate the entire picture clockwise, while rotating the yoke counter-clockwise will turn the picture counter-clockwise on the screen - all this regardless of the position in which the picture tube may be mounted. A pattern tilted in the mask is shown by Fig. 12.

The picture tube ordinarily is turned to the position which allows most convenient or safest position of the lead for the second anode. Of course, a rectangular tube will be in such position that the width of the face is horizontal as it is viewed, but this kind of tube may be turned half way around without

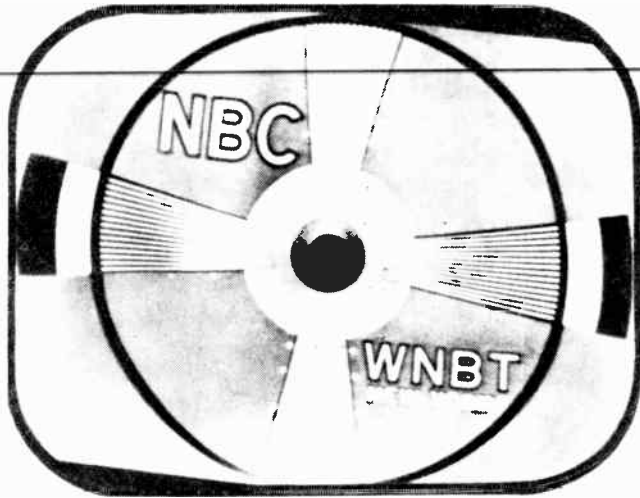

Fig. 12. This pattern is tilted slightly clockwise in the mask. Rotating the yoke counter-clockwise will correct the tilt.

altering the squareness of pictures formed on its screen.

When pictures or a raster do not align squarely within the mask of the cabinet, it is necessary only to loosen the yoke fastenings while rotating the yoke to correct tilting of pictures. Be sure to tighten the yoke fastenings after the operation is completed.

### CENTERING WITH DIRECT CURRENT.

An electron beam is deflected one direction by a magnetic field of one polarity, and the opposite direction by a field of opposite polarity. Field polarities reverse when there is reversal of current in deflecting coils. Were coil current to remain in either direction, without change, the beam would be shifted in the corresponding direction and would remain there.

Assume that there actually is a steady direct current in a pair of deflecting coils. This steady current will move the electron beam off center. In addition to the direct current we shall add the sawtooth alternating current that deflects the beam for pictures. Deflection will extend to equal distances each way from the beam position fixed by the direct current. Pictures or a raster will be centered at the beam position determined by the direct current.

How far pictures are shifted will vary with strength of direct current. The amount

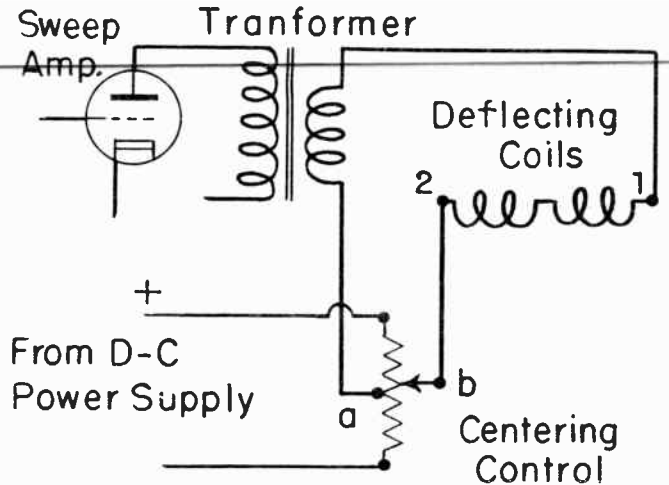

Fig. 13. An electrical centering circuit which allows shifting pictures various distances in opposite directions.

of shift may be controlled by adjusting the direct current. Which direction pictures are shifted will depend on which way the direct current flows in the deflecting coils.

A circuit for electrical centering or centering by means of direct current is shown by Fig. 13. A sawtooth deflecting current is caused to flow in the coils by connecting them to the secondary of a transformer in whose primary circuit is the sweep amplifier tube. Direct current for centering is taken from a control potentiometer having a fixed center tap a in addition to slider b.

Terminal 1 of the deflecting coils remains at a d-c potential proportional to that at center tap a, because of the indirect connection between them. D-c potential at terminal 2 of the coils is the same as at the slider of the control. If the slider is moved toward the more positive end of the potentiometer, the slider and coil terminal 2 become positive with reference to tap a and terminal 1. Direct current then will flow from 1 to 2 through the coils, and pictures will be shifted one direction.

With the slider moved toward the less positive and relatively negative side of the potentiometer, relative d-c polarities at the coil terminals are reversed. Direct current will flow from 2 to 1 through the coils, and pictures will be shifted oppositely to the first direction. D-c potential difference across the

# LESSON 50 – MAGNETIC DEFLECTION

coils, and strength of direct current, depend on how far the control slider is moved away from the center tap. This determines how far pictures are shifted. Which direction the control slider is moved from the center tap determines polarity of the direct current and direction of picture shift.

This type of control on vertical deflection coils will move pictures straight up or down on the screen, not diagonally. When applied to horizontal deflection coils, pictures will be moved straight across the screen. Adjustments are much easier with electrical centering than with other methods.

Fig. 14 shows a practical circuit for both vertical and horizontal electrical centering. The vertical centering circuit and control are the same as just explained. Following the vertical centering potentiometer on the B-power line is a horizontal centering potentiometer. There is no fixed center tap on this control. Relatively positive d-c potential from the top of this potentiometer is applied through the horizontal transformer secondary to the high side of the coils, while a less positive and relatively negative potential is applied from the slider to the low side of the coils.

Direct control potential for horizontal centering always tends to cause d-c flow from bottom to top of the coils in the diagram.

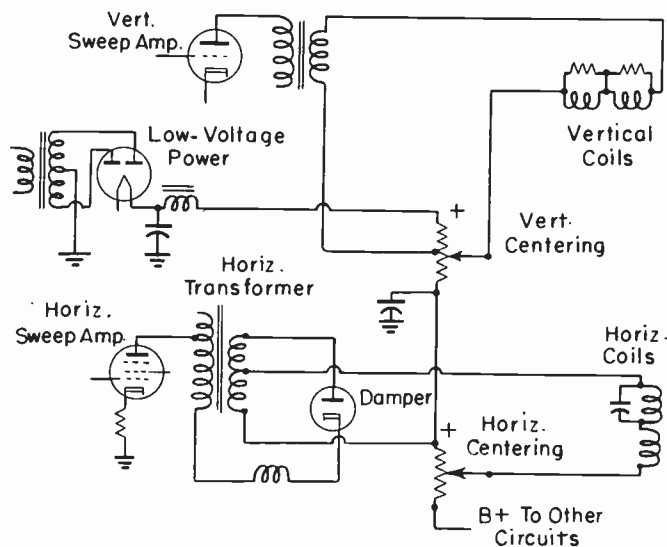

Fig. 14. Vertical and horizontal electrical centering.

Merely changing the strength of the horizontal centering voltage, without altering its polarity, shifts pictures to either the right or left. This comes about because there is another d-c voltage of opposing polarity due to rectified currents and voltage drops in circuits for the damper and horizontal sweep amplifier tubes. These circuits are connected through the transformer and indirectly through ground to the deflecting coils.

The opposing d-c voltage tends to shift pictures always in one direction. The effect of the adjustable horizontal centering voltage is to either reduce or over-balance the opposing d-c voltage. Thus pictures may be shifted either direction.

Electrical centering may be used with electrostatically focused picture tubes, thus avoiding the need for any kind of centering device on the tube neck. This method of centering may be used also with magnetically focused picture tubes. In this latter case, service adjustments are made by placing both electrical centering controls at their mid-positions while tilting the focus coil or shifting a PM focuser to center a raster or picture. Small adjustments of centering thereafter may be made only with the electrical controls until a different picture tube is installed.

## REMOVAL AND REPLACEMENT OF PICTURE TUBES

Whenever you handle a picture tube, wear shatterproof goggles and heavy gloves with leather or other "non-skid" palms and fingers. Allow no unprotected persons near an exposed picture tube. Most technicians commence their careers by following these rules. Few stick to them, but some of these wish they had. Provide yourself with one or more pieces of heavy canvas or duck about a yard square. Wrap a piece loosely around a tube being handled; it would stop most of the flying glass in case of accident. Don't hold a picture tube close against your body when carrying it.

The weakest part of a picture tube is where the neck joins the flare or cone. Therefore, never place any stress on the

## COYNE - *television home training*

neck. Never carry a tube by its neck. Support the weight of a picture tube at the face end, hold the neck only enough to guide the tube into or out of its supports. Also, be sure to support the tube with your hands until it rests firmly in its mountings.

The next weakest part of a picture tube is where the face attaches to the flare or cone. Be exceedingly careful not to bump this part. This precaution applies especially to metal-shell tubes. Of course, no part of a picture tube should be bumped against anything hard, nor should anything hard be allowed to hit the tube. Do not use metal tools of any kind near a picture tube. Avoid scratching the glass, for even a small scratch may start a crack, which becomes a break.

While a picture tube is out of its regular supports rest it only with the face down on a soft surface, such as a piece of folded cloth. Never place a tube so that its weight is on the flare and on the base or neck at the same time.

To remove a tube from its carton place the carton as marked on the outside, whereupon the face of the tube will be up. Lift by placing your hands on opposite sides of the flare or cone just below the face. If possible, keep picture tubes in cartons while removed from a chassis or cabinet. Retain enough cartons for this purpose.

The metal cone or flare and the glass face of metal-shell tubes operate at the full voltage or charge of the second anode. The lip or rim around the face is enclosed by a plastic insulating ring which, in turn, rests on the supports. Sometimes there is an insulating sleeve over the entire metal shell. Over the top of the plastic ring, and part way down its sides, is a band or strap of fabric, plastic, or metal which holds the tube firmly on its supports. You will observe that rectangular metal-shell tubes are supported only at the curved portions of the four corners around the face.

Filter capacitances in the high-voltage circuit for the second anode should be discharged before working around a picture tube in any way. Electric charges may be held for hours, and they can give you a snappy but

not dangerous shock. Your reaction to the shock might be such as to cause accidents.

Discharge a metal-shell tube by holding one bared end of an insulated wire firmly on chassis metal, then touch the other bared end to the metal cone or flare, or to the metal lip if exposed, or to a metal connector which has remained on the lip.

To discharge an all-glass tube, grasp the second anode cable connector by its insulating cover, pull it off the tube, then touch the metal of the connector to chassis metal. Discharge the tube coatings by holding one bared end of the insulated wire on chassis metal, then touch the other end to the anode connection on the tube.

REMOVE CHASSIS WITH PICTURE TUBE FROM CABINET. In most receivers the picture tube is mounted on the chassis, and remains so while the chassis is taken out of its cabinet. Instructions for removal of the chassis and tube as a unit are in the lesson dealing with television alignment.

Before attempting to pull the chassis, make a final examination to see that everything is free and clear. In a few receivers a frame supporting the front of the tube on the chassis is fastened also to the cabinet by threaded studs, from which the nuts must be removed. Bolts or screws holding the chassis in the cabinet may be at the sides or front, accessible only from inside. Chassis mounted on their sides usually slide in grooves on the cabinet wall.

Keep your hands away from the metal shell of a picture tube until high-voltage filter capacitances can be discharged. Do this discharging as soon as the shell of a metal tube can be reached. With any tube, discharge the filters as soon as the chassis is out of the cabinet, if not before.

REMOVE PICTURE TUBE FROM CHASSIS. After the chassis and picture tube are out of the cabinet, take the tube off the chassis as follows. See Fig. 15.

1. Discharge the high-voltage filter capacitances, if not done before.



## LESSON 50 – MAGNETIC DEFLECTION

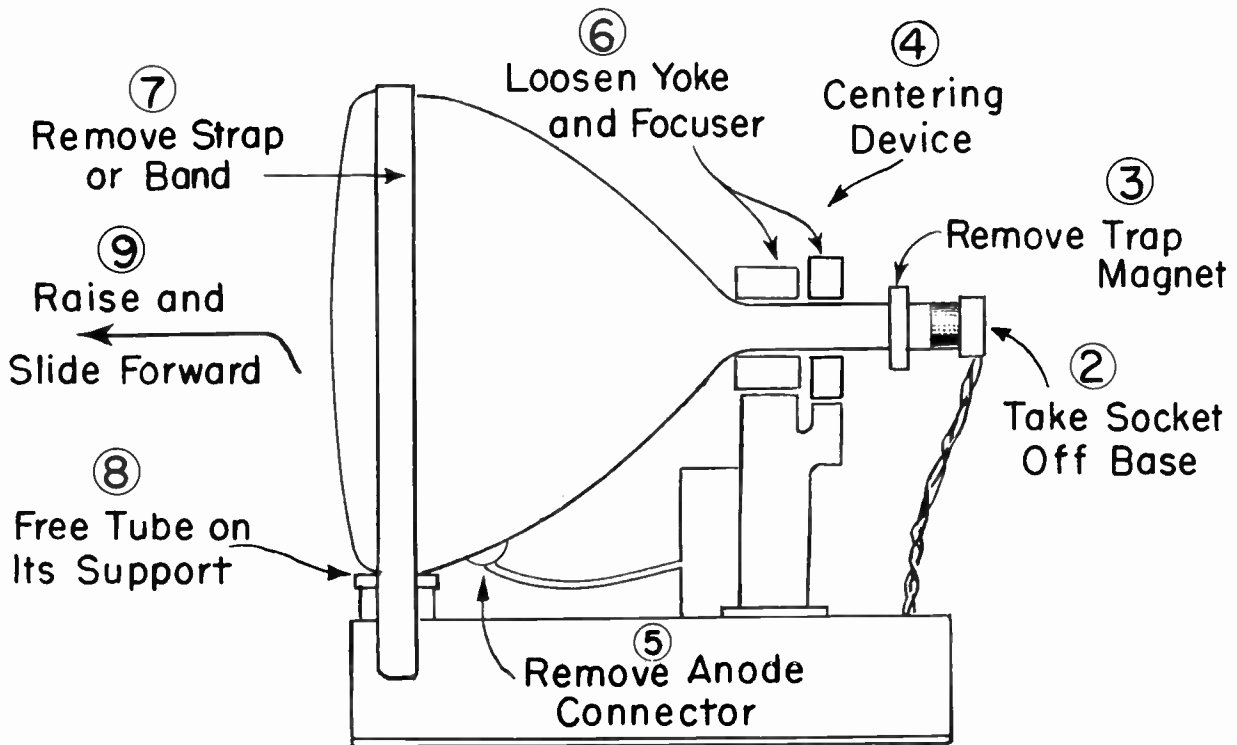

Fig. 15. Steps in removing a picture tube from its chassis.

2. Pull the socket off the picture tube base.

3. Note the position of the ion trap magnet in relation to base pin numbers and distance from the base, then slide the magnet off over the base.

4. Remove a centering device which slides off the neck of an electrostatic focus tube.

5. Note the position of the second anode connector or clip, then take off the anode lead or cable.

6. The deflection yoke and a focus coil or magnet will remain on the chassis. Loosen the supports of these units to allow easy movement of the tube neck and base through them when the tube is withdrawn.

7. Inspect the supports and fastenings for the picture tube on the chassis. There may be a fabric or plastic strap fixed at one end to the chassis and held by a clamp at the other end, or there may be clamps at both ends. There may be a metal band or rod, covered or protected wholly or partially with

insulation. This rod or band may be fastened at one or both ends by threads and nuts, or it may be divided and held together at one side or at the top. In any event, loosen or remove this member so it will be completely out of the way as the tube moves forward.

8. The front of a glass tube or insulation on a metal tube may stick to the chassis supports. Gently rock the tube a little to one side and the other to relieve any sticking, which could cause the tube to let go with a jerk later on. Usually it is necessary to raise the front of the picture tube to clear the supports before the tube will slide forward. In a few receivers it is necessary to loosen the yoke bracket on the chassis and slide this bracket back.

9. Slide the tube forward until the neck and base have come through the yoke. Support the tube chiefly at the front, while guiding the neck and base without exerting undue pressure. Handle the tube as directed earlier.

**REMOVE CHASSIS - TUBE REMAINS IN CABINET.** The picture tube, deflecting yoke, and focus coil or PM focuser if used,

## COYNE - *television home training*

may remain in the cabinet when the chassis is removed. To take out the chassis proceed thus:

1. In the same way as when removing chassis and tube together, remove or disconnect the cabinet back, control knobs, speaker, built-in antenna, and pilot lamp.

2. As when preparing to take a picture tube off its chassis, remove the socket, the ion trap magnet, any centering device which slides over the base, and the high-voltage second-anode cable from the picture tube.

3. Disconnect the cable going from chassis to deflecting yoke, and focus coil it used. This connection usually is with a plug and socket.

4. A ground lead goes from chassis to metal supports holding the picture tube in the cabinet. There may be only a pressure contact, otherwise disconnect the lead.

5. In a few receivers the yoke and focuser must come off the picture tube neck before the chassis will come out of the cabinet. These parts will then be on a mount which is detachable from the tube supporting frame.

6. Make sure that no electrical or mechanical connections remain between the picture tube or its accessories and the cabinet, and that the chassis will clear all these parts. Then take out bolts or screws holding the chassis in the cabinet, and withdraw the chassis.

REMOVE PICTURE TUBE FROM CABINET. The picture tube, yoke, and focuser usually are supported by a cushioned metal frame making these parts a structural unit. The frame fastens to the cabinet with various arrangements of screws, studs, and nuts. It may be necessary to remove the yoke and focuser from the tube neck before fastenings for the tube support are accessible. In some receivers the picture tube and its accessories are on a platform or shelf which slides out of the cabinet after the chassis has been removed.

A picture tube may be removable through the front of the cabinet after the chassis has

been taken out from the rear, or the tube may be removed with the chassis still in the cabinet after all connections between the two have been separated. In general, such removal of the tube requires taking off part of the cabinet molding around the mask, and for removal of the front protective plate of glass or plastic, with or without the mask. It is then possible to free the frame which holds the tube, and to take this frame and the tube from the cabinet. Nuts or screws holding the tube frame may be accessible only from inside the cabinet.

For servicing it is convenient to leave the picture tube in the cabinet while connecting it electrically to chassis circuits. Long extension cables for tube base connections and others for a yoke and focus coil are available from supply stores. At one end is a plug with pins that fit into the socket on the chassis. At the other end is a socket which fits onto the tube base or the connector for yoke and focuser.

If the speaker field coil is used as a filter choke for the low-voltage power supply, the speaker must be temporarily connected to the chassis during service work. Failure to do this before turning on the power may damage the power supply rectifier and also the first filter capacitor. Also, a ground connection must be made from the chassis to a metal frame which supports the picture tube.

REPLACING PICTURE TUBES. Before replacing a tube in its cabinet, clean the face of the tube and the inside of the cabinet window with any good window-washing liquid and soft cloths. Cabinet windows of plastic are easily scratched. Many of the more recent receivers have removable safety windows, allowing cleaning of the window and also the picture tube face without removing the tube. The manner of detaching the safety window depends entirely on the make and model of receiver.

An electrostatic charge is produced on the outside of the picture tube face by electron action on the inside. This charge attracts dust, which clings to the tube face and remains there to build up a dark coating which seriously reduces picture brightness.

## LESSON 50 – MAGNETIC DEFLECTION

There are a number of so-called "anti-static" fluids which may be applied to the outside of the tube face with a soft cloth, and which form a coating that retards collection of dust over long periods. These fluids do not reduce light transmission, but they give the tube face a slightly frosted appearance. This helps to reduce glare from external sources of light.

DISPOSING OF PICTURE TUBES. For certain types of picture tubes there is a "glass allowance", meaning that you can turn in a tube which is electrically defective, but otherwise undamaged, for some credit on the purchase price of a new tube. Other tubes which are to be discarded must be devacuated (internal vacuum relieved) before disposed of. Should anyone be injured by implosion of a tube which you have discarded, you may be held legally liable, and suffer severe financial penalties.

• If a discarded tube is to be destroyed, place it in a regular tube carton tightly closed

or in any strong packing box which may be closed, and drive some piece of metal, such as a pinch bar, through the container to penetrate the flare of the tube.

Should you wish to keep the tube intact, for display or other purposes, place the tube, neck up, in a carton or other strong box. Under the face and all around the tube up as far as the base place plenty of heavy cloths or paper. Then drill a hole down through the end of the locating lug on the center of the tube base. Use a twist drill 1/8 to 3/16 inch in diameter, smaller sizes may snap off when they strike the internal glass or metal. Drive the twist drill with a geared hand drill or an electric drill. Proceed slowly if you wish to avoid displacing the heater-cathode and control grid elements. Even when using an electric drill you can hear the in-rush of air as the tube neck is penetrated. Unless you are absolutely positive of devacuation on the first attempt, drill a second hole to make sure.

