

COYNE
PRACTICAL APPLIED
ELECTRICITY



Refrigeration servicing offers great opportunity for the trained man. This view shows a modern compressor being adjusted. Thousands of these compressors are used in both commercial and household refrigeration units.

COYNE PRACTICAL APPLIED ELECTRICITY

A Set of Complete Practical Books
For Home Study
and
Field Reference
On

Electrical principles, telephones, wiring, meters, D.C. and A.C. motors, controls, and equipment, household appliance repair, Rural Electrification, Armature winding, Generators, Diesel Electric Plants, Automotive Electricity, Batteries, Electrical Refrigeration and Air Conditioning, Industrial Electronics, Radio Electric Welding — laws, rules, etc. — Over 3,000 subjects, 5,000 Electrical facts, thousands of photos and diagrams.

By
THE TECHNICAL STAFF
of the
COYNE ELECTRICAL SCHOOL

Copyright 1945 by
COYNE ELECTRICAL SCHOOL
500 So. Paulina St.
Chicago, Illinois

All rights reserved. This book, or any parts thereof may not be reproduced in any form without written permission of the Publishers.

Printed in United States of America

FOREWORD

ELECTRICITY is the greatest force known to mankind.

ELECTRICITY is leaping ahead at an unbelievable rate. It is moving into practically every part of the world and has become **the most important factor in modern civilization**. Practically every month the Kilowatt hour demand sets a new high—it has been doing this for the past 25 years. **ELECTRICITY**, even though it is one of America's youngest industries, already employs directly and indirectly over 3 million people.

All of our marvelous developments in Radio, Television, Electronics, Radar, etc., employ **electrical** power and the principles of **Electricity**. It is truly **one of the world's greatest industries**.

Because of the tremendous opportunity in the field of **Electricity**, there have been many books written on the subject. Most treat with **one** specific phase of **Electricity**. This set of books—Coyne Practical Applied Electricity (of which this volume you now read is an integral part)—covers the entire field.

This set is **NEW**. It includes the very latest methods and explanations of Electrical installation, operation and maintenance.

COYNE PRACTICAL APPLIED ELECTRICITY WRITTEN BY A STAFF OF EXPERTS

Most Electrical publications are written by **one** man and can therefore **only** cover his own specific knowledge of a subject. **COYNE PRACTICAL APPLIED ELECTRICITY**, however, represents

F O R E W O R D

the combined efforts of the entire Coyne Electrical School Teaching Staff and the assistance of other authorities on the subject. These men have a wide field and teaching experience and practical knowledge in electricity and its allied branches.

HOW THIS SET WAS DEVELOPED

In submitting any material for these books these experts kept two things in mind—1. MAKE IT SIMPLE ENOUGH FOR THE “BEGINNER”—2. MAKE IT COMPLETE, PRACTICAL and VALUABLE FOR THE “OLD TIMER”. All material that was submitted for these books by any individual was then rewritten by an editorial group so that added explanations for the benefit of clarity and easier understanding could be included.

Coyne Practical Applied Electricity can pay you big dividends every day “on the job”. However, if you only use the set occasionally when you **MUST BE SURE** before going ahead on a job—the set will pay for itself many times over.

Coyne Practical Applied Electricity is to an electrician what a set of complete law books is to a lawyer or a set of medical books is to a doctor. Regardless of whether a lawyer or a doctor is “just starting out” or is an “old timer” and has been practicing his profession for many years he has many occasions to refer to his reference books. Many doctors and lawyers spend thousands of dollars on complete sets of reference books—they find it a very wise investment.

In **ELECTRICITY** the need for good reference books is just as great. So, when you make a purchase of this set you are not just buying a set of books—you are making an investment in your future that can pay dividends all your life.



PRESIDENT
COYNE ELECTRICAL SCHOOL

TABLE OF CONTENTS

Electrical Refrigeration and Air Conditioning	1 - 304
Radio	305 - 372
Electrical Refrigeration Principles —	1 - 26
Nature of heat and cold—sensible and latent heat— effect of pressure on evaporation temperatures—heat transfer — refrigeration by evaporation — cycles — questions.	
Refrigeration Systems and Cycles —	27 - 48
Parts, diagrams — open and hermetic sealed units — 2 temperature refrigerators—multiple systems.	
Refrigerator Parts, Construction and Operation —	49 - 80
rotary type compressors—rollator or gear type com- pressors — evaporators—evaporator temperatures—oil bound evaporators—control valves—low and high side floats—valves—capillary tubes—thermostatic expan- sion valves—pressure switch settings—switches—cab- inets—motors—questions.	
Refrigerants and Lubricating Oils —	81 - 99
common refrigerants, sulphur dioxide — testing — methyl chloride—freon—ammonia—carrene—F114— oils — carbon dioxide — methyl formate — symbols — amount of oil needed—questions.	
Absorption Type Refrigerators —	100 - 120
cycle—air cooled absorption unit—intermittent absorp- tion system—installation—flare connections—soldering —questions	
Refrigeration Servicing —	120 - 210
troubles—commercial installations—remedies—com- pressors — discharge valves—bearings—shaft seals— rings—rotary types—float type control valves—control switch troubles — thermostatic controls — evaporator troubles — condensers — discharging — recharging— dehydrators — pressure & temperature—adding oil— liquid line troubles — sludge — filters—service opera- tions — compressor efficiency tests — safety rules— overhauling—motors—questions.	
Motors and Cabinet Troubles —	211 - 248
troubles—capacitor type motors—cabinet repairs— overload relays—tools—multiple installations—2 tem- perature valves—snap action valves—control switches —water cooler and ice cream freezer units—codes— calculating service loads—questions.	
Air Conditioning —	249 - 304
types of systems—heating and cooling of air—dehu- midifying — psychrometers — charts — circulation— ventilation—selecting the proper fan—filtering—blow- ers & ducts—duct installation—heat load calibration— table of air duct sizes—insulation—installation & test- ing—single room coolers—questions.	
Radio —	305 - 372
elements — transmission — reception — receivers — antennas — reactance — impedance — resonance — selectivity — coupling — filter circuits — tuning — diode rectifier—tubes—triodes—grid bias—plate circuit load —pentodes—screen grid tubes—voltage amplification— tube characteristics—symbols—variable mu tubes—de- tectors—complete receivers—beam tubes—superhetero- dyne receivers—volume controls—audio-frequency am- plifiers—stages (limiter and discriminator) frequency modulation — amplifiers — feedback — power sup- plies — circuits.	

ACKNOWLEDGMENTS

We wish to acknowledge and express our appreciation for the assistance and co-operation given by the following companies, in supplying data and illustrations for the preparation of this Electrical Set.

GENERAL ELECTRIC COMPANY
WESTINGHOUSE ELECTRIC & MFG. CO.
ALLIS CHALMERS MFG. CO.
POWER PLANT ENGINEERING JOURNAL
AMERICAN BROWN BOVERI CO.
CUTLER HAMMER, INC.
PHILADELPHIA ELECTRIC CO.
EDISON STORAGE BATTERY CO.
PHILADELPHIA BATTERY CO.
WALTER BATES STEEL CORP.
FAIRBANKS MORSE CO.
HOSKINS MFG. CO.
ALLEN-BRADLEY CO.
DELTA STAR MFG. CO.
NATIONAL CARBON CO.
CENTRAL SCIENTIFIC CO.
OHIO BRASS CO.
GRAYBAR ELECTRIC CO.
WELSH SCIENTIFIC CO.
CENTRAL SCIENTIFIC CO.

You will note that in some places in this Set we have explained and shown illustrations of some of the earlier types of Electrical equipment.

WE HAVE A DEFINITE REASON FOR DOING THIS, namely, many of the earlier units are much easier to understand. An important point to keep in mind is that the **BASIC PRINCIPLES** of these earlier machines are the same as those of the modern equipment of today.

Modern equipment has not materially changed in principle—**IT IS MERELY REFINED AND MODERNIZED.** It is from the earlier basic theories and simple beginnings that the complicated mechanisms of today have been developed. **IT IS TO THESE EARLY BEGINNINGS WE MUST OFTEN TURN IN ORDER TO GET A FULL UNDERSTANDING OF THE PRESENT ADVANCED TYPES OF EQUIPMENT.**

In the early days many of the parts and mechanism of Electrical equipment were visible whereas today much of it is not. However, the **PRINCIPLES OF THE EARLY EQUIPMENT ARE SIMILAR TO THOSE OF MODERN ELECTRICAL APPARATUS.**

SO IN VARIOUS PLACES IN THIS SET, WE SHOW YOU SOME OF THIS EARLIER EQUIPMENT BECAUSE ITS CONSTRUCTION IS SIMPLER AND EASIER TO UNDERSTAND AS YOU STUDY THE MODERN EQUIPMENT. THEN FROM THESE EARLIER TYPES OF EQUIPMENT WE CARRY YOU ON TO THE VERY LATEST DEVELOPMENTS IN THE FIELD.

HOW TO USE THIS SET OF BOOKS

Coyne Practical Applied Electricity will be of use and value to you in exact proportion to the time and energy you spend in studying and using it.

A Reference Set of this kind is used in two distinct ways.

FIRST, it is used by the fellow who wishes to make Electricity his future work and uses this Reference Set as a home training course.

SECOND, it is especially valuable to the man who wishes to use it strictly as a Reference Set. This includes electricians, mechanics or anyone working at any trade who wishes to have a set of books so that he can refer to them for information in Electrical problems at any time.

You, of course, know into which group you fall and this article will outline how to properly use this Set to get the most value for your own personal benefit.

How To Use This Set As A Home Training Course In Electricity

The most important advice I can give the fellow who wishes to study our set as a home training course in Electricity is to start from the beginning in Volume 1; and continue in order through the other 6 volumes. Don't make the mistake of jumping from one subject to another or taking a portion of one volume and then reverting back to another. Study the set as it has been written and you'll get the most out of it.

Volume 1 is one of the most important of the entire Set. Every good course of training must have a good foundation. Our first volume is the foundation of our course and is designed to explain in simple language terms and expressions, laws and

How To Use This Set of Books

rules of Electricity, upon which any of the big installations, maintenance and service jobs are based. So, become thoroughly familiar with the subjects covered in the first volume and you will be able to master each additional subject as you proceed.

One of the improvements we made in this set was to add "review" questions throughout the books. You will find these questions in most cases at the end of a chapter. They are provided so "beginners" or "old timers" can check their progress and knowledge of particular subjects. Our main purpose in including the "review" questions is to provide the reader with a "yardstick" by which he can check his knowledge of each subject. This feature is a decided improvement in home study material.

Above all, do not rush through any part of these books in order to cover a large amount at one time. You should read them slowly and understand each subject before proceeding to the next and in this way you will gain a thorough understanding as you read and think it out.

For the special benefit of the fellow desiring to learn Electricity at home, we have prepared a great number of diagrams and illustrations. Refer to these pictures and diagrams in our books regularly.

How To Use Coyne Practical Applied Electricity Strictly As A Reference Set

The man who is interested in using these books mainly for reference purposes will use it in a little different way than the fellow who is trying to learn Electricity as a trade. Some of the types of fellows who use this set strictly for reference purposes are: home owners, electricians or mechanics, garage owners or workers, hardware store owners, farmers or anyone who has an occasional use for electrical knowledge. Those types of fellows should use this set in the following manner.

If some particular type of electrical problem presents itself, refer immediately to the **Index**—it will give you the section, in which the subject is covered.

How To Use This Set of Books

Then, turn to that section and carefully read the instructions outlined. Also read any other sections of the set mentioned in the article. As an example, in checking over some information on electric motors, some reference might be made to an electrical law of principles contained in Volume 1 of the Set. In order to thoroughly understand the procedure to follow in working out the electrical problem, you should refer to Volume 1 and get a better understanding of the electrical law on principles involved.

Use The Master Index To Locate Electrical Subjects

Thousands of men use this Set in their daily problems, both on the job and around the home as well. If you follow the instructions outlined you will be able to locate any information you may want at any time on your own electrical problems.

And here's a very important point. Although this set of books starts in Volume 1 and proceeds through the other 6 volumes in order, it makes an ideal home study course—nevertheless, **any individual book in the series is independent of the others and can be studied separately.** As an example, Volume 3 covers D.C. motors and equipment. If a man wanted to get some information on D.C. machines **only** he could find it **completely covered in this volume** and it would not be essential to refer to any other volume of the set unless he wanted some additional information on some other electrical principle that would have a bearing on his problem.

This feature is especially beneficial to the "old timer" who plans to use the set mainly for field reference purposes.

We believe, however, that the entire set of 7 volumes should be read completely by both the "beginner" or the expert. In this way you get the greatest benefit from the set. In doing so the experienced Electrician will be able to get very valuable information on subjects that he may have thought he was familiar with, but in reality he was not thoroughly posted on a particular subject.

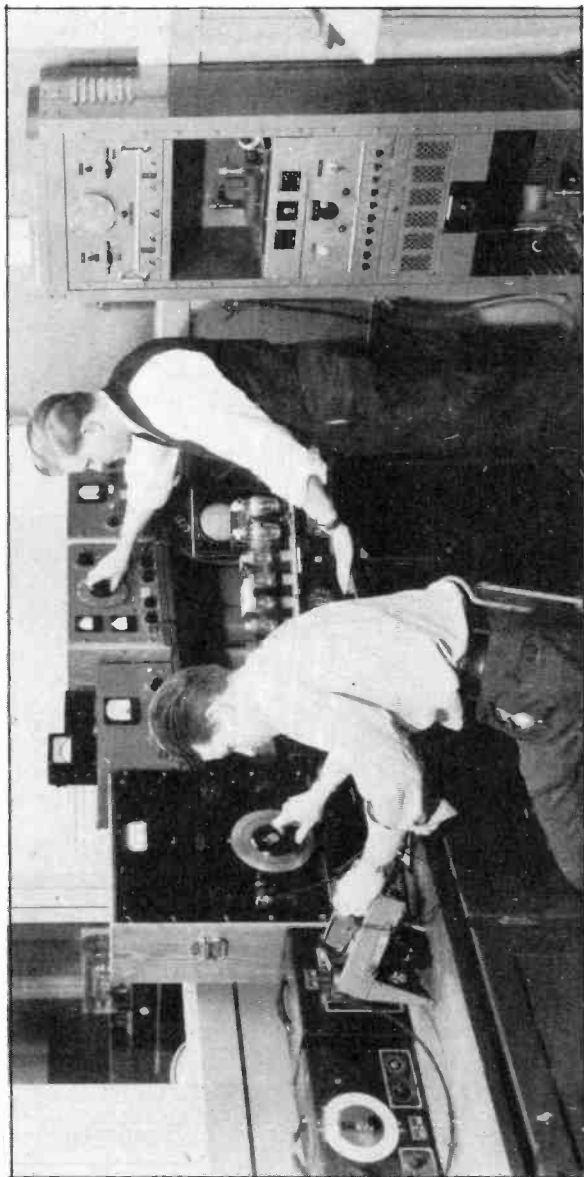

This modern test room in one of America's largest radio manufacturing plants includes equipment for testing all parts of radio and sound equipment. The subject of Radio for the Electrician is covered in the last chapters of this volume.

ELECTRIC REFRIGERATION AND AIR-CONDITIONING

During the past few years Electric Refrigeration and Air-Conditioning have rapidly grown to be one of the greatest industries in this country. The speed with which this great new industry has developed is almost unbelievable.

Up to 1925 there were only 75,000 electric refrigerators installed in the United States. In 1926, over 210,000 more units were added, and in 1927, sales jumped to 390,000 units. In 1931, over 965,000 more homes were equipped with electric refrigerators.

During the depression, this great industry continued to expand, and in 1935, the new units installed reached 1,688,600. Then, in the single year of 1936, over 2,000,000 more electric refrigerators were added bringing the total to over 10,000,000 of these machines in use in this country. Since then the Refrigeration Industry has continued to grow and develop at an amazing pace. Note the chart in Fig. 3, which clearly shows this sensational rate of growth in the number of household refrigerators made and sold each year.

This tremendous growth of the electric refrigeration industry has created an enormous demand for trained men in the manufacturing, installing and servicing of these interesting machines.

There are still many millions of electrically wired homes that have no electric refrigerators, and the number of these units in service will undoubtedly be doubled within the next few years.

Just try to picture the number of men required to install and service all these units and you will realize the splendid opportunities that exist in this field for trained service men to work at interesting good paying jobs for refrigeration companies and shops, or to start a service shop or business of their own.

In addition to the millions of refrigerators now used in homes, there are also many thousands of large refrigeration machines in use in ice plants, meat packing and food storage plants, refrigerated railway cars, refrigerated trucks, ice cream plants, food freezing plants, meat markets, stores, restaurants, etc.

Refrigeration Principles

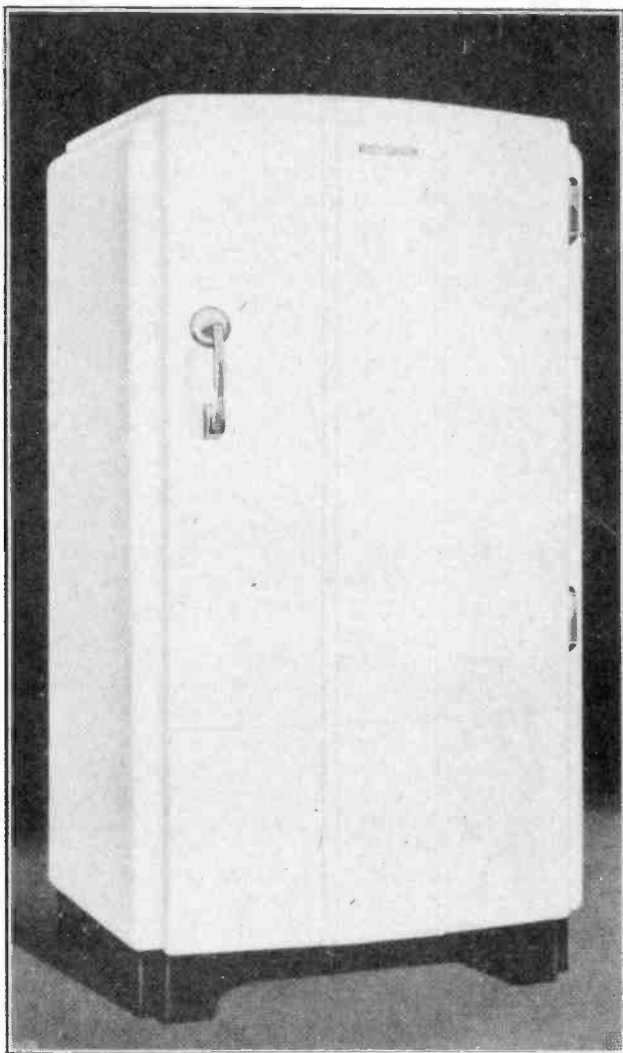

Fig. 1. Photograph of a modern electric refrigerator for domestic or home use. Note the beautiful cabinet design, which has been one of the factors in the great popularity and great number of sales of units of this type. The food storage compartment and operating mechanism are completely enclosed within the cabinet. Courtesy General Electric Company.

Electric Refrigeration

Air-conditioning is another great new field which has developed from Refrigeration, and although its real growth has only started within the last several years, it has already become a great industry employing thousands of trained men. And the work



Fig. 2. Another view of a modern electric refrigerator with the door open showing the cooling unit in the top of the cabinet, and some of the various food articles which can be stored and preserved in electric refrigerators. Courtesy General Electric Company.

in this fascinating new field is only just well begun. Homes, offices, stores, hotels, restaurants, theatres, schools, radio studios, hospitals, and even factories and manufacturing plants are being air-conditioned, for summer cooling, winter heating, and year-round washing, filtering, and humidity control of the air we breath and live in. Fig. 6 shows a convenient type of room cooling unit, and Fig. 7 shows a central air-conditioning plant located in the basement of a building.

Refrigeration Principles

Air-conditioning has become a necessity in the manufacture of many articles, and to increase business in many hotels, stores, theatres, restaurants, and other commercial establishments.

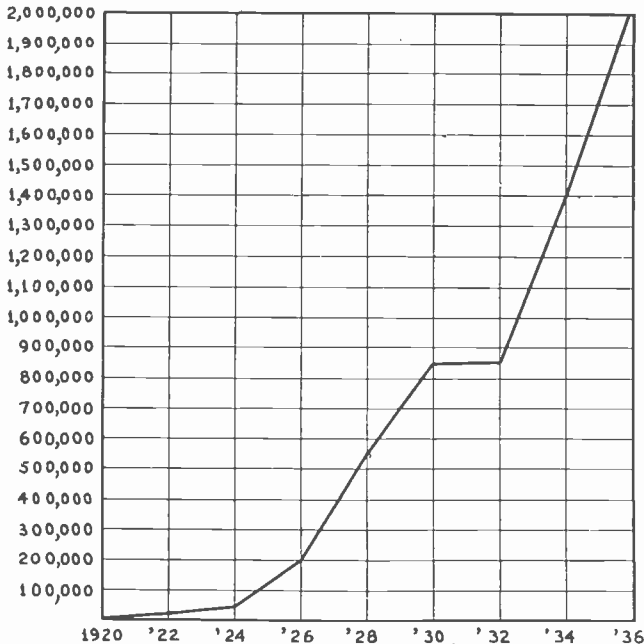

Fig. 3. The above chart graphically shows the rapid and almost continual rate of growth of the vast electric refrigeration industry. Note that in a period of only ten years, the number of yearly sales of household refrigerators increased from 200,000 per year to over 2,000,000 per year.

The increased efficiency and improved health of employees in air-conditioned plants is making air-conditioning essential and economical from this angle. The increased comfort and improved health provided by the clean, crisp, cool air in homes in the summer, is creating a demand for air-conditioning in thousands of homes each year. It will only be a short time before millions of average homes are equipped for comfort cooling in the summer, just as they are for comfort heating in the winter.

Air-conditioning systems use refrigeration machines to cool the air, and both electric refrigerators and air-conditioners use electric motors, electric

Electric Refrigeration

temperature controls, electrically operated valves, fuses, switches, etc. Therefore, a combination training in Electricity, Refrigeration and Air-Condition-

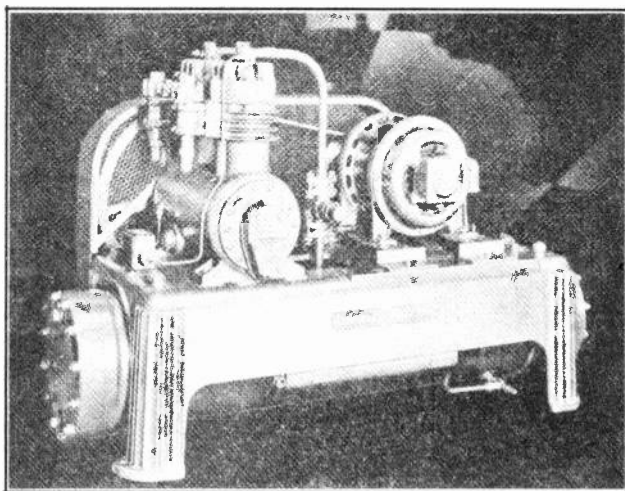

Fig. 4. Photograph of a multiple cylinder electric refrigeration machine for commercial use. Note how the electric motor drives this compressor through a "V" belt connection. Also note the condenser cylinder underneath the frame. Many trained refrigeration men are needed to install and service such equipment. Courtesy General Electric Company.

ing should help to qualify you for a real job in this field.

So study these lessons carefully and thoroughly. **A good refrigeration service man must know the fundamentals of Refrigeration.** He must know how the equipment works and why it works, in order to know what is wrong when it does not work.

1. WHAT IS REFRIGERATION?

Refrigeration is the process of reducing the temperature of a certain body or space by removing some of the natural heat.

For hundreds of years people have been trying to cool certain objects or bodies below the temperature of the atmosphere. Early attempts were rather crude, and limited to only a few degrees of temperature reduction.

Liquids and foods were often placed in cool caves where the sun's heat could not reach them and

Refrigeration Principles

where cool water and the process of natural evaporation kept them cooler than the surrounding air.

It was found that evaporation of perspiration or moisture from the human body reduced the surface temperature and carried away the body heat much more rapidly. Liquids were kept cool by placing them in slightly porous stone jars, through which part of the liquid continuously evaporated, thus cooling the remainder.

Snow and ice were often saved from winter seasons and used in the hot summer months to preserve food and to cool beverages. In more recent years, ice became quite commonly used in ice boxes in the average home, and commercial harvesting, storage, and sale of ice became an extensive industry.

Then, with the development of mechanical refrigeration equipment, the manufacture of ice for use in ice boxes in city homes became a substantial industry. Ice is still used in some homes, but it has the disadvantage of not maintaining an even temperature in the ice box, and of being rather messy and inconvenient due to the necessity for frequent ice replacement and the disposal of the water from the melted ice.

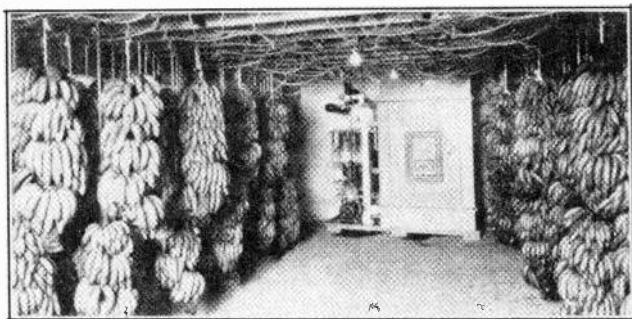

Fig. 5. Interior view of a refrigerated room used for cooling and storing fruits. Note the refrigeration unit in the background. Courtesy York Ice Machine Corporation.

The development of the electric refrigerator has provided a much more convenient, efficient and economical refrigerating unit for home or commercial use. Its popularity and efficiency, as well as practical necessity, are borne out by the tremend-

Electric Refrigeration

ous growth in the number of units sold in the past few years. Figs. 1 and 2 show views of one popular make of modern household refrigerator.

The principal reason for refrigeration is, of course, the preservation of food such as meats, fruits and vegetables, which will rapidly spoil and

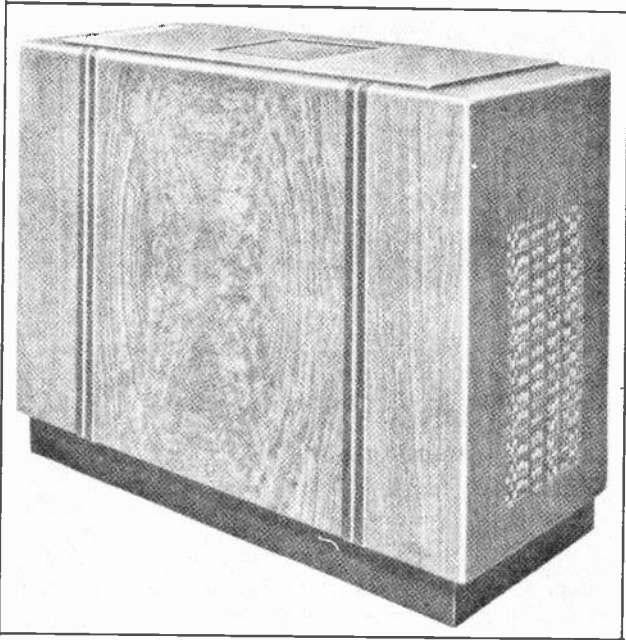

Fig. 6. This view shows a room cooling unit for air-conditioning small offices or rooms in the home. Such units provide cool, clean, crisp air for more comfortable and healthful working and sleeping conditions. The electric refrigeration unit which cools the air, and the circulating fans are enclosed within the decorative cabinet. Courtesy Westinghouse Electric & Mfg. Corporation.

decay if kept in warm places. This spoilage is caused by the growth of bacteria which can only thrive or multiply at warm temperatures. Bacteria cannot develop at temperatures below 40 to 45 degrees F. (Fahrenheit). Fig. 2 shows a variety of food articles that can be preserved in a refrigerator in the home, and Fig. 5 shows a refrigerated cold storage room for preserving fruits.

The modern electric refrigerator can be set to maintain these proper food preserving temperatures

Refrigeration Principles

very accurately, and will also provide much lower temperatures, even below zero F. (Fahrenheit), for freezing of ice cubes, ice cream, or other desserts. These machines will provide this service at a cost of a few cents a day and with reliable operation over years of time with very little service or attention. Very often the saving on food spoilage, and the ability to buy and store larger quantities of foods will, in a period of several years, more than pay for the cost and operation of an electric refrigerator.

2. NATURE OF HEAT AND COLD

In order to obtain a proper understanding of refrigeration principles, it is necessary to first understand the nature of heat and cold.

Heat is a form of energy, or molecular activity, and is present to a certain degree in all things. The hotter any material becomes, the faster the motion of the molecules of which all substance or matter is composed. Heat is supplied to the earth by the sun's rays, and is also produced by oxidization or burning of combustible materials. All atmosphere or air contains a certain amount of heat even on the coldest winter day. All ordinary materials and bodies, whether in solid, liquid, or gaseous state, contain a certain amount of heat. If enough heat is applied, it will cause solids to melt into a liquid state, and if still more heat is applied, the liquid will boil and change into a vapor. For example, ice melts into water, and water boils and evaporates into steam. See Fig. 9.

Cold is merely the absence of heat, or rather a partial absence of heat, because, although we may extract most of the heat from a body or space, it is not possible by any known means to remove quite all of the natural heat.

We are accustomed to thinking of zero temperature as a point 32 degrees below the freezing point of water, which is the coldest temperature that can be obtained by a freezing mixture of ice and salt. However, the theoretical absolute zero is 459.6 degrees, or approximately 460 degrees below zero on the Fahrenheit scale. This is the temperature at

Electric Refrigeration

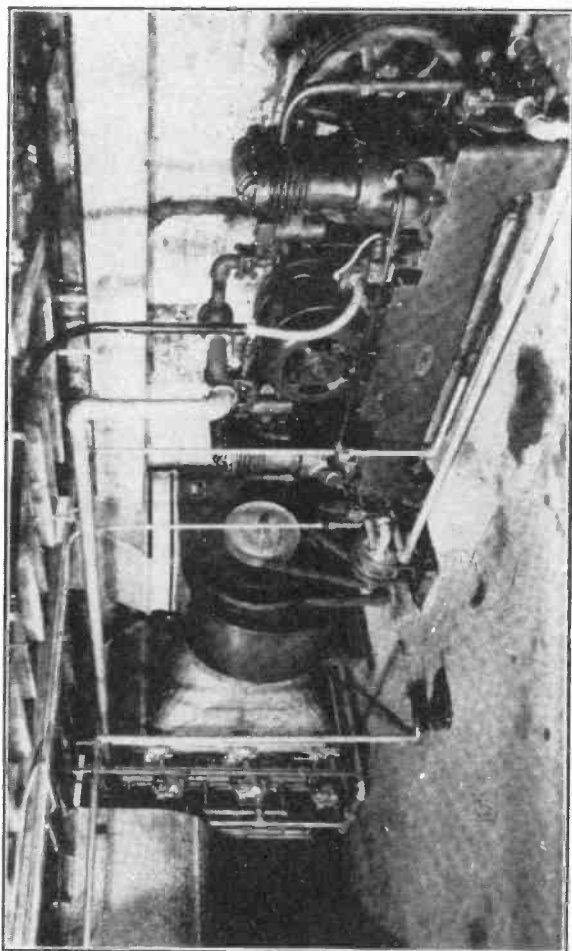

Fig. 7. Photograph of a centrally located air-conditioning plant. Note the electric motor-driven double unit compressor on the right and the air washing and circulating equipment on the left. Many plants of this type are now in use in homes, stores, restaurants, theatres, etc. Photo—Courtesy York Ice Machine Corporation.

Refrigeration Principles

which there would be no movement of the molecules of any matter or material if it were cooled to that low temperature.

In order to better understand and deal with heat, we must have a unit for measuring it. The standard unit of heat is the British Thermal Unit, or B.T.U. This unit refers to the **quantity** of heat contained in a given space or volume of any material.



Fig. 8. Interior view of a modern air-conditioned lunch-room. Note the air delivery ducts and openings along the ceiling. Air-conditioned eating places are much more popular and generally do a much greater business than those that are not so equipped. Courtesy York Ice Machine Corporation.

The standard B.T.U. is the amount of heat required to raise the temperature of one pound of water one degree F.

When the ice in Fig. 9 melts, it absorbs heat from the surrounding air and cools the air. When the water in the pan boils it absorbs heat from the burner flame.

The more a given quantity of heat energy is concentrated in one spot, the higher the **temperature** becomes. Temperature is measured in degrees. There are two scales of temperature measurement called the **Fahrenheit** and the **Centigrade** scales. The Fahrenheit scale is the one most commonly used on ordinary thermometers. The thermometer

Electric Refrigeration

is a convenient device to measure the temperature by the expansion of mercury or some liquid in a thin glass tube which has a scale marking on the glass or mounted alongside it. See Fig. 10 which shows a comparison of the Fahrenheit and Centigrade thermometers.

3. HEAT TRANSFER

Heat energy follows a natural law in that it **always tends to flow from bodies of higher temperature to those of lower temperature.**

Heat can be transferred from one material or space to another by three methods known as **conduction, convection and radiation.** Heat conduction refers to the flow of heat through the molecules of solids. An example of heat transfer by conduction is demonstrated in the flow of heat to the handle of a teaspoon when one end is immersed in a cup of hot liquid, or in the heating of the handle of a frying pan where the pan is held over a fire. Most metals are good conductors of heat, copper and brass being much better conductors than iron or lead. See Fig. 11-A.

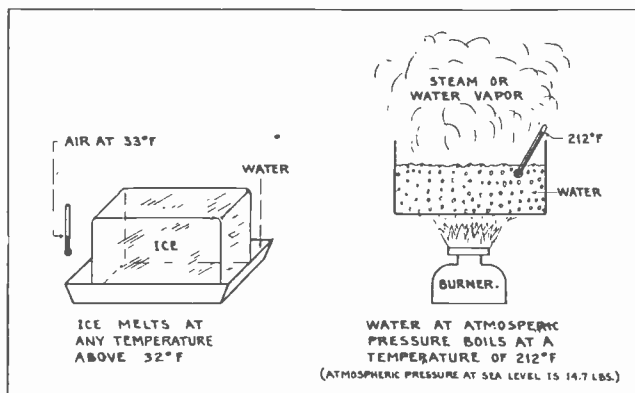

Fig. 9. The above illustration shows how the absorption of heat by ice will cause it to melt into water. Also how the further absorption of heat by the water will cause it to evaporate into steam or water vapor.

Heat transfer by **convection** means the carrying of heat from one place to another by the actual movement or circulation of heated air, water, or other gases or liquids and can be accomplished by

Refrigeration Principles

the natural circulation of air or water when heated. See Fig. 11-B. Heat transfer by convection can also be accomplished by setting up air currents around a hot object by means of a fan, or by circulating currents of water or other liquids around a hot object or material. A hot air furnace for home heating is an excellent example of heat transfer by convection.

Heat **radiation** is demonstrated by the heat rays or waves which are thrown off through space by the sun, by a hot stove or fire place, an incandescent light bulb or other highly heated object. Such heat rays being very similar to light rays, except of lower frequency and longer wave length. See Fig. 11-C. When heat energy is radiated through space, it may not heat the space through which it passes, but does heat up objects which the heat rays strike.

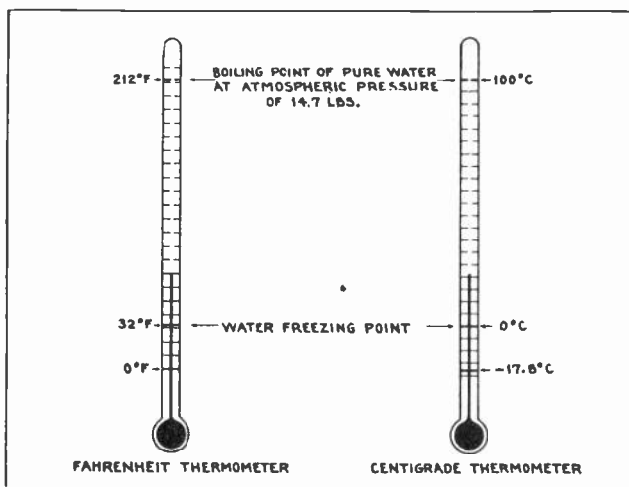

Fig. 10. Diagram showing the comparison between Fahrenheit and Centigrade thermometers. Carefully note how the zero points, freezing points and boiling points compare on these two scales.

If one end of an iron bar is heated red-hot in a flame and then withdrawn, it will lose its heat by all three methods, radiation to the surrounding air, convection by surrounding air currents, and conduction to the cooler end of the bar and anything with which it may be in contact.

Electric Refrigeration

Although there is no perfect insulator of heat, some materials are such poor heat conductors that

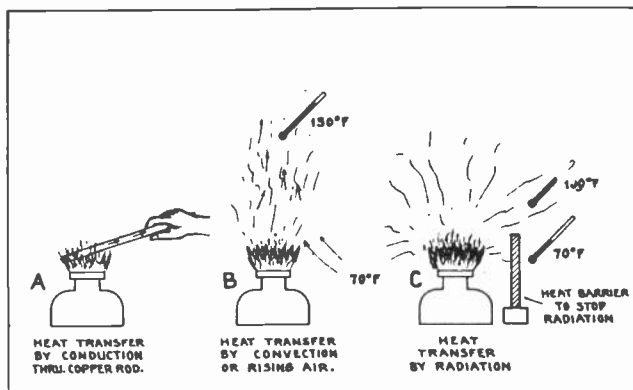

Fig. 11. The above illustration shows three different methods of heat transfer, by conduction, convection and radiation. Examine these illustrations closely while studying the accompanying explanations in the lesson material.

we term them **heat insulation materials**. Cork, sawdust, asbestos and some other fibrous and porous materials are good heat insulators. Such materials can be used to hold most of the heat in a certain space or to exclude most of the heat from a certain space. The space within the hollow walls of refrigerators cabinets is generally filled with some such heat insulating material.

4. SENSIBLE HEAT AND LATENT HEAT

The heat which we can feel or detect with our senses is known as **sensible heat**. For example, if water is heated over a flame, one can feel or detect the rise or increase in temperature by immersing your finger in the water. In other words, when the temperature of a liquid or any substance rises, sensible heat is being absorbed, or as the temperature of a substance drops, sensible heat is being given off.

The term **specific heat** refers to the relative capacity of a substance for absorbing heat. Water is taken as a standard and is given a specific heat of 1.00. As a comparison the specific heat of cast iron is .1298, ice has a specific heat of .502, copper .093, brass .09, gasoline .535, methyl alcohol .6, etc.

Refrigeration Principles

The specific heat rating of any substance indicates the quantity of heat that would be required to raise the temperature of a given quantity of the material one degree in temperature. For example, it requires only half as much heat to raise the temperature of a pound of ice one degree as would be required to raise the temperature of a pound of water the same amount.

We can determine the amount of heat needed to effect a certain change in temperature of any substance by multiplying the weight of the substance by its specific heat and by the temperature increase desired.

The term **latent heat** refers to the amount of quantity of heat that is required to **change the physical state** of a substance from a solid to a liquid, or from a liquid to a vapor, **without changing the temperature of the substance.**

For example, it requires 144 B.T.U.'s to change one pound of 32 degree ice to one pound of 32 degree water. In other words, a certain amount of heat is needed to change any solid to a liquid without any rise in temperature.

The foregoing example illustrates the **latent heat of fusion** or melting of the ice. The **latent heat of evaporation** refers to the amount of heat required to change a liquid to a vapor. For example, it requires 970 B.T.U.'s to change one pound of 212 degree water into steam at 212 degrees.

Therefore, we note that although one B.T.U. is required to raise the temperature of a pound of water one degree F., it actually requires nearly one thousand times as much heat to convert a pound of water into steam at no appreciably higher temperature.

This is an important point to remember, that a **considerable amount of heat must be added to cause a substance to undergo a physical change from a solid to a liquid or from a liquid to a vapor.** This latent heat is stored in the substance and again given off when the substance changes back to its original state by cooling.

The term **condensation** refers to the process of changing a vapor or gas back to a liquid. When this happens, the substance gives off the same

Electric Refrigeration

amount of latent heat as it required to change it from a liquid to a vapor. If we chill steam or absorb the heat from it, it will condense back into water. When warm moist air is passed over a cold water glass or cold metal pipes, some of the moisture will condense in the form of water drops on the surface of the glass or pipe.

5. EFFECT OF PRESSURE ON EVAPORATION TEMPERATURES

You undoubtedly know that ordinary water boils or evaporates at a temperature of 212 degrees, when under atmospheric pressure. It is also commonly known that atmospheric pressure, or the weight of air at sea level, is about 15 pounds per square inch. (14.7 lbs. to be more exact.) The air pressure on top of a high mountain or up several thousand feet in an airplane is much less than 14.7 lbs.

Any pressure lower than atmospheric pressure is called a vacuum, or more correctly a partial vacuum. Vacuum is measured in inches on a mercury column in a glass tube, by the action of air pressure against gravity, causing the mercury to rise in the tube. A perfect vacuum or absence of all pressure is calculated to be 30 inches on the mercury column. Commercial pumps and equipment can produce a vacuum of over 29 inches.

If water is placed in a closed container and the pressure upon the surface of the water increased to 25 pounds per square inch, then the water will not boil or evaporate until a temperature of 267 degrees F. is reached. If we reduce the pressure on the water below atmospheric pressure, say to a 10 inch vacuum, it will then boil at 192 degrees F. See Fig. 12.

Keep in mind this important rule, that **the higher the pressure on any liquid, the higher will be its boiling point.**

There are other liquids or chemicals which boil at temperatures much lower than the boiling point of water. For example, sulphur-dioxide, a chemical commonly used in refrigerators, will boil at a temperature of 14 degrees F. at atmospheric pressure. This is 18 degrees below the freezing point of water.

Refrigeration Principles

At 56 lbs. pressure, the boiling point of sulphur-dioxide is 90 degrees F. Under a 9 inch vacuum sulphur-dioxide will boil at zero F., and under a 21 inch vacuum, it will boil at -30 degrees F., or

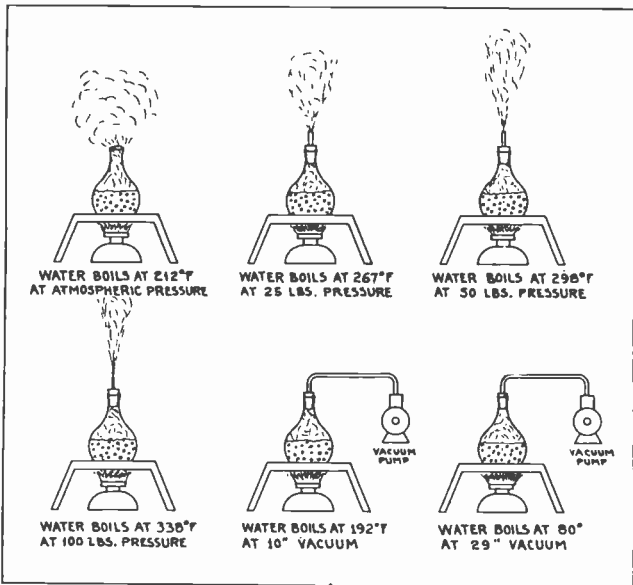

Fig. 12. The above sketches show the very important effects of pressure and vacuum on the boiling point of water. Keep this important principle well in mind.

30 degrees below zero. Ammonia, which is also used in commercial refrigerators will boil at a temperature of 27 degrees below zero F., at atmospheric pressure.

Because of the very definite effect which pressure has on the boiling points of various liquids, it is important for you to understand the relationships between pressure and boiling points, and also to know how to measure vacuum and pressure.

Pressures of air, steam, water or any liquid or vapor can be conveniently measured in lbs. per square inch, by means of common pressure gauges such as shown in the upper view in Fig. 13. You have undoubtedly seen or used such gauges on air compressors, steam boilers or water pumps.

These gauges are operated by the pressure of the air, steam or liquid on a thin metal diaphragm or

Electric Refrigeration

bellows, or on a curved metal tube, against the action of a spring or the tension of the springy metal. The movement of the diaphragm or curved tube under application of pressure is transferred

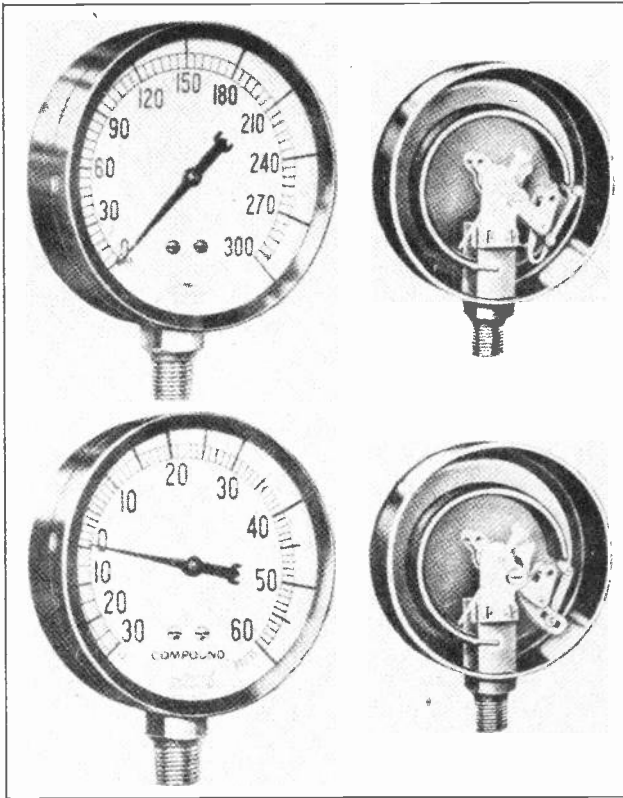

Fig. 13. In the upper view is shown a common type of pressure gauge used for measuring pressures of refrigerant gases and thereby determining operating conditions of refrigeration machines. In the lower view is shown a compound pressure and vacuum gauge such as commonly used by refrigeration service-men. Courtesy J. P. Marsh Corporation.

by mechanical connection to a needle or pointer which in turn moves over a marked scale to indicate the pressure in lbs. per square inch.

In the gauges shown in Fig. 13, a semi-circular tube of oval cross section is employed as the active element. This tube is closed at one end, the open

Refrigeration Principles

end being connected, through the fitting at the bottom, to the source of pressure to be measured. As gas is admitted to this blind-ended tube, the pressure of this gas causes the tube to straighten, and this motion is communicated through a rack and pinion mechanism to the pointer on the dial. It is particularly important to note that the reading of the gauge is an indication of the **difference** between the pressure **inside** the gauge tube, and the pressure **outside** the gauge tube. In other words, the ordinary pressure gauge indicates the **Difference in Pressure** between the inside and outside of the tube. Lowering the pressure on the outside of the gauge tube will have exactly the same effect as raising the pressure inside the gauge tube. This explains why a gauge attached to a given drum will read higher when it is located several thousand feet above sea level than the same gauge will read on the same drum at sea level. The pressure on the outside of the gauge tube is atmospheric pressure and, as this pressure falls with increasing elevation above sea level, the gauge reading increases even though the pressure of the gas inside the gauge tube has not changed, because the **difference in pressure** between the inside and the outside of the tube has been increased by lowering the pressure on the outside of the tube. Readings of high accuracy therefore demand consideration of the elevation at which the gauge is used.

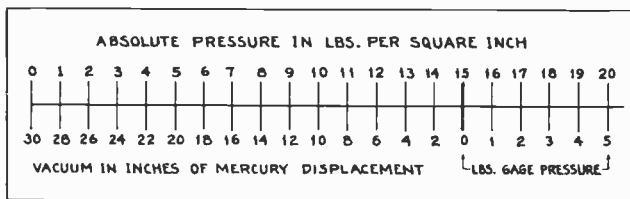
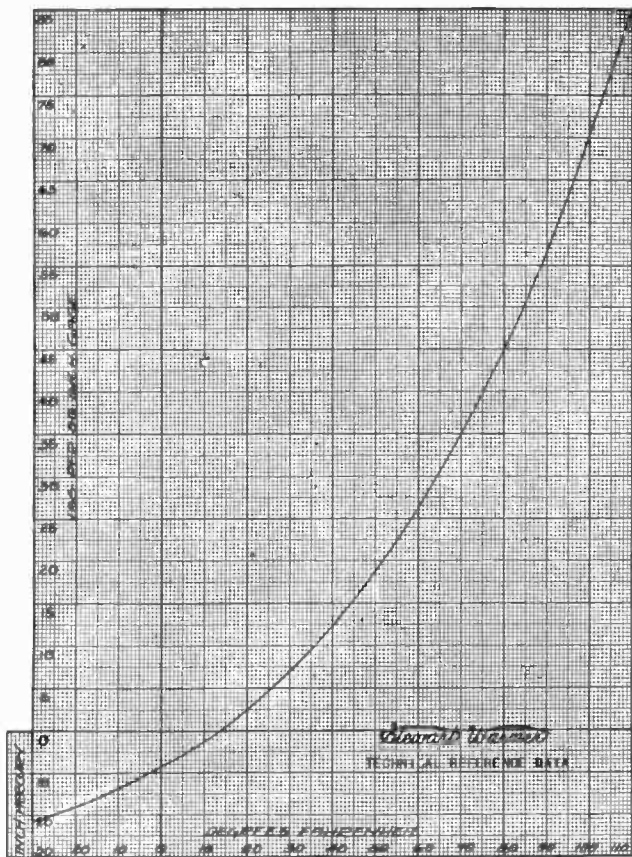

Fig. 14. This diagram shows relation between inches vacuum and pounds absolute pressure. Note that gauge pressure starts at 15 pounds absolute pressure.

Ordinary pressure gauges, of course, only indicate pressures above atmospheric pressure, because ordinarily atmospheric pressure affects both sides of the gauge diaphragm or tube equally. Therefore, the zero "0" point on an ordinary pressure gauge

Electric Refrigeration

really starts at 15 lbs. atmospheric pressure, and a gauge pressure reading of 25 lbs. would mean 25 lbs. above atmospheric pressure, or 15 plus 25 equals 40 lbs. absolute pressure. Absolute pressure equals gauge pressure plus 15.



Sulphur Dioxide Pressure-Temperature Curve

Fig. 15. Chart showing the boiling point of sulphur-dioxide (SO₂) refrigerant at various pressures and vacuums. Refer to this chart often while studying about pressures and evaporation. Courtesy Stewart-Warner Corporation.

A perfect vacuum or complete absence of all pressure (if such were possible to obtain) can also be called zero absolute pressure. It so happens that a cubic inch of mercury weighs about $\frac{1}{2}$ lb., and

Refrigeration Principles

therefore each inch of mercury displacement on the mercury vacuum gauge is equal to approximately $\frac{1}{2}$ pound pressure per square inch. The scale or chart shown in Fig. 14 shows the relations between inches vacuum from 30 inches to zero, and lbs. pressure from zero absolute to 15 lbs. absolute, or atmospheric pressure.

Gauges can also be made to indicate vacuum or pressures below atmospheric pressure by arranging a diaphragm or tube for double action, to be moved one way by pressure and the other way by suction or vacuum. See the lower view in Fig. 13. The pointer is arranged to set at zero for atmospheric pressure and moves to the right of zero to indicate lbs. pressure per square inch, and to the left of zero to indicate vacuum in inches. Such gauges are called **compound gauges** and are very convenient for use in refrigeration testing and service.

(Note: wherever the term pressure is used in these lessons it refers to gauge pressure, unless otherwise specified.)

The curve in Fig. 15 shows the effect of pressure or vacuum on the boiling point of sulphur dioxide, which is one of the most commonly used refrigerants. Carefully examine this chart and note that the boiling point of SO_2 (sulphur dioxide) varies from 30 degrees below zero F. at 22 inch vacuum, to 110 degrees F. at 85 lbs. pressure.

6. PRINCIPLES OF REFRIGERATION

As we have previously stated, **Refrigeration is simply a process of reducing the temperature of a certain substance or space by removing some of the heat from that body or space to bring its temperature below that of the surrounding air.** In most refrigerators, this process is continuous or frequently repeated, in order to hold the temperature down to the desired level, even though some heat leaks into the box or room.

We have learned that heat will flow of its own accord from points of high temperature to points of lower temperature. We know that heat will escape from a hot object by radiation through the air, by conduction through any metal or solid parts

Electric Refrigeration

of the hot object, and by convection due to the circulation of air around the hot space or object. See Fig. 11.

If we were to blow a stream of air from a fan across the top of an electric heater, the air stream would absorb and carry away a great deal of the heat produced by the heater. We could also remove heat from a hot object or space by circulating cool water over the object or through the space and allowing the water to absorb some of the heat and carry it away. If this same water were then passed through an ice compartment or some space which is cooler than the water, it could be made to give up its absorbed heat and again be re-circulated to carry away more heat from the object or space we desire to cool.

One of the most common ways of accomplishing refrigeration by mechanical means is by compress-

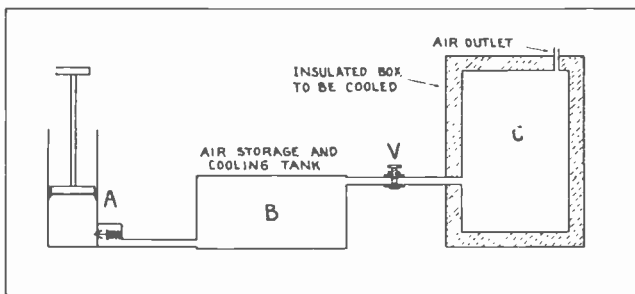

Fig. 16. Diagram illustrating a simple method of accomplishing heat transfer and refrigeration by means of compressed air.

ing some gas or refrigerant to literally squeeze the heat from it.

Did you ever notice how hot an automobile tire pump, or any other air pump becomes when it is used to compress air? The reason for this is that ordinary air contains a certain amount of natural heat and if we compress a large volume of this air into a very small space, we concentrate its heat, thus raising the temperature of this smaller volume of air.

Another very interesting example of the surprising amount of temperature increase that can be produced by compressing air is the fact that in Diesel

Refrigeration Principles

engines when the air is compressed to about 500 pounds pressure, its temperature raises to over 1000 degrees F., or hot enough to ignite fuel oil.

The reverse of this principle is also true. If highly compressed air were stored in a metal cylinder for a period of time, the heat concentrated by

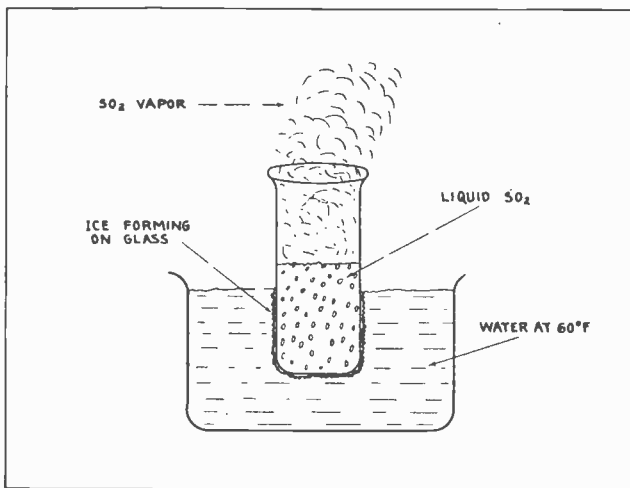

Fig. 17. The above sketch shows an elementary method of refrigeration by the rapid evaporation of liquid sulphur-dioxide due to its very low boiling point. This is a basic principle of refrigeration and should be carefully observed.

compression would escape by conduction through the metal walls of the cylinder to the surrounding air. Then if the air in the cylinder was suddenly released and allowed to flow out, it would carry away the little remaining heat it contained and the space within the cylinder would become icy cold.

Therefore, simple mechanical refrigeration can actually be accomplished by means of an air pump, air cooling cylinder and an insulated box such as shown in Fig. 16. The air pump at "A" can be used to compress air into the cylinder "B" where it can be held by means of the check valve and hand valve until its heat of compression escapes to the surrounding atmosphere.

Then, if the hand valve "V" is opened and this air from which the heat has thus been extracted is allowed to enter the insulated cabinet "C" and ex-

Electric Refrigeration

pand, it would cool the space inside the cabinet. By repeating this process, the cabinet could be kept cool.

Instead of using air for refrigeration, we use some other **chemical or gas which absorbs heat and releases it more readily than air**, and is thus cheaper to operate with. Such materials are known as **refrigerants** and will be explained more fully a little later.

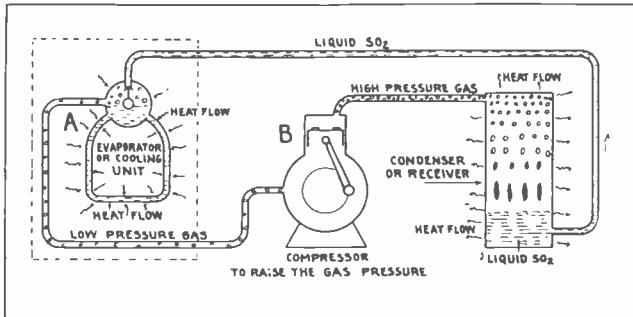

Fig. 18. Diagram of a simple refrigeration system illustrating the refrigeration cycle of a compression type refrigeration unit.

7. REFRIGERATION BY EVAPORATION

Another simple way to produce refrigeration is by the evaporation of a liquid into a vapor or gas. We have learned that when water evaporates or boils it absorbs heat from the air, the body or the fire which is causing its evaporation or boiling.

We have found that evaporation of perspiration cools the human body. We know that if the finger is moistened and held up in a draft of air, the side which the air strikes will become cooler. If the finger is moistened with gasoline and held in an air draft, it will be cooled more rapidly because gasoline has a boiling point of 147 degrees F. instead of 212 degrees F., and therefore evaporates much more rapidly and produces more cooling effect.

We have previously mentioned that sulphur-dioxide has a boiling point of 14 degrees F., which means that this chemical or liquid will boil violently if exposed to the heat of ordinary air at normal room temperature.

Refrigeration Principles

The very rapid evaporation of sulphur-dioxide causes it to rapidly absorb heat from the air and therefore cool the surrounding air. If a small quantity of sulphur-dioxide were placed in a glass tube, and this tube immersed in 60 degree water as shown in Fig. 17, the heat from the water would flow through the glass tube and be rapidly absorbed by the evaporation of the liquid SO_2 . The water immediately surrounding the glass tube would be chilled and frozen to ice and the entire quantity of water would be cooled by convection, or circulation of the water.

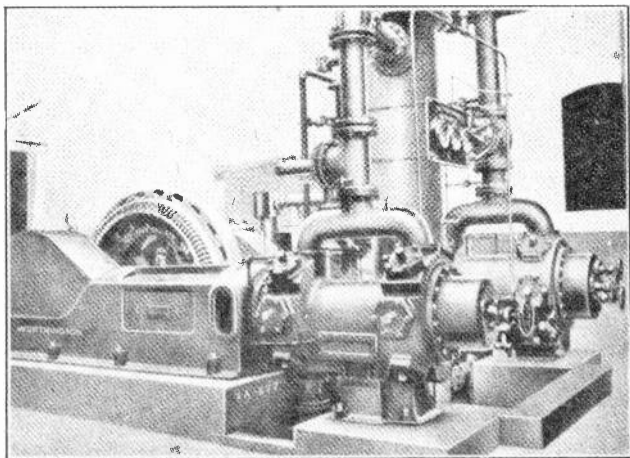

Fig. 19. Photo of a large commercial refrigeration machine. Note the two large horizontal compressors are both driven by direct connection to one large electric motor. This machine is capable of producing the same cooling or refrigerating effect as the melting of 600 tons of ice per day. Such plants provide good jobs for trained operators. Courtesy Worthington Pump & Machinery Corp.

This is actually a very simple system of refrigeration, but it is a very expensive one because the chemical vapor escapes to the open air and is wasted. In actual mechanical refrigeration systems, this chemical vapor is kept in a closed metallic system, compressed, and condensed back into liquid form and used over and over again to cool the same space. See Fig. 18.

In this figure the evaporator at "A" absorbs heat from the air within the enclosure shown by the dotted lines. This causes the liquid SO_2 in the evapo-

Electric Refrigeration

rator tank and tubes to change into a low pressure vapor or gas. The compressor at "B" draws off this gas from the evaporator and compresses it to a much higher pressure and temperature so that the gas will condense and give off its heat to the surrounding air.

The pressure set up in the condenser or receiver by the compressor, forces this liquid SO_2 back to the evaporator to be used over again whenever the float valve drops to admit more liquid. In other words, the SO_2 refrigerant absorbs heat dur-

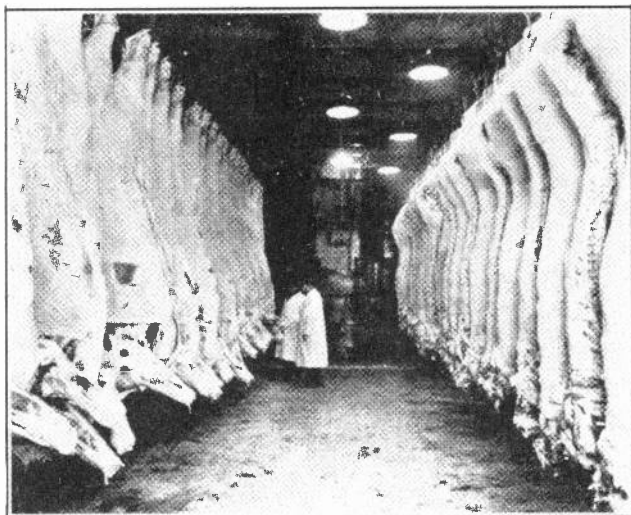

Fig. 20. Photographs of one section of a large meat chilling and storage room which is kept at very low temperature by means of mechanical refrigeration. Courtesy Carrier Corporation.

ing evaporation like a sponge absorbs water. Then the refrigerant gives off its load of heat when compressed, similarly to squeezing the water from the sponge.

Your next lesson will cover types of refrigeration systems, various refrigerant chemicals, and detailed information on the various parts of refrigerators. However, before proceeding with this next lesson be sure to have a thorough understanding of these vitally important fundamental refrigeration principles which are covered in this lesson. If you do this it will enable you to understand the

Refrigeration Principles

following lessons much more easily, and will also prepare you to service these interesting machines more efficiently.

EXAMINATION QUESTIONS

1. What is Refrigeration?
2. What is the principle use we make of refrigeration?
3. In your own words briefly explain the difference between heat and cold.
4. What is sensible heat?
5. What is latent heat?
6. Name and briefly explain the three methods of heat transfer.
7. What unit do we use for quantity of heat, and how much heat does it represent?
8. How does pressure affect the boiling point of liquids?
9. A. What is the chemical called that is used to absorb heat in refrigeration systems?
B. Name one chemical that is commonly used for this purpose.
10. Name the three important parts of a compression type refrigerator.

Electric Refrigeration

REFRIGERATION SYSTEMS AND CYCLES

There are two common types of mechanical refrigeration systems in use. These are known as the **compression system** and the **absorption system**.

The compression system uses a motor driven compressor as shown in Figs. 1, 2, and 3. The absorption system uses heat from the burning of gas, oil, or other fuel, to set up the required pressures and circulation of the refrigerant. The compression system is the one most extensively used in popular types of household and commercial refrigerators. It is also the one which requires the most mechanical service and will therefore be explained in detail in these lessons. The absorption system will be explained more fully in a later section.

Small compression units are in use by the millions in household refrigerators while many thousands of larger compression units, called commercial refrigerating machines, are in use in meat markets, stores, restaurants, packing plants and air-conditioning installations. The principal difference between household or domestic units and commercial units is in their size and their application. The parts and principles are practically the same otherwise.

1. PARTS OF MECHANICAL REFRIGERATORS.

All compression type refrigerators have eight important parts. (1) the compressor, (2) the condenser, (3) the control valve, (4) the evaporator, (5) the electric switch, (6) the electric motor, (7) the refrigerant chemical, and (8) the cabinet.

Other auxiliary parts and devices are often added to improve the operation of refrigerators, but the above named parts are the most essential and the ones of which the refrigeration service man must have a thorough understanding.

As we learned in the preceding lesson, the **compressor** is used to compress the low pressure gas

Refrigeration Cycle

coming from the evaporator, into a high pressure gas suitable for condensing. The compressor also serves to move or force the liquid refrigerant to flow from the condenser to the evaporator.

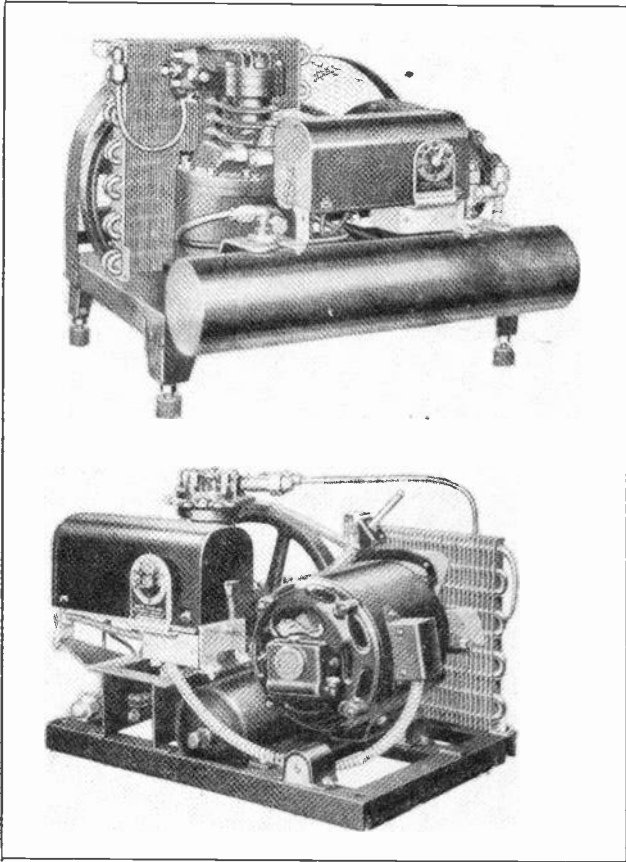

Fig. 1. Above are shown two electrical refrigerator units commonly known as condensing units. These units include the compressor, motor, condenser, receiver, and control switch.

The **condenser** is used to radiate or give off the heat from the high pressure gas, thereby causing it to condense to a high pressure liquid. Carefully note the construction of the condenser shown directly back of the motor and fan in Fig. 3. The

Electric Refrigeration

condenser generally discharges its condensed liquid refrigerant into a cylinder or drum called a **receiver**, where it is held under pressure until needed again at the evaporator. Frequently the compressor, condenser, and receiver are all mounted on one base and the whole assembly called a **condensing unit**.

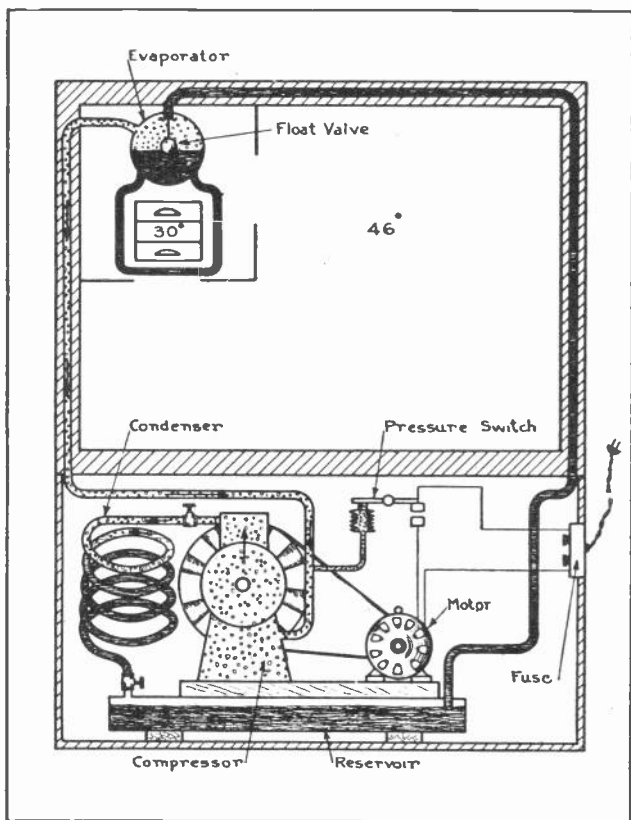

Fig. 2. This diagram shows the circulation of the refrigerating solution throughout the machine, and also illustrates the general principles of the mechanical refrigeration cycle.

The **control valve** is a sort of throttle valve used to control or limit the flow of liquid refrigerant to the evaporator as needed. This valve also serves to separate the **high pressure side** of the system from the **low pressure side**.

Refrigeration Cycle

The high pressure side includes the condenser, receiver, and liquid line, or everything from the discharge side of the compressor to the control valve at the evaporator. The low pressure side includes the evaporator, suction line and intake side of the compressor.

The **evaporator** is used to contain the liquid refrigerant which absorbs and removes heat from the air in the space to be cooled, and in so doing, evaporates into a low pressure gas which is drawn off by the compressor.

The **electric switch**, sometimes called a pressure switch, is used to automatically start and stop the motor and compressor as often as necessary to maintain the desired temperature in the refrigerator.

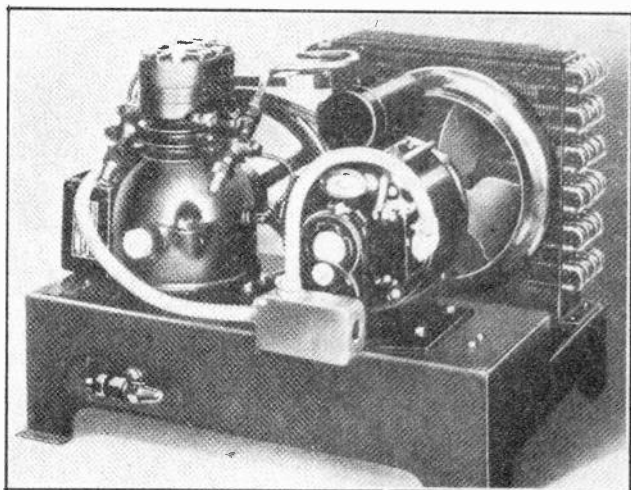

Fig. 3. This photograph shows a modern electric refrigerator condensing unit. Note the compressor and driving motor which are connected together by means of a "V" belt and pulleys. Also carefully note the construction of the condenser which is located behind the fan on the motor pulley. Courtesy General Electric Co.

The **electric motor** is used to drive or operate the compressor and is therefore a very important part of any electric refrigerator. These motors should be kept in good condition at all times if the unit is to function properly.

The **refrigerant** is used to absorb heat at the evaporator, inside the cabinet or room which is to

Electric Refrigeration

be cooled, and carry this heat through the compressor to the condenser where it releases or gives off the heat to the surrounding air, or to running water in case the condenser is water cooled instead of air cooled.

In the case of the household refrigerator or large cabinet type commercial units, the cabinet is also an important part. The cabinet is usually heavily insulated and equipped with a tightly sealed door to prevent as much as possible the leakage or entrance of heat to the cooled space inside.

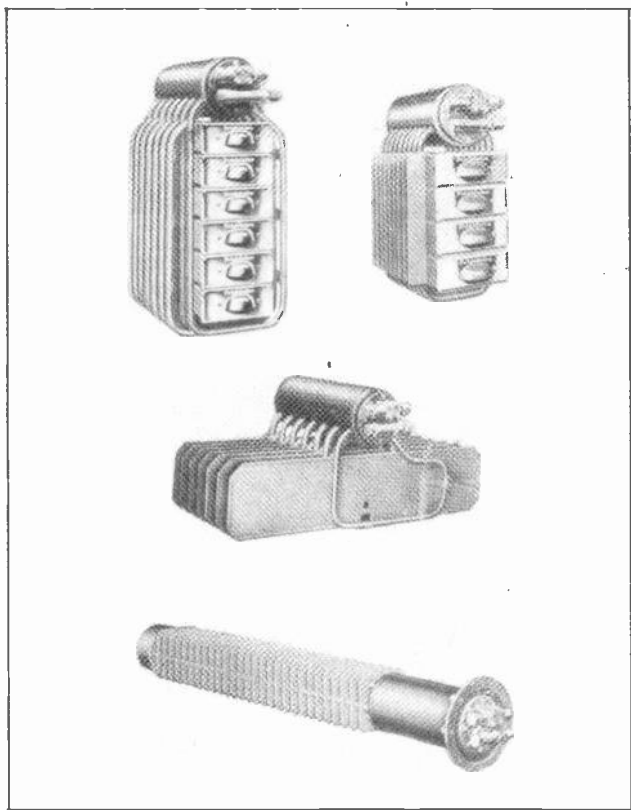

Fig. 4. Several types of evaporator units. Note the coils of tubing and the metal fins which are attached to the refrigerant drum to aid in absorbing the heat from the air in the refrigerator.

All of the above mentioned parts, including the cabinet are shown in the diagram in Fig. 2. The

Refrigeration Cycle

upper view in Fig. 1 shows a condenser, compressor, control switch box and liquid receiver. The lower view in this figure shows the motor in the foreground. Fig. 3 shows a modern "condensing unit," as these assemblies are often called. Note the com-

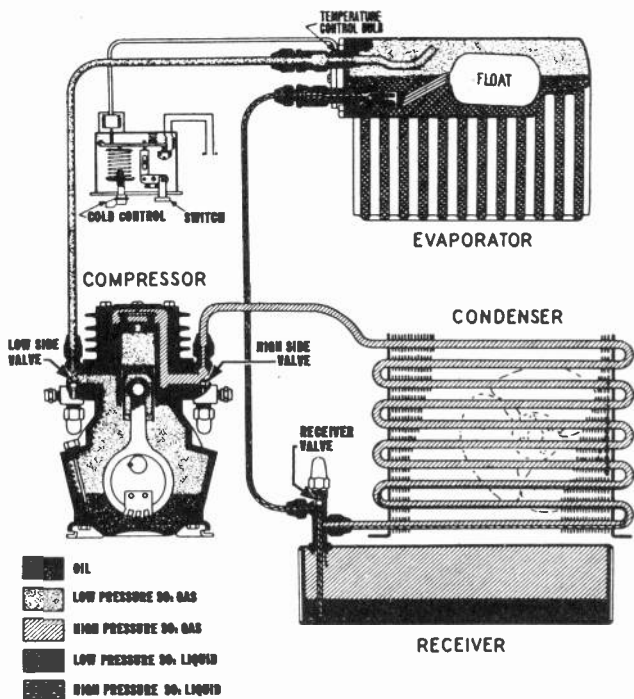

Fig. 5. The above diagram clearly illustrates the refrigeration cycle of a Stewart-Warner household refrigerator. Examine carefully each part shown and trace the flow of refrigerant throughout the system while reading the accompanying instructions in the lesson. Courtesy Stewart-Warner Corp.

pressor, motor, condenser, control switch and liquid receiver all mounted on one base. The receiver is underneath the base.

2. REFRIGERATION CYCLE.

The term "refrigeration cycle" refers to the series of events which occur repeatedly in the operation of a mechanical refrigerator. Briefly it is as follows:

Electric Refrigeration

Heat is first absorbed by the liquid refrigerant at the evaporator, changing the liquid into a gas. The gas is compressed and forced into the condenser where it gives off its heat to the cooling air or water and condenses back into a liquid, ready for use once more in the evaporator.

You should have a thorough understanding of this mechanical refrigeration cycle and principle in order to properly operate, service or repair refrigerators.

Referring again to Fig. 2, let us trace out this refrigeration cycle in detail. In the evaporator tank and tubes, we have liquid SO_2 shown by the darkly shaded area. As heat is absorbed from the air in the refrigerator through the metal walls of the evaporator, the liquid refrigerant evaporates or boils, creating sulphur-dioxide gas or vapor. This gas flows under its own pressure out through the left hand pipe toward the compressor. As long as the compressor is idle this gas cannot escape beyond it because of the compressor valves, and therefore gradually builds up a pressure as evaporation continues.

You will note that this gas pressure is also applied to the thin metal expansion bellows or slyphon of the pressure switch. When the evaporation pressure builds up to about 5 lbs. pressure in machines of this type, the thin metal bellows expands enough to snap the switch closed and start the motor which drives the compressor. The running compressor then sucks in the sulphur-dioxide gas from the evaporator line and compresses it to about 55 lbs. pressure, forcing it into the coils of the condenser.

When the gas is thus compressed, its temperature is raised to about 100 degrees, which causes it to give up its heat through the copper tubing and fins of the condenser, to the outside air which is of lower temperature.

A set of fan blades on the driving wheel of the compressor or on the motor pulley, forces air through the condenser coils and assists in cooling them and carrying away the heat.

Refrigeration Cycle

When the gas is thus chilled it condenses back into a liquid and is forced on into the reservoir or receiver where it is held under pressure until the float valve opens again, admitting it to the evaporator.

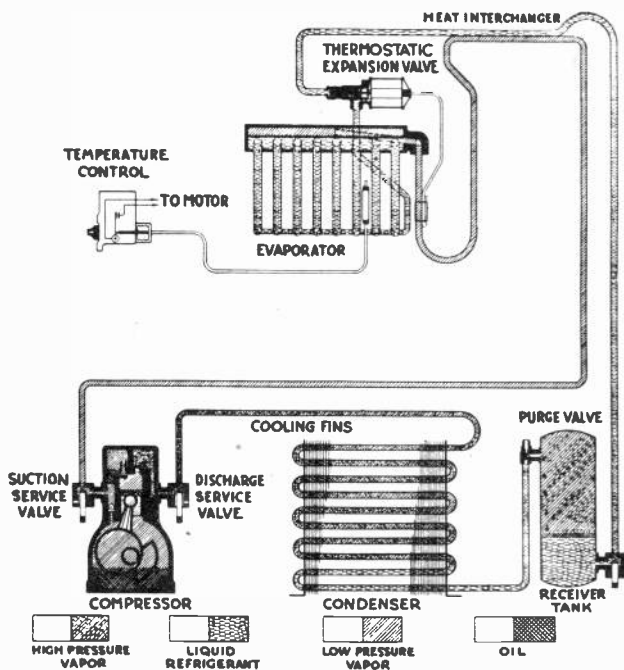

Fig. 6. Cycle diagram of a Fairbanks-Morse refrigerator. Note the different shadings used to represent the refrigerant vapor and liquid and the lubricating oil, and then carefully trace this refrigeration cycle until you thoroughly understand its operation. Also note the similarity between this unit and the one shown in Fig. 5. Courtesy Fairbanks-Morse Co.

When the compressor has run long enough to reduce the gas pressure on the evaporator line and syphon bellows to about a 9" vacuum, the bellows will contract and open the pressure switch, stopping the motor and compressor.

If the temperature in the refrigerator is still too high, the evaporator will soon build up enough gas

Electric Refrigeration

pressure to start the compressor again, and this cycle is repeated as often as necessary to keep the desired temperature in the cabinet.

When the liquid level in the evaporator is lowered by evaporation, the float valve shown in Fig. 2 allows more liquid SO_2 to again enter from the

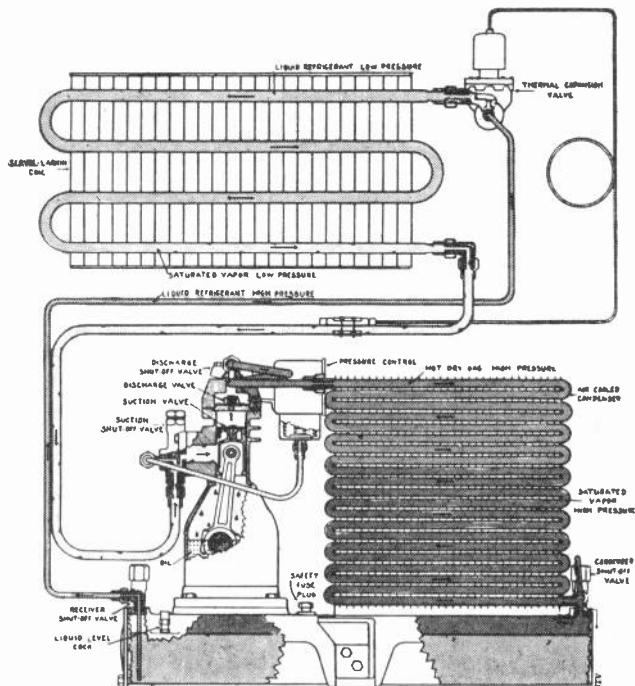

Fig. 7. Cycle diagram of a Serval refrigerator using a dry type evaporator, thermal expansion valve, air-cooled condenser, and reciprocating compressor. Courtesy Serval Corp.

receiver or liquid line where it has been held under pressure. Ordinarily the liquid in the receiver will not boil, as it requires about 90 degrees F. to boil, SO_2 at 55 lbs. pressure. This same feature acts as a safety control to prevent the evaporator from building up too high pressures if the motor or compressor should fail.

When the gas builds up to 40 lbs. pressure, evaporation stops unless the room and box tempera-

Refrigeration Cycle

tures are above 75 degrees F. When the compressor reduces the gas pressure to 9" vacuum, the liquid SO₂ of course boils easier and faster at this low pressure. This greatly increases the rate of heat absorption at the evaporator, and speeds up the process of refrigeration. So we can now see how extremely important are the evaporator, compressor, and condenser in this type of mechanical refrigerator, and also how important it is to have an absolutely air tight system on all the parts and connecting tubing of such a unit, so no gas or liquid can escape, or no air enter the system.

3. CYCLE DIAGRAMS OF COMMON UNITS.

Although there are many makes of refrigerators on the market, the general principles of most of them are very much the same, and even the mechanical arrangement of parts is often very similar. Therefore, if you carefully study these general principles and become familiar with some of the more common units you should be able to easily understand and service most any type.

In Fig. 5 is shown the cycle and parts diagram of a Stewart-Warner domestic, or household refrigerator. In this diagram you will also note the same important parts, such as evaporator, compressor, condenser, receiver, control valve, and starting switch. The motor is not shown in this case.

Examine each of these parts very carefully and trace the cycle of operation by referring to the code markings shown underneath the compressor, so you can quickly recognize high or low pressure gas, high or low pressure liquid, or oil when you see them in the system.

Note that here again the heat is absorbed by the low pressure liquid in the evaporator, causing the liquid refrigerant to boil or vaporize into low pressure gas which in turn passes down the large tube on the left to the compressor.

Here the gas is compressed to increase its temperature and is then forced thru the condenser where it is chilled and condensed back into liquid

Electric Refrigeration

and forced into the receiver. From the receiver it passes under pressure back to the evaporator, whenever the float lowers and opens the valve.

Note the oil in the compressor crank case and also forming a thin layer on top of the liquid refrigerant in the evaporator. Some of this oil is picked up by the refrigerant gas and carried back to the compressor.

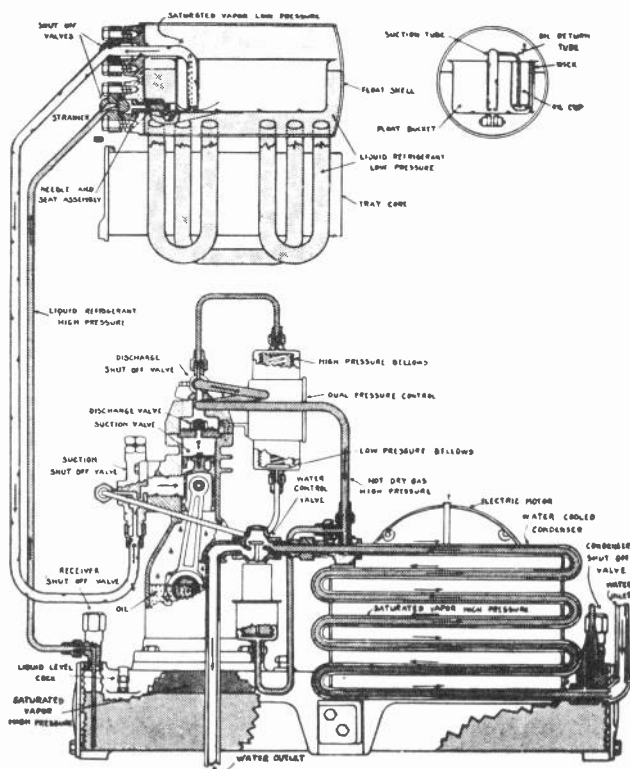

Fig. 8. Cycle diagram of a Servel unit using a flooded evaporator, low side float valve, and water-cooled condenser with a water flow control valve. Courtesy Servel Corp.

Note that the control switch for the motor of this unit is operated by a temperature control bulb attached to the evaporator, instead of by a pressure switch connection to the suction line as in Fig. 2.

Refrigeration Cycle

Also note the low side and high side valves on each side of the compressor, by means of which the compressor can be shut off from the balance of the system and removed from the cabinet for repairs.

One of the compressor check valves is in the piston head and one is in the cylinder head.

Fig. 6 shows the cycle chart of a Fairbanks-Morse domestic refrigerator. Again you will note that the same general principle and the same important parts are used, as in the machine in Fig. 5. Although in the machine shown in Fig. 6, the liquid receiver is in a slightly different position, it still receives the condensed high pressure liquid refrigerant from the condenser. This unit uses a thermostatic expansion valve instead of a float valve to control the flow of liquid to the evaporator. It also uses a thermostatic expansion bulb attached to the side of the evaporator to control the motor starting switch. Each of these devices will be fully explained in the next lesson.

Carefully trace the flow of refrigerant throughout this system as with those previously shown, and observe the different shadings which represent gas, liquid and oil. Note that both the suction and discharge valves of the compressor in this unit are located in the cylinder head, instead of the suction valve being in the piston head as in Fig. 5.

Also note the suction service valve and discharge service valves, which although referred to by a different name, serve the same purpose as the low side and high side valves shown in Fig. 5.

Fig. 7 shows a diagram of a Servel household type refrigerator using a dry type evaporator with a thermal expansion valve, and an air-cooled condenser. Carefully examine all parts of this diagram and note the names and descriptions marked for each part.

Fig. 8 shows a diagram of another Servel refrigerator using a wet type or "flooded evaporator" and float valve control, and a water cooled condenser of the double tube type. Carefully examine all parts of this system.

Electric Refrigeration

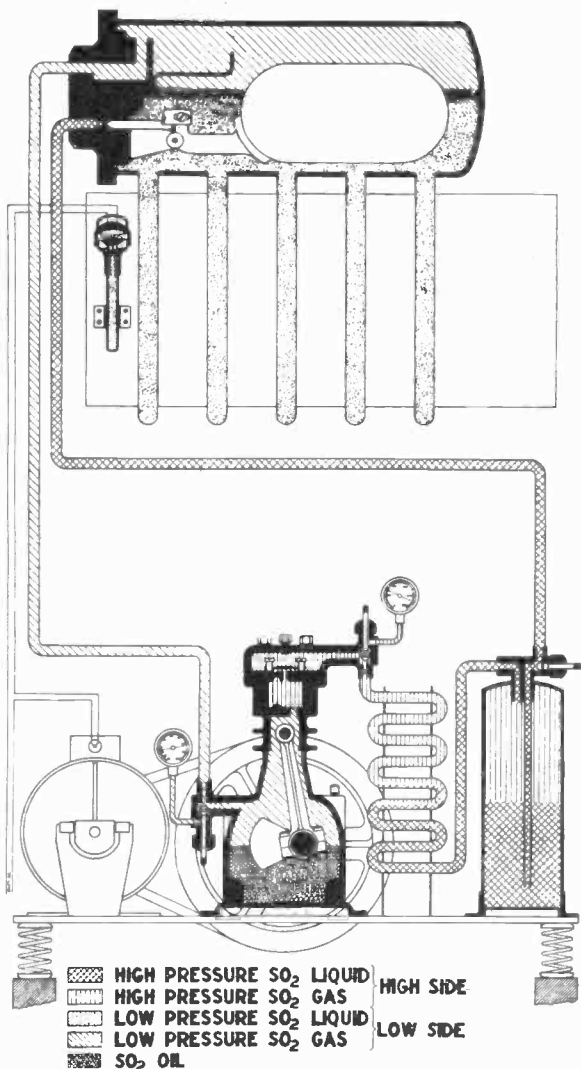
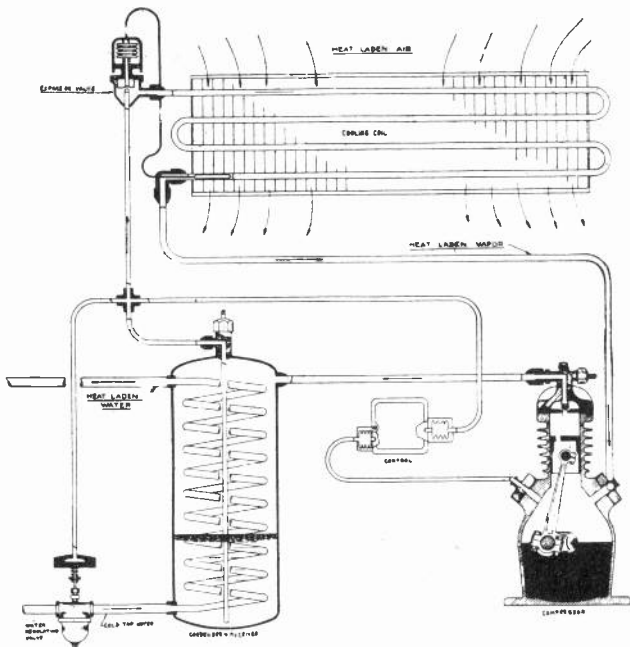

Fig. 9. Cycle diagram of a Kelvinator household refrigerator. Note the construction of the low side float valve in the evaporator and carefully check the flow of refrigerant and the operation of this unit. Courtesy Kelvinator Manufacturing Co.

Refrigeration Cycle

Fig. 9 shows a diagram of one of the earlier types of Kelvinator units, and clearly shows the construction of the float valve in the evaporator. This unit has the electric switch for the motor located right on the side of the evaporator and operated by the expansion of a non-freezing solution in the pressure bulb attached.

Fig. 10 shows a commercial refrigerating unit. Note the similarity of general operation and parts with the household units.



Copeland Commercial Refrigeration Cycle

Fig. 10. Cycle diagram of a Copeland commercial refrigerator. Carefully check all parts of this system and note the water-cooled condenser and water regulating valve. Courtesy Copeland Manufacturing Co.

4. OPEN AND HERMETIC TYPE UNITS.

By far the greater majority of household refrigerators now in service use condensing units of the "open unit" type, in which the compressor, motor

Electric Refrigeration

and condenser are accessible for repairs and service operations in the field. Practically all large commercial refrigeration machines are of the open type.

There are, however, several makes of "hermetic units" in which the compressor and motor are tightly or "hermetically" sealed inside a welded steel housing. Such a unit is shown in Fig. 11, with the compressor and motor sealed in the steel casing at the

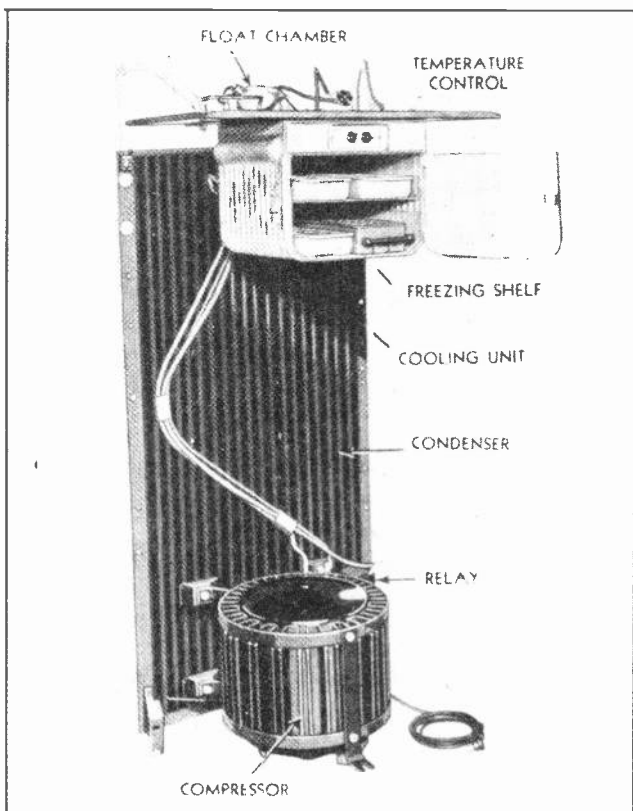

Fig. 11. This photograph shows the important working parts of a modern General Electric household refrigerator. Note the construction of the evaporator or chilling unit above, the condenser at the rear, and the hermetically sealed compressor unit at the bottom. Courtesy General Electric Co.

bottom. The evaporator is located above and a flat vertical type condenser at the rear. Also see Fig. 1,

Refrigeration Cycle

in lesson 95. These units cannot be repaired or overhauled in the field, but are usually returned to the factory for replacement or sent to a specially equipped service shop for repairs when they become defective.

The purpose of this hermetically sealed construction is to reduce the possibility of leakage of the refrigerant gas or liquid, at tubing connections, compressor shaft seals, etc.

Although hermetic units cannot be conveniently overhauled or repaired in the field, special auxiliary service valves are available for attachment to these

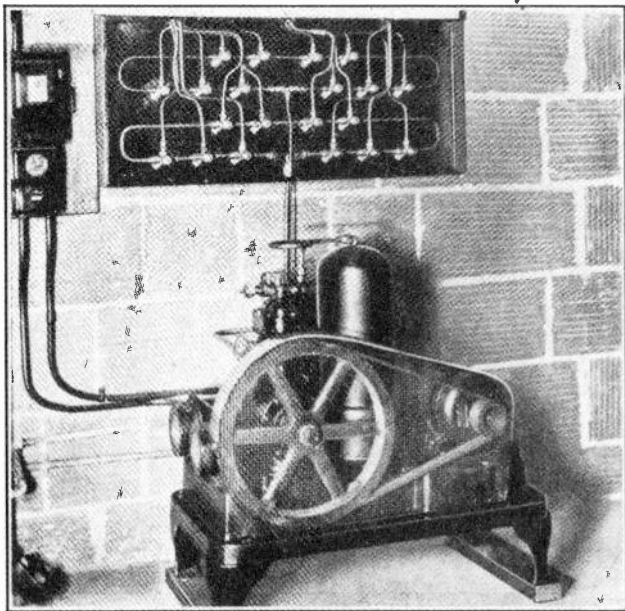

Fig. 12. This view shows the condensing unit and valve manifold panel for a multiple refrigeration system such as used in large apartment buildings. Courtesy Servel Manufacturing Co.

units to permit discharging or recharging the refrigerant, or removing air from the system, etc. There are, of course, other service operations on the evaporator, control valve, electric switch, etc., which can be performed right in the field on refrigerators using hermetic compressor units.

Electric Refrigeration

Some compressors and motors are enclosed in a gas tight housing with a removable plate or cover to make them accessible for servicing. These are called semi-hermetic units.

TWO TEMPERATURE REFRIGERATORS

The advent of quick frozen vegetables, meats, and fish have introduced to the manufacturer of household equipment the need for designing units capable of developing the lower temperatures required to keep such foods in good condition. As the temperatures required are lower than those possible with household units of the ordinary type, special two-temperature type units have been manufactured to meet this demand.

An illustration of one type of refrigerator designed for the so-called deep freezing associated with the preservation of quick frozen foods is here shown. This particular unit, which in construction is similar to many others, is equipped with two evaporators, one placed in the main food compartment and held at a temperature of about 28 degrees Fah, while the other is located in the frozen food section with the ice cube trays and held at a temperature of 5 degrees below zero Fah.

The diagram illustrates the principle of operation of this unit. After the refrigerant is liquefied in the condenser, it passes through the dehydrator and capillary tube where it is reduced in pressure to conform to approximately a 28 degree boiling point as it enters the food compartment evaporator. Part of the liquid evaporates here to maintain the food compartment temperature. The remainder of the liquid and low pressure gas passes through the Differential Pressure Control (D.P.C.) valve into the freezing compartment evaporator. This D.P.C. valve, as may be observed from the diagram is constructed like a spring loaded check valve. This valve further restricts the flow of the refrigerant and produces about a 20 lb. pressure drop. The liquid in the second evaporator is consequently under a lower pressure; thus its boiling point is reduced to about -5 F. maintaining a lower evaporator temperature. This arrangement provides two different temperatures in the same refrigerating system.

Refrigeration Cycle

From the second evaporator where the remaining liquid evaporates, the low pressure gas passes through the accumulator and suction line to the compressor. As noted in the diagram, the accumu-

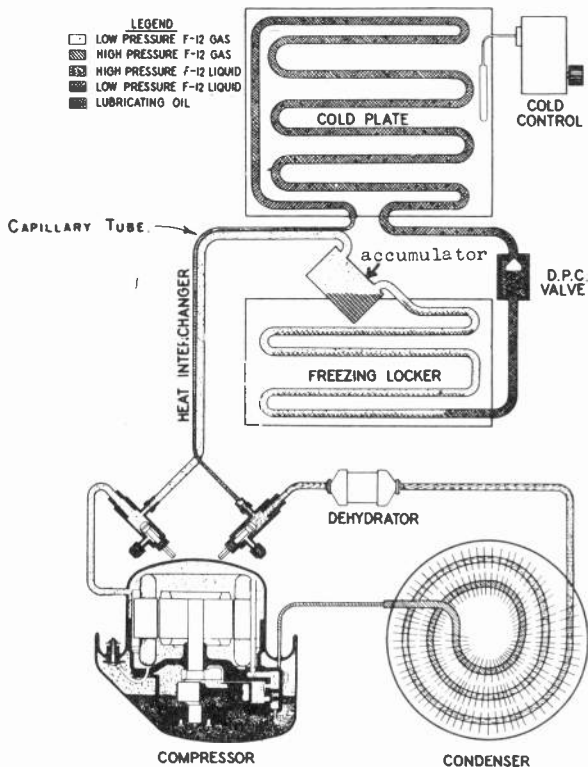

lator is located at the outlet of the second evaporator. This accumulator traps any liquid that may be carried through with the gas and thus prevents this liquid refrigerant from entering the suction line until it has completely evaporated.

5. MULTIPLE SYSTEMS.

Sometimes one large compressor and condensing unit is connected up with tubing to several evaporators located in separate cabinets or rooms, with the flow of refrigerant separately controlled to each

Electric Refrigeration

evaporator by separate control valves. See Figs. 12 and 13. Such systems are called multiple systems, and are often used in large apartment buildings and some commercial installations.

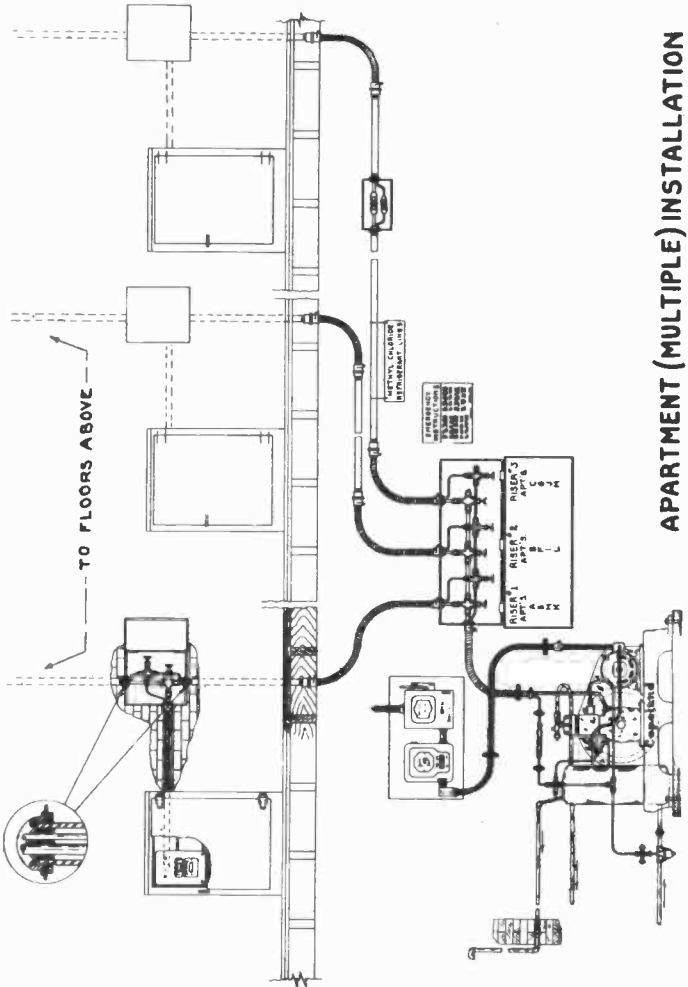

Fig. 13. Diagram showing general arrangement of electrical connections and refrigerant connections for a multiple refrigeration system. Courtesy Servel Manufacturing Co.

Refrigeration Cycle

This type of installation costs less than the use of a number of separate small compressors, and permits locating the large central condensing unit in the basement or some out of the way place, thus eliminating any compressor noise in the apartments.

In some multiple installations, one main liquid line is run from the condensing unit throughout the building, and separate branch liquid lines tapped off this main to feed the various evaporators, which may be located in individual refrigerator cabinets in each apartment. The gas from each evaporator can be returned through separate suction lines to one main suction line leading back to the compressor.

However, more recent installations generally have separate liquid lines and separate suction lines run to each evaporator, and all of these lines connected to a main header or valve manifold right at the compressor as shown in Figs. 12 and 13. Then by use of valves in each line any one refrigerator can be entirely separated from the others in case of trouble.

The separate control valves used with individual evaporators in multiple systems, are generally of the low side float type. That is, float valves in the evaporator tank, which is in the low pressure side of the system. Many such multiple installations have all evaporators set for the same temperatures.

However, there have been developed more recently two special adjustable valves for use with evaporators using low side float valves. These are known as **snap action valves** and **two temperature valves**, which when installed in the suction lines of multiple system evaporators, permit maintaining different temperatures in the various evaporators.

One of the disadvantages of such multiple refrigeration systems is that in case of trouble with the main condensing unit all refrigerators in the building are put out of service. For this reason many apartment building owners prefer complete, separate, self contained refrigerators in each apartment.

Electric Refrigeration

EXAMINATION QUESTIONS

1. A. Name the two common types of mechanical refrigerator systems.

B. Which system did you study in this lesson?

2. Name the important parts used in the refrigerator system studied in this lesson.

3. A. For what purpose is the electric motor used on an electric refrigerator?

B. The evaporator?

4. What is meant by the term refrigeration cycle?

5. Briefly describe the refrigeration cycle.

6. For what purpose is the pressure switch used as shown in Fig. 2?

7. For what purpose is the control valve or float valve used?

8. Briefly explain the difference between "open units" and "hermetic units".

9. Where are the following parts usually located when used in a multiple system:

A—Evaporators

B—Motor

C—Condenser

D—Compressor

10. A. What is the one advantage of using a multiple system in apartment houses?

B. What is one disadvantage of such a system?

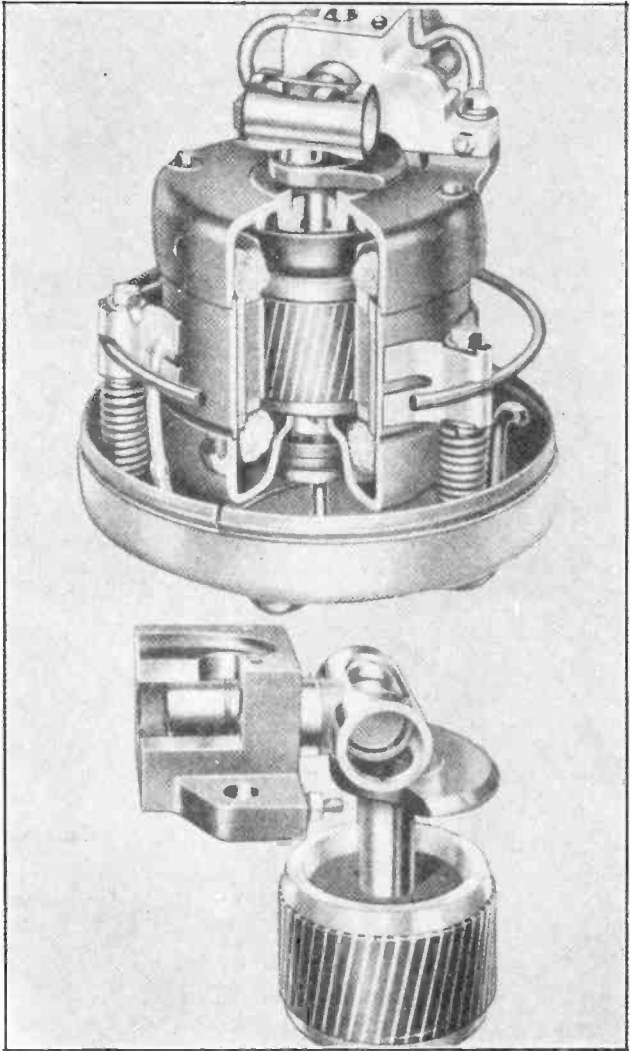

Fig. 1. The above views show the construction of the compressor and motor used in the General Electric hermetic type unit. Courtesy General Electric Co.

REFRIGERATOR PARTS, CONSTRUCTION AND OPERATION

1. COMPRESSORS—RECIPROCATING TYPES.

There are several different types of refrigerator compressors in common use. One of the most common and popular of these is the single acting, reciprocating compressor which is constructed very much like the ordinary air compressors which were explained in earlier lessons. These reciprocating compressors have the advantages of being very low in manufacturing cost, and easy to repair. They have the disadvantages however of being somewhat noisy in operation and slightly lower in efficiency than some of the rotary type compressors.

Fig. 3 in lesson 94 shows a single cylinder reciprocating type compressor mounted on the condensing unit base and connected by a "V" belt to its driving motor on the right. Most of the compressors of this type used in small household refrigerators are single cylinder units, while those for large household units and for commercial units may have from two to four cylinders, to increase their capacity for handling larger volumes of gas.

Fig. 2 shows a sectional view of a two cylinder compressor with the important parts numbered and named. Examine this view very carefully to become familiar with all these parts. You will note that the principal parts of such a compressor are the crank case, cylinders, pistons, piston pins, valves, connecting rods, crank shaft or eccentric shaft, drive wheel, bearings, and shaft seal.

Due to the somewhat porous nature of the cast iron or steel used in the construction of compressor crank cases, there would normally be some tendency for refrigerant gases to slowly leak through these metal walls. To prevent this, compressor housings are often given a solder bath or galvanizing dip to fill the pores of the iron.

Early types of compressors used pistons which were ground to a very close fit with the cylinder walls and which did not use any piston rings. Many of the later types of compressors use pistons having

Compressors

piston rings to provide a better seal with the cylinder walls and thereby improve the compressor efficiency. Many reciprocating compressors rely on oil splashed up from the crank case to lubricate the

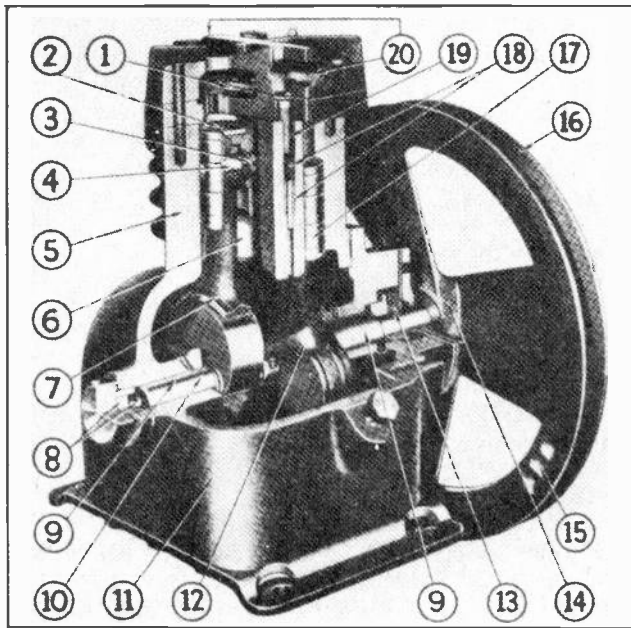

KEY TO NUMBERS ON CUT-AWAY COMPRESSOR

- | | |
|--|---|
| 1. Multi-reed discharge valve. | 10. One-piece drop-forged eccentric shaft. |
| 2. Spring-disc intake valve. | 11. Extra large crankcase. |
| 3. Spring thrust washer. | 12. Directional oil distributor. |
| 4. Lubricated wrist pin. | 13. Balanced seal. |
| 5. One-piece body. | 14. Fan blade type spokes. |
| 6. Diamond-bored, micro-honed, hand-lapped cylinder walls. | 15. Balanced flywheel. |
| 7. Diamond-bored connecting rod. | 16. V-belt drive. |
| 8. Shaft thrust ball with hardened insert and plug. | 17. Selective fit pistons. |
| 9. Diamond-bored overize bearing. | 18. Cylinder and piston oiling system (Patent pending.) |
| | 19. Suction line screen. |
| | 20. Service valves in head cap. |

Fig. 2. Carefully study each part shown in this excellent sectional view of a reciprocating compressor such as used in domestic and small commercial refrigerators. Thoroughly familiarize yourself with the name and purpose of each part while studying the accompanying lesson material. Courtesy Copeland Refrigeration Corp.

pistons and connecting rod and bearings, although some compressors use oil pumps and pressure lubricating systems.

Electric Refrigeration

The suction and discharge valves in these compressors may be located in the piston head and cylinder head or in some cases they are both in the cylinder head. These valves are frequently of the reed type, merely consisting of thin flat steel reeds held lightly against the valve openings by their flat springs or their own spring tension. Thus the gas can be forced thru the valve in one direction by the pressure built up by the piston. Then on the down-stroke of the piston, the valve reed is held tightly closed against the valve seat by the spring and by the back pressure of the gas. See Fig. 3-A and

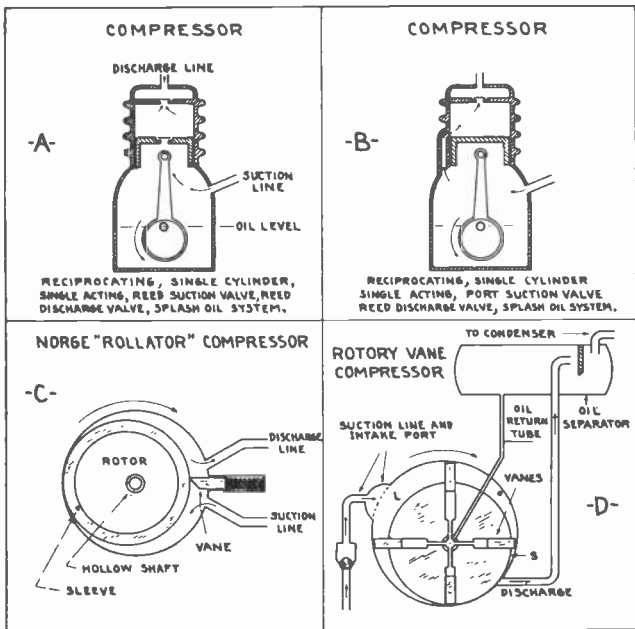

Fig. 3. The above diagrams show several types of reciprocating and rotary refrigerator compressors. Examine and check every operation carefully while reading the lesson material.

Fig. 4.

Some compressors use disc or flat plate type valves while others use poppet type valves which will be explained later. In some cases the suction valve is merely a port or opening in the side of the cylinder wall; this port being opened and closed at the right period by the piston passing over it.

Compressors

See Fig. 3-B. Also note the several types of compressor valves shown in Fig. 4.

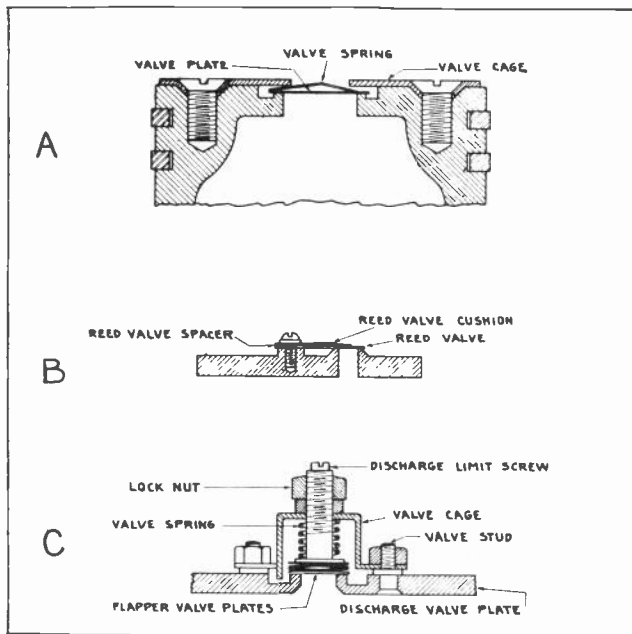

Fig. 4. These diagrams show the construction of several types of refrigerator compressor valves.

Another type of compressor used in some refrigerators is of the double acting type, using a scotch yoke or eccentric cam instead of a crank shaft and connecting rod, to move the piston back and forth in its stroke.

This type of compressor is somewhat more efficient but is also more complicated than the ordinary reciprocating compressor. Sparton and Wellsbach refrigerators use these double acting compressors.

One of the most important parts of a reciprocating compressor is the shaft seal which is designed to prevent leakage of gas at the point where the drive shaft passes through the crank case. There are several types of shaft seals in use, one very common type being the syphon bellows type seal shown in Fig. 7 and also in the compressor in Fig. 2. In this type of seal a spring holds a smoothly

Electric Refrigeration

ground seal ring tightly against a smooth shoulder on the shaft.

One special bellows type of shaft seal is shown in the sectional view of the compressor in Fig. 8. Note the parts of the seal which are shown removed from the compressor. These seals must be maintained in perfect condition in order to prevent gas leakage, and they are therefore one of the compressor parts which may need frequent attention from the service man.

Large commercial refrigerator compressors often use packing glands in which soft packing is wrapped around the shaft and tightly compressed against the moving shaft surface by a plate or collar over the packing gland.

2. ROTARY TYPE COMPRESSORS.

There are several types of rotary compressors used in refrigeration machines for domestic service. Some of these are called **rotary vane** compressors, **stationary vane** compressors, "**rollator**," and **rotary gear** type compressors.

Fig. 3-D shows a diagram of a rotary vane compressor having four vanes or blades set in slots in the revolving rotor. The rotor and vanes revolve in an iron casing which fits closely against the flat sides of the rotor. The vanes are held outward against the rim of the casing, either by centrifugal force or by small springs placed in the slots behind the blades.

The rotor and its shaft are located off center with the rotor casing, or in other words, they are not concentric with the casing. By examining the figure you can see that as the blades revolve past the intake and discharge ports they will trap gas in the larger area "L," between the rotor and casing, and squeeze the gas down into the smaller area "S," where it is forced out through the discharge opening at increased pressure.

A check valve must be used in the suction line from these compressors to prevent back flow of the gas when the compressor is idle. All rotary compressors revolve in a clockwise direction when facing the drive end.

Several of the advantages of this type compressor

Compressors

are that they will handle large volumes of gas with quite high efficiency, and they are very quiet in operation. They are also made for high speed operation and can therefore be direct connected to the motor shaft, thus eliminating belt drives.

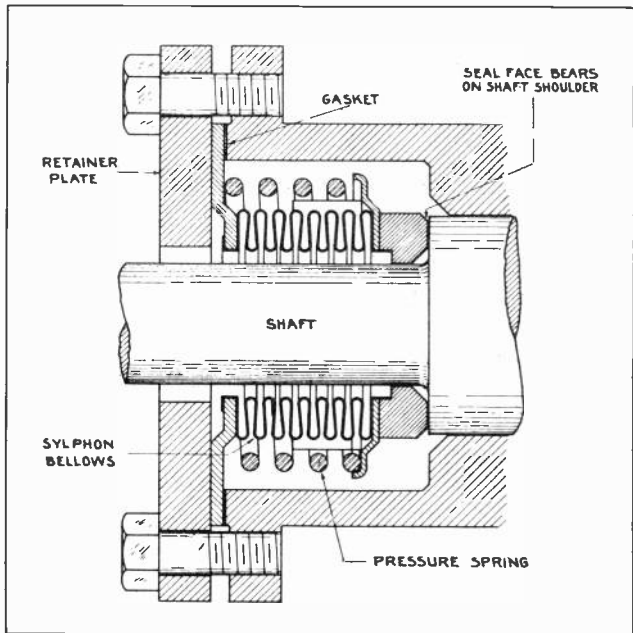

Fig. 7. Carefully examine all details of the syphon bellows type shaft seal shown in the above diagram. This type of seal is extensively used in domestic type refrigerators.

Most reciprocating compressors are equipped with a drive pulley for "V" belt or flat belt drive from the motor pulley. However, some of the smaller ones are made for direct connection to the motor shaft. See Fig. 1.

3. "ROLLATOR" AND GEAR TYPE COMPRESSORS.

Another type of rotary compressor is the stationary vane "rollator" unit used in the Norge refrigerator. See Fig. 3-C. In this compressor a round iron rotor with flat sides, and equipped with a free metal sleeve, is mounted eccentrically (off center) on the drive shaft and rotated in a casing having a

Electric Refrigeration

single stationary vane which is held against the rolling, wobbling sleeve by a spring. The stationary vane separates the high pressure side from the low pressure side.

As the rotor revolves the sleeve rolls around the inside wall of the casing and sucks in gas from the suction line, and squeezes it out of the discharge line.

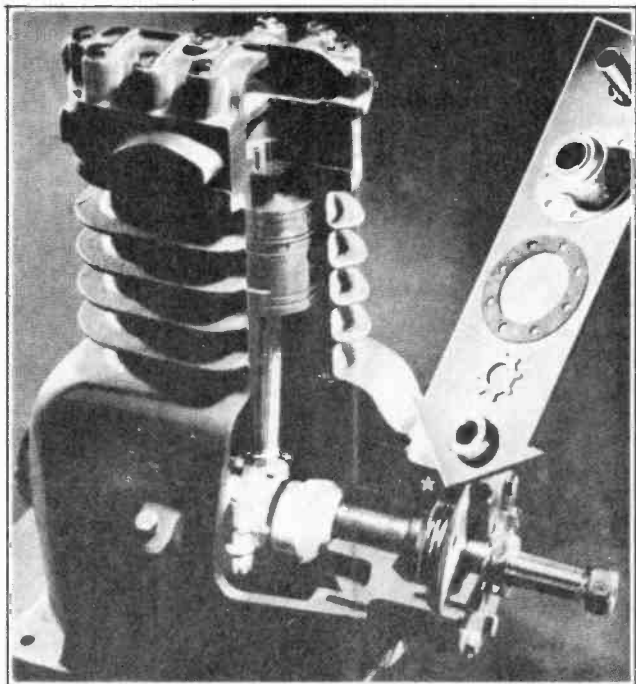

Fig. 8. Sectional view of a two cylinder reciprocating type compressor showing pistons, crank shaft and shaft seal. Courtesy Mills Novelty Co.

The clearance between the sides of the rotor and the casing of these compressors is .0003 inch and an oil film provides the seal to prevent gas leaking back between the rotor and casing.

Rotary gear type compressors are used in some refrigerators. See Figure 10. Two herring bone gears, one the driven gear and the other an idler, are enclosed in a housing. Gas enters at the suction side and is carried in the spaces between the

Compressors

gear teeth and the casing, around to the discharge side where it is compressed out due to the meshing of the gear teeth closing up these spaces.

Gear wear in these compressors is rather rapid due to the very close fit required between the teeth of the two gears to prevent back flow of the gas.

Refrigerator compressors are usually driven by electric motors, and are connected to them by belts, gears, or direct shaft connection. Belt driven compressors generally operate at $\frac{1}{4}$ to $\frac{1}{3}$ of motor speed. "V" belts are better than flat belts because they have better traction or grip on the pulleys, and are less likely to slip off the pulleys.

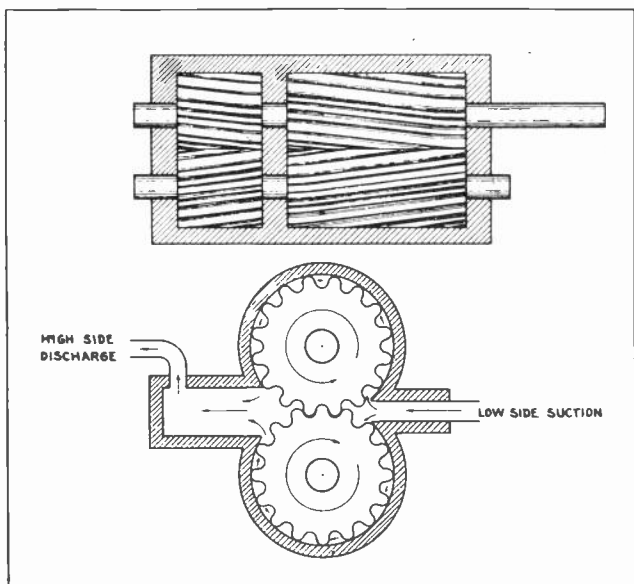

Fig. 10. Diagram showing the construction and operation of a rotary gear type compressor such as used in some refrigerators.

There should generally be about $\frac{1}{2}$ " of slack or "belt play" in either direction when moving the belt up and down midway between the pulleys.

Pulleys should be kept lined up to prevent excess belt wear and noise. The compressor pulley is generally stationary and the motor pulley is movable. Therefore proper belt alignment can be obtained by shifting the motor pulley on its shaft.

Electric Refrigeration

4. CONDENSERS.

Refrigerator condensers are made in both air-cooled and water cooled types. The great majority of those used on domestic units are air-cooled, while those used on large commercial refrigeration or air-conditioning machines are generally water cooled.

Water cooled condensers have a much greater heat absorbing capacity for a given size than air-cooled condensers. However, the low cost and simplicity of air-cooled condensers makes them much more popular for use in ordinary household refrigerators.

As previously explained, the primary purpose of a refrigerator condenser is to give off the heat of the high pressure refrigerant gas to the cooling air or water, and thereby chill the gas enough to condense it back to a liquid.

Most condensers are made of copper tubing, as copper is an excellent conductor of heat and therefore very efficient in transferring the heat of the gas through the tube walls to the cooling air or water.

Simple condensers can be made of loops or coils of plain copper tubing of $\frac{1}{4}$ to $\frac{1}{2}$ inch or larger diameter, as shown in Figure 12-A. The heat transfer efficiency of a condenser can be greatly increased, however, by the use of copper fins attached to the tubing wall as shown in Figure 12-B, to increase the metal surface area in contact with the cooling air.

In some condensers these fins are merely pressed tightly on to the tubes, while in others they are soldered on, or formed as an integral part of the copper tube itself, by a special machine with revolving dies. The better the contact or joint between the tube and fins, the more efficient will be the condenser.

Another type of condenser, known as the radiator type, has continuous metal fins joining all the tubes, as shown in Figure 12-C. One foot of radiator fin type tubing will do as much work as 6 to 8 ft. of plain tubing of the same diameter. A very good view of an air-cooled condenser is shown in the unit in Figure 3 of lesson 94. Other air-cooled condenser views can be seen in Figures 5, 6, and 7 of lesson 94. Such condensers are cooled by air cir-

Condensers

culated by a fan on the motor or compressor pulley, or sometimes on a separate fan motor. The air velocity is generally from 400 to 500 ft. per minute.

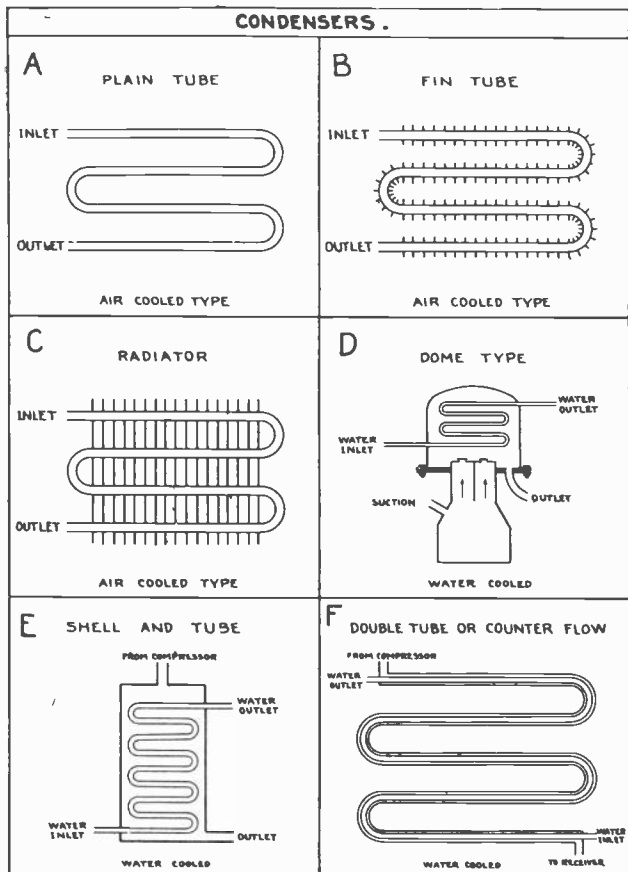

Fig. 12. The above diagrams show the construction of several different types of air-cooled and water-cooled condensers such as used in electric refrigerators.

Water-cooled condensers are made in **dome type**, **shell and tube type** and **double tube type**.

A dome type condenser is shown in Figure 12-D, and consists of a gas dome mounted directly over the compressor cylinder head to receive the hot gases discharged from the compressor. Cooling water is circulated through coils of copper tubing

Electric Refrigeration

inside the dome, and absorbs the heat from the gas as it contacts these coils.

A shell and tube type condenser is shown in Figure 12-E and is quite similar to the dome type except that they are usually in cylindrical form and can be mounted either vertically or horizontally.

A double tube or "counter flow" condenser is shown in Figure 12-F, and consists of a small copper tube within a large one. The gas is circulated through the large tube in one direction and the water is passed through the smaller tube in the opposite direction. This is one of the most efficient types of condensers made.

Water-cooled condensers have an automatic water regulating valve to control the flow of water to match the load on the compressor and to maintain a temperature difference of about 20 degrees between inlet and outlet water. For example, if the inlet water temperature is 50 degrees F., the outlet water temperature should be about 70 degrees F.

Such a valve is shown with the water-cooled condenser in Figure 8 in Lesson 94. Another water-cooled condenser is shown with the unit in Figure 10 in Lesson 94.

5. EVAPORATORS.

You have learned that the function of the refrigerator evaporator is to absorb the heat from the air in the cabinet and transfer this heat to the liquid refrigerant, which in turn vaporizes into a gas which carries the heat away outside the cabinet to the compressor and condenser.

Therefore evaporators are also made of copper because of its excellent heat conductivity. Evaporators generally consist of a drum or header to which a number of copper tubes are connected. Some evaporators use finned tubes similar to those used in condensers.

Evaporators are often classified as **flooded type** or **dry type**, according to the amount of liquid refrigerant they normally contain. Those having liquid drums or headers and low side float valves are flooded type units, and their tanks or drums are usually $\frac{2}{3}$ to $\frac{3}{4}$ filled with low pressure liquid refrigerant.

Evaporators

Those using expansion valves to discharge the liquid directly into the tubing or manifold are dry type units.

FLOODED TYPE EVAPORATORS

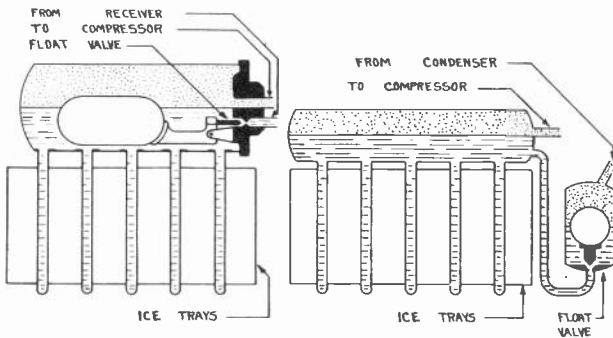

Figures 2, 5, 8 and 9 in Lesson 94 show several styles of flooded evaporators, while Figures 7 and 10 in Lesson 94 show dry type units. Examine and compare each of these carefully. Figure 11 in Lesson 94 shows an evaporator with the door open to the space or compartment surrounded by the tubing. This is one of the coldest spots in the refrigerator and is used for chilling and freezing desserts, and ice cream, and for making ice cubes.

Figure 9 in this lesson shows a cut-away view of an evaporator using a high side float valve to control the flow of refrigerant. Figure 14 shows an excellent view of a modern evaporator used in the Fairbanks-Morse refrigerator. Carefully note the construction features and the various parts which are marked in this view.

6. DIRECT AND INDIRECT EVAPORATORS.

Evaporators are also classed as **direct** or **indirect** types. The direct type of evaporator has its tubes or flues exposed directly to the air in the cabinet. The indirect type has the tubes enclosed in a metal tank. The space around the tubes in the tank is filled with a non-freezing brine solution.

The brine is sometimes referred to as a **hold-over solution**, and in addition to conducting the heat from the tank walls to the evaporator tubes, the heat absorbing capacity of the solution lengthens

Electric Refrigeration

the running periods and idle periods of the refrigerating cycle, thereby reducing the number of starting and stopping operations.

DRY TYPE EVAPORATORS

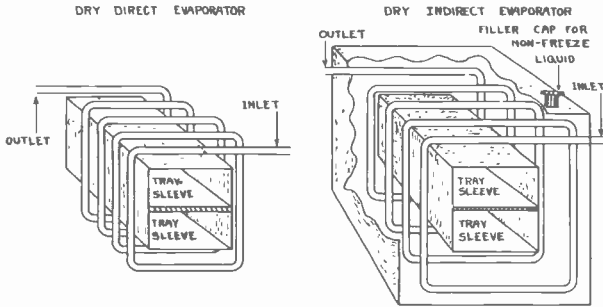

These non-freeze solutions may be made of 40% denatured alcohol and 60% water; or 40% radiator glycerine and 60% water; or $2\frac{3}{4}$ lbs. of calcium-chloride to one gal. of water. Some refrigerator

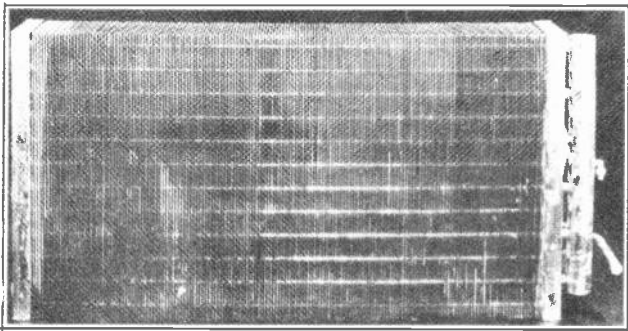

Fig. 13. Photograph of a large commercial type evaporator. Note the fins which are attached to the tubes to more rapidly absorb the heat and air. Courtesy York Ice Machine Co.

manufacturers use other special patented chemical non-freeze solutions.

The brine tank should be kept completely filled within about $\frac{1}{4}$ " of the top for efficient operation, and the solution should be kept at the proper strength or it may freeze and burst the tank.

One of the most efficient types of evaporators is the **direct, dry fin** type, because of its great active

Evaporators

surface and rapid rate of heat transfer. This type of evaporator when used in large commercial units does not frost over, because, although its temperature is low enough to cool the cabinet, it is not low enough to freeze moisture on its surface. See Fig. 13.

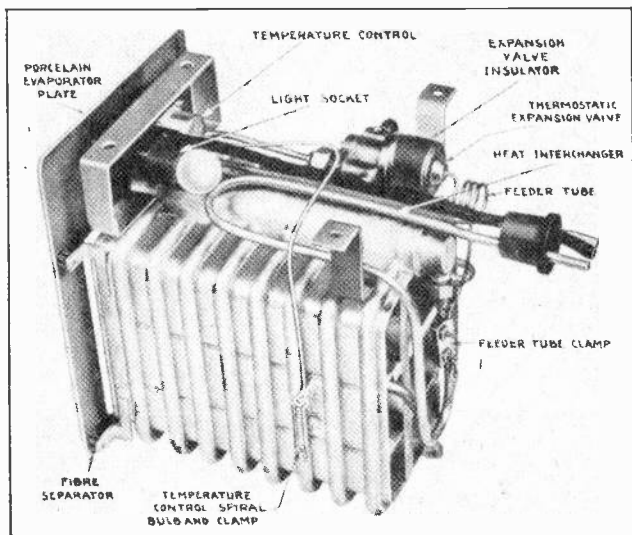

Fig. 14. Carefully examine this excellent photograph of an evaporator used in a modern household refrigerator. Note the details of construction and all the parts which are named in this view. Courtesy Fairbanks-Morse Co.

Many other types of evaporators need to be defrosted occasionally by shutting off the refrigerator until the frost melts off the tubes. Otherwise they may become so covered with frost as to prevent proper air circulation and heat transfer.

Figure 13 shows a large dry type evaporator such as frequently used for cooling large commercial refrigerator boxes, meat storage boxes, walk in coolers, etc.

EVAPORATOR TEMPERATURES

The temperature at which any given evaporator operates depends upon the application. The range of temperatures inside the refrigerated space, and the range of temperatures for the evaporator is shown in the table given below. For example, the

Electric Refrigeration

temperature in a household cabinet should be about 45 degrees, and the temperature at the evaporator to maintain this degree of cold should approximate 5 degrees.

This table may be used in conjunction with the pressure-temperature chart for, after the evaporator temperature for a given application has been determined, the correct low-side pressure needed to produce the selected evaporator temperature may be found by reference to the pressure-temperature chart.

Application	General	
	Temp. Required	Evap. Temperature
Beverage Coolers	36 to 38	18 to 28
Bottle Coolers	36 to 38	18 to 32
Candy Cases	68 to 70	25
Cases and Counters		
Top Display, Back Bunkers	40 to 42	-10 to 35
Top Display, Overhead Coil	40	0 to 35
Full Display, End Bunkers	33 to 35	5 to 40
With Platter and Top Coils	38 to 40	5 to 40
Combination, Double Duty	35 to 40	0 to 35
Delicatessen, Overhead Coil	45 to 50	0 to 40
Full Display, One Coil on Top	40	-10 to 35
Dehumidifiers	60 to 80	22 to 30
Florist Coolers	50	10 to 40
Frozen Food Cabinets	0 to 5	-5 to -15
Household Cabinets	45	5
Ice Making Cabinets	5° Brine	-5
	10° Brine	0
Ice Cream Cabinets		
Serving Cabinets	5° Brine	-15 to 15
Hardening Cabinets	10° Brine	-20 to -5
Milk Coolers and Tank Types	40	5 to 40
Dry Type	45	10
Reach-In Boxes	40	0 to 35
Room Coolers	70 to 90	15 to 45
Salad Pans, Wet Type	40 to 42	15
Frosted Type	15 to 24	0
Soda Fountain		
No Syrup Cooling	5° Brine	-20 to 25
Regenerative Type	5° Brine	-20 to 15
Walk-In Coolers		
Vegetables	50	15
Meats	44	10 to 40
Meats	40	5 to 35
Meats	36	5
Light Freezer	30	0
Sharp Freezer	20	-5
Water Coolers	45	33
	40	32
Bakeries	36 to 38	28

The above represents the range of temperatures employed for the applications indicated. The low-side pressures can be adjusted to provide the evaporator temperature desired.

Control Valves

OIL BOUND EVAPORATORS

An oil bound evaporator may be caused by the compressor slugging through an excess amount of oil. The float assembly is designed to return a certain amount of oil which naturally circulates through the system, but when the amount of oil coming through becomes excessive it is not returned fast enough and the oil tends to replace the refrigerant. The trouble in the compressor may be caused by oil baffles being out of place or the trouble may be in the design of the compressor. In this case the condition may be remedied by placing an oil separator or trap in the compressor outlet.

The trouble may also be caused by an overcharge of oil in the system.

If the float is out of calibration so that the float rides too low, oil will tend to accumulate in the evaporator, and this condition may also cause the evaporator to become oil logged.

After the cause of this trouble has been remedied, the oil may be returned from the evaporator by placing hot water in the ice cube trays. A more positive means would be to remove the evaporator and dump the oil out. If this is done the oil level in the compressor should be checked to make sure it has sufficient oil.

When overhauling a low side float system, the proper amount of oil should be placed in the evaporator.

The normal oil charge carried in these evaporators should be obtained from manufacturers specifications whenever these are available. Otherwise a good general rule to follow is to add from 4 to 6 ounces of oil to the average household evaporator. For larger evaporators increase this amount in proportion to the size of the float header.

7. CONTROL VALVES, LOW AND HIGH SIDE FLOAT VALVES.

As previously explained, all refrigerator evaporators use some kind of control valve to **limit or regulate the flow of refrigerant** to the required amount to maintain the proper cabinet temperature.

Several of the more common of these valves are as follows: **Low side float valve, high side float**

Electric Refrigeration

valve, automatic expansion valve, thermostatic expansion valve, and the capillary or choke tube.

You no doubt already have a fair understanding of the low side float valve from the views shown in Figures 5, 8, and 9

High side float valves are located in the liquid receiver.

As the liquid from the condenser accumulates in the receiver, the float rises, opens the needle valve and allows more liquid to enter the evaporator.

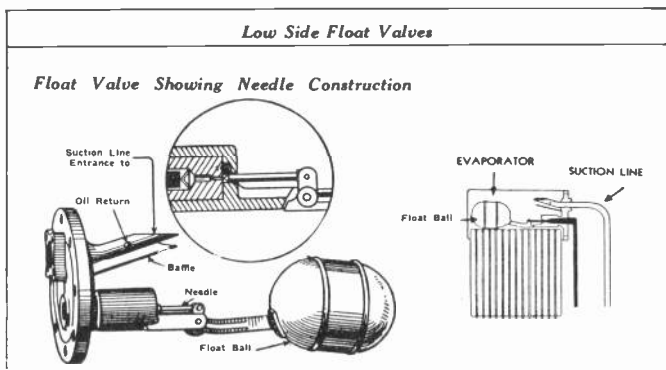

Low side float valves are located inside the drum of the flooded type evaporator and consist of the float ball or pan, float arm, pivot, body, needle and needle seat. Its operation is as follows: When the low pressure liquid evaporates the liquid level drops, causing the float to lower and due to the action of the pivot the needle is withdrawn from the valve seat, or opening, allowing additional liquid refrigerant to enter the evaporator from the high pressure liquid line.

When the liquid level rises, the float also rises and at a certain level again closes the needle valve. There are no adjustments on this type of control valve and they are calibrated or set at the factory.

Units using low side float valves require a greater quantity of refrigerant for the charge than those using high side floats or expansion valves.

Control Valves

High side float valves are located in the liquid receiver. See Figure 9. As the liquid from the condenser accumulates in the receiver, the float rises, opens the needle valve and allows more liquid to enter the evaporator.

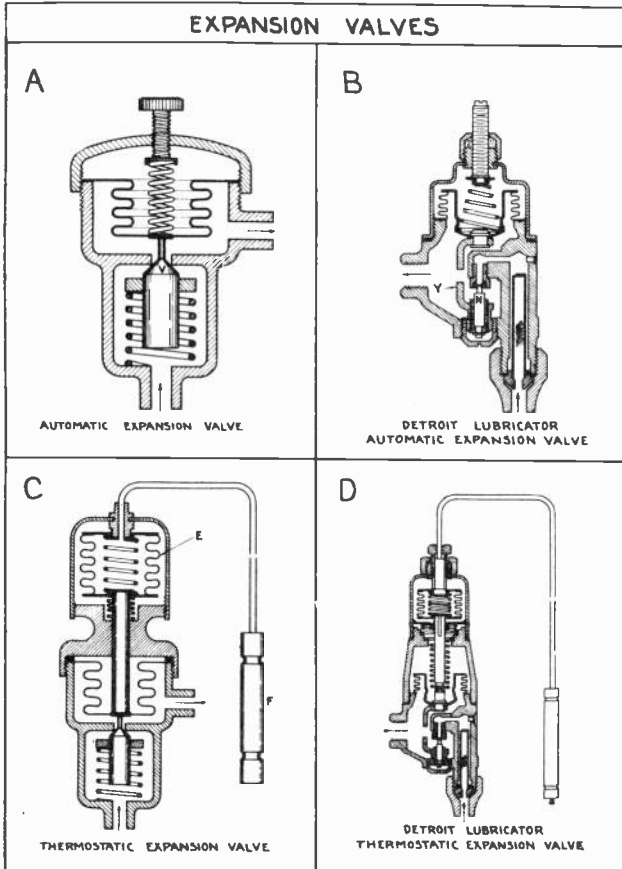

Fig. 15. The above diagrams illustrate the construction and operation of automatic expansion and thermostatic expansion control valves such as commonly used with dry type refrigerator evaporators.

When this type of valve is used, the liquid line between the float valve and evaporator becomes part of the low pressure side of the system and the tendency of the refrigerant to evaporate and expand in this line frequently causes it to frost over.

Electric Refrigeration

This can be prevented by insulating the liquid line from the point where it leaves the float chamber to the point where it enters the evaporator, and thus

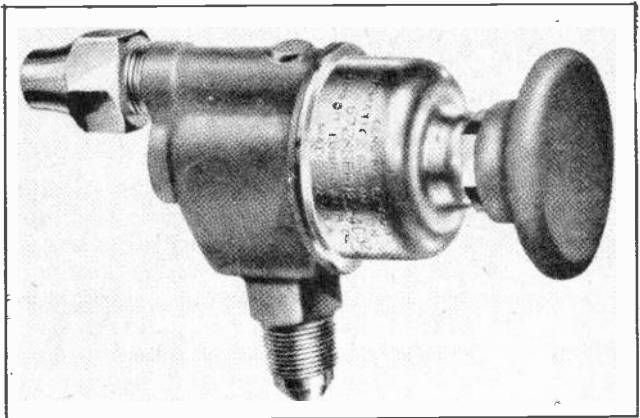
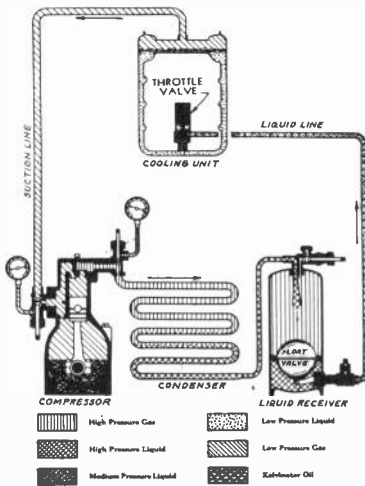

Fig. 16. Photograph of an automatic expansion valve. Note the soft rubber cap over the adjusting nut. Courtesy Detroit Lubricator Co.

preventing moisture contacting its cold surface and condensing and freezing on the tubing.

Flooded System Using High Side Float Valve



THROTTLING VALVE

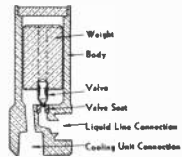

REPLACEMENT HIGH SIDE FLOAT

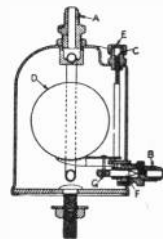

Another method recently developed for preventing frosting of the liquid line on refrigerators using

Control Valves

high side floats, is to install a throttle or choke valve in the liquid line near the evaporator. This maintains enough back pressure in the liquid line to prevent evaporation and chilling. When ordering throttle valves for this purpose, be sure to specify the type of refrigerant used.

8. CAPILLARY TUBES.

On some refrigerators a capillary or choke tube is connected in the liquid line near the evaporator and used in place of a float valve to regulate the flow of refrigerant to the evaporator. These tubes are usually made of copper with a very small opening, and from 8 to 18 feet long, and wound in a spiral or coil.

The resistance to the flow of the liquid refrigerant through the long and very small opening in the tube, restricts the flow to the evaporator and maintains sufficient pressure in the receiver and condenser. These tubes are made of the right size and length at the factory and there is no adjustment on them except by changing their length.

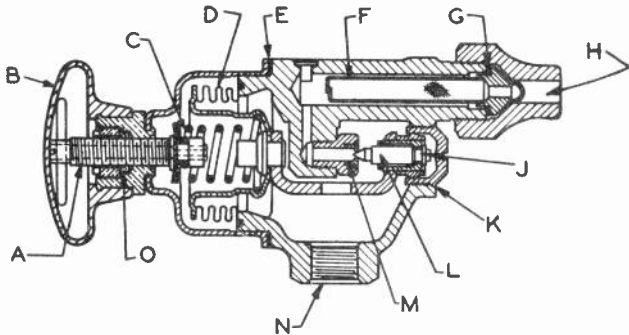

A—Adjusting screw.
B—Adjusting screw breather cap
C—Adjusting spring.
D—Bellows.
E—Moisture tight joint.
F—Strainer.
O—Copper gasket.

H—Inlet connection $\frac{1}{4}$ " copper tube.
J—Needle Swivel.
K—Plug hermetically sealed with solder.
L—Stainless steel needle.
M—Stainless steel seat.
N—Outlet connection.
O—Moisture tight packing.

Fig. 17. Sectional view of an automatic expansion valve. Carefully examine all working parts and note the names of each as marked. Courtesy Detroit Lubricator Co.

9. AUTOMATIC EXPANSION VALVES.

One of the most popular types of control valves used with domestic refrigerators is the automatic expansion valve. See Figure 15-A and B, and also

Electric Refrigeration

Figures 16 and 17 which show various views of automatic expansion valves. These valves are operated by the pressure of the gas in the evaporator or low side.

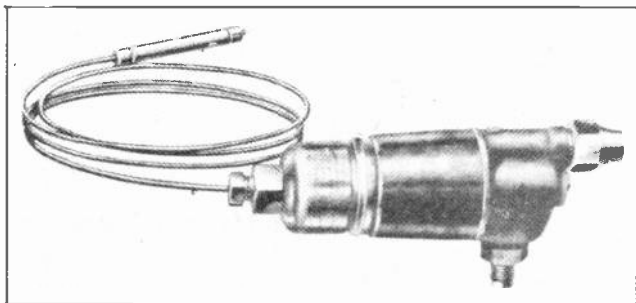

Fig. 18. Photo showing a thermostatic expansion valve with its power bulb and connecting capillary tubing. Courtesy Detroit Lubricator Co.

Figure 15-A shows a diagram of a very simple expansion valve, and if you will carefully observe its operating principle you will find that other types of slightly different construction, nevertheless operate on very much the same principle.

The liquid line supplies liquid under pressure to the bottom connection of this valve. If there is plenty of liquid in the evaporator, the pressure from the evaporated gas will push upward on the siphon bellows and hold the valve "V" closed.

When the liquid supply in the evaporator is reduced and the gas pressure on the bellows is lowered, the top spring and atmospheric pressure combined will force the valve open and permit more liquid to flow into the evaporator, through the right hand opening. Therefore, we can see that these valves operate automatically to permit the flow of liquid refrigerant to the evaporator as needed.

The valve shown as 15-B operates on the same principle, except that the needle valve "N" is connected to the siphon bellows by means of the yoke "Y."

Note the adjusting screws on the top of both of these expansion valves. By means of these screws, the valves can be adjusted to maintain the right amount of refrigerant in the evaporators. Turning the screws clockwise increases the amount of refriger-

Control Valves

erant, while turning them counter clockwise decreases the flow of refrigerant.

Automatic expansion valves maintain practically constant low side pressure all the time the compressor is in operation, regardless of the evaporator temperature.

Carefully examine and note the names of all parts of the expansion valve shown in Figure 17. Note the strainer "F" in the liquid line opening. Sometimes these strainers become clogged and prevent proper flow of liquid refrigerant. They are therefore removable for cleaning.

The rubber cap over the adjusting screw is to prevent moisture entering the valve body. Grease is sometimes packed around this screw for the same purpose in case there is no protective cap.

10. THERMOSTATIC EXPANSION VALVES.

Thermostatic expansion valves are very similar in general construction and use to the automatic expansion valves, except that the thermostatic valves have an extra control bellows "E" and a power bulb "F" to make these valves self-adjusting. See Figures 15-C and D.

The power bulb is filled with a volatile liquid and attached to the top bellows chamber by means of a small copper tube. The power bulb is clamped to the suction line near the evaporator as shown in Figures 6 and 7 in Lesson 94, and Figure 14 in this lesson. Carefully note the arrangement of the power bulbs and thermostatic valves in each of these figures.

When the evaporator or suction line temperature raises, the volatile liquid in the power bulb expands and applies increased pressure on the bellows and push rod, opening the valve to admit more refrigerant. As soon as the added refrigerant has chilled the evaporator and reduced its temperature and that of the suction line, the liquid in the power bulb contracts or the vapor condenses and releases the pressure on the bellows, allowing the valve to close.

This type of valve is very commonly used in commercial refrigerating units, and on direct expansion air-conditioning units, as well as on some household

Electric Refrigeration

units. Note the adjusting nut at the top of the valve in Figure 15-D.

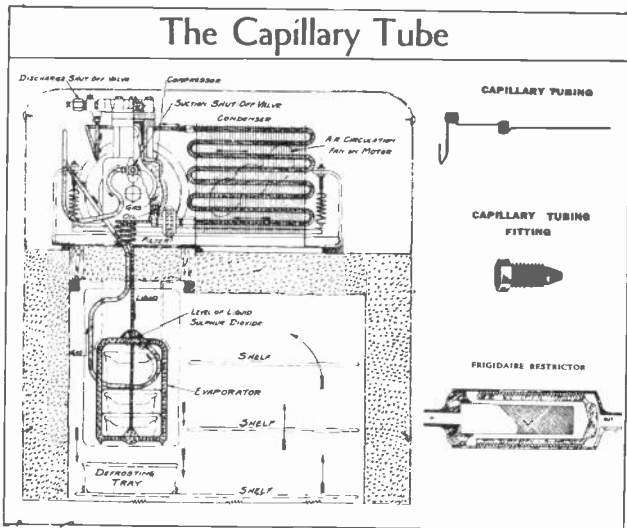

The capillary tube liquid control device is used with flooded type evaporators. In some few cases it is used with the continuous tube or dry type evaporators in which case an accumulator must be used at the outlet end of the evaporator to trap and evaporate any liquid which may be slopped thru the evaporator and thus prevent it from frosting the suction line.

The capillary tube consists of a length of tubing of very small inside diameter tubing (about $1/64''$). This tube is designed to feed the necessary amount of refrigerant to the evaporator and also to produce the correct pressure drop from the high to the low side. The longer the tube, and the smaller the diameter, the more restriction is offered to the flow of liquid. A good filter is always located ahead of this tube to prevent it from becoming clogged. The Frigidaire restrictor consists of a threaded plug inside a brass-shell so arranged that the liquid has to follow the path of the thread. This provides exactly the same action as a capillary tube.

Control Switches

11. ELECTRIC CONTROL PRESSURE SWITCHES.

One of the smallest, and yet one of the most important units on an electric refrigerator is the electric control switch. This unit starts and stops the motor and compressor, and controls the running time and the temperature of the refrigerator. These switches and their operating mechanisms are often called **pressure-stats** or **thermo-stats**, according to their method of operation.

Pressure type control switches have electrical contacts which are opened or closed by a sylinder bellows which is connected by a tube to the low pressure side of the refrigerator unit, so that the switch is operated by the variations in gas pressure in the evaporator of suction line. See Figures 2, 5,

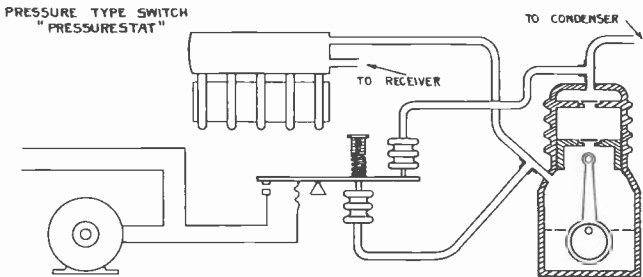

and 7 in Lesson 94 and note the arrangement of the control switches with these units. As the cabinet temperature increases the gas pressure in the evaporator and suction line also increases, causing the bellows to expand and close the switch to start the motor.

As the motor and compressor continue to operate the cabinet is cooled and the gas pressure in the evaporator and suction line are reduced. This allows a spring to collapse, the bellows, opening the switch and stopping the motor and compressor until the low side gas pressure again rises.

Figure 20 shows one common type of pressure switch which is used extensively on household and

Electric Refrigeration

small commercial refrigerators. Carefully note all the parts which are marked in this view. These switches have an adjusting nut to change the temperature range at which the refrigerator will operate. See this range adjusting nut in Figure 20.

APPROXIMATE PRESSURE CONTROL SETTINGS

Type of Evaporator	Application	Sulphur Dioxide		Methyl Chloride		Freon-12	
		Off	On	Off	On	Off	On
Flooded-direct	Commercial or Domestic refrigerator	8 in.	6 lb.	5 lb.	17 lb.	10 lb.	25 lb.
Flooded or dry-direct	Ice cube maker	14 in.	0 lb.	0 lb.	11 lb.	4 lb.	17 lb.
Flooded-indirect	Ice cream Cabinet	14 in.	6 lb.	0 lb.	6 lb.	4 lb.	12 lb.
Flooded-indirect (Sweet water bath with ice accumulation on coils)	Beverage or water cooler	0 lb.	6 lb.	11 lb.	19 lb.	17 lb.	27 lb.
Dry-indirect (sweet water bath with ice accumulation on coil)	Beverage or water cooler	2 in.	6 lb.	10 lb.	19 lb.	16 lb.	27 lb.
Dry-direct fin coil (non-frost)	Walk-in-cooler; Reach-in-cooler; Show case	6 in.	10 lb.	6 lb.	24 lb.	12 lb.	33 lb.
Forced draft unit coolers	Walk-in-cooler; Reach-in-cooler	0 lb.	12 lb.	12 lb.	27 lb.	18 lb.	36 lb.
Dry-indirect fin coils	Ice-cream trucks & ice cream hardening rooms	16 in.	2 in.	3 in.	9 lb.	2 lb.	15 lb.
Dry-indirect (Eutetic Brine Solution)	Ice-cream trucks	18 in.	14 in.	6 in.	0 lb.	1 lb.	4 lb.
Dry direct fin coils	Air Conditioning (Comfort Cooling)	9 lb.	21 lb.	23 lb.	40 lb.	32 lb.	52 lb.

PRESSURE SWITCH SETTINGS

As the temperature in the evaporator is determined by the pressure in the evaporator, it follows that this temperature can be adjusted by altering the pressure setting of the pressure type of control. The table of approximate pressure switch control settings indicates the cut-in and cut-out pressures used on various types of evaporators for the applications indicated. For example, the table indicates that the correct pressure switch settings for a do-

Control Switches

mestic or commercial type of refrigerator that employs a flooded and direct type of evaporator is 8 inches of vacuum for the cut-out pressure, and 6 pounds for the cut-in pressure. Operating between these limits, the proper evaporator temperature would be maintained.

With the above setting, the switch would start the unit when the pressure in the low side of the system rose to 6 pounds. The compressor would then run until the low side pressure was reduced to 8 inches of vacuum at which time the switch would operate to stop the machine. The unit would then remain idle until the pressure on the low side again reached 6 pounds when the cycle would be repeated.

Note that the pressure switch setting is different for different refrigerants. The type of machine mentioned above would need a cut-in setting of 17 pounds pressure and a cut-out setting of 5 pounds if methyl chloride were used instead of sulphur dioxide; therefore, to set pressure switches correctly, one must know the type of evaporator used, the application of the refrigerator, and the kind of refrigerant employed.

12. COLD CONTROL SWITCHES.

Some control switches often called "cold control" units are operated by a power bulb attached to the evaporator or suction line, instead of by a direct gas

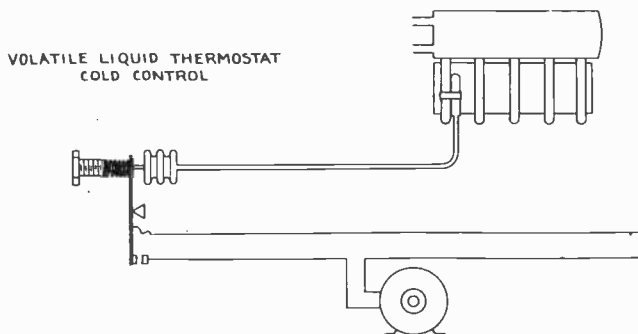

line connection into the low pressure side of the system. These are called thermal control switches, because the pressure to expand or contract their

Electric Refrigeration

bellows is governed by the temperature of the volatile liquid in the power bulb.

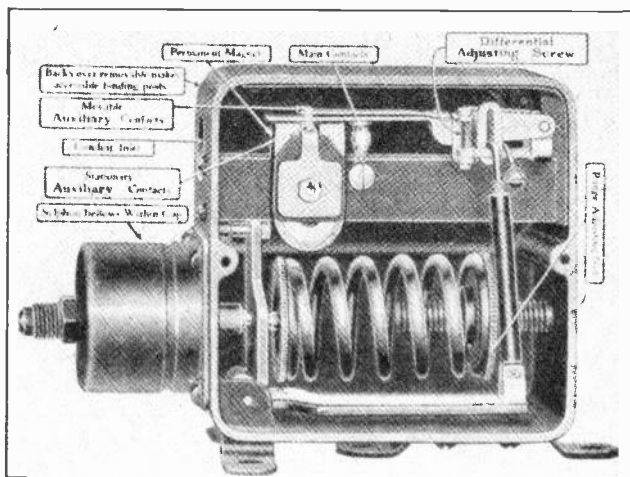

Fig. 20. This view shows the construction and parts of a pressure type electric control switch such as used to start and stop the motor in electric refrigerators and thereby maintain proper operating temperatures. Courtesy Penn Electric Switch Co.

Figure 21 shows a very popular type of thermal control switch with its power bulb and cold control adjustment. This type of switch can be installed on any ordinary refrigerator in a few minutes, and many service men make good money equipping old style units with this new switch and cold control.

Large commercial refrigerators may require motor starters to start their heavy duty motors. In such cases the control switch is often used to close a circuit to a magnetically operated motor starter.

13. BI-METAL THERMOSTATS.

Some refrigerator control switches use a curved strip of two dissimilar metals or a thermostat element to tilt or operate a mercury switch that is connected in the motor circuit.

You are already familiar from earlier lessons, with the manner in which two unlike strips of metal will bend or warp if riveted or welded together and then heated. By anchoring one end of a spiral strip of

Control Switches

brass and nickel steel, and attaching the mercury switch tube to the free end, the switch will tilt and close or open a circuit whenever temperature changes cause the strip to bend. These switches are also adjustable by rotating or shifting the element housing a small amount in either direction.

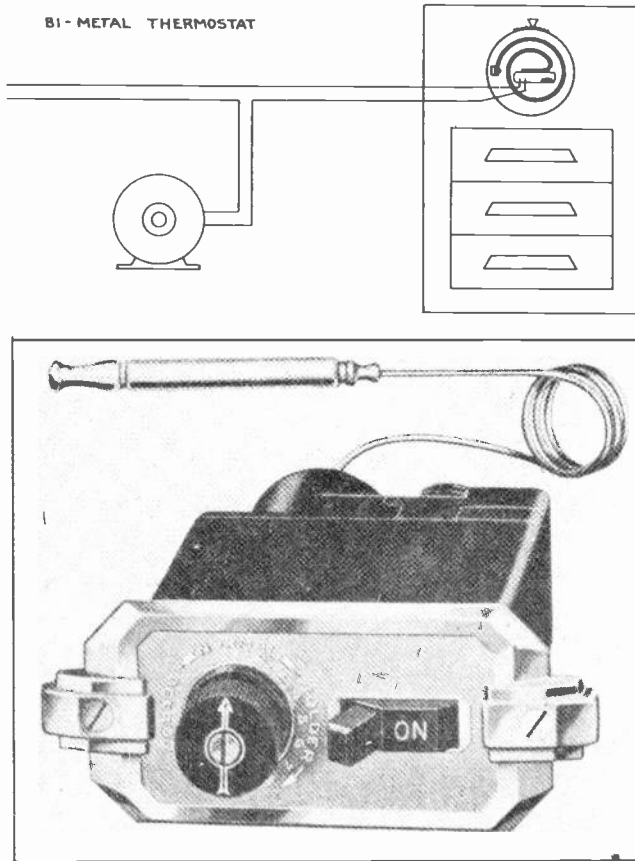

Fig. 21. Photo showing a thermal operated control switch of a type which can be conveniently attached to any household refrigerator. Note the on-and-off switch and the cold control knob. Courtesy Tagliabue Manufacturing Co.

14. PENCIL TYPE SWITCHES.

This type of switch is a self-contained unit having its power bulb in to the lower part of the switch.

Electric Refrigeration

This power bulb is filled with a low freezing point solution of alcohol and water.

The whole switch unit is clamped to the side of the evaporator like the unit shown in Fig. 9. When the evaporator temperature lowers the solution freezes and expands enough to open the switch contacts and stop the motor and compressor. When the evaporator temperature rises the solution melts and contracts, allowing the switch to close and start the motor once more.

15. ELECTRIC MOTORS.

Electric motors used to drive refrigerator compressors range in size from $\frac{1}{6}$ h.p. to $\frac{1}{2}$ h.p. for household units, and from $\frac{1}{2}$ h.p. to several hundred h.p. each for commercial units.

These motors may be either D.C. or A.C. according to the available power supply. As most homes are supplied with alternating current, the great majority of domestic refrigerators use A.C. motors.

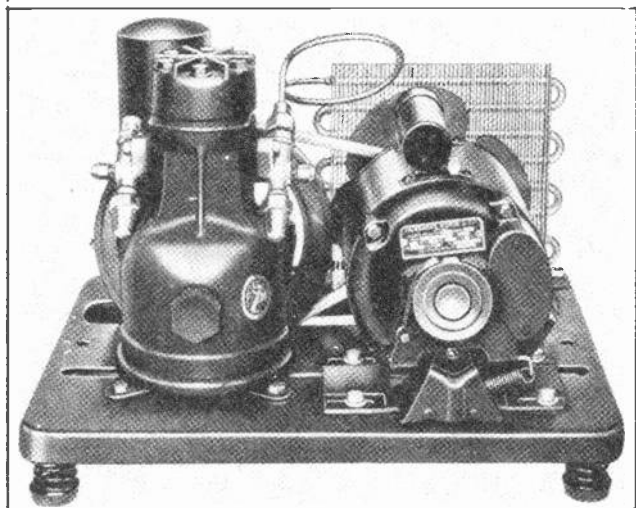

Fig. 23. Note the mounting arrangement of the capacitor type drive motor on this condensing unit. Courtesy Fairbanks-Morse Co.

A.C. refrigerator motors for domestic units are commonly of the repulsion induction, single-phase, split-phase, or capacitor motor types. Large com-

Refrigerator Motors

mercial refrigeration plants use squirrel cage or slip ring induction motors and synchronous motors.

Many of the earlier refrigerators used the commutator type repulsion motor because of its good starting torque at moderate starting currents. However, this motor has the disadvantage of commutator and brush wear and troubles, and is somewhat noisier in operation.

Single-phase split-phase induction motors with centrifugal starting switches are extensively used, especially with rotary compressors where the required starting torque is not so great.

A more recent type of capacitor motor, using a capacitor or condenser to obtain the split-phase effect and improved torque, has become increasingly popular in recent years. These units are very quiet in operation, have good starting torque, and very few wearing parts, and are therefore becoming more and more extensively used for household and small commercial refrigerators.

All of these types of motors have been explained in earlier lessons on A.C. motors so we will not devote much time to them here. However, the electric motor is such an important part of any electric refrigerator that its care and service requirements should never be overlooked by the refrigeration service man.

Figure 23 shows a capacitor type motor with its condenser mounted on top of the motor. These condensers occasionally puncture or burn out and can be easily and quickly replaced with a new unit at very moderate cost.

Motors in household refrigerators are frequently mounted on rubber or spring mountings to reduce vibration and noise. Note the special spring and belt tightener support on the motor in Figure 23.

16. CABINETS.

The cabinet is one of the most important parts of a refrigerator, because it not only serves as a convenient storage space for the food articles to be preserved, but it should also prevent as much as possible of heat leakage from the warm air in the room to the cold interior of the cabinet.

Electric Refrigeration

Therefore, the walls of refrigerator cabinets are insulated with several inches of cork, hair felt, asbestos fibres, tree bark, kapok, corrugated paper, aluminum foil, dry zero (ciba tree seed pod fibres), etc.

The doors are sealed with rubber or composition gaskets to close up all possible cracks through which warm air and heat might enter. Great reductions in the cost of electric power for operating electric refrigerators can be made by use of proper cabinet insulation. Cabinet wall insulation is often wrapped in water-proof paper or coated with asphalt paint to prevent absorption of moisture which would destroy the heat insulating value of the material.

The food storage compartment and evaporator or cooling unit are located inside the insulated space. The motor, compressor and condenser, or heat dispensing units are of course located outside of this space; usually in the bottom, although sometimes at the top of the cabinet. The section of the cabinet in which they are located is not heat insulated, but instead should have a free circulation of air to carry away the heat they liberate.

Modern household refrigerator cabinets are generally made of pressed steel, and are streamlined, attractively designed, and covered with high-grade enamel in white or other colors. DeLuxe models have the inside of the cabinet lined with porcelain enamel, and some cabinets are porcelain enameled inside and out.

Domestic cabinets range in size from 4 cu. ft. capacity to 8 cu. ft. capacity. They are equipped with wire grill shelves to permit free circulation of cold air in the cabinet. Some units have convenient sliding shelves, door shelves and trays, interior electric light, and other special conveniences.

Small cabinets usually have a single door, while larger ones may have two or more doors. Doors that latch on the right open from right to left are called left-hand doors, while those that latch on the left and open from left to right are called right-hand doors. Door latches are made to hold doors tightly closed, and the doors should be opened only

Cabinets

when necessary and then promptly closed again, to avoid wasteful operation and excess frosting of evaporator coils due to moisture condensed from the air.

Cabinets and coolers for meat markets, stores, and other commercial units are generally of wood construction. Quite frequently they consist of an outside wall of $\frac{7}{8}$ " oak, then a layer of waterproof paper, and an inner wall of $\frac{7}{8}$ " tongue and grooved ash boards which are coated with odorless varnish or shellac.

The thickness of cork insulation, or its equivalent, recommended for various cabinet temperatures are as follows:

- 20 degrees F. to —5 degrees F., 8 inches of cork.
- 5 degrees F. to 5 degrees F., 6 inches of cork.
- 5 degrees F. to 20 degrees F., 5 inches of cork.
- 20 degrees F. to 35 degrees F., 4 inches of cork.
- 35 degrees F. to 45 degrees F., 3 inches of cork.
- 45 degrees F. and up 2 inches of cork.

EXAMINATION QUESTIONS

1. A. Name 3 types of refrigerator compressors.
B. Name ten important parts of reciprocating compressors.
2. Name three types of valves used in refrigerator compressors.
3. Briefly describe a siphon, bellows type shaft seal and state its purpose.
4. Name two general types of condensers.
5. Name two general types of evaporators.
6. Why are evaporators and condensers commonly made of copper?
7. Briefly explain the difference between automatic expansion valves and thermostatic expansion valves.
8. What is the purpose of the electric control switch in an electric refrigerator?
9. Name three types of electric motors commonly used with household refrigerators.
10. Briefly describe the construction of a domestic refrigerator cabinet.

Electric Refrigeration

REFRIGERANTS, LUBRICATING OILS

It is highly important for the refrigerator service man to have a good general understanding of the nature and characteristics of the more commonly used refrigerant chemicals. This knowledge will help you to better understand the operation, behavior and troubles of different types of refrigerators using these various refrigerants, and it will also help you to properly and safely handle the refrigerant chemicals when charging, installing or servicing refrigerators.

We have already mentioned that a **refrigerant** is any chemical that is used for absorbing, transferring and releasing heat in the process of refrigeration. It has also been shown that air or water can be used, but that they are not nearly as efficient as certain other chemical refrigerants which absorb heat more readily by evaporation at low temperatures, and give off heat easily by condensation at lower pressures.

A good refrigerant should have as many as possible of the following properties:

1. High latent heat of evaporation, meaning high heat absorbing capacity.
2. Low boiling point at atmospheric pressure, meaning easy to evaporate, and thus absorb heat.
3. Low condensing pressure and temperature, meaning easy to condense and release its heat.
4. Non-injurious to health, lungs and eyes.
5. Non-inflammable and non-explosive.
6. Non-injurious (not corrosive) to metals.
7. Non-injurious to lubricating oils.
8. Stable in chemical composition (does not change chemical form).
9. Easy to test for leaks.
10. Low in cost.

1. COMMON REFRIGERANTS

Among the most commonly used refrigerants are sulphur-dioxide (SO_2), methyl-chloride (CH_3CL), freon or "F12" (CCL_2F_2), ammonia (NH_3), carbon-dioxide (CO_2), methylene-chloride or "carrene"

Refrigerants

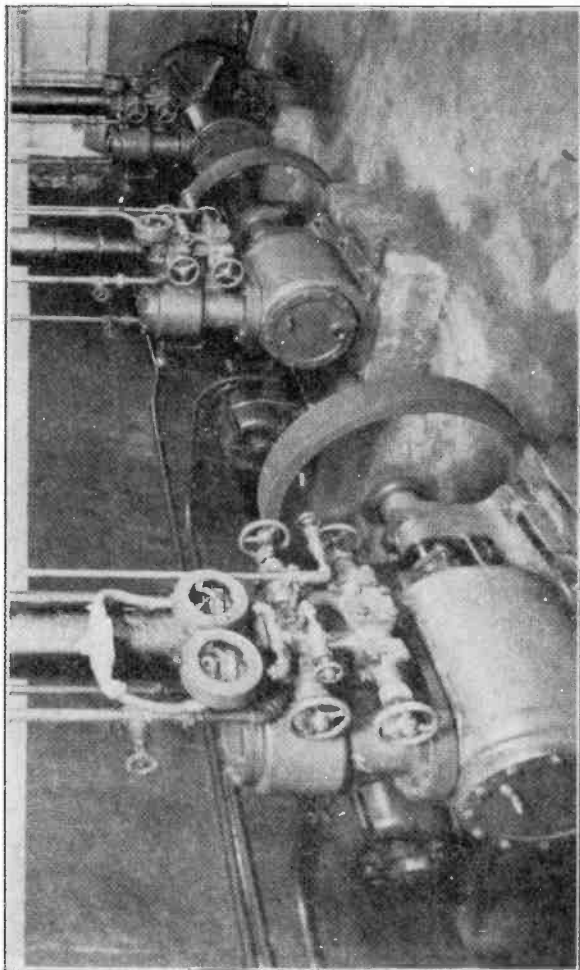

Fig. 1. This photo shows three twin-cylinder refrigeration compressors, all driven by "V" belts to electric motors and supplying refrigeration for a large commercial installation. Courtesy Carrier Co.

Electric Refrigeration

(CH_2CL_2). Isobutane or "Freezol" C_4H_{10} Methyl formate and "F114" are also used in some units. The letters in parenthesis after each refrigerant are the chemical symbols or formulas for these chemicals. For example SO_2 means 1 part sulphur and 2 parts oxygen; CH_3CL means 1 part carbon, 3 parts hydrogen, and 1 part chlorine, etc.

Sulphur-dioxide is one of the most commonly used refrigerants for household refrigerators. Methyl-chloride is also extensively used in household units and in small commercial units. Freon is one of the more recently developed refrigerants which has become very popular in both domestic and commercial units. Ammonia is one of the most efficient and most commonly used refrigerants in large commercial refrigerating plants, ice plants, etc., and is also used in gas operated absorption type units for home use.

The more common of these refrigerants can be purchased from refrigeration supply houses in convenient sized steel drums, for use in filling or "charging" refrigerators. SO_2 is sold in 5, 10, 25, 35, 70 and 150 lb. drums. CH_3CL is sold in 3, 6, 15, 40, 60, 90, and 130 lb. drums. Ammonia in 50, 100 and 150 lb. drums, etc. See Fig. 2.

Some of the most common refrigerators and the refrigerants they use are as follows:

Absopure.....	Methyl-chloride
Bohn.....	Sulphur-dioxide
Brunner.....	Methyl-chloride
Buckeye ($1\frac{1}{2}$ to 2 lbs.).....	Sulphur-dioxide
Carbondale.....	Freon or methyl-chloride
Carrier.....	Freon, sulphur-dioxide, methyl
Coldspot (1 lb. 14 oz.).....	Sulphur-dioxide
Copeland (1 to $1\frac{1}{4}$ lbs.).....	Methyl-chloride or isobutane
Crosley (2 to $2\frac{1}{4}$ lbs.).....	Sulphur-dioxide or "Thermon"
Electric.....	Sulphur-dioxide
Electrokold ($1\frac{1}{2}$ lbs.).....	Sulphur-dioxide
Electrolux (gas unit).....	Ammonia
Fairbanks-Morse ($1\frac{1}{2}$ lbs.)	Sulphur-dioxide

Refrigerants

Frigidaire (1 to 2½ lbs.)	Freon, sulphur-dioxide, or F114
General Electric (1 to 2 lbs.)	Sulphur-dioxide or methyl-formate
Gibson (2 to 3½ lbs.)	Sulphur-dioxide
Graybar Ilg Cold (10 oz.)	Isobutane
Grunow (3 to 4 lbs.)	Carrene
Holmes	Ethyl-chloride
Hot Point (1 to 3 lbs.)	Sulphur-dioxide
Howe	Methyl-chloride
Ice-O-Matic (2½ to 5 lbs.)	Methyl-chloride
Icyball (Crosley)	Ammonia
Jack Frost	Sulphur-dioxide
Kelvinator (2 to 3 lbs.)	Sulphur-dioxide
Leonard	Freon or sulphur-dioxide
Lipman	Methyl-chloride, freon or ammonia
Majestic (1½ lbs.)	Sulphur-dioxide
Mayflower (1½ to 4 lbs.)	Sulphur-dioxide
Nash	Methyl-chloride
Norge (5½ lbs.)	Sulphur-dioxide
Reliance	Freon or methyl-chloride
Servel (1 to 1¾ lbs.)	Methyl-chloride
Stewart-Warner (5 lbs.)	Sulphur-dioxide
Sunbeam (1 lb. 14 oz.)	Sulphur-dioxide
Universal	Sulphur-dioxide or Freon
Wayne	Sulphur-dioxide
Westinghouse	Freon or sulphur-dioxide
York	Freon or ammonia
Zerozone (1 to 1¼ lbs.)	Sulphur-dioxide

You will note that the approximate amount of refrigerant charge for recent models of domestic units is given for some of the above machines, merely to give you a general idea of the amount of refrigerants used.

Fig. 3 shows the boiling points of several common refrigerants at various pressures and vacuums, and Fig. 4 gives the pressure-temperature characteristics of common refrigerants. Carefully examine these charts as they contain valuable information

Electric Refrigeration

which you may often wish to refer to when working with refrigerants.

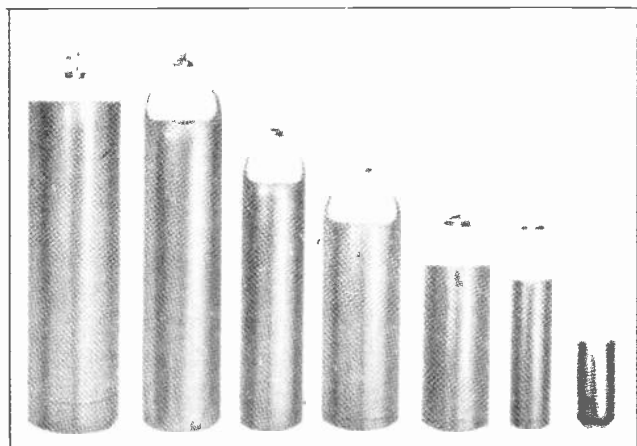

Fig. 2. Several types and sizes of metal cylinders or drums which are used for shipping and handling refrigerant chemicals.

2. SULPHUR-DIOXIDE

Sulphur-dioxide is a colorless liquid and is obtained by burning sulphur and air or oxygen. It remains in liquid form when kept sealed under pressure but vaporizes very rapidly when exposed to air. SO_2 vapor has a very strong and unpleasant sulphur odor which is highly irritating to eyes, nose, throat and lungs, if inhaled in strong mixtures.

SO_2 is non-inflammable and non-explosive, and has a boiling point of 14 degrees F. at atmospheric pressure. SO_2 is a very stable chemical and does not break down under the pressures and temperatures encountered in ordinary refrigerators. It will not harm lubricating oils unless it is allowed to absorb moisture.

Sulphur-dioxide absorbs a certain amount of lubricating oil and circulates it through the system, thus actually aiding lubrication. Any surplus oil will float on the surface of the SO_2 liquid as the oil is lighter in weight than SO_2 .

Refrigerants

Dry SO_2 having less than .003 per cent of moisture is non-corrosive to the metals commonly used in refrigerator units. If moisture, even in very small amounts, is allowed to get into SO_2 , it will form sulphurous acid which will attack iron and steel, and may cause the compressor pistons, cylinders

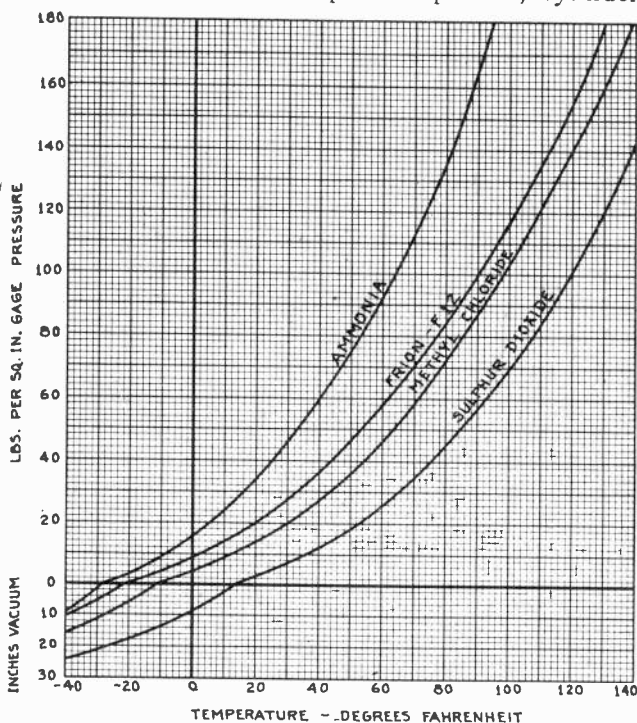

Fig. 3. The above chart shows the boiling points at various pressures and -vacuums, of several of the most commonly used refrigerants. Examine this chart carefully as you may wish to use it for future reference.

and bearings to "seize" or stick and stop the compressor. In such cases it is best to remove the entire SO_2 charge, overhaul the compressor, thoroughly dry out the entire system and replace the refrigerant with a new charge of dry SO_2 .

A simple test for moisture in SO_2 is to immerse a small piece of clean bright steel in a small quantity of SO_2 which has been drawn from the refrig-

Electric Refrigeration

TEMP. °F	SULPHUR DIOXIDE SO ₂	METHYL CHLORIDE CH ₃ CL	FREON F-12	METHYLENE CHLORIDE CARBENE CH ₂ CL ₂	ISOBUTANE (CH ₃) ₂ CH	AMMONIA NH ₃	CARBON DIOXIDE CO ₂
-40	23.5	15.8	11.0			8.7	
-35	22.4	13.7	8.4			5.4	
-30	21.2	11.4	5.5			1.6	
-25	19.6	9.1	2.3			1.3	
-20	17.9	6.1	0.5		14.6	3.6	204.8
-15	16.1	3.0	2.4		13.0	6.2	227.9
-10	13.9	0.2	4.5	28.08	11.0	9.0	255.3
-5	11.5	2.0	6.8	27.81	8.8	12.2	275.5
0	8.9	3.8	9.2	27.48	6.3	15.7	298.8
5	5.9	6.2	11.9	27.11	3.3	19.6	324.8
10	2.6	8.7	14.7	26.69	0.2	23.8	853.3
15	0.5	11.2	17.7	26.19	1.6	28.4	384.8
20	2.5	13.6	21.1	25.06	3.5	33.5	417.3
25	4.6	17.2	24.6	24.98	5.5	39.0	452.3
30	7.0	20.6	28.5	24.27	7.6	45.0	488.3
35	9.6	24.3	32.6	23.48	9.9	51.6	527.3
40	12.4	28.1	37.0	22.63	12.2	58.6	565.5
45	15.5	32.5	41.7	21.72	14.8	66.3	604.3
50	18.8	36.3	46.7	20.67	17.8	74.5	646.3
55	22.4	46.3	52.0	19.49	20.8	83.4	686.8
60	26.2	48.1	57.7	18.19	24.0	92.9	733.3
65	30.4	52.8	63.7	16.72	27.5	103.1	783.8
70	34.9	57.8	70.1	15.09	31.1	114.1	836.8
75	39.8	65.2	76.9	13.43	35.0	125.8	887.3
80	45.0	72.3	84.1	11.54	39.2	138.3	940.3
85	50.6	79.4	91.7	8.44	43.9	151.7	
86	51.7	80.8	93.2	8.22	44.8	154.5	
90	56.6	87.3	99.6	7.32	48.6	165.9	
95	62.9	95.4	108.1	5.02	53.7	181.1	
100	69.8	102.3	116.9	2.40	59.0	197.2	
105	77.2	110.4	126.2	0.19	64.6	214.2	
110	85.0	118.3	136.0	1.62	70.4	232.3	
115	93.3	127.8	146.5	3.12	76.7	251.5	
120	106.2	139.3	157.1	4.75	83.3	271.7	

Fig. 4.—Table showing the temperature-pressure relations of common refrigerants. The figures above the black lines indicate vacuum while those below the black divider lines indicates pressure. For example, the pressure of sulphur-dioxide in a closed container at 70 degrees F. would be 34.9 pounds, methyl 57.8 pounds, Freon 70.1 pounds, etc.

Refrigerants

erator unit and placed in a dry glass covered with a dry cloth. Allow the SO_2 to evaporate and examine the surface of the steel for dark spots or signs of corrosion, which will develop, if moisture is present.

3. TESTING FOR LEAKS. SAFETY PRECAUTIONS:

Refrigerators using sulphur-dioxide refrigerant can be tested for leaks with a small cloth or brush soaked in 26 per cent ammonia. By passing this ammonia soaked swab along near the tubing, valves and parts of the unit, a cloud of white smoke-like vapor will appear when the ammonia gets near to any SO_2 leak. **Do not get aqua ammonia on copper or brass fittings as it will corrode them.**

In case of a large leak or very much SO_2 vapor in the air, it will have a strong irritating odor when inhaled, and serves to warn persons to leave any room in which it may be free.

Strong SO_2 vapor is very irritating to the nose, eyes, throat and lungs, and service men should **always have available a gas mask**, equipped for SO_2 for any emergencies when working with machines using this refrigerant.

Goggles should be worn to protect the eyes wherever there might be any chance of SO_2 splashing or squirting into them. In case of SO_2 getting into the eyes it should be immediately washed out with clean oil and a doctor should be consulted.

While SO_2 vapor will usually not be inhaled in sufficient quantities to be seriously harmful to humans, it may cause illness if too much is inhaled. It may also be fatal to birds and other pets. Therefore, any pets should be removed from a room in which SO_2 vapor is present. SO_2 is also injurious to plants.

Sulphur-dioxide should always be handled with extreme caution. It can be neutralized by discharging it through a jug of strong lye water. Ammonia vapor also neutralizes SO_2 vapor.

Low side operating pressures on machines using SO_2 generally range from 0 gauge pressure to 8"

Electric Refrigeration

vaccum, with average refrigerant temperature of about 5 degrees F. High side pressures with SO_2 generally range from 4 lbs. below to 4 lbs. above the temperature of the cooling air.

4. METHYL-CHLORIDE

Methyl-chloride is very extensively used in domestic refrigerators and in small commercial units. Methyl-chloride is a mixture of chlorine, hydrogen and carbon. It can be maintained in liquid form if kept under pressure or at temperatures below -11 degrees F. When exposed to air at room temperatures, it boils or evaporates rapidly. The vapor is colorless and sweet smelling.

Methyl-chloride has a boiling point of about 11 degrees below zero F. (-11 degrees F.). It is inflammable (combustible) and explosive when mixed with air in proportions of about 8 to 17 per cent methyl by volume.

However, there is little danger of explosions with methyl-chloride as the amount of methyl used in an ordinary household refrigerator, if mixed with the air in the average kitchen would not make a mixture nearly strong enough to explode. It should be kept away from flames however.

Methyl-chloride is a stable chemical and does not harm or dilute lubricating oils objectionably. It does not mix with water. Therefore any water that might get into a refrigerator using methyl-chloride can be removed by a **dehydrator** or filter unit containing activated alumina or calcium oxide, placed in the liquid line.

Low side operating pressures of systems using methyl-chloride generally range from 5 to 12 lbs. gauge pressure. High side operating pressures may range from 15 to 35 lbs. above the temperature of the condenser cooling air.

Methyl-chloride vapor when inhaled in considerable quantity has an intoxicating effect on humans, and excessive exposure to the vapor may cause illness. Anyone becoming ill from over exposure to methyl fumes should be placed in fresh air and encouraged to breath freely.

Refrigerants

Goggles should be worn to protect the eyes from any direct contact with liquid methyl-chloride, as it will boil or evaporate so rapidly when in contact with warm flesh that the tissues would be frozen.

Methyl-chloride leaks can be located by covering suspected joints or parts with a film of soap suds or oil and watching for bubbles. Another method is to use a Halide torch, the flame of which will

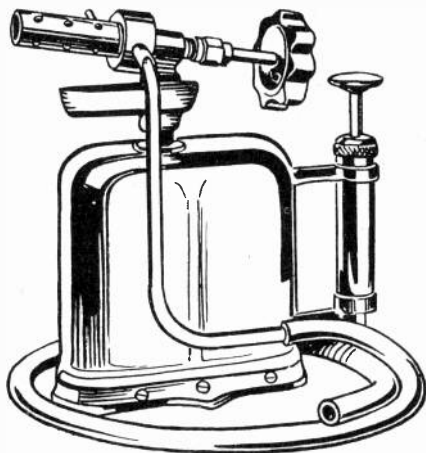

Fig. 5. This view shows a Halide torch of the type used for testing refrigerating systems for leaks. Note the rubber breather tube, the end of which is held near the suspected joints when testing for leaks.

turn from pale blue to blue-green in the presence of very minute quantities of methyl vapor. See Fig. 5. The end of the rubber breather tube is held near to the suspected joints or fittings when testing for leaks.

The Halide torch burns alcohol (U. S. chemical formula No. 5). Another type of torch which burns prestolite gas is also used for leak testing.

If the air in a room is all mixed with strong methyl vapor this type of torch or lamp is of little value, as the flame burns green continually and will not show where the leak exists. However, if the surrounding air is pure so that the flame

Electric Refrigeration

normally burns blue, then when the breather tube of the torch is brought near to the leak, the flame turns green.

5. FREON

The chemical name for Freon or F12 is dichlorodifluoromethane (CCl_2F_2) (But who cares? Call it Freon or F12.) It is made by substituting fluorine for the chlorine in carbon tetra-chloride. Freon vapor is colorless and practically odorless, and has a boiling point of about -22 degrees F. at atmospheric pressure.

One of the distinct advantages of Freon is that it is non-inflammable, non-irritating and non-toxic. However, it has the disadvantage of somewhat lower latent heat value than methyl or SO_2 .

Freon is from 3 to 4 times as dense as methyl-chloride or sulphur-dioxide, and therefore all tubing, valves and fittings in a refrigerating system using Freon should be made larger to permit free circulation of the proper amount of refrigerant.

Freon mixes readily with lubricating oils and does not harm their lubricating properties. However, oils of higher viscosity, about 150 to 300, and entirely free of moisture should be used with Freon.

All moisture should be kept out of systems using either Freon or methyl-chloride, or it may form ice at the control valves and interfere with liquid flow to the evaporators. Water can be removed with dehydrators in the liquid lines as previously mentioned in the article on methyl-chloride.

Low side pressures with Freon units range from about 12 to 21 lbs. gauge, average refrigerant temperature. High side pressures range from about 90 to 150 lbs.

Freon leaks can be detected with the Halide torch and will cause the flame to burn blue-green as with methyl leaks. Leaky joints can also be noticed by signs of oil at the joint.

Protect the eyes with goggles when handling liquid Freon. In case of liquid Freon getting into the eyes, drop sterile mineral oil in the eyes and

Refrigerants

then wash out with water. If liquid Freon gets on the skin it may freeze the tissues, and should be treated the same as frost bite.

6. AMMONIA

As previously stated, ammonia is one of the most efficient refrigerants for commercial refrigeration machines, as it has a very high latent heat value of 565 B.T.U. per lb. Ammonia is not used so much in domestic units of the mechanical compression type because of the rather high condensing pressures and due to the fact that ammonia fumes are dangerous if inhaled in large quantities.

Ammonia is a chemical mixture of nitrogen and hydrogen, and has a boiling point of -28 degrees F. at atmospheric pressure. Its vapor is colorless, somewhat inflammable or explosive with proper mixtures of air, and very injurious to inhale. The service man should **always wear a gas mask when working in ammonia fumes.**

Ammonia leaks can be located with a burning sulphur taper or sulphur coated stick. A white vapor will be produced when the sulphur flame contacts the ammonia fumes.

Low sides pressures on ammonia refrigerating systems range from about 20 to 29 lbs. High side pressures range from about 150 to 200 lbs.

Ammonia does not harm lubricating oils. It has a high affinity for water (readily absorbs water) so it is somewhat difficult to keep perfectly dry. Anhydrous ammonia (dry ammonia) does not harm copper or brass tubing or fittings, but aqua ammonia (ammonia mixed with water) will attack or "eat into" copper or brass.

7. CARBON-DIOXIDE

At ordinary pressures and temperatures, carbon-dioxide (CO_2) is a colorless, odorless, non-toxic, non-inflammable, non-explosive refrigerant gas. It has a boiling point of 79 degrees below zero F., at atmospheric pressure. Even at 300 lbs. pressure CO_2 will boil at slightly over 5 degrees F.

Electric Refrigeration

Therefore carbon dioxide requires very high pressures and water cooling for condensing. It is not used with air-cooled condensers or in household units.

CHEMICAL OR TRADE NAME.	CHEMICAL FORMULA.	BOILING POINT, AT ATMOSPHERIC PRESSURE.	A-E.V. SETTINGS FOR DOMESTIC PRESSURE.	HIGH SIDE PRESSURE FOR COOLING UNITS.	LOW SIDE PRESSURE FOR AIR TEMPERATURE.	LATENT HEAT OF VAPORIZATION IN BTUS PER LB. AT 5°.	INFLAMMABLE OR NON-INFLAMMABLE.	OFFENSIVE ODOR.	METHOD OF TESTING FOR GAS LEAKS.	DEHYDRATION METHOD.
1. SULPHUR DIOXIDE.	SO ₂	14°	6"	68	169		SAFE	YES	26% AMMONIA SWAB.	HEAT.
2 METHYL CHLORIDE.	CH ₃ CL.	-11°	6	100	178		INFLAMMABLE.	NO.	HALIDE TORCH.	CHEMICAL.
3. FREON OR FIZ.	CCl ₂ F ₂	-22°	12	115	69		SAFE	NO.	HALIDE TORCH.	CHEMICAL.
4 AMMONIA	NH ₃	-28°	20	175	565		INFLAMMABLE EXPLOSIVE.	YES.	SULPHUR PAPER.	HEAT.
5 ISOBUTANE	C ₄ H ₁₀	10°	3"	60	159		INFLAMMABLE	NO.	LIQUID SOAP.	CHEMICAL.
6. ETHYL CHLORIDE	C ₂ H ₅ CL	54°	20"	30	177		INFLAMMABLE	NO.	HALIDE TORCH.	CHEMICAL.
7 CARRENE.	CH ₂ CL ₂	105°	28"	8"	149		SAFE	NO.	HALIDE TORCH.	CHEMICAL.
8. METHYL FORMATE	C ₂ H ₄ O ₂	86°	26"	11	231		SAFE	NO.	LIQUID SOAP.	HEAT.
9 CARBON DIOXIDE.	CO ₂	-108°	300	900	115		SAFE.	NO.	LIQUID SOAP	CHEMICAL.
10 FREON-II	CCl ₃ F	75°	24"	5	93				HALIDE TORCH.	CHEMICAL.

Fig. 6. The above chart gives convenient condensed information on the characteristics of common refrigerants. Carefully examine this chart and become familiar with its material so that you can use it for future reference.

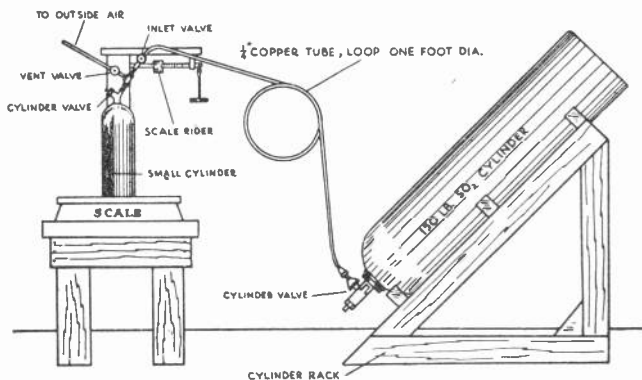

Fig. 7. The above diagram illustrates the method of transferring SO₂ refrigerant from a large shipping cylinder to a small service cylinder. Note the air-vent for purging the transfer tube of air, also the scales for weighing the amount of refrigerant placed in the small cylinder. The large cylinder is inverted so that any vapor in this cylinder will rise above the liquid and force liquid refrigerant to flow through the tube.

Refrigerants

Carbon-dioxide ice at temperatures of 109 degrees or more below zero F., is sometimes used to refrigerate or chill boxes or cars and to preserve ice cream or other frozen foods in transit. When the CO_2 ice melts it changes directly into a gas and therefore leaves no messy liquid in the package or compartment.

8. METHYL FORMATE, CARRENE, AND F114

Methyl formate is the refrigerant used by General Electric Co. in some of their refrigerators. The liquid is colorless and the vapor has an odor similar to ether. It is anesthetic if inhaled, and, is highly inflammable. When no moisture is present in methyl formate, it does not attack metals, but if water gets with it, formic acid is produced which severely attacks metals. Its boiling point is 86 degrees F. at atmospheric pressure. Low side pressure is 26" vacuum and high side pressure is about 2" vacuum under normal conditions.

Carrene (CH_2Cl_2) is used in Grunow refrigerators. This refrigerant has a boiling point of 105 degrees F. at atmospheric pressure. For this reason, the entire cycle of a machine using carrene is operated at some degree of vacuum, and the refrigerant is never compressed above atmospheric pressure. With room temperature at 80 degrees F. the low side pressure on a unit using carrene is about 27 inch vacuum, and high side pressure is 8 inch vacuum. Carrene is non-toxic and non-inflammable.

Leaks are difficult to detect with systems using methyl formate or carrene as the refrigerant is never at a pressure above atmosphere, so leaks are of air into the system rather than refrigerant out of the system.

F114, or dichloro-tetrachloride-ethane, is used by General Motors in some of their models. F114 has a boiling point of 38 degrees F. at atmospheric pressure. It is odorless and non-inflammable. The approximate low side pressure on machines using this refrigerant is 16.2 inches vacuum, and the high side pressure about 21.2 lbs. gauge.

Electric Refrigeration





































	DISCONNECT SWITCH		HAND SHUTOFF VALVE		HEAT INTERCHANGER
	THERMOSTAT (SELF CONTAINED)		THERMAL BULB		CONDENSING UNIT AIR COOLED
	THERMOSTAT (REMOTE BULB)		SCALE TRAP		CONDENSING UNIT WATER COOLED
	PRESSURESTAT		DRIER		COMPRESSOR
	HAND EXPANSION VALVE		STRAINER		A.C. MOTOR
	AUTOMATIC EXPANSION VALVE		HIGH SIDE FLOAT		D.C. MOTOR
	THERMOSTATIC EXPANSION VALVE		LOW SIDE FLOAT		ONE LINE COMPLETE FUSES
	EVAPORATOR PRESSURE REGULATING VALVE. THERMOSTATIC THROTTLING TYPE.		GAGE		
	EVAPORATOR PRESSURE REGULATING VALVE. THERMOSTATIC THROTTLING TYPE.		FINNED TYPE COOLING UNIT NATURAL CONVECTION		COOLING TOWER
	EVAPORATOR PRESSURE REGULATING VALVE. SNAP ACTION VALVE.		PIPE COIL		EVAPORATIVE CONDENSER
	COMPRESSOR SUCTION-PRESSURE LIMITING VALVE. THROTTLING TYPE.		FORCED CONVECTION COOLING UNIT		SOLENOID VALVE
	COMPRESSOR SUCTION-PRESSURE LIMITING VALVE. THROTTLING TYPE.		ICE MAKING UNIT		PRESSURESTAT WITH HIGH PRESSURE CUT-OUT

Fig. 8. Above are shown the most common symbols used for representing various pieces of refrigeration equipment in construction and installation diagrams. Examine each symbol carefully and remember where to find them for future reference.

Refrigerants

The refrigerant charge for various types of domestic units may vary from about 1 lb. to 6 lbs., depending on the size of unit and the type of refrigerant used. As there are so many different models, and as models change from year to year we will not attempt to state the correct charge for every unit in this lesson. The service man should follow the information given in the manufacturers bulletins for this data or from the tag on the base of the unit on all late model refrigerators. However the amount of refrigerant charge for several common models is given with the table of oil charges in article 10. Fig. 6 gives in condensed form some very valuable and convenient information on various refrigerants, for your present and future reference.

The chart shown above provides much useful information on the refrigerants used in domestic and commercial installations. By referring to the proper column, the characteristics of any refrigerant may be determined. Taking sulphur dioxide as an example, the table shows that the boiling point of this chemical at atmospheric pressure is 14 degrees Fah.; the low side pressure for a machine using this refrigerant and an automatic expansion valve (A.E.V.) for domestic applications should be 6 inches of vacuum. With an operating low side pressure of 6 inches of vacuum the high side pressure should be 68 pounds gauge. This chemical has an offensive odor. That the method of testing sulphur dioxide systems for leaks is to use a swab saturated with 26 per cent ammonia; and that the method for drying out sulphur dioxide systems is to use heat. Similar data on other common refrigerants is to be found in this chart. Note that where pressures listed are below atmospheric, they are given in inches of vacuum; all other figures represent pounds per square inch above atmospheric pressure, that is, pounds per square inch gauge pressure.

9. REFRIGERATOR LUBRICATING OILS

Of course we know that the wearing parts of refrigerator compressors must have proper lubrication to permit quiet, efficient operation and to

Electric Refrigeration

prevent excessive wear. This applies especially to the crank shaft or eccentric shaft bearings, the eccentric or connecting rod bearings, piston pins or wrist pins, pistons, cylinder walls and valves. Some compressors use only the splash system of oiling, while others use fuel pumps and pressure to force oil to important bearings, through holes in the crank shaft.

Only a good grade of **highly refined mineral oil** should be used in refrigerators. The oil should be entirely **free of all moisture and dirt**. Moisture in the oil in a machine using SO_2 causes sulphurous acid to form and "freeze up" or stick the compressor. Dirt tends to clog up needle valve openings and gets under compressor valves, causing them to leak. Poor grade oils may tend to carbonize and carbon will clog compressor valves and control valves.

A good grade of oil in a refrigerator may last and remain good for many years if all dirt and moisture are kept out of the system. Various oil companies and refrigeration supply stores can generally furnish proper grades of oil for various refrigerators and the refrigerants they use. It is well to follow the recommendations of refrigerator manufacturers on the type of oil for their unit.

Oil of the proper viscosity should be selected, according to the type of compressor and the refrigerant used.

For reciprocating compressors using SO_2 , oil of 150 to 200 viscosity should be used. For rotary SO_2 compressors, 95 to 160 viscosity oil is recommended. For reciprocating compressors using methyl-chloride, 200 to 300 viscosity oil is satisfactory. Freon machines using reciprocating compressors use 300 to 500 viscosity oil, and for rotary compressors 300 to 325 viscosity. Rotary compressors for Carrene use oil of 300 to 325 viscosity.

With machines where extremely low temperatures are obtained the "pour test" of the oil should be checked to be sure the oil will flow at the low temperatures.

Refrigerants

10. AMOUNT OF OIL REQUIRED FOR COMMON UNITS

The oil charge for common domestic refrigerators ranges from about $\frac{3}{4}$ pt. to 2 qts. The correct oil charges for several common types of domestic machines are as follows:

Coldspot	$\frac{3}{4}$ pt.	Frigidaire..	7, 10 & 16 oz.
Copeland	$\frac{7}{8}$ pt.	Gibson	16 oz.
Crosley	10 to 25 oz.	General Electric..	2 qts.
Dayton	22 oz.	Grunow	36 oz.
ElectroKold	12 oz.	Hotpoint	2 qts.
Fairbanks-Morse ..	20 oz.	Ice-O-Matic	
Norge	$1\frac{3}{4}$ pt.	$1\frac{1}{2}$ to $2\frac{1}{2}$ pts.
Sparton	14 oz.	Kelvinator....	24 to 26 oz.
Stewart-Warner ..	24 oz.	Leonard.....	15 to 24 oz.
Servel	1 pt.	Universal Cooler..	$1\frac{1}{2}$ pt.
Universal (Ro-		Westinghouse	$\frac{7}{8}$ pt.
tary)	32 oz.	Zerozone	$\frac{7}{8}$ pt.

If too much oil gets in to a flooded type evaporator, it will interfere with proper operation of the unit.

A common indication of this condition is a rumbling noise in the evaporator. It can often be corrected by filling the ice cube trays with boiling water to cause the refrigerant to boil violently and carry some of the excess oil back to the compressor with the rush of vapor.

EXAMINATION QUESTIONS

1. What is the purpose of the refrigerant as used in mechanically operated refrigerators?
2. Name ten properties which a good refrigerant should have.
3. Name five different refrigerants used in common refrigerators
4. Using the table shown on page 8 determine the pressure or vacuum at 10 degrees F. for each of the following refrigerants:
 - (a) Sulphur Dioxide
 - (b) Methyl Chloride
 - (c) Isobutane
 - (d) Ammonia
5.
 - (a) Explain how you would test for leaks in a system using sulphur dioxide.
 - (b) What protection should be used for eyes and lungs when working around leaky refrigerators?
6.
 - (a) Of what does methyl chloride consist?
 - (b) What is the chemical symbol for methyl chloride?
7. Describe two different methods which may be used to locate leaks in a system using methyl chloride as the refrigerant.
8. Give one advantage and one disadvantage of Freon as a refrigerant.
9.
 - (a) Why is ammonia a very popular refrigerant for use in commercial plants?
 - (b) Why is it not much used in home type refrigerators?
10.
 - (a) What kind of oil is recommended for use in refrigerators?
 - (b) Does moisture have a good or a bad effect on the oil?

ELECTROLUX

ABSORPTION TYPE REFRIGERATOR

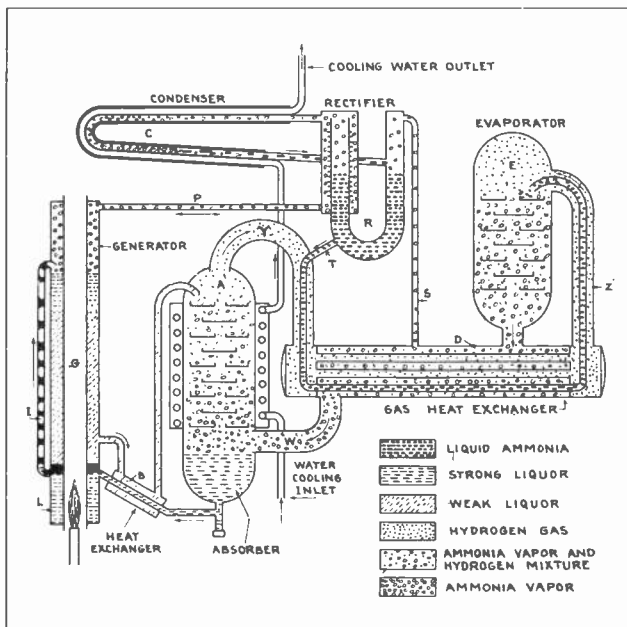

Fig. 1. This diagram clearly illustrates the operating principles of the Electrolux absorption type refrigerator. Carefully study and check each part of the cycle as explained in the accompanying instructions.

Electric Refrigeration

ABSORPTION TYPE REFRIGERATORS

We have previously mentioned the absorption type of refrigeration system as one that uses heat instead of a mechanical compressor to set up the required pressures and flow of the refrigerant.

Domestic or household type absorption refrigerators generally use a small gas burner or kerosene or oil burner to generate the necessary heat and pressure. Large commercial absorption refrigeration systems in meat packing plants, ice plants or air-conditioning installations sometimes use exhaust steam from engines in the power plant to furnish the required heat.

One advantage of the absorption system is the absence of moving or wearing mechanical parts. A disadvantage however is that the system is somewhat more complicated and very difficult to service in the field in case it does get out of order. It also discharges some odor and smoke from the burning gas or oil. The Electrolux is one common make of absorption refrigerator.

The operation of this type of unit is based on the fact that pressure can be produced by heat, and also on the fact that certain gases can be absorbed by water, and then driven out of the water again by means of heat.

We know that air expands when heated, and also that water boils when heated and forms vapor or steam which expands and creates pressure if kept confined in a closed vessel or boiler. We also know that if two different liquids having different boiling points are mixed together and then heated, the one having the lowest boiling temperature will evaporate or boil out of the other liquid first.

Water will absorb ammonia vapor and the mixture becomes aqua-ammonia. The Electrolux absorption type refrigerator uses distilled water, ammonia and hydrogen gas. These materials are sealed tightly in a welded steel system or unit having a pressure of about 200 lbs. throughout the entire system. See Fig. 1.

The ammonia acts as the refrigerant, the water serves as an absorber for the ammonia and the

Absorption Type Refrigerators

hydrogen gas creates a **partial pressure** which permits the ammonia to evaporate at low temperature.

One of the fundamental principles of this absorption type unit is based on Dalton's law for gases, which states that, "the total pressure of a mixture of gases is approximately equal to the sum of the individual pressures, which each gas or vapor would produce if it alone filled the enclosed space."

By taking advantage of this fact, in the absorption refrigerator the evaporator is filled with hydrogen gas to provide a partial pressure or low pressure in which the ammonia can readily evaporate. The total pressure in the evaporator is the same as in other parts of the system, but as part of the pressure is due to the hydrogen gas, the actual ammonia vapor pressure is lower in the evaporator than in other parts of the system. Or we might say for the purpose of illustration that hydrogen gas molecules have an attraction for ammonia vapor molecules and thereby make it easier for the ammonia to evaporate when in the presence of hydrogen gas.

Carefully examine Fig. 1 and become familiar with the name and location of each part of this system. Note the evaporator, gas heat exchanger, absorber, cooling water coils, rectifier, condenser, generator and small heat exchanger.

1. ABSORPTION SYSTEM CYCLE

Now let us trace out the cycle of operation. We have liquid ammonia in the U shaped section of the rectifier, at slightly higher level than the top of the small curved tube entering the evaporator on the right. This will force some ammonia to flow out of the rectifier, down through tube "T", through the gas heat exchanger and up into the evaporator or cooling unit which is filled with hydrogen gas. Here the ammonia trickles down over a series of small trays or pans where it absorbs heat and, due to the partial pressure produced by the hydrogen gas, the ammonia readily evaporates.

The hydrogen gas in the evaporator, being lighter than ammonia vapor, tends to stay in the top of

Electric Refrigeration

the evaporator. However, when this hydrogen gas mixes with the ammonia vapor it becomes heavier and the mixture passes down through the large opening in the bottom of the evaporator to the gas heat exchanger. Here the cool vapor mixture discharging from the evaporator cools the hydrogen gas which is returning through the tubes of the heat exchanger to the evaporator.

From the heat exchanger the mixed hydrogen and ammonia gases pass through the large tube "W" into the lower part of the absorber. In the absorber, water or weak liquor is continually trickling down over a series of baffle plates and absorbs the ammonia vapor, freeing the hydrogen gas.

The hydrogen gas being lighter, now rises and passes out of the absorber through the large curved tube "Y", back through the center tubes of the gas heat exchanger and up through the large tube "Z" into the evaporator once more.

The water and ammonia or strong liquor now in the bottom of the absorber, flow through the center tube of the small heat exchanger into the lower section of the generator. Note that this lower section of the generator is separated from the upper section.

The heat from the gas flame causes the water and ammonia to bubble and forces small charges of water and ammonia up through the percolator tube "I" to the top section of the generator where further heating drives the ammonia out of the water in vapor form.

This ammonia vapor passes off through the tube "P", to the outer section of the rectifier. Here the metal cooling fins condense out any water vapor that might have been carried with the ammonia vapor. This water flows back through tube "P" to the generator.

The rectified ammonia vapor passes on through the water-cooled condenser where it is condensed into liquid and flows out into the U shaped receiver section of the rectifier, once more ready to enter the evaporator and start the cycle over again.

Absorption Type Refrigerators

Referring back to the upper section of the generator again, when the ammonia is driven off from the water, the remaining water or weak liquor flows out through the small curved tube, through the outer section "B" of the small heat exchanger and up into the absorber to pick up more ammonia vapor again.

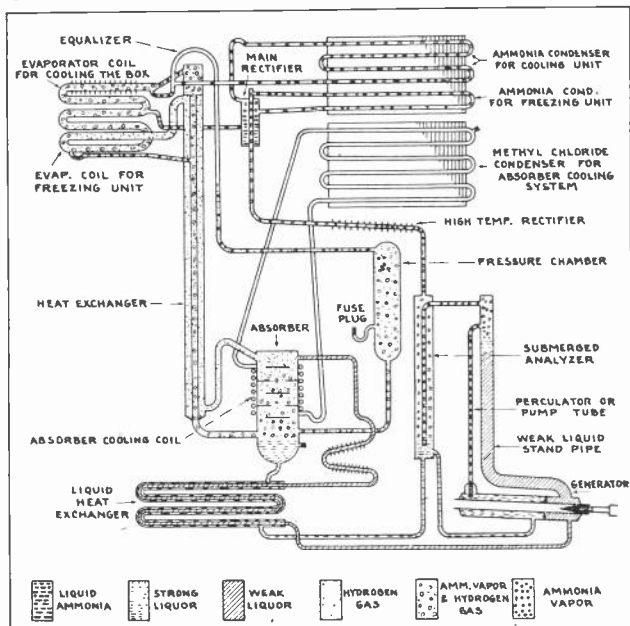

Fig. 2. Cycle diagram of an air-cooled absorption type refrigerator. Note that the absorber in this unit is cooled by methyl-chloride instead of by running water as in the preceding unit.

The cooling fins in the left-hand section of the rectifier are kept cool by the evaporation of a certain amount of ammonia in the U shaped section of the evaporator. The ammonia vapor thus produced goes out of the top of the left center section, and through the condenser with the vapor from the generator.

2. AIR-COOLED ABSORPTION UNIT

Fig. 2 shows a diagram of an air-cooled Electro-lux absorption refrigeration unit. The operating

Electric Refrigeration

principle of this unit is the same as that of the water-cooled unit shown in Fig. 1. The parts are merely arranged in different positions and the generator tube is horizontal instead of vertical.

Instead of using running water to cool the condenser, this unit uses an air-cooled condenser which is divided into three separate sections. One section condenses ammonia for the cabinet cooling unit, and one section condenses ammonia for the freezing unit. The third section condenses methylchloride which is used instead of water for cooling the absorber.

Carefully observe the code markings for the various gases and liquids and trace out the cycle of operation for this unit.

The absorption refrigeration systems just explained are of the continuous operating type, the liquids and vapors being constantly circulated. The rate of circulation, evaporation and refrigeration is controlled by adjusting the gas burner to vary the amount of heat produced and applied at the generator.

3. INTERMITTENT ABSORPTION SYSTEM

Another type of absorption refrigeration system which is similar in principle and simpler in construction and operation is the intermittent absorption unit such as the Trukold refrigerator manufactured by Gibson Co., and sold by Montgomery-Ward; or the Superflex unit made by Perfection Stove Co.

These two units are quite similar in operation and construction. In these units the burner is operated for several hours during the generating part of the cycle, and then the burner is off during the refrigeration part of the cycle. See Fig. 3 which illustrates the operation of the Superflex unit.

A special solution is used around the evaporator coils, which freezes up during the refrigerating period and remains cold, or never completely thaws out during the normal generating period. This produces a sort of cold holdover effect to keep the unit at nearly constant temperature throughout the off and on periods.

Absorption Type Refrigerators

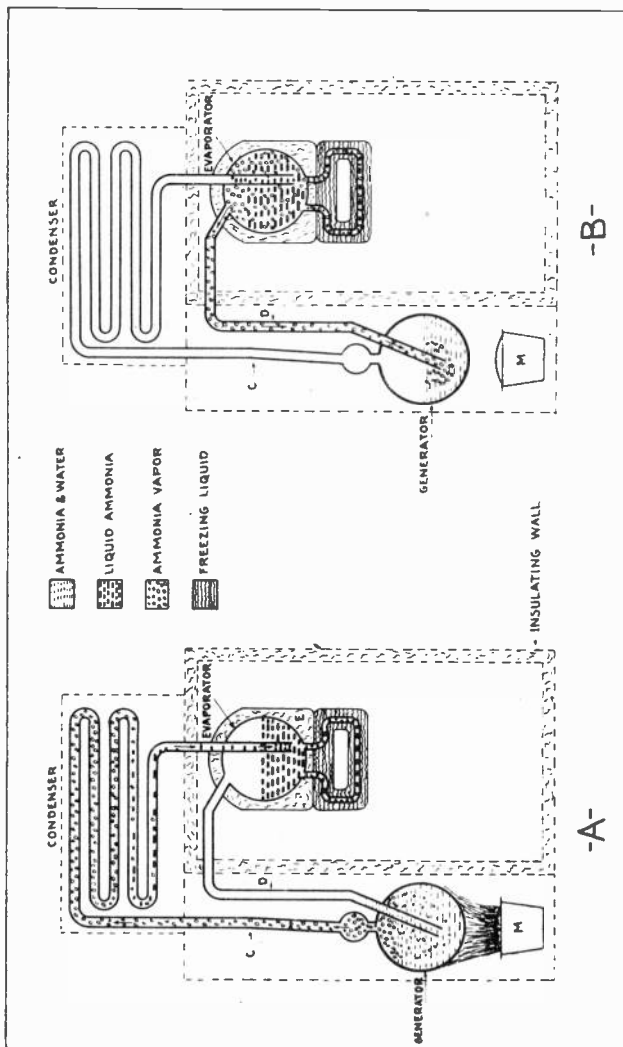

Fig. 3.—The above illustrations show the operating cycle and principles of an intermittent type absorption refrigerating unit in which the generator operates during part of the cycle and the evaporator operates during the remainder.

Electric Refrigeration

Referring again to Fig. 3-A you will note that while the burner is operating ammonia vapor is being driven out of the water and ammonia mixture and forced up through tube "C" to the condenser which is located in a tank of water on the top of the cabinet. Here the ammonia vapor is condensed and the liquid ammonia goes down into the evaporator.

The ammonia vapor from the generator will not pass up through tube "D" to the evaporator, because the lower end of this tube is submerged under the liquid in the generator. The vapor pressure forces the liquid to rise part way up in this tube until its gravity pressure balances the vapor pressure and forces the vapor through the condenser.

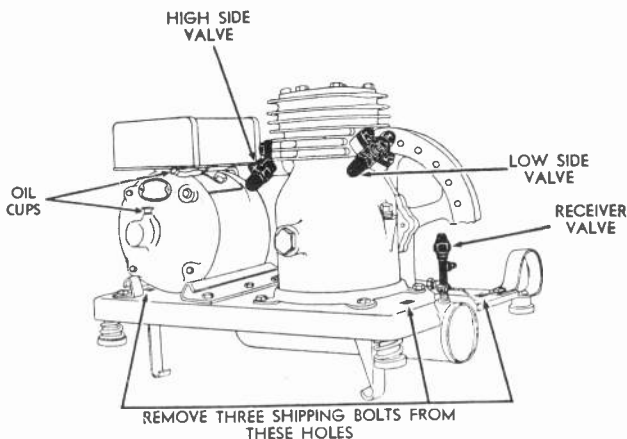

Fig. 4. Diagram showing the location of the high side valve, low side valve, and receiver valve on a Stewart-Warner condensing unit. These valves must be opened before placing the refrigerator in service. Courtesy Stewart-Warner Corp.

When the burner is shut off as shown in Fig. 3-B, the generator cools and its pressure drops. Then evaporation of the ammonia in the evaporator starts. The ammonia vapor leaves the evaporator through tube "D" and returns to the generator where it is again absorbed by the water. Another reason for having the lower end of tube "D" sub-

Absorption Type Refrigerators

merged in the water in the generator is to force the ammonia vapor to bubble up through the water to effect thorough mixing and more complete absorption by the water.

During evaporation the ammonia vapor in the evaporator cannot pass up tube "E" to the condenser because the lower end of this tube is also submerged and the vapor pressure forces some liquid up the tube until the gravity pressure of the liquid forces the vapor out through tube "D" to the generator.

4. INSTALLATION OF REFRIGERATORS

Most modern household refrigerators are complete self-contained units, with all parts of the unit assembled, connected and pre-tested at the factory. Therefore, many people think that all there is to installing such a refrigerator is to set it in any convenient place in the kitchen and insert the plug on the end of the electric cord in the nearest outlet.

There is, however, considerably more involved in making a proper installation of a new refrigerator, if it is to give satisfactory operation and operate over long periods with a minimum of service requirements.

If the unit is shipped or delivered crated, it should be uncrated very carefully to avoid marring the finish of the cabinet.

Carefully unpack all loose interior parts, trays, shelves, etc., clean them and place them in their proper locations. Check the door latch to see that it operates freely and properly and holds the door snugly closed.

In selecting a location for the refrigerator, you should of course consult the owner as to his or her desires and convenience. However, it is important to place the unit on a firm, level spot on the floor, and away from any sources of heat, such as stoves, radiators, hot air registers, chimneys, gas ranges, etc., and out of direct sun rays.

In leveling the refrigerator, do not rely on guess work or haphazard methods. Instead use a spirit level, and if necessary shim up one side or the other with thin pieces of wood, linoleum or cardboard, un-

Electric Refrigeration

til the machine is accurately leveled. The operation and performance of the unit will be considerably better if this extra care is taken.

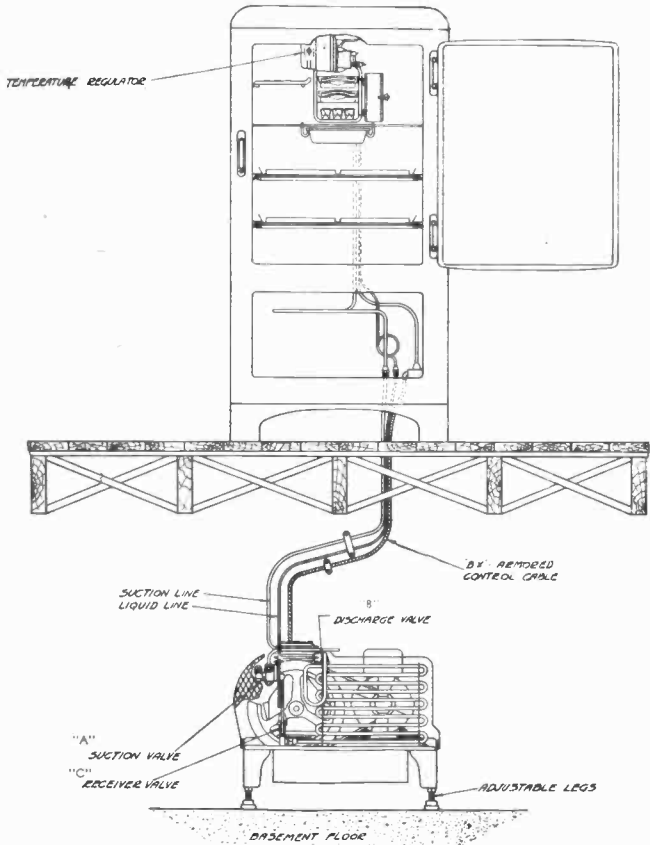

Fig. 5. Diagram showing the method of installation of a refrigerator with a condensing unit located in the basement some distance from the cabinet.

Be very sure that the back of the cabinet is located several inches from the wall so that the warm air discharged from the condenser can freely circulate or escape and carry away the heat from the

Installation

condenser. If this important point is overlooked the unit may operate continuously or it may fail to cool down to the proper temperature. There should also be several inches clearance at both sides of the refrigerator.

Remove anchor bolts and blocking which are used to hold the condensing unit in place during shipping. This permits the unit to rest freely upon its rubber or spring mountings, and prevents excessive vibration being transferred to the cabinet.

Before starting the unit, remove the valve caps from the low side valve, high side valve and receiver valve shown in Fig. 4. Then using a suitable wrench, **open these valves by turning their stems all the way to the left**, (counter-clockwise) until they seat firmly. **Never use a plier or pipe wrench** on these valve stems or you may damage the square corners of the soft metal from which they are made.

Also before starting the unit be sure to check the motor name plate to make certain that its voltage rating is correct for the current supply available. Keep the electric cord clear of the belt, fan and pulley. Instead of connecting the refrigerator to an ordinary convenience outlet on the regular lighting circuit, it is often advisable to install a separate circuit and outlet wired direct to the service cabinet in the basement. This will prevent the refrigerator causing the house lights to dim when the motor starts.

Check the belt for proper tension and alignment. Although the motor has probably been previously oiled at the factory, it is well to make sure that the oil cups are filled with a good grade of medium machine oil. Number 20 automotive oil is satisfactory.

Carefully observe any starting instructions that may be on the tag or in the envelope attached to the shipping crate or to the unit. Also check over all flare nuts, tubing connections and gasket joints with a flashlight, an ammonia swab, Halide torch or soap suds, according to the type of refrigerant used, for any possible trace of leaks. Then the unit should be ready to insert the plug in the elec-

Electric Refrigeration

tric outlet and push the starting button or switch to start the refrigerator.

If the machine starts to "slug" oil or liquid refrigerant and vibrate excessively or operate jerkily, quickly pull the plug for a few seconds, and repeat this several times if necessary, until the machine settles down to smooth operation.

While checking the operation of the unit to make sure that it is working smoothly and quietly, and that the evaporator is chilling, clean off any grease marks on the cabinet and clear away any packing material, or waste left from the uncrating.

If you have a recording thermometer it is advisable to install it in the refrigerator for a day or so to check and have a record of the box temperatures and the on and off periods of the condensing unit.

5. REMOTE INSTALLATIONS

In cases where the refrigerator cabinet and evaporator are to be located in the kitchen and the condensing unit located in the basement or some other room as shown in Fig. 5, then it will be necessary for the installation man to connect up the two units by means of copper tubing for the liquid and suction lines, and electrical wiring for the control switch.

This type of remote installation is sometimes used to eliminate from the kitchen the heat developed by the condensing unit and also the noise of operation of this unit. For the average household refrigerator $\frac{1}{4}$ inch copper tubing may be used for the liquid line and $\frac{5}{16}$ or $\frac{3}{8}$ inch tubing for suction line. The electric wires may be run in BX, Romex, conduit, or open wiring where the latter is permitted. One large hole about $1\frac{3}{8}$ inch in diameter may be bored in the floor to take both tubes and the wiring, or small individual holes can be drilled if preferred.

Measure the required length of tubing carefully and prepare the ends of the tubing by flaring them to take the proper flare fittings for secure connections to the condensing unit and evaporator.

In remote installations using SO_2 the compressor should always be located lower than the evaporator,

Installation

to permit oil to return to the compressor. Avoid any loops or oil traps in the tubing. In case a horizontal run is necessary, make the tubing slope toward the compressor to drain back any oil.

Always keep in mind whenever installing or repairing any refrigerator, the **importance of making secure, leak proof connections in all tubing**, so that

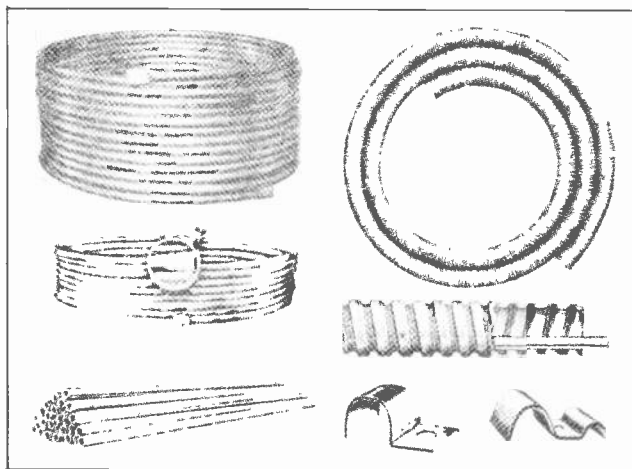

Fig. 6. In the views on the upper left are shown coils of copper tubing such as used for refrigeration installations while at the lower left is shown a number of pieces of larger hard drawn copper tubes. On the upper right is shown a piece of flexible metallic armor or sheath for protection of copper tubes and at the lower right are shown two types of clips for mounting tubing on walls or cabinets.

refrigerant cannot leak out of the system, and so that air or moisture cannot enter the system. For this reason **extreme care should be used in making tubing flares, tightening flare nuts, making soldered or sweated joints in tubing, etc.**

In some large cities there are certain code rules or ordinances governing the safe installation of refrigeration equipment. Therefore, before installing any remote systems, multiple systems or commercial units in any large cities, be sure to become familiar with the local code or rules.

Fig. 6 shows two coils of copper tubing at the upper left and some pieces of large hard drawn cop-

Electric Refrigeration

per tube at the lower left. On the upper right is shown a piece of flexible metallic armor or sheath through which refrigerator tubing lines are often run as shown in the center right hand view, to protect them from mechanical damage. At the lower right are shown two types of clips used to hold liquid and suction lines in place on walls or on cabinets.

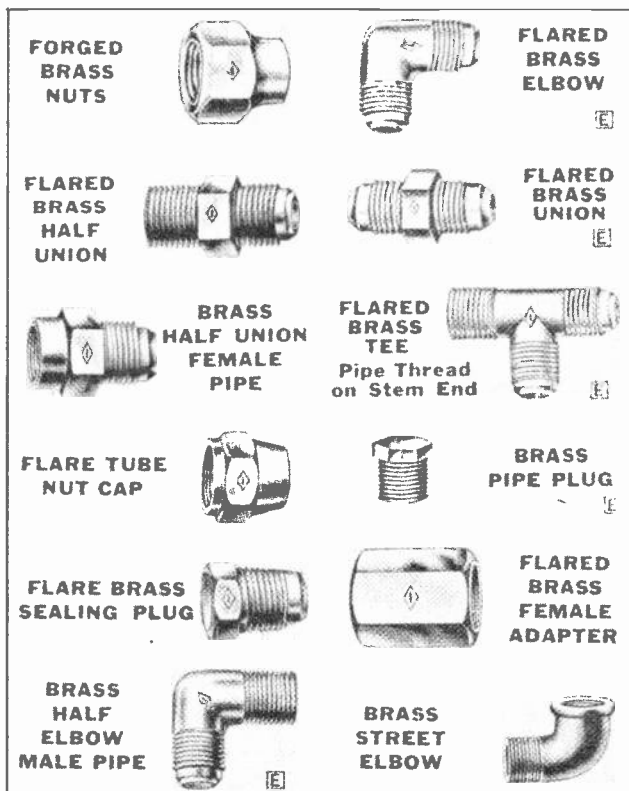

Fig. 7. Above are shown several types of common fittings used for making flare type connections to copper tubing. Carefully note the shape and the name of each of these fittings.

Copper tubing used for refrigerator lines should be seamless to prevent possibility of leaks. It should also be dehydrated (all moisture removed) and the end sealed. This is usually done by the

Installation

manufacturer before shipping the coils of tubing. Heavy walled tubing should be used for long runs.

In case of installations using long runs of tubing you should always "purge" or blow out all air and moisture with refrigerant before making final connections. First attach the receiver end of the liquid line securely to the receiver and then crack the receiver valve open slightly to allow refrigerant vapor to blow all air out of the tube. Then quickly attach the evaporator end of this tube to the evaporator.

Next open the valve again and blow out the evaporator. Then attach the suction line to the outlet of the evaporator and crack the receiver valve open again until refrigerant vapor comes out of the compressor end of this tube. Then attach this end to the compressor.

Long tubes can also be dehydrated by heating in a dry oven for several hours or by drawing a vacuum on them and heating moderately with a torch.

Before fully opening the receiver valve, be sure to check the entire system for leaks, with about 5 lbs. pressure on the system.

Fig. 7. shows a flare nut at the upper left, and several of the more common types of brass fittings used with flare nuts for connecting copper tubing to compressors, condensers, iron piping, gauges, etc. Carefully note the name, shape, and threads of each of these fittings.

6. MAKING FLARE CONNECTIONS

In order to attach flare nuts and couplings to copper tubing the end of the tube must first be cut off squarely, reamed to remove all burrs and flared or spread open on the top to provide a grip for the flare nut. Carefully examine the several views shown in Fig. 8.

The quickest and best method of cutting and flaring tubing is with the cutting and flaring tools of the type shown in Fig. 9. The tube cutter shown in the lower view will, if properly used, make a smooth square cut which is essential to securing

Electric Refrigeration

a good flare. The flaring tool shown in the upper view is made to handle several sizes of tubing and will make a smooth leak proof flare if properly used.

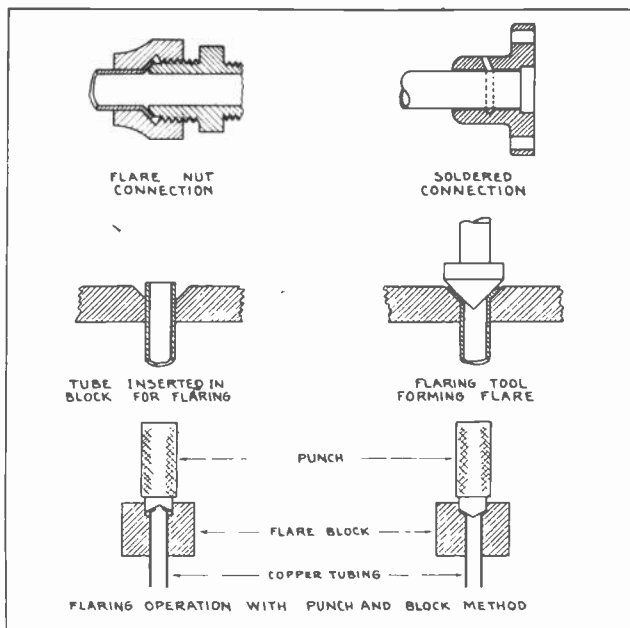

Fig. 8. The above views show how various types of tubing connections can be made. Note how the flare nut grips the tubing in the upper left view. Compare the methods of flaring the tube with the common type flaring tool in the center views and with the punch and block in the lower views.

Copper tubing can of course be cut with a hack saw, the end filed smooth and square and reamed out with the file stem, and flared with a punch and block of the type shown in the lower view in Fig. 8. However, we do not recommend this method except in emergencies, as much better flares can generally be secured after a little practice with the tools shown in Fig. 9.

When cutting refrigeration tubing, always hold the end downward so that metal chips will not get inside the tubing. After cutting, reaming and flaring the tube end, it is advisable to hold the tube

Installation

vertically and tap it to remove any possible dirt or metal chips that might have entered the tube.

• To make the cut, place the tube in the "V" shaped groove of the cutter and tighten the thumb screw

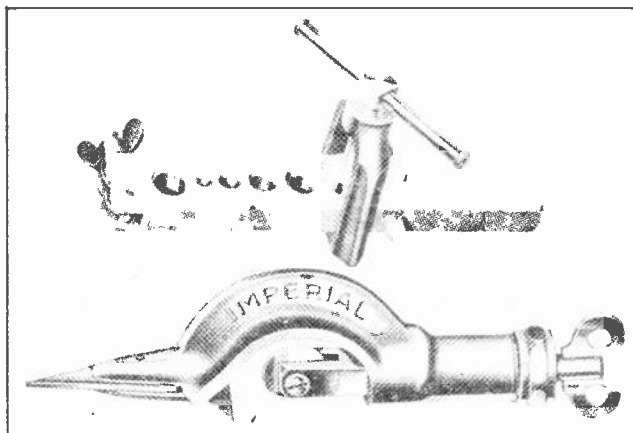

Fig. 9. The top view in this illustration shows a popular type of flaring tool while the lower view shows a convenient type of tube cutter. Courtesy Imperial Brass Company.

to set the cutter wheel on the copper very lightly. Revolve the cutter around the tube, tightening the cutter wheel just a little each time around. Don't rush this job or try to cut too much at each turn or the copper will be heavily burred inward at the end of the cut.

After the cut is made, carefully ream out all of the burred edge from the inner wall of the tube with the sharp pointed reamer shown on the left end of the cutter in Fig. 9. Take very light cuts when reaming and don't try to remove all burr in one scraping with the reamer, or the inner corner of the tube opening may be nicked or scored, making a good flare almost impossible.

After cutting and reaming, insert the end of the tube in the proper size opening in the flaring tool. Let the tube end project about $1/32''$ beyond the surface of the flare block or clamp and close the clamp jaws securely on the tube. Then screw down the flare plug until it spreads the tube end down firmly on the beveled edge of the block.

Electric Refrigeration

Keeping the flare plug clean and lightly oiled helps to make a good flare. The inner surface of the flare must be smooth, polished, and free of any burr or scoring or it will not form a leak proof seat on the flare fitting. If a bad flare is made on

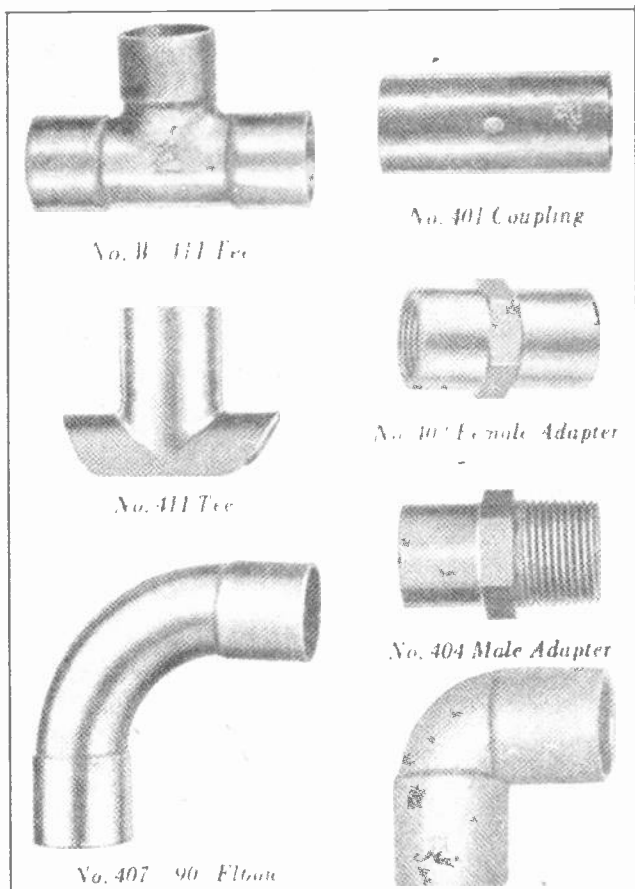

Fig. 10. Several types of solder or "sweat" type fittings for use with large copper tubes in refrigeration installations. Courtesy Chase Copper and Brass Company.

the first operation, cut the flared tip off with the tube cutter and flare the tube again. Wipe all oil off the flared surface before connecting the tube in the flare fitting. Always be sure to put both

Installation

flare nuts on the tubing in proper position before making the flares, because these nuts cannot be put on after the tube is flared.

When making bends in copper tubing do not bend it too sharply; never with a bend radius of less

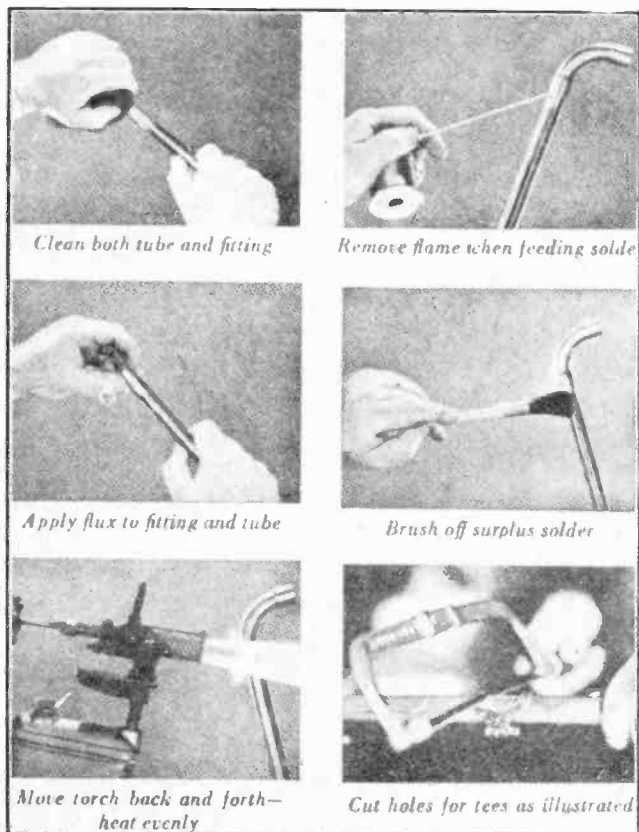

Fig. 11. Carefully examine and study the above views which show the correct method and procedure for making soldered connections with sweat type fittings.

than five times the tube diameter. That is for $\frac{1}{4}$ " tubing, the bend radius should not be less than $1\frac{1}{4}$ ", or a complete 180 degree bend or loop not less than $2\frac{1}{2}$ inches across. For $\frac{1}{2}$ " tubing, the bend radius should not be less than $2\frac{1}{2}$ inches, or a 180 degree loop not less than 5 inches, etc.

Electric Refrigeration

When making any close bends always use a spring tubing bender to prevent flattening the tubing.

7. SOLDERED OR SWEAT TYPE CONNECTIONS

On large commercial refrigeration and air-conditioning installations where large hard drawn copper tubes are used, flared fittings cannot well be made with ordinary tools, so soldered or "sweated" joints are made with fittings such as shown in Fig. 10. There are many other types and sizes of sweat type fittings made for connections of this type on copper tubing. These fittings are made with openings just a few thousandths of an inch larger than the outside diameter of the pipe or tube they are to be used with. This permits hot molten solder to flow in between the metal surfaces of the tube and the fitting by the force of capillary attraction.

Capillary attraction, or the attraction between surface molecules of the tube metal and the molecules of the liquid solder, will draw molten solder into such a joint several inches or more if desired. The solder does not need to be poured in or run downward as it will flow up or sidewise equally well if the metal surfaces are properly cleaned, fluxed and heated, and if there are no large spaces due to dents in the tubing, or due to the use of oversize fittings.

In order to obtain good soldered joints be sure to have the fitting and the tube well lined up and not cocked at an angle with each other. See Fig. 11 which shows the proper method of making soldered or sweat type connections on copper tubing. First, thoroughly clean the inside of the fitting and the outside of the tube and with No. 00 steel wool, until these surfaces are bright and shiny. Then apply an even coating of a good grade soldering flux to both the surface of the fitting and the tube end.

Then heat the joint with a torch as shown, and as the metal becomes hot enough to melt solder, apply the solder at the edge of the joint and the solder will melt and flow into the joint. When a line of solder appears all around the edge of the joint the connection is complete.

Installation

While the solder is still molten, remove the surplus from the edge of the joint with a cloth or brush, and examine the joint to see that it is filled all around. Do not allow the tube or fitting to move or shift for a few seconds after soldering or until it cools enough for the solder to set.

EXAMINATION QUESTIONS

- What is the purpose of a burner in an absorption type refrigerator?
 - What type of refrigerant is commonly used in absorption type units?
- What is the hydrogen gas used for in the Electrolux refrigerator?
- Explain briefly the function or purpose of the generator in Fig. 1.
 - The rectifier
 - The absorber
- Briefly explain the cycle of operation of the intermittent type absorption unit shown in Fig. 3.
- Mention at least five important items to check or do when installing a domestic refrigerator.
- What precautions should be taken in the location of the condensing unit, and in running the tubing on remote installations.
- Why are refrigeration lines often run in flexible metallic sheath?
- Explain how you would make a flare connection on refrigerator tubing.
- Name six common types of flare fittings.
- Explain how you would proceed to make a soldered or sweat type joint in refrigeration tubing.

Electric Refrigeration

OPPORTUNITIES IN REFRIGERATION SERVICING

Servicing of household and commercial refrigerators provides some of the finest opportunities for profitable and interesting work for the trained electrical and refrigeration man. With well over ten million of these units now in use and with over two million new units being installed annually, you can perhaps get some picture of the vast extent of this field.

Add to this the fact that the refrigeration industry is so new that there has not been sufficient time to train an ample number of thoroughly competent refrigeration men and you can see why the services of such men are in great demand.

Refrigeration manufacturers employ hundreds of trained field service men. Refrigeration dealers, department stores and electric shops employ thousands of service men. Many trained men prefer to operate an independent service shop of their own and handle service calls on units in the homes, restaurants, stores, offices, beauty parlors, meat markets, theatres and other places in their neighborhood.

Modern refrigerators are very well made and if properly installed should give excellent service for many months with only minor adjustments and servicing. However, refrigerators, like any other mechanical device, have moving parts which wear and need replacement, particularly if these parts are not properly lubricated, or if they are not properly adjusted at the time of installation. Then there is always the possibility of some of the refrigerant chemical leaking out of the system, and the possibility of air, moisture, or dirt getting into the system and interfering with proper operation of the unit.

For the man who has a thorough understanding of refrigerator parts and principles and also a good knowledge of electric motors, controls, switches, and thermostats, the location and remedy of ordinary refrigerator troubles should be comparatively easy.

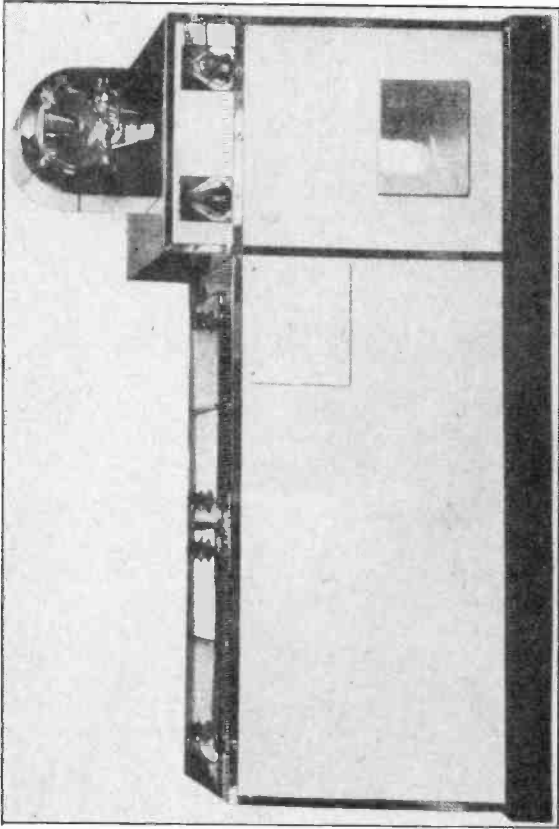

Fig. 1. This photo shows a modern electric ice cream freezing machine. An electric refrigerating unit is used to produce high speed freezing of the ice cream and also to maintain the chilling and hardening compartments at temperatures from freezing to 10 below zero. Thousands of these machines are in use in drug stores and confectioneries throughout the country. Courtesy Mills Novelty Co.

Electric Refrigeration

1. SERVICE, PERSONAL AND MECHANICAL

On most service calls the service man will find two things in need of attention. One is the mental attitude of the customer who is usually somewhat irritated or "put out" because the refrigerator fails to operate properly. The other, is the refrigerator itself which may have developed a rather serious defect or which may only need a minor adjustment at the hands of a skilled service man.

You should never repair the refrigerator without also giving some attention to restoring the customer's or owner's confidence in their refrigerator. In some cases, the job may be largely one of diplomatically teaching the customer how to operate the unit and what to expect of it. Many times service calls or complaints are merely the result of improper use or abuse of the refrigerator.

In many cases the trouble is due to faulty installation of the unit. Therefore, you should always first examine the machine with this in mind. Review of the instructions on refrigerator installation, given in the preceding lesson, should help you to quickly detect and remedy many of these more common troubles such as—refrigerator too close to wall or closed in so that ventilation of the condenser is restricted; unit located too close to radiator or other source of heat; low voltage of the electric supply; plug fallen from socket or receptacle; insufficient lubrication; motor and compressor pulleys not properly aligned; air or moisture in the system, etc.

2. ANALYZING REFRIGERATOR TROUBLES

There should be nothing very mysterious or confusing about the ordinary refrigerator service call to the man who thoroughly understands the operation of the unit and the function of the various parts, providing he will **methodically observe symptoms, test the parts, and think out his problems.**

Recalling the important parts of the ordinary refrigerator we find that there are not so many places for troubles to occur. **Most common defects due to wear or faulty adjustment will be found in**

Service

the compressor, evaporator, control valve, control switch or motor. On following pages we will discuss several of the more common troubles that may occur in each of these units, and also their symptoms and remedies.

However, the intelligent service man will carefully check for several other faults external to the working mechanism before starting to tear down or take apart the machine.

3. PRELIMINARY OBSERVATIONS

For example, it is advisable to first check the unit to see that the power supply has not been interrupted by a blown fuse, or plug out of the socket. If the power supply is O.K. and the unit fails to operate, check the starting switch and control switch for stuck or dirty contacts, broken springs, etc. If the unit will run, check the motor for worn brushes, broken or weak brush springs, dirty or burned commutator, lack of oil or worn bearings. Also check for loose pulley, and for loose or badly worn belt. Check the compressor to see if it operates freely and quietly or if it is tight or noisy.

Sometimes a stuck float valve will stop the flow of refrigerant at the evaporator and very often the valve can be freed by jarring or shaking the evaporator or float valve body.

Be sure to check the cabinet to see that the door closes tightly and that the gasket is in place and tightly fills the space between the door and the cabinet. Also make sure that the cabinet has not been pushed back too tight against the wall, or that the condenser is not filled or clogged with dust and lint, thus restricting the air flow.

The above mentioned items are frequent causes of service calls, and as they can all be checked in a few minutes they should be eliminated before spending much time on more elaborate tests or service operations.

If none of the above preliminary tests disclose the trouble, then we are ready to make a more thorough and definite diagnosis of the service complaints and other symptoms which may not be visible, but which can generally be detected with the aid of service gauges.

Electric Refrigeration

4. USE OF SERVICE GAUGES

Every service man should have these gauges on hand at all times, and be thoroughly familiar with their use. Just as a doctor must first diagnose a case of illness by careful analysis of all the symptoms, so should the refrigeration service man carefully analyze the indications of his gauges, and any other noticeable symptoms, as well as any information from the owner regarding any peculiar actions or operation of the unit just previous to the service call.

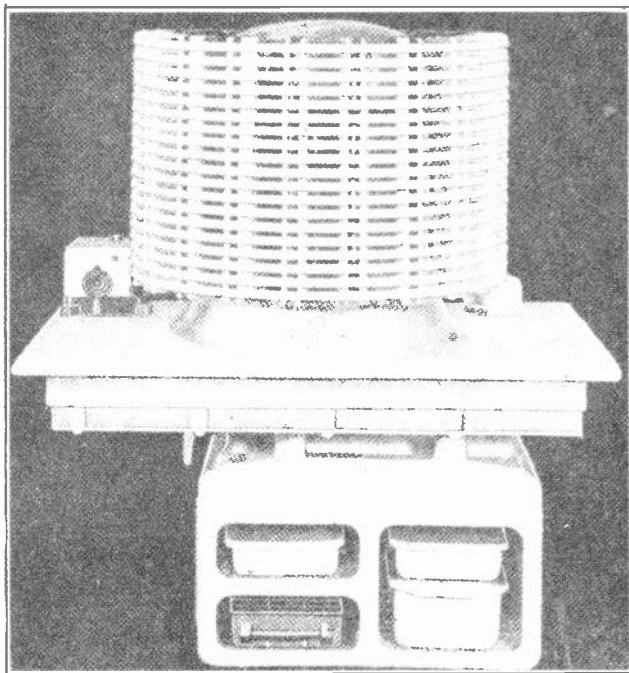

Fig. 2. Above is shown one type of General Electric refrigerating unit which can be quickly removed from the top of the cabinet for replacement by another unit in case of any defect or service requirement. Note the condenser coil located around the hermetically sealed motor and compressor unit. Courtesy General Electric Company.

We have learned that all common compression type refrigerators have rather definite ranges of low side and high side operating pressures when operating normally. Therefore, by checking these

Service

pressures with service gauges, we can quickly detect certain symptoms of abnormal or faulty operation of the unit.

For example, we know that ordinary domestic refrigerators using SO_2 normally have low side pressures of 0" to 8" vacuum, and high side pressures of about 70 to 90 lbs. for ordinary room temperatures. Machines using methyl-chloride should have low side pressures of 5 to 12 lbs. and high side pressures of 15 to 25 lbs. above the cooling air temperatures, or about 80 to 100 lbs. Normal high and low side operating pressures for other types of refrigerants are given in the chart in Figure 6 of Lesson 96.

With these figures known, the trained refrigeration service man can usually diagnose many of the more common refrigerator troubles from the readings of his service gauges, combined with other general symptoms and observations which will be explained later.

For example, when gauges show **low side pressure below normal**, we can generally assume that the machine has a **clogged or stuck control valve** at the evaporator, or a **plugged liquid line** or strainer. Something is probably preventing the normal supply of refrigerant reaching the evaporator, and there is not enough liquid to evaporate and build up normal vapor pressure on the low side.

If the gauge shows **low side pressures above normal**, it is probably due to an inefficient compressor, caused by **leaking compressor valves**, or compressor operating too slow due to the **motor not running at proper speed**, or to a **loose belt**. Or the cause may be an undercharge of refrigerant particularly on machines with low side float valves. It may also be due to a control valve being stuck open or adjusted for too great a flow of refrigerant.

When the gauge shows **high side pressure below normal**, it usually indicates an undercharge of refrigerant.

If **high side pressure is above normal** it may be due to **faulty operation of the condenser** due to restricted air flow, dirt clogged condenser, or failure of water supply on a water cooled unit. Or it may be due to an **overcharge of refrigerant**, a control

Electric Refrigeration

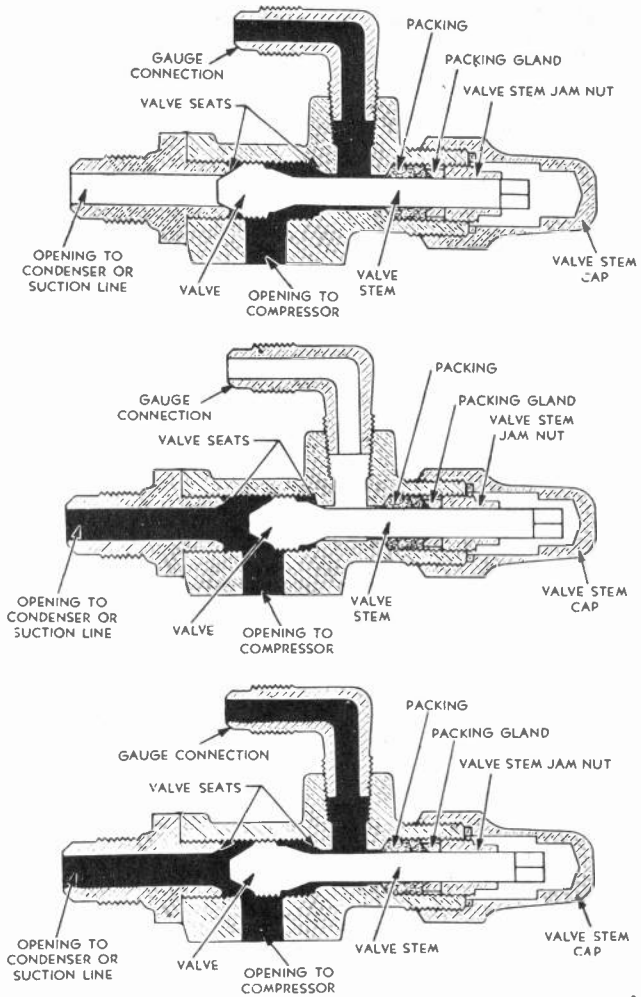

Fig. 3. These diagrams show a refrigerator service valve with the valve plug in three different positions. In the top view, the valve is closed, stopping the flow of gas from the evaporator to the compressor, but permitting gauge readings of the crank case pressure. In the center view the valve is shown open for normal operation of the unit and the gauge opening is closed for attachment or removal of the gauge. In the lower view, the valve is shown "cracked" or in neutral position to allow gas flow for operation of the unit and to permit gauge readings of the low side pressure. Carefully examine all parts shown in each of these views. Courtesy Stewart-Warner Corp.

Service

valve stuck shut, or due to air in the system.

Therefore you can see how important it is for the service man to have service gauges on hand and to know how to properly use them and diagnose their indications.

5. SERVICE VALVES

As mentioned in an earlier lesson, the gauges commonly used by the service man are the pressure gauge, and the compound gauge which indicates both pressure and vacuum. Two of these gauges were shown in Figure 13, Lesson 93.

These gauges can be attached to the low side and high side service valves on the compressor to take vacuum and pressure readings while the unit is operating. The location of these service valves was shown on the compressor in Figure 4, Lesson 97, and they can also be seen on a number of the units shown in earlier lessons.

Figure 3 shows sectional views of a service valve with the valve plug in three different positions. We will assume that this valve is to be used on the low side of the compressor, although the high side service valve would be of the same type. The top view shows the valve in closed position, for shutting off the flow of gas from the evaporator to the compressor. In this position, the gauge can indicate the gas pressure in the compressor crank case as shown by the black area which indicates the path of the gas through the valve.

The center view shows the valve fully opened for normal operation of the unit, to permit the flow of refrigerant gas from the evaporator to the compressor. Note that in this position the gauge is shut off. The valve should be in this position when installing or removing the gauge. When no gauge is in use, the gauge connection is tightly sealed with a blind cap which screws over the end of the gauge connection, or with a gauge-fitting plug in case the valve is not equipped with a gauge connection.

In the lower view the valve is shown "cracked," or turned $\frac{1}{4}$ turn to the right, which opens the port back of the valve just enough to allow the gas pressure to register on the gauge. In this position it

Electric Refrigeration

also permits the flow of gas from the evaporator to the compressor. This is known as the neutral position. Carefully study all three of these views until you are sure that you thoroughly understand the operation and function of these service valves and that you know when the valve is closed, open, or cracked for gauge readings. (Note—The Majestic and Crosley refrigerators use service valves which operate exactly opposite to the common type of valve shown in Fig. 3. The Majestic and Crosley valves are closed when turned all the way to the left.)

Keep in mind at all times that the proper use of gauges on these service valves will give the service man some of his best clues to the reasons for faulty operation or troubles in refrigerators. A great deal of time can generally be saved by carefully diagnosing the indications of the service gauges as explained in Article 4.

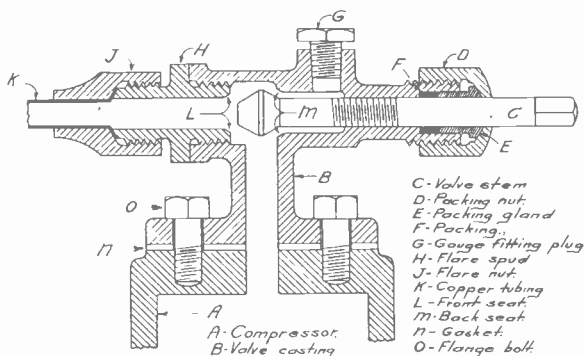

INSERT TABLE

In order to simplify service operations such as adding or removing refrigerant, adding or removing oil, removing air (purging) or removing defective parts, most refrigeration systems are equipped with service valves. Service valves consist of the following:

1. Suction service valve (SSV)
2. Discharge service valve (DSV)

Service

3. Receiver shut-off valve or king valve (KV)
4. Other shut-off valves in the system

In order to determine the pressure existing in the high and low sides of the system, gauges are installed in the service valve connections, the pressure gauge in the DSV and the compound gauge in the SSV.

When manipulating service valves, **never** front seat the DSV and operate the compressor unless the gauge fitting port is open, as this action may result in blowing a gasket and on large compressors may even blow the head off the compressor. If a gauge is installed in the DSV, the gauge will be ruined if the compressor is operated with the valve front-seated.

When manipulating service valves, do not turn the valve stem too tight. Merely turn it snugly to the seating position.

If the valve leaks at the packing, proceed as follows:

1. Stop the unit and back-seat the valve.
2. Remove the packing nut and gland.
3. Remove the old packing.
4. Repack the valve with graphite string or packing washers, then replace the gland and nut. Tighten the packing nut and if necessary add more packing.

When service valves are stuck or difficult to turn, loosen the packing gland as this will sometimes remedy the trouble. The packing glands on some valves require the use of special wrenches to loosen or tighten them.

Some units are not equipped with standard service valves, but the operation of the valve can usually be determined by observing the position and external construction of the valve casting. Two such examples of special service valves may be found on the Majestic and Crosley conventional units.

On the Majestic unit, the DSV and SSV are constructed differently. The gauge connection on both valves is on the end of the valve where the tubing connection is located on standard service valves. To shut off the gauge connection, the valve has to be front-seated and this is the normal running position. The SSV on the Majestic unit contains a check

Electric Refrigeration

valve and when this valve is back-seated the suction line from the evaporator is shut off. The construction of the DSV is such that with the valve back-seated, the discharge port from the compressor is shut off. Therefore, it is imperative to **NEVER UNDER ANY CIRCUMSTANCES OPERATE THE MAJESTIC COMPRESSOR WITH THE DSV BACK-SEATED.** Since the gas is not able to escape thru the back-seated valve, it will continue to build up pressure in the compressor housing until the bellows in the shaft seal bursts.

In the Crosley conventional unit, the construction of both the DSV and SSV is the same. The gauge connections on the service valves are in the same position as they are on standard service valves, but the flanged connection to the compressor housing is on the end of the valve instead of on the side. The procedure for installing gauges on these valves is exactly the same as for standard service valves. It is, however, impossible to make a compressor efficiency test, since when the SSV is front-seated, both the gauge connection and the suction line connection are shut off from the compressor and the gauge will, therefore, not register the vacuum being drawn in the compressor housing. With this compressor **UNDER NO CIRCUMSTANCES OPERATE THE COMPRESSOR WITH THE DSV FRONT-SEATED.**

6. COMMON REFRIGERATOR TROUBLES

Now let us consider a few of the more common refrigerator troubles or complaints as the customer might see or report them. Some of these complaints are as follows:

1. Refrigerator does not run at all.
2. Refrigerator runs too much, or all the time.
3. Unit operates too often or on short cycles.
4. Cabinet or food compartment is too warm.
5. Cabinet or food compartment is too cold.
6. Cabinet temperature satisfactory but ice cubes freeze too slowly.
7. Ice cubes freeze satisfactorily but cabinet is too warm.
8. Desserts do not freeze.

Service

9. Refrigerator is noisy.
10. Overload button trips out.
11. Motor runs too hot.
12. Water in cabinet or dripping on floor.
13. Moisture on cabinet frame near edge of door.
14. Bad taste in ice cubes.
15. Bad taste in milk, cream, or butter.
16. Objectionable odors.
17. Evaporator frosts too much.

Now let us see what might be the cause of some of these common troubles and also what their symptoms and remedies would be. Of course, the symptoms may be slightly different with different types of refrigerators, but in general the following symptoms or indications would apply to many common makes of units, and particularly to machines

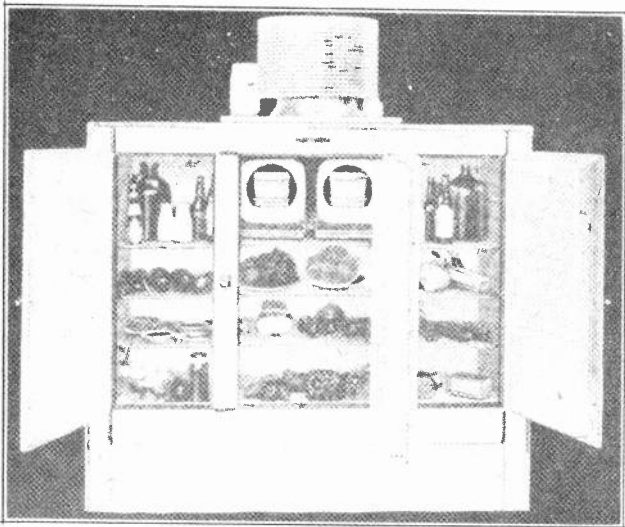

Fig. 4. A large domestic refrigerator showing the proper arrangement of food articles so that the shelves are not over crowded and so that air is permitted to circulate freely over the evaporator and throughout the cabinet. Courtesy General Electric Company.

using flooded evaporators and low side float controls.

Each of these common troubles is set out in an article heading. Under each trouble are given a

Electric Refrigeration

number of possible causes of this trouble, and under each cause are given common symptoms or indications and the remedies. Study these troubles, symptoms and remedies carefully and try to understand the reason for each by applying your knowledge of refrigerator principles and operation.

7. REFRIGERATOR DOES NOT RUN AT ALL

First let us take trouble number one and list some of its probable causes, along with the indications and remedies.

- A. **Cause:** Open circuit in the electric supply line. Probably a blown fuse or a plug out of the socket.
Indication: No voltage at motor terminals when tested with a test lamp or meter.
Remedy: Locate the open circuit and repair it.
- B. **Cause:** Low voltage at the motor.
Indication: Motor terminal voltage 90 volts or less when tested with a voltmeter.
Remedy: Use shorter and heavier extension cord or run new wiring from the meter and service box to the outlet at the refrigerator if necessary.
- C. **Cause:** Defective cold control.
Indication: Circuit open in cold control even when bulb is warm, and refrigerator will operate when power is connected direct to motor terminals.
Remedy: Repair or replace cold control.
- D. **Cause:** Stuck compressor.
Indication: Compressor flywheel cannot be turned at all by hand.
Remedy: Repair or replace compressor.
- E. **Cause:** Defective motor, or wrong type of motor.
Indication: Normal voltage at motor terminals but motor does not run.
Remedy: Repair or replace the motor.

Service

- F. **Cause:** Refrigerator located where surrounding air temperature is below 30 degrees F., such as on a back porch, where so little heat leaks into the cabinet that the control bulb temperature is not raised enough to switch on the compressor.

Indication: Partial defrosting of evaporator or very slow ice freezing.

Remedy: Advise owner that refrigerator be located in a room with temperature above 60 degrees F. for satisfactory ice freezing.

- G. **Cause:** Overload button out.

Indication: Shows on visual inspection.

Remedy: Push in the button, and check overload coil to see that it is correct for the motor used.

8. REFRIGERATOR RUNS TOO MUCH OR ALL THE TIME

- A. **Cause:** Cold control won't cut out.

Indication: Low cabinet temperature.

Remedy: Make sure cold control bulb is in good contact with the evaporator. Also adjust or replace the cold control if necessary.

- B. **Cause:** Control set at coldest position.

Indication: Low cabinet temperature.

Remedy: Advise owner that refrigerator operates most economically with pointer in number one position.

- C. **Cause:** Undercharge of refrigerant.

Indication: Rushing or hissing noise in evaporator. Warm liquid line. High low side pressure (on units with low side float.)

Remedy: Locate and repair the leak and recharge the unit with correct amount of refrigerant, until gauge shows correct high side pressure.

- D. **Cause:** Leaky float valve needle due to dirt or chip between needle and seat.

Indication: Frosted suction line.

Electric Refrigeration

Remedy: On units using low side float valves flush the control valve by closing liquid receiver valve and operating the unit for five minutes to lower the liquid level in the float chamber

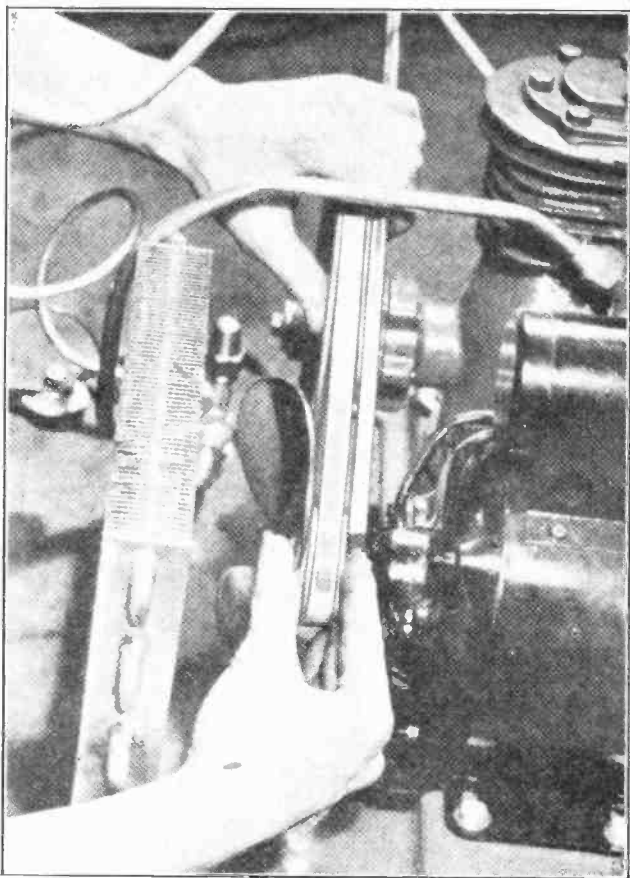

Fig. 5. This view shows the proper method of aligning the belt and pulleys on a refrigerator motor and compressor. The motor pulley is loosened and adjusted to line up with the compressor flywheel. Courtesy Stewart-Warner Corp.

and cause needle to withdraw from its seat. Then open receiver valve quickly and permit liquid refrigerant to rush into the float chamber. This will usually wash the dirt from the needle

Service

or valve seat. Repeat the operation once or twice if necessary.

On units using expansion valves turn adjustment all the way to the left and allow compressor to draw a good vacuum. Then turn the adjustment rapidly all the way to the right to allow liquid to rush through. Then set control at normal.

E. **Cause:** Leaky control valve needle due to scored needle or valve seat.

Indication: Frosted suction line which cannot be corrected by flushing as above described.

Remedy: Pump down the system by closing the receiver valve and operating compressor until all refrigerant is withdrawn from the evaporator. Then remove and replace the defective valve or part.

F. **Cause:** Stuck float valve needle mechanism.

Indication: If needle is stuck open, the suction line will frost up. If needle is stuck closed there will be a high vacuum on the suction side and frost will disappear from the evaporator.

Remedy: Make sure the evaporator is level. Try to jar needle loose by tapping the float header lightly with a brass hammer. If this does not correct the trouble, replace the defective valve or part.

G. **Cause:** Condenser clogged with dirt, or poor air circulation over condenser. Improper pitch of fan blades.

Indication: High head pressure. Also high temperature in the unit compartment.

Remedy: See that cabinet is at least three inches from the wall. Clean any dirt or lint from the condenser and make sure that air can circulate freely through the condenser. Repair or replace fan if necessary.

H. **Cause:** Refrigerator located too near a stove, radiator or other source of heat.

Electric Refrigeration

Indication: High head pressure and high temperature in the unit compartment.

Remedy: Remove the refrigerator to a cooler location or shut off the source of heat if possible. Recommend a remote installation of the condensing unit if necessary.

I. **Cause:** Inefficient compressor.

Indication: Low head pressure or high back pressure. Also smooth glassy appearance of frost on the evaporator. Long running periods, short idle periods.

Remedy: Check compressor for efficiency as will be explained later. Replace leaky valves, or if cylinders are scored replace the compressor.

J. **Cause:** Compressor running at less than normal speed.

Indication: Loose belt, wrong motor pulley, low line voltage, oil on the belt, stiff compressor, high head pressure.

Remedy: Correct belt tension. Make sure correct motor pulley is used. Check the voltage at the motor. Replace oily belt. Change compressor if defective. Locate cause of high head pressure and make necessary repairs as will be explained later.

K. **Cause:** Overloaded refrigerator:

Indication: Placing hot foods in refrigerator. Leaving cabinet door open longer than necessary. Poor gasket or poorly fitting cabinet door. Freezing unusual amounts of ice.

Remedy: Caution owner that foods should be cooled to room temperature before placing in refrigerator. Caution owner to keep cabinet door closed as much as possible. Replace bad gasket or repair door. Advise owner that freezing extra quantities of ice will make any unit operate longer.

Service

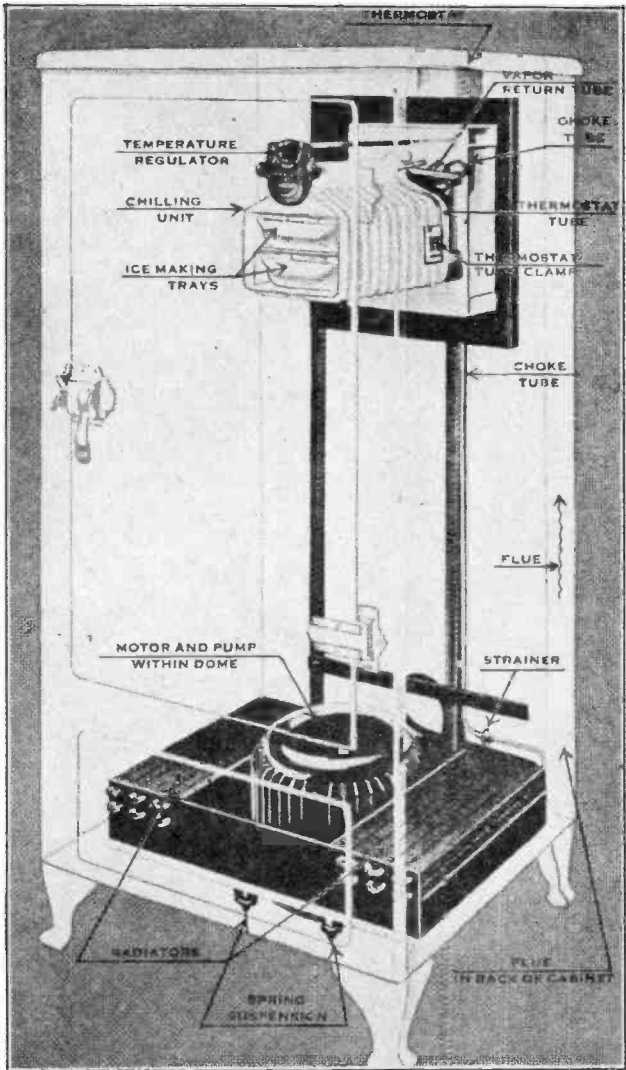

Fig. 6. Phantom view of a Servel hermetic refrigerator. Note the location of the hermetically sealed motor and compressor, and the condensing unit in the bottom of the cabinet. Also note that the evaporator and condensing unit are mounted together on a frame so that the entire mechanism can be removed from the back of the cabinet for servicing. Courtesy Servel Manufacturing Corp.

Electric Refrigeration

9. UNIT OPERATES TOO OFTEN OR ON SHORT CYCLES

- A. **Cause:** Leaky discharge valves in compressor.
- Indication:** Low head pressure. Crank case pressure builds up quickly when low side valve is closed.
- Remedy:** Repair or replace discharge valve assembly.
- B. **Cause:** Slight leak at float valve needle due to dirt, or due to box being tilted forward in case unit uses low side float valve.
- Indication:** Some frost-back on suction line.
- Remedy:** Flush needle valve or tap float header sharply. Replace header and float if necessary. Level the box if tilted.
- C. **Cause:** Slight shortage of refrigerant.
- Indication:** Low side pressure builds up rapidly after unit stops.
- Remedy:** Check first for leaky valves and if valves are O.K. add refrigerant.
- D. **Cause:** Control adjusted for too narrow temperature range.
- Indication:** Frequent starting and stopping of unit.
- Remedy:** Adjust cold control for wider temperature range.

10. CABINET TOO WARM

- A. **Cause:** Cold control set at "defrost" or winter operating position.
- Indication:** No frost on evaporator, long "off" periods and short "on" periods.
- Remedy:** Reset the cold control and instruct the owner on its correct use.
- B. **Cause:** Cold control out of adjustment.
- Indication:** Evaporator partially defrosted and ice cubes freeze very slowly.
- Remedy:** Readjust cold control.

Service

- C. **Cause:** Cold control will not cut in due to loss of gas from its power bulb.
Indication: Unit will not run.
Remedy: Replace the cold control or power bulb.
- D. **Cause:** Not enough refrigerant in the system.
Indication: Hissing noise in the evaporator, warm liquid line, partial defrosting of the evaporator, low head pressure, and high back pressure on units using low side floats.
Remedy: Locate the leak as previously explained, repair the leak and then add refrigerant until the hissing stops, or until gauge shows proper high side pressure.
- E. **Cause:** Too much frost on the evaporator.
Indication: More than $\frac{3}{8}$ " of frost on the evaporator.
Remedy: Defrost the evaporator and instruct the owner on this important matter. Explain that too heavy a coating of frost on the evaporator prevents proper circulation of the cabinet air over the evaporator tubes or fins, and also acts as an insulator, interfering with the proper transfer of heat. Many people have the mistaken idea that a lot of frost means that the unit is operating efficiently. This is not true.
- F. **Cause:** Inefficient compressor due to leaking valves.
Indication: Unit runs too much of the time and crank case pressure builds up quickly when the unit is stopped.
Remedy: Check the efficiency of the compressor as explained in the next lesson and repair or replace the compressor.
- G. **Cause:** Not enough air circulating through the unit.
Indication: High head pressure and dirty condenser.

Electric Refrigeration

Remedy: Be sure that air can freely enter and leave the unit compartment, and clean all dirt and lint from the condenser.

H. **Cause:** Restricted air circulation over food

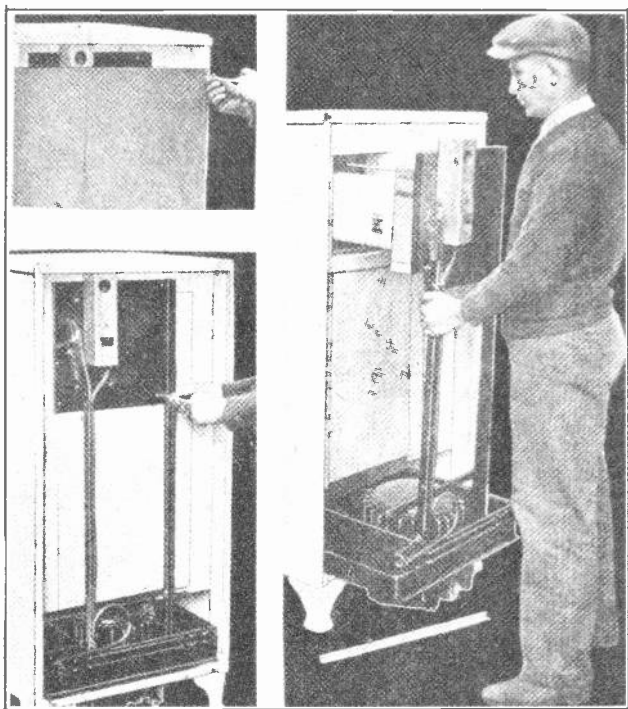

Fig. 7. Above three views illustrate the convenience with which a Servel hermetic unit can be removed from the cabinet for servicing. First the back panel is removed from the cabinet as shown in the upper left view. Next the screws holding the evaporator in place are removed as shown in the lower left view. Then the entire unit is removed from the cabinet as shown on the right. Courtesy Servel Manufacturing Corp.

and evaporator.

Indication: Foods packed too closely on shelves, or shelves covered with oil cloth or paper.

Remedy: Instruct owner not to crowd or cover the shelves.

11. CABINET TOO COLD

A. **Cause:** Cold control set too cold.

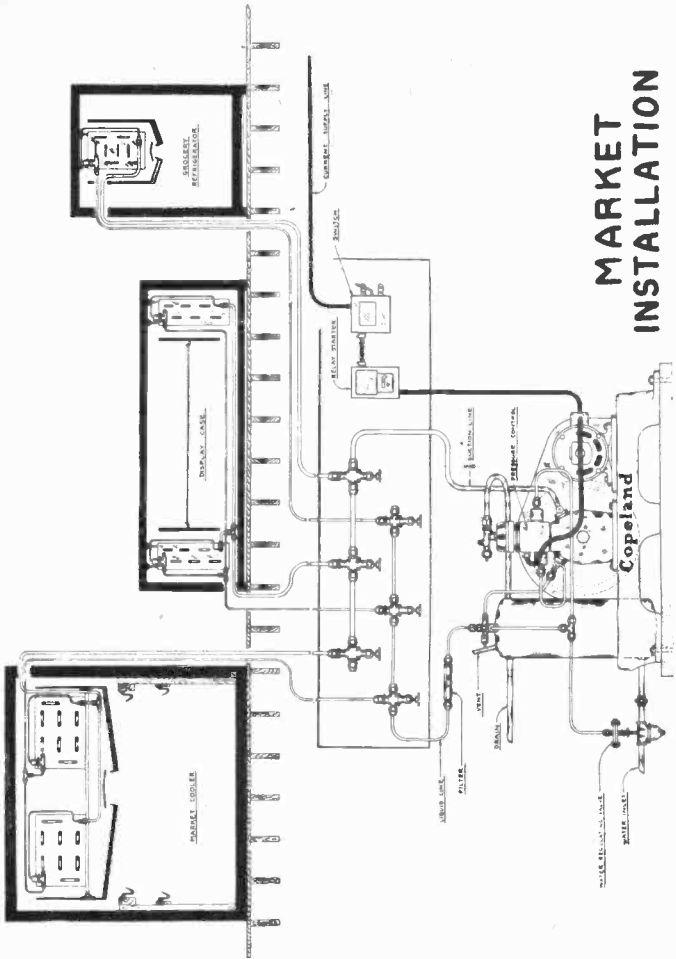

Fig. 8. This diagram shows a multiple installation with the water cooled condensing unit located in the basement and feeding refrigerant to three cabinets in a grocery and meat shop. Note the separate shut-off valves on the liquid and suction lines to each cabinet. Also note the liquid line strainer, cooling water connections, water regulating valve and the electrical wiring installation. Courtesy Copeland Manufacturing Co.

Electric Refrigeration

Indication: Unit runs too long, cabinet temperatures too low and excessive frost on the evaporator.

Remedy: Explain to the owner that correct cabinet temperature and more economical operation may be obtained by setting the cold control for slightly warmer operation, except when quick freezing of ice or desserts is required.

- B. **Cause:** Cold control defective or not correctly adjusted.

Indication: Unit runs too long and too often and cabinet temperatures too low.

Remedy: Readjust, repair or replace the cold control.

- C. **Cause:** Control bulb not clamped tightly to evaporator or float header.

Indication: Unit runs too long and excessive frost on the evaporator.

Remedy: Clamp the control bulb tightly in place.

- D. **Cause:** Refrigerator located where surrounding temperatures are too low.

Indication: Foods freeze in the cabinet although the unit operates very little. Air around refrigerator at 60° F. or lower.

Remedy: Locate the unit in a room where the surrounding temperature is 60 degrees F. or higher.

12. CABINET TEMPERATURE O.K. BUT ICE CUBES FREEZE SLOWLY

- A. **Cause:** Cold control out of adjustment.

Indication: Long "off" periods and short "on" periods.

Remedy: Readjust or replace cold control.

- B. **Cause:** Refrigerator in too cold a location.

Indication: Room temperature near box below 60 degrees F.

Remedy: Move box to warmer room.

- C. **Cause:** Customer may expect more rapid freezing than is possible.

Service

Indication: Nature of customer's complaint.

Remedy: Advise the customer on length of time required and also to use the coldest position of the cold control during freezing of ice.

- D. **Cause:** Control may be set at defrost position.

Indication: Can be noted by examining control knob position.

Remedy: Instruct the customer on the correct use of the cold control.

- E. **Cause:** Customer may be using rubber ice trays.

Indication: Can be noted by examining ice trays.

Remedy: Advise customer to use metal trays for more rapid freezing of ice.

- F. **Cause:** Ice in ice cube tray sleeve or jacket, due to water spilled and frozen.

Indication: Ice visible upon inspection of ice tray compartment.

Remedy: Clean out ice sheet from sleeve or compartment.

13. ICE CUBES FREEZE O.K. BUT CABINET IS TOO WARM

- A. **Cause:** Unit not defrosted often enough.

Indication: More than $\frac{3}{8}$ " of frost on the evaporator.

Remedy: Instruct customer about defrosting whenever frost becomes $\frac{3}{8}$ " thick.

- B. **Cause:** Poor air circulation in cabinet.

Indication: Food packed too closely on shelves, or covering used on shelves.

Remedy: Instruct customer not to crowd shelves and never to cover them with paper or oil cloth as this interferes with proper air circulation.

- C. **Cause:** Overloading the unit by putting hot foods in the cabinet.

Indication: Finding hot foods in cabinet or excessive frost on evaporator due to vapors from hot foods.

Electric Refrigeration

Remedy: Advise customer to allow foods to cool to room temperature before placing them in the cabinet.

14. DESSERTS DO NOT FREEZE

- A. **Cause:** Wrong cold control adjustment.
Indication: "Cut in" and "cut out" pressures or temperatures wrong.
Remedy: Adjust or replace cold control.
- B. **Cause:** Too much flavoring extract or sugar in the desserts. Alcohol and sugar are more difficult to freeze.
Indication: Nature of desserts found in freezing compartment.
Remedy: Advise customer on this point.
- C. **Cause:** Not enough time allowed for freezing.
Indication: Nature of customers complaint.
Remedy: Advise customer that extracts containing alcohol are harder to freeze than water.

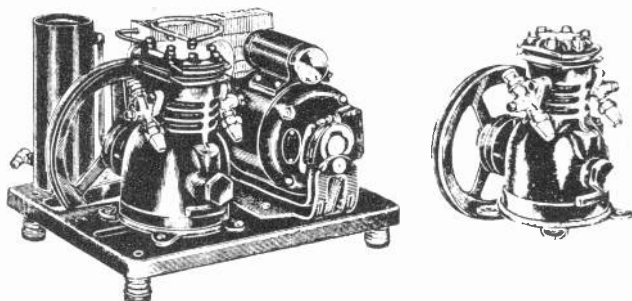

Fig. 9. Separate compressor or complete condensing units such as shown above can be purchased from refrigeration supply houses for use by the serviceman in replacing defective units in domestic refrigerators. This permits the old units to be taken out and serviced in the shop at leisure without tying up the customer's refrigerator.

- D. **Cause:** Use of rubber or non-metallic trays for freezing.
Indication: Rubber trays found in freezing compartment.
Remedy: Advise customer that freezing is quicker in metal trays.

Service

15. REFRIGERATOR IS NOISY

- A. **Cause:** Shipping bolts or blocks left in place when unit was installed.
Indication: Excessive vibration of entire refrigerator.
Remedy: Remove shipping bolts or blocks as explained under installation in Lesson 97.
- B. **Cause:** Loose liquid or suction lines.
Indication: Rattling or rubbing of tubes against each other or against cabinet.
Remedy: Clamp tubing securely in place and pad with rubber plugs, hydrolene or tape where tubes enter the box or touch each other.
- C. **Cause:** Unit not resting evenly on spring mountings.
Indication: Excessive vibration of unit.
Remedy: See that unit rests evenly on mountings.
- D. **Cause:** Dry or scored shaft seal faces.
Indication: Squeaking noise at shaft seal, and oil leak at shaft seal.
Remedy: Re-surface seal faces or replace seal and use replacement seal face if too badly scored.
- E. **Cause:** Not enough oil in system.
Indication: Hot and noisy compressor.
Remedy: Balance pressure on crankcase to between 0 and 1 lbs., remove oil plug and measure oil with a clean, dry rod. Locate and repair oil leak and place correct charge of oil in the unit.
- F. **Cause:** Loose compressor, motor, condenser, fly wheel, fan pulley or belt.
Indication: Rattling noise coming from one of these parts.
Remedy: Tighten loose part, or all parts if necessary.
- G. **Cause:** Not enough oil in motor bearings.
Indication: Motor is noisy even when belt is removed and bearings are hot.

Electric Refrigeration

Remedy: Fill the oil cups on the motor and if necessary replace the motor or the motor bearings.

- H. **Cause:** "Slugging" of oil through the compressor valves.

Indication: Sharp knocking noise, usually at the start of the operating cycle.

Remedy: Be sure compressor has correct charge of oil and then correct high back pressure or anything which might cause liquid refrigerant to get into compressor.

- I. **Cause:** High head pressure due to overcharge of refrigerant, air in the system, dirty condenser, poor air circulation over the condenser or failure of water supply.

Indication: High pressures indicated by gauge at high side service valve. Observation of dirt on the condenser or restricted air flow over condenser. No water flow. Overload relay trips out or fuse blows.

Remedy: Purge excess refrigerant or air from the system as explained in the following lesson. Clean the condenser and make sure that air can flow over it freely. Also check water supply if condenser is water cooled.

- J. **Cause:** Compressor flywheel or fan pulley out of line.

Indication: Frayed or broken drive belt. Rattle due to end play in the motor.

Remedy: Properly align the flywheel and fan pulley.

- K. **Cause:** Broken or frayed drive belt.

Indication: Usually a slapping noise.

Remedy: Replace belt, check belt tension and align pulley and flywheel if necessary.

- L. **Cause:** Refrigerator setting on weak or shaky flooring.

Indication: Floor will spring or cabinet will rock when you tread heavily on the floor.

Service

Remedy: Have floor strengthened or move refrigerator to another location. If neither of these remedies are possible, then mount the refrigerator on 2"x4" pieces, which extend across floor joists.

M. **Cause:** Refrigerator legs not touching floor evenly.

Indication: Box wobbles.

Remedy: Shim up legs until box is steady.

N. **Cause:** Belt too tight.

Indication: Less than 1/2" play, up or down.

Remedy: Adjust belt tension.

16. OVERLOAD BUTTON TRIPS OUT

A. **Cause:** Low line voltage at motor.

Indication: Lights dim excessively when motor is started. Voltage below 95 at motor terminals at instant of starting.

Remedy: Locate and correct the cause of low voltage. Check for poor socket contacts or long, undersize extension cord. Run new wiring from service switch if necessary. If voltage is low at house service switch notify power company.

B. **Cause:** Air in system.

Indication: Excessive head pressure, overheated condenser, evaporator partially or entirely defrosted.

Remedy: Purge air from system as explained in following lesson.

C. **Cause:** Stiff compressor.

Indication: Compressor hard to turn by hand even though head pressure is normal.

Remedy: Repair or replace compressor.

D. **Cause:** Defective motor.

Indication: Motor does not run, or runs very slow, hot and noisy.

Remedy: Repair or replace motor.

Electric Refrigeration

17. MOTOR RUNS TOO HOT

A. Cause: Motor overloaded due to stiff compressor, high head pressure caused

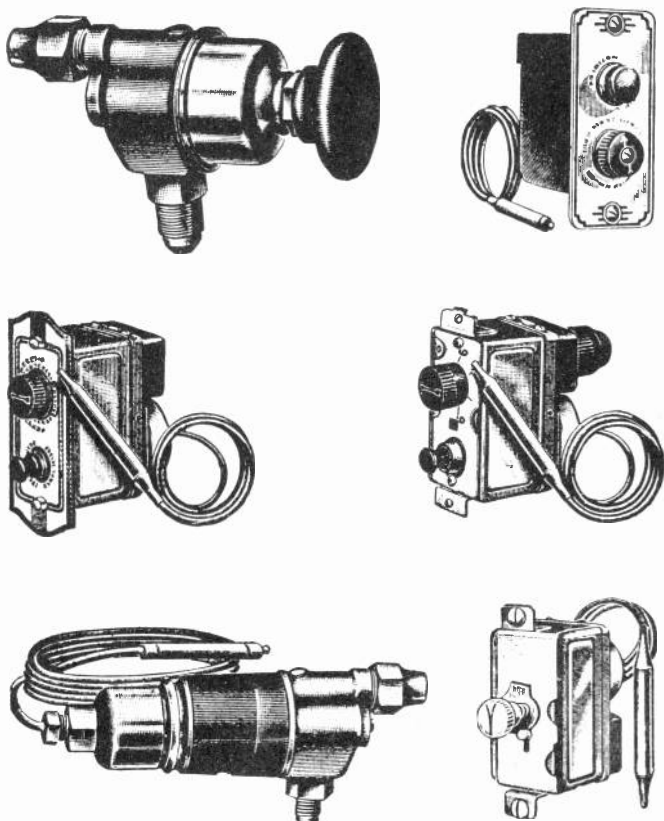

Fig. 10. Above are shown several types of cold control units and an expansion valve and thermostatic control valve which can be purchased from refrigeration supply houses for replacing defective controls on refrigerators.

by air in system or overcharge of refrigerant, worn motor bearings, belt too tight.

Indication: Motor too hot to touch without discomfort. Odor of burning insulation. Motor operates slow and noisy.

Remedy: Repair or replace compressor,

Service

- purge excess air or refrigerant from the system or repair motor bearings.
- B. **Cause:** Defective brushes or starting switch.
Indication: Sparking at commutator or brushes, motor growls and does not come up to full speed.
Remedy: Repair brushes or starting switch and clean commutator as outlined in lesson on A. C. motors.
- C. **Cause:** Under-voltage at motor.
Indication: Motor runs noisy and does not come up to full speed. Meter test shows motor terminal voltage below 95.
Remedy: Locate and correct cause of low voltage as explained in Article 16 under cause "A."
- D. **Cause:** Defective capacitor or condenser on capacitor type motors.
Indication: Motor fails to start or runs slow and noisy.
Remedy: Replace capacitor.
- E. **Cause:** Brushes set in wrong position on repulsion-induction motors.
Indication: Sparking at brushes, motor fails to start or come up to full speed, or motor runs slow and noisy.
Remedy: Shift brush holder mechanism to point where motor starts and runs best.
- F. **Cause:** Lack of oil in motor bearings.
Indication: Bearings dry, hot and worn.
Remedy: Fill oil cups and replace bearings if necessary.
- G. **Cause:** Defects in motor winding. Grounds, shorted coils, open circuit in starting or running winding.
Indication: Motor fails to start, or runs slow and noisy. Windings overheat in spots. Test for grounds and shorts as explained in motor lessons.
Remedy: Rewind or replace motor.
- H. **Cause:** Poor air circulation through unit compartment, or thru motor because of openings being plugged with dirt.

Electric Refrigeration

Indication: Evident upon inspection.

Remedy: Clean motor and provide for free air circulation through unit compartment.

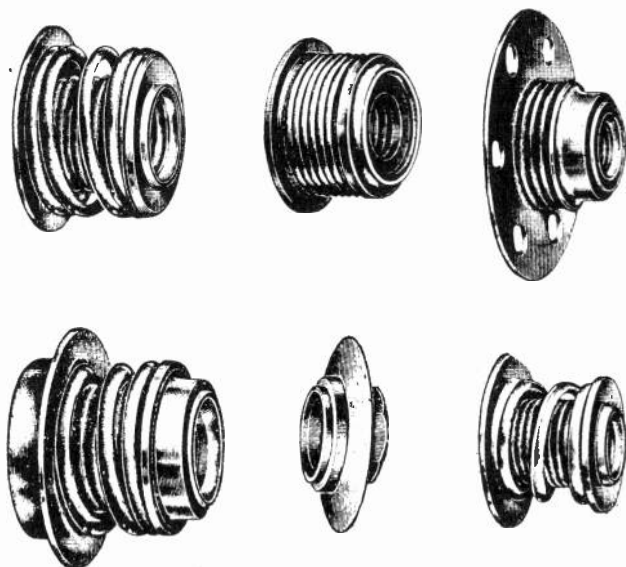

Fig. 11. Several types of syphon bellows and diaphragm type shaft seals for replacing defective seals on household or small commercial refrigerators.

18. WATER IN CABINET OR DRIPPING ON FLOOR

- A. **Cause:** Defrosting tray may have overflowed due to waiting too long before defrosting the evaporator.

Indication: Defrosting tray full of water, and question customer on time of defrosting.

Remedy: Instruct customer to defrost unit whenever frost becomes $\frac{3}{8}$ " thick.

- B. **Cause:** Water or other liquids spilled in cabinet.

Indication: Water or liquids on other foods and on bottom of cabinet.

Remedy: Show customer the source of the water.

- C. **Cause:** Cabinet door left open too long.

Service

Indication: Moisture condensing on inside of cabinet walls.

Remedy: Instruct customer not to leave door open any longer than necessary.

D. **Cause:** Poor air circulation in food compartment.

Indication: Shelves covered or overcrowded.

Remedy: Uncover shelves, rearrange food articles and instruct customer on need of good air circulation.

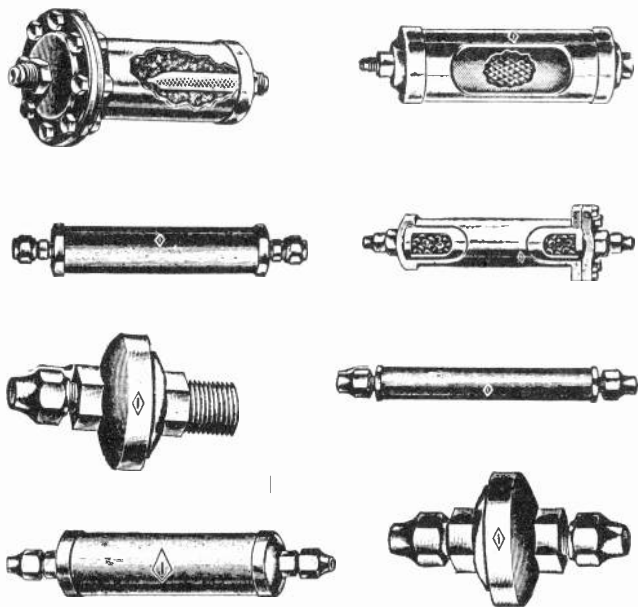

Fig. 12. The top four units in this view are dehydrators for connection in the liquid lines of refrigerators to remove moisture from the refrigerant. The lower four units are strainers for connection in the liquid lines to remove dirt or scale which might otherwise clog control valves and interfere with their proper operation. Dehydrators and strainers of this type can be purchased from refrigeration supply houses by the service man.

E. **Cause:** Leaky float valve.

Indication: Frost on suction line.

Remedy: Repair or replace float valve assembly as explained in next lesson.

F. **Cause:** Defective door gasket, warped door or door hinges out of line.

Electric Refrigeration

Indication: Inspection will show these defects. Moisture most noticeable near edges of door. Close the door on a single piece of newspaper and if gasket and door are fitted properly the paper strip should not pull out easily.

Remedy: Replace gasket or repair door or hinges.

19. BAD TASTE IN ICE CUBES OR IN MILK, BUTTER AND CREAM

A. **Cause:** Water from melted frost getting in ice trays when defrosting.

Indication: Empty the ice trays and defrost the unit. Check and see if water has run into ice trays.

Remedy: Advise customer to scald and re-fill ice trays after defrosting.

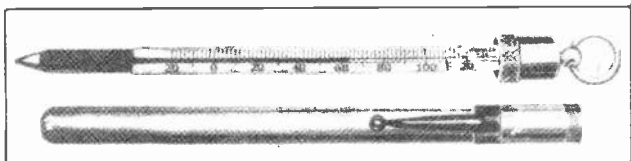

Fig. 13. The above view shows a convenient pocket type thermometer and case such as used by refrigeration servicemen in checking the temperatures of refrigerators under test.

B. **Cause:** Slight refrigerant leak.

Indication: Noticeable odor of refrigerant, or use ammonia, soap suds or torch test.

Remedy: Repair leak and wash the inside of cabinet thoroughly with soap and water and then with a mild solution of water and baking soda.

C. **Cause:** Refrigerator defrosts between cycles.

Indication: Evaporator only partly covered with frost.

Remedy: Reset cold control or determine cause for warm evaporator.

D. **Cause:** Storage of milk, butter, or cream in open containers.

Service

Indication: Evident upon inspection.

Remedy: Instruct customer to keep milk, butter and cream in closed containers because they readily absorb odors from other foods or the refrigerator.

E. **Cause:** Brine leak in units with indirect evaporators.

Indication: Odor of brine, and brine leaking from evaporator tank.

Remedy: Locate and repair leak or replace evaporator.

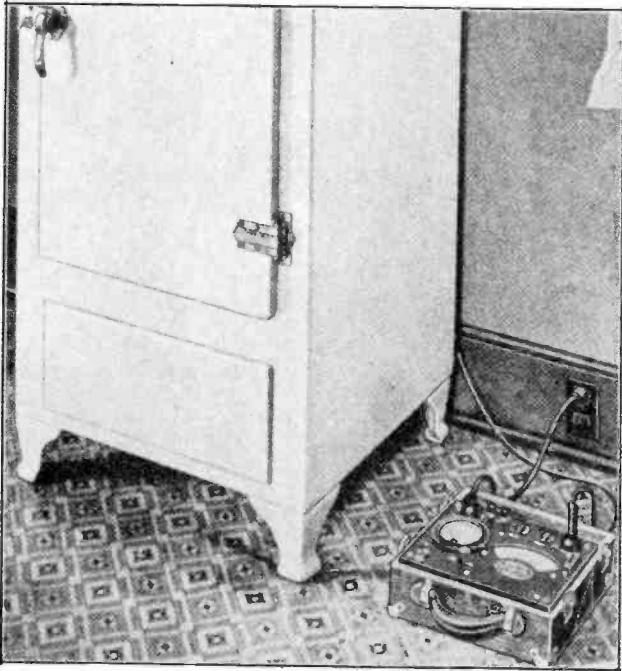

Fig. 14. This photograph shows how a convenient portable meter can be used for checking the amount of current consumed by a refrigerator, the amount of current drawn by the motor during starting, and the amount of voltage drop on the line. A meter of this type is extremely valuable to the serviceman in testing for motor or line troubles or in demonstrating the economy of operation of an electric refrigerator. Courtesy Servel Corp.

20. OBJECTIONABLE ODORS

A. **Cause:** Particles of stale food left on shelves or in corners.

Electric Refrigeration

Indication: Evident upon careful examination of inside of cabinet.

Remedy: Wash cabinet interior with soap and water and then with soda water solution.

- B. **Cause:** Milk, meat juices or other liquids spilled in cabinet and seeped into cracks at corners or bottom of cabinet.

Indication: Usually some traces can be seen, or the nature and location of the strongest odor may be apparent to the experienced service man.

Remedy: Remove base strips if possible, clean out food, wash or flush with hot soapy water and seal crevices with hot hydrolene or other sealing compound.

- C. **Cause:** Leak of refrigerant inside of cabinet.

Indication: Noticeable odor, or test with ammonia, soap suds, or torch.

Remedy: Locate and repair the leak and wash out cabinet.

- D. **Cause:** Refrigerator shut down for long periods with water in the trays and the door closed.

Indication: Musty odor when door is opened.

Remedy: Instruct customer that whenever a refrigerator is to be shut down for more than a few days, the evaporator should be defrosted and wiped dry, trays should be emptied and dried, food compartment cleaned and dried and the door left open.

21. EVAPORATOR FROSTS TOO MUCH

Causes: Cabinet door open too long and too often, leaky door gasket or poorly fitting door, hot foods placed in cabinet, or cold control set too cold.

Indication: Question owner about door opening and hot foods, examine door

Service

and gasket, check cold control.

Remedy: Advise owner about door opening, repair door or gasket, set cold control.

You should find the preceding list of common refrigerator troubles, indications and remedies very helpful if you will refer to it often during any refrigeration service work you may do.

EXAMINATION QUESTIONS

1. In addition to repairing the refrigerator what other duty should the service man perform?
2. Name five parts of a refrigerator where trouble may develop due to wear or faulty adjustment.
3. What preliminary tests should be made when a refrigerator motor fails to operate?
4. Of what value to the service man are service gauges?
5. Name three causes which will prevent a refrigerator from operating, and give the indication.
6. (a) What would be the cause of rushing or hissing noises in the evaporator?
(b) How would you remedy this condition?
7. How would a loose belt or low line voltage effect the compressor speed?
8. What would be the indication of a leaky discharge valve in the compressor?
9. Name three causes and give the remedy for ice cubes freezing too slowly.
10. Name three causes and give the remedy for noisy operation.

Electric Refrigeration

REFRIGERATION SERVICE PROCEDURE

The servicing and repairing of electric refrigerators offers excellent opportunities for interesting and profitable work, both spare time and full time, in practically every town, city and neighborhood. In fact, there is an actual shortage of refrigerator service men in many localities. Even in communities that do have several so-called refrigerator service men, too often they can do only a few of the simpler service jobs but are unable to find or repair many of the troubles that occur in refrigerating units and electric motors and controls, because they are not adequately trained to do this work.

These are the conditions that, along with the ever increasing number of electric refrigerators in use in both city and farm homes, should mean REAL OPPORTUNITIES for you if you thoroughly learn the refrigeration service methods as covered in these lessons.

1. COMPRESSOR TROUBLES

First we will consider the compressor as this is one of the most important parts of any refrigerator, and having a number of moving parts which are subject to wear, the compressor should have close attention from the service man. As the compressor is virtually the heart of the refrigerating unit we can readily see that in order to secure efficient and economical operation of the refrigerator, the compressor must be in good condition.

Some of the most common troubles that occur with reciprocating compressors are as follows:

1. Discharge valve not seating properly.
2. Suction valve not seating properly.
3. Worn pistons or piston rings
4. Shaft seal faces not seating properly, or siphon bellows broken.
5. Leaky gaskets.
6. Worn bearings on crank shaft, connecting rod or wrist pin.
7. Noisy compressors.
8. Lack of oil.
9. Leaks in crankcase casting.

Rotary compressor troubles may be due to:

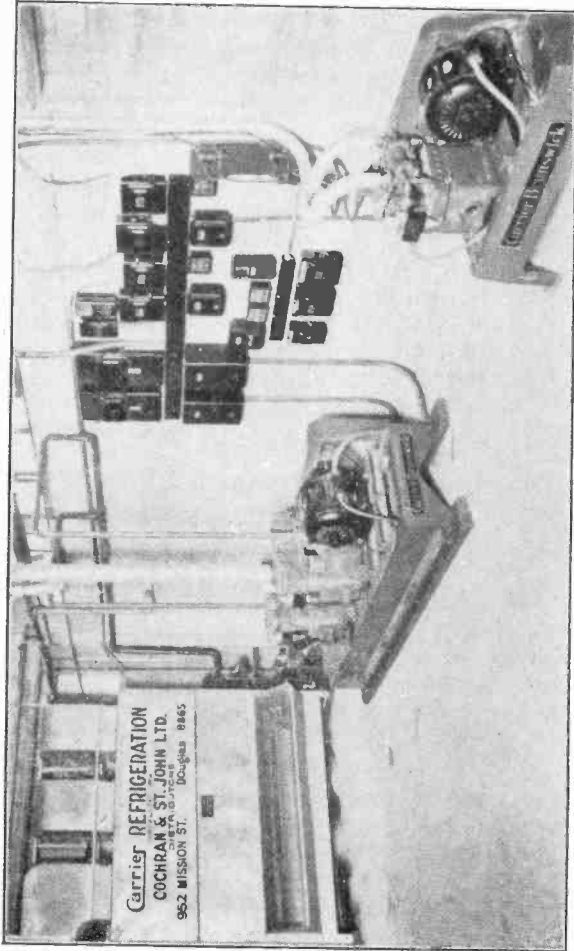

Fig. 1. The above photograph shows a very neat installation of two commercial refrigeration units in the basement of a meat market. The unit on the right is a two cylinder motor driven compressor while the unit on the left has two four cylinder compressors each driven by a separate motor. Note the electrical wiring and switch box installation for these units. Courtesy Carrier Corporation.

Electric Refrigeration

1. Worn bearings.
2. Worn rotor.
3. Worn casing.
4. Worn vanes or broken vane springs.
5. Defective or leaky check valves.
6. Lack of oil.
7. Defective shaft seal.

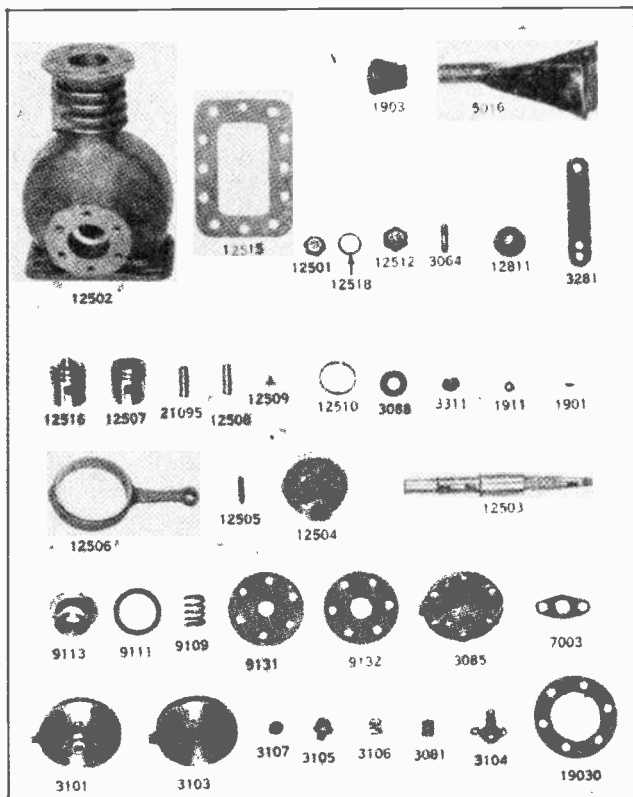

Fig. 2. Above are shown a number of replacement parts for a single cylinder refrigerator compressor. Note the compressor body, pistons, piston pins, piston ring, eccentric rod, eccentric, eccentric shaft, shaft seal, cylinder head, valve plates, gaskets, etc. Courtesy Kelvinator Corporation.

In many cases when certain of these compressor parts become badly worn or defective, the most practical and economical thing to do is to discard them and replace them with new parts which are

Service

obtainable from refrigeration service and supply stores. Standard replacement parts for most common makes of refrigerators are usually available in well stocked supply houses. Figs. 2 and 3 show a number of these common replacement parts for single cylinder and multiple cylinder reciprocating compressors.

In many instances, however, defects such as leaky valves, leaky shaft seals, etc., can be serviced right on the job.

2. COMPRESSOR EFFICIENCY TEST

To test the efficiency of a compressor, attach a compound gauge to the suction service valve as described in the preceding lessons. Turn the valve stem all the way to the right and start the unit. If the compressor is in good condition, the compound gauge should almost immediately show a vacuum which will rapidly increase to a 20" vacuum or more.

When the vacuum will increase no further, stop the unit and allow it to remain idle for five or six minutes. If at the end of this period, the vacuum has not changed, it shows that the compressor valves, shaft seal and gaskets are in good condition.

If the compressor does not hold a good vacuum during this period it indicates a leaky discharge valve, leaky suction service valve or a leaky shaft seal. However, if there was no odor or no signs of any leak of refrigerant before starting the unit then the trouble is very likely to be a faulty discharge valve.

If when the compressor is started it requires a long time to pump a vacuum, it usually indicates a defective suction valve, but it may also be due to an inefficient discharge valve. In either case the compressor should be removed and both valves put in good condition, by lapping or replacing as will be described in later paragraphs.

If the compressor starts to "slug oil" while drawing the test vacuum, stop the unit for a few minutes and then start it again, repeating this several times if necessary.

To test a compressor for a leaky shaft seal or for

Electric Refrigeration

loose or blown gaskets, the pressure on the low side should be built up by allowing the compressor to stand while the refrigerant in the evaporator builds up gas pressure in the compressor base or crank case. Then test for refrigerant leaks at the gasketed joints or shaft seal by means of the ammonia swab, torch test or soap suds test as previously explained.

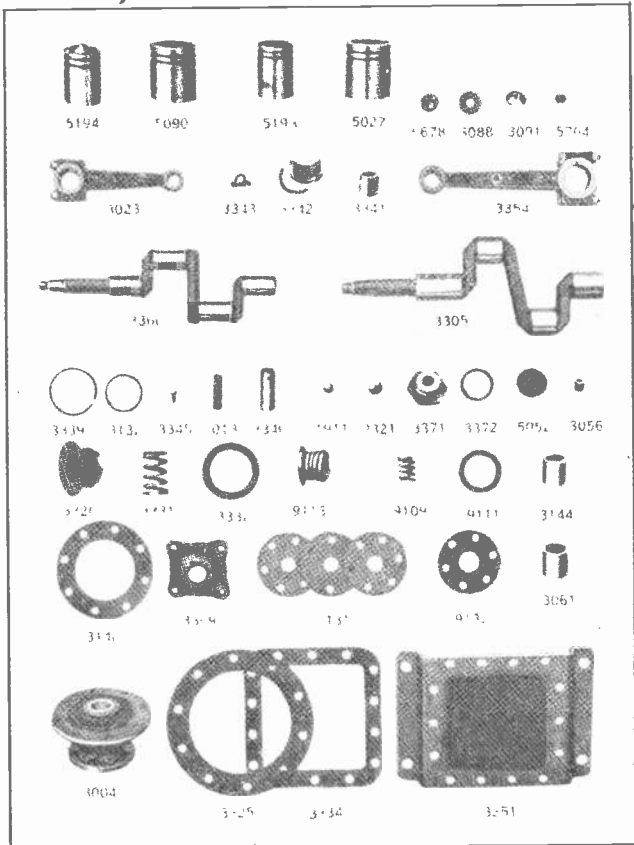

Fig. 3. This figure also shows a number of replacement parts for two cylinder compressors. Note the pistons, connecting rods, bearings, crank shafts, piston pins, piston rings, piston seals, valve plates, gaskets, etc. Courtesy Kelvinator Corporation.

If there is a leak around the gaskets it may be due to vibration having loosened some of the compressor bolts. In this case, tighten the bolts and

Service

test for further leaks. If this does not remedy the trouble, the gaskets should be replaced with new ones.

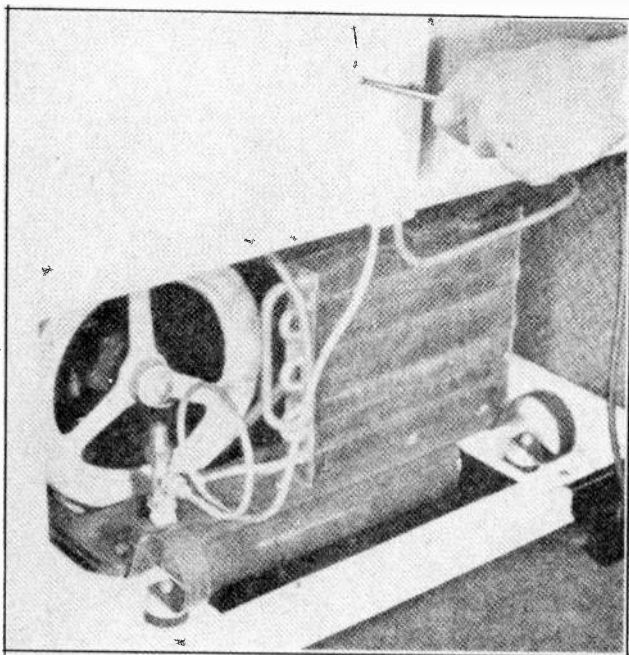

Fig. 4. When removing a condensing unit from the cabinet, be sure to loosen all tubing and wiring so they will not be broken or strained when the condensing unit is pulled out of the cabinet. Courtesy Stewart-Warner Corporation.

In case it becomes necessary to remove the compressor and condensing unit from the cabinet in order to disassemble it for repairs to suction or discharge valves, seals, bearings, pistons, etc., proceed as shown in Figs. 4, 5, 6 and 7.

First make sure that tubing and wiring are loose and free to permit unit to be removed. Then carefully work the unit out onto the floor where it is conveniently accessible for servicing. A piece of linoleum, canvas or building paper should be used to protect the floor.

3. SHAFT SEAL TROUBLES

As explained in preceding lessons compressor shaft seals have highly polished surfaces on the

Electric Refrigeration

shaft seal face or shoulder and on the bellows seal face, with a film of oil between these faces to prevent wear. If for any reason this oil film breaks down or disappears, a squeak similar to a belt

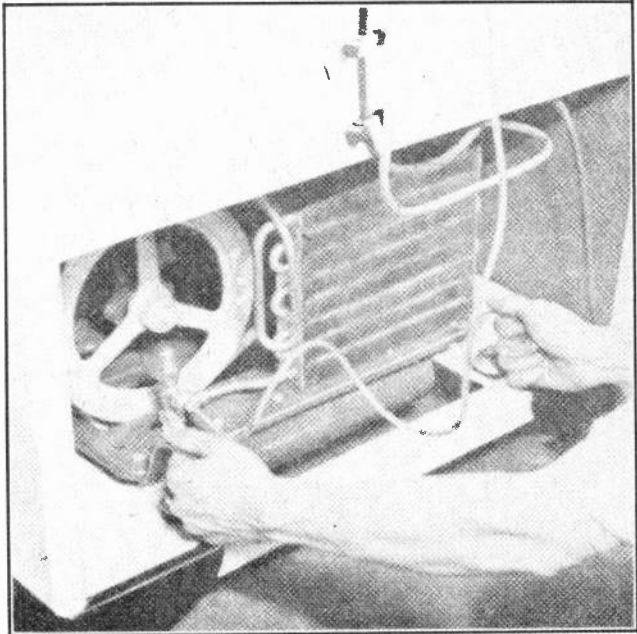

Fig. 5. Here the tubing is shown loose from the back of the cabinet and the serviceman is preparing to pull out the condensing unit. Courtesy Stewart-Warner Corporation.

squeak will be noticed, and if the compressor is allowed to continue running in this condition, the seal faces will become scored or roughened. This will allow refrigerant to escape whenever gas pressure exists in the crank case; or it will permit air to be drawn into the compressor whenever a vacuum exists in the crank case.

In the case of a leaky shaft seal, it is necessary to remove and reface the seal by lapping or polishing, or replace it by installing a new seal. Before the reconditioned seal or new seal is installed be sure that the seal face on the crank shaft shoulder has a smooth and well polished surface. If this surface is rough or grooved, it should be turned

Service

down or polished smooth with a shaft seal facing tool. Or if this is not possible, a replacement shaft seal face should be installed. If necessary, a complete new crankshaft can be installed without very great expense.

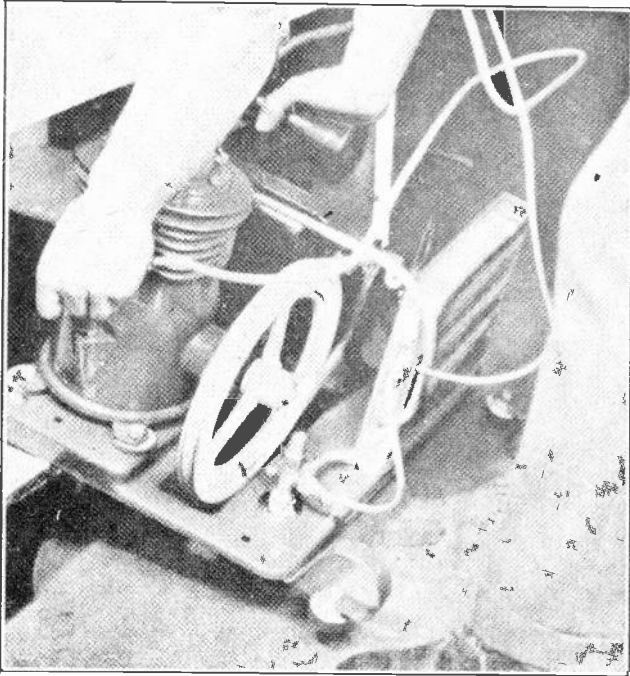

Fig. 6. By grasping solid parts on the compressor, motor or condensing unit frame, the unit can be slid out of the cabinet as shown above. Courtesy Stewart-Warner Corporation.

When a compressor has been fitted with a new shaft seal, or when replacing a reconditioned seal be sure that both seal faces have a film of good compressor oil or vaseline between them, and also see that a charge of new oil is put in the compressor. After reassembling the compressor, it should be run from twenty to thirty minutes before reinstalling it in the refrigerator.

4. LAPPING OF SHAFT SEALS AND SEAL RINGS

For resurfacing or lapping bellows seal faces, a lapping block such as shown in Figs. 8 and 9 can be

Electric Refrigeration

used. In emergencies a piece of flat plate glass can be used as a lapping block. Generally two different lapping blocks are used, one for the rough lapping with pumice stone or bon ami and the other for the finish lapping or polishing with fine emery powder, powdered sulphur and oil, or lapping rouge.

For the rough lapping, mix a small amount of fine pumice stone or bon ami with an equal amount of clean compressor oil. Spread a thin film of this paste over the surface of the lapping block. Then grasp the bellows assembly lightly between the

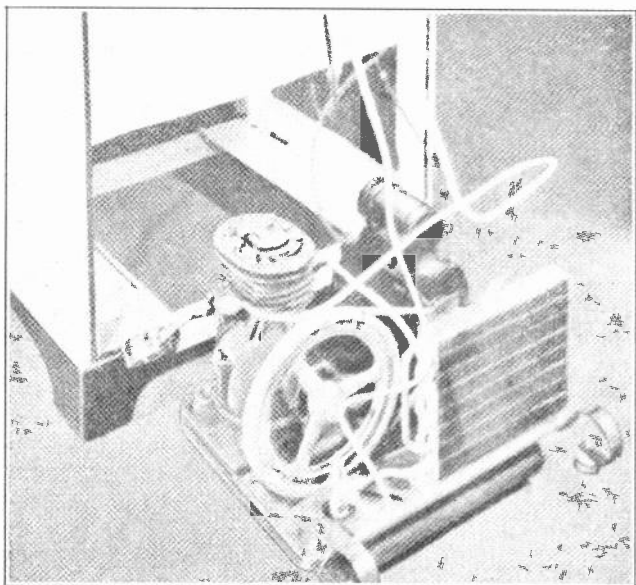

Fig. 7. Here the condensing unit is shown completely removed from the cabinet and in convenient position for adjustment and servicing. On some refrigerators, the tubing is not long enough to permit removal of the condensing unit without pumping down the system and disconnecting the tubing. Courtesy Stewart-Warner Corporation.

thumb and fingers as shown in Fig. 8, let the seal surface rest flat on the block with very light pressure and grind with a rotating or figure 8 motion.

After lapping until the surface appears to be flat and true it can be tested with a surface testing block. To make this test, thoroughly wash the seal in gasoline or carbon tetra-chloride to clean all lapping paste and material from the seal, including the

Service

inside of the bellows. Then place the dry ring surface on the surface testing block and rotate several times. The face of the seal ring should then show a bright polished finish extending over its entire surface.

To lap the shaft seal ring, mix a very thin paste of number 303 emery and compressor oil and spread this paste thinly over the surface of the lapping block. Then rotate the seal face of the shaft seal ring on this block as shown in Fig. 9, being very careful not to allow the seal ring to tip when lapping. The seal face must be flat on the block to obtain a true surface which will not leak.

Never lap a bellows seal with emery or on the emery block, as emery particles might become imbedded in the soft bronze ring, and when the seal is reassembled and the compressor started, these particles would rapidly wear away the seal faces and cause another leak.

5. LAPPING OF DISCHARGE VALVES

To lap the seats of discharge valves use a lapping block and pumice paste as shown in Fig. 10, following a procedure similar to that described for lapping seal rings, and being careful to keep the valve seat flat on the block during the lapping process.

After lapping valve seats thoroughly, clean them with gasoline or carbon tetra-chloride and wipe dry. Reassemble the discharge valves, using new valve reeds or springs if the old ones are worn or eroded. Coat the surface of the valve seat with compressor oil when reinstalling.

On compressors using poppet valves, the valve seats can be lapped or cleaned by wrapping a $\frac{3}{4}$ " strip of Luminox sandpaper around the valve and placing this lapping device in the valve seat so that the valve holds the sandpaper firmly against the valve seat. Rotate this lapping device back and forth until the valve seat is clean and true.

If discharge valves are badly worn or damaged, it is often more practical to replace the entire valve and valve seat with a new replacement valve assembly. In some cases, however, a troublesome valve leak may be caused by a mere particle of hard dirt

Electric Refrigeration

or scale which has become lodged between the valve reed and the valve seat, and which can be easily cleaned off.

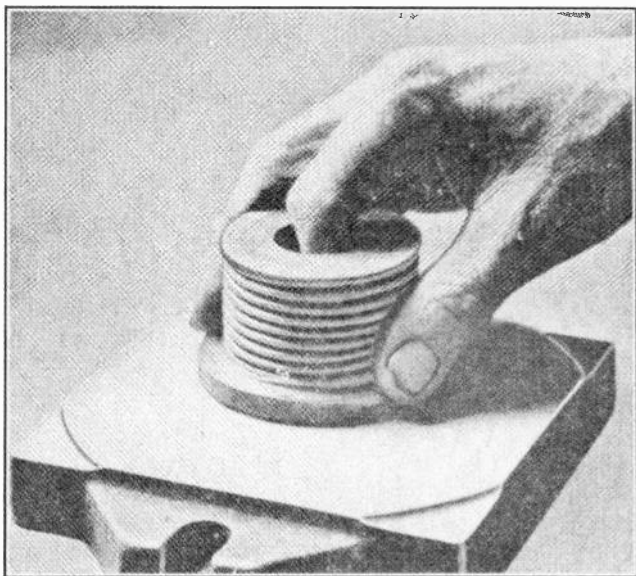

Fig. 8. The above photo shows how to hold a bellows type shaft seal on the lapping block for lapping or polishing the face of the seal. Courtesy Servel Manufacturing Company.

After repairing or replacing compressor valves, be sure to give them a thorough test by running the compressor and watching the compound service gauge as previously explained.

6. DEFECTIVE PISTONS OR RINGS

When compressor pistons and rings become worn too much, it allows gas to escape back between the sides of the pistons and cylinder to the crank case during the compression stroke. This greatly reduces the efficiency of the compressor, and the condition would be indicated by low high side pressure and by continuous or too frequent operation of the compressor as well as improper refrigeration of the unit.

If the pistons and rings are not too badly worn, a new set of rings may remedy the trouble. If the

Service

piston is badly worn, it may be necessary to replace it with a new piston. It may even be necessary to regrind the cylinder to bring it back to a smooth round surface and then fit the compressor with slightly oversized pistons and rings to match the new cylinder diameter.

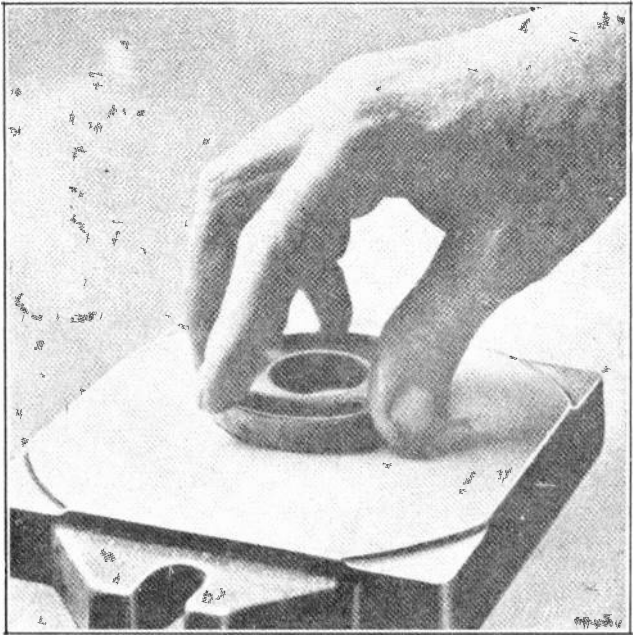

Fig. 9. This view shows the method of lapping a bellows seal ring. The ring should be held perfectly flat on the block while lapping with a rotating or figure 8 motion. Courtesy Servel Company.

7. COMPRESSOR BEARINGS.

When compressor bearings become badly worn, if the shaft surface is not seriously worn or rough, new bearings can be installed and the trouble thus remedied. If the shaft is badly worn, it can be re-ground and polished and refitted with slightly undersized bearing to match the new diameter of the shaft.

In case the crank bearings or eccentrics are badly worn, the crank shaft or eccentric shaft and eccentric rods can be replaced with new ones.

Electric Refrigeration

If piston pins become loose and noisy they can be replaced with new pins, also replacing the pistons if necessary, because of the pin holes being worn too large.

On large compressors which use crank shafts and connecting rods with split bearings such as shown in Fig. 3, bearing play or wear can be taken up and remedied by removing shims and tightening the connecting rod bearing bolts to close up the split bearing shell. Be careful not to remove too many shims or tighten the bearings too much or they will overheat and shortly burn out or give more trouble.

8. REPAIRS TO ROTARY TYPE COMPRESSORS

Some of the troubles which the service man will most frequently encounter with rotary compressors are:—low oil charge, indicated by compressor running hot and noisy; leaky check valves, indicated by whistling noise heard by placing ear against line near valve, or by unit short cycling; leaky shaft seals, indicated by odor of refrigerant or by leak tests previously described.

In addition to these troubles, weak or broken vane springs, worn vanes, rotors or sleeves, and worn bearings are also troubles which the serviceman can repair. In case of a badly worn compressor, in which the rotor, casing, and bearings are all worn, the most practical remedy would be to replace the compressor, with a new unit from the factory.

In case of low oil charge, fresh oil can be added as explained in Art. 21 on adding oil.

In case of leaky check valves, the unit must be discharged as explained in Art. 15. Then the dirty or defective valve can be removed and cleaned or replaced.

In case of a leaky seal on a rotary compressor the seal should be removed and resurfaced or replaced as explained in Articles 3 and 4 on repairing seals on reciprocating compressors. If the unit has two service valves, these can both be closed thus isolating the compressor from the rest of the system. The compressor can then be removed for repairs to seals or other parts.

If the unit has only one shut off valve then it is necessary to discharge the unit by means of a

Service

special charging and purging valve such as shown in Fig. 11 which attaches to the shut off valve. When the stem of this charging-purging valve is turned to the left or toward open position, it turns the stem of the shut off also; allowing the refrigerant to discharge through the charging-purging valve, and through an attached tube to service drum or neutralizer as explained in Art. 15.

In case of broken vane springs as used with the Norge Rollator compressor, a small cap or plate at the side of the compressor can be removed for easy access to, and replacement of the vane spring. Before removing this cap or plate, be sure to balance the pressure on the compressor so that gauge shows about 1 lb. pressure in compressor, as explained in article 10.

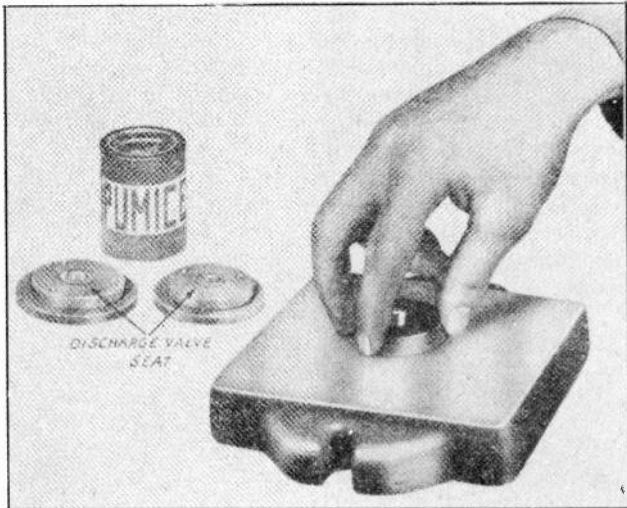

Fig. 10. Valve seats can also be lapped on a lapping block with lapping compound as shown above. Courtesy Servel Manufacturing Co.

In case of worn rotors and vanes on rotating vane type compressors, or in case of worn rotor and sleeve on the Rollator compressor, a complete new rotor unit can be obtained from the factory and replaced in the old compressor casing. To perform this operation, both service valves must be closed or the unit discharged to permit removal of the compressor.

Electric Refrigeration

- A limited amount of wear and clearance can be compensated for by use of a heavier grade of oil.

9. FLOAT TYPE CONTROL VALVES

We have previously learned that the control valve or throttle valve is one of the vitally important parts of any refrigerator, as it controls or regulates the flow of refrigerant to the evaporator and thereby regulates the temperature maintained in the cabinet. You will also recall that control valves are of three

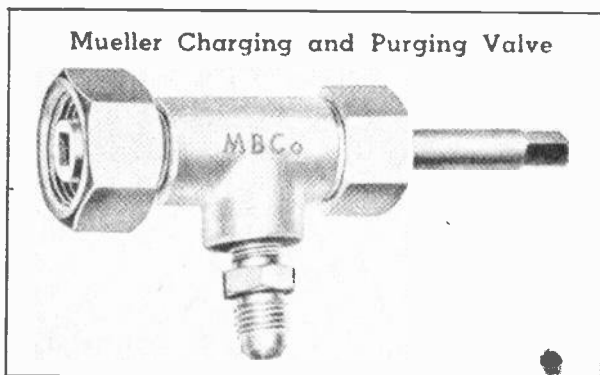

Fig. 11. Charging and purging valve such as used in connection with the regular shut-off valve for charging or purging rotary type compressors which are not equipped with regular low side and high side service valves. Courtesy Mueller Brass Company.

principal types known as float type valves, thermo-static valves and pressure operated valves.

If the control valve becomes stuck or defective, the flow of refrigerant cannot be properly regulated and the unit will not refrigerate properly. If the control valve sticks in an open position, too much refrigerant will flow, the suction line will frost over, the low side pressure will become abnormally high and the compressor will probably run continuously.

If the control valve sticks in a closed position not enough refrigerant will flow, the unit will not cool properly and the low side pressure will be abnormally low.

Float valve troubles may be caused by a leaky float, stuck float arm or mechanism, by dirt or scale lodged in the needle valve opening, or by needle

Service

becoming pitted. A method of flushing dirt from this opening was explained in Article 8, Lesson No. 98. If this does not eliminate the trouble, then it may be necessary to remove the float valve header and repair or replace the valve.

In many cases, a stuck float valve can be freed by jarring the valve header or evaporator with a hammer and a block of wood or a brass rod. In case this fails to free the valve, it may be necessary to remove the valve header to make repairs or replacements.

10. REMOVING FLOAT VALVE HEADER

If it becomes necessary to remove the float valve header from an evaporator, you should proceed as follows: First install the pressure and compound service gauges, then close the receiver valve or "king valve" and set the cold control at the coldest position. Next remove and empty the ice trays, fill them with hot water and replace them in the evaporator.

Leave the cabinet door open and renew the hot water in the ice trays several times until all refrigerant is removed from the evaporator. Operate the compressor until all refrigerant vapor has been pumped from the evaporator, by which time the frost should have disappeared from the evaporator and it should feel warm to the touch. When the compound gauge registers 20" of vacuum and all parts of the evaporator are warm to the touch, it may be assumed that all refrigerant has been removed from the evaporator.

Before removing the old float and header be sure to have the new or replacement header and float all ready with new gaskets, for immediate replacement so that the float chamber will be opened the shortest possible time.

Also before removing the header, crack the receiver valve open just long enough to **balance the pressure** or to cause the compound gauge on the suction service valve to register one pound pressure, then close the compressor low side service valve.

On some units it is advisable to tilt the evaporator or cabinet backwards so that the front end of the

Electric Refrigeration

evaporator is about one inch higher than the back end, in order to avoid spilling out any oil which may remain in the evaporator, when the header is removed,

Be sure to wipe the front of the evaporator absolutely dry so that no moisture will get into the unit when it is opened.

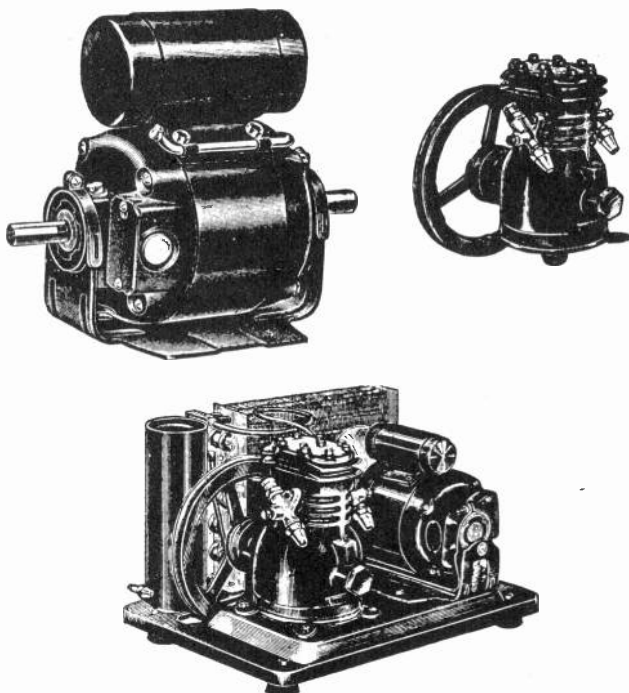

Fig. 12. Complete replacement motors, compressors, or entire condensing units such as shown above can be obtained from the refrigeration supply houses for replacing defective units.

Disconnect the liquid and suction lines from the header and plug the ends of both lines with flare type seal plugs or rubber stoppers to prevent dirt or moisture from getting into these lines. It is also advisable to cap the float fittings if the job cannot be immediately completed.

Caution: Always use goggles and extreme caution when actually removing the valve header because in some cases enough refrigerant may be released from the oil in the evaporator to build up a pressure

Service

and cause refrigerant and oil to be blown into the face of the serviceman if proper caution is not observed.

First loosen, but do not remove the header bolts and then loosen the header by tapping with a hammer. After the header is loose remove the bolts and take out the float mechanism, being very careful not to bend or damage it.

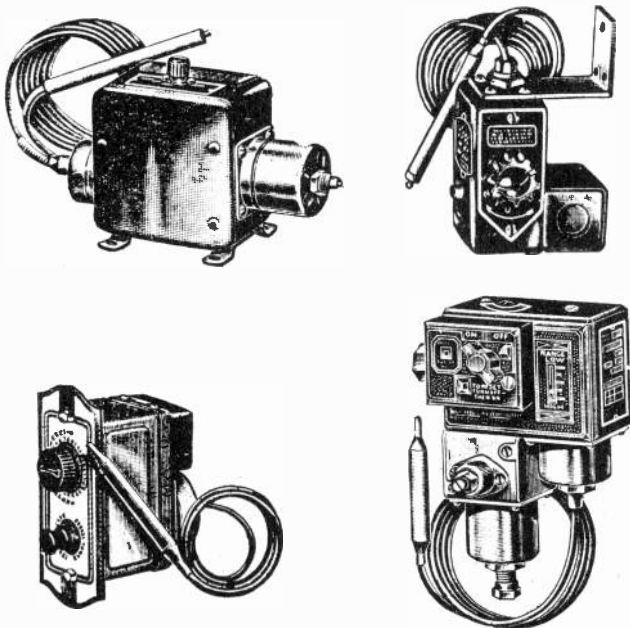

Fig. 13. Several types of cold control units which can be obtained for replacing defective controls or for installation on old refrigerators which were not originally equipped with such controls.

Next clean off the gasket face of the float chamber, being careful not to get any dirt in the float chamber. Then replace the new or repaired float and header, using a new gasket, and tighten the bolts evenly and firmly all around.

Reconnect the liquid line and suction line. Loosen the flare fitting at suction service valve and purge the air from the lines and evaporator by cracking the receiver valve open until refrigerant odor can be noted at the loose fitting.

Electric Refrigeration

Then tighten all connections and open the low side valve, crack receiver valve open until compound gauge shows 5 lbs. pressure. Test all connections for any possible leaks. If no leaks show then open receiver valve and again check for leaks before operating the unit.

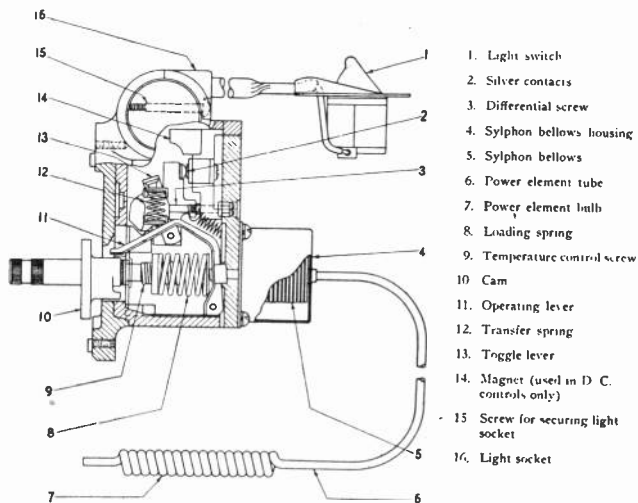

Fig. 14. Sectional view of a refrigerator control switch showing the contacts, springs, pressure bellows and power bulb. Examine each of these parts carefully while studying the lesson material on control switch repairs. Courtesy Stewart-Warner Corporation.

11. REPAIRING PRESSURE TYPE OF THERMOSTATIC CONTROL VALVES

Pressure or thermostatic type valves may also give trouble by becoming stuck or clogged and may be freed by flushing as previously explained in Article 8, Lesson 98, or by rotating the adjusting screws from fully closed to fully opened position and back to normal.

Thermostatic valves may fail to operate properly due to the power bulb becoming loose from its connection to the evaporator or suction line, in which case the remedy is to securely tighten this connection.

These valves may also fail due to loss of liquid from the power bulb. On many of these pressure

Service

or thermostatic valves, the power bulb and pressure bellows can be conveniently removed and replaced with new elements without opening any connection to the evaporator or the suction or liquid lines.

In case the complete control valve needs to be removed for cleaning or repairs, the same procedure should be followed as previously explained with regard to closing the receiver valve, boiling out all refrigerant from the evaporator, pumping the low side down to 20" vacuum by running the compressor, then cracking the receiver valve open to build up one pound pressure before loosening the bolts and removing the valve header.

If pressure does not build up when receiver valve is cracked, it indicates the control valve is stuck closed and liquid line may be full of refrigerant. In this case carefully bleed the liquid line by loosening the flare fitting at the receiver valve.

Also exercise the same caution previously mentioned with regard to any refrigerant which might escape from the evaporator when it is first opened. Also follow carefully each step of the purging operation to remove all air that may have entered the evaporator or lines while they were open.

12. CONTROL SWITCH TROUBLES

As explained in the list of common refrigerator troubles and symptoms in Lesson 98, faulty operation of a refrigerator may be caused by a defective control switch. You will recall that control switches are connected in the motor circuit and consist of a set of contacts which are operated by a pressure bellows or a thermostat strip.

One of the most common troubles occurring with control switches is dirty, burned or pitted contacts. Repeated opening and closing of these contacts to start and stop the motor hundreds of times each month will naturally cause them to burn and corrode a certain amount.

In some cases, these contacts may become burned and melted so that they stick together causing the refrigerator to run continuously even though proper temperature or excessively low temperature has been reached in the cabinet. The force exerted by

Electric Refrigeration

the pressure bellows or thermostat element may not be sufficient to break the contacts apart.

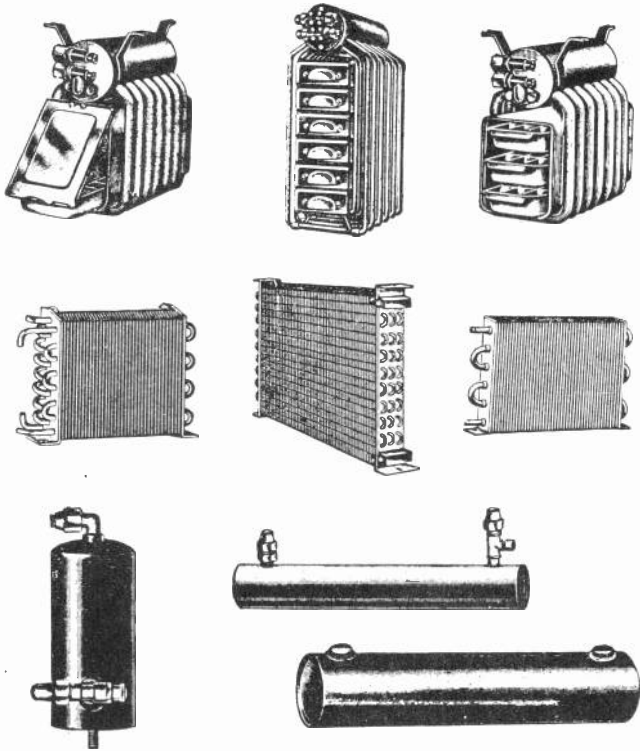

Fig. 15. Several types of evaporators, condensers and receivers which can be obtained by the serviceman from refrigeration supply stores for replacing defective units on old refrigerators.

When contacts are found to be stuck, dirty or pitted they should be carefully cleaned with fine sandpaper, emery cloth or a contact point file. Be sure to keep the contact faces flat and parallel so that they make a contact of sufficient area to be of low resistance and thus prevent overheating.

Another common trouble with control switches is a weak or broken spring. This fault can easily be remedied by replacing the defective spring with a new one at a cost of a few cents.

In case of a leaky pressure bellows or a warped or defective thermostat element, these can also be

Service

replaced with new ones. Sometimes control switches may fail to operate properly because the power bulb is loose from the evaporator, or has not been properly installed.

HEAD PRESSURE — CONDENSER TEMPERATURE CHART

When the temp. of the cooling medium (in degrees Fah.) at the inlet to the condenser is:	With the low side pressure set for 6" of vac. the high side pressure with SO ₂ should be:	With the low side pres. set at 6 lbs. the high side pres. with Methyl Chloride should be:	With the low side pressure set at 12 lbs. the high side pres. with Freon should be:
60°	57	87	100
65°	62	95	107
70°	68	100	115
75°	72	104	119
80°	78	115	127
85°	86	119	137
90°	94	129	147
95°	106	139	156
100°	110	148	167

Values in this table are based on an evaporator temperature of 5 deg. Fah.

13. EVAPORATOR TROUBLES

Aside from the float valve which is located inside of some evaporators there is little else about an evaporator to give trouble. Float valve repairs have been covered in a preceding article. However, evaporators may give trouble due to leaky gaskets at the float valve header, or in some cases, the evaporator may become rusted or corroded so that slight refrigerant leaks develop somewhere in the tank or tubes.

In case the trouble is caused by a leaky gasket, the gasket should be replaced with a new one. When performing this operation, follow the same procedure in pumping down the unit and then setting up a slight gas pressure before removing the header and gasket, as explained under article 10 on removing float valves. Also follow the same procedure in purging any possible air from the evaporator after replacing the gasket and valve header.

Electric Refrigeration

When it becomes necessary to remove and replace an evaporator the first step is to install service gauges and pump down the unit to a 20" vacuum as explained in Article 9 of this lesson, for removing float valves. Also crack the receiver valve open just long enough to cause the compound gauge to register about one pound pressure, so that a slight amount of refrigerant will force its way out of the evaporator and lines, instead of permitting any air to be sucked in when the connections are opened. Also follow the same precautions regarding opening the connections or header slowly and protecting the eyes from any liquid refrigerant that might escape when the connections are first opened.

The new evaporator which is to be used for replacing the old one should be right on hand for installation as quick as the old unit is removed. After installing the new evaporator be sure to purge it and both the liquid and suction lines of any air which might have entered them when the connections were open. After installing an evaporator or any other new part in a refrigerator, be sure to check all joints and connections for leaks.

On evaporators of the indirect type using a brine solution and brine chamber, the brine level should be kept within $\frac{1}{4}$ " of the top of the brine compartment. If a bad brine leak develops, it is generally best to replace the entire evaporator. The defective evaporator may possibly be repaired later in the service shop by soldering, brazing or welding.

14. CONDENSER TROUBLES

If the condenser of a refrigerator does not function properly, and cool and condense the high pressure gas from the compressor, the refrigerator will not operate satisfactorily or produce the low temperatures desired in the cabinet and in the ice cube chamber.

One of the most common condenser troubles is caused by the condenser becoming clogged with dirt so that the cooling air cannot properly circulate through its tubes and fins. This trouble can be easily remedied by thoroughly cleaning the condenser with a brush and vacuum cleaner. The condenser can also be washed with carbon tetra-chloride

Service

to remove any grease or oil accumulations. Grease or oil, if left on a condenser will cause it to collect dust and lint from the air much more rapidly.

Condensers may in some cases develop leaks due to corrosion or to mechanical abrasion by being bumped with some sharp object, or by vibration and rubbing of some metal part against the condenser.

To remove and replace a condenser it is necessary to discharge or remove the entire charge of refrigerant from the unit as described in the following article. After the new condenser has been installed, the unit should be recharged as explained in Art. 17, and the usual tests made for leaks as previously explained.

The air velocity through air-cooled condensers should be from 400 to 500 feet per minute to accomplish proper cooling and condensing of the high pressure gas. The top coil of a condenser when properly operating should be about 25° F. above room temperature.

If a condenser tube is sharply bent or dented it may restrict the flow of gas and cause high head pressure.

On water-cooled condensers the water control valve sometimes becomes clogged with sediment and restricts the flow of cooling water, preventing proper condensing. This valve should be set or regulated for a 20 degree temperature difference between inlet and outlet water.

HEAD PRESSURE AND CONDENSER TEMPERATURE

The pressure on the high-pressure side of any refrigerating system is determined by the temperature of the condenser cooling medium, the low-side-pressure setting, the type of refrigerant used, and the condition of the condenser. If the low-side-pressure setting is different than that given in the chart, the high-side pressure will be changed, that is why the low-side pressure is specified at the head of each column. The low-side-pressure settings are those required to maintain a 5 degree temperature inside the evaporator; these are the settings usually employed on domestic refrigerators.

Electric Refrigeration

If the temperature of the air at the inlet to the evaporator is 60 degrees then, according to the chart, the head pressure on a Sulphur Dioxide unit should be 57 pounds; the reading on a Methyl Chloride unit 87 pounds; the high-side pressure on a Freon unit 100 pounds.

Although the chart is made up on the basis of an air cooled condenser, the values given could be used for water cooled condensers provided the **mean** temperature of the water were employed. Most water cooled condensers are adjusted so that the outlet water is 20 degrees higher in temperature than the inlet water; therefore, if the temperature of the inlet water were 80 degrees, and the temperature of the outlet water were 100 degrees, the mean temperature of the cooling medium would be 90 degrees. Using this value in the table, we find that with a water-cooled Freon unit, for example, the head pressure should approximate 147 pounds.

Pressures considerably above normal indicate restricted circulation, dirty condenser, air in the system, etc. Remember that to use the table effectively, both the high-side pressures must be determined, for if the low-side pressure rises, the head pressure will go up also. The head pressures given in the table are correct only when the low side pressure and the temperature of the condenser cooling medium are as specified.

15. DISCHARGING A REFRIGERATOR UNIT

When it becomes necessary to remove the refrigerant charge from a refrigerator unit, in order to replace a condenser or receiver, or to completely overhaul the system, or merely to renew with a fresh charge of refrigerant and oil, the following steps should be taken. First, connect several feet of tubing or a discharge hose to the discharge service valve gauge opening by means of a half union fitting. The other end of this tube is attached to an empty service drum by means of a "T" fitting, to which a pressure gauge is also attached. See Fig. 16. Then purge the air from the discharge line by leaving the fitting loose at the drum and cracking the discharge service valve open until gas blows all air from this line. Then tighten fitting at the drum.

Service

Next open the valve on the service drum and close the discharge service valve all the way to the right so that when the compressor is operated, the refrigerant will discharge through the gauge opening and tube into the drum.

Then operate the compressor until all parts of the unit, such as evaporator, condenser, receiver and lines are all warm, showing that all refrigerant has been removed from them. The compound gauge on the low side service valve should also show a high vacuum.

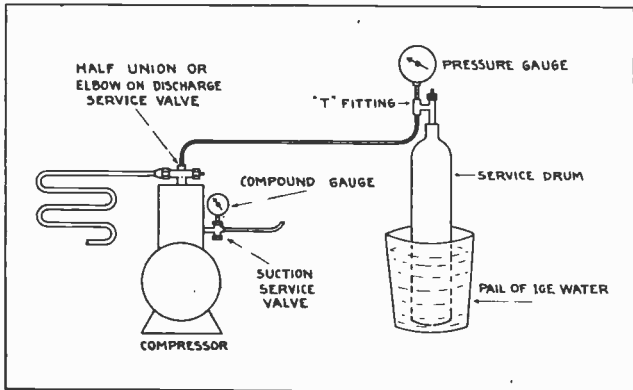

Fig. 16. The above diagram shows the method of connecting a refrigerant service drum to a compressor for discharging the refrigerant from the unit. Observe this diagram carefully while reading the accompanying explanation in the lesson.

While pumping the refrigerant out of the unit and into the service drum, the pressure gauge attached to the drum should be watched to see that the pressure does not exceed 125 lbs.

The service drum should be immersed in a bucket of cold water to cool it and condense the refrigerant so as to keep the pressure down and permit all of the charge to enter the drum. Stirring the water or pouring some over the top of the drum will help to keep the drum cool.

After the refrigerant has all been pumped out of the unit and into the drum, if the entire unit is to be overhauled, the valve on the drum should be closed and the discharge line and fittings disconnected. However, if the unit was discharged for the purpose of removing just one part such as the receiver or

Electric Refrigeration

condenser, then the pressure should be balanced by cracking the discharge service valve open or to the left, just long enough to allow refrigerant from the drum to flow back and build up about one lb. pressure in the system, as indicated by the compound gauge on the suction service valve.

16. DISCHARGING AND NEUTRALIZING WORTHLESS REFRIGERANT

In case the unit only contains a small amount of refrigerant which it is not desired to save, and especially if the refrigerant is non toxic and non-irritating, then the gas can be discharged to open air, by attaching a longer tube to the discharge service valve and extending this tube out of a door or window.

In case of discharging any appreciable quantity of SO_2 , if no service drum is available, or if the refrigerant is bad and not worth saving, it can be neutralized by discharging it slowly through an earthenware or glass jar of lye water or caustic soda. This is done by immersing the end of the discharge line well down in the lye water, and watching to see that no gas bubbles reach the surface. This means that all gas is being absorbed or neutralized by the solution. About $1\frac{1}{2}$ lb. of lye per gal. of water makes the proper neutralizing solution.

Be careful not to open valve too far or the discharge pressure may cause violent bubbling and splash lye solution on the floor. This solution is injurious to paint, varnish, clothes, hands and face.

17. RECHARGING A REFRIGERATOR

After a refrigerator has been discharged and overhauled, it can be recharged with refrigerant as follows: First, the entire system should be thoroughly dehydrated by baking all parts such as compressor, evaporator, condenser, control valve and receiver in an oven at a temperature of about 235 degrees F. for 10 to 12 hours. If the units are connected together and have a vacuum drawn on them by an external compressor, then 5 to 6 hours is usually sufficient.

Service

After dehydrating the parts in the oven they should be plugged with hot air still in them and removed, for assembly and connecting up in the refrigerator. After connecting up the parts close the discharge service valve all the way to the right, remove the gauge plug and run the compressor to pump all air out of the system through this opening, and draw a good vacuum of 20 to 24 inches on the system. Before drawing this vacuum, the correct oil charge should be put in the compressor. Then install pressure gauge at high side service valve and open this valve by turning the stem all the way to the left. Then crack the valve $\frac{1}{4}$ turn to the right to permit the gauge to indicate pressure.

Next open the suction service valve all the way to the left and remove the gauge to permit attaching a charging hose or tube.

Connect the charging hose or tube securely to the service drum, which contains the fresh refrigerant

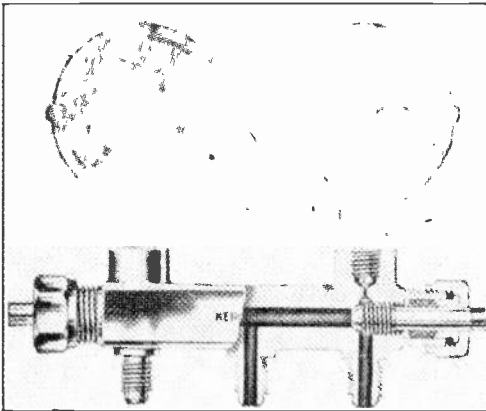

Fig. 17. Sectional view of a valve manifold with gauge attachment fittings for every convenient charging, purging, and testing of refrigerators. This type of valve manifold is a very useful and popular piece of equipment in the serviceman's tool kit.

erant for the charge. Use a "T" fitting at the service drum and attach the compound gauge to one end, and the charging line to the other end. Attach the other end of the charging line to the half union on the suction service valve gauge opening but do

Electric Refrigeration

not tighten the fitting more than "finger tight" until after purging the air from this charging line. Crack the valve on the service drum slightly open until an odor of refrigerant is noticed, showing that all air is out of the charging line and then tighten the fitting at the suction service valve.

Next turn the suction service valve all the way to the right, start the compressor and slightly open the valve on the service drum, permitting refrigerant to be drawn into the system by the compressor. Do not open the service drum valve too far or pressure of the refrigerant in the drum may build up too high a pressure on the low side of the compressor. Watch the compound gauge and maintain a charging pressure of about 5 to 15 lbs. Charging at too high a pressure will overload the compressor.

PRESSURE AND TEMPERATURE

The fact that there is a definite relationship between pressure and temperature in the evaporator has already been discussed; however, while it is essential that the serviceman understand this relation, it is equally important that he be able to obtain specific data on the low side and high side pressures to be encountered in his field.

Practically all domestic refrigerators of the ordinary type, and many commercial units designed for comparable applications are set to operate at a low side pressure that will cause the liquid refrigerant in the evaporator to be brought down to a temperature of 5 degrees above zero Fah. before the machine cuts out. For example, on a domestic refrigerator using sulphur dioxide, the low side pressure should fall to 6 inches of vacuum before the machine stops; in a similar unit using methyl the low side pressure should drop to 6 pounds of pressure before the unit stops. The chart given below provides values that will show the relationship between the temperature of the liquid refrigerant in the evaporator and the low side pressure for practically any domestic or commercial application. It should be understood that these values are approximate, and they must be expected to vary slightly under different operating conditions. The data given here is particularly useful in the setting of pressure type electric switches.

Service

It should be noted that the evaporator temperatures refer to the refrigerant temperature **inside** the evaporator. The temperature of the outside of the evaporator shell may be above this value by from 5 to 10 degrees.

EVAPORATOR TEMP. AND LOW SIDE CUT-OFF PRESSURE

EVAP. TEMP.	-40	-30	-20	-10	-5	0	5	10	20	30	40
SO ₂	23"	21"	18"	14"	12"	9"	6"	3	3	7	12
METHYL CHLOR.	16"	12"	6"	0	2	4	6	9	14	20	28
FREON F-12	11"	6"	0	5	7	9	12	15	21	28	37
AMMONIA	9"	2"	4	9	12	16	20	24	34	45	59

18. DETERMINING AMOUNT OF CHARGE

To determine when enough refrigerant charge has entered the unit, watch the high side pressure gauge, and when it indicates about 15 lbs. over normal high side pressure, close the service drum valve all the way to the right. The amount of charge can also be determined by weighing the service drum before starting the charge and during the charging operation, by having the drum setting on a scale and noting its decrease in weight. Make sure that the charging hose is free and slack, or the charging tube if used should have a loop in it so that it bends easily and does not interfere with the scale indication.

After enough charge has apparently entered the unit, stop the compressor, close the drum shut off valve, turn the suction service valve all the way to the left and then crack it $\frac{1}{4}$ turn to the right to permit compound gauge at the drum to indicate low side pressure. Then cycle the unit, observing both low side and high side pressures to see that they are correct.

If the charge is still low, turn suction service valve all the way to the right and open drum valve to add more refrigerant.

Considerable time can be saved on this operation if a gauge manifold such as shown in Fig. 17 is used. This permits readings of high and low side valves, charging, purging, etc., by merely adjusting the valves

Electric Refrigeration

The several diagrams in Figs. 18 and 19 show the method of connecting this test manifold to the compressor service valves, and also show the proper settings of the various valves for several of the most important service operations. Examine each of the diagrams and the valve positions very closely and refer to these figures whenever necessary for later reference on the job.

19. DEHYDRATION WITHOUT AN OVEN

In case an oven is not available for dehydrating the parts of a disassembled refrigeration unit, a fair job of dehydration can be accomplished by flushing the parts with carbon tetra-chloride to wash out any sludge or dirt and the bulk of any moisture that might be inside the parts or tubing. Then if possible, blow out the lines and parts with compressed air to speed the drying of the carbon tetra-chloride.

The parts of the unit can then be assembled in the refrigerator and heated by carefully passing a torch over their surfaces while a vacuum is drawn on the system by opening the discharge service valve and running the compressor.

Be very careful not to heat any of the parts to temperatures above 250 degrees F., or some of the soldered joints might be loosened.

As a final means of removing the last traces of moisture a dehydrator such as shown in Fig. 12, Lesson 98, should be installed in the liquid line between the receiver and control valve at the evaporator.

These dehydrators contain such drying agents or materials as calcium chloride, calcium oxide, or activated alumina. These materials have a high moisture absorbing ability and as the refrigerant is circulated through such a dehydrator the moisture is absorbed by the material in the dehydrator.

Calcium-chloride or calcium-oxide is best for quite rapidly absorbing larger amounts of moisture, while activated alumina is good for thoroughly absorbing small quantities of moisture.

Calcium-chloride or oxide dehydrators should not be left in the system more than a few days as the chemical may dissolve or break down and mix with the refrigerant. Activated alumina dehydrators can

Service

be left in the system indefinitely if desired. However, the activated alumina units can be reused in other machines by removing them and baking them out at temperatures of 215 to 250 degrees F. to drive out the moisture.

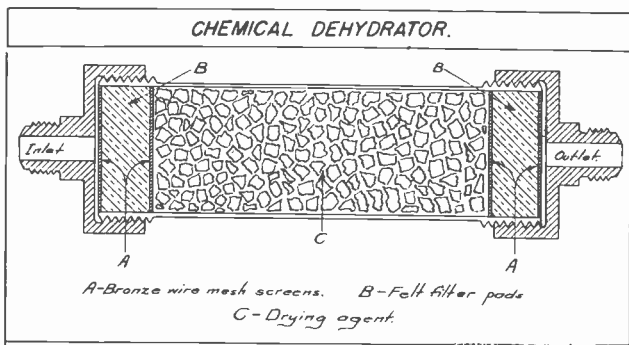

Chemical dehydrators are used in Methyl Chloride and Freon systems to remove moisture. The dehydrator is usually installed in the liquid line at the king valve. It is filled with a moisture absorbing chemical which may be one of the following: calcium chloride, calcium oxide, drierite (calcium sulphate), activated alumina, or silica gel.

A comparison of these various dehydrating chemicals is given below

Calcium chloride is sometimes used as a temporary drier to quickly absorb the moisture. It must not be left in the system for longer than a day.

	ADVANTAGES	DISADVANTAGES
Calcium Chloride	Cheap Available in all locations Will absorb large amounts of water	Corrosive to the system if it is left in the system any length of time and if it gets out into the piping system. Will corrode iron and steel parts and also solder joints
Calcium Oxide	Cheap Efficient Has acid neutralizing value	Breaks down to finely divided particles on absorption of moisture. These particles might get through the filter and into the lines clogging other strainers or filters.
Drierite (Calcium Sulphate)	Reasonable in cost Efficient Can be re-activated by heating	Breaks down into small particles but not as objectionable from this standpoint as calcium oxide.
Activated Alumina	Reasonable in cost Will not break down into finely divided particles Can be re-activated by heating	Not quite as efficient as other driers' Does not have as much moisture absorbing capacity as some other agents.
Silica Gel	High Efficiency High moisture absorbing capacity Will not break down Can be re-activated by heating	High Cost

Therefore, dehydrators are not usually sold and installed permanently, but are more often rented to the customer for a week or so and then removed, refilled and used in other units.

Electric Refrigeration

20. REMOVING CONDENSING UNIT WITHOUT DISCHARGING SYSTEM

In some cases it may be desirable to remove an entire condensing unit consisting of the compressor, condenser, receiver and motor, and take it into the service shop for major repairs, or to replace it with a new condensing unit.

In such cases, the condensing unit can be disconnected and removed from the refrigerator, and a new one installed if desired, without discharging the refrigerant from the system.

This is done by "pumping down" the unit so that the entire charge of refrigerant is locked in the condenser and receiver.

To do this, we first stop the unit and install a compound gauge at the suction service valve. Then close the king valve or liquid line valve at the receiver and start the compressor.

Run the unit until the compound gauge shows a 20" vacuum. Fill the ice trays with hot water and warm the evaporator and lines with hot cloths or with a torch to drive out all traces of refrigerant.

Next stop the compressor, close the discharge service valve all the way to the right and crack the receiver valve open just enough to build up $\frac{1}{2}$ to 1 lb. pressure on the compound gauge.

The entire condensing unit can then be disconnected by loosening the flare fittings and tubing lines at the suction service valve and the receiver king valve.

If these lines are immediately corked with rubber stoppers or metal plugs and kept corked while a new condensing unit is being installed, and if the time required is not over 30 minutes, the system may not need to be purged of air when reconnected.

21. PURGING AIR FROM THE SYSTEM

If the lines are not plugged, or if there is a period of several hours or more before the condensing unit is reinstalled, then any air should be purged from the system.

After running the unit for a time any air in the system will usually be trapped in the condenser and receiver. To purge this air from a household unit having a discharge service valve, you need

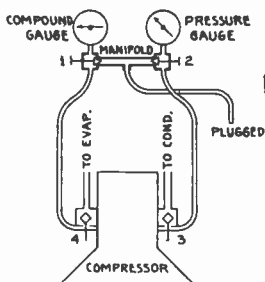

FOR GAUGE READINGS

- VALVE 1 CLOSED
- VALVE 2 CLOSED
- VALVE 3 CENTER POSITION
- VALVE 4 CENTER POSITION

FOR LEAK TEST

- VALVE 1 OPENED
- VALVE 2 OPENED
- VALVE 3 CENTER POSITION
- VALVE 4 CENTER POSITION

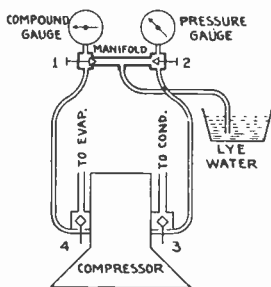
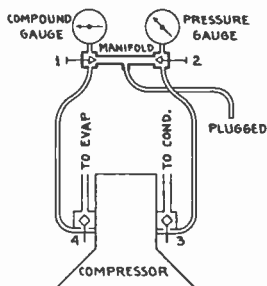

PURGING

- VALVE 1 CLOSED
- VALVE 2 OPENED
- VALVE 3 CENTER POSITION
- VALVE 4 CENTER POSITION

Fig. 18. The above diagrams show proper methods of connecting valve manifold and service gauges for testing and purging refrigerator systems. Carefully observe the position of all valves for each test and refer to these diagrams when making any such tests on refrigerators.

Electric Refrigeration

only stop the unit, remove the gauge or plug from the gauge fitting and crack this valve about $\frac{1}{4}$ turn to the right and the air from both the receiver and condenser will discharge through the gauge opening.

If the unit is charged with SO_2 it is best to attach a tube or charging hose and purge through a lye solution as previously explained under discharging a unit, so that any SO_2 that might escape with the air will be neutralized.

When purging **slowly** through a proper lye solution, the air will bubble to the top as the lye solution does not absorb the air. When no more air bubbles are seen, the air is all out and only refrigerant is escaping. Then turn the discharge service valve back to the left.

Another good way to tell when the air is out of the unit is to hold one hand on the receiver tank while purging. When this tank begins to sweat or get cold, it indicates that the refrigerant inside it is starting to boil and that the air is probably all out of the unit.

On commercial machines or others that have no discharge service valve, air can be purged by cracking open or loosening the flare nut fitting at the connection from the condenser to the compressor. The compressor should of course be idle when purging air.

22. ADDING OIL CHARGE

When it is necessary to replace the oil charge in a refrigerator that has been discharged and disassembled for overhaul, the correct amount of clean, dry refrigerator oil of the proper grade can be poured into the oil filler opening on the compressor by removing the oil plug. On compressors having no oil plug, the oil can be placed in the compressor before it is assembled. This should be done before the unit is evacuated and charged with refrigerant.

The correct amount of oil charge can be determined from the factory tag which is attached to the condensing unit of late model refrigerators, or from the data in Article 10, Lesson 96, for some common types of units.

When charging or adding oil to a unit that is

Service

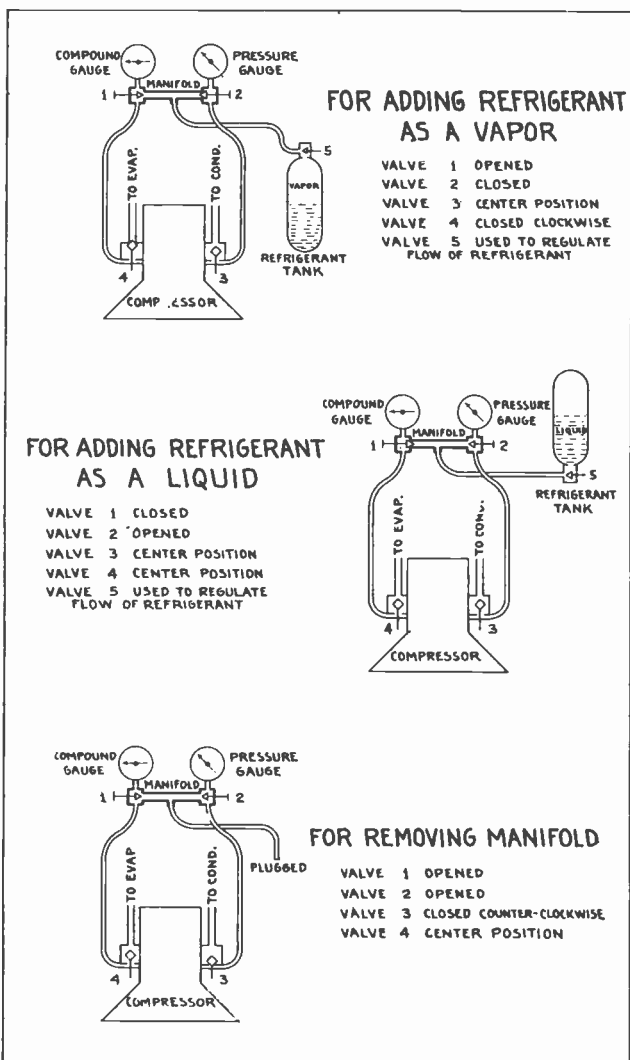

Fig. 19. These diagrams show proper connection of valve manifold, service gauges and the correct valve positions for charging refrigerating systems and for removing the valve manifold.

Electric Refrigeration

operating and already charged with refrigerant, a convenient procedure is to use the connection and fittings shown in Fig. 20. This device consists of several short lengths of tubing equipped with a compound gauge, tee fitting and pet cock.

Turn the suction service valve all the way to the left and attach a compound gauge. Let the compressor stand idle a few minutes until gauge shows a lb. or so of pressure on the low side. This pressure is to be used to purge the oil line.

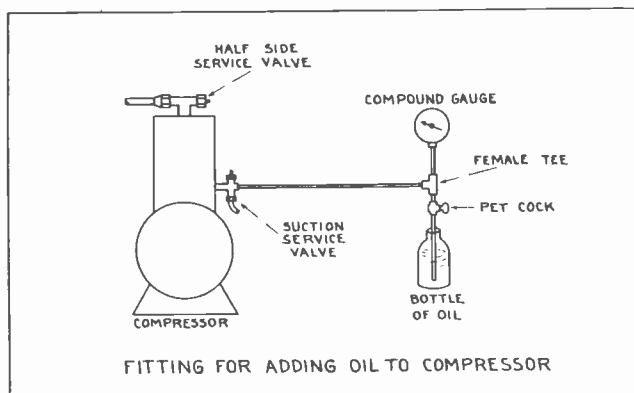

Fig. 20. A very convenient device for adding oil to refrigerator compressors can be made with short lengths of tubing, compound gauge, and pet cock as shown above.

Then turn the suction service valve all the way to the left, remove the gauge and attach the tubing as shown in Fig. 20. Next immerse the other end of the tube or charging device in a bottle containing slightly more than the correct charge of oil. This tube should be down near the bottom of the oil.

Now open the pet cock and crack the suction service valve slightly open just long enough to purge all air from the charging tube. Also be sure that this tube is clean and dry.

Then close pet cock and turn the suction service valve all the way to the right. Start compressor and pull a good vacuum and then stop the compressor.

Next open the pet cock and allow the charge of oil to be drawn into the compressor by the vacuum

Service

on the low side. Be careful to close the pet cock before the oil level in the bottle reaches the lower end of the tube, so that no air will be drawn in to the unit.

Then turn suction service valve all the way to the left and disconnect the charging tube and plug the gauge opening.

23. RECEIVER TROUBLES

Sometimes scale will collect in a liquid receiver and clog the end of the liquid line so that refrigerant cannot flow. The remedy for this trouble is to remove the receiver and clean it out or replace it with a new one.

A common symptom of this trouble is abnormally high vacuum on the low side and a cold liquid line, due to the restriction acting as an expansion valve and causing refrigeration to take place in the liquid line.

A receiver can be removed by the same procedure as explained in Article 15 on "discharging a unit."

In some cases, receivers may develop leaks at welds, tubing connections or sand holes in the metal and allow refrigerant to escape. Such leaks can be detected by the leak tests previously described. The remedy would be to remove and replace the receiver drum or repair the leaks by brazing or welding.

Normally a receiver is only partly filled with liquid refrigerant and the space remaining in the upper portion is filled with gas and acts as part of the condensing surface. If a unit is overcharged this space may become filled with liquid, thereby reducing the condensing area and causing high head pressure.

24. LIQUID LINE TROUBLES

Liquid lines on household units and small commercial units of a ton or two capacity are usually of $\frac{1}{4}$ " tubing. If smaller tubing is used it may become clogged by sediment or a gummy deposit on its inner walls.

Liquid line bends should be gradual (not less than 3" diameter for $\frac{1}{4}$ " tubing) and soldered type

Electric Refrigeration

fittings are preferable to flare type fittings, because the latter may work loose with vibration and cause leaks of liquid refrigerant.

25. LIQUID LINE FILTERS

Filters such as shown in Fig. 12, Lesson 98, are often installed in liquid lines of refrigerators to collect dirt and scale and prevent clogging of control valves and sticking of compressor valves.

These filter units generally contain a fine mesh screen or felt pad with a screen. They sometimes become clogged and can then be removed and cleaned by washing out with carbon tetra-chloride, or the filter pads can be replaced.

On some refrigerators small strainer screens are mounted in the body of the control valve, where the liquid line attaches. In other units strainers are built into the compressors at the suction line connection. These strainers sometimes clog and need to be cleaned. It is advisable to install liquid line filters on old refrigerators when overhauling or reconditioning them.

26. SLUDGE

Old refrigerators often become clogged at control valves or liquid lines by sludge which is formed from carbonized oil and refrigerant.

This sludge can be dissolved and freed to a certain degree by introducing into the system about one tablespoonful of a special fluid known as "Xylene." Xylene is obtainable from refrigeration supply stores or from the Barrett Co., 40 Rector St., New York City, N. Y., who are the manufacturers.

27. CARE OF SERVICE VALVES

Low side and high side service valves normally have their stems covered with a brass seal cap. Their stems are also packed with graphite packing to prevent refrigerant leaks.

Whenever these valves are uncapped and used, it is advisable to check or tighten the packing nut.

When closing or opening service valves, always use a proper valve stem wrench. A very convenient type of wrench is the ratchet wrench such as shown in the next lesson under refrigerator service tools.

Service

You should have several valve stem wrench adapters on hand for the common sized valve stems. **Never use a plier or pipe wrench** on these soft brass valve stems or their corners will be ruined.

When operating service valves, be careful not to seat them too tightly or both the valve seats and stems may be damaged.

SERVICE OPERATIONS

To simplify the instruction of the different service operations, a step-by-step procedure will now be given for each of the most frequently employed service techniques. With the aid of this material, the charging, discharging, purging, and removal of parts may be effected without difficulty.

The abbreviations employed are SSV for suction-service-valve, DSV for discharge-service-valve. When the ordinary service valve is turned all the way to the left, it is said to be **back-seated**; when it is turned all the way to the right it is **front-seated**.

INSTALLATION OF GAUGES

The proper procedure for installing gauges is as follows:

1. Stop the unit.
2. Back-seat the service valve.
3. Remove the gauge fitting plug.
4. Insert a half-union (usually $\frac{1}{8}$ " IPT by $\frac{1}{4}$ " SAE flare thread).
5. Connect the gauge to the half-union with a short length of tubing. Leave the flare nut at the gauge loose.
6. Crack the service valve and hold open until a strong odor of gas is noticed at the loose connection. This is to purge the air out of the gauge tube.
7. Tighten the loose connection and start the unit.
8. Crack the valve away from its back-seat to get a gauge reading. If the gauge needle vibrates too much, turn the valve stem slowly to the left until a fairly steady reading is obtained.

The procedure for removing the gauge is as follows:

1. Stop the machine.
2. Back-seat the service valve.

Electric Refrigeration

3. Remove the gauge and half-union.
4. Insert the gauge fitting plug and check for leaks.

Compressors with Shut-off Valves

Some compressors are equipped with a discharge shut-off valve in the head instead of the regular discharge service valve. The gauge fitting port will be in the compressor head. To install a pressure gauge on this type of compressor, proceed as follows:

1. Stop the unit.
2. Install a compound gauge in the SSV first.
3. Front-seat the SSV. If there is no vacuum on the base of the compressor, start the unit and operate until the compound gauge shows a vacuum. This procedure is to prevent gas in the low side from surging up thru the compressor valves and out the gauge fitting port in the head when the plug is removed.
4. Close the discharge shut-off valve in the head.
5. Remove the gauge fitting plug and install the pressure gauge.
6. Be sure to open the shut-off valve again before starting the compressor. Otherwise the gauge may be ruined.

COMPRESSOR EFFICIENCY TESTS

Shaft Seal Leak Test

To test the shaft seal and other compressor parts for refrigerant leaks to the atmosphere, place hot water in the ice cube trays to build up about a 40 lb. pressure in the low side of the system. Then test for refrigerant leaks using 26% ammonia for sulphur dioxide systems and a halide torch for methyl chloride and freon systems.

Valve Test

1. Stop the unit.
2. Install a compound gauge in the SSV and a pressure gauge in the DSV. The high side pressure should be at least 40 lbs. before starting this test.
3. Front-seat the SSV and start the unit. The compound gauge should begin to show a vacuum that rapidly increases to at least 25 inches. If the compressor pulls a vacuum

Service

slowly at first, it may be due to the fact that gas is boiling up out of the oil which may be saturated with refrigerant. During this pump-down procedure, the compressor may slug oil. This will be indicated by a knocking noise in the compressor valves. If this noise becomes too violent, stop the compressor for a few minutes until the oil foam settles, then start up the unit again.

4. When the vacuum will finally increase no farther, stop the unit. Crack the SSV to build the crankcase pressure back up to zero lbs. Then front-seat the valve again.
5. Start the unit and time it to see how long it takes to pull a vacuum the second time. It should pull down to at least a 25" vacuum in less than $\frac{1}{2}$ minute.
6. Stop the unit and allow it to remain idle for 5 minutes. The vacuum reading should remain steady during this off-period.

If during the above test, the compressor pulls the vacuum very slowly or will not pull a vacuum greater than 15 inches, the reed suction valve is usually leaking. If the compressor pulls a vacuum but will not hold it, the reed discharge valve is leaking.

Excessive clearance between the top of the piston and the bottom of the valve plate may also cause the compressor to be inefficient. This can be due to using a gasket material that is too thick or to worn wrist pins and bearings. When the piston is at top dead center, the clearance between the piston and valve plate should be from .007 to .010 of an inch.

Ring Test

1. Stop the unit and install a pressure gauge in the DSV.
2. Start the unit and allow it to operate for a few minutes so that the pistons, rings and valves will have a good film of oil on them.
3. Stop the unit and front-seat the DSV.
4. Start the unit. **Caution — be sure to keep your hand on the switch.** When the pressure gauge registers 125 lbs. pressure, **stop the unit.** If the rings are in good condition,

Electric Refrigeration

this pressure will be attained rapidly (in a few revolutions). If the rings are leaking, the high pressure gas will blow back to the compressor base and the pressure will not attain 125 lbs. rapidly or perhaps not at all.

5. After the test, back-seat the DSV immediately to place the unit in normal operating condition.

CHARGING AND DISCHARGING REFRIGERANT

General Procedure for Discharging a Refrigeration System

1. Stop the unit, and install a compound gauge in the SSV.
2. Back-seat the DSV, remove the gauge fitting plug and install a half union.
3. Connect one end of the charging line tightly to this half union and the other end loosely to the drum.
4. Purge the air from the line by cracking the DSV. When a strong odor of gas is evident at the loose connection, all of the air has been removed, then close the drum valve and tighten the connection.
5. Open the service drum valve.
6. Front-seat the DSV.
7. Place the chemical drum in a pail of cold water and start the unit. On flooded systems place hot water in the ice cube trays.
8. When the compound gauge shows a good vacuum and there is no frost on the evaporator or receiver, the unit is discharged.
9. Stop the unit, close the service drum valve and remove the charging line.
10. Place a gauge fitting plug or a pressure gauge in the DSV and back-seat the valve.

Pumping Out Air

Before charging a completely discharged unit, care must be taken to see that all air is removed. The procedure for removing the air is as follows:

1. With the unit idle, front-seat the DSV.
2. Remove the gauge fitting plug from the DSV.
3. Install a compound gauge in the SSV,

Service

4. Start the unit and allow it to operate until a good vacuum is obtained (25 to 28 inches), then stop the unit. The air will be pumped out thru the gauge fitting port in the DSV and into the atmosphere. Hold a rag over the open DSV fitting during this operation to prevent any oil that is slugged thru the discharge valve from being pumped onto the walls or floor.
5. Insert a gauge fitting plug or pressure gauge in the DSV and back-seat the valve.

General Procedure for Charging by the Gaseous Method (Low Side Charging)

1. Stop the unit.
2. Install a pressure gauge in the DSV.
3. Back-seat the SSV and install a tee fitting ($\frac{1}{4}$ " SAE flare-one end $\frac{1}{8}$ " IPT).
4. Install a compound gauge on tee.
5. Connect the charging line between remaining branch of tee and drum.
6. Loosen flare nut at gauge and purge air out of line by cracking the drum valve. Then close drum valve and tighten flare nut.
7. Front-seat the SSV and start the unit.
8. Open the drum valve slowly to keep the pressure down to about 5 or 10 lbs. above normal low side pressure.
9. When the drum begins to get cold and the pressure drops, place the drum in a pail of warm water.

Place or hang drum on a scale so the proper amount of refrigerant by weight may be added. When adding refrigerant to an undercharged unit, place SSV in neutral position then open and close the drum valve intermittently and observe the operating pressures and the evaporator frost line during the time the drum valve is closed. When the operating pressures are normal and the evaporator is completely frosted, the unit is fully charged. Then add from $\frac{1}{4}$ to $\frac{1}{2}$ lb. to give the system a little reserve (except on high side float and capillary tube systems).

Detailed Procedure for Charging Various Types of Systems—High Side Float Systems

The amount of refrigerant charge is very critical

Electric Refrigeration

in this type system. When charging a completely discharged system, front-seat the SSV and charge the refrigerant in at a pressure slightly above normal low side pressure. Charge in the proper amount of chemical by weight plus about 2 oz. to compensate for gas losses in purging. When adding refrigerant to an undercharged system, connect the drum, purge the charging line, and place the SSV in the neutral position. Then start the unit and open and close the drum valve at intervals of one or two minutes depending upon the head pressure. If head pressure increases more than 10 or 15 lbs. above normal, close drum valve until it settles down again. Continue this procedure until the suction line frosts out from the evaporator a few inches. Operate the unit for 10 or 15 minutes to allow any oil that has accumulated in the evaporator to return to the compressor. If the frost disappears from the suction line, add a little more refrigerant. When properly charged the suction line should frost 3 or 4 inches out from the evaporator.

During the above charging procedure, maintain a pressure in the refrigerant drum about 20 lbs. higher than the low side pressure in the unit. This can be accomplished by placing the drum in a pail of warm water.

Any condition indicating air in the system should be corrected by purging thru the purge valve on the float chamber. On floats lacking such a purge valve, air may be purged thru the DSV on the compressor. Quite a bit of refrigerant gas will be lost when purging at the DSV; therefore, enough refrigerant should be added to compensate for this loss.

Capillary Tube Systems

The amount of refrigerant charge in a capillary tube system is equally as critical as it is in high side float systems. The operating characteristics of these two systems are very similar, therefore, the procedure for charging is the same, except that the capillary tube system should be charged more slowly.

Low Side Float Systems

When charging a low side float system, use the general method of charging thru the low side by

Service

front-seating the SSV and drawing in the proper amount by weight.

When adding refrigerant to an undercharged system, add refrigerant intermittently until the loud hissing noise in the evaporator has ceased and it is frosting properly. Then add from $\frac{1}{4}$ to $\frac{1}{2}$ lbs. to give the system a reserve of liquid in the receiver tank. The charge in this type system is not so critical. Any excess refrigerant will be stored in the receiver tank.

Expansion Valve Systems

Use the same general procedure for these systems as for low side float systems. When adding refrigerant to an undercharged unit, charge intermittently until the entire evaporator is frosted. Then add from $\frac{1}{4}$ to $\frac{1}{2}$ lbs. to give the unit a reserve of liquid in the receiver.

After any charging procedure observe the operating pressures during a running cycle to see that they are approximately correct.

Charging by the Liquid Method (High Side Charging)

This method of charging is usually used for charging commercial systems and for some hermetically sealed domestic units. Care must be taken to see that the refrigerant drum is absolutely clean and contains no sediment or foreign material as this would be carried into the system with the liquid.

The machine should remain idle during the charging procedure. When charging a completely discharged unit, all air should be evacuated from the unit. This may be done by operating the unit with the DSV front-seated and blowing the air out through the open gauge fitting port in the DSV. On hermetically sealed units, it is usually necessary to use an auxiliary compressor to draw out the air. Before charging an under-charged unit, it should be stopped and allowed to remain idle until the head pressure has dropped to the maximum saturated vapor pressure of the refrigerant.

With the machine still idle, the procedure for charging is as follows:

1. Place the refrigerant drum in hot water at 125°F for a few minutes until the drum

Electric Refrigeration

- pressure is from 10 to 25 lbs. higher than the head pressure of the unit to be charged.
2. Connect a short charging line to the drum.
 3. Back-seat the DSV and install a half union.
 4. Connect the drum to the DSV, purge the connection and tighten.
 5. Place the DSV in the neutral position.
 6. Invert the drum and open the drum valve. (Do not open the drum valve before the drum is inverted). Then the weight of the liquid plus the vapor pressure above it will force the liquid refrigerant out of the drum, through the condenser and into the receiver. When the liquid is flowing out of the drum, a hissing noise will be heard. When this subsides the drum is empty or the pressures have become equalized. In this case apply heat by again placing the drum in hot water.
 7. When the system is fully charged, close the drum valve first to allow the liquid to drain out of the charging line into the system. Then back-seat the DSV and remove the drum and charging line.

When charging a completely discharged unit, charge in the proper amount by weight. When charging an under-charged unit, add a few pounds, then close the drum valve and place the service valves in normal operating position. Operate the unit for a few minutes to observe the operating pressures and the frost-line on the evaporator. When these are normal, the unit is fully charged. Most commercial units have sufficient receiver capacity to hold a few pounds of reserve refrigerant; in which case, an amount equal to about 10% of the regular charge may be added to compensate for gas losses in purging and minor service operations.

Transferring Refrigerants from One Drum to Another

Refrigerant may be transferred in the liquid form from a large supply drum to smaller drums by the following procedure:

1. Place the supply drum in hot water (not to exceed 125°F) to raise its pressure.
2. Place the small drum in a pail of cold water

Service

- (preferably ice water). Set the pail with its contents on a scale and record its weight.
3. Invert the supply drum, raising it above the small drum, and connect the two together with a flexible charging line looped in such a manner as not to interfere with the weight recorded on the scale.
 4. Open both drum valves and allow the desired amount of chemical to enter the small drum (Not to exceed its rated capacity).
 5. Close supply drum valve first and allow the tube to drain out into the small drum before closing its valve.

Cleaning Service Drums

The service man should carry two drums for every refrigerant he uses, one to be used as a supply drum and the other as a service drum. To keep the supply drum clean and free from oil it should never be used to discharge a unit. In many cases, when a refrigeration system has been in use for a time, it will contain sludge and deposits of foreign material. The service drum should be used to discharge a dirty system. Dirty refrigerant may be reclaimed by pumping it out of the service drum in vapor form through a chemical dehydrator charged with silica gel or calcium oxide.

A dirty cylinder may be cleaned by first evacuating it, then removing the valve and flushing it out with carbon-tetra-chloride or some other solvent. To thoroughly dry it out, it should be baked in a bake oven for four to five hours at 240°F while drawing a vacuum on it at the same time. If the drum contains a fusible plug, this should be removed during the baking process.

Safety Rules

1. Handle refrigerant drums carefully. Do not drop them or tip them over.
2. Never allow a refrigerant drum to be exposed continuously to the sun.
3. When applying heat to a service drum, submerging it in hot water (not to exceed 125°F) is preferable. Never under any circumstances apply a torch to any refrigerant container unless a pressure gauge is installed where it will register the pressure created

Electric Refrigeration

by the heat. Safe pressures will vary according to the refrigerant as follows:

- (a) Maximum safe pressure for SO_2 —
135 lbs.
 - (b) Maximum safe pressure for CH_3Cl —
175 lbs.
 - (c) Maximum safe pressure for CCl_2F_2 —
190 lbs.
4. Never exceed the maximum rated capacity when filling a refrigerant cylinder.
 5. Be careful when opening up any part of a refrigerating system (especially low side float evaporators). Even though the system has been discharged, vapor may still be boiling up out of the oil and may create enough pressure to blow refrigerant saturated oil into your face. Wear goggles.
 6. Never try to stop a liquid refrigerant leak with your hand or fingers. The rapidly expanding liquid will absorb heat from your hand or any part of your body that it comes in contact with. A bad case of frost-bite may result.
 7. Do not open the service drum valve more than 4 or 5 turns as it may screw clear out and cause a bad accident besides losing all the refrigerant in the drum.

BALANCING THE PRESSURE TO REMOVE DEFECTIVE PARTS

On the majority of conventional type refrigerators, the entire refrigerant charge can be pumped into the liquid receiver. When this is possible, the following parts can be removed without discharging the system:

1. Liquid line.
2. Liquid control valve (except a high side float or a capillary tube).
3. Strainers in the liquid line.
4. Dehydrators in the liquid line.
5. Evaporator.
6. Suction line.
7. Compressor.

The procedure is as follows:

1. Close the king valve and start the unit.
2. Run the compressor until the evaporator is

Service

entirely defrosted and about a 25" vacuum is obtained on the compound gauge.

3. Crack the king valve and bring the low side pressure back up to zero or one lb. pressure.
4. Close the king valve again and front-seat the DSV.

The pressure is now balanced from the DSV back thru the low side of the system to the king valve and any part between these two points may be removed. If necessary, the time required for this procedure may be lessened by the use of boiling water in the ice cube trays.

Purging Air from a Unit

An indication of air in the system is given by high head pressure and the failure of this pressure to drop back several pounds when the unit stops.

The air will be trapped in the condenser and receiver tank. Some units have a purge valve on the receiver tank. On this type unit the procedure for purging is as follows:

1. Stop the unit and allow it to remain idle for about two minutes.
2. Crack the purge valve and allow air and gas to slowly escape until the bottom of the receiver tank begins to get cool. Then close the purge valve.
3. Start the unit and operate for a few minutes. If the presence of air is still indicated, repeat the purging procedure.

On units which contain no purge valve, remove the gauge fitting plug or gauge from the DSV and purge system by cracking the DSV.

Some refrigerant will be lost during the purging procedure. After purging, the unit should be checked for proper refrigerant charge.

REMOVING AND INSTALLING A COMPRESSOR

To remove a compressor, proceed as follows:

1. Stop the unit and install a compound gauge.
2. Balance the pressure on the compressor
 - (a) Front-seat the SSV.
 - (b) Start the unit and operate until it shows a good vacuum.
 - (c) Stop the unit and crack the SSV until the vacuum builds up to zero lbs. pres-

Electric Refrigeration

sure. Then front-seat the SSV again.

(d) Front-seat the DSV.

3. Remove the service valve flange bolts and break the valves away from the compressor body.
4. Remove the compressor base bolts and lift it off the machine base.
5. Take off the fly-wheel at once.

In case the compressor won't pump, proceed as follows:

1. Front-seat the SSV and DSV.
2. Remove the gauge fitting plugs or gauges and allow any refrigerant in the compressor to escape into the air. (If the unit is charged with sulphur dioxide the odor will be very objectionable if the SO_2 is purged into the air. In this case pour some 26% ammonia on a rag and hold close to the fittings where the gas is being purged off. The ammonia will neutralize the SO_2 and kill most of the odor.)
3. Then proceed as in steps 3, 4, and 5 above.

On compressors with a discharge shut-off valve in the head instead of the regular DSV, the general procedure is the same as for a unit with standard service valves. The only exception is, that instead of removing the DSV from the compressor head, the whole cylinder head must be removed from the compressor. The head with its shut-off valve closed is then left on the discharge line to the condenser to trap the refrigerant in the rest of the system while the compressor is being repaired.

Some refrigerators having this type of shut-off valve are as follows:

1. Some models of Frigidaire
2. Some models of Zerozone
3. King Kold
4. Cold Coast

To re-install a compressor proceed as follows:

1. Put on the fly-wheel.
2. Bolt the compressor in place on the machine base.
3. Use new service valve gaskets, dipped in compressor oil, and bolt the service valves in place.

Service

4. Install a compound gauge on the SSV.
5. Remove the gauge fitting plug from the DSV.
6. Start the compressor and operate until the vacuum will increase no farther. Air in the system will be pumped out thru the open gauge fitting port in the DSV.
7. To remove any remaining air, crack the SSV and allow gas to pass from the suction line thru the compressor and out thru the gauge fitting port in the DSV to the atmosphere. When a strong odor of gas is evident, replace the gauge fitting plug or the pressure gauge, back-seat both valves and start the unit.

OVERHAULING A COMPRESSOR

When overhauling a compressor extreme care must be taken to keep all work absolutely clean and free from moisture. The general procedure is as follows:

1. Clear a space on the work bench.
2. Secure a container in which all bolts and small parts can be placed as they are removed.
3. Center-punch mark the compressor parts before disassembling.
4. Drain out the old oil.
5. Examine all valves and valve seats very carefully. Any valve seats that are not in perfect condition should be lapped until a perfectly smooth clean surface over the entire seat is obtained. They may be lapped on a lapping block using an approved lapping compound or plain Bon Ami and oil. For lapping recessed seats in pistons a disc valve may be used and the lapping compound will be the same as that mentioned above. If this procedure does not restore the valve seat to perfect condition the whole valve plate or piston should be replaced.
6. Replace or lap all valves that are not in perfect condition.
7. Replace or re-surface the shaft seal.
8. Replace worn wrist pins or bearings.
9. Wash all parts thoroughly in carbon-tetrachloride or some other solvent.

Electric Refrigeration

10. Lubricate all valves, valve seats, and seal surfaces before reassembling the compressor.
11. When assembling a compressor, it is standard practice to use new gaskets on all parts and to oil both sides of the gasket with clean compressor oil before putting it in place.
12. Be sure to tighten the bolts on the compressor head and housing evenly otherwise leaks, cracked castings or broken bolts may result.
13. After the compressor is assembled, add the correct amount of oil to the crankcase.
14. Connect a short piece of tubing from the DSV to the SSV.
15. Take the compressor to the testing bench, connect it to a motor and operate it for at least an hour.
16. After the running period, check the condition of the compressor with a regular efficiency test. The DSV should be connected to an air pressure hose which will enable the compressor to pump against a head pressure of from 40 to 80 lbs.
17. Check the shaft seal for leaks. This may be done by connecting an SO₂ refrigerant drum to the SSV. This will subject the crankcase and seal to about 40 lbs. pressure. Any leaks may be located by using an ammonia swab. The test may also be made by connecting an air pressure hose to the SSV to build up a 40 lb. pressure in the crankcase. Place the compressor in a pail of water until the shaft seal is submerged. The appearance of bubbles will indicate a leak in which case the seal must be resurfaced again or replaced.
18. If the compressor break-down was due to moisture, it should be taken to the bake oven and dehydrated.
19. Remove the service valves and plug the suction and discharge ports with cork or wooden plugs. Remove the fly-wheel, then return the compressor to the unit and re-install.

In the case of rotary compressors, leaky or defective check valves should be replaced. Broken vane springs should also be replaced.

EXAMINATION QUESTIONS

1. Name six common troubles of refrigerator compressors.
2. State briefly how you would make a compressor efficiency test.
3. Describe briefly the proper method of lapping a shaft seal.
4. How can a stuck float valve often be quickly freed or loosened?
5. How would you proceed to remove a float valve header for repairs to the valve?
6. Name two common control switch troubles.
7. Explain briefly how you would discharge the refrigerant from a unit into a drum.
8. Describe two methods of dehydrating a refrigerator unit.
9. How would you proceed to add oil to the oil charge in a domestic refrigerator.
10. A. What is the purpose of the liquid line filter?
B. What type of tool should always be used for opening or closing service valves?

Electric Refrigeration

REFRIGERATOR MOTOR AND CABINET TROUBLES MULTIPLE AND COMMERCIAL REFRIGERATING SYSTEMS

All household or domestic refrigerators of the compression type have their compressors operated by fractional horsepower electric motors, usually $\frac{1}{8}$ to $\frac{1}{4}$ h. p. size. Practically all of the small commercial refrigeration units of the compression type are also operated by electric motors ranging in size from $\frac{1}{4}$ h. p. to 10 h. p. or more. Many of the large commercial refrigerating units and ice machine compressors are also driven by electric motors.

Therefore, the electric motor is one of the most important parts of any electric refrigerator and should be given close attention and proper care by the service man. If the electric motor which drives the compressor, is defective or operating at speed below normal, the refrigerator will of course not function properly. If the electric motor fails to start when the refrigerator control switch closes its circuit, then the refrigerant will not be circulated through the system and the machine will not refrigerate.

Many refrigeration servicemen, although fairly capable on repairs to compressors, evaporators and control valves, are often very weak on their knowledge of electric motor and controller troubles and repairs, and therefore neglect a great deal of very profitable service work of this nature. When we consider the fact that there are over 10,000,000 electric refrigerators in use we can readily see the opportunities for profitable repair work on refrigerator motors.

2. COMMON MOTOR TROUBLES

The most common troubles with such motors are lack of oil, worn bearings, worn brushes, loose brush springs, brushes stuck in holders, dirty or pitted commutator, stuck or defective starting switch on split-phase A.C. motors, and winding troubles such as grounds, shorts, opens, or burned out winding. And, don't forget that failure of the motor to operate may be due to nothing more than a loose plug at the socket, a broken wire, or a

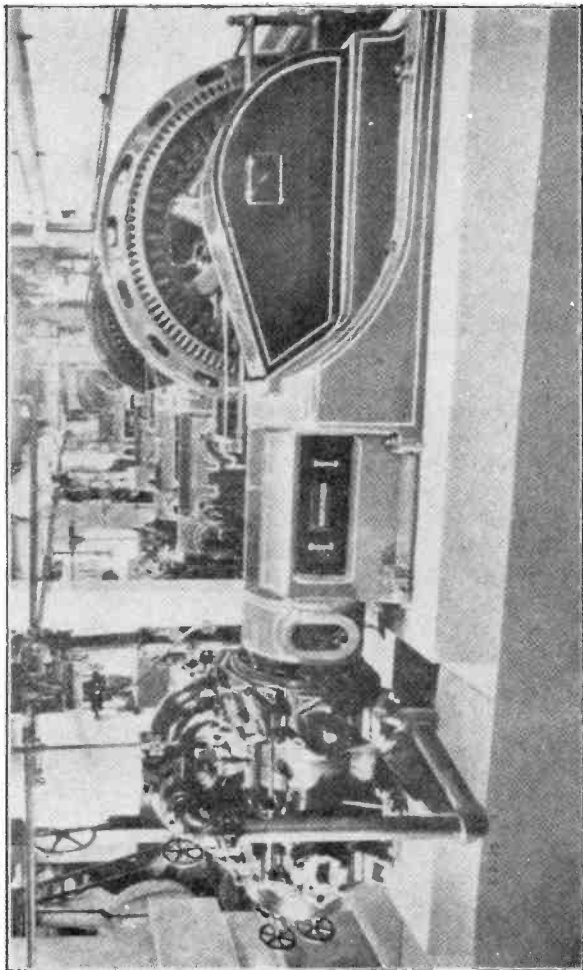

Fig. 1. Photo showing five large electric motor driven refrigeration compressors such as used in ice plants, cold storage buildings and air-conditioning systems. These five machines have a cooling capacity equal to the melting of 1600 tons of ice per 24 hour day. Courtesy Worthington Pump & Machinery Co.

Electric Refrigeration

blown fuse. Always check these things first and make sure that proper voltage is available at the motor terminals, before suspecting the motor.

The remedies for the other motor troubles just mentioned are obvious and were explained in earlier electrical lessons. It is generally a simple matter to clean a commutator with sandpaper or turn it down in a lathe if necessary; or to fit new brushes, replace weak brush springs, renew worn bearings, free up or repair a starting switch, etc. Fig. 2 shows the parts of a disassembled motor of the repulsion-induction or commutator type.

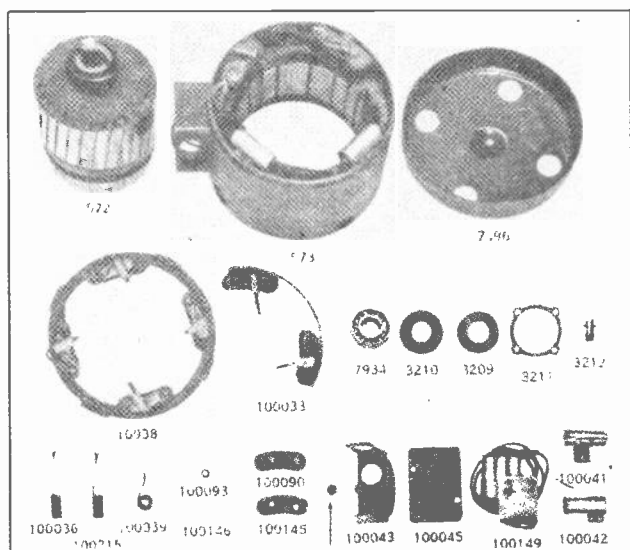

Fig. 2. This view shows the important parts of a disassembled refrigerator motor of the repulsion-induction type. Courtesy Kelvinator Corp.

Refrigerator motor windings will not often burn out unless the unit is badly overloaded or develops a stuck compressor and if the fuse or circuit breaker fails to operate. Oil soaked windings sometimes develop shorts or grounds, which may in some cases be cleared by washing out the winding with gasoline or carbon-tetrachloride, and then drying and coating the winding with good insulating varnish and baking it in an oven.

Service

If a motor winding burns out completely, a new motor or spare used motor can be substituted and the old one rewound or exchanged.

3. CAPACITOR TYPE MOTORS

Capacitor type motors such as shown in Fig. 3 are becoming more and more popular and common on domestic refrigerators, because they have no commutators or brushes to wear out or give trouble or to cause radio interference.

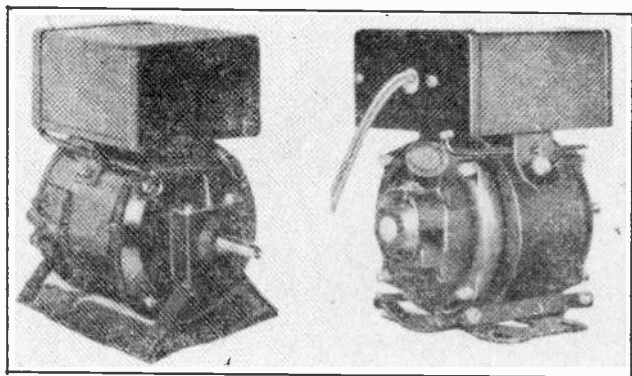

Fig. 3. Two popular types of capacitor motors such as are used by the millions on domestic refrigerators. Note the condensers on top of the motors.

The connection diagrams of three common type capacitor motors are shown in Figs. 4 and 5. Carefully note the connections of the capacitors, the starting and running windings, centrifugal switches, overload relays, thermotron overload device, cabinet light switch, cord, etc.

If the condensers or capacitors on capacitor type motors burn out or become open-circuited or shorted, the motors will not operate. In such cases, a new capacitor from the factory or refrigeration supply house is generally used to replace the defective capacitor, as it is not usually practical to try to repair these condensers.

A simple test for these capacitors is to connect a 10 or 15 watt lamp in series with the condenser and a 110 volt A.C. line. If the lamp lights dimly the condenser is probably good. If the lamp lights at full brilliancy the condenser is shorted. If the

Electric Refrigeration

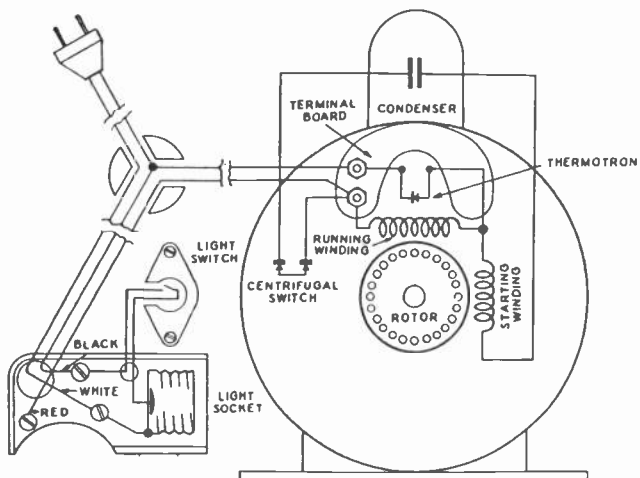

DELCO MOTOR WITH THERMOTRON

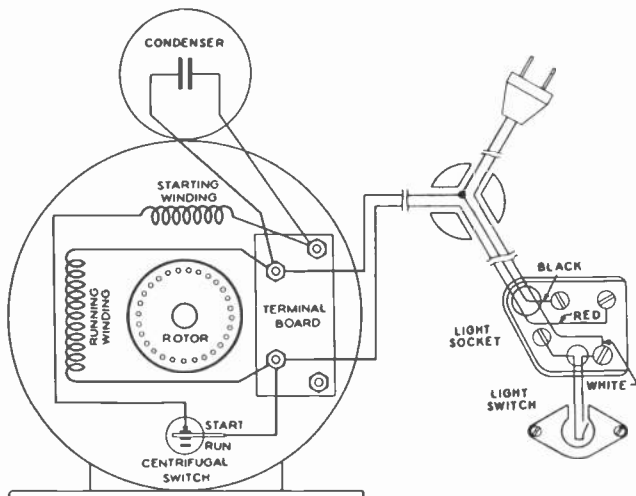

G.E. MOTOR

Fig. 4. Diagrams of circuit connections of two very common capacitor type refrigerator motors. Note carefully the connections of the starting switches, condensers, motor windings, light switch, etc.

Service

lamp does not light at all the condenser circuit is open.

Another simple test is to touch the condenser leads to an A.C. line and then remove them from the line and short circuit them. If a spark occurs when the leads are shorted, it indicates a good condenser. If no spark occurs, the condenser is open or shorted. If the condenser is badly shorted, it may blow the fuse when the leads are touched to the A.C. line.

Many service shops have a standard charge of \$0.75 for motor inspection, \$2.95 for minor repair job, \$5.35 for major repair job, and \$7.60 for complete rebuild jobs on $\frac{1}{6}$ h. p. motors, and slightly higher on $\frac{1}{5}$ or $\frac{1}{4}$ h. p. motors.

Inspection service covers inspection, air cleaning, minor adjustments, oiling, testing and repainting.

Minor repairs cover inspecting, cleaning and repair or replacement of small parts such as brushes, bearings, etc., but not including a new condenser.

Major repairs cover inspection cleaning, minor parts replacement, and rewinding of the stator, but does not include a new condenser.

Complete rebuilding covers all of above mentioned items and a new condenser.

4. CABINET REPAIRS

As explained in Article 16, Lesson 95, refrigerator cabinets for modern domestic refrigerators are generally made of pressed steel with enamelled surfaces both inside and outside. The insulated portion of the box, in which the evaporator or chilling unit and food articles are located, generally has walls several inches thick which are filled with insulating material having low heat conductivity.

The condensing unit is always located outside of the insulated food compartment so that the heat of the condenser can be blown away by the cooling air (or carried away by water in the case of water-cooled units). The condensing unit compartment may in some cases have a certain amount of sound insulating material on its surfaces to confine the noise of the compressor.

Refrigerator cabinet doors are also thick and heavy and filled with insulating material, and

Electric Refrigeration

equipped with soft gaskets to prevent leakage of heat or warm air into the cabinet. See Fig. 6. There is not much to get out of order on the well-made refrigerator cabinet, except that doors sometimes lose their proper fit due to worn hinges, worn latches or worn gaskets. The remedy for these troubles would be to replace or line up the hinges, adjust or replace worn latches, and replace defective gaskets.

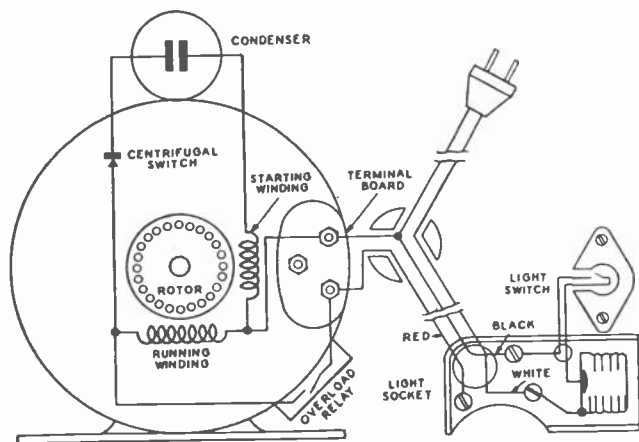

WAGNER MOTOR WITH OVERLOAD RELAY

Fig. 5. Another connection diagram of a popular capacitor type refrigerator motor.

In some cases, doors on old refrigerators may become warped so that they do not fit closely against the door frame, and thus permit warm air to enter the cabinet. This can be remedied by placing soft balsa wood or sponge rubber shims, behind the regular door gasket at points where the edge of the door does not fit closely.

If it becomes necessary to make any holes or openings in an enameled cabinet, the porcelain enamel should first be removed very carefully with a sharp center punch or small chisel. Then the metal can be drilled with an ordinary hand drill or electric drill. Great care must be used to prevent cracking or chipping the enamel around the edges of the opening.

Service

If the paint or enamel on the inside of the food compartment becomes damaged or discolored, it can be re-enamelled with a spray gun or brush. Always use high grade enamel for this purpose as cheap or soft finish paints will rapidly discolor and may develop a bad odor after a period of service.

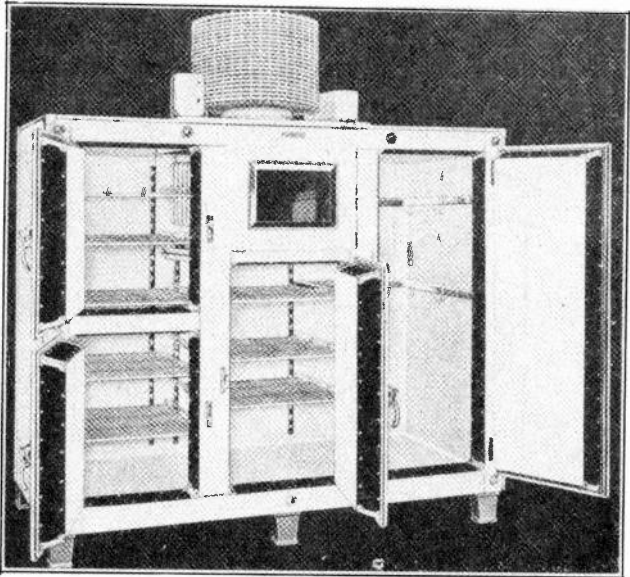

Fig. 6. View of a large refrigerator cabinet, opened up to show door construction, door liners, cabinet lining, etc. Courtesy General Electric.

In case the enamel on the outside of a cabinet becomes scratched or damaged, these spots can be repaired or patched with special Duco patching enamels or porcelain patching materials. Tuttle's Tite-On cement, or another material called Vite-Re-Pair are both good patching materials.

Patching kits sold for this purpose generally consist of a supply of filler material and several different shades of coloring material so that with reasonable care the color of the original surface can be very well matched.

To prepare the damaged spots for patching, the edges should first be sanded smooth with very fine

Electric Refrigeration

sandpaper, and all sanding dust removed with a clean dry cloth.

On old boxes on which the enamel has become badly marred or discolored, a complete repainting or re-enamelling job can be done with a small spray gun and will greatly improve the appearance of the cabinet. Such cabinet refinishing jobs often afford a very profitable part of the overhaul jobs on old refrigerators.

Fig. 7 shows a diagram of the interior of a large commercial cabinet or cooler with two evaporators suspended from the top of the cabinet. Note the manner in which the air should circulate over the evaporators and thru out the box. Also note the drain baffles which are located underneath the evaporators to carry off any moisture from condensation or defrosting of the evaporators.

Fig. 8 shows another view of such a drain baffle. Note how the sheet metal fins are constructed and overlapped to catch all water and prevent it from dripping on the food, and yet permit free circulation of the air in the box.

Fig. 9 shows a glass front display cabinet such as used for refrigerating and preserving meats and food articles in meat markets and grocery stores. Such display cases are cooled by evaporator coils located in the top or back section.

5. REFRIGERATION SERVICE TOOLS

In order to save time and efficiently perform service jobs every refrigeration service man should have a proper kit of tools. A number of refrigeration service tools are specially adapted to this type of work and without these tools the work would be very inconvenient and many common service jobs could not be done at all.

However, most of the ordinary service jobs can be performed with a few rather inexpensive tools, and then if one desires to set up a complete service shop and equip it for the more complete overhaul jobs, additional tools and equipment can be added as needed.

Some of the most essential tools are as follows:
Compound gauge (60 lbs. to 30" vacuum)
Pressure gauge (0 to 300 lbs.)

Service

Set of flaring tools
Tube cutter
Ratchet wrench
Set of valve stem adapters
Set of socket wrenches

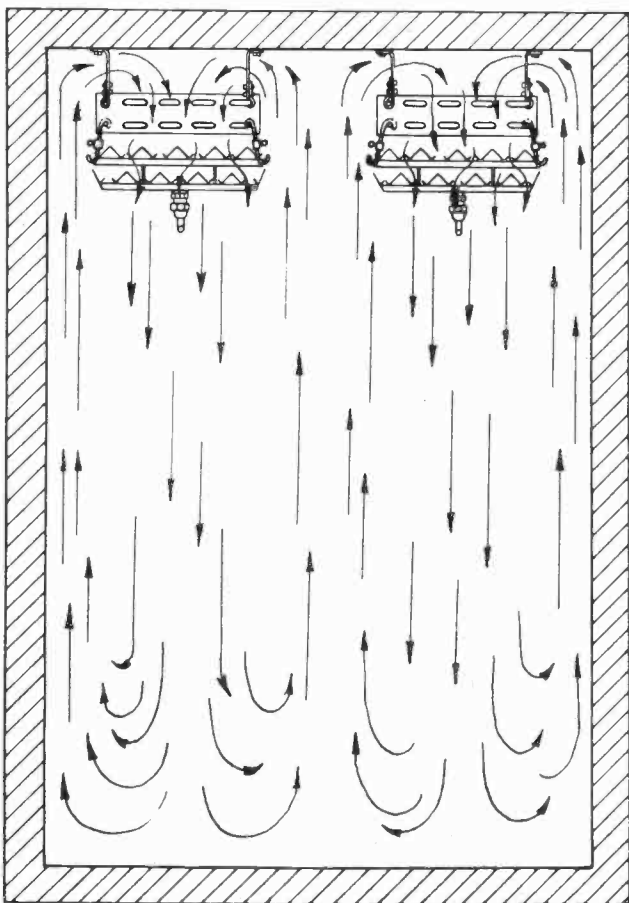

Fig. 7. This diagram shows the location of two direct dry type evaporators in the top of a commercial refrigerator cabinet, and also shows how the cool air should circulate in the cabinet.

Set of open end wrenches
Thin model 6" adjustable wrench
Thin model 10" adjustable wrench

Electric Refrigeration

Pocket type thermometer
6" screwdriver
10" screwdriver
Side cutting pliers
Long nose pliers
Small pipe wrench
Hack saw
Blow torch
Soldering copper
File

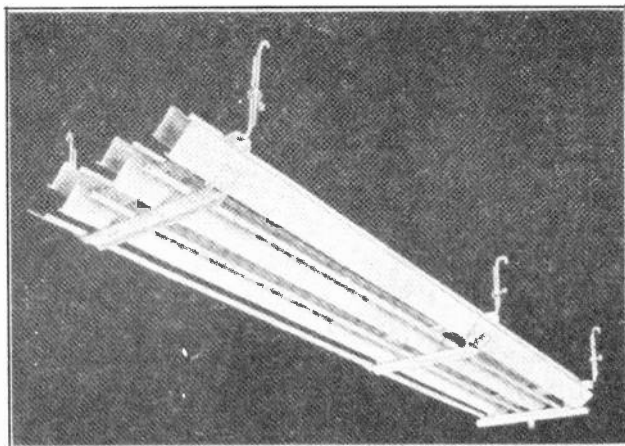

Fig. 8. Drain baffles such as used underneath large commercial refrigerator evaporators to prevent dripping of water from condensation or defrosting.

Set of spring type tubing benders
Packing gland wrench
Bottle of 26% ammonia
Small can of white lead.

Additional tools and articles which are very convenient are as follows:

Service gauge manifold
Purging hose
Set of 12 point box socket wrenches
Leak detector torch
Wheel puller
Gas mask
Goggles
Hand vacuum pump for setting pressure type controls

Service

Several service drums
Paint spray gun
Recording thermometer.

It is also advisable for the service man to have on hand several sheets of $\frac{1}{32}$ " thick gasket material

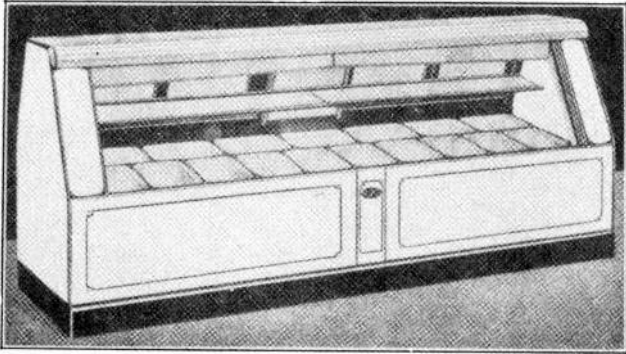

Fig. 9. Glass front refrigerated display case for meat market or grocery store use.

of both lead and asbestos types, several rolls of dehydrated copper tubing of $\frac{1}{4}$, $\frac{5}{16}$, $\frac{3}{8}$, $\frac{1}{2}$ and $\frac{5}{8}$ sizes, and an assortment of the most commonly used tubing fittings such as ells, tees, unions, flare nuts, cap nuts and plugs:

A small paint spray gun is also very handy for doing profitable cabinet refinishing jobs. Figs. 10 and 11 show a number of the more common refrigerator tools.

A very convenient and economical drying oven for dehydrating refrigerator parts can be made from an old, large-sized domestic refrigerator cabinet equipped with a gas burner or heated by an electric resistance type heating unit or several large lamp bulbs.

The box should be equipped with a small opening or vent to carry away moist vapor and with a thermometer to check the temperature.

An overhauled refrigerator compressor can be used for evacuating the parts to be dehydrated, while they are in the oven, by connecting them to the suction side of the compressor by means of copper tubing run through the wall of the cabinet.

A very convenient type of thermometer for use in checking cabinet temperatures on refrigerators

Electric Refrigeration

when servicing or adjusting cold control switches, is shown in Fig. 12. This thermometer has a length of capillary tubing attached to the element so that the thermometer can be set on top of the cabinet and the capillary tubing extended inside the cabinet, and the door closed on this tubing.



Fig. 10. Above are shown some of the most commonly used refrigeration service tools.

The tubing is armored and is so small that it does not injure the tube or the door gasket when the door is closed on the tube. This makes possible frequent observation of cabinet temperatures without repeatedly opening the door.

6. SERVICING MULTIPLE INSTALLATIONS

Multiple refrigeration systems such as used in apartment buildings, stores and restaurants were

Service

described in Lesson 94, and you will recall that such systems consist of a centrally located condensing unit of proper size, connected to a number of separate evaporators which may be located at various places in cabinets or coolers throughout the building.

Servicing any part of the condensing unit on the ordinary multiple system is approximately the same as servicing the condensing unit of an ordinary single refrigerator. One exception is that due

COMPLETE SPRAYING OUTFIT

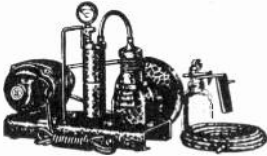

AUTOMATIC STAPLER

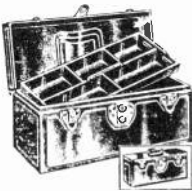
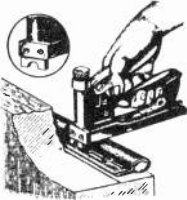

KING TUTT PORCELAIN REPAIR KIT



IMPERIAL CONTROL PUMP

A brass pump used to adjust the temper-



DETECTO LIGHT



SMALL SERVICE CYLINDER WITH I. C. C. STAMP



WABASH WHEEL AND GEAR PULLER

Fig. 11. These refrigeration service tools are also very convenient for the service man to have.

to the greater amount of refrigerant which is generally contained in the evaporators and longer runs of tubing of the multiple system, if the system has no valve manifold, it is usually necessary to pump down and discharge some of this refrigerant into service drums before the condensing unit can be removed. This is due to the fact that the condenser and receiver will probably not hold all of the re-

Electric Refrigeration

frigerant from the system. However, if the system has a valve manifold and shut-off valves near the condensing unit, this is not necessary.

Fig. 13 shows a diagram of a typical multiple system in which the condensing unit is connected through valve manifolds and tubing lines to four different cabinets or coolers in a restaurant.

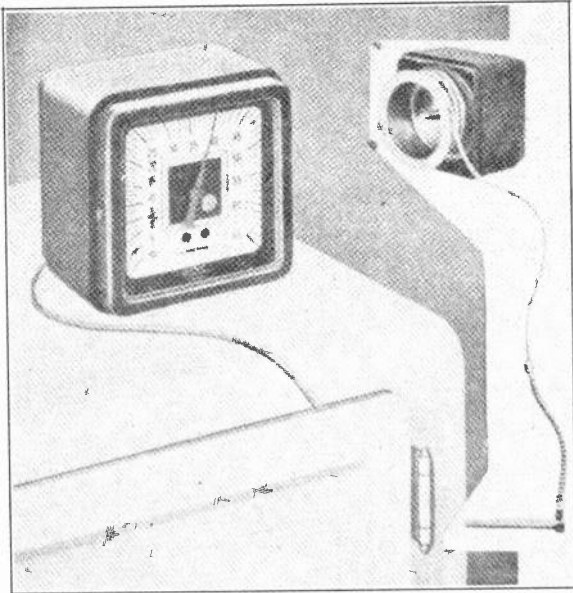

Fig. 12. A very convenient type of thermometer for checking refrigerator cabinet temperatures without repeatedly opening the door, after making adjustments.

Fig. 14 shows a diagram of another multiple system such as would be used in a six flat apartment building. Note that separate liquid and suction lines are run from each evaporator to shut off valves on a valve manifold panel located in the basement or wherever the condensing unit is placed.

Fig. 15 shows another multiple system using main liquid line and suction line risers with shut-off valves located where the short liquid and suction lines from each evaporator attach to these risers. This system is not as convenient or as much approved as the one in Fig. 14.

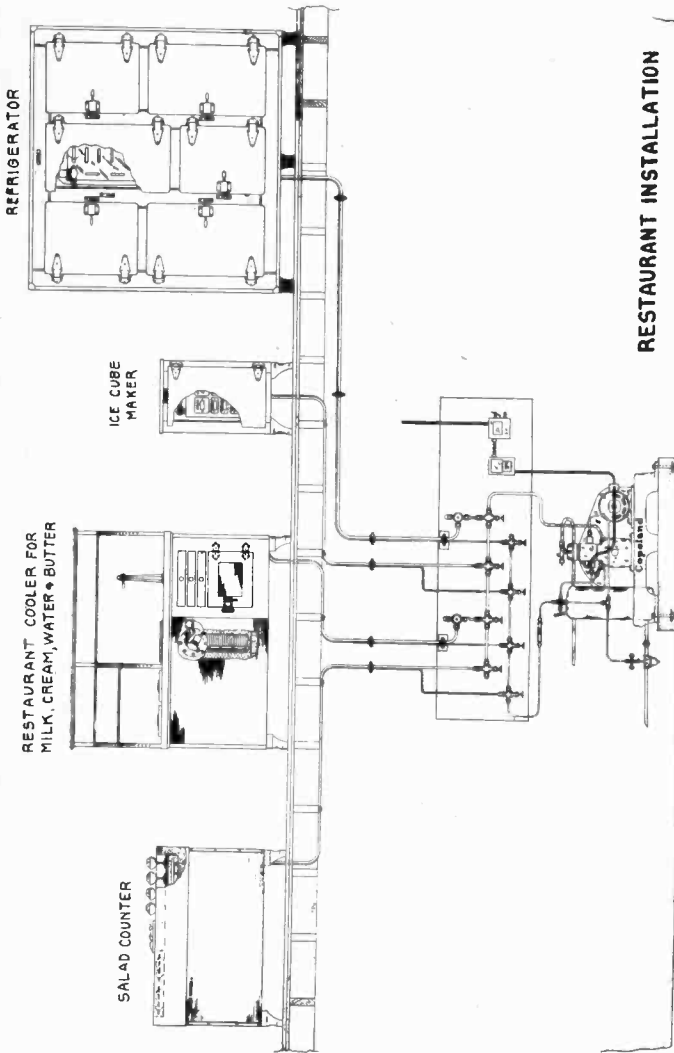

Fig. 13. Diagram showing arrangement and connections of a commercial refrigeration system in a restaurant. Note the separate liquid and suction lines running from the valve manifold panel to each cabinet.

Electric Refrigeration

To service an evaporator on a multiple system on either of these types, it is only necessary to close off the liquid shut-off valve to that particular evaporator and allow the condensing unit to continue to run until all refrigerant has been drawn from the evaporator. Then close the suction line shut-off valve to isolate the evaporator from the rest of the system. Due to the long liquid and suction lines this pumping down of one evaporator in a multiple system may require several hours, or over night.

However, it does not interfere with the operation of other evaporators on the system. The prompt pumping down of the defective evaporator can be speeded somewhat by filling the ice trays with hot water and applying hot cloths to the float chamber.

7. TWO-TEMPERATURE VALVES

Some multiple refrigeration systems use special control valves known as **two-temperature** valves, to maintain two or more evaporators at different temperatures, although they may all be supplied with refrigerant from the same condensing unit. For example, we may desire to have one evaporator on a multiple system maintain a temperature of 20 degrees F., another evaporator 25 degrees, and another 35 degrees, etc. This can be accomplished by means of the two-temperature valves just mentioned, by using one of these valves to control each evaporator and by adjusting each valve for the desired temperature.

Two-temperature valves are of two common types, namely, the mechanical or pressure operated type and the electrical or solenoid operated type. The pressure type two-temperature valves are used in the suction lines to **control the back pressure on the evaporators** and thereby control the rate of evaporation and refrigeration. The solenoid valve is used in the liquid line to **control the flow of refrigerant to the evaporator** and thereby control the amount of refrigeration and the evaporator temperature.

Fig. 16 shows a view of a Barostat pressure type two-temperature valve, such as used in the suction

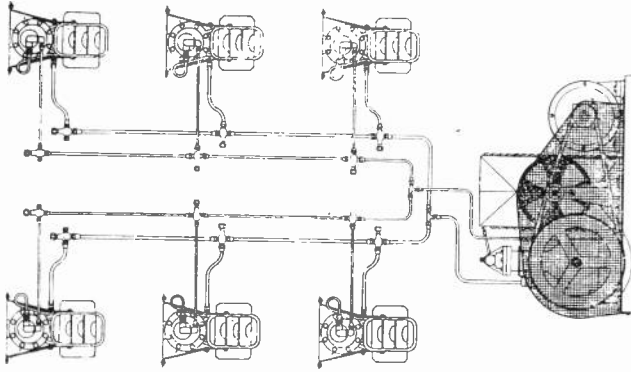

Fig. 15. This diagram shows a six evaporator multiple system with liquid and suction line risers, and shut-off valves located at each evaporator.

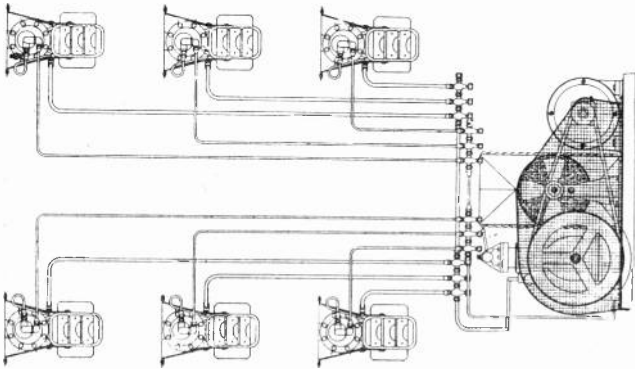

Fig. 14. Diagram of a multiple system with six evaporators and separate liquid and suction lines from each evaporator to the valve manifold at the condensing unit.

lines of multiple system evaporators, as shown in Fig. 19. You will note that these valves can be used to control the individual evaporator temperatures in multiple systems using all flooded type evaporators, in systems using all dry type evaporators or in systems using a combination of flooded and dry type evaporators. All three types of systems are shown in Fig. 19.

With the pressure type two-temperature valve, when the evaporator temperature rises, its gas pressure also rises and acts through the suction line on a diaphragm in the valve, causing the valve to open and allow more rapid flow of the gas from the evaporator to the main suction line. This lowers the evaporator pressure and speeds up evaporation, thus producing more refrigeration or cooling effect.

When the evaporator cools sufficiently, its rate of evaporation is decreased, the gas pressure drops allowing the valve to partially close and build up higher back pressure again.

8. SNAP ACTION VALVES AND SOLENOID VALVES

Some two-temperature valves are of the **snap action** type as shown in Fig. 18. Instead of gradually opening or closing, these valves snap wide open or tightly closed when the evaporator back pressure changes sufficiently to operate the diaphragm or bellows. Such valves are less likely to stick or become clogged with small particles of scale or dirt that may get in the system.

They also allow more immediate response of the evaporator and quicker chilling when the valve opens, in case of sudden loads on the refrigerator cabinet, such as when large amounts of warm foods are placed in them.

Fig. 17 shows two views of a solenoid valve for use in the liquid line of an evaporator. Such valves are operated by a thermostat located at the evaporator, or in the cabinet or room in which the temperature is to be controlled.

When the evaporator or cabinet temperature rises, the thermostat closes an electrical circuit to the solenoid, causing it to open the liquid line valve and admit more refrigerant to the evaporator. When

Service

this added flow of refrigerant cools the evaporator sufficiently, the thermostat opens the circuit and the solenoid allows the liquid line valve to close.

9. ADJUSTING TWO-TEMPERATURE VALVES

Each of these various types of valves has an adjusting nut or screw at the valve or thermostat to adjust or set the valve for the temperature range to be maintained.

The Barostat pressure type valve has adjustments both on the top and bottom of the valve. The top adjustment will raise or lower equally the cut-in or cut-out pressures, about one pound for every two and one-half turns. The bottom adjustment will go the full range of pressure differential of the valves in about one revolution. Any changes in pressure differential should be made by small turns of the bottom adjustment, that is about $\frac{1}{8}$ turn at a time.

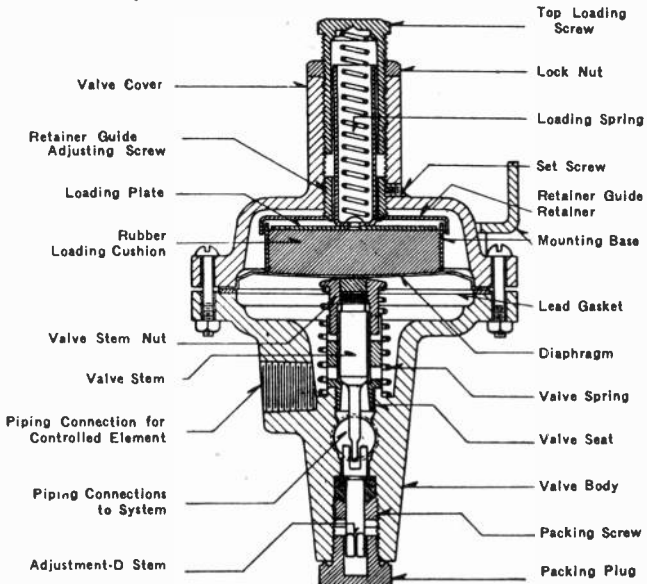

Fig. 16. Sectional view of a Barostat two-temperature valve such as used for controlling temperature on separate evaporators in a multiple system.

To increase the temperature turn the top screw clockwise, and to lower the temperature turn it counter clockwise.

Electric Refrigeration

To widen the differential or range between cut-in and cut-out pressures, turn the lower adjustment clockwise and to narrow the range, turn it counter clockwise.

When adjusting two-temperature valves to set the temperatures of a number of separate evaporators on multiple systems, it is advisable to adjust the higher temperature units first, and the low temperature units last, because otherwise the higher back pressures of the high temperature units may feed back against the suction line control valve of the low temperature units and interfere with their normal operation.

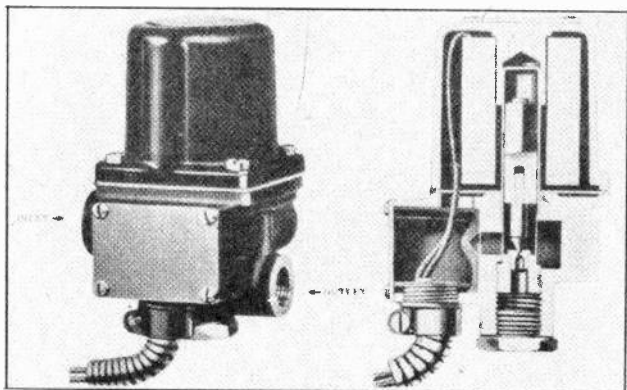

Fig. 17. Two views of a solenoid valve such as used in liquid lines to evaporators for controlling the temperature by starting and stopping the flow of liquid refrigerant.

Adjusting the highest temperature units first eliminates the necessity of repeated checking or service "call backs" on the lower temperature units. This saves time for the serviceman and helps to keep a better satisfied customer.

10. GENERAL TIPS ON MULTIPLE SYSTEMS

When servicing multiple or commercial refrigerating systems, you should **keep in mind that their operating principles, common troubles and general service requirements are practically the same as those of household units.** The multiple or commercial systems merely use larger compressors and

Service

condensing units, longer lines of tubing, larger evaporators or a greater number of evaporators, and more control valves. The servicing or adjustment of each compressor, motor, evaporator, or control is much the same as for those on smaller refrigerating units or systems.

Careful study of the multiple system diagrams shown in these lessons, and of diagrams of any multiple or commercial systems you may have to

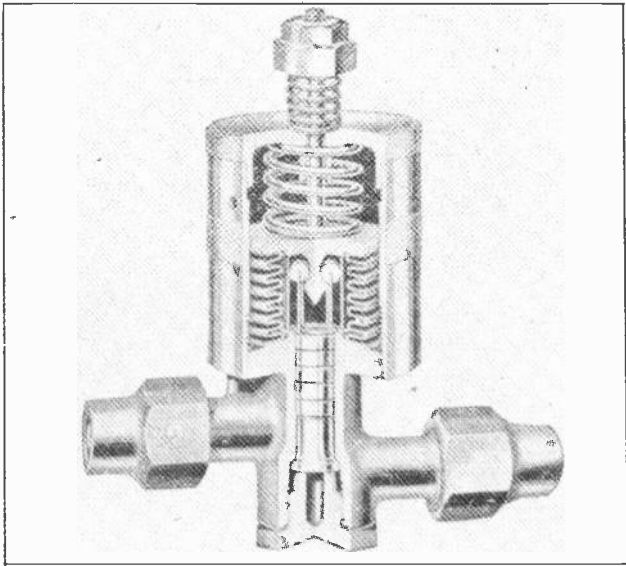

Fig. 18. Sectional view of a snap-action valve for temperature control on evaporators in multiple systems. Courtesy Mueller Brass Company.

operate or service, will make the systems much easier to understand and enable you to apply your knowledge of refrigeration principles and troubles to any ordinary system.

The longer liquid and suction lines used with multiple systems should be carefully checked for leaks at all connections, couplings and fittings, and at any place where damage might possibly occur to the tubing.

Electric Refrigeration

Liquid lines for multiple systems in apartment buildings are generally of $\frac{1}{4}$ " tubing. Suction lines for systems using 1 to 3 cabinets should be of $\frac{3}{8}$ " tubing, for 4 to 7 cabinets $\frac{1}{2}$ " tubing, and for 8 or more cabinets $\frac{5}{8}$ " tubing, etc.

FLOODED SYSTEM

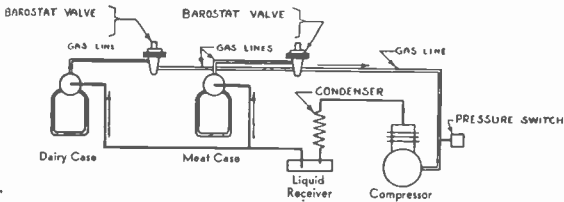

FLOODED AND DRY SYSTEM

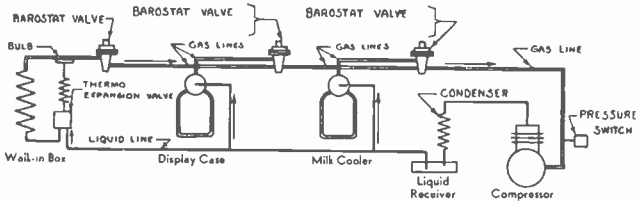

DRY SYSTEM

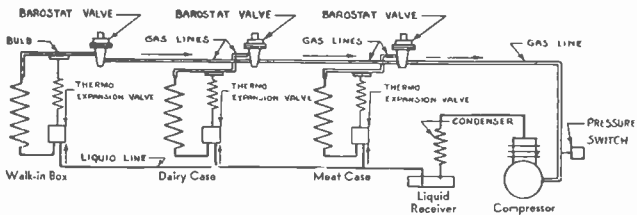

Fig. 19. The above three diagrams show connections of a flooded system, a dry system, and a combined flooded and dry system, using Barostat two-temperature valves for separately controlling the temperatures on each evaporator.

11. LOCAL REFRIGERATION CODES AND ORDINANCES

Some towns and cities have a set of code rules or ordinances governing the installation and operation of multiple and commercial refrigeration installations, from the angle of safety to the public or occupants of the building in which such equipment is located.

Service

Such rules are designed to prevent the possibility of injury to persons, which might result from the leakage or escapement of quantities of refrigerants which are of a toxic, irritating, or explosive nature.

In general, these code rules govern the amount of toxic or non-toxic refrigerants which can be used in a system in certain types of buildings, and also govern the location of direct type refrigerating units using large amounts of refrigerants, in certain rooms or sections of the buildings.

For purposes of classification under code rulings, refrigerating systems are divided or classified into groups or divisions according to the amount of refrigerant they contain. For example, systems containing 6 lbs. or less of refrigerant are in one group, 6 to 20 lbs. of refrigerant in another group, 20 to 100 lbs., 100 to 1000 lbs., and 1000 or more in other groups, etc.

Complete, self-contained household units are not subject to such rigid rules as most of these units use less than 6 lbs. of refrigerant, and a few use from 6 to 20 lbs.

On larger multiple or commercial systems containing 100 lbs. or more of refrigerant, a leak would naturally be much more dangerous. On such systems it is generally required that the condensing unit and all parts containing refrigerant be located in a machinery room having self-closing, tight-fitting doors, and either natural or mechanical ventilation. The purpose of this provision is so that any escaping refrigerant would not get into other parts of the building, but would be carried directly to the outside of the building.

In hospitals, homes for children or aged people, or other places where people would be helpless to leave the building, the rules are very strict and require that large refrigerating units be installed in machinery rooms having doors leading only to the outside of the building, and no doors opening into the rest of the building.

One rule in effect in certain large cities is that no multiple system in apartment buildings shall contain more than 50 lbs. of sulphur-dioxide or methyl-chloride, or 100 lbs. of dichlorodifluoromethane.

Electric Refrigeration

Another rule states that no evaporators shall be placed in sleeping rooms. Another rule is that on multiple systems in dwellings, each liquid line or suction line riser shall be equipped with a shut-off valve at or near the condensing unit.

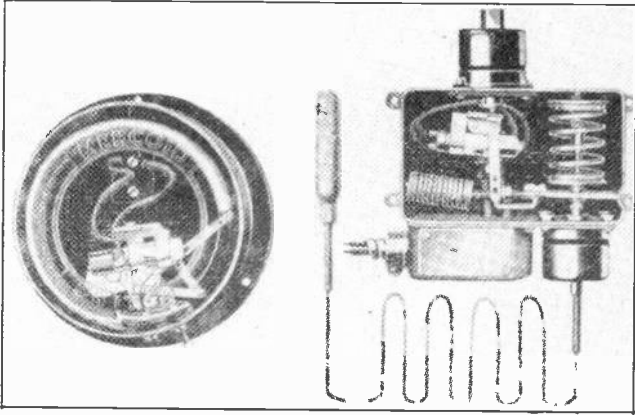

Fig. 20. Two different types of mercury switch controls. Note the mercury tubes with flexible wire leads attached. The tubes can be tilted by pressure bellows and bulb or by thermostat strips.

On certain large installations it is required that the system be provided with an automatic relief or discharge valve which is set to automatically discharge the refrigerant through a line direct to the outdoors in case of excessive pressure being built up in the system. Emergency manual relief valves are also to be provided in some systems to permit the release of refrigerant to the outside of the building in case of fire, which would cause excessive refrigerant pressures to be built up in the system.

Other rules govern the thickness and strength of materials that shall be used for tubing lines, evaporators and condensers in certain installations, to make sure that they will safely withstand the normal or maximum pressures that are likely to be built up in the system.

Indirect refrigerating systems in which brine is used to carry the heat from cooling coils to the refrigerator evaporator, permit all refrigerant chemicals to be kept out of the rooms to be cooled, and confined to safe quarters or locations in basement machinery rooms.

Service

In air-conditioning systems, the evaporators containing refrigerant can be kept out of the air ducts or path of the air, by use of brine circulated from the evaporator to cooling coils located in the air stream. On small air-conditioning systems or self-contained room coolers this is not necessary if other safety rules are complied with.

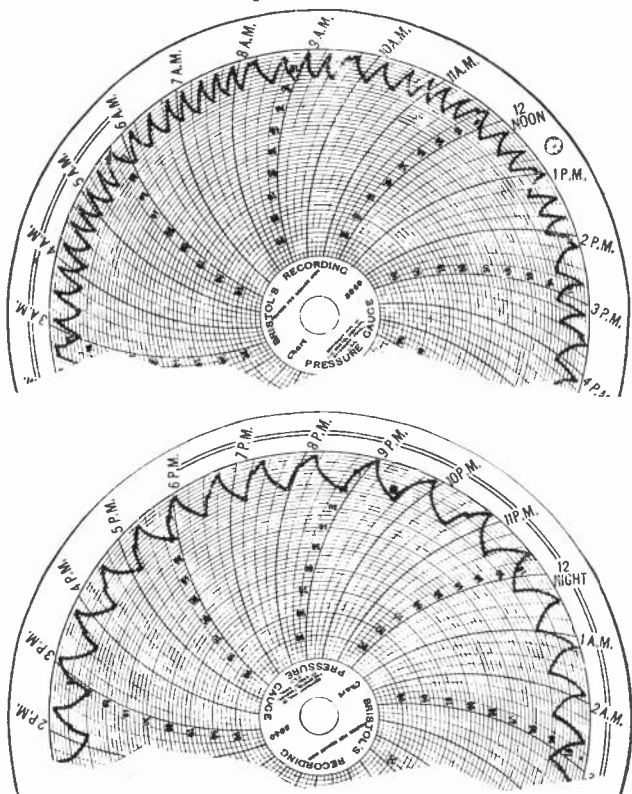

Fig. 21. Note the difference in these two recording thermometer charts taken before and after adjusting the controls on a refrigerator.

Every refrigeration service or installation man, or operator of commercial refrigeration plants, should secure a copy of the local code rules of his city and become thoroughly familiar with these rules, and then comply with them faithfully for the safety of his customers and for the good of the industry and his own reputation as a safe and responsible workman.

Electric Refrigeration

12. MERCURY TYPE CONTROL SWITCHES

Many control switches for modern refrigerators use a mercury type circuit breaker to open and close the electrical circuits by the action of a power bulb and bellows or a thermostat which tilts a small mercury tube, into which are sealed the electrical terminals or contacts. A decided advantage of this type of switch over the ordinary open metal contact switch is that it has no exposed contacts to burn, corrode or cause fire hazard.

The tube containing the mercury may be of either glass or metal and is evacuated to prevent the formation of an arc when the circuit is broken. When the tube is tilted slightly, the pool of mercury flows from one end to the other, opening or closing the circuit between small metal electrodes which are sealed into the tube and connected to flexible wires on the outside. Two control switches of this type are shown in Fig. 20. Carefully examine their construction and parts.

The life of these mercury type switches is usually much longer than that of the open contact types and they are much more trouble free and reliable in operation.

13. RECORDING THERMOMETERS

Recording thermometers are often used for making tests on household or small commercial refrigerators, or for checking the operation of large commercial units. These thermometers consist of a box or case in which is located a temperature operated element which moves a pen over the face of a paper chart which is driven by a time clock mechanism in the case.

Fig. 21 shows two charts taken from a recording thermometer which was used to check the operation of a refrigerator before and after adjustment of the controls. The up and down points of the black line traced by the pen indicate the variations in temperature in degrees as marked on the radial lines of the chart. This variation being caused by the starting and stopping, or cycling of the compressor due to the cutting in and out of the pressure switch control.

Service

The distance or spacing between points on the ink line indicate the time intervals of the cycles of operation. The time is marked around the outside edge of the chart. You will note that these cycles were very short or only of a few minutes duration. Also note that the peaks of these lines have a broader top with an extra dip at 2:35 A. M., 5:40 A. M., 8:10 A. M., 9:35 A. M., 11:40 A. M., etc. These dips indicate the only times at which the float valve opened.

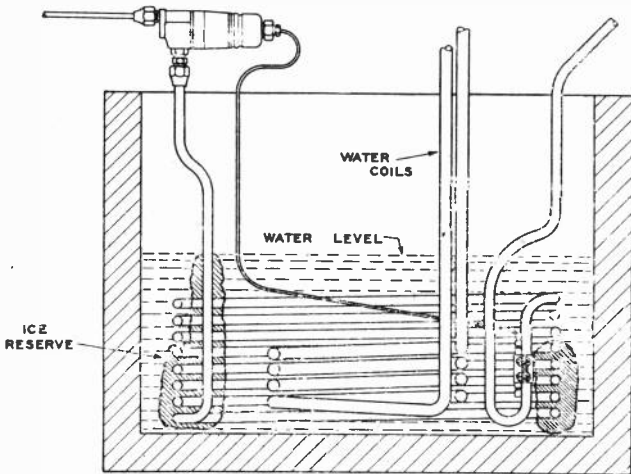

Fig. 22. Refrigerator evaporator coil used in a drinking water cooler.

Note the difference in the lower view which shows a chart taken on the following day after the controls were adjusted by raising the "cut-on" point to permit the float valve to open once during each cycle. Notice that this reduced the number of starting and stopping operations or cycles of the compressor and also produced lower average refrigeration temperature.

14. WATER COOLER AND ICE CREAM FREEZER UNITS

Fig. 22 shows a refrigerating or cooling coil in a drinking water cooler. Note that both the refrigerating coil and the drinking water coil are submerged under water, which conducts the heat from

Electric Refrigerator.

the drinking water coil to the chilling coil. In other words, the cooling coil which contains the refrigerant is not in direct contact with the drinking water.

Note the expansion valve which is connected between the liquid line and the evaporator coil, and controlled by a power bulb which is attached to the suction line of the evaporator coil. Also note the ice which has formed around sections of the cooling coil and which acts as reserve or stored refrigeration between on and off cycles of the evaporator.

Fig. 23 shows a complete cycle diagram of a commercial type refrigerating unit such as used with a modern ice cream freezing machine and hardening cabinet coil, through their respective expansion valves.

Fig. 24 shows a diagram of a large ammonia refrigerating system such as used for ice plants or cold storage buildings. Carefully examine all parts of this system and note the two expansion coils or chilling coils, one of which is located in the cold storage room and the other in a freezing tank. Also note the condenser, receiver, oil separator or oil trap, and the reserve ammonia drum.

The operation of this type of refrigerating plant is very similar to that of the household multiple or small commercial systems which you have previously studied. The compressor may be driven by an electric motor connected to it by means of a belt on the large flywheel. The compressor increases the pressure of the ammonia vapor and passes it through the oil trap and valve "M" to the condenser. The oil trap collects the excess oil which might be carried over from the compressor with the ammonia vapor. This oil which accumulates in the oil trap can be drawn off through valve "I" and returned to the compressor. This prevents excessive accumulation of oil in the liquid receiver.

During operation of this system, liquid ammonia flows through the small pipe to the expansion valves, "J" and "J" at the two expansion coils where it evaporates into ammonia vapor. The vapor flows back through valves "O" and "O" and the large pipe or suction line to the compressor.

Service

Note the pressure gauges which are attached to the suction and high side lines and also the main shut-off valves "A" and "B" located in the suction and pressure lines at the compressor.

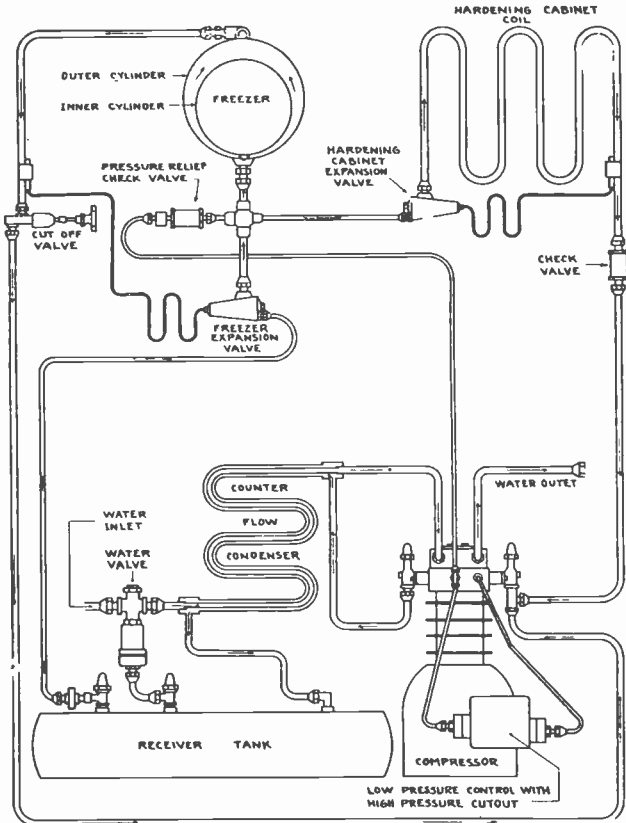

Fig. 23. Cycle diagram of a commercial refrigerating unit used in an ice-cream freezing machine and hardening cabinet. Courtesy Mills Novelty Co.

Extreme care should be used in operating or servicing ammonia systems because ammonia vapor is very dangerous to inhale, and liquid ammonia will quickly freeze any parts of the body with which it may come in contact. Even a few breaths of strong ammonia vapor may render a person unconscious or helpless. Therefore, extreme care should be used to prevent leakage of ammonia from

Electric Refrigeration

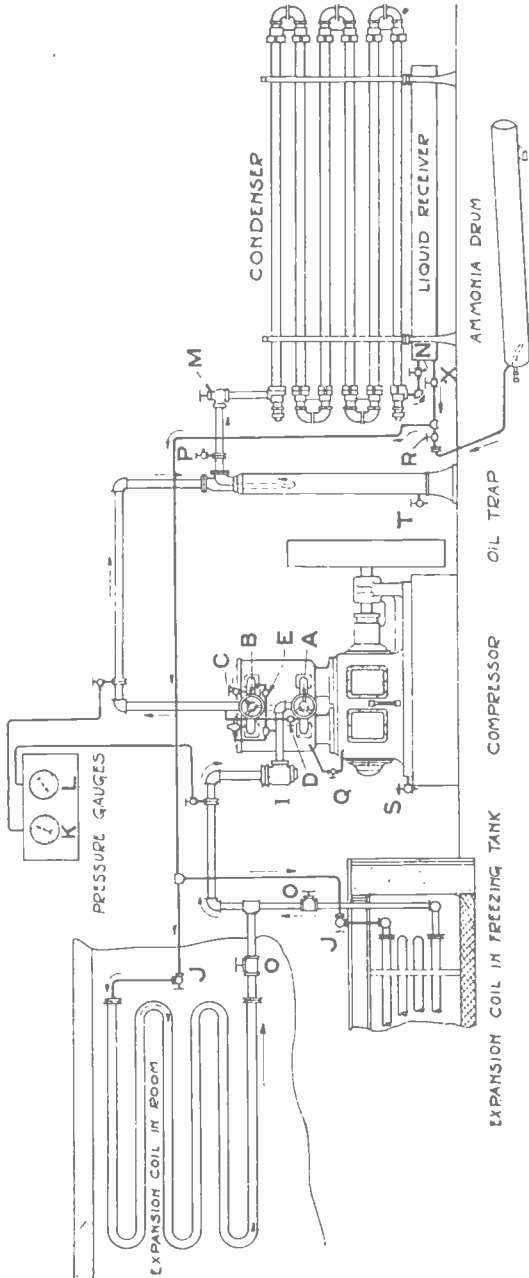

Fig. 24. Diagram of a large ammonia refrigerating system for cooling a cold storage room and an ice freezing tank.

Service

the system, and goggles and gas mask should always be immediately accessible when operating such units, or worn when opening up any parts of these systems which might contain ammonia refrigerant.

The piping and connections, evaporator coils and condenser coils of ammonia refrigeration systems are made of iron pipes and iron pipe fittings. No copper tubes or parts are used with ammonia, as ammonia attacks or corrodes copper very rapidly. Special ammonia gauges are also used with ammonia refrigerating plants for this reason.

When it is necessary to add refrigerant to a system such as shown in Fig. 24, the valve "R" is opened to permit liquid ammonia to flow from the tilted drum directly into the liquid line. If necessary the pressure in the drum can be raised by warming the drum with hot water.

To purge air from this system, open the valve "P" on the line between the oil trap and condenser. A purging tube can be run through a bucket of water, as water readily absorbs ammonia vapor. Spilling water on the floor of the plant or spraying it in the air will quickly absorb ammonia vapor or fumes.

Operators of large refrigeration or ice plant systems and machinery should secure copies of the manufacturers operating and service bulletins which always provide valuable information on their particular type of equipment. Fig. 5, Lesson 95, shows a sectional view of a commercial refrigeration compressor which would be well for you to re-examine at this time.

15. CALCULATING SERVICE LOADS FOR REFRIGERATORS

In some cases the refrigeration service and installation man may be called upon to calculate the service load in B.T.U. on a certain refrigerator cabinet, and to select or specify the proper size of refrigerating unit to handle this load or cool the cabinet to the desired temperature.

Electric Refrigeration

The following two charts and data will greatly simplify such problems.

Number 1

Temperature difference in degrees Fahrenheit	Thickness of Insulation (Cork or Equivalent)				Glass	
	2½"	3"	3½"	4"	Double Thickness	Triple Thickness
40 degrees	84.0	72.0	64.0	60.0	440.0	280.0
50 "	105.0	90.0	80.0	75.0	550.0	350.0
60 "	126.0	108.0	96.0	90.0	660.0	420.0
70 "	147.0	126.0	112.0	105.0	770.0	490.0
80 "	168.0	144.0	128.0	120.0	880.0	560.0
90 "	189.0	162.0	144.0	135.0	990.0	630.0

Number 2

Temperature difference in degrees Fahrenheit	USE OF CABINET			
	Florist	Grocery or Normal Market	Busy Market or Fresh Killed Animals	Restaurant or Short Order
40 degrees	40.0	65.0	95.0	120.0
50 "	50.0	80.0	120.0	150.0
60 "	60.0	95.0	145.0	180.0
70 "	70.0	114.0	167.0	210.0
80 "	80.0	130.0	190.0	240.0
90 "	90.0	146.0	214.0	270.0

The service load on a refrigerator is based on the amount of heat units or B.T.U. which leak into the cabinet or room through the walls and windows, through the door opening whenever the door is opened to insert or remove food or other articles, or when persons enter the large "walk in" types of coolers. Also the heat that is stored in warm foods, meats or other articles which are placed in the cabinet.

To calculate the load on a given cabinet, both of the above charts should be used. Chart number one gives the heat leakage in B.T.U. per 24 hrs., per sq. ft. of outside wall surface. In figuring this total surface include walls, ceiling, floor and door areas.

Glass windows should be figured separately from regular wall and ceiling surfaces, using the figures in the last two columns, as the heat leakage is much greater thru each sq. ft. of glass than it is thru insulated cabinet walls.

Service

If wood is not used on both sides of the cabinet walls, deduct $\frac{1}{2}$ " from the cork insulation thickness given in the table. That is, use the B.T.U. figures in a column for cork $\frac{1}{2}$ " thinner than the wall actually is, to allow for the greater leakage due to the absence of the wood.

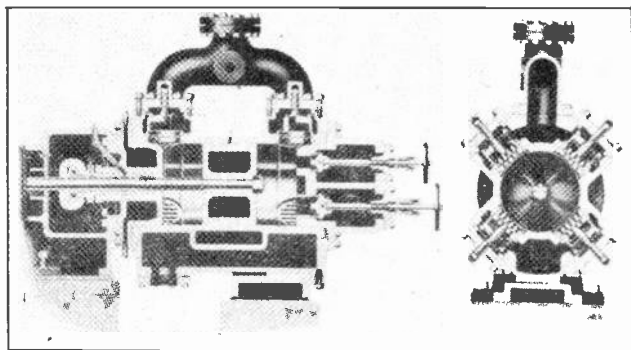

Fig. 25. Sectional view of compressor cylinder and valves for large commercial refrigeration compressors such as shown in Fig. 1.

After calculating the total heat loss by leakage thru walls, by means of table number 1, then use the second table to determine the heat gain in B.T.U., due to the average number of door openings and the class of food or other items put in the cabinet, under various classes of service such as, florist shop, grocery, meat market, restaurant, etc.

These heat load values in B.T.U. per cubic foot of total inside space of the cabinet, per 24 hrs., is given in the second table.

Then add the total B.T.U. figures calculated from tables one and two, to determine total heat load.

For example, suppose we have a meat market "walk in" type cooler, 6 ft. wide, 10 ft. long and 8 ft. high outside dimensions, with a triple glass window 3 ft. x 5 ft. and 4" cork insulated walls. The temperature in this cooler is to be maintained at about 35 degrees F., or 50 degrees below the warm weather room temperature, of say 85 degrees F.

By referring to chart No. 1 we find that for a 50 degree temperature difference on a box with 4"

Electric Refrigeration

cork insulation, the heat leakage per sq. ft. of wall surface will be 75 B.T.U. per 24 hr. day. The leakage per sq. ft. through triple glass windows at a 50 degree temperature difference is shown to be 350 B.T.U. per 24 hours.

To get the total cabinet wall area we proceed as follows:

Two side walls 10 ft. long and 8 ft. high would be $2 \times 10 \times 8 = 160$ sq. ft.

Two end walls 6 ft. wide and 8 ft. high would be $2 \times 6 \times 8 = 96$ sq. ft.

Ceiling and floor of 6 ft. wide and 10 ft. long would be $2 \times 6 \times 10 = 120$ sq. ft.

Then $160 + 96 + 120 = 376$ sq. ft. total surface. From this we will deduct 3×5 or 15 sq. ft. for the window, leaving 361 sq. ft. for walls, floor and ceiling.

Then with the leakage factor of 75 B.T.U. per sq. ft., as shown in table 1, $361 \times 75 = 27,075$ B.T.U. heat leakage through walls.

For the window, 15 sq. ft. \times 350 B.T.U. per sq. ft. leakage factor = 5,250 B.T.U. leakage.

So from our cabinet dimensions and the data in chart number 1, we find $27,075 + 5,250$ or 32,325 B.T.U. heat leakage from the 85 degree room temperature into the 35 degree cabinet interior temperature.

Now from table number 2, we find that the service load on a cabinet in a busy meat market, due to door openings and fresh meats placed in the cabinet, etc., is 120 B.T.U. per cu. ft. of gross interior cabinet space (gross interior means total space including shelves, meat, air, etc.)

For a cabinet 6 x 10 x 8 ft. outside measurement with walls, floor and ceiling of 4" cork plus about 2" boards on inner and outer walls, or 6" total wall thickness, the inside dimensions would be 5 x 9 x 7 or 315 cu. ft.

Then $315 \times 120 = 37,800$ B.T.U. service load. Adding this to the heat leakage load, we have $32,325 + 37,800 = 70,125$ B.T.U. total load or heat to be removed from the cabinet every 24 hours.

Now to determine the proper size compressor or condensing unit to do this job, we should keep the following important facts in mind.

Service

Melting 1 lb. of Ice Absorbs 144 B.T.U.

Therefore melting 100 lbs. per 24 hours, absorbs 14,400 B.T.U. during this time. Or melting 1 ton (2,000 lbs.) of ice will absorb 288,000 B.T.U.

Refrigeration compressors commonly have their capacity rating or refrigerating effect stated in lbs. or tons I.M.E. (Ice Melting Equivalent.)

Therefore, a compressor rated at 200 lbs. I.M.E. would produce the same cooling or refrigeration effect per 24 hours as the melting of 200 lbs. of ice per 24 hours. Or a unit rated as 1 ton I.M.E. would cool as much as melting 1 ton of ice per 24 hours.

The average $\frac{1}{6}$ h.p. domestic unit produces about 160 lbs. I.M.E.

The $\frac{1}{4}$ h.p. unit about 220 lbs. I.M.E.

The $\frac{1}{2}$ h.p. unit about 500 lbs I.M.E.

On domestic units the evaporator temperatures are rather low for freezing ice cubes and desserts.

On units for meat market boxes the evaporator temperature need not be so low, so the unit will handle a little more B.T.U. load, or

$\frac{1}{4}$ h.p. unit about 300 lbs. I.M.E.

$\frac{1}{2}$ h.p. unit about 700 lbs. I.M.E.

1 h.p. unit about 2000 lbs. or 1 ton I.M.E.

Therefore, we can figure about 1 ton I.M.E. per h.p. of commercial compressor size, for continuous operation of the compressor.

If we wish to have the compressor run periodically or in "on and off cycles" and operate about 18 hours out of the 24 hour day, then in order to accomplish the same refrigerating effect the compressor and condensing unit would need to be correspondingly larger.

So for our cabinet, having a total heat load of 70,125 B.T.U. per 24 hours, the compressor would have to remove this heat load in 18 hours of actual running time. Therefore the compressor must remove $70,125 \div 18$ or 3895 B.T.U. per hour.

Then $3895 \div 144 = 648$ lbs. I.M.E. rating for the compressor. So we find that a $\frac{1}{2}$ h.p. unit would be about right for this job.

Therefore we can see that with the aid of the charts given in this lesson it is a comparatively

Electric Refrigeration

simply matter to calculate the heat load and size of compressor required to cool a cabinet or room of a given size, to a certain temperature below that of the surrounding air.

In determining the proper size of direct dry type, non-frosting evaporator to be used for such a cooling job, we can allow about 300 B.T.U. of heat absorbing capacity per sq. ft. of evaporator surface per 24 hours. This means total evaporator surface, including fins.

EXAMINATION QUESTIONS

1. Name three types of single phase A.C. motors which are commonly used on domestic refrigerators.

2. Name five common troubles which may develop in refrigerator motors.

3. When testing a condenser from a capacitor type motor with 10 watt lamp connected to a 110 volt A.C. line what would the following conditions indicate?

A—Lamp lights dimly

B—Lamp lights brightly

C—Lamp does not light at all.

4. For what purpose are two-temperature valves used?

5. Briefly explain the procedure to follow when removing for repairs, an evaporator on a multiple system.

6. Why are code rules governing installation and operation of refrigerators used in some towns and cities?

7. Name three or more code rules governing refrigerator installation.

8. For what purpose are recording thermometers used in connection with refrigerators?

9. Is copper used for the piping, connections, coils, etc., in a system using ammonia refrigerant? Why?

10. What would be the B.T.U. service load on a refrigerator unit for cooling a cabinet used in a florist shop? The cabinet is 5 ft. wide, 10 ft. long, 8 ft. high outside dimensions, and has a triple glass window 2 ft. x 5 ft. The walls are insulated with 4" cork and the temperature difference is to be maintained at about 50 degrees F.

AIR CONDITIONING

In starting to study the subject of air conditioning, let us first thoroughly understand what air conditioning is. Many people are talking about Air Conditioning as one of our greatest new industries. An industry that is growing by leaps and bounds and providing new jobs for thousands of trained men, and more comforts and better health for people in their homes and at their work.

We hear about air conditioned theaters, restaurants, hotels, stores, offices, homes and factories, trains and ships. But few people know exactly what air conditioning is.

Correctly used, the term **air conditioning** means **controlling the temperature, circulation, humidity, and purity of the air we breathe and live in.** Or more broadly speaking, complete air conditioning means **heating** the air in winter, **cooling** it in summer, **circulating** the air and **renewing** it in both seasons, **dehumidifying** (removing moisture) when the air is too moist, **humidifying** (adding moisture) when it is too dry, and **filtering** or washing the air to remove dust, pollen and germs both summer and winter. Any system which only performs one or two of these functions, but not all of them is not a complete air conditioning system.

Many people have been lead to believe that air conditioning meant simply the cooling of air by refrigeration, but this is not correct. This operation should be termed **Comfort Cooling.**

When we consider the full scope and possibilities of air conditioning, we can readily see what a tremendous effect it can have on our **comfort, efficiency and health** in our daily lives at home and at work, if our work is indoors. It is easy to see why air conditioning has captured the interest of people all over the country, and why it has such a tremendous growth ahead of it.

For hundreds of years people in cold climates have been heating their homes, shops and offices to make them comfortable in winter. But only in recent years have we learned how to economically

Principles

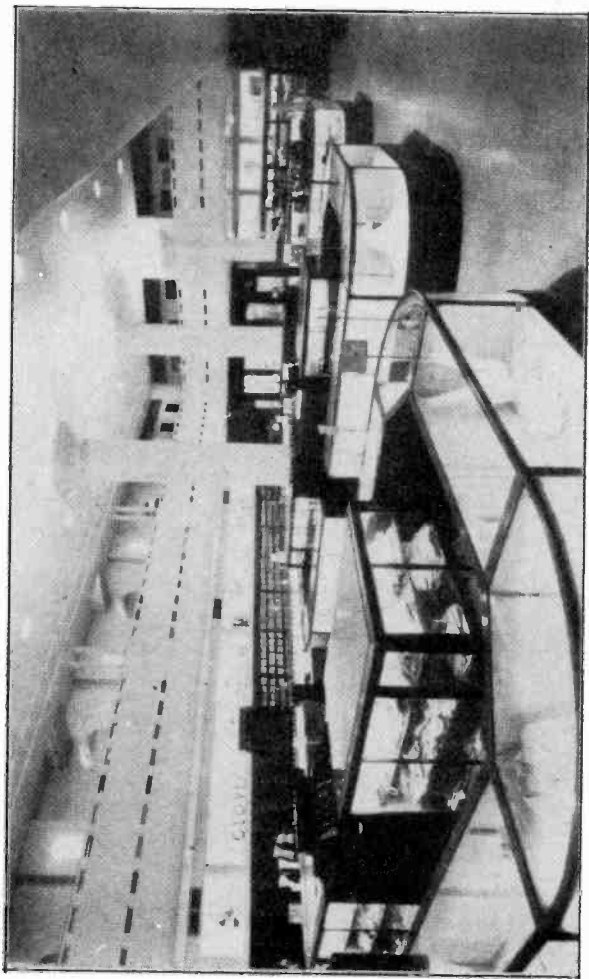

Fig. 1. Photo of the interior of a modern, air-conditioned store. Note how clean and inviting the walls, ceilings and show cases can be kept with dust free, conditioned air. Courtesy York Ice Machinery Corp.

Air-Conditioning

cool them for better comfort and health in the hot summer months.

We have also learned how to control the humidity or moisture content of the air, which greatly affects the comfort of human beings. Then too, we have learned how to remove about 98% of the dust, dirt and disease germs from the air we breathe. The prevention of the spread of many contagious diseases in this manner is one of the great blessings of air conditioning.

When we consider the fact that the average person daily breathes a total amount of air weighing 5 times as much as all the food and water they consume in a day, we can see the importance of having this air properly conditioned.

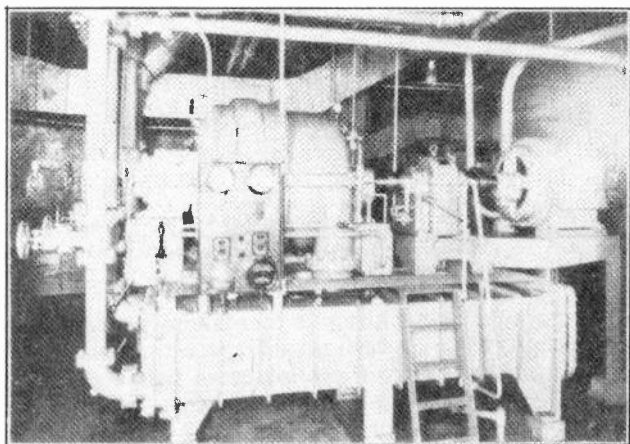

Fig. 2. Large refrigeration unit for an air-conditioning system in a department store. Note the motor driven rotary type compressor above, the water cooled condenser below, and the controls and gauges on the small panel at the front. Courtesy Carrier Corp.

Even when it is necessary for certain persons to work in the heat of the outdoor sun or in hot buildings during the day, think of the comfort of being able to come home to a good nights rest in a cool air conditioned sleeping room. Compare this with nervously and sleeplessly tossing through half the night in a bed wet with perspiration.

Principles

Theater owners were quick to recognize the advantages and comforts of air conditioning and today there are hundreds of air conditioned motion picture theaters. There are still thousands of others to be air conditioned and most of these will install such systems soon, as few people will go to a hot stuffy theater if there is an air conditioned one near by. Tests made on a large group of theaters showed that air conditioning increased their business over 25%.

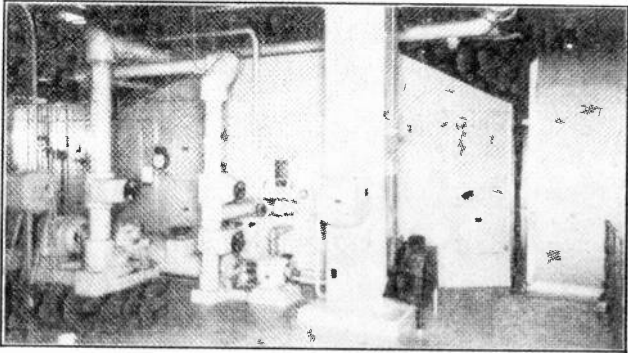

Fig. 3. Air-conditioning unit mixing chamber or "plenum chamber" for the air-conditioning system of a department store. The cooling coils, heating coils, and air washing sprays are located in the large rectangular chamber, and the blower fan is on the right. Note the electric motors, starters, control valves and recording thermometer. Courtesy Carrier Corp.

Restaurants are finding it increasingly profitable to air condition. A test of a large number of restaurants showed that their business was increased about 35% by air conditioning. More patrons go to the air conditioned restaurants, and they eat more food in cool comfort than they do when hot, sweaty and uncomfortable.

Department stores, clothing shops, barber shops, beauty parlors, and dental offices, have all shown very profitable increases of business by air conditioning. Entire huge sky-scraper office buildings are now air conditioned, resulting in their earning higher rent and keeping more fully occupied with tenants.

Thousands of railway passenger coaches and Pullman cars have been air conditioned, resulting in

Air-Conditioning

cleaner, cooler, more comfortable traveling facilities and increased numbers of passengers.

In the very near future many of our modern passenger automobiles will undoubtedly be equipped with air conditioning.

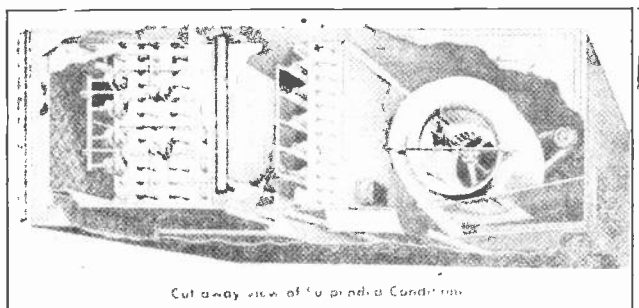

Fig. 4. Cut-away view of a ceiling suspended type air conditioner. Note from left to right, the filter screen, cooling coil, heating coil and blower. Courtesy Airtemp, Inc.

Many factories and industrial plants are now air conditioned for reasons of better employee working efficiency and health, as well as for more economical production of better quality products.

Such processes as printing, baking, enameling, the manufacture of textiles, flour, chewing gum, candy, paints and varnishes and many other articles can be done much more speedily and with much higher quality of product, if the air in such plants is maintained at proper temperatures and a proper degree of humidity or moisture content.

In such plants huge air conditioning systems using refrigerating units with capacities equivalent to the melting of thousands of tons of ice per day, are in common use.

In certain plants where manufacturing processes or materials create unfavorable atmospheric and working conditions, because of heat, dust, fumes, etc., air conditioning becomes a vital factor in the preservation of employees health and efficiency.

Even in this machine age the cost of man power is one of the biggest items of production costs. Therefore, if by proper air conditioning we can reduce fatigue and increase energy, reduce dullness and increase alertness, reduce irritation and increase

Principles

contentment, reduce carelessness and increase interest, the investment in such air conditioning equipment will pay good dividends.

Even mines have found it profitable to air condition to permit operations at lower levels where human life and labor could not otherwise be maintained, because of the high earth temperatures encountered at such great depths below the earth's surface.

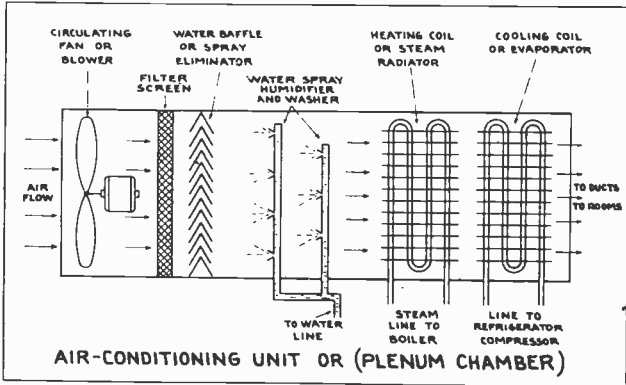

Fig.5. Diagram showing how air can be filtered, washed, humidified or dehumidified, cooled or heated all in one chamber or unit.

With costs of air conditioning equipment becoming lower each year with increasing mass production, millions of homes will be air conditioned during the next few years. Over 200,000 homes were air conditioned in 1936.

So we can readily see the enormous possibilities and opportunities which air conditioning opens up for trained men.

1. TYPES OF AIR CONDITIONING SYSTEMS AND UNITS

Air conditioning equipment is of two general types, known as **central air conditioning plants** and **individual room coolers**.

Central air conditioning plants for homes, offices, factories, theaters, etc., have the heating unit, refrigerating or cooling unit, filter unit, humidifier and circulating fan or blower located in one compact unit or group in the basement or machinery room, with ducts to carry the conditioned air to the vari-

Air-Conditioning

ous rooms or departments. See Figs. 2, 3, 4, 5, 6 and 7.

Individual room coolers are generally in the form of a compact cooling unit, humidifier, filter and blower, all contained in a neat cabinet to be located right in the living room, dining room, sleeping room or office which they are to cool. See Figs. 8, 9, 10 and 11.

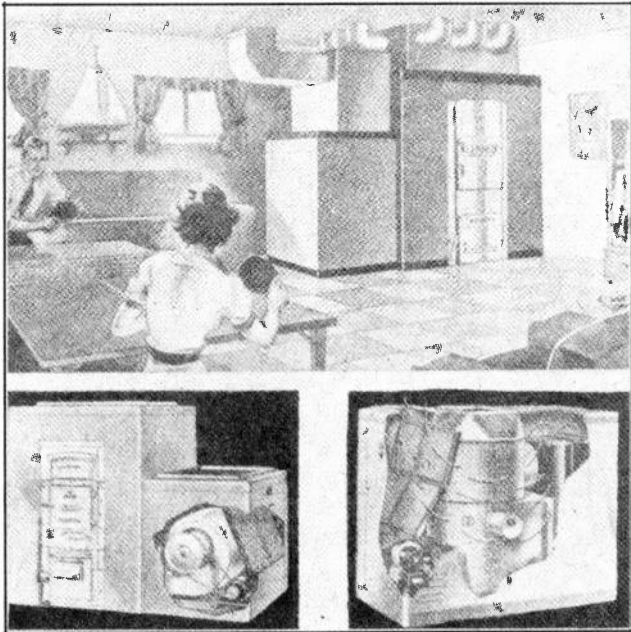

Fig. 5. Upper view shows a combined furnace and air cooling and cleaning unit, or summer and winter air conditioner installed in the basement of a home. The lower views show cut-away views of these units. Courtesy Lennox Furnace Co.

Some of these room coolers have an air-cooled or water-cooled refrigerator condensing unit contained in the same cabinet. Others may have the refrigerating unit located in the basement, with copper tubes run up through the floor to carry the refrigerant to one or more coolers in the occupied rooms.

Some of these self-contained units also include a heating coil for winter use, while others rely on

Systems

the existing heating system to warm the rooms in winter seasons.

Air conditioning systems are also classed as **direct** and **indirect** systems. In the direct type of system the refrigerant evaporator or cooling coil is located in the air stream and is in direct contact with the air to be cooled. In the indirect type of system water is chilled by circulation around the refrigerant evaporator, and then piped through a cooling coil or to spray nozzles in the air stream.

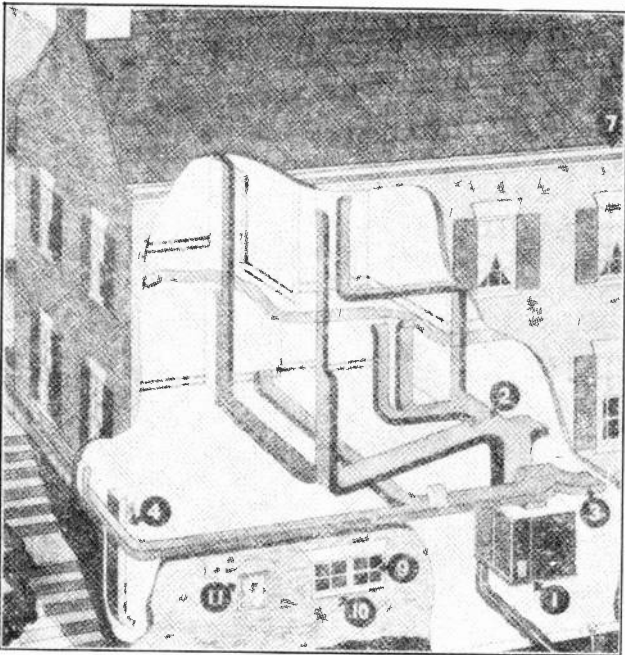

Fig. 7. Cut-away view of a two-story house and basement, showing layout of ducts used to carry conditioned air to the various rooms, and back again to the conditioning unit in the basement. Courtesy Superior Sheet Steel Co.

The indirect system is safer on large installations because the evaporator containing the refrigerant chemical is not located in the air duct, and in case of a refrigerant leak none of the gas could enter the air stream. On small units such as individual room coolers however, the direct system is generally used.

Air-Conditioning

2. HEATING OF AIR

As previously mentioned, heating the air in homes and other buildings is one of the functions of a complete air conditioning system. However, methods of heating are so well known that we will not attempt to cover this function or part of the system here, except in a general way.

For hundreds of years, homes in the cool climates have been heated by fires. First in open fire places, then in wood burning and coal burning stoves, and more recently by means of furnaces burning coal, oil or gas.

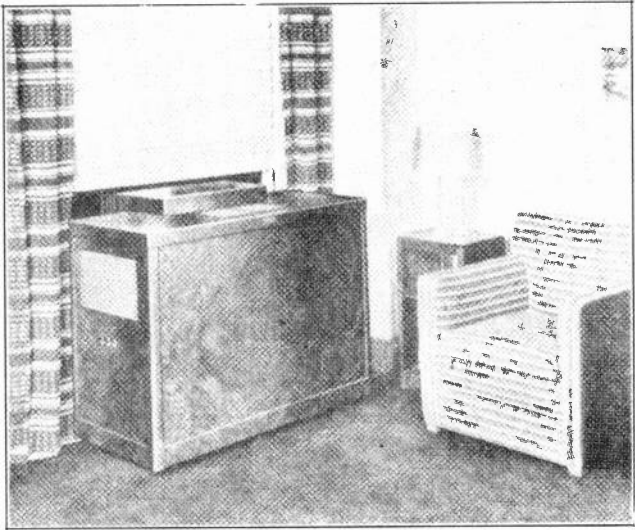

Fig. 8. Photo showing convenient portable room cooling unit located in a living room. This electrical cooling unit draws air from the window for cooling and ventilating the room, and also for cooling its own refrigerator condensing unit. Courtesy Pacific Mfg. Corp.

Fire places heat the air principally by radiation of heat from the open fire. Stoves heat the surrounding air by conduction of the heat through the iron jacket and then by radiation and conduction to the air.

Hot air furnaces heat the air by direct contact of the air with the hot iron jacket of the fire box.

Systems

Such furnaces are often located in the basement and the air rises through sheet metal ducts to the rooms above, due to convection, and the tendency of the warm expanded air to rise. Or, in some cases, electric fans or blowers are used to speed up the air circulation and increase the heat transfer efficiency. Some modern hot air furnaces also have air filters and humidifiers to clean and moisten the air. See Fig. 6.

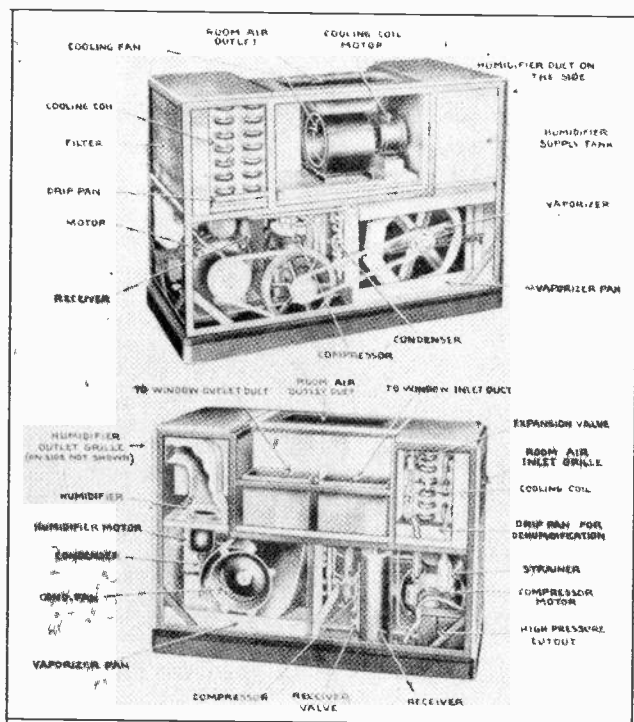

Fig. 9. Two excellent views of a room cooler unit with cover removed to show all working parts. Note the location and names of all the parts as marked on the photos. Courtesy Pacific Mfg. Corp.

Hot water and steam heating systems use water or steam to carry the heat through pipes from the furnace or boiler to radiators in the rooms above.

Modern heating plants have the temperature automatically controlled by means of electrical thermostat switches which open or close an electrical cir-

Air-Conditioning

cuit to the oil burner motors, solenoid gas valve, or in some cases motor operated coal stokers or draft controls.

In planning a heating system for a home or other types of buildings we must consider the size of the building, total area of walls and windows, amount of insulation, maximum difference between outside and inside temperatures and the amount of heat leakage in order to calculate the total heat load or size of heating unit needed.

These same factors and several others, must be considered when calculating the size of an air condition system required for a given building. They will be explained in detail in later paragraphs.

3. COOLING THE AIR

By far the most common method of cooling the air in air conditioning systems, is by means of refrigerator units very similar to those you have just studied for refrigeration. In fact, practically all you have learned so far about refrigeration principles and equipment can be applied to air conditioning.

However, in some installations, ice is used to cool the air by blowing the air through a chamber filled with ice. In other cases where plenty of cool well water is available, this water is sometimes circulated through cooling coils through which the air is passed. This provides a very economical means of cooling the air.

To cool the air by refrigeration we simply locate a dry type evaporator in the air path so that the air in passing through this coil becomes cooled. Or, as previously mentioned we may cool water with the evaporator and then pass this chilled water through a finned coil located in the air stream.

Evaporators or cooling coils for air conditioning units and systems have extra large finned surfaces, to provide more contact of the cold metal with the passing air and thereby improve the heat absorbing efficiency of the coil.

Note the evaporator coils shown in Figs. 4, 9 and 10.

As previously mentioned, air is sometimes cooled and washed by passing it through a cold water spray. In such units a solid blanket of fine water

Systems

spray is produced by forcing the cold water under pressure, through a set of spray nozzles.

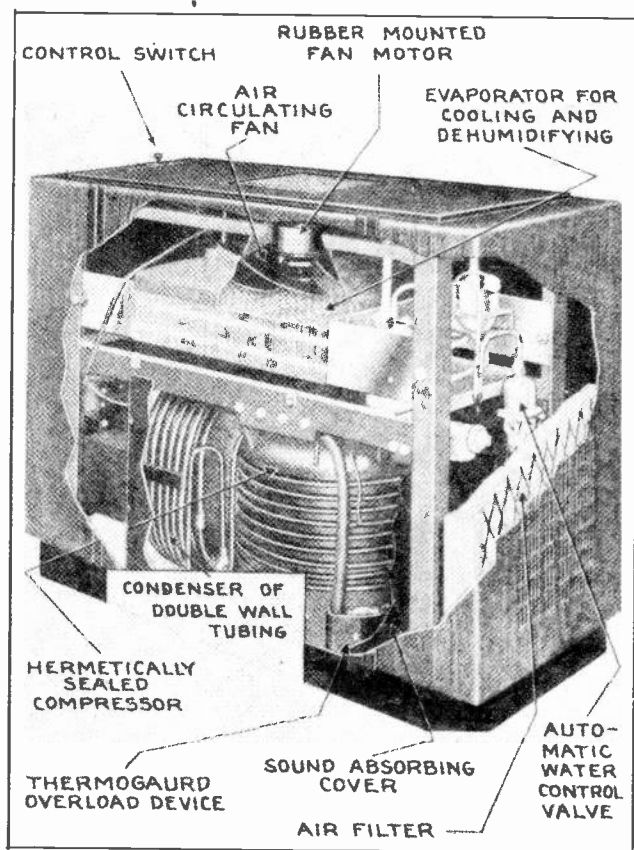

Fig. 10. Cut-away view of another type of electrical room cooler unit. Note the location and description of all the parts shown. Courtesy Westinghouse Electric Co.

4. PROPER AMOUNT TO COOL THE AIR

When conditioning the air inside a building for comfort and health, we should be careful not to cool the air to a temperature too much below that of the outside air.

While it is true that cooler air is both more comfortable and more healthful than excessively hot summer air, it is not advisable or healthy for per-

Air-Conditioning

sons to go directly from extremely hot air into a place that is too cool. In other words the contrast or temperature differential between the outside air and that of the air conditioned space should not be too great. Usually a temperature reduction of 10



Fig. 12. Photo of the inside of a modern air-conditioned general office. Note the duct outlets along the ceiling beams. Much better efficiency and health can be maintained in such air-conditioned offices. Courtesy Jewell Tea Co.

to 12 degrees is sufficient to greatly increase the comfort factor, and is much more healthful than a drop of 15 to 20 degrees or more.

In some of the first air conditioning installations, theaters and restaurants in which they were installed advertised and maintained inside temperatures of 70 degrees when the outside temperatures were from 90 to 100 degrees. This is not a healthful condition because the sudden and excessive temperature drop is likely to cause persons to become chilled and to develop colds.

The normal temperature of the human body is about 98.6 degrees F. This body heat is developed by the combustion of oxygen and food materials which are taken in by breathing and eating. In other words the human body is something like a house with a stove or furnace, and has its own heating plant within it.

Systems

When the surrounding air temperature is lower than that of the body, the excess body heat is given off to the air by radiation and conduction and through the evaporation of perspiration. The rate of this heat escapement and the control of the body temperature is effected by what is known as the metabolism system of the body.

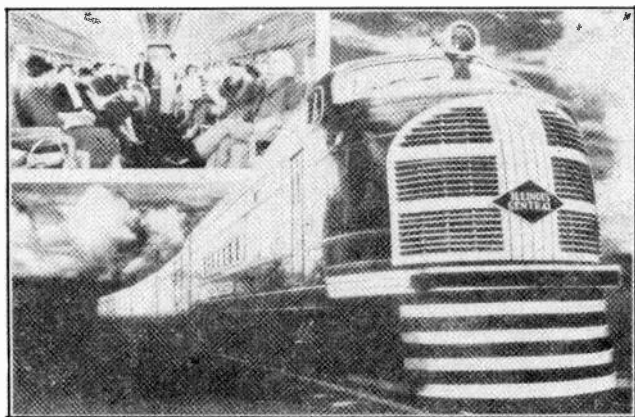

Fig. 13. Outside and inside views of a modern air-conditioned stream-lined Diesel-Electric train. The air inside is as cool, clean and refreshing as the air among the clouds outside. Courtesy Illinois Central Ry.

If the surrounding air is at higher temperature than 98.6 degrees F. then heat cannot flow by conduction from the body to the air, and can only be dissipated by the evaporation of perspiration.

We are then inclined to feel uncomfortably warm and this condition tends to exhaust nervous energy and reduce working efficiency.

Another effect of working in too high temperatures is that people are inclined to change their diet and eat more fruits and salads, and avoid meats, starches and sweets because these latter foods generate more body heat. However, if the air temperature is reduced to a more comfortable degree, we can then eat more of the heavier foods which produce more body energy and strength, thereby increasing our working efficiency and reducing tiredness.

A normal person when at rest gives off heat at

Air-Conditioning

the rate of about 400 B. T. U. per hour. When exercising moderately this rate is increased to about 600 B. T. U. per hour. When exercising vigorously

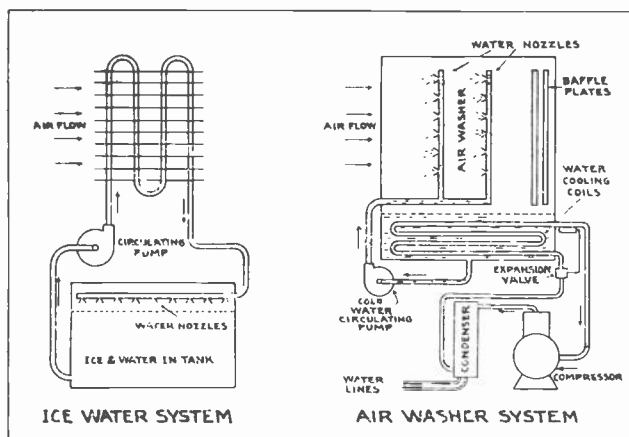

Fig. 14. The diagram on the left shows a simple method of cooling and dehumidifying air by circulating ice water through the finned cooling coil above. On the right is shown an indirect system, using a refrigerator unit to cool water, and then circulating the cold water through spray nozzles to cool and clean the air.

or doing heavy labor, the rate rises to 800 B. T. U. per hour, or even to 1,000 B. T. U. in some cases.

This body heat given off by persons in a room or building must be taken into account when planning an air conditioning system. This will be explained in detail later.

Keep well in mind, however, that the temperature of an air conditioned space which is to be occupied by humans, should not be lower than 10 to 12 degrees below outside temperature. While a temperature of 70 degrees F. is normally a comfortable and healthful temperature for building interiors during winter months, when outside summer temperatures are 95 degrees the inside temperature should not be lower than 82 degrees. This amount of temperature reduction will usually be found quite comfortable providing the humidity or moisture content of the air is reduced to the right value.

You have probably often heard the statement that "It is not so much the heat as it is the humidity," that causes discomfort on a hot summer day.

Systems

This is quite true because the humidity or moisture content of the air does affect the rate of evaporation of perspiration on the skin, and thereby affects the feeling or sensation of heat or cold.

In a series of laboratory tests made on a group of people, 98% of the group were comfortable at 73° F. and 70% relative humidity (R. H.), but when the R. H. was reduced to 30% these persons were comfortable at 79° F. Of this same group, 50% were still comfortable at 79° F. and 70% relative humidity, and when the R. H. was reduced to 30%, they were comfortable at temperatures up to 85° F.

5. DEHUMIDIFYING THE AIR

The amount of moisture in the air is referred to as **relative humidity**, meaning the percentage of moisture as related to the total amount which the air will hold or carry when it is saturated. The saturation point of air will depend upon its temperature. The warmer the air the more moisture it will hold before becoming saturated or reaching the

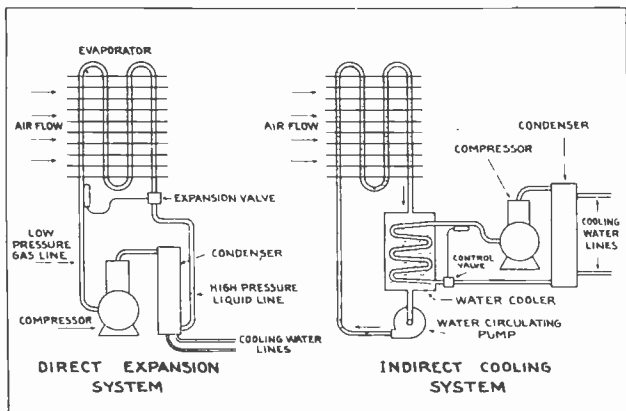

Fig. 15. On the left is shown a diagram of a direct type cooling system in which refrigerant from the compressor is fed through the air cooling coils of the evaporator. On the right is shown an indirect system using cold water to chill the air cooling coil and to carry the heat to the water cooler where it is absorbed by refrigerant from the compressor and condenser unit.

dew point, at which the moisture begins to fall or settle from the air.

For example air at zero degrees F., is saturated when it contains one-half grain of water per cubic

Air-Conditioning

foot. Air at 70 degrees F. is saturated when it contains 8 grains of water vapor per cubic foot. Air at 83 degrees F. will hold 12 grains of water vapor per cubic foot, and at 90 degrees F., 16 grains, before becoming saturated.

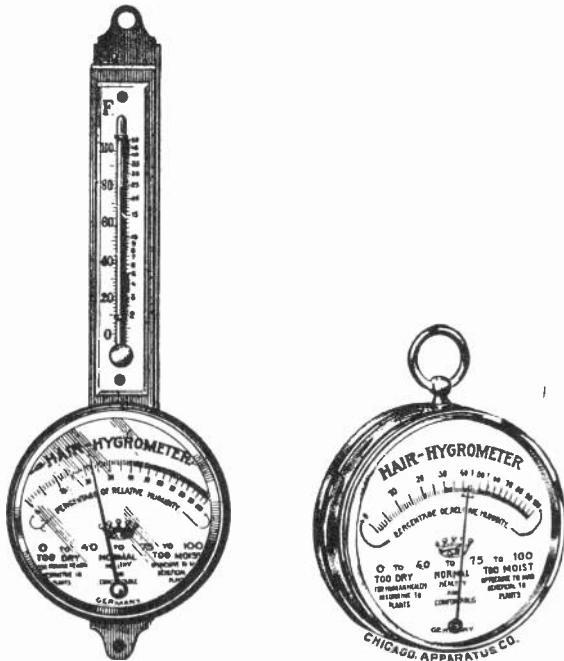

Fig. 16. Two types of hair operated hygrometers for indicating the approximately relative humidity of air. Courtesy Chicago Apparatus Co.

NOTE: 7000 grains of water equal one pound or approximately one pint of water. It is a rather surprising fact that the air in a normal sized living room or private office may easily contain a gallon or more of water on a warm day when the relative humidity is high. The air in an average size room weighs about 170 lbs.

The quantity of moisture actually contained in a given volume of air is called its **absolute humidity**. For example, if air at any temperature contains six grains of moisture per cubic foot, then its absolute humidity is said to be six grains per cubic foot.

As previously mentioned the relative humidity

Systems

of air is expressed in percentage of the total amount of moisture required to saturate the air at a given temperature. For example, if the saturation point of air at 70 degrees F. is 8 grains per cubic foot, then if 70 degree air contains 4 grains of moisture per cubic foot, its relative humidity would be 50%. Or if this air contained 6 grains of moisture per cubic foot its relative humidity would then be 75%.

The relative humidity of air on a hot summer day may often rise to 70 or 80%, and make the heat much more oppressive to persons than it would be if the air were drier.

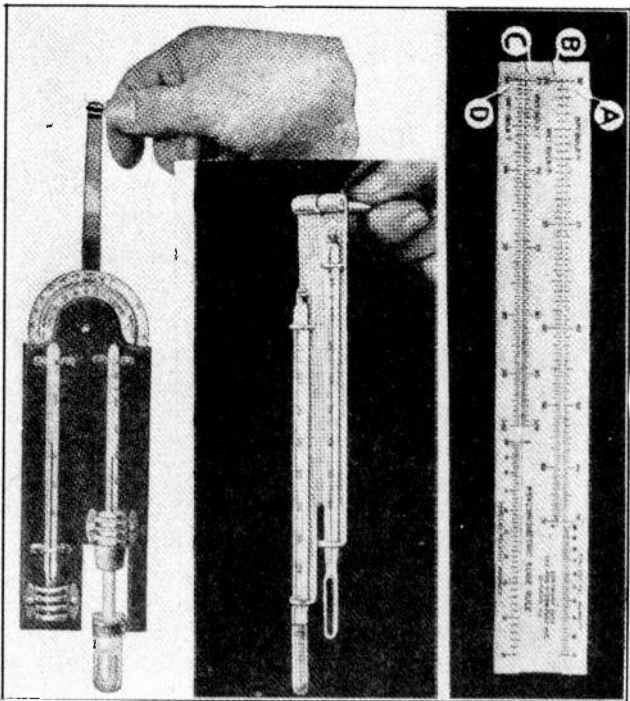

Fig. 17. Two types of sling psychrometers and a psychrometric slide rule, used for determining the relative humidity of air, for establishing comfort conditions in air-conditioned buildings.

Proper relative humidity for most comfortable and healthful conditions ranges from 35% to 65%, or a good average is about 50% relative humidity

Air-Conditioning

The humidity or moisture content of air is also very important in the processing or manufacture of certain articles in manufacturing plants. For example, textiles handle better when not too dry or too damp. Textile fibres that are too dry tend to become brittle and break and also repel each other and fray out due to static electricity. Properly humidified air will prevent this and also keep down objectionable dust.

The manufacture of flour in flour mills is also greatly improved by proper humidity which prevents stickiness or extreme dryness and dust. The handling of paper in printing plants is greatly facilitated by proper moisture content in the air, to prevent static on the paper.

Chewing gum can be produced in much better quality when made under proper humidity conditions. The softness or hardness of bread loaves and other baked goods can be controlled by adjusting the relative humidity of the air in bakeries.

Therefore, we can readily see how important it is to be able to control the humidity of air for reasons of comfort, health and efficiency. Many large plants have complete air conditioning systems installed because the improvement in quality of product and speed of production will more than pay for the cost of installing and operating the system. In addition to this economy feature the improved comfort, health and efficiency of employees makes it of added advantage and profit to air condition many plants.

Excessive moisture can easily be removed from air by passing it through cooling coils or cold water sprays. It is quite commonly known that chilling air will cause part of its moisture to condense. Most everyone has seen this effect where moisture condenses on the surface of a water glass or pipe containing cold water. Chilling moisture laden air to the dew point will cause the water vapor to settle out of the air like dew or heavy mist.

In air conditioning machines the water which is condensed in the cooling coils drains off into a drip pan and drain pipe.

The percentage of relative humidity can be very

Systems

accurately controlled, in fact controlled within one per cent or less, by means of humidistats which operate electric controls on the atomizing water sprays or jets. This in turn controls the amount of moisture that will be added to the air.

6. HUMIDIFYING AIR

During winter weather when the outside air is cold and dry, or of low relative humidity, and when this air is further dried out by operation of heating plants in buildings, the humidity of the inside air often becomes much too low for comfort, health or efficient processing of various articles. It is a rather astonishing fact that the air in the average home during winter months is often drier than the desert air in Death Valley. The relative humidity in Death Valley, California, is about 23% while that of the air in homes often falls as low as 18 or 20%. A given amount of outdoor winter air at zero temperature and a typical relative humidity of 40%, will, when heated to 70 degrees F., have a relative humidity of only 5% to 6%.

Such dry air, or "thirsty air" as it might be called, very rapidly absorbs moisture from the tissues of the mouth, throat, nose and lungs and causes these surfaces to become parched and irritated, and highly susceptible to inroads of disease germs. Many cases of colds, flu, bronchitis and other such ills can be prevented by proper humidification of the air in buildings during winter months.

Humidification, or addition of moisture to the air can be accomplished by passing the air through fine, mist-like sprays of water, or through steam jets. In some cases, it is accomplished by passing the air over moisture soaked pads. Radiators and furnaces in homes are often equipped with evaporator pans filled with water. The warm air which is circulated over and around these pans will pick up considerable moisture in this way.

Air will absorb water like a sponge, and like the sponge, air can only hold so much water and then it becomes saturated. Its relative humidity is then 100%. As explained in Article 5, the warmer the air, the more moisture it will absorb before becoming saturated.

Air-Conditioning

- 1 lb. of air at 20° F. will hold 20 gr. of moisture.
- 1 lb. of air at 50° F. will hold 54 gr. of moisture.
- 1 lb. of air at 75° F. will hold 131 gr. of moisture.
- 1 lb. of air at 100° F. will hold 300 gr. of moisture.

The relative humidity of air can be approximately determined by means of an instrument called a **hygrometer**, such as shown in Fig. 16. This device has a pointer which is caused to move over a scale by the expansion and contraction of strands of hair or other organic fibres which are very sensitive to moisture. Hair, which is commonly used in these instruments, expands when moistened and contracts when dried.

7. PSYCHROMETERS

Another method of more accurately determining the relative humidity of air is by the use of a **sling psychrometer**, two types of which are shown on the left in Fig. 17. This device consists of a dry bulb and a wet bulb thermometer mounted on a frame with a handle to permit them to be rotated or swung rapidly through the air.

The dry bulb thermometer is of the ordinary alcohol or mercury type. The wet bulb thermometer is similar except that its bulb is covered with a soft absorbent cloth or wicking material, which should be moistened in clean water of **approximately room temperature**.

When the psychrometer is swung rapidly through the air, the moisture from the wicking will evaporate into the air and the process of evaporation will cool the bulb so that the wet bulb thermometer gives a lower reading than that of the dry bulb thermometer.

The rate of evaporation will depend on the relative humidity of the air at the time and place of the test. The lower the R. H. or the drier the air, the faster will be the evaporation and the greater the difference between the readings of the dry bulb and wet bulb thermometers.

Then, by taking these two readings at the same instant and checking them on a special psychrometric slide rule or chart, we can determine the relative humidity of the air.

Systems

The sling psychrometer shown on the left in Fig. 17 has a convenient circular slide rule attached. For the psychrometer shown in the center of this figure, we use the straight slide rule shown on the right.

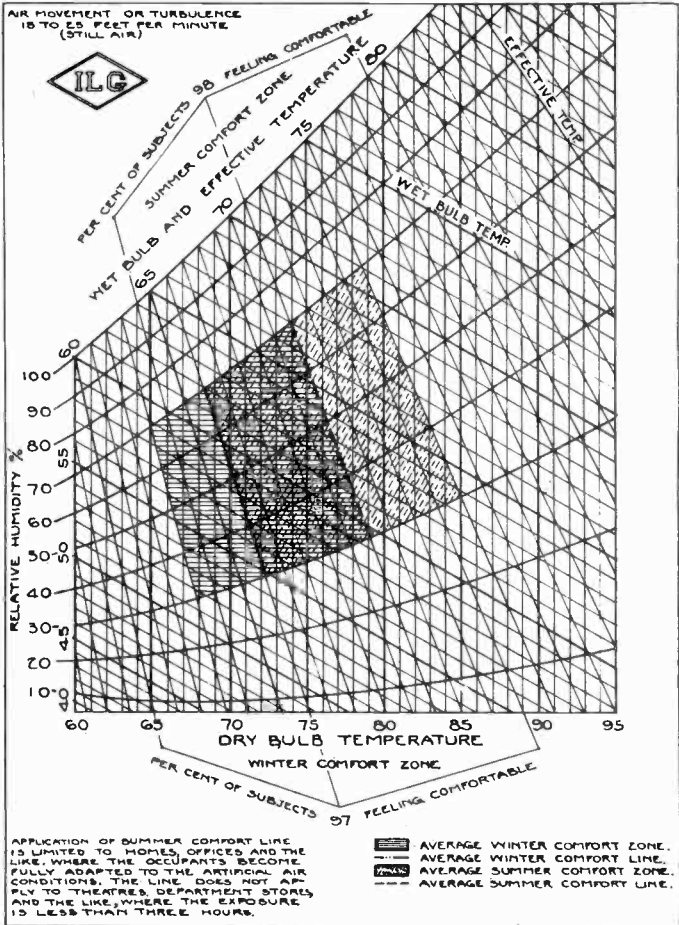

Fig. 18. Simplified psychrometric chart showing comfort zones, for determining proper temperatures and humidities for comfort and health. Study this chart carefully and become familiar with its use while reading the lessons material pertaining to it.

For reading the instrument shown on the left we first take the dry bulb reading and set this figure on the outer scale at the 100% marking on the inner scale.

Air-Conditioning

Then holding the instrument well away from the body, rotate it rapidly through the air about 50

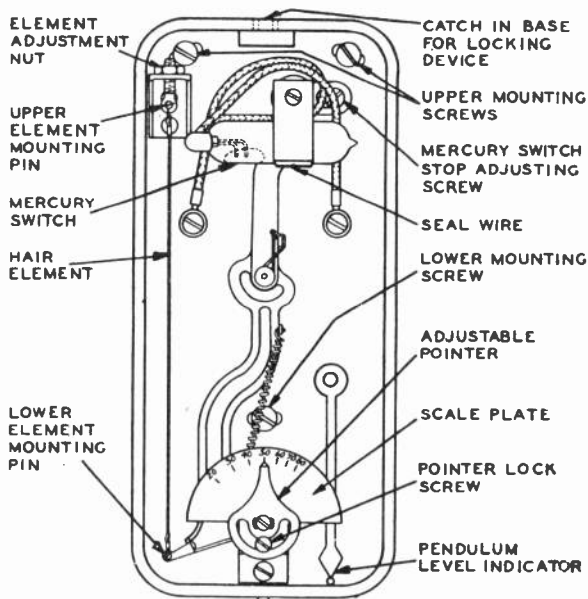

Fig. 19. Diagram of a humidistat such as used for controlling humidity in air-conditioning installations. An electric switch is operated by expansion and contraction of strands of human hair. Courtesy Minneapolis Honeywell Corp.

revolutions, or until wet bulb thermometer will go no lower. Then quickly take the wet bulb reading and locate this figure on the outer scale, and read relative humidity directly opposite on the inner scale.

To use the other type of psychrometer and the straight slide rule shown in Fig. 17, twirl the thermometers and take both readings. If the wet bulb temperature is below 50 degrees F., use scales A and B on the slide rule. Set the wet bulb reading on scale "B" opposite the dry bulb reading on scale "A." Read the R. H. at the right end of scale "A" directly above the pointer or arrow on scale "B."

If the wet bulb temperature is above 50 degrees F., use scales "C" and "D." Set wet bulb temperature on scale "C" opposite dry bulb temperature on

Systems

scale "D." Read the R. H. at the right end of scale "D" below the pointer on scale "C".

Examples for checking correct use of the slide rule would be as follows: Wet bulb temperature of 48 degrees F. and dry bulb temperature of 59 degrees F. would indicate 43% R. H. Wet bulb tem-

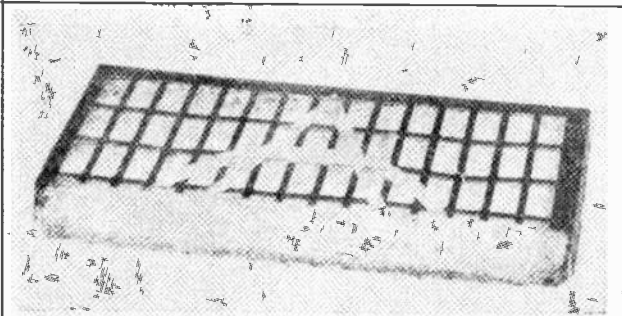

An unretouched photograph showing the filter before being used.

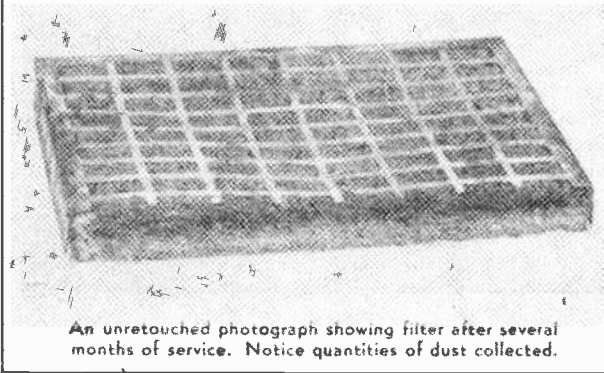

An unretouched photograph showing filter after several months of service. Notice quantities of dust collected.

Fig. 20. Two views of a section of an air filter, showing the amount of dirt removed from the air by such filters. This shows how air conditioning improves health by keeping such dirt out of the lungs of persons in air-conditioned buildings.

perature of 56 degrees F. and dry bulb temperature of 63 degrees F. would indicate 64% R. H.

The wicking on the bulb of the wet bulb thermometer should never be allowed to get dirty or greasy or it will cause inaccurate readings by slowing up the normal rate of evaporation.

Air-Conditioning

8. PSYCHROMETRIC CHARTS

Another convenient method of determining relative humidity when wet and dry bulb temperatures are known, is by means of a **psychrometric chart**, a section of which is shown in Fig. 18. The chart we have shown in this figure is one which has been cut down for convenience, and covers dry bulb temperatures from 60 degrees to 95 degrees F.; wet bulb temperatures from 40 to 85 degrees F., and relative humidities from 10 to 100%.

This chart has also been shaded in the center portion to show average winter and summer comfort zones, or desirable relative humidities for comfort at the dry bulb temperatures commonly encountered indoors in summer and winter seasons.

Note that the most desirable average values (center area of shaded comfort zone) are at about 70 degrees to 75 degrees F. dry bulb temperature, 60 degrees to 65 degrees F. wet bulb temperature, 40 to 60% relative humidity, 67 to 72 degrees F. **effective temperature**.

Also note that the dry bulb, wet bulb and dew point temperatures are the same at 100% saturation, as shown by the intersection or joining of the vertical dry bulb lines and the angular wet bulb lines at the 100% relative humidity line. This line also represents saturation or dew point at the various temperatures.

With any two of these factors known, all the others can be quickly determined with the aid of such psychrometric charts.

Air conditioning equipment installation and service men should be thoroughly familiar with the use of psychrometric charts. Larger and more complete charts, covering wider temperature ranges can be obtained from principal manufacturers of air conditioning equipment.

Relative humidity can be automatically controlled by means of a **Humidistat** such as shown in Fig. 19, and which would be located in the air conditioned room or space. This device consists of a mercury switch operated by the expansion or contraction of strands of hair, something like the hygrometer, except that in the humidistat the expanding element operates a switch.

Systems

An adjustment is provided as shown at the bottom of the diagram in Fig. 19, to set the desired humidity at which the switch is to operate and open or close the circuit to a solenoid operated valve in the water line to the humidifier spray unit.

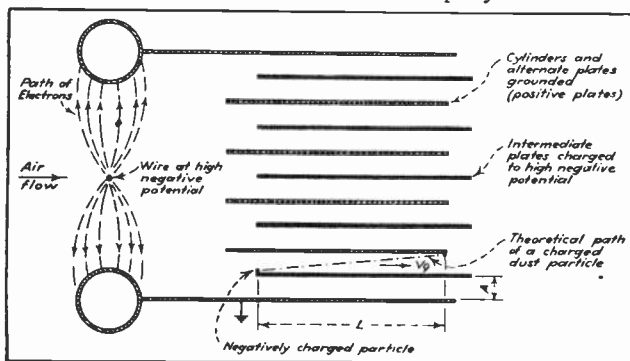

Fig. 21. Diagram illustrating the principle of operation of an electrostatic dust precipitator or collector, which will remove extremely fine dust and smoke particles from the air. Courtesy Electric World.

9. FILTERING AND CLEANING AIR

As previously mentioned, a great deal of the dirt, dust and disease germs which are normally contained in air, especially in large cities and industrial areas, can be removed by passing the air through filter screens or pads of various types of construction.

One of the most commonly used types of air filters in air conditioning systems, is made of spun glass or glass wool which is coated with a thin film of oil. Such filters are highly efficient and will remove 98% of the dust and many of the disease germs normally in the air. Fig. 20 shows 2 of these filter pads, one of which is clean and the other of which is loaded with dirt collected from the air while in service in an air conditioning unit.

Another method of removing dirt from the air is to wash it by passing it through fine water sprays or "scrubbers." Sometimes both the water spray and filter are used in the same air conditioning unit for more thorough purification of the air.

Still another method which is highly effective in removing dust particles from the air, is known as

Air-Conditioning

the electrical precipitation process. This system uses high voltage electricity to charge a set of metal tubes and plates which are located in the path of the air stream. See Fig. 21 which shows one type of electrostatic dust precipitator. The dust particles, in passing near these highly charged metal electrodes take on by induction a static charge of a polarity opposite to that of the electrodes. This causes the charged dust particles to be attracted to the metal electrodes, where they cling until dislodged by jarring the electrodes.

During the period while one set of precipitator electrodes is being cleaned the air is usually bypassed by means of dampers through another set of electrodes. Shutting off the flow of air through the set which is being cleaned permits the dust to settle to the bottom of the chamber from which it can be removed.

Air cleaning or filtering is highly important in many industrial plants and in bakeries and food producing plants. For example, automobile painting departments can only produce a fine finish on the cars if the air is free of dust. In tobacco manufacturing plants, it is highly essential from the standpoint of the employees' health to have the highly irritating tobacco dust removed from the air. In shops or laboratories handling watches and meters and other delicate instruments the air must be kept clean. In breweries air filtering and washing removes highly infectious yeast and mould germs from the air.

Filtering or cleaning air in homes, offices, stores and theaters, to remove dust, weed pollen and germs, affords great relief to hay fever sufferers and reduces diseases such as colds, flu, etc.

Cleaning the air in homes, offices and stores also helps to keep walls, drapes, rugs, furniture and clothes much cleaner, and thereby reduces laundry and cleaning bills. So we can readily see the importance of the cleaning function of air conditioning.

In addition to cleaning the air, some air conditioning systems are also equipped to absorb odors or to introduce into the air stream some material to produce pleasing odors to offset disagreeable odors.

Systems

Electric ozone generators are used with some air conditioners to neutralize foreign odors. Ozone consists of a form of oxygen which has been changed from its original form by application of high voltage. It has a peculiar characteristic odor which has a tendency to neutralize disagreeable odors.

EXAMINATION QUESTIONS

1. What does complete air conditioning include?
2. Briefly explain the difference between an "individual Room Cooler" and a "Central air conditioning system"?
3. What is the difference between a "direct" and an "indirect" air conditioning system?
4. Is it advisable to always cool a room down to an ideal temperature of about 70 degrees? Why?
5. What is meant by the term "Relative Humidity"?
6. What term do we use to indicate the quantity of moisture actually contained in a volume of air?
7. In what way may moisture be removed from the air?
8. In what way may moisture be added to the air?
9. For what purpose are the following instruments used?
A. Hygrometer B. Psychrometer C. Humidistat
10. Describe one type of filter which is commonly used as an air filter in air conditioning systems.

Air-Conditioning

CIRCULATION OF AIR VENTILATION

One of the most important functions of any air conditioning system, and yet one of the least costly, is the circulation of the air, or proper ventilation. Proper movement and distribution of the air in a room or building is necessary to provide proper comfort and health conditions. It is also necessary to provide a certain amount of fresh air or a certain number of changes of air per hour for healthful conditions.

A minimum of 20 cubic feet of fresh air per minute should be provided for each person in any room. City health departments require this in all public buildings such as schools, theaters, restaurants, stores, etc. Some cities require 25 to 30 cubic feet per person per minute.

Human beings consume the oxygen in the air and liberate nitrogen and carbon dioxide by breathing. A fresh supply of oxygen is absolutely necessary to sustain life, health and a clear mind.

When heating or cooling the air in a building, a certain amount of the air can be recirculated, but a certain amount of fresh air must be added continually. Normally about 25% of fresh air is added in the circulation system.

Air in occupied rooms becomes stagnant and foul with odors if it is not circulated and renewed. In heated rooms if the air is not kept in motion the warm air rises to the top of the room, creating unnecessarily high temperatures in this upper level, with resulting high heat leakage loss through ceilings unless they are very heavily insulated. It is therefore more efficient to keep the air in motion.

Body odors, cooking odors, tobacco smoke, etc., can be removed from homes, offices and other buildings very economically by means of electric ventilating fans such as shown in Fig. 4. In buildings having only ordinary winter heating plants such added ventilation is a decided advantage.

During hot summer months the temperature of kitchens, bedrooms and offices can be considerably lowered by means of ventilating fans to remove the

Ventilators

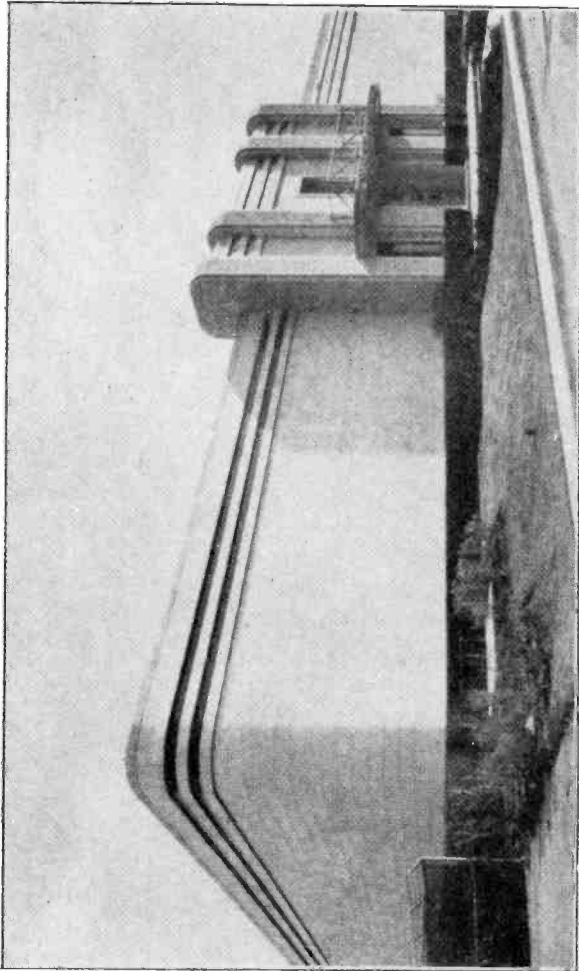

Fig. 1. This photo shows a modern air-conditioned building. Modern electric air-conditioning and electric lighting permit such buildings to be constructed without windows, thus shutting out noise, dirt, heat and cold very effectively. Courtesy National Aluminate Corp.

Air-Conditioning

heat from cooking appliances, electric lamps, air-cooled refrigerator condensers, body heat, etc.

1. ATTIC VENTILATORS

A great deal of comfort cooling in homes can be accomplished during the summer months by use of attic ventilators or large fans placed in the attic. By proper location of such fans and proper adjustment of doors and windows downstairs, such fans can be made to blow out the hot air from the attic and draw in cool night air through the various rooms of the house. See Fig. 5.

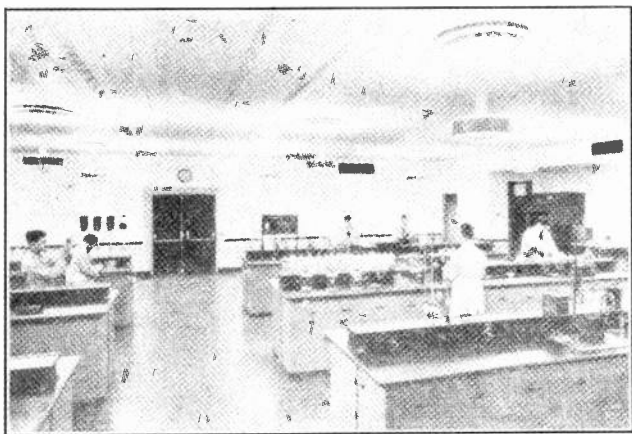

Fig. 2. Interior view of spotlessly clean air-conditioned chemical laboratory, in the building shown in Fig. 1. The advantages of air-conditioning in chemical laboratories, food manufacturing plants, and fine instrument shops are very apparent. Courtesy National Aluminate Corp.

When we consider the fact that with the hot sun beating on the roof all day, attic air temperature will often reach 120 to 130 degrees F., we can readily see the benefits of removing this heated air from the house. As much as 40% of the total heat entering an uninsulated one story house during a hot summer day comes through the roof. (Note, about three-fourths of this heat can be kept out of the rooms of the house by proper insulation of the attic floor.)

In many localities even though outside air temperatures during the day may reach 90 to 100 de-

Ventilators

degrees F., in the evening after sundown the outside temperatures commonly drop to 70 to 80 degrees F. With a proper size attic ventilator set to automatically turn on in the early evening and turn off in the morning, and changing the entire air in the house every 10 or 15 minutes, temperature reductions of from 5 to 10 degrees or more can often be accomplished.

By closing most of the doors and windows during the day, a well insulated house may be kept considerably cooler if all walls, floors and furniture are well cooled down at night.

Attic ventilation provides a very inexpensive means of securing considerable comfort cooling during summer months. Many home owners who cannot afford complete air conditioning gladly welcome such an installation when fully acquainted with its advantages.

Another benefit of moving or circulating the air through rooms in the summer, is that when air in motion comes in contact with the human body it increases the rate of evaporation of perspiration, thereby producing a sensation of coolness. Note how the window curtains in the upper view in Fig. 6, are blown inward from the window by cool night air drawn in by an attic fan of the type shown in the lower view.

SELECTING THE FAN SIZE

The air change required in a room differs with the conditions found therein. The worse the air conditions, the faster the air should be changed; restaurants for instance need a more rapid air change than do offices. Air conditions in a given type of building are fairly uniform and it is possible to generalize on the rate of air changed advocated for various classes of buildings. Note listing below.

If it is desired to change the air in a room once each 5 minutes as an example, figure cubical contents of room by multiplying length, width and height. Divide this figure by 5, the rate of air change, giving the amount of air the fan should handle per minute. They are rated in this manner.

Complete circulation throughout room is obtained by placing fan as far as possible from air intake.

Air-Conditioning

For installation data, see booklet "Simple Instructions for Installing Ilg Ventilating Fans."

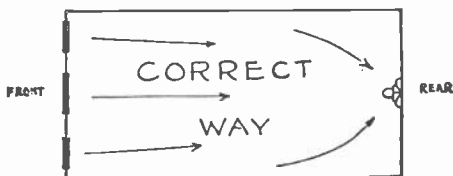

AIR CHANGE TABLE

CLASS OF BUILDING	FOR VENTILATION AND COOLING	FOR GOOD VENTILATION
Offices, Stores	2 Minutes	5 Minutes
Restaurants	1 Minute	2 Minutes
Factories (general ventilation)	3 Minutes	6 Minutes
Garages	3 Minutes	6 Minutes
Churches, Theaters, Halls	2 Minutes	5 Minutes
Home Kitchens	1 Minute	2 Minutes
Home Cooling	2 Minutes on floor below attic space	
Farm Barns	60 CFM per cow, 30 CFM per horse	

2. BLOWERS AND DUCTS

Complete air conditioning systems of the central plant type use blowers and ducts to circulate the conditioned air to the various rooms, and to return the air from the rooms to the conditioning plant. See Fig. 3 in this lesson and Figs. 6, 7, and 12 in Lesson 101.

Instead of fans with propellor type blades, centrifugal blowers of the type shown in Fig. 7 are generally used with central conditioning plants. These blowers provide a better positive pressure which is required to force the air to flow through the resistance of long ducts and resistance offered by filters, cooling and heating coils, and louvres through which the air must pass.

When selecting or ordering such blowers for any given air conditioning system, the proper size and power of the blower is determined by the required amount of air in cubic feet per minute (C.F.M.), the size and length of the ducts, the area and type of cooling coil, heating coil, filters and louvres through which the air must pass. The resistance of the ducts, coils, etc., to the flow of air is measured

Blowers and Ducts

and stated as **static pressure** in "inches of water column," meaning the amount which a column of water would be raised in a tube by the pressure required to force air through the resistance of the devices at a given velocity.

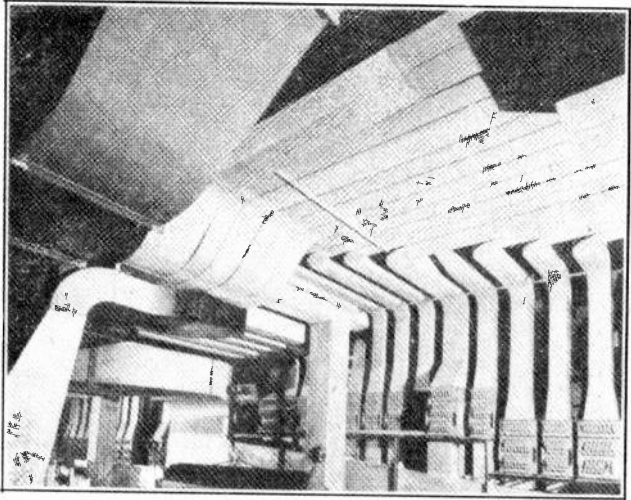

Fig. 3. View of part of the air duct system in the building shown in Fig. 1. Note the neat duct layout and the cooling coils installed in each duct in this rather unusual installation. Courtesy National Aluminate Corp.

The table in Fig. 8 gives approximate duct sizes required to carry various amounts of air in C.F.M. at given velocities. For average resistance conditions a one h. p. motor driven blower will deliver about 2500 C.F.M. On large installations blower manufacturers will recommend the proper size and type of blower according to the requirements and construction features of the system.

As a general rule, air velocities through ducts are not over 800 ft. per minute, as at higher velocities the friction losses are high and the noise level is greatly increased. Velocities of 400 to 600 ft. per minute are much more common.

Blowers are often coupled to plenum chambers or ducts by means of a flexible canvass coupling to prevent transfer of blower vibration and noise to the duct system, which would carry the noise throughout the building.

Air-Conditioning

3. DUCT OUTLETS

Duct outlets are generally located in the ceilings or high up on the walls of rooms, so that the air will discharge or distribute downward. Duct openings to return the used air from the room to the conditioner, are generally located in the walls near the floor.

In some cases, however, the direction of air flow may be reversed and pass from bottom to top of the room, or from side to side. It may also enter a room at the center of the ceiling and be taken out at the sides of the ceiling, or enter at one side of the ceiling and leave at the other side.

Ducts should be equipped with a sufficient number of openings to provide even distribution of the air and prevent strong drafts. The temperature variation at different points in the room should not be over 4° F.

Duct openings are provided with grilles or louvres, both to improve appearance and to improve air distribution. Fig. 9 shows two grilles for duct openings. These grilles are equipped with louvres (slanting vanes) to direct the air flow in the desired direction. They also have adjustable dampers operated by the pull chains shown.

Ducts are usually made of sheet metal, with the joints soldered or tightly bolted together to prevent leakage loss of the conditioned air. In some cases, however, the spaces between joists of walls may be used as ducts.

The inside surfaces of ducts should be smooth to reduce air friction as much as possible. Duct turns or bends should be rounded to reduce turbulence and to permit a smooth flow of air.

4. DUCT INSULATION

If ducts are exposed to air that is much warmer or colder than the conditioned air they are carrying the outer surfaces of the ducts should be covered with insulation. Sheet cork or asbestos covering materials are commonly used for this purpose.

Such insulation prevents considerable loss of heat and also deadens noise that might otherwise travel

Blowers and Ducts

along the ducts. Slabs or strips of cork or asbestos covering are generally cemented to the metal surfaces of the ducts with asphalt cement as shown in Fig. 10.

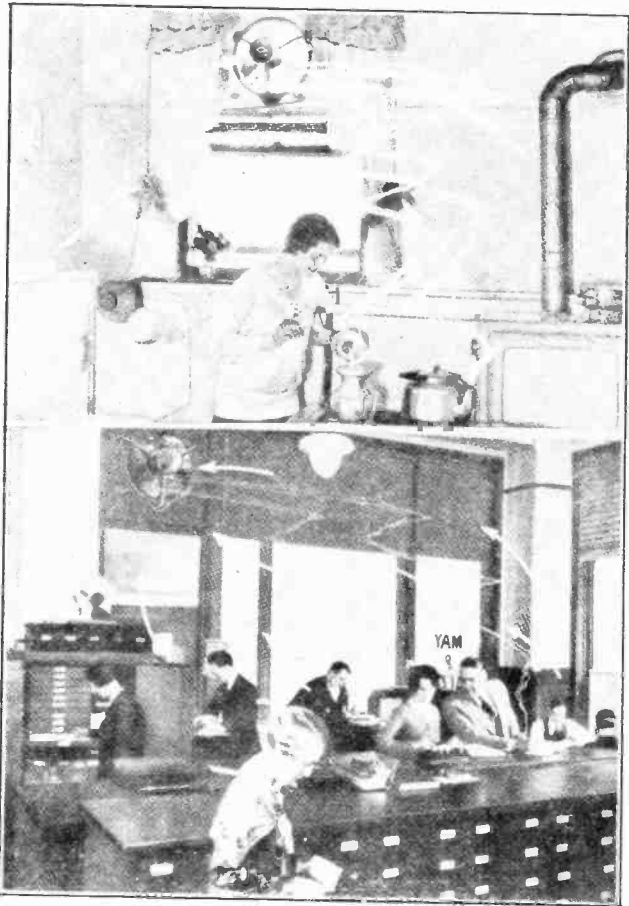

Fig. 4. Upper view shows how a ventilation fan removes odors and heat from a kitchen. Lower view shows ventilator removing smoke and heat from an office. Courtesy Ilg Electric Ventilating Company.

In some installations, the ducts are also lined with sound absorbing material to prevent any noise from the air or from vibration in the building.

Fig. 11 shows a duct layout for one floor of a

Air-Conditioning

simple office or hotel building. Fig. 12 shows a diagram of a complete air conditioning system of the indirect type. Note the refrigerating unit, water cooler, plenum chamber with its heaters and cooling and dehumidifying sprays, fan, ducts, etc.

Dampers are used in the ducts to regulate the distribution of air to various rooms, and at air inlets and outlets to the plenum chambers to regulate

Brez-Air mounted in attic side wall with ventilating louvres

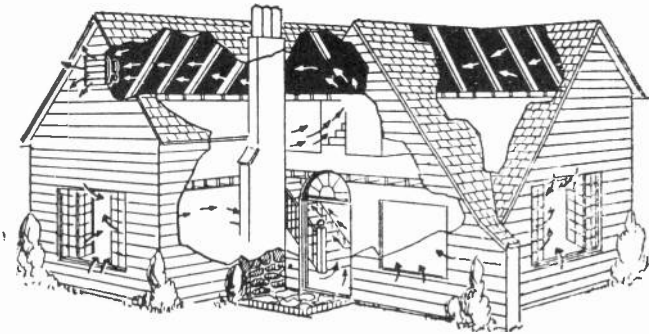

Brez-Air Fan mounted in box which stands on attic floor.

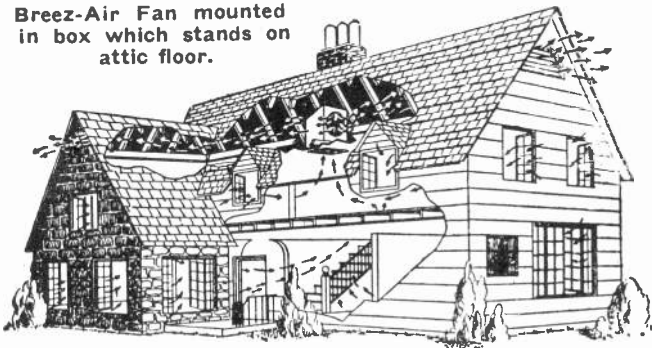

Fig. 5. These two diagrams show how attic ventilator fans can be used to remove heat from attics and draw cool night air into all the rooms of the home.

the mixing of fresh air and recirculated air. Note the dampers at "D" in Fig. 12.

5. SIZE OF AIR CONDITIONING UNITS REQUIRED

The exact size of refrigerating unit required for cooling the air for any given building can be cal-

Conditioning Unit Sizes

culated by considering the size of the building, type of building construction, class of service, temperature difference to be maintained between inside and outside air, maximum outside temperatures, and total heat load or heat gain in B.T.U. The heat comes from such sources as leakage through walls, doors and windows, infiltration of heat through open doors, and with fresh air used for ventilation, body heat of occupants, heat from electric lights, appliances, motors, cooking ranges, etc.

However, for simple reference purposes we can generally figure that under average conditions a one ton refrigeration unit, if run continuously, will cool

1000 cu. ft. of storage space to 32 degrees F.

4000 to 6000 cu. ft. of residence space to 75 degrees F.

8000 cu. ft., or 15 seats, in a theater to 75 degrees F.

3000 to 5000 cu. ft. of store space to 75 degrees F.

3000 to 5000 cu. ft. of dining room space to 75 degrees F.

3000 to 8000 cu. ft. of candy factory space to 68 degrees F.

$\frac{3}{4}$ gal. of drinking water per minute to 40 degrees F. or

Freeze .6 ton of ice per 24 hours.

Freeze .75 ton of fish per 24 hours.

We can also figure that a $\frac{1}{2}$ to 1 ton unit will operate an individual room cooler for the average size living room or small private office, and cool the room to 10 to 12 degrees below outside temperatures if the room has average insulation and not too many windows exposed to direct sunlight.

The following table gives good average or desirable wet and dry bulb temperatures and relative humidities for summer comfort conditions with various outside temperatures.

The values given in this table are those recommended by the air conditioning manufacturers Association (A.C.M.A.)

Air-Conditioning

Outside dry bulb temperature	Inside		Inside relative humidity per cent
	temperatures dry bulb	- wet bulb	
85	74	64	60
85	74	59	35
90	77	67	62
90	80	63	40
95	79	68	58
95	82	65	40
100	80	69	58
100	83	65	38
105	81	70	58
105	84	66	39

Typical examples of heat loads or size of refrigerating units required for various classes of buildings are given in the following table and should prove helpful as an approximate guide to unit size requirements.

	Tons of refriger. per 1000 sq. ft. of floor area.	Tons of refriger. per 1000 cu. ft. of bldg. vol.
Department stores....	3	.21
Office buildings	2.8	.26
Restaurants	9.5	.81
Theaters	8.8	.23
Residences	4	.30

The approximate kilowatt hours required per h. p. of compressor size, per season for such buildings are as follows:

Department stores	1100 kw. hrs. per h. p. per season
Office buildings	1000 kw. hrs. per h. p. per season
Restaurants	800 kw. hrs. per h. p. per season
Theaters	500 kw. hrs. per h. p. per season
Residences	900 kw. hrs. per h. p. per season

We can generally figure a cost of about \$400.00 per ton installed, for refrigerating units for air conditioning.

6. HEAT LOAD CALCULATION

As we have previously stated, to determine the size of refrigeration unit needed to cool a given space or building, we must take into account the heat load from several different sources. The most important of these are the heat that leaks in through

Conditioning Unit Sizes

walls, ceiling, floor, windows and doors; the heat that enters with the fresh air used for ventilation; the heat from electric appliances, motors, and gas burners, and the heat from the bodies of persons occupying the space to be air conditioned.

We have already learned that each person will give off about 400 B.T.U. per hours when idle, 600 B.T.U. when doing light work, and 800 or more B.T.U. when doing heavy work.

We also know that electric lamps and appliances give off about 3.41 B.T.U. per hour per watt of elec-

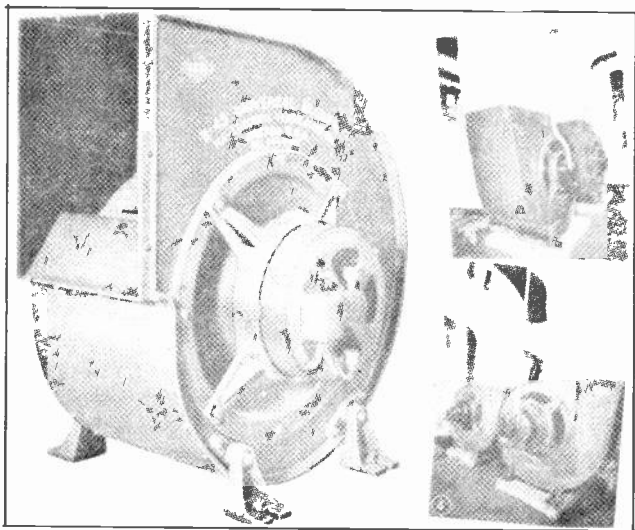

Fig. 7. Large centrifugal fans or blowers of the type shown above are used to circulate air through ducts of air-conditioning systems. Courtesy Ilg Electric Ventilating Co.

tric energy consumed. On large motors it is simpler to figure 2540 B.T.U. per h. p. per hour.

Gas ranges and ovens give off about 500 B.T.U. per cu. ft. of manufactured gas burned, or about 1000 B.T.U. per cu. ft. of natural gas.

Now if we also knew the **heat leakage factor per sq. ft.** of various common building materials, then with a knowledge of the **maximum outdoor temperatures** and the **desired indoor temperature**, it should be a simple matter to calculate the total heat

Air-Conditioning

load in B.T.U. per hour from these various sources.

Therefore, the following data on heat leakage in B.T.U. per sq. ft., per degree of temperature difference, per hour, should be valuable in estimating the size of refrigeration unit required to handle the heat load or to cool a given building.

TABLE OF AIR DUCT SIZES
 SIZE IN INCHES OF RECTANGULAR AIR DUCT REQUIRED
 FOR PASSAGE OF A GIVEN VOLUME OF AIR AT A GIVEN VELOCITY.

VELOCITY IN FEET PER MINUTE	CUBIC FEET OF AIR PER MINUTE									
	100	200	300	400	500	1,000	1,500	2,000	2,500	3,000
350	6 x 8	8 x 12	12 x 12	12 x 14	12 x 18	18 x 24	22 x 28	24 x 36	28 x 38	28 x 44
400	6 x 6	8 x 10	10 x 12	12 x 12	12 x 16	18 x 20	20 x 28	24 x 30	28 x 32	28 x 40
450	6 x 6	8 x 8	8 x 12	12 x 12	12 x 14	16 x 20	20 x 24	24 x 28	28 x 30	28 x 34
500	6 x 6	8 x 8	8 x 12	10 x 12	12 x 12	16 x 18	20 x 22	24 x 24	26 x 28	28 x 32
550	6 x 6	8 x 8	8 x 10	10 x 12	10 x 14	16 x 18	20 x 20	22 x 24	24 x 28	28 x 28
600	4 x 6	6 x 8	6 x 12	8 x 12	10 x 12	16 x 16	18 x 20	20 x 24	24 x 26	26 x 28
650	4 x 6	6 x 8	6 x 12	8 x 12	10 x 12	14 x 16	18 x 18	20 x 22	24 x 24	26 x 26
700	4 x 6	6 x 8	6 x 10	8 x 12	10 x 10	14 x 16	16 x 20	20 x 22	22 x 24	24 x 26
750	4 x 6	6 x 8	6 x 10	8 x 10	10 x 10	14 x 14	16 x 18	20 x 20	22 x 22	24 x 24
800	4 x 6	6 x 6	6 x 10	8 x 10	8 x 12	14 x 14	16 x 18	18 x 20	22 x 22	24 x 24

DUCT SIZE IN INCHES GIVEN IN COLUMNS ABOVE

Fig. 8. Convenient table for determining proper duct sizes for handling various quantities of air at different velocities.

We know that the heat conductivity of different materials varies considerably, or that the heat leakage through glass is much more rapid than through wood or brick. We also know that the greater the area exposed to two different temperatures, the greater will be the total heat leakage. And, of course, the higher the temperature difference between outside and inside air the more rapid will be the heat leakage.

That is why the following heat leakage values are stated in B.T.U. per sq. ft., per degree of temperature difference, per hour; (B.T.U./sq.'/°/hr.)

7. HEAT LEAKAGE FACTORS IN B.T.U. PER SQ. FT. PER HR. FOR VARIOUS COMMON BUILDING MATERIALS

Plain glass	1.1
Double glass45
Wood siding and sheathing on 2 x 4 studs, plastered26
Wood siding and sheathing on 2 x 4 studs, plastered and ½-in. insulation between studs15

Heat Load Calculation

Wood siding and sheathing on 2 x 4 studs, plastered and space filled with insulation....	.11
Brick veneer, sheathing, studding, plastered....	.25
Brick veneer, 8-in. hollow tile, no interior finish26
Brick veneer, 8-in. hollow tile, furred and plastered20
Brick veneer, 8-in. concrete, no interior finish	.36
Brick veneer, 12-in. concrete, no interior finish	.33
Plain brick, 8-in. no interior finish39
Plain brick, 8-in. furred and plastered.....	.26
Plain brick, 12-in. furred and plastered.....	.22
Plain tile, 10-in., no interior finish.....	.25
Plain tile, 10-in., furred and plastered.....	.20
Plain concrete, 6-in., no interior finish.....	.58
Plain concrete, 12-in., furred and plastered....	.41
Stucco, wood sheathing, studding, plastered....	.30
Stucco, on 8-in. hollow tile, furred and plas- tered23
Stucco, on 8-in. concrete, furred and plastered	.30
Outside doors, 1 -in. thick69
Outside doors, 1½-in. thick52
Outside doors, 2 -in. thick46
Inside Partitions:	
Single glass partition.....	.75
Double glass partition.....	.50
Single metal partition.....	.91
Double metal partition.....	.53
Studding with metal lath and plaster on one side55
Studding with metal lath and plaster on both sides33
Studding with metal lath and plaster on both sides and 2-in. space filled with insulation12
Hollow tile, 4-in., no plaster39
Hollow tile, 4-in., plastered on both sides	.33
Brick, 4-in., plastered on both sides.....	.37
Wood door, 1-in. thick, in partition.....	.43
Ceilings and Floors:	
Average wood floors28
Average concrete floor33
Average well-built wood roof20
Average well-built concrete roof25

Air-Conditioning

Plastered ceiling, no attic floor or insulation above55
Plastered ceiling, 4-in. joists and 1-in. wood floor above44

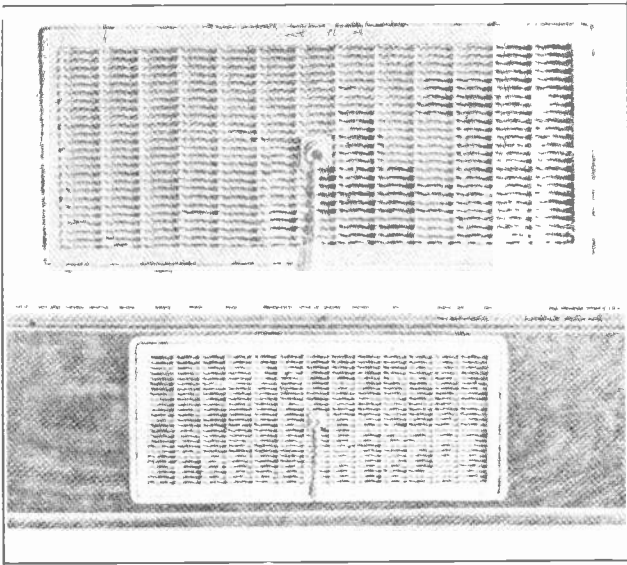

Fig. 9. This view shows grilles for mounting over air duct openings in ceilings, walls or base boards. Note damper control chain and louvres for controlling and directing the air.

Plastered ceiling, 4-in. joists and 1-in. wood floor above, filled with 2-in. insulation14
Concrete, 4-in. no ceiling finish, no floor above51
Concrete, 8-in. no ceiling finish, no floor above41
Concrete, 4-in. plaster underneath, 1-in. wood floor above.....	.34
Concrete, 4-in. suspended metal lath and plaster underneath, 1-in. wood floor above19

Note, floors of the first story of a building can be ignored in the heat leakage calculation for cooling jobs if there is a basement underneath, as basement temperatures are generally lower than those in the rooms above.

Heat Load Calculation

8. SOLAR HEAT OR SUN EFFECT

In addition to the heat leakage through walls, due to the difference in temperature between inside and

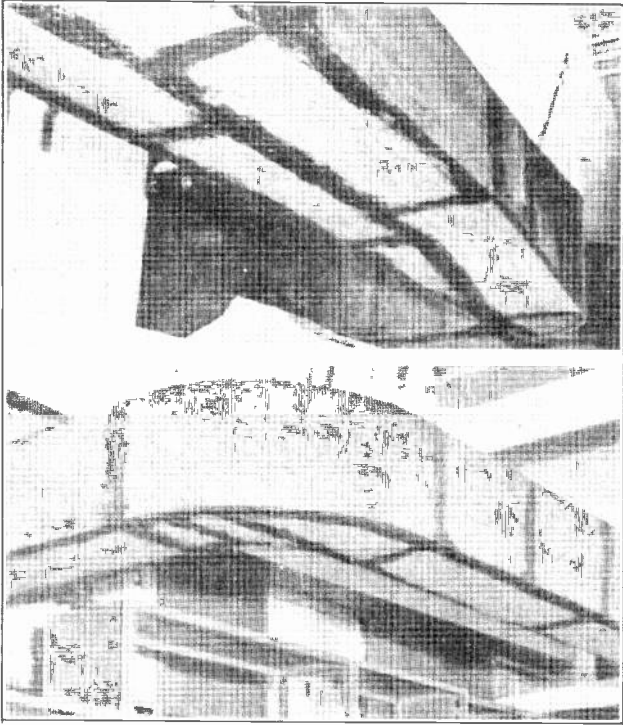

Fig. 10. Two views of air ducts, covered with slabs of cork insulation which is cemented in place and has joints sealed with asphalt cement. Courtesy Armstrong Cork Co.

outside air, we also have the radiant heat of the sun to consider, wherever sun strikes any part of the building for certain hours of the day.

Average figures to allow for this heat are as follows:

- 250 B.T.U. per hr., per sq. ft. of glass sky light.
- 15 B.T.U. per hr., per sq. ft. of ordinary roof.
- 10 B.T.U. per hr., per sq. ft. of ordinary wall.
- 100 B.T.U. per hr., per sq. ft. of south windows.
- 180 B.T.U. per hr., per sq. ft. of east windows.

Air-Conditioning

180 B.T.U. per hr., per sq. ft. of west windows.

For windows shaded by awnings, merely double the normal temperature difference or heat leakage factor in calculating the total heat leakage and sun effect.

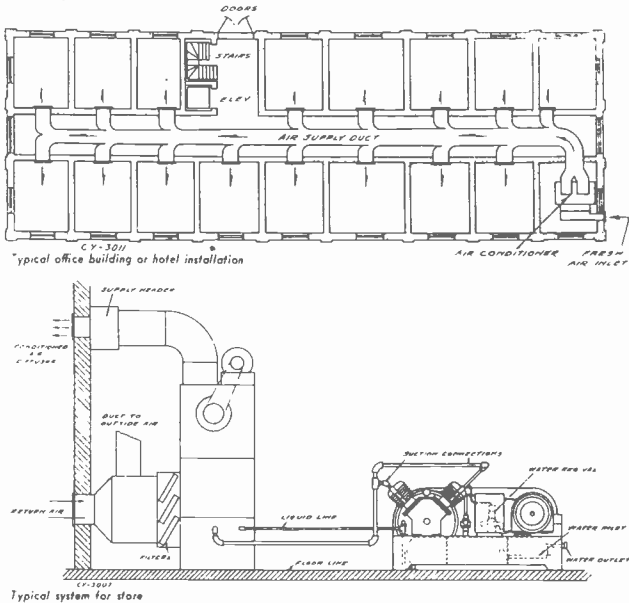

Fig. 11. Top diagram shows duct layout for distributing conditioned air to a group of small offices. Lower diagram shows the air-conditioning unit and refrigerating compressor and condenser for a store or office. Courtesy Carbondale Machine Corp.

For north windows, or windows entirely shaded by other buildings use only normal heat leakage factor.

9. HEAT CONTAINED IN FRESH AIR

As previously mentioned, considerable heat enters a building with the fresh air taken in for ventilation. This heat is carried by the air in two forms. There is the sensible heat contained in the warm air itself, and there is also the latent heat of vaporization stored in the moisture carried by the air.

To condense this moisture and dehumidify the air requires considerable refrigeration or cooling

Heat Load Calculation

capacity, as the moisture gives off the same amount of heat when condensed, as was required to evaporate it from liquid to vapor, or 1050 B.T.U., per lb. as we learned in an earlier Refrigeration Lesson.

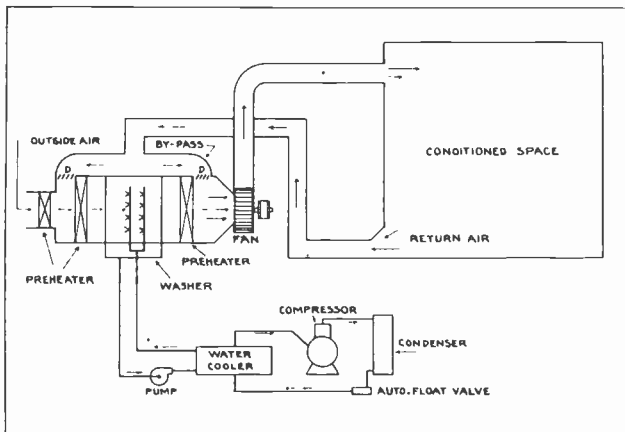

Fig. 12. Diagram of another type of air-conditioning system, showing heater coils, spray cooler and dehumidifier, by-pass dampers, blower, ducts, compressor, etc.

The table on page 22 gives approximate average amounts of heat that must be removed from each 1000 cu. ft. of air per hour in various localities, to dehumidify the air from its average humidity in that locality to the proper humidity for comfort.

	B.T.U. Per 1000 cu. ft.		B.T.U. Per 1000 cu. ft.
Locality	air per hr.	Locality	air per hr.
Atlanta	636	Miami	544
Boston	506	Minneapolis	466
Chicago	400	New Orleans	544
Cleveland	518	New York....	529
Dallas	655	Philadelphia	445
Denver	655	S. Francisco	496
Kansas City..	540	San Antonio	670
Los Angeles..	506	Tampa	593

Or we can use an average value of .63 B.T.U. per cu. ft. of air entering the building.

Air-Conditioning

We should keep in mind that at least 3 complete changes of air per hour are required in buildings containing very many people. For example:

Offices	should have 3 changes per hour.
Stores	should have 4 changes per hour.
Restaurants	should have 6 changes per hour
Homes	should have 3 changes per hour.

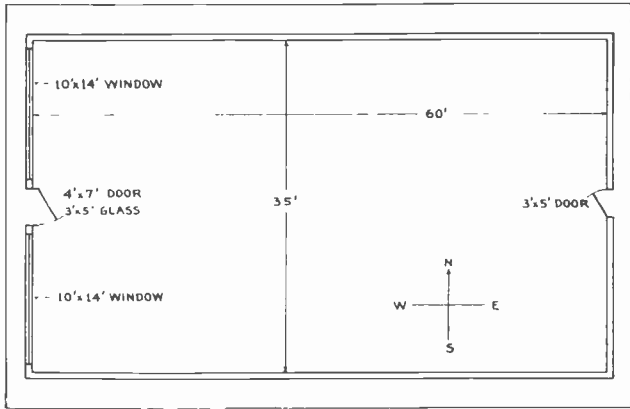

Fig. 13. Floor plan of a simple shop building to be air conditioned. See explanation of heat load calculation in accompanying lesson material.

In addition to the heat which enters with ventilating air, we also have to contend with the heat in the air that leaks into buildings through walls and through cracks around doors and windows. Figured on average wind velocities of 15 miles per hour, this is equivalent to from 1 to 2 additional air changes per hour on average buildings.

10. INSULATION OF BUILDINGS

By reference to the heat leakage factors given for various types of building construction, you will note a great reduction in heat leakage per sq. ft. on walls and ceilings that are insulated.

Therefore it is highly important for best economy in air conditioning that buildings be properly insulated. Both the initial size and cost of the equipment, and the yearly operating cost can often be cut in half by properly insulating the building. These

Heat Load Calculation

savings apply to both winter heating costs and summer cooling costs.

Most modern homes that are being built nowadays have insulation included in the walls and ceilings when they are built. Celotex, flax-linum, Cabot's quilt or other forms of fibrous insulation, $\frac{1}{2}$ " or more in thickness is commonly used between the brick or siding and the plaster.

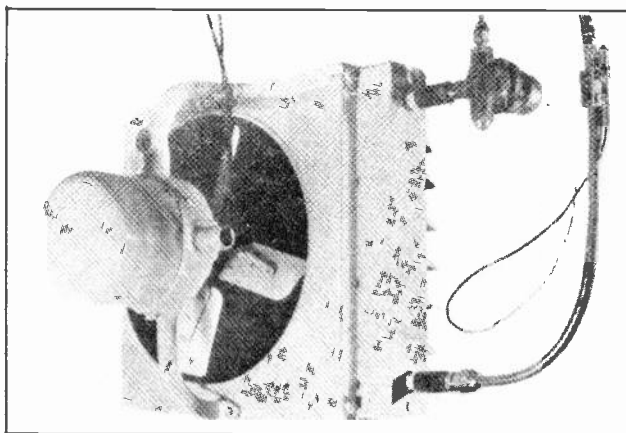

Fig. 14. Compact unit type evaporator or air cooling unit and fan. Note control valve and power bulb on the liquid and suction lines. Courtesy Ilg Electric Ventilating Co.

In some buildings the spaces between studding of walls and joists of ceilings is filled with porous or fluffy insulation material such as rock wool or expanded mica, etc. This form of insulation can generally be applied to older homes that were not insulated when built. Such insulation can often be poured or blown into the space between studding, from the attic.

Awnings over the windows to keep off the heat of the direct sun also reduce the amount of heat entering a building in summer, and thereby reduce the cost of air conditioning.

11. HEAT LOAD PROBLEM IN STORE

Now, with the foregoing data and information, let us calculate the heat load, and the size of refrigerating unit required to cool a given building

Air-Conditioning

Let us assume a simple store or shop building such as shown in Fig. 13, built of 8" brick, furred and plastered, one story or 14 ft. high and 35 ft. wide by 60 ft. long, with no windows on the sides, one 3 x 7 ft. door in the rear, one 4 x 7 ft. door and two 10' x 14' plate glass show windows with awnings in the front.

The building contains a maximum of 15 people, and uses 16 150-watt lights. There is a basement underneath so we can ignore heat leakage through the floor as there are no large motors or heat producing appliances in the basement. Only the roof and west side are exposed to sun, the other sides being shaded by adjoining buildings.

We will assume that the temperature of the air inside the building is to be kept 10 degrees F. below the outside air temperature. We can easily total our heat load in B.T.U. per hr., as follows:

To figure one side wall, we first get the area in sq. ft., or $14 \times 60 = 840$.

Then multiply this by our heat leakage factor of .26 B.T.U. per sq. ft. or $.26 \times 840 = 218.4$.

Then multiply this figure by 10 degrees temp. differential or $10 \times 218.4 = 2184$ B.T.U. per hr. heat leakage through this wall.

Or, to simplify totaling the heat from all sources, we can set down the figures in the following manner (Note: K=heat leakage factor, and TD=temperature differential):

Walls	Size	Construction	Area	K	TD	B.T.U. Per Hour
No. wall	14 x 60	8 in. br., fur. & pl.	840 ft. x	.26	x 10	=.....2,184
So. wall	14 x 60	8 in. br., fur. & pl.	840 ft. x	.26	x 10	=.....2,184
E. wall	14 x 35	8 in. br., fur. & pl.	490 ft. minus			
	3 x 7	door or	21 sq. ft.	=469 ft. x	.26 x 10	=.....1,219
Door	3 x 7	2 in. wood	21 ft. x	.46	x 10	=..... 97
W. wall	14 x 35	8 in. br., fur. & pl.	490 ft. minus			
		308 ft. of windows & doors	182 ft. x	.26	x 20	=..... 946
(Note: T.D. factor doubled to compensate for sun effect on this wall.)						
Glass windows and glass in door.....			295 ft. x	1.1	x 20	=.....6,490
(Note: T.D. factor doubled for sun effect on glass with awnings.)						
Door frame		2 in. wood	13 ft. x	.46	x 20	=..... 120
Ceiling	35 x 60	4 in. pl., 2 in. insul.	2100 ft. x	.14	x 20	=.....5,880
(T.D. factor doubled for sun effect on roof.)						
Electric lights			16 x 150 x	3.41		=.....8,184
People, max.			15 x 400			=.....6,000
Ventilation—3 changes per hour.....	.14 x 35 x 60		= 29,400 cu. ft.			
			3 x 29,400 x	.63		=.....55,566
Infiltration			2 x 29,400 x	.63		=.....37,044
Total						125,914

Heat Load Calculation

One ton of refrigeration supplies 12,000 B.T.U. per hr., therefore $125,914 \div 12,000 = 10.49$ or approx. 11 ton unit required to cool this building.

If the building already has a hot air heating plant, it may be possible to install the refrigerating unit, humidifier and blower in the basement near the furnace and feed the cool air through part of the same ducts used by the heating plant. Or it may be necessary to install some new ducts to handle the required volume of ventilating and cooling air, and to discharge the cool air at the proper points in the building for good distribution and air circulation.

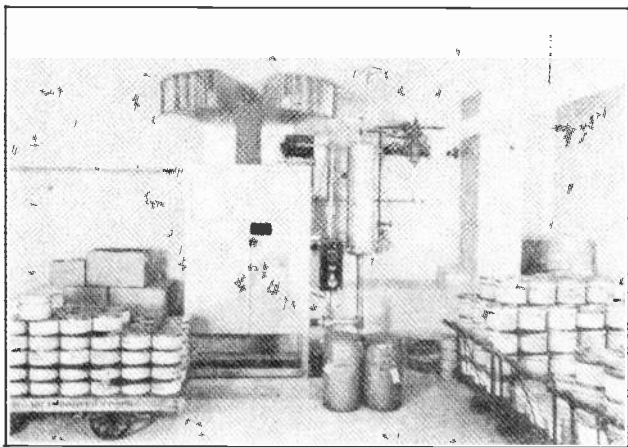

Fig. 16. Commercial unit type air conditioner for storage rooms, etc. Courtesy Carrier Corp.

12. UNIT TYPE COOLERS

In some cases where a hot water or steam heating system may already be installed in the building, and where it might be difficult to install ducts, it may be desirable to use several individual cooling, circulating and dehumidifying units located at various points in the space to be cooled. See Fig. 14 which shows a direct evaporator of this type, housed in a neat casing and with a fan behind it to circulate the air.

Air-Conditioning

Fig. 15 shows several units of this type installed at various points to distribute cool air in a store. Refrigerant can be fed to all of these coolers from one large compressor and condensing unit located in the basement or in a back room.

If a central plant system is to be used, a unit similar to one of those shown in Figs. 2, 3 and 4 in lesson 101, or Figs. 11 and 12 in this lesson, may be used.

13. RESTAURANT COOLING PROBLEM

In another case, suppose we have a job of comfort cooling a one-story restaurant dining room space that is 10 ft. high, 20 ft. wide and 75 ft. long. The walls are brick veneer with sheathing, studding and plaster. Only the roof, south and east sides are exposed to sunlight, and the roof has a 6 x 10 ft. skylight. North wall has three 3 x 5 windows.

Let us assume that the restaurant uses 10 200-watt lamps and 10 60-watt lamps. A 5500-watt toaster is used about 2 hrs per day, and a gas coffee urn consuming about 20 cu. ft. of manufactured gas per hr., is used continuously. This urn has a ventilated canopy which carries away about 70% of the heat produced by the gas.

The restaurant seats about 94 persons during the busier hours and has 6 employees in the dining room space. We will not consider the kitchen range or other heat producing equipment or employees in the kitchen, as the kitchen is not to be cooled by refrigeration, but will have a separate large ventilator fan.

The east wall or front has two 6' x 6' plate glass windows and one 3' x 7' door (2" wood) with 2.5' x 4' glass. The rear partition has two 3' x 7' doors (1" wood) to kitchen.

We wish to cool the dining room space to 12 degrees below outside temperature and kitchen temperature. Assume the kitchen temperature averages about the same as outside temperature and is separated from the dining room by a partition of ordinary studding with metal lath and plaster on both sides.

Heat Load Calculation

The heat load can be estimated as follows:

Walls	Area	K TD	B.T.U.s Per Hr.
So. wall	10' x 75' x .25 x 12.....		2,250
	Doubled for sun effect		2,250
No. wall	10' x 75' minus 45' for three 3' x 5' windows equals 705' x .25 x 12.....		2,115
Windows	three 3 x 5=45' x 1.1 x 12.....		594
E. wall	10' x 20' minus 72' plate glass windows and 21' door=107' x .25 x 12.....		321
	Doubled for sun effect.....		321
Plate glass windows:			
	two 6' x 6' x 1.1 x 12.....		950
	Doubled for sun effect (with awnings)....		950
Door	(3' x 7' with 2.5' x 4' glass)		
Glass	2.5' x 4' x 1.1 x 12.....		132
	Doubled for sun effect.....		132
Door frame	11' x .46 x 12 (2" wood and double for sun).....		122
W. Partition:			
	10' x 20' minus two 3' x 7' doors or 42' equals 158' x .33 x 12.....		626
Two 1" wood doors:			
	3' x 7' = 42' x .69 x 12.....		348
Roof (average wood) 20' x 75' = 1500' minus			
	6' x 10' skylight equals 1440' x .20 x 12....		3,456
	Doubled for sun effect.....		3,456
Skylight	6 x 10 x 250 (sun effect).....		15,000
Skylight	6 x 10 x 1.1 x 12 (leakage).....		792
Ventilation	10 x 20 x 75 = 15,000 u. ft. air space, 6 changes per hour: =		
	6 x 15,000 x .63.....		56,700
Infiltration, 2 changes per hour: =			
	2 x 15,000 x .63.....		18,900
94 people, cus-			
	tomers sitting 94 x 400.....		37,600
6 employees,			
	light work 6 x 600		3,600
Lamps.....	10 x 200W x 3.41		6,820
Lamps.....	10 x 60W x 3.41		2,046
Electric toaster	5500 x 3.41 = 18,755		
Divided by 12 as toaster is only used 1/12 of day.			
	18,755 ÷ 12 =		1,563
Coffee urn	20 x 500		10,000
			Total 171,044

Air-Conditioning

Then $171,044 \div 12,000 = 14.25$ tons of refrigeration required, or a 15 ton unit would be proper size.

By following this same procedure, it is a simple matter to calculate the heat load and size of cooling unit required for a small private office, living room, bedroom, or complete home, or most any other type of building.

In addition to the central air conditioning plants and room coolers previously described, some companies make complete individual air-conditioning units for use in commercial buildings, store rooms, etc. See Fig. 16.

Some of these units contain their own water cooled compressor and condensing unit, while others are connected by copper tubing to liquid and suction lines of central condensing units. Steam coils are also provided in many of these units for winter heating.

14. INSTALLATION AND TESTING

When connecting up evaporators and condensing units for air conditioning systems, sweated or soldered connections are preferred for all liquid and suction lines.

Copper tubing lines of ample size should be used, depending on the size of the units and the length of the lines. Otherwise resistance to the flow of liquid and gases may restrict proper operation of the unit. Manufacturers of refrigeration units or air conditioning equipment usually specify the proper size of lines, depending on the type of refrigerant used.

Liquid and suction lines should be covered with insulation to prevent sweating or dripping due to condensation of moisture, which would occur if the air were allowed to contact these cold lines.

Some small air conditioning systems use methylchloride, but most large systems use Freon, because of its greater safety factor. Some systems use Carrene, and as previously mentioned, others use steam jet systems and chilled water.

After installing any air conditioning system, all lines and units should be carefully tested for leaks

Installation

before charging the system with refrigerant.

Carbon-dioxide gas, which can be purchased in metal drums, is very good for pressure testing air conditioning lines and systems. The CO₂ can be fed through a pressure reducing valve, until proper pressure is built up in the system, as shown by a pressure gauge. Then inspect and clean all joints and cover with soap suds or liquid soap to test for leaks while under pressure.

After testing for leaks, if the system is leak proof, allow the CO₂ gas to discharge to the air. It is harmless. (Note: Never use compressed oxygen for testing refrigerant lines, as it is explosive.)

Next purge all remaining CO₂ and air from the lines and parts, with refrigerant gas as explained in earlier lessons.

Extreme care, good workmanship and critical inspection and testing should be exercised on all air conditioning installations. Also consult local authorities or ordinances on who is permitted to install certain types of large systems in cities, or in public buildings. Strictly follow all local safety rules and code rules.

After an installation is complete and ready to start in operation, observe the following procedure before starting the condensing unit: (1) check compressor and motor for proper oil content and lubrication; (2) open the receiver intake valve between condenser and receiver; (3) open discharge valve on compressor head; (4) open return or compressor intake valve. After opening these last two valves, close them back part way until gauges operate smoothly when compressor is running; (5) slowly open the king valve or refrigerant supply valve at the receiver discharge line; (6) open solenoid valve by means of control switch or thermostat. If all electrical circuits are complete the pressure control should then start the motor as soon as back pressure builds up on the low side; (7) check the condenser cooling water supply, open the hand valves and see that the automatic water flow control valve operates properly to control the flow of condenser cooling water according to the load on the unit; (8) See that pressure control switch is prop-

Air-Conditioning

erly connected to both high and low sides of the compressor, and that it is operating properly to shut off the unit before head pressure gets too high or back pressure too low. **This is an important safety precaution.** (9) See that solenoid valves and expansion valves at evaporators are properly working and that the expansion valves are properly adjusted for the desired evaporator temperatures of 37 to 39 degrees F.

Service requirements for refrigerating units of room coolers and air conditioning systems are similar to those previously explained for domestic and commercial refrigerators.

Now, after careful study and review of this important and valuable instruction on air conditioning, keep ever on the alert for opportunities to apply your knowledge to increase your earnings, whether working for some refrigeration and air conditioning company, or selling, installing and servicing refrigeration and air conditioning equipment in a business of your own.

This is one of the greatest fields of opportunity for well trained, "live wire" electrical and refrigeration men.

EXAMINATION QUESTIONS

1. What is the minimum amount of fresh air per hour which should be provided for each person in a room?

2. Of what value are attic ventilators in homes where complete air-conditioning systems are not used?

3. How is the air circulated in a complete air-conditioning system of the central plant type?

4. What material is commonly used for insulating air ducts?

5. Under average conditions how much refrigeration is required to cool a thousand cu. ft. of storage space to a temperature of 32° Fahrenheit?

6. What size air duct should be used to allow 500 cu. ft. of air to pass through per minute at a velocity of 400 ft. per minute?

7. What would be the "heat leakage factor in B.T.U. per sq. ft. per hour in each of the following building materials? A. Plain 12" concrete wall furred and plastered? B. Stucco, wood sheathing wall, with studding and plaster?

8. How many additional B.T.U. per hour should be allowed per sq. ft. of south window area when estimating the heat load in a certain building? (No awnings on windows.)

9. Briefly explain how air-conditioning lines and units may be tested for leaks before charging the system with refrigerant.

10. Calculate the heat load and estimate the size of refrigerating unit required to cool a building similar to the one described in Article 11. The building is to be the same in all respects except the side walls, which are to be wood siding and sheathing on 2 x 4 studs, plastered and the space filled with insulation. Show your figures.

Radio

ELEMENTS OF RADIO

With one or more radio receivers in practically every home, and with public address, intercommunicating systems, and other applications of radio receiving principles on every hand, there is no need to dwell upon the importance of a knowledge of radio for electrical men. Fortunately, radio is just another branch of electricity, so with a knowledge of electricity, radio is easily understood.

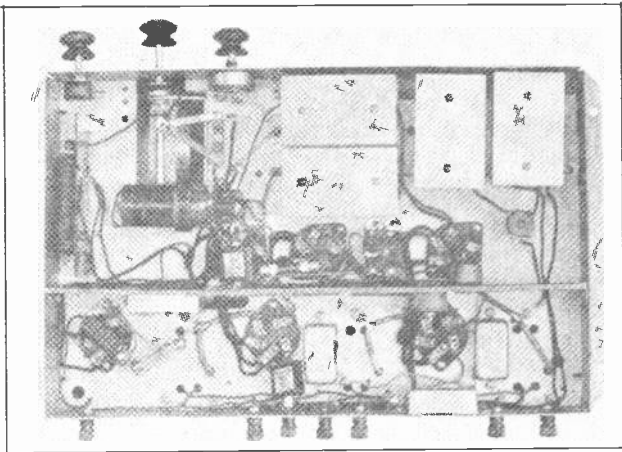

Fig. 1.—Bottom view of a radio receiver chassis.

In radio, as in all other electrical fields, we deal with resistance, inductance and capacitance, with conductors and insulators. Looking at a radio receiver you see resistors, capacitors, inductors, transformers, and their connections. The only parts which introduce new principles are the tubes.

Radio transformers, capacitors and other parts differ in appearance and construction from parts used in other electrical apparatus chiefly because radio makes use of alternating currents and voltages at exceedingly high frequencies, frequencies ranging from thousands to millions of cycles per second. However, the basic principles are unchanged. You have the great advantage of being well acquainted with these basic electrical principles, so all you need do is learn their application in radio.

Transmission and Reception

Before commencing to study radio it would be an excellent plan to refresh your memory on alternating currents in general, and especially on the behavior of alternating currents in inductances and capacitances. This will mean a review of reactance, impedance, and the principles of simple transformers.

TRANSMISSION AND RECEPTION

Fig. 2 shows what happens at a transmitter, from which radio signals are sent through space to be picked up at a distance. First we have sound waves, which may be voice or music. Sound waves are air vibrations occurring at frequencies between about 16 and 16,000 cycles per second, depending on the pitch of the sounds. These are **audio frequencies**, abbreviated a-f or A.F. The microphone acts like a telephone transmitter, in which the

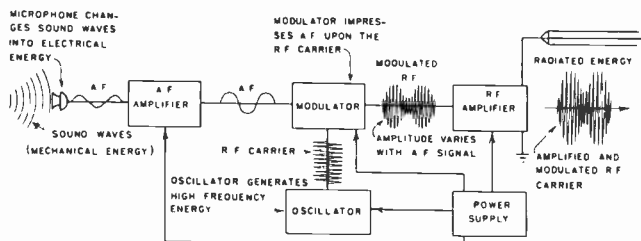

Fig. 2.—A radio transmitter, from microphone to aerial.

sound waves produce corresponding audio-frequency changes of voltage. These small audio-frequency voltages are increased in the a-f amplifier, and are passed along to the modulator.

The oscillator produces voltages and currents which, for broadcasting, have frequencies of from 500,000 to 1,600,000 per second. These are radio frequencies, abbreviated r-f or R.F. Instead of speaking about the number of cycles at these high

Radio

frequencies we usually speak of kilocycles, which are thousands of cycles. In broadcasting we have radio frequencies of 500 to 1,600 kilocycles.

The r-f voltages are fed into the modulator where they combine with the a-f voltages from the a-f amplifier. The result is modulated radio frequency voltages, which are voltages whose frequency is radio frequency but whose strengths or amplitudes vary according to the audio frequencies from the a-f amplifier. The modulated radio frequency voltages are strengthened by the r-f amplifier, and then go to the aerial or antenna where they produce electromagnetic radiations which travel through space with the speed of light.

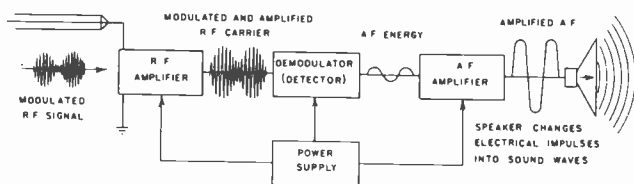

Fig. 3.—A radio receiver, from antenna to loud speaker.

In Fig. 3 the radiation is reaching the antenna of a radio receiver. In the antenna circuit are produced modulated r-f voltages which are applied to the r-f amplifier. These weak r-f voltages are strengthened in this amplifier and are passed along to the demodulator, which usually is called the detector. The detector gets rid of the r-f changes and leaves only the changes which occur at audio frequencies. These a-f voltages are strengthened in the a-f amplifier and fed into the loud speaker which changes them to sound waves which are

Transmission and Reception

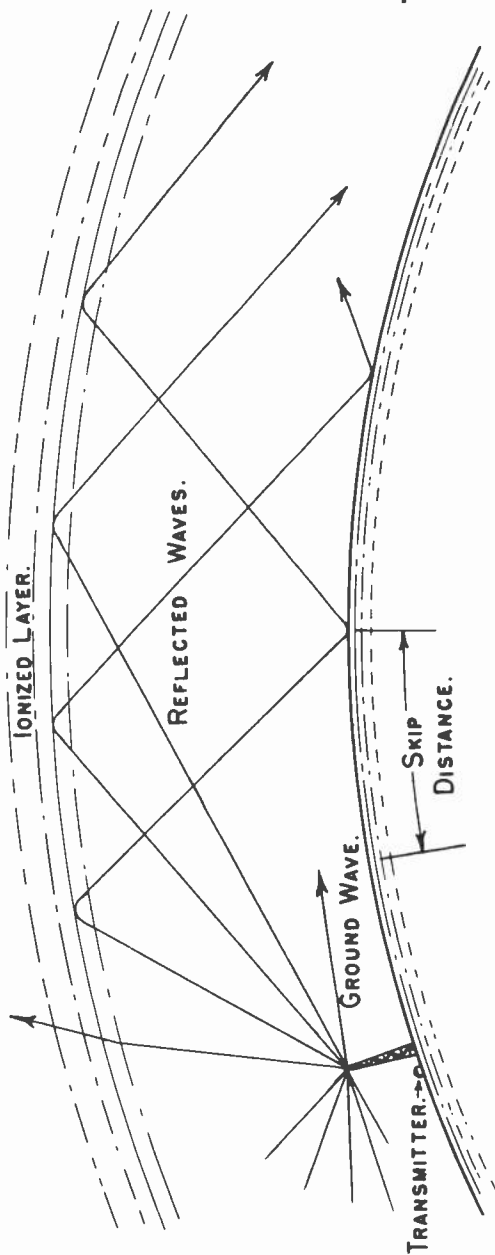

Fig. 4.—The ground wave and the sky wave as they travel away from a transmitter

Radio

heard at practically the same instant that the original sound waves enter the distant microphone.

Part of the radiation travels for possibly 50 miles as a ground wave. Some of the remainder is reflected back from an ionized layer in the atmos-

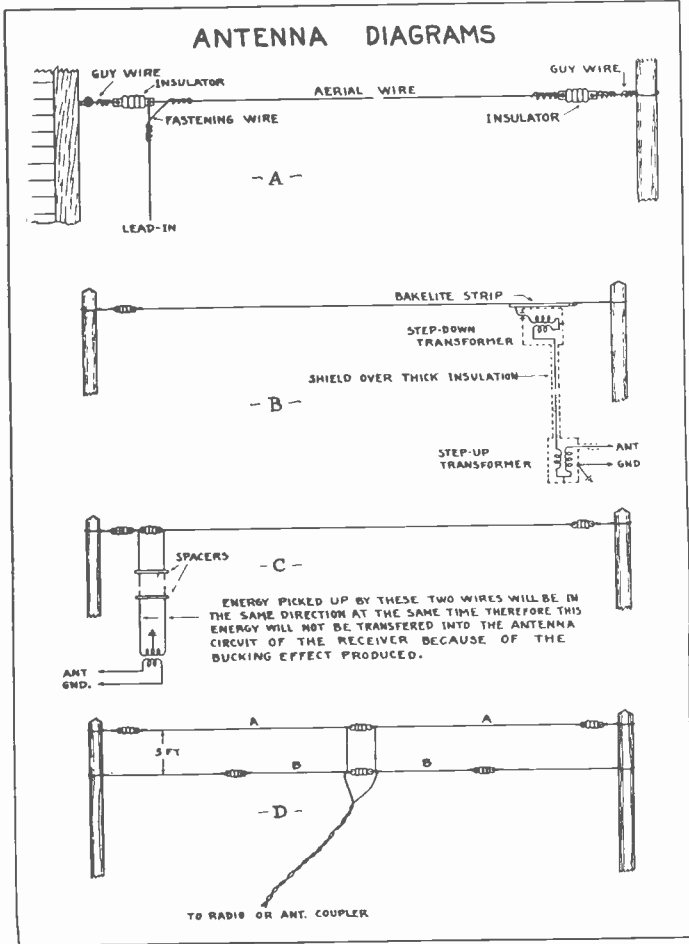

Fig. 5.—Various types of receiving antennas.

phere about 70 miles above the surface of the earth, as shown by Fig. 4, while part of the radiation passes through this layer and is lost. Between the farthest point reached by the ground wave and

Transmission and Reception

the nearest point at which reflected waves come back to earth there is a skip distance within which signals from the transmitter cannot be received.

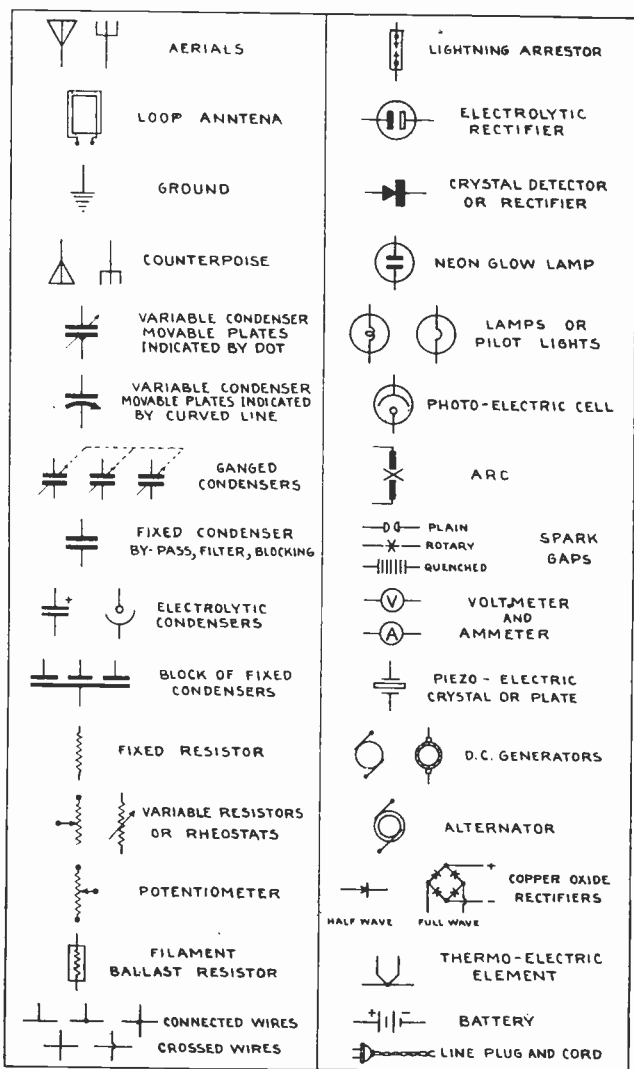

Fig. 6.—Some of the symbols which are used in radio circuit diagrams.

Radio

Several types of receiving antennas are shown by Fig. 5. A common style is shown at **A**. At **B** the lead-in is enclosed by a grounded metallic shield to prevent its responding to unwanted high-frequency radiations from sources other than the transmitter. Such interference is avoided at **C** by using a double lead-in. At **D** is shown an antenna having long sections (**A**) which respond well to broadcast frequencies, and short sections (**B**) which respond well to "short-wave" signals which are of higher frequencies. Such antennas are used with receivers which may be tuned either to broadcast or to short-wave signals.

Symbols which are generally employed in radio circuit diagrams are represented in Fig. 6. Note especially the manner of showing capacitors or condensers and the adjustable resistors, rheostats and potentiometers.

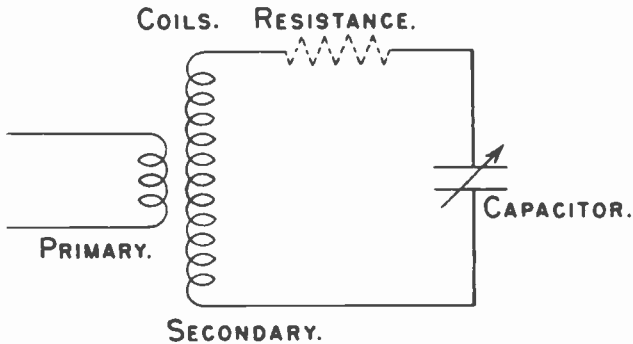

Fig. 7.—The circuit of a tuned radio-frequency transformer.

REACTANCE AND IMPEDANCE

One of the most important circuit elements in all radio receivers is the "tuned radio-frequency transformer" represented with symbols in Fig. 7 and pictured, for one construction, in Fig. 8. The coils are of the air-core type because, at radio frequencies, there is plenty of reactance without having to use iron cores to provide high inductance which would be needed at low frequencies. The capacitor is of an adjustable type such as you often have seen in radio receivers. The resistance represented by its symbol in broken lines stands for the

Reactance and Impedance

resistance of all the conductors, not for a separate resistor unit. In this circuit we have inductance of the coils, capacitance of the capacitor, and resistance of the wires and connections.

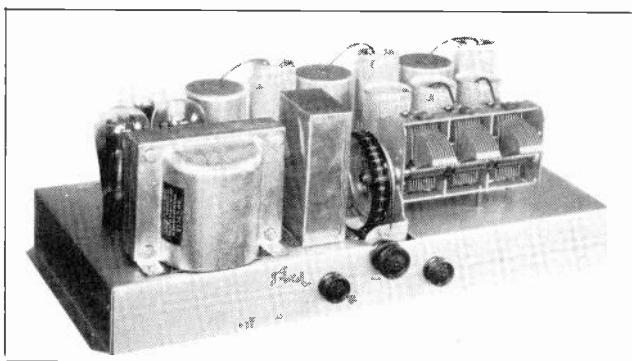

Fig. 8.—One type of construction employed for tuned radio-frequency transformers.

Doubtless you recall that the inductive reactance of a coil increases directly with frequency. As frequency increases the inductive reactance shows a steady rise as shown at **A** in Fig. 9. Capacitive reactance of a capacitor decreases as the frequency increases; not steadily, but proportionately to the reciprocal of the frequency. Thus the capacitive reactance of a capacitor changes as shown at **B** in Fig. 9.

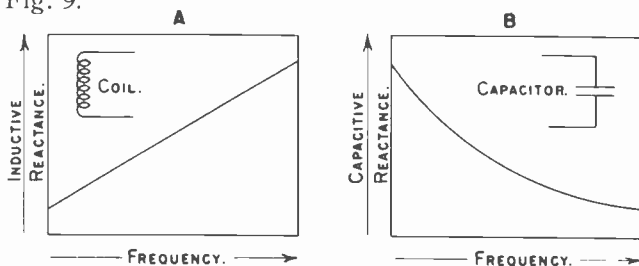

Fig. 9.—How the reactances of a coil and a capacitor vary as the frequency is changed.

The resistance of the conductors which form an r-f coil is so small that the impedance of the coil is but very little more than its inductive reactance. Impedance, as you will remember, is the total opposition to alternating current, and is equal to the square root of the sum of the squares of

Radio

reactance and resistance. Likewise with a capacitor; the resistance of its conductors is so very small that the impedance is practically the same as the capacitive reactance.

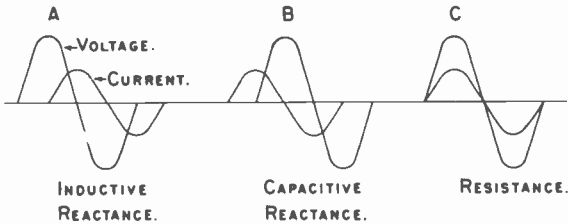

Fig. 10.—How inductive and capacitive reactances affect the phase of current in relation to the applied voltage.

Probably you will recall also that we speak of inductive reactance as positive reactance, and that inductive reactance causes the current to lag behind the applied voltage as shown at **A** in Fig. 10. Capacitive reactance is called negative reactance, and causes the current to lead the applied voltage as at **B**. Thus the effects of inductive and capacitive reactances are exactly opposite in a circuit. Were there neither inductance nor capacitance in the circuit, but only resistance, there would be neither kind of reactance, neither lagging nor leading current, and the current and voltage would be in phase as at **C** in Fig. 10.

RESONANCE

Now let's go back to the radio-frequency transformer in which we have both inductance and capacitance. Supposing the frequency is gradually increased. As shown in Fig. 11, the inductive reactance will increase while the capacitive reactance decreases. At some certain frequency, represented at the crossing of the two curves, the two reactances become exactly equal. But since one reactance tends to cause a lagging current while the other tends to cause a leading current, the result of having equal and opposite reactances is that the current neither lags nor leads the voltage, but is in phase with the voltage.

For all practical purposes we have done away with both the inductive reactance and the capacitive reactance, and have remaining only the resistance

Tuning

of the circuit to oppose flow of alternating currents—provided those currents are of the frequency at which the reactances become equal. This frequency is called the **resonant frequency**. Alternating current in the coil and capacitor combination may be very large at the resonant frequency, because it is limited only by the very small resistances of the circuit. At other frequencies the current is limited by reactances as well as by resistance, and will be proportionately smaller than at resonance.

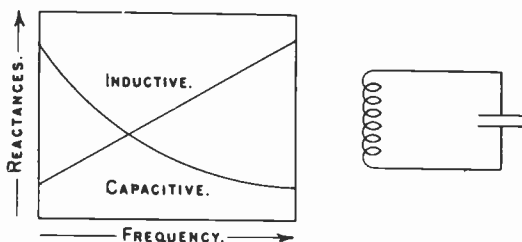

Fig. 11.—The reactances in the tuned circuit vary with frequency, and at one particular frequency they become equal.

TUNING

The circuit of Fig. 11 is resonant only at the frequency corresponding to the reactances of the coil and the capacitor. To change the frequency of resonance we must change either the inductance of the coil or the capacitance of the capacitor, thus changing their reactances. If, as in Fig. 12, we use an adjustable or variable capacitor, changes of its capacitance will change its reactance so that we effectively move the capacitive reactance curve one way or the other with reference to the inductive reactance curve. Thus the adjustable capacitor allows making the circuit resonant at any of a wide range of frequencies, and to only one of these frequencies at one time.

A similar effect may be had by altering the inductance of the coil, but power losses in adjustable capacitors are less than in adjustable inductance coils, so adjustable capacitors usually are employed. Adjustment of either the capacitance or the inductance in making the circuit resonant at a

Radio

certain frequency is called **tuning**. Receivers are tuned to the radio frequency of a signal by varying the capacitance of capacitors in circuits which are thus made resonant to the desired frequency.

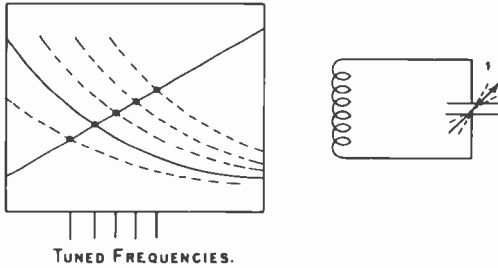

Fig. 12.—An adjustable capacitor allows shifting the frequency of resonance.

When the applied voltage in the primary of the tuned transformer is at the resonant frequency of the tuned secondary circuit large currents are induced in the secondary. As indicated in Fig. 13, the ends of the secondary winding become alternately positive and negative. The accompanying alternating voltages across the secondary circuit, which are at resonant frequency, may be delivered to a radio tube or to any following circuit.

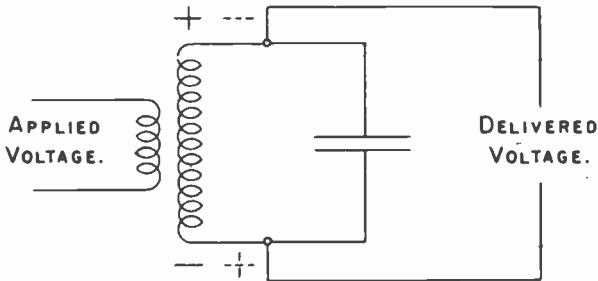

Fig. 13.—Opposite ends of the r-f transformer become alternately positive and negative.

If a coil and capacitor are connected in series across a source of voltage and current, as in Fig. 14, and if the frequency of the source is gradually varied, the impedance of the coil-capacitor combination changes with frequency. The impedance decreases as we approach resonance, become of

Tuning

minimum value at resonance, then increases again as we leave the resonant frequency. This is the action in a **series resonant** circuit. At the resonant frequency we have minimum impedance, and consequently have maximum current in the coil and condenser.

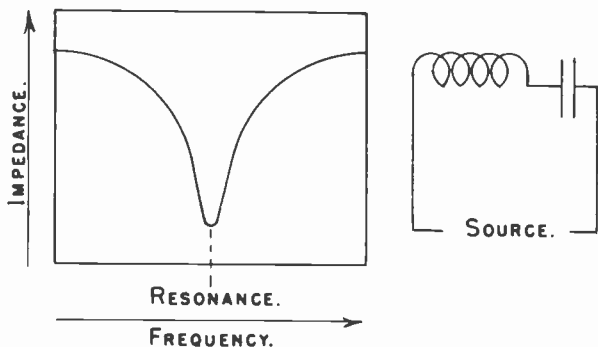

Fig. 14.—Impedance of a series resonant circuit is minimum at resonance.

If the coil and capacitor are connected **in parallel** across a source, as in Fig. 15, the impedance of the coil-capacitor combination again changes with frequency, but now the impedance, with respect to the source, becomes maximum at the resonant frequency. Note that this maximum impedance is that presented to **currents from the source**. The coil and capacitor still are in series with respect to each

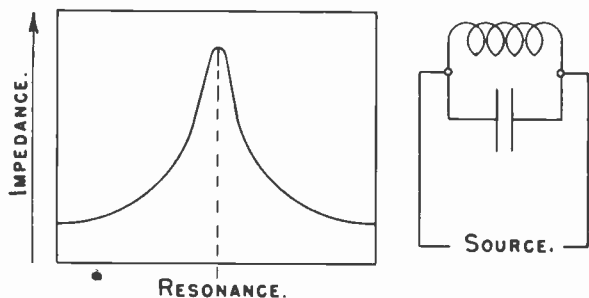

Fig. 15.—Impedance of a parallel resonant circuit is maximum at resonance.

other. The impedance in the coil-capacitor circuit alone is minimum at resonance, and at resonance we

Radio

have the maximum current moving back and forth between the coil and condenser. But in the external

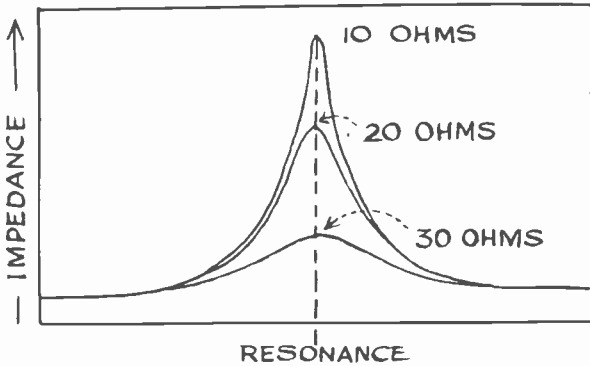

Fig. 16.—The impedance of a parallel resonant circuit is decreased as the high-frequency resistance of the circuit increases.

circuit, or in the circuit which includes the source, we have **minimum current**. This is the action with a **parallel resonant circuit**.

SELECTIVITY

At resonance the impedance of a series resonant circuit is equal to the resistance of the circuit, so the greater the resistance the greater will be the impedance at resonance. With a parallel resonant circuit the impedance to current from an external source varies with resistance of the resonant circuit, but this impedance offered to an external source increases as the resistance of the resonant circuit decreases. This effect is shown by Fig. 16.

The ability of a radio circuit, or of a radio receiver, to respond strongly to one particular radio frequency and to oppose all other frequencies is called **selectivity**. Selectivity depends on the shape of the impedance curve. Since the shape of the impedance curve varies with resistance of the tuned circuit, selectivity depends on circuit resistance. Since the voltage developed across a given circuit varies directly with the impedance of that circuit, the curves of Fig. 16 might represent voltages across a tuned circuit of Fig. 15 just as well as they represent impedances.

Selectivity

To have satisfactory reception from some radio station we might require a voltage almost as great as secured at the peak of the 10-ohm curve of Fig. 16. This 10-ohm curve is reproduced in a full line in Fig. 17, and the required voltage level is indicated at **A**. If the tuned circuit were to have 20 ohms

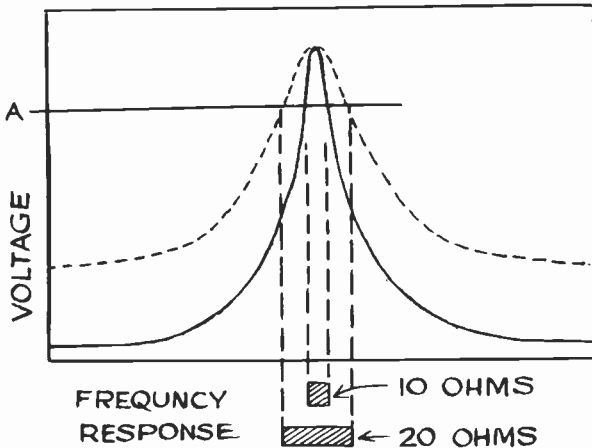

Fig. 17.—The selectivity of a low-resistance circuit is greater than that of a high-resistance circuit.

resistance its response would follow the 20-ohm curve of Fig. 16. To obtain the necessary voltage we would have to apply more power, thus raising the 20-ohm curve to the position shown by a broken line curve in Fig. 17. But now the relatively broad 20-ohm curve will respond to a range of radio frequencies much greater than the narrow range to which the 10-ohm circuit responds. The greater frequency range of the high-resistance tuned circuit might easily allow reception of signals from two or more transmitters at the same time, while the narrow range of the low-resistance circuit would restrict reception to a single transmitter.

The resistance about which we are talking is not exactly the same as the resistance of the conductors to direct currents or to low frequencies,

Radio

such as power line frequencies. Rather it is **high-frequency resistance**, which corresponds to the total loss or the total voltage drop due to ordinary resistance, to dielectric losses, and to skin effect combined. Skin effect is the effect of very high frequencies which cause most of the current to travel only through the outer parts or through the skin of the conductors rather than through the entire body of the conductors.

The merit of a coil in a tuned circuit is called the **Q** of the coil. The **Q** of a coil is equal to its inductive reactance divided by its high-frequency resistance. The **Q** remains practically constant over a wide range of frequencies because the high-frequency resistance increases with frequency just about as rapidly as does the inductive reactance. Radio coils usually have **Q**'s of between 100 and 800. The greater the **Q** the greater is the selectivity.

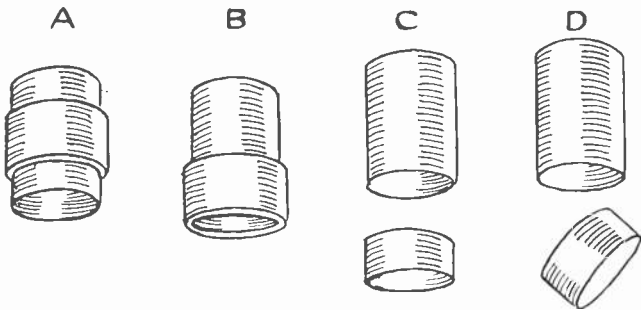

Fig. 18.—Coupling between coils is varied by changing their relative positions.

COUPLING

When two circuits are arranged, as in a transformer primary and secondary, so that energy may be transferred from one circuit to the other, the circuits are said to be **coupled**. Maximum coupling between two coils is obtained when their axes are in line and when their lengthwise centers coincide as at **A** in Fig. 18. Coupling and energy transfer are decreased by moving one coil lengthwise with reference to the other, as at **B**. Coupling and energy transfer are still further decreased with the coils separated as at **C**, while their axes still are in line.

Filter Circuits

The greater the separation the smaller the coupling and the less the energy transfer. Inclining the axes, as at **D**, reduces the coupling and energy transfer. With the axes at right angles there would be very little energy transfer. Coils between which there is a high rate of energy transfer are said to be **close coupled**. If there is relatively small transfer the coils are **loose coupled**.

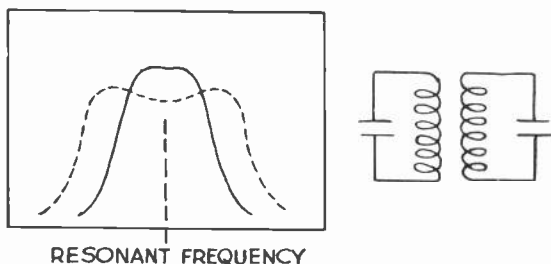

Fig. 19.—Close coupling of tuned resonant circuits causes a flat-topped resonance curve.

Sometimes we tune both the primary and secondary circuits of a transformer, as in Fig. 19. If the coupling between coils is very loose the resonance curve of the transformer will be like that of a single coil and capacitor; Fig. 15 for example. If the coupling is made closer, the resonance curve will have a flat top, as shown by the full-line curve of Fig. 19. If the coupling is made very close there will be two humps in the curve, as shown by the broken line. The steepness of the sides of the curve increases with the Q of the coils. Flat-topped response often is employed to receive a definite frequency band, say 10 kilocycles, with sharp cutoff for other frequencies either lower or higher.

FILTER CIRCUITS

Capacitors and inductance coils may be combined in circuits called **filters** which pass or reject high frequencies or low ones, or which pass or reject certain ranges or bands of frequencies. The low pass filter of Fig. 20 has inductances in series with the line and capacitances across the line. At low frequencies the inductive reactance is small and the capacitive reactance high, so low frequencies pass through while high frequencies are opposed by the coils and bypassed by the capacitors.

Radio

The high pass filter has capacitances in series with the line and inductances across the line. Low frequencies are opposed by the high capacitive reactance at such frequencies, and are bypassed through the relatively small inductive reactances. High fre-

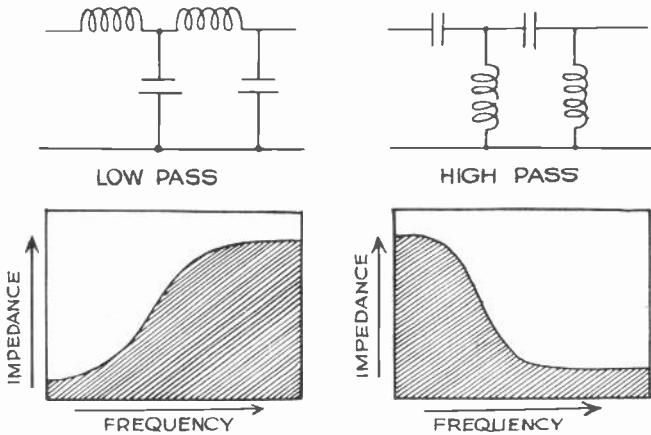

Fig. 20.—How the low-pass and high-pass filters behave with changes of frequency.

quencies pass through the capacitors with relative ease, and are not bypassed by the inductive reactances, which are large at the high frequencies.

The band pass filter of Fig. 21 has a series resonant coil and capacitor in series with the line. This combination has small impedance at frequencies near resonance, so passes such frequencies. Parallel resonant circuits are across the line. These reject the frequencies near resonance, but bypass frequencies either higher or lower. Thus the impedance is low for a certain frequency band and high for other frequencies.

The band stop filter has a parallel resonant circuit in series with the line, so that frequencies near resonance are opposed by a high impedance. These frequencies are bypassed through series resonant coils and capacitors across the line. Thus there is high impedance to a certain range or band of frequencies near resonance, but low impedance to other frequencies which pass through the filter

Radio Tubes

quite easily. Direct current will go through the low pass and the band stop filters, but not through the high pass or the band pass filters.

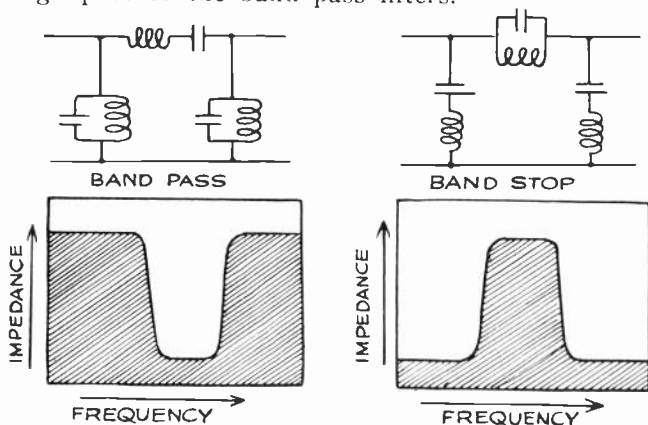

Fig. 21.—Band-pass and band-stop filters pass or stop a relatively narrow range or band of frequencies.

RADIO TUBES

Now that we are acquainted with most of the circuits employed in radio we are ready to study the tubes which are used with these circuits to control and strengthen the r-f and a-f voltages and to change alternating current from power and lighting lines into direct current where it is needed.

Radio tubes may be divided into two general classes. In the first class are all the **amplifiers**, in which small changes of voltage control relatively large changes of current flowing through the tubes. In the second class are all the **rectifiers**, which change alternating current into direct current. All tubes have a bulb or "envelope" of glass or metal from which all but about 1/100,000,000 of the original air has been pumped; these are called **high vacuum** tubes. All the amplifiers are used in this highly evacuated state. Some rectifier tubes have small quantities of inert gases admitted to their envelopes after evacuation; others are of the high vacuum type.

The simplest tube, represented in Fig. 22, consists of a filament and a plate within the vacuum, or the gas-filled space, inside the envelope. The

Radio

filament is heated by a source **A**. Voltage is applied between plate and filament by source **B**, with its positive terminal connected to the plate and its negative terminal to the filament. Current flows from the positive terminal of the source to the plate, through the vacuum or gas-filled space, into the filament, and back to the negative of the source.

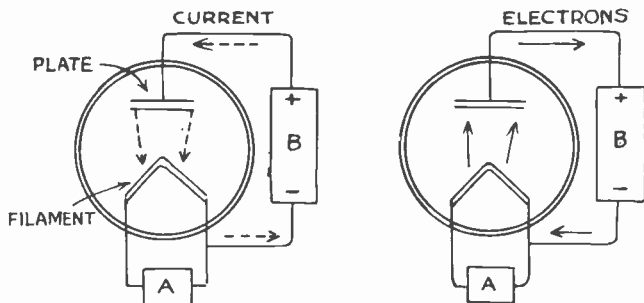

Fig. 22.—Conventional current flow and actual electron flow in the two-element tube, or diode.

It is customary to speak of current as flowing from the positive terminal of a source through any load and back to the negative terminal of the source. However, this assumed direction of flow is merely a convention, retained in use because in the early days electricity was thought to flow in this direction. The only actual flow in a circuit is flow of electrons, which are particles of negative electricity. Since anything which is negative is attracted by something else which is positive and repelled by something else which is negative, the negative electrons must flow from the negative of the source to the filament, from filament to plate through the envelope space, and from plate back to the positive of the source.

Electrons leave the filament, or are emitted from the filament, quite freely when the filament is hot. Only extremely high voltages, used with very small spacings, will draw electrons from a cold filament. All amplifiers, and practically all rectifiers in general use, employ heated filaments.

Any element through which electrons enter a gas or vacuum may be called a **cathode**. The heated filament is a filament-cathode, represented at the

Diode Rectifier

left in Fig. 23. Any element through which electrons leave a vacuum or gas may be called an **anode**, so the plate is an anode. The cathode, from which electron emission takes place, may be a separate element as shown at the right in Fig. 23. Then we have a separate heater element inside the cathode. The tube at the left commonly is called a filament type, and that at the right a heater type. Tubes having only two active elements, a cathode and an anode, are called **diodes**.

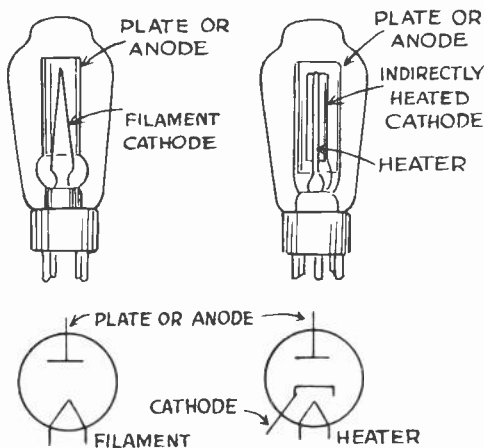

Fig. 23.—The construction of filament type and heater type diodes.

DIODE RECTIFIER

If a diode is placed in series with a source of a-c voltage, current will flow through the tube and the circuit only during the half-cycles in which the plate is positive and the cathode negative. Current cannot flow in the opposite direction because there can be no electron emission from the cold plate. Consequently, the alternating voltage can produce pulses of current only during half of each cycle, and all these pulses are in the same direction as shown by Fig. 24. Any current which flows always in one direction is a direct current so the diode delivers pulsating direct current from an alternating voltage. The diode is a rectifier.

Negative electrons leaving the cathode make the cathode somewhat positive, so a cloud of electrons

Radio

remain near the cathode because of attraction between the relatively positive cathode and the negative electrons. These electrons near the cathode form the **space charge**. Since two negative bodies

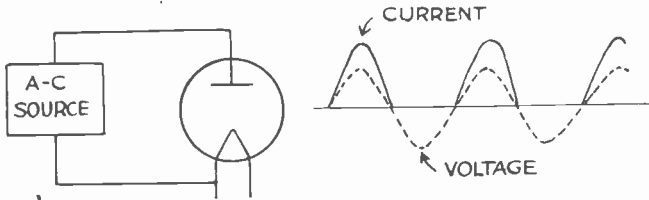

Fig. 24.—A rectifier allows pulsating direct current to flow when an alternating voltage is applied.

repel each other, the space charge repels additional electrons being emitted from the cathode. Voltage applied between plate and cathode, called plate voltage, overcomes the effect of the space charge and draws emitted electrons from the cathode to the plate. This corresponds to a current flow from plate to cathode.

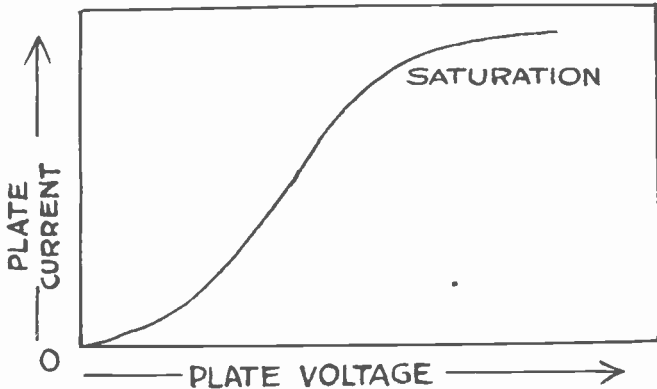

Fig. 25.—Plate current increases from zero to saturation as plate voltage is increased.

Fig. 25 shows how current in the plate-cathode circuit changes with plate voltage. With the first increases of plate voltage the current rises slowly, because of the space charge effect. As voltage is increased, and the plate made more positive with respect to the emitter it draws many more electrons from the space charge, the space charge effect is lessened, and the current increases at a rapid rate.

The Triode

If the plate voltage is still further increased, the space charge electrons are completely removed from around the cathode. Thereafter, even with further increase of plate voltage, the plate current can increase only if the rate of emission is increased by heating the cathode to a higher temperature. Plate current levels off at a value called **saturation current**.

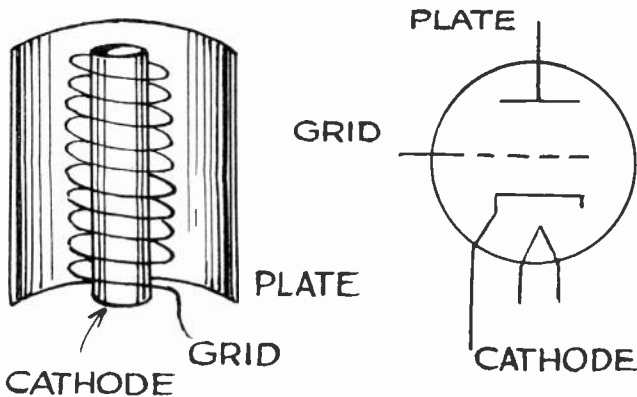

Fig. 26.—The control grid of the triode is between the cathode and plate.

THE TRIODE

Now we shall add a third element to the tube, as in Fig. 26, to form the type of tube called a **triode**. The third element is a coil of fine wire having spaced turns. It is called the **control grid** or just the **grid**. The grid is located quite close to the surface of the cathode, so it is right in the midst of the space charge. If the grid is made positive with reference to the cathode, the positive charge of the grid will counteract much of the effect of the negative space charge. Then it will take but moderate plate voltage to cause a large current flow or electron flow between cathode and plate. On the other hand, if the grid is made negative with reference to the cathode, the effect of the negative charge on the grid is added to that of the negative space charge, and emission of electrons from the cathode is strongly opposed. Then even a high plate voltage can draw relatively few electrons from cathode to plate, and there is but small plate current.

Radio

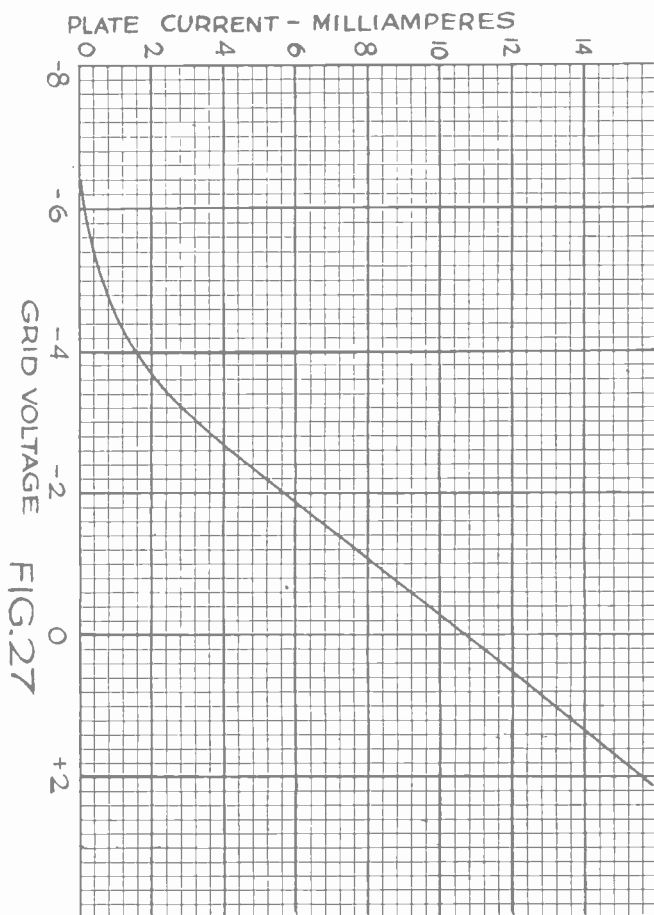

FIG. 27.—How the plate current varies with changes of grid voltage while the plate voltage remains constant.

Grid Bias

The voltage of the grid with reference to the cathode, which is the voltage difference between these two elements, is called **grid voltage**. Fig. 27 shows the effect on plate current of varying the grid voltage in one type of triode while maintaining a plate voltage of 100. When the grid voltage is zero, meaning that it is the same as the cathode voltage, the plate current is 10.7 milliamperes. With the grid 2 volts positive the plate current becomes 15.6 milliamperes. With the grid successively 2 volts and 4 volts negative the plate currents are 5.7 and 1.6 milliamperes, and when the grid is made 6.4 volts negative the plate current is stopped completely, which is called **cutoff**.

In Fig. 28 the secondary of a tuned r-f transformer is connected between the grid and cathode of the tube whose performance is shown by Fig. 27. If the a-c peak voltage developed in the transformer and applied to the grid is one volt, the grid voltage will change from one volt positive to one volt negative in each cycle. The plate current will change accordingly, from 13.1 milliamperes to 8.2 milliamperes in each cycle. Note that the plate current is a pulsating direct current, flowing always in one direction, but pulsating between 13.1 and 8.2 milliamperes.

GRID BIAS.

During half of each cycle of grid voltage in Fig. 28 the grid is positive with reference to the cathode. Electrons flow from the cathode to a positive grid just as to a positive cathode, although the small grid voltage causes but small flow. The resulting current in the grid must flow through the transformer to the cathode. This path from grid to cathode is called the **grid circuit**. When grid current flows through whatever impedances there may be in the grid circuit there are corresponding voltage drops. These voltage drops, which occur only while the grid is positive, combine with r-f voltage induced in the transformer to make the total voltage during the positive half-cycle differ from that during the negative half-cycle, when there is no grid current. The result is distortion, which means that the variations in plate current do not faithfully follow the

Radio

form of variations in r-f voltage applied to the grid circuit.

To overcome distortion due to grid current the grid must remain negative with respect to the emitter during the whole cycle of applied voltage. This we do by applying to the grid a negative voltage which is independent of the a-c voltage coming

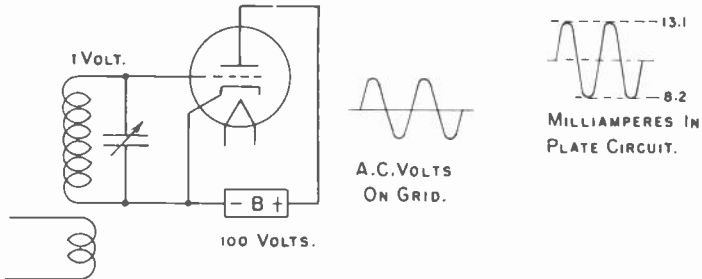

Fig. 28.—Grid voltage changes come from the secondary winding of a tuned r-f transformer.

from the transformer. In the case of Fig. 28 we might make the grid one volt negative. Then, when the voltage from the transformer becomes one volt positive it will just balance the original negative grid voltage and the actual grid voltage with respect to the emitter will be zero. When the transformer voltage (to the grid) becomes one volt negative it will add to the original negative grid voltage and the actual grid voltage will be two volts negative. Instead of the grid voltage varying from one volt positive to one volt negative, as in Fig. 28, it will vary from zero to two volts negative, and always will remain on the negative side of the zero point. The grid voltage which maintains the grid always negative is called grid bias voltage.

A commonly used method of obtaining negative grid bias is to place between the cathode of the tube and the grid circuit a resistor, as at the left in Fig. 29. Plate current returning from the cathode to the B source flows in the direction of the arrow through the bias resistor. The cathode end of the resistor becomes positive and its other end, connected through the coil to the grid, becomes negative. Thus the grid is maintained negative with reference to the cathode.

Plate Circuit Load

With the bias resistor used alone, the changes of plate current cause changes of voltage across the resistor, and the grid bias varies with every change of plate current. This difficulty is avoided as shown at the right in Fig. 29, where there is a bypass capacitor **C** in parallel with the bias resistor **R**. The varying plate current of Fig. 28 really is a combination of a steady direct current and an alternating current. The fluctuations, which are the a-c "component" of the plate current, go through the capacitor **C** of Fig. 29, while the average steady-current component goes through resistor **R** to produce a practically constant grid bias.

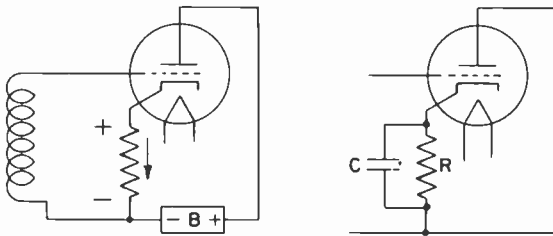

Fig. 29.—Negative bias for the grid may be obtained with a resistor in the cathode lead.

The grid of a tube may be negatively biased not only with the arrangement of Fig. 29, but by connecting the cathode end or filament end of the grid circuit to any point which is more negative than the cathode of the tube which is biased.

PLATE CIRCUIT LOAD

We have produced in the plate circuit of the tube a pulsating direct current whose pulsations correspond to the pulsations of a-c voltage applied between grid and cathode. But in order to make use of these plate current pulsations we need some kind of load in the plate circuit. The load might be the primary of another high-frequency transformer, it might be a resistor, or anything else in which a voltage is to be developed.

In Fig. 30 we have a plate load represented by a 10,000-ohm resistor. Any other resistance or impedance load would act generally in the same manner. Let's assume that we have a 1-volt negative bias on the tube whose performance is shown by

Radio

Fig. 27, and that we are applying 1-volt a-c to the grid. The grid voltage then will vary between zero and 2 volts negative. With no signal applied to the grid, the grid voltage will be 1 volt negative and, with 100 volts on the plate, the plate current will be 8.2 milliamperes. With 8.2 milliamperes (0.0082 ampere) flowing through the plate circuit resistor of 10,000 ohms the voltage drop in this

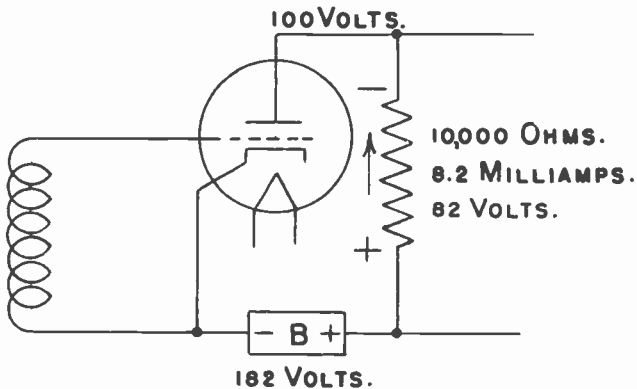

Fig. 30.—A load in the plate circuit of the tube.

resistor will be 82 volts. In order that the plate-to-cathode voltage may be 100 volts the source B must furnish this 100 volts and in addition the 82 volts which forces plate current through the 10,000-ohm resistor. Thus the source B must furnish 182 volts in order that we may have 100 volts for the plate.

Now let's see what happens when alternating voltage is applied to the grid. During the half-cycle in which the alternating voltage is positive it makes the grid less negative with respect to the emitter. With the grid less negative more plate current will flow. More plate current through the plate load resistor increases the voltage drop in this resistor. Then more of the 182 volts from the B-supply is used in the resistor and we no longer have 100 volts on the plate. Consequently when the grid reaches zero voltage we do not have 10.7 milliamperes of plate current shown by Fig. 27 but,

Plate Circuit Load
PLATE CURRENT-MILLIAMPERES.

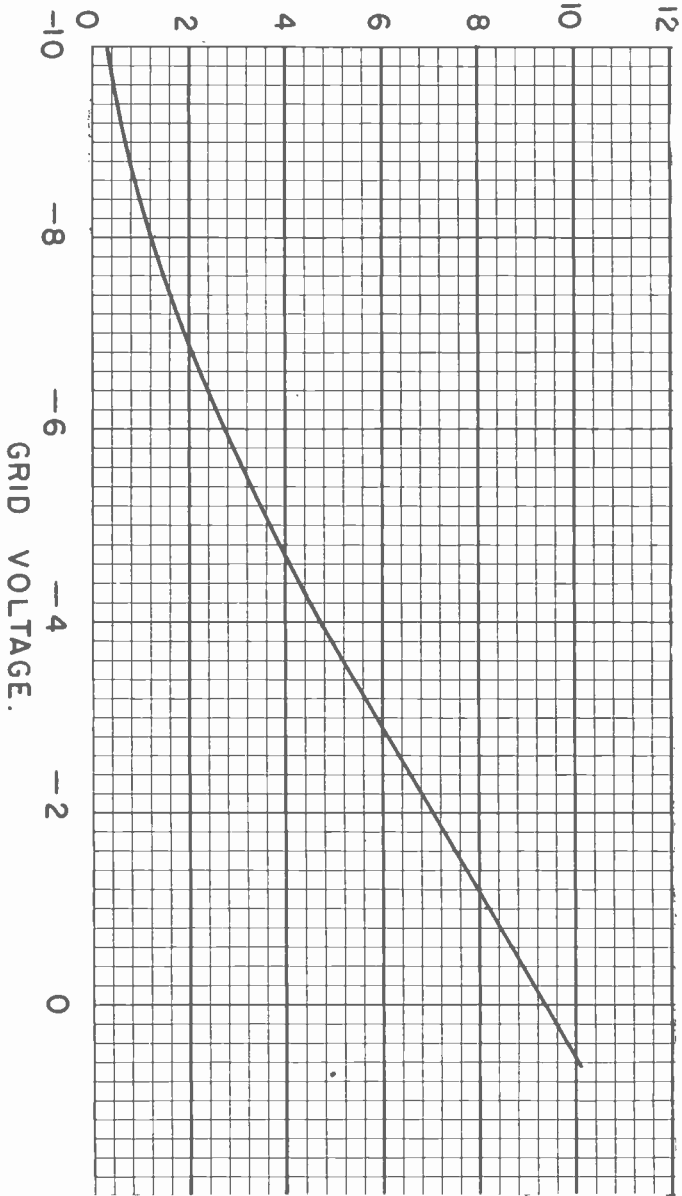

Fig. 31.—The grid-voltage, plate-current curve which shows dynamic performance of the tube.

Radio

because of the reduced plate voltage, have only about 9.4 milliamperes as shown by Fig. 31.

On the opposite half-cycles of signal voltage the grid is made more negative and less plate current flows. But the lessened plate current produces a smaller voltage drop in the plate load resistor, so more of the 182 volts from the B-supply remains for the plate. This higher plate voltage causes the plate current to be about 7.0 milliamperes with the grid 2 volts negative (Fig. 31) instead of the 5.7 milliamperes shown by Fig. 27. The curve of Fig. 31 shows how plate current varies when the plate load resistance (or impedance) is 10,000 ohms, and the B-supply voltage is 182 volts. This is a curve of "dynamic" performance, showing what happens when the tube is working. In Fig. 27 we had a curve of "static" performance, showing changes when the tube does no work but merely varies its plate current with no plate circuit load.

VOLTAGE AMPLIFICATION

With one volt of alternating potential on the grid of the tube in Fig. 30, with a negative bias of one volt, with a load resistance of 10,000 ohms, and a B-supply of 182 volts, the plate current varies between 7.0 and 9.4 milliamperes. The plate voltage will vary between 90 and 113 volts. Since the B-supply maintains 182 volts, the voltage drop in the load resistor will be the difference between B-supply voltage and plate voltage, so voltage across the resistor will vary between 69 and 92 volts. The resistor voltage varies by 23 volts due to an a-c grid voltage change of one volt. We have **amplified** the grid voltage 23 times by using the tube. The **amplification factor** of this tube, working under these conditions, is 23.

Since the grid remains negative at all times there is no grid current to consume power. The power put into the grid circuit is only the very small amount necessary to maintain the currents which circulate back and forth between coil and capacitor. Yet in the plate circuit we have power corresponding to a change of 7.0 to 9.4 milliamperes, which is a change of 2.4 milliamperes or 0.0024 ampere, in 10,000 ohms of resistance. This is about

Tube Characteristics

58 milliwatts of power. Other types of tubes may be designed and operated to deliver many watts of power in their plate load.

TUBE CHARACTERISTICS

Tube manufacturers publish ratings which list commonly used plate currents, plate voltages, and grid voltages. In addition there are listings of amplification factor, of plate-to-cathode resistance in the tube, and of mutual conductance or transconductance.

Amplification factor is a number found by dividing a change of plate volts by the change of grid volts which accompanies it, with the plate current remaining unchanged. **Plate resistance** in ohms is found by dividing a change of plate voltage by the accompanying change of plate current in amperes, with the grid voltage remaining unchanged. **Mutual conductance**, which more often is called **transconductance**, is found by dividing a change of plate current in amperes by the accompanying change of grid volts, with the plate voltage remaining unchanged. The smaller the changes which are measured the more accurate will be the results.

Amplification factor, plate resistance and transconductance indicate in a general way the ability of a tube as an amplifier. But these characteristics are measured with one factor, voltage or current, remaining unchanged. All the voltages and currents vary constantly with the tube in actual operation, so the characteristics are of limited usefulness in calculating actual performance.

SCREEN GRID TUBES

As indicated at **A** in Fig. 32 the plate and control grid of a triode act like two plates of a capacitor whose dielectric is the vacuum between them. The capacitance of the plate and grid is in series with the grid circuit and in series also with the plate circuit. Consequently, changes of voltage in the plate circuit tend to produce voltage changes in the grid circuit. These voltages may either oppose or assist the changes of grid voltage which represent the a-c signal. There is a "feedback" of energy from the plate circuit to the grid circuit and we may have **regeneration** with which voltage changes

Radio

fed back to the grid circuit are amplified in the tube, passed into the plate circuit, again fed back, and finally built up to great strength. The regenerative voltages and currents may almost completely overcome the signal voltages which it is desired to amplify.

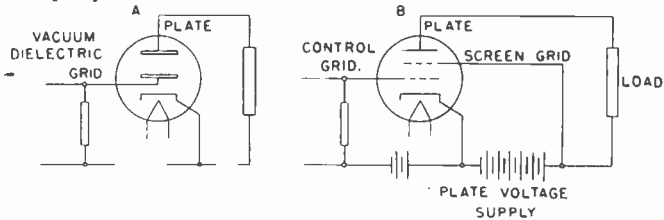

Fig. 32.—The grid and plate act as the two plates of a capacitor having the vacuum or gas as its dielectric. The screen grid reduces the coupling effect of this capacitance.

The danger of feedback through the tube capacitance is lessened by placing between the control grid and the plate an additional open-mesh grid called the screen grid as shown at B in Fig. 32. The tube with four active elements may be called a **tetrode** or a screen-grid tube. The screen and plate are closer together than the control grid and plate, so voltage changes on the plate which would affect the control grid of a triode now effect chiefly the screen and are diverted through the screen and its connection to the voltage supply.

The voltage of the screen with reference to the cathode may be made as high or nearly as high as the plate voltage. The strong positive charge thus placed on the screen exerts a strong attraction on negative electrons with the result that electrons from the cathode are greatly speeded in their travel through the control grid. Some electrons enter the screen, but most of them go through its open spaces and reach the plate. Plate current is almost unaffected by changes of plate voltages through most of the usual operating range, and depends almost wholly on screen voltage. Control grid voltage varies the plate current as it does in a triode. The voltage amplification which is possible with a screen grid tube is many times that obtainable with a triode. However, the plate current is smaller than in the triode and only small grid voltage changes may be handled.

Pentodes

PENTODES

The screen grid tube suffers from the effects of "secondary emission," which is emission of electrons from a cold surface when that surface is violently bombarded by other electrons striking it at high velocity. At **A** in Fig. 33 are indicated electrons traveling in the desired manner from the cathode through the control grid and screen grid to the plate. A high voltage on the screen gives these electrons such high velocity as they near the plate that they literally knock secondary electrons out of the plate.

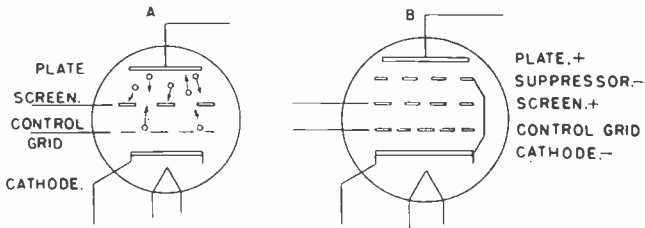

Fig. 33.—Secondary emission from the plate (A) is reduced by the suppressor grid (B) of the pentode.

Secondary electrons leaving the plate go instantly to the screen because the screen has a high positive voltage. If there are large changes of voltage in the plate circuit it is possible for the plate voltage to sometimes become lower than the screen voltage, with the result that there is a large flow of secondary electrons from plate to screen. These electrons leaving the plate are, in effect, subtracted from those arriving at the plate from the cathode, and thus there may be a material reduction of plate current.

To lessen the effect of secondary emission there is placed between the screen and the plate still another grid called the **suppressor grid**, as shown at **B** in Fig. 33. This five element tube is called a **pentode**. The suppressor most often is connected directly to the cathode, so is at the same voltage as the cathode and is negative with reference to the plate. This negative suppressor so close to the plate has a strong repelling effect on secondary negative

electrons attempting to leave the plate and go to the screen, so secondary emission is almost wholly suppressed."

The pentode retains the high amplification of the screen grid tube, yet will handle large changes of plate voltage without the feedback which may occur in a triode. Pentodes are used both for voltage amplification of extremely weak signals, and for power amplification.

BEAM TUBES

The beam tube suppresses secondary emission without the use of a suppressor grid, instead employing a particular design arrangement which provides midway between the screen grid and the plate an electric field of very low intensity. Such a design is illustrated in Fig. 34.

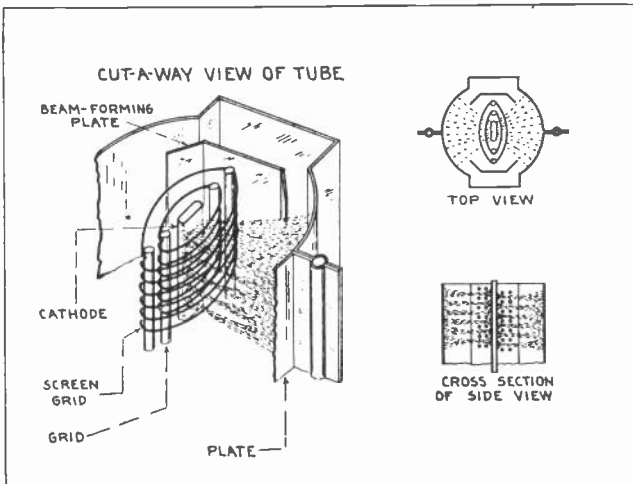

Fig. 34.—Electron flow in a beam tube, which acts much like a pentode but has no suppressor grid.

In the region of the low intensity field, which means a region of relatively small voltage which speeds the electrons, the electrons slow down to such an extent as to accumulate. The accumulation of negative electrons has a space charge effect similar to that of the space charge around a cathode, and repels secondary electrons in the same manner as would a suppressor grid. Screen current is made

Variable-MU Tubes

small in the beam tube by the design of the screen grid, which is such that the screen wires are in the shadow formed by the control grid in the electron stream from the cathode. That is, the screen wire is placed where there are relatively few electrons because they have been deflected by the negative control grid wires which are directly between the screen wires and the cathode surface. Beam tubes have high power outputs in relation to the applied grid voltage changes.

VARIABLE-MU TUBES

The word "mu" is the English name of a Greek letter which is the symbol for amplification factor. So a variable-mu tube is a tube having a variable amplification factor. Such a tube is a modified tetrode or pentode in which the control grid has some wires widely spaced and others close together.

If the grid bias is made highly negative there is produced a negative charge or a negative field which is very strong where the grid wires are close together. Then electrons from the cathode are stopped by this field, and the only ones which get through to the plate are those passing where the grid wires are farther apart.

By varying the grid bias we vary the area of the cathode from which emission is practically stopped by the negative field, and, simultaneously, vary the area from which emission may proceed to the plate. The variable-mu tubes may be used with special circuits which vary their grid bias in accordance with the strength of a received signal, thus providing automatic volume control to compensate for changes in the strength of a signal.

TUBE SYMBOLS

Fig. 35 shows symbols for the types of tubes which have been discussed in preceding pages, also a number of other types. We shall talk about converters and mixers when examining superheterodyne receiver circuits. There are a number of types of multi-purpose tubes having within a single envelope the element structures for two or more complete functions. For example, a single envelope may include two triodes, two diodes and

Radio

a triode, two diodes and a pentode, a pentode and a rectifier diode, and so on. Such tubes introduce

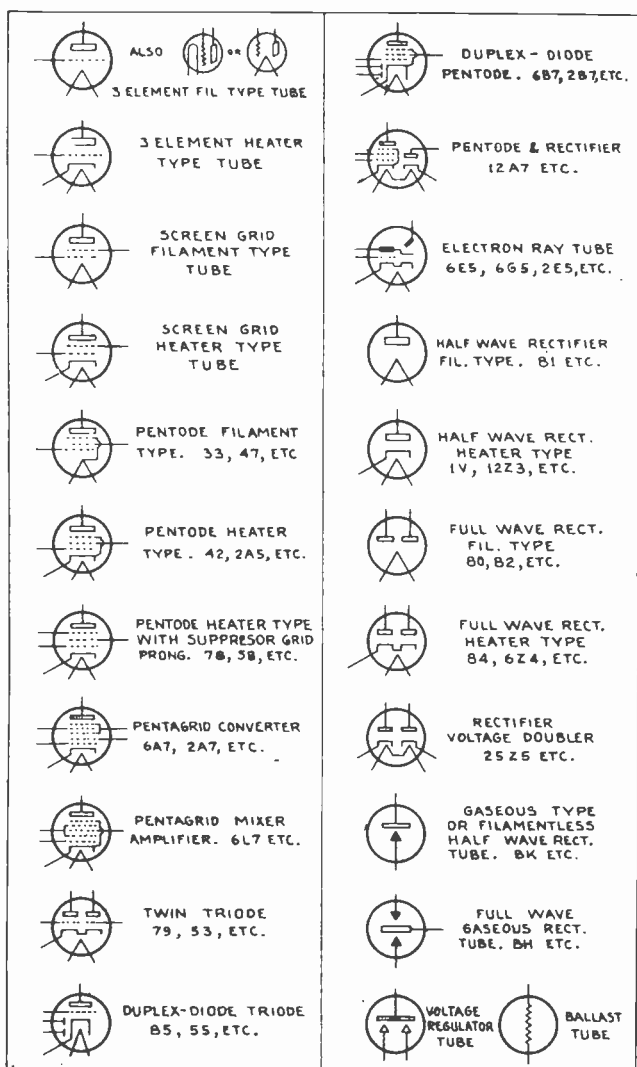

Fig. 35.—Symbols which represent various types of radio tubes.

no new principles, since each section performs like a separate tube of that particular type.

Tubes

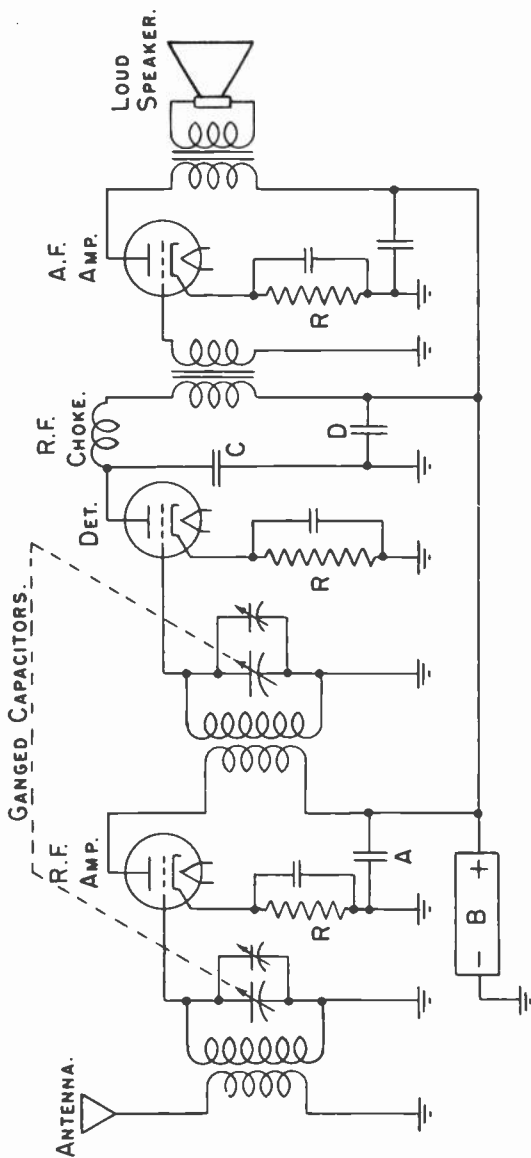

Fig. 36.—The circuits of a complete 3-tube receiver including one r-f amplifier, a detector, and one a-f amplifier.

Radio

COMPLETE RECEIVERS

Fig. 36 shows all the circuits for a 3-tube receiver. The first tube is an r-f amplifier which amplifies r-f voltages coming from the antenna through the tuned transformer in the grid circuit of this tube. The second tube is a detector which produces in its plate circuit the relatively low-frequency a-f voltages corresponding to the modulation. The third tube is an a-f amplifier which amplifies the a-f voltages coming to it from the detector through an iron-cored transformer. In the plate circuit of the a-f amplifier is the primary of another iron-cored transformer whose secondary is connected to the loud speaker.

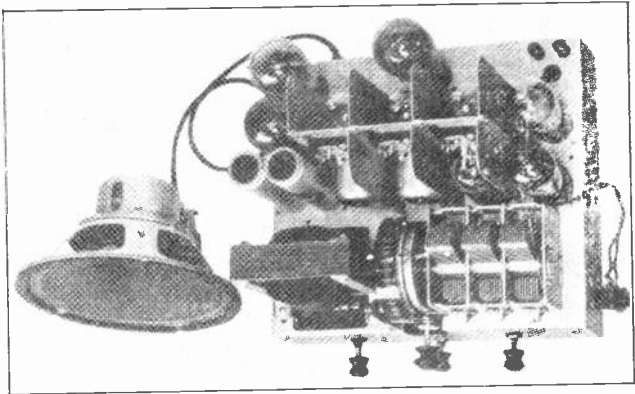

Fig. 37.—Top view of a receiver chassis. A three-gang tuning capacitor is in the lower right-hand corner of the chassis. At the left is the loud speaker.

The resonant grid circuit transformers of the r-f amplifier and detector are tuned by two adjustable capacitors built as a single ganged unit and operated together by the tuning knob. Ganged capacitors may be seen in the lower right-hand corner of the receiver chassis illustrated by Fig. 37. In parallel with each of the tuning capacitors are small trimmer capacitors which are adjusted to compensate for slight differences in capacitance of the tuning units, thus allowing both circuits to be accurately tuned to the same radio frequency. Trimmers usually are adjusted with a screw driver or socket wrench from the rear or bottom of the chassis.

Receivers

The trimmer adjustment should be made at the high-frequency end of the band, which means with

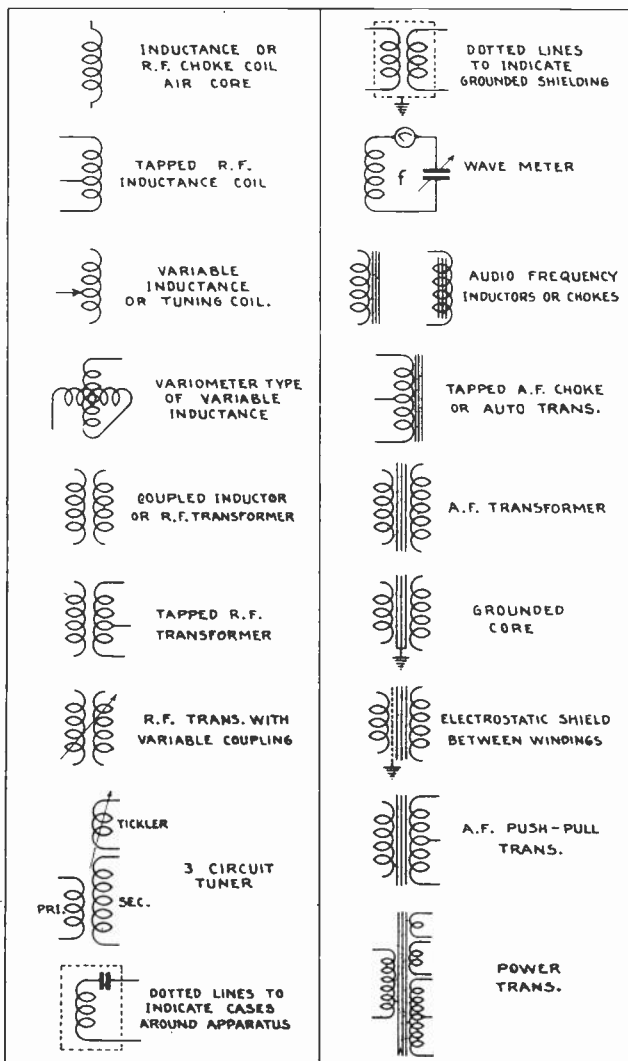

Fig. 38.—Symbols for coils and transformers used in radio circuits.

the plates of the large tuning capacitors out of mesh. Were this adjustment attempted at the low-

Radio

frequency end of the band, with the tuning capacitor plates in mesh, it would take a large change in the trimmer capacitance to make any noticeable change in the total capacitance. With the tuning capacitors out of mesh, and having small capacitance, a very small change of trimmer capacitance makes a relatively great change in total capacitance and it is possible to make an accurate adjustment.

Instead of using trimmer capacitors the end plates of the tuning capacitors may be slit so that a portion of these plates may be bent slightly to alter the capacitance at any particular setting. This allows alignment of the two or more tuned circuits so that they "track" throughout the entire range of frequencies to be received.

At R-R-R in Fig. 36 are shown the biasing resistors and bypass capacitors for the three tubes. The three plate circuits, after going through their transformer primaries, all connect to the positive side of a common B-supply whose negative side is grounded. Note that the portions of all the grid circuits from cathode to grid-transformer secondary are completed through ground connections on the metal of the chassis. Bypass capacitor **A** completes the plate circuit, from transformer primary back to cathode of the tube, so that high-frequency voltages may pass through this capacitor with little impedance rather than having to go through the B-supply and the ground connections. Fig. 38 shows symbols for various types of coils and transformer both r-f and a-f, which may be used in circuit diagrams.

DETECTORS

The detector of Fig. 36 produces a-f changes of voltage in its plate circuit because it is operated with a highly negative grid bias; hence may be called a **grid bias detector**. Another name for this particular method is **plate detection**, because of the fact that detection occurs in the plate circuit voltages. At **A** in Fig. 39 is shown the circuit for such a detector, and at **B** is shown its action.

The characteristic curve of Fig. 39 shows the relation between plate current and grid voltage changes, just as they are shown by Figs. 27 and 31. At the bottom of the diagram is represented the r-f

Detectors

voltage which is applied to the grid of the detector tube. The bias is so far negative that the negative half-cycles of the applied r-f voltage bring the grid voltage to the cutoff point. Consequently, as shown toward the right from the characteristic curve, these negative alternations of grid voltage reduce

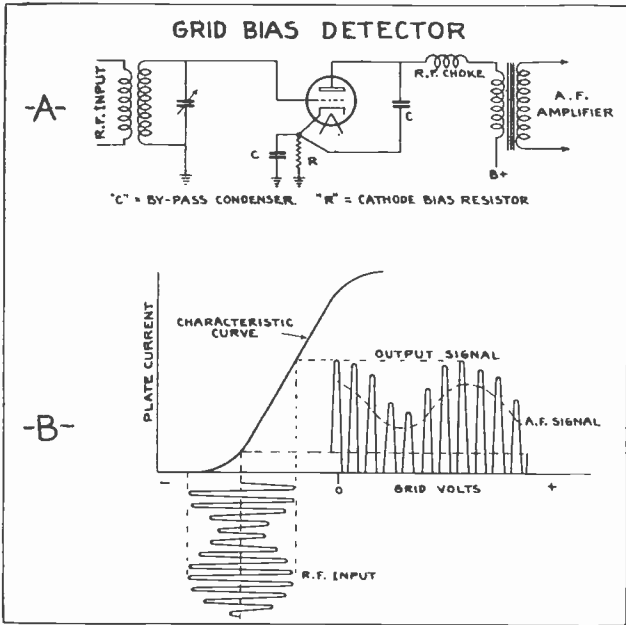

Fig. 39.—The circuit for a grid bias detector (A) and the manner in which alternating grid voltage produces a partially rectified plate current whose average value changes at audio frequency (B).

the plate current to zero. The positive alternations of the applied r-f voltage make the grid less negative, so that operation is higher up on the characteristic curve. These positive alternations thus produce corresponding changes of plate current, as shown toward the right. In the plate circuit we now have a pulsating direct current, flowing always in the same direction. The average value of these one-way pulsations follows the modulation, consequently this average plate current follows the audio frequency.

The high-frequency changes in the plate circuit of the detector are bypassed to ground through

Radio

capacitor **C** of Figs. 36 and 39. As a further preventative against allowing high-frequency voltages to reach the primary of the following iron-cored transformer, a radio-frequency choke coil is placed between plate and transformer. This choke has high impedance at radio frequencies, but very low impedance at audio frequencies which are to reach the transformer. The audio-frequency circuit for the detector plate is completed through the large-capacitance capacitor **D** to ground and through ground to the detector cathode, so that a-f changes need not go through the B-supply. Note that we have amplification as well as detection.

Another method of detection, seldom used nowadays, produces a grid voltage varying at audio frequency by means of a resistor and capacitor in parallel with each other and in series between the r-f transformer and the grid of the tube. The resistor, called a grid leak, usually is of about one megohm resistance, and the capacitance is about 0.00025 microfarad. Such an arrangement makes a grid leak detector.

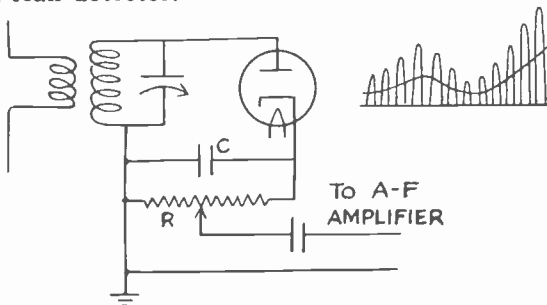

Fig. 40.—Using a diode tube for a detector.

A diode tube may be used as a detector with the circuit of Fig. 40. One end of the tuned r-f transformer is connected to the plate of the diode, while the other end is connected to the cathode through capacitor **C** and the adjustable rheostat or potentiometer **R**. Radio-frequency voltages are rectified by the diode; only the positive half-cycles producing current in the diode and its connected circuit. The result is a series of d-c current pulses whose average value follows the modulation or the a-f signal.

Volume Controls

The diode current passing through resistor **R** produces voltage changes at audio frequency across this resistor. These voltage changes are delivered to the following audio-frequency amplifier. Radio-frequency changes pass through capacitor **C**, which is of such capacitance as to have low reactance to the r-f changes, but high reactance to the a-f changes which thus are forced through the resistor. Audio-frequency voltage to the a-f amplifier is increased as the slider on **R** is moved to the right and are decreased as it is moved to the left. Thus the potentiometer **R** may be used as a volume control.

Diode detectors and grid leak detectors allow current to flow in the tuned circuit, which reduces selectivity. A well designed diode detector produces less distortion than either a grid leak or a grid bias detector. A grid bias detector usually has less distortion than the grid leak type. The grid leak detector is very sensitive to weak signals, but its high sensitivity is not needed with modern high-gain r-f amplifiers between antenna and detector.

VOLUME CONTROLS

Volume controls may be inserted in almost any circuit of a receiver where they reduce or increase the r-f or a-f voltages delivered to following stages. Some receivers have volume controls in more than one circuit. A common method employs an adjustable biasing resistor in the cathode lead of a variable- μ tube, thus making the grid more or less

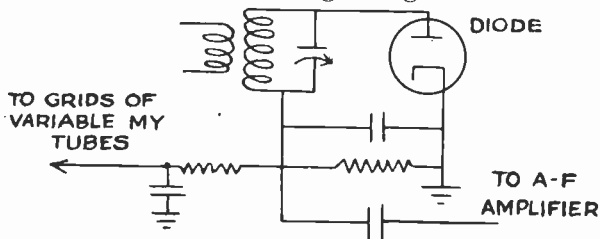

Fig. 41.—Automatic volume control voltage for variable- μ tubes may be taken from the circuit of a diode detector.

negative to decrease or increase the amplification of the tube.

Automatic volume control, abbreviated **AVC**, may be had by taking the bias for one or more variable-

Radio

mu tubes partly from a rectified portion of the r-f signal. The amplification of a variable-mu tube thus may be decreased when signal strength increases, and increased for weak signals; by this method a fairly uniform loud speaker output is obtained as the antenna signal varies. Fig. 41 shows how a connection may be taken from a diode detector for grid bias of variable-mu tubes.

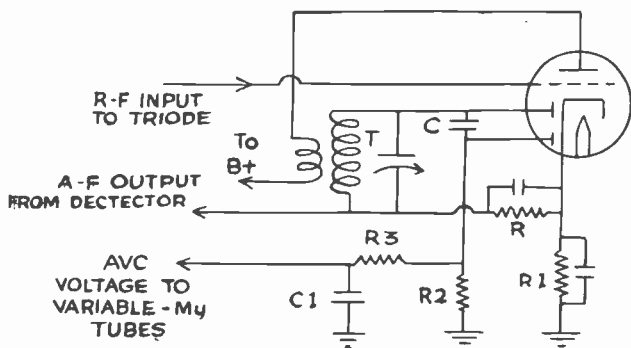

Fig. 42.—A circuit used for delayed automatic volume control, with which weak incoming signals are not affected by the automatic feature.

Variable-mu tubes are designed to operate with a minimum bias of about 3 volts, which usually is provided by a cathode biasing resistor with the AVC bias voltage in series. With simple AVC circuits even a weak signal causes some reduction of amplification. This fault is avoided with delayed automatic volume control, for which one type of circuit is shown by Fig. 42. This circuit includes a duplex-diode triode tube containing two diode plates, a triode plate and grid, and a single cathode for all three. Duplex-diode pentodes are used similarly, with an additional connection for screen voltage.

The upper diode plate and the cathode of the tube in Fig. 42 act as the diode detector, with the diode plate connected to the tuned circuit T and with the other end of the tuned circuit connected to the cathode through resistor R with its bypass capacitor, just as in the circuits of Figs. 40 and 41. The a-f output from this diode detector is taken through the connection shown to the a-f amplifier.

Audio-Frequency Amplifiers

The lower diode plate and the cathode form the AVC diode. Part of the energy going to the plate of the detector diode goes through the small capacitor **C** to the AVC diode section. Biasing resistor **R1** keeps the plate of the AVC diode at a negative voltage which prevents it from rectifying and from producing an AVC voltage until the peak voltage reaching it through capacitor **C** counterbalances this negative voltage. Thus no AVC voltage is produced with very weak signals which do not provide enough voltage on the plate of the AVC diode to overcome its negative voltage. Thus, for weak signals, the sensitivity of the receiver remains the same as though there were no AVC system.

When stronger signals are received, enough voltage reaches the AVC diode to overcome its negative plate voltage. Then there will be current through resistor **R2** and a voltage drop across this resistor. The r-f and a-f variations of this voltage are filtered out by the impedance of resistor **R3** and the bypass effect of capacitor **C1**. The remaining variations of direct current are applied to the grids of the variable-mu tubes just as with any other AVC system. The triode section of the tube acts merely as the r-f amplifier which precedes the detector. We have in the single envelope an r-f amplifier tube, a detector tube, and an AVC tube.

AUDIO-FREQUENCY AMPLIFIERS

Fig. 36 shows the rather common practice of connecting (or coupling) a detector to an a-f amplifier tube, and the a-f tube to a loud speaker, by means of iron-cored audio-frequency transformers. Such transformers often have a step-up voltage ratio, primary to secondary, so that there is a certain amount of voltage gain in the transformers in addition to that obtained in the tubes. Transformer response may fall off at low audio frequencies because the reactance of the primary decreases with frequency decrease. High-frequency response may be limited by the by-passing effect on the secondary winding of the grid-to-cathode capacitance in the following tube. There is capacitance between the grid and the cathode just as there is between the grid and the plate.

Radio

Fig. 43 shows the circuits in a resistance coupled a-f amplifier. The detector is like that of Fig. 36, but instead of having in its plate circuit the primary of an iron-cored transformer there is the resistor R_p of Fig. 43. The a-f changes of plate current produce a-f changes of voltage across this resistor. These a-f voltages pass through capacitor C_1 to the grid of the first a-f amplifier tube. Resistor R_g connects the grid of the a-f tube through ground to the cathode of this tube, and, in combination with the biasing resistor in the cathode lead, maintain the necessary negative bias in the grid. With a negative bias such as to prevent grid current there is no current and no voltage drop in resistor R_g , so the grid bias depends entirely on the regular biasing resistor.

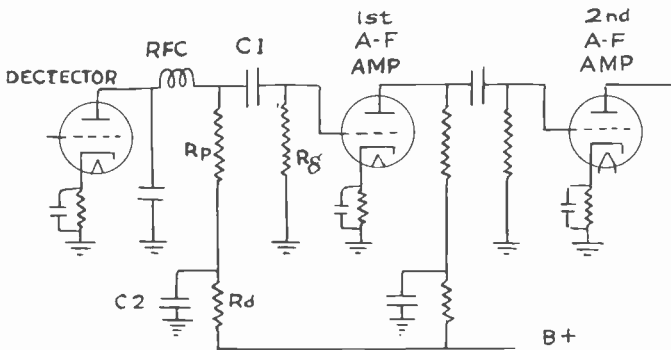

Fig. 43.—The circuits used for resistance coupled audio-frequency amplification.

Capacitor C_1 not only passes a-f voltages from tube to tube, but at the same time prevents the high d-c voltage for the plate of the detector from reaching the grid of the first a-f tube. Resistor R_p is the coupling resistor, while resistor R_g merely serves to complete the grid circuit from the grid of the amplifier tube to its cathode. The impedance to a-f currents of resistor R_d forces the a-f changes to return to the cathode of the detector through bypass capacitor C_2 . Otherwise these a-f changes would go through the B-supply, and in the resistance of the B-supply would produce voltage drops which would affect the other tubes connected to the same B-supply.

Superheterodyne Receivers

The amplification of a resistance coupled amplifier falls off at low audio frequencies because, at these low frequencies, the impedance of capacitor C1 becomes greater. This effect is noticeable chiefly below 50 cycles. The amplification falls off at audio frequencies above about 5,000 cycles because the capacitances of the elements in the tubes tend to bypass these high frequencies around the coupling resistors and thus to reduce the voltage drops across the resistors. At frequencies between about 50 and 5,000 cycles the resistance coupled amplifier may be designed to give very uniform amplification.

If coils having high inductance are used instead of resistors R_p and R_g of Fig. 43 we have what is called an impedance coupled amplifier. The inductance coils have high impedance to a-f currents, but have low resistance to direct currents. Thus there is less d-c voltage drop in the inductors than in resistors, and the voltage of the B-supply may be considerably less than for resistance coupling. The amplification of an impedance coupled amplifier at various audio frequencies is about the same as that of a resistance coupled amplifier.

SUPERHETERODYNE RECEIVERS

For reception other than from nearby transmitters it is desirable to have great overall amplification in order that very weak signals may produce satisfactory loud speaker volume. The amplification of one tube and its coupling circuits is limited, so great total amplification is had by using several stages, each consisting of a tube and its coupling circuits. But the number of stages of amplification is limited because of undesired feedback effects, because there are slight changes of voltage in early stages which are amplified along with the signal by following stages, and because of other electrical difficulties which become rapidly more troublesome at higher and higher radio frequencies.

The superheterodyne receiver, after moderate amplification of the r-f signal, changes the frequency to one which is much lower, possibly in the neighborhood of 500 kilocycles, but retains the modulation. This lower frequency signal then is amplified by one or more stages in which the gain may be

Radio

made quite high without encountering the difficulties met with in original signal frequency amplification. The lower signal frequency is called the **intermediate frequency**. It finally is changed to audio frequency in a detector, and the audio frequency is amplified by one or more stages and fed to the loud speaker.

The intermediate frequency is produced by combining with the incoming signal frequency another frequency produced within the receiver by means of a tube acting as an oscillator. When currents at two different frequencies are fed into a single circuit there will be in that circuit not only the two original frequencies, but two others which are equal to the sum and to the difference of the two. For example, if the received frequency is 1,000 kilocycles and the local oscillator frequency is 1,460 kilocycles, the resulting frequencies will be equal to $1,460 - 1,000$, which is 460 kilocycles, and to $1,460 + 1,000$, which is 2,460 kilocycles. Each of these new frequencies will have the modulation of the received signal.

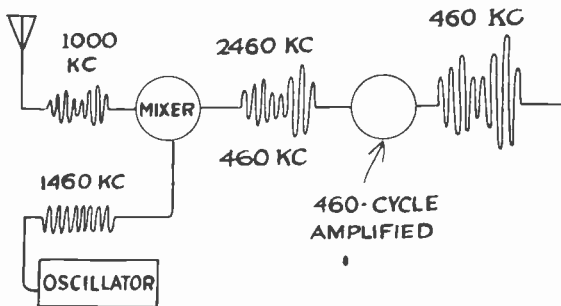

Fig. 44.—How the signal frequency and the local oscillator frequency are mixed in the superheterodyne receiver to produce an intermediate frequency.

What happens with the particular frequencies being considered is represented in Fig. 44. From the antenna we have 1,000 kilocycles and from the oscillator 1,460 kilocycles, both of which go into the mixer tube. In the output of the mixer will be modulated intermediate-frequency voltages of 2,460 and 460 kilocycles. The following amplifier circuit is tuned to 460 kilocycles, which it amplifies strongly

Superheterodyne Receivers

while practically rejecting the 2,460-kilocycle signal to which it is not tuned.

Fig. 45 shows in a simple block diagram the several sections of the superheterodyne receiver. The 1,000-kilocycle received signal is amplified by one stage of r-f amplification and fed to the mixer, sometimes called the first detector. The oscillator, tuned to 1,460 kilocycles, feeds its steady voltage to the mixer. The one or more stages of the intermediate-frequency amplifier are permanently tuned to 460 kilocycles. The demodulator, or second detector, recovers the a-f voltages, which are amplified in the a-f amplifier and fed to the loud speaker.

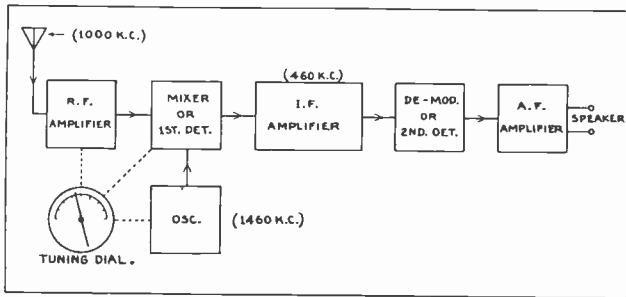

Fig. 45.—The principal parts or sections of a superheterodyne receiver. The r-f amplifier, the oscillator, and the mixer have circuits which are simultaneously tuned.

The tuning capacitors for the r-f amplifier, the mixer, and the oscillator are ganged and operated together by the tuning dial. The inductances and capacitances in these three tuned circuits are such that, in the receiver shown, the oscillator frequency always remains 460 kilocycles higher than the frequency to which the r-f amplifier and mixer are simultaneously tuned. Thus the intermediate frequency remains 460 kilocycles no matter what the frequency of the incoming r-f signal, and the intermediate-frequency amplifier tuned circuits may be permanently tuned to 460 kilocycles.

Fig. 46 shows the portion of the circuits which connect together the mixer tube, the oscillator tube, and the first intermediate-frequency amplifier tube in one style of superheterodyne receiver. The mixer operates like a grid bias detector with bias voltage furnished by a resistor in its cathode lead. In the

Superheterodyne Receivers

lator pickup, are shielded from each other by the screen which surrounds the signal grid. The suppressor grid is connected to the cathode inside the tube.

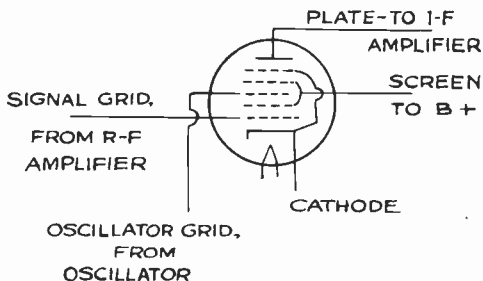

Fig. 47.—The pentagrid mixer tube may be used instead of the grid bias type of mixer.

A multi-element tube may act as both oscillator and mixer. One class of tubes used in this manner includes the **pentagrid converters** such as the 6A7 and many others. A circuit using a 6A7 pentagrid converter is shown by Fig. 48. The single cathode functions in both the oscillator and mixer sections. The oscillator section includes grid number 1, nearest the cathode, as the control grid for a triode oscillator, and grid number 2 as the plate or anode. The oscillator grid (1) is connected to a tuned circuit, and to the coil of this tuned circuit is coupled a coil connected between the oscillator anode (2) and the B-supply. Grid number 2 is called the anode grid.

Grid number 4, connected to the preceding r-f tuned transformer, is the control grid for the mixer-amplifier section. This grid is surrounded by grids 3 and 5 which act as a screen grid to shield the mixer section from the oscillator section. The plate of the pentagrid converter is connected to the first i-f transformer in the usual manner. The oscillator current, which flows in pulses at the oscillator frequency, allows electrons to shoot through the anode grid (oscillator plate) in pulses which occur at the oscillator frequency. This stream of electrons passes through the signal grid (4) on its way to the plate, and is modulated by both the signal frequency and the oscillator frequency to produce the intermediate frequency.

Radio

In the short-wave bands, where frequencies are higher than in the broadcast band, the usefulness of the pentagrid converter is limited by action occurring between the oscillator and signal sections. For operation at high radio frequencies as well as at broadcast frequencies there are converters with six, seven and eight elements; called respectively triode-hexode converters, triode-heptode converters, and octode converters.

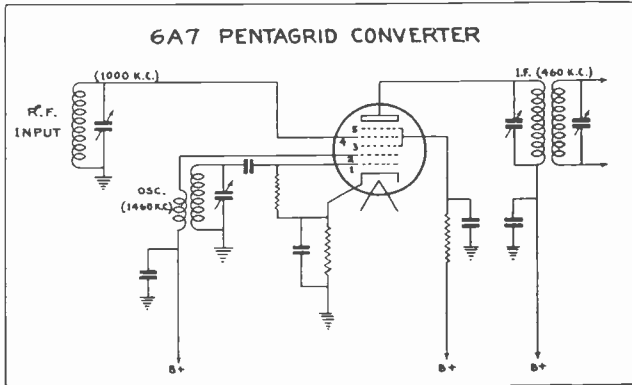

Fig. 48.—A circuit for a pentagrid converter which acts both as an oscillator and a mixer.

Fig. 49 shows at **A** how any one of several tuned circuits, each covering a different band of radio frequencies, may be switched into the grid circuit of either an r-f amplifier tube or a mixer tube. At **B** is shown a wave band switch having three contact bars and nine movable contacts which are moved simultaneously. The primary circuit is completed from the B-supply through one or more of the coils **P1**, **P2** and **P3**. The secondary circuit is completed from the ground connection **K**, through the capacitor, and coils **c**, **b**, **a** and **x** to ground **L** on the long bar. Coil sections are switched in or out to suit the frequency band to be received.

FREQUENCY MODULATION

The radio-frequency voltages so far considered have been of the type in which the frequency of the transmitted energy remained constant so long as there was no modulation. When this "carrier"

Frequency Modulation

energy is modulated with an audio frequency the amplitude or value of the radio-frequency voltage rises and falls in accordance with the modulating audio frequency. Actually, because two frequencies are combined in a single circuit, there is in that

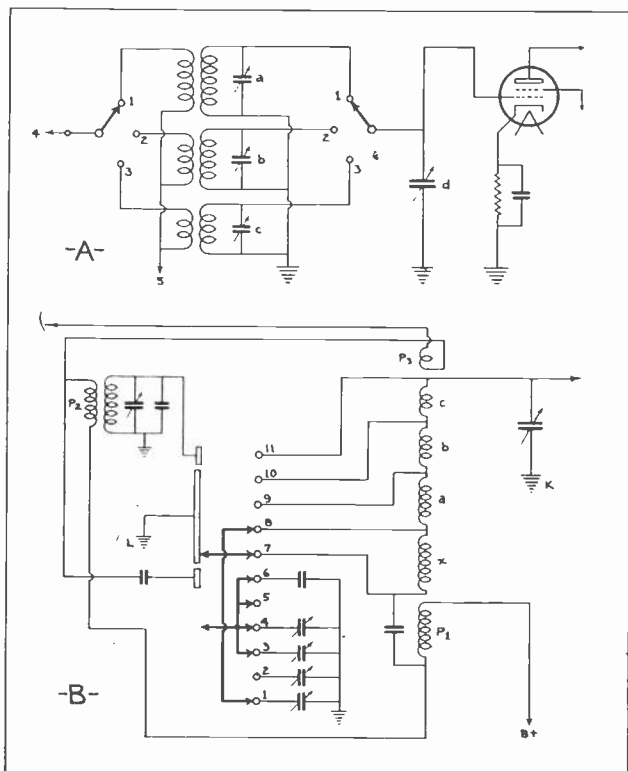

Fig. 49.—Wave band switching for receivers designed for short-wave reception as well as broadcast reception.

circuit additional frequencies equal to the carrier frequency plus the audio frequency, and to the carrier frequency minus the audio frequency. For example, with a carrier of 1,000 kilocycle frequency (1,000,000 cycles) modulated with audio frequencies whose maximum is 10,000 cycles, there is transmitted and received a range of frequencies extending from 990,000 to 1,010,000 cycles. This general system of transmission and reception is called am-

Radio

plitude modulation. The radio-frequency signals or voltages may be represented as at **A** in Fig. 50.

In another system of transmission and reception the modulation of the radio-frequency carrier is ob-

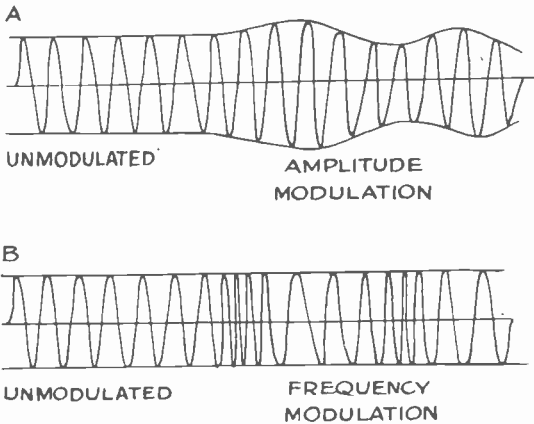

Fig. 50.—The difference between amplitude modulation (A) and frequency modulation (B).

tained by varying its frequency, while its amplitude remains constant. This is called **frequency modulation**, usually abbreviated to F-M. It may be represented as at **B** in Fig. 50. The chief advantage of frequency modulation is that the signal is stronger in proportion to the background noise than with amplitude modulation provided the changes of frequency caused by modulation are several times as great as the highest audio frequency to be transmitted and received. The frequency "swing" in F-M broadcast work is usually about 75 kilocycles, while transmitted audio frequencies often reach no higher than 5,000 cycles and seldom much over 10,000 cycles.

An F-M receiver is essentially a superheterodyne receiver with the second detector or demodulator replaced by a limiter stage and a frequency discriminator stage as indicated by the block diagram of Fig. 51. Another major difference between the A-M (amplitude modulation) superheterodyne and the F-M receiver is in the band of frequencies to which the i-f amplifier must respond. In the A-M receiver

Frequency Modulation

it is necessary that the i-f amplifier handle a frequency range of only 30 kilocycles even when the audio frequencies reach as high as 15,000 cycles. In an F-M receiver which is to handle a frequency

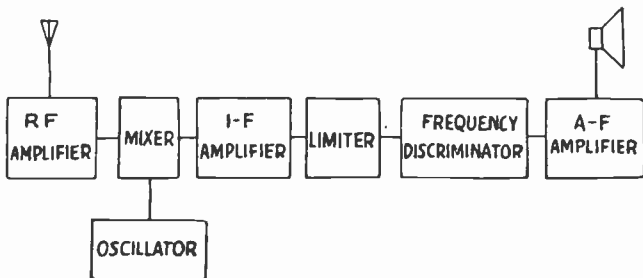

Fig. 51.—The principal parts of a frequency modulation receiver. The limiter and frequency discriminator replace the demodulator or second detector of the superheterodyne.

swing of 75 kilocycles the i-f amplifier must care for a frequency range of 150 kilocycles. The limiter of the F-M receiver serves to remove any amplitude modulation which may be present in the amplified i-f voltages. The discriminator recovers the audio frequency signal and passes it on to the a-f amplifier.

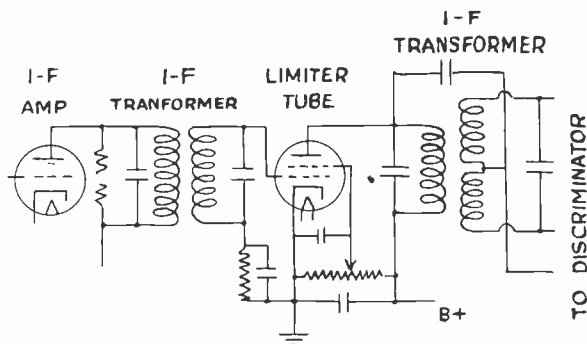

Fig. 52.—Circuits for the limiter stage of an F-M receiver.

LIMITER STAGE

Fig. 52 shows circuit connections for one type of limiter stage in an F-M receiver. The general arrangement is similar to that of an intermediate-frequency amplifying stage in any superheterodyne receiver. Across the primary of the i-f transformer

Radio

which is between the last i-f amplifier tube and the limiter tube is a resistor which increases the range of frequencies to which this transformer responds. You will recall that the greater the resistance associated with any tuned circuit the broader is its resonance curve. Here we add resistance so that the transformer may handle the wide frequency range used in the F-M receiver.

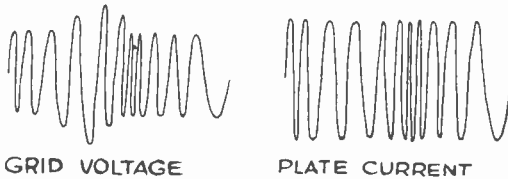

Fig. 53.—The limiter removes amplitude modulation from the amplifier i-f voltage, but retains the frequency modulation.

The i-f transformer which follows the limiter tube has a center-tapped secondary because in the following discriminator stage there are two diode detectors. The limiter tube is shown as a screen grid type. It might have also a suppressor grid, then being a pentode. Screen voltage is adjustable by means of a voltage divider connected between B+ and ground (which connects to B-), with the screen connected to the slider of this divider.

The action of the limiter is shown by Fig. 53. Here the grid voltage is of varying frequency, or is frequency modulated. But in addition there is some variation of amplitude. This additional amplitude modulation might result from static, from electrical disturbances in the power supply, or from interference due to any nearby electrical apparatus. The grid voltage, which has both frequency modulation and amplitude modulation, produces in the plate circuit a current having only frequency modulation. The limiter eliminates undesired amplitude modulation and retains the frequency modulation which represents the audio frequencies being transmitted.

The limiter tube acts in this manner because it is operated at very low voltages on both plate and screen, possibly at 15 volts on the plate and 10

Discriminator Stage

volts on the screen. These low voltages are capable of drawing from cathode to plate only a limited electron flow regardless of changes in grid voltage. Then relatively small changes of grid voltage will cause corresponding changes of plate current, but grid voltages in excess of a certain value cannot cause corresponding increases in plate current. These excessive grid voltages are those corresponding to the unwanted amplitude modulation, but since they cannot cause excessive plate current the effects of amplitude modulation do not appear in the plate circuit.

It is apparent that the grid voltage must remain above a certain minimum strength on the limiter grid. If the grid voltage is less than required for producing the plate current changes which are limited by the plate and screen voltages, then the plate current will vary in amplitude as well as in frequency. I-f amplification in preceding stages must raise the grid voltages to this minimum value or above in order that the limiter may remove any amplitude modulation. Adjusting the screen voltage by means of the voltage divider of Fig. 52 controls the maximum plate current which may flow in the limiter tube.

DISCRIMINATOR STAGE

The discriminator stage of the F-M receiver, for which a typical circuit is shown by Fig. 54, is the equivalent of the demodulator or second detector in a superheterodyne receiver. The i-f transformer shown at the left in Fig. 54 is the same one shown at the right in Fig. 52. The discriminator tube is a twin diode type having two plates and two cathodes in a single envelope. The plates are connected to the preceding i-f transformer. The cathodes are connected to opposite ends of center-tapped resistor **A-B**, one end of which is grounded. Since the diodes are rectifiers their circuit carries direct current. The direct-current circuit is completed from the center tap between **A** and **B** to the center tap of the i-f transformer secondary through inductance coil **C**.

The operation of the discriminator circuit in separating the a-f modulation from the frequency modu-

Radio

lated voltages depends on three things. First, the center tap of the i-f transformer secondary divides the voltage across the tuned circuit of the secondary. This is the voltage induced in the secondary by variations of current in the primary of the transformer, just as in any other transformer. Second, the voltages across the primary of the i-f transformer reach coil **C** through the coupling capacitor **D**. With respect to the voltages applied to the two sections of the twin diode the coil **C** is common to both halves of the i-f transformer secondary. Thus there are two voltages on each diode; the voltage in the i-f transformer secondary and the voltage across coil **C**. Third, the controlling factor in operation of the discriminator is the phase relationship between the two voltages just mentioned. This relationship depends on the frequency of the incoming signal and on the frequency at which the i-f transformer secondary is resonant. Remember that the incoming frequency varies with modulation.

Supposing that the incoming signal is not modulated but remains of constant frequency, which is the intermediate frequency so far as the discriminator is concerned. If the i-f transformer secondary is tuned exactly to this intermediate frequency the phase relations between the two voltages on each diode are such that no audio frequency changes appear across resistors **A-B**. Then no sounds are heard from the loud speaker.

Now assume that the received signal, and the i-f voltages, are modulated and that their frequency varies. The secondary of the i-f transformer is not resonant at the higher and lower frequencies of modulated voltage. At frequencies above resonance the circuit acts like an inductance, and for frequencies below resonance it acts like a capacitance. The phase relation between voltages applied to the diodes then shifts in such manner as to cause unbalance in the diode currents. This unbalance occurs at the a-f rate at which the intermediate frequency changes, due to modulation. Alternating voltages which are produced between point **E** and ground have the same wave form as the a-f modulating voltage. These audio frequency changes are passed on to the a-f amplifier in which they are strengthened and fed to the loud speaker.

Amplifiers

AMPLIFIERS AND AMPLIFICATION

According to the manner in which changes of plate current are related to the changes of grid voltage which cause them, r-f and a-f amplifiers may be specified as class A or class B amplifiers. The

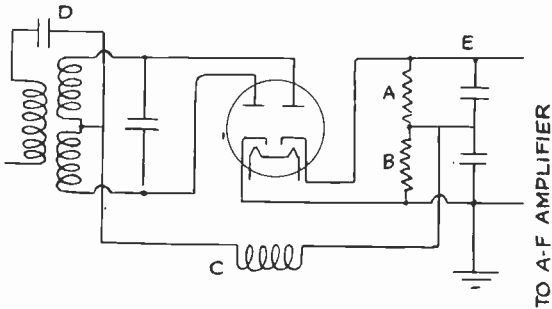

Fig. 54.—Circuits for the frequency discriminator of an F-M receiver.

operation of a class A amplifier is shown by Fig. 55. The grid bias voltage and plate voltage are such that changes of plate current occur only on a portion of the characteristic curve which is practically straight. Characteristic curves were shown in Figs. 27 and 31, and were explained in connection with those figures. The bias is sufficiently negative that

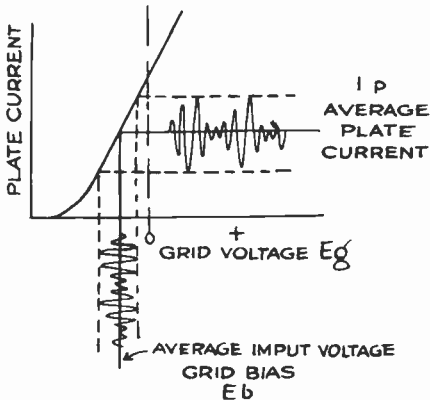

Fig. 55.—Grid voltages and resulting plate voltages in a class A amplifier.

the grid does not become positive even at the positive peaks of applied voltage. Since the form of the

Radio

waves in the plate circuit follows almost exactly the form of the voltage waves in the grid circuit the class A amplifier will give high fidelity amplification with a single tube.

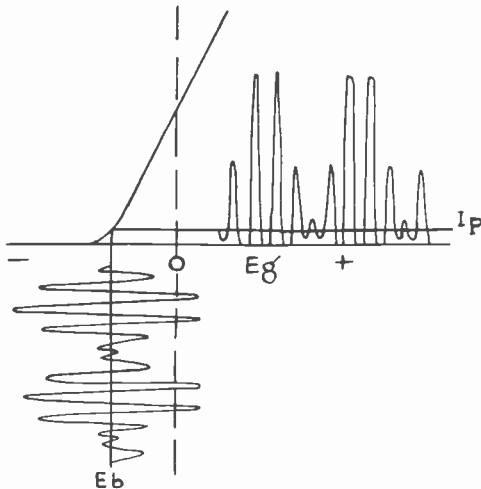

Fig. 56.—The operation of a class B amplifier, in which plate current is partially rectified.

Fig. 56 shows the operation of a class B amplifier. The grid bias is such as to bring the plate current nearly to cutoff. With no signal voltage applied to the grid the plate current is very small. With signal voltage on the grid, plate current flows essentially only during positive half-cycles of the grid signal voltage. Grid signal voltages may be great enough that operation occurs over the entire straight portion of the characteristic curve. Since the grid becomes positive at times there is grid current in the grid circuit.

A single r-f amplifier tube may be operated as a class B amplifier. There will be distortion because of the incomplete negative half-cycles, but since the r-f components of the distortion are of at least twice the frequency of the input voltage they are practically eliminated by the filtering effect of the r-f tuned circuits. In an a-f amplifier operated class B the distortion frequencies overlap the frequencies which are to be reproduced, and because a-f ampli-

Amplifiers

fier circuits are not tuned a single tube will produce an undesirably distorted signal from the loud speaker.

To avoid the distortion of a single tube operated as a class B amplifier two tubes are used in a push-pull circuit as shown by Fig. 57. The grids of the push-pull amplifiers are connected to opposite ends

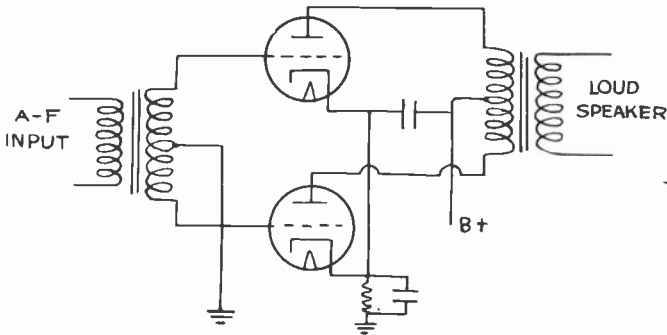

Fig. 57.—Connections for a push-pull amplifying stage in which the tubes are operated as class B amplifiers.

of a center-tapped secondary winding of the input transformer, whose primary is connected to a preceding stage of a-f amplification or to the detector output. The plates of the push-pull tubes feed into a center-tapped primary winding of an output transformer, whose secondary may feed the loud speaker, or, sometimes, an additional push-pull stage. One of the push-pull tubes operates during each half of the cycle. The resulting quality or fidelity is comparable to that of class A amplification, and the efficiency or power ability is much greater.

Some amplifiers are of class AB, in which operation is intermediate between class A and class B. In some of these, called class AB₁, no grid current flows at any time, while in others, class AB₂, a little grid current flows when the grid voltage peaks become of maximum positive value.

Class C amplifiers, whose operation is shown by Fig. 58, have so much distortion, even in push-pull systems, that their use is practically limited to certain special types of R.F. tuned amplifiers designed to respond to input voltages of constant amplitude. In class C operation, the grid is negatively biased

Radio

beyond the plate current cutoff point. Thus there is no plate current until the grid becomes sufficiently positive to overcome the excess negative bias beyond the cutoff point.

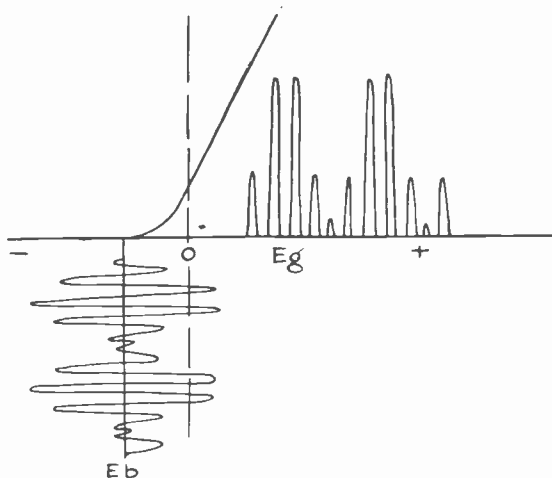

Fig. 58.—Operation of a class C amplifier in which negative grid bias is greater than required for cutoff of plate current.

FEEDBACK

Whenever the voltages or currents of, both the grid and plate circuits pass through any impedance which is common to both circuits there may be, and usually will be, a feedback of energy from the plate circuit to the grid circuit, or even from the circuits of one tube back to those of a preceding tube. Uncontrolled feedback may cause distortion and other difficulties in operation. The many bypass capacitors, and the many small resistors and choke coils found in all receivers are for the purpose of preventing feedbacks by completing the plate and grid circuits for each tube through paths of low impedance through the capacitors and by opposing feedback currents with resistors and choke coils.

Controlled feedbacks may be employed to improve the performance of a receiver. If the feedback voltage is in phase with the grid voltage the grid voltage is strengthened and we have **regeneration**. If the feedback is in opposite phase the grid voltage is

Amplifiers

lessened and we have degeneration. Regeneration may be used to increase the overall amplification. If the amplifier has a high voltage gain it may be desirable to use some degeneration, which results in improved quality. The chief difficulty in employing feedback is that changes of impedances with changes of frequency may allow a controlled feedback to become uncontrolled. The shielding between stages must be carefully designed and applied when feedback is employed.

Regeneration has the same effect in increasing total output as would be had with less high-frequency resistance. Therefore, regeneration improves both sensitivity to weak signals and selectivity which builds up the wanted signal while excluding others. Degeneration is frequently employed in a-f amplifiers, where it makes operation more nearly independent of impedance changes with frequency changes, and where it reduces distortion which arises within the amplifier itself; thus reducing the noise level more than it does the signal level.

POWER SUPPLIES

Every receiver requires three different ranges of voltage for its operation. First, it is necessary to have a low voltage for current that heats the filaments or the cathode heaters of the tubes. This current may be direct or alternating. Filament or heater voltage may be called A-voltage, and its source may be called the A-supply. Second, direct current at high voltage is required for the plates and screens of the tubes. This voltage may be called B-voltage, and its source called the B-supply. Third, there must be direct voltages of moderate values for biasing the grids of the tubes. This voltage most often is secured with a resistor in the cathode or filament lead, as in many preceding diagrams, but it may be supplied by resistors in the B-supply circuit. Biasing voltage may be called C-voltage.

A power supply furnishing A-, B-, and C-voltages for an a-c operated receiver is arranged in general as shown by Fig. 59. Part A is a transformer whose primary is connected to the a-c line. The secondary furnishes low voltage and current for filaments and heaters, in this case $2\frac{1}{2}$ volts, and also high voltage

Radio

for rectified direct current and direct voltages for plates, screens and grids. **Part B** is a rectifier, shown here as two diodes which, together, provide full-wave rectification. Full-wave and half-wave rectification is explained in detail in the section on Rectifiers and Converters. **Part C** is a low pass filter whose operating principle was shown and explained with Fig. 20. This filter changes the pulsating direct current from the rectifier into practically smooth direct current for **Part D** which is a voltage divider. From taps on the voltage divider resistance system are taken the various voltages and currents required for plate and screen circuits. In the diagram of Fig. 59 there are additional resistors which furnish 3, 9 and 45 volts of negative bias for grids.

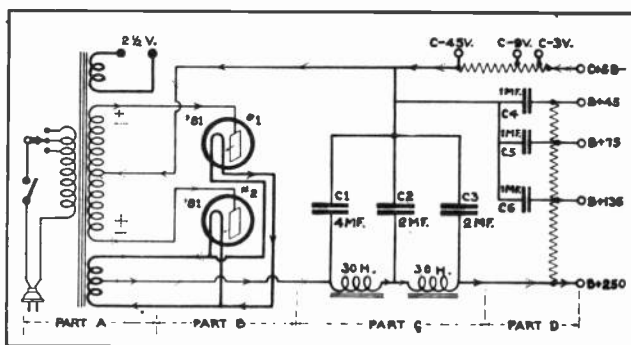

Fig. 59.—A complete power supply system which furnishes voltage and current for filaments, heaters, plates and screens, and which furnishes biasing voltages for grids.

The C + and B — terminal of the power supply would be grounded for receivers using ground returns for plate circuits and grid circuits. Then current from the several B + terminals of the power supply would flow through plate and screen circuits to ground, from ground would come to the C + and B — terminal of the power supply, and then would pass through the C-voltage resistors to the center tap of the transformer secondary. This current causes voltage drops in the resistors, these drops being suitable for grid bias since all the voltages are more negative than that of B—

Amplifiers

Bypass capacitors are connected to each of the B+ voltage terminals so that rapid fluctuations of voltage in any one plate or screen circuit are bypassed to the low voltage point as shown, or else to ground. Thus the fluctuations of voltage in one circuit do not reach the other circuits to cause feedbacks.

In some receivers the voltage divider resistors are grouped together as indicated by Fig. 59, but frequently these resistors and their bypass capacitors are mounted wherever convenient among other parts. Such a distribution of voltage divider resistors is shown by Fig. 60, which is the circuit for a 4-tube superheterodyne with a full-wave twin diode rectifier in its power supply. Diagram **A** is a complete circuit diagram for the whole receiver. Diagram **B** shows separately the field winding of the loud speaker, which acts as an inductance for the filter, and shows the voltage divider resistors as they would appear were they grouped together. Starting from the speaker field in diagram **A** it is easy to trace through the various voltage divider resistors, which form a circuit like that of diagram **B**. The ohmmeter in diagram **B** is not a part of the receiver, but is a test instrument connected as shown when checking resistance in the filter and voltage divider.

A device designed for the transmission of voice or music by radio **must** be provided with:

1. Some means whereby air pressure variations (sound) may be changed into equivalent electrical impulses. This is the function of the **microphone**.
2. A section designed to generate the radio frequency A.C. carrier energy. This is the function of the **oscillator**.
3. An arrangement which will impress the audio frequency energy upon the R.F. carrier. This is the function of the **modulator**.
4. Some device that will cause the modulated energy to be radiated into space. This is the function of the **transmitting antenna**.
5. A source of electrical energy; that is, a **power supply**.

Amplifiers

voltage in any one plate or screen circuit are bypassed to the low voltage point as shown, or else to ground. Thus the fluctuations of voltage in one circuit do not reach the other circuits to cause feedbacks.

In some receivers the voltage divider resistors are grouped together as indicated by Fig. 59, but frequently these resistors and their bypass capacitors are mounted wherever convenient among other parts. Such a distribution of voltage divider resistors is shown by Fig. 60, which is the circuit for a 4-tube superheterodyne with a full-wave twin diode rectifier in its power supply. Diagram **A** is a complete circuit diagram for the whole receiver. Diagram **B** shows separately the field winding of the loud speaker, which acts as an inductance for the filter, and shows the voltage divider resistors as they would appear were they grouped together. Starting from the speaker field in diagram **A** it is easy to trace through the various voltage divider resistors, which form a circuit like that of diagram **B**. The ohmmeter in diagram **B** is not a part of the receiver, but is a test instrument connected as shown when checking resistance in the filter and voltage divider.

A device designed for the transmission of voice or music by radio **must** be provided with:

1. Some means whereby air pressure variations (sound) may be changed into equivalent electrical impulses. This is the function of the **microphone**.
2. A section designed to generate the radio frequency A.C. carrier energy. This is the function of the **oscillator**.
3. An arrangement which will impress the audio frequency energy upon the R.F. carrier. This is the function of the **modulator**.
4. Some device that will cause the modulated energy to be radiated into space. This is the function of the **transmitting antenna**.
5. A source of electrical energy; that is, a **power supply**.

If a relatively large amount of power is to be radiated, amplifying stages in both the R.F. and the A.F. sections will be required.

Radio

A device designed for radio reception of voice or music **must** be provided with:

1. A means of picking up the desired transmitted energy. This is the function of the **receiving antenna**, and **tunable resonant circuits**.
2. Some means of recovering the A.F. impulses from the modulated R.F. carrier. This is the function of the **demodulator**.
3. A device for changing electrical impulses into sound. This is the function of the **loud speaker** or **headphones**.
4. A source of electrical energy; that is, a **power supply**.

Radio

AIRCRAFT ELECTRICAL WIRING SYMBOLS

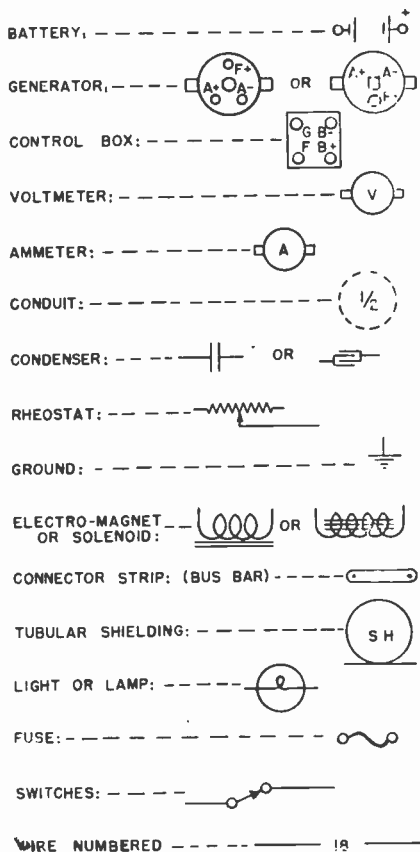

Most commonly used symbols for aircraft radio men.

INDEX

A

- Absorption, types of refrigerators, 101
- Air conditioning, commercial types (photo), 298
 - combination furnace and cooling, 255
 - ceiling type, 253
 - cooling the air, 259
 - cutaway photo, home installation, 256
 - dehumidifying the air, 264
 - filters of, 272
 - filtering the air, 274
 - grilles, 291
 - heat leakage, factors in material, 289
 - heat load calculations, 287
 - humistat, 271
 - humidifying, 268
 - heating the air, 257
 - installation & testing, 301
 - insulation of buildings, 295
 - air in the system, 206
 - principles of, 249-255
 - plenum chamber, 254
 - photo system for store, 251-252
 - photo, York Ice Machine Co., 10
 - photo, office installation, 261
 - photo of train, 262
 - restaurant cooling problems, 299
 - room cooler - Westinghouse, 260
 - room coolers, 7-258
 - types of, 254
 - unit, Westinghouse, 7
- Ammonia, 92
- Ammonia systems, 241
- Amplification, 333
- Amplifiers, 362-372
 - class B operation, 363
- Antennas, radio, 309
- Audio frequency, amplifiers, 348

B

- Baffles, for draining water (photo), 221
- Band, wave, 356
- Barostat, two temperature valve (diagram), 230
 - valve, on flooded system, 233
 - on dry system, 233
 - on flooded & dry system, 233
- Bearings, on compressor, 168
- Bias, grid, 328
- Blowers, 281
- Boiling point, 19

C

- Cabinet, repairs, 216
- Cabinet, G.E. refrigerator
 - photo, 218
 - refrigeration, 78
- Capillary tubes, 68
- Carbon dioxide, 92
- Carrene, 94
- Carrier unit (photo), 251-252
- Changes, voltage (radio), 329

- Charge, determining amount of, 186
- Charging, gaseous method, 200
 - general procedure for, 200
 - low side, 200
 - high side float systems, 200
 - capillary tube systems, 201
 - low side float systems, 201
 - expansion valve systems, 202
 - liquid method, 202
 - photo, valve, 171
- Chart, head pressure, condenser
 - temperature, 178
- Chemical dehydrator, 188
- Circulation, 277-304
 - refrigeration, 29
 - blowers & ducts, 281
 - selecting the fan, 280
- Circuits, filter type, 320
 - plate load, 330
- Cleaning service drums, 204
- Compressors, commercial refrigerators, 244
 - bearings, 168
 - construction of, 48
 - cutaway photo, 50
 - gear type, 54
 - efficiency test, 197-160
 - installation of, 206
 - overhauling of, 208
 - shaft seals (photo), 151
 - reciprocating types of, 49
 - removal of, 206
 - rotary type, repair, 169
 - rotary, type of, 53
 - rotary gear type diagram, 56
 - rollator type, 54
 - syphon bellows type of, 54
- Codes, refrigeration, 233
- Cold control units, (photo), 149
- Cold control switch, (photo), 175
- Compressor, 2 cylinder reciprocating type, 55
 - types of, 51
- Condenser, (photo), 177
 - troubles in, 178
 - types of, 57-60
- Condensing, units, 28
 - Stewart-Warner unit, 107
- Connections, flare, 114
 - soldering a sweat type, 119
- Controls, volume, 346
- Control switch, troubles in, 175
- Condenser temperature, chart, 178
 - temperature & head pressure, 178
- Condensing unit, removal from cabinet, 162-165
 - removal without discharging, 189
- Converter, 6A7 pentagrid type, 355
- Cooler, room, 7
- Cycle, absorption system, 102
 - definition, 32
 - diagrams, 36-39
 - Fairbanks Morse (photo), 34
 - Kelvinator (photo), 39
 - Stewart-Warner, 32
 - refrigeration, 27-49
 - Servel Co., 35

D

- Defective parts, refrigeration, 205
- Dehumidifying, (photos), 263-264
- Dehydrator, 187
 - photos, 152
- Detectors, 343
- Delco, motor with thermotron, 215
- Discharging, general procedure of, 199
 - neutralizing refrigerant, 183
 - pumping out the air, 199
 - refrigerant from unit, 182
 - refrigerator unit, 181
- Discharge valves, lapping of, 166
- Drinking water cooler, evaporator in, 238
- Dry system, 2 temp. valves, 233
- Ducts, 281
 - photos, 292
 - installation of, 283
 - outlets for, 283

E

- Efficiency test, compressor, 159
- Evaporation, 22
- Evaporators, 60-63
 - direct types of, 60
 - dry types of, 220
 - indirect types of, 60
 - Fairbanks Morse type, 62
 - pressure temperature chart, 63
- Ilg, photos, 296
 - photos, 177
 - in drinking water cooler, 238
 - temperature & low side pressure table, 186
 - temperatures, 62
 - troubles in, 178
 - units of, 31-32
- Expansion valve, photo, 149

F

- Fans, centrifugal (Ilg), 288
- Feed back, 365
- Filter, 272
 - circuits, 320
 - diagrams of, 321
- Fittings, 113
 - sweat types of, 117
- Flaring, 115
 - tools for, 116
- Flooded system, 2 temp. valves, 233
 - flooded & dry system, 233
- Freon, 91
- Frequency, 315
- Frequency modulation, 355

G

- Gauges, installation of, 196
 - use of for service, 125
- General Electric, cabinet,
 - photo, 218
 - capacitor motor, 215
- Grid, bias, 328
- Grilles, air conditioning, 291

H

- Head pressure, 180
 - condenser, temperature chart, 178
- Heat, latent, 13
 - load calculation (air cond.), 287

- methods of, 13
- transfer of, 21
- Hermetic, units, 40
- High side charging, 202
- Humistat, 271
- Hygrometers, 265

I

- Ice cream freezing, unit, Mills, 122
 - units, 238
 - diagrams, 240
- Impedance, 311
- Installation, market type ref., 142
 - remote (refrig.), 111
- Insulation, buildings, 295
 - chart, 80

K

- Kelvinator, rep. ind. motor
 - parts, 213
 - single cylinder compressor
 - parts, 159
- Kelvinator, 2 cylinder
 - compressor parts, 161

L

- Lapping, bellows ring, 168
 - discharge valves, 166
 - how to hold bellows (photo), 167
 - seal rings, 164
 - shaft seals, 164
 - valve seat, 170
- Liquid line, filters in, 195
 - troubles in, 194
- Load, plate circuit, 330
- Low side charging, 200

M

- Meat market installation,
 - refrigeration, 158
- Mercury type switches, 237
 - photo, 235
- Meter, portable for refrig.
 - servicing, 154
- Methyl chloride, 89
- Methyle formate, 94
- Methods, soldering connections, 118
- Mills Novelty Co., ice cream freezing unit, 240
- Motors, capacitor type, 214
 - photo, 214
 - drive, capacitor type, 77
 - capacitor type with overload relay, 213
 - common troubles, 211
 - GE — diagram, 215
 - running hot, 149
 - with thermotron, 215
- Mueller Brass Co., snap action valve, 232
- Multiple system, diagram, 228
- Multiple and commercial refrig. systems, 223-248
- Multiple systems, general types, 231
- Multiple installations, servicing of, 223

N

- Neutralizing, worthless refrigerant, 183

O

- Oils, 96
 - amount needed, 98
- Oil charge, 191
 - fitting for adding, 193
- Ordinances, refrigeration, 233

P

- Parts, frequency modulator receiver, 358
- Pentode tubes, 336
- Pistons, defective, 167
- Power, supply, 366
- Pressure, balancing of, 205
 - difference in, 18
 - on low side, 186
 - gauges, 17
 - temperature relation, 87
 - and temperature, 185
- Psychrometers, chart, 270
- Purging, air from unit, 206
- Purging, valve, 171

Q

- Questions, air conditioning, 304
 - air conditioning, 276
 - refrigeration, 26-47-99-80-120-248-210-156

R

- Radio, 305-372
 - antennas, 309
 - couplings, 319
 - detectors, 343
 - diode rectifier, 324
 - elements, 305
 - feedback, 365
 - frequency modulation, 355
 - grid bias, 328
 - impedance, 312
 - reactance, 311
 - resonance, 313
 - reception, 306
 - selectivity, 317
 - symbols, 310
 - tubes, 322-328
 - tuning, 314
 - transmission, 306
- Reactance, 311
- Receiver, troubles in, 194
 - 3 tube type, 340
 - complete, 341
- Reception, 307
- Receivers, superheterodyne, 350
- Recharging, a refrigerator, 183
- Rectifier, diode, 324
- Refrigerator display case,
 - grocery, 222
 - for meat market, 222
- Refrigerants, 81-84
 - common, 81
 - transferring from drums, 203
 - types of, 83-86
- Refrigeration, absorption
 - types, 101-105
 - by evaporation, 23
 - condensers, 57-60
 - comparison, Fahrenheit & Centigrade, 12
 - cabinets, 78

- capillary tube, 71
- cycles, 27-49
 - Kelvinator, (photo), 39
 - definition, 5
 - evaporation on temperature, 15
 - gauges, 17
 - GE unit (photo), 3
 - growth of field, 4
 - heat absorption (diagram), 11
 - heat methods, 11
 - transfer, 11
 - installation of, 108
 - large size domestic units, 132
 - lubricating oils, 81-84
 - multiple systems, 44
 - nature of heat & cold, 8
 - opportunities in field, 121
 - operation, 49-80
 - parts, construction & operation, 49-80
 - pressure & boiling point, 16
 - principles of, 3-9
 - (photo) Worthington Pump Co., 24
 - General Electric Co., 30
 - York Ice Machine Co., 6
 - refrigerants, 81-84
 - systems & cycles, 27
 - sensible heat & latent heat, 13
 - 2 temperature types, 43
- Rings, defective, 167
 - tests, 198
- Refrigeration receivers, 177
- Refrigerator motor and cabinet troubles, 211-223
- Refrigerator service procedure, 157-210
- Repairs, rotary type compressors, 169
- Replacement parts, mercury switch controls, 235
 - repulsion-induction motor, 213
 - receivers, 177
 - condensers, 177
 - cold control units, 174
 - evaporators, 177
 - compressors, 173
 - motors, 173
 - condensing units, 173
- Resonance, 313
- Restaurant refrigeration installation, 226
- Rooms, cold storage, 25

S

- Safety rules, 204
- Seal rings, lapping of, 164
- Sensible heat, 13
- Servel Mfg. Co., lapping, 170
 - photo, 138
- Service drums, 204
 - safety rules for handling, 204
- Service gauges, correction for testing, 190
 - connections for charging, 192
- Service loads, calculations of, 242
- Service tools, 224
- Service valves, care of, 195
- Service, bad taste in ice cubes,
 - milk or butter, 153
 - compressors, 157
 - condensers, 158
 - control switches, 157

Service—Cont'd.

- desserts won't freeze, 145
- evaporator frosts too much, 155
- evaporators, 178
- ice cubes freeze too slowly, 143
- liquid line troubles, 194
- methods of testing, 133-140
- motor runs too fast, 149
- motor troubles, 211
- objectionable odors, 154
- overload button trips out, 148
- preliminary observation, 124
- personal and mechanical, 123
- refrigerator is noisy, 146
- shaft seal troubles, 162
- water in cabinet, 151
- Shaft seals, lapping of, 164
- leak test, 197
- Sludge, 195
- Snap action valves, 229
- photo, 232
- Solenoid valves, 229
- photo, 231
- Stage, discriminator, 360
- limiter, 358
- Switches, cold control, 74
- electric control pressure, 72
- pencil type, 76
- setting for pressure control, 73
- Sulphur dioxide, 85
- Systems, apartments, 45
- intermittent absorption, 105
- multiple, 44
- refrigeration, 27
- Sylphon bellows, 151
- Symbols, radio, 310-339-342

T

- Tables, air change, 281
- air duct sizes, 289
- insert, 129
- Temperature, pressure chart, 64
- Testing, for leaks, 88
- Thermometers, recording type, 237
- for checking cabinet temperatures, 225
- charts, 236
- pocket type, 153
- Thermostatic valves, pressure type, 175
- Thermostatic control, valve
- Photo, 149
- Thermostats, bi-metal, 75
- Tools, flaring, 116
- Transfer, of heat, 21
- of refrigerants, 203
- Transmission, 306
- Triodes, 326
- Troubles, 133-140
- analyzing, 123
- cabinet too cold, 141
- cabinet too warm, 139
- common types of refrigeration, 131
- compressor, 157
- condenser, 179
- control switch, 178
- desserts do not freeze, 145
- evaporator frosts too much, 155
- evaporator, 178
- motor, 211
- refrigerator is noisy, 146
- ice cubes freeze but cabinet too warm, 144

Troubles—Cont'd.

- motor runs too fast, 149
- overload button trips out, 148
- receiver, 194
- shaft seal, 162
- units operate too often, 139
- Tubing, 112
- Tubes, radio, 322
- beam type, 337
- capillary, 68
- characteristics of, 334
- pentode, 336
- screen grid, 334
- variable mu, 338
- Tuning, 314
- Two temperature valves, 227
- adjustment of, 230
- Barostat, 230
- dry system, 233
- flooded & dry system, 233
- flooded system, 233

U

- Units, air conditioning size of, 285
- air cooled absorption, 104
- Unit, commercial air conditioning, 298
- condensing, 28
- Servel type, 42
- evaporator, 31
- open, 40
- principles, intermittent type, 106

V

- Valves, automatic expansion, 67
- control, 66-69
- float type, 171
- for purging, 171
- for charging, 171
- low side float, 64
- low & high side float, 64
- service, 127
- service of, 195
- snap action type, 229
- photo, 232
- solenoid type, 231
- two temperature type of, 227
- adjustment of, 230
- thermo-expansion, 70
- thermostatic control, 175
- Valve header, removal of, 172
- Valve manifold, connections for removing, 192
- connections for charging, 192
- for testing, 190
- for purging, 184
- Valve seat, lapping of, 170
- Valve test, 197
- Ventilation, 277-304
- Ventilators, attic type, 279
- Volume controls, 346

W

- Wagner Co., motor with overload relay, 217
- Water drain baffles, 221
- Water cooler units, 238
- Wave band, 356
- Worthless refrigerant, discharging, 183
- Worthington Pump Co. compressor, 212

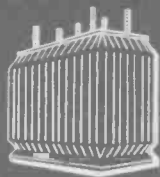

PRACTICAL
Electrical and Radio
Books
for
PRACTICAL MEN

