

CORRESPONDENCE

FOR YOUR GUIDANCE

You are about to commence a course of training which can have a tremendous influence for the good upon your future career. I know that you are enthusiastic to make the very most of your training, and that is why this guidance booklet has been written.

In the pages which follow, I want to set out clearly before you all the main advantages and facilities the Australian Radio College offers you. I want to go further than this, I want to show you how you can use these facilities to get the very most out of your association with the College.

Before you commence studies, read right through this booklet, from beginning to end - make sure that you are thoroughly acquainted with what it contains. When you have finished, do not place it where it may be lost, but keep it carefully filed, for preference, with your lessons. Keep it where you can refer to it at any time.

This booklet can mean £.S.D. to you in every way, because it is the fingerpost to all those extra A.R.C. Services which will help you to spell "SUCCESS" after your name.

Finally, I want you to feel that even after you have completed your training we continue to be interested in your welfare. All the A.R.C. Services will be gladly extended to you at all times. They are not just for the period of your training, but are lifetime services, which will be always available to help and guide you in all radio matters.

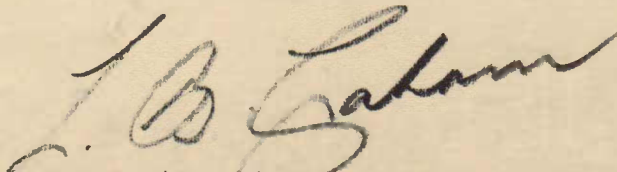
M.I.R.E. (Aust.) Fellow of the Television
Society (England)

PRINCIPAL.

STUDY PROCEDURE.

To obtain the greatest benefit from this course of radio training and in order to master it rapidly and easily, you should carefully follow these simple rules. Throughout your course you should make frequent references to these 'guide posts'. In this way you will make more rapid and thorough progress.

This course has been carefully planned and prepared. The practical experience of many famous engineers has contributed to make this the most up to date and thorough radio training available.

1. First, take one lesson at a time and read through it easily, as if you were reading an interesting book. This will give you a general idea of what the lesson is about. But - it is not enough to just read your lessons. You must study them. So read through it again, this time studying it carefully, and, if necessary, taking notes of the most important points. Just half an hour of concentrated and uninterrupted application to your lessons will benefit you more than three or four hours of half-hearted application.

NOTE: When you have answered the examination questions to the first lessons, post them to the College in the envelope provided. In the meantime, carry on with your study of Lesson No. 2. When we receive your answers to Lesson 1, they will immediately be corrected and returned to you with your next lesson.

2. Make sure that your whole mind is on your subject. Never be careless in your study. Habits are made merely by doing one thing three or four times. Therefore, every time you carelessly study your lesson you are strengthening a habit that is bad for you. On the other hand, if you study your lessons properly by giving your full attention to them, you are strengthening a good habit.

Always keep your mind on the subject in the lesson under review. Do not read any part of your lesson while you are thinking of something else.

3. A certain time set aside each day will benefit you more than two hours to-day, none to-morrow and one the next day and so on. Be systematic in your work and your progress will be more rapid. Learn a little at a time. Retain what you learn by not trying to cover too much ground immediately. A little each day will result in surprising progress by the end of a few weeks.
4. Never lay aside a lesson to pick up the next one unless you are sure, in your own mind, that you understand everything taken up in that lesson.

That is the most important thing I can tell you at this time. It's so important that had I room, I would print these few words in letters the size of this page. It's so important that nothing I can say would be too strong on this point You will, I am sure, read your lesson sheets carefully, just as I have asked you to do.

5. There are questions at the end of each lesson sheet. These questions are based on subjects covered in that particular sheet. Should you find yourself unable to answer any question, don't give up and let it go at that. Instead, go back over the lesson sheet until you locate that part of the lesson covering the question you can't answer --- there you will find the information that will enable you to answer the question that was bothering you ... But answer the question tomorrow, not at the moment of reference.

This information is always there. No questions are ever asked that are not fully covered in the text of each lesson, and by reading or studying each lesson carefully you will always be able to answer each and every question easily and correctly. So, again read each lesson sheet carefully.

6. When doing examinations write out the question on your answer sheet before you write your answer. Make sure that your name and address are clearly shown at the top right hand corner on the front or first sheet. While neatness and spelling are not essential, it will be of benefit to you to be as neat and correct as you can. It is only by striving towards perfection that we reach it.
7. Finally, I want you to look on us as friends. The aim of every member of the staff is to assist you. Do not hesitate to write in if you require help and advice with your studies.

SYLLABUS.

TELEVISION, FREQUENCY MODULATION AND FACSIMILE COURSE.

1. What television, frequency modulation and facsimile are.
2. Source of television signals.
3. Cathode ray tube--principles and operation.
4. Electronic scanning and television camera tubes.
5. Video amplification.
6. Transmission of television signals.
7. Aerials.
8. Television receivers.
9. Image reproduction.
10. Beam deflection synchronisation.
11. Receiver power supplies.
12. Colour television.
13. Recent television developments.
14. General characteristics of frequency modulation.
15. Frequency modulated transmitters.
16. Frequency modulated receivers.
17. Audio frequency systems and typical receivers.
18. Alignment and servicing of frequency modulation receivers.
19. Facsimile transmission.
20. Facsimile receivers.

PLEASE NOTE.

"TELEVISION, FREQUENCY MODULATION AND FACSIMILE COURSE."

It is brought to the notice of students engaged upon the above course, that this guidance booklet was originally compiled as a prefix for the student about to commence our Radio Service Engineering Course. However, with the exception of minor details, all information contained herein, is applicable to students engaged upon our Television, Frequency Modulation and Facsimile Course.

Minor alterations are.....

Page Reference.

Page 6....The T. F.M. and F. Course is comprised of one section only, therefore the one original set of service covers is supplied for the complete course.

Page 8....Average rate of study is two lessons per month.

Page 12...Since the A.R.C. Fault Finder refers to servicing work, it is not supplied with the T. F.M. and F. Course. However, if you require one, these are available from the A.R.C. Sales Department.

Page 12...Two sets of stiff covers are required if you wish to bind the complete course.

POSTAGE ON LESSONS

The College pays postage on all lesson matter and correspondence sent to you. You pay postage on all lesson matter and correspondence sent to the College.

The Post Office allows a special rate on lesson matter sent by students to the College provided it is unsealed. The rate for unsealed lesson matter is only 3d. for the first 2 ozs. For each additional 2 ozs. an extra amount of 2d. is charged. This means that all average lesson examination papers you return, which normally weigh under the 2 ozs., will only cost you 3d. Any sealed matter must be paid for at ordinary postage rates. With every lesson, you receive a printed return envelope for your examination answers. There are two methods of treating these envelopes when taking advantage of the special unsealed postage rate.

1. You can fold the flap over the contents of the envelope. This method makes it possible for the contents to be shaken out and cannot, therefore be high recommended, although it is used extensively.

Be sure to fasten your return envelope carefully. Also never send your fees with lessons, unless you seal the envelope and for preference, register it.

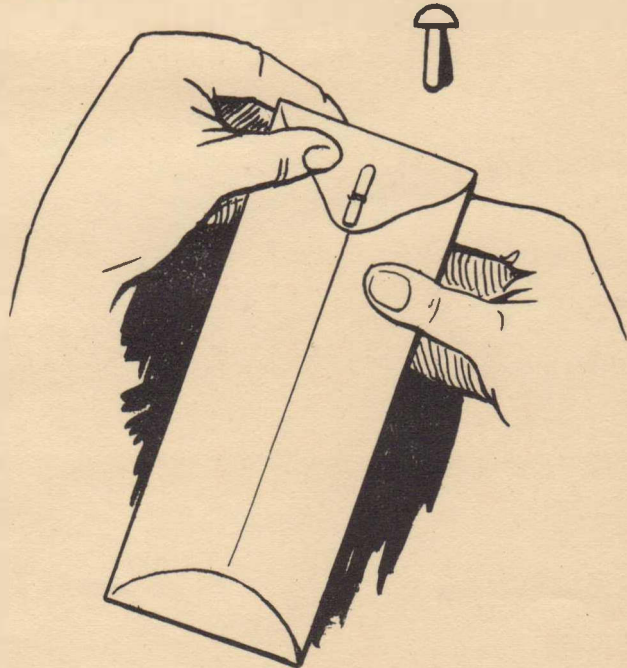

2. You can fasten the back of the envelope and the flap together with a round edged paper fastener. Make sure it is a round edged paper fastener, and not a pointed one, because the latter are banned by the Post Office through their habit of cutting the Postman's hands.

When your examination questions reach the College, they are corrected the same day, or at the latest the day following, and immediately returned to you with another lesson and return envelope.

THE A.R.C. BADGE.

The College badge is given to every student, free of charge, when he enrolls. It is designed to screw into the buttonhole on the lapel of your coat. You should wear this badge always because it will help you in many ways. The wearers of this badge are joined in a bond of fellowship which extends around the world. You will find A.R.C. students in all parts of Australia and the Empire ---- they are recognised by the blue and gold badge.

Many a student who has successfully applied for a radio position has attributed his success in becoming placed in large measure to the fact that he was immediately recognised, by means of the badge, as a Student of the Australian Radio College.

It helps in many ways too. The A.R.C. badge has opened many a prospective customer's door for the student in business for himself.

This badge is recognised by the Radio Industry and public alike, as the hall mark of all that is excellent in radio training.

EXAMINATIONS & AWARDS.

Your first lessons reach you in the special service covers supplied with each Section of the course. You will notice from the training syllabus that there are three Sections to the Course. When you commence a new Section, you receive another pair of service covers, making in all, three sets of covers. The purpose of these service covers is to help you keep your lessons always fresh and clean. When you have finished studying all the lessons in your Course, and all your lesson examination papers have been returned to, and corrected by the College, it will be necessary for you to thoroughly revise right through the entire course. However, you will be notified of revision procedure when you reach that stage. After you have completed your revision, a Final Examination paper will be sent to you. Note, you do this examination in your own home, it is not necessary to travel to the College for the Final Examination. It is left to the student's own sense of honour not to refer to his lessons when doing the Final Examination. In any case, the fellow who copies from his lessons in any examination, however insignificant that examination might be, is definitely defrauding only himself. It proves beyond doubt that he has not absorbed the knowledge, and sooner or later it will prove fatal to whatever object he had in view when commencing the Course.

If by any chance there are any points upon which you are not quite clear, do not hesitate to communicate with the College immediately. We are always only too pleased to give you any advice and co-operation you require with your studies. A.R.C. Instructor Engineers are helpful, friendly and completely reliable men. They all have many years' experience of radio engineering work - student's problems in particular. Call on them always, for advice and assistance with your lessons.

Upon successfully passing the Final Examination to the "Radio Engineer's & Serviceman's Course", you are awarded the A.R.C. Certificate, and Certification Card. The Certificate should be framed and hung upon the wall of your study or workshop. The Certification Card should be kept in your pocket and produced when you are making Service Calls or at other times when certification of your technical qualifications might prove to your advantage.

The Diploma, which is the highest recognition made by the College, is only awarded after the student has successfully studied the A.R.C. Advanced Radio & Television Courses.

At Right: The A.R.C. Certification Card.

Below: The A.R.C. Diploma, Certificate & Lessons.

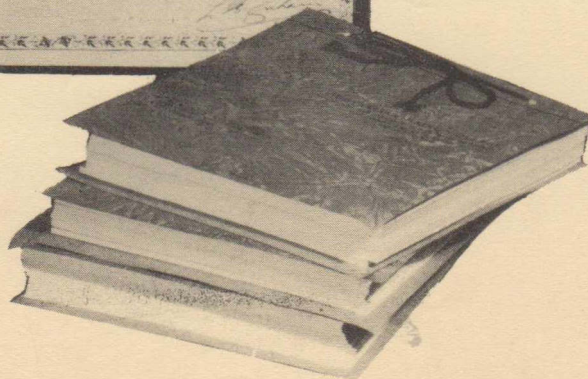
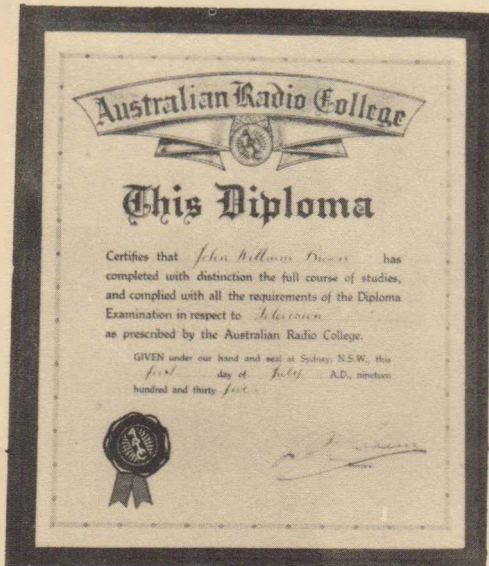

WHEN SENDING MONEY.

Be very careful when you are sending money for fees, etc. to the College. First, it should definitely not be included with your lesson examination answers, unless the envelope containing them, is sealed. If there is any possibility of the letter going astray, it is far better for you to register it.

Make all money orders, postal notes, cheques, etc, payable to

AUSTRALIAN RADIO COLLEGE PTY. LTD.

Broadway.

and see that your envelope is addressed to the College, and not to individual members of the staff.

We make a practise of returning all receipts immediately we receive a remittance. Therefore, if you do not receive your receipt within a reasonable time of the despatch of your remittance, please notify our accounts department, and the necessary search will be carried out.

Make sure your name and address accompanies your remittance.

RATE OF STUDY.

So that you should see exactly where you stand with the amount of study your fees payments will allow you to do, the following should be noted carefully.

1. Students paying cash in advance for the whole course, may progress through their training at as great a speed as they wish.
2. Students paying for the course by the alternative cash payment plan of three cash payments within six months, may progress through the First Section as fast as they wish after their first cash payment. After their second cash payment they may progress through the Second Section, as fast as they wish, and after their third and final cash payment, they may complete the course as fast as they wish.
3. Students paying for their training on the monthly plan, will, if they progress at a good average pace, complete the course at about the same time as they finish paying for it, namely in about sixteen months. Under this payment plan, students may be trained at the rate of approximately three lessons per month. This is quite a good speed for anyone who is employed during the day time and only has his spare time to devote to training. Actually, one lesson per two weeks would be a medium pace.

The monthly fees payments were arrived at after due attention had been paid to the average fellow's rate of progress, and were designed so as not to retard his rate of progress in any way.

In the case of a student who finds that he has much more than the average amount of time to devote to lessons, and wishes to progress quickly with his training, it would be to his advantage to pay either cash in advance for the balance of his course, or make the three cash payments within six months. Either of these two plans will **save him money**. If he cannot see his way clear to pay according to either of these two plans, he can arrange with the College to increase his usual

monthly payments to a figure which will enable him to progress at the pace he wishes. Everyone will agree that this is quite a fair and equitable basis of fees payments.

In any case, no matter what your problems, if any, might be in regard to fees, you will always find us ready to co-operate with you in a sincere effort to see that you get the very most out of your training.

Just as some students wish to progress at a faster rate than average, so there are some who through illness, pressure of work or some other urgent reason can only proceed at a slow rate. Although the majority of students can comfortably complete the Radio Service Engineering Course in the normal time of 17 months (complete Radio & Television Course, 26 months) the College is happy to allow an extra 6 months (complete Radio & Television Course, 9 months) without any extra charge. However, if a student is so slow that the normal period plus the extra free period is exceeded, then a small extra charge will be made, the extent of the charge depending upon the amount of the course remaining to be completed at the time.

The reason for this surcharge will be readily understood in these days of rapidly rising costs, when it is realised that the fees for the course are determined prior to enrolment and the College is committed to supply instruction and material for a period of two years or so ahead; regardless of the way costs increase during this period. However, if a student wishes to prolong his course beyond even the extra free period granted by the College, then obviously a small charge will be necessary to cover the increases in the cost of labour and materials for the uncompleted part of the course.

If you regularly complete two and a half or three lessons per month you will not have to pay extra, so endeavour to study regularly.

PAYING FEES

We ask students wherever possible to have their monthly fees payments sent to the College on or about the 15th of each month. This helps us to keep our records efficiently by recording all fees payments at about the same time each month. A few days before the 15th of the month, we send a fees reminder statement, to remind the student that the month's fees day is approaching.

To save confusion and delay, please make all fees payable to "Australian Radio College Pty. Ltd." In the case of postal notes, money orders, etc., they should be made payable at BROADWAY, which is our nearest Post Office. Do not, under any circumstances, make the money payable to individuals, but always to the College.

FREE EMPLOYMENT SERVICE

If you aim to become placed in a radio position, the College will give you

every co-operation to find a job, both whilst you are a student, and at any time after you have finished your course.

Naturally, we cannot guarantee to find a position for any student because so much depends both upon the manner in which a student progresses with his training, and the number and variety of positions available when he has completed his training. However, many hundreds of students have been placed in worthwhile jobs in the past, and the demand by employers on the employment service is increasing.

A point to be kept in mind is that employment cannot necessarily be found for a student shortly after commencing the course. Quite frequently, especially in the case of junior students, we are able to place them after a short period. In the case of senior students, the rule is, that a student must have a thorough knowledge of the principles of radio engineering before any employer would consider an application for employment. These engineering principles are only obtained by the student absorbing his training right to the final lesson in his course.

Throughout your training, you are urged to endeavour to apply the knowledge we give you in every possible manner. This can be done in various ways. To engage in radio set building, and spare time radio service work are the two most profitable that can be suggested.

When you reach a stage of proficiency in your training, make enquiries for employment in suitable radio quarters in your district. Quite frequently, students are able to find good positions without the assistance of the College. One thing the College does guarantee is to give students every assistance and co-operation in finding suitable Radio Employment. Thousands have been placed in the past, and the efficiency and scope of the Employment Service is actually increasing. You stand an even better chance than those who have been placed by the College in the years that have passed.

FREE BUSINESS ADVICE SERVICE.

If you have any radio business problems, do not hesitate to seek the advice of the College Business Executives. They will at all times, gladly extend to you their sound advice which is based upon many years experience of all radio business matters.

You may intend commencing a radio business of some description, maybe you have a plan drawn up for a sales campaign; perhaps you have some special mailing pieces in mind, - no matter what your business problems might be, the College is always ready to assist and co-operate in any direction if required. This Service also operates for the lifetime of the student, and not just for the period whilst he is studying.

FREE TECHNICAL CONSULTATION SERVICE.

If you **require** any technical advice **or** information, the College engineers are always at your **service**.

It frequently happens that when a **student first starts** in a radio position, or commences a service business he comes across a **knotty problem** which may puzzle

him for the time. A.R.C. students never need worry about such problems because the Free Technical Consultation Service is always ready to help them out.

This Service is as close to you as your nearest telephone or letter box. All you need is to give us full details of your problems, and your queries will be answered immediately.

This Service is a lifetime Service - which means that you may use it, not only whilst you are training, but even after you have finished your Course, - in fact for the rest of your life.

You should gain confidence from the knowledge that such a service exists, confidence to tackle each and every technicality that may come your way.

"SERVICE" OUR COLLEGE MAGAZINE

This is a magazine originated and produced by Members of the College, Business and Technical Staff. In "Service" you will find articles on business management, sales campaigns, the latest technical improvements, vocational and employment aids. From time to time details of new circuits and how to build them are given, the latest in test equipment, what other Countries are doing in Radio, Refrigeration notes, and indeed any articles which are considered of value to A.R.C. Students are included in "Service". It is YOUR paper, designed to keep you up to date with trade and technical matters.

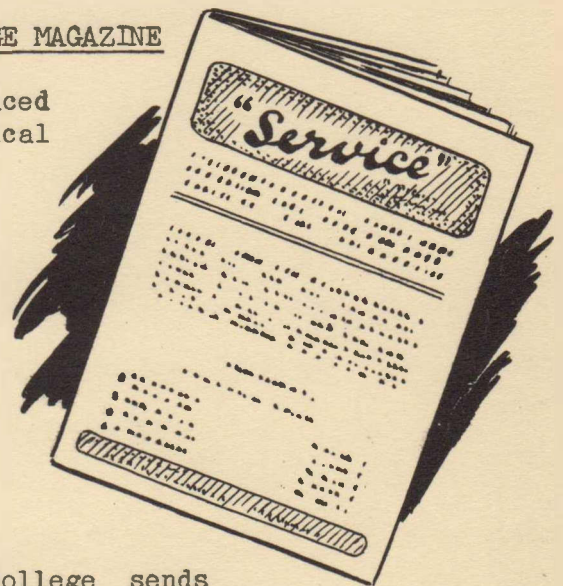

There is no charge for "Service", the College sends it to you post free as each edition is produced. When you have finished your course, you may continue to receive "Service" by paying the small annual subscription of eight shillings (8/-d). You should keep your copies carefully filed, because you will find it extremely useful at all times.

A.R.C. FAULT FINDER

The A.R.C. Fault Finder is a series of bound foolscap size service sheets, dealing with all faults found in radio receivers. It folds into quite a small chart and is designed to slip into your pocket. Originally designed by the College engineers, this Fault Finder is printed and compiled specially for the College. Its purpose is to supply the serviceman with a quick reference chart which can be carried with him when he is "on the job".

Each fault common to radio receivers is taken in turn, it's probable cause given, how to locate it, and finally how to rectify the trouble. There's not a radio service engineer can afford to be without this pocket service aid. They are given to you free when you enrol.

EXAMINATION WRITING PAPER.

You will find it an excellent plan to carefully file all of your corrected lesson examinations. They will prove of distinct benefit to you later on for reference purposes. The handiest and perhaps best place to file them, is with your lessons, for preference, immediately following the lesson to which they refer.

At the same time it is nice to have them clean and uniform, - it gives an air of efficiency of the manner in which you go about your training.

The A.R.C. printed examination writing pads will help you do all this. They are punched precisely the same as your lessons, to allow you to file them with the lessons. The pads are appropriately printed at the top, with special provision for your name, address, percentage of marks, etc. In addition to the punched printed pads, plain pads, similarly punched are available for use as plain follower pages for your examination answers. Full prices are shown on a separate sheet.

REPLACEMENT LESSONS.

If you have the misfortune to lose or damage any of your lessons, you can obtain replacement copies from the College Lesson Department. See separate list for prices.

STIFF LESSON BINDERS.

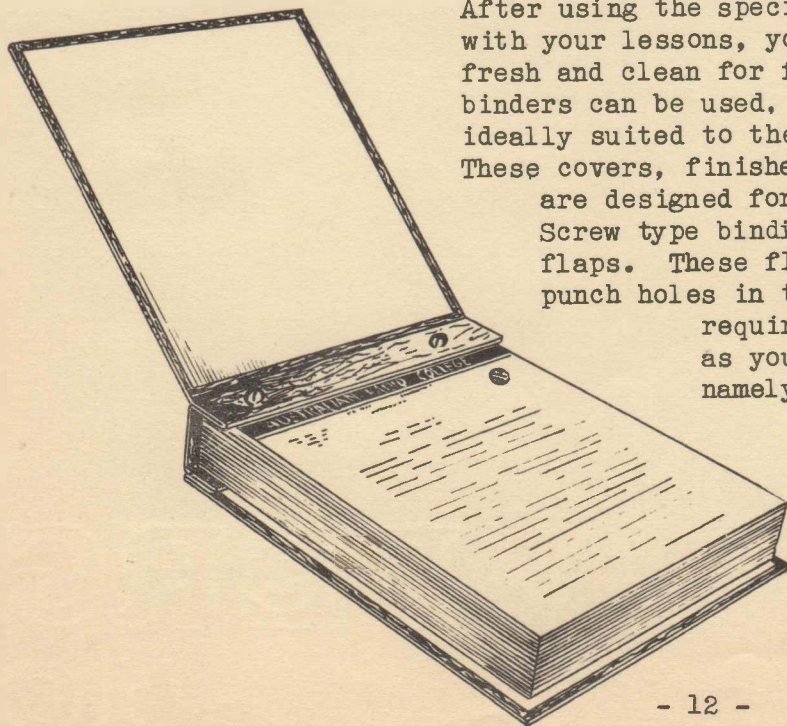

After using the special flexible service covers supplied with your lessons, you will want to keep your lessons fresh and clean for future reference. Various types of binders can be used, but the College has designed covers ideally suited to the purpose.

These covers, finished in attractive leather grained fabric, are designed for filing your lessons. Nickel plated Screw type binding posts fasten them to the inside flaps. These flaps are punched to coincide with the punch holes in the lessons. Three sets of covers are required to bind the complete Course, which, as you know is divided into three sections namely, Lessons 1 to 18A - 19 to 34 - and 35 to 50. (See Price List)

A.R.C. Buying Service.

If you are interested in building radio receivers, experimental apparatus, or in radio business activities of any kind the College can save you pounds. The A.R.C. Buying Service will introduce you to Firms which will supply your requirements at the very lowest prices. Arrangements have been made with a well known Trade Distributor to specially cater for A.R.C. Students requirements. Should you anticipate commencing either a full time or part time radio business, the Buying Service will advise you of the best agencies to take on, will help you obtain them, and will gladly give you any information upon running such a business.

Flexible Study Covers.

If you wish to keep your lessons clean and tidy whilst studying them, you should obtain one of the special flexible covers produced for the College. These covers are made of strong imitation leather fabric with two press studs at the top. The studs are spaced to suit the punched holes in your lessons. Up to three lessons at a time can be accommodated in these covers. They are ideally suited for studying purposes whilst travelling, and allow the lessons to be conveniently rolled up without damage or creasing to lessons or covers.

AUSTRALIAN RADIO COLLEGE

E. S. & A. BANK BUILDINGS, Corner CITY RD. and BROADWAY, SYDNEY
Telephones: M 6391 and M 6392. Post Lessons to Box 43, Broadway

This lesson sheet is published for the exclusive use of
students of the Australian Radio College Pty. Ltd.
(All rights reserved)



TELEVISION, FREQUENCY MODULATION AND FACSIMILE COURSE.

LESSON No. I.

WHAT TELEVISION, FREQUENCY MODULATION AND FACSIMILE ARE.

Time in retrospect is ever an absorbing study - just as occurrences in past years are affecting our lives and activities at the present, so many happenings of to-day provide a pointer to the future. Our parents remember, perhaps more vividly than we, the advent of the motor car (so-called "Horseless Carriage"), aeroplane, telephone, telegraph - all milestones marking the road of civilisation's progress. From the turn of the 20th Century, almost every branch of the sciences has made what may only be called amazing strides, due in no small measure to the tremendous fillip given to these matters by the stern requirements of the two Great Wars. This is unfortunate, and reflects badly on the weaknesses and shortcomings of human nature as a whole. Facts remain however; and it is probable that this 20th Century of ours will go down in history as the period of greatest and most rapid scientific progress!

It is hopeful to reflect that (during his allotted span of life) each of us in his own way contributes something to the well-being or otherwise of his fellows - good or bad, important or insignificant, depending on the character, abilities and intelligence of the individual. The calibre of men like Marconi, Baird, Armstrong, de Forest, Fleming and Hertz, is well-known, for these names, together with many others, are those of the pioneers in the particular branch of the sciences which interest us so much. So, in our backward glance at the early workers in the field of Television, we encounter a German gentleman named Nipkow, who virtually made this business of "seeing by wireless" possible. Paul Nipkow's contribution to the art was the avowedly simple device known as a "Nipkow Disc", of which he completed a first experimental model in 1884. Just how it works will be told later on. As the years rolled on, many another name was added to the ever growing list of experimenters, engineers and scientists, each adding, in his own way, to the progress of Television towards the goal of perfection.

It is logical to assume that any intelligent person who has the necessary fundamental knowledge of Television could, in time, contribute to the art, and this course has been prepared to provide a thorough grounding, not only in Television, but in Frequency Modulation and Facsimile as well. Although these three services are more or less in commercial use at the present time, much remains to be done,

and in this direction, individual experiment and research are likely to prove the most fruitful sources of discovery.

At this juncture, we must all realise, quite obviously, that in general, academic schooling of a very high order is essential to understand fully the complex mathematical treatments which all engineering sciences involve, Television, Frequency Modulation and Facsimile being no exception. Equally, on the other hand, much useful work may be done by we humbler folk with practical ability, and the right kind of basic and thorough training, as will be imparted to the diligent and conscientious student, by this course. Further, in this latter regard, unbounded opportunities will be available in this entirely new industry of Television as it becomes established in this country. The phrase "new industry" is used advisedly above, and applies also to Facsimile to some extent, and to an obviously lesser degree to Frequency Modulation. Personnel requirements, for the factories set up to manufacture Television apparatus, will be met mainly by local resources, so the future holds promise, not only on the manufacturing side as a tester or assembler, but in the service and maintenance of these new types of apparatus, and possibly in the laboratories associated with the factories. In addition operators and servicemen will be required on the transmitting side. It is refreshing to note that in 1938, in London alone, there were over ten thousand television receivers--the thought occurs here that for "sales minded" technicians, a very large field will present itself.

In answer to a question, as yet unasked, it is considered appropriate to explain here, why the three subjects of Television, Frequency Modulation and Facsimile, have been incorporated into a single course of study. Well, in the main, all three have a measure of common ground. First, and perhaps foremost, an ultra high frequency carrier wave is utilised in each case, (for reasons you will appreciate as the course unfolds) and so the practice and principles involved in working at these frequencies are the same. Then, there is the consideration that Television and Facsimile differ only in the basic fundamental that, whereas the former deals with an image or scene in motion, the latter concerns only "still" pictures or objects in an inert state, such as post cards, photographs, or pictures and newsprint in a newspaper or magazine--in effect the difference between a motion picture and a photograph.

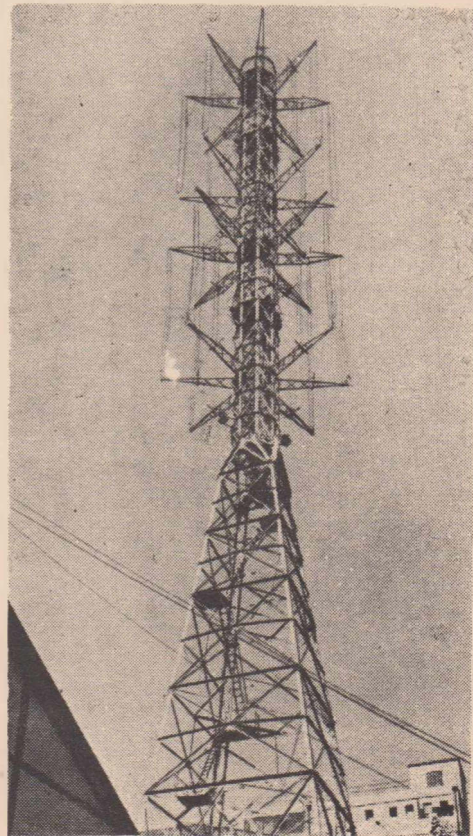

Fig. 1.
View of Television Transmitting Aerials at
Alexandra Palace, London.

After this short preamble, let us digress a little, divide the following text into three sections, "A", "B", and "C", and treat in some detail the history and progress of Television, Frequency Modulation and Facsimile up to the present day.

SECTION "A". TELEVISION.

First, what is television to the man in the street? Definitions a-plenty are given by various authorities with slightly divergent viewpoints, but we can safely say here that "any means whereby a scene in motion, such as a football match, may be seen in intelligible detail at a point remote from the actual scene itself" is a system of Television. Of course, the inference is that the scene must be reproduced at the remote point at the same time as it occurs at the first place, whence it is transmitted. It is possible to take a moving picture of a cricket match, and after the film is developed, this could be shown in a picture theatre a year after it actually happened! Need we say that motion pictures are not

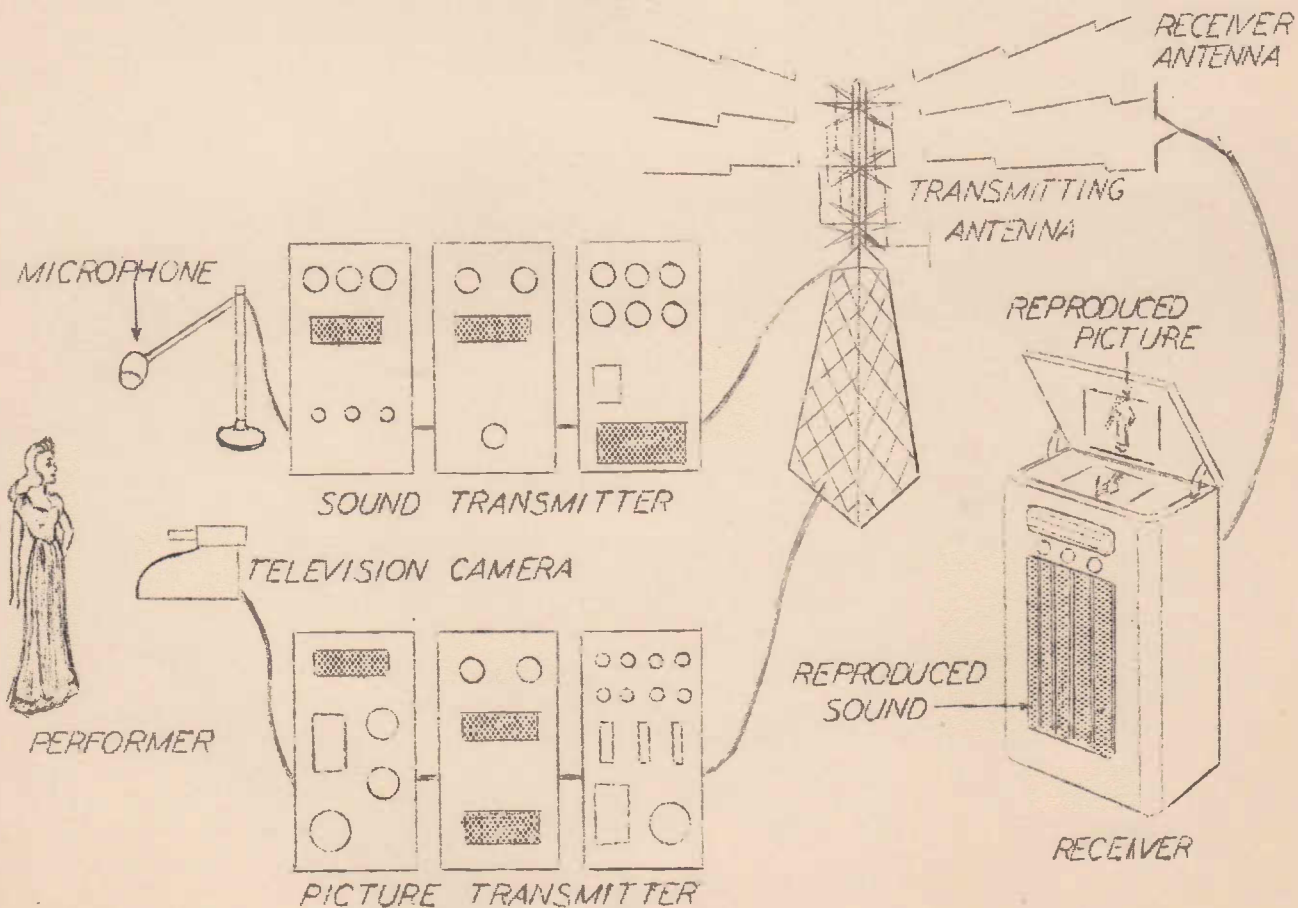

FIGURE 2.
GENERAL ARRANGEMENT OF TELEVISION SYSTEM.

Television! Just imagine sitting at home in front of a Television receiver, and seeing a surf boat riding the waves at Bondi, and you have grasped the idea.

It is quite clear that Television will open up a very pleasurable new era in home entertainment. Settled comfortably in our favourite chair, we will be enabled to watch any sporting event of sufficient importance to warrant its Televising, and it is probable that our great sportsmen will prove the most effective salesmen for Television equipment.

The motion picture industry is watching the development of Television very closely, as it has many uses in conjunction with the making of "talking pictures". For instance, it may be inconvenient to take a Television camera on a small boat, to capture the thrills of a yacht race--but, a small movie camera, the accepted thing on these occasions, could record the scenes and these items of interest may be retaken with a Television camera, and broadcast to people's homes shortly after the race. The only time delay here, would be due to developing of the film, and this, in these enlightened days, is a matter of a few short minutes. Take another example of how Television ties in with motion pictures. Perhaps you are, perhaps you are not aware that a movie is not made in one continuous film, but of countless "scenes", taken one at a time and lasting maybe two or three minutes. This enables the scenery to be suitably arranged for every "shot", and eliminates the necessity for actors and actresses to memorise an entire play. Well now, if plays and serial stories are to be successfully telecast it is logical to assume that something of the same process outlined above, will be followed. It would be very convenient to film a play in short pieces, and telecast the completed film. In this way it is readily seen that the film makers will give the progress of Television a helping hand, and also, in its turn, Television will prove of assistance to the movies. For the sake of completeness it may be useful to add, that in the normal broadcasting of a radio play or serial story, the players do not have to dress for the part, and neither have they to memorise their lines, as these may be read direct from the script. Obviously, if we are to see the actors, as in Television, the above technique is out of the question. Enough, then for the "man in the street". Let us now take in something of the history of this great new science of Television, holding, as it does, such promise for us all.

Initially, we have to thank nature for her happy thought which makes Television, and in fact motion pictures, possible. This chance, if chance it is, of nature is called "persistence of vision", and is reasonably self-explanatory. Simply it means, that, after our eyes have seen some object, the image persists for a

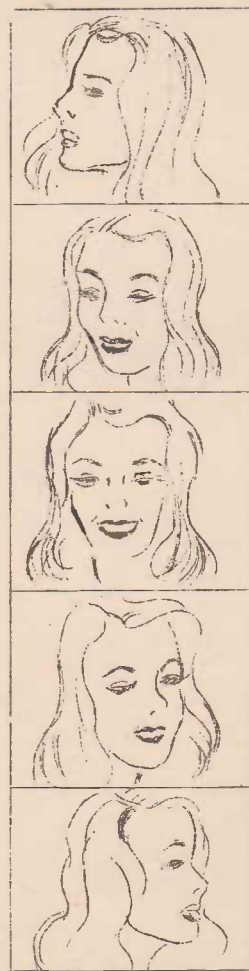
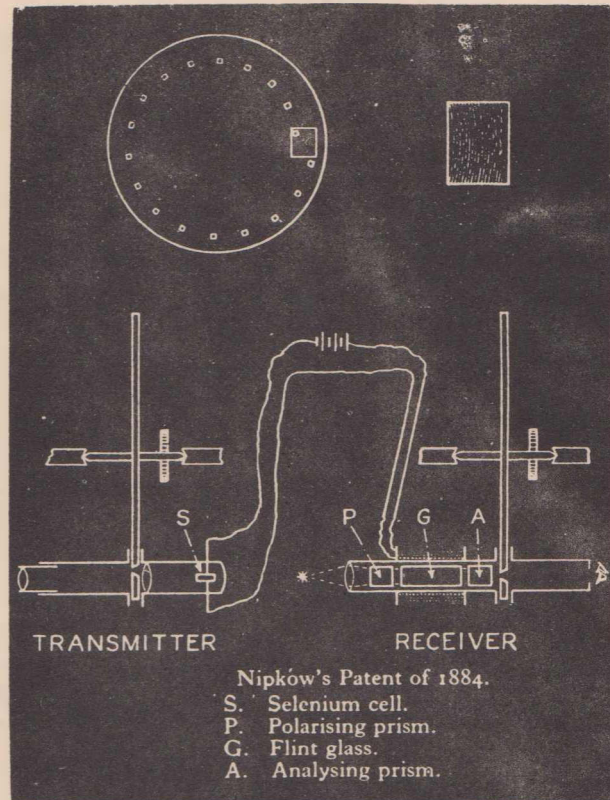

Fig. 3.
INSTANTANEOUS PICTURES OF
A GIRL TURNING HER
HEAD, ILLUSTRATING PRIN-
CIPLE OF CINEMATOGRAPH.

short space of time after we have ceased to look at it. This period of time, almost constant, irrespective of difference in age or sex in different individuals, is 1/10th second. If then, we can present a series of pictures to the eye at the rate of 10 per second, a continuity is obtained. Hence moving pictures function by the expedient of filming a moving scene in ten or more fixed pictures per second, each one differing slightly from its fellow. Actually, 10 pictures per second is not a very satisfactory rate as all persons who saw the first efforts at movies are aware, as a great degree of flicker was evident. Remember how once we talked of going to the "flicks"? The modern motion pictures are shown at the rate of 24 pictures per second, and this practice accounts for their excellence to-day.

Mr. Paul Nipkow, of whom we spoke earlier, knew about the eye's characteristic of persistence of vision, and he realised that if a moving scene could be captured in terms of 10 or more stationary pictures per second, it would appear to the observer as a moving picture; if reproduced in some manner at this rate. He also realised that it would be impossible to transmit by

wire a picture as our eye sees it, that is instantaneously. To our eyes, a whole scene is encompassed or taken in at a single glance. If you look at a house on a hill, you see at once, not only the house, but the surrounding country, every detail of the trees and flowers, as well as the windows, chimney, doors and the hundred and one other items that may be in the picture. Now, Mr. Nipkow could not see any way of transmitting such a scene to a remote point, unless it was divided up in such a way as to provide some form of varying electrical current. Incidentally, no-one else has thought out a way to transmit a complete scene either, right up to the present day. Now, let us imagine our house on the hill and sundry horses and dogs together with the people who inhabit the house, moving in and around the place in the course of their day's activity. It is only necessary to adopt the scheme used in the movies to take a film and when shown on a screen, all the movements are apparently reproduced. Take as a start, one of the still pictures comprising the film and let us see how it could be resolved into electrical current impulses.



NIPKOW'S ORIGINAL PATENT OF 1884,
RELATING TO TELEVISION.

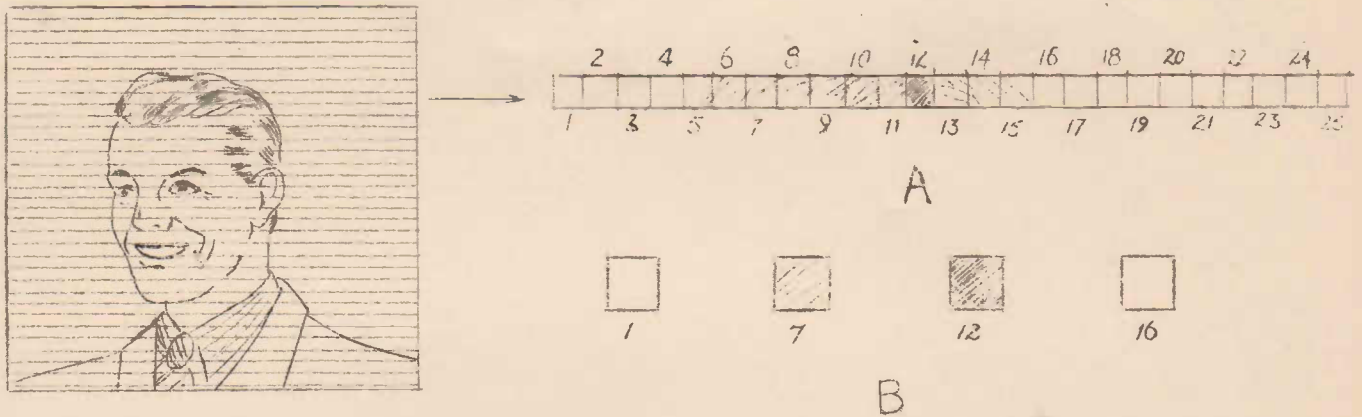

FIGURE 5.
SCANNING A SCENE.

Look carefully at the portrait on the side of Fig. 5 and notice the lines drawn across it which effectively divide it into strips, one of which is shown in an enlarged form at "A". It is at once seen that any picture can be so divided to provide a number of narrow strips, each of which present varying degrees of light and shade throughout its length, depending, of course, on the subject matter of the picture in question. Shown at "A" in Fig. 5, then, is a portion of the man's head in which the hair is clearly indicated. Going a step further, we may further dissect this strip into a number of smaller compartments, and at "A" we have shown 25 divisions, four of these being shown in greater detail at "B". The adoption of a numbering system for the strip gives a clear idea of just what has been done so far.

The next step is to focus a beam of light onto each little sub-division in turn, or, in other words, arrange for a light spot to travel the length of each strip (into which the picture is divided) and then return to travel in turn over the next strip lower down the picture, and so on until the whole has been covered by the spot. It is fairly readily apparent why this process is called "scanning" a picture, as that is precisely what our moving spot of light does.

Next we introduce a device called a photo-electric cell, which is so placed as to catch the light reflected from the picture as the spot passes over it. Varying intensities of reflected light, caused by the shadings in the strips as the light spot scans them, cause current to flow in sympathy in the electrical circuits connected to the cell. Of course, a pure white portion such as No. 1 in Fig. 5B will reflect the most light, and a dark portion such as No. 7 will reflect the least.

Operation of the photo-cell and its associated circuits will be detailed in following lesson work, but it is considered essential to grasp concisely, even in this early lesson, the necessity for scanning a picture in order to convert a reflected light into the form of alternating or pulsating current.

Harking back to our old friend, Mr. Nipkow, we now know just what his problem was - a means for accomplishing the scanning of a picture had to be found. His answer to the question is diagrammed, somewhat crudely, in Fig. 6, but if this is

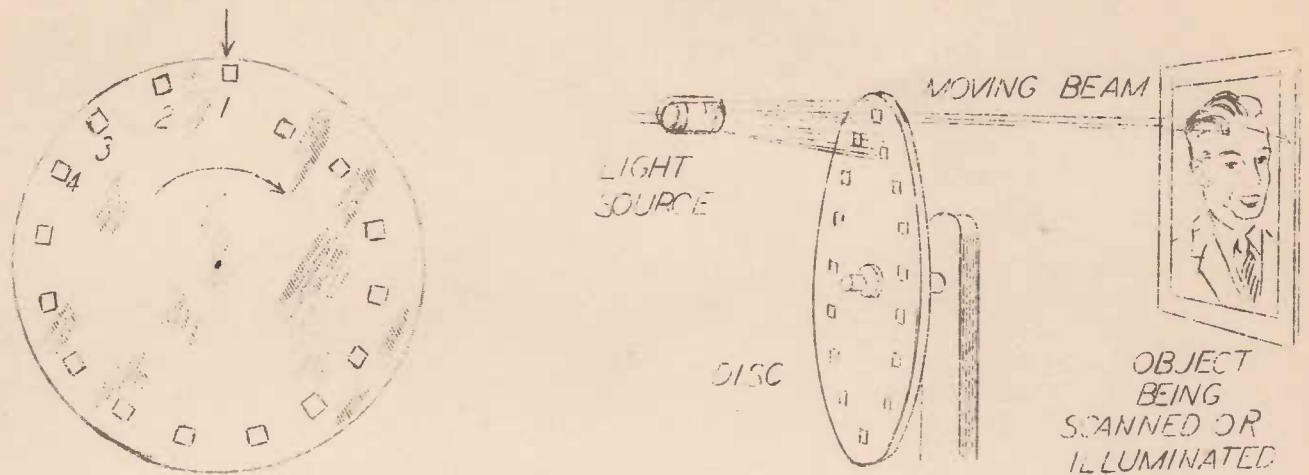

FIGURE 6.
SCANNING BY MEANS OF NIPKOW DISC.

studied closely, more will be conveyed to you than several pages of the written word. As can be seen, the disc is caused to revolve in such a manner as to cause a beam through hole No. 1 to sweep across the top strip of the picture. Light through hole No. 2 sweeps across the second top strip and so on. Well now, it is only necessary to revolve the disc once to accomplish a complete scan of the entire picture, and were we to stand in front of the disc whilst this process was taking place, the individual spots of light would merge into a continuous blur, conveying an impression to our eyes of having seen the complete picture directly. If the man portrayed in Fig. 6 happened to be a live artist rendering the "Donkey Serenade", or some such number, we would like to see his lips and face move as he sang his song. This may be accomplished by rotating the disc more than ten times per second (remember - persistence of vision?) and we have it!

The reasons behind the fairly lengthy exposition of the virtues of Mr. Nipkow's scanning disc, particularly at this early stage of the course, are chiefly in the cause of analogy. By this is meant that it is vitally important to have fixed firmly in your mind the necessity for, and the principle of, scanning. Nowadays, as will be told later in the course, the scanning disc is considered obsolete, as electronic means achieving the same result have been developed. But, and we labour this point, the principle remains.

Having established this process of scanning a scene in our minds, we may pass on to the most interesting subject of Television's historical progress, saying no more about Paul Nipkow, but examining the contribution made by other pioneers. About the year 1900 Weiller took out patents for a mirror drum scanning device, consisting basically of a drum with many mirrors set at different angles around

its periphery, light from an aperture being projected from the revolving drum, through a magnifying glass or lens, onto a screen. The staggered placing of the mirrors caused the light spot to traverse the screen in a series of adjacent lines. Then in 1907 two eminent scientists conceived the idea, quite independently, of using a cathode ray tube in conjunction with the mirror drum scheme of Weiller's. These men were Boris Rosing and Campbell Swinton. Now, the examples given are some indication of the host of systems, some of them little more than suggested methods put forward by these early workers. All these schemes had a common failing - they were simply theories and suggestions, and it was impossible to present any practical results. This lack of tangible result was due, almost entirely, to the absence of some means of amplifying the

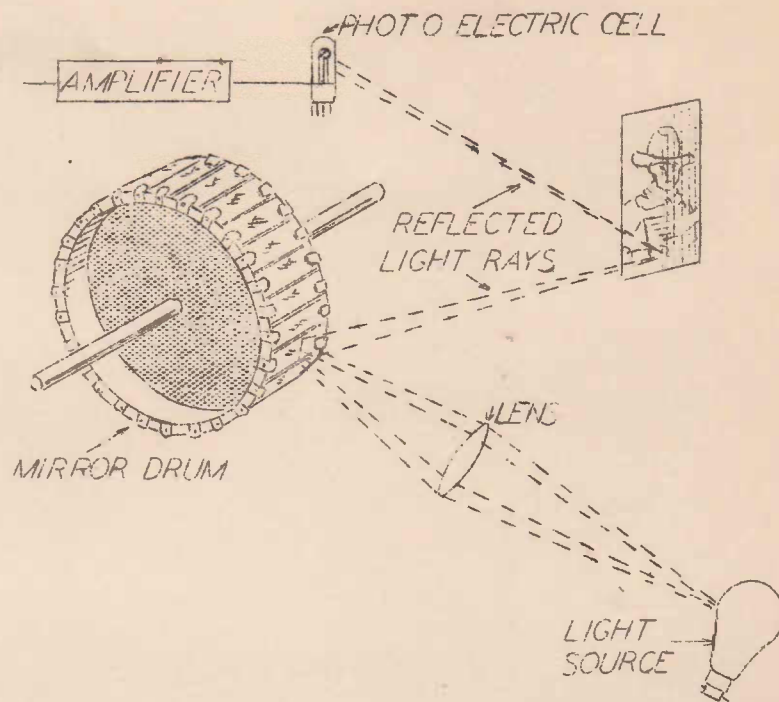

FIGURE 7.
MIRROR DRUM SCANNING DEVICE INTRODUCED ABOUT
1900.

minute currents caused to flow through the early, crude photo cells or selenium tubes, by the light reflected from the action of a scanning device. The difficulty was overcome when, in 1913, de Forest and Fleming produced the first radio valve which could be used for amplification. With the advent of this device, it occurred to one, John Logie Baird (often called "the father of Television") that the essentials for a successful Television system were now at hand, and in 1923 he had some success, with the simplest of apparatus, in transmitting shadows. By 1925, his apparatus had reached a stage where it was capable of sending the outlines of simple objects over a short distance by wireless, and in this year a demonstration was staged in the London emporium of Selfridges. From here on, progress became more rapid, and about the time of Baird's demonstration, C. F. Jenkins in America successfully transmitted an outline of a simple object. Then in 1926 Baird televised a crude image at a demonstration before the Royal Society. With the coming of 1930 the standard of Television had improved to such an extent that faces could successfully be recognised at the receiver, and in 1932 the B.B.C. London commenced regular transmission. However, the pictures were lacking in detail, and, moreover, had the severe drawback of flickering due to the low repetition rate of 12.5 pictures per second. In America the interest in Television became intense, and the old Telephone and Telegraph Co. gave a demonstration in 1927, causing numerous people to become interested in the new art, and to commence experimental transmission. All these early systems were mechanical in their

operation, but improvements finally enabled the B.B.C. to increase the number of lines (strips of picture shown earlier in Fig. 5A) from the early 30, to 90, then 120, 180, and finally to 240, and this rate of scanning was used with a picture repetition rate of 25 pictures per second, making for a fairly reasonable overall definition. We come now to the trend towards electronic rather than mechanical television, with the cathode ray taking the place of the scanning arrangements as discussed so far. The tendency is to avoid cumbersome mechanical methods, as electronic systems are much more flexible and in every way more desirable. The cathode ray tube has made this electronic approach to Television possible, and the sketch of Fig. 8 indicates the essentials of the structure and gives an inkling also of how it functions.

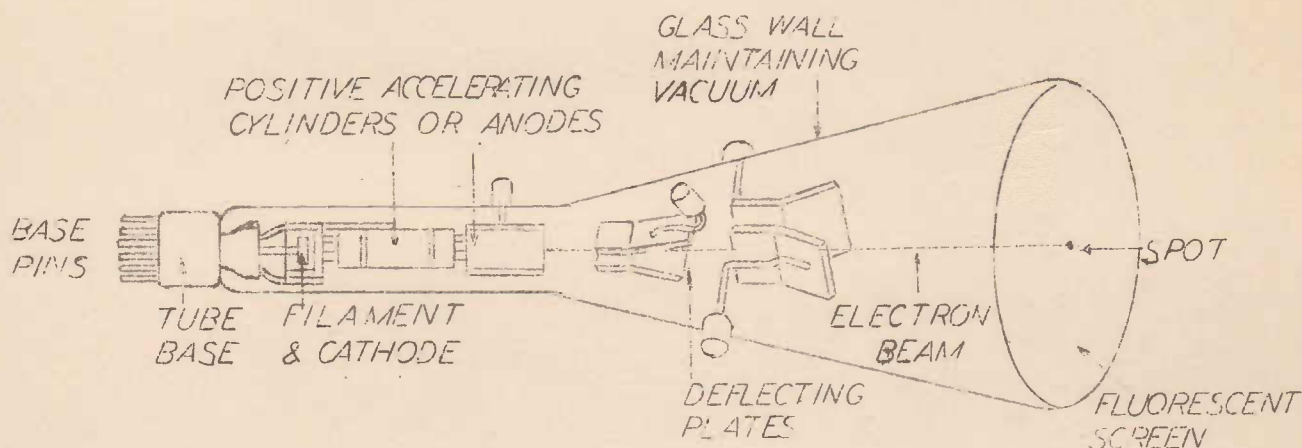

FIGURE 8.

The cathode emits electrons as in any normal radio valve, and these are formed into a beam by the focussing and intensifying effect of the accelerating cylinder or anodes. This narrow beam is then shot through a small hole in the end of the cylinder furthest from the cathode, passes through the two pairs of plates for deflection and finally impinges on the fluorescent screen at the end of the tube, causing a tiny spot of light to show. Now, if it is required to deflect this spot over the face of the screen, it is merely necessary to swing the beam in either a vertical or horizontal direction, by making one plate in each pair positive with respect to its fellow, the value of this voltage determining the degree of deflection. Here then, is the perfect solution to Television reception. We have a ready made spot of light, a means of moving it anywhere on the screen at almost any speed required, added to which its intensity may also be varied at will by suitable adjustment of the anode structure. All this, and no cumbersome mechanical parts!

The cathode ray tube principle has also been applied to the transmitting end in the guise of a television camera. So called an "Iconoscope" or "Orthocon" in America and an "Emitron" or "Super Emitron" in England, the basic principle is the same, and these names are trade designations by various manufacturers for

what may be correctly styled a "picture tube". Fig. 9 gives an idea of what a modern picture tube looks like.

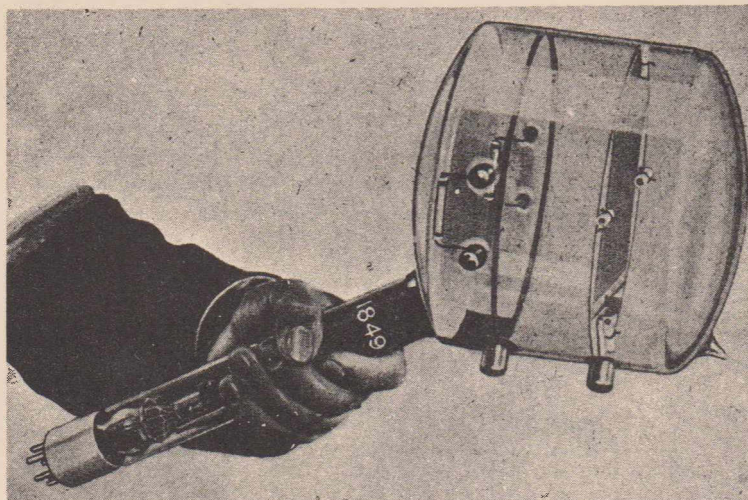

FIGURE 9.
A TYPICAL TELEVISION CAMERA TUBE.

It is not intended that the student should study the operation of this tube at the present stage, for the technical details will be dealt with at a more appropriate point later on in the course. Let it be sufficient to note here that the tube does the complete job of scanning the scene and converting the light variations to electrical impulses, which are then passed to the transmitting apparatus. The picture tube is introduced to you at this stage, however, because its development (which has taken place in both England and America) has been a most important and substantial step in the history of television. It has made possible the raising of the quality of television broadcasts to a point where the art, from an entertainment and commercial point of view, is here to stay. The tube is incorporated into a self-contained

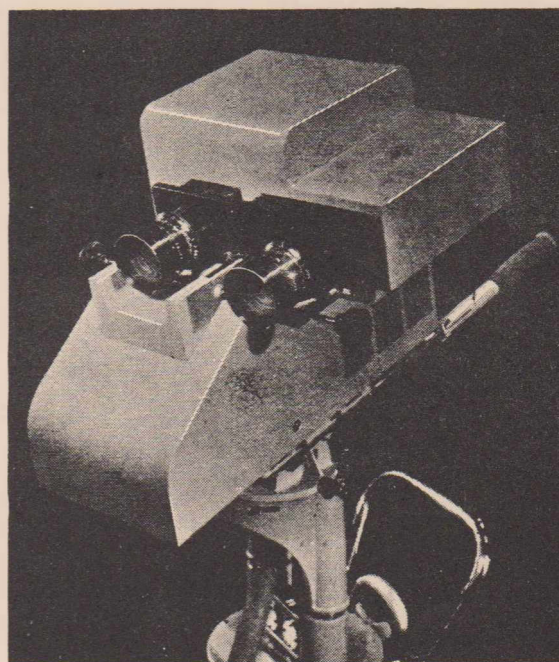

FIGURE 10.
MODERN TELEVISION CAMERA - EMPLOYING
A PICTURE TUBE.

and compact unit together with lens to view the scene. In this form it is known as a television camera. Its advantages over older scanning systems lie in its sensitivity - its portability - and its ability to "scan" a scene in very great detail. Its comparatively great sensitivity has eliminated the necessity for excessively powerful lighting in studio scenes, and made possible the efficient televising of outdoor scenes, even on dull days. In this connection the camera fitted with a tele-photo lens has been specially developed as a portable unit, being connected to the main apparatus by a cable up to 1,000ft. and more in length. In this way pictures of sports events, processions, etc. having real entertainment value, as distinct from mere novelty appeal, have been transmitted. With respect to its ability to scan a scene with great detail, it is interesting to note the claim, in the case of the latest Emiscopes in use in the London Service immediately prior to the war, that these tubes had the capability of producing an electrical picture signal containing very much greater detail than could be handled by the remainder of the apparatus then in use (amplifiers, modulators, etc).

This is an important and interesting point for the reason that the chief defect of television pictures has been the lack of detail which could be reproduced, and one of the greatest, if not the greatest, factor which resulted in this state of affairs had been the limitations of the older mechanical methods of scanning the picture. But now, with the development of the electron camera type of tube, the position has been virtually reversed. Speaking of the period immediately prior to the War, the situation was one whereby the clarity and detail of the received picture was limited mainly by the inability of the circuits in both transmitter and receiver to handle, without distortion, the wide band of frequencies which (as the student will appreciate after studying later lessons) is necessary for reproduction of a high quality picture. Then came the War, causing the closing down of television services in Europe. For six or so years, very little, if any, direct research or development was carried on in connection with television. But remember the saying; "It's an ill wind that blows nobody any good". With the war came a tremendous impetus to the development, in all major countries, but mainly in England and America, of that miracle of modern science, Radar (or Radio Location). In England, secretly, research had been carried on in connection with Radio Location for several years, and the device was in practical operation around that Island's coast before the war commenced. But up till this time more or less conventional components and amplifying circuits were in use. With the immediate peril to England on the outbreak of War, the best brains in electronics and physics in England (and slightly later, in America) were mobilised, working with almost unlimited funds to develop Radar to the highest pitch possible. Now the general principle of Radar is quite different from that of Television, but the point is, that those war years have seen the development, in connection with Radar, of just those types of components (particularly amplifying, oscillating and cathode-ray tubes) and circuits for which we have been waiting for the further perfection of television. And so the future appears to hold great promise from the technical viewpoint. With the application of these new circuit techniques at both transmitting and receiving —

ends, the full potentialities of the electron camera type of television tube (which itself will undoubtedly undergo further development) will be realised. We can look forward to the day (probably sooner than most of us might expect) when television pictures will be equal to the best ever thrown on to a cinematograph screen.

In tracing the history of television, we have kept our eye (as have most of the experimenters and scientists engaged in the science) on the development of a clear black and white picture for the home receiver. There have been, however, several other aspects of television which have claimed the attention of many of the notable pioneers, including Baird. These include large screen television (whereby the image is projected onto a large screen such as in a cinema theatre), television in natural colour, television giving pictures having a stereoscopic effect in giving the effect of depth in the image, wired television for telephones, and finally Baird's Noctovision. We shall take those developments in turn, and say a few words about each.

Large Screen Television:- The main difficulty here is to find means of projecting the image with sufficient illumination on to a screen of picture theatre dimensions. Some success however, had been achieved before the war. At least one London theatre provided television on the normal motion picture screen. The Coronation procession was televised and screened thus in London in 1937. The apparatus is very costly, and the trend will probably be to fit out one theatre in each large city in which only scenes of great national interest or importance will be screened.

Colour and Stereoscopic Television: Baird has achieved some success in obtaining pictures in more or less natural colours. As in technical colour films, three basic colours are used, those when blended in varying proportions are made to produce an almost unlimited range of shades. Stereoscopic television produces "3 dimensional" images similar to those which you may have seen on the films as a novelty (remember wearing the coloured glasses?). This development is still well within the experimental stage only.

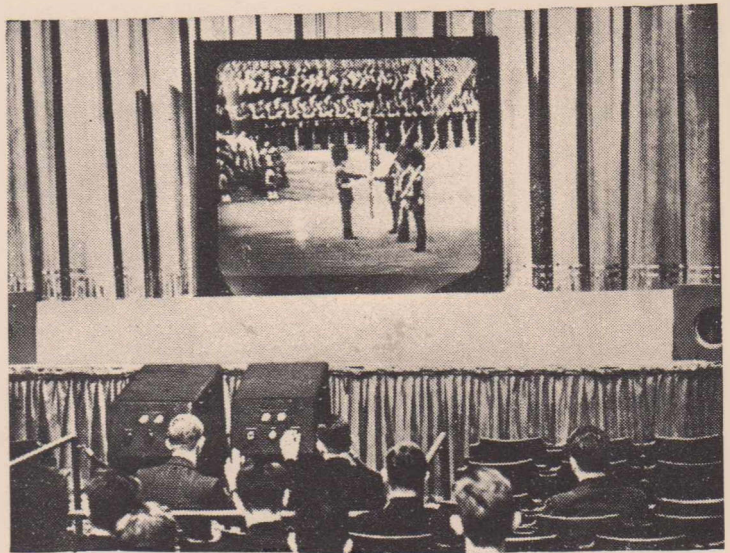

Fig. 11.

Reproduction on the screen of a London Theatre.

Television Telephone Service: This was developed in Germany before the war, and enabled persons miles apart, not only to converse with but also to see each other. Whether the utility of such a service, once the novelty appeal had worn off, would be sufficient to claim the demand of the public

(an essential in all commercial propositions) is doubtful. One could visualise many objections to such a service. How much easier it is to "tell off" a person over the phone when you cannot see him (or her)! Think, too, of the delay you would be occasioned should you phone your latest lady friend when she was in the bath! Probably the greatest usefulness for the service is its ability to enable the signing of a legal document to be witnessed at a remote point.

Baird's Noctovision: About 1928, Baird succeeded in televising a subject while sitting in darkness. He made use of the fact that most photo-electric cells are affected by infra-red rays, which, however, have no effect on the eye. Of course the picture was reproduced at the receiving end in visible light rays. This idea may have possibilities from the point of view of navigation in fog. Infra-red rays will penetrate fog of sufficient density to blot out completely the visible light rays upon which ordinary sight depends.

Elements of a Simple Television System: Before temporarily leaving television to introduce you to Frequency Modulation Radio, let us attempt to give you an overall view of a simple television system. We will not attempt to explain the detailed operation of any section of the transmitter or receiver, but will simply state its purpose and what it does. Here an excellent analogy or comparison may be drawn with an ordinary radio communication system.

Where Television is like Radio Telephony.

The easiest way to get a clear insight into television is to compare its workings with the workings of sound radio. It is fortunate that there is nothing to "un-learn", that all the rules and laws applying to sound radio apply also to television or to "sight" radio.



FIGURE 12.

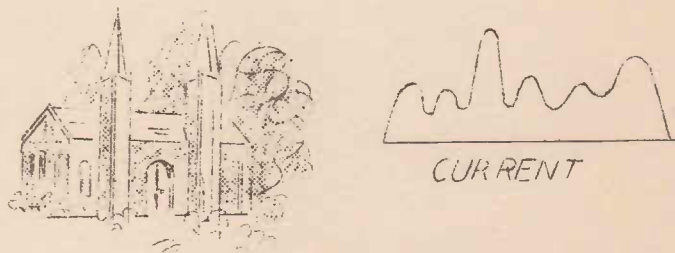

FIGURE 13.

The difference between sound radio and television is that we deal with sounds in the one case and in the other we deal with lights and shadows which make up a picture.

In radio telephony we take the sounds apart. For example, a voice consists of changes in air pressure which might be represented as at the left in Fig. 12. These changes in air pressure produce corresponding changes in electric current

through the microphone and the currents are represented as at the right in Fig. 12. The sounds have been broken down into changes of electrical current.

These current changes persist throughout the whole system until they reach the loud speaker. In all parts except the microphone and the speaker we are concerned with changes in electrical current and voltage - we are not concerned directly with sounds. We don't transmit sound; we transmit nothing but electrical effect.

In television we actually take the pictures apart. If the objects or the people are in motion, this motion corresponds only to a series of rapidly changing pictures, so it is possible to consider each picture separately and take it apart separately.

Whereas the voice in Fig. 12 is made up of numerous changes in air pressure or air "density", the picture of Fig. 13 is made up of various degrees of light and shadow or of various densities of shading.

The first problem in television is to change the lights and shadows of the picture into rises and falls of electric current. Then the picture has been made to take an electrical aspect something like that in Fig. 13 at the right.

Earlier in this lesson you got an inkling of how the Nipkow disc together with a photo-electric cell created a varying electric current corresponding to the varying light and shade of different portions of the picture. The current graphed in Fig. 12 is, as you already know, called an audio current, because it is the electrical counterpart of a sound wave. The current may be called a "picture" current, but it is better known as a "video" current. It is a current produced so as to simulate or follow the variations in light as the scene is scanned. Note that in the television system, the microphone is replaced by the scanning disc and photo-electric cell (or in modern systems the television camera).

Referring to Fig. 14, the audio frequency current representing the sound is amplified, and then caused to modulate the R.F. current (set up by an oscillator) by varying the amplitude of the latter at the audio frequency. The modulated R.F. current is then amplified and passed to the aerial where it sets up corresponding radio waves which travel through space. These waves cause a modulated R.F. current to be set up in the receiver aerial. The R.F. current is amplified in the receiver and then passed to the detector, which demodulates it, producing an audio frequency current exactly similar in form to that produced by the microphone. This A.F., after amplification, then operates the speaker, which is simply a sound reproducer, reproducing a sound wave exactly similar (in theory) to the original.

If you now compare the television system (Fig. 14b) with this telephony system you will see that all sections do exactly the same type of job, except the "picture current producer" in the form of the photo-electric cell, together with scanning disc or electron camera (this taking the place of the microphone) and the "picture producer" (taking the place of the speaker) which consists of a variable light source and a scanning disc or cathode ray tube. (More of this later). The video current representing the light variations from different portions of the picture, after amplification is made to modulate the R.F. current from the oscillator.

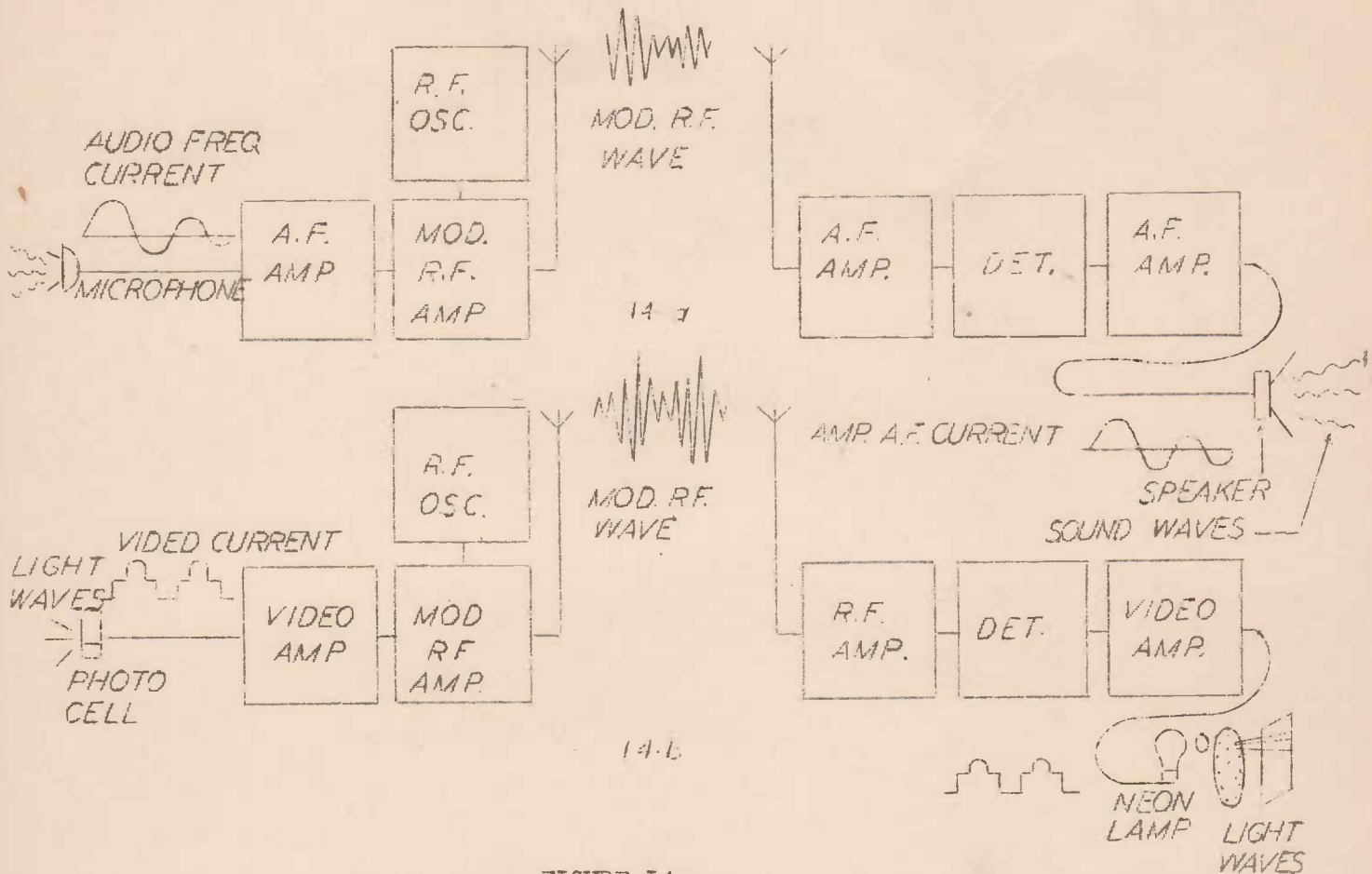

FIGURE 14.
BLOCK DIAGRAMS COMPARING SOUND AND TELEVISION BROADCASTING AND RECEPTION.

This current in the transmitting aerial sends out into space a radio wave, modulated with the video (in place of audio) signal. The television receiver also follows closely the lines of the radio telephone receiver. The detector here demodulates the modulated R.F. wave reproducing a replica of the original video frequency current in the transmitter. This video current must now be made to reproduce the original light variations and hence build up an image of the original scene being televised. This section we may here style "the picture reproducer" (corresponding to the sound reproducer - the loud speaker).

The picture reproducer in our simple crude system under discussion is a Neon Lamp together with a Nipkow scanning disc. The Neon Lamp (see Fig. 15) consists of two metal plates (electrodes) in a glass globe which has been evacuated of air, but which contains a small quantity of the gas neon. When an electrical potential is applied between the plates of the lamp, an electrical discharge takes place through the rarefied neon gas, causing the more negative plate to glow with an orange-pink light. Now the electrical picture (video) signal from the detector of the receiver is applied, after amplification, to this neon lamp in

such a way that the brilliancy of the illumination varies in sympathy with the signal. In this way we have reproduced a replica of the light variations which fall on the photo-electric cell as each part of the picture or scene is scanned at the transmitter.

Assembling the Picture:

The simplest method of reconstructing the picture is by the use of our scanning disc set up somewhat as shown in Fig. 16. The television lamp is placed behind the disc in such a position that its plate completely covers the space which may be viewed by an observer looking through any one of the holes in the disc. That is, the height of the plate is such that it extends above the height of the hole which is farthest out, and so that it extends below the hole which is closest in towards the disc's centre.

A screen or "mask" is placed in front of the disc and through this screen there is an opening which is just the size of the picture to be reproduced. Therefore, the observer's line of sight cannot pass either to the right or left of the picture size or area.

The holes in the disc are sweeping across the space at the back of which is the lamp's plate. The observer will see the glow of the plate through the screen opening and through the disc holes. Therefore, his view is forced to sweep across the plate's surface. At least, his vision really does sweep across the plate surface because everything is dark except the plate surface which glows through the disc and screen.

The observer's line of vision is carried across the surface of the lamp's plate about as shown at the right of Fig. 16 where the enclosed area represents the size of the picture. One hole after another in the disc sweeps across the plate surface until the whole surface has been covered just as it was covered by the scanning beam of light at the transmitter.

If the glow from the plate does not change, the picture area will appear as a dull pink evenly distributed. The color is pink because that is the color assumed by the lamp's plate. But if the amount of light from the plate is

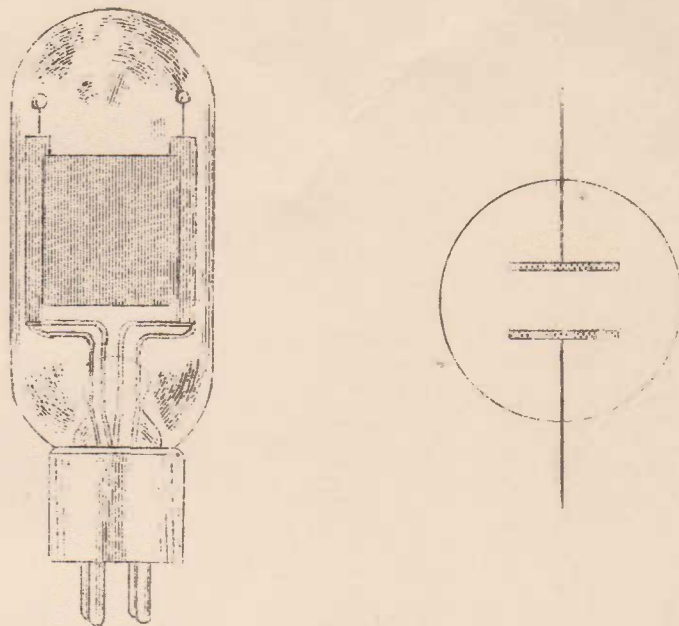

NEON LAMP AS USED IN OLD TELEVISION
RECEIVERS.
FIGURE 15.

changing, then the amount of light seen by the observer will change as the disc holes move from place to place.

If the glow of the plate is bright with a given disc hole in a certain position

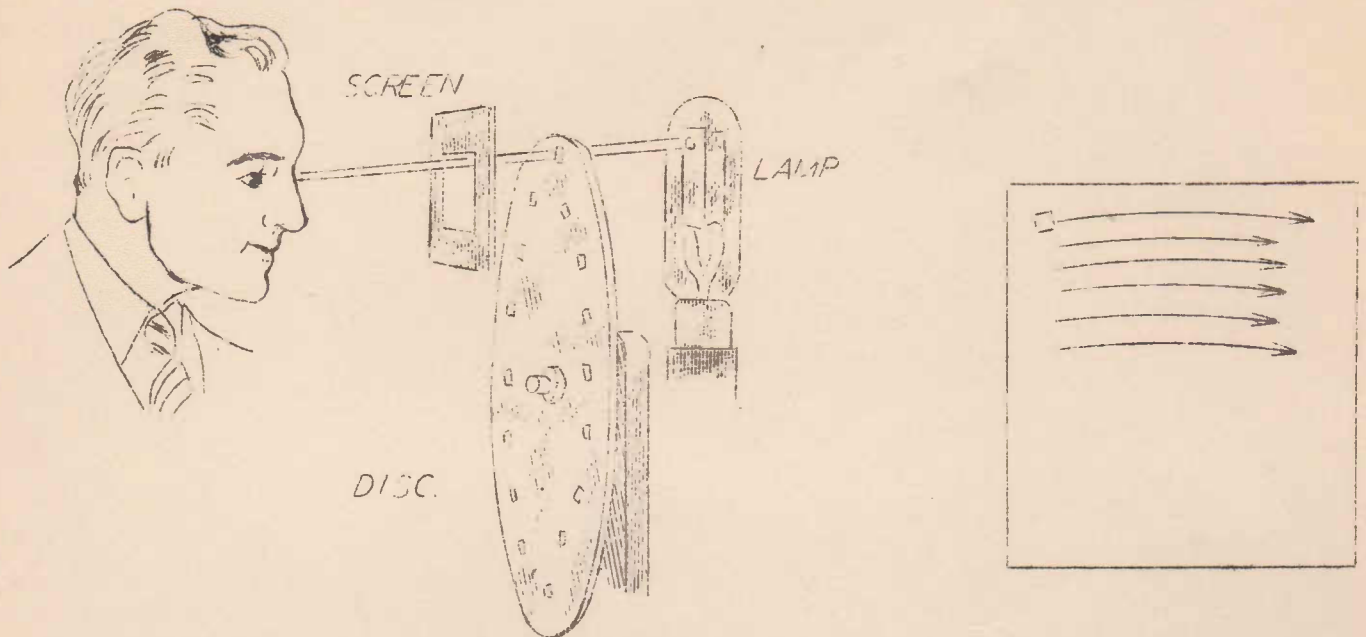

FIGURE 16.

that particular position will appear bright to the observer. Then if the glow is reduced with another hole in another place that new position will appear darker. Proper distribution of these light and dark places will make it appear that the lights and shadows are distributed over the picture area in a definite pattern, this pattern being that of the lights and shadows in the picture being transmitted. Thus we have reconstructed the scene which is being scanned at the transmitter.

By using a simple lens system the light beam passing through the Nipkow disc holes may be focussed onto a small screen, so that a spot of light scans the latter in step with the scanning light spot at the transmitter. In this way, as the light spot's brilliancy varies in sympathy with the picture signal, the scene is reproduced, and may be viewed indirectly on the screen.

WHY REPRODUCING THE PICTURE IN TELEVISION IS MORE DIFFICULT THAN REPRODUCING THE SOUND IN RADIO TELEPHONY.

In the case of sound transmission each sound, occurring at any moment, even a complex sound such as is produced by a large orchestra is represented by a single current variation (at audio frequency). In the case of transmitting a picture, however, each light variation, causing a single current variation, represents only a single part or element of each picture, a series of which constitute the whole scene. We have seen, therefore, how the picture is scanned, so that the light

variations, which make up the whole picture, are dealt with in turn. In this way, the original picture was broken into "elements" which were broadcast separately, and in order. We have seen further how these separate light variations were re-created at the receiver. Now, to produce an intelligible picture, it is obvious that the picture elements be reproduced at the receiver in the same order, and at the same speed. This means that the light spot, falling at any moment, on the receiver screen should occupy the same relative position on that screen as the spot or element of the original picture being scanned at the transmitter. To achieve this state of affairs the receiver's scanning disc must rotate at the same speed exactly as, and in step, with the disc at the transmitter.

The technique of ensuring this desired state of affairs is known as "synchronization". To ensure that the receiver's disc does keep "in step" or "in synchronism" special synchronizing signals are sent out by the transmitter, at regular intervals. These synchronizing signals serve the purpose of slightly speeding up the velocity of rotation of the receiver's disc, if it tends to become too slow, and vice versa.

In modern television systems using cathode-ray tubes, the scanning of the scene is performed by beams of electrons. The necessity for synchronising the electron beam in the receiver's cathode-ray tube with that which scans the image of the scene which is focussed on the television camera's screen, still applies.

Synchronizing signals, which appear as a special regular modulation of the carrier wave are therefore still used. The methods of utilising these signals (which methods are fully dealt with in a later lesson) are, however, purely electronic, and the results achieved are much more reliable than those which could be obtained with the older mechanical methods of scanning. As a matter of interest Fig. 17 is included to show the type of trouble encountered when synchronization is faulty, resulting in pictures drifting across the screen or from top to bottom.

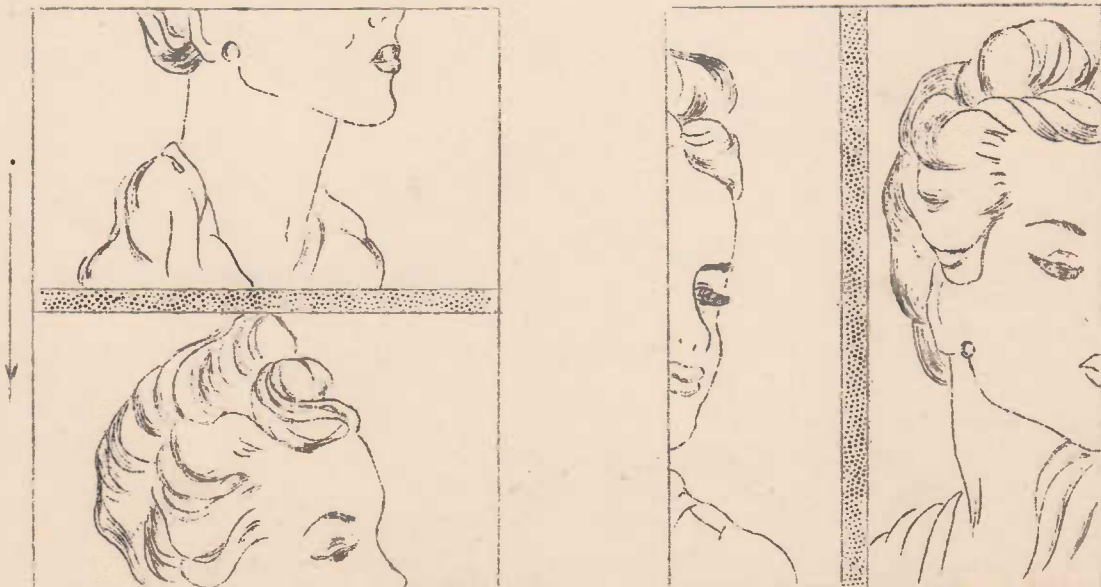
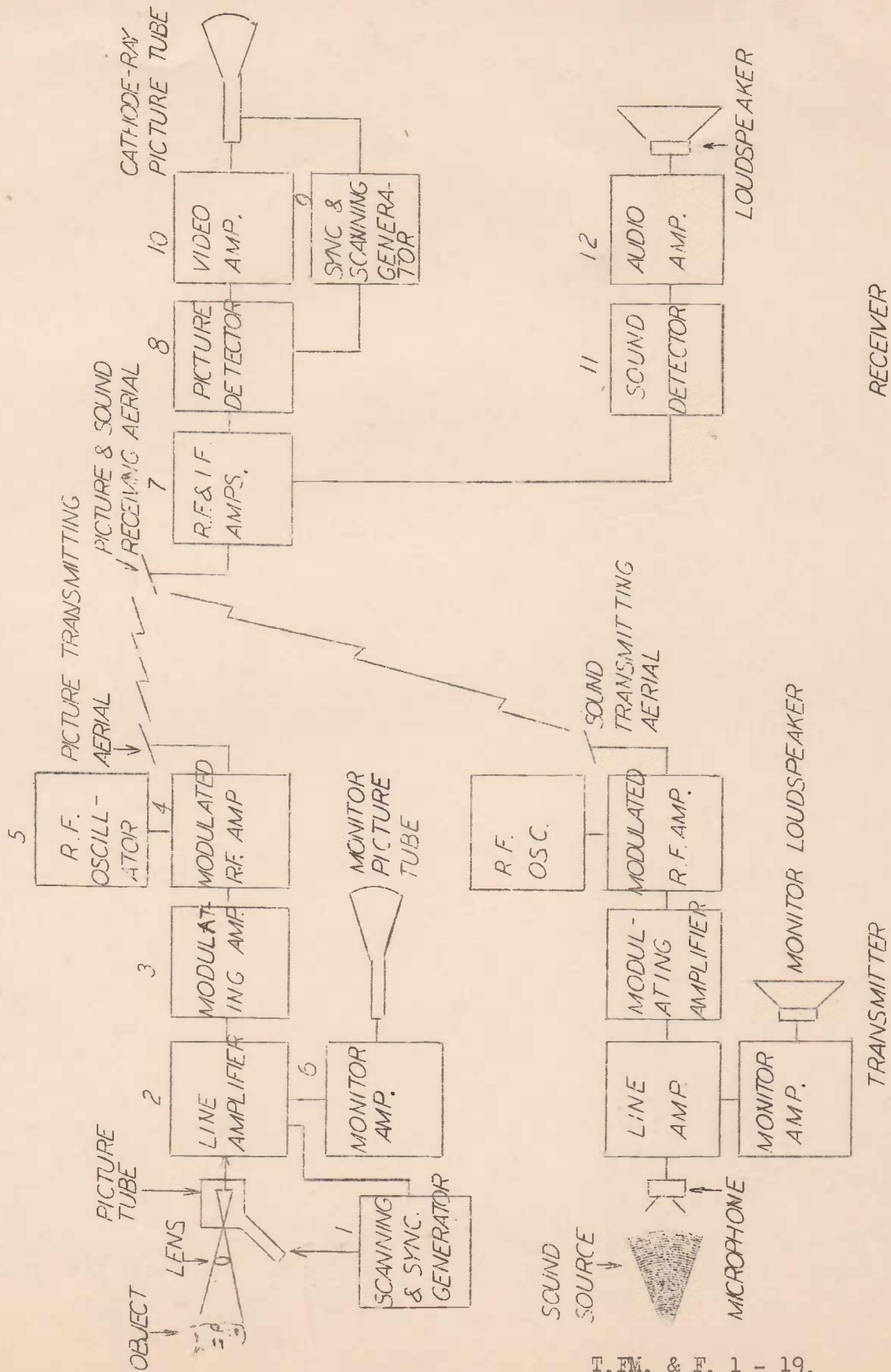

FIGURE 17.
SHOWING ONE EFFECT OF FAULTY SYNCHRONIZATION.

FIGURE 18.

ELEMENTS OF A TYPICAL TELEVISION SYSTEM.



BLOCK DIAGRAM OF A MODERN TELEVISION SYSTEM:

Fig. 13 shows in block schematic form, the overall arrangement, from televised scene to receiver screen, of a modern television system. The associated sound transmitter and receiver are also included. This diagram should be compared with that of the simple system of Fig. 14b.

Note that the Nipkow disc and photo-electric cell have been replaced by a modern picture tube, and the neon lamp together with its disc, in the receiver, has given way to a cathode-ray tube. Block (1) is a valve-oscillator which produces alternating voltages, having a special waveform which, when applied to the picture tube, cause the electron beam to scan the image on the screen of the tube. The special synchronizing signals are also obtained from this oscillator and applied to the outgoing wave. Block (2) simply amplifies the electrical picture (video) signal from the picture tube, and may be separated from the actual transmitter by a line of considerable length. Block (3) gives further amplification, raising the level of the signal sufficiently to modulate in block (4) the R.F. carrier produced by block (5). Block (6) is a video (picture signal) amplifier which operates a cathode-ray tube of the receiver type. This gives a reproduction of the scene for monitoring purposes in the transmitter control room.

With reference to the receivers, note that both the vision and sound modulated waves are picked up by the same aerial and applied to the same R.F. amplifier. (It might be remarked here that the sound carrier and picture carrier are not identical, but usually occupy adjacent channels. The first R.F. amplifier is sufficiently broadly tuned to cover both). The picture and sound carriers are separated at Block (7) by using the heterodyne method to produce lower and distinct "intermediate" frequencies. The two signals are henceforward treated separately as shown. Block (8) is the detector which demodulated the picture carrier signal. Note also that at this stage the synchronizing signals are then used to synchronize the scanning generator (Block 9) which causes the electron beam in the cathode-ray tube to scan the screen. Returning to the picture signal proper, this is amplified by Block (10) and the varying amplified voltage applied to the "grid" of the C.R.T. where it varies the intensity of the electron beam. In this way the varying degrees of light and shade, which constitute the different parts of the picture are reproduced on the screen. The sound carrier is detected in Block (11), the audio frequency signals are amplified in Block (12) and reproduced by the loudspeaker.

In passing, it is opportune to remark that although some technical matter has been included in this, the first introductory lesson, such has been considered necessary. It will be found that a good basis has thus been prepared for the ready absorption of the detailed lesson work to follow.

So now, we come more or less to the present time, when Television has reached a stage where the definition is comparable with that achieved by home movies of the 16 millimetre variety. Of course, there is still a long way to go before the excellence of clarity of the modern 35 M.M. theatre projection film is achieved.

The average picture size in a typical modern Television receiver is of the order of 9" X 12" and this is adequate for most home users.

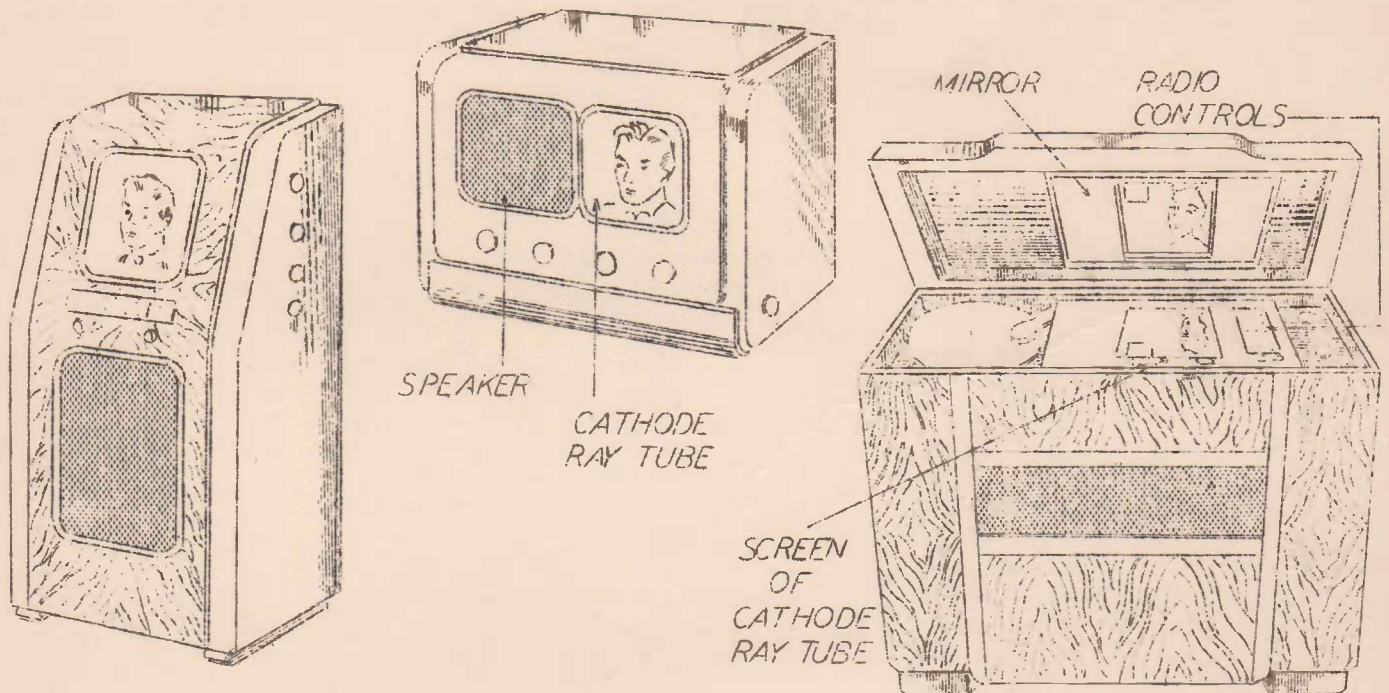

TYPICAL TELEVISION RECEIVERS.

FIG. 19.

Fig. 19 has been included to illustrate the standard and appearance of typical present-day Television receivers. It is noteworthy that in the elaborate "radio-phonograph-vision" unit the screen of the cathode-ray tube is not viewed directly, but is rather projected onto a mirror in the lid for added convenience and styling. At this point we temporarily leave the fascinating subject of Television, until future lessons, when its intricacies will be revealed, and we come now to the second section of this lesson, which is Frequency Modulation.

SECTION "B". FREQUENCY MODULATION.

Most people who have ever owned a conventional radio receiver can recall the annoying experience of having their favourite programme marred by interference in the form of static. Additionally, through the years, a continuous striving after greater fidelity of reproduction has been exhibited by engineers engaged on the development and design of domestic radio receivers. As far as "man-made" static is concerned, the position has steadily worsened with the passing of time.

More housewives are acquiring vacuum cleaners and refrigerators to ease their domestic burdens, factories are becoming more numerous and thus interference due to their electric motors and other devices is on the increase. All this is a good sign, in as much as it denotes the diversion of scientific activities to a purpose beneficial to mankind - why, even the mere male may now have an electric razor to remove his daily growth of stubble!

Radio reception, however, is on the losing side, as far as the above advances are concerned, and it is not surprising that an effort has been made to devise some scheme whereby the reception of radio programmes is possible with even greater fidelity and with little or no static to impair the performance, even in city buildings containing moving staircases and elevators. Furthermore, in country districts, reception is oftentimes impossible due to static of natural origin. In non-technical language the results obtained by the use of a system of Frequency Modulation are reduced static and noise together with an increase of possible fidelity.

The whole matter of Frequency Modulation is an old one, as it appears to have had its origin shortly after the invention of the "Poulsen arc", when it was found impossible to 'key' the arc as in spark transmitter practice, and thus some new method of modulation was required.

The idea of varying the frequency of the carrier wave, in order to modulate it, was suggested. Various proposals to achieve this were put forward, but no practical success came of those. Frequency Modulation was, therefore, discarded entirely in favour of Amplitude Modulation, until the introduction of the vacuum tube.

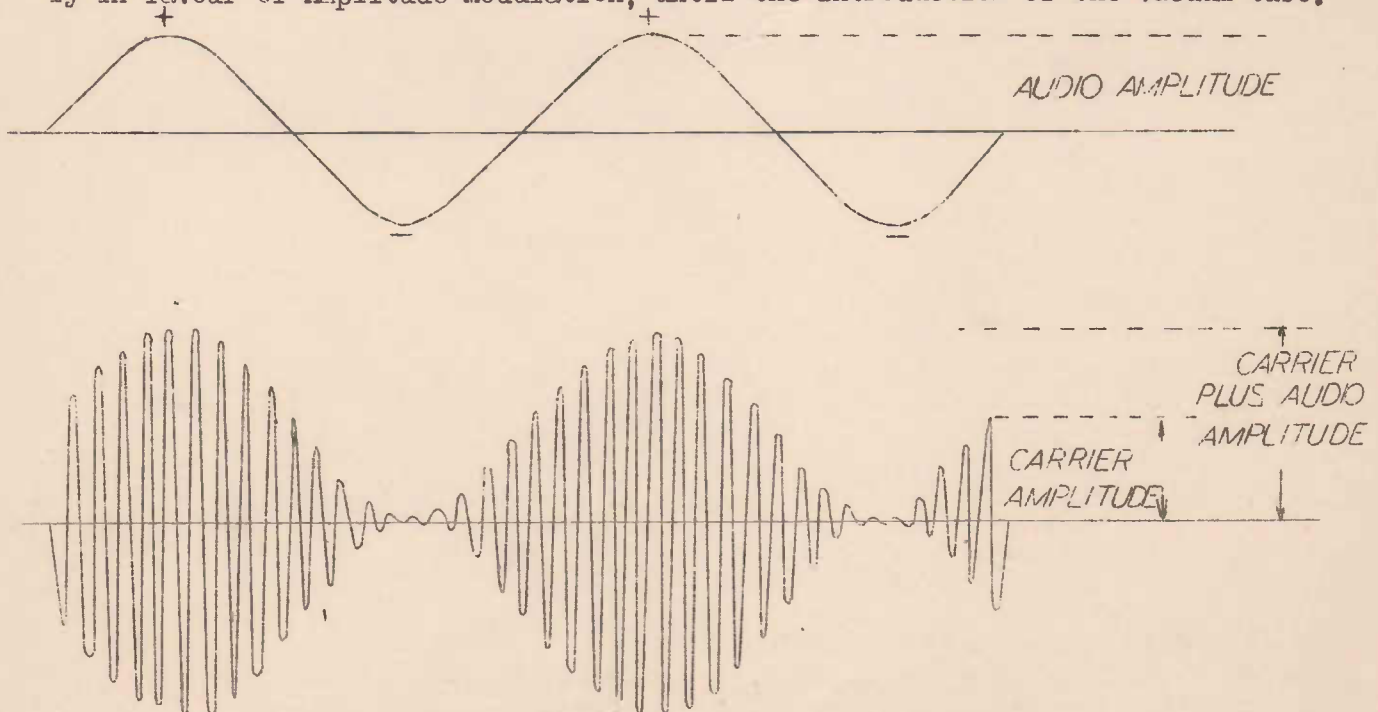

AMPLITUDE MODULATION - CONSTANT FREQUENCY - VARYING AMPLITUDE.
FIGURE 20.

It is considered opportune at this juncture to explain the basic theory lying behind the two most practical methods by which it is possible to impress intelligence at audio frequency, on a radio frequency carrier wave. Firstly, we have the means at present in universal use of Amplitude Modulation, in which the amplitude or magnitude of the R.F. carrier is caused to vary in sympathy with the audio frequency modulation. Fig. 20 gives us an idea of what this is all about.

This diagram should strike a familiar note as it has appeared in varying forms in most radio textbooks, and has also been featured and explained in the "A.R.C. Radio Service Course".

The following facts, however, should be kept in mind. When a wave is amplitude modulated, the carrier frequency is held constant while the amplitude only is varied in sympathy with the audio signal. The rate at which the amplitude (or strength) of the R.F. wave is varied is the frequency of the A.F. signal (or pitch of the sound note). The extent to which the Amplitude is varied (i.e. the depth of modulation) represents the amplitude of the A.F. signal (or the loudness of the original sound).

Now with frequency modulation, the amplitude or strength of the R.F. carrier

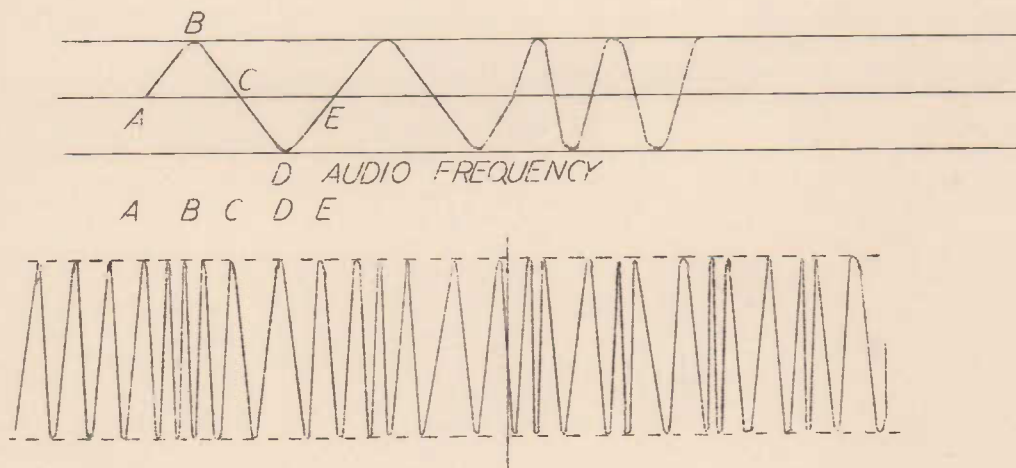

FREQUENCY MODULATED CARRIER- CONSTANT AMPLITUDE, VARYING FREQUENCY.

FIGURE 21.

wave is held constant, while its frequency is varied or "swung" around its nominal value at a rate equal to the sound frequency (A.F.). The amplitude or strength of the audio frequency current determines the extent (i.e. the number of cycles/sec.) to which the carrier frequency is varied. Fig. 2I illustrates the nature of a frequency-modulated carrier. Note that the amplitude of the R.F. Carrier remains constant until the A.F. modulating voltage begins to modulate it at "a". Then during the positive half-cycle of the A.F. the frequency of the carrier continuously increases until the A.F. reaches its peak at "b". As the A.F. cycle decreases towards zero at "c" the frequency of the carrier is progressively decreased to its normal or average value (point "c"). During the negative half-cycle of the A.F. modulating voltage a similar action occurs, except that in this case the freq. (R.F.) of the carrier is reduced, for the duration of the half-cycle, below the average or middle value (see "cd" of Fig. 2I). Note that the strength or amplitude of the R.F. carrier remains constant the whole time. This allows the transmitter modulated and power amplifier tubes to be working at their maximum rated powers the whole time, whereas, with amplitude modulation, these tubes are worked to the limit on the occasional peaks of modulation only.

A numerical example will serve to further illustrate. Suppose the carrier has an unmodulated frequency of 40 megacycles/sec. For the loudest sound to be handled (i.e. for 100% modulation), it might be decided to swing the frequency of the carrier between 39.9 mc/sec and 40.1 mc/sec, around the mean value of 40 mc/sec. This is a frequency "deviation" of .1 mc/sec (or 100, KC/sec) on either side of the average frequency, or a band width of .2 mc/sec (200 KC/sec). The rate at which the frequency is "swung" between these two limits is the audio frequency of the modulating voltage. For example, if a note of 2,000 cycles/sec is being broadcast, then the carrier frequency is varied around its average value at 2,000 times per sec. For a modulating voltage of one-half the Amplitude (i.e. a weaker sound) of the greatest which can be handled, the carrier frequency would be varied between 39.95 mc/sec and 40.05 mc/sec., i.e. a deviation of only .05 mc/sec (50KC/sec). This would represent 50% modulation.

Again, suppose the carrier is to be modulated with a lower frequency sound signal, say 1,000 c/sec., in this case the carrier's frequency would be "swung" around its mean value (40 mc/sec) at a rate of 1/000 times per second.

Summarizing, the nature of a frequency modulated (abbreviated F.M.) carrier is such that:-

- (1) The number of cycles/sec. by which the carrier frequency is deviated from its normal or mean value represents the depth of modulation (intensity of sound).
- (2) The rate at which the carrier's frequency is deviated between the two limits on either side of its mean frequency represents the frequency of modulation (i.e. the audio frequency).

With the introduction of the vacuum tube, the idea of Frequency Modulation was revived. By this time the relationship between the band width required and the

frequency of the modulating current was well understood in connection with amplitude modulation. It was realised, for example, that to modulate a carrier with audio-frequencies ranging from say 0 to 7.5 Kc/sec. a band width of 15 Kc/sec. is required (due to the generation of side-bands). Now the idea occurred that by using frequency modulation, the band width could be reduced to only a fraction of that required by the older method of modulation. The suggestion was that the frequency deviation of the carrier could be limited to, say, 2 Kc/sec., giving a total frequency variation of only 4 Kc/sec. (as compared with the 10 Kc/sec. channel allowed with A.M. methods). It was thought, as the student will also probably think at this stage) that this limitation of band-width would not limit the range of audio-frequencies which could be superimposed on the carrier; for with F.M. a high audio frequency could be made to modulate the wave simply by swinging the carrier frequency over a part or the whole of the 4 Kc/sec. band at the desired rate - a rate to which there was no limit. In this way, it was hoped to obtain high fidelity transmission even though a narrow band-width was used.

In 1922, however, Carson published a paper showing, mathematically, that no reduction in band width was possible without a loss in fidelity. Carson showed that a band width of at least twice the highest modulating frequency was required, this situation arising from the fact that frequency modulating a carrier resulted in side-band frequencies being produced in much the same way as occurred with amplitude modulation. This proved that F.M. conferred no advantages from the point of view of fidelity for a limited band width - in fact, it demonstrated that amplitude modulation was the best system from this point of view. Carson finally came to the conclusion that "Consequently this method of modulation inherently distorts without any compensating advantages whatsoever".

As a result of Carson's conclusions F.M. was again practically forgotten until 1936, when Edwin Armstrong published a lengthy paper on the subject. This publication was the result of many years research carried out at Columbia University, New York, and the construction of a complete system by R.C.A. in 1933-4.

Armstrong's work demonstrated that the chief merit - and this was a very substantial one - of F.M. - was that noise due to "static", man-made electrical interference, and valve "hiss", could be virtually eliminated by the correct application of this new system. This was an aspect of the question not previously considered by other workers. Strangely enough, it was further demonstrated that, although F.M. reduces noise, even when using the same band width as for A.M., the greatest benefit was obtained in this connection by utilising a band width as wide as possible. Consequently, Armstrong employed a frequency deviation as wide as 75 Kc/sec. on either side of the mean carrier frequency - a total band width of 150 Kc/sec. Simple arithmetic will show that only six stations could operate in our present broadcast band (550-1,500 Kc/sec.) if such a band width were universally employed. Moreover, the band width would form too large a proportion of the carrier frequency to allow of the efficient design of selective tuning circuits.

Armstrong's solution to these difficulties was to select a carrier frequency in the ultra-high frequency band. In the experimental system constructed 41 mc/sec. was used. Working at these high frequencies there is ample "room" for these wide band widths.

So effective did Armstrong's suggestions prove to be, that working with a transmitter of only 20 watts power on the Empire State Building in New York and a receiver sixty miles distant, results comparable with the reception of 10,000 watt stations using the conventional system were achieved. Armstrong's theoretical work (the results of which were borne out by practical laboratory tests) shows that, under favourable conditions, F.M. will reduce noise by as much as 1,000 or more to 1.

A disadvantage of the system is a characteristic of all ultra-high frequency transmissions, viz., the reception is practically limited to points which lie in a straight line from the transmitting aerial. This means that a transmitter has a line-of-sight coverage, thus limiting the reliable range to 30-50 miles, depending on the heights of transmitter and receiver aerials, and the nature of the land surface. To overcome this a system of narrow band F.M. has been proposed which may possibly find acceptance on the lower frequency bands. Fidelity would suffer here, but, on the other hand, some of the noise reduction properties would be retained to a lesser degree.

Another advantage of the F.M. system which may prove a very important one, is the almost complete immunity of a F.M. transmission from interference created by another F.M. transmission operating within the same wave-band. Provided the desired signal is more than twice as strong as the undesired one, this immunity is practically 100 per cent complete. With amplitude-modulated waves, on the other hand, the desired signal must be at least 100 times as strong as the interfering signal before the latter is effectively "swamped out".

To sum up, then, we can say that F.M. enables the reception of clearer signals less effected by noise and static than A.M. signals, and because of this property of the system small powers only are required. As far as improved tonal quality is concerned, this is incidental only and not due to any peculiar or distinct advantage of F.M. over A.M. The point is that A.M. stations are limited to a band width of 10 Kc/sec., so that the present broadcast band will contain the requisite number of stations, and if this limitation did not prevail, there is no limit to the possible frequency range of the conventional A.M. transmission. Bear in mind though, that to get a good clean signal through a bank of noise a very large radiated power would be required if the system is working on the A.M. principle, but only a small power is necessary to achieve the same thing if F.M. is used. Here then, is a great advantage, as F.M. transmitters may be cheaply constructed and will enable country folk to obtain clear and clean reception regardless of local noise and atmospheric conditions.

Fig. 22 shows in block form the basic circuit arrangement for a F.M. receiver, The similarity to A.M. systems will be obvious, except for the action of items like the limiter and discriminator in the receiver, and the reactance tube in the transmitter. Two separate transmitters have been shown in Figs. 23A and 23B, because there are two schools of thought at the present time on the subject of modulating the frequency of the carrier. The reactance-tube method of F.M. is shown at "A" in Fig. 23, together with the automatic frequency control unit necessary with the reactance tube to maintain the average carrier frequency constant.

The second scheme shown at "B" is somewhat more complicated in its action in as much as instead of a reactance tube a complex 90° phase shifting network is employed in conjunction with a crystal oscillator. This is the Armstrong system at present in commercial use in America. Further details of these systems are contained in a later lesson.

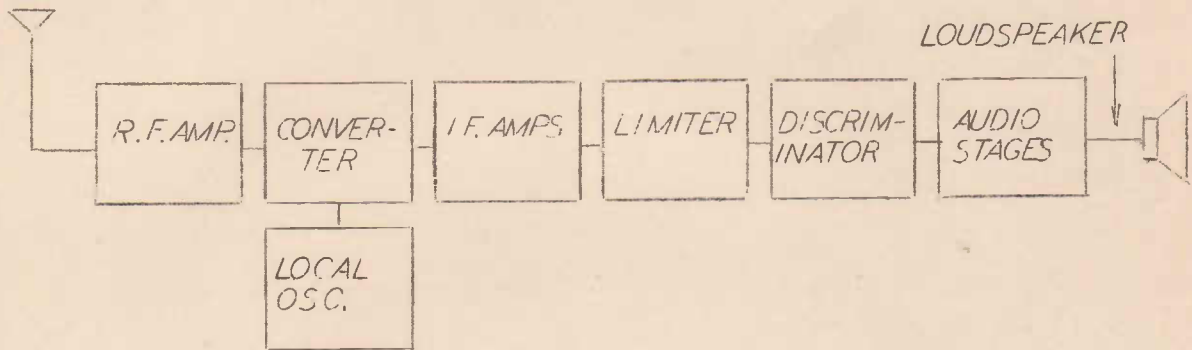

SIMPLE BASIC RECEIVER FOR FREQUENCY MODULATED CARRIERS.

FIG. 22.

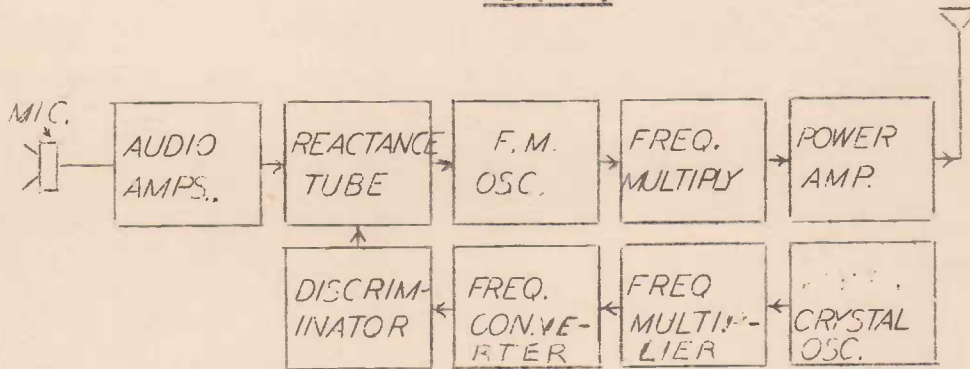

FIG. 23A.

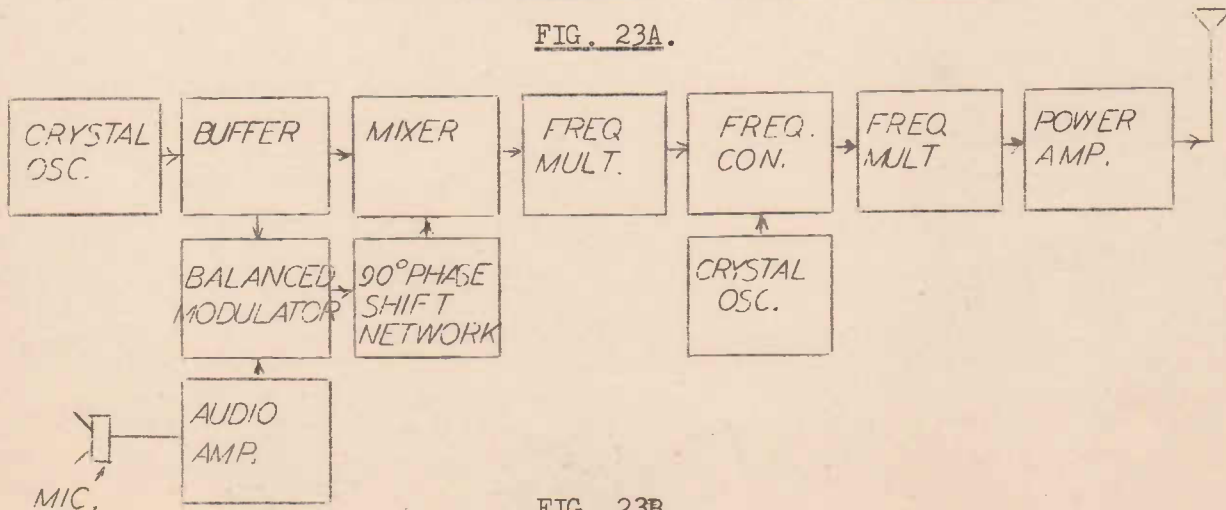

FIG. 23B.

TWO BASIC FORMS OF F. M. TRANSMITTERS.

There will always be both Amplitude, as well as Frequency Modulation, and it is merely confused thinking to assume that either one will entirely supercede the other - rather is it a matter of using the most suitable means to achieve a certain end. There are cases where A.M. has definite advantages over F.M. and vice versa, which state of affairs ensures that both services will develop to everybody's benefit.

SECTION "C". FACSIMILE TRANSMISSION.

Facsimile is a very simple thing to understand as it is almost self-explanatory, in so far as it concerns the reproduction of a newspaper, photograph, postcard, or any other similar item, in such detail that this aforesaid reproduction shall be an exact copy or facsimile of the original. Literally, any object which is a direct and detailed copy of another may be styled a facsimile of it. An Australian pound note is a facsimile of another Australian pound note, and so on.

But - and it's a big But - here we are concerned with copying something by some means in, say, Melbourne, and sending by wire or radio link related electrical impulses, which when picked up by a receiver in, perhaps, Sydney, will reproduce on a paper an exact replica of that something still down in Melbourne. This is what is meant by Facsimile. In America attachments are marketed, which, when fitted to a normal radio receiver, enable the purchaser to have reproduced in his own home, a news bulletin or paper. Mr. Suburban American just turns on the works before retiring for the night and "hey presto!" when he wakes in the morning a neat roll of printed paper is located near his radio receiver.

As mentioned briefly earlier, it is not necessary to have the link between sender and receiver a radio one; in this application wired systems are often used and prove very satisfactory. Actually we have had Facsimile services in one form in use in this country for some time, for example, the Sydney-Melbourne picturegram service, and the overseas radio-gram service operated by the P.M.G.'s Department and "A.W.A. Beam" service.

As in television, it is necessary to "scan" the picture or diagram in order to set up a succession of electrical impulses corresponding to the various parts or elements of the subject. Now in the case of television, remember, a whole picture must be dissected and reproduced at the receiving end in a small fraction of a second, this being necessary to create the illusion of motion. In facsimile transmission, however, we are not burdened with this time limit, as it is a still picture which is being dealt with. We may say that a facsimile picture bears the same relation to a television picture as does a magic lantern image to that of the cinematograph. In practice a facsimile picture may take anything between a few minutes to one hour to reproduce.

The picture or diagram to be reproduced is usually mounted on some sort of drum as in Fig. 24. Here the drum is mounted on a spindle having a screw thread. A stationary spot of light is focussed on the one end of the drum. As the drum is rotated the spot of light traverses the picture in a spiral fashion, so completely scanning it.

The light reflected from the picture will vary with the light and dark portions as the drum rotates. This varying reflected light produces corresponding current variations in the photo-electric cell.

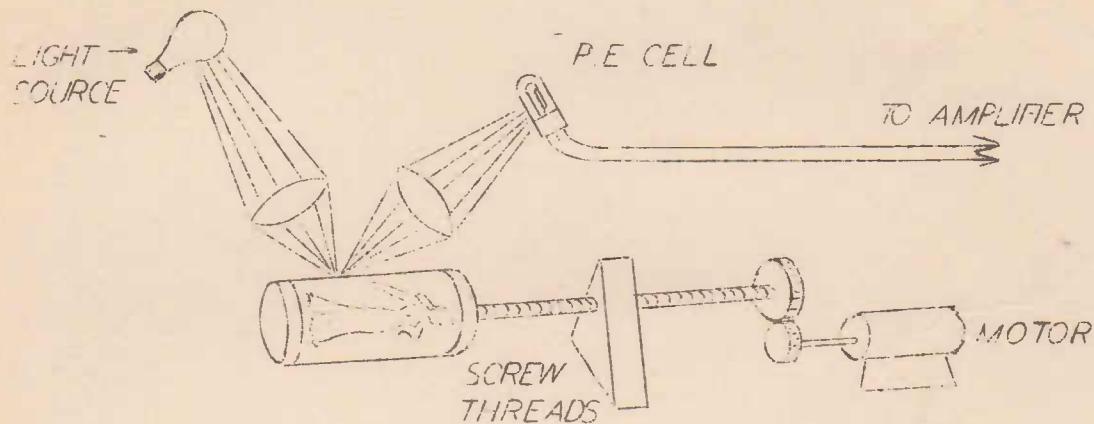

FIGURE 24.

In other arrangements the drum remains stationary, and the beam of light rotates around the picture in spiral fashion. Of course, the result is the same.

The electrical impulses are now amplified and used to modulate a high frequency carrier current which in turn may be carried over a line to the receiver (picture-gram or cable-gram) or caused to radiate a radio wave (radio-gram).

At the receiver, the carrier is detected or demodulated, the resulting current being a replica of that produced by the photo-cell.

To reproduce the picture a similar drum is used as that shown in Fig. 24 at the transmitter. The picture-signal is caused to vary the brilliancy of a light source which is focussed to a spot on a photographic film or paper around the drum. The receiver drum is rotated at the same speed, and exactly in step with the transmitter drum. In this way the light spot traverses the photographic film producing, due to the normal chemical action of such a film, varying shades of light and dark elements in sympathy with the picture current variations.

Where it is desired to send only prints or diagrams, a simplified system is used. Here it is necessary to reproduce two shades only - black and white. The transmitter sends a current for white portions of the diagram, etc., and no current for black. The current used to modulate the carrier in such a system would look something like that illustrated in Fig. 25.

At the receiver, the reproduced signal current is made to operate a stylus. When a current is being received, and for the duration of that current, the stylus

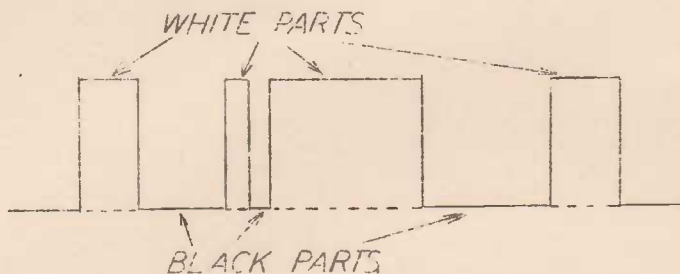

FIGURE 25.

is lifted from or does not act on the paper, leaving it white. When no current is received, the stylus is made to act upon the paper colouring it grey or black.

In this lesson we have investigated the general principles of three interesting new services. Naturally, the comparatively brief and general description of each will set you thinking and puzzling over some of the more intimate technical details. The following lesson papers will deal firstly with television equipment, and then later with frequency modulation and facsimile equipment in considerable detail, so that, as you progress, any points which at present are puzzling you, will be explained.

T.F.M. & F LESSON 1.

EXAMINATION QUESTIONS.

1. What characteristic of the eye makes television possible.
2. Although feasible systems for television were suggested as early as 1880, no practical success was achieved until 1923. Why was this so?
3. The following represent a list of components or sections in an ordinary radio telephonic system. Name the corresponding components or sections in a television system:-
(a) microphone, (b) loudspeaker, (c) audio amplifier, (d) modulator.
4. Explain briefly the meaning of "scanning". Why is scanning necessary in television transmission?
5. What have television and the cinematograph in common as regards the reproduction of moving pictures?
6. Explain briefly the difference between frequency modulation and amplitude modulation.
7. What is the chief advantage of frequency modulation over amplitude modulation?
8. Name one advantage and one disadvantage of "wide-band" F.M. compared with "narrow-band" F.M.
9. What is the main point of difference between Facsimile transmission and television?
10. Describe a simple method of scanning the picture or diagram to be transmitted by a facsimile system.

PLEASE NOTE POSTAL ADDRESS - Cnr. Broadway & City Rd., Sydney-
for return of papers, correspondence etc.

NOTE: Write on one side of the paper only.
Always write down in full the question before you answer it.
Answer the questions as fully as you can, giving complete explanations and sketches wherever possible.
Remember that you learn by making mistakes; so give yourself an opportunity of having your mistakes found and corrected.
Don't hesitate to ask for further explanation on any point, we are always ready to help you.

AUSTRALIAN RADIO COLLEGE

E. S. & A. BANK BUILDINGS, Corner CITY RD. and BROADWAY, SYDNEY
Telephones: M 6391 and M 6392. Post Lessons to Box 43, Broadway

This lesson sheet is published for the exclusive use of
students of the Australian Radio College Pty. Ltd.
(All rights reserved)



TELEVISION, FREQUENCY MODULATION & FACSIMILE COURSE

LESSON 2.

SOURCE OF SIGNALS.

KEY TELEVISION IS TECHNICALLY MORE DIFFICULT THAN SOUND TRANSMISSION:

In Lesson 1 we discussed some of the difficulties which faced the early workers in television - difficulties which were long realised by many of them before even the crudest of solutions were practically devised.

Nipkow, for example, in 1884, clearly saw that it was not possible to transmit in one piece a complete picture or scene (even though no motion was involved). It was his brain-child to deal electrically with each portion of the picture in turn, by the method known as "scanning", which was made possible by his famous disc. Thus, the general principle, which rules the operation of all modern television systems, was established, at least in a theoretical way.

Prior to this date the photo-electrical properties of selenium (made use of in the selenium photo-electric cell) had been discovered. Hence, a method was immediately available to Nipkow and others for converting the varying light impulses to corresponding electrical changes.

So, even at this early date, it appeared to be theoretically possible to transmit these electric current impulses

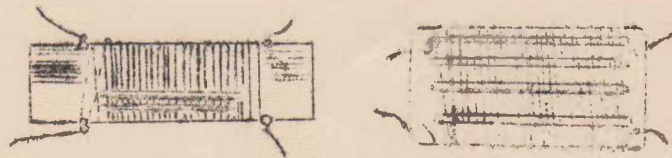

FIGURE 1.

Two early types of Light Sensitive Cells. At the left, strips of selenium are placed across two spirals of wire lying in grooves in an insulating tube. At the right, the wires are wound over the strips of selenium placed on a flat card.

at least over wires to a distant point where, if the current changes were converted back into light variations, in the correct order or pattern, the picture could be re-created, element by element.

The reason why no success was achieved was due to the fact that the "picture-signal" output from the photo-cell was too minute to serve any such useful purpose.

It was not until some years after the invention of the amplifying thermionic valve (in 1914) that practical success was achieved by Baird and others. The student should observe that the lack of means for amplifying an electrical signal was the difficulty which for many years baffled all workers in the television field. In the field of sound telephony, on the other hand, this absence of amplifying methods did not prevent the realisation of practical success. The electrical audio frequency output from the simplest of microphones is sufficient, when transmitted through wires (at least for a short distance) to

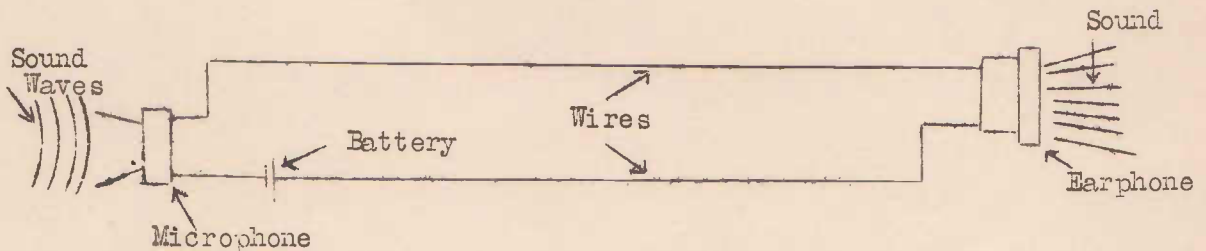

A SIMPLE PRACTICAL TELEPHONE SYSTEM.

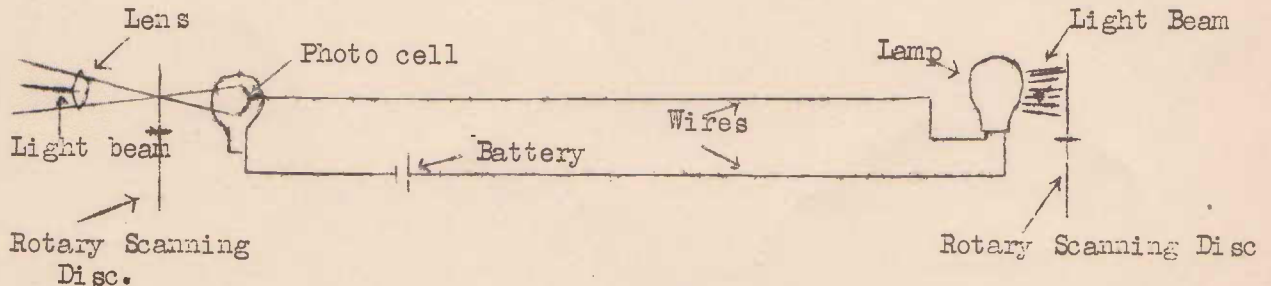

A SIMPLE "WIRED" TELEVISION SYSTEM - NOT PRACTICABLE

FIGURE 2.

operate an car-phonc.

The problems in television, however, have deeper roots than those already discussed. These problems are bound up with the nature and characteristics of the eye itself. It is comparatively simple to "fool" the human ear (or rather the sense of hearing) by means of an artificially reproduced sound. For example, although the human ear is sensitive to sound waves lying in frequency between about 16 cycles/sec. and 15,000-20,000 cycles/sec., the sense of hearing is very well satisfied indeed if a radio loudspeaker reproduces only those frequencies lying between 50 cycles/sec. and 7,500 cycles/sec. (this representing the performance of a high-fidelity wireless set). As a further example of the lack of discrimination of the ear, it is of interest to note that ear detects no undesirable effect if the phase relationship between different sound frequencies are altered during transmission. In television, on the other hand, phase changes in transmitter or receiver produce an effect in the reproduced scene which are readily perceived by the eye.

The position may be summed up simply by saying that television apparatus (at both transmitting and receiving ends) necessary to transmit a picture which is reasonably good to the eye must be much more perfect technically than the corresponding radio telephony apparatus used to transmit a sound with which the less critical ear will find no fault.

One of the major technical difficulties in television is to devise means to produce at the transmitter an electrical picture signal of sufficient quality to represent adequately the picture or scene to be televised. It will be the object, therefore, of this lesson, to discuss and explain the principles underlying the generation of this picture signal.

Before we can intelligently study the technical aspects of this problem, however, we must fully realise the nature of the job which we are tackling. We must know what the human eye demands of an artificially reproduced picture or scene if the desired degree of realism is to be experienced.

Now we all realise that the eye allows us to "see" by utilising light waves. We are so familiar with light, or rather the effects and sensations which light produces in our minds, acting per medium of our eyes, that we rarely stop to contemplate its true nature. The first question, therefore, is

"WHAT IS LIGHT?": Light is an electromagnetic form of energy which travels through space with a wave-motion. This definition will be made clearer if it is stated that light waves are of exactly the same type as radio-waves. What then is the difference between light and radio waves? The difference is one of frequency and wave-length only. This difference, however, is an extremely great one. Light waves bear a very much higher frequency and shorter wave length than have radio waves.

For Radio communication purposes electro-magnetic waves lying in frequency between 550,000 cycles/sec. (550 Kc/sec.) and, say, 40,000,000 cycles/sec. (40 mega-cycles/sec.) are in use. The wave lengths of these range from 550 metres down to 7.5 metres. The visible light waves, on the other hand, have frequencies lying between about 400,000,000 mega-cycles/sec. and 800,000,000 mega-cycles/sec. The wave lengths corresponding to these frequencies are .00000075 metres and .00000037 metres.

Note how vastly different these are from the corresponding values for radio waves.

It may be of further interest to note that radio and light waves are not the only examples of electro-magnetic radiations. We have, in addition: - Cosmic Rays (which have their source somewhere in space outside the earth's atmosphere); X-Rays (used for medical and industrial purposes); Ultra-Violet waves (not visible, but to which most photographic plates are sensitive); Infra-Red waves (used for special photographic and other purposes); and ordinary Heat waves. Fig. 3 will show clearly how all of these are related from the frequency point of view. It should be noted that the visible light waves form a comparatively small band of frequencies in the whole range from the lowest (Radio Waves) to the highest (Cosmic Rays). We may say that the eye can see only the light-waves because its construction is such that it is sensitive only to these particular frequencies.

WHAT IS COLOUR? The colour of a light wave depends upon its frequency. Fig. 3 shows that the lowest frequency light-wave to which the eye can see is red. The highest frequency light-wave is violet. The other main colours; orange, yellow, green blue, have gradually increasing frequencies in that order. The strength or intensity of a light wave should not be confused with its frequency (colour). A strong light of some particular shade of red will have the same frequency as that of a weaker light of the same colour.

WHAT IS WHITE LIGHT? White light is a mixture of light waves of all colours (frequency) in the proportion they appear in natural sunlight. The incandescent filament of an electric light globe sets up light waves of all colour frequencies in approximately this proportion.

WHAT IS BLACK? Black is not really a colour at all, but the absence of all light. A black object is one which reflects to the eye no light whatsoever. Since all objects reflect some light, no object is absolutely black. The proverbial black cat in the coal-mine at midnight would probably be the nearest thing to a black object!

WHY DO DIFFERENT OBJECTS APPEAR TO HAVE DIFFERENT COLOURS? When white light (a mixture of all colour frequencies) falls on a surface, that surface might reflect equal proportions of all the colour frequencies, and we would say the object is white. Another surface might absorb all colours in the white light except red, which it reflects. Since the reflected light which strikes the

ELECTROMAGNETIC WAVES

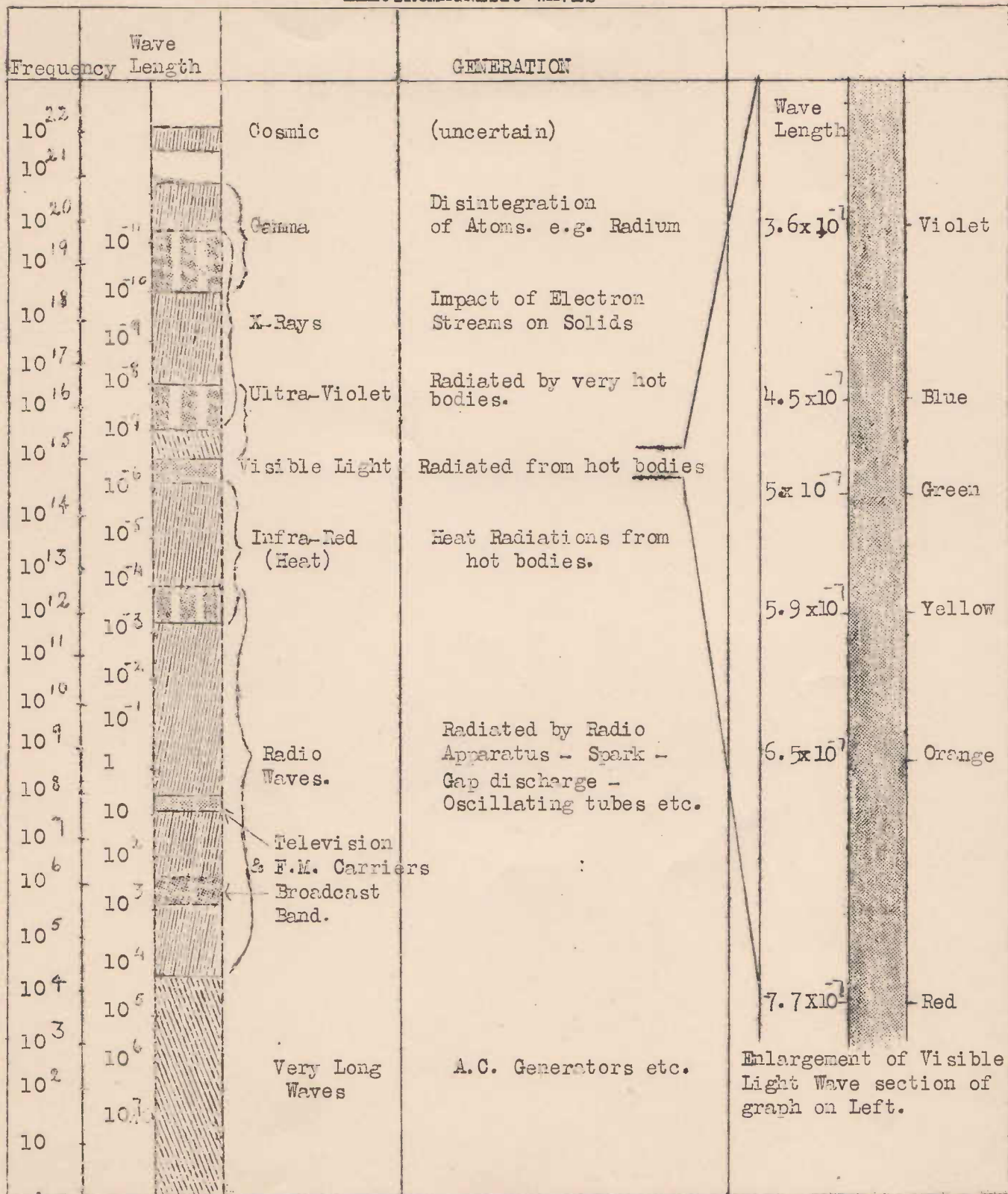

FREQUENCY IN CYCLES/SEC — WAVELENGTH IN METRES
 $10^4 = 10,000$ etc — $10^{-1} = \frac{1}{10,000}$ etc.

FIGURE 3.

eye is red, we would say that red was the colour of the object. A blue surface would absorb all colours in the white light except blue, which it reflects to the eye, and so on.

THE FUNCTIONS OF THE EYE: When we look at a picture or scene light waves of different colours and intensities, which are reflected from the various elements or details of the scene, enters the front of the eye, where a lens (Fig. 4) focuses them on the retina to form an image of the actual scene. This action is similar to that of a camera (see Fig.9 later in the lesson). The retina is a sort of screen covered with minute nerve ends, each of which convey separately to the brain the sensation of light intensity and colour. Thus all the details of the scene may be taken in simultaneously. The chief functions of the eye are:-

- (1) The ability to distinguish between degrees of light and shade, i.e. to evaluate different light intensities;
- (2) The ability to distinguish detail in the scene, each detail being dealt with by a single, or small group, of nerve ends on the retina;
- (3) The ability to distinguish colour;
- (4) The ability to distinguish motion in the image;
- (5) The ability to distinguish "depth" in the scene.

WHAT DOES THE EYE REGARD AS ESSENTIAL IN AN ARTIFICIALLY REPRODUCED PICTURE?

To achieve some sense of reality in reproducing a scene by artificial means, which is our problem in television and in cinematography, we must give attention to:-

- (1) Reproducing considerable detail;
- (2) Reproducing considerable variations in light intensities, i.e. in light and shade;
- (3) Creating the illusion of motion.

The technique of generating an electric current which can be "carried" to a distant point where it can be used

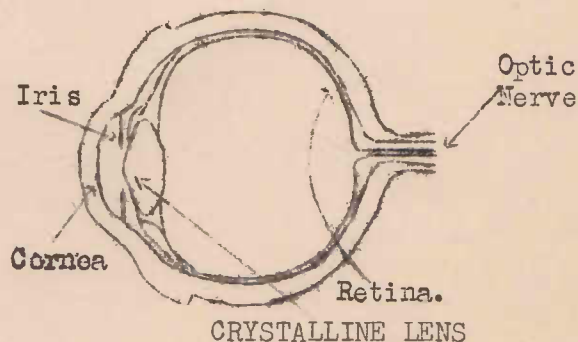

THE EYE.

FIGURE 4.

to reproduce these essentials in an image of the actual scene, will form the subject matter of the remainder of this lesson.

It will be noted that colour and "depth" are not considered essential for a sense of realism. This statement is justified by experience in cinematography, where considerable realism can be obtained in ordinary "black-and-white" images. Of course, colour, if natural, adds to the realism, as does depth (as those of us who have seen the experimental "stereoscopic" films will well realise). It might be remembered here that both colour and depth or stereoscopic effects have been realised in television, but the technical difficulties are considerable. Some description of the methods used to produce these effects will be given in a later lesson.

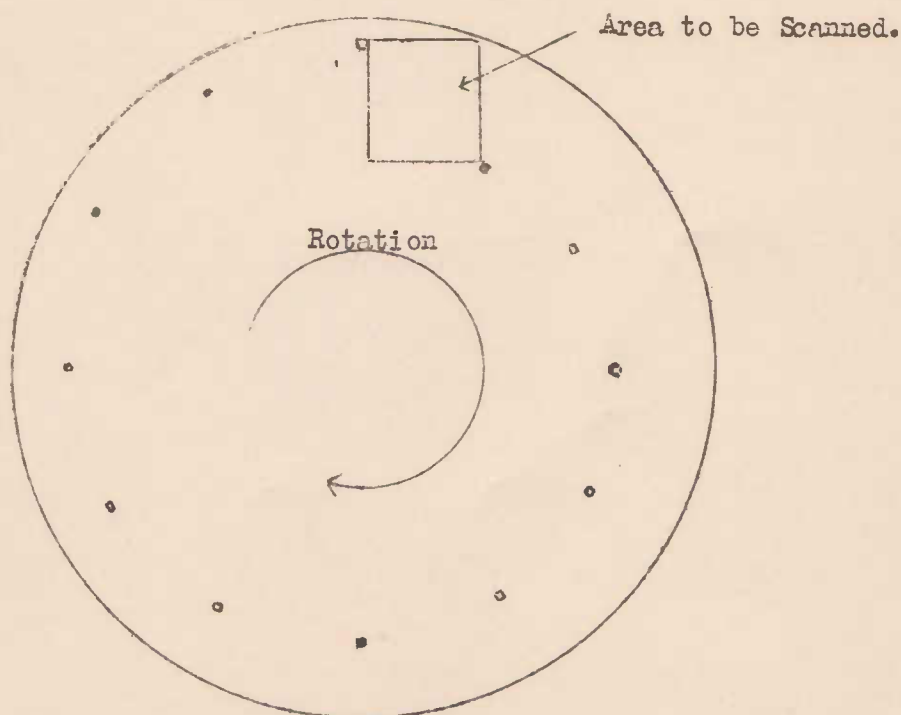

SCANNING DISC -- SHOWING POSITION OF HOLES IN
RESPECT TO EACH OTHER AND TO SCANNED AREA.

FIGURE 5.

THE SCANNING DISC:

In Lesson I, we described briefly how the Nipkow Scanning Disc, in conjunction with the Photo-Electric Cell, could be used as a source of picture signal. We shall now examine in more detail the operation of this disc, in order to assess its efficiency, and to give a better understanding of the technique of breaking up the picture or scene into small sections or elements in the process of creating the electrical signal in the transmitter.

A plan of a simple scanning disc is given in Fig. 5, showing the spiral arrangement of the holes. Note that each hole is closer to the centre of the disc compared with the previous one by a distance equal to the width of the hole. This is necessary in order that the strips of the picture scanned by the spot of light from successive holes lie adjacent to each other, as shown in Fig. 6. There should be no overlapping of the scanned strips, for this will result in a distorted reproduction at the receiver. Neither should there be gaps between adjacent strips as this will result in portions of the picture being entirely missed, with consequent loss of detail.

Since the first (outermost) hole of the disc scans a roughly horizontal strip at the top of the picture and the last hole scans a strip at the bottom of the picture it is evident that the whole picture is scanned by a number of strips exactly equal to the number of holes in the disc.

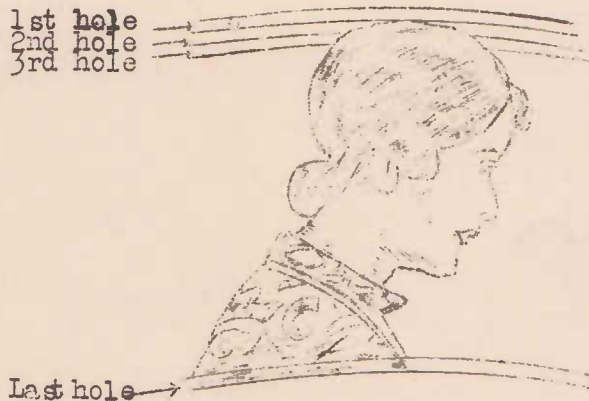

Futhermore, a complete scan will be achieved in one revolution of the disc. These facts will be made clear by reference to Fig. 5. As one revolution is being completed the innermost scanning hole will be just finishing its scanning strip at the bottom right hand corner of the picture. At this moment the first scanning hole will be about to commence its excursion across the top of the picture, beginning at the top left-hand corner.

Another important point to notice is that the distance between successive holes around

FIGURE 6.

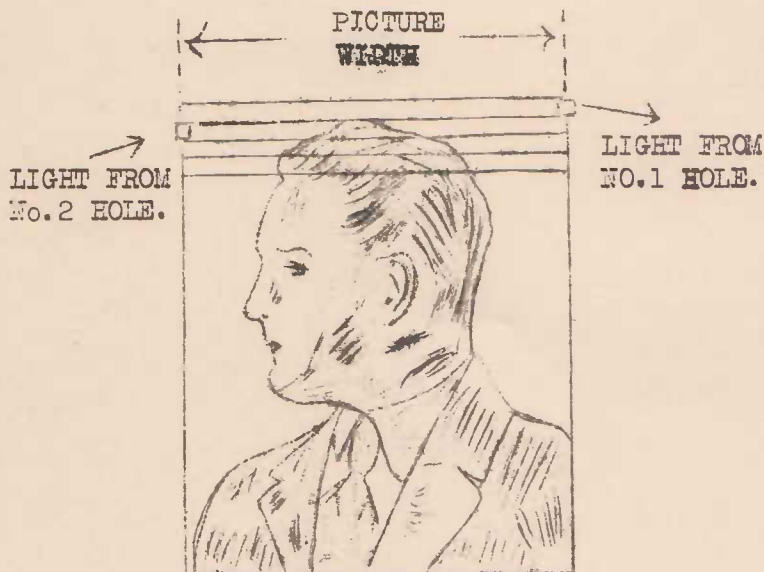

FIGURE 7.

the disc is equal to the width of the picture.

Suppose we are scanning the picture of Fig. 7, the light spot from hole one has just finished its sweep across the picture and is leaving the right hand edge. At this instant the light spot from hole number two is just commencing its sweep at the left hand edge. The two spots must not be on the picture at one time, because the photo-cell must not be affected by two areas at one time. On the other hand, there must be no appreciable gap of time between the leaving of one spot and the coming of the next, for this would represent a waste of scanning time. Therefore, the separation between holes is the width of the picture

or of the frame as shown in Fig. 5. There is a final fact concerning the "geometry" of the scanning disc. The difference between the distances of the first hole and the last hole from the centre of the disc is equal to the height of the picture or "frame". This is evident from Fig. 5, where a rectangle representing the frame is shown superimposed on the disc. Fig. 6 will, perhaps, make this point clearer. The first hole is at such a distance from the disc centre that it scans the top edge of the picture. The distance of the last hole is such that its light spot scans the bottom edge of the picture. So the difference between these two measurements must be the picture's height.

Summarising these points in the disc's construction, the following should be remembered as they will be referred to later in discussing the limitations and disadvantages of mechanical methods of scanning:-

- (1) The number of strips or lines by which the picture is scanned is equal to the number of holes in the disc.
- (2) The number of complete pictures or "frames" scanned per second is equal to the number of revolutions made in one second by the disc. For example, to transmit, say 25 pictures per second, to give the illusion of motion in the scene, the disc must rotate 25 revolutions per second, or $25 \times 60 = 1,500$ revolutions per minute.

- (3) Adjacent holes must be separated by a distance equal to the width of the picture.
- (4) The difference in the distances of the first and last hole from the centre of the disc is equal to the height of the picture.

METHODS OF USING THE SCANNING DISC. AT TRANSMITTER: The method used for scanning large pictures or scenes is illustrated in Fig. 8.

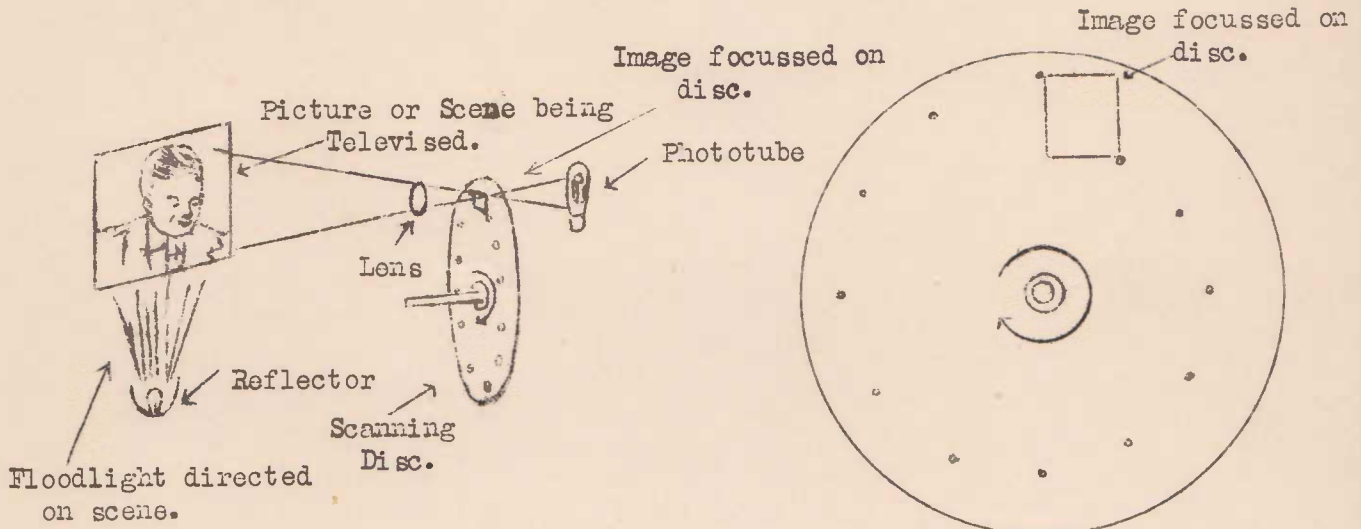

FIGURE 8.

Here the picture or scene is focussed by means of a lens to form a small image on the disc as shown. The action of the lens is similar to that of a camera, whereby an image of the scene is thrown on to the film at the back of the box, as shown in Figure 9.

The image of the tree appears inverted, this being a characteristic of the lens' focussing action.

Returning to Figure 8, note that the image on the disc must be the correct size for the positioning of the disc holes as discussed in the previous section.

The disadvantage of this system is that the whole scene being televised must be brilliantly lighted. The amount of light falling on the photo-cell at any instant is that passing through one small disc hole, and, therefore, coming from one small point of the picture or scene being televised.

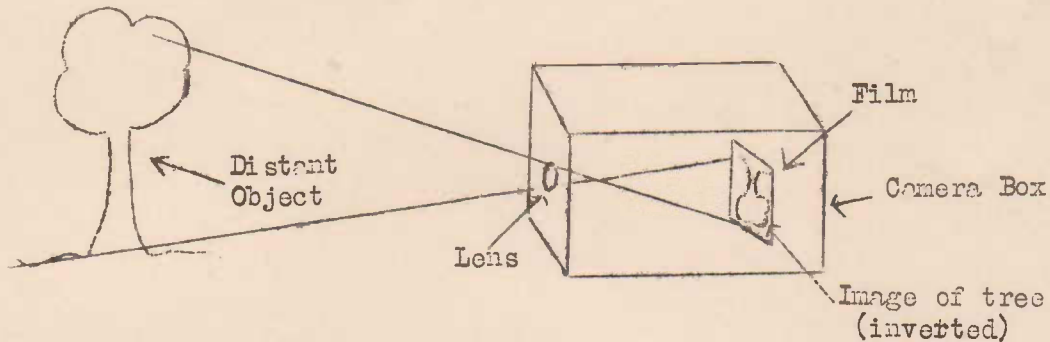

FIGURE 9.

The whole scene, consequently, must be extremely brightly illuminated if the photo-cell is to produce a sufficiently large amount. This rules out the possibility of televising outdoor scenes, except under the most favourable circumstances of strong sunlight.

In the case of studio scenes extremely powerful arc lamps must be used. These lamps give out so much light and heat that the conditions under which the announcer and other performers work are most uncomfortable. Even with ideal lighting conditions, however, the electrical output from the photo-tube is extremely minute.

The other system of using the scanning-disc is that known as the "Flying-Spot" method illustrated in Figure 10. There light from a powerful arc light is

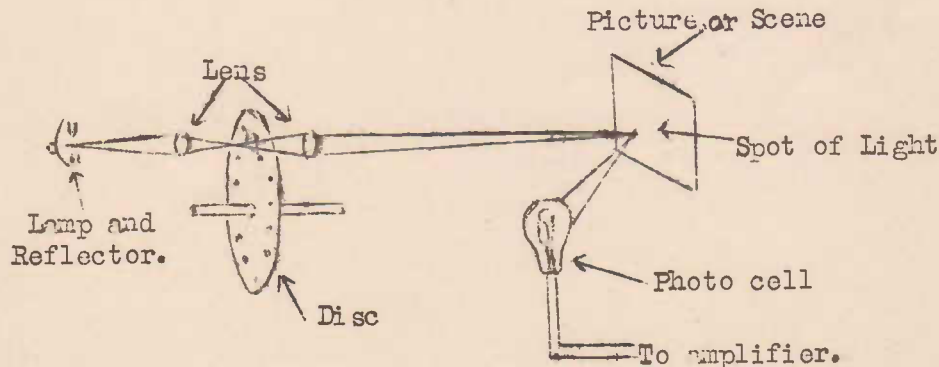

FIGURE 10.

focussed, by means of lenses through each disc hole in turn on to the scene or picture being televised. With this system all the light available from a given source is concentrated on the small part of the picture or scene being scanned at a given moment.

The brilliancy of the scanned areas will, therefore, be much more intense than in the case when the whole scene is "flood-lit". In this way the flying-spot method makes much more economical use of the available light from the source.

An interesting advantage of this method, compared with the "flood-light" system, is that, although the brilliancy of the light-spot may be intense, the apparent lighting of the studio scene may be quite moderate, or even dim. The reason for this is that the spot of light traverses the whole area in, say, only one twenty-fifth of a second. Owing to the persistence of vision effect the eye is conscious only of the average light spread over the whole area in that time. This average brilliancy will be much less than the actual brilliancy of the spot itself.

There are several disadvantages of this method of disc-scanning, however. One is that the system is not suitable for dealing with large scenes. A second is that the scene must be in complete darkness except for the light from the scanning spot. Any external lighting covering the whole scene would cause the photo-cell to receive light continuously from all parts of the scene, and this would "mask" the effect of the flying spot. This limitation, therefore, rules out the possibility of televising outdoor scenes.

A third failing lies in the difficulty of utilising all of the reflected light from the scanned spot. Although the arrangement gives maximum illumination for the small area being scanned at any instant, the situation is not as good as it might seem. The reason for this is that a single photo-cell would "collect" only a small fraction of the scene. The reason for this may be realised by referring to Figure 11. Light reflected from an unpolished surface is "diffused". The reflected

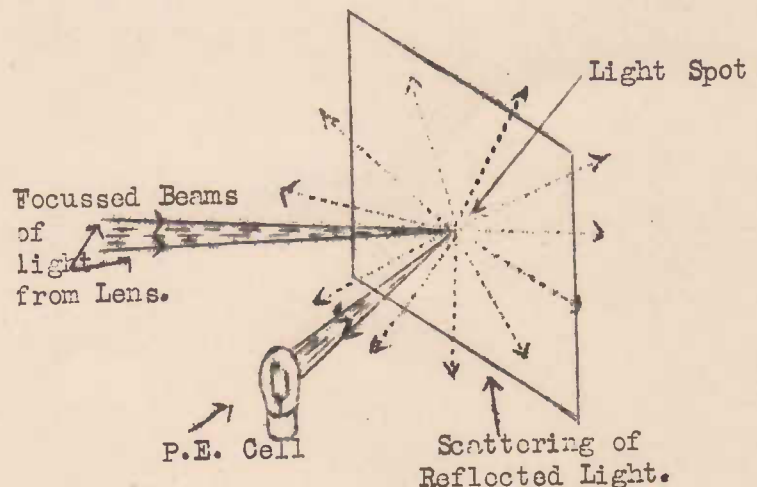

FIGURE 11.

light spreads out in all directions, and only those light rays which happen to be reflected in the direction of the photo-cell will have the desired effect of setting up an electric current.

This latter failing is minimised in practice by using a number of photo-cells clustered around the scene, and all connected electrically in parallel. Further, by using large reflectors having somewhat the same shape as those used for a car's headlights a better effect may be obtained. As shown in Fig. 12 all reflected light rays falling over the reflector's surface will be concentrated or focussed on to the photo-cell. This reflection is acting in the "reverse manner" to that of a car's headlamp.

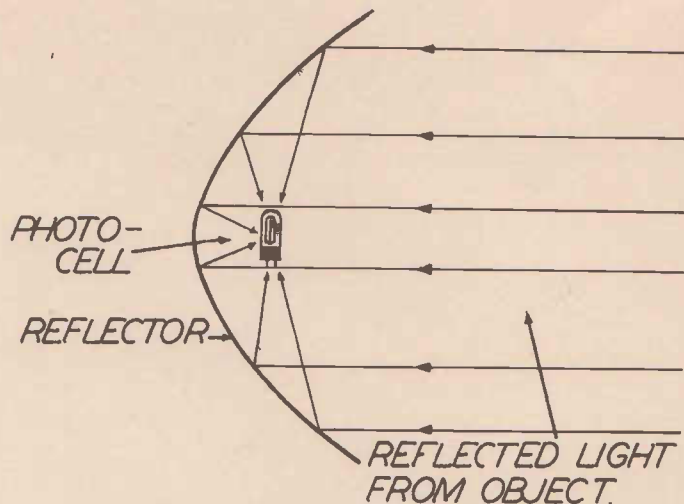

FIG. 12.

FIGURE 12.

Figure 13 is a photo of the interior of an early television studio using the flying-spot method of mechanical scanning. Note the eight reflectors used to gather the light reflected from the televised object. Of course, each reflector is fitted with a photo-tube. The scanning disc and lens system are visible at the rear of the booth.

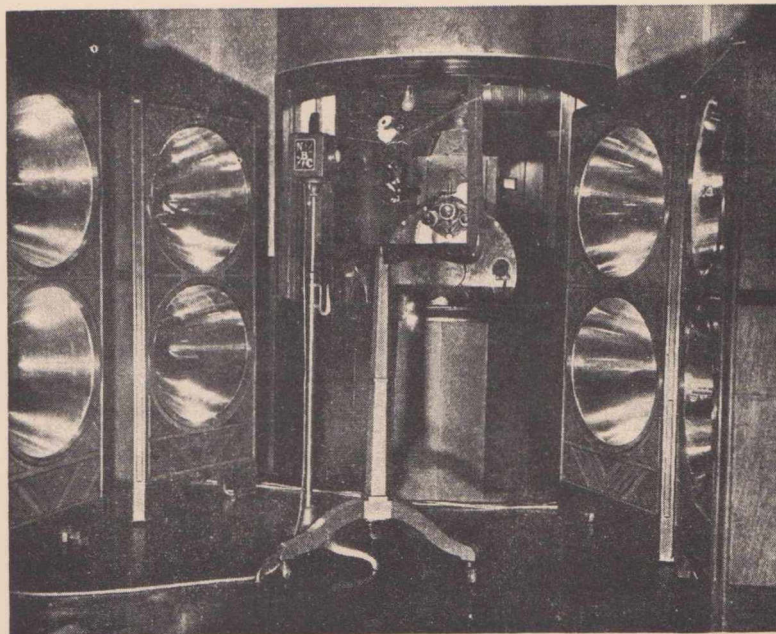

FIGURE 13.

CHANGING LIGHT ENERGY TO ELECTRICAL ENERGY - THE PHOTO-ELECTRIC EFFECT:

When light falls on the surface of certain substances, a strange phenomenon occurs - electrons are set free from that substance, in somewhat the same way as they are emitted

by heat in a thermionic valve, and the surrounding space becomes electrically charged. This is the photo-electric effect upon which the operation of the photo-cell, and also the Iconoscope television tube, depends. Two substances which exhibit this important effect are potassium hydride (a combination of metal potassium with the gas hydrogen) and caesium, a metal. The former substance is commonly used in photo-electric cells, while the latter is found in both P.E. cells and the Iconoscope. Before describing the construction and operation of the photo-cell it will be helpful if we explain briefly the main principles of this phenomenon.

All substances consist of tiny atoms which in turn are made up of a central body or nucleus, around which move in orbits one or more tiny particles called "electrons". The nucleus contains one or more "protons", which are the smallest particles of positive electricity, while electrons are the smallest particles of negative electricity. Innumerable different substances exist having widely different characteristics (such as weight, colour, hardness, etc.) depending upon the various numbers of protons and electrons which exist in each of their atoms, and also upon the patterns or arrangements of these electrical particles. An important point to remember, however, is that all electrons are identical no matter from which substance they have been derived. When some of the electrons of a substance are "free" to move from atom to atom within a substance (as in the case of an electrical conductor) and are made to flow, we have an electric current.

Now, when light falls on a surface and is absorbed, electrons in the material are set into vibration or oscillation. In those substances, which are described as being photosensitive (i.e. light sensitive) some of these agitated electrons receive sufficient energy from the light wave to cause them to break from the solid's surface. When this occurs, the solid itself will have acquired a positive charge (due to loss of negative electrons) and hence the "free" electrons will be attracted back to it again. Thus, if a steady light is shone on the surface of such substance, electrons will be continually leaving that surface, and eventually finding their way back to it again.

At any given moment there will exist a "cloud" of "free" electrons in the space just outside the surface, as illustrated in Fig. 14.

If now we apply a positive potential to a metal plate placed near the photo-sensitive material, the "free" electrons which have been emitted from the latter by the action of light will be attracted to this plate. The metal plate can be made positive with respect to electron-emitting body by using a small battery as in Fig. 15.

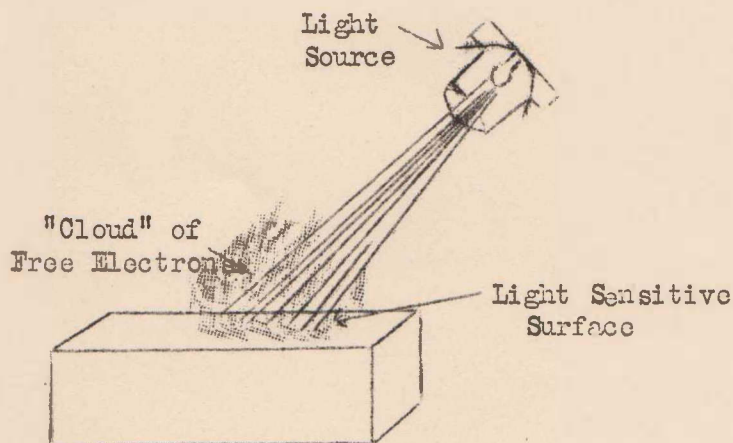

THE PHOTO-ELECTRIC EFFECT
FIGURE 14.

As the positive plate collects the electrons a corresponding electric current flows in the external circuit (i.e. in the wires connected to the battery). If now the amount of light falling on the surface were increased, a greater electron emission would occur, and a heavier current would flow in the circuit. In this way, we have a means of controlling an electric current simply by varying the intensity or amount of light.

THE PHOTO ELECTRIC CELL.

A commonly used type of photo-electric cell or photo cell is shown in Fig. 16 along with its symbol. This cell or tube consists of a glass bulb containing two elements. One element consists of a thin metal rod or ring called the anode which corresponds to the plate in the radio tubes we have been accustomed to. The other element is the active material applied to a curved metal plate and is called the cathode. The cathode active material corresponds to the cathode or filament in the ordinary tube because it emits the electrons which are drawn over to the anode or plate.

There are two general classes of photo-electric cells. In one the air has been exhausted and a vacuum remains within the bulb. This is called the vacuum type of cell. In the other a small amount of the gases argon or helium is admitted into the bulb after the air is exhausted. This is called the gas-filled cell. The gas cell is more sensitive than the vacuum type and was the one generally used in television work.

In order to make our ordinary radio tubes do work as amplifiers or detectors we apply a positive voltage or potential to their plates. In the photo cell we likewise apply a positive voltage to the anode or rod which corresponds to the plate. We make the anode positive with reference to the cathode just as we make the plate of an amplifying tube positive with reference to its cathode.

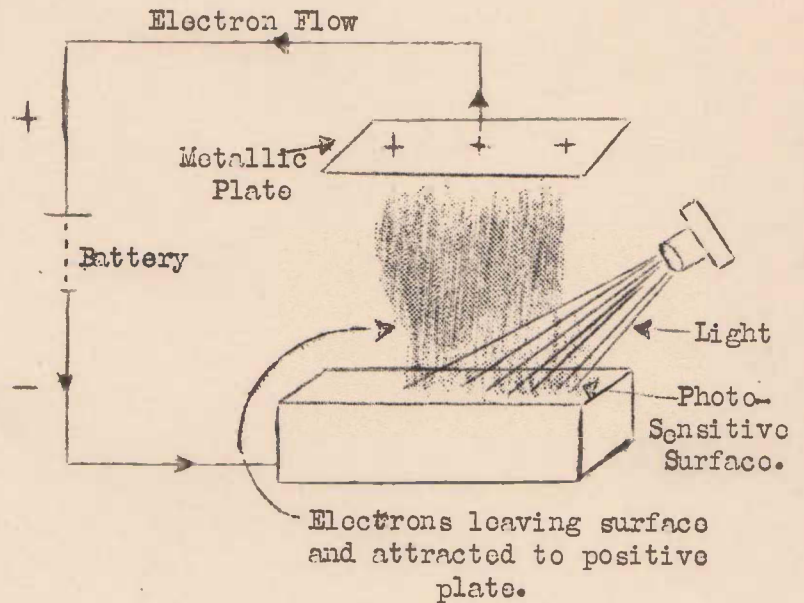

FIGURE 15.

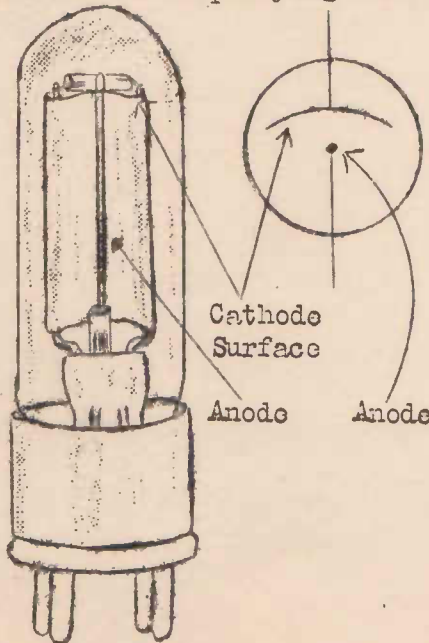

FIGURE 16.

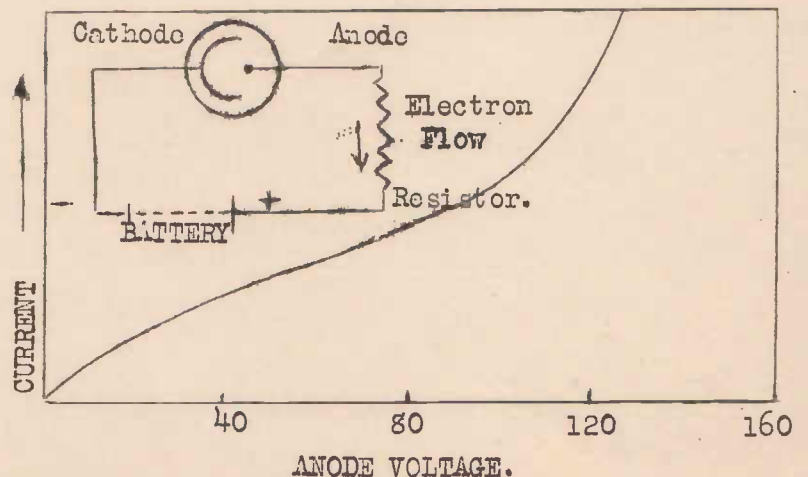

FIGURE 17.

As soon as this voltage is applied to a photo cell there is a flow of electrons from the cathode to the anode. This is exactly what takes place in the ordinary radio tubes, but in those tubes we have to have a heated cathode while in the photo cell we use the cathode in a cold condition, at ordinary room temperature.

Were we to hook up a photo cell, a battery and a resistor as shown in Fig. 17, there would be a flow of electrons from the cathode to the anode and this stream would pass through the resistor.

The amount of current flowing in the circuit of Fig. 17 depends on two things for a given photo cell. It depends on the voltage applied to the anode end and on the amount of light entering the window of the cell. This is not much different from the amplifying tubes where the plate current depends on the plate voltage and on the grid voltage. The anode voltage of the photo cell corresponds to the plate voltage of the radio tube, and the amount of light entering the photo cell corresponds to the grid voltage in the amplifying tube.

The rise of anode current with increase of anode voltage (the amount of light remaining constant) is about as shown in Fig. 17 for a gas cell. The current is extremely small in amount, being measured in microamperes or in millionths of an ampere. We have currents running between 1 and 10 microamperes under ordinary conditions. The steady anode current, which corresponds to steady plate current, is fixed by the anode voltage for any given amount of light. If we apply an anode potential of 80 volts we will have some steady value of current, say 3 microamperes, until the amount of light entering the cell is either increased or decreased. Most gas filled cells cannot operate with more than 90 volts applied.

If we admit more light through the window of a photoelectric cell, all other things remaining the same, the anode current will increase. If we cut down on the amount of light entering the cell the anode current will become smaller. You might place a lamp at a certain distance from the cell and adjust the anode voltage for a certain amount of current. As you moved the light source farther and farther away from the cell, less and less light would enter the cell's window and the anode current would drop off as shown in Fig. 18. Bringing the lamp closer would put more light into the cell and the current would go up. Increasing and decreasing the amount of light entering the cell causes the cell's anode current to increase and decrease correspondingly.

The curve in Fig. 18 does not show just how the cell current behaves with change of amount of light because as a lamp or other source is moved further from the cell the amount of light drops off as the reciprocal of the square of the distance between lamp and cell, not directly as the distance. If we make the proper corrections, so that our curve shows the cell current or

anode current with respect to the total amount of light passing through the window, we will have a curve like that in Fig. 19. The important thing just now is that the amount of light affects the anode current of the photo cell just as the grid voltage effects the plate current in an amplifying radio tube. If we work on a straight part of the curve in Fig. 19 we will find that equal changes of light produce equal and corresponding changes of anode current.

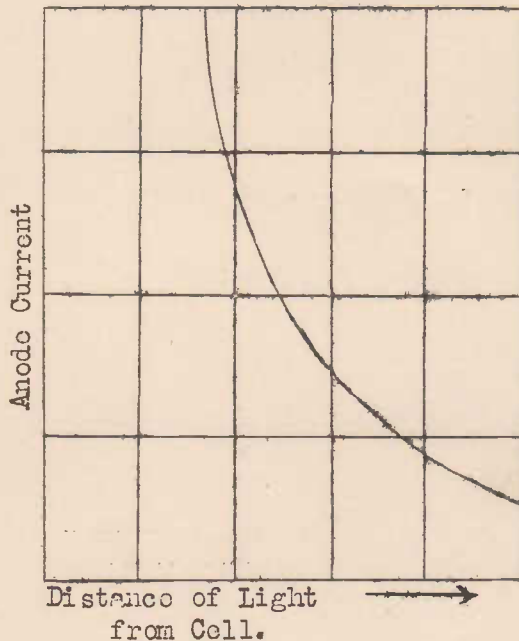

FIGURE 18.

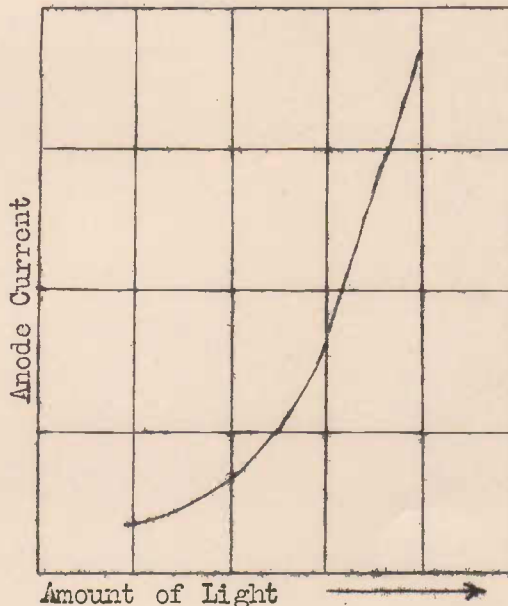

FIGURE 19.

PRODUCTION OF THE PICTURE SIGNAL:

As has been mentioned previously, scanning disc and photo-electric cells are not used in modern methods of television transmission, but it is far easier to obtain a clear understanding of the principle of scanning from a mechanical system than from the less tangible electronic system. For this reason, we are examining in some detail the action of what might be regarded as an obsolete television system, but we are doing it deliberately so as to impress the fundamentals and to lead gently up to electronic scanning systems which will be described in following lessons.

We are now in a position to follow through exactly the manner in which a scanning beam of light divides up a picture or scene into a large number of

small parts or elements, and how the photo-cell converts the varying degrees of light and shade of these elements into a pulsating electric current. This current output from the photo-cell we have called the "picture-signal", and is used to modulate the outgoing wave from the transmitter in the same way as the audio-frequency, or sound-signal current, from a microphone is used in radio telephony work.

Let us consider the system of scanning known as the flying-spot method illustrated in Fig. 8. Suppose the disc has 32 square holes, and the picture of Fig. 20 is being scanned. The whole picture will be covered by the spot in 32 horizontal sweeps from left to right.

These paths traced out by the spot will in practice be slightly curved. In Fig. 20, however, these paths, or "lines", as they are termed, have been drawn perfectly straight. This has been done partly for simplicity in the explanations which follow, and also because it represents the most desired state of affairs for efficient scanning, and, further, it more truly represents the modern electronic method of scanning.

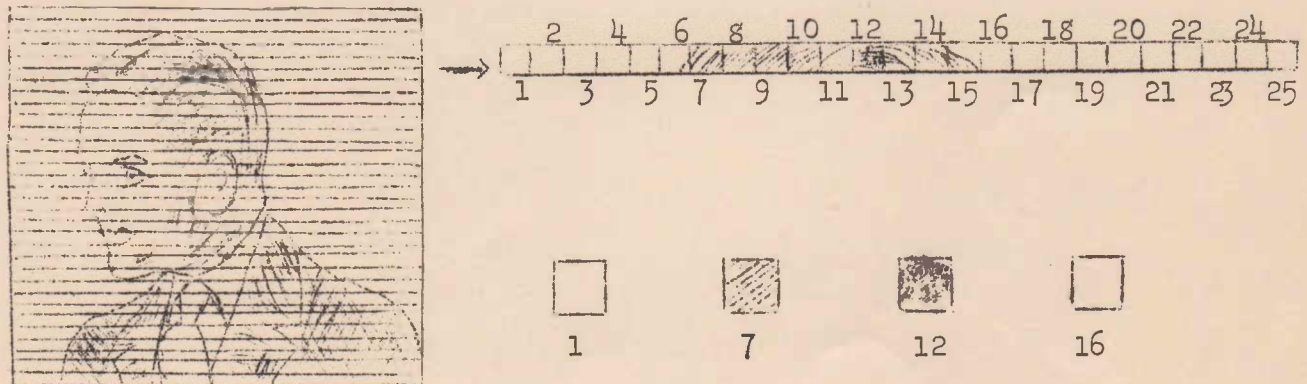

FIGURE 20.

The area enclosed in Fig. 21 might represent that of the picture in Fig. 20. We start off by directing our light beam onto the small square at the upper left hand corner. This may be considered as one of the small numbered divisions shown in Fig. 20. If the surface illuminated by the beam is light in colour we will have a great deal of reflected light, if it is very dark we shall have but little reflected light. The light beam gives us an amount of light which represents the tiny area being illuminated. In the illustrations these areas have been shown as being of quite considerable size, but as a matter of fact it takes up to 300,000 of such spots to make up the complete area of the picture in a modern system.

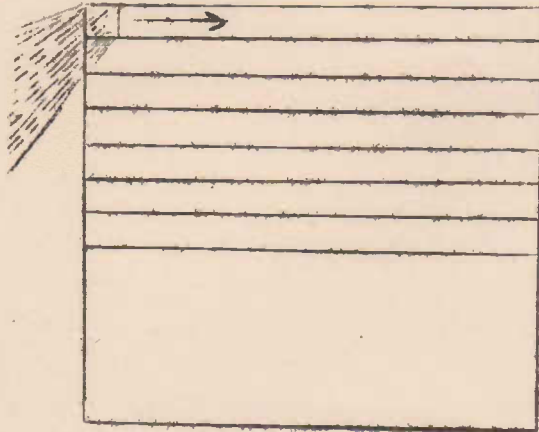

FIGURE 21.

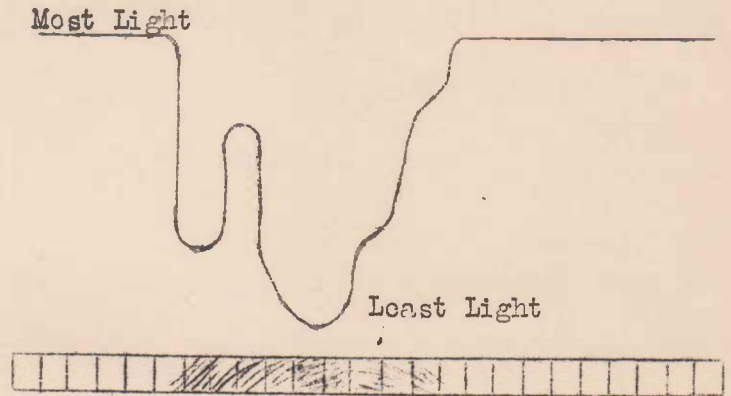

FIGURE 22.

EFFECT OF MOVING THE LIGHT BEAM:

In Fig. 21 we begin operations by directing the light beam at the upper left hand corner of the area to be covered. Now we will move the beam towards the right as shown by the arrow. That is, we shall sweep the light beam across one of the horizontal lines in Fig. 20. As the beam moves over different parts of the object or picture there is reflected back a varying amount of light, depending on the shade or color of the spot being illuminated at one instant.

Were the beam to sweep over the line drawn out by itself in Fig. 20 we would have a varying amount of reflected light as shown by the irregular curve in Fig. 22. We would have the most reflected light from the white spots, medium amounts of light from spots of somewhat darker shade and the least light from the darkest spots. The curve of Fig. 22 really represents the part of the picture which has been illuminated by one sweep of the light beam, but represents it as rising and falling amounts of reflected light.

As the beam comes to the end of the top strip in Fig. 21, it is lowered a little bit and sweeps the second strip, then it is lowered still further and sweeps the third strip. So the action goes on until the light beam has been played over each part of the whole picture or whole object being scanned. The amount of reflected light is continually varying as shown in Fig. 22.

Now we are ready to change the variations of light into variations of electric current.

This reflected light is allowed to fall on the photo-tubes' cathode. Since we have seen that the current flowing through the photo-cell is proportional to the amount of light, this current will vary in a manner exactly similar to the variations of the curve of Fig. 22. The similarity between the "light curve" and the current curve is brought out in Fig. 23. Note that maximum reflected light (i.e. when the scanning spot is directed on a white part of the picture) causes maximum reflected light (when the spot is on the darkest part of the line) results in the maximum current. Note that the photo-tube's current does not fall to zero at any point as the spot scans this line. This is because there is still some light reflected from the picture, even at the darkest part of the line shown in Fig. 22. If there were a jet black part in the picture the tube's current would fall right to zero as the light spot passed over this part.

It should be clearly understood that the current variations shown in Fig. 23 occur in the very small interval of time during which the scanning spot is traversing one line only of the picture. Each of the other thirty-one lines of Fig. 20 will result in its own series of current variations. Some lines will cause more variations, others less, depending upon the number of light changes in the picture as the spot moves horizontally across it.

The student who has followed carefully the preceding notes will probably have realised one important fact, viz. that the smaller the size of the scanning spot the greater will the number of changes in reflected light be, and, therefore, changes in current produced in the photo-cell. He will, possibly, also have guessed that the amount of fine picture detail which will be transmitted will depend upon the number of

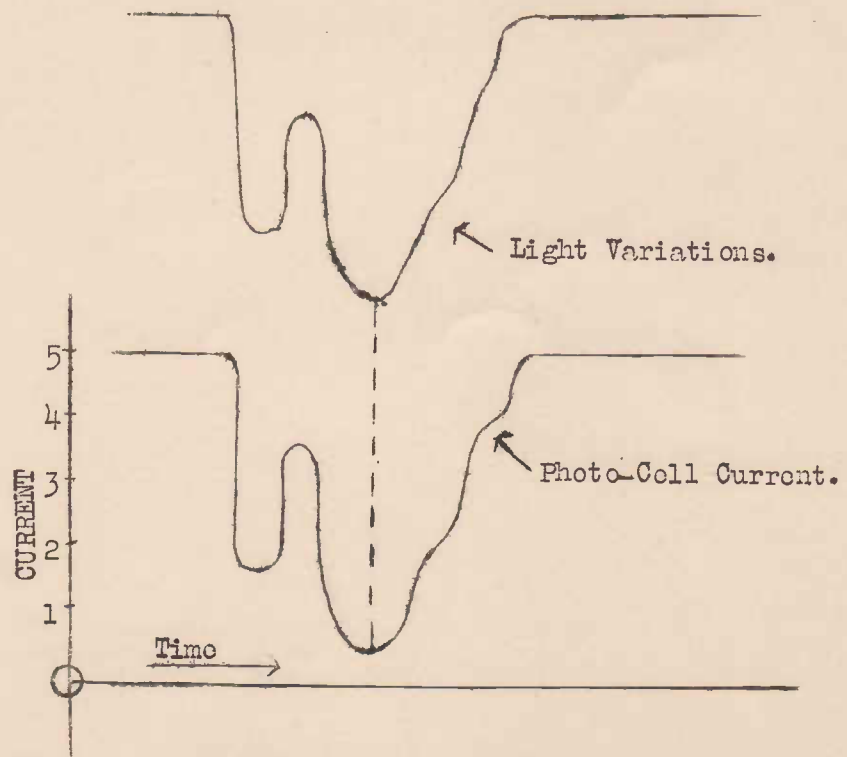

FIGURE 23

those current variations which can be generated in the photo-cell by the scanning system.

THE PICTURE ELEMENT

If we minutely examine a newspaper reproduction of a photograph, we shall see that it consists of a large number of small black dots separated one from the other by white paper. If the dots are comparatively widely separated the effect produced when viewed at ordinary reading distance is a light grey. If the dots are more closely packed a darker shade is produced. If the dots are touching each other a practically black area results. The varying lights and shades which represent the picture are thus produced by the distribution of these "elementary" dots which constitute the picture structure. Each of the dots is called the "picture element". Now it is evident that the smallest detail which will show up in the picture will be the size of a single dot. Anything smaller than this will not appear as separate and distinct detail. For example, if the picture shows a man's head the individual hairs cannot be seen, even if a magnifying glass is used. The thickness of a single hair is less than the diameter of a dot, i.e. a picture element. Such details as the individual hairs in a man's head, therefore, simply do not appear in the reproduction.

Now, if we were to procure the original photograph from which the newspaper picture was reproduced, and we examined it under a microscope we would see that it was also made of many minute dots, these actually being grains of metallic silver which appear black. These dots, however, would be very much smaller than those of the newspaper picture. Hence we could say that the picture-elements of the photograph were much smaller than those of the newspaper print. The photograph would, of course, show very much greater detail - we might even be able to distinguish the separate hairs on the man's head. The important point to note is that the amount of detail which appears in any artificial reproduction of a scene, i.e. in a picture, depends on the smallness of the picture-elements, and, therefore, upon the number of them used in the structure of that picture.

PICTURE ELEMENTS REPRODUCED IN A TELEVISION SCANNING SYSTEM:

Returning to the question of picture scanning with a disc system, the tiny spot of light illuminates one fraction of the whole picture at any one moment. We would expect that the area of this spot would represent the smallest portion of the picture, which would cause a current variation in the photo-cell - i.e. it would represent a picture-element.

In order to understand more clearly the above statement, it should be remembered that the current flowing through the photo-cell is proportional to the total light falling on its cathode at any moment.

To illustrate, consider Fig. 24, where the light spot has an area equal to

the square ABCD, and is moving along the line from left to right.

In position 1 the light spot is covering an area of the picture which includes four black squares, representing details of the picture. The light reflected to the photo-cell would come mainly from the white parts of the area ABCD, and the photo-tubes current would assume a certain value. When the spot had

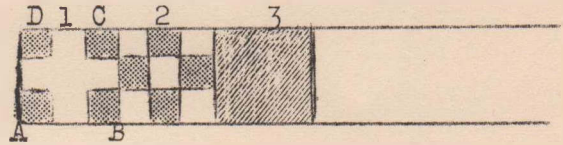

FIGURE 24.

moved to position 2 the tube's current would be exactly the same as for position 1; for the total light reflected from the area covered by the spot would be unchanged. In position 3, light is reflected from the whole area, but the total light received by the photo-cell for this portion of the picture might be the same as before. Hence as the beam scans the picture from left to right no change in picture-current occurs. At the receiver, all three areas, 1, 2 and 3, would appear alike - i.e., a uniform grey. The picture details represented by the eight black dots in positions 1 and 2 would be completely missed out - because they are smaller than the picture-element determined by the size of the light beam ABCD.

In order to observe how this all-important question of area of light spot affects the amount of detail reproduced, consider the scanning of the picture in Fig. 25, using sixteen lines.

Say we have a light beam of the size indicated by the small square in the upper left hand corner of the picture. This beam will sweep across the first or top line without change in light, since everything is white. On the second line we have the subject's hair which is dark and which makes an abrupt change. The corresponding rise and fall of light might produce passable results and indicate the top of the man's head.

But supposing we continued on until the beam rested on the subject's right eye. The beam would be illuminating the part of the picture shown enlarged over towards the right. Here we have part of an eyebrow, part of the skin around the eye, part of the eye's "white", also the iris and the pupil - quite a collection of lights and shadows. But, coming from this spot, which is illuminated, would be a single beam of light for the window of the photo cell. The cell's anode current could assume only one value at this instant; it could not assume a whole collection of values all at once. This one value of anode current would represent the average shading of the area shown at the right in Fig. 5. In place of the various parts making up this eye, we would have the same average current which would result if this spot did not contain an eye at all, but contained only a part of the subject's coat,

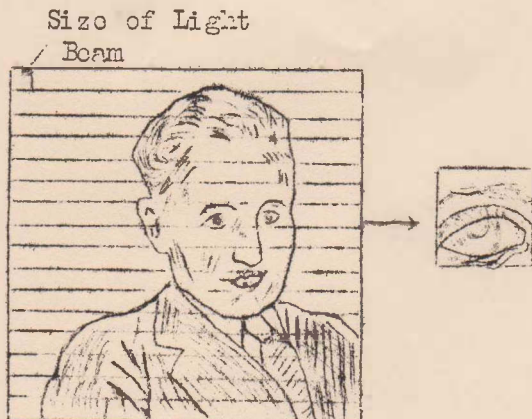

FIG. 25.

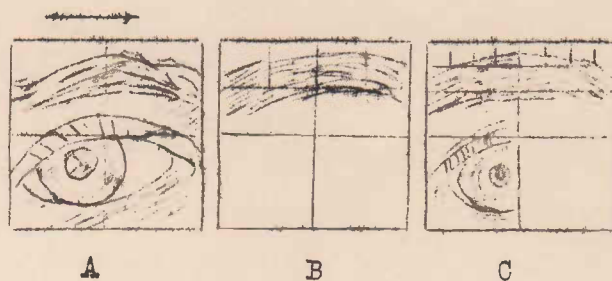

FIG. 26.

which is an oven grey.

It is evident that our light spot is too large. Say we make it one quarter the size so that we have the division shown at "A" in Fig. 26. As the beam sweeps across in the direction of the arrow it is covering not only the eyebrow but also parts of the skin on both sides. Once more the reflected light would be of a value representing the average of the dark eyebrow and the lighter skin. Even though we were able to recognise that a face was being transmitted, the subject would have no eyebrow - only a darker place on his face. When this smaller beam came along to the eyeball on the next line below the results would be even worse because there is a greater detail to be transmitted.

Again cutting the size of the beam as at "B" in Fig. 26, we would actually begin to get some changes of shade as the beam travelled across the eyebrow and would have corresponding changes for the eyeball below. But to show the eye's expression as denoted by the position of the iris and pupil with reference to other parts we would have to use a beam so small it would give us the areas shown at "C" in Fig. 26. Then there would be a real change between the white of the eye and the darker coloured iris and pupil.

In Fig. 25 we started with a light beam of such size that it would illuminate the whole picture in 256 squares. At "A" in Fig. 26, we have divided these original squares into four parts each, making a total of 1024 areas. This was not small enough, so at "B" we made a similar division and would have 4096 such parts in the original picture. To get any real detail we made a third division at "C", which would give us a beam dividing the whole picture into 16,384 small elementary areas.

From this analysis of the picture in Fig. 26, you can see that the detail of

the picture or the amount of information conveyed in the changing electric currents depends on the number of parts into which we divide the picture. The greater the number of parts the greater will be the amount of detail brought out. The fewer the parts the less detail will show and the more all the different features will run together into even shades. With modern systems a scene may be represented by as many as 300,000 individual areas.

HOW NUMBER OF LINES AND NUMBER OF PICTURE-ELEMENTS ARE RELATED:

It should now be evident that the all-important factor in producing a picture-signal containing a great amount of detail (i.e., a large number of current changes) is the number of lines used in scanning the scene.

In order to obtain a large amount of these picture-elements and current changes, we have found it necessary to work with a light spot of small size, now the smaller the size of the light spot the greater the number of times

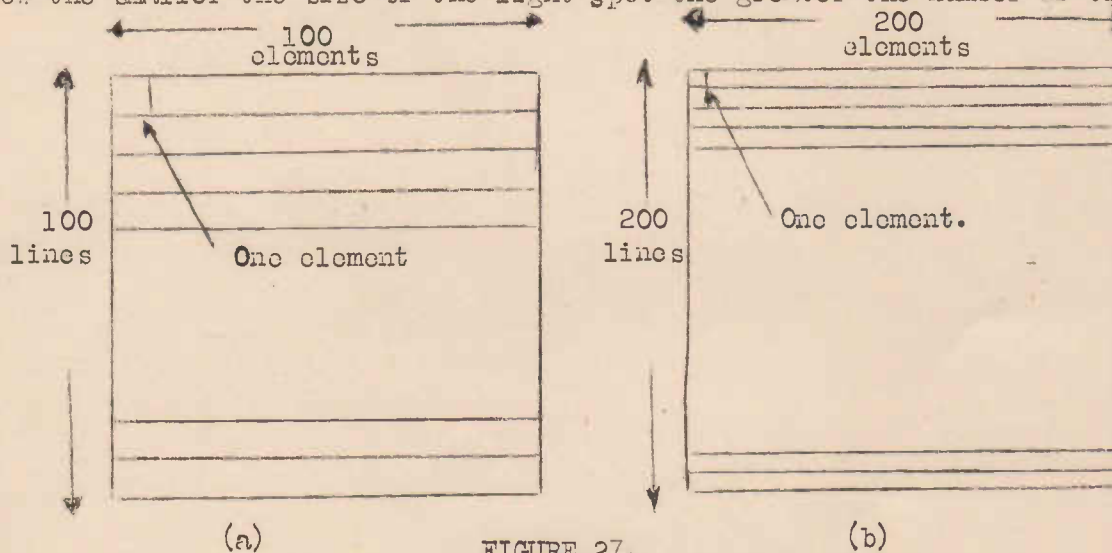

FIGURE 27.

it will have to traverse the picture, i.e., the larger the number of lines. Considering a square picture in Fig. 27 suppose at (a) we have 100 lines. The number of elements in each line will also be 100. The total amount of areas equal to the area of the light-spot, i.e. the number of elements in the picture will be $100 \times 100 = (100)^2 = 10,000 = (\text{number of lines})^2$. Now suppose in Fig. 27 (b) we have increased the number of lines to 200. The number of picture elements will now be $(200)^2 = 40,000$. This is four times the number of elements when using 100 lines, and will result in four times the detail.

In present day television practice the picture is not square, but the width is usually either four-thirds or five-fourths the height. Referring to

Fig. 28 and comparing with the 100 line square picture of Fig. 27 (a), we see that the number of elements in each line is one and one third times as great. Here the total number of elements in the picture will also be increased in the ratio of $\frac{4}{3}$ compared with the square picture. The number of elements will be

$$(\text{number of lines})^2 \times \frac{\text{Picture Width}}{\text{Picture Height}}$$

The ratio $\frac{\text{Picture Width}}{\text{Picture Height}}$ is frequently referred to as the Aspect Ratio. Hence we may write:-

$$\text{Number of Picture Elements} = (\text{Number of Lines})^2 \times \text{Aspect Ratio.}$$

NUMBER OF PICTURE ELEMENTS PER SECOND.

In order to utilise the persistence of vision effect, and to produce the illusion of motion, it is necessary, as explained previously, to scan the picture at least ten times per second. The number of complete scannings per second is called the "Picture Frequency". The number of picture elements converted to current changes by the photo-cell in every second will, therefore, be the number of picture-elements in the picture multiplied by the picture frequency, i.e. -

$$\text{No. of Picture Elements per sec.} = (\text{No. of lines})^2 \times (\text{Aspect Ratio}) \times (\text{Picture Frequency}).$$

For example, in the case of 400 line scanning, 25 pictures per second, the number of picture elements converted to picture-signal current changes in each second is:

$$(400)^2 \times \frac{4}{3} \times 25 = 5,333,333 \text{ per sec. - an enormous number.}$$

HOW MANY LINES?

When we speak of a "high-definition" picture we refer to a picture which is clear-cut and contains a great number of sharp details. A low-definition picture is one which is indistinct and blurred due to lack of the necessary detail. Considering the formula given above the number of picture--

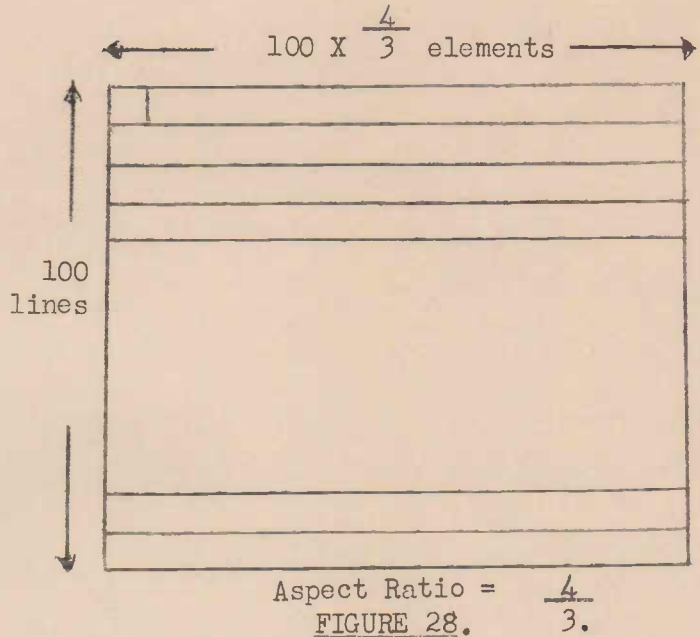

elements contained in the signal, it is seen that the number of lines used in the scanning system is all-important in producing a high-definition picture at the receiver.

In the early days of television, when revolving discs and other similar mechanical devices were the only means of scanning the picture, a number as low as 30 lines was used. This gave a very poor picture - much too poor to give any real entertainment value. A reproduction of a 30-line picture is shown in Fig. 29. Note the extreme lack of detail, and also the marring of the picture by the scanning lines (vertical scanning), which are clearly visible. (An original photograph is also shown for comparison).

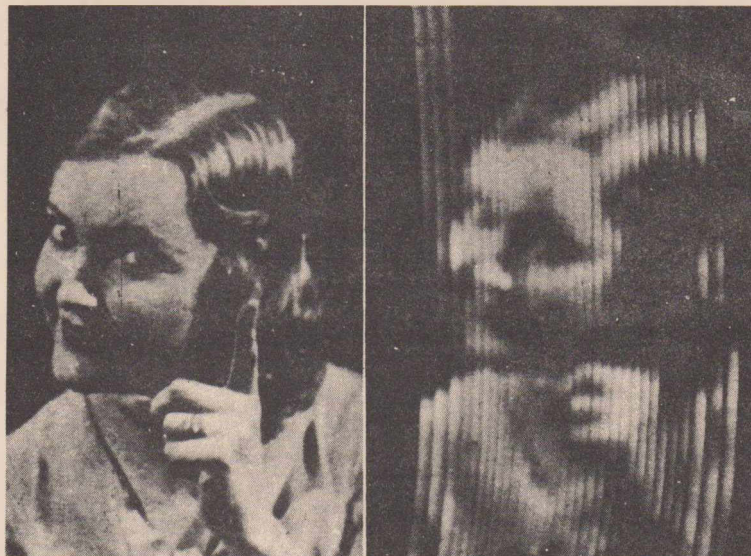

FIGURE 29 - 30-LINE TELEVISION

The photograph at the right is of the screen of a 1932 model television receiver employing 30 line scanning in a vertical direction.

The British Broadcasting Commission's first transmissions in 1932 were of 30-lines. As time went on, the number of lines was increased to 90, then to 180, and, finally, to 240, using mechanical methods of scanning.

With the development of electronic methods of scanning, the ambition immediately was born to reproduce pictures equal in quality to the home cinematograph of the 16 m.m. variety.

Now the number of picture-elements contained in each picture of a 16 m.m. film was known to be in the vicinity of 120,000-150,000. If we consider a 400 line television picture of the same shape as a cinematograph picture,

i.e. Aspect ratio 4 to 3, the number of picture-elements from our formula above is:-

$$(400)^2 \times 4/3 \approx 213,000 \text{ elements.}$$

This would appear to give considerably more detail than the 16 m.m. film. However, in deriving the formula above from the simple theory explained a number of factors were not considered. For example, it is found that, on the average, 400 lines will not produce 400 details or elements in a vertical direction.

The latter point can be understood by referring to Fig. 30. Here the object being scanned is a vertical bar containing a number of alternate black and white segments, the heights of which are equal to the width of the scanning lines.

As in Case A (Fig. 30) the bar is so positioned that a scanning line passes directly over a black segment or element and the corresponding current in-

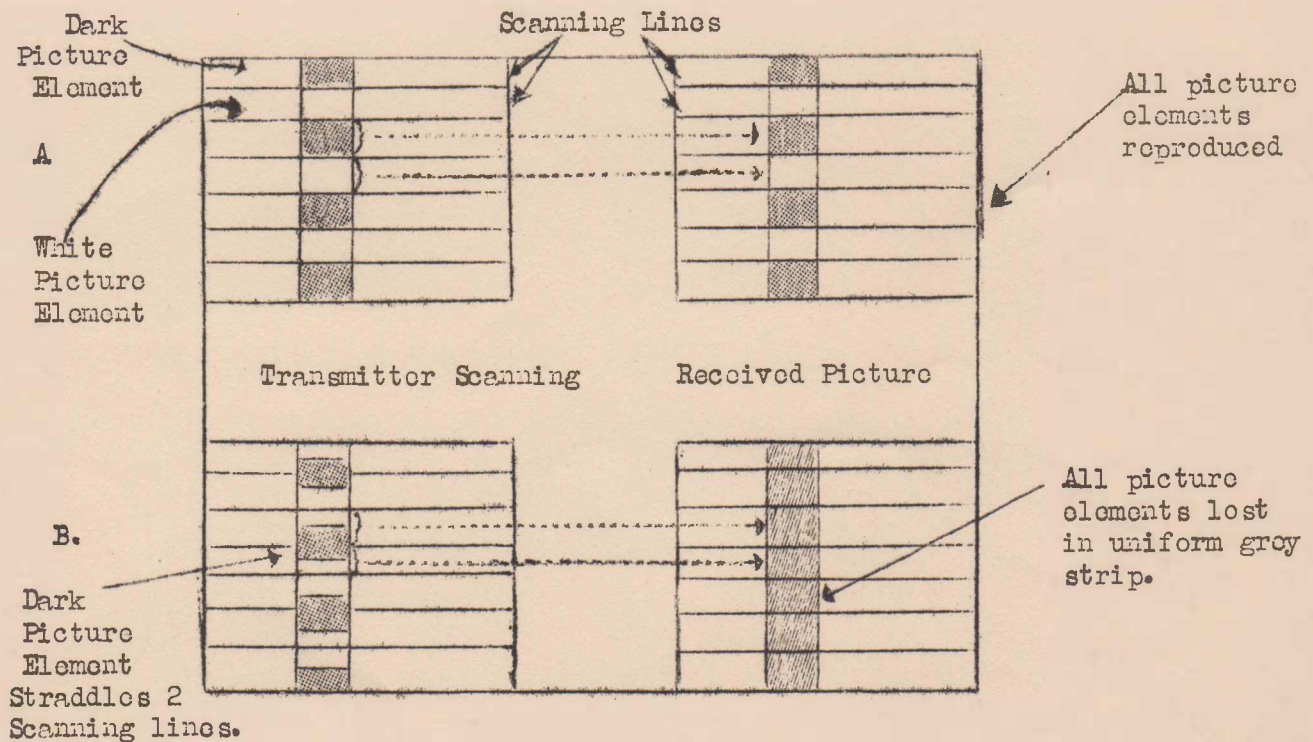

FIGURE 30.

pulse reproduces a black element at the receiver. The next scanning line passes directly over a white element, and a white element is reproduced in the receiver.

In Case B, however, the bar is so positioned that each element straddles two scanning lines. In this case, as the scanning spot passes across the bar, the area illuminated will be half black and half white, and the amount of light producing the picture-signal will be the same as if the whole area were a uniform grey, intermediate between black and white. The bar reproduced at the receiver will therefore be a uniform grey, and it will be impossible to distinguish between the black and white spots, i.e., the detail is entirely lost.

In the one case (Case A, Fig. 30) where the picture-elements are passed directly over by the scanning lines, all of these elements show up in the reproduced picture, i.e., the number of picture elements on a vertical line contained in the signal will be exactly equal to the number of scanning lines used, as assumed in our simple theory earlier.

In Case B, however, where each element "straddles" two scanning lines, it is possible that the signal will contain no current changes whatever, and the number of elements reproduced on a vertical line is zero.

In practice, of course, the subjects transmitted are not segmented vertical lines, but whole pictures, containing a scattered, non-uniform, arrangement of picture-elements, some of which fall directly on a scanning line, others of which straddle two lines. Theoretical investigations, and practical tests, have shown that, on the average, on a vertical line the number of picture-elements which will show up is slightly more than 75% or $3/4$ of the number of scanning lines. In other words, when using 400 lines, about $400 \times \frac{3}{4} = 300$ or more details will be reproduced in a vertical direction in the picture.

Taking, then, our previously calculated number of 213,000 picture elements in the whole picture for 400 line scanning, we should modify this figure by multiplying by $3/4$, giving an actual number of $213,000 \times \frac{3}{4}$, or a little over 150,000 picture-elements. Thus it is seen that 400 line scanning should give a picture which compares very favourably with the best 16 m.m. cinematograph image.

For the reasons discussed above it was decided, before the War, to choose a number of lines in the vicinity of 400. In England the B.B.C. chose 405 lines, and the number used in America was 441. Later, in 1941, the standard in the latter country was raised to 525 lines. When treating electronic scanning methods in a later lesson, it will be seen that not all the lines actually scan the picture area. Hence, assuming that 500 of the lines are "active" in scanning we have - No. of Picture-Elements = $(500)^2 \times 4/3 \times \frac{3}{4} =$

250,000. This is better than the 16 m.m. cinematograph (150,000 elements) but not up to the standard of the full size (35 m.m.) cinema picture, which contains about 500,000 picture elements.

INTER-LACED SCANNING:

As pointed out previously it is found, in order to produce the illusion of motion, that it is adequate to transmit between 20 and 30 complete pictures per second. In cinematography 24 separate photographs, showing moving objects and persons in slightly different positions, are used per second. This rate, however, is not sufficient to eliminate entirely flicker. This problem is solved in cinematograph projection by projecting each image twice in rapid succession. As each picture or frame on the film strip appears before the projector a shutter interrupts the light, thus showing on the screen two images for each frame. This produces 48 separate impulses of light to the eye, and flicker completely disappears, leaving the effect of continuous and steady illumination of the screen.

In a previous calculation we found that scanning at the rate of 25 pictures per second (using 400 lines) the picture signal would contain roughly 5,330,000 current changes per second. If we were to increase the scanning rate to 50 pictures per second, in order to eliminate flicker, this number of current changes would double, i.e. increase to 10,660,000. Now, we would find it impossible, using our circuits at present available, to handle this enormous number of rapid current changes in each second.

Each pair of current changes, that is, an increase or decrease in current followed by a decrease or increase respectively, would correspond to one cycle of current at the output of the camera. Consequently, our picture signal containing 5,330,000 current changes would correspond in a way to an alternating current of 2,665,000 cycles per second. The amplifiers handling the video frequency signals should be capable of amplifying all frequencies up to 2,665,000 cycles per second with absolute uniformity and this is a tremendous task compared with audio frequency amplifiers, which only are required to operate at frequencies up to about 10,000 cycles per second.

A signal containing more than 10 million elements would involve frequencies of about five million cycles per second, and the uniform amplification of frequencies up to this value, while not altogether impossible, is too difficult to be considered practicable.

An ingenious scanning system has been devised, however, which allows us to produce the flicker-free effect of 50 pictures/sec., without increasing the frequency of picture-signal current changes. This system is known as "Inter-laced Scanning", and is now in universal use.

Scanning is described as interlaced when the picture area is completely scanned in two successive steps as illustrated in a simple way in Fig. 31. Here the scanning beam covers the picture in alternate lines, 1,3,5,7, etc., leaving strips equal in width to one line between each line of the scan. When the beam has reached the bottom right-hand corner of the frame, it shifts back to the beginning and commences to

cover the strips omitted in the first scan, i.e., it covers alternate lines, 2,4,6, etc. Thus all details in the picture will be covered in two operations - each operation using one-half of the total number of lines of the scanning system. If, for example, 400 lines in all are used, the picture area will be completely covered, in alternate strips, in 200 lines. This, in England, is called one frame; in America it is called one field. The second frame or field is formed by the remaining 200 lines filling in the gaps missed during the first field.

It should be noted that a single field, consisting of only half the scanning lines, will reproduce the effect of a complete picture, although such picture does not contain all the detail. The missing detail will, of course, be supplied by the succeeding field, consisting of the other half of the scanning lines. This second field will also create to the eye, at the receiver, the effect of a complete picture lacking full detail. In this way, during the time taken for a complete scanning, the eye receives the impression of two complete pictures, as against one, if the scanning were done by adjacent lines. In other words the picture repetition rate would appear to be doubled, and the flicker would be greatly reduced.

The student should take care to understand clearly how interlacing reduces flicker, and should any doubt remain in the mind the following numerical illustration should be studied where the question is tackled from a slightly different angle. Suppose 400 line, interlaced, scanning is used, the complete

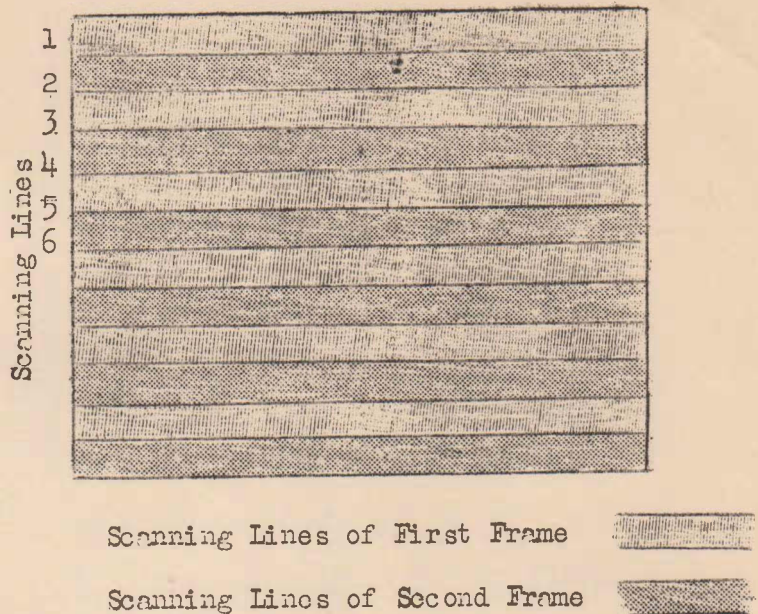

FIGURE 31. INTERLACED SCANNING.

scanning process taking $1/25$ th of a second, i.e., a complete picture frequency of 25 pictures/sec. After $1/50$ second, 200 of the lines would have covered the picture along alternate lines (1, 3, 5, etc.). At this instant the spot would leave the bottom right hand corner of the picture area and return to the top left hand corner commencing on line 2. Now the point to which the spot has returned is only the thickness of one line away from the position it occupied when commencing the first scan. If the receiver screen is viewed from normal distance this small displacement of the scanning spot will not be distinguished by the eye, and it appears that the spot has returned to its original position, and the second scanning is being repeated over the same lines. The apparent frequency (each picture consisting of the full 400 lines) is kept at 25 per second. As far as flicker is concerned we have achieved an effect at least as good as the 48 pictures/sec. of the cinematograph.

LIMITATIONS OF MECHANICAL SCANNING.

Mechanical methods of scanning represent great difficulties, and have many faults when high-definition pictures are required. Many of these could be listed, but we will content ourselves with considering the structure of a simple Nipkow disc designed for 400 line scanning, and, in considering the speed at which the scanning spot moves for a picture frequency of 25 per second.

Such a disc would require, of course, 400 holes arranged in an accurate spiral. If the picture is 8" high, the width of each line, and, therefore, the diameter of each disc hole, would be $8/400" = .02"$ (one fiftieth part of an inch). For a picture 10" X 8" an extremely large disc about 106 feet in diameter would be required as will be evident by referring again to Fig. 4, where the relationship between picture and disc dimensions is shown. The technical difficulties of constructing a disc with accurate positioning of the holes to produce adjacent lines are considerable.

Consider now the speed at which the light spot would move - this being also the speed of the outer parts of the disc. If a picture is completely scanned in $1/25$ sec., each line will take $1/25 \div 400 = 1/10,000$ sec. If the picture is 10" wide, this is the length of each line, and the speed of the spot will be $10" \div 1/10,000 = 100,000$ inches per second. This is a speed of nearly $1 \frac{2}{3}$ rd miles per second.

It will be evident that working with these high scanning speeds, mechanical methods become almost out of the question, and we resort to electronic methods, where we use beams of electrons which can be moved about with the required agility.

SUMMARY OF DEFINITIONS AND STANDARDS:

Picture Frequency: The number of complete pictures transmitted per second. 25/sec. in England, 30/sec. in America.

Line Frequency: The number of lines scanned in one second. Line frequency = picture frequency multiplied by the number of lines in the picture.

Frame (England) or Field (America): In the case of interlaced scanning, a coverage of the complete picture area by one-half of the scanning lines along alternate strips. There are thus two or more frames or fields per complete picture. (N.B. in America the term "frame" is used to mean the same thing as "picture").

Picture Element: The smallest area of the picture which can be transmitted as a complete picture. The picture element is approximately the area of the scanning spot. (The number of picture elements is given approximately by $(\text{No. of lines})^2 \times \text{Aspect Ratio}$).

Dot Frequency: The number of picture elements transmitted per second, divided by 2.

Aspect Ratio: The ratio of the length of the picture to its height. In England the Aspect Ratio is now 5:4; in America 4:3.

T. FM & F. LESSON 2.

EXAMINATION QUESTIONS.

1. What do you consider the three most essential requirements which must be fulfilled by a television system in order to produce a picture having real entertainment value? Give brief reasons for your choice.
2. Explain why a certain object, illuminated by "white light" appears to have a characteristic colour, say blue.
3. The scanning light spot at the transmitter passes in turn over a black area, a green area, and a white area of the picture. Explain why the photo-tube's current would rise from zero (or approximately zero) to an intermediate value, and then to a maximum value.
4. Explain the meaning of "Interlaced Scanning".
5. What is the advantage gained by interlaced scanning?
6. With the aid of a diagram, describe and explain the operation of a photo-electric cell.
7. A simple Nipkow disc containing 30 holes, is rotating at 900 revolutions per minute. What is (a) the picture frequency (b) the line frequency? (c) Give two reasons for the poor quality or the reproduced picture.
8. What is the purpose of the synchronising signals which are found in the modulation of a television transmitter's wave?
9. A television transmitter scans the scene with 180 lines at a picture frequency of 20 per sec. How many picture elements are dealt with per second if the aspect ratio is 5:4?
10. Interlaced scanning is carried out with a total of 405 lines and a picture frequency of 25 pictures per second. What is (a) the frame frequency (b) the line frequency?

PLEASE NOTE POSTAL ADDRESS - Cnr. Broadway & City Road, Sydney -
for return of papers, correspondence etc.

AUSTRALIAN RADIO COLLEGE

E. S. & A. BANK BUILDINGS, Corner CITY RD. and BROADWAY, SYDNEY
Telephones: M 6391 and M 6392. Post Lessons to Box 43, Broadway

This lesson sheet is published for the exclusive use of
students of the Australian Radio College Pty. Ltd.
(All rights reserved)



TELEVISION, FREQUENCY MODULATION & FACSIMILE COURSE

LESSON NO. 3.

CATHODE RAY TUBES.

The Cathode Ray tube is perhaps the most versatile and useful of all electronic devices. As has been pointed out in our first two lessons, its functions in the television field are: (1) as the picture "reproducer" in the receiver and (2) in the advanced and modified form, known as the "Electron Camera", as the source of the picture signal at the transmitter. Its advantages over other devices, used to serve these purposes, lie mainly in the fact that scanning may be performed at very rapid rates, since no mechanical movement is necessary, and also in that all control (such as synchronising the scanning of the screen at the receiver with that of the scene at the transmitter) may be achieved by purely electrical methods.



FIGURE 1.

12" CATHODE RAY TUBE

In addition, however, to these functions, the cathode ray tube may be used to serve many other purposes. For example, it may be used as an "electrostatic" voltmeter, which enables us to measure voltages (D.C. or A.C.) when other types of voltmeters may be useless due to the fact that they interfere with the normal operation of the circuit under examination. Again, the tube is incorporated into the service instrument known as the cathode ray oscilloscope or oscillograph. This device allows us actually to see a graphical representation of an A.C. voltage at any point in a radio or television receiver. The oscilloscope is practically an essential in carrying out service work on a television receiver, and the time has come when engineers and servicemen are realising just how useful this

device can be as an aid in testing and checking ordinary receivers of sound programmes. For these reasons we shall deal, in due course, with the details of circuits and operation of the cathode ray oscilloscope.

THE NATURE OF A CATHODE RAY.

The cathode ray tube is really a very special type of thermionic vacuum tube. As is usual when approaching anything new in the field of electronics (which includes television), we can always go back to the things we learned about radio in general. We almost invariably find that we have only a different adaptation of the same old principles. Here we are going back to the elementary principles of the vacuum tube.

When you first studied the behaviour of vacuum tubes used in radio, you learned that electrons, which are minute negatively charged particles, are emitted from the heated cathode and are attracted towards the positively charged plate.

Now a "cathode ray" is essentially the same as the electron stream in the ordinary tube, except that the electrons are not allowed to spread out in all directions, but travel in a beam, more or less narrow, towards the positively charged plate.

In Figure 2 we have represented an experimental type of "cathode ray" tube. Note the cathode, which is heated to a high temperature in order to cause it to throw off a "cloud" of electrons. Note also the anode or plate, to which a high positive potential has been applied, which causes it to attract the electrons from the cathode. These electrons move at extremely high velocity, in a pencil-like stream or beam. This is the "cathode ray".

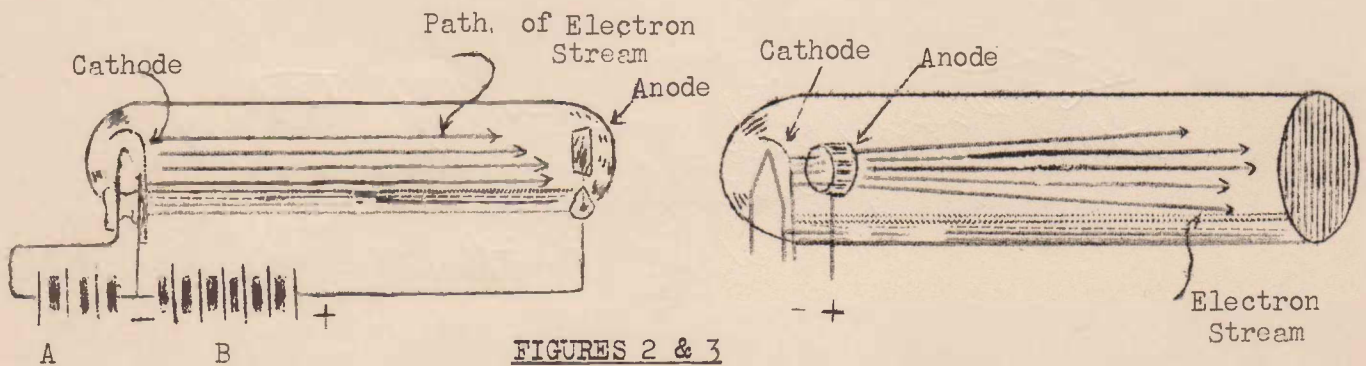

In Figure 3 we have made a slight alteration in the construction of the anode. The anode or plate has been made in the form of a ring or a short cylinder and has been brought close to the cathode or filament. The electrons are still drawn from the cathode to the anode but they are travelling so very, very fast that many of them fail to stop there and keep right on going through the

anode opening and continue on towards the far end of the tube.

The greater the anode voltage, that is the greater the potential difference between the anode and cathode, the faster the electrons travel, and the more of them that get up to such a speed that they pass right through the opening in the anode. Also, the more nearly perfect is the vacuum in the tube, the faster the electrons travel, and the farther they go beyond the anode. Under certain conditions the speed of the electrons in the beam approaches the speed of light which is 186,000 miles per second.

FOCUSING THE BEAM.

The simple tube of Figure 3 produces a beam of electrons, but this beam is not "focused". To focus the beam we must "squeeze" all the electrons together so that they do not spread out. We want these electrons gradually to converge, so that they all strike the far end of the tube at practically the same point. The idea of focusing may be illustrated by reference to the action of a lens system on light rays. In Figure 4 the rays from the source are diverging, or spreading out. The first lens bends these rays, to some extent, towards each other, that is, it produces a partial focusing effect. The second lens completes the action by further bending of the rays until they all converge towards a point "f", called the focal point.

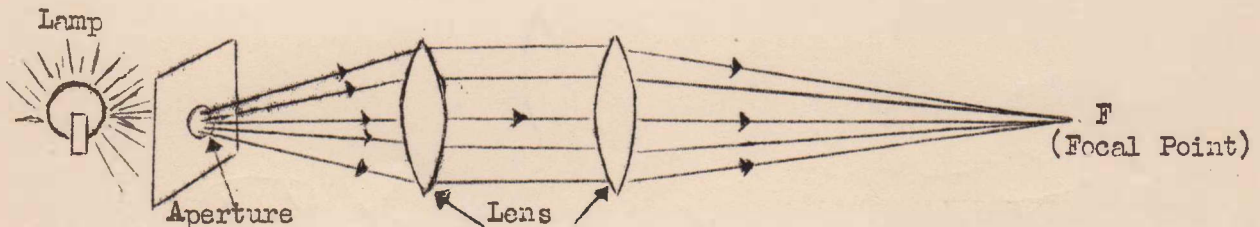

FOCUSING LIGHT RAYS BY MEANS OF A LENS SYSTEM.

FIGURE 4.

Although two lenses are shown in Figure 4, light rays may be focused by means of a single lens, although the effect is usually less perfect. Further, a lens system consisting of more than two is sometimes used, this producing still more perfect results.

In the case of the electron beam in a cathode ray tube, a method of focusing is necessary, because, no matter how narrow the beam is as it leaves the cathode, it will always tend to spread out. This is due to the fact that the electrons are all negatively charged, and will therefore tend to repel each other.

outwards. Three methods may be used for focusing:

- (a) By the use of a trace of gas in the tube
- (b) By the use of electrostatic fields.
- (c) By the use of magnetic fields.

(a) The method of gas-focusing, as it is called, used to be very popular for laboratory work on account of its simplicity. A small quantity of inert (i.e. inactive, chemically) gas, such as argon or helium, is introduced into the tube before it is sealed off. This means that the space in the tube will be filled with gas molecules, or particles, which will be in the way of the electrons as they shoot up the tube. The electrons will collide with the gas molecules and "ionise" them by collision. This means that when a collision occurs the moving electron of the beam knocks off, or forces out, one or more electrons belonging to the gas molecule. The molecule, being electrically neutral in its normal state, is thus left with a positive charge, and is now called a positive ion. After the electron beam has passed up the tube we can therefore imagine its path strewn with positive ions. These will act as a kind of core to the beam, and, being positive, they will therefore neutralise the repulsion existing between the electrons. As a result the beam will cease to fan out and will eventually become narrower, i.e. it will be focused on the screen.

The principal advantage of gas-focusing is the low anode voltage required, and some tubes will operate on 300 volts. On the other hand the beam is only sharply focused for one particular value of beam intensity. In television receiver work it is necessary to vary the beam intensity to correspond with the varying degrees of light and shade of the picture elements. We therefore require some different focusing method, one which will maintain a good focus of the beam as its intensity, or strength is varied. Again, when gas-focusing is used, the focus is lost, and distortion occurs, when the beam is deflected or moved about at high frequencies over the screen. Hence the method is unsuitable for television scanning purposes, where it is required to move the beam at the line-frequency, which in the case of a 400 line, 25 pictures per second, system is $400 \times 25 = 10,000$ cycles per second. For these reasons gas-focused tubes are not used in television, but are included here in order that the student will have a picture, as complete as possible, of the most important device, the cathode ray tube.

ELECTROSTATIC FOCUSING. The electrode assembly for producing a focused electron beam in an electrostatic type tube is shown in Figure 5. Note, by the way, that the glass envelope shape has been altered to allow of a longer screen.

As will be seen, there are now, in addition to the cathode, three electrodes within the tube. These include two anodes, and a control electrode occasionally called the grid. The latter, to which a negative potential is applied in relation to the cathode, performs the same function as in an ordinary amplifying tube, i.e. it controls the value of the electron stream which flows from the cathode towards the anodes. Note, however, that this control electrode has a very different structure from the grid of the tubes you are familiar with.

It consists of a hollow cylinder which almost completely surrounds the cathode except for a small hole in its end. Being negative, the walls of the cylinder will turn back any electrons which happen to be thrown out towards them by the heated cathode. If the anodes are sufficiently positive, however, a thin stream of electrons will be drawn through the control cylinder's aperture. In this way, the control cylinder serves the additional function of aiding in the beam focusing action.

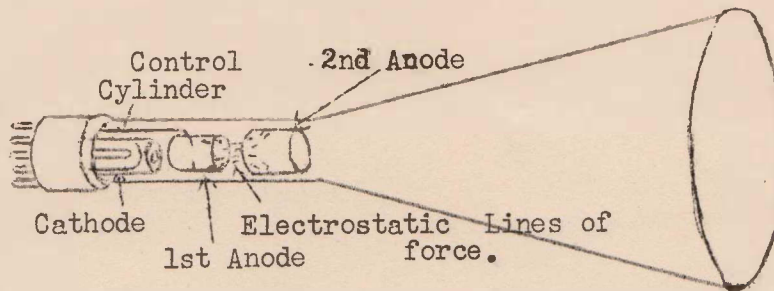

FIGURE 5.

The two anodes are in the form of hollow cylinders (Fig. 5). The one nearer the cathode is called the "first", or the "focusing" or the "accelerating" anode. The other is called the "second" or "main" anode. Both are given a high positive potential with respect to the cathode, but the voltage on the second is usually about three to five times as great as that on the first. For example, if the first anode is at a potential of, say 600V, the second would be in the vicinity of 3,000 volts. In the case of tubes used in television receivers for picture reproduction the final anode is worked at voltages ranging from 2,000 to 10,000. These very high values are necessary to produce on the screen a picture of satisfactory brilliance. Oscilloscope tubes usually work at lower voltages than these, although the potential of the second anode is rarely below about 1,000 volts.

The anode assembly, in addition to performing the functions of forming the electron beam (the "cathode ray"), also serves the purpose of focusing it to a fine spot on the screen at the large end of the tube. To assist in explaining how the focusing effect is brought about the student should refer to Figure 6, which shows in diagrammatic form the electrode assembly.

The first anode, by virtue of its positive potential, attracts electrons from the cathode through the control electrode's aperture, so forming a fairly narrow beam. By the time these electrons have reached the vicinity of the first anode they are travelling at high speed and tend to shoot straight through this hollow electrode. They then come under the influence of the more positive second anode which accelerates them to an even greater speed, with the result that they pass right on, finally striking the screen at the far end of the tube.

Note that, after the electrons leave the grid aperture, they fan out, as explained earlier. On entering the electrostatic field existing between the

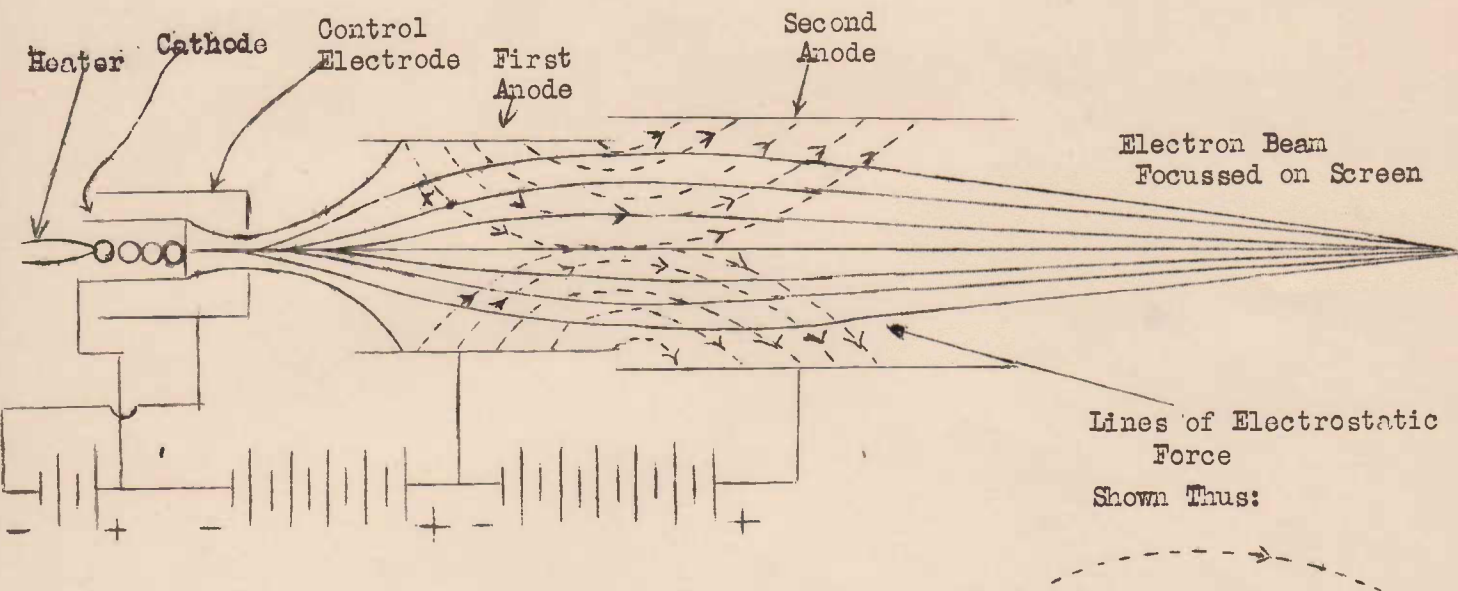

FIGURE 6.

two anodes, however, their paths are shown bent inwards towards the central axis of the tube. The net effect is that, no matter in what direction the individual electrons were travelling when they entered the field of the anode assembly, they are all travelling in converging lines after leaving it. These paths are such that all the electrons in the beam will meet over a very small area on the screen's surface, provided that the voltages are correctly adjusted.

In order to understand how the electron paths are "bent" to bring about this focusing action, it will first be necessary to recall a few points about electrostatic fields.

An electrostatic field is the type of field set up between the plates of a simple two-plate condenser when a potential difference is created between them, as in Figure 7 (a). The battery forces a negative charge on the left hand plate, and positive charge on the opposite plate. The lines drawn between the plates are called "lines of electrostatic force" and simply represent the lines along which forces will act upon any charged particles placed in the field. For example a negative electron at X will be impelled along the line in the direction of the arrow, for it will be attracted by the positive plate and simultaneously repelled by the negative.

The heavy lines in Figure 7 (b) represent an electrostatic field, the arrows representing the direction of the force which would act upon a negatively charged particle. Suppose an electron travelling in a straight line at high velocity enters the field at A. Immediately the field is entered a force

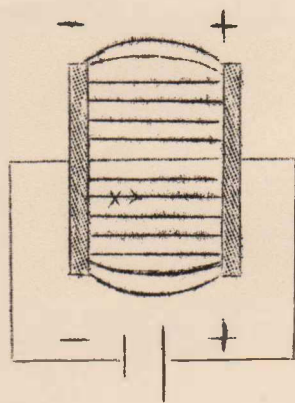

"A"

Lines of Electrostatic Force.

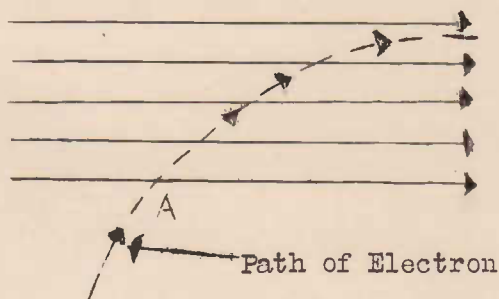

Path of Electron

"B"

FIGURE 7.

will act upon the electron in the direction of the lines of force, viz., horizontally to the right. The result is that the electron's path will be curved to the right, i.e. in the direction of the field.

Referring again to Figure 6, an electrostatic field exists between the first and second anodes, since they are at different potentials. The dotted lines with the arrows represent the direction of the forces which will act upon electrons in the field. An electron which travels straight along the central line or axis of the tube will not be deflected to right or left, because it is travelling parallel to the lines of force.

In the event, however, of an electron diverging from the central path after leaving the central cylinder, the case is different. Suppose such an electron enters the field between the two anodes at X, so that it is moving partially across the lines of force. In this case the electrostatic field will exert a force, acting in the direction of the dotted lines, with the result that the electron's path is bent so that it is turned back towards the central line as shown. The greater the extent to which the electrons have diverged, or spread out, before entering the anodes' field the greater will be the amount of bending of their paths. The net result is that, providing this field is of the correct strength, all electrons will converge in such a way that they strike the distant screen at practically the same point, i.e. the beam is focused.

In practice the job of bringing the beam to a sharp focus on the screen at the end of the tube is achieved by using a potentiometer to vary the voltage on the first anode. Since the second anode is usually worked at a fixed potential, any change to that of the first will alter the potential

difference between the two, and hence the strength of the electrostatic field. If this field is not exactly the correct value the beam will tend to focus at a point in front of the screen, or beyond it. In the former case the electrons will converge to a point, and then diverge or spread out again as at (a) in Figure 8. In the latter case the screen will intercept the moving electrons before they reach their point of focus, as at (b) in Figure 8. The result will be the same in both cases - instead of seeing a small, sharp spot of light on the screen, there will appear a large area of light with ragged edges. Correct focussing is shown at (c) Figure 8.

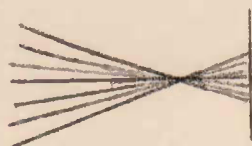

Incorrect Focussing

"A"



Incorrect Focussing

"B"



Correct Focussing

"C"

FIGURE 8.

Although we have assumed two anodes in discussing the focusing action, modern electrostatic tubes for television purposes usually employ three anodes. This allows of a more nearly perfect focusing of the beam for all degrees of beam intensity. When two anodes only are used, alterations to the control cylinder potential tend slightly to de-focus the beam. This, of course, is undesirable. A three-anode assembly may be compared with a three-lens optical focusing system used for cinematograph or other purposes when a sharply focused light beam is required. In the case of these tubes, focusing adjustments are usually made by potentiometer control of the potential on the second anode, the potentials on the first and third being maintained at fixed values.

The electrode assembly of a modern three anode television tube is shown in Figure 9. This picture also shows the "deflecting" plates, which have yet to be discussed.

Although, in our explanations of focusing - action above, the anodes were described as consisting of short hollow metal cylinders, their structure may vary from this in the case of a tube as illustrated in Figure 9. One or more of the anodes may consist of a simple circular disc of metal having a central hole or aperture. (see Figure 10 (b)) Another common structure consists of a cylinder fitted with one or two apertured discs as in Figure 10 (c). In all cases the theory of the focusing action is similar to that explained for simply hollow-cylinder construction. It should be noted that in the case of a multiple-anode tube, each anode, or rather the electrostatic field existing between any two anodes, forms an "electron lens" (analogous with a light lens) and helps

in the focusing action. The complete job of focusing is a function of the whole assembly, as in a multiple-lens light beam system.

MAGNETIC AND ELECTRO-MAGNETIC FOCUSING.

It has long been known that moving electrons may be deflected in their paths by means of a magnetic field, and experimenters hit upon this method of cathode-ray focusing quite early in the history of cathode-ray tubes. As a matter of fact magnetic focusing was used before electrostatic and hence the order in which we have dealt with the subject here is not identical with that of its historical development.

Let us summarise the important facts in relation to the action of a magnet field upon moving electrons. Firstly a magnetic field is the field of force set up by either a permanent magnet, or a coil of wire carrying a current. Figure 11 shows the nature of the fields of a straight bar permanent magnet and of a "solenoid" type of coil.

The "lines of magnetic force" are usually regarded as running, outside the magnet, from North Pole to South Pole. Note that the field outside the coil at (b) Figure 11 is exactly similar to that of the bar magnet at (a). Hence the right-hand end of the coil will act as a North Pole, and the left-hand end as a South. Inside the coil, however, the lines are parallel and concentrated and run in the opposite

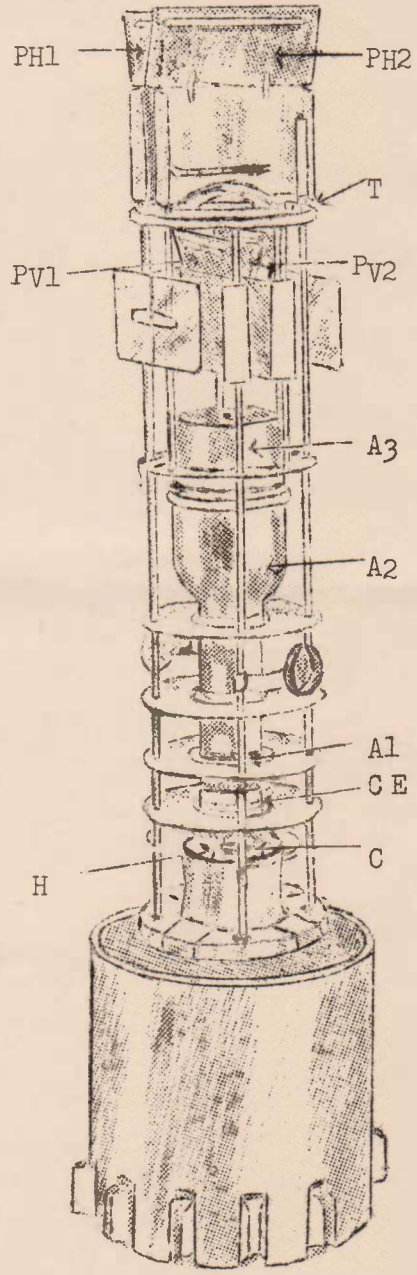

INTERNAL STRUCTURE OF CATHODE RAY TUBE.

Side Views

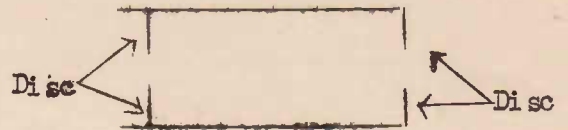
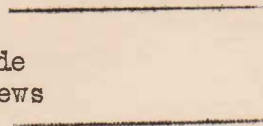

End Views

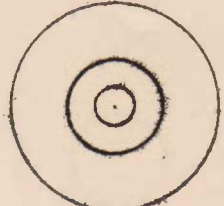
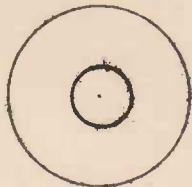
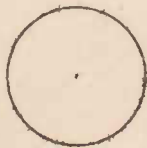

Cylinder
(a)

Disc
(b)

Cylinder with Discs
(c)

Three types of Anodes - Longitudinal Sections above, and sections below.

FIGURE 10.

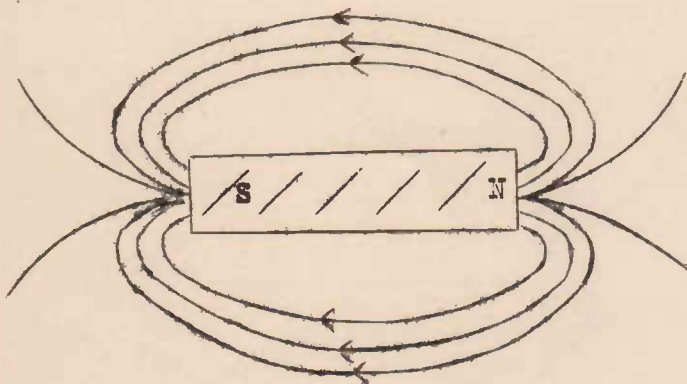

(a)

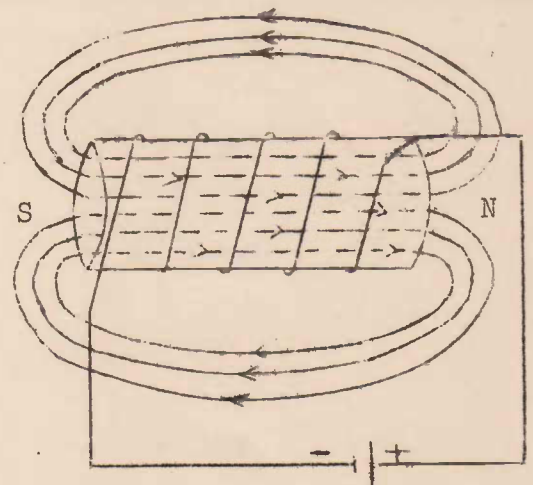

FIGURE 11.

direction. It is this part of the field in which we are interested when dealing with electro-magnetic focusing.

Consider, now, the well-known action of a magnetic field on a conductor, such as a straight piece of wire carrying an electric current in a magnet field. This is the underlying principle of the electric-motor. At (a) in Figure 12 the current-carrying conductor is lying parallel to the field - i.e. the current is flowing parallel to the field. In this case there is no force whatever acting on the conductor. At (b) the current is flowing across the field, i.e. at right-angles to it.

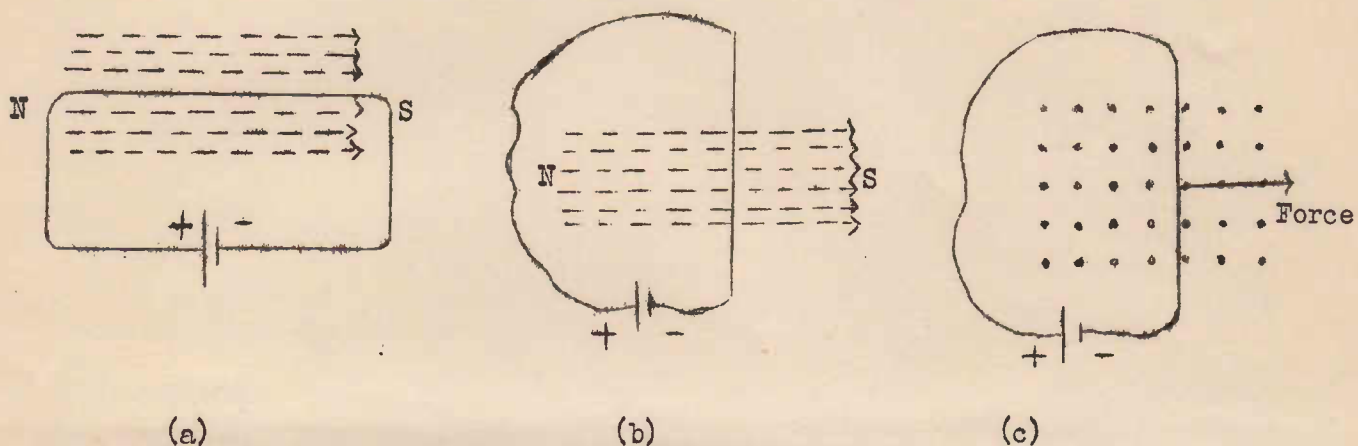

FIGURE 12

We now find that a force will act on the conductor, impelling it out from the paper. At (c) we have depicted the situation at (b), but now viewed "end-on" to the lines of magnet force, which are therefore shown as dots. The force on the conductor is to the right as shown. Note, then, that when a current carrying conductor lies across a magnet field, a force acts upon it in a direction at right-angles to both the lines of force of the field and to the conductor itself.

If we now remember that a current in a solid conductor is simply a flow, or drift, of electrons through that conductor, we may deduce the action of a magnetic field upon a stream of electrons, such as constitute the beam in a cathode ray tube. Such a beam may be regarded as an electric current in space, and the forces acting upon it when it enters a magnetic field will be exactly similar to those which act upon a current in a solid conductor.

Referring to Figure 13, suppose we are viewing a magnetic field "end-on" (as was done at (c) in Figure 12). The dotted line represents a stream of electrons, travelling at high velocity, and entering the field from the direction as shown. These moving electrons, representing a "current" will, when they enter the field, experience a force acting always at right-angles ~~to~~ to their direction of motion. The result will be that each electron's path will be turned, or deflected, continually to the right. The path of an electron beam will therefore be a spiral as shown.

The principle construction of magnetically focused cathode ray tube is shown in Figure 14.

The cathode and grid structure are as previously described. The anode here consists of a simple disc with a central aperture. The focusing coil is wound around and outside the tube. The magnetic field produced inside the tube is as shown. A steady direct current is passed through the coil. After the electron beam passes through the hole of the anode, some of the electron path's begin to fan out. Electrons which pass directly down the central axis of the tube move parallel to the lines of magnetic force, and are therefore not affected by the latter. An electron which has "fanned-out" however, will enter the field at an angle. Cutting across the lines of force it will experience a force at right-angles to the lines of magnetic force and at right-angles to its direction of motion.

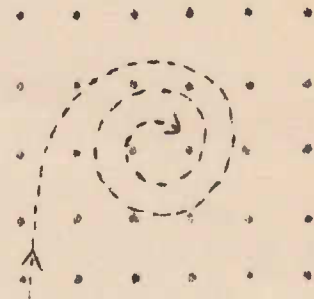

FIGURE 13.

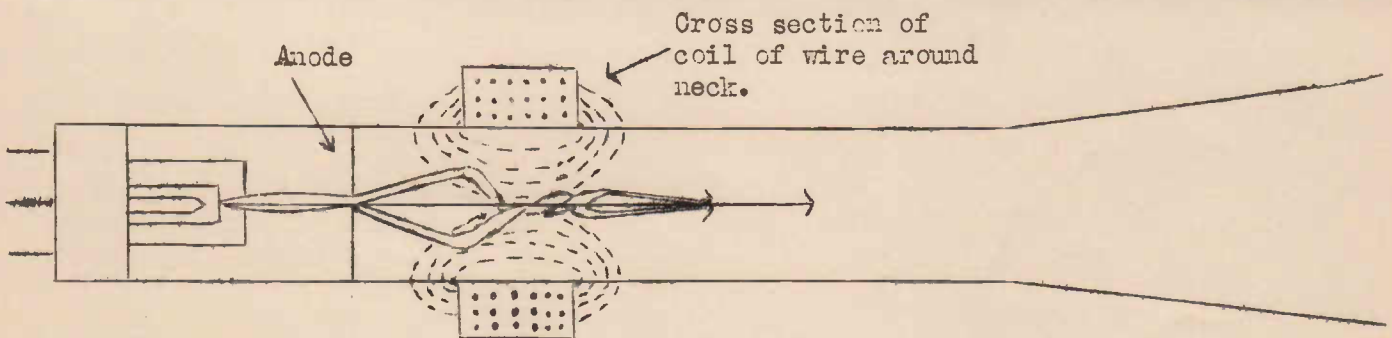

FIGURE 14

It will therefore, while in the field, move in a spiral path. At the same time it also possesses a general movement down the length of the tube. To visualise the net path taken by the electron, imagine a coil of wire wound on a tapered point of wood as in Figure 15, a battery being connected so that an electron-stream flows in the direction shown.

In this way all electrons, which enter the coils field (Figure 14) at an angle, will commence to rotate around the central axis of the tube as they continue their motion towards the screen. Moreover, the whole time, as a result of the

spiral motion they will be getting closer and closer to this central axis. Of course, as soon as the electrons leave the magnetic field the spiral rotation will cease, but they all will possess an inwards motion, which is carrying them closer and closer towards the central axis. At some distant point, which should be on the screen, all electron paths will converge together, and we will have a sharply focused beam.

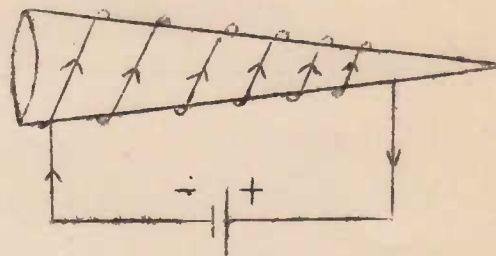

FIGURE 15

The focusing coil is often enclosed in a soft iron hollow ring-like case, in which has been left an air-gap. (Figure 16) This confines the magnetic field within the coil, except for those lines which "escape" through the gap. In this way a more concentrated field within the glass tube is obtained, and "stray" fields, which upset the focus, are avoided.

The factors which affect the focus are the position of the coil in relation to the anode, and the magnitude of the current. In practice, provision is made to adjust both of these. A rough focus is obtained by moving the coil on the neck of the tube, and a final adjustment, to sharpen the focus is carried out by adjusting the value of the coil's current.

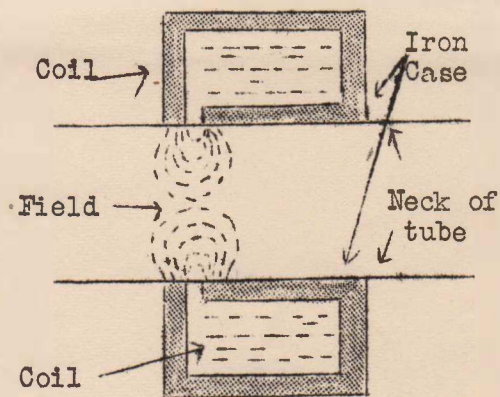

FIGURE 16.

MAKING THE ELECTRON BEAM VISIBLE.

We have so far seen how it is possible to produce a high-velocity stream of electrons which strike the large end of the tube at its central point. We have discussed the methods by which this beam may be narrowed down until its dimensions, at the point of impact on the screen are almost as small as we choose to make them. If the "cathode-ray" is to replace the light beam of mechanical systems for television scanning purposes, it remains to render the beam visible by causing it to give out light waves as it strikes the screen.

FLUORESCENCE.

As you look at an amplifying tube in action, you see no visible evidence of the flow of electrons within the tube -- at least you see no evidence when the tube is being operated properly. In the cathode ray tube, having a high degree of vacuum, you likewise see nothing of the ray as it travels through the length

of the tube.

The end of the ray is made visible by a property of certain substances which is called "fluorescence". When a film of such a substance is struck by the cathode ray there is produced a bright glow where the substance is caused to fluoresce. There are a number of such substances, among them being zinc orthosilicate, called "willemite", also calcium sulphide and calcium tungstate. Instead of describing these substances by their chemical names, we generally refer to them by number, such as "Phosphor No. 1" and so on. Phosphor No. 1 produces a green light, Phosphor No. 2 produces a bluish white light, Phosphor No. 3 produces a yellow light, Phosphor No. 4 gives a white light and Phosphor No. 5 gives a blue light. Phosphors 1, 2, 3, and 5 are used mainly in cathode ray tubes intended for use as electrical test instruments, while Phosphor No. 4 has been specially developed for television purposes as it produces a black and white picture similar to ordinary moving pictures.

In the cathode ray tube we now apply one of these fluorescent substances, preferably Phosphor No. 4, to the far end of the tube. Then as the cathode ray strikes this surface of prepared glass there is produced a bright spot of light having a size proportional to the size of the ray and a brilliancy proportional to the strength of the ray.

Just like the grid in a radio valve, the control electrode is given a negative bias with respect to the cathode. The amount of bias determines the amount of electrons which it allows to pass through to the rest of the tube and consequently determines the brilliancy of the picture. Making the control electrode more negative, reduces the number of electrons and dims the spot of light, while making the control electrode less negative increases the electron flow and makes the spot more brilliant.

Just as the signal voltages are applied to the grid of an amplifying valve and produce changes in plate current, so the signal voltages, from our television receiver, are applied to the control electrode of the cathode ray tube and produce corresponding changes in the brilliancy of the spot of light.

POWER SUPPLY FOR CATHODE RAY TUBES.

We shall first consider the question of supplying the various electrode potentials and the heater current for a typical three-anode electrostatic type tube.

The majority of these tubes require 2,000 - 6,000 V on the final anode, and for television purposes the latter figure is the most common. The potentials gradually increase from the small negative potential (say 50 V max.) for the control electrode to the high positive potential on the final anode. These voltages are invariably obtained by a chain of resistances across an H.T. supply from a rectifier. These resistances form a voltage divider which allows us to tap off the required voltage for each electrode. A typical power supply is shown in Figure 17.

It will be noted that the final anode is at earth potential, while the cathode is at a high (5000 V negative) potential with respect to ground. This is common practice in electrostatic type tubes, and the reason will be fully understood after reading the section on "deflection" later in the lesson. It should be fully realised now, however, that the third anode, although at zero potential with respect to earth, is at a positive potential of 5,000 V with respect to the cathode.

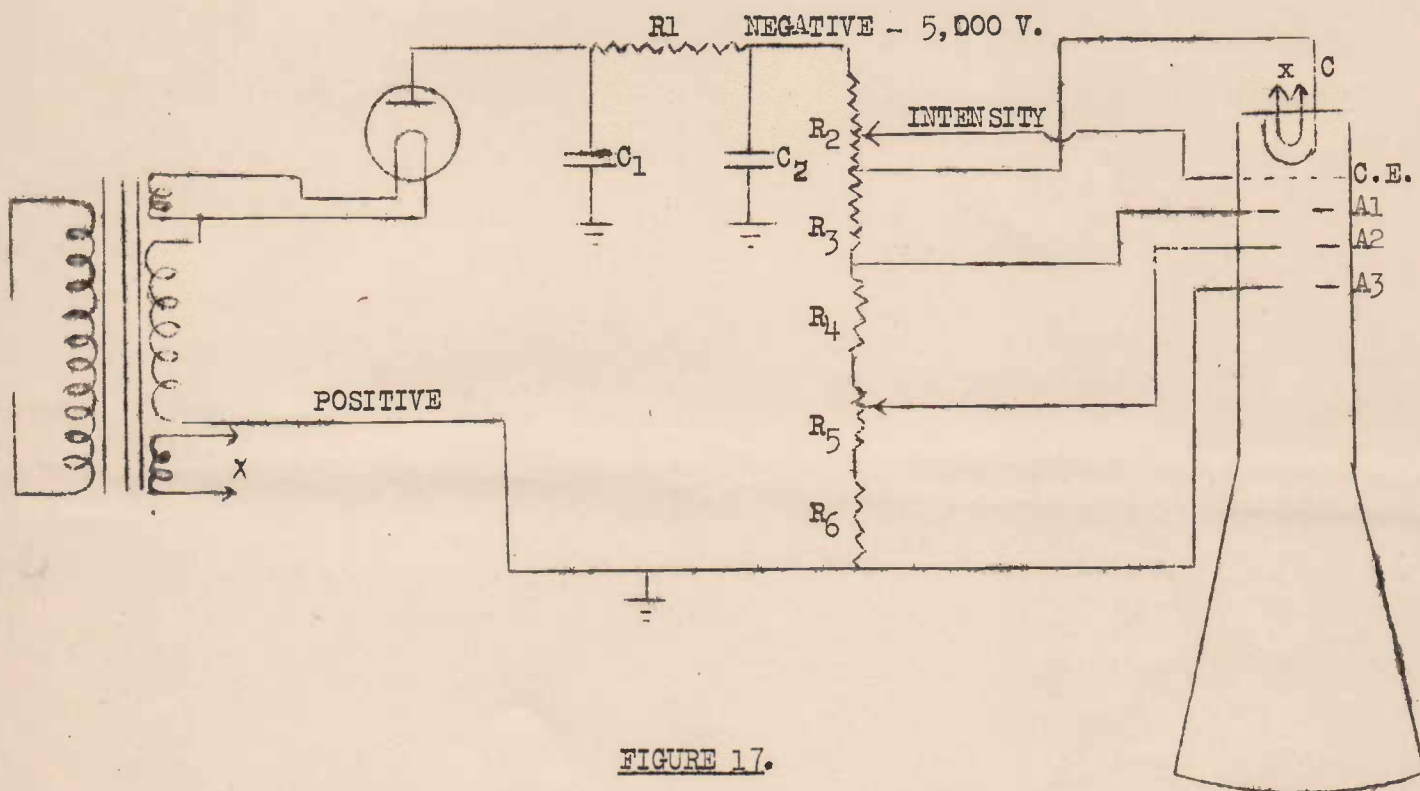

FIGURE 17.

The current taken by the electrodes is very small, and the only drain on the H.T. supply apart from the resistance load is the current which flows in the beam itself. This seldom exceeds 100 micro amperes (0.1 m.a.). As a consequence the design of the power supply is greatly simplified. For example resistance capacity filtering or smoothing may be used. Condensers C_1 and C_2 , a Resistor R_1 and the other resistors in the chain form the filter circuit. In practice R_1 and C_2 may be omitted, C_1 being simply a small capacity (.5 or .25mfd) of high voltage rating. The total resistance in the chain may be as high as 10 Megohms.

The Intensity Control is a potentiometer which allows the negative potential on the control electrode, with respect to the cathode, to be adjusted. This, as has been explained varies the beam's intensity, and therefore the brightness of the spot on the screen. In a television receiver, the video signals are also applied to the control electrode.

The Focus control allows of adjustment to the second anode's (A2) potential. Correct setting of this control produces a sharply defined spot on the screen. In a two-anode tube the focus would be controlled by adjustment to the potential of the first anode.

Note that the cathode, and the heater, which is connected electrically to it, are at a high negative potential with respect to the metal chassis. The transformer heater winding for the cathode ray tube must therefore be insulated for high voltages.

In the case of magnetically focused tubes there are usually only two voltages to supply -- that for the control electrode and for the single anode. The cathode is usually at ground potential, while the anode is at a high potential (positive) above ground. The focusing coil is supplied with a low voltage direct current from a separate supply.

DEFLECTION OF THE BEAM.

The cathode ray tubes so far described are capable of producing a sharply focused electron beam which will result in an intense spot of light which remains stationary at the centre of the circular screen. In order that the tube might be a useful instrument either as a television picture reproducer or as an oscilloscope, it will be necessary to provide means whereby the spot of light may be moved to any point of the screen.

This is accomplished by bending, or deflecting the electron beam, within the tube, sideways, or upwards, or in both directions simultaneously. Deflection of an electron beam may be brought about, as we have seen in principle when dealing with focusing by means of (a) an electrostatic field, or (b) a magnetic field. Both methods are in use in modern tubes.

ELECTROSTATIC DEFLECTION.

Consider first the moving of the beam vertically across the screen. This may be done by two more or less flat and parallel metal plates, called "deflector" plates, within the neck of the tube, and on the screen side of the final anode. (Figure 18.)

These plates are placed horizontally, and have connections which pass through the glass walls of the tube. Sometimes one plate is connected internally to the final anode, and is therefore at ground potential.

If both plates are connected to ground the beam will pass straight through them, without deflection, and will strike the centre of the screen. Suppose now we apply a potential difference between the two plates by means of a battery as in Figure 19. The electrons in the beam will be attracted towards the positive plate and repelled from the negative as the beam passes between them. This will cause a bending of the beam upwards as shown. The spot will now be found

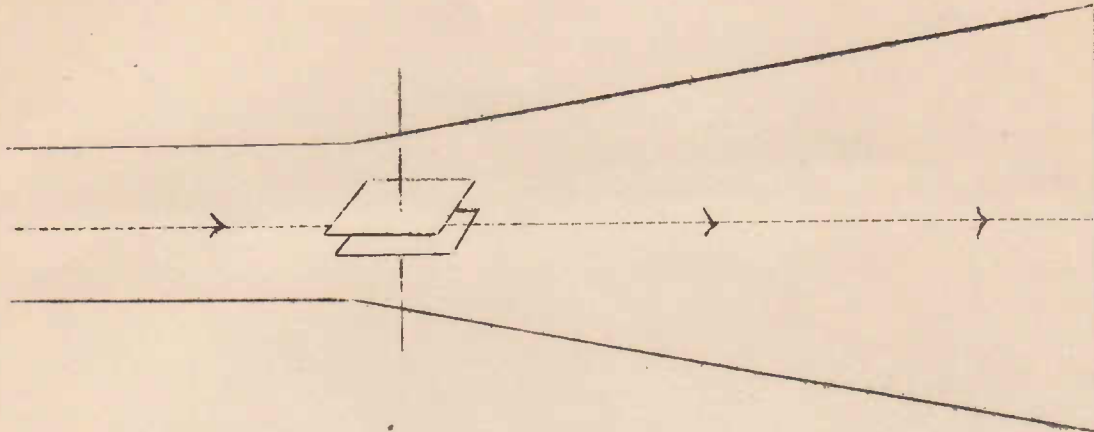

FIGURE 18.

at the point X on the screen directly above its central point.

The amount of bending of the beam, and therefore the amount of movement of the spot away from the centre of the screen will depend on several factors:-

- (a) The potential difference between the deflector plates.
- (b) The length of the deflector plates.
- (c) The anode voltage used in the tube.

Concerning (a), the deflection will be found to be almost exactly proportional to the applied P.D. between the plates. For example if the voltage is doubled, the movement of the spot away from the centre of the screen is doubled, and so on. It is this fact which allows the cathode ray tube to be used as an electrostatic voltmeter. If the number of volts required to produce say 1 cm deflection of the spot is known for a given tube (operated under given conditions of anode voltages), an unknown voltage may be measured by applying it between a pair of deflector plates, and measuring the actual deflection of the spot.

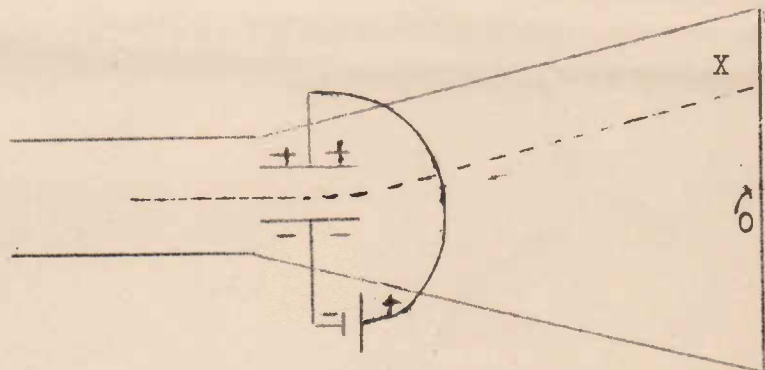

FIGURE 19.

With reference to point (b) above, the longer the plates, then the greater the length of time during which each electron is passing between them. If the electrons remain a longer time under the influence of the plates the greater will be amount of the bending of their paths. The plates cannot, in practice, be made too long, however, for this would limit the amount of deflection which could be obtained. A large deflection might possibly result in the electron

stream actually striking the plates before emerging from between them. To avoid this the plates are often flanged out as may be seen by reference to Figure 9.

The final point (c) is of importance. If the anodes' voltages are increased the electrons in the beam will be given an increased velocity. For a given deflecting force produced by the deflector plates, the actual amount of bending of the beam will now be decreased (and vice versa). This effect may be understood if one imagines a ball thrown across wind. The faster the ball is thrown, the less will be the deflection, or curving of its path.

Deflection Sensitivity. This term is used in order to compare the ease with which the spot may be deflected from the central point of the screen of different types of tubes, or for the one tube working under different anode ratings. The deflection sensitivity is defined as the amount of deflection, measured in millimetres, produced by a potential difference of one volt applied between a pair of deflector plates. This value, in the case of high voltage tubes, works out usually as a fraction of a millimetre. Since 1 mm equals about 1/25 of an inch it will be seen that quite a large voltage will be required to move the spot right to the edge of the screen. For example, suppose that the deflection sensitivity for a pair of plates of a tube is given as 0.25 mm/volt. If the tube's screen is 12 inches in diameter, the spot must be moved 6 inches to move it from the centre to the outer edge. This deflection is $6 \times 25 = 150$ m.m., taking 1 inch = 25 mm. The potential difference required between the deflector plates will be $150 \div 0.25$ volts = $150 \div \frac{1}{4} = 600$ volts. To move the spot right across the screen from one side to the other, a distance of 12 inches, a total potential difference change of 1200 volts will be required.

It should be noted that the deflector plates of Figure 19, which are mounted horizontally will produce only a vertical movement of the spot. If it is desired to move the spot horizontally across the screen as well, a second pair of plates is required. These will be mounted vertically, but are called horizontal

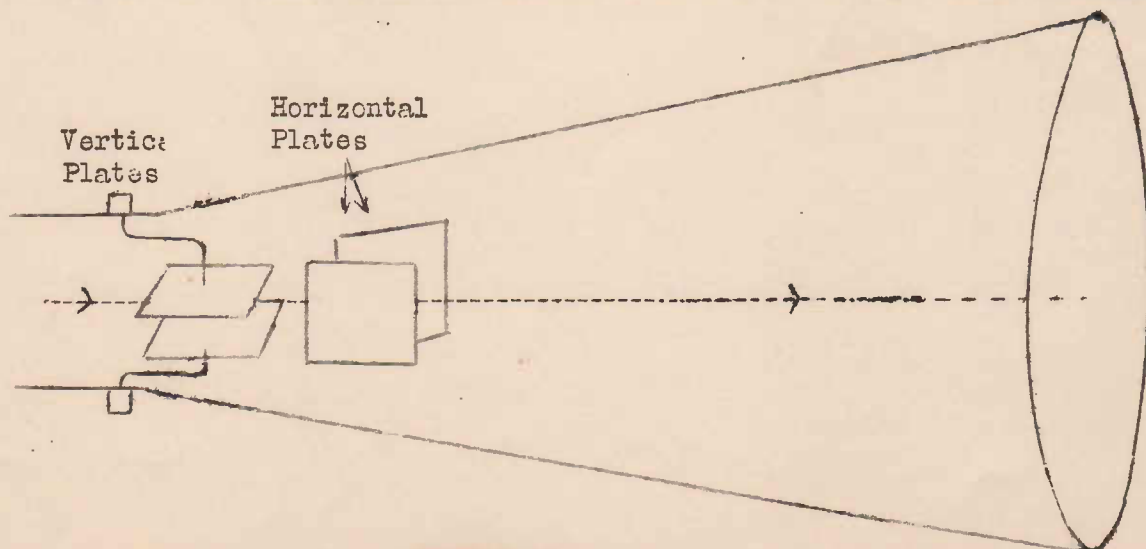

FIGURE 20.

deflector plates because their action on the beam and spot is in a horizontal plane or direction. The two pairs of plates are shown in Figure 20.

MAGNETIC OR ELECTRO-MAGNETIC DEFLECTION.

The deflection of the beam explained in the last section was brought about by utilising the electrostatic field produced between a pair of plates, which may be regarded as forming a simple condenser, when a potential difference was applied between them. A magnetic field may, however, also be used for deflection of the beam.

The effect of a magnetic field was explained in some detail when dealing with magnetic focusing, and this section should, if necessary, be re-read. The **important** point to remember is that the bending of the electron is at right-angles to (not parallel with) the lines of magnetic force.

Magnetic deflection is illustrated in Figure 21, where a horseshoe permanent magnet produces vertical lines of force through the tube. When the moving electrons pass through this field, their paths will be bent outwards from the paper towards the observer. At (b) in this figure, the front view of the screen's tube is shown, where a deflection of the spot to the left is indicated. Of

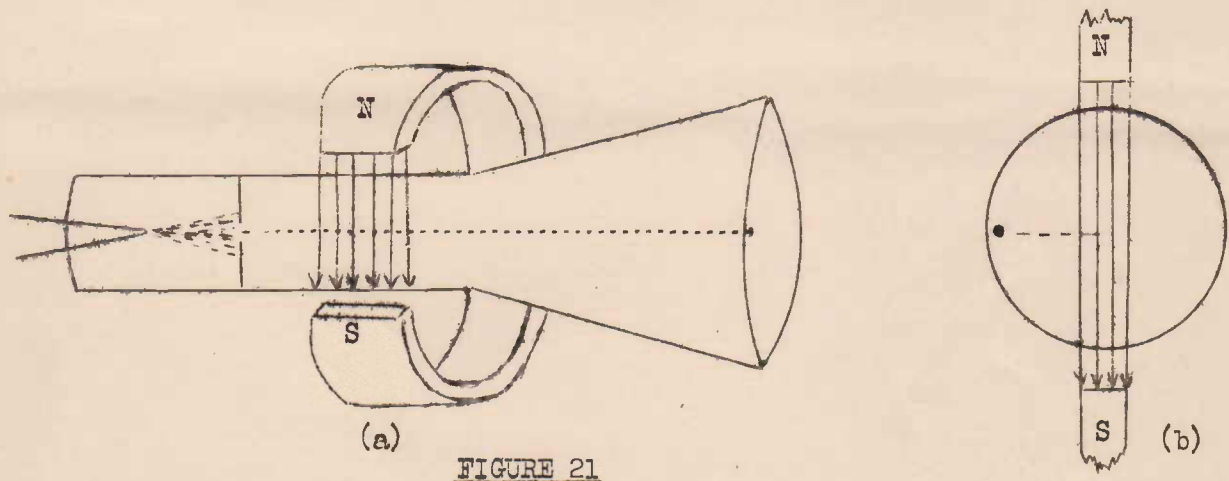

FIGURE 21

course, if the polarity of the magnet (and therefore the direction of the lines of force) were reversed, the spot would be moved to the right. The amount of deflection obtained will depend upon the strength of the magnetic field, as well as upon other factors mentioned under electrostatic deflection.

The magnetic field produced by a current carrying conductor is exactly the same as that produced by a permanent magnet. The two magnetic poles shown in Figure 21 may therefore be replaced by a pair of coils to produce a similar field for deflection. Such a pair is shown in Figure 22. The coils, are placed on either side of the neck of the tube and are shaped like a saddle to fit the rounded glass surface. In this case the coils produce a horizontal field through

the tube, and are therefore used for vertical deflection. To obtain horizontal deflection a separate pair of coils would be required. These would be placed horizontally one above, and one below the tube.

The amount of deflection occurring will depend on the number of turns in the pair of coils concerned, and upon the current flowing (as well as the speed of the electron beam which is controlled by the anode voltage used, as explained above under electrostatic deflection). The deflection may therefore be controlled by varying the current in the coils. Reversing the direction of current flow will reverse the magnetic field produced and will therefore cause a reversal of deflection of the light spot on the screen.

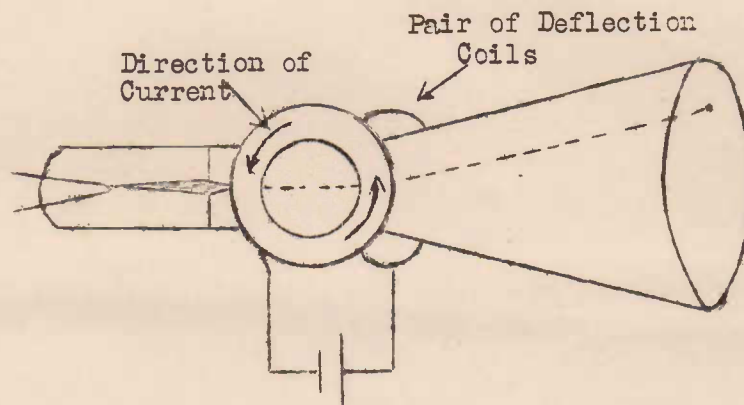

FIGURE 22.

Cathode ray tubes which use magnetic focusing and deflection usually have but a single anode, which may take the form of a disc with a central aperture as shown in Figure 21. In some cases the anode is simply a conducting coating on the inside of the tube walls. It will be appreciated also that the internal electrode structure of an electro-magnetically focused and deflected tube is very much simpler than that of an electrostatic type tube. This makes for reduced manufacturing cost, and also allows of a much shorter tube for a given screen diameter. This latter point is an important one when considering the problem of incorporating a large screen tube in a television receiver, and the tendency now is well in favour of the magnetic tube for picture reception.

SPOT POSITIONING.

Due to inaccurate alignment of the electrodes of a tube, the spot of light, when no voltages are applied to the deflector plates (or no current to the deflector coils), may not be in the exact centre of the screen. It will be necessary to correct this defect by electrical methods. On the other hand it may be desired, under certain circumstances, to move the spot to some position other than the centre of the screen.

In the case of electromagnetic tubes, this spot "shift", as it is called, is achieved by altering bodily the position of the focus coil on the neck of the tube. Adjustments for moving the coil are provided.

Spot shift, in electrostatic tubes, is carried out by electrical methods. Steady voltages, whose values may be adjusted by means of potentiometers, are applied between each pair of deflector plates. One method -- the method usually used for television receiver tubes -- is shown in Figure 23.

The final anode, it will be remembered, is usually grounded, the cathode of the tube being maintained at a high negative potential (say - 5,000 V). In figure 23, however, the final anode is connected to the centre point of a resistor across a comparatively low voltage source, say 300 V, the negative side of which is earthed. This means that the anode will be at a potential of +150 V with respect to ground and its potential with respect to cathode will be

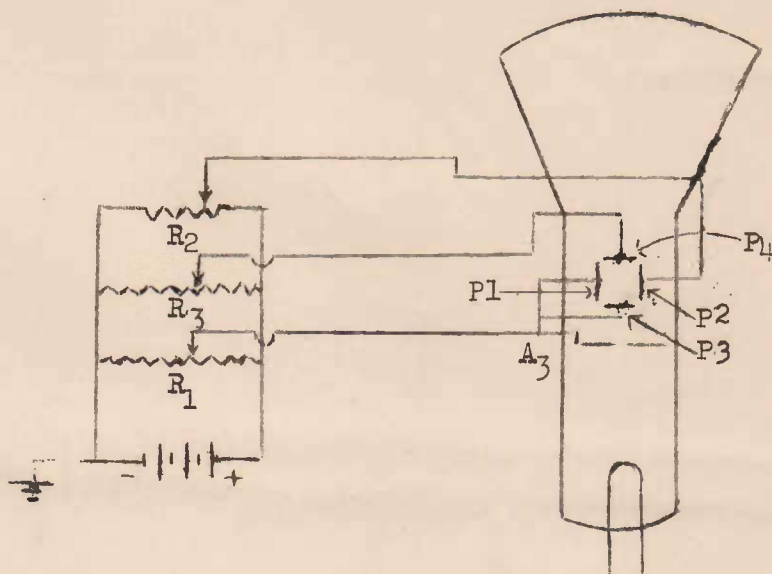

FIGURE 23.

$5,000 - 150 \text{ V} = 4,850 \text{ V}$. instead of the full 5,000 V, if portion of the output from the 5,000 volt power supply appears across the resistor R_1 . This slight reduction in anode working voltage will not, however, materially effect the operation of the tube. The voltage source in Figure 23 may, in practice be the ordinary H.T. supply, as distinct from the cathode rays tubes' V.H.T. (very high tension) supply. In this case the final anode voltage may be $5000 + 150$ or 5150 volts positive with respect to the cathode ray tube's cathode.

R_1 is paralleled by two potentiometers R_2 and R_3 connected respectively to deflector plates P_2 and P_4 of the tube. Deflector plates P_1 and P_3 are connected to the final anode, i.e. to a point + 150 V above ground. Incidentally the representation of the deflector plates in Figure 23 is purely a diagrammatic one, and is usually used in circuit diagrams.

When the sliding contact of R_2 is at its central point, the potential applied to P_2 is + 150 V with respect to ground. That is, with this adjustment, there is no potential difference between P_1 and P_2 . If the sliding contact is moved to the right, P_2 will take up a steady positive potential with respect to P_1 , and the spot will be moved to a new position on the screen. Moving the sliding contact of R_2 to the left, will apply a negative potential to P_2 in respect to

P 1, and the spot will be moved in the opposite direction.

The potentiometer R3 operates in an exactly similar manner on plates P3 and P4. R2 is the horizontal shift control, and R3 the vertical shift control. By adjustment to both R1 and R2 the spot may be moved to any desired position on the screen, limited only by the range of voltages which may be applied between each pair of plates, in this case $300 \div 2 = 150$ V.

A.C. VOLTAGE BETWEEN DEFLECTOR PLATES.

If an A.C. voltage is applied between any one pair of deflector plates, or an A.C. current passed through a pair of deflector coils, the observer will see a straight line of light on the screen.

This effect will be explained by reference to Figure 24 showing at "A" a front view of the screen with the two vertical deflector plates of an electrostatic tube.

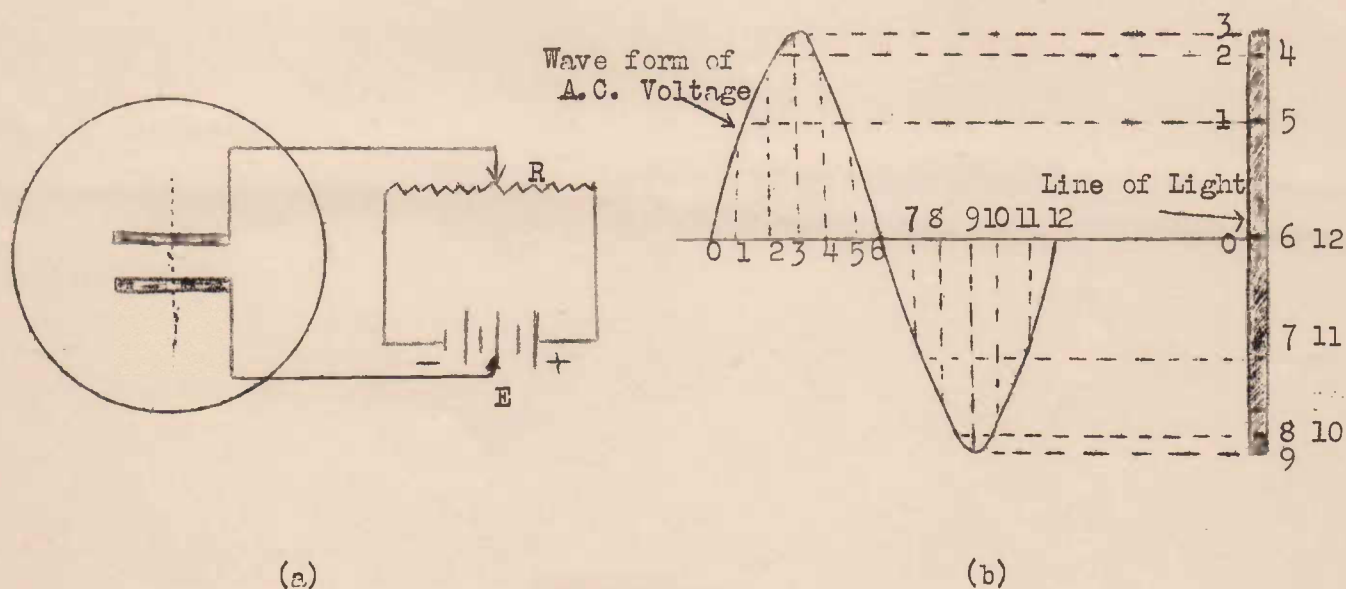

FIGURE 24.

The plates are connected to a potentiometer (R) and Battery (E) circuit in such a way that the voltage between them is zero when the sliding arm of R is at the centre point. As the arm is moved to the right the upper plate will take up a positive potential with respect to the bottom, and the spot will move from the central position up the screen. The farther the arm is moved from the centre of R, the greater will be the P.D. between the plates, and therefore the greater the spot movement. Remember that the displacements of the spot is proportional to the voltage applied, so that equal increases in voltage will cause equal displacements of the screen. Moving the sliding arm of R to the left will reverse the polarity of the P.D. between the plates, so that the lower one will

become positive with respect to the upper. This will cause a downward movement of the light spot on the screen.

If now the sliding contact is moved at a very rapid rate backwards and forwards, the spot will perform a correspondingly rapid movement up and down on the screen and the eye will perceive a continuous and steady line of light. The persistence of vision effect applied here, as well as a persistence of fluorescence, whereby any point on the screen continues to glow for a short period after the spot has passed.

It should be noted that this backward and forward motion of the potentiometer arm applied an alternating voltage between the deflector plates. If now the circuit of Figure 24 (a) is replaced by source of A.C. having a sine-wave form, the effect will be the same except that the A.C. changes smoothly in the sine wave shape.

Referring to Figure 24 (b) the voltages at 0, 6 and 12 are zero and leave the spot in the central position. The peak positive voltage at (3) produces the maximum upward deflection, and the peak negative voltage at (9) produces the maximum downward deflection. Other positions of the spot, 1, 2, 4, 5, 7, 8, 10, 11, with the corresponding values of instantaneous voltages are shown, as it moves continuously to fill in the solid line of light.

Observe the following points: (a) the thickness of the line depends upon the diameter of the spot, and this is determined by the sharpness of focus. (b) The distance travelled between (2) and (3) or (3) and (4) is less than that between (0) and (1) or (5) and (6). Since these represent equal periods of time, it means that the speed of travel of the spot is slower near the ends of the line than near the centre. The effect of this will be that the line may appear slightly brighter near the ends, than near the middle. The spot movement is said to be non-linear, and this non-linearity is due to the fact that the rate of change of current of sine wave form is not constant, but is most rapid near the points of zero current. (c) The length of the line is an indication of the peak value of the A.C. If the deflection sensitivity of the tube is known, the peak value of an unknown A.C. may be obtained by applying it between a pair of deflector plates and measuring the length of the "trace", as the line is called.

OBTAINING A LINEAR TRACE.

For television purposes it is necessary, as the student should realise at this stage, to sweep the spot across the screen at a uniform rate in order to secure correct scanning. Further, having moved the spot in one direction, say left to right, across the screen, it is necessary to return it to the left-hand side in the shortest possible time. As we have seen, a sine-wave voltage will satisfy neither of these conditions.

The type of A.C. voltage required for this "linear" sweep is that having a Saw-tooth wave form (Figure 25).

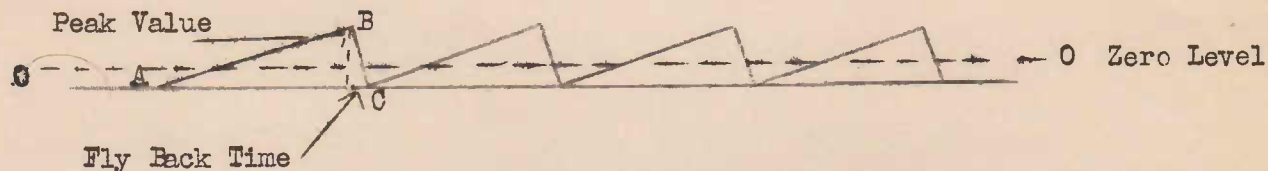

SAW-TOOTH VOLTAGE

FIGURE 25.

Here the voltage rises from negative value at A, at a uniform rate, to some maximum positive value at B. The voltage then returns, very rapidly to its former value at C. This completes one cycle. The number of those cycles per second is the frequency. The effect of applying such a voltage between, say, the horizontal deflector plates, of a tube is shown in Figure 26. The spot will move across the screen from X to X' at a uniform rate as the voltage rises from A to B. Then as the voltage is suddenly returned to its negative value at C, the spot will rapidly return to X, and the trace will commence again under the influence of the second cycle. If the frequency is high enough a continuous line of light will appear.

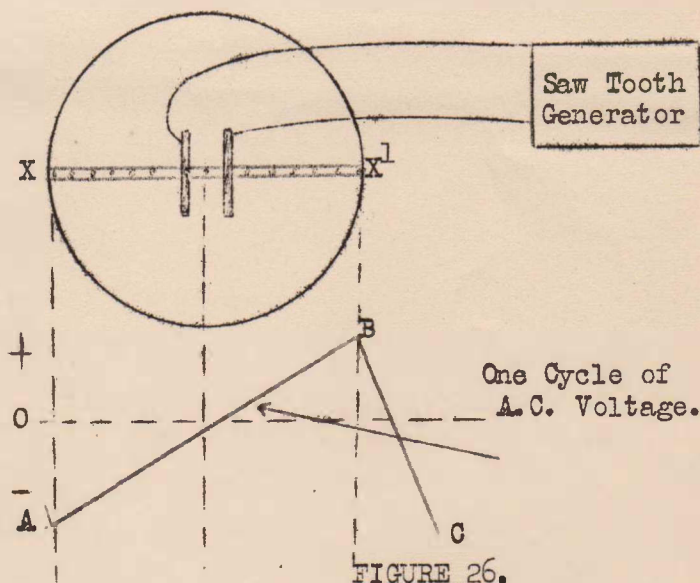

FIGURE 26.

APPLICATIONS OF SAW-TOOTH VOLTAGE.

Saw-tooth voltages are generated in special generator circuits, the operation of which will be dealt with in detail in a later lesson.

We are interested here in the use of saw-tooth voltages on the deflector plates of cathode ray tubes in two main connections: (a) in oscilloscopes for observing wave forms of voltages under test and (b) for scanning purposes in television transmitter and receiver.

In relation to (a) above, the saw-tooth voltage is applied between the horizontal deflector plates, and the unknown voltage (say the sine wave voltage) between the vertical deflector plates. When this is done the spot will trace

out a graphical representation (in this case the well-known sine curve) upon the screen. Further details of the oscilloscope circuits and operation are dealt with in a later lesson.

Referring to (b) above, suppose it is required to scan, at the receiver, a 400 line picture, 25 pictures per second. The line frequency is $400 \times 25 = 10,000$ cycles per second, this being the rate at which the spot must trace out horizontal lines. A saw-tooth generator -- the horizontal scan generator -- operating at this frequency 10,000 cycles per second is connected between the horizontal deflector plates. Another saw-tooth generator of frequency 25 cycles per second ("picture" or "frame" frequency) is applied between the vertical plates (Figure 27).

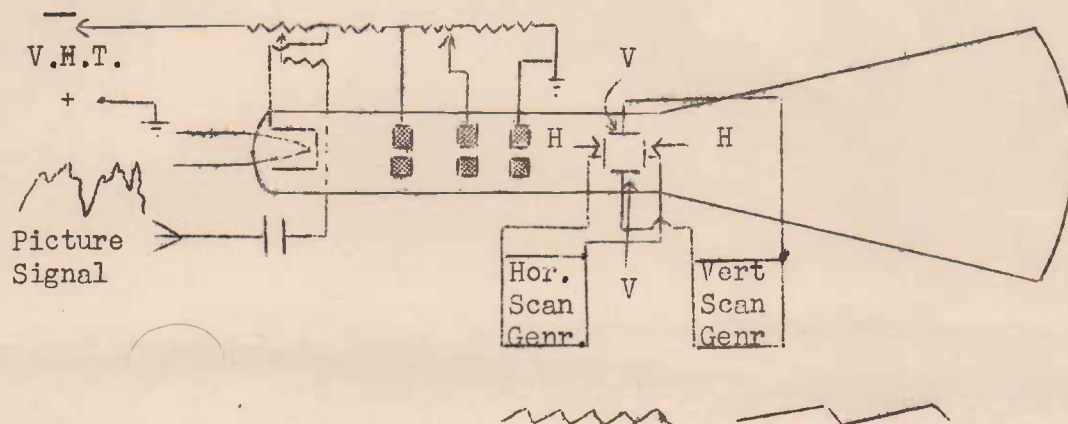

FIGURE 27.

Each cycle of the horizontal scan generator sweeps the spot across the screen from left to right in $1/10,000 = .0001$ sec., and then almost instantaneously returns it to the left hand side, when the next cycle begins a second sweep, and so on. Simultaneously with this action the vertical scan generator is slowly (comparatively) moving the spot in a vertical sense down the screen. This results in the spot finishing each horizontal line slightly below (a distance equal to the width of the spot itself) the level at which it commenced the line. As a consequence the subsequent line will be adjacent to, and slightly below, its predecessor, as shown in Figure 28. It will be observed also that this method of scanning results in the lines being at a small angle to the horizontal, this peculiarity being due to the continuous downward motion produced by the saw-tooth voltage on the vertical plates, which motion acts simultaneously with the horizontal scanning sweep. Such angle, however, is immaterial, and is so small in the case of a

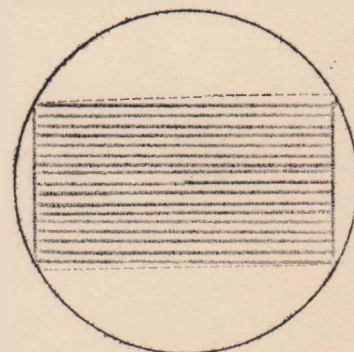

FIGURE 28.

400 line scan as to be unnoticeable.

After a time equal to $1/25$ sec. the vertical saw-tooth oscillator will have moved the spot down the screen a distance equal to the picture height. In this time the horizontal oscillator will have performed $10,000 \times 1/25 (f \times t) = 400$ cycles, i.e. 400 "lines" will have been traced out. At this instant the "frame" frequency saw-tooth voltage will suddenly fall to its minimum value, and the spot will "switch" to the top left-hand corner of the screen to commence a new scan.

Consider now the manner of reproducing the picture. The picture (video) signal from the detector of the receiver is applied to the grid (or control cylinder) of the tube. The grid potential, varied at the signal frequency, produces corresponding changes in electron beam intensity, and therefore in spot brightness on the screen. This method of operating the tube is universally used, and is known as "intensity modulation". So we have the spot of light continuously traversing the screen in the normal scanning manner, while at the same time its brilliancy is varying in accordance with the light from the picture elements at the transmitter. In this way, ~~assuring~~ we provide means for ~~maintaining~~ correct synchronisation of transmitter and receiver scanning, a reproduction of the original scene will appear on the screen. The average brightness of the picture may be adjusted by means of the intensity control, shown in Figure 27, which adjusts the negative bias on the grid. Maximum sharpness or clarity in the picture is secured by adjustment to the focus control which operates on the second anode. If the picture is not correctly centred or "framed" on the screen manipulation of the two "position" or "shift" controls (explained above) is made.

TELEVISION, FREQUENCY MODULATION & FACSIMILE COURSE

LESSON NO. 3

EXAMINATION QUESTIONS.

- (1) State briefly the nature of a cathode ray.
- (2) A certain two-anode electrostatic tube operates normally with 500 V on the 1st anode and 2,000 V on the second. If only 1500 V is available for the second anode what voltage (approx.) should be applied to the 1st anode? What will be the result if this readjustment to the latter's potential is not made?
- (3) Explain briefly the principles underlying focusing of (a) an electrostatic tube (b) and electromagnetic tube.
- (4) What is meant by "deflection sensitivity" as applied to an electrostatic tube? How is this property affected (if at all) by (a) increasing anodes' voltages? (b) Increasing negative potential on control electrode?
- (5) State two advantages of the electromagnetic type tube over the electrostatic.
- (6) An electrostatic tube has a deflection sensitivity of 0.25 mm/volt. The spot is adjusted to be exactly at the centre of the screen, then the following voltages are applied in turn between the horizontal deflection plates (a) a steady D.C. of 100V (b) A.C. of R.M.S. value 100 V. State in each case the affect as seen on the screen.
- (7) Give two reasons why sine wave voltages (or currents) are unsuitable for television scanning purposes.
- (8) A tube has a horizontal deflection sensitivity of 0.3 mm/V and a vertical of 0.25 mm/volt. State completely the characteristics of the two voltages (waveform, frequency, peak value) required to produce a 400 line picture 4" high, at 25 pictures per second, aspect ratio being 5:4 (take 1" = 25 mm).
- (9) What coloured light is produced by Phosphors 1 to 5 employed in cathode ray tubes?
- (10) State briefly the purpose of the following controls, mentioning the electrode upon which they operate:--
(a) Focus control, (b) Intensity control, (c) Vertical position (or shift) control.

AUSTRALIAN RADIO COLLEGE

E. S. & A. BANK BUILDINGS, Corner CITY RD. and BROADWAY, SYDNEY
Telephones: M 6391 and M 6392. Post Lessons to Box 43, Broadway

This lesson sheet is published for the exclusive use of
students of the Australian Radio College Pty. Ltd.
(All rights reserved)



TELEVISION FREQUENCY MODULATION AND FACSIMILE COURSE.

LESSON NO. 4.

ELECTRONIC SCANNING AND TELEVISION ELECTRON CAMERAS.

Having studied in the last lesson how a narrow electron beam may be formed, focused, made to give out light, and deflected at practically any desired speed for scanning purposes, we propose now to deal with developments of cathode-ray tubes for producing the electrical picture signal at the transmitter. It should be understood that the tubes explained so far are only useful for picture reproduction at the receiver. They provide means only for producing a spot of light which may be moved in the usual scanning fashion, and which may be varied in intensity by the incoming signal to reproduce the varying lights and shades of the original picture elements. They do not, however, provide means of creating an electrical signal from the varying lights and shades of the scanned scene at the transmitter. It is the purpose of this lesson, therefore, to describe and explain several types of tubes which have been developed to produce the picture signal at the transmitter. All of these tubes make use of focussed electron beams and are a special development of the ordinary cathode ray tubes. We shall consequently refer to all of them by the general term "Electron Cameras".

THE FARNSWORTH CAMERA.

This ingenious device was the first tube developed to make use of the great advantages of electronic scanning. It might be mentioned here that electronic scanning at the receiver, i.e. the use of the ordinary cathode ray tube, was put into practice while mechanical methods were still relied upon at the transmitter. The improvement of picture definition, by increasing the number of picture lines, and therefore the scanning speeds, was thus largely held up pending the application of electronic scanning at the transmitting end.

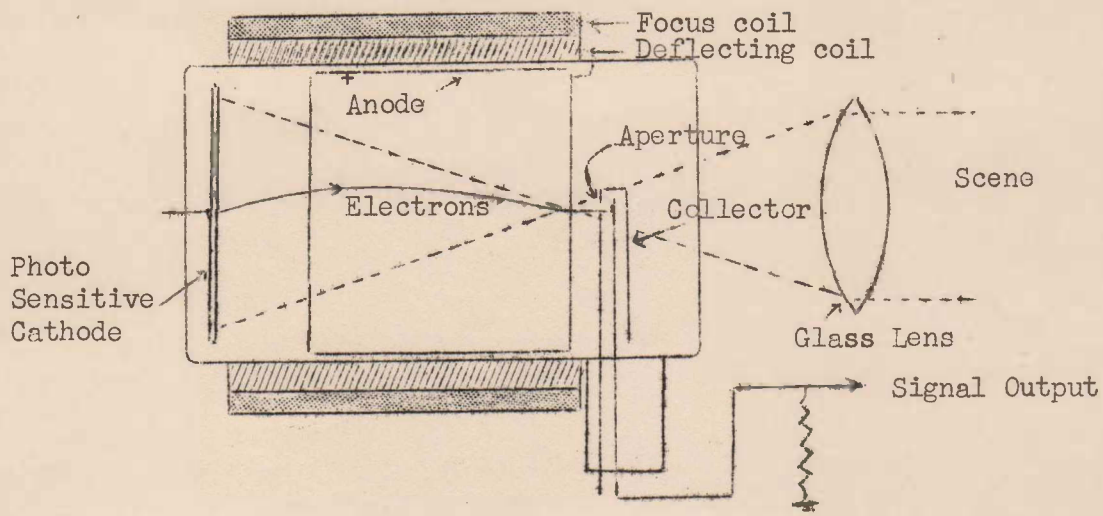

FIGURE 1.

Figure 1. shows the Farnsworth Camera. At the left-hand end of the tube we have a cathode in the form of a flat plate coated over its whole surface with a photo sensitive material, such as caesium. Light is focused, by means of a lens system, onto this cathode, in much the same way as the lens focused an optical image of the scene on to the plate in an ordinary camera. Electrons are liberated, due to the photo-electric effect, from the cathode surface. These electrons will be liberated proportionately to the amount of illumination at any point. The light image is thus converted into an "electron image" near the surface of the cathode, the density, or concentration, of the electrons varying with the light and shade of the various parts of the picture.

Immediately the electrons are freed from the cathode by the action of light, they are attracted up the tube by a hollow cylindrical anode, to which a positive potential is applied.

If these liberated electrons were left to themselves they would diffuse, that is electrons in the regions where the density was high would spread out into the less dense regions, so that very quickly we would have an ordinary photo-electric current, of uniform electron density, flowing up the tube. If this occurred the electron image would be lost, the electron current being simply proportional to the average illumination of the cathode.

To prevent this diffusion of the liberated photo-electrons as they move up the tube they are subjected to a magnetic focusing field of the type used in ordinary cathode-ray tubes for focusing the beam. The result is that when the electrons have reached the far end of the tube they are still concentrated in their original densities as when they were liberated from the cathode, i.e. the "electron image" has been retained.

The magnetic focussing field is produced by a coil of wire wound around the outside of the tube. This coil carries a steady current. It should be noted that the action of the focusing field is not to produce a concentrated beam of electrons as in an ordinary cathode-ray tube, but rather to form an electron image at the right-hand end of the tube from the electron image produced at the cathode by the photo-electric action. The function of this focusing field might be likened to the focusing effect of a lens where used to project a light image on to a screen, by controlling the diverging light waves reflected from an object.

At the far end of the tube is the collector electrode which is surrounded by a screen except for a small hole which corresponds to the scanning aperture. As a consequence, the collector will collect only those electrons which pass through the hole, i.e. only the electrons of one point of the electron image. Now with this arrangement the scanning aperture cannot be moved to scan the whole picture (as with the Nipkow disc). Instead the electron image is moved, as a whole, in such a way that the electrons passing through the hole to the collector are taken from the image in a succession of scanning lines. This is accomplished by two sets of scanning coils which act similarly to the deflecting coils of a cathode-ray tube. One set of coils moves the electron image, bodily, in a horizontal direction at the "line" frequency while the other moves it vertically at the slower picture or frame frequency. These deflections are, of course, obtained by using saw-toothed currents in the scanning or deflector coils.

The useful output from the tube is the electron current flowing from the collector electrode. It will be seen that this current varies in sympathy with the varying amounts of light reflected from different parts of the scene, as the scanning action proceeds.

The Farnsworth Camera, sometimes called an "image disector", thus does away with the difficulties of mechanical scanning, but its output in the form described is no greater than that of the ordinary photo-tube. This drawback was overcome by the use of the electron-multiplier described below.

HOW WEAK PICTURE SIGNAL OUTPUTS HAVE RESTRICTED TELEVISION.

The picture signal (video) current output from a photo-electric cell (or from the Farnsworth tube in its original form) is very minute -- much smaller than the audio output from a microphone. It might be thought, at first, that this position could be rectified by using more amplifying stages, or stages having greater gain. The student probably, however, realises that it is impossible to amplify effectively, an extremely weak signal. In the case of audio amplification a very weak signal would be drowned in "noise", no matter how great the overall gain of the amplifier might be.

This "noise" is due to two causes:-- (a) the "shot" effect, due to irregular emission from the heated cathode of the amplifying tube, (b) the generation of irregular voltages across the resistor in the input circuit of the tube, due to continuous random motions of the electrons in it. Unless the signal voltage

is considerably greater than these "noise" voltages very high gain in the amplifiers will be useless, for the latter will be amplified as well as the signal.

In the case of television signals the undesired voltages which are generated in all amplifying circuits will appear on the scene as flashes of light, and might completely "mask" the signal if the latter is very weak. These voltages will therefore, be referred to as "masking" voltages where dealing with television work.

It will be appreciated, then, that the photo-electric devices so far dealt with are useless unless the scene can be very brightly illuminated. Such illumination requires very special studio arrangements, and the televising of outdoor scenes would normally be impractical.

THE ELECTRON MULTIPLIER.

This device, first suggested in 1919, but developed considerably by Dr. Zworykin and Farnsworth since that date, largely overcame the difficulties associated with the amplification of the very weak outputs from the photo-electric devices. It is incorporated, in various forms, in the very latest electron cameras to boost still further the extreme sensitivity of these tubes.

Various types of electron multipliers have been developed to a high state of efficiency. All types, however, operate on a common principle -- they all utilise the phenomenon known as "secondary emission", whereby a single electron striking a solid surface may liberate from that surface a number of other electrons. This effect occurs, or tends to occur, at the anode of the ordinary amplifying valve, where, since it is undesirable, a suppressor grid is included to reduce it.

Only one type of electron multiplier will be described here since the general principle of operation of all types, and in particular the net results obtained is the same in all cases. This is illustrated in Figure 3, where we show a type of photo-electric tube into which an electron-multiplier has been incorporated between the photo-sensitive cathode and the collecting anode.

Light falling on to the photo-sensitive cathode at the left hand-end of the tube liberates a few electrons. A number of pairs of plates are arranged at intervals down the tube, the upper plates P1, P3, P5, P7 being "staggered" with respect to the lower ones P2, P4, P6 and P8. Gradually increasing potentials are applied to the pairs of plates as they go down the tube. The "photo" electrons thrown off by the cathode are first attracted towards plate P1, but a strong magnetic field applied across the tube deflects them on to plate P2. This plate is coated with a substance which readily emits secondary electrons, and on impact of the electrons

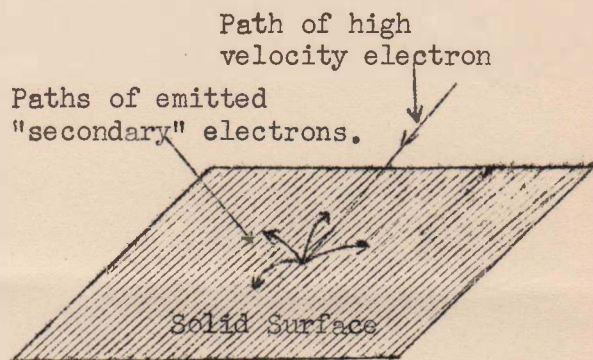

FIGURE 2.

SECONDARY EMISSION OF ELECTRONS.

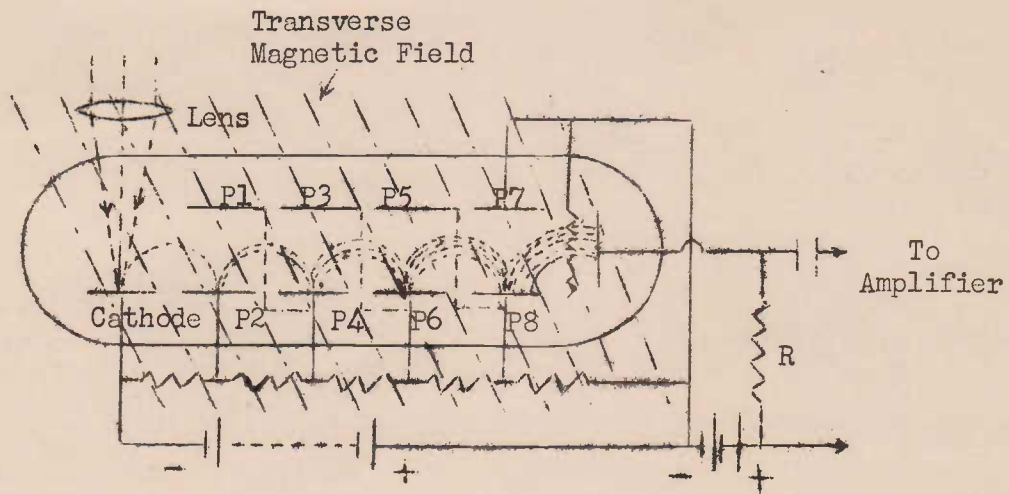

FIGURE 3.

ELECTRON MULTIPLIER.

arriving from the cathode a large number are emitted. These in turn are attracted towards P3 but strike P4, due to the deflecting magnetic field. Here many more "secondary" electrons are emitted, and so on until the number which are finally collected by the anode may be hundreds or thousands of times as great as those originally freed at the cathode. Thus we have a comparatively large electron current flowing through the resistor R, across which corresponding voltage changes appear. The latter are then fed to the external circuit and amplified further in the usual way.

The electron-multiplier is really an amplifier, but it possesses the advantage over ordinary thermionic tube amplifiers in that extremely great amplification may be obtained with very little "noise" or "masking" voltages. It will be noted that there is no hot cathode to produce the "shot" effect, and no large resistors (as in the input circuits of tube amplifiers) across which random voltages due to thermal agitation would appear. Dr. Zworykin's electron multiplier gave an amplification of 5,000,000 — an extremely high figure.

The electron multiplier was introduced into Farnsworth's camera to increase its sensitivity. The multiplier was enclosed in the shield containing the simple collector electrode of Figure 1. The primary electron stream was that entering through the shield's aperture. These electrons set up a series of secondary emissions from a number of plates in a manner similar to that described in connection with Figure 2. In this way

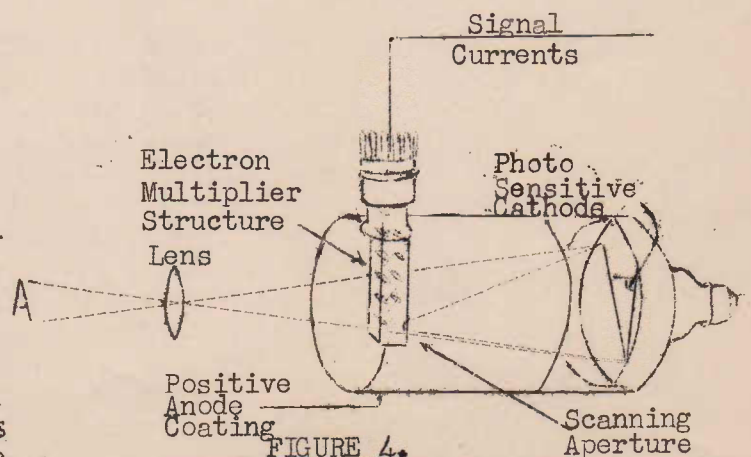

FIGURE 4.

A MODERN IMAGE DISSECTOR TUBE.

the output of the camera was magnified many times.

A drawing of a modern image dissector is shown in Fig. 4. This tube was specially developed for the transmission of motion picture film images. For this purpose, where intense lighting may be used, the image dissector is eminently suitable, as it does not introduce certain technical difficulties which are characteristic of some of the "storage" type cameras described below. These latter types, however, have displaced the image dissector in the field of ordinary studio and outdoor work.

LOW SENSITIVITY DUE TO INEFFICIENT USE OF AVAILABLE LIGHT.

The extremely small current output from the photo devices so far discussed is largely due to the failure of the systems to utilise fully all the light available on the scene. Considering mechanical scanning, the light spot remains on each picture element for only a minute fraction of a second. Suppose for example that the picture contains 150,000 elements the area of an element being taken as the area of the light-spot. If the picture is scanned at 25 pictures/sec, these 150,000 elements are swept by the spot in $\frac{1}{25}$ second. The time for which the spot remains on any one element will therefore be $\frac{1}{25} \div 150,000$ second = $\frac{1}{3,750,000}$

sec. Since the number of electrons emitted by a photo-sensitive surface is affected by the light, as well as the light intensity, the reason for the extremely minute current outputs of photo-cells, and the like, will be apparent. Summarising, then, the light only affects a particular picture element for $\frac{1}{150,000}$ th of the total scanning period (i.e. time for 1 complete scan). For the remainder of the period, i.e. $\frac{149,999}{150,000}$ of it, this particular element is remaining in darkness.

A somewhat similar state of affairs exists in the case of the image dissector. In this device light from the entire scene illuminates the photo-sensitive surface, but the light effectively used, at any moment, is that confined to producing the electrons which are entering the aperture of the shield around the anode or electron multiplier. All the light producing other electrons, at the same instant is wasted, since these electrons do not enter the aperture. For a picture containing 150,000 elements, as before, only $\frac{1}{150,000}$ th of the total number of photo-electrons emitted during a scan period are utilised, the rest are wasted. It will be seen therefore, that the theoretical efficiency of these devices is very low -- only $\frac{1}{150,000} \times 100 = .0007\%$ (approx).

STORAGE TYPE ELECTRON CAMERAS -- THE "ICONOSCOPE" AND EMITRON".

Rosing and Campbell - Swinton suggested, very early in the history of television, that the great wastage of light explained above might be avoided by devising some method of "storing" the photo-electric effect. Practical success was first achieved by Zworykin in America, in 1925, when he applied for his patent on the "Iconoscope". Since then parallel work, following Campbell-Swinton's original suggestion, was carried out by the E.M.I. (Electrical and Musical Instruments) company in England. The latter resulted in a camera similar to the Iconoscope and called the Emitron.

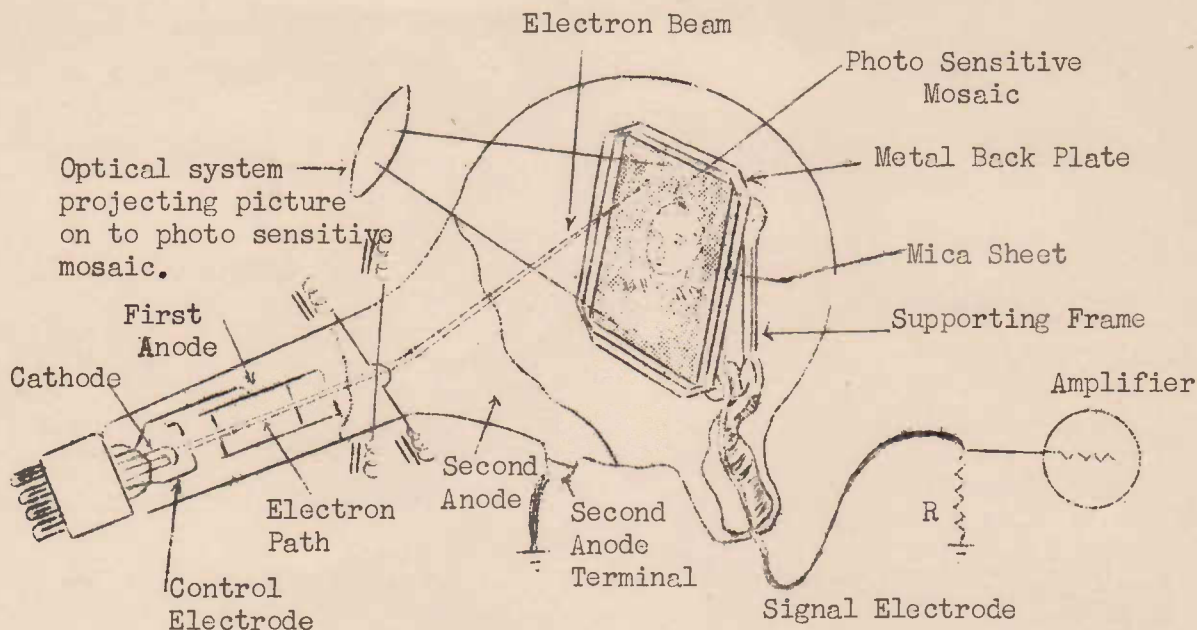

FIGURE 5.

AN ICONOSCOPE-EMITRON
TYPE OF TUBE.

An "Iconoscope-Emitron" type camera is shown diagrammatically in Figure 5. The tube contains an "electron-gun" and beam deflection coil as in an ordinary cathode-ray tube. Electrostatic focusing, using two anodes is used, the second anode being a metallic coating on the inside walls of the tube, as shown in Figure 5. The deflection of the beam for scanning purposes is achieved electromagnetically, by using two pairs of deflection coils outside the tube neck. The image to be televised is focused on to a special photo-sensitive plate, usually referred to as the mosaic, because of the nature of its construction, described below. A photograph of an Iconoscope is shown in Figure 6.

The mosaic consists of a thin sheet of mica, about $\frac{1}{1,000}$ th inch thick, and measuring about 5" X 4". The front side of this sheet, i.e. the side upon which the light image is focused is covered with millions of tiny globules of silver, each globule being coated with a thin layer of photo-sensitive caesium. The globules are isolated and insulated one from the other. The back of the mosaic sheet is covered with a thin metallic conducting layer (the "signal plate") to which the wire band which conveys the electrical signal to the external circuits, is connected. Each silver globule may be regarded as the cathode of a tiny photo-electric cell, which emits electrons when light falls upon it. The millions of these tiny cells all have a common collector electrode, which is the second anode of the tube's electron gun. Electrons liberated from the mosaic drift back towards this second anode which collects and removes them. A simple explanation of the operation of the tube is given in the succeeding paragraphs.

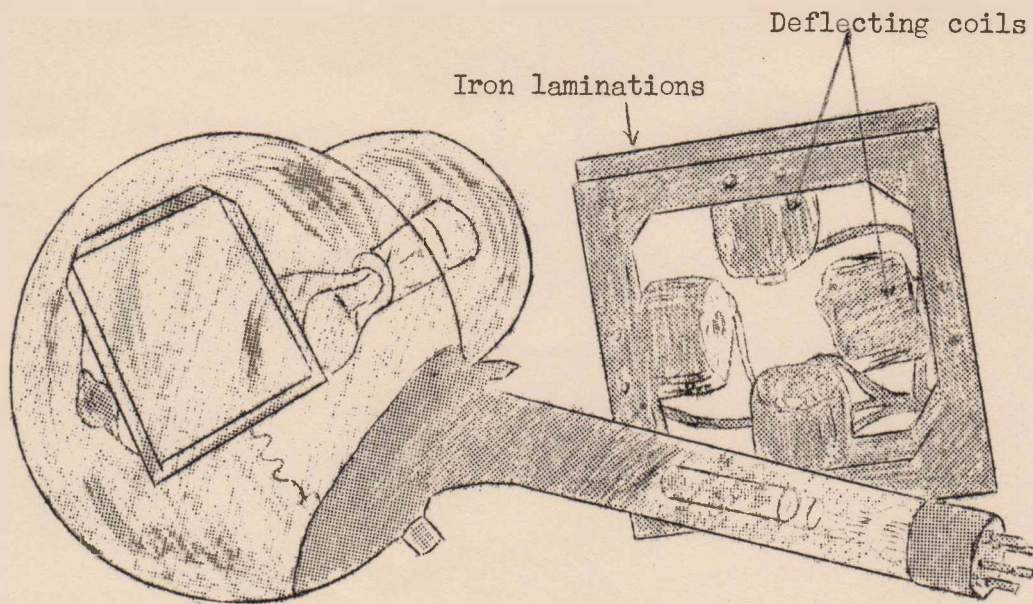

FIGURE 6.

AN ICONOSCOPE TUBE.

When a light image is focussed on the mosaic electrons are liberated from the surface proportionately to the light intensity at any point. Each silver globule forms a tiny capacity with the metal signal plate, the mica being the

dielectric. Thus the whole mosaic may be considered as consisting of millions of tiny condensers, all of which have one common plate -- the signal plate on the back of the mica. This idea is illustrated in Figure 7.

The effect of the emission of electrons from the globules will, therefore be to leave them positively charged (with respect to the signal plate). Remembering that the amount of electron emission is proportional to the light intensity of the mosaic at any point, it will follow that the degree of charge over the mosaic surface will vary with the light and shade distribution of the light image focused from the scene being televised. We can therefore visualise the light image building up an electrical image or pattern on the mosaic surface.

In the absence of scanning, this electrical image would remain indefinitely if the insulation of the mica were 100% perfect. It is for this reason that the iconoscope is sometimes described as the "cathode-ray tube with a memory"!

Now let us see what happens when the mosaic is scanned. The scanning, of course, is carried out by the electron beam which is formed, focused, and deflected in

FIGURE 7.

SHOWING HOW EACH GLOBULE TOGETHER WITH SIGNAL PLATE AND MICA DIELECTRIC FORMS A TINY CONDENSER.

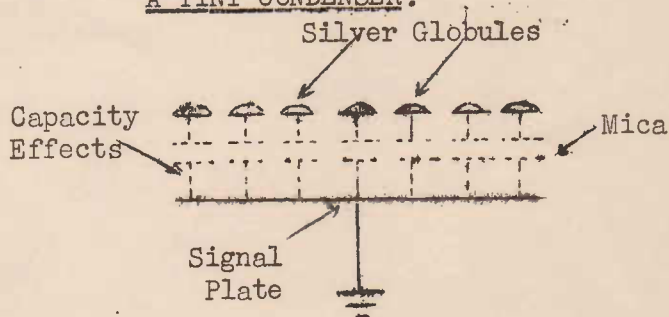

the normal scanning motion just as described in the previous lesson.

Of course interlaced scanning is used, whereby the beam first scans every other line, thus covering one complete "frame". The second frame scanning fills in the lines omitted during the first frame. How interlaced scanning is achieved electronically will be explained in a later lesson, but Figure 8, will indicate how the electron beam moves over the mosaic. Here 405 lines are used. The beam, in the

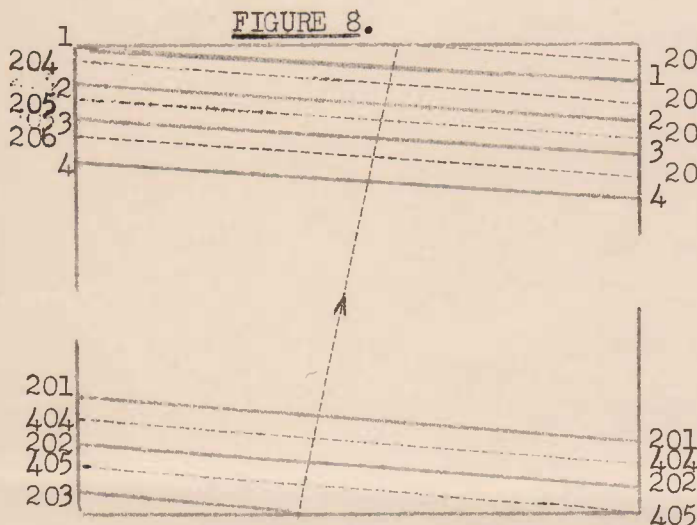

FIGURE 8.

INTERLACED SCANNING.

$$202\frac{1}{2} \times 50 = 10,125 \text{ c/sec.}$$

first frame scans the heavy lines marked 1, 2, 3, 4 ---- 203. The 203rd line only traverses half the screen, then the beam is jerked back, and scans the other half of the 203rd line at the top of the screen. The next frame is now commencing, and the dotted lines are scanned, filling in the gaps left by the first frame. Note that each frame consists of $202\frac{1}{2}$ lines - a total of 405 for the whole picture scan.

Both line and frame deflection of the beam is achieved by magnetic coils which are symbolised in Figure 5 (also see Figure 6). If the picture frequency is 25/sec. the frame scanning frequency will be 50/sec (2 frames per second) and the line scanning frequency will be

As the scanning beam passes over any particular globule the positive charge caused by the emission of electrons from the latter is instantly neutralised, with a corresponding electron movement from the back signal plate through the external resistor (see Fig.5). This current will represent one part of the "Picture signal" current, and its value will depend upon the amount of charge the globule in question had acquired, and therefore upon the light intensity reflected from the corresponding point of the scene. As the scanning beam passes over the mosaic all the globules will be progressively discharged in turn, and hence the current output from the tube will vary according to the intensity of the charge of the "electrical image" on the mosaic surface.

The electrical action involved in the foregoing explanation may be further elucidated by reference to Figure 9.

Here a single globule on the mosaic surface is represented as the cathode Pc of a small complete photo-electric cell P. The anode of this cell, Pa, is the collector electron, i.e. the second anode of the camera gun. C. represents the capacity effect existing between globule and the metal signal plate at the back of the mosaic. Light falling on the photo-sensitive globule Pc emits electrons which are collected by Pa. This leaves the left-hand plate of C positively charged with respect to the right hand plate. Remember that this charging action is going on comparatively slowly, for the whole time, and the final charge reached

depends upon the light intensity coming from the particular point of the picture scene in question. When the scanning beam passes rapidly over the globule the positive charge on the left-hand plate of C is instantly neutralised, with a corresponding electron movement away from the right-hand plate through R. The voltage developed across R will thus be proportional to the intensity of the light.

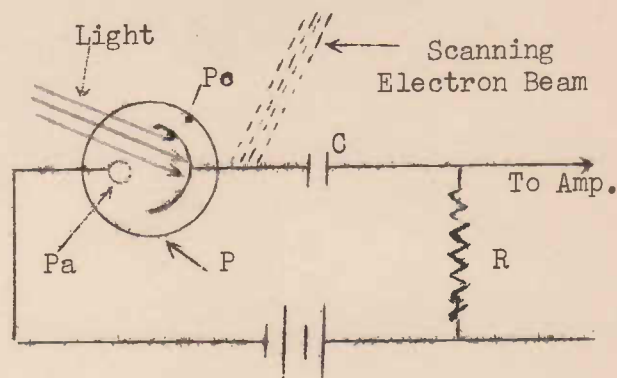

FIGURE 9.

THE ADVANTAGE OF THE "STORAGE" ACTION.

The important point to note is that, although the scanning beam is acting upon each element of the mosaic for only $\frac{1}{150,000}$ (assuming 150,000 picture elements) of the total scanning period (say $\frac{1}{25}$ th sec), the light is effective for the whole of this scanning period. As soon as the mosaic globule is discharged by the beam passing over it, the light gets busy in storing up a charge on that globule for the next $\frac{1}{25}$ th second until the scanning beam returns again. For this reason one would expect that these "storage" type tubes would be 150,000 times as sensitive as devices in which no such storage action takes place. In actual practice the Iconoscope-Emित्रon type of tube is only 5% to 10% efficient, i.e. only 5 - 10% of the output predicted from the above theory of operation is actually realised. Even so this gives a sensitivity from 7,500 to 15,000 times as great as that of the old systems.

WHY THE STORAGE ACTION OF THE ICONOSCOPE IS NOT 100%.

The storage efficiency of this type of tube is comparatively low for several reasons: (a) all of the electrons emitted by the light are not collected and many return to the mosaic, (b) loss of globule charge due to secondary emission.

(a) The photo-sensitive globules, together with the collector anode form very inefficient photo-cells, because the voltage difference between them is only several volts, which does not produce an electric field to draw off from the mosaic all of the emitted electrons, i.e. the photo-emission is not saturated. The result is similar to that which would be obtained if an ordinary photo-tube were operated at a low collector anode potential. Of the electrons emitted from the mosaic then, many will return to it, and the globules will not be charged to the extent they otherwise might be. This factor reduces the sensitivity to a factor of about $\frac{1}{2}$ or $\frac{1}{3}$ rd.

The student might wonder why there is any potential difference at all between the mosaic and the collector (second anode), since no voltage is applied between them from an external source. The mosaic takes up a potential several volts negative with respect to the second anode (which is at ground potential) due to the electron beam continually impinging upon it. Consider the scanning beam in operation when no light is falling upon the mosaic. The latter will be collecting the electrons of the beam, and its charge as a whole will tend to go more and more negative. But the high velocity electrons will knock secondary electrons out of the surface and some of these will return to the collector. The mosaic.

in practice, is found to take up an equilibrium potential of several volts negative when, for every electron arriving to it from the beam, one secondary electron leaves it. This means that the collector (second anode) is several volts positive with respect to the mosaic.

(b) Loss of efficiency due to secondary electrons occurs thus. Each beam electron liberates, on the average, about 4 or 5 secondary electrons, and, as explained under (a) above, most of these eventually return to the mosaic. At any moment, therefore, there will exist a cloud of these electrons just outside the mosaic, (Figure 10), forming a negative space-charge (similar to the space-charge surrounding the cathode in an ordinary thermionic tube).

This negative space charge will tend to repel, back to the mosaic photo-electrons which are emitted by the light image, so retarding the building up of the desired electric charge image. It is thought that this secondary electron effect reduces the tube sensitivity by another one-third.

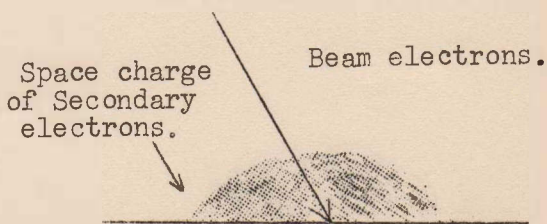

Thus, as a result of the two factors discussed under (a) and (b) above it appears that the sensitivity of the iconoscope-emitter type camera would be about 1/9th ($1/3 \times 1/3$) or 1/12th ($1/4 \times 1/3$) of that which would be obtained if 100% "Storage" action were achieved. In practice a storage efficiency ranging between 5 and 10% is obtained.

SPACE CHARGE DUE TO SECONDARY EMISSION. FIGURE 10.

"SPURIOUS" SIGNALS AND "SEADING" CORRECTION.

By these we mean electrical signal output from the tube which is not due to the light image. Spurious signals appear in the output of the tube even when no light at all appears on the mosaic, and are due to the secondary electrons falling back on the mosaic in an irregular, or non-uniform manner. We will not attempt to explain the details of how these spurious signals are generated, but will simply note their nature, and discuss how they are compensated for.

If the mosaic were scanned by the beam in the absence of any light upon it, the electrical output, say measured in the plate circuit of one of the transmitter's video amplifiers, should be a D.C., represented by a straight line in Figure 11 at (a) (i.e. no A.C. signal). Instead, however, it is found, due to the undesirable action of the secondary electrons that, during the scanning of one line, the current output varies as shown at (b). Note that there is a curve or "bend" in the graph of the current, as well as a gradual upward "tilt" as the scanning proceeds from left to right. A similar effect occurs as the scanning beam moves from the top of the screen towards the bottom at frame frequency. Since the effect of more light normally produces an increase in current, the effect of

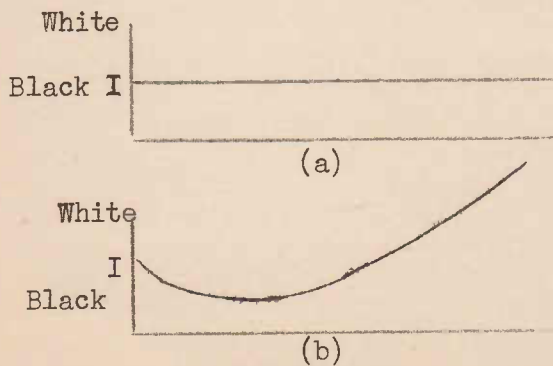

FIGURE 11.

those undersired signals would be to produce a shading on the receiver scene, whereby the right-hand side of the picture is lighter than the left and the bottom of the scene is lighter than the top. When an actual scene is scanned the real video signal will be superimposed upon this spurious signal as shown at (a) in Figure 12. Here we have shown the output for three scanned lines.

These "bend" and "tilt" spurious signals are compensated for in practice, at the transmitter by generating equal and "opposite" signals (see Fig. 12b) in special "bend" and "tilt" generators, and mixing these with the camera's output. One pair of "bend" and "tilt" generators is necessary for the line correction, and another pair for the frame correction. The result obtained for line "shading" correction, as it is called is shown at "c" in Fig. 12.

It will be noted that the camera also generates a large amplitude signal in the interval between the end of one line and the beginning of the next (i.e. where the beam is rapidly returning from the right-hand edge of the screen to the left). This spurious signal would overload the amplifiers, and is therefore suppressed, by means of special circuits. The result is now shown at (d) Fig. 12. It will be noted that a time-interval gap remains between successive scanning lines. This gap is made use of for carrying synchronising voltage pulses, shown inserted at (e)

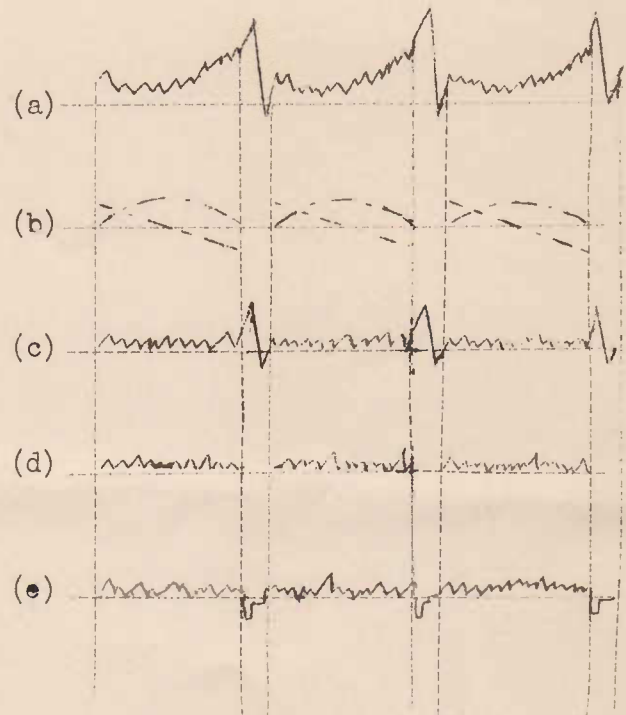

FIGURE 12.

(Fig.12). These are shown as sharp negative surges of voltage, and when separated from the rest of the signal in the receiver, are used to ensure that the latter's line scanning saw-tooth generator keeps in step with that at the transmitter. It might be mentioned here that additional voltage pulses are inserted at the end of each frame, for the purpose of synchronising the receiver frame scanning saw-tooth generator with that of the transmitter's electron camera.

THE IMAGE ICONOSCOPE AND SUPER-EMITRON TYPE CAMERA.

These are similar cameras, the one being a development of the American Iconoscope, and the other a development of the Emitron in England.

The operation of this type of tube combines that of the Farnsworth Image Dissector and the Iconoscope (or Emitron). The sensitivity is about 10 times that of the latter type tubes.

Referring to the diagram of Figure 13, a lens system focuses the light image on to a transparent photo-electric cathode Pc. This emits electrons, proportional to the light intensity at any point, from its rear surface, thus forming an electron image as explained in connection with the image dissector.

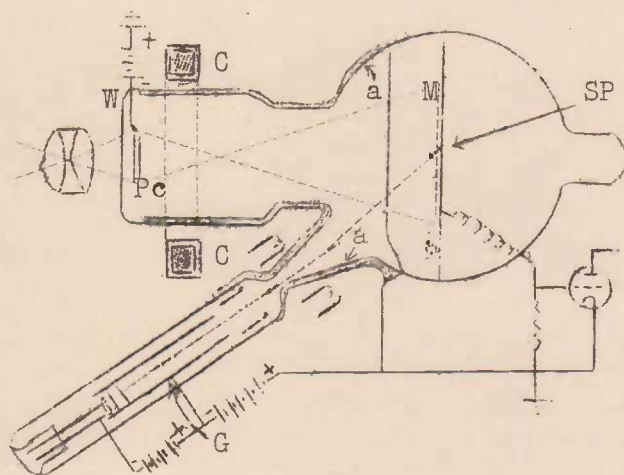

FIGURE 13.

THE IMAGE ICONOSCOPE.

These emitted electrons are accelerated up the tube by an anode, taking the form of a conducting coating on the inside surface of the tube, and maintained at a high positive potential (500V) with respect to the photo-cathode. The iron-clad magnetic coil C. produces a magnetic field within the tube, and this focuses the electron streams, thus projecting the electron image on to the "mosaic" or screen M. This is not photo-sensitive, and is not really a mosaic at all, but simply a sheet of insulating mica backed by a metal signal plate.

When the photo-electrons from Pc impinge on the mosaic at high velocity they release a larger number (about 5 times as large) of secondary electrons. These latter are drawn away to the anode, which is extended around the walls of the bulb. Thus the mosaic's surface is positively charged, in a pattern similar to that of the original light image. Note that the charge distribution on the mosaic surface cannot "spread" and wipe out the "charge image" because the surface is a good insulator.

The tube has an extension containing an electron-gun and deflector coils, which produces an electron beam, just as in the iconoscope, which scans the mosaic. The action from now on is similar to the earlier type tubes. The electrons in the beam progressively discharge the various sections or elements of the mosaic, thus causing current impulses in the circuit connected to the signal plate (SP).

The gain in sensitivity over the older type tubes is due to two factors. Firstly a powerful field is available (500V) to draw all of the electrons emitted by photo-electric action away from the cathode. Secondly an electron multiplier effect occurs at the mosaic screen. A single photo electron from the cathode impinging upon this screen causes that particular point to loose, say 5, secondary electrons - a net loss of 4 electrons. Remembering that a loss of electrons means a positive charge it will be seen that the charge distribution on the screen, corresponding to the image, will be much stronger than in the case of the Iconoscope or Emitron.

An additional advantage gained by this type of tube is that the photo-cathode, upon which the light image is focused is quite close to the end of the tube, where a

ground glass window (W) Fig. 13 is provided. This allows lenses of short focal length to be used. Thus it has been found possible to adopt miniature camera technique, using the high quality lenses specially developed for small cameras. The tube is also particularly suitable for outdoor telephoto work because of its high sensitivity, and also because of the fact that high quality telephoto lens can be obtained to suit it.

The Image Iconoscope (and Super Emitron) also produce spurious "tilt" and "bend" signals described earlier, these being due, as in the case of the Iconoscope, to secondary emission caused by the scanning beam. The student should take care not to confuse this secondary emission with that caused by the "electron image" electrons falling on the mosaic. The latter is advantageous, since, as explained, it results in an increase in sensitivity, due to the electron multiplication effect.

THE ORTHICONOSCOPE.

Details of the Orthiconoscope (Orthicon for short) were released early in 1939. The tube, unlike the Iconoscope, has a "storage efficiency" of 100%, i.e. full advantage is taken of storing the effect of the light by building up the charge on the mosaic during the whole scanning period. Furthermore, since no secondary emission occurs in the new tube it produces no spurious signals. The sensitivity is from 10 to 20 times as great as the Iconoscope.

A schematic diagram of an orthicon is shown in Figure 14.

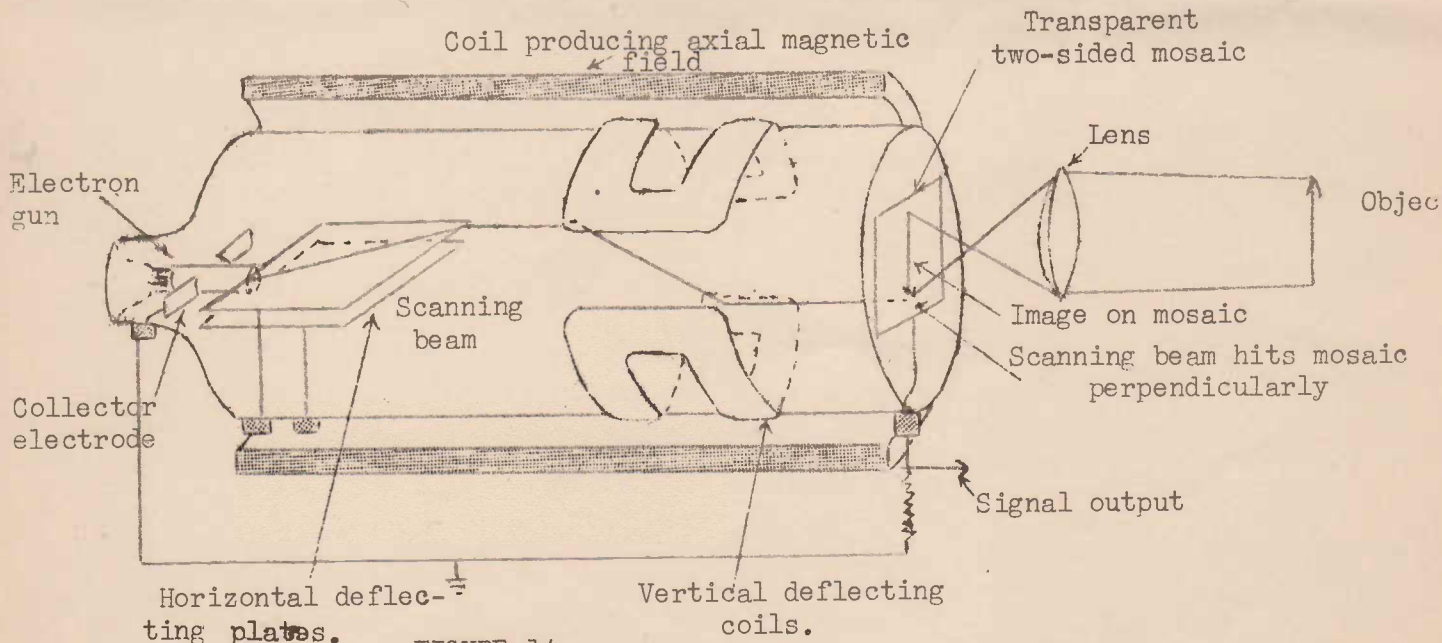

FIGURE 14.
DIAGRAM OF ORTHICON.

The secret of the success of this tube is that secondary emission at the mosaic is avoided by using an electron scanning beam which strikes the former at very low velocity. This low velocity beam is achieved thus:- an electron beam is produced,

in the usual manner, by the electron gun, shown at the left of Figure 14. In this gun the anode is at a high potential in respect to the cathode. Hence as the electrons leave the gun's aperture they have a fairly high velocity. After they leave the gun, however, and as they pass up the tube towards the target screen, or mosaic, the electrons are continually decelerated, or slowed down, to a low velocity. The reason for this is that the screen itself is at cathode potential; hence between the screen and the final anode of the gun there exists an electrostatic field which is continually acting against the electron stream.

This state of affairs is illustrated in Fig. 15. When the screen is at zero (or cathode) potential the electrons in the scanning beam will be stopped just in front of the screen. They will then turn back and will be finally collected, and removed by a special collector electrode shown as a flat rectangular plate near the electron gun (Fig. 14). Thus, when no light falls on the screen the latter collects no electrons

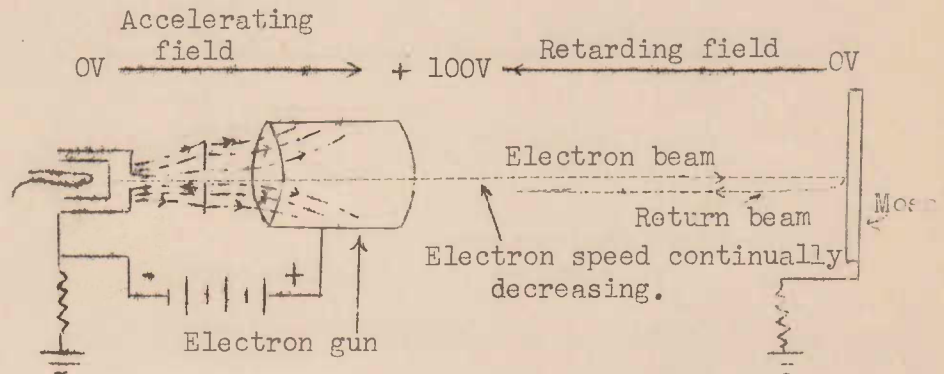

FIGURE 15.

The screen or mosaic itself is a transparent plate upon whose outer surface the light image is focused. The inner surface of the screen is photo-sensitive, and emits electrons proportionately to the light intensity at the various points on its surface. Hence, as in the iconoscope, an electric charge image is built up. Note that the charges on this surface are positive, since electrons have been lost from it by photo-emission.

The scanning beam is made to scan the screen line by line, frame by frame. When the beam encounters an area which is "black", i.e. no light, it is turned back as described above, and the screen collects no electrons. When an illuminated area is encountered, however, this area will be slightly positive, and electrons from the beam will be collected, sufficient to neutralise the charge. When this occurs a number of electrons will now move away from the signal plate to the external circuit. This current will represent the signal for that particular signal area. The greater the light intensity on any point, the greater will be the electric charge produced, and hence the greater the number of electrons collected from the beam, and the greater the signal current.

Since there is no secondary emission from the screen no spurious signals are produced, and no hindrance is encountered by the photo-electrons (due to the light) in leaving the surface. Furthermore a powerful field drawing off the emitted photo-electrons is available (about 100V) between the screen and the collecting electrode. (Remember that in the case of the iconoscope type tube this field was only several

volts, and insufficient to remove all the electrons released from the mosaic). These two factors account for the substantial increase in sensitivity.

In the development of this tube it was found that great difficulties were encountered in focusing a low velocity beam when the latter was being continually deflected for scanning purposes. The chief of these was that the beam became de-focused when deflected to any point not near the centre of the screen. Now in an ordinary cathode ray tube, as in the iconoscope etc, the beam is rarely if ever, striking the screen perpendicularly. It was found that if the beam could be made always to fall on the screen in a perpendicular manner, despite the fact that it was being continually deflected, then de-focusing occurred.

For these reasons a special method of beam deflection, for scanning purposes is employed. A coil wound around the whole length of the tube produces a magnetic field parallel to the tube itself. This coil focusses the beam, and guides all electrons in parallel paths perpendicular to the screen (see magnetic focusing, lesson 3). For horizontal or line deflection a pair of electrostatic plates are used. Note, however, that the beam is only deflected while between these plates;

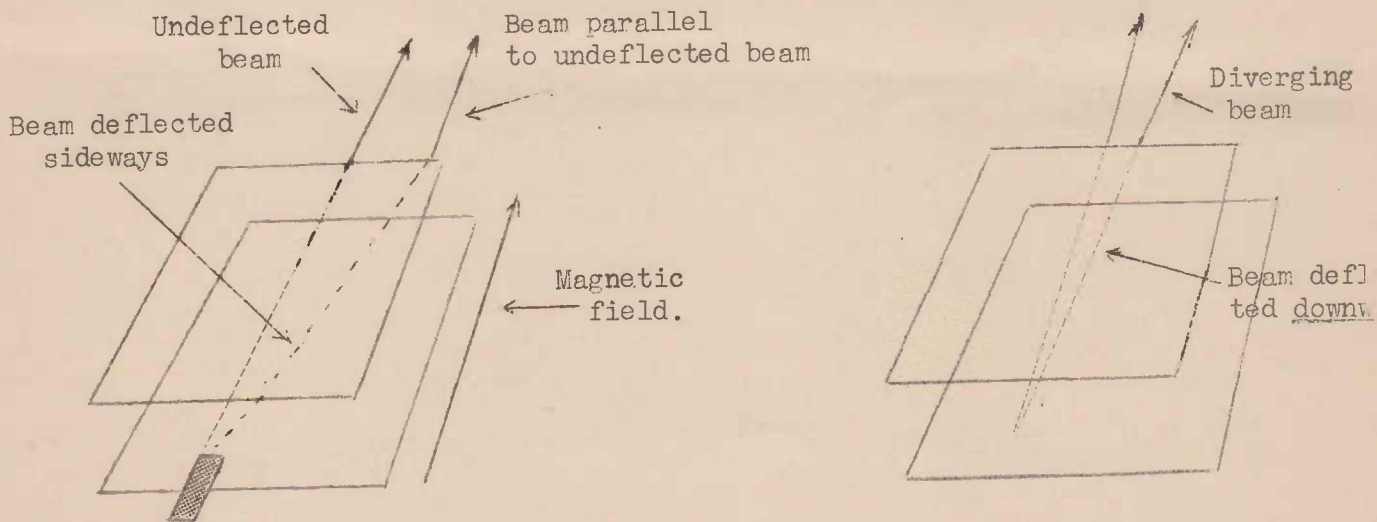

Electrostatic Deflection in Magnetic Field.

Ordinary Electrostatic Deflection

(a)

(b)

FIGURE 16.

after emerging from them the powerful magnetic field causes the electron beam to travel parallel to the tube again. The nature of this deflection is shown in Fig. 16(a). As a result of the powerful axial magnetic field combining with the electrostatic field of the plates a peculiar effect occurs. Instead of the beam being deflected in a direction perpendicular to the plates, it is deflected parallel to them. Figure 16(b) shows ordinary electrostatic deflection, for comparison purposes.

In this way the beam can be deflected right across the screen, and yet it always strikes it in a perpendicular manner.

The vertical deflection for frame scanning is brought about by a pair of magnetic coils which produce a vertical field across, or transverse to, the tube (Fig. 14). Here also the beam is deflected only while passing between these coils, and after emerging from them moves perpendicular to the screen, as shown in Fig. 14.

Here the deflection occurs in two fields acting at right angles to each other, and the deflection is found to be in a direction parallel to the lines of force of the deflecting field. (Remember that, normally, magnetic deflection is at right-angles to the magnetic deflecting field.)

THE IMAGE ORTHICON.

This is a very recent type of electron camera and is a development of the ordinary orthicon. The image orthicon separates the functions of converting a light image into an electrical image, and of scanning the image. Because of this division of functions each component can be designed for maximum performance, thus obtaining a high degree of sensitivity.

Figure 17 shows a somewhat simplified schematic diagram. The image is focused on to a transparent photo sensitive surface which emits electrons from its inner surface, thus forming an electron image as in the case of the Image Iconoscope and

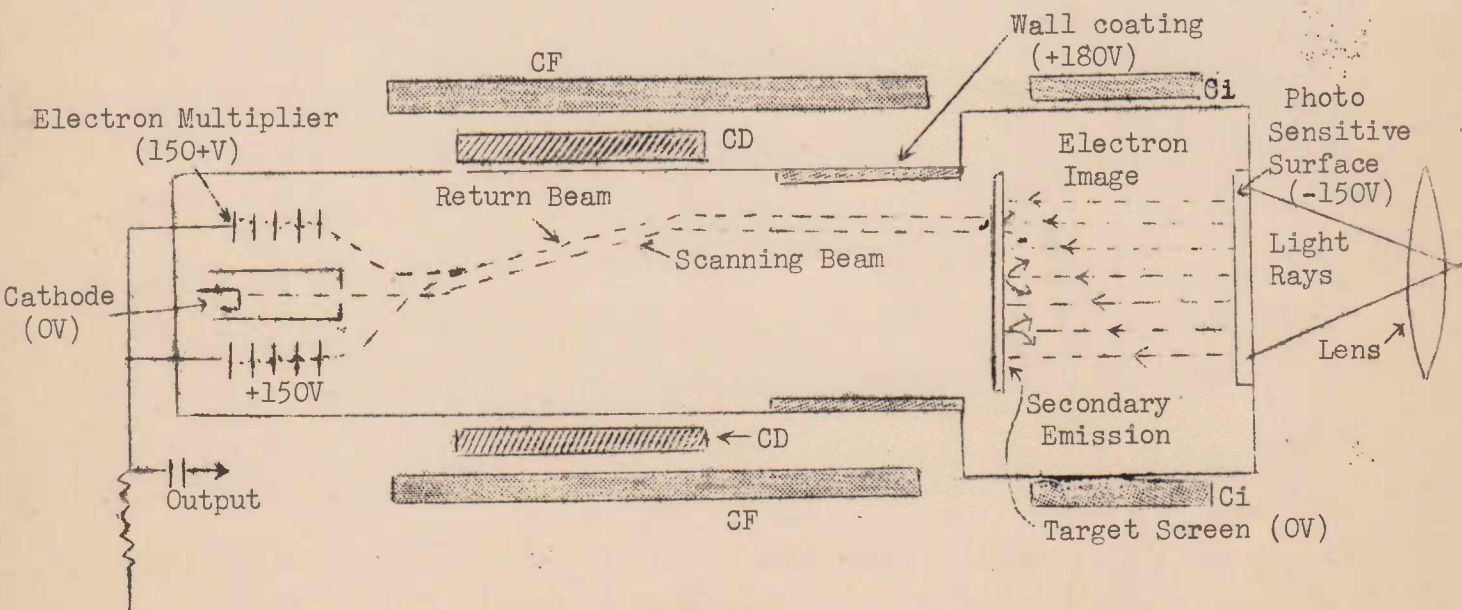

FIGURE 17.

Farnsworth Image Dissector. Referring to Figure 17, the photo-sensitive surface is at a potential of -150V, while a wall coating further up the tube is at - 180V. This provides a field which accelerates the emitted electrons towards the target

screen. The electron image is focused by means of a magnetic field due to coils Ci. The photo-electrons of the electron image impinge upon the target screen, and each one dislodges from the latter several electrons by secondary emission, thus leaving the surface with a positive charge. In this way the right-hand side of the screen is covered with positive charges forming an electric charge image as described in the case of the image iconoscope.

Now the target screen is a very thin semi-conductor, being a glass plate.001 inch³ thick. The conductivity of this plate is sufficient for the positive charges formed upon the right-hand surface to seep through in the time required to scan one picture (say 1/25th sec.), thus charging the left-hand surface with a similar charge (positive) distribution (or image). The conductivity over the surface, however, is not sufficient for the charges to spread appreciably in this time and wipe out the image.

The scanning beam is formed in the conventional manner. As in the ordinary orthicon coils CF provide a focusing magnetic field which extends over practically the whole path of the electrons. The result is as previously described, viz. the beam is only deflected while in the transverse (i.e. across the tube) field due to the deflector coils CD, and after leaving the latter travels perpendicularly to the target screen, thus avoiding de-focusing. Two sets of deflector coils - one set for horizontal line scanning are provided - although one set only is shown.

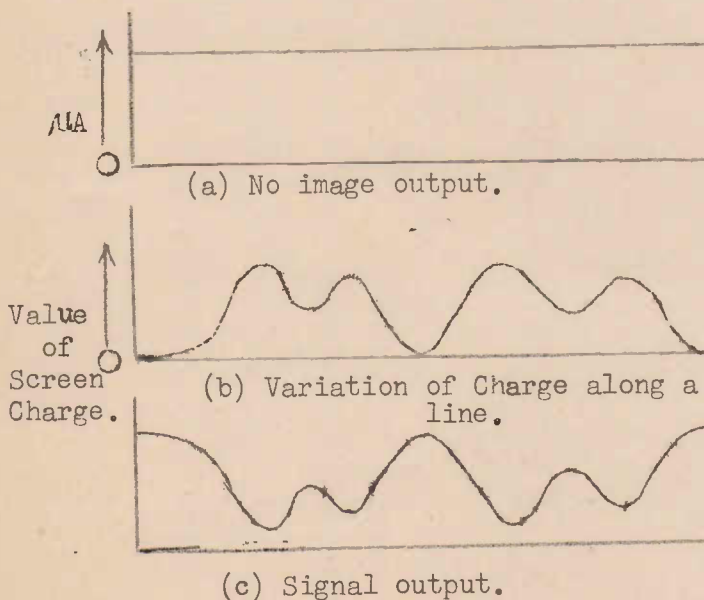

FIGURE 18.

in Fig. 18 is shown the charge variation along one scanning line. As the beam scans this line not all of the beam electrons will be reflected back from the screen, but the latter will collect sufficient to neutralise the positive charges on its

As in the case of the ordinary orthicon a low velocity beam is used, due to the fact that the target screen is at zero or cathode potential (when no image is received). As explained earlier, in this condition the beam will come to a halt just before the screen and then will turn back, almost exactly retracing its original path. Instead of returning to the anode of the electron gun, however, it will be attracted to the more positive plates of the electron multiplier. Thus, when no light image falls on the tube, the output current is a steady D.C. equal to the full value of the beam current, as at (a) Fig. 18.

When a light image is received electric charges are produced on the screen surface, the sizes of the charges varying with the light intensity at the various points. At (b)

surface. Hence the return beam current will equal the forward beam current less those electrons collected. The return beam current will therefore decrease in value when the screen positive charge image is intense, i.e. when the light from the scene is intense and vice versa. This return beam current is shown at (c) in Figure 18. It is this return current, collected by the electron multiplier near the gun, which forms the signal. Note that the electrical signal output is an inverted or negative one, unlike that of other tubes. The electron multiplier produces an amplification of the signal current of several hundreds of times.

The charge image on the target plate is built up for the whole time between successive scans, and since all photo-electrons are utilised 100% storage efficiency is obtained. The secondary emission effect from the target screen gives a further gain, as of course does the electron multiplier. Those facts, together with the one mentioned earlier, that each component can be separately designed for maximum efficiency results in an extremely sensitive camera. It is claimed that the sensitivity exceeds that of a 35 mm super XX cinema film -- which means that scenes may be televised with the most adverse conditions of lighting.

CA RA CONTROL APPARATUS.

Having reviewed the various types of electron cameras which have been developed to produce the picture signal, we shall conclude this lesson by a brief description of the circuits which are closely associated with the camera itself, and of the camera control apparatus.

Figure 19 shows a typical set-up.

The first stages of the amplifiers are built into the camera itself. Fig. 20 shows an Emitron Camera with four stages of amplification built in. The signal is then fed to the so-called "A" amplifier. It is into this stage that the "shading" signals, from the special generators shown, are fed to correct for the spurious "tilt" and "bond" signals. Of course with the later type cameras, such as the Image Iconoscope, Orthicon and Image Orthicon, these generators are not required, since no such undesired distortion occurs in the camera output.

A number of cameras, of which two are shown may be used. The different cameras may be focused on different parts of an outdoor event, such as a cricket match, and the operator can, at will, fade one picture into another by means of the fading control shown.

The "B" and "C" Amplifiers are video amplifiers, the former having a variable gain.

The "Suppression generator" provides voltage pulses, at line scanning frequency, and, these fed into the suppression mixer, block out the spurious signals formed between successive scanning lines.

The sync. generators provide the synchronising voltage pulses, which are fed into the signal, between successive scanning lines and successive scanning frames. These pulses partially fill the gaps left after suppressing the spurious signals eliminated in the previous stage.

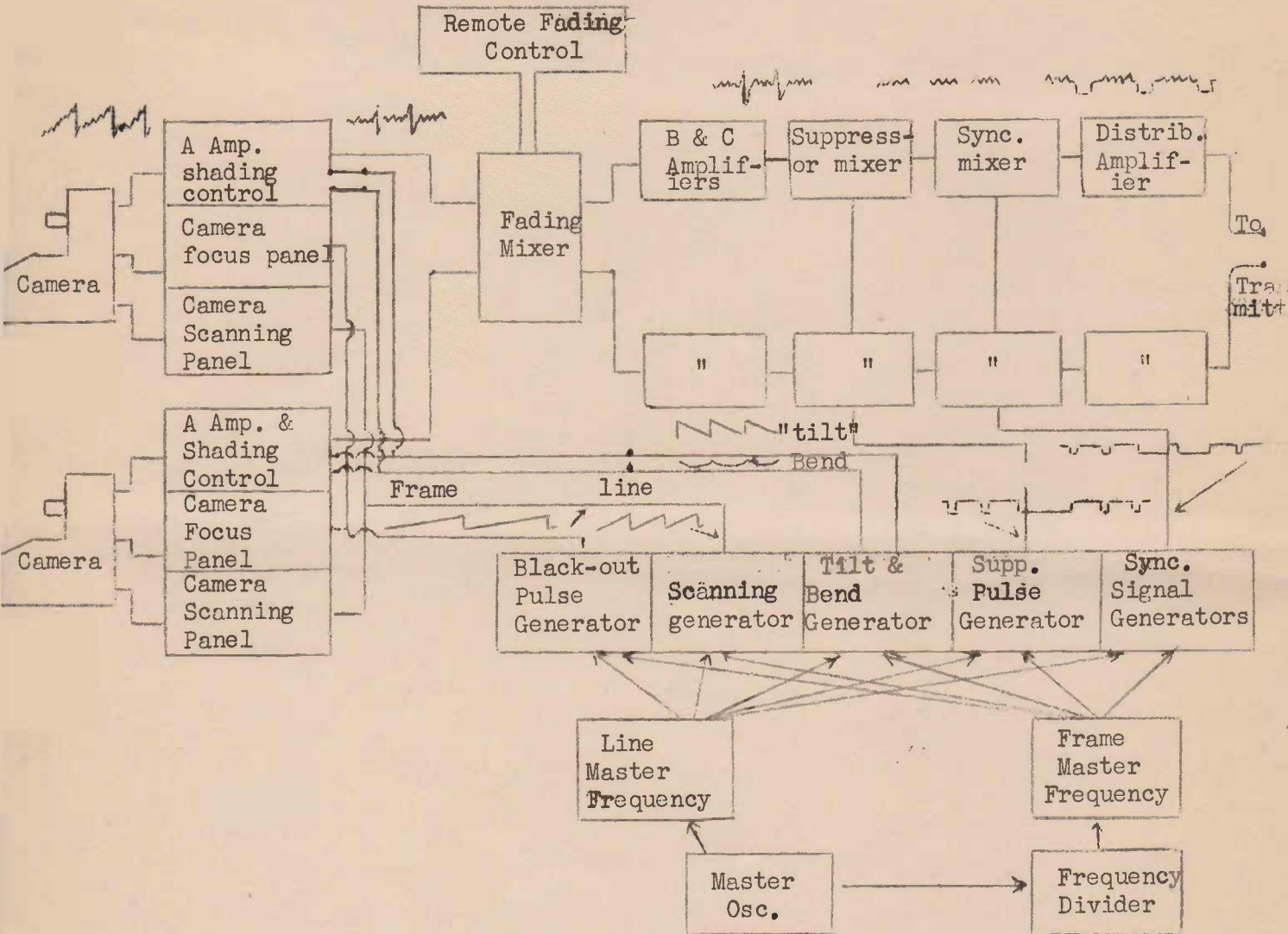

FIGURE 19.

The final signals are taken, by means of special lines, or links (described next lesson) to the transmitter and monitoring units.

The camera scanning generators provide the line and frame frequency saw-tooth voltages

(or currents) which deflect the camera beam for interlaced scanning purposes. Here the frame frequency is 50/sec, giving a picture frequency of 25/sec: (remember two frames per picture with interlaced scanning.) The line frequency is, with 405 lines equal to $405 \times 25 = 10,125/\text{sec}$.

All of the generators used are fed from a single master oscillator, in order to ensure correct synchronisation. This master oscillator is "locked" to the frequency of the power mains (50c/sec).

The signals in the various stages of the equipment are shown by their waveform graphs.

In the next lesson we will follow the passage of the video signals through the transmitter.

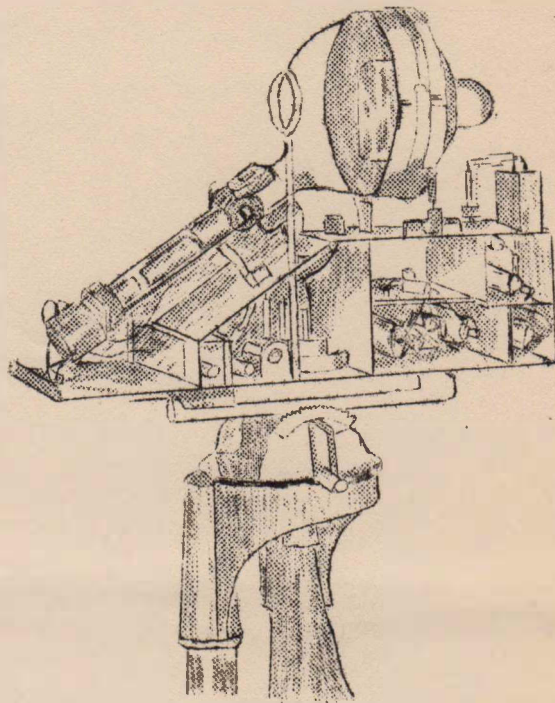

FIGURE 20.

T.FM & F. LESSON NO. 4.

EXAMINATION QUESTIONS.

- (1) Why are the current impulses from a photo-electric cell so very weak when used as a source of picture signal?
- (2) What is the chief advantage of the electron-multiplier as a pre-amplifier of the picture signal compared with an ordinary thermionic tube?
- (3) Upon what effect or phenomenon does the operation of the electron-multiplier depend.
- (4) Describe the nature of the mosaic in an iconoscope tube.
- (5) What is meant when it is said that the "storage" efficiency of the iconoscope is between 5 and 10%?
- (6) Explain the difference between the electron image and the charge in the Image Iconoscope or Super-Emitron type of tube.
- (7) What is meant by "spurious" signals in an electron camera's output? State briefly the chief cause of spurious signals.
- (8) What is the chief characteristic in the operation of the Orthicon tube? What was the idea behind the development of this design?
- (9) State three reasons for the great sensitivity of the Image Orthicon tube.
- (10) How does the signal output of the Image Orthicon differ in nature from the outputs of all other tubes discussed in this lesson?

AUSTRALIAN RADIO COLLEGE

E. S. & A. BANK BUILDINGS, Corner CITY RD. and BROADWAY, SYDNEY

Telephones: M 6391 and M 6392. Post Lessons to Box 43, Broadway

This lesson sheet is published for the exclusive use of
students of the Australian Radio College Pty. Ltd.
(All rights reserved)



T.F.M. & F. LESSON NO. 5.

VIDEO AMPLIFICATION

We are all familiar with the term "Audio Signal" or "Audio Frequency Signal" used in connection with radio telephony. This Audio signal (Latin-Audio = I hear) cannot, of course be heard directly. It is in the form of an alternating voltage or current, which, however, has the required frequency and wave form necessary to reproduce the desired sound when passed through the appropriate reproducing device, viz: the loudspeaker.

In the case of the vision side of television transmission, it is the "video" signal (Latin - Video = I see) which corresponds to, or is analogous to, the audio signal of sound transmission. This video signal is not itself visible, being also a varying electric current or voltage whose frequency and wave form are such that when passed into the television receiver reproducer, the cathode ray tube, it re-creates a visible picture or scene.

If we consider carefully a complete sound transmission and reception system we will realise that the audio signal is not to be found throughout the whole of the circuits. Referring to Figure (1) (a) the signal voltages are generated by the microphone, and persists throughout the amplifying circuits to the modulated amp. These are the audio amplifying stages of the transmitter. Once passed into the mod. amp. the audio signal, as such disappears. From this stage onwards, the signal is of radio frequency, although, of course, it is "modulated" in such a way that the audio signal may be caused to reappear again in the receiver. This re-appearance takes place in, or after, the detector. From the latter stage the audio signal persists right through the audio amplifier stage to the speaker.

In a similar manner, the video signal is generated by one or another of the electron cameras described in the last lesson and is passed through the various transmitter stages to the modulator, where it "modulates" a much higher (radio) frequency signal.

The video signal reappears again after the detector in the receiver. It then persists through the final stages until the cathode ray tube is reached (see (b), Fig. 1)

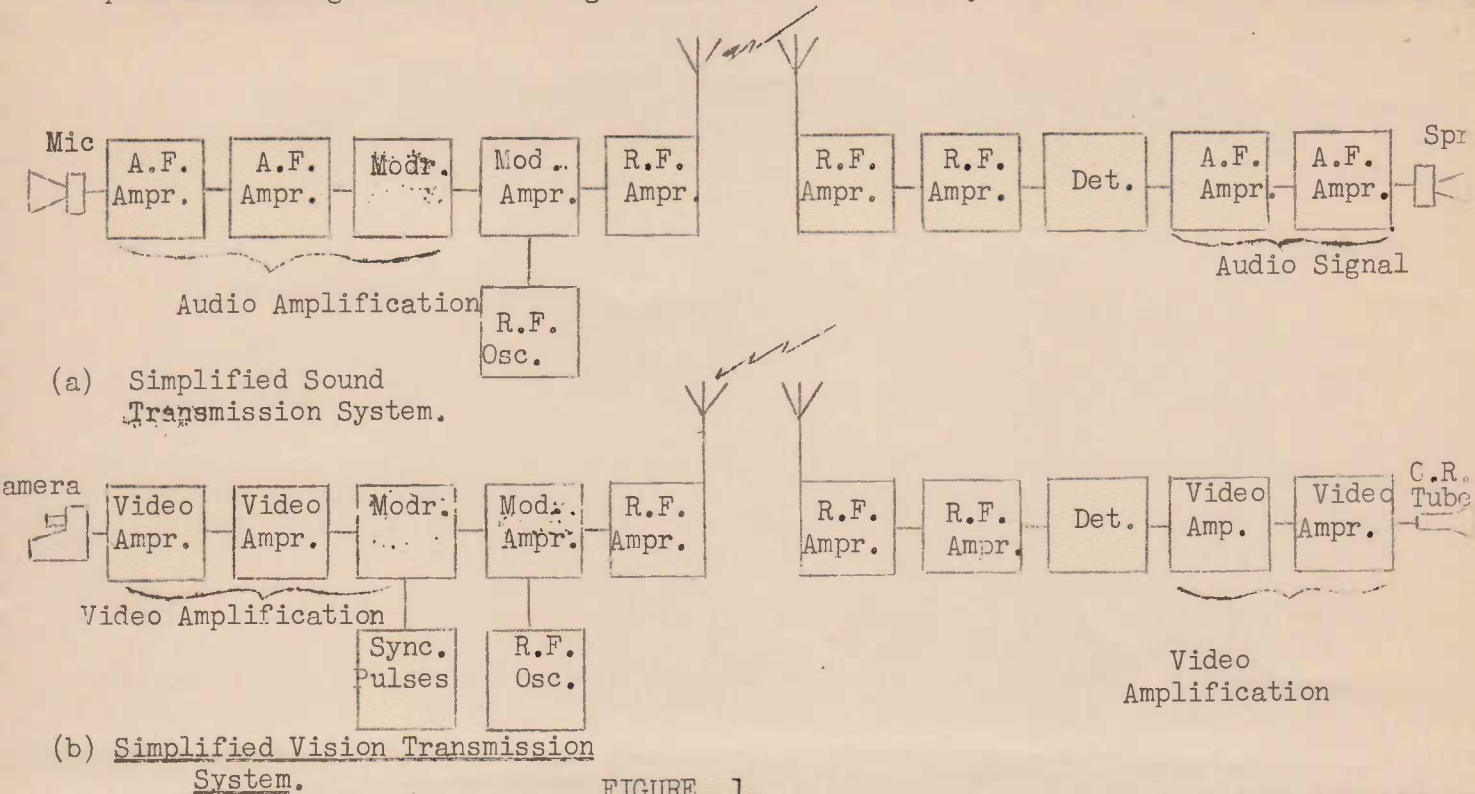

FIGURE 1.

This lesson, then, will deal with the problems associated with those stages between the electron camera and the modulator in the transmitter, and, in the case of the receiver, the stages existing between the detector and the cathode ray reproducing tube. The modulated radio-frequency signal, which cannot be used directly to reproduce the scene, we shall henceforth refer to as the "television" signal. The transmitter and receiver stages which handle the latter will be dealt with in subsequent lessons.

THE NATURE OF THE VIDEO SIGNAL.

The video signal consists of a series of current or voltage changes, as shown in Figure 2. Each change in current or voltage corresponds to a change in light intensity reflected from the scene as the latter is scanned. The changes are shown as occurring in groups, each group separated from the next by a short gap or time interval. Each group corresponds to the signal generated in one scanning line. The gaps represent the short intervals taken by the scanning spot to return from the right hand side of the picture to the left. Figure 2 shows the signal for three complete lines.

The frequency of the video signal varies over a very wide range indeed, and upon the ability of the video amplifiers to handle this range of frequencies will depend the quality of the reproduced signal.

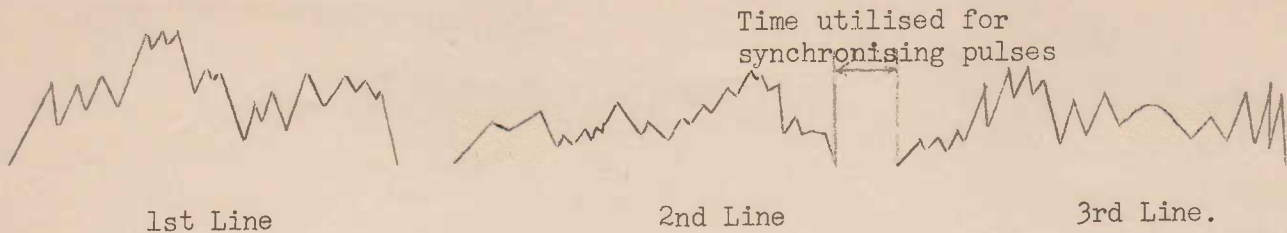

FIGURE 2.
VIDEO SIGNAL FOR 3 LINES.

THE FREQUENCY OF THE VIDEO SIGNAL.

We shall first discuss the upper frequency limit of the video signal. This will depend primarily upon the amount of picture detail which the electron camera can handle. In Lesson 2 it was explained how the performance of a scanning system could be measured in terms of a number of "picture elements". This section should be re-read if necessary. It was pointed out that the number of those elements, and therefore the picture detail which could be reproduced depended mainly, but not entirely, on the number of scanning lines used. This also determines the number of changes in the signal current occurring in one second. The formula given for the number of picture elements per second was:-

$$\text{Number of Picture Elements per sec.} = (\text{No. of Lines})^2 \times \text{Picture Frequency} \\ \times \text{Aspect Ratio} \times \frac{7}{10}$$

This formula, however, does not give the frequency, measured in cycles/sec., of the camera output current. The reason why this is so may be understood by referring to Figure 3.

Here we suppose the scanning beam is scanning a line consisting of a number of alternate black and white squares, each square element being equal to the size of the spot. This will represent a pattern giving the greatest amount of picture detail, since, as we have already seen, (Lesson 2), picture elements which are smaller than the scanning spot cannot be reproduced as separate details.

As the leading edge of the scanning beam passes from the beginning of the line onto the first black spot the reflected illumination from the spot will be gradually decreasing. The video current will therefore decrease from some maximum value to a minimum (from (a) to (b)).

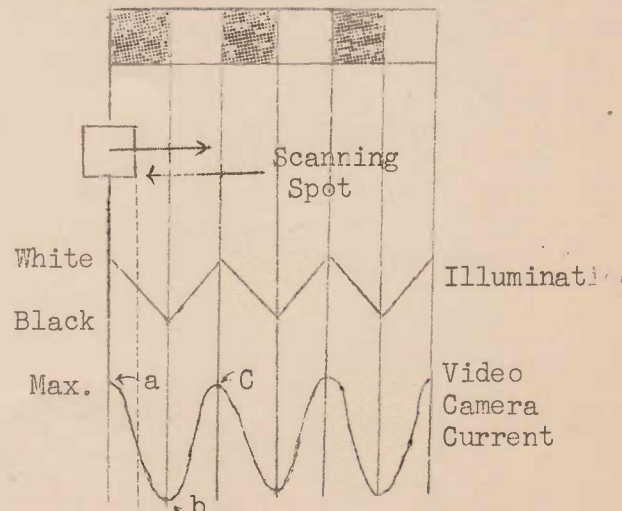

FIGURE 3.
SHOWING HOW THE SCANNING BEAM GIVES
RISE TO A FREQUENCY OF HALF THE NUM-
BER OF PICTURE ELEMENTS.

The word "illumination" here refers to the coverage of the scene by the scanning beam and may be the illumination by light through holes in the scanning disc, in the older disc system, or the "illumination" by electrons of the mosaic or target screen in the modern electron cameras.

Then as the leading edge of the spot moves off the black onto the next white square the current will rise. When the white square is completely covered the current will have attained its maximum value again at (c). Note carefully two facts: (1) the scanning beam has travelled a distance equal to two picture squares or elements, (2) the video current changes represent one cycle only. When the beam has moved a distance equal to the length of the scanning line, and is lying over the last white square, six picture elements will have been covered. In this time however, the video current has performed three complete cycles only.

From the above considerations it follows that the frequency of the video current, measured in cycles/sec., will be one-half of the number of picture elements scanned in one second. This fact enables us to alter the formula repeated above to give this frequency instead of the number of picture elements per second, thus:

$$\text{Frequency of Video Signal} = \frac{(\text{No. of Lines})^2 \times \text{Picture Freq.} \times \text{Aspect Ratio} \times \frac{7}{10}}{2}$$

The frequency of the signal, using the above formula, will be in cycles/second.

Notice that we have divided the right hand side of the equation by two. Remember that the factor $\frac{7}{10}$ was a figure arrived at by theoretical considerations, and practical experiments, to account for the fact that some picture elements are not reproduced even though they be no smaller than the scanning spot (see Lesson 2).

The formula still requires a certain amount of modification, on account of the fact that the original result for the number of picture elements was based on the assumption that no time was lost between successive scanning lines, i.e. that each new line was commenced immediately after the end of the previous one. In actual fact, however, a time interval of 15% of the total time for the line trace occurs between successive lines. This short interval occurs as the scanning beam is returning rapidly from the right hand side to the left hand side of the screen, and is utilised for carrying the line synchronisation pulses (see Figure 2). This means that the actual scanning of each line must be done in 85% of the time available in the ideal case. In other words the scanning speed, and therefore the rate of repetition of picture elements (and cycles in the video current) will be increased by $\frac{100}{85}$ times. Hence the corrected formula for video frequency is:-

$$\begin{aligned} \text{Video Frequency} &= \frac{(\text{No. of lines})^2 \times \text{Picture Freq.} \times \text{Aspect Ratio} \times \frac{7}{10} \times \frac{100}{85}}{2} \\ &= \frac{(\text{No. of lines})^2 \times \text{Picture Freq.} \times \text{Aspect Ratio} \times \frac{7}{17} \text{ C/Sec.}}{2} \end{aligned}$$

Taking an actual case, consider scanning of 525 lines, 30 picture per second,

aspect ratio being $\frac{4}{3}$.

$$\text{Video Frequency} = (525)^2 \times 30 \times \frac{4}{3} \times \frac{7}{17} = 4,500,000 \text{ C/sec. (approx.)}$$

i.e. a frequency of 4.5 megacycles/sec.

This figure represents approximately the highest video frequency dealt with in the standard equipment for black and white reproduction at present in use in America.

In England, at present, where a total of 405 lines are used, with a picture frequency of 25/sec, and an aspect ratio of $\frac{5}{4}$, the highest video frequency is about 2.1 megacycles per second.

It should be remembered that these results obtained from the formula represent the maximum video frequency which we will obtain in scanning the picture, no matter how much detail the picture might contain. It is a frequency which allows a horizontal resolution or definition equal to the vertical resolution or definition. It represents the most severe requirements.

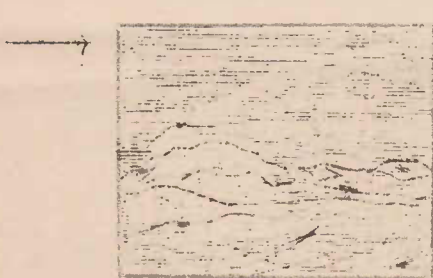
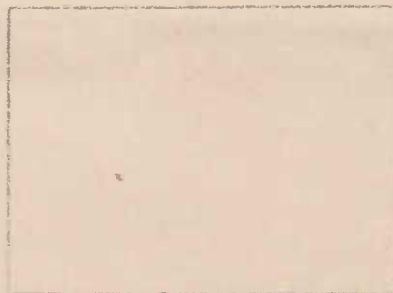

FIGURE 4.

Horizontal or
Line Scanning →



Vertical or
Frame
Scanning ↓

FIGURE 5.

If we were to transmit a simple picture having no fine detail and no sharp outlines from black to white or vice versa, we would not come anywhere near this maximum or "limiting" frequency. The changes in current brought about by the changes in light while scanning across the picture would be comparatively gradual, and gradual changes of current are equivalent to a low frequency. A picture of this kind is shown in Figure 4.

Scanning across the line indicated by the arrow we find only comparatively few changes from light to dark and from dark to light, and these changes are comparatively gradual. This means a low video frequency. If there were any sharp outlines or fine detail in the picture the light changes and current changes would be more rapid, and would be equivalent to a much higher frequency. We could say that in the average type of picture the frequencies produced would be very much less than the maximum obtained from the formula above.

The video frequency obtained from the formula may be taken as the highest possible one we shall have to handle. What, then, is the lowest frequency? If the

picture consisted of no changes in light and shade at all, for example a white wall (having no fly marks on it) as in Figure 5, it might be thought that the video frequency from the camera would be zero. This is not the case however. Every time the scanning beam comes on to the picture area the camera produces a sudden rise in current, and every time it leaves the area a corresponding fall. This represents one cycle (one rise and one fall) in output current, and occurs at the line frequency, say 10,125 cycles per second for 405 lines, 25 pictures per second. This is, of course, by no means a very low video signal. But in addition to the line scanning we have the vortical frame scanning, see Figure 5. When the beam passes on to the frame at the top of the picture a sudden rise in camera current occurs, with a sudden drop when the beam leaves the frame $\frac{1}{50}$ sec. later (with interlaced scanning). Hence the camera output will contain a frequency of 50 cycles/sec.

Now it is important that the video amplifiers be able to handle a frequency as low as 50 cycles/second. In practice they are designed even better than this, to amplify without loss of gain or distortion, frequencies down to 25 cycles/sec. which is the picture frequency. The necessity for this low frequency will be seen if a picture containing a gradual increase (or decrease) in shading from top to bottom is considered. To reproduce a complete picture containing this gradual shading (as well as the super-imposed detail) it will be necessary for the amplifiers to handle effectively a frequency equal to the rate of repetition of the pictures, viz: 25 per second.

Our video frequency, then, will range from 25 cycles/sec. to between 2 and 4 megacycles/sec. Compare this with the usual range of audio frequencies, from about 100 cycles/sec to, say, 7,500 cycles/sec. at the most. It is immediately obvious that a video amplifier must be much more carefully designed than its counterpart - the audio amplifier.

REQUIREMENTS OF A VIDEO AMPLIFIER.

The video amplifying stages of a television transmitter or receiver must satisfy the following conditions:-

- (a) Amplify equally well all signals whose frequencies extend over the video range. In other words there must be no variation in gain with frequency.
- (b) Produce no phase distortion in the signal. Phase distortion means the introduction of a time delay in the signal passing through the amplifier, whereby different frequencies are delayed for varying amounts of time.

The idea of "phase" and the meaning of phase shift and phase distortion will be discussed a little later in the lesson.

WHAT TYPE OF AMPLIFIER?

It will be recalled that several methods of inter-stage coupling are used in audio amplification work. These are:- (a) Choke Capacity (Impedance) Coupling, (b) Transformer coupling and (c) Resistance capacity coupling.

Of these, the first two are right out of the question. Choke coupling, for example, will not give a "flat" response over an extended range of frequencies. The reason for this is that, as the frequency rises the reactance of the choke increases, yielding an increased amplifier gain, until some particular frequency is reached when the gain rapidly falls off. The latter effect is due to stray capacities, between the windings and in the valves, "shunting" the inductance of the choke. A somewhat similar result is obtained when using transformer coupling. Figure 6 shows a typical amplification curve (gain plotted against frequency) for a transformer coupled amplifier. Using triode tubes, a fairly flat curve may be obtained over a limited range for audio work. In the graph shown the useful part of the range is from about 200 cycles/second to about 2 or 3 thousand cycles/sec. Note that the gain has fallen to a very low value at about 11,000 c/sec.

Remembering that we require equal amplification for all frequencies over a range from 25 cycles/sec up to about 500,000 cycles/sec. it will be realised just how far short of our requirements this type of amplifier coupling falls.

For wide-range amplification we must depend on the resistance-capacity coupled amplifier. The merit of this type of amplifier lies in the fact that the value, measured in ohms, of a pure resistance does not vary with frequency.

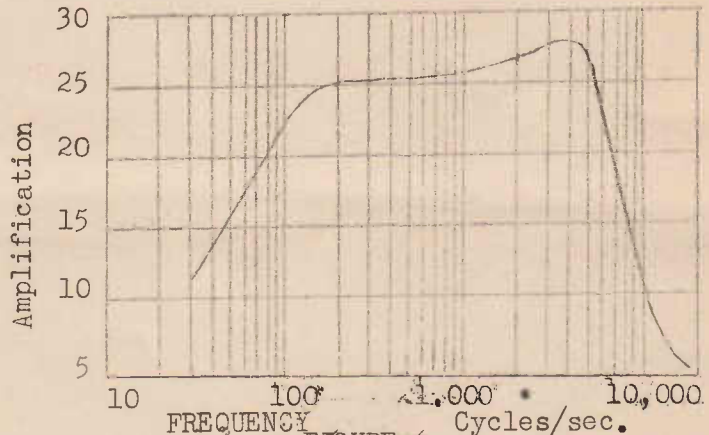

FIGURE 6.

CHARACTERISTICS OF RESISTANCE-CAPACITY COUPLED AMPLIFIERS.

The essentials of a voltage amplifier, with the necessary resistor and capacity for developing the signal voltage, and passing the latter on to the next stage is shown in Figure 7.

The load resistor R_L in the plate circuit develops, or builds up, the A.C. signal voltage, and the coupling condenser C_c passes the latter to the grid of the next tube. The greater the value of R_L , the larger will be the output voltage from the stage, that is the greater the gain.

The voltage gain (G) from such a stage is usually calculated from formula (1) below, when a triode tube is used.

$$G = \frac{\text{Amplification Factor} \times \text{Load Resistance}}{\text{Plate Resistance} + \text{Load Resistance}} \quad (1)$$

When a pentode valve is used a more useful formula is:-

$$G = \text{Mutual Conductance} \times \text{Load Resistance} \quad (2).$$

In both of these formulae there is no factor which appears to vary with the frequency of the signal. It would seem therefore that such an amplifier would amplify signals of all frequencies equally well; and, in point of fact, the resistance-capacity amplifier does have a very flat amplification curve over a much greater frequency range than can be handled by stages using other coupling arrangements. A "frequency response"

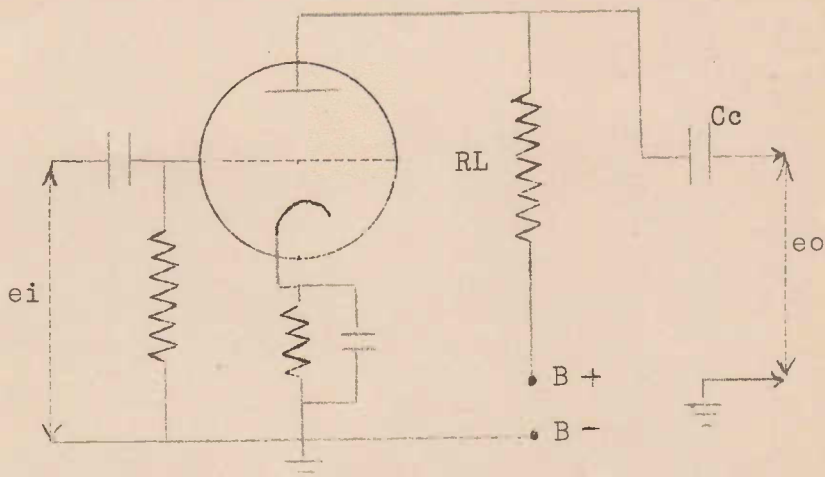

FIGURE 7.

curve (i.e. graph showing variation of gain, or amplification, with frequency) is shown, for a typical audio resistance-capacity coupled amplifier, in Figure 8.

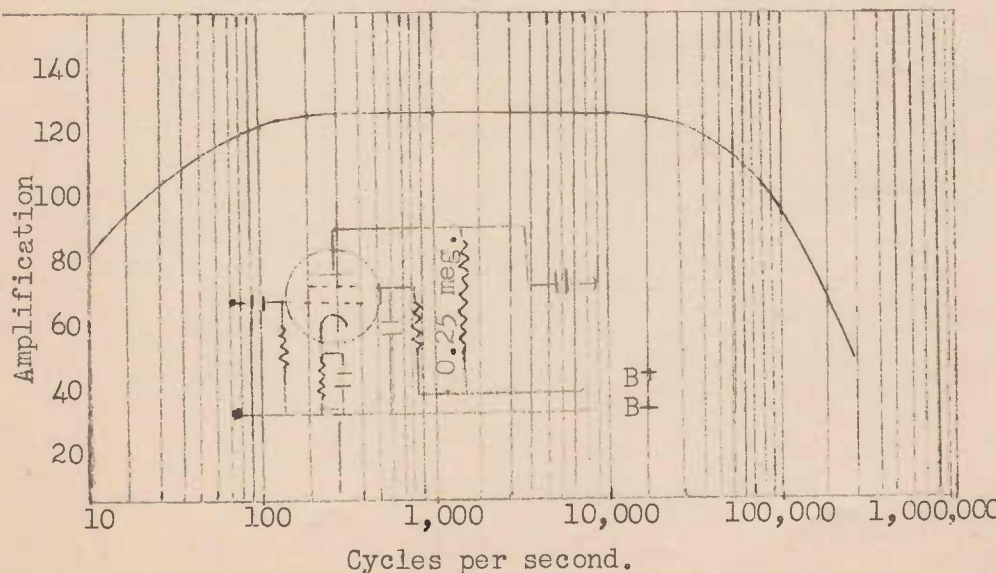

FIGURE 8.

This curve should be compared with that given for a transformer coupled amplifier in Figure 6. Note that the "response" over the middle range of frequencies is much flatter, and that the gain is maintained to a much higher frequency, compared with the former case. The curve of Figure 8 is drawn for a typical audio voltage amplifier -- a 6 J 7 operating with a .25 meg. plate load resistor. Note that the response is "flat"

over a range of frequencies from about 200 cycles/sec up to 30,000 cycles/sec. At

100,000 cycles (100 Kc/sec.) the gain has dropped off to about .7 of its normal value, and thereafter there is a rapid deterioration. Similarly at the low frequency end of the curve there is a serious loss of gain below 50 cycles/sec. The high frequency response of this amplifier is more than adequate for audio-amplification work, but hopelessly inadequate for video amplification, where the response must be flat up to at least 2.5 megacycles/second.

We have seen then that even a resistance-capacity coupled amplifier suffers from a loss of gain at both high and low frequencies. What are the reasons for these losses? We shall consider each case separately.

THE HIGH FREQUENCY RESPONSE.

The formulae (1) and (2) given above are accurate for the middle frequencies where the only factor which appreciably affects the gain, apart from the characteristics of the tube itself, is the load resistance in the plate circuit. At high frequencies, however, the load resistor is seriously "shunted" by the reactance of "stray" capacities, with the result that the total impedance in the plate circuit may be very much less than the actual value of the resistor itself. When this occurs, we should replace the term "load resistor" in the formulae for gain (1) and (2) given above by "Total impedance in plate circuit", and then a lower result for the gain will be calculated.

This effect of stray capacities shunting the load resistor is illustrated in Figure 9, where the latter is represented by R_L . The "stray" capacities whose total effect is represented by C_T arise from several different causes discussed below. Notice that C_T is in parallel with R_L , and remember that the total effect of two impedances in parallel is always less than either impedance alone. The value of the stray capacities, may be anything up to 100 micro-micro-farads (100 mmfd), 50 mmfd being quite a representative value. Now this, measured by ordinary standards, is a very small capacity and its effect in shunting R_L at low and medium frequencies is entirely negligible. To explain this point remember that the reactance, measured in ohms, of a capacity is given by

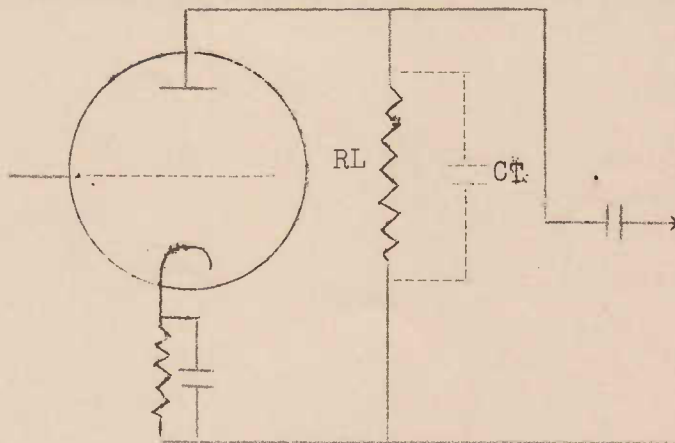

FIGURE 9.

entirely negligible. To explain this point remember that the reactance, measured in ohms, of a capacity is given by

$$\text{Reactance in ohms} = \frac{1}{2 \pi f c} \text{ ohms.}$$

Where $\pi = 3.14$ (approx.), f is frequency in cycles/sec., and C is capacity in farads.

Now, since C_T (stray capacities) is small this reactance will be very large (much

larger than R_L) at low and medium values of frequency (f). Hence, in this case, the shunting effect of C_T on R_L will be negligible, and no loss of gain will be suffered. As the frequency of the signal increases, however, the reactance of C_T becomes smaller and smaller. When this reactance is reduced to a value not very much larger than R_L , the shunting effect becomes noticeable, and the gain begins to fall off, as shown by the curve of Figure 8.

The gain for a pentode tube at any high frequency will be given by:-

$$G = (\text{Mutual Conductance}) \times (\text{Total Impedance in Plate Circuit}) \quad (3)$$

Where Total Impedance in plate circuit = impedance of R_L and reactance of C_T in parallel.

As the frequency increases further, the reactance of C_T is further reduced, and hence plate load impedance becomes smaller. At very high frequencies the reactance of C_T may be only a small fraction of R_L , and the gain as calculated from formula (3) may be reduced to a value less than one. This, of course represents a loss in signal amplitude instead of a gain. An interesting and important case is the one when the frequency is such that the reactance of C_T exactly equals the resistance of the plate load resistor. When these conditions obtain the total plate load impedance works out at $.707 (1/\sqrt{2})$ of the value of the resistor alone. With a pentode this reduces the gain to $.707$ of its normal value. (Note: in the case of two equal resistances in parallel, the effective value of the combination is one-half of each branch. With a resistance and capacity in parallel, however, the calculation is not so simple, and the effective value works out as stated at $.707$ of each equal branch. See Figure 10).

In Figure 8. the gain at 100 Kc/sec. is about $.707$ of that at middle frequencies, this representing the frequency where the reactance of the stray shunting capacities equals the load resistance. As the frequency is increased still

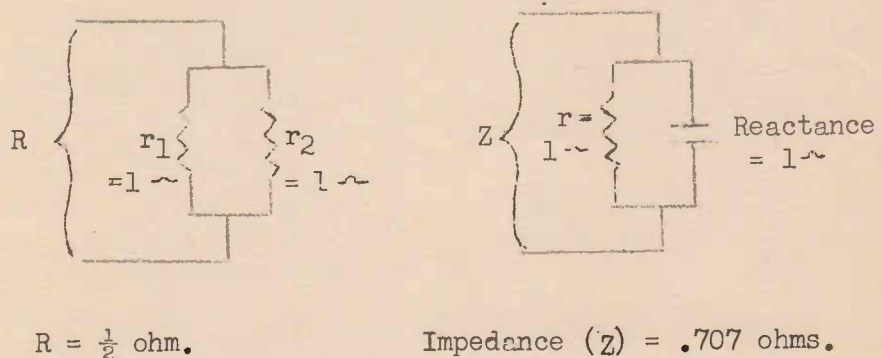

FIGURE 10.

further this reactance falls below the value of R_L , and the response curve is seen to fall off very rapidly.

The stray capacities, which cause the loss of gain at high frequencies, consist of:-

(a) Wiring capacities to ground, i.e. capacity effects existing between the plate lead of the tube and ground, plus similar capacities between the grid lead

of the next tube and ground. These are represented by C_w in Figure 11.

(b) The output capacity (C_o) of the tube itself, i.e. the capacity measured between the plate of the tube and cathode.

(c) The input capacity (C_i) of the following tube, i.e. the effective capacity between grid and cathode of this tube.

All of these capacities are in parallel with each other, and also in parallel with the load resistor R_L . The total stray capacity (C_t) is therefore the sum of C_w , C_o and C_i and in Figure 9 has been represented by the "lumped" capacity C_t in parallel with R_L .

In addition to distributed capacity one must also consider the effect of the plate load resistor of V_1 and the grid leak resistor of V_2 . The frequency-

voltage characteristic of a resistance capacity coupled amplifier is not determined by any of these factors alone but by a combination of all three.

At middle and high frequencies the ultimate load presented to the plate of the first valve, and thus the gain of the amplifier, will be equal to R_L and R_g (Fig.12) in parallel. At low frequencies we can no longer afford to neglect the reactance of the coupling condenser C (Fig. 12), which is in series with R_g . The grid of the valve is connected to the junction point of C and R_g , consequently as the reactance of C increases, at low frequencies, the voltage supplied to the grid of V_2 will be reduced.

At extremely high frequencies the gain of the amplifier is limited not merely by the resistive combination of R_L and R_g but by the impedance of the parallel combination of R_L , R_g and the circuits stray capacities.

The inter-electrode capacities of a triode tube are indicated in Figure 12, where C_{gk} is the capacity between grid and cathode, C_{gp} is that between grid and plate, and C_{pk} that between plate and cathode. The latter represents the "output" capacity shown in Figure 11.

The input capacity shown in Figure 11 is not simply the grid cathode capacity, as might be expected. The inter-electrode capacities referred to are characteristics of the tube itself, depending only upon the electrode sizes and spacings. The input capacity, which is measured under actual operating conditions between grid and cathode capacity, and varies with the stage gain. The reason for this is due to an important phenomenon, known as the "Miller Effect".

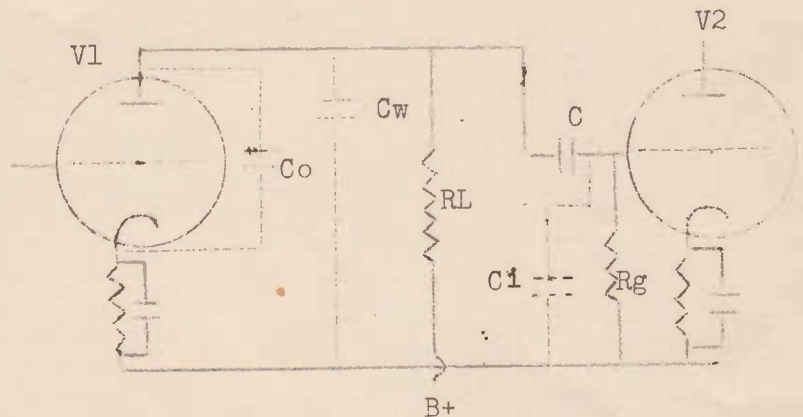

FIGURE 11.

THE MILLER EFFECT.

Consider first the input capacity of a tube when the tube is not operating, e.g. when there is no load resistor in the plate circuit as represented by the broken line short circuiting the plate load resistor in Figure 13a. If an alternating voltage is applied between grid and cathode as at (a) in Figure 12 an alternating current will flow between the input terminals, its value depending upon the total effective capacity between these terminals. One capacity which contributes to this current flow is the grid-cathode capacity (C_{gk}). But since a capacity exists

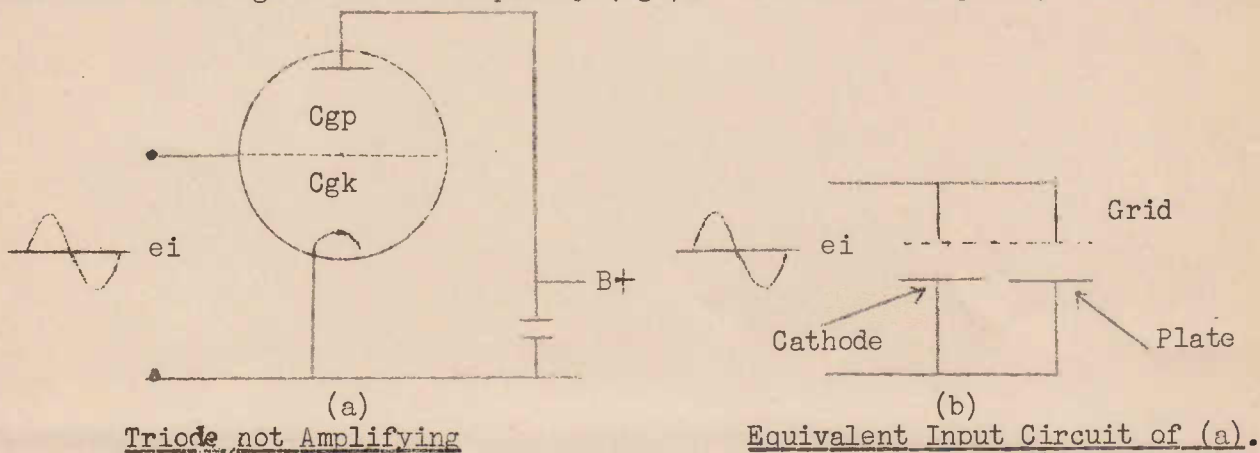

FIGURE 12.

between grid and plate (C_{gp}), and since the plate is connected back to the cathode by way of the $B+$ by-pass condenser (Figure 12 (a)), the input voltage will cause an additional A.C. flow via this plate circuit path. Now the total input alternating current is the sum of these two branch currents which pass through C_{gk} and C_{gp} respectively. In other words C_{gk} and C_{gp} must be regarded as in parallel with one another as far as the input signal voltage is concerned. Hence, in the case of zero amplification or gain, the total input capacity (C_i) is the sum of C_{gk} and C_{gp} , i.e. $C_i = C_{gk} + C_{gp}$.

Now suppose a load resistor is inserted in the plate circuit and the stage gain is, say, 20. (Fig. 13). Further, suppose that the input voltage has a peak value of 1V. This latter voltage is applied directly across C_{gk} , and an A.C. flows through this capacity and has a value depending upon the size of C_{gk} . In addition, there still exists, between the input terminals, the path via the grid-plate capacity. Now the A.C., due to input voltage, flowing through C_{gp} will be much greater than what it was in the non amplifying state, due to the fact that the A.C. voltage acting across C_{gp} is much greater than the 1V input voltage.

The reason is as follows: Since gain is 20 times, the A.C. voltage, measured between plate and cathode will be 20V. (peak). The peak value of the A.C. voltage between plate and grid will be the 1V (peak) between grid and cathode, plus the 20V (peak) between plate and cathode -- a total A.C. voltage of 21V (peak). These voltages are added because when, for example the grid voltage is at its negative peak of --1V, the plate A.C. voltage will have gone 20V positive (remember grid

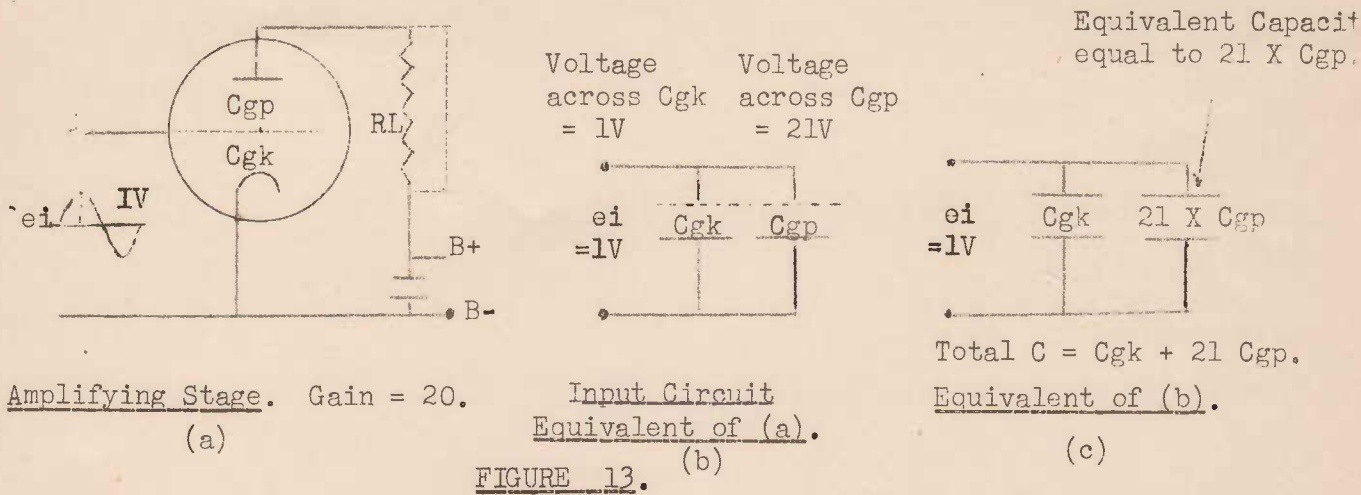

FIGURE 13.

and plate A.C. voltages out of phase). Hence, at this instant, the peak voltage between grid and plate will be 21V.

Now this 21V A.C. acts across C_{gp} (See (b) Fig. 13) an alternating current to flow through this capacity 21 times as great as was the case when no amplification was occurring (see Fig 13 (b)). As far as the input signal is concerned the net result is the same as though we connected a simple condenser, of capacity equal to C_{gk} , in parallel with another condenser whose value is 21 times as great as C_{gp} . This is shown at (c) in Figure 13.

The total input capacity is thus equal to grid-cathode capacity plus 21 times grid-plate capacity, i.e.

$$C_i = C_{gk} + 21 C_{gp}$$

or $C_i = C_{gk} + (20 + 1) C_{gp}$.

Now since 20 here represents the stage gain we may write:

$$C_i = C_{gk} + (G + 1) C_{gp}$$

As an illustration, take the case of the 6B6-G (75) tube, with $C_{gk} = 2.7$ m.m.f.d, $C_{gp} = 1.7$ mmfd and stage gain $(G) = 60$.

$$\begin{aligned}
 C_i &= 2.7 + (60 + 1) \times 1.3 \text{ mmfd.} \\
 &= 2.7 + 61 \times 1.3 \text{ mmfd.} \\
 &= 83 \text{ mmfd. approx.}
 \end{aligned}$$

It will be observed that in a case like this the grid-plate capacity causes far more trouble than does that existing between the grid and cathode itself.

The electrical effect whereby the input capacity of a tube is greatly increased as a result of the presence of capacity between grid and plate, is known as the "Miller Effect".

For practical purposes the best way of visualising the action is that an extra capacity is "reflected" into the grid circuit from the plate circuit. Note that the amount of this reflected capacity depends directly upon the stage gain obtained.

From the foregoing it will be realised that the Miller Effect is an important factor in adding to the total stray capacities which shunt the load resistor, and cause a deterioration in gain towards the high frequency end of the video range. The Miller Effect is not nearly so serious in the case of pentode valves as it is in triodes. The screen grid of a pentode shields the grid from the plate, and thereby reduces the grid-plate capacity almost to zero. For example in the case of the pentode 6AC7 the $C_{gp} = 0.015$ mmfd compared with 1.3 mmfd for the triode 6B6. If both tubes are producing a stage gain of, say, 20, the "Miller Effect" capacity for the pentode is only $(20 + 1) \times .015 = 21 \times .015 = 0.315$ mmfd. compared with $(20 + 1) \times 1.3 = 21 \times 1.3 = 27.3$ mmfd. for the triode.

It must be remembered that with a pentode valve the "Miller Effect" and grid-plate capacity are not the sole factors influencing the high frequency response of an amplifier. We have also to consider the effect of its grid-cathode capacity and grid-screen capacity on the gain at high frequencies of the preceding valve. These capacities would add to those due to "Miller Effect" and C_{gp} thus reducing slightly the advantage which the pentode holds over the triode in the matter of improved high frequency response.

INCREASING THE HIGH FREQUENCY RESPONSE.

Referring back to Figure 8 it will be realised that the frequency point at which the gain of the amplifier commences to fall must be very greatly extended, if the video range of 25 c/sec -- 2 or 4.5 mc/sec is to be adequately covered.

This may be partially achieved by the following methods:-

- (a) Reducing to a minimum the stray capacities across the load of the stage concerned.
- (b) Reducing the value of the load resistor.

With reference to (a) above, wiring capacities may be kept down by careful design. Long plate and grid leads should be avoided, particularly if they run close and parallel to a metal chassis. The wire should be as thin as possible, consistent with mechanical rigidity. Tubes specially designed for video amplification usually have the grid connected to a base pin instead of a metal cap. This avoids the necessity for using a long lead passing through the chassis from the plate of one tube to the grid of the next.

Secondly a tube should be chosen having a low output capacity. Video tubes are specially designed having this characteristic. The miniature "acorn" tubes are especially valuable in this respect.

Thirdly the input capacity of the following tube should be kept as small as possible.

This generally involves the use of a following pentode on account of the very small plate-grid capacity of this type of tube, as explained above. In this way the Miller Effect is minimised. The Miller Effect may be further reduced by reducing the gain of the following stage. Another expedient which has the effect of decreasing the input capacity is the use of negative feed-back (degeneration). This feed-back is sometimes achieved simply by omitting the by-pass condenser across the cathode bias resistor.

Concerning (b), above, the size of the load resistor in the plate circuit has a very important bearing on the highest frequency which can be handled without loss of gain.

Earlier in the lesson it was pointed out that with a pentode valve the gain falls to .707 of its normal value at that frequency which gives a reactance of the stray capacities equal to the load resistance. If the load resistance is reduced to one-half, the reactance of the stray capacities will also have to be reduced to one-half before the gain in the new case falls to .707 of its value at middle frequency. This means that the signal frequency will be doubled

(since reactance = $\frac{1}{2\pi fc}$ ohms) before the response curve shows any serious drop. This, of course, is assuming that the stray capacities remain equal in the two cases. Thus halving the load resistance will approximately double the high frequency range of the amplifier, and so on. Figure 14. shows the effect of various values of load resistor upon high frequency response. Of course, reducing the load resistor will reduce the normal gain of the amplifier for all frequencies.

This is the price we pay for the wide-band amplification obtained. When studying the

curves of Figure 14 it should be remembered that a logarithmic scale is used for frequency, and that the improvement in high frequency response obtained by reducing RL is much greater than a casual glance at the diagram would seem to indicate. For example when using a 50,000 ohm resistor the upper frequency limit of the amplifier is about 80 Kc/sec. When the load resistor is reduced to $\frac{1}{50}$ of this value, viz: 1,000 ohms the frequency response will be flat up to 2,000 Kc/sec. (2 mc/sec.). An even greater relative improvement would be obtained if a pentode tube were used. In the case of pentodes it may be taken as a rule that the upper frequency limit increases proportionately to the reduction in plate load resistor.

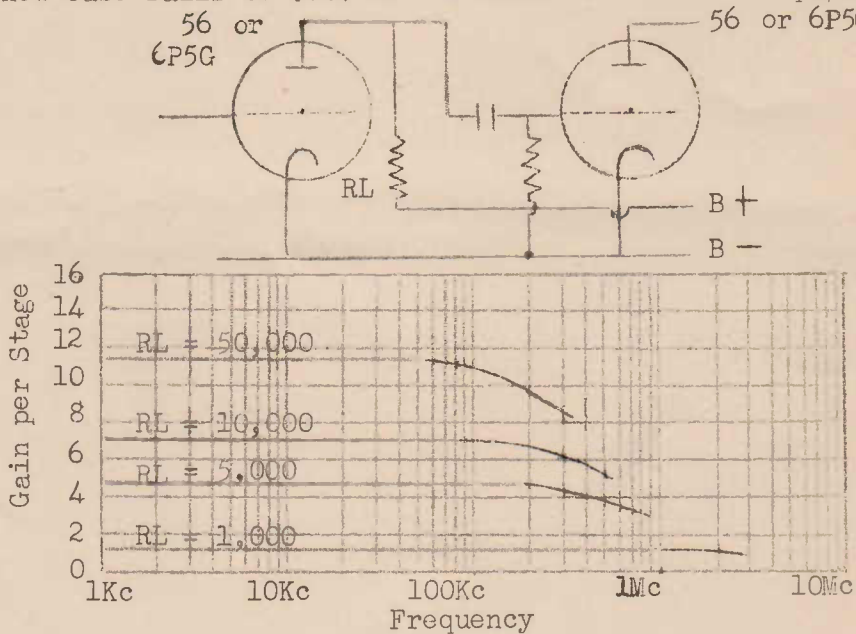

FIGURE 14.
GAIN-FREQUENCY RESPONSE CURVE OF A R-C COUPLED AMPLIFIER SHOWING EFFECT OF EXTENDING RANGE AT THE EXPENSE OF GAIN.

Referring again to Figure 14, we see that the amplifier will nearly cover our required video frequency range by reducing RL to 1,000 ohms. But when this is done the amplification is reduced to nearly one. This, of course is no good, since it would mean that all signals would appear at the output of the amplifier with no greater amplitude than they possessed at the input. In practice we would require a load resistor at least 5 or 10 times 1,000 ohms.

Since we desire to use a load resistor of the smallest possible value, and yet still retain some appreciable amplification, the solution of this problem is to choose a tube having a very high value of mutual conductance (Gm). Formula (2) given above for stage gain shows that loss of gain experienced by reducing RL may be offset by increasing Gm. Since Gm may be defined as

$$G_m = \frac{\text{Change in Plate Current}}{\text{Change in Grid Voltage}}$$

a high Gm will mean that a given signal voltage on the grid will produce large changes in plate current; and these will be capable of developing large signal voltage changes across the (comparatively) small plate load resistor. Now a high Gm will involve a comparatively heavy d.c. plate current. We find therefore that a tube specially designed as a video voltage amplifier, with large Gm, carries a very much larger plate current than does a tube used for audio voltage amplification. In this respect a video voltage amplifier tube is more closely similar to a power amplifier for audio work. For example the 6AC7 pentode (designed as a video voltage amplifier, as well as an I.F. amplifier) has a Gm of 9,000 $\mu\text{A}/\text{V}$ and carries a normal plate current of 10 m.a. Compare this with the audio voltage amplifier 6J7, having a Gm of 625 $\mu\text{A}/\text{V}$. when its plate current is 0.56 m.a.

From the foregoing it will be noted that the most important characteristics of a tube as a video amplifier are a higher value of mutual conductance and low values of inter-electrode capacities. The amplification factors alone are no criteria whatever of different tubes' relative merits as video amplifiers; for a large value of amplification factor might (and often does) mean a large value of plate resistance, with comparatively low values of plate current and mutual conductance. Since tubes designed as output power amplifier for audio work usually have high values of Gm, they are sometimes used for voltage amplification of video signals. For example the beam power tetrode 6V6 having a Gm of 4,100 $\mu\text{A}/\text{V}$ makes quite a good voltage video amplifier if the video range is not too wide.

Since large values of Gm mean close spacing of the grid wires and close spacing between grid and cathode within the tube, it is unfortunate that this results in an increase of inter-electrode capacities. It requires very careful design in order to obtain large Gm's and low values of these capacities. The term "Figure of Merit" is sometimes used to denote the efficiency of a tube as a video amplifier.

$$\text{Figure of Merit} = \frac{\text{Mutual Conductance}}{\text{Total Electrode Capacities}}$$

This figure should be as high as possible.

HIGH FREQUENCY COMPENSATION.

We have seen that it is impossible even when using specially designed tubes, to

extend the frequency range of an ordinary resistance-capacity coupled amplifier to that required in television. The problem is solved in practice by "boosting" the higher frequencies, where the amplifier gain begins to fall off due to the shunting effect on the load resistor by stray capacities. This process is known as high frequency compensation.

This compensation is achieved by connecting a small inductance, or two inductances, in the plate circuit of the tube. The principle of the various schemes depends upon two important facts, viz:-

- (1) The impedance of a parallel tuned circuit rises as the resonant frequency of the circuit is approached, and is a maximum at the resonant frequency.
- (2) The voltage developed across either L or C in a series tuned circuit increases as the resonant frequency is approached, and is a maximum at the resonant frequency.

In Figure 15 is shown at (a) a parallel tuned circuit, consisting of L and C, across which an alternating voltage of variable frequency is applied. As the frequency of the voltage is varied, the impedance of the circuit varies, and is a maximum at the resonant frequency of L and C. This is shown by the graph at (b), where f_r is the resonant frequency.

At (a) in Figure 16 is shown a series tuned circuit, consisting of an inductance L and capacity C in series. A variable frequency voltage is applied across this circuit. Here the current through the circuit increases as the resonant frequency is approached, and becomes a maximum at resonance. When the current through C (or L) is a maximum the voltage (A.C.) developed across C (or L) will also be a maximum.

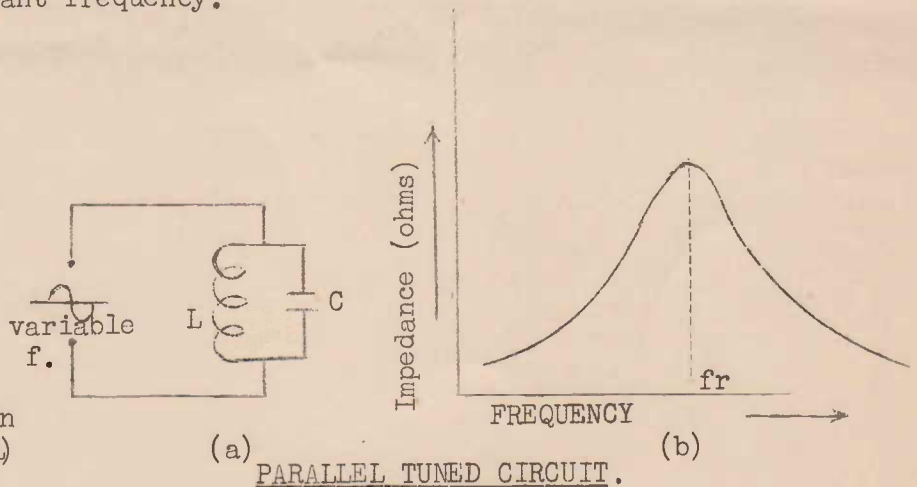

FIGURE 15.

The manner in which the voltage across C increases to a maximum as the resonant frequency is approached is shown at (b) Figure 16.

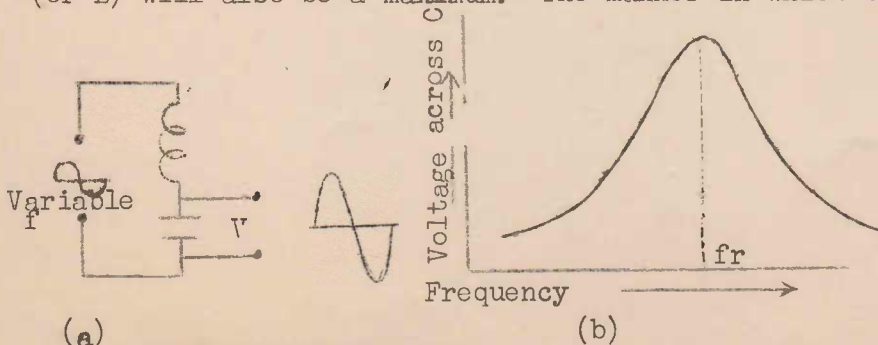

FIGURE 16.

"SHUNT PEAKING" COMPENSATION.

Figure 17 shows how a small "peaking" inductance coil may be inserted in series with the load resistor to compensate for the effect of stray capacities at high frequencies.

The condenser CT dotted in represents the total stray capacities.

Inductance L and capacity CT form a parallel tuned circuit with the resistance RL in one branch as shown at (b) in Figure 17. Remember that the B+ end of L is connected to ground, i.e. to the lower side of CT, by means of the high tension by-pass (or filter) condenser C, as shown at (a). In Figure 17(b) this condenser is omitted since its reactance is negligible at all signal frequencies, and it therefore acts as a short-circuit.

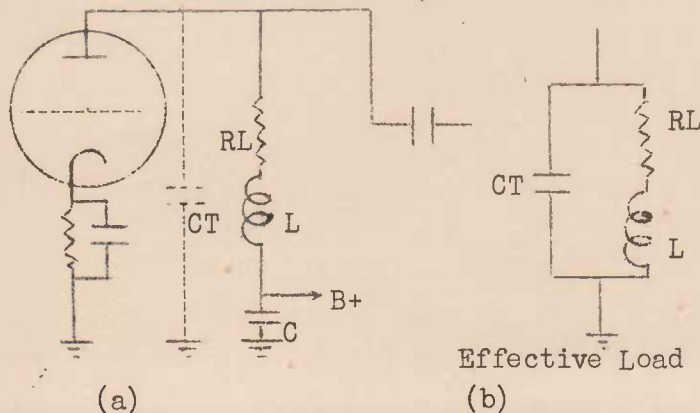

The value of L is chosen so that the resonant frequency of the parallel circuit lies a little above the highest frequency it is desired to amplify. As this frequency is approached the impedance of the parallel circuit tends to rise, as explained above. Since this circuit now forms the effective load in the plate circuit, the effect described compensates for the loss of gain which otherwise would occur due to CT shunting RL.

(a) SHUNT PEAKING COMPENSATION. (b) FIGURE 17.

shown in Figure 18. Here, with no compensation the gain is shown as dropping off at about 200,000 c/sec. The compensation has maintained the gain curve "flat" up to a frequency of 1,000,000 C/sec (lmc/sec). Note that the gain actually rises

The effect of the compensation is

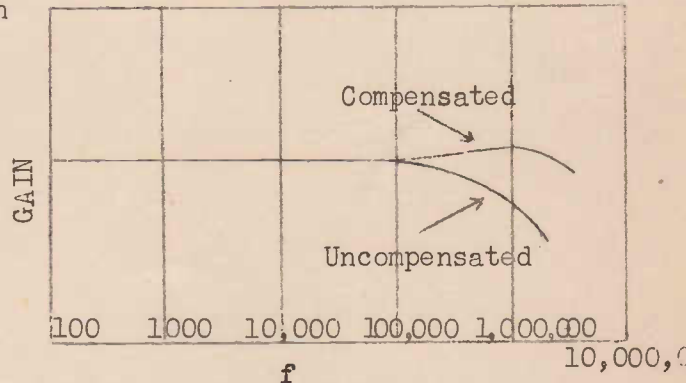

FIGURE 18.

slightly after this as the resonant frequency of L and CT is reached.

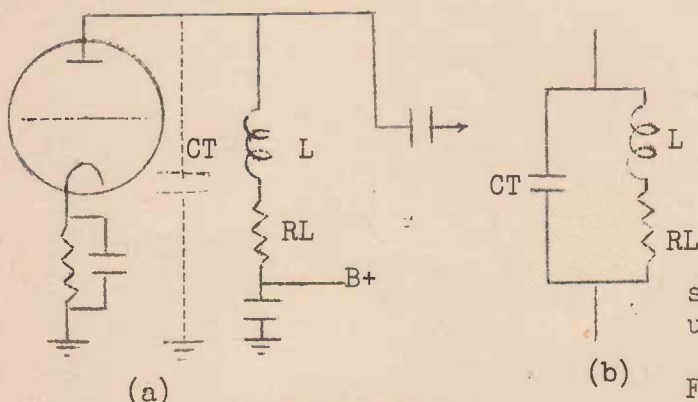

FIGURE 19.

the "peaking" coil L is placed between the tube's plate and the load resistor. The effective plate load is shown at (b), and is seen to be electrically equivalent to that of the first arrangement.

Figure 19 shows a slightly different arrangement of "shunt peaking" compensation, where

It should be remembered that the peaking coil is a very small inductance, and its effect is entirely negligible in the circuit, until the very high frequencies are reached. The same, of course applies to the stray capacities Cs.

SERIES PEAKING COMPENSATION.

Here (Figure 20) the peaking coil is placed in the load to the grid of the next valve. Note that L separates the output capacity (C_o) of the first tube from the input capacity (C_i) of the next tube. L and C_i form a series tuned circuit which resonates at a frequency just outside the desired video range. In deriving the "equivalent" circuit, shown at (b) the coupling condenser has been omitted, since at high signal frequencies it is, in effect, a short circuit. Note that the output voltage to be applied between grid and cathode of the next stage is taken from across C_i , see (b) Figure 20.

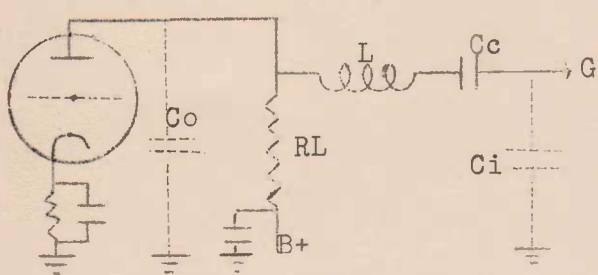

(a)

FIGURE 20.



(b)

As explained above, as the resonant frequency of the series circuit L and C_i is approached, an increased voltage is obtained across C_i . This compensates for the loss of gain due to the shunting effect of C_o upon R_L .

This series peaking has the advantage that it divides the total stray capacities into two parts, shown as C_o and C_i . It will provide a flat response to a much higher frequency than can be attained with shunt peaking.

vide a flat response to a much higher frequency than can be attained with shunt peaking.

COMBINATIONS OF SHUNT AND SERIES PEAKING.

A very effective arrangement is shown in Figure 21. Compare this circuit with that of Figure 19, and note the difference. Here the output to the grid of the next tube is taken from the lower ($B+$) end of L .

The equivalent plate load is shown at (b) Figure 21. Note that as in series peaking the inductance separates the output capacity of the tube (C_o) from the input capacity of the next tube (C_i). This capacity C_i is in series with L , thus tending to produce a voltage step-up to off-set any loss of gain due to the shunting effect of C_o . The latter shunting effect, in addition is minimised as a result of C_o forming a parallel tuned circuit with the combination of L and C_i . Thus the characteristics of series and parallel peaking are combined in this circuit.

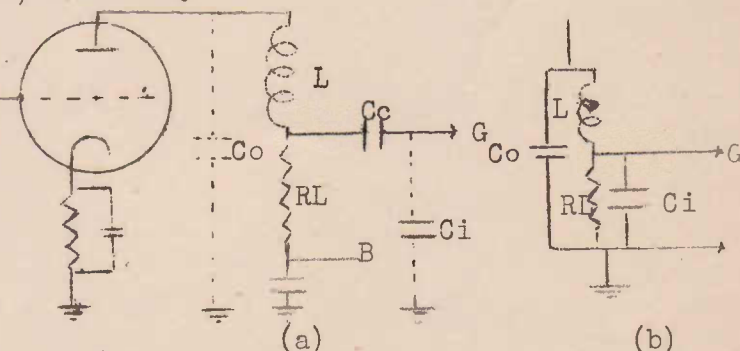

(a)

FIGURE 21.

(b)

By making use of two inductances, a direct combination of shunt (parallel) peaking (Figure 22) and series peaking (Figure 20) may be obtained, as shown in Figure 22.

COMPARISON OF SHUNT, SERIES, AND SHUNT-SERIES COMPENSATION.

It is found that the characteristics of series compensation are such that, for the same high frequency response, a larger load resistor may be used than for shunt compensation. This of course means a higher stage gain. If series-shunt is used a still higher load may be inserted, Hence the shunt-series combination is the best method from the point of view of gain for a given frequency response, or of frequency response for a given gain. In the following table the relative gains for the three methods, covering the same frequency range are shown.

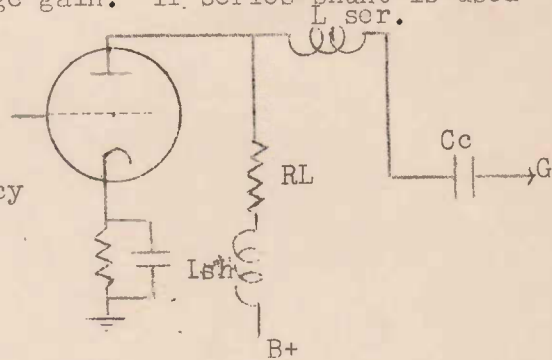

FIGURE 22.

Type	Gain
Uncompensated	.707
Shunt	1.0
Series	1.5
Shunt-Series (Fig. 22)	1.8

LOSS OF GAIN AT VERY LOW FREQUENCIES. Referring back to the frequency-response curve (Figure 6) of an uncompensated amplifier, we have seen that below a certain frequency the amplifier gain falls off, slowly at first, then rapidly. The reasons for this effect are:-

- (1) Reactance of coupling condenser C_c increasing and becoming appreciable to very low frequencies.
- (2) Inefficient by-passing of cathode bias resistor by by-pass condenser at low frequencies.
- (3) Inefficient by-passing of screen dropping resistor by screen by-pass condenser at low frequencies (in the case of screen-grid tubes)

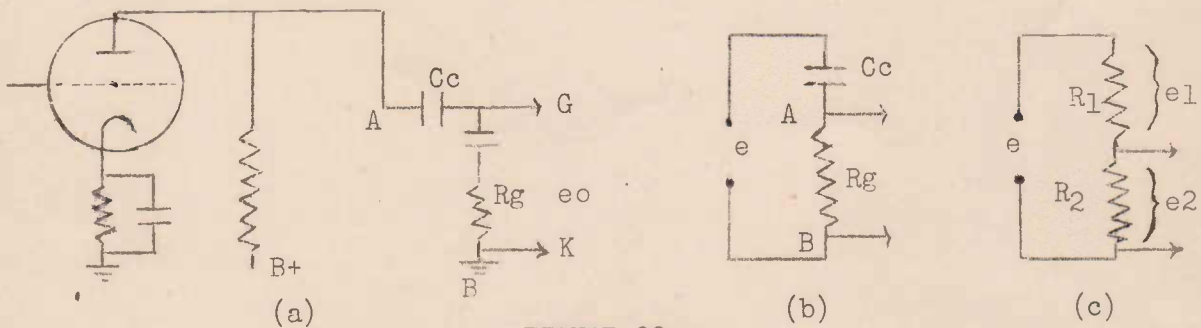

FIGURE 23.

At (a) in Figure 23 the signal voltage developed by the stage is applied between the points A and B- (ground across the combination of the coupling condenser (C_c) and grid resistor R_g). These form an A.C. voltage divider and only that fraction of the total voltage which is developed across R_g is applied between grid and cathode of the next tube. This idea is illustrated diagrammatically at (b) Figure 23. A simple resistance voltage divider is shown, for comparative purposes at (c).

At all but the very low frequencies the reactance of C_c is negligibly small compared with R_g , and practically all the signal voltage appears across R_g . At very low

frequencies, however, the reactance (measured in ohms) might become large. When this occurs the total voltage divides between C_c and R_g , as in the divider shown at (c). Now, only that A.C. voltage developed across R_g is utilised as the output of the stage. That appearing across C_c is lost. As the frequency falls further, the reactance of C_c is further increased, and the output voltage across R_g , and on the grid of the next valve, suffers a further reduction. In this way the loss in gain becomes more and more serious as the frequency of the signal is lowered. At the frequency at which the reactance of C_c equals R_g only .707 of the voltage applied between A & B will reach the grid of the following tube.

Concerning the effect of the cathode by-pass condenser, refer to Figure 24(a). The purpose of the by-pass condenser C_k is to provide a low impedance (low reactance) path for the A.C. signal component of the plate current, in order that the cathode potential might remain at a steady positive value with respect to ground. (i.e. so that the grid bias might remain steady).

At all except the very low frequencies, the reactance of C_k is very small, and this purpose is realised. At some very low frequency, however, the reactance of C_k is no longer negligible, and the A.C. component of plate current is forced to flow through the impedance of R_k and C_k in parallel. In other words R_k is not completely by-passed. An un-by-passed cathode resistor is shown at (b) Figure 24. The result will be that the cathode potential will rise and fall with the plate current variations due to the signal. When the grid goes positive, plate current rises, cathode also goes more positive. When the grid goes negative, plate current falls, and cathode potential also falls (i.e. less positive or more negative). The effect of these cathode potential variations is thus partially to cancel the A.C. signal voltage applied between grid and cathode. This means a weaker signal, or a loss of gain.

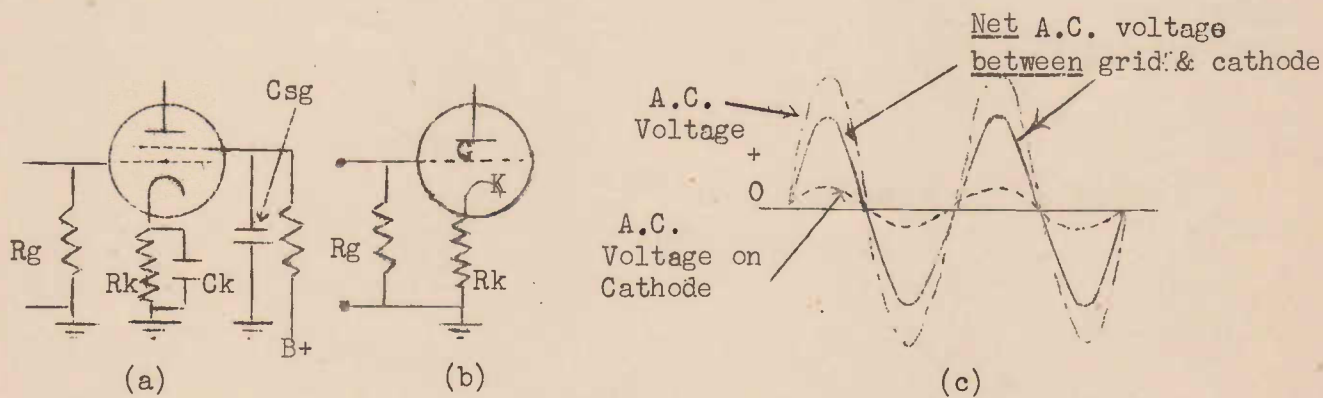

FIGURE 24.

The A.C. voltages on grid and cathode (measured in respect to ground) and the net P.D. between grid and cathode, are shown at (c) Figure 24. Note that this P.D. is always the difference between grid and cathode potentials.

The by-passing action of the screen by-pass condenser (CSG) shown at (a) in Fig. 24 is similar to that of C_k . Its purpose is to maintain the screen grid at a steady D.C. potential. At low frequencies, when the reactance of CSG becomes large, the

by-passing action becomes ineffective, and the screen's potential rises and falls in a similar manner to that of the plate. The screen-grid tube then operates in a similar manner to a triode, with a consequent loss of gain.

MINIMISING LOSS OF GAIN AT VERY LOW FREQUENCIES.

The low frequency loss of gain due to the coupling condenser C_c may be minimised by:-

- (a) Increasing value of grid leak R_g .
- (b) Increasing the capacity of coupling condenser C_c .

Bearing in mind the voltage-divider action of the grid circuit as shown at (b) in Figure 23 it will be seen that, in order to obtain the maximum value of output voltage across R_g , the resistance of R_g should be as large as possible and the reactance of C_c as small as possible. The reactance of C_c can only be reduced, for a given frequency, by increasing the condenser's capacity. Thus for a good low frequency response we require a large grid-leak and a large coupling capacity. The product $C_c \times R_g$ will therefore be a measure of the low-frequency response of the coupling circuit. This product is sometimes called the circuit's "Time-Constant" for a reason which will become apparent in later lessons.

There is a limit to the value of the grid leak for any particular type of tube. For most tubes this limit is 1 megohm or less. The question then arises, is there any limit to the value of the coupling condenser we might use? In practice, we are limited here too, for two reasons. In the first place, larger condensers usually have a greater leakage across the plates. If the coupling condenser is made too large the effect of any leakage will be to cause an incorrect value of grid bias, due to a leakage from the plate (at high potential) of the previous tube. This will produce a distortion of the signal causing a distorted image on a television screen. Again, a large capacity condenser is bulky in size, and will therefore add to the stray capacities to ground, causing a loss of gain at high-frequencies.

The poor response at low frequencies may also be improved by using cathode and screen by-pass condensers of the maximum practical capacities. A point to remember here is that the smaller the resistor being by-passed the greater must be the capacity of the by-pass condenser. Sometimes we find the cathode by-pass condenser omitted entirely. The result, of course, will be a reduction of gain, but this occurs at all frequencies, and the flatness of the frequency-response curve will be improved.

LOW FREQUENCY COMPENSATION.

Even though the precautions dealt with above are carried to the limit, we find that the low frequency response is not good enough. This is particularly the case when a number of video stages are used in cascade. Under these conditions any "drooping" of the response curve at low (or high) frequencies will be magnified by the number of stages used.

Low frequency compensation is achieved as shown in Figure 25.

An extra resistor R_F is placed in series with the normal load resistor R_L . R_F is shunted by a condenser C_F . The capacity of the latter resistor is such that, at all but the very lowest of frequencies C_F effectively by-passes R_F , and the load in the plate circuit is simply R_L . At very low frequencies however, when the gain commences to fall off due to the causes previously discussed, the reactance of C_F rises and forces part of the A.C. component of plate current through R_F . In this way the total impedance in the plate circuit increases as the frequency becomes lower. Remembering that the gain depends upon the load in the plate circuit it will be seen that the amplification will be boosted where it tends to fall off due to other causes. By careful design of the amplifier, choosing correct values of R_F and C_F in relation to R_L , C_k , R_k , C_{sg} and R_{sg} , the response curve may be maintained flat down to a few cycles/sec.

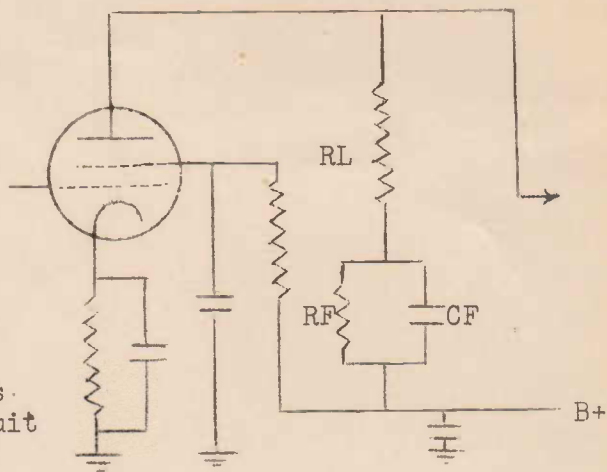

FIGURE 25.

PHASE DISTORTION.

Lack of phase distortion was mentioned earlier in the lesson as a requirement of a good video amplifier.

When an A.C. voltage is applied across a pure resistance the current remains "in phase" with the voltage as shown at (a) Figure 26.

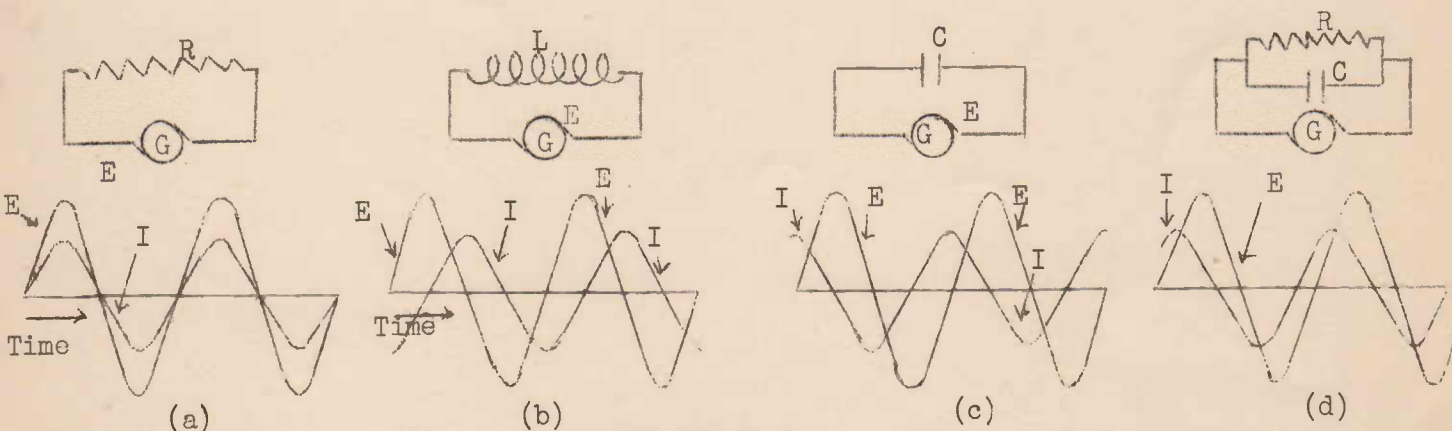

FIGURE 26.

When however the circuit contains reactance (either due to an inductance or a capacity) a difference in phase between voltage (E) and current (I) occurs. If the circuit contains "pure" reactance, i.e. either a condenser or an inductance alone, E and I are out of phase by $\frac{1}{4}$ cycle, as shown at (b) and (c) Figure 26. This represents a phase "difference" or phase of 90° (1 cycle = 360°). In the case of the inductance the current "lags" behind the applied voltage, since, as

the graph at (b) shows, I reaches a peak value $\frac{1}{4}$ cycle or 90° later than E attains its corresponding peak. When capacity is in the circuit, as at (c), E and I are also 90° out of phase, but here I is in advance of E by $\frac{1}{4}$ cycle or 90° . In other words the current "leads" the voltage. If the circuit contains a combination of resistance and reactance (e.g. for a capacity in parallel with a resistance as at (d)) a phase difference also occurs, but the current and voltage are now less than 90° out of phase. The phase angle in such a case as this depends upon the relative values of reactance and resistance. Now the reactance of a given capacity changes with frequency. Therefore if the frequency of the voltage across the circuit shown at (d) changes, the phase angle will also change.

Summarising we may say that, if reactance is present in a circuit, a phase displacement of current occurs. The graphs of Figure 26 show that this phase displacement represents either a time lag or a time advance in the signal.

In a video amplifier the reactances are negligible at normal frequencies. At very high, and very low frequencies the ~~effects~~ effects of stray capacities, coupling condensers etc. become appreciable, and these signals suffer a phase displacement, or a time lag or advance. This will result in the picture elements, corresponding to these frequencies, being reproduced a little later or early (usually the former) on the screen. Such a displacement will obviously result in serious distortion of the image.

Both the high-frequency and low-frequency compensation circuits described tend to correct these phase displacements, as well as the amplifier gain. A good video amplifier may therefore be designed to yield uniform gain, without serious phase distortion, over a wide frequency range.

THE CATHODE FOLLOWER.

This is an "amplifier" in which the load resistor is placed entirely in the cathode lead, i.e. in the lead from B- to cathode. The tube's plate is connected directly to B+ (or sometimes through a filter circuit to exclude the last traces of 50 or 100 cycle/sec. power voltages or "hum". The circuit is shown in Figure 27. The input voltage E_i is applied between grid and ground as is normal. The output voltage, however is that developed across the cathode resistor R_k . The tube may be either a triode or a pentode, providing the Mutual Conductance (G_m) is high.

The word "amplifier" was inserted in inverted commas, because the cathode follower's gain is always slightly less than 1, i.e. it produces no real gain at all, but rather introduces a slight loss. What then are its advantages and its uses? We may state that the stage has a very high input impedance and a very low

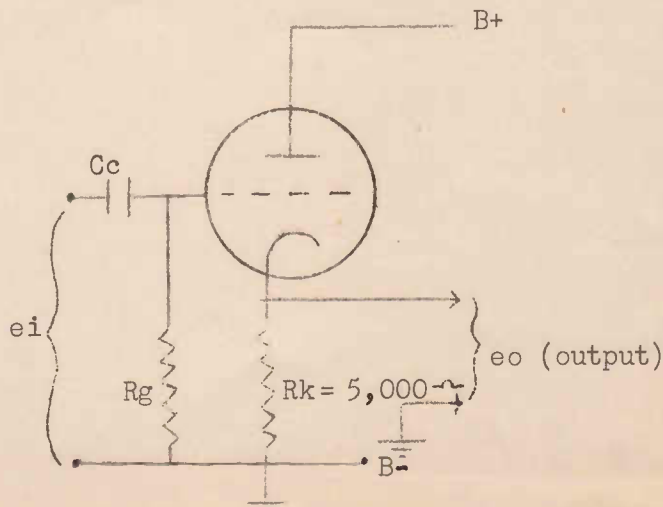

FIGURE 27.

output impedance, and proceed to explain the meaning of these terms, and how they may be turned to our advantage.

OPERATION OF THE CATHODE FOLLOWER.

Referring to Figure 27. Suppose the input signal voltage (E_i) applied between grid and ground is 10V. This A.C. voltage causes the plate current to vary accordingly, and develops a varying (A.C.) P.D. across R_k . The result is that the cathode potential will rise and fall (at signal frequency) in respect to ground. For example when the grid goes 10V positive (with respect to ground), plate current will increase, developing a larger voltage across R_k , i.e. cathode potential will also rise. Suppose the increased voltage across R_k is 9.8V +. Although the grid potential has increased by 10V with respect to ground, the increase in respect to cathode is only $10V - 9.8V = 0.2V$. On the other hand when the grid goes 10V negative with respect to ground, plate current will fall, the voltage drop across R_k will decrease by 9.8V, and the cathode will go 9.8V less positive (i.e. more negative). Once again the grid-cathode potential has changed by only .2V. Notice that the cathode potential follows that of the grid, and nearly, but not quite, completely cancels the signal voltage. Only a small fraction of the latter, i.e. $\frac{.2}{10} = \frac{1}{50}$, is effective in driving the tube.

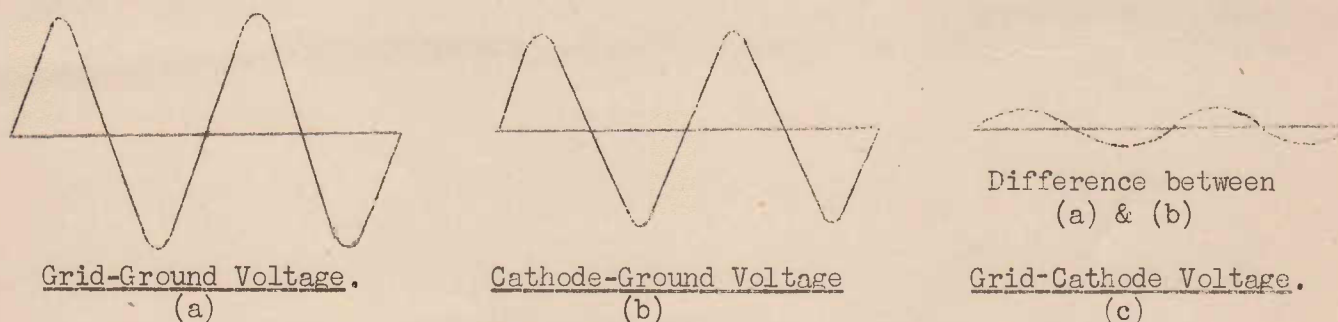

FIGURE 28.

The grid, cathode, and grid-cathode voltages are shown in Figure 28.

The first important point to notice from this explanation is that the gain of the stage must always be less than one. The output voltage (E_o) is that taken across R_k (i.e. it is the cathode A.C. voltage shown at (b) Figure 28) and this is 9.8V, compared with an input of 10V. The cathode, and output voltages cannot equal or exceed the input voltage, because if it did the latter would be completely cancelled, and the tube would not operate at all. In the case given the stage gain is $\frac{9.8}{10} = .98$.

Secondly notice that the effective A.C. voltage operating across the tubes grid-cathode capacity (C_{gk}) is only .2V, i.e. $\frac{1}{50}$ of the total input voltage. This will mean that the A.C. current through C_{gk} will be only $\frac{1}{50}$ of the value it would normally be. The result is that the reactance of C_{gk} appears to be increased by 50

times, or in other words the effective electrical value of C_{gk} is reduced to $\frac{1}{50}$ of its normal value. This is what we mean when we say the input impedance of the cathode follower is very high. It is obvious that the shunting effect on the previous amplifier stage, at high frequencies, will be greatly reduced, with an improved high frequency response.

OUTPUT IMPEDANCE OF THE CATHODE FOLLOWER.

With regard to the term "output impedance" of a device, we mean here the resistance or impedance across which the output voltage is developed. For example in an ordinary pentode amplifier with a plate load of 5,000 ohms, the output impedance is 5,000 ohms. We have previously seen that the shunting effect of given stray capacities on the amplifier gain is less if the load resistor (output impedance) is reduced.

In the circuit of Figure 27 the load resistor (R_k) of the cathode follower was shown as 5,000 ohms. Due to the electrical action of the circuit, however, the output impedance is very much less than this. This may be seen in a general way as follows. Suppose R_k (Fig. 27) is reduced to 2,000 ohms, i.e. $\frac{2}{5}$. The output voltage will not fall to $\frac{2}{5}$ of its former value, because any reduction in output voltage (i.e. cathode voltage) releases a greater amount of the total input voltage to drive the tube. For example the result might be that the output voltage falls only to, say, 9.5V. If this occurs the A.C. voltage acting between grid and cathode will increase to .5V (10V- 9.5V), as against .2V before. Thus, a small reduction in output (cathode) voltage - from 9.8V to 9.5V- will increase the active grid-cathode voltage by $\frac{5}{2}$ times. This may be seen clearly by referring back to the voltage curves of Figure 28. The result will be that the A.C. plate current will correspondingly increase, i.e. by $\frac{5}{2}$ times. This increase in A.C. component of plate current, flowing through the cathode load resistor (R_k), will easily offset the reduction of this resistor from 5,000 to 2,000 ohms, as far as the stage's output voltage is concerned. Actually in the case taken, the output voltage would not quite be reduced to 9.5V. Thus we see a reduction of load impedance of 80% (5,000 ohms to 2,500 ohms) causes a reduction in gain of less than 0.3V in 9.8V, i.e. a reduction of about 3% only.

Now as previously explained the effect of stray shunting capacities is to reduce the effective load impedance of a stage. Since, as we have seen, the output voltage of a cathode follower is practically independent of the value of this load impedance it will be appreciated that this type of circuit will show up to advantage when it has to feed into a circuit which introduces large values of stray capacities.

It may be shown mathematically that the output impedance of a cathode follower is equal to $\frac{1}{G_m}$ ohms, where G_m is the mutual conductance of the tube. For example, in the case of the 6AC7 tube, with a G_m of approx. 9,000 $\mu A/volt$, (i.e. $\frac{9}{1,000}$ A/Volt) the output impedance will be $\frac{1}{G_m} = \frac{1}{9/1,000} = \frac{1,000}{9} = 110$ ohms (approx) --

An extremely low value, when we say the output impedance is 110 ohms we mean that the electrical action of the circuit is such that the output voltage appears

as though it were developed across only 110 ohms, instead of the actual 5,000 ohms used in the circuit. This idea is illustrated in Figure 29, where R_o equals the output impedance $\frac{1}{G_m} = 110$ ohms as calculated.

SUMMARY OF CHARACTERISTICS OF CATHODE FOLLOWER

- (1) Stage gain less than unity.
- (2) Output Impedance very low ($= \frac{1}{G_m}$ ohms. approx.)
- (3) Input impedance very high.
- (4) Output voltage in phase with input voltage (see Figure 28).

USES OF CATHODE FOLLOWER.

A cathode follower is sometimes used between successive amplifying stages to reduce the shunting effect of the input capacity of one tube on the load resistor of the previous stage.

In Figure 30 V1 and V3 are ordinary pentode amplifying stages, incorporating low- and high- frequency compensation. V2 is a cathode follower, acting as a type of "buffer" between V1 and V2. The shunting, at high frequencies, upon the load of V1 is greatly reduced on account of the very high input impedance of V2. Also the input

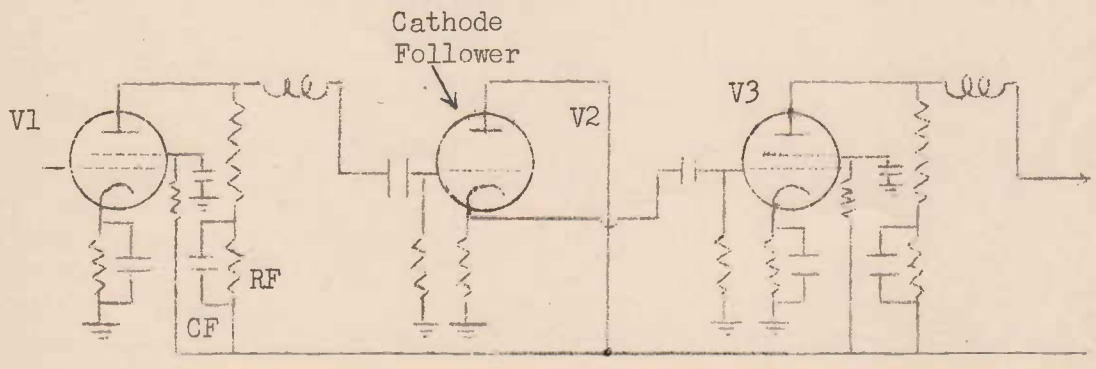
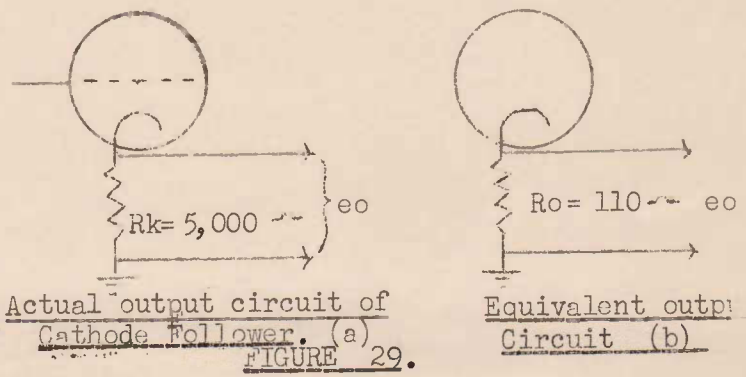

capacity of V3 is unimportant, since it is across the low output impedance of the cathode follower V2, upon which it has, as we have seen, very little effect. In this way the overall high frequency response of the amplifier is greatly improved.

Another typical use of the cathode follower is as an output stage when the amplifier has to feed into a low impedance cable, as shown in Figure 31. Here the cathode follower V2 acts as an impedance matching device between the amplifier V1 (of high output impedance) and the cable whose impedance may be very low. The

purpose here may be compared with that of the output speaker transformer in a sound receiver, where it is necessary to match the high output impedance of the speaker's voice coil.

THE ELECTRON MULTIPLIER.

In this lesson we have discussed the problems of video amplification, and how the ordinary resistance-capacity coupled amplifier may be designed, and modified, to meet them. In the future

it seems very probable that the electron-multiplier, discussed in relation to electron cameras, might find general application for video amplification purposes. The electron multiplier has the virtue that it can yield considerable amplification, without the introduction of appreciable masking (noise) voltages, over a very wide range of frequencies. In the meantime, however, the thermionic tube can, as we have seen, perform the task of amplifying our picture signals very well indeed, even if the stage gain is low compared with that which can be achieved from the same tube as an audio frequency amplifier.

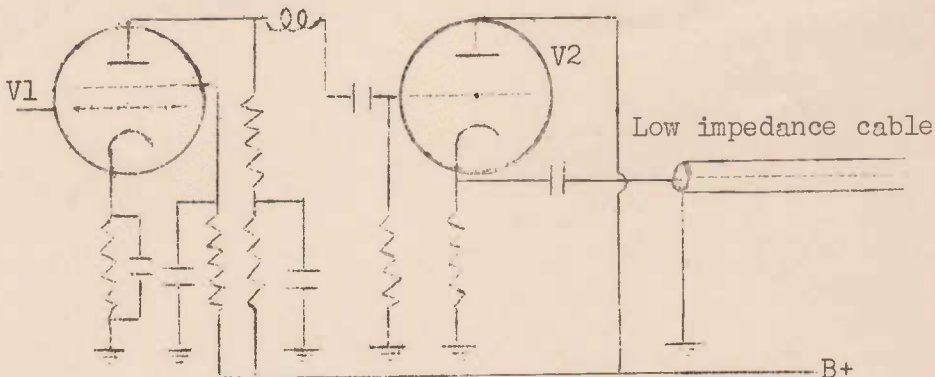

FIGURE 31.

T.F.M. & F. LESSON NO. 5.

EXAMINATION QUESTIONS.

- (1) State approximately the range of video frequencies which will be present in a television system operating with 400 lines at 25 pictures per second.
- (2) What will be the effect on the reproduced picture if the video amplifiers have an inadequate high frequency response?
- (3) Why does the gain of an amplifier with resistance-capacity coupling fall off when the frequency of the signal becomes high?
- (4) State three methods of improving the high-frequency response of a r-c. amplifier (without applying high-frequency compensation).
- (5) What is meant by high frequency compensation? Draw simple circuit diagrams illustrating three methods of high-frequency compensation. Name the method illustrated in each case.
- (6) State three different ways in which the low-frequency response of a pentode amplifier with cathode bias may be improved.
- (7) Draw a simple circuit diagram illustrating an amplifier incorporating low-frequency compensation. Explain very briefly how the low-frequency "boosting" is brought about.
- (8) What are the ~~three~~ most desirable features to look for in choosing a tube for video amplification?
- (9) Draw a circuit diagram of a cathode-follower stage, showing clearly the input and output terminals.
- (10) State the approximate gain figure for a typical cathode-follower stage. What is the main characteristic and use of such a stage?

AUSTRALIAN RADIO COLLEGE

E. S. & A. BANK BUILDINGS, Corner CITY RD. and BROADWAY, SYDNEY
Telephones: M 6391 and M 6392. Post Lessons to Box 43, Broadway

This lesson sheet is published for the exclusive use of
students of the Australian Radio College Pty. Ltd.
(All rights reserved)



T.F.M. & F. LESSON NO. 6.

TRANSMISSION OF TELEVISION SIGNALS.

If one is interested purely in the reception side of telephonic communication a study of details and techniques of transmission can be largely dispensed with. A knowledge of the general principles involved, and in particular a clear picture of the nature of the final product of the transmitter, viz: the modulated wave will usually suffice. In the case of television, however, this does not apply. A television transmitter has a much more exacting job to do than that of the ordinary broadcast sound transmitter. The former must produce and radiate a wave carrying the exceptionally wide range of frequencies involved in the picture signal. In addition the transmitted signals must be modulated in such a way that the receiver can reproduce not only the video frequencies corresponding to the picture details, but also the average light or shade on the original scene. Further the signal must contain the "pulses" which accomplish the complicated and difficult synchronisation of receiver with transmitter.

It should be realised, then, that the design and operation of a television receiver is very closely bound up with the nature of the particular transmitter radiating the signal. It is unfortunate that any radical improvement or re-design of the transmitter necessitates a re-design or complete scrapping of the receiver. For example suppose it is decided to improve the picture definition by an increase in the number of lines. The old receiver, without undergoing substantial operations, would be quite useless for receiving the improved signal. The functions and mode of operation of many of the receiver circuits are so closely related to the corresponding techniques in the transmitter that a study of one without the other would be rather a fruitless undertaking.

The above observations are made lest the student who feels that his interests lie entirely in the field of reception should underestimate the importance of this particular lesson.

THE FREQUENCY OF THE VISION CARRIER WAVE.

In the earlier days of television transmissions were carried out on frequencies in

the low or medium bands, i.e. on frequencies similar to those with which we are so familiar in connection with ordinary broadcast work. With the development of higher definition pictures, however, it was soon realised that carrier waves lying within the ultra-high frequency band were an absolute essential. By the ultra-high frequency band we mean the region above about 30 megacycles per second and upwards. This corresponds to wavelengths of 10 metres and less. For comparison purposes it should be remembered that our broadcast transmitters operate on frequencies ranging from 550 Kc/sec to 1.6 megacycles/sec. (the medium-waves). The regular short-wave transmissions extend from about 1.6 mc/sec up to 23 mc/sec. The graph of Fig. 1 will show clearly how these various frequencies are related.

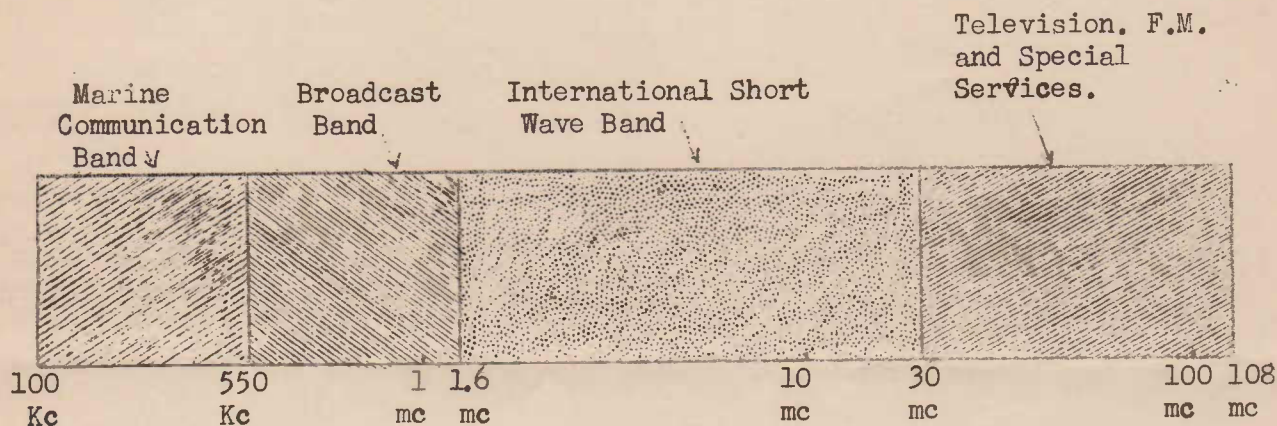

WAVE BANDS ALLOTTED TO VARIOUS SERVICES.

FIGURE 1.

REQUIRED BAND WIDTH OF A TELEVISION SIGNAL.

The question now arises why are these high (comparatively) carrier frequencies used? The reasons are several. In the first place it would be a technical impossibility to use medium wave frequencies if we are to carry all the "information" contained in the video signals generated by our modern electron cameras using 400 or more scanning lines. In the previous lesson we have seen that with a 441 lines 30 pictures per second system, as at present used in America, the video frequencies range up to a figure in the vicinity of 3 megacycles/sec. It is this frequency, of course, which corresponds to the audio frequency in radio telephony, and which modulates the outgoing carrier wave. With regard to the subject of modulation the following important facts should be recalled. When a carrier signal is amplitude modulated, the amplitude (strength) of the carrier signal is caused to vary at a rate corresponding to the frequency of the modulating signal. When a carrier signal of varying amplitude is analysed, it is found that the effect of modulation is to generate additional signals having frequencies above and below the carrier frequency. These additional signals are known as "side-band" frequencies. Each frequency in the modulating signal will produce two side frequencies -- one above and one below the carrier frequency. The side-frequencies

differ from that of the carrier by an amount exactly equal to that of the modulating signal itself. For example, suppose a carrier of 50 megacycles/sec. is modulated by a video modulating frequency of 2.5 megacycles per second. Two side frequencies 52.5 ($50 + 2.5$) mc/sec. and 47.5 ($50 - 2.5$) mc/sec. would be produced. The other (lower frequency) modulating video signals would each result in a pair of side-bands lying within these limits -- 47.5 and 52.5 mc/sec.

Keeping these facts in mind it is seen that for a video signal ranging up to 2.5 mc/sec. a band-width of 5 mc/sec. would be required. Obviously it would be theoretically impossible to use a carrier of frequency less than 2.5 mc/sec. for this would involve lower side-bands extending down to zero frequency. Practical considerations require that the carrier frequency be many times -- preferably at least 10 times -- the band-width involved. This will mean a carrier in the ultra-high frequency range.

In England, at the present time a video signal ranging up to 2.5 mc/sec. is used. This requires a bandwidth of 5 mc/sec. for the vision channel. The radio frequency of the carrier wave is 45 mc/sec. which corresponds to a wavelength of 6.6 metres. The accompanying sound is broadcast on a separate carrier of frequency 41.5 mc/sec. (i.e. 7.2 metres). The sound channel allows for audio frequency modulation up to 10 Kc/Sec, a band-width of double this figure, i.e. 20 Kc/Sec. being provided.

Figure 2 shows the range of frequencies for the complete vision and sound transmission.

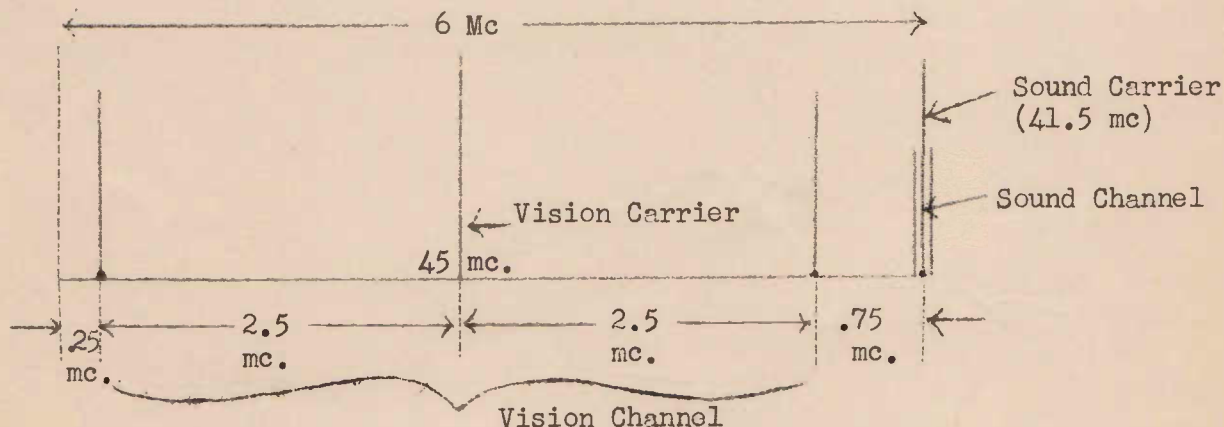

FIGURE 2.

Note that a gap of .75 mc is allowed below the lowest side-band frequency and the sound channel. This is to prevent the vision signals being picked up by the sound section of the receiver. A margin of .25 mc is allowed at the upper frequency end of the channel to separate it from the next television channel. The whole television system thus occupies a channel 6 mc/sec wide as shown. Note that nearly all of this 6 mc is occupied by the vision signal.

A characteristic of high-definition television broadcasts is the width of the frequency channel required. Unless the ultra-high frequencies were used, very few stations could operate within a region without interference to one another.

SINGLE SIDE-BAND TRANSMISSION.

In America the N.B.C. makes provision for a video signal ranging, theoretically, up to 4 mc/sec. This would normally require a vision channel 8 mc. wide, which is too great, even with a carrier of the order of 40-50 mc/sec. The channel would form nearly $\frac{1}{5}$ of the carrier frequency, rendering it difficult to design tuned circuits to accommodate all the side-band frequencies without distortion, and, in addition, leading to other technical difficulties. The problem is solved by utilising "single sideband" transmission.

Since each modulating (video) frequency generates a pair of sideband frequencies -- one above and one below the carrier frequency -- it is obvious that the upper sidebands contain exactly the same information as the lower sidebands. Hence, by eliminating one set of sidebands the channel width may be halved, and perfectly good communication obtained.

In America, most of the lower side-band frequencies are eliminated, after modulation, by means of a band-elimination filter circuit. The first 1.25 mc. of this side-band is transmitted, because if it were attempted to cut out all of these frequencies the carrier frequency itself would be reduced in strength and distorted. Since, however, the remaining 3.75 mc. of the lower sideband is not broadcast, the width of the television channel is reduced by the latter figure.

This type of transmission is sometimes called "vestigial" or "quasi-single-sideband" transmission. A typical channel is shown in Figure 3.

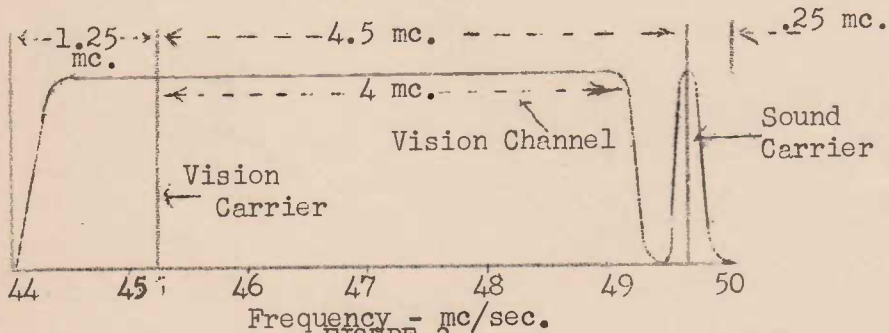

Note that the vision carrier is displaced towards the lower end of the television channel. The total width of the latter is 6 mc/sec., as before, but the wave carries video signals up to 4 mc/sec, as against 2.5 mc/sec, when using double sideband transmission.

FIGURE 3.

In the case of carrier frequencies at present in use in England and America, viz: 40-50 mc/sec, single sideband transmission confers the important advantage of considerably reducing the width of the channel required. The system, however, involves technical difficulties, and with the introduction of higher carrier frequencies of the order of hundreds of megacycles (as seem certain in time) the question of band-width will become less important, and the method will probably be discarded.

CHARACTERISTICS OF ULTRA-HIGH FREQUENCY WAVES.

Radio waves having frequencies above about 30 or 40 mc/sec. behave, in many respects, very differently from those with which we have been acquainted in ordinary sound transmission on the medium frequencies.

The chief of these differences are:-

- (1) They provide little more than "line-of-sight" communication.
- (2) They are practically free of natural "static", although particularly susceptible to "man-made" static (e.g. automobile ignition interference).
- (3) They are more readily directed in a beam. This point will be left to the next lesson.

Considering the line-of-sight characteristic it should be remembered that communication over a distance, say a hundred miles or more, is made possible by the wave being reflected back to the earth from the ionosphere -- an electrified layer of particles in the upper atmosphere. The direct wave is blocked, beyond a certain range (depending on the height of the transmitting aerial), by the curvature of the earth. (See Fig. 4.)

Ultra-high frequency waves are not reflected by the ionosphere, but pass into the latter and are either absorbed by it or lost in space. Communication, with such frequencies is therefore dependent entirely upon the direct -- (or ground) wave. Referring to Figure 4 the maximum range of the direct wave would be about the point D, where the distance TD is, T in a typical case, about 30 to 60 miles. The line-of-sight distance depends upon the height, above the land surface, of the observer, and also the nature of the country (whether flat or mountainous etc). It is important, therefore, that a television transmitter aerial be situated as high as possible above the ground. In New York the N.B.C's aerial is atop the Empire State building -- well over 1,000 feet above ground, and a coverage of about 60 miles radius is easily obtained.

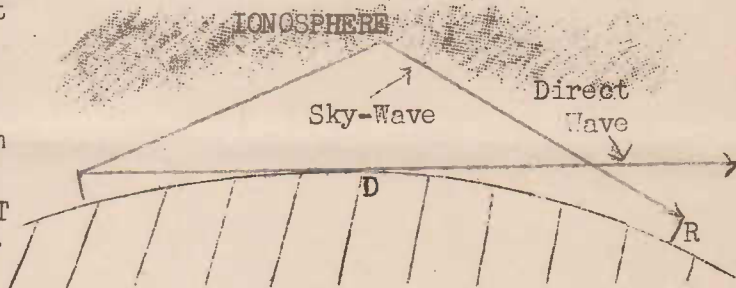

FIGURE 4.

This limitation of the range of a television signal is due only to the ultra-high frequency characteristic of the signal -- a characteristic which is required for other reasons already discussed. The fact that the signal of one transmitter is contained entirely within a limited area is in several respects, a decided advantage. In the first place indirect reception (from a sky or reflected wave) involves phase distortions, particularly when a wide range of side-band frequencies is involved. Phase distortions in the case of amplitude modulated sound reception does not affect the quality of the signal to any great extent. The effect of such distortions on a television signal, however, is so serious as to render the reproduction practically useless. Hence, even if we could use medium waves for television, with the greater range obtained, the reception at points distant from the transmitter would not be worth while.

Secondly the restricted coverage of the ultra-high frequency wave reduces the problem of interference between different transmitters situated in different cities. The question of such interference is an important one, on account of the

Broad channels required by television transmitters, and the consequent scarcity of the number of separate channels available. Transmitters situated perhaps only 100 miles apart, may, in some cases be operated on the same frequency, since the wave of one would not extend to the region covered by the other.

THE VISION TRANSMITTER.

In tracing the passage of a picture signal from its source -- the original scene -- through the television system until it finally reaches the receiver's reproduction tube, we shall now take up the story from the point reached in Lesson 4. It was explained how the electron camera generated the video signal, how the latter was amplified, and how the synchronising pulses were inserted. Figure 19 of the lesson showed in block form, the main studio equipment. Now the actual transmitter may be situated at some distance from the studio, and it will be necessary to discuss how the video signal is transferred from one to the other.

LINKING STUDIO AND TRANSMITTER.

The video signal from the studio is a very complicated affair, with a frequency range from 25 c/sec up to several megacycles/sec. Ordinary telephone lines or cables are quite inadequate for transferring such a signal, for the higher frequencies would be lost, and phase distortion would be introduced.

The usual link used between studio and transmitter is a special concentric cable of low loss. The construction of such a cable is shown in Figure 5. A hollow cylindrical sheath encloses a solid conductor or wire, the two being separated by insulating material. The sheath acts as one conductor, and the central wire as the other. This type of cable is also sometimes called a "coaxial" cable.

The linking cable must be designed to carry currents of all frequencies in the video signal, say from 25 cycles/sec up to 3 or 4 mc/sec., without attenuating, or reducing, one current more than another. This requires special insulating materials, since most insulators used in ordinary radio work absorb much more electrical energy when the frequency is high than they do at low frequencies.

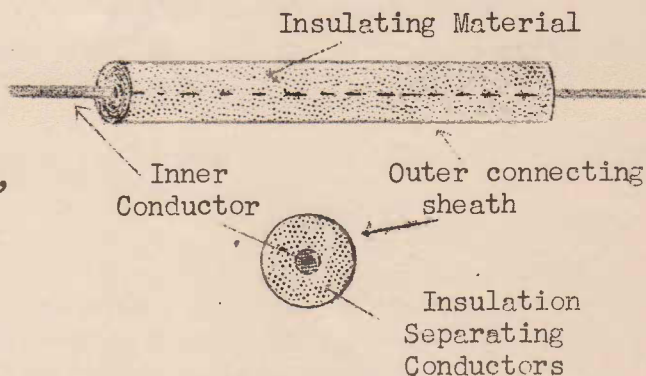

FIGURE 5.

An important characteristic of the coaxial cable is that the outer cylindrical conductor also acts as a shield. For this reason the video signal is free from electrical interference from outside sources.

Another use of the concentric or coaxial cable is for linking the television camera with the studio equipment. In the previous paragraphs we have been discussing the task of carrying the complete video signal to a distant transmitter for radiation. Now we are going back in the system to the original camera signal. When outdoor

events are being televised the camera may be some distance from the actual studio. Providing the distance is not too great a coaxial cable may be used. Used in this connection a complete coaxial cable is required for each camera, together with a number of ordinary wire conductors to operate camera electrode circuits, deflection circuits etc. Usually all these conductors are included in the single cable, the coaxial cable (for the camera video signal) and other wires being separated by insulating material. Figure 6 shows a typical cable of such a type. Note that two concentric cables, together with auxiliary wire circuits are provided.

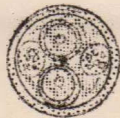
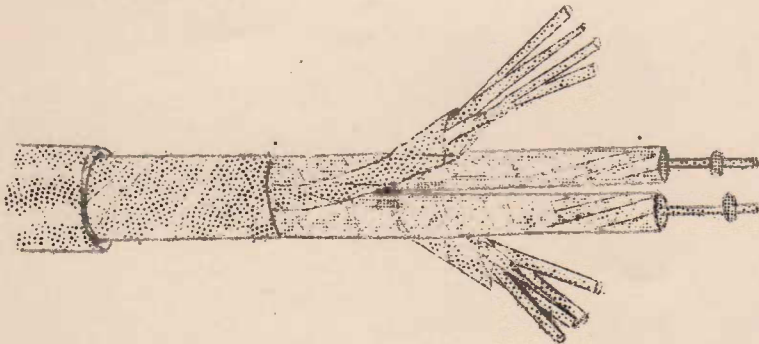

FIGURE 6.

comparatively low or intermediate frequency of the order of 20-30 mc/sec. This, of course, is still a "carrier" frequency carrying the video modulation. The intermediate frequency is then amplified, and finally the frequency is stepped up to that of the station's normal channel, usually between 40 and 70 mc/sec. At this frequency it is radiated at high power. Note that the transmitter vision receiver consists only of R.F. and I.F. sections. No detection or demodulation is carried out.

Figure 7 shows a typical radio link as used in one of the New York stations, where the main transmitter is distant 12 miles from the studio. Note, in addition to the points discussed in connection with the vision signal, that the sound signal uses frequency modulation. The transmitter's receiver which picks up the linking signal demodulates the wave, thus re-producing the original audio signal. The latter is used to modulate the high power wave generated at a frequency adjacent to that of the vision signal.

GENERATION OF ULTRA-HIGH FREQUENCY CARRIER.

The generation of stable radio frequencies in excess of about 30 mc/sec. presents considerable difficulty. The reason for this is that, in order to maintain the constancy of frequency required for the allotted channel, crystal control of the oscillation is essential. Now quartz crystals, used for this purpose, cannot be ground for higher frequencies than 30 mc/sec.

Returning to the question of linking studio with the radiating transmitter, a system which is gaining favour, particularly when considerable distances are involved is the radio link. This system involves the use of a complete low powered transmitter at the studio. The main high powered transmitters, some distance away are provided with receivers to pick up the signal from the studio -- one receiver for the vision signal and the other for the sound. The linking vision transmitter (low powered) is usually operated on a very high frequency -- up to 200 mc/sec. At the main transmitter this frequency is reduced by means of a converter to a

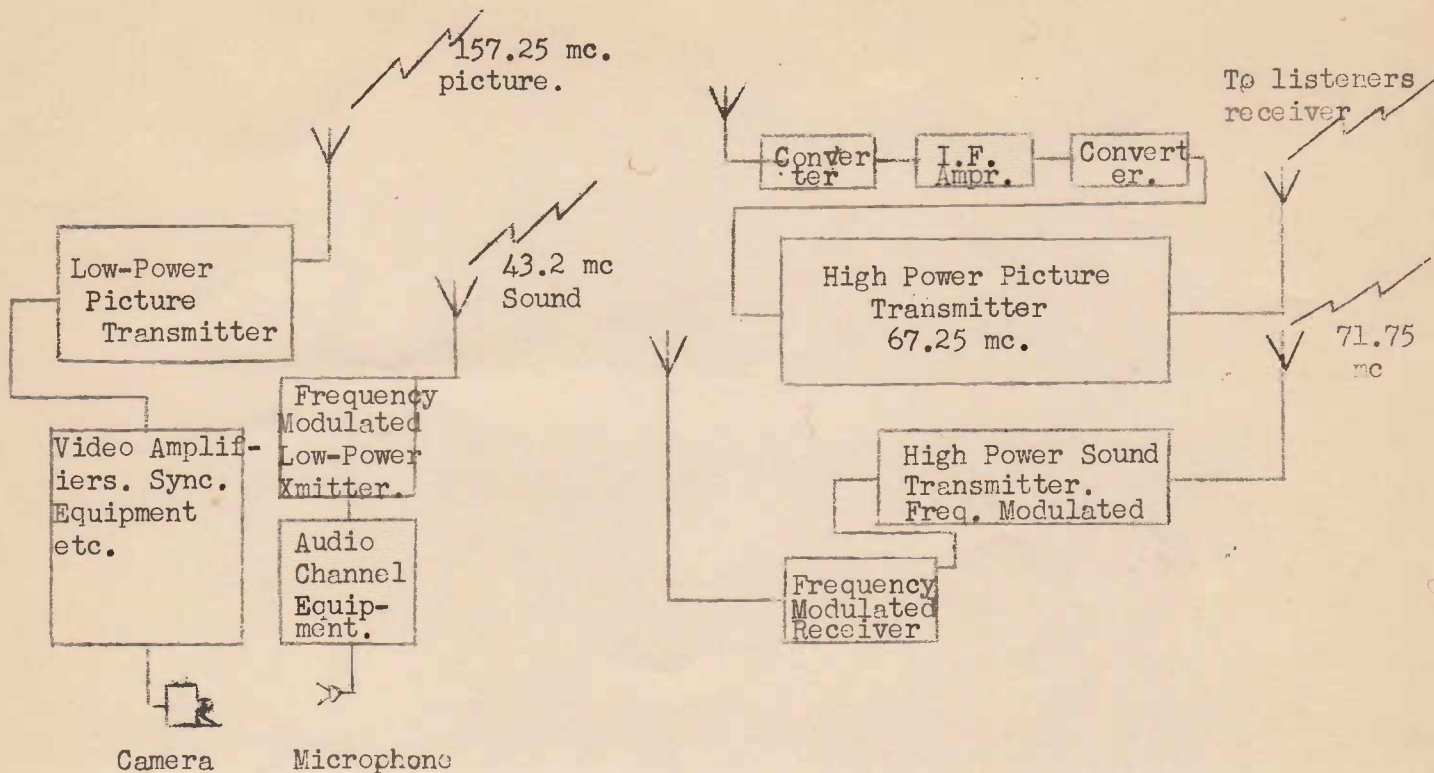

STUDIO ← 12 miles → TRANSMITTING STATION.

FIGURE 7.

The system in more or less general use comprises a low-powered oscillator (say 5 to 10 watts) controlled by a crystal ground for a frequency of about 5 mc/sec. Remember, in this connection, that the frequency is determined by the thickness of the crystal, the latter acting as if it were a tuned circuit. The thicker the crystal, the lower the frequency, and vice versa. Although, as stated above, a crystal may be ground thin enough to produce a frequency as high as 30 mc/sec, this comparatively low frequency is preferred to obtain the advantages of greater frequency stability, which the thinner crystal lacks.

FREQUENCY MULTIPLIERS.

Since it is desired, for reasons already discussed, to radiate the signal in the ultra high frequency region of 40 mc/sec or higher, it is necessary to step-up the frequency of the lower powered oscillator from the 5 mc/sec or so to that of the carrier chosen. This frequency multiplication is achieved by special amplifying stages known as "Frequency Multipliers".

A frequency multiplier is simply an amplifier, operated so as to produce considerable distortion of the input voltage, and with its plate circuit tuned to a harmonic of the original voltage.

Figure 8 illustrates the principle of the circuit. Applied to the grid is an A.C.

sine-wave voltage of, say, frequency 5 mc/sec. The tube is heavily biased (near cut-off), so that the plate circuit current is greatly distorted compared with the input voltage. As shown at (b) (Fig. 8) the tubes output current

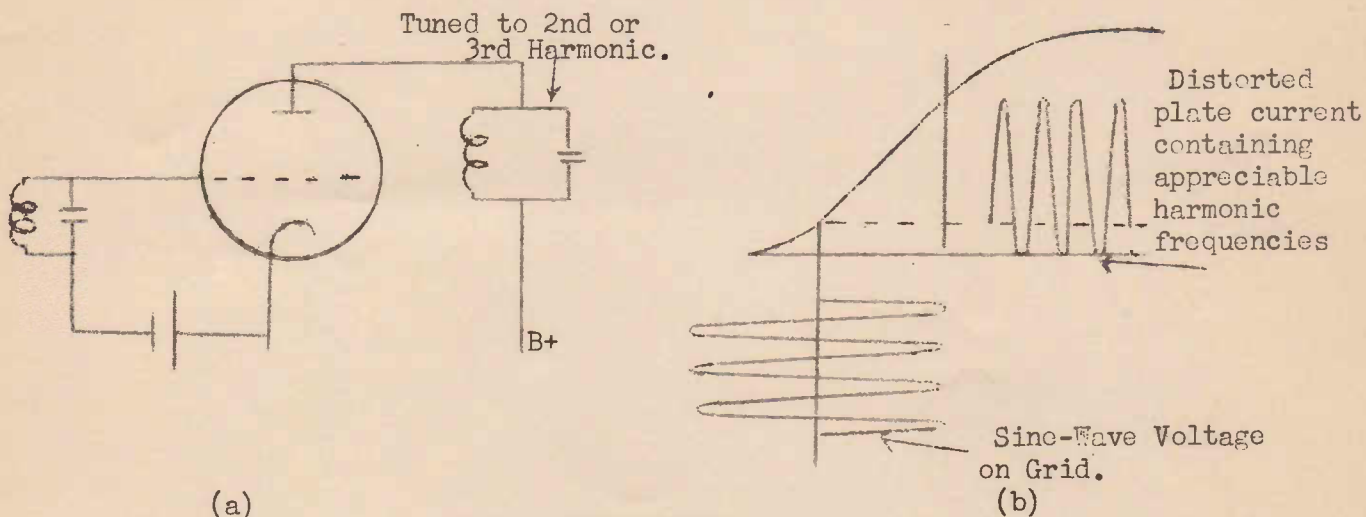

FIGURE 8.

contains an A.C. current of the same frequency as that of the input, but one having practically all the negative half-cycles cut off. Now, when a sine-wave current is distorted, and the resulting current is analysed, the latter is found to contain a number of harmonics, i.e. currents whose frequencies are multiples (twice, three times etc) the original frequency (called the fundamental). These harmonic currents are all of pure sine-wave form. The greater the distortion, the greater will be the number of harmonics generated, and the stronger they will be.

The plate tuned circuit (Figure 8a) is adjusted to have a resonant frequency tuned either to the second or the third harmonic of the original input frequency. When tuned to the second harmonic the stage is called a Frequency Doubler. When tuned to the third harmonic it is called a Frequency Tripler. The plate tuned circuit will emphasise the harmonic frequency to which it is tuned, and will virtually eliminate all other frequencies (including the fundamental, i.e. the input frequency). In this way, if a voltage of frequency 5 mc/sec is applied to the grid of the tube, the output voltage will be either 10 mc/sec. (Frequency Doubler) or 15 mc/sec. (Frequency Tripler). By using a number of these frequency multiplier amplifying stages the frequency of the low powered 5 mc/sec. oscillation may be stepped up to the final carrier frequency which is usually between 40 and 70 mc/sec.

Figure 9 shows in block-diagram form a typical 7.5 Kilowatt transmitter for the vision signals. The crystal oscillator operates at a frequency of 5.65625 mc/sec. The frequency is then progressively increased by three frequency multiplying stages, producing an over-all frequency multiplication of eight times, yielding finally the carrier frequency of 45.25 mc/sec. The signal, at this final frequency is then handled by three R.F. voltage amplifiers before being passed on to two power amplifiers -- the Intermediate and the Final Power Amplifier. The latter are operated Class C and supply the antenna with the 7.5KW required.

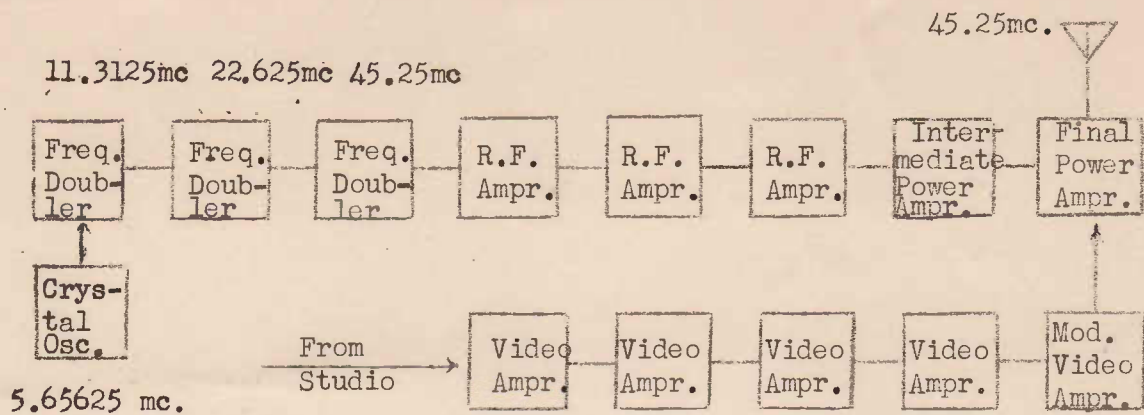

FIGURE 9.

Note that the modulation of the radio-frequency carrier is carried out in the final power amplifying stage. This is called "High-level" modulation, and is the usual, though not universal, practice. The video signal from the studio, consisting of camera signal plus synchronising pulses, at a level of about 1.0 volt (peak to peak) is built up by five video amplifiers to a level of 350 volts which are necessary to modulate the powerful final R.F. amplifier.

MODULATION OF THE CARRIER WAVE.

Thus far we have discussed in some detail the generation of the video signal and the generation of the radio frequency carrier current. The time has now come when we must consider the problem of how the video signal is superimposed upon the carrier-wave -- that is the problem of modulation.

Amplitude modulation of the vision signal is universally adopted -- that is the amplitude, or strength, of the carrier current is made to vary in step with the video modulating current. Two questions now arise. The first of these questions is: shall we cause the amplitude of the carrier to rise or to fall when the picture brightness increases? When we arrange matters so that the carrier strength increases with an increase in picture brightness, and to decrease as the spot traverses a darker area the modulation is called Positive Modulation. When the reverse action occurs, i.e. when the carrier amplitude decreases with an increase in brightness, and increases when the light from the picture decreases, the modulation is said to be negative. The second question is: how will we insert the synchronising pulses (already briefly mentioned in a previous lesson) so that the latter will not interfere with the actual picture signal? To answer both these questions we must examine in more detail the nature of the complete video signal in the modulating stage (see Fig.10) of the transmitter.

THE COMPOSITE VIDEO SIGNAL-POSITIVE AND NEGATIVE SIGNALS.

Figure 10 shows at (a) a positive video modulating signal for three complete scanning lines. Note that the signal is represented by a varying (or pulsating) direct current, and not an alternating current as in the case of an audio modulating signal. The video current is divided into two sections. The upper section

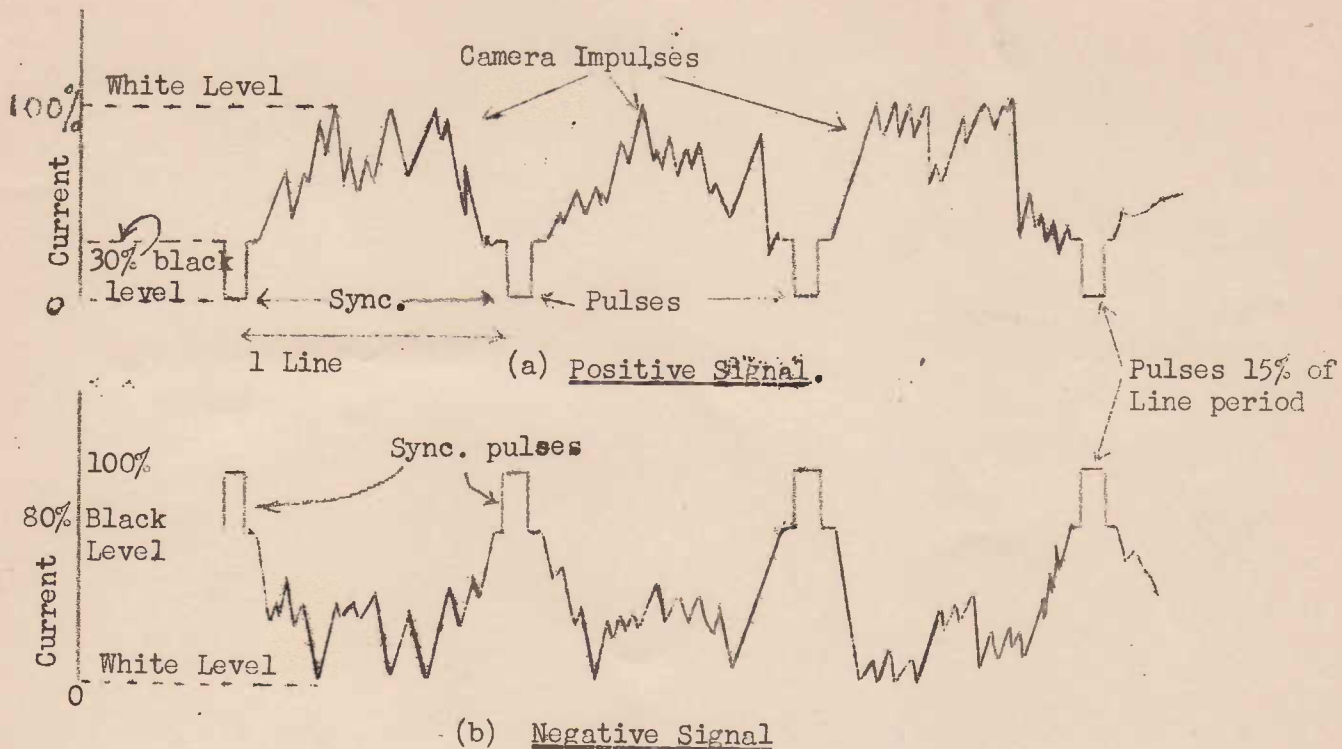

VIDEO SIGNALS.
FIGURE 10.

comprising about 70% (i.e. from 30% to 100%) of the maximum amplitude is devoted to the camera signal. Within this range the variations in current represent the variations in light and shade as the picture is scanned. Note that maximum current represents a pure white portion of the picture, and 30% current represents pure black, i.e. no reflected light from the scene. The lower section of the composite video current, i.e. from zero to 30% maximum is devoted to the synchronising signals. These consist of short duration downward (or "negative") pulses inserted in the gaps between successive lines. During each of the gaps or intervals the scanning beams (at both transmitter and receiver) are returning from the right hand side to the left of the screen, preparatory to commencing a new line. The synchronising pulses, representing sudden or abrupt changes in voltage are utilised in the receiver to regulate the frequency of the saw-tooth oscillator which provides the horizontal movement of the electron beam (i.e. the line scanning). The gaps between the lines represent a time of about 15% of the line interval (i.e. the time taken to scan one complete line). Note that the synchronising pulses occupy a time rather less than the total interval between the lines. This is to avoid any possibility of the pulses interfering with the picture signal.

The effect, then, of the synchronising pulses is to reduce the video signal's amplitude from 30% to zero. Any current less than 30% of the peak represents "blacker-than-black" or, as it is called, infra-black. It is obvious that the sync. pulses could not show up on the receiver screen, since they represent voltages less than that which produces pure black.

At (b) in Fig. 10 a negative video signal is shown. Here picture signals are

represented by current variations extending from zero up to about 80% of the maximum amplitude. Zero voltage is utilised to represent pure white, and the 80% level pure black. This means that an increase in voltage represents a decrease in light intensity, and vice versa. Hence the term "negative" signal. In this case voltages ranging from 80% to 100% of the peak represent the "blacker-than-black" or ultra-black region. It is this region that is occupied by the sync. pulses. That is, the sync. pulses are represented by sudden increases in voltage from the 80% peak level up to the max. (100%) peak level. The 80% or black level is sometimes called the "blanking" level, because all picture signals above it are blacked out.

In the case of both positive and negative signals it should be appreciated that the receiver will be able to separate the synchronising pulses from the actual picture signal, because of the difference in amplitude of these two parts of the composite video signal. Just how this is done will be dealt with in the appropriate lesson on receivers.

POSITIVE AND NEGATIVE MODULATION.

The result of utilising each of the two types of video signal to modulate the outgoing wave in the final power amplifier of the transmitter is shown in Fig. 11.

At (a) positive modulation is shown, and at (b) negative modulation. Remember when referring to this diagram that the radio-frequency carrier current is an alternating one with both positive and negative half cycles. The effect of the modulation in either case is to vary the amplitude of this radio-frequency alternating current -- both positive and negative half-cycles being similarly effected. Lines are shown joining the peaks of the r.f. half-cycles and these lines are replicas of the modulating video signal. Such lines represent what is known as the modulation envelope. Note that the envelope for the positive half-cycles is exactly similar to that for the negative half-cycles. Henceforth, for this reason, we shall only show the envelope for the positive half-cycles.

Referring to Figure 11 (a) note that the carrier amplitude is increased to 100% (100% modulation) for a white element of the picture, and reduced to 30% of peak amplitude for jet black. The sync-pulses, between lines, reduce the carrier strength further, from 30% to zero.

In the case of negative modulation at (b) Fig. 11 pure white is represented by zero carrier amplitude, and jet black by 80% of peak amplitude. The carrier is only increased to 100% by the sync. pulses occurring between lines.

POSITIVE AND NEGATIVE MODULATION COMPARED.

For positive modulation it is claimed that electrical interference is less liable to cause synchronisation troubles. Experiment has shown that such interference causes sudden sharp increases in carrier amplitude, rather than reduction in this amplitude. Since with positive modulation, the sync. pulses cause a reduction of carrier amplitude (from 30% to zero) the latter will be relatively immune from the effects of electrical interference. Such interference, on the other hand,

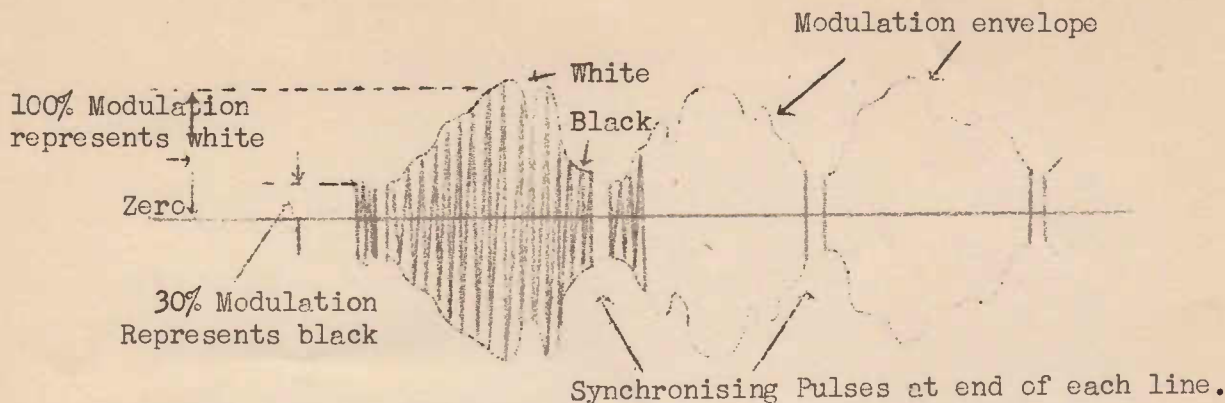

FIGURE 11 (a)

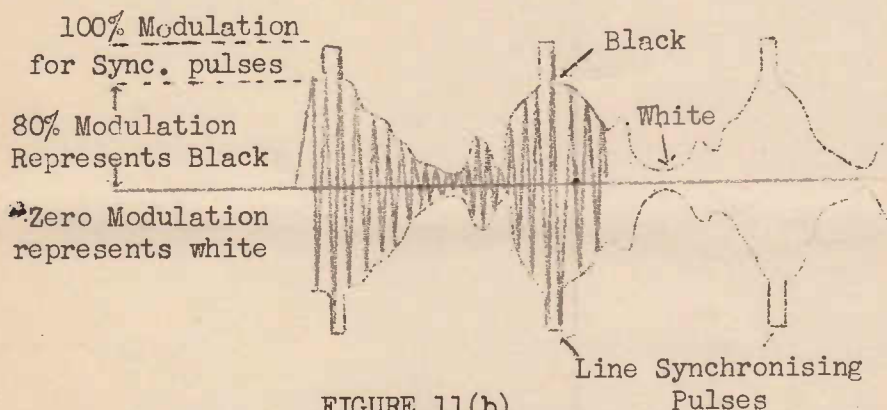

FIGURE 11(b)

causing sudden rises in carrier amplitude, will result in white flashes on the screen, marring the reproduced picture.

If negative modulation is used the interfering impulses may carry the carrier amplitude into the infra-black region of the carrier's modulation, which region is occupied by the sync. pulses. The effect of

this is that the receiver could mistake an impulse above the 30% level caused by interference for a true sync. pulse. The result would be that the receiver's scanning would lose synchronisation with that of the receiver.

From the point of view of the picture information, however, negative modulation has the advantage. Interference, resulting mainly in increases in carrier amplitude, would result in dark flashes on the screen. Dark flashes are much less noticeable than bright (white) flashes.

With improvements in sync. equipment experience has shown that synchronisation is not unduly affected by interference when negative modulation is used. It appears, therefore that the advantages of negative as compared with positive, modulation, outweigh the disadvantages. It seems certain that in future negative modulation will be adopted everywhere. It might be mentioned here that, at present, positive modulation is used in England, and negative in America. Henceforth we shall only refer to negative modulation.

ELECTRONIC INTERLACED SCANNING.

To complete our description of the nature of the video signal which modulates the

carrier in the transmitter's output stage, we must also discuss the nature of this signal during the frame retrace period, i.e. the interval of time when the scanning beam is returning from the bottom of the picture to the top.

No picture signals, of course, are transmitted during this frame retrace interval, which is utilised for sending special pulses for synchronising the receiver's frame (or vertical saw-tooth oscillator). Since the method known as "Interlaced" scanning is now in universal use, and further since the nature of the vertical or frame sync. pulses are closely bound up with this type of scanning, it will now be necessary to explain briefly how interlacing is achieved electronically.

The student should recall that interlaced scanning involves the tracing of the lines not in a consecutive fashion, but alternately. That is, during any one "frame" every other line is traced out over the whole picture area. Similarly, during the following frame, alternate lines are traced, but these are adjusted to fill in the gaps missed during the first frame. This involves two complete frames per complete picture.

The mode of interlacing the lines for a complete picture is illustrated in Figure 12. We are here supposing that 405 lines per picture are used. The lines traced out during the first frame are shown by continuous black lines in the diagram. Those traced during the next frame are shown by dotted lines. During the first frame lines numbered 1 to 202 are completely covered, and line No. 203 is half covered. This is usually referred to as an "odd" frame. The student should recall that while the horizontal saw-tooth oscillator is moving the electron beam across the picture, the vertical saw-tooth oscillator is simultaneously moving it down the picture, but at a much slower rate. This, of course, is responsible for the fact that the lines are sloping slightly, instead of being perfectly horizontal. In the time that one line is scanned from left to right, the vertical saw-tooth oscillator has moved the beam down a distance equal to the width or thickness of two lines. This is achieved by operating the latter oscillator at twice the picture frequency, viz: a frequency of 50 cycles/sec, instead of 25 c/sec. In this way alternate lines are missed.

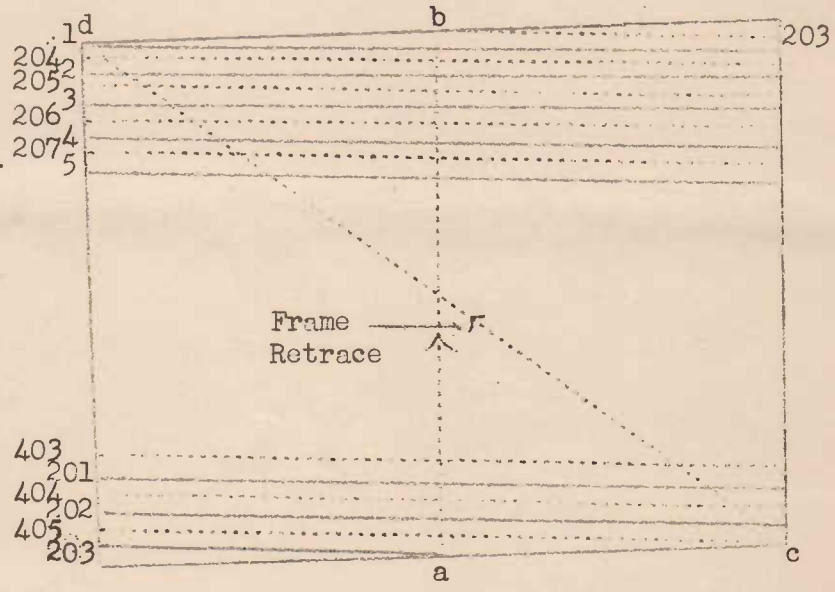

FIGURE 12.

When the 203rd line has only half traversed the picture, the vertical sync. signal (acting upon the vertical saw-tooth oscillator) suddenly causes the spot to flick back to the top of the picture (see a.b. Fig.12), completing the 203rd line there.

This is the beginning of the next frame. During this frame the lines 204 to 405 are traced out, covering those portions of the picture missed during the first frame. This is called an "Even" frame. At the end of the complete 405th line the vertical oscillator suddenly shifts the beam from the bottom to the top of the picture, and the horizontal (line) oscillator moves it from the left to the right. Hence the beam returns abruptly from c to d., to begin the next odd frame. Note the reason for using an odd number of lines, like 405, for scanning. This gives $202\frac{1}{2}$ lines per frame, and the odd half-line gives the necessary shift to produce the interlacing.

The diagram of Figure 12 represents an idealised case. Here, for simplicity, it was assumed that the beam could return from the bottom of the picture to the top instantaneously, i.e. that the retrace was zero. In practice this time is very short compared with the line taken for uniform downward motion, but still it is sufficient for about 10 line oscillations to occur. This means that at the end of any frame 10 lines (or so) must be "blanked" out, otherwise the frame retrace would show up as a zig-zag path on the screen. Since there are two frames per picture 20 lines (out of the 405) in all will not be used for sending picture information. These are the so-called "inactive" lines. Note that with 405 line scanning only 385 (405 minus 20) are actually used to transmit picture information.

THE VIDEO (MODULATING) SIGNAL BETWEEN FRAMES.

The synchronising signals for timing the horizontal (frame) saw-tooth generator in the receiver are transmitted, as a modulation of the carrier waves, in the intervals between successive frames, i.e. every $\frac{1}{50}$ th second (50 frames/sec.).

The student will appreciate that the receiver must be able to distinguish between the framesync. pulses and the line sync. pulses, these latter recurring every $\frac{1}{10,125}$ of a second ($405 \times 25 = 10,125$ lines/sec). For this reason the frame pulses must differ in some way from the line pulses. Further the intervals between frames will differ, depending upon whether an odd or an even frame has just been completed.

As mentioned above, an appreciable interval of time will elapse between the end of one frame and the beginning of the next. This interval is usually 5% ($\frac{1}{20}$ of $\frac{1}{50}$ sec. = $\frac{1}{1,000}$ sec. or more. The student should recall the method whereby (lesson 3) the beam is moved for scanning purposes. A voltage which rises and falls with a saw-tooth wave-form is applied between a pair of deflector plates in the camera tube or cathode ray tube. These saw-tooth voltages are generated by special oscillators. Figure 13 shows one and a half cycles of a saw-tooth voltage as used for the frame scanning. The frequency here is 50 cycles/sec, so that the time for one cycle (ac) is $\frac{1}{50}$ sec. As the voltage gradually rises from a, b the beam moves at uniform speed down the screen. During the whole of this time, of course, the horizontal saw-tooth generator operating at the much higher frequency of 10,125 c/sec. is moving the beam across the screen for line scanning. When the voltage has risen to (b) Figure 13 the beam has reached the bottom of the picture, and one frame is completed. Now the voltage falls to zero, not instantaneously but along bc.

This moves the beam back to the top of the screen, for the beginning of the next frame. The time represented by dc , during which the beam is returning from bottom to top of the picture is called the "fly-back" time.

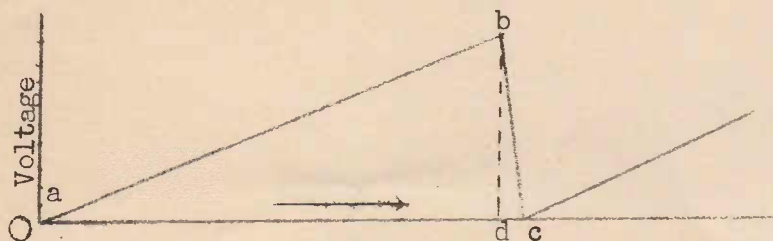

FIGURE 13.

interval which occurs between frames, gives us ample opportunity to insert the frame sync. pulses. Note also that during this between-frames interval about 10 complete lines will be traced.

The first job then will be to suppress the line signals between frames. This is done by impressing a "blanking" signal on the video signal for the duration of 10 complete lines. The blanking signal simply raises the signal amplitude to the "black" level for the duration of the intervals (see (a) Figure 14). This of course will obliterate any camera picture signal (which occurs below the 80% black level).

The synchronising pulses are now superimposed on the blanking signal. These pulses of course carry the modulation up to 100%. The interval at the end of even frames is shown at (b) Figure 14. Line 405 has just been completed during the previous even frame.

The camera signal is blanked out at this instant and 8 broad pulses for frame synchronising follow. These eight broad pulses (each having a duration of half a line) form the frame sync. signal. On account of the great difference between the wave-form of this frame sync. signal and the line pulses, it is possible by using special circuits at the receiver to separate the two.

Following the frame sync. pulses there are 6 lines which carry line sync. pulses, but no camera signal. This allows the line synchronisation to settle down, before the next frame commences on line number 11.

The interval at the end of odd frames is somewhat different. This is shown at (c) Figure 14. When line number 203 is half completed the blanking signal cuts out the camera signals and the frame sync. signal commences. This, as before, consists of eight broad pulses covering four complete lines. Note that the blanking signal persists as before for 10 whole lines. The next frame therefore commences at the latter half of line number 212.

The important point to realise is that provided the sync. signals get through to the receiver undistorted, odd frames must commence at the beginning of a line,

Now the point is, that in designing saw-tooth oscillators of this frequency it is difficult to obtain a fly-back time less than about 5% or $\frac{1}{20}$ of the period of one cycle (ac in Fig. 13). In practice, therefore the fly-back time, dc is, as calculated above, about $\frac{1}{1,000}$ sec. or so. This

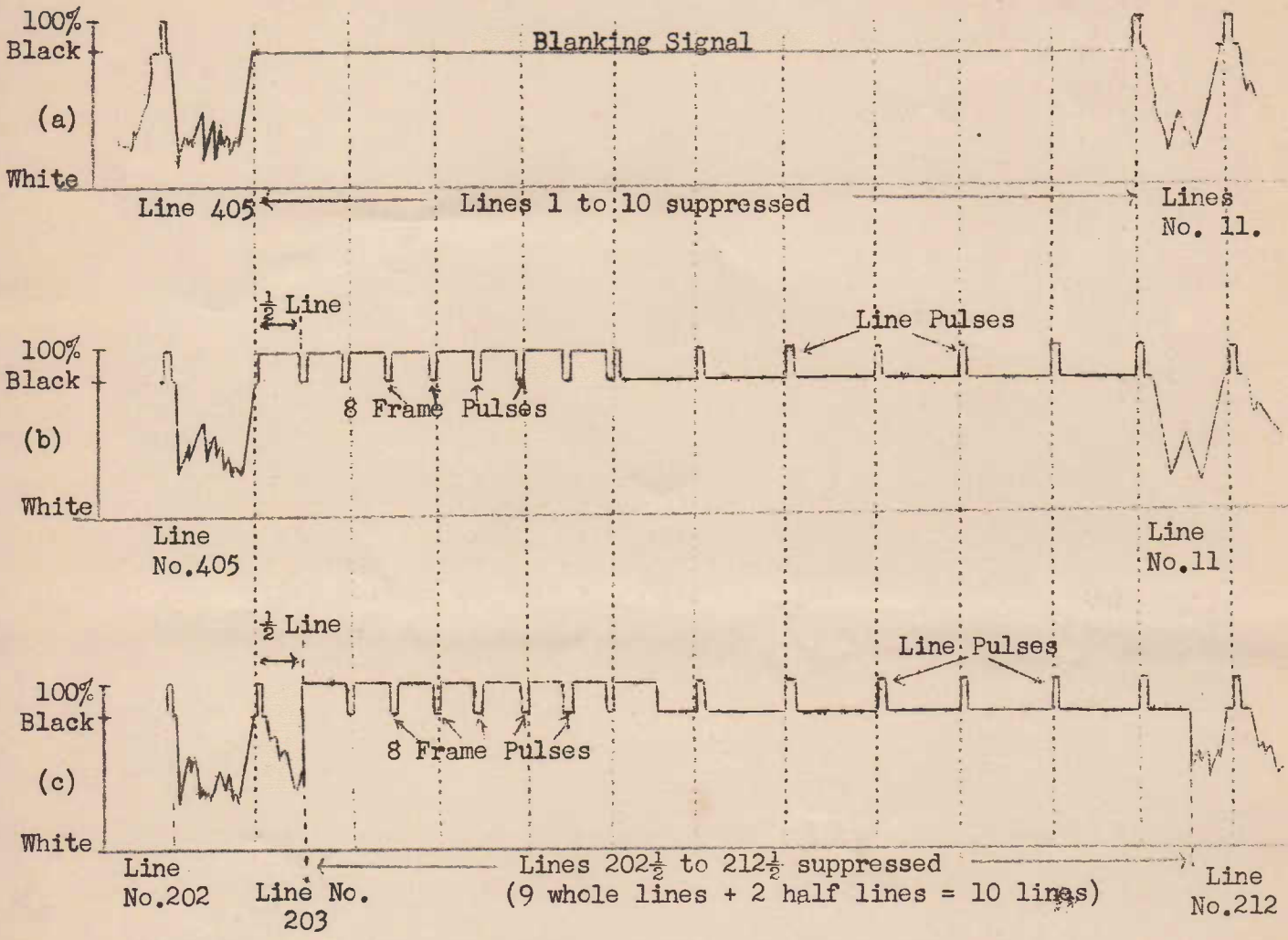

(a) and (b) at end of even frames; (c) at end of odd frames.

FIGURE 14.

and end half way through a line, while even frames must commence on the latter half of a line and end at the finish of a complete line. This, as explained in connection with Figure must automatically ensure correct interlacing. Note that the system involves the use of an odd number -- like 405 or 441 -- of scanning lines per complete picture.

THE SOUND CHANNEL.

As explained earlier in the lesson the present system is to transmit the sound on a separate channel adjacent to that used for the vision. The receiver's aerial tuning may thus, if broad enough, bring in both vision and sound signals simultaneously.

Since the vision channel must, for reasons already discussed, be located within ultra-high frequency range (above 40 mc/sec), this system also involves the choice of an ultra-high frequency for the sound. Now these frequencies are eminently suited for frequency-modulation with its associated advantages of freedom from interference and high fidelity. For this reason the tendency at present is to use amplitude modulation for the vision signal, and frequency modulation, on a separate, but adjacent, channel for the sound. The B.B.C. in England, however, uses amplitude modulation for both.

SINGLE CARRIER FOR VISION AND SOUND.

With the development of a new type of modulation for sound, known as Pulse Modulation, it has been found possible to transmit the sound on the same carrier as ~~is used for the vision signal.~~

In the case of this system the sound modulates the carrier only during the brief intervals between scanning lines, which interval is also used for the sync. pulses. Instead of transmitting the sound programme continuously it is found to be sufficient to transmit a larger number of "snap-shots" of the sound every second. The receiver may be so designed as to reconstitute the programme from these snap-shots. An analogy may be drawn here to a series of cinematograph "stills" which when passed through a projector at a sufficiently rapid rate will produce the illusion of a moving picture. Similarly a series of sound "stills" when passed through a receiver can reproduce a continuous sound programme. Whereas, however, the eye is satisfied with 24 picture snap-shots per second, the ear requires at least 6,000 sound snap-shots per second if intelligible sound is to be received.

If a 405 line, 25 picture per second system is used, as in England, the line frequency is 10,125 lines per second. This allows us to send 10,125 "snap-shots" of the sound every second, by inserting them during the line intervals.

A number of systems of pulse modulation have been developed. The most successful for television purposes, seems to be that whereby the width of special pulses (placed in the line intervals) is made to vary with the instantaneous amplitude of the modulating sound voltage. This is called pulse-width modulation. In pulse-height modulation the height of the pulse is caused to vary with the instantaneous value of the modulating voltage. A third system is to vary the repetition frequency of the pulses with the modulation (pulse-frequency) modulation. Still another arrangement is to vary the position of the sound pulses -- the exact position of any one pulse depending upon the amplitude of the modulating voltage at that instant. This is called pulse-phase modulation.

The idea of pulse-height and pulse-phase modulation is exemplified further in Figure 15. At (a) ~~is shown~~ the modulating (audio) voltage. At (b) the pulses vary about a mean height in accordance with the amplitude of the modulation at that instant. At (c) the pulses have constant repetition frequency, and constant height, but their width varies with the modulation as shown.

If pulse-width modulation is used, the maximum width of the pulses during the

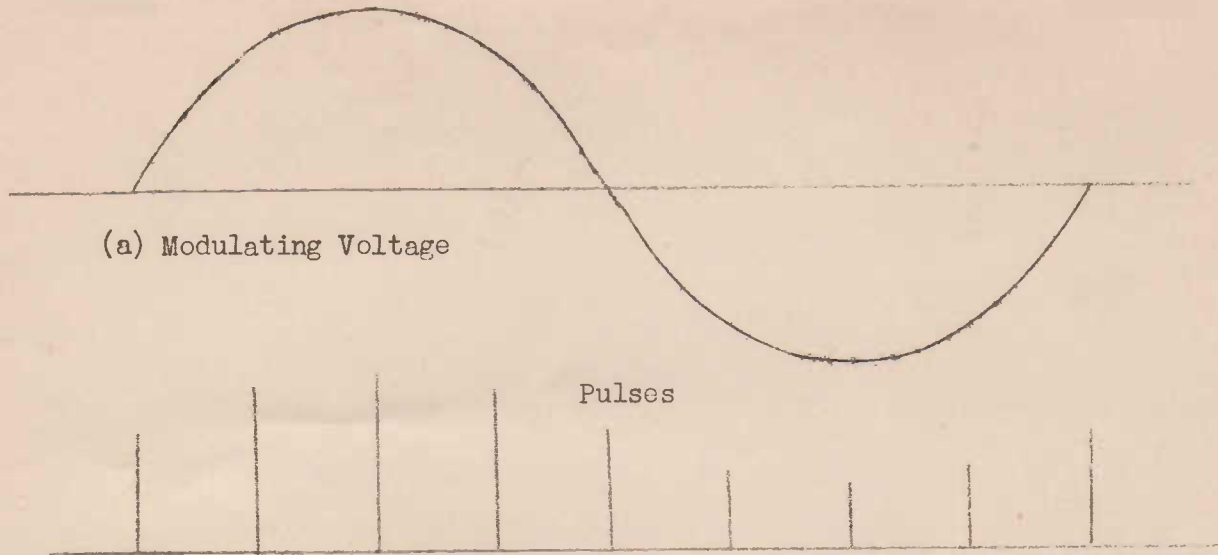

(a) Modulating Voltage

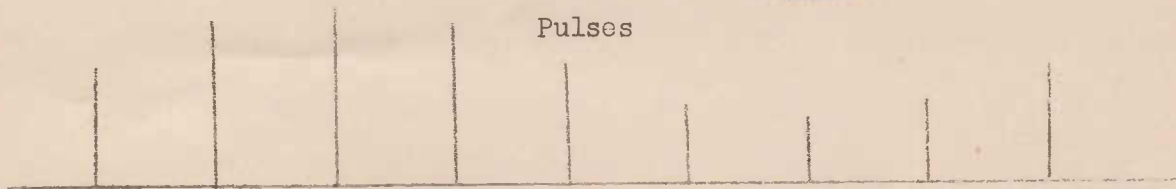

(b) Pulse height modulation. Pulses constant repetition frequency. Variable height.



(c) Pulse-Width Modulation. Pulses constant repetition - Frequency variable width.

FIGURE 15.

modulation must be somewhat less than the line sync. pulses between lines. When the line frequency is 10,125 sec, the gap between lines is usually about 10% of the line interval, i.e. a time of only about $\frac{1}{101,250}$ of a sec. (i.e. approx. 10

micro-seconds). The widest sound pulses (i.e. those of longest duration) must be considerably less than this, which means that the narrowest pulses are of extremely short duration indeed.

The wave form of a complete video signal together with sound-pulses (width modulation) is shown in Figure 16 at (b). Here positive modulation is used. The sync. pulses therefore, as explained, reduce the signal amplitude to zero (negative pulses). The sound pulses, superimposed upon those sync. pulses, increase the signal amplitude to 100%

A problem is to provide means of separation, at the receiver, of the sound pulses from the vision signal. Earlier it was explained how the sync. pulses could be separated from the vision. This was done, in the case of positive modulation, by limiting the vision signal to the range of 30% to 100% modulation. The sync. pulses then operated in the range 30% - 0% modulation. When pulse modulation is

used for sound, one method of separation is to further limit the vision signal so that pure white is something less than 100% modulation, say 80%. Then the vision signal occupies the range 30% (black) to 80% (white) of peak modulation. Since the sound pulses extend to 100% modulation their upper 20% may be "sliced off" in the receiver without interfering with the vision signal. In this way separation is achieved.

Advantages claimed for pulse-modulation are many. They include (1) a simplified receiver (2) freedom from interference (3) total band-width of television channel is reduced (4) mutual interference between sound and vision channels is eliminated, (5) installation and maintenance costs of transmitter are reduced, for no separate transmitter is required for the sound programme.

Experiment and theory show that the maximum frequency (audio) of modulation is

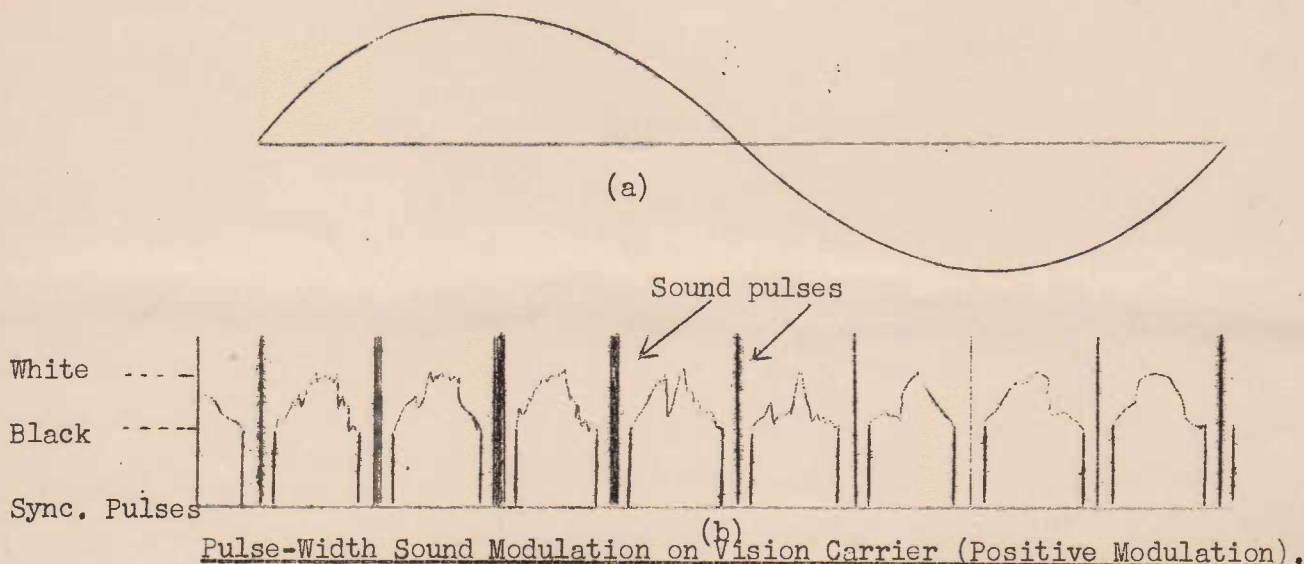

Pulse-Width Sound Modulation on Vision Carrier (Positive Modulation).

FIGURE 16.

one-half the frequency of repetition of the pulses. In the case of a 405 line, 25 picture/sec. transmission this repetition frequency is 10,125 per sec. (i.e. the line frequency). Therefore the audio frequency transmitted is limited to about 5,000 cycles/sec. This gives sufficient tonal quality for the average listener, but falls short of high-fidelity transmission. Of course if the number of lines of the scanning system is increased, the repetition frequency of the pulses will be correspondingly increased, thus allowing of a high audio frequency modulation limit. A likely trend seems to be the introduction of very-high definition (600 lines) colour television, operating in the vicinity of 600 mc/sec ($\frac{1}{2}$ metre). The line frequency in this system would be 15,000 per sec., allowing of an audio frequency limit with pulse modulation of 7,500 cycles/second.

T. FM & F. No. 6.

EXAMINATION QUESTIONS.

1. State two reasons for the use of ultra-high frequency carriers for television purposes.
2. What is meant by "single side-band" transmission? What is its advantage?
3. In modern television systems why is the sound carrier channel situated adjacent to (either just above or just below) the picture carrier channel.
4. State three characteristics of ultra-high frequency waves compared with medium and low frequency waves.
5. Why is it unsatisfactory to use an ordinary telephone cable or line for the purpose of linking a distant television camera to the studio? Mention briefly the methods in use.
6. What is the function of a frequency multiplier? Explain briefly the reason for using this method to obtain the ultra-high frequency required for the carrier.
7. Explain the difference between positive and negative modulation of a picture-carrier.
8. Explain carefully why, in the case of negative modulation, the picture modulation is limited to 80% of the total signal amplitude.
9. In the case of interlaced scanning why is an odd number of lines used?
10. Why is no separate sound carrier required when pulse modulation is used? State the advantages claimed for this system.

AUSTRALIAN RADIO COLLEGE

E. S. & A. BANK BUILDINGS, Corner CITY RD. and BROADWAY, SYDNEY

Telephones: M 6391 and M 6392. Post Lessons to Box 43, Broadway

This lesson sheet is published for the exclusive use of
students of the Australian Radio College Pty. Ltd.
(All rights reserved)



TELEVISION, FREQUENCY MODULATION & FACSIMILE.

LESSON NO. 7. AERIALS.

The question of aeri-als is relatively more important in television work than it is in the case of normal radio telephony in the broadcast band. The student well knows the lack of attention usually displayed in the installation of an aerial for the home-radio. Certainly excessive carelessness is often shown in this respect, the performance of a receiver being frequently marred to some degree by failure to observe simple elementary principles. The fact remains however, that the performance of the average broadcast receiver is not critically affected by the aerial installation under the great majority of operating conditions. And in only rare cases is any great knowledge of aerial theory and technique required by the serviceman.

When we are dealing, however, with ultra-short wave communication in general, and in television in particular, the aerial installation looms much larger in the picture. The performance of a television receiver can be made or marred by the type of antenna system provided, and the manner of its installation. The term "antenna system" has been used here purposely to include the so-called "lead-in". The design and adjustment of the latter is of at least equal importance as that of the aerial proper.

The underlying reasons for this stress on the antenna system of a television receiver are bound up with the ultra-short-wave (high frequency) nature of the carrier wave, and also with the necessity to avoid relative phase-shift (i.e. time delay) in the handling of the different parts of the signal. These points will be explained as the lesson progresses.

RESONANT AND NON-RESONANT AERIALS.

A resonant or tuned aerial is one which, like an ordinary tuned circuit, responds best to one particular frequency. As we shall see the resonant frequency of an aerial depends upon its length. This length, therefore, must bear a definite relationship to the wave-length of the desired signal. In normal broadcast reception the antenna usually shows very little resonant effect, and, in any case, rarely is any attempt made to tune it to the received wave.

THE HALF-WAVE DIPOLE.

The fundamental resonant aerial is that called the Half-Wave Dipole. This consists simply of a straight length of wire, or more usually a rigid rod, having a length approximately equal to one-half of the radiated or received wavelength. In normal television practice the antenna is broken at the centre and each part is connected to one of a pair of wires forming what is known as a transmission line or "feeder". The arrangement is shown in Figure 1.

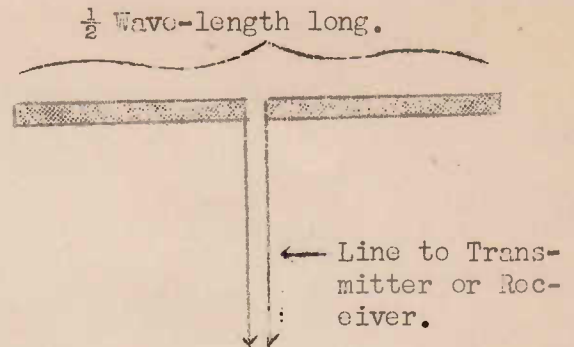

HALF-WAVE DIPOLE "CENTRE-FED".
FIGURE 1.

The transmission line or feeder serves, in the case of a transmitting antenna, to feed the radio-frequency energy from the transmitter to the aerial for radiation. In the case of reception the line feeds the received signal from the antenna to the receiver's input circuit.

"DISTRIBUTED" CAPACITY AND INDUCTANCE OF A CONDUCTOR.

The student may at first find it difficult to image how a simple straight conductor can act as a tuned or resonant circuit. We commonly regard as the essential components of the latter a coil of wire possessing the electrical property known as inductance, together with a condenser whose electrical property is that known as capacity or capacitance. Inductance, it will be recalled, is that property whereby a circuit opposes or tends to oppose any change (i.e. increase or decrease) in current flowing in the circuit. Capacity is the property of a circuit to store an accumulated electric charge, positive or negative. Now even a straight piece of wire, isolated in space, possesses these two properties to some small degree.

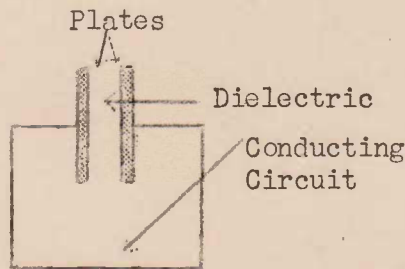
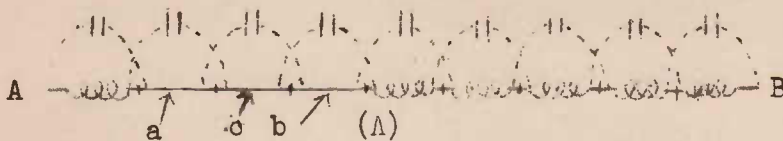

(B)
FIGURE 2.

The inductance and capacity, however, of such a simple conductor, are not "lumped", or concentrated, as in the case of a coil and a condenser respectively, but they are distributed over the whole extent of the wire.

To understand this idea of distributed capacity refer to Figure 2 where a straight conductor AB is shown. This wire may be regarded as consisting of a very large number of small sections, or "elements". Two of such elements are shown labelled "a" and "b". These two elements form, in effect, a condenser, since they consist of conducting material and they are separated by the surrounding air which is an insulator, and acts as a dielectric. To be sure the two elements of the wire are also connected by the intervening section of wire c, which is a conductor, but this

does not destroy the capacity effect existing between a & b. For comparison purposes a condenser, consisting of two metal plates separated by a dielectric is shown at (b) Figure 2. Although the two plates of this condenser are shown connected by a conducting circuit this in no way affects the value of the capacity formed by them.

Returning to the conductor of Figure 2(a) we can say that between every pair of small elementary lengths of the wire there exists a small capacity effect, and the sum total, or effective value, of all these small capacities is known as the distributed or self capacity of the wire.

Dealing now with the question of the distributed inductance of a straight conductor several fundamental electrical facts and ideas should be recalled. The first of these is that whenever a current flows (i.e. a charge moves) a magnetic field is created around the conductor involved. This field is a circular one, the lines

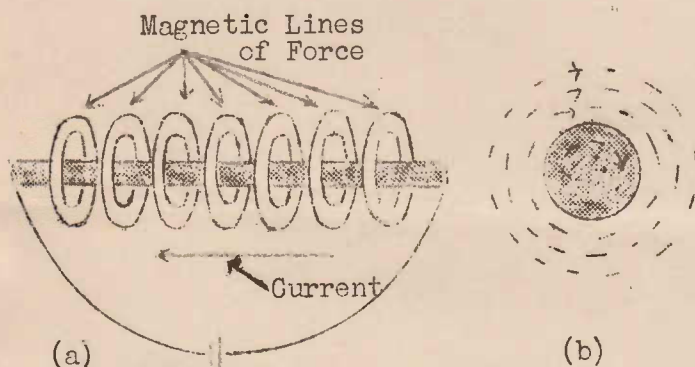

FIGURE 3.

of force forming a series of concentric circles or rings around the conductor. Figure 3 shows the way in which these lines of force are distributed around the current-carrying conductor; a "side-on" view of which is shown at (a). At (b) a cross-sectional, or "end-on", view illustrates clearly the circular nature of the field. Note that some of the lines of magnetic force exist within the conductor, these being mainly due to that part of the current flowing

near the centre of the latter. Now if the current is increased extra lines of force are created, and the field expands outwards. Thus we have a moving magnetic field, a part of which will cut across the metal of the conductor inducing an electro-motive-force (e.m.f.) in it. This emf. opposes the direction of current flow, tending to prevent the increase of the latter. Similarly if the current flowing is decreased, the magnetic field is weakened, and lines of force collapse inward into the conductor. This moving field (or part of it) again cuts the conductor and induces the e.m.f., which, however, is in the reverse direction to that of the former case. The induced e.m.f. is now acting in the same direction as the direction of current flow, and tends to prevent the decrease in current, i.e. to maintain it at its original value.

Note that in both cases the self-induced e.m.f. acts in such a direction to oppose any change in the intensity of the current. It is this property of a circuit which is known as its self-inductance. Of course, in the case of a closely wound coil of wire the effect is greatly magnified, due to the more powerful magnetic field produced by the current, and also to the fact that a greater percentage of the total field actually cuts the wire when the current changes in value. But the important point here is that a simple straight conductor possesses some inductance, even though its value, measured say in micro-henrys is small. At low and medium frequencies the effect of the inductance of short lengths of wire is usually so small as to be negligible. Working at ultra-high

radio frequencies, however, the current changes are so rapid that the distributed inductance may have quite an appreciable effect.

Thus we have seen that a straight conductor possesses the electrical properties of inductance and capacity. Now the student well knows that any circuit possessing these two properties can act as a resonant or tuned circuit, whereby either a maximum or a minimum impedance is offered to the applied alternating e.m.f, depending upon how the latter is applied to the combination of inductance and capacity.

In Figure 4 we have shown a source of alternating e.m.f. (G) applied across a series tuned circuit at (a) and a parallel tuned circuit at (b). Concentrating on the series case, remember that when the frequency of the applied e.m.f. coincides with the resonant frequency of the circuit, the reactances of the inductance and the capacity are then equal, and instead of adding, as in the case of resistances, they cancel each other. This leaves only the resistance of the wires to oppose the A.C. In other words the impedance of the circuit, at resonance, will be small, and the current correspondingly large. A series tuned circuit may allow a very heavy current to flow, even though the applied e.m.f. is small.

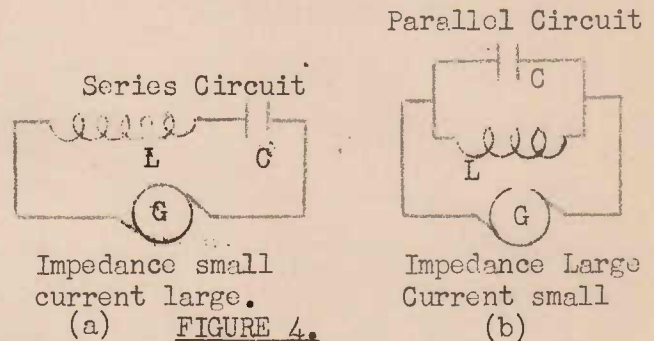

In Figure 5 we have shown a straight conductor AB, broken at the centre in order to insert a source of alternating e.m.f., directly applied as at (a) or indirectly applied by means of a transformer as at (b). It is found that an A.C.

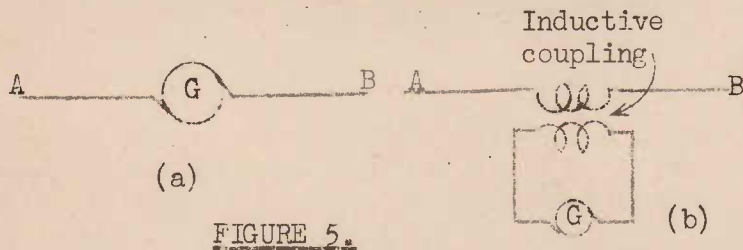

FIGURE 5.

will flow in the conductor due to the fact that it possesses distributed -- or self-capacity.

The reactance of this small capacity, however will be very large, and therefore the current may be very small. But remember that the conductor also possesses inductance. If the frequency of the generator is adjusted it will be found that, at some particular frequency (ultra-high) the reactances of the inductance and capacity will cancel out, and a heavy alternating current will flow. Actually the conductor acts like a series resonant circuit. Since the inductance and capacity of the wire are very small, the resonant frequency will be very high (remember that resonant frequency of a tuned circuit is given by the formula.

$$f = \frac{1}{2\pi\sqrt{LC}}$$

RELATIONSHIP BETWEEN RESONANT FREQUENCY AND LENGTH OF A HALF-WAVE AERIAL.

It is found that the resonant frequency of an aerial of this type is indirectly proportional to its length. That is to say, the longer the aerial, the lower the resonant frequency, and vice versa. The actual thickness of the wire or rod of

which the aerial is made has no bearing whatever upon this frequency. In practice the resonant frequency of a half-wave aerial is very easy to calculate. This frequency corresponds to a wavelength approximately double the total length of the aerial. In other words the aerial's length is one-half a wavelength of the radiated wave corresponding to the given frequency. The reason for the name "half-wave" aerial is therefore obvious. To illustrate, let us calculate the resonant frequency of a half-wave dipole 3 metres long (1 metre = 39.32 inch). The frequency will be that corresponding to a wavelength of 6 metres. Now:-

$$\begin{aligned} \text{Frequency} &= \frac{300,000,000.}{\text{Wavelength (in metres)}} \\ \text{(in cycles/sec.)} &= \frac{300,000,000.}{6} = 50,000,000 \text{ c/sec.} \\ &= 50 \text{ mc/sec.} \end{aligned}$$

ALTERNATING CURRENT AND VOLTAGE DISTRIBUTION IN A HALF-WAVE AERIAL.

By utilising our knowledge of a tuned circuit consisting of capacity and inductance, we have seen how it is possible for a straight conductor to resonate at some particular frequency. It will be informative at this stage to consider the nature of current flow and the electrical potential at different points in the conductors when "excited" by a transmitter at its resonant frequency.

First of all it will be necessary for the student to recall that every substance contains a large number of negative electrons and normally, an equal number of positive protons. The charges of these unlike electrical particles therefore cancel each other, and the material is said to be electrically neutral, or uncharged. In the case of a conductor a large proportion of the electrons are free to move at random among the atoms of the material. A net movement in one particular direction of these "free" electrons is called an electric current. If, by means of a battery, or other means extra "free" electrons have been forced into a body, so that the electrons exceed the protons in number, the body is said to be negatively charged. On the other hand if a deficiency of electrons has been created, by removing some of the latter from the body, a positive charge is built up. This positive charge is, of course, due to the minute positive charges of the protons, which are now not completely cancelled by those of the electrons. Remember, however, that the protons are firmly fixed within the atoms, and cannot be moved by ordinary methods.

Consider now the conductor of Figure 6. excited at its resonant frequency by a source of alternating e.m.f. applied at its central point, and acting as a half-wave dipole. Before the voltage begins to act all parts of the conductor will have zero charge as at (a), since the free-electrons are evenly distributed throughout its whole length. If the voltage first begins to act in such a direction that electrons are forced to the left, some of these will flow, or be displaced, in that direction. These displaced electrons will build up a negative potential in the left-hand half of the aerial. The right-hand half will become positively charged, due to the fact that some electrons have moved away from it. This state of affairs is shown at (b) Figure 6. The ability of the conductor to store charges in its various sections is exactly what we meant previously when we said that it possessed distributed self-capacity.

As the applied voltage now falls off to zero, and then reverses, electrons will

move along the conductor to the right. The charges shown at (b) will first disappear (c), and then reversed charges will appear as at (d). This process will continue indefinitely.

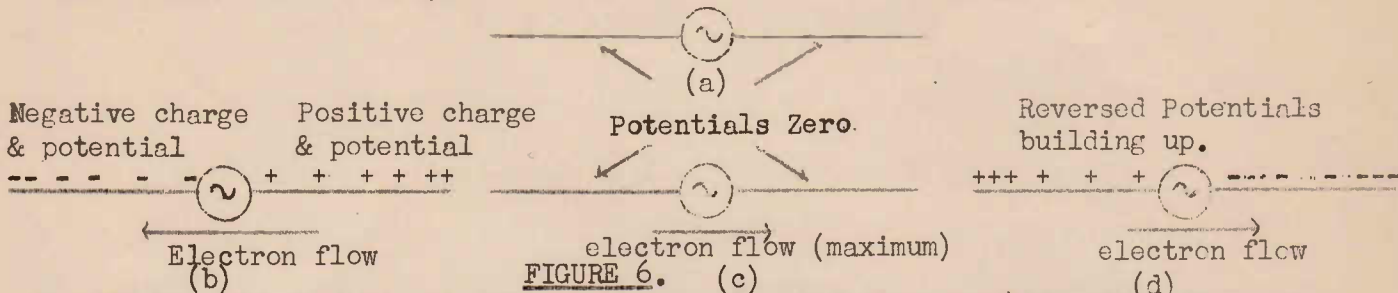

It will be evident that, at every point in the conductor an alternating flow of electrons is taking place at the frequency of the applied e.m.f. The size or amplitude of this current will be a maximum at the centre of the conductor, where the electrons have the greatest freedom of movement (back and forth). Near the ends of the conductor, on the other hand, the current flow will be very small, since electrons cannot leave these ends, and their motion is therefore greatly restricted.

The potential (pressure) distribution is quite different from that of the current. The charges become most concentrated at the ends of the conductor, as shown by the crowding of the + and - signs in Figure 6. The potentials, which are built up by these stored charges will therefore be a maximum at these points. Note that the potential at any point on the aerial is of an alternating character, since it continually changes in value and sign. The potential at the exact centre of the wire will always remain at zero (except for the small voltage of the generator).

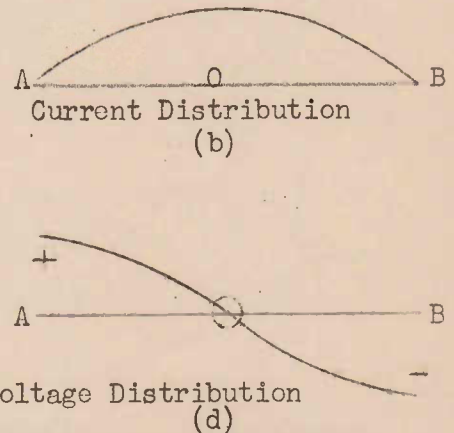
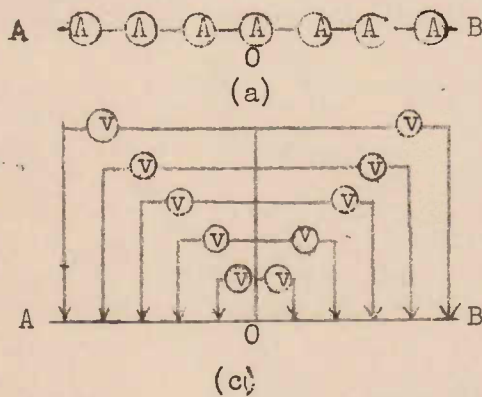

FIGURE 7.
CURRENT AND VOLTAGE CURVES FOR A RESONANT HALF-WAVE AERIAL.

The mode of oscillation of a half-wave dipole may be clearly illustrated by drawing curves showing how the current and voltage vary in magnitude and sign (direction) at all points along it.

In the diagrams of Figure 7. AB represents a conductor excited at its resonant

frequency when behaving as a half-wave dipole. The applied exciting voltage is not actually shown in the diagrams.

We could imagine the current at various points along the conductor to be measured by an A.C. ammeter (or series of ammeters) placed as shown at (a) Figure 7. Remember that such a meter shows a steady reading, which is generally the R.M.S. value, or the peak value, (usually the former) of the alternating current. We would find that the meter at the centre (o) of the conductor would show the maximum reading. The deflections on the other meters would gradually fall off as we go from the centre of the wire towards the ends. At (b) Figure 7 we have plotted a curve showing how the current values vary over the length of the conductor.

The diagram at (c), illustrates, at least in a theoretical way, how we may measure the potentials at various points along the aerial, all potentials being measured in respect to the central point (o) of the conductor. (Actually, in practice, it would be extremely difficult to measure the potentials in this way, owing to the fact that the impedance of the voltmeter would not be sufficiently high to avoid "loading" of the aerial).

In the case of these potentials, which, remember are also of an alternating character, we would find that the maximum readings are obtained for the end points of the conductor, with a zero (or minimum) reading for the central point. A reading at any other point would have an intermediate value between the maximum and zero.

The Potential or Voltage distribution curve is plotted at (d). The curve, as drawn, actually conveys more information than the meters would show. It indicates, in addition to the relative magnitudes of the voltages, the fact that, at any given instant the potentials of the two halves of the dipole are of opposite sign. At the instant shown, the left-hand half of the conductor is shown as positive, and the right-hand as negative. Of course, a fraction of a second later, the potentials will reverse, so that the left-hand end would be negative, and the right-hand end positive. The state of affairs illustrated by the potential curve at (d) could be described by stating that the potentials of the two halves of the dipole are "out of phase".

In a similar manner the current curve at (b) conveys more information than that relating simply to the magnitudes of the current. The curve is plotted entirely on one side of the zero line to indicate that the currents at all points along the conductor "are in phase". That is the currents, at any given moment, will either be all to the left, or all to the right.

THE IMPEDANCE OF A HALF-WAVE DIPOLE.

Impedance is a measure of opposition to alternating current flow, and is equal to the ratio: $\frac{\text{alternating voltage}}{\text{alternating current}} = \frac{E}{I}$.

Impedance (Z) is measured in ohms.

By the impedance of an antenna we mean the impedance presented by it to the

transmitter (or rather to the feeder-line from the transmitter).

Now since, as illustrated by the curves at (b) and (d) of Figure 7, the values of the current, and voltage vary at different points along the dipole, it is obvious that the impedance will also vary, depending upon the point at which the antenna is "fed". The impedance, at any point is equal to the ratio of $\frac{E}{I}$ at that point. At the centre, voltage is shown as zero, and current as a maximum. Therefore the impedance at the central point would appear to be zero (Zero Voltage / Max. Current). At either end the voltage is a maximum, and the current zero. Therefore the impedance at these ends appears to be infinite (Max. Voltage / Zero Current). The impedance will thus increase from zero at the centre, to a very large value as we move towards either end.

This variation of impedance along the dipole is illustrated by a curve in Figure 8.

COMPARISON WITH SERIES FED AND PARALLEL FED RESONANT CIRCUITS.

If the source of alternating e.m.f, i.e. generator or transmitter, is inserted in the centre of the dipole, the latter is said to be "centre-fed". This method is illustrated at (a) in Figure 9.

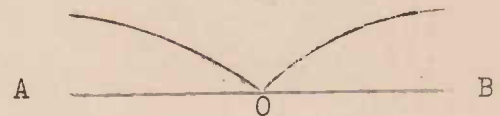

IMPEDANCE CURVE OF HALF-WAVE DIPOLE. FIG. 8.

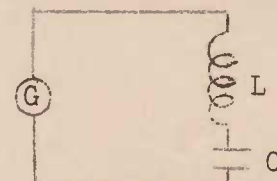
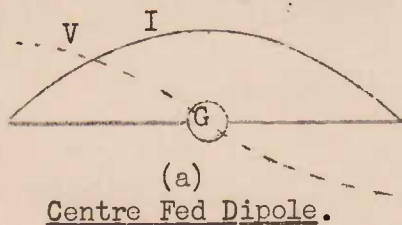

(b)
Series Fed Resonant Circuit

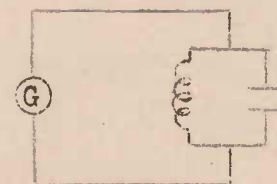
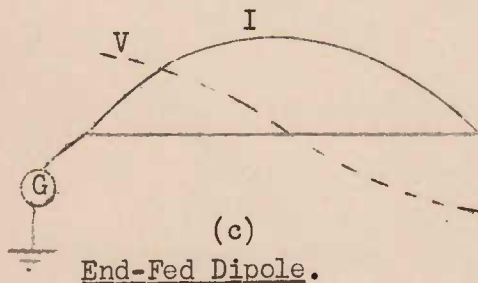

(d)
Parallel-Fed Resonant Circuit

FIGURE 9.

Here the antenna may be strongly excited by a low-voltage generator, but the current delivered by the latter will be large. The impedance presented to the generator will be zero (or at least small). The conditions obtaining in this case may be compared with those of an ordinary series resonant circuit shown at (b) where the impedance presented to the generator is (in the ideal case i.e. no circuit losses) zero, the current through the generator is large, but the voltage across it is very small.

A very different state of affairs exists if the dipole is end-fed as shown at (c). Here one terminal of the generator is connected to one end of the aerial, the other terminal being earthed.. (Note :- the internal impedance of the generator should be large, otherwise the normally large A.C. voltage at the end of the dipole will be grounded, and the normal mode of oscillation of the antenna will be completely modified).

In this case the impedance presented to the generator by the antenna is very large (theoretically infinite). For efficient excitation of the antenna the generator must be of high voltage, but it will be called upon to deliver only a small current, as will be seen from the current and voltage curves. When end-fed the dipole behaves as a parallel tuned circuit (see (d)) where the impedance is high, and the generator current small.

RADIATION RESISTANCE OF AN ANTENNA.

So far we have considered only the properties of inductance and capacity of the aerial conductor. The latter will, of course, also possess resistance. The **D. C.** resistance is normally negligibly small, but working at the ultra-high frequencies, due to skin-effect, dielectric losses etc. it might amount to several ohms. Even so, this r.f. resistance certainly would never exceed about 10 ohms. Yet we find that the impedance measured at the centre of the dipole (which is theoretically zero if resistance effects are neglected) is in practice around about 80 ohms. Whence comes this extra resistance?

It must be remembered that resistance in a circuit results in the loss of electrical energy in the form of heat energy. Conversely any loss of electrical energy in the form of heat (for example in nearby dielectrics) or other energy losses, causes an increase in the effective resistance of the circuit. Now a transmitting antenna is continuously losing energy in a special way, namely in the form of the radiant energy of the outgoing wave. This continual outpouring or loss, of energy gives rise to an increase in the effective resistance of the antenna. This extra resistance, due to radiation, is known as the Radiation Resistance of the antenna. The radiation resistance of all half-wave resonant dipoles is 73 ohms. Remember this figure.

If the centre-fed half-wave dipole is compared with a series resonant circuit, see Figure 9 (a) and (b), the effect of the radiation resistance will be apparent. If a resistance of 73 ohms were placed in series with the inductance and capacity of the circuit shown at (b) Figure 9. the impedance presented to the generator would be increased from zero to 73 ohms. Similarly the effect of the 73 ohms radiation resistance will be to increase the impedance of the dipole at its central point by this amount. Actually, in practice, the central-point resistance of a dipole is usually taken at about 80 ohms, the extra 7 ohms allowing for ordinary radio-frequency resistance losses.

To understand the effect of the 73 ohms radiation resistance upon the impedance offered by the dipole to the generator when "end-fed" consider the case of the parallel tuned circuit of (d) Figure 9. When the tuned circuit contained no resistance, the impedance measured across it was infinite. If a resistance

were inserted in either arm (L or C) of the circuit the result would be to lower the impedance presented to the generator. Similarly the effect of the 73 ohms radiation resistance of the dipole is to lower the end-point impedance from an infinite value to a much lower value. The impedance of a dipole, measured at either end is found to be about 2,000 ohms. Note, however, that this impedance is still much higher than that measured at the centre (80 ohms).

THE "ELECTRICAL LENGTH" OF AN ANTENNA.

In an earlier section of the lesson it was pointed out that a half-wave dipole of given length had a particular frequency at which it would resonate. It was therefore stated that this resonant frequency corresponded to a wavelength approximately double the length of the antenna. In other words the **antenna's** length is approximately one-half the wavelength of the radiated wave when excited at its resonant frequency.

The reason for this inter-relation of wavelength with physical length of the aerial may now be roughly visualised by reference to the current and voltage distribution curves of figure 7. These curves may be regarded as representing "standing" waves (of current and voltage respectively) upon the wire. The idea of "standing" waves, as distinct from "travelling" waves along a conductor, or radiant, waves in space will be elaborated upon in more detail at a later stage in the lesson, under the heading of transmission lines. At the moment, however, it is sufficient to note that "the standing-wave" (of frequency equal to the resonant frequency of the aerial) gives rise to the electro-magnetic wave radiated into space. Furthermore, as the curves of Figure 7 show, exactly one-half a complete standing wave exists upon the antenna. Consequently the wavelength of these standing waves, and therefore the wavelength of the radiation is twice the length of the wire.

In explaining the current distribution in such an aerial it was assumed that the latter was completely isolated in space. In practice, however, the aerial is in more or less close proximity to surrounding objects. The small capacity effects which exist between such objects and the wire itself modify the form of the standing wave of current, and result in the antenna acting as though it were roughly 5% longer than its actual length. In other words, if the wavelength of the radiation from a half-wave dipole is measured, and the figure divided by 2, the result, instead of corresponding exactly with the length of the wire, will be approximately 5% greater than the latter.

Wavelength at resonance

The length $\frac{2}{1}$ is called the "Electrical Length" of the antenna. Summarising, we may state that the "physical" (or actual) length of a dipole is approximately 95% of the "electrical" length. In calculating wavelength and frequency (at resonance), therefore, 5% must be added to the measured length of the wire before applying the calculations illustrated at an earlier point in the lesson.

DIRECTIONAL PROPERTIES OF A HALF-WAVE DIPOLE.

An antenna of this type does not radiate (or receive) equally well in all directions. Referring, at the moment, to a transmitting aerial, the dipole radiates most strongly in directions perpendicular to its length. The radiation in directions parallel to its length is practically zero.

These directional properties of an antenna may best be illustrated by means of a "Polar" Diagram. Such a diagram shows at a glance the relative intensities of the radiated wave (or the received signal) for all directions around the aerial.

The Polar diagram for a half-wave aerial is shown in Figure 10. The diagram takes the form of two circular "lobes", forming an idealised "figure-of eight". Here AB represents the aerial. The signal strength radiated in any given direction is proportional to the length of the line drawn from the point (o) in that

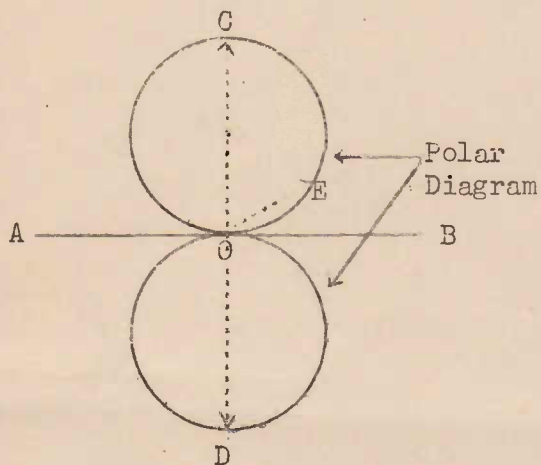

direction to the boundary of the polar diagram. For example the radiations in the directions OC and OD (perpendicular to the wire) are proportional to OC and OD, which are equal and are a maximum. The signal strength in the direction OE is proportional to the length of OE which is approximately one-half of OC. Hence the signal radiated in the direction OE will be one-half the strength of that radiated in the direction OC (or OD). Note that the strength of the waves radiated in the directions OB or OA is zero.

FIGURE 10.

If it is imagined that one is observing the antenna from above, i.e. looking down upon it, then the diagram shows the relative signal strengths for all directions taken in a horizontal plane.

Assuming that the antenna AB of Figure 10 is placed horizontally, (i.e. parallel to the ground,) the polar diagram drawn is described as a "horizontal" polar diagram.

If now the antenna, while still placed horizontally, is viewed "end-on" as shown in Figure 11, the relative signal strengths observed in all directions measured outwards from the aerial, in the plane of the paper will be equal. The polar diagram will therefore be simply a circle. This is the "vertical" polar diagram, because the plane taken is perpendicular to the ground. Actually the circular diagram would only be observed if the antenna were well above the ground. When placed horizontally and close to the earth the radiation from a dipole is greatly modified by reflection from the ground of those waves radiated in a downward direction.

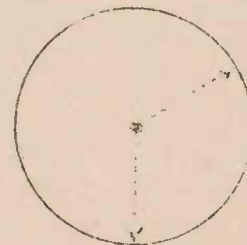

POLARISATION OF THE WAVE.

The "Polarisation" of a wave is determined by the arrangement of the transmitting antenna, and depends upon whether the electric field of the radiation is parallel to the earth (horizontal) or perpendicular to it (vertical).

FIGURE 11.
VERTICAL POLAR DIAGRAM
(HORIZONTAL DIPOLE).

The nature of an electro-magnetic (radio) wave should be recalled. It consists of two alternating fields -- an electrostatic field and a magnetic field. The lines of force of the electric field are at right angles to those of the magnetic field, Both fields move through space (with the speed of light), in a direction which is perpendicular to both the electric and the magnetic lines of force.

A vertically placed dipole will radiate a wave having the electric field in a vertical plane, and the magnetic field in a horizontal plane. This is called a vertically polarised wave. In the case of a horizontally placed dipole, on the other hand, a horizontally polarised wave is radiated. The electric field will now be in a horizontal plane, with the magnetic field in a vertical plane. Both types of polarised waves are illustrated in Figure 12.

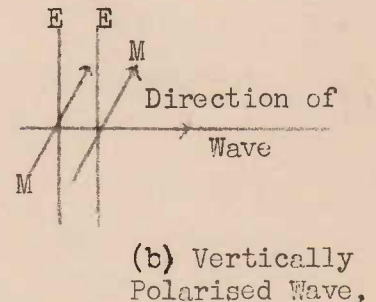
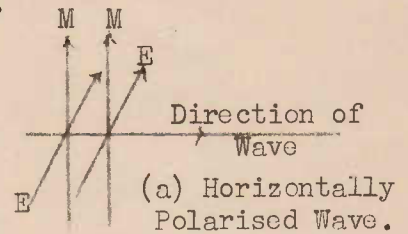

E = electrical field
M = magnetic field.

FIGURE 12.

The nature of the polarisation of the wave radiated from a television transmitter is of utmost importance when considering the erection of the receiving antenna. If vertical polarisation is in use, i.e. if the transmitter's radiating conductor or conductors are vertical, the receiver's dipole must also be placed vertically. Conversely for horizontal polarisation and a receiving dipole placed parallel to the ground is required.

THE RECIPROCAL RELATIONSHIP BETWEEN A TRANSMITTING AND RECEIVING AERIAL.

Both theory and practice show that, whatever property an antenna exhibits when used for transmitting purposes, then the same property is exhibited in a reciprocal, or inverse, manner, when the aerial is used for reception. For example it has been seen that the half-wave transmitting dipole presents, at its centre, an impedance of about 80 ohms to the exciting generator, this impedance being due mainly to radiation resistance. The aerial was found to act as a series resonant circuit, containing 80 ohms series resistance. Now, when used for reception purposes the aerial acts as a source of e.m.f. ("e"), (which e.m.f. is induced in it by the "received" wave), for application to the receiver. The antenna, still acts as though it possessed an impedance of 80 ohms at its centre. The receiving aerial may now be regarded as a "generator" of "internal impedance" 80 ohms, as illustrated in Figure 13.

As a further example of this reciprocal property, we may cite the case of the antenna's directional characteristics. The polar diagrams of Figure 10 and 11 apply equally well when the aerial is used for reception as it does when used as a radiator. That is, maximum signal strength is received for waves arriving from directions CO and DO (perpendicular to aerial) and zero strength from directions AO and BO ("End-on"). Thus a horizontal television receiving dipole should be placed at right angles to the direction from which the signals will arrive from the transmitter.

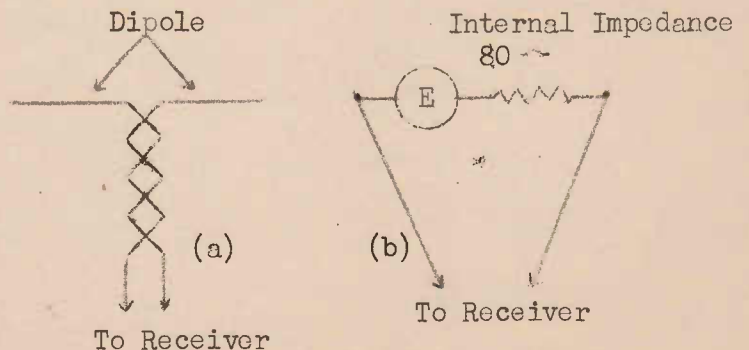

Receiving Dipole (a) & its Equivalent Circuit (b).

FIGURE 13.

TRANSMISSION LINES.

Transmission lines are used, as far as television is concerned, for transferring r.f. energy from the transmitter to the antenna or from the antenna to the receiver. In both cases the line must be carefully designed and adjusted, if efficient operation is to be ensured. In the case of ordinary broadcast radio reception the receiver is usually fed from the aerial by means of a single wire, known as the "lead-in", possessing no particular electrical properties. In the case, however, of television reception, operating with a resonant aerial, such a casual arrangement would prove quite inefficient. Improper design or adjustment of this important unit of the reception system would result, not only in loss of sensitivity, but even more importantly, in serious distortion of the received image.

PHYSICAL CONSTRUCTION OF A TRANSMISSION LINE.

There are several types of transmission lines in use. These, though differing considerably in physical construction, all possess similar electrical properties.

The first type is that known as the parallel -- or twin-wire. This consists, usually, of a pair of parallel wires, of fairly heavy gauge (e.g. 14 S.W.G.), separated and held in place by "spacers" of insulating material placed at regular intervals, as shown in Figure 14. The spacers may be circular, as shown or simply flat strips of insulating material to hold the wires the required distance apart and parallel to one another.

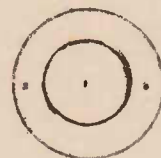
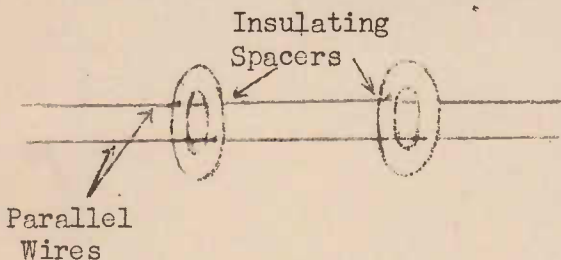

FIGURE 14.

Spacer
End-View

A second, and very common type of transmission line in television receiver installations is that known as the "twisted-pair", consisting of two rubber covered wires twisted together and enclosed by a covering of cotton braid or other material similar to ordinary power flex.

A third type, used mainly in transmitting equipment, is the "coaxial" or concentric line, illustration in Figure 15. Here one conductor, in the form of a wire, is run centrally through the other conductor, the latter consisting of a cylindrical tube. The two are separated by means of low-loss insulating material.

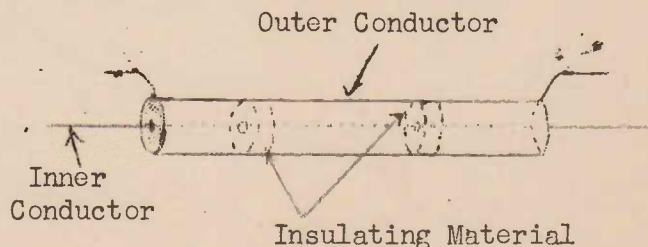

FIGURE 15.

ELECTRICAL PROPERTIES OF TRANSMISSION LINES.

In order to explain the operation of transmission lines a simple twin parallel wire line will be considered. It will

be understood, however, that the following explanation will unless otherwise stated, refer to all types of line.

ELECTRICAL WAVES ALONG A LINE.

Suppose we have a line consisting of a pair of 12 S.W.G. wires mounted upon poles, as shown in Figure 16, and extending away an infinite distance. The near end of this transmission line is shown leading into a building which is supposed to contain a radio-frequency generator or oscillator feeding the line with an alternating voltage of constant amplitude. The R.F. generator is provided with a vacuum tube voltmeter to measure the sending potential, and a thermo-ammeter indicating the current passing into the line, as shown in Figure 17.

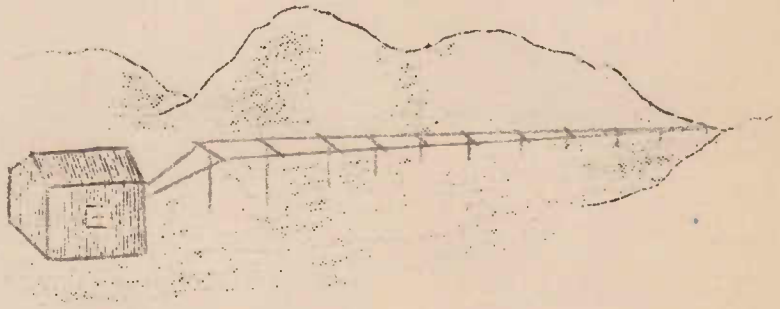

FIGURE 16.

Now suppose the voltmeter reads 600 V (R.M.S.) and the ammeter 1A (R.M.S.). When the output is connected (by means of the double pole-double throw switch shown) to an unknown resistor R. The value of this resistor must be, by Ohm's Law, $R = \frac{E}{I} = \frac{600}{1} = 600$ ohms. Further suppose that the test engineer, by throwing the switch

applies the output to the line, and the meters register the same readings as before, viz: 600V and 1A. It is obvious that the line must present an impedance to the generator exactly equal to the resistance of the resistor, that is 600V.

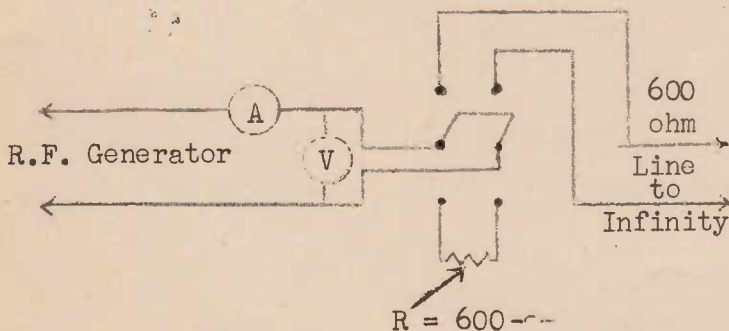

FIGURE 17.

There is one important difference, however, between the case of the resistor and that of the line. The energy output from the generator when connected to the resistor is being all dissipated in the latter (in the form of heat). The transmission line possesses comparatively little resistance, and therefore the energy from the generator is not immediately dissipated as heat, but must pass continuously along the line. This energy is transferred down the line in the form of electrical waves, which will, theoretically in this ideal case, travel for an infinite distance.

The nature of these "guided" waves, and the manner of energy transfer may be understood more clearly by reference to Figure 18 where the distributed self-inductance of the wires is indicated by small coils, and the capacities between small sections, or elements, of the adjacent wires are shown by small condensers. We may state the

inductance and capacity per unit length (e.g. per foot) of the twin-wire line in micro-henrys and micro-farads or micro-micro farads, respectively.

If a potential is supplied to the input end of the line the first condenser C_1 will charge up through the first set of inductances L_1 until the voltage across its plates equals that of the generator. C_1

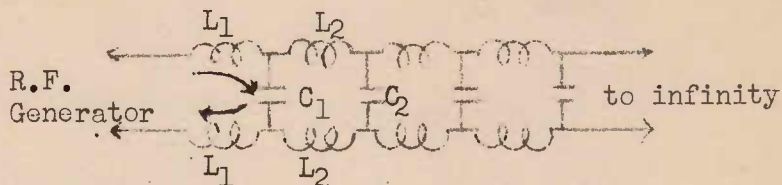

FIGURE 18.

then discharges through L_2 , charging C_2 , which in turn discharges through the next set of inductances to the next capacity and so on. In this way each part of the line is, in turn, subjected to voltage and current surges, which passes down the line with a velocity equal to a radio wave in space, viz: 186,000 miles per second.

In actual practice, of course, the inductance capacity effects of the line are not "lumped" as illustrated in Figure 18, but are evenly distributed over its whole length.

If the line is fed by a generator supplying continuous r.f. voltage, the "wave" motion will also be continuous, each capacity being, in turn subject to a continuous charge and discharge of an alternating character.

An important point to notice is that the currents in the two wires at any given point on the line will, at any given instant, be in opposite directions. Consider, for example the case where C_1 (Figure 18) is charging through the two halves of L_1 . The direction of the charging current is shown in the diagram, and it is clearly seen that the current in the upper wire is opposite to that in the lower wire. Of course a fraction of a second later, during the next half-cycle of the r.f. voltage, both currents will reverse, as C_1 charges in the other sense.

The fact that the currents in opposite wires are opposed to each other at all points of the line, means that there is very little electro-magnetic (radio) wave radiated into space from it. The reason for the latter statement is that the electric and magnetic fields produced by the current in one wire will be practically cancelled by the opposing fields set up by the current in the other wire. This desirable condition will only be realised, of course, if the spacing between the wires is comparatively small (small, that is compared with the length of the wave).

THE CHARACTERISTIC OR SURGE-IMPEDANCE OF A TRANSMISSION LINE.

We have seen in connection with Figure 17 that a given line of infinite length will present a characteristic impedance to a generator connected to it. In the case cited this was 600 ohms when the line consisted of twin-wires of 12 S.W.G. separated by 8". If either the thickness of the conductors (i.e. the gauge of the wires), or the spacing between them, or both, were altered it would be found that this impedance would have a different value. It appears, then, that a line constructed with a given gauge of wire, and a given spacing will have a "characteristic"

impedance. This characteristic impedance is sometimes called the "surge" impedance of the line. It should be noted that a line presents its characteristic impedance to alternating voltages of all frequencies. In other words the line show no resonant effect. The only stipulation we have made is that the line in each case, is regarded as of infinite length, or at least, in a practical case, of very great length compared with a wavelength. A little later we shall see how this stipulation may be modified.

Factors Controlling the Characteristic Impedance of a Line.

As stated above the characteristic impedance, which we shall henceforth designate by Z_0 depends only on the thickness of the conductors and the spacing of the wires. It is obvious that these factors will determine the distributed inductance and capacity per unit of length of the line.

If the spacing of the wire is increased Z_0 will be increased, (but not proportionately) and vice versa. If the thickness of the wire, on the other hand, is increased, Z_0 is decreased, and vice versa. For the sake of those students who are familiar with logarithms, the following formula for Z_0 is given:-

$$Z_0 = 276 \log \left(\frac{d}{r} \right) \text{ Ohms.}$$

Where d = spacing between conductors, r = radius of each conductor, (see Fig.19).

In any actual case "d" may be measured directly, and "r" may be obtained, for any given gauge, by referring to standard wire tables.

In the case of a coaxial or concentric line, Z_0 depends upon the inner radius of the outer tube or cylinder, and upon the outer radius of the inner conductor or tube. The formula is:-

$$Z_0 = 138 \log \left(\frac{r_2}{r_1} \right) \text{ Ohms.}$$

Where r_2 = inner radius of outer conductor

r_1 = outer radius of inner conductor.

(See figure 20)

In the case of the "~~twisted-pair~~" type of line, the Z_0 is not easily calculated, for the spacing between the wires is not uniform. In this case, however, the characteristic impedance may be taken as in the vicinity of 80 - 140 ohms.

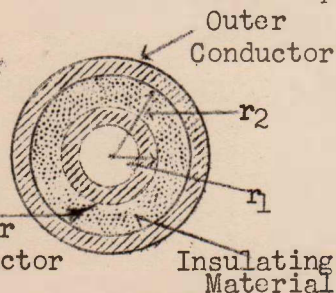
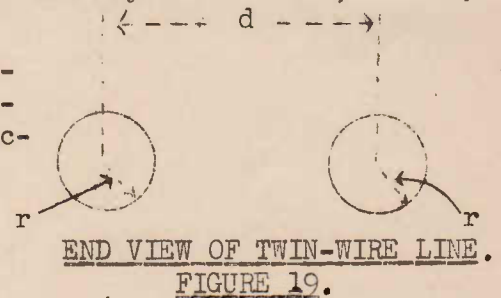

FIGURE 20.

For comparison purposes the Z_0 of the parallel twin-wire type is usually found to be in the range 200 - 600 ohms. It is difficult to reduce Z_0 below 200 ohms in this type, because the spacing between the wires becomes too small for practical convenience. For the coaxial type, Z_0 is, in practice, usually found to be in the vicinity of 70 ohms.

TRANSMISSION LINE OF FINITE LENGTH-LOAD MATCHING.

In considering the operation of the transmission line earlier, the line was considered to be of infinite length, so that the energy from the generator could pass down the line continuously in one direction. This energy

transfer was considered as a wave motion of current and voltage. Its transmission was seen to be due to each "elementary" condenser becoming charged through the inductance of the corresponding "element" of the line, and then discharging through the inductance of the next adjacent element of the line. In this way the capacities of succeeding sections progressively become charged, at the speed of an electro-magnetic wave, viz: 186,000 miles/second.

Suppose now we consider the case of a piece of transmission line of definite length, open-circuited at the end remote from the generator. Such a line is represented as consisting of small inductance and capacity effects in Figure 21 at (a).

When the generator is switched on, a wave passed down the line from left to right, as described; the final condenser becoming charged up. This condenser cannot pass its charge further to the right on account of the open-circuit. In discharging, therefore, it sends a current back along the line. In this way a wave is initiated from the right-hand end of the line, and travels back as a reflected wave. We now have two waves, one passing from generator to the right and the other (reflected wave) in the opposite direction.

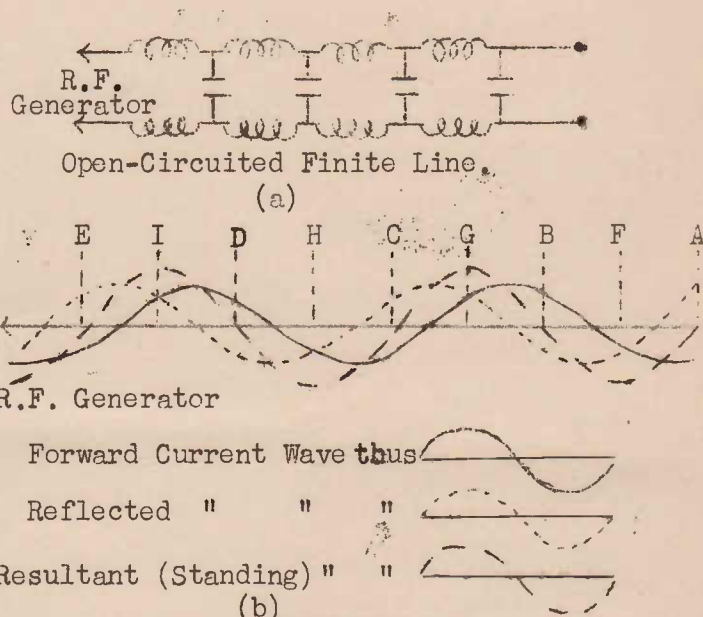

FIGURE 21.

The net A.C. current and voltage at the sending terminals may be greatly modified, due to the reflected wave either adding to (if in phase) or subtracting from (if out of phase) the initial generator voltage and current. The result is that the ratio of $\frac{E}{I}$ at the generator,

and therefore the impedance presented to the latter, may be considerably different from the characteristic impedance of the line, as measured when the line is of infinite length.

Another important effect caused by the reflected wave is that, if the current is measured at different points along the line, at some points it will be very large, and at other points it will be zero! (or at least very small). This is due to the reflected wave reinforcing the forward wave at certain points, and cancelling it at others. The forward current wave, the reflected current wave, and the resultant (or net) current wave are illustrated at (b) in Figure 21 (b). The waves are shown for one wire only. Those on the other wire will be similar but opposite in phase. The important thing to notice is that at certain points (A,B,C,D and E) on the line the current is always zero, due to the forward and backward waves always cancelling at these points. Ammeters inserted at A, B, C, D, and E would never show any reading of current. Meters inserted at points F, G, H, I, on the other hand would record maximum readings, because the forward and reflected waves reinforce each other at these points. The resultant wave obtained is called a Standing Wave.

The idea of standing waves may be illustrated by citing the case of a wave motion along a rope. Imagine a boy shaking the end of a rope which extends to infinity, as in Figure 22 at (a). A wave motion will travel continuously down the rope from left to right. All points of the rope will be affected by the motion. This is a travelling wave, and is analogous to the case of the infinite transmission line. Now consider a finite length of rope tied to a wall as at (b). If the rope is continuously shaken a standing wave will be created, whereby certain points on the rope (A,B,C) will remain (comparatively) at rest. Other points, (D,E, F) will be in a state of continuous oscillation or agitation. The motions of the points B and C due to the forward wave are cancelled by the wave reflected from the wall, at all instants.

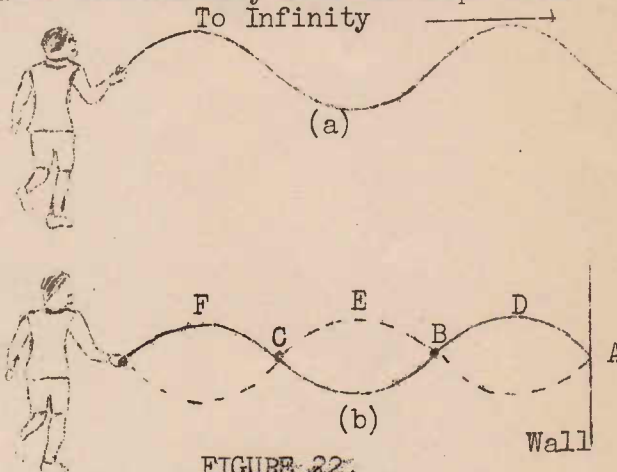
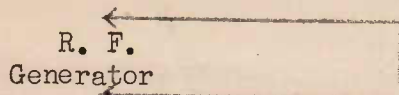

FIGURE 22.

The above description is for the case of an open-circuited line. If the line is short-circuited as in Figure 23 a reflected wave will also be found, resulting in the formation of standing-waves as before.



MATCHING A LINE TO A LOAD.

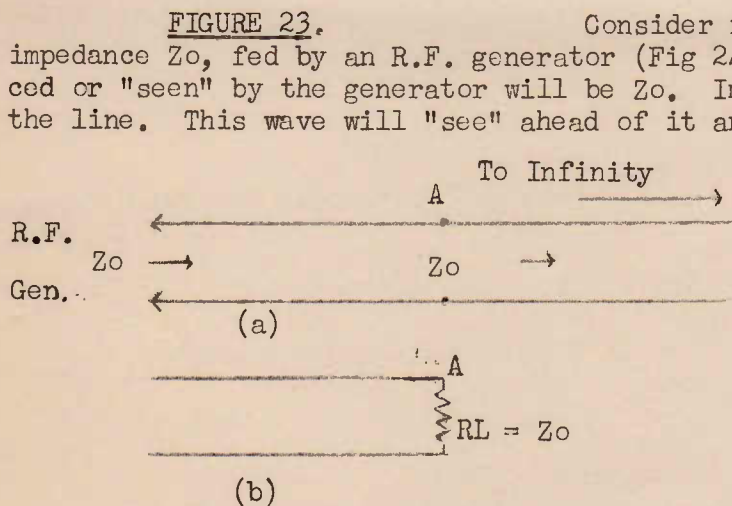

FIGURE 24.

reflection. As far as the generator is concerned the line in case (b) will appear exactly as at (a), i.e. of infinite length. Therefore the actual impedance "seen" by the generator will be the characteristic impedance of the line.

The reason no reflection occurs at A is that the resistance of $RL (= Z_0)$ is just right for the normal discharge of the capacity of the last element of the line preceding the point A. The result is that the wave will therefore proceed to the right as in the case of the infinite line at (a). Where the line is terminated by resistance equal to Z_0 , however, the energy of the wave, instead of travelling on forever, is quickly dissipated in the form of heat in RL . This is just

what we require. All the energy passed into the line by the generator, travels down the line and is received by the load.

If R_L is greater or less than Z_0 , reflected waves will be set up. The strength of these reflected waves will depend upon the amount of mis-matching. The reflected wave will reinforce the forward wave at certain points, and oppose it at others, resulting in the formation of standing waves. If a meter is moved along the line points of minimum current and others of maximum current will be found. The current will never be zero, however, as in the case of an open-circuited or short-circuited line, because the reflected wave will be weaker than the forward, so that complete cancellation can never occur. The ratio:-

Max. current at points of reinforcement.
Min. current at points of cancellation.

is called the "standing-wave ratio".

This ratio may be measured in practice and is an indication of the amount of mis-matching. If the standing wave ratio is 1 it indicates that the current is the same for all points on the line. This means no reflected wave is sent back by the load, and the line is correctly matched ($R_L = Z_0$).

The current (or voltage) at different points along the line may be observed in practice by using one of the devices as shown in Figure 25. These are called Standing Wave indicators. The indication may be moved along the line, maximum and minimum readings being noted. No variation in reading as the indication is moved down the line indicates correct load matching.

LOAD MATCHING OF A TRANSMISSION LINE AT THE SENDING END.

It is a well known fact that if an A.C. generator is to deliver maximum power into a load, then the load impedance must equal the internal impedance of the generator. In the case of a transmission line, therefore, it is important to ensure correct load matching at the

"sending" end as well as at the receiving end. The load imposed on the generator is, of course, the characteristic impedance (Z_0) of the line (assuming the line is correctly terminated by an impedance of value Z_0). For correct matching at the sending-end, therefore, the internal impedance of the latter should equal Z_0 ohms. Mis-matching at the sending end will mean that the maximum amount of power is not accepted by the line, and passed by it to the final "load" at the receiving end. An important (undesirable) effect occurs if both ends are incorrectly matched. The energy of a wave reaching B (Figure 26) is partially absorbed by the load R_L . The rest of the energy is reflected from B back along the line to A, where some of the reflected energy is again reflected down the line. In this way a reflected wave may pass backwards and forwards along the line until it is all absorbed partly by R_L and R_i (internal impedance of generator) and partly by the losses of the line itself. Such a state of affairs means that of the total energy fed into the line

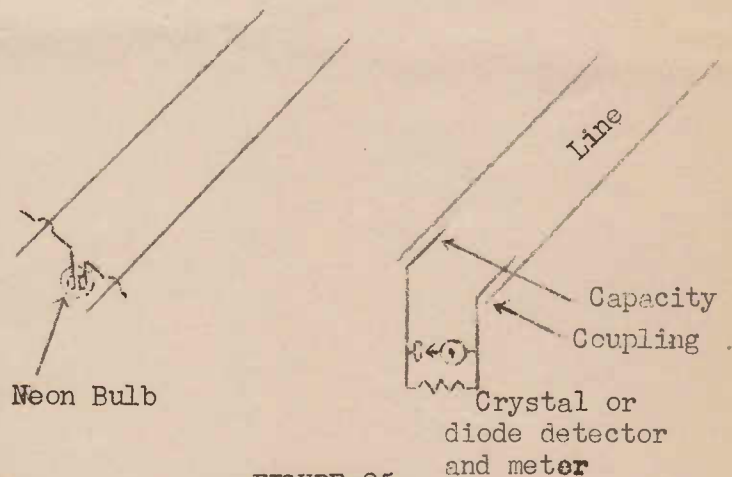

FIGURE 25.

at A at any given moment only a fraction will be received in the load RL when the wave first passes the length of the line. A small interval of time later, after the reflected wave has had time to pass back along the line and down again, RL will receive a little more of this energy, and so on. This effect as explained later causes serious distortion in the case of a transmission line coupling a receiving aerial to a television receiver.

TRANSMISSION ANTENNAE.

In the problem of transmission of television signals there are two important considerations to be dealt with. The first concerns the directivity of the radiation. It is desirable to direct as large a proportion as possible of the radiated energy towards the area of population to be covered, and to prevent radiation in the direction of the sky, where it serves no useful purpose. If vertical polarisation is used, a single dipole has desirable properties, in that it radiates no energy vertically upwards, and a maximum of energy in the direction of the horizon. On the other hand it radiates equally well in all horizontal directions, and cannot be used, therefore, to concentrate the horizontal radiation towards a particular city. If horizontal polarisation is used, the dipole radiates no energy in the horizontal line which coincides with the length of the dipole, and maximum energy in a direction perpendicular to that line, both horizontally and vertically upwards. Hence, by placing the dipole broadside on to the direction of the area of population, maximum signal strength will be directed there. The sky-ward radiation, however, is wasted in this case, but it may be suppressed by employing special multi-element radiators.

A system of "crossed" dipoles, designed for more or less uniform radiation in all horizontal directions, but which suppresses sky-ward radiation, is shown when viewed from above, in Figure 27. Here 4 dipoles forming the sides of a square are fed from a central "junction box", via short-lengths of coaxial cable. The dipoles are fed so that the current in any one is of opposite phase to the current in its opposite fellow. If a point in space above the system be considered, the wave arriving from any dipole will be cancelled by the equal and oppositely phased wave from the opposite dipole. Note that such a point in space is equidistant from all the dipoles, so that out-of-phase waves setting out from a pair of dipoles will still be out of phase when they reach the given point. This means that the net radiation upwards is zero. In other words the vertically radiated wave is entirely suppressed.

In the case of a wave radiated horizontally the situation is different. Consider a point in the same horizontal plane as the dipoles, say to the right of them. At any

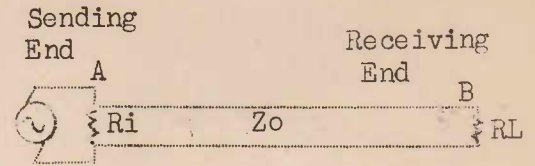
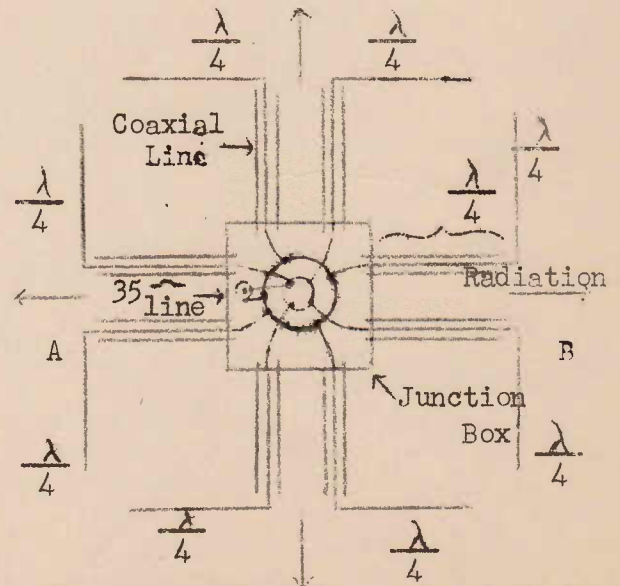

FIGURE 26.



TELEVISION TRANSMITTER RADIATOR - "CROSSED" DIPOLES AND COAXIAL LINES. HORIZONTALLY POLARISED WAVE. FIG. 27.

instant the waves radiated by dipoles A and B are 180° out of phase. A fraction of a second later the wave radiated to the right by dipole A will have reached dipole B. Now the distance between the dipoles is exactly one-half a wavelength. Hence in this time the wave from A will have changed its phase by an amount equal to $\frac{1}{2}$ wavelength, i.e. 180° . The result is that the wave radiated from A at the original instant will be exactly in phase with the radiation from A as it passes the latter dipole. This means that the two waves will reinforce each other at all points to the right of A. Figure 28 will show clearly how this additive effect occurs. Here the plane of the paper is supposed to represent a vertical plane, the dipoles being viewed "end-on".

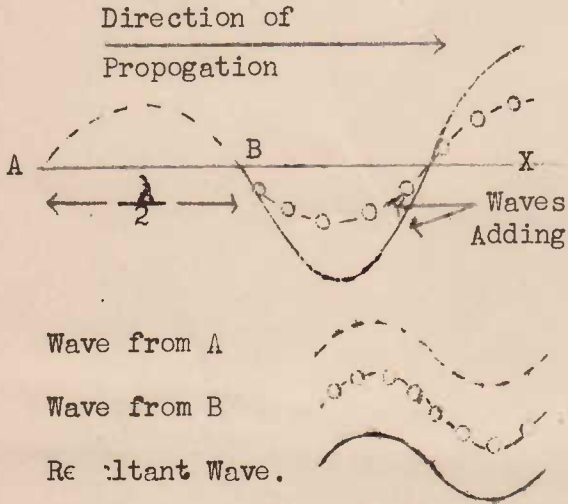
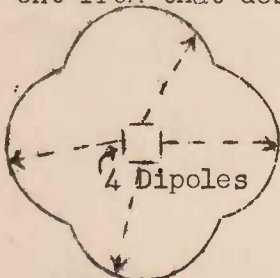

FIGURE 28.

radiator on the mast depicted in Figure 30. Actually in this figure the electrical arrangement is that known as the "folded" dipole system, which is somewhat different from that described above.



HORIZONTAL POLAR DIAGRAM.

(a)

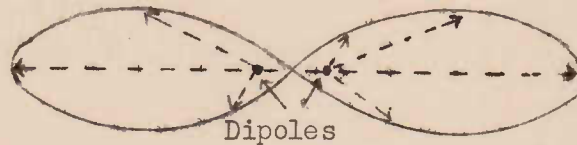

VERTICAL POLAR DIAGRAM.

(b)

FIGURE 29.

As explained in this lesson a dipole is resonant at one frequency only, when its impedance (measured at the centre of the radiator) is a minimum and purely resistive. At frequencies on either side of this resonant frequency the impedance rises and becomes partly reactive. In this respect the dipole behaves exactly like a series resonant circuit. If the sidebands are not to be appreciably weakened or distorted this de-tuning effect must be made negligible over the width of the transmission channel. The problem is solved in practice by heavily "loading" the radiator elements with resistors, and by special shaping of them. The lower radiator of Figure 30 shows one system. Here four radiators protrude from a curved

Figure 29 shows the horizontal polar diagram of the system at (a). Note that radiation is roughly uniform in all horizontal directions. Such a radiator would be used when the transmitter is situated near the centre of a populated area to be covered. At (b) is shown the vertical polar diagram. Note that the energy is concentrated into a horizontal radiation pattern, the skyward wave being reduced to a minimum.

The dipoles of this type of radiator are sometimes curved, so that the four of them form the circumference of a circle. The appearance of such an arrangement is shown by the upper rad-

The second problem to be considered in transmitting antennae concerns the antenna impedance over the frequency band of the transmission. This band, as we have seen in an earlier lesson is usually wide; up to 6 mc./sec. for the video carrier.

collar-like conductor. The radiators themselves, instead of being simple straight conductors, are of an ellipsoidal shape. In the figure the upper radiation (previously referred to) is used for sound transmission (ultra-high frequency F.M.), while the lower, just described, is used for the picture transmission.

RECEIVING ANTENNAE.

The antenna system of a television receiver requires to be much more critical than that of a broadcast receiver. This applies equally as much to the lead-in arrangement as it does to the actual aerial itself.

In the first place it should be made clear that usual practice is to use a single receiving aerial for both the picture signal and the sound. The two signals, lying in adjacent frequency channels, are "sorted out" in the early stages of the receiver.

Television receiving antennae are usually of the simple dipole type. Sometimes special arrangements of several dipoles (multi-element "arrays") are used, when special directional properties are desired.

In erecting an antenna the first point to consider is the polarisation characteristics of the transmitted wave. In England vertical polarisation has been in favour, and in this case the receiver dipole must be placed so that its length is perpendicular to the ground. If the wave is horizontally polarised, as in America the dipole is erected parallel with the ground.

Secondly, the direction from which the signal arrives must be considered. Remember the dipole has directional properties such that maximum signal strength is absorbed when the dipole length is at right-angles to the direction of the wave. In other words, the dipole must be placed "broadside-on" to the line joining transmitter to receiver. If it is desired to operate upon more than one transmission, a compromise must be decided upon in this respect.

Figure 31 shows the necessary orientation of antennae for vertically polarised wave at (a) and horizontally polarised wave at (b).

DISTORTION DUE TO REFLECTIONS.

Ultra-high frequency waves are particularly susceptible to reflection from large objects such as city buildings. In this way waves from a transmitter may arrive at a receiver from different directions, and having covered paths of different lengths. Figure 32 shows a receiver antenna R receiving a "direct" wave from the transmitter T along the path TR. A wave is also received having travelled the path

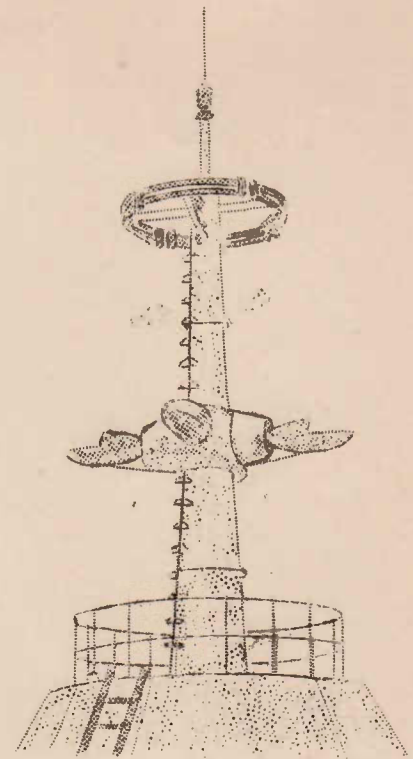

FIGURE 30.
TELEVISION TRANSMITTING
ANTENNAE.

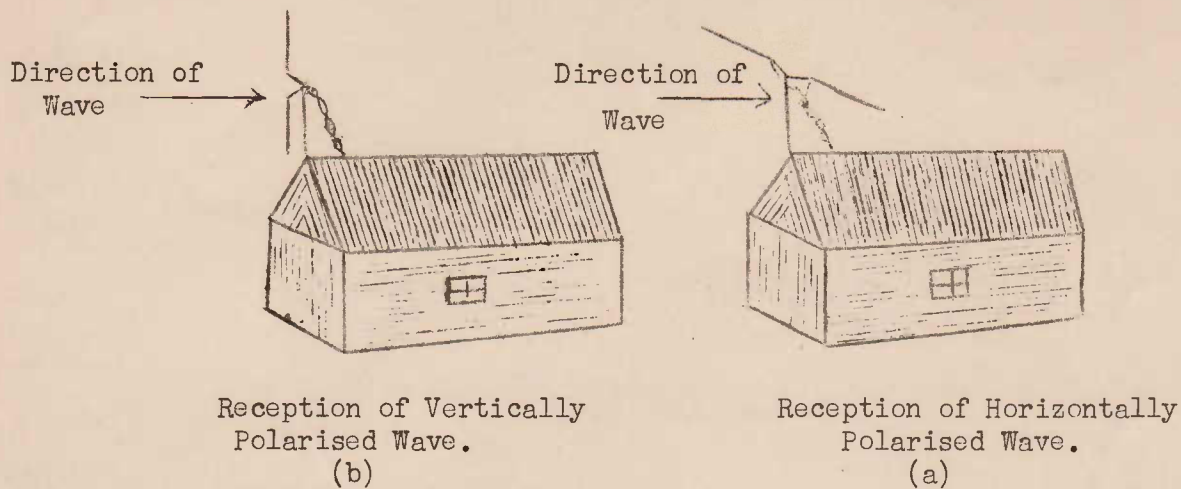

FIGURE 31.

TOR, due to reflection from the building B. The effect is to produce a blurred image on the receiver screen due to the reproduction, twice, of each picture element. The reproduction of a particular picture element due to the reflected wave will not appear on the screen in exactly the same spot as that produced by the direct wave. To understand this remember that the picture elements are superimposed on the r.f. wave in succession, and in the form of modulation. Now imagine that at the present moment a particular picture element appears as modulation on the wave just leaving T. This picture element will be reproduced on the receiver screen a short time later -- the time the direct wave takes to pass directly from T to R. The same picture element will be reproduced a second time -- a little later

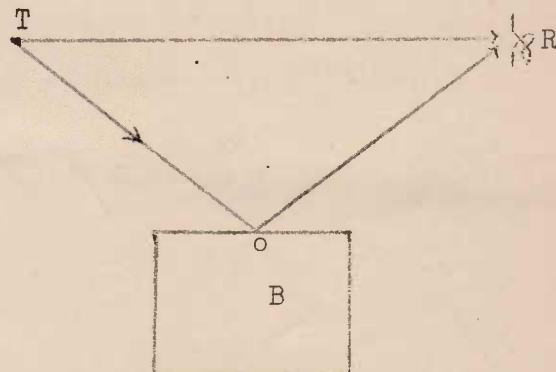

FIGURE 32.

still -- by the wave travelling the route TOR. This path is longer than TR, and hence the time taken will be longer. The result will be that two identical picture elements will appear on the screen side by side, since the scanning beam is continuously moving, at high velocity, over the screen. A blurred image will result.

Such reflections can be discriminated against by turning the dipole until it is more or less end-on to the direction from which the reflected wave is arriving. Of course this may involve orientating the dipole so that it is not square-on to the direct wave, with a resultant loss in signal strength. In practice a compromise in this respect must be effected.

LENGTH OF RECEIVER DIPOLE.

As previously discussed, the dipole, to be resonant, must have an electrical length equal to one-half of the wavelength of the desired signal. (Remember that the physical length is only about 95% of the electrical length). If a single transmission

only is to be considered the problem, then, is simple. Suppose, however, a number of stations, with a frequency band of, say, 44 mc/sec. to 108 mc/sec. are to be received. Once again a compromise must be resorted to. It is usual to design the antenna in this case so that it is resonant at a frequency known as the "geometric centre" of the range. This is calculated by multiplying the two extreme frequencies and taking the square root, thus:-

$$\text{geometric centre} = \sqrt{44 \times 108} = 70 \text{ mc/sec.}$$

The dipole is designed so that it is $\frac{1}{2}$ wave-length long at 70 mc/sec. A certain amount of de-tuning effect will be experienced for frequencies on either side of this, but since the losses in the antenna system are usually fairly heavy, the antenna, considered as a tuned circuit, is very broadly tuned, and it is found in practice that the band of frequencies can adequately be covered by a single aerial.

FEEDING THE SIGNAL FROM DIPOLE TO RECEIVER.

The "lead-in" is almost invariably a transmission line, properly "matched" at both ends. It should be noted that here the dipole itself may be regarded as an A.C. generator supplying the input to the line. The internal impedance of this "generator" is about 80 ohms (the "radiation" resistance and ordinary resistance of a dipole). Hence the line must be matched to this 80 ohms impedance, if maximum energy is to be transferred to it from the antenna. Again, if the receiver input (aerial circuit) is to absorb maximum energy from the line, and if reflections in the line are to be avoided, the load imposed upon the line by this input circuit must be equal to its characteristic impedance (Z_0).

Transmission lines used in practice are of the parallel (twin) wire, coaxial cable, or twisted-pair types. The parallel-wire type usually has a higher impedance (Z_0) (usually hundreds of ohms) and therefore requires special matching devices at the centre of the dipole (impedance 80 ohms). One matching method is that known as the Delta-match illustrated in Figure 33. The dipole is unbroken at the centre, and the transmission line is flared out, the dimensions being shown for a 600 ohm line. The theory of this matching method is rather complicated and will not be discussed in detail here.

The effective load on the other end of the line must also be equal to its characteristic impedance -- 600 ohms in this case. The transformer effect is usually used for matching purposes here. The load imposed on the line will depend upon the natural impedance of the input circuit of the receiver and the turns ratio of the transformer. The arrangement is shown in Figure 34. Note that the centre point of the primary coil is grounded. The reason for this is to cause cancellation of any signal pick-up in the two wires of the transmission line. These signals will cancel out in the two halves of the primary coil, so that all signal fed to the receiver comes

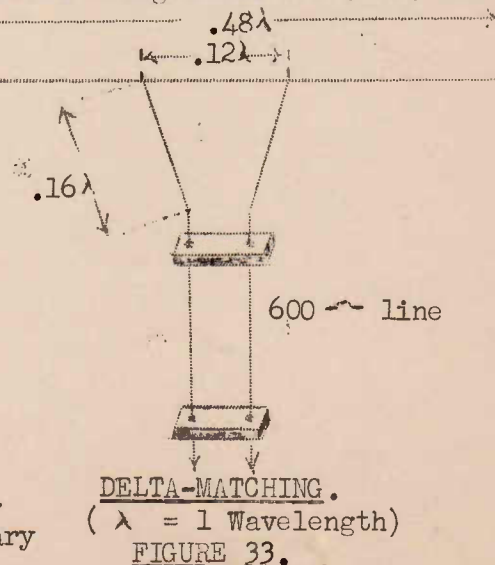

from that absorbed in the dipole itself. This precaution is called "balancing" the line.

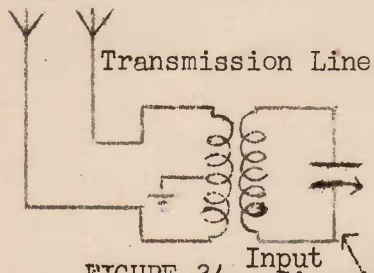

FIGURE 34. Input Circuit

The twisted-pair type line has a lower characteristic impedance -- usually 50 to 150 ohms -- so that direct coupling to the dipole ($Z_0 = 80$ ohms) is in most cases satisfactory (See Fig. 35). The attenuation, due to r.f. losses, of the twisted-pair is, however, high. Although this results in loss of signal strength, the high attenuation is actually an advantage in damping out reflections, due to imperfect load matching, as discussed below. For these reasons the twisted-pair is usually to be favoured above all other types for ordinary household reception purposes.

DISTORTION DUE TO LINE REFLECTIONS.

If the transmission line from the dipole is not correctly matched at both ends, reflections, producing standing waves are set up, as previously discussed. These line reflections cause exactly the same type of screen distortion as occurs when the antenna receives a wave reflected from an object, as shown in Figure 32. If the line is not accurately matched to the load of the input circuit, a part of the energy, instead of being absorbed by the receiver, is reflected back along the line. If imperfect matching also occurs at the antenna end, the wave is again reflected towards the receiver. The reflected wave may pass back and forth several times along the line. Each time it strikes the receiver end, a part of it is passed to the receiver screen. In this way a picture element may be "laid down", at adjacent points, several times on the screen, with consequent blurring of the image. If the line is short, the time taken for the reflected wave to travel twice its length will be extremely short, and in this case, the distortion will be negligible, since the picture elements will fall practically on top of each other. If a long line is used, however, the distortion can be very serious.

The fault is largely avoided if a high loss twisted-pair line is used, because the reflected wave is virtually wiped out, by attenuation, in travelling the double-length of the line. Obviously, however, the best method of preventing the trouble is to design the antenna system, together with the receiver input circuit, so that correct matching at both ends of the line is obtained.

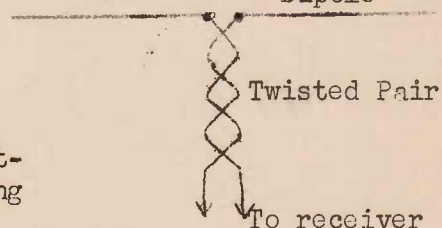

FIGURE 35.

T. FM & F. LESSON NO. 7.

EXAMINATION QUESTIONS.

1. Explain with the aid of a diagram the meaning of the terms distributed self capacity and inductance of a straight conductor.
2. Draw a diagram showing a half-wave dipole. Insert curves to show how the magnitudes of the current and voltage vary over the antenna length when it is operating on its resonant frequency.
3. What is meant by the radiation resistance of an antenna? What is the value of the radiation resistance of a half-wave dipole measured at its centre?
4. What is the correct physical length of a half-wave dipole to be operated on 90 mc/sec?
5. What is a polar diagram? Sketch a horizontal and vertical polar diagram for a half-wave dipole placed horizontally.
6. Give and explain one reciprocal property of a dipole when used for reception and transmission.
7. What factors determine the characteristic impedance of a twin-wire transmission line? Under what conditions would the input impedance of the line equal its characteristic impedance?
8. What effects may be encountered if a receiver's transmission line is not correctly matched at both antenna end and receiver end?
9. Explain the meaning of the term "polarisation of a wave". Should a receiver's dipole be vertical or horizontal to receive a vertically polarised wave?
10. Why may the presence of large buildings near a receiver aerial result in a blurred picture?

AUSTRALIAN RADIO COLLEGE

E. S. & A. BANK BUILDINGS, Corner CITY RD. and BROADWAY, SYDNEY
Telephones: M 6391 and M 6392. Post Lessons to Box 43, Broadway

This lesson sheet is published for the exclusive use of
students of the Australian Radio College Pty. Ltd.
(All rights reserved)



T.F.M. & F. LESSON No. 8.

TELEVISION RECEIVERS.

The broad general principles underlying the reception of television signals are identical with those you have learned about in your earlier lessons on ordinary sound broadcast receivers. For this reason we shall concentrate here on elucidating the special problems which are characteristic of the reception, amplification, and detection of the high frequency, wide-band wave which constitutes the television signal. A great deal of this explanation can be illustrated by block diagrams to replace full circuit diagrams. Whenever this is done the student should be ever ready to apply, in his own mind, the knowledge of electronic technique already acquired in the study of broadcast reception. He should understand that, unless the contrary is stated, a "block", representing a stage, or section, of the receiver, operates in the same general manner as its counterpart in the more humble broadcast set.

THE SPECIAL PROBLEMS OF TELEVISION RECEPTION.

As has been pointed out in an earlier lesson of this series the complete television signal as broadcast from the transmitter is rather a complicated affair. In the first place it consists, in the case of the system at present in general use, of two separate waves -- one carrying the vision signal, the other the sound -- lying in adjacent frequency channels. The first problem will therefore be that of picking up and tuning in this "dual" signal, and thence separating the two in order that each finally reaches its proper destination, viz: the cathode ray tube in the one case, and the loudspeaker in the other.

Then again, as will be recalled the vision signal itself consists of two parts, the true picture or video signal, and the synchronising pulses. These must, by special methods, be separated one from the other, and made to perform their allotted tasks.

A third special problem is that of handling the ultra-high radio frequencies which we have seen are characteristic of television signals. For efficient tuning and

amplification of these frequencies, extending up to many scores of megacycles, requires somewhat special design for the amplifying circuits.

Finally, but of great importance, is the problem of handling the wide-band signals which are characteristic of modern high-definition signals. It will be recalled that these band widths run up to 3 or 4 megacycles, as against several kilocycles in sound broadcast transmissions. The problem in this connection is mainly one of the correct design of the I.F. amplifiers, and also, of course, any stages of video amplification employed after detection.

In addition to the above mentioned problems of tuning, separation of vision and sound, and wide-band amplification, there is of course the important function of operating the cathode-ray tube to build up, from a series of picture-elements, a re-creation of the original moving scene. This part of the receiver incorporates, such as "saw-tooth" oscillators which have no counterpart in the ordinary broadcast model. The operation of the cathode-ray tube, together with its associated circuits will be deferred until the next lesson. Here we shall deal with the sound and video tuning, mixing, amplifying (R.F. I.F. and video), and detection circuits.

TYPES OF RECEIVERS.

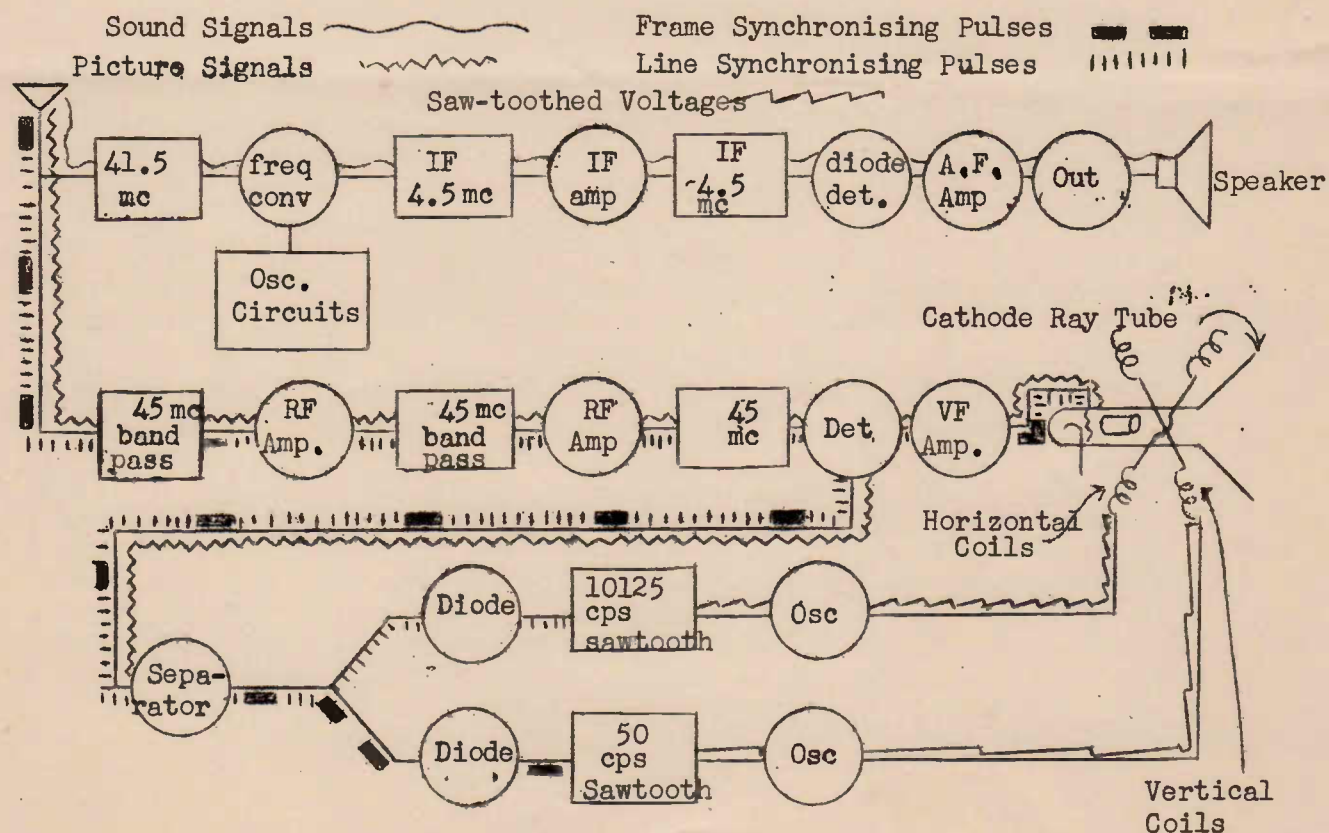

FIGURE 1.

Just as it is possible to use a straightforward TRF receiver or a superheterodyne for the reception of signals from broadcasting stations, so it is possible to use either a T.R.F. or superheterodyne circuit for receiving either or both the vision

signal and the sound signal. Some receivers have employed superhet circuits for both vision and sound signals. Others have used a superhet circuit for sound and a TRF circuit for vision. Still others have used a TRF circuit for sound and a superhet circuit for vision, while it is also possible to use a T.R.F. circuit for both. Regardless of the type of reception adopted, the general principles are exactly the same as those you have learned about in your earlier lesson papers.

Figure 1 is a "block" diagram of a television receiver employing a superhet section for the sound signal, and a TRF circuit for the vision. The two sections represent two entirely separate receivers except that they operate from a single dipole. Although this antenna is "resonant", its tuning is broad and will, due to various "losses", amply cover the entire sound and vision channels.

In the diagram (Figure 1) the circles represent valves, while the rectangles are tuning circuits. The receiver is supposed to be operating upon a television signal consisting of a sound carrier of 41.5 mc/sec, and a vision channel of carrier frequency 45 mc/sec, with side-bands extending from, say 43.5 mc to 46.5 mc. The sound signal, picture signal, and sync. pulses are shown as per the key at the top of the diagram. Remember that the sync. pulses are superimposed, as modulation on the 45 mc. vision carrier.

The sound carrier is separated from the vision carrier by a sharply tuned r.f. circuit adjusted to 41.5 mc. This signal is then reduced to the I.F. of 4.5 mc. by means of the frequency converter (1st detector). Compare this I.F. with that commonly used in broadcast reception (455 kilo-cycles).

The remainder of the sound receiver corresponds in principle exactly with any conventional superhet-receiver.

The picture carrier, which contains the vertical (frame) and horizontal (line) sync. pulses is fed into tuned circuits designed and adjusted to pass the band of frequencies comprising the 45 mc. carrier itself together with its necessary side-bands. This band-pass "filter" cuts off rather sharply frequencies above and below the vision channel. In particular it eliminates, or greatly reduces the sound signal which must be prevented from reaching the picture screen, where it would cause interference to the reproduced scene. In the case of the receiver illustrated, the vision section is T.R.F. consisting of 2 stages of r.f. amplification. Each stage is tuned to the picture signal, so that by the time the latter has reached the detector, the last traces of the sound signal have been suppressed.

The detector may be of any of the usual types employed in a T.R.F. receiver. In this stage, of course, the signal is de-modulated, i.e. the video signal is separated from its carrier. This video signal, representing the picture elements, is then amplified by one or more stages of wide-band amplification. Video amplifiers were discussed in detail in Lesson 5. The video signal is then applied to the control grid, or modulating electrode, of the cathode-ray tube.

It will be observed that the two sync. signals, which were also separated from the carrier by the detector, are "side-tracked" at this stage into that section of the receiver which produces the saw-tooth voltages (or currents) for beam deflection. The discussion of this part of the receiver will require considerable space, and is therefore deferred until the next lesson, where it will be treated in detail.

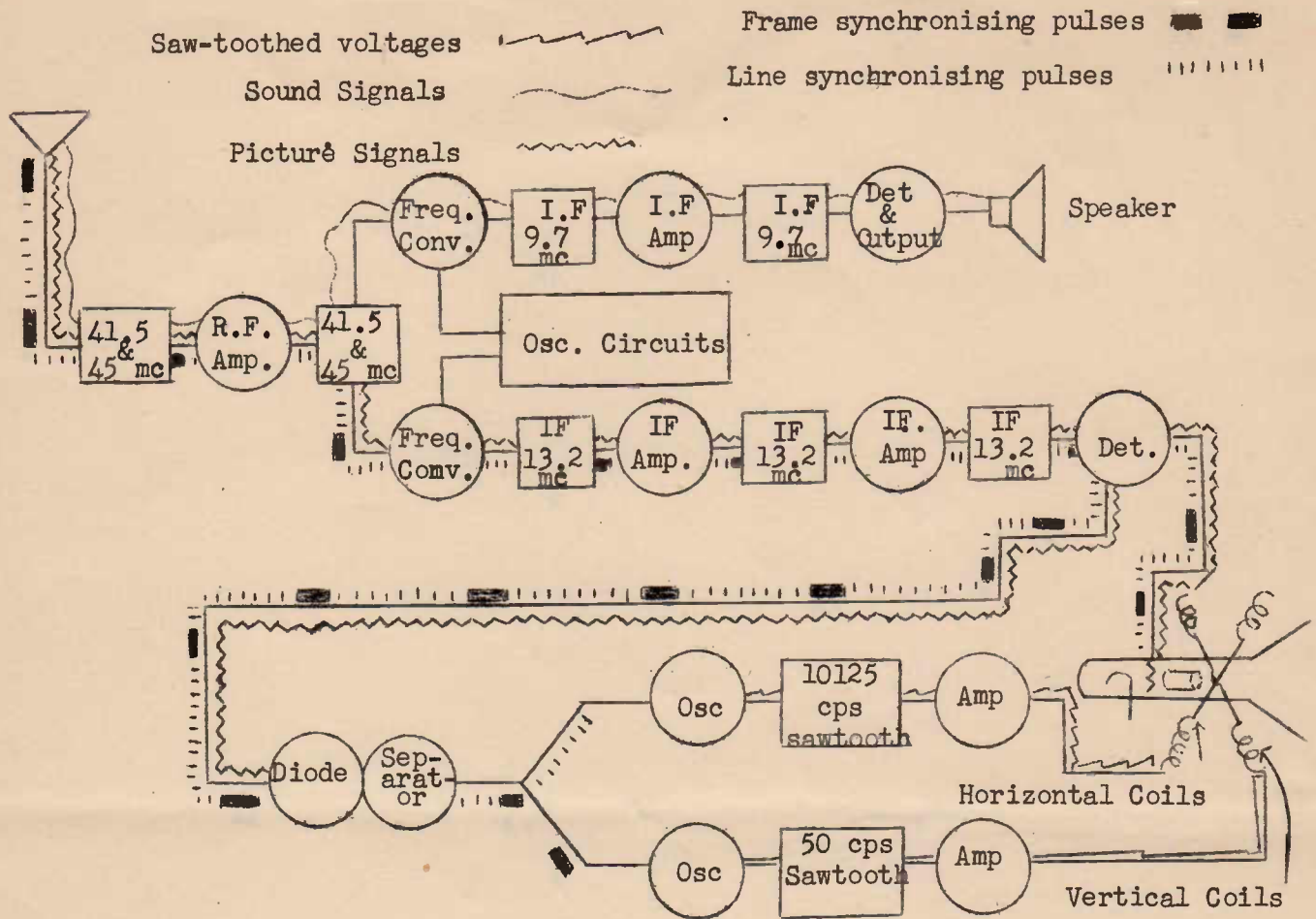

FIGURE 2.

Figure 2 shows another typical receiver layout, in which both sound and vision sections employ the super-heterodyne principle. In this case both signals are passed through the one R.F. amplifier, which is sufficiently broadly tuned to cover the entire television band. For the channel cited, this will extend approximately from 41.5 mc. to 46.5 mc. The two signals are then separated by more sharply tuned circuits, and passed into their respective frequency converter stages. These reduce the frequencies to the I.F.'s of 9.7 mc. and 13.2 mc. respectively. The sound section then follows, in principle, the conventional superhet. layout. The picture signal passes through two stages of I.F. amplification, where the tuned circuits have broad characteristics to accommodate the wide band of side-frequencies (e.g. 3 mc.).

The detector is normally of the diode type. Such a detector if sufficient amplification is obtained from the previous R.F. and I.F. stages, will produce a video signal strong enough to operate the cathode-ray tube directly. Hence, as shown in Figure 2, some receivers do not contain any stages of video amplification.

As in the first receiver described, the sync. pulses are diverted, at the detector stage, into those cathode-ray tube auxiliary circuits which provide the beam scanning. It will be observed that no attempt is made to suppress the sync. sig-

nals from the modulating electrode. Such suppression is unnecessary; for, as will be shown clearly in the next lesson, these signals, although serving no useful purpose at this electrode, cannot cause any undesirable interference with the picture formation.

The diagrams of Figures 1 and 2 will give the student some idea of the functions to be performed by a television receiver, and of the number of valves and components required. It would be as well to mention now that it is practically universal practice to utilise the superheterodyne principle in both sound and vision sections of the receiver as in Figure 2. We shall now proceed with a more detailed discussion of the particular problems associated with the aerial, mixer, I.F. and detector stages of such a typical receiver.

THE INPUT (AERIAL) STAGE.

The function of this stage is to accept the composite (sound and vision) signal from the antenna (to which it must be matched -- see previous lesson), and to transfer these two carriers either directly to the converter valve or valves, or firstly to an R.F. amplifier.

The use of an R.F. amplifier has the advantage of improving the signal-to-mask ratio (in the same way as it improves the signal-to-noise ratio in an ordinary superhet). It also results in a slightly improved over-all amplification and selectivity. The more usual practice, however, is to omit an R.F. amplifier, as the number of valves in a typical television receiver is comparatively large. Another reason for omitting this stage is that a considerable simplification in the tuned (input) circuits is thereby achieved.

The input or aerial stage consists of a tuned circuit or circuits sufficiently broadly tuned to cover the entire television channel, which, including the vision and sound carriers (with sidebands) may be as wide as 5 mc. If a single circuit is used this broad tuning is mainly achieved as a result of the "loading" of the circuit due to the antenna and transmission line circuits which are coupled across it. These losses have the same effect as a resistance connected in parallel across the tuned circuit (See Figure 3).

The input circuit or circuits are usually inductively tuned, i.e. they employ coils with adjustable iron cores. The tuning capacities then consist of the stray wiring and valve input capacities.

If the receiver is designed to be tuned to a large number of television channels it is usual to employ a separate circuit for each channel. The stations are then selected by a suitable switching arrangement

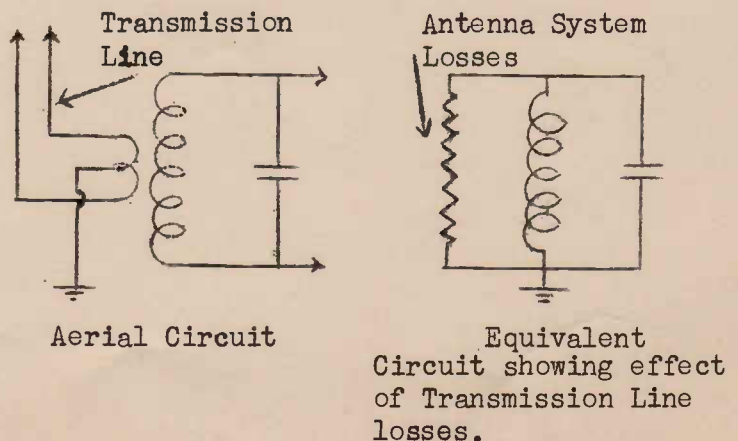

FIGURE 3.

as shown in Figure 4. Notice here that five channels are provided for. The primary of each coupling coil consists of a metal strap, stamped from sheet, and

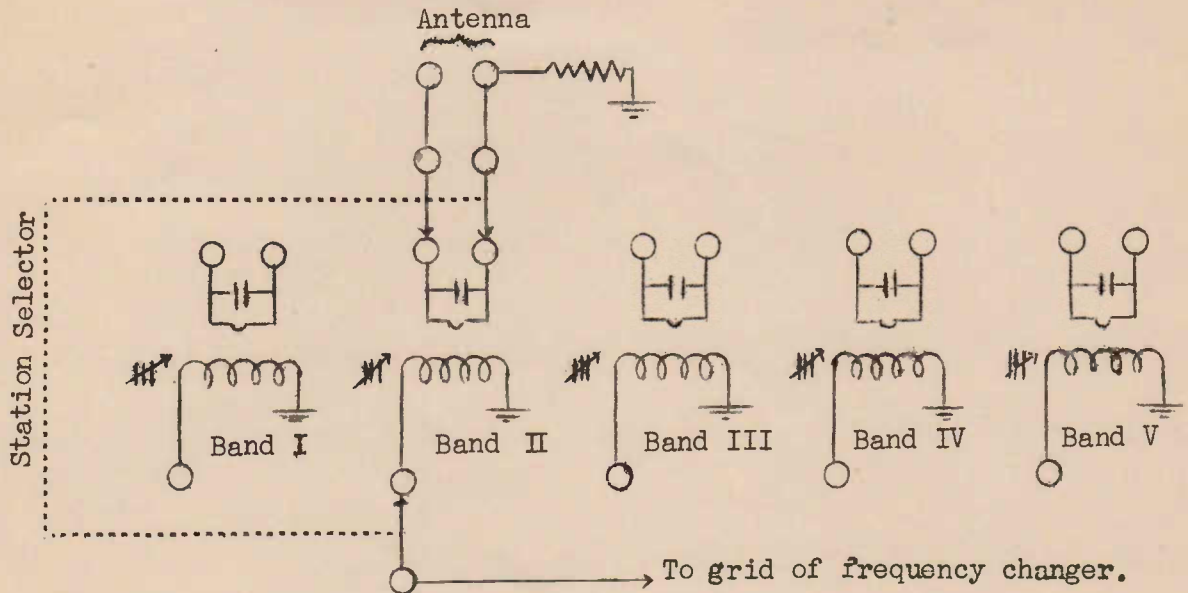

FIGURE 4.

consisting of but a single turn, intended to match the impedance of a 75 ohm transmission line. The secondaries are tuned by means of powdered iron cores which fit within the coils. The five channels provided for are 44 to 50, 50 to 56, 66 to 72, 78 to 84 and 84 to 90 mc.

Coupled circuits, to produce a band-pass effect, are often used in preference to a single circuit. The idea here is not to increase the selectivity of the receiver (the over-all selectivity of a typical receiver is due almost entirely to the I.F. stages), but to improve the ratio of signal-to-mask (noise) ratio. When a single circuit is sufficiently broadly tuned to cover a band of several megacycles it has a very low "Q", and produces no voltage amplification of the signal. On the other hand it passes to the converter a maximum amount of "thermal agitation" voltages. Briefly it may be stated that the sharper the tuning of a circuit (i.e. the higher its "Q" value) the greater will be its signal-to-random voltage ratio. The requirement of wide tuning range to cover the whole television signal, together with the advantages of comparatively high "Q" circuits may be obtained by using several circuits designed to produce a band-pass or "filter" effect.

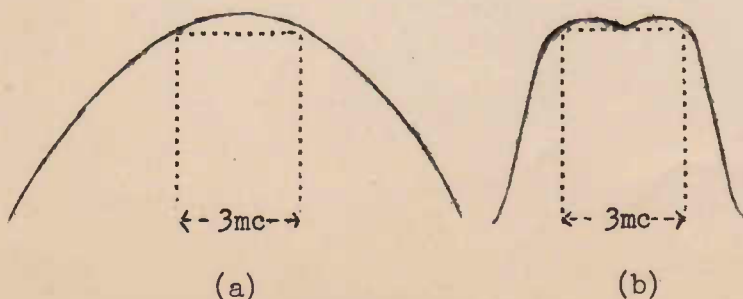

FIGURE 5.

A comparison between the characteristics of a single broadly tuned circuit (at a) and a "band-pass" arrangement (at b), consisting of several tuned circuits is shown in Figure 5. In each diagram the dotted line represents the "ideal" selectivity curve required for a 3 mc. channel. At (a) it is shown that, in order to cover approximately this band using a single circuit, the tuning has to be broadened (by resistance loading) to

such an extent that frequencies well outside the channel are not greatly attenuated. Even so there is some attenuation of the upper side-band frequencies of the signal. The curve obtained at (b) is that of a band pass "filter" arrangement. Here the signal channel is adequately covered, yet frequencies outside the band are sharply cut off.

When a receiver is designed to operate on a single station only (i.e. when no provision is desired for selecting one of a number of television channels) the input circuit may be constructed to yield sharp resonance for the comparatively very narrow sound channel. In the case of the simple input circuits so far described the sound signal, occupying a band of perhaps only 10 Kc. in width, is passed to the converter grid through the common input circuit which will accept a band of frequencies extending over several megacycles. This results in a lowered over-all amplification and signal-to-noise ratio as far as the sound section of the receiver is concerned.

In Figure 6 is shown an input circuit which provides selective resonance for the sound signal. Separate converter valves are used for video and sound channels.

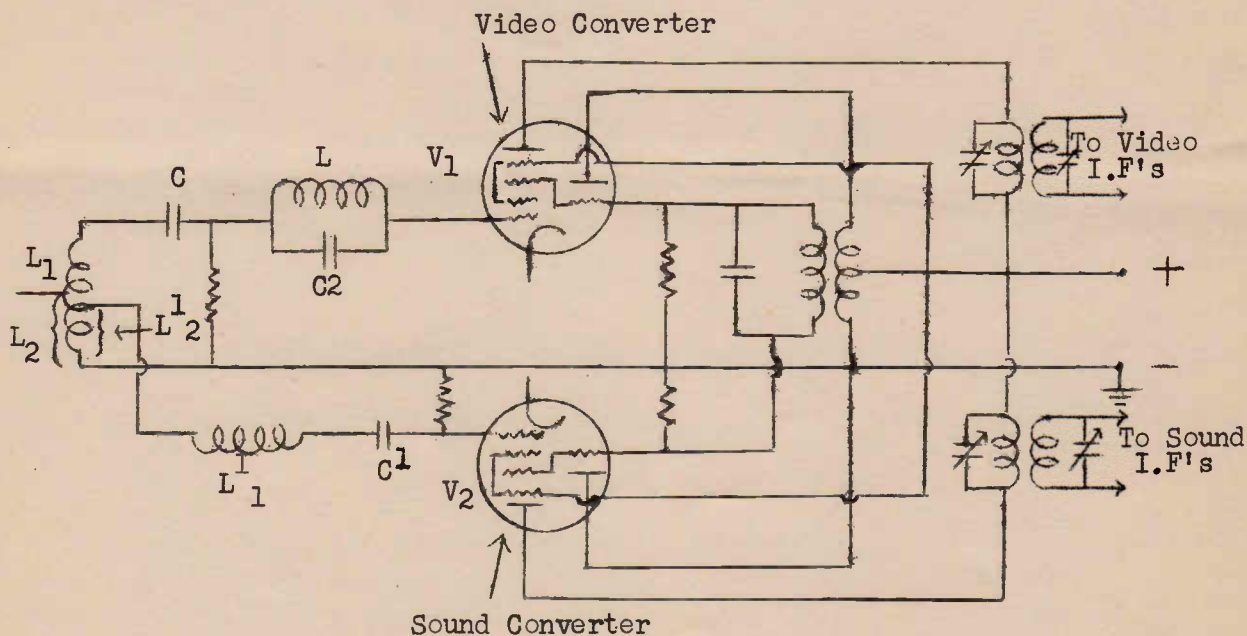

FIGURE 6.

The input circuit which accepts the broad band representing the composite signal consists of coils L_1 and L_2 and condenser C . Coils L_2 , L_1 , and condenser C^1 form a sharply tuned circuit of the band-pass type, adjusted to the frequency of the sound carrier. It allows only the comparatively narrow band of frequencies, representing the sound signal, to pass to the grid of the lower converter. Circuit LC^2 forms a parallel resonant circuit, tuned sharply to the sound carrier. This circuit offers a large impedance to the sound frequencies, but passes comparatively freely the wide band of frequencies representing the picture signal to the video converter.

THE CONVERTER STAGES.

The function of the converter stage is, as in the case of an ordinary broadcast

receiver, to produce lower frequencies, viz: "intermediate" frequencies, which may then be more efficiently amplified and separated. Note, however, that in the case of television work, there are two separate carriers (vision and sound) to consider, and two separate intermediate frequencies to produce. Systems which have been, and still are, used to generate the two I.F.'s are several in number:-

- (1) Separate converter valve for each channel, each valve functioning as both oscillator and mixer for its own channel.
- (2) Separate mixer valves for each channel, but using a separate valve for producing the local oscillations for both channels.
- (3) A single mixer valve for both carriers, but employing a separate valve for producing oscillations, and
- (4) A single converter valve which acts as both oscillator or mixer for both channels.

(NOTE:- We are here using the term "converter" when a valve performs the dual function of producing the locally generated oscillation and "mixing" it with the incoming carriers. The term "mixer" is used when the valve is relieved of the job of generating the local oscillations, by the employment of a separate valve for this purpose.)

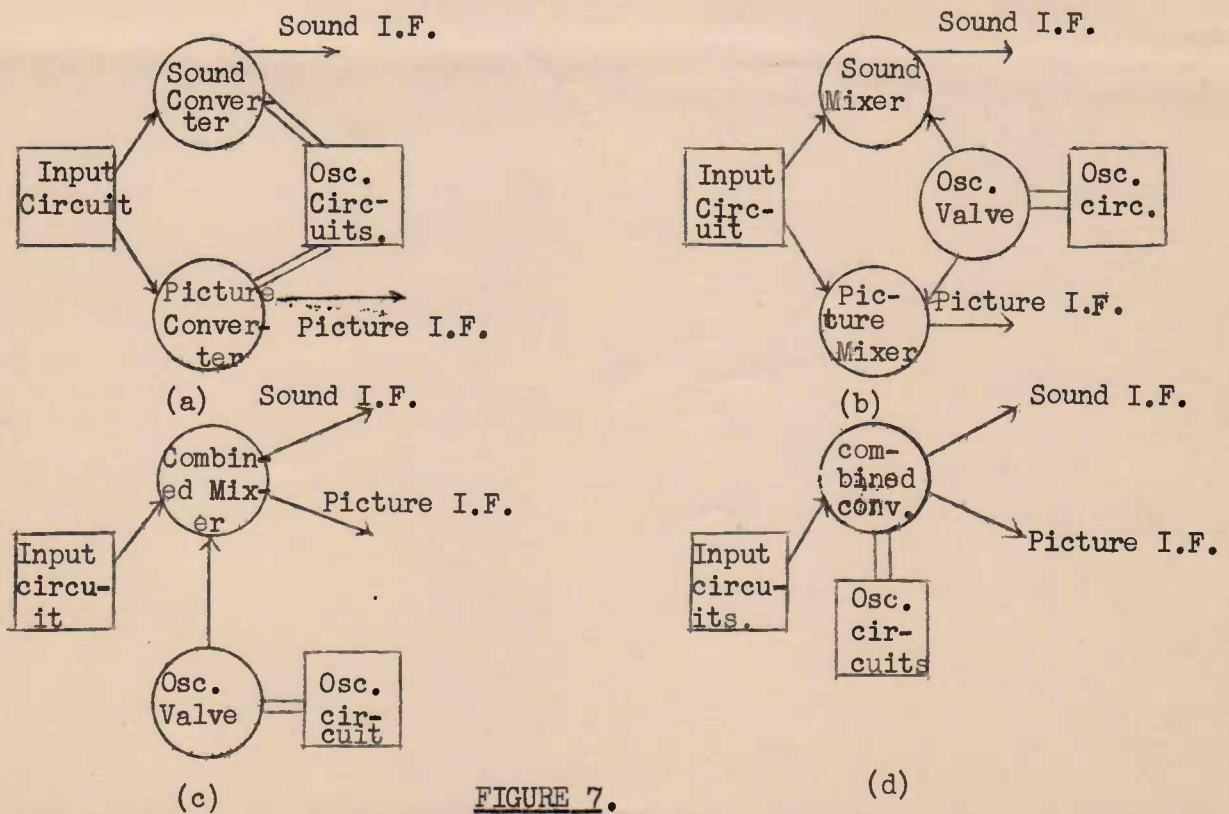

FIGURE 7.

The four systems are illustrated diagrammatically in Figure 7. In the case of systems (1) and (4), at (a) and (d) respectively, the valves perform the double function of mixer and oscillator. Systems (2) and (3), at (b) and (c) employ separate valves for oscillator and mixer functions. From another point of view

(a) and (b) are similar -- in that the mixing of sound and picture carriers (with oscillator frequency) is carried out in separate valves. By the same token (c) and (d) may be compared, for in both these arrangements mixing for sound and picture signals is achieved within a single valve, the two I.F.'s being then separated by selective circuits.

COMPARISON OF CONVERTER SYSTEMS.

Whether or not a separate oscillator valve is used depends mainly upon the television frequency or frequencies the receiver is designed for. It is found that for carrier frequencies above about 70 Mc. it is virtually necessary to use a separate oscillator valve. Working at these high frequencies (which are common in the U.S.A.) it is very difficult to maintain a stable oscillator frequency, independent of the signal frequencies, when a single converter type valve is used. This is due to coupling effects occurring within the valve, between the different frequencies involved. In addition, a considerable loss of power in the oscillator frequency is involved.

When operation is on the lower frequencies, however, as in the case of the B.B.C. transmissions on 40 odd M.C, the use of combined converter type valve is quite satisfactory (See Fig 7 (a) and (d)), and has the advantage of reducing the number of valves in the set.

With regard to the question of the mixing of the sound and picture signals within separate valves (as at (a) and (b) -- Fig. 7), or within a single valve (as at (c) and (d)), the problem again depends largely upon the intended purpose of the receiver. If operation is to be confined to a single television transmission advantage may be taken of separating the sound and picture carriers in the input circuits, whereby selective resonance, particularly for the sound signal, may be employed, as described earlier in this lesson. This plan necessitates the use of separate mixer valves. When, however, the receiver is designed for switching to different television channels, as is commonly done in America, it is virtually impossible to carry out any separation of sound and picture carriers in the input (aerial) circuits. In this case, as explained each input circuit (for each television channel) is a simple tuned circuit, and separation of sound and picture signals is carried out after the single mixing stage, by means of the circuits tuned to the separate Intermediate Frequencies.

Summarising, we may state briefly that in America the arrangement at (c) Figure (System 3) is most favoured. English receivers, on the other hand seem to prefer the arrangement illustrated at (a) in this diagram.

SOME OSCILLATOR AND MIXER CIRCUITS.

The oscillator tuning is one of the most critical adjustments in the entire receiver. The oscillator must therefore be designed to operate at a very stable frequency, i.e. the latter must not vary appreciably with supply voltage or temperature changes. Two circuits which seem to show the highest degree of freedom from frequency instability are the "floating-cathode" type shown at A in Figure 8 and the tuned plate circuit, two versions of which are illustrated at B and C in the same figure. All these circuits are really modified versions of the Hartley oscillator.

The condenser C_v in each case is used as a trimmer.

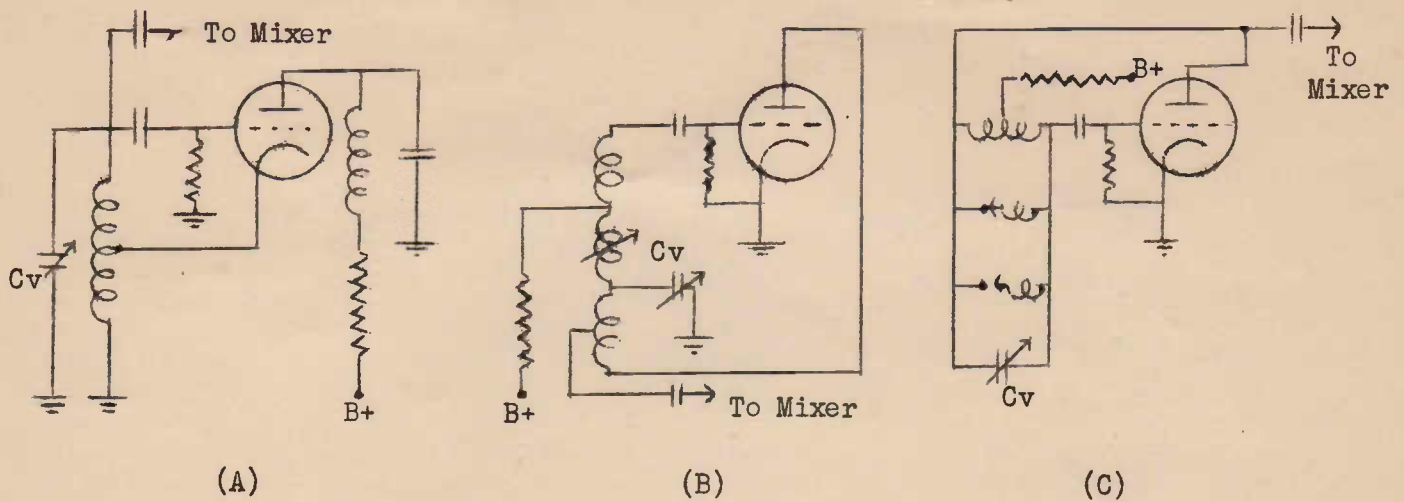

FIGURE 8.

Simple tuned-grid oscillators, as found in broadcast receivers are rarely used.

A Push-pull type of oscillator, with grid-tuning may be used when the receiver operates with separate converter tubes for each channel. An example of this arrangement was given back in Figure 6. Here the triode sections of the two converter tubes, acting in push-pull maintain in oscillation the single tuned circuit which is connected in their grid circuits.

With reference to this circuit note that the function of the hexode section of V1 is limited to the generation of the video I.F., the hexode section of V2 being used for the sound I.F. Observe also that the picture I.F. which occupies a broad frequency band, is transferred to the following stages by means of an untuned (r.f.) transformer. The sound I.F. on the other hand, is amplified selectively by means of tuned coupled circuits, as is common practice in broadcast receiver design.

An example of a complete converter stage employing a single mixer valve for both picture and sound channels, together with a separate oscillator is shown in Fig. 9.

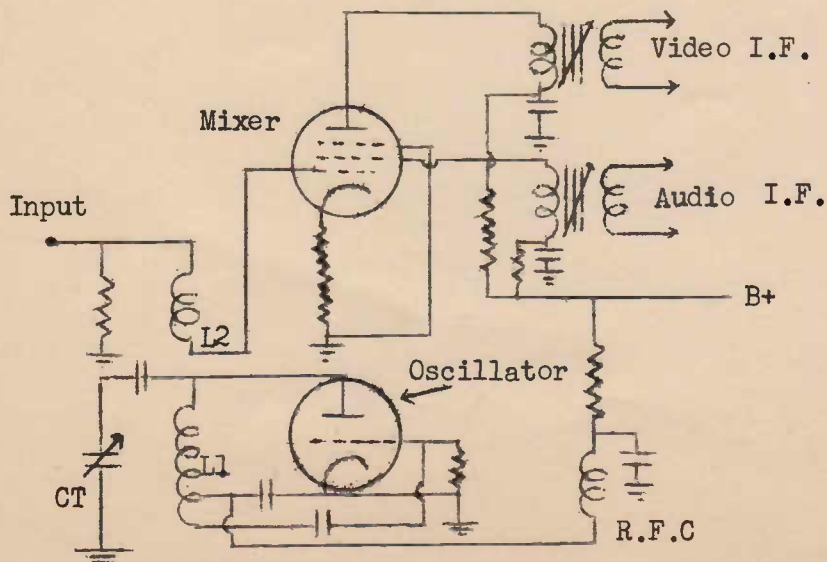

FIGURE 9.

Here the oscillator consists of the Hartley circuit with a triode valve. The oscillator's tuned circuit consists of the tapped coil L_1 , and trimmer condenser CT . The mixer valve is a pentode of high mutual conductance. The oscillator frequency is injected directly into the grid by means of the coupling coil L_2 . This arrangement gives the highest sensitivity.

An interesting point
T.F.M & F.8/10.

about this circuit is that while the picture I.F. signal is taken, as usual, from the plate of the mixer, the sound I.F. is taken from the screen-grid, which is not by-passed.

THE TWO INTERMEDIATE FREQUENCIES.

At this stage it should be clearly understood how the two I.F.'s are produced from a single oscillation with the receiver. Suppose the sound carrier has a frequency of 49.5 mc. and the picture carrier is of 45 mc. If an oscillator frequency of 58 mc. is "mixed" with both these carriers a number of frequencies will emerge. One of these is the difference between 58 Mc and 49.5 Mc., viz: 8.5 Mc., and this is the sound I.F. Another frequency produced is the difference between the oscillator frequency and the picture carrier frequency, viz. $58 - 45 = 13$ Mc. This is the video I.F. As will be explained fully a little later it is always desirable to arrange matters so that the sound I.F. is below the picture I.F., as in the case cited.

Now if the transmission is such that the sound carrier is below the picture carrier, then the oscillator frequency must be adjusted to a value below both carriers if sound I.F. is to be below picture I.F. (Read this once again!) The student should, at this juncture consider a number of hypothetical cases for carrier frequencies and oscillator frequency, and on each occasion figure out for himself what the I.F.'s will be. If this is done the following points should be clear. Assuming that it is desired to produce a sound I.F. below the picture I.F, then

- (1) If sound carrier is above picture carrier, oscillation frequency should be above both.
- (2) If sound carrier is below picture carrier, oscillator frequency should be below both.
- (3) In all cases the separation between the I.F. channels is equal to the separation in the carriers. It follows, therefore that while the frequencies of the two I.F.'s may be varied by adjustment to the receiver's oscillator circuit, the difference between the two is fixed for any given transmission.

With reference to points (1) and (2) above, it is desirable, from the transmitter's point of view to generate the picture carrier at the lower frequency. The reason for this is that, when operating in the region of U.H.F.'s. the lower the actual frequency the greater the efficiency and power which may be obtained. Greater difficulty is experienced in generating sufficient power to override interference in the case of the picture signal than in the case of the sound.

From the point of view of receiver design however it is better to have picture-carrier above sound carrier, since this results in a lower receiver oscillator frequency. The point here is that it is much easier to design a converter oscillator of sufficient frequency-stability and power when the frequency is kept to a minimum.

So it appears to be six of one and half-a-dozen of the other! In the English B.B.C. transmissions it has been the practice to operate on the picture carrier-above-sound-carrier-system, involving an oscillator frequency below both. The opposite

system is in use in America.

REASON FOR THE HIGH INTERMEDIATE FREQUENCIES.

The Intermediate Frequencies used in Television are of a much higher order than those with which you are familiar. In an example given above the Figures 13 Mc (for picture) and 8.5 Mc. (for sound) were quoted. Note that these are still high radio-frequencies - in fact they approach in value the carrier frequencies used in the communication short-wave band. The question may well be asked: why not "convert" the television carriers to much lower frequencies, where amplification may be effected with greater efficiency?

The answer to this question is, in the main, bound up with the great width of the band necessary to incorporate all the video components in the picture signal. As we have seen previously this band is usually several megacycles in width. Remember that when the converter reduces the carrier signal to the lower intermediate frequency, the width of the band should in no way be reduced. If such a narrowing of the band were introduced in the converter or I.F. stages, it would mean a loss of the higher video frequencies in the picture signal, with a resultant deterioration in picture detail and sharpness.

Suppose then our picture channel extends over a frequency range of 3 m.c. It would be clearly impossible to design tuned circuits having a "centre" frequency of less than 3 mc, and yet still pass this frequency band. Even with an I.F. of 13 mc. the band pass required is nearly one-quarter of the centre frequency of the I.F. circuits, Figure 10 illustrates the problem here.

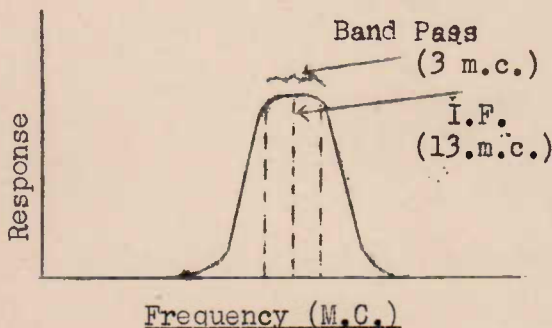

FIGURE 10.

A second reason for choosing frequencies like 8 - 13 mc for the television I.F.'s, is that this particular section of the electro-magnetic frequency spectrum is in very little demand for other services. If an I.F. corresponding to the carrier frequency of some other broadcast were selected, the television receiver would suffer from serious interference; for its I.F. circuits would readily pass the interfering signal from direct pick-up and insufficient selectivity in the R.F. stages of the receiver.

The student may still be wondering why the sound I.F. is not operated on something like, say 465 K.C, since the band-width argument does not apply to it. The point here is that, as explained earlier the separation between picture and sound I.F.'s. must, of necessity, be equal to that existing between picture and sound carriers, as radiated from the transmitter. And remember that picture and sound are transmitted on adjacent carriers, separated by something like 4.5 m.c. in the u.h.f. range. Hence, if 13 m.c. is the lowest practicable picture I.F, the sound I.F. must be either $13 + 4.5 = 17.5$ mc. or $13 - 4.5 = 8.5$ mc. As has been stated earlier the sound I.F. is always fixed at a value lower than the picture I.F. The reason for this arrangement now emerges. In the interests of sound I.F. amplifier gain, the latter I.F. might as well be as low as possible, since only a narrow band of audio frequencies is carried by it.

THE SOUND I.F. CHANNEL.

The I.F. stages for amplification of the sound signal follow very closely along

conventional lines, i.e. the inter-stage coupling consists of a pair of coupled tuned circuits. The operating frequency is, of course, much higher, as has been explained. This will necessitate coils and condensers having considerably lower values of inductance and capacity respectively.

There is one point of interest, however, in respect to these I.F. stages. They are designed to pass a band of frequencies having a width several times that of the audio modulated I.F. Whereas the audio frequencies extend only to a maximum of 15 K.C. per sec., the tuned circuits are designed for a band-pass of anything between 40 to 100 K.C. per sec. This, of course, will ensure high quality in the sound reproduction since there will be no possibility of "cutting" the higher side-bands of the modulated signal. The main reason, however, for this apparently excessive band-pass in the I.F. stages, is not connected with fidelity, so much as with oscillator design and adjustment. The oscillator signal, which is used to produce both the picture and sound I.F., has a frequency in the ultra-high-frequency range, say, for example 50 m.c. Any variation in this frequency will cause an unequal variation in I.F. An oscillator designed to operate so that its frequency does not vary more than 0.1% represents a high degree of precision both from the point of view of initial adjustment and that of frequency stability. Now 0.1% of 50 M.C. is 50,000 C. or 50 Kc. Hence, if the oscillation frequency "drifts" by this amount, the sound (and picture) I.F. will also change by 50 Kc. It is obvious, therefore, that if the sound I.F. stages were designed to pass a band of frequencies only 10 or 20 Kc. in width, it would be impossible to maintain the I.F. signal accurately in the centre of this pass-band. The result would be that oscillator adjustment would be much too critical to get the sound signal through the I.F. stages; and even if the correct initial adjustment could be made, the sound would continuously come and go, due to "drift" in the oscillator frequency.

This point will be appreciated more clearly, perhaps, by reference to Figure 11, where the selectivity characteristic of an 8.5 m.c. I.F. stage is illustrated. Here the band-pass is 50 Kc. The audio I.F. signal, of say width 10 Kc. is shown in two "positions" in respect to the circuit's characteristic. The figure shows how the actual I.F. may vary by approximately 25 Kc. below or above its correct value without any loss in signal strength or cutting of side-bands.

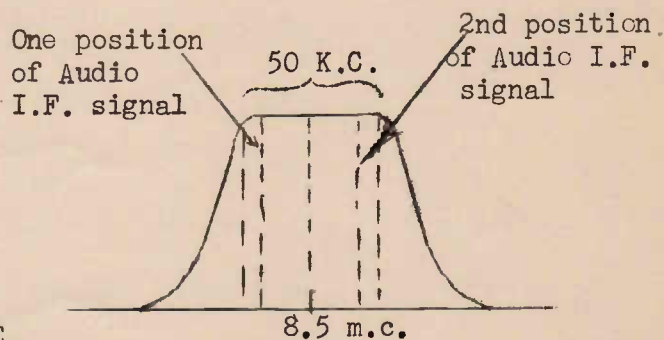

FIGURE 11.

USE OF THE DOUBLE-SUPERHETERODYNE PRINCIPLE.

A sound I.F. of the order of 455 Kc. may be obtained by the use of a second converter for the sound signal above. The first converter lowers the signal frequency to, say, 8.5 m.c. The second converter, producing an oscillation differing in frequency by 460 K.c. above or below 8.5 m.c., causes a further reduction in frequency.

The use of the double super-het. is not, however, in favour. Due to interaction between the two oscillators numerous whistles and "ghost-signals" are produced, and only extreme care in design and shielding will prevent this. In any case the use of a second frequency converter stage to reduce the I.F. to 455 Kc. would not overcome the problem of oscillator frequency drift because any drift would pass

through the second frequency converter and would be present in the new I.F. A drift of 25 Kc. in 455 Kc. would be an impossibly large amount for ordinary I.F. transformers.

THE PICTURE I.F. CHANNEL.

Here we are referring to those stages (usually two or more) whose function is to selectively amplify the modulated picture (video) signal passed on from the converter. This section of the receiver is, from our point of view one of the most interesting and important in the whole circuit. Interesting, because the inter-stage coupling circuits may appear quite unfamiliar to the ordinary radio serviceman. Important, because these stages have to meet such stringent design conditions that the over-all performance of the receiver may be made or marred by them.

First of all the student should have a clear picture of the job the picture I.F. stages are to perform. They are required to amplify an extremely wide range of frequencies, all of which are higher than the radio-frequencies to which the broadcast technician is accustomed. The amplification must be uniform over this wide band, i.e. the "response" characteristics of the circuits must be flat over the given range. Moreover, the circuits must "cut-off" sharply frequencies outside the lower and upper limits of the picture I.F. band. For example a typical case for a modern receiver would be a picture I.F. band extending from 8.75 mc. to 12.75 mc. -- a width of 4 m.c! Amplification over this band must be flat. Now, in the case cited the sound I.F. would be on 8.25 mc. and this -- only .5 mc. below the lower limit of the picture I.F. band -- must be totally eliminated by the picture "band-pass" circuits. This means a high degree of selectivity (see Figure 12).

And all this wide band uniform amplification sharp selectivity must be achieved despite the fact that the band-width to be passed forms a very large fraction ($\frac{2}{5}$) of the central frequency.

The student should, at this stage, have observed an important point, namely that selectivity is an essential even though the receiver has to cope with but a single television transmission. The reason for this is, of course, that each transmission employs two carriers. The sound carrier must not be able to pass through the picture I.F. carrier, for otherwise serious interference to the picture formation on the screen would result. Of course if the receiver is located within the coverage area of two or more transmitters the question of selectivity becomes of even greater importance.

BAND-PASS COUPLING CIRCUITS.

The response characteristics required (as described above) for the inter-stage coupling of the video amplifiers may be obtained by two general methods:-

- A. Over-coupled circuits loaded with resistances.
- B. Circuits based on band-pass "filter" design.

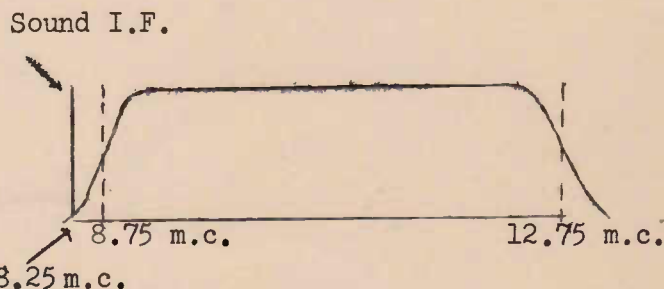

FIGURE 12.

Actually there is no sharp distinction between the two types, but for our purposes we shall discuss them separately.

OVER-COUPLED CIRCUITS. RESISTANCE "LOADED".

The student should already be familiar with the general theory involved under this heading, but we shall quickly review the subject.

Briefly the main points are as follows. Suppose we have two tuned circuits, tuned to the same frequency (f_0), and loosely coupled by mutual induction (m)

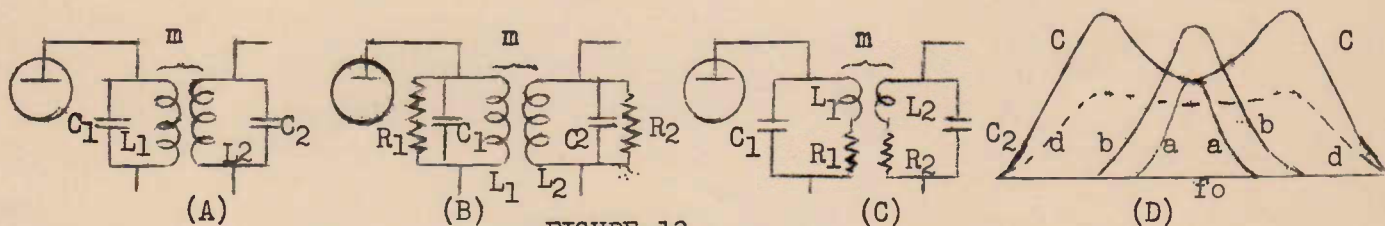

FIGURE 13.

between the coils (see A Figure 13). The response curve will be like curve "a" Figure 13(D). If the coupling is now increased the peak of the curve will rise, until at a certain value of coupling known as "critical coupling" or "optimum coupling", a maximum peak is reached (curve b), still at frequency f_0 . Further increases in coupling (m) will lead to the formation of two peaks, one below, the other above the frequency f_0 . This is known as "double-peaking" or "double-humping". See curve "c" Figure 13(D). Still greater degrees of coupling would cause the peaks to move further apart and to become more distinct.

Suppose now we connect resistors R_1 and R_2 either across (in shunt with) the tuned circuits, as at B, or in series with them, as at C. The effect is to lower the peaks, without appreciably reducing the response in the region between them. A curve similar to "d" results. Note that the amplification for frequencies between the peaks is substantially uniform, but for frequencies outside them considerable attenuation is experienced. This is the band-pass effect desired.

The width of the band passed depends upon the frequency-separation of the "peaks"; and this in turn depends on the degree of coupling. But if the band-pass is further increased by tightening the coupling the hollow between peaks becomes more pronounced. To "flatten-up" the curve again we must increase the loading or clamping of the circuits by means of the resistors R_1 and R_2 . The increased loading lowers the over-all "Q" and dynamic impedance of the coupled circuits. Since this dynamic impedance forms the plate-load of the valve it will be seen that a loss in stage gain will be suffered.

Summarising, we may say that the wider the pass band for which the circuits are designed, the lower will be the stage gain achieved. With the modern tendency towards wider band (higher definition) transmissions it appears that the loaded over-coupled circuit method is proving inadequate. For this reason the use of more complicated coupling systems, designed upon the "filter" theory, and employing perhaps 3 or 4 resonant circuits per stage, is becoming more and more common.

INTER-STAGE COUPLING CIRCUITS BASED ON "FILTER" THEORY.

The circuits referred to now usually dispense with mutual induction coupling

between the two tuned circuits, and employ instead an impedance which may be either inductive or capacitive in nature.

Figure 14 shows at (a) a pair of tuned circuits, coupled by the mutual inductance (m) existing between the two coils L . This is the arrangement already discussed.

At (b) is shown a band-pass "filter" in which the mutual inductance (m) is replaced

by a self-inductance (KL) equal in value to m . The A.C. current in the first LC tuned circuit flowing through the inductance KL develops an A.C. voltage across it. This voltage is then transferred into the second L.C. tuned circuit. KL acts as a "common coupling impedance", and serves the same purpose as the mutual inductance (m) in circuit (a).

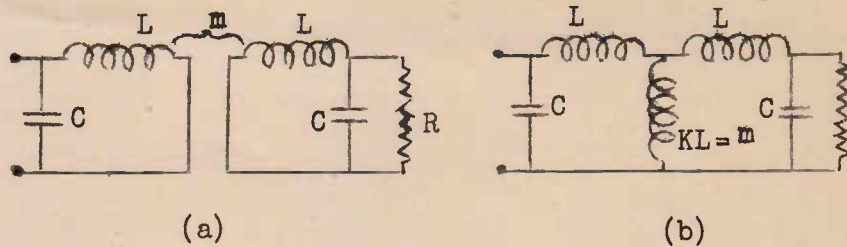
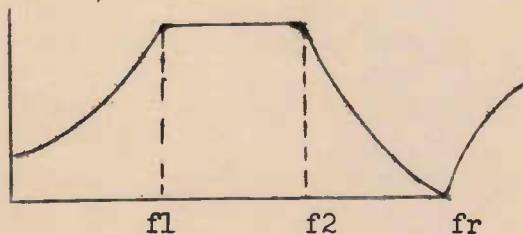
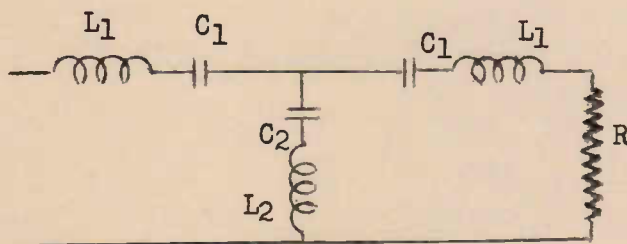

FIGURE 14.

Actually, the two circuits of Figure 14 are identical in performance. Circuit (b), however, has the advantage over (a) in that the mutual inductance (m) of the latter is too difficult to adjust and control with sufficient accuracy, in production. The constants (L, C and K) of circuit (b) may be precisely designed, using the "filter" theory, starting from a known value of R , for any desired bandwidth.

The circuit of Figure 15 shows a typical band-pass filter for inter-stage coupling. The two identical tuned circuits consisting of the component L_1 and C_1 are coupled by means of the series resonant circuit L_2 C_2 . The type of characteristic obtained



is also shown in the figure. Here f_1 and f_2 are the upper and lower frequency limits of the video I.F. band, and f_r is some frequency which it is desired to reject completely. At any frequency lying between f_1 and f_2 (i.e. the video I.F. band) the coupling circuit L_2 C_2 is not at resonance, and therefore offer an impedance across which a voltage is developed for application to the second tuned unit L_1 , L_2 . This is impedance coupling. An advantage of this type of circuit is that, by proper choice of the components L_1, C_1, L_2 and C_2 practically 100% rejection of one particular frequency (f_r) may be achieved. This frequency is usually chosen to be that of the audio carrier.

FIGURE 15.

the latter may be entirely eliminated. Note that L_1 and C_0 form a series tuned circuit, which at resonance has practically zero impedance. At any video I.F.

A combination of capacitive and tuned circuit coupling is shown in Figure 16. By choosing L_1 and C_0 to resonate at the adjacent audio carrier frequency

frequency there is considerable impedance across the coupling branch (L1, C1, Co) and the overall characteristic of the circuit is such that uniform response is obtained over the desired range.

TYPES OF VALVES FOR VIDEO AMPLIFICATION.

In the discussion on loaded over-coupled circuits for interstage video I.F. coupling it was pointed out that the heavy resistive loading lowered the "dynamic" impedance of the circuits.

The wider the band-pass required, the lower this impedance had to be. The same general principle applies to all the circuits just described.

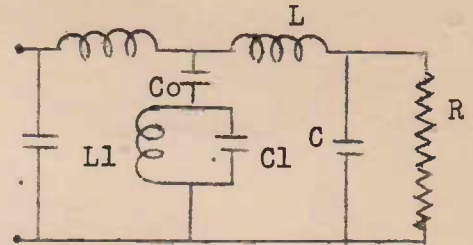

FIGURE 16.

Now the gain of a stage using a pentode valve is given by:-

$$\text{Gain} = G_m \times R_d.$$

(G_m = mutual conductance of valve, R_d = dynamic impedance of plate load.)

The load in the plate circuit of a video I.F. amplifier is, of course, the overall impedance of the coupling circuits used. If ordinary pentodes were employed the stage gain, on account of the low value of this impedance, might quite well be negligible or even non-existent.

To compensate for the low value of R_d , valves having very high values of G_m have been developed. One such type has been mentioned in the lesson on Video Amplification, viz: the 6AC7 (1852), having a normal plate current of 10 m.a., and a G_m of 9.6 m.a. per volt or 9600 micromhos. Actually, in practice the same types of valves are used for r.f. and I.F. amplification as for video amplification (after detection).

A recent development in the way of valves for I.F. amplification is the "secondary emission" tube. In this type the secondary emission within the tube is used to augment the electron flow liberated by thermionic emission from the cathode. In this way a greatly increased plate current is obtained, resulting in unusually high values of G_m -- e.g. 13,000 micromhos. The use of these amplifier valves has made it possible to reduce the number of stages of I.F. amplification to two where three were used before.

THE SECOND DETECTOR (VIDEO) STAGE.

This stage serves a similar purpose to the corresponding stage in audio work. It demodulates the modulated I.F. (or R.F.) signal. The output of the detector should be substantially the same as the input of the modulator in the transmitter. In other words this output is the real video signal, consisting of voltage changes representing both picture signals and synchronising pulses.

Although plate detection has been used, the only common type is the familiar diode detector, and we shall here confine ourselves only to the latter.

LOSS OF DETECTOR OUTPUT FOR HIGH VIDEO FREQUENCIES.

In Figure 17 is shown a simple diode detector. The rectified (detector) video

voltage is developed across the diode load R_c just as in audio work. In video detection, however, we are faced with an additional problem due to the high value

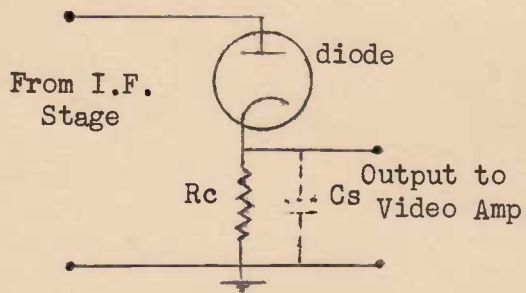

FIGURE 17.

of those frequencies representing the fine detail in the picture. Across R_c exists various stray capacities consisting of wiring capacities to earth and cathode-earth capacity. These are represented by C_s in Figure 17, and appear in parallel with the load R_c . The reactance of C_s is high at low and medium frequencies, and therefore the "shunting" effect on R_c is negligible. However, at the higher video frequencies (which may extend up to 4 m.c., C_s seriously shunts R_c . The problem here is identical with the shunting effect of stray capacities across the plate load in video amplifiers. The effect of the shunting is to reduce the total impedance across which the video voltage is developed, with a consequent loss in high frequency output. This effect is countered in practice in exactly the same manner as was used for "high-frequency compensation" in amplifiers, i.e. by "peaking" coils and/or tuned circuits. The result is that instead of finding a simple resistor, by-passed by a condenser for the diode load, we find instead all manner of complicated circuits consisting of L, C and R.

Figure 18 shows one such arrangement. In addition to the diode load resistor R, we have coils L_1, L_2 and condenser C, in addition, of course, to the unavoidable stray capacity C_s . The network of components is so designed that its impedance, between points A and B, remains practically constant over the entire video range from, say 50 c/sec up to 4 mc/sec.

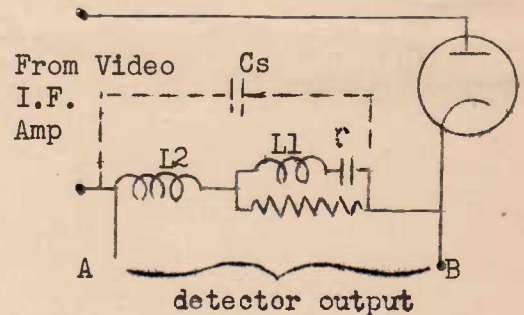

FIGURE 18.

Another problem not so easily overcome in video detection is the elimination of the r.f. or I.F. component from the video amplifiers. It will be remembered that the r.f. or I.F. is kept out of audio amplifiers from the detector's output by the simple expedient of connecting an r.f. by-pass condenser, of small capacity, from plate of the 1st A.F. amplifier tube to earth. In audio work this method is satisfactory since the I.F. is of the order of 455 Kc/sec. compared with, say 10 Kc/sec. for the highest audio frequency. Hence it is easy to choose a capacity which will effectively eliminate the I.F., without attenuating the highest A.F.

In the case of video detection, on the other hand the I.F. (say 12 mc/sec) may be only 3 times as high as the highest video frequency. A simple by-pass condenser of sufficient capacity to eliminate the I.F. would also seriously reduce these higher video frequencies.

The problem is usually solved simultaneously with that of the loss of high video frequencies due to stray capacities shunting the diode load. Actually the "load circuit" shown in Figure 18 may be adjusted to have a constant impedance from zero up to the highest video frequency, but an impedance which drops suddenly above that.

The I.F. may be very effectively eliminated by use of a "filter" circuit of the type shown in Figure 19. The filter consists of coils L, condensers C and 2C and the load resistor R_c, "terminating" the filter. This circuit may be designed to have an impedance characteristic as shown -- constant from zero frequency up to 4 m.c. and cutting off sharply at 8 m.c. Thus it is seen that the video range is covered without high frequency loss, but the I.F. (12 m.c.) is entirely eliminated.

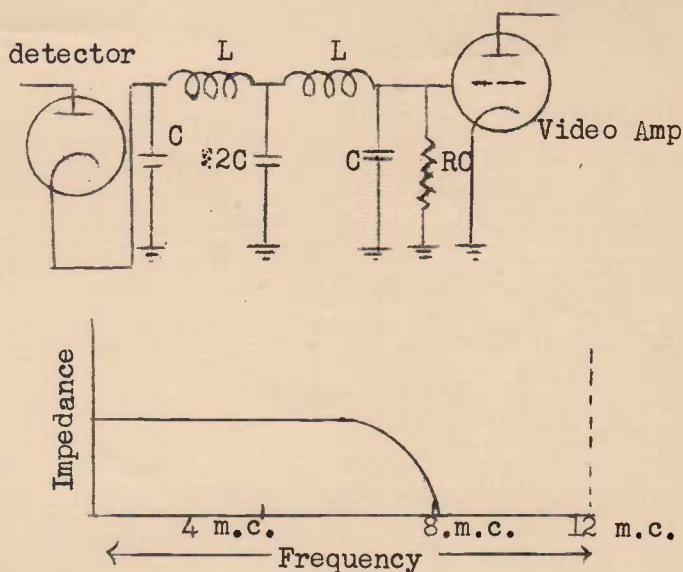

FIGURE 19.

AUTOMATIC GAIN CONTROL.

A.V.C. or A.G.C. is not extremely necessary, in television receivers, since very little "fading" is experienced on the u.h.f.'s. However, variations in supply voltage will affect the receivers gain. Any variation in the video output level to the cathode-ray-tube has the effect of varying the picture contrast. The eye is very sensitive to such changes. Hence some receivers employ an a.g.c. circuit in their picture sections.

An a.g.c. circuit in the picture I.F. amplifier is quite different from the a.v.c. system for audio work. This is because the a.g.c. voltage must not vary with the average level of the picture r.f. signal. The reason for this is that this average level of signal is determined by the brightness of the scene being televised, and it would not do for the a.g.c. to counteract the variations in picture brightness.

Now assuming negative modulation at the transmitter the peaks of modulation, (representing the sync. pulses) remain constant at the transmitter. Hence any variation in the peaks of modulation at the receiver's detector would mean either a fading of the signal or a change (unintentional) in receiver gain. For these reasons the a.g.c. voltage for application to the I.F. valves grid's is determined by the peak amplitude of the signal.

To achieve this a peak-voltmeter arrangement is used as shown in Figure 20. The peak voltmeter is an over-biassed triode, with a load resistor in the cathode circuit. This triode normally carries no current. On the signal peaks, the positive voltage developed across the diode load (R_c), and applied to the triode's grid causes the latter valve to conduct. This charges the condenser C₁, which is so large that it cannot discharge appreciably through the resistors. Thus C₁ charges up to a voltage whose steady value depends upon the amplitude of the peaks of the signal. This a.g.c. voltage is amplified by means of a direct-coupled amplifier, and thence applied to the grids of the picture I.F. amplifier. Note that the a.g.c. amplifier inverts the voltage to give correct polarity.

VIDEO AMPLIFICATION.

The video signal obtained, after detection, is similar to that produced by the tele-

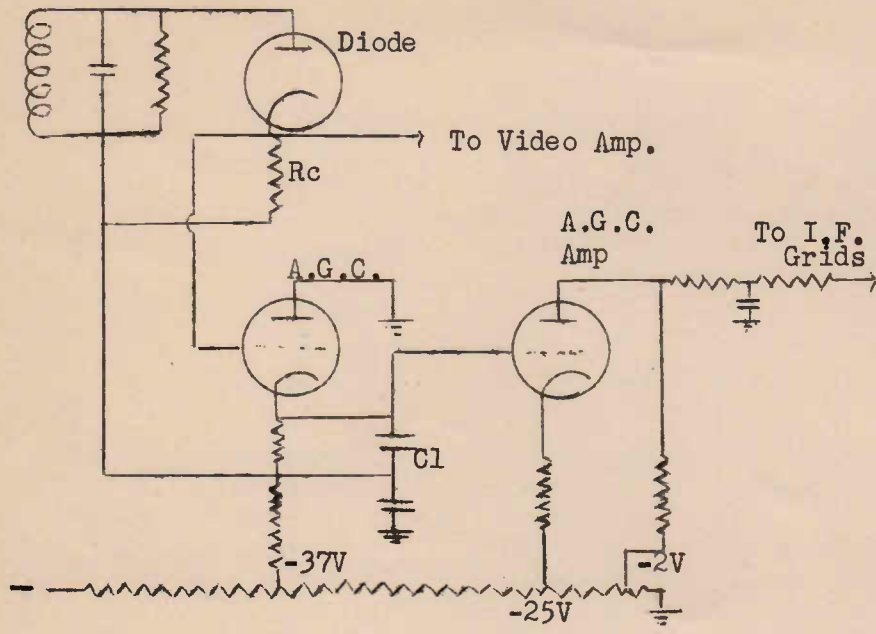

vision camera at the transmitter. In some receivers no provision is made for amplification of this signal, the detector's output being applied directly to the grid of the cathode-ray-tube. When amplification of the video signal is considered necessary, one, two or even three stages may be used. These video amplifiers have been described and explained in detail in Lesson 5.

FIGURE 20.

T.F.M. & F. LESSON NO. 8.

EXAMINATION QUESTIONS.

1. Why is it that the aerial input circuit of a television receiver usually has a low value of "Q" and poor selectivity?
2. What explanation could you give for the fact that "ganged" condensers are not used for oscillator and aerial tuning in a television receiver?
3. A television signal consists of a 45.25 m.c. picture carrier and a 49.75 m.c. sound carrier. What should be the oscillator frequency for I.F.'s of 12.75 M.C. (picture) and 8.25 m.c. (sound)?
4. Why does the use of a separate oscillator valve become virtually essential when operating on carrier frequencies above about 70 m.c?
5. Explain why considerable selectivity is required in the design of both picture and sound I.F. stages, even though the receiver is within range of but a single transmitter.
6. What is the main reason for not using a picture intermediate frequency below about 8. m.c?
7. Explain briefly the effect of over-coupling a pair of tuned circuits, and then "loading" them with resistors.
8. Why must valves having a high value of "Gm" be used in a picture I.F. Amplifier?
9. The diode load of a picture detector usually consists of one or more inductance coils, as well as a resistor. What is the purpose of these?
10. Referring to picture I.F. amplifier automatic gain control, what would be the (undesired) effect of utilising a control voltage proportional to the average value of detector output?

AUSTRALIAN RADIO COLLEGE

E. S. & A. BANK BUILDINGS, Corner CITY RD. and BROADWAY, SYDNEY

Telephones: M 6391 and M 6392. Post Lessons to Box 43, Broadway

This lesson sheet is published for the exclusive use of students of the Australian Radio College Pty. Ltd.
(All rights reserved)



T.FM & F. 9 LESSON NO. 9.

IMAGE REPRODUCTION.

APPLYING THE VIDEO SIGNAL TO THE CATHODE RAY TUBE.

In Lesson 4 we studied the methods used to produce an electric current which varied in sympathy with light variations as the picture was scanned. Lesson 5 explained how this video current could be used to modulate an R.F. carrier wave. In the last lesson (Lesson 8) we arrived at the stage where the modulated wave was "detected", and a replica of the original video signal was re-created across the diode load. We shall now, in logical sequence, proceed to explain the methods and techniques involved in reproducing, on a cathode-ray tube's screen, variations in light corresponding to those original variations as the scene was scanned at the transmitter.

At this stage Lesson 3 on Cathode-Ray Tubes should be revised, paying particular attention to the use of the control electrode for varying beam current and spot brightness. The idea of moving the beam for "scanning" purposes should also be fully grasped, although the details of the "auxiliary" circuits used in a television receiver for this job will be deferred until the following lesson.

POLARITY OF DETECTOR OUTPUT.

In applying the detector output to the control electrode of the C.R.T. (Cathode Ray Tube) care must be taken to ensure that the polarity of the video voltage on this electrode is correct. If correct precautions are not taken in the design of the detector and any video amplification stages used, a "negative" picture may result. The effect is shown in Figure 1. where at B a negative picture is illustrated. Comparing this with the picture at A it

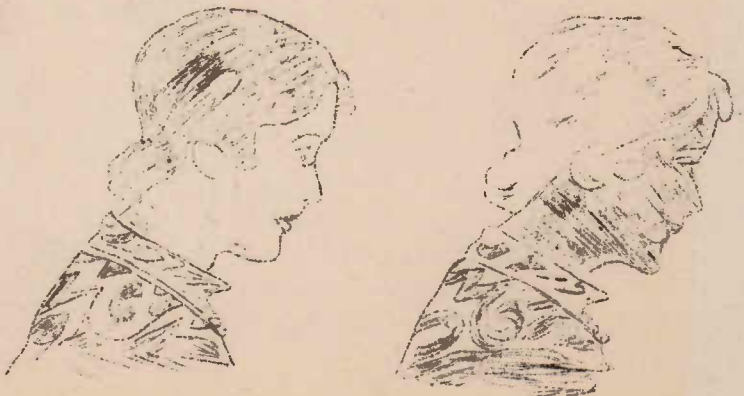

FIGURE 1.

is seen that light portions have become black and vice-versa. The result may be exactly compared with the negative (i.e. the originally exposed film) of a photograph.

To obtain a correct "positive" picture the video voltage on the C.R.T. control electrode must be going positive as the transmitter scanner moves from a darker to a lighter portion of the scene (and vice-versa). Remember, in this connection, that a more positive voltage on the C.R.T. control electrode will increase the electron stream, and brighten the light spot on the screen. Conversely a negative going voltage will reduce the electron stream, and the spot will become dimmer.

Now, when using a diode as detector there are two possible methods of connection -- the conventional connection, known as "cathode-above-ground" connection shown at A (Figure 2) and the "anode-above-ground" connection as shown at B.

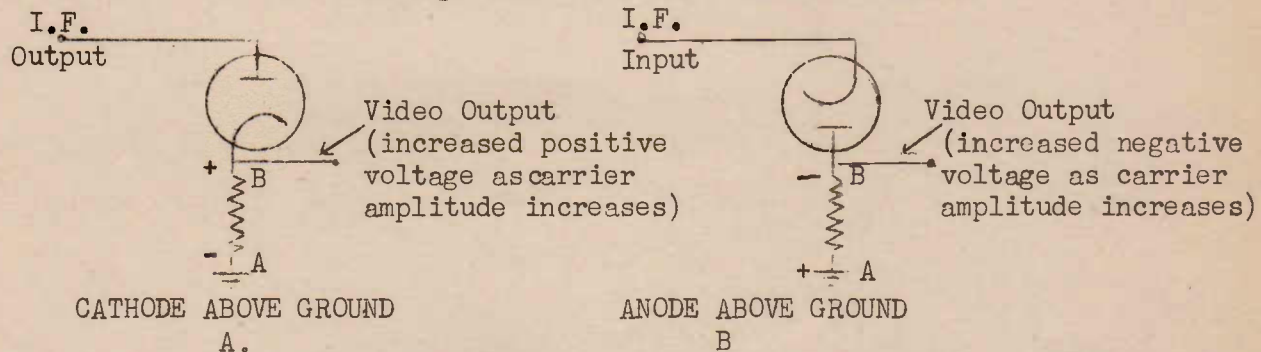

FIGURE 2.

Referring first to the cathode-above-ground connection (Figure "2A") any increase in carrier voltage applied to the anode will result in an increased electron flow upwards through the load resistor, i.e. in the direction from A. to B. This results in the voltage at B (detector output) going more positive. Now if the transmitter were using positive modulation of its signal, an increase in carrier amplitude represents an increase in light intensity. Hence in this case the detector output would be correct for direct application to the C.R.T. However, if a single stage of video amplification were used between detector and C.R.T. a negative picture would result (since the output of an amplifier stage is reversed in polarity compared with its input). If two stages of amplification were inserted the polarity would again be correct. Summarising we may state that, using a cathode-above-ground diode on a positively-modulated signal, either no stages or an even number of stages of video amplification are required.

Referring still to the cathode-above-ground connection (Figure 2A), but considering now a negatively-modulated signal, any increase in carrier amplitude applied to the detector anode would represent a decrease in light intensity. But, as before, the detector output voltage, at B, would go more positive. If this were applied directly to the control electrode of the C.R.T. the spot would become brighter. The polarity is now incorrect. A negative picture would result. To obtain a positive picture the polarity of the detector's output voltage must be reversed before applying the latter to the C.R.T. This may be done by using one or three stages of video amplification, i.e. an odd number of stages.

In the case of the anode-above-ground connection of Figure 2B, any increase in carrier amplitude again results in an increased electron flow through the tube, but this time, the electrons, in flowing from cathode to anode, flow downwards

through the load resistor from B to A. This increases the voltage drop across the load resistor with the result that point B (output) becomes more negative than before. The following results will be left to the student to figure out for himself:-

For correct picture polarity anode-above-ground connection --

- A. Positive Modulation -- an odd number of video stages required.
- B. Negative Modulation -- no stages or an even number of video stages required.

It should be noted here that with improved I.F. amplification, the tendency has been to eliminate all video amplification, applying the detector output directly to the control electrode of the C.R.T. This means that when receiving negatively-modulated signals (as is universal in the U.S.A.) the anode-above-ground connection, as shown in Figure 2B must be used.

THE DIRECT-CURRENT COMPONENT IN VIDEO SIGNAL.

The D.C. component of the video signal refers to the average value of the current (or voltage) about which the variations (representing the picture elements) occur. The video signal consists of a pulsating direct-current or voltage as shown in Figure 3 at A. The variations in current are caused by the variations in light intensity as the scanning beam moves across the scene, and they represent the

elements or detail of the picture. A direct-current as at Figure 3A may be considered as consisting of an alternating current (positive and negative half-cycles), shown at B, superimposed upon a steady direct-current as shown at C (Figure 3). This direct-current component has the same value as the average value of the pulsating D.C. representing the complete video signal. The average value of this signal is shown by the dotted line in Figure 3A.

Now suppose we consider two video signals as represented on the same graph in Figure 4. Both signals have identical A.C. components, but the D.C.

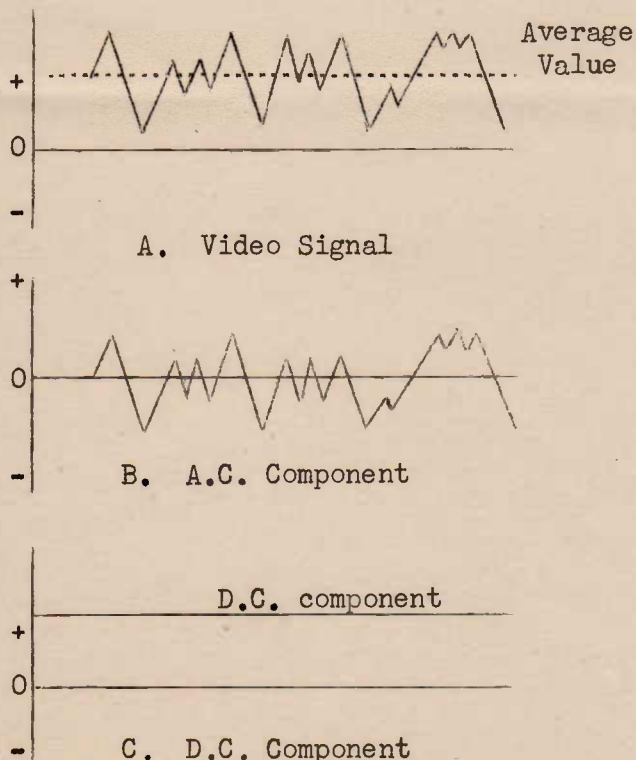

FIGURE 3.

component of signal A is greater than that

of signal B. Now what has caused the difference between those two signals? Since they have identical A.C. components they represent the same picture elements, but the average value of A is greater than the average value of B. This means that the average amount of light on the scene resulting in signal A is greater than the

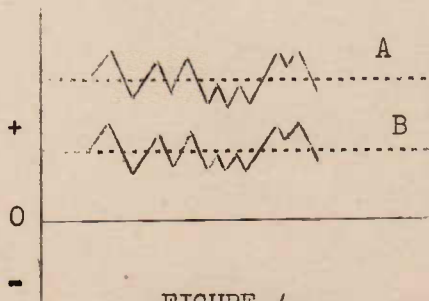

FIGURE 4.

average amount on the scene producing signal B. For example signal A might have been obtained from a scene bathed in bright sunlight, while signal B might have been caused by the same scene when the sky was over-cast.

When at a cinema, we are able to appreciate how the brilliance portrayed on the screen varies. Bright sunshine, twilight, semi-darkness etc, each has its place, and in this way complete entertainment is obtained. The importance, then, of applying the D.C. component of the video signal, as well as the A.C. component, to the C.R.T. control electrode will be realised.

The video signal first re-appears in the receiver across the diode load, after de-modulation. This voltage will be a D.C. one, varying about an average level as the picture elements are scanned.

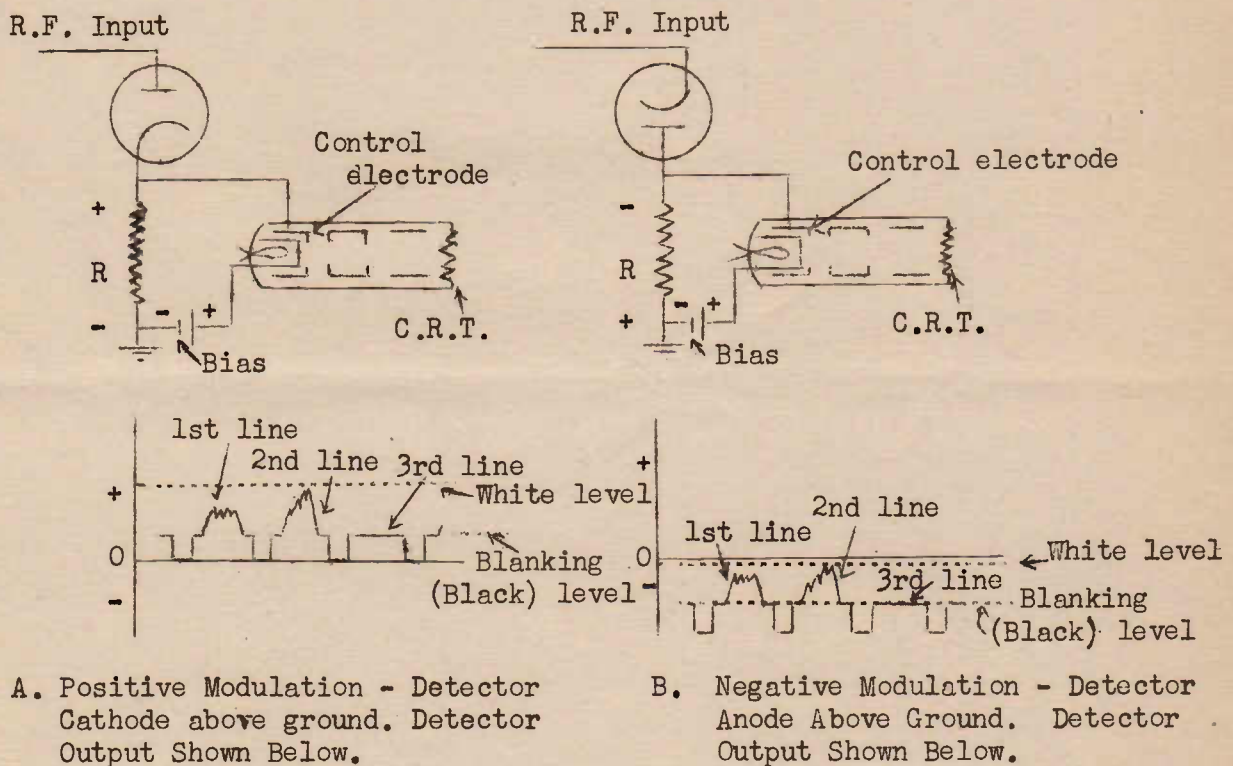

FIGURE 5.

In Figure 5 the two possible cases are shown. At A we have a detector connected with cathode above ground, operating on a positively modulated R.F. (or I.F.) signal. At B is shown a diode with anode above ground for reception of a negatively modulated signal when no stages of video amplification are used. In either case it is seen that the video voltage developed across the diode load is a positive video signal (i.e. a positive-going voltage corresponds to an increase in light intensity, and vice versa). But note that in case A the average value (i.e. D.C. component) of the output voltage is positive; while in case B this D.C. component is negative.

In both cases the detector outputs are shown for three scanning lines. The second line has a higher average value than the first, representing a greater average value

in illumination. The signal voltage for line 3 remains at the black (blanking) level for the whole duration of the line. This line corresponds to an entirely black strip of the scene.

APPLYING DETECTOR OUTPUT TO C.R.T.

It will be remembered that the control electrode of a C.R.T. functions in a very similar manner to the control grid of an ordinary amplifying valve. If given a negative voltage in respect to cathode the electron beam (anode current) is reduced, resulting in reduced brightness of the light spot on the screen. If this control electrode voltage is made sufficiently negative "cut-off" occurs, as in an amplifying tube. This condition corresponds to black in a picture on the screen.

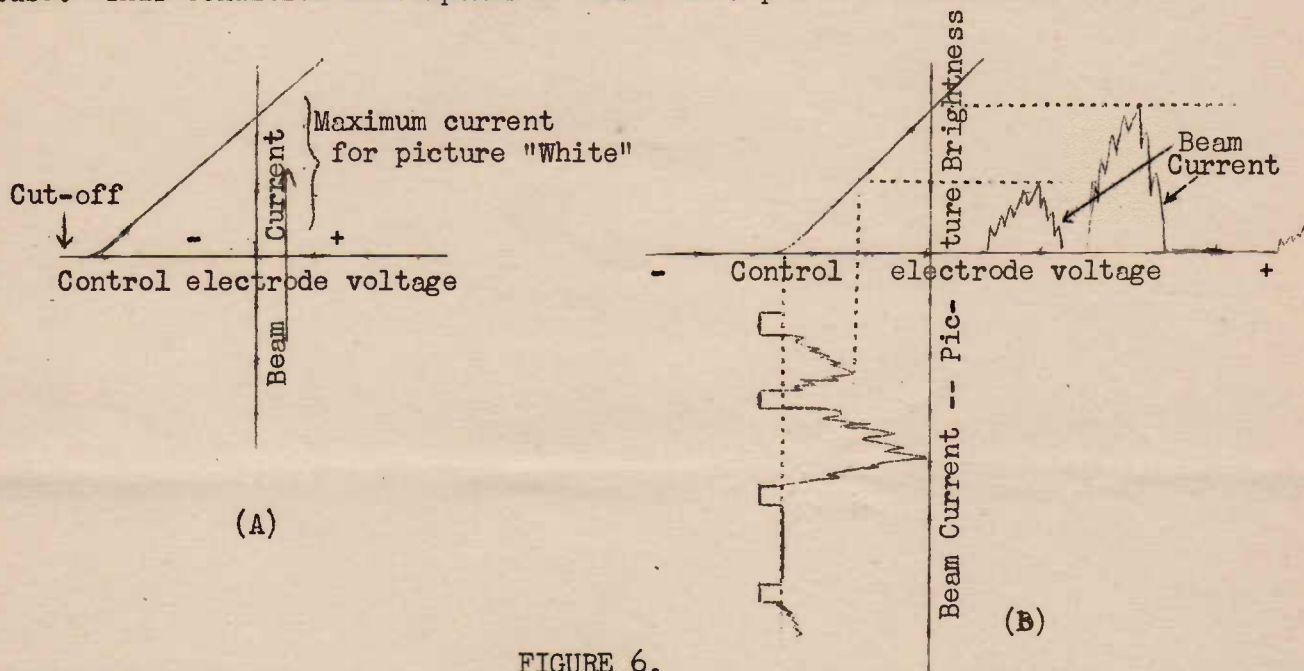

FIGURE 6.

Figure 6A represents a control electrode-beam current characteristic for a typical tube. In practice control-electrode voltage is always maintained negative, by the application of a bias voltage (as in the case of class A amplification using triodes, pentodes etc).

The video signal from the detector is applied between control-electrode and cathode of the C.R.T. so that its black ("blanking") level corresponds to the C.R.T.'s negative control electrode cut-off bias. Now referring back to the detector output, shown in Figure 5, it is seen that this black level is a positive voltage in case A, and a negative voltage, (though not necessarily the cut-off value) in case B. These voltages must therefore be adjusted by the application of the correct values of bias voltage in either case. In Figure 5 the bias voltages are represented for simplicity by simple batteries. Figure 6B illustrates in a graphical way the net result. The bias voltage places the signal black level at the tube's cut-off voltage. Note that the sync. pulses carry the control-electrode voltage even more negative, and therefore for the duration of these pulses the screen will remain black. During line scanning a beam current proportional to the signal voltage flows. The screen illumination is, of course proportional to this current. Note that during the scanning of any line, not only is the picture detail portrayed (by the current variations) but the average illumination of the picture is brought out also.

LOSS OF D.C. COMPONENT OF VIDEO SIGNAL.

When employing one or more stages of video amplification between detector and C.R.T. the D.C. component of the video signal is lost. This is due to the capacitive coupling normally used between stages.

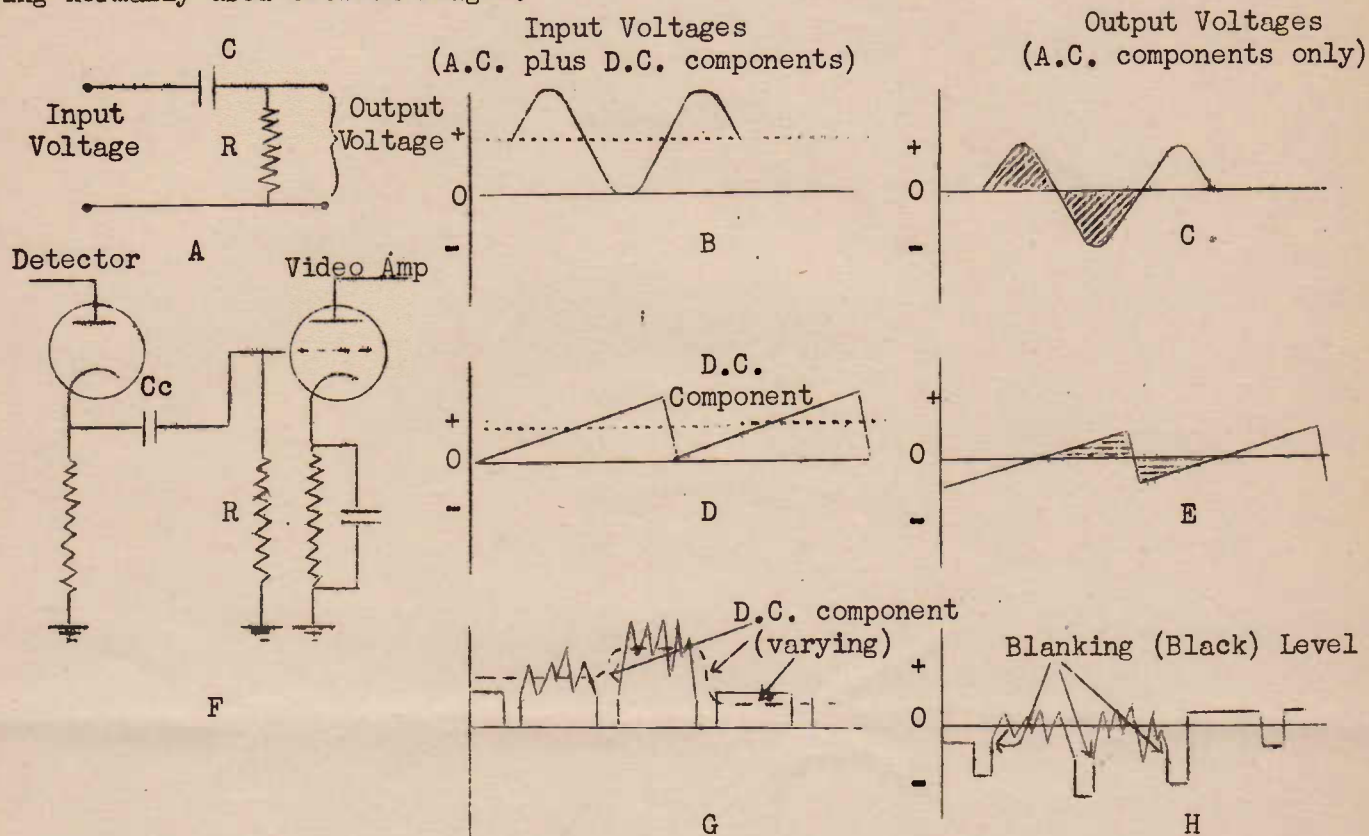

FIGURE 7.

It is important to understand clearly what happens when a voltage consisting of an A.C. and D.C. component is passed through a network involving a condenser as in Figure 7A. The condenser blocks the D.C. component, passing only the A.C.

At B and D are shown two examples of voltages containing D.C. components. The corresponding output voltages obtained across R (Figure 7A) are shown at C and E respectively. These are pure A.C. voltages. Note that the voltages adjust themselves so that the areas contained by the positive half-cycles are equal to the areas contained by the negative half-cycles.

At F (Figure 7) is shown a diode detector resistance-capacity coupled to a video amplifier. The detector output voltage, containing both A.C. and D.C. components, is graphed at G. Note that the D.C. component varies for the three scanning lines shown, as the average illumination changes. Since this D.C. component is completely lost after passing through the coupling condenser C_c , the voltage on the grid of the video amplifier is as at H. The average illuminations of all the lines are now the same. Hence a true portrayal of the picture will not be obtained. Another important point to note is that the voltage level corresponding to black varies as the average illumination changes. This will be seen by carefully examining graph H of Figure 7. Summarising then, we may say that loss of the D.C. signal component: (1) Results in

a flat, drab picture having no contrasts in over-all illumination, and (2) Renders it impossible to maintain the signal blanking (black) level at the cut-off value of control electrode potential. The seriousness of this latter point will be realised later when dealing with scanning generators.

D.C. RESTORATION.

The loss of the signal D.C. component, when using video amplifiers after detection, is remedied by utilising a special circuit known as a D.C. Restorer. Such a circuit creates a D.C. voltage, proportional to the original voltage, representing the average picture illumination, and varying with it. This D.C. voltage is then applied, together with the A.C. signal voltage from the plate of the last video amplifier, to the control electrode of the C.R.T. The process is sometimes also called D.C. reinsertion.

CHARGE AND DISCHARGE OF A CONDENSER THROUGH A RESISTOR.

Before explaining the operation of a D.C. Restorer Circuit it will be necessary to discuss the exact manner in which a condenser charges through a resistor when a D.C. voltage is suddenly applied across the circuit, and also the nature of the discharge of the condenser through the resistor. We shall go into this subject in some detail, because the ideas developed will be necessary to explain, not only D.C. Restoration, but also the manner in which the two sets of sync. pulses are separated, and, again, the action of certain types of saw-tooth generators. In this way, we hope to at least partially kill several birds with the one stone.

Consider the circuit of Figure 8. When the switch S is closed the D.C. voltage E is applied across C and R in series. Electrons will flow around the circuit away from the lower plate of C, through R, and onto the upper plate of C. In this way C commences to become charged. The electron flow will only cease when the potential difference across C equals the battery e.m.f. "E", the condenser then being "fully" charged. The charging action, however, will not occur instantly after

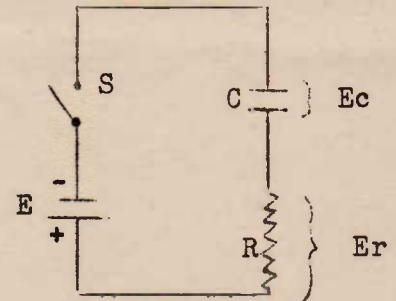

FIGURE 8.

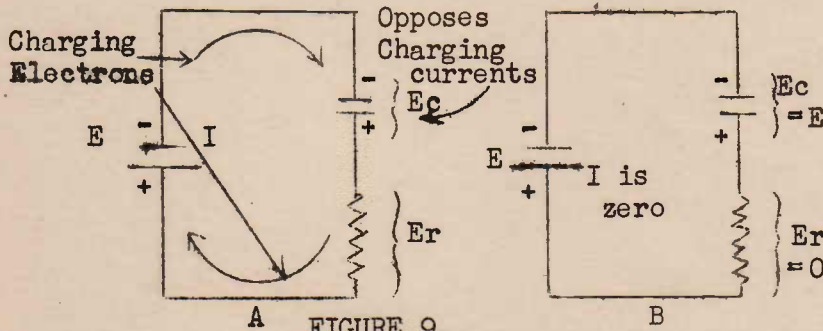

FIGURE 9.

closing S, for the resistor R limits the rate of electron flow (i.e. the current). This means that the voltage across C (E_c) doesn't jump up to its final value instantly, but rises more or less gradually. The current flowing around the circuit will have a maximum value the instant after S is closed. As time goes on, however, and C acquires a charge this current will gradually

decrease in value. The reason for this is that as C charges it produces a back "pressure" or voltage (E_c) which opposes the applied e.m.f. "E" (see Figure 9A). The greater the charge on C becomes, the greater this back pressure (E_c), and the smaller the charging current.

Now the value of the current in the circuit at any instant of time determinates

the rate at which C is charging. It follows that, as time goes on, after closing S, the rate of rise in condenser voltage (E_c) decreases as the value of E_c approaches the value of E. Hence the condenser will charge (i.e. E_c will increase) in accordance with a curve something like that in Figure 10. It will be noted that as C approaches full charge, the rate of further rise in E_c becomes very slow indeed. The consequence is, theoretically, that it will take an infinita time for the condenser to become fully charged. For practical purposes, however, we could assume that the charging process was complete after a time "t" shown on Figure 10. When this occurs the voltage across C equals the applied voltage E. No further current flows because the two equal voltages in the circuit, E and E_c , oppose and cancel each other (see Figure 9B).

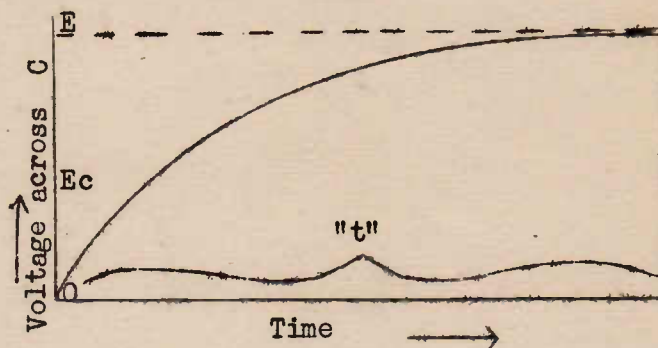

FIGURE 10.

The average slope or steepness of the curve in Figure 10 is a measure of the rate at which C charges through R. This rate depends upon two factors -- the value of the capacity and the value of the resistor. If either, or both of these are increased, the rate of charging will decrease. Conversely, a reduction in value of C or R, or both, will result in a more rapid charging process. Actually the charging time depends upon the product C multiplied by R (written C.R). Figure 11. shows the charging curves for different values of C.R. Curve A is for a medium value of C.R. Curve B, showing a more rapid charging rate, is for a smaller value of C.R, and curve C, for a larger value of C.R. shows a slower charging process.

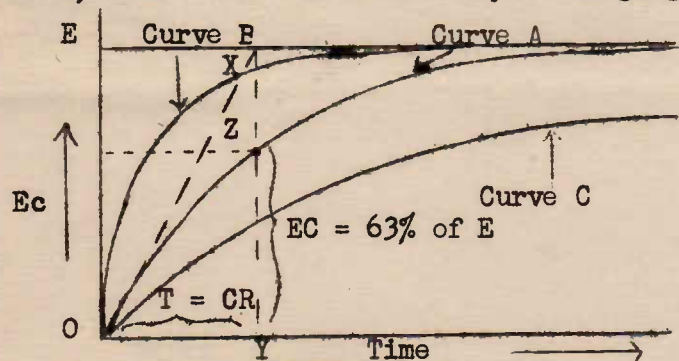

FIGURE 11.

to $C \times R$ (C in farads, R in ohms) the condenser voltage E_c , rises, in all cases, to 63% of the applied voltage E. This is shown in reference to curve A in Figure 11. where in the time $T = CR$, E_c has risen to approximately $\frac{2}{3}$ of the value of E. The Time Constant, then, is given by the formula: $T = C.R$.

Where T is in seconds, C in Farads, R in ohms. The formula is also correct if C is measured in microfarads and R in megohms (T still being given in seconds).

For example suppose a battery of 100V is connected across a resistor of 3 megohms in series with a condenser of 2 microfarads. The Time-Constant of the circuit is $T = 3 \times 2 = 6$ seconds. This is the time required for the condenser voltage to rise to 63% of 100V, i.e. to 63V.

The time-constant of a resistance-capacity circuit may be regarded as the time which would be taken for the condenser voltage to rise to the full value of the applied voltage, assuming that the rate of charging continued at its initial rate for the whole time. If this occurred the condenser voltage would rise according to the

dotted line OX in Figure 11. The time taken to attain full charge is OY. Note that in a time equal to OY the condenser voltage actually only attains a value equal to 63% of E.

Equally as important as the rise in condenser voltage is the manner in which the resistor voltage (E_r) changes with the charging process. When the switch of the circuit in Figure 8 is first closed all of the applied voltage E instantly appears as a voltage drop across R. This follows from the fact that, at this initial instant there can be no voltage across C (since C has not yet had time to acquire a charge). Now since the sum of the voltage drops around a circuit is always equal to the applied e.m.f, i.e. since $E = E_c + E_r$, and E_c is zero, therefore, at this instant $E = E_r$. Then, as time progresses, E_c commences to acquire a continually increasing charge, and E_c rises, with the result that E_r falls in value. When C is fully charged, i.e. $E_c = E$, E_r must have fallen to zero. This fact can also be seen by observing that now the current in the circuit is zero; and if the current through R is zero, the voltage drop across it (E_r) must also be zero.

Figure 12 shows the changes in Resistor Voltage (E_r) from the instant of closing the switch. When S is closed E_r rises instantly from zero to the full value E. Then as time progresses E_r falls off as shown by the heavy curve. The dotted curve in this figure represents the rise in E_c . A comparison of the two curves will bring out a most important point. When the voltage in a CR circuit is suddenly changed, this change in voltage instantly appears across the resistor. No such sudden change can appear across the condenser, because the condenser voltage can only be changed by altering the charge on it -- and this takes time, i.e. time for electrons to flow around the circuit.

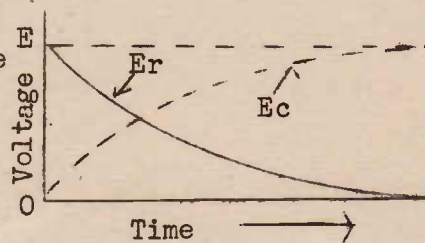

FIGURE 12.

Now consider the manner in which a charged condenser discharge through a resistor.

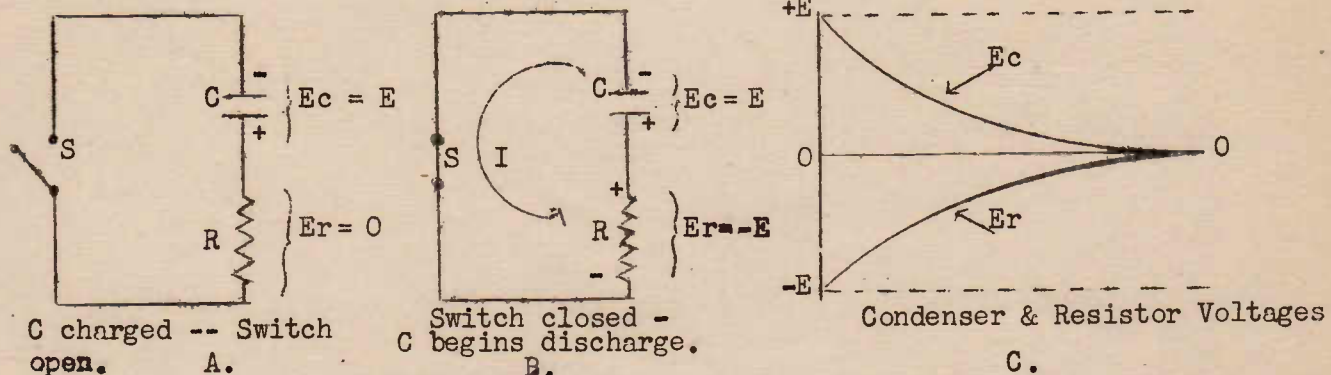

FIGURE 13.

In Figure 13A we will suppose that C has been previously charged to a voltage E. With S open, no current flows and C maintains its charge. On closing S electrons instantly start to flow around the circuit (Figure 13B). The charged condenser may be regarded as a source of e.m.f, such as a battery of voltage E. Hence at the instant of closing S the full voltage E is applied across the resistor. Note, however that the resistor voltage is of reverse polarity or sign to the condenser

voltage. This is seen from the + and - signs in Figure 13B. Hence if we call the condenser voltage (E_c) positive we must call the resistor voltage (E_r) negative. This fact may also be appreciated by considering that the total voltage around the circuit must be zero (since there is no externally applied e.m.f. in the circuit). Therefore, $E_r + E_c = 0$, from which we deduce that $E_r = -E_c$.

Thus, when S is first closed E_r instantly jumps from zero to the negative value $-E$, as shown in the lower curve of Figure 13C.

Now as time progresses, the condenser gradually discharges, and the voltage across it (E_c) falls towards zero according to the upper curve of Figure 13C. Since the voltage across R is always equal in value to that across C, but of opposite sign, E_r gradually changes from the negative value $-E$ towards zero, as shown by the lower curve of Figure 13C. This curve is exactly the same shape as that for E_c , except that it is inverted in respect to the latter. In a time equal to the Time-Constant of the circuit (CR) both voltages will have been reduced by 63% of their former value, i.e. to a value equal to 37% of E . Eventually, of course, the condenser will become completely discharged, and both voltages will be zero.

D.C. RESTORER CIRCUITS.

A D.C. Restorer consists essentially of a condenser, a resistor, and a rectifier (usually a diode) connected as in Figure 14. For reasons which will be apparent directly circuit A is called a "Negative" D.C. Restorer, while B is a "Positive" D.C. Restorer.

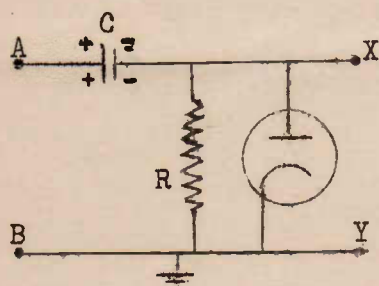

Negative D.C. Restorer

A.

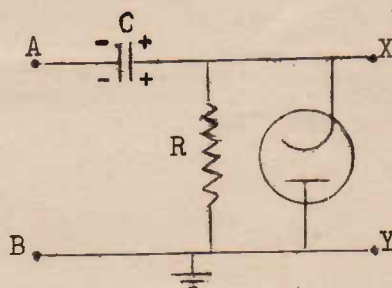

Positive D.C. Restorer.

B.

FIGURE 14.

is shown with an amplitude 2V, varying between +2V and -2V. Since the lower side of the circuit is earthed we may assume that the potentials of points B and Y are always zero.

To explain the action of the negative D.C. restorer we shall assume that a pure A.C. voltage (zero D.C. component) of square wave-form, as shown at A Fig. 15 is applied between the input terminals A and B of the circuit Fig. 14A. This voltage

When the input voltage between A and B (Figure 14A) suddenly rises to +2V, this voltage instantly appears across the resistor R, i.e. between X and Y, (see resistor voltage in section on charge and discharge of a condenser through a resistor). This means that the potential of the output terminal of the circuit also suddenly rises to +2V (see rise cd Figure 15(b)). Now this state of affairs will not continue for any length of time; very rapidly the output voltage will fall to zero as shown by the curve dg in Figure 15 (b). The reason for this is that the anode of the diode becomes positive with respect to its cathode. The valve thus becomes a conductor, and electrons will flow from cathode to anode, and thence on to the right hand plate of condenser C (Figure 14A). The condenser will therefore rapidly

charge till the potential difference between its plates is 2V. Since the output terminal X of the circuit is connected to the right-hand plate of C, its potential will be 2V more negative than the input terminal A. That is point X will have zero potential as shown at "g" Figure 15 (b). While the input voltage remains at +2V (see be, Figure 15(a)) the output voltage will remain at zero. When the input voltage suddenly changes from +2V to -2V, as shown by the fall e.f, Figure 15(a), the output voltage at X will suddenly fall from 0V to -4V, -- see point "h" Figure 15(b). Note that the potential of output terminal X is always 2V more negative than that of the input terminal A. This is due to the potential drop from left-hand to right-hand plate of the charged condenser. Now while the input voltage remains at -2V (see Figure 15(a)) the output voltage will remain practically at -4V (see h.k. Figure 15(b)). Actually during this time the condenser may discharge slightly through R (Figure 14A), which would result in the output voltage rising slightly in the positive direction. In practice, however, the time-constant C X R is made very long in comparison with the duration of half a cycle of the A.C. voltage. Hence we may assume that once the condenser was initially charged by diode conduction on the first positive half-cycle of the input voltage, this charge will be maintained indefinitely. In any case any slight loss of charge of C during a negative half-cycle will be almost instantly replaced on the next positive half-cycle when the diode again conducts. (It should be unnecessary to point out that C cannot discharge through the diode on the negative half-cycles, for the latter's anode will then be negative in respect to its cathode.)

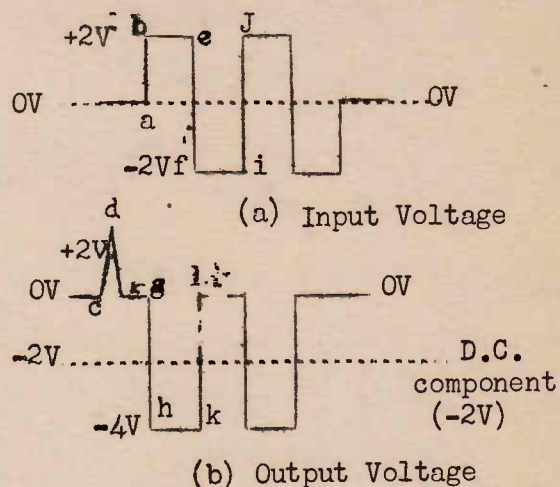

FIGURE 15.

The whole action of the D.C. restorer may be summarised thus: on the first positive half-cycle of the input voltage the condenser is charged by diode conduction, producing a P.D. between condenser plates equal to the amplitude of the A.C. voltage (2V). From this instant the potential of the output terminal X (Fig 14A) of the circuit will always be 2V more negative than the input terminal A. Thus when the input voltage is at +2V, the output voltage is at $+2V - 2V = 0V$. When input voltage is -2V, output voltage is $-2V - 2V = -4V$.

Comparing the graphs of Figure 15, the result is just as if the graph representing the input voltage were moved downwards a distance equal to 2V. Whatever the amplitude of the input A.C. voltage might be, the positive peaks of the latter will be shifted, and held, or "clamped" on the zero volts line. For this reason the circuit is often called a "Clamping" Circuit.

The output voltage (Figure 15(b)) has no positive half-cycles -- it is a pulsating D.C. voltage having a D.C. component equal to -2V (See Figure 15(b)). Thus starting with a pure A.C. voltage we have developed or established a D.C. component without in any way losing the A.C. component. Since the D.C. component which is developed is negative, the circuit responsible is called a negative D.C. Restorer.

Considering now the Positive D.C. Restorer of Figure 14(b). operating on a square-

wave A.C., the diode first operates to charge the condenser on the first negative half-cycle of the input voltage. When input terminal A goes negative, this voltage is applied across the diode, such that its cathode is negative in respect to its anode. This is the same as saying that anode is positive in respect to cathode. The diode now conducts to charge the condenser so that its right-hand plate is positive in respect to its left-hand plate. This condenser charge is now maintained, any slight discharge through R being replaced by diode conduction on the next negative input voltage half-cycle. The P.D. thus developed across C results in the output voltage at X (Figure 14.) being always 2V more positive than the input voltage, as illustrated in Figure 16. Note that a positive D.C. component of +2V is established in this case, and the negative peaks of the A.C. input voltage are "clamped" to the zero volts level.

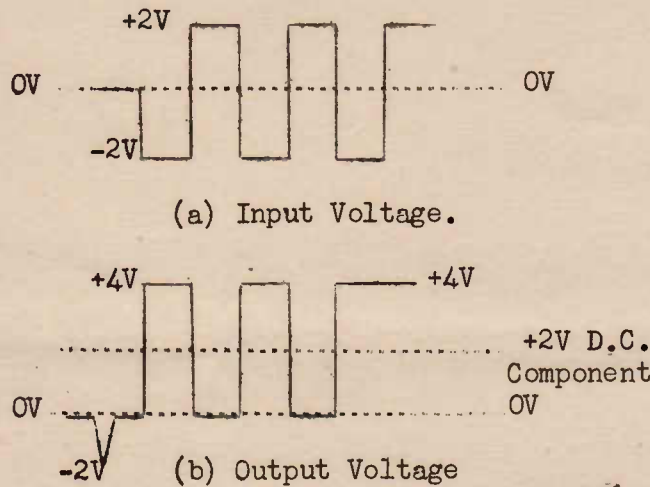

ACTION OF POSITIVE D.C. RESTORER.

FIGURE 16.

negative D.C. restoration is shown at the right. Note that the positive peaks (peaks of sync. pulses) are now held or "clamped" on the zero volts line. The result is that a D.C. component of signal is established replacing that lost by the blocking action of coupling condensers. Note also how the value of this D.C. component varies as the average illumination of the lines changes. A third important result achieved is that the blanking (black) level now remains at a constant voltage for all ten scanning lines.

ACTION OF D.C. RESTORERS ON TYPICAL VIDEO SIGNALS.

In a television receiver the D.C. restoration is achieved either in the anode circuit of the final video amplifier, or in its grid circuit. Now the video signal in the anode circuit of this stage must be a positive one, and here a positive D.C. restorer is used. On the other hand the signal at the grid of this final amplifier is a negative video signal, and negative D.C. restoration action is required if inserted at this point (See Figure 17).

At the left of Figure 18A is graphed a negative video signal which has lost its D.C. component. This a pure A.C., whose graph takes up a mean position about the zero line. The result of

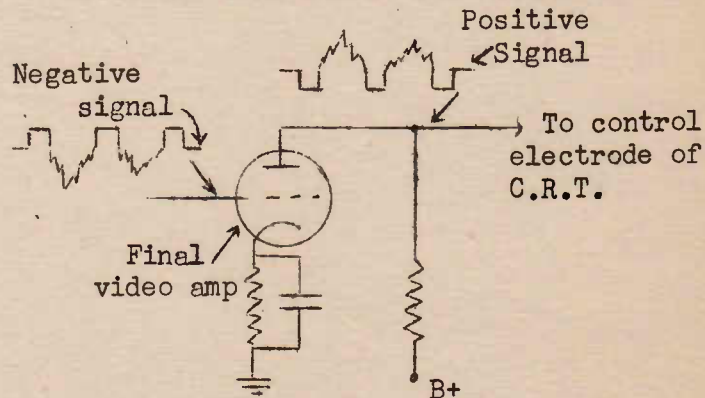

FIGURE 17.

The action of a positive D.C. restorer on a positive video signal is shown at B in Figure 18. The results are similar to those described above.

TYPICAL D.C. RESTORER CIRCUITS.

In some television receivers the use of a separate diode for D.C. restoration is avoided by operating the final video amplifier with zero grid bias. (See Fig. 19). Here grid current will flow whenever the signal voltage carries the grid more positive than the cathode. The grid, together with the cathode of the amplifying valve acts like a diode. Hence the condenser Cc, resistor Rg and the grid circuit of the valve (acting as a diode), constitute a D.C. restorer (negative type) similar to that of Figure 14A. The

graphs of Figure 19 show at (a) the A.C. signal voltage (no D.C. component, and varying black level). The voltage on the grid, due to the "clamping" action of the circuit will be as at b. Here the positive peaks (the tips of the sync. pulses) have been held to the zero volts line. The black level, at this point in the circuit will be a negative voltage, equal to the amplitude of the sync. pulses (which remain of constant amplitude for a given signal and given receiver amplification. The signal at the tube's anode, which is applied directly to the control electrode of the C.R.T, is shown at (c) Fig. 19. Note that the signal now

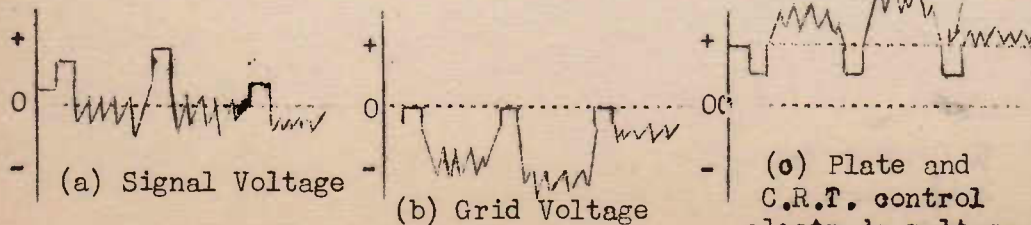
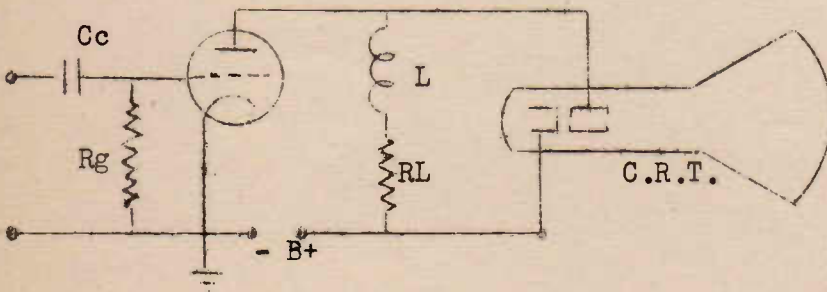
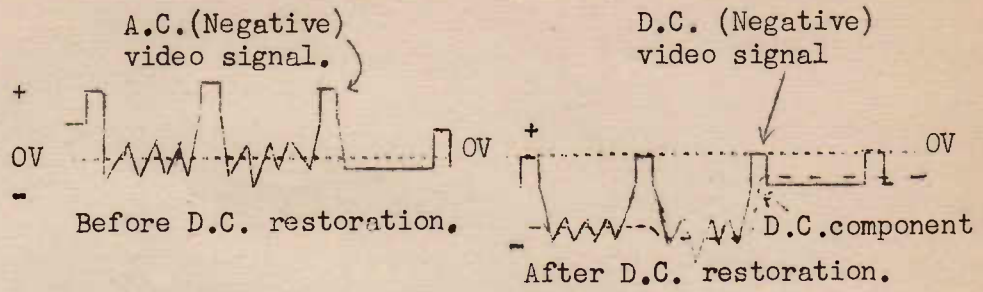
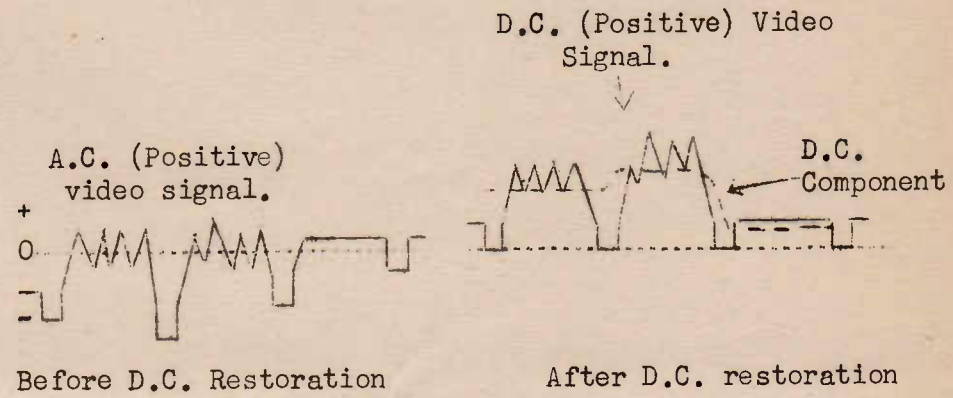

FIGURE 19.



A. ACTION OF NEGATIVE D.C. RESTORER.



B. ACTION OF POSITIVE D.C. RESTORER.

FIGURE 18.

will be as at b. Here the positive peaks (the tips of the sync. pulses) have been held to the zero volts line. The black level, at this point in the circuit will be a negative voltage, equal to the amplitude of the sync. pulses (which remain of constant amplitude for a given signal and given receiver amplification. The signal at the tube's anode, which is applied directly to the control electrode of the C.R.T, is shown at (c) Fig. 19. Note that the signal now

is a positive one due to phase reversal action of the amplifying tube. The black level of the signal will be fixed at some positive voltage. (Remember that for every voltage on the grid of a given tube there will be a corresponding anode voltage.)

The control electrode of the C.R.T. requires negative bias, such that the black level of the signal corresponds approximately to the cut-off value. This bias is provided by the voltage drop across the anode load resistor (RL) (Figure 19) due to the D.C. flow of anode current through it. This drop is, of course, such that the upper end of RL is more negative than the lower. Hence control electrode is more negative than cathode of the C.R.T.

If the circuit is correctly designed, the effect of signal voltage on the control electrode will be as in Figure 20.

This circuit has two serious defects: the video tube draws heavy plate current in the absence of a signal (since it has no steady bias), and the control electrode of the C.R.T. assumes cathode potential in the event of the plate current of the video tube failing.

These defects are avoided by the use of a separate diode for D.C. restoration as shown in Figure 21. Here V1 is the final video amplifier, RL and Cc being its plate load resistor and coupling condenser respectively. The positive video signal developed across RL is applied across Cr and Rr in series. Rr is shunted by the diode V2. It will be noted that Cr, Rr and V2 form a positive D.C. restorer exactly like that of Figure 14B.

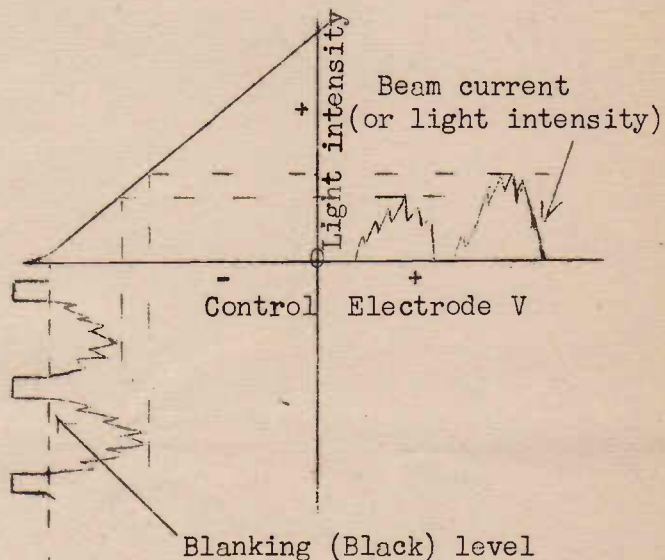

FIGURE 20.

The video signal voltage at the point X (upper end of Rr) will therefore be "clamped" or held such that the lower tips of the sync. pulses are always on the zero volts level. The picture pulsations will, of course, go positive in respect to this zero voltage. In other words the diode circuit is acting as a positive D.C. restorer. Now the D.C. voltage on the control electrode of the C.R.T. is identical with

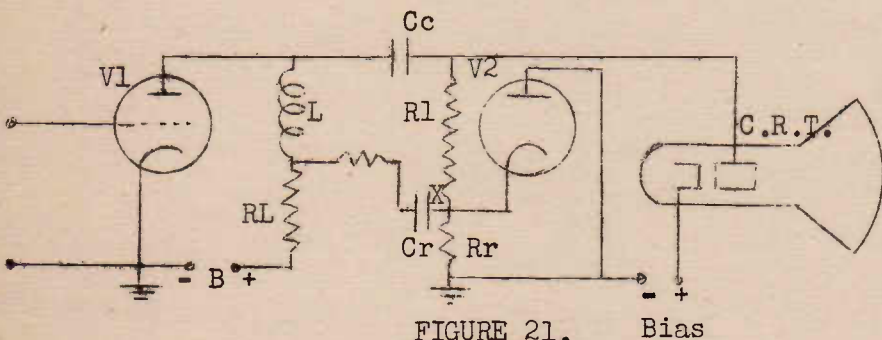

FIGURE 21.

that at point X, since there is no voltage drop across RL (RL carries no direct current). C.R.T. control-electrode bias is obtained by applying a positive voltage (with respect to ground) to the tube's cathode as shown.

BRIGHTNESS AND CONTRAST CONTROLS.

A television receiver, like a broadcast receiver, incorporates a number of variable

controls, to allow adjustment of the equipment for best reception. The television receiver is, of course, a "dual" receiver consisting of two sections -- one for sound and one for picture reproduction. Each section has, in general, its own separate set of control knobs. It might be mentioned here, however, that in the case of a receiver designed for operation on several different channels, the "station selector" is common to both picture and sound sections. This, as explained in the previous lesson, usually takes the form of a selector switch which brings into circuit the appropriate antenna and oscillator coils for the television transmitter it is desired to receive.

Of those controls directly concerned with picture reproduction, it will be convenient at this point to deal with those usually described as the "Brightness" and "Contrast" controls. These are dealt with together, for their actions are inter-dependent; that is an adjustment to one of them usually necessitates an adjustment to the other.

The Brightness Control allows adjustment of the C.R.T. Control electrode bias (in relation to the tube's cathode). In other words it allows us to set the "black" level of the signal on this electrode to about the cut-off value of bias (see Fig.22).

At A (Figure 22) the setting of the Brightness Control is correct. The "blanking" level (base of sync. pulses) of the video signal corresponds to cut-off tube bias, and therefore to zero illumination of the screen. The sync. pulses themselves lie entirely in the "infra-black" region.

If the control is set too high, as at B (Figure 22) the over-all brightness or illumination of the screen will be increased, but pure black will be represented by some screen illumination. This, of course is undesirable. In addition the scanning "retrace" will be visible. It will be remembered that, during the line sync. pulse intervals the light "spot" is moving back rapidly from right to left on the screen, before commencing a new scanning line. The screen should be "blacked-out" during these short intervals when no picture detail is being received. If the brightness control is set too high the retrace lines will be visible on the screen, thus marring the picture.

The effect of setting the brightness control too low is illustrated at C (Figure 22). Here the black level

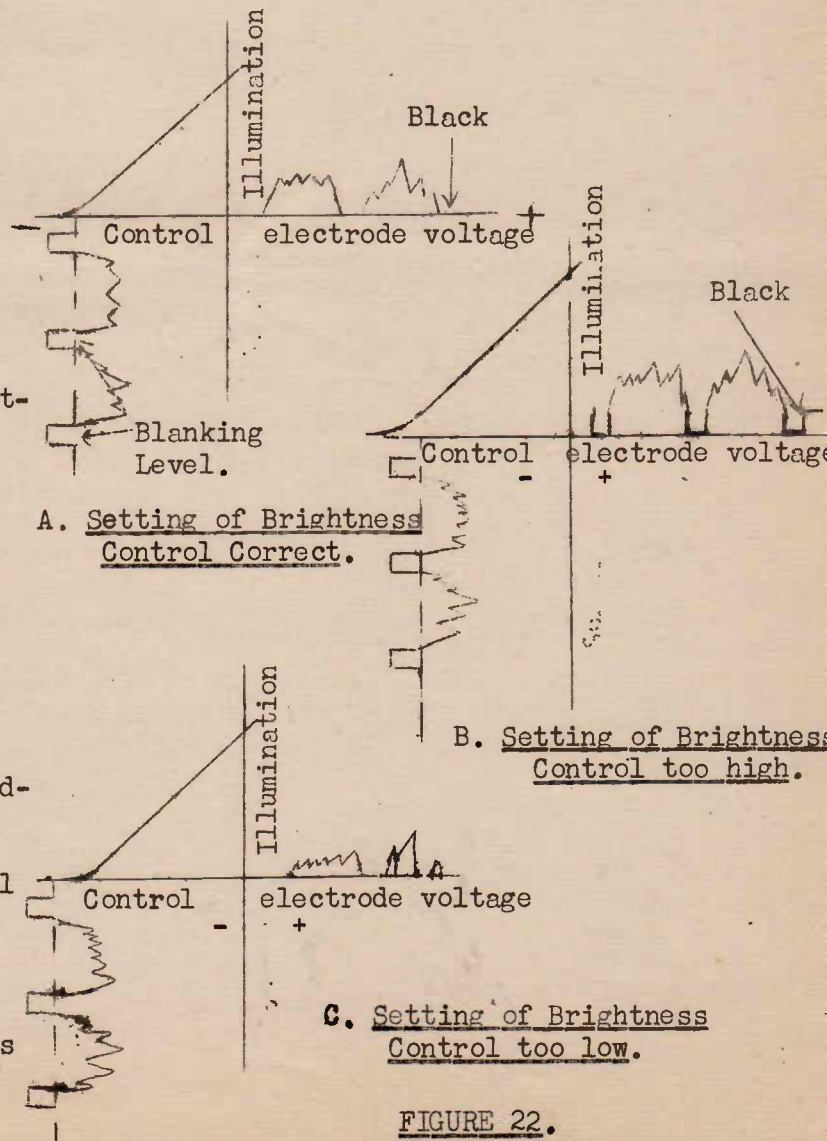

FIGURE 22.

of the picture signal is set beyond cut-off. This will mean that dull (though not black) sections of the original picture will be portrayed by black on the screen (i.e. no screen illumination). It will result in loss of shadow detail.

The correct setting of the brightness control is such that the retrace lines just become invisible on the C.R.T's screen.

The Contrast Control varies the receiver's amplification and consequently the video voltage applied to the cathode-ray tube. It corresponds to the volume control in a broadcast receiver. Whereas the latter operates by tapping off a portion of the detector's output, however, the contrast control usually adjusts the bias on the picture I.F. amplifier tubes. These tubes are of the remote cut-off (i.e. variable- μ) type.

The effect of increased receiver gain is shown in Figure 23. At A is graphed a typical video signal (2 lines). B shows the effect of turning up the contrast control, i.e. increased amplitude of the A.C. signal. C and D show the signals after D.C. restoration. A comparison of B and D will show that increased receiver gain not only increases the amplitude of the A.C. component of the signal, but it also increases the D.C. component.

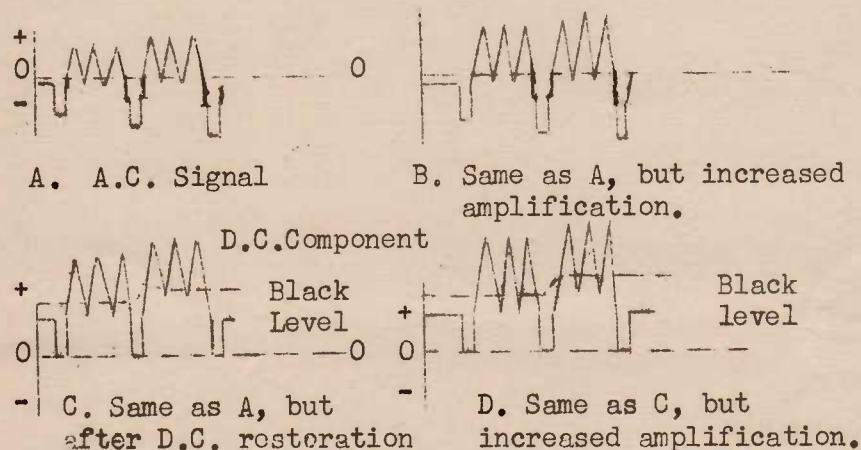

FIGURE 23.

Increase of the amplitude of the A.C. component means that the difference between the light spots and the darker spots on the screen is accentuated. This, up to a point, augments the clarity of the picture detail. We say, "up to a point", because if the control is turned too high, control electrode current will flow on the positive peaks of the picture signal, resulting in "distortion" which results in a lack of detail in the bright areas. This effect corresponds to overloading in a sound receiver by turning the volume control too high so that grid current flows in one of the amplifying tubes.

It will be observed that actually the contrast control also alters the over-all or average brightness of the picture, but it is reiterated again that the brightness control should always be set so that the "retrace" lines are just obliterated. This involves adjusting the black level of the signal approximately to the C.R.T's cut-off bias. Now if graphs C and D of Figure 23 are compared it will be observed that an increase in contrast control raises the black-level (tops of sync. pulses). Hence each adjustment to the contrast control will, in general involve a re-adjustment of the brightness control in order to bring this black level back to the cut-off value of C.R.T's control electrode bias.

T.FM & F. LESSON NO. 9.

EXAMINATION QUESTIONS.

- (1) State the polarity ("positive" or "negative") of the picture obtained in each of the following cases:-
 - (a) Cathode-above-ground detector, positive modulation, one video stage.
 - (b) Cathode-above ground detector, negative modulation, two video stages.
- (2) What is meant by the D.C. component of a video signal? What does it represent in the picture reproduction?
- (3) What components in a receiver cause a loss in the D.C. component? Why?
- (4) A battery of voltage 10V is connected in series with a switch S, a condenser C of .05 mfd and a resistor R of value 3 megohms. Answer the following questions:-

On closing S what is,

 - (a) the initial current in the circuit
 - (b) the initial voltage across R,
 - (c) the initial voltage across C?
- (5) After what period will the voltage across C (in question 4) be 6.3V (approx)?
- (6) Draw graphs showing how the voltages across C & R (in question 4) change from the moment before S is closed.
- (7) Draw a circuit diagram of a positive D.C. restorer, showing graphs of a pure A.C. input voltage and the corresponding output voltage.
- (8) State two defects which would appear in the picture reproduction if the D.C. component of the signal were not reinserted.
- (9) What voltage does the Brightness Control vary? What is the effect of having this control (a) too "low" (b) too "high"?
- (10) What is the function of the Contrast Control? At what point or points in the receiver does it usually operate?

AUSTRALIAN RADIO COLLEGE

E. S. & A. BANK BUILDINGS, Corner CITY RD. and BROADWAY, SYDNEY

Telephones: M 6391 and M 6392. Post Lessons to Box 43, Broadway

This lesson sheet is published for the exclusive use of students of the Australian Radio College Pty. Ltd.
(All rights reserved)

T. FM & F. LESSON NO. 10.



BEAM DEFLECTION & SYNCHRONISATION.

The sections of the receiver to be dealt with in this lesson concern the formation of the scanning pattern on the C.R.T. screen. Scanning, it will be remembered, is achieved by simultaneous horizontal and vertical movements of the electron beam in the picture tube. Such movements are brought about by the application of saw-tooth voltages (or currents) to two pairs of "deflection" plates (or coils) within the tube. This lesson, then, will cover those stages or circuits of the receiver whose final outputs are applied to these deflection electrodes. The problems associated with the application of the video signal to the control electrode have already been fully dealt with.

The circuits concerned, and their proper relationship to each other, and to the receiver's detector and video amplifying stages (if any), are shown in Fig. 1. They include the horizontal and vertical scanning generators (followed by suitable amplifiers), the sync. pulse "clipper" circuit sync. amplifier, and two circuits for separating the horizontal sync. pulses from the vertical.

It must be remembered that the scanning generators, known also as "sweep circuits" or "Time Bases", are really self-maintained oscillators, which produce electrical oscillations having a "saw-tooth", or modified saw tooth, waveform. The vertical scanning oscillator operates at a much lower frequency (the "frame" frequency) than does the horizontal scanning generator (the latter operates at the "line" frequency). The problem of "interlaced"

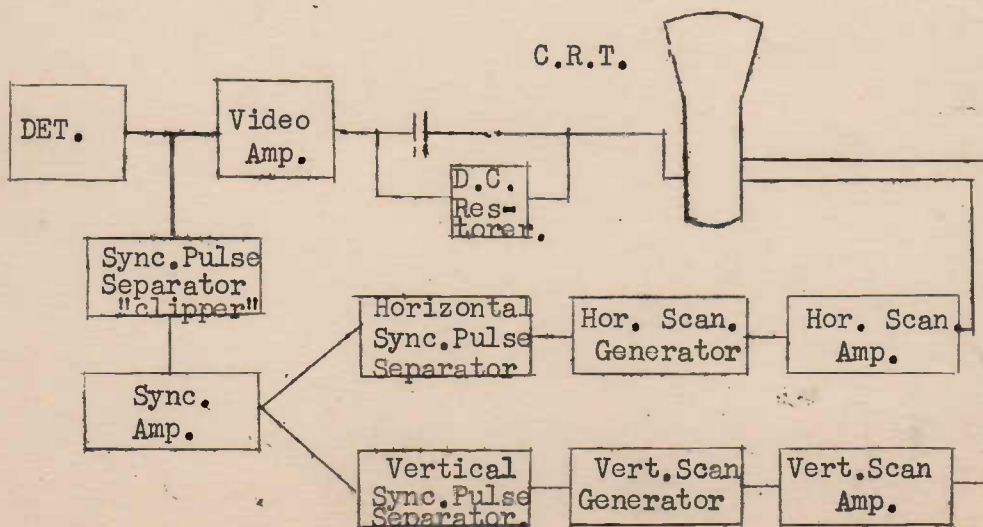

FIGURE 1.

scanning should, at this stage, be revised, if necessary. To give an example illustrating how these two frequencies are related, suppose we are operating upon a system using 405 "lines", 25 pictures per second. If interlaced scanning is used the C.R.T's electron beam must trace out 50 frames per second (2 frames per complete picture). The vertical scanning generator will therefore be required to generate 50 complete cycles of saw-tooth voltage per sec. Since the horizontal generator must cause 405 horizontal lines to be traced out for every complete picture, its frequency will be $25 \times 405 = 10,125$ cycles/sec.

The example shows that the vertical scan generator operates at the frame frequency (not the picture frequency). The horizontal scan generator has a frequency equal to the picture frequency multiplied by the number of lines per complete picture.

Now the student well knows that it is an impossibility to design any oscillator to run continuously at any exact frequency. Such factors as variations in supply voltage, temperature changes etc. will always lead to a certain degree of frequency "instability". This applies particularly to the special types of generators used for producing saw-tooth oscillations. On the other hand it is especially important that the scanning generators in a television receiver maintain, with a high degree of accuracy, their allotted frequencies. More important still, it is essential that, in the case of the horizontal (line) scanning the generator commences each cycle at the precise instant that the picture information for the beginning of that line is being received on the incoming wave. The student should be careful to note that, even if the scanning generator is operating at its correct frequency, the receiver line scanning may well be out of step with that at the transmitter. This would mean that each line on the receiver's screen would commence at any instant when picture information corresponding to some portion of the scene other than the left-hand edge is being received. The effect, of course, would be a displacement, in a horizontal direction of the picture details, as shown in Figure 2. For similar reasons to these it is equally important that the vertical ("frame") scanning generator be controlled to commence each of its saw-tooth oscillations exactly in step with those of the corresponding generator at the transmitter.



Again, it is important that an exact timing relationship should exist between the actions of the two scanning (horizontal and vertical) generators of the receiver. This is essential in order to achieve accurate interlacing of the lines. In the discussion of interlaced scanning in an earlier lesson it was pointed out that each vertical oscillation moving the beam downwards for "odd" frames should cease on a half line, while each vertical oscillation for "even" frames should end at the completion of a whole line. This was essential in order that the lines traced out during an even frame would fall on the spaces "skipped" by the lines of the previous odd frame.

FIGURE 2.
HORIZONTAL DISPLACEMENT
OF PICTURE DETAIL AS RES-
ULT OF LACK OF CORRECT
LINE SYNCHRONISATION.

From the foregoing it will be realised that although the scanning generators are self-maintained oscillators, designed to operate approximately at their allotted frequencies, it is essential that they be controlled and "governed", externally, so that each saw tooth cycle is executed at the precise moment as required by the incoming signal. This external control of these generators is provided by the synchronising pulses which are

superimposed, at the transmitter, on the television wave itself.

In dealing with the television receiver so far, we have followed the received signal through from aerial to detector, and thence, as far as the true video signal, representing picture detail, is concerned, through the video amplifier to the control electrode of the C.R.T. Referring back to Figure 1 we note that at a point in the receiver immediately following the detector there is a "parting of the ways" as far as the "composite" video signal is concerned. At this point the synchronising pulses (line and frame) are separated from the composite signal, and side-tracked to the scanning generators for the accurate timing control required for the latter. Hence we come to the first of the special circuits or stages of the receiver to which this lesson is specially devoted -- namely the ".ync. Pulse Separator" or "Clipper".

SEPARATION OF SYNCHRONISING PULSES FROM VIDEO SIGNAL.

Although the sync. pulses and the camera signal are both superimposed (as modulation) on the one carrier wave it is possible to achieve a separation of the former from the latter owing to the difference in amplitude which exists between them.

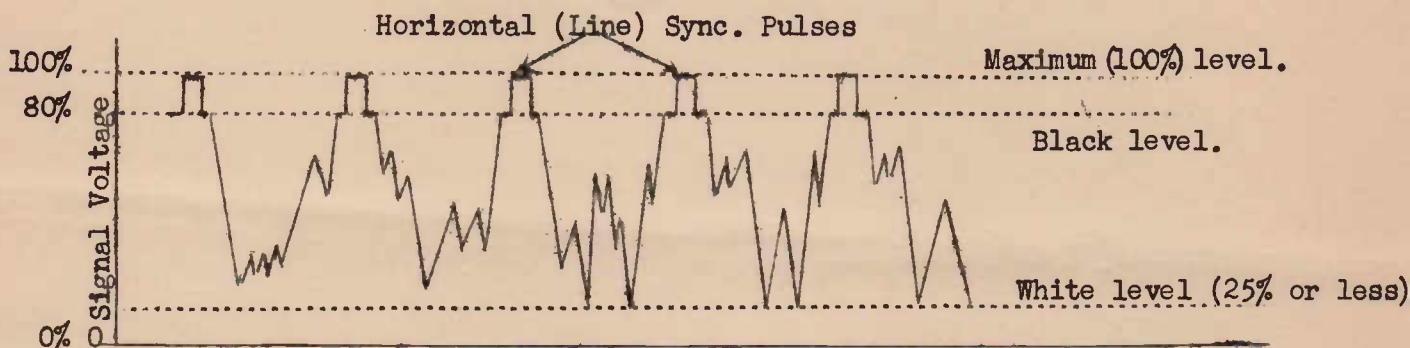

FIGURE 3.

A typical "negative" video signal is shown in Figure 3. Such a signal, of course, is the result of "de-modulating" the R.F. or I.F. carrier wave by the receiver's detector. The maximum (100%) level shown represents the detector's D.C. output when peak carrier amplitude is being received. The 80% level is the D.C. voltage across the detector's load when the carrier's amplitude has been reduced by 20% due to modulation, and so on. The actual value in volts of these levels will of course depend upon the strength of the particular wave being received as well as the overall amplification of the receiver up to the detector stage. Now, as has already been explained, the picture information is conveyed by voltage variations between the 25% (or less) level and the 80% level. Here the 80% level represents a detector output which when finally applied to the control electrode of the picture tube will produce no light (black) on the screen. Any increase in signal above this black (80%) level will therefore have no effect on the screen. Thus the region between the 80% and 100% levels is referred to as the "infra-black" or "blacker-than-black" region. It should be observed that the sync. signals are confined entirely to this particular region.

Separation of the sync. pulses is brought about by applying the composite video signal to a tube (diode, triode, or pentode) so biased that no current can flow through it until the infra-black region, (which contains the sync. pulses), is

reached. This involves obtaining a value of negative bias such that the blanking (black) level of the applied signal corresponds to the plate-current cut-off of the valve. "Fixed" bias methods, such as battery bias or "back" bias (derived as a P.D. across a resistor in the power supply) are unsuitable for the purpose, for the reason that the blanking level of the signal does not remain constant, but ordinarily varies with the average level of scene illumination, as explained under the section on D.C. restoration. Instead, some method of self or automatic-bias must be used.

Common types of "clipper" circuits using triodes (or pentodes) are shown in Figure 4. At A grid leak bias is obtained. The positive peaks of the sync. pulses carry the grid positive, and grid current flows. This charges the condenser C with the

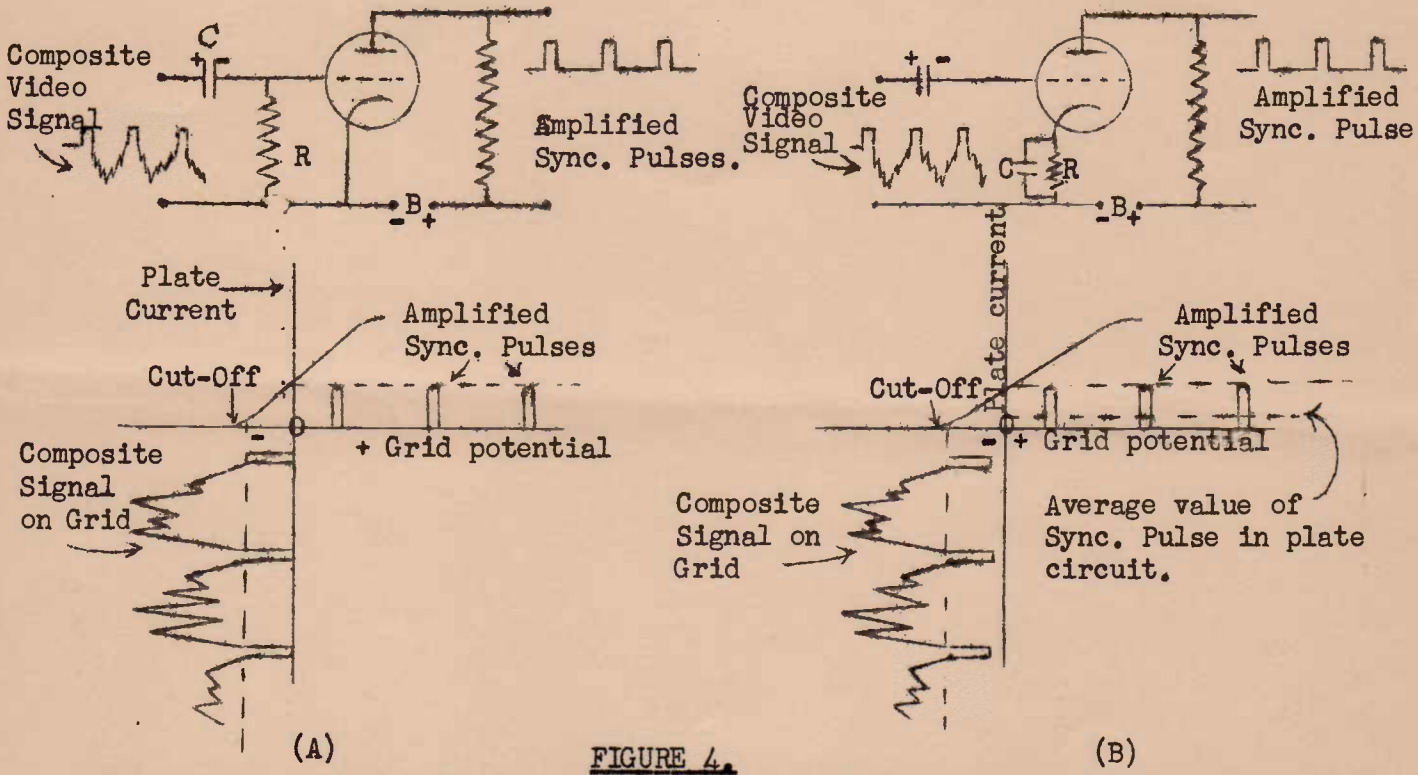

FIGURE 4.

polarity shown in the figure. During the periods between the sync. pulses C will, of course, begin to discharge through R. The time-constant R.C, however, is made very large, and consequently this discharge will be negligible. In any case, any such loss will be made good the next time a sync. pulse carries the grid positive. The net result is that the tips of the sync. pulses are "clamped" approximately to the zero grid volts level, as in the action of a D.C. restorer. The condenser C is maintained in a charged condition. The P.D. across this condenser constitutes the grid bias, which is of such value that the blanking level of the signal is fixed at a negative voltage equal to, or slightly greater than, the grid-volts cut-off point (see lower diagram Figure 4A). Plate current can only flow when the tube's grid voltage is less negative than this cut-off point, i.e. during the sync. pulses. The sync. pulses, and not the camera signal, will therefore appear in the plate circuit.

At B in Figure 4 is shown a circuit using cathode bias. The cathode resistor R is

very much larger than would be used for ordinary cathode bias purposes. The bias is obtained by the presence of the amplified sync. pulses in the plate circuit of the tube. These plate current pulses are "averaged out", as far as the cathode resistor R is concerned, by the condenser, C . The average of the plate current pulses is shown by the lower dotted line in the graph of Figure 4 B. This is the current (steady D.C.) which flows through R , and creates a P.D. which constitutes the grid bias. The value of this average plate current multiplied by the resistance of R , should give a voltage at least equal to the cut-off value of grid volts. If this condition is satisfied, then plate current will flow only when the applied signal exceeds the blanking or black level, and only sync. pulses will appear in the plate circuit. Using tubes of high G_m a cathode resistor of about 10,000 ohms is required.

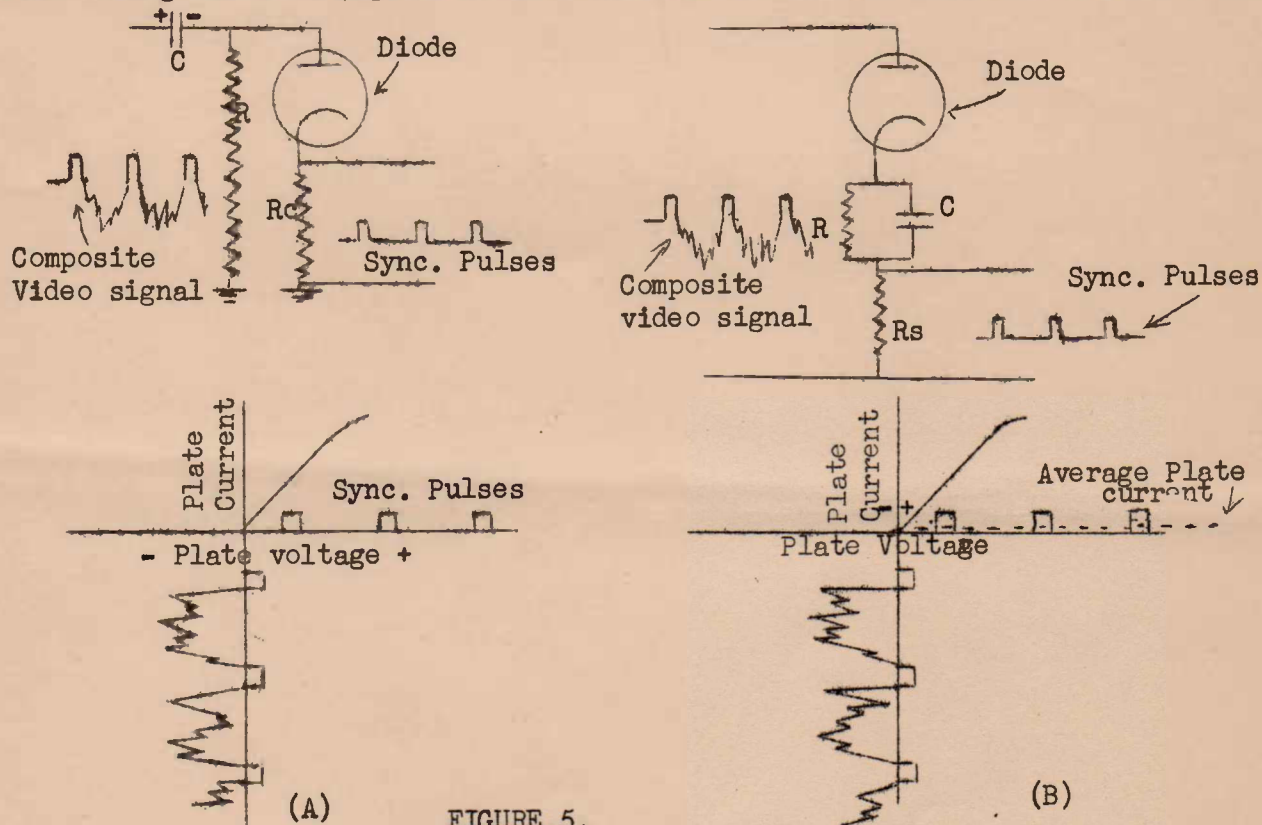

FIGURE 5.

Two circuits using diode tubes are shown in Figure 5. The circuit of A operates in a very similar manner to that of Figure 4A, in that bias is obtained by building up a charge on the condenser C as a result of plate current flow during the sync. pulse periods. To obtain a bias sufficiently large to ensure that plate current flows only during these periods the time-constant $R.C.$ is made very large. The electrical action will be clearly understood by referring to the graph of Figure 5A. The anode is biased negatively to such an extent that the video signal must rise to the blanking level before current flows through the valve. The plate current pulses develop corresponding voltage pulses by flowing through the cathode resistor (un-bypassed) R_c .

The operation of the diode circuit of Figure 5B should be compared with that of Figure 4B. In both, cathode-bias is used. The condenser C averages out the pulses of plate current. The average current is shown by the dotted line in the graph. It is this average plate current, flowing through R , which produces the steady negative

bias. The bias is such that the blanking level of the signal corresponds to the zero anode volts level, in order to ensure that sync. pulses only appear in the plate current flow. These pulses of plate current, flowing through the un-bypassed resistor R_s , develop the required pulses of voltage for application to the scanning generator.

SEPARATION OF LINE SYNC. PULSE FROM FRAME SYNC. PULSES.

The circuits described in the previous section separate the synchronising pulses from the main video signal. These sync. pulses, however, consist of two types -- those used to control the line (horizontal) scanning generator, and those whose purpose it is to synchronise the frame (vertical) scanning generator. These two types must be separated one from the other in order that they might perform their allotted tasks.

Referring to Figure 6, (a) shows a negative signal delivered from the receiver's detector, (b) gives the positive video signal as applied (via the video amplifiers) to the C.R.T's control electrode, and (c) represents the sync. pulses as separated from the rest of the video signal by the "clipper" circuit. Concentrating upon graph (c) of this diagram the first four pulses are line sync. pulses for application to the horizontal scanning generator. These consist of a number of single voltage pulses, of short duration, each occurring at the beginning of each horizontal line traced out by the generator. At the end of each frame (i.e. when the spot reaches the bottom of the picture area) the screen becomes blacked out by the signal returning to the blanking (black) level, as shown in Figure 6 at (a). In addition, there follow a number (six are shown) of pulses occurring at twice the line frequency. These despite their higher frequency (as explained later), will keep the line scan generator operating in correct synchronisation. At the same time they allow a short period for the frame (vertical) generator to settle down before commencing its next cycle, which lifts the spot to the top of the screen for the next frame. These six pulses are therefore called "equalising" pulses. Following the equalising pulses the true frame sync. pulses occur. The latter consist of a number (six are shown) of broad pulses as shown in graphs (a), (b) and (c) of Figure 6. (Note:- All pulses in graph (b) are of reverse polarity to those of graphs (a) and (c). This is due to the fact that graph (b) is a "positive" signal, while graphs (a) and (c) represent "negative" signals). At this stage it should be clearly understood that each line is terminated (and the next line begun) by a single narrow pulse. Each frame, on the other hand, is terminated by a series (six as shown) of the broad pulses. As will be explained these six broad pulses are added or "integrated" to form a single large pulse as shown in graph (e) of Figure 6.

Graph (d) for this figure shows the output of the horizontal sync. pulse separator. Note that for the whole time during the interval separating the frames this output contains line sync. pulses, occurring at double the line frequency.

We now proceed to explain the circuits responsible for this separation of the two types of synchronising pulses.

LINE PULSE SEPARATION.

The sync. pulses used for line scanning synchronisation, as shown in Figure 6(a) are usually obtained by using what is known as a "Differentiating" circuit. This consists of an R.C. combination, from which the output is taken across the resistor,

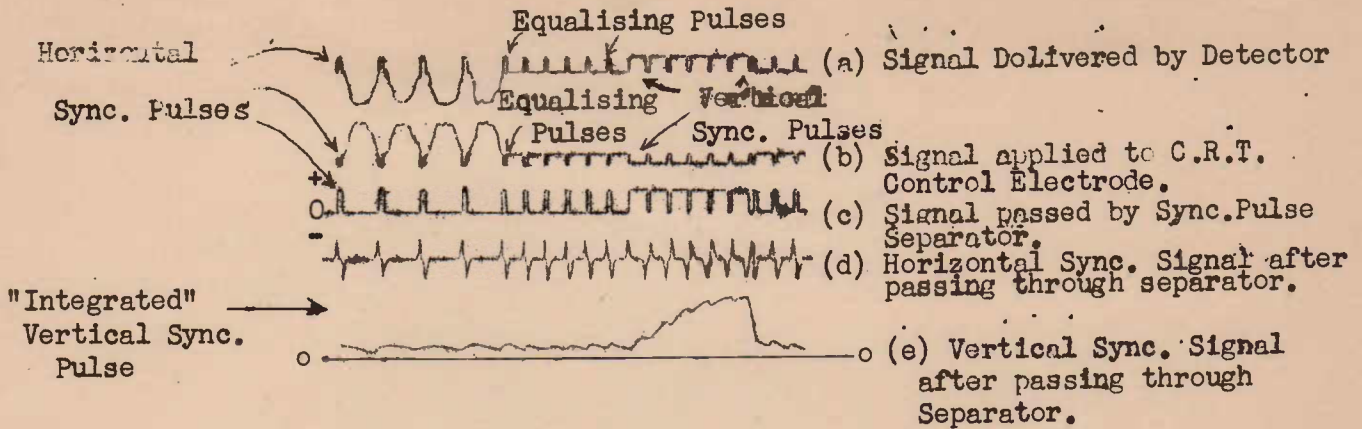

FIGURE 6.

as shown in Figure 7. This is the circuit shown in block form in Figure 1, as "Horizontal Sync. Pulse Separator".

Referring to Figure 7 we shall suppose that some sort of generator G is applying a voltage of square-wave form to R and C in series, as shown in the accompanying graph on the left. Further, we will suppose that the time-constant (R multiplied by C) of the circuit is very short compared with the half-period of the applied voltage (i.e. the time taken by half a cycle -- b c in left hand graph).

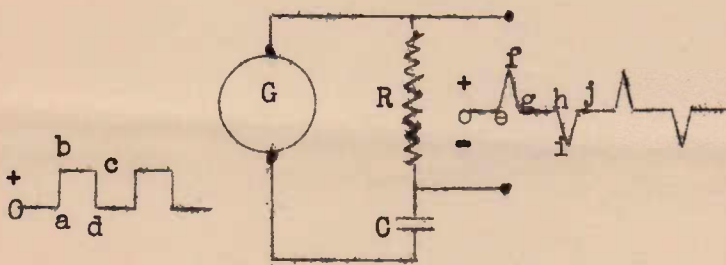

FIGURE 7.

Initially, the full voltage a.b. will all appear across R (output) as shown by "e.f" in the output voltage. Now, on account of the very short time constant of R.C. the condenser will very quickly charge up to the applied voltage, and, as it does so, the resistor voltage will accordingly fall to zero. This fall in output voltage is shown by curve "f.g" on the graph (figure 7). For the remainder of the input voltage half-cycle ("b.c") C will remain charged, and the voltage across R will remain at zero -- see "g.h". When the input voltage suddenly falls to zero at the end of the half-cycle ("c.d") C commences to discharge through R. The full voltage of C is suddenly applied across R in the reverse, or negative direction. Hence, at this instant the resistor voltage suddenly jumps, negatively from h to i as shown on the output voltage graph. In a very short time the condenser becomes completely discharged, and the resistor voltage falls from the negative value i to zero at j, where it remains for the rest of the input half-cycle. All of this process will be repeated on the next cycle of the square-wave input.

The effect of the differentiating circuit of short time-constant upon a square-wave voltage should be carefully noted. Every time the input voltage suddenly changes

in value, a sharp pulse, of short duration, is produced in the output. A rise in input voltage results in a positive output pulse, and a fall in input voltage causes a negative pulse in the output. Note that these negative pulses occur in the output, even though the input voltage itself never goes negative.

For line sync. pulse separation in a television receiver the combined sync. pulse signal, consisting of both line and frame pulses, and representing the output of the "clipper" circuit, is applied across a differentiating circuit. The output, taken across the resistor, was shown at (d) Figure 6. The sync. pulses of Figure 6 (c) may be regarded as constituting a series of square waves having positive half-cycles of short duration. The time-constant of the line pulse differentiating circuit should be even shorter than this short period. The resultant output voltage graph (Figure 6 (d)) shows that an extremely sharp positive pulse results every time the input voltages takes a sudden rise (i.e. at the left-hand edge of a sync. pulse of Figure 6(c)). Likewise an equally sharp negative pulse results whenever an input pulse suddenly falls to zero.

The output of this line sync. pulse separator as shown at Figure 6 (d) consists, during any one frame, of a sharp positive pulse (together with its accompanying negative pulse) at the end of each line, i.e. at line frequency. During the period existing between two successive frames a slight modification occurs. The output pulses occur at double the line frequency. This is a result of the nature of the sync. signal between frames, when the "rises" and "falls" in voltage occur at the end of every half-line (see Figure 6 C). As will be clearly understood later, however, pulses at double the line scan. generator frequency are quite effective in synchronising it at its correct line frequency. Remember, by the way, that the line generator continues to trace out lines even during the interval when the vertical (frame) scan generator is returning the spot to the top of the screen before commencing the next frame.

It might be mentioned at this stage, that, although the differentiating circuit produces a series of both positive and negative pulses at line frequency (or double line frequency), as shown in Figure 6 (d), it is only the positive pulses which are effective in synchronising the line scan. generator.

INDUCTIVE METHOD OF LINE PULSE SEPARATION.

The well-known fact that a large counter e.m.f. is induced in an inductance whenever a current changes suddenly, may be utilised for developing a series of sharp

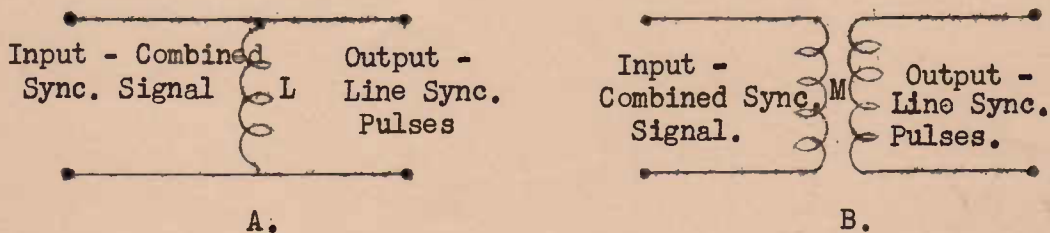

pulses occurring only at line frequency or double line frequency. Either Self - or Mutual-Induction may be used as shown in Fig. 8.

If the combined sync. pulse signal as shown

FIGURE 8.

in Figure 6(c) is applied to the input of either of these circuits, the current

through the coil suddenly changes at the "leading" or "trailing" edge of a line pulse. These sudden changes in current induce counter e.m.f.'s of self-induction in the case of circuit A, and of mutual induction in the case of circuit B. It is these induced e.m.f.'s which represent the output line sync. pulses. The outputs, as for the differentiating circuit, will be substantially, as shown in Figure 6(d). Except of reversed polarity, a sudden rise of current at the beginning of the pulse will produce a negative voltage peak. The succeeding fall of current will produce a positive peak of counter E.M.F. Only the negative pulses would be utilised for line synchronising in this case. They would be converted first to positive pulses before applying to the line scan generator, by passing them through a single valve stage for phase reversal and amplification.

FRAME (VERTICAL) SYNC. PULSE SEPARATION.

The frame or vertical pulses occur at a much lower frequency than do the line pulses. They occur only at the end of every frame, instead of at the end of each line. As we have already seen, any two frames are separated by a number (usually six) of broad pulses separated one from the other by negative pulses of short duration. (see graphs (a) (b) and (c) of Figure 6). The question may well be asked: why not have a single broad pulse extending over the period occupied by the six? The reason has already been partly explained. By breaking up the frame sync. signal by downward or negative pulses (at double line frequency), the output of the line pulse separator will continue to maintain the line scan generator in synchronisation during the period in which the spot is moving from bottom to top of the screen between frames. This period of time, short though it is, is sufficiently long for the horizontal (line) generator to trace out many cycles. If the frame sync. signal were not broken or "serrated" by these negative pulses of short duration, the line scan generator could easily get out of synchronisation in the interval between frames.

The purpose of the frame sync. pulse separator is to "integrate" or add up the six broad frame pulses into a single large pulse for application to the vertical scan generator. At the same time the separator must virtually eliminate the effect of the higher frequency line pulses.

The circuit usually employed for this purpose is that known as the "integrating" circuit. The latter consists simply of a combination of R&C from which the output is

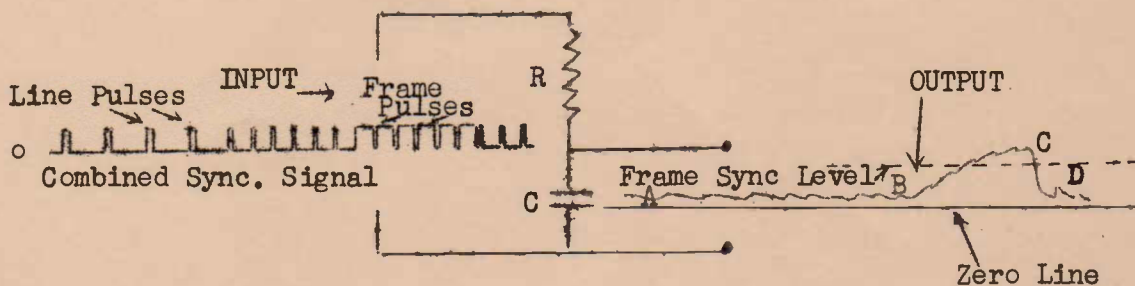

FIGURE 9.

taken across the condenser as in Figure 9. (Compare this circuit with the Differentiating Circuit of Figure 7).

The time constant of the R.C. combination is made long compared with the duration

of the line pulses (and the negative pulses separating the frame pulses).

During the tracing of a frame the line pulses will have but little effect on the circuit's output. This is due to the long time-constant R C. When a time pulse is applied across the input the condenser will not have sufficient time to charge up to any great extent. What charge is acquired due to a line pulse will be practically entirely lost, due to condenser discharge, in the period which elapses before the next pulse arrives. The net effect is that, during frames, a small average positive charge is maintained on C, as shown between A and B on the output voltage graph of Figure 9. The small "kicks" in this average voltage are due to the time pulses. Now when the first of the six broad frame pulses arrives, the condenser voltage will rise to a higher level. This is due to the fact that the duration of the frame pulse is longer, and the condenser has time to acquire a larger charge than that due to a short line pulse. When the first broad frame pulse ends only a small fraction of this extra charge is lost, since the "gaps" of zero voltage separating the individual frame pulses are of very short duration. The arrival of the second frame pulse, of comparatively long duration, will result in a further increase in condenser charge, with but small loss at the end of this pulse. The net effect is seen between B and C of the output graph (Fig.9). The six broad frame pulses gradually build up a large voltage across C. When the last of the frame pulses passes, the condenser discharges to its former level. The action of the circuit has been to **integrate** the six separate frame pulses, occurring between any two frames, into one large pulse of sufficient amplitude to be effective in synchronising the vertical scan generator. Note that the line pulses appear in the output only as a ripple of negligible amplitude. This output, then, will appear as a series of large pulses, occurring at frame frequency, i.e. the frequency of the vertical scan generator.

TYPICAL PULSE SEPARATOR CIRCUITS.

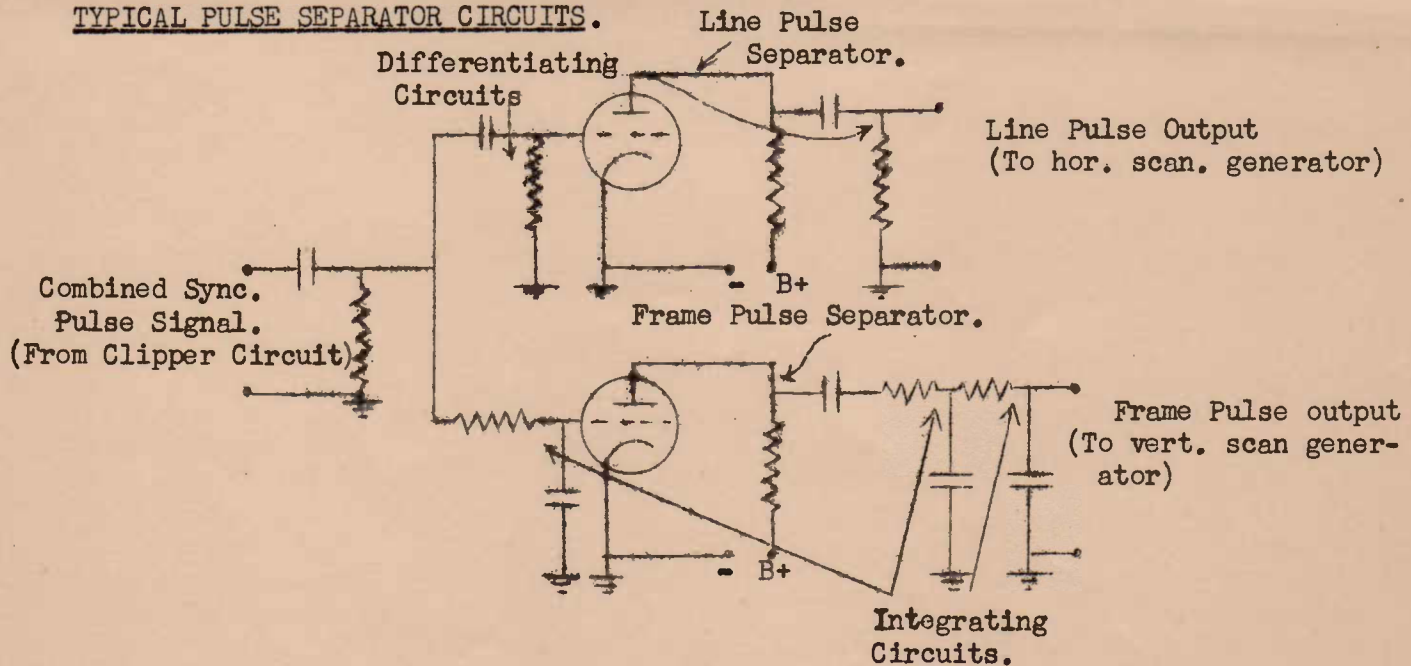

FIGURE 10.

The Differentiating and Integrating Circuits for line and frame pulse separation are usually included in the grid or plate (or both) circuits of amplifying valves.

Figure 10 shows a line pulse separator and a frame pulse separator on a single diagram. For more efficient line pulse separation, two differentiating circuits (one in the grid and the other in the plate circuit of the upper valves) are used. Three integrating circuits (one in the grid and the other two in the plate circuit of the valve) are utilised for the frame pulses.

GENERATION OF SAW-TOOTH WAVES.

For linear deflection of the C.R.T.'s electron beam to produce the scanning pattern it is necessary, as has already been explained, to generate voltages of "saw-tooth" form. Assuming for the moment electrostatic deflection two such voltages are required. The one, having a frequency equal to the line frequency is applied between the pair of deflection plates producing horizontal movement of the beam. The other, at frame frequency, operates upon the remaining pair of deflection plates, causing the much slower up and down movement of the scanning spot. It should be understood, consequently, that the two saw-tooth generators used are exactly similar in principle. Their only difference is one of frequency.

Most types of saw-tooth generators have one thing in common. The shape of the voltage generated in every case is obtained by alternately charging a condenser through a resistor and then rapidly discharging it by means of a virtual short circuit.

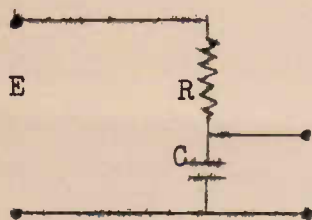

(A)

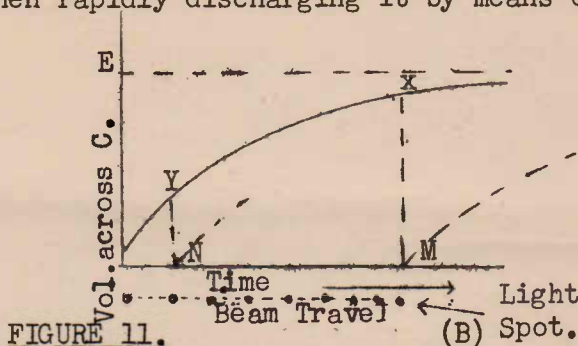

FIGURE 11.

If a steady D.C. voltage E is applied across an R.C. circuit as in Figure 11 at A, the voltage across C will rise in a manner shown by the curve at B. This rise in voltage is not a uniform

or "linear" one, but becomes less and less rapid as the condenser voltage approaches the applied voltage E.

If, by some means, the condenser were suddenly discharged, by momentarily applying a short circuit across it when the voltage reaches the point X (Figure 11B), thus reducing the latter to zero, a single cycle of a modified saw-tooth wave would be traced out. This cycle would immediately be followed by a similar cycle, as the condenser commenced to charge again. The application of such a voltage to the horizontal deflection plates of a C.R.T. would result in a non-uniform (i.e. "non-linear") movement of the spot across the screen (See Figure 11B), as the voltage rose. The sudden discharge of C (XM Figure 11B) would quickly return the spot to its original point.

Two points emerge from the foregoing discussion. Firstly, generation of saw-tooth voltages may be achieved by making use of an R.C. circuit together with some means of periodically discharging the condenser with great rapidity. For the latter purpose a rotating mechanical switch could be used, but for high frequencies, mechanical methods are unsatisfactory. Below we shall discuss various electronic arrangements which perform this function of condenser discharge.

The second point referred to above, is that, owing to the curved nature of the con-

condenser charging graph, a non-linear trace (as it is called) would be produced on the screen with the result that the picture would be expanded on the left of the screen and compressed together on the right. This difficulty may be overcome in several ways. One way, would be to replace the resistor, through which the condenser charges, by some "constant-current" device, such as a pentode valve as shown in Figure 12A. To understand the function of the pentode, the reason for the non-linear rise in condenser voltage, when charging through a fixed resistor, should be understood. As the condenser voltage rises, the voltage across the resistor correspondingly falls. This results in a decrease in the current flowing through R. ($I = \frac{E}{R}$). It is this current which is responsible for the condenser charge. Hence as time progresses, the charging current, and therefore the rate at which the condenser charge increases, falls off, as shown by the curve of Figure 11. Now it is a well-known fact that the anode current of a pentode valve remains substantially constant for a wide variation of voltage applied between anode and cathode. In Figure 12A the resistor has been replaced by the anode circuit of a pentode. The grid and screen potentials are fixed at constant values by means of separate sources of e.m.f., Eb and Es. As C becomes charged from the source E, the voltage across the pentode progressively decreases, as explained for the resistor. Despite this reduction in voltage across the pentode, however, the condenser charging current flowing through it remains constant. As a result the condenser voltage rises in a uniform manner, as shown by the curve of Figure 12B.

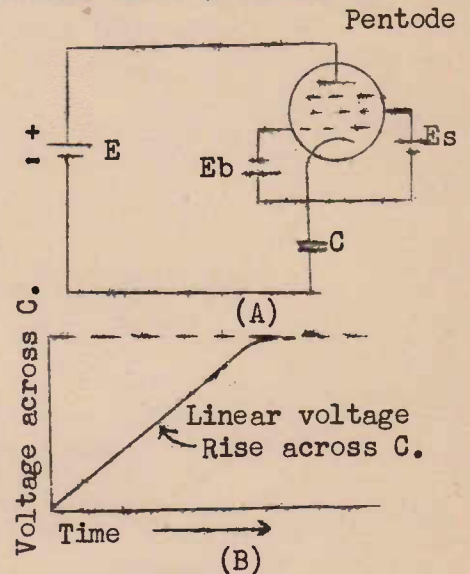

FIGURE 12.

This method of obtaining a linear "trace" has the disadvantage of introducing two extra tubes (one for each saw-tooth oscillator) into the receiver. A second method, using an ordinary resistor as in Figure 11A, is to restrict the rise of condenser voltage to a small fraction of the full applied e.m.f. Referring to the graph of Figure 11B it will be observed that the early part of the charging curve is, for all practical purposes, straight. Suppose, then, that the discharging device used is adjusted to discharge C when the voltage has risen to the point Y instead of X (Figure 11B). The voltage suddenly falls to zero and a new cycle commences. It is found that if the condenser voltage is limited to about one-tenth of the applied e.m.f. (E) a substantially linear saw-tooth wave will be obtained.

The disadvantage of this method is that the amplitude of the saw-tooth voltage obtained is small. The amplitude required for scanning purposes may be calculated by reference to the deflection sensitivity of the C.R.T. used. If this figure is given as 0.5 mm. per volt, it means that a voltage of 1 volt applied between a pair of deflection plates will cause a spot displacement of 0.5 mm. If the screen is 20 cms. (200 mms) across we shall require $200 \div 0.5 = 400V$ for full deflection. In other words a saw-tooth voltage of amplitude 400V must be generated. If linearity is obtained by limiting the condenser voltage to $\frac{1}{10}$ th of the supply voltage, the latter would require to be 4,000V. This is a very wasteful method of obtaining full deflection. A better way would be to use a supply voltage of, say, 400V, producing a saw-tooth wave of amplitude 40V, and then to follow the saw-tooth gen-

erator by an amplifying stage of stage-gain 10.

THE GAS FILLED TRIODE.

The gas filled triode is the first of the devices we shall describe to perform the function of periodically discharging the condenser when its voltage has reached the required value.

The gas filled triode is actually a "soft" valve, i.e. a valve into which a trace of gas has been purposely introduced before sealing off. The valve goes by many other names -- e.g. gas-filled relay, gas valve, gaseous discharge valve, thyatron etc.

The tube contains a cathode, anode, and grid, although the function of the latter is quite different from the control grid in an ordinary triode.

When the cathode is heated, the electrons emitted collide with the gas particles and ionise them, as we saw in the case of the gas-focussed cathode ray tube. The positive ions move in the direction of the more negative cathode and neutralise the negative "space-charge" which normally exists in the anode-cathode space. As a result the impedance of the valve is very much lower than that of an ordinary triode being only a few ohms, and the anode current when the valve is ionised is very heavy, being only limited by the cathode emission.

If the grid is maintained at zero potential, and the anode potential of a gas filled triode is gradually increased from zero, it is found that, at first, no current flows through the valve. When the anode potential has reached about 20 or 30V the gas becomes ionised, and a heavy anode current suddenly flows. The purpose of the grid is not to control the anode current, but to determine the anode voltage at which the discharge takes place. For example if the grid potential is maintained at say $-5V$, instead of at zero, the anode potential may have to be increased to 100V before the tube "strikes", i.e. ionisation occurs and anode current flows. Once ionisation has taken place any variation in the grid bias will have no effect on the value of anode current.

The most important point in the operation of a gas filled triode is the difference between "ionisation" and "de-ionisation" anode potentials. While it may be necessary to increase the anode voltage to, say, 100V (depending upon the fixed value of grid bias used) before ionisation occurs, and anode current flows, this potential may be decreased practically to zero before the current ceases. The cessation in anode current is due to the fact that, at some very low value of anode potential (the "de-ionisation" value) negative electrons combine with positive ions to produce neutral gas atoms.

The use of a gas filled triode in generating saw-tooth voltages is shown in Figure 13.

The R.C charging circuit is connected directly across the supply (H.T.) voltage. The gaseous discharge tube is across the condenser, which it periodically discharges as explained below. A constant negative voltage (bias) is applied to the tube's grid through the resistor R_g . The operation is as follows. When the H.T. is switched on the charging of C through R commences. The output from the circuit

is taken from across the condenser. Hence as C charges, the output voltage rises as shown by "ab" on the graph. As the voltage across C rises, the tube's anode

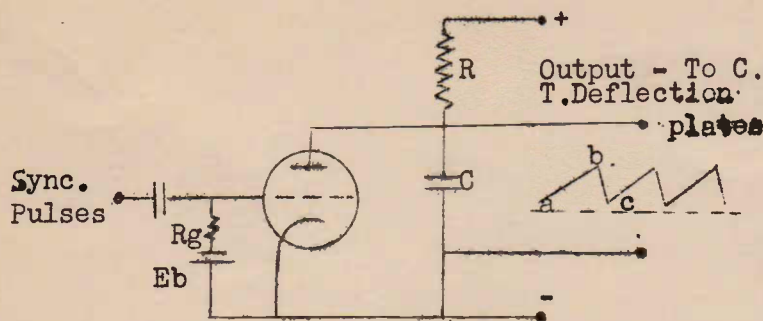

FIGURE 13.

discharge suddenly ceases and C commences to charge again. In this way a series of saw-tooth voltage cycles are traced out, as shown by the graph. Note that the gas-tube acts as an automatic switch, discharging C periodically when the voltage across it has reached a certain value.

It is important to observe the function performed by the grid. The potential on the latter only determines the value of anode potential (which equals voltage across C) at which the sudden discharge occurs. The grid potential has no effect either upon the value of discharge current, or upon the potential to which the anode must fall before the discharge ceases (the "de-ionisation" potential). It is obvious that, by altering the grid bias, the condenser voltage at which discharge occurs, may be adjusted. In other words alteration to grid bias results in a control over the amplitude of the saw-tooth wave generated. In practice this bias is adjusted so that the condenser voltage can only rise to about one-tenth of the supply voltage. When this is done the saw-tooth wave will be substantially linear, as already explained.

The frequency of the oscillations generated is determined mainly by the time-constant of the R.C. combination, since the latter determines the rate of condenser charge, and therefore the time taken for each cycle. By arranging for variation in C (e.g. by using a number of condensers together with a selector switch), or variation in R (by using a rheostat) the frequency of the oscillator may be adjusted over a given range.

It should also be observed that any alteration to the amplitude of the saw-tooth voltage, will also cause some change in frequency. For example, if the amplitude is increased, by increasing the grid bias negatively, each cycle will occupy a longer period of time and the frequency is therefore decreased.

In practice the grid bias is frequently obtained by means of an adjustable cathode resistor (e.g. a 500 ohm wire-wound resistor) heavily by-passed by means of a large condenser (e.g. 25 mfd. electrolytic). This condenser acts as a reservoir, maintaining a current through the resistor, and therefore negative bias, during the periods when no current flows through the valve (i.e. when the charging process is going on).

SYNCHRONISATION OF THE OSCILLATOR.

When used as a television receiver scanning generator, the oscillator frequency

is adjusted approximately to the correct value (line or frame, as the case may be) by the choice of R and C. The exact frequency is maintained, and each cycle is commenced at the precise moment required, by utilising the synchronising pulses coming from the sync. pulse separator.

Referring back to Figure 13, it will be observed that provision is made to "inject" these pulses onto the tube's grid via a condenser.

Providing the generator is working at approximately its correct frequency, the condenser (and therefore anode) potential will be nearing the discharge (ionisation) point when the sync. pulse arrives on the grid (See Fig.14). The effect of a positive sync. pulse is to reduce momentarily the negative grid bias. This in turn reduces the tube's ionisation potential. Since anode potential should, at this instant, be nearing ionisation potential, the net effect will be that the

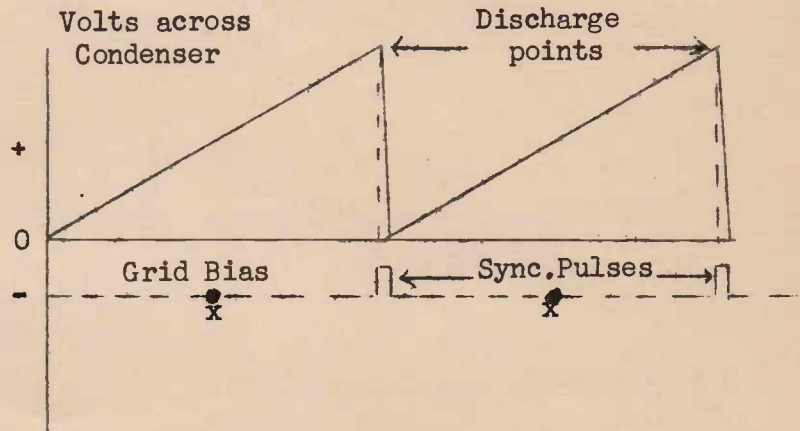

FIGURE 14.

sync. pulse will immediately initiate the discharge. In other words the sync. impulse automatically discharges the condenser at the end of each line or frame, and so causes the next line or frame to commence at the correct moment.

Earlier in the lesson it was stated that in the intervals between frames the horizontal pulses occurred at double the line frequency. It was further stated that the pulses occurring at the half-line points would not interfere with the scanning of the line scanning generator. The reason may now be understood. Referring to Figure 14, pulses occurring at the points marked X, could have no effect on the tube's operation. At each of these points the anode potential is still well below the normal ionisation point, and such pulses could have no chance of reducing the latter sufficiently to cause a discharge through the valve. Only those pulses occurring at whole-line periods, when the ionisation potential has nearly been attained, can therefore produce synchronisation.

USE OF "HARD" TUBES FOR CONDENSER DISCHARGE.

Due to the irregularities which occur in the "de-ionisation" process in a gas filled tube, and also due to the fact that this process requires some small, though appreciable, time to complete, this type of "saw-tooth" generator tends to be unstable, particularly when operating at high-frequencies. Despite this, however, the tube has been found to operate quite satisfactorily for both line and frame scan. generators in England. In America, on the other hand, other methods of automatically discharging the condenser were sought. Realising the precise manner in which the ordinary hard vacuum triode may be controlled engineers there decided to abandon the gas filled tube and to adopt the common triode for the purpose.

Now, as we know, the flow of current, or lack of it, through an ordinary triode, must be controlled externally by application of voltages to its grid. In the case of a "hard" tube, anode current flows while there is any potential on the anode,

provided that the grid potential is not more negative than the cut-off point. If the negative grid potential is made to exceed this cut-off point, absolutely no current flows, and the tube acts as an open circuit.

Utilising these principles the triode may be adapted to function as a discharge switch for the condenser in an R.C. charging circuit. The method is illustrated in Figure 15. Here R.C. is the charging circuit, connected across the H.T. supply. The triode is connected across C as shown. The valve is biased negatively, well beyond cut-off, so that no current can normally flow through it. If the circuit is left to itself, let us see what happens. C gradually charges up through R from the source. As the voltage across C increases, so does the anode potential of the valve. Now, since the negative bias on the grid of the latter is sufficient

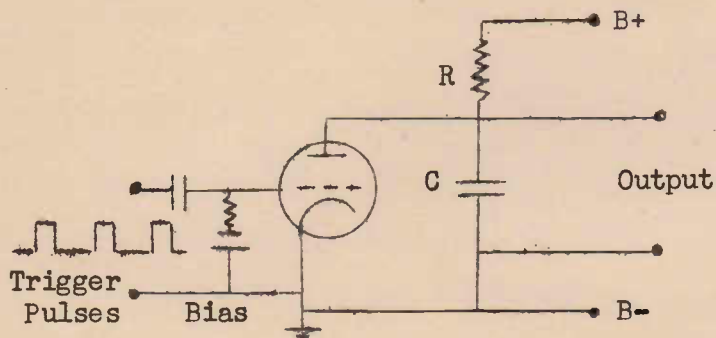

FIGURE 15.

to ensure cut-off for all likely anode potentials, no discharge of C through the tube can occur. Hence C will finally charge up to the full supply voltage, and no further action will occur.

Suppose, however, that sharp regularly occurring pulses, of high amplitude and short duration, are applied from some external source to the grid, as shown in Figure 15. The effect of a large amplitude positive pulse is to momentarily cancel the negative bias, and to allow a heavy surge of anode current to flow, as shown in Figure 16. This means, that, for the short period that each pulse remains on the grid, the valve acts as a very low resistance (virtually a short-circuit) across the charging condenser of Figure 15.

The net result is shown in Figure 16. The condenser charges in the absence of a pulse from the grid. When a pulse arrives the valve becomes conducting, and the condenser is rapidly discharged. When the pulse passes, the valve again becomes in effect an open-circuit (due to cut-off bias) and C commences again to charge through R (Figure 15).

Thus we see that a "hard" valve used to discharge the condenser does not act automatically as does the gas filled triode. To imitate the action of the latter we must apply to the triode pulses from an external source. These pulses are called "trigger" pulses, since they imitate the discharge action. A separate valve used to supply these trigger pulses is sometimes called the "triggering" valve.

IMPULSE GENERATORS.

Whence do we obtain the regularly occurring pulses, necessary to cause the circuit of Figure 15 to generate a series of saw-tooth waves? It might be thought at first that these could well be the sync. pulses emerging from the appropriate sync. pulse separator. These signal sync. pulses, however, would vary in amplitude

with the signal received, and normally would be of insufficient amplitude and sharpness for the purpose. Furthermore, if we relied upon those for operation of the generator, such operation would only take place when an actual signal was being received. In the absence of a signal the scanning generators would be inoperative, and the scanning pattern would disappear. This is undesirable, because the stationary spot on the screen might result in a "burn" to it, destroying the normal fluorescence. What we require is a "pulse generator", producing a regular series of large pulses of constant amplitude and short duration. The incoming sync. pulses could then be used simply to synchronise the generator in a manner similar to that described for the gas filled tube.

There are many types of pulse generators, but we shall only describe two types -- (1) The Blocking Oscillator and (2) The Multivibrator used together with an R.C. Differentiating Circuit. We choose these two because they appear to be in most common use, they are among the most reliable, and lastly, most other types may be regarded as modifications of them.

THE BLOCKING OSCILLATOR.

More fully described as the Single-Cycle Blocking Oscillator, this type of Impulse Generator is illustrated in

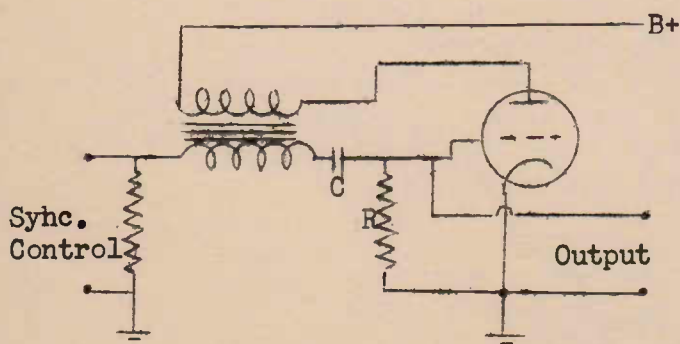

FIGURE 17.

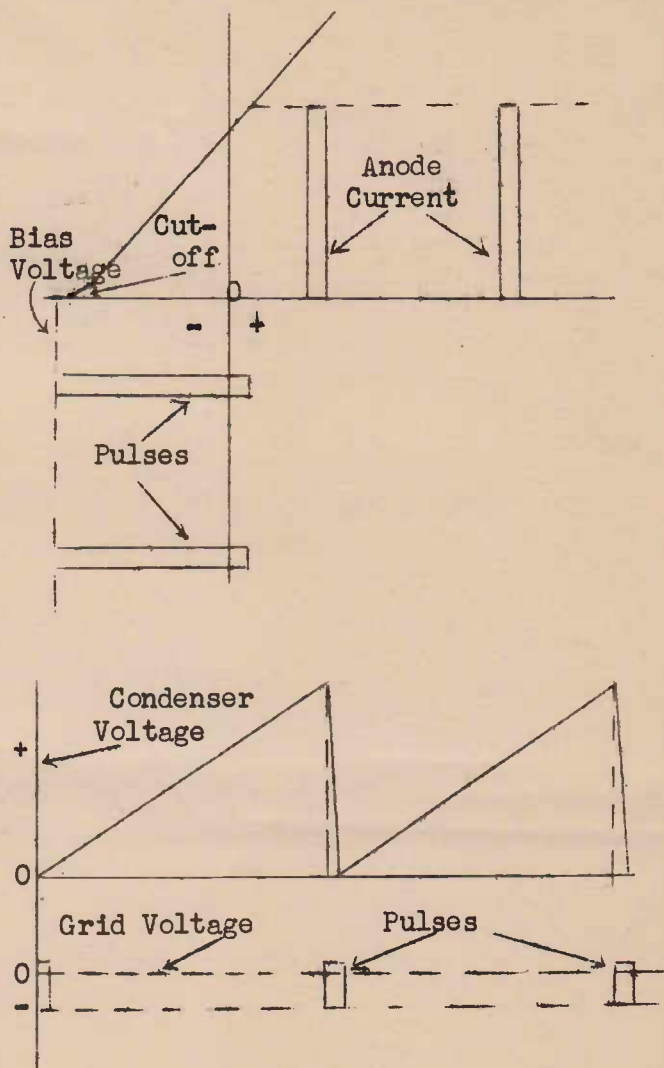
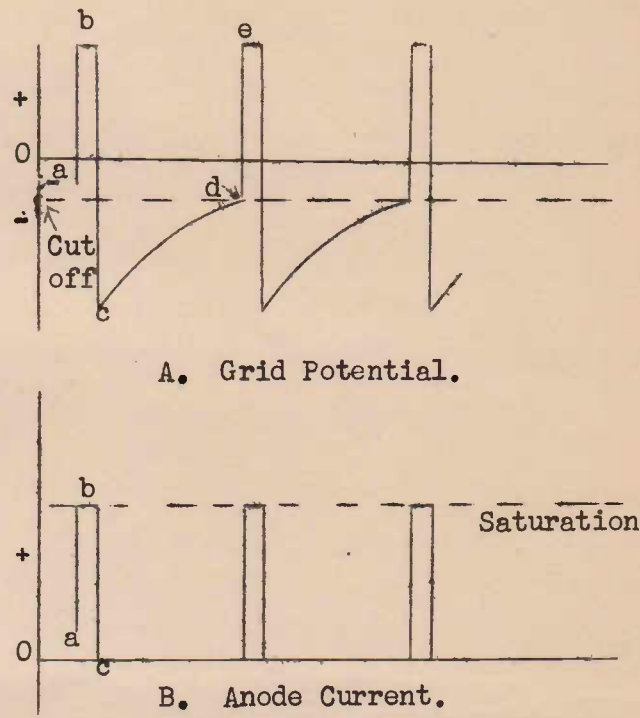

FIGURE 16.

figure 17. The circuit resembles an ordinary "feed-back" oscillator for generation of sine-waves, except that the coupling between plate and grid circuits is very "tight". An iron-cored transformer is used, the coefficient of coupling being practically unity.

The operation is as follows: when the supply voltage is switched on the circuit begins to oscillate in the ordinary way, by virtue of the coupling between anode and grid through the transformer T. Suppose that the oscillation starts with the grid at some negative point, (see

point "a" Figure 18A,) and going positive. This causes an increase in anode current, which in turn induces a "feed-back" voltage in the grid coil of the transformer. The sense of the windings of this transformer are such that an increase in (anode) current through the primary induces a positively going voltage on the grid. This increase in grid voltage causes a further increase in anode current, resulting in a still more positive voltage on the grid. The net result is that, in an extremely short period of time the grid is driven to a large positive potential with respect to cathode (see "a.b" Figure 18A), while the plate current increases to saturation (see "a.b" Figure 18B). Since the plate current cannot further increase, the positively going feed-back voltage on the grid will now disappear. At the same time the grid will be collecting electrons from the cathode, because of its positive potential. This grid current will very rapidly charge up the condenser C (Fig. 17), the right-hand plate being negative. The grid thus finds itself suddenly driven negative well beyond cut-off -- see "b.e" Figure 18A. The anode current will accordingly fall suddenly from saturation value to zero -- see "b.c" Figure 18B.



A. Grid Potential.

B. Anode Current.

FIGURE 18.

Now the grid potential will remain negative while the charge on the grid condenser persists. The only path available through which C may discharge is by way of the grid leak R. This discharge will be comparatively slow since R is large (i.e. the time-constant R.C. is comparatively long). As C discharges through R, the grid potential "relaxes" from point "C" towards "d" (Figure 18A), according to the discharge curve shown. During this period, since grid potential is still more negative than cut-off (dotted line) anode current remains at zero.

As soon as the grid potential reaches and just passes point "d" (Figure 18A) anode current commences to flow. The increase in anode current produces, by feed-back, a further positive (or less negative) voltage on the grid, this, in turn, resulting in a further increase in current. Therefore, as before, as soon as point "d" is reached, grid potential virtually jumps to the very positive value "e". The process is then a repetition of the actions already described.

It is necessary that the oscillatory circuit comprising the transformer inductance and distributed capacities, be highly damped so that oscillations in the coils will abruptly cease when the grid is driven negative.

Referring to Figure 18A it will be observed that on the grid (forgetting the negative potentials) a series of short duration positive pulses are produced. These form the generator's output, and are used to "trigger" the discharge valve in the sync. generator, as previously described.

The rate of repetition of the pulses depends upon the time taken for the grid

condenser to discharge through the grid-leak to the valve's cut-off potential. Hence the "pulse repetition frequency" will depend mainly on the time-constant $R \times C$ (Figure 17). R and C have comparatively high values (long time-constant, and therefore low repetition frequency) in the vertical (frame) deflecting circuit, and smaller values for the horizontal (line) circuit.

SYNCHRONISING THE BLOCKING OSCILLATOR.

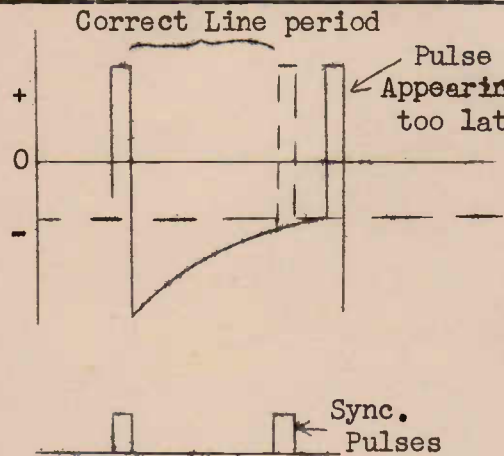

The signal sync. pulses are applied, for timing purposes to the grid of the valve as shown in Figure 17. The synchronising action may be understood by imagining that the pulse generator is running at too low a frequency, i.e. the time between generated pulses is too long, as illustrated in Figure 19. If this state of affairs exists the discharge of C through R (Figure 17) is too slow, and by the time the second sync. pulse shown in Figure 19 arrives the grid potential has not quite reached the cut-off level at which plate current commences to flow. The effect of the positive sync. pulse, however, is to immediately lift the grid potential to this cut-off level, thus initiating

FIGURE 19.

the next generator pulse (as shown by the dotted line in Figure 19) before it would otherwise occur.

THE MULTIVIBRATOR.

The circuit of a simple multivibrator may best be visualised by regarding it as a two-stage resistance-capacity coupled amplifier, in which the output from the plate of the final valve is applied back to the input (grid) of the first.

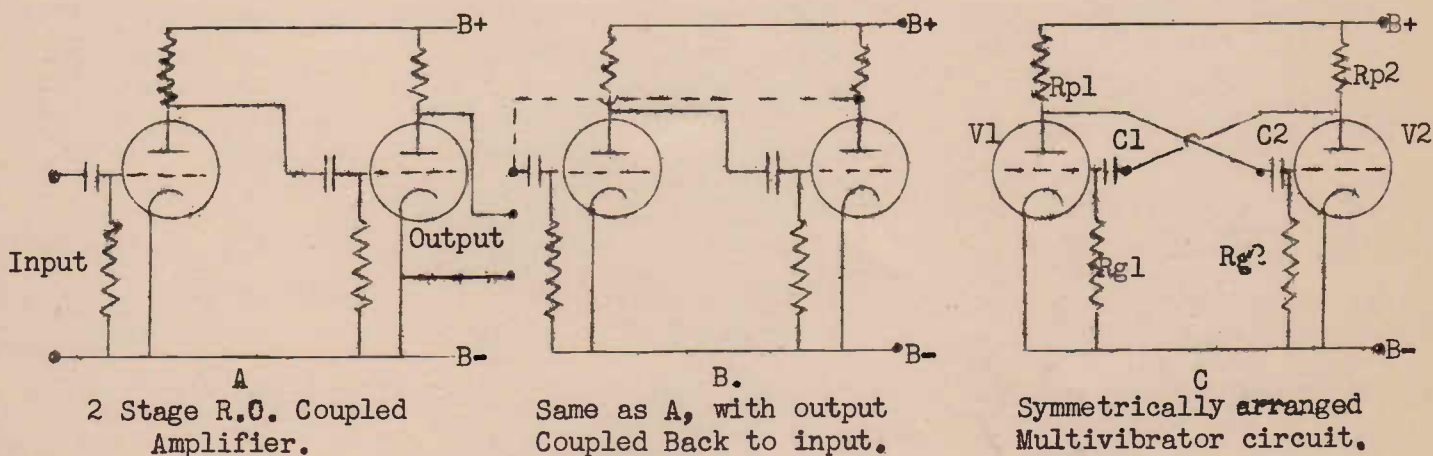

FIGURE 20.

The development of the circuit is shown in stages in Figure 20. The circuit at (c) is identical with that at B, except the method of drawing it brings out more clearly its symmetrical or balanced characteristic.

In the explanation of the operation of the circuit which follows, we shall use the

following symbols for brevity:-

Vg1 = Voltage on grid of 1st valve.
Val = " " anode " " "
Ia1 = Anode current of " "
Vg2 = Voltage on grid of 2nd valve etc.

Suppose, at any moment the anode current of the first valve (Ia1), owing to some slight irregularity, increases slightly. This causes Val to fall a fraction. The decrease in Val is applied through C2 (Figure 20) to the grid of the second valve, with the result that Vg2 goes a little negative. Hence Ia2 is reduced, causing a rise in Va2. This rise in Va2 is applied through C1 as a positively going voltage on grid of 1st valve (i.e. an increase in Vg1). The effect of this is to cause Ia1 to increase still further. The important point is, that any small change in current or voltage at any point in the circuit gives rise to a series of changes which result in a further and larger change at the given point. In the case cited an initial small chance increase in Ia1 initiates a series of cyclic changes around the circuit with the result that Ia1 is almost instantly increased to saturation value. At the same time Vg1 is driven very positive, and hence grid current flows in the first valve. This grid current charges condenser C1, the negative charge on its left-hand plate (Figure 20C) then driving the grid very negative, well below cut-off.

Thus we find V1 in a state of cut-off, while V2 is conducting heavily. The anode potential of V1 (Val) will be at full supply value, while Va2 will be at some lower value, due to the flow of current through Rp2 causing a voltage drop across the latter.

Now V1 will remain cut-off for some appreciable time, since its negative grid potential can only be reduced by the comparatively slow discharge of C1 through Rg1 (Figure 20C). (The time constant Rg1 X C1 is fairly long.) When the negative potential on the grid of V1 has been reduced to the cut-off value, the first small increase in Ia1 will give rise to a series of rapid changes around the circuit whose net effect is to drive the second valve into a cut-off condition. V2 will now remain non-conducting, with V1 conducting normally, until C2 has had time to discharge sufficiently through Rg2.

The important point which emerges from the above approximate description of the circuit's operation is that, at any given moment, one valve is cut-off, while the other is conducting, and that this state of affairs is periodically and abruptly reversed. Considering any one valve, the anode current will vary as at A, Figure 21, varying alternately between a normal value and zero. The corresponding anode potential is shown at B in the same figure. This potential alternates between full supply value or B+ (when the valve is cut-off) and some lower positive value (when the valve conducts).

The output of the multivibrator is normally taken from the anode of either valve. Note that this output voltage is one of square wave-form. Actually such a wave-form is only obtained from a symmetrical circuit (i.e. when the circuit components of one valve are equal to the corresponding components of the other valve), and also when the plate load resistors are small in value compared with the grid leaks

(See Fig.20C). Waveforms of many varieties may be obtained by using unsymmetrical circuits and by taking different values for resistors and condensers.

The frequency of the square-wave illustrated will depend upon the time that each

grid is held below cut-off, and this in turn will depend mainly upon the time-constants $Rg1, C1$, and $Rg2, C2$ (Figure 20C).

It now remains to convert the square wave obtained from the multivibrator to a series of pulses of short duration in order to "trigger" the discharge valve.

This is achieved by applying the square-wave voltage from the anode of one of the valves of the multivibrator across an R.C. differentiating circuit, as shown in Figure 22A. The final output taken across

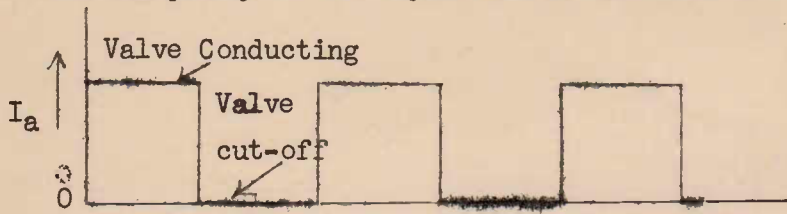

(A) ANODE CURRENT

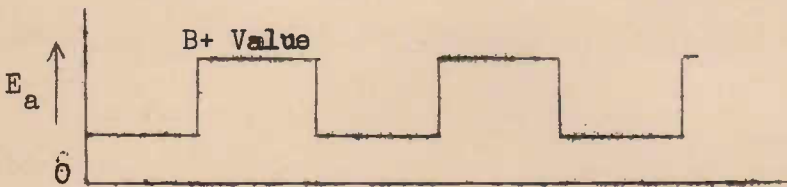

(B) ANODE VOLTAGE

FIGURE 21.

Rd will be a series of sharp pulses as shown.

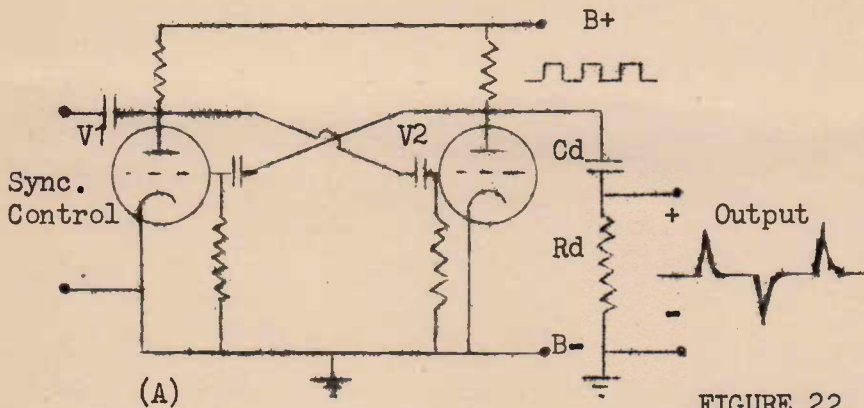

(A)

FIGURE 22.

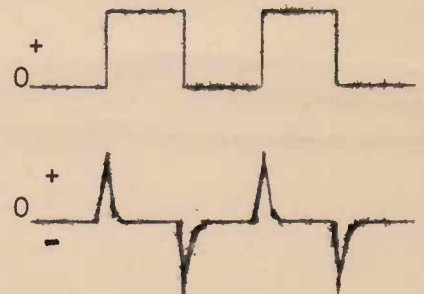

(B)

in voltage) of the square-wave produce positive pulses, while the "trailing" edges (i.e. the falls in voltage) of the square-wave result in negative pulses (see Fig. 22B). Actually only the positive pulses are used for triggering the discharge valve.

SYNCHRONISING THE MULTIVIBRATOR.

As shown in Figure 22A the signal sync. pulses are applied to the anode of V1. Actually this is equivalent to applying them to the grid of V2 (for 1st anode is connected to 2nd grid by the coupling condenser).

The synchronising action is very similar to that described for the blocking oscillator. If the multivibrator is running too slowly, a positive sync. pulse, arriving before a cycle has ended, lifts the grid potential to the cut-off level, thus commencing the new cycle earlier than would otherwise occur.

GENERATING SAW-TOOTH CURRENTS FOR MAGNETIC DEFLECTION.

The simple R.C. charging circuit together with its discharge valve, as described earlier, produces a voltage of saw-tooth wave-form. Such a voltage, however, if applied to an inductance coil (such as the deflecting coil of a C.R.T. designed for magnetic deflection) will not produce a saw-tooth current, which is necessary for linear deflection.

The reason for this lies in the inductive property of the coil. It may be shown mathematically (and verified experimentally) that a saw-tooth current will flow through a pure inductance (i.e. no resistance) only when a square-wave voltage is applied across it.

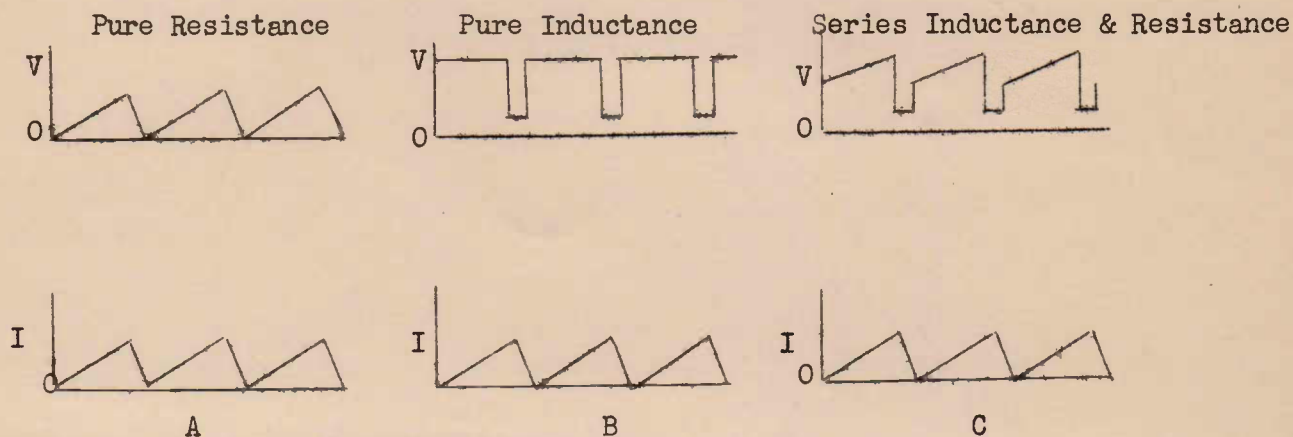

FIGURE 23.

applied across it.

In Figure 23 at A is shown a saw-tooth voltage producing a saw-tooth current through a pure resistance. At B is the case for a pure inductance. Here, in order to obtain a saw-tooth current, the voltage must have the square-wave form shown. Now any practical coil contains inductance in series with resistance. The voltage required to produce a saw-tooth current through such a combination will therefore be a combination of the saw-tooth voltage of A and the square-wave voltage of B. Such a combination is shown at C (Figure 23). The saw-tooth part of this voltage may be regarded as overcoming the resistance of the coil, while the square-wave part overcomes the inductive effect.

A voltage having the wave-form shown in the upper diagram of Figure 23C may be generated by modifying the simple R.C. charging circuit by including an extra resistance.

Figure 24 shows a gas filled triode circuit to which this modification has been made. Comparing this diagram with that of Figure 13 it will be noted that an extra resistor R2 has been added. The output is now taken from across the series combination R2 and C.

At an instant when the tube becomes non-conducting, the supply voltage is suddenly applied across R1 and R2 and C in series. Now we know that when a voltage is suddenly applied across an R.C. combination, the full voltage instantly appears across the resistance, and none initially appears across the condenser. If the

resistance in the circuit is divided into two parts, the initial voltage will be

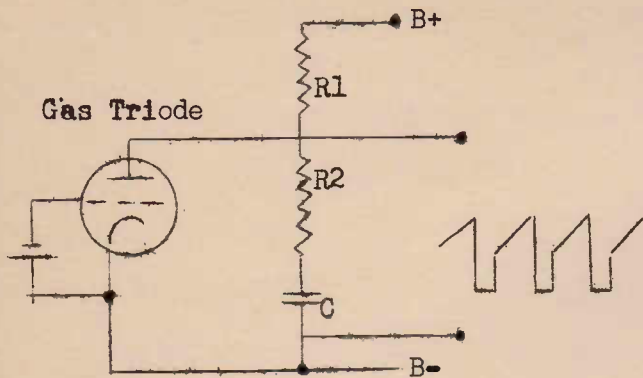

FIGURE 24.

divided between them in proportion to their values. For example, if in Figure 24, R2 is one-quarter of R1 + R2, then one-quarter of the supply voltage will initially appear across R2, and therefore in the output, when the cycle of oscillation commences. This abrupt rise in voltage is represented by "ab" in Figure 25. Now as time goes on the potential across C rises in the more or less linear manner as shown by "b.d". This further rise, towards the full supply voltage, will, of course, appear in the output also, since the latter is taken across C as well as across R2 (Figure 24).

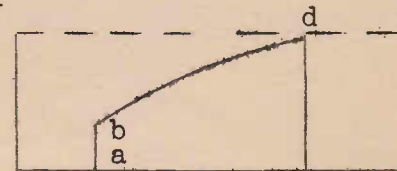

FIGURE 25.

By choosing suitable values of R1 and R2 the output voltage from the scan generator may be modified to produce a current of saw-tooth waveform in any pair of deflecting coils.

DEFLECTION AMPLIFIERS.

The output from each scan generator is passed through an amplifying stage before application to the deflection electrodes.

In the case of electrostatic deflection, push-pull amplification is used, in order to obtain the large peak to peak output voltage required (400V and above) necessary for full deflection. Push-pull amplification also avoids a de-focussing effect on the beam which occurs when single valve amplification occurs.

In the case of electro-magnetic deflection a single valve output is used together with a step-down transformer to increase the current output. For full deflection the square-wave current must rise to a value of the order of 250 m.a.

T.FM & F. LESSON NO. 10.

EXAMINATION QUESTIONS.

- (1) Which receiver stage prevents the picture signal from entering the scanning generators? What would be the effect of picture signal impulses upon the latter?
- (2) Why is fixed bias unsuitable for a "clipper" circuit?
- (3) Why is the vertical (frame) sync. signal between any pair of frames broken up into a number of separate pulses?
- (4) State briefly the difference between a Differentiating and an Integrating Circuit.
- (5) Name two faults which could occur as a result of faulty scanning generator synchronisation?
- (6) What function does the grid of a gas-discharge tube perform?
- (7) How would you vary (a) the amplitude (b) the frequency of a saw-tooth generator, employing a gas filled tube.
- (8) What is the function of an Impulse generator in a television receiver? Name two types of Impulse generators.
- (9) What determines the frequency of a Blocking Oscillator?
- (10) If the line scan. generator of a receiver completely failed, what would you expect to see on the screen?

AUSTRALIAN RADIO COLLEGE

E.S. & A. BANK BUILDINGS, Corner CITY RD. and BROADWAY, SYDNEY

Telephones: M 6391 and M 6392

Post Lessons to Box 43, Broadway

This lesson sheet is published for the exclusive use of students of the Australian Radio College Pty. Ltd. (All rights reserved)



T.FM & F. LESSON NO. 11.

RECEIVER POWER SUPPLIES.

It is a much more complicated problem to provide sources of D.C. power for a television receiver than it is for an ordinary broadcast set. In the case of the latter we simply require a power unit whose purpose it is to convert the 240 V. A.C. from the mains into a supply of 200-300V D.C. for the "high-tension" (B+), a supply of (usually) 6.3V A.C. for the cathode heaters of the amplifier valves, and a supply of (usually) 5V A.C. for the rectifier filament. The student is familiar with the more or less standardised power unit which will fulfil these functions.

Now let us recall again the comparative complexity of the modern television receiver. In addition to the sound receiver section (see Fig. 1) we have the picture receiver proper, the scanning generator (time-base) section, and finally the C.R.T. itself. All of these sections, excepting the last mentioned, require two power sources -- one at about 250V. D.C. (the normal B+ supply) the other being a low-voltage A.C. (usually 6.3V) for the heaters. At first consideration it might be thought that an ordinary power unit, making use of a full-wave rectifier for the B+, and a single low voltage transformer winding for the heaters, could be used, without difficulty, to supply all these three sections.

A difficulty, however, arises in the large current out-put which would be required. The total number of valves involved may be many times that used in the ordinary broadcast receiver. Nevertheless, in the case of the smaller television receivers a full-wave rectifier

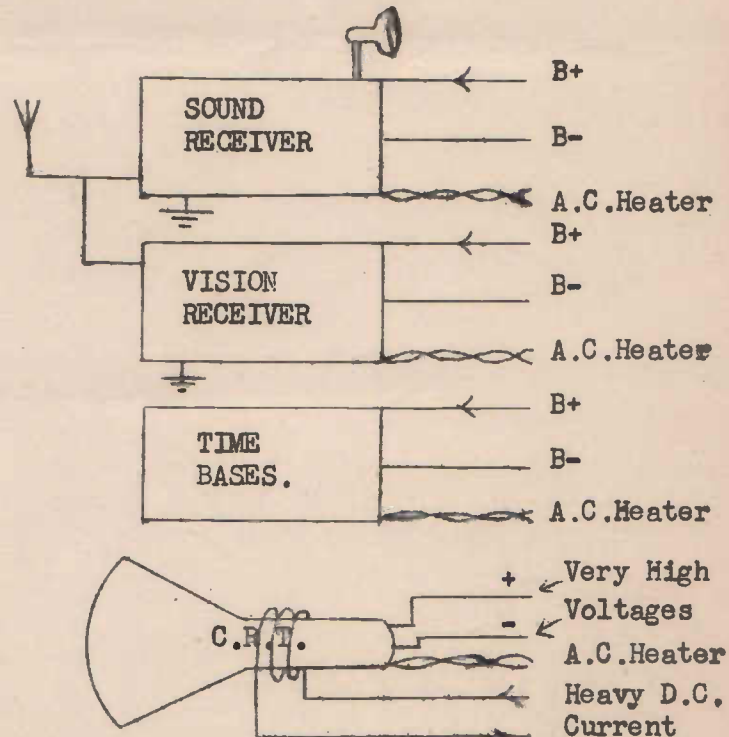

FIGURE 1.

(For Magnetic Focus Only)

tube such as the 5U4G, having an output drain of 175 m.a, used in conjunction with a suitable transformer, is adequate to supply the three receiver sections.

In the case of the larger receivers the difficulty may be overcome by utilising two full-wave rectifiers in parallel. This will, of course, providing the transformer is of sufficient current rating, double the available output current.

The power for the cathode-ray picture tube must be obtained from a separate source. Here we require a high D.C. voltage of at least 2,000V, but perhaps as high as 10,000 V (or even 25,000V for the projection-type tubes). In addition we want a low A.C. voltage (say 6.3V) for the C.R.T. cathode-heating. The latter must be provided from a separate transformer winding, when the heater is connected internally to the C.R.T. cathode. The reason is that the latter is not, in general at ground potential, (as are the heaters of all other valves). If heater and cathode of the C.R.T. are not internally connected, then, of course current may be drawn from the one heater winding supplying all other tubes. Finally, if magnetic focussing is used, we require a comparatively heavy direct current (100 -- 200 m.a.) for the focus coil. The latter is usually obtained by passing all, or part, of the low-voltage B+ supply through this coil.

It appears, then, that we shall require a dual-power-supply. The unit supplying the high voltages for the C.R.T, together with its heater current, is usually referred to as the "High-Voltage" supply. The other providing the high-tension (B+) at about 250 V. for all other tube, is known as the "Low-Voltage" supply.

POWER TRANSFORMERS.

It is possible to use but a single transformer for the two power units, all secondaries being wound, suitably insulated one from the other, on the same core. These secondaries will comprise: centre-tapped winding for the full-wave rectifier, low voltage heater winding, low voltage filament winding for filament of the full-wave rectifier (all these belong to the "low-voltage" power unit), and in addition, for the "high-voltage" unit, a winding of very many turns providing an A.C. voltage for rectification, and finally a low-voltage winding for the rectifier's filament. These windings are shown in Figure 2.

THE "HIGH-VOLTAGE SUPPLY".

The high-voltage power unit usually makes use of a half-wave rectifier (i.e. a single diode). Full-wave rectification requires a centre-tapped transformer winding, which is impracticable when operating at several thousands of volts. The difficulty lies in bringing out a centre-tap with sufficiently good insulation to prevent a break-down where it comes in contact with those turns of the winding which are at high-potentials. In any case half-wave rectification is quite adequate for the purpose since the current drain taken by the C.R.T. is extremely small.

The electron beam of the latter represents a current of only about one-tenth or so of a milliamp. A bleeder circuit of very high resistance, taking only one or two

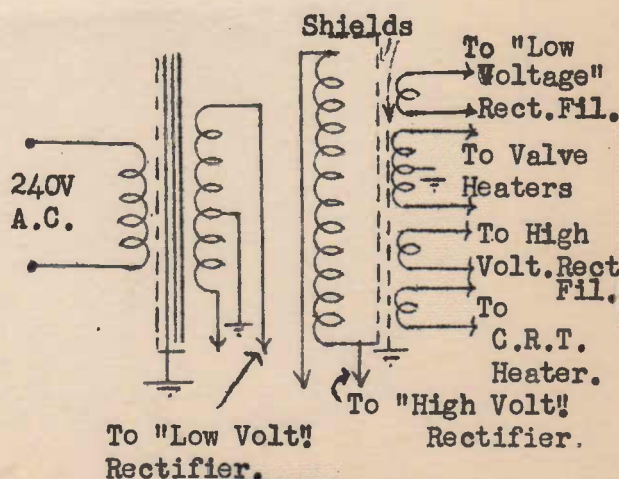
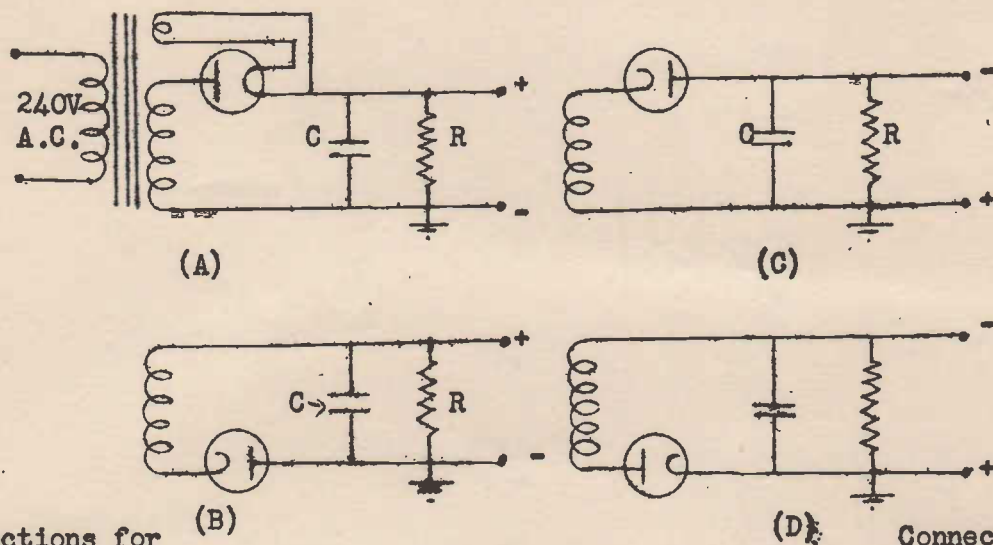

FIGURE 2.

milliamps is usually used. With such small currents required there would be but little point in using full-wave rectification.

HALF-WAVE RECTIFIERS.



Connections for Positive Output.

Connections for Negative Output.

FIGURE 3.
HALF-WAVE RECTIFICATION.

Figure 3 illustrates various methods of connecting a single diode to the secondary of a power transformer for half-wave rectification. In all diagrams but the first (A) the transformer primary, and the diode's filament winding, have been omitted. This has been done in order to bring out more clearly the simple theory of the circuits' operation. The secondary of the power transformer should be regarded as a source of alternating e.m.f, which is to be converted to a steady direct current. The diode acts as an almost perfect rectifier, i.e. a device which permits current flow in one direction only around the circuit.

Note the effect of the different connections shown in Figure 3. Circuits A and B produce a positive output voltage (with respect to ground) across R. Circuits C and D give a negative output. A slightly better filtering (smoothing) action is obtained in cases A and C compared with that obtained in cases B and D. When a positive output is required the connections are almost invariably made as in circuit A. When negative outputs, in respect to ground, are required, however, circuit D is often used in preference to that shown at C. Although a greater percentage ripple could be expected from circuit D, this arrangement has the advantage that the filament of the diode is at D.C. zero potential. The significance of this is that, in certain cases, the filament current for the diode may be taken from the transformer heater winding which is used for other values in the receiver. The heaters of the latter are, of course, always at ground potential. In the other circuits (A, B and C) shown in Figure 3 note that the diode filament is at a high D.C. potential (positive or negative) with respect to ground. Hence, in these cases, a separate rectifier filament winding, adequately insulated for high potentials, must be used.

RESISTANCE-CAPACITY FILTERING.

Since the average student is accustomed to power supplies utilising a choke

(inductance), together with one or more condensers for smoothing purposes, it will be well to explain briefly the operation of a resistance-capacity filter.

A resistor, (or even a series of resistors) is a much smaller, lighter and cheaper component than an iron-cored choke. It may well be asked, therefore, why resistance-capacity filtering is not used in the "low-voltage" power supply. The reason is connected with the fact that such power supplies are called upon to deliver comparatively heavy current drains. Now the choke, or resistor, whichever is used, must, for effective smoothing action, present a very great impedance to the A.C. "ripple" component, which it is desired to eliminate from the output. If a resistor is used this same high impedance (in this case pure resistance) will be presented to the D.C. component of the output as well as to the A.C. Hence it is seen that the D.C. drain from the rectifier will be limited to a very small value. This does not constitute a draw-back in the case of high-voltage power supplies used to operate cathode-ray tubes, since, as already pointed out, these tubes require only a fraction of a milliamp. for their beam currents.

In the case of the "low-voltage" power supplies, on the other hand, a current output of several hundred milliamps is usually required. This means that the D.C. impedance of the filter system must be comparatively low. At the same time we still require the high impedance to the A.C. ripple voltage. A choke may present an impedance of many thousands of ohms to the ripple frequency (100 cycles/sec for full-wave rectification), while its D.C. resistance may be only several hundred ohms.

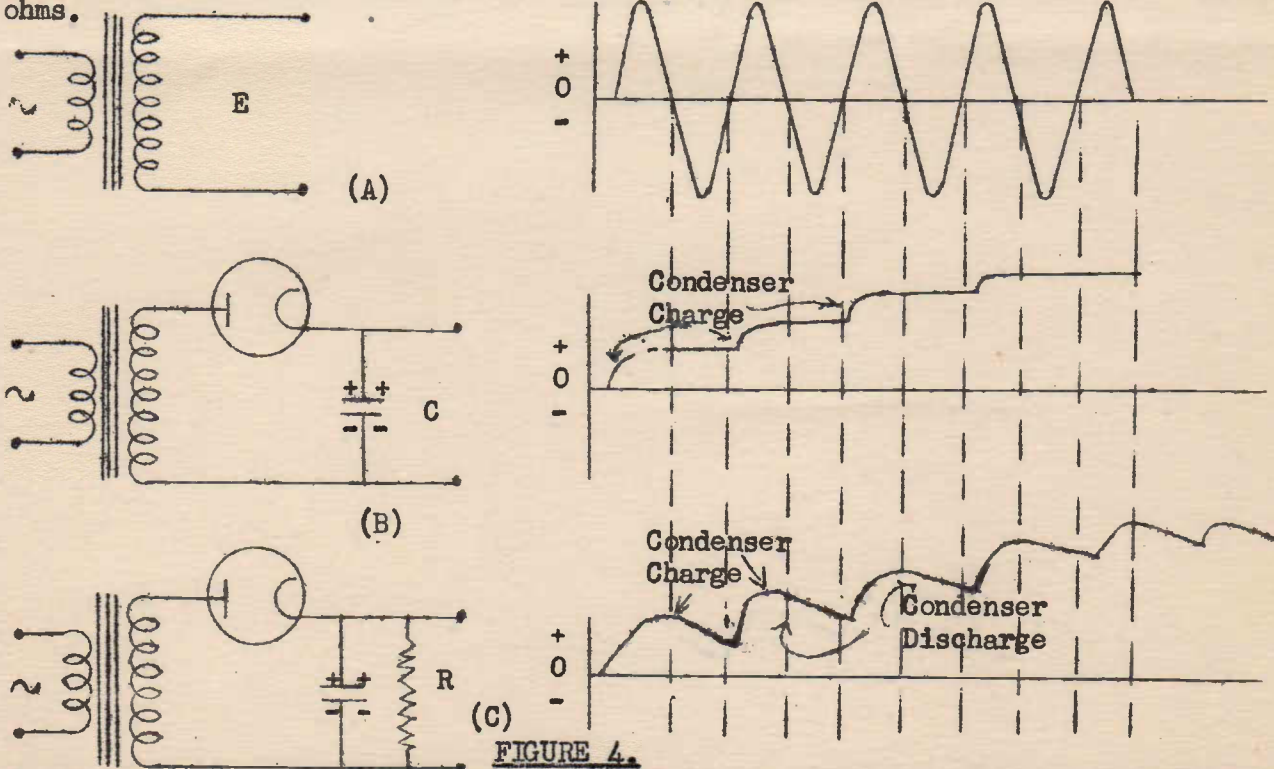

FIGURE 4.

The theory of the resistance-capacity filter may be simply explained as follows. An A.C. voltage, to be converted to a D.C. is obtained from the transformer secondary as shown in Figure 4A. At B we have shown a diode, in series with a condenser, connected across the secondary. The diode passes current only on the positive half-cycle of the voltage shown at A. Hence on these half-cycles the condenser C of Fig 4B will charge up. During the negative half-cycles the conden-

ser must retain its charge, since no discharge path is provided for it, the valve being completely non-conducting. After a few cycles (depending upon the transformer impedance and diode resistance which determine the charging rate) the condenser will become charged to a voltage equal to the peak voltage of the applied e.m.f. Thereafter the diode passes no further current, and the condenser remains charged. This charging process is illustrated in the graph of Figure 4B.

When a bleeder resistance is connected across C, as shown in Figure 4C, the condenser charges, as before when the diode conducts on the positive half-cycles of the A.C. voltage. During the negative half-cycles, when the diode is non-conducting, C discharges partially through R. This rate of discharge will depend upon the time-constant $C \times R$. If the latter is long compared with the period of one-half a cycle, the fall in condenser voltage will be very small during the time the diode is not conducting (see lower graph Figure 4). In any case the charge lost through R will be replaced by diode conduction on the peak of the next positive half-cycle.

The net result is a D.C. voltage which rises and falls with the applied e.m.f. This rise and fall constitutes the "ripple" voltage. Note that the frequency of the ripple equals that of the mains voltage (50 C/sec). (In full-wave rectification the ripple frequency is double the mains frequency). Note also that the amplitude of the ripple will be negligibly small provided that the time-constant $C \times R$ is long compared with the period of half one cycle of the A.C. (i.e. $\frac{1}{100}$ th of 1 second). This follows since the drop in condenser voltage due to discharge through R during a negative half-cycle will be very small.

VALUES FOR BLEEDER RESISTANCE AND FILTER CONDENSER.

The degree of filtering obtained depends, then, upon the time constant $C \times R$. For a given percentage ripple C may be large, and R small, or C may be small and R large. Since the cost of a condenser designed to withstand voltages of several thousands of volts increases faster than the capacity it is desirable to keep C as small as possible. On the other hand if C is made too small, R must be so large as to reduce the bleeder current to too small a value. The effect of this is to reduce the "regulation" of the power supply -- i.e. its ability to maintain a constant output voltage for varying load-currents. In a television receiver the load current of the high-voltage supply is the beam current of the C.R.T. The latter current varies with the video signal applied to the control electrode. A typical compromise is to choose a bleeder of total value 2 to 5 megohms, and a filter condenser between 1 m.f. and .3 m.f.d.

DOUBLE SECTION R-C. FILTER.

An improvement on the simple R-C filter described is to add an extra resistor R_f between the diode and the bleeder (R_b) and an extra condenser C_1 (See Fig. 5).

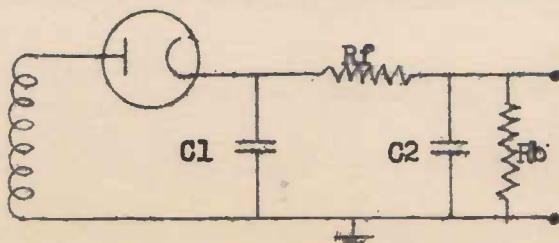

The action is as follows. C_1 charges on the positive half-cycles as already explained. On the negative half-cycles C_1 discharges (slightly) through R_f and R_b in series. Since R_b is usually about ten times as large as R_f , most of the discharge voltage, and therefore the ripple, appears across R_b , and is thereby

FIGURE 5.

applied across C2. This condenser is charged to the peak value of the discharge voltage, which in itself is partially filtered. The discharge of C2 can take place only through Rb -- the time constant $C2 \times Rb$ being long. Hence the output voltage, partially filtered by the RfC1 combination, is further smoothed by RbC2.

The advantages of the double-section filter, compared with the single-section, lie in the smaller values of capacity which may be used for the same degree of filtering. Typical values are .025 to .05 m.f.d for C1 and C2, about .5 meg. for Rf and 5 meg. for Rb. These condensers are very much cheaper than those of the order of .5 mfd. Again, the much smaller stored charges in the smaller capacities minimises the danger of severe shock. A disadvantage of the double section filter is that a slightly reduced output voltage is obtained, due to the voltage drop across Rf. This voltage drop is not effective in the output, which is taken across Rb only. An example will better illustrate this point. Suppose that Rf (Fig.5) is .5 megohms, and Rb 4.5 megohms. Rf is one-tenth of the total resistance between the rectifier cathode and ground. If the total voltage between the latter two points is 5,000 V, one-tenth of this, i.e. 500 V, will appear as a voltage drop across Rf. The remaining 4,500 V, appearing across Rb will represent the rectifier's output.

THE BLEEDER NETWORK.

The electron gun of a cathode ray tube requires several voltages of varying magnitudes, all being measured in respect to cathode. These different voltages are obtained by tapping off the required amounts from the total rectifier output. The bleeder, represented by Rb in previous diagrams, is therefore composed, in practice, of a series of resistors rather than a single component. One or more of these resistors is usually in the form of a carbon-type potentiometer, to allow a variable voltage to be tapped off for C.R.T. control purposes.

Perhaps the most usual arrangement is to establish the C.R.T. control electrode at ground potential, by connecting it directly to the lower (ground) end of the bleeder network, as shown in Figure 6. We are referring here, of course, to a rectifier producing a positive output. Resistors R1, R3 and R5 are of the ordinary fixed carbon type. R2 and R4 are potentiometers. Since no current flows in the control electrode circuit (just as no current flows in the grid circuit of an amplifying tube when negative bias is used), there will be no potential drop across Rg (Fig 6). In other words the D.C. potential of the control electrode is maintained at ground level. A variable tap is taken for the cathode at a higher point in the chain, i.e. at a point which is positive in respect to ground. This ensures that the control electrode is negative in respect to the cathode. The negative bias is varied by varying the positive potential (in respect to control electrode) of the cathode as shown. The resistor R1 ensures that some negative bias is always on the control electrode. Since the value of negative bias on the

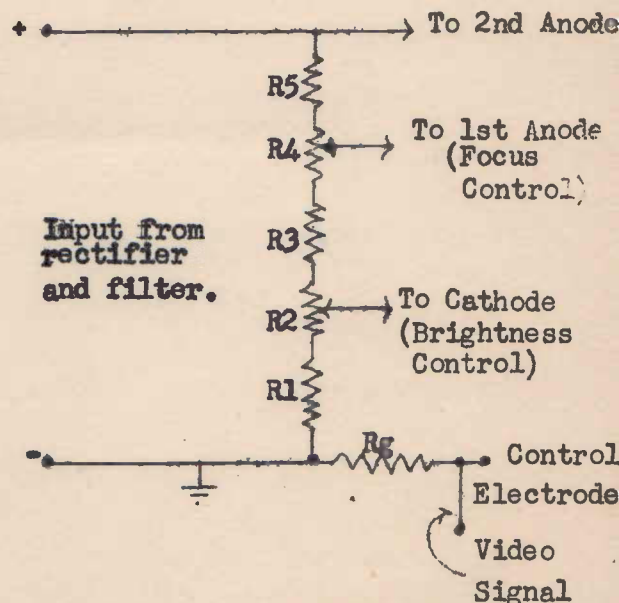

FIGURE 6.

control electrode determines the intensity of the electron beam, adjustments to R2 will vary the average brightness of the picture. R2 is therefore described as the Brightness Control.

The full positive output of the supply is applied to the second anode of the C.R.T. A lower positive potential is applied to the first anode, by taking a tap at a lower point down the bleeder voltage divider. This tap is from the moving arm of potentiometer R4 (Figure 6). Provision is made here for a variable voltage on the 1st anode for focusing purposes as explained under the section on cathode ray tubes. Hence R4 constitutes the Focus Control. This control, of course, determines the size of the scanning spot, and hence the quality of the picture. Since the correct setting of the focus control is, up to a point, a matter of individual taste, the knob, in some receivers is brought out to the front where ready adjustments may be made to it. Generally speaking, however, the focus only requires occasional adjustment, as when the receiver is first installed, or when the C.R.T. is replaced. For this reason most manufacturers regard the control as of the "pre-set" type, and therefore in most receivers it is accessible only from the back or chassis of the set.

The resistors R3 and R5 serve to limit the variable voltages which may be safely applied to the cathode (for bias) and to the 1st anode (for focus).

OTHER METHODS OF OBTAINING CONTROL ELECTRODE BIAS.

Instead of earthing the control electrode it is sometimes found that the cathode is at earth potential. With this arrangement it is necessary to provide some variable source of negative potential (with respect to ground). This is usually done by some method of back bias, usually in the negative lead of the low-voltage power supply.

A very common arrangement is to place the control electrode at the same potential as the anode of the final video amplifying tube, and to provide the negative bias by applying some more positive potential to the C.R.T. cathode.

The advantage of this arrangement is that the final video amplifier may be directly coupled (i.e. without the use of a coupling condenser) to the control electrode.

A typical circuit is shown in Figure 7. The low-voltage supply is of 300V, from which lower voltages are tapped off using a bleeder resistor R1, R2, R3. The full 300V. is used for high tension for all values except the final video amplifier 6V6, which is operated from a tap giving about 260V. for plate and one giving 75V for the screen. The low screen voltage is used to prevent the tube from drawing excessive current when no signal is applied to its grid. Note that this tube is operated without cathode bias.

The cathode of the C.R.T., is not at ground potential, but at some positive potential which may be varied from, say, 200V. up to 300V, the full B+ voltage. Since the control electrode is connected to the anode of the 6V6, its potential is below 260V. The net result is that control electrode is negative with respect to the cathode. The potentiometer R4, (which is in series with R5 across the low-voltage supply) provides a means of varying the C.R.T.'s control electrodes bias, and therefore constitutes the Brightness Control.

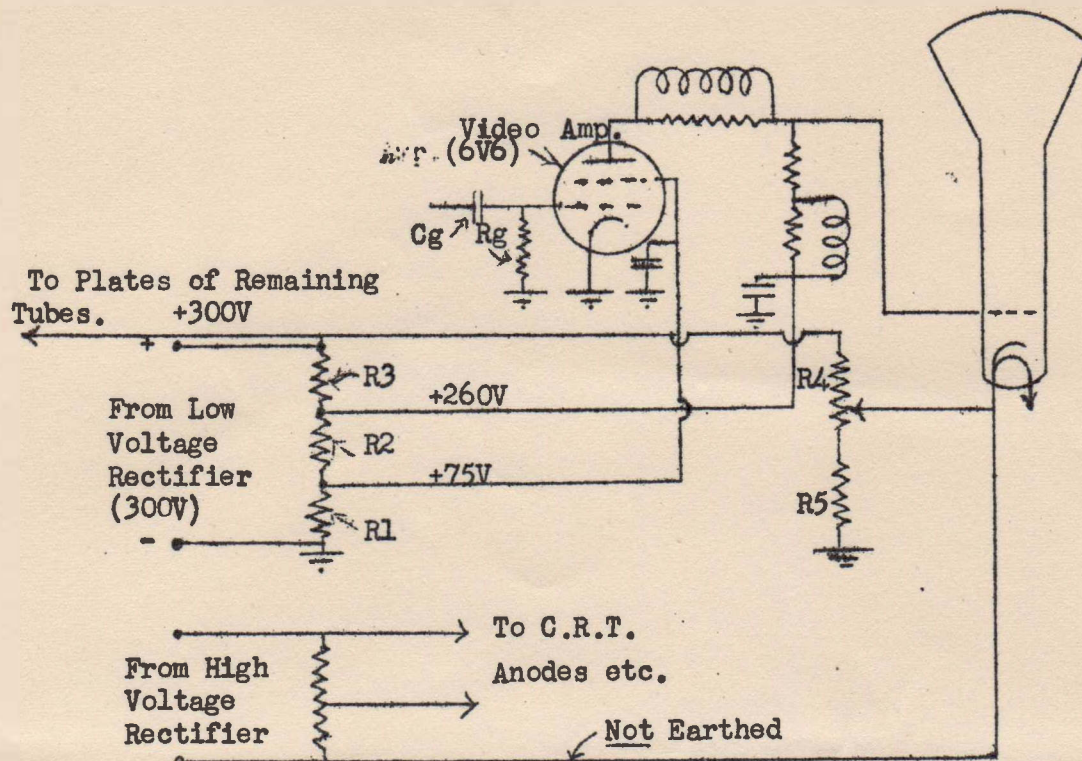

FIGURE 7.

A further interesting point concerning the circuit is that the negative side of the high-voltage supply is not earthed, but is practically at 300V.+, being connected, together with the C.R.T. cathode to the moving arm of the potentiometer across the low-voltage supply. In this way, the full high-voltage supply is applied between 2nd anode and cathode of the C.R.T.

It was stated above that the main advantage of this system, which operates the C.R.T.'s control electrode at a potential equal to that of the anode of the final video amplifier, is that direct coupling may be used for the latter's output. This greatly simplifies the problem of D.C. restoration. The D.C. component of the video signal is restored at the grid of the final amplifier. As shown, the tube (6V6 in Figure 7) is operated without cathode bias. When no signal is being received the video amplifier's bias is zero. As soon as the video signal is received the grid draws current, thus creating a negative bias which, if the grid condenser and leak (Cg and Rg) are of correct values, will be of such value as to maintain the grid potential always at the blanking level of the signal. In other words Cg, Rg and the grid circuit of the tube, acting as a rectifying diode, constitutes a simple D.C. restorer circuit. Since the plate of the amplifier is directly coupled to the control electrode there will be no further loss of the D.C. component.

INTER-CONNECTION OF HIGH-AND-LOW VOLTAGE SUPPLIES.

It is possible to augment the high voltage available for operation of the C.R.T. electron gun, by applying between final anode and cathode the total voltage of both high-and low-voltage power units. The manner in which this is achieved is

illustrated in Figure 8. Here the negative side of the high-voltage rectifier unit is not earthed, but is connected to the positive (output) lead of the low-voltage unit. The result is that the two outputs are effectively connected in series, so that the total voltage of the positive lead of the high-voltage circuit, measured in respect to earth, is the sum of the outputs of the two rectifiers. For example if the two outputs are 300V. and 2,000V., the potential of the high-voltage output lead (in respect to earth) is 2,000V. + 300V. = 2,300V. Actually the arrangement here is very similar to that of Figure 7. But in order that the increased high-voltage is effective in operating the C.R.T., the cathode of the latter must be earthed, as shown in Figure 8. The question of bias now becomes one of obtaining a negative voltage (in respect to ground) from some point in the circuit, for application to the C.R.T.'s control electrode. This may be accomplished by means of a back

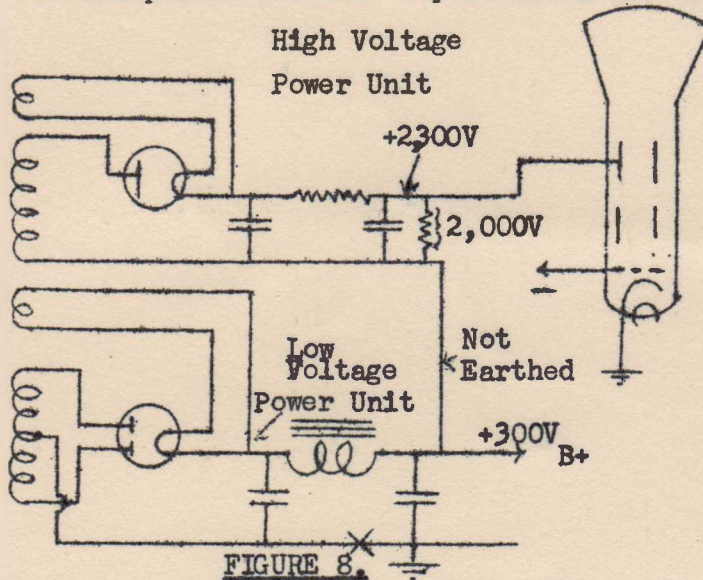

bias resistor included at point "X" in Figure 8.

FIGURE 8.

D.C. POTENTIAL APPLIED TO DEFLECTION PLATES AND "SHIFT" CONTROLS.

Referring still to the electrostatic type of C.R.T, we must now consider the D.C. (or average) potential at which the deflection plates are operated. So far in these lessons we have simply stated that an alternating voltage of saw-tooth wave form (from the scanning generator amplifier) is applied between each pair of plates, for horizontal and vertical movement of the beam.

These A.C. saw-tooth voltages are, of course, applied from the amplifiers through coupling condensers.

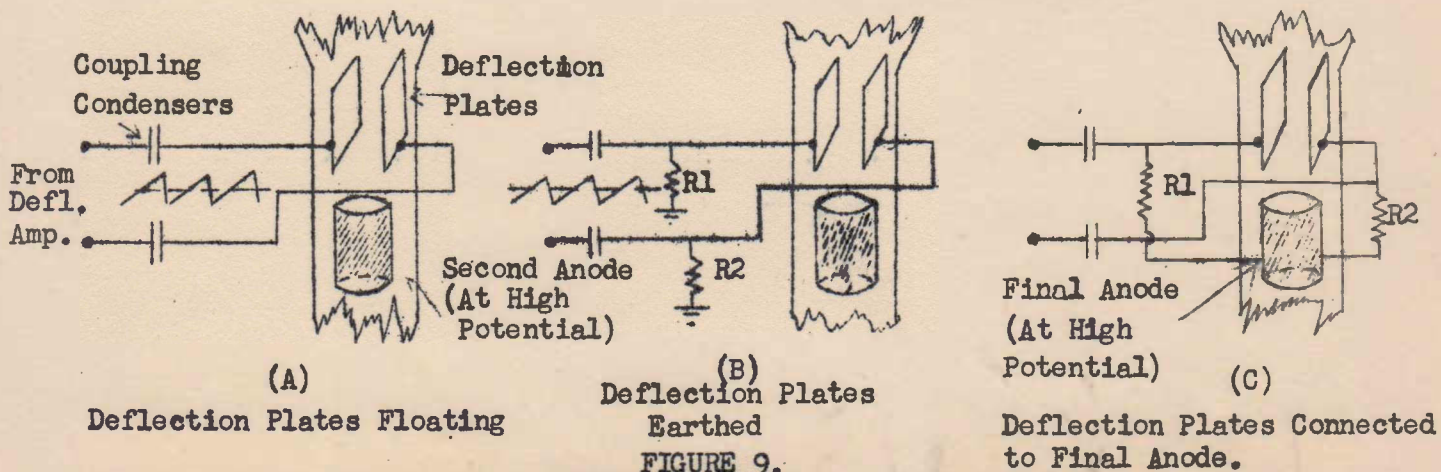

FIGURE 9.

As a general rule each of the deflection amplifiers (amplifying the saw-tooth

outputs from the scanning generators) is of a push-pull type, consisting of two valves, producing output voltages from their plates 180° out-of-phase with each other. These out-of-phase saw-tooth voltages are shown at A, Figure 9, applied through coupling condensers to a pair of deflection plates. In this diagram the plates are shown "floating", i.e. there is no D.C. path connecting them to ground. Such an arrangement is unsatisfactory. Although the deflection plates form no part of any circuit which carries a direct current, they can, and will in practice, collect electric charges. Such charges can arise, for example, as the result of slight leakage through the coupling condensers. The result will be that the plates may build up large, and variable, potentials. This will lead to unstable operation of the tube. The effect is similar to that obtained when an ordinary amplifying valve is operated with a "floating" grid.

At B in Figure 9 the deflection plates are shown connected to ground through resistors R1 and R2. These resistors are of large values (1 or more megohms) and prevent the A.C. voltages being short-circuited to earth. At the same time R1 and R2 will maintain the plates at earth potential, as far as D.C. voltages are concerned. With this arrangement it should be noted that, even when the A.C. voltages are applied to the plates, the average potential of the latter is, at all times, zero. This point will be clearer by referring to Figure 10. The

two saw-tooth voltages are 180° out-of-phase as shown at A and B. The average of these is obtained by adding, for all instants of time, the instantaneous values of the voltages. When voltage A is, say, positive, voltage B is an equal amount negative, and the average or net voltage is therefore zero for the two plates as a whole.

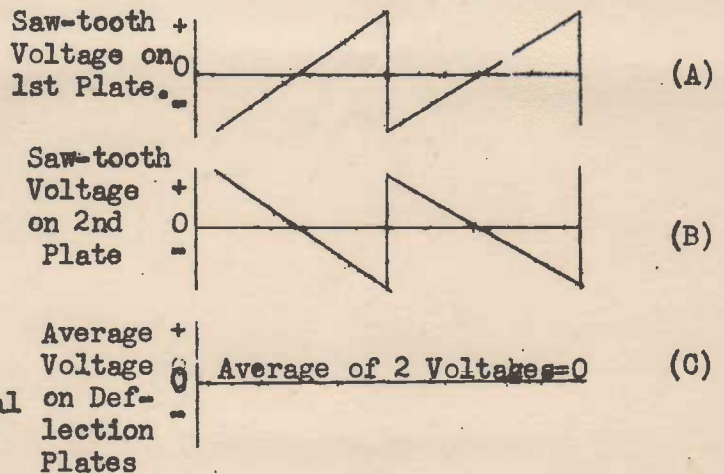

In the case of a television receiver however, where the final anode of the C.R.T. is operated at a high positive potential: with respect to earth, there is a serious objection in placing

the deflection plates at zero potential. Between these plates and the final anode there will exist a large potential difference (equal to the high-voltage rectifier's output), and therefore a powerful electrostatic field. This field will seriously interfere with the correct focusing of the electron beam. It will be remembered that this focusing action is brought about by carefully adjusted electrostatic fields between the cathode and the several anodes within the tube. Any other field must be avoided.

FIGURE 10.

To eliminate the electric field between the deflection plates and the final anode, we must place both these points at the same potential, so that no potential difference exists between them. This could be done by connecting the plates to the final anode via high resistances as shown at C, Figure 9. The tube would now operate correctly. The saw-tooth voltage from the amplifier would now simply

carry one plate more positive than the average potential, while the opposite plate goes an equal amount more negative. This alternating potential difference between the pair of plates will swing the beam backwards and forwards to produce the scanning motion. At the same time the average potential of the pair of plates will remain constant at a value equal to the final anode potential, and hence no de-focusing effect will occur.

The student should not forget that the C.R.T. contains two pairs of deflection plates, (one for horizontal deflection, and the other for vertical deflection). The foregoing discussion applies equally well for one pair as for the other.

PICTURE "SHIFT" OR "CENTRING" CONTROLS.

In the manufacture of an electrostatic type C.R.T. the job of mounting the comparatively large and heavy electrodes within the glass envelope proves a very difficult one. The result is that, in any particular tube, it is rarely found that the beam spot falls exactly at the centre of the screen when no deflection voltages are applied. This means that when the scanning system is operating the picture frame will not be perfectly centred with respect to the tube's screen.

To overcome this difficulty we require two controls, one to move the spot, if necessary to left or to right, the other to shift it either up or down, as required. These controls are called "Horizontal Shift" (or "Centring ") and "Vertical Shift" (or "Centring ").

Beam Shift is brought about by making provision to apply, between each set of deflection plates, a D.C. potential difference whose value and polarity may be adjusted as required. The usual method of doing this is as shown in Figure 11. Included in the bleeder circuit, at its positive end is an extra resistor R1, of such value that a P.D. of perhaps several hundred volts is developed across it. The final anode is connected to the centre point of this resistor, so that the potential of this electrode is actually slightly less than the output voltage of the rectifier. Also connected to the centre point of R1 is the right-hand plate of the horizontal deflecting pair. This connection is made via the resistor R4 (of large value) which avoids short-circuiting of the A.C. saw-tooth voltage. In this way the right-hand plate is maintained permanently at a D.C. potential equal to that of the final anode. The resistors R4, R5, R6 and R7 are the ones previously indicated in Figure 9.

Across R1 (in parallel with it) is connected a potentiometer R2, the moving arm of which goes, via R5, to the other horizontal deflection plate. Now when the moving arm of R2 is in its central position the potential applied to left-hand deflector plate is equal to that of the centre point of R1, i.e. to the final anode and right-hand plate potential. In this position no potential difference exists between the pair of plates.

Now suppose the moving arm of R2 is moving towards the upper end of the resistor. The potential picked off will now be more positive than that of the central point of R1. Consequently the potential applied to the left-hand deflection plate will be more positive than that on the right-hand plate, and the beam will be deflected to the right. In this way the picture may be adjusted centrally upon the screen, as far as horizontal position is concerned.

An exactly similar system is duplicated for action on the vertical deflection

plates. For this purpose we have the potentiometer R3, and the resistors R6 and R7.

Condensers C1 and C2 serve to smooth out sudden fluctuations in voltage when the shift controls are moved, thus to give a smooth motion of the picture to left or right, or up and down.

HIGH-VOLTAGE PRECAUTIONS.

Special care must be exercised in the mounting of all leads and components in a television receiver which are at the very high voltages. Wiring, for example, should be well separated from the chassis, and sharp turns and points which tend to aid an electrical discharge.

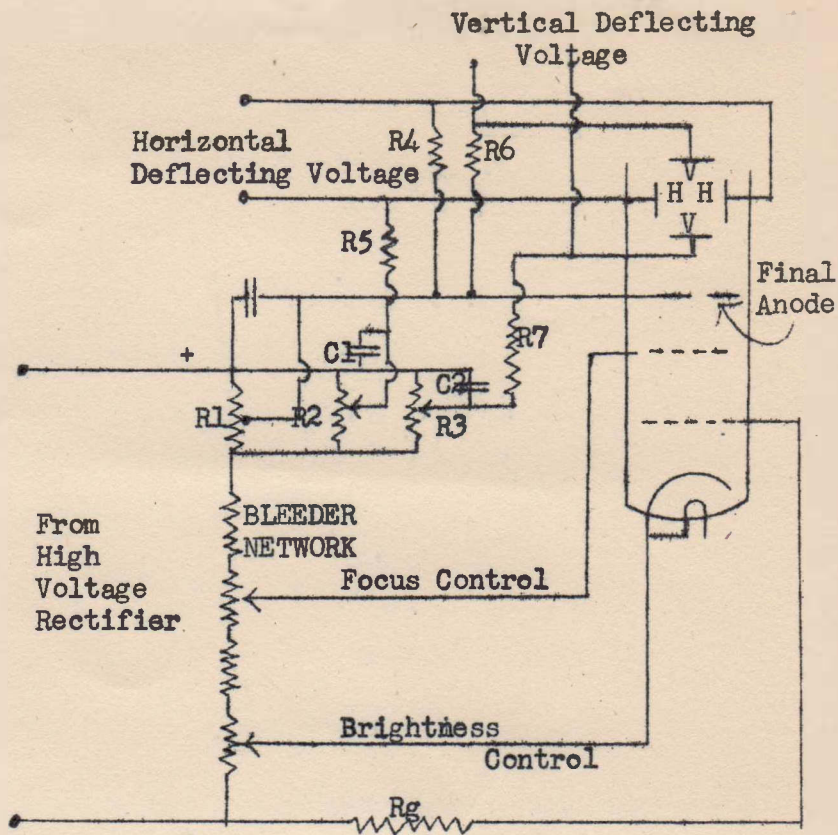

FIGURE 11.

In particular it should be noted that potentiometers used for Focus Control and Picture Shift are at very high voltages with respect to earth. It would never do to mount these potentiometers directly upon the side of the metal chassis, even though the component's resistor, and moving arm, are internally insulated from the metal shaft. Such insulation is inadequate to withstand voltages of several thousands volts. The usual method is to mount these potentiometers on a special panel of insulation within, and well separated from the main metal chassis. The shafts are long, and incorporate a length of insulating material as shown in Figure 12.

In order to safeguard service mechanics, and receiver owners, all high-voltage wirings are usually enclosed so that they are inaccessible without automatically switching off the high-voltage power supply.

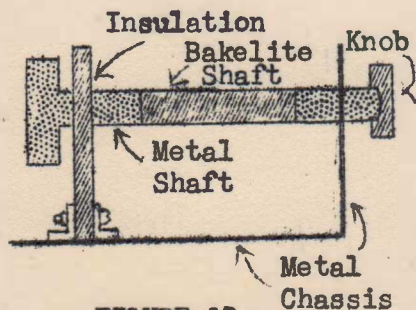

FIGURE 12.

Another important point concerns the coupling condensers through which the deflection voltages are applied from the amplifiers to the deflector plates. A pair of these condensers is shown back in Figure 9A. The wires on the right-hand side of these condensers are at several thousand volts. Their left-hand plates, on the other hand are at comparatively

low voltages, something less than the low-voltage B+ supply. Hence the condensers must be of a special high-voltage rating to withstand the large potential differences between their plates. Such condensers are much larger and more

costly than the more humble types, of similar capacity, having ratings of only 400 - 600 V.

MAGNETIC FOCUSING.

Since most of our space has been taken up in describing the application of the power supplies to electrostatic type tubes it must not be concluded that this type is more important, or even in more common use, than the electro-magnetic tube. Actually electro-magnetic deflection and focusing is becoming more and more important, and will probably completely supersede the electrostatic methods, particularly where a large screen is required. We are taking less space over the electro-magnetic type simply because there is less to explain.

The circuits are much simpler, particularly from the point of view of high-voltage considerations.

When electro-magnetic deflection is used we do not have to worry about operating the deflection system at high voltages. The deflection coils, wound outside the tube are operated with low-voltage saw-tooth currents as already explained in an earlier lesson. There is no question of defocusing effects occurring.

If magnetic focusing is also used, the problem is further simplified. The electron gun then operates at fixed potentials, and it may involve but a single high-potential anode. Hence the bleeder circuit of the high-voltage power unit will be less complicated.

The methods of obtaining control electrode bias are exactly the same as already described.

ELECTRO-MAGNETIC FOCUSING.

This type of focusing, it will be remembered, is achieved simply by passing a steady direct current of several hundred milliamps through a coil wound around the neck of the tube. The current used is usually the total (or part) of the low-voltage power supply. The deflection coil is placed in series in the negative (earth) lead of the supply. Since this coil is of low resistance there is but little potential drop across it. Such potential drop would, of course, subtract from the total output voltage of the power unit available for operating picture and sound circuits.

The arrangement is shown in Figure 13a. The total current supplied from B+ to the tubes, and returning via the chassis to the centre tap of the transformer, will split between the deflection coil and the rheostat R1 in series with R2. By adjusting R1 the fraction of this total current passing through the deflection coil may be varied.

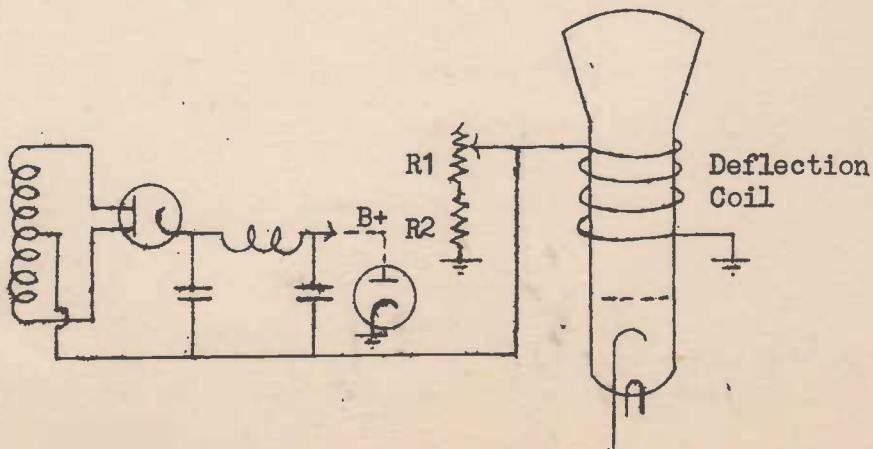
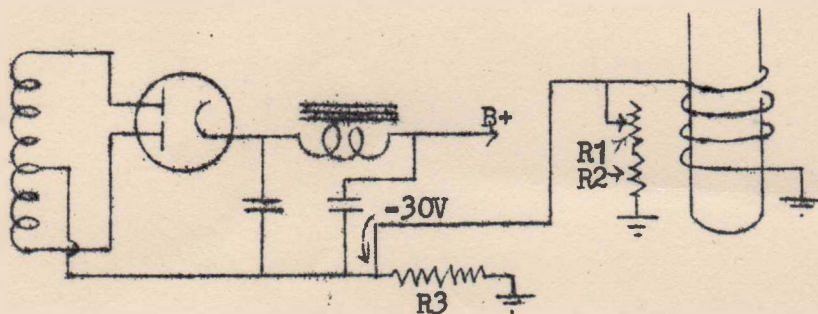

FIGURE 13a.

to produce fine focusing of the beam. The presence of R2, in series with the rheostat, ensures that some current will pass through the coil for all settings of R1.

A modification of this system is shown in Figure 13b. Here a resistor R3 has been



placed in the negative lead of the low-voltage supply. This resistor is of such value that a P.D. of about 30V is developed across it (similar to "back-bias"). This voltage is then applied across the deflection coil and rheostat R1 in parallel. R1 acts, as before, as the focus control.

FIGURE 13b.

RADIO FREQUENCY HIGH-VOLTAGE SUPPLIES.

High-voltage power supplies operating from the 50 C/S mains are not particularly efficient or suitable for operating C.R.T's.

In the first place they can invariably supply many times the current which is necessary to operate the electron gun. The latter requires only a fraction of a milliamp. The reason for this is that it is not practicable to wind the secondary of the power transformer with thinner wire which would reduce the unnecessarily high current capacity, and at the same time reduce the weight and size of the transformer. Furthermore the voltage step-up of a power transformer depends entirely upon the turns-ratio between primary and secondary. To obtain the very high voltage required we must have a large turns ratio; and since we must have at least 4 or 5 turns per volt in the primary (in order to adequately magnetise the iron core), this means that the secondary winding must consist of a very large number of turns. Such a transformer is very large, heavy and expensive.

Again the capacities of the smoothing condensers in the filter system of a rectifier depend upon the ripple frequency, which equals the supply frequency for half-wave rectification. Operating with the low frequency of 50 C/sec. these capacities must be comparatively large (of the order .25 or .5 mfd).

Another difficulty to be overcome is the presence of stray magnetic fields. The electron beam is very susceptible to stray fields, and more complete shielding of the power unit is necessary than in the case with the ordinary sound receiver.

Most of these difficulties and drawbacks would be reduced or eliminated if, instead of drawing our A.C. power for rectification from the 50 cycles mains, we had some source of radio-frequency power instead. Such a source of power could be created in the receiver by using a special small r.f. oscillator.

If this were done, we could use a small and light weight r.f. transformer for the necessary voltage step-up instead of a heavy iron-covered 50 cycle power transformer.

An additional advantage would involve the filter condensers to smooth the rectified output. The "ripple" frequency of, say, 1,000,000 C/sec. could be effectively filtered by means of condensers of very low capacity, .005 mfd or less. Since large condensers of high voltage rating tend to be costly, the saving would be quite appreciable.

The shielding of an r.f. power unit is also much simplified. Adequate shielding is obtained simply by enclosing the unit within a can similar to that using for r.f. coil shielding. This is very much lighter than the heavy iron shields required for a 50 C. power transformer. The circuit of a simple r.f. high-voltage power unit is shown in Figure 14.

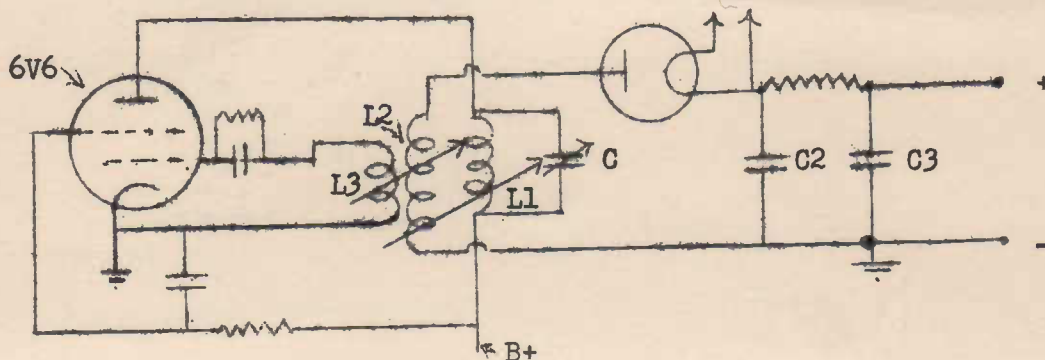

FIGURE 14.

The valve (6V6, or similar type) is acting as an r.f. oscillator of the tuned-plate type. Coil L1 and condenser C form a tuned circuit. L2, together with its stray and self-capacities also acts as a tuned circuit, having the same resonant frequency as L1C. All three coils L1, L2 and L3 are wound on a former so that coupling exists between them. L3 provides the feed-back voltage to the grid, necessary to maintain self-oscillations.

An r.f. oscillation, at a frequency which mainly depends upon L2 and its stray capacities is set up in the circuit L1C. L1 and L2 constitute a step-up transformer. Hence whatever r.f. voltage is developed across L1 is magnified many times in L2.

The voltage across L2 is now applied to a diode acting as a half-wave rectifier. This part of the unit is exactly as described previously, except that the filter condensers C2 and C3 may be very much smaller in capacity than would be required in the conventional power unit for the same degree of filtering.

Although the unit requires an extra valve, it is very much lighter than one operating directly from the 50 cycle mains.

The power required to operate the oscillator valve (at about 300V) can be supplied by the ordinary low-voltage power unit of the television receiver.

The high-voltage output (D.C.) obtained is adjusted approximately with the screen dropping resistor. The screen voltage applied will determine the gain of the tube, and hence the amplitude of the r.f. voltage across L1. This in turn will determine

the r.f. voltage developed across L2, and applied to the diode for rectification. Fine adjustment may be made to the output voltage by adjusting C1. If the circuit L1 C1 is de-tuned from the operating frequency (as determined by L2 plus stray capacities) the size of the oscillations will be reduced. This, of course, will affect the final D.C. output obtained.

Such units as these are usually operated at a comparatively low radio-frequency, usually between 100 K.C. and 1 M.C. A higher frequency (which would still further simplify the filtering) is difficult to obtain, because L2 must have a fairly large number of turns, to produce the necessary voltage step-up. Any increase in L2 will lower the frequency of oscillation. The figures given for frequency represent a practical compromise.

An additional advantage of the r.f. power supply, not mentioned earlier, lies in its safety from the point of view of electric shock. Although the voltage output, of course, may be very high, the power available is limited. This power is limited to the power output (r.f.) of the oscillator valve, which, though quite adequate to operate a C.R.T. is insufficient to produce in the human body a dangerous shock. Since, also, the filter capacities are small, the energy stored in them is also quite small. In this connection the student should be aware that condensers (unless of very small capacities) in high voltage circuits can be very dangerous things.

A field in which the high-voltage r.f. power unit may find extensive use is that of portable battery equipment. An r.f. oscillator of the type described may quite well be operated from ordinary radio batteries and this makes possible the design of television receivers for operation in areas where A.C. power mains are not available.

T.F.M & F. LESSON NO. 11.

EXAMINATION QUESTIONS.

- (1) Why may half-wave rectification, with resistance-capacity filtering be successfully used for the High Voltage power supply of a television receiver?
- (2) Draw a simple circuit diagram showing the connections required for half wave rectification, with a negative output, and diode filament earthed.
- (3) Upon what quantity does the degree of filtering of a simple resistance-capacity filter depend?
- (4) Name the controls in a television receiver which may take the form of potentiometers in the bleeder circuit of the high-voltage supply.
- (5) What is the advantage of operating the grid of the C.R.T. at (or near) the plate potential of the final video amplifier?
- (6) Why should the average potential of a pair of deflection plates in a C.R.T. be fixed at a value equal to that of the final anode of the tube?
- (7) Which power supply is associated with the control of focus in an electro-magnetically focussed tube? State briefly the method usually used.
- (8) Give two reasons to explain why an r.f. type high-voltage power supply may be much lighter in weight than the conventional type.
- (9) How may fine adjustment be made to the output voltage of an r.f. power supply?
- (10) In what ways does the use of a magnetically controlled tube simplify the circuits of a receiver.

AUSTRALIAN RADIO COLLEGE

E.S. & A. BANK BUILDINGS, Corner CITY RD. and BROADWAY, SYDNEY

Telephones: M 6391 and M 6392

Post Lessons to Box 43, Broadway

This lesson sheet is published for the exclusive use of students of the Australian Radio College Pty. Ltd. (All rights reserved)



T.F.M & F. LESSON NO. 12.

COLOUR TELEVISION.

In black-and-white or monochrome television the system reproduces only the varying intensities (brightness) of the different elements of the picture or scene, irrespective of their colours. It does not differentiate between lights of the same brightnesses but of different colours. The result is similar to that of a black-and-white photo, where, on the final print objects of all different colours, (providing they reflect the same amount of light in the original scene) are reproduced by the same shade of grey.

At this stage the student should re-read the early lesson which dealt with the

MEGA-MEGA CYCLES.

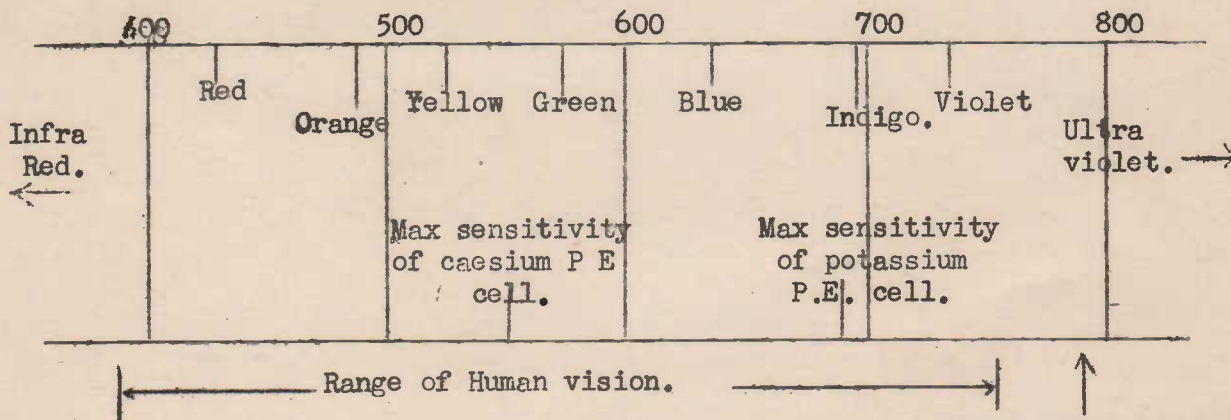

FIGURE 1.

COLOUR SPECTRUM.

fundamentals of light. He should, in particular, make sure that he understands the following points:- (1) the brightness of light depends upon the amplitude (strength) of the light-wave. (2) The colour of light depends upon the frequency of the light-wave. (3) The colour "spectrum" consists of the following colours (in order of increasing frequency) red, orange, yellow, green, blue, violet). (4) White light consists of a mixture of all colour frequencies in the proportions they appear

in sunlight. (5) No colour is pure. For example a green light consists of a band of frequencies of which those around the green portion of the spectrum predominate. The frequencies present, however, may extend to the yellow, or even (in weaker proportions) down to the red parts of the spectrum. Similarly, in "green" light, there may be some light wave frequencies corresponding to blue or even violet light. The narrower the band of frequencies, the purer will be the green light.

Colour television makes use of the same general principle as is used in colour photography. This principle involves the super-imposition of 2, or 3 separate pictures, each of different colours to produce a picture in natural colour (i.e. showing all the colours of the spectrum).

The principle may be explained thus. Suppose we view a coloured scene through a red-coloured glass. Such a glass (or "filter") will readily pass, or transmit, red light, but it will tend to absorb, or block, light of other colours. The red glass, however will not entirely block all other colours. It will pass lesser amounts of yellow, and still lesser amounts, perhaps, of green. It may entirely block blue light. A scene viewed through such a filter will have a decided reddish tinge. Blue objects will appear black (absence of light), since no light from them can get through. If now we view the same scene through a green glass, the light from green objects will be readily transmitted, together with smaller amounts of yellow and blue. Finally we use a blue-violet glass, blue is readily passed with smaller amounts of green, and perhaps still smaller quantities of yellow. Red, however, may be entirely blocked.

The effect of each filter on passing, or transmitting the different coloured lights is shown graphically in Figure 1a.

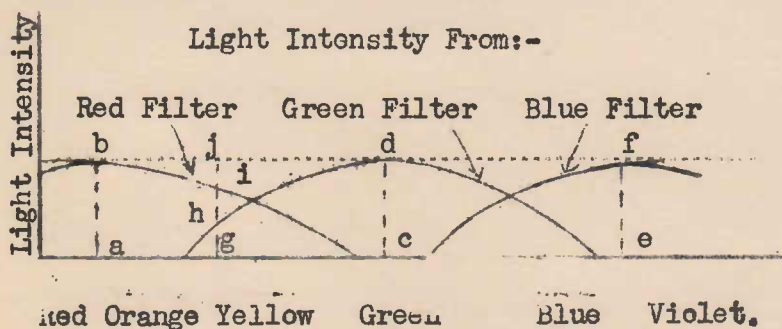

FIGURE 1a.

Suppose now, as in colour photography, 3 separate pictures were taken using in turn the red, green, and blue filters. Without delving into the details of colour photography, the three negatives so obtained are printed in their respective colours. Finally the three pictures are superimposed in such a way

that the total light received by the eye from the composite picture is the sum of the lights produced by each component picture. The result is a picture in natural colour. Red objects in the scene would be catered for entirely by the picture obtained when using the red filter. Similarly greens would be reproduced from the green-filter picture, and violets from the blue-violet filter-picture. Intermediate colours would be fully catered for, each of these colours having light contributed from a pair of pictures. For example, returning to Figure 1a, consider 3 objects of colours red, green and blue respectively. The red filter would pass a maximum amount of light (ab) from the red object. The green filter would pass the maximum light (cd) from the green object. Similarly the blue-violet filter would pass the maximum light (ef) from the blue object. Assuming that the three objects were of equal brightness these amounts of lights transmitted by the respective filters (and therefore reproduced in the final picture) would be equal,

i.e. $ab = cd = ef$ (Figure 1a). Note that the red filter passes no light from the green or blue objects, etc.

Now consider a yellow object, equal in brightness (light intensity) to the red, green and the blue objects. Referring to Figure 1a, the red filter passes an amount of yellow light from this object equal to gi . The green filter passes an amount equal to gh . Since the total light appearing in the final composite picture is the sum of the lights from the separate pictures, the total yellow light appearing would be equal to gi plus $gh = gj$. Since gj is equal to ab or cd or ef , the yellow object would appear in the picture equally bright as the red, green or blue. In a similar way all other intermediate colours would be catered for.

From the foregoing it is seen that the three colours red, green and blue-violet can be combined to reproduce all the colours of the rainbow, and therefore, also, white light (since "white" light is simply the effect on the eye of a mixture of all colours). Such colours (red, green, blue) are called "primary" colours. If the student still doubts that the effect of adding these three primary colours is white light a simple experiment should convince him. Cut out a disc of cardboard about 2 or 3 inches in diameter. Divide the disc into three equal segments as shown in Figure 2. Paint these respectively red, light green and blue. Double a length (about 18" or 2 ft) of thin elastic and pass the end through two small holes near the centre of the disc. (Fig.2). Tie the ends of the elastic together. With the disc at the centre of the doubled length of elastic pull in and out on the elastic, so making the disc spin rapidly in one direction, then the other. The coloured lights reflected from the segments will mix in the eye, and the disc will appear a uniform white. At first a dirty greyish colour may be obtained, but by experimenting with particular shades of red, green and blue, something approaching white, or at least very light grey, will be obtained.

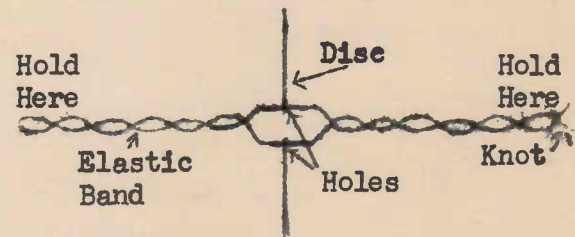
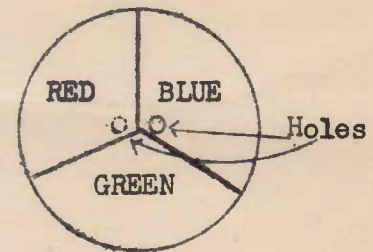

FIGURE 2.

All natural colours may be simulated by the use of but two colours. For example if a filter of yellowish-red, and one of greenish-blue are used, a picture in more or less natural colour may be obtained. In this case the filters would need to be of less pure colours than in the case where three colours were used. That is each filter would be required to transmit some amounts of most of the colours of the spectrum. Two colours which when mixed will produce all colours of the spectrum (and, therefore white light) are called "complementary" colours.

The two-colour system has been used in television, but it is now generally considered that three colours are necessary for a high degree of colour naturalness.

TRANSMITTING COLOUR PICTURES.

In all systems of colour television it is first essential to analyse the original

picture or scene into its "primary" colours by using colour "filters". The light transmitted through each of these three filters is converted into a video signal by allowing it to fall on a photosensitive surface (such as that contained in a television camera). In this way three separate video signals are generated, corresponding to the three primary colours. These three signals must be conveyed intact through the ether to the receiver. There are two main systems which have been developed with considerable success. These are called the "Sequential" system and the "Simultaneous" system.

In the sequential system the three pictures (corresponding to the three primary colours) are sent in turn, or in sequence, over the one carrier wave. At the receiver the three pictures are reproduced, in turn, as they arrive. At any one moment only one colour is being sent and reproduced. If the rate of alteration of the colours is rapid enough, however, the three colours will merge into each other as a result of the "persistence of vision" effect of the eye.

In the simultaneous system the three video signals representing the separate primary colours are sent simultaneously by using three separate carriers, or sub-carriers. The three primary colour pictures are reproduced simultaneously at the receiver by utilising three separate picture tubes. The primary colour pictures are mixed by projecting them on to a single screen.

Both systems produce pictures of similar standards of definition and colour quality, if the same total bandwidths for transmission are used.

The essential different between Sequential and Simultaneous system is illustrated in a purely diagrammatic way in Figure 3.

THE SEQUENTIAL SYSTEM.

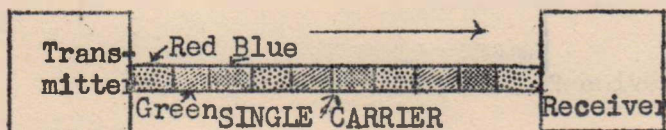

Each Rectangle Represents a Frame.

- Red Frame
- Green Frame
- Blue Frame

(A) SEQUENTIAL SYSTEM

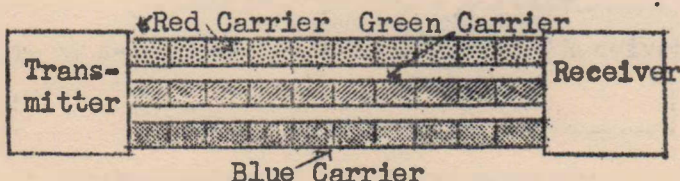

THREE SEPARATE ADJACENT CARRIERS

(B) SIMULTANEOUS SYSTEM

FIGURE 3.

We shall describe the details of this system first, since, chronologically, its initial development preceded that of the Simultaneous system. It has been commonly described as the mechanical system since, to date, most apparatus used in its development has made use of mechanically rotated discs at receiver and transmitter. This, however, is not a very good or significant term, since, as we shall see later, these discs may be avoided by using techniques originally developed for the Simultaneous system. They are also eliminated in a special C.R.T. developed by Baird. If this is done the system becomes an entirely "electronic" one.

The Sequential system, recently demonstrated by the C.B.S. (Columbia Broadcasting System) in America made use of a rotating colour filter wheel in front of the television camera, and a similar wheel rotating synchronously in front of

the c-r tube at the receiver. These colour wheels consist, in their simplest form of three segments, each segment being a colour filter for one of the three primary colours- red, green and blue (Figure 4). The filter material is some coloured transparent material such as a coloured glass etc. The wheel is rotated at such a rate before the television camera that the latter "perceives" the scene for an interval of time exactly equal to one field. (Note the terms "field" and "frame" are now used in the American sense; i.e. a "frame" means a complete scanning of both "odd" and "even" lines; a "field" denotes a coverage of the picture area by one set of lines -- even or odd -- only.) Thus while each filter section is before the camera the picture area is scanned completely by alternate lines, and the video signal generated represents the variations of light intensity for the colour only. The camera output therefore represents a succession of "fields", each for a different colour.

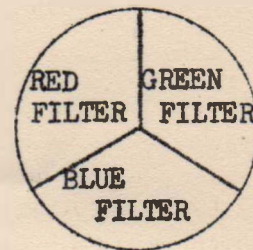

FIGURE 4.

At the receiver the c.r. tube screen is viewed through the rotating colour filter wheel. This wheel rotates at the same speed as that at the transmitter, so that each filter section covers the tube for an interval of time equal to one field. The two-wheels must further be synchronised so that when the transmitter is scanning the scene through say, a red field, the red filter is before the c.r tube in the receiver. Similarly for the other filter sections. The system is illustrated in a simple diagrammatic manner in Figure 5.

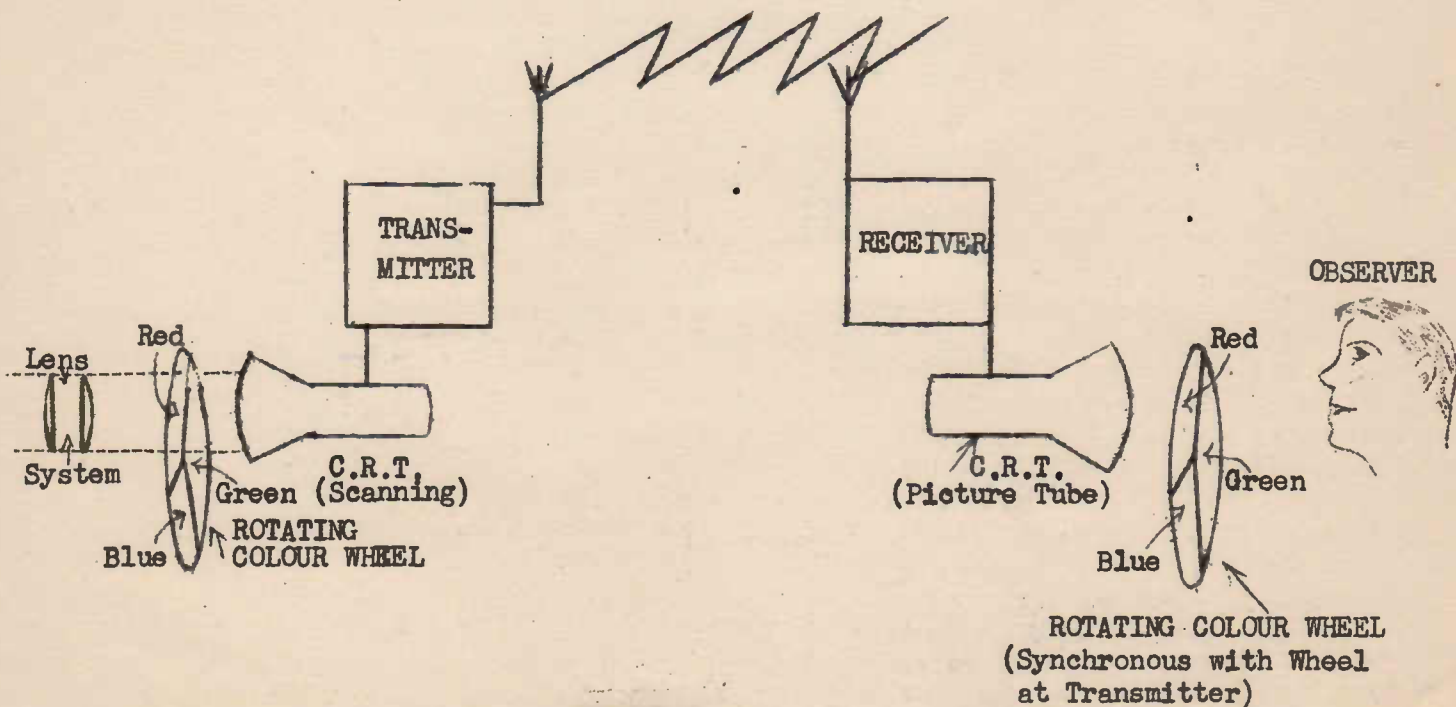

FIGURE 5.

PRINCIPLE OF SEQUENTIAL COLOUR SYSTEM.

The C.R. tube at receiver has a white phosphor, i.e. a screen producing a white light. The different colours are produced successively by viewing the light

emitted through the different filter sections in turn. It should be noted, therefore that the colours, as such, are not actually transmitted from transmitter to the receiver. The video signal for any frame, whether it be for red, green or blue, consists simply of a varying voltage, the variations representing different intensities of light. Signals for all frames, therefore, when applied to the C.R.T. control electrode will produce a white light of varying degrees of brightness. But the C.R.T. screen is seen at any moment through a coloured filter. Hence the light seen at any given moment will be either red, green or blue, according to the filter section in front of the screen. For example consider the frame interval of time that the red filter section remains before the receiver screen. During this interval the C.R.T. spot is tracing out lines with varying light intensity corresponding to the variations in light intensity of the red portions of the original scene. This is so because the television camera, for the interval under consideration, is "perceiving" the scene through the red section of its wheel. At the receiver the viewer sees only variations of red light, since the white light from the C.R.T.'s screen is viewed, for this interval through a red filter. The same thing happens for each of the other two colour frames. The necessity for perfect synchronisation between transmitter and receiver colour wheels is thus obvious. Now, provided that the rate of repetition of the sequential colour frames is sufficiently rapid, the eye will not see the separate colour pictures individually, but these will blend together giving the effect of a naturally coloured picture. Colours other than the three primary colours (for example yellow, orange, bluish-green etc) will be produced, as previously explained, by blending of the primary colours in varying proportions.

"FLICKER" CONSIDERATIONS.

In black-and-white television flicker has been eliminated by transmitting the fields at a sufficiently fast rate - 50 fields per second, or 25 completely interlaced frames (or pictures) per second (30 and 60 respectively in America). The smooth merging of the separate fields is also enhanced by using phosphors of fairly slow decay rates (i.e. phosphors which continue to glow for some appreciable fraction of a section after the spot has passed).

In the sequential colour system the phosphor must have a sufficiently fast decay rate to ensure that the light from one colour frame has completely disappeared before the next frame commences. This complicates the flicker problem. Of greater and more fundamental importance than this aspect of the flicker problem, however, is the serious flicker which is seen when a large area of the one colour is transmitted by this system. Suppose 50 fields per second (to correspond with the standard for black-and-white transmission) are used. When a large area of, say, blue sky is transmitted, the blue is only reproduced during one of every three fields. The red and green fields do not cater for blue. Hence the blue sky is reproduced only $50 \div 3$ or $16\frac{2}{3}$ times per second. This is too slow and produces quite noticeable flicker.

To reduce the flicker to a standard comparable with that of the black-and-white system, therefore, each colour should be transmitted 50 times per second, i.e. 50 red fields, 50 green fields and 50 blue fields per second, a total of 150 fields per second. This means that each field should be scanned in one-third of the time involved in black-and-white transmission. Hence the scanning spot should move three times as fast over the mosaic in the television camera. The net result of this requirement is that the video frequency would be three times as great for a given

number of scanning lines and therefore a given standard of definition. This, of course would involve a signal having a band-width three times as great as that required for a nominally equivalent black and white picture. It might well be mentioned here that the post-war standard decided upon in America for black-and-white transmission is 525 lines per picture. This same standard has been used for the experiments in colour television.

Thus we see that if the same number of scanning lines and a frame frequency three times as great is used colour television should provide a picture of equal definition as (i.e. containing the same amount of detail) and comparable lack of flicker with that obtained in the black-and-white system. Actually, it is claimed, with those standards the apparent effect is better in the case of the colour picture. This is due to the fact that the improved naturalness due to the inclusion of colour, masks, as far as the human eye is concerned, any deficiencies in lack of detail etc. Thus the improvement obtained is a "subjective" one, i.e. the viewer thinks he is seeing a more finely detailed picture -- and, after all, this is the important thing.

CARRIER FREQUENCIES REQUIRED.

Since the sequential colour system involves a range of video frequencies three times as great as that necessary for black-and-white transmission for the same number of lines in each field, the width of the r.f. channel will also be three times as great. Where 4 mc/sec. was used for black-and-white 12 mc/sec. will be needed for colour. It is impossible to incorporate signals having such bandwidths in the part of the spectrum so far used for black-and-white, viz 40-100 mc/sec. For this reason it has been decided to devote that part of the spectrum between 400 and 1,000 mc/sec. to colour television. (Note that 1,000 mc/sec. represents a wave-length of only 0.3 metres or 30 cm.)

SOUND-ON-VISION TRANSMISSION.

The C.B.S. organisation in its experiments on the sequential colour system decided to make use of a sound-on-vision system for transmitting the accompanying sound. In this system the sound is carried on the picture carrier during the small intervals between lines (i.e. during the time allowed for spot "fly-back" or "retrace" at the end of each line, and before the next).

In an earlier lesson a system of sound-on-vision transmission, using pulse modulation was mentioned. The system used by C.B.S, however, is somewhat different. It is not pulse modulation. "Bursts" of an 8 mc. frequency modulated wave are superimposed on the picture carrier (485 m.c) between each pair of lines. An 8 mc. oscillation is generated at the transmitter and frequency-modulated with the sound. The 8 m.c. voltage, thus modulated, is then used to modulate the much higher frequency picture carrier in the "gaps" between lines. This modulation of the picture carrier with the 8 m.c. sub-carrier (as it is called) is amplitude modulation -- just as a 4 mc. (say) video signal amplitude modulates the carrier.

The modulation "envelope" of the picture carrier is shown in Figure 6. Here the intervals between the lines are, of course, exaggerated. Actually, in practice, these gaps each occupy only 8% of the total line period. No attempt either is made to show the frequency deviation representing frequency modulation of the 8 mc. sub-carrier.

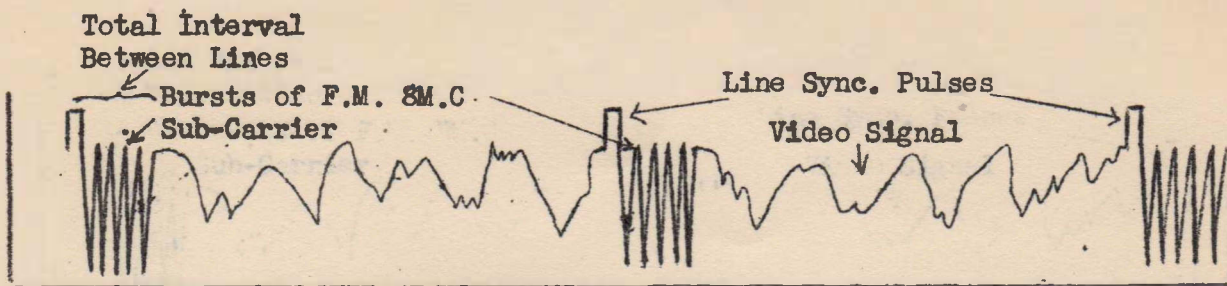

FIGURE 6.

At the receiver the bursts of 8 mc. sound carrier appear immediately after the picture second detector, together with all the video frequencies representing picture detail. This will be understood if it is kept in mind that both video frequencies and 8 mc. sound carrier are used to amplitude modulate the vision carrier. Immediately after the vision detector the 8 mc. sub-carrier (still frequency modulated) is picked out by means of a circuit tuned to 8 m.c. The sound carrier is then passed to a discriminator circuit, which is really a special type of detector for F.M. This circuit reproduces the original audio frequencies carried as F.M. on the 8 mc. wave.

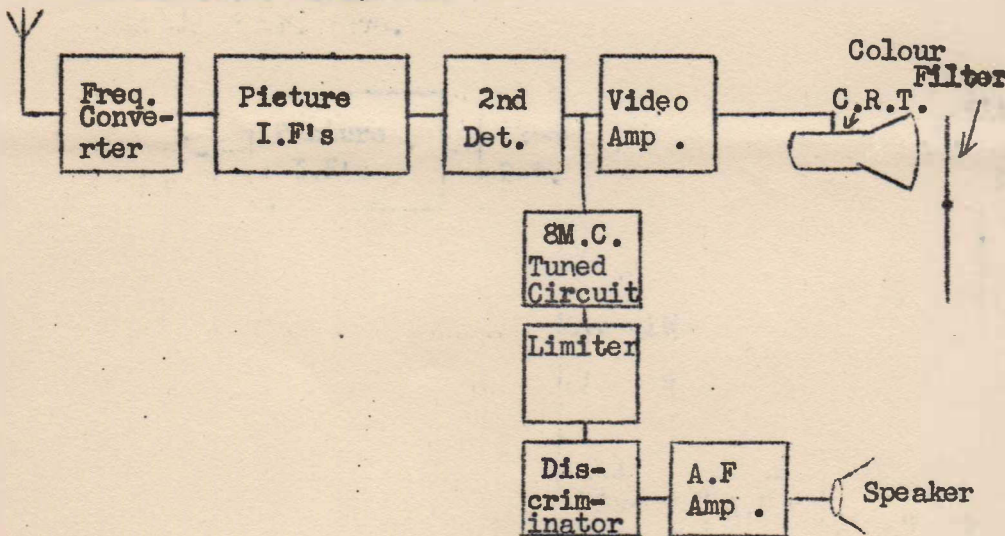

FIGURE 7.

The arrangement is shown in Figure 7. The "limiter" shown before the discriminator (F.M. detector) is designed to eliminate any amplitude modulation on the sound carrier. This, in effect prevents any video frequencies being carried as amplitude modulation, and finally reaching the speaker.

Note that the system eliminates the necessity for a separate sound intermediate frequency

channel.

The fact that the sound is not carried continuously does not really matter. The rate of repetition of the sound sub-carrier "bursts" is that of the line frequency (30,000 C/sec. or more). This is above the audio-frequency, and the sound will appear to the ear as continuous.

THE SIMULTANEOUS SYSTEM.

This system requires, at the transmitter, the simultaneous generation of the three primary colour video signals. To achieve this, the camera arrangement involves a "beam-splitting" optical system whereby a focussed image (in natural colours) of the scene is split into the three primary colours--red, green, and blue.

The arrangement is shown in Figure 8. Two "colour-selective" mirrors are used.

These are made of a semi-transparent material which possesses the property of re-reflecting light of one of the primary colours, and transmitting (i.e. passing) all other light colours. The coloured scene is focussed by means of a lens system. Falling upon the first colour-selective mirror, (which is red-selective), a reddish image is reflected on to the mosaic of the first camera, where it is scanned to produce the "red" video signal. All other colour components pass through this mirror, and fall upon the second colour-selective mirror, which is blue-selective. The green components of the image are not affected by this mirror and pass straight through it, forming a greenish image on the mosaic of a second camera shown at the right of Figure 8. This gives the green channel. The blue light waves in the light image are reflected from the surface of the second mirror and from the blue image on the mosaic of a third camera at the bottom of Figure 8, which produces a video signal corresponding to the varying intensities of blue light.

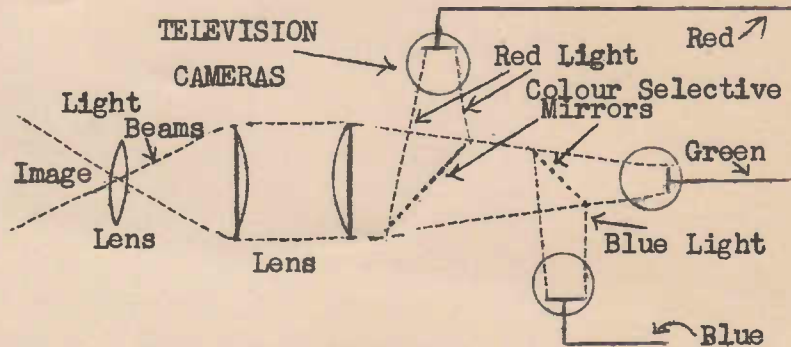

FIGURE 8.
BEAM SPLITTING CAMERA.

The three separate video signals are used separately to modulate three separate carrier waves. These have frequencies as close as is possible to each other without their side-bands overlapping. Hence the over-all band-width of the television channel is only very slightly in excess of three times the width of a single channel.

The three separate video signals are used separately to modulate three separate carrier waves. These have frequencies as close as is possible to each other without their side-bands overlapping. Hence the over-all band-width of the television channel is only very slightly in excess of three times the width of a single channel.

At the receiver the composite signal is picked up by a single aerial, and either (after frequency conversion) fed through three separate I.F. channels, or through a single channel. In the latter case the three colour channels are separated before the second detector by means of wave-filters (i.e. wave-traps).

After detection the three separate video signals are applied separately to the control electrodes of three separate c.r. tubes. These tubes are fitted with fixed colour filters, or use special colour phosphors. In either event each tube produces an image in its own primary colour. The coloured images are mixed to form a single image in natural colour, by projecting the three images, using lens, on to a single screen.

Figure 9 shows the three small 3" projection type cathode-ray tubes used in the simultaneous type receiver developed by the R.C.A. organisation in America. Projection lens (removed, and held by the technician) project the three images on to a screen in the lid of the receiver.

Note that no moving parts are used in this system.

In this (simultaneous) system the blending of the colours is inherent (i.e. it does not depend upon the persistence of vision for colour blending). Also each colour field is repeated at the field frequency. Further the phosphors may have slow decay rates, since each colour uses its own phosphor, and there is no necessity for all the light to disappear before the next frame arrives. For these reasons a very

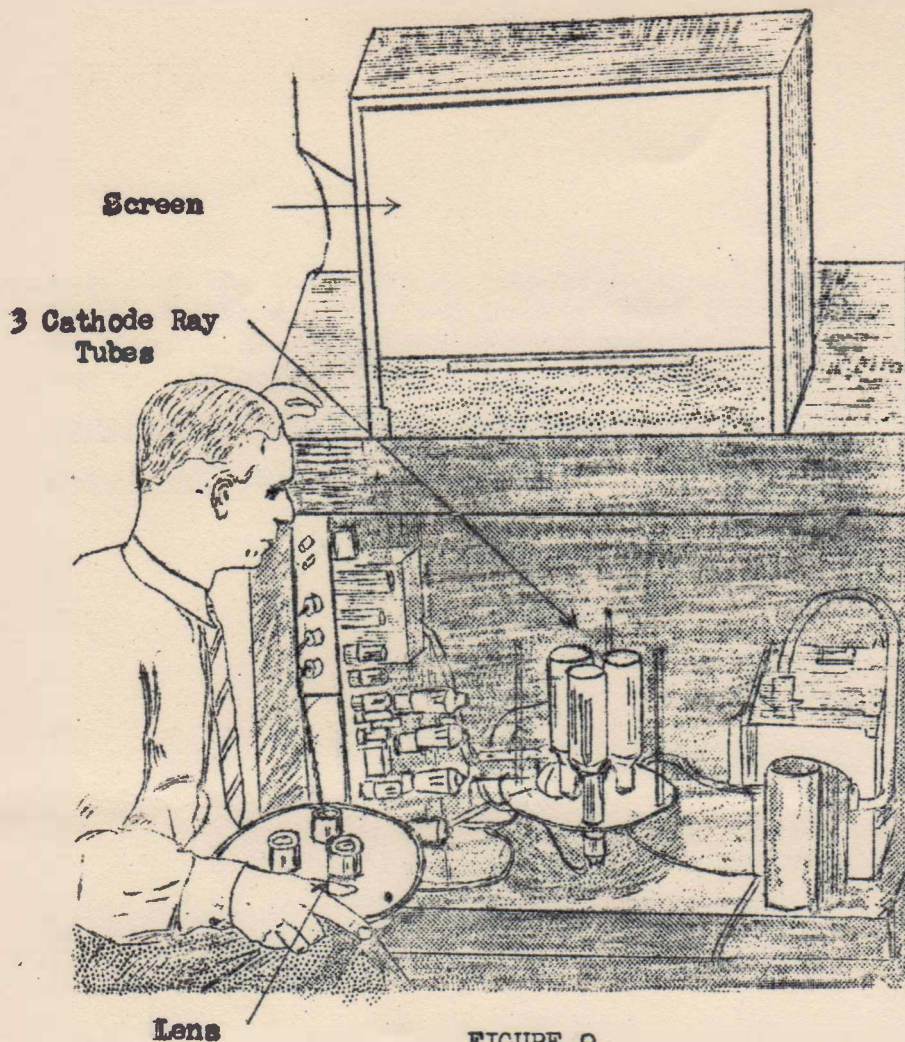

FIGURE 9.

black-and-white system. But since, there are three colour channels each television channel would have a total band-width three times (approx) as great as that for the black-and-white. This equals the figure for the sequential system operating at 150 fields per.sec.

ELIMINATION OF ROTATING DISCS IN SEQUENTIAL SYSTEM.

The sequential system could be made purely electronic by utilising, at the transmitter, the beam-splitting camera arrangement developed for the simultaneous system, and substituting, in the receiver, the three separate projection C.R.T.'s. in place of the single tube with rotating disc.

If this were done it would be necessary to "key" the three cameras at transmitter in sequence. This would involve an electronic switch which would switch into the modulator the three colour signals in turn. Similarly, at the receiver, an electronic switch would be required to "key" the separate C.R.T.'s, so that each tube would be operated in turn at field frequency. Note that only one transmitter camera, and one receiver C.R.T. would be in use at any one moment.

COMPARISON OF SEQUENTIAL AND SIMULTANEOUS SYSTEMS.

Band-Width Required. For comparable standards of definition and flicker performance,

much slower field rate may be used than is necessary for the sequential system. In America the rate has been chosen to coincide with that of the black-and-white transmissions, i.e. 60 fields per second (30 complete frames or pictures per sec.). In England, and in this country the corresponding rate (owing to the difference in power supply frequency) would be 50 fields per sec.

With this field rate the system probably gives a flicker performance superior to that of the sequential system operating at 150 fields/sec. The performance, as regards flicker, would also be much superior to that of the black-and-white system using 50 fields/sec.

The video frequency range for each colour channel in the simultaneous system would equal that of the

the two systems require about the same total band-width. The sequential system uses a single wide band, while the simultaneous system uses three separate narrower bands. In each case the band-width required is about three times that used in black-and-white transmission. Actually, for reasons given above, using equal total band-widths the simultaneous system could be expected to give superior flicker performance to that obtained from the sequential system.

BRIGHTNESS:- The simultaneous system produces a brighter picture. Reasons are:- (1) When using rotating discs the mosaic at the transmitter and the phosphor in the C.R.T. at the receiver must have rapid decay times in the sequential system. Thus the advantage of light-storage effects is lost. (2) If the trio of C.R.T.'s at the receiver use coloured phosphors the light loss due to colour filters is avoided. Since these filters absorb 85 to 90% of the light a much brighter picture will result in this way. Of course if the three tubes, together with keying arrangements, were adapted for use in the sequential system, both systems would be on a par in this respect. (3) Apart from the above points there is a fundamental reason for a brighter picture from the simultaneous system. In the sequential system only one light-source is on at any one moment, operating sequentially with different colours, whereas in the simultaneous system all three light sources operate at once. Hence, other things being equal, the simultaneous system should produce a picture three times as bright. This is one of the main considerations in favour of the simultaneous system, since the problem of picture brightness has been one of the most difficult to solve in colour television.

EQUIPMENT COST. The sequential system requires, in general simpler equipment. It uses only one camera, transmitter, antenna, receiver, I.F. amplifier, video amplifier and picture (c.r.) tube. The simultaneous system requires three separate transmitter sections and antennae for three colour carriers, usually three I.F. amplifiers and detectors in the receiver, and three separate video amplifiers and picture tubes.

OTHER COMPARISONS. One of the main disadvantages of the simultaneous system is that, so far, a direct viewing screen is out of the question. The three colour pictures must be combined by the projection method. This involves costly lens systems. A possible solution of this problem would be the use of Baird's "Telechrome", developed in England and described in the next section of this lesson.

Both systems make use of normal methods for beam scanning synchronisation. The sequential system signal however, requires extra sync. pulses to time the mechanically driven colour filter wheel. Even if the use of the colour wheel is avoided by making use of the three projection tubes, the electronic switch which keys the tubes for the different colour frames must be synchronised with the corresponding switch at the transmitter.

BLACK-AND-WHITE RECEPTION FROM COLOUR TRANSMITTER.

By tuning a black-and-white receiver to the "green" carrier of a simultaneous system signal normal black-and-white reception may be obtained. Experiment has shown that the video signal obtained from the green filter carries the majority of the fine detail of the picture, and is quite adequate for black-and-white reception.

Since each of the colour channels operates at the same field and line frequency as used for black-and-white, it would be easy to convert a normal receiver to

operate on the green carrier of a colour transmitter. All that would be required is an r.f. converter to reduce the carrier frequency to that for which the receiver was originally designed.

This is an important point when considering conversion from black-and-white television to colour. It would mean that receivers designed for black-and-white would not be rendered obsolete. For this reason alone the simultaneous system may be favoured rather than the sequential.

BAIRD'S "TELECHROME".

This is a special form of C.R. tube designed for operation on a sequential system without the use of filters (either fixed or rotating). It has made possible a purely electronic system with direct viewing of the screen. The colour picture appears directly on the fluorescent screen.

For a two-colour system the tube takes the form shown in Figure 10.

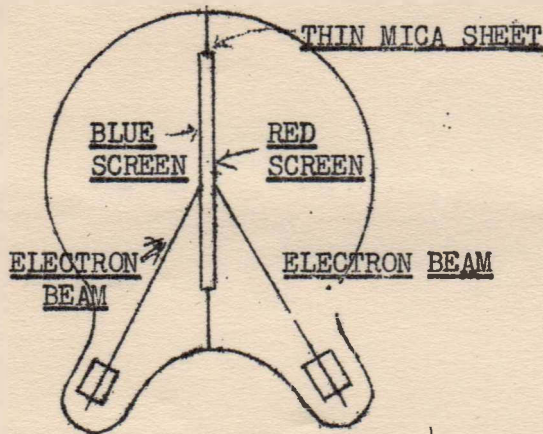

FIGURE 10.

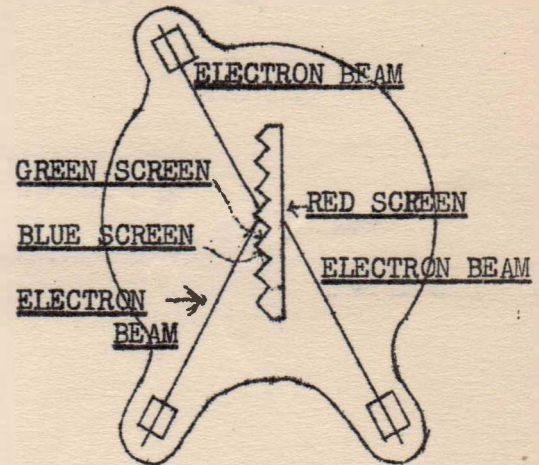

FIGURE 11.

Two electron beams scan opposite sides of a thin transparent mica screen, one side of which has been coated with orange-red fluorescent powder, and the other with blue-green fluorescent powder. The two electron beams are modulated with two video signals corresponding to the two colours. Since the screen is transparent the two colour pictures merge into a single picture in natural colour.

Where three colours are to be used one side of the screen is ridged as shown in Figure 11. The front side of the screen gives the red image, one side of the back ridges give the blue components, and the other side of these ridges produce the green. Three electron beams are now used. Note that of the two beams scanning the ridged surface, each beam only impinges upon one side of the ridges.

The tubes give very bright pictures due not only to the absence of filters, but also due to the fact that phosphors producing the correct colours are chosen. Colour phosphors produce more light than do white phosphors for the same accelerating voltages.

Baird's system is a sequential one, the three electron beams being keyed in turn for the different colours. There appears no reason however, why the tube should not be used in a simultaneous system, the three beams being continuously modulated by the separate colour signals. This should produce a very bright picture indeed.

T.FM & F. LESSON NO. 12.

EXAMINATION QUESTIONS.

- (1) Explain why the video signal produced by an ordinary television camera when viewing, a blue object against a black back ground, is identical with that obtained when viewing a red object against the same back ground.
- (2) What is the function of a colour filter?
- (3) What is meant by "primary colours"?
- (4) State the fundamental difference between the sequential and simultaneous systems of colour television.
- (5) Considering a two colour system involving rotating colour filters at transmitter and receiver, what would be the effect on the received picture if transmitter and receiver wheels were completely out of synchronism?
- (6) In the case of a sequential system explain why flicker may be noticeable when reproducing a large area of blue sky.
- (7) What is the function of a colour selective mirror?
- (8) What is the chief advantage gained by the use of a "telechrome" picture tube?
- (9) Why is a wider frequency channel required for colour television than for black-and-white television?
- (10) State one important advantage of (a) The sequential system over the simultaneous system (b) the simultaneous system over the sequential system.

AUSTRALIAN RADIO COLLEGE

E.S. & A. BANK BUILDINGS, Corner CITY RD. and BROADWAY, SYDNEY

Telephones: M 6391 and M 6392

Post Lessons to Box 43, Broadway

This lesson sheet is published for the exclusive use of students of the Australian Radio College Pty. Ltd. (All rights reserved)



T.F.M & F. LESSON NO. 13.

RECENT DEVELOPMENTS.

We shall devote the first part of this lesson to a description of the circuits and controls of two modern television receivers. In this way the student will have an opportunity of visualising as a whole, the techniques involved in the latest black-and-white (as distinct from colour) sets. At the same time the descriptions will serve to gather up the "loose-ends", and provide a revision of the detailed explanations of particular sections which have been spread over several lessons in this

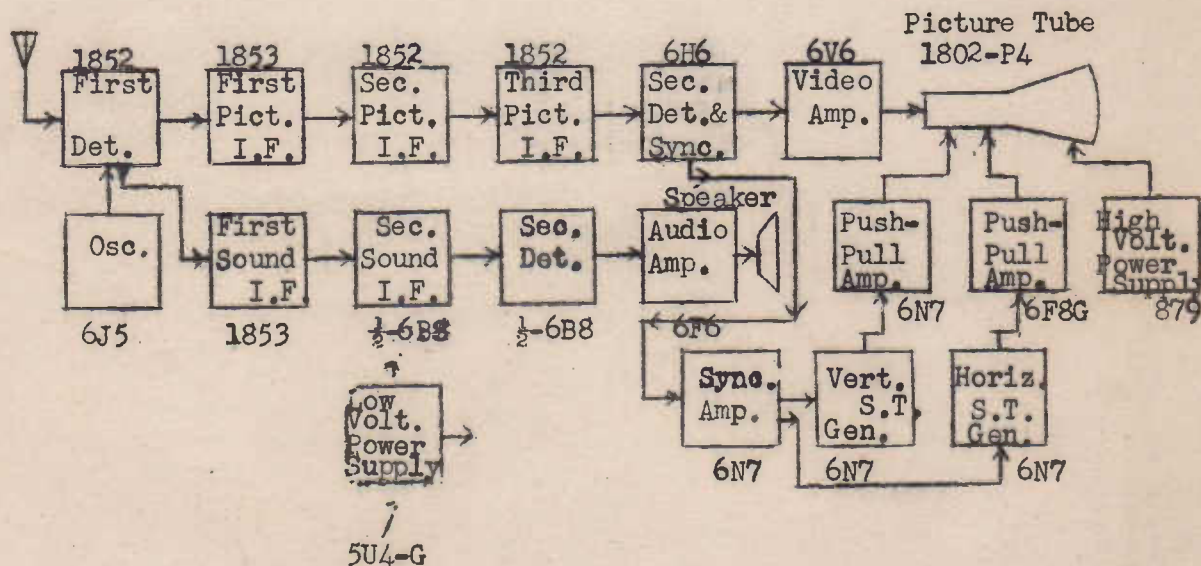

FIGURE 1.

series. We have no hesitation in spending considerable time over the circuits given, since it now appears that, for black-and-white transmission, the techniques and standards for transmission, modulation and receiver design have reached a fairly

static state, from which very little fundamental deviation is to be expected for a few years.

We would qualify the above remarks on two scores. Firstly, the sound sections of the receivers whose circuit diagram are given in Figures 2 and 4, are for amplitude modulation (A.M.), whereas, in America, frequency modulation has been decided upon as standard practice. This practice is certain to continue there for some considerable time, and if replaced would give way to the sound-on-vision method, whereby some type of pulse modulation, (already briefly described) is superimposed on the picture carrier. It seems very probable however, that for quite a time to come sound will accompany the scene either as an amplitude or frequency modulated carrier slightly separated in frequency from the vision carrier. At this stage in the course, however, it is impossible to say more about the details of an F.M. sound section of a television receiver. The subject of F.M. will be covered in later lessons.

The other exception we would like to make to our general remarks on standardisation above, concerns colour television. The latter has made remarkable progress and has reached such a standard of definition and naturalness overseas that its commercial adoption seems a certainty in the immediate future. At the present moment it has passed the stage of laboratory development and has reached that of final "field" tests. These tests, to determine the best of the several systems which have been developed, and to provide data, on one or two doubtful points of performance, seem near completion. Colour television, then, is a thing which must not be ignored, even if we are content to consider only the immediate future.

As has been explained colour transmission requires a bandwidth at least three times as great as that required for black-and-white, and a very much higher portion of the frequency spectrum - 400 to 1,000 m.c. - has been chosen for its use. These extremely high frequencies have never before been used for civil or commercial purposes, and were only used extensively for the first time during the latter years of the war for improved operation of Radar devices. The use of such frequencies will, of course, mean considerable modification to techniques used in receiver design. This development of colour television will not, however have any immediate effect on the standards for black-and-white television. The plan, both in England and America, is, eventually, to introduce colour television as a separate and additional service, not materially affected the present standards decided upon for the black-and-white system.

A TYPICAL SMALL-TUBE TELEVISION RECEIVER.

Figure 1 shows a block diagram of a typical television receiver using a 5 inch-tube of the electrostatic type. Such a receiver would be representative of the mantel-models or less ambitious cabinet sets at present in use in America.

The full circuit diagram is given in Figure 2.

It will be observed that the receiver contains seventeen tubes, seven of these (6H6, 6B8, 6F8, and four 6N7's) being dual-tubes.

Referring to the circuit diagram of Figure 2, and commencing at the antenna, note that five signal channels are provided for. For each of these we have a separate input circuit and a separate oscillator circuit. The desired station is chosen by means of a switch. In passing it might be mentioned that in America sets are equip-

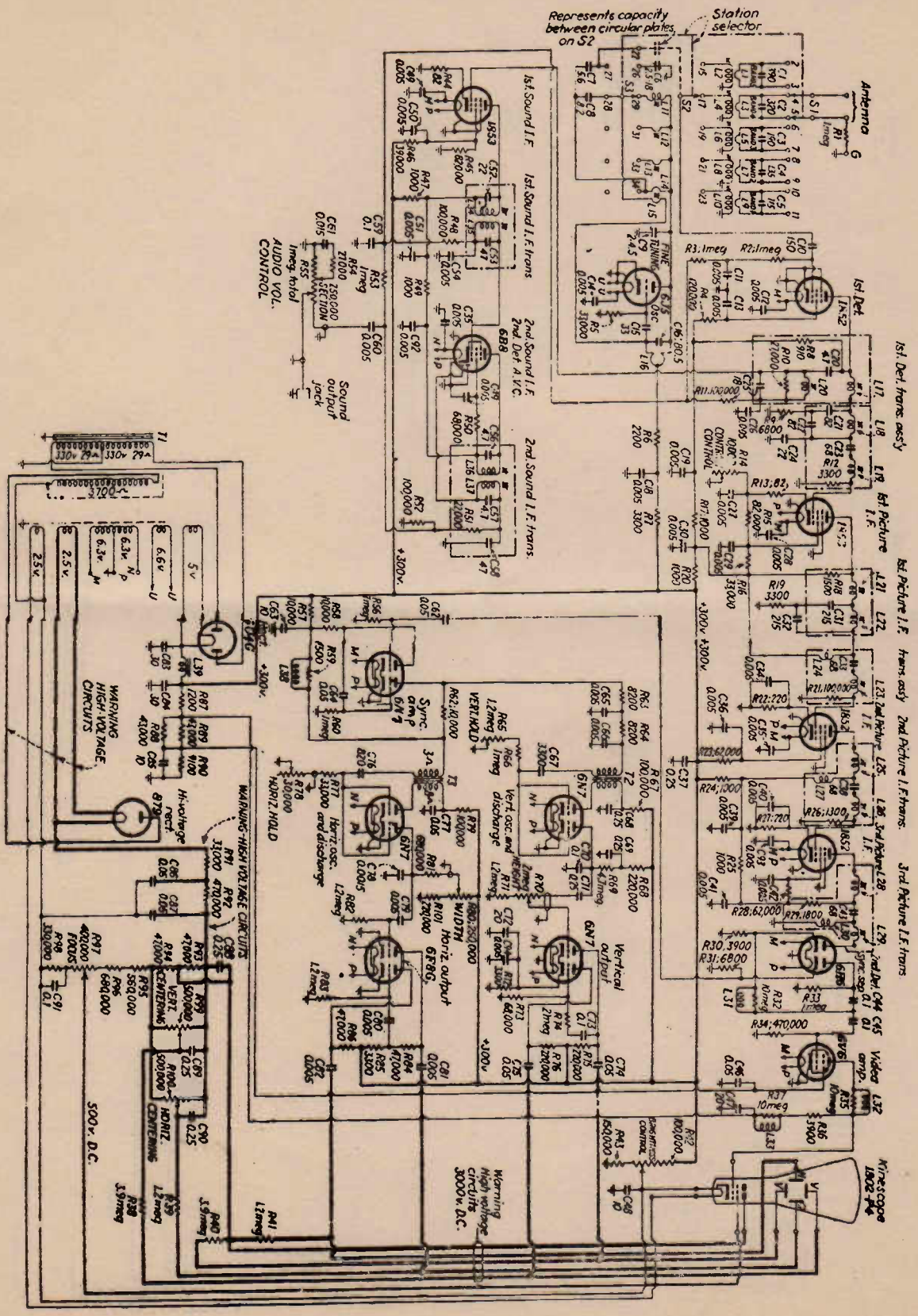

Fig 2

ped for anything up to five channels, although, even there, at present no more than two or three stations are in operation in any one locality.

Each input circuit is broadly tuned to accommodate both vision and sound carriers of the signal. These, for any one transmission extend over a wave-band of about 6 megacycles.

The primaries of the input circuits each consist of but a single turn, this being usually a metal strap stamped from sheet, and intended to match the 75 ohms characteristic impedance of a transmission line from the antenna.

For frequency conversion a single mixer tube (frequency changer) is used for vision and sound, this being a 6AC7 (1852) of high mutual conductance -- about 9,000 microamps. per volt. A separate oscillator (6J5) produces an oscillation, which when injected into the mixer together with the two carriers develops the two desired I.F.'s. for vision and sound. This system has already been described. The separation of the sound and vision signals is then carried out by the respective I.F. tuned circuits.

The vision I.F. stages employ an 1853 valve followed by two 1852's. The 1853 is similar to the 1852 except that it is a remote cut-off (variable mu) tube while the latter have a sharp cut-off characteristic. It should be observed that manual gain control is operated upon the grid of this remote cut-off 1853. This provides a variation of the overall gain of the picture receiver, and is known as the contrast control.

The vision I.F. tuned circuits are of the band-pass type which have a "flat" characteristic over the wide frequency band representing the modulated vision signal.

The duo-diode 6H6 is used for vision detection and sync. pulse "clipper". The "detected" (demodulated) signal from the first diode section is passed to the final video amplifier (6V6) and also to the second diode section of the 6H6. R33 and C44 develop a negative bias on the plate of this diode of such value that the valve passes current only when the signal rises above the black level, i.e. only for sync. pulses. Positive pulses representing these sync. pulses are taken from the cathode of the sync. separator and applied to the grid of the 1st triode section of the sync. amplifier (a 6N7). This tube acts as an amplifier, each section reversing the polarity of the signal. Since the polarity of the pulses is positive on the 1st grid, the output from the second plate will also be positive.

Returning to the picture video signal, this is applied, from the detector, through a "peaking" coil to the grid of the 6V6. The latter tube is operated without bias. The grid circuit, together with the coupling condenser and leak, thus forms a D.C. Restorer for re-insertion of the D.C. component, as previously explained. The output of the 6V6 is directly coupled to the control electrode of the C.R.T. Thus no further loss in D.C. component is suffered. This direct coupling is made possible by operating the cathode of the C.R.T at a voltage of little more positive than the anode of the 6V6. This system has been discussed in the lesson on "power supplies".

Returning to the synchronising circuits the separation of the frame and line sync. pulses is brought about immediately following the sync. amplifier. The inductance L38 acts as a differentiating circuit developing high peaks of voltage on the sharp edges of the line sync. pulses. These voltage pulses, occurring at line frequency,

are applied, for synchronising purposes, to the horizontal scanning generator. The series of broad sync. pulses, which occur between frames is applied to a double integrating circuit consisting of R63, C65, R64, and C66. The time constant of each of these R-C sections is long (comparatively), and the net effect is to integrate, or "add-up" the separate frame pulses into a single large pulse. These large pulses emerging from the integrator occur at frame frequency, and are used to "time" the vertical scanning generator.

Both scanning generators are of the blocking oscillator and hard-discharge tube variety. The first triode section, in each case, serves as the single-cycle blocking oscillator which produces sharp pulses of voltage at a frequency determined by the time constant of the R-C circuit consisting (in the case of the horizontal scan generator) of the condenser C76 and resistor R78. The latter is a rheostat which provides an adjustment to the frequency of pulse production. When the latter frequency is adjusted approximately to its correct value (i.e. line frequency) the line sync. pulses become effective in "locking" the oscillator exactly to line frequency. Thus horizontal lines will be traced out "in step" with the incoming signal information. If the control is far off adjustment the oscillator will operate at its own frequency, the sync. pulses having no chance of assuming control. When this occurs the C.R.T. will trace out horizontal lines at a frequency differing from that of the transmitter, and the effect is a movement, or drifting of the whole picture as a whole across the screen in a horizontal direction. Adjustment of the control has the effect of "holding" the picture stationary on the screen. The rheostat (R78) is therefore called the Horizontal Hold Control.

Vertical movement of the picture is prevented by adjustment to the rheostat R65. This acts in an exactly similar manner to the Hor. Hold Control, and is called, naturally, the Vertical Hold Control.

These two "Hold" controls require only rare adjustment and are usually only accessible at the back of the receiver.

The second triode section of each scanning generator tube (6N7's) serves to discharge the condenser which, together with its associated condenser forms an R-C charging circuit. This circuit consists (in the case of the horizontal scanner) of the C78 and R81. The condenser is charged through the resistor from the B+ supply. The triode section of the 6N7, "triggered" by the scan. generators' pulses, periodically discharges the condenser. In this way a saw-tooth voltage is developed across C78. The vertical scanning generator operates in a similar way.

The output amplifiers for the saw-tooth voltages are of interest. These consist of a 6N7 for the vertical output and a 6F8 for the horizontal output. Both valves have two triode sections, and act as "Paraphase" push-pull amplifiers. Consider the 6F8. The input voltage (saw-tooth) is applied to the first grid, and an amplified 180° out-of-phase voltage is developed across the plate-load, consisting of R84 and R85 in series. The stage gain is about 15. Of this output voltage, that developed across R85 is applied to the second grid of the 6F8. Since R85 (3300 ohms) forms about $\frac{1}{15}$ of the total plate load ($R84 + R85 = 47,000 + 3,300 = 50,300$ ohms) about $\frac{1}{15}$ of the output of the 1st triode is applied to the second grid. Hence the signal voltage on the grid of the second triode will equal that on the grid of the first triode, but the two will be out-of-phase. Consequently equal, and out-of-phase voltages will appear on the two plates. These two output voltages

are applied through condensers C81 and C82 to the horizontal deflecting plates, producing a push-pull deflection. The vertical output amplifier acts in a similar way. An important point about the paraphase amplifier is that the total peak-to-peak output is doubled that obtained from each tube section. This is an important consideration when large deflecting voltages are required with limited high-tension available for the amplifier tube plates.

The power supplies use but a single transformer operating a 5U4G (for the "low-voltage" supply) and an 879 (for the "high-voltage" supply). The circuits are of standard type explained in detail in the lesson on power supplies. The student should trace out the circuits in detail, noting particularly the operation of the controls for Horizontal and Vertical Centering (or Shift), and the method of obtaining bias for the C.R.T.

A LARGE SCREEN TELEVISION RECEIVER.

Figure 3 shows, in block form, the different sections of a larger receiver designed for operation of a 12" screen C.R.T. The full circuit diagram is given in Figure 4. This receiver employs electro-magnetic focusing and deflection. The magnetic tubes are becoming ever more popular for home receivers. They are cheaper than the electrostatic type, and may be made very much shorter in length. This allows of a tube of large diameter to be fitted into the confines of the radio cabinet.

The circuit involves 22 tubes in all (including the C.R.T.) many of these serve a dual purpose. The student should study the circuit noting how the various principles explained in previous lessons are applied in the complete receiver. The points discussed in the following paragraphs should be particularly noted.

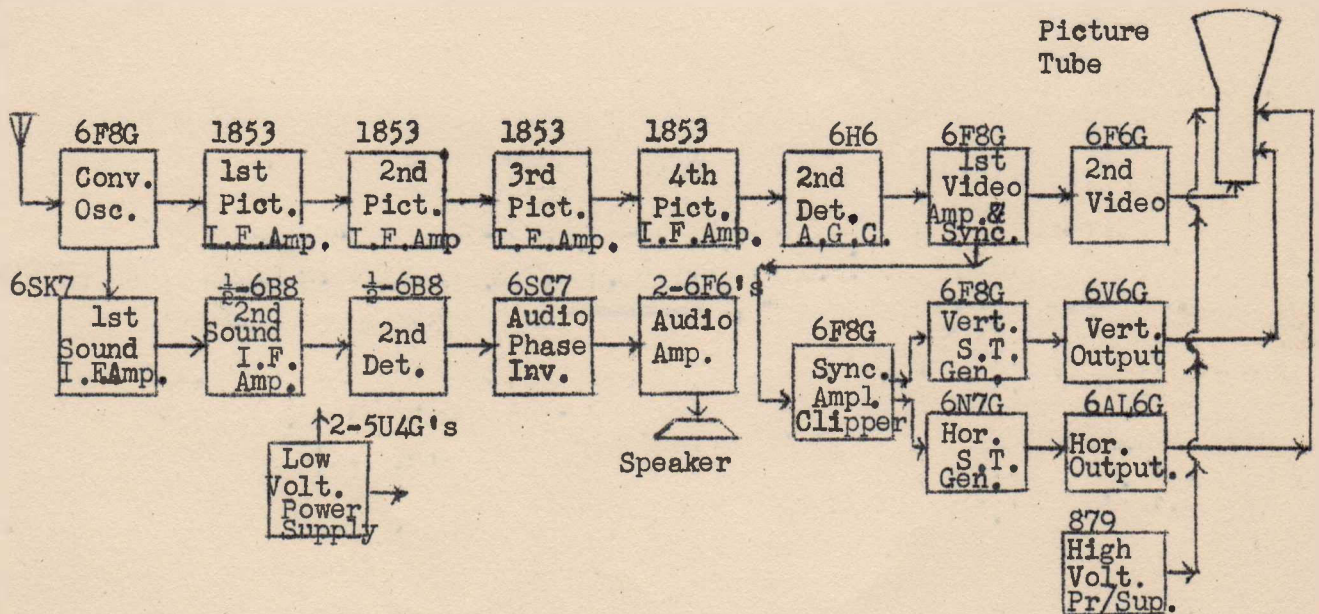

FIGURE 3.

The converter employs but one tube. This however is a 6F8, one triode section of which is used as oscillator. The other triode section serves as mixer. Thus the functions of generating the heterodyne oscillation, and mixing it with the incoming signal are kept separate.

Station selection is carried out by push-button operating in the input and the oscillator circuits. Vernier tuning, operating only in the oscillator circuit, allows the selected station to be finely adjusted. In practice this adjustment is carried out while listening to the sound. Since picture and sound carriers are separated in the television channel by a fixed frequency difference, correct adjustment of the sound will ensure accurate picture signal tuning.

Four stages of picture I.F. amplification are used. Automatic Gain Control, obtained from one diode section of the 6H6 video detector, operates on the grids of the first three I.F. amplifiers. The grid bias of these tubes may also be controlled manually (for gain control) by means of the potentiometer R67, which picks off a fraction of a 30V. negative potential developed in the "low-voltage" supply. This controls is, of course, the "Contrast Control".

Sync-pulse "clipping" is performed by the second triode section of the 6F8, the first section of which serves as first video amplifier. This clipper triode operates with a large automatically developed bias, grid-current flowing only on the tips of the sync. pulses.

D.C. Restoration is carried out at the control electrode of the C.R.T. itself. No direct coupling is employed between the final video amplifier and the control electrode. C.R.T. bias is applied by operating the control electrode slightly positive with respect to ground and tapping off a still more positive voltage, for application to the cathode, by means of R52 (Brightness Control) which operates in a resistor network connected between B+ and ground.

For scanning, a multivibrator type oscillator is used for generating the line (horizontal) saw-tooth wave. A Blocking Oscillator is used for vertical scanning. In each instance the output is amplified by a power output type valve, yielding saw-tooth currents, of sufficient amplitude to operate the deflection coils.

The Power Supplies employ separate transformers for "low-voltage" and "high-voltage". The low-voltage supply is of the full-wave type using a complete 5U49 for each diode. Note that the diode plates are connected together in each tube. This arrangement is necessary to yield the large current output consumed by the numerous tubes in the circuit. The R-C filter of the "high-voltage" supply consists of R80, C77 and C78. Notice that this filter follows the bleeder R81, R82, R83, R84, R85, R86. Six separate resistors rather than a single one of equivalent value, are used for the bleeder in order to obtain adequate power dissipation and to minimise surface leakage.

Focus of the beam is achieved by passing a fraction of the low-voltage supply current through the focusing coil. Adjustment is made to the focusing current by means of rheostat R75 (Focus Control).

TELEVISION RECEIVER CONTROLS.

At different points in these lessons we have described the various controls incorporated in a television receiver. The mode of operation of each control has been

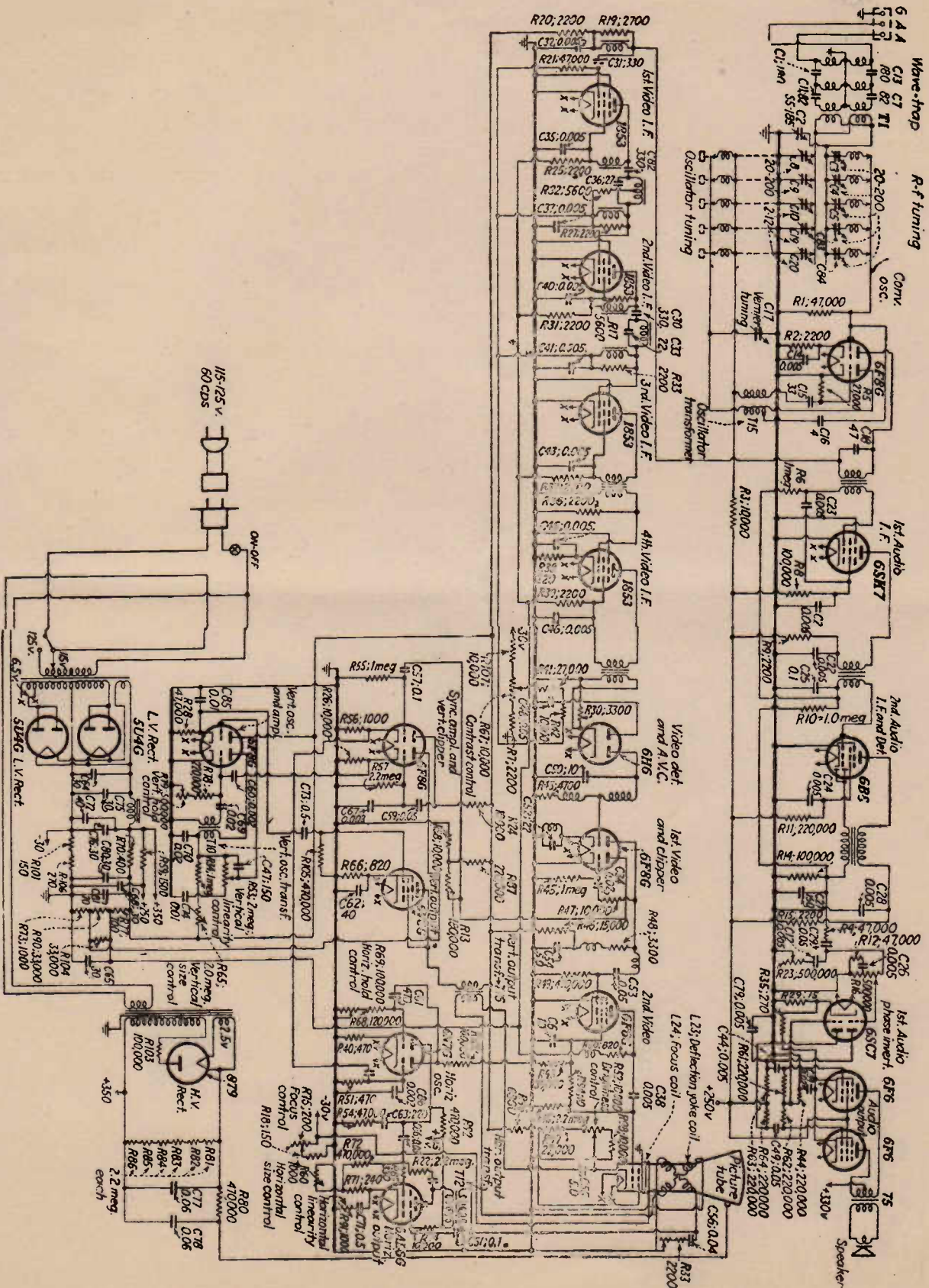

explained when dealing with the particular section of the receiver involved. At this point the student will probably appreciate a summary of the various controls, and a statement of the present trend as to their incorporation in a modern receiver. They are:-

- (1) Station Selector. A switch or set of push-buttons operating so as to bring into circuit sets of coils and/or condensers (aerial, r.f, oscillator) for the several channels for which the receiver is designed. In England, where sets are manufactured only for operation on the single B.B.C. broadcast this control is not provided. In America sets are manufactured to receive anything up to five or six different transmissions.
- (2) Fine Tuning. This operates a trimmer condenser providing a small variation of oscillator frequency, and is provided principally so that the operation may ensure that the sound I.F. frequency falls within the narrow band-pass provided. Where the receiver is designed for but a single channel this control may or may not be provided.
- (3) Contrast Control: This is really a gain control, operating upon the picture I.F. amplifier. As has been explained variation of the gain principally affects the contrast between high-lights and dark sections of the picture. This is one control which is always to be found at the front of the cabinet.
- (4) Brightness Control: Adjusts the bias on the C.R.T. control electrode. Although this control allows adjustment to the over-all brightness of the picture, only very little variation is permissible, because the C.R.T. bias must operate at or near the blanking level of the video signal applied to the tube so that black objects appear black or so that the "flyback" trace is not visible. Adjustment affects mainly the detail in the dark parts of the picture. The control is often of the pre-set type, available only at the back of the receiver, or on the chassis. It has to be operated in conjunction with the contrast control.
- (5) Horizontal and Vertical Centering Controls: Also called Picture Shift, Picture Position etc. Controls. They adjust the position of the picture on the screen in a horizontal and vertical sense respectively. In the case of the electrostatic type C.R.T. they operate usually in the bleeder network of the high voltage power supply. When electromagnetic tubes are used they are purely mechanical controls, allowing adjustment of the deflection coils on the tube's neck. These controls are almost invariably of the pre-set type.
- (6) Picture Width and Picture Height Controls: These control the amplitudes of the horizontal and vertical saw-tooth (scanning) voltages or currents, and hence allow adjustment of the picture dimensions on the screen. They usually operate so as to vary the deflection amplifiers' gains. Usually "pre-set" controls. See R60 and R65 in Figure 4.
- (7) Horizontal and Vertical "Hold" Controls: These allow some adjustment to be made to the horizontal and vertical scanning frequencies respectively. They operate on the scanning generators. Incorrect adjustment will mean that these generators are not operating close enough to the transmitter's scanning frequencies for the synchronising impulses to be effective. The result is a movement of the picture as a whole over the screen in a horizontal or vertical direction. They are of the "pre-set" type.

(8) Focus Control. Adjusts the C.R.T.'s electron beam focus, to produce a small bright spot on the screen. The adjustment determines the sharpness or clarity of the picture. The focus control is usually of the "pre-set" type, but in some receivers it is brought out to the front panel.

(9) Sound Volume and Tone Controls. Operate on the sound receiver as in ordinary broadcast practice.

PRESENT TRENDS IN TELEVISION RECEIVER CONTROL.

The present trend, particularly in England, is to reduce the number of controls available to the operator at the front of the receiver to a bare minimum. Some receivers in that country have only one television picture control available - the Contrast Control. Additionally, of course, there is the sound volume control. These are essential because their setting will depend upon the strength of the received vision and sound carriers at any one time. All other controls are then of the "pre-set" type, intended to be adjusted only by a technician when the receiver is first installed, or when component replacements are made.

In America the practice has been to provide more knobs for the operator to manipulate. Next in importance to Contrast Control are, of course, "fisc tuning" and "station selection", then "Focus" and "Picture Brightness".

TELEVISION RECEIVER TYPES.

Receivers in production overseas may be divided into the following types.

(1) Vision Receiver with Sound Converter. This type is the cheapest available and is intended for use in conjunction with an ordinary radio receiver having pick-up terminals. In this way the audio sections and speaker of the broadcast receiver may be utilised for the television sound reception.

(2) Television Vision and Sound Receiver. A self contained set for receiving the television vision and sound broadcasts. Will not pick-up sound transmissions from broadcast or short-wave stations.

(3) Complete Television and Broadcast Receiver. Incorporates vision and television sound receiver plus an ordinary broadcast (sound) receiver.

(4) Complete Television and World Range Receiver. This is the same as (3), except that the purely sound receiver covers also the short-wave band. Often a phonograph motor and pick-up are also provided.

SCREEN PRESENTATION.

We may also classify receivers according to the method employed for viewing the screen. The smaller receivers universally use direct viewing of the C.R.T. screen. Most of the larger receivers (with screens up to about 12" or even 14" screens) also use this method. Figure 5 shows a "direct viewing" receiver incorporating television vision and sound receivers and an all wave radio receiver. Some receiver, employing the larger tubes, have a mirror in the cabinet lid which reflects the image from the screen of the C.R.T. which is placed in a vertical position. Figure 6 shows one of this type.

A large screen projection type receiver is shown in Figure 7. This employs a 3" projection type tube, operating at 25,000 V. The image is projected first on to a mirror, thence to the back surface of a ground-glass screen measuring 22" X 18". The screen rises automatically into position when the cabinet lid is opened. The receiver is intended for use in large rooms such as hotel lounges, clubs, small halls etc.

CARRIER-DIFFERENCE RECEPTION OF TELEVISION SOUND.

One of the chief obstacles to be overcome in introducing television into a country is that of producing a receiver of sufficiently low cost. The public will not, naturally, outlay a large sum for an extra receiver, particularly in the early stages of television when, perhaps, only several hours per week of television service is provided.

The higher cost of television receivers, compared with the ordinary broadcast sets, is largely due to the great number of components required. In the reception of a television signal we have two separate aspects of the signal to consider -- the vision "information" and the sound "information". In general, the two signals are dealt with independently within the receiver, i.e. separate channels are provided. In the standard type of black-and-white receiver in use overseas the only sections which are common to both vision and sound signals are the input circuits, the oscillator, and (usually) the mixer. Separate I.F. amplifiers, detector, and video or audio amplifiers are used. The result is a very large number of valves (14 plus the C.R.T. is about a minimum), together with associated condensers, resistors, coils etc.

The use of Pulse Modulation, explained in an early lesson, or "bursts" of sound sub-carrier (see lesson on Colour Television) have been suggested, and in some cases, used, to eliminate at the receiver, the separate I.F. channel. These, however,

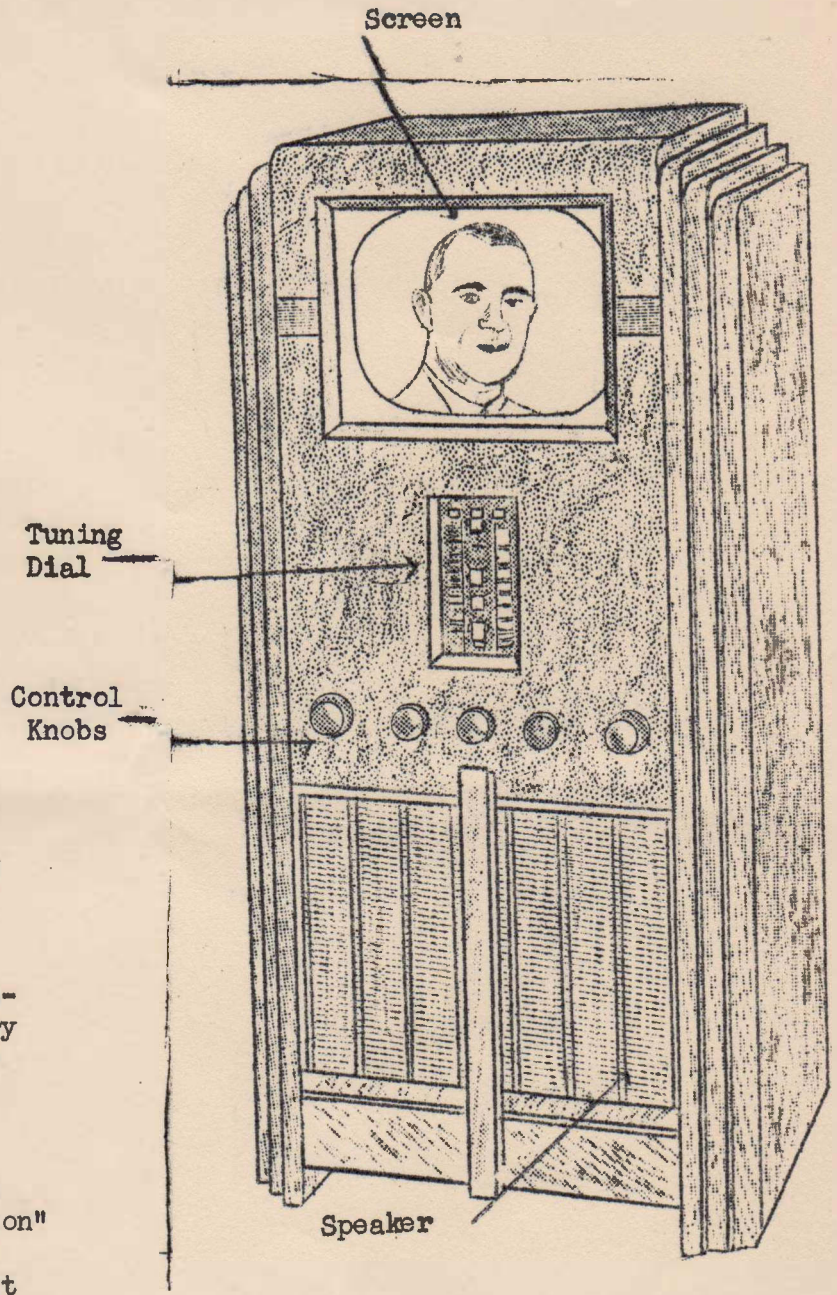

FIGURE 5.
A DIRECT VIEWING RECEIVER (PICTURE 10" X 8".)

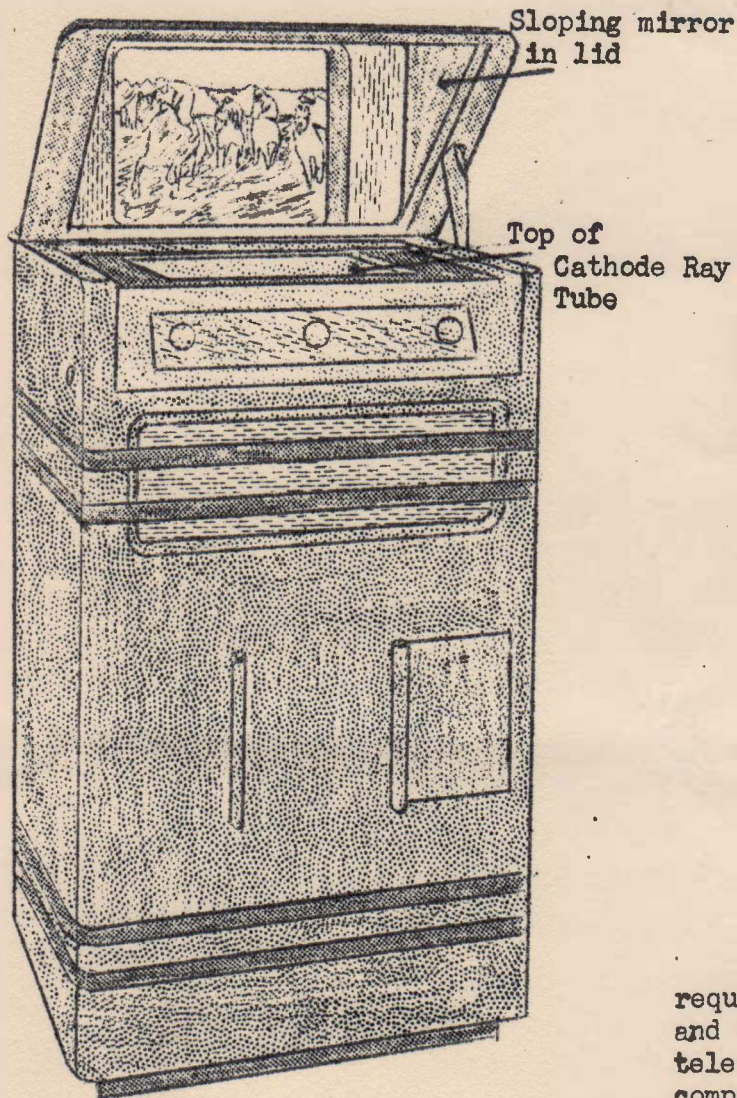

FIGURE 6.
RECEIVER EMPLOYING MIRROR VIEWING OF
C.R.T. SCREEN.

will operate upon the standard television signals now in use in America. Such a signal (to refresh the student's memory) consists of a channel of total width 6 megacycles. The vision carrier is amplitude modulated, and, together with side-bands occupies a channel 4 mc. wide. The sound carrier is frequency-modulated and lies in frequency 4.5 m.c. below the vision carrier. The sound carrier is varied in frequency (by modulation) 25 kilocycles/sec. above and below the control frequency. Thus the sound carrier is 50 kilocycles/sec. in width. A receiver operating upon the Carrier-Difference Principle not only dispenses with a separate I.F. section for sound, but also requires little in the way of audio amplifiers. The saving in tubes and other components will therefore well be realised. Just how this rather amazing receiver operates will now be explained.

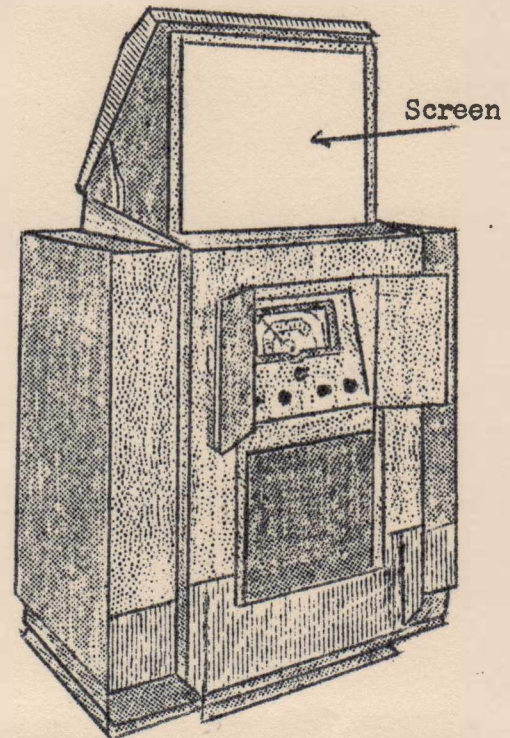

FIGURE 7.
A PROJECTION TYPE RECEIVER.

require an entirely new transmission system and have, so far, been confined to colour television. In addition they provide a comparatively poor signal-to-noise ratio for the sound, which is radiated only for a small percentage of the total time. Although improvements will undoubtedly be made in this respect.

The Carrier-Difference method of reception

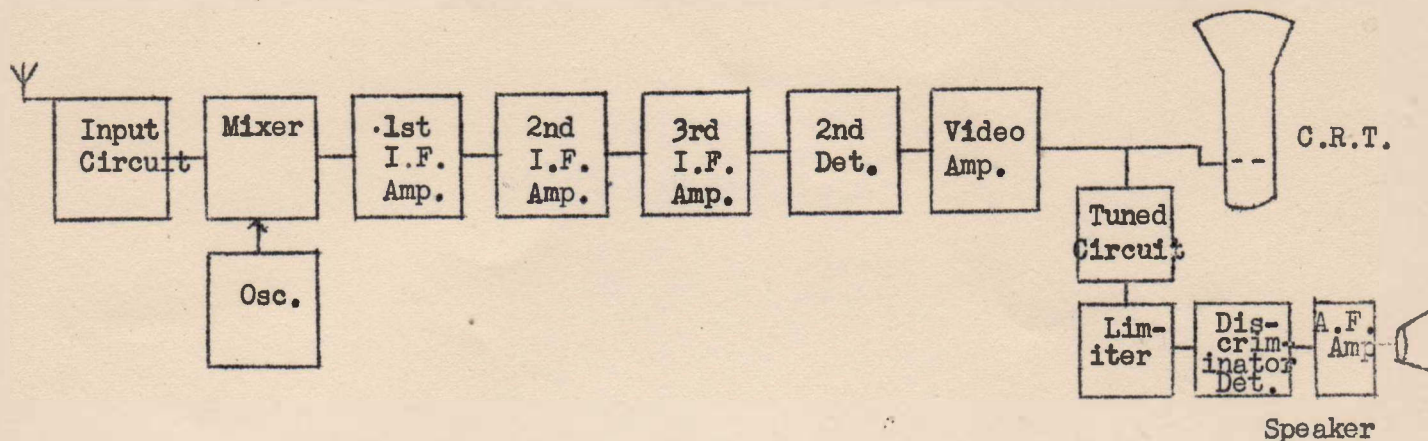

FIGURE 8.

A block diagram of the receiver is shown in Figure 8. As stated there are no sound I.F. amplifiers. The sections from input to C.R.T. grid follow along fairly conventional lines for a vision receiver. The converter (oscillator and mixer) "beats down" (heterodyne principle) both picture and sound signals to their intermediate frequencies. The I.F. amplifiers are sufficiently broadly tuned to cover the entire television channel vision and sound -- 6 megacycles/sec. wide.

Suppose after the converter stage the picture I.F. carrier is 12.75 m.c. and the sound carrier is 8.25 m.c. -- a frequency difference of 4.5 m.c. The sound carrier, frequency modulated, will have its frequency varied or "swung" (at an audio frequency rate) by anything up to 2.5 kilocycles (.025 m.c.) above and below the centre frequency of 8.25 m.c. That is the sound carrier will continually be changing between maximum limits of 8.275 m.c. and 8.225 m.c. These frequencies, together with the picture carrier and its side-bands are applied to the detector stage.

THE SECOND DETECTOR'S OUTPUT.

Let us now recall the action of an ordinary detector, such as a diode, upon an amplitude modulated wave. Figure 9 shows at A such a modulated wave. The "modulation envelope" is shown by the dotted lines. This wave may be regarded as consisting of the carrier wave and a sideband (both radio frequency) differing in frequency by an amount equal to the modulating frequency. These are shown at B (Figure 9). In other words we may say that the result of "adding" the carrier and sideband of Figure 9B is to produce the modulated wave of Figure 9A. Usually there are two side-bands for every modulating frequency, but one is sufficient (remember "single-band" transmission). The one shown in Figure 9B is the lower side-band, since it is lower in frequency than the carrier.

On detecting the modulation wave of Figure 9A the detector's output will contain a component as at C (Figure 9). This component is of the modulating frequency. Now instead of visualising the detector's input as shown at A, we may regard it as the carrier and sideband equivalent of Figure 9B. The output, of course, is still as at C.

From the foregoing discussion the following important point emerges. If we apply to a detector's input two frequencies f_1 and f_2 (both of constant amplitude) a frequency equal to their difference, $f_1 - f_2$ (or $f_2 - f_1$) will appear in the output. This is apparent also in the case of a frequency converter in a superheterodyne

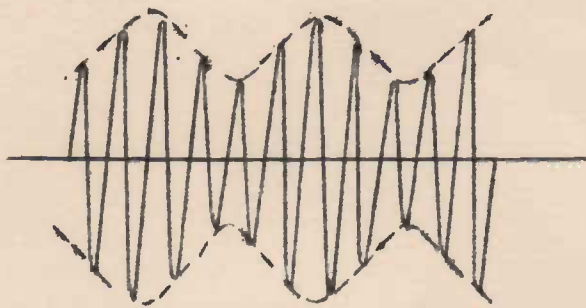

(A) Amplitude Modulated Carrier

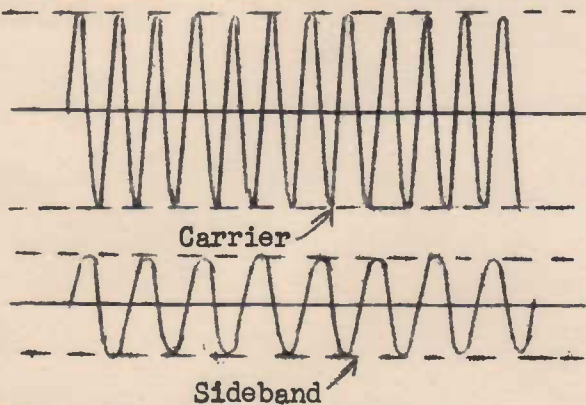

(B) Carrier and Lower Sideband.



(C) **FIGURE 9.**

For example at the moment when the sound carrier is at the central frequency 8.25 m.c. the detector output will contain a component equal to 4.5 m.c. (i.e. 12.75 m.c. -- 8.25, i.e. difference between picture and sound carriers). At a moment when the sound carrier has moved up to 8.275 m.c. (due to F.M.), the detector output will contain a component of 12.75 -- 8.275 = 4.475 m.c. Again, if the sound carrier is at 8.225 m.c. we will obtain a component of 12.75 - 8.225 = 4.525 m.c.

Thus the detector output contains, in addition to the video frequencies representing the picture detail, a frequency which varies about 4.5 m.c. (Difference between the two carriers). This frequency may go up to 4.525 m.c. or down to 4.475 m.c. -- a variation of .025 m.c. or 25 kilocycles on either side of the central frequency. The rate at which the frequency varies up and down represents, of course, the audio frequency. Hence the detector produces a 4.5 m.c. sound carrier, frequency modulated at audio frequency.

This sound signal is amplified together with the video frequencies proper, by the video amplifier(s) of the receiver. Hence the video amplifier(s) must be "flat" up to, at least, 4.525 m.c.

The sound signal is separated from the video signal right at the C.R.T. control electrode as shown in Figure 8. This is achieved, as shown, by means of a circuit tuned to 4.5 m.c. This part of the circuit is shown in detail in Figure 10. The circuit L1 C1 forms a parallel resonant circuit (rejector circuit) tuned to 4.5 m.c. This circuit will offer a large dynamic impedance to frequencies in

receiver where the signal frequency and oscillator produce an intermediate frequency output equal to their difference.

Returning now to the television receiver. We have applied to the detector's input the picture carrier (frequency 12.75 mc), the side-band frequencies of the picture signal, together with a frequency varying around 8.25 m.c. going, at times up to 8.275 m.c, and down to 8.225 m.c. The latter, of course, represents the F.M. sound signal. The detector will act upon the picture signal side-bands together with the picture carrier, to produce the various video frequencies representing the picture detail.. Each of the latter, of course, will have a frequency equal to the difference between the carrier frequency and the particular picture side-band frequency. In addition, the detector will have no way of distinguishing between the sound signal frequency and a side-band of the picture signal. In other words the detector will treat the sound signal frequency just as though it were another side-band of the picture carrier wave.

the vicinity of 4.5 m.c. In this way the frequencies representing the sound signal will be blocked from the C.R.T. control electrode. At the same time a large "circulating" current of frequency 4.5 m.c., or thereabouts, will flow around L1 C1 (this is a characteristic, remember, of a parallel tuned circuit). This current will induce a large voltage in L2 (tuned by C2). The latter voltage, representing a sound carrier or intermediate frequency of 4.5 m.c, frequency modulated with the audio frequencies, is from this point passed to a "limiter" stage, thence to the "discriminator". The operation of the latter circuits will be explained in detail under the section on "Frequency Modulation". It might be mentioned here, however, that the "discriminator" is really a F.M. detector. The audio frequencies emerging from the discriminator are then passed through audio amplifiers of conventional design to the speaker. Not much audio amplification will be necessary, because the sound signal, in the form of the 4.5 m.c. F.M. "carrier" has been amplified by the video amplifiers of the receiver.

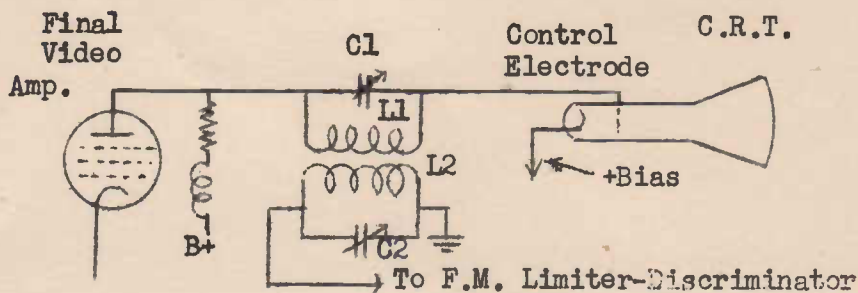

FIGURE 10.

OTHER ADVANTAGES OF THE "CARRIER-DIFFERENCE" SYSTEM.

In addition to simplicity and low cost of the carrier difference type of receiver, the system confers other important advantages. All these advantages depend upon the fact that the sound "carrier" frequency finally applied to the discriminator-detector is fixed at the difference between the original picture carrier and sound carrier radiated by the transmitter, viz: 4.5 m.c. This cannot be altered by, say, variations of local oscillator frequency, as in the conventional system.

If the oscillator frequency changes or drifts in a conventional receiver due to B+ changes caused by heating up etc. the sound I.F. frequency will change by an equal amount. This may move the frequency of the signal (which is F.M.) sufficiently far away from the operating point for which the discriminator-detector is designed to cause the sound to fade out or become distorted. If the power supply voltage changes are rapid (due, for example, to a ripple voltage at power frequency) the sound I.F. is caused to change at the same rate. In other words the sound I.F. is frequency modulated at ripple frequency. The result is a power supply hum in the speaker.

These effects are not present in a receiver designed for carrier-difference reception. Any change in sound I.F. due to oscillator frequency changes are counter-balanced by an equal change in picture I.F. In all cases, as stated previously, the F.M. signal applied to the discriminator has a centre frequency equal to the difference between vision and sound carriers -- and this is fixed at the transmitter.

Microphonics, due to oscillator changes caused by vibration of the electrodes, are similarly avoided.

A further advantage is that the tuning of the receiver is simplified. In the conventional receiver the tuning is carried out on the sound. The tuning (which controls the local oscillator frequency) is accurately adjusted for maximum sound. This automatically gives the approximate correct adjustment for the picture. The tuning involves careful adjustment of the control so that the sound I.F. produced falls within the narrow I.F. amplifier channel provided for it. It is quite possible to have the picture roughly tuned in, yet the sound is inaudible. This is due to the fact that the picture I.F. channel is so much wider (approx. 50 times) than that provided for the sound. In the case of the carrier-difference receiver, on the other hand, the operator may tune for the clearest picture possible. The picture fades, as the tuning control is turned away from the correct point, long before the sound does. This is a feature unavailable in the conventional receiver.

The art of television is rapidly advancing and improving, almost every month we see some new idea, perhaps an improvement to an existing system, perhaps a simpler and cheaper way of performing some task or perhaps some substantial change, but the principles set down in the foregoing lessons may be taken as fundamental. With the tremendous amount of money and effort spent bringing television to its present high state of development, it is inconceivable that the fundamental principles of scanning a scene into individual picture elements which are used to modulate a carrier wave and thus are transmitted one by one to be reassembled at the receiver into complete pictures at a rate exceeding 20 times per second, will be superseded for many years, if ever. Of course, there will continue to be improvements and advancements and new systems which will carry out the fundamental principles mentioned above, more efficiently, but the information contained in these lessons will form a sound foundation upon which an understanding of future developments can be based.

We do not know as yet how long it will be before a television service is established in Australia nor the exact technical nature of the service but it will certainly be based on the principles explained in the foregoing lessons and consequently a thorough familiarity with the contents of these papers will place the student in a position which will enable him to easily understand and appreciate the technicalities of whatever system is ultimately introduced.

T.FM & F. LESSON NO. 13.

EXAMINATION QUESTIONS.

- (1) If the horizontal centering control (R100) of Figure 2 were moved towards the top of the page, in which direction would the picture on the screen move (viewed from the front of the screen)?
- (2) State 2 advantages of a "Paraphase" amplifier for deflection voltage amplification compared with a single tube output.
- (3) Why must C74 and C81 (Figure 2) have a very high voltage rating?
- (4) Why are electro-magnetic tubes preferable to electrostatic types when a large screen is required?
- (5) Why is it essential to provide a knob on the front of a receiver for Contrast Control whereas most other controls may be of the "pre-set" type?
- (6) What is the chief advantage of the carrier-difference method of reception?
- (7) Why is very critical adjustment of the oscillator frequency unnecessary in a "carrier-difference" receiver?
- (8) Explain how you would proceed to adjust the fine-tuning control.
(a) in the case of a conventional receiver (b) in the case of a "carrier-difference" type of receiver.
- (9) At what point in a "carrier-difference" receiver is the sound signal extracted from the vision signal?
- (10) Why is it absolutely essential that the video amplifiers of a conventional carrier difference receiver be approximately "flat" up to about $4\frac{3}{4}$ mc/sec? What would happen if these amplifiers had an upper frequency "cut-off" of, say, 3 mc/sec?

AUSTRALIAN RADIO COLLEGE

E.S. & A. BANK BUILDINGS, Corner CITY RD. and BROADWAY, SYDNEY
Telephones: M 6391 and M 6392 Post Lessons to Box 43, Broadway

This lesson sheet is published for the exclusive use of students of the Australian Radio College Pty. Ltd. (All rights reserved)



T.FM & F. LESSON NO. 14.

GENERAL CHARACTERISTICS OF FREQUENCY MODULATION.

We now take up the detailed study of the transmission of sound by Frequency Modulation (F.M.) of the carrier wave. The nature of F.M. was explained in Lesson 1, and its main advantages over A.M. were stated. Section B of that lesson should now be re-studied.

THE NATURE OF F.M.

As has been explained an F.M. wave remains of constant amplitude, but its frequency is varied above and below the mean carrier frequency. The amount that the frequency is increased above or decreased below this mean frequency for the loudest sound being handled is called the Frequency Deviation. Hence the total frequency "swing" is twice the frequency deviation. For example if in any one system a carrier of 50 mc/sec. and a deviation of 75 Kc/sec. (.075 mc/sec) is chosen, the frequency swings between $50 + .075 = 50.075$ mc/sec. and $50 - .075 = 49.925$ mc/sec.

when the loudest sound is being transmitted. This is a total swing of .15 mc/sec or 150 kc/sec, i.e. twice the deviation. It should be clearly understood that for weaker sounds (i.e. modulating voltages of smaller amplitude) the frequency variation is less than this. The amount of frequency change of the carrier is directly proportional to the amplitude of the modulating voltage, and therefore depends upon the varying loudness of the sounds being transmitted.

The pitch of the sound note being transmitted, and therefore the frequency of the modulating voltage is represented by the rate at which the carrier frequency is changed between its upper and lower limits.

These points should be made quite clear by reference to Figures 1 and 2. In Fig. 1 a wave with a single cycle of each of three modulating voltages having identical frequencies but different amplitudes. (Note:- for simplicity in both Figures 1 and 2 the r.f. cycles are represented by straight vertical lines instead of sine curves. When these lines come closer together an increased radio-frequency is indicated, when the lines move apart the frequency of the radiated wave is decreasing). At A. Fig.

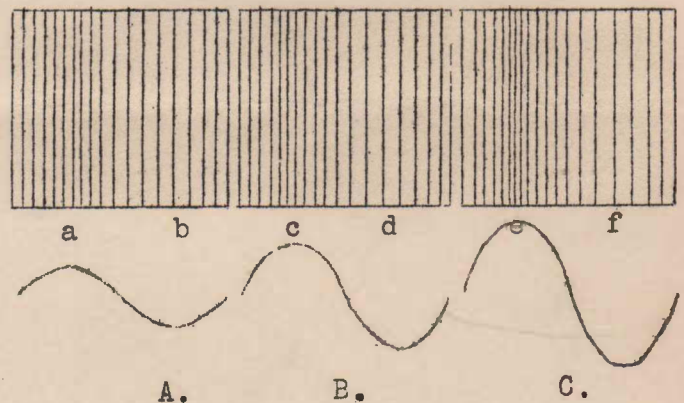

FIGURE 1.

1 we have a modulating voltage of small amplitude (weak sound). At B a stronger modulating voltage is shown. C shows a voltage which we will suppose has the greatest amplitude which can be handled (giving a frequency variation equal to the maximum deviation).

Note that when the modulating voltage is at its positive peak the frequency of the wave is increased to a maximum (points a,c,e Figure 1). When the modulating voltage is at its negative peak the wave frequency is a minimum (points b,d,f. Fig.1). The point we wish to stress, however, is that the frequency "swing" is greater in the case of the larger amplitude modulating voltage. The maximum frequency reached in Figure 1C is at "e", and this is higher than that of Figure 1, at "a". Similarly the lowest frequency in the case of 1C (at "f") is lower than the lowest frequency in the case of 1A (at "b").

Consider now the periods in which the frequency of the wave is "swung" in the three cases of Figure 1. It will be noted that the time of frequency swing is the same in every case. In Figure 1A the wave's frequency changes from its maximum to its minimum in a time equal to ab . In 1B the time taken is cd , and in the case of 1C it is ef . All of these time intervals are equal one to the other, because each equals the half-period of the modulating voltage -- and remember the three modulating voltages are identical in frequency, therefore their periods are equal.

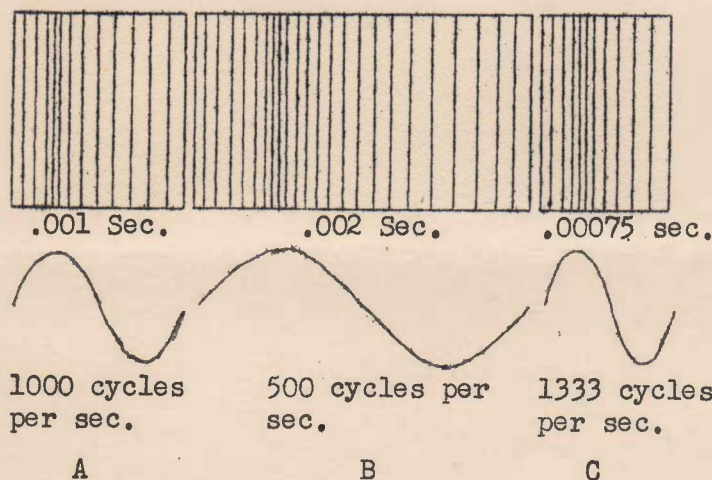

FIGURE 2.

A, and a still higher frequency one at C. The three voltages, however, all have the same amplitudes. The graphs show that the frequency deviations (above and below the mean frequency of the wave) are equal in all cases. The rate of frequency change between the maximum and minimum limits, however, is slow in case B, faster in case A, and still faster in case C. The rate of frequency swing, thus depends upon the modulating frequency.

BAND-WIDTHS REQUIRED.

It was pointed out in Lesson 1 that in the early stages of the history of F.M. it was thought that by choosing a small frequency deviation, say 2 Kc/sec, the bandwidth of a transmission could be limited to 4 Kc/sec (twice the deviation) without any restriction upon the modulating frequency which could be super-imposed upon the wave. Thus it was hoped to "compress" within a narrow band of several Kc/sec in width (or even less) a modulated wave carrying all the audio frequencies up to the upper limit of audibility, about 15 Kc/sec. This possibility was exploded in 1922 by Carson, who showed that a frequency band at least double the highest audio frequency is required, no matter how small the maximum deviation was made. Let us see why this is so.

The reason is due to the fact that when the carrier is frequency modulated, the variation in frequency brought about prevents the individual cycles being of exact sine-wave shape. In other words the separate cycles are distorted. This is illustrated in an exaggerated form, in Figure 3, where a single cycle of the wave is shown when the frequency is being increased (by modulation). Curve number one represents a pure sine-wave for comparison purposes.

Now it is a well known fact that when an A.C. is distorted from the pure sine-wave shape, extra frequencies called harmonics are generated. In other words it may be stated that an A.C. having a non-sine-wave shape may be produced by combining two or more sine-wave frequencies. In general, the greater the difference between the wave-form, the greater the number of extra frequencies involved.

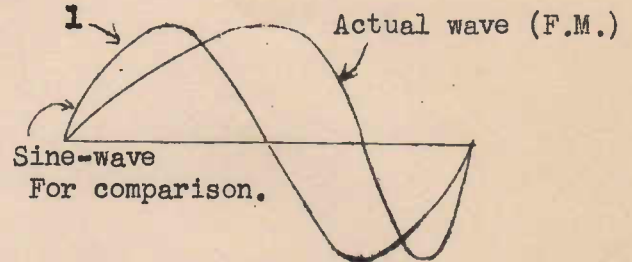
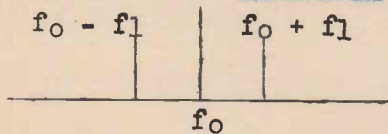

FIGURE 3.
SINGLE CYCLE OF F.M. WAVE FOR INSTANT WHEN FREQUENCY IS INCREASING.

An exact mathematical analysis shows that an F.M. wave contains all the side frequencies of an A.M. wave, plus additional ones. If a carrier of frequency f_0 is amplitude modulated with a pure note of frequency f_1 , two side frequencies having frequencies $f_0 + f_1$ (the higher side frequency) and $f_0 - f_1$ (the lower side frequency) are produced in addition to the carrier. This is represented diagrammatically in Figure 4A.



A.M. - carrier + side frequencies for single modulating frequency f_1

FIGURE 4A.

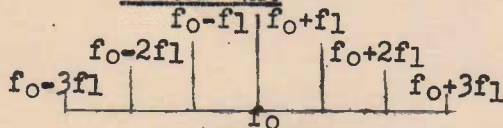

FIGURE 4B

F.M. CARRIER AND SIDE-BANDS FOR SINGLE MODULATING FREQUENCY f_1 .

sec. are to be handled, for we shall have first-order side-bands extending 15 Kc/sec above and below the carrier frequency.

For wide frequency deviations, the higher order side-bands, $f_0 + 2f_1$, $f_0 - 2f_1$, $f_0 + 3f_1$, $f_0 - 3f_1$, etc. become important, extending up to the limits of the frequency deviation involved. Hence for deviations like, say 75 kc/sec, we may take the band-width to be identical with the total frequency swing-in this case 150 Kc/sec.

Assuming we require the highest fidelity transmission (i.e. incorporation of the complete range of audio frequencies up to 15 Kc/sec), we may summarise the question

of band-width thus: There is a lower limit below which the band-width of the channel may not be reduced, no matter how small a frequency deviation is used. This is of course 30 Kc/sec, the same as would be required for A.M. For wide deviation systems the band-width may be taken to be twice the deviation employed. This, of course, may be many times the audio-frequency range, viz: 15 Kc/sec.

THE NATURE OF STATIC.

By "Static" we mean interference to a carrier wave produced by sudden electrical discharges in the ~~aether~~. These electrical discharges may occur naturally (the so-called "atmospherics") or they may be man-made, occurring in electrical machines of different varieties. In all cases the electrical discharges are really "sparks", i.e. discharges of electricity through the air between two points. In the case of "atmospherics" the discharges occur between cloud and cloud, or cloud and earth, and are called "lightning". In the case of man-made static the discharges are of smaller magnitude, but occur, usually, closer to the receiving aerial.

OSCILLATORY NATURE OF AN ELECTRICAL DISCHARGE.

An electrical discharge (spark or lightning) takes place through air when the latter's natural insulating properties break down.

Consider Figure 5 at A we have a simple circuit containing an air-gap of sufficient width to prevent a flow of current. Suppose now the e.m.f. "E" is increased until the electrical "strain" across the air-gap causes the air molecules to become ionised, i.e. broken into "free" electrons and positively charge particles. The air in this state forms a conducting path of low resistance, and a large current flows (Fig. 5B). The current however does not simply flow in one direction, as may be expected. For some appreciable time after the discharge commences, the current surges back and forth in an alternating or oscillatory fashion. This is due to the fact that the circuit contains small amounts of self or distributed-capacity and inductance, these forming the equivalent of an oscillatory or resonant circuit, as shown at C, Figure 5. The oscillatory discharge will, of course, eventually die out, due to "damping" of it by the resistance in the circuit.

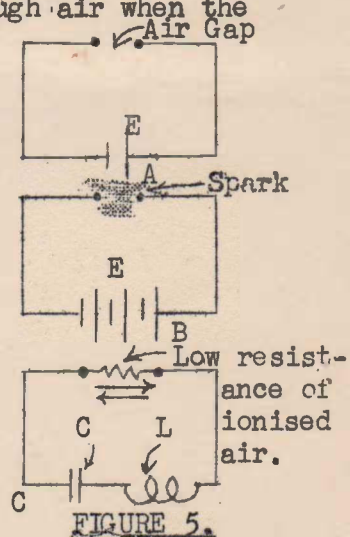

FIGURE 5.

The obvious effects of electrical discharge of light and sound. There is, however, another most important effect. This is an electromagnetic wave generated and sent out into space. The alternating current associated with any sudden electrical discharge is usually of high-(radio) frequency, since the values of inductance and capacity associated with the circuit are usually small. Now we know that the flow of a high frequency current always produces an aether wave of the radio type.

The above considerations hold for sudden electrical discharges whether occurring naturally (lightning) or by man-made machines (car ignition, electric motor commutators, diathermy machines etc). The frequencies of the waves produced may cover all conceivable values.

CIRCUIT "NOISE" AND VALVE "HISS".

It is well known that even in the absence of external static a low hiss is to be heard in an ordinary receiver. This is caused principally by "thermal agitation" in the input circuit of the receiver, and "shot effect" occurring in the r.f. valve (if any) and the converter valve.

Thermal agitation refers to the random vibratory motion of the molecules and free electrons in a substance. This motion goes on continually within any substance, and its average value depends upon the temperature of the body. In Figure 6A the small circles represent the fixed molecules and the dots the free electrons. As indicated by the arrows these electrons are continually darting about in all directions, with very varied velocities. Suppose now a current (D.C.) is forced to flow through a conductor. The current takes the form of a general drift of the free electrons in one direction, say to the right, as in Figure 6B. Here the fixed molecules have, for simplicity been omitted. Superimposed on this average drift we have the rapid and random motion, due to thermal agitation. At any one moment it might so happen that

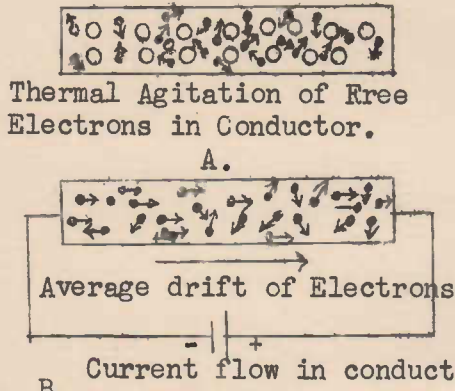

B. Current flow in conductor. FIGURE 6. or. more electrons are darting to the right than the average number. When this occurs the current is increased a little above average. A moment later the opposite state of affairs might exist, and the current may be reduced a little. The point is that no current is absolutely steady, but has very minute fluctuations, due to "thermal agitation" superimposed upon it. These fluctuations occur at all possible frequencies (including radio-frequencies). Such fluctuations in current, flowing through impedances, develop corresponding voltages, which are amplified by the valves in the receiver.

Voltages due to thermal agitation are very minute, but when they occur before the first amplifying tube in the receiver they are amplified by all the stages in the receiver. For this reason, in designing a receiver, we usually have to consider only those occurring in the input circuit

The "shot" effect referred to results from the fact that the stream of electrons flowing from cathode to plate is made up of a series of particles rather than a continuous flow. As a result the electron flow to the plate is somewhat irregular, resembling hailstones striking a surface, and this gives rise to slight irregularities in the plate current of the tube. A further irregularity is due to the fact that the emission itself from the heated cathode is subject to haphazard variations. Those fluctuations in plate current are minute, but they occur over an almost unlimited and continuous range of frequencies.

HOW "NOISE" VOLTAGES BECOME AUDIBLE:

Thus we have seen that in the early stages of a receiver there will exist, in addition to the r.f. signal voltage, voltages representing almost every conceivable frequency. Of these latter some are due to waves in the aether caused by static (and which induce corresponding c.m.f.'s in the aerial), and others are generated within the circuits and valves themselves due to the several phenomena we have described. All of these latter interfering voltages we describe as "noise".

It should be clearly understood, however, that the "noise" voltages which result in actual sounds in the speaker are not in the first place, of audio frequency. This will be realised if it is remembered that the tuned circuits of the I.F. stages will not pass audio frequencies. These stages will block all but a narrow band of frequencies around the I.F. for which the receiver is designed. (Note:- random voltages, occurring at audio frequencies after the detector can generally be neglected because there is insufficient amplification in the remaining valve stages to bring them up to audible level). The question then arises is how are these "Noise" voltages carried through the stages (including "tuned" stages) of the receiver to appear as audio frequency voltages in the output to the speaker?

Assuming, for the moment, a conventional A.M. receiver, we shall consider only the state of affairs when a station carrier is being received, since this is the only case which really interests us here. Together with this carrier frequency there will be present "noise" voltages of all conceivable frequencies. Some of these noise frequencies will be adjacent to the carrier frequency, i.e. they will differ from the latter by an amount equal to an audio frequency. To all intents and purposes such a noise frequency will appear to the carrier, just as though it were one of the latter's own side-band frequencies. Consequently, in the detector's output there will appear an audio voltage equal to the difference between the "noise" frequency and the carrier frequency. Putting this in a different way we may say that each noise frequency which differs from the carrier frequency by an audio frequency amount will modulate the carrier at this audio frequency rate.

This point may be further clarified by referring to Figure 7 where "a" represents carrier frequency, surrounded by "noise" frequencies of varying amplitudes, and differing from the carrier frequency by varying amounts. In this figure cd represents the receiver band-width, which we shall suppose is double the audio-frequency range. It is obvious from the diagram that only those noise frequencies lying within this band (cd) will give rise, by modulating the carrier, to a "difference" frequency which lies within the band-pass of the receiver, and which will be audible. A "noise" frequency like "x" will certainly "beat" with the carrier, modulating it at a frequency equal to the difference between its own frequency and that of the carrier. This modulation frequency, however, even if passed by the receiver's amplifiers, will be too high to be audible. The noise heard in the speaker will be due to the sum total of all those voltages in the detector's output produced by frequencies lying in the range cd (Figure 7) around the central carrier frequency.

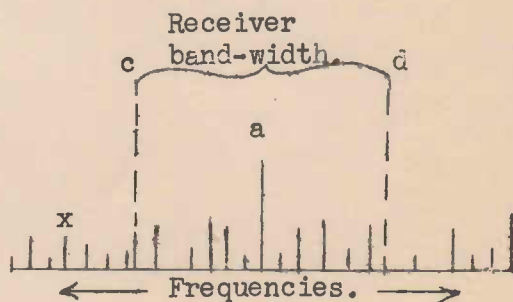

FIGURE 7.

HOW FREQUENCY MODULATION REDUCES NOISE.

We have seen that interfering voltages present in the early stages of a receiver and due to static, thermal agitation, valve hiss etc, produce audio voltages which operate on the speaker, by modulating the carrier wave. Now this modulation is mainly of the amplitude type. A noise voltage, if lying adjacent to the carrier in frequency, alternately works into and out of step with the latter. Thus the amplitude of the carrier is increased and decreased at a rate depending upon the difference between the two. This is amplitude modulation.

Now an F.M. receiver does not respond to amplitude modulation. It employs a type of detector (the "discriminator") which is sensitive mainly to frequency modulation. In any case we usually have preceding the discriminator a "limiter" stage, whose purpose it is to "level off" any undesired A.M. It would appear, therefore, that F.M. should eliminate all noise. This is not quite the case however.

Mathematical analysis, as well as practical experiment, have shown that the "noise" voltages do cause some phase or frequency "flutter" of the carrier. In other words a small amount of frequency modulation by "noise" voltages occurs. This will appear as noise in the speaker. If we compare the performances of an A.M. system and an F.M. system employing the same band-widths (this would be classified as a narrow band F.M. system) we find that the F.M. system displays distinct advantages over the A.M. systems as far as noise performance is concerned.

HOW INCREASING THE F.M. BAND-WIDTH REDUCES NOISE.

The reduction in noise interference, which is characteristic of an F.M. system, becomes really important when large deviations, and therefore wide band-widths are employed. The greater the deviation used for full modulation, the more negligible the noise effects become. When the modulating signal (A.F.) is made to cause large variations of carrier frequency the comparatively small deviations caused by an interfering r.f. "noise" voltage become virtually "swamped out".

A simple numerical example should make this point clear. Suppose we have an r.f. noise voltage which, by interaction with the r.f. carrier, causes a frequency change of say, 1.5 k.c./sec. Consider first a "narrow band" F.M. system having a deviation (max) of 7.5 Kc/sec. (note: the latter is the deviation for maximum modulation, i.e. for the loudest sound being transmitted). The "noise" voltage in the detector output will be $\frac{1.5}{7.5} = \frac{1}{5}$ of the signal voltage representing the loudest sound. This

gives a signal-to-noise power ratio of 25 to 1. Such a noise would cause some interference to the signal. Now consider an F.M. system employing a deviation of 75 Kc/sec. (again for maximum modulation). In this case the noise voltage in the detector's output will be only $\frac{1.5}{75} = \frac{1}{50}$ of the maximum signal voltage. The signal-

to-noise power ratio in this case is $\frac{50}{1} = 2,500$ to 1. Thus, by increasing the

deviation and therefore the band-width used by 10 to 1, the noise, on a power basis, will be reduced relative to the signal by the ratio of 2,500 to 25, i.e. 100 to 1.

Summarising, we may state that, as between two F.M. systems of different band-widths, the signal-to-noise power ratio in the rectified output will vary directly as the square of the deviation and band-width. The advantage of using large deviations and band-widths thus becomes obvious.

For "Wide-Band" F.M. the frequency deviation has been fixed at 75 Kc/sec. This, of course, is the frequency swing on either side of the centre carrier frequency, for maximum modulation, i.e. for the loudest sound handled. Weaker sounds will result in smaller frequency swings than this. The band-width required is thus 150 Kc/Sec. Compare this figure with a band-width of 20 Kc/sec. as used by A.M. broadcast stations.

REQUIREMENTS OF HIGH FIDELITY REPRODUCTION.

The special prov. of F.M. has become that of high fidelity. It should be under-

stood, however, that high fidelity is not a natural characteristic of a F.M. system.

The requirements of high fidelity are:-

- (1) The system should be capable of handling at both transmitter and receiver the full range of audio frequencies, say from 30 cycles/sec. up to about 15,000 cycles/sec.
- (2) The system should reproduce the full "dynamic range" of the original sound. "Dynamic range" refers to the range of sound volume (depending upon amplitude of the A.F. voltage). In other words the difference between the maximum sound level and the minimum sound level in the speaker should equal that of the original sound.
- (3) The high degree of "naturalness" obtained when (1) and (2) are satisfied should not be marred by electrical interference or noise. It is found that the advantages of wide A.F. response and wide dynamic range are only really appreciated by the ear in the absence of any interfering back-ground noise.

It is possible to satisfy condition (1) above in a typical F.M. system because the band-width is used (150 Kc/sec) is many times the range of audible frequencies. In the case of a conventional A.M. system, however, where the band-width is limited to 20 Kc/sec, the maximum audio frequency which can be handled is 10 Kc/sec. (half the band-width). The higher audio frequencies from 10,000 c/sec. up to 15,000 c/sec. or so are lost.

With reference to the dynamic range of the reproduction, an A.M. system is somewhat limited in this respect. Conventional broadcast stations have been limited to a certain minimum sound volume because at low levels random noise voltages in the transmitter's circuits "drown out" the desired signal. In addition, the peaks of the sound signal must be prevented from causing over-modulation, and hence distortion. To satisfy both conditions an appreciable amount of "volume compression" is used, whereby the dynamic range is considerably limited.

In the case of F.M, on the other hand, there is no need to limit the low volume levels, because the system, as we have seen, is particularly free from back-ground noises. In this way a much wider dynamic range is achieved.

Thus a wide-band F.M. system with its wide A.F. response, and large dynamic range, together with the absence of distracting noise, is capable of extremely natural reproduction. The improvement is particularly noticeable when reproducing large orchestras, where great variations in sound frequency and amplitude occur.

THE CAPTURE EFFECT.

Another important advantage of F.M. over A.M. is that which has been described as the "Capture Effect". This is an effect which occurs as a result of a peculiar combined action of the Limiter and Discriminator stages of the receiver, whereby when two signals are received, the stronger one takes complete control of the receiver, thus eliminating entirely the weaker signal. The effect is 100% complete when the stronger signal is only twice the strength of the weaker. In the case of A.M., interference from a weaker signal is not virtually "swamped" until the stronger

signal is 100 times as powerful as the weaker.

This Capture effect means that when F.M. is used interference between adjacent signal channels, and, in most cases even interference between signals occupying the same channel, is practically unknown. The reasons for this effect will be fully explained in a later lesson on Receivers.

TYPICAL CARRIER-FREQUENCIES.

As a result of the wide frequency band used the ultra-high frequencies must be used for F.M. Any frequency above about 40 mc/sec is suitable but, of course, large sections of the spectrum above this figure are already in use for television.

Formerly in America F.M. transmissions were confined to the band 42-50 mc/sec. Latterly, however, the band between 88 and 108 mc/sec. has been assigned for F.M. The first channel has a central carrier frequency of 88.1 mc/sec, the second at 88.3, and so on at intervals of .2 mc/sec (= 200 kc/sec) up to 107.9 mc/sec. Thus 100 separate channels are available. In Australia, so far, the only band allocated for F.M. is this 88 -- 108 mc/sec. band.

DISTANCE LIMITATIONS.

As we have already explained in the television lessons, frequencies above about 40 mc/sec. have a very limited coverage. Reception is limited to a distance a little beyond the line of sight. The "line of sight" is shown by the heavy line in Figure 8. The actual path of the received wave is shown by the dotted line. The extra distance (over and above the line-of-sight distance) is obtained as a result of a bending of the wave by an effect known as "diffraction" due to the presence of the earth.

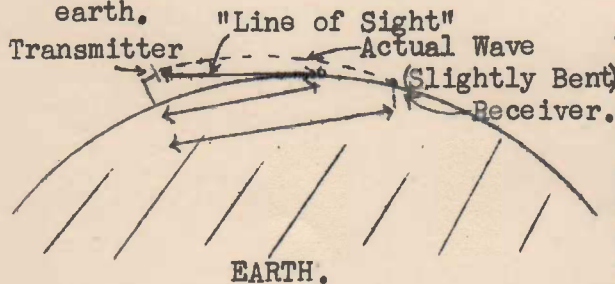

The coverage may be extended by increasing the height of the transmitter antenna (also by increasing the height of the receiver aerial). The distance reached by the wave is, of course, also affected by the nature of the terrain. Certain areas may be "shielded" by the presence of mountains or hills. Under average conditions the range may be taken to be about 50 miles.

FIGURE 8.

COVERAGE OF WIDE AREAS BY UNATTENDED RELAY STATIONS.

The fact that the area which can be covered by a wide-band F.M. system operating on U.H.F. is severely limited might at first suggest that the system is not suited for a country like Australia of large areas and small population.

The F.M. system, however, is peculiarly adapted for the use of unattended, low-power, automatic relay stations. These relay stations would be situated at high points (e.g. on mountain tops) over the country-side. They could operate on exactly the same frequency as the main station. Such a system is impracticable with an A.M. system because of interference between 2 or more signals coming from different transmitters of the relay network. One effect which would occur would be heterodyne "howls" due to the interaction of two different carriers. It is an impossibility to synchronise exactly the frequency of the carrier of a relay station with that of the main transmitter. Such interference effects do not occur with F.M.

due to the "capture effect". Experiments in America have shown that it is a practical impossibility to obtain interference between 2 transmitters operating on the same frequency. In one experiment a car was fitted up with a receiver and attempts were made to find a point between 2 transmitters operating on the same frequency (but sending different programmes) where interference occurred. Theoretically it should be possible to find such a point, e.g. where the ratio of the signal strengths was less than two to one. However no such point was found, even though a point was picked out where simply opening the door of the car resulted in the receiver "switching" from one programme to the other.

It should be clear from the foregoing discussion that if a large area were covered by a number of relay stations, then a receiver at any given point would simply respond to whichever transmitter was producing the strongest wave at that point.

Another factor to remember is that the relay stations would be comparatively cheap to install and operate. Each need only of very low power as a consequence of the freedom from static interference peculiar to F.M. Further, the cost of maintaining permanent staffs for each relay station does not occur.

It might be mentioned that such a system has been very successfully tried out on large highways in America, for providing complete coverage for patrol cars.

FREQUENCY MODULATION FOR TELEVISION SOUND TRANSMISSION.

As has been pointed out in the Television lesson frequency modulation of the sound carrier is now universally employed. F.M. is particularly suited for this purpose, as an ultra-high frequency sound carrier must be used, in order that it might lie adjacent to its companion vision carrier. By using F.M. the attendant advantages of freedom from noise and high fidelity are obtained.

In America a standard deviation of 25 Kc/sec. (instead of the usual 75 Kc/sec deviation) is used. This involves a band-width of 50 kc/sec. The deviation has been restricted somewhat, compared with that used for other F.M. purposes, mainly in order to limit the over-all width of the composite television channel (vision and sound).

VECTOR TREATMENT OF ALTERNATING CURRENTS AND VOLTAGES.

At this stage it will be necessary to explain a simple graphical method of representing alternating quantities (currents and voltages) whereby the latter may be readily compounded together. This theoretical work will be absolutely necessary for a proper understanding of the work which follows in subsequent lessons. In addition the student will find that this "vector" treatment of A.C, as it is called, will give him a better understanding of A.C. theory in all its applications to radio generally.

WHAT IS A VECTOR?

For our purpose a vector may be regarded as a line of given length and drawn in a given direction. The direction of the vector is of equal importance to its length or magnitude. More strictly a vector is a quantity which may be represented (in magnitude and direction) by such a line. For example consider a force of, say, 51 lbs weight. In considering the effect of such a force acting on a body

its direction of action is of equal importance to its magnitude (51 lbs. weight). For example if we have a force of 51 lbs acting in a northerly direction its effect on a body would be quite different from that of another 51 lb. force acting in, say, a north-easterly direction. These two forces, though of the same magnitude (51 lbs) must be regarded as different; for they have different directions.

Force is only one example of a Vector; there are many other quantities however, which possess both magnitude and direction (e.g. velocity).

Consider Fig. 9. At A we have an example of equal vectors. The two lines representing them have identical lengths and directions. In all other cases (B, C and D) the pairs of vectors are unequal; for in every case the 2 vectors differ either in magnitude or direction or both.

COMPOUNDING VECTORS.

The process of finding a single vector which is equivalent to, or has the same effect as, two vectors is called "compounding" the vectors, or finding the "vector sum", or finding the Resultant of the vectors.

TWO VECTORS ACTING IN THE SAME DIRECTION.

The Resultant, or Vector Sum of two vectors acting in the same direction is the simple arithmetical sum of the two. The resultant acts in the same direction as the two original vectors.

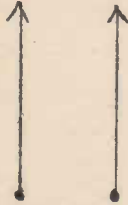

Identical vectors
equal magnitudes
same directions.
Figure 9A.



Different vectors
unequal magnitudes
same directions.
Figure 9B.



Figure 9C
Different vectors.
Equal magnitudes
Different directions.

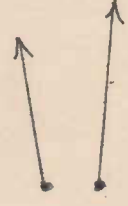

Figure 9D
Different vectors.
unequal magnitudes
and directions.

Suppose we have two vectors acting in the same direction as shown by "a" and "b" Figure 10A. The resultant is a vector acting in the same direction (viz. towards the top of the page) equal in the magnitude to $a + B$. This may be seen clearly by considering the net effect of two forces, say of 3 lbs. and 5 lbs. weight respectively, acting in the same direction. The net or resultant force is one of 8 lbs acting in this direction. Thus at A, Figure 10, the resultant of the two vectors may be obtained by placing the two "end to end" AB represents vector "a" and BC represents vector "b". The resultant is represented by the line AC.

TWO VECTORS ACTING IN OPPOSITE DIRECTIONS.

In this case the Resultant is a single vector having a magnitude equal to the simple difference of the two original vectors, and acting in the direction of the larger. Refer to Figure 10B. The two vectors "a" and "b" act in opposite directions, and "a" is larger than "b". The resultant is obtained by placing vector "b" at the arrow end of vector "a". Thus AB represents vector "a", BC represents vector "b" and the difference AC represents the resultant. The resultant equals "a" minus "b", and acts in the direction of the larger vector "a". Note that if the two vectors were equal magnitude and opposite direction the resultant would be zero, i.e. the two vectors cancel each other.

RESULTANT OF VECTORS NOT ACTING IN THE SAME STRAIGHT LINE - THE PARALLELOGRAM OF VECTORS.

If the vectors do not act in the same straight line their resultant is neither the simple arithmetical sum nor the arithmetical difference of them. Neither does the Resultant act in the same direction as either of the original vectors.

We find the Resultant in this case by a simple graphical method, known as the parallelogram of Vectors, illustrated in Figure 11. Here we have two vectors "a" and "b" acting in different directions. To find the resultant we draw the vectors starting from a common point O, as shown to the right of Fig. 11. Here OA = "a"

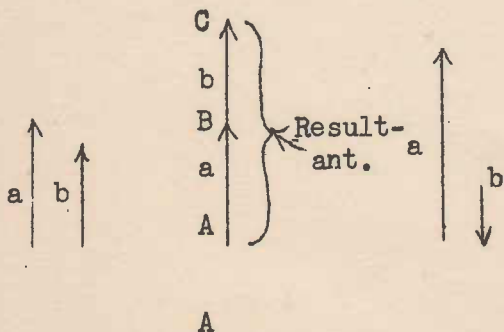

Figure 10.

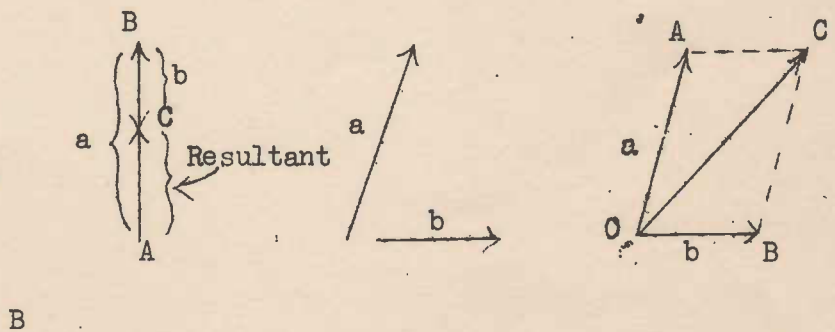

Figure 11.

in magnitude and direction. Similarly OB = "b" in magnitude and direction. Now

complete the parallelogram OA CB by drawing AC parallel to OB and BC parallel to OA. Then the resultant is represented by the diagonal OC of the parallelogram. OC represents a vector which would have the same net effect as "a" and "b" acting together. For example if OA and OB represented forces acting on a body in the directions shown, these forces being proportional in magnitude to the lengths of the lines OA and OB, then the two forces would be equivalent to a single force acting in the direction OC, and having a magnitude proportional to the length of OC.

HOW AN ALTERNATING VOLTAGE OR CURRENT MAY BE REPRESENTED BY A VECTOR.

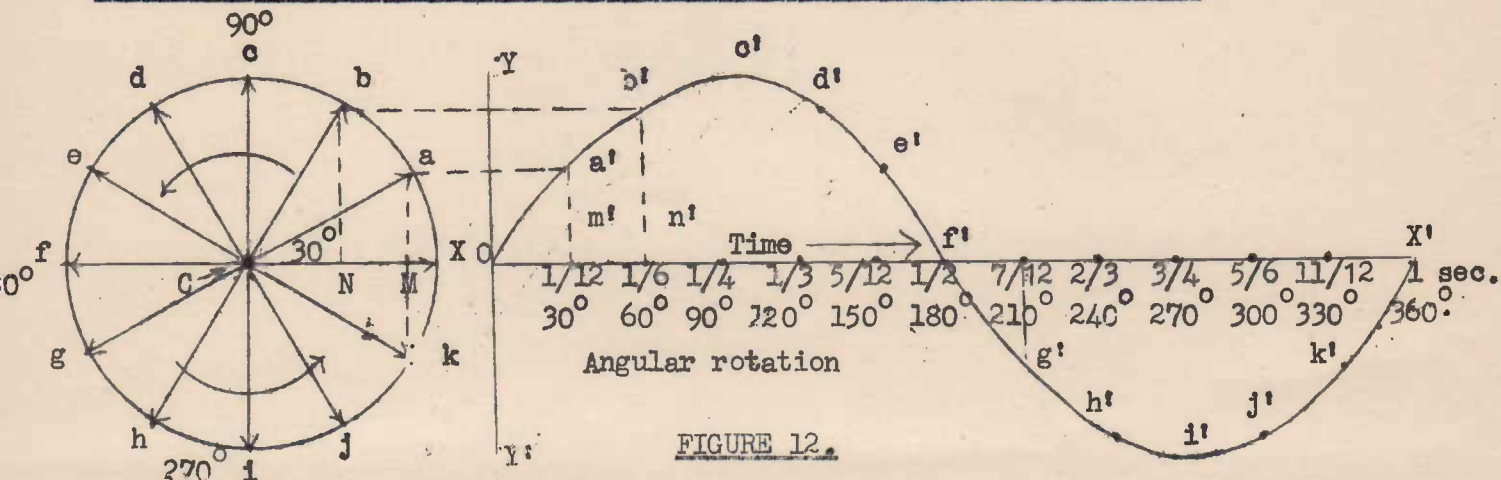

FIGURE 12.

referring to Figure 12, on the right we have a "sine curve" representing an alternating current or voltage. This curve may be considered to be traced out in the following manner. Take a circle whose radius OC is equal to the peak value or amplitude of the A.C. (shown on the left of Figure 12). We shall call this circle the "circle of reference". Let the radius rotate around the circle, at a constant rate, in a counter-clockwise direction as shown, say at a rate of 1 complete revolution per second. In the figure, Ca, Cb, Cc etc. represents twelve positions of the rotating radius. Each position is separated from the next by an angle of $\frac{360^\circ}{12} = 30^\circ$. Now on the right of the circle take two axes

OX' and YOY', representing time or angular rotation in degrees along OX', and amplitude, or instantaneous value along the vertical axis YOY'. In this way, on the horizontal axis m' corresponds to the instant of time when the rotating radius has passed through an angle of 30° , and is in the position Ca. Hence M' is marked $\frac{1}{12}$ sec. or 30° . Similarly n' represents the instant of time (or the corresponding angle) when the rotating radius is in position Cb.

Now the graph is traced out by plotting points each of whose vertical distances from the horizontal axis is equal to the perpendicular from the end of the rotating radius to the line fCX in the circle. For example when the radius is in position Ca, the point a' is plotted on the graph making a'm' equal to aM, at the point m' = $\frac{1}{12}$ S or 30° . Similarly b'n' equals bN and represents the height of

Cb', and so on. If all such points are plotted, the sine curve Oa' b' c' etc. is traced out.

Note that one complete revolution of the radius Cx traces out one cycle of A.C. Hence in the case chosen the cycle will occupy 1 second. That is the frequency in this case is 1 cycle/sec.

Thus we may imagine the A.C. sine curve to be traced out by a straight line of constant length (equal to the peak value of the A.C.), rotating at a constant rate (equal to the frequency of the A.C). This line referred to (the rotating radius of the circle in Figure 12) has, at any particular moment of time a given length (or magnitude) and a given direction. Hence it may be regarded as a vector.

Certainly the direction of the vector is continually changing. For example at zero time its direction is Cx (Figure 12). One-twelfth of a second later (30° later) its direction is Ca, etc. Such a vector is called a rotating vector.

Summarising, we may state: Any alternating quantity (e.g. current or voltage) may be represented by a rotating vector, whose length or magnitude equals the peak value of the A.C, whose rate of rotation equals the frequency of the A.C, and whose direction, at any moment, represents the "phase" angle of the A.C. (see below).

PHASE OF AN A.C.

The term "phase" refers to the particular point on the A.C. curve at any moment of time. The term "phase angle" means the difference, in degrees, between any point and the zero point, the latter being usually taken when the A.C. is rising from zero in the positive direction. For example, in Figure 12 the phase angle of the point b' on the curve is 60° , relative to the zero point O. Note that the phase angle is also given by the angle between the position of the rotating vector, at the given moment, and the zero position of that vector. In Figure 12, for example the phase angle of the point b' on the curve is given by the angle between CX and Cb, in the circle of reference, viz. the angle bCX.

PHASE ANGLE BETWEEN TWO A.C.'s OF THE SAME FREQUENCY.

Consider now the two A.C.'s shown in Figure 13. These having the same frequencies (since each completes a cycle in the same time as the other). They have, however, different amplitudes and phases. The A.C.'s are represented by rotating vectors on the left of the figure. The radius of OX of the large circle is the vector representing the A.C. marked A. The radius OX₁ of the small circle is the vector representing the A.C. marked B. When the vector OX for curve A is in the position OX, the vector for curve B is in the position Oa, i.e. 30° ahead of OX. As the vectors continue to rotate, at constant and equal speeds, the angle between them will remain at 30° . For example when current A is at position b' (peak value) its vector is in the position Ob in the circle. At this same instant of time current B has passed its peak, and is at c'. Its vector is now in the position Oc in the circle, still 30° ahead of the larger current, the phase angle being the angle bOc.

The important point to note is that, although the directions of the vectors are continually changing, the angle between them remains constant. Thus we may adequately represent the phase angle between two A.C.'s by showing their vectors for one instant of time only. From the points of view of amplitude and phase the two

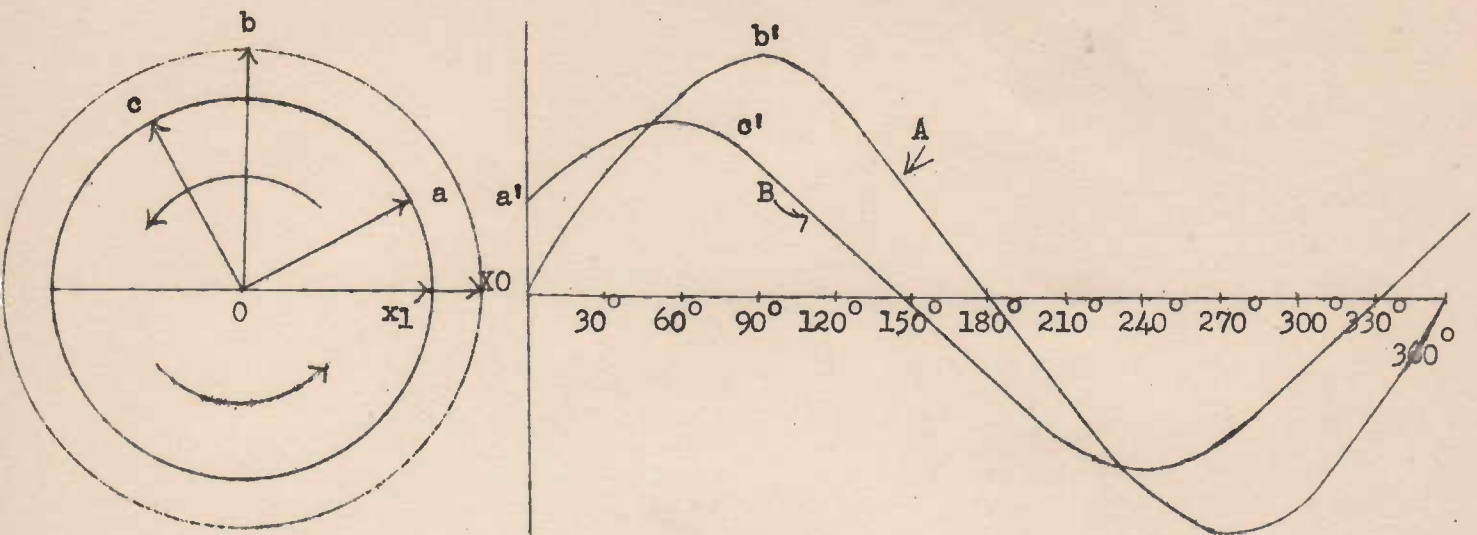
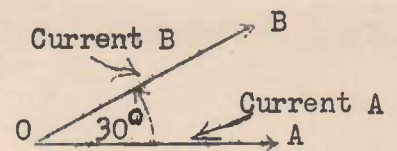

FIGURE 13.

A.C.'s shown in Figure 13 could be represented by the simple vector diagram of Figure 14. The current B would be said to be "leading the current A", because it is in advance from the point of view of phase with respect to A (vectors are always considered as rotating in a counter-clockwise direction). Conversely, current A is "lagging the current B".



VECTOR SUM OF ALTERNATING CURRENT OR (VOLTAGES) OF THE SAME FREQUENCY.

FIGURE 14.

Two out-of-phase A.C.'s may be compounded into a single A.C. by laboriously drawing their curves with the correct phase difference, and for a large number of points plotting their sums of differences, depending upon whether they are, at the moment considered, aiding or opposing. The new curve obtained will be their vector sum or Resultant.

If the A.C.'s have the same frequency, this job may be much more readily obtained by compounding their two vectors.

Figure 15 A(i) shows two currents I_1 and I_2 in phase (vectors in same straight line). The Resultant current is obtained by placing the 2 vectors "end-to-end" as shown at A(ii). The resultant is then the simple sum of the two, and is in phase with the original currents. The length of the vector marked R, gives, of course, the peak value of the resultant current.

If the two currents are 180° out of phase (i.e. exactly opposing) their vectors are as at B(i) Figure 15. The Resultant is obtained by placing the vectors as shown at B(ii), the resultant then being the simple difference. Note that the resultant current is in phase with the larger of the two original currents (viz. I_1).

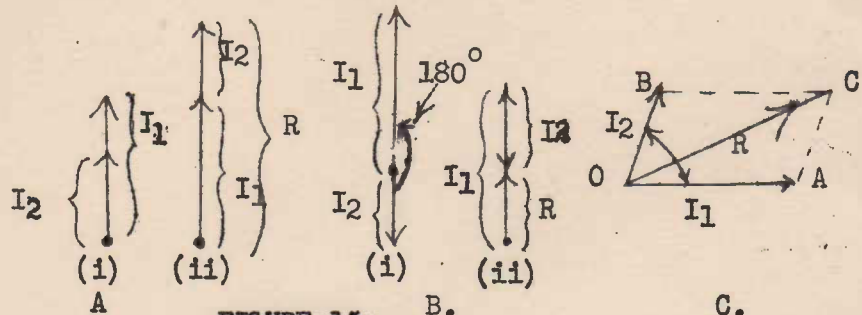

FIGURE 15.

If the two currents have any other phase difference, we make use of the parallelogram of vectors. For example at C, Figure 15 the two current I_1 and I_2 have a phase difference equal to the angle $\angle AOB$. Their resultant is obtained by completing the parallelogram $AOBC$, and taking the diagonal OC . Note that the resultant OC is not

in phase with either I_1 or I_2 . The resultant "leads" I_1 in phase, but "lags" I_2 . In other words the resultant lies in phase somewhere between I_1 and I_2 .

In all cases of Figure 15 the lengths of the vector lines I_1 and I_2 were taken to represent the peak values of the currents, and the length of the vector line R obtained then represented the peak value of the resultant current. If, however, I_1 and I_2 were represented by lines proportional to the R.M.S, or Effective Values of the currents, then the line representing the resultant R would give the R.M.S. value of the resultant.

PHASE ANGLE BETWEEN AC'S OF DIFFERENT FREQUENCY.

If two A.C.'s have different frequencies, the phase angle between them does not remain constant, but continually varies. At certain instants they will be in phase; at other instants they will be 180° out-of-phase. In fact the phase angle between them takes up all possible values. This can be seen if it is remembered that the frequency of an A.C. is given by the rate of rotation of its vector. If the two A.C.'s have different frequencies, their vectors therefore rotate at different speeds.

For example, suppose the two A.C.'s I_1 and I_2 , start off in phase as shown at Figure 16A. Further, suppose I_2

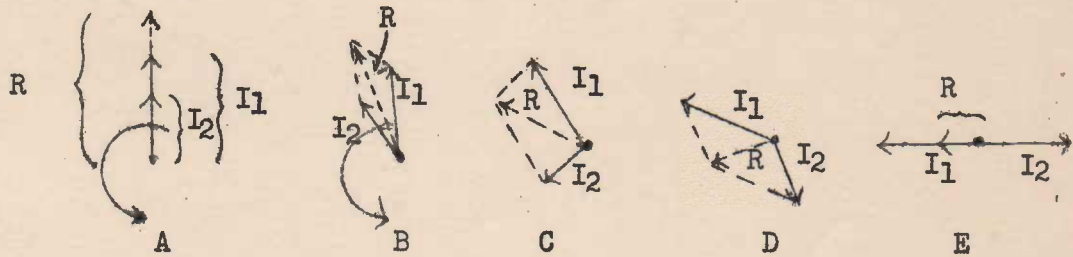

FIGURE 16.

has a higher frequency than I_1 . The I_2 vector, rotating faster than that of I_1 , will draw away from the latter, as time goes on, as shown in the subsequent diagrams. At E the vectors are 180° out of phase, i.e. the A.C.'s are exactly opposing each others. As time proceeds further the phase angle will be reduced, and eventually they will be in phase again, as at A.

Since the resultant of the two vectors depends upon the phase angle between them (as well as the amplitudes) it is obvious that the amplitude of such a current will vary with time. The resultants are shown by the dotted lines in Figure 16.

Note that the magnitude of the resultant (i.e. the length of the line) varies between a maximum when the currents are in phase at A, and minimum when the currents are 180° out-of-phase at E. An example of this continual variation of phase angle between two currents (or voltages) and continual variation in amplitude of their resultant is when two r.f. currents "beat" together, giving a resultant current whose amplitude varies between a maximum equal to the sum of the two, and a minimum equal to their difference. The rate of variation of the amplitude is the rate at which they get into and out of step, and this is equal to their difference in frequency. The resultant is an amplitude modulated wave, having a modulation frequency equal to the difference frequency.

PHASE ANGLE BETWEEN VOLTAGE (E) AND CURRENT (I) IN A CIRCUIT.

When a source of A.C. voltage (E) is applied to a circuit containing resistance only (see Figure 17A) the current and voltage are in phase. This is obvious, for when the voltage is zero, the current will also be zero; when the voltage is at its peak in any one direction, the current is also at its peak in that direction. The fact that E and I are in phase is shown by the vector diagram in Figure 17A.

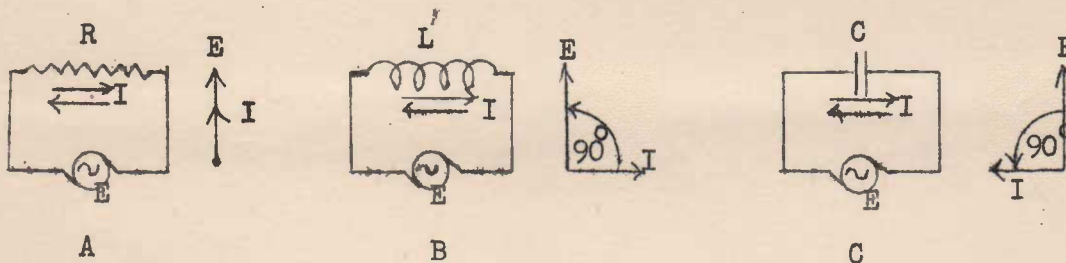

Consider now a circuit containing pure inductance (L) (i.e. resistance of coil negligible). The opposition to the applied e.m.f. (E) in this case takes the form of a counter e.m.f. of self-induction. This is an e.m.f.

FIGURE 17.

induced in the coil by the magnetic field due to the current continually expanding and contracting as the current changes in value. The moving lines of magnetic force thus cut the coil inducing an e.m.f. in it. Now we know that such an induced e.m.f. always opposes the applied e.m.f. (E). In other words the induced e.m.f. is 180° out of phase with the applied e.m.f.

Consider Figure 18, where a.b.c. etc. represents the current flowing. As the current increases from a to b the magnetic field expands. The rate of expansion of the field depends upon the rate of increase of the current. Now the current is increasing at its maximum rate at "a". As the current becomes larger, the rate of increase falls off, as shown by the steepness of the curve ab. Hence at "a" the field will be expanding rapidly, cutting the coil, and inducing a maximum counter e.m.f. in it. This e.m.f. will oppose the current increase, and hence will be negative (current increasing in positive direction). Hence when the current is at "a", the counter e.m.f. will be at its negative peak a_1 . When the current reaches its peak at b, the rate of change of current is momentarily zero, the field is not moving, and the

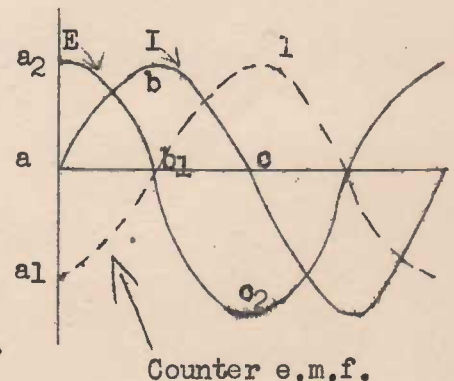

FIGURE 18.

induced counter e.m.f. is zero, shown at b_1 . Now as the current begins to fall off, the magnetic field contracts, cutting the coil in the opposite direction, thus inducing an e.m.f. which acts in the same direction as the current, thus tending to oppose the latter's decrease. Hence as current goes from b to c , the counter e.m.f. rises positively from b_1 to c_1 .

This counter e.m.f. of self-induction, represented by curve $a_1 b_1 c_1$ (Figure 18), remember, is always 180° out of phase with the applied voltage E . Hence E will be represented by curve $a_2 b_1 c_2$ etc.

Comparing now the curve for the applied e.m.f. E and the current I it will be observed that the current "lags" the voltage by 90° -- since I reaches its peak at b (say) $\frac{1}{4}$ cycle ($= 90^\circ$) later than E reaches its peak at a_2 .

The Vector diagram showing current I , counter e.m.f. of self-induction (E_1) and applied voltage E is shown in Figure 19. Note that the current (I) lags the applied e.m.f. by 90° , but leads the counter e.m.f. (E_1) by 90° . E and E_1 are equal and opposite.

Finally consider the case of an e.m.f. (E) applied to a circuit which is purely capacitive, as in Figure 17C. As the applied voltage (E) (Figure 20) rises from zero the current I will at first be large. The reason for this is that even when the voltage is only a minute fraction of a volt a large current will flow, due to the fact that there is no resistance in the circuit and no opposing charge in the condenser. (Remember $I = \frac{E}{R}$, hence I may be large even

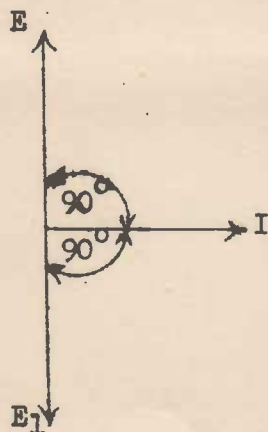

FIGURE 19.

if E is small, provided that R is negligible). Hence as the e.m.f. first rises from point "a" the current (I) will be a maximum at a_1 . As the applied e.m.f. rises further towards b the current falls off (see $a_1 b_1$). This is due to the fact that the condenser is now acquiring a charge, and developing an e.m.f. which opposes the charging current. By the time that E has risen to b , the condenser has become fully charged, i.e. the P.D. across its plates is equal to the applied e.m.f. Hence, at this instant the net e.m.f. in the circuit is zero, and the current is zero at b_1 . As the applied e.m.f. falls off towards zero (see bc) the condenser begins to discharge against this weakening e.m.f. Hence the current around the circuit is now flowing in the negative direction, as shown by $b_1 c_1$. If this argument is continued, the curve for I will be obtained for a full cycle, as shown in Figure 20. Note that the current leads the voltage by 90° , for the current peaks occur $\frac{1}{4}$ cycle ($= 90^\circ$) before the corresponding voltage peaks. The vector diagram, illustrating this phase relationship between voltage and current in such a circuit was shown at C in Fig. 17.

As the applied e.m.f. falls off towards zero (see bc) the condenser begins to discharge against this weakening e.m.f. Hence the current around the circuit is now flowing in the negative direction, as shown by $b_1 c_1$. If this argument is continued, the curve for I will be obtained for a full cycle, as shown in Figure 20. Note that the current leads the voltage by 90° , for the current peaks occur $\frac{1}{4}$ cycle ($= 90^\circ$) before the corresponding voltage peaks. The vector diagram, illustrating this phase relationship between voltage and current in such a circuit was shown at C in Fig. 17.

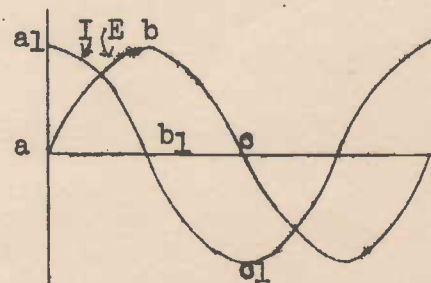

FIGURE 20.

PHASE MODULATION.

Having covered sufficient elementary vector theory we now are in a position to

return to modulation methods, and to carry the theory of this subject a little further in preparation for the next lesson.

A third method of modulation is that known as Phase modulation. This is a method whereby the phase of the carrier is continually varied above and below that of an unmodulated voltage. The amplitude of the wave remains constant, and the amount of phase deviation is proportional to the A.F. modulating voltage amplitude. The rate of phase change depends only upon the frequency (A.F.) of the modulating voltage.

In Figure 21 OA is a vector representing the amplitude and phase of the carrier r.f. voltage. To phase modulate this carrier the phase is first advanced by the angle AOB, and then retarded as shown by the angle AOC. These angles are equal and represent the phase deviation. The size of the angles will, of course, depend upon the amplitude of the modulating voltage at any instant. In Figure 22 we have shown at A the modulating voltage, at B the r.f. wave, which remains at constant amplitude, but whose phase is continually varied (an unmodulated carrier is represented

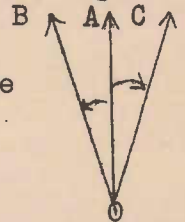
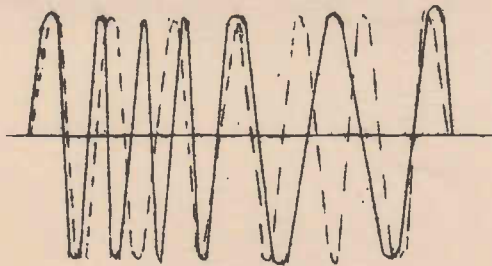
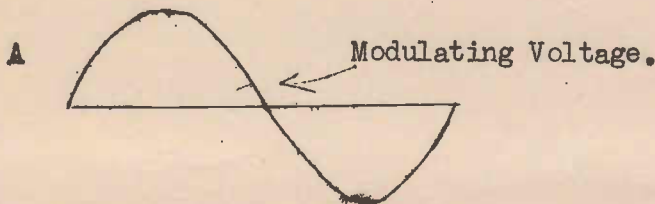

FIGURE 21.

by the broken line) and at C. the phase of the wave for the positive peak of modulation, for zero amplitude of modulating voltage, and also for the negative peak of the modulation. Note that when the modulation voltage goes positive, the phase angle is advanced (i.e. rotated in the counter-clockwise direction), and when the modulation voltage goes negative the phase angle is retarded (i.e. rotated in the clockwise direction).



B. Phase Modulation Carrier.



C. Showing Phase variation.

FIGURE 22.

HOW PHASE MODULATION CAUSES AN EQUIVALENT FREQUENCY MODULATION.

an A.C. we must rotate its vector at a faster rate. A faster rate of rotation of the vector means an increase in frequency. This may be seen by referring back to Figure 16, where the phase of current I_2 was continually advancing in respect to the phase of I_1 , due to the fact that I_2 had the higher frequency. In a similar manner, if the phase of a current is, for a certain period of time, retarded, the frequency of the current while the retardation of phase is continuing, must be decreasing. Hence if the phase of a carrier swung backwards and forwards by modulation, there will be a certain "equivalent" swing of frequency.

To advance the phase of

The above point may be further elucidated by considering the following example. Suppose a certain modulating voltage "swings" the phase of the carrier backwards and forwards through a total angle of 36° . This will be the phase change brought

about by each cycle of the modulating voltage. Suppose this modulating voltage has a frequency of 50 cycles per second. The phase of the carrier is varied by 36° every $\frac{1}{100}$ th second, i.e. in the time from the positive peak of one half cycle to

the negative peak of the succeeding half cycle. Therefore the average rate of phase change is 36° for every $\frac{1}{100}$ th sec. This is $36 \times 100 = 3,600^\circ$ per second. Since

$360^\circ = 1$ cycle this rate may also be expressed as $\frac{3,600}{360} = 10$ cycles / sec. Hence a phase swing of 36° at a modulation frequency of $50 \frac{360}{360}$ cycles/sec. will involve an average equivalent frequency swing of 10 cycles/sec. of the r.f. carrier. This is an important point and will be referred to again in later lessons.

DIFFERENCE BETWEEN FREQUENCY & PHASE MODULATION.

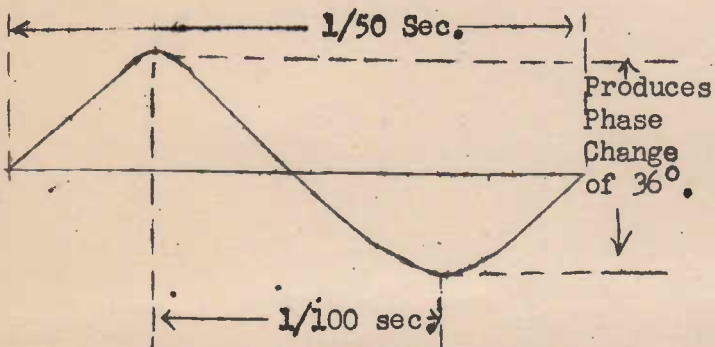

FIGURE 23.

Since Phase Modulation causes a frequency change, how does it differ from Frequency Modulation? The difference may be explained by taking another example similar to that given above, but one in which the modulation frequency is, say 500 cycles per sec. In this case the phase will be varied 36° in every $\frac{1}{1,000}$ sec. (i.e.

in the time occupied by each half cycle of the modulating voltage). This is a phase change at the average rate of $36,000$ per sec. or $\frac{36,000}{360} = 100$ cycles per sec.

Thus the average change in carrier frequency becomes 10 times as great when the modulating frequency is increased 10 times, even though the amplitude of the modulation voltage remains constant. Now for pure F.M. we stressed the point that the frequency deviation should depend only on the amplitude of modulation, and not upon the frequency of modulation.

Summarising we may say that phase modulation involves an "equivalent" frequency modulation (not a true F.M.) whereby the frequency deviation depends upon both the amplitude and frequency of modulation. The deviation is directly proportional to each of these factors.

True F.M. will, of course also involve an "equivalent" phase modulation (P.M.). The phase deviation involved, however, will vary with the modulation frequency. Hence the P.M. produced is not true P.M., the latter involving a phase deviation which is independent of frequency, depending only upon the amplitude of modulation.

True phase modulation is not used, as such, for communication purpose. The above discussion of it, however, is necessary, because one of the main methods of frequency modulating a transmitter is first to phase modulate it, and then to convert the "equivalent" F.M. obtained into true F.M. by employing a correcting circuit. It might also be mentioned here that random noise r.f. voltages cause a small phase modulation of an incoming carrier. It is the "equivalent" frequency modulation caused by this phase modulation which results in some noise interference in an F.M. receiver.

This will be discussed in a later lesson.

T.FM & F. LESSON NO. 14.

EXAMINATION QUESTIONS.

- (1) In an F.M. transmitter an audio modulating voltage of amplitude 50V, and frequency 1,000 cycles per sec. causes the frequency of the carrier to vary between 50.05 mc. per sec. and 49.95 m.c per sec. What would be the amplitude and frequency of an audio voltage causing a carrier swing between 50.01 mc/sec and 49.99 mc/sec and back to 50.01 mc/sec 500 times per second ?
- (2) Upon which property of the modulating voltage does the instantaneous bandwidth of an F.M. signal mainly depend (consider only wide-band systems ?)
- (3) Name three types of "noise" voltages whose effects are greatly reduced by F.M.
- (4) Place the following systems in order of merit from the point of view of signal-to-noise ratio : (a) A.M. system of band-width 12 kc/sec. (b) F.M. system of Band-width 150 kc/sec, (c) A.M. system of bandwidth 20kc/sec, (d) F.M. system of band-width 50 kc/sec.
- (5) What is meant by the "Capture Effect ?"
- (6) Why it is possible to obtain a wider Dynamic Range in the case of an F.M. system compared with an A.M. system.
- (7) An A.C. voltage of 4V leads one of 3V (peak values) by a phase angle of 60° . Draw an accurate vector diagram to obtain their Resultant. What is the peak value of the resultant voltage ? What is its phase compared with the 3V e.m.f. ?
- (8) Draw rough vector diagrams showing the phase relationship between voltage (E) and current (I) in each of the following cases :-
 - (a) Circuit containing pure resistance.
 - (b) Circuit containing pure inductance.
 - (c) Circuit containing pure capacity.
- (9) In the case of a phase modulated carrier, the phase is varied through a total angle of 24° , what is the equivalent frequency swing, if the modulating voltage has a frequency of 750 C/sec ? What would be the frequency swing for a modulating voltage of the same amplitude but whose frequency is 150 C/sec.
- (10) Assume in this circuit that the reactance of L equals the reactance of C, and that the current (I) is in phase with the applied voltage E. Draw a rough vector diagram representing (a) the counter e.m.f. across L (EL), (b) the counter e.m.f. across (C) Ec and (c) the voltage across R (Er).

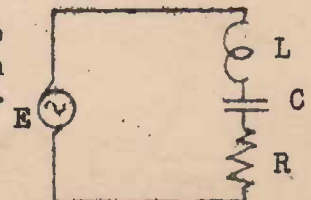

AUSTRALIAN RADIO COLLEGE

E. S. & A. BANK BUILDINGS, Corner CITY RD. and BROADWAY, SYDNEY

Telephones: M 6391 and M 6392. Post Lessons to Box 43, Broadway

This lesson sheet is published for the exclusive use of students of the Australian Radio College Pty. Ltd.
(All rights reserved)



T. FM & F. NO. 15 FREQUENCY MODULATED TRANSMITTERS.

Any F.M. transmitter system may be divided in four main parts or sections.

- (1) The section which frequency-modulates the primary or master frequency.
- (2) The frequency-multiplier section.
- (3) The power step-up section.
- (4) The radiating antenna.
- (5) The Power Supply units.

These are shown in block form in Figure 1.

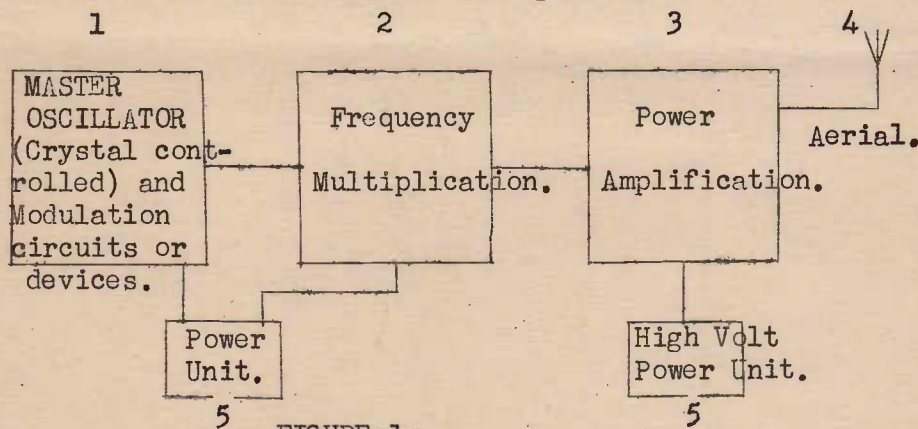

FIGURE 1.

Unlike the usual practice in A.M. transmitters, Figure 1 shows that most of the essential operations in F.M. transmitters are accompanied at low-power levels. As a matter of fact the operations carried out in blocks (1) and (2) of Figure 1 are carried out

with power levels as customary as in receiver tubes. This greatly simplifies the transmitter design. By the time the signal has passed through the frequency multiplication stages (Block 2, Figure 1) it is completely formed, i.e. it is already in the form required for radiation. It now requires only to subject this signal to power amplification the exact amount of which depending upon the power output desired from the station. It may, therefore, be said that a low-power transmitting station (say 250 watts) is more or less the same as a high powered one, of, say 50 kilowatts. The only difference would be in the number and power rating of power-amplifier stages.

METHODS OF MODULATION.

Frequency modulation methods may be divided into two main classes. (1) Direct F.M. methods. These bring about a direct frequency modulation of the master oscillator's frequency. They include (a) the condenser-microphone method, and (b) the

reactance tube method. (2) The Indirect F.M. Method, in which the audio modulating voltage first amplitude modulates the r.f. signal. The amplitude modulation is then transformed to Phase Modulation, which in turn is converted to true Frequency Modulation. This is the Armstrong method, used in the experimental work of the latter gentleman prior to the presentation of his famous paper on F.M. in 1935 to the Institution of Radio Engineers (America).

These methods of frequency modulating an r.f. carrier will be dealt with in turn.

THE CONDENSER MICROPHONE METHOD OF MODULATION.

This method is based upon two main facts:-

- (1) The capacity of a condenser depends upon the distance separating its plates; and
- (2) The resonant frequency of a tuned circuit depends on the total capacity used in conjunction with its inductance.

In this system one plate of a condenser acts as a diaphragm of a microphone. The sound waves vibrate this plate causing the distance between it and the fixed plate to vary in sympathy with the sound. In this way the capacity of the condenser varies at a rate dependant upon the frequency of the sound, and by an amount which depends upon the strength of the sound.

The Condenser-microphone forms part of the tuned circuit of the transmitter's primary oscillator, as shown in Figure 2. The variations in capacity of the tuned circuit LC result in a corresponding variation of the latter's frequency. Thus frequency modulation of the r.f. current generated results.

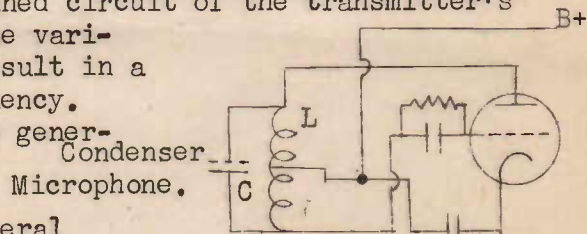

FIGURE 2.

The condenser-microphone system is not in general practical use. It suffers from many disabilities, one being the difficulty of obtaining sufficient capacity, and sufficient capacity variation while at the same time having a sufficiently light diaphragm to respond faithfully to the sound waves.

THE REACTANCE TUBE.

By this term is meant a valve which acts in a circuit just as though it were an inductance. In order to understand how a valve may act in this unusual manner - it first will be necessary to consider the phase relationship between current and voltage in a circuit which contains both resistance and reactance in series.

We have already seen that in the case of a circuit which contains only resistance the current and voltage are in phase. We have further seen that if the circuit contains only reactance (i.e. the opposition presented to an A.C. by capacity, or inductance) then the current and voltage are 90° out of phase. If the reactance is capacitive (i.e. due to a condenser) the current leads the voltage by a phase angle of 90° . If the reactance is inductive (due to inductance) the current lags the voltage by 90° . These three cases are shown for revision purposes in Figure 3. Here X_c stands for capacitive reactance, and X_L for inductive reactance.

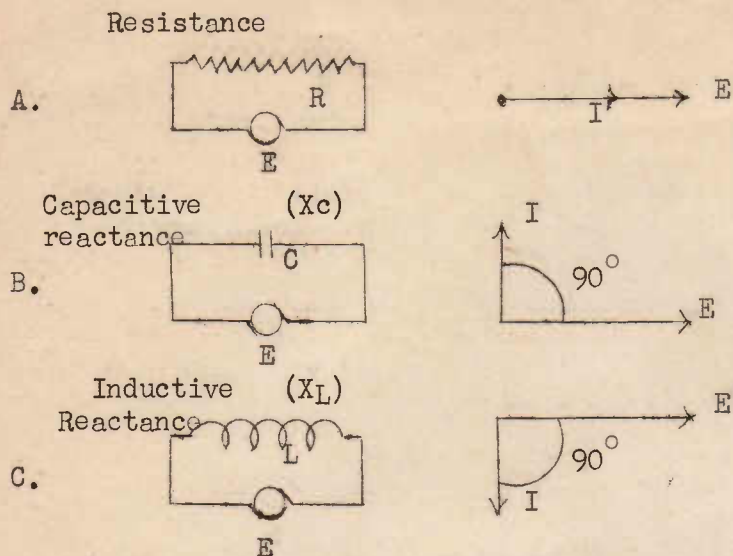

FIGURE 3.

since the total circuit current flows through each. What then, is the phase relationship between this current and the voltage applied across the circuit?

Consider Figure 4A, where we have an applied voltage E_a (A.C.) applied across a condenser in series with a resistor. The reactance of the condenser is represented by X_C , and depends not only upon the capacity of C but also upon the frequency (f) of the applied e.m.f. (E_a), being given by the formula

$$X_C = \frac{1}{2\pi fc} \quad \text{where } \pi = 3.1416 \text{ and } C \text{ is capacity in farads.}$$

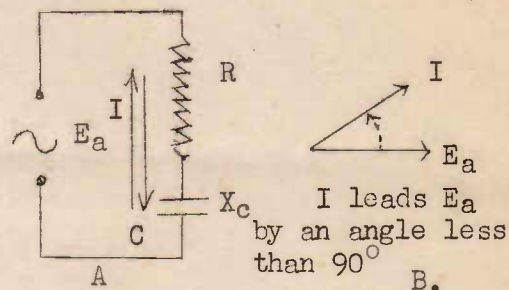

FIGURE 4.

The resistance (R) in the circuit will tend to maintain the current (I) in phase with the applied voltage (E_a). The effect of the reactance (X_C) of C , on the other hand, will be to tend to cause this current to lead the voltage by 90° . Obviously the same current cannot be both in phase and 90° out of phase with voltage. The net result will be that current will lead the voltage by some phase angle having a value between 0° and 90° (see Fig. 4B). The exact phase angle will depend upon the relative magnitudes of the resistance (which tends to maintain E and I in phase) and the reactance (which tends to produce a phase angle of 90° between E and I). For example if R is very large compared with X_C (circuit nearly purely resistive) E and I will be very nearly in phase. If X_C is very large compared with R , I will lead E by a phase angle nearly, but not quite, equal to 90° . If X_C and R have equal values (for the frequency of the applied e.m.f.) the phase angle will lie mid-way between 0° and 90° ; i.e. I will lead E by 45° .

Figure 5(a) shows a simple graphical method of obtaining the phase angle between E and I , when the resistance and reactance of the circuit are known.

Here we treat resistance, reactance and total circuit impedance as vectors. Drawing OA having a length depending upon the value of R (in ohms), we draw OB at right-angles to OA , and make this line a length depending upon the reactance

These reactances are, of course, measured in ohms, as in the case of resistance. The question now arises, what happens if the circuit contains both reactance and resistance in series, as in Fig. 4 at (A)? Here we are considering capacitive reactance in series with the resistance, but a similar argument would apply for inductive reactance.

The first thing to realise is that there is only one current in this circuit, since the components are in series. The current through the resistor will be identical with that through the condenser,

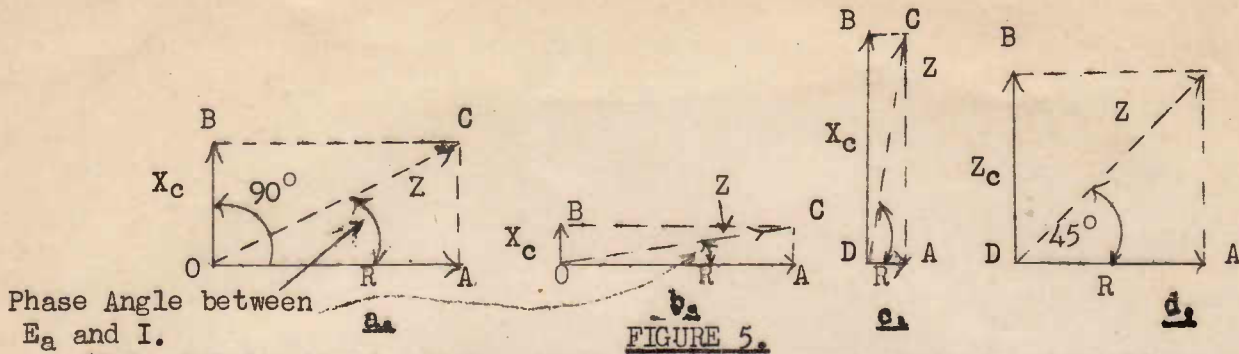

FIGURE 5.

(X_c) of C (in ohms). Note, further, that we draw OB in the direction of a leading phase angle (i.e. counter-clockwise direction from R (OA)). The reason for this is that X_c tends to advance the phase-angle of the current by 90° . We then complete the parallelogram OBCA, as for the parallelogram of vectors when finding the vector sum of two A.C. voltages. Joining the diagonal OC, the angle AOC then represents the phase angle between voltage (E_a) and current (I) in the circuit. The fact that the vector OC is leading the vector OA (resistance) in this diagram indicates to us that the current is leading the voltage by the angle quoted.

Actually this diagram will give us, in addition to the phase angle between E and I, the value of the total circuit impedance (Z). For, since we have regarded R (OA) and X_c (OB) as vectors, the diagonal of the parallelogram OC must represent the resultant of these two circuit components, viz, the impedance (Z) of the circuit.

Diagrams (b), (c) and (d) show several other cases for various values of R and X_c . Notice at (b) where R is large compared with X_c the phase angle between E and I is small (i.e. E and I nearly in phase). When X_c is large compared with R (at (c)), the current leads the voltage by nearly 90° . When X_c and R are equal, I leads E by 45° (i.e. E and I $\frac{1}{2}$ of a cycle "out-of-step").

Incidentally, we might mention here that a circuit containing inductive reactance (XL) and resistance (R) in series, could be treated in a similar way, as shown in Figure 6. Here the inductive reactance vector (XL) is shown lagging the resistance vector (R) by 90° , because XL tends to cause the current to lag the voltage by 90° . The net effect is that I lags E by an angle given by AOC. We are now in a position to understand the "reactance tube", as used for modulation purposes in some F.M. transmitters.

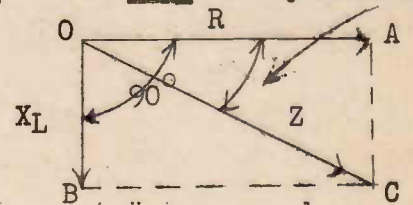

FIGURE 6.

In the schematic of Figure 7, V_1 and the tuned circuit LC form an r.f. oscillator of the Hartley type. Normally this oscillator would produce oscillations whose frequency depends only upon L and C of the tuned circuit. The r.f. voltage developed across the tuned circuit LC by these oscillations is applied across the series combination RC_1 . Here LC may be regarded as a source of A.C. e.m.f. Now the value of R is made very large compared with the reactance (X_c) of C_1 at the frequency of operation. This means that for practical purposes the current through RC_1 will be in phase with the voltage across it. (see Figure 5B). This current through RC_1 will develop an alternating potential difference across C_1 . This voltage across C_1 , which we shall call E_c lags the voltage applied across the combination RC_1 by almost 90° .

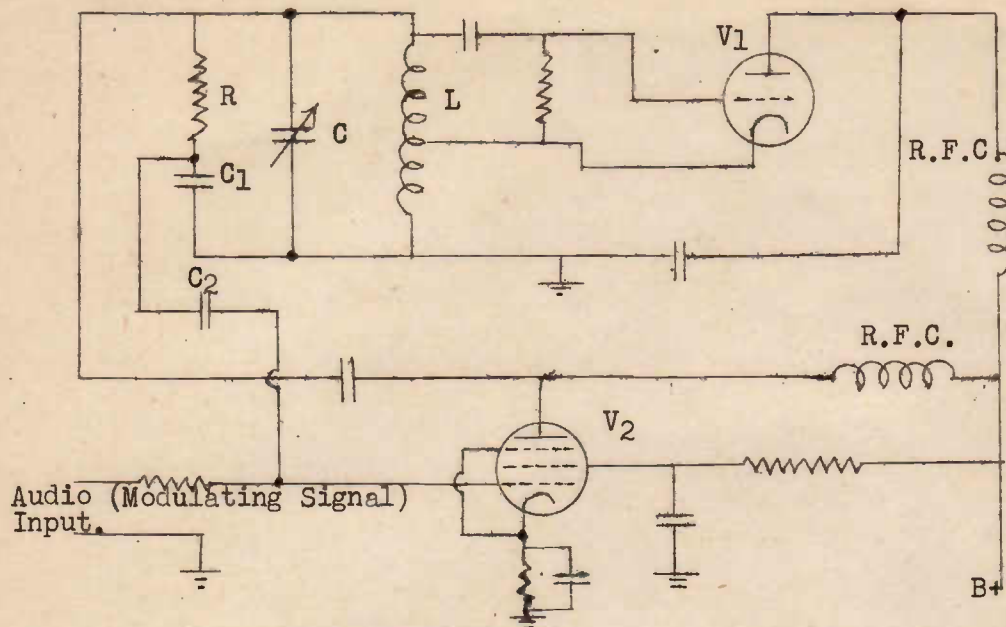

FIGURE 7

The reason for this may be understood by referring to Figure 8. Here OA is a vector representing the total A.C. voltage (E), applied across the RC combination (Figure 7). This voltage, of course, is that developed across the LC circuit of that figure by the oscillation produced. The current flowing through R and C will be nearly in phase with E. This current is represented by OB. (Figure 8) the small leading phase angle being BOA. Now, as we have seen at an earlier stage in these lessons, the current through a con-

denser leads the voltage applied it by 90° . This is the same as saying that the voltage across the condenser lags the current by 90° . Hence, in Figure 8, since OB represents the current through C_1 , the voltage across this condenser will be represented by the vector OC, lagging by 90° the vector OB. For practical purposes the angle COB may be taken as 90° . Hence we may say that the voltage across C_1 (Fig.7)) lags the voltage across the RC_1 combination (that is that of the tuned circuit LC) by practically 90° .

Referring again to figure 7, the voltage across C_1 is applied to the grid of V_2 , through the condenser C_2 . Now remember that the plate current through a valve is in phase with its grid voltage, i.e. plate current and grid voltage rise and fall in step. Hence plate current of V_2 is in phase with voltage across C_1 (Eo). But since E_c lags the voltage across the tuned circuit LC by 90° , this means that the plate current of V_2 also lags this voltage (E) by 90° .

Now note that the voltage across V_2 (i.e. voltage between its plate and cathode) - its plate voltage - is identical with that across LC (E)., for V_2 is connected directly across this tuned circuit. Hence we arrive at the important conclusion that the current through V_2 lags by 90° (practically) the voltage across it. This fact is illustrated by the vector diagram of Figure 9.

Now we know that in a circuit containing only inductive reactance the current lags by 90° the voltage. The vector diagram for such a circuit would be identical with that of Figure 9. To all intents and purposes, therefore, the valve V_2 of Figure 7 acts as though it were a pure inductance. A valve acting in this manner is described as a Reactance Tube.

Negligible Phase Angle Between E and I.

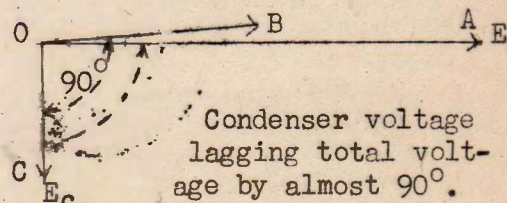

FIGURE 8.

HOW THE REACTANCE TUBE CAUSES FREQUENCY MODULATION.

The oscillator consisting of V_1 and LC of Figure 7 could be the primary oscillator of an F.M. transmitter. The tube V_2 (as far as its plate circuit is concerned) is connected in parallel with the inductance L of the tuned circuit. Hence the effective inductive (which together with condenser C determines the frequency of oscillation is made up of the inductance of the coil (L) together with the "inductance" of the reactance tube V_2 , in parallel. The effective inductance of two inductances L_1 and L_2 , say, in parallel is calculated in a similar manner as for resistances, thus

$$\text{Effective inductance} = \frac{L_1 L_2}{L_1 + L_2}$$

Any variation of either of the inductances (L_1 or L_2) will therefore affect the effective inductance, and so vary the frequency of oscillation of any tuned circuit of which they form part.

If, then, we can vary the inductance effect contributed by the reactance tube V_2 of Figure 7 we will vary the frequency of oscillation of the tuned circuit. This variation of reactance tube's inductance can be brought about by alteration of its grid bias. Such an alteration would change the tube's amplification, and hence alter the magnitude of the r. f. component of the plate current. For example if the grid bias is changed in the positive direction the r.f. current in the tube's plate circuit will increase. This is equivalent to a decrease in the "inductance" of the reactance tube. The effect of such a positive voltage on the grid will therefore be to decrease the total effective inductance of the tuned circuit consisting of C, L and V_2 in parallel (Figure 7), and therefore to increase the frequency of oscillation.

Conversely, a more negative voltage on the grid of V_2 will cause an increase in the effective inductance of the tuned circuit, resulting in a decrease in frequency.

Suppose now we apply the audio modulating voltage to the grid of V_2 , as shown in Figure 7. During the positive half-cycles of A.F. the tube's grid potential is made less negative, resulting, as explained above, in an increase in the frequency of oscillation generated by V_1 . Similarly the negative A.F. half-cycles will cause a decrease in this frequency. In other words the r.f. oscillation is frequency modulated by the A.F. signal. Of course, it will require careful design of the various circuit components of Figure 7 if the frequency deviations obtained are to be proportional to the amplitudes of the varying audio frequencies voltages.

A block diagram of a commercial F.M. transmitter using a reactance tube modulation is shown in Figure 10. Blocks 1 and 2 comprise the primary oscillator and reactance tube modulator, and together would comprise a circuit similar to that shown in Figure 7. This primary oscillator operates at one-half the radiated frequency. The F.M. modulated output from Block 2 (Figure 10) is doubled in frequency by Block 4. This puts the signal into its proper channel. The frequency doubler will also double the frequency deviation representing the modulation. Block 5 consists simply of power amplifiers to raise the power of the radiated

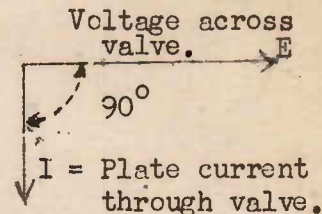

FIGURE 9.

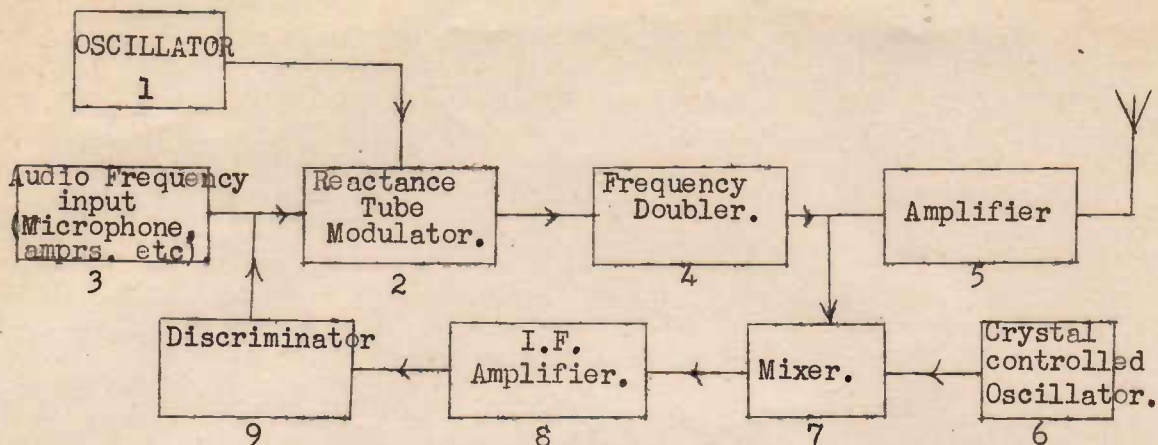

FIGURE 10.

signal to the desired level.

The remaining Blocks - 6, 7, 8 and 9, - of Figure 10 are solely for the purpose of maintaining frequency stability. The primary oscillator (Block 1) does not produce a particularly stable frequency. Direct crystal control of the oscillator is generally not practicable when the output from the latter is modulated by a reactance tube. In this transmitter an ingenious method to hold the centre frequency of the output steady is used. Block 6 is a stable crystal-controlled oscillator operating near the frequency of the transmitted signal. A portion of this signal from the doubler output is fed, together with the crystal oscillator's output into a mixer which produces an "Intermediate Frequency" of comparatively low value. Any variations in the frequency of the primary oscillator (Block 1) will cause the frequency of this I.F. to alter likewise. Block 6 is a circuit which gives a D.C. voltage output proportional to any variation of the I.F. away from its correct central frequency. This D.C. output is applied to the reactance tube's grid with such polarity that it corrects the original frequency drift. Remember that altering the bias on this grid causes a variation in the primary oscillator's (Block 1) frequency. Block 6 is called a "discriminator" and is similar to the discriminator detector in an F.M. receiver. The detailed operation of this device will be dealt with in the lesson on Receivers. Actually this discriminator is used here exactly in the same manner as in an ordinary automatic frequency control equipped receiver.

THE INDIRECT F.M. SYSTEM - OR ARMSTRONG SYSTEM.

This method as stated earlier involves the production of amplitude modulation first, then in effect, the transformation of this A.M. into Phase modulation. The equivalent F.M. produced by this P.M. is then "corrected" to ensure "true" F.M., i.e. where the frequency deviation is proportional only to the amplitude of the modulating voltage, and not to the audio frequency of this modulating voltage.

In order to understand how A.M. may, in effect, be transformed into P.M. and F.M. we must delve a little more deeply into the differences between these several forms of modulation, particularly from the point of view of their side-

bands.

SIDE-BAND DIFFERENCES BETWEEN A.M. AND P.M. OR F.M.

It was stated briefly in the previous lesson that F.M. involved the production of side-band frequencies just as in the case of A.M. If the frequency deviation is large, however, we may have a whole series of side-bands for every modulating voltage. The "first-order" pair of side-frequencies are similar to those produced by A.M., as they differ from the carrier frequency (one above, the other below) by a frequency equal to the audio modulating frequency. For example if f_0 is the carrier frequency and f_1 represents one particular audio modulating frequency, then the "first-order" pair of side-frequencies have frequencies $f_0 + f_1$ (the upper side-frequency) and $f_0 - f_1$ (the lower side-frequency). In addition to these, however, we have (for F.M.) a "second-order" pair of side-frequencies which differ from the carrier (or central) frequency by twice the audio frequency modulation voltage. These second-order side-frequencies will therefore have frequencies $f_0 \pm 2f_1$, where f_0 and f_1 are as stated above. Similarly the "third-order" pair of side-frequencies will have frequencies $f_0 \pm 3f_1$, and so on.

The relative importance of the various pairs of side-frequencies depends upon the frequency deviation used. More accurately it depends upon the ratio of the frequency deviation to the modulating frequency. This ratio is called the "Modulation Index", i.e.

$$\text{Modulation Index (M)} = \frac{\text{Change in Carrier Frequency (Deviation)}}{\text{A.F. Modulating Frequency.}}$$

For example if an A.F. of 7,500 C./sec. is producing a deviation (change in carrier frequency) of 37.5 K.C./sec. (= 37,500 C./sec.), the modulation index (M) equals

$$\frac{\text{Deviation}}{\text{Modulating Frequency}} = \frac{37,500}{7,500} = 5.$$

Figure 11 shows the side-frequencies (with their relative amplitudes) produced for various values of modulating index (M). It will be seen that, as at A in this figure, when M is small (i.e. small deviation) all side-frequencies may be neglected except the two "first-order" ones. For small deviations (relative to the modulating frequency), therefore, the situation as regards side-bands is identical with that produced by A.M. Remember that in the case of the latter form of modulation, only a single pair of side-frequencies is formed for any given modulating frequency. Returning to Figure 11, we see that as the deviation (for a given modulating frequency) is increased more and more higher-order side-frequencies become important. It should, of course, be understood that, in these diagrams the first-order side-frequencies are those closest to the carrier (or centre) frequency - one side-frequency on either side of the latter. The second-order side-frequencies are represented by the next pair of lines moving outwards from the carrier frequency, and so on. Further, remember that the gap between any pair of lines representing side-frequencies is equal to the modulating frequency (A.F.).

The important point brought out by Figure 11 and which we wish to stress at this stage is that if M. is 0.5 or less, i.e. for small deviations an F.M. wave may be adequately represented by a carrier wave and a single pair of

side-bands, just as in the case of A.M. The omission of the higher-order side-bands, under these conditions, will not materially affect the result. The same applies for P.M., since both P.M. and F.M. involve a continual variation of carrier frequency.

The question now arises: If an F.M. (or P.M.) wave and an A.M. wave each involve a carrier frequency and the same pair of side-bands, how can they differ? The answer to this question involves the phase relationship which exists between the side-bands and the carrier in each case. In the case of A.M., the side-band frequencies are in phase or 180° out-of-phase with the carrier at the instants when the audio modulating voltage is at its peaks. For F.M. (or P.M.) the side-band frequencies are 90° out of phase with the carrier when the audio modulating voltage is at its peaks, (positive or negative).

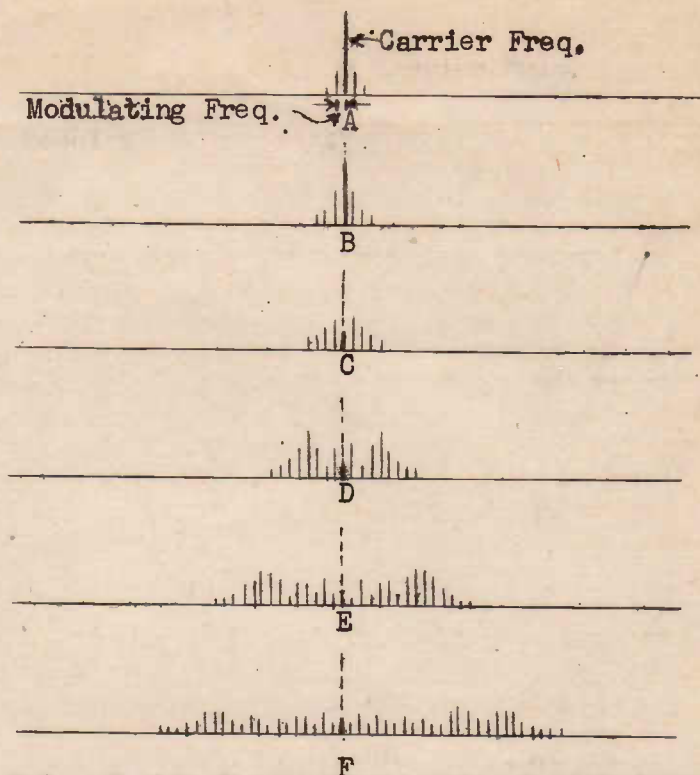

Sets of side frequencies produced with increasing deviation and constant modulating frequency, i.e. for different FIGURE 11. values of "M".

PHASE RELATIONS BETWEEN CARRIER & SIDE-BANDS FOR A.M.

First let us see how the addition (vector addition) of a carrier frequency, and two side-band frequencies (all of constant amplitude) will produce an amplitude modulated wave (i.e. one of constant frequency but of varying amplitude). Consider Figure 12, where at A is shown the A.F. modulating signal. Suppose, for the sake of argument the frequency of this signal is 10,000 cycles/sec. Then the time represented by a.e. on the graph (i.e. time for one cycle is $\frac{1}{10,000}$ sec. At B we have the unmodulated r.f. carrier (I_0). Since there are 10 r.f. carrier cycles in the time a.e., i.e. $\frac{1}{10,000}$ sec., the carrier frequency must be $10 \times 10,000 = 100,000$ c./sec. (= 100 K.C./sec.). Note that the amplitude (peak value) of the modulating voltage at A is one-half the carrier amplitude. This will give 50% modulation, so that the modulated carrier's amplitude (shown at E) will rise to twice its mean value (on the positive peaks of modulation) and fall to one-half its mean value (on the negative peaks of modulation). Note that the frequency of the modulated carrier I_m (at E) is identical with that of the unmodulated carrier I_0 (at B) - since in both graphs we have the same number of cycles (viz. 10) in the time a.e. This, of course, is in agreement with what we already know, i.e. amplitude modulation causes no change in carrier frequency. Our aim at the moment, however, is to investigate how the three radio frequencies represented by graphs B, C and D, all of constant amplitudes and constant (but different) frequencies may com-

A. A.F. Modulating Signal

B. R.F. Carrier Current (Unmodulated) I_0

C. Upper Sidefrequency I_1

D. Lower Sidefrequency I_2

E. Modulated Carrier I_m

F. Vector Addition of Sidefrequencies I_1 & I_2 and Carrier I_0

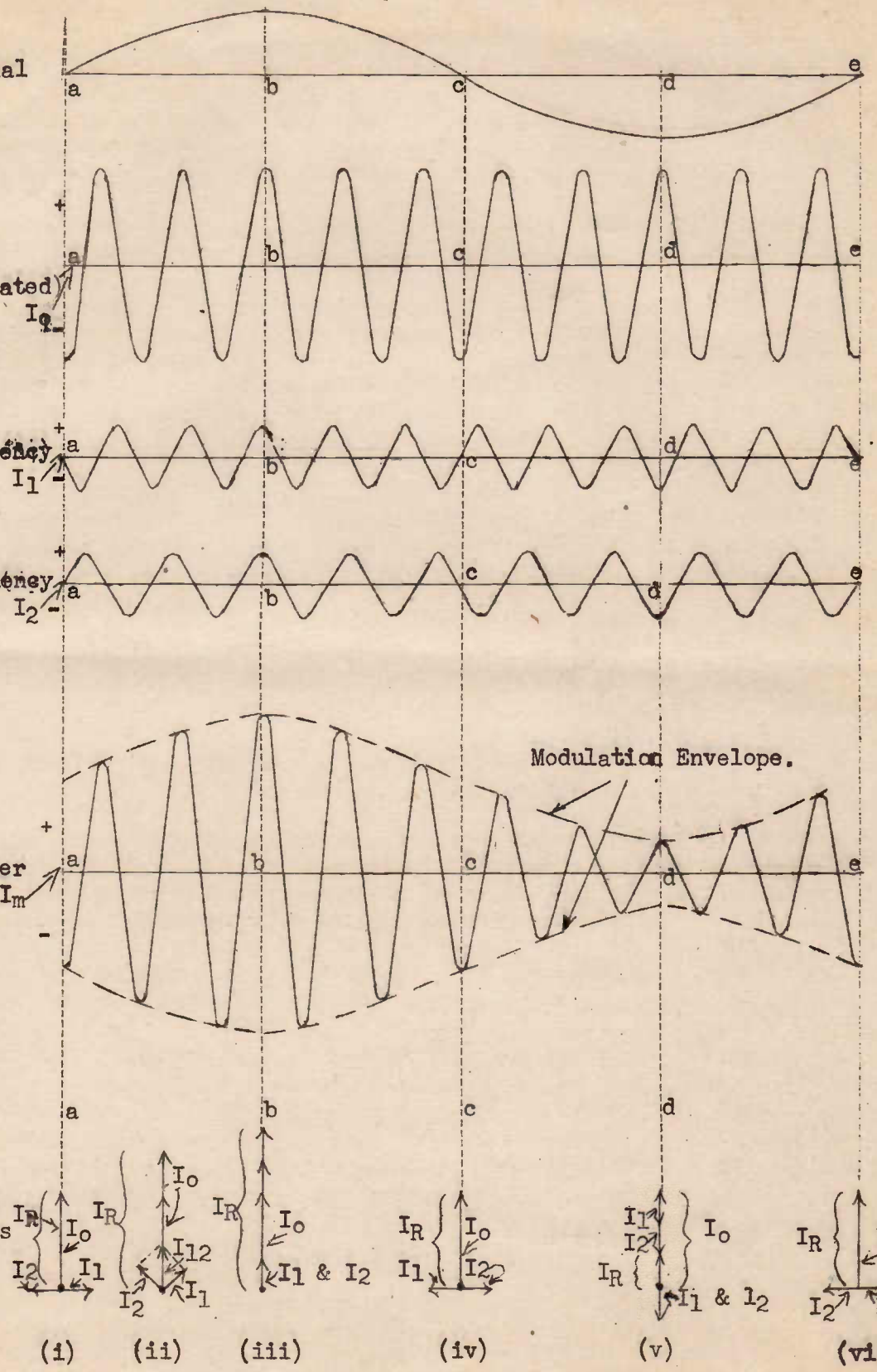

Fig. 12.

bine to give the modulated result shown at E.

At C, we have an upper side-frequency. Here are shown 11 complete cycles in the time a.e. ($\frac{1}{10,000}$ sec.), so that the frequency is $11 \times 10,000 = 110,000$ C./sec. (= 110 K.C./sec). Note that this frequency lies above the carrier frequency (100,000 C./sec.) by an amount equal to the audio frequency of the modulating signal (10,000 C./sec.). Graph D shows the lower side-frequency of 90,000 C./sec. (9 cycles in $\frac{1}{10,000}$ sec.). This also differs from carrier frequency by an amount equal to the modulating frequency.

Note that, for the 50% modulation shown, the amplitude of each of the side-frequencies is one-quarter of the amplitude of the unmodulated carrier.

Now let us consider the relative phase relationships between the carrier and its two side-frequencies shown in graphs B, C and D (Figure 12). At the instant marked "a" in the graphs the upper side-frequency is just commencing to go negative. At this same instant the carrier has already reached its negative peak. This means that the upper side-frequency (I_1) is, at this instant lagging by $\frac{1}{4}$ cycle or 90° the carrier. This is shown in the vector diagram F (1) (Figure 12) where the vector representing the carrier is drawn in a direction up the page. I_1 is drawn towards the right of the page making an angle of 90° with I_0 . This represents a lagging phase for I_1 compared with I_0 . (Remember that the conventional direction of vector rotation is counter-clockwise). Now look at the lower side-frequency graph (D). At instant "a" the wave is just beginning to go positive whereas the carrier does not begin to go positive till $\frac{1}{4}$ cycle later (see graph B). This, of course, means that side-frequency I_2 is leading the carrier by $\frac{1}{4}$ cycle or 90° . Now since I_1 lags I_0 by 90° and I_2 leads I_0 by 90° this also means that I_1 and I_2 (the 2 side-frequencies) are 180° out of phase. This may also be seen by direct comparison of the graphs (C and D) of I_1 and I_2 . At instant "a" I_1 is just beginning to go negative. At the same instant I_2 is just beginning to go positive. This shows that they are of opposite phase (phase angle = 180°).

These additional phase relationships are also shown by vectors at F (1). I_2 is drawn to the left showing a leading phase angle relative to I_0 . The vector diagram shows clearly that, at this instant "a" I_1 and I_2 are 180° out of phase; for their vectors are drawn in opposite directions.

The lengths of the vectors I_0 , I_1 and I_2 are of course equal, respectively, to the peak values of the currents I_0 , I_1 and I_2 .

Adding the vectors of Figure F(1) we notice that the vector sum of I_1 and I_2 is zero (equal and opposite vectors). This leaves as the resultant of I_1 , I_2 and I_0 a vector equal to I_0 , and in phase with I_0 , as shown by I_R on the diagram. This agrees with graph E, where at "a" the instantaneous amplitude of the modulated carrier equals vector I_R which is equal to the amplitude of the unmodulated carrier (I_0).

Now the phase relationships shown at F (1) do not persist indefinitely. The vectors, it must be remembered, are continually spinning counter-clockwise with speeds representing the frequencies of the currents they represent. Since I_1 represents the highest frequency it will be rotating counter-clockwise at a faster rate than I_0 . Hence the angle between these two vectors will be

diminishing as time goes on. Now in the subsequent vector diagram of Figure 12 F we have shown vector I_0 in a fixed direction (vertically) and have represented only the relative rotations of I_1 and I_2 in respect to I_0 . This is done because we are interested only in the relative phase relationships of I_1 and I_2 in respect to I_0 . Thus at a moment later, F(ii), we have shown a diminished angle between I_0 and I_1 compared with that shown at F(i). The vector I_1 , initially lagging I_0 by 90° is now "catching up" in phase on I_0 .

In a similar manner the angle between I_0 and I_2 vectors will be diminishing, since I_2 (initially ahead of I_0) is rotating counter-clockwise at a slower rate than I_0 . In effect I_0 is "catching up" on I_2 . We have shown this at F(ii) by imagining that vector I_0 has remained fixed, and vector I_2 has rotated clockwise at a rate equal to the difference between the rates of actual rotation of I_0 and I_2 .

Concentrating now on vector diagram F(ii), we obtain the vector sum of I_1 and I_2 by completing the parallelogram giving the vector marked I_{12} as the resultant. The resultant of all three vectors is then obtained by adding I_{12} to the end of I_0 , giving I_R . This of course will represent the modulated carrier in amplitude and phase. Note: (1) the amplitude of the resultant wave (length of I_R) is increasing as the side-frequencies move more and more into phase with I_0 , and (2) the phase of the resultant is still identical with that of the unmodulated carrier (this follows since vector I_R (Fii) is still in the same direction as I_0). The latter point, of course, means that the modulation produces no change in carrier phase, and therefore no phase or frequency modulation.

Figure 12 F(iii) gives the state of affairs a little later at an instant of time (marked "b") when the wave is at a modulation peak. Vector I_1 rotating less rapidly than I_0 and vector I_2 rotating more rapidly than I_0 are now both in phase with I_0 , and the resultant (I_R) is, at this instant a maximum. (See also points marked "b" on graphs B, C, D and E.)

As time goes on I_1 continues to rotate counter-clockwise with respect to I_0 and I_2 continues to rotate clockwise (relative to I_0). As shown in Diagram iv (figure 12F) the side-frequencies are once again 90° out of phase with I_0 , and 180° out of phase with each other (see points "C" on the graphs). Later still, as the vector rotation continues the vector I_1 and I_2 will be in the same direction downwards as shown at 12 F(v). The side-frequencies are now in phase with each other, but 180° out of phase with I_0 (carrier). To obtain the resultant in Figure 12 F(v) vectors I_1 and I_2 have been placed at the "arrow end" of vector I_0 , and their sum is subtracted from the latter. The resultant is I_R as shown. Here the modulated wave has a minimum amplitude.

Summarising, the important points to note from the foregoing discussion are:-

- (1) The side-band frequencies are in phase with the carrier at the positive peaks of the modulation voltage (i.e. when the modulation envelope is at a peak). See points "b" in the graphs (Figure 12).
- (2) As time continues the upper side-band vector rotates counter-clockwise, and the lower side-band vector rotates clockwise in respect to the carrier vector. These rates of relative rotation are equal, each depending upon the difference between side-band frequency and carrier frequency.
- (3) As a result of (2) the angles between the side-band vectors and the carrier are always equal (see Figure 12 F(ii)). Hence the resultant of the side-

bands (I_{12}) is always in line with carrier vector (I_0). This means that the side-bands do not change the phase of the modulated carrier (I_R is always in phase with or 180° out of phase with I_0).

- (4) Since there is no change in carrier phase due to the side-band vectors (i.e. due to modulation) no frequency modulation results.

(When only one single audio frequency is modulating the carrier, there will simply be one single upper side-frequency and one single lower side-frequency as in the examples just quoted. When complex tones, especially music, are being broadcast there may be simultaneously a number of upper and lower side-frequencies. The groups of side-frequencies then are called "side-bands".)

PHASE RELATIONS BETWEEN CARRIER AND SIDE-BANDS FOR P.M.(OR F.M.).

Suppose now that the graphs representing the side-frequencies of Figure 12(C and D) are moved bodily towards the left of the page through a distance equal to $\frac{1}{4}$ cycle. This is equivalent to advancing the phase of the side-frequencies by 90° relative to the carrier, and the situation is shown in Figure 13, at C and D. Note that the upper side-frequency I_1 (figure 13C) is now in phase with the carrier, and the lower side-frequency I_2 (Figure 13D) is 180° out of phase. These phase relationships are shown in the vector diagram at F(i). The side-frequencies being equal and 180° out of phase cancel each other and have no effect upon the carrier (vector I_0).

Remember that the side-frequency vectors are rotating at equal and constant speeds relative to I_0 , I_1 rotating anti-clockwise and I_2 clockwise. The situation is shown for an instant about $\frac{1}{8}$ cycle later at (ii) (Figure 13F). The side-frequency vectors I_1 and I_2 now have a resultant I_{12} as shown. The vector representing the modulated carrier is obtained by obtaining the vector sum of I_0 and I_{12} , and is I_R as shown. Note that the effect of the side-bands has been to advance the phase of the carrier through an angle equal to that between I_0 and I_R in this diagram.

A little later still the situation is as shown at (iii) (Figure 13F). This diagram shows the conditions for the instant of time marked "b" on the graphs, i.e. for the positive peak of the modulating voltage, I_1 and I_2 are now in phase with each other, and 90° out of phase (leading) with the unmodulated carrier (I_0). The resultant of I_0 , I_1 and I_2 , representing the modulated carrier is I_R . Note that the angle through which the carrier phase has been advanced (marked "A") has increased still further.

As I_1 and I_2 continue to rotate this phase angle "A" will now begin to decrease, becoming zero at time "C". This is shown at Figure 13F (iv) where I_1 and I_2 are 180° out of phase with each other, and therefore cancel. The carrier is thus simply I_0 at this instant.

A quarter of a modulating voltage cycle later I_1 will have rotated anti-clockwise and I_2 clockwise, so that both vectors are pointing to the right of the page (see Figure 13F (v)). The resultant I_R of I_1 , I_2 and I_0 again represents the instantaneous value of the modulated carrier. Note now that the effect of the side-frequencies has been to retard the carrier phase of the carrier by an angle "A". (I_R lags I_0 by "A").

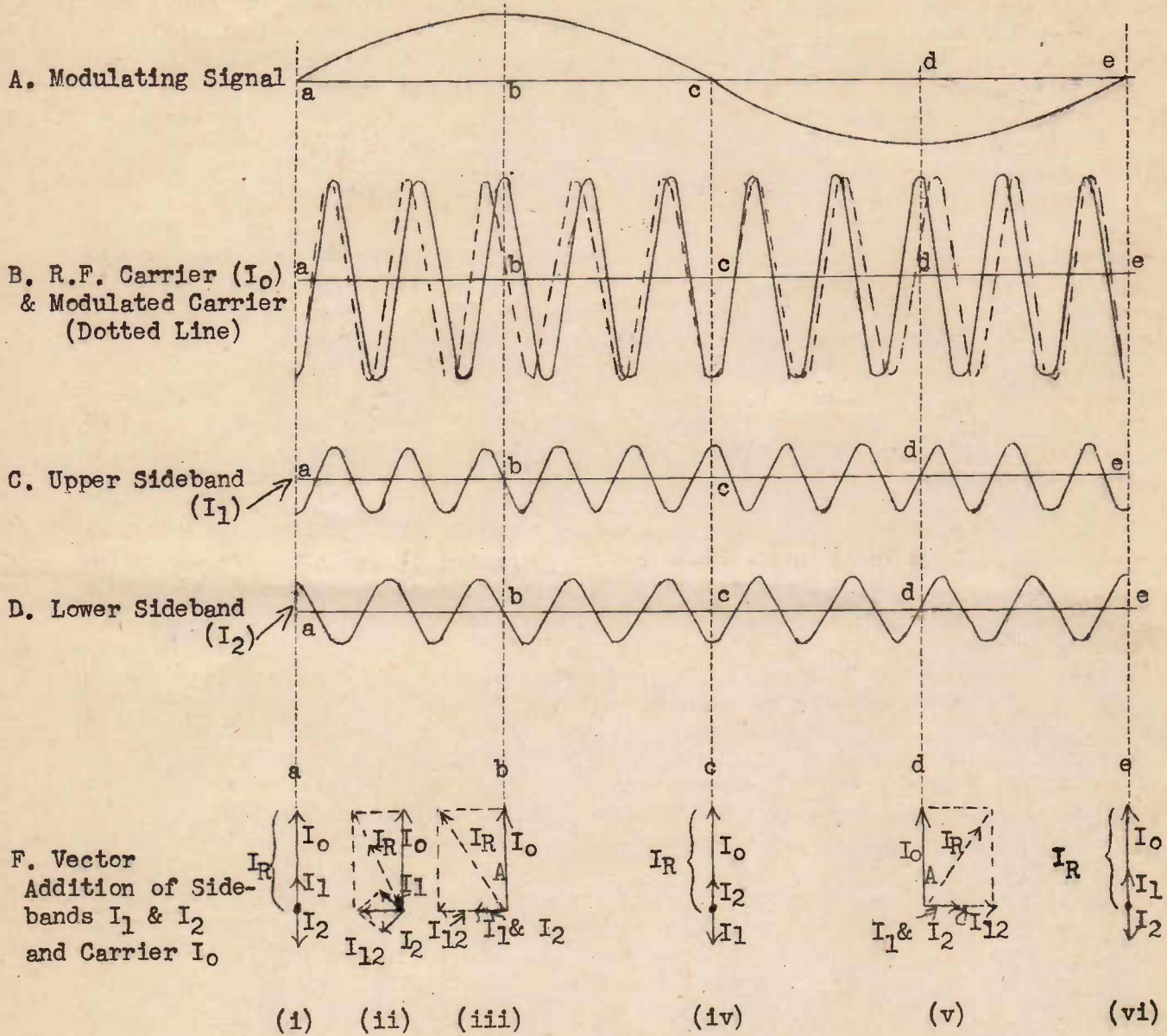

Fig. 13.

As time continues from this point the angle between I_R and I_O will commence to decrease. At point "e" the phase of the modulated carrier (I_R) is identical again with that of the unmodulated carrier (I_O).

Note carefully the net effect of the side-frequencies acting upon the carrier. The modulated carrier vector I_R oscillates back and forth about the mean position I_O , through a total angle equal to $2A$. In other words the phase of the carrier is alternately advanced and retarded at modulation frequency. This is phase modulation, which, as we have seen produces an equivalent frequency modulation.

Observe the effect on the frequency of the carrier. Between points "a" and "b", when the phase of the carrier is being advanced (i.e. vector I_R rotated anti-clockwise) as shown at (iii) Figure 13F, the carrier frequency has been increased, as shown by the dotted line at B between points "a" and "b". Between "c" and "d" as the phase is being retarded (vector I_R rotating clockwise) the carrier frequency is below the mean value. This can be clearly seen by counting the number of dotted line cycles between "c" and "d" Figure 13B, and comparing with the number of full-line cycles between the same two points.

A further important point brought out by Figure 13 is that the amplitude of the carrier remains fairly constant. The vector I_R , representing the modulated carrier in amplitude and phase (at F) remains practically of constant length. This is only true if the angle A representing the maximum phase deviation is comparatively small. This is so because we have considered only the first-order pair of side-frequencies. Longer deviations would involve additional higher-order side-frequencies which we have neglected.

CONVERTING A.M. TO P.M.

Figures 12 and 13, and the accompanying discussion have thus shown that the only difference between A.M. and P.M. (for small deviations) is in the phase relationship between the pair of side-bands and the carrier. In the case of A.M. the side-bands are in phase with the carrier at the instants corresponding to modulating signal peaks; in the case of P.M. the side-bands are 90° out of phase with the carrier at the same instants.

If, then, we can take the side-bands produced by A.M., and electrically shift them in phase through 90° relative to the carrier the result will be P.M. The "equivalent" F.M. thus produced may then be connected to yield "true" F.M. This is the principle of the Armstrong method.

THE ARMSTRONG "INDIRECT" METHOD OF F.M.

Figure 14 shows, in block form, the principal sections in the Armstrong Modulator. Here block (3) is an amplitude modulator so designed that it balances out the carrier voltage, its output containing only the two side-bands produced by the modulation. Into this modulator we feed the audio modulating signal (from the microphone) together with a part of the carrier signal from block (1). The remainder of the carrier signal is amplified (block 4) and passed to the frequency multipliers.

The two side-bands, produced by amplitude modulation are fed to block (5) where

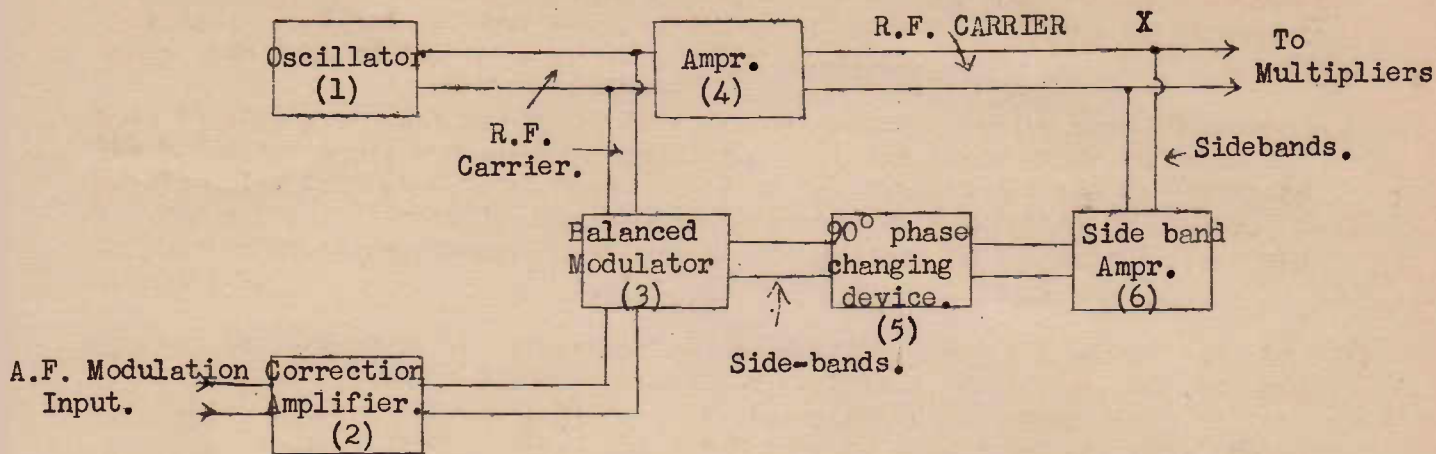

FIGURE 14.

their phase is shifted through 90° . The side-bands are now recombined with the carrier signal coming from block (4). These side-bands immediately after leaving the modulator were in phase with the carrier at the instants of modulating voltage peaks (since they were produced by A.M.). After phase-shift they will therefore be 90° out of phase with the carrier at modulation peaks. The effect of the 90° phase changing device may be visualised by comparing graphs C and D of Figure 12 with C and D of Figure 13. The vectors at F in these two figures also show the change produced. The phase relationship between the side-bands and carrier is now such that phase modulation would result.

As we have earlier explained phase modulation involves an "equivalent" frequency modulation, but the frequency deviation is proportional to the modulating (audio) frequency as well as to the amplitude of the modulating signal. This means that the frequency variations will double if the audio modulating frequency is doubled even though the amplitude of the latter signal remains unchanged.

To counter-act this effect the modulating signal is put through a correction circuit included in block (2) Figure 14 before being used for modulation. This correction circuit acts in such a manner that the amplitude of the modulation signal is inversely proportional to its frequency. This will exactly off-set the effect of phase-modulation whereby the frequency deviations in the final output are directly proportional to A.F. signal frequency. The output from the transmitter will be therefore true F.M.

THE MODULATION SIGNAL CORRECTION CIRCUIT.

The correction circuit which does this job of changing the output from true P.M. to F.M. consists simply of a resistor and condenser in series, the microphone signal being applied across the two, while the output is taken from across the condenser only, as shown in Figure 15. The value of resistance is made large compared with the reactance of the condenser even for the lowest audio frequency. This means that the impedance of the circuit remains substantially constant for all audio frequencies of modulation. Thus the alternating current through R.C. (figure 15) does not alter with frequency. Now the reactance (X_C) of C varies

inversely with the frequency ($X_C = \frac{1}{2\pi fc}$)

The voltage across C is given by $E = I \times X_C$ where I is the current (A.C.) through R and C. Since I remains practically constant for all frequencies, but since X_C varies inversely with the frequency E will also vary in the latter manner.

THE BALANCED MODULATOR.

The balanced modulator (block 3, Fig. 14) used for A.M. with carrier suppression is more or less a push-pull amplifier as shown in Fig. 16. The carrier frequency is applied to the grids of the two tubes in phase. Hence, by using a transformer output in the plate circuits, with a centre-tapped primary, voltages of this frequency will cancel out in the output.

The modulating voltage is applied in opposite phase to the two screen-grids by means of a centre-tapped transformer. Now remember that out-of-phase voltages applied to the grids (or screen grids) of a push-pull amplifier will produce signals in the plate circuits which add in the secondary of the output transformer. In addition the A.F. modulation signal and the r.f. carrier signal will combine in the valves as in ordinary modulation theory, to produce amplitude modulation. The resultant output will therefore be an A.M. signal from which the carrier frequency has been suppressed. In other words the output will contain the side-bands, representing the modulation, only.

PRODUCTION OF THE 90° SIDEBAND PHASE-SHIFT.

The changing of the phase of the sidebands by 90°, necessary to convert the A.M. to F.M. is usually carried out in the output transformer of the balanced modulator of Fig. 16.

The principle involved may be stated thus:- "The A.C. voltage induced in the secondary winding of a transformer is 90° out of phase with the current flowing in the primary".

Consider Fig. 17. The current I_p in the primary sets up a magnetic field which expands and contracts in step with this current. This moving magnetic field, cutting the secondary will induce an e.m.f. (E_s) in

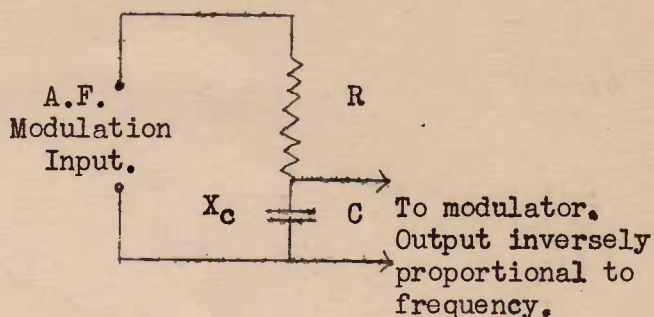

Fig. 15

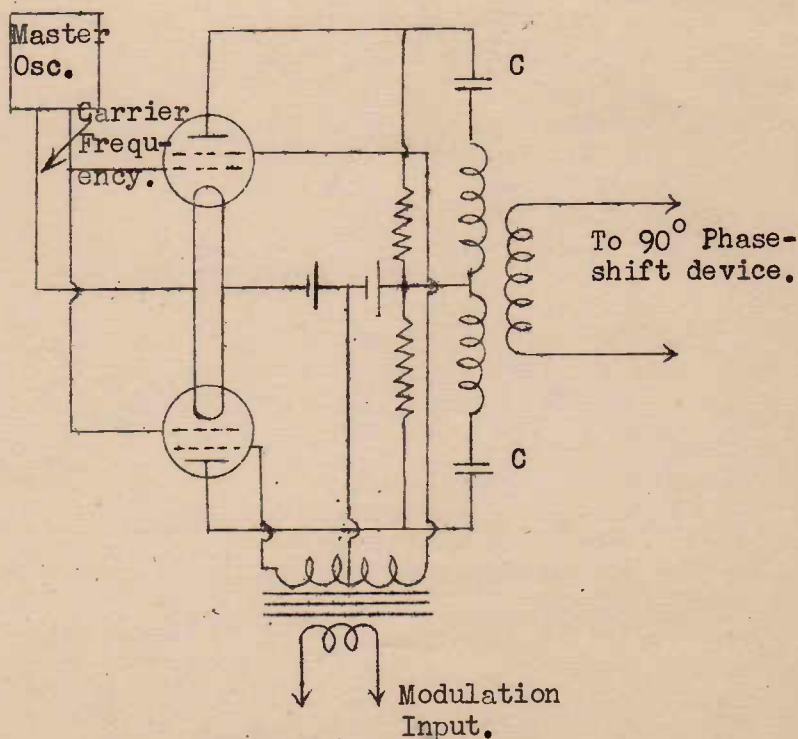

Fig. 16.

the latter. The instantaneous value of this voltage at any moment will have a value depending upon the rate of movement of the magnetic field, and therefore on the rate of change of primary current. Referring to Fig. 18, at points a and e the current, although small in value, is changing at a maximum rate. At these instants the magnetic lines of force will therefore be moving at a maximum rate across the turns of the secondary coil, and the induced e.m.f. will have a maximum value, as shown at b and f. At points c, and g on the other hand, the current is momentarily neither increasing or decreasing, the magnetic lines of force are therefore stationary and the induced e.m.f. (E_s is zero - see points d and h.

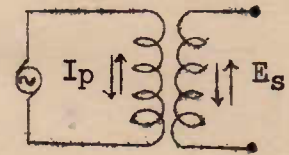

Fig. 17.

The induced e.m.f. in the secondary (E_s) will therefore be represented by the dotted curve of Fig. 18. Note that this is 90° out of phase with I_p . This phase relationship is also illustrated by the vectors of Fig. 18.

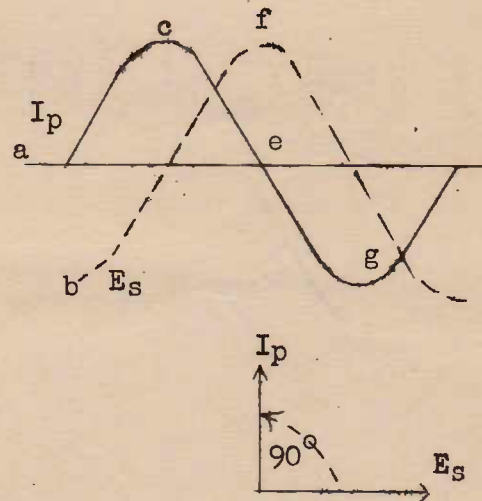

Fig. 18.

Referring back, now, to Fig. 16, the currents in the primary of the output transformer, representing the sidebands, will induce corresponding e.m.f.'s in the secondary, with a 90° phase-shift. These secondary voltages are then applied to the grid of the side-band amplifier, without further phase change. The side-band signals are then re-combined with the unmodulated carrier as shown in Fig. 14.

The condensers marked "C" in Fig. 16 are for the purpose of preventing any phase shift in the plate circuits of the valves. A valve's plate current will be in phase with its grid voltage only if there is no reactance due to inductance or capacity in the plate circuit. Now the inductances marked "L" in the plate circuits will tend to cause the A.C. component of plate current to lag by 90° . If we place capacities in series with the inductances in these circuits such capacities will tend to cause the current to lead by 90° . If the reactances of "C" and "L" in each circuit are equal, therefore, the two phase effects will off-set each other and the current will suffer no change in phase. In effect "L" and "C" form a series resonant circuit. The consequence of this action of the condensers "C" is that the sidebands represented by the currents in the primary of the output transformer of Fig. 16 have a phase relationship (relative to the unmodulated carrier) which corresponds to amplitude modulation. The side-band signals in passing from primary to secondary of this transformer then suffer a phase shift of 90° , and when recombined with the unmodulated carrier at "X" (Fig. 14) their phase is correct to produce frequency modulation.

FREQUENCY MULTIPLICATION.

The amount of frequency deviation obtainable with the Armstrong method in particular is quite small. The phase shift produced in the manner explained in connection with Fig. 13 must, for the reasons given, be kept small say 30° .

Now in a previous lesson it was explained how the equivalent frequency modulation produced by a certain phase shift depended upon the modulation frequency as well as the angular phase change itself. In that discussion we calculated the average frequency deviation (measured over half a cycle of modulation) by dividing the total number of cycles by which the frequency was varied by the time taken, i.e for half a cycle. It must be remembered, however, that when the frequency is swung backwards and forwards the rate of frequency change is not constant over the cycle of modulation, and therefore the average frequency change will be something less than the peak deviation (in the same way as the average value of an alternating current is less than its peak value).

A formula which will give the peak equivalent frequency deviation knowing the phase deviation, and the modulating frequency is :

$$\Delta F = \frac{\Delta A \times f}{57.3} \quad \text{where :-}$$

ΔF = the peak value of the frequency deviation.

ΔA = the peak value of the phase modulation, measured in angular degrees.

f = modulating frequency.

(Note: the symbol Δ is the Greek letter "Delta", meaning here a small change in") Thus ΔF means a small change in the carrier frequency, and represents the deviation. Note that this formula brings out clearly the point made in an earlier lesson, viz. that for a given phase change the equivalent frequency deviation is directly proportional to modulating frequency.

Returning to the Armstrong modulator we saw that the maximum phase deviation was limited to 30° . The amount of frequency modulation produced at, say, the lowest frequency of modulation, 50 cycles per. sec. will be given by the formula above thus :

$$\Delta F = \frac{\Delta A \times f}{57.3}$$

where $\Delta A = 30^\circ$, $f = 50$.

Therefore $\Delta F = \frac{30 \times 50}{57.3} = \frac{1500}{57.3} = 26$ cycles per sec. approx.

But for wide-band F.M., we require a deviation of 75,000 cycles per sec. !

The required frequency swing is obtained by using a series of frequency doublers or triplers. These were described briefly in the lesson papers dealing with Television. A frequency multiplier, it will be remembered is simply an amplifier producing distortion (and therefore harmonics of the input frequency) and containing a resonant circuit in its plate lead tuned to one of these harmonics.

A frequency doubler will double all the frequencies applied to its grid. Hence if an F.M. signal is applied not only is the mean carrier frequency doubled, but also the frequency deviation.

In the case cited above, where we wish to increase the frequency deviation 26 cycles per sec. a total frequency multiplication of $\frac{75,000}{26}$, or nearly 3,000 times would be required. Now if straight out frequency multiplication were used, and the radiated wave were to have a frequency of, say, 93 m.c. per sec., the primary frequency at which modulation occurs would be required to be $\frac{93,000,000}{3,000} = 31,000$ c. per sec. - only about double the highest audio frequency of modulation.

This difficulty is overcome by operating the primary oscillator at about 100 K.c per sec., stepping up the frequency (and deviation) by several multipliers, to, say 1,200 K.c per sec. or higher, and then reducing the frequency (without reducing the deviation) to a low value again, before using additional multipliers. This reduction in carrier frequency is achieved by heterodyning the carrier with an oscillator to produce a kind of intermediate frequency. This heterodyning action, although reducing the mean (carrier) frequency of the F.M. wave will leave the deviation (increased by multiplication) unchanged. By carrying out this process of successive multiplication and frequency "division" over and over again, the final deviation of 75 Kc per sec. may be obtained.

THE POWER AMPLIFIERS.

These are no different in general principle from those used in A.M. transmitters. There is one important point to note, however, Since the amplitude of the F.M. signal remains constant, the amplifiers may be operated continuously at their full rated power output. In the case of an A.M. transmitter the power amplifiers must be designed to handle a peak power output 4 times that of the unmodulated carrier. On the peaks of amplitude modulation (for 100% modulation) the carrier voltage is twice the unmodulated value. This means that the power for maximum modulation amplitude is four times that for the unmodulated carrier, since power is proportional to the square of the voltage (or current). Hence the amplifiers are working at low efficiency. When F.M. is used the power amplifiers are working at saturation continually, and maximum power efficiency is obtained.

TRANSMITTING AERIALS.

As for television, operating at the ultra-high frequencies, resonant aerials, usually dipoles or "stacks" of dipoles, are used. The aerial system is designed so that very little signal is radiated sky-wards, since a sky-wave would not be reflected back to earth, but would be lost in space. The aim is to get maximum field-strength into the direct-wave. The lesson on transmitting antennas in the television section may well be referred to here.

LESSON 15 - QUESTIONS.

- (1) Why would it be a comparatively simple job to redesign an F.M. transmitter for a different level of radiated power ?
- (2) A resistance of 5,000 ohms is connected in series with a condenser whose reactance (at the frequency of the applied voltage) is 4,000 ohms. Draw an accurate vector diagram to find the phase angle between applied voltage (E_a) and current I.
- (3) Referring to Fig. 4, draw a vector diagram showing vectors for applied voltage (E_a), current (I), voltage across R (E_r), and voltage across C (E_c).
- (4) Under what conditions may an F.M. wave be considered as consisting of a carrier and a single pair of side frequencies ?
- (5) What is the phase relationship between sidebands and carriers in the following cases :
 - a. A.M. - positive peaks of modulating voltage.
 - b. F.M. - positive peaks of modulating voltage.
 - c. A.M. - zero points of modulating voltage.
 - d. F.M. - zero points of modulating voltage.

Illustrate with vector diagrams.

- (6) State the principle involved in converting A.M. to P.M.
- (7) Why is frequency multiplication absolutely necessary in the Armstrong system of modulation ?
- (8) What is the purpose of the modulating signal connection circuit in the Armstrong system ?
- (9) Why is an F.M. transmitter more economical from the point of view of power consumption compared with an A.M. transmitter ?
- (10) In a transmitter an F.M. signal of carrier frequency 5 m.c per sec., and deviation 10 Kc. per sec., is heterodyned with an oscillator frequency of 4 m.c per sec. (for frequency "division") what are the frequency limits of the resulting F.M. signals ?

AUSTRALIAN RADIO COLLEGE

E. S. & A. BANK BUILDINGS, Corner CITY RD. and BROADWAY, SYDNEY
Telephones: M 6391 and M 6392. Post Lessons to Box 43, Broadway

This lesson sheet is published for the exclusive use of students of the Australian Radio College Pty. Ltd. (All rights reserved)

FREQUENCY MODULATION RECEIVERS.



GENERAL COMPARISON OF F.M. AND A.M. RECEIVERS.

Although F.M. and A.M. receivers are required to operate on signals which differ greatly in nature and operating characteristics there is no very great difference in the general over-all structure of these two pieces of electronic apparatus. The similarity in the sequence and functions of the various stages of the two types of receivers will be realised by a comparison of the two block diagrams of Fig.1.

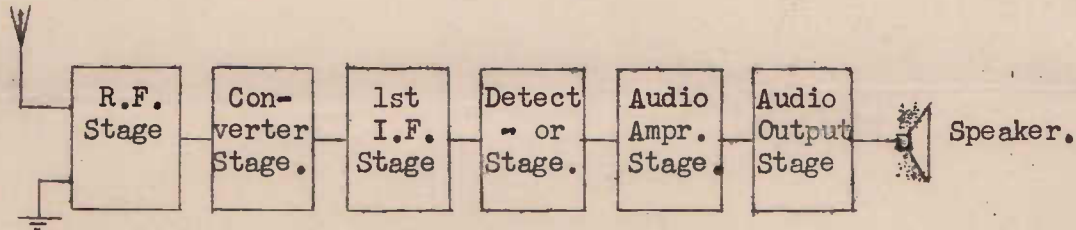

A. BLOCK DIAGRAM OF TYPICAL A.M. RECEIVER.

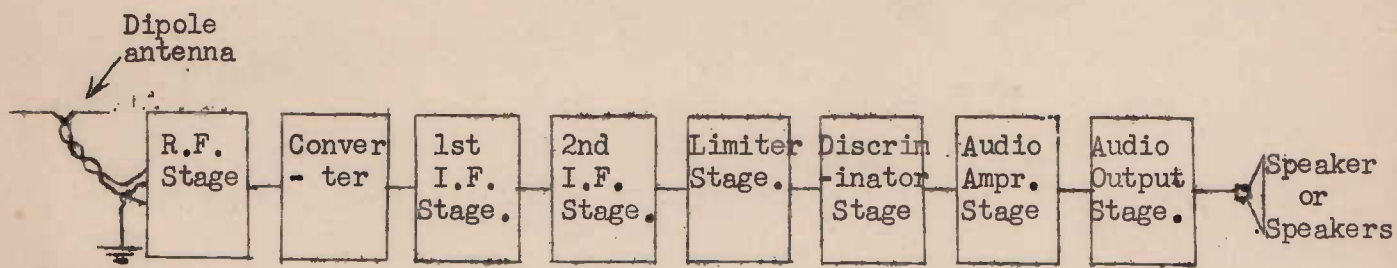

B. BLOCK DIAGRAM OF TYPICAL F.M. RECEIVER.

Figure 1.

Here each receiver shown possesses an R.F. amplifier, converter stage, I.F. amplifiers, audio amplifier and power output stage. All of these stages follow in the same order in the two types of receivers, and perform the same functions. It must be understood, however, that in order to realise the full potentialities with regard to signal-to-noise ratio and fidelity (including A.F. frequency response and dynamic range) of the F.M. system the receiver must be designed to satisfy more stringent specifications than those to which we have been accustomed.

The only radical differences between the F.M. receiver and the more humble A.M. type are seen to be (Fig. 1) - the incorporation of a Limiter Stage and the use of a special type of detection, called the Discriminator Detector. The Limiter has no counterpart in the A.M. receiver, and the Discriminator is made necessary in order to convert the frequency modulation into amplitude changes before separating the audio from the radio signal in - more or less - the ordinary way. Actually a very recent development has made it possible to dispense with the Limiter stage by the use of a special type of F.M. detector known as the Ratio Detector. These points, however, will be discussed in detail in due course as we proceed.

Despite the similarities in the general lay-out of the two types of receivers, the advent of F.M. has necessitated a somewhat different approach towards the problem of receiver design. In the past we have always regarded high sensitivity and freedom from noise as desirable but antagonistic qualities in a receiver. For example in the case of the A.M. system we have had to compromise between these two properties; an increase in sensitivity (over-all amplification), while increasing the output from a weak signal, also increases the total amount of noise. Similarly selectivity has always been a compromise between inter-channel inference and fidelity. An increase in band-width beyond 10 K.C. per sec. while improving the audio-frequency range, has invited "monkey-chatter" and other signs of interference from an adjacent channel. On the other hand, reducing the band-width to less than 10 K.C. per sec., while increasing the selectivity, and, incidentally, the signal-to-noise ratio, has cut off more of the high notes from a signal already trimmed to 5,000 cycles.

Frequency modulation lessens, or entirely eliminates, these compromises. An important characteristic of the F.M. receiver is that an increase in sensitivity not only improves the response to weak signals but actually, in general, reduces the noise level. Hence considerable sensitivity is desirable from all points of view.

Some degree of compromise between selectivity and adequate handling of the signal band is still required in the F.M. receiver. However it is a much easier job to obtain adequate selectivity without band-cutting. This advantage derives largely from the fact that providing the desired signal is more than twice as strong as the interfering signal at the detector (discriminator), interference cannot occur. The reason for this will be fully explained later in the lesson. However, if a weak signal is tuned in on a receiver having too broad a selectivity curve, it might be possible for a strong signal, operating on an adjacent channel, to take control whenever the latter's frequency gets within the band-pass of the tuned circuits. Even this possibility is remote because of the line-of-sight limitation of the u.h.f. waves, coupled with the fact that it is the practice to assign adjacent channels only to stations whose service areas do not overlap. Nevertheless it is considered good design practice to attempt to obtain a fairly sharp cut-off in the receiver's selectivity characteristic on either side of the pass-band of 150 K.C. per sec.

Let us now consider each section of an F.M. receiver, starting from the aerial and working through to the F.M. detector. The audio sections of the receiver, including power-output stages and loud speakers will be deferred until the next lesson. Here we shall discuss the special problems which relate to each stage or section and which arise from the use of an u.h.f. signal and the use of the new system of modulation.

Many of the principles involved in the operation of frequency converters and I.F. amplifiers are, of course, identical with those to be found in A.M. receivers, and are already well known to the student.

F.M. RECEIVER AERIALS.

In the past we have been accustomed to locating the receiver antenna anywhere it would fit, and making it of any convenient length. The lead-in has been simply a single length of wire connected to one side of the input circuit, the other side of the latter being earthed. Such a type of aerial may be more or less satisfactory for F.M. work in certain localities where the signal field-strength is high, and man-made static is low. In general however, the tuned or resonant aerial connected by a properly matched transmission line should be used.

Actually the technique of F.M. antenna design and installation is practically identical with that for Television work. The lesson on "Antennas" in the Television section of this course should, at this stage, be re-read.

THE R. F. AMPLIFIER STAGE.

The functions performed by the R.F. stage in an F.M. receiver are for the most part similar to those in an A.M. type. The more important of these are :-

- (1) To increase the receivers sensitivity.
- (2) To reduce the signal-to-noise ratio.
- (3) To increase selectivity.
- (4) To keep r.f. signals at the I.F. frequency from entering the I.F. stages.
- (5) To discriminate against the image frequency and to prevent "double-spotting".

In the case of a F.M. receiver Nos. (3), (4) and (5) of these are relatively unimportant. The r.f. tuned circuits, due to strong capacities and high r.f. losses cannot be made very selective. Again the I.F. frequency has been fixed at a value - 10.7 megacycles - which will not be used for other transmissions - hence (4) above is unimportant. Again the high value of I.F. chosen in relation to the width of the F.M. band (88 to 108 m.c., i.e 20 m.c.) will render function (5) above unnecessary.

This leaves functions (1) and (2) as the important ones. In the case of A.M. reception these are quite separate functions. In F.M. receivers, on the other hand they are closely inter-related. As stated early in this lesson anything which increases the sensitivity before the limiter stage will improve the signal-to-noise ratio in an F.M. receiver. Since sensitivity is such an important factor in an F.M. receiver, therefore, and because of the difficulty of obtaining a high stage gain (on account of the high I.F. employed), anything which adds to the over-all amplification before detection is to be encouraged. For this reason an R.F. stage is almost invariably incorporated in an F.M. receiver, although seldom in an A.M. receiver.

The use of an R.F. stage improves the signal-to-noise ratio in another quite different way. The main source of random tube noise in any receiver - A.M. or F.M. - is in the converter. This is particularly the case when operating at u.h.f.'s. The use of an R.F. stage, before the converter, raises the signal level without amplifying the "noise" from the latter tube, and thus the signal-to-noise ratio is improved by a factor equal to the r.f. gain. The same action, of course, occurs in the case of the A.M. receiver.

Ordinary tubes with which we are familiar would be practically useless at frequencies of about 100 m.c. per sec. Special miniature tubes, having low inter-electrode capacities and high mutual conductances - 3 or 4 times normal - have been developed for F.M. receivers. With such tubes an R.F. stage gain of 5 and greater can be realised. It might also be mentioned here that a voltage gain of a similar amount may be obtained from the resonant dipole aerial. Thus a total R.F. gain, before the converter, of 25 and upwards is possible. Such a gain, for the two reasons given above, is of the greatest consequence.

THE CONVERTER STAGE.

The function of the converter stage is similar to that in A.M. receivers. It is required to convert the F.M. signal in the 88 - 108 m.c. band into the I.F. of 10.7 m.c. It is of great importance to maintain this I.F. very close to the centre of the band-pass of the I.F. transformers. Hence the oscillator associated with the converter must be made extremely stable to prevent frequency drift.

A typical converter stage is shown in schematic form in Fig. 2.

Many precautions not shown in Fig. 2 are taken to prevent frequency drift. These include mechanical placement of the components, the size factor, and special design of the coils. In addition temperature compensating condensers are used. One of these is shown near the 47 ohm resistor. This resistor is placed very close to the condenser in order to warm it up very rapidly to the maximum operating temperature. Without this resistor the set might drift off the station before the temperature inside the chassis rose high enough to affect the condenser.

STATION SELECTION AND TUNING.

Formerly, when the 42 - 50 m.c. per sec. band was in universal use in America for F.M. it was common practice to tune over the band by the conventional ganged condenser method. With the advent of the higher 88 - 108 m.c. per sec. band this method is hardly practicable. At these frequencies the presence of small stray capacities render accurate "tracking" extremely difficult. The tendency now, therefore, is to use a separate tuned circuit for each channel together with a selector switch. The technique is similar to that described for television receivers. A fine-tuning control is provided in order to adjust each signal accurately to the centre of the I.F. channel.

CHOICE OF THE INTERMEDIATE FREQUENCY.

The choice of the I.F. for u.h.f. F.M. work is based on similar considerations to those which must be taken account of when fixing a suitable I.F. for ordinary A.M. reception.

It will be recalled that the use of the superheterodyne principle for reception may involve a number of special types of interference which are peculiar to this particular system. The main types of such interference are :-

(1) Image interference - This is interference resulting from the fact that the intermediate frequency (f_i) will be produced in the mixer by any incoming signal differing from either above or below - the oscillator frequency (f_o) by an amount equal to f_i . For this type of interference between two stations to occur their frequencies would therefore have to differ one from the other by twice the intermediate

frequency (i.e. by $2f_1$). For example if two stations having frequencies f_1 and f_2 differing by $2f_1$ (f_2 greater than f_1 , say), and the oscillator frequency (f_0) were set mid-way between these, then both signals may be heard. In this case we have $f_2 - f_0 = f_1$ and $f_0 - f_1 = f_1$; i.e. the I.F. (f_i), for which the receiver is designed, would be produced by either signal f_1 or f_2 . If the receiver's design is such that the oscillator frequency (f_0) operates above the desired signal frequency, then f_1 would represent the desired signal, and f_2 would be an interfering undesired signal. The interference would represent the "image" of the signal frequency f_2 . If, on the other hand the receiver were designed to operate with oscillator frequency (f_0) below the tuned signal, then in the case cited f_2 would be the desired signal and f_1 would produce the undesired image. In either case it will be noted that

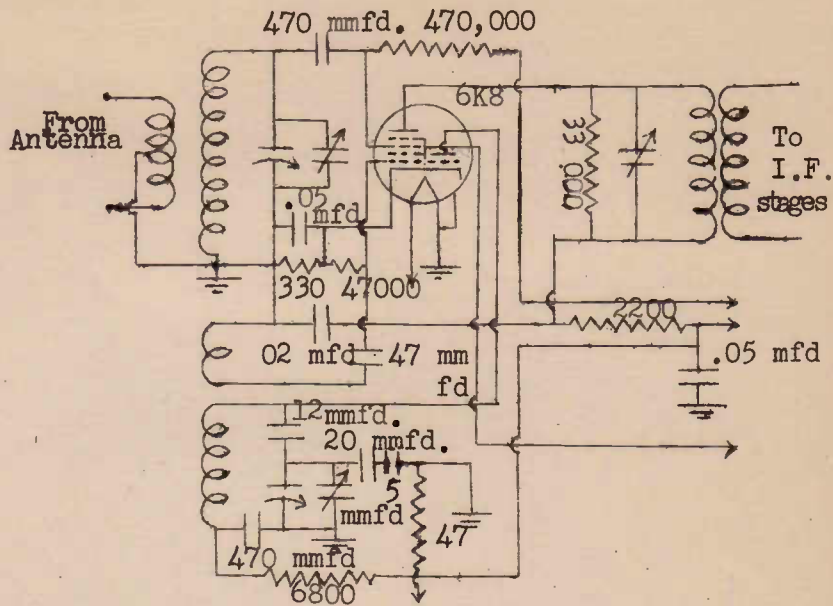

A TYPICAL CONVERTER STAGE. Fig. 2.

f_i must be one-half the difference between the two interfering signals i.e. $f_i = 1/2 (f_2 - f_1)$. Hence if the I.F. (f_i) is more than one half the difference between the highest and lowest frequencies in the particular band under consideration image interference cannot occur.

(2) Interference due to harmonics of the oscillator beating with undesired signal frequencies. For example an undesired signal frequency differing from twice the oscillator frequency (2nd harmonic) by an amount equal to the I.F. may give rise to interference. Putting this in symbols, any signal frequencies equal to $2f_0 \pm f_i$, $3f_0 \pm f_i$ etc. could cause trouble.

(3) Interference caused by two signal frequencies differing by an amount equal to f_i beating together in the mixer stage, and thus producing the intermediate frequency. If f_1 and f_2 denote two such signal frequencies then interference may occur if $f_2 - f_1 = f_i$.

In F.M. work, as in A.M., interference types (1) and (3) above may be reduced, or entirely eliminated, by increasing the frequency of the I.F. (f_i). It must be remembered that the receiver's r.f. tuned circuits are not adjusted to the undesired signal, and hence tend to discriminate against it before the mixer is reached. For image interference we have $f_i = \frac{1}{2} (f_2 - f_1)$ and for interference type (3) $f_i = f_2 - f_1$. Hence in either case increasing f_i will mean a greater frequency difference between f_2 and f_1 , with the result that the undesired signal may be more effectively suppressed before frequency conversion. Of course, the additional selectivity before conversion obtained by the use of a tuned r.f. stage will, as in A.M. work, largely remove interference of all three types.

The frequency band assigned for F.M. transmission, as already stated, is 88 - 108 m.c. A comparatively high value, viz. 10.7 m.c. has been chosen for the intermediate frequency channel. This is more than one half of the total band width of 20 m.c., and hence as explained under (1) above image interference cannot occur.

The oscillator, unlike broadcast A.M. operation, is worked below the signal frequency. Hence the oscillator frequency will range from $88 - 10.7 = 77.3$ m.c. to $108 - 10.7 = 97.3$ mc. Interference from oscillator harmonics can hardly occur, since the lowest frequency harmonic (the second harmonic) would be 154.6 m.c., far above the frequency to which the r.f. circuits would be tuned, viz. 88 m.c. It will be noted that this type of interference can hardly occur whenever the total width of the transmission band is small compared with the carrier frequencies used. In F.M. work this band is 20 m.c. wide which is small compared with the lowest carrier frequency in the range, i.e. 88 m.c.

THE INTERMEDIATE FREQUENCY STAGES.

The I.F. stages of an F.M. receiver perform the same functions as those in A.M. receivers, viz. they should :

- (1) Produce a considerable amount of amplification of the signal before detection in order to raise the former to a level sufficient for efficient operation of the detector stage.
- (2) Discriminate sufficiently against all but the desired signal to avoid interference, while at the same time passing uniformly all the important side-bands of the modulated I.F. frequency.

In an F.M. receiver it is most important that the I.F. amplifiers yield a high over-all gain. If the signal level is not sufficiently high at the Limiter stage (immediately before the frequency detector) the advantages of noise suppression will be largely lost. As we shall see the Limiter does not operate until the signal strength reaches a certain minimum level at its input. Amplitude modulation, produced by "noise" voltages and other interference will pass through and produce audio frequency voltages in the final stages, thus resulting in noise in the output. Thus we have a situation which is just the opposite to that to which we have been accustomed. With A.M. the noise (not the signal-to-noise ratio) increases with receiver gain. With F.M., on the other hand, a high degree of gain before detection will result in practically noise-free reception under normal conditions.

For these reasons at least two stages of I.F. amplification are necessary. Many receivers use three stages. Although some voltage gain is obtained from the resonant dipole, and some from the r.f. stage, most of the amplification, before detection, must be produced by the I.F. stages. Working with an I.F. of 10.7 m.c. (as compared with 455 K.C. in broadcast receivers) the gain per stage tends to be low. If we were to use the same type of valves as commonly met with in A.M. broadcast sets (e.g. 6U7) the over-all gain in the I.F. section would be quite inadequate, even if using three stages. To off-set the increased r.f. losses associated with amplification at higher frequencies, valves having very high values of mutual conductance (at least 2 or 3 times normal) and low values of inter-electrode capacities are used. From the point of view of gain the problems of the I.F. stages are similar to those discussed for the same stages in a television receiver. The r.f. pentode 6AC7 (1852), having a G_m of 9,200 μ A. / volt (discussed in the television section) has proved very satisfactory for I.F. F.M. amplification. The latest tendency is to develop miniature type tubes having large values of G_m . One such tube is the

6BA6, which is used for both r.f. and I.F. amplification. Typical tubes, and their characteristics, for all stages of an F.M. receiver will be discussed in a later lesson.

COMPARISON OF I.F. BAND-PASS REQUIREMENTS FOR F.M., A.M., AND TELEVISION.

The band-width of a wide-band F.M. signal (deviation = 75 K.c per sec.) is taken as 150 K.c. per sec. This is very much wider than that for the ordinary A.M. signal which is, as transmitted, certainly no wider than 20 K.c. per sec. Actually the I.F. transformers of an average broadcast set pass a band of only about 10 K.c. per sec. or even less. Thus we see that the I.F. stages of an F.M. receiver must be designed to pass a band of frequencies 15 to 20 times as wide as is required for A.M. At the same time it should be realised that the band-width of an F.M. signal is not nearly as wide as that used in television. Here the picture I.F. amplifiers are required to pass a modulated signal having sidebands covering a range of anything up to 4 m.c. per sec. Now we have seen in the Television Lessons that it is possible to design I.F. stages, operating in the vicinity of 10 m.c. per sec. to pass this very wide band. The job, however, usually requires the design of very complicated circuits for inter-stage coupling, filter-circuit theory usually being resorted to. By comparison, therefore, it appears that it should not be very difficult to obtain a flat-topped I.F. curve, operating at 10.7 m.c per sec. to cover a band of only 150 K.c per sec. as required for F.M. The I.F. transformers have the same general form as those to which we are accustomed, i.e. they usually have both primary and secondary windings tuned. Two common methods of obtaining the necessary band-pass are in use : (1) over-coupling the primary and secondary, which tends to give the double-peak effect, and (2) use of damping resistors across the coils. Both methods are generally used concurrently. A typical I.F. curve is shown in Fig. 3. This gives the output voltage of the last I.F. stage for different frequencies above (shown as positive frequencies), and below, (shown as negative frequencies), the centre carrier frequency. Note the slight double-hump effect due to over-coupling. A narrow-band A.M. signal is shown, for comparison purposes, on the graph.

EFFECT OF INADEQUATE BAND-PASS.

In A.M. work the effect of too narrow a band-pass in the I.F. stages is to cut the higher side-frequencies resulting in a loss in the higher audio frequencies. The result is a loss of fidelity.

In an F.M. receiver, however, a somewhat different action occurs. When receiving an F.M. signal the full band-width of the channel is only used on the loudest sounds, for only then the frequency of the r.f. wave is deviated the full 75 K.c per sec on either side. Weaker sounds, irrespective of their audio frequency will result in smaller deviations, and sidebands which do not extend over the whole 150 K.c. per sec. band. Hence the effect of band-

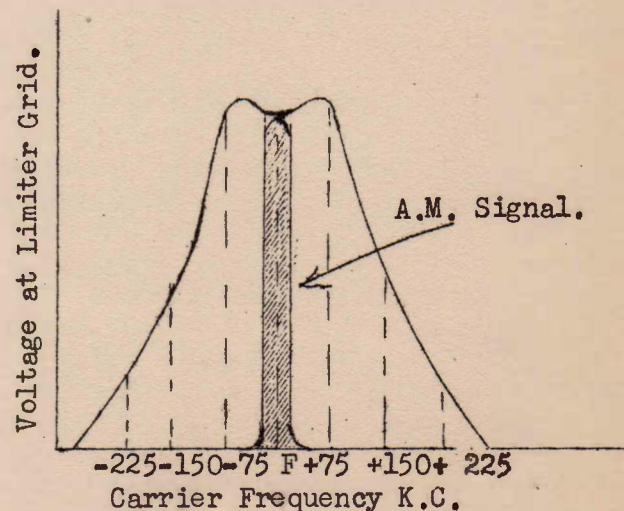

Figure 3.

cutting will be to "clip-off" the loud peaks of the sound signal, causing distortion. The effect would be somewhat similar to that occurring in the reception of an A.M. signal when using an overloaded valve.

PRACTICAL I. F. CIRCUITS.

Partial schematics of two commercial I.F. amplifiers are shown in Figs 4 & 5.

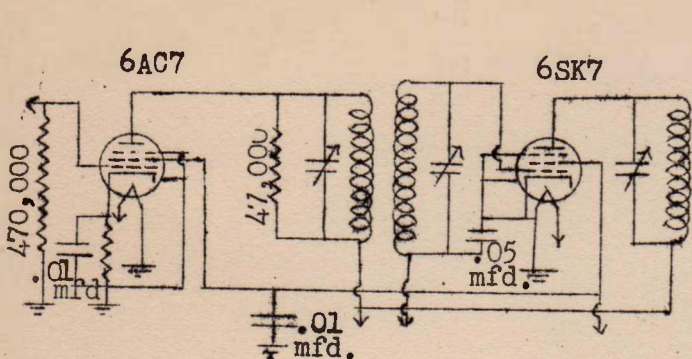

Figure 4.

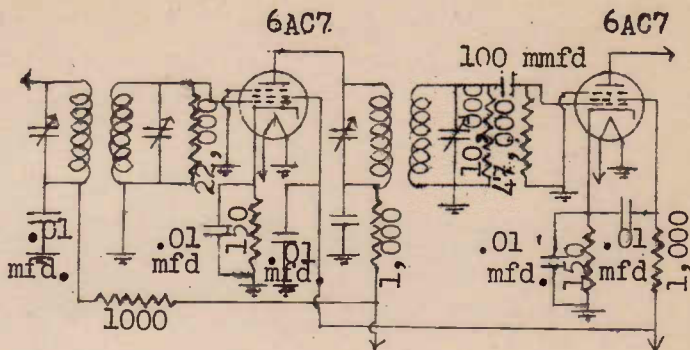

Figure 5.

THE LIMITER STAGE.

So far we have been discussing circuits which have almost exact counterparts in A.M. receivers. The limiter is the first radical departure from conventional practice. Most of us have learned from experience that an overloaded amplifier is a prolific source of distortion in A.M. receivers. This is quite natural, since our object in the A.M. receiver is to provide an exact replica of all amplitude changes of the carrier, and anything which tends to suppress these changes will distort the signal.

This distortion does not affect the final result in F.M. work, provided it occurs before detection. Its only effect will be to cause harmonics of the I.F. signal. Since the lowest of these harmonic frequencies (i.e. the second harmonic) will be double the I.F., a tuned circuit (or low-pass filter) may be used in the plate circuit of the limiter to remove them.

The limiter is simply an amplifier which is normally operated in a completely overloaded condition. Now the output of an F.M. receiver is supposed to depend upon frequency deviations or changes only. Any changes in the amplitude of the r.f. (or I.F.) voltage reaching the discriminator detector will yield changes in the A.F. output. Such changes we have seen, are due to interfering "noise" or possibly an undesired carrier heterodyning with the desired signal. The limiter, since it operates in a very overloaded condition, has a constant output, provided that the amplitude changes due to interference are not too great.

The simplest type of limiter is a valve having a sharp cut-off (e.g. 6J7, 6AC7, 6SJ7) operated with low values of screen and plate voltage and a fixed bias. The plate characteristic of such an amplifier is shown in Fig. 6. At "A" we have a very weak I.F. voltage at the limiter grid. This signal is amplitude modulated due to noise. Note that operation is entirely upon the straight part of the characteristic and the plate current output is a replica of the input. No limiting action occurs, and the undesired amplitude modulation remains. With such operation the full noise

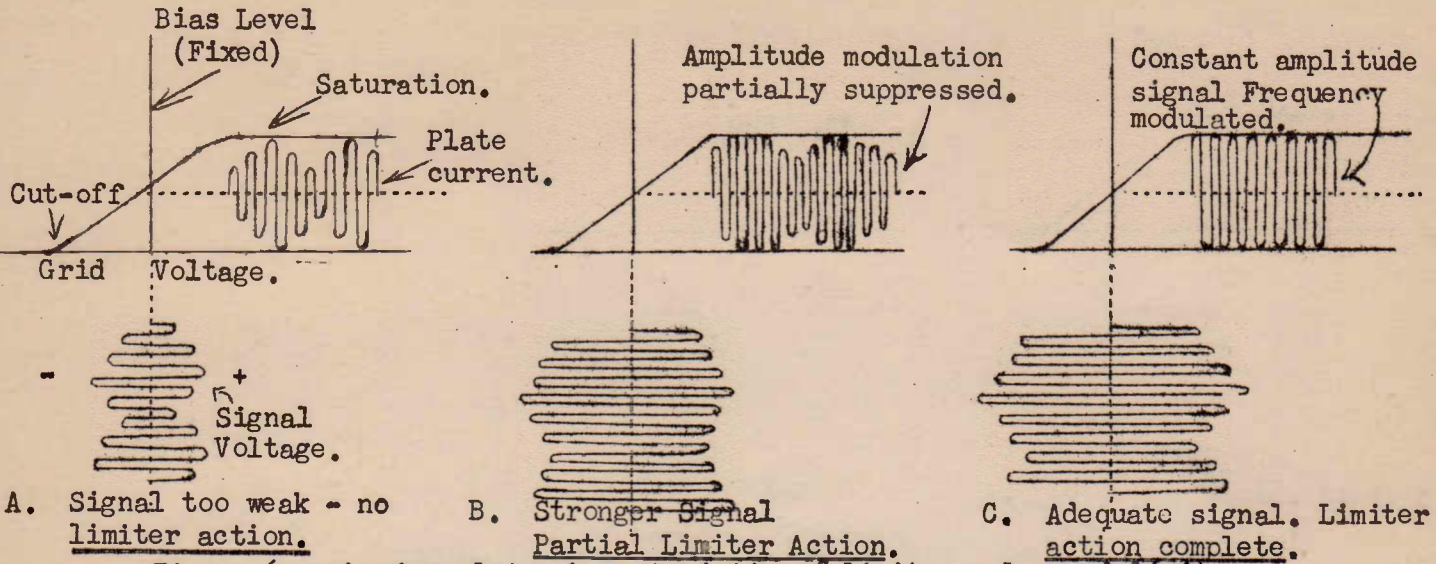

Figure 6 - showing plate characteristic of limiter valve and limiter action on three signals of different strengths at limiter grid.

suppression characteristics of F.M. would not be realised. At "B" we have a somewhat stronger signal (due, for example, to more r.f. and I.F. amplification in the receiver). On the larger positive peaks of the r.f. voltage, plate current saturation is reached. Similarly on the larger negative r.f. peaks plate current cut-off occurs. The result is that portions of these larger peaks will be lopped off, resulting in some amplitude limitation. The smaller r.f. peaks, however, are not sufficiently large either to cause saturation or cut-off. The output from the limiter stage therefore contains some amplitude modulation, and reception will not be as quiet as it should be. At "C" the signal on the limiter grid is of sufficient amplitude to cause plate current saturation and cut-off for all cycles of the r.f. The result is an output current of constant amplitude. All amplitude modulation due to noise has been suppressed.

Note carefully that any frequency variations due to modulation in the input signal will appear unaltered in the limiter's output. These frequency variations represent, remember, the desired audio signal, which is "recovered" from the modulated wave by the discriminator.

The output from the limiter (Fig. 6 (c)) has the r.f. cycles flat-topped. This amounts to severe distortion of the r.f., but as remarked earlier the only effect is to generate harmonics of the r.f. (actually the I.F). These harmonics can be easily removed by a tuned circuit. Hence the signal passed to the discriminator will be a pure sine wave of constant amplitude and varying around the I.F. centre frequency with the frequency modulation.

The importance of having sufficient r.f. and I.F. amplification in order to bring the weakest signal to be received up to a level necessary to ensure complete limiter action, should now be obvious.

PRACTICAL LIMITER CIRCUITS.

Although the plate-current saturation method was used to explain limiter action, the more usual type of limiter is that depending on what is known as grid limiting. This is simply a sharp-cut-off tube operating with the grid-leak type of bias. Screen and plate voltages are usually lower than normal in order to reduce the negative grid voltage required for cut-off, and to avoid excessive plate current when no signal is being received.

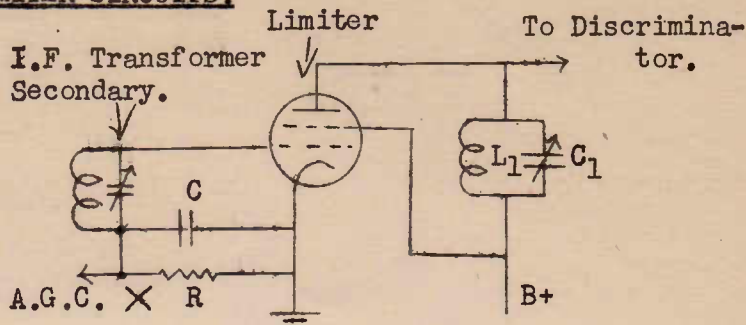

Figure 7.

A circuit diagram of a grid limiting stage is shown in Fig. 7. The grid leak and condenser are "R" and "C" respectively. $L_1 C_1$ is a circuit tuned to 10.7 M.c, (the I.F.). This has a high impedance to the I.F. and passes it on to the discriminator. To the higher frequency harmonics, produced by the limiter distorting the individual r.f. cycles, however, it acts as a short-circuit. In this way such harmonic frequencies are eliminated.

The grid action of this circuit is very similar to that of a grid-leak detector, with which the student is already familiar. Briefly, the grid bias potential is initially zero. On the arrival of the first positive peak of the I.F. signal the grid is momentarily driven positive, and grid current flows, charging the condenser "C" (left-hand plate negative). After several cycles "C" is charged to a value almost equal to the amplitude of the r.f. signal. This value then represents the negative bias developed, as shown in Fig. 8. The resistor "R" allows the charge on "C" to leak off only slowly - but sufficiently quickly to allow the average grid bias to change with any amplitude variations of the r.f. signal. The net effect, as will be observed from the diagram is that the positive peaks of the signal voltage are held practically at a constant level (a little positive in respect to the cathode). The changes in amplitude of the negative peaks are doubled as a result. But the plate and screen voltages are such that these negative peaks all fall below the cut-off voltage. The plate current will therefore be as shown in Fig. 8. All (or practically all) amplitude modulation has been suppressed. Frequency modulation will remain.

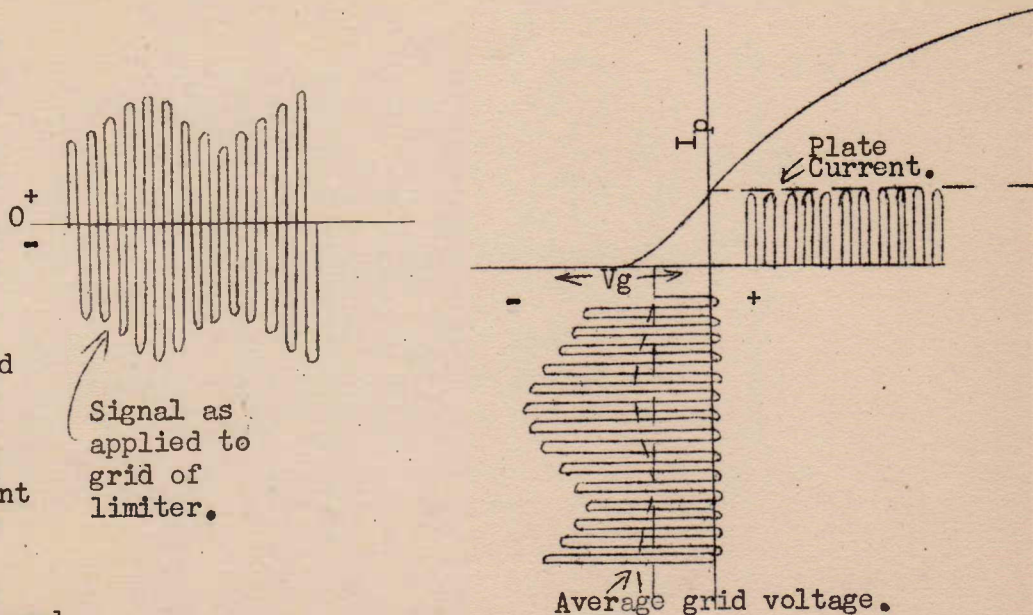

Figure 8.

For limiting action to be complete, as shown in Fig. 6C, it will be necessary, of course, to raise the signal strength to a certain minimum value before it arrives at the limiter grid.

EFFECT OF LIMITER ON GAIN.

On account of the low values of screen voltage required for proper limiting action, the limiter stage rarely produces any appreciable gain; in fact there is often a loss of signal strength involved. Some engineers strongly advocate the use of two limiters in cascade, as this improves the overall amplitude limiting action, especially on "transients" i.e. large amplitude pulses of very short duration. In this case a total gain of about 3 to 5 may be realised. Of course with the development of improved tubes for this particular job greater gains may eventually be possible.

AUTOMATIC GAIN CONTROL.

Automatic gain control, equivalent to A.V.C. in an A.M. receiver, is usually incorporated in an F.M. set. The conditions in the two types of receivers, however, are quite different. It must be remembered that the signal strength obtained from the I.F. section of an F.M. receiver and applied to the frequency discriminator is determined solely by the threshold level of the limiter's output - providing of course we consider only signals which operate the limiter normally. Any variation in the gain of the receiver before the limiter will not affect the output volume, provided that such gain is not reduced so far as to reduce the signal strength at the limiter grid below the threshold level.

What then is the reason for using automatic gain control? The reason is to prevent overloading of the I.F. valves on very strong signals. Such overloading, of course, would not cause distortion in the same way as in an A.M. receiver, since the effect is simply one of amplitude limitation, which does not affect the frequency modulation. However if a strong signal carries the grids of the I.F. valves positive on the positive peaks, grid current would flow. This means that the input circuits of the valves would act like a comparatively low resistance. Such a resistance effect would appear as a small shunt resistance across the previous tuned circuit. This would cause additional damping of that circuit, resulting in a broadening of its frequency characteristic on strong signals.

The grid type limiter is particularly suitable for A.G.C. Referring back to Fig. 7 the grid circuit of the limiter really acts like a diode detector, "R" acting as the diode load. The average voltage (negative) at the point X will increase with signal amplitude. This voltage is applied back to the I.F. valves' grid as in conventional practice.

DETECTION OF F.M. SIGNALS.

We now consider the problem of converting frequency changes back to amplitude changes so that they may operate the speaker.

THE DISCRIMINATOR

An F.M. "detector" which has proved very satisfactory is that known as the Discriminator (for it is capable of discriminating between frequency variations).

A typical circuit is shown in Fig. 9. The input transformer (to which the signal is applied from the limiter) is the same as the other I.F. transformers except that its secondary has a centre top. A pair of diodes are used, these usually being contained in the same tube.

The signal voltage is applied from the primary of the transformer to the secondary in two separate ways: in addition to the usual electro-magnetic coupling between the coils there is the coupling to the centre tap via the condenser "C".

The reactance of the latter condenser is very small at 10.7 M.c, and hence there is practically no voltage drop across it. It thus appears that the r.f. voltage applied to each diode plate may be regarded as the net result of two separate voltages transferred from L_p to L_s (Fig. 9). In order to understand the operation of the discriminator we must consider the effect of each of these secondary voltages on each of the diode plates.

The tuned circuit $L_s C_s$ is adjusted to resonance with the centre frequency of the carrier, viz. 10.7 M.c. At this point we must digress a little to explain the phase relationships and impedance effects which exist in a series tuned circuit at and near resonance. Consider Fig. 10A where we have an inductance, capacity and small resistance, together with a source of small A.C. voltage, in series. In the lesson on "Transmitters" it was explained how, in a series circuit, the reactances and resistances may be represented by vectors in order to obtain the total impedance. It was pointed out there that an inductive reactance vector is shown lagging the resistive vector by 90° , while a capacitive vector is shown leading the resistive vector by 90° . The lengths of the vectors are in all cases, of course, proportional to the reactances or resistances.

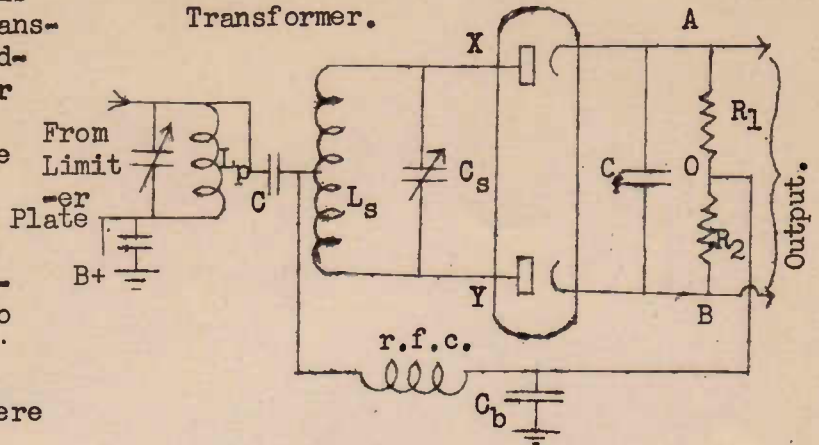
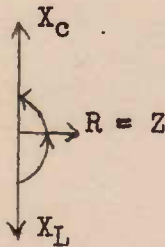
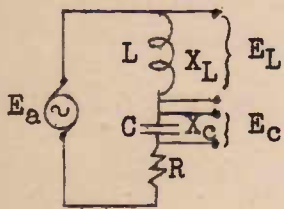
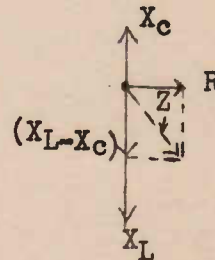

Figure 9.



At Resonance.



Applied Frequency Above Resonant Freq.

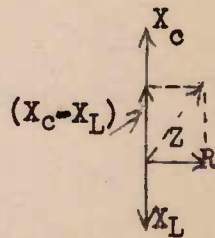

Applied Freq. Below Resonant Freq.

"A"

"B"

"C"

"D"

Figure 10.

At B in Fig. 10 the vector diagram for the resonant condition is shown. At resonance $X_C = X_L$, and since these two vectors are 180° out-of-phase (exactly opposing) they will cancel. This leaves R as the only impedance in the circuit, i. e. $Z = R$, and the circuit is purely resistive. Current and applied voltage will be in phase. Also, since R is normally small compared with X_C or X_L , the "circulating" current flowing will be large.

Suppose now that the frequency of the generator in Fig. 10A is increased above the resonant frequency $X_L = 2\pi fL$ will be greater than before. $X_C = \frac{1}{2\pi fc}$ on the

other hand, will be reduced in value. The new vector diagram is at C. (Fig. 10). X_L and X_C are still 180° out-of-phase, but they are no longer equal. Their vector sum is now $(X_L - X_C)$ in the direction of the larger, X_L . In other words the circuit now shows an inductive, as well as a resistive effect. The resultant Z lags on R by an angle less than 90° . This means that the current will lag the voltage by the same angle. Again suppose that the frequency of the generator is reduced below resonance. X_C will now be greater than X_L . The resultant of X_L , X_C and R, viz. Z, now leads R by an angle less than 90° . The circuit is capacitive, and I leads E. (see Fig. 10D)

Now let us consider the phase relationships between the voltages across the three components of the circuit and the current at resonance, above resonance, and below resonance. There is only one current, I, in the circuit of Fig. 10 A, but we may consider a number of voltages. We shall represent the applied voltage by E_a , the voltage drop across L by E_L , and that across C by E_C (see Figure 11 A).

Now consider the voltage drop across L. The current through L must lag the voltage across it by 90° , (since it possesses inductive reactance only). In other words the voltage drop across L must lead the current by 90° . Now the current through L is the total circuit current represented by I in Fig. 11 A. Therefore the voltage drop across L (E_L) will lead I by 90° , as shown at A. By a similar argument the voltage drop across C (E_C) will lag I by 90° . Note that both E_L and E_C are 90° out of phase with the applied voltage E_a . Care should be taken at this point not to confuse the vector diagrams for impedances (Fig. 10) and voltages and current (Fig. 11).

Above resonance the current (I) lags E_a by some angle, as was shown in connection with Fig. 10 C. This phase relationship between E_a and I is now shown at Fig. 11 B. The

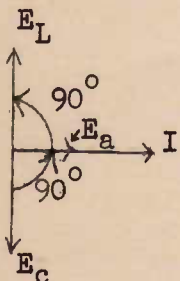

A. At Resonance.

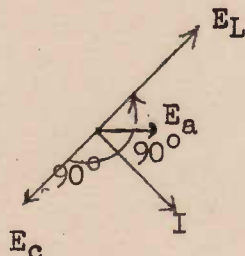

B. Frequency Above Resonance.
Figure 11.

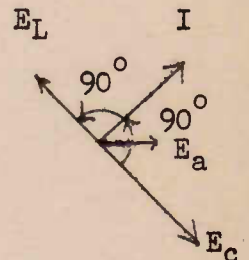

C. Frequency Below Resonance.

voltage across L must still lead I by 90° . Similarly the voltage across C must still lag I by 90° . These vectors are also shown at Fig. 11 B. Note now that E_L leads E_a by an angle less than 90° , and E_C lags E_a by an angle greater than 90° .

The case for the frequency, below resonance is shown at C, Fig. 11. Here I leads E_a by an angle less than 90° (circuit capacitive). E_L and E_C respectively lead and lag I by angles equal to 90° .

Note that both voltages, across L and C may be much larger than the applied voltage (E_a). This explains how a series tuned circuit can produce a voltage magnification or gain. Note also, the all-important point that the phase angles of E_L and E_C depend upon the amount by which the applied frequency differs from the resonant frequency, when the applied frequency is above the resonant frequency of the circuit, the phases of E_L and E_C are retarded; conversely when the applied frequency falls below the resonant frequency these vectors are advanced in phase, the size of the phase angles again depending upon the extent of the frequency deviation.

ACTION OF THE DISCRIMINATOR AT RESONANCE.

We shall now return to the circuit of Fig. 9. Let us first of all consider the primary voltage (E_p) applied through the condenser C to the centre tap of the secondary. Due to this coupling E_p will appear on each diode plate. This may be seen by referring to Fig. 12 where we have replaced the diodes by vacuum tube voltmeters. At the same time we have imagined that the primary of the transformer has been moved away from the secondary so that no magnetic coupling exists between them. Under these conditions the only transfer of primary voltage (E_p) will be via condenser C. The reason why the full value of E_p appears at X and Y, (Fig. 12) is that there is no flow of A.C. current through L_s , because vacuum tube voltmeters act as open circuits. As a result there will be no A.C. voltage drop across each half of L_s . In the actual circuit (Fig. 9) the resistors R_1 and R_2 are very large compared with the reactance of each half of L_s and the r.f. current between the centre tap of L_s and earth (via condenser C) will be negligible. Hence practically the full value of E_p will be applied to each diode plate. Note also, that this transfer of E_p to each diode occurs without change in phase, since negligible current flows.

The important point here is that E_p , which is applied through C to the centre tap is measured with respect to earth, and therefore has no tendency to cause a circulating current to flow around the tuned circuit $L_s C_s$. In addition to the primary voltage transfer via condenser C, there is, of course, a transfer on account of the induced voltage (E_i) in the secondary. This induced voltage (E_i) will normally be only a

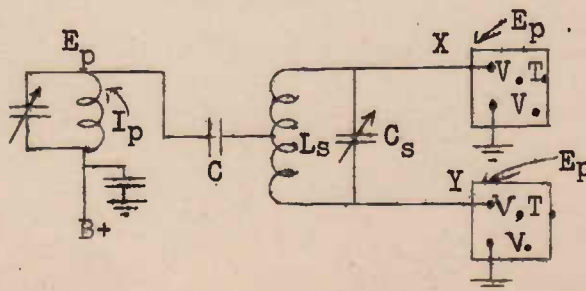

Figure 12.

small fraction of the total primary voltage (E_p), since the coupling between primary and secondary is loose. Although small, however, E_i will at, or near, resonance cause quite a large current to flow around the tuned circuit $L_s C_s$, and this current will in turn develop a voltage drop (r.f.) across the coil which may be many times as large as E_i . Hence on each diode plate we may imagine that the total r.f. voltage is the vector sum of 2 voltages - one due to condenser C , the other due to the normal transformer action.

DISCRIMINATOR ACTION WHEN SIGNAL IS AT CENTRE FREQUENCY.

First consider the case when the incoming wave is modulated, i.e. the I.F. frequency is at its centre value to which the secondary circuit of the transformer is tuned. We shall start from the current flowing in the primary coil of the transformer (I_p). The voltage across this coil (E_p) will lead I_p by 90° . This phase relationship is shown in Fig. 13 in both sine-wave and vector form. Now I_p in the transformer primary will induce a comparatively small voltage (E_i) in the secondary, such that the induced voltage E_i lags the primary current (I_p) causing it. (Note: in a previous lesson we explained how an induced voltage lags the current causing it. At that stage we were considering the voltage induced in a coil by a current flowing in the same coil. Here we are considering a voltage induced in a secondary coil by a current flowing in the primary. The result will be the same, however, since the same magnetic field produces both induced e.m.f's). The induced voltage E_i in the secondary is shown lagging I_p in Fig. 13. This induced voltage E_i in L_s (Fig. 9) may be considered as a small generator placed in series with L_s and C_s as shown in Fig. 14. Since a resonant condition exists a comparatively large current (I_s) will be set up, circulating around the tuned circuit, which, at resonance acts like a pure resistance. Hence I_s will be in phase with E_i . (Refer back to Fig. 11, if necessary). I_s is also shown in sine-wave and vector form in Fig. 13. Now this current, flowing through L_s will cause a voltage drop (r.f.), E_s across L_s , the voltage across the coil leading the current by 90° (this was explained in connection with Fig. 11). E_s leading I_s by 90° and therefore lagging E_p by 90° is also included in Fig. 13. The student should be careful to distinguish between the small voltage induced from the primary (E_i) into the secondary, and the much larger voltage drop (E_s) developed across the latter by the resonant current (I_s). (See Fig. 14).

Now the voltage E_s across the secondary is applied to the diode plates, together with E_p , which was transferred, without change in magnitude or phase via the condenser C of Fig. 9. Each diode plate, however, only receives one half of E_s , because of the centre-tapping of the coil. The phase of E_s shown in Fig. 13 was that which exists if we were measuring the voltage at the upper end of the secondary in respect to the

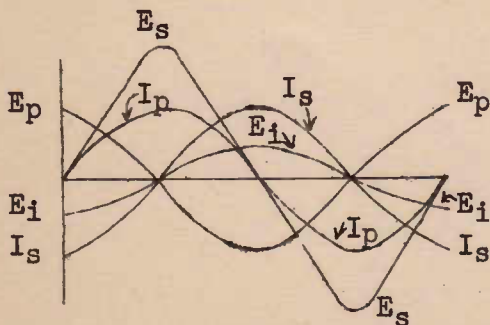

Figure 13

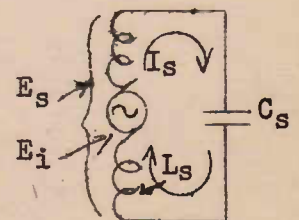
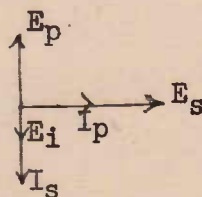

Figure 14.

primary. This is so because the primary voltage (E_p) as represented in the diagram was assumed to be measured from its upper end, in respect to its lower. Now if we viewed the voltage at the upper end of the secondary with respect to its centre-tap (call it E_{s1}), this voltage will be only half of E_s , but will be in phase with E_s ; i.e. $E_{s1} = \frac{1}{2} E_s$. This (E_{s1}) is the voltage applied to the plate of the upper diode, together with the voltage E_p . Considering now the lower diode, in addition to E_p we have the voltage developed across the lower half of the secondary (Fig. 9) applied to it. Call this latter voltage E_{s2} . E_{s2} will also be one half of the total E_s , and it will be 180° out of phase with E_{s1} or E_s . The reason for this is that we are now measuring the voltage from the lower end of the secondary with respect to the centre tap, whereas E_{s1} was measured from the upper end. (Remember that when the voltage at one end of a coil is going, say, positive, with respect to the centre tap, that at the other end of it is going negative, (i.e. the voltages at the two ends are 180° out of phase).

Figure 15 shows the two voltages on the two diode plates; E_p and E_{s1} in the case of the upper diode, and E_p and E_{s2} in the case of the lower diode. These are added vectorially as shown in Fig. 15. Note that the resultant voltages on the two diodes are equal in amplitude.

These voltages on the diode plates, remember, are alternating r.f. voltages. Each diode will rectify the voltage applied to it in the usual way. The rectified currents of the two diodes will flow in opposite directions through the respective load resistors R_1 and R_2 of Fig. 9. These rectified currents will be equal, since the r.f. voltages on the two diode plates are equal and the resistors R_1 and R_2 are equal. Therefore the voltages developed across R_1 and R_2 will be equal and opposite, and the total voltage measured between A and B (Fig. 9) will be zero. This is the discriminator's output when the carrier frequency is at its centre value.

DISCRIMINATOR ACTION WHEN SIGNAL IS ABOVE CENTRE FREQUENCY.

Consider now what happens where, due to modulation, the carrier (and therefore the I.F.) frequency rises above its centre value. I_p , E_p , and E_1 will have the same phase relationships as before, and as shown in Fig. 13. The secondary current, however will no longer be in phase with the induced voltage E_1 causing it, because the series tuned circuit L_s , C_s of Fig. 9 now is no longer at resonance. Since the frequency is above resonance this circuit now presents an inductive reactance to the current, as was explained in connection with Fig. 10 earlier. As a result the secondary current (I_s) will lag the voltage E_1 by some angle (see also Fig. 11). The angle of lag will depend upon how much off resonance is the frequency, i.e. upon the frequency deviation due to modulation.

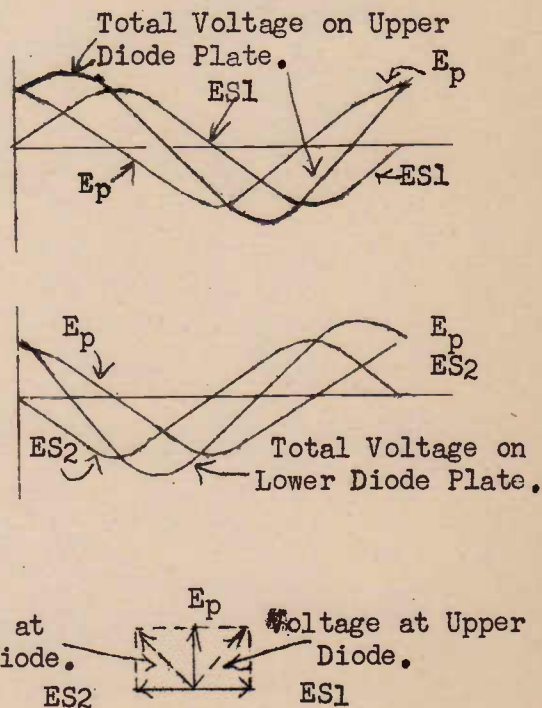

Figure 15

The vector diagram of Fig. 16 shows the new conditions. Here I_s is lagging E_i by about 45° . The voltage across the secondary (E_s) will still lead the current through it (I_s) by 90° , as shown. This diagram should be compared with that of Fig. 13. The voltage across the upper-half of the secondary (E_{s1}) is still in phase with the total voltage (E_s) across it, and the voltage across the lower half E_{s2} (shown dotted in Fig. 16) is 180° out of phase with E_s as before. The separate

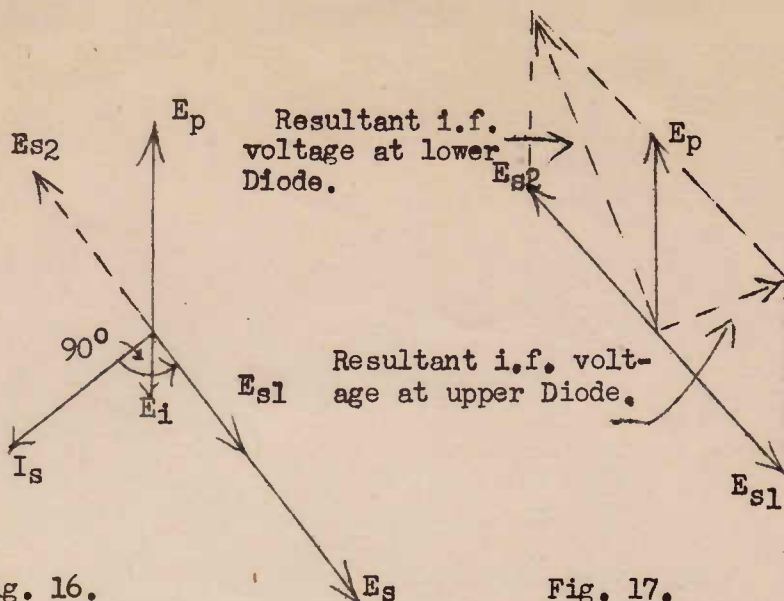

Fig. 16.

Fig. 17.

voltages at the upper diode (E_p and E_{s1}) and at the lower diode (E_p and E_{s2}) together with their resultants are shown on the combined vector diagram of Fig. 17. Note now that the resultant r.f. voltage at the lower diode plate is greater than that at the upper diode plate. Consequently, the rectified D.C. current through resistor R_2 will be greater than that through R_1 (Fig. 9). This means that the voltage drop across R_2 will be greater than that across R_1 , and therefore the total voltage across the output ($R_1 + R_2$), which is the difference between these, will no longer be zero. Point A in Fig. 9 will be more negative than point B. Since point A usually connects to the grid of the first audio tube, we may say that the output is negative in this case.

It should be noted, at this stage, that the value of the output voltage will depend upon the amount of frequency deviation of the signal. A bigger deviation from the resonant frequency than that considered will result in a greater lag in I_s compared with E_i in Fig. 16. This will increase further the resultant r.f. voltage on the second diode plate, and reduce that on the first diode plate. The net output (rectified) voltage will thus be larger.

DISCRIMINATOR ACTION WHEN SIGNAL IS BELOW CENTRE FREQUENCY.

When, due to modulation the I.F. frequency falls below the resonant point, the discriminator's tuned circuit will become capacitive. (Refer back to Fig. 10D). As a result the secondary current (I_s) will lead the induced voltage causing it, with a consequent readjustment to the phase of the vectors E_s , E_{s1} , and E_{s2} , as shown in Fig. 18. The resultant r.f. voltages on the diode plates are now as represented in Fig. 19. The upper diode will now deliver the larger rectified current, i.e. the current through R_1 will be larger than that through R_2 , and point A will become positive with respect to B (Fig. 9).

Thus we see that as the frequency swings above and below the centre value, due to modulation, the discriminator develops an alternating voltage across its load. The frequency of this output voltage will be identical with that of the rate of frequency swing, i.e. it will be the audio frequency.

A typical discriminator characteristic, showing how the output voltage will vary with frequency deviations, above and below the centre frequency, is shown in Fig. 20.

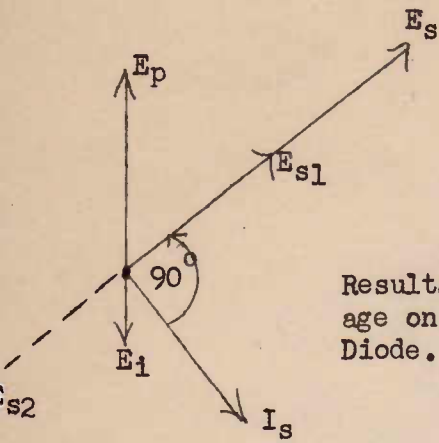

Figure 18.

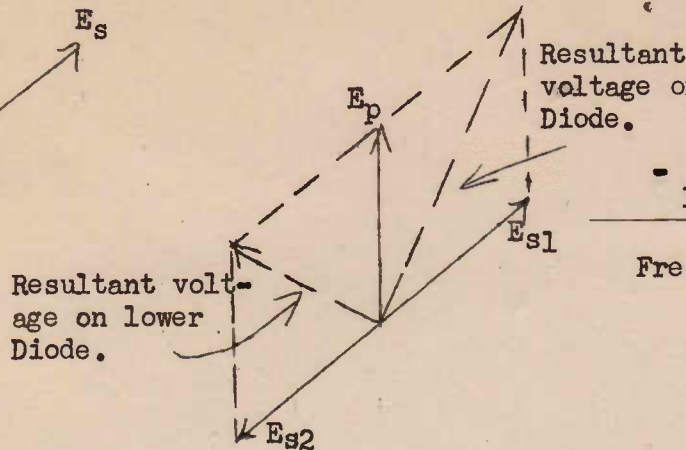

Figure 19.

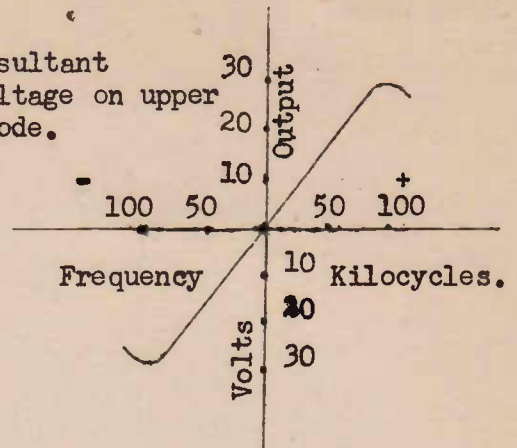

Figure 20.

HOW THE DISCRIMINATOR WILL RESPOND TO AMPLITUDE VARIATIONS.

The output voltage of the discriminator is really the difference between the rectified voltage outputs of the diodes - these latter voltages being developed across the resistors R_1 and R_2 of Fig. 9. When the carrier (I.F.) is at the centre frequency of the discriminator tuned circuit the r.f. voltages on the diode plates are equal, and consequently the rectified (D.C.) voltages across R_1 and R_2 are equal. Under these conditions the total output developed across $R_1 + R_2$ must be zero, irrespective of the carrier amplitude. Hence variations in r.f. amplitude (due to noise) occurring when the carrier is at its centre frequency cannot cause variations in discriminator output. But under actual conditions of reception the carrier frequency is at the centre frequency for only a very small fraction of the total time. Amplitude modulation occurring where the carrier is deviated from its centre value will result in changes in the discriminator output. For this reason we have stated that it is necessary to precede the discriminator stage by one or more stages of amplitude limiting, otherwise the receiver will display very little, if any, superiority over the conventional type from the point of view of noise suppression.

To see how variations in amplitude of the I.F. carrier affect the output consider the following example. Suppose that the undeviated carrier results in a d.c. voltage of 10V across each diode load. The total output will be zero since these voltages are equal and opposite. Then if the carrier deviates in such a way that the r.f. voltage applied to the first diode increases, and that applied to the second diode decreases, the rectified voltage across the first diode resistor may increase to 15V while that across the other resistor decreases to 5V. The output will now be $15V - 5V = 10V$.

Now take another case. Suppose the carrier becomes stronger, so that under zero-deviation conditions the voltage across each diode load resistor is 20V. The same frequency deviation as in the first case will increase the first diode's output to 30V and decrease that of the second diode to 10V. The net output will now be $30V - 10V = 20V$. Thus an increase of carrier amplitude will double the discriminator output for the same frequency deviation. In other words the discriminator is

sensitive to amplitude changes as well as to frequency changes. If an F.M. detector could be made unresponsive to amplitude changes the full benefits of F.M. could be obtained without the necessity for limiting and the large amount of r.f. and i.f. gain required for normal limiter action.

THE RATIO DETECTOR.

This is a practical detector having the desired characteristics mentioned above. It is based on the idea of having the detector's output voltage proportional only to the ratio of the two r.f. voltages applied to the separate diodes, and not to the difference of these voltages as in the conventional discriminator. The separate r.f. voltages applied to the diodes are developed from the F.M. carrier as was explained in connection with Figs. 15, 16, 17, 18 and 19 earlier in the lesson. A little thought will show that if the carrier amplitude is changed all the voltages represented by the vectors of these diagrams will change in the same proportion. Hence the ratio S_1/S_2 (say) of the r.f. voltages on the diodes will remain constant with changes in carrier amplitude. ~~Changes in~~ carrier frequency (due to F.M), however, will alter the ratio S_1/S_2 . In the examples quoted above this ratio increased from 1/1 with no frequency deviation to 3/1 with frequency deviation in one direction. Note that the ratio was the same in the two examples - 15/5 in the first case, and 30/10 in the second - although the differing amplitudes gave rise to an output signal twice as large in the second case as in the first.

The principles underlying the operation of the Ratio Detector may best be explained by reference to the simple "equivalent" circuit of Fig. 21. The battery of total voltage E , is connected directly across the diodes (which are in series with each other) as shown. This battery of constant e.m.f. (E) and negligible internal resistance will thus maintain the total D.C. voltage across the two diodes at the constant value E . Note further that in the absence of an r.f. signal the diodes will not conduct, since the polarity of the battery is such that the diode plates have a negative bias (in respect to their cathodes). Thus when the battery is connected the equal condensers C_1 and C_2 will charge up, one half of E appearing across D_1 , and the other half across D_2 . In other words, the voltages E_1 and E_2 , as measured by D.C. voltmeters, will be such that $E_1 = E_2 = \frac{1}{2} E$. The output is taken between A and B, where B is the centre tap of the battery. Then since $E_1 = E_2$, the P.D between A and B will be zero.

Now suppose an r.f. signal comes in. Actually the separate r.f. voltages for the two diodes are obtained by the same type of phase-changing circuit as was described for the discriminator. In Fig. 21, however, for simplicity, these separate r.f. voltages (S_1 and S_2) are shown applied to the diodes by means of separate transformers. If the carrier is at its centre frequency S_1 equals S_2 , and if these are of sufficient amplitude to overcome the negative bias on the diodes the latter will conduct equally.

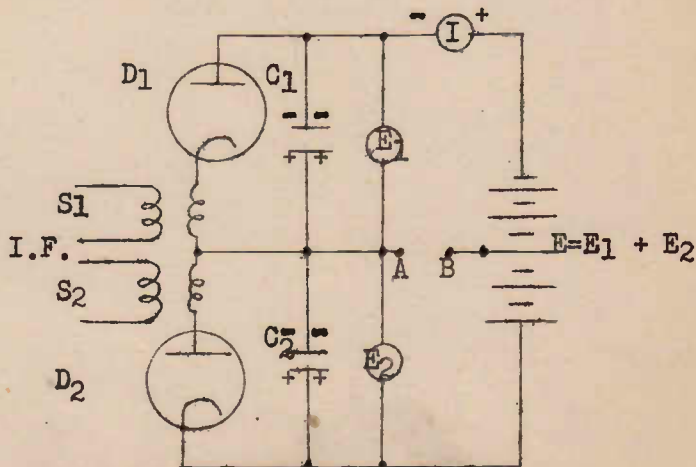

"Equivalent" Circuit of the Ratio Detector.

Figure 21.

Now the diodes are so connected that the rectified D.C. current of each diode flows

through the other diode, and will be measured by the ammeter I. The output voltage, measured between A and B, however, will remain at zero. This point may be better realised by referring to Fig. 22 where each diode may be represented (as far as D.C. rectified current is concerned) by an equivalent D.C. voltage source (V_1 or V_2) in series with a resistor (R_1 or R_2) representing the internal impedance of the tube. The P.D. between A and B must be zero, providing $V_1 = V_2$ and $R_1 = R_2$.

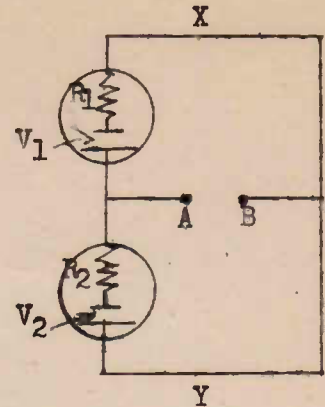

Figure 22.

If now the r.f. signals S_1 and S_2 are both increased, but remain equal, the rectified current measured by I (Fig. 21) will increase, but the potential at A remains unchanged, and the P.D. between A and B remains zero. Refer again to Fig. 22. If V_1 and V_2 both increase (but $V_1 = V_2$ still) the potential at A will not alter.

Suppose now that, due to frequency deviation of the I.F. the r.f. voltage (S_1) applied to diode 1 increases and that (S_2) applied to diode 2 decreases - say S_1/S_2 becomes equal to 2/1. Diode 1 will tend to conduct more vigorously and the condenser C, (really an r.f. by-pass condenser) will charge more fully. That is E_1 (Fig. 21) will increase. But since $E_1 + E_2$ must remain constant (equal to the fixed battery voltage E), E_1 can only increase if E_2 decreases. The reduction in r.f. voltage applied to D_2 will, of course, in this case, also tend to reduce the D.C. voltage (E_2) across C_2 . The result will be that the ratio E_1/E_2 increases to 2/1, i.e. $S_1/S_2 = 2/1$.

The voltage at A will now be more positive than it was before, since E_1 has increased, and therefore there will be an output voltage between points A and B.

Let us now consider an amplitude change of the applied signal. If both S_1 and S_2 increase in the same ratio (due to an amplitude increase of the I.F. signal) both diodes will conduct more heavily, and there will be a tendency for the charges on the condensers C_1 and C_2 to increase. But since the total voltage $E_1 + E_2$ across these condensers must remain constant at the battery voltage, both E_1 and E_2 cannot increase. The result will be that providing the ratio S_1/S_2 remains unaltered ($= 2/1$) the voltages E_1 and E_2 will not change, and the ratio E_1/E_2 will remain equal to 2/1. Thus amplitude changes will have no effect on the output.

To see how really efficient is the ratio detector in suppressing amplitude changes, let us take an extreme case. Suppose at the instant when the signal deviation is such that $S_1/S_2 = E_1/E_2 = 2/1$ the r.f. wave is suddenly and momentarily reduced to zero (due for example to 100% amplitude modulation caused by impulse interference). When this occurs the diodes will suddenly become non-conducting due to the negative bias provided by the battery, and the absence of r.f. voltage. The voltage at A will remain at the value it had immediately prior to the cutting off of the wave. The reason for this is that the potential at A cannot now change, because this point is entirely isolated from the rest of the circuit by the non-conducting dielectric of C_1 , C_2 and the cut-off diodes (see Fig. 21). Hence while the r.f. signal is zero electric charge cannot leave or approach the point A. This means that although the r.f. wave drops to zero the output remains unchanged. Fig. 23 shows oscillograph pictures of the audio outputs of A, a discriminator and B, a ratio detector when the signal is momentarily cut-off at points 1, 2 and 3. The effect, in the case

of the Ratio Detector, is even less on the ear than the visual representation.

We have thus seen that the audio output taken from point A (Fig. 21) depends upon the variation in the ratio E_1/E_2 and this ratio depends only upon the ratio of S_1/S_2 and not on the absolute values of S_1 and S_2 . In the extreme case, for maximum deviation in one direction, E_1 would become equal to E and E_2 would be zero. For maximum deviation in the other direction E_2 would become equal to E , while E_1 would reduce to zero. Thus the maximum in amplitude of the audio voltage output, (measured in respect to the centre tap of the battery) would be $1/2 E$, no matter how great the frequency deviation.

Now the circuit of Fig. 21 is not a very practicable one. To provide sufficient output audio voltage the value of E would have to be fairly large (since it determines the maximum output available). This would mean, however, that weaker signals could not be received at all, because the r.f. diode voltages must overcome the negative bias provided by this battery before they can conduct.

What we require is a source of voltage E which changes automatically with the average carrier level of the signal received, but one which does not vary with audio frequency fluctuations. This is achieved in the practical circuit of Fig. 24. Here the battery is replaced by a resistor R bypassed by a condenser C_B . R carries the D.C. rectified current of the diodes, which develops a voltage across it with polarity as shown, and having a value depending upon the strength of the signal received. The voltage across R remains constant for all variations occurring at audio frequency, as a result of the smoothing or filtering action of C_B , which is a large value electrolytic condenser. The output is taken from the point A, measured in respect to the cathode of the lower diode. R_2 is a volume control potentiometer of such large resistance that it does not upset the normal operation of the circuit as previously described. In this circuit the audio voltage will not have an average value of zero, but will vary about a negative level equal to $1/2$ the voltage across R . This of course is immaterial

The output is thus really the output of the lower diode. If the volume control were connected across the upper diode the net result would be very little different because the audio frequency changes in voltage across the two diodes are equal, although opposite in polarity. The steady voltage across R , which readjusts itself with changes in average signal level is also used, as shown, for A.V.C.

The ratio detector is, as the student will agree, a most ingenious circuit, and will probably render the limiter-discriminator combination obsolete. Despite its obvious advantages, however, it suffers from several disadvantages as compared with the discriminator. The relative merits and de-merits of the two detector units will be compared in detail in the discussion on typical receiver construction incorporated in the lesson which follows.

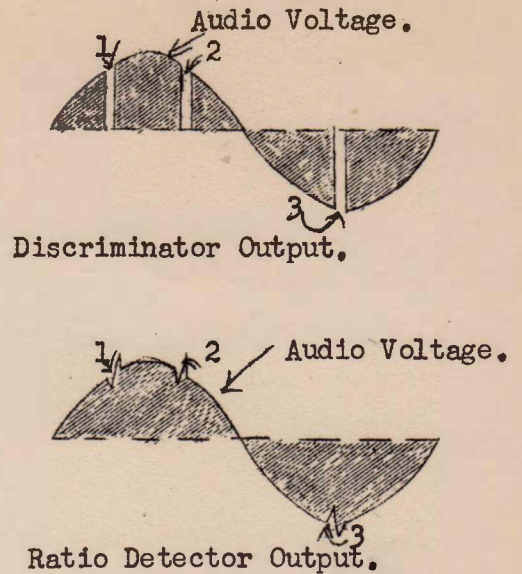

FIGURE 23 showing effects of momentary 100% Amplitude Modulation on Audio Outputs of Discriminator and Ratio Detector.

HOW INTERFERING R.F. (NOISE)
VOLTAGES AFFECT THE F.M. DETECTOR.

The explanation of the effect of interfering signals in F.M. detectors, presented in the remainder of this lesson, cannot, unfortunately, be presented in simple words but requires a somewhat mathematical treatment illustrated by vector diagrams. If you are able to understand clearly the application of vectors, you should not find much difficulty in understanding the following pages, especially if you study them over several times. If you make several attempts and feel that you cannot fully understand the remainder of this lesson, do not worry as it is not of extreme importance. It simply provides proof of the fact that interference is far less severe with F.M. than with A.M.

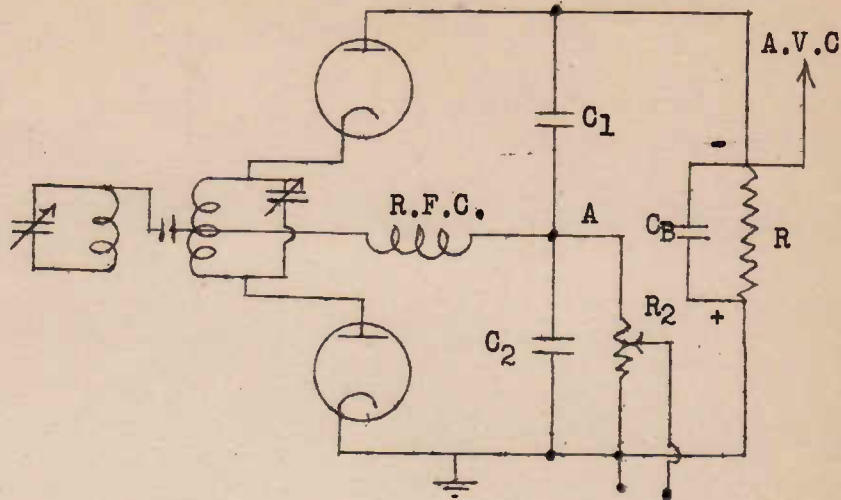

Figure 24.

In any case commence studying the following pages with particular care and thoroughness and you will probably find that you understand them quite well. If not, then simply continue with the next lesson.

We have earlier in these lessons explained how noise or interference in a radio receiver is due to a whole series of r.f. voltages which "beat" with the carrier and modulate it to produce an audio voltage after detection. It was pointed out how such an interfering voltage caused both amplitude and a certain amount of phase, and consequently frequency modulation. We now take up this subject again to show just how effective the F.M. system's immunity from noise can be.

Consider an incoming carrier of frequency f_c and voltage amplitude V_c , together with an interference voltage (r.f.) of frequency f_i and amplitude V_i . These two voltages will "beat" (or heterodyne) together, causing a modulation of the carrier at a frequency which equals their difference ($f_i - f_c$) (suppose f_i is greater than f_c , i.e. interference frequency lies above carrier frequency). The depth of amplitude modulation produced will depend upon the ratio
$$\frac{\text{Amplitude of Interference Voltage}}{\text{Amplitude of carrier voltage}} = \frac{V_i}{V_c}$$

For example if $V_i = \frac{1}{2} V_c$, the percentage modulation will be $V_i/V_c \times 100\% = \frac{1}{2} \times 100\% = 50\%$. In this case the audio noise voltage produced after detection in an A.M. receiver will be one half the amplitude of the audio signal representing the loudest sound which can be heard. Of course, as already explained, the noise voltage will only give rise to an audible sound if the interfering r.f. voltage has a frequency which differs from that of the carrier by an amount which does not exceed the A.F. limit, viz. 15,000 cycles per sec. In other words, for audible interference ($f_i - f_c$) must not exceed 15,000 cycles per sec.

A simple vector diagram will show the relative effects of such an interference voltage as regards amplitude and frequency modulation. Referring first to Fig. 25, the carrier and interference voltages may be represented by vector lines, each of constant

length, and rotating at speeds (constant) depending upon their frequencies. At A the two r.f. voltages are in phase. The two will not remain in phase because their

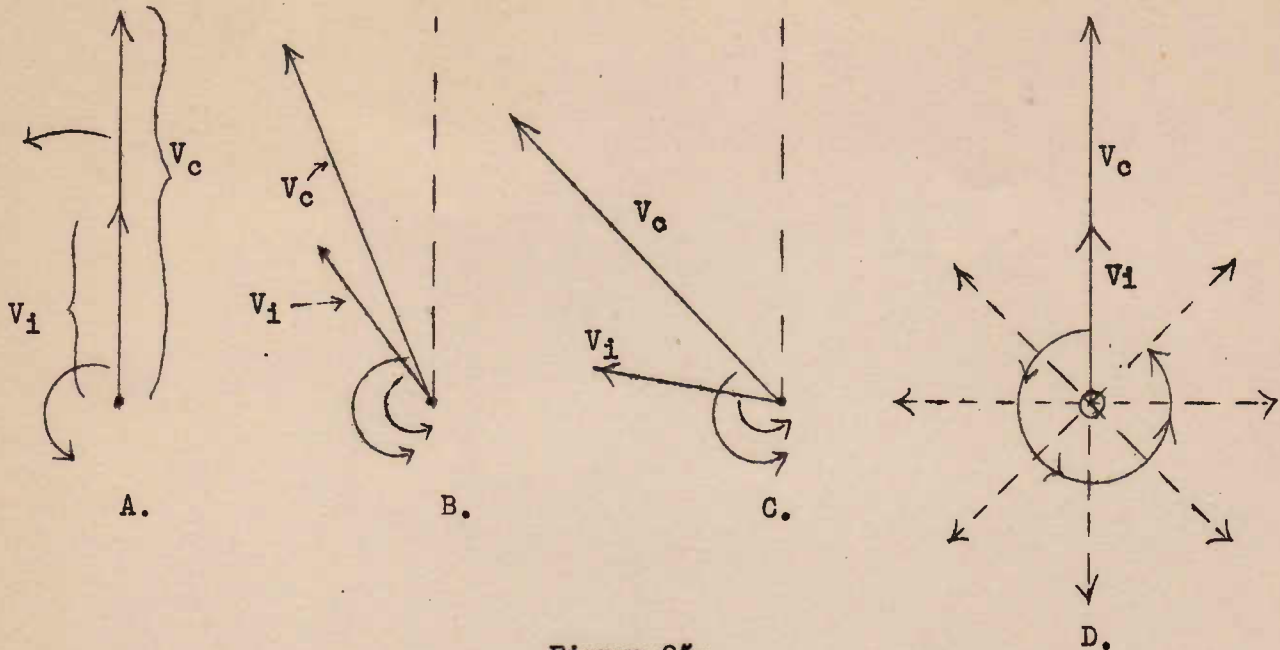

Figure 25.

frequencies are different. The vector representing V_c will be rotating (counter-clockwise) at a rate of $360 \times f_c$ degrees per second (since 1 cycle = 360°). Vector V_i will have a rate of rotation equal to $360 \times f_i$ degrees per second.

If the interfering voltage (V_i) lies in frequency above the carrier it will be rotating at the faster rate. Hence, a small fraction of a second later, the vectors will be as at B (Fig. 25), and later still as at C. Vector V_i is drawing away from vector V_c , at a rate equal to the difference of their separate rates of rotation, i.e. at a rate = $360 f_i - 360 f_c = 360 (f_i - f_c)$ degrees per sec. It is this relative rate of rotation between the two in which we are interested. Hence, as shown at D (Fig. 25) we could imagine that vector V_c remains fixed (pointing vertically) and that vector V_i was rotating counter clockwise around the point O at a rate equal to the difference between their rates of rotation, viz. $360 (f_i - f_c)$ per sec. To visualise this it could be imagined that the page, as a whole was rotated around O at a speed of $360 f_c$ degrees per sec. Then V_i would actually be rotating at $360 \text{ times } (f_i - f_c) + 360 f_c = 360 f_i$ degrees per sec).

In fig. 26 we have transferred the centre of rotation of V_i to the point A (the end of the vector V_c , which is still imagined to be fixed in direction). As at Fig. 25D, the vector V_i in Fig. 26 is imagined to be rotating at a rate of $360 (f_i - f_c)$ degrees per sec. We have transferred V_i to this new position because it is easier to "compound" the two vectors by the "triangle of vectors", when drawn "end-to-end" in this manner. Referring to this diagram (Fig. 26) as V_i rotates the resultant of V_i and V_c (viz. the vector representing the modulated carrier) will continually change in direction and magnitude (i.e. amplitude). Where V_i is in the position AB the resultant will be OB (a maximum). At this instant the phase of the modulated carrier (OB) is the same as the unmodulated carrier ($OA = V_c$). A little later when V_i is at

AC, the resultant (completing the triangle of vectors OAC) will be OC. Later still when V_i is in position AX the resultant is OX. As time goes on and V_i reaches the position AB' the resultant is OB'. At this instant the modulated carrier's amplitude has reached a minimum value. Further rotation of V_i will change the resultant modulated carrier to position OY, and eventually back again to OB.

Note that as the vectors get into and out of phase the carrier is amplitude modulated, as shown by the continual change in the length of the resultant vector. The carrier's amplitude is changed in the ratio of V_i/V_c , and the percentage modulation is $\frac{V_i}{V_c} \times 100\%$. This is the noise amplitude modulation.

In addition to the amplitude modulation there is a phase (and therefore "equivalent" frequency) modulation. The phase of V_c is first advanced (from OB to OX) through an angle AOX, and then retarded to OB', and back to OY. The resultant vector "oscillates" between the two limits OX and OY. Its rates of rotation are momentarily zero at OX and OY, and a maximum when passing the position OB. The movement of this resultant vector may be likened to that of an oscillating pendulum.

We have already seen earlier that if the phase of a carrier is increasing, its frequency must be momentarily higher than the frequency of the unmodulated carrier. Conversely if the phase of the modulated carrier is decreasing it must have a frequency below that of the unmodulated carrier. Hence in Fig. 26, when the resultant carrier vector is moving from OY towards OX (phase advancing) the modulated carrier frequency must be above the unmodulated frequency. Similarly when this vector is moving from OX towards OY (phase retarding) the modulated frequency lies below the unmodulated frequency.

In positions OX and OY the phase is momentarily unchanging, and hence at these moments the carrier's frequency is neither above nor below its unmodulated frequency i.e. it is at its centre value, and the frequency deviation is zero.

The carrier frequency will reach its maximum value (i.e. maximum positive frequency deviation) when the phase is advancing at its greatest rate, i.e. when the oscillating vector is moving through the position OA in a counter-clockwise (right to left) direction. By a similar argument the frequency deviation will have a maximum negative value when the vector is moving through OA in the clockwise direction.

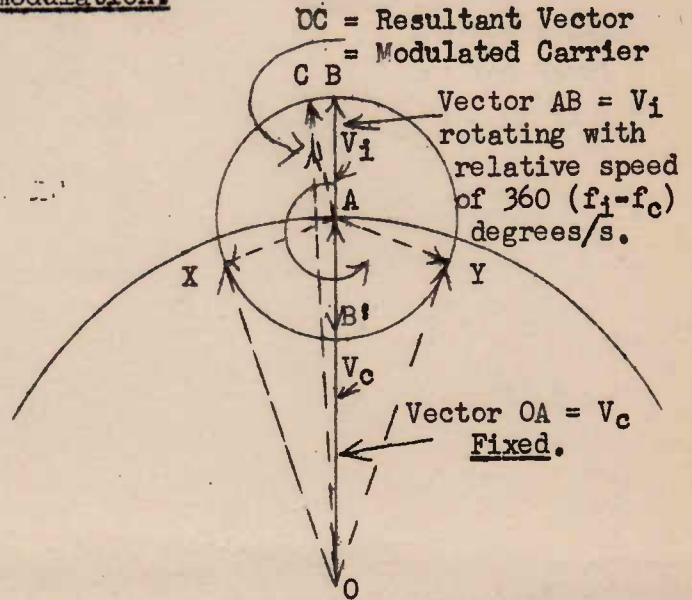

Phase Modulation of Carrier by Interference
R.F. Voltage of Constant Amplitude and
Frequency. Phase Oscillates between Limits
OX and OY.
Phase Deviation = Angle AOX
= Angle AOY.

Figure 26.

Figure 26 thus illustrates an important point concerning phase and frequency modulation; when the phase deviation is at a peak (OX or OY) the frequency deviation is zero; conversely when the phase deviation is zero (position OA) the frequency deviation is at a peak (above or below the central frequency depending upon whether the resultant vector is moving to left or to right).

Figure 26 will also tell us the amount of frequency modulation of the carrier (V_c) produced by the interfering voltage V_i . As we have just seen the peak frequency deviation will occur when the resultant vector is in the position OA. At this instant the interference vector V_i and the carrier vector V_c are in the same straight line. V_i is in the position AB, say, and is rotating counter-clockwise, at a rate $360 (f_i - f_c)$ degrees per sec. Its rotation is causing a counter clockwise rotation of the carrier vector, but the latter rate of rotation is slower than $360 (f_i - f_c)$. The reason for this is that the rotating line AB is shorter than the fixed line OA, and AB rotates through more than 90° in the same time that OA rotates through only a few degrees to OX. If V_i (AB) is small compared with V_c (OA) it is not very hard to see that the rate of rotation of the resultant will be only the fraction $AB/OA = V_i/V_c$ of the rate of rotation of AB (V_i). Thus if $AB = 1/10 OA$, then the resultant is turning at a rate equal to $1/10$ of that of AB. Since the rate of rotation of $V_i = 360 (f_i - f_c)$ we have:

$$\begin{aligned} \text{Rate of Phase Change of Resultant} &= 360 (f_i - f_c) \times \frac{V_i}{V_c} \text{ degrees per sec.} \\ &= 360 (f_i - f_c) \times \frac{V_i}{V_c} \div 360 \text{ cycles per sec.} \end{aligned}$$

$$\text{i.e. Frequency change or Frequency deviation} = (f_i - f_c) \times \frac{V_i}{V_c} \text{ cycles per sec.}$$

We thus have the important resultant that the frequency deviation (peak) produced by the interaction of an interfering r.f. voltage (V_i) upon the carrier (V_c) depends not only upon the ratio of the amplitudes of the two voltages, but also upon the difference in their frequencies.

This difference in frequency ($f_i - f_c$), it should be remembered, is the rate at which the two r.f. voltages move into and out of phase, and represents the modulation frequency. Consider a few examples.

Example 1. If $(f_i - f_c) = 15,000$ c. per sec. and $\frac{V_i}{V_c} = \frac{1}{5}$

$$\text{Frequency deviation} = 15,000 \times \frac{1}{5} = 3,000 \text{ cycles per sec.}$$

Example 2. If $(f_i - f_c) = 7,500$ cycles per sec. and $\frac{V_i}{V_c} = \frac{1}{5}$

$$\text{Frequency deviation} = 7,500 \times \frac{1}{5} = 1,500 \text{ cycles per sec.}$$

Thus when the modulation frequency is at the limit of audibility (a high pitched noise) the amount of frequency modulation is twice as great as when the modulation frequency, and the pitch of the sound, is halved.

We saw earlier that the amount of audible interference produced in an A.M. receiver depended only upon the ratio of interfering voltage amplitude to carrier amplitude (i.e. upon V_i/V_c) and was the same for all noise frequencies. In the case of F.M., on the other hand, the amount of noise produced depends upon the frequency difference between the interfering voltage frequency and carrier frequency. Those interfering

voltages lying close to the carrier frequency will produce very little audible noise, i.e. low audio frequency noise will be negligible. The most noise will result from these voltages which lie relatively far away from (above or below) the carrier frequency. In other words, in the case of F.M., unlike that of A.M. noise is not uniformly distributed over the audio spectrum.

Consider now a narrow-band F.M. system in which the maximum deviation, i.e. that corresponding to 100% modulation (maximum sound) is 15,000 cycles per sec. Consider further an interference voltage lying 15,000 cycles per sec. away from the carrier frequency, and therefore producing an audible sound of this frequency. The frequency deviation produced will be

$$\begin{aligned} \text{Deviation} &= (f_i - f_c) \times V_i / V_c \text{ cycles per sec.} \\ &= 15,000 \times V_i / V_c \text{ cycles per sec.} \end{aligned}$$

Since, in this case, a deviation of 15,000 cycles per sec. produces the maximum sound (i.e. corresponds to 100% modulation) the noise modulation will be

$$\frac{15,000 \times V_i / V_c}{15,000} = \frac{V_i}{V_c} \quad \text{This is the same amount of noise modulation as would be produced in an A.M. receiver - see line AB - Figure 27.}$$

Consider now a case where $f_i - f_c = 1,500$ cycles per sec, the noise-to signal voltage amplitude ratio (V_i / V_c) being the same as before. The frequency deviation produced is $1,500 V_i / V_c$ cycles per sec. i.e. 1/10 of the former value. The noise modulation (and therefore the level of the interference in the A.F. stages) will also be 1/10 of the value quoted above i.e. only $1/10 \times V_i / V_c$ - see line C.D. Figure 27.

These examples should show, as illustrated by the graph OB in figure 27, that noise in an F.M. receiver increases with audio frequency, from zero at zero frequency to a maximum at the limit of audibility, viz. 15,000 cycles per sec. At this frequency, in the narrow-band system the noise interference becomes as bad as in the A.M. system.

The important point, however, is that in the latter system the noise remains at the AB level (Fig. 27) for the whole range of audio frequencies, as shown by the horizontal line BE. Hence, even considering an F.M. system of the same band-width as the ideal A.M. system, an improvement in noise is obtained, tests showing that on a power basis the improvement is 3 to 1.

By using a wide-band F.M. system a much greater improvement is obtained, as already discussed in an earlier lesson. If, for example, the deviation is 75,000 cycles per sec. the maximum noise modulation which results (where $f_i - f_c$ equals 15,000 cycles per sec) is :

$$\frac{15,000 \times V_i}{75,000 \times V_c} = \frac{1}{5} \times \frac{V_i}{V_c}$$

Figure 27.

This improvement, on a power basis, due to increasing the band-width by 5 times is 25 to 1, or 75 to 1 compared with the A.M. system. Actually the improvement is much greater than this, due partly to an ingenious method whereby the higher audio frequencies (which are most affected by noise interference) are pre-emphasised in the transmitter, and then subjected to a corresponding de-emphasis in the receiver, thus, incidentally also reducing the noise at those frequencies where it is most pronounced. This point will be taken up again in a later lesson.

THE CAPTURE EFFECT.

This effect, whereby one signal, providing it is more than about twice the strength of a second signal, will take virtually full control of a receiver, has been already mentioned. It has been stated that in practice the net effect of the phenomenon is that it is almost impossible to experience interference as between two stations.

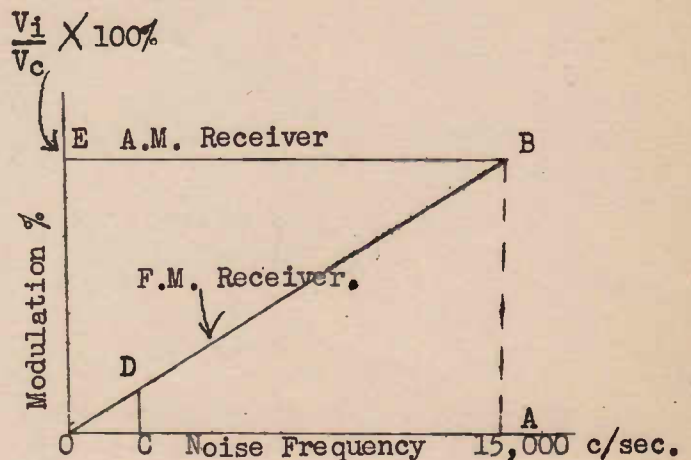
A weaker, interfering, carrier normally causes interference by beating with, and modulating, the stronger carrier. We can now easily understand the action in an F.M. receiver by using the diagram of Fig. 25 where vector V_i represented a weaker r.f. signal modulating (in amplitude and frequency) a stronger r.f. signal (f_c). The interference modulation was seen to be :

$$\left(\frac{f_i - f_c}{D}\right) \times \frac{V_i}{V_c} \quad \text{where } D = \text{the peak deviation.}$$

In this formula we may now take V_c and f_c to represent the amplitude and frequency, respectively, of the stronger carrier. V_i and f_i will represent the amplitude and frequency of the weaker interfering carrier. The formula shows that if the two carriers have the same frequency, i.e. $(f_i - f_c)$ equals zero, absolutely no interference modulation of the stronger signal can occur. If the two carriers are close together ($(f_i - f_c)$ small) the interference will be negligible. Hence it is impossible to experience the type of interference due to two carriers heterodyning as occurs with A.M. systems. The worst possible interference occurs when the signal frequencies differ by 15,000 cycles per sec. In this case the interference modulation for a case where $V_c = 2 \times V_i$, i.e. $\frac{V_i}{V_c} = \frac{1}{2}$ is

$$\frac{15,000}{75,000} \times \frac{1}{2} = \frac{1}{5} \times \frac{1}{2} = \frac{1}{10}$$

This is a voltage ratio. On a power basis the ratio of Interfering Signal equals Desired Signal

$$\left(\frac{1}{10}\right)^2 = \frac{1}{100}$$

Actually this worst possible condition only occurs for a very small fraction of the total time, even if the two carrier's centre frequencies differ by 15,000 cycles per sec. The reason for this is that when the carriers are modulated their frequencies are continually changing, so that, at any given moment, the frequency difference will probably be either less than 15,000 cycles per sec. (when the interference modulation is less pronounced) or above 15,000 cycles per sec. (when the interference is above the range of audibility).

It thus appears that the so-called Capture Effect results from the same action in the F.M. receiver as that which results in the relative immunity from noise due to "static" thermal agitation and "shot" effect. In considering the action of r.f. noise voltages we assumed that the carrier was unmodulated by speech or noise. The situation, however, is practically unchanged when F.M. is superimposed on the signal. When this occurs the carrier frequency simply moves up and down between its deviation limits over a band 150 K.c wide. Since noise r.f. voltages occur at every frequency the result will be that only those voltages which differ from the instantaneous carrier frequency by 15,000 cycles per sec. or less will be effective in causing interference.

LESSON 16 - EXAMINATION QUESTIONS.

- (1) Why is high sensitivity in the R.F. and I.F. stages usually a more important consideration in an F.M. receiver than in an A.M. receiver?
- (2) Explain why the problem of oscillator stability is rather a difficult one to solve in F.M. receiver design. Mention methods used to secure adequate stability.
- (3) What would be the oscillator range of frequencies for a band of signals from 88 to 108 m.c. per sec., if the I.F. is 10.7 m.c. per sec?
- (4) Why cannot Image Interference occur when operating on a band 88 - 108 m.c. per sec. with I.F. of 10.7 m.c. per sec.?
- (5) What would be the effect of an inadequate I.F. band-pass in the I.F. stages of an F.M. receiver?
- (6) What are the necessary operating conditions for a valve used as a Limiter (grid limiting)?
- (7) Why is very little, if any, amplification obtained from a limiter?
- (8) What is the reason for Automatic Volume (or gain) control in an F.M. receiver?
- (9) How do the output voltages of a discriminator and an ordinary A.M. diode detector differ when the signals, in each case, are unmodulated?
- (10) What is the chief difference in the principle of operation of a Ratio Detector compared with a discriminator?

AUSTRALIAN RADIO COLLEGE

E. S. & A. BANK BUILDINGS, Corner CITY RD. and BROADWAY, SYDNEY

Telephones: M 6391 and M 6392. Post Lessons to Box 43, Broadway

TELEVISION, FREQUENCY MODULATION & FACSIMILE COURSE.

This lesson sheet is published for the exclusive use of students of the Australian Radio College

LESSON 17.

AUDIO SYSTEMS AND TYPICAL RECEIVERS.

(All rights reserved)



Section A - Audio Frequency Systems.

The audio signal derived from the demodulation (detection) of an F.M. wave - as explained in the previous lesson - is exactly the same type of signal as that obtained from an A.M. wave. If, however, we were to use in an F.M. set an audio system as customarily designed for a conventional A.M. receiver we would fail to realise one of the main advantages - that of high fidelity - which is characteristic of this new method of broadcasting.

The usual low-fidelity audio amplifiers and speaker to be found in the great majority of receivers seriously attenuates the very low frequencies and the high frequencies above about 5,000 cycles per sec. There would be but comparatively little advantage, however, in extending this frequency range of the audio section when using A.M., because the system, in its present form, is incapable of transmitting the higher frequencies without giving rise to undesirable interference and noise.

The "wide-band" F.M. system, on the other hand, is fully capable of transmitting the entire audio spectrum - extending up to 15,000 cycles per sec. and more. It is most desirable, therefore, that the audio amplifiers and speaker of an F.M. receiver should be capable of handling, without discrimination, all frequencies passed on from the detector stage. To obtain this high fidelity special consideration must be given to the voltage amplifiers, to the power amplifier, to the output transformer, and to speaker construction and speaker mounting. It will be the purpose of Section A of this lesson to describe and explain the special characteristics of these several sections of an audio system suitable for a good F.M. receiver.

DE-EMPHASIS OF HIGH AUDIO FREQUENCIES AFTER DETECTION.

In the grid circuit of the first audio voltage amplifier in an F.M. receiver there is usually to be found a special

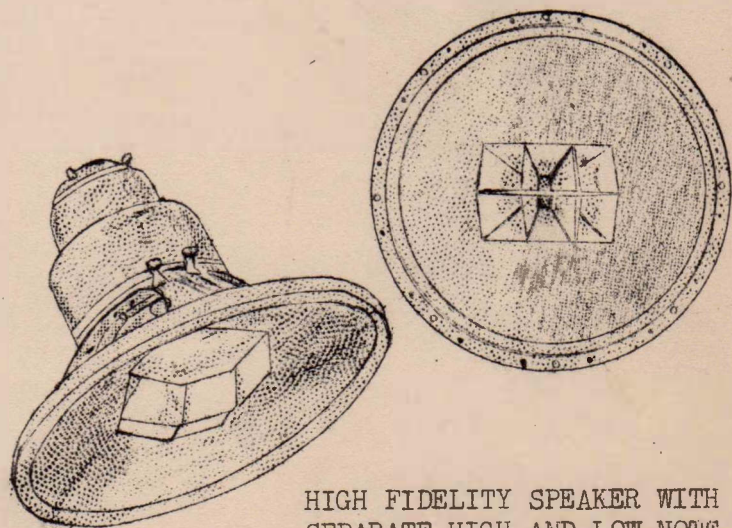

HIGH FIDELITY SPEAKER WITH SEPARATE HIGH AND LOW NOTE CHANNELS.

Figure 1

resistance capacity or inductance-resistance filter network. The necessity for this filter is due to an ingenious method of taking advantage of the particular manner in which interference (noise) voltages affect the audio output from an F.M. detector. As previously pointed out, "noise" in an F.M. receiver, unlike that in an A.M. receiver, is not uniformly spread over the audio frequency spectrum, but is more pronounced at the higher of these frequencies. If we were to measure the intensity of the noise in the output from an F.M. detector at all frequencies from zero up to the limit of audibility (say 15,000 cycles per sec.) the intensity would increase with frequency as shown by the straight line "A" in Figure 2. Here we are assuming, of course, that all amplitude modulation due to noise has been fully suppressed by limiters or by the use of a "ratio detector". For comparison purposes the graph of noise - versus - frequency for an A.M. receiver has also been shown in Fig. 2 (line "B"). In the latter case the line is horizontal, indicating that the effect of noise is uniformly distributed over the whole of the A.F. range.

This peculiarity of the noise characteristic of an F.M. system is taken advantage of, in practice, to still further reduce the effect of interference. In the modulator of the transmitter it is customary for the higher audio frequencies of the signal to be pre-emphasised or accentuated over and above the lower frequencies. In the receiver, after detection, the higher audio frequencies in the signal are de-emphasised or de-accentuated as compared with the lower frequencies. The effect of such de-emphasis is to produce a proper balance again among the various components of the A.F. signal, while at the same time reducing the strength of the noise voltages at these higher frequencies where they are more pronounced.

A simple A.F. de-accentuator network is shown in Figure 3. The audio output from the F.M. detector is applied across an R.C. circuit and the signal applied to the 1st A.F. amplifier is taken from across the condenser C. At low frequencies the reactance of C is much larger than R and practically the full detector output is applied to the A.F. amplifier. As the signal increases with frequency the reactance of C decreases. Since the circuit consisting of R and C acts as an A.C. voltage divider the percentage of the total signal which is passed on to the amplifier becomes smaller and smaller as the frequency increases. The values of R and C must, of course, be properly proportioned so that the de-emphasis obtained matches the amount of pre-emphasis utilised at the transmitter.

In the case of the ratio detector the high A.F. de-emphasis may be conveniently achieved by choosing suitable values of the condensers across the diodes and the condenser applying the signal to the centre-tap of the transformer secondary. The total effective value of these capacities appears across the output impedance of the circuit, which in practice is comparatively low. Hence, at the higher audio frequencies a certain amount of by-passing action may be brought about.

AUDIO VOLTAGE AMPLIFIERS:

A good A.F. voltage amplifier in an F.M. receiver should amplify uniformly all sound frequencies from 30 cycles per sec. to 15,000 cycles per sec. This is not a wide range when compared with the requirements of a television video amplifier, but is somewhat wider than that which most audio

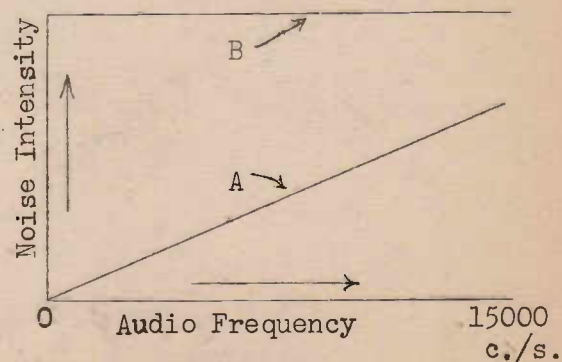

Figure 2

amplifiers in A.M. receivers are capable of handling.

We have already discussed in detail in the television lessons the causes of loss of gain in resistance capacity coupled amplifiers at the very low and at the very high frequencies. These points should now be recalled.

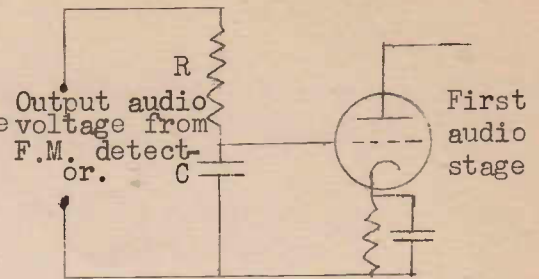
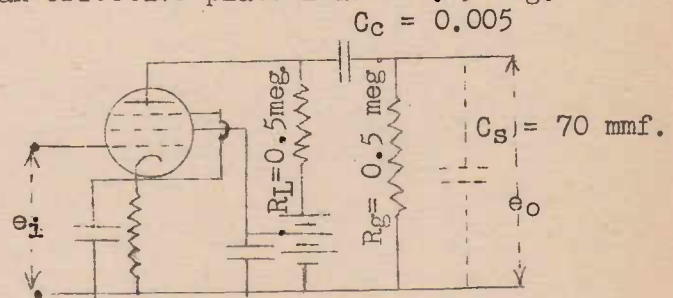

Figure 3.

The main differences between a typical A.F. voltage amplifier in an F.M. receiver compared with the corresponding stage in an A.M. receiver are :-

- (1) A somewhat lower value of load resistor, particularly when using a pentode, to extend the high-frequency range.
- (2) A valve having in general a larger value of mutual conductance, to offset the loss of gain at all frequencies due to the smaller load resistor.
- (3) All valves are almost invariably of the "single-ended" type, i.e. they have no grid caps. Instead the grid connection in each case is brought out to one of the base pins. This reduces the length of the plate-to-grid lead between valves, thus reducing the stray capacity to ground, and improving the high-frequency response.

To realise just how inadequate would be a typical pentode R.C amplifier refer to Fig. 4. Here we show a plate resistor of .5 meg. followed by a grid resistor (for the next stage) also of .5 megohm), giving an effective plate load of .25 meg. The stray capacities (shown by C_S), having a typical value of 70 $\mu\mu\text{f.}$, consist of course of the output capacity of the stage, together with the input capacity of the next stage, and stray wiring capacity. Note that the gain begins to fall off rapidly at about 3,000 or 4,000 cycles per sec. while at approx. 16,000 cycles per sec. it is down to 50%.



A useful fact to remember when judging the higher frequency response of an R.C. amplifier is that the gain is down to 0.707 of its normal value at that frequency at which the reactance of the stray-capacities is equal to the effective load resistance (or, in the case of triodes, to the effective value of the load resistance in parallel with the valves internal plate resistance). Thus, in the case illustrated, at 9,000 cycles per sec. the reactance of $C_S = 70 \text{ u.u.f.}$ works out at approximately 0.25 megohms.

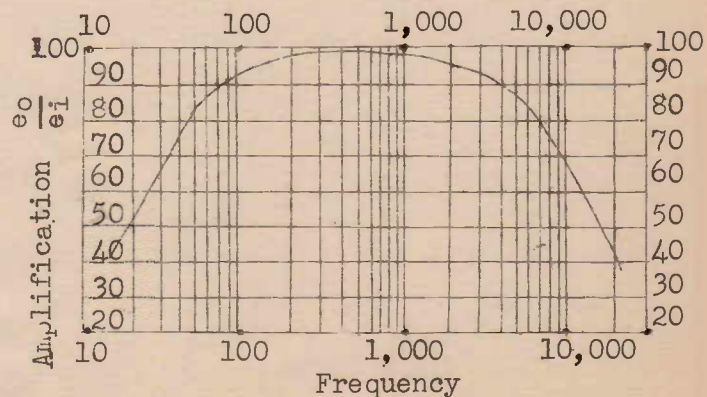

Figure 4

A value equal to the effective load. From the graph of Figure 4 it will be seen that the gain at 9,000 c. per sec. is about 0.7 of its normal value.

Suppose now we were to reduce the load resistor to 0.1 meg. The effective value of the plate load would now be that of 0.1 meg. in parallel with 0.5 meg. (the grid resistor). This is $\frac{.1 \times .5}{.1 + .5}$ meg. = .083 meg. about one third of its former

value. The frequency could now be increased to three times 9,000 cycles per sec. i.e. 27,000 cycles per sec. before the reactance of C_g became equal to the effective value of the load resistance, and therefore before the gain fell off to 0.707% of normal value. Thus it is seen that when using a .1 meg. load in parallel with a .5 meg. following grid resistor, the higher audio frequencies up to, say, 15,000 cycles per sec. could be adequately accommodated without any appreciable loss of gain occurring. The position would be even better if we were to use single-ended pentodes, of low internal capacities (as is the usual practice). In this case the stray capacities would be less than the 70 μ .u.f. assumed above.

With reference to the low-frequency response, it is desirable to extend the latter down to about 50 cycles per sec. otherwise the reproduction will sound high-pitched and "tinny". Any extension of the high-frequency range of an audio amplifier, without a compensating extension of the low-frequency range, produces a very noticeable lack of tonal balance in the reproduced sound. It might be remarked, in this connection, that one purpose of tone control in an ordinary A.M. receiver is to attenuate the higher frequencies (even though these might extend up to only 3,000 - 5,000 cycles per sec.) to offset the absence of the very low frequencies. For high-fidelity reproduction both the very high and the very low frequencies must be adequately handled, not only in order that all essential components of the original sound are reproduced, but also in order to preserve a natural balance between the high and low tones.

The low-frequency response of an amplifier depends upon the time-constant product $C \times R$ where C = capacity of the grid coupling condenser, and R = effective value of the grid resistor (R_g) in series with the preceding valve's plate resistance and load resistor (in parallel). In the case of a preceding triode, which has a low plate resistance, R may be taken simply as the grid resistor (R_g). Even with pentodes, if the preceding plate load resistor is comparatively small (as in high-fidelity work) R , for rough purposes, may be taken as the value of the grid leak (R_g).

Figure 5 shows the effect of various values of grid coupling condenser (C_c) when the grid resistor is 0.5 meg. It will be seen that for negligible low frequency attenuation C_c must be .02 m.f., or higher when the resistance is 0.5 megohm. These curves may be used for any value of resistance providing the capacity is multiplied by the correct factor. For example if the resistance were 1 megohm instead of .5 megohm curve A would hold for a grid condenser of capacity $.001 \times \frac{1}{.5} = .0005$ m.f. The reason for this is that the time-constants $.001 \times .5$ secs. $\frac{1}{2}$ and $.0005 \times 1$ sec. are equal.

THE POWER AMPLIFIER.

Any common type of power output valve e.g. a 6V6, is suitable for an F.M. receiver. The main considerations to be satisfied in respect of the output stage are:-

- (1) There should be abundant power output (watts) available.
- (2) Distortion should be kept to a minimum.

With reference to point (1) above it should be remembered that the peaks of audio power from an F.M. signal are considerably higher than those from an A.M. signal even though the average level of the sound is the same in the two cases. This is because the F.M. signal provides a much wider "dynamic range" than does the A.M. signal. The audio signal in the latter case is considerably "compressed" before modulation at the transmitter. The maximum power output rating of the power valve or valves of an F.M. receiver, therefore, should be many times the average power at which it is desired to operate the set, otherwise the volume peaks will be cut off and distorted.

For ordinary domestic purposes where the receiver is operated in a small room, and a high level of average output is not required, a single pentode or beam power tetrode, such as the 6V6, is considered adequate. In the case of the more ambitious receivers, however, from which it is desired to obtain the full benefits of the wide dynamic range of the high fidelity signal, several of such valves either in parallel or in push-pull - preferably the latter - should be used. Whether a single valve or two valves are used it cannot be too strongly stressed that the stage should be correctly designed and adjusted to give the maximum undistorted power of which the valves are capable. Such points as correct plate load and correct grid bias (as published in the data sheets) should be given close attention.

With reference to the question of distortion mentioned under (2) above little need be said here. The same considerations apply as in the A.M. receiver. Negative or inverse feed-back is especially recommended in all cases in order to reduce distortion generated within the valve.

THE OUTPUT (SPEAKER) TRANSFORMER.

A high-quality speaker transformer is essential for high fidelity output. Correct design of the other sections of an audio amplifier for full audio frequency range is useless if the speaker transformer is inadequate.

It should be recalled that the impedance "reflected" into the primary of a correctly designed transformer depends only upon the load imposed upon the secondary, and the "turns ratio". If the secondary load is a pure-resistance, then the primary impedance should also appear as a pure resistance. The value of this primary

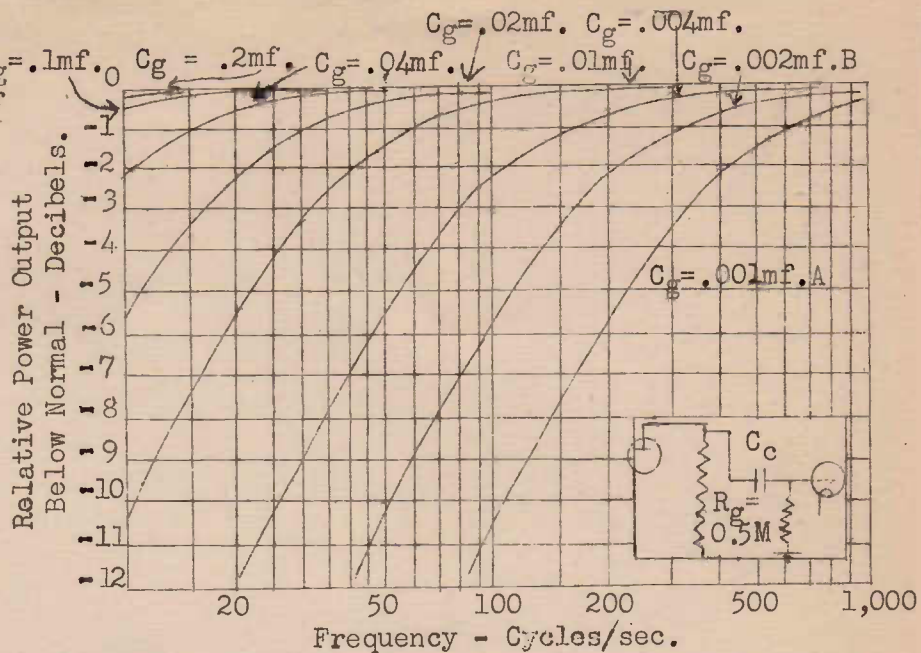

Showing reduction in gain due to effect of grid-coupling condenser. Note. Each division (1 Decibel) on the vertical scale represents a change in sound intensity which is just noticeable by the human ear.

Figure 5.

resistive impedance, in such a case is given by

$$Z_p = Z_s \times \left(\frac{T_1}{T_2}\right)^2$$

where Z_p = "Reflected primary impedance

Z_s = Load imposed on the secondary.

T_1 and T_2 = No. of turns on primary and secondary respectively.

Reflected
Primary
Impedance
 $Z_p = Z_s \times \left(\frac{T_1}{T_2}\right)^2$

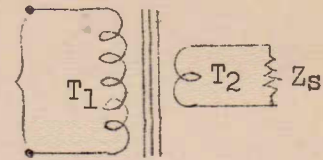

Figure 6.

See Figure 6.

The important point to note is that the load imposed on the output valve (and therefore the power output obtained) should not vary with frequency. If, however, we look at a typical amplification frequency curve for a power amplifier with output transformer (Figure 7) we note that although the output remains substantially constant over a considerable range of the middle frequencies, it does fall off sharply at the very low and the very high frequencies. What causes this loss of output at these extremes of frequency?

LOSS OF OUTPUT AT LOW FREQUENCIES DUE TO SPEAKER TRANSFORMER.

Although the primary of an output transformer consists almost entirely of inductance the reactive effect of the latter is entirely masked at all but the very low frequencies. The reason for this is that the resistive impedance ($Z_s \times \left(\frac{T_1}{T_2}\right)^2$), reflected into the primary by the electro-magnetic coupling effect, really appears in parallel with the primary inductance as shown in Figure 8. Now at all except the very low frequencies the reactance L_p is very much larger than $R_s \times \left(\frac{T_1}{T_2}\right)^2$. Hence, for all except the very low frequencies the load imposed on the valve (R_L Figure 8) is practically equal to the reflected impedance only - and the latter is independent of frequency.

At the very low frequencies, however, the reactance ($2\sqrt{f}L_p$) of the primary inductance might fall to such a value as to cause an appreciable shunting of the reflected impedance (Z_p). The effective load (R_L) in the plate circuit of the power valve then becomes reduced in value, and the output falls off.

Summarising we may say that undue falling off in the gain from a power amplifier at the lower frequencies may be due to insufficient primary inductance in the output transformer. To maintain a constant output down to say 50 cycles per sec. the output transformers primary must have a larger inductance than to be found in a typical unit as used for A.M. work. This normally involves a larger iron core and a larger number of

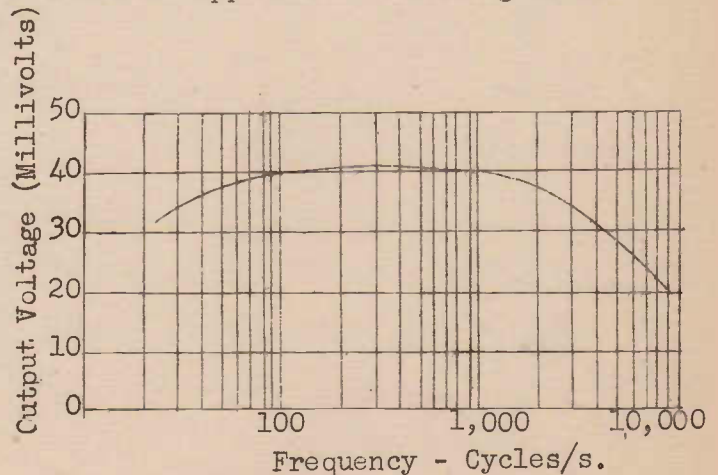

Figure 7.

primary turns, together with a corresponding increase in the secondary turns in order to maintain the turns ratio $\frac{T_1}{T_2}$ constant.

Figure 9 shows the improvement in low frequency response in a typical circuit when the primary inductance is increased from 3.7 henries to 11.1 henries. Note that the primary inductance has no effect on the output at the middle and high frequencies.

LOSS OF OUTPUT AT HIGH FREQUENCIES DUE TO SPEAKER TRANSFORMER.

The falling off in output at the high frequencies is usually described as being due to the "leakage inductance" of the transformer. In the ideal transformer all of the magnetic flux (lines of force) of the primary should "cut" or pass through all of the turns of the secondary. Similarly all of the secondary flux should cut all the primary turns. In a practical transformer, however, a certain small percentage of the magnetic flux of each coil fails to cut the other coil. (See figure 10). A mathematical analysis shows that the effect of this leakage flux is the same as if an extra small inductance were placed outside the transformer, but in series with the primary into which is reflected the impedance $R_s \times \left(\frac{T_1}{T_2}\right)^2$. See figure 11.

Now at low and medium frequencies the reactance ($2\pi fL_L$) of this "leakage inductance" is negligibly small compared with the reflected impedance $R_s \times \left(\frac{T_1}{T_2}\right)^2$. At the higher frequencies, however, the reactance of L_L becomes appreciable and results in a loss of output.

Another serious effect of leakage inductance occurs when the latter resonates with stray capacities in the circuit. These stray capacities consist of capacity between the transformer windings themselves together with wiring and valve capacities external to the transformer. Since both leakage inductance and stray capacities normally have low values the resonant frequency is usually high, but it may fall within the audio frequency range for which the transformer is designed. If this occurs a small band of these higher-frequencies will be accentuated unduly, i. e. the frequency - response curve will depart from the desired linearity and will show a sharp peak in the higher frequency range. In a well

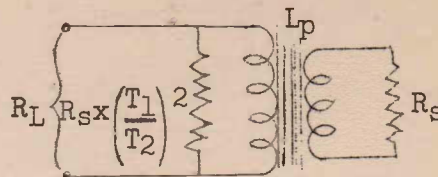

Figure 8.

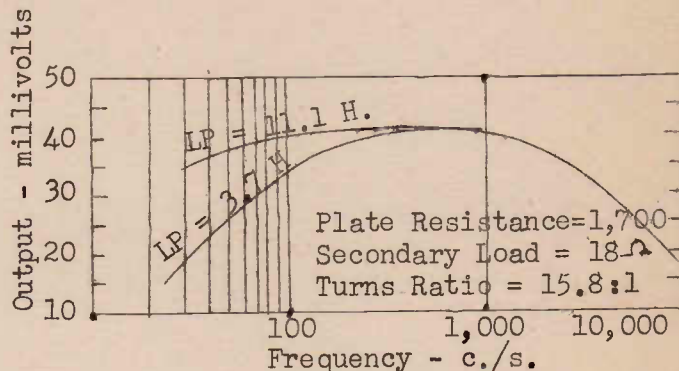

Figure 9.

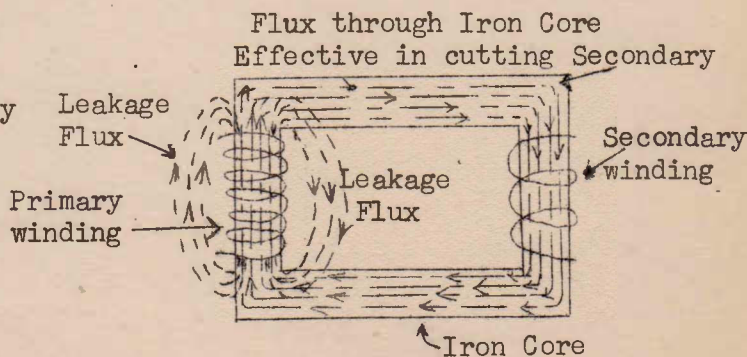

Figure 10.

Showing leakage of Primary Magnetic Flux.

designed transformer the resonant peak of the combined leakage inductance and stray-capacities should fall somewhat above the higher frequency limit for which the transformer is designed. If this condition obtains the resonant peaking effect may be utilised to offset, to some extent, the reduction in gain at the higher frequencies within the designed range, which reduction is due to the presence of the leakage inductance above.

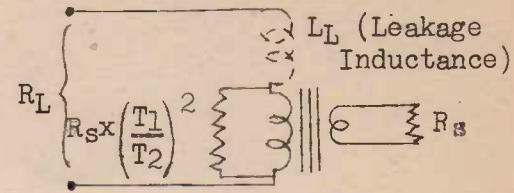

Figure 11.

Leakage inductance is reduced by:

- (1) Winding the coils on a central iron-leg of the iron core, the windings being divided into a number of sections with primary and secondary interlaced.
- (2) Using iron of high magnetic "permeability".
- (3) Having a core of large cross-sectional area.

Winding capacities are reduced (to raise the resonant peak referred to above) by dividing each section of the transformer windings into sub-sections spaced apart by small distances.

It will now be realised that an ordinary output (speaker) transformer considered satisfactory for a low fidelity A.M. receiver would be quite inadequate to handle the frequency range 30 - 15,000 cycles per sec. desirable in F.M. work. Increasing the normal primary inductance to avoid loss of gain right down to 30 cycles, and reduction of the leakage inductance to maintain the response up to 15,000 cycles involves higher costs in manufacture. Nevertheless it would be unreasonable to counteract the results of proper design for high fidelity in other parts of the receiver by the use of a low quality output transformer.

HIGH QUALITY SOUND REPRODUCTION - LOUD SPEAKERS.

Having retained the full range of audio frequencies right up to the output of the speaker transformer it still remains to convert this electrical signal into sound wave power without discriminating against, or favouring, any band of frequencies within the range.

The position is this : we have in the secondary of the speaker transformer electrical power distributed over a wide range of frequencies. The job is to convert this electrical power into acoustical or sound power with the same degree of efficiency for all frequencies within the range. Now the design requirements for an electro-acoustic device (e.g. loud-speaker) to operate efficiently at high frequencies are quite different from the requirements for high efficiency at low frequencies. For this reason it is a very difficult technical problem to construct a single electro-acoustical device to operate uniformly over the frequency range of say 30 - 15000cycles per sec.

THE PRODUCTION AND NATURE OF A SOUND WAVE.

In order to understand the material which follows in these pages concerning high-fidelity sound reproduction, it will first be necessary to grasp a few simple fundamentals relating to the manner in which an air sound wave may be produced, and the nature of such a wave.

Referring to Figure 12 - suppose AB is a flexible metal disc, caused to vibrate bodily at audio frequency by, say, some electrical means. Suppose further that at the present moment the disc is moving in the direction y to x. The air on the right-hand side of the disc, since it possesses a certain amount of weight, and therefore inertia, will

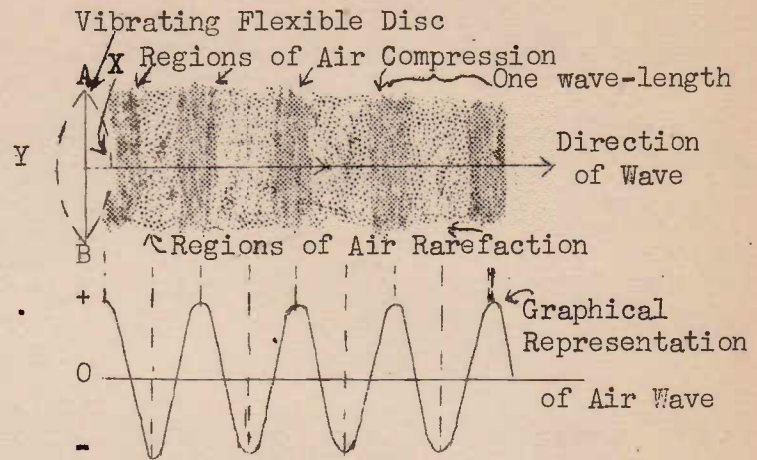

Figure 12.

not have time to flow away from the moving disc. The result will be that the air particles will be compressed together to some extent, i.e. a region of high air pressure is built up. Then, as the disc moves back in the direction x to y a partial vacuum will be created behind it, since the air particles have insufficient time to flow into the space. In other words a region of rarefaction will result. In the meantime the region of compression will have moved onwards to the right at the velocity of sound. Thus as the rapid vibration of the disc continues a "compression wave" moves continuously to the right. Of course a similar wave (not shown) will also move out to the left of the disc. It should be understood that the air, as a whole, does not flow bodily in the direction of the wave. Actually each individual air particle simply performs a vibratory or oscillatory motion about its normal average position. It is the positions of the air compressions and rarefactions which continually change or move. The diagrammatic representation of Fig.12 may be imagined as a sort of "snap-shot" of the state of affairs at any one instant of time.

The air wave may be represented by the usual sine-curve by depicting regions of compression as positive half-cycles, and regions of rarefaction as negative half cycles, as shown in Figure 12.

The frequency of the wave (i.e. the "pitch" of the sound) will depend upon the number of air compressions passing any point per second. The intensity of the wave (i.e. the loudness of the sound) will be determined by the intensity of the pressure in the regions of compression, and this will depend, among other things, upon the amplitude of vibration of the disc. The speed at which the wave moves through air is approximately 1120 ft. per sec., irrespective of the frequency and intensity. The wave length is the distance between any two adjacent points of maximum air pressure. (See Figure 12). The wave length (in fact) of sound wave may be calculated from the formula :
$$\text{Wave length} = \frac{1120}{\text{Frequency}}$$
 feet. Speed = 1120 ft./sec. is correct for

17° C temp. and normal barometric pressure.

Thus the wave length of a sound wave of frequency 224 cycles per sec. is $\frac{1120}{224} = 5$ ft.

HOW THE SOUND INTENSITY VARIES WITH THE FREQUENCY OF VIBRATION AND THE DIAPHRAGM AREA.

Suppose a rigid diaphragm (Figure 13A) is caused to vibrate by the application of some constant force to it. (in the case of a loudspeaker the force is one developed

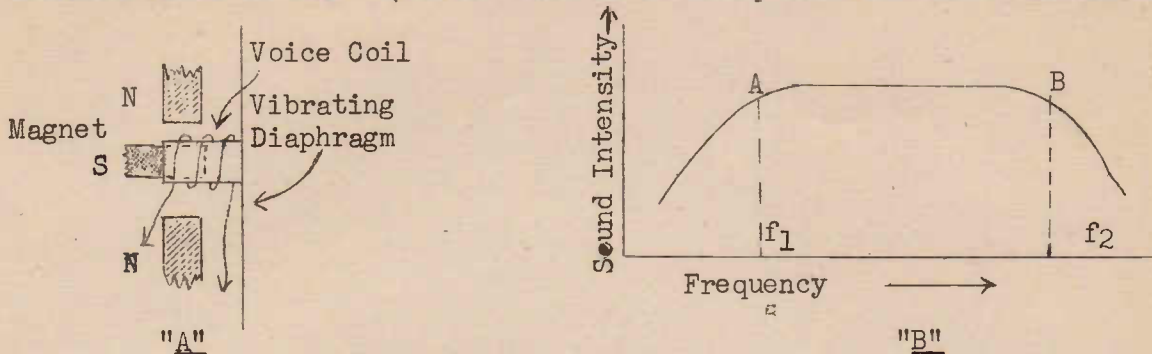

Figure 13.

by the flow of the alternating audio-frequency current in the voice-coil which is situated in a magnetic field). If the frequency is continually increased it is found that the intensity of the wave set up varies as shown in Figure 13B.

At low frequencies the vibrating diaphragm does not get a chance to "bite" on the air very effectively. At those frequencies the air tends to slide around the edges as the surface moves backwards and forwards. As a result the air pressures developed, as explained in connection with Figure 12, are not very high, and the sound wave's intensity is small. As the frequency increases the "bite" on the air becomes more and more effective and this tends to result in a more intense wave. On the other hand the amplitude of vibration of the diaphragm decreases as the frequency increases. The cause of this reduction in the amplitude of vibration is due to the mass of the diaphragm. As the frequency increases it becomes ever more difficult to move this mass back and forth at the desired rate. Since the force available to cause the vibration was assumed constant, the result will be that the amount of vibration produced will fall off with increase in frequency. The result of this reduction in amplitude of vibration would be, of course, (other things being equal) to reduce the intensity of the sound wave.

It thus appears that, with increase in frequency, there are two opposing tendencies as far as the strength of the wave is concerned. The improved "bite" on the air tends to produce a more intense wave. On the other hand the falling off in amplitude of vibration tends to result in a weaker wave.

At very low frequencies (below f_2 Figure 13B) the former tendency more than offsets the latter, and the wave intensity increases to a maximum at A, corresponding to frequency f_1 .

Over a certain range of frequencies f_1 to f_2 (Figure 13B) the ever increasing "bite" on the air, and the ever decreasing amplitude of vibration just about off-set each other, with the result that the wave intensity remains substantially constant.

It is found that when the frequency is such that the diameter of the diaphragm equals one half a wave length, the "squash" of the air to the sides of the vibrating surface

becomes negligible. In other words the "bite" on the air becomes practically 100% at this frequency, and therefore does not improve further as the frequency goes up. The frequency at which this occurs is represented by f_2 in Figure 13B. As the frequency increases further above f_2 the amplitude of vibration, due to the effect of diaphragm mass, will of course continue to decrease. The result will be that as the frequency of vibration increases above f_2 , the wave intensity will rapidly fall-off.

Summarising, the frequency-sound intensity characteristic of a rigid vibrating diaphragm, operated by a constant force (due, say to an audio current of constant amplitude in the "voice coil"), we have the following points :-

- (1) The sound intensity remains constant over a certain frequency range.
- (2) The lower-frequency limit (f_1 Figure 13B) of this constant range is determined by the area of the diaphragm. The limit may be lowered by using a larger diaphragm, for the latter will present a larger vibrating area to the air, and will thus secure a better "bite" at the lower frequencies.
- (3) The upper frequency limit of the constant range (f_2 , Figure 13B) also depends upon the size of the diaphragm. This frequency limit, however, can only be raised by reducing the diaphragm size. It was pointed out that the frequency f_2 corresponds to a wave length twice the diameter of the diaphragm (i.e. diameter = $\frac{1}{2}$ wave length).

For example, in the case of an 8" diaphragm (e.g. an 8" cone speaker), the frequency (p) at which the acoustic power begins to fall off will be that corresponding to a wave length of $2 \times 8" = 16" = 1\text{-}1/3$ ft. This frequency is $1120 \div 1\text{-}1/3 = 3360 \div 4 = 840$ cycles per sec. If a diaphragm of diameter only 4" were used the corresponding frequency would be double this, i.e. 1680 cycles per sec.

The fundamental difficulty encountered in wide-range (high-fidelity) sound reproduction should now be obvious. The efficient reproduction of the very low frequencies requires a diaphragm (or cone) of large area, but this is detrimental to the high frequencies. If the latter are to be reproduced without loss, a small diaphragm is desirable, but this cuts out the very low frequencies. Let us see how this problem may be solved.

PERFORMANCE AND LIMITATIONS OF A TYPICAL SPEAKER.

It will first of all be necessary to recall the action of a typical cone speaker and see how far its performance satisfies the requirements of high fidelity reproduction.

It is assumed that the mechanical-electrical principles of operation of the dynamic type of speaker are already familiar to the student. The following points, however, will be stressed. The alternating current, at audio frequencies in the voice coil cause it to move in a left and right direction across the page (Figure 14), and this oscillatory motion, at sound frequency, is transferred to the cone, which acts as the vibratory diaphragm. Now if a rigid cone were used the sound output would be constant over only a very limited frequency range as explained in connection with Figures 12 and 13. The problem is this: if a large cone is used the lower frequencies will be well catered for, but the higher frequencies will not be adequately reproduced. On the other hand a small cone will favour the higher

frequencies at the expense of the low. The problem is partly overcome by using a cone of "corrugated" construction. Stiff rigid sections in the cone surface are separated by corrugations possessing a certain amount of elasticity or "give", as shown in Figure 14.

Considering an 8" speaker at low frequencies up to about 800 - 1000 cycles per sec. the stiffness of the corrugations is such that the cone vibrates as a whole, and the effective area utilised in producing sound waves equals the whole cone area. Up to this frequency corresponding to f_2 in Figure 13, as we have already seen for an 8" cone, the acoustical power output remains practically constant, but above it there would be a marked falling off in the output. Somewhere about this 800 - 1,000 cycles frequency mark, however, the cone corrugations begin to "give" with the result that the amplitude of vibration of the outer sections of the cone is less than that of the inner sections. As the frequency increases the "give" of the corrugations becomes more and more pronounced, until at about 3,000 or 4,000 cycles per sec. only the inner portion of the cone is moving. The net effect of this action is that the effective area of the cone in use decreases with increase in frequency (in the range 1,000 to 3,000-4,000 cycles per sec.). The resulting decrease in mass of the vibrating section allows of a greater amplitude of vibration than would otherwise occur. Such increase in vibration amplitude tends to off-set the tendency for the acoustical power to decrease.

It is thus seen that in the case of a typical 8" speaker the corrugated structure of the cone extends the high frequency limit, at which a fall in output commences, from about 1,000 cycles per sec. to about 3,000 or 4,000 cycles per sec. Above the latter frequency the mass of the voice coil itself is the limiting factor. To extend the range still higher a lighter voice coil must be used, and this in practice means that the whole speaker construction must be smaller. But a small cone would be detrimental to the low frequencies. The problem of raising the upper-frequency limit to a value which is adequate for high-fidelity reproduction such as is required in an F.M. receiver will be taken up a little later in the lesson.

Consider now the low-frequency response of the typical speaker. Even though we have the comparatively large diaphragm area of, say, an 8" cone, the response would begin to fall off below several hundred cycles. This is not good enough even for ordinary medium-fidelity work. What happens at these low frequencies is that the cone, as it vibrates, simply pumps air from one side of it to the other, thus preventing the building up of high pressures necessary for a strong sound wave.

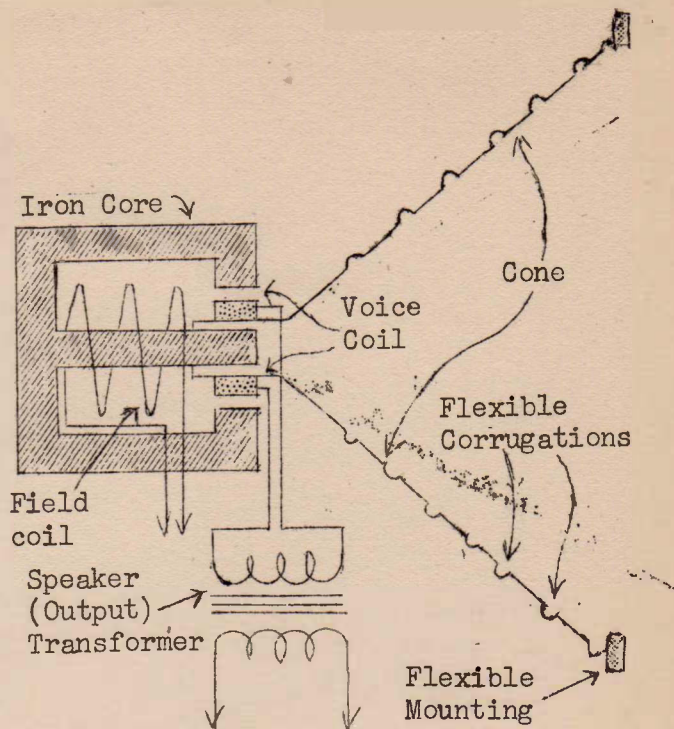
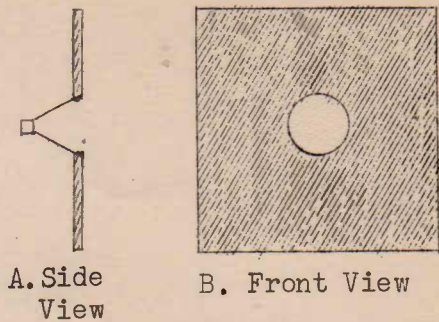

Figure 14.

BAFFLES

To prevent this flow of air from front to back (and vice versa) of the vibrating cone it is necessary to surround the cone with a "baffle". A "baffle" may be defined simply as a piece of more or less sound absorbent material which increases the acoustical or air path between front and rear of the cone. In the ordinary use of the term the baffle is flat, surrounding the speaker cone as shown in Figure 15.



Square Speaker Baffle.

Figure 15.

The lower the frequency it is required to handle the larger the baffle should be. A rough rule to give the diameter of a circular baffle is as follows :- Baffle diameter = one-half wave length of lowest frequency for which little or no loss of power is required. For example if frequencies down to 150 cycles per sec. are required baffle diameter should be $\frac{1}{2} \times \frac{1120}{150} = 3.7$ ft. (approx). If a square baffle were used the length of its side should be equal to, or perhaps slightly less than, this figure.

If a baffle of regular shape, say a square or circle, is used, it is found that a frequency about double the lowest frequency for which the baffle is designed there is a sharp dip in the response. This is due to the wave radiated from the back of the cone tending to cancel the normal radiation from the front at this particular frequency. Referring back to Figure 12, and the discussion relating to that diagram, it will be seen that at an instant of time when the diaphragm is moving forward an air compression is being set up in front while at the same moment an air rarefaction, or partial vacuum is created behind. This means, that at, any given moment the air waves radiated forward and backwards are 180° out of phase.

In the case of a listener situated on the axis, and in front of the cone, as at O in Figure 16, it must not be imagined that all the sound he hears comes from the front of the cone alone. It must be remembered that sound waves (particularly low frequency sound waves with which we are dealing at the moment) are capable of bending around corners. Hence some of the sound heard at O will have originated at the back surface of the cone. In the absence of a baffle, the sound waves arriving at O from front and back surfaces will be practically 180° out of phase and partial cancellation will result. This type of cancellation of two waves is called "destructive interference". Actually the purpose of a baffle is to alter the 180° phase relationship between the two waves, and so prevent this destructive interference. When a baffle is used, the wave from the back of the cone has to travel an extra distance equal to AB + BC (Figure 16) in getting to the point O, compared with the distance travelled by the front-surface wave. This distance is called the "path-difference" of the two waves. The effect of this extra path difference is to delay the wave from the rear surface by a time equal to that taken for it to travel the distance AB + BC. This alters the 180° phase relationship between the two waves, and so prevents (or at least reduces) the destructive interference. When, however, the path difference equals one wavelength (corresponding to a phase change of 360°) the two waves which start out from their respective surfaces 180° out of phase are once again 180° out of phase when the one from the back of the cone reaches the point C

(Figure 16). Hence for that particular frequency for which the path difference $AB + BG$ equals one wavelength the situation is much the same as if no baffle were present, and serious destructive interference between the two waves results. The net effect is a sudden dip in the response curve at this frequency.

It will be observed (Figure 16) that the path difference is measured from a point A on the edge of the cone outwards to the edge of the baffle, then down the front of the latter to the edge of the cone again. In the case of a square baffle the path difference may be taken as the length of the side of the square minus the cone diameter. Thus in the case of a 36" square baffle and an 8" cone the path difference is $36" - 8" = 28" = 2\frac{1}{3}$ feet. This distance equals one-wavelength of a sound wave when the frequency is

$$\frac{1120}{2\frac{1}{3}} = \frac{1120 \times 3}{7} = \frac{3360}{7} = 480 \text{ cycles per sec.}$$

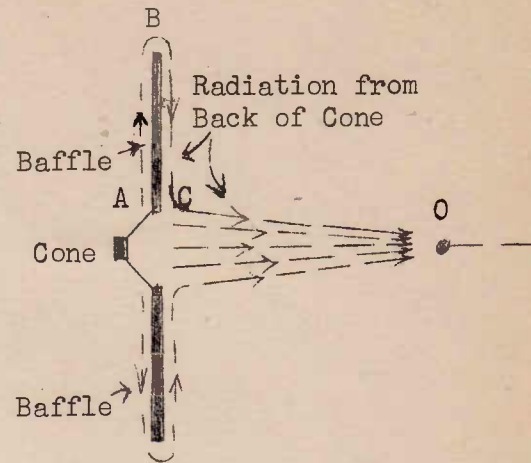

Figure 16.

Somewhere around this frequency a serious dip in the sound intensity measured in front of the speaker would result.

The effect described above may be greatly reduced by the use of an irregularly shaped baffle, where the path differences, measured from back to front of the cone, vary considerably. For such a baffle the destructive interference of the two waves is spread over a wide frequency range. Instead of a pronounced dip in the vicinity of one particular frequency, we then obtain only a negligible reduction in intensity spread over this frequency range, as shown in Figure 17.

RADIO CABINETS.

The receiver cabinet is not merely a container to house the chassis, but also serves the purpose of a baffle, separating the two surfaces of the speaker cone by an appreciable air path. For good low frequency response the shortest air path from the back of the cone, out the back of the cabinet, to the front surface of the cone should be as long as possible. Since there are a number of paths of different lengths by which the sound waves emitted from the back of the cone can pass to the front of the receiver, the cabinet acts like an irregular baffle, and the effects of destructive interference of the sound waves are not serious being spread over a wide frequency range as in curve B of Figure 17.

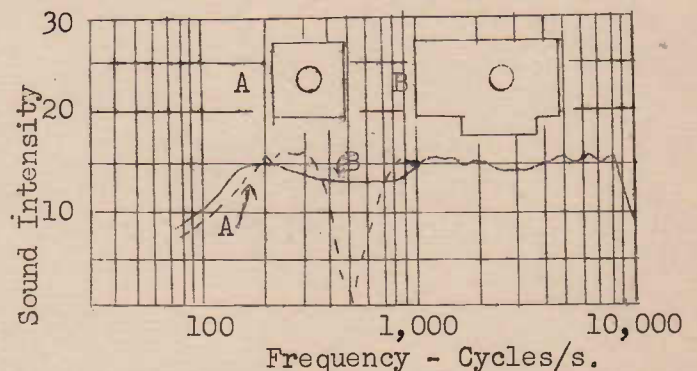

Showing effect of destructive Interference of Waves from front and rear surfaces of cone in case of, A, Square Baffle, and B, Irregular Baffle.

Figure 17.

RESONANCE IN RADIO CABINETS.

The enclosed (or semi-enclosed) volume of "air" within a radio cabinet has a natural or resonant frequency of vibration of its own. This resonant frequency in the case of the average floor-model cabinet is usually about 140-150 cycles per sec. When the speaker is emitting a frequency coinciding with this resonant frequency of the cabinet, the resonant effect causes a peak in the output. Such a peak it must be remembered, is equally as bad as a "dip" in the output if high fidelity is desired.

Cabinet resonance effects may be minimised by proper design and location of the parts to break up the large air mass into a number of smaller masses.

MECHANICAL RESONANCE IN SPEAKERS.

Another effect which may detract from the linearity of the frequency-sound intensity curve of the acoustical system is that due to a mechanical resonance effect of the voice-coil assembly. The voice-coil is suspended by the "spider" which gives an elastic support, allowing the coil to vibrate under the influence of the forces electro-magnetically generated within it. There is one particular frequency (about 100-150 cycles per sec. in the case of the ordinary 8" speaker) at which the voice-coil tends to oscillate of its own accord. When the sound frequency coincides with this, the amplitude of oscillation becomes very great, causing a peaking effect in the response curve.

Actually, in the case of the ordinary low-fidelity receiver this speaker resonance is usually taken advantage of to boost the bass notes. It occurs at a frequency somewhat lower than that at which the low frequency response begins to deteriorate, and therefore gives a "boost" at frequencies where such is desirable. However, when really high-fidelity results are required this method of increasing the bass response is not a very good one. For such purposes it is therefore desirable to use a speaker in which the voice-coil's mechanical resonant frequency is below the lowest frequency which is to be reproduced.

HIGH FIDELITY REQUIREMENTS.

So far we have investigated the problems encountered in obtaining an acoustical output which is uniform over a considerable frequency range. It has emerged that for the low frequencies a large cone area, together with a proportionately large voice-coil unit is required, whereas best results are obtained in the high frequencies range when using a small cone and voice coil. It has been explained how, using a single speaker, the low frequencies are improved by using a large "baffle" area (in the form of a cabinet), and how the high frequency range is extended to some extent as a result of the corrugated construction of the cone.

We have seen that the ordinary radio receivers acoustical system is capable of producing a sound output which is reasonably uniform over a range from, perhaps 100 cycles per sec. up to approximately 3000-4000 cycles per sec., despite certain "peaks" and "dips" resulting from such phenomena as "destructive interference" of air waves travelling by different paths, mechanical resonance of voice-coil, and cabinet resonance. Such a performance, while adequate for the low fidelity signal carried by an A.M. carrier is really not good enough if the full advantages of the high-fidelity F.M. signal are to be enjoyed.

We shall now describe methods whereby, firstly, the high frequency range, and then the low frequency range, may be improved.

A WIDE-RANGE MOVING COIL SPEAKER.

In the case of the conventional speaker it was pointed out that the upper frequency limit (3000-4000 cycles per sec. for an 8" cone) was set by the mass effect of the moving coil itself. For higher frequencies the effective mass of the latter must be reduced.

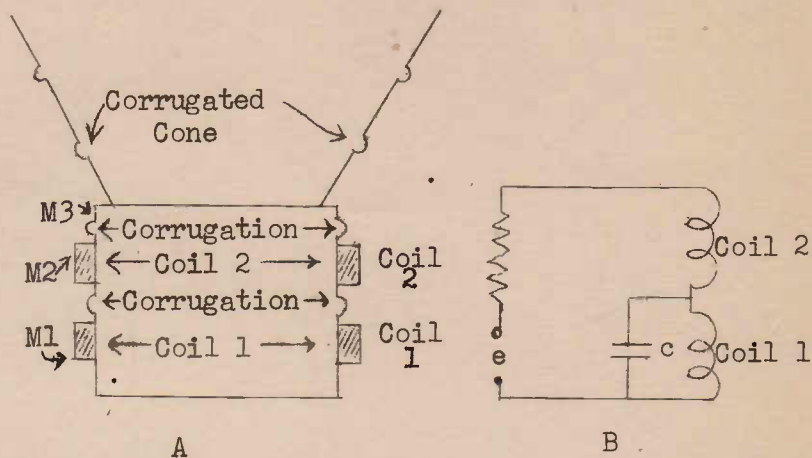

Figure 18 shows diagrammatically the construction of the moving coil of a speaker which provides this requirement.

The voice-coil is divided into two sections, connected in series as shown at B. The voice coil cylinder is divided into three separate masses (shown as M1, M2, M3 at A) by two elastic corrugations.

Below 1,000 cycles per sec. the unit moves as a whole, and both coils are effective, acting as a single coil as in an ordinary speaker. In the range 1,000 - 4000 cycles per sec. the action is gradually transferred to coil 2 alone. In this range the corrugation between the two coils begins to "give", and, at the same time, coil 1 becomes partially by-passed, as far as the A.F. current is concerned by condenser C (Figure 18B).

In the range 4,000 - 6,000 cycles per sec. coil 2 above is effective, the first corrugation allowing it to move, while coil 1 remains almost at rest. At the same time, in this range the by-passing action of the condenser is practically 100% complete.

Above 6,000 cycles per sec. the corrugation between coil 2 and the remainder of the cylinder (M3) becomes partially effective, thus reducing the effective mass upon which the coil has to act.

The net effect of this action is that the mass of the vibrating voice unit is progressively reduced, thus off-setting the reduction in amplitude of oscillation which would result if the mass remained constant. This type of speaker is capable of a uniform response over practically the entire audio range.

DUAL SPEAKERS.

Perhaps the best method of securing wide-range reproduction is by using dual speakers - one for the low notes (bass) and one for the higher frequencies (treble). The low frequency speaker is usually of large diameter (12" and more), has a rigid cone (i.e. no corrugations), and is fitted with a large voice coil necessary to drive the heavy cone adequately for low frequency operation. The treble speaker is smaller and of particularly light construction (especially as regards the voice-coil). The two

speakers are mounted close together in order to produce correct phasing of the sound waves.

The bass speaker usually handles frequencies up to only 400 cycles per sec. Above this the treble speaker alone is effective. Since the latter is not called upon to handle anything below 400 cycles per sec. it may be designed to reproduce very high frequencies indeed.

The acoustical power from the output stage is divided for the two speakers by means of a special filter circuit having a "cross-over" point at 400 cycles per sec. A typical circuit is shown in Figure 19 together with the frequency characteristic for the two filter sections. Below 400 cycles per sec. the reactance of C_2 is high and that of L_2 is low, with the result that practically no output appears across L_2 . This prevents damage to the more delicate H.F. unit by the L.F. currents. At these frequencies the reactance of L_1 is low and that of C_1 is high. Since L_1 and C_1 in series form a voltage divider, practically all the output appears across C_1 , and is thus applied to the large speaker.

Above 400 cycles the reactances of C_1 and C_2 become comparatively low, and those of L_1 and L_2 comparatively high. The net result is that at these frequencies practically the full output appears across the treble speaker, and a negligibly small amount across the bass.

The curves of Figure 19B show that such a circuit has a very sharp "cross-over" point, and that the impedance of the whole unit remains remarkably constant for all frequencies.

Figure 1 of this lesson showed a single unit which incorporates dual, but separate speakers. In this unit the H.F. speaker is really a horn type, the small horn passing through the centre of the voice-coil which operates the L.F. cone. The H.F. horn is of "cellular" construction to flare out the sound waves which have a tendency to be concentrated in a beam at the very high frequencies.

IMPROVING THE BASS RESPONSE - THE ACOUSTICAL LABYRINTH.

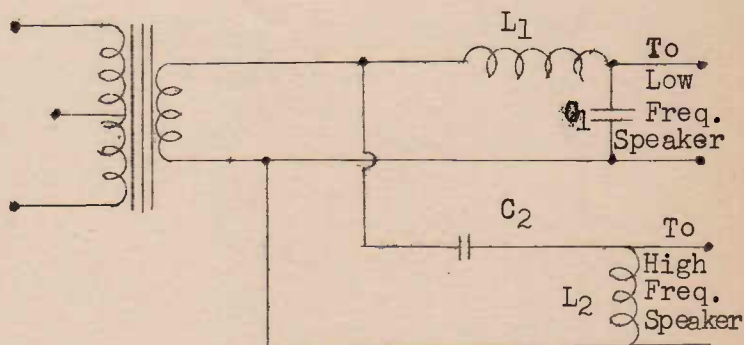

A.

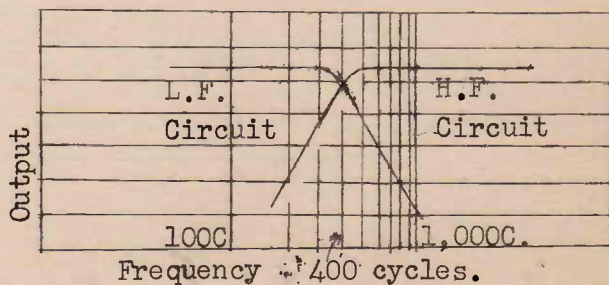

B.

Figure 19.

At very low frequencies even with a large speaker, it has been pointed out that the response drops off due to the cone simply "pumping air" from one side to the other. Or, what amounts to the same thing, it may be imagined that the two waves radiated from the two surfaces partially cancel each other.

The speaker cabinet, acting as a baffle will, if large enough, prevent this effect. But from the data given

under the heading of "Baffles" it will be realised that an extremely large cabinet would be required to handle adequately frequencies down to say 40 or 50 cycles per sec.

This improvement in the bass response may be realised by use of an "Acoustical Labyrinth". The dictionary definition of a "labyrinth" is a "winding or tortuous passage or path". This is

exactly what the acoustical labyrinth is - as far as the sound wave radiated from the rear surface of the speaker cone is concerned.

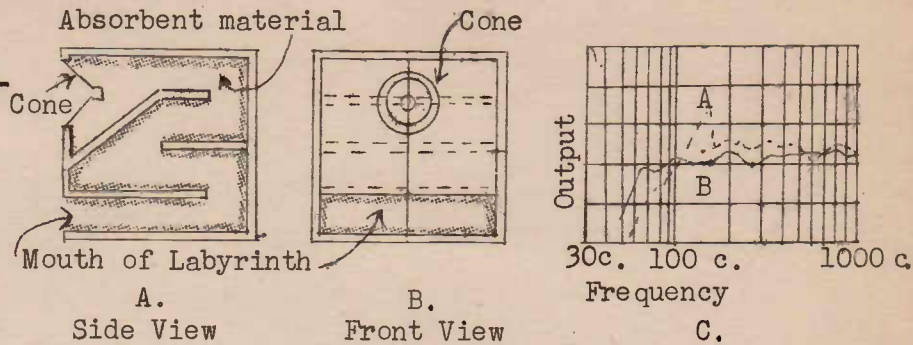

Figure 20 - The Acoustical Labyrinth.

The construction of the labyrinth will be understood after reference to Figure 20 where, at A, a cross sectional view, and at B a front view, are shown.

As seen here, we have a folded passage-way, lined with sound absorbent material, leading from the back of the speaker, and opening out at the front of the cabinet. The length of the passage is usually equal to $1/4$ wave-length of a sound wave having a frequency equal to the speakers mechanical resonant frequency, say 75 cycles per sec. for a large good quality speaker. It is found that an open-ended passage-way of air like this, produces a form of anti-resonant effect at a frequency for which its length equals $1/4$ wavelength. This anti-resonance is taken advantage of to off-set the mechanical resonance at about 75 cycles per sec.

At double this frequency, viz. 150 cycles per sec. the air column in the labyrinth tends to resonate, but no apparent peak in the output results because this is about the "cut-off" frequency of the system. For higher frequencies than 150 cycles the speaker is unable to vibrate the large volume of air in the labyrinth, and the rear surface wave from the cone is entirely absorbed. Above this cut-off frequency, in other words only direct radiation from the front of the cone occurs.

Another merit of the acoustical labyrinth is that it prevents cabinet resonance, by removing the large volume of air normally enclosed. Fig. 20C shows the effect of a labyrinth on the low frequency response. Curve A is for a normal cabinet without a labyrinth. Note the sharp peak due to cabinet resonance. Curve B shows the improvement obtained by incorporating a labyrinth. Note that the peak due to cabinet resonance no longer occurs. The curves also show improvement in the very low frequency response.

If a dual speaker system is used, the H.F. speaker may be mounted above the L.F. unit, a shelf may separate the two, and the labyrinth built into the bottom only.

THE VENTED "BAFFLE" OR VENTED ENCLOSURE.

The acoustic labyrinth, as a device for improving the response curve in the low frequency range, and extending this curve downwards to the very low (bass) frequencies, is rather a costly arrangement. A cheaper method of securing these advantages is to make use of a special type of baffle system known variously as Vented, Tuned or Reflex

Enclosure or Baffle.

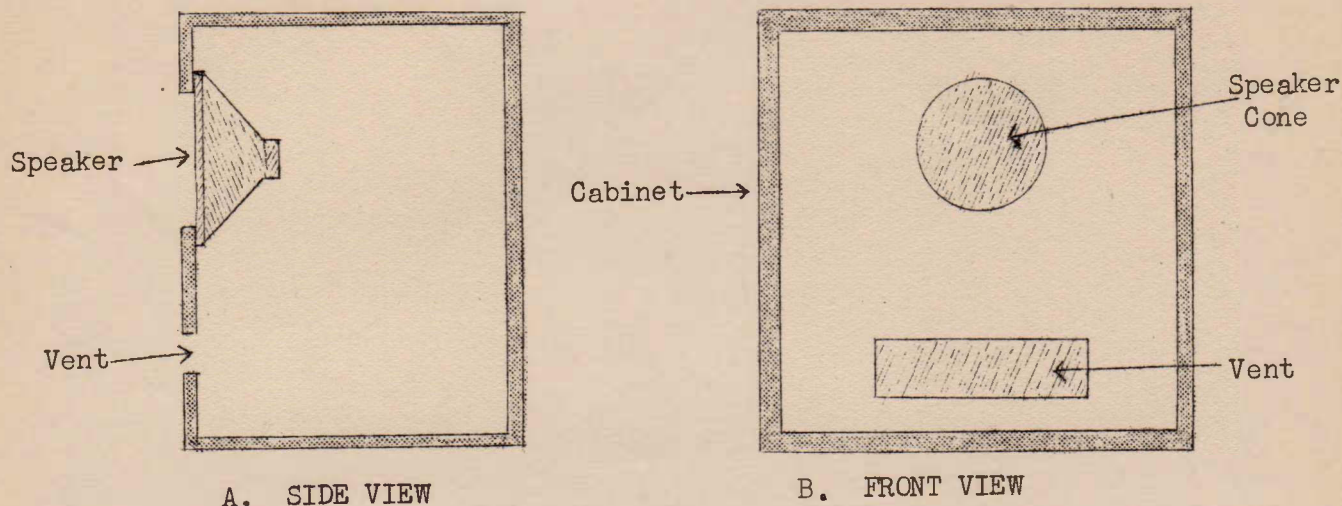

The Vented Enclosure. Fig. 21.

We have seen that the chief defects of the low frequency response in the case of a speaker mounted in an ordinary cabinet are :-

- (1) Insufficient "baffle" area, resulting in loss of the very low frequencies due to rear surface and front surface waves cancelling.
- (2) Cabinet Resonance
- (3) Speaker (Mechanical) Resonance. The latter two both result in undesired peaks in the lower frequency range.

The purpose of the Vented Enclosure is to control the radiation from the rear of the speaker, so as to off-set the two resonant effects mentioned above, and to extend the low frequency response of the system.

The Vented Enclosure, illustrated in Figure 21, consists simply of a cabinet (which houses the speaker) and which is completely enclosed except for a "vent" or opening in the front and preferably close to the speaker itself. The box, or cabinet is either constructed out of sound absorbent material, or lined with a suitable material, such as felt. The vent may be of any convenient shape (it is usually circular or rectangular), but its area is made equal to the effective radiating surface of the speaker cone.

When air is enclosed in a confined space having a single orifice or opening, the air in the orifice can be made to resonate at a particular frequency, which is governed by the volume of air enclosed, and the area of the orifice. A common example of this effect may be observed when a stream of air is blown across the mouth of a bottle. Another example, of course, is the conventional radio cabinet.

The volume of air in the enclosed cabinet is adjusted so that the resonant frequency of the vented enclosure is equal to the bass resonant frequency of the speaker itself.

The result is that the peak in the output due to the latter is off-set by the resonance of the enclosed air. The reason for this cancellation effect is due to the vented enclosure behaving, at resonance, in a manner analogous to a parallel resonant electrical circuit, where the impedance rises to a peak at resonance.

The best way to understand the action of such a system as this is to compare mechanical and acoustical resonance effects with those which occur in electrical circuits containing inductance, capacity and resistance.

Consider Figure 22 where we represent a weight of mass M attached to an elastic steel spring which is anchored at P . For the moment we will imagine that M rests upon a perfectly smooth surface (i.e no resistance to motion). If the mass is pulled outwards (stretching the spring) and then released it will oscillate about its mean position (X) as shown, the spring being alternately stretched and compressed. If there were absolutely no resistance oscillation would continue indefinitely. In practice the oscillation would die out due to resistance effects. The frequency of oscillation depends upon two things - (1) The mass of the weight, and (2) the "stiffness" of the spring. Here it would be better to speak of the "compliance" of the elastic spring, the latter quality being the reciprocal or opposite of the stiffness, so that a spring of great stiffness would have only small compliance and vice versa. In this mechanical system an increase in mass of the weight would result in a lower resonant frequency of oscillation, and vice versa. This is due to the property of inertia and momentum of a mass, whereby there is a tendency to oppose any change (increase or decrease) in its velocity.

Hence "Mass" may be likened to inductance (L) of an electrical circuit as shown at B in Figure 22. Consider now the effect of the compliance of the spring upon the frequency of oscillation. If the compliance is increased (i.e. "stiffness" decreased) the resonant frequency would be lowered, and vice versa. Thus the compliance of an elastic system may be compared with the capacity (C) of an electrical circuit.

Carrying this idea further, suppose now that there is resistance to motion between the mass of Figure 22A and the surface upon which it rests. This resistance (if comparatively small) will not affect the resonant frequency, but will increase the total impedance to oscillatory motion of the system. Thus mechanical resistance may be compared with electrical resistance (R).

Consider now the conventional speaker. The moving coil and cone possesses mass which we will represent by L_s . This L_s must also take into account the air loading of the cone, for a certain mass of air (depending upon the cone area) must be moved as the cone vibrates. The compliance, represented by C_s , is due to the elastic support of the "spider" and also to a certain amount of "give" or elasticity in the cone itself. The speaker system also possesses mechanical resistance (R_s) due to imperfect elasticity, and also, due to acoustical radiation losses (just as we may take into account the loss of energy of an antenna system due to radiation by supposing the circuit to contain an extra radiation resistance).

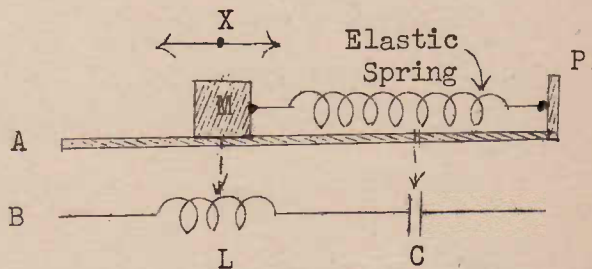

Showing a mechanical oscillatory system (A), and its electrical equivalent (B).

Figure 22.

The electrical equivalent of the speaker is shown in Figure 23. At that frequency when the "reactance" of the mass equals the "reactance" of the "compliance" a resonant condition is set up, just as in the analogous electrical circuit. This is the bass resonance which occurs at about 70 - 120 cycles per sec. in the case of the conventional speaker.

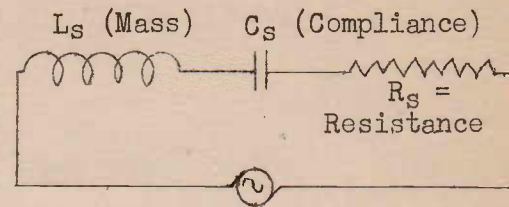

Figure 23.

Now consider a simple acoustical or air system as in Figure 24. At A we have a cylinder with a closely fitted piston totally enclosing a volume of air. Air is compressible, i.e. elastic. If the piston is pushed down, the air is compressed by an amount depending upon the force applied and the volume of enclosed air. This volume of air therefore possesses "stiffness" and, hence, "compliance", corresponding to capacity of an electrical circuit. If the air is totally enclosed it does not possess any appreciable mass reactance, corresponding to inductive reactance. Hence an enclosed air mass cannot have a resonant frequency of oscillation, just as a circuit possessing capacity only has no particular resonant frequency.

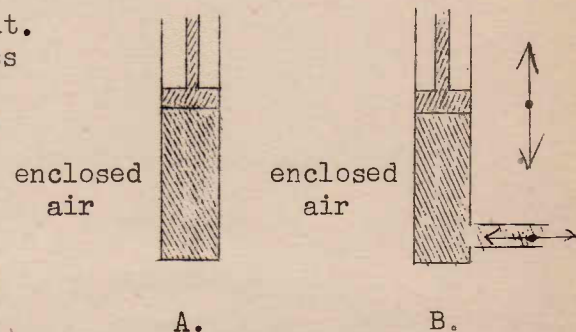
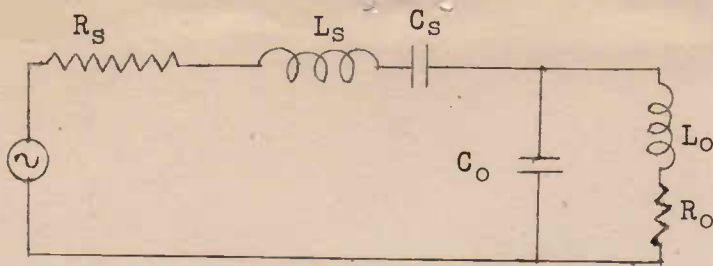

Figure 24.

At B (Figure 24) the partially enclosed volume of air has a vent or opening via the pipe as shown. If the piston is rapidly moved up and down, the air will be alternately compressed and rarefied, and an oscillatory flow of air will take place through the pipe. Within the pipe the rate of flow of air will be rapid, and the "reactance" of its mass will exert an appreciable effect. The mass of the air within the pipe, or vent will thus act like inductance in an electrical circuit.

Returning now to the problem of speaker response, suppose we enclosed the back of the speaker in a totally enclosed box. The wave radiated from the back of the cone would be completely contained, and could not have any effect on the front surface radiation. In this respect the enclosed box would act like an infinite baffle, and it might be expected that very good low frequency response would be obtained. Although some improvement may thus be obtained, under certain conditions, another effect off-sets the improved baffle action. The compliance of the enclosed air volume is in series with the speaker compliance, and therefore increases the effective stiffness of the moving coil and cone. At low frequencies the "reactance" of this compliance becomes large, and reduces the amplitude of the cone movement. As a result the acoustic output will fall off rapidly as the frequency decreases.

In the case of the vented enclosure the corresponding electrical circuit is shown in Figure 25. The symbols represent effects due to the properties of the system shown under the diagram. Note that L_0 is due to the mass of air only in the immediate vicinity of the vent. The air in this region will be moving rapidly in and out of the opening. In actual fact at low frequencies the air at the vent will be vibrating in exactly the same manner as that in the immediate vicinity of the cone itself. Hence at these frequencies, the vent cross-section acts just like a vibrating diaphragm.



R_s = Cone Support Resistance + Radiation Resistance

L_s = Moving Coil + Cone Mass + Mass of Air in vicinity of cone.

C_s = Cone and "Spider" Compliance.

R_o = Acoustic Losses in Enclosure.

L_o = Mass of Air in and near Vent.

C_o = Compliance of Enclosed Air Volume.

EQUIVALENT ELECTRICAL CIRCUIT OF SPEAKER IN VENTED ENCLOSURE.

Figure 25.

latter, which current would otherwise be large due to the series resonance of these components.

From the physical view-point, what happens is this. When the vented enclosure resonates, there is a large movement (oscillatory) of air in the vent, but the resonant effect is such that it imposes a large opposing impedance on the back of the speaker. The result is that the speaker cone is held practically stationary, at this frequency which normally would result in large cone movements. Actually at the bass resonant frequency of the speaker, practically all the sound output comes from the vent opening. The effect of the parallel resonance effect of the vented enclosure in cancelling the speakers bass resonance is shown at A in Figure 26.

At frequencies above the common resonant frequency of the speaker and vented enclosure the tuned circuit $L_o C_o$ of Figure 25 becomes capacitive, (being a parallel circuit) while the series circuit $L_s C_s$ becomes inductive. At some particular frequency the capacitive reactance due to the vented enclosure resonates with the inductive reactance of the speaker, and a subsidiary peak, shown at B (Figure 26) results. Below the resonant frequency of either circuit alone, $L_o C_o$ becomes inductive while $L_s C_s$ becomes capacitive. At some particular frequency these inductive and capacitive reactances are equal and a series resonant effect resulting in the peak in output shown at C (Figure 26) results.

Summarising, Figures 25 and 26 show how the vented enclosure acting in conjunction with the speakers mechanical resonance improves the low frequency response, by yielding two separate resonant peaks of comparatively small amplitude, and spread over a considerable frequency range. The effect is exactly comparable with the wide band-pass obtained in I.F. amplifiers when using a pair of over-coupled tuned circuits to

It will be observed that in the diagram (Fig. 25) L_s and C_s (of Speaker) form a series resonant circuit, while L_o and C_o (due to the vented enclosure) form a parallel resonant circuit, in series with the speaker. The enclosed volume is so proportioned in respect to the vent area (and therefore to the latter's air mass) that L_o and C_o resonate at the same frequency as L_s and C_s , the latter being the bass resonant frequency of the speaker itself. In this circuit $L_o C_o$ presents a high dynamic impedance at resonance. This impedance, being in series with L_s and C_s reduces the current through the

yield the "double-hump" effect. Not only does the vented enclosure level off the response curve over the bass frequency range, but extends this range downwards to a considerable extent, as a comparison of the two curves of Fig. 26 will show.

The vented enclosure may be utilised to house the receiver apparatus. A separate cabinet is not a necessity. Of course the presence of this electrical equipment within the enclosure would reduce the effective volume of enclosed air, and this must be taken into account in adjusting the resonant frequency. A typical enclosure using a 12" speaker whose resonant frequency when loaded in an "infinite" baffle is 60 cycles per sec. would about 12" deep, 20" wide and 49" high. The vent would be a single circular hole approximately 9" in diameter, or a rectangular aperture about 16" x 4".

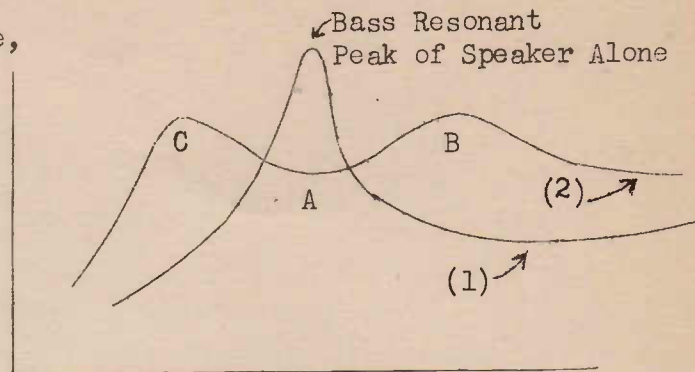

Curve (1) - Speaker in ordinary baffle.
Curve (2) - Speaker in vented enclosure.

Figure 26.

SECTION B. - RECEIVER TYPES AND CONSTRUCTION.

If an F.M. receiver is to fulfil its special purpose, viz. higher quality sound reproduction with freedom from interference, it requires, as we have seen, more circuit components, also more careful design and construction than to be found in the average A.M. receiver. The great desirability, if not the absolute necessity, for high quality audio systems, involving large reserves of power output, large speakers and cabinets (for adequate baffle action) practically rules out the small mantel set and the dry battery portable type.

Then again we have to consider the fact that F.M. is not (for many years at least) entirely supplanting A.M. This means that many people will demand a receiver capable of receiving signals from all station - F.M. and A.M., and this adds to the complication.

HOW MANY VALVES ?

Owing to the higher frequency of operation (R.F. and I.F.), and the necessity for the flat-top on the I.F. selectivity curve, the gain per stage is very much less than with an ordinary A.M. broadcast receiver. A good F.M. 8-valve receiver may actually be less sensitive than a 5-valve A.M. receiver on the medium wave band. This reduced gain per stage would be even lower, only that high gain valves are used in the R.F. and I.F. stages, with transconductance two or three times normal.

Using these special valves, designed for F.M. work, it would appear that the minimum number of valves required (for F.M. reception only) is eight, comprising R.F. amplifier (6BA6), Converter (6BA6) 1st I.F. Amplifier (6BA6), 2nd I.F. Amplifier (6BA6), Ratio Detector (6HG-GT), A.F. Amplifier (6SQ7-GT or equivalent, e.g. 6SF7-GT), Power Amplifier (6V6-GT) and Rectifier (5Y3-GT). The valve type numbers in brackets are suggested types only. A smaller and cheaper set could possibly omit either the r.f. Amplifier or one I.F. stage. Such a receiver, however, would only be satisfact-

ory in areas of high signal intensity, e.g. in the inner metropolitan area.

It is stressed that the arrangement given above would represent only a quite unambitious receiver. For a larger receiver designed for those demanding the maximum in high fidelity reproduction, at least an additional two valves would be required - a phase splitter and an extra power output valve for push-pull. Then again the larger receiver possibly would incorporate a discriminator detector together with a limiter stage or stages. This would mean an additional valve if one stage of limiting were used, or two additional valves if two limiters (or alternatively an extra I.F. amplifier) were incorporated. Such a receiver would therefore require up to 11 or 12 (or even more) valves.

DISCRIMINATOR OR RATIO DETECTOR ?

The Ratio Detector was described in an earlier lesson, and several of its more obvious advantages pointed out there. Let us now compare the two detection systems in greater detail.

Advantages of the Ratio Detector over the Limiter - Discriminators are :-

- (1) No necessity for "limiters" which contribute practically nothing to the receiver's gain.
- (2) Less I.F. and R.F. gain required, as there is no "threshold" level to be reached at the detector stage input. The reduced high frequency gain in turn minimises difficulties relating to instability due to regeneration in these high-frequency stages, and also minimises the tendency for "noise" voltages to phase - modulate the signal.
- (3) The Ratio Detector affords the same degree of immunity from interference on the very weak signals as on the strong, whereas the Limiter Discriminator detector may fail to provide any noise suppression whatever on the very weak signals.
- (4) The Ratio Detector probably suppresses impulse interference (where the carriers may be momentarily entirely "blotted out") more effectively than does the Limiter Discriminator.

On the other hand the Ratio Detector appears to suffer several disadvantages as compared with the Limiter-Discriminator -

- (1) It introduces slightly more distortion.
- (2) It is more difficult to align for linear conversion.

Summarising, it appears that, certainly in all receivers where it is desired to limit the number of valves used, the Ratio Detector is to be preferred. Probably, however, in the case of the higher priced quality receivers, where the number of valves incorporated is not an important consideration, the Limiter - Discriminator will be retained.

COMBINING A.M. AND F.M.

The greatest difficulty is that of providing a receiver, at reasonable cost, which is capable of handling both F.M. and A.M. signals.

Possible combinations are :-

- (1) F.M. and medium wave broadcast A.M. only.
- (2) F.M./A.M. - dual wave.
- (3) F.M./A.M. - all-wave or multi-band.
- (4) F.M./A.M. - short-wave band only.
- (5) F.M./A.M. - multi short-wave bands only.

If completely separate channels are provided for the A.M. and F.M. signals in those combined receivers, it is obvious that a very large number of valves and other components would be required. This, of course, would result in a very expensive receiver.

There is no difficulty in using a common audio section for the two types of signals, but for best results it is considered that separate R.F. and I.F. channels are required. The higher priced receivers in America are of this type, using up to 24 valves in all.

To provide a combined F.M. and A.M. receiver of reasonable cost, however, it is necessary to use the same valves for both signal types. Although this involves several difficulties it is quite a practical scheme.

COMBINING F.M. AND A.M. HIGH FREQUENCY CHANNELS.

With this arrangement, separate r.f. coils and I.F. transformers must of course, be used for the F.M., the A.M. medium band, and the A.M. short-wave band(s) (if any). The switching must, therefore, cover the aerial coils, r.f. transformers, oscillator coils, also possibly I.F. transformers, and small shunt or series condensers in each section of the gang condenser.

Difficulties to be overcome are a result of the high mutual conductance valves necessary for F.M. These are actually beneficial on the A.M. short-wave bands, although over-loading of the converter is likely to occur on strong signals. This effect, however, is easily overcome by reducing the gain of the R.F. transformer.

If ordinary transformers were used on the medium-wave A.M. band the gains of the stages would be so high as to be impracticable. Valves would be overloaded, and difficulties experienced due to regeneration causing self-oscillation (i.e. instability). To avoid these troubles a number of expedients are used such as reduction of gain by using high-loss transformers, heavy shunting by resistors across the coils, tapping down of the transformers, or a combination of two or more of these.

When a common I.F. channel is used for both A.M. and F.M., a common arrangement to simplify the over-all switching mechanism is as follows :-

In each stage the two I.F. transformers' primaries and secondaries are connected in series, the F.M. coil being closer to the plate or grid of the valves as shown in Figure 27. When receiving F.M. the 10.7 mc. transformer's primary has a high dynamic impedance at its resonant frequency and keeps the signal out of the 450 K.C. A.M. transformer. On switching to A.M. the F.M. transformer's primary acts like a short circuit at 455 K.C. and allows the 455 K.C. signal to pass on to its proper transformer. In order to avoid any possibility of interference from high-frequency signals which may reach the I.F. stages, the switching arrangement sometimes provides a short-circuit across the F.M. transformers when receiving A.M.

CONSTRUCTIONAL DETAILS - LAYOUT OF RECEIVER.

The chassis layout of the different stages and components of an F.M. receiver follows the same general technique as for A.M. receivers. Shielding in the R.F. and I.F. stages, however, must be even more efficient than that to be found in a modern A.M. type.

All coil units and I.F. transformers, including the discriminator transformer (which consists of a primary in the plate circuit of the limiter, and, a centre-tapped secondary connecting to the two detector diodes) are enclosed in metal cans, as in usual practice.

All leads carrying high-frequency currents should be as short as possible to reduce stray wiring capacities. As already mentioned all valves are of the single ended-type, i.e. no grid-cap is used. This allows of short leads from the plate circuit of one stage to the grid of the following valve.

The usual precautions to keep 50 cycles per sec. power supply voltages out of the circuits should be taken. This involves such points as adequate magnetic shielding of the power transformer, reasonable isolation of the rectifier valve and circuits, and twisting together the heater leads. It may be mentioned here that any 50 cycle fluctuation applied to the converter valve may give rise to a 50 cycle frequency modulation of the I.F., which will appear as a 50 cycle (not 100 cycle) hum in the speaker output. This is due to the varying voltages applied to this valve affecting the input capacity due to the "Miller-effect". Such capacity, of course, helps to determine the oscillator frequency. If this frequency is thus caused to vary at 50 cycles per sec. so will the resulting intermediate frequency.

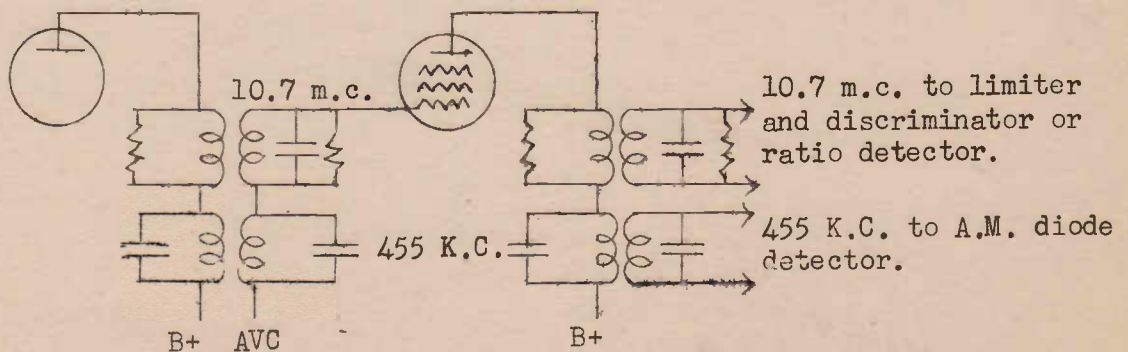

Figure 27.

EXAMINATION QUESTIONS - LESSON NO. 17.

1. Explain briefly the purpose of high audio frequency de-emphasis in an F.M. receiver ? Where, in the receiver, is this de-emphasis effected ?
2. Why is adequate power handling capacity a very important consideration in an F.M. receiver ?
3. With reference to a power output transformer what is meant by "Leakage Inductance ?" What is the effect on the output of an undue amount of leakage inductance ?
4. What are the requirements of a loud-speaker for high efficiency at
 - (a) very high frequencies ?
 - (b) very low frequencies ?
5. What is the purpose of the "corrugations" in the cone of the usual type of speaker?
6. What places the final limit on the high-frequency response of the usual type of speaker ?
7. What is the purpose of a "baffle ?" What should be the minimum dimensions of a baffle designed for full response down to 150 cycles per sec. ?
8. Why is an irregular baffle to be preferred to one of regular shape ?
9. Name two types of non-electrical resonance effects which may mar the output of a speaker system ?
10. What factors determine the required volume of a vented enclosure ?

Please NOTE Postal Address:

{ AUSTRALIAN RADIO COLLEGE PTY. LTD.,
Box 43, Broadway, Sydney. N.S.W.

NOTE: Write the lesson number before answering the questions.

Write on one side of the paper only.

Always write down in full the question before you answer it.

Use sketches and diagrams wherever possible. One diagram in many cases is equivalent to pages of explanation.

Remember that you learn by making mistakes; so give yourself an opportunity of having your mistakes found and corrected.

Don't hesitate to ask for further explanation on any point, we are always ready to help you.

Write your name and full address at top of paper. If you have made arrangements with the College to have your lessons returned to any particular address - state this at the top of the page.

AUSTRALIAN RADIO COLLEGE

E. S. & A. BANK BUILDINGS, Corner CITY RD. and BROADWAY, SYDNEY
Telephones: M 6391 and M 6392. Post Lessons to Box 43 Broadway

This lesson sheet is published for the exclusive use of students of the Australian Radio College Pty. Ltd.

(All rights reserved)

T.FM & F. LESSON 18.

INSTALLATION, ALIGNMENT AND SERVICING OF F.M. RECEIVERS.



EQUIPMENT REQUIRED FOR TESTING AND SERVICING F.M. RECEIVERS:

The two outstanding virtues of F.M. are :

1. A substantial improvement in signal to noise ratio.
2. Its ability to produce a wide-range acoustic output with very low distortion.

In order to take full advantage of these potentialities of F.M. the design requirements of an F.M. receiver are more stringent than those of the A.M. type, and the adjustment and setting up (alignment etc.) should be even more carefully carried out. In the case of the ordinary low-fidelity A.M. receiver even quite large errors in alignment and other adjustments may not result in a perceptible falling off in the quality of the output. This is because the frequency range of the acoustic output is so limited in the system, and because distortion, at the best is not particularly low, and consequently the ear does not appreciate further deterioration in quality until the adjustments to the circuits are well off their correct values. In a good F.M. receiver, on the other hand, almost perfect reproduction is possible when the set is properly set-up, and equipped with a good quality loud-speaker. As a result any distortion, noise and departure from linearity in the acoustic output curve introduced by even quite small errors in voltage and tuned circuit settings become, by comparison, quite noticeable to a critical ear. It behoves the serviceman, therefore, to acquire the knowledge and skill necessary to carry out scientific and accurate methods of aligning and otherwise adjusting F.M. receivers.

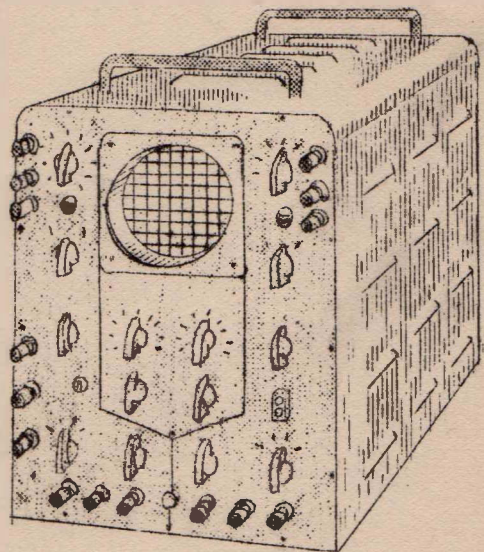

A CATHODE RAY OSCILLOSCOPE.
FIGURE 1.

Despite what has been said above, however, it should not be thought that there is anything particularly difficult in servicing an F.M. receiver, nor is any large amount of new and unusual equipment necessary.

The following is a list of equipment which is adequate to carry out all routine tests,

fault-finding and alignment of an F.M. receiver.

- (1) A multimeter incorporating the usual voltage and current ranges and an ohm-meter (for continuity tests).
- (2) A screw-driver of low-loss insulating material.
- (3) A V.H.F. Signal Generator (unmodulated) covering the frequency range 88-108 m.c. per sec.
- (4) An R.F. Signal Generator (unmodulated) covering the I.F. band usually 10.7 m.c. per sec.

Items 3 and 4 will probably be the one instrument.

In addition to the above the following equipment is desirable :

- (1) A centre-zero scale micro-ammeter reading to about 50 or 100 microamps on either side of zero. This is useful for certain tests on the discriminator.
- (2) A 0-100 microamp-meter as an output meter for alignment adjustments. If this is not available the 0-1 milliamp range of a multimeter can be used.

For servicing commercial receivers which, it is assumed, are correctly designed in the first place, the above equipment is entirely adequate. Other more costly equipment which although not essential is desirable, particularly if alterations to circuit design are to be made, is described later in this lesson. This includes :

- (1) A Frequency-modulated Signal Generator covering the I.F. of the receiver (10.7 m.c.) and producing a frequency deviation of ± 75 Kc per sec.
- (2) A Cathode-Ray Oscilloscope.
- (3) A valve voltmeter.
- (4) An audio oscillator covering the range 30-15,000 cycles per sec.

ROUTINE TESTS AND FAULT-FINDING:

Most faults in any type of receiver are due to broken down resistors and condensers, and broken or short-circuited leads. Such faults involve open and short circuits. The technique of locating such faults in an F.M. receiver is exactly the same as for an A.M. receiver. The only instrument required is a continuity tester or ohm-meter.

Concerning voltage checks it is important to remember that any departure from the correct values may have, relatively, a more serious effect in an F.M. receiver than in the case of an A.M. receiver. Particular care should be taken to adjust accurately the plate, screen and bias voltages of the power output tube(s). Wrong values here introduce distortion which mars the normal high-fidelity of the output. Again, low voltages on any of the R.F. or I.F. valves may reduce the pre-detection gain to such a point that the limiter does not operate to saturation, with the result that the noise level is higher than it should be. Thirdly, very important voltages to check are those on the plate and screen of the limiter(s). These should be much lower than

customarily used on an ordinary amplifying valve. Typical values lie between 25 and 40V, depending upon the valve used and the receiver design. The correct value should be ascertained from the data supplied by the manufacturer of the particular receiver under test. A limiter plate and screen-voltage which is too high may mean that the stage is not working at saturation (as it should), and amplitude variations of the signal will be passed. The result will be a high noise-level in the output. On the other hand a voltage which is too low will result in inadequate speaker output (low volume). In this connection it should be remembered that the limiter fixes the level of the I.F. signal which is applied to the discriminator for detection.

RECEIVER ALIGNMENT:

The essential receiver tests to be carried out are as follow :

- (1) Alignment of the Discriminator.
- (2) Adjustment of the Limiter.
- (3) Alignment of the I.F. stages.
- (4) Alignment of the R.F. stages including oscillator and R.F. circuit trimmer adjustments for correct "tracking".
- (5) Customary A.F. section tests.

These tests will be explained in the order given above.

ALIGNMENT OF THE DISCRIMINATOR:

This test should be the first to be carried out (after, of course, testing all circuit voltages). The equipment necessary is :

- (1) The F.M. unmodulated signal generator capable of delivering a calibrated output of 0.1 volts at the intermediate frequency.
- (2) The centre-scale micro-ammeter, or if not available a 0 - 1 milliammeter.
- (3) The 0-100 micro-ammeter (or alternatively the 0-1 milliammeter may be used).
- (4) An alignment screw driver.

A typical discriminator circuit, together with the preceding limiter is shown in Figure 2. The Signal generator output is adjusted to the I.F. of the receiver (usually 10.7 m.c) and applied to the grid of the stage preceding the discriminator.

The primary of the discriminator transformer is aligned first. To do this the 0-100 micro-ammeter is inserted between the points marked Y Y in Figure 2, and a piece of wire is connected between the points marked XX. It is a good idea to carry a short length of insulated wire with a spring clip at each end for this purpose. The latter short-circuits the secondary of the transformer, and so eliminates any effects the closely-coupled secondary may have on the primary tuning. It should be remembered at this point that the r.f. voltage applied to each diode plate of the discriminator

is the vector sum of the two r.f. voltages - one which is applied through a condenser (via the centre tap) from the primary transformer circuit, and the other which is developed across each half of the secondary due to the normal circulating current in this circuit. The latter is eliminated in this adjustment by means of the short-circuit XX.

SECOND LIMITER TUBE.

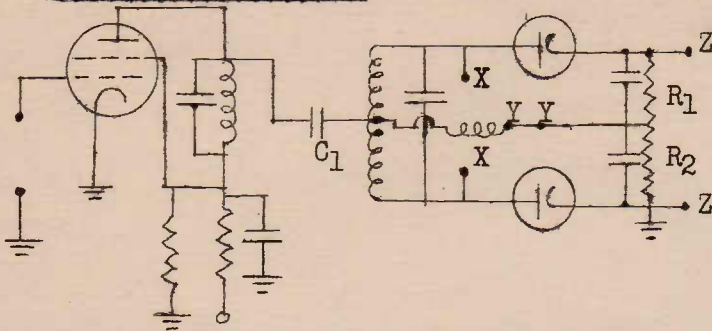

TYPICAL DISCRIMINATOR SYSTEM SHOWING COUPLING TO FINAL LIMITER STAGE AND TEST POINTS. VALUES FOR THE KEYED COMPONENTS ARE C₁ - 50 mmf.; R₁, R₂ - 0.1 megohm.

FIGURE 2.

The primary coil of the transformer is now adjusted until the micro-ammeter at YY shows a maximum reading. Note that this meter is reading the total rectified currents of the two diodes. A maximum reading here indicates, therefore, that maximum voltage is being applied from the primary. The primary will therefore be peaked at the correct I.F.

Next to align is the secondary of the discriminator transformer. The short-circuit is removed from XX, and the meter removed from YY. The centre-scale micro-ammeter is converted into a high-impedance voltmeter by connecting a one megohm resistor in series with it. This meter is connected across the discriminator output, between the points ZZ of Figure 2. For a signal equal to the centre-frequency of the I.F. the secondary circuit of the transformer should be at resonance, so that the r.f. voltages developed across each half of the coil, and applied to the diodes, should be equal, resulting in zero output between ZZ. If the meter shows a deflection on either side of zero this therefore indicates that the secondary is not correctly adjusted. Adjustment is therefore made until a zero reading on the output meter is obtained.

It is of importance to remember that both terminals of the transformer secondary condenser are well above ground potential, and, therefore, a well insulated screw driver is needed for this adjustment. The adjustment is, besides, rather critical since it balances the discriminator.

An alternative method of aligning the discriminator, which avoids the use of the meter in the position YY and the short circuiting of the secondary between XX (Figure 2) is as follows :

The signal generator output is connected to the limiter-grid and the output meter connected between ZZ, as before. In the case of this method the secondary is adjusted first. Adjustment is made for a zero reading on the output meter. The frequency of the signal generator is now re-adjusted to a value say 75 K.c. per sec. above the centre frequency and the reading on the high-resistance output meter noted. Signal generator frequency is next reduced to a frequency 75 K.c. per sec. below the centre frequency. The output meter will now deflect in the opposite direction. Unequal deflections would indicate that the primary adjustment is incorrect. Hence the primary is adjusted until equal and opposite meter deflections are obtained from the \pm 75 K.c. off centre frequencies. Since adjustment to the primary may de-tune the secondary (due to the tight coupling between them) it will now be necessary to re-adjust the latter circuit to give zero meter reading for a 10.7 m.c. signal, as explained above. It may be found that the whole procedure has to be repeated several

times before both circuits are correctly aligned.

If a centre-scale micro-ammeter is not available for the output meter any meter having a sensitivity of not less than 1,000 ohms / volt (i.e. 1 m.a. for full-scale deflection) and an internal resistance of not less than 1 megohm may be used. The 0-1,000 volts range on a good quality multimeter would satisfy these requirements.

In the case of the first method of alignment described, and the case of the secondary peaking in the second method, a zero adjustment of voltage was required. A slight backward deflection of the needle off the scale will do no harm while the adjustments are being made. In the case of the primary alignment by the second method it would be necessary to reverse the leads of the meter between the points ZZ (Figure 2) when the signal generator frequency was shifted from 75 K.c above the centre frequency to a value 75 K.c below the latter.

In connection with the second method described above it may be desirable to defer the discriminator alignment until after the alignment of the I.F. transformers. If this is done the signal generator may then be connected to the converter input, so that the signal will be amplified by the I.F. stages. These deflections obtained in the output meter for the 75 K.c off centre-frequency adjustments of the signal generator will then be larger, allowing of more accurate adjustment of the discriminator primary winding. If the output meter available is not of sufficient sensitivity and/or if the r.f. output of the signal generator is small this procedure may be absolutely essential if an accurate adjustment is to be obtained.

The above tests on the discriminator should be completely adequate for a commercially designed receiver where it may be assumed that the discriminator band-pass and linearity are satisfactory when alignment is correct. If there is any doubt about the stage's performance, however, due for example to having replaced any circuit components, a complete output curve may be obtained as follows. After having aligned the I.F. stages (see below) the signal generator is connected to the converter grid and the output meter connected between points ZZ (Figure 2) as before. The signal generator frequency is moved away from the centre frequency in steps of 5 or 10 K.c. per sec. depending upon the accuracy required in the curve, and the accuracy with which the generator frequency may be set. The D.C. voltage across the diode load, as shown on the output meter, is noted for each frequency setting. Readings are recorded for frequencies both above and below the centre-frequency. A curve is plotted similar to those shown in Figure 3. Here two curves are given one for a signal of 2.5 millivolts and the other for 0.5 millivolts at the converter grid. The curve obtained should be linear for a total frequency range appreciably wider than twice the maximum (i.e 150 K.c. per sec.). This margin is required to allow for the fact that the I.F. may not be exactly at its correct centre frequency (10.7 m.c.) when actually receiving a station. A discriminator characteristic which is barely wide enough will mean that if the receiver's tuning is only very slightly incorrect distortion will result due to the frequency excursions on loud sounds carrying the signal frequency off the linear portion of one end of the characteristic. It should be remembered, in this connection, that a band-pass which is too narrow anywhere in the I.F. stages results in amplitude distortion due to cutting off the loud sounds, rather than in a reduction of the high audio frequency response, as is the case with A.M.

ALIGNING THE I.F. STAGES:

The procedure for aligning the I.F. stages is, in general, very similar to that followed in an ordinary A.M. receiver. The main difference lies in the use of an

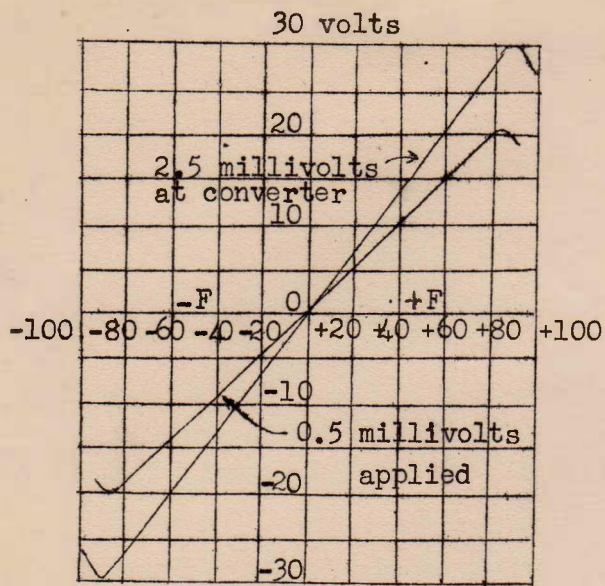

F = Centre Frequency.

FIGURE 3.

typical two-stage limiter. The transformer between the limiter valves V1 and V2 is in every respect similar to those in the preceding I.F. stages (not shown), and it must be aligned together with the others to the correct I.F.

The initial rough procedure is as follows:- Having connected the microammeter in series with R₁, as shown, the signal generator is adjusted to the correct centre I.F. value, and the output applied to the grid of V₁, (Figure 4).

The secondary of transformer T₁ is first adjusted for a peak reading on the output meter, then the primary of the same transformer is similarly adjusted. In making these adjustments it is important to keep the strength of the signal generator output low - only just sufficient to produce a decided peak in the meter reading when making the adjustments. The reason for this to ensure that the limiters are operating below the "threshold" level, i.e. below the "knee" of the curve shown in Figure 5, where saturation occurs. When the signal is

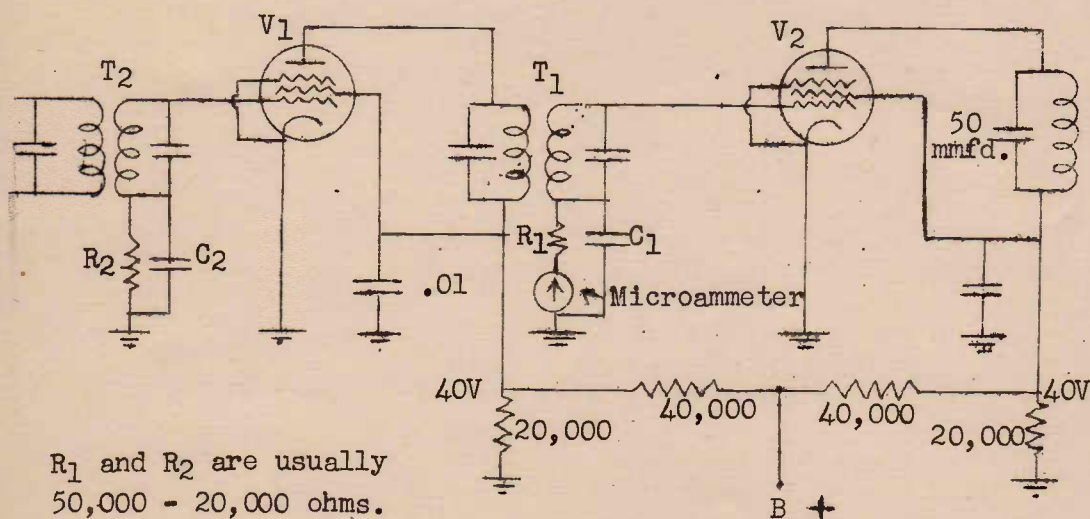

R₁ and R₂ are usually
50,000 - 20,000 ohms.

A TWO-STAGE LIMITER CIRCUIT SHOWING METHOD OF CONNECTING MICROAMMETER FOR I.F. ALIGNMENT.

FIGURE 4.

unmodulated R.F. signal, also in the method of measuring the tuned circuit response, and in the special precautions taken to ensure that the I.F. transformers are adjusted symmetrically with respect to the centre frequency.

As an output indicating device the 0-100 micro-ammeter is used, being connected in series with the grid return of the limiter. If two limiter stages are used the meter is connected in the grid circuit of the last limiter, as shown in Figure 4. This really converts the last limiter value into a vacuum tube voltmeter.

The circuit of Figure 4 is a

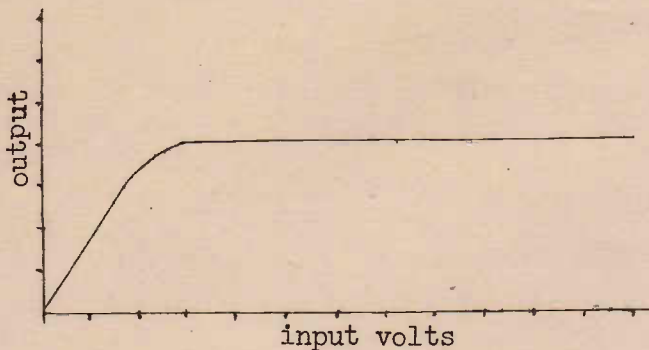

LIMITER CURVE.

FIGURE 5.

the next valve, moving back towards the converter, and the I.F. transformer following this value aligned, and so on. Finally to align the I.F. transformer immediately following the converter stage the signal generator is connected to the converter grid itself.

Compared with the gain found in an ordinary A.M. receiver it will be found that the gain in the F.M. receiver is extremely high. To give a typical example a 20 micro-volt signal on the converter grid should produce 20 microamperes in the output meter for a value of R_1 (Figure 4) of 50,000 ohms. This represents a voltage gain of 100,000. The converter usually has a gain of between 5 and 10, while the I.F. stages each yield a gain in the region of 50 or 60. Great care is therefore necessary in connecting the signal generator to the converter grid, if oscillations due to input-output coupling are to be avoided. A suitable method is indicated in Figure 6. First the connection from the r.f. circuit to the grid lug on the converter valve is unsoldered. This is necessary because this r.f. circuit is tuned to 88 - 108 m.c. and would act as a short-circuit to ground for the output of the signal generator which is at the I.F. (usually 10.7 m.c.). The end of the shielded signal generator cable is terminated with a 0.01mf. condenser, loaded by a non-inductive resistor of low value, say 100 ohms. The condenser and resistor must be contained within a shield. The condenser prevents damage to the signal generator in the event of the lead being accidentally connected to a high voltage point. The resistor damps out any oscillations due to feedback.

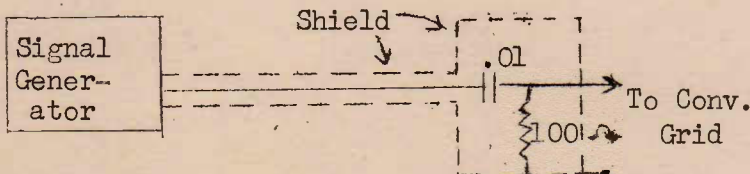

TERMINATION FOR COUPLING OF I.F. SIGNAL GENERATOR TO CONVERTER INPUT OF F.M. RECEIVER.

FIGURE 6.

sufficiently weak to ensure that this occurs the first limiter V_1 of Figure 4 acts as an ordinary linear amplifier with a gain between 10 and 20. If the limiters were operated to saturation by the signal very little peaking of the transformer would be observed on the meter, because the limiter action is such that it tends to flatten out the output, and so obscure the resonance effect of the tuned circuits.

Having adjusted the last I.F. transformer (T_1) Figure 4, the signal generator output is moved to the grid of the preceding tube (not shown in Figure 4) and the transformer T_2 is aligned as before, adjustment being made to the secondary first, then the primary. The signal generator is again moved to the grid of

In carrying out the alignment process described above a most important point to keep in mind is that as the signal generator is moved back stage by stage towards the converter, its output should be progressively attenuated so that only the smallest useful reading is obtained on the output meter. This, of course, is to prevent the limiters from operating above the threshold level.

SYMMETRICAL PEAKING OF THE I.F. STAGES:

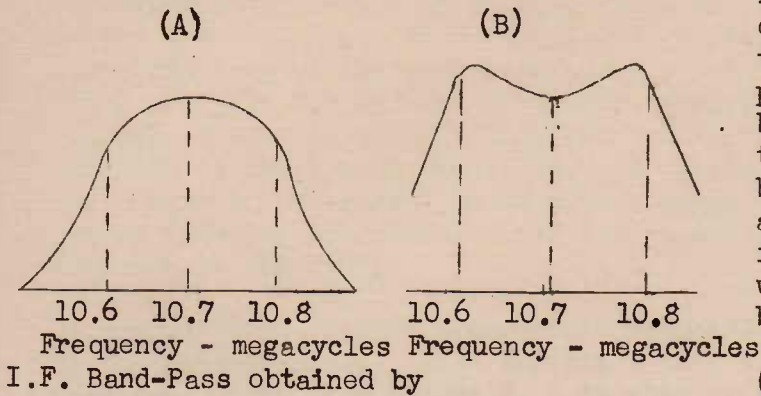

I.F. Band-Pass obtained by
A. Heavy Damping, and B. Overcoupling.

FIGURE 7.

In some receivers the above simple procedure may be quite sufficient to adjust the I.F. stages for efficient reception. In other receivers, however, it will be found that although the transformers have been peaked for maximum response, they have not been symmetrically aligned with respect to the centre I.F. At this stage it should be remembered that the I.F. transformers are designed to pass a wide band of frequencies - at least 150 K.c wide. This wide band-pass is obtained, as has already been explained by two main methods :

- (1) Heavy damping of the tuned circuits.
- (2) Over-coupling of the circuits to yield the double peak effect - or a combination of both of these.

Figure 7 shows the two main characteristics. If heavy damping alone is resorted to the only peak in the curve occurs at the centre frequency of the I.F. channel. In this case the procedure described above, if carefully carried out, should be sufficient to obtain correct alignment.

It is a good idea, however, to check the over-all I.F. characteristic after the initial aligning process described above, and to make minor adjustments to each tuned circuit if necessary. This checking of the over-all characteristic is done by leaving the signal generator at the converter grid, but re-tuning it to a frequency which is 40 K.c below the centre frequency, and noting the reading on the output. Then the frequency is adjusted to a value of 40 K.c. above the centre frequency, and noting the response on the meter again. These two readings should be equal if the curve is to be symmetrical about the centre-frequency. The procedure is then repeated for frequencies which are ± 75 K.c off the centre frequency. For a good over-all alignment these readings should again be equal, and should not be less than 1/10 of the reading obtained at the centre frequency. If it is found that unequal readings are obtained for a pair of off-centre frequencies, small adjustments may be made to the various stages (leaving the signal generator at the converter grid) until a symmetrical response is obtained.

It may be found that no symmetrical response can be obtained by small re-adjustments to the transformers. This indicates that the I.F. characteristics are of the double peak type shown at B Figure 7. In this event the stages should be completely re-aligned using one of the methods described below.

ALIGNING OVER-COUPLED I.F. TRANSFORMERS:

If the I.F. stage design is such that the response characteristics have the double-peak as shown at B Figure 7, the simple method of adjustment for a maximum response with the signal generator set at the correct centre value of the I.F. will give an unsymmetrical alignment. This means that although the I.F. transformers give a

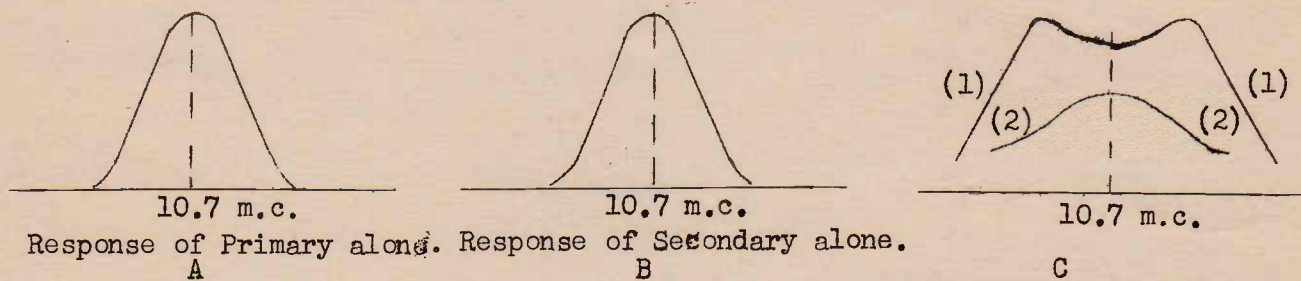

FIGURE 8.

1. Combined response for above critical coupling.
2. Combined response when coupling has reduced below critical by heavy damping.

maximum response at the centre I.F., this latter frequency does not lie at the centre of the pass-band of the circuits. Instead the centre-frequency (10.7 m.c) would fall at a point relative to the curve which would correspond to one or the other of the side peaks (See Figure 7B). The result, when receiving a signal, would be that either the upper or lower side-band (depending upon which peak the circuits happended to be aligned at) would be much stronger than the other, resulting in serious distortion. Two main methods of aligning double-peaked circuits may be employed.

FIRST METHOD:

One method is to align each stage roughly as before, starting at the last stage before the last limiter and working back towards the converter, as described. The process is then repeated while heavily damping, by means of a resistor, one winding of each transformer while the other winding is being tuned. This damping reduces the co-efficient of coupling between the circuits below the critical value, and so temporarily eliminates the double-hump effect. The theory of the method will be understood by reference to Figure 8. Each circuit of a transformer is, or should be tuned individually to the correct I.F. centre frequency, as shown at A & B. When coupled above the critical point, however, the individual resonance peaks disappear, and are replaced by two peaks lying above and below the separate resonance frequencies, as shown by curve (1) Figure 8 C. If one of the coupled circuits is damped heavily enough to reduce the coupling to a value below the critical value, the double peaks of the combined curve disappear, and are replaced by a single peak at the correct centre frequency, as shown by curve (2) Figure 8.

SECOND METHOD:

A more accurate method of aligning double-peak circuits is as follows. If the alignment is not too far out the signal generator is connected to the converter grid. The frequency of the generator is then swept on each side of the centre frequency noting the meter responses (meter still connected in the grid return of the limiter). In this way the two correct peaking frequencies are found. These should lie symmetrically on either side of the correct centre frequency. Unequal meter responses for the two peak frequencies indicate the alignment is somewhat off. Having noticed carefully (from the signal generator calibration) the frequency of one of the peaks, (say the lower) we start to align the I.F. amplifier stage by stage, starting from the last and working back towards the converter as previously described. In this process, however, we align on the lower peak alone, the frequency of the signal generator being set at the value previously noted for it. After the entire I.F. amplifier has been aligned, we now set the signal generator to the correct centre I.F. (10.7 mc.) and connect it to the converter grid, and note the meter response. Then the signal generator is adjusted to a frequency 75 K.c. above the centre frequency and the response noted. Finally a frequency 75 K.c. below the centre frequency is applied and the response again noted. The latter two readings should be equal, if not the entire process must be repeated.

THIRD METHOD:

Sometimes the alignment is initially so poor that it is difficult to determine the correct peaking frequencies. It is then best to set the signal generator at a frequency which is 50 K.c. below the correct centre frequency (viz. at a frequency equal to 10.65 M.c) and then to align stage by stage for maximum response at this off-centre frequency. Here again we begin with the stage next to the limiter and work back towards the mixer. In making the adjustments the trimmer condensers are first set towards maximum capacity setting and then reduced until maximum response is obtained. This ensures that the transformers will be aligned on the lower, and not the higher, peaks. The signal generator is then set at frequencies 75 K.c. first above, then below the centre frequency, the output being applied to the converter grid. If the over-all transmission curve is symmetrical these two responses should be equal. Also test for frequencies ± 50 K.c. from the centre frequencies. Again the meter responses should be equal. If this is so it indicates that we guessed the peaking frequency correctly when we initially set it 50 K.c. off centre. If the responses for the frequencies ± 75 K.c. off-centre were not equal it indicated that the incorrect off-centre peaking frequency was assumed. The entire process is then repeated with a somewhat higher off-centre frequency while aligning the individual stages. If the alignment proves to be even more unsymmetrical than before (as indicated by the meter responses for ± 75 K.c. off-centre, and also ± 50 K.c. off-centre frequencies) this indicates that the correct peaking frequencies lie closer to the centre frequency than 50 K.c. The alignment is therefore repeated for an off-frequency of somewhat less than 50 K.c. The process is repeated until equal symmetrical peaks with respect to the centre frequency are obtained.

If the correct off-frequency for the double peaking was guessed correctly in the first place, the process is just as rapid as for aligning single-peaked circuits, since the alignment is based on obtaining readings only for the lower peak frequency, or for the upper peak frequency. Usually the manufacturer provides information for the correct peaking frequencies, so the method of repeated alignment may not be necessary.

OVER-ALL CHECK OF I.F. AND DISCRIMINATOR ALIGNMENT:

At this stage it is a good idea to check the alignment so far carried out. To do this the signal generator is connected to the converter grid. The meter for measuring discriminator output is connected between points ZZ (Figure 2). The meter for measuring total diode current is connected between YY as before. First the frequency is set at the centre value (10.7 m.c.). The meter at ZZ should show a zero reading, and that at YY a maximum reading (noted by swinging the frequency slightly about 10.7 m.c.). Next the frequency, is set at ~~75 Kc. above~~ ~~centre frequency,~~ and ~~then 75 Kc. below.~~ The readings on the meter at ZZ in these latter two cases should be equal.

It should not be thought, however, that this over-all characteristic test alone is an indication that the individual stages are correctly aligned. It cannot be too strongly stressed that it is always necessary to align the separate I.F. stages as previously described. A symmetrical over-all transmission curve for the I.F. stages does not indicate that distortionless reception will be obtained. The curves for individual stages might be a long way out, yet the overall curves looks correct.

LIMITER TESTS:

Previously, before proceeding with the I.F. alignment, we checked the limiter voltages. If these were correct and circuit components were in good condition and of the values recommended by the manufacturer, the limiter should function normally. However if there is any doubt about the limiter operation, the following simple test may be carried out. The meter (preferably 0-100 μ A.) is connected in the diode return lead at YY (Fig. 2). The signal generator, set at the correct centre I.F. is connected to the converter grid by the method previously described. A number of readings on the meter are noted for various voltages applied from the signal generator. These voltages, of course, are varied, and read off from the attenuator control on the instrument. A curve like that illustrated in Figure 9 is plotted. In a typical receiver a curve something like that shown should be obtained. Note that complete limiter saturation occurs above a signal voltage of about 50 microvolts at the converter grid. If the "threshold" level was very much above this figure it would indicate that the limiter would not be sufficiently effective in reducing noise interference on the weaker signals.

R.F. and OSCILLATOR ALIGNMENT:

For these adjustments an unmodulated signal generator covering the band 88 - 108 m.c. is required. Actually a generator operating up to 54 m.c. would be satisfactory, for the second harmonic of the output could be used.

The signal generators output is applied to the input terminals of the receiver as shown in Figure 10. For these adjustments the 0 - 100 microammeter connected in the grid return of the last limiter is again used as an output meter. First the signal generator is adjusted to produce a frequency of 108 m.c. per sec. and the tuning dial of the receiver adjusted so that it reads 108 m.c. per sec.

The oscillator trimmer C_1 (Figure 10) is

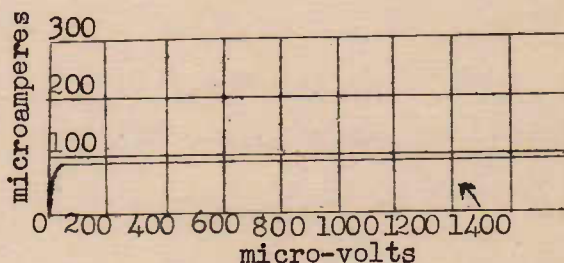

TYPICAL LIMITER CURVE MEASURED BETWEEN
CONVERTER GRID AND DISCRIMINATOR OUTPUT.

FIGURE 9.

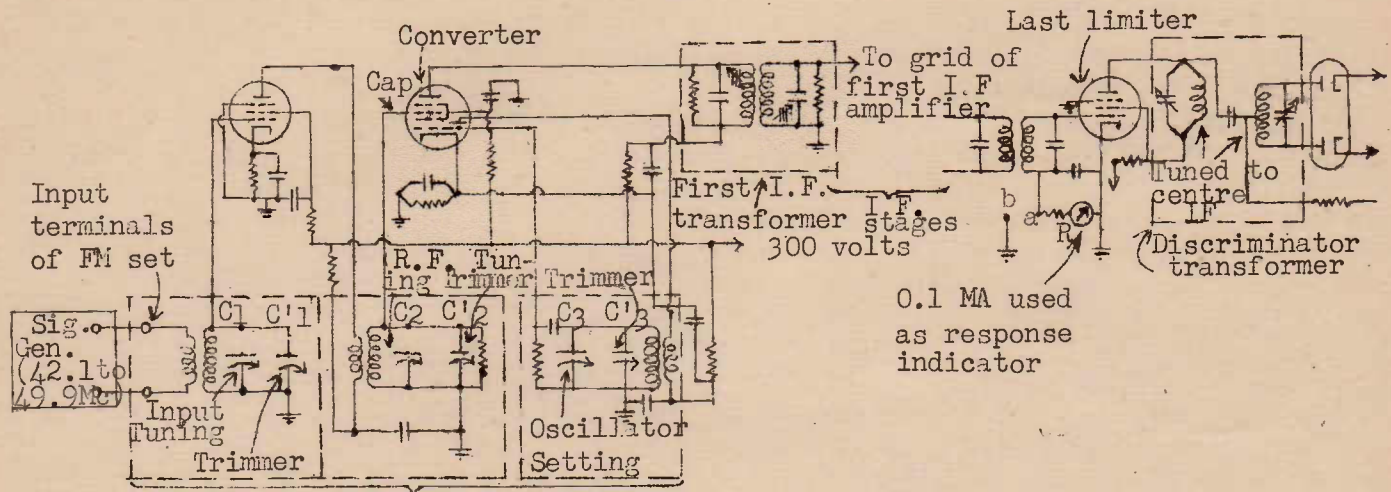

Trimmer condensers C'1, C'2 and C'3 have to be adjusted in the alignment of the input tuner.

FIGURE 10.

now adjusted for maximum response in the output meter. It is important at this stage to reduce the signal generator output until it is only just sufficient to indicate decided maximum effects on the meter. The R.F. and aerial trimmers C'1 and C'2 are now also adjusted for maximum meter response. A further reduction in generator output may be required when making these adjustments to prevent saturating the limiters.

The next step is to check the tracking. This is done by setting the frequency of the signal generator to such frequencies as 107, 106 and 105 m.c. in succession down to 88 m.c. In each case the dial of the receiver is set for maximum response as noted by the grid-current meter of the limiter tube. For proper tracking the microammeter indications should be practically equal in all cases. If this is not so a compromise has to be made with respect to the trimmer C'1 and C'2 settings, as in ordinary A.M. technique.

It has been pointed out that a receiver may be designed to operate with the oscillator frequency (F_0) either above or below the tuning frequency (F_1). With an intermediate frequency as high as 10.7 m.c. no possibility of adjusting the oscillator frequency on the wrong side of the tuning frequency exists, providing the following check is made.

After making the initial adjustments at 108 m.c. suppose it is found that the tracking cannot be improved by re-setting trimmers C'1 and C'2. This indicates that the receiver was designed for the oscillator frequency on the other side of the tuning frequency as shown on the dial. Hence the necessary correction may be made, the alignment process of the tuning circuits being repeated.

In carrying out the alignment of the r.f. stages, difficulties due to double-peaking circuits (as described in connection with some I.F. stages) never occur. These r.f.

circuits are more than adequately damped for the required band-pass by the high r.f. losses which occur at 88 - 108 m.c. Hence if correctly peaked by the simple procedure described, the band-pass requirements in this section of the receiver will take care of themselves.

ADDITIONAL EQUIPMENT FOR DYNAMIC TESTS OF THE I.F. & DISCRIMINATOR STAGES:

The tests and alignment procedure previously described were carried out by using an unmodulated signal generator. To check the band-pass of the I.F. stages we varied the frequency step by step, taking separate readings on the output meter for each setting. Since an F.M. receiver is sensitive to frequency variations, rather than to amplitude variations, it would be an advantage if we had available a signal generator whose signals were frequency modulated with a deviation of ± 75 K.c.

A FREQUENCY MODULATED SIGNAL GENERATOR:

A suitable instrument of this type consists of a fixed oscillator operating at a frequency of say 20 m.c per sec. which is frequency modulated by means of a reactance tube to whose grid a suitable A.F. voltage, say 400 c. per sec. may be applied. The output of this oscillator is heterodyned with that of another oscillator tunable between, say, 28 and 33 m.c. per sec. The resulting output will be a frequency modulated signal, tunable between $28 - 20 = 8$ m.c. and $33 - 20 = 13$ m.c. This covers the I.F. (10.7 m.c.) of an F.M. receiver. The arrangement is shown in block form in Figure 11.

For fidelity tests this signal generator must be applied at the receivers converter grid. This is good enough for fidelity tests, because the broadly tuned r.f. circuits have little effect on the receivers over-all fidelity. By using the instrument together with a cathode-ray oscilloscope (described below) an actual visual picture of the I.F. curve may be obtained.

THE CATHODE RAY OSCILLOSCOPE (OR OSCILLOGRAPH):

Some mention was made of this instrument in a lesson on cathode ray tubes in the Television Section. The device consists of an ordinary electrostatic type cathode ray tube fitted with suitable power supplies

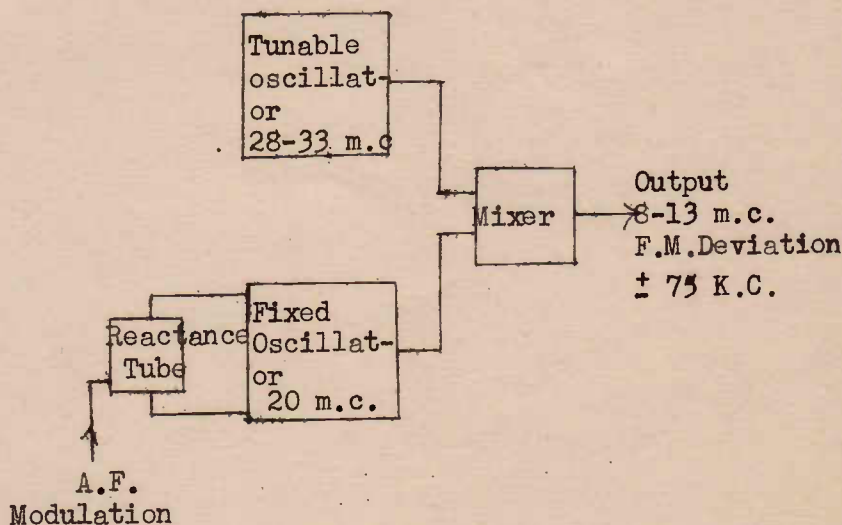

An F.M. Signal Generator suitable for I.F. Tests.

FIGURE 11.

for the filament heating and high electrode voltages. In addition it has a saw-tooth voltage generator (usually of the gas filled triode type), whose frequency is variable over a considerable range (say 20 - 50,000 c. per sec). The output of this oscillator is applied to the "horizontal" plates, and produces a linear "sweep" horizontally across the screen of the tube. The effect of this sweep is to produce a bright narrow line of light across the tube. The voltage which is to be tested or observed is applied to the vertical deflection plates. These plates are usually provided with a high fidelity video amplifier, so that weak voltages may be amplified. The instrument is, of course, fitted with controls to adjust the beam intensity, focus, and positioning of the spot on the screen (the latter involving vertical and horizontal shift controls). A block diagram of a typical oscilloscope is shown in Figure 12. The general appearance of the instrument is illustrated in Figure 1. Say a sine-wave voltage of 400 cycles per sec. is applied, via the vertical amplifier to the vertical deflection plates of this instrument. In the absence of any horizontal deflection, the effect would be simply to move the spot of light up and down on the screen, to produce a vertical line of light.

Suppose now that a saw-tooth voltage, also of 400 cycles per sec. were applied from the sweep oscillator to the horizontal deflection plates. In the absence of the sine-wave voltage on the vertical plates a straight horizontal line of light would appear across the screen. The spot would move through successive positions 0, 1, 2, 3, 4, 5, 6, 7, 8, as shown in Figure 13. For a frequency of 400 cycles per sec. the time taken to move from one of those positions to the next would be $\frac{1}{400} \times \frac{1}{8} = \frac{1}{3,200}$ sec., and

the movement would thus occur at a uniform speed. On reaching position 8, the spot would then, in a very short period of time (the fly-back time), return to position 0, and the next cycle would commence.

In the presence of both voltages the sine-wave voltage on the vertical plates, and the saw-tooth one on the horizontal plates, the spot would be forced to move in both vertical and horizontal directions. If both voltages commenced their cycles at the same moment the spot would move, due to these simultaneous movements, successively through positions a, b, c, d, e, f, g, h, and i., so tracing out a curved line of light, which would be a visual representation of the sine-wave voltage under test. On reaching position 8 (or i) the spot is rapidly shifted to position 0 (a) again, and the same movement is repeated. Due to the "persistence" of vision effect a continuous and stationary sine-wave

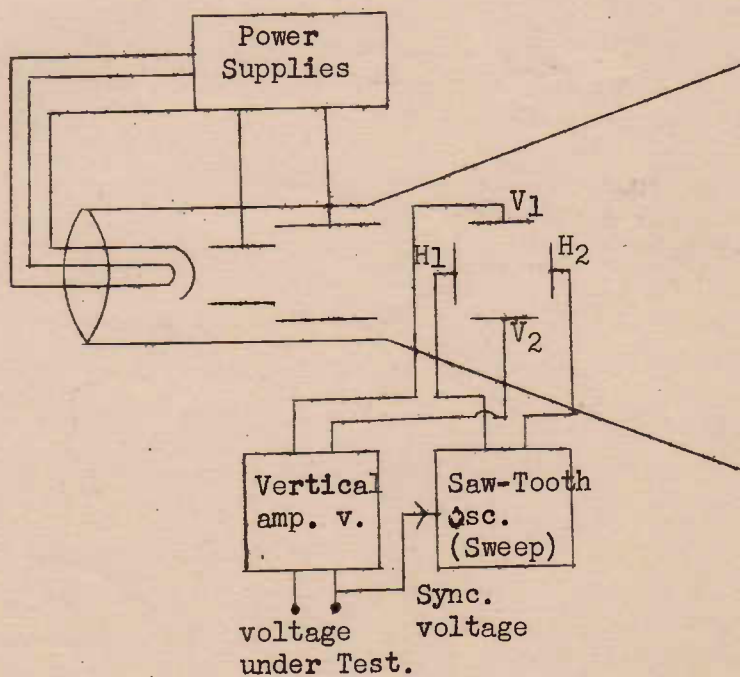

FIGURE 12.

curve would be seen just as though such a curve were drawn on paper.

In this way the cathode-ray oscilloscope (abbreviated C.R.O) allows us to obtain on a screen a graphical representation of any alternating voltage under test. The action is not limited to a sine-wave form. For example a square-wave voltage, or any other type, would produce its exact wave-form on the screen.

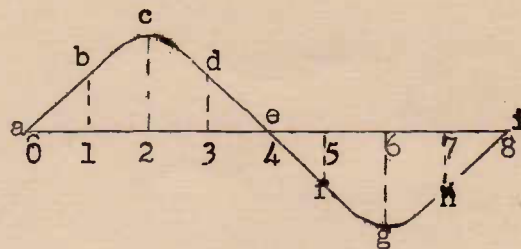

FIGURE 13.

To produce a stationary picture of the wave on the screen it is necessary that the voltage under test and the sweep voltage are correctly synchronised. This means that their frequencies must bear exactly a certain relationship to each other. In the case of the example explained, where a single cycle of the test voltage was observed, the two must have exactly equal frequencies. If the latter differs slightly the trace appears to drift continuously across the screen in one or the other direction. If the sweep voltage frequency were exactly one-half the frequency of the voltage under test, two complete stationary cycles of the latter would be observed; for the test voltage would perform two complete cycles in the time taken to move the spot once horizontally across the screen. Thus to observe two or more stationary cycles the sweep saw-tooth voltage must have a frequency which is an exact sub-multiple of the voltage under test.

To obtain this necessary synchronisation for test voltages of various frequencies, the sweep oscillator is provided with a frequency control knob, usually providing settings between about 25 cycles per sec. to 50,000 cycles per sec. Exact synchronisation is obtained by injecting a small portion of the test-voltage into the grid circuit of the sweep oscillator tube (see Figure 12). In practice the trace is made as stationary as possible by adjustment to the sweep frequency knob. Then the sync. control, which controls the amount of voltage applied to the grid of the sweep oscillator tube is turned up, just enough to cause the trace to "lock" on the screen. This synchronising action was explained in the second lesson devoted to Television Receivers. In the case of the sweep generators in video receivers the sync. voltages which set and hold the frequencies of the generated saw-tooth voltages are, of course, the sync pulses which are separated from the incoming signal. Here the sync. voltage is a portion of the voltage under observation.

DYNAMIC METHOD OF ALIGNING I.F. STAGES:

The use of the F.M. signal generator, together with a C.R.O. provides a speedier method of aligning the I.F. stages, and at the same time shows the operation of the receiver under conditions which closely approximate actual reception of an F.M. wave.

The F.M. signal generator is provided with a saw-toothed voltage at audio frequency usually by taking some of the saw toothed voltage from the sweep oscillator in the oscilloscope. This audio signal is fed into the generator via the grid of the modulating reactance tube as shown in Figure 11. The centre frequency of the resulting F.M. voltage from the generator is adjusted to 10.7 m.c. and applied to the receivers converter grid, using preferably the method illustrated in Figure 6.

The vertical plates of the cathode ray oscilloscope are connected between points "a" and "b" in the grid circuit of the last limiter of Figure 10. Note that this connection means that the voltage developed across the limiter grid resistor by the rectified grid current flowing through it is providing the vertical deflection on the screen of the C.R.O.

If the I.F. stages of the receiver are already correctly aligned, a stationary picture of their characteristic somewhat like that shown in Fig. 14 should be obtained on the screen of the CRO. No difficulty will be experienced with synchronisation because the frequency deviation of the oscillator is produced by voltage from the oscilloscopes saw tooth oscillator circuit and must at all times be synchronised with the horizontal movement of the light spot.

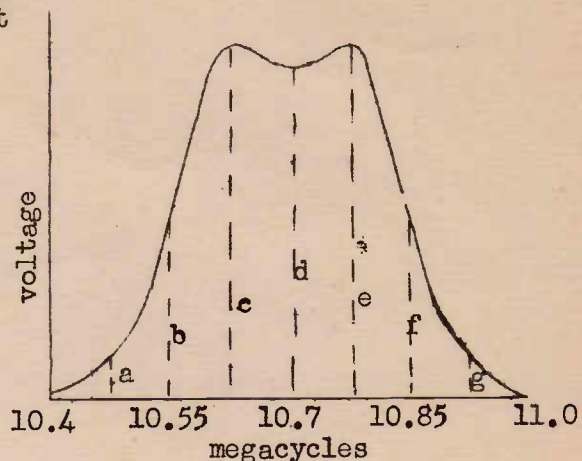

FIGURE 14.

In order to understand how such a picture is built up, suppose that the r.f. output of the signal generator is frequency modulated at 400 cycles per sec. and that a deviation of ± 300 m.c. per sec. (0.3 m.c. per sec) is being produced. Then the signal applied to the receiver is being "swept" over a frequency range of 10.4 m.c. per sec. (10.7 - 0.3 m.c) to 11.0 m.c. per sec. (10.7 + 0.3. mc.).

Now although the amplitude of the r.f. voltage applied to the converter of the receiver remains constant for all instantaneous frequencies, the amplitude of the voltage applied to the grid of the limiter will vary with these instantaneous frequencies. The reason, of course, is that the signal has passed through the I.F. tuned circuits which are frequency selective, i.e. the amplitude of the voltage passed depends upon the instantaneous frequency, as shown by the dotted lines a, b, c, d, e, f and g of Fig. 14. The D.C. voltages applied to the vertical plates of the C.R.O. will also vary as the lengths of those dotted lines, for the grid circuit of the limiter simply rectifies the r.f. voltage of varying amplitude which is applied to it. Hence the vertical displacement of the spot on the screen of the C.R.O. will depend upon the instantaneous frequency of the generator, in the same manner as the lengths of the dotted lines vary with the frequency as shown in Figure 14.

Simultaneous with the above, the C.R.O.'s saw-tooth oscillator sweeps the spot across the screen from left to right. During one of these horizontal movements the vertical displacement will pass through successive values proportional to a, b, c, d, e, f, g (Figure 14). The result will be that the spot follows the curve, and will trace out a line of light of the shape shown. On reaching the right-hand side of the screen the spot is abruptly moved to the left-hand side again, and a new trace begins. As a result of the rapid rate at which the curve is repeatedly traced out (about 400 times per second), and thanks to the "persistence of vision" effect, a continuous and steady line, representing the overall characteristic of the I.F. stages, is seen.

If a good symmetrical curve like that shown is not obtained no attempt should be made to improve it just by random adjustments to the I.F. transformers.

Just as in the case of the static method of alignment previously described the stages should be separately adjusted commencing with the last one before the limiter. Hence

the F.M. signal from the generator is applied to the grid of the last I.F. valve. First the secondary, then the primary of the following transformer is adjusted for a good shaped curve. Next the F.M. signal is applied to the previous grid, the amplitude of the signal being reduced to give a curve the same height as before, and the second last transformer aligned, and so on. Finally a compromise setting is made for all I.F. stages until a good-looking response curve is obtained. These compromise settings should on no account vary much from those obtained for the single-stage adjustments.

FAULTS PECULIAR TO F.M. RECEIVERS:
AMPLITUDE DISTORTION DUE TO SIDE-BAND CUTTING:

In the case of A.M. reception inadequate passing of the side-bands results only in a reduction of fidelity due to excessive loss, before detection, of the higher audio frequencies of modulation. We have seen that a characteristic of the F.M. system is that the higher side frequencies are only produced on the peaks of modulation, i.e. on the loud sounds. Any action within the receiver which restricts the passage of those side-frequencies which lie well out from the centre-frequency of the signal will result in an undesired type of volume compression, which, if severe, will be observed as a severe distortion on reception of loud music etc.

Assuming that the receiver has been correctly designed in the first place, and also assuming that the audio section is in order, this type of distortion is usually traced to one of the following causes :

- (1) Incorrect alignment of I.F. (including discriminator) transformers.
- (2) Unequal, or broken down, discriminator load-resistors (R_1 and R_2 Figure 2).
- (3) Mis-match between discriminator diodes.

With reference to (1) above, the obvious remedy is to re-adjust each I.F. transformer separately, as already described. Once again the importance of individual alignment of each transformer by one of the methods given is stressed.

Loss of balance between the discriminator load resistors is a common fault, particularly in a receiver which has been in use for some time. It is most important that these resistors, which have a typical value of 100,000 ohms each, should be equal within about 10%. A breakdown of one resistor will, of course, completely unbalance the discriminator and ruin reception. Serious unbalance, however, can also be present in the absence of a complete breakdown. Carbon resistors have a habit, with age and use, of increasing in value far above their ratings. Such an increase in resistance may go unnoticed in the case of a resistor anywhere else in the receiver, but it is most important that discriminator load resistors are maintained at values which approximate closely to each other.

Complete or partial loss of emission of one of the discriminator diodes (fault (3) above) will have the same effect as unequal load resistors. This fault will mean that unequal voltages will be developed across the latter even though the I.F. voltages applied to the two diode plates are equal.

Actually the presence of unequal discriminator load resistors, or mis-matched diodes will be indicated when attempting to align the discriminator transformer. If it is

found that a correct balance of the stage is impossible to obtain by following the methods described then the diodes and resistors should be tested and replaced if necessary.

RECEIVER INSTALLATION - ANTENNAS:

The home installation of an F.M. receiver involves no new problems to the service engineer, except insofar as the antenna system is concerned.

For reception of a powerful signal it may be found sufficient simply to ground one of the aerial coil terminals and to connect a short piece of wire of several feet (10 ft. at the most) to the other. Or again pick-up may be used from the power lines as is sometimes done for A.M. receivers.

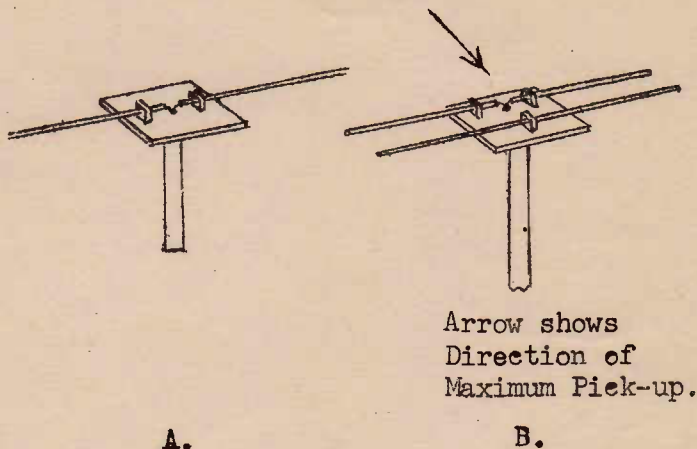

FIGURE 15.

Normally however the resonant dipole is to be preferred in all cases. The resonant effect obtained from such an aerial gives an additional high-frequency gain of several times. In addition, since the matched lead-in used with a dipole is free from signal pick-up, ignition noise and other forms of undesired interference are greatly reduced.

For F.M. both horizontally and vertically polarised waves are used (see Lesson on Television Antennas). For reception of a vertically polarised wave the dipole is mounted normally, in a vertical position, while for horizontal polarisation the aerial should be parallel to the ground. Figure 15A shows a simple method of mounting a pair of stiff metal rods to form a dipole for reception of a horizontally polarised wave. The method would serve equally well for vertical mounting.

Sometimes, due to certain ground effects and reflections of the wave the "plane of polarisation" of the signal may be rotated or twisted, with the result that best reception may be obtained with the dipole neither horizontal or vertical, but set at some other angle to the ground. Such effects cannot be predicted, and therefore a certain amount of experimentation in setting up the antenna is required.

It will be remembered that a dipole has pronounced directional properties as indicated by the horizontal and vertical polar diagrams of Figure 16. Maximum pick-up occurs when a wave is striking the antenna at right-angles to its axis. Zero (or minimum) pick up occurs for a signal arriving end-on.

The polar diagram of Figure 16A shows that in the case of horizontal polarisation the the receivers antenna will favour some signals more than others. This property may be taken advantage of to reduce the pick-up from a powerful signal and to increase that from a weaker signal. It is simply a matter of setting the aerial so that best all round results are obtained from the different transmitters operating.

If vertical polarisation is used, Fig. 16B shows that the antenna, which is in this case mounted vertically, will favour all signals equally well.

REFLECTORS:

A reflector is simply a metal rod of length equal to, or a little greater than, the total length of the dipole, and separated from it by a distance equal to one-quarter ($\frac{1}{4}$) of a wavelength. With such an arrangement the aerial pick-up for a signal arriving in the direction of the arrow (Figure 15B) is increased over and above what it would be in the absence of a reflector. Conversely, for a signal arriving from the opposite direction the pick-up is correspondingly reduced.

Vertical and horizontal polar diagrams for a dipole with reflector are shown in Figure 17. As will be seen from

these diagrams a reflector may be used to increase the pick-up from a weak signal arriving from one direction, while at the same time decreasing that from a powerful signal coming from the opposite direction. This is true whether a horizontal or vertical dipole is used. Note, however, that in the first case signal pick-up arriving from a direction at right angles to that which gives maximum, is still practically zero, while in the second case this pick-up is still considerable.

MOUNTING AND INSTALLING THE ANTENNA SYSTEM:

It will be remembered that the dipole type of aerial should have a physical length of about 95% of one half-wave length of the signal it is desired to receive. A convenient formula for calculating the length of each rod (i.e. half the dipole) is :-

$$L \text{ (inches)} = \frac{2,770}{F \text{ (megacycles)}}$$

If it is desired to use the dipole for reception of any station within the F.M. band (as is usually the case) F should be taken to represent the mean frequency of the band. The latter extends from 88 to

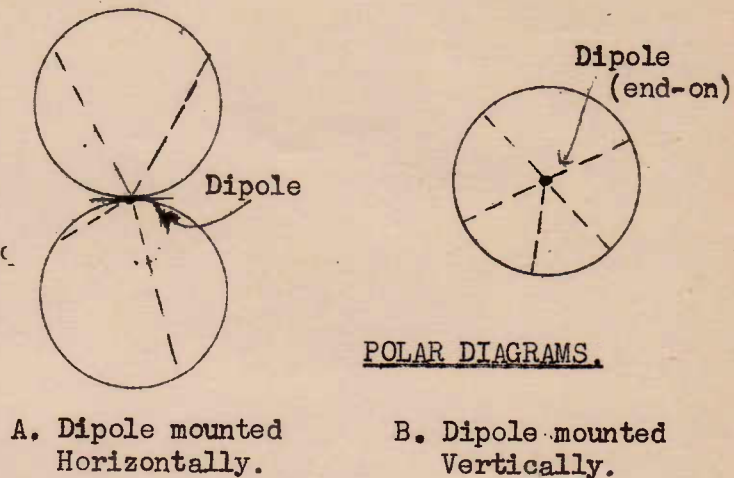
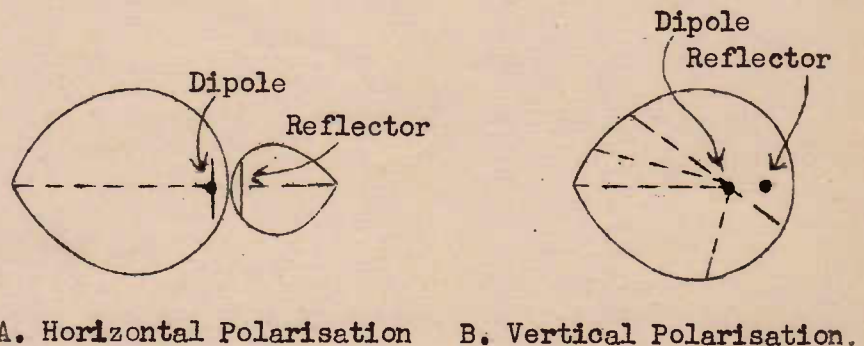

FIGURE 16.



EFFECT OF REFLECTORS ON DIPOLES.

FIGURE 17.

108 m.c., and the mean frequency is $\frac{88 + 108}{2} = 98$ m.c.

LOCATION OF AERIAL:

It is normally essential, as in television work, that the dipole aerial be located high enough to be in a direct line of sight with the transmitters radiator. In the case of a receiver located in a large block of flats this may mean a little extra work in placing the dipole near the top of the building. The difficulties associated with such an installation, however, are not as great as first may be imagined. The dipole itself is quite small, and if the transmission line is correctly matched and "balanced" with respect to the input circuit no pick-up of noise will result. A long lead-in of this type will simply mean some loss of signal strength.

USE OF U.H.F. ANTENNA SYSTEM FOR BROADCAST RECEPTION:

It will be remembered that the transmission line lead-in from a resonant aerial is connected as shown in Figure 18 at A. In this way the equal voltages induced in the pair of feed-in wires oppose and cancel each other in the r.f. input transformers primary. The signal pick-up is confined entirely to the dipole itself.

Now many receivers are designed to operate on the broadcast band as well as the u.h.f. band for F.M. reception. Such receivers, of course, have separate sets of coils (r.f., converter and I.F.) for the two bands. A switching system allows instantaneous change-over from F.M. reception to A.M. reception on the broadcast band. With such an arrangement the difficulty arises that the short dipole may not give sufficient pick-up on these lower frequencies. Remember that no resonant effect will occur on the broadcast band. To avoid the use of a separate aerial for A.M. reception a common arrangement is shown at B and C Figure 18. A three-pole two-way switch is hooked up as shown. Actually this switch would form a section of a multiple wave-change switch which controls the change-over from F.M. to A.M. in other appropriate parts of the dual-

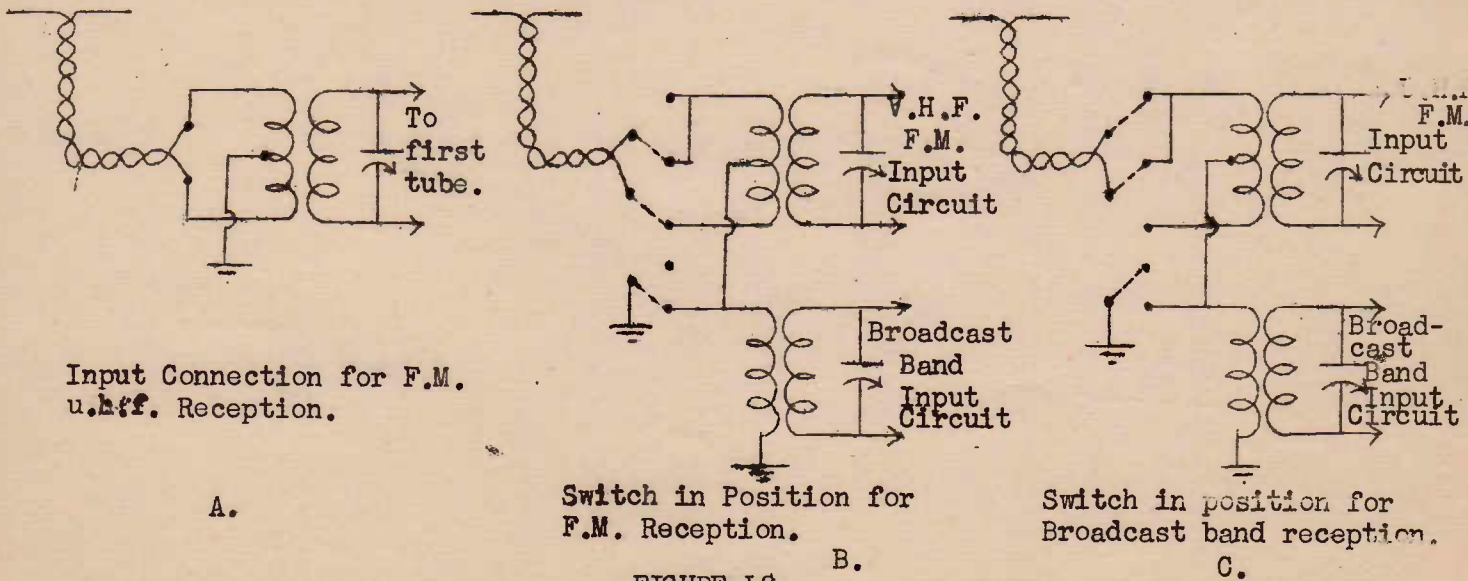

FIGURE 18.

receiver. With the switch in the position shown at "B" (Figure 18) the connections are identical with those at "A" for u.h.f. F.M. reception. Note that the broadcast circuit is earthed. When the switch is thrown to the other position shown at "C" the two wires of the transmission line are connected together, and the pair are in effect connected through one-half of the u.h.f. coil across the broadcast transformers primary. Now the pair of wires of the transmission line will act as a single conductor, and the lead -in will behave as an ordinary untuned aerial. The half of the u.h.f. coil will not affect the broadcast signal, since it will act as a short-circuit at these comparatively low frequencies. The noise reducing properties of F.M. equipment give this type of transmission considerable advantage over A.M. for use at high carrier frequencies and without any doubt, it will be used both for commercial communication purposes as well as high quality broadcast entertainment in the future.

LESSON T. FM & F. 18

Q U E S T I O N S.

- (1) Which voltages in an F.M. receiver do you consider the most critical (i.e. require the most accurate adjustment ?).
- (2) State approximately the value of the voltage you would expect to find on a limiter screen. What would be the effect if this voltage were too large ?
- (3) Referring to Figure 2 explain why adjustment to the discriminator transformers secondary would have a greater effect upon the reading in the meter at ZZ than would adjustment to the primary circuit.
- (4) Why is it desirable that the characteristic curve of a discriminator is linear over a frequency range considerably wider than the bandwidth of the signal (150 K.c. per sec) ?
- (5) In carrying out I.F. alignment describe with the aid of a circuit diagram how you would observe the I.F. stages response.
- (6) Does maximum response, as measured in the meter in Figure 4, always indicate correct alignment of an I.F. stage ? Explain.
- (7) Give two reasons why a dipole is to be preferred to an untuned aerial, even when the signal field-strength is high.
- (8) Calculate suitable lengths for the two halves of a dipole to cover the band 88 - 108 m.c. per sec.
- (9) What is a "reflector" as used in an antenna installation ? State the correct length and positioning of such a reflector. What advantage does it confer ?
- (10) If you find it impossible to obtain a correct balance of the discriminator, what faults would you look for ?

AUSTRALIAN RADIO COLLEGE

E. S. & A. BANK BUILDINGS, Corner CITY RD. and BROADWAY, SYDNEY

Telephones: M 6391 and M 6392.

Post Lessons to Box 43 Broadway

This lesson sheet is published for the exclusive use of students of the Australian Radio College Pty. Ltd. (All rights reserved)

T. FM & F. COURSE.

LESSON NO. 19.

FACSIMILE TRANSMISSION.



The elementary principle of Facsimile transmission has been explained in Lesson 1, the appropriate section of which should be revised before proceeding with this and the next lesson.

IMPORTANT DIFFERENCES BETWEEN FACSIMILE & TELEVISION:

As has been explained in Lesson 1 the same general principle of scanning is common to both Television and Facsimile systems. In both systems a light spot (or its equivalent) traverses the picture area to be transmitted, dealing with each picture element sequentially (i. e. in turn). The variations in reflected light as these picture elements are traversed give rise (in a photo-electric cell, or equivalent device) to the pulsating video signal. In both systems this signal is used to modulate a carrier wave which may be despatched over a wire or radio link, to the distant receiver. At the receiver, the picture signal is recovered (by "detection" of the carrier), and used to re-construct an image of the original. This involves, as we have seen, the use of a scanning system in the receiver, locked in synchronism with that at the transmitter.

Beyond the above similarities in principle Television and Facsimile show striking divergences in technique. These arise from the difference in the requirements of the two systems, which are :

- (1) Facsimile is required to produce a permanent record of the transmitted picture, whereas Television produces a non-permanent or transient reproduction.
- (2) In order to produce a "moving" picture by taking advantage of the eye's persistence of vision, television must handle a large number

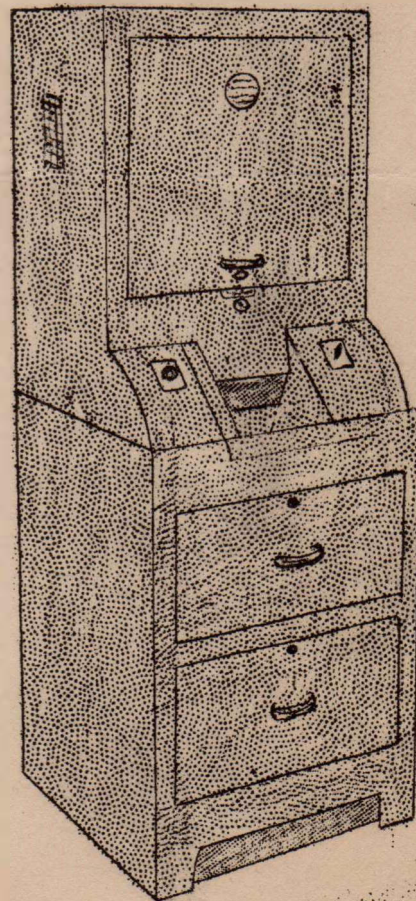

Automatic Telegraph Facsimile Transmitter.
FIG. 1.

(2) of complete scannings per second, whereas in facsimile work the picture may (contd.) be scanned as slowly as desired (theoretically at least).

The point made under (1) above leads to great differences in the picture reproducing equipment of the two systems. In the place of the cathode-ray tube in a television receiver the recorder in a facsimile unit traces a permanent record on photographic film, from carbon paper, on electro-chemical sensitised paper or by one of several other methods to be discussed in due course.

With reference to point (2) above the fact that there is no theoretical time-limit on the scanning rate is most important from the technical point of view. It means that the band-width of the picture signal may be very narrow compared with that of a Television signal. This in turn makes it possible to send the signal on low and medium frequency carriers, such as those already in use for ordinary radio broadcast purposes. Hence the problem of special ultra-high frequency transmitting and receiving equipment does not arise. In fact, we can, if we desire, use a carrier frequency lying in the audio range - as low as 1,000 or 2,000 cycles per sec. Carriers such as these are actually used, especially for land-line, as distinct from radio transmission.

A clear perspective of the difference in scanning rates of the two systems should be visualised. In television the picture or scene is completely scanned in 1/25th second. A facsimile equipment, on the other hand, may handle a given picture, diagram, or print, by a single scanning in several minutes. If it is remembered that the "dot" frequency of the picture (video) signal is proportional to the scanning rate (for a given number of scanning lines) the much lower frequencies at which facsimile operates will be appreciated. To quote some comparative figures, many facsimile systems do not involve picture signals higher in frequency than about 1,000 cycles per sec. and even the very latest and fastest systems involve frequencies which do not exceed about 13,000 cycles per sec. which can easily be handled by a conventional F.M. transmitter (which is designed to handle modulation frequencies up to 15,000 cycles per sec). Compare these figures with the video frequency of a high-definition television system - say 4,000,000 cycles per sec.

A further implication of the comparatively low scanning rate is the suitability of mechanical methods of scanning which greatly simplify the production of a permanent copy of the subject matter at the receiver. Actually nearly all facsimile systems utilise mechanical scanning devices at both transmitter and receiver. These are cheaper and simpler in general than any possible electronic alternative.

PRACTICAL APPLICATIONS OF FACSIMILE TRANSMISSION:

The electrical transmission of pictures, prints and diagrams has many applications. A few of these may be listed :

- (1) Transmission of news photographs as between city and city, country and country. (Radio or Telephone line link).
- (2) Radio Weather Map Service - to ships at sea.
- (3) Industrial Plant Facsimile System - for sending permanent facsimile copies of plans, diagrams, specifications etc. between different sections of a factory, or between plant and plant.

- (4) Tape Facsimile Systems. These send copies of type-written information on a continuous tape, at reading speed, and may replace Tele-type apparatus for communicating market and financial information.
- (5) Facsimile Duplicating Apparatus - for Office use. In the case of this equipment the "transmitter" and receiver are situated at the one spot. A diagram etc. from which a large number of copies are desired is scanned by the "transmitter" and the receiver recorder produces a stencil from which any number of copies may be prepared by ordinary office methods. The apparatus has been reduced to such a degree of simplicity that untrained office personnel can easily operate it.
- (6) Automatic Telegraph Facsimile System - For regular telegraph business chargeable at telegraph rates, the addressee receiving a teleprinter or facsimile process telegram. In this system the transmitter resembles an ordinary letter box in the street, on a railway station, or at some other busy location. The customer merely presses a button on the cabinet and inserts the written telegram in a slot. A facsimile recorder at the receiving post-office reproduces an exact copy which is delivered to the addressee.
- (7) Home Broadcast Facsimile - This is, of course, the branch of the facsimile art in which we are most interested. For over one hundred years a tremendous amount of experimentation has been devoted to developing and perfecting facsimile transmission. Much of this work has been carried out by individuals and large corporations in connection with the first six applications listed above. Nevertheless it would be safe to say that the driving force underlying nearly all the work done has been the desire to provide the public with a home service to supplement sound broadcasting. Such a service, of course, needs to be nearly 100% automatic and fool-proof in operation. Moreover it should turn out the printed information as it is received, without any processing operation whatsoever, and at a reasonably rapid rate. It is only in very recent years that these requirements have been satisfied.

TRANSMITTING PROCESS :

The processes involved in a facsimile transmitter are :

- (1) Scanning of the picture to produce the electrical picture signal.
- (2) Modulation of a carrier or Sub-carrier.
- (3) Production of synchronising and/or phasing (framing) signals.

The picture signal produced from the scanning process in most systems does not exceed one or two thousand cycles per second. Even in the latest and fastest systems developed for home broadcast purposes it falls well short of the highest audio frequency (say, 15,000 cycles per sec). Hence, generally speaking it is possible to use this signal to modulate a carrier (or sub-carrier) which itself is of audio frequency. Such a sub-carrier is almost universally used whether the transmission is to be over telephone line or by means of a radio transmitter. It might well be asked why the necessity of this sub-carrier? Why is the picture signal not amplified directly and in the case of land-line communication passed directly over the line? In the case of radio transmission why is not the picture signal used for direct modulation of the radio frequency transmitted wave?

REASON FOR THE SUB-CARRIER:

The main reason for the sub-carrier is that the picture signal varies in frequency from zero (direct current) upwards. This signal is of course obtained from the output of a photo-tube, which is normally very weak. Before it can be used for modulation of a powerful radio carrier, or passed over large lengths of telephone line it must be amplified. The amplification of such a signal (extending down to zero frequency) would require a d.c. amplifier. Such amplifiers are subject to gradual changes of frequencies often termed "drift" and are therefore avoided. The difficulty is overcome by the use of a comparatively weak sub-carrier which is directly modulated by the output from the photo-cell. To illustrate this point suppose that the picture signal has a frequency range 0-600 cycles per sec. Modulating a sub-carrier of frequency say 1300 cycles per sec. would give rise to a modulated signal having side-bands ranging from 700 cycles per sec. ($1300 - 600$ cycles per sec) to 1900 cycles per sec. ($1300 + 600$ cycles per sec). Such a signal can now easily be raised in level, by the use of conventional audio amplifiers to any desired level, for subsequent modulation of an r.f. carrier, or for direct transmission over telephone lines.

It should be observed that in the case of the figures chosen, the lowest frequency to be amplified is 700 cycles per sec, instead of zero. Hence no special precautions are required in the design of the amplifiers from the point of view of low-frequency response.

The point is that the use of a sub-carrier takes care of the "D.C. level" of the signal, for this level is represented by the amplitude of the sub-carrier. To illustrate this point suppose the light spot is scanning a uniform dark grey (no detail) part of the picture. The photo-tube signal will be a small direct current and the sub-carrier will be a current of 1300 cycles per sec. of small amplitude. If now the light-spot passes to a portion of the picture which is a uniform white the photo-tube output will be a direct current of larger value than before, and the sub-carrier will be a larger amplitude A.C. still of 1300 cycles per sec. frequency. Thus we see that the D.C. levels of the picture are represented by the levels (amplitudes) of alternating currents which relative levels will be maintained even after passing through many stages of conventional amplification and through the process of modulation of the radio-frequency carrier - see Fig. 2. Note that the radiated r.f. wave in the case of radio transmission always has a modulation (that of the



A. Sub-Carrier for uniform Dark Grey.

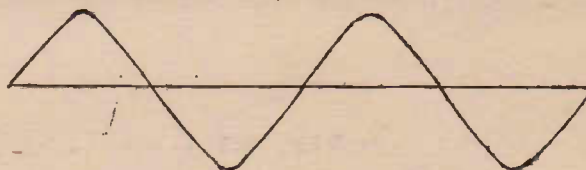

B. Sub-Carrier for Uniform White.

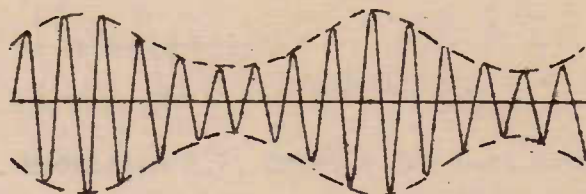

C. Modulated R.F. Carrier for Dark Grey (A)

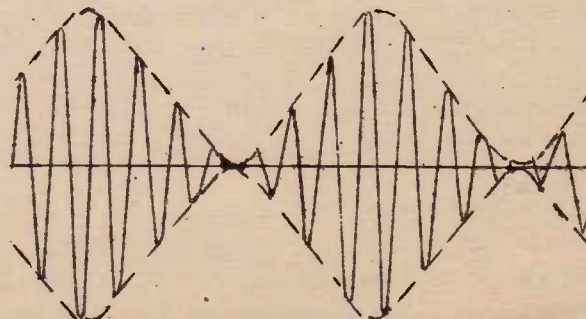

D. Modulated R.F. Carrier for Uniform White(B)

FIGURE 2.

sub-carrier) superimposed on it. It is stressed that the diagrams of Fig. 2 are for a signal transmitting no detail. When the picture signal (from the photo-tube) is a varying current, due to the scanning of picture detail the sub-carrier itself will be modulated, and the modulation envelopes of graphs C and D (Fig. 2) will themselves have a modulated form.

The difference between the technique of maintaining correct D.C. level in facsimile and television systems should be carefully noted. In television we depend upon the more complicated method of establishing a D.C. level by special circuits in the transmitter, and the practice of restoring this level by the use of D.C. restorers in the final stage of the receiver. This method further involves the difficulty of designing video amplifiers of good low-frequency response. The easier facsimile technique is made possible by the comparatively slow scanning speeds, and low frequency picture signals involved.

The use of the sub-carrier has a further advantage in the case of telephone line transmission. If the picture signal were amplified directly (by D.C. amplifiers) and sent over the lines the latter would have to handle a frequency range from 0 to 600 cycles per sec. (in the example quoted). In this instance the ratio of highest frequency to lowest is infinity. Now transmission lines have different attenuation (loss) characteristics for different frequencies, and great distortion would result in the case of such a ratio of maximum to minimum frequency. When the sub-carrier is used the highest frequency is 1900 cycles per sec. and the lowest 700 cycles per sec, a ratio of only $\frac{1900}{700} = \frac{19}{7} = 2.6$ to 1 (approx.). Ordinary telephone lines can easily handle such a ratio without selective attenuation.

TRANSMISSION METHODS:

The methods of changing variations in picture density into corresponding electrical impulses by the process of scanning, fall into two main classes :

- A. Electro-mechanical.
- B. Electro-optical.

In the case of electro-mechanical systems (which are now rarely used) a current is caused to vary by some mechanical device operated by raised surfaces constituting the picture surface or object to be transmitted. The first system of electrical facsimile used this method, which takes us back to a date over a century ago (1842) when an English physicist, Alexander Bain, devised an apparatus which incorporated all the essentials to be found in a modern facsimile system. For this reason it will be briefly described.

A simplified sketch of Bain's system taken from his original patent is shown in Fig.3. This sketch shows only the basic elements of the transmitting and receiving apparatus. Briefly the operation was as follows :- Printers metal type was used at the transmitting end. A pendulum carrying a light, resilient contact swung past the face of the type, completing a battery circuit between transmitter and receiver whenever it touched the raised portions of the type. For each beat of the pendulum the type was dropped down a step at a time. Thus each letter of the type was "scanned" in roughly horizontal lines. At the receiving end a similar pendulum and contact operated over a paper soaked in potassium iodine solution (a chemical which turns dark brown when an electric current passes through it). The paper was traversed past the pendulum in the same manner as the type at the transmitter. An electrical arrangement was provided whereby

if one pendulum preceded the other slightly it was held back until the other reached the same position and both started together. Current from a cell, switched by the transmitting contact passed via the receiving contact through the paper producing a brown stain.

Bain's system as an example of electro-mechanical scanning was, of course, in a very crude form. It gave only pure brown and white representations with no gradations in tone. It will be observed, incidentally, that the use of pendulums for synchronisation of transmitter and receiver anticipated by many years a method which, until very recently, was considered to be the best frequency standard available. Bain's transmitter was very little used, but his recorder, known as Bain's Chemical Telegraph was used for many years for recording Morse Code signals.

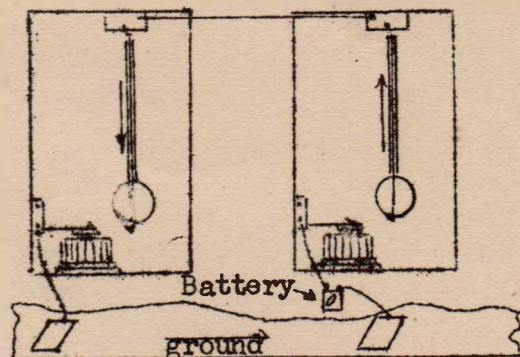

FIGURE 3.

Another example of the Electro-mechanical scanning method was a system (Belin, 1897) in which the photograph for transmission was reproduced in relief on a special gelatine surface. This was scanned by a stylus, which as it traversed the hills and hollows of the picture surface worked, mechanically, a rheostat, which in turn created variations in the electric current. In 1909 the rheostat was replaced by a microphone, whose diaphragm was vibrated by the stylus as the latter moved over the rough surface of the picture. This system gave quite good gradations of tone in the finished product. Belin's system proved quite practicable.

Turning now to the Electro-optical systems, it will be understood that these are systems in which variation in light originate the electrical picture signal. Practically all modern systems are of this type. The "heart" of such a system is, of course, the photo-cell, already explained in the television lessons. In all of these systems a brightly illuminated portion of the picture is focused on to the photo-cell, usually with a microscope "objective" lens. The most usual arrangement is to wrap the picture around a cylindrical scanning drum, the latter being rotated and at the same time "traversed" in a direction parallel to its axis relative to the scanning area or spot. The result is that the picture is scanned in a spiral position. The principle of this type of scanning has already been explained in Lesson 1.

In order that the photo-cell is affected only by a single small element of the picture two methods are used. In the first a small spot of light is focussed on the picture by means of a "condenser" lens a small aperture being included in the system to ensure that the light spot has the correct size depending upon the number of scanning lines and the size of the picture. In the other arrangement the picture is flood-lit and a picture element is selected by placing a small aperture in the objective lens system which focusses the light on the photo-cell. The two methods, it might be observed, correspond exactly to the old "flying-spot" and to the flood-light systems, respectively, in television. The two possible arrangements are illustrated in Figs. 4 and 5.

In each case the lens system is so designed that the photo-tube receives, at any one moment, light reflected from an area of the picture equal to the aperture dimensions.

Hence the aperture is made to have a size equal to the scanning spot dimensions required by the system. These dimensions depend in turn upon the number of scanning lines per inch. The aperture is usually rectangular, one side being equal to the width of a scanning line (e.g. 1/100 inch for 100 lines per inch scanning). It is found in practice to be better to have the other side of the aperture slightly less than this, in order to give greater definition (detail) measured along a scanning line.

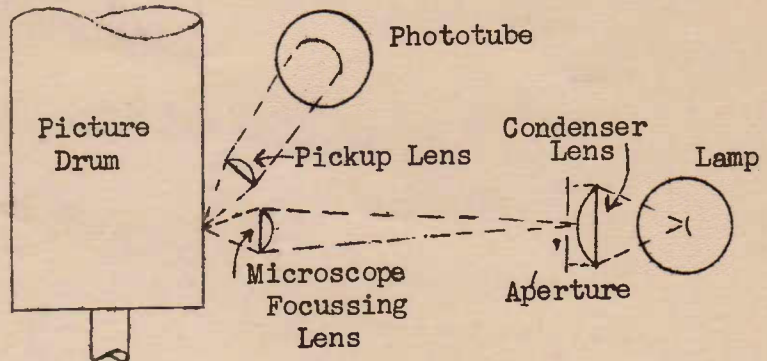

FIGURE 4.

It will be observed that in the case of the so-called flood-lit system (Fig.5) the whole of the picture area facing the light source is not illuminated. For economy of light, "condensing" lens are used to concentrate the light on a comparatively small area. This illuminated portion, however, is very much larger than the scanning "spot". The advantage of this arrangement is that any wrinkling of the picture on the drum does not shift the position of the transmitted image.

For certain commercial applications (e.g. photos transmitted for newspaper reproduction) it is desirable to operate directly from the photograph negative. This requires transmitted rather than reflected light, i.e. the photo-tube must pick up light which has passed through the picture, rather than light which has been reflected from its surface. If a scanning drum is used this would appear to necessitate placing either the light source or the photo tube inside a transparent drum. A more convenient arrangement is that shown in Fig. 6.

Here use is made of a glass prism to turn, by reflection, a beam of light through a right angle. The prism is a wedge-shaped piece of glass as shown in Fig. 7. A

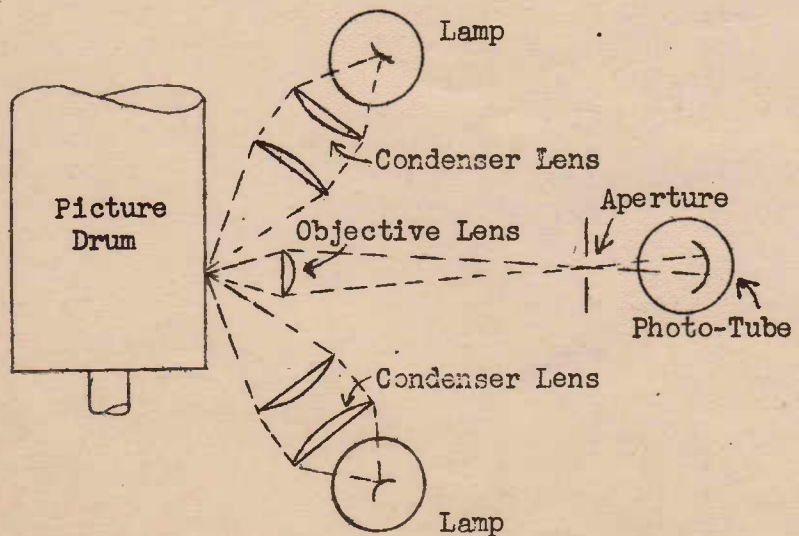

FIGURE 5 .

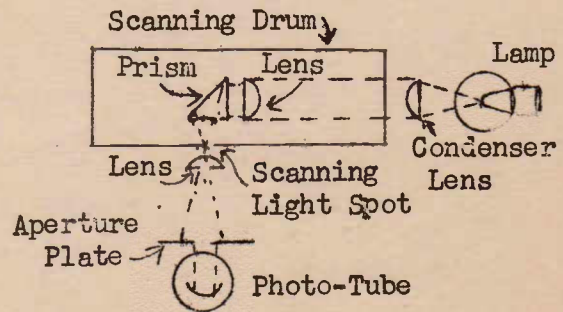

FIGURE 6.

light ray OX entering the prism through the surface A.B.C.D. continues on to the point X on the surface B.C.F.E. Providing the angle at which the ray OX meets this surface is less than a certain critical value (depending upon the optical properties of the glass) the ray will not emerge from the surface but will be reflected in the direction XY. This is called "total internal reflection". Thus although the glass is perfectly clear and is not coated with any metallic material the surface B.C.F.E. acts like a perfect mirror.

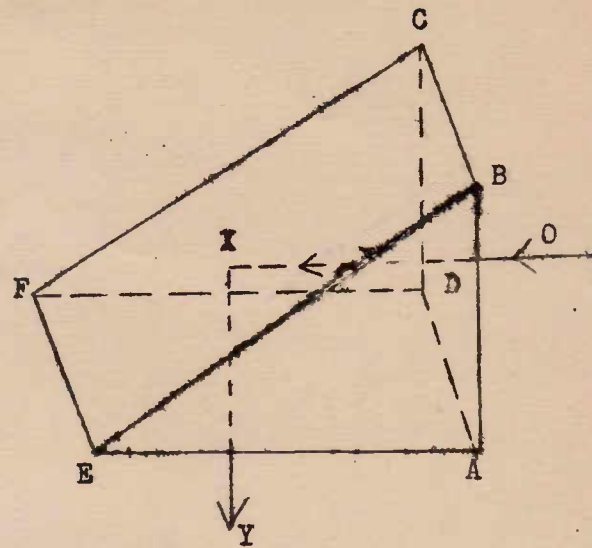

FIGURE 7.

Returning to Fig. 6., the light from the lamp passes into the drum, parallel to the axis of the latter. The lens inside the drum would, in the absence of the prism, focus the beam to a point somewhere to the left of the prism. Due to the presence of the latter, however, the light rays are turned downwards and focussed rather sharply on the transparent film which is wrapped around the drum (the drum material itself must, of course, be transparent). The amount of light passing through the film will depend upon the shade of grey of the particular portion of film being scanned. This "transmitted" light is picked up by another lens and after passing through the aperture (which determines the exact size of the spot being scanned) falls upon the photo-tube. The chief advantage of this method is that more light may be transmitted through a negative than may be reflected from a paper. Hence a less sensitive amplifier is required.

TECHNIQUE OF MECHANICAL SCANNING:

The simple principle of the drum method of spiral scanning has already been explained. The picture or printed matter to be transmitted is wrapped around the drum which is rotated at a constant rate by a motor. At the same time the drum is given a slow longitudinal movement, parallel to its axis, relative to the light source, often by means of a fine screw thread. The result is that the scanning spot traversed the picture in a spiral manner around the drum. The mechanical arrangements which have been used to achieve this are extremely numerous, and there is no point in attempting to describe the details of various designs. However, Fig. 8. is included to show a typical arrangement which illustrates in simplified form the basic principles of most systems.

The drum, motor and gears together with a "lead screw" are mounted on a framework which can move along a slide attached to the main frame. Also fixed to the latter is a nut which engages the lead screw. The electric motor drives, through suitable gears both the rotating drum and the lead screw. The latter is simply a shaft of steel which is threaded somewhat like an ordinary bolt. Since the nut is fixed the lead screw, as it rotates must move bodily from right to left. In so doing it carries with it the framework which also carries the drum. Hence the latter is given both a rotational and a longitudinal movement. Since the light source is fixed it is easily seen how the scanning spot traces out a spiral path around the cylinder.

In order that the scanning lines which encircle the drum lie adjacent to each other the rotational speed must bear a definite relationship to the speed at which the drum is moved

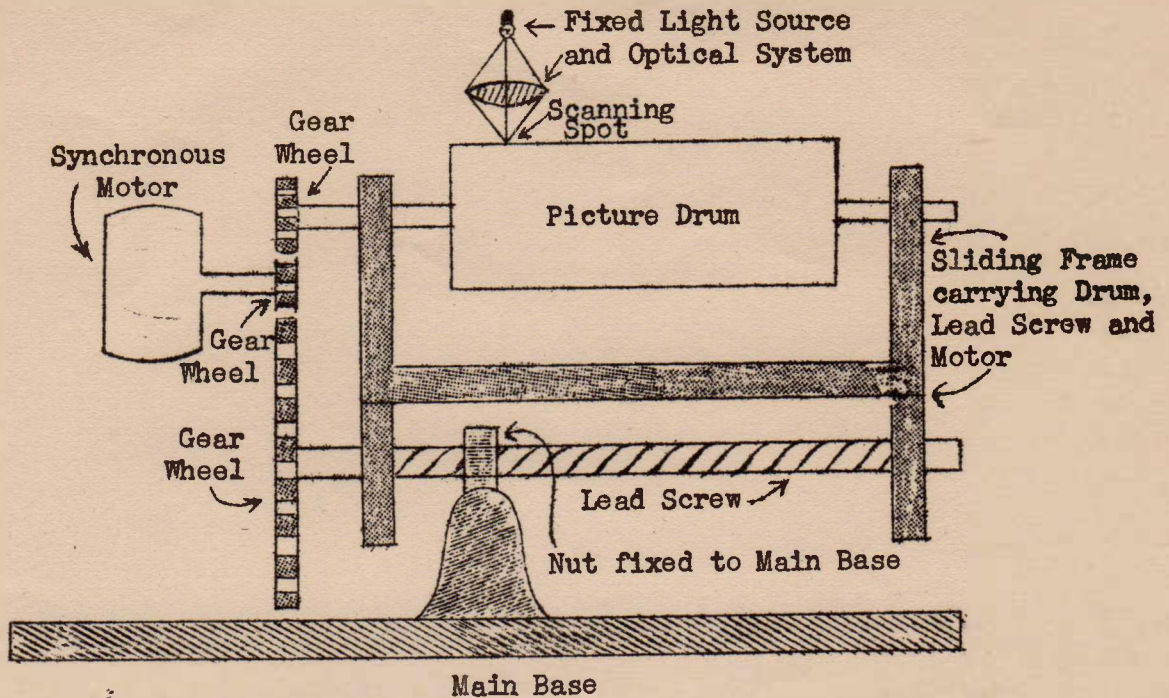

FIGURE 8.

along. The distance moved in one revolution of the drum should be equal to the width of a scanning line. If, for example, 100 lines per inch are used, the lead screw should shift position of the drum through only one-hundredth of an inch for each revolution. These conditions are obtained, and are fixed for good, by correct design of the gearing ratios in conjunction with the screw pitch.

The reason for the popularity of this drum spiral method of scanning is that both motions required for scanning are obtained from rotational movements. The method lends itself to great accuracy in tracing the scanning lines, and in synchronising receiver with transmitter (synchronisation is dealt with in detail in the next lesson).

The disadvantages of the system are :

- (1) The sheet of material to be transmitted must be of the special dimensions to fit the drum.
- (2) It does not lend itself to continuous operation of transmitter and receiver. When one sheet has been sent the apparatus must be stopped at both transmitting and receiving ends. This renders purely automatic operation at the receiving end impossible (see next lesson).

CONTINUOUS SCANNING METHODS:

Broadcast Facsimile for home purposes could never be really acceptable until satisfactory methods of continuously scanning a long roll of paper were developed. This necessitates the tracing of horizontal lines across the paper in a manner similar to that of television.

Various arrangements whereby the scanning "head" is given a reciprocating movement, moving the scanning spot to and fro across the paper, which is at the same time drawn slowly between rollers, have been tried. These, however, are, intrinsically, mechanically complicated, inaccurate, and difficult to synchronise.

One such arrangement, nevertheless, has proved fairly satisfactory. This utilises a special reverse lead screw. The latter consists of a shaft of steel having two screw grooves cut around it. One groove passes down the shaft rotating in, say, a clockwise direction. The other passes down the shaft rotating counter-clockwise. The two grooves are really continuous - each joins the other at both ends of the shaft. The construction of this ingenious device may better be realised by referring to Fig. 9. The reverse screw is placed lengthways at the base of the transmitter, and is stationary, except of course, for its rotational motion which is obtained from the synchronous motor. A "follower" engages the screw thread. This follower is simply a piece of metal shaped at one end to fit the groove. The follower cannot rotate, but is free to move along a slider parallel with the lead screw. As the latter rotates the follower moves at a uniform rate, say from left to right along the screw. When it reaches the end of the screw the grooves reverse as shown in the sketch, and the follower begins its reverse journey along the screw.

The follower conveys moving force to the analyzing head, consisting of the light source and optical system for focussing the light to a spot. In this way the scanning spot is given a regular to and fro horizontal movement. The transmitted information is printed on a long roll of paper which is passed between rollers, correctly geared to the motor. Hence as the paper passes slowly downwards in front of the analyzing head, the latter scans it in horizontal lines. Of course the speed of horizontal motion of the scanning head must bear a proper relationship to the speed at which the paper is passed through the rollers, in order that the scanning lines lie adjacent to each other.

It should be observed that this device gives a scanning action in horizontal lines somewhat similar to that made use of in television. There is one important difference, however. The reverse screw makes the analyzing head work in both directions; there is no quick "fly-back" as in television electronic scanning.

A continuous transmitter scanner which avoids the use of reciprocating parts is illustrated in Fig. 10. The paper to be scanned is moved, by means of friction rollers lengthwise along a semi-cylindrical surface. The picture is scanned by light spots through a slot cut across this semi-cylindrical form. The optical system consists of a pair of lens and prism "microscopes" which rotate on the axis of the semi-cylinder.

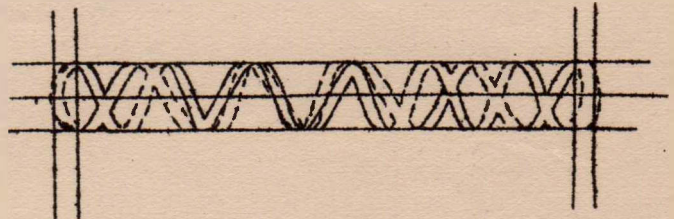

Suppose that the optical system is rotating clockwise when looking at it from the right-hand end of the diagram (Fig. 10A). Further suppose that at this instant the light-spot marked "A" (from the

FIGURE 9.

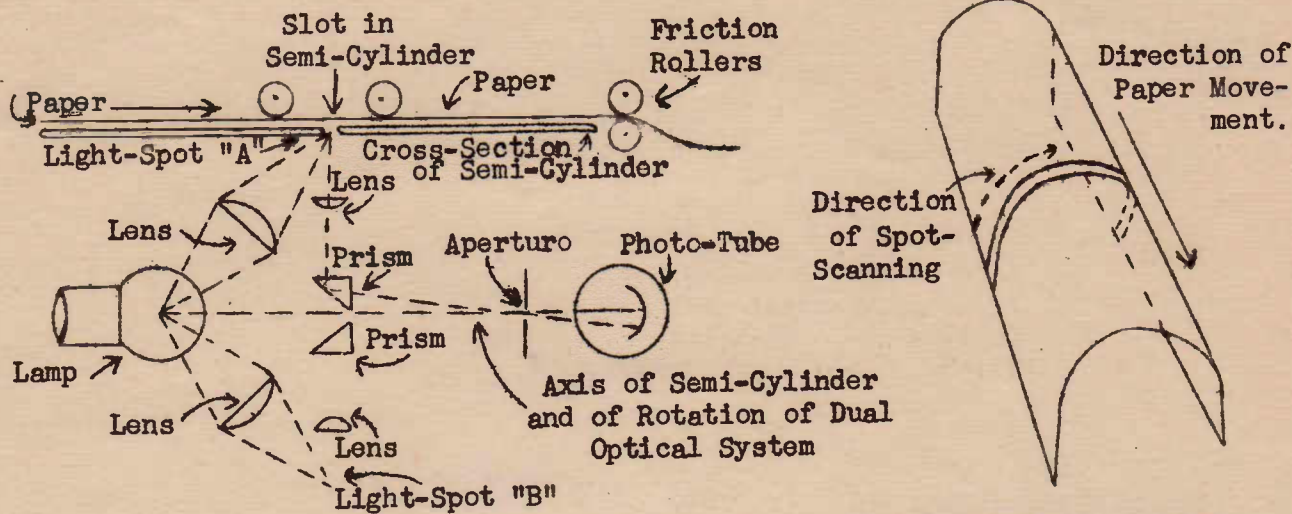

B. CONSTRUCTION OF SEMI-CYLINDRICAL GUIDE.

THE ALEXANDERSON SCANNER.
A CONTINUOUS TRANSMITTER SCANNER.

FIGURE 10.

upper lens-prism system in the figure) is just commencing to move along the slot at the left-hand edge of the paper. For the next half-revolution of the "scanning head" light-spot A will be scanning the paper. By the time this spot has passed right around the semi-circular groove light-spot B will just be commencing to scan along the latter from the left-hand edge of the paper. In the meantime, of course, the paper has been shifted through a small distance along the length of the semi-cylindrical guide, at right-angles to the groove. Hence the paper will be scanning by a series of nearly horizontal scanning lines. Note that the scanning occurs in one direction only across the paper, as in television.

The photo-tube is actuated by light reflected from the paper passing over the groove. This light is focussed and deflected on to the photo-tube by means of a lens and a prism, as shown.

This type of continuous scanner may be operated using a long length of paper unwinding from a spool at one end of the semi-cylinder on to another spool at the other end. Alternately individual pictures or articles of printed matter may be inserted at will into the scanner while the latter remains in continuous operation. There is no necessity to stop the scanning process in order to change copy or re-load. The only condition which needs be satisfied is that the width of the paper does not exceed the semi-circumference of the scanning surface.

MODULATION METHODS:

The lowest frequency of the picture signal is, theoretically, zero (an even picture tone). The highest frequency occurs when scanning the finest detail. In most commercial

applications, such as newspaper photo facsimile the highest frequency rarely exceeds 1,000 cycles per sec. and may be much less (e.g. 500 - 600 cycles per sec.). This permits of the direct modulation of a sub-carrier - the advantages of which have already been discussed. In the case of the commercial applications referred to the sub-carrier usually has a frequency of 1200-1300 cycles per sec. Home (broadcast) Facsimile usually demands a higher transmission speed, which produces a picture signal of higher frequency. This in turn means that the sub-carrier must be raised in frequency so that at least several cycles of sub-carrier are included in the highest picture frequency element. For broadcasting over an ordinary amplitude modulation station the highest sub-carrier which can conveniently be used has a frequency of about 3,000 cycles per sec. Such a sub-carrier could handle a picture signal ranging up to approximately 2,000 cycles per sec. This would produce side-bands (of the sub-carrier) between 1,000 cycles per sec. (3,000-2,000 cycles per sec) and 5,000 cycles per sec. (3,000 + 2,000 cycles per sec). Hence the latter figure (5,000 cycles per sec) would represent the highest modulating frequency for the radio-frequency carrier wave. The total band-width would be twice this, viz. 10,000 cycles per sec. which equals approximately one broadcast band channel.

Such a system as that referred to above for use in conjunction with a standard A.M. broadcast station can broadcast material at the rate of about 5 square inches per minute. This may sound slow, but it represents approximately 65-75 words per minute of ordinary printed matter.

In order to obtain faster transmission speeds the latest development in America is to make use of the F.M. broadcast stations. In this case a sub-carrier of 10,000 cycles per second is amplitude modulated with the picture signal. The resulting output is a band of frequencies extending from 7,000 cycles per sec. to 13,000 cycles per sec. Such a system can send 28 square inches of material per minute, which, in case of printed material, represents a rate much faster than can be read.

It will be observed that in each case cited so far the sub-carrier together with its picture signal modulation products lies entirely within the audio range. As a consequence the signal may, after conventional audio amplification be applied directly to the voice (microphone) circuits of a standard transmitter (A.M. or F.M.), as illustrated in Fig. 11.

GENERATION OF THE SUB-CARRIER:

Since the sub-carrier is of audio frequency it is usually generated by some non-electronic method.

One method is to insert in front of the photo-tube a chopper wheel which breaks the light-beam at a regular rate (the sub-carrier frequency). This wheel is usually driven by the scanning drive motor.

The frequency at which the light is interrupted is, of course, higher than the highest picture frequency obtained from the scanning process.

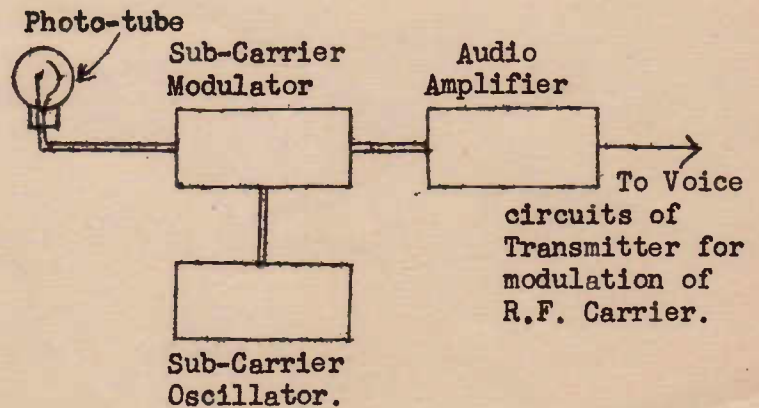

FIGURE 11.

When a uniform part of the picture (i.e. no detail) is being scanned the photo-tube output will consist of regular pulses of constant amplitude at chopper frequency. When a detailed part of the picture is scanned the reflected light varies with the detail, and the amplitude of the chopped pulses will vary accordingly. The result is really a modulated signal. Since the chopper rate is an audio frequency (say 3,000 cycles per sec) the output may be handled by a conventional audio amplifier.

A modulated sub-carrier may similarly be obtained simply by supplying the photo-tube from an A.C. source (at sub-carrier frequency) instead of using a D.C. source. The A.C. source is frequently an alternator (or A.C. generator) driven by the scanning motor, or it may be any convenient type of vacuum tube oscillator.

Another method of modulating the light-beam is that which makes use of a mirror galvanometer. The latter consists simply of a very small and light mirror suspended in the optical system of the scanner and caused to vibrate by means of an electro-magnet supplied with an A.C. at sub-carrier frequency. (See Fig. 12). As the mirror vibrates the amount of light which it passes through the aperture, and hence the intensity of the scanning spot varies. The result will be that the photo tubes output will be a pulsating current, modulated by the picture signal.

FREQUENCY MODULATED SUB-CARRIER:

In order to minimise the effects of electrical interference (including atmospheric)

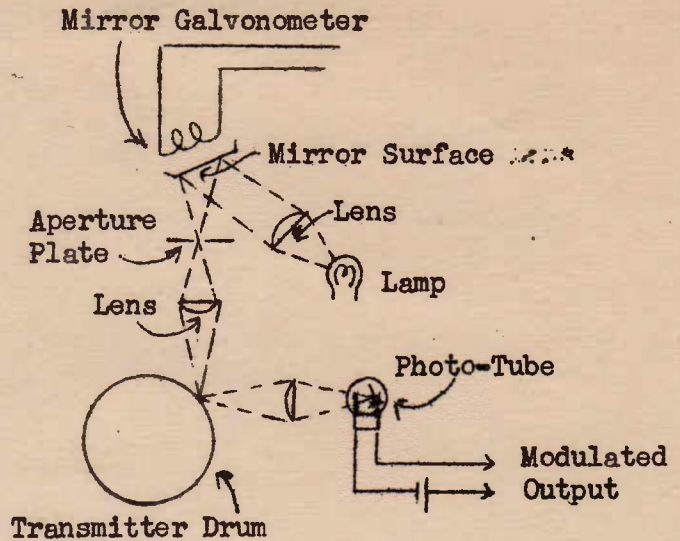

FIGURE 12.

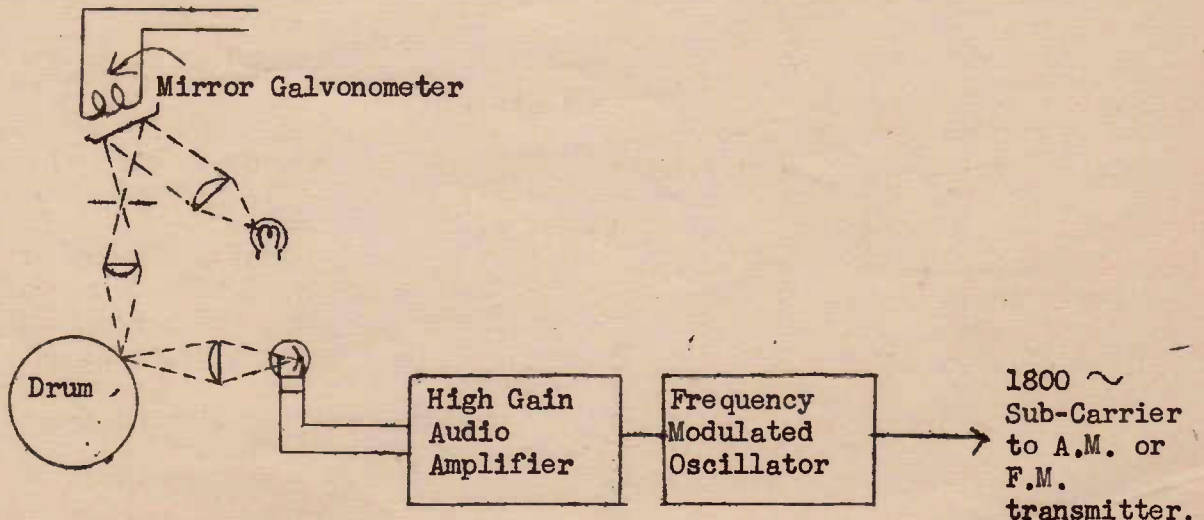

FIGURE 13.

frequency modulation of the sub-carrier is also used. One such system is illustrated in Fig. 13. Where an initial amplitude modulation is first produced by means of a mirror galvanometer (or chopper wheel etc.). This initial A.M. is introduced in order that the signal may be raised in level (by means of an ordinary audio amplifier) sufficiently to operate a frequency modulator. The latter is fed by an 1800 cycles per sec. sub-carrier frequency, and modulation produces a deviation of ± 200 cycles per sec. The deviation to 1600 cycles represents black and that to 2,000 cycles represents white. It should be closely noted that the modulated sub-carrier is represented by a range of audio frequencies between 1600 and 2000 cycles per sec. The output may therefore be used in several ways:

- (1) For direct transmission over a land-line.
- (2) For application to the audio circuits of a broadcast Amplitude Modulation Transmitter.
or
- (3) For application to the audio circuits of a broadcast Frequency Modulation Station.

Thus far we have traced the various methods whereby the visual information contained in a "still" picture or piece of printed matter may be converted into an electric signal suitable for transmission over conventional wire or radio links. It remains to investigate in greater detail the apparatus in use for reconvertng this signal back into a facsimile of the original. The main problems are those associated with the "recording", in a permanent manner, of the received information, and of synchronising the receiver and transmitter apparatus. These will be dealt with in detail in the next lesson.

QUESTIONS - LESSON NO. 19.

- (1) What are the two main differences in the requirements of a Facsimile system compared with those of a Television system ?
- (2) Why is it possible to transmit a facsimile signal over a sound broadcast station ?
- (3) Name a most important requirement of a home broadcast facsimile system which is not usually satisfied in most commercial applications.
- (4) Explain the reason for the use of a sub-carrier in radio facsimile transmission ?
- (5) What considerations fix the frequency of the sub-carrier in a radio facsimile system.
- (6) Into what two main classes may scanning systems be placed ?
- (7) A drum scanner has a circumference of 8" and a length of 12". If the drum rotates 100 revolutions per minute, and 125 scanning lines per inch are used, how long will it take to transmit the picture.
- (8) What is the main disadvantage of drum (spiral scanning) methods ?
- (9) Describe one method of producing a modulated A.F. sub-carrier ?
- (10) Describe one method adopted to minimise electrical interference with facsimile signals.

Please NOTE Postal Address: { AUSTRALIAN RADIO COLLEGE PTY.LTD.,
Box 43, Broadway, Sydney. N.S.W.

NOTE: Write the lesson number before answering the questions.

Write on one side of the paper only.

Always write down in full the question before you answer it.

Use sketches and diagrams wherever possible. One diagram in many cases is equivalent to pages of explanation.

Remember that you learn by making mistakes; so give yourself an opportunity of having your mistakes found and corrected.

Don't hesitate to ask for further explanation on any point, we are always ready to help you.

Write your name and full address at top of paper. If you have made arrangements with the College to have your lessons returned to any particular address state this at the top of the page.

AUSTRALIAN RADIO COLLEGE

E. S. & A. BANK BUILDINGS, Corner CITY RD. and BROADWAY, SYDNEY

Telephones: M 6391 and M 6392.

Post Lessons to Box 43 Broadway

This lesson sheet is published for the exclusive use of students of the Australian Radio College Pty. Ltd.
(All rights reserved)

T. FM & F. - LESSON NO. 20. FACSIMILE RECEIVERS.



When we refer to a Facsimile Receiver we naturally mean the complete apparatus which accepts the signal produced and sent out by the transmitter, and uses it to reproduce a copy of the original information. In the case of radio facsimile this apparatus will consist of a more or less conventional radio receiver (less audio stages and speaker) together with the "recorder". The latter comprises a rectifier (detectors), amplifier, mechanical scanning system including electric motor, and apparatus for synchronising purposes. For reception of signals sent by wire, where no radio frequency carrier is used, the receiver will consist of the recorder section only, together with an additional small amplifier similar to an audio amplifier, for raising the signal to the desired level.

As we have seen in the previous lesson the usual practice at the transmitting end is to superimpose the "picture" signal on a sub-carrier and then to use this modulated sub-carrier as the modulation voltage for the transmitted r.f. wave. Since the sub-carrier, together with its side-frequencies lies entirely within the audio frequency range, it is obvious that any radio receiver designed to operate in conjunction with the transmitter will handle the signal just as if it were handling speech or music. In fact when a broadcast transmitter is handling a facsimile signal any sound receiver tuned to the station will emit a continuous whistling sound. This sound, of course, is due to the de-modulated audio frequencies representing the facsimile sub-carrier and its side frequencies.

The facsimile signal, represented by the modulated sub-carrier is taken directly from the radio receiver's detector stage. After undergoing a stage of amplification it is applied to a diode detector (rectifier) which separates the "picture" signal from its sub-carrier. It will be remembered that the sub-carrier is frequently not very much higher in frequency than the upper limit of the picture signal itself. Hence the value of the filter condenser(s), which follows the detector and whose purpose it is to by-pass the carrier while not affecting the modulation, is rather critical. Too small a capacity will not

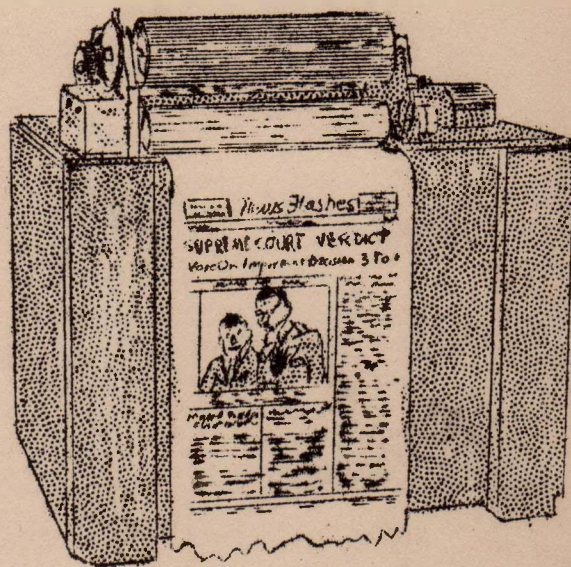

A Modern Home Recorder.

FIGURE 1.

remove the sub-carrier sufficiently, while if this condenser is too large it will unduly attenuate the higher-frequencies of the picture-signal with resultant loss in detail. In ordinary sound radio work the carrier frequency is normally at least 50 times the highest audio frequency. Hence practically any small mica condenser (.0001 - .0005 mfd, say) will effectively remove the r.f. component without affecting the audio frequencies appreciably. In facsimile work, on the other hand, the sub-carrier may have a frequency only 1-1/2 or 2 times the highest picture frequency. It requires fine judgment, therefore, in choosing a capacity which will differentiate between these two frequencies. In replacing such a by-pass condenser it is important to use one having a capacity exactly equal to that originally inserted by the designer. Instead of a simple by-pass condenser a more elaborate filter, consisting of inductors and condensers tuned to resonate at and reject the sub-carrier frequency, is often used.

After detection (of sub-carrier) the picture signal is passed on to the printer amplifier. The nature of this amplifier depends upon the particular method of "recording" used (see below). In all cases, however, this amplifier must be of the D.C. type, i.e. it must not contain capacity coupling in either its grid or plate circuits. The reason for this, of course, is that the picture signal involves frequencies ranging from zero (direct current) upwards. Use of a capacity coupled amplifier would result in loss of the D.C. component of the signal, which, in turn, would result in elimination of the normal shading of the picture. Only the fine detail would be reproduced.

The circuits described above, and which normally form part of a complete recorder unit, are shown in "block" form in Fig. 2. Sub-carrier detectors and recorder amplifiers will be treated in more detail at a later stage in this lesson.

RECORDING METHODS:

Perhaps the most interesting section of a facsimile receiver is that part which gives the visual reproduction of the original information scanned at the transmitter.

A very large number of methods of recording or printing have been developed. Each of these usually has its own particular merits, and the method used in any particular instance depends largely upon the application of the facsimile systems under consideration. The chief methods may be classified under the following headings :-

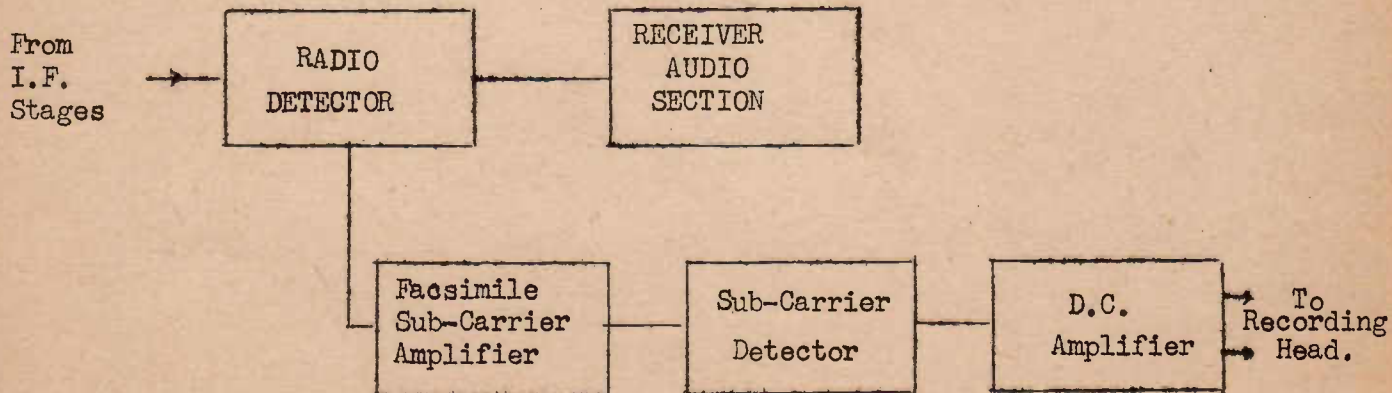

FIGURE 2.

- (1) Purely mechanical.
- (2) Photographic.
- (3) Heat methods.
- (4) Ink Spray Method.
- (5) Carbon Paper.
- (6) Electro-chemical (Electrolytic) Methods.

MECHANICAL RECORDERS:

Under this heading we have systems in which some kind of stencil (as used on an ordinary office duplicating machine) is wrapped around the receiver scanning drum. An electromagnetic precussion unit takes the place of the light-source of the transmitter. This electromagnetic "scanning head" punctures the stencil as dictated by the electrical signal while the scanning process proceeds. Of course, only line drawings, plans, and print can be reproduced in this way. When the process is complete the stencil is removed and may be used as a master copy on an ordinary office duplicating machine to produce as many copies of the original as desired.

For business use a transmitter and recorder may be mounted on one carriage with a double length drum. The material to be duplicated is wrapped around the drum at one end, while the stencil is wrapped around the other end. The optical system and photo-cell then scan the original on one half of the drum, while the precussion unit re-produces the copy as a stencil on the other half. This machine can be made to operate with a minimum of controls, and is useable by general office staff with no particular training.

PHOTOGRAPHIC METHODS:

The photographic method is still the best for re-producing a photograph of high tonal quality. Either a photographic "positive" film or "negative" paper is wrapped around a drum similar to that of the transmitter. A light source and optical system for focussing the light onto the drum is used. The mechanical scanning mechanism is usually a replica of that at the transmitter. As the photographic film (or paper) is scanned in spiral lines the facsimile signal varies the amount of light falling on it.

The light falling on the film may be varied in several ways, two of which will be described here. The first is an electrical method which is very simple. This makes use of what are variously known as "Glow Tubes", "Crater Tubes" or "Hot Dogs". These are simply tubes of the neon type constructed so that the glow takes place in a crater formed in one of the electrodes. This provides a fairly brilliant point-source of light, i.e. the light emanates from a very small area, and so may be focussed to a fine point for scanning purposes. The simple system is illustrated in Fig. 3.

The neon type lamp is used because light emitted will vary instantly with variations in signal current, and also because a small source of light may be obtained as described. Furthermore a neon tube may be operated by a very small current at one or two hundred volts. Hence it may be fed by the plate current of an ordinary valve to whose grid the signal is applied (see "Printer Amplifiers" below).

The second method of varying the intensity of the light spot is a mechanical one. Here a steady source of light from a filament type lamp is used and the method involves "valving" the amount of light reaching the film. This may be achieved by means of a mechanical "oscillograph", and light apertures as shown in Fig. 4.

Light from the lamp is focussed on to the mirror of the oscillograph. This mirror is free to turn and is actuated by a "moving-coil" in the magnetic field of a magnet. The coil of the oscillograph is fed by the rectified signal. Light reflected from the mirror is thus caused to sweep across a fixed aperture so that more or less light passes this aperture depending upon the strength of the signal. The light that passes the aperture is then focussed on to the sensitised paper or film on the drum. The aperture which receives the light reflected from the mirror of the oscillograph is specially shaped so that the variations in the amount of light which it passes, in relation to the signal amplitude, is adjusted to produce the correct tonal shadings in the reproduced picture.

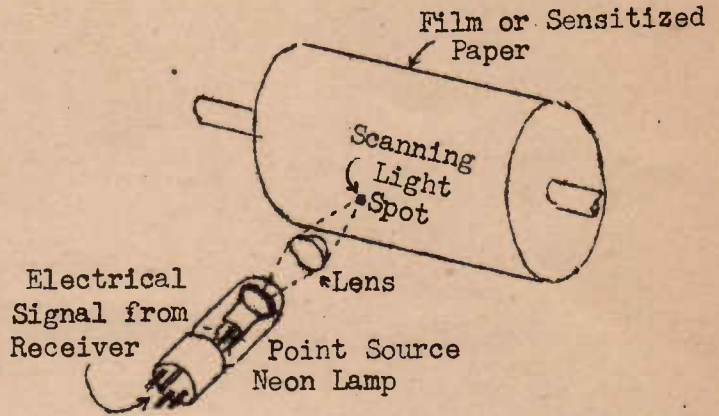

FIGURE 3.

INK SPRAY METHOD:

In this recorder a continuous spray of atomised ink projected onto the paper is used. The spray is regulated by a balanced armature magnetic driver, which is fed by the received rectified signal. The scheme is shown in simplified form in Fig. 5.

A fine jet of "atomised" ink is continuously emitted by the nozzle. The amount of ink which reaches the paper on the drum, however, is regulated by the signal which operates the deflecting wave. In this way, as the paper is scanned, the various shades of dark and light are reproduced. Plain white paper, of course, is used on the drum for recording. The picture requires no special processing after the scanning is completed.

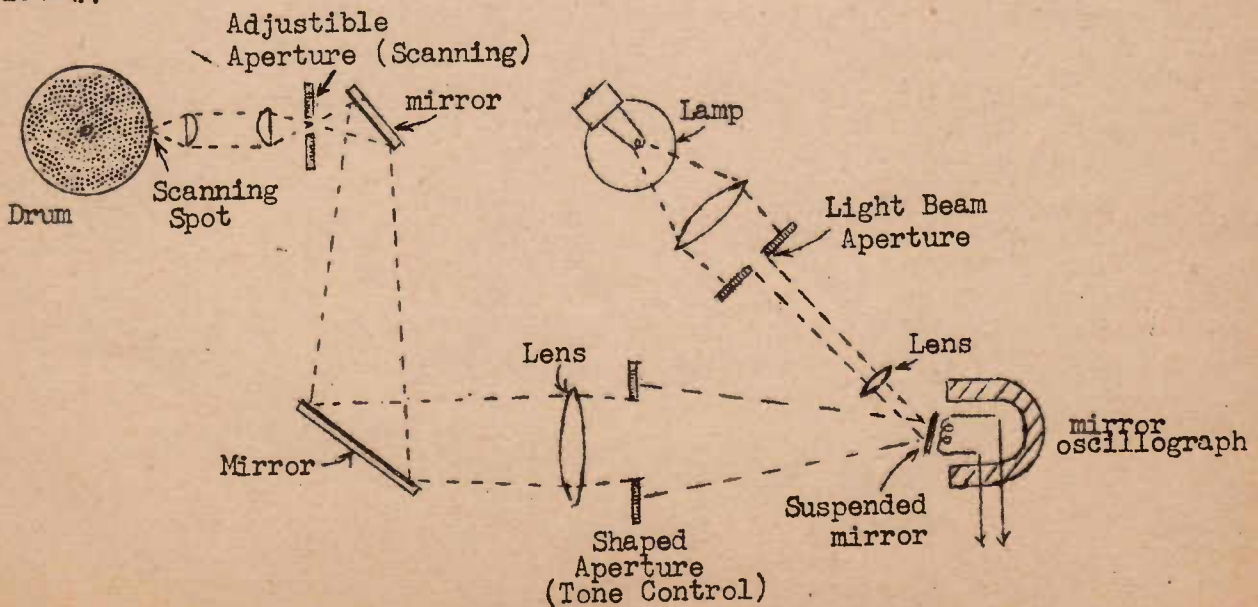

FIGURE 4.

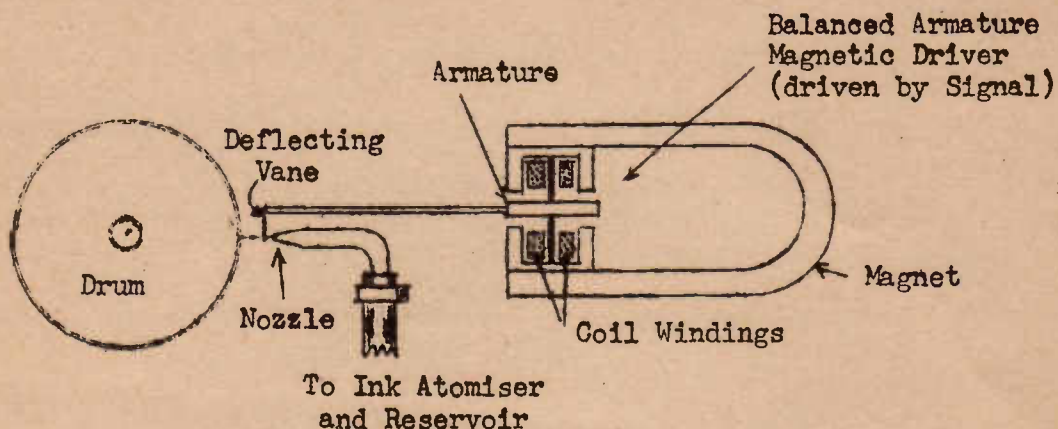

FIGURE 5.

HEAT METHODS:

There are two types of paper which are sensitive to heat: Chemically treated paper usually with a coating of some nickel salt, and waxed papers. In both cases a fine jet of heated air, regulated by the signal, is directed on to the paper surface.

In the case of the heat-sensitive paper the heat decomposes the salt on the surface leaving a black residue. The degree of darkness produced depends, of course, on the amount of heat applied, and this is regulated by the electrical signal which operates on the hot air jet.

When waxed paper is used the heat of the jet melts the wax surface. When the scanning is complete the paper is washed over with water ink. The difference in the inking between the areas of crystalline (unmelted) and melted wax provides the difference in intensity of the picture.

A third type of paper, of recent development, which might be included under this heading of "Heat methods" is that by the name of "Teledeltos". This paper is coated on one side first with a layer of carbon and then with finely divided metal. The metallised surface is placed in contact with a metal recording drum. The scanning "point" is a metal stylus which presses against the outer surface of the paper. The received signal, at about 100-200V is applied between the stylus and the metal drum with the result that burning of the paper takes place producing a dark mark. The latter is due to the black carbon showing through where the burn has occurred. The intensity of the burn depends upon the potential applied, and this is determined by the signal voltage; gradations of tone are therefore obtained.

CARBON PAPER:

In this system a sheet of plain white paper is placed on the recording drum. A sheet of carbon paper is placed face downwards over the white paper. The scanning is done by means of a metal point (stylus) actuated by a simple electro-magnet. The signal current is passed through the coil of this electro-magnet which applies varying pressure to the stylus. The heaviest pressure would produce black, and no pressure would give white.

An advantage of this carbon paper method is that as many as eight separate copies may be produced at a time with the one scanning process. Carbon paper is specially adaptable to the "helix" method of continuous scanning, described later in this lesson.

ELECTRO-CHEMICAL METHOD:

This method actually goes back to the earliest history of facsimile (Bain's system 1842); it also represents the very latest in fast, continuous recording for home receivers.

The principle of operation depends upon the fact that when an electric current is passed through certain chemicals, a chemical change, resulting in a change in colour, or darkness, occurs. Paper is impregnated with such a chemical and the rectified signal current is caused to pass through it. The paper turns dark to an extent depending upon the signal current amplitude. In earlier recorders the paper was wrapped on a metallic scanning drum and the scanning point was represented by a metal stylus. The signal was applied between the stylus and drum. In the case of the latest system the helix type scanner (see below) is used.

For many years the Electro-chemical paper recording was not very popular, for the reason that the papers available had to be wet while the recording was proceeding. Furthermore many of the papers had to be processed afterwards in order to obtain a permanent recording. However, in very recent years papers have been developed which operate in a dry condition, require no processing, and give an instantaneous record as the scanning proceeds.

REQUIREMENTS OF A HOME FACSIMILE RECEIVER:

Facsimile systems for commercial purposes have been very successfully used for a number of years. Most of these, however, are not suitable for home use, for several reasons. In the first place they usually require more or less skilled operators and are not automatic in operation. It is usually necessary to replace the paper or film on the recorder after each scanning. This re-loading process usually requires several minutes. Again many of such systems use a type of printing which requires special processing after the scanning process is complete.

The principal requirements of a home unit may be summarised as under :-

- (1) The scanning should be continuous.
- (2) The scanning rate should be fast - in the case of printed matter at least as fast as can be read.
- (3) The printing should be visible while the recording is proceeding.
- (4) The recorded material should not require any processing in order to make it visible or permanent; in addition the use of moist or wet papers for recording should be avoided.
- (5) Synchronisation and Phasing (see below) should be automatic.
- (6) The recording paper should be comparatively inexpensive.

Consider now the relative merits of the various recording methods which have been described. The photographic method gives the best pictures as far as tonal quality is concerned, but does not satisfy conditions (1), (3) (usually), (4) and (6) above. The heat methods frequently require special processing and utilise tricky apparatus to produce the jet of hot air. The "Teledeltos" paper, which is really a burning method

has proved quite satisfactory. Ink Sprays are not adaptable to fast operation and are best suited for pure black and white reproductions. The carbon paper method is particularly adaptable to continuous recording, and immediately prior to the war was the most favoured method for home recording. The chief objection to this method is that the speed of operation is limited. This is due to the fact that the printing mechanism is mechanical, consisting usually of a stylus or printer bar operated by electromagnets. The inertia of such a system limits the scanning speeds which may be used. However, speeds which produce 4-1/2 square inches of useful recording per minute are obtainable. This represents, in the case of printed matter, 45 words per minute, of type writing, or 110 words per minute of typical newsprint. This may be regarded as satisfactory for printed material, but is really too slow when reproducing pictures, diagrams, plans etc.

Another disadvantage of the carbon paper method is that the printed matter does not show up immediately it is produced. This, of course, is due to the fact that the carbon paper obscures the recording paper. However, in some systems, it is possible to see the result soon after the signal has been received.

The electro-chemical sensitive papers were not at first suitable for home recording because they had to be used in a wet condition. Furthermore, some of them required processing to give a permanent record. However, in very recent times, papers have been developed which operate dry, which give an instantaneous impression, a permanent recording, and which are reasonably inexpensive. This development has given a tremendous impetus to home broadcast facsimile. A modern system - the Hogan system in America - uses such a recording paper and operates at a speed which gives over 28 sq. inches of material per minute. In the case of printed matter this is a speed very much faster than can be read or spoken.

CONTINUOUS RECORDING:

Continuous recording necessitates the use of a long strip of paper which may be gradually used by winding from one spool to another. The scanning must obviously be performed in horizontal lines across the width of the paper.

The earlier attempts at continuous recording involved a scanning head to which was given a to and fro (reciprocating) motion to trace out the lines. Such a reciprocating motion, however, required mechanical apparatus which was complicated and inherently inaccurate. Furthermore, the synchronisation of such apparatus was extremely difficult. This problem was solved by the development of the helix type of scanning recorder (mentioned earlier in this lesson). Since this device was developed in the first place for use with carbon paper we shall describe it as such, and then show how a slight modification (and simplification) renders it suitable for use with electro-chemically sensitive paper.

The secret of this device is the helix itself. A helix is like a single thread of a screw drawn around the surface of a cylinder, and may be visualised with the aid of Fig. 6. Starting from a point "A" at one end of the cylinder, on its surface, we draw a curve which completely encircles such cylinder once, and finishes up at a point "C" at the opposite end. One-half of this curve - from A to B - would be visible in this figure. The other half - from B to C - is on the rear surface of the cylinder and could not be seen.

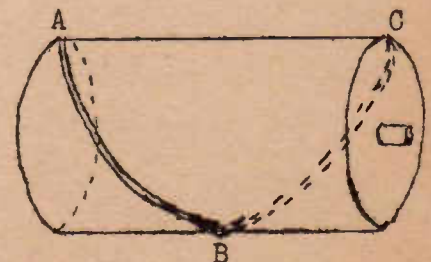

FIGURE 6.

Hence it is shown by a dotted line in the diagram.

In the actual apparatus the helix is a ridge of metal encircling a scanning cylinder. The carbon and recording paper is not wrapped around this cylinder, but is slowly drawn over it by means of rollers (see Figs 7 and 7A). The cylinder simply acts as a guide. A Printer Bar, operated by an electromagnet, bears across the whole width of the paper. The paper is "pinched" at one point only at a time - at the point where the bar is pressing against the raised helix.

Imagine now that the paper is stationary (i.e. paper feed rollers not working) but the scanning helix is rotating at 75 r.p.m. The point of intersection of the printer bar with the raised helix (i.e. the scanning "spot") will move horizontally across the paper at the rate of 1 "stroke" or line in $1/75$ th of a minute. The carbon will trace out a dark line horizontally across the white paper (assuming that the printer bar is depressed). As the helix continues to rotate the same line would be traced over and over again. Suppose now that the paper rollers are set in motion drawing the paper through at a slow rate corresponding to a displacement equal to the thickness of a scanning line for one revolution of the helix (i.e. in $1/75$ minute). The recorder will now trace out nearly horizontal scanning lines across the paper, each line lying adjacent to the next.

The signal is applied to the printer bar driver giving a push-pull action which raises the bar off the paper for "white", and presses it down heavily for "black". Half-tone signals will depress the bar with a force depending upon the shade of the original picture element. In this way the whole "picture" will be built up in a manner analogous to the action which occurs in a television system which does not use "interlacing" of the lines.

It should be observed (Fig. 7A) that after the two strips of paper pass under the printer bar the carbon is separated from the white. The carbon paper is led away by a guide to

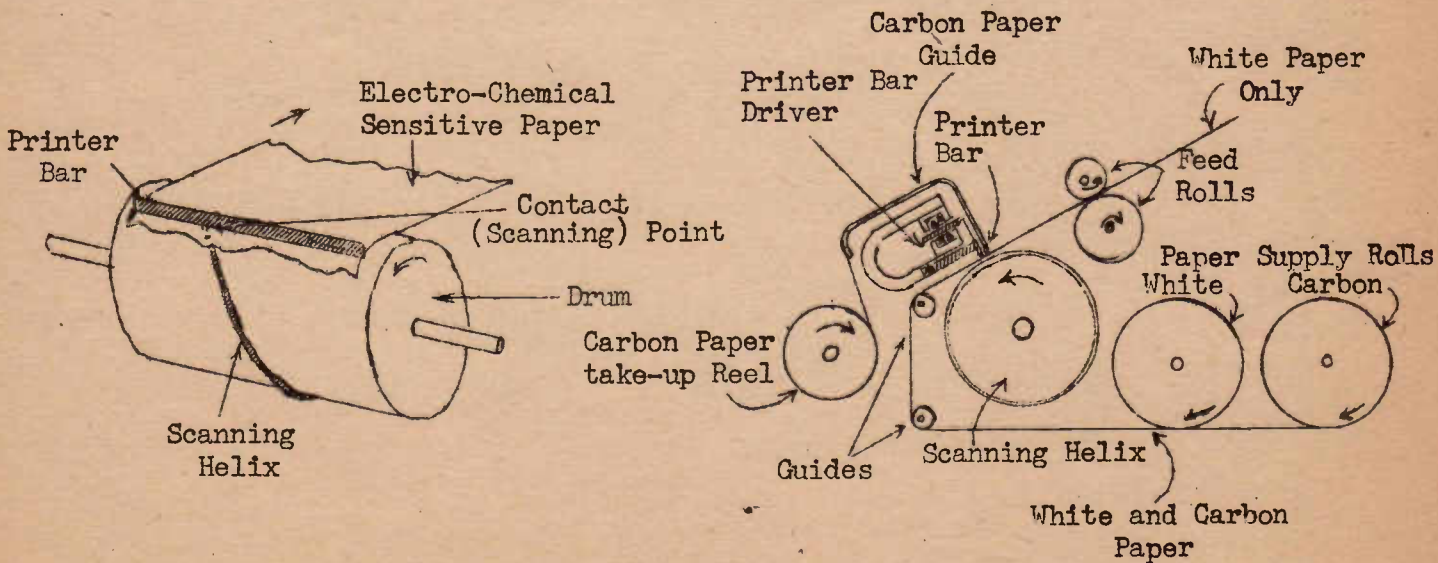

FIGURE 7.

FIGURE 7A.

a separate reel which stores it until the recorder is re-loaded. The purpose of this is to allow the "reader" to see the received information soon after the actual recording takes place. Thus one of the chief disadvantages of older systems of carbon recording is overcome.

From the above description of the action of this recorder it will be seen that the speed of the linear motion of the paper through its rollers must bear a fixed relationship to the speed of rotation of the scanning helix. This relationship is easily obtained, and fixed for good, by driving both paper-feed rollers and helix from the one motor through suitable gears.

The important thing about this ingenious type of recorder is that while producing a to and fro motion of the scanning "point" there is no such reciprocating motion of any of the mechanical parts. All mechanical motions involved in the actual tracing of the lines are rotational. Hence this recorder is just as mechanically accurate in operation and as easy to synchronise as the drum type where the paper is wrapped around the cylinder.

THE HELIX RECORDER WITH ELECTRO-SENSITIVE PAPER:

This represents the latest thing in fast, continuous, easily operated, home recorders. The printer bar is replaced by a simple metallic blade which rests across the paper very much as shown in Fig. 7. The signal, at 100-200V, from the output of a D.C. voltage amplifier is applied between the printer blade and the metal helix.

The manner in which the "lines" are traced out is exactly similar to that as described in connection with the carbon recorder. There is, however, now no motion of the printer blade. The picture signal forces a minute current through the paper which is treated with a chemical which turns dark to an extent depending upon the voltage applied. The Hogan System in America - mentioned earlier - uses this helix recorder with sensitised paper. The paper is supplied in rolls 400 ft. long and $9\frac{1}{2}$ inches wide. This is sufficient for 24 hours continuous operation, or 2 to 4 weeks, of normal home service. The loading of the recorder with the paper is somewhat similar to the re-loading of a camera, and is even simpler to carry out.

In the Hogan Recorder the helix drum rotates at the rate of 360 r.p.m. This means that 360 scanning lines are traced every minute. The number of lines per inch is 105. Hence the length of paper scanned per minute is $360 \div 105 = 3\frac{1}{2}$ " (approx). Since the paper is $9\frac{1}{2}$ inches wide the area scanned per minute should be $9\frac{1}{2} \times 3\frac{1}{2} = 33\frac{1}{4}$ square inches. Allowing for margins a useful area of information equal to 28.1 square inches is actually obtained every minute.

The frequency range of the facsimile signal (sub-carrier and side-bands) is 7,000-13,000 cycles, which may be easily handled by an F.M. broadcasting system, although the frequency is too high for A.M. stations. The home recorder, complete with its associated circuits (pre-amplifier, sub-carrier detector, and recorder amplifier) is supplied for attachment to any F.M. receiver. The size of the recorder unit is about that of a typewriter.

An even smaller and cheaper recorder is represented in Fig. 8. This unit produces a single column 4.1 inches wide at the same scanning rate and speed as the unit just described, namely 105 lines per inch and approx. 3.5 inches per minute. Thus it scans approx. 14 square inches per minute.

HOME BROADCAST OPERATING TECHNIQUE:

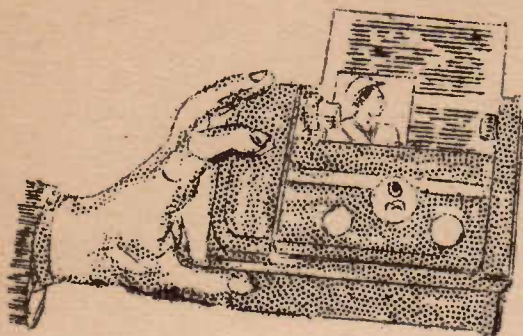

A SMALL HOME REPRODUCER.

FIGURE 8.

The range of material which may be used for a home service is very large. We might mention, for example, the following: latest news flashes (home newspaper), weather information (including maps), diagrams, charts etc. to illustrate talks and educational topics put out over the oral system, receipts for the housewife, photographs of the latest events in the day by day life of the nation etc.

With the systems in operation at present it is not possible to send facsimile and speech over the same broadcasting station - one would interfere with the other. Instead

broadcasting stations mainly use the hours from 12 mid-night to 6 a.m. for facsimile. In these six hours the home recorder can be continuously receiving and recording visual information. When the citizen arises in the morning he has available about 100 ft. of paper $9\frac{1}{2}$ " wide printed with a wide variety of information. The continuous recorder makes this possible.

Although several systems of continuous scanning at the transmitter were mentioned in the previous lesson, it is not necessary to use these in a system designed for continuous automatic recording in the home. The helix arrangement is not suitable for adaptation to transmitter scanning, and the other types described in the last lesson have disadvantages which usually outweigh their advantages. As a result the drum method of spiral scanning is still largely in favour.

In order to see how spiral drum scanning may be used in conjunction with helix continuous recording we shall describe what is done in the case of the Hogan system.

At the transmitter the information is printed on sheets $9\frac{1}{2}$ " wide by 12" long. A drum of length 12" and circumference $9\frac{1}{2}$ " (diameter approx. 3") is used. A sheet is wrapped in the drum so that its $9\frac{1}{2}$ " dimension passes around the drum, the 12" dimension being along the drum. Note that the lines of printed matter will encircle the drum. With spiral scanning the length of a scanning line is approx. equal to the circumference of the drum - in this case $9\frac{1}{2}$ ". If now both transmitter drum and receiver helix are rotated at the same speed (360 r.p.m. in the case of the Hogan system) the "lines" will be traced at the speeds at both transmitter and receiver. When the whole length (12") of the transmitter drum has been scanned, the home recorder will have printed a strip of paper 12" long (and $9\frac{1}{2}$ " wide).

It must be remembered that the home recorder is passing paper through continuously. In order that no large blanks appear on the paper it is important that no time is lost at the transmitter between the end of the scanning of one 12" x $9\frac{1}{2}$ " sheet and the beginning of the next. This is simply taken care of by providing several drum scanning units at the transmitter. By the time one scanning is complete the transmission of the next sheet is commenced by switching from one scanning unit to the next.

RECORDER AMPLIFIERS:

By the "Recorder Amplifier" we mean a circuit which will accept the signal (modulated sub-carrier, from a conventional receiver) and then perform the two functions (1) Detect the modulated sub-carrier, (2) Amplify the separated picture signal in a manner suitable for operation of the particular type of recording unit used.

There is nothing new about the detection process. Diode detection is usually employed. However, full-wave rectification (as in an ordinary receiver power unit) is generally the rule. The advantage of this is that the sub-carrier component which has to be filtered out after rectification has double the frequency of the sub-carrier itself. This may be seen by referring to Figure 9, and also by considering the action of the conventional power-supply rectifier. Thus the filtering (by-passing) of the carrier component from the picture signal (represented by the modulation) is more efficiently carried out.

The final recorder amplifier itself must be, as already stated, of the D.C. type. Recorder amplifiers may be classified thus:-

- (1) Those giving increased output on "black" signal, i.e. on decrease in sub-carrier amplitude.
- (2) Those giving increased output on "white" signal, i.e. on increase in sub-carrier amplitude.
- (3) Those designed for operation of a "push-pull" printer as used in ink, carbon etc. recorders.

It will be recalled that the transmitter photo-tube's output is a maximum when scanning white. Further, since direct modulation of the sub-carrier is used the latter will have maximum amplitude for white and minimum for black. In all those recorders which print on white paper the amplifiers output should be zero on a "white" signal (maximum sub-carrier amplitude) and the output should be a maximum on a black signal. If this is the case a white signal will leave the white paper unmarked and a black signal will actuate the printer (mechanically, photographically or mechanically) to produce a dark mark. On the other hand an increased output from the amplifier might be required to produce a white mark on the finished product. This is the case when recording on a photographic "negative" film. It is also the case with some types of electrically sensitive paper where the paper itself is black, or coloured, and the signal breaks the coloured chemical down to produce white.

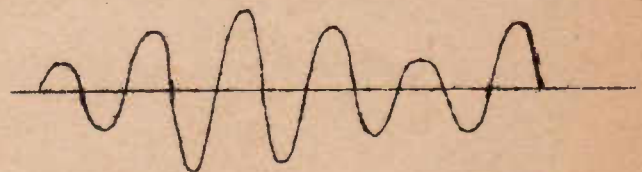

A. Modulated Sub-Carrier

Carrier pulses have frequency double the Sub-Carrier.

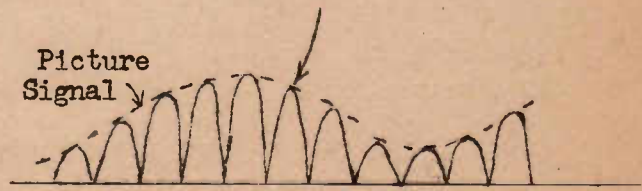

B. Rectified Sub-Carrier
(Full Wave Rectification)

FIGURE 9.

An example of type (1) amplifiers is shown in

Fig. 10. The modulated sub-carrier is applied to the detector (a duo-diode) through an audio frequency transformer having a centre tapped secondary. The rectified output

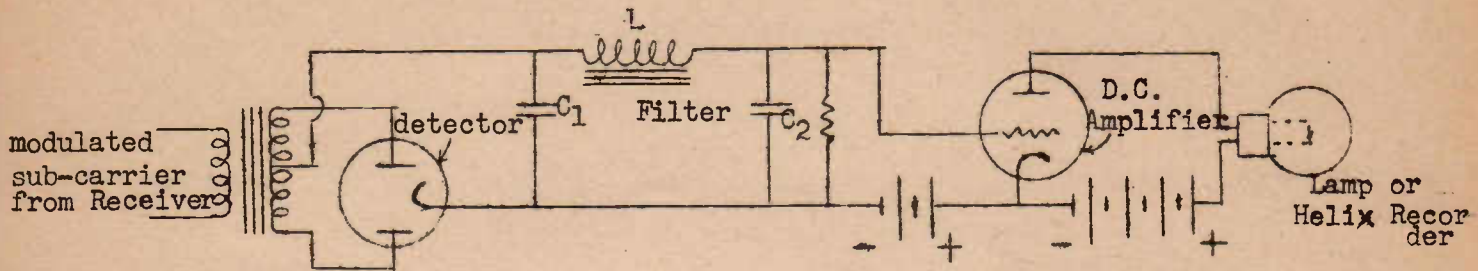

FIGURE 10.

is filtered from the sub-carrier component by means of the filter L , C_1 , C_2 and directly coupled to the amplifier valve. The latter is biased by means of the battery (or equivalent) and the output from the detector. The bias is such that when "white" is being transmitted (maximum amplitude sub-carrier) the tube is cut-off. Any decrease in sub-carrier amplitude due to a darker portion of the picture being scanned will reduce the negative potential of the transformer centre-tap (measured relative to the rectifier's cathode). This reduces the negative bias on the amplifier grid, and plate current will flow through this tube. When sub-carrier amplitude is a minimum (pure black) the plate current should have its maximum allowable value.

By reversing the output from the filter section to the amplifier this circuit may be converted into the type (2) above. In this case the bias should be adjusted so that its nett value when sub-carrier is at minimum amplitude (black) is at the cut-off point. Then any increase in amplitude (change towards white) will reduce the negative bias allowing plate current to flow.

With reference now to the third type of amplifier specified above it should be pointed out that any mechanically operated recording "head" (e.g. stylus, printer-bar) could be operated with an electro-magnet driver applying force ~~in a~~ single direction, say downwards on to the paper when a black signal is received. The printing device could be lifted by means of springs for a white signal. Such an arrangement, however, due to the inertia of the "head" does not work well at high frequencies. Hence it would be suitable only for slow recording rates or where no great detail is required.

The push-pull balanced armature type drivers, as used on the helix-type carbon recorders are somewhat similar in construction to the old magnetic type speakers. A pair of coils are wound on a soft iron armature which is balanced in the field of a permanent magnet. The polarities of the coils are such that the current through one causes the armature to be pushed in one direction, while the current in the other tends to move the armature in the opposite direction. If both currents are equal the nett force on the armature is therefore zero. When, however, one current exceeds the other the armature is pushed, or turned, in a direction depending upon whichever coil is carrying the larger current. In this way a push-pull action is conveyed to the stylus or printer bar via an arm connected to the armature.

A circuit suitable for operating such a balanced armature driver is shown in Fig. 11.

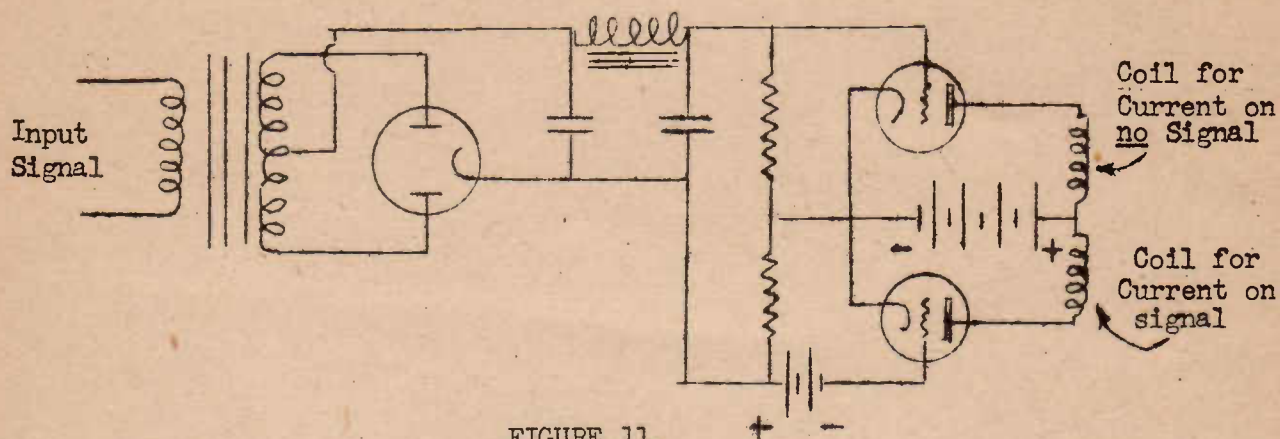

FIGURE 11.

The input system of rectification and filtering (detection) is the same as before. Two output tubes, acting as a sort of push-pull amplifier are used. When no signal (or minimum signal) is received the lower tube is biased to cut-off, while the upper tube operates with zero bias, and therefore carries full plate current; under these conditions the upper coil would hold the stylus or printer bar hard down on the paper to produce black.

When the signal amplitude increases towards full white, a negative bias (due to the rectified signal voltage) is applied to the upper tube resulting in a reduction in its plate current. At the same time the rectified signal reduces the negative bias on the lower tube, allowing plate current to flow through the coil to which it is connected. The net result of these two actions is that the armature pressure on the printer bar is reduced. When maximum signal (full white) is received the upper tube is cut-off and the lower carries full plate current. The effect of this is to reverse the force on the printer bar, and hold it off the paper. If the amplifier is properly designed the sum of the plate currents of the two tubes is constant for all input signal amplitudes.

A practical circuit, showing push-pull amplifiers connected to a pair of drivers working a printer bar is shown in Fig. 12. Here two full-wave rectifiers are used. The upper full-wave rectifier utilises the pair of diode plates in the 6R7 tube whose triode section is merely a pre-amplifier for the modulated sub-carrier signal. The outputs from the two rectifier systems varies the bias on the two output tubes in a manner similar to that of the previous circuit. Note that the lower tube is biased to cut off (as in Figure 11) while the upper has zero bias when signal amplitude is zero.

The use of the two electro-magnetic drivers is usually considered necessary when operating a long printer bar, in order to give uniform action along its whole length. These, however, are simply connected in series with each other.

TRANSMITTER-RECEIVER SYNCHRONISATION:

So far we have been assuming that the transmitter and receiver scanning drums have been rotating at exactly the same speeds and have started off in step with each other. We

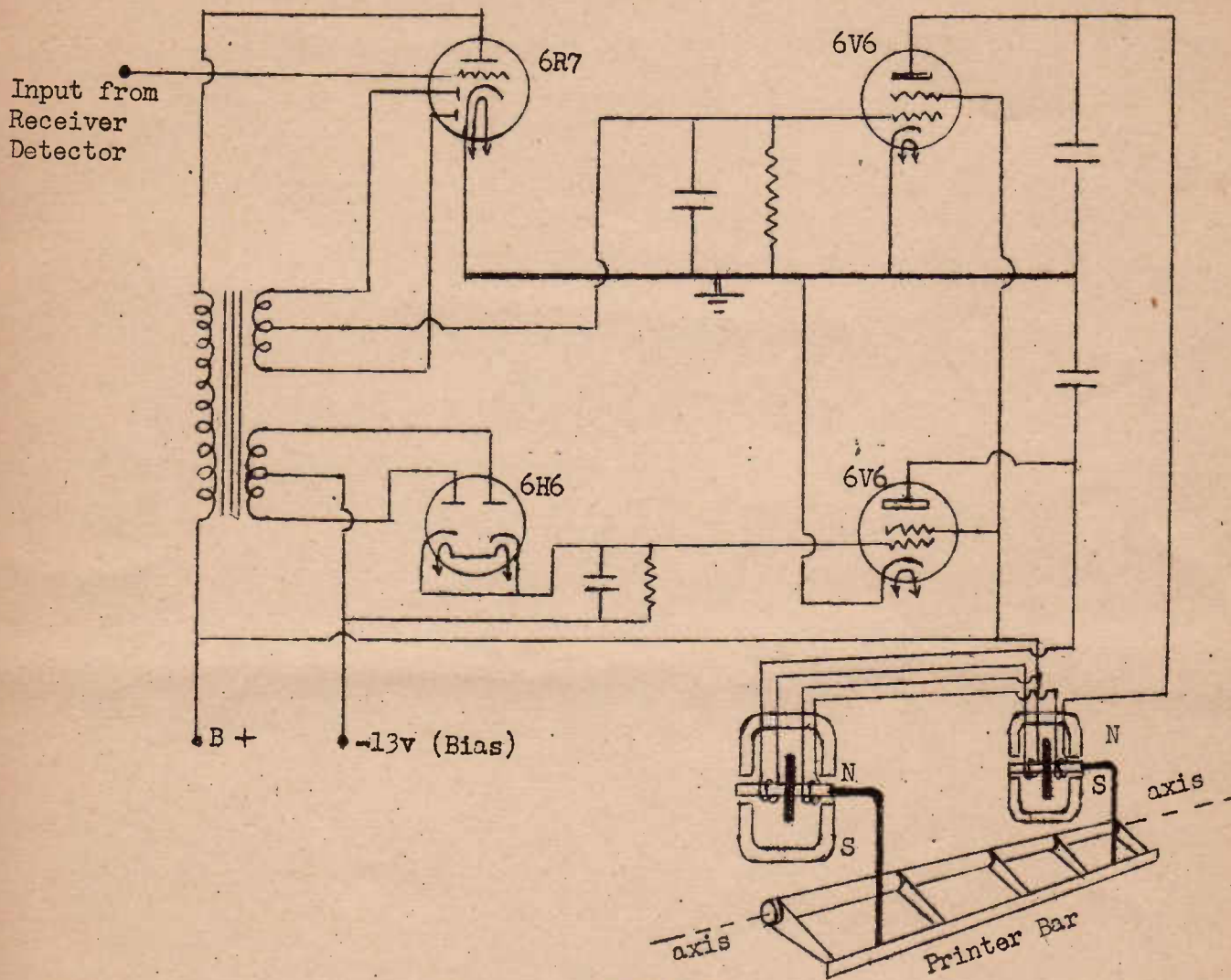

FIGURE 12.

must now examine methods which achieve this important job of synchronisation.

Visualising for the moment a system using spiral drum scanning at both ends we can easily see that synchronisation involves two aspects.

- (1) Speed synchronisation.
- (2) Phase synchronisation or "Framing".

By speed synchronisation we simply mean the job of ensuring that both drums are driven at the same (or very nearly the same) speeds of rotation. By phase synchronisation we mean the job of ensuring that the drums rotate so that when the transmitter scanning commences at the top of the picture the receiver recording commences at the right point on the recording paper. With good speed synchronisation it is usually necessary to obtain correct phasing only at the commencement of each scanning.

SPEED SYNCHRONISATION:

Speed synchronisation is usually achieved by driving the drums with synchronous motors. A synchronous motor is an A.C. motor which tends to rotate at one speed only, independent of the load. This speed depends directly on the frequency of the supply current, and on no other factor.

When both transmitter and receiver are operated from the same power supply system almost perfect synchronisation is obtained. Even though the supply frequency from the power house might vary through wide limits, both transmitter and receiver motors will be affected in the same way, and no loss of synchronisation is experienced.

When, however, the receiver is operated from a different A.C. supply, or a D.C. supply this method is not satisfactory. This fact may better be realised when it is stated that a speed accuracy of one part in at least 100,000 must be maintained for good results. When no common power supply is available it is necessary to establish a common "frequency standard" at both transmitter and receiver. This may be done in two ways.

TUNING FORK OSCILLATORS:

The common frequency standard may be established at transmitter and receiver by using valve oscillators frequency controlled by means of tuning forks. The tuning fork here takes the place of a crystal in a crystal-controlled oscillator as it is more suitable than a quartz crystal for low frequency operation. The circuit diagram of a typical tuning-fork controlled oscillator is shown in Fig. 13.

The important fact about a tuning fork is that it vibrates mechanically at a frequency which remains very constant. An initial vibration of the fork, which is magnetised, induces an e.m.f. at the same frequency in the coil (Fig. 13). A part of this e.m.f. is fed back to the grid circuit of the oscillator tube. As a consequence the plate current varies. The magnetic field of this coil acting upon the steel fork sustains its vibration. Thus the action continues, at a frequency determined only by the tuning fork's physical construction. By using identical tuning fork oscillators at both transmitter and receiver, identical frequencies will be available for driving or controlling the drums by means of synchronous motors. The outputs from the oscillators, of course, must be subject to considerable power amplification in order to drive the drums directly. To overcome the necessity of these power amplifiers special D.C. motors have been designed whose speed may be regulated by the application of small amounts of power from the frequency standard oscillator. Most of the power used to drive the motor then comes from the D.C. source.

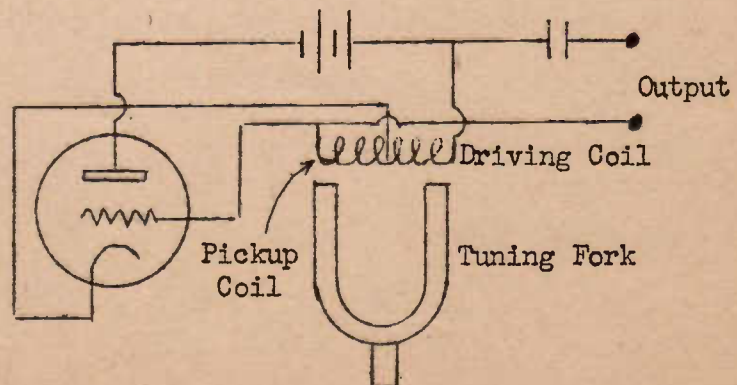

SIGNAL SYNCHRONISATION:

The second method of establishing a common frequency standard at both transmitter and

FIGURE 13.

receiver involves the broadcasting of a special synchronising tone or signal from the transmitter. In order that this signal does not interfere with the picture information its frequency is usually fixed at a value lower than the lowest side frequency of the modulated sub-carrier. After detection in the radio receiver the sync. signal is separated from the modulated sub-carrier by means of a filter circuit. The tone is then amplified and used to drive (or control) the receiver's synchronous motor.

PHASING METHODS:

Methods which have been used from time to time to obtain correct phasing of the two drums are very numerous and varied. Most of these have involved manual adjustment of the receiver drum before scanning commenced. In point of fact many present day systems designed for commercial applications, where skilled operators are available, still use manual or semi-manual methods of phasing. Such methods, however, are not suitable for home reception where compact and automatic equipment is really a first essential. Most of the methods are in any case obsolete, and therefore we shall not deal with them in detail.

Typical of such systems, however, was the provision of a black band around the end of the drum at which scanning commenced. At one point on this band, corresponding to the edge of the picture (and, therefore, the beginning of a scanning line, was a white spot) see Fig. 14. At the commencement of operations both drums were set in rotation. Every time the transmitter scanning light passes the white spot a pulse was transmitted. This pulse was amplified at the receiver and fed to a neon lamp, which would therefore glow momentarily for every revolution of the transmitter drum. At the same time another neon lamp was caused to glow every time the receiver's drum scanner passed the edge of the recording paper. The receiver operator, slowed his motor until both lamps were glowing simultaneously. This meant that the drums were correctly phased. The next step was to bring the receiver motor back to its synchronous speed, and thenceforth scanning proceeded, automatically. In some systems the phasing was done by ear, a loudspeaker replacing the neon lamp.

AUTOMATIC PHASING METHODS:

Most automatic phasing methods use some form of clutch between the motor drive and drum at both transmitter and receiver. The receiver clutch, which applies the drive, is engaged automatically by a phasing pulse sent from the transmitter.

One of such systems - one which operates only at the beginning of a scanning - uses a clutch at the receiver designed to slip entirely freely or grab hard. The phasing pulse is created at the transmitter by the white spot method of Fig. 14. On pressing a button at the transmitter the receiver motor starts revolving (as well, of course, as the transmitter motor and drum). The receiver clutch, however, does not immediately engage, so that the drum remains stationary in a position ready to commence the first scanning line. As soon as the transmitter pulse is

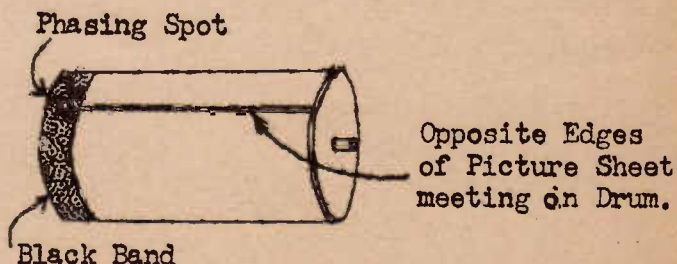

FIGURE 14.

received an electro-magnetic switch operates the clutch which suddenly grabs hard. Hence the receiver drum commence revolving in phase with the transmitters'.

Another somewhat similar method operates as follows. The transmitting driver is started by operating a switch which trips a magnetic clutch between the motor drive and the drum. This clutch has only one tooth, and so the transmitting drum always starts in the same phase relationship to the drive. A mechanical contact on this drive makes once each revolution, sending a phasing pulse to the receiver. This pulse operates an electro magnet at the receiver which trips a special clutch. This receiver clutch consists of a single pawl (ratchet) bearing a fixed angular relationship to the start of the paper on the drum which is made to engage with a 100-tooth ratchet wheel on the drive. The pawl engages the nearest tooth on the ratchet wheel when the pulse arrives. Hence the maximum phasing error that can occur is $\frac{360^\circ}{100} = 3.6^\circ$.

PHASING OF HELIX CONTINUOUS RECORDER:

Any of the above described methods could be applied to a helix type recorder. This follows because the helix drum rotates at the same speed as if a spiral scanning drum were used, further, one revolution of the helix produces a single scanning line just as in the other system. The methods, described, however, only give correct phasing at the beginning of the transmission. With synchronous motor drives this is sufficient to ensure that the phasing would remain correct during the normal scanning time for a drum - say 10 to 15 minutes. Using continuous recorders, however, where operation might proceed over a period of 6 hours the method would be unsatisfactory, as sufficient accuracy in speed control to maintain the correct phasing over such a long period, could not generally be obtained.

Continuous recorders are usually correctly phased by sending a very powerful pulse at the beginning of every scanning line. These pulses are formed by metal contacts on the transmitter drum. If the drums rotate at 360 r.p.m. (for rapid recording) the pulses would form a tone of 6 cycles per sec. This, however, does not interfere with the picture information, for the individual pulses arrive only at the end of a line (at the edge of the paper).

A circuit breaking device is mounted on the receiver helix drum. This device is used in conjunction with a line-framing relay. The circuit breaker carries a breaking arrangement which comes under the relay armature at the instant the scanning point goes off the edge of the paper. If the line-frame signal generated by the transmitter arrives at the same instant the circuit is such that the relay is not actuated, and the motor drives the recorder steadily in its correct line-framing position. If, however, the recorder circuit-breaking device is in another position when the line-frame signal comes in, the relay momentarily opens the motor circuit causing it to slip below synchronous speed. This occurs every revolution until the two drums work into frame again. This automatic phasing normally functions only at the beginning of a programme, the synchronous motors maintaining the correct phasing thereafter. During the programme, however, the correct phasing might be lost due to the signal fading out, or the power at the recorder failing for a short period. In such cases the machines will attempt to re-frame when normal conditions are restored, but may not complete the operation until the margin comes through at the end of the 12" sheet. The remaining pages of the programme will then be correctly recorded.

OTHER AUTOMATIC EQUIPMENT IN HOME RECORDERS:

With referen~~x~~ce to the home recorder we have now reviewed equipment which will allow of purely automatic operation once the receiver is switched on. It only remains to make automatic this switching on (and off) process and we have the "game sewn up". The desirability of incorporating automatic switches for this purpose will be realised when it is remembered that the current facsimile broadcast practise is to send out visual information in the early hours of the morning from say 12 to 6 a.m. when the transmitter is not in use for audio purposes. The receiver, and recorder could of course be switched on before retiring and switched off when arising. But this would involve a waste of power and of recording paper.

The latest home recorders incorporate a special time switch. The latter involves a special clock (which may be set like an alarm clock) and which actuates an electro-magnet, switches or relays at the times set for the beginning and the end of the facsimile programme. Figure 15 shows the back of a modern recorder giving a view of the time-switch.

This fascinating subject of "facsimile" is only in its infancy at the present time and doubtless many remarkable improvements will be developed as time goes by. However, the principles, as explained in these papers, appear to be firmly established and once they have been clearly understood and digested, the student will find himself in a position to easily understand any gradual improvements or developments as they occur.

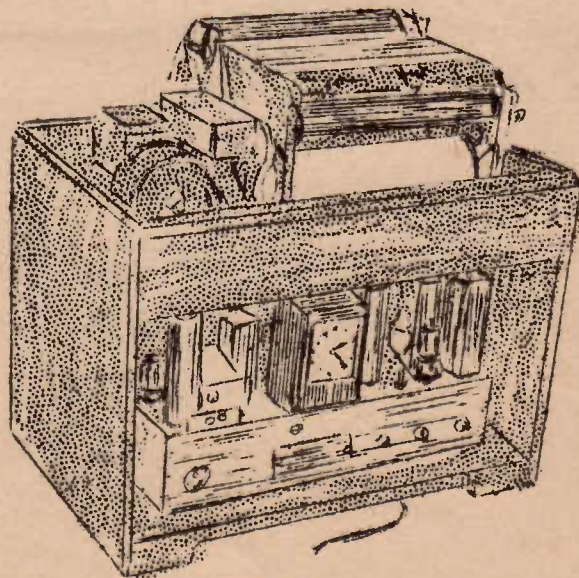

REAR VIEW OF HOME REPRODUCER.

FIGURE 15.

QUESTIONS.

- (1) Describe the circuits involved in a typical facsimile recorder unit. Give a block diagram. Why must the final amplifier be of the direct - current type ?
- (2) Explain one advantage of using full-wave rectification of the facsimile sub-carrier.
- (3) Make a list of the principal methods of recording, and discuss their relative merits and limitations.
- (4) What is meant by a "light-value" in connection with recording equipment ?
- (5) Discuss the principal features required of a home recorder.
- (6) Explain briefly the principle of operation of the helix type recorder.
- (7) A facsimile system is required to provide a definition of 125 lines per inch, and to print 2.5 inches of paper per minute. What must be the rate of rotation of the helix drum ?
- (8) Classify recorder amplifiers into three types and explain the type of recording for which each type would be suitable.
- (9) What two functions have to be performed in transmitter-receiver synchronisation ?
- (10) A rectangular picture is transmitted using spiral drum scanning at both transmitter and receiver. What would be the effect on the picture if
 - a. Drums were started in phase, but speed synchronisation was incorrect.
 - b. Speed synchronisation correct, but pictures were not started in phase.

“The Radio-T.V. Training Centre”

E. S. & A. BANK BUILDINGS, Corner CITY RD. and BROADWAY, SYDNEY
Telephones: BA4891 and BA4892

AUSTRALIAN RADIO AND TELEVISION COLLEGE PTY. LTD.

Telegrams “RADIOCOLLEGE” Sydney

This lesson sheet is published for the exclusive use of
students of the Australian Radio and Television College
Pty. Ltd. (All rights reserved)

Post Lessons to Box 43, Broadway

LESSON NO.1.

THE WONDERS OF RADIO & TELEVISION.

You are entering a new field - one probably new to you and comparatively new to the whole world, To those on the outside, radio is a science, a profession, an industry. To those on the inside it may be any or all of these, and in addition it is their greatest pleasure at the same time.

Of all new things that ever came into our lives, radio has had the quickest rise from, an obscure beginning to tremendous importance. Go back only a few short years and there were no homes with radio receivers. To-day there are hundreds of millions of homes having radio receivers and about one hundred million throughout the world with television receivers,

A GREAT INDUSTRY.

Radio and its “offspring” - Television - have brought more real enjoyment to more people in less time and at less cost than any other thing in our history. Before radio, we all pointed to the motor car as the wonder of our time. It too, brought pleasure into the lives of millions of men and women, but the cost was high. The cost of radio entertainment is small - everyone can enjoy it and afford it. To-day there are many millions of people “listening in”.

Radio is a means of communication between men. It is the newest means and already may be called the greatest means because it is free from so many of the limitations which beset the older methods. Before we had radio we had the telephone and the telegraph, but they called for miles of connecting wire. With radio there are no wires between sender and receiver; and we may send signals over vast bodies of water; over impassable mountains and to great distances where these difficulties would make it impossible or at least very uneconomical to string wires.

RADIO'S ACHIEVEMENTS

Because a single radio signal sent from one transmitting station may be picked up and reproduced at thousands of receivers, this new science has done wonderful things. First among radio's benefits we should mention life saving at sea because this was the earliest great

accomplishment and is still The greatest from The standpoint of doing good for humanity. The importance of life saving is recognised by all branches of radio. When a distress call, the well known "S.O.S," goes over The air, everything else within bounds stops and the whole world of radio "stands by" until those in trouble have been given assistance.

Some of the greatest achievements of radio have been during times of fire, flood and devastating storms. Wires may go down, rail communication may be washed out and roads may be rendered impassable - but a radio amateur with his low powered transmitting set at the scene of trouble and another of his kind in a distant city will remain as a connecting link to carry appeals for help that will save hundreds of lives and relieve the sufferings of all those in the danger zone. Another great work of radio is done in the service of the law and order, Police departments everywhere are using radio to trace down and capture criminals, within a few minutes of their misdeeds. Fire brigades, Ambulance & services, Electric & Water supply authorities, Taxi cab services and countless other organisations are using radio link to provide us with a better standard of living.

Coming down to the. more ordinary things in radio we find entertainment of every kind - the finest or music from the most famous orchestras, drama from accomplished actors, songs from the greatest artists and a choice of many different programmes to choose from. Religious teachings are carried everywhere, Education is being sent into the most remote places and to those having no other opportunity to. Learn. Lectures are given on every conceivable subject from playing golf to calculating an income tax. The provision of entertainment and information visually as well as audibly made possible by Television has already had a tremendous influence on the lives of millions.

Businesses of every kind are being helped by radio. The finest broadcasts ere in reality forms of advertising. Many stations send out information of special value to tanners and to other classes of business men. This service includes market prices, time signals, weather reports, warnings of wind and temperature changes - in fact almost every class of information that is needed by almost every class of people. News events are broadcast everywhere almost as soon as the events have taken place.

Radio competes with the long established cables in sending telegraphic, messages over the oceans and there is a regular telephone service by radio between Australia and most countries. Now several communication companies carry radio messages, both in telegraphic code and in ordinary spoken words, to every party of the world.

The advancement of aviation as a public convenience depends to a great extent on, radio because here is the only possible means of communication between the aviator when he is far up in the air and those on the ground, and when darkness has fallen radio beacons, guide the airplane straight and true on its course and radio messages warn the pilot of troubles ahead and tell him how to shape his course to avoid them.

YOUR OPPORTUNITIES

What does all this mean to you? It means that you are getting in on the ground. floor of our youngest, healthiest and fastest growing business. Nobody in the

whole radio – television industry has more than a few years start on you. Great things are done every year but the year following sees still greater advances. The radio you know to-day will be out of date a year from now, and you may be one of those helping to put through the changes -- who knows?

With such a field of usefulness, with so many important duties to perform, with so many kinds of services to render, is it any wonder that radio grows by leaps and bounds? It is an acknowledged fact, a fact being given the greatest prominence by all radio business organization, that the greatest need to-day is manpower, or to be more correct, brain power. Dealers everywhere are bidding for the services of competent radio and television technicians. Public institutions and all amusement enterprises are demanding men to operate and care for their costly equipment. Manufacturers of receivers and radio parts of all kinds are looking for men with radio training. Radio is a business which, in only one or its branches, that of broadcast reception and receivers, has grown in money value to a total of about Thirty million pounds in Australia alone.

Radio men have not increased their numbers at any such rate nor anywhere near such a rate, In 1922 there were about two thousand receiving sets and a few amateur broadcasters. Now there are more than two million receivers and some hundreds of broadcasters .in Australia. For every single radio man in 1922 there should be a thousand such men to-day just in the building, selling and .servicing of broadcast, receivers, All the other branches of radio have grown proportionately and the newer branches are growing even more rapidly than the older ones.

The growth of radio has opened dozens of different paths to real money, paths too numerous to even allow a listing of them all. In the manufacturing end you can become an inspector, a tester, a valued assistant in some laboratory, a superintendent. You can enter the selling field and make money by telling people about complete receivers, certain accessories, amplifiers for theatres and other amusement places, or complete radio installations for homes, hotels, hospitals and other institutions. You can become a dealer in any of these devices. You can open your own service business or can join some of the growing service organizations. You can enter the employ of a broadcast station. Technicians for the manufacture, installation and maintenance of industrial electronic equipment (for controlling high powered machines and heating equipment), or “X” ray apparatus and of Electronic computers or electronic “brains” are sought from those with a sound basic knowledge of radio and electronic principles. We can't tell you of all the chances you will have because by the time you're ready there will be still more chances than to-day.

Whatever your ambitions are it is essential for you to start with, basic fundamentals and to build up your knowledge progressively on firm foundations. Regular and systematic study of the following lessons will carry you steadily forward until you have covered the carefully planned and comprehensive syllabus of this course. The first section of the course covers mainly fundamental principle's and particularly the characteristics of the various component parts which make up a radio and television receiver. The second section explains the way in which the various parts are grouped together to form “stages” in a receiver. The third section is devoted mainly to efficient and systematic methods of fault location and the fourth section deals with Television.

THE ROMANCE OF RADIO

A little way back we said that nobody in radio had more than a few years start. Practically speaking, that's true, but of course radio history goes back further than that. One of the first, if not the very first patents on radio or "wireless" apparatus was granted to Professor Dolbear in 1882 and he then made the forecast that some day it would be possible to establish wireless communication between points more than a half mile apart. Thirty-six years later a radio telegram was sent from Carnarvon to Sydney, a distance of more than twelve thousand miles.

The very beginning, of radio goes a long way back although the experimenters of that day had little or no idea of what they were starting. In 1840 high frequency oscillations were produced by Joseph Henry and these oscillations are the basis of all radio as we know it now. In 1885 a man named Preece maintained telephonic speech between two electric circuits completely insulated from each other and separated by a quarter of a mile. Two years later Heinrich Hertz founded the theory of modern radio waves which are often called Hertzian waves,

Another ten years passed, each one filled with hard work by many great minds, and then Marconi communicated over a distance of nearly two miles. Thereafter things moved in a hurry and in the year 1897 the distance of transmission was increased first to four miles, then to ten and finally to more than fourteen miles. The public began to hear about this new thing but most people did more laughing than believing.

In all this preliminary work radio telegraphy was the big thing and radio telephony or the transmission of speech and music was little more than an interesting experiment. Marconi received the letter "S" in code, at St. Johns, Newfoundland, from Poldhu, England, seven years before Professor Fessenden in America was able to maintain radiophone communication for a distance of six hundred miles between Washington, D.C., and Brandt Rock, Massachusetts.

In 1918 we saw rapid development of the vacuum tube or valve, without which our home radio and most of the other applications would be still but a shadow of their present perfection. This gave, a great start to the new science, which began its evolution from a curiosity into a necessity, Three years later the U.S.A. Government issued the first broadcasting license to station KDKA of the Westinghouse Electric & Manufacturing Company at Pittsburgh, U.S.A. Then the public took up radio in dead earnest

THE FIRST RECEIVERS

The very first radio sets, as shown in Fig. 1, for home use comprised two coils of wire, a piece of mineral called crystal (generally galena or iron pyrites), a long wire strung out of doors and a pair of headphones operating much like the telephone receiver you hold to your ear.

A little later came receiving sets employing a vacuum tube or valve which worked in a pair of headphones, The "fans" of those days played every conceivable trick on that one tube to make it pull in more miles. It was nothing uncommon to find a receiver with a front panel a foot and a half square with a dozen to twenty knobs and dials - all for working that single tube.

Nowadays our modern home receivers have but one tuning control one volume control and these operate up to ten tubes.

The single tube in the first sets was a "detector" which received the radio waves and turned them into a form which would produce sound on the phones. The more ambitious constructors put one or two extra tubes between the detector and the head-phone connection, replaced the phones with a loud speaker and entertained the whole family at the one time.

The next development put tubes ahead of The detector, between the aerial and the detector. Those were the days of "DXing" for everybody, The letters in radio mean long distance reception.

The whole object of early broadcast reception was to listen to some station clear across on the other side of the country. The programme was of no importance whatever, just so that the station was a thousand miles or more away. To-day the emphasis is placed on perfection of tone quality. Most people claim now that they are well satisfied with the programmes from the "locals" provided the selections are worth hearing. But just the same, try stealing up behind some of these local enthusiasts on a cool winters evening and see what they're tuning for. If what they're after is a "local", then their idea of distance must be the moon.

We are sure there can be no denial of this statement that nothing or a scientific nature ever before took such a firm hold on the, popular imagination as did radio. There was no such thing as a factory-built receiver and every one of us built our own. Radio parts stores sprang up everywhere, and you could buy the now obsolete slide tuners, loose couplers, variometers and a hundred other necessities on every corner.

The boy of the family would take a box made of cardboard, add some wire, a crystal detector, and somehow get hold of a pair of headphones. That started it and about a week later you would see the boy and his dad ride to town on Saturday to come home loaded with bundles. In a few nights the neighbours came in to listen to America -even if they didn't hear it.

Enterprising manufacturers observed these happenings and concluded that here lay a fertile field for sales. The factory-built receiver entered the contest and gradually made headway. The first of the ready-made sets were expensive in comparison with the home-made article and most of them weren't so good. But times have changed and to-day The mass produced factory job has the better of the argument with the set built at home by a novice. While the "bread board" set, as the home made receiver has been called, is now way in the background, we still have with us two classes of receivers the factory built and the "custom built".

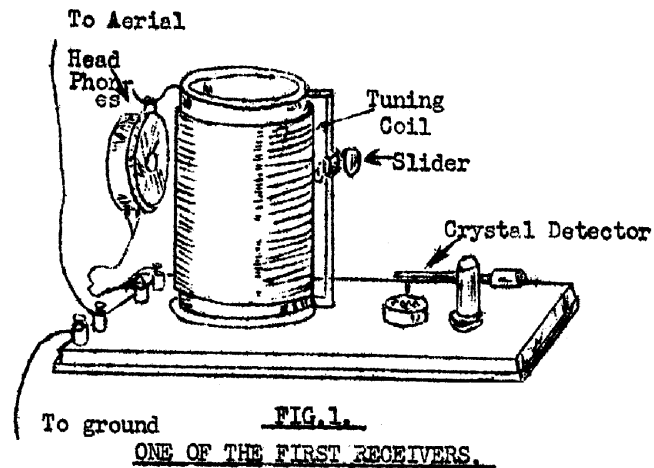

Custom built receivers are built by professional radio men, generally using kits or sets of parts which are designed to operate well together in making a really high grade set equal to factory built ones in performance. This business of custom set building is one of the branches of radio in which you can make money even before you complete your course of study. Complete kits of matching parts are readily available from which you can build almost any kind of radio receiver, amplifier, test instrument, or Television receiver, when you have obtained sufficient knowledge from these lessons.

WHAT IS RADIO

We've talked about the radio business and could go on talking about it for a long time, but no doubt you're anxious to get down to radio itself. What is it? what makes it? How does it act? Why is it able to do such wonderful Things? We will find out.

Practically everything in radio is concerned with. one of its two main divisions, the transmitter or the receiver. Between these two parts must be something to carry the signals from one to the other, In many of the commercial applications of radio and in some applications to home use, wires or metal conductors are used to carry the impulses or signals and we have what is called wired radio or carrier telephony. But for broadcasting and for most of the other uses with which you will become familiar we use "space radio" and transmit the signals through space by sending them up into an aerial at the transmitter and catching them on the aerial at the receiver.

TWO WAYS TO LEARN RADIO

If this were to be an ordinary radio course both it and you would be put of date because we would teach you only details and tell you about certain parts and piece of apparatus which are here to-day and gone to-morrow.

What we are going to learn first is the how and the why of it all. Fundamental principles don't change, only the application of these principles that change. For example, back in 1924 we might have taught you about the construction of the coupling coils for the then famous neutrodyne receiver. But to-day the latest thing is the superheterodyne, and you wouldn't have known a thing about it. So here's the point - had we taught you about the principles of coupling you would have understood the coupled circuits of the Neutrodyne in 1924 and would have been equally well able to understand how two coupled circuits to-day work together in picking out a certain band of frequencies or sounds we want to listen to in the modern superheterodyne

Of course you will learn about the latest applications of all the principles in radio, this to give you a clean start from the day you graduate. But behind all this will be one of the few men who know what makes things happen. Then nothing that comes along in the future will mystify you in the least. It will make the difference between the methods called "cut and try" and the methods of the man who knows his whole subject from the inside out.

The first lessons you will study are more important than you will realise until you are nearly

through with your course. Nothing that could be said now will make you understand just how important are these first ideas. They are the foundation of all your future knowledge and like the foundation of a great building, all that is built upon them will fall down if the foundation isn't right. Radio is a branch of the science of electricity and for your studies we will start off with electrical actions. However, even in the preliminary work we will stick closely to those electrical actions which are used in radio transmission, reception and reproduction.

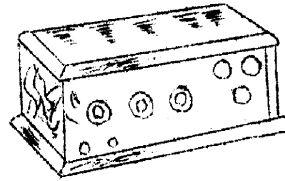
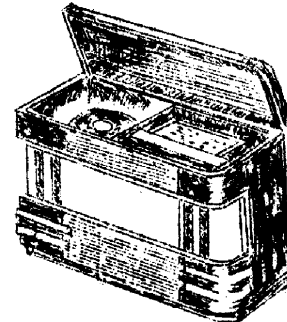

FIG. 2.

PRINCIPLES
REMAIN THE
SAME.



We might as well tell you, right here that a student of radio must learn quite a great deal about electricity. He needs much more of such knowledge than would actually be required in many of the older applications of electricity. That does not mean that you couldn't learn to operate radio devices, to build radio receivers, or even repair these pieces of apparatus without knowing a single thing about the underlying reasons for electrical actions. With a good memory, a lot of hard work and quite a bit of what is called common sense, it is entirely possible to enter the radio business with very little real knowledge. The trouble is that the man who works that way will be of very limited usefulness, his resources will be slight and it won't be long until he'll be looking to the really well trained man as his boss.

ELECTRICITY.

This electricity that makes, radio possible is not easy to define, Ever since Franklin pulled electricity out of the clouds with his kites and a key, men have been trying to discover exactly what electricity is. Scientific workers were carrying out experiments in electricity throughout the whole of the nineteenth century and gradually built up in their minds a picture of the way in which this invisible force behaved in electrical circuits. As will be explained more completely later, these early scientists formed the opinion that an electrical current moved around the circuit from the positive terminal of a battery or generator to the negative terminal.

In 1897, Professor Thompson startled the scientific world with quite a new conception of the

nature of electricity and proposed what has become known as the “electron theory”. The electron theory is very convenient for explaining the actions of radio valves, television cameras, television picture tubes and other such electronic devices. However, a great many people with a fundamental knowledge of electrical principles, particularly those who have studied electrical engineering without the necessity for considering valve action, prefer the older fashioned, conventional idea of an electric current as mentally pictured by the early scientists, and for this reason, we will particularly in these early lesson papers, use the conventional idea of current wherever it seems to offer a simpler and more readily understood explanation of some electrical action. However, when we are dealing with the behaviour of radio valves you will find that we will refer frequently to the electron theory and talk in terms of electron flow rather than current. Later on as we advance further into the technicalities you will find that we will use more and more the idea of electron flow for our explanations. This may sound very confusing to you, to have two different pictures of the one action but you find, as we advance steadily from lesson to lesson that a clear mental understanding of electrical behaviour is formed in your, mind without any undue confusion,

Before we dip into radio itself, you must know a little about electricity, This is necessary because radio can't be described even in the simplest manner without using two or three electrical terms.

In all electrical work, radio or anything else, the electricity itself is used only to carry energy from one place to another or to store energy in one place. Other things besides electricity are used for similar purposes, A belt between a steam engine and some piece of machinery is used to carry energy from the engine to the machine. The steam engine may be compared to an electrical generator, the machine to an electric motor and the belt to the electricity carrying energy between them The two carriers of energy are shown in Figure 3.

A very important thing to realise from an examination of Figure 3 is that it makes little, if any difference to the transmission or energy from the engine to the machine, whether the leather belt moves in a clockwise direction or in a counter-clockwise direction. In either case, the movement of the leather belt is able to carry energy from one device to the other, regardless of in which direction it actually turns,

The same principle applies to the generator and motor shown at the righthand side of Figure 3. The two wires linking the two machines make possible the circulation of electricity which enables energy from the generator to produce a turning force inside the motor. In the case of the leather belt, we could look closely at the belt and find out whether it is turning in a clockwise or an anti-clockwise direction but in the case of the electric wires, at the righthand side of Figure 3, there is no easy way of knowing whether the electricity is moving in a clockwise or counter-clockwise direction in the wires, The important thing is that the actual direction in which the electricity moves does not matter to us. The important thing is to realise that electricity in motion is able to carry energy from one point to another.

Now for an example of storing energy. You store energy every time you wind up the clock store it in the main spring. Electricity may carry energy into a device called an electrical condenser, keep it there and release it later, The clock spring is like the condenser and the

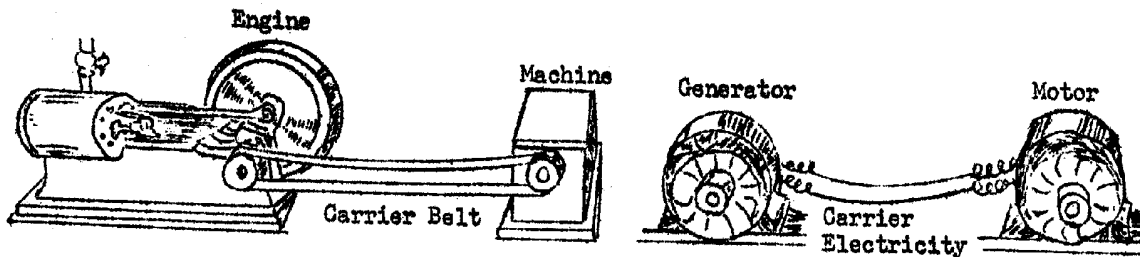

Figure 3.

strain on the spring is like the electrical energy which remains stored until released,

Electricity itself, before any work is done upon it, contains no energy any more than the belt driving a piece of machinery contains energy. Electricity put in motion will do work and so will the moving belt do work the clock spring, until it is put under strain by winding, contains no energy. Electricity put into a condenser places parts of the condenser under strain and electricity from the condenser will then do work, Remember then that the electricity is only a medium through which we may transmit energy by causing the electricity to move or with which we may store energy by causing the electricity to produce a strain, and it is not used up in the process.

If you take a pipe filled with water as in Fig. 4 you may compare the water with electricity. The water might be used to carry energy from one place to another just as is done in any hydraulic system. Once again notice that it does not matter whether the water circulates in a clockwise or counter-clockwise direction in Fig. 4. It will still drive the turbine and carry energy from the pump to the turbine. It is the movement which is important, not the direction.

If you take a tank as in Fig. 5 you may store energy by forcing water up into it. Later on The water will give up its energy and do work if you allow it to flow down, out of the tank over a water wheel or through a water pump.

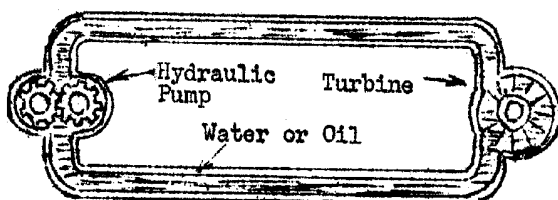

Figure 4.

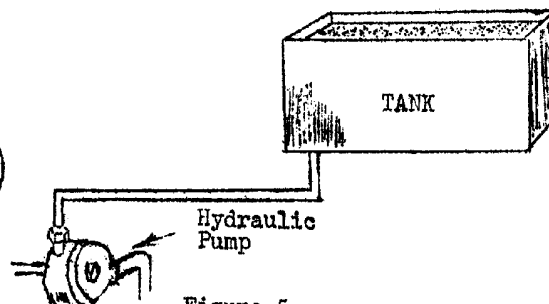

Figure 5.

ELECTRON THEORY

Some of the early workers in electricity, during the eighteenth century, discovered that if a battery were connected to two metal plates, immersed in a conductive liquid as shown in Figure 6, the metal plate connected to the positive terminal of the battery would gradually be dissolved and transferred through the liquid to deposit on the plate connected to the negative terminal. For instance, if the plate connected to the negative terminal, called the "cathode", is a piece of steel and the sheet of metal connected to the positive terminal, called the "anode", is copper and the liquid between is a solution of copper sulphate crystals in water then gradually, the copper plate will be dissolved and a film of copper will build up on the steel until all of the immersed surface is coated with copper. This is the principle of electroplating which is used nowadays not only to deposit copper on steel but for the purpose of nickel plating, chromium plating, silver plating and in fact any metal can be deposited in a film on another metal by this technique.

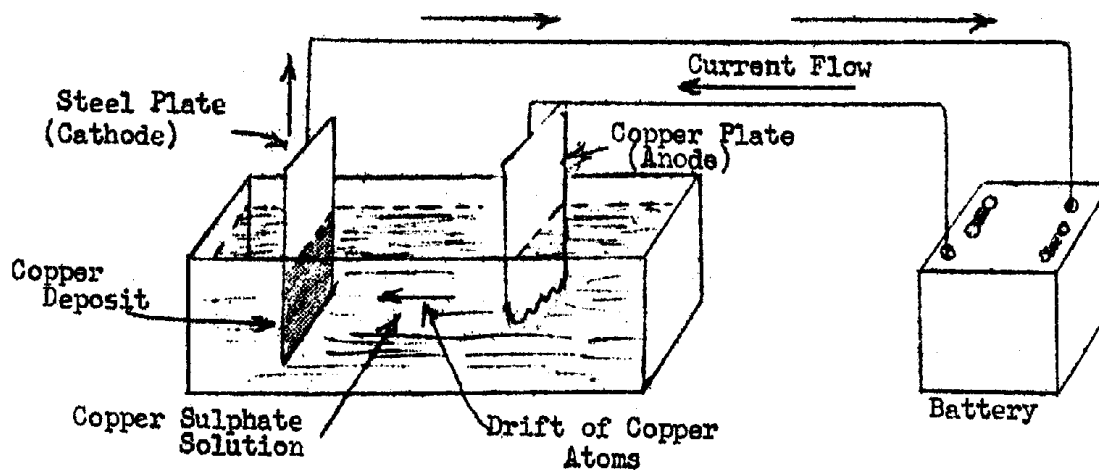

Figure 6.

The fact that the metal connected to the positive terminal dissolves away and is carried across through the liquid to build up on the negative plate suggests that the metal is carried by a current of electricity which appears, consequently, to move from the positive terminal of the battery, to the positive plate, through the liquid from positive to negative, to the negative plate and back, to the negative terminal at the battery.

It was largely the observation of the transference of metal, in electroplating tanks, which firmly led scientists to believe that currents moved from positive to negative.

As a result of Professor Thompson's investigations and subsequent work we now know that all materials on this earth are made up of groups of atoms, either of the one kind or of several kinds chemically joined together. There are 92 fundamentally different materials occurring naturally on this earth, and consequently there are 92 different types of atoms. All the other infinite variety of materials are simply made up of mixtures or compounds of the 92 elements. Although for many years, in fact, up until 1897, atoms were thought to be the tiniest particles of any material, we now know that each atom in itself is like a miniature solar system with a

a miniature solar system with a central nucleus, like a sun, and a number of tiny little planets called "electrons" which move in orbits around the central body.

The central body in all materials is very large and massive compared with the size of the tiny little planetary electrons. In fact, even in the case of the lightest material, which is hydrogen gas, the central nucleus has a mass about 1,836 times as great as that of the single little planet which moves about it. As we progress through the range of 92 different types of elements, from the lightest to the heaviest, which is uranium, we find that each one in turn has one additional planetary electron capable of moving around the outside of the central nucleus. The tiny electrons are so small that they are usually considered as having no weight or mass but nevertheless each one represents a basic tiny particle or electron charge and we know that any electrical phenomena takes place it is due to the movement of these tiny little electrons and not to the atoms of material themselves.

Of the 92 elementary substances many have their electrons tightly bound to their own particular nuclei. These substances are known as insulators because the electrons cannot be readily made to move from one atom to the next. On other hand, there are quite a large number of materials in which one or more the outer electrons can be easily detached from its own particular nucleus and made to move progressively from one atom to another through the materials. These materials are known as "conductors" and comprise the various metals, carbon and one or two other substances.

The electrons will not move in great quantities in any direction through a length of conducting material unless there is an electrical pressure applied, to push or suck them along. The electrical pressure is often known as an "electron moving force" or "electromotive force" or simply as a "voltage". The tiny little electrons, although they occur as particles of 92 fundamentally different materials, are in themselves all alike. It is only the number and arrangement of electrons together with the different nuclei in the centre which provide each of the 92 substances with entirely different physical and chemical characteristics. However, the electrons themselves are all identical and consequently are able to move from atoms of one material, say iron, to another material, say copper, and then perhaps on to a third material which may be silver without the materials themselves changing in any way. Figure 7 gives some idea of the way in which the electrons are enabled to drift around a circuit made up of a number of different conducting materials under the influence of an E.M.F. or voltage.

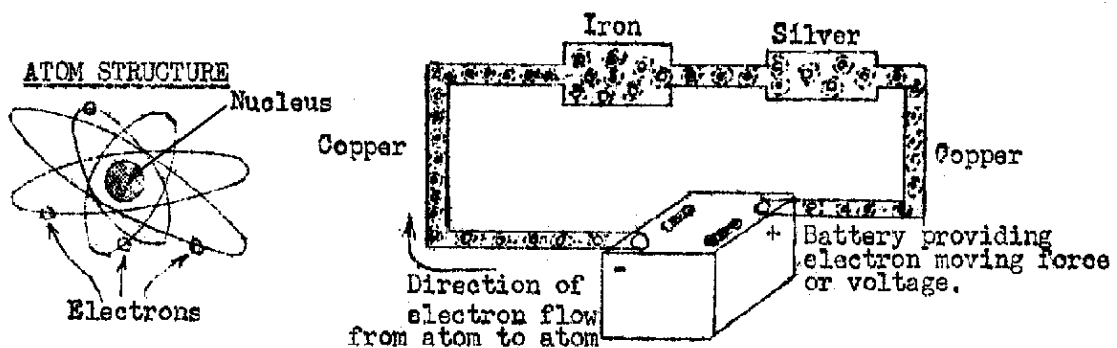

FIGURE 7.

You will notice in the diagram, that we have shown the electrons as moving away from the negative terminal of the battery and towards the positive terminal. This seems completely contradictory to our previous idea of direction of current flow, as illustrated with the electro-plating tank in figure 6.

In practice, we now know that electrons represent individual negative charges of electricity and in electrical work, as with magnetic poles, similar charges repel one on other and dissimilar charges attract, so that the negatively charged electrons are repelled away from the negatively charged terminal of a battery and move around the circuit, travelling from atom to atom throughout the length of conducting materials, until finally they are sucked in by the attraction at the positive terminal of the battery, pumped internally through the battery and recirculated over and over again.

As the electrons move from negative to positive you are doubtless, wondering why the copper appears to move from positive to negative in our illustration of Figure 6. As electrons are identical in all materials and do not have the full properties of copper or of any other metal, on their own, it is obvious that it was not electrons themselves which were responsible for the dissolving of copper at the righthand plate of Figure 6 and the building up of copper at the lefthand plate of Figure 6. Because copper appeared at the lefthand plate it is obvious that what is drifting through the liquid in the tank is actually atoms of copper and not just simply electrons. Had the early scientists been able to see some visible effect of the electrons themselves they would have realised that the electrons are moving from negative to positive but of course due to the very small size of electrons (it would take somewhere about 36,000 million million million million of them to weigh one ounce) it was quite impossible for them to directly see the electrons moving and consequently they could not tell which way the electrons themselves were flowing.

The reason the copper moved from the positive to the negative side of the circuit in Figure 6 is that each time an electron is torn away from an atom, in order to move on through the circuit it momentarily leaves the atom with a slight positive charge. Each of the atoms in the liquid is at times left momentarily with this slight positive charge and the positive charge is repelled by the positive terminal of the circuit and attracted towards the negative terminal so the atoms of copper are gradually made to drift, through the liquid to deposit on the negative terminal on the lefthand side of, Figure 6.

This drift physical matter from positive to negative can only really take place in the case of liquids or gases. In solid materials such as wires, switch contacts, coils and metal frames, the atoms are so rigidly fixed in place that they cannot move, but this does not stop the electrons from moving inside the atoms from one atom, to another progressively around the circuit.

Because of the earlier ideas of current flowing, from positive to negative people these days still often refer to the term current as moving from positive to negative, but in reality we now know that the underlying force of all electrical actions are the tiny "electrons" moving from negative to positive. Although this seems very contradictory and difficult, do not worry much about it at this stage because it will become much clearer for you later on.

Just as it made little difference in which direction, the belt rotated in the left hand aide of Fiure3 or whether current flowed in a clockwise or electrons in an anticlockwise direction in the two wires at the right hand side of Figure 3, or whether droplets of water moved in a clockwise or anticlockwise direction at the top of Figure 4, so for these early lesson papers, the important thing is to realise that it is the movement of electricity which enables various electrical actions to occur, and for the time being you should not worry very much about which direction the electricity actually moves in.

VOLTAGE AND CURRENT

You have heard the tern “electric current” and “electron flow” and everyone speaks familiarly about “voltage”. You should know exactly what these terms mean. We can again compare electricity with water to make things clear. Look at a water tap or faucet in any plumbing system, You know that. there is water pressure at the back of that tap and you know that opening the tap will allow that pressure to cause flow of water. Were we talk of electricity the pressure would be the voltage and is measured in a unit called the volt. Water pressure is sometimes called “head” or simply pressure and is generally measured in pounds to the square inch.

Movement of water is often called a current of water and is measured as a rate of flow in gallons per second or gallons per minute. Movement of electricity in wires is called electric current and its rate of flow is measured in a unit called the “ampere”. An ampere of electricity actually consists of a little over 6 million million million electrons passing any point in a circuit in one second. The one word “ampere” takes into account both quantity and time so that we don’t ever say amperes per second or anything like that. Amperage is not a measure of quantity, it is a measure of rate of flow. It does not correspond gallons in hydraulic measurements, but as it takes into account both quantity (electrons) and time(seconds) it corresponds to gallons per minute or second.

In the water system, with the tap shut off there was pressure, but no current of water. Similarly in the electric circuit, with the current shut off by a switch, there is still electric pressure or voltage but there is no current or amperage, (Fig. 8). You may have electric pressure without current, but in no ordinary circuit can you have a current flow without voltage or pressure to produce it, by pushing the electrons around the circuit, remember this and a lot of your work will be easier.

Now here’s something else of importance. Electric current and electric voltage don’t mean the same thing and they don’t measure similar properties of electricity. The question has been asked “How many volts ate there in one ampere?” That amounts to saying “How many pounds per square inch are there in one gallon per minute?” Ridiculous of course. From now on when we speak of volts or voltage remember that we mean electrical pressure or driving force, nothing more. And when, we speak or electric current remember that we mean flow of electricity as measured in amperes and nothing else.

There's nothing wrong in speaking of a "high voltage current" or of a "low voltage current" just so long as you know exactly what you are saying. The first would mean an electric current forced along by a high pressure or voltage and the second would mean a current forced along by a lower voltage. In the following lessons you will learn a lot more about the electric current, but you can't go on with this first one until you have clearly in mind the distinction between voltage and current.

ALTERNATING CURRENTS.

In the greater part of this radio work you will be dealing with electricity in the form of "alternating" current, so called because the voltage and flow increase and decrease and work first in, one direction, then in the other. The study of alternating current is very profitable and intensely interesting.

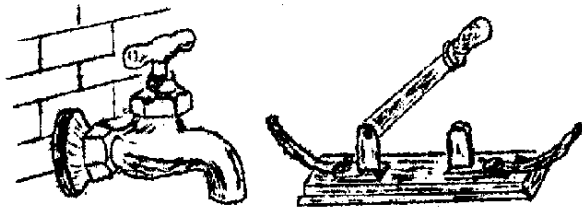

FIGURE 8.

The electricity that comes from a battery is in the form of direct current. This direct current acts always in the same direction. The things it will do are not nearly so important nor so interesting as the actions of alternating currents and in radio you will find that direct current is of little importance when compared with alternating current.

Once more going back, to a comparison between water and electricity, you realise that all the pipe Fig. 4 is filled with water all the time. In an electric circuit all the wires are filled with electrons all the time. If the wires are separated at some point and a battery connected there, the battery's energy or voltage will push the electrons around through the wires from atom to atom, moving them around through the circuit away from one side of the battery and back into the other side. When electricity is thus moved around through a circuit, always flowing in the one direction, we have a direct current.

Now we, might again take the water piping of Fig. 4 and by means, of a double acting plunger pump, push the water, first one way and then the other as in Fig. 9. The water in one section of piping would stay there and never get around into any other section. It would just move back and forth in one part of the piping. Since the whole system of piping is completely filled with water, movement back and forth of the water in one section would cause a similar back and forth motion in all the other parts.

An electric circuit, as stated before, is always full of electrons. Now if you make the electrons in one part of the circuit move back and forth or "alternate" you will make the, electrons in all the other parts move in a similar manner and you will have an "alternating" current. The electricity in one part of the wiring just moves one way for a little distance, then moves back but never leaves that part of the circuit.

In the direct current circuit, movement of the electricity at any place may be made to do work. In an alternating current circuit, movement of the electricity may likewise be made to do work at any point in the circuit. The moving electricity contains energy whether the movement be always in one direction or alternating back and forth. So you see, it's not really difficult to understand the difference between the action of direct current and the action of alternating current and you can see why we have stressed that the actual direction of movement is not important

The two kinds of current are being explained at the same time because you should understand them equally well. Some of us who went to school a while back learned about direct current first and then took up the study of alternating current or "A.C." So far as radio is concerned that was putting the cart before the horse. In radio we put emphasis on alternating current because that is what is produced in the aerial by the radio wave. In the great majority of modern sets, the sole and only source of power for increasing the signal strength is that taken from the alternating current light and power wires which enter our houses and buildings. In the operation of a radio set it may be necessary to change some of the alternating circuit into direct current - but we always start off with A.C.

In alternating current circuits we will run into many astonishing effects. We can almost always compare electrical effects and actions with other effects and actions of common things that we use in our everyday lives. A comparison of that kind is called an analogy. For example, when we say that a certain action of electricity is illustrated by a similar action of water, we have used analogy

ELECTRICAL OPPOSITION

You are going to find conditions under which electricity seems to have inertia. Inertia is that property which makes a thing try to keep on doing just whatever it may be doing at any time. It is inertia that makes it difficult to set a railway car in motion and it is inertia which tends to keep that car going once it is started. You will find electric circuits in which it is hard to get the electric current to flow and then, after it is started the current wants to keep on flowing all by itself. Those are the circuits which contain coils of wire.

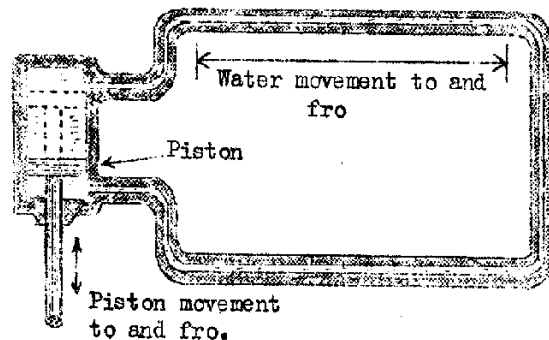

FIGURE 9.

You will find still other circuits containing condensers. A condenser is nothing more than two plates of metal separated or insulated from each other. We can send electricity on to the plate of one of these condensers and it seems to condense there or to remain there.

Alternating current will pass through a coil and will pass through a condenser. It does not pass through either of them freely, but meets with considerable opposition in both. We call this opposition "reactance". In a coil we have one kind of reactance, in a condenser we have another kind, but they both oppose the flow of alternating current. Now here is one of the most wonderful effects of alternating current. If you were to take a coil and condenser, as in Fig.10, both of which furnish opposition to the passage of alternating current, you would naturally think that putting them together in a circuit would increase the total opposition, would add the oppositions, or reactances, together. Yet you will find that by taking a given amount of reactance found in a coil and using with it an exactly equal amount of the kind of reactance found in a condenser, the two will cancel and you apparently will have no reactance at all in the circuit. The alternating current will appear to go through that circuit just as though neither the coil nor the condenser were there at all.

FREQUENCY.

While we're talking about alternating current we might as well go a little further. You were told that such a current goes first in one direction and then in the other direction through a wire - that's why it is called "alternating". In ordinary house wiring circuits it goes in one direction for one hundredth part of one second, reverses and goes the opposite way for one hundredth part of a second. The number of complete reversals or cycles in one second is called the "frequency" of the current. If a certain current makes a complete change twenty-five times a second and another current makes the change fifty times in a second, the latter current makes its change more frequently than the former and we say it has higher frequency.

Current at frequencies such as twenty-five or fifty cycles per second behave quite well, stays where it is put and goes about, its work with little fuss. But in radio we are going to get into some extremely high frequencies. When you listen to a radio station that comes in about the middle of the tuning dial you are getting the effects of an alternating current having a frequency of about one million cycles per second. Remember this means that the current goes in one direction a million times per second.

Look at your watch while the little hand passes the space of one second. Then try to count up to a million. Imagine getting one million changes like the four in Fig. 11 in one tick of a clock.

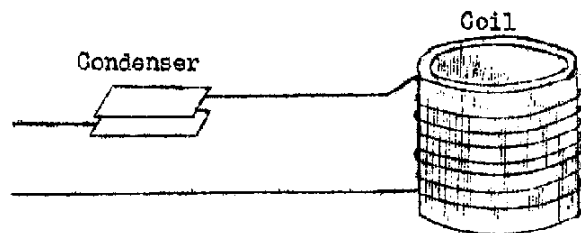

FIGURE 10.

When we get alternating current at such frequencies like this, it does some very astonishing things. Insulating covering such as you find on ordinary electric wiring doesn't mean much to high frequency currents. They fly about through space at their own sweet will. If they're traveling along a wire and come to a corner most of them will turn the corner, but some of them may keep right on in the old direction.

This high frequency current which goes ahead and reverses million times a second is surpassed in radio and television by other currents which alternate their direction hundreds of millions of times a second. Think what that means. These real high frequency currents do things that are still more wonderful. They let men in Australia talk with others in Great Britain, half way around the world. They let men send out a signal in one direction and catch it as it comes from the other direction after having gone right around the earth. It take about one-seventh of second for signal to encircle the globe. They also make possible the modern marvel of Television.

WAVE MOTION

We said a transmitter is the apparatus which changes sound into electric waves, while the receiver is the apparatus which changes electric waves back into sound. Since we have talked about electric waves or radio waves, we might as well investigate the subject of wave motion right here

Fortunately there, are many common examples of wave motion and you have see a least two of them many times. One example is found in water waves, another is found in a waving field of grain such as you could see any day in late summer.

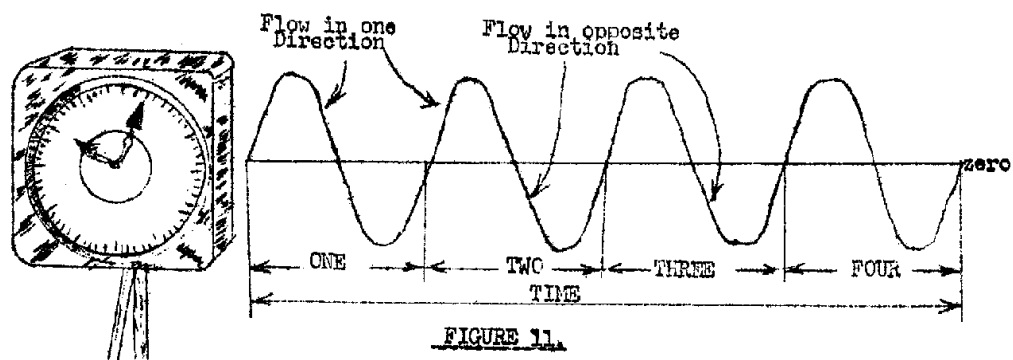

FIGURE 11.

Any "wave" is a disturbance in some substance during a period of time, the disturbance, moving away from the source of the thing which started it.

If you drop a stone into a pool of water a whole series of ring-shaped waves will spread out in all directions at a certain speed. The wave as a whole appears to move. Yet if you were to place a cork on the water you would find that the cork moved up on the crests and down into the troughs, but did not travel sideways or get any further away from the point at which you dropped the stone.

If you watch a gust of wind strike a grain field you will see the grain wave in great crests and troughs and the waves will move slowly all the way across the field. Yet you know that when the waves cease you will find every stalk of grain in the same position it occupied before the waves passed. I want you to see that a wave is just a passing disturbance in something or other.

Now if you send up into transmitter's aerial powerful high frequency currents, there will be electric waves or radio waves started off as disturbances.

The disturbance or waves will follow one another out into space at great speed and travel to great distances away from the transmitter

THE TRANSMITTER

Now let's look at some of the parts which enter into a transmitter. All of the main divisions are indicated in Figure 12. First we have a "microphone" which is directly affected by the sounds we desire to transmit and to receive. You probably have in your own home one example of a microphone - the telephone transmitter into which you speak. The microphones used in broadcast stations are much finer types of instruments than the telephone type, yet the underlying principles are much the same. The microphone is a device which causes sound to produce changes in an electric current so that the amount of, current increases and decreases. The next part in the transmitter is an "amplifier", a collection of parts which allows the comparatively feeble microphone currents to control much greater amounts of electrical energy so that from the amplifier we may secure currents carrying considerable energy.

Now we come to two parts of the transmitter which work together. They are called

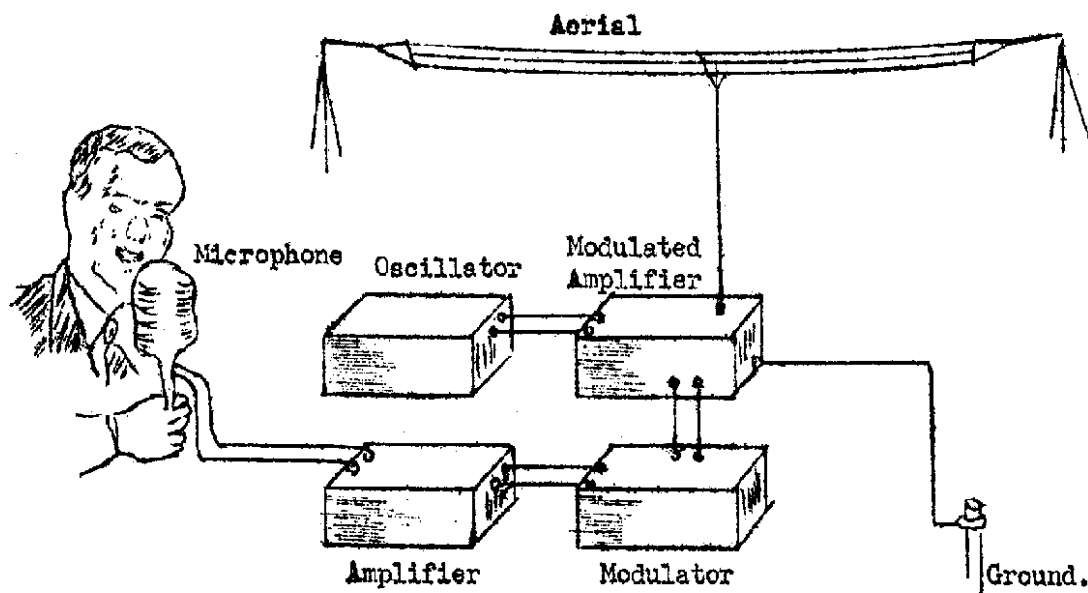

TRANSMITTER.
FIGURE 12.

the "oscillator" and the "modulator". The oscillator consists of radio tubes and other parts which generate or produce alternating currents of very high frequency. The modulator also contains tubes and its function is to take the electric currents from the microphone amplifier and add them to the current from the, oscillator in the modulated amplifier. As a result we have the high frequency oscillator current combined with the other currents which represent the changes in sound that are reaching the microphone.

There may be still more amplifier apparatus to further strengthen the currents and finally the high frequency, oscillations with which have been combined the sound changes are carried into the transmitting aerial where they affect the ether and start the radio waves off toward the receivers which are waiting.

In these few paragraphs we have outlined the functions or purposes of the principal parts of a transmitter. To fill in the gaps and make the descriptions complete will require many lessons further along in the course, but right here we want you to have a fairly complete mental picture of the whole subject. This picture will be of the outlines only but on it we will build up the whole body of your future knowledge. Much the same process occurs with Television, the television camera which turns light reflected from a subject into corresponding electrical pulsation taking the place of the microphone in Figure 12.

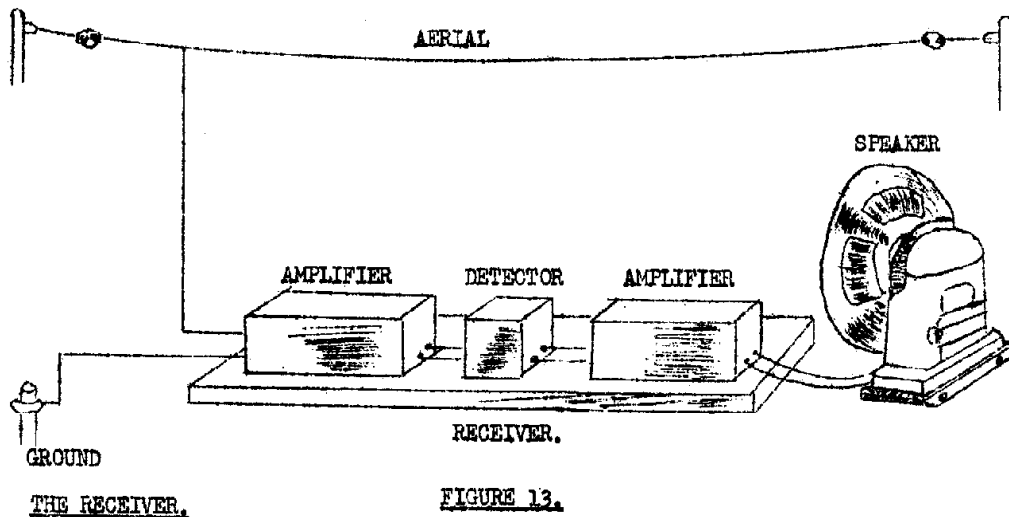

We will now assume that the radio waves have left the transmitting aerial, and have reached the aerial of a receiver far away.

Let us see, what parts are needed at the receiving end of our radio system in order to change the radio waves back into sounds, Fig. 13 shows first the aerial consisting of one or more wires placed in space where, they are struck by the radio waves. The waves generate exceedingly small electric voltages in the aerial. The aerial connects to an amplifier quite similar in action to the amplifier used at the transmitter and it increases the signal's power quite a bit.

The third part of our receiver is called the detector. It is a radio tube operated in such a way that it separates the high frequency currents from the electrical changes that represent the sounds that we desire to hear. You recall that in the transmitter we had a modulator which combined the, sound effect with the high frequency currents and here in the receiver we have a detector which reverse the process and really may be called de-modulator.

Following the detector we will find another amplifier which adds power to the sound signal current and this greater power operates a loudspeaker.

The microphone at the transmitter changed the sound into varying currents and now in the receiver the loudspeaker changes the varying electrical currents back into sound.

SEEING NEW THINGS

You may feel by this time that you have been told so many new things that your mind is fairly muddled and that you don't understand a great deal of what we have been talking about. We don't want you to feel that way. It is necessary for you to have a brief glimpse of the whole matter of electricity and radio, but you are going to find that each thing will be so thoroughly explained in later lessons, that you will have mastered the idea before you are aware of it. Each one of the things taken up in this lesson, and many more which we haven't said anything about, is going to be discussed very, very fully and you are going to see just what the applications are so that you can use them as your tools.

It is going to be necessary for you to learn theory as well as practise because you won't be able to advance without knowing the fundamentals, but you will find that we are going to take up theory in such, easy steps that you are going to learn it without difficulty. You are going to be able to apply it and make money out of it. Were you to learn only about the construction and operation of radio devices, you wouldn't need to do a lot of thinking. This method would only test your ability to remember things - like learning the multiplication tables when you were a little fellow. But when you learn why something happens it is going to start you off on a new mental track many a time. There is no reason at all why you won't discover new things in radio and new or better ways of doing the old things.

An old hand in any branch of science or art has a hard time seeing new things, He has learned to believe that everything has been thought of, that the knowledge he has gained covers the whole field. Anything that can't be explained by the rules he knows just can't be, that's all. He's like the man who saw the elephant for the first time and declared that there ain't no such animal. But you won't feel that some things can't be done - perhaps they can be done, and you can try them.

THE JOB YOU'LL FILL.

Here's a little more advice. For the time being don't attempt to decide just what opening you will fill. As you get into this business it will be only natural that you will like some parts more than others. Now, anyone will agree that a man makes more money and is more successful in work that is a pleasure to him. Therefore, study everything as it comes along and don't make up your mind until you get near, the finish. There are so many specialised applications of electronics that you are sure, to find one which will appeal, particularly to you.

You have started on the road to becoming a radio man. This lesson has just opened door. The next one is the next step on the way. That step is going to give a vision of the broad scope of radio. You should see the whole picture before start, to study the various parts. In the next lesson you will be, told briefly simply of the various steps from the point where music or speech is produced at broadcasting station until it is heard in your loud speaker.

EXAMINATION QUESTIONS – NO. 1.

1. Do we use up the electricity when work is done?
2. Can electrical energy be stored? Explain
3. When electrical pressure is present, must there be electrical current also?
4. Do amperes and volts measure the same thing?
5. What is the name of the unit which measures electrical pressure,?
6. What kind of electric current flows first in one direction, then in the other?
7. What kind flows always in one direction?
8. What kind of electric current has frequency?
9. In what direction do “electrons” move around a circuit, positive to negative or negative to positive?
10. When we use the old fashioned term, “current”, in what direction do we generally imagine it as flowing?

PLEASE NOTE POSTAL ADDRESS:- Box 43 Post Office. Broadway.

NOTE:- Write on one side of the paper only.

Always write down, in full the question before you answer it.

Answer the questions as fully as you can giving complete explanations and sketches wherever possible.

Remember that you learn by making mistakes; so give yourself an opportunity of having your mistakes found and corrected.

Don't hesitate to ask for further explanations on any point, we are, always ready to help you.

"The Radio-T.V. Training Centre"

**E. S. & A. BANK BUILDINGS, Corner CITY RD. and BROADWAY, SYDNEY
Telephones: BA4891 and BA4892**

AUSTRALIAN RADIO AND TELEVISION COLLEGE PTY. LTD.

Telegrams "RADIOCOLLEGE" Sydney

**This lesson sheet is published for the exclusive use of
43, Broadway
students of the Australian Radio and Television College
Pty. Ltd. (All rights reserved)**

Post Lessons to Box

LESSON NO.2.

FROM TRANSMITTER TO RECEIVER

In this lesson and the one following we will start off with sounds of speech or music going in the at the transmitter and will end with those sounds coming out of a loud speaker at the receiver. This is going to give you a complete birds-eye view of the whole field of radio. I want you to have such a complete picture in your mind that, as you study each separate part, you will know exactly where it fits and how its work affects all the other parts.

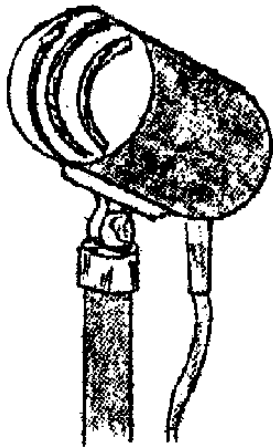

Figure 1.

WHAT WE DO WITH SOUNDS

In the first lesson you learned that the microphone in a transmitter is quite similar in its action to the telephone in your home. With the microphone we take great precautions to keep vibrations, other than those of the sounds broadcast, from being Transmitted. The microphone is used where-ever possible in a "Sound proof" studio and is supported on sponge rubber. The microphone is so sensitive that it is affected by the slightest noise. While listening at the loud speaker you often will hear the sound of a speaker's breath.

The microphone contains a diaphragm which is caused to vibrate by air movements which represent sounds. Connected to the diaphragm are parts which change their electrical resistance as they are moved by the diaphragm. These parts are carrying an electric current all the time the microphone is in use and the changing resistance makes the current change accordingly. The changing current in the microphone is made to bring about changes of voltage in other circuits and parts, so that we translate the sounds into voltages.

In other types of microphones the movements of the diaphragm cause other parts to move and to generate an alternating voltage. As these voltages are generated by movements caused sound waves they are similar to the sound

sound waves in frequency and in “waveform”. In radio work we often find it convenient to represent. rise and falls of voltage or current which occur as time goes by as a rising and falling line. In Fig. 2 is such line. It shows the changes caused when a speaker utters the sound of the letter “O” as it is used in the word “ton”. The drawing shows the voltage changes during the one two-hundredth part, of a second, These, changes repeat over and over gain as the letter is being sounded.

Alternating voltages or currents, especially those representing radio or television signals, are very frequently represented graphically as in Fig..2. The horizontal line or scale always represents units of time such as seconds or fractions of seconds such as milliseconds or microseconds. A millisecond is one thousandth part of a second and a microsecond is one millionth part of a second. The vertical distance above or below the horizontal line, represents the strength or amplitude. of the Voltage or current

Diagrams such as Fig. 2 are often called “waveform” diagrams as they show the exact way in which the strength of sound waves or radio waves or electrical waves change from moment. to moment of time.

The problem in radio is to take such voltage changes as in Fig. 2, get them through the space between transmitter and receiver, then change them back into sound again. You will grant that the accomplishment of this object is a wonderful thing - one of the most wonderful things in the modern world.

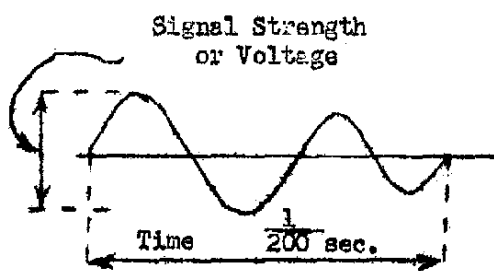

FIG. 2.

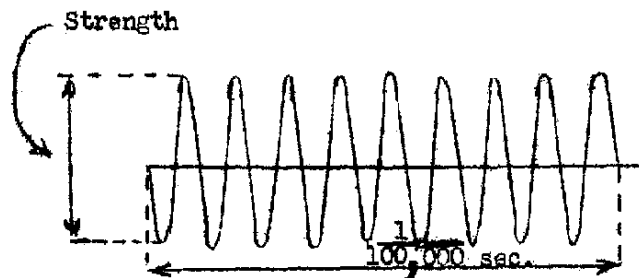

FIG. 3.

THE CARRIER WAVE

The oscillator, about which you were told in the first lesson, is a part of the transmitter which produces alternating current of exceedingly high frequency. You remember that the frequency is the number of complete reversals, or cycles made by the current or voltage in one second. Just as we represented the sound voltages in Fig. 2 by the wavy line, so we will represent the oscillator voltages changes by a line like the one, in Fig. 3 These voltages changes just go up down at a tremendous rate, but they always go up and come down the same distance. These are the voltages that produce the radio waves that leave the transmitters aerial, and fly away into space

“I said the voltage changes are always the same. They remain the same as long as no sounds are being sent out, but in a moment we are going to alter

them as the sounds commence to come through. The steady waves produced by voltages like those of Fig 3 make up what we call the transmitter's "Carrier Wave".

Fig. 3 shows ten complete reversals of the alternating current or its voltage. If we were to compare this drawing with the actual frequency of a broadcast station found near the middle of the dial, these ten complete "cycles" would take place in the one-hundred-thousandth ($1/100,000$) part of a second.

While on the subject of cycles we want to understand a word which is common in radio language. That word is "Kilocycle". In radio, we frequently have to talk about millions of cycles, and if we did not have this short-cut expression they would sometimes be tongue-twisters. So, we use the term kilocycle to mean one thousand cycles. If we want to say 500,000 cycles, we would usually say 500 kilocycles. You can see that is very much easier.

For high frequency short wave applications, especially in connection with television frequencies of many millions of cycles per second are involved, or describing these frequencies we often use the term megacycle. One megacycle is the same thing as one million cycles

MODULATION

In the process of getting this audio wave ready to leave the transmitter's aerial our next job is that of combining the sound voltages, like those of Fig. 2 with the carrier wave voltages shown by Fig.3.

You can get an idea of how this is done by looking at Fig. 4. Of course this only shows the general idea of the thing -- do not take all these drawings, for actual complete layouts. In Fig. 4 we have the modulated amplifier handling the carrier frequency the high frequency which produces the carrier wave that travels through space. The modulator is handling the sound frequencies received from the microphone and acts on the mod. amp. in such a way as to control or, regulate the strength of its output. The output from the mod. amp., controlled in its strength or voltage according to the sounds from the microphone, is fed into the aerial system and is radiated into space as a carrier wave.

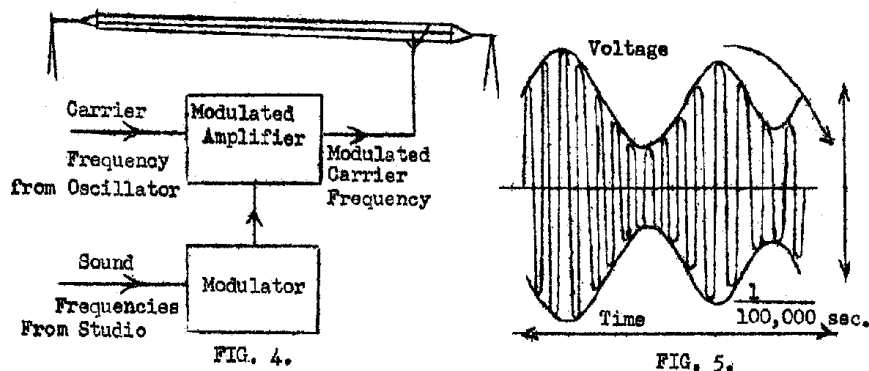

The result of combining these two frequencies is this: the rise of sound voltage are added to the voltage of the carrier and make the carrier voltage higher at that point. The drops of sound voltage then lower the carrier voltage when the sound voltage lowered.

The way the sound voltage combine with the carrier's voltage is shown in Fig. 5. The result is a rise and fall of the carrier voltage. Notice that we have shown the carrier's frequency as remaining unchanged, that it is only the voltage that is altered. Later on you will see how these changes of voltage are made to change the frequency of a different current.

The drawing in Fig. 5 is not very accurate. If we were to compare the carrier frequency of Fig. 3 with the sound frequency change of Fig. 2, you would find that the whole width of the ten cycles in Fig. 3 extend only across the one-five-hundredth part of Fig. 2. To make them actually match and show the true relation of sound changes to carrier frequency, we would have to either divide Fig. 2 into five hundred parts, and use only one of them, or we would have to make Fig. 3 five hundred times as wide as it is. Then you would have the real picture. In the actual radio wave there are no such abrupt voltage changes as is indicated in Fig. 5, they are about five hundred times as gradual as this.

The changes of Fig. 5 are, what we call a "Modulated carrier wave". Here, as you can see very plainly, we have both the carrier frequency and the sound frequencies. The gradual rise and fall of voltage represents the sounds sent into the microphone, while the high, frequency part is capable of carrying the disturbance through miles and miles of space. Now we will shoot this modulated carrier up into the aerial of the transmitter and see what happens next.

If the disturbance caused by such a radio wave were to start out from somewhere around Sydney, it would arrive on the exact opposite side of then earth in less than one-fifteenth part of a second. The time required for each change in the wave to reach a receiver anywhere in Australia, would. be a might small fraction of a second. Now we will take it for granted that the wave has reached the aerial of a receiver which you are going to investigate.

CATCHING THE RADIO WAVE

We are going to let the radio wave pass along on an elevated wire, called the receiving aerial, and the earth or ground under the wire. Perhaps it would be better to say that we will put up an aerial where the wave will pass along it, because we do not have to let the wave do anything -- it will do what ever it pleases and we will have to take advantage of its action.

In Fig.. 6 you will Bee these parts as used at a receiver. The aerial is connected to a "lead-in" wire, which, is attached to one end of a coil. The other end of the coil is connected to a "ground-wire" that runs down to a piece of iron or some other conductor of electricity which is buried in the ground.

As the radio wave passes through the space in which the aerial which is erected, the effect of the wave is to first raise the aerals voltage, then lower its voltage. As a general rule we consider that the great mass of earth

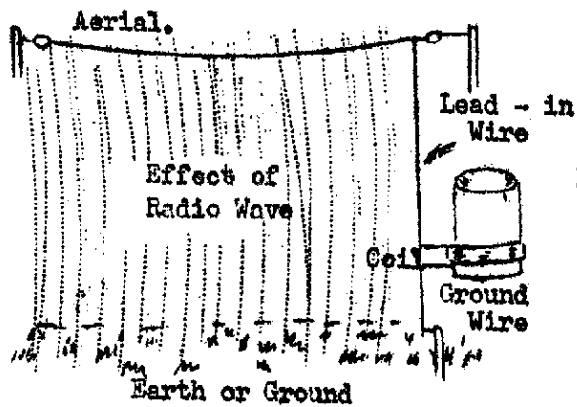

FIGURE 6.

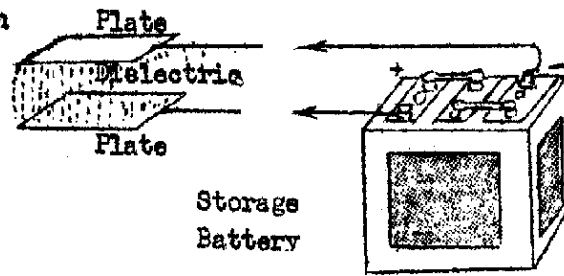

FIGURE 7.

beneath our feet has no voltage at all. Then, when there is electrical pressure, or voltage which could cause a current of electricity to flow toward the earth, we say that the body or the thing having such pressure is at a "Positive voltage" with respect to the earth. If a body is in such a condition that electric current tending to flow toward it from the earth, then we say it is at a "Negative" voltage with respect to the earth. From this standpoint, voltages that are higher than that of the earth are called positive voltages, while those which are lower than that of the earth are called negative voltage. Of course, we are going into all these things in great detail later on, and we will then consider these actions in terms of "electron" behaviour.

Electrons are minute electrical charges, or "grains" of electricity upon the behaviour of which all electrical phenomena depend. However, until we get around to studying electron characteristics more fully, we will use the more familiar and conventional, if old fashioned, idea of a current, of electricity which we picture as flowing from a positive point or point of high electrical pressure to a negative point or point of lower electrical pressure or voltage in explanations in these early lessons.

For the time being just remember that the radio wave causes changes of voltage between aerial and earth. First there is a voltage that makes current flow from the aerial down through the coil and to the ground. Then, at the next instant, there is a reversal of voltage and the tendency is for current to flow up into the aerial. Do you see that this gives us an alternating current through the coil?

CONDENSER

For a few moments we will have to leave the aerial to consider something that was barely mentioned in the first lesson sheet -- a condenser. There is nothing in all electrical science simpler than a condenser. It is just two metal plates separated by some substance that does not easily permit the flow of electric current. Anything that allows electricity to flow through it easily is called a "Conductor" and, anything which opposes and practically prevents

the flow of electricity is called an “insulator”. Then we can say that a condenser consists of two conductors insulated from each other. The insulation between the plates or conductors of a condenser is called the dielectric. These parts are shown and named in Fig. 7

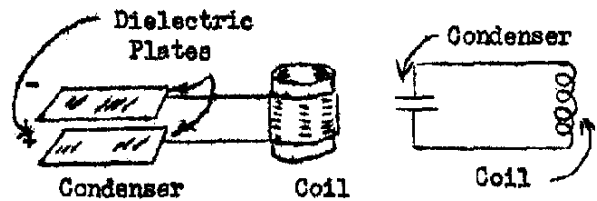

Figure 8.

The condenser of Fig. 7 consists of two flat metal plates with air as the dielectric between them. Over at the right hand side of the drawing is an ordinary electric battery like the one in an automobile. You know that such a battery has two terminals, one marked with a plus (+) sign to indicate that it is positive, and the other marked with a (-) sign to show that it is negative. That means that with those terminals connected together by a wire, the pressure at the positive terminal will be higher than the pressure at the negative terminal and current will flow from positive to negative.

If you were to connect the two terminals of the battery in Fig. 7. to the two plates of the condenser You would not have a flow of current from one side of the battery to the other because, the dielectric of the condenser is an insulator and prevents flow of current through it. Yet, while there would be no continuous flow of current, you would actually change the condition, the electrical condition, of the plates. The top plate would be at a higher pressure than the bottom one. The top plate would, as we say, have a “negative charge” while the bottom plate would have a “Positive charge”. You might then remove the battery and the two plates would stay charged.

In Fig. 8 are shown the two “charged” plates connected to a coil of wire. Since the electrical condition of the lower plate is positive and of the upper plate negative, there will be a flow of current through the coil winding from the lower plate to the upper one. Since the condenser plates contain only a little bit, of energy, there will be only a little current flow and then there will not be any voltage difference remaining between the plates.

In radio we have a sort of shorthand system to show the various parts we use. Over at the right hand side Fig. 8 you can see this “Shorthand” for the condenser and the coil. We call these representations of radio parts by the name of “Symbols”

THE AERIAL AS A CONDENSER

In Fig. 9A you will see the receiver's aerial and ground. We said that a condenser consists of two conductors with a dielectric between them. The aerial wire is one conductor, the earth or ground is another conductor and the air between them in a first class dielectric. Therefore, this aerial and ground are, in effect, the same as the two condenser plates shown in Fig, 9C.

We use symbols for everything in radio, so in Fig. 9B you have the corresponding symbols for aerial and a ground, and in Fig. 9D is the symbol for the two plates representing a condenser such as Fig. 9C,

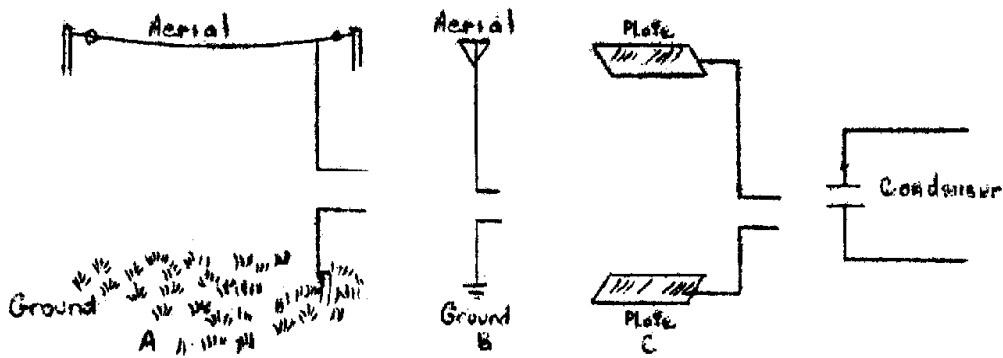

Figure 9

The radio waves passing through the space between aerial and ground, as in Fig. 6, charge the aerial alternately positive and negative. Because such an aerial system when considered in connection with the ground, is electrically similar to a big condenser it is often convenient to think of it as a condenser. The alternating charges on the aerial produce an alternating current in coil connected between aerial and ground as in Fig. 6. store this fact way in your memory for a little while because before long we are going to use something which is produced by this current passing through the coil.

ELECTROMAGNETIC LINES.

At some time or other you have played with a toy horseshoe magnet and have let it pick up nails and other small objects made of iron or steel. If you lay a nail on the table top, as in Fig. 10, and bring such a magnet near it, the nail will finally jump to the magnet and will be held there. Between magnet and nail there is some kind of force at work. It is invisible, you cannot see it, but Just the same it is there.

If you were to tie a string around the middle of the nail and hang it up, as in Fig. 11, then bring the magnet near the nail, the nail would swing around and point toward the end of the magnet. Because it is not as difficult to swing the nail around as to pull it across the table top, the action will show up in Fig. 11 with the magnet much further from the nail than with the arrangement of Fig. 10.

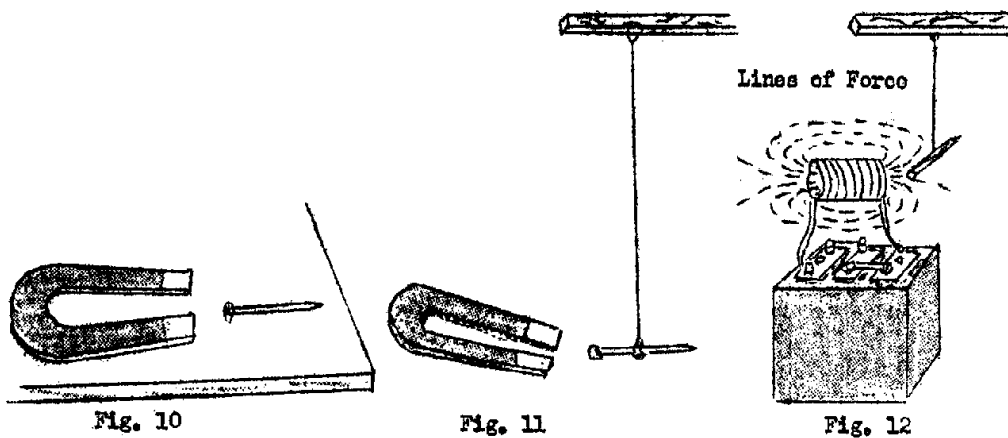

Now you might take some wire and make it into a coil somewhat like the one of Fig. 12. If you then connect the ends of this coil to a battery, current from the battery would flow through the coil. This coil, with current flowing through it, would swing the suspended nail just as the magnet swings it. The same kind of force that exists around the magnet exists also round the coil of wire. We say that this force is a “magnetic field” or an “electromagnetic field” and that it consists of (invisible) “lines of force” as indicated in Fig. 12. The coil of Fig. 12 is called an “electromagnet”. The two kinds of fields are exactly similar even though one is produced by permanent steel magnet and the other is produced by an electromagnet that has the properties of a magnet only while current flows through it. The nail sly tries to line up with the linen of force which surround it.

ENERGY

The magnetic field around the coil represents “energy” and the charge upon the plates of a condenser likewise represent energy. But before we go on, you must know a little about this thing energy which will be mentioned many and many a time as we talk about the performance of radio parts.

Energy is the ability to do work. There are a good many forms in which we may have energy. some things have energy, or are able to do work because of their position or shape. The weight on the clock in Fig. 13 has energy (will do work) because it can drop and change position. If you twist a rubber band it has energy because of its shape and it will do work as it untwists. The charges on condenser plates have energy because they will do work as the positive charge and the negative charge come together and neutralise each other.

Other things ham energy because of their motion. The spinning flywheel of Fig. 13 contains energy and will do work if connected to some piece of machinery. A heavy weight thrown through the air contains energy and will do work if it strikes some object. The moving field around a coil contains energy of this general nature.

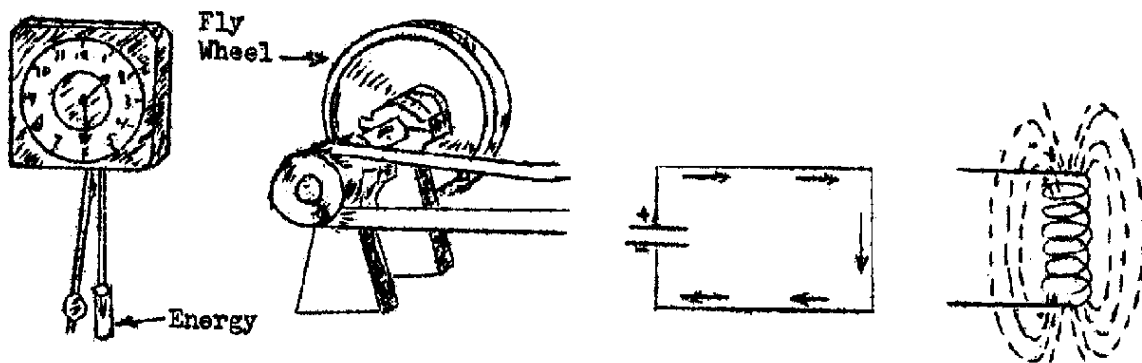

FIGURE 13.

OSCILLATING SYSTEMS

Now we are going to do some things with energy. At the left hand side of Fig. 14 you will see a cross beam, hinged or pivoted at its centre carrying a heavy weight on one end and attached to a coiled spring at the other end. As shown in the left hand drawing, this mechanical system is in balance, the spring is just holding the weight.

Suppose you were to pull the weight down into the position shown in the centre drawing of Fig. 14. This would stretch the spring and it would contain more energy than it contained in the first position. Were you then to let go of the weight the spring would contract and in contracting it would raise the weight as shown in the right hand drawing. In this position the weight contains more energy than it contained in the left hand drawing because it has been raised to a higher position.

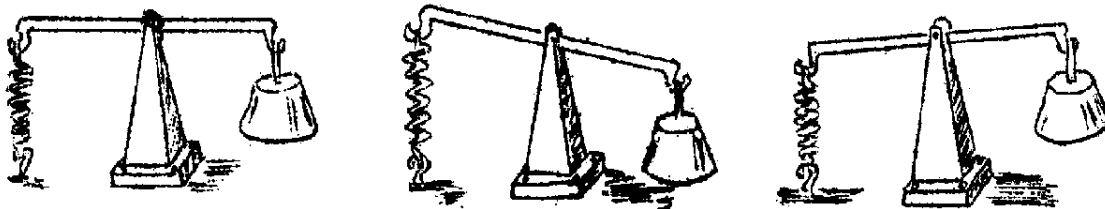

FIGURE 14.

Then the weight would tend to drop and in dropping would stretch the spring again. So the action would go on, the spring stretching and compressing the weight rising and falling.

With the parts in the positions shown by the centre drawing of Fig. 14, most of the energy of this mechanical system is contained in the stretched spring. Then the spring expends its energy in raising the weight. With the positions shown in the right hand drawing the energy is contained in the elevated weight, which is capable of using its energy to again stretch the spring. The energy oscillates or swings back and forth between the spring and the weight until it finally is used up in overcoming the friction of the moving parts.

OSCILLATING ELECTRIC CURRENT

The most useful arrangement of parts in the whole field of radio is shown in Fig. 15. Look at it carefully. There is nothing more than a coil connected to a condenser. A coil and condenser, connected together, make what is called an oscillating circuit or an "oscillatory circuit". Energy will oscillate back and forth between the coil and condenser until it is finally used up by electrical friction, in other words, by electrical resistance in the conductors used in the circuit and its parts.

The coil and condenser at the left hand side of Fig. 15 contains no energy. Now we will assume that the condenser plates have charged. Then the condenser contains energy. This difference in voltage between the condenser plates will cause current to flow from one plate to the other and in so

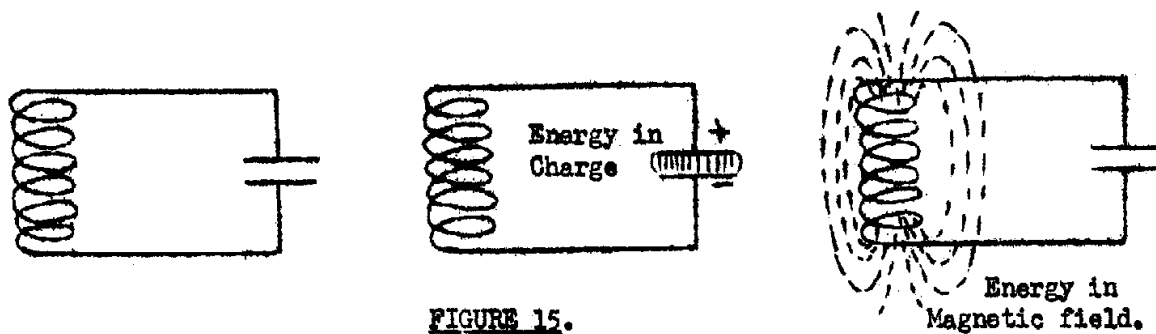

FIGURE 15.

flowing it must pass through the coil.. Whenever current commences to flow through a coil, it rises to the highest value and then falls to zero, there is a rising, and falling magnetic field or a moving field produced around the coil. This field contains energy, low of current from the condenser through the coil will naturally commence at zero, then will quickly rise and will commence to fall again to zero as the voltage difference or electrical pressure between the plates disappears.

The magnetic lines of force which appeared around the coil, due to the current in the coil, will drop back into the coil when the condenser's voltage has been "discharged" and is no longer able to keep the current flowing. As the lines of force drop back through the turns of the coil they generate a voltage in the coil, winding. This voltage produced in the coil causes the flow of current to keep going in the same direction, until the energy, represented by the magnetic field has been all transferred to the condenser as a new charge opposite to the original charge. By the time all of the magnetic lines of force have collapsed back through the turns of the coil to its centre, and have disappeared, all of the energy represented by the magnetic field will have been transferred back into the condenser. As there is now no voltage generated in the coils by the collapsing lines of force, there is nothing to hold the new charge in the condenser so this new charge then exerts itself in producing a current back through the coil in the opposite direction to the original current. This new Current again produces lines of force which again generate a voltage, and so the action keeps going until all the original energy has been used up in the resistance of the circuit. So here, in the electrical system, we have electrical energy oscillating or swinging back and forth between the coil and condenser, very much as in Fig. 14 we had mechanical energy changing back and forth.

PRODUCING VOLTAGE

You will be able to answer the question about getting the energy started just as soon you have learned about another big thing in radio. That big thing is called "coupling". It is the action that enables us to get energy from one electrical circuit over into another electrical circuit even when there are no wire connecting the two circuits. together.

When you were being told about the oscillating circuit, it was said that the lines of force dropping back through the wires of the coil produced a voltage in these wires. That statement is correct - such, an action really does take place. We would like to explain it all to you, but we cannot go that deeply

into, things in this lesson. A little further along we will dig into all these things and get to the bottom of them but only just a few of the very beginnings can be crowded into these first lesson.

The first time you have a chance, look inside the electric lighting generator on a motor car. Of course, you know that such a generator produces electric voltage which causes a flow of current to light the lamp and charge the battery. Inside the generator you will see a part that turns around or rotates. This part (called the armature) carries a lot of wires. If you look very carefully you will see that the armature rotates between iron pieces around which are wound coils of wire. These iron pieces are electromagnets.

The electromagnets of the generator produce a field of lines of force. The armature wires are moved through this field and this movement of conductors through lines of force produces the voltage. Any conductor moving through any magnetic field will have voltage generated in the conductor. It is the movement between these two, the conductor and the field, that produces voltage.

One single conductor, such as one strand of wire in our generator would have to cut through one hundred million lines of force in one second to have one volt developed in it. We seldom come across such strong or concentrated magnetic fields but by using many strands or turns of wire and by making the conductor move through the field, or the lines of force move past the conductor in a much shorter time than one second, we can have quite large voltages "induced" in a coil.

It does not make a particle of difference whether the field remains, stationary with the conductor moving, whether the conductor remains stationary, while the field is moved, or whether both the conductor and field move at the same time. In each case, as long as there is relative movement between field and conductor, voltage is generated.

We have not talked about coupling yet. We had to explain ,about producing voltage by movement of conductors and fields before we could commence with the coupling part. Now that we are able to generate a voltage we can go back all the way to the aerial circuit of Fig. 6.

COUPLING

In Fig. 6 we had an aerial on which voltage changes were being produced, by the radio wave. The aerial circuit is shown in symbols in Fig. 16. The changing voltages on the aerial will cause alternating currents in the coil. When the alternating current is changing from one direction to the other, for just an instant there is no flow either way. Then there is no field around the coil because no current is flowing through it.

Then the current will commence to increase and the lines of force will extend out a little way from the coil as shown by the lines, closest around the coil of Fig. 16. e.g. the current increases, the coil's field will finally, extend way out to the position shown by the outer lines. Now notice carefully that there we have a movement of the lines of force.

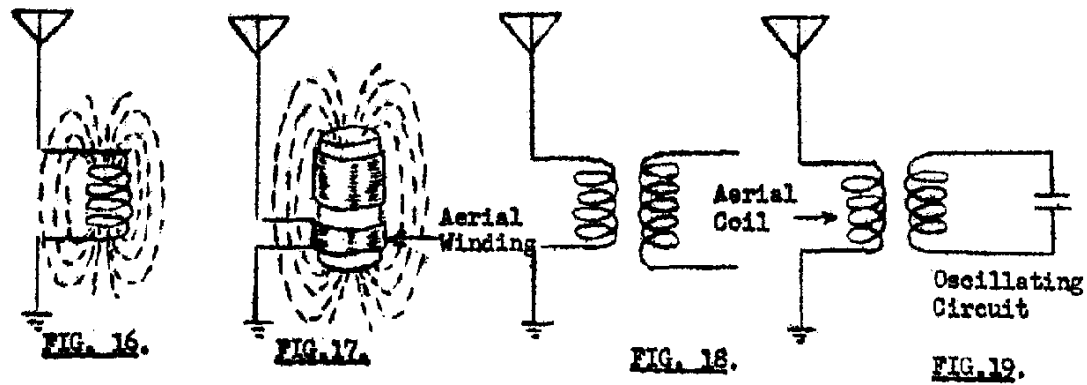

In Fig. 17 we have placed the aerial winding from Fig.16 on the bottom of a piece of tubing and on this same tubing have placed a second winding. Now the lines of force produced by the changing current in the aerial wining will pass not only through the aerial wining itself, but also through the other winding as indicated by the line of Fig 17.

The movement of the field of the aerial winding, as this field expands and contracts makes lines of force move through wires or conductors which make up the second coil. You know that movement of lines of force through wires will produce a voltage in those wires. Therefore, a voltage is produced in the second coil. The voltage is a form of energy and will produce flow of current if given a chance. So we have started with energy in the aerial winding and have produced voltage or energy in the second coil. There is no wire connection between the coils, but we say they are “coupled”. We are transferring energy from one circuit to another by moans of electromagnetic coupling, by means of electromagnetic line of force. The two coupled circuits or coils of Fig, 17 shown in symbols by Fig. L8. You can see it is a lot easier to draw symbols than to draw pictures.

In. Fig. 19 we have added one more part to the ones shown in Fig. L8. We have put a condenser between the ends of the second coil, and there you have our oscillatory circuit in which energy will swing back and forth. That is how we get energy into our circuit to start with. We just couple the oscillatory circuit to the aerial circuit, the voltage produced in the second coil will charge the condenser, the condenser will “discharge” through the coil and so the action goes on.

RESISTANCE

In explaining the oscillating mechanical system of Fig. 14 it was stated that the energy would continue to swing back and forth until it was used up in overcoming friction in the moving parts. The spring would give back its energy and the coil would do likewise. Those parts do not use up the energy, they just take it and hold it for while. But the pivot bearing takes energy to overcome its friction and that energy is not given back into either the spring or the weight.

In electrical work we have something which corresponds to friction in mechanics. Electrical friction is called “resistance”. Resistance changes

electrical energy over into heat. There *are* several devices which make use of this ability of resistance to produce heat. The electric lamp turns electric energy into and light. The electric stove and electric flat iron use electric energy to produce heat energy.

In most radio parts we do not want any more resistance than is absolutely necessary. True, there are a few places where resistance really helps us out in controlling the amount of current which will flow through a circuit. But as a general rule we do not want to waste any of the precious energy in heat, we want to save it *to* produce sound.

Every electrical conductor, every wire, every piece of metal, everything through which electricity flows - all have resistance. All of them use up our electrical energy and change it to heat energy which is of no use to us.

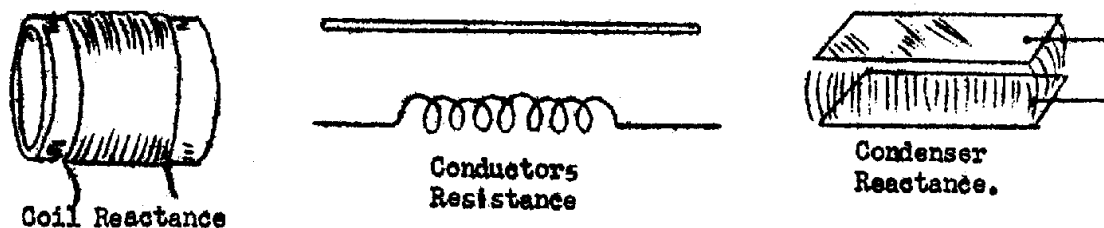

FIGURE 20.

Therefore, in all the circuits we are investigating just now we want as little resistance as we can possibly get. Resistance is reduced by using short connections instead of long ones, by using large wires instead of small ones, and by using material which is a good conductor of electricity. Copper is the best conducting material that is cheap enough to use for wires and connections.

REACTANCE

In all condensers we have electrical resistance because they are made out of conductors, out of copper wires and other metal parts to carry the current. But in addition to the resistance, these part have another very important electrical quality - they have "reactance" The word itself really tells you its meaning. Parts having reactance are able to re-act. You know what "act" means and you know what the prefix "re-" means about the same as back. So these things act beck. When you twist a spring it reacts by untwisting. When you lift a weight it reacts by falling down again. Remember, as shown in Fig 20, that, coils and condensers have this property of reactance.

I have already explained that energy put into a coil will produce a magnetic field around the coil and this field will then return the energy to the coil. I have also explained that energy put into a condenser produces a charge on the condenser plates and this charge will then give back the energy. These are the actions taking place in Fig. 15.

Even though the coil and condenser will return their energy to us, it requires an effort to get energy into them in the first place. Even though a spring will untwist and return energy, you have to do work to twist the spring to begin with. Even though an elevated weight will do work as it drops, it takes work or energy to elevate it in the beginning. Coils and condensers oppose rise and fall of current through them.

This means that they oppose flow of alternating current through them because of their reactance. The amount of opposition offered to alternating current by a coil or by a condenser is measured in a unit called the "ohm". We say that a coil has a reactance of certain number of ohms and we say that a condenser has a reactance of a certain number of ohms. So here we have one common measuring stick that applies to the action of both coils and condensers - we can measure both of them in ohms.

BALANCING THE REACTANCES

The next thing we are going to figure out is how to let the tiny amount of energy coming down through the aerial coil of Fig. 19 produce the greatest possible amount of energy to oscillate back and forth in the oscillating circuit coupled to the aerial coil. Of course, you will say that we must reduce the resistance of the oscillating circuit so that the energy will not disappear in the form of heat. You are exactly right - we will reduce the resistance. That is the first step. Then we will work on the reactance of the coil and the condenser.

If you pull down on the weight in Fig. 14 and then let it go, the spring will make the weight bounce up and down, or, oscillate, at a certain rate of speed -- so many oscillations Per second. Were you to change the amount of weight or were you to change the strength of the spring, the oscillations would be at different rate.

They would be either faster or slower. We get a similar effect in the coil and condenser. For any one size of coil and one size of condenser the electrical oscillations will take place at a certain frequency or at a certain rate of speed. If you change the size of the coil and use the same condenser, the frequency will be different. If you change the condenser and use the same coil, again the frequency will change.

For each particular frequency there is a right combination of coil and condenser. When you get this right combination it becomes very easy for the electrical energy to oscillate back and forth at that frequency. With the right combination for certain frequency you would find that the reactance of the coil and the reactance of the condenser were alike Then the two reactances balance each other and the result is just as though there were no reactance at all. Then we find the greatest possible flow of current back and forth and we have done everything possible to prevent loss of energy.

To assist the maximum possible flow of current at any particular frequency, we generally use an adjustable or variable condenser or an adjustable coil so that the two reactances can be made exactly equal so as to encourage the strongest oscillations of current. We will see how this is done in the next lesson.

WHAT WE HAVE DONE SO FAR.

Here are the highlights, of this lesson, the things you must remember; we have an alternating current in, the aerial coil. This current produces lines of force which get energy over into an oscillating circuit. The energy swings back and forth between the coil and condenser in the oscillating circuit. This circuit will receive the greatest possible amount of energy when the reactances of the of the coil and condenser are equal and when the resistance is low.

EXAMINATION QUESTIONS -- No.2.

1. What is the name of the instrument in the broadcasting station which changes sound into electrical impulses?
2. What is the name given to 1000 cycles?
3. What kind of electric current flows in the aerial circuit?
4. What is the name of the electrical instrument which consists of two metal plates insulated from each other? What is its purpose?
5. Does the magnetic field around the coil contain energy?
6. What two important electric devices are needed for an oscillating system?
7. How is energy transferred from one coil to another which is coupled to it?
8. Does it make any difference whether the lines of force move or one of the coils moves in order to have the lines of force generate voltage?
9. What electrical property is like friction?
10. What is the real meaning of the term "reactance"? What radio parts possess this property?

Please note Postal address: AUSTRALIAN RADIO & TELEVISION COLLEGE PTY.LTD.
Box 43, Broadway, Sydney, N.S.W.

NOTE:- Write the lesson number before answering the questions.
Write on one side of the paper only.
Always write down, in full the question before you answer it.
Use sketches and diagrams wherever possible. One diagram in many cases is equivalent to pages of explanation
Remember that you learn by making mistakes; so give yourself an opportunity of having your mistakes found and corrected.
Don't hesitate to ask for further explanations on any point, we are, always ready to help you.
Write your name and full address at top of paper. If you have made arrangements with the College to have your lessons returned to any particular address -- state this at the top of the page.

“The Radio-T.V. Training Centre”

**E. S. & A. BANK BUILDINGS, Corner CITY RD. and BROADWAY, SYDNEY
Telephones: BA4891 and BA4892**

AUSTRALIAN RADIO AND TELEVISION COLLEGE PTY. LTD.

Telegrams “RADIOCOLLEGE” Sydney

**This lesson sheet is published for the exclusive use of
students of the Australian Radio and Television College
Pty. Ltd. (All rights reserved)**

Post Lessons to Box 43, Broadway

LESSON NO.3.

CHANGING ELECTRICITY INTO SOUND.

The energy that comes into your receiver by way of the aerial is so small that the force of a falling feather would be tremendous in comparison. Yet before we are through with it, the tiny impulse is going to control sounds so loud that they could be heard by a thousand people from one loud speaker.

Now you can see why it is exceedingly necessary to guard every particle of power against loss and why we work so hard to carry every bit of energy through from one receiver part to the next without losing efficiency in between.

SELECTING A FREQUENCY.

In the previous lesson I said, “Notice the carrier’s frequency remains unchanged, it is only the voltage that is altered.” That is the key to the whole problem of selecting one station to listen to.

Suppose you have a receiver located somewhere as shown by the map in Fig.1. There are powerful radio transmitters in Sydney, Brisbane, Melbourne, Adelaide and all those other cities. Right near you is one of the strongest stations - the one in Sydney, Say it is eight o’clock in the evening. Every station is on the air with all its power. How are you going to listen to a programme from Melbourne for half an hour and then change over to a programme from Brisbane, or even choose the one particular programme you wish to hear, from the many Sydney stations.

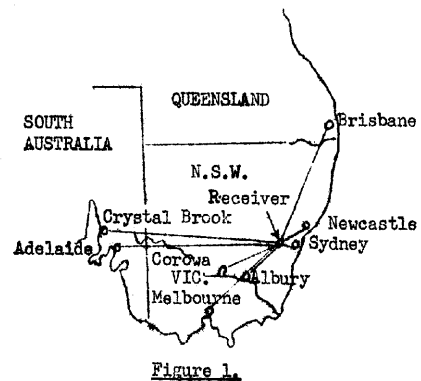

The only thing that makes radio reception possible under these existing circumstances is the fact that different stations use different frequencies

for their carrier waves. A Melbourne station may use a frequency of 800,000 cycles (800 kilocycles) and a Newcastle station may use a frequency of 1,200,000 cycles (1,200 kilocycles) per second. We will now see just how it is possible to select either one and exclude the other

We will make the selection by working with the coil and condensers in the oscillatory circuit.

COIL REACTANCE CHANGES WITH FREQUENCY.

In Fig. 2 you will see three coils. They are exactly alike in every way. If you were to send current at a frequency of 800 kilocycle through such a coil you might find its reactance to be 1000 ohms. Raising the frequency to 1000 kilocycles would raise the reactance to 1250 ohms, and raising the frequency to 1200 kilocycles would raise the reactance to 1500 ohms. Then the reactance of this coil at Melbourne station's frequency would be 1000 ohms and at the Newcastle station's frequency would be 1500 ohms.

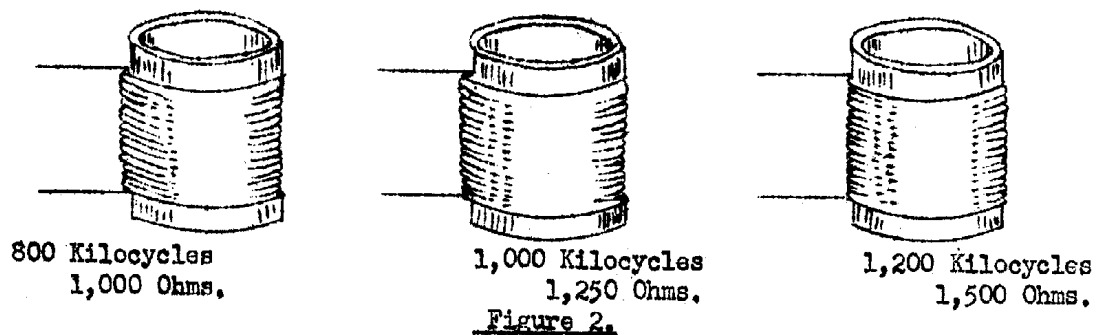

CHANGING THE CIRCUIT'S REACTANCE.

You saw in Fig. 2 how a coil's reactance changes with frequency. Looking at

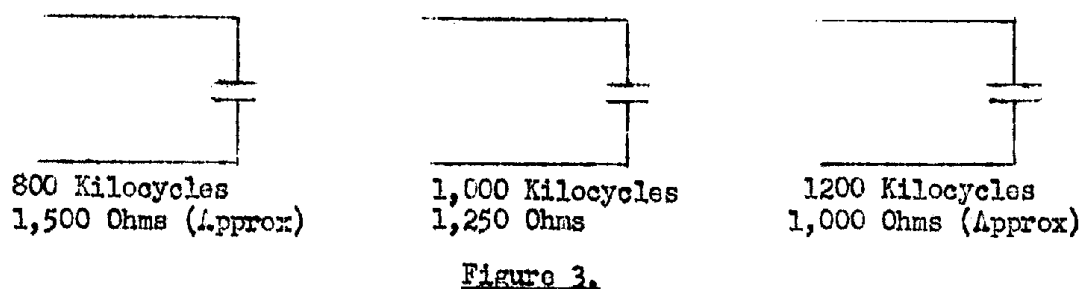

Fig.3 you will see that a condenser's reactance also changes with frequency. But here is an important difference, The coil's reactance gets greater and greater as the frequency gets greater, but the condenser's reactance works just the other way around. The condenser's reactance, gets smaller and smaller as the frequency increases.

Fig. 3 shows the same condenser working at three different frequencies. At a frequency of 800 kilocycles the reactance is it is 1250 Ohms, and at 1200 kilocycles the reactance is approximate 1000 ohms. Compare these reactance's for the condenser with the reactances for the coil in Fig. 2. Notice that the coils' reactance increases with the frequency and the condenser's reactance decreases with the frequency,

Take a coil just like the one shown in Fig. 2 and connect it with a condenser like one in Fig. 3 which has a reactance of 1250 ohms at a frequency of 1000 kilocycles as in Fig. 4. Now we have an oscillatory circuit. There is the most energy in an oscillatory circuit and the greatest amount

of current will flow back and forth between the coil and condenser when their reactances are exactly equal. Now in this circuit at which of the three frequencies will the oscillating current have the greatest amount of energy? At the 1000 kilocycles,

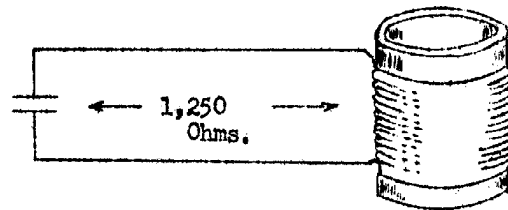

Figure 4.

of course, because at this frequency the reactance of the coil is exactly the same as the reactance of the condenser and as we saw earlier, would tend to cancel the other.

It would be possible to take a circuit like that in Fig. 4, apply a certain frequency to it and then change the condenser for one that would equal the coil's reactance at this frequency. This would be the circuit's most sensitive frequency. It is the frequency to be received. But you know that we do not reach into our radio receivers change condensers when we are tuning.

What we really do is change the condenser without reaching inside the receiver, without taking out one condenser and putting another in its place. We simply use a variable condenser made something like the one shown in Fig. 5.

This variable condenser consists of a number of plates divided into two sets or groups. All the plates in one group are connected together and all those in the other group are connected together, but the two groups are insulated from each other. This amounts to the same thing as our two plate condensers as you see in Fig. 6.

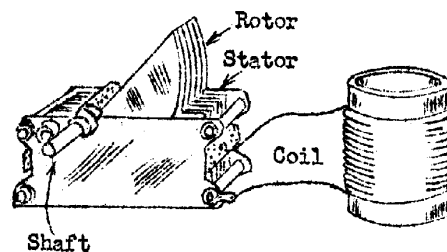

Figure 5.

At the left hand side of Fig. 6 are the two plates of a large condenser. The top plate is marked "A" and the lower one is marked "B". Over at the right we have divided one large "A" plate into three smaller "A" plates, all connected together. Similarly we have divided the single large plate into three smaller "B" plates and connected them together.

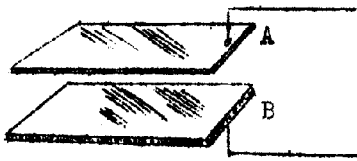

Figure 6.

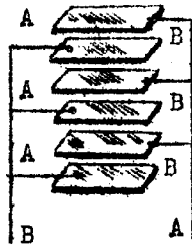
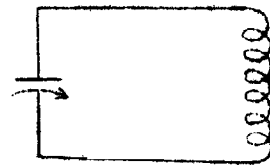

Figure 7.



By sliding the "A" plate out from between the "B" plates we will lessen the effect of the condenser. The further apart the plates are moved the smaller will be the capacity of our condenser. Getting the plate further apart is just the same thing, electrically, as using smaller plates. The variable condenser of Fig. 5 is made so that the plates marked "Rotor" move out from between those marked "Stator" when you turn the shaft. This changes the effective capacity of the condenser and thereby changes its reactance.

The coil and the variable condenser of Fig. 5 are shown by symbols in Fig. 7. All we have done to show that the condenser is variable, is draw a curved arrow to represent one set of plates. The arrow indicates that the condenser's value can be varied while it is in use.

Turning the shaft of the variable condenser so that the condenser's reactance is made equal to the coil's reactance at the frequency to be received is the operation called "tuning". The tuning dial on a receiver operates the shaft of the tuning condensers which move the condenser plates in or out.

RESONANCE.

To the coil shown in Fig 5, we will add or couple, an aerial coil as in Fig.8. The aerial coil catches some of the carrier waves' energy, gets it first, so we call it the "primary" coil or winding. The other coil gets the energy second, so we call it the "secondary" coil or winding. To the secondary winding is connected a variable tuning condenser.

We will say that you want to receive a broadcast station transmitting on a carrier frequency of 1000 kilocycles per second. If the secondary coil of Fig,8 were like the coil of Fig. 2 it would have a reactance of 1250 ohms at this frequency of 1000 kilocycles. Then

you would take hold of the shaft of the tuning condenser and turn this shaft slowly until the plates were in such position that the condenser's reactance would be 1250 ohm at the frequency of 1000 kilocycles. Just as the condenser plates Come into the right position you would have the greatest possible energy and current in the secondary circuit. This current would then be at the frequency of 1000 kilocycles.

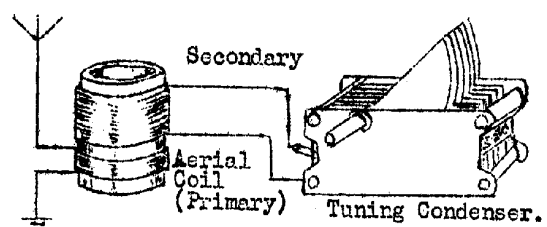

Figure 8.

Now supposing you turn the condenser plates in either direction away from this position. The reactance of the coil and condenser will no longer match for a frequency of 1000 kilocycles and there will be very little current produced in the secondary winding by that frequency.

All this time, the serial and the primary winding are being affected by all the radio waves from all the stations on the air. Look back at Fig. 1, and you will see what I mean. As you turn the variable condenser's plates you are continually changing the condenser's reactance, and before you turn the plates very far you will find that the coils reactance and the condenser's reactance will again match on another frequency of some other station. Then you would have maximum energy at a new frequency coming from the other station.

When a coil reactance and a condenser's reactance match or are equal to each other for a certain frequency we say that the circuit (coil and condenser) is "resonant" for that frequency. When a circuit is resonant at a given frequency, it will carry the greatest possible current at that frequency. All other different frequencies will then produce very little, if any current in the circuit.

Now we are able to pick out the carrier wave of any station we wish to hear. All we have to do is tune our oscillatory circuit to resonance at the desired station's frequency of carrier wave. This carrier wave along with its modulations, will come in very strongly, while all the other stations will be so weak that we will not hear them if we have a first class receiver.

WHAT CAN WE HEAR

Vibrations of the air cause our ear drums to vibrate and are distinguished by our brains as sounds. Things which vibrate at a low frequency or low rate, such as the strings of a bass viol in an orchestra, affect our ears as low pitched sounds, while those at high frequency or high rate of speed affect our ears as high pitched sounds. Very few people can distinguish, as sound, vibrations at a rate or frequency below fifteen per second or higher than a rate of fifteen thousand per second. The frequencies of all vibrations between 15 per second and 15,000 per second are called "audio frequencies" because they are audible as sound.

The very lowest frequency at which any Australian broadcast station at present sends out its carrier wave is 540,000 cycles per second - so we do not have a chance of hearing anything at this frequency. What we have to do is separate the carrier frequency and the modulation which was put on it in the first lesson. We will save the modulation and listen to it, but will get rid of the carrier.

THE DETECTOR

When you learned about THE modulation of the carrier wave, you were shown the effect in a drawing like Fig. 9. This is a picture showing how the alternating currents behave in the aerial circuit. Our first step in getting rid of the carrier frequency is to cut off or rectify one part of the wave or alternation, leaving an effect like that in Fig. 10.

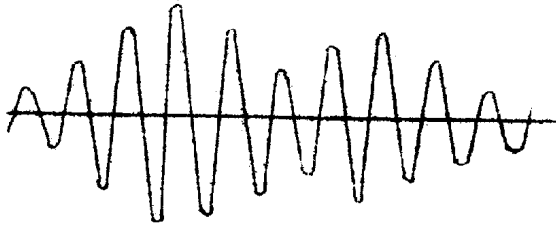

Figure 9.



Figure 10.

One of the easiest ways to do this is with a “crystal detector” shown in Fig. 11. The crystal, a piece of the mineral called galena, is mounted in a cup and connected to one wire terminal. Resting lightly on the surface of the crystal is a small, sharp wire point called the “cat whisker”. The “cat whisker” is connected to the other wire terminal of the detector. The symbol for a crystal detector is shown to the right in Fig. 11.



Figure 11.

Electric current will flow across the contact between cat whisker and crystal in one direction, but not in the other. Consequently, if the current shown in Fig. 9. is applied to the crystal it will cut off one half of the alternations giving the current the wave form shown in Fig. 10.

The type of crystal detector shown at the left of Fig. 11 is an old fashioned type in which the cat whisker had to be probed on to many spots on the crystal’s surface to find a “sensitive” position. The modern type of crystal detector, used in many modern radio and television receivers has permanent contact between the cat whisker and germanium, or silicon crystal and is called a “germanium diode” or “silicon diode”.

If you take a whole lot of small current impulses in rapid succession like those of Fig. 10 their average effect will be a gradual rise and fall of current as shown by the broken line in Fig. 12. Taken by itself, this gradual rise and fall look like the line at the bottom of Fig 12, and this is the kind of a rise and fall of voltage we had in the microphone at the transmitter.



Figure 12.

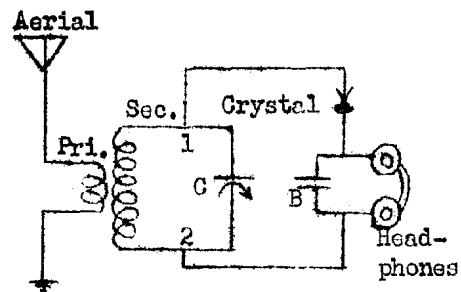

Figure 13.

Now we will take the circuit of Fig.8, change it over into symbols, add a crystal detector and pair of headphones, and we will have Fig. 13. As the current swings back and forth in the oscillatory circuit composed of the secondary winding and the tuning condenser "C", the voltage between these points "1" and "2" rises and falls. The changing voltage between these points will send current through the line containing the crystal and the headphones. The pulsations of current shown at the top of Fig. 12 are still radio frequency. In order to make use of this pulsating current it must be changed over to a slowly rising and falling current, like that at the bottom of Fig. 12, representing the audio frequencies or sound. To do this we connect the small "bypass" condenser "B" in Fig. 13, across the headphones. The action of this condenser is like a storage tank - it stores up energy which it receives in the form of pulsations, and allows it to flow out steadily. When a pulsation of current comes through the crystal, some of it goes into the condenser to charge it up and the rest goes through the headphones. When the current through the crystal stops for an instant this condenser discharges itself by producing a flow of current through the headphones, until another pulsation comes along from the crystal to charge the condenser again. So you see that the condenser allows a steady current through the headphones like that shown at the bottom of Fig. 12, even though it comes in the form of pulsations from the crystal.

PRODUCING SOUNDS.

The inside of a headphone looks somewhat like Fig. 14. Current from the radio circuit flows through the two wires and through the coil which is wound around the small permanent magnet. Between the end of this magnet and the thin, flexible steel diaphragm there is a very small air gap. The permanent magnet always pulls the diaphragm downwards. As more current flows around the coil (during rises of signal voltage) the magnet's strength is changed then as the current decreases, the magnet's strength is again changed. This changing strength of the magnet changes the pull on the diaphragm with the result that the diaphragm vibrates according to the current and voltage changes described in Fig. 13. Since these are the same kind of changes that came from the transmitter microphone, the headphone reproduces the sounds that are spoken into the microphone many miles away.

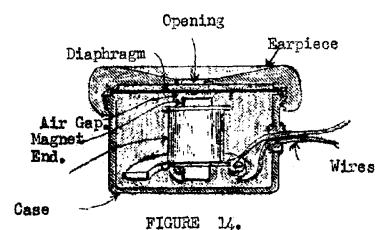

FIGURE 14.

There you have a complete radio system - all the way from the microphone to the headphones - all the way from sound at the transmitting station, through electrical actions back into sound at the headphones.

There is one serious fault to find with the receiver of Fig. 13. It will not produce loud sounds. With the receiver built exactly as shown you could get headphone reception from stations within about twenty-five miles of your receiver. Twenty-five miles is not, far enough and headphones are not loud enough. Now we will correct these faults. Firstly, you will realise that the basic requirements of a radio receiver are (1) an aerial system to change passing radio waves

into voltages, (2) an oscillatory circuit to select the one lot of signals we wish to hear, (3) a detector of some sort to pick out the audio signals and discard the carrier wave which has finished its job of carrying the audio frequency sounds through space, and (4) a headphone or similar device to turn the studio frequency signals back into sounds again.

RADIO TUBES.

One of the most wonderful devices ever produced by man is the vacuum tube or valve, used in radio circuits. Before we were able to get and use vacuum tubes in our sets there was comparatively little public interest in radio reception. But since the tube became available you know what has happened.

If you were able to cut open an ordinary radio tube of the simplest kind, the parts would appear as they are shown in Fig. 15. The outside is a glass bulb similar to a tiny electric lamp bulb.

Practically all the air is removed from this bulb, leaving a vacuum. Then, working from the outside towards the inside we first come to a sheath of thin metal which is called the "Plate". Inside the plate is a coil of wire with a lot of space between its turns. This wire is called the "grid". Inside the grid is a straight or V-shaped wire called the "filament". The plate, the grid and the filament are called the elements of the tube.

Looking down at the top, the three elements are arranged as in Fig. 16; filament wire inside, grid between filament and plate, and the plate outside. The symbol for this kind of radio tube is shown in Fig. 17. Here again you see the grid between the filament and the plate.

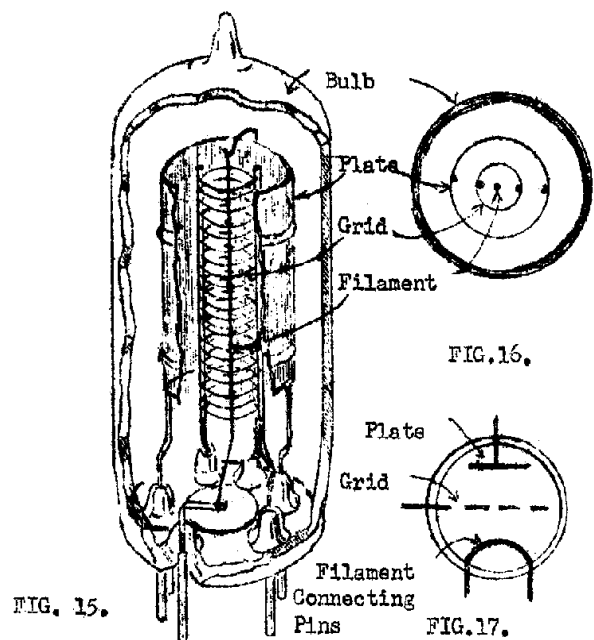

THE TUBE AS AN AMPLIFIER

To use one of these radio tubes we connect it up as in Fig. 18. The two ends of the filament are connected to a battery called the "filament battery" or "A" battery. This will make the filament light up and become very hot. Then we connect the plate to a coil and connect the other end of this "plate coil" to the positive side of another battery called the "plate battery" or "B battery".

As explained in Lesson 1, there are always two different ways of thinking about the direction of current flow. The old fashioned idea was to picture a flow of electric current as something which moved around an electrical circuit from positive to negative.

As a result of professor Thompson's investigations and theories, we now know that actually electrical phenomena are due to the movement of tiny particles called "electrons" which move around the circuit from negative to positive.

It is difficult, at this very early stage in your training, to know whether to describe the action or circuits in terms of the popularly used term "current" which is assumed to flow from positive to negative, or to explain phenomena in terms of "electrons". As so many people start a course of training such as this with some sort of general knowledge of electricity, those people usually find it more simple, to begin with, to talk about electric current, and to leave discussions concerning electrons until later on in the course. In fact, we will do just this. In our early lessons we will generally talk in terms of current flow and occasionally refer to electrons to keep you familiar with them, but as you proceed into the more advanced lessons you will find that we will concentrate more and more upon electronic action and gradually discard the idea of current flow.

You may say "why not do this right from the beginning?" It is really too big a jump for most people to start right at the outset by dealing only in terms of electrons and flatly contradicting any idea of current flowing from positive to negative. As you read on through this lesson and the remainder, you will find that it is often much simpler to explain some subjects in terms of current flow and others in terms of electron flow and consequently, we will at times use one form of description and other times the other, whichever is more appropriate. This is not bad practice as it will exercise your mind to look at each problem in two different ways, which is just what we have to do in practice because this conventional idea of current, formulated by early scientists, is so firmly impressed in everybody's mind that it is very difficult to just completely discard it and think only in terms of electrons.

In Figure 18 we have shown a number of arrows which indicate the direction of electron flow through the circuit. The application of current from the filament battery to the filament of the valve makes the filament hot and this heat in effect boils electrons out of the atoms of the filament material, thus freeing them in space inside the valve around the filament..

The electrons being negatively charged particles of electricity are attracted by the positive voltage provided by the positive terminal of the plate battery. This positive voltage sets up an electric field across the space inside the valve to the plate and then they move on around the circuit from atom to atom through the plate wire, the wire comprising the plate coil, the wire leading to the battery, and they are pumped internally through the plate battery and pushed out at the negative terminal to replace those electrons which were "emitted" from the filament.

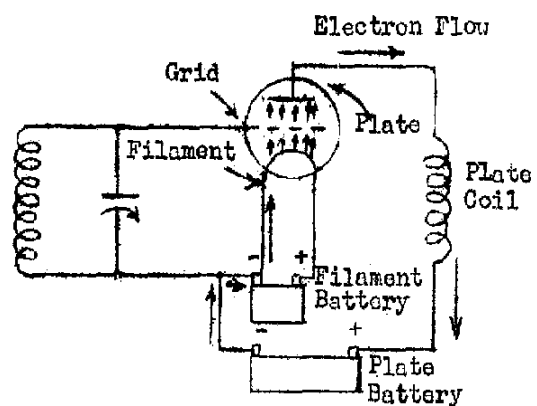

Figure 18.

In this way the filament never runs out of electrons but is kept readily supplied by the fact that the plate battery simply acts like a pump sucking electrons in at its positive terminal and pushing them out at the negative terminal to keep them circulating through the valve and through the other parts of the circuit.

The other way of looking at this action is simply to say that the plate battery provides plate current then, because we are talking in terms of "current", we would form a mental picture in our mind of the current starting from The positive terminal of the battery, moving up through the plate coil across to the plate, through the valve to the filament and back to the negative terminal of the battery.

As pointed out In Lesson 1, the real direction does not matter very much as long as we do understand the fact that here is a circulation of electrical charges in the circuit and it does not really matter whether we know for sure whether they travel in a clockwise or anti-clockwise direction. You will see from Figure 18 that whether we Think in terms of electrons moving across from the filament to the plate or in terms of current moving across from the plate to the filament, in either case our electricity has to pass through the grid.

The grid consists of a number of strands of wire with fairly wide spaces in between and the electrons or currant, in passing through these narrow spaces between the grid wires are influenced by whatever electrical charge is supplied to the grid. A positive voltage reaching the grid will increase the number of electrons moving or the value of current, whereas a negative voltage supplied to the grid will reduce the number of electrons moving across the valve, or the current flowing through it.

The grid is connected to one end of the oscillatory circuit in much the same manner as the crystal was connected in Fig, 13. The other end of the oscillatory circuit is connected to the tube's filament. Now the voltage changes produced across the oscillatory circuit act on the grid and filament. First they will make the grid voltage higher than that of the filament, then they will wake the grid voltage lower than that of the filament. In other words, with reference to the filament, the grid becomes alternately positive and negative.

The grid is the more important element in our tube. When the grid becomes positive as in Fig. 19, it helps the electrons leaving the filament to pass cross to the plate, thus making it much easier for plate current to flow. Then as the grid becomes negative as in fig. 20,

it makes it much more difficult for electrons to pass through it and for plate current to flow. As The grid is made positive with reference to the filament, the plate current increases, As the grid is made negative with reference to the filament, the plate current decreases. The grid controls the action of the plate current.

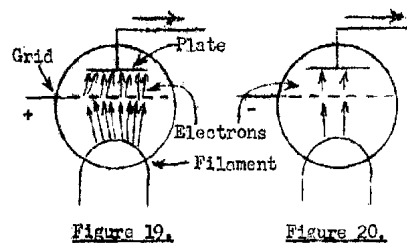

We will now take our crystal receiver and cut it apart on the broken line of Fig. 21. In between the parts we will connect a vacuum tube as in Figure 22. The voltage changes which were applied to the crystal in Fig. 21 are applied to the tube's grid in Fig. 22. The plate circuit of the tube, or the coil in this circuit is coupled to another coil in a circuit containing the crystal detector and the headphones.

If you were to listen to a certain station on the receiver of Fig. 21, then listen to the same station on the receiver of Fig. 22 you would find the sound from the headphone in Fig. 22 several times as loud as those in the phones of Fig. 21. The tube has "amplified" the signal strength. The increase in strength comes from energy from The plate battery.

A certain voltage applied to the grid of a curtain tube makes itself felt eight times as strongly in the tube's plate circuit. Such a tube is then said to have an "amplification factor" of eight. Various tube have amplification factors of from three up to over a thousand. That is the number or times They multiply the strength of a signal applied to them. With the circuit or Fig. 22 the voltage's in the crystal circuit would be eight times as strong as the voltages in the tube's grid circuit provided the tube had an amplification factor of eight and provided we neither lost or gained voltage in other ways, actually we always lose a certain amount of voltage and the full amplification factor of a tube is realised in practice.

DETECTOR ACTION OF A TUBE.

You probably know that most modern receivers do not make use of crystal detectors. Years ago the crystal detector was displaced by the vacuum tube working as a detector.

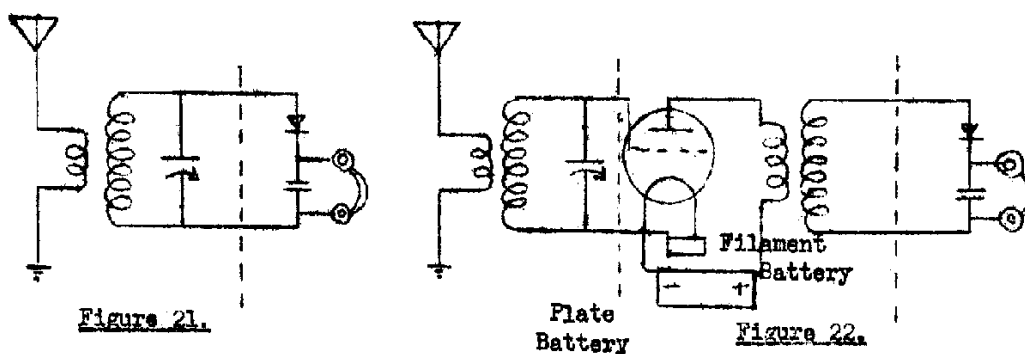

There is no end to the things such a tube can be made to do and we can use the same identical tube as either as an amplifier or as a detector.

When we use a tube as an amplifier, voltages such as those shown by the curve the on the left hand side of the tube in Fig. 23 will come out of the tube magnified as shown by the curve on the right. The rises and falls of voltage in the amplified signal are exactly similar to the rises and falls before amplification they are greater, that is all. This is The action in an amplifier. In a detector it is different.

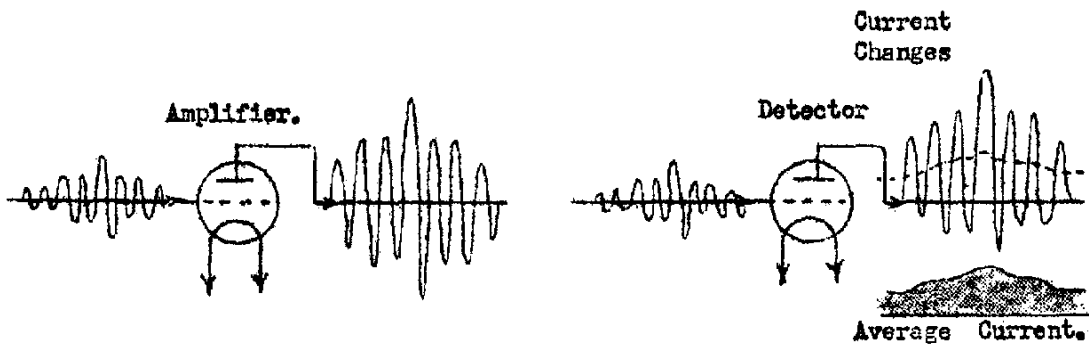

Figure 23

Figure 24.

In explaining Figs. 17 and 18 it was said that increasing the grid's voltage increased the plate current and that decreasing the grid's voltage lowered the plate current. In an amplifier that is exactly true but in a detector we arrange things so that the voltages in the tube's output circuit are not just magnified pictures of the voltages in the input circuit. To use a tube for a detector we may either use a "diode" tube which has just a plate and filament but no grid. A diode tube has exactly the same action as a crystal detector in that it allows current to flow easily in one direction but prevents it flowing in the other direction. Most modern radio receivers use diode detectors. Another way of "detecting" signals is to use a tube with a grid and pick such values of plate voltage and grid voltage that increasing the grid voltage will make the plate current increase in proportion - but decreasing the grid voltage will not make the plate current decrease in proportion. We simply fix things so that the plate current can drop only a little, but so that it can still rise as much as the positive grid voltage allows it. Then we get an effect like that in Fig. 24. The output current at the right of Fig. 24 is almost the same as in Fig. 12.

Now the increases of current, shown above the horizontal line, are far greater than the decreases of current below this line. The average effect of these current changes, which is produced by the action of the bypass condenser,

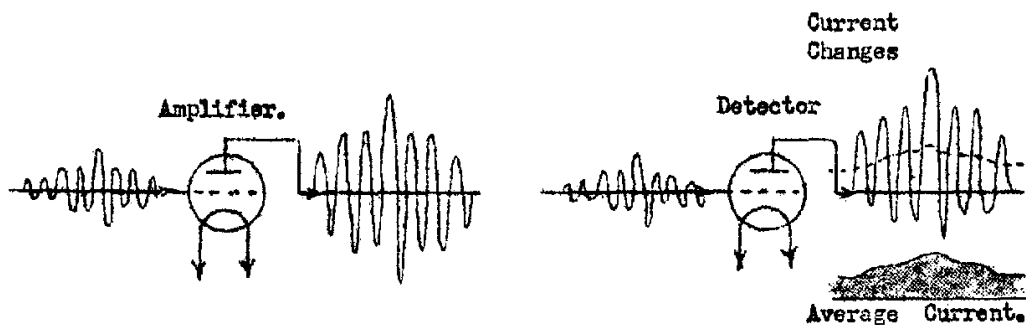

Figure 23

Figure 24.

will be above the line and will be about as indicated by the broken line drawn through the curves. This average current changes in just about the same manner that the voltage changed in the microphone circuit when we were studying the transmitter. So here again we are back with changes that are gradual and that will affect a pair of headphones or a loud speaker.

Again we will take our crystal receiver, as shown in Fig, 25 and this time will remove the crystal detector and substitute for it a vacuum tube detector, This makes the complete receiver look like The arrangement of Fig. 26. Even when used as a detector, the tube does some amplifying at the same time, consequently the sounds from the phones in Fig. 26 will be much louder than those from the phones in Fig. 25.

You will notice in Fig, 26 that we have lettered the filament battery "A"; the plate battery "B" and added another battery. This is merely more of radio's language. We call the battery supplying the filament with electricity the "A" battery; the plate battery, the "B" battery and the grid battery, the "C" battery. You will also notice that we have marked all battery terminals plus (+) or minus (-) in the circuit of the detector tube. The purpose of this "C" battery will be taken up more in detail in a later lesson. We just show it here to make the circuit complete so that you will know where it goes in the tube circuit later on in our lessons on tubes. Notice that we still have a bypass condenser placed immediately after the detector.

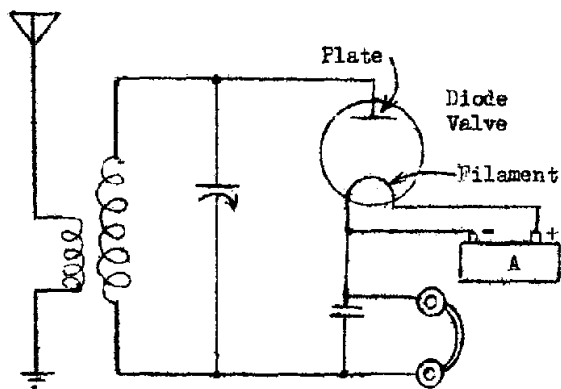

FIG. 27

Only one of the three common ways of using a tube as a detector has been described. This circuit is generally called a "plate rectification" system or else a "grid bias detector" system, because of the manner in which we control the plate and grid voltages. There is another circuit which was very popular. It uses a small condenser in the grid circuit and a high resistance connection between the grid and the filament. The second circuit is called a "grid-leak detector" or a "grid rectification" system.

Do not bother learning these names now because we will have more to do with detectors later on.

The third way is to use a simple "diode" tube in the circuit of Fig, 27 which is almost the same as Fig. 25. The diode detector, like the crystal does not amplify at the same time as it detects.

AUDIO FREQUENCY AMPLIFICATION.

You already know that our ears will not respond to vibrations at such high frequencies as come directly from the transmitting station. We have to get rid of these high frequencies and keep only the average rise and fall of current to affect

the diaphragm in a head-phone or a loud speaker. The detector only changes the frequency. All the circuits and parts between the aerial and the detector carry the high frequencies of the carrier wave. These frequencies are called "radio frequencies" because they are the frequencies at which the wave is transmitted through space. And as mentioned before, all the audible frequencies are called "audio frequencies." and they are found in the circuits and parts following the detector.

In Fig 22 and again in Fig. 23 the amplifier tube is working in between the aerial and the detector, therefore it is working at radio frequencies. We call a tube in this position a radio frequency amplifying tube. This name refers only to the kind of work the tube is doing, the same tube might be used as a detector or as an amplifier of the audio frequencies. In the latter case we would call it an audio frequency amplifying tube.

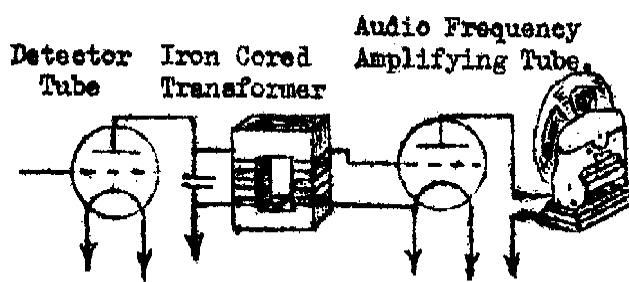

Figure 28.

When we are handling currents at audio frequencies we frequently use the system shown in Fig. 28. Here we couple the plate circuit of the detector tube to the grid circuit of the following amplifying tube through an iron-cored transformer. This transformer has the two windings, plate and grid, or primary and secondary wound upon an iron core.

The currents in the plate circuit magnetise the iron and it then has a very strong magnetic field, a field many times stronger than the field with an air core coupling device like that in Fig.8.

The iron makes a better coupling for a comparatively low audio frequency than we could get with the coil wound on a hollow tube. The audio frequency amplifying tube, working through its iron-core transformer strengthens the signal voltages so that the plate current from the audio tube can operate a loud speaker rather than headphones.

There are other ways of "coupling" audio frequency signals from the detector to the audio amplifier apart from the use of an iron cored transformer. However, we will leave the other methods until later lessons.

A COMPLETE RECEIVER.

Now let us see what we have built up. Our complete radio receiver is shown in Fig. 29 with pictures of all the parts. First we have the aerial and ground connected to the coupler coil with its two windings. The secondary winding is tuned with a variable condenser and this oscillatory circuit is connected to the grid of the radio frequency amplifying tube.

The plate of the radio frequency tube connects to the primary winding of an air-cored transformer. The transformer's secondary winding is tuned with a second variable condenser to provide a second chance of getting rid of unwanted signals, and this oscillatory circuit is then connected to the grid of the detector tube.

The plate of the detector tube connects to the primary winding of the iron-cored transformer with its bypass condenser and the secondary winding of this transformer connects to the grid of the audio frequency amplifying tube. The plate of the audio tube connects to the loud speaker. The wires marked "B" all lead to the plate battery.

The filament wires have not been drawn in because They are not important to us now.

When the two tuning condensers are adjusted to make their circuits resonant at the frequency we want to receive what happens? The aerial brings in a very small alternating voltage to the coupler. We will say all the tubes have an amplification

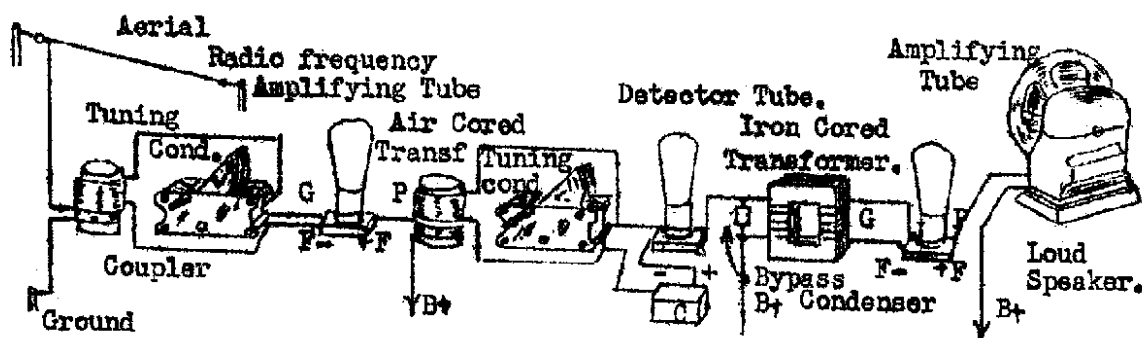

Figure 29.

factor of eight. The radio frequency tube multiplies this signal strength by eight, Then the detector may be assumed to again multiply it by four, and four times eight in thirty two, which represents the amplification so far applied to the signal. The detector really amplifies a little less than an amplifier tube and we say four for its amplification factor just to see what happens. Then the iron-cored audio frequency transformer will give us a little gain in voltage, say three times. So we multiply our figure of thirty-two by three, and get 96 times the original signal strength. Finally, the audio frequency tube again multiplies its input by eight, and we come to the loud speaker with a signal amplified to 768 times the strength in the aerial circuit. We have done this with only three tubes, and you know that many receivers use six or eight tubes, each much more efficient than the simple types we have described here. Some modern 5 valve sets are capable of multiplying the signal received from the aerial over a million times before it goes to the loudspeaker.

We can show all the parts of Fig. 29 a lot simpler by using symbols as in Fig. 30. This receiver is shown both ways so that you will understand the reason we almost always use symbols to illustrate our radio circuits. Notice the difference between the symbol for an air-cored transformer and the symbol for an iron-cored transformer.

It is important to realise that at the very heart of any radio receiver is a detector. We cannot have a radio receiver without some sort of detector to discard the high frequency carrier wave which has completed its task and pick out from it the lower frequency audible signal which we may hear. Of course, other essentials are some sort of tuning system to enable us to select the one set of signals we wish to listen to and some device such as a loudspeaker or headphones to convert the electrical pulsations back into sound Thus we may again repeat that the circuit of Figure 13 is the simplest basic circuit for a radio receiver.

The performance of a receiver of this type can be considerably improved by providing additional amplifying valves, to boost up weak signals before they reach the detector.

This principally allows the receiver to operate in conjunction with simpler and less efficient aerials or from stations which are situated a greater distance away than is the case with the simple receiver of Figure 13.

If we are dissatisfied with the use of headphones for reproducing the sound, and wish to strengthen them so that they are powerful enough to drive a loudspeaker then it is necessary to introduce audio amplifiers following the detector.

THE FOUNDATION OF YOUR TRAINING

In this lesson and the two before it we have covered the whole field of radio transmission and reception.. We have gone all the way from the microphone in the broadcast station to the speaker in a far away home,

We have paid little attention to details. We have, so to speak, been hitting only the "high spots". You have been given a framework into which you can fit every fact that you get in the lessons to come. Later on, when we talk about a detector, an amplifying tube, a tuning condenser, or any part of the transmitter you will not be wondering just what part that unit plays in radio - you will just fit it into this preliminary outline and will immediately understand its effect on all the other parts and their effect on it.

In these pages you have been studying you often must have thought we were travelling along at a high rate of speed, barely dipping into one subject only to leave it for another. Now you know why we did things that way - so that your structure of radio knowledge would have a secure and complete foundation

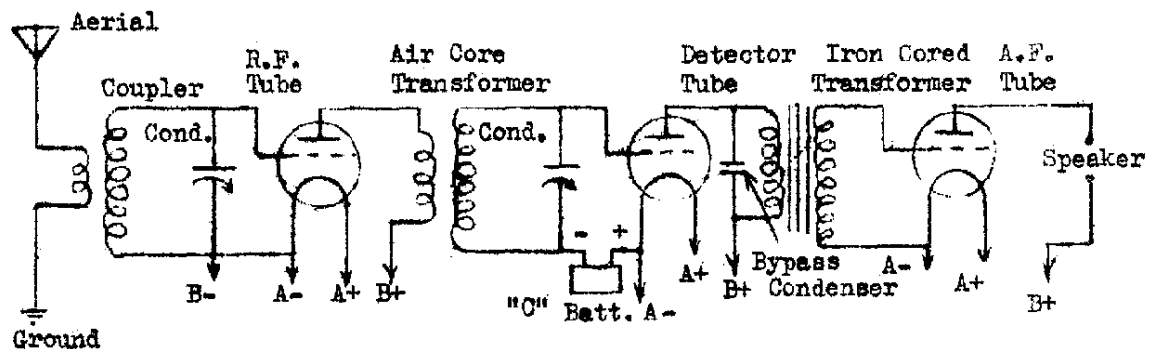

FIGURE 30.

EXAMINATION QUESTIONS - No.3

1. In what unit do we measure reactance?
2. How do you tune a radio receiver?
3. Does condenser's reactance increase or decrease with an increase of frequency?
4. what is resonance?
5. Describe the action of a crystal detector.
6. What are the three elements of a radio tube?
7. What does a change in strength of the magnet in a headphone do?
8. To what part of the tube is the A-battery connected? What is its purpose?
9. When The grid of a radio tube is positive, does it increase or decrease the plate current?
10. what is the name of the part between detector and audio amplifying tube in the receiver described in this lesson? What does it consist of?

Please NOTE Postal Address: (AUSTRALIAN RADIO COLLEGE PTY.LTD.,
(Box 43, Broadway, Sydney. N.S.W.

NOTE: Write the lesson number before answering The questions.

Write on one side of the paper only.

Always write down in full the question before you answer it.

Use sketches and diagrams wherever possible. One diagram in many cases is equivalent to pages of explanation.

Remember that you learn by making mistakes; So give yourself an opportunity of having your mistakes found and corrected

Don't hesitate to ask for further explanation on. any point, we are always ready to help you.

Do not copy directly from the lesson.

Write your name and full address at top of paper. If you have made arrangements with the College to have your lessons returned to any particular address - state this at the top of the page.

“The Radio-T.V. Training Centre”

**E. S. & A. BANK BUILDINGS, Corner CITY RD. and BROADWAY, SYDNEY
Telephones: BA4891 and BA4892**

AUSTRALIAN RADIO AND TELEVISION COLLEGE PTY. LTD.

Telegrams “RADIOCOLLEGE” Sydney

This lesson sheet is published for the exclusive use of students of the Australian Radio and Television College Pty. Ltd. (All rights reserved)

Post Lessons to Box 43, Broadway

LESSON NO.4.

ERECTING THE AERIAL

WE are going to assume that you have as your very first job in radio the erection of a first class aerial. This is important work because the performance of the finest receiver that money can buy will be ruined if it is connected to a makeshift aerial.

The sounds which come out of the loud speaker are supposed to be magnified reproductions of whatever the aerial collects from space. A good aerial collects signals that are good to hear, a poor aerial collects more noise than anything else, and some aerials are so very poor that they will not even collect the noises.

Supposing you have reached the home or a man who has Just become the proud owner of a modern radio receiver. You are to make the installation for him. Such work is probably one of the most common problems in radio servicing and because it is so common it is often neglected sadly. Handled in almost slovenly fashion. As a result the set owner becomes dissatisfied and critical right in the beginning because the sounds he hears are anything but what the salesman led him to expect.

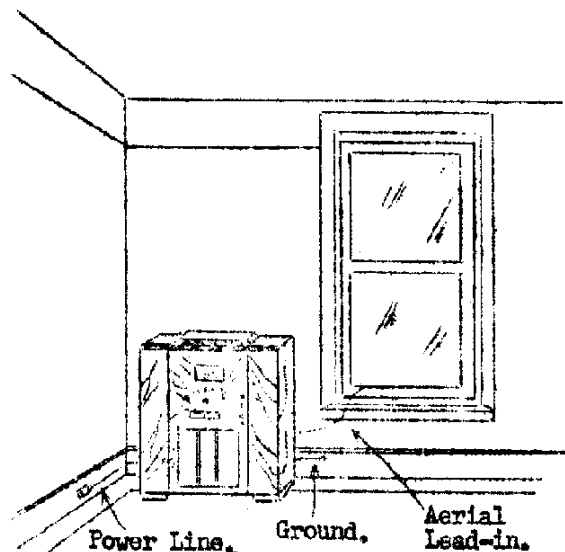

Figure 1.

LOCATING THE AERIAL

Naturally, your very first step will be to decide on the best location for the aerial. Here you must use judgment; weighing the advantages and disadvantages of each possible position, considering the kind of receiver, the personal likes of its owner,

The usual type of electric receiver require three connections; one to the aerial, one to the ground and one to the power or light lines for its. electrical supply, as in Fig. 1.

The wire connecting the receiver to the aerial is called the "load-in", It must be exceedingly well insulated, securely supported and well spaced from practically all objects along its pathway. As a general rule the lead-in may most conveniently come through frame or ventilator. The set owner may even allow the lead-in to come right through the building wall. The point at which the wire emerges from the building the outside will have a great deal to do with the location of the aerial itself.

The ideal location for an aerial is between the building housing the receiver and some support at a little distance away, as shown in Figure 2. Here the aerial extends right out over the ground with nothing but air between it and the earth.

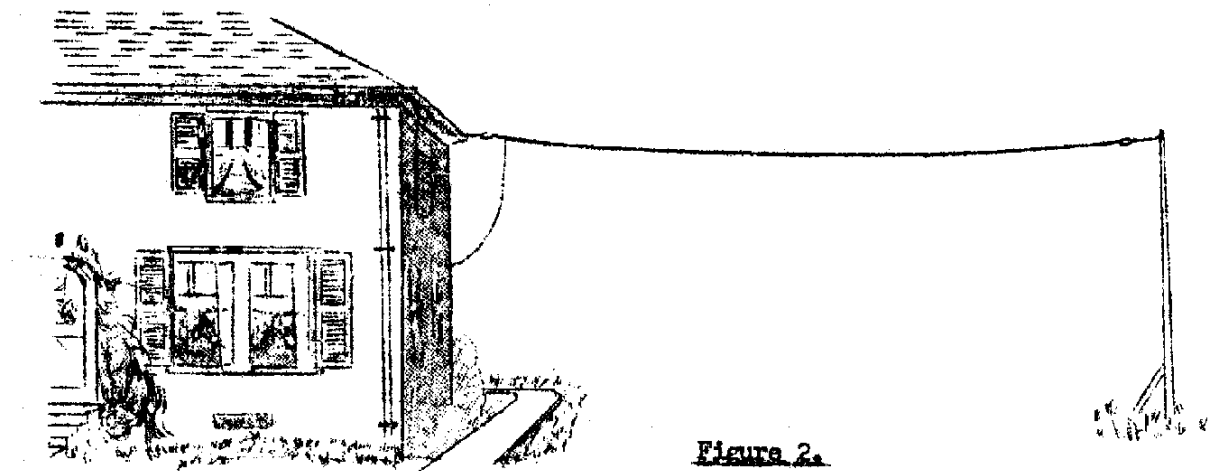

An aerial of this kind is really a large condenser and between the two plates of a condenser you can't have anything better than air from the standpoint of saving every bit of energy from loss.

Your own knowledge of condensers will tell you that the more miscellaneous objects there are between the plates of this condenser, the poorer the result will be. That just stands to reason. So having placed the receiver inside the home, you go outdoors and look over the situation - hoping to find a nice clear space over which you can swing the aerial wire.

AERIALS ON ROOFS

In many locations there is not enough clear space around a building to accommodate the aerial. Then you may be forced to choose a location on the roof something like that shown in Fig. 3. Here one wire is strung over the top of the gable to act as an aerial. Such an arrangement is very unsightly. The wire may be partially concealed by running it along the side of the house just under the eaves,

This position also being shown in Fig. 3. In a flat roof, like the one shown one in Fig. 4, you can conceal the aerial fairly well.

There is no objection to running the aerial between a building and a tree as in Fig. 5, or between two trees with the lead-in running over to the building. When a tree is used you must remember that it sways in the breeze and to allow for this movement you must support the aerial at end with a strong coiled spring as shown.

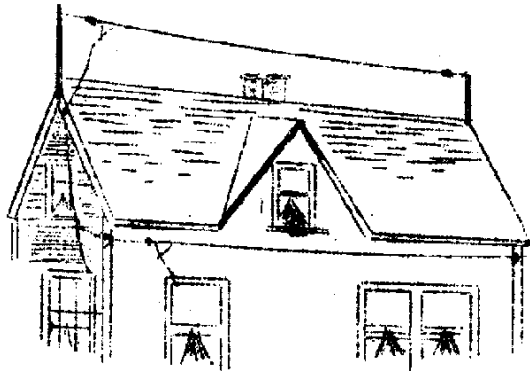

Figure 3.

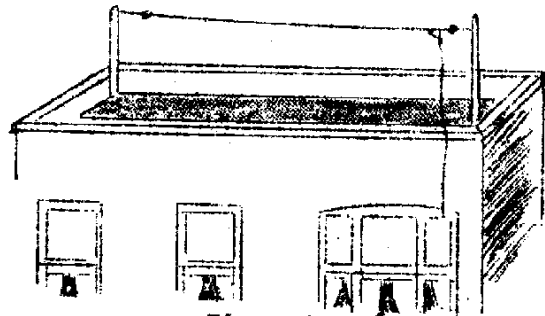

Figure 4.

As you can see in Fig. 6, one end of the spring is attached to a solid support, an aerial insulator is attached on the other end of the spring and the aerial itself is attached to the insulator. Movement may also be taken Up by a weight and pulley arranged as in

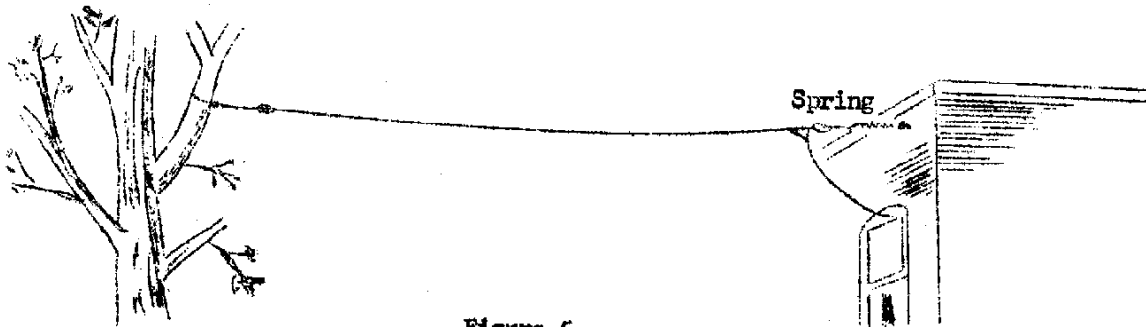

Figure 5.

Fig. 7. The weight will rise and fall as a tree or other moving support sways back and forth. The pulley scheme is not so good because it will squeak with every movement after a little time, and the pulley might jam and cut the wire or rope,

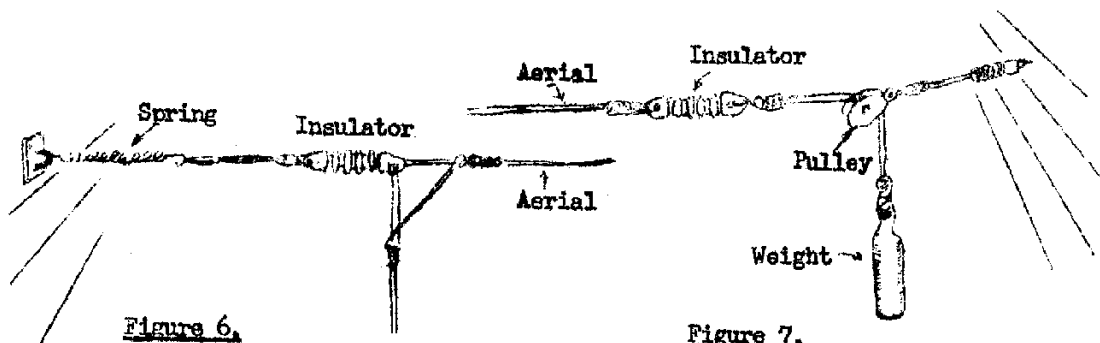

Figure 6.

Figure 7.

The previous three pages should not be interpreted as a complete condemnation of the indoor type of aerial. This is so far from our intention because indoor aerials are today undoubtedly in the majority, so far as ordinary radio receivers are concerned. They may also be used, under certain conditions, with television receivers. This apparent paradox obviously needs some explanation and so here it is.

The sound which is heard from the loudspeaker of a radio receiver is a combination of programme material speech or music - and noise. The noise component of the total signal can be classified as noise which is developed within the receiver and noise which reaches the receiver from some external source. External noise may reach the receiver through the power mains or it may be picked up by the aerial-earth installation.

All radio receivers have a certain residual internal noise level due to thermal agitation of electrons in conductors and random emission of electrons from valve filaments and cathodes. Both of these effects produce a steady background hiss quite distinct from the intermittent crackles and scratching noises which may be produced by a fault in some part of the receiver or by external noise signals. Receiver noise is related primarily to the design of the equipment and as there is, generally, little that the serviceman can do to reduce such noise, his major aim should be to ensure that the signals fed to the receiver shall be many times greater than the internal residual noise level.

The strength of the signal fed to the receiver depends upon many factors. Some of the most important of these are the power of the signals radiated from the broadcast station within range of the receiver, the distance between the receiver and transmitters, the geographic location of the receiving equipment, that is, whether it is located at the top of a hill or at the bottom of a valley and the efficiency of the aerial-earth installation. The first three factors are, of course, beyond the control of the user of a receiver and whether or not the third one is favourable or not depends upon the person responsible for receiver installation.

If the only signals picked up by a radio receiver's aerial are those actually radiated by the various transmitting stations, aerial installations would present no great problem. However, such desirable conditions rarely exist because invariably there will be some interfering noise signals which will be picked up also with the required radio signals. These noise signals may be due to entirely natural causes such as an accumulation of electrical charges in the atmosphere, or to radiation from power lines and electrical machinery.

The two effects are related in that each is caused by an arc between two points of opposite potential. With natural atmospheric disturbance the spark discharge is manifest in its most violent forms during an electrical storm, it is then visible as lightning and audible as severe intermittent crackling from the loud-speaker of a radio receiver. One can do nothing towards alleviating noise due to natural atmospheric without impairing the quality of received programme material.

Noise due to "man-made" disturbances commonly emanates from certain types of electric motors due to sparking between brushes and commutator, faulty switches in industrial or household electrical installations or thermostats in refrigerators or household electrical irons. All those devices can create what is, in effect, a miniature lightning flash, the audible result of which is much the same noise created by the natural lightning flash. Like the natural static discharge the spark causes radio frequency energy to be radiated either directly from the point where the arc occurs or from the power mains wires to which the equipment is connected. The greater part of the interfering noise is due to the latter effect.

In the case of a good outdoor aerial installation erected well in the clear, away from, and preferably at right angles to, overhead power lines and with as much height as possible, very little of this "man-made" interference is picked up by the horizontal section of the aerial and so a favourably high signal to noise ratio is likely to result, except when the level of atmospheric disturbance is high. There can be no doubt then that a good outdoor aerial will always provide the best signal to noise ratio. However, erection of an outdoor aerial of adequate height and length is not always possible, particularly in congested metropolitan and suburban areas. The flat-dweller is at a particular disadvantage in this regard, although, at first sight, it may seem that he would actually have an advantage over people forced to use an aerial little above ground level because an aerial erected on the roof of a tall building, such as a modern block of flats, has apparently satisfied one cardinal specification for a satisfactory aerial installation, namely, height. The aerial would certainly have considerable height in relation to the surface of the earth, perhaps in excess of 100 feet, but this does not necessarily make the installation a good one because the electrical or effective height of the aerial may be no more than a few feet. Why?

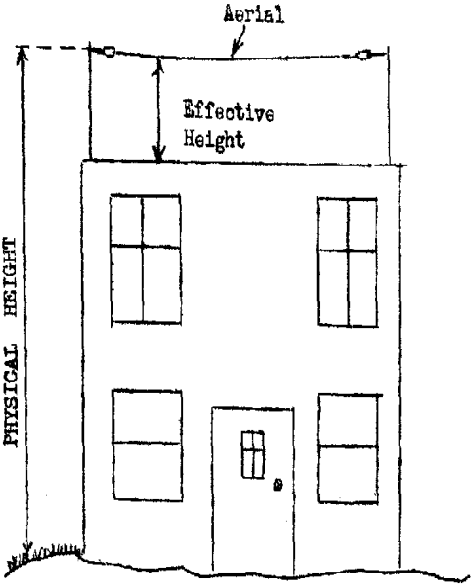

FIGURE 8.

The height of an aerial corresponds to the distance between the plates of condenser. One plate is the aerial wire, the other plate is the ground. In Figure 8 the ground is, in an effect, carried right up to the roof of the building because of the metal reinforcement which is characteristic of many modern buildings. The actual ground in the earth is connected to the roof by the metal girders which form the framework of the building. Therefore, considered electrically, the roof is the ground so far as the aerial is concerned. The physical height of the aerial is its distance up in the air above the earth's surface. The effective height - the height that really counts - is the aerial's distance above the nearest conductor that is connected to ground, in This case the roof.

if there is a tree under an aerial the effective height is lowered because the moisture in the tree makes it a fairly good conductor and it raises the electrical ground up towards the aerial. Any other conducting materials or objects under the aerial have a similar effect.

In congested areas, therefore, there is little point in relying upon an outdoor aerial which trust, of necessity, be limited in length and height, It is for this reason that one rarely sees an outdoor aerial for broadcast reception in city and suburban locations. An indoor type of aerial is by far the most commonly used. One can be certain that the signal to noise ratio will be no worse than with an inefficient outdoor aerial. It may, in fact, be slightly better,

The degree of electrical noise picked up by an indoor aerial is likely to be greater than that received by a highly efficient outdoor aerial, because the indoor aerial must invariably be run near to electrical wiring within a house. It will, as a consequence, more readily be affected by interfering noises radiated by the electric wiring. However, so strong is the signal radiated by most present day broadcast stations that the ratio of signal to noise is still perfectly satisfactory in all but highly industrialised areas where the considerable amount of electrical machinery used may create an excessively high noise level. The major points to be observed when installing an indoor aerial are discussed in the next lesson.

THE GROUND CONNECTION

It was mentioned earlier that a radio receiver's aerial acts as one plate of a condenser with the ground as the second plate, Although this statement was originally made in reference to an outdoor aerial, it is equally true with aerials of the in-door type and so one should take just as much care with the ground connection when an indoor aerial is used as when we are installing one of the outdoor types. The Standards Association Wiring Rules specify "Permanent earthing conductors shall be of stranded copper and shall not be smaller than 7/.029" diameter"(which means 7 strands of No. 22 gauge copper). There shall be insulated cables, the insulation being 600 megohm grade." As indicated above, this specification applies whatever type of aerial is used.

KINDS OF GROUNDS.

The ground which you really desire to reach as directly as possible is permanently moist earth. Your ground connection must attach to some good conductor, usually a piece of metal, that runs down into such moist earth. The most convenient ground connection in most buildings is a cold water pipe coming in from the water mains. Within practical limits there is no better ground than such a water pipe. Your connection should be made to the pipe as near as possible to its entrance into the building.

All kinds of pipe joints introduce more or less resistance - the reason for making the connection close to the street service pipe is to keep on the right side of joints. A connection made to hot water pipes, gas pipes or drain pipes often will prove quite unsatisfactory because there are too many joints before any conducting path reaches moist earth.

Should The building have no water service from supply mains you can make a good ground connection by dropping a copper wire down into a well or into the bed of a stream or any body of water. Failing to find any easily reached body of water, you will have to drive a pipe down into the earth and drive it deep enough to reach moisture.

IRON PIPE GROUNDS

Permanently moist earth may be found at any depth between one foot and eight feet below the surface. Nothing will be gained by driving the lower end of the pipe down further than the point at which it reaches moisture. On the other hand, it is necessary that you get the pipe down as far as the permanent moisture or you won't have a good ground during dry weather.

There is no easy way of knowing how deep to drive a pipe. For a good job in ordinary locations you can use a galvanised pipe about six feet long and drive it down until only about six inches remain above ground. This isn't such a hard Job because you don't need to use a large pipe. If the ground is fairly soft and contains but a few rocks, a pipe three-quarters of an inch in inside diameter is strong enough. Iron pipe is always specified by its inside diameter. To prevent splitting the top of the pipe, have the end threaded and screw a coupling or a cap on as far as

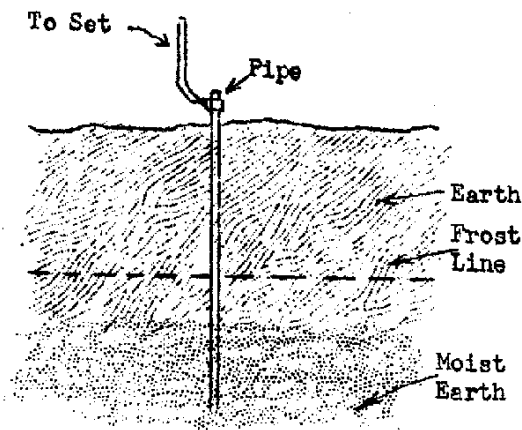

FIGURE 9.

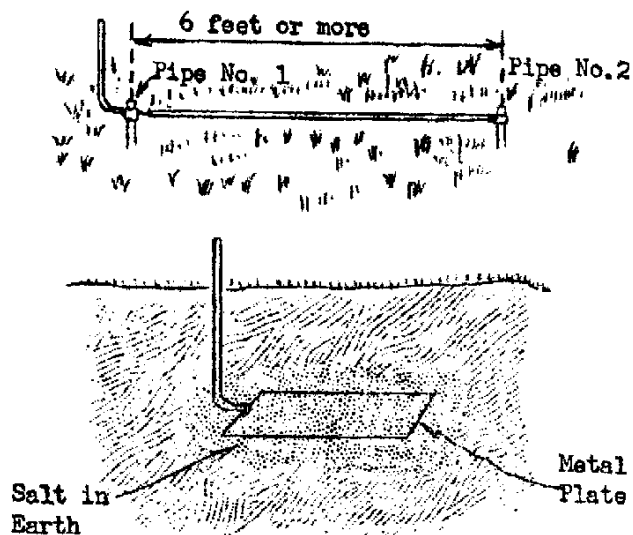

FIGURE 10.

it will go. Any size pipe is good enough as an electrical conductor. Nothing will be gained by running a copper wire down inside the pipe.

In addition to going down to permanently moist earth as indicated in Figure 9, your ground pipe must extend below the frost line or the depth to which the earth freezes in cold weather, if you are in a climate where this may happen.

It is possible that you will get better results by using two pipes connected together in place of a single pipe. When you use more than one pipe have them at least six feet apart as in Figure 10, otherwise The two won't be appreciably better than one.

If, for any reason, it is difficult to drive a pipe deep enough to make a good ground, you can bury a steel or iron plate several feet below the ground surface as shown in Figure 10. After you dig the hole, throw in a liberal quantity of rock salt, then a little earth, some more salt and then place the metal plate. Cover the plate with mixed salt and earth for two or three inches before finally covering it with the plain earth, the salt attracts and holds moisture around the plates.

The best connection to a buried plate is that made by having the end of a large copper wire welded to the metal of the plate. If this cannot be done, bolt the end of the wire on to a cleaned spot of the plate and cover the joint with a quantity of hot pitch or tar.

An iron pipe ground will give best results when driven into ashes, refuse, rubbish or old dumps of any kind. Good results will be had when the pipe is in loam clay or shale which is free from gravel and stones. Sand, stone and gravel make poor grounds because they don't hold moisture and the greater the percentage of these in the soil the poorer will be the ground.

THE GROUND CLAMP

The attachment of the ground lead to the pipe or other metal part serving as the ground must be made with considerable care because this attachment will always be in an out-of-the-way place and in a place quite likely to be damp. Dampness causes oxidation or rusting of the metal and radio currents pass through oxides with the greatest difficulty.

A soldered joint would be best, but it is practically impossible to solder to a cold water pipe without first draining the water. Even then it is difficult because the pipe carries away the heat about as fast as it can be furnished. The best connection that may be made conveniently is secured with a ground clamp

You can see two styles of ground clamp in Figure 11. The one at the left is simply a metal band fitting around the pipe. The outer surface of the pipe must be thoroughly cleaned with a file or coarse sandpaper until bright metal shows. The inner surface of the clamp must be similarly cleaned. After the clamp is in place the joint between it and the pipe should be liberally covered with varnish or tar to keep out the moisture.

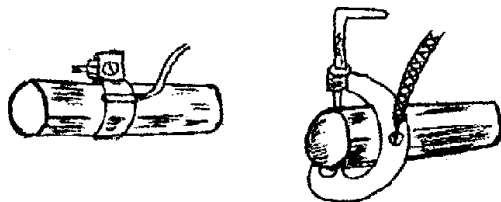

FIGURE 11.

A more positive kind of ground clamp is shown at the right hand side of Figure 11. This clamp has three sharp points that dig into the metal of the pipe, Two points are fixed and the third is on the end of the screw. Such a clamp is easily applied and is almost certain to reach in to the clean metal. Even with this type it won't do any harm

to cover the points with varnish or tar to exclude moisture. Any kind of ground clamp will require re-tightening every few months.

AERIALS FOR VERY HIGH FREQUENCIES

In the previous lesson you were introduced to an effect called "resonance" which occurs when equal amounts of inductive and capacitive reactance are present in a circuit. Under such conditions a circuit will be resonant at the frequency where equality of reactances occurs.

With most tuned circuits you are likely to encounter in the first three sections of the course, tuning is carried out by using known values of inductance and capacity, one, usually the capacity, being variable. With such an arrangement we say that the circuit is tuned by "lumped" values of inductance and capacity. In addition to "lumped" inductance and capacity one will invariably be aware of other small values of inductance and capacity scattered throughout a circuit. Capacity may exist between wiring and a metal chassis, between coils and a shield which encloses them, and between the internal elements of a valve. These are called "stray" capacities and in a well designed circuit are kept to a minimum. There are, however, other values of inductance and capacity which are inevitable and cannot be eliminated.

The distributed capacity and inductance, as they are called, can exist between individual sections of even a straight conductor or wire. The reason for this is explained in our Television Receiver Servicing Course, which may be taken on completion of this Radio Service Course.

When an alternating voltage is applied to circuits in which the inductive and capacitive constants are distributed rather than "lumped", oscillatory current circulates in the form of a wave motion which is similar in every way to the wave which is radiated by a broadcast station and like it, has the velocity of light. If the alternating voltage is applied to a single conductor, the wave which is propagated along the conductor will be reflected at the far end and travel back to the starting point where reflection may again take place. If only a single pulse is applied to the conductor the resultant current wave will travel back and forth along it, suffering some loss at each reflection until it eventually dies away. This reflection is similar to the effect of a sound wave being reflected from a hard surface, such as the wall of a room. The sound "bounces" off the reflecting surface and travels back towards its starting point.

You have already learned that an alternating voltage or current has frequency. As the wave motion mentioned above is of an alternating nature, it too will have frequency. In addition it has another property to which we do not normally refer when speaking of ordinary alternating voltage or current, namely wavelength. This property is discussed in some detail in the next lesson and so we shall not make further reference to it here beyond stating that the wavelength of an alternating wave motion is the distance measured between two succeeding peaks or two succeeding troughs.

Now returning to the alternating wave motion along a straight conductor, when the length of the conductor is equal to half the wavelength of the alternating wave propagated along it, the reflected wave will arrive back at the starting point just as

the next cycle of current is about to commence, if we continue to apply an alternating voltage through the conductor. Under these conditions we say that the conductor is resonant at the particular frequency where its length is equal to half the wavelength of the disturbance. The voltage and current distribution along the half wavelength conductor is shown by Figure 12. The current impulse travelling

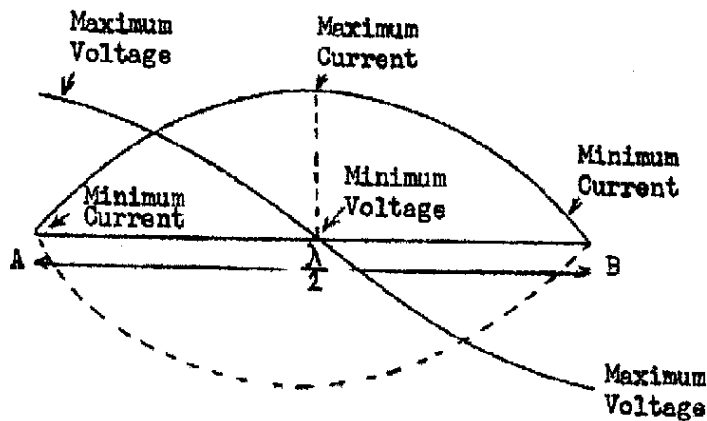

FIGURE 12.

along the line A to B has a minimum value at the starting point, rises to its peak value when one-quarter of the distance has been travelled and then falls to the minimum value again at B. Reflection occurs at this point and the reflected wave will travel back to A. The wave due to reflection at B is indicated by dotted lines in Figure 12.

Reflection will again occur at A and this time the reflected wave will be travelling along the conductor together with the third half cycle or current which has commenced to flow at exactly the same time.

We say that the two currents are in phase with each other and so their two values will add together.

If an A.C. meter is placed in the exact centre of the conductor it will register a maximum reading. On the other hand if it is placed at either A or B it will give a zero reading.

Because current is surging back and forth along the line at a certain frequency we may think in terms of electrons starting at one end, rushing down to the opposite end, and, after a momentary pause, returning to their starting point.

When the electrons pause at either end of the line, their velocity is zero and so the current flow at this point will also be zero. Having started on their journey the electron velocity will increase steadily until it reaches a maximum at the centre of the line. Thereafter the velocity decreases at the same rate, reaching zero during the pause at the opposite end of the line. Thus we have maximum flow of current at the centre of a line and minimum flow at either end.

As the electrons pause at alternate ends of the line preparatory to reversing their direction of travel, we will have a condition whereby a large number of electrons will be congregated at one end while a relatively small number will be present at the opposite end of the conductor. At this instant there will, therefore, be a maximum

difference of potential between the ends of the conductor. At its centre where we have neither a maximum nor minimum number of electrons there will be no difference of potential. In other words there will be a maximum difference of potential between opposite ends of the conductor and zero voltage at The centre.

When a conductor conforming to the conditions set out above comes within the influence of a radio wave having a wavelength, which is twice the length of the conductor, a greater amount of energy will be generated in the conductor than by a transmission having any other frequency. In other words The conductor is resonant at one particular frequency. This is precisely what would happen if we made the length of an aerial wire equal to the half wavelength of a particular transmission. The aerial would be tuned to that particular frequency. This does not mean that the aerial would receive one station to the exclusion of all others because the tuning effect would be very broad for reasons which will become apparent as you proceed with your studies. This, however, is not the reason why such an aerial would be impracticable for receiving stations within the medium wave broadcast band, a station having, for instance, a carrier wave frequency of 1000 kilocycles. The major drawback is the physical size of an aerial designed to be resonant at this frequency. The wavelength corresponding to a frequency of 1000 kilocycles is approximately 300 metres, that is, nearly 1000 feet. The length of a half wave aerial designed to operate at 1000 kilocycles, therefore, would be 500 feet, an inconveniently large size, even for country districts, and so for reception of medium wave transmissions we compromise by using the greatest length of aerial that can be conveniently employed.

Resonant aerials conforming to the half wave length dimension are quite feasible for reception of stations operating at a high carrier wave frequency because in this case the wavelength of the transmission will be comparatively short. The wavelength of a 30 megacycle carrier wave would be between 30 and 40 feet. This places the half wavelength at between 15 and 20 feet and so installation of an aerial designed to be resonant at a frequency of 30 megacycles would not be a difficult matter even in comparatively congested areas. At the higher frequencies used by television transmitters and frequency modulation broadcasting stations, the problem becomes even less acute. For instance, an aerial designed to be resonant at the centre of a band of frequencies allotted to frequency modulation broadcasting stations in Australia, namely 88 to 108 megacycles, would have a total length of only about 4 feet.

The method of installing resonant aerials conforming to a half wavelength dimension differs from that followed with the more conventional types used for reception on medium frequencies. With half wave V.H.F. aerials an earth connection does not play the significant part it does with the more conventional type of aerial-earth installation. With the V.H.F aerial both ends of the aerial coil primary winding are connected to the aerial as shown by Figure 13. For maximum signal pick-up, the broad side of the aerial faces towards the particular station one wishes to receive.

Connection of a half wave resonant aerial to a radio receiver is not merely a matter of running two separate wires from the aerial to the radio receiver as may appear from Figure 13. The lead-in from aerial to receiver is a very special type of cable having a characteristic impedance of approximately 72 ohms.

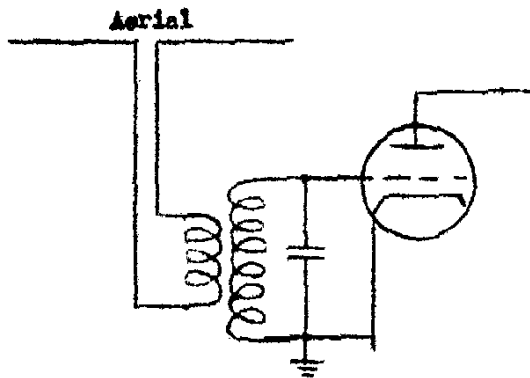

FIGURE 13.

This impedance of 72 ohm has nothing to do with the actual resistance of the conductors but is related to the distance separating the two leads from each other and the diameter of each lead. This means that whether the lead-in is 1 foot long or 20 feet long its characteristic impedance will still be 72 ohms for a particular spacing and wire diameter. Our Course dealing with The servicing of Television and Frequency Modulation Receivers covers this subject in detail and explains why the lead-in, cables should have this particular value of impedance.

The running of the lead-in from aerial to receiver should be arranged with some care. The leads should not come closer than about 6" to large areas of metal, particularly where such

such metallic objects are grounded. Particular care should be taken to ensure that the lead-in cannot flap about due to wind agitation and consequently suffer abrasion due to contact with rough surfaces. These precautions, of course, also apply to the running of a lead-in from an ordinary out-door aerial of the type discussed in the early part of this lesson.

The lead-in may be held away from walls and other objects and at the same time prevented from flapping about by means of stand off insulators of the type indicated by Figure 14, The manner in which these insulators are used is shown by Figure 15.

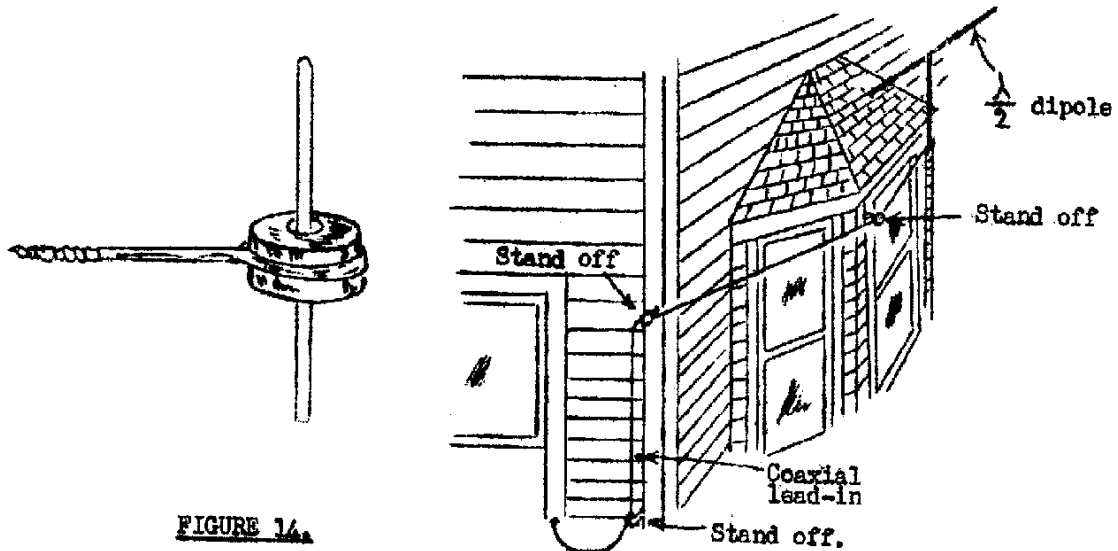

FIGURE 14.

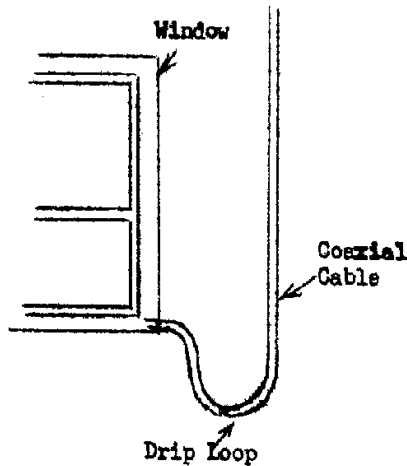

FIGURE 16.

The lead-in may enter the house through a ventilator or through a hole in the lower section of a window frame. In either case a loop should be left in the cable as shown by Figure 16 to allow rainwater to drip outside the house rather than be conveyed inside along the lead-in cable.

SOLDERING.

There can be no doubt that the ability to make a good soldered joint must be rated as a most essential accomplishment for the radio and television serviceman.

A radio or television receiver constructed without the use of soldered connections would be entirely impracticable. Even though it may perhaps be coaxed into

working at first, before very long crackles and noises would interfere with reception and the receiver would soon become inoperative. It is essential for all the connections in a radio receiver to be soldered and consequently it is most important for you to learn the art of soldering efficiently and quickly.

The reason for the widespread use of solder in radio receiver construction is the fact that the amount of electricity which will flow in any circuit is dependant upon the resistance of the paths through which it has to flow. Most metals have a fairly low resistance and if their surfaces are perfectly clean, merely clamping them together will initially cause a low resistance path so that normal values of current can pass through the connection. However, all metals in contact with the air will eventually have a film of oxide formed on their surface. This oxide is, in the case of iron, called rust. Other metals also have a film which is not always as apparent as in the case of rust on iron but nevertheless exists to some degree. The oxide films on metals are normally fairly good insulators of electricity and consequently would increase considerably the resistance to the path of electricity and reduce the current to a lower than the correct value. Eventually the thickness of the oxide film may become so great, as the result of moisture in the atmosphere, that in a radio circuit it may completely prevent current from flowing. This may happen even though the oxide film may only be a fraction of a thousandth of an inch in thickness and hardly noticeable to the eye.

The use of soldered connections is not so important in high voltage circuits, such as those used for electric power and lighting, because the high voltages used are strong enough to cause any oxide film to break through and for the current then to be able to flow directly from one metal surface to the other. With receivers, however, some of the signal voltages are only a few thousandths or even millionths of a volt in strength and these low voltages are not enough to drive electric current

through an oxide film of any appreciable thickness. The film will form even on pieces of metal which are fairly tightly clamped together, due to air getting in between the surfaces and corroding them. One certain way of ensuring a permanent connection of low resistance between two pieces of metal is to exclude any possibility of air reaching the surfaces across which the current has to flow and at the same time bridging the gap between the two pieces of metal with a third metal, solder, which is itself a good electrical conductor.

Solder is not a very strong metal and consequently should not be relied upon where a great deal of mechanical strength is required. It is always preferable to make a strong mechanically secure joint before the solder is applied. By mechanically secure joint we mean one that you can't twist or pull apart after it is made. To commence making a joint between two wire ends you cross them as at "a" in Figure 17. Then you wrap the ends around as at "b" in this illustration. To connect the end of one wire to some point along the length of another one, you start as at "c" in Figure 17 and end as at "d". Stranded wire may be handled as already explained or you may divide the strand into two groups as at "e" in Figure 17. Place the two wire ends together so that the split of one wire engages the split of the other. Then, as at "f", twist one group of strands around in one direction and twist the other group from the same wire in the other direction around the second wire.

In making a wire joint ready for soldering, it is assumed that the surface of the

copper is absolutely clean. To make sure it is clean, use a knife blade and scrape away every particle of enamel, or any other insulation and of copper oxide until the whole surface to be soldered is bright and shining. This cleaning should always be done before the joint is twisted together. Do the cleaning even though the wire is brand new. Then, after the ends are twisted into place, again scrape the outside of the joint or rub it with a piece of sandpaper. Thorough cleaning of the two surfaces to be soldered is the most important factor in making a good soldered joint.

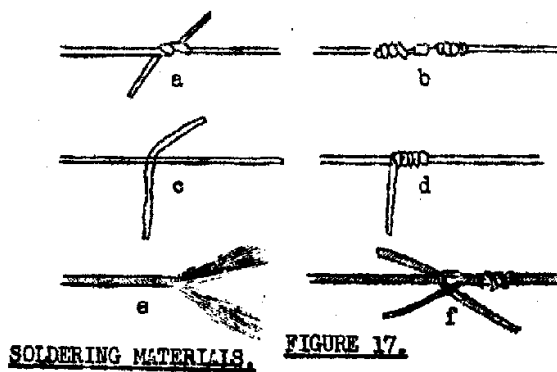

Soldering is most easily done with a good electric soldering iron of liberal size. The copper tip extending out from the heating element of the iron should be from three-eighths to one-half inch in diameter and should extend about two inches from the heater. A tip shaped as shown in Figure 18 is best for wire soldering. If you can't use an electric iron, just as good work can be done with one heated by a blow lamp, but it is more troublesome to care for the torch. In heating an iron with the torch, keep the tip of the iron in the blue part of the flame as in Figure 19.

If you get the tip into the yellow flame a coating of soot will be will have to be cleaned away thoroughly before the deposited on the copper and soldering operation.

Wire solder or strip solder is easier to use than bar solder. Resin-cored solder will make it unnecessary to use a separate flux but it is generally easier to make a clean neat joint with the plain wire solder. Above all, never use acid-core solder because joints made with it will surely corrode and cause high resistance after a time. Most soldering pastes contain materials which cause corrosion therefore don't use any of them unless you can be certain they contain neither acid nor salts of any kind. The purpose of any flux is to remove the oxide from the metal just as you are ready to solder, leaving the copper ready to unite with the solder. The safest and most generally satisfactory flux for radio work is plain resin. You can get resin in powdered form or in crystals and keep a small supply in a tin dish or a can cover as you do your work. Another method of using resin is to dissolve it in methylated spirits until it forms a thick paste. This paste should be kept in an air-tight container when not in use, to prevent the methylated spirits evaporating and the paste drying up.

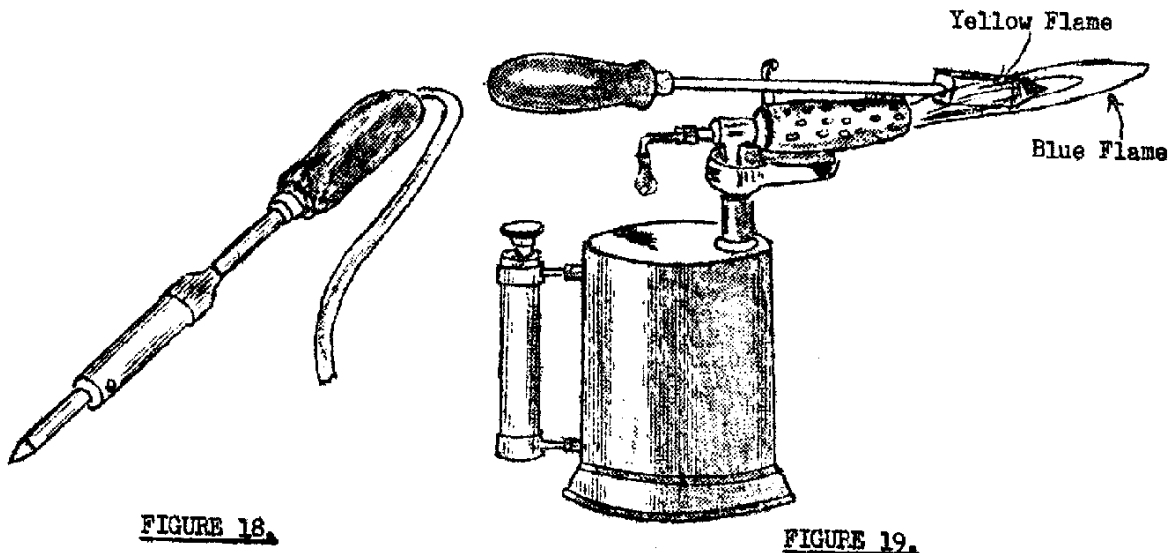

FIGURE 18.

FIGURE 19.

PREPARING THE SOLDERING IRON.

If the tip of the soldering iron isn't of the approximate shape shown in Figure 18, use a file and make it that way. Then clean the tip for a distance of half an inch back from the end by filing it down all around until you see nothing but clean, bright copper everywhere. Then polish the cleaned surface with emery cloth or sand paper. Finally, heat the iron just as though you were ready to solder.

When the iron gets good and hot touch the tip to the resin flux and while doing this, rub the end or tip of the iron with solder. The solder will flow over the cleaned portion of the tip and leave a bright coating there. This process is called "tinning" the iron. After an iron is used for a long time it will need to be re-tinned.

File off the tip and perform the operation in the manner just explained. While you are doing soldering job you will notice that the tinned tip gets dull or blackens in spots. To remove this coating, rub the hot iron on a piece of heavy cloth which you can keep handy for the purpose.

You can tell when an iron gets hot enough by touching the tip with a piece of wire solder. A properly heated iron will cause the solder to flow like water the instant the two touch. An iron that is too hot will blacken rapidly at the tip, while one that is just right will remain quite bright or will show just a faint brownish tinge or film over the bright tinning. An iron too hot will hurt its own surface and will require cleaning and re-tinning, but an iron not hot enough will fail to make a good joint. Therefore, keep the iron hot,

SOLDERING A JOINT.

Now that you have a mechanical joint, well cleaned, and have a properly shaped iron, well heated, you are ready to apply the solder.

When using wire solder, first heat the joint by applying the iron to it, then drop on a little of the resin flux. The resin will smoke. Hold the hot iron underneath the joint until the wires get really hot. Then, as in Figure 20, dip the end of the wire solder into the resin and touch it to the joint. If things are properly heated, the solder will flow down into the joint, completely filling the spaces in and around the wires. It is very important to apply the heat long enough to do this because unless each of the metal surfaces is heated to the melting point of the solder, the solder will not "wet" the two surfaces and a "dry" joint will result. The ultimate effect of such a joint will be internal corrosion and high resistance between the two surfaces and this can create a considerable amount of trouble in any radio or television receiver. A "dry" joint can also result if contact between the two surfaces to be soldered is not firmly maintained until the solder applied to the work has cooled sufficiently to set hard. One further word of warning. Do not attempt to solder wire or any other metal to aluminium. While this can be done, very special techniques and materials are involved, and it is better left to experts in this field.

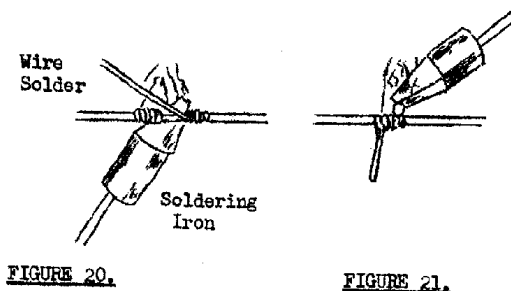

If you are using bar solder instead of the wire form you first heat the joint and apply a small amount of resin flux just as before. The easiest way to apply the solder is to have a quantity of resin in on side of a flat tin dish and a piece of solder in the other side of the same dish. Then you touch the tip of the hot iron to the resin and quickly move it over and touch the solder. The solder will melt and some of it will stick to

the tip of the iron. With the least possible delay move the iron with its drop of molten solder over to the joint as in Figure 21, and slowly rub the iron tip over the top of the wire joint. As the wires get hot the solder will run down around them and complete the joint. The purpose of soldering an electrical joint is to provide a good conducting medium between two parts carrying electricity and to prevent oxide from forming on the surfaces and increasing the resistance of the joint.

I think we can best conclude this lesson by summarising the rules for successful soldering.

- (1) The iron must be clean and well tinned.
- (2) The two surfaces to be joined must be thoroughly cleaned of all forms of oxide film so that both surfaces of metal are bright and shining.
- (3) The correct amount of flux is that which will completely evaporate during the soldering operation without leaving any surplus remaining.
- (4) The soldering iron must be left in contact with the work long enough to enable both surfaces to be joined, to be heated to a temperature higher than the melting point of solder, about 450 or 460 degrees F., So that the solder flows readily from the iron and spreads evenly over both surfaces. If the iron is not left in contact with the work long enough to heat each surface sufficiently, the solder may be pasted onto the work but it will be found later that the solder will peel off easily when given a slight pull. This is known as a "dry joint".
- (5) When the solder has run freely onto the work and the soldering iron is removed, care should be taken not to shake or disturb the work or the solder until it has had time to cool and solidify. If the work is shaken when the solder is in the plastic state, before it finally sets hard, a bad connection will often result as the solder will not effectively grip the wire it surrounds.

EXAMINATION QUESTIONS - NO. 4.

1. Why may an inefficient aerial-earth installation completely ruin the performance of even the best of radio receivers ?
2. If an aerial wire is 100 feet above the level of the earth and 10 feet above the roof of a reinforced concrete building, what is its electrical height ? Explain the reason.
3. Which brings clearer reception, an outdoor or an indoor aerial ?
4. Would you always choose an outdoor aerial when installing a radio receiver ? Explain.
5. Is it practical to use a resonant aerial for reception of stations operating within the band 525 kc/s to 1605 kc/s,? Explain.
6. How would you connect a resonant half-wave aerial to a receiver ? Give a diagram.
7. How far from a building wall would you carry a lead-in wire?
8. what are the four most important points to consider in running a ground from the set ?
9. How deep would you drive an iron pipe to be used for a ground connection ?
10. What is the safest kind of soldering flux for radio work? Why ?

Please NOTE Postal Address: (AUSTRALIAN RADIO AND TELEVISION COLLEGE
(PTY. LTD.
(Box 43, Broadway, Sydney, N.S.W

NOTE : Write the lesson number before answering the questions.
Write on one side of the paper only.
Always write down in full the question before you answer it.
Use sketches and diagrams wherever possible. One diagram in many cases is equivalent to pages of explanation

Remember that you learn by making mistakes; so give yourself an opportunity of having your mistakes found and corrected.

Don't hesitate to ask for further explanation on any point, we are always ready to help you.
Do not copy directly from the lesson

Write your name and full address at top of paper. If you have made arrangements with the College to have your lessons returned to any particular address - state this at the top of the page.

"The Radio-T.V. Training Centre"

**E. S. & A. BANK BUILDINGS, Corner CITY RD. and BROADWAY, SYDNEY
Telephones: BA4891 and BA4892**

AUSTRALIAN RADIO AND TELEVISION COLLEGE PTY. LTD.

Telegrams "RADIOCOLLEGE" Sydney

This lesson sheet is published for the exclusive use of students of the Australian Radio and Television College Pty. Ltd. (All rights reserved)

Post Lessons to Box 43, Broadway

LESSON NO.5

DESIGN AND INSTALLATION OF SPECIAL AERIALS

The aerial you studied in the other lesson on this subject is the most common type of all. Its circuit consists of an overhead wire, connected to the lead-in, then to the first coil in the receiver, and from there to the ground connection. All these parts are shown in Fig. 1, both in pictures and in symbols.

This form of aerial is often called an "L-type" or an "inverted L-type" because its general shape, with the lead-in at one end, resembles an inverted capital letter "L". The lead-in is generally, but not always, connected to one end of the aerial. Sometimes, as in Fig. 2, the lead-in is connected near the centre of the aerial's length. This arrangement makes what we call an aerial of the "T-type"; because the aerial and lead-in resemble the capital letter "T".

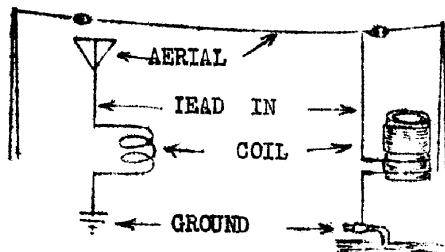

Figure 1.

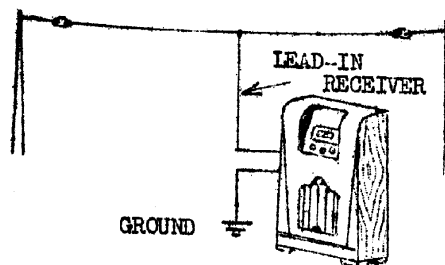

Figure 2.

All the aerials referred to so far have used a single overhead wire. Sometimes, when there is not sufficient space to accommodate a single wire aerial of the required length, we resort to the use of two or more parallel wires instead of the single wire. Then we have a multiple wire aerial.

The separate wires of such an aerial are all of the same length and are spaced at least two feet apart by means of spreaders. The spreaders are pieces of hard wood about one inch square with small holes bored through them. A spacing of two feet is required in order that this aerial may have greater signal collecting ability than a single wire of equal length. There is very little advantage in spacing greater than two feet. A two-wire aerial is shown in Fig. 3 with the lead-in attached at one end. In Fig.4 you can see a three-wire aerial with the lead-in attached near its centre.

A two-wire aerial having each wire of the same length as the one wire of a single

aerial will collect a stronger signal than the signal wire, but the signal will be nowhere near twice as strong. Likewise, the three wire aerial will collect more signal than the two-wire type, but it will not collect fifty per cent more. Multiple wire aerials are generally between fifteen and thirty feet in over-all length.

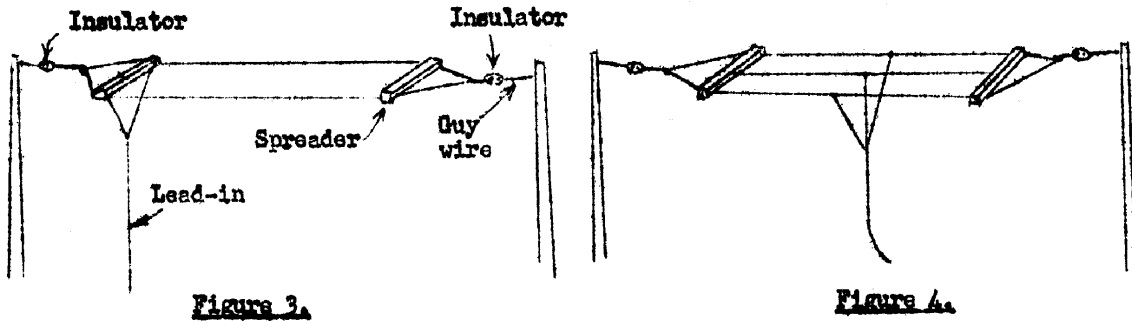

Because modern receivers require such a small amount of aerial signal for satisfactory operation, it is very seldom necessary, even in country districts to obtain the equivalent of a single wire more than fifty feet long, but this can be done with a two-wire aerial about thirty feet long or with a three-wire aerial twenty feet long. All of the wires in the multiple aerial are connected together by the lead-in attachment.

The wires may be attached to the spreaders by either of the methods shown in Fig.5. At the right the wire is passed through the hole in the spreader and wrapped once around the wood, At the left the aerial wire does not pass through the hole in the spreader but is fastened by a second short piece of wire which passes through the spreader and is wrapped around the aerial wire. There is no need for insulation between the wire of the aerial and the wood of the spreader because all the aerial wires are connected together anyway.

IS A GROUND CONNECTION NECESSARY?

In the last lesson, it was pointed out at some length, that the aerial and ground connections act as the two terminals of a source of voltage or "generator" which supplies the weak signal voltages necessary to operate a receiver. The last lesson also explained the normal path of current surging to and fro between the aerial and ground and passing through the aerial coil of a receiver on its way. This circulating current then generates voltages in the secondary winding of the aerial coil, which are responsible for the sounds we hear from the receiver's loudspeaker.

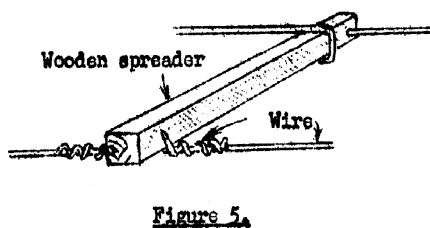

It would appear from the foregoing that if the ground wire were detached from a receiver operated with an aerial only, the circuit would be broken, current would cease to flow and the receiver would fail to work. Despite this, you have possibly seen numerous receivers, particularly those which function from alternating power mains, operating without a ground wire and found that they work quite loudly. The reason the receivers are able to operate is shown in Figure 6. In the case of an ordinary receiver operating from the alternating power mains, power from the mains is converted into suitable voltages for the valves by means of a power transformer. A power transformer is something like the iron cored audio transformer described in Lesson 3. It consists of a primary winding of copper wire wound around the centre leg of a set of iron laminations but insulated from these laminations by means of a good quality insulating material to prevent the power mains voltage jumping straight from the primary winding to the core.

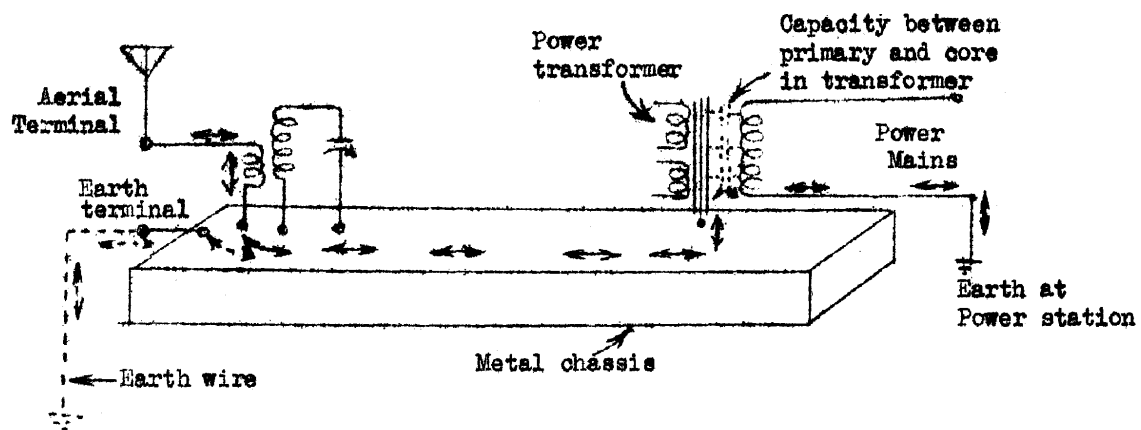

Figure 6.

Over the top of the primary winding is another layer of insulating material and then, in turn, come additional windings to supply power to the various valves in the receiver although the primary winding is insulated from the iron laminations, both the primary winding of copper wire and the laminations are conductors and because they are separated by an insulating material they form a small condenser effect which allows radio frequency current to pass through.

If we connect an aerial to the aerial terminal of the receiver, as shown in Figure 6, radio frequency current can pass from the aerial down through the aerial primary winding to the metal chassis. Because there is no ground wire on this receiver, there is no metal path to earth for the radio current so instead it passes from the metal chassis to the iron laminations of the power transformer, which are bolted on to the chassis and then through the capacity effect between the laminations and primary, into the primary winding and then through the power mains wiring to ground at the power station or at some intermediate point where capacity of other electrical appliances provides an easy path for the radio frequency current to reach the earth.

Although an actual ground wire is not connected to the receiver illustrated in Fig. 6, radio frequency current can nevertheless circulate through the aerial coil, finding its way ultimately to ground at some remote point, and this enables the receiver

to work just about as loudly whether it has an earth wire actually connected to it or not, In fact, in some areas the receiver may actually have slightly stronger signals reaching its aerial coil when operated without the ground connection because the power main wires are high and well insulated from the earth and in themselves act as quite an effective aerial so that there is a strong voltage difference between the receiver's aerial and the power mains wiring. Connecting a ground wire to the earth terminal of the receiver in these cases would reduce the loudness of signals slightly. This may lead you to conclude that it is better to operate, power main receivers without an earth wire rather than with one. However, there are other factors which we must take into account in deciding whether an earth wire should be used or not.

One of the first of these factors is safety. Although the insulation we have described, between the primary winding and iron core of a power transformer is always tested in good order in a new receiver, it is always possible for the insulation to deteriorate due to heat and age and possibly to ultimately break down. If a ground wire is not connected to the radio chassis then it is possible for the voltage from the power mains to reach the metal chassis of the receiver, should the insulation fail. This in itself may not be dangerous because radio chassis are normally enclosed in wooden or plastic cabinet. However, without an earth wire connected to the chassis the power mains voltage would be able to pass through the aerial primary winding reach the aerial terminal and then also reach the aerial lead attached to this terminal and it might be possible for someone to come into contact with this wire and at the same time and receive an electric shock. For this reason it is safer to use a ground wire. If a short circuit should develop in a power transformer when ground wire is used, the heavy current flowing to ground will "blow" the power fuse so that no danger will exist.

There is a second reason which makes the use of a ground wire desirable on power mains operated sets. From Figure 6 you can see that the current which circulates through the aerial coil is that resulting from the voltage difference between the aerial itself and the power mains wiring. At various points along the power mains there are all sorts of electrical devices not only in the building in which the radio receiver operates but also in other buildings up and down the street. Various machines, particularly those employing electric motors with carbon brushes, or thermostats, produce forms of electrical interference which can be converted by the radio receiver into annoying "crackles" and "bangs" from the loudspeaker. The current disturbances responsible for these noises, like radio signals, can travel from the power mains, through the capacity in the power transformer, to the metal chassis, and then from the chassis through the aerial coil to the aerial. As a result we have not only radio signal current passing through the receiver's aerial coil but also surges of current originating from the power mains. These surges of current are quite weak and are not dangerous in way but when amplified by the valves in the radio receiver can result in annoying buzzes and crackles from the loudspeaker.

By connecting an efficient earth system to the earth terminal as shown at the left hand side of Figure 6, in dotted line, the noise voltages will, in many instances, be diverted away from the aerial coil and will not be heard to the same degree from the loudspeaker. This provides an improvement in "signal to noise ratio" which makes listening more enjoyable.

When the earth wire is attached to the earth terminal, there is a complete and easy path for radio signal current, from the aerial, through the aerial coil in the receiver,

to chassis and then down to the ground itself, without this current having to circulate back through the power transformer and power main wiring. In the case of radio disturbances originating in the power mains wiring, although these small amounts of energy may find their way through the capacity in the power transformer to the receiver chassis, instead of them continuing through the aerial coil to the aerial they will also pass through the ground wire to the earth and will thus be diverted away from the aerial coil and will not be effective in generating "noise" signals.

From this explanation you will realise that in many districts the attachment of an earth wire to a power mains operated receiver may not make the signals any louder but may make, noise disturbance much weaker therefore providing more enjoyment as a result of the improved signal to noise ratio.

GOUND WIRES FOR BATTERY OPERATED RECEIVERS.

In the case of radio receivers which operate from batteries and which consequently have no connection to the power mains, there is no possibility of radio current from the aerial circulating through the aerial coil and continuing on to ultimately reach ground unless a good ground wire is attached to the earth terminal of the receiver. For this reason it is most important, in the case of battery operated receivers, to have An efficient earth system as this plays just as much part in determining the strength of signal current flowing through the receiver's aerial coil as does the aerial itself.

Of course, there are some battery operated receivers which have a self-contained loop aerial in which the signal voltages are directly developed within the loop coil itself. In strong signal areas, these receivers do not require any external aerial or ground wire. You will find a more complete description of this type of aerial in the latter pages of this lesson.

In the case of mobile installations such as in motor cars and aeroplanes, the ground terminal of the receiving equipment is connected to the metal body of the motor car or of the aeroplane and the large metal surface takes the place of an actual connection to ground in forming the second plate of a condenser of which the aerial itself is the other plate. You will remember from the last lesson, that in an ordinary installation the aerial and ground connections form two condenser plates widely separated in space and that the passing radio signals generate a voltage between these two conductors. The same principle applies in the case of mobile installations with the aerial and car or aircraft body acting as the second condenser plate. Thus no actual connection to the earth itself is necessary.

COUNTERPOISE.

In a few rare cases, particularly when attempting to use battery operated receivers in districts where it is difficult to get a satisfactory ground connection, you can apply the principle used in motor cars and aircraft even in household receivers. These conditions may exist when the earth is exceedingly dry and sandy, where the receiver is located where there is only rock beneath it or when the receiver is in an upper floor of a high building. In such cases we may employ a counterpoise as illustrated in Figure 7. You will remember that it is necessary to form a large condenser consisting of widely spaced conducting surfaces. If we cannot use the

earth itself as one of the conducting surfaces, then we can erect an aerial wire as high as possible and erect another wire underneath it and parallel to it to form the second plate of the condenser. This second wire is called a "counterpoise".

The counterpoise may consist simply of a single wire placed directly underneath the aerial or even two or three wires spread a little apart.

It is desirable that the wire employed for a counterpoise be insulated wire similar to that employed for a receiver "lead-in".

The wire itself may in many instances be tacked under the floor of a building or, in the case of an outdoor aerial, parallel with and directly under the aerial itself. Of course, in this case it must be erected high enough to allow people to walk under as it would be likely to trip people if

placed only a foot or so above the earth's surface.

Another possible arrangement is to use 3/.036 or 7/.029 copper wire covered with P.V.C. type plastic insulation and bury thin wire a foot or so under the surface of loose sandy soil. This would have the effect of making what would normally be soil of very poor conductivity into a good conductor and would provide a satisfactory form of combined counterpoise and earth system for a battery operated receiver.

The signal strength from an aerial and a good earth around will be much greater than from the same aerial and any counterpoise. The only reason for using a counterpoise is inability to install the usual kind of ground. It is seldom necessary to go to the trouble of erecting a counterpoise for receivers operating from power mains, because there is capacity in the power transformer which allows RF current to pass between the power mains and the receiver chassis, so that the power mains will act as a counterpoise and will provide quite good reception without there being any connection to the receiver's ground terminal.

NOISE REDUCING LEAD-IN.

In some areas electrical noise or "man made static", as it is sometimes called, may be very bad and seriously interfere with the reception of broadcast stations. Apart from the noise currents which reach the aerial coil of a receiver in a power mains operated set operated without an earth wire, as described in connection with Figure 6, another way in which the noise impulses, brought into the building by the power mains, can reach the aerial coil is by radiation from the power mains through space to the nearest part of the aerial system, which is the lead-in, and of course are carried by the lead-in to the aerial terminal of the set. This applies even when an earth wire is used.

If the aerial itself can be placed at a good height and well away from the building or power wires carrying interference, so that it will not pick up a strong interfering signal, then we shall have good clear reception of radio signals without any annoying noise or crackles.

The difficulty lies in preventing the lead-in wire from picking up the noise signals without seriously affecting its ability to carry radio signals from the aerial to the receiver.

SHIELDED LEAD-IN.

One method sometimes employed to prevent the lead-in wire from picking up the noise signals is to cover the lead-in wire with a sleeve of flexible metal braid. The metal braid should be connected to ground and forms a complete metal case or shield around the lead-in wire which prevents the noise impulse from directly reaching the lead-in.

The hollow metal braid can be purchased separately and slipped over ordinary

lead-in wire or wire is available with the metal braid already around it. Both the separate braid and the shielded wire are fairly costly and for this reason, together with the fact that the metal braid being connected to earth is so close to the lead-in wire that it causes quite a considerable loss of radio signals, the system is not very frequently used.

Figure 8 shows the arrangement of a shielded lead-in.

TWISTED PAIR LEAD-IN.

Another simple method for preventing the lead-in wire from introducing interfering noises into the receiver is shown in Figure 9.

In this system, two pieces of lead-in wire (usually 1/.044 250 volt grade) are twisted together like ordinary electric light flex. At the aerial end one wire is

1.5 - 7

connected to the aerial wire and the second wire is either left disconnected or can be joined to the wire or rope for joining the two insulators together; this will hold the second wire in place and prevent it from untwisting.

Unless the receiver is already designed to operate with this type of lead-in, an alteration will have to be made to the set. Normally, one end of the primary winding on the aerial coil of a receiver connects to the aerial terminal while the other end connects to earth. An additional terminal should be mounted on the chassis of the set and insulated from it. If there are only 20 turns or so on the aerial primary, it may be possible to make a connection to the centre one thus providing a centre tap. If this is so, the earth end of the aerial primary winding should be disconnected from its normal place in the circuit and connected to the new terminal and the centre tap connected to the earth terminal. We now have two

aerial terminals and the earth terminal. The two ends of the twisted lead-in should connect one to each of the aerial terminals while the earth wire is connected to the earth terminal. If it is not possible to make a centre tap connection to the existing primary, it may be a simple matter to rewind the primary altogether to provide a centre tap.

In this system any noise impulses in the vicinity of the lead-in will induce signals in both wires of the lead-in, but these are connected to the receiver in such a way that any signals picked up by one of the lead-in wires will act against and neutralize any signals picked up by the other wire, consequently the noises are not heard from the loudspeaker. Signal voltages induced in the aerial wire by the various broadcasting stations will be conducted by the lead-in wire which connects to the aerial, to the receiver and through one half of the primary, and will of course take the normal path through the set.

Due to the small distance between the two lead-in wires this system is not very efficient in conducting the signals from the aerial to the receiver and so reduces the signal strength by quite a considerable amount.

DOUBLET AERIAL

Figure 10 shows the arrangement of a doublet aerial. It simply consists of a long aerial wire broken at the exact centre and joined by an insulator. Two lead-in wires are also used with this system, one being connected to the inner end of each of the aerial wires.

The lead-in wires used with this system should not be closely twisted together but should be spaced 3 inches apart, crossing each other about every eighteen inches two feet.

To space the lead-in wires correctly and to enable them to cross at the required points, transposition blocks are employed every eighteen inches or two feet along the length of the lead-in.

A transposition block consists of a plastic substance having a shape similar to that shown in Figure 11. One lead-in wire is brought down to the top left hand slot in the block, passed through the slot, diagonally across the back of the block to the bottom right hand slot then through this slot and continue on down to the next block. The second wire comes to the top right hand slot, through this slot, diagonally across the front of the block, through the slot in the bottom left hand corner and down to the next block.

L.5 - 8

This system, like the last requires that the end of the aerial winding which normally connects to earth, be disconnected and brought to an additional aerial terminal, but no centre

tap is needed. Some receivers are wired up with the aerial coil arranged in this manner and require no alteration when used with a doublet aerial.

The principle of operation of the doublet is somewhat similar to that of the last system. Any noise impulses will induce equal voltages in both the lead-in wires and these will counteract one another in the receiver and, so will not be heard, but signals are picked up on the two halves of the aerial and instead of counteracting, add to one another and so are, handled by the receiver.

None of the above systems will produce as strong a signal in the receiver as an ordinary T or L type aerial of similar length, consequently they are generally only used in districts where the amount of electrical noise is very severe.

All of the aerial systems shown so far if over 50 ft. in length or 30 ft. in height, must be protected against damage which may be done by discharge of atmospheric electricity through their wiring and the connected parts in the receiver. Lightning is one form of atmospheric electricity, or electricity generated in the air, but there are lots of other kinds of atmospheric electricity as well. The purpose of a lightning arrester is to provide a path through which such electricity, of whatever variety, may escape from the aerial into the earth without going through the receiver or coming into the building containing the receiver.

During an electrical storm, or a thunder storm the air and clouds are heavily charged with electricity. This electricity does its best to escape from above and come down to the earth. Any metal object which is elevated may be in the path of this electricity, and since the aerial is such an object it is necessary that we provide protection. Ordinary electric charges which collect on the aerial flow harmlessly to ground through the aerial circuit of Figure 1, passing through the parts of the receiver. During a storm these charges increase and it is possible that their passage through the receiver may cause some damage - even to the extent of setting fire to things. This is what the lightning arrester prevents. Should an aerial suffer

L.5 - 9

a direct hit from a lightning flash, no arrester or anything else would prevent serious damage or complete destruction of everything in the lightning's path. This is a rare occurrence and the stroke undoubtedly take place in exactly the same manner and same place whether or not an aerial were there.

The principle of all lightning arresters is shown in figure 12. Two metal points are placed between aerial and ground, which means that they are connected across the first coil winding in the receiver. Radio signals meet the high resistance of the gap between the arrester points and flow around through the coil as usual because of their inability to jump across the gap. But should the aerial suddenly be charged with a large quantity of electricity during a storm, this electricity would not take time to pass around through the coil (being opposed by the coils "reactance") but would instantly jump across the gap. Passage of the electricity across the arrester

gap produces a spark or arc.

Immediately such an arc is formed it provides a low resistance path between the arrester points and all the electricity which has collected on the aerial passes through the arrester to ground and does no harm in the receiver. The points in the lightning arrester are placed at such a distance apart that a pressure of 500 volts will cause an arc between them. No radio signal is more than a fraction of one per cent of this voltage and any electrical discharge which might cause damage develops well over 500 volts - so the arrester does its work very easily.

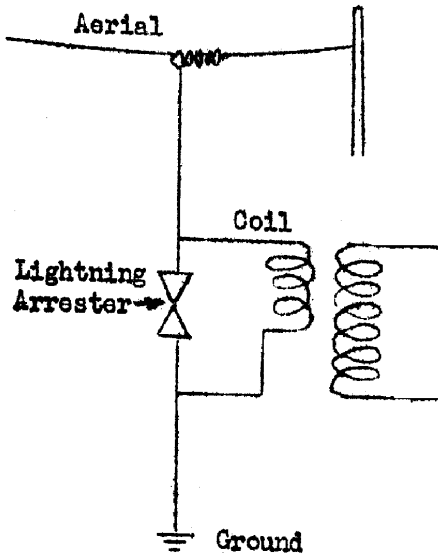

Figure 12.

TYPES OF LIGHTNING ARRESTER.

Some lightning arresters have their points made from carbon spaced apart by a thin sheet of mica around which the electrical discharge takes place when they work. Other types have points formed by small brass or bronze pins extending into a glass tube which is sealed to keep out moisture and dirt which might short circuit the arrangement and form a conducting path between the points, when all the signals from the aerial would go right down into the ground without having to pass through the coil in the receiver.

There are a few kinds of lightning arresters having the points, formed by wires sealed into the end of a glass tube from which the air has been pumped, leaving a vacuum. The electrical resistance or opposition to current flow is much less in a vacuum than it is in air, consequently the points can be kept further apart in the vacuum than in air and still allow the 500 volts to make a spark pass between them.

L.5 - P.10

The construction of one commonly used type of lightning arrester is shown in Fig. 13.

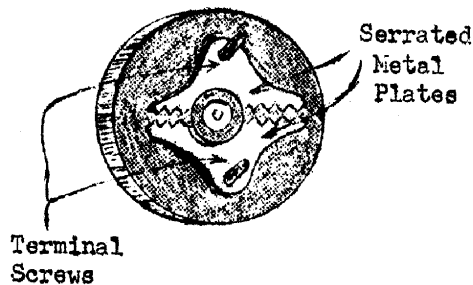

FIG. 13.

This type consists of two brass plates with serrated edges insulated in a moulded bakelite container. The tip of each serrated edge are exactly opposite one another shown in Figure 13, so that any large voltage can easily jump across the small gap between them.

When this type of arrester is screwed down on flat surface by means of a

screw through its centre, the two plates are enclosed in a moisture proof compartment so that moisture or dust cannot bridge the gap between the plates and allow radio signals to leak away to earth instead of passing into the receiver.

IMPORTANT – FIRE UNDERWRITER’S RULES

It is absolutely necessary that some form of arrester which has been approved by the Fire Underwriters be attached to every radio installation having an outdoor aerial over 50 ft. in length or 30 ft. in height. Failure to observe this rule may make it difficult or impossible to collect insurance in case of damage from fire.

The special type of aerials shown in Figures 9 and 10 each require the use of two lightning arrestors. As each system is provided with two lead-in wires, it is necessary to prevent either of these wires from conducting electrical discharges into the building, consequently, a lightning arrester must be connected to each wire and the earth terminal of each arrester connected together and to the ground.

The method of connecting the arresters to the doublet or twisted pair lead-in is shown in Figure 14.

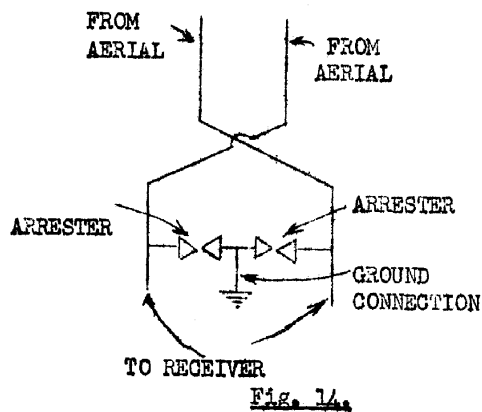

TELEVISION AERIALS.

The form, dimensions, principle of and method of connecting television aerials to television receivers differ considerably from similar characteristics for radio reception. Due to the very much higher carrier frequencies involved for television transmission quite different aerials are needed for T.V. and consequently we will not attempt to deal with them at this early stage of your course. Due to the quite different types of aerials required for T.V. and radio, it is best to use entirely separate aerials for the television receiver and radio receiver.

L.5 – P.11

INDOOR AERIALS.

We will now consider the case of areas where signals are so strong that an outdoor aerial is not necessary. The next best thing is an indoor aerial - a wire placed within the building and taking the place of the overhead wire in the usual installation. Let me say here that no other form of aerial can compare with the regular outdoor type as a collector of signal energy. All other kinds are less effective no matter what claims to the contrary you may hear about. This does not mean that a receiver must have an outdoor aerial to do good work. The receiver may be powerful enough to need but the slightest hint of a signal in order to produce satisfactory volume. Then it will do good work with some inefficient kind of aerial. But it will be still more powerful with a good outdoor aerial.

Any form of indoor aerial requires that the receiver be equipped with the same kind

or ground that is used when an outdoor aerial is employed. All of the care that is taken with the ground for use in an outdoor aerial circuit must also be taken when the indoor type is used.

An indoor aerial concealed behind a room moulding is shown in Fig. 35. For this kind of aerial, the picture moulding type, we use thin flexible, stranded plastic or rubber covered wire. In running such an aerial, attempt to keep it away from metal piping of any kind, from telephone wiring, from conduits carrying power and light wires from signal bell wires and from all such things. Nearness to any kind of electrical circuit will allow impulses from that circuit to cause annoying sounds to come from the loud speaker when those circuits are in use.

As an alternative to the picture rail when, the wire may be run around the skirting board, near the floor or under the edge of a carpet, but signals in these positions will be weaker than the aerial is higher up.

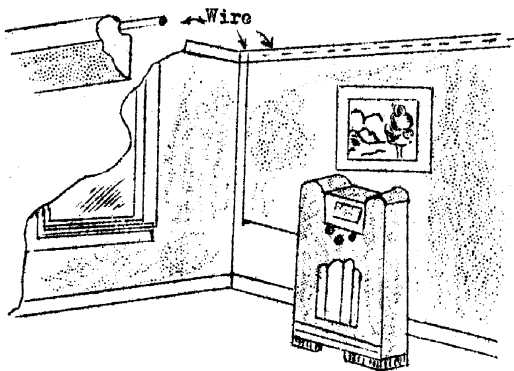

Fig. 15.

The indoor aerial collects less energy than the outdoor kind therefore it is allowable to use a greater length of wire for the indoor job than for the outdoor. Wire at the back of a moulding may be run nearly all the way around one good-sized room, or it may be run through several rooms. It is impossible to run these concealed indoor wires in straight lines, but it is advisable to string them out to the greatest possible length, running through several rooms in line if wire around two walls of one room does not provide sufficient signal strength.

You can use an indoor aerial with any kind of a receiver having three or more tubes. The average indoor job is not half as effective in bringing through the distant stations as a good outdoor aerial. Therefore, the distance range of an ordinary set will be limited. The quality and clearness of reception will be excellent on nearby stations.

However, if you are working with powerful receiver, with one the newest superheterodyne sets or with any set having five tubes or more, the indoor aerial is very satisfactory even on stations at a distance of many hundreds of miles from the receiver, unless noises transferred to the aerial from the electric power mains are very bad.

Before leaving this matter of indoor aerials, it is very desirable that you provide a first class ground. This will help matters a lot. Also the greater the length of the indoor aerial, the stronger will be the signals it brings in, but the less selective the set will be.

LIGHT AND POWER WIRES FOR AN AERIAL

If you or your customer, should wish to get along without even an indoor aerial there are still simple methods of bringing signal impulses to the receiver. One method makes connection to the lighting circuit wires which come into the building. We will take these aerial arrangements in the order of their excellence. Best of all is the outdoor type, next comes the indoor aerial, then the power or light line type and so on.

If you will stop to consider it you will realise that the electric wires coming into any building meet many of the requirements of an aerial. They are insulated and they extend out into space. Of course, it is out of the question to make a direct connection from these wires to the aerial post of a receiver because their high voltage would send a great rush of current through the coils and other parts and would cause a disastrous fire. We make our connection through a small condenser.

You recall that the effect of an alternating current will pass through a condenser. Radio signals produce alternating voltage and currents in any elevated wire or for that matter in any wire at all that may be in their path. Consequently, you will find radio signal impulses in all light and power wires.

One method of extracting the high frequency radio signals from the power mains wiring but at the same time safely holding back the low frequency power mains voltage is to employ a small condenser with a capacity of about .0005 mfd. connected as shown in Fig 16.

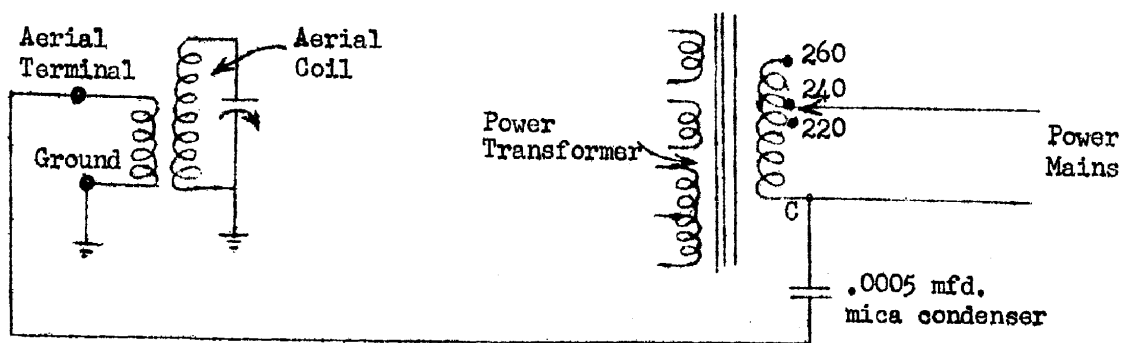

Figure 16.

The reactance of .0005 mfd. condenser to the radio frequency of one megacycle per second is only about 300 ohms and this value is not sufficient to appreciably restrict the radio frequency current. At the power mains frequency of 50 cycles per second however, the reactance of the same condenser increases to a value of about six million ohms and this is sufficient to hold back any dangerous current at the power mains frequency itself.

Unfortunately, it is not an easy matter to install a condenser as shown in Figure 16. This work would require removing the radio chassis from its cabinet so as to give access to the point where the power flex is connected to the terminals of the power transformer. One could then solder one end of the .0005 mica condenser to one of the two wire leads in the power flex at the point where the flex solders to the power transformer connections. The other end of the condenser would then be connected through a length of hookup wire to the aerial terminal.

Fortunately, there is a much simpler way of extracting radio signals from the power mains, without the work of soldering a condenser into position as shown in Figure 16. In Figure 17, you will notice that we make use of the stray capacity inside the power transformer, to couple our radio signals from the power mains through to the metal chassis of the set, as described earlier in connection with Figure 6. The only thing which looks different about Figure 17 is the fact that we have connected a ground wire to the aerial terminal of the receiver instead of to the ground terminal. Nothing is connected to the earth terminal of the set.

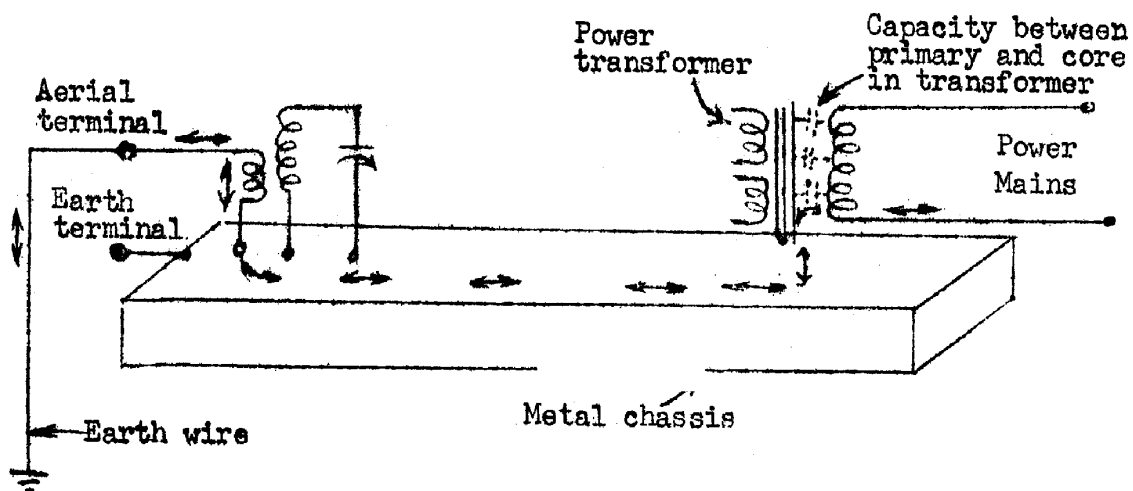

Figure 17.

In Figure 17 you can see that any radio frequency energy present in the power mains wiring can find its way through the stray capacity in the power transformer to the transformer's core and then through the bolts which hold the transformer to the chassis, to the metal chassis itself. The radio currents then pass through the metal chassis to the earth end of the aerial primary coil and pass through this coil to the aerial terminal. From here they are able to pass through the earth wire itself to ground so that there is a complete circuit through which radio frequency current may flow to and fro.

This arrangement works quite well and is very easy to apply to any receiver by simply connecting an earth wire to the aerial terminal in place of the aerial wire.

The earth wire should preferably connect to a water pipe or earth pipe driven into ground as explained in Lesson 4, although in some cases good results can be obtained by connecting the earth wire back to the earth pin in a three-pin power point.

The disadvantage of the arrangement shown in Figure 17 is that by depending upon the radio frequency voltages picked up in the power mains for our signal and encouraging radio frequency energy from the power mains to flow through the aerial coil, by connecting the earth wire to the aerial terminal, we will also have any electrical, noise impulses, produced by power operated equipment, flowing through the aerial coil as well as the radio signals and consequently the signal to noise ratio is not as good as when a separate aerial and earth wire are used in the conventional manner.

LOOP AERIALS.

All of the aeriels described so far have been suitable for connecting to the aerial terminal of an ordinary type of receiver. Because of the size and awkwardness of installation of these aerial systems there have been many attempts to reduce the aerial to a size small enough for it to be fitted inside the radio cabinet. Some receivers have been fitted with a short length of wire fitted to the back of the cabinet but these are usually not very satisfactory,

The most practical form of small aerial is to enlarge the first tuning coil to such a size that it picks up broadcast signals and is then known as a "loop aerial". This system is most commonly used in small battery operated portable receivers so that the receiver may operate without the necessity for any other aerial or for an earth wire, in the case of battery operated sets an earth connection, is only needed to complete the normal aerial circuit so that when a loop aerial is used, neither an external aerial or earth wire is needed.

The greater the length and, height of a loop aerial, within reasonable limits, the greater will be the voltage developed in it by signals from a certain broadcasting station so designers endeavour to make the loop aerial coil as large in size as possible. Figure 18 shows an oval shaped loop aerial, wound on a piece of insulating material and intended to be attached to the back of a radio cabinet. In an endeavour to obtain the largest possible size, and consequently efficiency, many

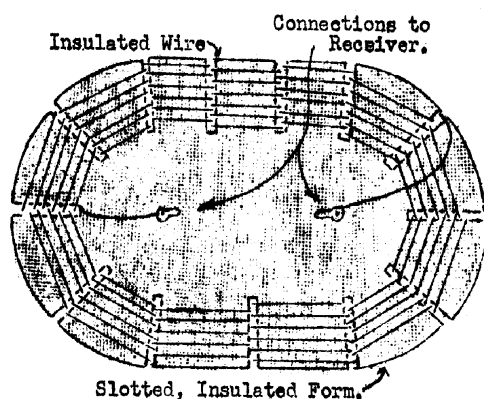

Fig. 18.

portable receivers have a shallow groove cut around the inside of the wooden cabinet. The loop aerial coil is wound in this and the whole cabinet is then covered with leatherette or fabric so that the aerial is not visible. This is illustrated in Figure 19.

The number of turns of wire used to form the loop aerial is fairly critical, because the inductance has to be just right to be tuned by the tuning condenser to the range of broadcast frequencies, Figure 20 shows the way in which the loop aerial is connected to the tuning condenser and to the grid of the first valve. Because of

Approx. 10 to 20 turns of enamel covered wire wound in groove around cabinet.

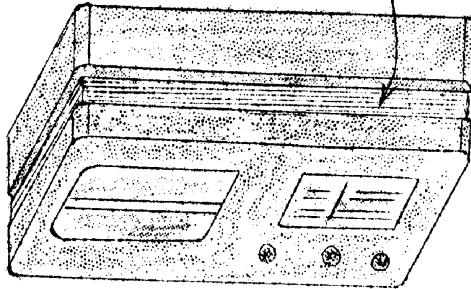

Figure 19.

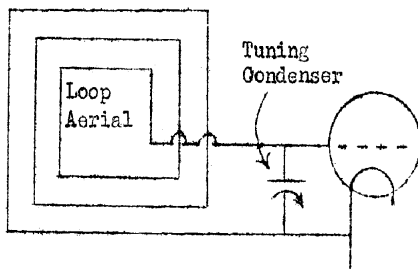

Figure 20.

In Figure 23 if we are looking down from above, on a receiver containing a loop aerial, good reception will be received from stations lying in the direction A or B, moderately good reception will be obtained from stations in directions C, D, or E and hardly any signals will be obtained from stations in directions G or H. As a result, it is desirable to turn a receiver, containing a loop aerial, until the loop points approximately in the direction of the station

the large size of the aerial only a small number or turns is needed. Usually the number varies from about 20 down to 10, the larger the size, the fewer the turns. As it is difficult to obtain just the right amount of inductance in the loop aerial, some manufacturers wind a few turns less than the correct number and then add an additional small coil called a "loading coil" as shown in Figure 21. The adjustable iron core enables the total inductance of the loop and loading coil to be set to the correct value.

STRAP AERIAL

In some very small portable receivers, the size of the case is too small to permit winding an efficient loop aerial around it. One solution to this problem is to provide a carrying strap which may be placed over the user's shoulder. This strap is usually made of a double thickness of leather or plastic material with a single length of wire contained between the two thicknesses of material. This single turn loop has far too little inductance to be directly tuned as shown in Figures 20 and 21 and so is connected to a suitable primary winding on an aerial coil as shown in Figure 22.

DIRECTIVE EFFECT.

All loop aeriels are highly directive, that is, they will hardly respond at all to signals received from the two directions faced by the broad surfaces of the loop but they will be most sensitive to signals from a direction towards which the edges of the loop are pointing.

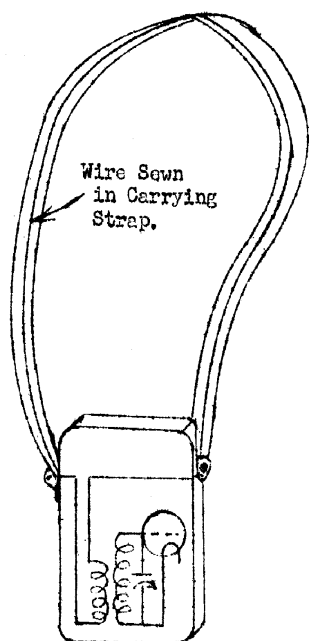

Figure 22.

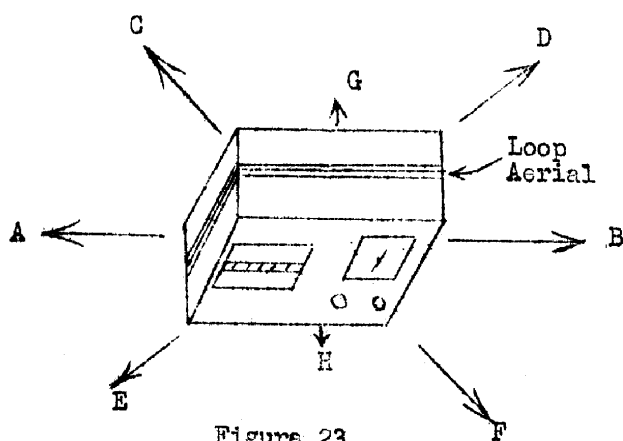

Figure 23.

it is desired to listen to, This is done by turning the receiver until the sounds from the loudspeaker are as loud as possible.

Loop aeriels are not as sensitive at picking up signals as an outdoor or indoor aerial and earth system but with a sensitive set will generally provide a range of about 50 miles, most sets fitted with a loop aerial are provided with an aerial and earth terminal as well, so that an ordinary aerial and earth can be connected if it is desired to receive weak signals from distant stations.

LOOPSTICK AERIALS

In order to provide efficient signal pick-up in a device smaller than the conventional loop aerial shown in Figure 13 or 19, and more efficient results than with the Strap Aerial shown in Figure 22, the aerial shown in Figure 23 has been devised. This consists of a length of compressed powdered iron particles formed into a rod about eight inches long and three-eighths of an inch in diameter. Wound over one section of this "ferrite" rod is a coil of wire which becomes the tuning coil for the grid circuit of the first valve in the receiver, just as the loop aerial forms the tuning coil in Figure 20.

The powdered iron particles used in the rod on which the coil is wound, will carry magnetic lines of force many times more readily than the air and consequently even though the coil winding shown in Figure 24 is much smaller than the one shown in Figure 18 or 19, the magnetic lines of force passing to and fro in the rod spread through the centre of the coil and generate voltages in the coil winding comparable with those produced in quite a large loop aerial similar to the one shown in Fig.19.

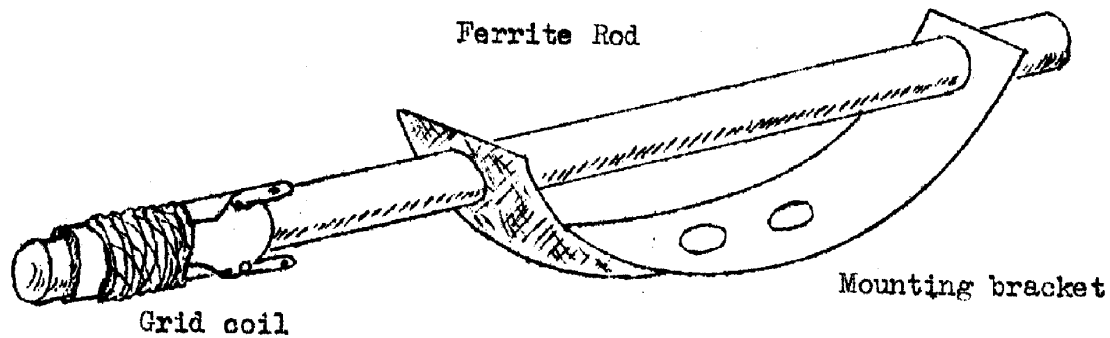

Figure 24.

The loopstick aeriels are not only fitted in many modern portable receivers but also in quite a number of power mains operated table model and small sets. Their use save the necessity for any external aerial and earth connections although once again, their efficiency does not compare with that of a moderate sized outside aerial and ground connection.

Like loop aeriels, the loopstick type of aerial has marked directional properties. The principles governing the directional pattern are the same as with the loop aerial in that reception is weak when transmitting stations lie in a direction which is broadside on to the coil winding and strongest reception is obtained from stations which are edge on to the coil winding. Due to the long iron core rod, which is threaded through the coil, the broadside direction from the coil winding is the direction in which the rod points. Therefore, the long rod or material should be set broadside to the direction from which it is desired to receive signals.

In employing any receiver equipped with a loop aerial or loopstick, it is desirable to rotate the aerial to determine the direction from which signals are loudest and to leave the receiver with the loop set in this direction.

RATIO OF SIGNAL TO STATIC

Every aerial will have two kinds of electric currents induced in it, or rather it will have induced in it currents from two different sources. One source is the transmitting station which you desire to hear. The other source is the combination of all the electrical disturbances in the air. The most troublesome disturbances are those coming from electrical apparatus and electric power mains.

To make a practical illustration of conditions, say that the strength of the atmospheric disturbances may be represented by the number 10, That number will indicate the loudness of the noises caused by static, then it is perfectly evident that a signal which produces a strength of 8 will be heard with great difficulty. A signal with a strength represented by 12 will be heard louder than the static noises, but will not be very enjoyable. If 20 represents the signal strength from the station to which you tune, the reception will be fairly satisfactory.

Now you can see that it is not just the strength or signal that counts in obtaining good reception, it is the proportion of static that comes in with the signal or the ratio of signal to static.

When we talked about the outdoor aerial you will recall that it was said that the ratio in a high and long aerial is more favourable than in a short and low aerial. It was also said that thin ratio is more favourable with the outdoor aerial than with the indoor type. The disturbances from the arrangements shown in Figures 16 and 17 may be quite bad, as the light wires sometimes carry quite strong disturbances.

In choosing the type of aerial you are going to use for a given installation, you should take this signal-static ratio into account. If you are working with a modern, powerful receiver you often can use one of the simpler forms of aerial in a good district. Upon first making an installation you can put up a temporary indoor aerial, let the owner use it for a few days, then find out whether he is satisfied. If he is content with the reception, than you have saved him the expense of the outdoor aerial. If he complains that he cannot hear enough distant stations, it will be time enough to erect the outdoor aerial.

FREQUENCY AND WAVELENGTH

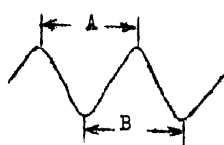

Fig. 25.

In The first lesson you will recall that I told you about the radiation of waves from a transmitter. The distance from either the crest or trough of one wave to the crest or trough of the wave ahead of it is called the length of the wave or the wavelength. If we represent radio waves as in Fig. 25 the distance between the crests, distance "a", or the distance between the troughs, distance "b", is the wavelength.

Wavelength is measured in a unit called the metre. This is the unit. of length in the French, or metric, system of measures. One metre is equal to 39 37/100 inches, almost exactly 39 3/8 inches.

All radio waves travel away from the transmitter with the approximate speed of light, about 186,000 miles in a second. Changing this speed to metres, it comes out that the speed of radio waves is 299,820,000 metres in a second. In round numbers you can say that the speed of radio waves is 300,000,000 (three hundred million) metres per second.

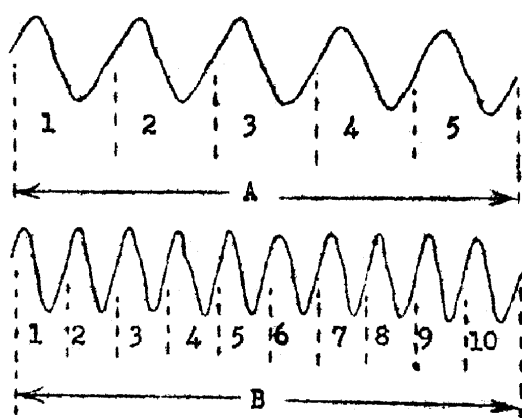

Figure 26.

Now look at Fig. 26, Within the distance "a" there are five complete waves. Within the distance "b" (which is the same length as "a") there are ten complete waves. The length of the waves at "a" is greater than the length of the waves at "b", The waves at "b" are coming from the transmitter more frequently than those at "a", consequently the frequency at "b" is greater than the frequency at "a".

From Fig. 26 you can see that the longer the waves or the greater the wavelength, the less will be the frequency.

Also the greater the frequency, the shorter the wavelength. They go opposite to one another. As one goes up the other goes down. Since the number of waves corresponding to the frequency must be contained within 300,000,000 metres (because the frequency is the number emitted in second) you can always find the length of one wave, or the wavelength, by dividing 300,000,000 by the number representing the frequency. Likewise, if you know the wavelength you can divide 300,000,000 by this wavelength and find the frequency. Of course, to get accurate figures you could use the number 299,820,000 instead of 300,000,000. If the frequency is in kilocycles (1000 cycles) you use 300,000 instead of 300,000,000.

In the earlier day of radio we always referred to the carrier wave as being of so many metres wavelength. That is no longer considered good practice. Nowadays we make it a rule to talk about frequency in place of wavelength. You can always change one to the other by performing the division as given above.

DATA SHEETS

As you progress with your radio studies there will be many kinds of information which you should have handy. This relation between frequency and wavelength is the first information you should have on hand. To save you the work of making all the divisions, the work is done for you and is given on a "Data Sheet". Frequencies are given in kilocycles, thousands of cycles. Here at the end of this lesson is the first one of these sheets. Many more will come with your future lessons. Preserve them carefully because at the end of your course they will provide you with an invaluable reference of the kind of information you use daily in your work.

DATA SHEET.

FREQUENCY AND WAVELENGTH. (broadcast Band)

Frequency In <u>Kilocycles.</u>	Wavelength In <u>Metres.</u>	Frequency In <u>Kilocycles.</u>	Wavelength In <u>Metres.</u>	Frequency In <u>Kilocycles.</u>	Wavelength In <u>Metres.</u>
1600	187.6	1230	243.8	860	348.6
1590	188.5	1220	245.8	850	352.7
1580	190.0	1210	247.8	840	356.9
1570	191.0			830	361.2
1560	192.5	1200	249.9	820	365.6
		1190	252.0	810	370.2
1550	193.5	1180	254.1		
1540	194.8	1170	256.3	800	374.8
1530	196.0	1160	258.5	790	379.6
1520	198.5			780	384.4
1510	199.0	1150	260.7	770	389.9
		1140	263.0	760	394.5
1500	199.9	1130	265.0		
1490	201.2	1120	267.7	750	399.8
1480	202.6	1110	270.1	740	405.2
1470	204.5			730	410.7
1460	205.4	1100	272.6	720	416.4
		1090	275.1	710	422.3
1450	206.8	1080	277.6		
1440	208.2	1070	280.2	700	428.3
1430	209.7	1060	282.8	690	434.5
1420	211.1			680	440.9
1410	212.6	1050	285.5	670	447.5
		1040	288.3	660	454.3
1400	214.2	1030	291.1		
1390	215.7	1020	293.9	650	461.3
1380	217.3	1010	296.9	640	468.5
1370	218.8			630	475.9
1360	220.4	1000	299.8	620	483.6
		990	302.8	610	491.5
1350	222.1	980	305.9		
1340	223.7	970	309.1	600	499.7
1330	225.4	960	312.3	590	508.2
1320	227.1			580	516.9
1310	228.9	950	315.6	570	526.0
		940	319.0	560	535.4
1300	230.6	930	322.4	550	545.1
1290	232.4	920	325.9		
1280	234.2	910	329.5		
1270	236.1				
1260	238.0	900	333.1		
		890	336.9		
1250	239.9	880	340.7		
1240	241.1	870	344.6		

All broadcast stations are given an assignment of a certain frequency in kilocycles on which to transmit their carrier wave. These frequencies are spaced 10 kilocycles apart. The above table includes all broadcast frequencies in use for regular receivers. The wavelengths given are all the result of dividing 299,820,000 by the frequency in cycles. In speaking of wavelength it is customary to mention the nearest whole number to the decimal given; thus we speak of 316 metres instead of 315.6 metres.

EXAMINATION QUESTIONS

1. Will an aerial having three parallel wires each 30 feet long, bring in signals three times as strong as a single wire 30 feet long ?
2. How far apart should you space the wires in a multiple wire aerial ?
3. What is the advantage of a doublet aerial system ?
4. Between what two wires do you connect a lightning arrester ? Explain its purpose.
5. Should a loop aerial be set broadside to or lengthwise towards a station it is desired to receive ?
6. Assuming a set to be sufficiently sensitive and selective, what limits the weakest signal which can be satisfactorily received.
7. Do you use a ground with an indoor aerial ?
8. Which collect the more static noise, a "power mains" aerial or a doublet aerial? Why ?
9. For best reception with a "4" tube set would you use an indoor or outdoor aerial? Why ?
10. Which has the greater or longer wavelength, a frequency of 780 kilocycles or one of 1110 kilocycles ? Work out these wave lengths.

Please NOTE Postal address: (AUSTRALIAN RADIO COLLEGE PTY. LTD.,)
(Box 43, Broadway, Sydney, N.S.W.)

Note: Write the lesson number before answering questions.

Write on one side of the paper only

Always write down in full the question, before you answer it.

Use sketches and diagrams wherever possible. One diagram in many cases is equivalent to pages of explanation.

Remember you learn by making mistakes; so give yourself an opportunity of having your mistakes found and corrected.

Don't hesitate to ask for further explanation on any point, we are always ready to help you.

Write your name and full address at top of paper. If you have made arrangements with the College to have your lessons returned to any particular address – state this at the top of the page.

"The Radio-T.V. Training Centre"

**E. S. & A. BANK BUILDINGS, Corner CITY RD. and BROADWAY, SYDNEY
Telephones: BA4891 and BA4892**

AUSTRALIAN RADIO AND TELEVISION COLLEGE PTY. LTD.

Telegrams "RADIOCOLLEGE" Sydney

This lesson sheet is published for the exclusive use of students of the Australian Radio and Television College Pty. Ltd. (All rights reserved)

Post Lessons to Box 43, Broadway

RADIO ENGINEERS AND SERVICEMAN'S COURSE.

LESSON NO.6

THE OPERATION OF CONDENSERS AND THEIR PART IN RADIO.

We might say in all truthfulness that every radio receiver and every transmitter is made up of four principal kinds of parts - condensers, coils, resistances and tubes. All the other parts, such as tuning dials, switches, panels and all the rest are there only because they allow you to control the operation of the receiver.

WHERE CONDENSERS ARE USED:

Possibly you think of condensers as used for tuning the receiver and do not think of these useful units as entering into many other portions of this work. Just to give you an idea of how much the average radio set depends upon its condensers, a circuit diagram of a very small and simple all-electric A.C. operated receiver is shown in Figure 1. This particular circuit is not currently used by radio receiver manufacturers but it still enjoys considerable popularity among beginner home constructors, because of its comparative simplicity. Although this circuit represents a very small type of receiver there are no less than 13 condensers used in it. From this you can judge what important parts condensers are in modern receivers, not only for tuning the receiver to the various stations, but for many other purposes as well.

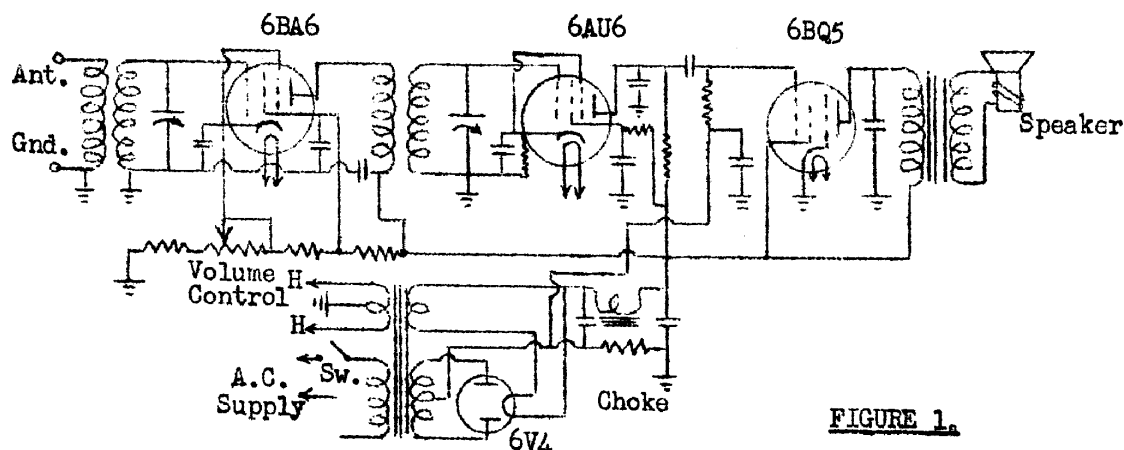

Commencing at the left hand side or aerial end of the diagram in Figure 1 we first of all have the first tuning condenser, a variable condenser of course. Between the "cathode" of the first tube, a "variable-mu" tube, and ground we have what is called a "cathode by-pass" condenser. The cathode is that part in an A.C. heater tube which takes the place of the filament in the ordinary tube which operates from an "A" battery. Then to the right of the first tube there is a condenser from the "screen-grid" of this tube to ground, and then another from the bottom of the air-core transformer primary also to ground. These are called the screen and plate by-pass condensers respectively.

Across the secondary of this air-core transformer is another variable tuning condenser. Actually this one and the one nearest the left of the circuit diagram are "ganged", or connected mechanically so that they both turn together as you move the tuning dial. All modern sets have their tuning condensers ganged in this way. The next condenser to the right is the "detector cathode bypass" condenser. Just to the right of the second tube, which is a pentode detector tube, there is a "detector screen bypass" condenser, and just above it is the "detector plate bypass" condenser - the condenser which works with the detector tube and which serves to smooth out radio frequency pulsations from the detector output.

Continuing to the right is the "coupling" or "blocking" condenser between the plate circuit of the detector and the grid circuit of the audio frequency amplifier. Below this and further to the right we have yet another bypass condenser, this one is known as the "grid decoupling" condenser. The third tube is the audio frequency amplifier, and this particular tube is called a "pentode" because it has five elements or parts in it. From the plate of this tube to ground is another condenser which is put there to improve the tone quality, and is called a "tone corrector". Right at the bottom of all you have followed so far is the "power unit" or the part which supplies all the tubes with their power from the alternating current power lines. The tube in this part of the set is called the "rectifier tube". It has two plates and a filament, and it changes the A.C. from the power or light socket into a pulsating or unsteady D.C. current to supply the plates of all the other tubes. In the bottom right hand corner of the diagram there are two more condensers. These are called "filter condensers", and their purpose is to "smooth out" or filter the uneven pulsating current from the rectifier and deliver it to all the min tubes as a steady unvarying direct current.

Remember we are going through this receiver just to show you how many different condensers are used in a modern set - don't attempt to memorise the names given or spend time studying the circuits, because we will have plenty of all that later on

KINDS OF CONDENSERS:

All condensers used in radio may be divided into two classes, variable condensers and fixed condensers. Variable condensers include all those whose capacity or condenser effect may be changed or varied while the condenser is in use. Fixed condensers include all those whose capacity is determined when they are built and in which the capacity cannot be changed afterwards.

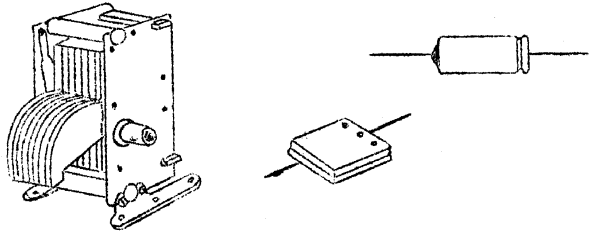

FIGURE 2.

Variable condensers, similar in a general way to the kind shown at the left in Figure 2, are used for tuning and for various other jobs where the capacity must be changed to let us secure the desired effect while the receiver is in operation.

Two kinds of fixed condensers are shown at the right hand side of Figure 2, The smaller one has mica for the dielectric between its plates and is called a mica condenser.

The larger one has paper as its dielectric and is called a paper condenser. Both these styles, mica and paper, are used quite generally throughout a receiver. The mica style is used where only a very small capacity is needed because large mica condensers are expensive and bulky. The paper style is used where more capacity is required than can be had economically in the mica type. The paper condenser contains more capacity within a given bulk or size than does the mica condenser, and the cost of paper condensers is much less than for mica condensers of the same capacity.

In this radio work you will come across a certain word quite often, especially in connection with condensers. The word is "electrostatic". It refers to anything pertaining to electricity which is not moving, to electricity at rest as you find it in a charged condenser.

When the two plates, or the two kinds of plates, in a condenser are charged we have in the dielectric or space between the plates what is called an electrostatic field. This field is indicated in Figure 3 as existing in the dielectric. The electrostatic field consists of electrostatic lines of force which are somewhat like the magnetic lines of force existing around a magnet.

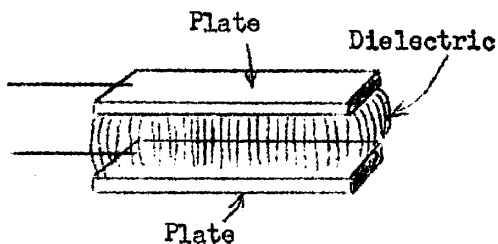

FIGURE 3.

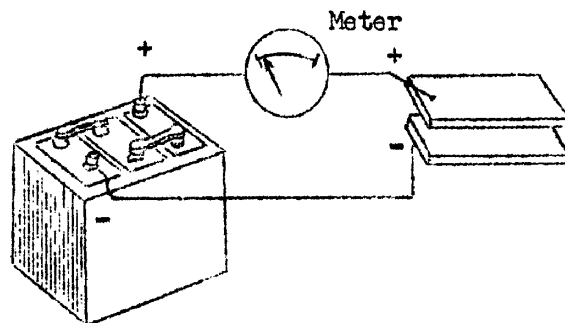

FIGURE 4.

THE CONDENSER CHARGE:

If you were to connect the two plates of a condenser to the two terminals of a battery as in Figure 4 and have in one of the wires a very sensitive ampere meter or ammeter to indicate flow of electric current, you would find that electricity did actually flow between the battery and the condenser. To understand the reason for this flow of current it is necessary to refer to that section of Lesson No. 1 dealing with Electron Theory and Atomic Structure. You will recall that all matter consists of a large quantity of individual atoms of a particular material and that each atom comprises a tiny solar system whereby the positive nucleus, the heaviest part of the atom, is surrounded by one or more planetary electrons. The planetary electrons, which are negative particles of matter, rotate about the positive nucleus in much the same fashion as planets of our own solar system rotate about the sun.

Any material which exists in solid, liquid, or gaseous form is matter and, as a consequence, will consist of innumerable atoms, each with its negative and positive charge. The dielectric material placed between the plates of a condenser is no exception. It may exist in solid (mica or paper), liquid (a special type of oil), or gaseous (air) form. When there is no difference of potential between the condenser plates, planetary electrons will rotate on a normal orbit in the manner indicated by Figure 5. For the sake of simplicity only one planetary electron is shown for each positive nucleus. In actual fact the only atom which exists in this simple form is the gas hydrogen. With any of the commonly used dielectric materials there would be several planetary electrons for each atom of the particular material.

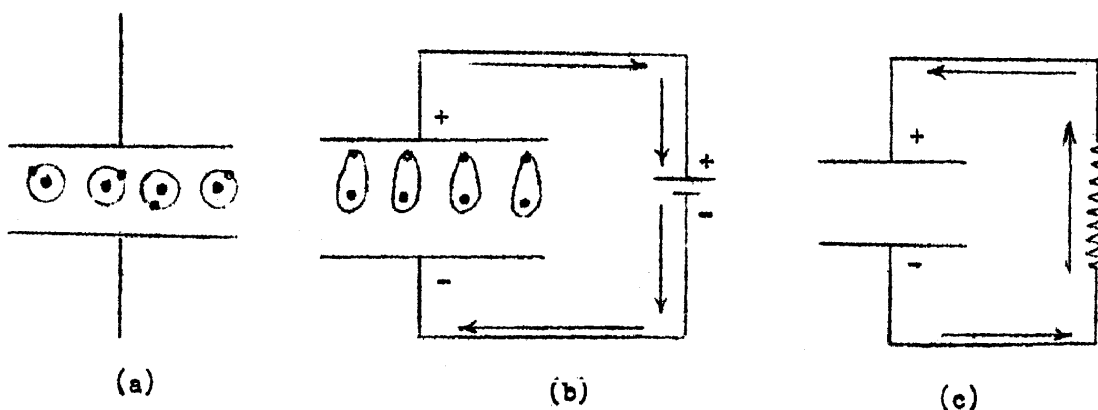

FIGURE 5.

If now the condenser plates are connected across a source of voltage so that the upper plate is connected to the positive terminal of the voltage source, and the lower plate is connected to the negative terminal, the electrons in the dielectric material atoms will try to obey the natural electrical law which states that points of unlike polarity are attracted towards each other while points of like polarity are repelled from each other. Because the dielectric material is always a very good insulator, electrons cannot move right through the material from one side to another as they can in a good conductor of electricity. Nevertheless, they will try to move through the material and in doing so will be diverted out of their normal orbits.

As a consequence of the combined effects of attraction and repulsion a condition of strain will be set up within the dielectric such that electrons are pulled towards the positive condenser plate and repelled by the negative condenser plate, while the positive nucleus will be drawn towards the negative plate and repelled by the positive plate. The effect is indicated by Figure 5(b)

Because a movement of electrons constitutes a flow of electrical current, the displacement of electrons within the dielectric material is responsible for a flow of electrical current within the dielectric. It must be clearly understood, however, that electrons do not move right through the dielectric from one plate to another and so out into the external circuit in which the condenser is connected. The flow of current continues only for as long as electrons in the dielectric are taking up their new positions. Immediately they have reached the limit of strain which is dictated by factors to be discussed later, further movement ceases and, as a consequence, displacement current in the dielectric ceases to flow.

Now there is a fundamental electrical law which states that electrical current cannot accumulate at any point in a circuit. The practical manifestation of Kirchoff's Law, as it is called, creates what, at first sight, may appear to be a contradiction of the previous statement that current does not flow right through dielectric materials from one plate of a condenser to the other. This contradiction is, however, apparent only and cannot be sustained when the operation of a condenser is carefully examined.

When a condenser is connected to a voltage source as in Figure 5(b), electrons in the upper plate of the condenser will be attracted by the positive pole of the battery and so will move around the external circuit from the upper condenser plates to the battery. On the other side of the battery, electrons are repelled by the negative battery terminals towards the lower plate of the condenser, and so will be moved around the circuit towards that point. Because the upper plate of the condenser is now deficient in electrons, it is said to have positive polarity and will cause the electrons in the dielectric material to be attracted towards it. Similarly the lower plate of a condenser, having a surplus of electrons, will be of negative polarity, and so will repel electrons in the dielectric material and, at the same time, attract the positive nucleus of dielectric material atoms. The movement of electrons around the external circuit and within the dielectric material will continue only until the dielectric atoms are strained to their limit. When this state is reached, electron movement throughout the circuit and in the dielectric will cease and the condenser is said to be charged. If the source of voltage is now removed the condenser will remain in a charged condition. With a perfect condenser stored in a completely evacuated container, the charged condition would be permanent. Because even the very best of insulating material does not have infinitely high resistance there is, inevitably, some leakage of current through the dielectric material. For similar reasons there will be some external leakage between the terminals of the condenser and the combined effect of the various leakage paths will be to slowly discharge the condenser over a period of time. Even so, a good quality condenser, in first class condition, will hold a charge for several weeks,

If the terminals of a charged condenser are connected together, either directly or through a certain value of resistance, the surplus of electrons on the negatively

charged plate will, by virtue of the external circuit be able to return to the positively charged plate and so make good its deficiency of electrons. when sufficient electrons have left the negative plate, the lower plate in Figure 5(b), to bring the number of electrons on the upper plate to their initial figure, a state of equilibrium will exist and there will now be no difference of potential between the two plates, electrons in the dielectric will no longer be under strain and so will return to their normal orbits. The condenser is then said to be discharged. The rate at which a condenser charges and discharges is dependent upon its capacity and the amount of resistance in series with it. This question of a condenser's time constant will be discussed in more detail in later lessons.

The small amount of current which flows during charge or discharge, and which quickly drops to zero, is called the displacement current or the dielectric current.

The amount of current which flows depends on four things. In the upper part of Figure 6 a small battery of low voltage is connected to the condenser plates. In the lower drawing we have a large battery of high voltage. There will be a greater flow of current with the higher voltage, the more the voltage the greater the amount of current.

In the upper part of Figure 7 we have small condenser plates and in the lower drawing we have larger plates. The larger the condenser plates the more current will flow on to them with the same voltage applied. In the upper part of Figure 8 the plates are separated by a considerable space and in the lower drawing the plates are very close together. The less the separation, the more current will flow, the size of the plates and the applied voltage remaining the same. The kind of dielectric material between the plates also has an effect on the amount of current which will flow.

Now you see that more current will flow with higher voltage, with larger plates and with less separation between the plates. Less current will flow with lower voltage, with smaller plates and with more separation between them. We are assuming that there is no change in the kind of dielectric between the plates.

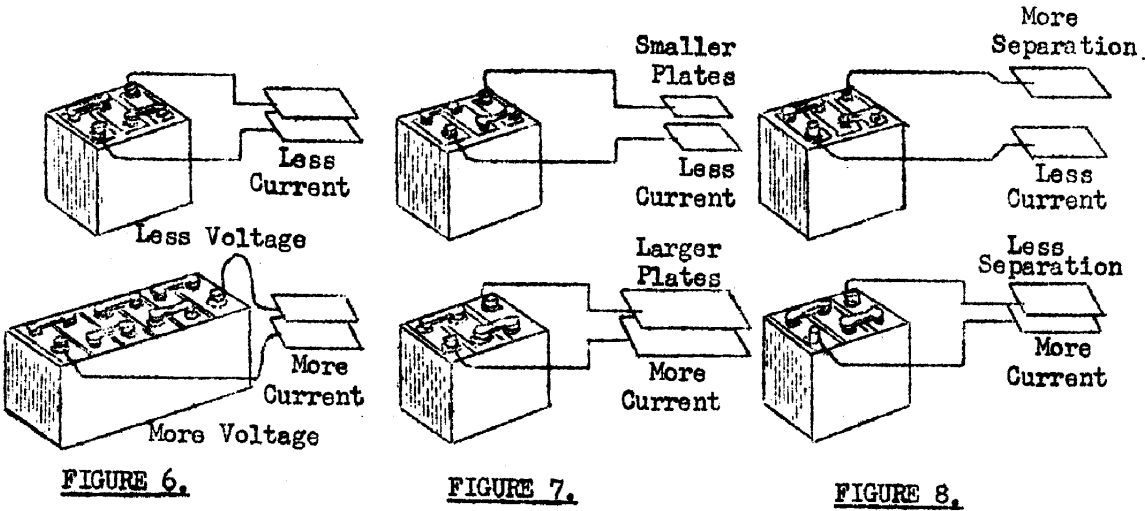

The "charge" of a condenser is the amount of electricity it will hold. The unit of measurement for condenser charge is the "COULOMB". One ampere of current flowing for a period of one second represents one coulomb of electricity. If the difference of potential between the plates of a condenser having a capacity of one farad is one volt, the condenser's charge would equal one coulomb. You now know that this amount depends on four things, but, in any given condenser, the kind of dielectric, the size of the plates and their distance apart remain the same.

In a fixed condenser these three things never change and in a variable condenser they will not change unless you move the plates. Then we can say that the amount of current flowing from the battery into the condenser depends on the voltage applied to the plates of any given condenser.

The voltage comes from outside the condenser but the other three things are within the condenser. The size of the plates. Their separation and the kind of dielectric between them all work together to determine what we call the "capacity" of the condenser. Large plates, small separation and certain kinds of dielectrics increase the capacity and make the condenser able to take a greater charge with a certain applied voltage. Small plates, great separation and other dielectrics reduce the condenser's capacity and allow it to take a smaller charge with the same applied voltage. Always remember that the applied voltage does not affect the capacity of a condenser. It affects only the condenser's charge.

MEASURES OF CAPACITY.

The capacity of a condenser is measured in a unit called the "Farad". A condenser having a capacity of one farad would be exceedingly large, entirely too large for any of our radio work. Therefore we use fractions of a farad as the practical units for speaking about condenser capacity.

One of the common units of capacity is the microfarad. Micro means the one millionth part of, so a microfarad is the one millionth part of a farad. This is the unit generally used in speaking of fixed condensers of the paper dielectric type. For tuning condensers and for the small mica dielectric condensers we need a still smaller unit in many cases, so we use the micro-microfarad. As you would guess, this means the millionth part of the millionth part of a farad, or, the one millionth part of a microfarad. Some time ago the prefix "pico" was adopted in Continental countries as a substitute for micro-micro. This practice has now spread to other parts of the world including Australia, so that it is customary now to refer to a small capacity condenser, say 0.0005 microfarad, as 500 picofarads rather than 500 micromicrofarads.

The tuning condenser at the left hand side of Figure 2 would probably have a capacity of about 420 micro-microfarads. The small mica condenser in the centre of that illustration might have a capacity of about 1000 micro-microfarads. The paper condenser at the right hand side of Figure 2 probably would have a capacity of one tenth or one half microfarad. There are still other measures of capacity, but none of them are used in practical radio work.

KINDS OF DIELECTRIC:

Three kinds of dielectric have already been mentioned - air, mica and paper. Air is the dielectric used in tuning condensers. It is also the dielectric for the aerial, which you will remember is a large condenser.

There is only one thing used as a dielectric with which a condenser will have less capacity than with air between the plates. That thing is a vacuum or the absence of air. All other materials used as a dielectric increase the condenser's capacity.

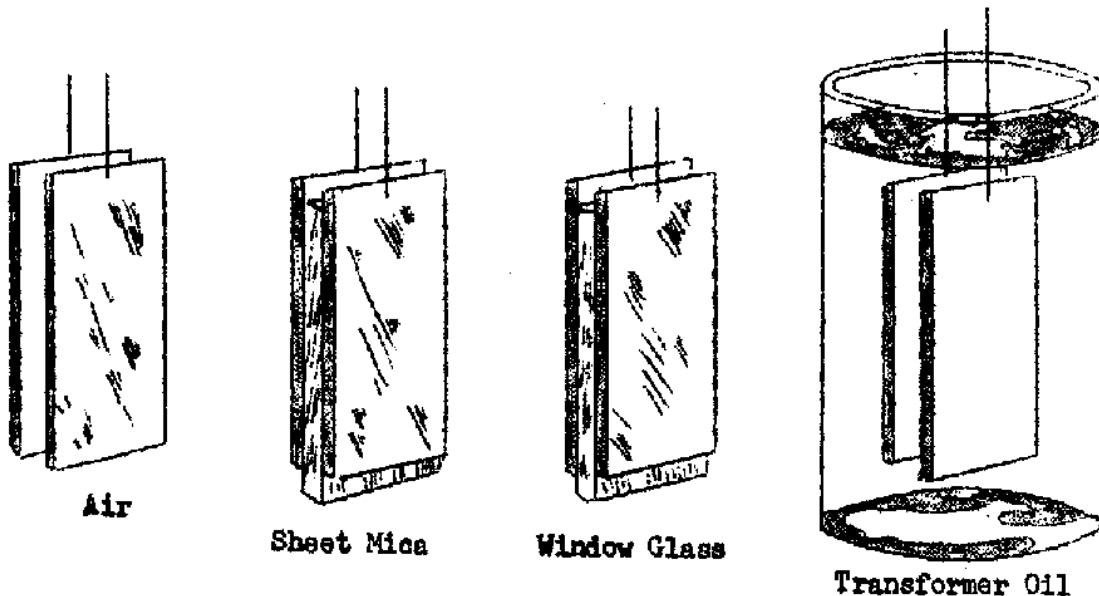

FIGURE 9.

The very interesting experiment illustrated in Figure 9 might be performed with various dielectric materials. We will assume that the condenser plates shown at the left are found to have a capacity of 2 micro-micro-farads when the dielectric between the plates is air. Were you to use mica for the dielectric, filling the space between the plates with this mineral substance, and were you to then measure the capacity you would find it somewhere around 10 micro-micro-farads. That word micro-microfarad is a long one, so we abbreviate it to "mmfd", or even "mmf". The abbreviation for picofarad is "pf".

Then to continue the experiment, supposing you removed the mica and substituted a piece of window glass. Measuring the capacity again, you would find it to be about 15 mmfds. You might even make a test with liquids by immersing the condenser plates. Should you use the kind of oil used for large power transformers you would find the capacity of your condenser to be about 5 mmfds.

You find that various kinds of dielectric materials multiply the capacity of the condenser by certain amounts as compared with its capacity when air is the dielectric. The number by which the capacity is multiplied is called the "dielectric constant" of the material. For example, you found that the capacity of the condenser in Figure 9 was increased from 2 mmfds, with air to 10 mmfds. with mica for the dielectric. Therefore the dielectric constant of the mica is 5, because 2 is multiplied by 5 to get 10.

Similarly, the dielectric constant of the glass is $7\frac{1}{2}$ because the original capacity, 2, is multiplied by $7\frac{1}{2}$ to give 15, the capacity with glass as dielectric.

This property of dielectrics by which they increase the capacity of a condenser allows us to make very small condensers with quite large capacities. The dielectric constant of paper used in fixed condensers is about $2\frac{1}{2}$. This paper can be had in very thin sheets, one-half thousandth of an inch being a commonly used thickness. Consequently, the condenser plates can come very close together - and you know that bringing the plates near each other increases the capacity. So we have plenty of capacity in small space due to the small separation between plates and to the multiplying action of the paper. The same effects are secured with mica, but since the dielectric constant of the mica is even greater than that of paper, the capacity of the mica condenser is still higher. However, mica cannot be made as thin as paper, so it would require a large condenser to get a capacity of say, one microfarad, in a mica condenser.

HOW ALTERNATING CURRENT EFFECT PASSES THROUGH A CONDENSER:

All through these lessons you have been told that the effects of alternating current will pass right through a condenser. Since the dielectric is an insulator and since you know that electricity cannot continue to flow through an insulator, or for that matter can hardly flow through an insulator at all, you must wonder how alternating current performs this apparently impossible thing.

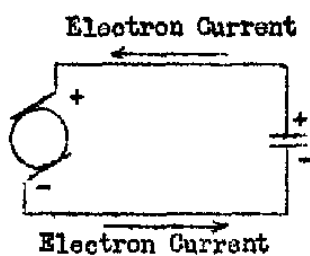

FIGURE 10.

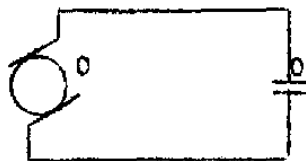

FIGURE 11.

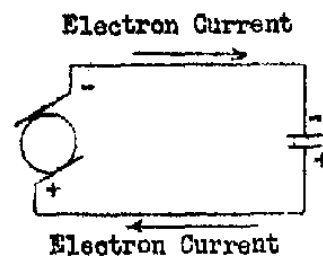

FIGURE 12.

To begin with, look at the diagrams in Figures 10, 11 and 12. Here we have a condenser connected to an alternating current generator. In Figure 10 the generator polarity is such that the upper brush is positive. As a consequence, electrons will be attracted away from the upper condenser plate towards the positive terminal of the generator. At the same time, electrons are moving from the lower brush, which is negative, on to the lower plate of the condenser. In other words, the generator is charging the condenser in such a manner that the top plate of the condenser is positive and the bottom plate negative.

As the generator continues to run, the potential difference between its terminals drops to zero as shown in Figure 11. That's the way alternating current acts,

first rising to its highest voltage in one direction, then falling to zero, and immediately afterward rising again to its highest voltage but in the opposite direction.

As the potential difference increases in the other direction, the conditions will be as in Figure 12. Now the generator polarity has been reversed. The upper brush is negative while the lower brush is positive. The movement of electrons will, therefore, be in an opposite direction to that shown by Figure 10. Electrons will flow from the lower plate of the condenser to the positive terminal of the generator and from the negative terminal of the generator to the upper plate of the condenser. Once again the condenser will be charged but with an opposite polarity to that indicated by Figure 10.

No current actually flows right on through the dielectric of the condenser. First the top plate receives a charge, then the bottom plate receives a charge. The current alternates back and forth in the wires, first flowing one way as the condenser is charged one way, then reversing and flowing the other way as the condenser's charge is reversed. So alternating current flows in this circuit containing a condenser just as it would flow in a circuit composed entirely of conductors. Of course, not as much current can flow with the condenser in the circuit as though it were replaced with solid wires, but a certain amount of current actually alternates back and forth. The amount of current that can flow in this circuit containing the condenser depends on the size or capacity of the condenser.

Now you can see how alternating current acts through a condenser. The condenser plates simply charge and discharge, first in one direction, then in the other and the current alternates back and forth in the wires included in the circuit.

HOW THE DIELECTRIC WORKS:

The action of a condenser can be made still clearer to you by going back to our old friend the water, and using another analogy or comparison of actions in water and electricity.

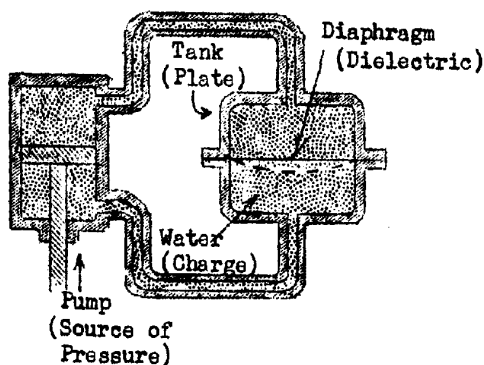

FIGURE 13.

In Figure 13 you will see a water pump connected to a tank which is divided into two parts by a diaphragm or partition across it. The pump, the pipes, and the tank are filled with water. The diaphragm is made of thin, flexible rubber.

The two parts of the tank correspond to the two plates of a condenser. The diaphragm corresponds to the dielectric. The two pipes correspond to two wires. The water corresponds to the electricity.

to revert to the older conventional idea of electrical current flowing from a point of high or positive potential to a point of low or negative potential. Now let us see what happens when the pump is set into operation.

As the Pump's piston is pushed upward, in the direction of the arrow along the piston rod, water will be forced over through the upper pipe into the upper part of the tank. The diaphragm stretches downward just as it is shown in the broken lines. The top tank becomes charged with more water and the water in that tank is under increased pressure. The diaphragm is placed under strain by this action.

In a condenser the top plate would be charged with an excess of electricity, the electricity would be under increased electrical pressure, or voltage, and the dielectric of the condenser would be placed under an electrical strain.

On the reverse motion of the pump plunger or piston the action in the tanks would be reversed. Water would flow out of the top tank and into the lower tank. The diaphragm would then be stretched in the other direction and the water in the lower tank would be under increased pressure. Similar things happen in the condenser. The lower plate accumulates an excess of electricity, and the dielectric is again placed under a strain.

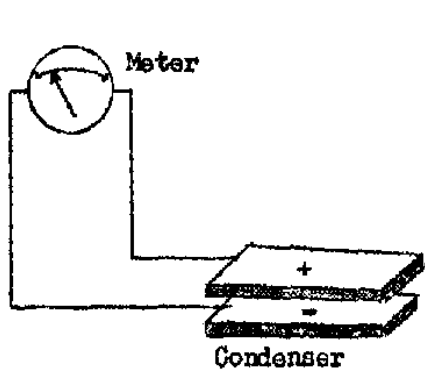

FIGURE 14.

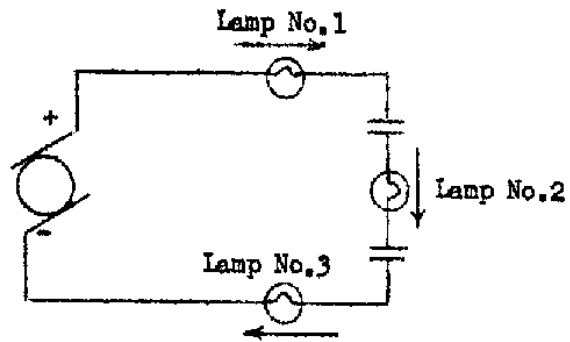

FIGURE 15.

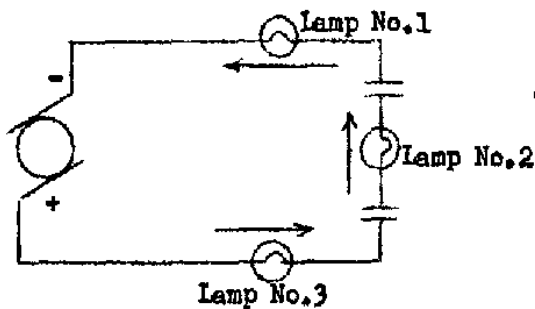

FIGURE 16.

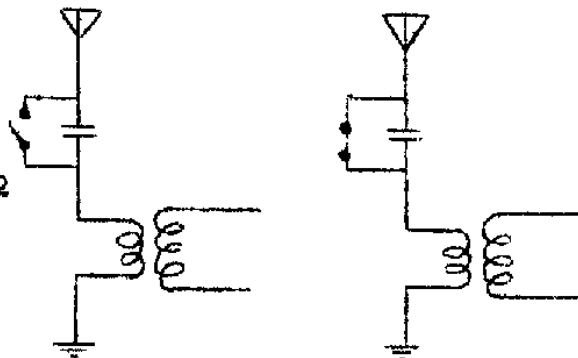

FIGURE 17.

Supposing with the diaphragm in the strained position of Figure 13 you were to release the pump piston - what would happen? The diaphragm would force water out of the tank and would draw water into the lower part of the tank. The tension or strain of the rubber in the diaphragm would do that. As the diaphragm came to the straight across position (shown in full lines) it would no longer be under strain, no more pressure would be exerted on the water in the top tank and there would be no further flow or water in the piping. Exactly similar actions take place in a condenser. With the condenser charged, one of its plates is at higher electrical pressure than the other plate. The dielectric is placed under electrical strain. If the two plates are connected together through a wire as in Figure 14, an electric meter in the wire or circuit would show a current to be flowing for an instant following the connection. As the voltage difference between the plates dropped to zero, or as the condenser became discharged, the flow of current would stop.

To make sure that you clearly understand the manner in which alternating current will act in a circuit containing condensers, let us take two condensers and three lamps or meters and connect them to an alternating voltage generator or power mains as shown in Figure 15. This is called a "series" circuit, because any alternating current acting in the circuit will have to act through each of the parts in turn before getting back to the second terminal of the generator. The lamps by lighting, or the meters by the movement of their needles, will tell us when current is passing.

When the upper brush of the generator is becoming positive, current will flow across through lamp No.1 and into the top plate of the upper condenser. When examining Figure 13, you saw that water, pumped into the upper part of the tank would strain the diaphragm downwards so that an exactly equal amount of water is pushed out of the lower section of the tank to go on around the pipes.

Exactly the same thing happens with the upper condenser in Figure 15. The current flowing into the top plate produces a strain in the dielectric and this causes an exactly equal current of electricity to go on, out of the bottom plate, through lamp No. 2, and into the top plate of the lower condenser. Here the same action again occurs. The dielectric in the lower condenser is strained and forces an equal current to go on, through lamp No.3 back to the negative terminal of the generator.

When the generator's voltage reverses, as shown in Figure 16, the current will simply act in the opposite direction, as shown by the arrows. As the generator produces alternating voltage, the current will act in the direction shown by Figure 15, for a tiny fraction of a second and will then reverse and flow in the direction shown in Figure 16, for a similar period and will then repeat over and over again, flowing firstly one way and then the other with each cycle of alternating voltage.

As the current is just as strong in any one part of the circuit as at any other part, the three lamps would light just as brightly as one another or three meters, if used, would all give the same reading as one another. Naturally, because of the opposition of three lamps and two condensers, a rather high voltage will be necessary to make enough current flow to light the lamps. The larger the capacity of the condensers, the greater the amount of current which can act through them and the lower will be the voltage needed to make any lamps light. The flow of current in Figures 15 and 16 can, of course, be readily modified to conform to the modern conception of electron movement from negative to positive. You will find it good practice to do this. It will help you to develop flexibility of thought.

AERIAL CONDENSER:

In some simple receivers there is included between the aerial terminal and the aerial coil a small condenser, often having a switch to cut it out of the circuit if desired, as in Figure 17. Placing a condenser between the aerial and the receiver has a very peculiar effect. As far as all electrical circuits are concerned, such a condenser shortens the aerial. You learned that a short aerial brings in less energy, makes the reception clearer and makes the receiver more selective, better able to pick out one station without interference from others. The aerial condenser does exactly the same thing. It allows less power to come to the set, but makes for clearer reception and greater selectivity.

The less the capacity of the aerial condenser, or the smaller this condenser, the greater will be its effect in shortening the aerial system and the more selective the receiver will be. The larger this condenser or the greater its capacity, the less effect it will have.

The purpose of the switch around the condenser is to prevent the condenser from having any effect at all on the reception while the switch is closed. At the left hand side of Figure, 17 the aerial condenser is shown with the switch open. Then the radio currents have to pass through the condenser on their way into the receiver.

At the right hand side of Figure 17 the switch is shown closed. Now it is so much easier for the radio currents to flow through the metal of the switch that practically none of them flow through the condenser, and it is just as though you had a continuous metal path or a wire between the aerial and the coil in the receiver. We say that the condenser is "shorted out" by the switch because the switch provides a path that is easier to follow, or "shorted", from the electrical standpoint.

Now let us see just what this aerial condenser really amounts to. The left hand drawing in Figure 18 shows the aerial, the aerial condenser "C", the first coil in the receiver, and the ground. The centre drawing illustrates the fact that the aerial and ground are really the plates of a big condenser. The right hand drawing shows aerial-ground condenser marked "A-G" and the aerial condenser "C" both in the one electrical circuit or line. So here we really have two condensers connected in "series".

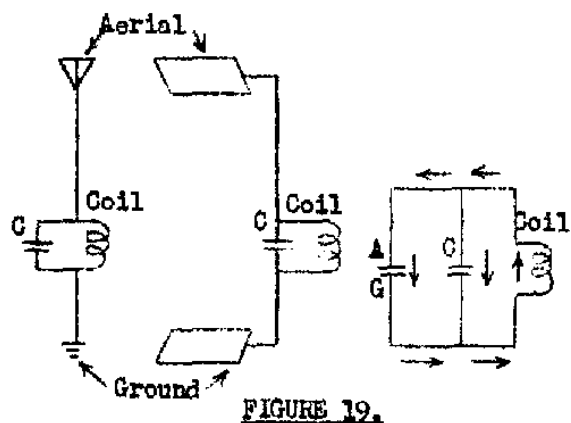
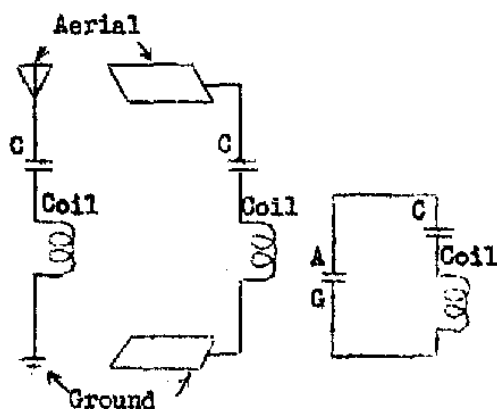

SERIES CIRCUITS:

A series connection is a connection or circuit in which all current passing through any one part in the connection or circuit must also pass through every other part in the circuit. At the right hand side of Figure 18 you can see that every bit of current passing through one of the condensers must also pass through the other one and through the coil as well. Therefore, this is a series circuit.

The total capacity or the combined capacity effect of two condensers connected in series is to make the capacity of the combination less than the capacity of either one or the condensers taken alone. Remember this fact; it is very important in radio work. Remember that you can reduce the capacity of a circuit by placing more condensers in series with the other condensers already there.

PARALLEL CIRCUITS:

Connecting the aerial condenser in series with the aerial, as in Figure 18, has the effect of lessening the capacity of the whole aerial system. There is another kind of connection by means of which we can increase the capacity of the aerial system. This other connection is called a parallel connection or parallel circuit.

At the left hand side of Figure 19 is shown an aerial condenser "C" connected in parallel. The centre drawing shows how the aerial and ground "plates" would appear with the aerial condenser. Over at the right the aerial and ground are shown as a small condenser "A-G" and the aerial condenser "C" connected in parallel with it.

A parallel circuit is a connection of parts made in such a way That current will divide between them, part of the whole current of the circuit flowing through each of the parts connected in parallel. Supposing the circuit at the right hand side of Figure 19 was an oscillatory circuit, like the ones explained in the earlier lessons. Current starting out from the coil would flow through both condensers, following the paths shown by the arrows. Part of the current will flow through condenser "C" and the rest will flow through condenser "A-G". Also, if these condensers were charged, the currents which they would give forth upon discharge would combine or join together and then flow through the coil. Remember that with parallel connections, the current will divide or will combine, part going to or coming from each of the parts in the parallel circuit.

EFFECT OF AERIAL CONDENSER IN PARALLEL:

The effect of the aerial condenser connected in parallel, as in Figure 19, is quite different from the effect of the same condenser connected in series. Connection of the condenser in parallel acts to lengthen the aerial system (electrically).

This effective lengthening of the aerial does not make any material change in the amount of power brought in, or in the clearness of reception or in the selectivity of the receiver. What the parallel condenser does actually do is to change the tuning of the aerial circuit. The circuit with this condenser in it will be resonant or will tune at a different frequency than were this condenser omitted.

Parallel aerial condensers are not used on ordinary present-day receivers used for ordinary broadcast reception.



FIGURE 21.

You have learned that when condensers are connected in series, the combined capacity is less than either of the condensers alone; also that when connected in parallel the combined capacity of two or more condensers is greater than either alone. But just how much is the capacity increased or decreased.

CONDENSERS IN PARALLEL:

You know that the capacity of a condenser increases as you increase the area of the plates - twice as much plate area gives twice as much capacity. When you connect two or more condensers in parallel as at the left in Figure 20, you are really adding the areas of all the top plates together, and also adding all the bottom plates together. This gives a plate area equal to all the separate areas added together, as shown at the right in Figure 20. Therefore, the combined capacity will also be equal to all the separate capacities added together, as also shown in Figure 20. So now you have a simple rule to remember - "To find the combined capacity of a number of condensers in parallel, add all the separate capacities together".

CONDENSERS IN SERIES:

The thicker the dielectric of a condenser, other things remaining the same, the less will be the capacity - twice the thickness or twice the distance between the plates will give half the capacity. Supposing you had two condensers, both the same size and both having one-eighth inch spacing between plates, connected to the top plate of the bottom condenser, and these two plates are then the same thing electrically. The bottom of the top dielectric is in electrical contact with the top of the bottom dielectric, and the result is that there is really one-quarter inch or twice the thickness of dielectric between the two connections "A" and "B", as shown at the right of Figure 21.



FIGURE 21.

The dielectric being twice as thick, any voltage on one plate will have less effect on the other plate and the capacity will only be half as much; that is, if the two condensers were 1 mfd. each, the combined capacity would be $\frac{1}{2}$ mfd. Then to find the combined capacity of two or more equal condensers or capacities in series, divide the capacity of one condenser by the number connected in series. Thus, if four 8 mfd. condensers were connected in series, the combined capacity would be 8 divided by 4, or 2 mfd.

For unequal condensers in series, the exact amount of combined capacity is not so easy to calculate. We will deal with this in a later lesson, but for the present remember that when condensers are connected in parallel, the combined capacity is greater than the greatest single capacity; but when connected in series, the combined capacity is always less than the smallest single capacity of the combination.

ELECTROLYTIC CONDENSERS:

Previously it was stated that mica was used as a dielectric only in condensers of very small capacity and that when we want a larger capacity than can conveniently be obtained with mica dielectric we use paper. Now there is also a limit to the maximum capacity available within reasonable physical dimensions when using paper as a dielectric.

A paper dielectric condenser having a capacity greater than about 1 microfarad tends towards bulkiness and also becomes very costly. When we consider that a modern receiver operated from A.C. or D.C. power mains may use condensers of up to 32 mfd. capacity while the vibrator power supply unit employed with many radios operating in country districts may incorporate filter condensers having capacities up to 500 micro-farads, the provision of condensers having the required capacity seems to present a first class problem. However, our difficulties are easily overcome by the electrolytic condenser.

Whereas the condensers with which we have so far dealt consist of two metal plates separated by a dielectric The electrolytic type has one plate of metal called the anode, while the other plate is a liquid or semi-liquid called the electrolyte. dielectric is a thin oxide film formed on the surface of the anode.

In one form of construction, the anode, which is a rod or cylinder, sometimes pleated, of chemically pure aluminium, is placed centrally in an aluminium can, while the space between the anode and can is filled with the liquid electrolyte. The anode is insulated from the can by means of a rubber bushing. The protruding end of the anode serves as one terminal of The condenser while the other connection is made to the metal can.

The principal reason why we are able to obtain large capacity within a comparatively small physical space with this type of condenser is the extreme thinness of the dielectric. You will remember that one of the factors governing the capacity of a condenser is the distance between the plates, and that the smaller the spacing between plates, the greater will be the capacity.

Because the oxide film which is formed on the surface of the anode during manufacture is so very thin there is very little space between the plates of the condenser and so we have increased capacity without undue increase in the physical size of the condenser.

All electrolytic condensers do not use a free liquid as the second plate. Some of them have the electrolyte suspended in an absorbent material such as linen or blotting paper. Although this latter type is sometimes called a dry electrolytic, the term "dry" is in this case, purely comparative. The liquid electrolyte is there, even though it is not free to move about.

Another very great advantage which the electrolytic condenser has over those using a mica or paper dielectric is its ability to withstand slight overload without suffering permanent damage. All condensers when they are made are rated to withstand a certain maximum voltage between the plates. You may have noticed condensers bearing the figures "400 volts working" after the capacity. This indicates that the maximum voltage which can be continuously applied to the plates is 400 volts. If this voltage is exceeded for any length of time the dielectric will break down and the condenser plates will be short circuited.

In the case of mica or paper dielectric condensers a breakdown of this nature is permanent and the condenser is of no further use. However, if a condenser of the electrolytic type is overloaded, provided that the overload is not too great, no permanent damage will result. If the cause of the overload is removed and the condenser is allowed to operate at a voltage below the normal working figure for a short period, the punctured dielectric will heal and the condenser will be as good as ever.

Unlike ordinary condensers, employing mica or waxed paper as the dielectric, electrolytic condensers must only be connected in a circuit in which direct voltage is present and the connections must be such that the anode is connected to the positive side of the circuit whilst the electrolyte is connected to the negative side, consequently in testing electrolytic condensers, care must be taken to see that the testing voltage is applied correctly, if misleading indications are to be avoided. Assuming that a battery is being used for testing an electrolytic condenser, the positive terminal of the battery should be connected to the anode of the condenser while the negative terminal of the battery should be connected to the electrolyte. In the case of the "wet" type of condenser the anode connection protrudes through the centre of the end of the can, while connection to the electrolyte is made via the can itself. With electrolytic condensers of the semi-dry type two leads are usually provided for connection to the plates. It is normal to have a red lead connecting to the anode while a lead of some other colour, usually black, connects with the electrolyte. Alternatively, one end of the container may be coloured red to indicate the positive connection, whilst the other end is uncoloured or coloured black.

A final point may be mentioned in regard to the wet electrolytic condenser and that is the necessity for always mounting in an upright position. When in operation, a certain amount of gas is generated in the condenser which normally escapes through a rubber covered vent in the top of the can. If the condenser is mounted in such a position that this vent is covered by the electrolyte, the pressure of gas set up within the can will force some of the liquid from it and the useful life of the condenser will be greatly reduced. Because of the fact that the electrolyte in the semi-dry type of condenser is not a true liquid such precaution is not necessary when using these. Care must always be taken with both types of condenser to ensure that they are not subjected to excessive heat. If they are mounted in close proximity to components which normally radiate a great deal of heat, such as rectifying valves, power transformers and so on, the life of the condenser will again be greatly reduced due to excessive evaporation of the electrolyte.

The appearance of both wet and "dry" type electrolytic condensers is shown in Figure 22.

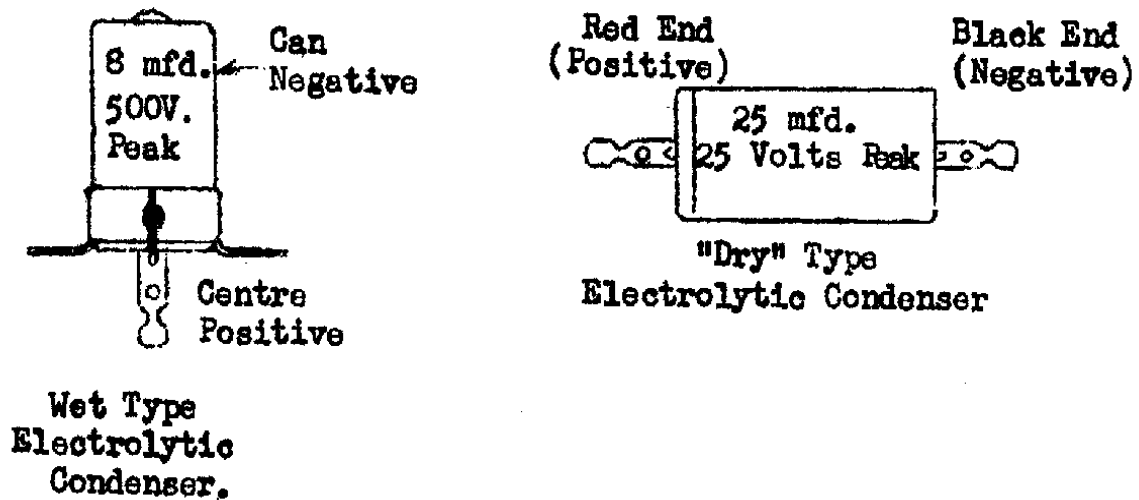

FIGURE 22.

CHECKING UP ON YOUR PROGRESS

Let Us see what you have accomplished in this lesson. You learned that condensers of one kind or another are used all over the set and also in the power unit. Those condensers include those with air as the dielectric, others with mica dielectric and still others using paper. Then you found that the capacity of a condenser is affected by three things:

- (1) the size of the plates,
- (2) the distance between the plates, and
- (3) the dielectric constant of the material between the plates.

You also learned that the amount of electricity or amount of charge taken by a condenser depends on the condenser's capacity and on the voltage applied. The farad is the unit in which capacity is measured, but for radio work we make our measurements in microfarads (mfd.) and in micro-microfarads (mmfds).

One of the most interesting things you have learned from this lesson is that certain kinds of dielectric increase or multiply the condenser's capacity several times over. You found out how it is that alternating current flows in a circuit even when a condenser is in the circuit. Also, during your investigations of aerial condensers you learned about series and parallel connections of condensers. Finally, you have been given some preliminary details of electrolytic condensers.

You have certainly covered a lot of ground - plenty for one lesson. Before you answer the examination questions, you should go right back to the beginning and read these pages over once more. You will be astonished at how much easier it will be for you to understand the action of condensers during that second reading.

EXAMINATION QUESTIONS – No. 6.

- (1) Does electric current flow right through the dielectric or a condenser, from one plate to the other ?
- (2) To increase the capacity of a condenser would you use larger or smaller plates ?
- (3) Will bringing condenser plates closer together make the capacity greater or smaller ?
- (4) Does the voltage applied to a condenser affect its capacity ? Explain.
- (5) In what two units do we measure the capacity of radio condensers ? Show their relationship.
- (6) If a certain condenser with air as its dielectric has a capacity of 30 micro microfarads, what will be its capacity with a dielectric of mica having a dielectric constant of 6 ?
- (7) Is mica used as the dielectric in radio condensers of large or of small capacity ? Why?
- (8) Which will allow more alternating current to flow, a condenser of small capacity or one of large capacity ?
- (9) To make an aerial electrically shorter, would you use a condenser in series or in parallel with it ? Why ?
- (10) If you wanted to get a capacity of 2 microfarads by using a number of 8 mfd. condensers, show how you would connect them.

(AUSTRALIAN RADIO & TELEVISION COLLEGE PTY. LTD
Please NOTE Postal Address: (Box 43, Broadway, Sydney. N.S.W.)

NOTE: Write the lesson number before answering the questions.

Write on one side of the paper only.

Always write down in full the question before you answer it.

Use sketches and diagrams wherever possible. One diagram in many cases is equivalent to pages of explanation.

Remember that you learn by making mistakes; so give yourself an opportunity of having your mistakes found and corrected.

Don't hesitate to ask for further explanation on a point, we are always ready to help you.

Write your name and full address at top of paper. If you have made arrangements with the College to have your lessons returned to any particular address -state this at the top of the page.

“The Radio-T.V. Training Centre”

**E. S. & A. BANK BUILDINGS, Corner CITY RD. and BROADWAY, SYDNEY
Telephones: BA4891 and BA4892**

AUSTRALIAN RADIO AND TELEVISION COLLEGE PTY. LTD.

Telegrams “RADIOCOLLEGE” Sydney

This lesson sheet is published for the exclusive use of students of the Australian Radio and Television College Pty. Ltd. (All rights reserved)

Post Lessons to Box 43, Broadway

LESSON NO.7

RADIO CIRCUIT TROUBLES AND HOW TO CORRECT THEM.

In this lesson we are on the trail of trouble. We are going to find out what goes wrong in electric circuits. A circuit is the path through which the electricity flows in getting to and passing through all the different parts we use. Radio circuits are made up of coils, condensers, resistances and the wires or other metal parts which connect THEM together.

All radio circuits are what we call “closed circuits”, or at least they are closed circuits as long as they are working correctly. A closed circuit is a pathway through which it is possible for either direct current or alternating current to flow from the source of voltage around through any parts contained in the circuit, and then back again to the voltage source. If the pathway is not complete all the way around we have an open circuit, and, unless it is opened, on purpose, an open circuit means trouble.

A closed circuit for direct current is illustrated in Figure 1. Here we have a battery furnishing current for the filament of a radio tube and a switch in one of the lines between the battery and the tube. Electrons will flow from one terminal of the battery over to the tube, through the tube's filament, to the switch, through the switch, and then back to the other terminal of the battery.

The current then passes through the battery itself, and once more comes out of the left-hand terminal.

This circuit of Figure may be opened by opening or turning off the switch; it might also be opened by one of the wires becoming disconnected, or breaking, by one of the terminals breaking, by a wire breaking or by the tube's filament burning out. Should this circuit be opened at any point, not a bit of current would flow in any part or it, The conductors would be full of electricity, but it could not get across the break or open place, and consequently could not move or flow.

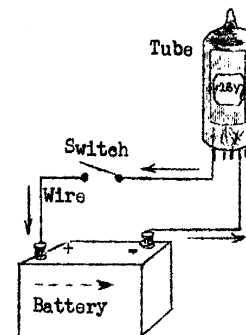

FIGURE 1.

Never forget that it takes but one open place in a circuit to put the whole circuit out of business, and that an open between the tube pin and the negative battery terminal will be just as effective in stopping any current from flowing as an open at any other point.

In the full lines of Figure 2 you have a closed circuit *for* alternating current. Of course any circuit which will carry direct current will also carry alternating current, but here in Figure 2 we have a circuit containing a condenser which would stop the flow of direct current. However, as you know, a condenser allows alternating current to flow in its circuit. This particular circuit carries audio frequency currents between the radio tube, the loud-speaker and power unit.

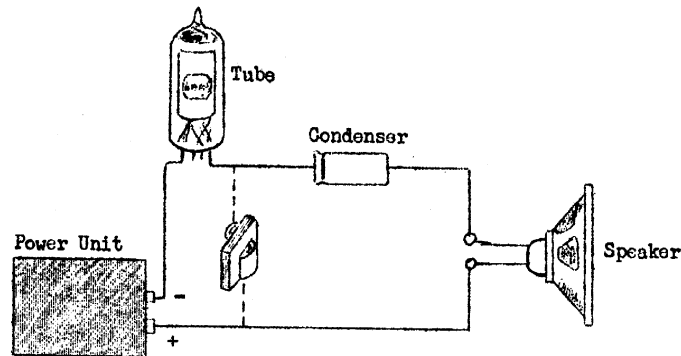

FIGURE 2.

Suppose the audio frequency current at some one instant is flowing out from the bottom terminal on the power unit. It passes into and through the speaker, acts through the condenser, and then goes to the "plate" in the tube. The current then passes across the space between the tube's plate and its filament, enters the filament and goes back into the power unit. This is a closed circuit for alternating current because alternating current can act through every portion of it. It is, at the same time, an open circuit for direct current because direct current cannot get through the dielectric of the condenser. As the direct current for the plate of the tube cannot pass through the dielectric of the condenser, we must provide another path so that the D.C. can flow from the power unit to the plate to enable the tube to operate correctly. The path for D.C. is provided by connecting an iron cored coil called a "choke" between the + terminal of the power unit and the plate of the valve as shown in broken lines in Figure 2. The D.C. will then flow in the plate circuit, which comprises the power unit, cathode-plate path within the valve and the choke, while the alternating signals act through the condenser and speaker.

ELECTROMOTIVE FORCE.

The thing that causes current to flow is called electromotive force. Voltage is electromotive force, and this force is measured by the unit called the volt.

You recall that in the very first lesson you were told that voltages mean electric pressure and nothing else. The abbreviation for electromotive force is “e.m.f.”

Electromotive force is produced by batteries, which change chemical energy into electrical energy or e.m.f. This force is also produced by generators which change mechanical energy or motion into e.m.f. There is a third method in which heat energy is changed to electrical energy. This method was used in motor vehicle radio receiver some years ago. The unit employed was called a “genemotor”.

ELECTRIC CURRENT.

When electromotive force or voltage is applied to a circuit, the electrons in the circuit will move, and these moving electrons are, in effect, an electric current. Now this fact is of great importance. A flow of electric current is brought about by a movement of electrons from one point to another in an electrical circuit. The one is, in fact, equivalent to the other. Many people find this difficult to grasp, primarily because of the unfortunate assumption, a long time ago, that an electric current flowed from a point of positive potential to a point of negative potential, an assumption accepted as fact because, at that time, little was known about electricity beyond the appreciation that it did certain things in a certain way. This assumption, or convention, had become so firmly entrenched by the time Professor Thomson published his, now proven, Electron Theory of matter, that the two ideas tended to exist for quite a long time with individual identities. They have, in fact, persisted to the present day, which is probably why so many students, while adopting a movement of electrons from negative to positive, cannot rid their minds of the belief that the resulting flow of electric current is a related but entirely separate phenomena which acts in an opposite direction - from positive to negative. So long as you remember that the older conception of current flow is merely a convention and cannot be separated from electron movement, there is no particular reason why you should completely avoid thinking in terms of conventional current flow. This conception is not incompatible with theories explaining the operation of radio and electrical equipment, but in this lesson we will concentrate on electron flow from negative to positive in order to get you used to the idea.

In the first lesson you learned that current flow is measured in a unit called the “ampere” and that the number of “amperes” indicates nothing except the flow or the rate at which electricity moves through a circuit. Remember, amperes do not measure the pressure nor do they measure the total quantity of electricity; they measure only the amount of electricity going past a given point in a given length of time.

In terms of electron movement, 6.28×10^{18} electrons passing a given point in a circuit in a period of 1 second represents current flowing at a rate of 1 ampere per second.

POLARITY.

Electrical polarity tells us whether one part of a component or a complete circuit is positive or, negative in relation to another part of such component or circuit. While it has become customary to relate polarity to pressure and infer that a point which is of positive polarity is at a pressure higher than that of the earth, and that a point which is of negative polarity is at a pressure lower than that of the earth, we must

be careful not to take the inference too far. It is true only if neither side of the component or circuit we are considering is connected to earth or ground. When such condition applies we regard the earth as being "neutral", or without polarity. There are two kinds of polarity, positive and negative. Positive polarity is indicated by the plus sign (+) and negative polarity is indicated by the minus sign (-). Terminals which are positive are often coloured red and those which are negative are often coloured black or green.

Take the batteries in Figure 3, all of which are used in radio. The storage battery is often used for furnishing filament current to the tubes. It has two terminals, one positive and the other negative. The dry cell is also used for filament supply in small sets using very small tubes. The dry cell terminals are not always marked, but the centre terminal is always positive and the outside terminal is always negative. To furnish current for the plate circuits of the tubes we often use what is called a "B-battery", made up of a number of small dry cells inside a case. Such a battery may have only two terminals, one positive and the other negative, but it often will have one negative terminal and several positive terminals, the different positive terminals being of different voltage, some higher than the others.

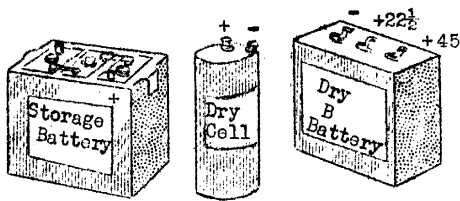

FIGURE 3.

The polarity of direct current remains constant. If, for instance, a potential difference of 6 volts exists across a D.C. circuit, side "a" of the circuit has positive polarity while side "b" has negative polarity, this particular polarity will exist for as long as voltage is applied to the circuit. Even though we may reduce the voltage to 3 volts or increase it to 9 volts, there will be no change in polarity, part "a" of the circuit will still be positive and part "b" will still be negative.

With alternating current we cannot have polarity in the same sense that it exists in direct current circuits. This does not mean that alternating current has no polarity but only that its polarity is periodically changing. At one instant of time one side of a circuit may be positive while the other side will be negative, while at a later instant of time polarity will be reversed. The point in the circuit which was previously positive will now be negative and the point which was previously negative will now be positive. These reversals of polarity take place at a regular rate which depends upon the frequency. The electric mains which supply A.C. power to your homes usually have a frequency of 50 cycles per second. This means that their polarity goes through a complete reversal 50 times each second.

POTENTIAL AND VOLTAGE

In this electrical work we have three words or names all meaning very much the same thing. These three are: Electromotive force, voltage and potential. each, however, has a slightly different meaning from either of the others.

Electromotive force means the pressure or voltage difference existing between the two terminals of a source, such as between the terminals of a battery or the terminals of a generator. E.M.F. is measured in volts,

Voltage, strictly speaking, means the difference in pressure between any point and the earth, assuming that the earth is neutral or is at zero pressure.

Potential means the difference in pressure between two points in an electric circuit. Potential differences are measured in Volts. Interchangeable with potential difference, is the term voltage drop. In figure 4 we have a circuit consisting of a battery as the source of e.m.f, a lamp, a resistance and the wires connecting them together. Now, of course, it is going to take a certain amount of pressure to send the current through the lamp. Consequently, there will be less pressure remaining at "b" than there is originally at "a". There is a difference of potential, or voltage drop between "a" and "b", this difference being the amount of voltage it requires to send current through the lamp. The voltage drop from one side to the other of the lamp is the potential difference between the two sides. Likewise, it will take some more pressure to get the current through the resistance, there will be a drop or loss of voltage between "e" and "d", and this is the potential difference between these two points. The arrows in Figure 4 do not represent the direction in which electrons are moving around the circuit, but rather do they indicate the direction in which voltage drops in the circuit are acting. Point "a" is more positive than point "b" or point "c", but point "c" is more positive than point "d". There is no easily measurable voltage drop between point "b" and "c" because the resistance between these two points is negligible.

There is no real need for you to be careful in your use of the words e.m.f., voltage and potential, because very few people are careful in this respect. However, you should understand the exact meaning of each of the words.

Figure 5 shows another circuit; this time we have one unit furnishing plate current, another furnishing filament current, also a radio tube and a transformer in the tube's plate connection. Electrons start out from the negative side of the plate power unit,

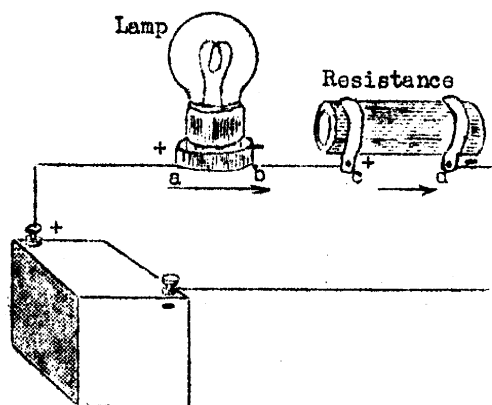

FIGURE 4.

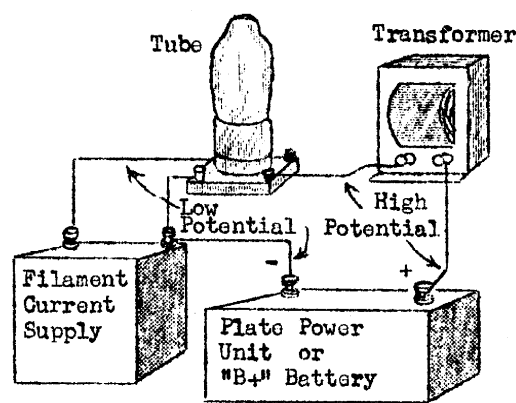

FIGURE 5.

go through the valve or tube and then through the transformer. There is a very great drop of voltage in the tube, practically all of though pressure disappearing right there. The parts of the circuit which are connected to the high side or positive side of the plate power unit make up what we call the high potential side of the circuit. From the transformer back to the power and filament supply units there is a negligible voltage drop

REISTANCE TO FLOW OF CURRENT

All materials oppose or hinder the flow of electric current through them. The opposition to flow of current is called the resistance. Here we are going to look into the matter of resistance to flow of both direct and alternating currents. Later on we will investigate other kinds of opposition to the flow of alternating currents, also the effects of what we call "high frequency resistance", which takes into account all the losses of energy which occur during the flow of alternating current at very high frequencies. Resistance which we will now consider is sometimes called "ohmic resistance". It is measured by a unit called the ohm.

The amount of ohmic resistance in anything depends on four factors: (1) The kind of material, (2) the temperature of the material (3) the length of the path through which current flows, and (4) the size around or distance across the path through which current is flowing.

Resistance depends on the kind of material; iron has more resistance than copper, and silver has less resistance than copper. Heat also affects the amount of resistance, a hot metal having more resistance than the same metal when cooler. Heat affects carbon just the other way around, carbon having less resistance when hot than when cold.

At the left-hand side of Figure b are two conductors. A conductor is any material of any part which carries electricity without much trouble or resistance. All metals



FIGURE 6.

are good conductors and most of the parts through which we carry direct current are made of metal. These two conductors at the left-hand side of Figure 6 are both the same size around, but the lower one is twice as long as the top one. Therefore, the resistance of the lower one is twice as great as the resistance of the top one because in the lower one the current has to travel through twice the

At the right-hand side of Figure 6 are two more conductor. If you cut straight across the top one and measured the space on the cut end you would be measuring the "cross sectional area". The cross sectional area of the upper conductor is 1 square inch and the cross sectional area of the lower one is 5 square inches. Therefore, the lower conductor has but one-fifth the resistance of the top one because in the lower one there is five times as large a path or as free a path through which current may flow. In these comparisons we assume the conductors to be of the same material.

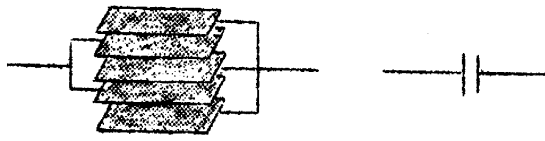

FIGURE 7.

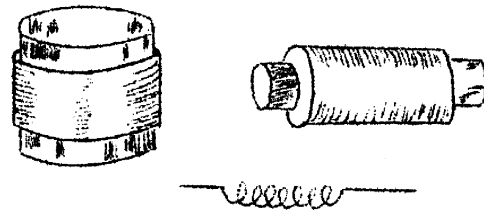

FIGURE 8.

Now remember, the longer a conductor the greater its resistance. Also, the bigger around, or the greater the cross sectional area of a conductor, the less its resistance. Long wires have lots of resistance, short ones have little resistance. Big wires have little resistance and small or thin wires have much more resistance.

All circuits and all parts have ohmic resistance to the flow of either direct current or alternating current. Coil and condensers oppose the passage of alternating currents with their property of resistance, but along with their reactance they always have ohmic resistance as well.

The condenser of Figure 7 may have only a small amount of reactance or opposition to flow of alternating current, but it will have exceedingly great ohmic resistance to the flow of direct current right on through it.

The coils of Figure 8 may have very great reactance to passage of alternating current through them, but since both of them are wound with quite large wire and with not a great length of wire, they will have fairly low ohmic resistance to the flow of direct current through them.

UNITS OF RESISTANCE.

The unit by which we measure resistance is called the "ohm", as stated above. An ohm is the amount of resistance in a circuit which allows a flow of one ampere of

current through it when there is a pressure of One volt. This relation between the ohm, the ampere and the volt is indicated in the circuit of Figure 9.

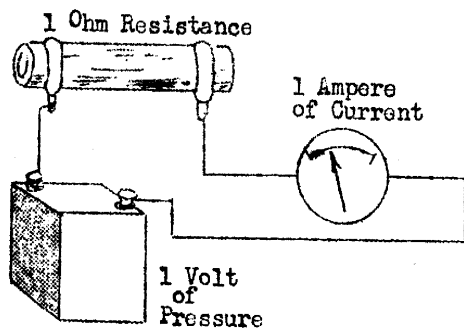

FIGURE 9.

The symbol for ohmic resistance is the letter "R". Sometimes we use the capital letter "R" and then again we use the small letter "r". The symbol for electrical pressure in volts is the capital "E" or the small letter "e", standing for e.m.f. The symbol for electric current in amperes is either the capital letter "I" or the small letter "i", standing for "intensity".

One thousand feet of number 12 gauge copper wire has a resistance of almost one ohm. There is one ohm resistance (approximately) in 127-1/5th feet of ordinary electric bell wire of number 20 gauge size. The standard ohm, or the "international ohm", is the resistance offered to the flow of unvarying current by a column of mercury 106-3/10th centimetres (41 85/100 inches) high and weighing 14.4521 grams (0.0318 pounds) at a temperature of zero centigrade (the temperature of melting ice). Do not try to remember this definition of an ohm; it is given to you just so you can read a really technical definition.

In radio work we sometimes use parts with so much resistance that we measure it in "megohms". One megohm is equal to one million ohms. Then again we make measurements of resistance so small that we use the "microhm". One "microhm" is the one millionth part of an ohm.

There is one more word to be explained to you now. It is "conductance". If a part has very high resistance it has very low or very little conductance. On the other hand, the conductance is high in a part which has but little resistance. Conductance is measured in a unit called the "mho", which as you see, is o-h-m spelled backwards. You will seldom use the words conductance and mho, but the sub-multiple "micromho", one millionth of a mho, is used very frequently when referring to the mutual conductance of a valve. The precise meaning of the term "mutual conductance" will be explained in later lessons.

METERS FOR RADIO WORK.

You will realise by giving the matter a little thought that practically any trouble in an ordinary electric circuit will make some change in the current, in the voltage, or in both current and voltage. To detect these changes we make use of two principal kinds of meter. One is the voltmeter, which measures differences in potential or voltages. The other is the ammeter which measures the rate at which current is passing through a circuit, that is the number of amperes. In radio perhaps we use a milliammeter more often than an ammeter. The milliammeter is a meter arranged so that it measures milliamperes. A milliampere is the one thousandth part of an ampere. We are often dealing with currents so small that it is most convenient to measure them in milliamperes.

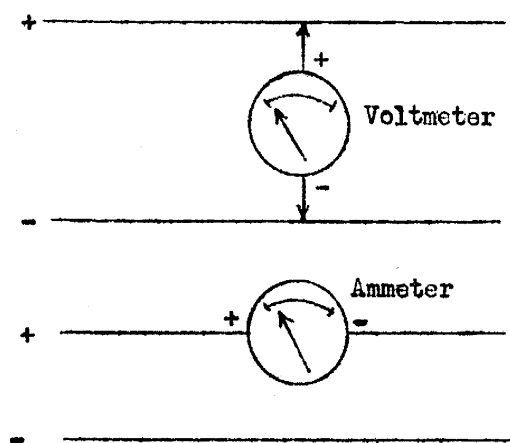

FIGURE 10.

In using a voltmeter it is always your intention to measure the difference of potential or voltage between two points in a circuit. Therefore, you simply touch the leads from the voltmeter to the two places between which you desire to measure the voltage, as the left-hand side of Figure 10. Voltmeters for measuring direct current have their terminals marked "+" and "-" or "Pos" and "Neg", standing for positive and negative. It is important that you touch the

positive meter lead to the positive side of a circuit and touch the negative lead to the negative side. Connected in this manner, the voltmeter - pointer will move across its scale and come to rest at the number corresponding to the number of volts difference between the two connections. If you connect a voltmeter the other way around, the pointer will move in the wrong direction, off its scale, and you will not get any reading. You are no more likely to burn out a meter by connecting it backward than by connecting it the right way; the worst you can do is to give the pointer such a snap that you bend it slightly.

In using a voltmeter you need not remove any wires or disconnect any wires. You just leave everything as it is and touch the meter's lead to the two points between which you are to make the measurement. Remember this about not taking off the wires.

You use an ammeter in the manner shown at the right-hand side of Figure 10. With an ammeter you want to measure the rate of flow of current through a circuit, therefore you must let all current flow through an ammeter. To do this you have to open up or break the circuit, which will leave two ends. Then you connect the ammeter in between these two ends so that the circuit is again closed, but is closed through the ammeter.

Ammeters and milliammeters for direct current are also marked positive and negative on their terminals. You should connect the positive terminal to the positive end of the circuit, sometimes called the high potential side of the circuit, a legacy from the days when it was believed that electric current actually flowed, like water, from a point of high pressure to a point of low pressure. The negative terminal of the meter is, of course, connected to the other side of the circuit which has been broken to admit the meter. In this way electrons will flow through the meter from its negative terminal to its positive terminal

USING THE VOLTMETER

The very first thing you must do in getting ready to use a voltmeter is to make sure the meter will stand the amount of voltage you intend measuring. That is, make sure that the voltage difference between the points at which you are going to connect the meter is no higher than the highest voltage shown on the meter's scale. If the voltage is much higher than the meter is designed to measure, you are quite sure to wreck the meter.

The most generally useful meters, either ammeters, milliammeters or voltmeters, have several different "ranges". That is, they are made with several positive terminals and one negative terminal, also with several scales on the one dial, as in Figure 11. Here is a meter with which the pointer may be made to move all the way across the dial with 10 volts, or with 25 volts or with 250 volts, or with 1000 volts. The terminal marked "Neg" is connected to one point and one of the other terminals connected to the other point. If you are measuring between points where you are sure the voltage is not more than 10 volts, you can make connection to the 10 terminal. The pointer in the position shown would then be indicating 5-volts. Were you to use the -volt terminal the pointer would be reading 12.5 volts. Were you using the 250-volt scale the meter would be reading 125 volts with the pointer as shown. You just count along from one marked position on the scale toward the next one, reading the scale which corresponds to the terminal you are using.

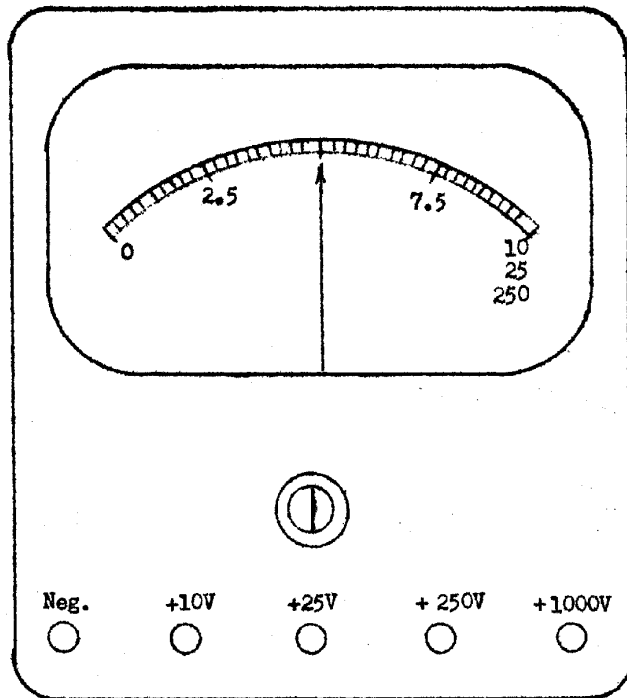

FIGURE 11.

You will notice that although there is a terminal marked 1000 volts there is no actual 1000-volt range marked on the face of the meter. When you use multi-range meters you may find that there are more provided than are actually marked on the meter face. Although there is no actual scale marked up to 1000 on the meter in Figure 11, there is a 10-volt range provided. What we have to do is read the voltage on the 10 volt range and multiply the reading obtained by 100. We multiply by 100 because 1,000 is 100 times 10, and with the needle at any point along the 10 volt range the actual voltage will be 100 times the reading indicated by the needle. For instance, if we connect to the negative and + 1,000V. terminals, and the needle points to 7 on the 10-volt range, then the actual voltage would be 100 times 7 or 700 volts. With the needle in the position shown in Figure 11, it is reading 5 volts on the 10-volt scale, but the actual voltage is 100 times 5 or 500 volts.

Another way we could determine the reading on the 1000 range would be to read the voltage on the 250-volt range and multiply by 4 instead of 100. The needle in Figure 11 is indicating 125 on the 250 volt range and multiplying this by 4 would give us 500 volts, the same as before.

The way to find out what is safe to do on a circuit when you do not know the approximate voltage is to start with the highest scale first. This reading will give you some idea of the actual voltage. Then, if the voltage is small enough you can drop to one of the lower scales.

In Figure 12 is shown a voltmeter being used in several different positions. In the position marked "A" you would be measuring the voltage drop through the transformer. In position "B" you would be measuring the voltage from the "plate"

terminal of the tube to the filament “-“ terminal of the tube; in other words, you will be measuring the voltage applied to the tube's plate. In position “C” you would be measuring the voltage applied to the tube's filament circuit. Notice how the polarity of the meter terminals is observed in making these connections.

USING THE AMMETER OR MILLIAMMETER.

In Figure 13 the same circuit is shown as used in Figure 12, but here using the current instead of the voltage. Notice that the wires are disconnected from their terminals and the meter connected between the terminal and the wire end which

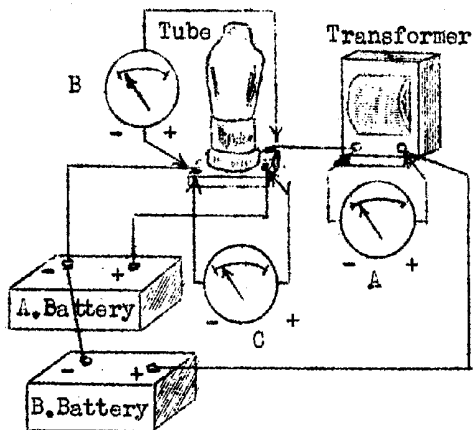

FIGURE 12.

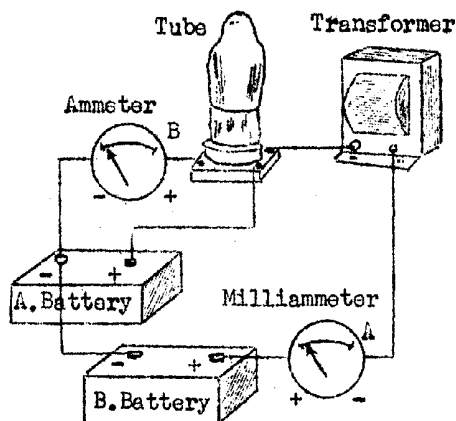
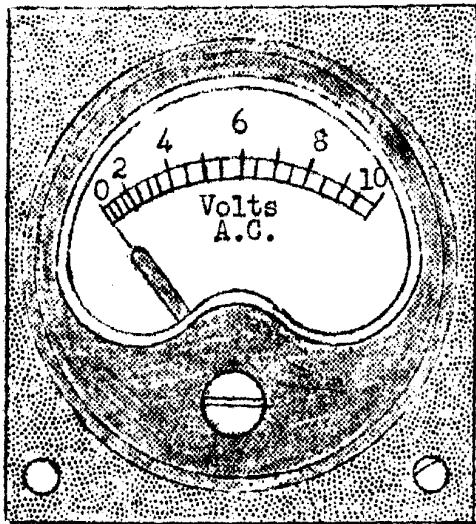

FIGURE 13.

was removed. In position “A” you would be measuring the current in the tube's plate circuit. This current would be small, consequently you would be using a milliammeter. In position “B” you would be measuring the current flowing to the tube's filament, and since this current is generally a fairly large fraction of an ampere, you would be using the ammeter.

Certain type of meters, both voltmeters and ammeters, will measure only direct current. If they are used on alternating current circuits, their pointers will always remain at zero. Other meters are designed especially for use with alternating current circuits. You generally will find the face of a meter marked as to whether it should be used for measuring direct current or alternating current, The kind of alternating current meters generally used in radio service work will also measure direct current, although the measurement may not be as accurate as with a regular direct current meter.

With A.C. meters you do not pay any attention to polarity because there is no long term polarity in A.C. circuits, for reasons explained earlier in this lesson. If you apply an alternating current meter to a direct current circuit, try it both ways around. The higher reading, should there be a difference, will usually be more nearly correct than the other one. On A.C. meters having more than one range



An A.C. Voltmeter.

FIGURE 14.

you will find one terminal marked with both the plus sign and a minus sign or with the letter "C". The letter "C" is an abbreviation for "Common". This terminal is treated as the negative terminal when used on direct current circuits. Another way of telling an A.C. meter from a D.C. meter is that most A.C. meters have the gradations or divisions of their scales crowded together at the low end, near zero, and spread out near the top of the scale while D.C. meters have their gradations evenly paced over the whole scale. These differences are shown in Figures 11 and 14.

You may have seen a serviceman dig into a case of trouble with a voltmeter equipped with a couple of long wires. He touches the ends of the wire here

and there during a few moments of work, then states quite confidently "the plate load for the audio frequency amplifier is open circuited", or perhaps, "the screen bypass condenser on the intermediate frequency amplifier is short circuited". Now, neither the resistor or condenser at fault provides any external indication that it is actually faulty, so how can the serviceman be so certain that his diagnosis is correct simply because he measure the potential difference between various points, or in other words, measures the voltage drop between those points.

To help you understand the principles involved let us take a simple filament circuit as shown by Figure 15. If the circuit shown is complete, electrons will flow away from the negative terminal of the battery, through the switch, then through the

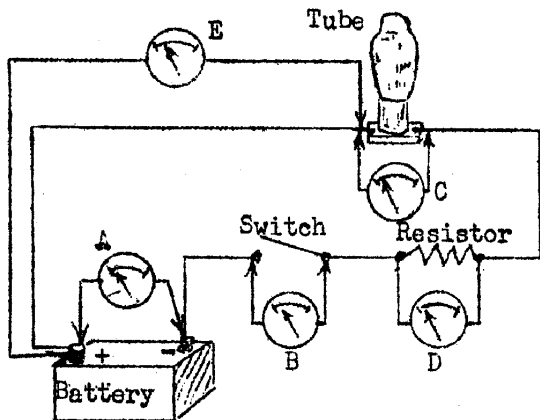

FIGURE 15.

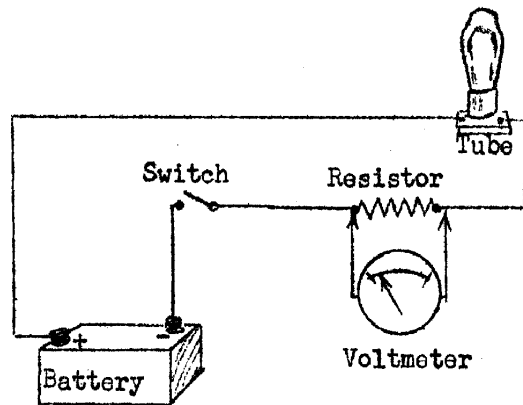

FIGURE 16.

resistor and finally through the valve filament to the positive terminal of the battery. A resistor, incidentally, is a device which has a known amount of resistance and can be used for controlling the amount of current flowing in a circuit or to create a certain voltage drop between two points.

Now test this circuit. Place the voltmeter at "A" and touch the two battery terminals. If the meter shows full battery voltage you know the battery is without fault. Now you move the voltmeter to "B" and touch the two sides of the switch. The switch should make a good connection of practically no resistance, so there should be practically no voltage drop through the switch. If the meter shows no movement of its pointer, indicating no voltage drop, you conclude that the switch is in good working order.

Next you move the meter to position "C" and touch the leads to the two filament terminals of the tube. The meter reads about 1.4 volts. Well, this kind of a tube is supposed to have 1.4 volts across its filament, so you know there is nothing wrong here. Then you change the meter to position "D", connecting it across the terminals of the resistor. The meter reads about 0.1 volt. Now let us see: the battery measured about 1.5 volts, the tube was taking 1.4 of those volts, and here we have the other 0.1 volt across the resistor. Then the resistor must be alright.

Finally, you might move the voltmeter to position "E", touching one of its leads to the positive terminal of the battery and the other lead to the positive filament terminal on the tube. Since a wire of the kind used between these points should have exceedingly low resistance, your meter will show but the slightest movement of its pointer, hardly enough to see at all, indicating practically no voltage drop and a good wire and good connection.

These tests showed the circuit and the parts in it to be in good condition. Of course you might have gone on and tested across the ends of the wires between battery and switch, between switch and resistor, and between resistor and tube.

Now look at Figure 16. Here you have exactly the same circuit as in Figure 15 - but now something is the matter - the tube filament won't light up. You would proceed with the same tests you used before, first testing the battery which would show correct voltage. Then you would get no voltage drop across the switch, showing it too to be alright. Testing the tube filament would show no voltage. Then you would test the resistor and here you find that the meter reads full battery voltage. That shows that the resistor is open circuited, that is, the wire in the resistor has broken, that no current is flowing through it, that you are getting the full voltage drop of the battery at this one place.

Just think for a minute. With the meter placed as in Figure 16, one side connects through the tube filament and the long top wire to the positive side of the battery. The other side connects through one wire, the switch, and another wire to the battery's negative terminal. With the resistor open, probably burned out, there is nothing between the voltmeter leads in the position occupied by the resistor - at least there is no electrical connection. Across the ends of such an open point you will always find the full voltage of the source. That shows an open circuit.

This is a good way of locating open circuits or defective parts. You simply get the wrong voltage drop across them. But there is one serious fault with this method it falls down when there is more than one open circuit, or more than one open point in one circuit. In Figure 16, supposing the resistor had actually been burned out, making an open point. But supposing too that the switch had been out of order, broken in such a way that it also made an open point. With no current flowing in the circuit because of the open resistor, you would get no voltage drop across the switch because you cannot get a drop of voltage without current flowing. Then you would have concluded that the switch was in order, yet it was not.

OTHER METHODS OF LOCATING OPEN CIRCUITS.

Now there is Shown in Figure 17 a test method that will locate any number of open points one after another provided you fix them as you come to them. You might say, "If this way is better, why how the other one?" There are several reasons; first you should understand all test methods; second, it is sometimes very much quicker to use the other method than the one which will be described now

In Figure 17 we have the same circuit we had in Figures 15 and 16. You take the voltmeter and attach its negative lead to the negative terminal of the battery at "1". You are going to leave that lead in that place all through this test. The first step is to touch the other voltmeter lead to the positive terminal of the battery. You should find normal full battery voltage, indicating that the battery is fresh.

Now you flow the circuit away from the positive terminal of the battery, reaching first the terminal on the tube socket at "2". Here you touch the positive lead from the meter. If the wire and the connections are good the meter will show full battery Voltage. If you get no reading it shows that there is an open circuit in the wire between the positive terminal of the battery and the filament terminal of the tube.

Next, at "3", you touch the other filament terminal of the tube socket with the meter lead. If you get no reading the tube's filament is burned out or If you obtain a reading, continue with the tests.

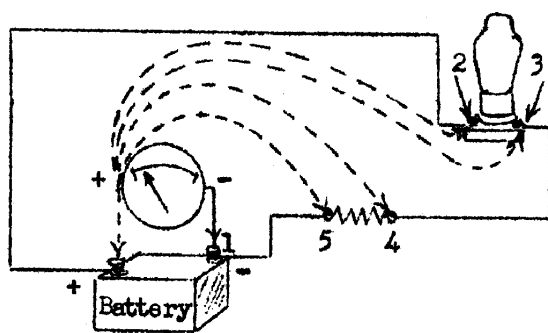

FIGURE 17.

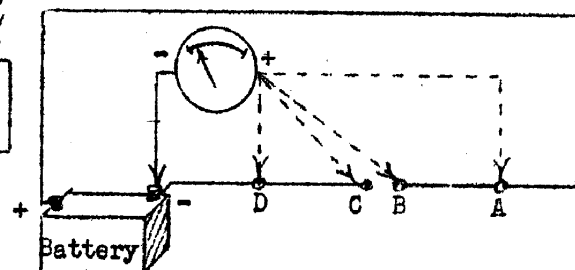

FIGURE 18.

Now you follow the circuit and come to the resistor. Touching, at "4", the end nearest the tube (which you just left), you may get no voltage reading or a full battery voltage. No voltage reading shows an open circuit in the wire between the tube and the resistor. Full battery voltage shows an open circuit between battery negative and "4". Then you go on, touching the other side of the resistor at "5". No reading here but full voltage reading at "4" shows a burned out or broken resistor. If, at this point, you still get full voltage reading, it shows that there is an open circuit in the wire between the negative terminal of the battery and the resistor.

In this test, just what have you been doing? You have been bridging across one after another in the whole circuit. You will see this more plainly in Figure 1, where there is shown only the battery, the meter and several points along a circuit. Of course, this really amounts to the same thing as the circuit of Figure 17.

In Figure 18 you can see the open circuit between "B" and "C". Supposing the positive meter lead is touched to "A". Electrons can flow from the negative battery terminal through the meter to "A", and back through the long wire to the positive terminal of the battery. The meter will, as a consequence, read full battery voltage.

Now touch the meter lead to "B" in Figure 18. Because current is prevented from flowing back to the battery by the break between "B" and "A", there will be no loss of voltage caused by any resistance between "A" and "B" and consequently the meter reading at "B" will also be full battery voltage,

Next you touch the meter lead to "C" but because of the break between "C" and "B", electrons cannot make their way from the negative terminal of the battery through the circuit back to the positive terminal of the battery, and so the meter will give no reading. You see, as soon as you have passed the open point in the circuit, you have no reading on the meter.

The rule is this: Working away from the battery, when you get no reading, an open circuit exists between the point then being touched and the last one at which a reading was obtained.

Of course, a test at point "D" would also show no reading.

SHORT CIRCUIT AND GROUNDS.

A short circuit is an accidental connection from one side of a circuit to the other side somewhere between the source of voltage and the part operated by the circuit. A short circuit is shown in Figure 19. Current normally should flow from the battery, through the resistor and valve filament, and back to the battery. But between the battery and the tube the two wires are touching each other. Electrons will follow the path shown by the arrows, leaving the battery, passing from one wire to the other, through the short circuit, and going directly back to the battery.

The resistance of the short circuit or the "short" is so low that little current will go on and pass through the resistor and the tube's filament. The battery will be rapidly discharged, but the tube will not light.

It is harder to locate a short circuit than to locate an open circuit because to find the short you really have to get rid of it, separate the shorted parts, before you can find it. That sounds almost impossible, but it is not.

A "ground" is one variety of short circuit. The short circuit shown in Figure 19 is between the wires. In Figure 20 is shown a ground. The ground occurs between a wire and some metal part through which current may flow. In many radio devices the metal framework or the metal brackets are used to carry current for one side of the circuit usually for the negative side of a direct current circuit. Then the metal is spoken of as a "ground", and it forms the grounded side of the circuit.

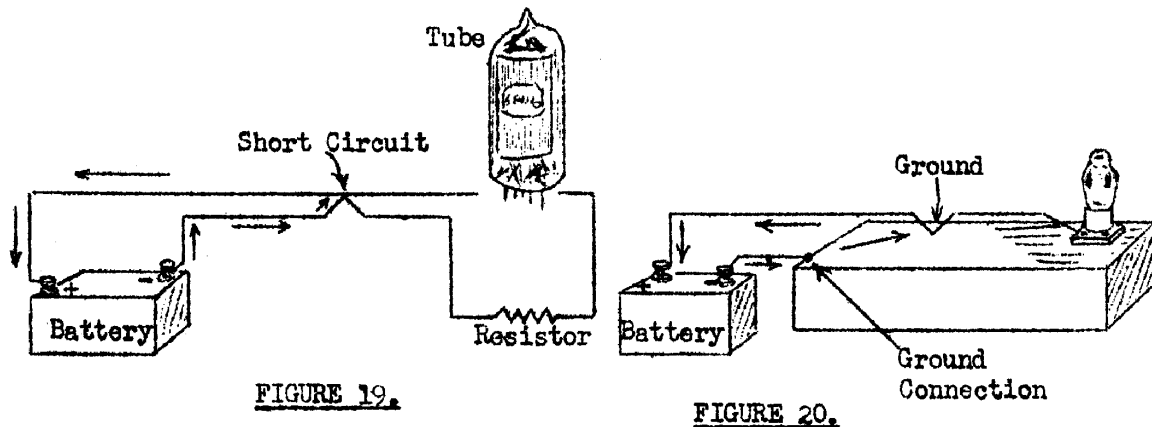

In Figure 20, the negative terminal of the battery is connected to the metal base. The wire between the positive side of the battery and the tube is touching the metal or is "grounded" where marked. Then the battery current flows through the wire to the metal chassis, then returns through the ground to the battery without ever reaching the tube.

Here we are speaking of the kinds of grounds which cause trouble. These might be called accidental grounds. Then there are also intentional grounds such as the attachment of the negative battery line to the ground connection in Figure 20. Both kinds of connections are grounds, but one is the kind we want while the other we do not want.

LOCATING TROUBLE IN ALTERNATING CURRENT PARTS.

In locating a case of trouble there is no difference in general rules whether the circuits and parts are carrying direct current or alternating current. We have looked for open circuits in direct current circuits containing a battery as the source of voltage. Direct current work was selected because the circuits for this current are generally more complicated than those for alternating current - they may have switches, rheostats, and other parts which are not used in alternating current tube circuits.

The chief difference between direct current circuits and alternating current circuits is that a battery forms the source of voltage for the D.C. parts and a transformer for the source for the A.C. parts.

In testing with alternating current you use the A.C. type of voltmeter, whereas for direct current circuits you use D.C. type of meter. All the tests in Figures 12 to 20 might be applied equally well to alternating current circuits. In place of the battery there would be a transformer; that would be the only difference. Of course, in the A.C. work you pay no attention to polarity, for reasons explained earlier in this lesson.

LOCATING SHORT CIRCUITS OR GROUNDS

We are going to do the work on shorts and grounds by illustrating with alternating current circuits. The filament or heater circuit for an A.C. tube is illustrated in Figure 21. The power line or light circuit is connected to one side of a transformer. A transformer is simply a device for changing one alternating current voltage to another alternating current voltage. Here we are stepping down the power line voltage to a lower voltage suitable for the tube. Some alternating current tubes have filaments exactly like those used for D.C. tubes. Others have what we call a "heater" which is placed inside a part corresponding to the filament in other tubes. Wires are connected between the heater terminals or the filament terminals of the A.C. tube and the transformer. Wires carrying alternating current in a receiver or in any radio parts are generally twisted together because this helps to reduce the tendency of the device to hum.

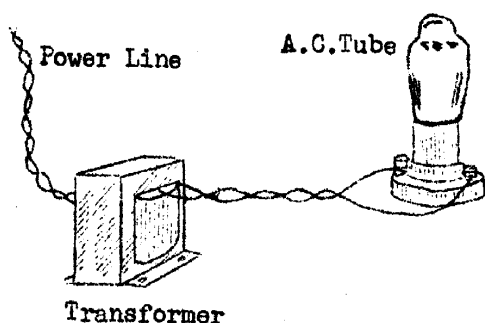

FIGURE 21.

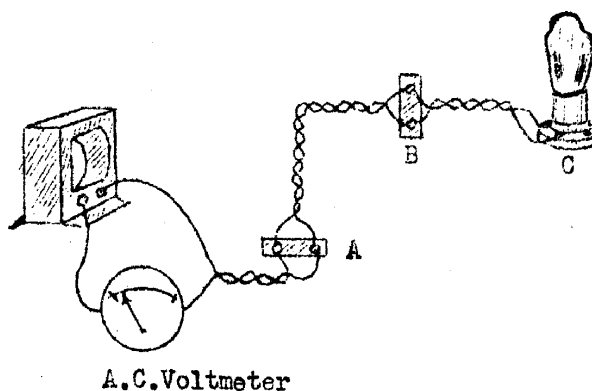

FIGURE 22.

Now we will locate the short in the A.C. circuit of Figure 22. The first thing to do is disconnect one of the wires at the transformer, connect it to one of the terminals of an A.C. voltmeter and connect the other meter terminal to the point on the transformer from which you removed the wire. Since there is a short somewhere in the circuit, current will flow through it. The current passing through the short circuit will now have to pass through the voltmeter and the meter's pointer will show a voltage reading.

This connection of the voltmeter prevents further damage from resulting because it reduces the flow of current to a very small amount. A voltmeter has a very high resistance and only a little current will flow through it even with full voltage applied to its terminals. A voltmeter takes just enough current to move its pointer.

Of course, you must remove any tubes or dial lamps which might be connected to the wiring, otherwise the current passing through the tubes or lamps will move the pointer and you will not know when you have found the short circuit.

Having connected the voltmeter, you commence opening up various points in the circuit. First you would take a wire off the junction post marked "A". If the meter's pointer drops back to zero you have not yet located the short. If the meter still continues to read voltage the short circuit is between the point at which you have disconnected the wire and the transformer. Then you can go on and remove a wire at "B". If the pointer drops to zero you will have to go on still farther, but if the voltage reading remains you know the short is between the point from which you have now disconnected the wire and the last point where you opened the circuit. You could go on still further and take one of the wires off the tube socket, indications would be the same as before.

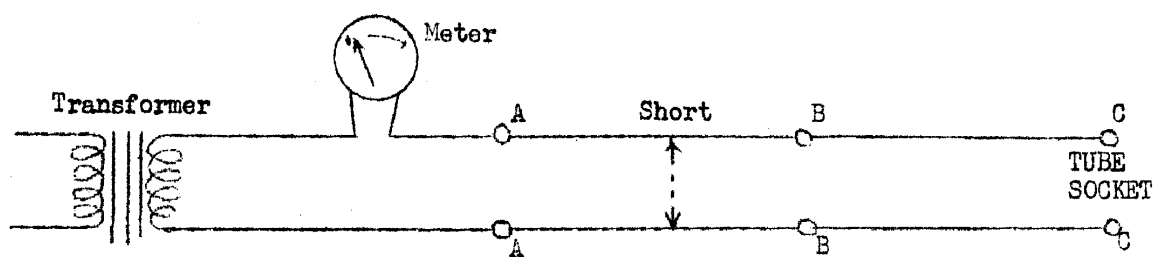

FIGURE 23.

Now, let us see just what you have been doing. In Figure 23 you can see how the circuit in Figure 22 would look if you straightened it out. Supposing there is a short where the wires are joined by the broken line arrow. If you disconnect a wire at "A" you have opened the circuit containing the transformer and the meter; consequently no current will flow and the meter's pointer will drop to zero. You go on and take off a wire at "B". Now you have not opened the circuit because current will still flow from the transformer, through the meter and through the shorted place in the wires. The meter's pointer will continue to read voltage.

Notice that as soon as you have passed the short, working away from the transformer or battery as the case may be, then the voltmeter will continue to read voltage. Until you reach the short, each opened connection will stop the current and make the meter read zero. So the rule is: The short exists between the first place at which the meter continues to read voltage and the last place at which the meter dropped back to zero,

Having once located a short circuit or an open circuit as existing in a certain part or in a certain section of the wiring, you just make a careful examination of that particular portion to find the exact point of the defect.

INDICATIONS OF SHORTS AND OPENS.

Either a short circuit or an open circuit will put out of action all parts in a circuit when they are in the line shorted or opened. For example, a tube will go out with either kind of trouble because with either kind the tube is prevented from getting enough current to operate it.

With a ground or a short circuit the wires will get hot and generally will smell hot. The transformer or battery will be badly overloaded. The battery will rapidly become discharged and the transformer will get very hot, will burn out a fuse or may burn out its own windings. When a short occurs, open the circuit near the battery or transformer just as quickly as you can get it open.

An open circuit is, usually, not so harmful as a short. It stops operation of the part or parts in the line, but that is about all although in some cases it may cause a harmful rise in voltage, a circumstance which will be discussed in a later lesson.

WHAT TO DO WHEN BATTERY IS DISCHARGED OR TRANSFORMER BURNT OUT.

In all the tests shown so far you have been using the battery or the transformer already in the circuit as your source of testing voltage. But supposing a bad short or ground has completely discharged the battery or has put the transformer out of business, what then?

The easiest way and one of the surest ways to get reliable indications from your tests is to put another battery in place of the discharged one or in place of the burned-out transformer. All you need is two dry cells connected together in series as in Figure 24. In as much as the only current they have to furnish is enough to operate your voltmeter, these two cells will last a long time. They will give three volts pressure, and this is plenty for all these circuit tests. Do not forget to put the testing, voltmeter in circuit before you connect up the battery.

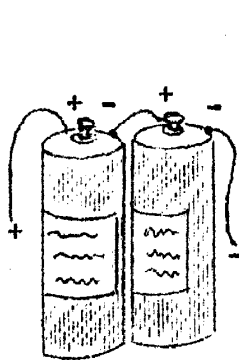

FIGURE 24.

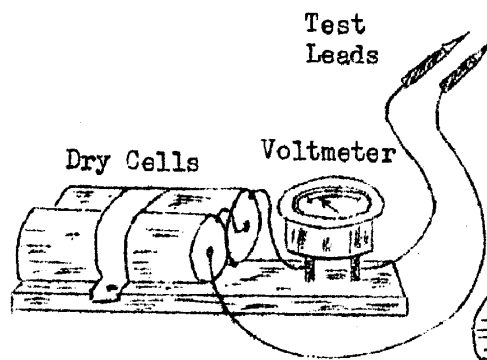

FIGURE 25.

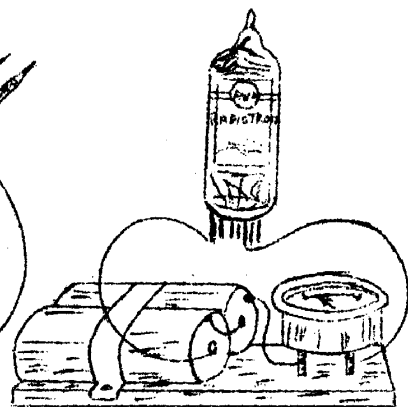

FIGURE 26.

A CIRCUIT TESTER.

The two dry cells connected to a voltmeter will make one of the handiest circuit testers you ever saw. The hook-up is made as in Figure 25. Connect the negative terminal of a voltmeter to the outside terminal of one cell, connect the centre terminal of this cell to the outside one of the other cell, attach a long test lead to the centre terminal of the second cell and connect another test lead to the tester's positive terminal. Instead of using the two large cells shown, you can use a 4½ volt torch battery or radio "C" battery as these are easier to carry about.

Connecting the two test leads to any two parts will show whether there is a conducting path between them. For example, in Figure 26 the leads are connected to the two filament pins of a radio tube. If the filament is good the meter will read about three or 4 ½ volt, the voltage of the two cells or battery. If the filament is burnt out the meter will show zero voltage, indicating an open circuit. The three or 4 ½ volts pressure will not hurt any radio parts, because with the voltmeter in the circuit you can never get more than a few thousandths or an ampere or a few milliamperes through it.

The circuit tester or "continuity tester" as it is called, will test for a continuous conductor anywhere you touch the two leads, but until you are better acquainted with all radio circuits, you had better use a tester of this kind only for testing parts that are disconnected from all other parts and wires or which are removed from a radio set. The reason for this advice is that several wires are hooked to most things so that they are included in many circuits. With the tester you would not know which of the circuits you are testing.

MULTIMETERS.

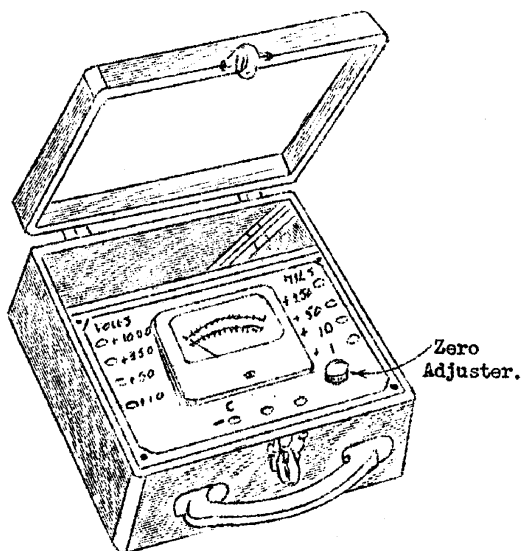

FIGURE 27.

Meters are extremely useful instruments for adjusting receivers and locating faults, and are really a necessity to anyone undertaking service work. Rather than purchase separate voltmeters and milliammeters it is considerably less expensive to purchase or make a "multi-meter" which can be used to measure both voltage and current. In addition, most multimeters contain a built-in battery so that they can be used as continuity testers and also to measure resistance in ohms. You will realise that a combined meter like this is far more convenient than a number of separate meters.

One type of multimeter is shown in Figure 27. This meter is provided with four separate ranges for measuring voltage. These ranges are 10 volts, 50 volts, 250 volts and 1,000 volts.

The terminals which are used when the meter is to be connected as a voltmeter are at the right-hand side of the panel. The ranges are 10, 50, 250 and 1,000 volts. The terminals for D.C. current measurement are at the left-hand side of the panel and range from 1 milliamperes to 250 milliamperes. The three terminals at the bottom of the panel are employed when the meter is used for continuity testing or for measuring resistance. The centre and left-hand terminals are used for measurement of resistance up to 100,000 ohms. The left-hand terminal is also the negative terminal for all voltage and current ranges. The centre and right-hand terminals are used for measurement of resistance up to 100,000 ohms. The knob in the lower right-hand corner of the panel is used for adjusting the needle to the zero position on the resistance ranges when the test prods are directly connected together. Before using the meter to measure resistance, the terminals or test prods should be directly connected together. The zero adjustment knob is then turned until the needle rests on the end of the ohm's scale marked "0". If an unknown resistance or circuit is then connected to the terminals the needle will indicate its resistance.

An enlarged view of the meter scale is shown in Figure 28. The ohms range is the one printed around the top of the scale, while the volt and milliamp ranges are marked below the scale.

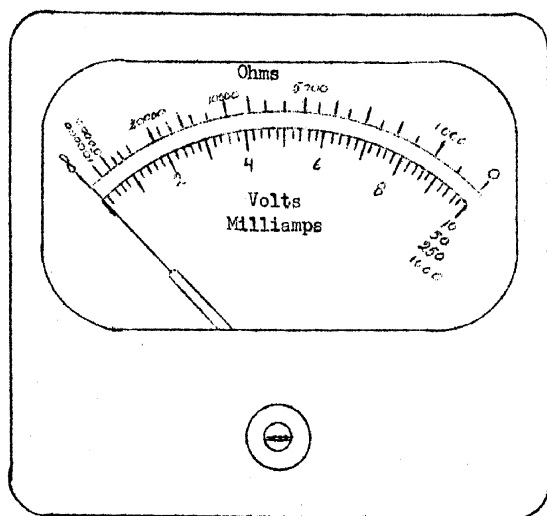

FIGURE 28.

Two most important points you should remember when using voltmeters or milliammeters are these: First, always select a meter with a range you know to be higher than the voltage or current you intend measuring. Second, voltmeters are connected to any two points in a circuit between which you wish to determine the difference in potential. Ammeters or milliammeters must always be connected in the circuit in which you wish to measure the current flowing.

EXAMINATION QUESTIONS – No. 7.

- (1) will current flow in any of the parts of an open circuit? Why?
- (2) Does the dielectric in a condenser always make an open circuit seeing that it is an insulator? Explain your answer
- (3) Mention the three common names of electrical pressure,
- (4) Which has the greater resistance, a thick wire or a thin one, both being of the same length and of the same material? Why?
- (5) Write down the letters which stand (1) for voltage, (2) for current, and (3) for resistance.
- (6) Can you measure D.C. voltages with an A.C. voltmeter?
- (7) To measure the voltage drop in a resistor, to what two points would you connect a voltmeter?
- (8) If you find a battery completely discharged, would you look for an open circuit or for a short circuit? Why?
- (9) With the positive terminal of the voltmeter in Figure 17 connected first to point 2 and 3, what reading do you get at each of those points, assuming the tube's filament short-circuited?
- (10) In using the continuity tester described in this lesson, does the meter remain at zero with a closed circuit or with an open circuit between the test leads?

"The Radio-T.V. Training Centre"

**E. S. & A. BANK BUILDINGS, Corner CITY RD. and BROADWAY, SYDNEY
Telephones: BA4891 and BA4892**

AUSTRALIAN RADIO AND TELEVISION COLLEGE PTY. LTD.

Telegrams "RADIOCOLLEGE" Sydney

This lesson sheet is published for the exclusive use of students of the Australian Radio and Television College Pty. Ltd. (All rights reserved)

Post Lessons to Box 43, Broadway

LESSON NO. 8

HOW TO READ THE LANGUAGE OF RADIO ENGINEERING IN WIRING DIAGRAMS.

You have looked at radio receivers, have looked inside them and know just how the parts appear. You also have looked at wiring diagrams and you know that a wiring diagram is certainly no photograph of a receiver. Yet to an engineer or to a first class radio man the wiring diagram is really a picture of the set and it shows things far more clearly than they can be shown by any photograph.

We are going to find out how to look at one of these diagrams and make it answer all kinds of questions in which you are interested. while performing service operations. First of

all, let's see just what kind of parts go into the make-up of a modern receiver and its power supply. We have the aerial and ground system, We have many different kinds of coils. There are condensers of various types and there are numerous resistors. Then come the wires and the switches. Into all this we put different kinds of tubes. Finally we add the loud-speaker. With some sets we also find a few other parts: batteries, meters, gramophone *pick-ups* and so on.

Each different type of all these receivers and power unit parts can be represented in a diagram by its "symbol". The symbol is a simple sign of some kind which stands for the thing you wish to represent. A symbol shows more than a picture of the outside of a radio part because the symbol lets you see

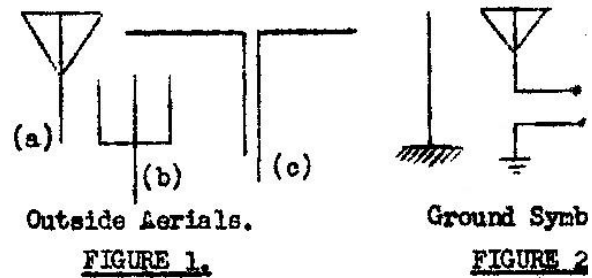

Outside Aerials.

FIGURE 1.

Ground Symb

FIGURE 2

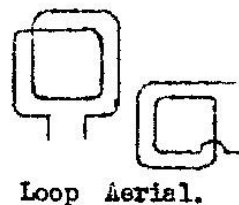

Loop Aerial.

FIGURE 3.

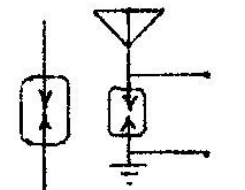

Lightning Arres

FIGURE 4.

just how the electrical circuits get through the part. With a picture of the outside you can follow the wiring up to the terminals, but there you have to stop. With a symbol you can follow right into the device, whatever it may be, and out the other side.

AERIAL SYSTEMS

Although a substantial measure of standardisation has been achieved with most circuit symbols, there are still a few where several alternative symbols exist. However, there is enough resemblance between the several symbols to allow of easy recognition. When one encounters a non-standard symbol for a particular component. Figure 1(a) shows a commonly used aerial symbol, while at (b) an alternative is shown. Figure 1(c) represents a high frequency dipole used with FM receivers and some T.V. sets.

Associated with most aerial systems there is a corresponding ground which forms a return path for radio frequency signals. Figure 2 shows the combined aerial earth system with the earth symbol at the lower part of the diagram. To the left of the combination symbol appears an alternative ground symbol which is frequently found in circuits of Continental - European origin.

The symbols for a loop aerial or coil aerial as shown by Figure 3 are easy to recognize because they show the wires just as they are arranged on a loop.

The lightning arrester symbol is shown in Figure 4, Over at the right hand side we have represented an aerial and ground with a lightning arrester between them and with wires running over to the receiver.

COILS AND TRANSFORMERS WITH AIR CORES

A plain air-core coil is indicated by the symbols in Figure 5. this is the kind of coil used in filters operating at radio frequencies and, sometimes, as the inductance in a radio frequency tuned circuit. This does not mean that the air core coil is found only in radio frequency circuits. On the contrary, this type of coil is frequently used in audio frequency dividing networks associated with multiple loud-speaker installations employed with high quality sound reproducing equipment.

If an air-core coil is arranged so that a connection may be changed to use more or less of the turns in the coil we call it an adjustable inductance or coil and use the symbols of Figure 6 with the small arrowhead indicating the adjustable connection.

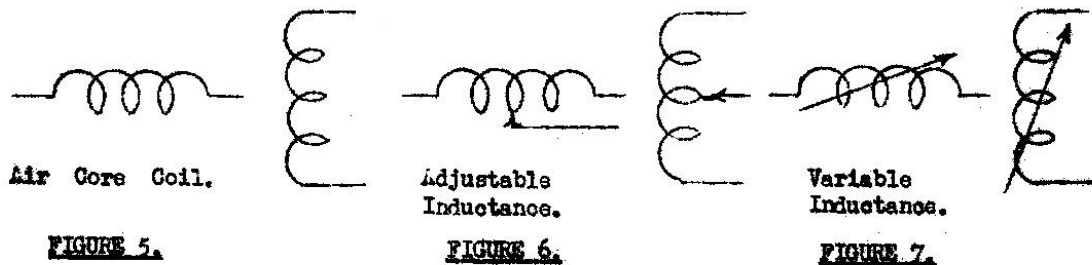

When an air-core coil is built in such a manner that its inductance is continually variable or changeable while the coil is working in the set we call it a variable inductance and the symbols for this arrangement are those of Figure 7. This long arrow drawn right through a symbol always means that the part may have its value changed while the receiver or other radio device is in operation.

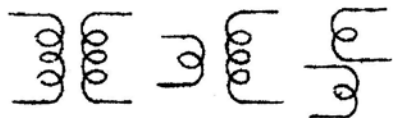

Air Core Transformers with Fixed Coupling.
FIGURE 8.

Symbols for air-core transformers or “couplers” are shown in Figure 8, All of these diagrams stand for two coils wound on one former or else on two separate formers which are in line with each other or close to each other so that there is coupling between the two coils. With coupled coils the relative positions of the symbols

representing individual windings does not necessarily indicate their true physical position in relation to each other. For instance, the individual coils representing the two windings of the transformers in Figure 8 may be wound side by side on their common former or one winding may be wound over the top of the other, insulated wire being used, of course, to prevent short circuit between the two windings. All of the symbols in Figure 8 indicate that the coupling between the coils is fixed and not adjustable or variable.

Variable coupling between air-core coils is now extremely rare, although it was commonly used in receivers manufactured 20 or more years ago, For the sake of completeness we have included a symbol for this type of coil. Another reason for its inclusion is that, strangely enough, current American practice is to use the symbol shown by Figure 9 for modern coils with variable inductance tuning by means of a movable magnetic core. The operation and application of this type of coil is, of course, discussed in detail in later lessons.

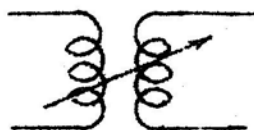

Air Core Coils. Variable Coupling.
FIGURE 9.

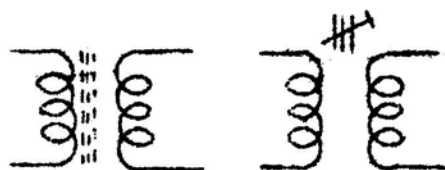

FIGURE 10.

At one time all transformers for use at radio frequencies were of the air-cored type. This does not mean that the transformers had nothing but air inside their windings, it means that no magnetic substance, such as iron or steel, was used inside the coils. Most air-cored coils were wound around a circular former made of some insulating material such as bakelite or specially treated cardboard.

Modern practice is to wind coils directly on to a magnetic core material or where facility for varying inductance is required on to a former having good insulating properties into which may be screwed “slugs” of magnetic material. The magnetic core materials used in such applications consist of special amalgamation or “mixes”, using various kinds of plastic or ceramic materials as a base. One well-known material pioneered by the Philips organisation is known as “Ferroxcube”. The presence of such a core is shown by the symbols illustrated in Figure 10. The one at the left

is frequently used to indicate a radio frequency transformer having a non-adjustable magnetic core. The core is indicated by broken parallel lines to distinguish it from the laminated core used in audio frequency coils. The diagram on the right of Figure 10 indicates that the amount of magnetic material within the core may be varied. This variation is achieved usually by tapping the inside of the coil former and screwing into it a threaded slug of the appropriate magnetic material. By screwing the slug into or out of the coil interior, the inductance of the coil may be changed. Sometimes the symbol for the movable iron core is shown at each end of the transformer to indicate that the inductance of both coils may be changed by screwing a slug into each end of the former.

Intermediate frequency transformers used in superheterodyne receivers of pre-World War 2 manufacture were mostly of the air-core variety with both windings tuned by small adjustable condensers. As intermediate frequency transformers operated only one frequency, usually 455 k.c. in modern receivers, it is only necessary to vary the capacity of their tuning condensers between very small limits. Once adjusted they are not touched again unless realignment becomes necessary. The symbol at the extreme left-hand side of Figure 11 shows one of the older air-core intermediate frequency transformers with variable capacity tuning. Those transformers are generally mounted in metal cans to shield them from interfering fields. The metal can when used is represented by a broken line around the symbol for the device which it shields as shown by the diagram.

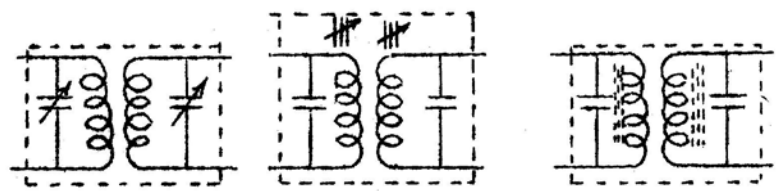

FIGURE 11.

Intermediate frequency transformers, like radio frequency transformers, are now provided with facilities for varying in their inductance over a small range. With this type the tuning condenser

across each winding has fixed capacity. The symbol for this particular type of transformer is shown at the centre of Figure 11. The fact that both windings are tuned by permeable slugs is indicated by the three short parallel lines traversed by an arrow, at the top of each coil symbol. Sometimes the adjustable iron core symbol is shown at the top and bottom of the coil, sometimes as shown at the right of Figure 11.

Sometimes for special purposes we use coils or windings with "taps" brought out at several points. For instance, you may find a 50-turn coil with a tap at the 10th turn from one end and another at the 25th turn. Then we use symbols like those in Figure 12. Of course, in a symbol you don't attempt, to draw as many turns as are used in the coil itself otherwise you would have a hard time showing an audio transformer with 20,000 turns. However, sometimes the relative size of the coils symbolising a transformer indicates whether one winding has more or less turns than the other. This is shown by the symbol at the right of Figure 12. In this case the tapped winding has more turns than the non-tapped winding on its immediate left. This is also apparent with the transformer symbols shown at the centre and right of Figure 15. With the centre symbol the three windings at the right each have a lesser number of turns than the winding on the left of the iron core symbol. On the other hand, the

transformer symbol at the right of Figure 15 would indicate a similar number of turns on each of the two larger windings while the small winding showing a single loop at the bottom of the diagram would have a smaller number of turns than either of the other two.

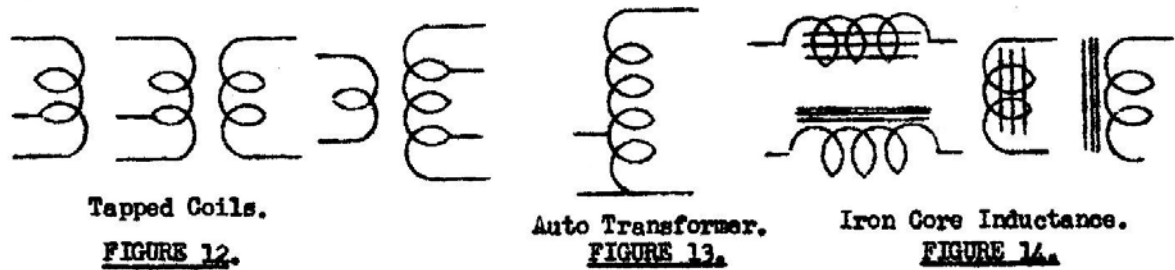

In most transformers we have two separate windings but there is one kind of transformer with one continuous winding which is called an "auto-transformer". Its symbol is shown in Figure 13. Once in a while you will find aerial couplers or radio frequency couplers using auto-transformers.

IRON CORE COILS AND TRANSFORMERS.

An iron core, consisting of a number of sheets of iron or steel, is indicated by several straight, parallel lines. To show a simple coil winding with an iron core we use the symbols of Figure 14. Those symbols indicate such things as audio frequency coupling chokes and power unit filter chokes. You can see that they are exactly like the air-core coils with the iron-core lines added.

The iron core used in coils for handling audio frequencies, or for use in the power unit, are not like the iron cores used in R,F, and I,F. transformers. These iron cores consist of sheets of iron or steel called "laminations". The laminations may be about one fiftieth of an inch in thickness and sufficient are used to make up a thickness of between half an inch and four inches, depending upon the application of a particular unit.

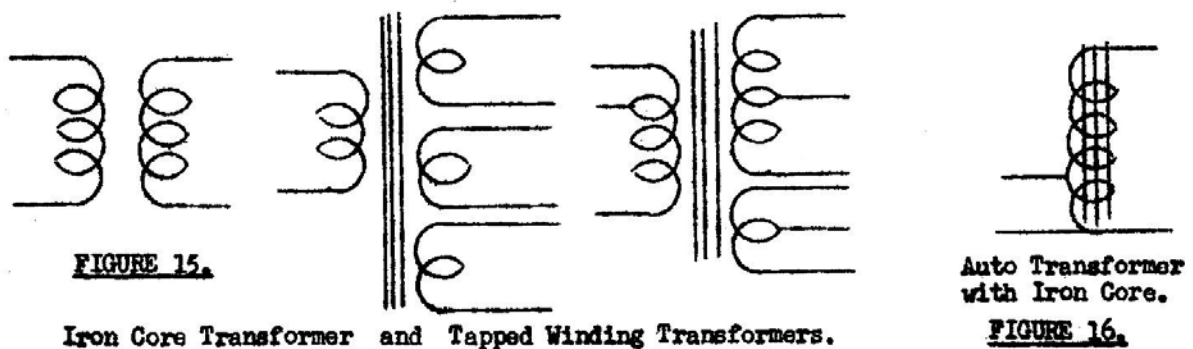

A transformer with two windings and an iron core is shown by the left hand symbol in Figure 15. This is generally the sign for an audio frequency transformer, but it also may indicate any other simple transformer such as one for furnishing filament or heater current to tubes. The other two symbols in Figure 15 indicate transformers with one

primary and two or more secondary windings as you will find them in power supply transformers. The right hand symbol in Figure 15 shows a power transformer with a tapped winding and two secondary windings, each secondary having a centre tap. Many power transformers have as many as five or six secondary windings all delivering different combinations of current and voltage to suit the tubes attached to them.

An iron core auto-transformer is indicated by the symbol in Figure 16.

CONDENSER SYMBOLS.

A fixed condenser of any kind, any condenser which is not variable in its capacity is indicated by the symbols of Figure 17. The one at the left is the standard symbol for all non-polarised condensers. This takes in all types having a dielectric of either treated

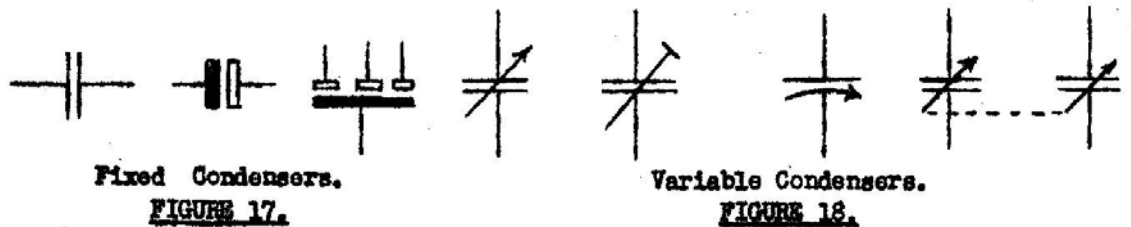

paper, mica, oil, or ceramic. The centre symbol in Figure. 17 is most commonly used to indicate an electrolytic condenser. This is a polarised type and must be connected into a circuit the right way round to avoid damage to itself and associated equipment. With this symbol the heavily shaded rectangle represents the negative plate of the condenser while the unshaded rectangle represents the positive plate. In some circuits the symbol for an electrolytic condenser is similar to the one shown at the left of Figure 17 but with positive and negative polarity markings to show which way the condenser is connected into the circuit.

In present day radio and television receivers and audio frequency amplifiers, considerable use is made of multiple condensers. Those are units containing several capacitors in a single container. Although multiple condensers are principally of the electrolytic type, this method of manufacture is also applied to condensers of the non-polarised type. A symbol at the right of Figure 17 shows a multiple electrolytic condenser containing three separate units, A common negative connection is used as shown by the long shaded rectangle, while the individual capacities are shown as separate unshaded rectangle, representing the positive plates.

Through the years the symbol for a variable condenser has undergone a number of changes, but finally standardisation has come in the form as shown by the symbols of Figure 18. Variable condensers are principally of two types, those used for continuously variable tuning over a particular band, the medium wave broadcast band for instance, and those whose capacity can be adjusted only through a narrow range. Those latter types are commonly called trimming condensers and they are used principally to “trim” a tuned circuit by bringing its total distributed capacity to a desired figure. The symbol for a “wide band” tuning condenser is shown second from the right in Figure 18. The fixed plates are represented by the heavily shaded rectangle while the moving plates are represented by the curved line with arrowhead.

In the average radio receiver there are at least two condensers of this type, both of which are operated from a single tuning control. The technical term for this type of condenser is a "tuning gang" or a "ganged" condenser. To indicate that the condensers are "ganged" and therefore operated by the one tuning control, the moving plates are connected by a broken line as shown at the right of Figure 18. "Ganged" condensers are not necessarily close together in a complete circuit, on the contrary, they are usually placed at some distance from each other on the printed circuit diagram but as long as the moving plates are joined by the dotted or broken lines, there is no doubt that the two sets of moving plates are joined mechanically and will both move together.

The two symbols at the left of Figure 18 represent the previously mentioned "trimmer" condensers of the semi-adjustable type. The condensers are termed semi-adjustable because, unlike the main tuning condenser, they are adjusted, not by a knob on the front panel of the receiver, but by a screw driver-like instrument called an alignment tool. The symbol at the left is the one most commonly used, although the one shown second from the left is often seen, particularly in circuits of English origin.

RESISTOR SYMBOLS.

The symbol for a plain fixed resistor of any kind is shown at the left in Figure 19. The centre symbol of Figure 19 represents a resistor with a sliding contact arm, such as may be used in series with any line to control voltage and current flow. Another way of showing a variable resistor is with the symbol at the right hand side of Figure 19.

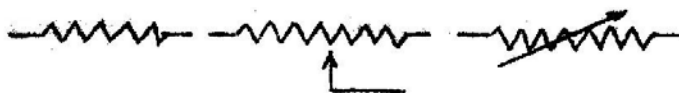

Fixed and Adjustable Resistors.

FIGURE 19.

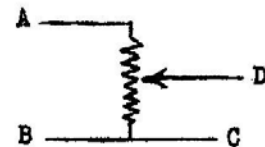

Potentiometers.

FIGURE 20.

Quite often in radio work we use a voltage dividing device called a "potentiometer". The symbol for which is shown in Figure 20. There is a steady flow of current and a consequent drop of voltage between points "A" and "B". The current and voltage to be used in another circuit are taken off between point "C" and the sliding contact "D". By moving "D" it is possible to apply any desired voltage to the circuit connected between "C" and "D". A potentiometer is commonly used in radio receivers as a volume control. The component controls the signal voltage delivered by the receiver's detector to the audio frequency amplifying stages and so varies the loudness of the sound heard from the loud speaker.

CONNECTING PARTS TOGETHER.

Of course, you know that wires forming electric circuits are shown by straight and curved lines. When two or more wires are joined we indicate the fact with a dot at the junction of the wires as shown at the left of Figure 21. If two or more lines cross without any dot at the point of apparent physical junction, this indicates that there is no electrical connection between these particular wires. This is shown at the right hand side of Figure 21. Some circuit draughtsmen, to avoid any possibility of error, use the "loop-over" effect shown in Figure 22 to

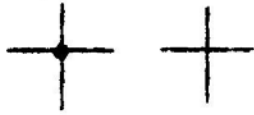

Wires Joined.

FIGURE 21.



Wires Crossing Without Joining.

FIGURE 22.

show that there is no electrical connection between two wires which have crossed over on the circuit diagram. This scheme is sometimes used even when the dotted junction for joined wires is employed but sometimes where “loop-over” is used to indicate no-connection, the junction of wires even without any dot at the junction is accepted as satisfactory indication that electrical connection exists. In reading circuit diagrams, therefore, one should be alert to this possibility. A safe rule to observe is that, if no dotted junctions appear at any point in the circuit but the “loop-over” method is used to indicate no-connection, one may be certain that all crossing of wires other than where a “loop-over” exists, indicates electrical connection.

SWITCHES.

Switches which May be opened And closed are shown by the symbols in Figure 23. On the extreme left are two types of single pole single throw switches. These types are used primarily as on-off switches. They simply make or break a circuit as required. In the centre is a double pole single throw switch symbol. This is also a simple on-off type of switch but it may be used to break both sides of one particular circuit or one side of two entirely different circuits. This type is sometimes used in battery-operated receivers where one pole is used to make or break the valve filament circuit while the other pole is used to make or break the high tension battery positive lead. At the right hand side of Figure 23 are two examples of double throw switch symbols. The top one is a double-pole double-throw type while the bottom symbol represents a single pole double throw type.

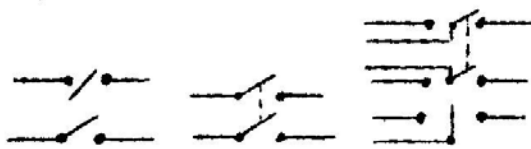

Switches.
FIGURE 23.

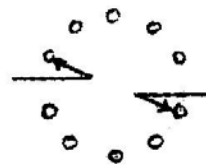

Plug One Type of Jack.

FIGURE 24.

Many switches used in modern equipment are of the rotary or so-called wafer type. Those switches come in a variety of multiple contact arrangements, and are too numerous to illustrate individually. The example we have chosen is a two pole 5 contact type. This is commonly known as a two by five type. As you can see from the diagram at the left hand side of Figure 24. this particular component will allow two circuits to be switched to five different positions. Switch symbols are comparatively simple and once you are familiar with the basic types as illustrated here, multiple types become more or less self explanatory.

A "jack" is a device for making rapid connection between circuits and, perhaps, at the same time bringing about other circuit changes by causing the insertion of a plug into the jack to make or break a number of separate circuits. You may have seen a telephone switchboard operator using these components. A jack plug is shown at the centre of Figure 24 while the jack with which it is used is shown at the right hand side of Figure 24. The jack shown is a double contact type and insertion of the plug will connect a circuit terminating in the plug to a circuit connected to the jack, at the same time the plug will push upwards the top contact on the jack and disconnect it from the centre contact. Like switches, jacks come in a variety of types but, if you are familiar with a basic type as illustrated by Figure 24, you should have no difficulty in analysing the more complex types. Jacks are very rarely seen on radio receivers, although they are not infrequently found on amplifiers either of the public address type or for high quality reproduction of recorded music.

VALVE SYMBOLS.

We are fortunate that the position with valve symbols is comparatively simple. A few years ago the situation was bordering on the chaotic because of the lack of agreement among technical draughtsmen regarding the manner in which even a simple valve such as a triode should be symbolised, in fact some of them must have spent many a sleepless night trying to figure out additional and even more confusing ways of drawing the symbol for this one particular type, - not forgetting the dozens of other types of valves to which they could devote their attention. Today the position is quite straightforward. So straightforward, in fact, that once you are familiar with the now

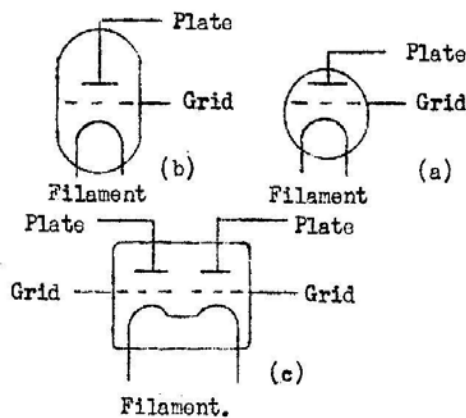

FIGURE 25.

standard symbols for the diode and triode valve, no difficulty will result in figuring out the function, in a circuit, of the multiple electrode types such as tetrodes, pentodes, octodes etc., whether they exist singly or in combination.

Figure 25(a) shows the now standard method of symbolising the directly heated or filament type triode, so far as the disposition of electrodes is concerned. There is still a little latitude regarding the shape of the valve envelope. Some circuit draughtsmen show the envelope as a true circle as at (a) in Figure 25, while others prefer the semi elliptical shape as shown by Figure 25(b). The filament is generally shown as an inverted "U". the grid appears as a broken line, while the plate is in the form of a heavily shaded rectangle. In some cases the plate may

appear as a single comparatively thin line, but this is unimportant, Figure 25(c) shows a common method of depicting a twin-triode valve, that is, two triode valves in a single glass envelope.

Figure 26(a) also shows a triode symbol but with a slight difference. This variety is known as an indirectly heated, or just heater, type valve. The heater when it

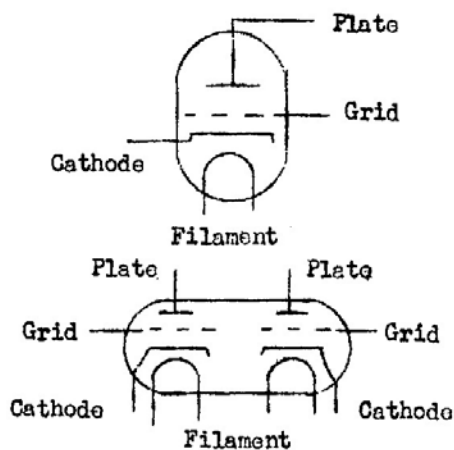

FIGURE 26.

is shown has generally the same form as the filament in a directly heated type, that is, an inverted "U" shape. The symbol at Figure 26(a) is still a triode in spite of the apparent addition of a fourth element. The important thing to remember here is that the heater is not an element in the same sense Filament that cathode, grid and plate are elements. The sole function of the heater is to bring the cathode to the temperature required for adequate emission of electrons. It is not directly associated in any way with the valve's "signal" circuit although sometimes due to faults within the valve it may contribute unwanted signals in the form of Filament "hum" and other forms of noise. Because of the "inert" nature of the heater, it is not customary, in drawing a circuit diagram, to include the complete heater circuit as is necessary when the circuit employs directly heated filament type valves. Some circuits, in fact, do not show the heater

at all, its presence is implied by the use of a cathode.

At (b) in Figure 26 another symbol for a twin triode valve is shown. As you can see as well as being of the heater type it is also drawn in a somewhat different manner. This particular symbol is used when each section of the valve is functioning in different parts of a circuit. The valve is shown as two separate units by simply splitting the envelope in half and placing each section in its appropriate portion. If, in a particular circuit diagram, a valve so treated was labeled "V5", one part would be shown as V5A and the other as V5B.

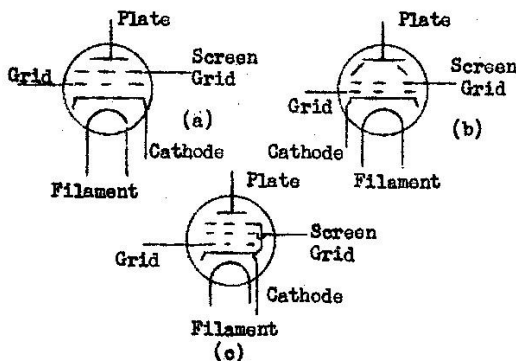

FIGURE 27.

As we stated earlier in this lesson, the ability to recognise a simple triode symbol gives one the key to recognition of the more complex types of valve because they are, after all, merely extensions of the basic triode. For instance, look at Figure 27(a). This symbol represents a "screen-grid" tetrode, a type of valve introduced during the mid 1920s, which remained in popular use as a radio frequency amplifier for several years. The symbol is equivalent to that of a triode with an *additional* grid located between the plate and the first grid. This type is no longer used

In present day receivers, but one is still likely to encounter older equipment in which they are employed. There is, however, a type of tetrode which is widely used in modern radio and television receivers called a "beam" power tetrode, or simply beam tetrode. The symbol for this latter type is frequently the same as that used for the older "screen-grid" tetrode, but occasionally it is shown as in Figure 27(b), with two short diagonal lines near the plate to represent, the "beam" forming plates. Although in practice the "beam" plates are normally connected to the cathode, usually internally, where they appear as a symbol they are generally left "floating".

There is yet another alternative for illustrating a "beam" tetrode (Figure 27(c)). This is exactly the same as the symbol for a pentode valve but some circuit designers prefer to use it because, in spite of its four elements, the "beam" tetrode behaves very like the five element pentode. This state of affairs would appear to open up a fine field for complete and utter confusion, but in reality it does not. Because first of all "screen-grid" tetrodes and "beam" tetrodes belong to different decades. There is little likelihood of both types appearing in the same circuit diagram, Secondly, the location of the valve symbol in a circuit diagram gives more than just a clue to the function of the valve which it represents, and thirdly, when either type is used in the power output stage of a receiver or amplifier, the manner of connecting it into the circuit is the same, so that it really does not matter whether one thinks of the valve as a tetrode or a pentode. That is all we need say about these two types at present. In later lessons you will learn much more about valves, Their Function and Application, and how apparently similar types may differ one from the other.

MULTI-ELEMENT VALVES.

The symbol for a pentode valve differs from that of a screen grid valve in that it has an additional grid in between the screen and the plate. In a pentode the screen is sometimes called an accelerator grid or it may also be called a, space charge grid, an auxiliary grid, or simply a screen. The additional element is called the, suppressor grid. A pentode may either be of the filament type or the heater type.

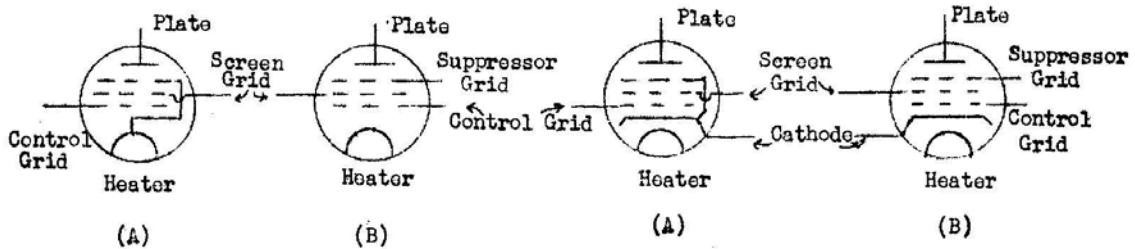

FIGURE 28.

FIGURE 29.

“The Radio-T.V. Training Centre”

**E. S. & A. BANK BUILDINGS, Corner CITY RD. and BROADWAY, SYDNEY
Telephones: BA4891 and BA4892**

AUSTRALIAN RADIO AND TELEVISION COLLEGE PTY. LTD.

Telegrams “RADIOCOLLEGE” Sydney

This lesson sheet is published for the exclusive use of
students of the Australian Radio and Television College
Ptv. Ltd. (All rights reserved)

Post Lessons to Box 43, Broadway

LESSON NO. 9M1

Everybody is more or less familiar with arithmetic but a little review of this subject is good for any practical man and unless you are sure you can handle it thoroughly, you should go over this lesson very carefully.

Arithmetic may be divided into five parts, namely: Addition, Subtraction, Multiplication, Division and Fractions.

Division may be divided into two classes, Long and Short Division, Fractions may be divided into common fractions and decimal fractions. Fractions are not a mathematical process such as addition, subtraction etc., but are merely an application of these processes to fractional parts of a unit, instead of whole units.

A unit is one complete thing. If one has a number, say 4,326, the 6 will occupy the UNITS place, because it represents the smallest value of the combination. The 2 represents 2 single units. The second figure from the right occupies the ten's place, and means that all figures in that place are multiplied by 10. In this case we have $2 \times 10 = 20$ + 6 = 26. The third figure from the right represents a still higher value. This number represents a value 10 times as great as the second figure, or 10 times 10 which is 100. This means that the figure occupying that place is multiplied by 100. In this case the figure is 3, which means that 3 is multiplied by 100, which equals 300. The fourth figure represents thousands, and means that all numbers in this place are multiplied by 1000. In this case we have 4, which means that 1000 is multiplied by 4. Our combination then contains 4 one thousands, 3 one hundreds, 2 tens, 6 ones. The total value of this combination is the sum of 4000 300 20 6, which is 4,326 units.

ADDITION.

Addition is probably the simplest of any mathematical calculation. Many errors are made in addition, but these are due to carelessness, as the process is very simple.

The symbol for addition is plus, written (+). This symbol means that the numbers which it connects are to be added together. For example, $3 + 2$ means that 2 units are to be added to three units. 3 units plus 2 units equals 5 units.

Where numbers are to be added they are usually written in vertical columns, and the result or sum placed under a horizontal line at the bottom. Thus:

$$\begin{array}{r} 3 \\ \hline 5 \end{array}$$

Any number of more than 9 units necessitates the use of two or more figures in expressing it. For example, 22, 46, 89, etc. The process of adding numbers of two or more figures is a little more complicated than adding units, but is practically the same.

For example, one may wish to find the sum of $22 + 33$. We will first place the numbers in a vertical column, and draw a horizontal line under them. It will be noticed that the units figures are directly under each other, and also the ten's figures, so that units are always added to units, and tens to tens, etc. We now add the figures in the units column and place the result below the horizontal line. We then do the same with the tens column. This gives us 5 tens, and 5 units, or 55. Thus:

$$\begin{array}{r} 22 \\ 33 \\ \hline 55 \end{array}$$

Larger numbers will involve a little more work. For example, we wish to find the sum of $56 + 98 + 47$. First we place our figures in a vertical column as in the previous example. We then add the right hand or units column, and find the sum to be 21. We place the 1, or unit figure, under the horizontal line, but the 2 or tens figure we place to the next column. Adding the second column we find the sum to be 18. To this we add the 2, which we carried over from the units column, and place the total number under the horizontal line, making a total sum of 201.

Thus:

$$\begin{array}{r} 56 \\ 98 \\ 47 \\ \hline 201 \end{array}$$

For any numbers larger than the above, the process is the same.

Examples for practice:

- Add the following numbers
- (1) 141, 3546, 456, 77 =
 - (2) 2176, 78,23, 5642, 4357 =
 - (3) 56714, 3, 2416, 12, 314, 2617, 2312 =

SUBTRACTION

Subtraction is the direct opposite of addition. Addition is finding the sum of two or more numbers, while subtraction is finding the difference in value of two numbers. The result obtained in subtraction is called the remainder.

The remainder is left, or remains after one number has been subtracted, or taken, away from another. The symbol for subtraction is called minus, and is written (-). Whenever this symbol appears, it means that one of the numbers which it connects is to be subtracted from the other. In subtracting one number from another, the number to be subtracted is placed under the number it is to be subtracted from. The units number of the number to be subtracted must be placed under the units number of the number subtracted from. This must also be observed regarding the figures representing tens, hundreds, thousands, etc.

The process followed in subtraction is as follows. Suppose we wish to find the difference between 366 and 142. First we place the 142 under the 366, in such a manner that like figures occupy places of like value. That is units are placed under units, tens under tens, etc. Having done this we subtract one value at a time, commencing from the units side. We first subtract the 2 units from the 6 units which leaves 4 units, which we place in the units space below the horizontal line. We then subtract the 4 tens from the 6 tens, leaving 2 tens, which we place below the horizontal line. We then subtract the 1 hundred from the 3 hundred, leaving 2 hundred, which we place in the hundreds space below the line. This gives us a remainder of 224. Thus: 366

$$\begin{array}{r} 366 \\ -142 \\ \hline 224 \end{array}$$

In cases where the number subtracted has less figures than the number subtracted from, the figures in the upper row are brought down to the remainder without being changed. For example -- we wish to subtract 122 from 26486.

Place the 122 under 26486 as previously explained, Subtract the 2 from the 6, on the right hand side, which leaves 4. Subtract the next 2, from 8 which leaves 6. After the first three figures are subtracted there is nothing left to subtract, so the 6 and 2 are simply brought down to their proper place in the remainder, giving a remainder of 26364. Thus:

$$\begin{array}{r} 26486 \\ -122 \\ \hline 26364 \end{array}$$

In cases where the unit to be subtracted is larger than the unit from which it is to be subtracted, it may be taken from the next figures on the left hand side in the upper row and added to the figure which will increase its value by ten. For example, suppose we wish to subtract 88 from 196. Arrange the numbers as before, 8 cannot be subtracted from 6 so we take 1 from the 9 in the tens column and add it to the 6. This now adds 10 to the 6, making it 16. Then 8 from 16 leaves 8. The 9, however, has had 1 taken from it, so it is now only 8. Then 8 - 8 = 0, the second figure in the remainder. There is nothing to subtract from the 1, so it is carried down to its place in the remainder, leaving a remainder of 108. Thus: 196

$$\begin{array}{r} 196 \\ -88 \\ \hline 108 \end{array}$$

Examples for practice:
 From 108 take 34 =
 Take 7024 from 10000 =
 6782 - 5694 =

MULTIPLICATION.

Multiplication is the process of finding the sum of one number taken a given number of times. Multiplication is in reality a short method of addition. For example, if we wish to find the sum of 25 times 36, instead of putting 25, thirty-six times in a column and adding them, we multiply 36 by 25, which gives the same result and is a shorter method.

The result obtained in multiplication is called the product. The number which is multiplied is called the multiplicand, the number which we multiply by is called the multiplier. In the example 20 multiplied by 10 = 200,

10 is the multiplier, 20 is the multiplicand, and 200 is the product. The process of multiplication is as follows: First place the multiplier under the multiplicand, and draw a line under it. Then start multiplying, commencing at the right, and taking one figure at a time. If the result obtained by multiplying one figure is more than nine, put down the unit, and add the "tens" figure to the result obtained from the next figure of the multiplicand. For example, we wish to multiply 143 by 5. First place the number as explained above. Then multiply the 3 by the 5, which is 15, 15 is more than nine, so we put down the 5, and carry the 1 to the next figure. Next multiply the 4 by the 5, which is 20. To this we add the 1, which we carried from the preceding number, which makes 21. We put down the 1 and carry the 2. We then multiply the 1 by the 5, which is 5. To this we add the 2 which we carried, making 7, and the total result is 715.

Thus: 143

$$\begin{array}{r} 5 \\ \hline 715 \end{array}$$

In cases where the multiplier contains more than one figure, multiply the multiplicand by each figure in the multiplier. Place the first product under the horizontal line, place the second product under the first result, only place it one space to the left. Do this with each succeeding result. Then draw a line under them, and add them all together. For example, multiply 426 by 324. First place the problem as previously stated. Multiply the 426 by the 4, following the method outlined in the preceding example. This gives a product of 1704. Next multiply by the 2, placing this product under but one space to the left. Then multiply by the 3, placing this product under the second product, and one space to the left. Then draw a line under them and add, which will give you the total product of the two numbers multiplied, which in this example is 138,024.

Thus: 426

$$\begin{array}{r} 324 \\ \hline 1704 \\ 852 \\ \hline 1278 \\ 138024 \end{array}$$

Examples for practice:

Multiply 7821 by 15 =

Multiply 1456 by 147 =

Multiply 5235 by 505 =

DIVISION

Division is the process of finding how many times one number is contained in another. For example, if we wish to divide anything into a certain number of equal parts, by division we can determine the exact size of each part. The result obtained in division is called the quotient. The number divided is called the dividend, and the number by which the dividend is divided is called the divisor. Division is the opposite of multiplication, just the same as subtraction is the opposite to addition. To divide one number by another, place the divisor on the left hand side of the dividend and draw a dividing line between them. Then start dividing at the left, dividing one figure at a time. If the first figure is smaller than the divisor, take the first two figures.

If there is a remainder after dividing one figure, carry the remainder on to the next. For example: Divide 12424 by 4. first place the number as explained above, then start dividing commencing at the left. 4 will not be contained in 1, so we consider the first two figures, or 12. Then 4 in 12, three times. Place the 3 above the line and proceed to the next figure which is 4. 4 is contained in 4 once, so place the 1 above the line. 4 will not be contained in 2, so we place an 0 above the line and carry the 2 to the next figure, thus making it 24. Then 4 is contained in 24 six times, which completes the problem, and gives a result or quotient of 3106.

Thus:
$$\begin{array}{r} \underline{3106} \\ 4 \overline{)12424} \end{array}$$

This process is called short division and is used when the divisor contains only one figure. In cases where the divisor contains more than one figure, a process called long division is used,

Examples for practice:

Divide 6354 by 2 =

Divide 900072 by 4 =

Divide 1134657 by 9 =

LONG DIVISION.

In long division, divide as in short division, with the exception that in long division instead of proceeding to the next figure we multiply the divisor by the quotient, place the result under the dividend, subtract it from the dividend, and divide the remainder by the divisor to obtain the next figure of the quotient. For example, we wish to find how many times 46 will be contained in 1058. First place the divisor, which is 46, a little to the left of the dividend, which is 1058, then draw a dividing line between them, and over the dividend. Then divide 46 into the first three figures of the dividend, which is 105. 46 will be contained in 105 two times. So we place a 2 above the line. Then we multiply the divisor by the quotient (2) and place the result below the 105, $2 \times 46 = 92$ so we place 92 below 105, and subtract, which gives us a remainder of 13. We next bring down the 8, so we now have a dividend of 138. We then divide the dividend of 138 by the divisor 46. 46 is contained in 138 three times, so we place a 3 above the line in the quotient. Then multiply the divisor 46 by 3, which we just placed in the quotient, and place the result below the dividend 138. $3 \times 46 = 138$. Place this below the dividend 138, and subtract. 138 subtracted from 138 leaves no remainder, and there are no more figures to bring down from the original dividend, so the problem is complete, and the quotient is 23, which means that 46 is contained in 1058 exactly 23 times. Thus:

$$\begin{array}{r} \underline{23} \\ 46 \overline{)1058} \\ \underline{92} \\ 138 \\ \underline{138} \end{array}$$

Examples for practice:

Divide 20,000 by 125 =

Divide 27,365 by 421 =

FRACTIONS.

A fraction is a part of anything which is less than one complete unit. Fractions may be added, subtracted, multiplied and divided, the same as a whole number can. A fraction represents the number of parts taken. For example, the fraction $\frac{4}{5}$ means that the whole is divided into five parts, and the fraction represents 4 parts of those parts.

The figure representing the number of parts into which the number is divided is written below a horizontal line. The figure representing the number of parts represented by the fraction is written above the line. The number above the line is called the numerator, and the number below the line is called the denominator. To add two or more fractions, first reduce them all to the same common denominator. Then add the numerators and, if their sum is greater than the denominator, divide by the denominator. For example, add $\frac{2}{3} + \frac{4}{5} + \frac{5}{6}$. First find a common denominator. 30 is the smallest number which will evenly contain 3, 5 and 6. Therefore, 30 is the lowest common denominator. Then find $\frac{2}{3}$ of 30, $\frac{4}{5}$ of 30 and $\frac{5}{6}$ of 30. $\frac{2}{3}$ of 30 = 20, $\frac{4}{5}$ of 30 = 24, and $\frac{5}{6}$ of 30 = 25. Then add these numerators 20, 24 and 25 together which will give a fraction of $\frac{69}{30}$. The numerator is larger than the denominator, so we will divide it by the denominator. $69 \div 30 = 2 \frac{9}{30}$. Therefore, $\frac{2}{3} + \frac{4}{5} + \frac{5}{6} = 2 \frac{9}{30}$.

LEAST COMMON DENOMINATOR.

The example above contains such denominators that their least common denominator can be seen by inspection to be 30. However, in many cases it will be necessary to find it as follows. Divide the denominator by a number that will equally divide two or more of them, then divide the remaining numbers and quotients by another number that will equally divide two or more of them. Continue this process as far as possible. The least common denominator then is the product of all the divisors and the numbers left. Example:- Find the least common denominator of $\frac{8}{35}$, $\frac{7}{30}$, $\frac{11}{45}$, and $\frac{5}{80}$.

$$\begin{array}{r} 5 \overline{)35, 30, 45, 80} \\ 3 \overline{)7, 6, 9, 16} \\ 2 \overline{)7, 2, 3, 16} \\ \hline 7, 1, 3, 8 \end{array}$$

Least common denominator = $5 \times 3 \times 2 \times 7 \times 1 \times 3 \times 8 = 5040$, which is also the least common multiple.

Examples for practice: Add $\frac{1}{2}$, $\frac{2}{3}$, $\frac{1}{4} =$
 Add $\frac{1}{6}$, $\frac{1}{8}$, $\frac{3}{4} =$
 Add $\frac{1}{2}$, $\frac{3}{4}$, $\frac{3}{8} =$

SUBTRACTING FRACTIONS.

To subtract fractions, reduce them to a common denominator and subtract the numerator. For example, subtract $\frac{1}{3}$ from $\frac{3}{4}$. First we must find a common denominator. The lowest number which will contain both 3 and 4 is 12. Therefore, 12 is the common denominator. Reduce the fractions to fractions having 12 as a denominator. This changes $\frac{3}{4}$ to $\frac{9}{12}$, and $\frac{1}{3}$ to $\frac{4}{12}$. Reducing fractions in this way does not change their value, as $\frac{3}{4}$ has the same value as $\frac{9}{12}$. Having reduced them to a common denominator, we subtract the numerator 4 from the numerator 9 which leaves a remainder of $9-4 = 5$ or $\frac{5}{12}$. Therefore, $\frac{3}{4} - \frac{1}{3} = \frac{5}{12}$.

Examples for practice:
 $\frac{3}{4} - \frac{5}{16} =$
 $\frac{5}{7} - \frac{3}{5} =$
 $\frac{9}{10} - \frac{4}{15} =$

MULTIPLICATION OF FRACTIONS.

To multiply fractions, multiply the numerators together, and multiply the denominators together. This will give the product of the fractions. For example, multiply $\frac{3}{4}$ by $\frac{4}{5}$. All that is necessary is to find the product of the numerators and also of the denominator. The product of the numerators is 12. $3 \times 4 = 12$. Therefore, the numerator in the answer will be 12. The product of the denominator is 20. $4 \times 5 = 20$. Therefore, the denominator in the answer will be 20, and the answer is $\frac{12}{20}$. Thus $\frac{3}{4} \times \frac{4}{5} = \frac{12}{20}$.

Examples for practice:

$$\text{Multiply } \frac{2}{3} \text{ by } \frac{15}{16} =$$

$$\text{Multiply } \frac{7}{8} \text{ by } \frac{32}{35} =$$

$$\text{Multiply } \frac{14}{24} \text{ by } \frac{46}{7} =$$

DIVIDING FRACTIONS.

In dividing fractions invert the terms of the divisor and multiply. For example, divide $\frac{7}{8}$ by $\frac{2}{3}$. Place the fraction the same as in multiplication, except in the divisor. The divisor, which is $\frac{2}{3}$ so inverted, will make $\frac{3}{2}$. Then find the product of the numerators and the product of the denominators, as in multiplication. This gives a result of $\frac{21}{16}$. The numerator is larger than the denominator, so we divide it by the denominator, which gives $1 \frac{5}{16}$ and $\frac{7}{8} \div \frac{2}{3} = 1 \frac{5}{16}$. Thus, $\frac{7}{8} \times \frac{3}{2} = \frac{21}{16}$ or $1 \frac{5}{16}$.

Examples for practice:

$$\text{Divide } \frac{5}{8} \text{ by } \frac{3}{8} =$$

$$\text{Divide } \frac{49}{65} \text{ by } \frac{14}{39} =$$

DECIMALS.

Decimals are the same as common fractions, except that they are always expressed in ten, or a multiple of ten. For example, $\frac{1}{2}$ would be expressed by .5, which is the same as saying $\frac{5}{10}$. This is shown by the decimal point which is a common period placed before the numerator. All figures on the right-hand side of this decimal point are fractional values of ten or some multiple of ten. If there is only one figure to the right of the decimal point, the fraction is expressed in tenths. If there are two figures at the right of the decimal point, the fraction is expressed in hundredths. Three figures expresses thousandths, etc. Thus:

$$.5 \text{ means } \frac{5}{10}$$

$$.05 \text{ means } \frac{5}{100}$$

$$.326 \text{ means } \frac{326}{1000}$$

In adding and subtracting decimals they should always be written so that the decimal points will be directly under each other, otherwise the fractional value will become mixed up with the whole numbers. In adding decimal fractions, place them with the decimal points under each other, and add. For example, add 256.5, 483.75, 746.045, 38.3. First place them with the decimal points directly under each other, then add the same as in whole numbers. Space off as many figures from the right as there are in the number having the largest number of spaces, and place the decimal point at this place. In this problem the largest number of spaces pointed off is three, so we point off three figures from the right and place the decimal point there. This gives a sum of 1524.595. Thus,

$$\begin{array}{r}
 256.5 \\
 483.75 \\
 746.046 \\
 \underline{38.3} \\
 1524.595
 \end{array}$$

In subtracting decimals place them with the decimal points under one another and subtract as with whole numbers. For example, subtract 125.4 from 288.9. First place them with the decimal points under each other. Subtract the same as in whole numbers. Then bring the decimal point straight down to its proper place. This will give a remainder of 163.5 or $163 - 1/2$. Thus :

$$\begin{array}{r}
 288.9 \\
 \underline{125.4} \\
 163.5
 \end{array}$$

In multiplying decimals, multiply the same as whole numbers, and point off as many spaces from the right as the sum of the decimals placed in the multiplier and the multiplicand. For example, multiply 124.62 by 12.4. Multiply the same as with whole numbers, then point off the sum of the decimal spaces in the multiplier and the multiplicand. There is one decimal place in the multiplier, and two in the multiplicand. The sum of $2 + 1 = 3$, so we point off three places in the product, making the answer 3545,288. Thus:

$$\begin{array}{r}
 124.62 \\
 \underline{12.4} \\
 49848 \\
 24924 \\
 \underline{12462} \\
 1545.288
 \end{array}$$

In dividing decimals, move the decimal point sufficient spaces to the right in both the divisor and dividend to make the divisor a whole number. For instance, if there are two decimal spaces in the divisor it would be necessary to move the decimal point two places to the right to make the divisor a whole number. At the same time it is necessary to move the decimal place in the dividend two spaces to the right. If there are less than two decimal spaces in the dividend, noughts can be added to make up the required number,

Now divide the new divisor into the new dividend until the decimal point in the dividend is reached. Before continuing with the numbers on the right of the decimal point in the dividend, place a decimal point after the portion of the quotient that has already been found. Continue to divide into the dividend and place the resulting numbers on the right of the decimal point in the quotient.

For example, divide 224.112 by 48.72. There are two decimal spaces in 48.72 so that the decimal point has to be moved two spaces to the right to make this a whole number which is 4872. As we have moved the decimal point in the divisor two places to the right we must do the same thing with the dividend which then becomes 22411.2. Divide the new divisor into the new dividend until the decimal point is reached and before continuing with the numbers on the right of the decimal point, place a decimal point after the portion of the quotient already found.

$$\begin{array}{r} \underline{4} \\ 4872 \overline{)22411.2} \\ \underline{19488} \\ 2923 \end{array}$$

Continue to divide into the dividend in the ordinary manner of long division and place the resulting numbers to the right of the decimal point in the quotient.

$$\begin{array}{r} \underline{4.6} \\ 4872 \overline{)22411.2} \\ \underline{19488} \\ 29232 \\ \underline{29232} \end{array}$$

Here are two other examples worked out for you. Follow through these carefully and make sure that you understand just how they are done.

Divide 14.035 by 3.5 :-

$$\begin{array}{r} \underline{4.01} \\ 35 \overline{)140.35} \\ \underline{140} \\ \dots 35 \\ \underline{35} \end{array}$$

Divide 966 by 4.2

$$\begin{array}{r} 42 \overline{)9660} \\ \underline{84} \\ 126 \\ \underline{126} \\ \dots 0 \end{array}$$

At various points throughout this lesson there are examples given for practice. The answers to those examples are set out below. Check through these answers and see how many you have worked out correctly. If you haven't already worked out the examples, do so straight away, before looking at the answers.

- | | |
|---------------------------------------|-----------------------------------|
| 141+3546+456+77 = 4220 | 27.365 ÷ 421 = 65 |
| 2176+7823+5632+4357 = 19998 | 1/2 + 2/3 + 1/4 = 1 5/12 |
| 56714+3+2416+12+314+2617+2312 = 64388 | 1/6+1/8+3/4 = 1 1/24 |
| 198-34= 164 | 1/2 + 3/4 + 3/8 = 1 5/8 |
| 10000 - 7024 = 2976 | 3/4 - 5/16 = 7/16 |
| 6782 - 5964 = 1088 | 5/7 - 3/5 = 4/35 |
| 7824 x 15 = 117360 | 9/10 - 4/15 = 19/30 |
| 1456 x 147 = 214032 | 2/3 x 32x35 = 30/48 or 5/8 |
| 5235 x 505 = 2543675 | 7/8 x 32/35 x = 224/280 or 4/5 |
| 6354 ÷ 2 = 3177 | 14/24 x 46/7 = 644/168 or 23/6 |
| 900072 ÷ 4 = 225018 | or 3 5/6 |
| 1134657 ÷ 9 = 126073 | 5/8 ÷ 3/8 = 40/24 or 5/3 or 1 2/3 |
| 20,000 ÷ 125 = 160 | 49/65 ÷ 14/39 = 1911/910 or |
| | 21/10 or 2 1/10 |

EXAMINATION QUESTIONS - 9M1.

- (1) (a) Add the following numbers:
4926, 3478, 5220, 9651, 4827, 5916, 1324, 5265.
(b) Subtract 38004 from 40001.
- (2) (a) Multiply 1856 by 799.
(b) Divide 4434288 by 637.
- (3) (a) Add $\frac{7}{16}$, $\frac{5}{12}$, $\frac{5}{8}$, $\frac{3}{4}$.
(b) Add $\frac{7}{18}$, $\frac{8}{9}$, $\frac{3}{14}$, $\frac{5}{7}$.
- (4) (a) Subtract $\frac{4}{15}$ from $\frac{9}{10}$.
(b) From $\frac{3}{4}$ take $\frac{5}{18}$.
- (5) (a) Multiply $\frac{3}{8}$ by $\frac{14}{27}$.
(b) Multiply $\frac{4}{5}$ by $\frac{9}{16}$.
- (6) (a) Divide $\frac{9}{16}$ by $\frac{3}{4}$.
(b) Divide $\frac{4}{5}$ by $\frac{3}{10}$.
- (7) Add the following numbers: 6.3, 4.72, 98.46, 54.3, 78.25.
- (8) (a) Subtract 18.9 from 47.02.
(b) from .9 take .0482.
- (9) Multiply 100.3 by .00405.
- (10) Divide 324.8 by 4000.

“The Radio-T.V. Training Centre”

**E. S. & A. BANK BUILDINGS, Corner CITY RD. and BROADWAY, SYDNEY
Telephones: BA4891 and BA4892**

AUSTRALIAN RADIO AND TELEVISION COLLEGE PTY. LTD.

Telegrams “RADIOCOLLEGE” Sydney

This lesson sheet is published for the exclusive use of students of the Australian Radio and Television College Ptv. Ltd. (All rights reserved)

Post Lessons to Box 43, Broadway

LESSON NO. 10

PUTTING ELECTRICITY TO WORK IN THE RADIO
CIRCUIT

We often wish to change the amount of current flowing in the various circuits of radio receivers and transmitters. We may want to change or control the current flowing in the filament of a radio tube, we may want to change or control the amount of current flowing in a tube's plate circuit, or we may want to control the amount of current in numerous other circuits to secure results which we desire. We secure this control by means of resistance.

In a water circuit the amount of water passing is controlled by a valve as at the top of Fig. 1. The valve, according to its position, offers more or less opposition or resistance to the flow of water. By turning the valve handle the water is regulated.

To control electric current, especially direct current, we use a rheostat which may be made to offer more or less resistance to the flow of electric current just as the water valve resists flow of water through it. As you can see at the bottom of Fig. 1, a rheostat consists of a considerable quantity of wire wound on to a form. An adjustable arm makes contact with the resistance wire. This arm may be turned by means of a knob on a shaft.

If current is flowing from “A” to “B” through the rheostat, moving the arm further

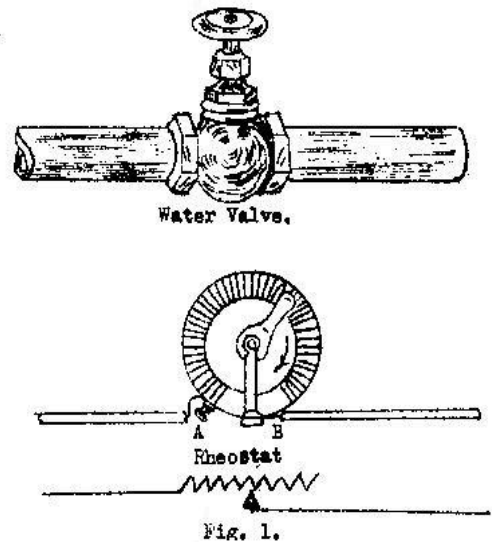

around in the direction shown by the arrow will cause the current to pass through more of the resistance wire. Consequently, with more resistance in the circuit, it will be more difficult for the current to flow and less current will pass through wires connected to the rheostat. Moving the contact in the other direction will allow the current to flow through less resistance and more current will flow. The symbol for a rheostat is shown in Figure 1.

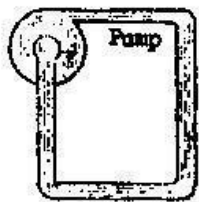

FIGURE 2.

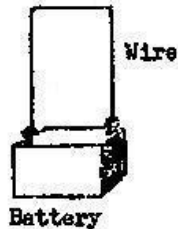
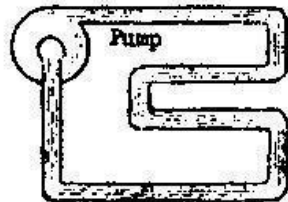

FIGURE 3.

THINGS WHICH AFFECT RESISTANCE.

It is perfectly evident that water driven by the pump through the short pipe at the left hand side of Figure 2 meets with less resistance to its flow than water driven through the longer pipe at the right. Likewise, if the pump is capable of exerting only a certain amount of pressure on the water, less water will be sent through the long pipe than through the short one in a given time.

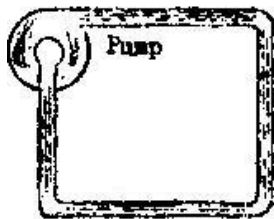

Figure 4.

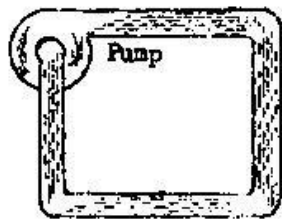

Figure 5.

The same rules apply to the electric circuits in Figure 3. There is less resistance in the short wire at the left than in the long one at the right, and if the voltage is the same in both batteries, less current will flow through the long wire than through the short one.

At the left hand side of Figure 4 there is a water pump forcing water through a very small pipe and at the right hand side the same pump is forcing water through a large pipe. It is easy to realise that the pump can drive more water through the large pipe than through the small one.

In Figure 5 at the left a battery is connected to a very thin wire and at the right the battery is connected to a large wire, The battery will force more electric current through the big wire than through the small one because the big wire has less electrical resistance than the small wire,

KINDS OF CIRCUITS.

Look at the circuit of Figure 6, Electrons start out from the battery's negative

terminal, flows through the valve filament, then through the rheostat, then through the switch and back again to the battery. This sort of circuit is called a “series” circuit because all of the electricity that leaves the battery must go through the filament, through the rheostat, through the switch and through every wire in the circuit. The definition of a series circuit says that all the current must go through all the parts.

Now look at Figure 7. One battery is connected to the filaments of three tubes. Trace out the path of current from one side of the battery around through the circuit and back to the battery. This kind of circuit is called a “parallel” circuit because the battery current divides part going through each of the tubes. You can

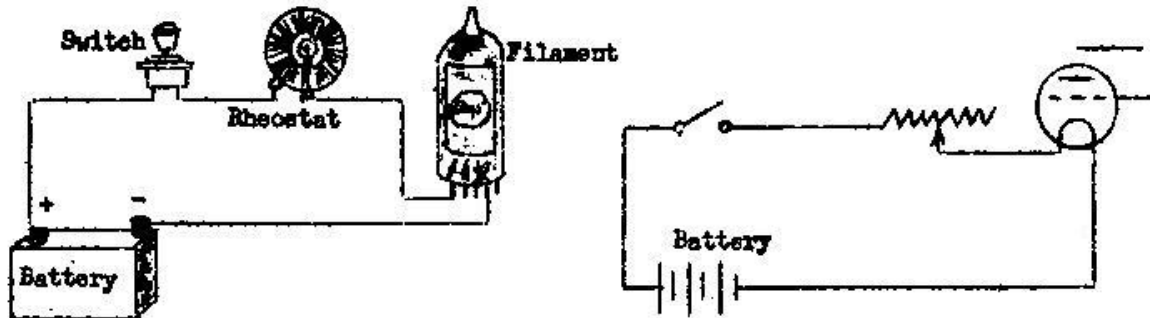

FIGURE 6.

see that the positive side of the battery connects to the positive filament terminal of each one of the three tubes, and the negative side of the battery connects to the negative terminals of all the tubes. You must remember that current divides in a parallel circuit, part taking each of the possible paths.

Notice the circuit diagram drawn out with symbols at the right hand side of Figure 6 and of Figure 7. See how much easier you can trace the circuit in this kind of a

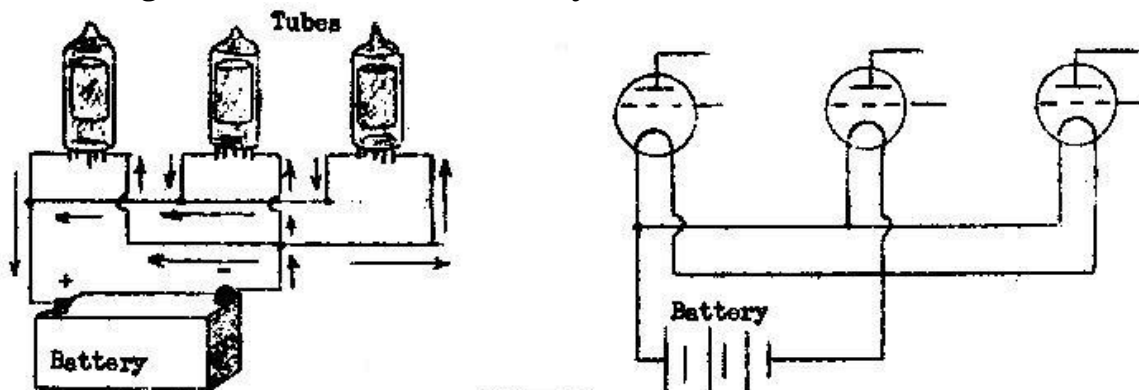

FIGURE 7.

diagram than in the picture kind. The diagram with symbols is often called a “schematic” diagram because it shows the “scheme” of things.

LEARNING WHAT HAPPENS IN A CIRCUIT.

Should you want to know just how much resistance is needed to handle a certain job

you certainly wouldn't want to fool around with a lot of different resistances until you located one that worked. Of course if you had an adjustable resistance or rheostat, it wouldn't be so bad but we don't use very many adjustable resistances for control of current in modern radio devices.

A German scientist, George Simon Ohm, discovered that there is a very definite relation between the number of amperes, the number of volts and the number of ohms in a circuit. He put his findings into a rule, one of the handiest rules we use in radio work, and the rule is called "Ohm's Law".

Ohm's law says that the number of amperes is equal to the number of volts divided by the number of ohms. We generally use letters to indicate these three electrical values "I" for current in amperes, "E" for pressure or electromotive force in volts, and "R" for resistance in ohms. Then we can write Ohm's Law this way

$$I = \frac{E}{R} \quad (1)$$

When you write one quantity above a line and write another below the line it means that you are to divide the top one by the bottom one. For example you write:

$$\frac{1}{2}$$

which means that 1 is to be divided by two or divided into two parts, each of which we call one-half. Here are some fractions made in this way and if you divide the top by the bottom you will get the answers given beside the fractions:

$$\frac{10}{2} = 5 \quad \frac{15}{3} = 5 \quad \frac{8}{8} = 1 \quad \frac{81}{9} = 9 \quad \frac{21}{7} = 3$$

In all these fractions the top is larger than the bottom and the result is a whole number which is equal to 1 or more. If the top is smaller than the bottom, the result will be less than 1 and you have a fraction.

There are two other ways in which we can state Ohm's Law, The first one, the one given above, says that the amperes are equal to the volts divided by the ohms. Another way of saying the same thing is: The resistance in ohms is equal to the number of Volts divided, by the number of amperes; or, in symbols.

$$R = \frac{E}{I} \quad (2)$$

The third statement of Ohm's Law is: The number of volts is equal to the number of amperes multiplied by the number of ohms, or:

$$E = I \times R$$

When writing "equations" "formulae" like this one the sign of multiplication (x) is omitted. Whenever you see two symbols or letters written next to each other it means they are to be multiplied together. So we write:

$$E = IR \quad (3)$$

Now, in formula (1) we have a statement of Ohm's Law by which we find the number of amperes which will flow in a circuit or in a part of a circuit when we know the resistance in ohms and the number of volts applied to the circuit or part of a circuit. We know the amperes are equal to the volts divided by the ohms.

The second form of Ohm's Law in formula (2) enables us to find out the number of ohms resistance of a circuit or part of it, when we know the number of volts applied and the number of amperes flowing.. We know that the ohms are equal to the volts divided by the amperes.

The third form of Ohm's Law in formula (3) enables us to find out the number of volts which might be acting on the circuit or part of a circuit if we know the number of amperes flowing and the number of ohms resistance. We know that the volts are equal to the amperes times the ohms.

You really must remember Ohm's Law. It is not so hard because all you have to do is remember the arrangement of symbols shown at the left hand end of Fig. 8. Just remember "E" over "I" times "R".

Now from this arrangement of symbols, if you want to find the number of volts, put your finger over the "E" (for Volts) and you read "I x R", so you know the volts are equal to the amperes times the ohms. If you want to find the number of amperes put your finger over the "I" (for amperes) and you read "E" over "R" or the volts divided by the ohms. If you want to find the number of ohms put your finger over the "R" (for ohms) and you see "E" over "I" or volts divided by amperes. Now we are going to put Ohm's Law to work.

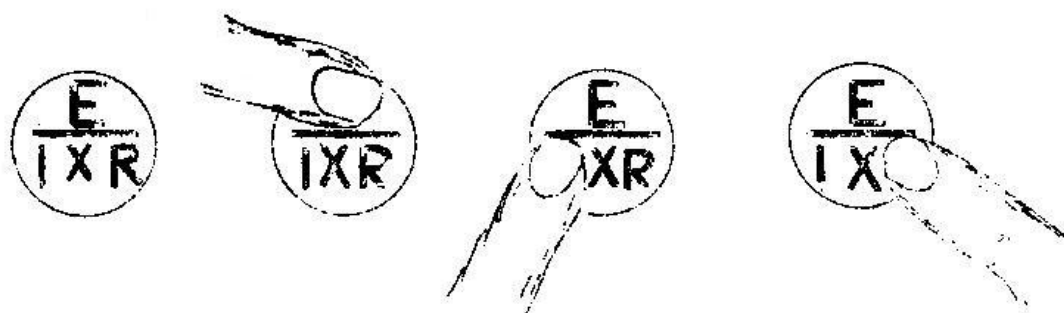

Figure 8.

USING OHM'S LAW

In Fig. 9. neglecting the resistance of the ammeter and the wiring., how many amperes flow in this circuit? Work out your own answer and write it down before you read another word.

We really do neglect the resistance of an ammeter because such an instrument has so very little of it. Also, when wires are fairly short, of good size, and carry only a very small current, we can neglect their resistance, Well, in Fig.4 the battery furnishes six volts pressure and the resistor has three ohms resistance. You know the volts and the ohms - how many amperes? Use fig. 8 put your finger over the "I" (amperes) and you see you must divide the volts by the ohms. The volts (6) divided by the ohms (3) gives 2 as the number of amperes flowing. Was your answer correct?

In Fig, 10 the two heavy wires run to the filament pins of a radio tube and an

ammeter connected in one of them reads 1 ampere. A voltmeter connected across the pins reads 6 volts. What is the resistance, in ohms, of the filament? Try this one too, before you read the answer.

Well, you want to find the number of ohms so, using Figure 8, put your finger over the "R" for ohms and you find that you should divide the volts by the amperes. The volts (6) divided by the amperes (1) gives 6 as the resistance of the tube's filament in ohms. How was your answer? In nearly all our radio work we use this very method for measuring unknown resistances. The only other easy way is with an "Ohmmeter" which is an instrument which reads directly in the number of ohms. The tube in Figure 10 in nothing imaginary, it is one of the "50" type in which the

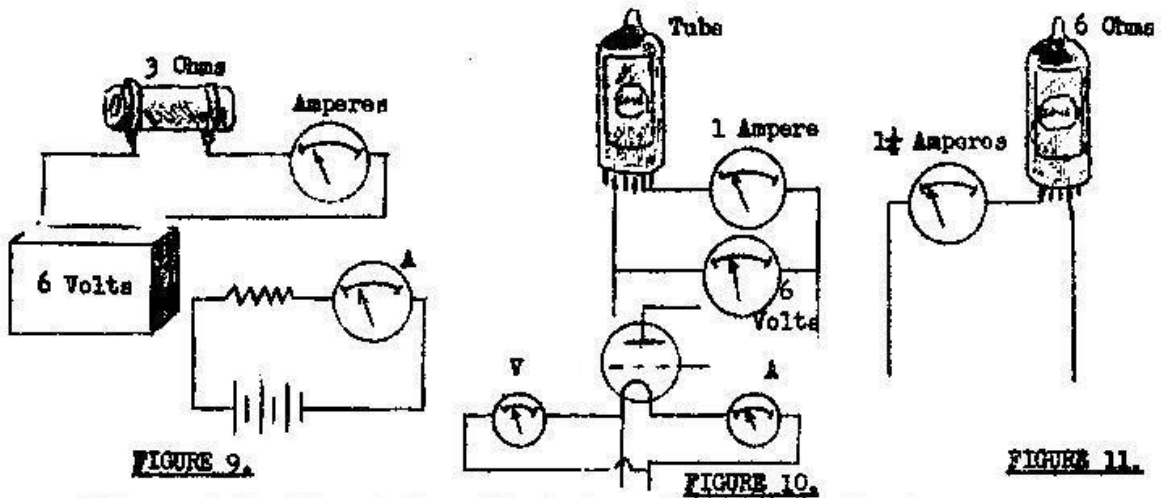

resistance of the filament is really 6 ohms. Now, knowing the filament resistance of this tube, 6 ohms, how many volts must you apply to the filament to make $1\frac{1}{4}$ amperes flow through it? This 50 tube may be worked with six volts on its filament and a current of one ampere, but to get the full power it is capable of delivering we have to send $1\frac{1}{4}$ amperes through the filament.

In Figure 11 we have the tube with its known filament resistance, 6 ohms, and the ammeter reads $1\frac{1}{4}$ amperes. Calculate the number of volts which must be acting on the filament. Again, using Figure 8, cover the "E" (for volts) and you see that you must multiply the amperes by the ohms. So, $1\frac{1}{4}$ (amperes) times 6 (ohms) gives as the number of volts needed to get this current through the filament. The "50" tube should be worked on this filament voltage.

There in Figures 9, 10 and 11, you have three practical applications of Ohm's Law. In one you found the amperes, in another you found the ohms and in the third you found the voltage.

In Figure 12 we have a circuit in which the ammeter shows 4 amperes to be flowing. A voltmeter connected across the circuit from "A" to "B" reads 2 volts. There is a "drop" two volts between these points. What is the resistance in ohms of the

part of the circuit between "A" and "B"? To find the calms we divide the volts (2) by the amperes (4), as shown in figure 8, and we get $2/4$. This fraction, $2/4$ is equal to $1/2$ or one half, so the resistance of this part of the circuit is one-half ohm.

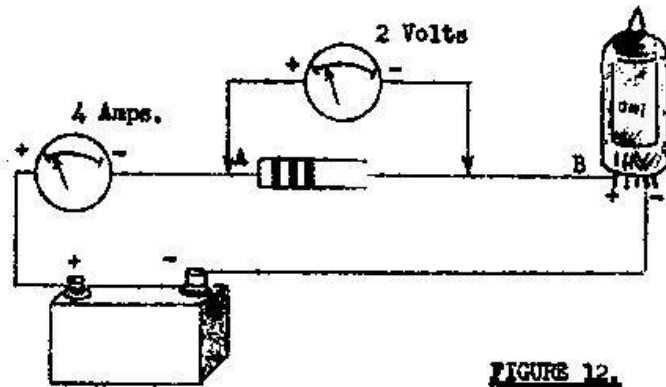
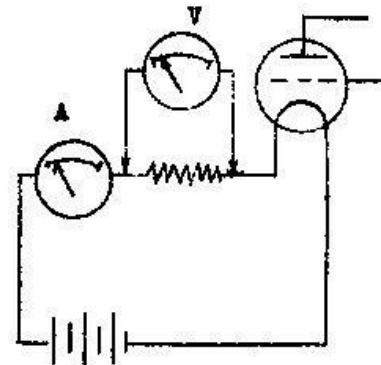

FIGURE 12.



Just to get some practice in using Ohm's Law, calculate the missing quantities in Figures 13, 14, and 15. In Figure 13 the voltage and the resistance are shown; find the currant in amperes. In Figure 14 you can read the voltage and the current; what is the resistance in ohms? In Figure 15 the resistance is given and you can read the current; find the number of volts. The circuits are all different and you will have to work each one separately -- the answer for one won't help get the others. Now don't read any further until you try for the answers.



FIGURE 13.

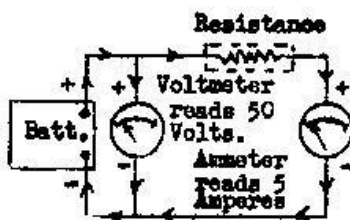

FIGURE 14.



FIGURE 15.

The answers are: Figure 13 -- two amperes. Figure 14 -- ten ohms. Figure 15 - twenty volts. How did you come out? In Figure 13 you should divide 10 (volts) by 5 (ohms) to get 2 amperes. In Figure 114 you should divide 50 (volts) by 5 (amperes) to get 10 ohms. In Figure 15 you should multiply 4 (amperes) by 5 (ohms) to get 20 volts. All these things are shown in figure 8, at least you can work them out with the help of Figure 8.

In Figure 16 you can see a resistor of the kind sometimes used in power units which furnish current to the plate circuits of radio tubes. This resistor is in three sections; one of 5,000 ohms, another of 15,000 ohms, and the third of 10,000 ohms resistance. Then the total resistance from top to bottom, "A" to "B", must be the total of these amounts, or 30,000 ohms. With a voltmeter you find that the voltage difference between "A" and "B" is 180 volts. How much current is flowing through the resistor?

You know the volts and the ohms. From Figure 8 you divide the number of volts by the number of ohms to find the number of amperes. So you have 180 divided by 30,000. Evidently there is very little current because the fraction, $180/30,000$ is a small amount. Small currents are measured in milliamperes, one milliampere being the one thousandth part of an ampere or, the other way around, one ampere being equal to 1,000 milliamperes.

When you wish to get the result in milliamperes, you start off by multiplying the top part of the fraction, the number 180, by one thousand. Then 180 times 1,000 is equal to 180,000. Now for the number of milliamperes, you have:

$$\frac{180,000}{30,000}$$

This means that you are to divide 180,000 by 30,000 and the result is 6 because 30,000 goes into 180,000 six times. Then we have the answer that 6 milliamperes of current will flow through the resistor in Figure 16.

Now we are going back to the "50" tube again, the tube which has a filament with 6 ohms resistance. In Figure 17 an ammeter connected in circuit shows only $\frac{1}{2}$ ampere.

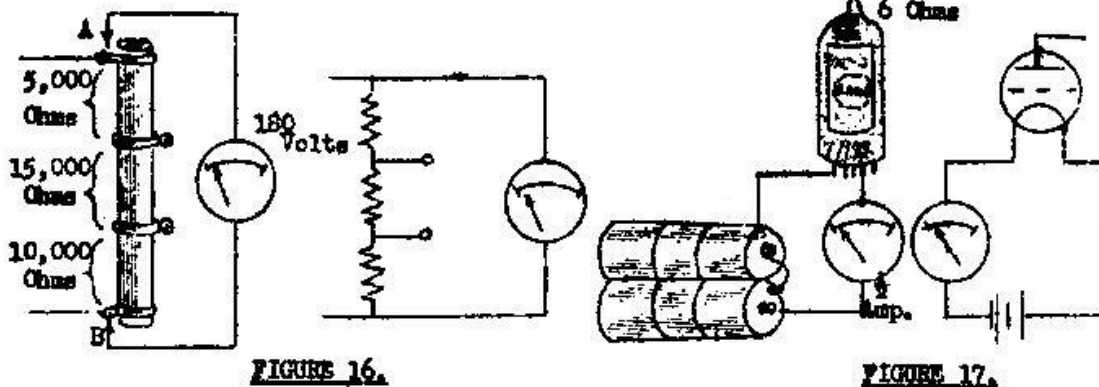

You know the filament's resistance, 6 ohms, and you know how much current is flowing through it. What is the voltage drop across the filament or what voltage would be shown on a voltmeter connected across the filament terminals? From Figure 8 you see that the amperes times the ohms will give the volts. So, $\frac{1}{2}$ times 6 gives the answer as 3 volt acting on the filament.

It is safe to say that Ohm's Law is one of the most useful rules with which a radio man can be acquainted. Radio men use this rule every day in their work -- most days several times over. You should be so familiar with Ohm's Law that you use it as a matter of habit.

To find the current in amperes flowing between any points you divide the voltage difference between the points by the ohms of resistance between the same points. You did that in Figures 9, 13 and 16.

To find the resistance in ohms between any two points you divide the voltage difference by the number of amperes flowing in the circuit between those points. You did that in Figures 10, 12 and 14

To find the volts drop between any two points you multiply the ohms resistance

by the current flowing between the points. That's what you did in Figures 11, 15 and 17.

RESISTANCE IN SERIES CIRCUIT.

The resistor of figure 16 consists of three parts connected in series, each part having a resistance different from that of the other two. To find the total resistance we added together the three separate resistances. The total resistance of all the parts of a series circuit to current flowing through the whole circuit is equal to the sum of all the separate resistances, and the current through each resistance will be equal to the current flowing through the whole circuit.

In Figure 18 we have a circuit containing a tube and a rheostat, also the connecting wires. The tube is a "71-A" type having a filament with 20 ohms resistance. The rheostat is a 6 ohm unit, that is, its total resistance is 6 ohms. But you can see

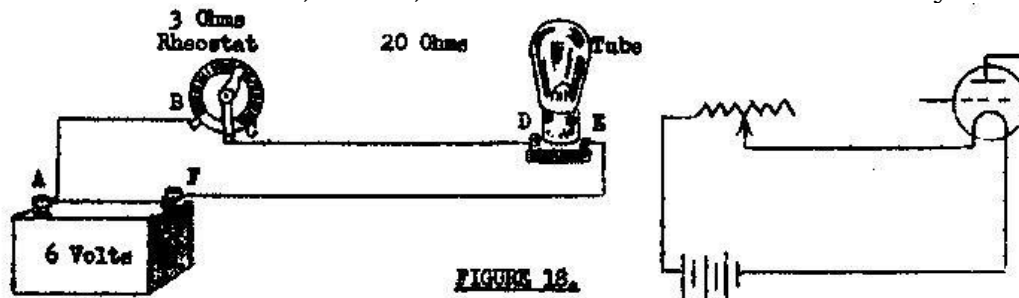

that the rheostat arm is not all the way around. The arm's position lets 3 ohms resistance remain in the circuit. The wires too have some resistance, just for illustration say the wire between "A" and "B" has $\frac{1}{4}$ ohm resistance, the wire from "C" to "D" has $\frac{1}{4}$ ohm resistance, and the wire from "E" to "F" has $\frac{1}{2}$ ohm resistance. Let us add up the resistances.

Wire A-B	$\frac{1}{4}$ ohm
Rheostat	3 ohms
Wire C-D	$\frac{1}{4}$ ohm
Tube filament	20 ohms
Wire E-F	<u>$\frac{1}{2}$ ohm</u>
Total Resistance	24 ohms.

This is the way you find the total resistance of any series circuit simply add together the resistances of all the parts. If the battery voltage is 6 and the circuit resistance is 24 ohms, how much current flows through the circuit? Divide 6 by 24, giving $\frac{6}{24}$ which is equal to $\frac{1}{4}$, There is a current of $\frac{1}{4}$ ampere flowing in the circuit. This is the current required to operate a "71-A" tube.

PARALLEL CIRCUITS.

At the left hand side of Figure 19 there is a funnel on top of a pipe one inch in diameter and one foot long. At the right hand side the funnel feeds two pipes, each one inch in diameter and one foot long. Through which of these arrangements will water travel more easily? Of course, that's too simple a question to deserve an answer.

At the left hand side of Figure 20 we have a battery connected to a wire of number 28 gauge size and two feet long. At the right hand side the same battery is connected to two wires as shown, each wire being number 28 gauge and two feet long. These two wires are in parallel with each other. Through which arrangement, one

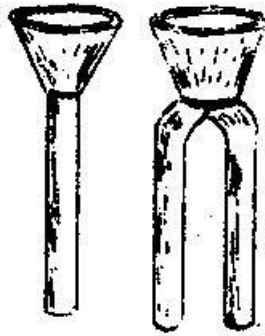

Figure 19.

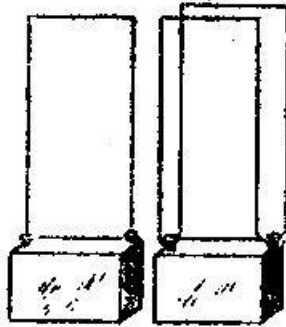

Figure 20.

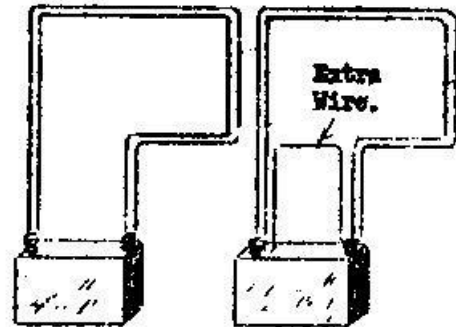

Figure 21.

or two, will the battery current flow more easily? Through the two wires, of course, because just as much current will flow through the second wire as through the first, and the two will take twice as much current as one. The resistance of two wires in parallel is less than the resistance of either or one alone.

In Fig. 21; at the left, there is a great big wire across the battery. You know that a big wire has but little resistance, consequently carries a lot of current. The resistance (with a given battery voltage) determines the amount of current and if more current flows there must be less resistance

At the right hand side of Fig. 21 there is a very small extra wire between the battery terminals. This little wire will carry a little bit of current, but this little current is in addition to the current already going through the big wire. No matter how small the extra wire, no matter how great its resistance (taken alone) it will carry some current and the two wires together will carry more than the big one alone. Therefore since the two wires carry more current their combined resistance must be less than the resistance of one alone.

If the big wire has a resistance of one ohm and the little one a resistance of 1000 ohms, their combined resistance will be less than one ohm because the two carry more current than either alone. That is the way resistances work in a parallel circuit.

RESISTANCE OF PARALLEL CIRCUITS.

In Fig. 22 there are two tubes connected with their filaments in parallel each filament has a resistance of 20 ohms. You know that twice as much current will

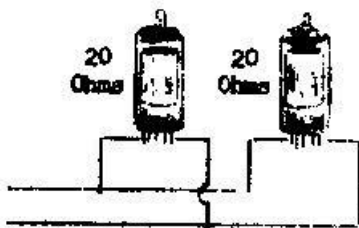

Figure 22.

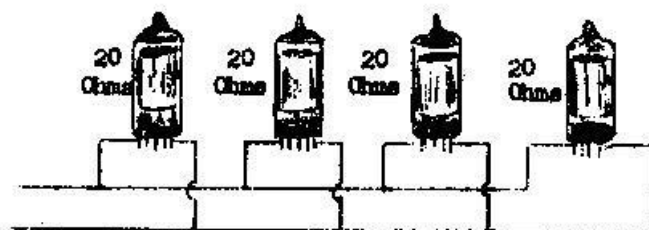

Figure 23.

flow through two tubes as will flow through one because they are just alike. Well, if twice as much current flows, the resistance of the two tubes together must be only half that of one tube. So, to find the resistance, of two equal resistances in parallel, you divide the resistance of one path by the number of paths. That's just what you did.

In Fig. 23 there are four tubes, each having 20 ohms resistance in its filament. If a certain amount of current flows through one of the filaments, four of them will take four times this amount of current. If the four tubes take four times the current taken by one, their combined resistances must be one-fourth that of one tube or 5 ohms. So again you divide the resistance of one path by the number of paths.

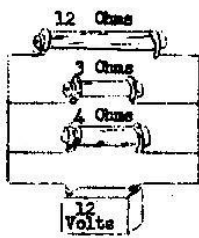

Figure 24.

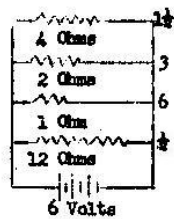

Figure 25.

COMBINING UNEQUAL RESISTANCE

Three different resistances are connected in parallel in Fig. 24. The top one is 12 ohms, the middle one is 3 ohms and the bottom one is 4 ohms resistance. What is their combined resistance? You know it will be less than 3 ohms because the combined resistance of parallel resistance is always smaller than the smallest one of the lot.

How much current will flow through the top 12 ohm resistor? You have 12 volts and 12 ohms. Divide the volts by the ohms to find the amperes - 12 divided by 12 is 12/12 or 1 ampere passes through this resistor.

Now take the middle resistor 3 ohms, the voltage is the same, 12, and dividing 12 by 3 (ohms) gives 4 amperes as the current flowing.

Then take the lower resistor, 4 ohms. Again dividing the volts 12 by the ohms you find that the current is 3 amperes. How much current you altogether?

CURRENTS THROUGH SEPARATE RESISTORS

12-ohm resistor	1 ampere
3-ohm resistor	4 amperes
4-ohm resistor	<u>3 amperes</u>
all resistors	8 amperes

Now we will find their combined resistance. From Ohms Law you know that the resistance in ohms is equal to the volts divided by the amperes. You have 12 volts and a total of 8 amperes, and 8 goes into 12 how many times? One and one-half times, so the combined resistance is 1½ ohms. That is one way to calculate the combined resistance with the help of Ohms Law.

Here is another example of this way of working. In Fig. 25 there are four resistors; 4 ohms, 2 ohms, 1 ohm and 12 ohms. The voltage is 6, and this 6 volts pressure acts across the ends of all the resistors. Find the current. It would be a good idea for you to cover the rest of this and work it out for yourself.

Current in 4 ohm resistor ... 6 divided by 4 ... $1\frac{1}{2}$ amperes
 Current in 2 ohm resistor ... 6 divided by 2 ... 3 amperes
 Current in 1 ohm resistor ... 6 divided by 1 ... 6 amperes
 Current in 12 ohm resistor ... 6 divided by 12 ... $\frac{1}{2}$ amperes

Total current through all resistors in parallel ... 11 amperes

To find the combined resistance, divide the volts by the amperes. Dividing 6 by 11 gives the fraction $6/11$ so the total resistance is six-elevenths of an ohm. The rule for finding the combined resistance of a number of different resistances in parallel by the method just shown is this: Find the current through each resistance by dividing the volts by the ohms; add the currents together and divide the volts by this total current in amperes to get the combined resistance in ohms. The combined resistance of resistors in parallel depends entirely on the resistors themselves - the applied voltage does not affect the resistance in any way at all. For example, in Figure 24 it would not matter whether 12 volts or one volt were applied, the combined resistance would remain at $1\frac{1}{2}$ ohms.

If you wanted to find the combined resistance of several resistances in parallel, but you did not know the voltage acting across them, you could assume any voltage at all, working out the resistances as already explained. You could choose one volt, for example, and still get the same result.

Suppose you did not know the voltage in Figure 24. Then you could imagine for the time being that one volt was applied. Then you would add the current this way :-

$$\begin{aligned} \text{Current through the 12 ohm resistor} & \dots\dots\dots 1/12 \text{ ampere} \\ \text{Current through the 3 ohm resistor} & \dots\dots\dots 1/3 \text{ ampere} \\ \text{Current through the 4 ohm resistor} & \dots\dots\dots 1/4 \text{ ampere} \\ \\ \text{Current through all the resistors} & \dots\dots\dots 1/12 + 1/3 + 1/4 \text{ amperes} \\ \\ & = 1/12 + 4/12 = 5/12 = 5/12 \text{ ampere} = 5/12 \text{ ampere} \end{aligned}$$

Now to get the combined resistance we divide the voltage applied, one volt, by the total current flowing., $5/12$ ampere. 1 divided by $5/12$ is equal to $12/5$ -- the fraction $12/5$ just turned upside-down. $12/5$ is equal to $2\frac{4}{5}$, which is the same combined resistance as we got before. e

Now let's go back and see just what we have been doing to find the combined resistance when we don't know the voltage applied. First. We divide the figure 1 by each of the single resistances, then add the resulting fractions together. We then divided the figure 1 by the result of this addition, this giving us the combined resistance.

The result obtained by dividing the figure 1 by any number is called the reciprocal of that number. So to get the combined resistance we really added the reciprocals of the separate resistances, and then took the reciprocal of the result, the final result being the combined resistance.

Let us take the example of Figure 25 and work it out this way. First we add together the reciprocals of each of the separate resistances, like this:-

$$1/4 + 1/2 + 1/1 + 1/12 = 3/12 + 6/12 + 12/12 + 1/12 = 22/12.$$

Now we take the reciprocal of 22/12 which is just 22/12 turned upside-down, or 12/22. 12/22 is the same as 6/11, or six elevenths of an ohm. You see, this is exactly the same result as we got working it out the other way.

Remember, to calculate the combined resistance of resistances in parallel by this method, add together the reciprocals of the separate resistances, then take the reciprocal of the result, this being the combined resistance.

One final point - when resistors are connected in series, the value of current flowing through each will be identical and will be the same as the value of current flowing through the complete circuit. The voltage drop across each resistor will be identical only if each resistor in the series circuit has the same value. If the resistors have dissimilar values the individual voltage drops will also be dissimilar. The lower values of resistance will develop a lower voltage drop than the larger values, but the value of current flow through each resistor will still be identical with the value of current flowing through the complete circuit.

When resistors are connected in parallel, conditions, so far as voltage drop and individual current flow is concerned, are reversed. That is, with the parallel connection the voltage drop across each resistor in the parallel network will be exactly the same, but the current flow through each will vary if the resistors have dissimilar values. This last statement is most important. The current flow through each resistor in a parallel connection will be dissimilar only if the values of resistors are dissimilar. Where the value of each resistor is identical, the current flow through each will be exactly the same value, but, - and this too is important - the current flowing through each resistor will be less than the value of current flowing through the complete circuit. If, for instance, four resistors each having the same value of resistance are connected in parallel, the value of current flowing through each resistor will be exactly the same and also equal to one quarter of the value of current flowing in the complete circuit.

HOW TO USE THIS INFORMATION.

The information given in this lesson will prove of the greatest possible value all through your radio work. We have talked a lot about resistances in this lesson. Here is a table giving you the resistances of all the common metals and of carbon. This table will give you an idea of how the resistances of these materials compare with one another.

RESISTANCES IN OHMS PER MILFOOT.

A "Mil foot" is a piece of material one foot long and having a diameter of one mil or one-thousandth of an inch. This unit is used because it is the unit in which we will later on specify the size of wire and from this table you will be able to calculate the resistance in ohms of a wire of any size, any length and any material

Aluminium	17.0	*Manganin.	264.7
Antimony	250.9	Mercury	576.2
Bismuth	721.9	Molybdenum	34.3
Brass	42.1	*Monel Metal	252.7
Cadmium	45.7	Nichrome	601.6
Carbon	22,000	Nickel	46.9
*Climax	523.7	Palladium	67.2
*Constaton	295.0	Phosphor Bronze	46.9
Copper (soft annealed)	10.4	Platinum	60.2
Copper (hard drawn)	10.6	Silver	9.6
*Excello	533.3	Steel (transformer grade).	66.2
German Silver (18% nickel)	198.5	Steel (Cast)	114.5
German Silver (30% nickel)	294.8	Steel (soft)	95.5
Gold	14.7	Steel (manganese)	421.4
Graphite	4,300.0	Tantalum	93.3
Iron (pure, soft)	60.2	*Therlo	282.9
Iron (cast)	435.0	Tin	69.2
Lead	132.3	Tungsten.	33.7
Magnesium	276.7	Zinc	34.9

* Materials marked with this star are mixtures especially for making resistance wires used in various kinds of resistors.

R.M.A. COLOUR CODE RESISTOR CHART

Black	0	Black	0	Black	-
Brown	1	Brown	1	Brown	0
Red	2	Red	2	Red	00
Orange	3	Orange	3	Orange	000
Yellow	4	Yellow	4	Yellow	0000
Green	5	Green	5	Green	00000
Blue	6	Blue	6	Blue	000000
Violet	7	Violet	7	Violet	0000000
Grey	8	Grey	8	Grey	00000000
White	9	White	9	Grey	000000000

EXAMPLE.

A resistor of 250,000 ohms would have a red body indicating that the first figure was 2, a green end indicating that the second figure was 5, and a yellow dot indicating that there are four noughts. Similarly, a 25,000 ohm resistor would have a red body and green end and an orange dot. In this case the dot would indicate that there are only three noughts after the first two digits.

Most resistors nowadays incorporate a fourth band, of colour. This fourth band has no direct relationship to the actual value of resistance, its purpose is to indicate the percentage tolerance under which the resistor has been manufactured. If a resistor has a silver band following the first three, the indication is that the resistor has been manufactured to a 10% tolerance. This means that the actual value may be either 10% greater or 10% smaller than that indicated by the first three colour bands. If the colour of the fourth band is gold, the resistor has been manufactured to a 5% tolerance. If there is no fourth band then the resistor has been manufactured to a 20% tolerance.

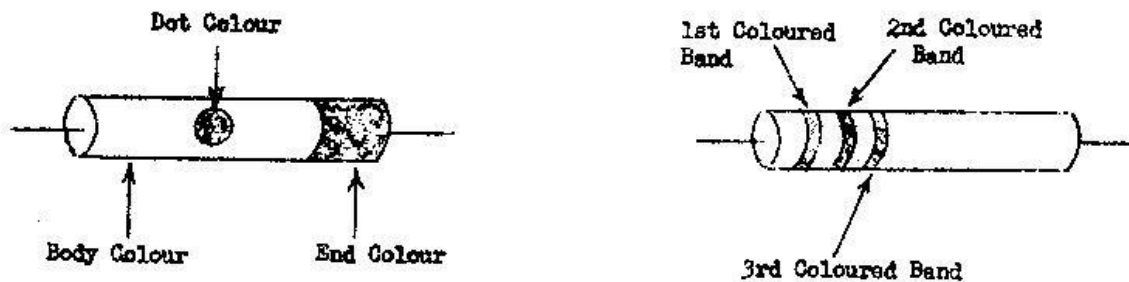

EXAMINATION QUESTIONS – No.10

1. If you know the number of amperes flowing through a circuit and know the number of volts applied across the circuit, how do you find the circuit's resistance in ohms?
2. The filament of a tube is carrying $\frac{1}{2}$ ampere when the voltage drop across it is 6 volts. What is the filament's resistance in ohms? Show how you arrive at the answer.
3. The size (cross sectional area) of number 20 gauge wire is practically four times that of number 26 wire. If 1,000 feet of number 26 copper wire (the smaller size) shows a resistance of 32 ohms, what is the resistance of 1,000 feet of the larger wire number 20?
4. With a rheostat set for 5 ohms resistance, 2 amperes flow through it. How many amperes will flow through when the rheostat is set for 10 ohms, all other conditions remaining the same
5. One "35" tube takes $1\frac{3}{4}$ amperes for its filament. How much current will be needed for four of those tubes in parallel?
6. A wire of number 34 gauge 1000 feet long has a resistance of 120 ohms. What is the resistance of 250 feet of the same wire?
7. If you apply 8 volts across the ends of a resistor through which you want 2 amperes to flow, what must be the resistance in ohms?
8. If You find that 3 amperes flow through a circuit and know its resistance is, 10 ohms, what is the voltage drop through this circuit?
9. One resistor measures 10 ohms resistance. What will be the combined resistance of four of these resistors in parallel? Show working.
10. Three resistors are connected in parallel. One has a resistance of 2 ohms another a resistance of 5 ohms, and the third a resistance of 10 ohms. What will be their combined resistance?

NOTE:- Show all calculations clearly in answers.

AUSTRALIAN RADIO AND TELEVISION COLLEGE PTY. LTD.

E. S. & A. BANK BUILDINGS, Corner CITY RD. and BROADWAY, SYDNEY
Telephones: BA4891 and BA4892

Telegrams “RADIOCOLLEGE” Sydney

This lesson sheet is published for the exclusive use of
students of the Australian Radio and Television College
Pty. Ltd. (All rights reserved)

Post Lessons to Box 43, Broadway

LESSON NO. 11 M2.

SQUARE ROOT

Square root is used a good deal in practical calculations, and it is as well to know how it is done. The product resulting from multiplying a number by itself is called the SQUARE OF the number. If a number is used as a factor three times, the resulting product is called the CUBE of the number. In order to show how many times a number is to be used as a factor a small figure is placed to the right and slightly above the number. This small figure 3 is called an EXPONENT, and shows to what power the number is to be raised. When the figure 2 is used as an exponent, it indicates that the number is to be raised to the second power, or, the square of the number is to be obtained. When the figure 3 is used as an exponent, it indicates that the number is to be raised to the third power, or, the cube of the number is to be found.

Thus 4^2 indicates that the 4 is to be raised to the second power or, to find the square of 4, which is done by multiplying 4×4 and equals 16. Thus 16 is equal to 4 raised to the second power, or, 16 to the square of 4. When the dimensions of a perfect square are known, the area in square units is calculated by finding the square of the length of one of the sides. For example, if a certain plot of land was in the shape of a square and the sides were 100 feet long, the number of square feet in the plot could be calculated by finding the square of the length of one of the sides. Thus, 100^2 equals 100×100 which is 10,000 square feet.

A ROOT of a number is one of the equal factors, which equal the number, when multiplied together. If a certain number is multiplied by itself in order to produce another number, the first number mentioned is the square root of the second. The square of 12 is 144 and is found by multiplying 12×12 . Thus 12 is the square root of 144. If the area of a square is known, the length of one side of the square can be obtained by extracting the square root of the area, Thus if a square yard contained 2000 square feet of ground each side of the yard is 50 feet long, which is found by extracting the square root of 2,500.

This process of finding the square root is merely the reverse of finding the power. The RADICAL SIGN $\sqrt{\quad}$ shows that some root of it is to be taken. The root desired is shown by a small figure called the INDEX which is placed above the radical sign, thus $\sqrt[3]{\quad}$ when no index is shown, the square root is understood.

The following rules are given and explained and if they are carefully followed step by step, a beginner should have but little difficulty in mastering the method.

- Rule 1. Separate the number into periods of two figures each, beginning at units.
- Rule 2. Find the greatest square of the left hand period, and place its root for the first figure in the quotient.
- Rule 3. Square this root and subtract the result from the left hand period and annex to the remainder the next period for the next dividend.
- Rule 4. Double the quotient already found for a partial divisor, and divide the dividend, disregarding the right hand figure.
- Rule 5. Annex to the partial divisor the figure last found. Place this figure as the second figure in the quotient. Subtract the product from the dividend and to the remainder annex the next period for the next division.
- Rule 6. Proceed in this manner till all the periods have been used and the final result shown in the quotient will be the square root of the number.
- Rule 7. If the number is not a perfect square, annex periods of two noughts each and continue the process.
- Rule 8. Point off decimal fractions in periods of two figures each beginning at the decimal point, progressing towards the right.
- Rule 9. To find the square root of a common fraction, reduce it first to a decimal fraction, or, extract the square root of the numerator and denominator separately.

In explaining the rules we will take number 23,409 as an example. Rule 1 says, "to separate the number into periods of two figures, each, beginning at the units". The unit is the first at the right. Beginning at units, the number should be divided into periods, thus :- 2'34'09. Rule 2 says, "find the greatest square of the left hand period and place its root for the first figure in the quotient". The left hand period in this case is 2. It should be understood that the left hand period is a complete period, although it contains but one figure in this case. To find the greatest square of 2, means to find the largest number which when multiplied by itself, is equal to, or less than 2. The greatest square of 2 is 1, and it is the only number which can be squared whose product is less than 2. Therefore, the greatest square of the left hand period is 1, and its root, 1, is placed in the quotient for the first figure of the required factor.

$$\sqrt{2'34'09} \text{ (Quotient)}$$

$$\sqrt{2'34'09} \text{ (1)}$$

Rule 3 says, "square this root and subtract the result from the left hand period, and annex to the remainder the next period for the next dividend". Square this root which is 1, and subtract the product from the left hand period, which is 2,

leaving a remainder of 1. To this remainder annex the next period, 34, making a dividend of 134.

$$\begin{array}{r} \sqrt{2'34'09} \left(1 \right. \\ \underline{1} \\ 1 \end{array} \qquad \begin{array}{r} \sqrt{2'34'09} \left(1 \right. \\ \underline{1 \ 34} \\ \end{array}$$

Rule 4 says “double the quotient already found for a partial divisor, and divide the dividend, disregarding the right hand figure”. By doubling the quotient 1, a partial divisor is found, which is 2. This partial divisor is placed to the left of the dividend.

$$\begin{array}{r} \sqrt{2'34'09} \left(1 \right. \\ \underline{1} \\ 2)1 \ 34 \end{array}$$

It should be clearly understood that this number is only a partial divisor, and a figure yet unknown is to be annexed before it can be divided into the dividend. By temporarily disregarding the right hand figure in the dividend, the dividend is converted into a partial dividend, and the partial divisor can now be divided into it, to approximately determine the figure which is to be annexed to the partial divisor. By disregarding the figure 4 of the dividend, 134, it is readily seen that the partial divisor 2 is contained in 13 six times, so that the next lower figure, which is 5, is selected.

There is no definite rule saying that the number lower than the quotient, obtained by dividing the partial divisor into the partial dividend, is to be selected. The actual number may be the quotient, one less than the quotient, as in the following example, or in some cases two less than the quotient. Until you have had some experience with these calculations it will be necessary to make a trial, commencing by using the quotient itself and if this is too large using the next lower number, and if the product is still too large the next lower number again.

$$\begin{array}{r} \sqrt{2'34'09} \left(1 \right. \\ \underline{1} \\ 2)1 \ 34 \end{array}$$

Temporarily disregarding the 4 Rule 5 says, “annex to the partial divisor the figure last found. Subtract the product from the dividend and to the remainder annex the next period for the next dividend”. This 5, which was last found, is annexed to the partial divisor 2, making a complete divisor 25, which is then divided into the complete dividend 134. This 5 is also placed as the second figure in the quotient. Multiply the divisor 25 by 5, as is done in long division, and subtract the product 125, from the dividend, 134, leaving a remainder of 9, to which annex the next period for the next dividend, making 909. Next double the quotient 15, which makes 30, for the next partial divisor.

$$\begin{array}{r} \sqrt{2'34'09} \left(15 \right. \\ \underline{1} \\ 2)1 \ 34 \\ \underline{1 \ 25} \\ 9 \ 09 \\ 30) \ 09 \end{array}$$

Rule 6 says, “to proceed in this manner until all periods have been used, and the

Maths.L.II M2 - 3.

final result shown in the quotient will be the square root of the number”

$$\sqrt{2'34'09} \left(\begin{array}{r} 153 \\ 2)134 \\ \underline{125} \\ 909 \\ 303) \end{array} \right.$$

$$\sqrt{2'34'09} \left(\begin{array}{r} 153 \\ 2)134 \\ \underline{125} \\ 909 \\ 303) \end{array} \right.$$

Rule 7 says, "if the number is not a perfect square, annex periods of two noughts each and continue the process."

$$\sqrt{6'24.00'00} \left(\begin{array}{r} 24.9+ \\ 4 \\ 44)224 \\ \underline{176} \\ 4800 \\ 489) \underline{4801} \\ 39900 \end{array} \right.$$

In this example the result does not come out even and the plus sign (+) is used to show that there was a fraction left over.

Rule 8 says, "point off decimal fractions in periods of two figures each, beginning at the decimal point and progress towards the right", as shown below.

$$\sqrt{.04'66'56} \left(\begin{array}{r} .216 \\ 04 \\ 41)066 \\ \underline{41} \\ 2556 \\ 426) \underline{2556} \\ 00 \end{array} \right.$$

Rule 9 says, "To find the square root of a common fraction, reduce to a decimal fraction and extract the square root, or, extract the square root of the numerator, and denominator separately", both methods being shown in to example below.

Find the square root of $\frac{1}{4}$

Find the square root of $\frac{900}{3600}$

$$\sqrt{\frac{.25}{.00}} \left(\begin{array}{r} .5 \\ .25 \\ \underline{.00} \end{array} \right.$$

$$\sqrt{\frac{9.00}{9}} \left(\begin{array}{r} 30 \\ 9 \\ \underline{00} \end{array} \right.$$

$$\sqrt{\frac{36.00}{36}} \left(\begin{array}{r} 60 \\ 36 \\ \underline{00} \end{array} \right.$$

Ans $\frac{30}{60}$

A Right Angle Triangle consists of three lines ; a horizontal line which is called the base and is known by the symbol "B", A vertical line called the perpendicular, which is known by the symbol "P" and a line connecting these two lines called the Hypotenuse and is

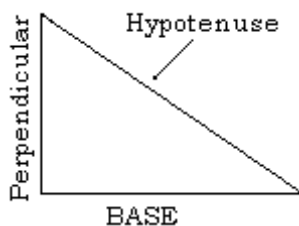

known by the symbol "H". The angle at the point where the Perpendicular and Base meet is always a right angle or a 90° angle. If you know the length of two sides you can find the length of the third as shown below.

Rule 10. The square root of the sum of the squares of the base and the perpendicular is equal to the Hypotenuse.

$$H \text{ equals } \sqrt{B^2 \text{ plus } p^2}$$

Problem. If the base of a right angle triangle is 40 inches long, and the perpendicular is 30 inches long, what is the length of the hypotenuse? By rule 10,

$$H = \sqrt{B^2 + p^2} = \sqrt{40^2 + 30^2} = \sqrt{1600 + 900} = \sqrt{2500} = 50 \text{ inches}$$

Rule 11. The square root of the difference of the squares of the hypotenuse and the base is equal to the perpendicular.

Problem. If the base of a right angle triangle is 40 inches and the hypotenuse is 50 inches, what is the height of the perpendicular? By rule 11.

$$P = \sqrt{H^2 - B^2} = \sqrt{50^2 - 40^2} = \sqrt{2500 - 1600} = \sqrt{900} = 30 \text{ inches}$$

Rule 12. The square root of the difference of the squares of the hypotenuse and the perpendicular is equal to the base.

$$B = \sqrt{H^2 - p^2}$$

Problem. If the perpendicular of a right angle triangle measures 30 inches, and the hypotenuse is 50 inches, what would be the length of the base? By Rule 12.

$$B = \sqrt{H^2 - p^2} = \sqrt{50^2 - 30^2} = \sqrt{2500 - 900} = \sqrt{1600} = 40 \text{ inches}$$

Following are six problems illustrating the method of calculating the square roots of various numbers. These should be carefully followed step by step until you are quite sure you thoroughly understand this method of working.

PROBLEMS.

(1) $\sqrt{3025} \text{ (55)}$

$$\begin{array}{r} 105 \overline{) 3025} \\ \underline{30} \\ 25 \\ \underline{25} \\ 00 \end{array}$$

(2) $\sqrt{1881} \text{ (43)}$

$$\begin{array}{r} 209 \overline{) 1881} \\ \underline{18} \\ 81 \\ \underline{81} \\ 00 \end{array}$$

(3) $\sqrt{3364} \text{ (58)}$

$$\begin{array}{r} 108 \overline{) 3364} \\ \underline{33} \\ 64 \\ \underline{64} \\ 00 \end{array}$$

(2) $\sqrt{5476} \text{ (74)}$

$$\begin{array}{r} 144 \overline{) 5476} \\ \underline{54} \\ 76 \\ \underline{76} \\ 00 \end{array}$$

(3) $\sqrt{1545049} \text{ (1243)}$

$$\begin{array}{r} 22 \overline{) 54} \\ \underline{44} \\ 10 \\ 244 \overline{) 1050} \\ \underline{976} \\ 74 \\ 2483 \overline{) 7479} \\ \underline{7479} \\ 00 \end{array}$$

(4) $\sqrt{.000441} \text{ (.021)}$

$$\begin{array}{r} 41 \overline{) .00441} \\ \underline{4} \\ 00 \\ \underline{41} \\ 00 \end{array}$$

$$H \text{ equals } \sqrt{B^2 \text{ plus } p^2}$$

ANOTHER METHOD OF WORKING SQUARE ROOT PROBLEMS.

If the above method of working square root problems proves difficult, try the method which follows. It is often found when looking at a problem from several angles, misunderstandings are easily overcome. No doubt, the following problem will help.

Find the square root of 55,225.

$$\begin{array}{r} 5 \ 52 \ 25 \ (235 \\ 4 \\ \hline 40 \ 1 \ 52 \\ 43 \ 1 \ 29 \\ \hline 460 \ 23 \ 25 \\ \hline 465 \ 23 \ 25 \end{array}$$

1. Begin at the right the numbers into periods of two figures each, because the square of any number having only one digit or figure will not occupy more than two places, and the square of any number having two digits will not occupy more than four places, etc. There will be as many places in the root as there are periods. In the example there are three places in the root.
2. Find the greatest square in the first or left hand period, which is (4), and place its root (2) as the first figure of the root.
3. Subtract the square (4) from the first period and bring down the next period (52), and annex it to the first remainder (1). This gives a new dividend (152).
4. Take two times the first figure of the root (2) and place it at the left of the next dividend, and annex one nought. This is a trial divisor. Find how many times this trial divisor (40) is contained in the dividend (152). Place the result (3) as the second figure of the root. Also add this second figure of the root (3) to the trial divisor (40). This gives the complete divisor (43).
5. Multiply the complete divisor (43) by the second figure of the root (3), and subtract and bring down the next period (25) and proceed as before until the root is found.

When the number is not a perfect square annex periods of noughts and continue the root as a decimal. If the trial divisor is not contained in the dividend, annex a nought to the divisor and also to the root and bring down the next period.

To extract the square root of decimals, begin at the decimal point and point off to the right, periods of two figures each, and, if there are whole numbers, also to the left, periods of two figures each, annex noughts if necessary, to make two figures in each period.

EXAMINATION QUESTIONS - MATHEMATICS LESSON-No.11 M2

1. What is the square root of 21609?
2. What is the square root of 5625?
3. What is the square root of 287296?
4. What is the square root of 288369?
5. What is the square root of 56644?
6. What is the square root of 56.25?
7. What are the dimensions of a square room containing 1600 square of floor space?
8. What is a right angle triangle?
9. What are the sides of a right angle triangle called?
10. State the three rules for finding the length of one side of a right angle triangle when the lengths of the other two sides are known.

Please NOTE Postal Address: (AUSTRALIAN RADIO AND TELEVISION COLLEGE
(PTY. LTD.
(Box 43, Broadway, Sydney, N.S.W

NOTE : Write the lesson number before answering the questions.

Write on one side of the paper only.

Always write down in full the question before you answer it.

Use sketches and diagrams wherever possible. One diagram in many cases is equivalent to pages of explanation

Remember that you learn by making mistakes; so give yourself an opportunity of having your mistakes found and corrected.

Don't hesitate to ask for further explanation on any point, we are always ready to help you.

Write your name and full address at top of paper. If you have made arrangements with the College to have your lessons returned to any particular address - state this at the top of the page.

“The Radio-T.V. Training Centre”

**E. S. & A. BANK BUILDINGS, Corner CITY RD. and BROADWAY, SYDNEY
Telephones: BA4891 and BA4892**

AUSTRALIAN RADIO AND TELEVISION COLLEGE PTY. LTD.

Telegrams “RADIOCOLLEGE” Sydney

This lesson sheet is published for the exclusive use of students of the Australian Radio and Television College Pty. Ltd. (All rights reserved)

Post Lessons to Box 43, Broadway

LESSON NO. 12

RADIO TUBES - THEIR CHARACTERISTICS AND OPERATION.

In one of the early lessons you were told a little about a radio tube or valve. One cannot overestimate the importance of this component because without it, modern radio simply would not exist. The tube as we know it to-day did not happen all at once. No one man invented it all. The beginning came about somewhat as shown in Figure 1. Back in 1884 Edison, the scientist was experimenting. He had a lighted filament inside of a glass bulb from which nearly all the air had been exhausted. Inside the bulb was another wire. This second wire was not heated but was connected to the positive side of a source of voltage and the negative side of that source was connected to the filament.

Edison found that when he connected a current measuring meter between one side of the lighted filament and the negative terminal of the additional battery shown at the right of Figure 1, first breaking the circuit at "X", he obtained definite indication of current flow between the lighted filament and the additional wire inserted into the bulb. As this experiment took place several years before Professor J.J. Thomson

stated his famous electron theory of matter, Edison regarded the current flow in the light of what was then known about electricity, that is, he assumed that the current was flowing from the additional wire, across the vacuum, to the lighted filament.

In Figure 2, the assumed direction of current flow is shown by the small arrows. It starts out from the positive terminal of the plate battery, or as we generally call it, the “B-battery”. This current then flows to the extra part in the tube, which is shown as a flat metal plate in Figure 2. The current leaves the plate, passes through the space between it and the filament and then flows through the filament. The filament battery or the

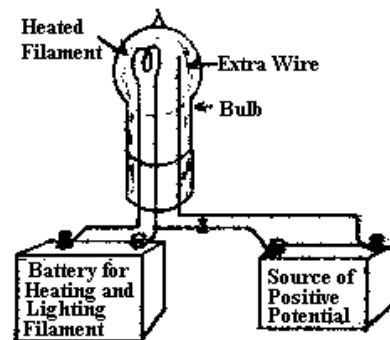

FIGURE 1

“A-battery” and the “B-battery” are connected together and current which has passed through the plate comes back to the negative side of the B-battery, thus completing its circuit.

THE TWO ELEMENT TUBE:

The filament is called one of the tube's “elements”. The plate is another element. Consequently we call a tube having a filament and a plate a two element tube, or “diode”. Such a tube is shown in Figure 3. The filament is here a straight wire. The plate is a cylinder of metal placed around the filament. These two elements are connected to pins or prongs on the base of the tube. Tubes of this general type are frequently used as detectors, as they function in much the same manner as a crystal detector.

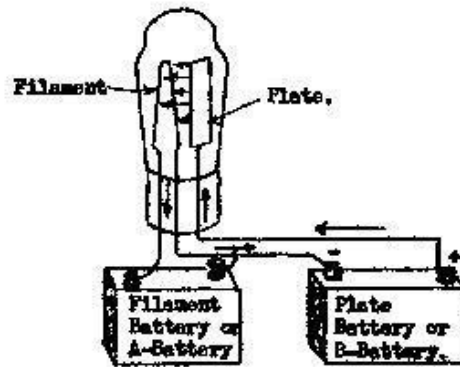

FIGURE 2.

You will also find that a large proportion of our present rectifier tubes are of the two element type. A rectifier changes alternating current to direct current.

In the two element tube there are two things which we may change in securing a change in the amount of current flowing in the plate circuit. One of them is the voltage applied to the plate, the greater the positive voltage on the plate, or the greater the difference in voltage between the plate and the filament, the more current will flow.

The other thing which we may change is the temperature of the filament. If the filament is cold no current whatever will flow between the plate and filament. As the filament is gradually heated it will reach a temperature at which a little current will flow. More and more heat allows more and more current to flow and as the filament lights up more and more brightly the plate current will increase. After the filament reaches a certain high temperature, the plate current no longer increases in proportion to the heat and beyond a certain point increasing the filament temperature causes practically no further increase in plate current.

Now we add a third element, the grid. This third element is the one which allows the tube to amplify or strengthen radio signals and to do many other remarkable things.

No plate current will flow until the filament is heated. There must be some good reason for this effect. There must be something different within the bulb when the filament is hot than when it is cold.

In Figure 4 we have three pieces of filament wire, greatly enlarged. The one at the left is supposed to be cold, the one in the centre is quite hot and the one at the right is very hot.

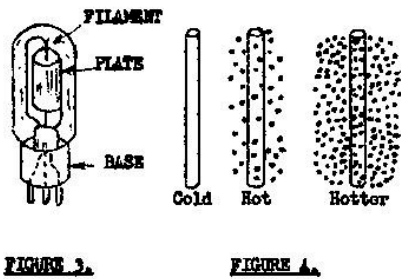

Nothing in particular happens in the space around the cold filament. But around the hot one a very peculiar action is taking place. This hot filament is sending out from its surface the things we call "electrons". The electrons fly out for a little distance, then fall back into the filament. The very hot filament is also sending out or is emitting electrons but it is sending out many more than before it became so highly heated and the emitted electrons travel away from the filament to a much greater distance before they again fall back.

The term "electron" is no stranger to you because it was introduced into the very first lesson. However, you will hear more about it from now on because it plays such an important part in the operation of a radio valve. Thorough understanding of what it is, what it does, will greatly simplify your more advanced studies. In Lesson No.1 we explained in some detail exactly what the "electron" is. In the following paragraphs of this lesson we propose to show you, in even greater detail, exactly what the "electron" does, but first of all here is a brief resume of the earlier discussion on the nature of the "electron".

ELECTRONS:

Of course you know that any common substance may be divided into smaller and smaller particles. Take salt, for instance. You can pulverize the salt as fine as you will and you still have salt. The smallest possible piece of salt would be called a "molecule" of salt.

You could take that molecule of salt and by chemical action you could break it down into two things. One would be the metal sodium and the other would be the gas chlorine. In place of salt you would now have one atom of sodium and one atom of chlorine. For years and years the scientists believed the atom to be the smallest division of matter. They considered that the various kinds of atoms were the materials of which everything was made up by combining the atoms in different ways.

Now we know that the atom is not the smallest thing in existence. The smallest thing is an electron. One or more electrons in combination with what is called a "positive nucleus" form an atom. An electron is electricity itself, it is a particle of negative electricity or is a negative charge.

You cannot possibly realize how small is one electron. If you had a ball or sphere of copper so small that 100,000 of them laid side by side would extend one inch it would be something pretty small. Yet in each one of those balls of copper there would be twenty thousand million (20,000,004,000) electrons.

Hydrogen gas is one of the lightest of all things in weight. It would take two hundred and fifty million (250,000,000) hydrogen atoms in a row to make a length

of one inch. And yet every one of those hydrogen atoms would weigh two thousand times as much as an electron. What you should remember out of all this is that an electron is negative electricity.

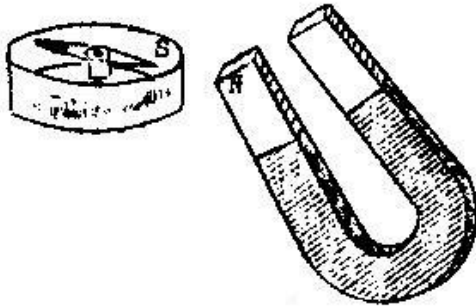

FIGURE 5.

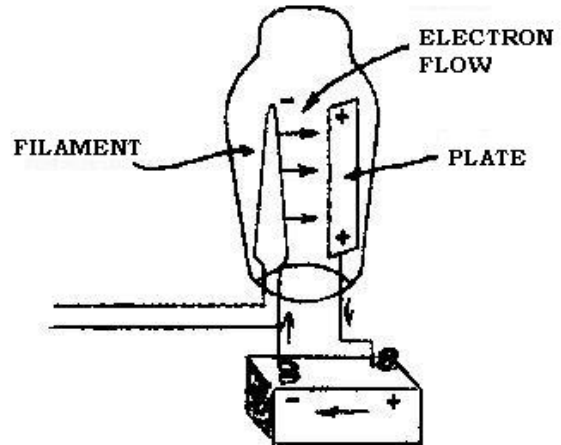

FIGURE 6.

ELECTRON FLOW:

Remember that the plate in a tube is at a higher potential than the filament, the plate is positive and the filament is negative with respect to each other. Any thing which is positive has an attraction for something also which is negative, the positive body exerts an attraction on the negative body and they tend to come together.

When you were younger you probably played with a magnet and a small compass, the kind of compass that tells you which way is north. Then you found that the positive or "North" end of the magnet would attract the negative or "South" end of the compass and that the north end of the compass was drawn toward the south end of the magnet as in Figure 5.

A similar sort of attraction exists between the positive plate and the negative electrons which are emitted by the hot filament. The electrons are negative electricity and are attracted to and are pulled over to the positive plate as indicated in Figure 6. As shown by the small arrows between filament and plate, the electrons leave the filament after being released by the heat, get caught by the plate's attraction and some of them fly across and enter the plate.

The electrons which travel across the space and get into the plate flow down through the wire to the plate battery, go through the battery and then go back into the filament at the connection between plate battery and filament battery.

If you will compare Figure 6 with Figure 2 you will see that we spoke of the electric current as flowing from the plate to the filament, but that the electron flow is from filament to Plate - Just the other way around. It is unfortunate that we

cannot think of current and of electrons as flowing in the same direction. The flow of current from plate to filament is what we call a "convention" - it is just an idea, or something assumed to be true by those who first worked with electricity. The fact of the matter is that electrons, which are really negative electricity, pass from the heated filament to the positive plate. We also have to assume, because it always has been assumed, that the current flows in the other direction.

This difference in direction of electron flow and current flow is very confusing. Perhaps you will be able to understand more clearly the action in a radio tube or circuit, if I explain how this apparent contradiction in the direction of flow came about.

In the early days of electricity, scientists knew that for certain electrical actions to occur, there must be a movement of electricity around a circuit. This movement of electricity was called a "Current" of electricity, just as we speak of a movement of water as a current of water. At that stage, they did not know exactly what it was that circulated nor the direction in which it moved. There is no way of seeing the current moving and no instrument was available to definitely show in which direction it moved. As it was necessary to have some way of visualising the action of the current and some way of referring to it, one terminal of a source of voltage was called the "positive" terminal, the other was called the "negative" terminal and current was assumed to flow from positive to negative.

Many years later it was definitely proved that a flow of electricity consists of a movement of electrons around the circuit in the direction from negative to positive, and it is now realised that a movement of electricity really consists of a flow of electrons. Nothing actually moves from positive to negative in an ordinary circuit. As the electrons are negative charges of electricity and similar charges are repelled from one another, obviously electrons would tend to move away from the negative terminal of a source of voltage around the circuit to the positive terminal.

Of course, before the "Electron Theory" was clearly understood, it had become common usage to speak of current as flowing from positive to negative and many text books were written along these lines. Even now, although we clearly understand that a movement of electricity consists of a flow of electrons from negative to positive, most people, in using the word "Current" still conform to the old assumption of a movement of electricity from positive to negative. Many text books also, whenever they employ the word "current" assume the flow from positive to negative but in explaining valve action it is common practice to refer to the term "Electron Flow" or "Electron Stream" and whenever these terms are employed, the modern conception of electrons moving from negative to positive is used.

From the above, you will have gathered that there is no difference between a current of electricity and the electron flow in a circuit. These are just simply two different terms and two different ways of looking at the same thing. Actually in any ordinary circuit, the only movement is that of the electrons from negative to positive and we only imagine that some force called "Current" is moving from positive to negative

The two filaments in Figures 7 and 8 are both heated to the same degree and are both emitting the same quantity of electrons. In Figure 7 only a small voltage

is applied to the plate, say that the plate potential to about twenty volts above that of the filament. The plate has a rather weak attraction for the electrons which form a cloud around the filament and only a few of these electrons are attracted over on to the plate. In Figure 8 conditions are different. The plate voltage is much higher, say it is ninety or one hundred volts, The filament is not emitting any more electrons than before but now the plate exerts a very strong attraction and many more of the electrons are drawn away from the space around the filament, and pulled on to the plate.

Increasing the plate's voltage causes a greater electron flow just as it causes a greater flow of current. You will find this true always; electron flow and current flow obey the same laws and obey them in the same way because they are really the same thing.

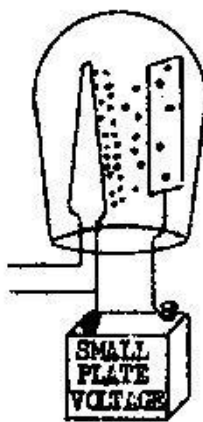

FIGURE 7.

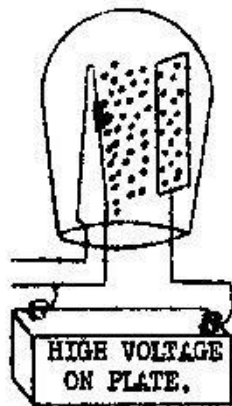

FIGURE 8.

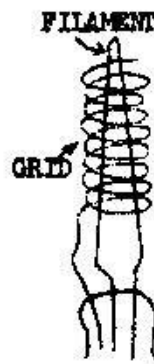

FIGURE 9.

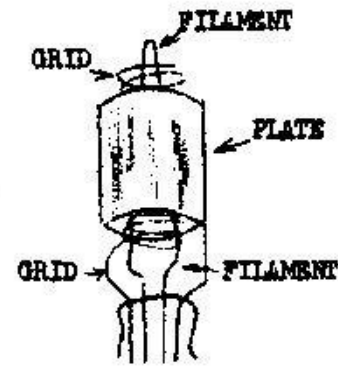

FIGURE 10.

When electrons leave the filament because of its heat, a certain amount of negative electricity has been removed from the filament. Therefore the filament is left more positive than before the electrons left it. Since the filament is then positive with respect to the electrons in the space around it, the electrons that are not drawn over to the plate are attracted by the filament itself and fall back into the filament. The cloud of electrons around the hot filament which are not attracted to the plate is called the "space charge".

HOW THE GRID CONTROLS THE TUBE'S ACTION:

Up to this time we have been using two elements in our tube. Now we will add a third. In Figure 9 you will see the usual filament and coiled around it another wire, the grid. The grid winds round and round the filament. At its lower end the grid is attached to one of the tube's prongs or pins, but the upper end is left without electrical connection, it just sticks up into space around the filament. In Figure 10 the plate has been put around the outside of the grid so that, from inside, we first have the filament, then the grid and finally the plate. This is

the way the three elements are actually arranged within the tube. In order to explain the grid's action it is convenient to show the three elements as in Figure 11. Here again the grid is between the filament and the plate, so this symbol for a three-element tube or "triode" really shows the relative positions of the parts.

Looking back at Figures 7 and 8 you will recall that a space charge of negative electrons exists all around the heated filament. Once this space charge exists around the filament, it makes the emission of more electrons from the filament more and more difficult. Positive and negative things attract each other and it is just as true that things alike in polarity repel each other. That is why the negative space charge repels the emission of any more negative electrons from the filament, and so hinders the flow of plate current. Two negative charges repel each other, or try to keep away from each other. The same thing would be true of two positive charges, they too would repel.

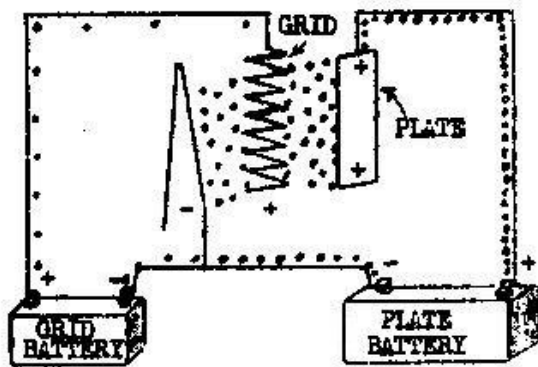

FIGURE 11.

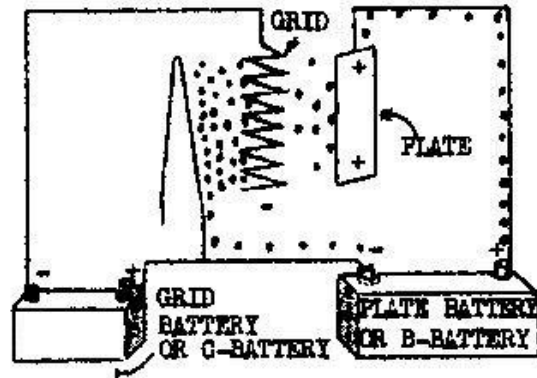

FIGURE 12.

Now look at Figure 11. You see the grid is located right in the midst of the space charge. You can also see that the potential of the grid is higher than that of the filament because the grid is connected to the positive side of a small battery of which the negative side is connected to the filament. Therefore, the grid is positive and the filament negative. Whenever the grid is at a higher voltage than the filament we say the grid is positive.

The positive grid counteracts to some extent the negative space charge. The electrons leaving the filament find fewer negative electrons or a less intense negative space charge to oppose their emission. Therefore, more electrons leave the filament. The positive grid acts to some extent like the positive plate, it pulls the electrons away from the filament and makes it possible for the emitted electrons to fly out further from the filament.

The plate in Figure 11 is held at a positive voltage by the plate battery. The voltage of the plate is very much higher than the voltage of the grid. Once the grid helps the electrons to get further from the influence of the filament, the plate steps in with its still greater pulling power and lots of these electrons are drawn over and on to the plate.

Since the grid is positive it attracts some of the electrons to it, they enter the grid and flow around through the battery and back to the filament. People who have become thoroughly addicted to thinking in terms of the older convention of current flowing from positive to negative will prefer to assume that current flows from the grid battery through the connecting lead to the grid and then across the space within the valve to the filament and from the filament back through the grid battery. However, we consider that the operation of a radio valve is far easier to understand if one thinks always in terms of the "electrons" which are emitted from the heated filament and their subsequent attraction towards any element within the valve which is at a positive potential in relation to the filament.

In Figure 11 the voltage of the grid is positive in relation to the filament, but it is nowhere near as high as the voltage of the plate. The electrons enter the grid and enter the plate in proportion to the voltages of the grid and plate. Inasmuch as the plate has much the higher voltage, it gets most of the electrons and the grid gets only a few. The real purpose of the grid in this case is to make it easier for electrons to get over to the plates when the grid is positive with respect to the filament.

In Figure 11, with the positive grid, there are a great many electrons flowing in the plate circuit and a few electrons flowing in the grid circuit. There is a correspondingly large current flowing in the plate circuit and a small current flowing in the grid circuit.

Now look at Figure 12. Here the grid is negative. We could say that it is at a lower potential than the filament because the grid is connected to the negative side of the small grid battery and the positive side of this battery is connected to the filament. When a battery is connected in this manner, so that it keeps the grid's potential below the potential of the filament we call it a "C-battery". Now we have a C-battery for the grid, a B-battery for the plate and an A-battery for the filament. In Figures 11 and 12 the A-battery is not shown because we do not need it for this explanation of grid action.

When the grid is negative with respect to the filament, the grid's action is just the reverse of what it is with a positive grid. Now the negative grid adds its effect to the always present negative space charge and the electrons emitted from the filament find it more difficult than ever to get far from the filament. They meet not only the repelling effect of the space charge but the repelling effect of the negative grid as well.

The result of the negative grid is that only a few electrons get far enough away from the filament to be attracted to the plate. Of course, a few electrons do get through the grid because the plate voltage is still as high as ever and the plate exerts a strong attraction for the electrons. Now there are comparatively few electrons flowing through the plate circuit and there is a proportionately small amount of plate current.

Because the electrons themselves are negative and the grid is also negative, these two negative charges repel each other. The negative grid keeps the negative electrons from entering the grid and there is no electron flow and no current flow whatever in the grid circuit. When the grid is negative with respect to the filament there is no flow of grid current. This is the condition we want for most purposes.

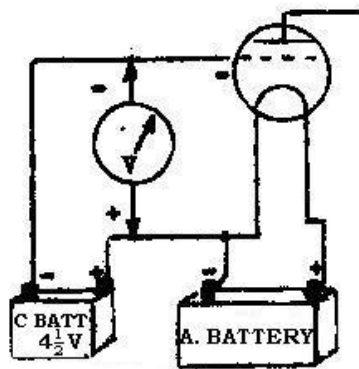

FIGURE 13.

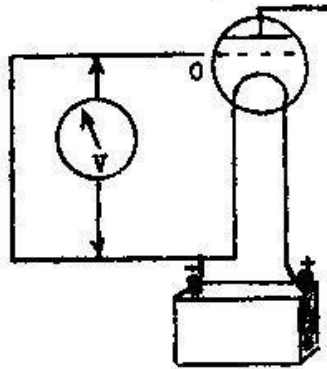

FIGURE 14.

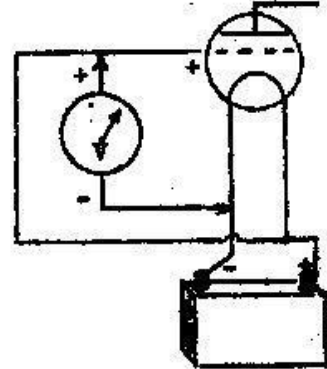

FIGURE 15.

We call the voltage of the grid with respect to the voltage of the negative side of the filament the grid's "bias". In Figure 11 the grid has a positive bias. In Figure 12 the grid has a negative bias.

In tubes having their filaments operating on direct current the grid bias is the voltage difference between the grid and the negative end of the filament. In Figure 13 there is a C-battery of $4\frac{1}{2}$ volts between the grid and the filament. The positive end of this battery is connected to the negative end of the filament or to the end of the filament which attaches to the negative side of the filament battery.

Since the negative side of the C-battery is $4\frac{1}{2}$ volts lower in potential than this battery's positive side and since the grid is connected to this point of lower potential, the grid must be $4\frac{1}{2}$ volts lower in voltage than anything connected to the positive side of the C-battery. Then the grid must be $4\frac{1}{2}$ volts lower than the negative end of the filament. Here we would say that the grid has a $4\frac{1}{2}$ volts negative bias. A voltmeter connected between the grid and the negative side of the filament will show the grid bias.

In Figure 14 the grid is connected directly to the negative side of the filament. Since these two parts are connected directly together they will be at the same potential, there will be no potential difference and we say the grid has a "zero bias". A voltmeter between grid and negative filament would read zero because there is no voltage difference.

In Figure 15 the grid is connected to the positive side of the tube's filament. This places the grid at a higher potential than the negative end of the filament because, of course, the positive end of the filament is at a higher voltage than its negative end. A voltmeter placed between the grid and the negative end of the filament would now show the grid at a higher voltage than the negative end of the filament and the grid would have a positive bias.

In these drawings illustrating different grid biases the tube is not doing anything

in particular. A little later on we are going to give this tube various kinds of jobs, the first of which will be to amplify a signal. The signal will raise and lower the grid's voltage but will not change the bias. We will have to make an addition to our definition for grid bias and say, grid bias is the difference between the grid potential and the potential at the negative end of the filament when no signal is being applied to the grid circuit.

OTHER NAMES FOR TUBE ELEMENTS:

We have been calling the part through which current (in the plate circuit) enters the tube by the name of "plate". The plate is often called the "anode" as marked in Figure 16. One name is as correct as the other. The plate current leaves the tube by way of the filament and therefore the filament may be called the "Cathode". The grid has but one name.

In the tubes shown you so far the electrons are emitted from the filament or the cathode, these two names here referring to one and the same part. There is another kind of tube, the, A.C. heater or indirectly-heated type, in which the cathode or electron emitter is separate from the part which supplies the heat. The construction of such a tube is shown in Figure 16.

The plate and grid of the A.C. heater tube are the same as similar parts used in any other tube. But in the A.C. heater tube there is no filament which carries the heating current and at the same time acts as the electron emitter. Taking the place of the filament there are two other parts, a heater element and a cathode element.

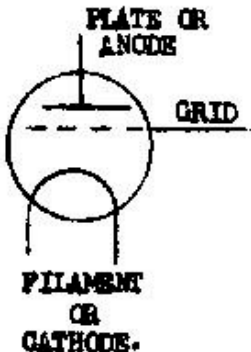

FIGURE 16.

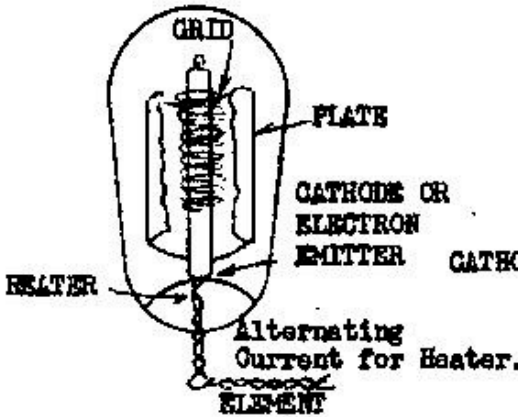

FIGURE 17.

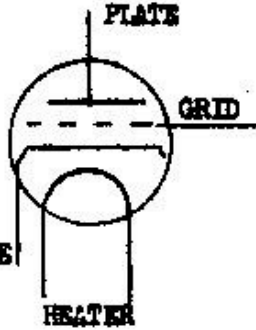

FIGURE 18.

Around the outside of the heater is the cathode, a cylindrical metal surface which is heated and which then emits electrons.

Whereas the tube construction of Figure 17 is designed especially for use with alternating current, it is also possible to use alternating current with which to heat the filaments shown in all the other illustrations. The heater type of tube is less apt to produce hum when used with alternating current than the filament type. There are certain jobs which are performed better by the heater tube and

others which are performed better by the filament types. One symbol for an A.C. heater type tube is shown in Figure 18. Other similar symbols are also used. As the heater and cathode are used together to emit electrons they are usually referred to as one element.

THE TUBE'S CIRCUITS:

In the filament type of tube the filament circuit includes the filament within the tube, the battery or other source of filament current and the wires connecting the two parts together.

The plate circuit of any tube includes all the parts through which the plate current flows. One plate circuit is shown in Figure 19. It includes the battery or other source of plate current, it includes any coils or resistances between the source and the tube's plate, it includes the plate itself, the space within the tube, the filament through which the current returns to the source and all the wires which connect these parts together. In following the plate current from its source all the way around and back again to the source you will have followed the plate circuit.

The grid circuit of a tube includes all the parts between the grid and the filament as shown in Figure 20. This particular grid circuit takes in the grid, then the coil, then the resistor, then the C-battery, then the filament, and it also includes the space within the tube and all the wires used to connect the other parts together. In A.C. heater tubes the cathode takes the place of a filament as far as these circuits are concerned.

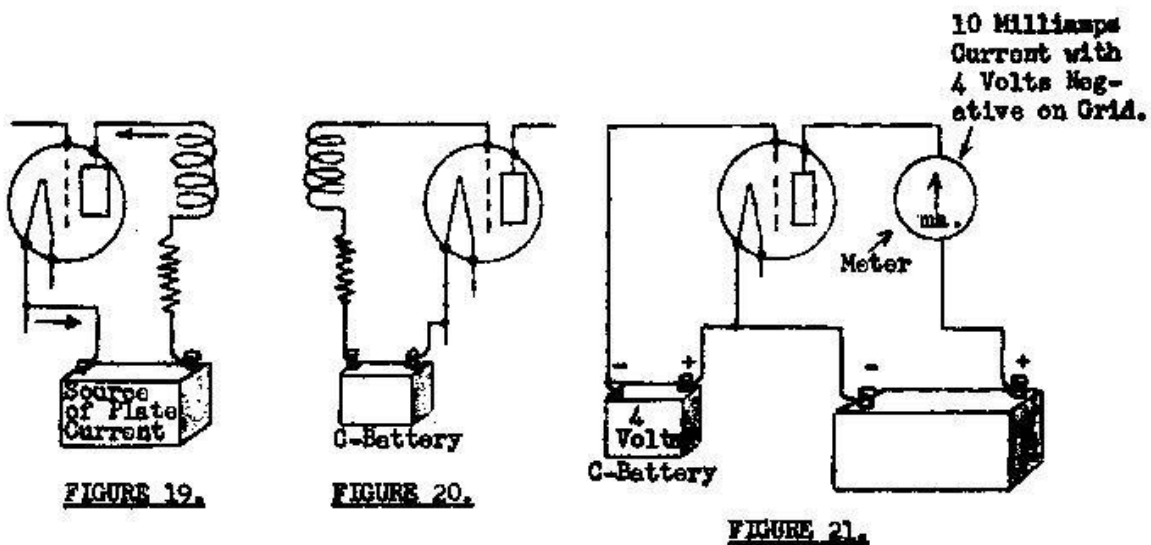

WATCHING THE GRID DO ITS WORK:

In Figure 21 you will see a tube with a 4-volt C-battery in its grid circuit and with a milliammeter in its plate circuit. We will say that the B-battery voltage applied to the plate is such that the 4-volt negative grid bias allows a current of 10 milliamperes to flow in the plate circuit. The word "milliamperes" is a rather long one so radio men generally speak of "mils" instead. Hereafter, when someone speaks of so many mils you will know that the number of milliamperes is meant.

You know that changing the voltage of the tube's grid will cause a change in the amount of current in the plate circuit. You know that the more strongly negative the grid is made the less current will flow in the plate circuit. Of course, making the grid less negative will reduce the repelling action on the emitted electrons, more of them will flow and there will be a larger plate Current.

We are going to change the grid's potential without changing the amount of bias. In Figure 22 you see the same circuit as in Figure 21 with the addition of another small battery, the one marked "extra voltage". This is a 2-volt battery.

Now look carefully. In Figure 22 the grid is connected to the negative terminal of the extra voltage. The grid was 4 volts negative to begin with because of the C-battery. Now we have made the grid still more negative by this extra 2 volts. So the potential of the grid is now 4 volts plus 2 volts, or 6 volts below that of the negative end of the filament. Making the grid more negative allows less flow of plate current and we find that the milliammeter now reads only 7 mils.

Next, look at Figure 23. We have just the same parts as in Figure 22 but the small battery giving an extra voltage has been turned end for end. Now the tube's grid is connected to the positive of this extra voltage. Does that make the grid positive? No, it does not.

Remember that the 4-volt C-battery is there in the grid circuit all the time. And that the extra positive voltage applied to the grid is really doing is lessening the negative voltage of the C-battery. The 2 volts extra is taken away from the original 4 volts negative bias so that the grid is now only 2 volts below the negative end of the filament in potential. That is, the grid is now only 2 volts negative.

With the grid only 2 volts negative it does not oppose the flow of plate current nearly so much as when it was 4 volts or 6 volts negative and upon looking at the milliammeter we find that the plate current has increased to 13 mils.

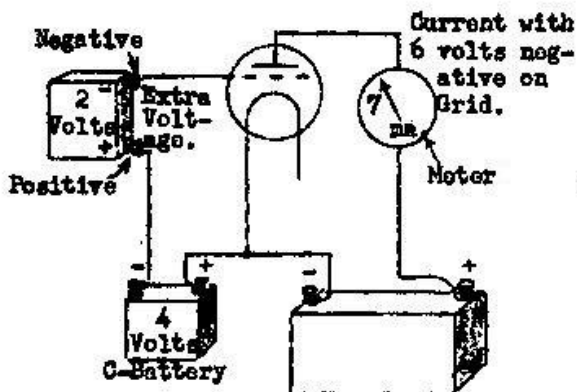

FIGURE 22.

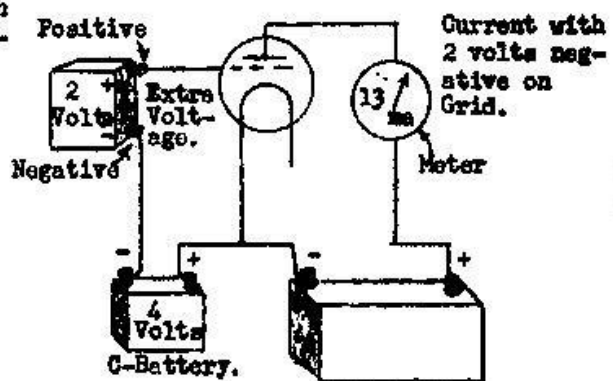

FIGURE 23.

Making the grid voltage more or less negative has changed the amount of plate current flowing. Notice particularly that, because of the C-battery, the grid's potential has always been below that of the negative end of the filament. The grid's voltage has changed, but all the changes have been on the negative side. It gets more or less negative, but it never goes over on the positive side with respect to the filament's negative end. The tube is "worked" with a negative grid potential at all times so that no current will flow in the grid circuit and so that all the electron flow will be in the plate circuit.

From what you have seen in Figures 22 and 23, it is perfectly evident that any extra voltage applied to the grid circuit will cause the plate current to change in step with all changes in the amount of this extra voltage. The illustrations just used brought out the fact that the plate current changes with changes in grid voltage, yet you did not really see a very clear picture of just how much effect the grid voltage had on the plate current. There is a way of letting you see those changes very clearly. It is by means of "graphs" or curves.

You often have watched the liquid in a thermometer rise and fall with changes in temperature. The liquid changes its length. You could draw straight lines which would correspond to the length of the thermometer's liquid just as they are drawn in Figure 24. One line represents a temperature of 20 degrees above zero, another represents zero, a third represents 50 degrees above zero and the last one corresponds to 20 degrees below zero.

Suppose you started at one o'clock some morning during cold weather and at each hour you drew a line corresponding in height to the height of the liquid in the thermometer at that hour. You might start off with 20 degrees above zero at one o'clock as in Figure 25, then at two o'clock mark off 15 degrees above, at three o'clock make a line standing for 10 degrees above, at four o'clock make one representing zero and so on as the lines are shown all the way through to twelve o'clock.

Anyone looking at Figure 25 could tell exactly how the temperature changed with the changing hours during that time. Still this method is not simple and clear enough. It is only the position of the tops of the lines that counts, so you might draw a line connecting all these tops together. The vertical lines are no longer of any use because the single new line tells the whole story; accordingly we will erase the vertical lines and leave the single line as in Figure 26. We have drawn a graph or curve showing the relation between hours of time and degree of temperature. With only a glance you can tell instantly that the temperature dropped to its lowest point near the middle of the period, was higher at the beginning and end, and was higher at the end than at the beginning.

Let us draw a graph telling the story of Figures 21, 22 and 23. In Figure 27 the horizontal or cross-wise lines indicate the number of milliamperes from zero (0) up to 15. They are equally spaced and divide the vertical lines into 15 equal parts. The vertical or up-and-down lines indicate the number of volts on the grid from zero (0) at the right down to negative 8 or minus 8 at the left. The three circles are placed where the lines cross for grid voltages and plate currents that we know. Then these three circles are joined by a single line which shows the effect of changing grid voltage on the flow of plate current.

In Figures 21, 2.2 and 23 we took readings with only three different voltages, with 2 volts, 4 volts and 6 volts negative. Suppose you want to know how many mils will flow with negative five volts on the grid. Look at Figure 27 at the vertical line drawn at 5-volt position. It crosses an imaginary crosswise line at the position for $8\frac{1}{2}$ mils and you can be sure that 4 mils will flow in the plate circuit when the grid is held at negative 5 volts.

There is no end to what you can determine from looking at a graph. A little way back you were told that heating the filament above a certain point would have very little effect on the electron emission or on the flow of plate current. In Figure 28 you are told the same thing in a graph. The temperature of the filament depends on the amount of current you send through it and the amount of current depends on

the amount of voltage you apply to the filament. The more the voltage, the greater the current and the higher the temperature.

Figure 28 shows the relation between the filament emission and the voltage put on the filament of a certain tube which normally requires 5 volts to operate it correctly.

The filament emission is measured in the number of milliamperes of current it allows to flow in the plate circuit. With a high plate voltage) the greater the emission the greater will be the amount of plate current. Notice that in Figure 28 there is no emission at all until you apply nearly 2 volts to the filament.

Th

en there

is a very slow increase until you get to about 4 volts

From that point the emission goes up more rapidly until, at 5 volts, it begins to increase less rapidly. From 4 volts to 5 volts the emission increased from 3 to 6 mils or an increase of

3 mils, But from 5 volts to 6 volts, the same voltage increase, the emission increased only from 6 mils to 7 mils or an increase of only one mil for the same increase in voltage. So you see, increasing the voltage above 5 volts does not

help much with the emission, Do you also see what a complete picture of the whole process we get from an examination of the graph in Figure 28.

Figure 29 shows a graph of the actual relation between grid voltage and plate current in the "27" heater type of tube, one

of the first indirectly-heated tubes. The plate milliamperes, from zero to 15, are arranged along the left hand edge. The grid voltages, from 4 positive down to 12 negative, are shown along the bottom edge. Zero grid voltage or zero bias is shown in a heavy line.

Ea

N 1

Notice

that the plate current is 9 mils with zero grid bias. With a drop in grid voltage, with this voltage becoming more negative, the plate current drops sharply to a point where the grid is 4 volts negative, then drops less rapidly with further decrease of grid voltage. When we get down around

8 volts negative the plate current is not decreasing nearly as rapidly for a given voltage drop as it was when nearer the zero point. When the grid voltage is made positive there is a rapid rise in the plate current. This graph tells you exactly how the plate current acts as the grid voltage is changed. i. graph makes a real picture

of changing conditions. With the help of graphs you will be able to learn how tubes amplify, how they distort, how they modulate a carrier wave, how they act as oscillators or generators of high frequencies, how they rectify alternating current into direct current and how they do all the other wonderful things a tube is capable of doing.

0	---				0		

1							
1~							
			~rr				
			rr~				
			8~				
				rrr	r		
				r~			
		~rr					
L			~~				
			~rr				
			rrr				

f, MFLIFIC: " ' TION ^G i. ND VOLUME;

2
;
7
~
~
3
9
:

Everyone who has heard anything about radio has heard about "amplification", and, of course, everyone has heard talk about "volume". In spite of the fact that many people seem to think these two mean the same thing, they are actually quite diff

erent. Volume is a measure of sound intensity. Loud music has more volume than

faint music. Volume affects the ears directly. If a loud speaker can make the

window panes rattle, it is delivering lots of volume, If you have to get your ear

alongside the speaker *to hear what is going on, there is not much volume.*

Volume

is sound intensity. Amplification is a *measure of how many times you multiply the strength of a signal.* If a part of your receiver takes in a signal *having a strength of 1 volt and then turns out that signal at a strength* of 20 volts, the signal has been amplified twenty times. This is very good amplification. Yet the volume may be so small that you can hardly hear it,

If you tune in a station 1,500 miles away on an ordinary receiver, you may be **amplifying the aerial signal hundreds or thousands of times,** Still., the original strength from *the aerial* may be so exceedingly small that the volume is hardly

worth speaking about. On the *other* hand you may take a *signal* from a station *only* three or four miles away, amplify it a comparatively little and get enough volume to drive people out of a room.

Amplification is the ability of a receiver or of any radio "amplifier" to multiply the strength of a signal. **Volume is the result of the strength of the incoming signal and the amplification applied to it.**

HOW ii TUBE 1,14

Suppose you had an outfit like *the one shown in* Figure 30.

There is an aerial *and* ground with a resistor connected between them.

The aerial and of this resistor is connected to the grid of a tube and the ground end is connected through a C-battery to the filament of that tube.

In the plate circuit of the *tube*, between the plate

and the B-battery, is a second resistor. Let us see what happens.

Aerial

Plate

FIGURE 30.

«s you know, radio signals reaching the aerial cause very small currents to flow between it and, ground. Carxent coming down from the aerial to the grid cannot flow through the space in the tube and the tube's filament to the ground resistor might be measured in millionths of a volt, but just to explain the action we will say the difference is 1j volts, This .1f volts is really applied to the tube's grid circuit and the grid becomes less negative than before, You know that increasing the grid's voltage or making the grid less negative, allows an increase of plate current, This increase of plate current will h.ave to pca s through the resistor in the tube's plate circuit,

7 Mils of Plate Current when Aerial Voltage is Positive.

0

0



4 Mils of Plate iCurrent when erial is tegat3.ve.



Grid voltage
when Aerial

is Positive,

Grid Voltage when w@rial is Negative.
C-Battery Voltage,

FIGURE .114. _____ FIGURE 3~.

We can "plot" the current changes on a graph, In Figure 31 there is drawn a heavy arrow pointing toward the value of plate current when the aerial voltage is positive. The plate current with the **aerial positive is higher than the current when there is no voltage from the aerial.** You can compare the graph of Figure 31 with that of Figure 29 and see how we use those curve)s.

In Figure 32 there is another graph on which the heavy arrow points towards the value of plate current when the aerial voltage is negative. **The grid voltage is now brought down below where it stands with no aerial voltage, or with only the C-battery voltage.** In Figure 31 we find 7 mils of plate current due to the aerial action raising the grid voltage, In Figure 32 w@ find only 4 mils of plate current **because the aerial action has lowered the grid voltage.**

Now we will. see what this **changing plate current does in the tube's plate circuit.** Of course, we have shown only one rise and fall of aerial voltage, but as the signal *continues to come in*, the rises and falls follow each other rapidly and the plate current rises and falls just as rapidly,

In Figure 33 w@ have the plate circuit resistor carrying the 7 mils of **current while the aerial voltage is positive.** The resistor has a value of 5,000 ohms and the voltage drop across it with 7 mils of current is 35 volts,

In Figure 34 w@ have the plate circuit resistor -^arrying only 4 mils of current while tht aerial voltage is nogetivo.

This reduced currrent produces a drop of only 20 volts,

connection because the resistance of the space between grid and filament is tremendously great. So the serial current flows down through the resistor to ground. Here you have current and resistance, consequently, according to Ohm's law, you must also have voltage drop. It is true that flow of the aerial current through the resistor causes a voltage drop and at the instant during which current flows downward, the top of the resistor is at higher voltage than the bottom. The actual potential difference between the two ends of the

L,12 - 16,

AUSTRALIAN RADIO AND TELEVISION COLLEGE PTY. LTD.

E. S. & A. BANK BUILDINGS, Corner CITY RD. and BROADWAY, SYDNEY
Telephones: BA4891 and BA4892

Telegrams “RADIOCOLLEGE” Sydney

This lesson sheet is published for the exclusive use of
students of the Australian Radio and Television College
Pty. Ltd. (All rights reserved)

Post Lessons to Box 43, Broadway

LESSON NO. 13.

MATHEMATICS No.3 - ALGEBRA

In Radio work practically all the problems we met can be figured out with simple arithmetic. However, we occasionally find a problem that is difficult to solve by arithmetic, but which can easily be solved by Algebra. Although Algebra is sometimes considered a somewhat difficult study, nevertheless, I am not going to take you into the deeper parts of it, for it will not be used in your Radio work. You will find this lesson just as practical and to the point as the rest of the Course. If after going over this lesson you find it hard to understand, carry on with your course but do not neglect this lesson entirely. I advise you to take this lesson section by section, and spend a few minutes each day or a couple of hours each week reading the one section over and over again until you understand it. By taking the lesson in small “doses” in this way, I feel sure you will be able to manage it before long. At the same time, you will not be delayed in your studies because you can carry on with your other lessons.

SIGNS AND SYMBOLS.

The same signs are used to indicate operations as in arithmetic. Thus + is read “plus or add to”; - is read “minus or “take from”; X means “multiply by”; and ÷ means divided by”. Instead of the multiplication sign between two symbols, the multiplication sign is often omitted and the symbols written side by side. For example, instead of writing ; $3 \times a \times b$, we would normally write $3ab$. Where symbols are written side by side in this manner. It is intended that they be multiplied together.

Symbols or letters are used to a very great extent in Algebra to represent numbers. When the letter is used to stand for a known number or quantity, a letter from the last part of the alphabet is chosen; while if the value of the letter is not known or an unknown quantity is to be represented, a letter the first part of the alphabet is chosen. The operations are thus performed with these symbols or letters as though they were numbers. However it is permissible to assign numerical values to these symbols when it is desired.

Another important use of symbols is that they enable one to abbreviate ordinary language in the solution of problems. For example:-

Three times a number equals 20 diminished or made less by 5. What is the number.

If we let n represent the number we can write the above statement and the question in the following way;

$$3n = 20 - 5$$
$$n = ?$$

The statement $3n = 20 - 5$ is called an equation in algebra and n is the unknown number. Furthermore:

$$3n = 20 - 5$$
$$3n = 15$$
$$n = 5 \quad \text{Hence 5 is the number.}$$

This example illustrates the algebraic method of stating and solving a problem.

ALGEBRAIC QUANTITIES

In algebra quantities are represented by one or more numerals or letters, or both combined. Thus we say $4XY$ AND $2A+3$. Remember that when no sign is written between a number and a letter, or between two letters, they are always to be multiplied together. Thus $5ab$ means that 5 is to be multiplied by a and by b .

We do not know the value of such an expression as $2x + 3y$ until definite values have been given to x and y . In one problem these symbols may have quite different values from what they have in another problem.

If we let $x = 3$ and $y = 5$, then the expression $2x + 3y$ has a definite value, namely $2 \times 3 + 3 \times 5$ or $6 + 15$ which, equals 21.

A factor of a product, or an expression is any one of the letters or numbers which multiplied together produce the product. Thus, in the expression $5mn$, 5, m , and n are each factors of the expression $5mn$, for if they are multiplied together the result will be the given expression.

An exponent is a little number written to the right and slightly above another number or letter to show how many times it is to be taken as a factor, that is multiplied by itself. Thus, in 3^2 , the 2 is the exponent and means that the 3 is to be multiplied by itself two times; namely $3 \times 3 = 9$. Similarly 5^3 means that 5 is to be taken as a factor three times, namely, $5 \times 5 \times 5 = 125$.

3^2 is read "three squared", while 5^3 is read "five cubed".

Likewise a^5 means that a is to be taken as a factor five times, namely :- $a \times a \times a \times a \times a$. Also $4a^2c^3 = 4 \times a \times a \times c \times c \times c$.

A coefficient is any one of the factors of a product. Thus in $5mn$, 5 is the coefficient of m , and m is the coefficient of $5n$, and n is the coefficient of $5m$. The 5 is called the numerical coefficient while the m or n is called the literal coefficient; because it is a letter while 5 is a number.

Parentheses () are often used to enclose a certain algebraic expression. If two or more numbers or letters are connected by any of the four operating signs and are enclosed in parentheses, the entire expression is treated as a single symbol or a single number. Thus $3(6 + 4) = 3 \times 10 = 30$. Likewise $6(x + y)$ means the sum of x and y multiplied by 6.

Square root in Algebra as in arithmetic is indicated by the sign $\sqrt{\quad}$. The symbol for cube root is $\sqrt[3]{\quad}$. The small figure in front-of the radical is generally called the index of the radical or root, sign.

ADDITION AND SUBTRACTION.

In order to add a number of expressions in algebra, we always place like terms under each other and then add their numerical co-efficients. Similar terms are terms having the same letters in them with the same exponents.

Thus similar terms are in the following manner:

$$\begin{array}{r r r}
 5ac & 9x^2y & 11\sqrt{a} \\
 7ac & 6x^2y & 5\sqrt{a} \\
 \underline{3ac} & \underline{7x^2y} & \underline{2\sqrt{a}} \\
 13ac & 22x^2y & 18\sqrt{a}
 \end{array}$$

NEGATIVE NUMBERS.

For certain purposes in algebra it is necessary to use negative numbers. A negative number is one having a - sign in front of it, thus -7, and indicates an “un finished subtraction”. Thus the + and - signs are used not only to indicate operations, but also to indicate the kind of number. The + sign is generally always omitted, and whenever a number is written without any sign preceding it, the + is always understood. Thus in making a thermometer a certain point on the stem is taken as zero, and temperatures are marked both above and below this point. Those above are generally called positive temperatures and preceded by a + sign, while those below zero are generally called negative temperatures and are preceded by a - sign. Similarly what a man actually has might be called a positive number, while his debts would be called a negative number and written with a - sign. This illustrates the use of negative numbers.

ADDING POSITIVE AND NEGATIVE NUMBERS.

If several algebraic terms are to be added which all have the same sign, they are written in a column and their numerical coefficients added up. The same sign is then given to the answer. Thus.

$$\begin{array}{r r}
 5ab & -6xy \\
 3ab & -3xy \\
 \underline{2ab} & \underline{-4xy} \\
 10ab & -13xy
 \end{array}$$

If however, two like terms are to be added and they have different signs, that is, one a positive and one a negative, then we subtract the smaller numerical coefficient from the larger and prefix to the difference the sign of the larger number. This rule is illustrated in the following examples, in which the two terms have unlike signs and are to be added.

$$\begin{array}{r r r}
 7mn & -8xy & 10ab \\
 -3mn & +3xy & -15ab \\
 +4mn & -5xy & -5ab
 \end{array}$$

The same principle applies when several positive and negative numbers are to be added. First all the positive coefficients are added and then all the negative coefficients are added, and the difference between the two sums with the sign of the larger is then the coefficient of the sum of all the terms.

SUBTRACTING POSITIVE AND NEGATIVE NUMBERS.

Whenever positive and negative numbers are to be subtracted, we change the sign of the subtrahend (that number which is to be subtracted) and then proceed just as we did in addition. Thus in each of the following examples the second number is to be subtracted from the first. In each case we change the sign of the second number and then proceed according to the rule given above for addition. However, it is not necessary to make this change of sign on paper, for we can do so mentally, and go ahead just as well. For convenience I have shown the changed sign in parentheses.

$$\begin{array}{r} 15mn \\ (+)-7mn \\ \hline 22mn \end{array} \qquad \begin{array}{r} 8xy \\ 10xy \\ \hline -2xy \end{array} \qquad \begin{array}{r} -12ab \\ (+)-18ab \\ \hline 6ab \end{array}$$

In the left hand example the sign of subtraction is - when changed it becomes + as shown within the parentheses. The problem then becomes adding a positive 15 and a positive 7, in the second example the sign of the subtrahend is changed from + to - and then we must add $a+8$ and $a-10$ which gives as a sum -2 . The right hand example is done in a similar manner.

MULTIPLICATION.

In multiplying algebraic terms there are two steps to perform. Either similar or unlike terms can be multiplied together. The product will be different from either one of the factors. The general rule for multiplication is the following.

First multiply the numerical coefficients in order to obtain the Coefficient of the product. The same letters occur in the product with the exponents equal to the sum of the exponents of the of letter in the factors. This rule is illustrated in the following example.

To multiply $2ab$ by $3a^2b$ we first multiply the numerical the numerical coefficients and then follow this by letter giving each letter an exponent equal to the sum of its exponent in the factors. The result becomes $6a^3b^2$.

If two terms with like signs (either both + or both -) are to be multiplied together, the sign of the product will be +. But if the signs are unlike the product is -. This is illustrated in the following examples.

$$-3mn \times -4mn = 12m^2n^2 \qquad 6ab \times -3a^2b^2 = 18a^2b^3$$

DIVISION.

In division there are two steps to follow as in multiplication. First we divide the: numerical coefficients as in ordinary arithmetic. Then we write the letters, but giving to each an exponent equal to its exponent in the dividend minus its exponent in the divisor.

Thus to divide $12m^3$ by $3m$, we first divide 12 by 3 and then follow the quotient 4 with

with the letter m, but subtracting the exponent in the divisor which is 1 from the exponent in the dividend which is 3. The quotient then becomes $4m^2$.

The rule of signs in division is similar to the rule in multiplication, that is, if two terms with like signs (both + both -) are to be divided, the quotient is +; but if the signs are unlike, the quotient is -. The following example will illustrate this rule.

To divide $18x^4y^3$ by $-3x^2y$ the quotient is $-6x^2y^2$

REMOVING PARENTHESES.

Often in algebraic work it becomes necessary to remove the parentheses, which enclose certain expressions. When the parentheses are preceded by a + sign (when no sign at all is there the + sign is understood) the parentheses can be removed without making any changes on the terms enclosed. However, when the parentheses are preceded by a minus (-) sign, then the sign of every term within the parentheses must be changed. This is illustrated with an example. Suppose we wish to remove the parentheses in the following example:

$$8a + (6a - 3b) - (7a - 13b + 15) + 10$$

Removing the parentheses and observing the rules just given you get

$$8a + 6a - 3b - 7a + 13b - 15 + 10$$

Combining terms the result becomes:

$$7a + 10b - 5$$

EQUATIONS.

An equation is a statement of equality between two equal numbers or number symbols. It consists of two numbers connected with an equal (=) sign. One is called the left hand and the other the right hand member.

An equation always contains a letter whose value is to be found. This letter is called the unknown.

To solve an equation means to find the value of, the unknown letter. The first step in solving an equation is to collect all the terms containing the unknown on the left hand side and all those not containing the unknown on the right hand side. Whenever a term is taken from one side of an equation to the other, it is necessary to change its sign.

I will now show you how to solve an equation. Let us use the equation

$$5x - 4 = 2x + 17$$

As I said, we transpose the term $2x$ to the left side and the -4 to the right side, and at the same time change the sign. The equation then becomes:

$$5x - 2x = 17 + 4$$

The next step is to combine terms, and we get

$$3x = 21$$

Lastly, we divide both sides of the equation by the coefficient of the unknown, and we thus obtain the value of the unknown, or x , in this manner.

$$x = 7$$

I will solve another equation for you, according to the same method. Follow the steps carefully.

$$\begin{aligned} 13n + 7m &= 5n - 17 \\ 13n - 5n - 17 &= -7 \\ 8n - 24 & \\ n &= -3 \end{aligned}$$

The solving of equations is often simplified considerably by multiplying or dividing, both side of the equation by the same amount or by changing the signs of both of the equation.

For instance, the equation $8 = 6 + 2$ is obviously correct. Supposing we multiply both side of this equation by 3.

$$\begin{aligned} 3 \times 8 &= 3(6 + 2) \\ 24 &= 18 + 6 \end{aligned}$$

If on the other hand we divide both side by the same amount say 2.

$$\begin{aligned} \frac{8}{2} &= \frac{6 + 2}{2} \\ 4 &= 3 + 1 \end{aligned}$$

You will realize that as long as we multiply or divide both side of an equation by the same amount, the answer is not affected. Now let us consider an algebraic equation.

$$3a = \frac{75}{a}$$

Multiplying both sides by "a"

$$3a \times a = \frac{75 \times a}{a}$$

$$\begin{aligned} 3a^2 &= 75 \\ a^2 &= 25 \\ a &= 5 \end{aligned}$$

In other cases it may be beneficial to divide instead of multiplying, take the equation.

$$3ax = 9a$$

Dividing both sides "a"

$$\frac{3ax}{a} = \frac{9a}{a}$$

$$\begin{aligned} 3x &= 9 \\ x &= 3 \end{aligned}$$

FACTORING.

Factoring is the process of finding those quantities or expressions which multiplied together produce a given number. For instance, the factors of the number 10 are 2 and 5, because 2 and 5 multiplied together produce 10. similarly the factors of 25 are 5 and 5, because 5 x 5 = 25.

There are many cases in factoring, but I will consider only the simplest one for none of the more complicated ones are likely to come up in your radio work.

Maths. Lesson 3 – 6.

The simplest form of factoring is that of determining the factors of a simple number or term, such as 10 or $25a^2b$, as already explained. This form is useful reducing or canceling fractions.

One of the most common processes is that of finding the factors of an expression which consists of two or more terms. These expressions are called polynomials. In this work it is generally not desirable to reduce the expression to the lowest possible factors, but to find the largest factor which is part of each term. This largest factor is called the highest common factor. For instance, in the expression $12 - 18 + 24$ the highest common factor is 6, because 6 is the highest number which is a factor of all three terms of the expression. The other factor which, when multiplied by 6, produces the complete expression is $2 - 3 + 4$ and is found by dividing 6 into the expression. The two factors could be written:-

$$6(2 - 3 + 4)$$

Now we will find the factors of the algebraic expression:-

$$25a^2b^3 + 15a^3b^2$$

It will be noticed that 5 is a factor of the numerical coefficient of each term, also that a^2 is the highest factor of both a^2 and a^3 in the two terms, and that b is the highest factor of b^3 and b^2 . Thus the highest common factor of the expression is $5a^2b^2$ because this is the largest quantity which is a factor of each term.

If we now divide the entire expression through by this factor we will get the two factors of the original expression. These factors are:- $5a^2b^2(5b + 3a)$

The $5b$ is, of course, found by dividing $5a^2b^2$ into $25a^2b^3$ while the $3a$ is found by dividing $5a^2b^2$ into $15a^3b^2$

FRACTIONS.

The expression a/b in which a and b represent numbers is called an algebraic fraction and is read "a divided by b" or "a over b". A fraction is merely an indicated quotient in which the numerator is the dividend and the denominator the divisor. The numerator and denominator are often called the terms of a fraction. Fractions in algebra are worked according to the same rules as in arithmetic.

The following facts are important to remember.

The numerator and denominator of a fraction may be multiplied or divided by the same number or letter without changing the value of the fraction. To illustrate, let us use the fraction $\frac{2a}{3b}$

We can multiply the two terms of this fraction by $5a$ and the fraction will still have the same value. The fraction then becomes $\frac{10ac}{15bc}$

A fraction is in its lowest terms when the numerator and denominator contains no common factors. The sign of a fraction is the + or - sign placed before the line separating the numerator from the denominator. There are thus three signs to consider, the sign of the fraction, the sign of the numerator and the sign of the

denominator. Thus in the fraction $-\frac{+5a}{-7b}$ the sign of the function is -, of the numerator +, and of the denominator -.

In a fraction the sign of both the numerator and denominator may be changed or the sign of the numerator and the sign of the fraction, or the sign of the denominator and the sign of the fraction, without changing the value of the fraction. Thus the above fraction could be rewritten in the following forms and have the same value in each case.

$$-\frac{+5a}{-7b} \quad -\frac{-5a}{+7b} \quad +\frac{-5a}{-7b} \quad +\frac{+5a}{+7b}$$

REDUCING A FRACTION TO LOWEST TERMS.

To reduce a fraction to its lowest terms we must factor both numerator and denominator and then “cancel” the common factors, that is those that occur in both. Thus to reduce a fraction we proceed as shown in the following examples:

$$\frac{12a^2b^3}{15a^3b^2} = \frac{\cancel{2}x\cancel{2}x\cancel{3}x\cancel{a}x\cancel{a}x\cancel{b}x\cancel{b}x\cancel{b}}{\cancel{3}x\cancel{5}x\cancel{a}x\cancel{a}x\cancel{a}x\cancel{b}x\cancel{b}} = \frac{4b}{5a}$$

MULTIPLICATION OF FRACTIONS.

whenever fractions are to be multiplied, we do just as we did in arithmetic, that is, we multiply all the numerators together and all the denominators to get the product. This is illustrated in the following examples:

$$\frac{2a}{3b} \times \frac{4a^2}{5b^2} = \frac{8a^3}{15b^3} \qquad \frac{5x^2}{7y^2} \times \frac{3a}{4b} = \frac{15ax}{28by}$$

DIVISION OF FRACTIONS.

Whenever it is necessary to divide a fraction, the general rule is to invert the divisor and then multiply. This is also illustrated.

Let us divide to expression $12a^3b^3$ by $\frac{2a}{3b}$

According to the rule just given you, we invert the $\frac{2a}{3b}$ so that it becomes $\frac{3b}{2a}$

Then we multiply $12a^3b^3$ by $3b$ and the answer becomes $36a^3b^4$. But this can be reduced to lower terms, for there are common factors in the numerator and denominator. It then becomes $18a^2b^4$.

Following is a further illustrative example:

$$\frac{24x^3}{15y^3} \div \frac{3x}{5y} = \frac{24x^3}{15y^3} \times \frac{5y}{3x} = \frac{120x^3y}{45xy^3} = \frac{8x^2}{3y^2}$$

A knowledge of algebra, while not essential in radio work will prove to be of considerable use if it can be attained. One of its most useful purposes is in connection with the various formulae found in various lessons throughout the Course. For instance, supposing a formula, is given for finding current when the resistance and voltage in a circuit are known. A knowledge of algebra allows us to change the

formula around so that we can find the resistance if the current and voltage are known, or so that we can find the voltage if the resistance and current are known.

Take the formula for current - $I = \frac{E}{R}$ Multiplying both sides of the equation by R.

$$I \times R = \frac{E \times R}{R}$$

$$I \times R = E$$

Divide both sides by I.

$$\frac{I \times R}{I} = \frac{E}{I}$$

$$R = \frac{E}{I}$$

We now have a formula for finding resistance. Again let us start with the same formula.

$$I = \frac{E}{R}$$

This is of course the same as saying $\frac{E}{R} = I$ Now multiplying both sides by R.

$$\frac{E \times R}{R} = I \times R$$

$$E = I \times R$$

Thus we now have a formula for finding voltage.

We will take another example to see how useful algebra can be to us. In the next lesson you will be told about a formula for finding the reactance of a condenser when of the current and the capacity of the condenser are known. This is the formula.

$$\text{Resistance in Ohms} = \frac{159,155}{\text{Cycles} \times \text{Microfarads}}$$

Multiplying both sides "cycles".

$$\text{Reactance} \times \text{cycles} = \frac{159,155 \times \text{cycles}}{\text{cycles} \times \text{Microfarads}}$$

$$\text{Reactance} \times \text{cycles} = \frac{159,155}{\text{Microfarads}}$$

Dividing both side by "reactance"

$$\frac{\text{Reactance} \times \text{cycles}}{\text{Reactance}} = \frac{159,155}{\text{Microfarads} \times \text{Reactance}}$$

$$\text{cycles} = \frac{159,155}{\text{Microfarads} \times \text{Reactance}}$$

We have now changed our formula around so that instead of finding reactance we can now find the frequency necessary to produce a certain reactance in a condenser of a certain capacity. By similar means we can change the formula to enable us to find the capacity in microfarads if we know the reactance we require and the frequency of the current.

Starting with the same formula

$$\text{Reactance} = \frac{159,155}{\text{cycles} \times \text{Microfarads}}$$

Multiplying both side by microfarads we have

$$\text{Reactance x microfarads} = \frac{159,155}{\text{cycles}}$$

Dividing both side by reactance

$$\frac{\cancel{\text{reactance}} \times \text{microfarads}}{\cancel{\text{reactance}}} = \frac{159,155}{\text{cycles} \times \text{reactance}}$$
$$\text{microfarads} = \frac{159155}{\text{cycles} \times \text{reactance}}$$

The same principles can be applied to practically any of the formulae given in the various lessons, so that even if only one formula is given you will be able to able to change it around and thus make it tell you a number of useful things.

Although there is a great deal more to study in Algebra, this, however as far as is necessary for you to do at this time. It may seem a little difficult at first because it is such a new subject, but if you will study it a little each day in connection with your other work, and I am sure you will master it without serious troubles.

For those of you who have taken Algebra at school this lesson should completely refresh your memories on the subject. For those who have not and still experience difficulty we suggest that in the meantime you carry on with the other lessons in the course as they come to you, but at the same time give an hour or two each week to this lesson on Algebra until you have completely mastered it. If you require a good elementary book on the subject, "Elementary Algebra" Parts 1 & 2, written by Barker & Bourne can be recommended. It gives examples of Algebraic problems for you to work out, together with answers, so that you can check your working. Most well known book-shops stock the book.

EXAMINATION QUESTIONS LESSON 13 M3.

1. Add the following , $4xy^2 - 2ab + 3xy^2 + 7ab$
2. (a) Subtract $-11xyz$ from $3xyz$
(b) “ $18ab$ from $6abx$
3. (a) Multiply $4ab^2c$ by $10abc^2$
(b) “ $2ab$ by $5axy$
4. Divide $12p^2q^5$ by $3pq^2$
5. Simplify the following $6a - (3ab+4a) - (5a +3ab - 15)$
6. Simplify the following equation:-
$$18x + 7 - 5 = - 4x + 40 + 6$$
7. Find the factors of $20 x^5 y^2 c^4 + 16 x^2 y^3 c^4$
8. Reduce the following fraction to its lowest terms.

$$\frac{3 x^3 y}{12 x^4 y^2}$$

9. Multiply $\frac{3x}{4a^2}$ by $\frac{-x^2}{4a}$
10. Divide $\frac{20 a^2 b}{15x^4}$ by $\frac{4ab}{6x^2}$

Please note postal address - Cnr. Broadway & City Roads Sydney –
for return of papers correspondences etc.

AUSTRALIAN RADIO AND TELEVISION COLLEGE PTY. LTD.

E. S. & A. BANK BUILDINGS, Corner CITY RD. and BROADWAY, SYDNEY
Telephones: BA4891 and BA4892

Telegrams "RADIOCOLLEGE" Sydney

This lesson sheet is published for the exclusive use of students of the Australian Radio and Television College Pty. Ltd. (All rights reserved)

Post Lessons to Box 43, Broadway

LESSON NO. 14.

OPPOSING THE FLOW OF ELECTRIC CURRENT.

You have been doing quite a bit of studying on the effects of resistance in various kinds of circuits and have found that resistance is very useful in allowing us to control the amount of current flowing. When you first took up the study of radio, you were told that resistance in electrical circuits corresponds to friction in mechanics. This is true because resistance changes electrical energy into heat, the heat passes away and the energy which produced it is lost as far as the circuit is concerned.

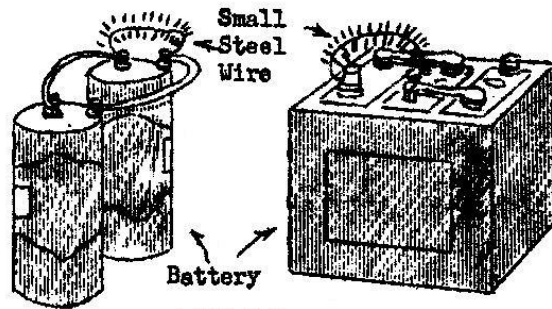

FIGURE 1.

In Fig. 1 is shown an experiment which illustrates the effect of resistance. If you use two dry cells, connected together as at the left, or if you use a single cell of a storage battery such as a radio A - battery or an automobile battery, you will have the source of electric energy. Then get hold of a small steel wire. Steel has considerable resistance. Then connect this wire between the fixed terminals of the car battery as shown in Figure 1. The ends of the wire must be bright and clean.

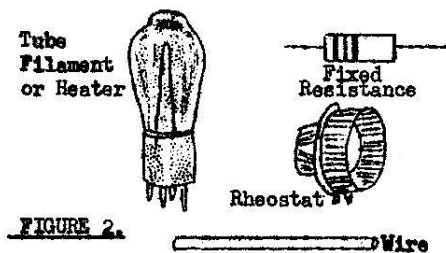

FIGURE 2.

The wire gets hot. Be sure you don't keep hold of it. Then it gets red hot, and finally a dazzling white heat just before the metal in the wire melts and burns apart.

You changed electric energy into heat energy, the heat was radiated into the air and it disappeared never to return. The resistance of the wire

changed the form of the energy, it allowed the production of heat and the final result was a loss of electrical energy. Resistance always represents a loss of energy.

Resistance opposes the flow of electric current. In order for the current to get through the resistance, the electricity has to work hard. The work produces heat, Resistance is not the only thing which opposes the flow of electric current.

There is resistance in every part through which electric current flows. Every conductor has ohmic resistance. Sometimes good use is made of the resistance. In Figure 2 the tube filament's resistance is used to make current heat the filament. The flow of current is controlled with the fixed resistor or with the rheostat. A rheostat is another name for a variable resistor used for the control of current flow. But every wire and every other current carrying part also has resistance even though it is undesirable.

It has been said that all conductors have resistance. They have resistance to direct current and to alternating current too. Therefore, even the coil and condensers in Figure 3 have resistance to alternating current or to any other current. Resistance is found wherever there is electric current flowing matter what kind of current,

OTHER WAYS OF OPPOSING CURRENT FLOW.

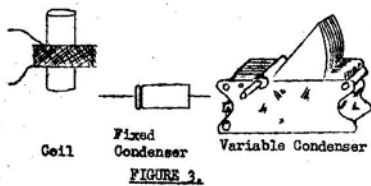

In an earlier lesson you learned that coils and condensers, such as shown in Figure 3. oppose current flow because they have a property called "reactance". You were told that reactance is the ability to "react" or give back energy. Coils and condensers absorb energy and hinder the flow of current, but then they give back the energy into the circuits. The effects of reactance were illustrated by showing you a

steel sizing which, after being twisted, will untwist and give back energy. You were also shown how a weight may be lifted and then, upon falling will give back energy or do work.

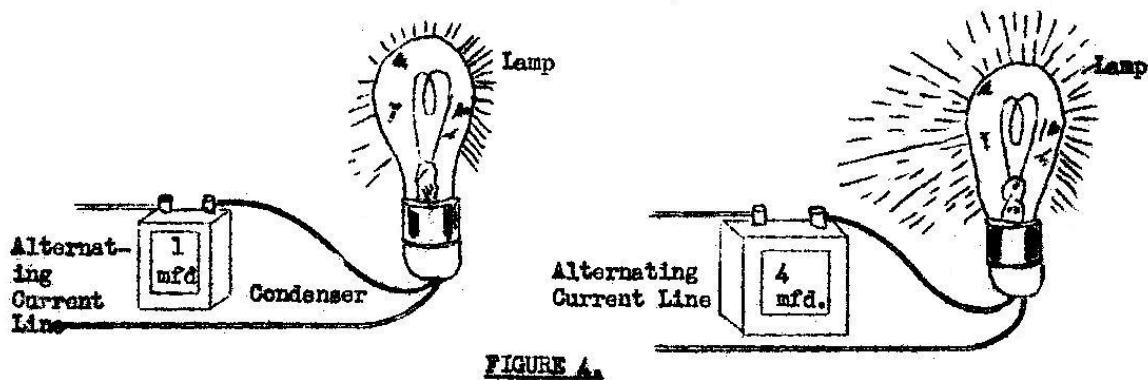

Reactance requires energy to overcome it in the first place, but the energy is then given back. You see there's a big difference between resistance and reactance.

In Figure 4 is shown another simple experiment, this one to show the effect of the reactance in condensers. Over at the left hand side of this picture is an ordinary house lighting lamp connected to an alternating current line with a direct wire on one side of the circuit and with a 1.-microfarad condenser in the other side. The lamp will light, but will light dimly. If the condenser was Left out and a direct connection made as shown by the broken line, then the lamp would light up brightly.

The condenser has a reactance. The reactance makes it difficult for the alternating current to flow to and through the lamp, consequently the lamp lights less brightly with the condenser in the circuit than when there is no condenser. The effect on the brightness of the lamp filament is as though we had connected in series with it a resistor having a value of 3180 ohms. The reactance of a 1 mfd. condenser at a frequency of 50 cycles per second is 3180 ohms. If you wish you may calculate this figure for yourself by using the formula for condenser reactance shown on the next page.

Now look at the right hand side of figure 4. Here we have substituted for the 1-microfarad condenser another condenser having a capacity of 4 microfarads, the reactance of which at 50 cycles per second is approximately 800 ohms. Now the lamp lights up much brighter than with the 1-microfarad condenser. More current must be flowing to and through the lamp with the large capacity condenser. The large condenser has less reactance than the small one and because it has less reactance it is easier for alternating current to act through it. now you can memorise the first rule about reactance in a condenser; MORE CAPACITY – LESS REACTANCE.

In the earlier lesson called "The Operation of Condensers and Their Part in Radio", you learned that alternating current can flow in a circuit containing a condenser by virtue of the fact that as current flows firstly into one plate, where it is stored, it forces an equal amount of electricity to leave the other plate and continue on around the circuit. Then a fraction of a second later the current reverses and flows into the plate from which it previously emerged at the same time causing an equal amount to leave, the plate which it originally entered. Now the opposition or reactance to the current which flows around the circuit from one condenser plate to the other naturally depends on the amount which can be stored in the condenser or on the capacity of the condenser. A large capacity condenser can store a large amount of capacity so that it is easy for the current to flow into and out of the plates. Consequently the reactance of a large capacity is low. A small capacity cannot store a large quantity of electricity so that there is more opposition or reactance to current flow in the circuit. This explains how the rule "MORE CAPACITY – LESS REACTANCE" comes about.

In Figure 5 is shown another experiment with a condenser, at the left a small condenser, one with 0,005 microfarad capacity, is connected between the aerial and the receiver. Whether the condenser is placed between aerial and receiver or whether a wire is run directly from the aerial without any condenser there will be practically no noticeable difference in the loudness of the signals. Evidently the condenser has but little reactance.

In Figure 5 at the right the same 0.005 microfarad condenser formerly used in the aerial line is connected between the receiver and the loudspeaker. With this condenser in the speaker line you will hear hardly a sound while with a direct wire to the speaker the loudness is as usual. In this position it is evident that the condenser has a great deal of reactance.

Now you will be told the difference between the condenser connection at the left and the one at the right. At the left the condenser is in a circuit carrying very high frequency, a circuit carrying radio frequency currents. At the right the condenser is in a circuit carrying comparatively low frequency or audio frequency. The condenser is the same in both cases, but its reactance to high frequencies is very little and its reactance to lower frequencies is very great. This condenser lets the high frequency currents through practically without hindrance, yet almost stops the low frequency currents. This gives the second rule for reactance in a condenser MORE FREQUENCY - LESS REACTANCE.

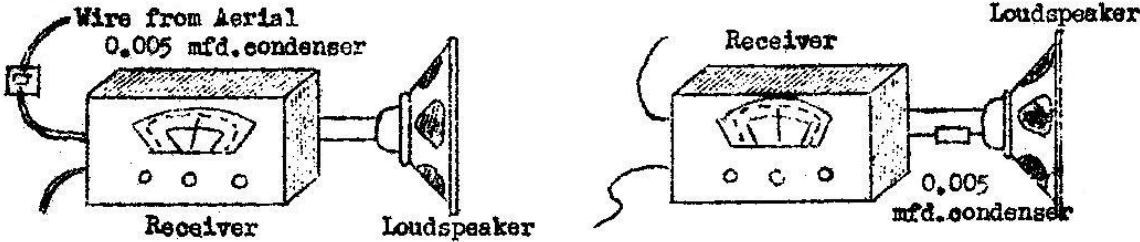

FIGURE 5.

It is very important that you memorise these two rules about reactance. Always remember “more Capacity -- less reactance” and “more frequency -- less reactance”, whenever you are dealing with condensers.

HOW TO CALCULATE A CONDENSER’S REACTANCE.

Anything which opposes the flow of electric current as measured in the unit called an “ohm”. Resistance is measured in ohms and so is reactance measured in ohms. To figure out the reactance of a condenser in ohms you have to know the condenser’s capacity and you have to know the frequency of the alternating current which is to flow through the condenser -- only two things.

Condensers are used in three different portions of a radio receiver, as follows:- (1) in the radio frequency amplifier, (2) in the audio frequency amplifier, and (3) in the power supply parts. In those three portions of the set we are handling three classes of frequencies. In the radio amplifier we are handling (1) high frequencies or radio frequencies measured in kilocycles. In the audio amplifier we are handling (2) lower frequencies or audio frequencies measured in cycles. In the power units we are handling (3) very low frequencies or power frequencies also measured in cycles. Three parts of a receiver are indicated in Figure 6.

First we'll take the formula for condensers used in the power supply units and in audio amplifiers where the frequencies are measured in cycles. The condenser capacities are measured in microfarads. Here is the formula:

$$\text{Reactance in Ohms} = \frac{159,155}{\text{cycles} \times \text{microfarads.}}$$

You multiply the number of cycles by the number of microfarads and divide the result into 159,155 which is the constant.

(Special note;- This constant, 159,155 is obtained by dividing 2Π or 6.28 into one million. In many text books Capacity Reactance formula is shown as

$$\frac{1}{2 \Pi FC} \text{ or } \frac{1}{CW}$$

where C equals capacity of condenser in farads and W equals $(2 \Pi \times F)$ and F equals the number of cycles per second. As a farad which is one millionth part of a farad.

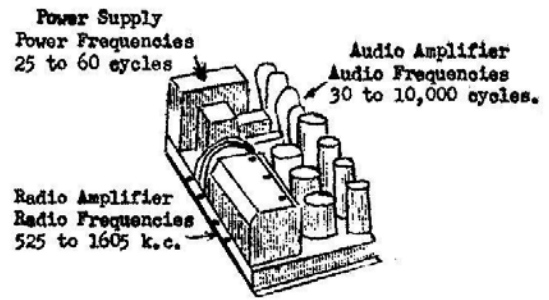

FIGURE 6.

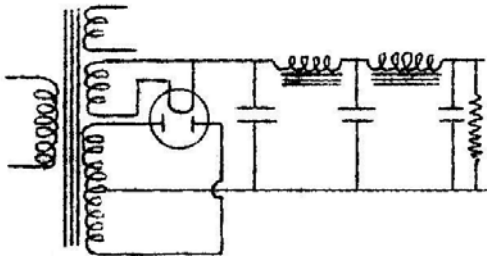

FIGURE 7.

In Figure 7 is a diagram of a typical power unit which contains three condensers of 2- microfarad capacity each. These condensers are acted upon by the power line frequency which in this case is 50 cycles. To find the reactance of each condenser we place these values in the formula as follows:

$$\begin{aligned} \text{Reactance in Ohms} &= \frac{159,155}{50 \times 2} \\ &= \frac{159,155}{100} \\ &= 1591 \text{ (approx.)} \end{aligned}$$

In Figure 8 is a diagram for one type of loudspeaker connection. A 2-microfarad condenser is placed between the tube's plate and one of the speaker leads. One of the keys on a piano produces a musical (audio) frequency of 1035 cycles. What is the reactance of the 2-microfarad condenser at this frequency? Again we place known values in our formula like this:

$$\begin{aligned} \text{Reactance in Ohms} &= \frac{159,155}{1035 \times 2} \\ &= \frac{159,155}{2070} \\ &= 77 \text{ (approx.)} \end{aligned}$$

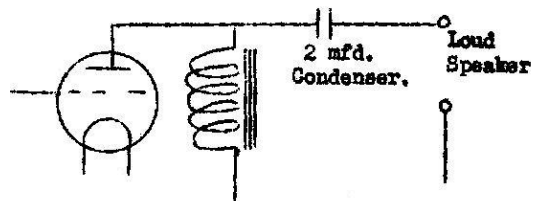

FIGURE 8.

Notice that at a frequency of 50 cycles the 2-mfd, condenser has a reactance of more than 1500 ohms while at a frequency of 1035 cycles the same condenser has a reactance of only 77 ohms. Here you see that the rule "more frequency – less reactance" holds good.

When considering the radio frequency end of the set we are going to deal with frequencies so high they are measured in kilocycles (thousands of cycles) so we will want a formula using kilocycles instead of cycles. We will still measure the condenser capacity in microfarads. Here is the now formula:

$$\text{Reactance in Ohms} = \frac{159}{\text{kilocycles} \times \text{microfarads}}$$

This looks a lot like the first formula, except that the number above the line is now "159" instead of "159,155".

In Figure 5 we connected a condenser of 0.005 microfarad capacity in the aerial circuit. At a frequency of 1000 kilocycles what is the reactance of this small condenser? We will put the known value into the second formula like this:

$$\text{Reactance in Ohms} = \frac{159}{1000 \times 0,005} = \frac{159}{5} = 32 \text{ (approximately)}$$

The number "0.005" is the same as 5/1000 and when we multiply the number 1000 by 5/1000 the result is 5. So we just divide the number above the line (159) by 5 and the answer is 32 ohms reactance for this condenser.

With this same condenser in the loudspeaker circuit, should the speaker attempt to sound the piano note of 1035 cycles the condenser's reactance would be more than 30,000 ohms. Here, again you see the working of the rule "more frequency -- less reactance".

THE REACTANCE OF A COIL.

Now that we have finished our investigation of the reactance in condensers we will look into the subject of reactance in coils. Both condensers and coils have reactance or opposition to the flow of alternating current. We will go back to experimenting with the house lighting lamp and connect it as in Figure 9.

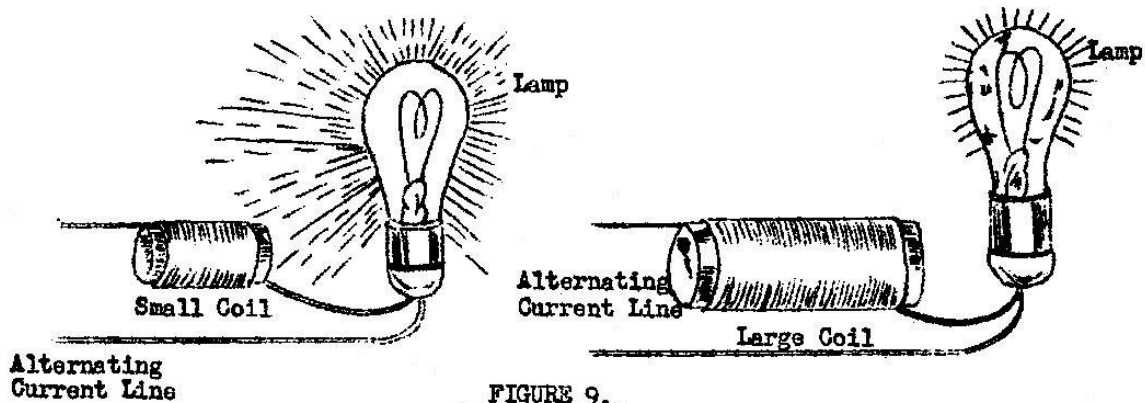

In the left hand illustration we have connected a small coil of wire in one of the two wires carrying alternating current to the lamp. The lamp does not light quite so brightly as without the coil in circuit., but still it does burn quite well. In the right hand picture we have changed coils and are now using a much larger one. The

lamp lights very dimly. Evidently the large coil has much more reactance to alternating current than the small one. We can be sure that it is not just the resistance of the coil that dims the lamp because current is coming from the power and light lines through a much greater length of wire than is contained in even the large coil, and the great length of wiring in the outside circuits does not dim the lamp.

In order to explain about the reactance of coils it will be necessary to go back quite a bit and explain first some very important things about the behaviour of a coil when alternating current flows through it.

LINES OF FORCE.

At same time in your life you have probably played with a horse-shoe magnet like those in Figure 10. You found that such a magnet would attract and hold nails and other small objects made of iron or stool, also that the needle of the compass would be attracted towards one of the ends or "poles" of the magnet. It is perfectly evident that some peculiar invisible force exists around the magnet's poles and in the space between them.

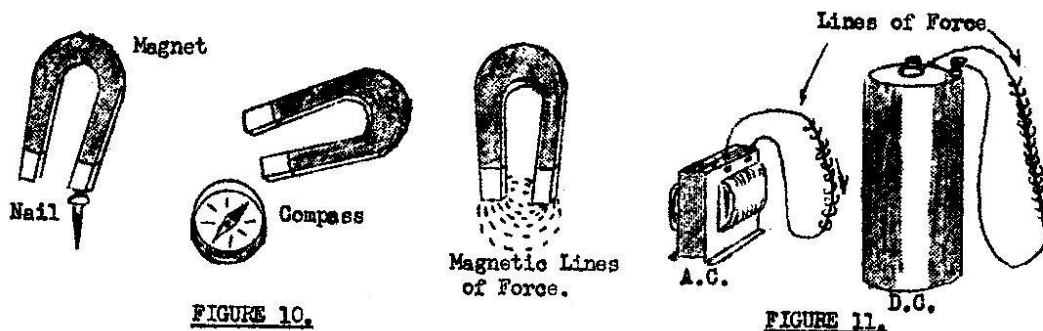

FIGURE 10.

FIGURE 11.

Between the magnet poles there are invisible "lines of force". The nail tries to come close to the magnet so that it can carry more of these lines. The Compass needle turns so that the lines pass through it from end to end. These lines of force make up what we call the "magnetic field".

There are similar lines of force around any conductor carrying current. If you have alternating current flowing through a wire or if you have direct current in the wire, there are lines of force around the wire as indicated in Figure 11.

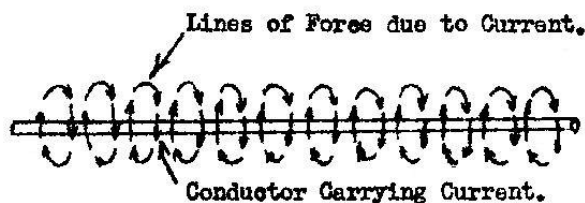

FIGURE 12.

These lines of force have direction, they whirl around in a certain direction. The direction travelled by the lines or by the force which they represent depends on which way the current is flowing in the wire. You can see what is meant in Figure 12. If the current flows from left to right, according to the arrows,

the lines would whirl in a clockwise direction as you looked at the right hand end of the wire. If you reverse the direction of the current, the direction of the lines of force will also reverse in direction around the wire.

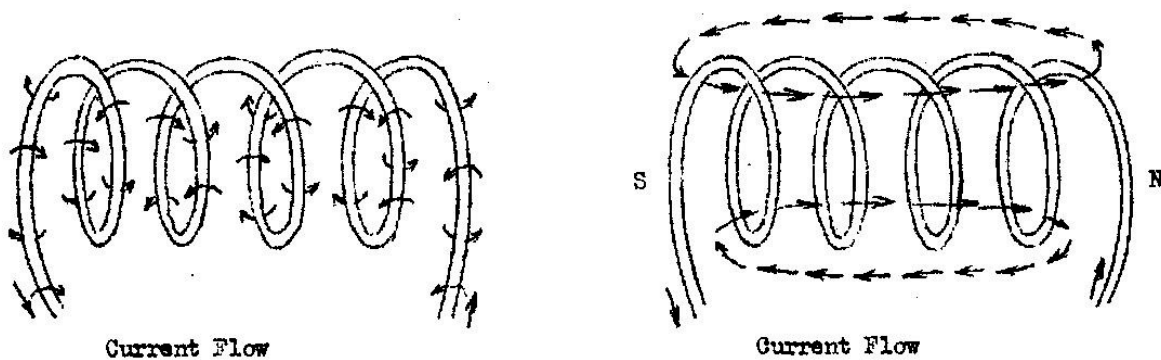

FIGURE 13.

In Figure 13 the straight wire has been formed into a number of loops or into a coil. Now the lines of force are closer together because you have brought some parts of the wire closer to other parts. The lines still whirl around the wire just the same as when it was stretched out straight. At the left hand side of figure 13 you will see that all the little arrows, representing lines of force, are travelling toward the left hand end of the coil while they are on the outside of the coil. What really happens is shown at the right. All the lines on the outside, which are flowing toward the left, join together and flow along together as shown. All the lines inside the coil likewise join together and flow together from left to right. All the lines of force inside the coil flow in one direction and all those on the outside flow in the other direction. The lines come out of the "IN" end of the coil and go back into the "S" end. Reversing the direction of current flow through the wire of the coil will reverse the direction of all the lines of force. Then the lines will go through the coil and around its outside in the other direction. Remember that there are no lines of force when no current is flowing and that there will be the greatest number of lines when the greatest amount of current flows.

Then if we take the coil at the left in Figure 14 and find that the ammeter shows zero, or no current flow, there will be no lines of force or no field around the coil. With a moderate amount of current flowing as shown in the next coil toward the right there will be a field of moderate strength or of a moderate number of lines around the coil. If the current is increased to the maximum amount shown in the centre drawing there will be a strong field or many lines around the coil. Then, decreasing the current as at the next picture will reduce the number of lines around the coil and if the current falls to zero, or stops, as at the extreme right the lines will disappear. This is exactly what happens around a coil carrying alternating current. First there is no field then it increases to its maximum strength or greatest number of lines as the current rises to its greatest flow in one direction. As the current dies down again, the field is reduced in strength and when the current drops to zero there is no field, no lines around the coil. As the alternating

current swings the other way, the process is repeated, the field builds up to the maximum number of lines of force, then drops back to nothing again.

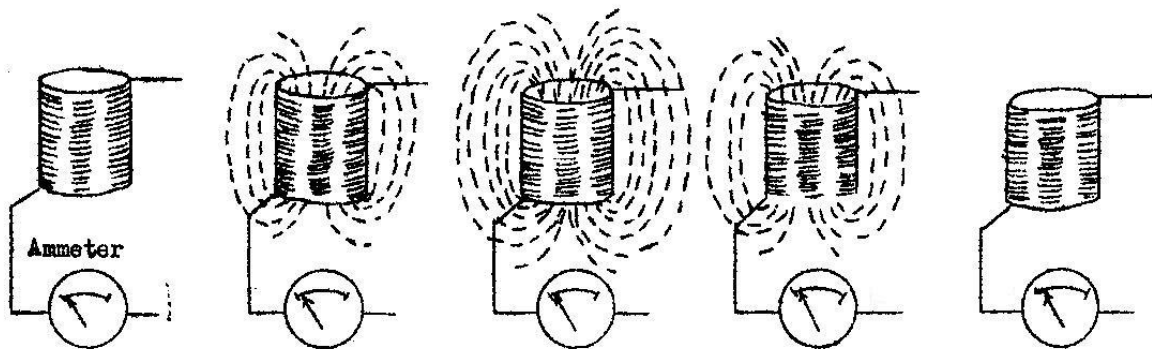

FIGURE 14.

With the action shown in Figure 14, the lines seem to rise out of the coil to spread out as their number increases, and then to drop back into the coil, finally to disappear altogether.

GENERATING ELECTRIC CURRENT.

In Figure 15 a hollow coil of wire is connected to a couple of turns of wire around an ordinary magnetic compass. If you were to plunge a bar magnet down into the coil while watching the compass needle, you would see the needle swing to one side. Then as you withdrew the bar magnet from the coil, the compass needle would swing the other way.

You have moved the magnet's lines of force down through the turns of wire composing the coil and the cutting of the lines through the conductor produced a voltage and the electric current in the coil and the wires attached to it. The tiny

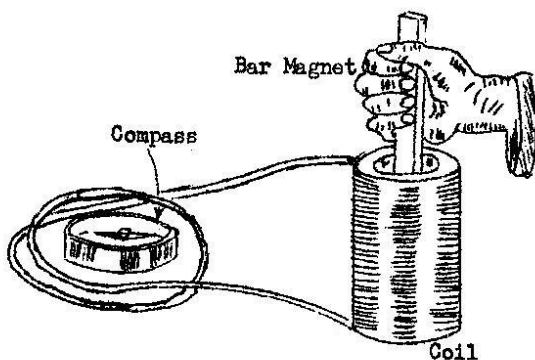

FIGURE 15.

lines of force in the wire around the compass caused its needle to swing. You know that lines of force appear around any wire carrying current, consequently the compass indication of lines of force shows that you have produced a current in the wire around it.

The faster you move the bar magnet into and out of the coil, the more the compass needle will swing or the farther it will swing. The more

rapidly the lines of force cut through the coil's conductors the greater is the voltage and current generated.

Exactly the same result could be secured were you to hold the bar magnet stationary and move the coil of wire up and down around the magnet. Any relative movement between the lines of force and a conductor produces a voltage in the conductor

COUNTER ELECTRO MOTIVE FORCE

If you look at Figure 14 you will realise that the lines of force rising out of the coil and falling back into it must be cutting through the coil's conductors. This movement of the lines of force produces a voltage in the coil of Figure 14.

In Figure 14 we had a voltage and current which caused the lines of force to appear in the first place. Then the movement of the lines also produced a voltage in the coil. Therefore, there must be two voltages in the coil -- one being the voltage that produced the lines of force: and the other being the voltage which the moving lines produced.

The second voltage, the one produced by the moving lines of force is called "counter electromotive force". Electromotive force is just another name for voltage, so we might as well say "counter voltage". Counter means opposite, or the other way round, so we find that counter electromotive force means a voltage acting in the opposite direction. It is true that the counter e.m.f. acts just opposite to the voltage originally applied to the coil. This action may be illustrated by the steam cylinder and flywheel of Figure 16. The original voltage is represented by the heavy flywheel. As the steam pressure is applied and tries to revolve the flywheel, the weight of the flywheel opposes

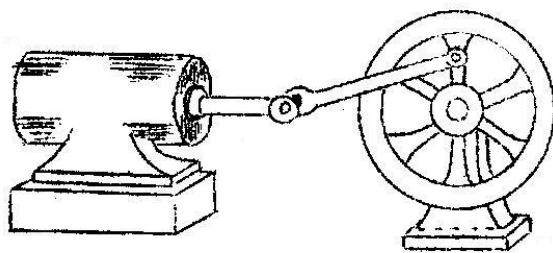

FIGURE 16.

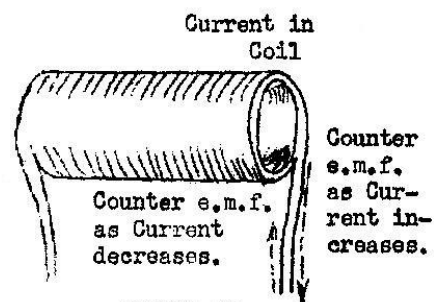

FIGURE 17.

the turning and acts against the steam pressure. Then, as the steam pressure decreases, the weight of the flywheel tends to keep the wheel revolving. A similar action takes place in the coil. While the current in the coil is increasing, or while the lines of force are rising out of the conductors and spreading out, the counter e.m.f. acts against the original voltage. This is shown in Figure 17.

Then, when the current in the coil commences to drop off, the lines of force move the other way, drop back into the conductors. This reverses the polarity of the

counter e.m.f. and it tends to keep the current from dying down, tends to keep the current flowing. The counter e.m.f. holds back the current as it tries to increase, then tries to keep the current flowing when it wants to decrease.

It was the counter electromotive force in the coils of Figure 9 which made the lamp burn dimly. This opposing voltage worked against everything that the regular line voltage tried to do. With the coils, and their counter electromotive force, in the lamp's circuit the regular voltage from the supply line was unable to get as much current to the lamp as it could have had the coils been out of the way.

In Figure 18 is shown a curve representing one complete cycle of alternating current such as might pass through the lamp circuit when no coil is included. The current rises to the value marked "8" in each direction. Now supposing we have a coil in the circuit. Then the alternating current may be represented by the curve in Figure 19. The opposing voltage, or the counter electromotive force, holds back the current and it can only rise to the value marked "5" in each direction. That's the way counter electromotive force acts; it reduces the amount of current that can flow in an alternating current circuit.

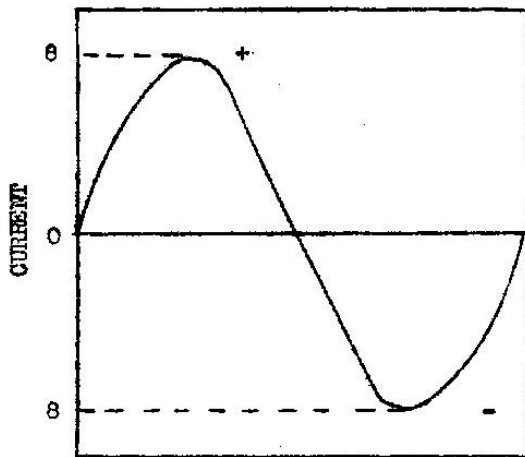

FIGURE 18.

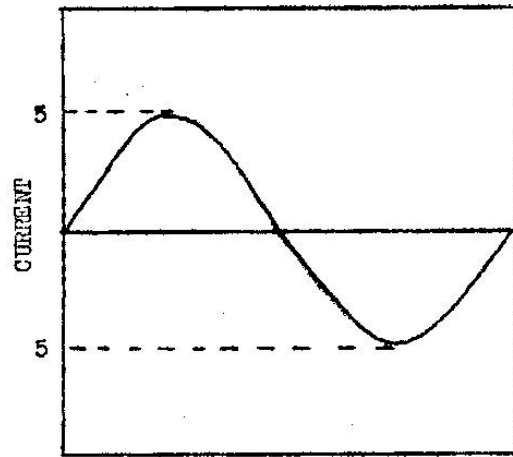

FIGURE 19.

EFFECT OF FREQUENCY ON THE COIL'S REACTANCE

During one cycle of alternating current the current rises to maximum in one direction, falls to zero and increases to maximum in the other direction and finally falls to zero again as indicated in the lower part of figure 20. Were this current flowing through the coil shown at the top of this illustration, there first would be a very strong field, then no field at all, then another strong field, and then no field again -- the strong fields occurring along with the maximum currents.

You have been told that voltage is generated by lines of force cutting through conductors. As the field around the coil of Figure 20 rises out of the coil its lines

of force cut through the coil's wires and voltage is generated. As the lines fall back through the wires another voltage is generated. This is the action that produces the counter e.m.f.

The more rapidly the lines rise out of the coil and fall back into it, the greater will be the rate at which the lines cut through the wires and the greater will be the voltage generated. You were told that the voltage generated depends on the number of lines cutting a conductor within a certain length of time. So the faster the lines cut, the greater will be the counter e.m.f. generated. The greater the counter e.m.f. the more the opposition to the action of the original voltage.

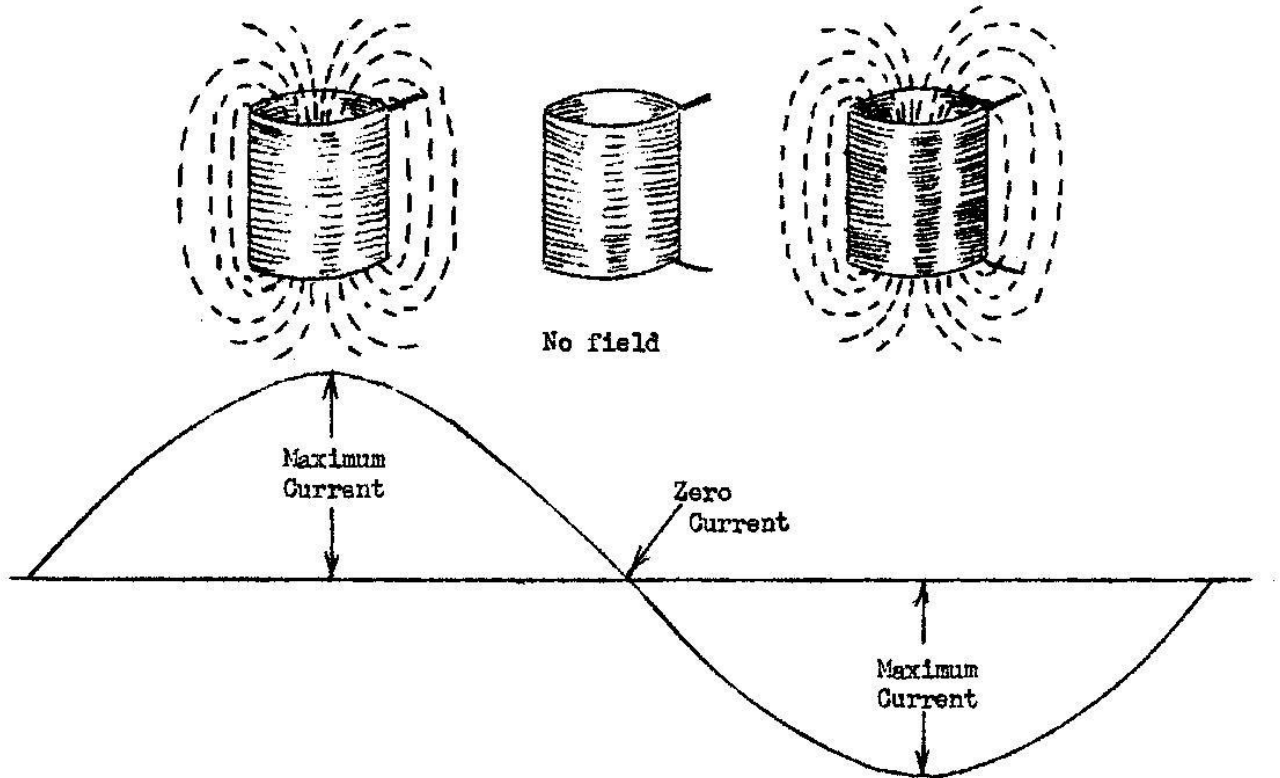

FIGURE 20.

As the frequency of the alternating current increases, the number of times the field rises out of and falls back into the; coil in one second will increase. Consequently the greater the frequency, the greater will be the counter e.m.f. and the more opposition there will be to the original voltage. So you see that increase of frequency increases the reactance of the coil since the opposition to the original voltage is what constitutes reactance.

Now you have the first important rule dealing with the reactance of a coil; **MORE FREQUENCY -- MORE REACTANCE.** This is just as important as the rules dealing with a condensers reactance and it is quite necessary that you remember it.

A little farther along you will be given the second rule for a coil's reactance; then you will know two rules applying to condensers and two similar ones applying to coils.

First you will be told about the name used for the ability of a coil to generate voltages in the way that has just been explained.

INDUCTANCE

The property of an electric circuit (such as a coil) by means of which it is able to generate voltage is called "inductance". When a coil generates voltage in itself the property is called "self-inductance". We have just seen how this self-inductance acts in a coil. If the voltage is generated in a different circuit, as is done when two circuits are coupled such as in a transformer, we call the property by the name of "mutual inductance".

The greater the coil's ability to generate a voltage within itself, the greater is the coil's inductance. The amount of inductance possessed by a coil depends on the size of the coil, on the size of the wire, and on the material around which the coil is wound

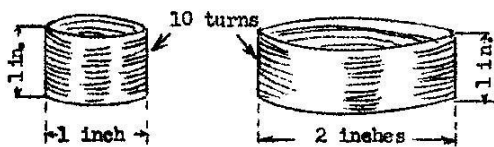

FIGURE 21.

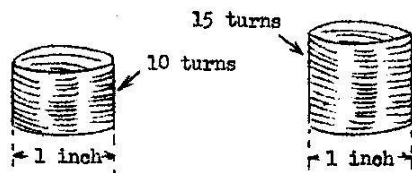

FIGURE 22.

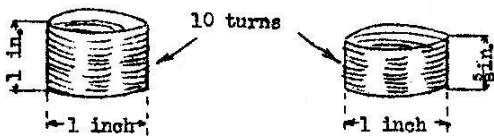

FIGURE 23.

The two coils in Figure 21 have the same number of turns of wire and are of the same length. But the one at the right is twice the diameter of the other one, therefore the right hand coil has much more inductance than the one at the left.

The left hand coil in Figure 22 has 10 turns of wire and the right hand coil has 15 turns of the same kind and size of wire. The two coils are of the same diameter. Because of more turns of the same wire, the right hand coil is longer than the other one. Because of the extra turns the right hand coil has more inductance than the one at the left.

The two coils in Figure 23 have the same number of turns of wire and are of the same diameter. The coil at the left is one, inch long and the one at the right is only $\frac{5}{8}$ inch long. Therefore, the effect is more concentrated in the right hand coil and the right hand coil has more inductance than the one at the left.

At the left In Figure 24 we have a coil with nothing but air inside it. The Inductance of this coil is determined by its diameter, its length and the number of turns of wire.



FIGURE 24.

At the right hand side of the illustration we have the same coil but now the space inside is completely filled with iron. Were you to measure the inductance of the two coils you would find that the one with the “iron core” has hundreds of times as much inductance as the one with the “air core”.

There you have the four things which affect a coil's inductance, (1) diameter, (2) number of turns, (3) length of winding, and (4) material inside the coil.

You have learned that the more counter voltage generated in a coil the more it opposes the flow of alternating current through it, or the more reactance the coil possesses. Now you have learned that the coil's ability to generate voltage is called inductance. Then it follows that the greater the coil's inductance, the greater must be its reactance. This is the second rule for coil reactance, MORE INDUCTANCE - MORE REACTANCE. Now you have the two rules for coil reactance to match the two for condenser reactance. You will notice that those two rules for coil reactance are just the opposite to the two for condenser reactance.

HOW TO CALCULATE A COIL'S REACTANCE.

A reactance of a coil is measured in ohms, just as the reactance of a condenser and the resistance of any circuit is measured in ohms. We will always find coils in three portions of any receiver, in the radio amplifier, in the audio amplifier, and in the power supply parts. The coils are handling three classes of frequencies -- radio frequencies, audio frequencies and power frequencies.

In order to figure out the reactance of a coil we must know its inductance and we must know the frequency of the alternating current which will pass through the coil. The inductance of a coil may be measured in any one of three common units, first comes the “henry” which represents quite a large amount of inductance. The henry is used for inductance measurements of coils having iron cores. Iron-core coils are used in transformers and in chokes for audio frequency amplifiers and for power supply units.

A smaller inductance unit is called the “millihenry” which is the one thousandth part of a henry. Transformer coils and choke coils used in radio frequency circuits may have their inductances measured in either millihenrys or in “microhenrys”. Here is the relation between the three, inductance units:

$$1 \text{ henry} = 1,000 \text{ millihenrys} = 1,000,000 \text{ microhenrys.}$$

Now you will be given three formulae used for calculating the reactances of coils when the inductances are given in henrys, millihenrys or microhenrys and when the frequencies are given in cycles or in kilocycles.

$$\text{Reactance in Ohms} = \frac{\text{Cycles} \times \text{henrys} \times 1000}{159} \quad (3)$$

$$\text{Reactance in Ohms} = \frac{\text{kilocycles} \times \text{millihenrys} \times 1000}{159} \quad (4)$$

$$\text{Reactance in Ohms} = \frac{\text{kilocycles} \times \text{microhenrys}}{159} \quad (5)$$

Another formula is sometimes used for calculating the reactance of a coil:

$$\text{Reactance in Ohms} = 2\pi fL$$

In this formula the symbol “ π ” is called “pi”, and is usually taken as 3,14. The letter “f” represents the frequency in cycles per second and “L” the inductance in henrys. If we multiply 2 by π as in the beginning, we have a value of 6.28.

Now $\frac{1000}{159}$ works out to be 6.28 and the rest of this formula (cycles x henrys) is

the same as the rest of formula 3. Therefore, this formula is exactly the same as formula 3 except that it is written in a slightly different way.

In Figure 25, showing part of a power supply unit, there is a “filter choke” having an inductance of 20 henrys. To calculate the reactance of this choke at a frequency of 120 cycles we will use the formula (3) and fill in the values as follows:

$$\frac{120 \times 20 \times 1000}{159} = \frac{2,40,000}{159} = 15,000 \text{ ohms (approximately)}$$

The resistance of a choke such as shown in Figure 25 may be between 200 and 300 Ohms. That would be its resistance to direct current and of course it offers the same amount of resistance to alternating current. Yet, in addition to the fairly low resistance, we find that this choke has a reactance to alternating current of 15,000 ohms. Direct current would flow through this choke quite easily but alternating current would have a hard time getting through because of the great reactance.

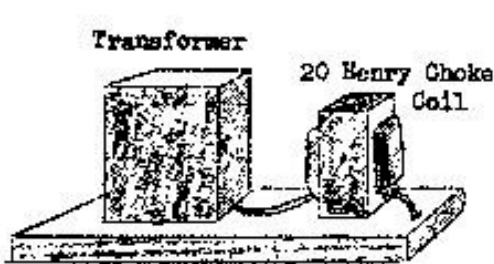

FIGURE 25.

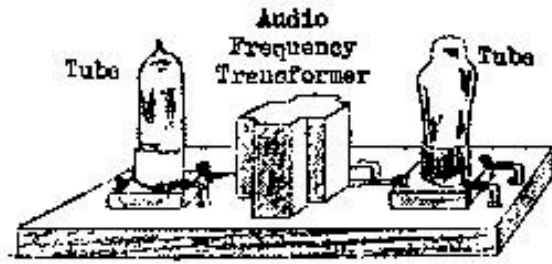

FIGURE 26.

In Figure, 26 we have part of a transformer coupled audio frequency amplifier showing the coupling transformer between two amplifying tubes. Although this arrangement does not conform to modern practice we have included it with a view to providing a simple example of impedance calculation. The same remarks may be made regarding the circuit diagram of Figure 27. This also is not typical of modern practice but has again been included as a concession to simplicity. The primary winding of this transformer has an inductance of 60 henrys. Supposing we are amplifying a musical note having a frequency of 500 cycles, to calculate the

reactance of the transformer at that frequency we use formula (3) again and fill in these new values as follows.

$$\frac{500 \times 60 \times 1000}{159} = \frac{30,000,000}{159} = 188,000 \text{ ohms (approximately)}$$

This shows you what very great opposition we have to alternating currents of audio frequencies when our coil has plenty of inductance. The circuits used around a detector tube are shown In Figure 27. On the left of the detector we have a radio frequency transformer in which the secondary coil or winding has an inductance of 170 microhenrys. To calculate the reactance of this coil at a broadcasting frequency of 1000 kilocycles we will use formula (5) and fill in the values given:

$$\frac{1000 \times 170}{159} = \frac{1700,000}{159} = 1070 \text{ ohms (approximately)}$$

In the case of this radio frequency transformer, we have a very high frequency; of 1000 kilocycles or of 1,000,000 cycles. Yet, because the inductance is very small, being measured in microhenrys, we have only a comparatively small reactance. You can see that the reactance does not depend on the frequency alone, nor on the inductance alone, but on the relation of these two to each other.

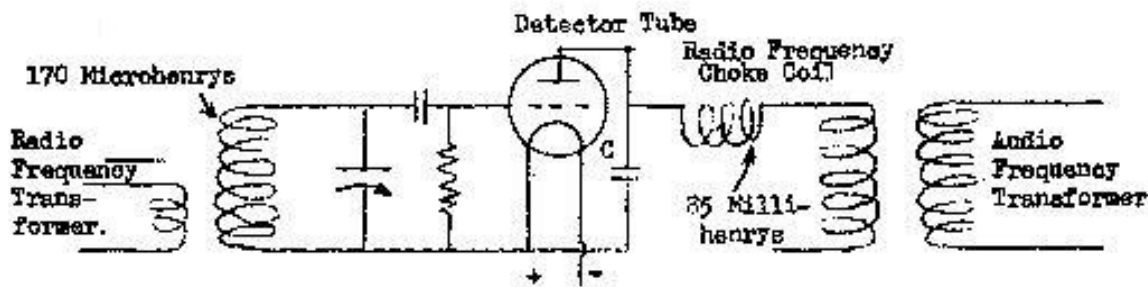

FIGURE 27.

Over at the right hand side of the detector tube in Figure 27 you will see a radio frequency choke coil having an inductance of 85 millihenrys. Let's figure out the opposition or reactance of this coil to radio frequency currents having the frequency of 1000 kilocycles. Here we will use the formula (4) and fill in the values this way.

$$\frac{1000 \times 85 \times 1000}{159} = \frac{85,000,000}{159} = 530,000 \text{ ohms (approximately)}$$

The purpose of the radio frequency choke coil is to prevent currents at radio frequencies from going over into the audio frequency transformer. You can see that this very high reactance of 530,000 ohms would certainly hold back these radio frequency currents and would force them to pass through the condenser marked "C" in figure 27. The reactance of the choke coil to audio frequency currents from the detector would be very low and these currents would go over into the audio frequency transformer.

We could use the more complicated formulae giving answers which would be slightly more exact, but our formulae here are easy to use and give answers accurate enough for all ordinary work.

In this lesson you have been given five different formulae for figuring out the reactances of condensers and coils. It is not necessary for you to memorise all of these formulae, but it is essential that you know at least one formula for calculating condenser reactance and one for coil reactance.

In all this work we are doing with reactances of coils and condensers, there is one point you should notice especially. We speak of reactance only when alternating currents are being considered. In order that reactance may appear we must have alternating current. There is no such thing as reactance to direct current, once the magnetic field surrounding a coil has reached the limit imposed by the normal resistance to direct current. To explain this last remark, let us take an example. It is assumed that we have a coil of wire with a resistance amounting to 100 ohms. If to the end of this coil, we apply an e.m.f. of 100 volts, one ampere of current will flow through the coil if the voltage is a direct one. However, one ampere of current will not flow through the coil immediately it is connected to the voltage source. There will be a short lag - only a fraction of a second - but - time lag nevertheless before the current flow reaches its full intensity of one ampere. The time lag is caused by the counter e.m.f. developed within the coil at the instant current commences to flow through it. As with A.C. the counter e.m.f. tries to prevent current flowing through the coil, but immediately the current flow has reached its maximum intensity, one ampere in this case, the field about the coil is no longer moving and, consequently, no longer creating a counter electromotive force within the coil as a result, all reactive opposition ceases until the circuit between the voltage source and the coil is broken. When the circuit is broken, the field surrounding the coil collapses and in doing so creates another counter electromotive force within the coil. This second counter electromotive force endeavours to keep current flowing through the coil and so creates a delay between the time the circuit is broken and the time current ceases to flow. This is the only way in which reactance will affect a D. C. circuit. In effect, reactance is continuously present in an A.C. circuit but only temporarily present in a D.C. circuit.

Resistance is different -- we have resistance to all kinds of currents, to alternating current as well as to direct current. Resistance is due to the size and material of the conductors. Reactance is due to the form of the parts and is greater where the conductors are formed into coils or into condensers. Now you will be told something about the combined effect of reactance and resistance on the flow of alternating currents.

IMPEDANCE.

You learned that every circuit has resistance, or ohmic resistance, to the flow of alternating current and to the flow of direct current. Resistance is always there. Reactance is there only when alternating current flows in the circuit. For the total opposition to the flow of alternating current, for the opposition offered by both the resistance and the reactance combined, we have new name. "impedance". This is a perfectly natural name because the impedance is the thing which impedes

the flow of alternating current. If you know the resistance of a circuit and also know that circuit's reactance, you can figure out the impedance.

Unfortunately we can't just add the resistance in ohms to the reactance in ohms and get the impedance in ohms. You haven't been told before, but impedance is measured in ohms - just as all other kinds of opposition to current flow are measured in ohms.

It is also unfortunate that the formula by which we figure out the impedance is not so easy to use as the formula for reactance. To figure out the impedance we have to "square" the resistance in ohms, then square the reactance; in ohms, then add the two squares together and extract the square root of their sum. That doesn't sound so very easy. The lucky thing about it all is that you do not often have to figure out the impedance of a circuit. In radio work we can get along by knowing the resistance and reactance separately.

The formula for calculating impedance is very important and should be memorised
It is as follows:-

$$\text{Impedance in ohms} = \sqrt{(\text{resistance})^2 + (\text{reactance})^2} \quad (6)$$

When you write a number with the figure 2 following it and a little above the line it means that you square the number. To square a number simply means to multiply it by itself. Thus, the square of 2 is 2 times 2 or 4. The square of 10 is 10 times 10 or 100.

Let's take a practical problem. Say you want to know the impedance of a circuit having a resistance of 6 ohms and a reactance of 8 ohms. You use the formula (6) and fill in the values like this:

$$\text{Impedance in ohms} = \sqrt{6^2 + 8^2}$$

The number 6 squared is 6 times 6 or 36. The number 8 squared is 8 times 8 or 64. Adding 36 and 64 we get 100. Then we have to figure the square root of 100. The square root of number is some other number which, multiplied by itself will give you the original number. Now 10 multiplied by 10 gives 100, so the square root of 100 is 10. We find that 6 ohms resistance and 8 ohms reactance in a circuit results in 10 ohms Impedance.

The impedance of a circuit is always less than the sum of the resistance and the reactance. The impedance is always greater than either the resistance or the reactance taken alone

Impedance in alternating current circuits measures the whole amount of opposition to flow of alternating current just as resistance alone measures the opposition in direct current circuits. If you know the impedance of a circuit you can use it in all the rules of Ohm's Law in place of the resistance when dealing with A.C. circuits.

EXAMINATION QUESTIONS No.14

1. Does reactance affect The flow of direct current or of alternating current? How?
2. In what units do we measure (1) reactance, (2) resistance?
3. Which has the greater reactance, a condenser of 2 microfarads capacity or one of 6 microfarads capacity? Why?
4. If the frequency of a circuit is increased, does the reactance of a condenser in the circuit go up or go down?
5. Which has more reactance a coil 2 inches in diameter, 3 inches; long and having 60 turns or a coil 2 inches diameter, 3 inches long and having 30 turns? Explain why?
6. Will a coil have more reactance at a frequency of 1,000 kilocycles or at a frequency of 600 kilocycles? Why?
7. In what units can we measure the inductance of a coil?
8. Which has more reactance, a coil of little inductance or one of big Inductance?
9. What two things do you have to know to calculate a condenser's reactance?
10. What do we call the combined opposition to alternating current of both the reactance and the resistance in the circuit? In what units is it measured?

PLEASE NOTE POSTAL ADDRESS - Cnr. Broadway & City Road, Sydney - for return of papers, correspondence etc.

AUSTRALIAN RADIO AND TELEVISION COLLEGE PTY. LTD.

E. S. & A. BANK BUILDINGS, Corner CITY RD. and BROADWAY, SYDNEY
Telephones: BA4891 and BA4892

Telegrams "RADIOCOLLEGE" Sydney

This lesson sheet is published for the exclusive use of students of the Australian Radio and Television College Pty. Ltd. (All rights reserved)

Post Lessons to Box 43, Broadway

LESSON NO. 15

Undoubtedly you have looked inside a radio set to see what happens as you turn the tuning knob. Only one thing moves or rather only one set of parts has any motion. The moving parts are one of the sets of plates of each section of the "tuning condenser".

In Figure 1 you will see one of these tuning condensers attached to a pulley drum which is part of the tuning dial mechanism. The tuning knob is attached to the drum, usually by cord or flexible cable, and as you turn this knob it rotates the drum and moves the condenser plates. If the receiver is in operation, movement of the condenser plates causes first one broadcast station to "come in" and fade out, only to be followed by another station. So it goes, all up and down the dial. You are "tuning" the receiver

Most tuning dials have the station call signs directly marked on them. The carefully designed tuning condensers and coils are so accurately made that

turning the knob and moving the dial pointer to a particular call sign will automatically move the tuning condenser plates to just the right position to tune in that station, if it is broadcasting.

A tuning condenser with its movable plates in three different positions is shown in Figure 2. Looking carefully at the condenser, you will see that its two principal parts are two sets of plates. The plates of one set are stationary and remain fixed in their original positions. The other plates are attached to a shaft and as the shaft turns, these plates move in between the fixed ones, depending which way you turn the dial.

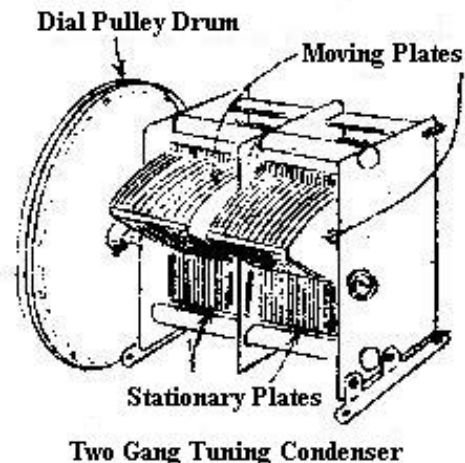

Figure 1.

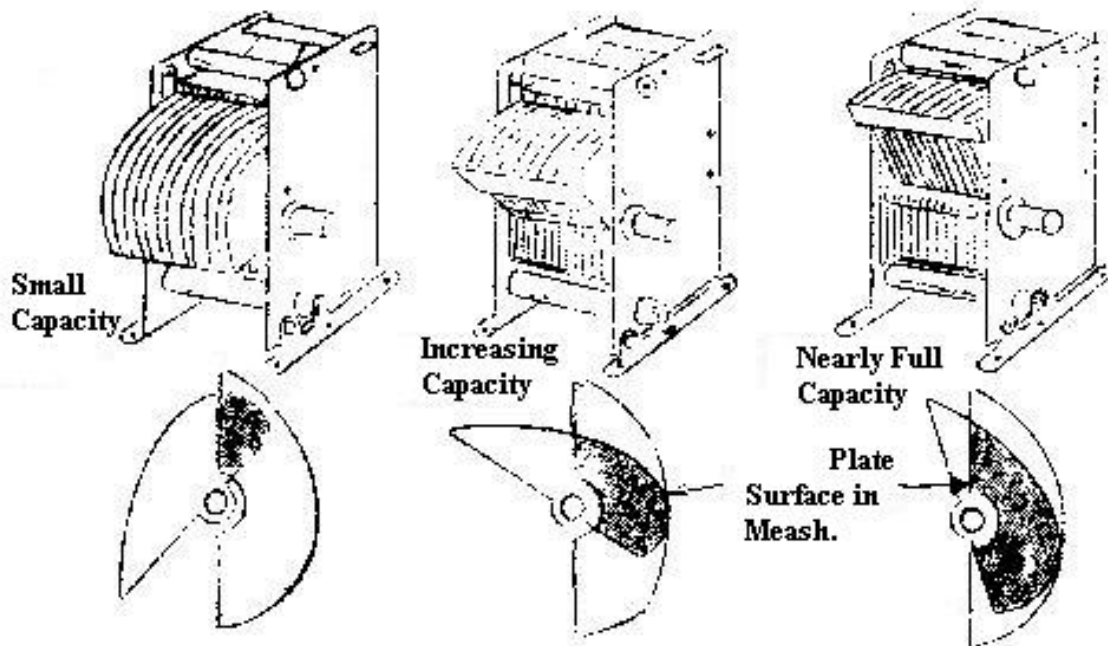

Figure 2.

The three pictures in the lower part of Figure 2 show what is happening, You recall that a condenser consists of plates separated from one another by a dielectric. Air is the dielectric of the tuning condenser. The only part of the plate surface which is effective in producing capacity is the part opposite another plate. The only part of the air dielectric which can be placed under an electrical strain is the part between the plates.

In the condenser at the left of Figure 2, only a small portion of the plate surface is in mesh or is opposite the surface of the stationary plates. Therefore, in this position the condenser has small capacity. Moving the plates farther into mesh as in the centre picture of Figure 2 increases the capacity because more plate surface is in use. Moving the plates nearly all the way in as at the right causes the condenser to have nearly its full capacity. When the plates are all the way in, you have the maximum possible capacity for that particular condenser.

Then the operation of tuning consists of changing the capacity of a condenser, or changing the capacity of several similar condensers all connected together. By this simple operation you are able to select from several hundreds of stations on the air at one time just one particular station to which you wish to listen. All the other stations are there, all of them are sending out radio waves, and all those waves are striking your aerial at the same time. Yet you hear but the one station. As far as your receiver is concerned there is only one difference between one transmitting station and another. The difference is indicated in Figure 3.

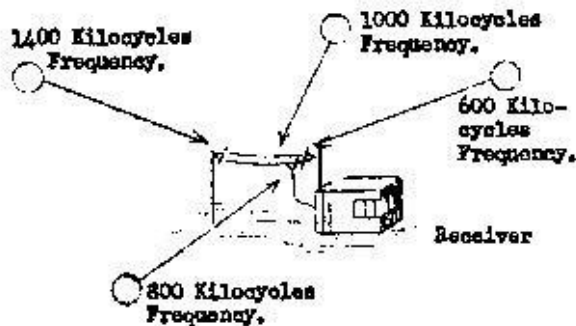

Figure 3.

The different stations send out "carrier waves" of different frequencies. Broadcasting stations use the frequencies between about 500 kilocycles and 1600 kilocycles.

A kilocycle, as you remember, in 1,000 cycles per sec.

Now we may conclude that changing the capacity of the receiver tuning condenser changes the frequency to which the set responds. The set accepts one frequency and at the same time rejects all the others.

Of course the same effect may be achieved by changing the inductance of the coil in a tuned circuit and this method is actually used in television receivers when changing from one channel to another. Variable inductance tuning is also used in some motor vehicle radio receivers. Further details about each of these specialised applications will be provided towards the end of this lesson.

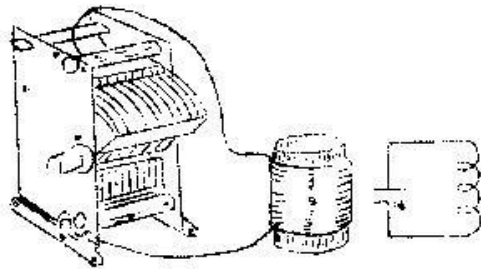

Figure 4.

Were you to trace out the connections made to each of the tuning condensers in the receiver, you would find that each one connects to a coil as in Figure 4. The symbol for such a circuit is shown at the right hand side of this illustration. Such an arrangement of coil and condenser makes what we call an "oscillating circuit" or an "oscillatory circuit". The action that takes place in one of these circuits is as follows:-

At the left hand side of Figure 5 we start off with a charge on the plates of the condenser. This means that one plate is at a higher potential than the other. The difference in potential causes a flow of current from one plate, through the coil winding and back to the other plate.

Flow of current through the winding produces a field of lines of force around the coil as shown at the right hand side of Figure 5. The condenser is discharging. This means that the voltage difference between the condenser plates is diminishing. Once the condenser is fully discharged, it has no voltage left to maintain the flow of current, so the current tends to stop. As it decreases, the magnetic field around the coil collapses back through the winding as at the left hand side of

Figure 6. Movement of the lines of force back through the winding generates a counter E.M.F. in the coil which tends to prevent the current from stopping, that is, positive at the bottom of the coil and negative at the top as shown. This counter E.M.F. actually forces the electrons to keep on moving in the same direction, that is, on into the top condenser plate and away from the bottom plate so that the condenser becomes charged again. But now the bottom plate is positive and the top negative. The circuit has completed one half cycle of its oscillation.

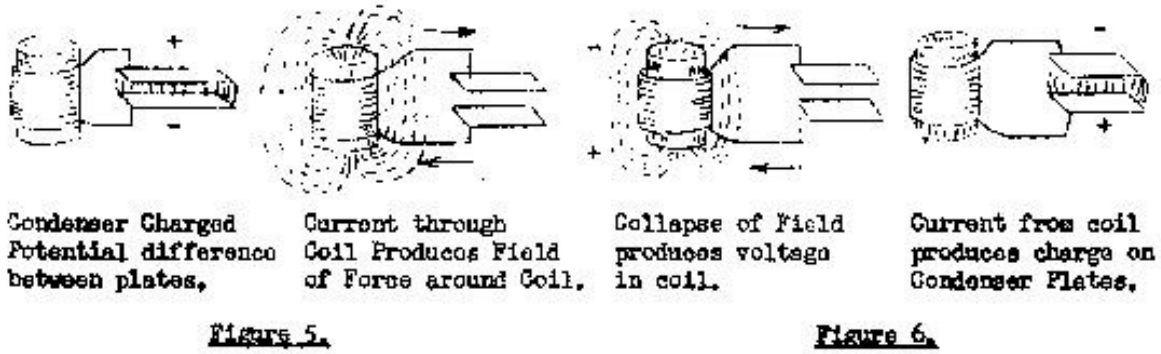

The energy of the falling lines of force now having been expended in charging the condenser, the charge of the condenser again exerts itself in causing electrons to flow back again from the top plate to the bottom. The lines of force are again set up and again keep the current going when the condenser's charge has been expended. This charges the condenser again, positive at the top and negative at the bottom, just as it was at the start.

The oscillating circuit has now completed one whole cycle; the entire process is repeated over again many times, the energy being stored at one instant in the condenser's charge and then in the coil's field. The preceding explanation has been based upon the modern conception of electron movement from the negative end of the circuit to the positive end. Although this conception of current flow was introduced in an earlier lesson we remain conscious of the fact that many students will have had some initial training in electrical theory and practice before commencing this Radio Course, and that such training may have assumed the older conventional idea of current flowing from positive to negative. As initial impressions are sometimes hard to change, many people brought up on the conventional idea prefer to retain it and think always in terms of current flowing from positive to negative. There is nothing fundamentally wrong with this provided one remembers always that a flow of current is actually a movement of electrons and that movement of electrons from negative to positive and flow of current from positive to negative simply represents two ways of referring to the same thing. For this reason we have made a practice of using both methods of expression so that students may think either in terms of electron movement or conventional current flow, whichever they prefer.

The preceding reference to the alternate charge and discharge of a condenser when connected in a tuned circuit may be changed to conventional current flow terminology

by simply reversing the direction of the arrows shown on the illustrations and transposing the terms "top" and "bottom" when referring to the condenser plates. However, do not overlook the fact that the respective polarity of the plates remain the same. At the left of Figure 5, the top plate of the condenser will still be positive while the bottom plate is negative and at the right hand side of Figure 6 the top plate will still be negative while the bottom plate will be positive.

Flow of current back and forth in this circuit means that the current must overcome the resistance of the circuit. Current flowing through a resistance means that power is being used up or converted into heat and lost. This loss of power gradually reduces the voltage and the amount of current flowing until finally the oscillations are reduced to nothing.

The number of oscillations and their strength thus depends on the voltage applied in the first place and on the resistance of the circuit. The greater the applied voltage the more powerful will be the oscillations and the longer will they continue. The greater the circuit resistance the weaker will be the oscillations and the quicker they will cease.

BALANCED REACTANCES .

In one of the early lessons, you were shown a picture of a spring and a weight on opposite ends of a pivoted beam. You can see the same thing in Figure 7. The spring is of such strength that it just balances or supports the weight, and, of course, the weight is just heavy enough to counteract the spring's tension.

If you compress the spring, then release it, the spring will stretch out and the weight will drop. Then the spring will contract and raise the weight. The weight will drop and stretch the spring. The spring will again contract and so the action will go on.

The spring in Figure: 7 corresponds to the condenser in the oscillatory circuit and the weight corresponds to the coil, Energy will oscillate back and forth between spring and weight, first appearing in the tension of the spring, then in the elevated position of the weight. The oscillations of the spring and weight Will continue until the energy is used up in overcoming friction of the beam's pivot.

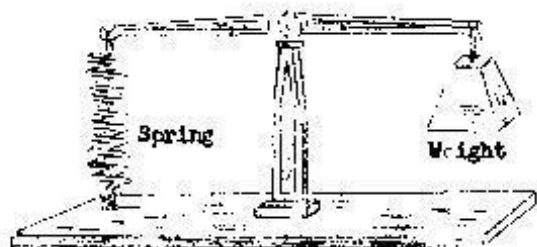

Figure 7.

This friction corresponds to the resistance of the oscillatory circuit.

If, in Figure 7, you were to use a very light spring or a very stiff one with the same weight, there would be a different balance between the energy contained in the spring and in the weight. The oscillations would be at a different rate than before. Likewise, were you to use a very light weight or a very heavy one with the same spring you again would

have a different balance and oscillations at a different rate, faster or slower.

We will find that a similar balance is required in the electric circuit if the oscillations are to be of the greatest possible strength at a certain rate or frequency.

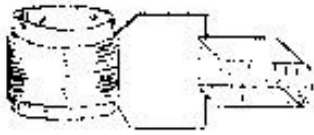

Figure 8.

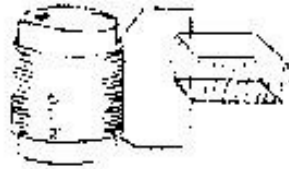

Figure 9.

In figure 8 we have a coil and a condenser which we will assume are correctly balanced for one particular frequency. They are balanced because the number of ohms inductive reactance of the coil is the same as the number of ohms capacitive reactance of the condenser.

Were you to use a much larger coil with the same condenser, as at the left hand side of Figure 9, the balance would be destroyed for that frequency but they would balance for some new frequency. And were you to use a much larger condenser with the same coil, as at the right hand side of Figure 9, you would again have an imperfect match for that particular frequency but again, they would balance for some other frequency.

In the last lesson you spent a great deal of time studying reactance. You discovered that reactance changes with frequency. Because reactance actually does change with change of frequency we must secure our balance between inductive and capacitive reactances for certain frequencies - the frequencies of the stations to which we wish to listen.

POSITIVE AND NEGATIVE REACTANCES.

You learned that the reactance of a coil increases with increase of frequency. As

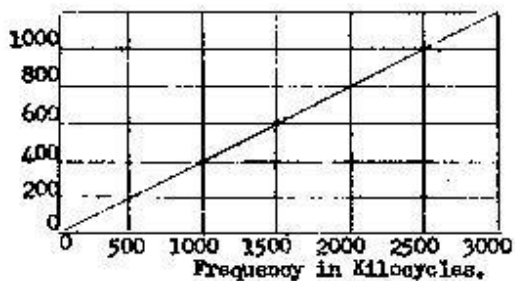

Figure 10.

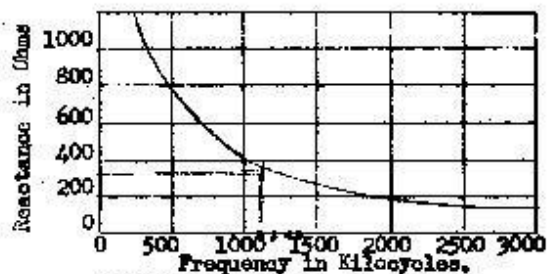

Figure 11.

L 15 - 6.

the frequency goes up the coil's reactance goes up with it. We call the coil's reactance "Positive reactance".

You also learned that the reactance of a condenser gets less and less as the frequency of the applied voltage is increased. As the frequency goes up the condenser's reactance goes down. We call the condenser's reactance "negative reactance". The reactance of a coil at various frequencies is shown by the graph in Figure 10. This coil has an inductance of approximately 64 microhenries. At zero frequency, which is direct current, the reactance is zero because there is no such thing as reactance unless we have a changing current. At a frequency of 500 kilocycles the coil's reactance is 200 ohms as shown by the graph. At 1000 kilocycles the reactance is 400 ohms, and so the reactance increases with frequency all the way up the line on the graph in Figure 14. This is positive reactance - it increases with increase of frequency.

The reactance of a condenser at various frequencies is shown in Figure 11. This condenser has a capacity of approximately 0.0004 microfarad. This is four ten thousands of a microfarad or 400 micro-microfarads. The reactance to direct current, zero frequency, is not shown because it would be so extremely high that the curve could not take it in. You remember that direct current cannot get through a condenser.

At a frequency of 500 kilocycles in Figure 11, the condenser's reactance is 800 ohms. At a frequency of 1400 kilocycles the reactance has dropped to 400 ohms. The reactance continues to drop as the frequency increases - here we have negative reactance.

COMBINING THE REACTANCES.

In Figure 12 graphs of Figures 10 and 11 have been combined. The top half of

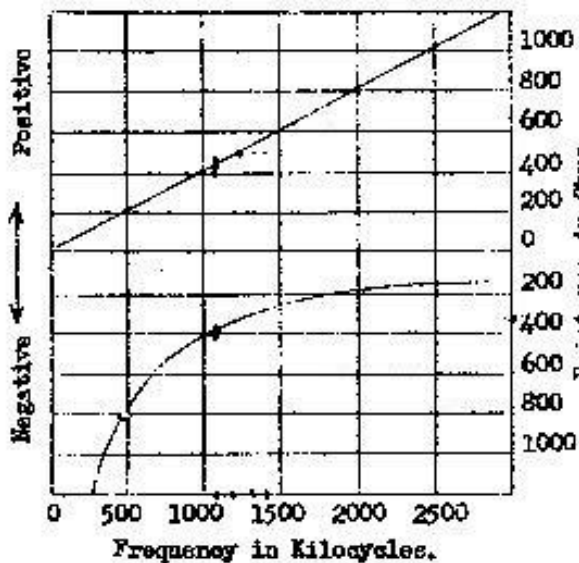

Figure 12.

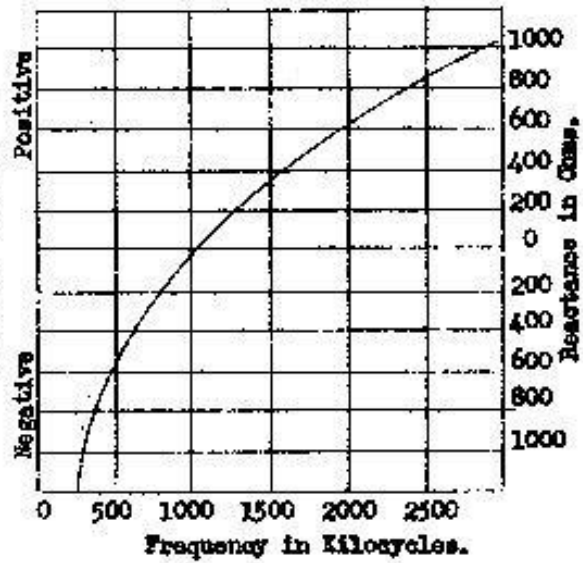

Figure 13.

this graph in Figure 12 is exactly like the graph of Figure 10, it shows the positive reactance of the coil. You will notice that the line for zero reactance is across the centre of Figure 12. The positive reactance is shown above this zero line and the negative reactance is shown below the zero line. Positive reactance increases as it gets farther above the zero line and negative reactance increases as it gets farther below the zero line.

The lower part of figure 12 is like Figure 11, but the curve has to be turned upside down because the number of ohms reactance increases as it goes downward. You will see that the lower part of Figure 12 shows the same number of ohms for each frequency as shown in Figure 11.

Now look at Figure 13. Here we have combined the reactances of Figure 12 into a single curve. Take the 500-kilocycle frequency for an example. In Figure 12 we have 800 ohms negative reactance in the condenser and 200 ohms positive reactance in the coil. So, the 200 ohms positive reactance is taken away from the 800 ohms negative reactance, leaving the difference, 600 ohms negative reactance at 500 kilocycles. Consequently the curve of Figure 13 shows that at 500 kilocycles frequency we have a negative reactance of 600 ohms. Now we'll take the 1000 kilocycle frequency. Looking at Figure 12, we have a positive reactance of 400 ohms in the coil. Down below we have a negative reactance of 400 ohms in the condenser. We combine the two reactances, 400 ohms positive and 400 ohms negative. They balance each other and we have no reactance. This happens at a frequency of 1000 kilocycles. Nothing opposes the flow of alternating current except the ohmic resistance in the coil and condenser - the reactance is gone. The curve of Figure 13 crosses the zero reactance line at 1000 kilocycles.

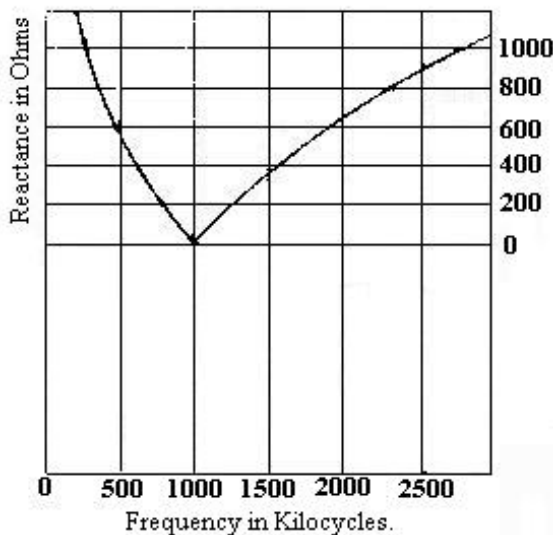

Figure 14.

Zero reactance is called "resonance". The circuit composed of a 64 micro henry coil and a 0.0004 microfarad condenser is resonant at a frequency of 1000 kilocycles. Continuing with the curve of Figure 13 at 1500 kilocycles we have 600 ohms positive reactance and 266 ohms negative reactance so the result is a positive reactance of the difference, or 334 ohms as shown by the curve. At 2000 kilocycles we have, From Figure 12 a positive reactance of 800 ohms and a negative reactance of 200 ohms. This makes a net reactance of 300 minus 200, or 600 ohms positive reactance. The rest of the curve of Figure 13 shows the net reactances at the other frequencies. In Figure 14 we have made one more

change. We have put all the net reactances from Figure 13 back above the zero line. The alternating current is opposed at low frequencies mostly by the negative capacity reactance of the condenser. At the frequencies above resonance the alternating current is opposed mostly by the positive inductive reactance of the coil. Except at resonance the alternating current is opposed by one reactance or the other really by the combination of the two. So to show the reactance to alternating current of various frequencies we can indicate it as in Figure 14.

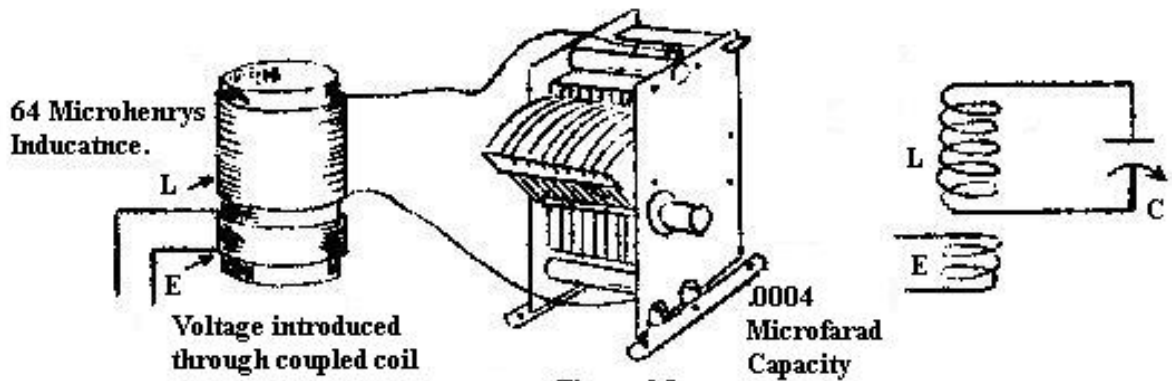
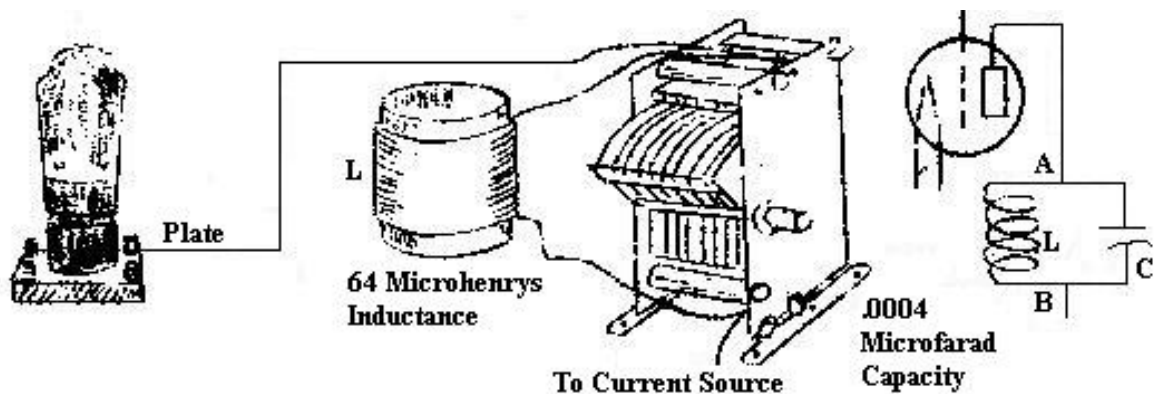

Figure 15.

AMOUNT OF CURRENT IN THE RESONANT CIRCUIT.

Voltage can be applied to a resonant circuit in any one of several ways. Two of the most common methods are shown in Figures 15 and 16. In Figure 15, voltage is introduced into the coil "L" through its coupling with Coil "E". A changing current in "E" produces a field which encloses "L" and generates a voltage in "L". Coil "E" may be included in the plate circuit of a radio tube.

The method shown in Figure 16 places the resonant circuit, coil "L" and condenser "C" in series with the plate circuit of the tube. This method is seldom used in modern practice. The impedance of the coil and condenser combination forms impedance in the plate circuit. We need a high impedance or high reactance in the plate circuit in order to secure good amplification from the tube. In the circuit of Figure 16 there is a drop of voltage between "A" and "B".



We now want to find out how much current flows in these resonant circuits at the different frequencies. The amount of current will depend on the voltage applied to the circuit and on the impedance of the circuit. The impedance is a combination of the reactance and the resistance. The reactance is shown in Figure 14. We will assume that the resistance of the circuit is 10 ohms, When we speak here of "resistance" we mean all the effects that act like resistance and which cause a loss of power in the circuit. We will study this resistance to high frequency currents later on. The resistance really changes somewhat with change of frequency, but to make this explanation simpler we will just say that we have 10 ohms resistance at all frequencies in the coil and condenser combination of Figures 15 and 16.

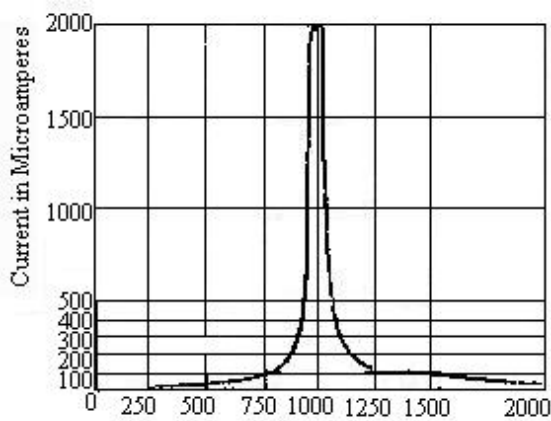

Figure 17.

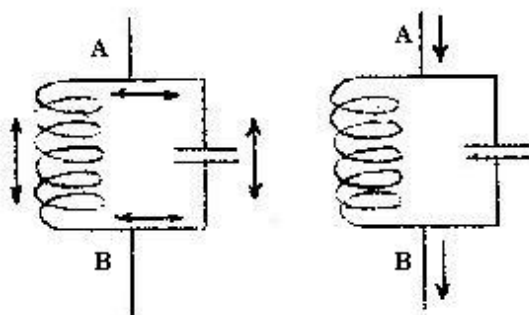

Figure 18

You could figure out the Impedance at various frequencies from the formula given in your last lesson, but to save you that trouble, following is a list of the reactances taken from Figure 14 and the impedance resulting from the 10 ohms resistance to high frequency alternating currents.

Frequency in Kilocycles.	Reactance in Ohms.	Impedance in Ohms.
250	1,100	1100.45
500	600	600.08
750	260	260.2
1,000	0	10
1,250	190	190.3
1,500	330	330.1
2,000	600	600.08

In this table you should notice something of importance. At frequencies quite far removed from the resonant frequency the impedance is almost exactly the same as the reactance. Closer to the resonant frequency, the impedance begins to rise more above the reactance. At resonance there is no reactance, but there is still impedances, the impedance at the resonant frequency being equal to the resistance of 10 ohms.

Now that we know the impedance

at the different frequencies, we will assume an applied potential of 20 millivolts 20 thousandths of a volt and figure out the amount of current which will flow in our oscillatory circuit. The current in microamperes is equal to the number of millivolts multiplied by 1000 and divided by the number of ohms impedance. Here is of current values.

<u>Frequency in Kilocycles.</u>	<u>Impedance in Ohms.</u>	<u>Current in Microamperes.</u>
250	1100.045	18.181
500	600.08	33.329
750	260.2	76.864
1,000	10	2000
1,250	190.3	105.097
1,500	330.1	60.588
2,000	600.08	33.329

In this list just look where the current goes at resonance, or at 1.000 kilocycles. At resonance we have 2,000 microamperes – many times the current that flows at any other frequency. The only way to really see electrical actions is to put them on a graph, so that's what we'll do with the values of the current in this list. They are plotted in Figure 17. The current at resonance goes up to a sharp peak, if the resistance is low.

OSCILLATING CURRENT.

The current which rises to 2,000 microamperes (2 milliamperes) in Figure 17 is the “oscillating current”. It circulates back and forth between coil and condenser, following the path shown by the arrows in the diagram at the left hand side of Figure 18. This oscillating current does not flow through from “A” to “B” in Figure 18. There is another current, called the “line current” which does flow from “A” to “B” in the right hand diagram of Figure 18 as shown by the arrows. You remember that our oscillatory circuit (at its resonant frequency of 1,000 kilocycles) had a coil reactance of 400 ohms. Then we are actually sending a current of 2 milliamperes (2,000 microamperes) through a reactance of 440 ohms. How much voltage does it take to do this?

The number of millivolts is equal to the number of milliamperes times the number of ohms. So, multiplying 2 (milliamperes) by 400 (ohms) we find that a pressure of 800 millivolts is acting round the circuit shown by the arrows in Figure 18. Here we have resonance producing an oscillatory potential of 800 millivolts, yet we applied only 20 millivolts across the ends of the circuit. We have 40 times the original voltage.

To any current of 1,000 kilocycles attempting to pass through this resonant circuit, as from “A” to “B” in Figure 18 at the right, there is a very great opposition. We had, in the case we are studying, 40 times the original voltage and we have 40 times the original reactance of 400 ohms. In other words we find that there is an impedance of 40 times 400, or 16,000 ohms to flow of current from “A” to “B” through the resonant circuit. This is called the circuit's “dynamic impedance”. Now look back at Figure 16. The oscillatory circuit in the plate circuit of the

tube has an impedance of 16,000 ohms to current at the resonant frequency of 1,000 kilocycles which flows through it from the tube to the current source.

We can learn the opposition, in ohms or dynamic impedance, of any resonant circuit at its resonant frequency to current through it from a simple formula. Here it is:

$$\text{Ohms} = \frac{\text{Inductance in Microhenries}}{\text{Capacity in Microfarads}} \times \text{Ohms of high frequency resistance}$$

As an example we will calculate the dynamic impedance of the circuit of Figure 16. We have 64 microhenries inductance, 0.0004 microfarad capacity and 10 ohms of high frequency resistance. Filling these values into the formula, we have :

$$\text{Ohms} = \frac{64}{0.0004} \times 10 = \frac{64}{0.004} = 16,000$$

Unless you got into the design of radio circuits you won't be using a formula such as this one very much. But it is likely that you may want to do some experimental figuring on your own account, so you are given this formula and lots of others similar to it. Even though you don't make use of this kind of information while you are studying your radio course this first time through, you will probably use it in your future work:

RESONANT FREQUENCY.

In order to make our circuit resonant at 1,000 kilocycles we used an inductance of 64 microhenries and a capacity of 0.0004 microfarads. We found that these two parts form a circuit which is resonant at the frequency which makes their reactance equal, because then the reactances balance out and leave only the resistance to oppose current flow. In Figure 19 the coil reactance curve of Figure 10 and the capacity, or condenser reactance curve of Figure 11 are drawn on the one graph.

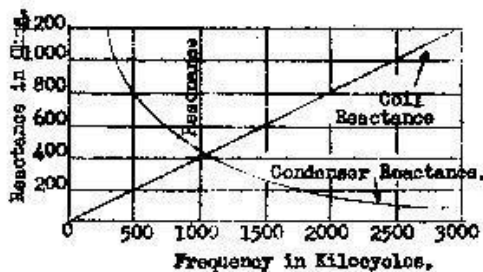

Figure 19.

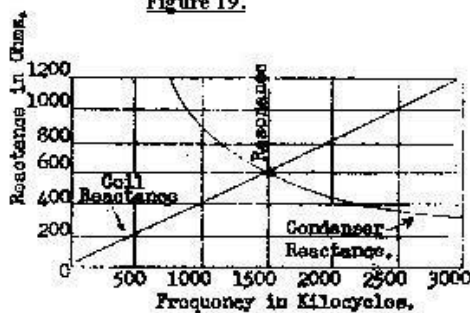

Figure 21.

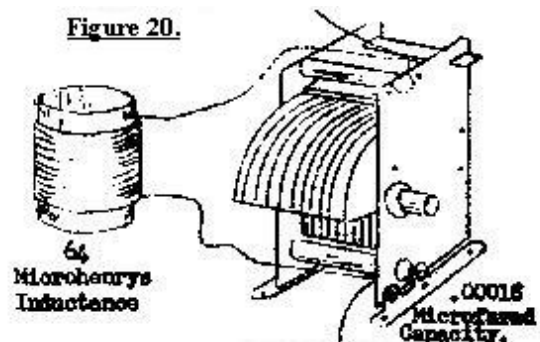

Figure 20.

Notice that the two curves cross each other at the resonant frequency, 1,000 kilocycles.

Now look back at figure 16 and notice the position of the condenser plates. They are nearly all the way in mesh. In Figure 20 the plates of the same condenser have been moved farther out of mesh. This has reduced the capacity of the condenser from 0.0004 microfarad to approximately 0.00018 microfarad capacity. It is more difficult for the alternating current to flow in this smaller capacity, consequently the reactance must be greater.

In Figure 21 the two reactance curves are again shown. The coil curve is the same as the one in Figure 19; for the 61, microhenry coil. But here the condenser curve is for the smaller capacity; the one of 0.00018 microfarad, which gives us greater reactance for each frequency. The two curves of Figure 21 cross each other at a frequency of 1500 kilocycles. So the coil and condenser of Figure 20 are resonant at 1500 kilocycles, whereas the circuit of Figure 16 (with the same parts) is resonant at 1,000 kilocycles.

Moving the condenser plates, changing the condenser capacity and changing its reactance has changed the point of resonance. With the condenser set as in Figure 16 we will have the greatest amplification at 1000 kilocycles while with it set as in Figure 20 the greatest amplification occurs at 1500 kilocycles.

Now you see how movement of the condenser plates in the receiver allows the reception first of one station transmitting, on one frequency, then allows reception of a different station because that station transmits on a different frequency.

Our next step is to take the condenser of Figure 16, leaving its plates in the position for 0.0004 microfarads capacity, and connect it to a larger coil. This new combination is shown in Figure 22. We will say that the coil in Figure 22 has an inductance of 256 microhenries, four times the inductance of the first coil.

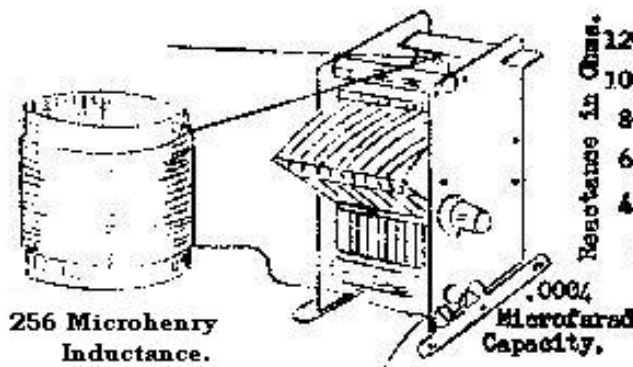

Figure 22.

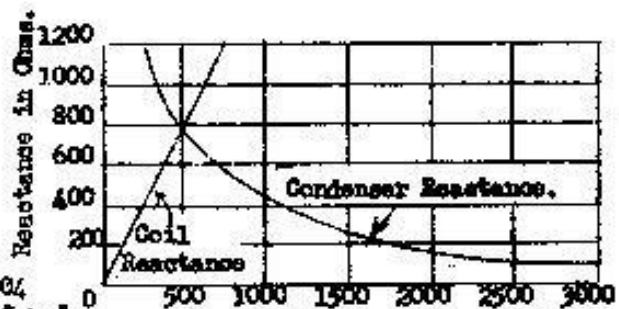

Figure 23.

We will make a new set of reactance curves for the parts in Figure 22. These curves are shown in Figure 23. The larger coil with its greater inductance makes the coil reactance go up very

rapidly with increase of frequency. The two reactance curves cross on the 500 kilocycle line, so this combination of 256 microhenries inductance with 0.0004 microfarad capacity is resonant at a frequency of 500 kilocycles.

Now it is quite apparent that changing the capacity, with the inductance remaining the same, will change the resonant frequency. Also that changing the inductance, the capacity remaining the same, likewise makes a change in the resonant frequency. It is also true that no matter what the inductance and no matter what the capacity of an oscillatory circuit, the combination will be resonant at some frequency.

The frequency at which a combination of capacity and inductance is resonant does not depend alone on the capacity. Neither does it depend alone on the inductance, It depends on the combination of capacity and inductance. We can truthfully say that the frequency of resonance depends on the product of the capacity and the inductance or on the capacity and the inductance multiplied together.

This can be made plainer with a simple example. Let the frequency be represented by the number "64". You might take a capacity represented by "8" and an inductance represented by "8". Multiplying 8 by 8 gives you 64. You might also take a capacity represented by "4" and an inductance represented by "16" because multiplying by 16 gives 64, the same result. Again you might take the numbers "2" and "32" and multiply them together to get "64".

It is the same with capacity and inductance. You may take a large capacity and a small inductance, a small capacity and a large inductance, or a moderate capacity and a moderate inductance. The combination of any of those pairs will give the same frequency.

To get resonance at some certain frequency you can use a big condenser and a small coil, a small condenser and a big coil, or a medium size in both condenser and coil- all resulting in resonance at the same frequency. Like all other actions in radio, there is a very definite rule for resonant frequency. It is stated by the following formula:-

$$\text{Resonant frequency in cycles} = \frac{1}{2\pi\sqrt{L \times C}}$$

In this formula "L" is the inductance in henries and "C" is the capacity in farads, It is generally more convenient to work in terms of microhenries and microfarads instead of henries and farads. To suit these units, formula (2) becomes:-

$$\text{Resonant frequency in cycles} = \frac{1,000,000}{2\pi\sqrt{\text{microhenries} \times \text{microfarads}}}$$

If we wish our answer to be in kilocycles Instead of cycles, formula (3) becomes:-

$$\text{Resonant frequency in kilocycles} = \frac{1,000}{2\pi\sqrt{\text{microhenries} \times \text{microfarads}}}$$

We can simplify formula (4) still further by dividing the "2" in the bottom line

into the "1,000" and obtaining the figure "159". Formula (4) can therefore be rewritten:-

$$\text{Resonant frequency in kilocycles} = \frac{159}{\sqrt{\text{inductance in microhenries} \times \text{capacity in mfd.}}}$$

This formula says that you are to multiply together the number of microhenries inductance and the number of microfarads capacity, then find the square root of the result. The number "159" is then divided by the square root you found. The final answer gives you the number of kilocycles at which that combination of capacity and inductance will be resonant.

It is generally rather hard to work out square roots, so these formulae would be difficult to use. Luckily there is a very easy way of finding what capacity is needed for any inductance or of finding what inductance is needed for any capacity when the combination is to be resonant at a certain frequency. You see, any coil can be made resonant at any frequency by choosing a proper condenser capacity to go with the coil. Also, any condenser or any capacity can be made resonant at any frequency by choosing the right coil to go with it.

In talking about condenser capacities we have been figuring in microfarads. That is a unit commonly used. One of the common tuning condensers has a capacity of 0.00042 microfarad. Decimals aren't as easy to work with as whole numbers and we can just as well speak of our condenser capacities in micro-microfarads, and get whole numbers. A capacity of 0.00042 microfarad is the same as a capacity of 420 micro--microfarads. A further abbreviation of terms is available in the picofarad. The picofarad has the same numerical value as the micro-microfarad, thus 420 picofarads represents the same value of capacity as 420 micro-microfarads. The abbreviation for picofarad is p.f.

All you have to do in changing microfarads to micro-microfarads is to add enough noughts (0) to the decimal figure so that you have six figures following the decimal point, then leave off all the noughts between the decimal point and the first number. To change 0.00042 microfarads, you add the noughts to make six figures and have "0.000420". Then you leave off everything to the left of the "4" and this gives you 420 - the number of micro-microfarads. Here is a list of all common condenser sizes with their capacities in both microfarads and in micro- microfarads or pf.

Microfarads.	<u>Micro-microfarads</u> <u>Or Picofarads.</u>
0.00042	420
0.0004	400
0.000385	385
0.00035	350
0.0003	300
0.00025	250
0.00015	150
0.0001	100

According to this way of naming capacities, the condenser of Figure 16 and Figure 22 has a capacity of 400 micro-microfarads and the condenser of Figure 20 has a capacity of 180 micro-microfarads. We had these odd amounts of capacity because the plates of these condensers are shown part of the way out of mesh. The capacities given in the list are the "maximum capacities" of standard tuning condensers. The maximum capacity is the capacity when the condenser plates are all the way in mesh.

OSCILLATION CONSTANTS.

To calculate the correct capacity or inductance to tune a circuit to resonance use is made of "oscillation constants" An oscillation constant is a number which can be divided by the capacity to find the inductance, or which can be divided by the inductance to find the capacity required to tune to resonance, at the frequency which corresponds to the particular oscillation constant used.

The oscillation constant for any frequency can be found by using either of the following formulae:

$$\text{Oscillation constant} = \frac{10^{12}}{(2\pi \times \text{frequency in kilocycles})^2}$$

$$\text{or Oscillation constant} = \left(\frac{159,155}{\text{frequency in kilocycles}} \right)^2$$

The highest frequency used in broadcasting is 1605 kilocycles. The lowest frequency is 525 kilocycles. In tuning a broadcasting receiver you have to make it resonant at 1605 kilocycles at one end of the dial and resonant to 525 kilocycles at the other end. All carrier wave frequencies are included between these limits. Consequently we are usually only concerned with the oscillation constants for those two extreme frequencies, because if the circuit can be tuned to the highest and to the lowest frequencies used by broadcasting stations it must also tune to all the frequencies in between those two.

The two important oscillation constants have been worked out by means of the above formula and that for 525 kilocycles is 91,809 and for 1,605 kilocycles 9,801. To find the number of microhenries inductance of a coil which will make a resonant circuit at either of these frequencies divide the oscillation constant by the condenser capacity in micro-microfarads. Any other frequency requires the use of the proper oscillation constant for it.

As an example, say you want to know the Inductance of a coil which will tune to 525 kilocycles with a condenser of 400 micro-microfarads capacity. You divide the oscillation constant, 91,809, by 400 and the result is 229.5 microhenries for the coil. Now find the coil inductance with which the same condenser will tune to 1,605 kilocycles. You divide the other oscillation constant, 9,801 by 400 and get as a result 24.5 microhenries inductance for the coil. But in ordinary radio receivers we don't change the coil - the coil remains the same for all frequencies, and we change the condenser capacity. So now we'll work with the fixed inductances.

The oscillation constants are the same - "91,809" for 525 kilocycles and "9,801" for 1,605 kilocycles. To find the required condenser capacity in micro-microfarads you divide the oscillation constant by the coil's inductance in microhenries. Supposing we have a coil of 210 microhenries inductance, what capacity is needed for 525 kilocycles. You divide the oscillation constant, "91,809", by 210 and get as a result 437.1 micro-microfarads for the condenser capacity. Then to find the capacity for 1,605 kilocycles you divide the other constant, "9,801", by 210 and find that you need a capacity of 46.6 micro-microfarads.

Now you will have to be able to change the condenser capacity from 437.1 micro microfarads at 525 kilocycles down to 46.6 micro-microfarads at 1,605 kilocycles. What size condenser will you use ? One of the standard sizes has a maximum capacity of about 420 micro-microfarads and since this is even greater than 437 when we add the parallel capacity of the usual trimming condenser amounting to about 30 micro-microfarads, we can use that size. Turning the plates out of mesh will gradually reduce the capacity. Good tuning condensers have a "minimum capacity", with their plates all the way out of mesh, which is one-tenth, or less, of their maximum capacity. If the parallel capacity introduced by the trimming condenser is included, the minimum capacity of the condenser is close to 1/10th of the maximum. So this 400 micro-microfarad condenser will reduce its capacity to about 45 micro-microfarads (one-tenth of 420 plus 30), This is below the smallest capacity we need for tuning so we can cover the whole broadcast range of frequencies with the condenser of 420 micro-microfarads capacity and the coil of 210 microhenries inductance.

Because the minimum capacity of 45 micro-microfarads is very close to the 46.6 micro-microfarads required to tune to 1,605 kilocycles with a coil of 210 microhenries inductance, we would find it necessary to make some adjustment to the parallel trimming condenser to ensure a more even margin or overlap at each extreme of the tuning range. The nature of the trimming condensers and the manner in which they are used will be explained in the next lesson.

The things to figure with are the maximum capacity of the tuning condenser and the oscillation constant for the lowest frequency, 525 kilocycles. Dividing that constant, "91,809" by the condenser-capacity will give you the number of micro henries inductance required in the coil. The other end of the dial, at 1,605 kilocycles, will be taken care of by the change in capacity as you turn the condenser plates out of mesh.

Here is a list of coil inductances needed with each of the standard tuning condensers to let you tune to resonance over the whole broadcast range of frequencies.

<u>Tuning Condenser Capacities.</u>		<u>Inductance of Coil</u>
<u>Microfarads.</u>	<u>Micro-Microfarads.</u>	<u>In Microhenries.</u>
0.00042	420	199.36 or 200
0.0004	400	209.3 or 210
0.000385	385	217.4 or 220
0.00035	350	239.22 or 240
0.0003	300	279.1 or 280
0.00025	250	334.92 or 340
0.00015	150	558.2 or 560
0.0001	100	837.3 or 840

We allow slightly more inductance than actually required so that the set will surely tune to the lowest frequency with a little left over. The two smallest sizes of condensers are not used in broadcast receivers because with coils of such large inductance we run into other troubles which you will be told about in a later lesson.

APERIODIC CIRCUIT.

The circuits which we have studied so far in this work sheet have been oscillatory circuits in which energy oscillates back and forth between a coil and a condenser. It is possible to have a circuit containing inductance and capacity and so much resistance that all the energy is used up during the first half cycle and the current does not reverse its direction at all, but just dies away without making an oscillation. Such a circuit is said to be "aperiodic", it has no period and when alternating current is applied to it no frequency can be found at which oscillations occur.

NATURAL FREQUENCY.

If a circuit has a certain amount of inductance and a certain amount of capacity it will be resonant at some particular frequency. At this frequency there will be the greatest possible flow of current in the circuit. We have used the name "resonant frequency" for this particular number of cycles per second at which the greatest flow of current takes place.

We might say that it is natural for the circuit to oscillate at the one frequency and we sometimes use the name "natural frequency". The natural frequency and the resonant frequency are the same.

FUNDAMENTAL FREQUENCY.

You have learned that any circuit oscillates at a frequency determined by the amount of inductance and the amount of capacity in the circuit. Later on in your studies you will find that, in addition to carrying a very large current at one resonant frequency, some circuits will carry currents almost as large at one or more other frequencies.

You might have a condition somewhat like that indicated in Figure 24 where the current increases at a number of different frequencies. The lowest frequency at which the current reaches a high value is called the "fundamental frequency" and is the resonant frequency of the circuit, the other frequencies of high current are called "harmonic frequencies". We use these terms mostly when we are speaking of aerials which radiate signals. These harmonic frequencies are always multiples of the fundamental frequency.

VARIABLE INDUCTANCE TUNING.

Earlier in this lesson it was stated that the frequency at which a tuned circuit resonates may be changed by altering the inductance of the coil. To tune to a lower frequency the inductance of the coil is increased while to tune to a higher frequency the inductance of the coil is reduced.

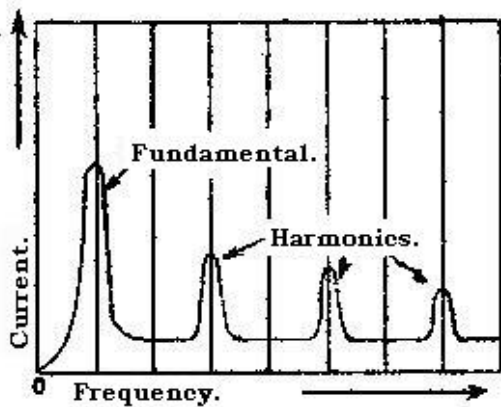

Figure 24

In the great majority of radio receivers, tuning is carried out by varying the capacity in the oscillatory circuits while the inductance remains at a fixed value. This method of tuning was also employed in radio receivers designed for use in motor vehicles until manufacturers realised that distraction of a driver's attention while tuning a radio receiver with the car in motion could create a traffic hazard. Some form of automatic or semi-automatic tuning was clearly desirable.

A direct result was the introduction of push-button tuning. This allowed the required station to be brought in by simply pressing the appropriate button on the instrument panel of the vehicle.

The first receivers of this type were merely adapted to use the standard variable capacitance method of tuning, in that the push-buttons were mechanically linked to the receiver's variable condensers, by a system of levers, so that depression of a particular button would automatically turn the condenser to a pre-set position and so bring in a particular programme. Usually at least five pre-set positions were available so that the user could have the choice of any one of five programmes. In an effort to do away with the somewhat bulky system of levers and gears required to actuate the variable condensers some manufacturers resorted to variation of inductance instead of variation of capacity when tuning from one station to another. One method of achieving this result employed a separate set of coils for each frequency required. If a choice of five different programmes was desired, five sets of tuning coils were installed. Depression of the appropriate push-button connected one set of coils into the tuning circuits and allowed that particular programme to be received. If, while listening to a station tuned by No. 1 set of coils, No. 2 button was depressed, No. 1 set of coils would be disconnected and No. 2 set connected into the circuit in place of them. As a consequence, one programme would be tuned out and another tuned in automatically. With this system variation of inductance for each set of coils was achieved by using a different number of turns for each set. A greater number of turns would increase the inductance of the coils while a lesser number of turns would reduce the inductance.

Another factor which influences the inductance of a coil is the permeability of the material on which the coil is wound. Permeability, a property of magnetic materials which is discussed in later lessons, indicates whether such material will provide a path for a large or small number of magnetic lines of force. If a material has high permeability it will provide a path for a comparatively large number of lines of force while if it has low permeability it will only provide a path for a comparatively few number of lines of force. If, with a core material

having a certain permeability, a coil has an inductance of so many microhenries, substitution of a metal having higher permeability will bring about an increase in the coil inductance. Conversely, the use of a core material having lower permeability will reduce the inductance.

A similar effect can be produced by changing the amount of permeable material used as core material. A greater quantity of material used in the core will raise the inductance while a reduction of the core material quantity will reduce the inductance.

This latter effect has been used in some push-button tuning units. In this type of unit only one set of coils is used. Tuning is carried out by moving a "slug" of high permeability metallic dust embedded in a plastic material in or out of the centre of the coils. Moving the "slug" further into the coils reduces the frequency at which the tuned circuits will resonate, while moving the "slug" in the reverse direction will reduce the inductance and so increase the frequency at which the tuned circuits will resonate. Movement of the "slug" is, of course, carried out by depressing one of a number of push-buttons. Each one is mechanically adjusted to move the "slug" to a pre-determined position, and thus provide a choice of programmes.

TELEVISION TUNING UNITS.

We see another application for variable inductance tuning in television receivers. The problems associated with tuning a television receiver from one station to another are vastly different to those related to the tuning of an ordinary radio receiver designed to operate on either the medium wave broadcast band or one or other of the short wave bands. Considering the short wave band of a normal dual wave receiver we find that the frequency coverage is usually between 7 megacycles per second and 23 megacycles per second, a bandwidth of 16 megacycles. The frequencies on which television stations in Australia operate either now or in the future range from the lower limit of Channel 1 (49 megacycles) to the upper limit of Channel 10 (216 megacycles). This represents a total bandwidth of 165 megacycles per second, approximately 10 times that required to tune over the short wave band in ordinary sound broadcasting. There can be no question of using variable capacity tuning to cover such an enormous frequency range because it would be impossible to provide a condenser with a sufficiently large ratio between maximum and minimum capacity which would, at the same time, have a sufficiently small minimum capacity to allow the tuned circuit to reach the extreme high frequency end of the television band.

The problem is overcome quite simply by using coils having fixed inductance, small inductance for the higher frequency channels and larger inductance for the lower frequency channels, and switching each set of coils in or out as we tune to a different channel.

As with any tuned circuit, resonance will only occur when inductance and capacity are both present and when the reactance of the inductive and capacitive components are equal. The tuning capacity in an ordinary radio receiver is quite obvious as it consists of a comparatively large variable condenser or condensers where there is more than one tuned circuit. The capacity which resonates with the inductance in television receiver tuned circuits is, however, not at all

obvious, being distributed throughout the circuit. There is capacity between adjacent turns of a tuning coil, between wiring and grounded metal surfaces, and also across input and output circuits of radio valves. The sum of all these capacities, together with very small values of inductance, is sufficient to provide a resonant circuit when we are working at the very high frequencies associated with television. Additional capacity in the form of a very small trimming condenser is provided to allow fine control of tuning after one has switched to the required channel.

In one form of television tuner, known as a "turret" tuner, each set of coils is wired directly to switch contacts set in a moulded plastic block. There are usually two such blocks for each channel. One strip containing the aerial and R.F. coil while the other contains the oscillator coil. The moulded blocks are clipped into a drum like structure which may be rotated by a shaft protruding through the front of the receiver cabinet. As the drum is rotated the contacts on the outside of the moulded strips connect with a set of spring "fingers" which connect the appropriate set of coils to the various grid and plate circuits of the valves associated with the tuner. To allow for slight variations of distributed capacity, the inductance of each set of coils may be increased or decreased slightly by altering the permeability of the core within small limits. A turret tuner of the type mentioned above is illustrated by Figure 25.

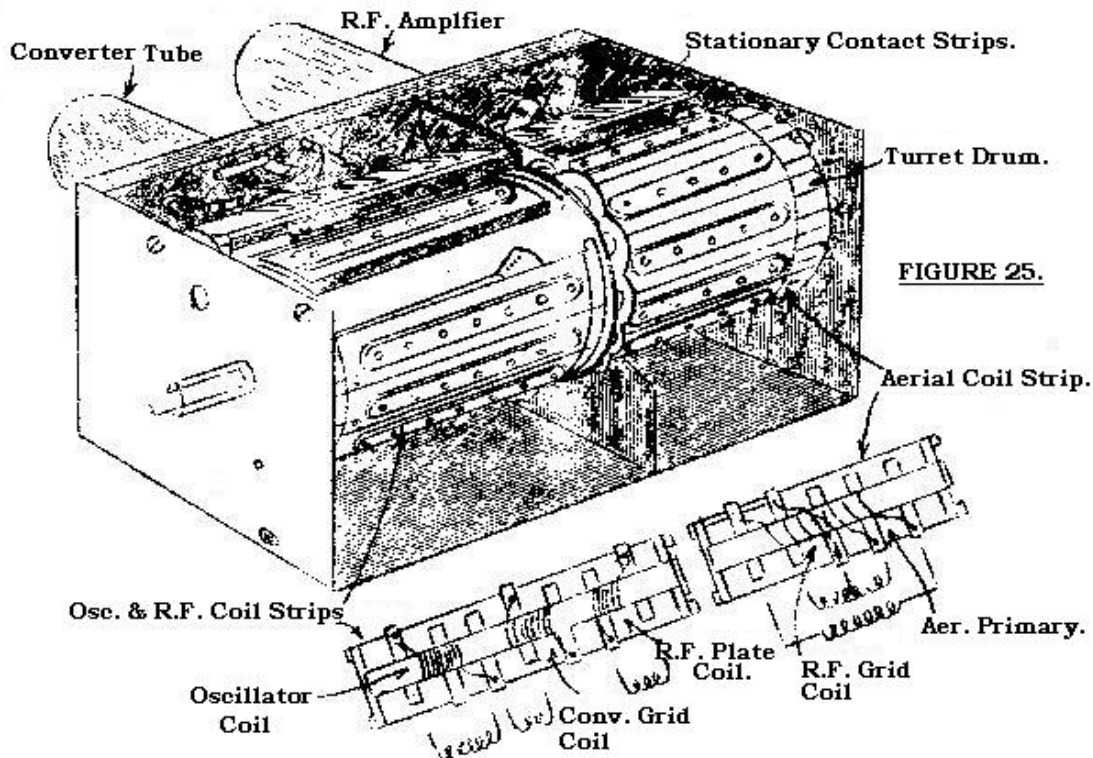

FIGURE 25.

SUMMARY OF THIS LESSON.

In this lesson you have studied the most important circuit in radio. The symbol for an oscillatory circuit composed of a coil and a condenser is almost a symbol of radio itself. When the reactance of the coil and the condenser are exactly equal they balance each other and allow current to oscillate in the circuit as easily as if there were no reactance there at all. Under these conditions current flows back and forth round the circuit, the energy being stored up in the circuit first in the condenser's charge and then in the coil's magnetic field.

This state of resonance only holds for one particular frequency, because if another frequency is applied to the circuit one of the reactances goes up while the other goes down, and so they are no longer equal and the current is opposed by the reactance that is left. If the capacity of the condenser is altered its reactance is also altered, and so the two reactances will now be equal at some different frequency, and a transmitting station of that frequency will now be received.

You have also learned that a circuit can be tuned by varying the inductance while the capacity remains unaltered and that the capacity used to resonate with a coil may not be actually visible but may be scattered throughout a circuit in distributed form. Distributed capacity is discussed with greater detail in later lessons dealing with its effect in audio-frequency amplifiers.

When a circuit is resonant the oscillating current rises to a very high value and builds up very high voltages across the combination of coil and condenser. This high voltage opposes any alternating current which is trying to pass through the parallel circuit from one side to the other and so makes a path of high impedance to it.

The more resistance there is in the oscillatory circuit the less will be the amount of oscillating current, the less the voltage developed across the circuit, and the less the circuit's impedance to current through it. We want as much impedance as possible to this current, so we always take care to keep the resistance as low as possible. Also the less the resistance in the circuit, the greater is the oscillating current at resonance in comparison with the current at any other frequency and the more selective the tuned circuit becomes.

The more reactance we have in the coil and condenser, that is the larger the coil and smaller the condenser, the more voltage we have built up across the circuit and the more amplification we get. However, if we make the coil too large and the condenser too small, our variable condenser will not be able to cover the whole of the range of frequencies we want to receive. So for receiving the broadcast stations on frequencies between 525 and 1605 kilocycles we generally use a variable condenser having a minimum capacity of 385 to 420 mmf. with a coil having an inductance of about 220 to 200 microhenries.

The size of coil for any condenser to give resonance at any other frequency can be found by using a table of oscillation constants, or by the formula given in this lesson.

OSCILLATION CONSTANT FOR ANY FREQUENCY EQUALS INDUCTANCE IN
MICROHENRIES X CAPACITY IN MICRO-MICROFARADS.

Frequency K.C.	Wavelength Meters.	Oscillation Constant.	Frequency K.C.	Wavelength Meters	Oscillation Constant.
100,000	3	2.5	650	461	60,000
75,000	4	4.5	600	500	70,400
60,000	5	7	550	545	83,730
50,000	6	10.1	500	600	101,300
30,000	10	28.2	490	612	105,500
15,000	20	113	480	625	110,000
10,000	30	253	470	638	114,700
7,500	40	450	460	652	199,800
6,000	50	704	455	659	122,600
5,000	60	1,014	450	667	125,300
3,000	100	2,820	440	682	131,000
2,000	150	6,330	420	714	143,900
1,600	188	9,890	400	750	158,300
1,500	200	11,270	375	800	180,100
1,400	214	12,930	350	857	207,000
1,300	231	15,000	325	923	239,000
1,200	250	17,600	300	1,000	282,000
1,100	273	20,900	275	1,091	335,000
1,000	300	25,300	250	1,200	406,000
950	316	28,100	225	1,333	502,000
900	333	31,300	200	1,500	633,000
850	353	35,200	175	1,714	828,000
800	375	39,600	150	2,000	1,127,000
750	400	45,100	125	2,400	1,622,000
700	428	51,700	100	3,000	2,530,000

EXAMINATION QUESTIONS – No. 15.

1. What difference is there between carrier waves of different transmitting stations that allows a receiver to select one station and reject the others ?
2. At resonance there is no net reactance in an oscillatory circuit. Then what is there in the circuit to prevent the oscillations from continuing indefinitely?
3. Is the reactance of a coil called positive reactance or negative reactance? Why ?
4. As the frequency increases does the reactance of a condenser become greater or less?
5. If, at 1100 kilocycles, a coil has a reactance of 500 ohms, what must be the reactances of a condenser to make the coil and condenser resonant at this frequency ?
6. What happens to the amount of current in an oscillatory circuit at resonance? Why ?
7. In order to tune a radio circuit to a lower frequency, do you increase or decrease the capacity of the tuning condenser ? Explain the reason.
8. If a circuit is resonant at a certain frequency and you want to use a coil of more inductance with the resonant frequency remaining unchanged will you have to use a condenser of greater or less capacity? Why ?
9. The oscillation constant for 550 kilocycles is 83,730. What must be the inductance microhenries of a coil to tune with a condenser of 410 micro-microfarads capacity at 550 kilocycles ?
10. If you find that a circuit is resonant at several different frequencies, is the fundamental frequency the highest or the lowest of those frequencies? What are the other frequencies called ?

AUSTRALIAN RADIO AND TELEVISION COLLEGE PTY. LTD.

**E. S. & A. BANK BUILDINGS, Corner CITY RD. and BROADWAY, SYDNEY
Telephones: BA4891 and BA4892**

Telegrams "RADIOCOLLEGE" Sydney

This lesson sheet is published for the exclusive use of students of the Australian Radio and Television College Pty. Ltd. (All rights reserved)

Post Lessons to Box 43, Broadway

LESSON NO. 16

VARIABLE CONDENSERS - THEIR PURPOSE, CONSTRUCTION AND USE.

Before getting into the subject of tuning condenser operation and construction we shall review briefly the work done by these condensers in radio circuits. The purpose of a tuning condenser is to make its circuit resonant at the carrier frequency which you wish to receive. At resonance, currents of this frequency are exceedingly large and currents at all other frequencies are very small in comparison.

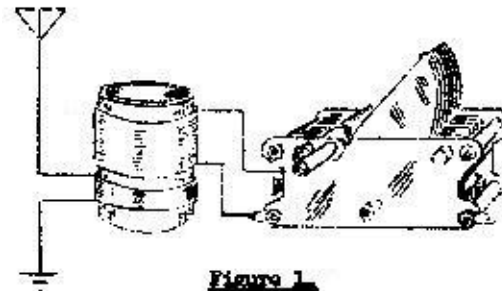

Figure 1.

A condenser tunes its circuit to resonance by changing its own reactance. As the plates are turned out of mesh, the condenser's capacity gets less and less, its reactance becomes higher and higher. The condenser's reactance is negative, while the reactance of the tuning coil is positive. Whenever the condenser's negative reactance is made to just equal the coil's positive reactance at a certain frequency, all reactance to currents of that frequency will disappear from the tuned circuit. With no reactance remaining, any signal at this resonant frequency will produce very great currents in the condenser-coil circuit and high voltages will be generated.

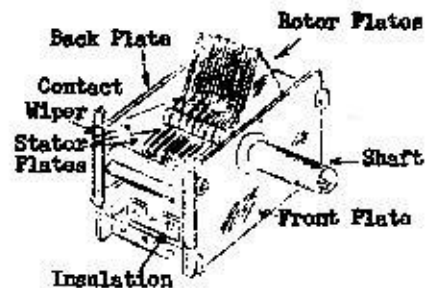

Figure 2.

Consider the coil and condenser of Figure 1, The coil has an inductance of 318 microhenrys and the condenser has a maximum capacity of 300

micro-microfarads or 0.0003 microfarads when the plates are all the way in mesh. Let us write down the reactance of the coil at several different frequencies used for broadcasting. Here they are;

550 kilocycles frequency	1100 ohms reactance.
750 kilocycles frequency.....	1500 ohms reactance.
1,000 kilocycles frequency	2000 ohms reactance.
1250 kilocycles frequency	2500 ohms reactance.
1500 kilocycles frequency	3000 ohms reactance.
1600 kilocycles frequency	3200 ohms reactance.

If you want to receive a signal from a station transmitting on any one of these frequencies, all you have to do is turn the condenser shaft until the condenser's reactance equals the coil's reactance for the frequency you want to get. From this list you see that the higher the frequency to be received, the greater must be the reactance of the condenser. To increase the reactance you have to turn the plates out of mesh, so the higher the frequency the further out of mesh you turn the condenser plates. That is all there is to tuning.

Were you to calculate the capacity needed in the condenser to match the coil's reactance at the frequencies in the foregoing list you would find that it would take about 265 micro-microfarads at 550 kilocycles and about 35 micro-microfarads at 1500 kilocycles. The capacity at the low frequency is about seven and one-half times the capacity for the high frequency. Therefore, the movement of the condenser plates must change the capacity by this proportion at least. As a matter of fact, most tuning condensers are made to change their capacity about ten or more times. That is, a condenser having a maximum capacity of 300 micro-microfarads will have a minimum capacity with its plates all the way out of at least 30 micro-microfarads, but generally much less. Most condensers currently manufactured have a minimum capacity between 11 and 15 micro-microfarads.

PARTS OF A CONDENSER.

A typical tuning condenser is shown in Figure 2. The plates which remain fixed in place are called the "stator", while those which are moved as the condenser's capacity is changed are called the "rotor". These are the two chief parts of the condenser. The rotor plates are carried by the condenser shaft, which, in turn, is mounted in two bearings one in each end plate. One bearing is in the front plate and the other is in the back plate. The two end plates, front and back, are held in their correct relative positions by spacer rods or a metal frame. This condenser is mounted on the receiver chassis by bolts passing through the mounting brackets.

The rotor plates, their shaft, the bearings, the end plates and the spacer rods all are made of metal and all fastened tightly together. Therefore, all these parts taken together form one electrical part of the condenser -- the rotor plate assembly. From the electrical standpoint these parts make up one part of the condenser and this part is provided with a rotor terminal or lug to which the outside wiring may be connected.

The other part of the condenser, considered electrically, is the stator. The stator plates are supported in the condenser of Figure 2 by small pieces of insulation, one

on the top and one on the bottom of the condenser. The stator is provided with a soldering lug to which wires may be connected.

ROTOR CONNECTIONS.

It is essential that a good electrical contact be maintained between the rotor plates and the rotor terminal no matter what the position of the plates and even while they are being moved from one position to another. It is not safe to depend on the shaft bearings to make this connection because these bearings finally collect dirt and become loose and in addition are usually greased. This results in noisy reception.

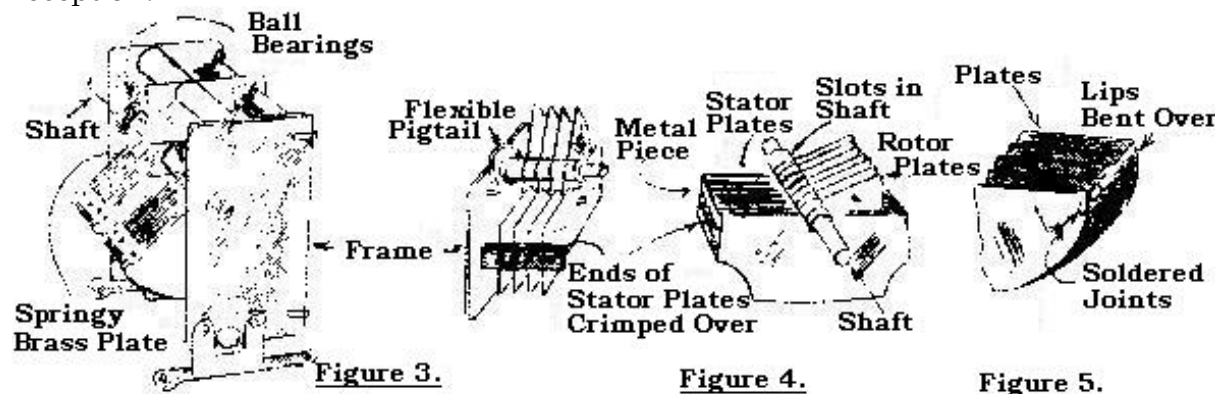

To provide a dependable contact, the condenser of Figure 2 has a contact spring or wiper to which the connection is soldered and bearing with considerable pressure against the shaft.

A similar method of insuring good electrical connection is shown applied to a "two gang" condenser at the left of Figure 3. Here a spring brass plate clips on to the centre section of the condenser frame and fits into two grooves cut in the rotor shaft. It is important that the rotor plates be "earthed" by means of a wire soldered to this spring brass plate. At the right of Figure 3 a short length of flexible wire or springy metal strip is attached between the shaft and frame. As the rotor plates move this "pigtail" connection coils up around the shaft or straightens out. Either of these methods provides a very satisfactory connection, but the spring wiper method has been the one most commonly employed during the last several years. It has the advantage that one end of the wiper may be extended to provide an effective ground connection to the rotor plates and condenser frame. The flexible pigtail type has a tendency to break under conditions of hard usage, leaving that particular rotor section with an inefficient connection to frame.

PLATE FASTENINGS.

Good electrical connection is of first importance throughout a condenser at all times. There must be the least possible resistance to flow of current between parts which are supposed to be connected together. One method of fastening rotor plates to their shaft is shown in Figure 3. Slots are cut on the shaft and the rotor plates are pressed firmly into the slots.

One method of fastening the stator plates is also shown in Figure 4. Here the edges of the plates are pressed into grooves in a metal piece at each end which connects all the stator plates together electrically. A very tight press fit insures a fairly secure joint.

When plates are made of brass or some metal which can be readily soldered it is better practice to run solder over the joints between plates and supports. Solder might easily be applied to the construction of Figure 4 by flowing it on to the plates and bushings where their edges come together. Some condensers have all the rotor plates fastened to each other and all the stators similarly fastened to each other with lips like those in Figure 5. The lip on one plate is bent over until it rests on the lip of the next plate and the joint thus made is thoroughly soldered, making all plates thus joined act as one electrical conductor. Most condensers are made with aluminium plates and as it is almost impossible to solder to aluminium, a good press fit has to be relied upon for good conductivity in these condensers.

The entire rotor plate assembly is sometimes cast as one piece of metal. The stator plates may also be cast as one piece. This construction is ideal from the electrical stand point but is quite costly.

Brass and aluminium are the two metals generally used in the construction of tuning condensers. Brass is an excellent conductor, it is not magnetic and has plenty of mechanical strength. Soldering to parts made of brass is very easily done. About the only objection to brass is that it corrodes but this is prevented by covering the surface with a thin layer of lacquer which protects the metal from the air and moisture.

Aluminium does not corrode as badly as brass. In order that there may be good electrical conduction between two surfaces of aluminium, both of them must be very clean and must be held together tightly to keep them clean.

Condenser plates must be strong and rigid to keep them from warping or from being bent out of shape (which would change the capacity). Aluminium is a very rigid metal and makes good durable plates. Brass is more flexible and is often ridged to give it stiffness. Whether the plates are thick or thin makes little difference. Thin plates reduce certain kinds of electrical losses while thick ones reduce resistance by providing a larger path for the currents flowing in the condenser and also prevent the possibility of the plates vibrating by the action of the loudspeaker and producing a howl in the speaker.

Some years ago, it was not unusual to find the outer plate at one end of each rotor section slotted so that individual portions of that particular plate could be bent nearer to or farther from its adjacent stator plate. This was done to facilitate "tracking" between the tuned circuits of superheterodyne receivers, a subject which will be treated at some length in later lessons.

CONDENSER INSULATION.

The stator plates are held rigidly in place and are kept properly spaced from the rotor plates by the insulation. You can see the insulation in Figure 2 for one type

of construction and In Figure 6 for another type. This insulation is often made of some kind of phenol compound such as "bakelite". The material used must have very great resistance to passage of electric current through it or over its surface. It must be of such nature that there is very little loss of electrical energy in it.

Bakelite and similar products, also certain kinds of glass and of quartz meet all requirements for condenser insulation. Hard rubber would be perfectly satisfactory as far as the requirements already mentioned are concerned, but hard rubber has not enough mechanical strength to fill the bill. This rubber will get out of shape and then the plates would change their positions or would even touch and cause a short circuit.

Whatever insulation is used should be kept as far as possible from the stator and rotor plates. The greater the distance, the less likely it is that some of the lines of force forming the condenser's field will stray from their proper place between the plates and pass through the insulation rather than through the air. The air between the plates forms the condenser's dielectric. The insulation should not form part of the dielectric and will not do so if it is kept away from the plates. It is also desirable to use the least possible bulk of insulation because reducing the amount of insulation further reduces the tendency of the electrostatic lines of force to stray away from their proper place in the condenser. The design of Figure 6 is good in this respect because there is only the one piece of insulation running across the bottom of the condenser.

Another method of placing the insulation out of the way of the plates is shown in Figure 7. Here the stator plates are joined together and supported by a metal bar. The ends of this bar are passed through the pieces of insulation which are attached to the end plates, running vertically as shown.

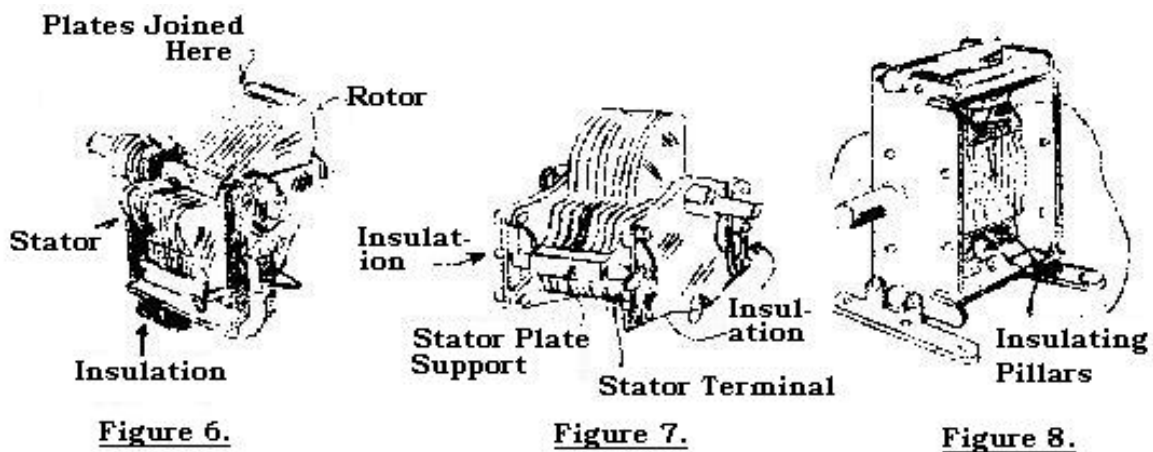

The distance, measured along the insulation, between the stator terminal and the nearest metal which is connected to the end plates and rotor assembly should be as long as it can be made. This practice makes it harder for electricity to leak across between stator and rotor of the condenser because any leakage current will have to travel further over the insulation with well spaced terminals. Notice how

this precaution is observed in the condenser of Figure 7. In some makes of condensers the insulation is reduced to a very small amount by using small balls or pillars about 5/32" in diameter made of isolantite or bakelite to insulate the stator plates. Figure 8 shows a condenser with a small isolantite pillar at the top and bottom of the stator plates.

NUMBER OF STATOR AND ROTOR PLATES.

At one time, in the earlier days of radio, tuning condensers were commonly rated in the number of plates. This rating is no longer in use; nowadays all condensers are specified according to their capacity in microfarads or in micro-microfarads, because after all it is the only specification which rapidly and definitely identifies a condenser. Specifying the number of plates can give no indication of capacity unless all manufacturers standardise on plate area and spacing between adjacent plates.

According to the old rating, a "43-plate" condenser had a capacity of 1000 micro microfarads or 0.001 microfarad; a "23-plate" condenser had a capacity of 500 mmfds, or 0.0005 mfd; a "17-plate" size had a capacity of 350 mmfds, or 0.00035 mfd.; and the "13-plate" condensers had a capacity of 250 mmfds, or 0,00025 mfd. These figures assume a measure of standardisation among manufacturers of the period. Some condensers have one more stator plate than they have rotors while others have one extra rotor plate. There is no definite rule either way. Still other condensers have an equal number of both kinds of plates.

The condenser at the left hand side of Figure 9 has five rotor plates and four stator plates. This brings a rotor plate at each end of the collection of plates. The rotor plates are electrically connected to the end plates, consequently are at the same potential. When two pieces of metal are at the same potential, there is no capacity affect between them. Therefore there is no capacity effect between the end plates and the outside rotor plates.

The condenser at the right hand side of Figure 9 has one extra stator plate,

therefore is a stator on each end of the collection of plates. The stators are insulated from the end plates, consequently there can be a potential difference and there is a capacity effect between the end plates and the stator plates. Because of this extra capacity to the end plates, the right hand condenser has slightly more total capacity

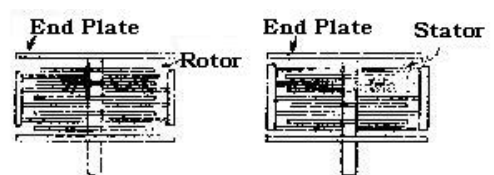

Figure 9.

than the left hand and, even though it has the same number and same size of plates.

STRAIGHT LINE CAPACITY CONDENSER.

The condenser of Figure 10 has rotor plates shaped like half circles or semi-circles. It is what we call a "straight line capacity" condenser because the capacity changes exactly according to Law far you turn the rotor.

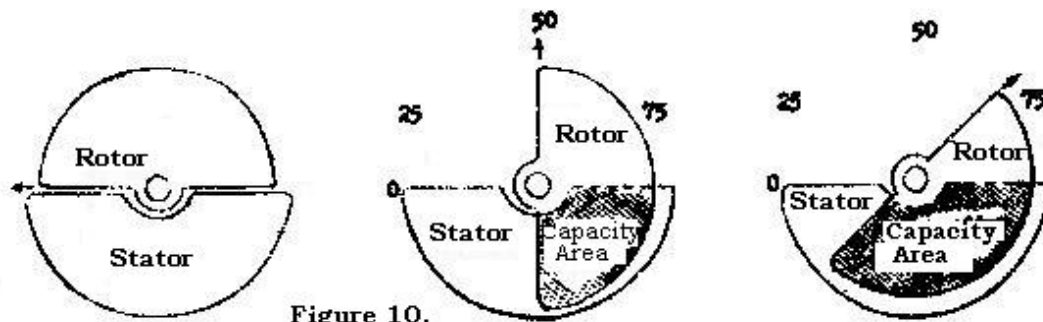

Figure 10.

In the centre drawing of Figure 10 the rotor has been turned half way through its total movement from “0” to “50” on the dial readings. Then half of the surface or area of the rotor plate is in mesh with the stator plates. The capacity of a condenser is in proportion to the plate area in mesh, so with the rotor turned half way in we have one-half the total capacity.

In the right hand drawing of Figure 10 the rotor has been turned to “75” on its dial, or three-quarters of the whole way into mesh with the stator. Then we have a capacity area of three-quarters of the whole rotor area and have three-quarters of the condensers total or maximum capacity.

We will assume a condenser of the straight line capacity type having a maximum capacity of 500 micro-microfarads. How many micro-microfarads, or what proportion of this maximum capacity, must we have to tune to various broadcasting frequencies?

First we must calculate the capacity needed for various frequencies. If the condenser is used with a coil having an inductance of 175 microhenrys the following list gives the amount of capacity needed for tuning to several places in the broadcast band.

550 kilocycles 482 mmfds.	1100 kilocycles 120 mmfds.
600 " 402 mmfds.	1150 " 109 mmfds.
650 " 343 mmfds.	1200 " 101 mmfds.
700 " 297 mmfds.	1250 " 93 mmfds.
750 " 257 mmfds.	1300 " 86 mmfds.
800 " 226 mmfds.	1350 " 79 mmfds.
850 " 201 mmfds.	1400 " 74 mmfds.
900 " 179 mmfds.	1450 " 69 mmfds.
950 " 160 mmfds.	1500 " 65 mmfds.
1000 " 145 mmfds.	1550 " 60 mmfds.
1050 " 131 mmfds.	1600 " 56 mmfds.

Now notice some things that this list brings out very clearly. Remember, with the straight line capacity condenser, the capacity is in exact proportion to the dial readings or to the amount you turn the condenser shaft. Also remember that there is a broadcasting channel every 10 kilocycles; that is, there are channels at 550, 560, 570, 580, 590, 600 kilocycles, and so throughout the entire range. In the list

given above, the capacity for every fifth channel or every fifth frequency is shown. In Australia not all the possible channels are actually used.

From 550 to 700 kilocycles we change from 482 mmfds, to 297 mmfds; a change of 185 mmfds for 150 kilocycles.

From 700 to 850 kilocycles we change from 297 mmfds, to 201 mmfds; or 96 mmfds. for 150 kilocycles.

From 850 to 1,000 kilocycles we change from 201 to 145 mmfds, or 56 mmfds. for 150 kilocycles.

From 1000 to 1150 kcs. we go from 145 to 109 mmfds.; 36 mmfds, for 150 kilocycles.

From 1150 to 1300 kcs. we go from 109 to 86 mmfds.; 23 mmfds. for 150 kilocycles.

From 1300 to 1500 kcs. we go from 86 to 69 mmfds.; 17 mmfds. for 150 kilocycles.

Between 550 and 700 kilocycles there are fifteen broadcast channels and we alter the condenser capacity 185 mmfds., more than one-third of the total capacity and more than one-third of our total dial movement for fifteen stations.

Between 1300 and 1450 kilocycles we again have fifteen channels, fifteen places to find stations, but we change the capacity only 17 mmfds. We would have a station for approximately each one micro-microfarad change. All across the dial gives us 500 micro-microfarads, so to separate these stations around 1450 kilocycles we would have to move the dial only one five-hundredth part of its total movement to get from one station to the next.

At one end of the dial you find stations separated by a movement of more than twelve mmfds., or a movement of $1/40$ of the whole dial. At the other end you find stations separated by only one mmfd. a movement of $1/500$ of the dial. At one end you will move the dial a long way to change from one station to the next one, while at the other one it would be almost impossible to make a movement small enough to go from one station to the next. Therefore, this type of condenser is not satisfactory for tuning purposes.

In the early days of radio we did actually use such condensers, but then there were only two broadcast channels whereas now there are more than 100 available channels. Straight line capacity condensers are now used only for laboratory and experimental work.

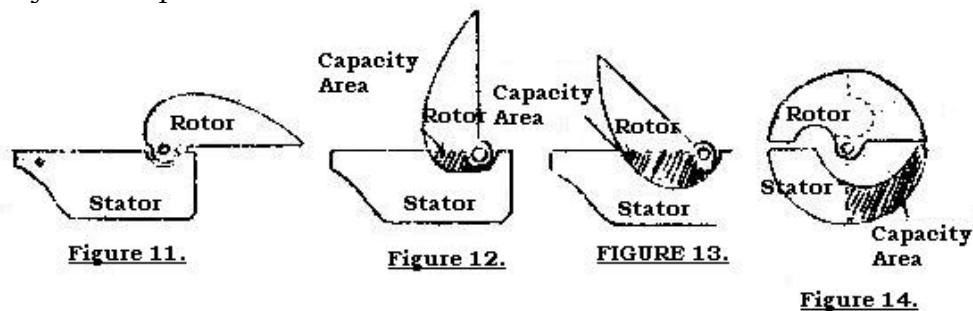

STRAIGHT LINE FREQUENCY CONDENSERS.

Since the broadcast stations are separated according to frequency, and since the separation between channels is 10 kilocycles from one end to the other of the whole range, it is but natural to build tuning condensers which have equal movements of their dials for change from one channel to the next. Such a condenser goes by the name of "straight line frequency".

The plates of a straight line frequency condenser, which are designed so that the rotor shape provides the straight line effect, would look somewhat like those in Figure 11. The rotor is long and has a sharp taper toward the outer end. The same condenser, in the position given by one-half of the total dial movement is shown in Figure 12. Notice that, although there has been a large dial movement or large movement of the rotor shaft, only a small portion of the plates is in mesh. Again look back at the list of capacities required for various frequencies. That list applies to a 500 micro-microfarad condenser which may be assumed to have a minimum capacity with the plates all the way out, of about 50 micro-microfarads. At 1600 kilocycles the list shows 56 mmfds., which is 6 mmfds. More than the minimum capacity of 50 mmfds. At that frequency of 1600 kilocycles we are using about 6 mmfds. of the variable capacity. At 1000 kilocycles we need a total of 145 mmfds. according to the list and this will be the 50 mmfds. minimum plus 95 mmfds. of the variable part of the capacity. So at 1000 kilocycles we are using about 95 mmfds. of the total variable capacity of 450 mmfds. We say the variable capacity is 450 mmfds. because we have to subtract from the condenser's maximum capacity, its minimum of 50 mmfds. Which is always there and which is not variable.

A frequency of 1000 kilocycles is about half way between 550 kilocycles and 1500 kilocycles, consequently is about half way around the dial movement for a straight line frequency condenser. In Figure 12 we have moved the dial half and have about one-fifth of the whole capacity area in use. Since from the foregoing paragraph, we need about 95 mmfds. of our variable capacity and have a total 450 mmfds. to work with, the capacity area of Figure 12 must be about right because 95 is about one-fifth of 450.

In Figure 13 the straight line frequency condenser has been turned further into mesh, to the position corresponding to about 800 kilocycles frequency. Here we have approximately 40 per cent of our whole variable capacity in use. You see, the capacity of this condenser increases very slowly at first, then more and more rapidly. This gives an even separation of stations on the dial because from our list of capacities and frequencies, you can see that the change of capacity must be more and more rapid for equal changes of frequency as we go up the dial.

It is possible to get the straight line frequency effect by proper shaping of the stator plates just as well as by shaping of the rotors. A stator shaped for straight line frequency work is shown in Figure 14. The capacity area with the dial turned through half its movement is shaded on the stator.

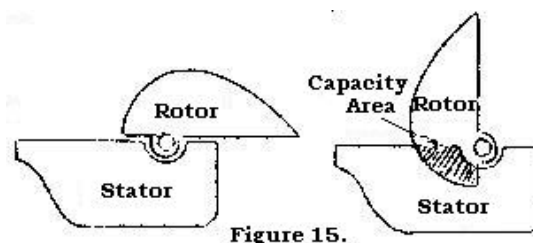

Figure 15.

STRAIGHT LINE WAVELENGTH CONDENSERS.

Before all broadcast stations were definitely assigned to certain frequencies, those stations as well as most other transmitters operated on “wavelengths” rather than on frequencies. You have already learned the relation between wavelength and frequency and how long wavelengths correspond to low frequencies.

In between the time of the straight line capacity condenser and the arrival of the straight line frequency type we used a good many “straight line wavelength” condensers. As you might suppose, those condensers provide separation according to wavelengths just as the newer type provides separation according to frequency. With the straight line wavelength unit you will find that a spacing of ten wavelengths at one part of the dial is the same as a spacing for any other ten wavelengths at some other part of the dial.

The shape of the plates of a straight line wavelength condenser are shown in Figure 15. You can see that turning the rotor plates half way on the dial divisions gives considerably more capacity area than a similar position for the straight line frequency type in Figure 12.

With a straight line wavelength condenser you got better separation of the high frequency stations than with the old straight capacity type, but you do not have as good separation as with the straight line frequency type. It is possible to use straight line wavelength condensers in modern receivers and have satisfactory separation on all except the stations operating at very high frequencies.

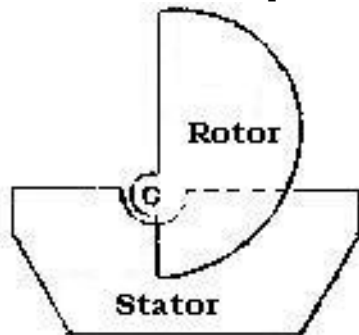

Figure 16.

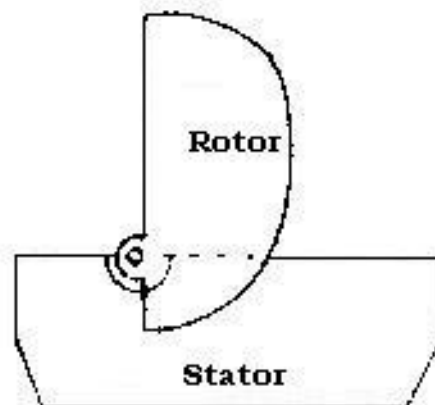

Figure 17.

A straight line wavelength condenser changes its capacity according to the “square” of the amount you turn it, and is sometimes called a “square-law” condenser. For example, the difference in capacity between “20” and “40” on a dial would be in proportion to the difference between 400 (square of 20) and 1600 (square of 40). Doubling the dial reading will give four times the capacity.

MODIFIED CONDENSERS.

A true straight line frequency condenser must use plates either of considerable overall size as in Figure 14 or else must use a large number of smaller plates to provide the required capacity. With the condenser of Figure 14 we find a very great width from one side to the other when the plates are all the way out of mesh. This width, of course, requires a lot of space within the receiver.

These objections to the straight line frequency condenser have led to the use of modified straight line frequency condensers. These are in between the true straight line frequency type and the straight line wavelength type in their shape and characteristics. They tend to bunch the high frequency stations closer together than true straight line frequency condensers, but they are better in this respect than the straight line wavelength or straight line capacity types. Nearly all modern sets use modified condensers to conserve space and give a better mechanical construction.

The problem of maintaining a satisfactory frequency-capacity relationship has been aggravated by the modern trend towards miniaturisation. As components, including variable condensers, have become smaller and smaller, manufacturers have been forced to adopt various modifications in physical shape to preserve an adequate ratio between maximum and minimum capacity. Two types of miniature variable condenser in current use are illustrated by Figures 16 and 17. Notice that even though both follow a modified straight line frequency characteristic, the shape of the rotor plates differs slightly.

CHANGING CONDENSER CAPACITIES.

Sometimes you find a tuning condenser which will not quite reach the stations on the highest frequencies or else will not quite reach those at very low frequencies. You can correct either of those conditions by using a small fixed condenser along with the regular tuning condenser.

To reach a higher frequency you need less capacity. To reach a lower frequency you need more capacity.

You can make the capacity less, so as to reach higher frequencies, by connecting a fixed condenser in series with the tuning condenser as in Figure 18. You can make the capacity greater by connecting a fixed condenser in parallel with the tuning condenser as shown in Figure 19. To make a series connection you take off the wire

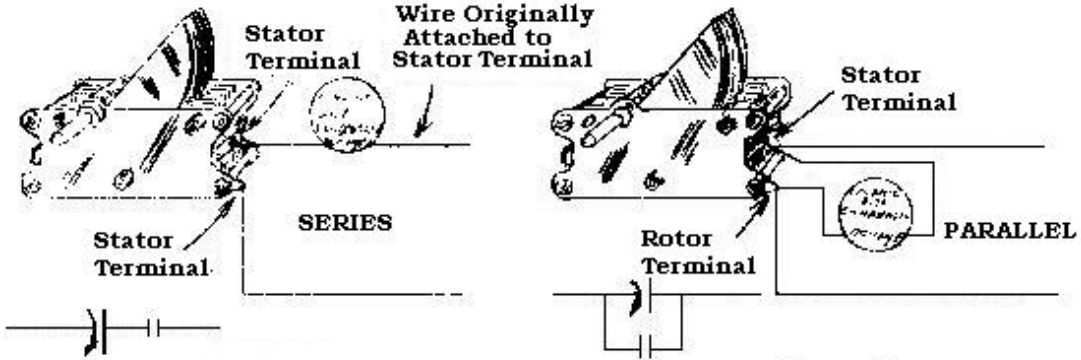

Figure 18.

Figure 19.

or wires connected to the stator terminal of the tuning condenser, connect one side of the small condenser to this stator terminal and attach the wire or wires removed to the other side of the small condenser. To make the parallel connection you do not take off any wires but just connect the extra condenser between the stator terminal and the rotor terminal as shown.

Although there is seldom any need to make such modifications as are outlined above, to modern receivers using factory built coils and tuning condensers conforming to present day standards, it is necessary for the student to be completely aware of the effects of series and parallel capacity because modern superheterodyne receivers make use of series and parallel condensers to achieve accurate tracking between dial pointer and station call-sign throughout the receiver's tuning range.

As you will learn in later lessons, a superheterodyne receiver takes a radio signal and mixes it with another signal developed by the receiver's own oscillator, the result being a third signal which is amplified, detected, or rectified, and converted to sound in the usual way.

Because the internally developed oscillation is always at a higher frequency than that of the incoming radio carrier wave, the section of the tuning condenser controlling the oscillator frequency must have a smaller capacity range than the other sections of the tuning gang. Reduction of the ratio between maximum and minimum capacity is achieved by connecting another small condenser in series with the oscillator tuning condenser. This condenser is called a "padder" or "padding condenser". As we have mentioned earlier, the theory related to the superheterodyne principle is discussed fully in later lessons.

When you use a series condenser you change the tuning for all stations, making them all come in with the tuning condenser turned further into mesh than before. If, before you used the series condenser, you received a given station at one point on the tuning dial, you will now have to turn the dial further in the direction that turns the plates into mesh in order to receive that same station. This will let you get stations which are at higher frequencies, but it will cut off some of the other end of the tuning range. As a general rule, when you cannot get far enough in one direction you have room to spare on the other end of the dial, so cutting off some of the other end does not make any difference.

When you use a parallel condenser you also change the tuning of all stations, but now you move them the other way on the dial. To get stations which you received before at certain dial settings, you will have to turn the dial further in the direction which moves the condenser plates out of mesh. Here again you will gain at one end of the dial and will lose at the other end.

If the set with which you are working uses a dial numbered from "0" to "100" you generally find the high frequency stations at the low numbers and the low frequency stations at the high numbers on the dial. Then, using a series condenser will move all stations up on the dial and will leave more room at the lower end for the high frequency stations. Using the parallel condenser will move all stations down on the dial, will leave more room at the upper end to receive more of the low frequency stations.

Now, about the size or capacity of the fixed condenser. You do not want much change of tuning capacity because much change will throw the tuning away off. With the series connection, the greater the capacity of the extra condenser, the less change you will make in the total tuning capacity. For tuning condensers of 500 mmfds. capacity you can try fixed condensers of 0.004, 0.005, 0.0075 and 0.01 mfd. capacity. These will change the total capacity from 10 per cent to about 5 per cent.

If the tuning condenser has less capacity than 500 mmfds., the same extra fixed condensers will work., but will give you a smaller percentage change in the total capacity, the easiest way is to make the connection., then try out the receiver to see how it tunes.

With the parallel connection, the smaller the extra fixed condenser's capacity the less change you will make in the total tuning capacity. You will not want to use any fixed condenser of more than 0.0001 mfd. capacity. Smaller sizes, such as 0.00008, 0.00006 and 0.00004 will make plenty of change in most cases.

CONDENSERS IN SERIES AND IN PARRALEL.

You must have noticed that with the series connection we want to use a large extra capacity, while with the parallel connection we want to use a very small extra capacity - yet both make about the same percentage change in the total capacity for tuning.

Condensers in parallel add their capacities together. The three condensers in Figure 20 are connected in parallel because current can divide between them part going through each one. Their combined capacity is the sum of the separate capacities, like this:

1000 mmfds. or .001 mfd.
250 mmfds. or .00025mfd.
500 mmfds. or .0005 mfd.
1750 mmfds. or .00175mfd.

It does not make any difference whether the condensers are of the fixed type as shown or are variable tuning condensers, or are part of one kind and the rest of another -- the rule holds good just the same. Condensers in parallel add their capacities. That is why, in Figure 19 for the parallel condenser, you add only a small one because then you make only a small change in the total capacity of the two condensers.

Another thing which must be considered is the following. All coils, in addition to having inductance and resistance, have a small amount of capacity. This capacity, generally called distributed capacity, exists between the various turns of the coil and between the coil and nearby metal parts. In addition, all valves have a certain amount of capacity between their grid and the other elements and also all wires in the receiver have a certain amount of capacity to other wires, metal objects and the metal chassis. While each of these condenser effects is very small in itself, we find that the combined capacity made up of the coil capacity, valve capacity and that of the wires joining these units generally mounts up to about 20 mmfds, in ordinary sets. You know that the coil and tube are wired in parallel with the variable condenser in ordinary tuning circuits, so you will realise that the 20 mmfds. or so of distributed capacity is in parallel with the tuning condenser and therefore must be added to the tuning condenser capacity. The addition of this extra capacity has the effect of decreasing the range of frequencies to which the circuit can be tuned.

Supposing our condenser has a maximum capacity of 385 mmfds, and a minimum capacity of 25 mmfds. The distributed capacity in the circuit amounts to 20 mmfds. Now the total maximum Capacity is 405 mmfds and the total minimum capacity is 45 mmfds, or a variation of nine times (the maximum capacity is nine times the minimum capacity).

The range of frequencies which the circuit will tune to is approximately equal to the square root of the change in capacity, so the variation in frequency in this case will be the square root of 9, or 3 times. This means that if the lowest frequency the

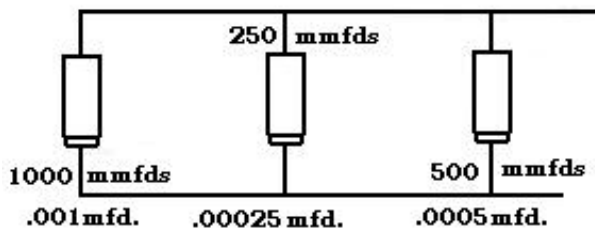

Figure 20.

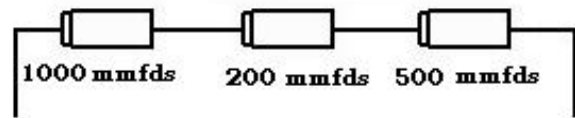

Figure 21.

circuit will tune to is, say, 525 K.C. to allow a small margin at the low frequency end of the broadcast band, the highest frequency will be 3 times 525 K.C. or 1575 K.C..

The important point to remember is that the distributed capacity must be taken into consideration when considering the tuning range of a particular condenser and coil.

When condensers are connected in series, as in Figure 21, the reciprocal of their combined capacity is equal to the sum of the reciprocals of the separate capacities. This is not so simple. You know that the reciprocal of any number is "1" divided by that number. For the three condensers shown in Figure 21 we would go about figuring their combined capacity by writing down the reciprocals like this:

$$\frac{1}{1000} + \frac{1}{200} + \frac{1}{500} = \frac{1}{\text{Combined Capacities}}$$

You have to change all the fractions so that they can be added; you change them all so they have the same "denominator" or the same number under the line. Then our figures look this way:

$$\frac{1}{1000} + \frac{5}{200} + \frac{2}{500} = \frac{8}{1000}$$

So we have 8/1000 amounting to the same as "1" over the "combined capacity". Then, turning this fraction upside down, we have 1000/8 as equal to the "combined capacity" divided by "1". Any number divided by one is the number itself, so 1000/8 is the combined capacity. This fraction is equal to 125, so the combined capacity of the three condensers is 125 micro-microfarads.

The combined capacity of any number of condensers in series with each other is less than the smallest separate capacity, is less than the capacity of any one of the separate condensers. If you remember this fact you will not often have to figure out the actual capacity of condensers in series -- just remember it will be smaller than the smallest of the separate capacities.

Now you have learned how to calculate the combined values of both series and parallel connections of condensers or capacities, and also of resistors or resistances and of

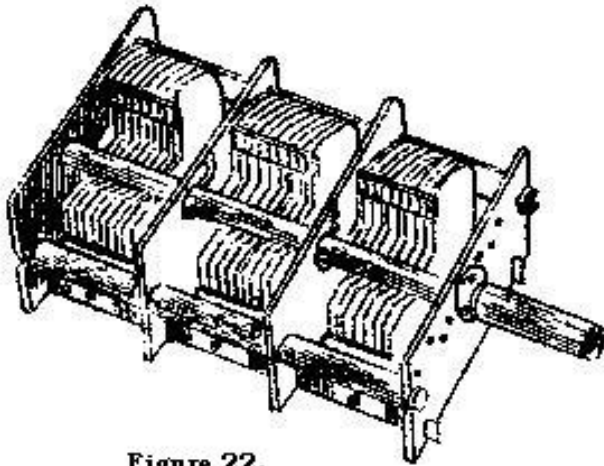

Figure 22.

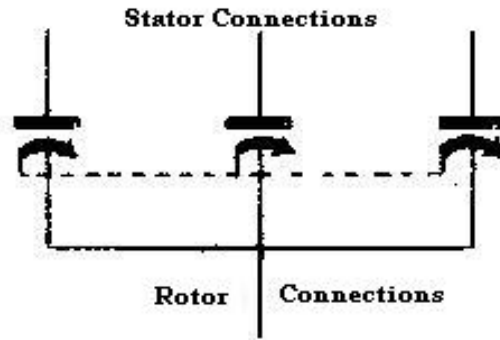

Figure 23.

coils or inductances. We have just dealt with capacities. The resistances and inductances were in earlier lessons. Here is a little table to remind you of what happens when we make series or parallel connections of these things.

Kind of Unit Being Handled

Combined Value.

	<u>When Connected in Series.</u>	<u>When connected in Parallel.</u>
Resistances	Add Separate Resistances.	Add Reciprocals.
Inductances	Add Separate Inductances.	Add Reciprocals.
Capacities	Add Reciprocals	Add Separate Capacities.

Of course, when you add the reciprocals, the sum of the reciprocals is equal to the reciprocal of the combined value. You can see from this table that resistances and capacities act just the opposite way.

GANG CONDENSERS.

In modern types of radio receivers we seldom, if ever, use single tuning condensers all by themselves. We “gang” them -- use several similar units all connected together so that their rotor plates move together.

Some receivers for broadcast work use one or more stages of radio frequency amplification. Each stage is tuned by means of a tuning condenser. In the earlier set, you would find three or more tuning dials and you would have to work first one then the others until you got them all in tune. With that kind of set it was a real job to find a distant station and only the real “fans” had patience enough to do it.

Every part of each tuned radio frequency stage is just like the corresponding part in each other stage. Therefore, when such a set is properly designed and built we can have all the condensers alike and can work them all together so that they all have the same capacity at any one time.

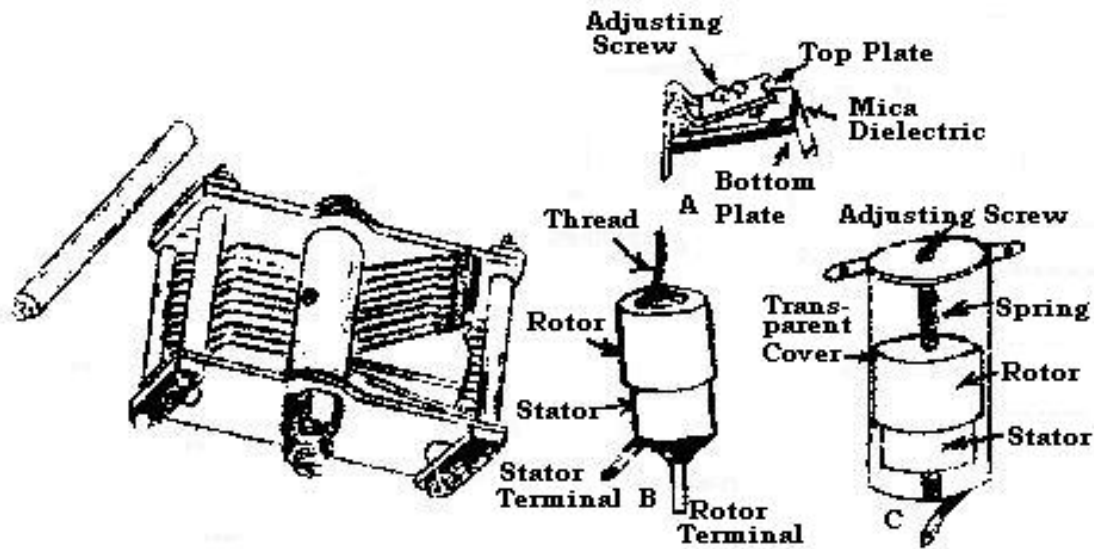

Fig. 24

Fig. 25

A typical gang condenser containing three tuning sections is shown in Figure 22. All of the rotor assemblies are attached to the one long shaft. Turning this shaft moves all the sections together. Using a common shaft connects all the rotors together electrically. This works out all right because the rotor side of all condensers is connected to the "B-minus" or the grounded side of the circuit in practically all receivers. Each stator plate assembly is thoroughly insulated and separated from all the other stators. The symbol for such a condenser, showing the electrical connections, is shown in Figure 23. The broken line shows that all the rotors are connected together.

It is not always convenient to have the several condensers all in one place; it may work out better to have the different ones separated by some space. Then a type such as illustrated in Figure 24 can be used. This condenser has a hole right through the centre of the rotor shaft from end to end. The separate condenser units may be mounted anywhere, just so they are in line with one another, and a single long shaft pushed through all of them. There are one or more set screws in the hollow rotor shafts of each condenser section and after the rotor plates are properly adjusted for position this screw is tightened down, fastening the rotor to the long shaft.

To successfully use a gang condenser of any kind requires exceedingly accurate workmanship and uniformity of materials in the radio frequency amplifier. You can realise that the slightest difference between coils, the least difference between the layout of the wiring or the slightest change between one condenser unit and another will throw the tuning all out of gear. Any of these things will make some slight change in either the capacity, the inductance, or both. Then the different stages will not tune together. One or two will be resonant at a frequency while the others are more or less off resonance. Then you will get only part of the amplification that the set should give because, of course, the voltage falls away off when you get a little bit off the resonant point.

In order to allow for slight variations in wiring and in other parts of different tuning stages, most gang condensers have fitted to each section a small extra

condenser connected in parallel with the main tuning condenser section. This small condenser is generally called a “trimmer”, a “compensator” or some similar name. One kind of trimmer condenser is illustrated in Figure 25a. It uses mica for the dielectric between the plates and secures a change of capacity by pressing the top plate down closer to the lower one by means of a screw. The plates are normally held apart by the springiness of the top plate. Turning the screw down forces the plates closer together and increases the capacity. Two other kinds of trimmer condenser are shown at “b” and “c”. Both, are air dielectric types. Capacity is changed by screwing two cylindrical sections one into or out of the other. Screwing the sections together increases the capacity.

Adjustment of 25(b) is by rotation of a small nut attached to the movable outer cylinder. Adjustment of 25(c) is by a screw set in the top of the enclosed assembly. Movement of the screw pushes or pulls the outer cylinder in or out.

The one illustrated at 25(c) is totally enclosed against dust and other foreign matter.

The symbol for a gang condenser equipped with small trimming condensers is shown in Figure 26. Around each main tuning section, in parallel with it, is connected one of the small trimming condensers. Those small condensers have maximum capacities of only a few micro-microfarads. After the receiver is ready for test, if it is found that that all tune exactly together, the auxiliary condenser for the stage out of line is altered in capacity just enough to make the needed correction. In many circuits the trimmer condensers are not

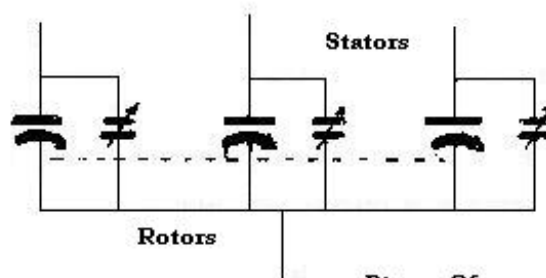

Figure 26.

actually shown connected to the condenser gang, but are completely omitted, it being understood that all modern sets use trimmer condensers either on the gang itself or connected to the coils.

TUNING DIALS.

The subject of tuning dials is really a mechanical one. A tuning dial has no electrical action and by simply looking carefully at these devices, you can always see how they work and what is wrong, if any-thing.

When tuning closely for distant stations the job is much easier if the condenser rotors are moved only a very little distance at a time. To allow this you often find some sort of reduction gear between the knob which is turned by the operator and the main dial and shaft which operate the condenser rotors. Flexible cords running over pulleys are very popular for this work. Other devices include toothed gears or friction wheels, all of which are designed so that it requires several turns of the

tuning knob to move the condenser rotors from their fully meshed position to the position where they are completely out of mesh. Those connections which reduce the motion of the condenser shaft are sometimes called “verniers”.

Yet another arrangement not often used nowadays, was to arrange the condenser at right angles to the front panel and to use a large circular, semi-circular or rectangular dial with a friction drive. Most dials are usually illuminated from the side by means of one or more small electric lamps similar to those used in torches. Power for the lamp is usually derived by connecting them to the source which supplies the filament or heater of the amplifying tubes.

Many older types of radio receivers are fitted with dials which have no station call-signs but are merely numbered 0 to 100. One may sometimes be tempted to “modernise” one of these receivers by fitting a new dial inscribed with station call-signs. However, any move in this direction should be carefully considered before actually making the replacement. If the receiver is a very old one, say of mid-1930 vintage, and there are still some receivers of that period in active use the result of such replacement is likely to be very disappointing.

Modern dials have a frequency calibration and, consequently station call-sign spacing which is related to a modified straight line frequency characteristic condenser having a capacity range of about 11 to 410 micro-microfarads. If we fit such a dial to a receiver tuned by condensers having different frequency capacity characteristics, and a noticeably smaller capacity range, considerable difficulty will attend any attempt to make the dial pointer coincide with the call-sign of the station to which we happen to be listening. In most cases it would probably be possible to achieve the desired result at one end of the dial but then one would find that the pointer would come nowhere near a required station's call-sign at the other end of the dial, or perhaps, even in the middle of the dial.

If it is particularly necessary that the replacement be made, reasonably satisfactory tracking will be achieved if the tuning condenser is also replaced by one suitable for use with the new dial, in which case some mechanical modification would undoubtedly be necessary because modern tuning condenser gangs are much smaller than those employed twenty or more years ago.

The products of present day condenser manufacturers are so similar in characteristics that we need not worry unduly about using a dial expressly designed for a particular condenser, but we most certainly should be careful about fitting a modern dial to an old receiver.

In this lesson we have gone quite deeply into the matter of tuning condensers and their action. The condenser is one-half the oscillatory circuit allows us to pick out the station we wish to hear. The other half is the coil or the inductance. One part of the resonant circuit is just as important as the other, the coil is just as important as the condenser, and the condenser is just as important as the coil.

EXAMINATION QUESTIONS No. 16.

1. Do you increase the capacity of a condenser as you tune to higher frequencies or to lower frequencies? Explain.
2. If the maximum capacity of a tuning condenser is 350 micro-microfarads, about what should be its minimum capacity?
3. Do the stator plates move or stand still.? Are they connected to, or insulated from the condenser frame?
4. Should the insulation of a tuning condenser be close to or far from the plates?
5. Can an old receiver be fitted with a modern dial showing station call signs, without any other modifications? Explain.
6. With a straight line capacity condenser are the stations crowded together at the high frequencies or at the low frequencies?
7. With a straight line frequency condenser does the capacity increase rapidly just as the plates start into mesh or when they are almost all the way in mesh?
8. if there is a separation of 20 dial divisions between stations 100 kilocycles apart when using a straight, line frequency condenser, how many divisions will there be between stations 50 kilocycles apart?
9. In addition to the capacity of the tuning condenser itself, what other capacities affect the range of frequencies to which a resonant circuit will tune?
10. If two condensers, one of 100 mmfds, and one, of 500 mmfds, capacity are connected in series, what will be their combined capacity?

AUSTRALIAN RADIO AND TELEVISION COLLEGE PTY. LTD.

E. S. & A. BANK BUILDINGS, Corner CITY RD. and BROADWAY, SYDNEY
Telephones: BA4891 and BA4892

Telegrams "RADIOCOLLEGE" Sydney

This lesson sheet is published for the exclusive use of
students of the Australian Radio and Television College
Pty. Ltd. (All rights reserved)

Post Lessons to Box 43, Broadway

LESSON NO. 17

COILS AND THEIR FUNCTION IN RADIO

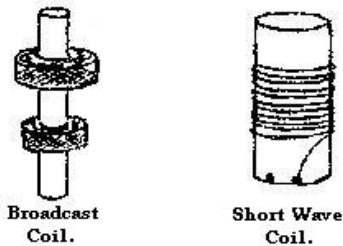

FIGURE 1.

The coils we use in radio are given the job of forcing the alternating currents to give up part of the energy being carried through the circuit. As those currents flow through the coil we have voltages produced or differences of potential produced across the coil from one end to the other. It is the coil's reactance to alternating current which makes the current work for us.

A coil has reactance because of the coil's inductance. Inductance is the ability of a coil to generate voltage within itself if or to generate voltages in some nearby circuit when there is a change of the current, flowing in the coil.

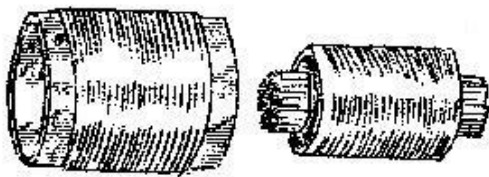

FIGURE 2.

Any coil of wire has inductance in radio transmitters and receiver we make use of many different kinds and shapes of coil. In radio receivers the most noticeable coils are those used in resonant circuits which tune the receiver to various stations. These are the coils you can see in Figure 1 and they are the kind we are going to investigate in this lesson. Frequently

these coils are enclosed in a metal screening "can" and so are not readily visible. Even if the "can" is removed from a modern tuning coil it is generally still invisible because of a complete coating of moisture excluding wax.

One kind of coil which may be used in parts of radio sets carrying high frequency or radio frequency currents is shown at the, left hand side of figure 2. This coil consists of a single layer of wire wound evenly and closely on the outside of a piece of tubing which is made from insulating material. We call this a single layer "solenoid coil".

Inside of the winding tube of the left hand coil in Figure 2 there is nothing but air. The inside, or the core of this coil is of air --- therefore, it is called an "air-core coil". At the right hand side of Figure 2 is a coil wound around a bundle of iron wires. This is called an "iron-core coil". Most coils used for carrying currents at radio frequencies are of the air-core type. The coils used in the audio frequency circuits and in the circuits handling power current at house lighting frequencies are of the iron-core type.

THINGS WHICH AFFECT INDUCTANCE.

The inductance of a coil depends on the number of turns of wire, on the length of the windings and on the diameter of the winding. Now, to this list, we will add two more things which have their effect on the coil's inductance.



Fig.3

Were you to test the air-core coil shown at the left hand side of Figure 3 you would find that it has very little inductance because it is a small coil and has only a few turns of wire. Then, taking a handful of iron wires or rods, you might slip some of them inside the coil as at the right hand side of

Figure 3. The effect of the iron would be to immediately increase the coil's inductance. The more iron you put inside the coil, the greater the inductance will become.

The reason for this action is very simple. Iron carries magnetic lines of force ever so much easier than air carries them. Therefore, with a given amount of power used in the coil, the iron will allow the production of many times the number of lines of force. The greater the number of lines, the greater the voltage generated and since the voltage is in proportion to the inductance we must have more inductance, so the kind of material in and around the coil changes the inductance.

Now we come to the last thing affecting a coil's inductance -- this being the "shape factor". The shape factor turns out to be nothing more than a number, a number which depends on the ratio of the coil's diameter to its length. A "ratio" is the relation of one thing to another written out in the form of a fraction. The ratio of diameter to length means the number which you get by dividing the diameter by the length. Thus, if the winding of a coil has a diameter of 4 inches and this winding is 2 inches long, you divide 4 by 2 and get as a result the number 2, which is the ratio. If the coil happened to be 2 inches in diameter and 4 inches long, you would divide 2 by 4 and get $2/4$ which is equal to $1/2$ or, in decimals is equal to 0.5 -- the ratio of the 2 inch diameter to the 4-inch length.

At the end of this lesson you will find a table or list of shape factors corresponding

to various ratios of diameter to length. To use this table you divide the diameter of the winding in inches by the length of the winding in inches. This gives you the ratio. Then you find this ratio in the table and opposite it you will find the shape factor number. If the ratio you get is between two of these numbers you can use a shape factor between the two.

All of our calculations here refer to single layer, close wound cylindrical coils like the type shown at the left hand side of figure 2. This is the most generally used kind of coil, and, for a given amount of wire, gives us the most inductance.

In figure 4 you can see all the things which affect the inductance of a coil, at least all which affect the inductance of the kind of coil we are investigating just now.

Notice that the "length of winding" has nothing whatever to do with the length of the piece of tubing on which the wire is wound. The winding length is the distance from one end of the wire part to the other end of this part. The "diameter" is the distance

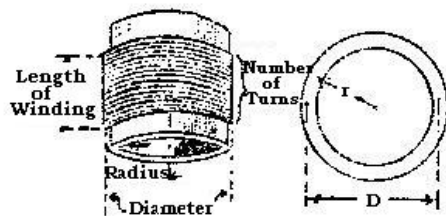

Fig. 4

from the centre of a wire on one side of the coil to the centre of a wire directly opposite. You can see what I mean by the dimensions marked "D" in the right hand drawing. The "radius" is the distance from the exact centre of the coil out to the middle of one of the wires in the winding -- the dimension marked "r" in the right hand drawing. The radius is equal to one-half the diameter. In determining these dimensions of the coil we are considering the wire winding only and do not take into account the form or tube carrying the winding.

As with everything in radio we can calculate the result of sizes and shapes by using a formula. Here is the way in which we work out the inductance of a coil:-

$$\text{Inductance in Microhenrys} = \frac{(\text{number of turns})^2 \times (\text{radius})^2 \times (\text{shape factor})}{\text{Length of winding} \times 10}$$

This formula says to square the number of turns, square the radius, multiply those two together and multiply the result by the shape factor. Then you divide that number by ten times the length of the winding. All dimensions are taken in inches.

Take this formula as an example: There are any number of things which it will tell you. Among other things it says that the inductance of the coil depends not on the number of turns directly, but on the square of the number of turns. The left hand coil in Figure 5 has 20 turns and the right hand one has 40 turns. Other wise they are alike, anyone would say that the right hand coil would have twice the inductance of the left hand one. But the formula says to square the number of turns, to multiply the number by itself. So you square 20 and get (20x20) 400. Then you square 40 and get (40 x 40) 1600.

So with no other difference between the coils except twice the number of turns in one of them, that one will have four times instead of twice the inductance.

Then take the coils of Figure 6. The only difference between them is that the left hand one is 4 inches in diameter and the right hand one is 2 inches in diameter. Then since the radius is half the diameter, they have radii of 2 inches and 1 inch. The formula (1) tells you that the inductance is in proportion to the square of the radius.

Squaring the left hand coil's radius gives (2x) 4, while squaring the radius of the right

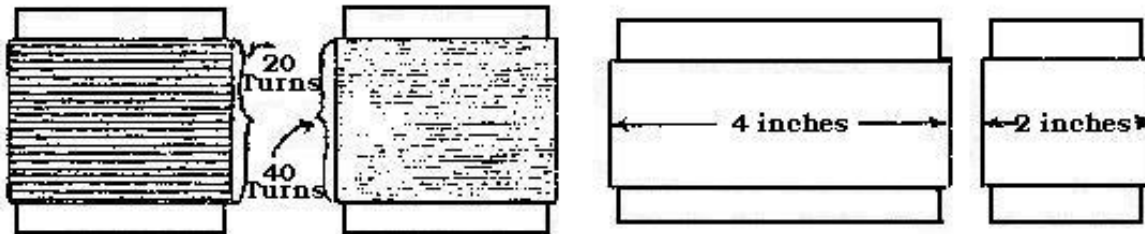

Fig. 5

Fig. 6

hand coil gives (1x1) 1. The left hand coil will have four times the inductance of the right hand one, yet has only twice the diameter or radius.

Once more look at the formula. You see that the “length of winding” is underneath the line. Any quantity underneath the line has an entirely different affect on the result from the effect of quantities above the line. To illustrate what is meant take the following fractions:

$$\frac{1}{2} \qquad \frac{1}{4} \qquad \frac{1}{10} \qquad \frac{1}{100}$$

You know that one-fourth is smaller than one-half, that one-tenth is smaller than one-fourth, and that one one-hundredth is smaller than one-tenth. Now you see that the larger quantity below the line, the smaller is the real value of the expression. Then look at the following quantities:

$$\frac{4}{2} \qquad \frac{6}{2} \qquad \frac{10}{2} \qquad \frac{100}{2}$$

We have four halves, then six halves, then ten halves, and finally one hundred halves. These are equal to the quantities 2, 3, 5 and 50. So you see that the, larger the quantity above the line, the larger is the final result.

Then, since the “length of winding” is below the line, we know that the greater the length or the longer the coil, the smaller will be its amount of inductance, all other things remaining the same. We can also tell that increasing the number of turns or increasing the radius will increase the inductance because these things are written above the line in our formula.

This formula for inductance has been taken and some of the things it tells you have been explained. Any other formula is equally instructive. If you examine them carefully and work out what effect a change in one quantity will have on the result you can learn all manner of useful facts.

Now we'll use the formula to work out the inductance of the coil in Fig. 7. We have 68 turns of number 30 double silk covered wire a length of 1 inch and having a radius of 1 inch. Dividing the diameter by the length (2 divided by 1) we get 2 for the ratio. The shape factor table gives, for the ratio 2, a shape factor of 0.526. Then we fill in the formula this way:

$$\frac{68^2 \times 1^2 \times 0.526}{1 \times 10} = \frac{4624 \times 1 \times 0.526}{10} = 243.2 \text{ microhenrys}$$

So we learn that the inductance of this coil is about 243.2 microhenrys.

What good does it do to know the inductance? Among other things it tells what size tuning condenser to use. You were told that the "oscillation constant" for 550 kilocycles is the number 83,730. To find the required tuning capacity in micro microfarads you divide the oscillation constant by the inductance in microhenrys.

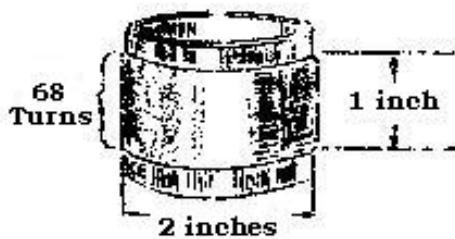

Figure 7.

Dividing 83,730 by 43 (microhenrys) gives approximately 345 micro-microfarads. One of the standard tuning condenser capacities is 350 micro-microfarads or 0.00035 microfarads -- so of course that is the tuning condenser to go with this coil of Figure 7.

EFFECT OF TUNING COIL INDUCTANCE.

The greater the inductance of the coil or the less the capacity of the condenser in a tuned circuit, the greater will be the voltage developed across that circuit. This means that a bigger coil or one

of greater inductance will increase the amplification. The amplification depends not only on the tube used but, also on the voltage drop in the circuit connected to the tube's plate.

It is possible, as you know, to use various combinations of inductance in the coil and capacity in the condenser to tune to the same frequency. In broadcast reception we can use any of the standard condenser with suitable coils and tune from 550 kilocycles to 1500 kilocycles. Here is a list of corresponding condenser and coil sizes with the reactances of the coil at 1500 kilocycles.

Condenser Capacity In Micro-Microfarads	Coil Inductance In Microhenrys	Coil Reactance in Ohms At 1500 Kilocycles
250	340	1500
300	285	2688
350	245	2311
400	215	2028
500	175	1651
1000	85	802

A reactance of 1500 ohms is considered to give good results in amplification. More reactance (due to greater inductance) is not objectionable and in fact gives greater amplification provided we do not run into other troubles such as oscillation. These will be explained in a later lesson. A tuning condenser of 500 micro-microfarads capacity is about the largest that will give really good amplification, that is, amplification that compares well with the average good receiver.

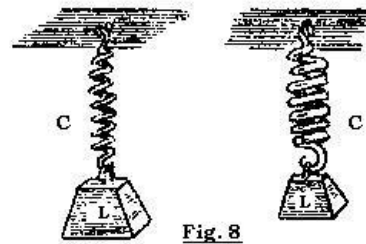

Fig. 8

To make a mechanical comparison with electrical actions in a resonant circuit you can always compare the inductance to a weight and the capacity to a spring. If, as at the left in Figure 8, you have a heavy weight (large inductance) with a comparatively small spring (small capacity) a pull on the weight will set it into oscillation which will be powerful and

which will continue for quite a long time. The lighter weight attached to a stiff spring, or the smaller inductance with a large capacity, as at the right hand side of Figure 8, will have shorter oscillations and these oscillations will die away quite rapidly. The advantage is with the resonant circuit made up of a large inductance and small capacity rather than with the one containing a large capacity and small amount of inductance.

INDUCTANCES IN SERIES AND PARALLEL

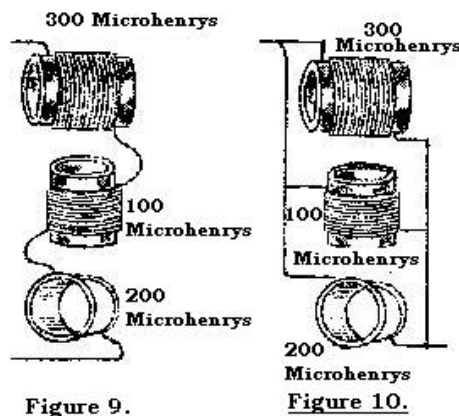

Figure 9.

Figure 10.

The three inductance coils of Figure 9 are connected together in series. That is all current flowing through any one of them must also flow through the others. We will assume that the three coils have inductances of 300 microhenrys, 100 microhenrys and 200 microhenrys. The total inductance of the three, connected in series is 300 plus 100 plus 200, or 600 microhenrys. Inductances in series add together just as resistances in series add together.

In Figure 10 we have the same three inductances in parallel so that the total current flowing through each of the coils. The case here is similar to that with

the parallel resistances. The inductance of the three coils combined in a parallel circuit is less than the inductance of the smallest one of the lot. To figure out the combined inductance we add the reciprocals of the separate inductances and this gives us the reciprocal of the total inductance. A "reciprocal" of any number is "1" divided by that number. Thus the

reciprocal of 2 is $\frac{1}{2}$ (which is 1 divided by 2). The reciprocal of 10 is $\frac{1}{10}$ (or 1 divided by 10.)

As an example we will calculate the total inductance of the three coils of Fig. 10.

The reciprocals are added as follows:

$$\frac{1}{300} + \frac{1}{100} + \frac{1}{200} = \frac{1}{\text{Inductance}}$$

To add those fractions we have to change them over like this:

$$\frac{2}{600} + \frac{6}{600} + \frac{3}{600} = \frac{11}{600}$$

So we have $\frac{11}{600}$ as the reciprocal of the inductance. We turn this fraction upside down, giving $\frac{600}{11}$ as the inductance. This cancels out to $54\frac{6}{11}$ microhenrys inductance for the three coils in parallel. Therefore inductances in parallel reduce the total inductance to an amount smaller than the smallest of the separate inductances.

OTHER THINGS AFFECTING INDUCTANCE

The items which we have considered are those which have the principal effect on a coil's inductance and they are the ones so ordinarily considered when we work out the inductance in building or remodeling a radio part. There is however, several other things which have a slight effect on inductance.

Frequency changes the apparent inductance of a coil. As the frequency increases, the inductance appears to increase with the frequency. The following list shows how one coil's apparent inductance increases over the broadcast band of frequencies:

Apparent Inductance at 550 kilocycles 300 microhenrys
Apparent Inductance at 700 kilocycles 306 microhenrys
Apparent Inductance at 1000 kilocycles 320 microhenrys
Apparent Inductance at 1500 kilocycles 355 microhenrys

In order to make up for the greater inductance at the high frequency, the tuning condenser's capacity at this frequency must be still smaller than you would naturally expect. The greater the inductance the smaller must be the capacity to tune to a given frequency. This frequency effect means that the condenser must be able to get down to a smaller minimum capacity than would be the case were the inductance to remain unchanged.

In addition to their inductance all coils have some capacity as well. There is capacity between the different turns of a coil because those turns are metal and they are separated by insulation (a dielectric). This makes a condenser. The resulting capacity is called "distributed capacity" because it is distributed all through the coils winding. We will study distributed capacity a little later on.

This distributed capacity helps to make the coil's inductance appear larger than it really is as the frequency is increased.

Now we will see something that makes the coil's apparent inductance smaller than its real inductance. If the coil, of Fig, 11 has an actual inductance of 300 microhenrys

placing the metal plates in the position shown will make the inductance seem or act as though it were somewhere around 290 microhenrys. Most modern receivers use metal "shielding" around coils and other parts and the effect of this shielding is to reduce the apparent inductance of the coils. Then larger tuning condensers must be used to obtain resonance at a frequency. Providing the shielding is correctly spaced from the coil it does not make a very great change in the apparent inductance.

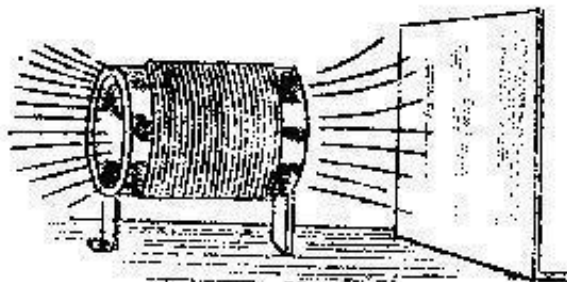

Fig.11



Fig. 12

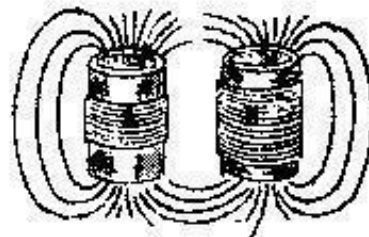

Fig. 13

MUTUAL INDUCTANCE.

The coil of Figure 12 has self inductance, the kind of inductance we have been studying so far. The self-inductance causes voltage to be generated when a change of current makes the lines of force rise and fall. Self-inductance considers the lines of force which cut through the conductors of the coil producing the lines.

The two coils of Figure 13 are placed close together and lines of force generated in either one of them will cut through the wire winding of the other one. Change of current in coil "A" will not only cause a voltage to be generated in coil "A", but the moving lines of force will cause a voltage to be generated also in coil "B". We have self inductance of coil "A", we have the self-inductance of coil "B", and in addition we have the "mutual inductance" which is a property of the two coils together. Mutual inductance is the property or ability of a coil to produce a voltage in another coil.

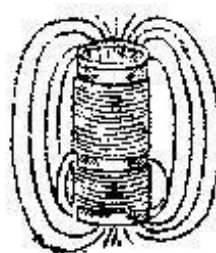

Fig. 14

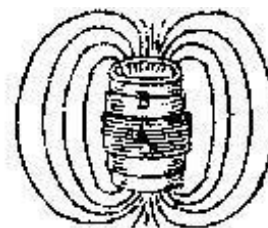

Fig. 15

The coils "A" and "B" may be placed end to end on a single piece of tubing as in Figure 14. Then nearly all the lines of force from one of the coils will pass through the conductors or turns of the other one. The amount of mutual inductance depends on the number of lines which link through both coils, consequently we have much more mutual inductance in Figure 14 than in Figure 13.

Mutual inductance is measured in the same units we use for self-inductance, namely, the henry, the millihenry and the microhenry.

In Fig. 15 coil "A" is wound right over the middle of coil "B" and right on top of "B". This gives the greatest possible mutual inductance for any ordinary construction because nearly all the lines from one coil must link with the other one.

The amount of mutual inductance depends on how close the two coils or two circuits are to each other. They are closer in Figs. 14 and 15 than they are in fig. 13 and we have more mutual inductance the closer we get the circuits to each other.

The amount of mutual inductance depends also on the size of the two circuits or coils. Big coils or coils having large amounts of self-inductance in themselves will have much more mutual inductance when brought together than smaller coils will have.

The shape or design or construction of the two coils or circuits has a great deal to do with the amount of mutual inductance between them. If a coil is built so that its field spreads out a little way, than the, lines composing the field won't link very well with other circuits and the mutual inductance will be lessened.

Ordinarily, two coils placed end to end as in Fig, 16 would have a considerable amount of mutual inductance because the field of one would pass through the turns of the other. But if a sheet of metal be placed between them as shown, there will

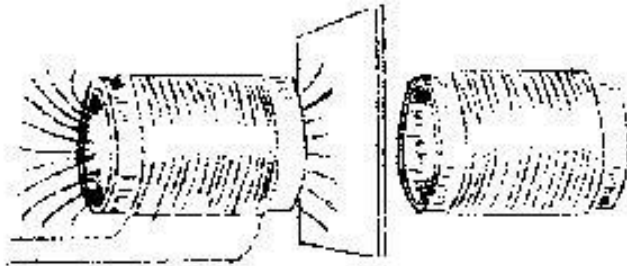

Figure 16.

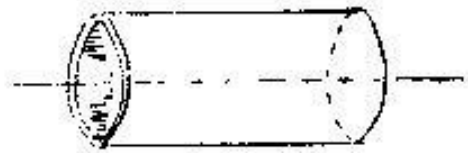

Figure 17.

be little or no mutual inductance. The lines will pass into the metal, will produce voltages in the metal instead of the neighboring coil, and the two coils will have practically no effect an each other.

Now we come to one of the most important things affecting the amount of mutual inductance between two coils -- the angle between their axes. The axis of a coil is a line drawn from end to end through the centre, as the line "A-B" in Fig. 17. The plural of the word "axis" used when speaking of more than one, is the word "axes".

In Fig, 18, the line "A-B" forms the axis of both coils. The axes of these two coils run together and form a single line. For a given distance apart of those two coils this single axis gives the greatest mutual inductance. If the coils are moved closer there will be more mutual inductance if they are moved farther apart there will be less mutual inductance, but as long as you keep the separation "1" between the coils, the single axis arrangement gives the most mutual inductance.

In Fig. 19 one coil has axis "A-B" and the other has axis "C-D". These two axes run in the same direction, they are parallel, but they don't form one single line. This arrangement gives less mutual inductance than the arrangement of Fig, 18. If the separation "1" in Fig. 19 is the same as the separation "1" in Fig. 18 separating the axes as in Fig, 19 will reduce the mutual inductance between the two coils

In Fig. 20 one of the coils has axis "A-B" and the other has axis "C-D". The two axes cross each other at "X". They are at an angle to each other. The amount of mutual inductance between these two coils depends on the angle between their axes.

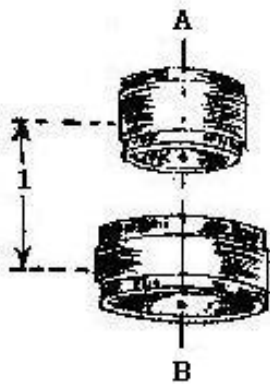

Fig. 18

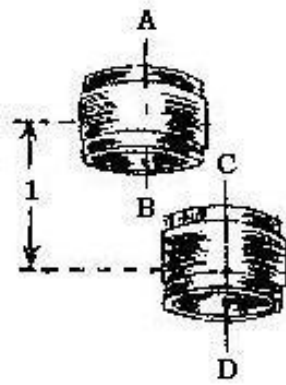

Fig. 19

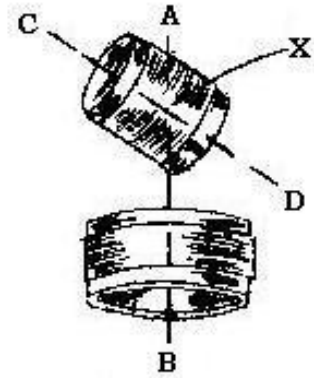

Fig. 20

In Fig. 21 we have the two coils of Fig. 20 with no angle or a zero angle between their axes. This, of course, gives the greatest possible amount of mutual inductance because most of the lines of force from each coil cut the conductors of the other coil.

In Fig. 22 the axes of our coils have been turned at an angle. The axis of one coil, line "A-B", is crossed by the axis of the other, line "C-D", at the point marked "X". Then we have the angle "A-X-C". In Fig. 22 we have about three-quarters as much mutual inductance as in Fig. 21.

In Fig. 23 the axes of the two coils have been turned to a greater angle. Axes "A-B" and "C-D" still cross at "X", but now the angle "A-X-C" is greater than it was in Fig.

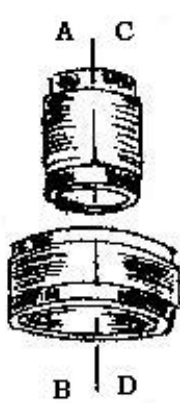

Fig. 21

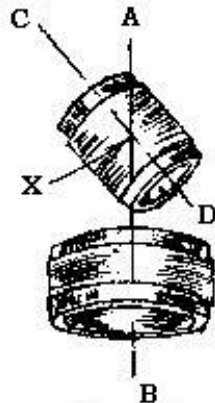

Fig. 22

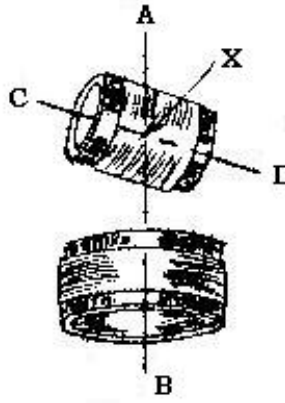

Fig. 23

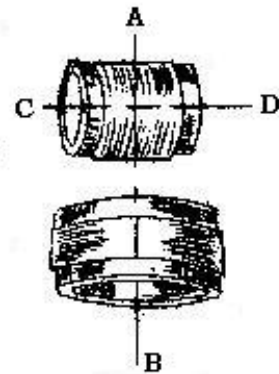

Fig. 24

22. This greater angle reduces the amount of mutual inductance which here is about one third as much as it was in fig. 21. The greater the angle between

The coils, the fewer lines of force from one of them can cut the conductors of the other.

In Figure 24 The axes "A-B" and "C-D" cross each other at a right angle, they make a square corner. This is the position of least possible mutual inductance between any two coils. If the axes of one crosses the axis of the other, and If the crossing is a right angle, very few lines from one coil will generate voltage in the other.

COUPLING.

When any two circuits are arranged so that the change of current flowing in one causes voltage in the other, the two circuits are said to be "coupled." With two coils having mutual inductance, change of current in one of them causes lines of force which cut the conductors of the other coil and generate a voltage in that the other coil. Therefore, two such coils are coupled and have coupling with each other.

All of the pairs of coils in Figure 13 to 24 are coupled by means of the lines of force which are "mutual" to both or which cut through the conductors of both. This coupling effect is due to the inductance of the coils because the inductance produces the lines of force which do the coupling. For this reason we call these couplings by the name "inductive coupling".

If you take the two coils separates by a great distance from each other, each one alone has self-inductance – it is capable of generating a voltage within itself. If you move these two coils towards each other they will commence to have mutual inductance. The closer they are brought to each other, the more the mutual inductance between them.

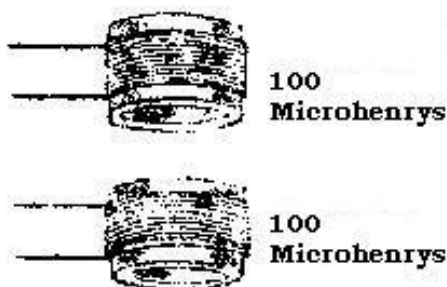

Fig. 25

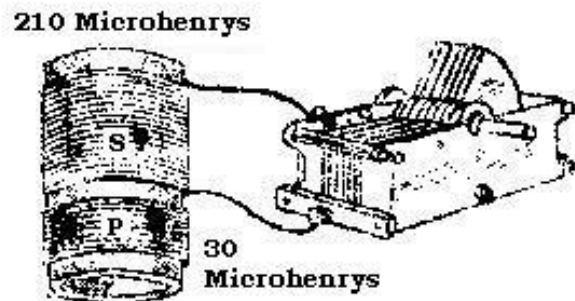

Fig. 26

The two coils then have their self-inductance and also have mutual inductances. The total amount of inductance is then more than the sum of the two self-inductances; it is the sum of these separate inductances plus the mutual inductance. You might take the two coils of Figure 25, each having a self-inductance of 100 microhenrys, and couple them as shown. Upon measuring the inductance of each coil you might find that it had increased to 130 microhenrys and in place of the combined inductances being 200 microhenrys (100 plus 100) it would be 260 microhenrys. The increase is due to mutual inductance which is added to the inductance of each coil.

Suppose you built the tuning coil marked "S" in Figure 26 and connected it to the

tuning condenser. Before adding the primary coil "P" though, inductance of the secondary "S" might be 210 microhenrys. But just the minute you added the primary with its own microhenrys, the mutual inductance would get to work and in place of the 210 microhenrys of the secondary you would have something more than 210 microhenrys, you would have added the mutual inductance to the original self-inductance of the secondary and you would change the tuning of the condenser.

Every time you change the coupling and thereby change the mutual inductance between two coils used for tuning a circuit you will change the tuning points of the condenser. If the condenser tunes the circuit to resonance at 600 kilocycles with a dial setting of 80 and you increase the coupling between primary and secondary, you will find that it takes less capacity and you will get the same 600 kilocycles resonance with a lower dial setting.

AMOUNT OF COUPLING.

If two circuits are coupled together so that change of current in one of them makes a considerable voltage in the other one we say that the circuits are "Close coupled" or that the coupling is close or "tight". If change of current in one of them makes only a little voltage change in the other we say that the circuits are "loose-coupled" or that the coupling is loose.

Any device which allows coupling between two circuits is sometimes called a "coupler". This word is more often applied to parts coupling the antenna circuit to the tuned circuits of the receiver than to parts used between two tubes within the set. If the coil "P" in Figure 26 were connected to antenna and ground the whole device, consisting of coils "P" and "S" together with the tubing on which they are wound, could be called an antenna coupler. There is no provision for easily varying or changing the amount of coupling between the two coils in Figure 26, so this particular job could be called a "fixed coupler".

If one coil is mounted, as in Figure 27, so that it may be moved with reference to the other one we can change the amount of mutual inductance and the amount of

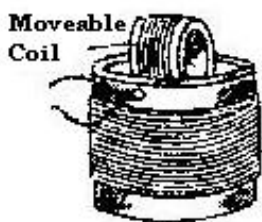

Fig. 27

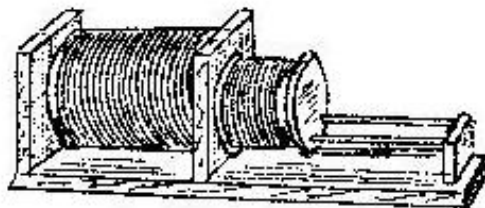

Fig. 28

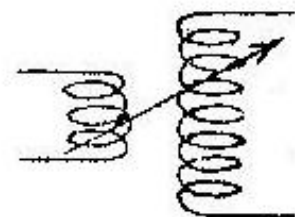

Fig. 29

coupling as was done in Figures 21 to 24. We can vary the amount of coupling and so we call such a device a "variable coupler". The name "vario-coupler" was once used to mean the same thing as variable coupler.

If two coils have the same line for their axes, bringing them closer together along this line will increase the mutual inductance and increase the coupling, while moving the coils further apart will reduce the coupling. A device for thus sliding one coil within another is shown in Figure 28. This is called a "slide coupler".

The slide coupler was used a great deal in some of the early crystal sets, but is now used chiefly for experimental work. The symbol for a variable coupler such as the types shown in Figures 27 and 28 is shown in Figure 29. The symbol shows the two coils with an arrow drawn through them. In radio symbols an arrow always means that the device may be altered while it is being used.

The amount of mutual inductance, and consequently the amount of coupling, depends on the self-inductance of the coil. The more self-inductance, the more mutual inductance and more coupling, with another coil. You also know that the inductance depends on the number of turns, the more turns the greater the inductance. So, by altering the number of turns, we can alter the coupling because we alter the inductance. This is what the device of Figure 30 accomplishes.

In Figure 30 we have a tap switch consisting of a movable arm which may be placed in contact with any one of a number of contact points numbered from "1" to "5". These taps are connected to the switch contacts. Current through the primary flows from "A" to "B". The switch arm is set on contact "3" therefore current flows from "A" goes to the top of the primary winding, then through all the turns between "A" and "3". From tap "3" the current goes over to the switch, through the contact, into the switch arm and to wire "B". we are then using all the primary turns between points "A" and "3" but are not using the turns between "3" and "5". If the primary consists of 25 turns, with 5 turns between each two taps, we have 15 turns working between point "A" and point "3".

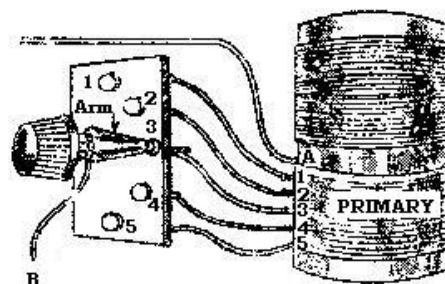

Fig. 30

Now if the switch arm is turned up to point "1", current through the primary can flow only through the five turns between points "A" and "1" on the coil. If the arm is moved all the way down to point "5" we will use the whole 25 turns Between point "A" and "5", because current from "A" must go through all these turns to reach wire "B". Thus moving the switch arm changes the number of turns which carry current and do work. This changes the primary coil's inductance and its coupling with the coil above it. This arrangement, in a considerably refined form, is used in the tuning section of some television receivers.

There are still other ways of using a part of any winding. One method is shown in Figure 3. Here we have a slider contact moved along a part of the winding which is bared of insulation. Current entering through wire "A" will go through the rod, into the slider, and will enter the coil at point "X" where the slider is making contact. This current will then flow through that portion of the coil between point "X" and the right hand end where it flows out through wire "B". The part of the coil between "X" and the left hand end is not used. The amount of the coil being used, or the number of turns being used, depends on the position of the slider. This changes the inductance of the coil and the amount of its coupling; to any other coil.

In certain types of transmitting sets you will find coils made of copper tubing as in Figure 32. Connections to such a coil may be made with a spring clip as used on Wire "A". Then current will flow only in that portion of the coil between the clip and the terminal. All the turns above the clip being unused, or else used in another part of the circuit. This is still another method of varying the amount of coupling. The symbol for couplings such as shown in Figures 31 and 32 is shown in Figure 33. Variable coupling devices are very seldom used in modern receivers, but are frequently found in old sets which you may be called upon to service at some time.

COEFFICIENT OF COUPLING.

The words "Loose coupling" and "close coupling" are not very definite. We have a definite measure of the amount of coupling, a measure which can be calculated. It is called the "coefficient of coupling" or the "coupling factor"

The closest possible: coupling is indicated by the number "1". This is called unity coupling. No matter how close the coupling, no matter how much the mutual inductance, the coupling can never be greater than "1". We indicate less amounts of coupling by decimal fractions. Thus, half as much coupling as unity coupling is indicated by 0.5

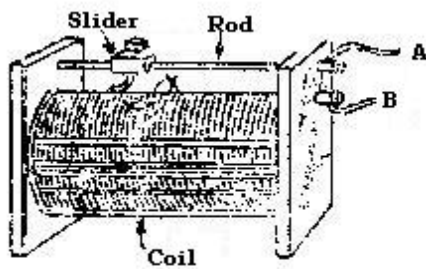

Fig. 31

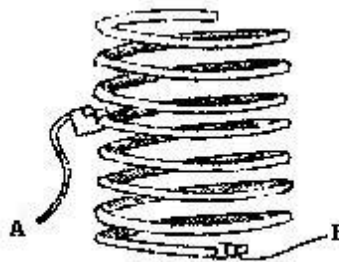

Fig. 32

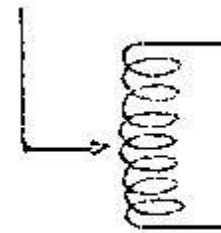

Fig. 33

which is the decimal fraction "five-tenths" or one half. A still smaller coupling would be indicated by the factor or coefficient 0.3, which is three-tenths.

These coupling factors may also be written as percentages. Thus, a coupling of one-half or 0.5 may be written as 50 per cent because fifty per cent of anything is one-half of it. Then a coupling of 0.3 would be 30 per cent and so on.

The official (Institute of Radio Engineers) definition of coefficient of coupling is as follows:-

"The coefficient of coupling is the ratio of the mutual or common impedance component of two circuits to the square root of the product of the total impedance component of the same kind in the two circuits. (Impedance components may consist of inductance, capacity or resistance)".

Following is the formula as arranged for inductive coupling:

$$\text{Coefficient of Coupling} = \frac{\text{Mutual Inductance}}{\sqrt{\text{first inductance} \times \text{second inductance}}} \quad (2)$$

The inductance may be measured in any unit - henrys, millihenrys, or microhenrys. But you must use the same unit all through the formula. If you use microhenrys to measure mutual inductance, you must use microhenrys to measure the inductances of the first circuit and of the second circuit.

Let's calculate the coupling factor for the coils in Figure 34. The left hand winding has an inductance of 32 microhenrys and the right hand one an inductance of 200 microhenrys. Their mutual inductance is 20 microhenrys. Putting these values into the formula, we have:

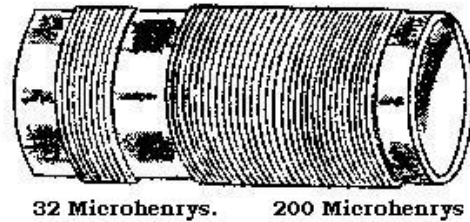

Fig. 34

$$\frac{20}{\sqrt{32 \times 200}} = \frac{20}{\sqrt{6400}} = \frac{20}{80} = 1/4 \text{ or } 25 \text{ per cent.}$$

FINDING THE MUTUAL INDUCTANCE.

In the example just worked out we found the coupling factor to be 25 per cent, But to do this we assumed that the mutual inductance is 20 microhenrys.

There is no simple method of calculating the mutual inductance between two circuits.

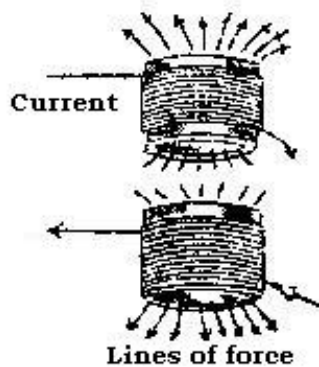

Fig. 35

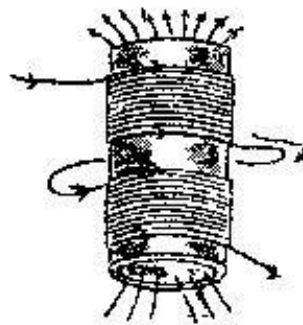

Fig. 36

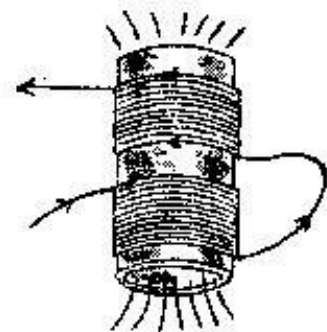

Fig. 37

We generally measure the actual inductances and from them learn the mutual as will be shown.

At the top of Figure 35 current is flowing around the coil winding in the direction shown by the arrow marked "current". This direction of current flow makes the lines of force come out of the top of the coil and re-enter the bottom. At the bottom of Figure 35 the direction of current has been reversed in its flow around the coil. This reverses the direction of the lines of force and now they come out at the bottom of the coil.

In Figure 36 the two coils are connected so that current flows around both of them in the same direction as shown by the arrows. The lines of force generated in one coil add their affect to the line of the other coil. The two sets of lines or the two fields help each other.

In Figure 37 the same are connected so that current flows one way around the top one and the opposite way around the bottom one. Now the lines of force from one coil oppose those from the, other coil because the lines, are trying to travel in opposite directions. If the coils are alike their fields are alike, and the fields balance each other to some extent. This s is called a “series opposing” connection.

In figure 36 we have the self-inductances working together, or adding and also have the mutual inductance of each coil. This means that the actual inductance is made up of the first inductance plus the second inductance plus twice the mutual inductance. In figure 37 we still have the two self inductances adding but the mutual inductance of each coil is opposing the self inductance so the total inductance now is the first inductance plus the second inductance – twice the mutual inductance.

To find the mutual inductance you first make the connection of figure 36, series aiding and measure the total inductance. Say in one case, you find it to be 2240 microhenrys. Then you change the connections to that of Figure 37, series opposing, and again measure the total inductance. It always will be less; say in this case it proves to be 160 microhenrys. Then you subtract the smaller value of inductance from the larger, 160 taken away from 240 and find that the difference is 80 microhenrys. This in the value of four mutual inductances, so you divide. it by 4. The number 80 divided by 4 gives 20 microhenrys as the mutual inductance between those coils.

The equipment necessary for measuring the total inductances in each case, is somewhat complicated so that it is not an easy matter to determine the mutual inductance.

OTHER KINDS OF COUPLING.

We have spent all this time on studying inductive coupling because it is by far the most useful and important coupling which we use in radio. There are, however, other kinds of coupling with which we will become quite familiar later on.

In Figure 38 there are two tuned circuits. One of them has s as its capacity the condenser “C1”, and as its inductance the two coils “L1” and “M”, which, as you can see,

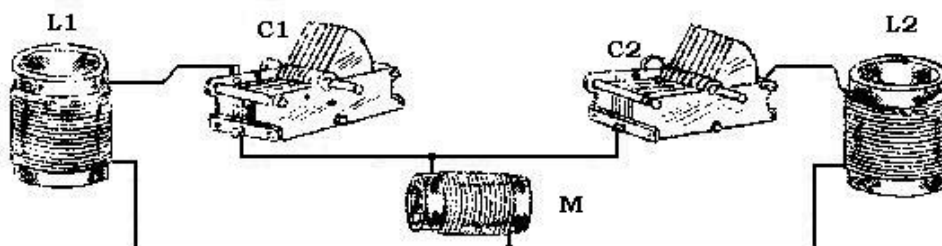

Fig. 38

are connected in series with each and the condenser. The other tuned circuit has as its capacity the condenser "C2" and as its inductance the two coils "L2" and "M" which are connected in series with each other and the condenser. Both tuned circuits contain the coil "M". The inductance "M" is mutual to both circuits and this mutual inductance provides coupling between the circuit containing "L1" and "C1" and the circuit containing "L2" and "C2". This arrangement is called "direct inductive coupling".

A direct inductive coupling is shown in symbols by Figure 39. This is the same circuit as shown in Figure 38, and the parts are similarly marked. The principle of direct inductive coupling is easy to see in Figure 39 and from this diagram you will be able to recognise such coupling when you see similar circuit arrangements in the future.

The circuit of Figure 40 is, with one exception just like that of Figure 39. The exception is that the mutual inductance "M" of Figure 39 is here replaced with a "Mutual Capacity" or a condenser marked "M". Were you to take out the coil "M" of Figure 38 and replace it with a condenser you would have the circuit of Figure 40. This arrangement is called "capacity coupling or capacitive coupling" because a capacity or condenser provides the reactance which is included in, or is common, to both tuned circuits.

The greater the reactance which is common to both circuits, the closer will be the coupling. You know that the voltage depends on the amount of reactance, the more the reactance the greater the voltage drop across it. More voltage means more energetic action and more coupling. So the more reactance, the more coupling.

In Figure 39 we can secure more reactance by using a coil having greater inductance in other words a larger coil. So a larger coil means a greater direct coupling. In Figure 40 we can secure more reactance by using a smaller condenser or one having less capacity. You remember, the less the capacity the greater its reactance. So with capacity coupling, we secure a closer coupling by using a smaller condenser.

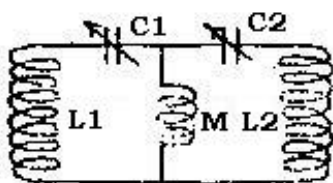

FIGURE 39.

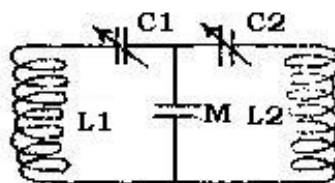

FIGURE 40.

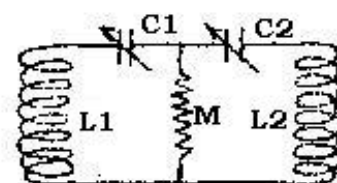

FIGURE 41.

In Figure 41 we have the resistor "M" common or mutual to the two circuits and this makes what we call "resistance coupling". This particular arrangement would not be used in practice because we do not wish to add resistance to tuned circuits. At least, we don't want to add the amount of resistance which would be required to give us a good degree of coupling.

An actual example of resistance coupling is shown in Figure 42. This is a resistance coupled audio frequency amplifier. The same circuit is shown in symbols by Figure 43.

The plate circuit of the left hand tube consists of the plate, the resistor "R", the current source "B", the connection "X", the filament "F1" and the space between filament and plate. The grid circuit of the right hand tube consists of the grid, the condenser "C", the resistor "R", the battery "B", the connection "X", the filament "F2", and the space between filament and grid. The purpose of condenser "C" is to prevent the high voltage the battery "B" from reaching the grid and making the grid positive. The resistor "R" is common to both the plate circuit of the left hand tube and the grid circuit of the right hand tube; therefore, it provides coupling between these two circuits. When we take up the matter of resistance coupled amplifiers we will make a complete investigation of this kind of coupling.

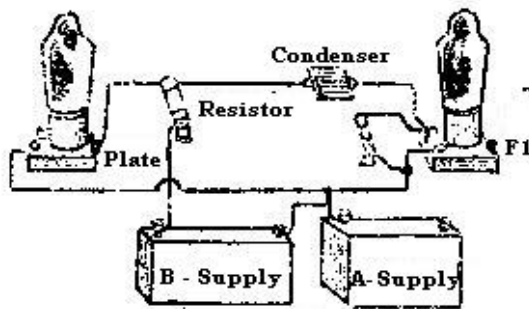

Fig. 42

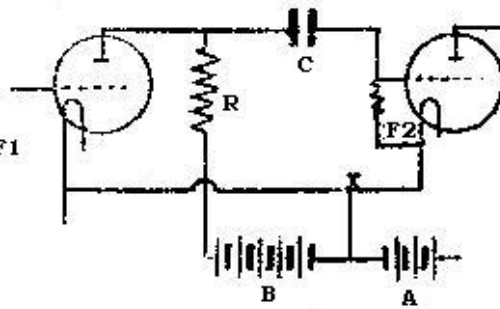

Fig. 43

LITZ WIRE.

From a previous lesson we learnt that the dynamic impedance or gain of a tuned circuit depends on the amount of resistance included in it. The more resistance the less the efficiency becomes. In modern receivers we endeavor to make all parts as efficient as possible, and special material is sometimes used in coils to make the resistance as low as possible.

Generally coils are wound with wire which consists of one strand covered with either enamel or silk insulation, but it has been found that the high radio frequency currents are carried more easily by wire consisting of several strands of very fine wire. Each strand is separately insulated from the others by silk or enamel insulation and all strands are twisted together and wound around with silk to hold them together. This type of wire is known as "Litzendraht" but is more frequently abbreviated to "Litz" wire. Usually 5,7,9 or 11 thin strands are used, but it is possible to obtain Litz wire with other numbers of strands.

A coil can be wound with litz wire to have exactly the same inductance as a similar coil wound with ordinary wire but it will be found that the resistance of the litz wound coil to H.F. currents will be much lower, so that a higher efficiency can be obtained.

IRON CORES FOR R.F. COILS

It is easy to realise that, if a coil can be made to have the desired inductance with only about half the normal length of wire, its resistance will be considerably

less than it otherwise would be.

Earlier in this lesson it was pointed out that the inductance of a coil can be increased by placing a certain amount of iron in the centre of the winding. If we require a certain inductance, to go with a particular tuning condenser to tune to the broadcast range of frequencies, we can obtain the necessary inductance by using fewer turns if we wire them over an iron core instead of using only air in the centre of the coil. The reduction in turns means that less wire will be required and as a result resistance will be decreased.

The type of iron core used in audio frequency or power transformers is not at all suitable for use in R.F. coils there would be tremendous losses which would result in very poor efficiency. To prevent serious losses from taking place, the cores are made of very fine particles of iron mixed together with some binding substance and made either in the form of a small rod or tube in the form of a bobbin.

Figure 44 illustrates the rod or tubular type of core which is usually about $3/8$ " in diameter and about $1/2$ " long. The coil winding could be wound directly on the core, but generally the core is placed inside a piece of insulating tubing and the coil wound on this.



Fig. 44



Fig. 45

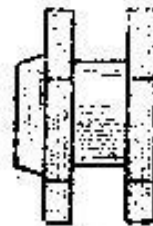

Fig. 46

The bobbin type of core is illustrated in Figure 45 and the parts forming it in Figure 46. The screw at the left of Figure 46 is used for holding the core to the holding strip. In the centre of the bobbin itself and at the right is a screw made of the same material as the bobbin which can be screwed inside the bobbin to vary the amount of iron in the core and consequently adjust the coils inductance.

Losses in the type of iron used in these cores are sufficiently low to permit them to be used in coils carrying any frequency up to the higher end of the broadcast band (1500 K.C.). Coils for higher frequencies than this are wound on ordinary air cored formers.

The formula given in this lesson for finding the inductance of a coil, does not apply to iron cored coils but only to the more usual air cored type. Due to the fact that the inductance depends on the quantity and characteristics of the iron used there is no simple formula for calculating the inductance of iron cored R.F. coils.

DATA SHEET.SHAPE FACTORS.

This is the factor used in formula (1) of Lesson 17 for determining the inductance in Microhenrys of single layer, close wound air core coils.

Diameter Divided by Length.	Shape Factor.	Diameter Divided by Length.	Shape Factor.	Diameter Divided by Length.	Shape Factor.
				6.20	0.280
0.00	1.000	1.9	0.538	6.40	.274
.05	.979	1.95	.532	6.60	.269
.10	.959			6.80	.263
.15	.939	2.00	.526		
.20	.920	2.10	.518	7.00	.258
		2.20	.503	7.20	.254
.25	.902	2.30	.492	7.40	.249
.30	.884	2.40	.482	7.60	.245
.35	.867			7.80	.241
.40	.850	2.50	.472		
.45	.834	2.60	.463	8.00	.237
		2.70	.454	8.50	.227
.50	.818	2.80	.445	9.00	.219
.55	.803	2.90	.437	9.50	.211
.60	.789			10.0	.203
.65	.775	3.00	.429		
.70	.761	3.10	.422	11.0	.190
		3.20	.415	12.0	.179
.75	.748	3.30	.408	13.0	.169
.80	.735	3.40	.401	14.0	.161
.85	.723			15.0	.153
.90	.711	3.50	.394		
.95	.700	3.60	.388	16.0	.146
		3.70	.382	17.0	.139
1.0	.688	3.80	.376	18.0	.134
1.05	.678	3.90	.371	19.0	.128
1.10	.667			20.0	.124
1.15	.657	4.00	.365		
1.20	.648	4.10	.360	22.0	.115
		4.20	.355	24.0	.108
1.25	.638	4.30	.350	26.0	.102
1.30	.629	4.40	.346	28.0	.096
1.35	.620			30.0	.091
1.40	.612	4.50	.341		
1.45	.603	4.60	.336	35.0	.081
		4.70	.332	40.0	.073
1.50	.595	4.80	.328	45.0	.066
1.55	.587	4.90	.324	50.0	.061
1.60	.580				
1.65	.572	5.00	.320	60.0	.053
1.70	.656	5.20	.312	70.0	.047
		5.40	.305	80.0	.042
1.75	.558	5.60	.298	90.0	.038
1.80	.551	5.80	.292	100.0	.035
1.85	.544	6.00	.285		

EXAMINATION QUESTIONS NO. 17

1. Air core coils used in circuits carrying high frequencies, or low frequencies ?
2. If you double the number of turns in a coil, leaving other things unchanged will the inductance be doubled more than doubled or less than doubled?
3. Which will give the greater voltage across the tuned circuit, a large condenser and a small coil or a small condenser and large coil? Why?
4. If three coils have inductances of 50 microhenrys, 100 microhenrys and 150 microhenrys are connected together in series, but have no inductive coupling, what will be their combined inductance?
5. Does the apparent inductance get larger or smaller as the frequency increases?
6. Which will give the greater coupling, separation of one inch or a separation of two inches between the centre of two coils having both their axes in the same straight line straight line? Why?
7. If you turn two coils so that their axes lie in one straight line will the mutual inductance be more or less than with the two axes turned at right angles?
8. If a coil has an inductance of 200 microhenrys and you couple to it another live coil having an inductance of 50 microhenrys, will the inductance of the first coil remain at 200 microhenrys or will it be more or less than this figure? Explain the reason.
9. Which will give the greater voltage in the secondary of a coupler, a coupling factor of 80% or one of 25%?
10. What is litz wire? What is its advantage over ordinary wire?

Please note Postal Address – Cnr. Broadway and City Rd., Sydney – for return of paper, correspondence, etc.

AUSTRALIAN RADIO AND TELEVISION COLLEGE PTY. LTD.

**E. S. & A. BANK BUILDINGS, Corner CITY RD. and BROADWAY, SYDNEY
Telephones: BA4891 and BA4892**

Telegrams "RADIOCOLLEGE" Sydney

This lesson sheet is published for the exclusive use of students of the Australian Radio and Television College Pty. Ltd. (All rights reserved)

Post Lessons to Box 43, Broadway

LESSON NO. 18

AMPLIFICATION – ADDING STRENGTH TO THE RADIO SIGNAL

Amplification is an important subject, because in any radio receiver all but two of its valves are amplifiers. In later lessons you will read much more on this subject when we come to radio frequency amplifiers, intermediate frequency amplifiers, and audio frequency voltage and power supplies. This lesson is a comparatively elementary introduction which will prepare you for the more specialised treatment of individual types later on.

AMPLIFICATION FACTOR.

Were you to apply a pressure of 40 volts to the plate of a valve, you might find that a millimeter in the plate circuit would read about 3 mills as in Figure 1. You could increase the amount of plate current by increasing the plate voltage. Using 60 volts on the plate you might find a current of about 5 mills as in Figure 2. It required a change of 20 volts (40 up to 60) in the plate circuit to raise the plate current 2 milliamperes.

In Figures 1 and 2 the grid circuit comes through the coil to the negative filament terminal of the valve, therefore the: grid has a zero grid bias. In Figure 3 we have inserted a small battery in the grid circuit. This battery raises the grid voltage by $2\frac{1}{2}$ volts. Now, with only the original 40 volts on the plate there is a plate current of 5 milliamperes, The $2\frac{1}{2}$ volt change in grid voltage has produced just the same change in plate current that was produced by a 20 volt change on the plate itself.

It took eight times as much change of plate voltage as of grid voltage to produce a given change in plate current. The 20 volts plate change divided

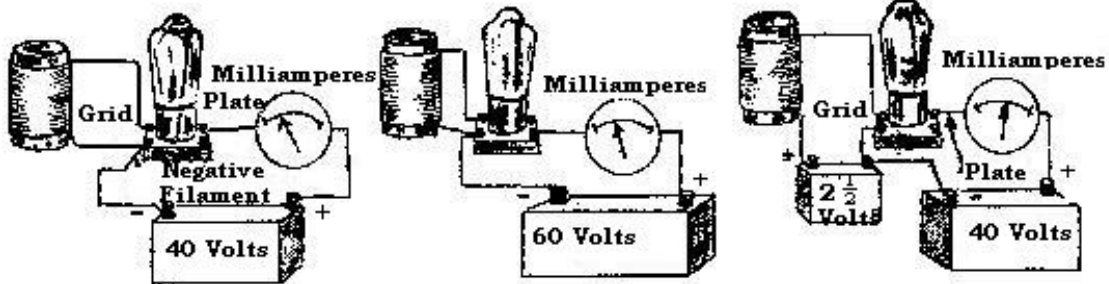

FIGURE 1.

FIGURE 2.

FIGURE 3.

by $2\frac{1}{2}$ volts grid change equals 8, or 8 times $2\frac{1}{2}$ equals 20. So we say that the amplification factor of this tube is 8.

You can see what a great advantage we gain by applying the signal voltage to the grid of a valve. A very small voltage on the grid releases or controls a whole lot of energy in the plate circuit. This energy comes from the B-Battery or from any power unit which supplies plate current to the valve.

A valve may be built to have almost any amplification factor desired. Some of the common types have factors as low as 3 while others have an amplification factor or a "mu" of 1000 and more. The less space there is between the wires of the grid the greater will be the "mu" of the valve because the electrons have to come closer to the grid wires in getting through from filament to plate. The smaller the diameter of the wire used for the grid the greater will be the amplification factor. The greater the distance between grid and plate, the nearer the grid is brought to the filament, the greater will be the grid's control of plate current and the greater the amplification factor.

Why use two valves, each with an amplification of 8, when we could apparently, obtain more amplification with only one valve with a "m" of 1,000? There are many reasons why, in some cases, it is preferable to use two valves to do the work of one, all of which will be explained in the more advanced lessons. Suffice it to say here that, as a general rule, the higher the amplification factor of a valve the smaller will be its permissible grid voltage swing before running into grid current on the one hand and down to the bend of its curve on the other. As a consequence, the very high "mu" valve may, in certain circumstances, be badly overloaded by its input signal, necessitating the use of another type which, while accepting a larger input signal voltage, will not amplify to the same degree.

VOLTAGE AMPLIFICATION AND POWER AMPLIFICATION.

The amplification we have been talking about so far has been voltage amplification. We have been getting a higher voltage drop in the plate circuit than that which is applied to the grid circuit of the valve. Voltage amplification is very fine in the radio frequency amplifying stages, it is fine in the detector stage and it is what we want in the audio frequency stages immediately following the detector. But high voltage alone will not operate a loudspeaker satisfactorily. To operate the speaker we must have power.

To operate the modern types of speakers with plenty of volume and with good tone quality under all conditions calls for about 3 watts of power. Having even more than 3 watts available will make for still better results. The "watt" is the unit of electrical power.

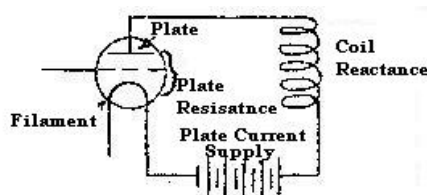

FIGURE 4.

VOLTAGE AMPLIFICATION.

The voltage amplification given by a valve depends on the "mu" or amplification factor. The amplification factor is the greatest multiplication of voltage you could possibly get under ideal conditions. It is the valve's limit of amplifying ability. In actual practice you can never quite reach this limit. Let us find out why.

In Figure 4 You will see a plate circuit including the valve itself, a source of plate current (such as a B-battery) and a coil which, as you know, has reactance. Change in plate current, or alternating current in the plate circuit, is opposed chiefly by the coil's reactance and by the resistance of the space between the valve's plate and

Filament. The opposition met with by alternating current in passing between the plate and the filament is called the "plate resistance" of the valve. In this circuit we have two large amounts of opposition to the plate current variations, the plate resistance and the coil reactance. Both of these are measured in ohms. The resistance of the wiring and of the battery or other source of plate current may be neglected because they are so very small.

In place of Figure 4 we can draw out the equivalent circuit of Figure 5 where the plate resistance is represented by the symbol for a resistance and where the coil's reactance is represented by another symbol for resistance. If current flows around this circuit of Figure 5, it will have to overcome these two resistances just as in Figure 4. Current flowing in the plate circuit would have to overcome the plate resistance and the coil reactance.

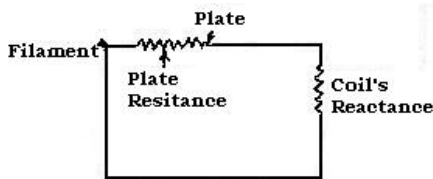

FIGURE 5.

You know that a flow of current through a resistance or through a reactance produces a drop of voltage across the resistance or across the reactance. Then let us take a circuit in which we have a plate resistance of 10,000 ohms, a coil reactance of 10,000 ohms and a current change of 10 milliamperes. According

to Ohm's Law, the voltage drop is equal to the ohms times the amperes. A current of 10 milliamperes is equal to 10/1000 ampere or to 1/100 ampere. So we must multiply 10,000 ohms by 1/100 ampere and we get as a result the number 100, which is the voltage drop across the resistance and across the reactance.

If you look back at Figure 4 you will realise that the only part useful to us in getting amplification from the valve or in making use of any voltage step-up in the plate circuit is the coil. The voltage drop across the coil's reactance is useful, because we can get at it to connect it up to something else. But the voltage drop across the valve's plate resistance is wasted because we cannot get in there to apply that voltage to anything else. Then, going back to the above example, the 100-volt drop across the coil reactance is useful and the other 100-volt drop across the plate resistance is lost.

Another example. Let us have the same plate resistance as before and increase the coil's reactance to 20,000 Ω double it. Assuming the same current change we will get the same voltage drop across the plate resistance, 100 volts, but we will get twice that drop, or 200 volts, across the increased reactance.

Suppose, in place of increasing the coil's reactance, we lowered it. The plate resistance is 10,000 ohms but the outside reactance is only 100 ohms. With the same current change of 10 mills or 1/100 ampere, multiplying the amperes by the ohms we multiply 1/100 by 100 and find that there is only one volt drop across the coil reactance. This one volt is not going to do much for us. Now you can see that the greater the external reactance or resistance is made, the greater will be the voltage drop across it and the greater will be the actual voltage amplification. The amplification depends on two things - on the "mu" of the valve and on the reactance or resistance in the valve's external plate circuit. It also depends on the valve's plate resistance.

In the first example the total voltage drop in the whole circuit divided evenly between the tube and the coil. In the second example we found one third the total voltage in the tube and two-thirds in the coil. In the third example we had one hundred times as much voltage lost in the tube as was made useful across the coil.

Let us use a tube with lower plate resistance, say 2000 ohms resistance between plate and filament, and a coil with 10,000 ohms reactance and have the same: 10 mils or 1/100 ampere current change. This arrangement would give a drop of only 20 volts in the tube and a drop of 100 volts across the coil. We now have five times as much useful voltage as lost voltage because of using a tube with lower plate resistance.

In all those circuits only so much work will be done for a given amount of power applied. We can get the work done inside the tube, where it does us no good, or we can get it done outside the tube where we can use it to good advantage. The proportion of the work which is useful depends on the relation between the plate resistance and the external reactance or resistance. The greater the external reactance and the less the tube plate resistance, the greater will be the available voltage and the greater the actual voltage amplification.

All of this can be put down in a formula, thus:

$$\text{Voltage amplification} = \frac{\text{Mu} \times \text{External impedance}}{\text{External Impedance} + \text{plate resistance}} \quad (1)$$

The term "electrical impedance" has been used rather than the reactance or the resistance. The impedance is the combination of the reactance and the resistance, in their opposition to alternating current. For practically all the work in amplification the ohmic resistance of the coils is so small in comparison with their reactance that we can just go ahead and use the number of ohms reactance without waiting to figure out the impedance. Of course, to be very exact, we should use the impedance value.

EFFECT OF FREQUENCY ON AMPLIFICATION.

Do you remember the two things which determine the reactance of a coil? They are the coil's inductance and the frequency of the applied voltage. Now, since the amplification depends on the reactance and the reactance depends on the frequency, then the amplification must depend on the frequency.

$$\text{Reactance in ohms} = \frac{\text{Cycles} \times \text{henrys inductance} \times 1000}{159}$$

Let us consider a circuit of a tube and a transformer. The tube's "mu" is 8½ and its plate resistance is 10,000 ohms. The transformer inductance is 100 henrys. We will calculate some amplification values. Say we are interested in a very low note, one of 100 cycles; also in one near "middle C" (about 250 cycles) and in a violin note of 3000 cycles. Because we are now interested chiefly in the tube, we will assume that the transformer's inductance remains, the same at all these frequencies in spite of the fact that there is really a slight change in its apparent inductance.

Now for the first frequency, the one of 100 cycles: putting the values in the reactance formula we have:

$$\frac{100 \text{ (cycles)} \times 100 \text{ (henrys)} \times 1000}{159} = 63,000 \text{ ohms reactance (approximately)}$$

For the 250 cycle frequency we have:

$$\frac{250 \text{ (cycles)} \times 100 \text{ (henrys)} \times 1000}{159} = 157,000 \text{ ohms reactance (approximately)}$$

And for the high frequency of 3000 cycles:

$$\frac{3000 \text{ (cycles)} \times 100 \text{ (henrys)} \times 1000}{159} = 1,890,000 \text{ ohms reactance (approximately)}$$

Now we have the following reactances:

Reactance at 100 cycles - 63,000 ohms
Reactance at 250 cycles - 157,000 ohms
Reactance at 3000 cycles - 1,890,000 ohms

These reactances can be used in the formula numbered (1) to find the voltage amplifications. At 100 cycles we would have:

$$\text{Voltage amplification} = \frac{8\frac{1}{2} \text{ (tube's } \mu) \times 63,000 \text{ (external reactance)}}{63,000 \times \text{(external reactance)} = 10,000 \text{ (plate resistance)}}$$

Working this example out we find that the amplification is about 7-3/10

Then we can take the same formula and substitute the reactances for the other frequencies. Here are the answers for all three frequencies:

Voltage amplification at 100 cycles, approximately 7-3/10

Voltage amplification at 250 cycles, approximately 8

Voltage amplification at 3000 cycles, approximately 8½

Now you can see that the higher the frequency, the greater the reactance, and the higher the amplifications. You can never get the full “mu” of the tube in voltage amplification because some of the voltage is always lost in the tube's plate resistance. But the higher the external impedance or reactance the closer you can come to this ideal amplification.

GRID RETURN.

The grid return of a tube is the point at which the direct current grid circuit is connected to the tube's filament circuit or to its cathode circuit. Fig. 6 shows the grid return to the negative side of the tube's filament. You can always find

the grid return point by starting at the grid itself and following the path which could be followed' by direct current until you reach either the tube's filament or the connection of its cathode. The cathode is the part of an A.C. heater type tube from which electrons are set free.

In following the grid circuit on its way to the grid return point, remember that direct current cannot pass through a condenser. You have to go through wires, coils, resistors and other conductors of direct current. In Fig. 7 the grid return is to the positive side of the filament. In Fig. 8 the grid return is through a C-Battery to the valve's filament.

The grid return to the cathode of an A.C. heater valve is shown in Fig. 9. In Fig. 10 there is a condenser between the grid and the coil in its high frequency circuit. Consequently, direct current could pass only through the resistor and this resistor forms part of the grid return circuit.

The point to which the grid return is made determines the bias voltage placed on the valve's grid. In Fig. 6 it has a zero bias because the grid return is made to the negative end of the filament. The valve in Fig. 7 is using a positive grid bias because the grid return is to the positive side of the filament. The valve in Fig. 8 has a negative grid bias because the grid return is made to the negative side of a C-Battery. In Fig. 9 the grid has a zero bias because its return is made directly to the cathode which corresponds to the negative side of an ordinary filament. The valve in Fig. 10 has a zero bias because the resistor in the grid return circuit connects to the negative side of the filament.

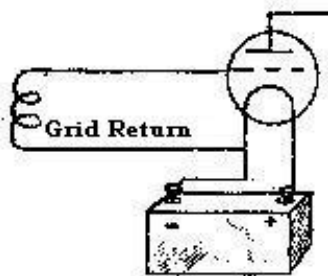

FIGURE 6.

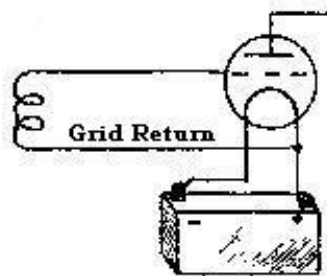

FIGURE 7.

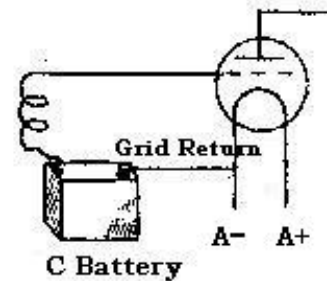

FIGURE 8.

The grid bias voltage is the difference between the potential of the negative side of a filament or the potential of a cathode and the potential of the point to which the grid is connected. If the grid return point is at a voltage higher than that of the negative filament or the cathode, then the grid has a positive bias. If the grid return is to a point at a voltage lower than the negative filament or the cathode, then the grid has a negative bias. If the return is to the negative side of the filament or directly to the cathode, then the grid has no bias or has a zero bias.

SOMETHING ABOUT DISTORTION.

Many times you have heard the word “distortion”. What does it mean?

In Fig. 11 the wavy line represents the alternating voltage applied to the grid of a valve and another similar line represents the amplified voltage in the plate circuit. The rises and falls of plate voltage are equal to each other, just as the rises and falls on the grid side are equal. The frequency is the same on both sides. The only change is in the strength of the signal there is no distortion.

In Fig. 12, the changes in the plate circuit side are not true reproductions of those on the grid side. The rises of plate voltage are not as great as the falls in plate voltage. Music or speech amplified in this manner would not sound right and the result would be called distortion. In Fig. 13 the rises of plate voltage are all out of proportion to the falls in plate voltage, and again we have distortion.

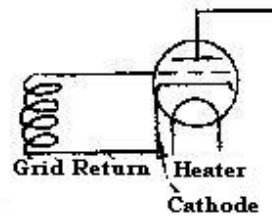

FIGURE 9.

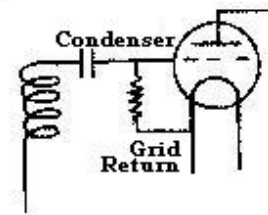

FIGURE 10.

If a true signal voltage is applied to the grid of a valve and if the reproduction of this signal in the plate circuit is not like the input voltage (except for being stronger) then we have distortion. This is true when the valve is being used as an amplifier. Of course the detector is different - it takes in radio frequency and gives out audio frequency

Correct grid bias will prevent most forms of distortion which may arise in an amplifying valve.



FIGURE 11.

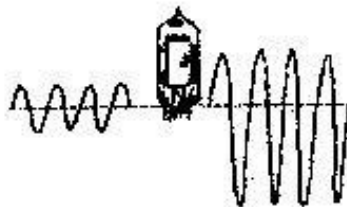

FIGURE 12.

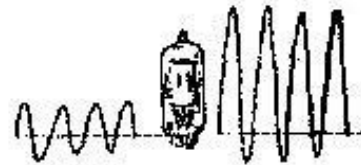

FIGURE 13.

You remember from a previous lesson that so long as the grid has a negative potential with respect to the filament or cathode, no electrons are attracted to the grid and no current flows in the grid circuit. While the grid is positive, however, it attracts electrons and there is a flow of current in the grid circuit.

Suppose you were using zero bias and were applying a 2 volt signal to the grid, that is, a signal which first swings the grid 2 volts positive and then 2 volts negative

This signal is shown at the left in Fig. 14. During the positive signal alternations a small grid current flows, but while it is negative no current flows, this gives a pulsating current in the grid circuit as shown at the centre of Fig. 14.

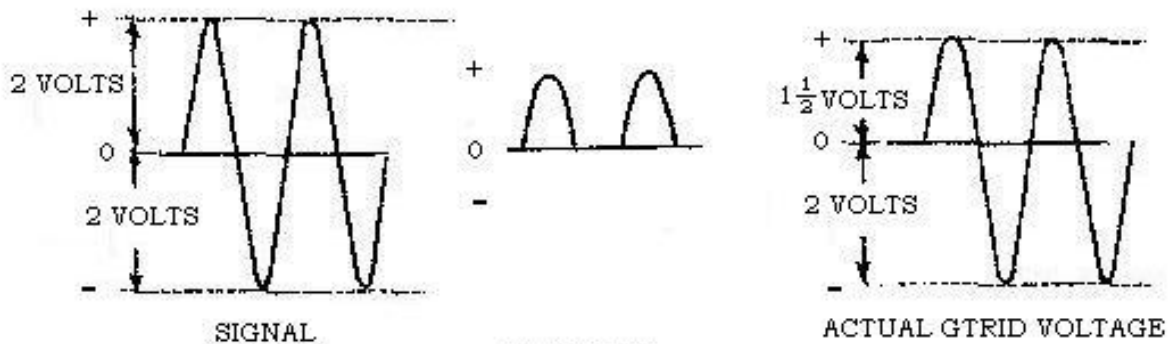

FIGURE 14.

It requires an expenditure of energy to force current to flow through the high resistance between grid and filament inside the valve when the grid is positive. When the grid is negative no such energy is required. It is the previous valve's plate circuit which has to supply the lost energy. Unfortunately this valve is not capable

of delivering much power, and if you attempt to take energy from its plate circuit to supply the grid of a following valve it fails to do its job. The result is that the voltage in its plate circuit falls off when energy is taken from it, and of course the voltage supplied to the grid of the next valve also falls off. Now this only occurs when the grid of the second valve is positive, so the decrease in voltage only happens on the positive signal alternations and not on the negative.

The result is shown at the right in Fig. 14. Instead of the grid going 2 volts positive as it should do, it only goes up to 1½ volts positive. Yet the negative alternations are unaffected, and the grid still goes 2 volts negative. Instead of having an equal rise and fall of grid voltage, it falls more than it rises. The result is that the signal is distorted even before it gets into the valve we are considering.

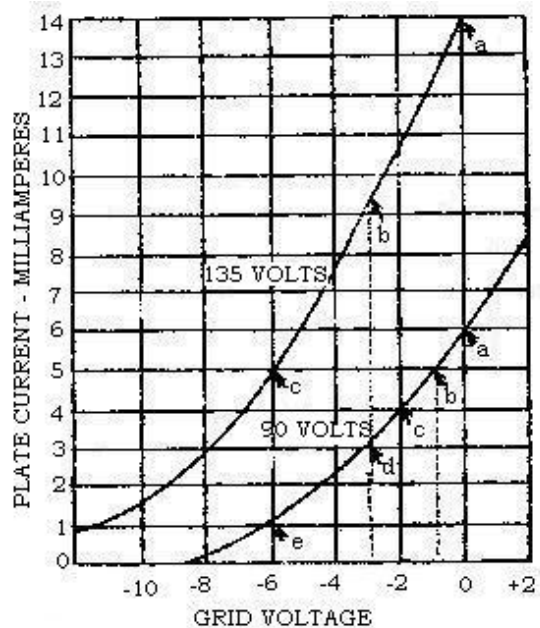

FIGURE 15.

GRID VOLTAGE.

This kind of distortion, due to grid current, really occurs in the previous valve, but the remedy lies in preventing the grid of the second valve from ever becoming positive. This can be done by applying a negative

bias at least as great as the strongest signal voltage to be handled by the grid. Then the signal just makes the grid alternately more negative and less negative. Since the grid is never positive no grid current flows and there is no distortion due to this cause.

In Fig. 15 are two curves for a valve on the same graph. One of them, the one lower down, shows the relation between grid voltage, and plate current when the plate voltage is 90. The other one higher up, shows the relation for 135 volts on the plate.

Look at the 90-volt curve in Fig. 15. At zero grid bias (point "a") the plate current is 6 mils. At 1 volt negative (point "b") the current is 5 mils. At 2 volts negative (point "c") it is 4 mils. At 3 volts negative (point "d") the plate current is 3 mils. So far we have one mil drop in plate current for each volt drop in grid voltage. But now, continuing on down, the curve commences to change its slope. From negative 3 volts down to negative 6 volts (point "o") the current drops from 3 mils to 1 mil, a change of 2 mils for 3 volts in place of one mil per volt as before.

Now suppose we put a steady negative grid bias of 3 volts (point "d") on the tube of Fig. 15 with 90 volts on the plate. If the incoming signal swings 3 volts positive, it will compensate for the grid bias and the actual voltage on the grid will rise to zero (point "a"). The 3-volt positive signal will increase the plate current from 3 mils to 6 mils.

Then, if the signal voltage swings evenly positive and negative, it will change over to 3 volts negative. This will add itself to the steady grid bias and the grid voltage will become 6 volts negative (point "e"). At 6 volts negative the plate current (as shown on the 90-volt curve) will become 1 mil. With even swings of signal voltage, 3 volts each way, the plate current will rise 3 mils (from 3 to 6) but will drop only 2 mils (from 3 to 1). This means distortion. Evidently the 3-volt steady bias is not the right one.

From the foregoing it will be seen that the total swing of signal voltage must be kept on a straight part of the grid-voltage, plate-current curve. Otherwise we will have distortion. The straight part of the 90-volt curve in fig. 15 extends from zero (point "a") down to 3 volts negative (point "d"). The steady bias voltage must be in the middle of the straight part, or at $1\frac{1}{2}$ volts negative. Then, with a signal that swings no more than 12 volts each way, up and down, the changes of plate current will be equal on both swings.

Now it is quite evident that the greatest signal voltage which may be amplified without distortion when 90 volts is applied to the plate is a signal of $1\frac{1}{2}$ volts. A stronger signal will result in distortion because it either will have to make the grid voltage become positive or else it will force it down to the part of the curve where the slope is changing rapidly.

The way we show an action of this kind is illustrated in Fig, 16. We start off with a regular grid voltage, plate current graph. From the bias voltage which is applied steadily to the grid, we draw a line straight downward, the line "a-e-i" in Fig. 16. On this bias line we draw a line representing the swing of the signal voltage.

In Fig. 16 the signal voltage cycle starts at "a" drops its voltage to 1½ volts negative at "c", then comes back to zero at "e", rises to 1½ volts positive at "g" and goes back to zero at "i".

If you follow upward on the 12 volt bias line you find it crosses the curve at 4½ mils plate current (point "x"). Consequently, with this 1½-volt negative grid bias, the plate current will be 4½ mils. Now, when the grid signal goes to "c", it makes the grid voltage go down to 3 volts negative. Following upward with the arrow on this 3-volt negative line, it crosses the curve at 3 mils plate current (point "y") so the current drops from 4½ mils to 3 mils.

As the signal voltage returns to its own zero at "e", the plate current rises to 4½ mils again because the grid voltage rises to 1½ volts negative. Then the signal voltage swings to 1½ volts positive (its own positive) at "g". This balances the steady grid bias of 1½ volts and the grid

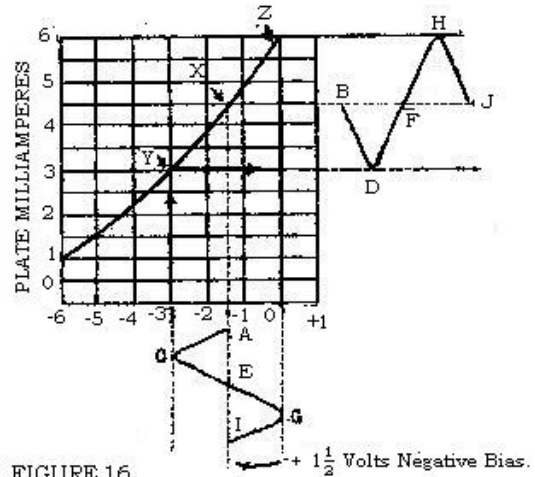

FIGURE 16.

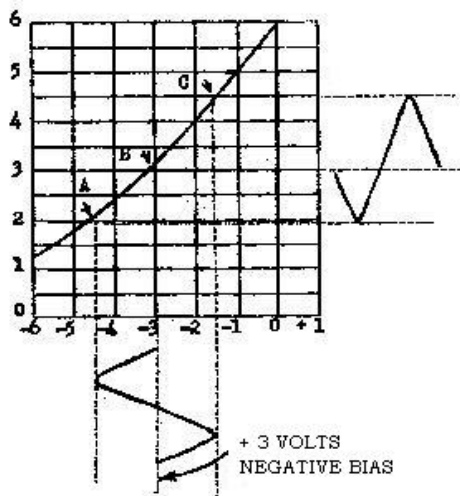

FIGURE 17.

voltage becomes zero. Following upward on the zero voltage line we find it crosses the curve at 6 mils (point "z"). Consequently, the plate current increases to 6 mils.

The resulting plate current curve is drawn at the right hand, side of the graph. With the signal voltage at "a", the plate current is at "b" on its curve. This point is on the 4½ mil line extended out from the graph. Then, with the signal voltage at "c" on its curve, the plate current is at "d" on the 3-mil line extended out to the right. The signal voltage at "e" brings the plate current to "f"; The signal voltage at "g" brings the plate current to "h"; and the signal voltage at "i" brings the plate current to "j" on its curve. Now we will see what happens with a 3-volt negative bias. This condition

is shown in Figure 17. The 3-volt line is extended downward and the signal with its 12 volt swing each way is drawn on this line. As the signal goes negative the plate current drops to a little less than 2 mils (point "a") from its steady point of 3 mils (point "b"). Then, as the signal voltage swings 12 volts positive the plate current rises to 4½ mils (Point "c"). So you see, with a grid swing of 12 volts each way, the plate current drops only a little over one mil but rises a full mil and one-half. The unequal fall and rise of plate current is shown over at the right hand side of the graph. We have distortion caused by too much negative grid bias.

HANDLING STRONG SIGNALS.

All this time we have been handling a signal of 1½ volts, one which swings 1½ volts positive and 1½ volts negative. But suppose we want to take care of a signal of 3-volt swing or a 3-volt signal, what then?

If you were to use a 3-volt bias, as in Fig. 17, so that the positive swing of the signal would not make the grid voltage go over on the positive side, you would have even worse distortion than shown in Fig. 17, because you would be working still further down on the negative side of the curve, where its slope is changing more and more. If you were to keep the 1½ volt bias of Fig. 16, the 3 volts positive of the signal would use up all the original bias and would throw the grid voltage way over onto the positive side.

This positive voltage on the grid would cause an uneven change of plate current, because a positive voltage allows grid current and produces less plate current change than the same amount of negative voltage, as already explained.

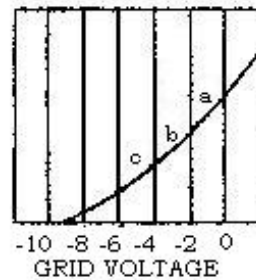

FIGURE 18.

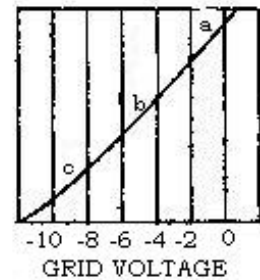

FIGURE 19.

To handle this stronger signal, the one of 3 volts, we must do two things, we must increase the plate voltage on the tube and we must also increase the negative grid bias. If you will look back at Fig. 15 you will see a curve drawn for 135 volts on the plate. In that curve there is an almost straight part from zero grid volts (point "a") at 14 mils, way down to negative 6 volts. (Point "b") at 5 mils.

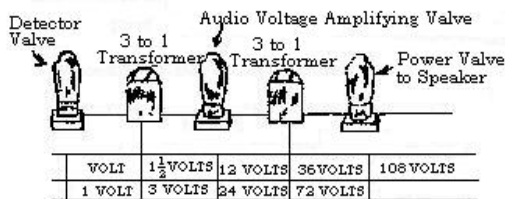

FIGURE 20.

This means that the grid voltage may change from zero down to 6 volts negative and produce equal rises and falls of plate current because all the change will come on the straight part of the curve.

Now, for our 3-volt signal, we can use a 3-volt negative bias. The steady plate current will be about 9½ mils (point "c"). When the signal voltage goes to 3 volts positive the grid voltage will become zero because the bias voltage will be exactly balanced and the plate current

will rise to nearly 14 mils. When, with the signal 3 volts negative the grid voltage will be 6 volts negative and the plate current will drop to 5 mils. There is a change each way of about $4 \frac{3}{8}$ mils in plate current.

The best we could do with the $1\frac{1}{2}$ volt signal was to get a plate current change of 3 mils (from 3 mils to 6 mils in Fig. 16). With the 3-volt signal and the proper plate voltage and grid bias we are able to get a plate current change of $8\frac{3}{4}$ mils (from 5 mils to $13\frac{3}{4}$ mils in Fig. 15). We not only have a great deal more change in current, but we are operating with higher voltages. With more current and more voltage too we are certainly getting a lot more power in watts.

For any valve, there are certain grid biases which correspond to certain plate voltages. When the plate voltage is made high enough to let the signal work on a straight part of the curve, and when the grid bias is equal to the greatest swing of signal voltage, the valve is going to do its best work. Then, and then only, there will be the least possible distortion.

The greatest signal voltage that can be handled is equal to the negative grid bias. Any greater signal will swing the grid voltage over onto a part of the curve that should not be used and distortion will result.

The strength of signal which a valve can handle without distortion depends on the shape of the grid-voltage, plate-current curve. The signal must not extend beyond the straight part of the curve. The length of the straight part depends on the plate voltage - the higher the voltage, the longer the straight part. When we speak of the straight part of the curve, we refer only to the portion which is on the negative side of the zero grid voltage line. The part on the positive side must never be used for the kind of amplifiers generally used in radio receivers.

The grid-voltage, plate-current curve in Fig. 18 is straight from "a" to "c", from zero down to 4 volts negative. Then the signal voltage may be allowed to swing between these points. The centre of the swing must be at "b", at the centre of the straight portion of the curve. As shown in Figs. 16 and 17, the signal voltage swings back and forth on the grid bias line. Consequently, in Fig. 18 we must use a 2-volt

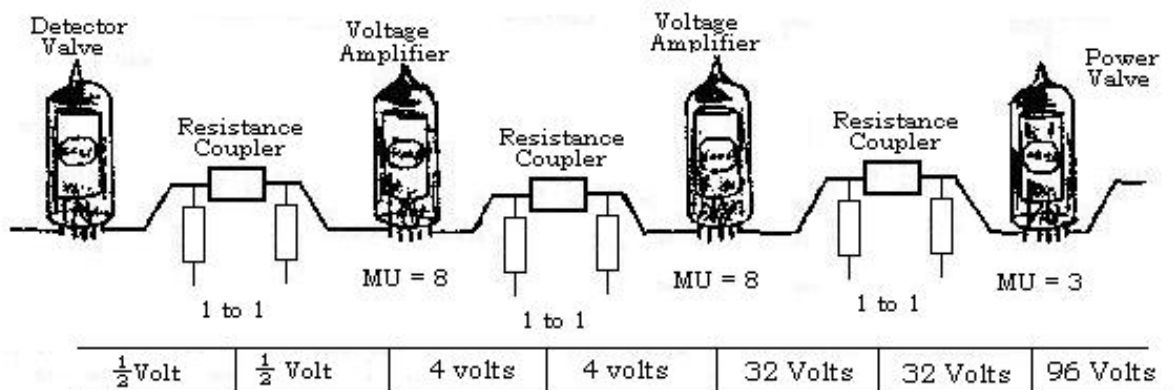

FIGURE 21.

steady grid bias - then the signal can swing up two volts and down two volts always working on the straight part of the curve. The greatest signal that can be handled is one having a swing of two volts positive and two volts negative in other words, a 2-volt signal.

In Fig. 19 the plate voltage has been raised. The grid-voltage, plate-current curve is higher up and its straight portion is correspondingly longer. The straight

portion extends from the zero line at "a" down to the 8 volt negative line at "c". We have 8volts within which to handle a signal. That means the signal voltage can swing 4 volts each way. 4 volts positive and 4 volts negative. To allow this 4 volt swing we will set the steady grid bias on "b", the 4 volt line. Then a 4 volt signal or any signal of less voltage, will stay on the straight part of the curve. A stronger signal, one of higher voltage, will run off the straight part of the curve and will cause distortion.

Now you can see that the strongest signal that can be handled is the one whose voltage is equal to the grid bias. In Fig. 18 with a 2-volt bias we can handle a 2-volt signal. In Fig. 19 with a 4-volt bias we can handle a 4-volt signal. In Fig. 16 with a 1½ volt bias we can handle a 1½ volt signal. This rule assumes that the bias is placed at the centre of the straight portion of the grid voltage, plate-current curve on the negative side of the zero line

Any signal having a voltage smaller than the grid bias will be handled without distortion because such a signal will stay on the straight part of the curve. The grid bias fixes the maximum signal strength.

HOW AMPLIFICATION IS LIMITED.

A type of audio frequency amplifying system which was commonly used at one time, is shown in Fig, 20. Following the detector tube we find a transformer which couples the detector to the audio voltage amplifying tub, then comes another transformer coupling it to the power tube.

Transformers used in audio amplifying systems are capable of stepping up the voltage furnished to them. The amount by which a transformer increases the voltage is called the transformer's ratio. The transformers shown in Fig: 20 are marked "3 to 1" because they multiply the voltage by 3.

We will assume that the detector tube delivers a signal of ½ volt. The transformer steps this voltage up to 3 times ½ making it 1½ volts. The amplification factor of the voltage amplifying tuba is 8½ but we will neglect the fraction and call the "mu" of this tuba 8. Then the 1½ volt signal is multiplied by 8 and comes out as 12 volts. This 12-volt signal is again multiplied by 3 in the transformer and comes to the grid of the power tube with a swing of 36 volts. The "mu" of the power tube is 3, so the 6-volt signal is multiplied by 3 and goes to the loud speaker as 108 volts. We started with ½ volt signal ended with 108 volts, so we multiplied the ½ volt signal by 216. The original signal comes out 216 times as strong so we have in this amplifier an "overall amplification" of 216. This calculation is not very accurate, because we have been making assumptions which are not strictly true.

To the grid of the voltage amplifying tube we applied a 1½-volt signal which this tube has no trouble in handling without distortion. To the grid of the power tube we applied a signal of 36 volts which is safely within the limit of 40½ volts which this tube can handle. So, providing the detector does not deliver a signal of more than ½ volt, this s amplifier will work without distortion.

Suppose the set were tuned in to a powerful local station, making the detector deliver a signal of 1 volt - what then? Then first transformer makes a 3-volt signal the voltage amplifying tube raises it to 24 volts and the second transformer delivers a 72-volt signal to the poor tube. The power tube will not handle anything more than 40½ volts without distortion and the sounds from the speaker are not pleasant to hear. To avoid distortion we would either have to turn down the volume control or use a larger power tube in place of the above power tube. This now power tube will have to handle signals up to approximately 80 volts without trouble.

Now we will take the audio amplifying system shown in Figure 21. Here we use resistance coupling instead of transformer coupling. Resistance coupling provides no step up ratio. As a matter of fact, there is a slight loss of voltage, but we will consider that the voltage is transferred from valve to valve without change. We will consider the detector as delivering $\frac{1}{2}$ volt and since the resistance coupler does not increase this voltage, the $\frac{1}{2}$ volt signal is impressed on the grid of the first audio valve. This valve, with its “mu” of 8, multiplies the $\frac{1}{2}$ volt by 8 and delivers 4 volts to the next coupler. There is no step-up in the coupler, so the second audio valve receives the 4 volt signal, multiplies it by 8 and produces 32 volts. This 32-volt signal is applied to the grid of the power valve and is raised to 96 volts by the power valve's “mu” of 3. No valve is overloaded. The first audio valve receives $\frac{1}{2}$ volt and the second one receives 4 volts on the grid, both voltages being well within the valve's ability to amplify without distortion. The power valve receives only 32 volts, whereas its limit is 44 volts. We have no distortion with a detector output of $\frac{1}{2}$ volt.

We will take another resistance coupled amplifier, the one in Figure 22. Here we have one of the high-mu type amplifying valves. This valve has an amplification factor or “mu” of 30, but in actual practice we can seldom realise an amplification of more than 20, so we will use this value of 20 in our calculation.

Starting as before with $\frac{1}{2}$ volt from the detector, this $\frac{1}{2}$ volt reaches the grid of the high-mu valve through the resistance coupler. The high-mu valve increases the signal to 10 volts ($\frac{1}{2}$ times 20) and the 10 volt signal reaches the grid of the power valve. Now we have only 10 volts for the power valve grid. Not much use using a power valve the same as above, because we have not enough voltage to get the best work out of such a valve. Also, the “mu” of the above power valve is only 3 and we would get only 10 times 3 or 30 volts into the speaker circuit. We will select a more suitable power valve.

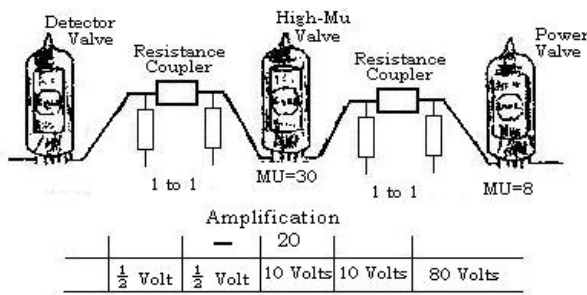

FIGURE 22.

Another power valve has an amplification factor of 8 and will handle signals up to $13\frac{1}{2}$ volts with 180 volts on its plate. This is the valve to use. It handles the 10 volt signal without distortion and delivers 80 volts into the speaker circuit instead of the 30 volts we would have secured with the previous power valve.

Every valve has its particular use. Some of them capable of handling strong signals without distortion. Others have large amplification factors. Some are designed to step-up voltages and are primarily “voltage amplifiers”. Others are designed to deliver considerable power in watts in their plate circuits and are called “power amplifiers”.

POWER AMPLIFICATION.

The power output of a valve, like any other electrical power, is measured in watts. Valve outputs are often measured in milli-watts; one milli-watt being the one-thousandth part of a watt.

The power depends on the voltage change and on the current change, or on the combination of these two things. The output voltage depends on the voltage applied to the valve's grid and on the "mu" or amplification factor of the valve. The "mu" raises the input voltage to the output voltage. The current depends on the plate resistance of the valve and on the impedance of the coils or resistances in the plate circuit. The parts of the plate circuit in which work is done are called the "load". So we call the impedance or reactance of these parts the "load impedance" or the "load reactance".

All of these things can be taken into account by using one formula. Here it is:

$$\text{Watts} = \frac{\text{Load impedance} \times (\text{amplification factor} \times \text{grid voltage})^2}{2 \times (\text{plate resistance} + \text{Load impedance})^2} \dots\dots(2)$$

The top part of this formula says: Multiply the amplification factor by the grid voltage and square the result, then multiply the number you get by the load impedance in ohms. The lower part says to add the plate resistance and the load impedance (in ohms) together and square the result, then multiply that number by 2. Finally, you divide the number you got from the upper part by the number you got from the lower part of the formula and that gives you the number of watts of power in the plate circuit.

The greatest amount of power is obtained when the number of ohms load impedance is exactly equal to the number of ohms plate resistance of the valve. But, strange as it may seem, we do not dare use the greatest possible power because with it we would have a great deal of distortion. Increasing the load impedance reduces the distortion and we find that satisfactory operation is secured when the load impedance in ohms is about twice as great as the valve's plate resistance in ohms. The exact load impedance which is best depends somewhat on various condition of operation, but it is a safe general rule to work on this external impedance as being twice the plate resistance for triode power valves. However, with special types of power valves known as pentodes it is from 1/4 to 1/8 of the plate resistance. Here is a list of the output powers secured from a small and a large power valve according to the formula:

VALVES "A" (Small power valve)

Grid Bias and Signal Voltage	Plate Voltage	Amplification Factor	Plate Resistance	Load Impedance	Power in Watts
16½	90	3	2500 ohms	5000 ohms	109
27	135	3	2200 ohms	4400 ohms	332
33	157	3	2100 ohms	4200 ohms	518
40½	180	2-9/10	2000 ohms	4000 ohms	767

VALVES "B" (Large power valve)

Grid Bias and Signal Voltage	Plate Voltage	Amplification Factor	Plate Resistance	Load Impedance	Power in Watts
9	135	7½	7500 ohms	15000 ohms	67
12	180	7½	7000 ohms	14000 ohms	129
18	250	7½	5600 ohms	11200 ohms	362
27	350	7½	5100 ohms	10200 ohms	894
35	425	7½	5000 ohms	10000 ohms	1530

These two tables will show you some very important things. Notice that the valve "A" will handle a stronger signal without distortion than can be handled by valve "B", Valve "A" will handle up to 40½ volt signals while valve "B" reaches its limit at a 35-volt signal, Yet, on the 35-volt signal, the valve "B" will deliver about twice the power (1530 milliwatts) that "A" will deliver with the larger input voltage.

You might look into a receiver and find a big power valve similar to "B" and you would expect great performance from it. But suppose that big valve were being supplied with only 180 volts on its plate. It would handle signals only up to 12 volts and would deliver only 129 milliwatts of power. The same plate voltage, 180, applied to valve "A" would allow handling a 40-volt signal and would allow an output power of 767 milli-watts. If you have available only 135 volts or 180 volts for the plate, then the "A" valve is far better than the "B" valve. At 135 plate volts, valve "A" will deliver 332 milliwatts, valve "B" will deliver only 67 milliwatts. At 180 volts the comparison is 767 milliwatts against 129 milliwatts.

But, if you want to handle a 33-volt signal and have the voltage available, then the valve "B" will deliver about 1400 milliwatts as against only 518 milliwatts for the valve "A". A big power valve is fine if you can "swing the grid" by applying a strong signal. But if you can bring to the power valve only a weak signal the fact that you use a big valve ahead of the speaker is not going to do you a bit of good. Those are the things a radio serviceman has to look out for. Many and many a time you will find grid biases away off from their proper values. Again and again you will find big valves operating with low plate voltages. Almost all good sets will operate to the satisfaction of anyone if you apply the most suitable valves for each part of the work, then operate those valves with the proper plate voltages and grid biases.

EXAMINATION QUESTIONS -- No. 18 & 18A.

1. How many watts of power will be required to light a filament taking 2 amperes of current with a pressure of 5 volts?
2. In the radio frequency amplifying valves are we interested in voltage amplification or in power amplification?
3. Which gives the greater voltage amplification, a load impedance of 12,000 ohms or one of 5,000 ohms? Explain why.
4. Will lowering the plate resistance of a tube increase or decrease the voltage amplification?
5. Does the voltage amplification of a valve with a transformer coupling increase or decrease with higher frequencies? Why?
6. To allow a valve to handle a stronger signal without distortion, would you raise or lower the plate voltage?
7. With a 3-volt signal and a 3-volt negative bias there is no distortion. If a 4-volt signal must be handled. What is it necessary to do in addition to raising the plate voltage? Why?
8. What is the minimum grid bias for handling a signal which swings 4½volts each way?
9. What is the greatest signal voltage that can be handled without distortion by a valve having 250 volts on its plate and a negative grid bias of 30 volts?
10. If you connect a 240 volt, 1000 watt radiator to a 120 volt power line, how much power is used? Why?

PLEASE NOTE POSTAL ADDRESS:- cnr. Broadway & City Rd, Sydney -
for return of papers, correspondence, etc.