

WESTINGHOUSE

# Engineer

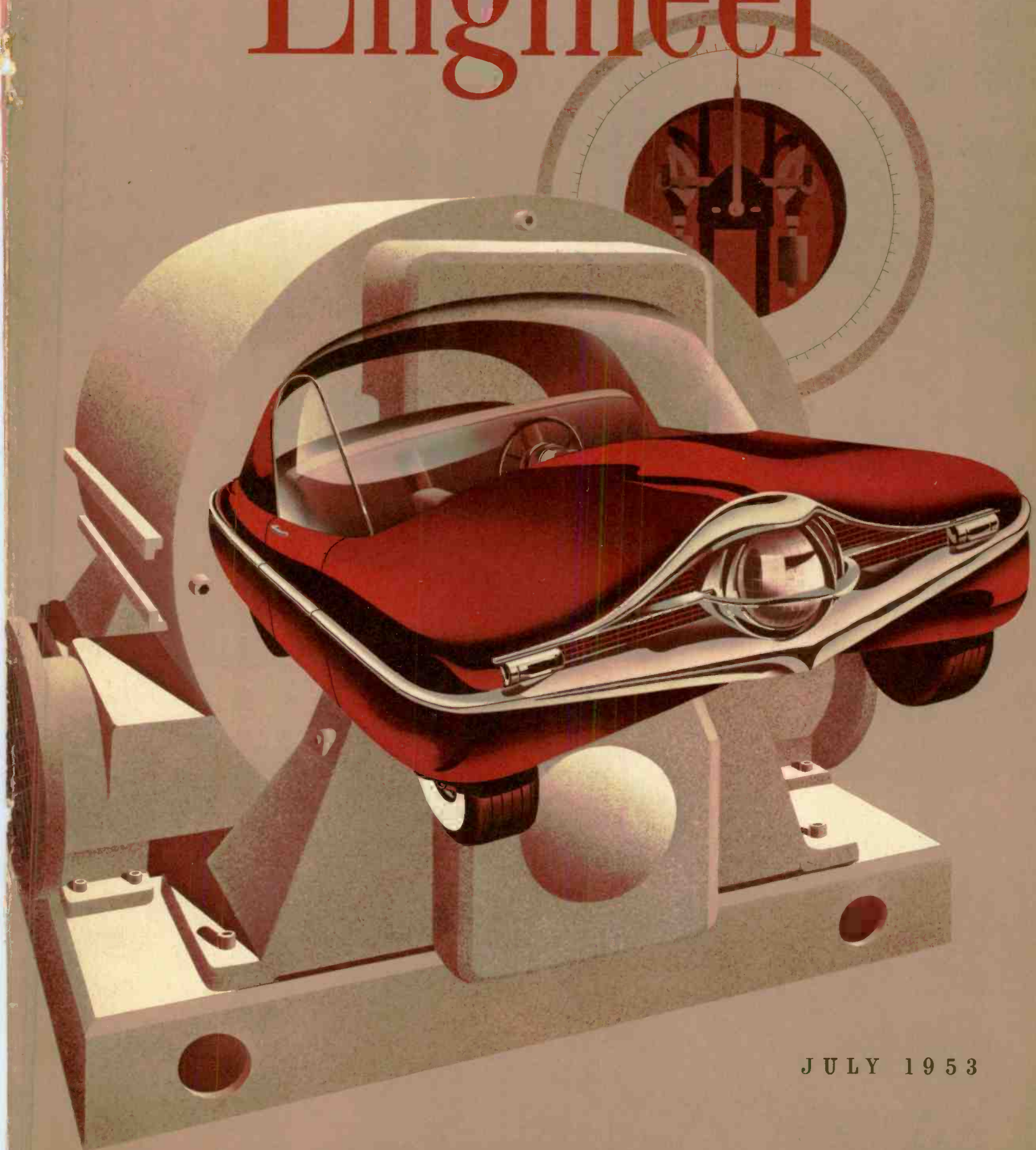

JULY 1953

# The Great Importance of *Almost Nothing*

"We don't know anything about iron, because we have never had any pure iron to study." This statement was made by Dr. J. A. Hutcheson, Director of Westinghouse Research Laboratories. It was made as a way of emphasizing the importance of impurities on the properties of materials, and the tremendous research drive to increase our meager knowledge of the true character of the elements and their combinations.

From the materials engineer's point of view the world was put together as a mixture of 92 elements. He rather grudgingly admits that there are but a few relative concentrations of compounds here and there. Every element in nature is contaminated more or less—usually more—with others. Furthermore, Mother Nature has pretty successfully resisted all efforts to effect complete separation. To make matters worse, in many, many cases an impurity affects the properties of a material all out of proportion to its relative amount.

There are innumerable examples. Research on conduction in gases has shown that the presence of one extraneous atom in one billion of certain gases produces a significant effect.

Semiconductors provide outstanding illustrations of the enormous effect of much less than trace amounts of foreign materials. In general, in selenium, germanium, or silicon used for consistent, high-quality rectifiers, certain undesired impurities must not exceed one part in a million, and the goal—sometimes attained—is an impurity ratio of one part in one hundred million. On the other hand, to obtain the desired elec-

trical characteristics in germanium and silicon rectifiers, selected impurities may be added in concentrations such as one part in a million. Furthermore, this seemingly insignificant amount of impurities must not be haphazardly distributed throughout the parent material. As the scientist describes it, an impurity gradient is necessary, which means to say the impurity atoms must be distributed throughout the base material in a certain fashion. Just the measurement of such incomprehensibly small amounts of impurities calls for methods that go beyond the limits of the spectroscope, heretofore considered about the ultimate in measuring sensitivity. Employed instead is an electrical method, dependent on measuring the Hall effect, in which is calculated the number of electrons per cubic centimeter participating in conduction.

What the impurities are makes a difference, too. In the case of semiconductors, if the impurity element is an atomic relative in the same family as the base element, the electrical conductivity is affected far less than would be the case if the impurity were from a neighboring family. In germanium, for example, a trace of silicon has virtually no effect, whereas infinitesimal additions of arsenic or gallium can change the conductivity by many orders.

Phosphors—which also are semiconductors—for fluorescent lamps are mightily affected by ultra-minute amounts of foreign materials. For example, one tenth of a part per million of copper in certain sulphide-type phosphors reduces the blue emission.

Several years ago, some pure uranium was required for an atomic reactor. In connection with such use, certain impurities, notably boron, must be absent or present in amounts of the order of five parts in ten million. This was required because boron captures neutrons, the particles necessary for the chain reaction.

The production of very low boron content uranium was a struggle because boron is a universal contaminant found in street dust, plaster from walls, and in the dust from cement floors.

During World War II production of badly needed three-element power tubes for radar was encountering baffling difficulties. Rejects were unaccountably high and variable. The difficulty was finally traced to the platinum wire used as the grid. It was discovered that some—but not all—of the suppliers of the platinum wire were using a lubricant

for the rolls that contained traces of calcium. Infinitesimal amounts of this calcium were rolled into the surface of the platinum, causing it to become an electron emitter and destroying its ability to act as a control grid.

Studies of the fascinating phenomenon of super-conductivity in the cold laboratory have disclosed that some metals, whose resistance should drop to zero or a very low value when cooled to within a degree or two of absolute zero, show a tendency to increase and conceivably may become infinite at absolute zero. Why? It's known that micro-trace impurities are to blame.

One metals-research man specializing in molybdenum, when asked about the properties of that important metal, shook his head sadly and replied that "No one knows the properties of pure molybdenum." Using the definition that a material is pure if further reduction of foreign inclusions causes no change in properties, demonstrably pure molybdenum has never been available.

One of the most troublesome of impurities is that of hydrogen in steel. Like the tiny tree root that cracks a granite boulder, hydrogen gas included in a mass of steel slowly works to the surface, greatly accelerated by heat, and can create enormously destructive forces. For example, massive shoes for waterwheel thrust bearings have been destroyed by the hydrogen—over a period of years—rising to the surface and forming blisters in the babbitt.

Possibly the most important and certainly one that is most absorbing of research effort is the study of materials. And here the greatest obstacle in the matter of impurities—impurities in such slight amounts that they might seem to be of no consequence—whereas actually they stand as almost an impenetrable wall between the scientist and an understanding of materials.

We say *almost* impenetrable. But scientists are not willing to admit that it is complete. By ingenious means they are driving wedges into this barrier. By melting of metals suspended electromagnetically in a vacuum they are approaching absolute purity. New techniques permit measurement of impurities of as little as one part in a billion. Substances can be examined at temperatures of less than two tenths of a degree above absolute zero or in atmospheres so rare that the pressure is  $10^{-11}$  mm of mercury—at this pressure the mean free path of molecules is 500 miles. Success comes slowly—but surely. C.A.S.

VOLUME THIRTEEN

JULY, 1953

NUMBER FOUR

On the Side

*The Cover*—Behind the millions of sleek, shiny, and smooth-running automobiles that flow from our production lines each year lies a vast amount of development and testing. An important part of this program is the testing of current models to assure that their performance meets design specifications; also there is the task of perfecting experimental models. A valuable part in this elaborate testing program is played by the dynamometer. It is this role of the dynamometer that artist Dick Marsh suggests on the cover.

•••  
A new turbine generator for the Detroit Edison Company will be one of the largest units ever built. Rated at 260 000 kw, this cross-compound machine will be installed in the River Rouge Station. The turbine will be designed for steam at 2000 psi, 1050 degrees F, reheating to 1000 degrees F.

•••  
Nuclear power will be the feature of the November issue of the Westinghouse ENGINEER. Included will be some of the fundamentals of nuclear physics, plus a discussion of some of the practical problems that are involved in the application of nuclear energy.

•••  
Seven eastern power companies will use an a-c network calculator to be installed in the industrial laboratories of The Franklin Institute in Philadelphia. The new calculator will incorporate 580 circuits to represent generators, transmission lines, transformers, and loads. The circuits will be in two separate units, one two-thirds and the other one-third of the total capacity. The units can be operated separately or together.

In This Issue

DYNAMOMETERS FOR AUTOMOTIVE TESTING ..... 114  
*Frank Slamar and C. P. Croco*

BUS DUCT—THE MODERN ELECTRICAL HIGHWAY ..... 118  
*W. F. Born and J. B. Wallace*

FACTORS AFFECTING SELECTION OF POWER-LINE CARRIER  
(Part II) ..... 121  
*R. C. Cheek*

PERSONALITIES IN ENGINEERING—HARRY C. COLEMAN ..... 124

GENERATOR INSULATION INSPECTION—A PROGRESS REPORT ... 126  
*J. S. Johnson*

CALENDERING LINE FOR RUBBER ..... 128

REGULATORS FOR THE MARINE INDUSTRY ..... 130  
*S. A. Haverstick*

POWER FOR UNDERGROUND MINES ..... 135  
*J. Z. Linsensmeyer and A. G. Owen*

HOLLOW-JET VALVES ..... 140  
*G. H. Heiser*

WHAT'S NEW! ..... 141

Ozone—Dry-type transformer tests—Communication system—A-C brakes—Generator manufacturing facilities expanded.

*The following terms, which appear in this issue, are trademarks of the Westinghouse Electric Corporation and its subsidiaries:*

Odorout, Precipitron, Rototrol, Silverstat, Sterilamp, Visicode

Editor ..... CHARLES A. SCARLOTT

Managing Editor .... RICHARD W. DODGE

Layout and Production ... EMMA WEAVER

Editorial Advisors { A. C. MONTEITH  
J. H. JEWELL  
DALE MCFEATTERS

Published bimonthly (January, March, May, July, September, and November) by the Westinghouse Electric Corporation, Pittsburgh, Pa.

Subscriptions: Annual subscription price in the United States and possessions is \$2.50; in Canada, \$3.00; other countries, \$3.00. Single copy, 50¢. Address all communications to Westinghouse ENGINEER, P.O. Box 2278, 401 Liberty Ave., Pittsburgh 30, Pa.

Indexing and Microfilm: Westinghouse ENGINEER contents are regularly indexed in Industrial Arts Index. Reproductions of the magazine by years are available on positive microfilm from University Microfilms, 313 N. First Street, Ann Arbor, Michigan.

THE WESTINGHOUSE ENGINEER IS PRINTED IN THE UNITED STATES BY THE LAKESIDE PRESS, CHICAGO, ILLINOIS

Below: View of engine test cell from hallway. Duplex plate glass windows permit good vision, but isolate noise of engine room. Right: One wing of Ford Motor Company's new test laboratory. Test cells can be seen on either side of the wide hallway that runs the length of the building. Far right: Control desk for engine test cell. Electrical controls and speed-indicating instruments are located in center. To left and right are devices to control and indicate engine performance. The dynamometer scale is behind the desk.

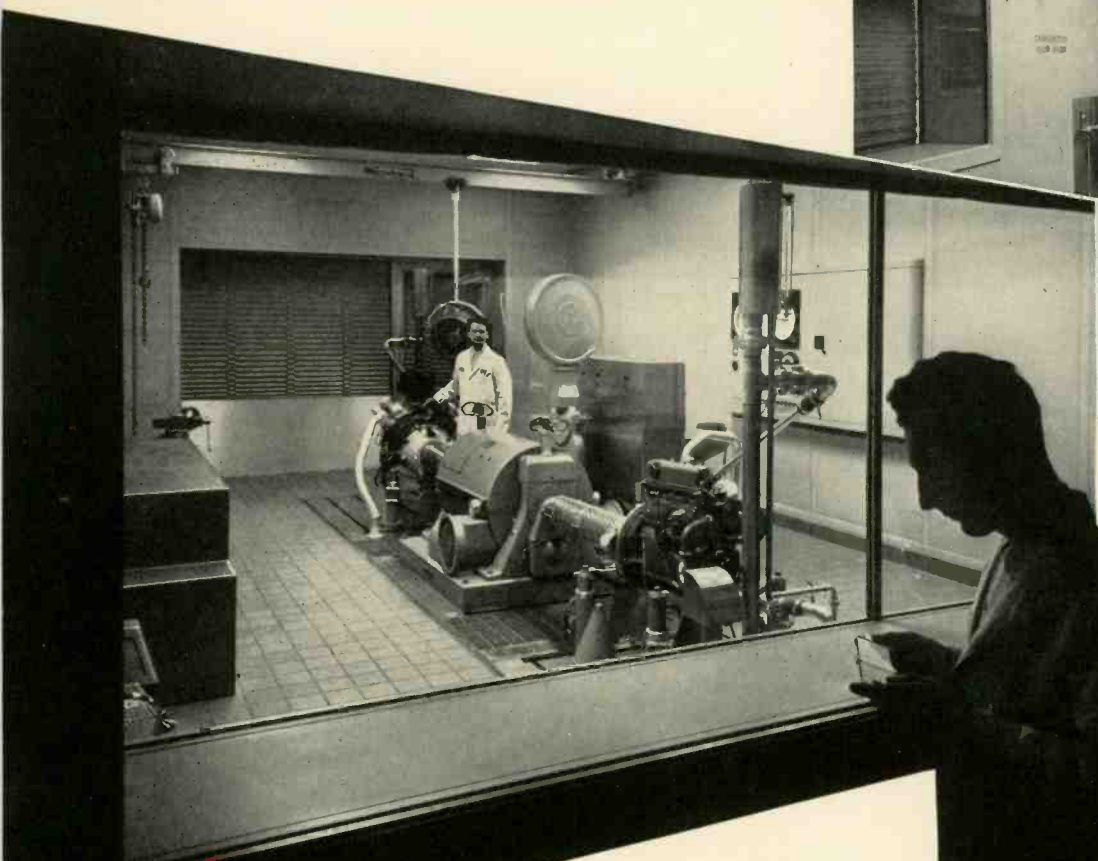

FRANK SLAMAR                      C. P. CROCO  
*Control Eng. Dept.*              *Eng. & Serv. Dept.*  
*Buffalo, New York*              *Pittsburgh, Pennsylvania*  
*Westinghouse Electric Corporation*

As new engine designs increase in horsepower, speed, and compression ratio, automotive engineers are finding it more and more important to measure power output accurately. The dynamometer is meeting this need. In addition, the dynamometer's ability to simulate actual operating conditions has made possible "road testing" in the laboratory.

# Dynamometers for Automotive Testing

THE DYNAMOMETER is applied today in virtually every industry where rotating machinery is tested. It is used for testing prime movers such as waterwheels, steam engines, and internal-combustion engines; driven machines such as pumps, fans and blowers; and power-converting or transmitting equipment such as gearing, transmissions, couplings, differentials, and belting. An accurate, reliable, and flexible device, the dynamometer has proved especially valuable in the automotive industry, where it permits a wide variety of laboratory tests under controlled conditions.

## What Is a Dynamometer?

A dynamometer is a device that measures either the torque delivered by an engine or motor or the torque required to drive a rotating piece of machinery. If the speed in revolutions per minute is measured at the same time, the horsepower absorbed or delivered can be calculated.

The usual electric dynamometer is a d-c or a-c motor with

its frame or stator mounted on trunnion bearings so it is free to rotate (see Fig. 1). Rotation is then prevented by a retarding force, usually a spring or platform scale. The turning force exerted on the stator is measured on the scale in pounds or other desired units. Multiplying this figure by the known length of lever arm of the turning force gives the torque. An accurate speed-indicating tachometer is connected to the dynamometer, since the horsepower calculations can be only as accurate as the speed reading.

Dynamometers are made to measure outputs or inputs from a fraction of a horsepower to thousands of horsepower. While some single-speed, special-purpose dynamometers are made using a-c motors, most dynamometers are d-c devices so they can be operated over a broad speed range; also, by

The authors acknowledge the assistance of several automobile manufacturers in providing background material. Particularly they are indebted to the Ford Motor Company for permission to photograph their new testing laboratory, recently dedicated during their fiftieth-anniversary celebration.

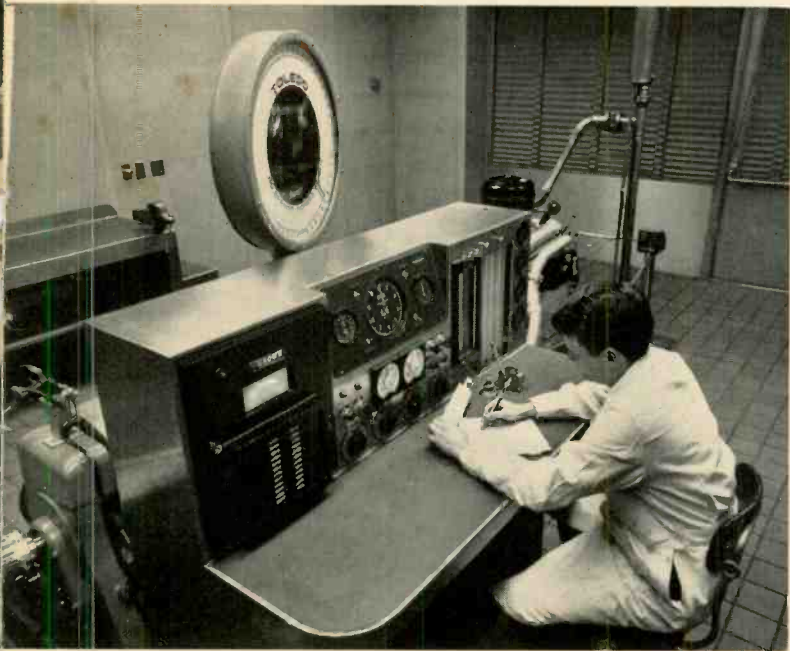

adjusting the armature voltage and field strength, very accurate settings of torque can be made.

The most important part of a dynamometer is the frame. It must be balanced and free to rotate with a minimum amount of friction in the bearings when torque readings are taken. Special trunnion bearings are made using two concentric ball bearings. The races between two rows of balls are fastened together and then geared to a shaft so they can be either rotated by hand or be motor driven. When the bearings are motor driven, they are rotated in opposite directions to cancel out friction drag. When starting or running under load, the stator is locked and is freed only when readings are being taken. This reduces shock to the scale mechanism.

Special linkages connect the dynamometer scale to the knife edge of the torque arm so that the scale will read positive for either direction of dynamometer rotation. Additional knife edges are normally provided on each side of the frame so that known weights can be hung from them to check scale readings. A hydraulic cylinder is sometimes used instead of a scale to restrain the stator. The hydraulic pressure, or the air

pressure necessary to balance the hydraulic pressure, is a measure of the torque exerted by the dynamometer.

A tachometer speed-indicating generator is usually geared to the shaft so that the readings of both rpm and number of revolutions can be made. When special speed-regulating control is required, an additional tachometer generator is belted to the shaft. The error signal from this generator is fed back into the control to regulate the speed.

Dynamometer control varies from a simple manually operated version to complex electronic speed and load control. When more accurate and broader speed ranges are required, a motor-generator set is furnished to supply the power for the dynamometer and variable-voltage control is used. An m-g set is also used when d-c power is not available, or when it is desirable to return power to the line.

### Dynamometer Control

The basic dynamometer control scheme consists of a dynamometer connected to a generator, which is coupled to a three-phase motor. When the dynamometer absorbs power, as in the case of loading an engine, it acts as a generator and delivers the power to the line. When the dynamometer is a source of power, as in the case of driving a pump, it acts as a motor taking power from the line. For the dynamometer to be flexible, it must have a speed-torque characteristic that can easily be made either constant speed or constant torque, or some arbitrary relation between speed and torque. Electronic regulators are well suited to provide these characteristics.

A block diagram of a control scheme using electronic regulators is shown in Fig. 2. The tachometer voltage is compared to the speed reference and the difference is applied to the regulator, which maintains the excitation of the generator at a value that gives minimum speed error. The regulator consists of a voltage amplifier and a grid-controlled rectifier that provides the excitation for the generator. The field current of the dynamometer is regulated at a value determined by the field-current reference. This reference is coupled to the speed reference in such a manner as to provide constant dynamometer field current up to base speed, and then reduced field currents above base speed to maintain constant armature voltage. This type of operation provides the dynamometer with a constant-speed characteristic.

If a characteristic is desired such that the speed drops with load when the dynamometer is motoring, and rises with load

Fig. 1

Fig. 1—Basic parts of a simple dynamometer.

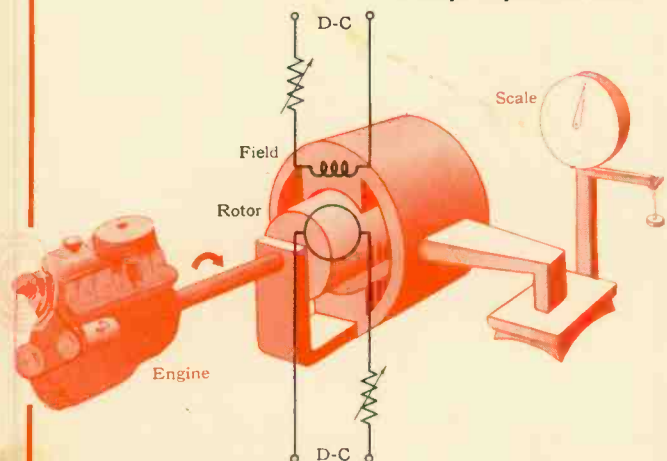
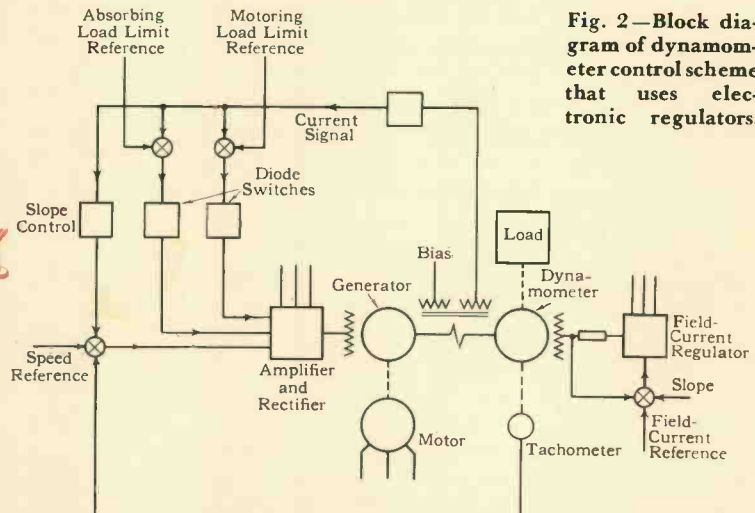
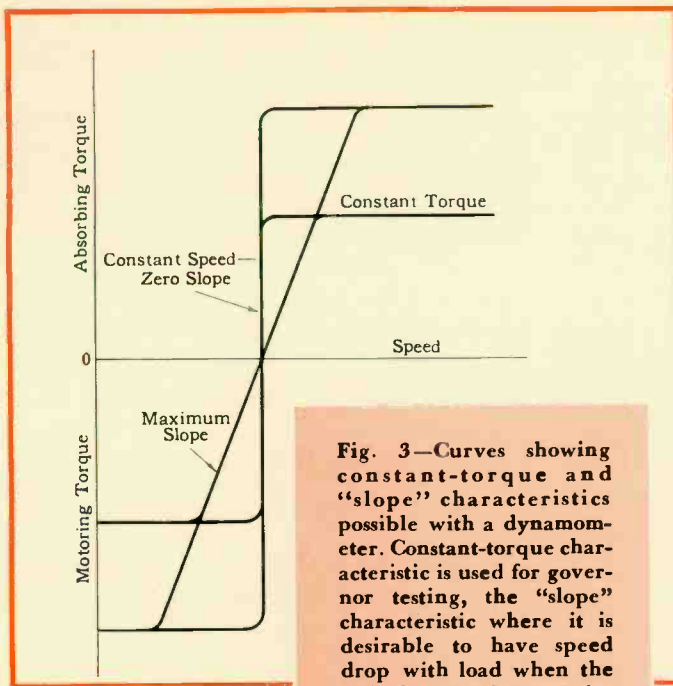

Fig. 2

Fig. 2—Block diagram of dynamometer control scheme that uses electronic regulators.





**Fig. 3—Curves showing constant-torque and "slope" characteristics possible with a dynamometer. Constant-torque characteristic is used for governor testing, the "slope" characteristic where it is desirable to have speed drop with load when the unit is motoring, or increase with load when the dynamometer is absorbing.**

when the dynamometer is absorbing power, "slope" control is added. This control provides a signal proportional to armature current, such that when the dynamometer is absorbing it adds to the speed reference, and when the dynamometer is motoring it subtracts from the speed reference. Changing the slope also changes the dynamometer field current so that operation above base speed does not result in either over-voltages or overcurrents.

The current signal, in addition to being used for slope control, is also compared to the absorbing load-limit reference and to the motoring load-limit reference. If the load current is less than the reference value, the diode switches prevent the current signal from reaching the regulator. When the current signal is equal to the reference value it is permitted to pass through to the regulator, and completely overcomes the speed signal. The dynamometer then operates with a constant-torque characteristic. The torque value is adjusted with the load-limit control. Load-limit values for absorbing and motoring can be set independently. These various modes of operation are illustrated in Fig. 3.

For some tests the torque must vary as the square of the speed. To accomplish this, two tachometers are used, each coupled to the dynamometer. The first tachometer provides the excitation for the second tachometer, so that the output voltage of the second is proportional to the square of the speed. This signal is compared to a current signal from the slope control, which results in a torque proportional to the square of the speed. A constant torque can be added to or subtracted from this by including a fixed signal.

**Axle-test cell at Ford Motor Company's new laboratory. The input dynamometer on the drive shaft is rated at 400 hp absorbing and 300 hp motoring, through a speed range of 1500 to 4000 rpm. Output dynamometers are rated at 150 hp absorbing, 120 hp motoring from speeds of 400 to 1600 rpm.**

## Typical Applications

The automotive industry employs the dynamometer for a wide variety of engineering and development tests. Although the device is by no means new to the industry, the modern dynamometer with its reliable, accurate, and sensitive control has advanced the art of automotive testing tremendously. Also, the ability of the dynamometer and its associated equipment to simulate road conditions, such as automobile inertia, wind resistance, and road grades, has made it possible to move automotive proving grounds indoors for many tests.

The advantages of laboratory testing of new or experimental designs are obvious. Laboratory tests can be conducted under controlled conditions, permitting tests to be performed always to the same reference or standard. Variables encountered in outdoor testing, such as temperature, wind, and rain, cannot affect indoor tests. The more accurate results obtained enable detection of incremental improvements in design.

### Engine Testing

One of the most common uses of the dynamometer is the testing of internal-combustion engines. In this test the speed-torque curve of the engine is obtained; also, data on such items as optimum spark setting, carburetor adjustment, and fuel consumption. Various engine variables, such as water, oil, and carburetor temperatures, oil and exhaust pressures, are held at a fixed value during these tests. Such tests are performed with the constant-speed characteristic of the dynamometer. The dynamometer is started and brought up to some low speed with the speed control. Under these conditions, the dynamometer is motoring as it cranks the engine. When the fuel and ignition are turned on, the machine then becomes a generator and absorbs the engine power. After all data is taken at full throttle, the fuel and ignition are cut off, causing the dynamometer to motor but at the same speed as under full throttle. The reading then is the frictional torque at that speed. Speed is then increased and the test repeated.

### Governor Testing

When the characteristics of an engine governor are desired, the dynamometer is operated with its constant-torque charac-

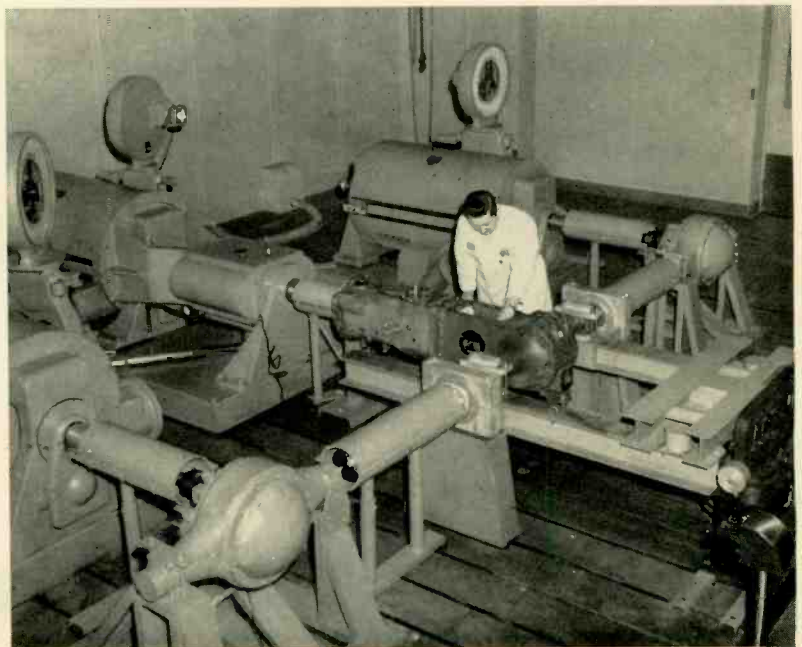

teristic, since the speed of the engine is fixed by the governor. In this test the speed control is set at some low value. When the maximum absorbing load limit is reduced to a value below the maximum torque available from the engine, the engine accelerates with constant torque until the governor limits the speed; it then remains at that speed and torque. As the maximum absorbing load limit is changed, the torque changes, while the speed is determined by the governor. The load can be changed from maximum engine torque to zero torque, giving the complete behavior of the governor under various load conditions. It is also possible to change the engine torque from maximum to zero in a single switching operation to simulate a mechanical failure such as a broken shaft. By repeating this test with various governor settings, curves are obtained of governor performance at all speeds.

#### Transmission Testing

In testing transmissions, the information required includes wear under specified speeds and loads, efficiency, and life. For automatic transmissions additional information, such as output speed, torque, and slippage under various load conditions, is important. For this test two dynamometers are used, one for input and the other for output. The input dynamometer is operated with a constant-speed characteristic, while the output dynamometer fixes the load by operating with a constant-torque characteristic. In testing the transmission characteristic of automatic transmissions, the input speed is fixed, and the output torque is increased until the input torque corresponds to the maximum engine torque developed at that speed. The acceleration characteristic of the transmission can also be determined by coupling a calibrated inertia to the output of the transmission.

#### Axle Testing

Information usually desired in testing axles includes such items as wear under various speeds and loads, efficiency, life, and deflections of the various members. This test requires three dynamometers, one input and two output. The input dynamometer rotates at constant speed; the two output machines operate at constant load. By adjusting the loads on the output shafts, and the speed of the input shaft, a

variety of output speeds and loads can be obtained for testing wear, life, and other factors. By setting the speed to a very low value, and loading the output, the deflections in the various elements of the axle assembly can be measured from no load to the rated load of the axle.

#### Chassis Testing

Chassis testing is performed with a complete automobile. This is designed to collect data in the laboratory where as road testing was previously required. The dynamometer in this case is coupled to two large drums that are in contact with the rear wheels of the car. The inertia of the rotating system can be adjusted to correspond to the inertia of the car under test by means of special plates that can be bolted to the drums when needed. The front of the car is supplied with a flow of air to provide cooling corresponding to the motion of a car at a given speed. With this arrangement, the overall performance of the car can be obtained by conducting a test similar to that for engines. For acceleration testing, a load in addition to the car inertia must be included; this corresponds to the wind resistance. To simulate this, the "torque proportional to speed squared" characteristic of the dynamometer is used. To simulate a car accelerating up a hill, the speed-torque curve is displaced by a fixed amount corresponding to the steepness of the hill. If downhill acceleration is desired, the speed-torque curve is displaced in the opposite direction.

These examples of dynamometer application in automobile laboratories are but a fraction of the applications for which the device is used in industry. Its use enables precise results, which in turn can be translated into improved machines.

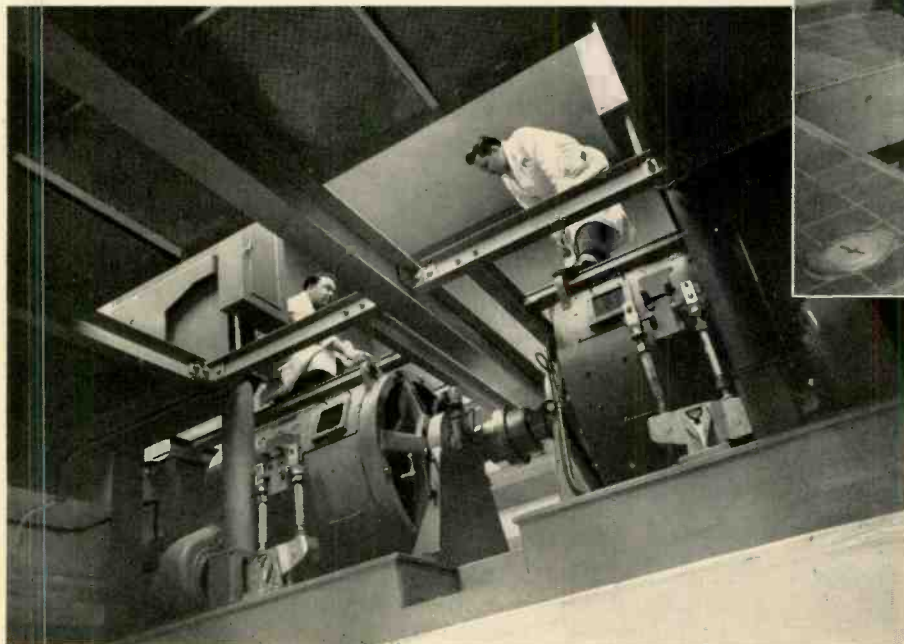

Left—Chassis-test dynamometers are rated at 200 hp absorbing, 150 hp motoring through a speed range from 200 to 700 rpm. Two cars or trucks can be tested simultaneously. Above—Large drums just under floor level in chassis test cell are in contact with rear wheels of car, and are flexibly coupled to dynamometers. Note inertia plates on drums.

# Bus Duct

## —The Modern Electrical Highway

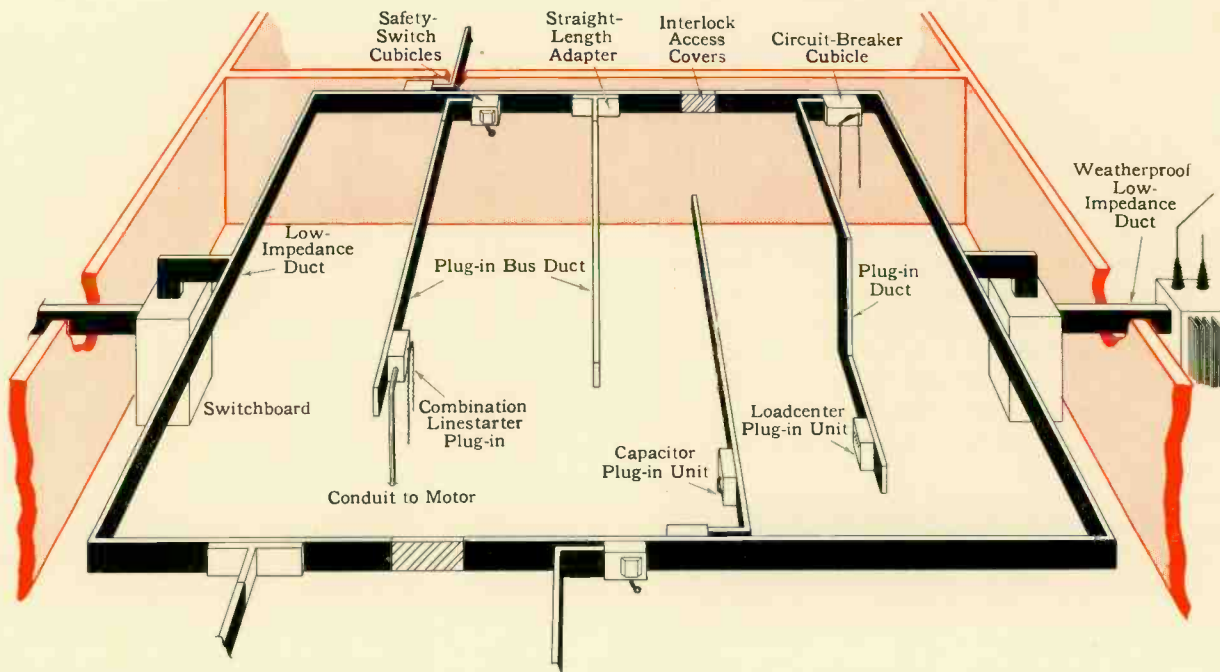

Flexibility to meet every eventuality is a tough element to incorporate in most electrical equipment. But it's here that bus duct shines. Installation or rearrangement of factory distribution systems or the addition of new equipment is only slightly more complicated than plugging in an electric toaster in your home. New components now add even greater flexibility.

W. F. BORN and J. B. WALLACE  
*Bus Duct Engineering, Standard Control Division*  
*Westinghouse Electric Corporation, Beaver, Pennsylvania*

THE KEY to the success of bus-duct electrical distribution systems lies in their ability to cope with the unpredictable, such as suddenly increased plant loading that calls for a quick increase in electrical capacity, or modernization and the problems of adding to and relocating production machinery.

In these instances the characteristics peculiar to bus duct make their best showing. Similarly, the possibility of encountering the same types of problems makes bus duct a highly desirable electrical distribution system for commercial buildings and institutions.

### Basic Components

Perhaps the main component is *plug-in bus duct*, the answer to most secondary distribution problems. With openings spaced every foot of its length for power take-off, this type of bus duct represents the most flexible way of transmitting power to the production area. Any change in the location of production equipment requires only a relocation of the plug-in unit along the bus-duct run, not an expensive major revision in the distribution system. Made in eight ratings varying

from 225 to 1500 amperes, this bus duct is available as a two-pole, three-pole, and three-phase, four-wire system with half- or full-size neutral.

While plug-in bus duct is the best way to distribute power to the machinery in a production area, quite often, in secondary distribution systems, large amounts of power must be carried over a considerable distance. *Low-impedance bus duct* with its closely spaced interlaced phase bars is the ideal duct for this job. It has a low voltage drop and uses the most economical amount of copper, and its rigid busbar supports enable it to withstand the high short-circuit stresses that could be applied to the system by the power source. *Low-impedance duct* with its low voltage drop works nicely in hotel or other commercial installations where a power riser is needed to supply lighting or air-conditioning load. *Low-impedance bus duct* that will carry up to 5000 amperes alternating current is available.

The third major type of bus duct takes the weather into account. When the source of power for the secondary distribution system is unsheltered from the weather, a bus duct



with a special enclosure is used. For relatively short runs in small ampere ratings, a *weatherproof-feeder* type of duct is available using one busbar per phase. For larger capacities, or where a high short-circuit stress may be encountered, or a low voltage drop in a long run is needed, the *weatherproof low-impedance duct* is used.

### Field-Developed Components

Matched with the above basic components are a host of standard accessories such as elbows, tees, crossovers, reducers, end closers, and cable tap boxes. Altogether these units make the ordinary complete electrical distribution system, or so the design engineer originally thought. As always happens, however, it was impossible to predict and design for all eventual field conditions. The result is that constant development has evolved a unique group of accessories that are not classed as standard—each is designed or can be adapted to solve a particular field problem. These field-developed components complete the bus-duct family.

#### Plug-in Bus Duct for 277/480 Volts

By using a three-phase, four-wire plug-in duct run over a production area, two different power demands can be supplied from the same run of duct. With the duct rated at 277/480 volts, a lighting load can be supplied from a three-phase, four-wire plug-in unit and from the same run a three-phase, 480-volt load can be supplied from a three-pole plug-in unit. The 277/480-volt rating plug-in duct is available with either a half- or full-size neutral.

#### Branch Protection from Higher Rating Bus Duct

To protect branch circuits that are being fed by higher rated plug-in or low-impedance bus duct, special circuit breaker and safety-switch adapter cubicles have been developed. These cubicles bring the plug-in openings in the branch runs as close to the feeder runs as possible, and keep all bus duct at the same elevation. The cubicles can also be used as a disconnecting means for the branch circuits. The elbow is built into the load end of the cubicle, and two of the cubicles, used with a standard straight length of low impedance or plug-in bus duct, bring the two branch circuits out on the same centerline.

If the low-impedance run is mounted flat, either for better heat dissipation or to meet space requirements, the branch circuits can be arranged in a similar manner.

When the bus duct is connected to a potentially high short-circuit-current source, there must be a device in the circuit that can interrupt these currents to protect the branch runs of plug-in or low-impedance duct. A DB circuit-breaker cubicle can be used for this protection, in which case the incoming duct is connected to the line studs of the DB breaker and the branch runs to the load studs.

For vertical runs of low-impedance duct, a DB circuit-breaker unit can be bolted to a splice in the duct, thus tying the line studs to the copper busbars. This unit has a draw-out breaker that can be rolled out of the enclosure for easy access. Safety-switch cubicles are used in essentially the same way as the circuit-breaker cubicles.

If no protection is required for the branch run, a straight-length adapter—made of plug-in bus duct—can be bolted to a splice in the low-impedance run. But when the main run is plug-in bus duct, additional branch circuits can be obtained by using two-foot straight lengths with stabs on one end. The stabs make it possible to locate the branch circuit practically anywhere along the run of plug-in duct. The current-carrying

capacity of the stabs limits the ampere capacity of the plug-in branch circuit, but for those applications where this limitation cannot be allowed, a higher rated unit can be bolted to the joint of the feeder duct.

#### Phase-Matching Flanges

Phase bars are interlaced in low-impedance bus duct. When the run of low-impedance duct terminates in a flange fitting at a switchgear unit or a transformer, the like phases must be tied together before a connection can be made to the bus work inside the switchgear or to the terminals in a transformer throat. This could require a cumbersome copper extension and additional space inside the switchgear unit. To get around this objection, a standard two-foot flange fitting has been developed that brings the like phase bars together inside the duct housing. In the ratings through 3000 amperes, using two bars per phase, the like phase bars are brought together without increasing the size of the duct housing. If necessary, the copper extensions can be manufactured to any length to accommodate the copper work of the switchgear unit, but eight inches is usually considered standard dimension.

#### Vertical Hangers

In many commercial distribution systems, such as those found in hotels or office buildings, the feeder run of bus duct originates in a switchgear unit located in the basement and rises through the building in a wiring space or abandoned elevator shaft. The standard hanger used to support the weight of vertical bus duct consists of an angle-iron bracket that is welded or bolted to the duct, with four coil springs attached to the brackets.

A typical installation of low-impedance bus duct.

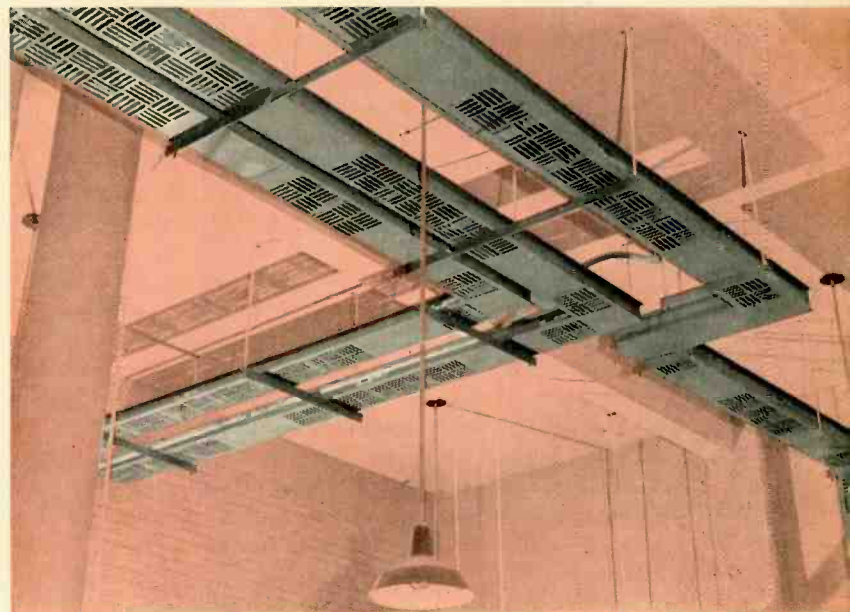

The tendency is toward bolted duct, which can be located anywhere along the run by the contractor when the duct is erected and does not require the accurate floor elevation measurements needed when the hangers are welded on at the factory. After the contractor has fastened the bolts securely to the mounting surface, the adjusting nuts are turned up until the entire weight of the duct above the hanger is spring

suspended. The springs are flexible enough to compensate for the thermal expansion of the duct. For the higher rating ducts, which weigh considerably more, a six-spring hanger is used.

#### Special Cable Tap Boxes

At each floor level in an office building or hotel there is usually a lighting panel or other load to be fed from the electric-power riser. Usually there is a minimum of space to make this power take-off. To help bus duct meet this chal-

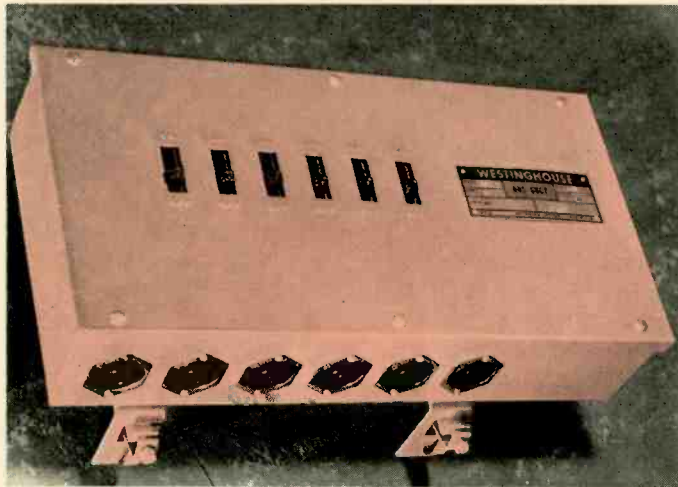

The new load-center plug-in unit with six circuit breakers.

lenge, a built-in cable tap box for the feeder run has been developed. With the run of duct mounted alongside the panels at each floor, the tap box and the lighting panel are joined together by a short conduit nipple. Thus a minimum of space is required for a neat, economical installation.

#### Field-Developed Plug-in Units

There are many standard plug-in units that use circuit breaker or fusible protection. But requirements cannot always be met with a standard plug-in unit, in which case a special unit is made to do the job. A description of a few of these further illustrates the important characteristic—adaptability—that does much to make bus-duct distribution systems the most versatile.

A load center plug-in unit with six circuit breakers and an insulated ground—for three-phase, four-wire plug-in bus duct—makes power available from six receptacles in the side of its enclosure. This unit is especially useful when a large number of small circuits of single-phase power are needed. This unit can also be made with as many as 12 branch circuits.

Another plug-in unit uses a linestarter protected by a circuit breaker. This unit can be supplied with a control transformer if a low-voltage control circuit is to be used, or a safety switch (type A) with fuse protection can be used ahead of the starter. Many varieties of the Life-Line combination linestarter are available.

When bus duct or any other method is used to supply power to the machinery in an industrial plant, the power factor of the entire system is reduced somewhat by the large number of motors on the system. To improve the power factor, a capacitor plug-in unit that incorporates fuse protection for the capacitor and cover-operated disconnect in the housing can be used. There are several ratings of capacitors—5 and  $7\frac{1}{2}$  kvar in the 230-volt rating, and 10 and 15 kvar in the 460- and 575-volt ratings.

#### Current-Limiter Fuses for Short-Circuit Protection

The current-limiter fuse, a recent development in the fuse-manufacturing industry, has a definite application in a bus-duct system. This fuse is designed to interrupt and limit high short-circuit currents to prevent damage to the system. To make use of this ability, the fuse can be placed in a switch cubicle built into the duct run at the point where the power service feeds the bus duct. It can also be used as a bolt-on unit to feed a branch run of plug-in duct from a low impedance run. Standard switches for conventional and current-limiter fuses are available.

#### Isolators and Interlock Access Covers

Any one of several different bus-duct systems can be used for a given production area. A popular system consists of a closed loop of duct with a source of power at each end of the loop. With both sources of power in operation, the loop of duct must be disconnected in two places to isolate one power source from the other completely. To accomplish this isolation, the bolts are removed from the busbar connections in two splices in the run, and pieces of insulating material are inserted between the busbars. While this is not the best method of isolating one run from another—an arcing fault could jump the gap—it is the most convenient and economical way, especially when used temporarily.

By relocating the isolators in the run, a changing power demand can be easily shifted from one power source to the other. To mark the location of these isolators, the access covers for that splice can be painted a different color from the rest of the duct. To make sure the isolators are not removed from the duct while the system is energized, an interlock access cover that requires a key from each power source for its opening is used. However, the best way to isolate a part of a plug-in bus-duct run is to omit a straight length from the run and use end closers on the open ends.

#### Special Designs Using Low-Impedance Busbar

Low-impedance duct, with each busbar insulated from the others, lends itself nicely to many different variations. As an example, the standard three-wire duct using two bars per phase could be used as two separate three-phase circuits with one bar per phase. By increasing the housing dimensions, more bars can be added to the duct to provide additional circuits.

A specially designed duct with eight busbars has been made to handle two single-phase circuits, one 400 cycles, the other 800 cycles. In this case, the conductor cross-sectional area had to be increased due to higher than normal frequencies. While this was an unusual application designed specifically for an electronics laboratory, it is an effective example of the versatility of bus duct.

#### Current Transformers

When the distribution system is all bus duct, from the entrance service to the production area, and the power is being supplied by the power company, current transformers are often necessary in the entrance duct to meter the amount of power being used. These current transformers can be built into the main circuit-breaker cubicles or into enclosures of their own. Another compact arrangement is to build a pull box for the current transformers over the main-breaker enclosure. Then this pull box can be sealed by the power company. Current transformer cubicles can be supplied for either three-wire or three-phase, four-wire bus-duct service in any desired ampere rating.

# Part II—Factors Affecting Selection of

# Power-Line Carrier

To be considered well dressed, a man must always wear clothes that fit him properly and are appropriate for the occasion. Power-line-carrier equipment, regardless of the function involved, must fit the system to which it is applied. A previous article discussed the system factors that affect the selection of carrier equipment; this one deals with the factors that must be considered in selecting carrier equipment for specific functions or end uses.

R. C. CHEEK  
 Assistant Manager, Application Engineering  
 Electronics Division  
 Westinghouse Electric Corporation  
 Baltimore, Maryland

CORRECT selection and application of power-line carrier requires study of the power system to which it will be applied, as well as consideration of power supply sources, ambient temperatures, and other external factors. These factors, which have been discussed previously,\* influence the selection

\*"Factors Affecting Selection of Power-Line Carrier" (Part I), by R. C. Cheek, *Westinghouse ENGINEER*, May, 1953, p. 107.

of carrier equipment for any function. The next step is to study the types of equipments available for specific end uses and to consider the requirements imposed by various end-use devices. The final selection of the equipment to fit the system and to handle the required functions can then be made.

### Voice Communication

Although a detailed discussion of the three types of carrier communication systems (manual simplex, automatic simplex, and two-frequency duplex)<sup>10</sup> is beyond the scope of this article, a short summary of the advantages and disadvantages of each may facilitate a choice for a given set of requirements.

Because simplex systems require only a single carrier frequency, they are applicable where communication among more than two points is needed. Because they are economical of space in the carrier-frequency spectrum, their choice may be dictated by frequency availability in some cases, even for point-to-point applications. Other considerations, such as the necessity of providing and adjusting a hybrid balancing network (i.e., networks that allow a carrier receiver and transmitter to terminate on a common pair of wires) with duplex systems, and the limited audio levels obtainable with poorly terminated telephone lines in some cases, dictate a simplex system even when ample carrier frequencies are available.

The two-frequency duplex system, however, is the only

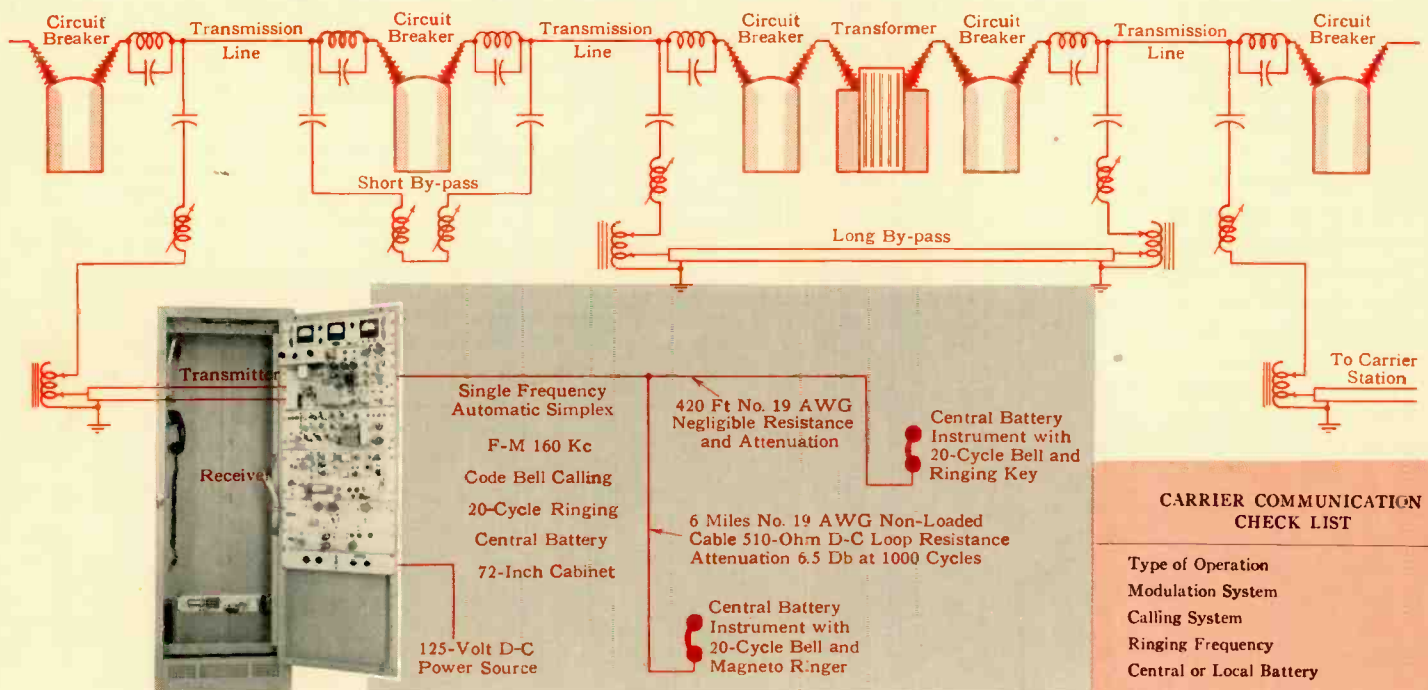

Before final selection of power-line-carrier communication equipment can be made, the telephone-line facilities available at each station installation and the user's preferences for certain details of operation must be known. This information, together with the overall system data, will enable a supplier to fit the system with equipment best suited to the user's needs and desires.

Fig. 2

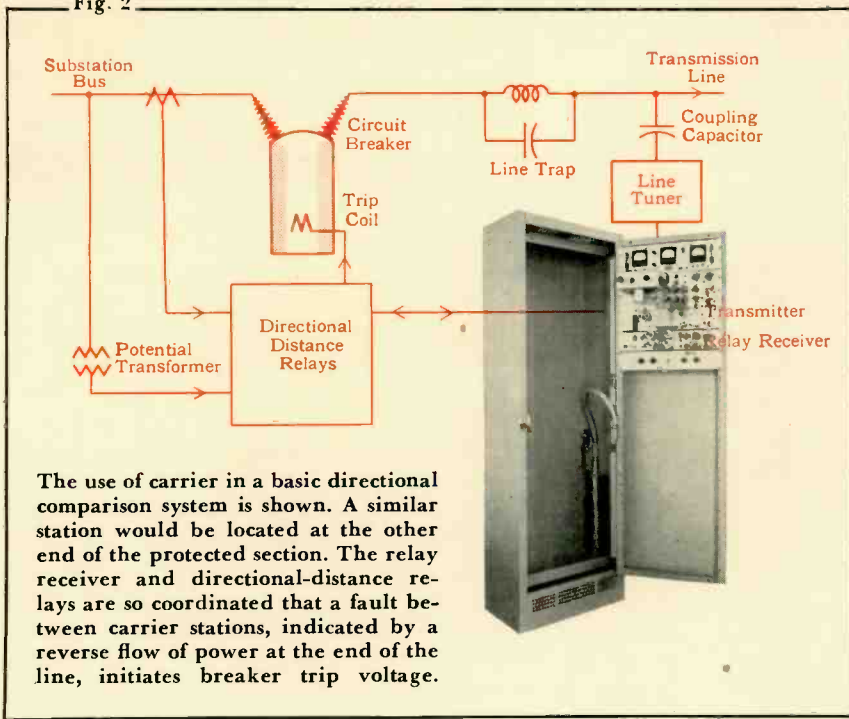

system that provides the exact equivalent in operation of a wire-line telephone system, in which either party can interrupt the other at any time. This consideration alone has often dictated the choice of the duplex system. However, modern automatic simplex systems, with rapid, automatic-click-free switching between "transmit" and "receive" conditions, can provide the practical equivalent of duplex operation and are often selected in place of two-frequency duplex systems.

Although the manual simplex system is the simplest to apply and adjust, the fact that handsets with control push-buttons are required prevents its use through telephone switchboards for integration with an extensive telephone network. Central-battery operation is always required to provide the control function; this means that no repeating coils, capacitors, or insulating transformers can be used in the telephone extensions unless by-pass devices are also used.

Many factors affect the ultimate choice of a particular type of operation and must be given consideration in arriving at the final decision. Included are the number of stations among which communication is required, the probable future expansion of the system, the necessity of providing extensions through PBX boards, the characteristics of the telephone extensions, frequency spectrum availability, the familiarity of probable users with the characteristics of each sys-

tem, and the preferences of such probable users.

### Modulation Systems

Although the amplitude-modulation system was used almost exclusively in power-line-carrier communication work until recent years, it has been practically superseded by the modern frequency-modulation and single-sideband systems. The only major advantage of frequency modulation over amplitude modulation for power-line-carrier work is the fact that, with proper limiting circuits, the FM system provides an automatic volume-control system that is practically instantaneous, and is effective over extremely wide ranges of variation in received signal strength. On the other hand, more bandwidth is required for an FM system with a frequency swing sufficient to give equivalent noise discrimination to an AM system of equal power. Where frequency spectrum must be economized, the single-sideband system provides the dual advantages of reduced bandwidth and improved noise discrimination as compared with the other systems, but it is somewhat more expensive. (Discussions of the relative advantages of these three systems are contained in references 11 and 12.) The usual choice is the FM system, except in applications requiring the utmost in frequency conservation, and noise and interference discrimination.

### Calling and Ringing Systems

Several types of calling systems are available for power-line carrier communication. By far the most popular of these is code-bell calling, in which the desired extension is indicated by a combination of long and short rings. These coded rings are generated by the calling party by means of a hand gen-

Fig. 3

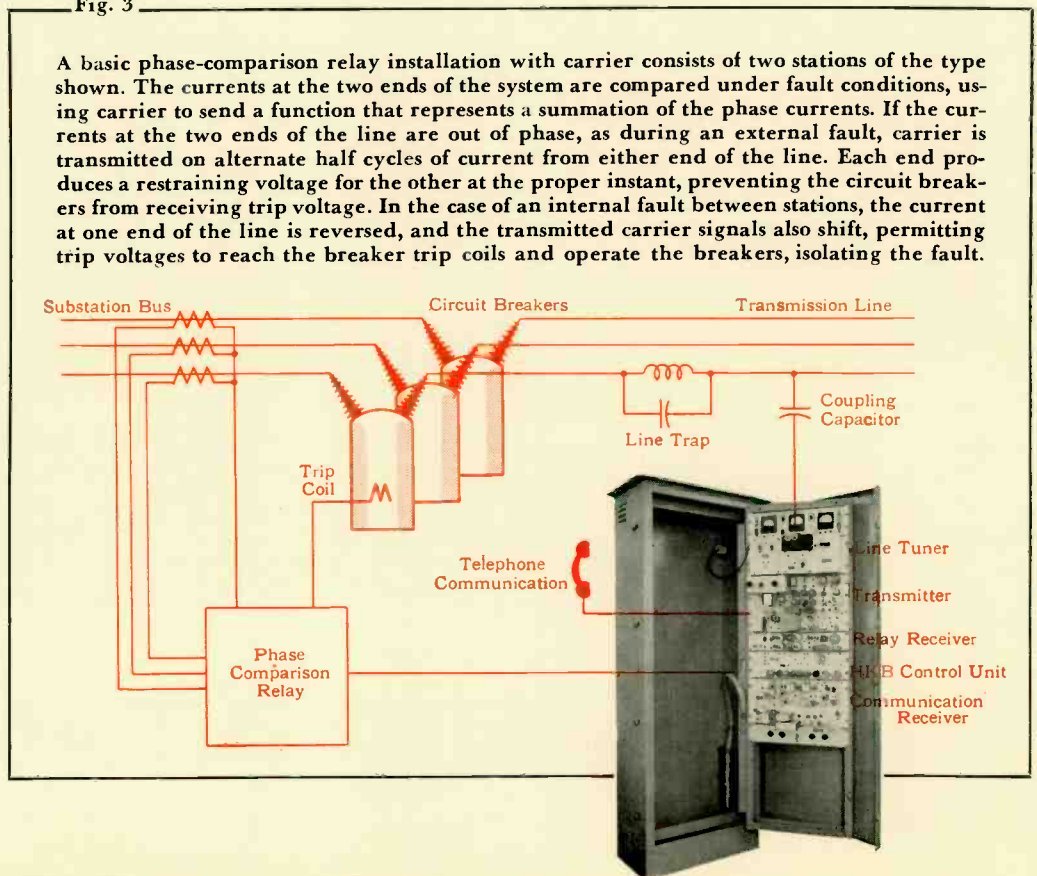
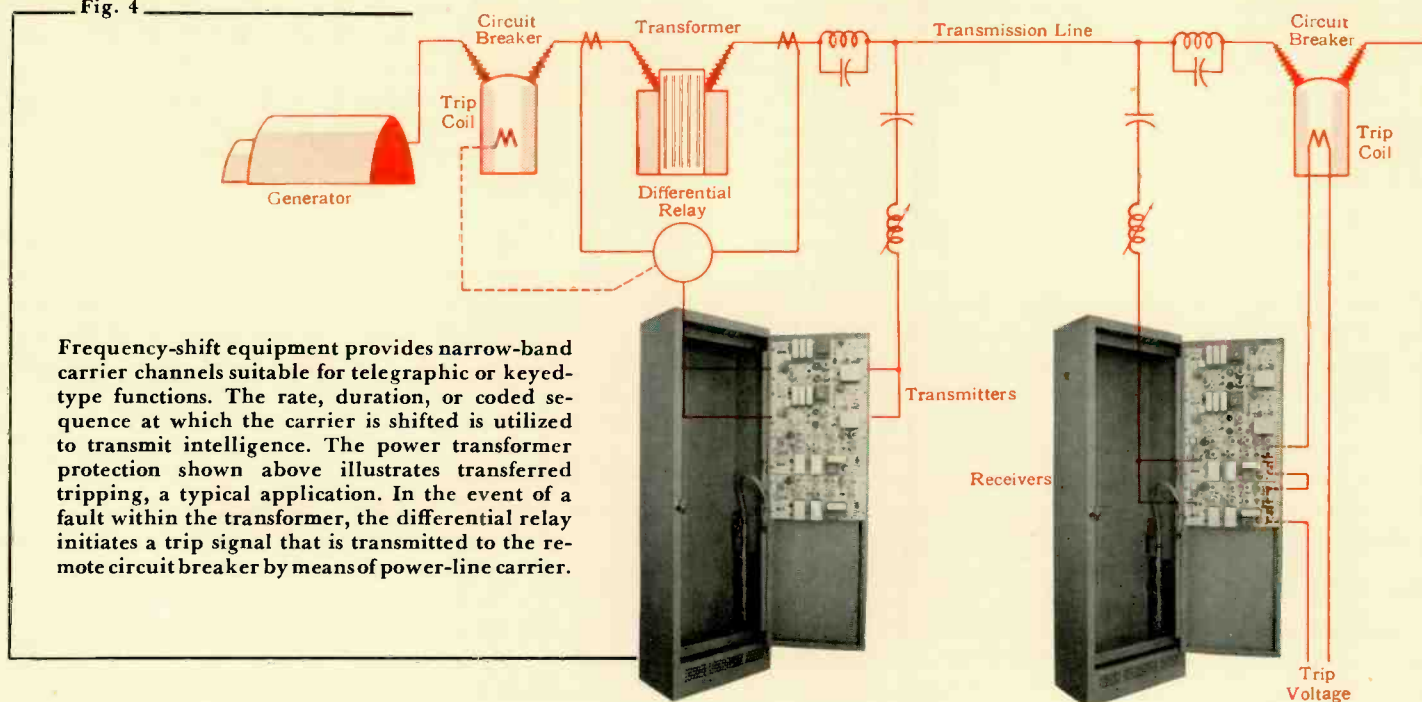

Fig. 4



Frequency-shift equipment provides narrow-band carrier channels suitable for telegraphic or keyed-type functions. The rate, duration, or coded sequence at which the carrier is shifted is utilized to transmit intelligence. The power transformer protection shown above illustrates transferred tripping, a typical application. In the event of a fault within the transformer, the differential relay initiates a trip signal that is transmitted to the remote circuit breaker by means of power-line carrier.

erator or a pushbutton on the telephone instrument. Ordinarily all the extension telephones on the carrier system respond to these rings. However, a degree of selective ringing can be achieved with this system at additional cost by installing at each telephone-instrument location a selective device set to respond only to a predetermined code ring.

If code-bell calling is chosen, as is usually the case, the number of extensions, their locations, and the amount of traffic the system will handle should be considered to determine whether code selectors are required to prevent too frequent ringing of all telephones.

In extensive carrier-communication systems, particularly multi-station systems using automatic simplex carrier assemblies with multiple extensions, it is occasionally desirable that full dial-selective service be provided. This considerably increases the cost of the carrier assemblies, but it provides a carrier-communication system with practically all the operating features of a private automatic-exchange telephone system. Dial-selective service has the additional advantage that the people using it are not required to decode every ring.

Another system, in less common use than the two already discussed, is voice calling. An amplifier and a loudspeaker are located in the vicinity of each telephone instrument, and the calling party calls the desired station by voice. The loudspeaker is automatically silenced when the desired party picks up the telephone instrument to answer the call.

The telephone instruments, when supplied by the carrier manufacturer, are usually those with high-impedance ringers that are rung by 60-cycle voltage supplied to the telephone extensions from the carrier set. If existing telephones are to be used, these must also contain high-impedance 60-cycle bells. Usually they will contain ringers that respond to approximately 20 cycles (i.e., so-called straight-line ringers). In this case, a source of 20-cycle voltage can be supplied with the carrier set (or a nearby source can be used) to coordinate with existing instruments, and all new instruments should be specified to have straight-line ringers.

A source of calling voltage is required at each telephone location. A 60-cycle voltage is usually available, and it can be applied to the telephone line through a key switch or push-

button to call distant stations. Unless 60-cycle bells are used in the system, however, the call does not ring other telephone extensions from the local carrier set. If it is desired that all extensions, including those from the same carrier set, be rung by such a call, a hand generator can be used to generate the approximately 20-cycle voltage required. In any case, it must be known in advance whether key-switch, pushbutton, or hand-generator calling is desired.

#### Central- Versus Local-Battery Instruments

A decision must also be made between central-battery and local-battery telephone instruments. With central-battery equipment, the carrier set provides a source of direct current that furnishes microphone current to the telephone. In the case of duplex equipments it operates a relay to turn on the transmitter when the handset is lifted from the cradle. Central-battery operation requires telephone extensions capable of carrying direct current, i.e., with no insulating transformers or repeat coils, and with a d-c loop resistance usually not exceeding 1000 ohms.

With local-battery equipment, each telephone location is provided with dry cells to furnish microphone current, and the telephone extensions need not provide complete d-c paths. This permits the use of insulating transformers in the telephone lines. In duplex carrier assemblies with this system, the transmitters must be on continuously because no control function can be provided.

#### Attenuation of Telephone Lines

Whether central- or local-battery operation is selected, there is a limit to the amount of voice-frequency and ringing-frequency attenuation that can be tolerated in the telephone extensions. The voice-frequency attenuation limit is 20 decibels with most types of carrier equipment. Duplex operation, with its requirement for a satisfactory hybrid balance, may impose a more severe limitation, depending on the nature of construction of the telephone extensions and the degree to which a satisfactory balance can be achieved. The ringing-frequency attenuation is closely related to the d-c resistance of the extensions, and 1000-ohms loop resistance is regarded

as a nominal limit for ringing two telephones simultaneously.

#### Coordination with Existing Communications Networks

Consideration has been given only to completely self-contained carrier communication systems, i.e., systems that are not to become a part of already existing facilities. All the ramifications of the problem of coordinating carrier communication systems with extensive networks involving PBX and PAX boards with all their variations cannot be discussed here. In general, careful study is required to insure that the requirements peculiar to the existing system are met by the carrier system. If the manufacturer of carrier equipment is to do the coordinating, he must have all available information on the characteristics of the switchboards involved, and single-line and block diagrams of the entire communications network. In some cases it is sufficient to describe the switchboards by manufacturers' type designations, but schematic diagrams and instruction manuals are preferable, along with a brief discussion of the circuits involved.

#### Supervisory Control

Conventional supervisory control systems of the pulse-code type, such as the Westinghouse Visicode system,<sup>13</sup> require a two-way telegraphic channel that is capable of transmitting at a rate of up to 15 pulses per second. It is important that the channel used be able to maintain a satisfactory mark-space ratio, and this precludes the use of highly selective low-frequency audio tones that are too sluggish in response. The

use of a two-way frequency-shift channel is generally the most satisfactory way of providing for supervisory control.

In single-station supervisory-control systems, in which only one station is controlled from a dispatching point, conventional frequency-shift carrier equipment is usually used. In multi-station systems several stations are under supervisory control from a single dispatching point. All stations, including the dispatching station, must be able to receive any signal transmitted by any station. In these applications, frequency-shift carrier equipment can be applied with transmitters keyed on and off by the supervisory equipment. This permits taking advantage of the sensitivity and selectivity of the frequency-shift receivers and avoids the interference that would occur among several frequency-shift transmitters all sending their "space" frequencies simultaneously.

#### Protective Relaying

The selection and specification of carrier equipment for protective relaying applications is simpler than for communication and most other applications. The variations in requirements are fewer. Noise and attenuation are less important in relaying applications than in others, because relaying channels are always applied to individual line sections rather than to extensive systems. However, consideration must be given in specifying and applying relaying carrier equipment to all the applicable factors discussed in Part I. Phase-to-ground coupling is almost universally used, and 129- or 258-volt d-c operation from station batteries is standard.

The only major decisions to be made, after the relaying system itself is selected, are those to determine whether the

## Personalities in Engineering

It was a cold, windy day in February, 1918 when the S3, one of the first of a new class of submarines, left Provincetown, Massachusetts, for its sea trials. On board was a young electrical engineer, Harry C. Coleman, two years out of Ohio State, who had gone to Westinghouse and steered his way into the Marine Engineering Section so he could combine his affection for the water with his new profession. Coleman was on board to observe the behavior of the new propulsion equipment. All went well enough until a dive was attempted. Instead of leveling off, the sub kept on diving, heading at 45 degrees for the bottom. All loose objects, including Coleman, tumbled into the bulkheads. Then the sub struck the sandy bottom, with a sickening sound of tearing steel.

"Right then," as Harry now tells it, "my enthusiasm for the sea diminished. That feeling was immediately intensified when I heard the skipper shout: 'Look for leaks forward'."

But the S3 and its shaken crew were fortunate. The bottom was sandy and the vessel nosed back to the surface. There were, luckily, no bad breaks, although the mushroom anchor had been torn away. Coleman's love of things marine likewise recovered and he went on to become one of the nation's outstanding engineers specializing in the

marine application of electrical gear.

In the 32 years, between that almost fatal day in 1918 and when he graduated in 1950 to his present administrative post as manager of all of Westinghouse's industry engineering groups, Coleman was a member of, and, since 1927, manager of the Marine Section, Industry Engineering. Throughout these years his first interest always was submarines. He helped in the conversion of the submarines from battery-powered motor drive to diesel-electric drive. He was a leading figure in adapting variable-voltage control to submarines. In the late 30's, during the development of the large fleet-type submarines that were to be so effective against the Japanese, Coleman made numerous contributions to the general problem of getting more power in a unit of space. His work with submarines was climaxed by his part in the negotiations and early planning for the world's first atom-powered submarine, the *Nautilus*, for which Westinghouse is building the reactor and power plant.

But Coleman's marine application efforts were not confined to submarines. He has helped apply electrical equipment to virtually every powered craft that floats. In 1916, the U. S. Navy decided to equip its new battleships, *Tennessee* and *Colorado*, with turbine-electric drive. Coleman was deeply involved in that application.

He was responsible for the overall engineering of the electrical systems for the Sperry gyroscopic ship stabilizers. He spent many days at sea adjusting and making tests on these equipments for yachts, destroyers, and merchant ships.

Then there were the turbine-electric tankers that were built in such large numbers in the early part of World War II. He helped design that propulsion system. When the Coast Guard introduced a new type of cutter in 1943, Coleman helped plan the turbine-electric drive. Here pilot-house control of synchronous motors was tried for the first time. World War II created a need for ice breakers of unprecedented power. The Coast Guard provided as the answer the diesel-electric "Wind" class ice breakers whose exploits during the war and since read like fiction. Westinghouse, with an assist from Coleman, supplied the electrical equipment.

Less glamorous but equally utilitarian are dredges used to keep river and harbor channels clear of muck. These now are quite generally diesel-electric powered. Coleman helped with these.

Not all of Coleman's experience as head of the Marine Application Section had to do with water craft. One of the assignments of his group was the engineering of wind-tunnel drives. In this capacity he was deeply involved with the 40 000-hp induction-motor drive for the

relaying carrier equipment will be used for other purposes such as emergency communication, telemetering, or supervisory control.

Emergency communication facilities have been supplied practically as standard equipment with relaying assemblies for a number of years. However, most power systems now have other communication facilities that are sufficiently reliable that the additional cost and complication of adding this function to the relaying equipment is no longer justified. Existing facilities are also usually available for use in initial adjustment and tune-up of the relaying assemblies. Elimination of emergency communication permits much closer spacing of relaying frequencies and results in an important saving in spectrum space.

#### Telemetering and Load Control

All of the factors discussed in Part I apply to the selection and application of carrier equipment for telemetering and load control. In relatively infrequent cases, channels for these functions are required between the two ends of a relaying channel. If a single telegraphic function is required, the relay carrier itself can be keyed to provide a suitable channel. If two or more functions are to be handled, individual audio tones can be applied to the relaying carrier to accommodate them without the necessity of providing separate assemblies. The exact combination of carrier units to provide such combined functions should be referred to the manufacturer for recommendation.

Channels for telemetering and load-control functions can be provided by assemblies using a number of audio-tone fre-

#### REFERENCES

- 10—"Power-Line Carrier Communication," by R. C. Cheek, *Westinghouse ENGINEER*, September, 1947, pp. 151-4.
- 11—"A Comparison of the Amplitude-Modulation, Frequency-Modulation, and Single-Sideband Systems for Power-Line Carrier Transmission," By R. C. Cheek, *AIEE Transactions*, Vol. 64, 1945, pp. 215-20.
- 12—"Power-Line Carrier Modulation Systems," by R. C. Cheek, *Westinghouse ENGINEER*, March, 1945, pp. 41-5.
- 13—"By a Flick of the Finger (Supervisory Control)," by W. A. Derr, *Westinghouse ENGINEER*, November, 1949, pp. 162-7.

quencies modulating a single-carrier transmitter, with corresponding tone receivers operating from a single carrier receiver at the opposite end of the channel. However, because of the many problems encountered in such applications, the trend over the past several years has been almost entirely away from the use of multiple tones. Instead, individual frequency-shift carrier units, crystal-controlled and closely spaced in frequency, provide an independent channel for each function.

In the selection and specification of frequency-shift equipment for telemetering, consideration must be given the type of telemetering equipment to be used. There are several basic systems (impulse-duration, impulse-rate, variable-frequency, etc.) and the characteristics of the equipment supplied by various manufacturers for each system are generally dissimilar. Although the basic frequency-shift carrier units are the same, regardless of the telemetering system to be applied, receiver-output circuit accessories of different types are required to accommodate different systems.

#### HARRY C. COLEMAN



Wright Field tunnel built in 1941. In 1946 Aviation Application Engineering was also placed under his jurisdiction.

Coleman is slight of build, with fine features. His manner is quiet, but his directness and self-assurance have gained him unusual success in winning the confidence not only of the men who work at his direction and his own management, but also those in the Navy and shipbuilders generally. Some evidence of this is the Navy Certificate of Meritorious Service awarded him in 1946.

When Coleman was made manager of Industry Engineering in October, 1950, his intimate association with things marine came to an end—a fact he acknowledges with a sigh. But he is not one to be easily deflected from an objective. Professionally, he is still a member of the Society of Naval Architects & Marine Engineers and the American Society of Naval Engineers.

A few years ago Coleman managed to purchase the original family homestead adjoining Lake Erie near Ashtabula. Every Friday evening during summer months, whenever business permits, one can see a gray Buick with a man of determined look at the wheel heading northward out of Pittsburgh. The weekends, Coleman spends tinkering with a Franklin automobile, 1929 model, with his fruit trees, his strawberries, numerous rebuilding plans—and on the water.

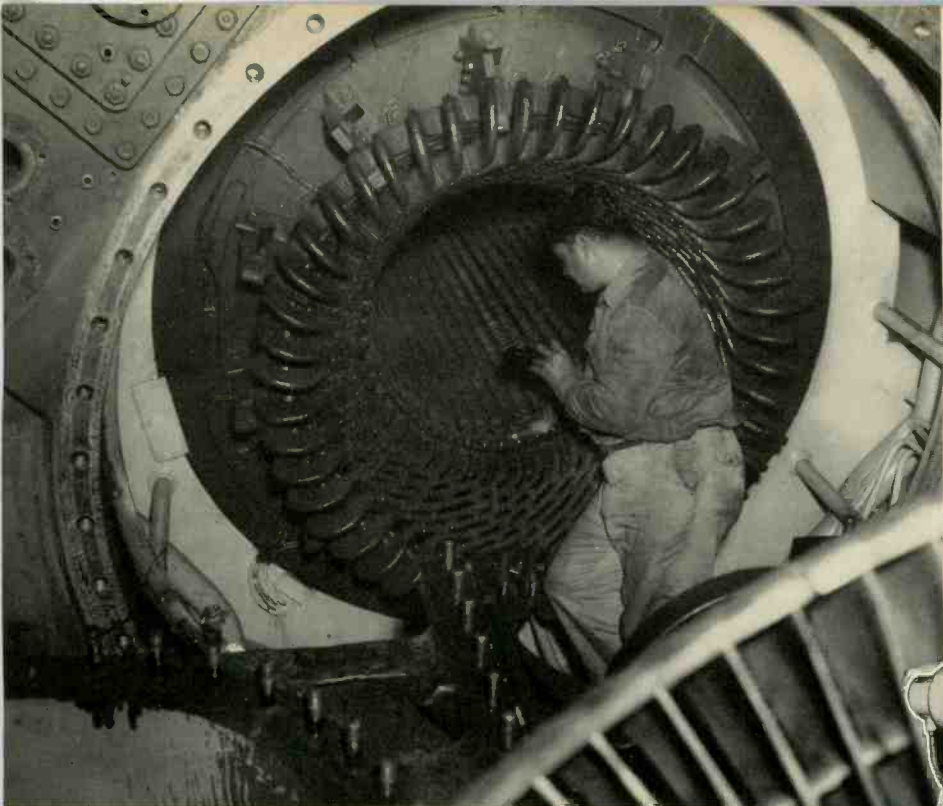

Left: Mechanical difficulties are sometimes spotted in making visual inspection. Here an inspector examines the stator of a turbine generator. Below, a bar-to-bar resistance check is made on a 3600-rpm direct-driven exciter for a hydrogen-cooled turbine generator.



# Generator Insulation Inspection

## —A Progress Report

J. S. JOHNSON, *Generator Engineering,*  
*Westinghouse Electric Corporation, East Pittsburgh, Pa.*

Generator insulation is subject to many aging, contaminating, and destructive influences, and is thus expended during service. Periodic inspection will not only spot conditions of insulation weakness, but will also uncover occasional mechanical trouble that could also lead to difficulty if not found in time to take the proper precautionary measures.

SINCE a maintenance-inspection service for generator insulation was established some three years ago, more than 200 field inspections have been made involving generator capacity in excess of 10-million kva. Machines inspected include turbine generators, waterwheel generators, and synchronous condensers 5000 kva or larger and ranging in service from one to 30 years. No machine tested has subsequently failed in service.

In a number of cases, minor maintenance operations were necessary, and while not of a critical nature, the conditions uncovered could have led to serious damage and prolonged shutdowns. Periodic inspections during normal machine shutdowns, together with the proper interpretation of the conditions found, improve the service reliability and the ultimate life expectancy of the units inspected.

For example, two similar generators developed slot-discharge difficulties. In the case of one machine, the condition was discovered during a routine maintenance and general overhaul conducted concurrently with a regular shutdown for turbine maintenance. The repairs on the stator winding required only five days, and the total cost of the corrective program was comparatively minor.



A physical inspection of a two-pole generator rotor.



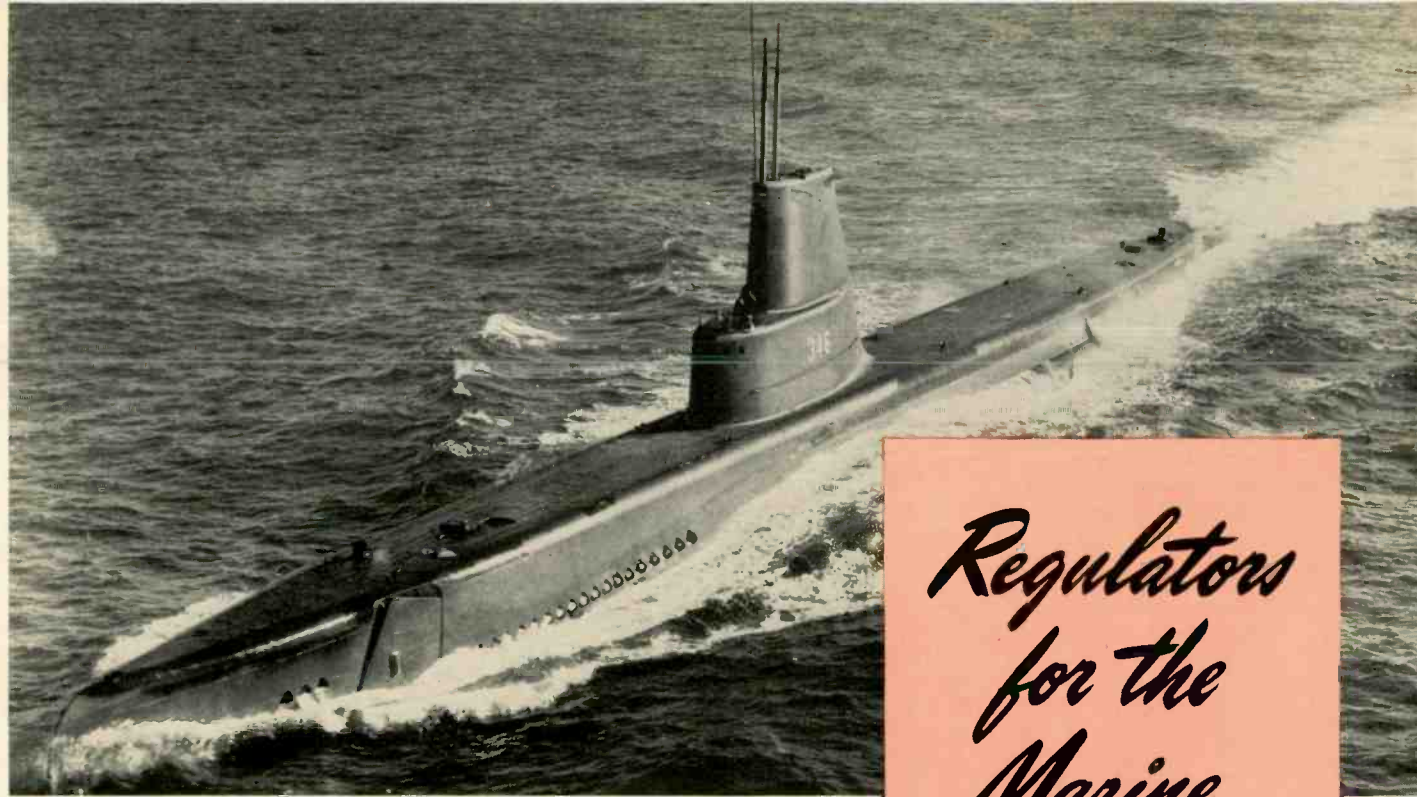

## Regulators for the Marine Industry

Ships are sometimes referred to as isolated "floating cities." Their successful operation thus depends to a large extent on integrated, precise, and reliable control of the various shipboard functions. The seagoing variety of regulators that perform these tasks have much in common with their landlubber relatives, but by the very nature of the job some have no exact land-based counterparts.

S. A. HAVERSTICK, *Manager, Marine and Aviation Sect., Industry Eng. Dept., Westinghouse Electric Corp., East Pittsburgh, Pa.*

THE APPLICATION of automatic regulating systems to ships offers as much, if not more, variety than is found in industrial installations. Within the hull of a modern passenger or fighting ship are contained regulators for accomplishing a myriad of tasks. While many of these applications are, for security reasons, classified, some can be discussed.

### Voltage Regulators

Probably the most important type of automatic regulator found in the marine industry is the voltage regulator used for auxiliary power systems. Every ship of any consequence has an auxiliary power system for ship's service. The generating plant for these systems may be as much as 12 000 kw for one of the Navy's large aircraft carriers. The voltage must be regulated within relatively close limits.

An example of modern voltage-regulating methods in the marine industry is the type WRN-11 voltage regulator. This regulator has found wide use in the Navy for ship's service generators varying in size from 60 to 1500 kw. It is of the rotary-amplifier type and consists of (1) a Rototrol exciter directly connected to the generator and (2) a static electrical measuring circuit. It is shown diagrammatically in Fig. 1. The output voltage of the generator is fed through a static measuring circuit whose output is a d-c potential that varies in polarity, according to a high or low condition of the generator voltage, to energize the control field of the Rototrol exciter. The terminal voltage of the exciter is regulated by this low-energy controlled field to effect the required change in the generator excitation and consequently the generator output voltage. Physically, the equipment involved in the WRN-11 regulator consists primarily of an automatic-control

unit and a so-called potential unit, together with a manual-control unit (not shown in the figure), a voltage-adjusting rheostat, and a current transformer. The potential unit is energized by the a-c generator voltage and current. Its output is a single-phase a-c voltage that is used to energize the automatic-control unit through the voltage-adjusting rheostat. This automatic-control unit is a voltage-sensitive device, the output of which is a d-c voltage; this output is then impressed upon the Rototrol exciter control field. When the generator output voltage is at the desired value, the output voltage of the automatic-control unit is zero. If the generator a-c output voltage increases above the regulated value, the d-c output voltage of the regulator will be in the direction to decrease excitation voltage through the Rototrol exciter. When generator voltage falls below regulated value, the opposite is true.

The voltage-sensitive device consists of two parallel circuits, one containing a capacitor and the other a saturating reactor. The volt-ampere characteristics of these two elements are shown in Fig. 2. The point where the two curves intersect is the balance point of the two impedances. The operation of the voltage regulator depends on the fact that, if the voltage increases above this point, the current through the reactor is greater than that through the capacitor. When the voltage decreases below the balance point, the capacitor current is greater. When any unbalance occurs, a current flows in the Rototrol control field. Since the voltage-sensitive circuit consists of elements responsive to frequency, some means of frequency compensation must be provided; this is introduced in the WRN-11 regulator by a circuit between the generator and the voltage-sensitive circuit. The effect of an

At the top of the page, the U.S.S. *Corporal*. Official U.S. Navy Photograph.

The other machine had not been inspected, and a service failure resulted, causing appreciable damage to the core. It was necessary to remove all the stator coils and re-stack about one third of the core. Some new coils were required. The repairs took three months, and cost 25 to 30 times as much as the minor corrective measures mentioned above, not including the loss of revenue while the machine was down.

Periodic inspection not only reveals insulation conditions, but occasionally spots mechanical difficulties that could lead to serious trouble. When the rotor of a 3600-rpm machine was removed in the course of an inspection, a rotor balance weight was found in the bottom of the stator bore. Evidences of excessive heating in four punching packages of one tooth were also noted. Apparently the packages had been struck by the balance weight, and the ends of the laminations on each package were welded together for one half to three fourths of an inch. Adjacent slot wedges were carbonized, and mica bond had melted out of the stator-coil insulation near the damaged punching packages. The damaged iron was repaired and two stator coils were removed and replaced with new spares that were on hand. The four days required for this unexpected work were still during the turbine maintenance period. Had the condition not been discovered and remedied, it undoubtedly would have resulted in a stator-winding insulation fail-

If conducting coil surfaces are not adequately grounded to the core, a slot discharge may occur. An analyzer that compares a simulated slot discharge with the condition existing in the machine under test detects such discharges. This 75 000-kva turbine generator will also be given dielectric absorption and overpotential tests.

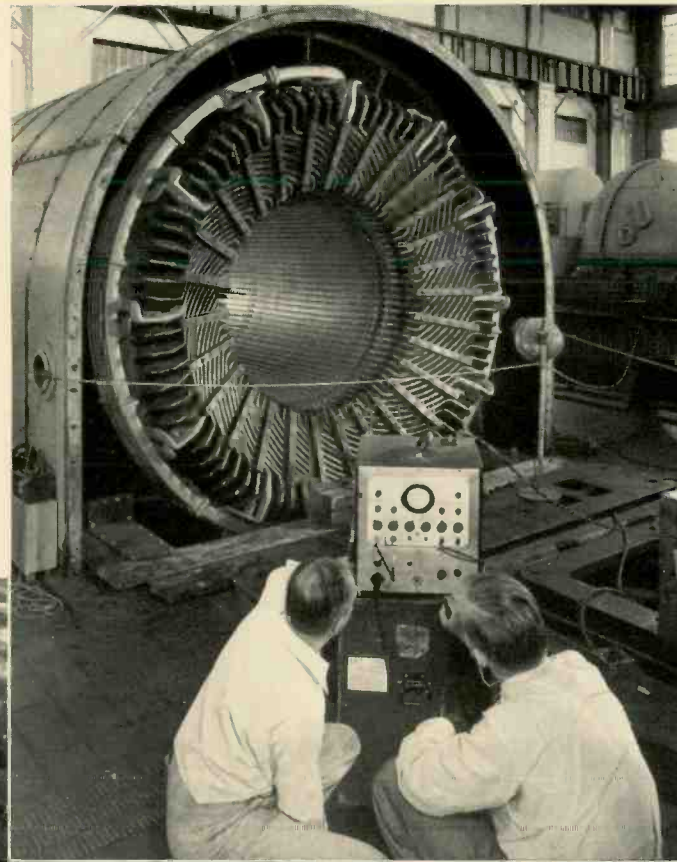

ure with considerable damage to the core, and the total outage time would probably have been several months.

Since spare generators are not carried on storeroom shelves, tests must of necessity differ from those used with other types of equipment so that test failures can be minimized. Yet the tests must be sufficiently searching to reveal weaknesses that are abnormal service risks. But if test failures do occur, effective and speedy techniques for field repair must be immediately utilized, and the skills and materials needed must be available. To date, no field repairs arising from test failures have extended outages beyond normal turbine maintenance.

Just as the last three years have seen significant progress in the development of field-repair techniques, so have test and inspection procedures been improved. In an earlier article\* on this subject the various maintenance tests were discussed in detail.

Among them was the d-c overpotential test, which was then relatively new, and with which limited experience was available. Three years of field experience have corroborated the conclusions based on laboratory studies that indicated the advantages of high-voltage direct current. Properly selected values of direct current are equally as searching as a-c potentials without producing the deteriorating effects on good insulation. Cumulative time effects of a-c testing make long or repetitive tests inadvisable, especially in those cases in which the insulation is only slightly stronger than the desired test level. Hundreds of d-c overpotential tests have been made and in all cases test failures led to the discovery of insulation in need of repair.

In utilizing d-c overpotentials in a one-minute breakdown-strength test, the 1.6 ratio of the d-c voltage to the a-c rms value that would be used in an a-c test has been found to be conservative and well adapted to this kind of test. This ratio, of course, varies with the condition of the insulation. For new, unused coils, the ratio is about 2.3; it is about 1.75 for new generators; and then it decreases because insulation weakens with service. The 1.6 is the minimum ratio that will ferret out insulation conditions that could conceivably develop into future trouble.

Some success has been reported in the nondestructive forecast of breakdown voltage by extrapolating the steady-state d-c leakage, or insulation resistance-voltage characteristic. A reliable test of this kind would be of great value because probable minimum insulation strength of a stator winding could be estimated without actually producing a failure. The test has been studied in the laboratory and on many machines, with the conclusion that nondestructive forecasting of machine insulation breakdown is possible, but not certain. The uncertainty does not appear to be related to the basic properties of the insulation, but to possible nonuniformity in winding breakdown level resulting from discrete areas of weakness.

The progress in the development of insulations and insulation test methods has grown out of the increased emphasis that has been placed on these and associated problems. One outgrowth of this general increased interest has been the AIEE-sponsored proposed Insulation Maintenance Guide for Large A-C Rotating Machinery.† Programs such as this, together with continuing awareness of the industry as a whole of the benefits to be gained from periodic visual inspection of insulation, will go far in helping provide the answers to the most effective combination of inspection and test methods.

\*"Check-ups for Generators," by J. S. Johnson, *Westinghouse ENGINEER*, March, 1951, p. 56.

†Recently released to the industry, the proposed guide will be published for comment and criticism. The essential purpose of the guide is to provide a medium for accumulating information on maintenance inspection and testing. This effort should stimulate further thought, discussion, and development that will lead to future revision and expansion.

# Calendering Line for Rubber

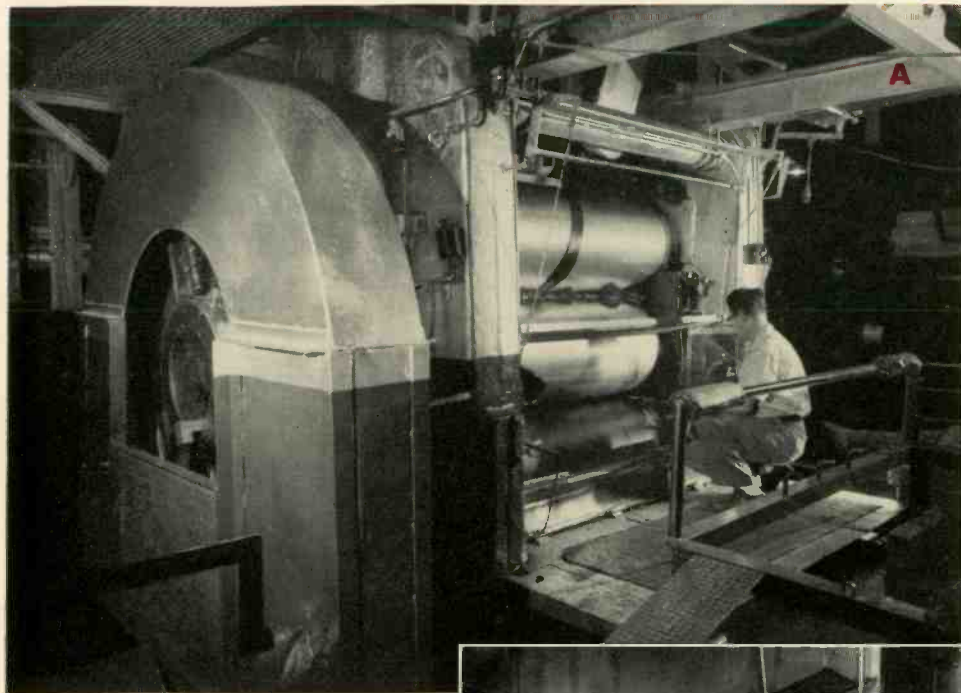

Last year in the United States, over four million passenger automobiles were manufactured. Multiply by five and that gives you a starting figure for the number of rubber tires needed. Then add the replacement tires, the truck and bus tires, tractor tires, airplane tires, trailer tires, and numerous and sundry others; the result is a grand total of well over 90 million rubber tires produced last year by the rubber industry. A huge business—even though it is but one part of the gigantic rubber industry!

Basically, a rubber tire consists of rayon, cotton, or nylon-cord fabric, impregnated with rubber, over which is placed a tread, sidewalls, and various reinforcing parts to produce the finished tire. One of the first processes is that of calendering a coating of rubber onto both sides of the fabric.

Preceding the calendering operation is a cord-dip machine, which is sometimes integrated with the calendering line, or may be physically separated from it. The fabric comes to the cord-dip machine in the form of parallel strands, perhaps a sixteenth of an inch or less apart. Sometimes

an occasional thread is woven at right angles to the others. This thread, called a "pick," holds the cords together for ease in handling, and occurs at intervals of about six inches. The basic purpose of the cord-dip machine is to coat the strands with a rubber solution; this improves the bond between the cords and the rubber that is later coated by the calendering process. After dipping, the cords pass through squeeze rolls to remove excess solution, then over drying drums.

Basically there are two different kinds of calenders—one a three-roll calender, of which two are used in a processing line (one for coating rubber on each side of the fabric), and a four-roll version, which coats both sides in the same stand. Fundamentally, however, the process is the same.

Plasticated (soft) rubber to be coated on the fabric comes to the line in a continuous strip about one-half inch by four inches. This soft rubber forms a wad or "bank" at the bite of the top rolls of the calender and is rolled into a thin strip, which is in turn rolled into the rubber fabric by the bottom rolls. In some cases the calender rolls are heated (to about 210 degrees F) by steam to keep the rubber soft. Heated rolls are also sometimes used previous to the calender, for drying out any moisture in the fabric.

From the calender, the rubberized fabric goes over a series of water-cooled drums where the material is returned to room temperature. Next in the line is a device called a festoon, which stores enough material to permit a reel change without stopping the calender. The festoon consists of a series of top rolls, fixed in position, and a floating set of bottom rolls. The rubberized fabric passes alternately over a top and a bottom roll throughout the length of the festoon. While a reel is being changed at the winder, the bottom rolls gradually descend, thus lengthening the fabric path and in effect providing a storage area.

At the end of the line are two separate wind-up arrangements. The festoon storage, plus the two available spools, enables the line to be run continuously, which contributes to product uniformity and high quality. If the line were stopped, all running adjustments would have to be made again when it was restarted.

The material from this processing line is a rubberized sheet about  $\frac{3}{8}$  inch thick and approximately 60 inches wide. After leaving the line, tire material is slit into bias strips of suitable width and built up into tire casings.

By comparison with a steel- or paper-processing line, the rubber-calendering process is relatively slow, operating at top speeds of from 200 to 300 feet per minute. Tension is controlled

before and after each calender by auxiliary motors with current regulators. Coordination of the two calenders is often accomplished by a dancer roll between them. When the second calender operates faster than the first, the dancer roll is moved downward by the fabric; this adjusts a dancer rheostat, which in turn adjusts the speed of the second calender motor. If, on the other hand, the second calender is too slow, the dancer roll moves upward, thus causing a correction in the opposite direction. Dancer limit switches are also provided to stop the line if for any reason synchronism is not maintained.

Other types of roll coordination are also used. For example, on one system the second set of rolls runs at a predetermined differential speed (higher or lower) than the first set. No dancer is required. This system is used for material that stretches under tension or has low strength.

The photographs on this page show a calendering line at the Memphis plant of The Firestone Tire and Rubber Company. The sketch below is an artist's schematic representation of a typical processing line.

A—The second set of calender rolls. The strip of rubber coming down over the top roll forms a bank at the bite of the two rolls; this, in turn, forms a rubber coating that is pressed into the fabric as it is fed between the bottom two rolls. Pushing the safety bar (near the top roll) causes all motors to stop by dynamic braking. B This is the gum dip machine, where the cords are dipped in a rubber solution. Uncoated fabric can be seen entering the dip tank in the background, and the coated sheet is emerging from the squeeze rolls in the foreground. C—The tension stand (left) and cooling drums (center). The rubberized fabric enters the tension stand under the floor panels at left. The 15-hp tension stand motor (foreground), the pull-roll motors, and the windup motors are all in parallel on a variable-voltage bus. The bus voltage is controlled by a pilot generator on the second calender motor, thus keeping the whole line in close synchronization.

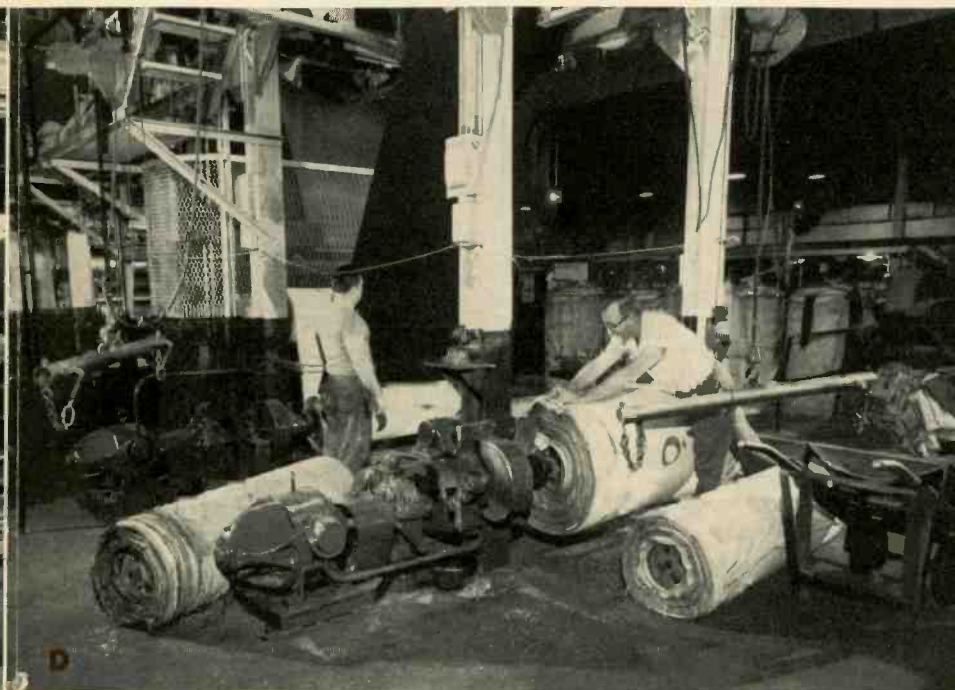
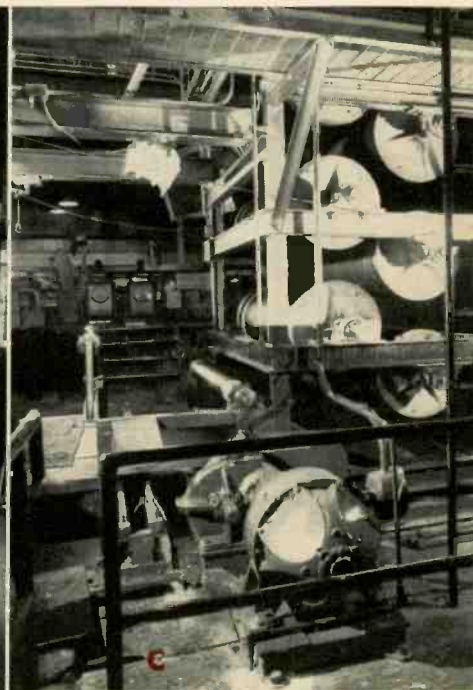
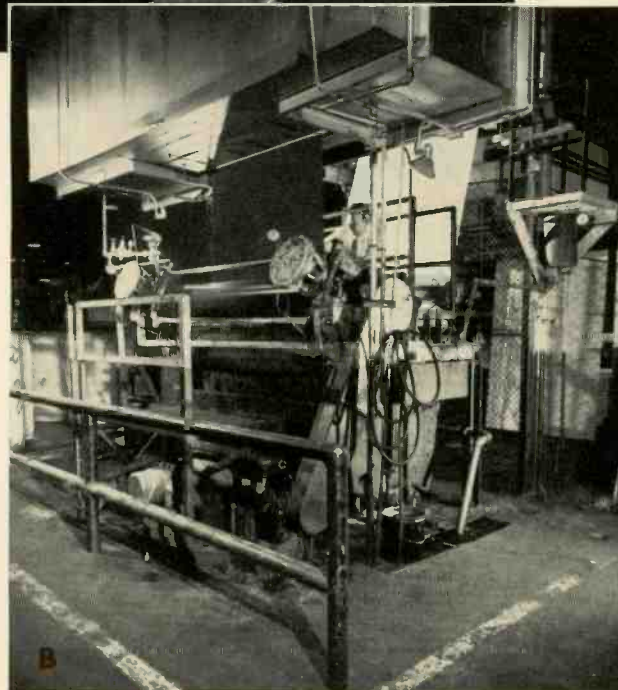

D—Here a finished roll is being removed from the winder, while another is being wound. Each winder has a 5-hp drive motor. E—The main m-g set (foreground) for auxiliaries includes a d-c adjustable-voltage generator, a-c motor, and d-c constant voltage exciter; the cabinet contains magnetic control for all calender auxiliary motors.

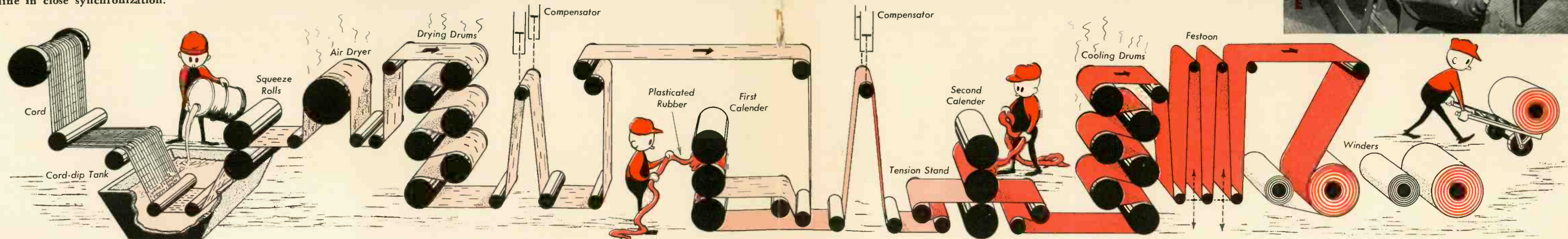

increase in frequency when the voltage-sensitive circuit is operating at the balance point is to increase the current in the capacitor branch and decrease that in the reactor branch. This causes control current to flow in the "raise" direction, which is the same effect that would be obtained by a decrease in voltage. In order to compensate for this effect, the voltage across the voltage-sensitive circuit must be increased as the frequency increases, or, conversely, it must be decreased as the frequency is decreased below normal. This response is obtained by means of a series condenser of the proper value such that it, together with the reactance of the circuit, will accurately compensate for frequency variation. The automatic-control unit used in the regulator responds to a single-phase voltage. Since the three phases of the a-c generator load are not always balanced, the voltage drop in the windings may be different. Correction for this condition is made by the positive-sequence filter circuit of the potential unit. This filter circuit involves the two current transformers (CT), which energize a mutual reactor (M) and resistor in series with the secondary of the potential transformer (PT). The voltage output of the unit is proportional, as a result of the filter, to a balanced three-phase voltage (the positive-sequence voltage) of the machine.

The performance of the WRN-11 regulator is approximately  $\pm 1$ -percent at rated frequency and at unity power factor. Its frequency compensation holds voltage within  $\pm 1.5$  percent for a  $\pm 5$ -percent frequency variation.

#### Stability Regulator

The Rototrol has found considerable application on board ship for stability regulation of a-c turbine-electric propulsion systems. On such drives, where minimum weight and size are essential, the synchronous propulsion motor driving the propeller is normally operated very near to its pull-out torque, and some means must be provided to insure a factor of safety for the sudden increases in load that occur when the vessel is maneuvering or operating in a rough sea. A stability regulator that controls excitation as a continuous function of the load uses a combination of current and line voltage to measure the load. While it would be possible to use a direct rheostatic type of control element, it has been found more expedient to use a rotary amplifier to control the exciter. This method of

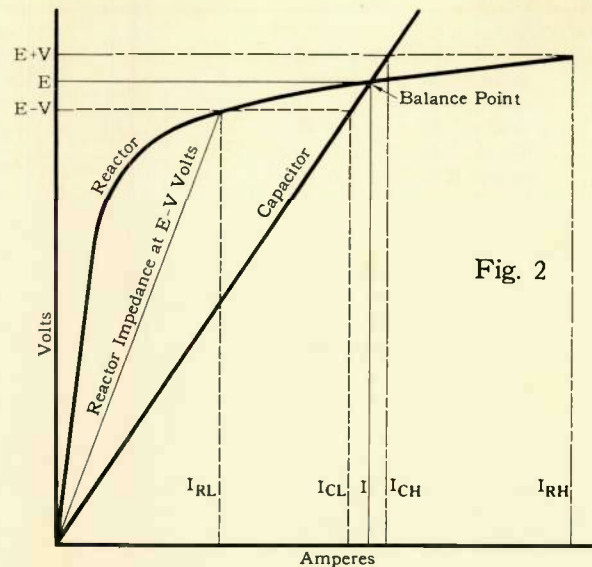

$I_{RL}$ —Reactor Current with Low Voltage  
 $I_{RH}$ —Reactor Current with High Voltage  
 $I_{CL}$ —Capacitor Current with Low Voltage  
 $I_{CH}$ —Capacitor Current with High Voltage  
 $I$ —Reactor or Capacitor Current at Normal or E A-C Line Volts

Fig. 2—Volt-ampere characteristics of the capacitor and reactor circuits for the WRN-11's voltage-sensitive device.

control eliminates the mechanical parts inherent with a rheostatic regulator, and substitutes a Rototrol with its associated electrical circuits.

The stability regulator must be able to follow load fluctuations as rapidly as they occur and maintain the field current on the propulsion motor and generator at a sufficiently high value to prevent pull-out. The circuit must be stable at all times and have no tendency to cause self-sustaining oscillations or hunting. A circuit of this type that has been used successfully for stability control is illustrated schematically in Fig. 3. The Rototrol in the circuit has three separate field windings. The first winding is excited by a constant-voltage d-c source that fixes the normal polarity and voltage of the excitation circuit. The other two fields on the Rototrol are variable. The field acting to increase excitation is pro-

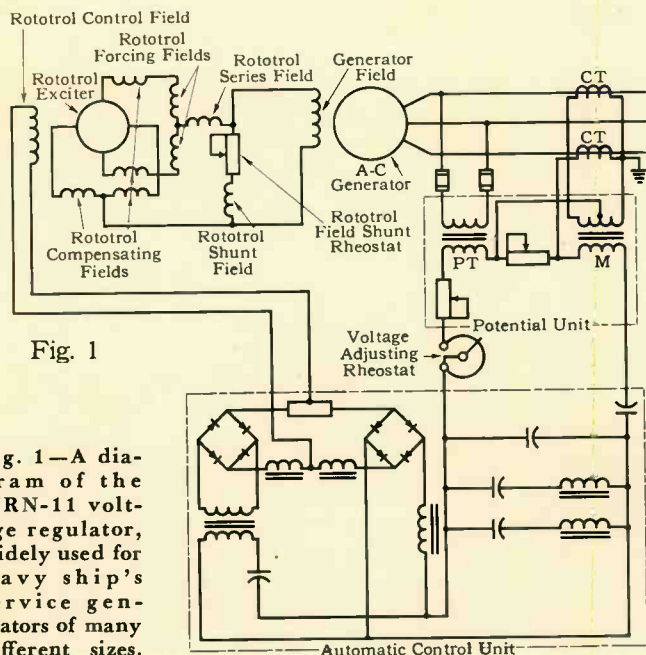

Fig. 1

Fig. 1—A diagram of the WRN-11 voltage regulator, widely used for Navy ship's service generators of many different sizes.

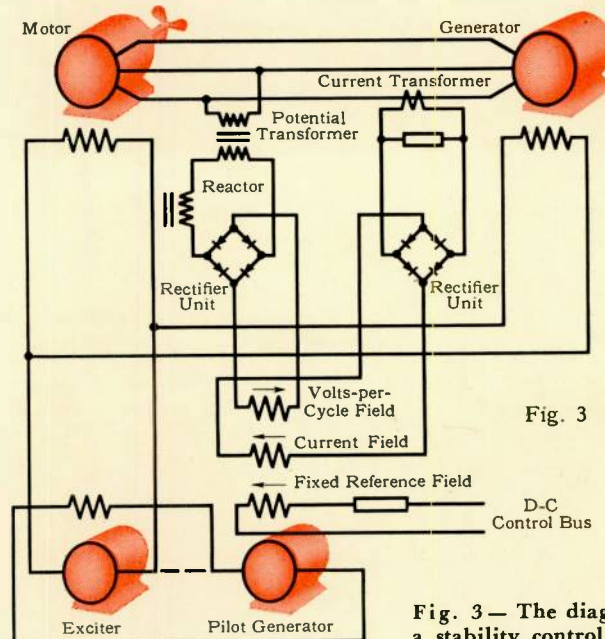
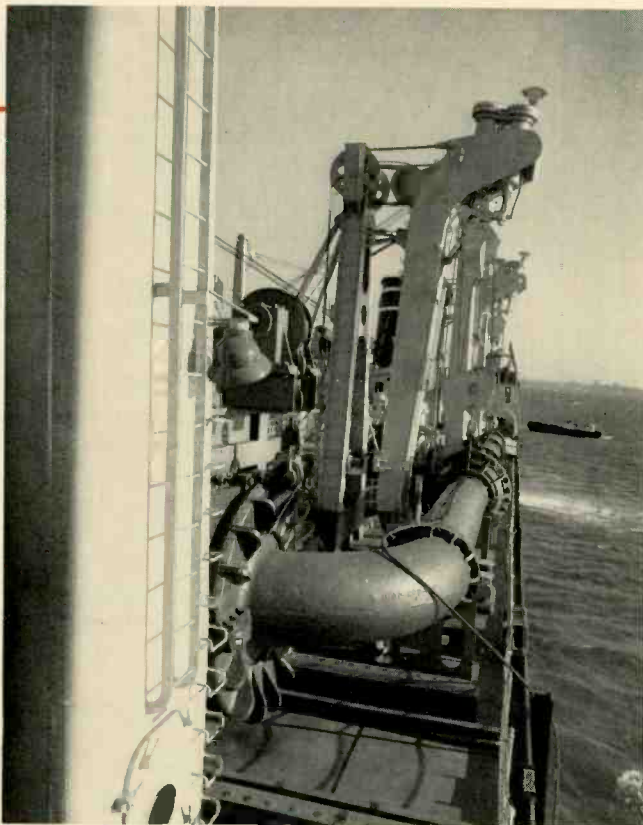
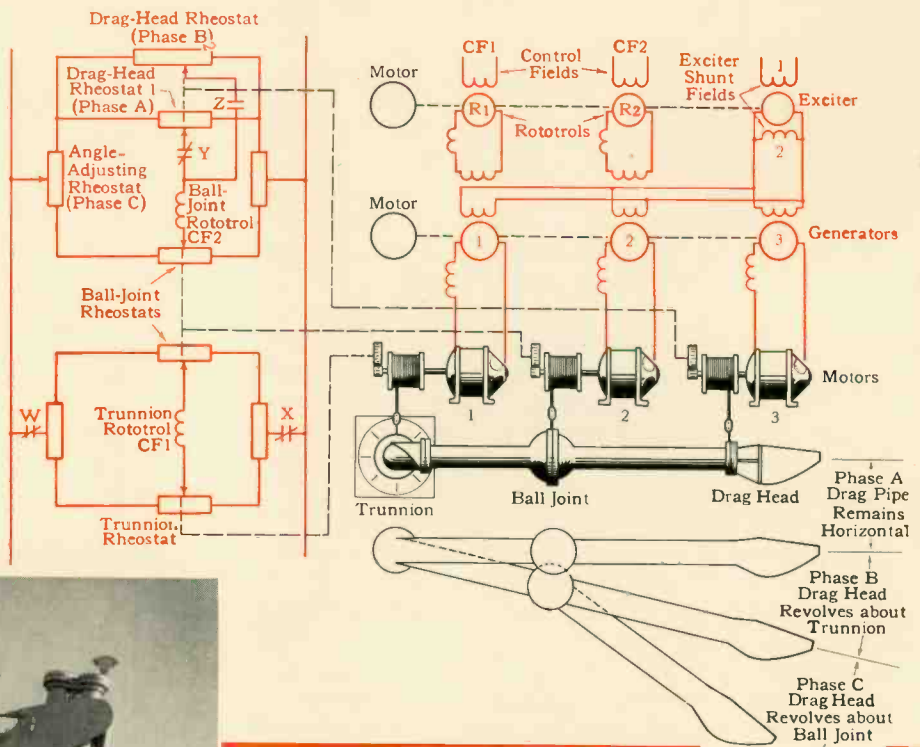

Fig. 3

Fig. 3—The diagram for a stability control circuit.

Fig. 4—A schematic diagram of the position-regulator system for the dredge drag pipe. For *Phase A* operation, contactors *W*, *X*, and *Y* are closed, and contactor *Z* is open. For *Phase B* operation, contactors *W*, *X*, and *Y* are open and contactor *Z* is closed. *Phase C* is accomplished by the angle-adjusting rheostat, with the contactors set for *Phase B* operation.

Directly below is the drag pipe in its "stored" position; at the bottom of the page is a photo of the Army dredge *Essayons*.



portional to load current, while the one acting to decrease excitation is proportional to the voltage divided by the frequency. At normal values of load, the two variable fields on the Rototrol are nearly equal and opposed so that the generator flux is produced chiefly by the constant-strength field. When the load increases, the propulsion-motor current rises and the voltage tends to decrease. Both of these effects, then, tend to increase the output of the exciter and raise the field current to carry the increased load. If the load falls off, the effects are exactly the opposite and the field current decreases. Rectifiers are provided in the regulating field circuits so that a d-c field is produced that is proportional to the alternating current in the propulsion circuit. The "volts per cycle" characteristic is obtained by using a reactor in the a-c circuit, as indicated in the schematic diagram. When the reactance of the circuit is high compared with the resistance

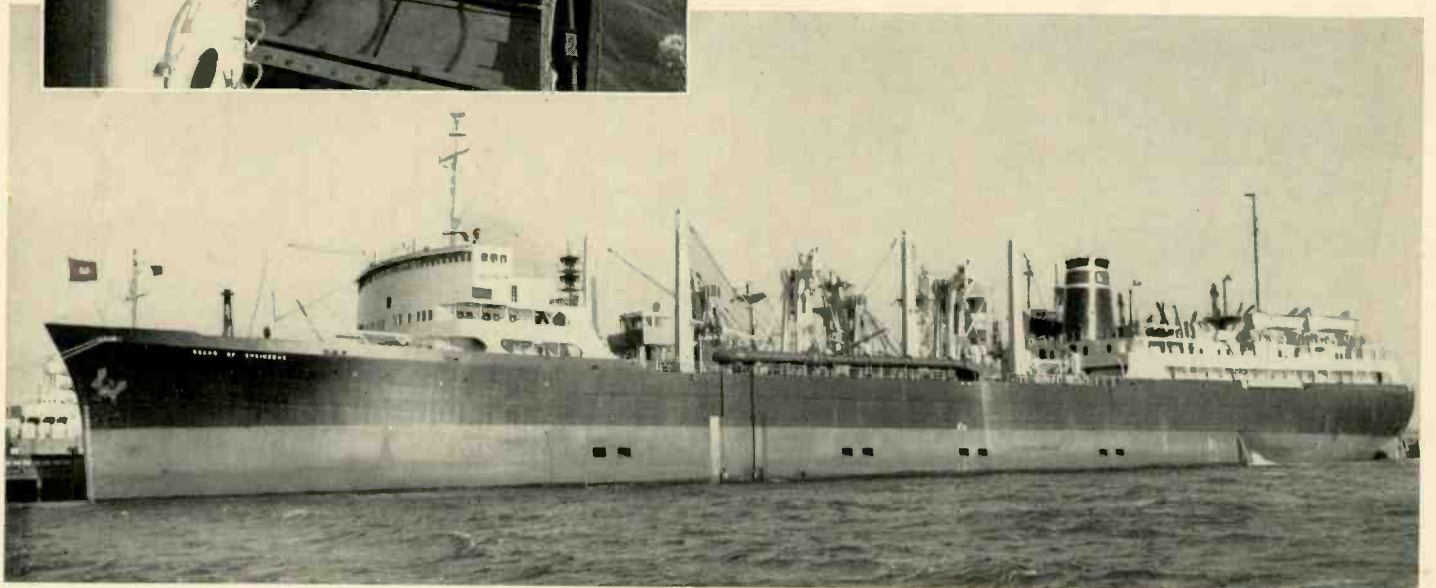

of the circuit, the current will be proportional to the voltage and inversely proportional to the frequency.

#### Positioning Regulators

A rather unusual regulator application for a marine installation was made on the seagoing hopper dredge *Essayons*, operated by the U. S. Army Corps of Engineers. A hopper-type dredge is a vessel whose function is to collect mud and silt from the bottom of harbor channels, and carry it out to sea where it can be dumped. The press has referred to these dredges as "seagoing vacuum cleaners." Silt and mud are sucked from the floor of the harbor by a long length of pipe called the "drag pipe," which is suspended over the side of the vessel. The mixture of mud, silt, and water is pumped into large hoppers on board the dredge. There the mud and silt settle out and the water is allowed to flow overboard. Once the hoppers are filled, the dredge puts out to sea where the mud is dumped through trap doors in the hoppers.

The drag pipe requires a very complicated hoisting system. The depth of the drag head must be changed frequently in accordance with the contour of the bottom of the harbor being dredged. For this application three winches are used to position the drag pipe. It is necessary that the winch drums maintain a fixed position with respect to each other in order that stresses are not set up in the drag pipe or that excessive rotation around the ball joint does not damage it. The speed of each hoist motor is controlled by varying the field of a single variable-voltage exciter, which simultaneously supplies field current to the three drag-hoist generators—one for each hoist motor. To maintain proper synchronism, two of the generator fields have Rototrol exciters that add or subtract from the respective generator voltages as the trunnion-and-ball-joint hoist motors tend to lead or lag the drag-head hoist motor as a reference. This automatic control is accomplished by means of rheostats that are geared to the winches themselves and are connected in a group of bridge circuits, as shown in Fig. 4. The unbalance of any bridge applies corrective field to the respective Rototrol exciter. During normal dredging operation only the drag-head and ball-joint winches are used and the drag pipe rotates around the trunnion as a pivot. For this operation, limit switches are used to remove the trunnion motor from the system. All three motors function, however, when the drag pipe is raised above the water line for stowing on deck.

#### Load Regulator

Sometimes a standard regulator can handle a regulation problem that is far afield from its usual application. Such was the case with a Silverstat regulator applied to a small d-c diesel-electric propulsion drive. It was used as a torque regulator and was connected into the propulsion-motor exciter-field circuit to provide maximum engine loading under various operating conditions, and also to limit the load on the diesel engine to its nominal rating. Stated in a different way, the desired function of the torque regulator was to regulate the motor field current so that the motor, under all conditions of operation, would absorb the maximum (but no more than the maximum) output of the engine at any given speed. To obtain this function, the current coil of the Silverstat was connected across the propulsion-motor commutating field winding and the potential coil was connected across the propulsion motor armature as shown in Fig. 5.

The two coils are so designed and connected that the ampere-turns of the current coil, which predominate, oppose those of the potential coil. As the regulator is set to operate

on a predetermined total number of ampere-turns, it is obvious that the motor current required to actuate the regulator is reduced as engine speed, and consequently the generator voltage, is reduced. As a result, the regulated motor current decreases in value as the engine speed is lowered.

To reduce hunting of the regulator, one winding of the damping transformer is connected in series with the current coil. The other winding is connected from the center tap of the motor-field discharge resistor to either the positive or the negative side of the field through a directional relay. This relay is so arranged that it will reverse its contacts on reversal of polarity of the generator field. In this way, the damping transformer is of proper polarity for both the ahead and astern operating conditions. Any change in the field voltage caused by action of the regulator induces a voltage in the transformer secondary. A change in the field current opposes a change in the regulator-coil current and therefore anticipates the change in the motor-field current, and consequently in the armature current, before it actually has been completed. This reduces overregulation and hunting. To reduce hunting still further, a dashpot was attached to the regulator armature lever.

During constant-operation conditions, the horsepower developed by the propeller varies approximately with the cube of the speed. If conditions change, however, and the resistance to the movement of the ship is increased, as would be the case if the ship picked up a tow, the power needed for any given speed is increased. If the ship were originally running at 100-percent speed and if no changes were made in the control, the motor would continue to operate at 100-percent speed and would simply try to draw more current to develop the increased torque imposed by the load. Such an overload condition is not desirable for the diesel engine, which ordinarily is not capable of withstanding any appreciable overload. The engine would stall unless the motor field were increased. Increasing the motor field slows down the motor to a point where the same horsepower is developed but at increased torque and decreased speed. This is the duty of the automatic torque regulator.

#### Electronic Regulator

Many electronic regulators have been applied in the marine industry. A simple, but interesting application is the electronic governor for a ship's service turbine-generator set. Electronic governors have the advantage of combining the high degree of sensitivity obtainable from electronic devices

Fig. 5—Diagram of a Silverstat regulator used to regulate torque.

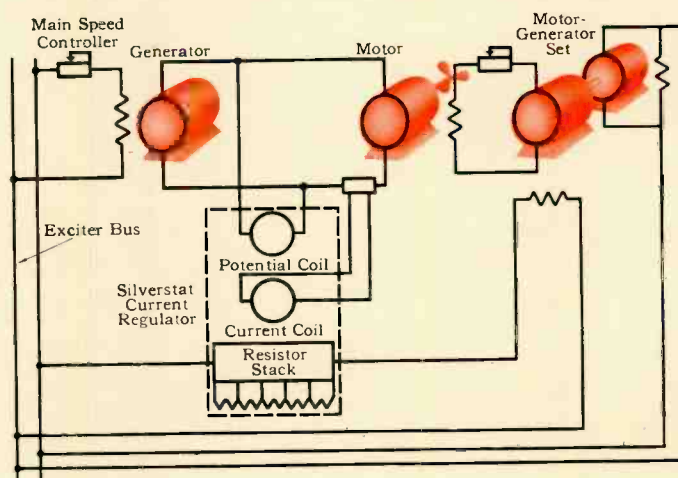

with the low-inertia, high-force characteristic of a hydraulic servomechanism. Because an electronic governor is electrically connected to the system, it does not have to be located physically at the turbine as would be the case with a mechanical governor.

This electronic governor was designed to give a maximum performance of one half of one-percent speed regulation during nonparallel operation of the unit. Maximum stability and transient response are obtained by using an anticipation network and a circuit that detects rapid rates of load change. The anticipation circuit introduces a signal proportional to the first derivative of the error signal. Essentially, it is a lead network that tends to compensate for lags occurring elsewhere in the system. The anticipation circuit aids both stability and transient response. The rate of load-circuit change aids only response. Since the usual governor responds to a change in speed, it can only detect a change in load by the speed change that results. It must wait for this change in speed before corrective action can be initiated. This delay is detrimental to good transient response. On the electronic governor it is relatively easy to introduce a voltage proportional to the rate of change of load, in such a way as to correct for a change in speed almost before the change occurs.

Many electronic regulating systems are presently undergoing considerable redesign to accommodate magnetic amplifiers. The rebirth of the magnetic amplifier as distinguished

from the saturable reactor is generally credited to the Germans, who prior to and during World War II developed countless applications for its use. By far the majority of these applications were in the marine and aviation fields. The German Navy used the device in its gun stabilizers and the Luftwaffe applied it to automatic pilots and ground-approach systems.

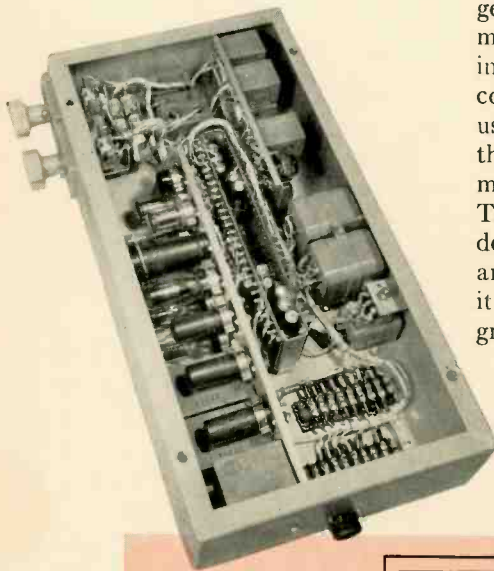

A photograph of an electronic governor for a ship's service turbine-generator.

### Magnetic-Amplifier Regulators

Submarines now in service depend on diesel engines for their prime source of power. This power is converted into electrical energy for propulsion; a storage battery of considerable size acts as a reservoir for the electrical energy generated. This permits continued operation of the propulsion motors when the submarine is submerged below snorkel depth and the diesels are shut down. The ship's service power system on such craft is superimposed on the battery system. Direct-current auxiliary loads are supplied directly, while a-c loads receive power through d-c to a-c motor-generator sets. Unfortunately, the battery, depending on the condition of its charge, may have a voltage anywhere between 450 and 710 volts. Since many of the a-c loads on the submarine must have a constant frequency as well as constant-voltage supply, it is necessary to provide rather involved speed and voltage regulators for the m-g sets. The speed regulator for such an m-g set is shown in Fig. 6a. The input-control transformer receives single-phase power at 450 volts from the generator and steps it down to 225 volts for the regulator circuits. The magnetic amplifier (see Fig. 6a) provides a means whereby relatively small control signals derived from the frequency- and voltage-reference circuits can control a relatively large current applied to the control-field coils of the motor. The parallel resonant circuit and the signal-voltage rectifier, together with the reference-voltage rectifier, furnish the principal control signals to the magnetic amplifier.

Power from the control transformer is applied to a frequency-sensitive network and to the magnetic amplifier. The output of this amplifier is applied to the main rectifier, where it is converted to direct current and then applied to the motor control field. The frequency-sensitive circuit (see Fig. 6b) consists of a bridge network, of which one leg is composed of the automatic speed-calibrating rheostat and a fixed resistance in series with a full-wave selenium rectifier. This leg is energized from the secondary of the control transformer. The other leg consists of a parallel resonant circuit (formed by a reactor and capacitors) in series with a similar full-wave rectifier. The resistive-leg output is a d-c voltage, used as a reference. The resonant-leg output is the regulating voltage.

These are but a few of the regulators found in the marine industry. There are many, many more. However, the examples outlined here serve as a graphic illustration of the variety of automatic regulating systems found on modern ships.

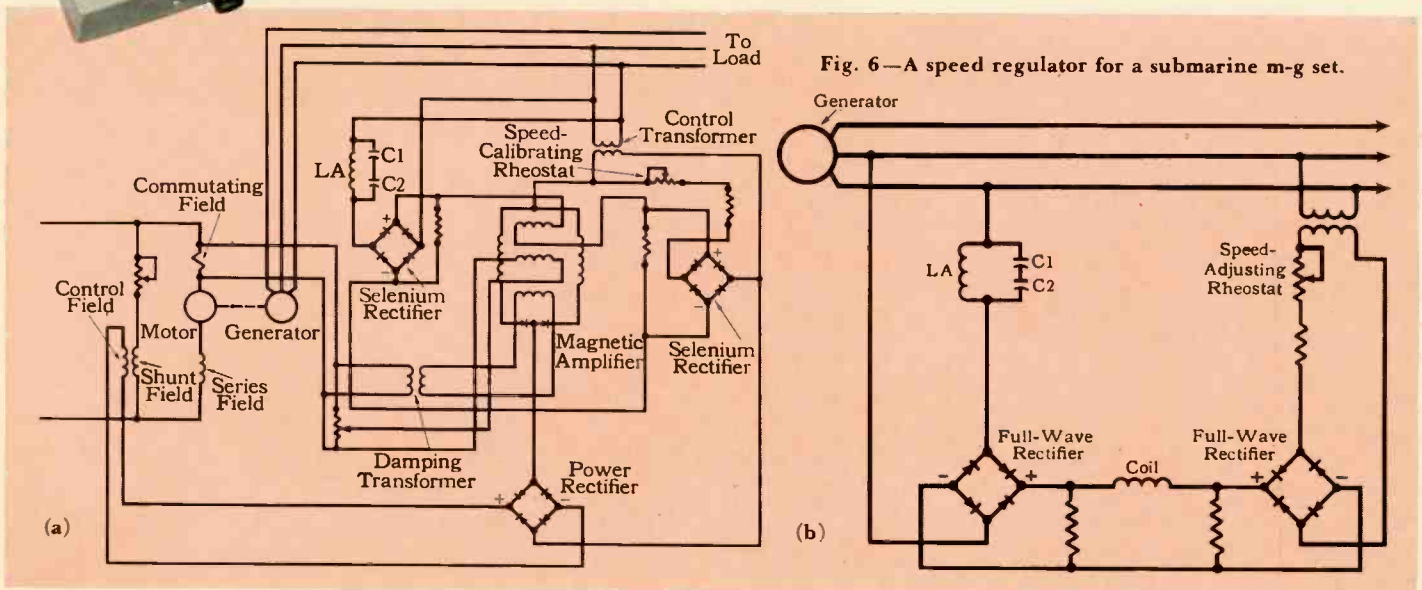

Fig. 6—A speed regulator for a submarine m-g set.

# Power for Underground Mines

Although an underground mine bears little physical resemblance to any kind of manufacturing plant, many of the basic electrical problems are closely related. The voltage regulation, size of conductors, and choice of a-c or d-c power, for example, are common problems, although mining does have some special considerations of its own.

J. Z. LINSSENMEYER and A. G. OWEN, *Mining, Petroleum, and Chemical Section, Industry Engineering Department Westinghouse Electric Corporation, East Pittsburgh, Pennsylvania*

**T**HE PROVISION of electrical power to underground mining machinery is a somewhat singular problem, requiring more rigid restrictions of installation than any other industry. This fact is particularly true in underground coal mining.

Until recent years, d-c powered transportation constituted the chief demand for electric power; thus less effort was required or expected in the direction of good voltage regulation or an adequate supply of power. Even today, 275-volt power commonly winds up at 160 volts at the machinery load. While such extremes in regulation can be lived with on d-c systems, even though highly undesirable, they cannot be tolerated in an a-c system.

## The Choice—A-C or D-C?

The distribution problem divides into two parts: First, the primary transmission of power from the point of entry to the load centers; and second, the distribution at utilization voltages to the apparatus, i.e., the mining machinery and transportation equipment.

The primary transmission invariably is alternating current in either an a-c or d-c system. The primary distribution terminates in a-c substations or d-c conversion units, the location of which is chiefly a function of fire hazard, accessibility, and necessity for portability. Generally speaking, either a-c or d-c drives can be successfully applied to all equipment with the exception of haulage applications.

This article is based on an AIEE paper presented at the Southern District Meeting in Louisville, Kentucky on April 23, 1953.

The utilization voltage is closely related to the regulation problem, but in many cases an optimum choice is prevented by state laws. As an example, a survey of the 18 states with a published code shows seven limiting the voltage at the face to 300 volts, eight making no mention of voltage at all, and three allowing voltages over 300 under certain circumstances.

In the comparison of a-c and d-c systems, voltage regulation is an important factor. Both a-c motors and controls require much better regulation than their d-c counterparts. The added elements of power factor, line reactance, high motor-starting currents and high contactor drop-out voltages tend to offset the greater voltage-compensating characteristics of the a-c system. The regulation of a d-c system is subject only to line resistance and relatively low motor-starting currents, and is not subject to the above-mentioned

An explosion-proof portable minepowercenter; this consists basically of a dry-type air-cooled transformer plus related circuit-breaker equipment. Inset photograph shows the AB breakers.



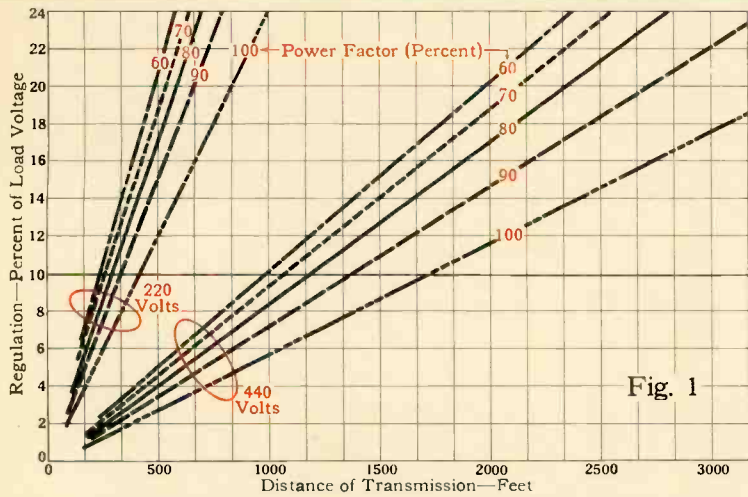

Fig. 1—The relative transmission distances at 220 and 440 volts a-c for 4/0 cable, for several different power factors.

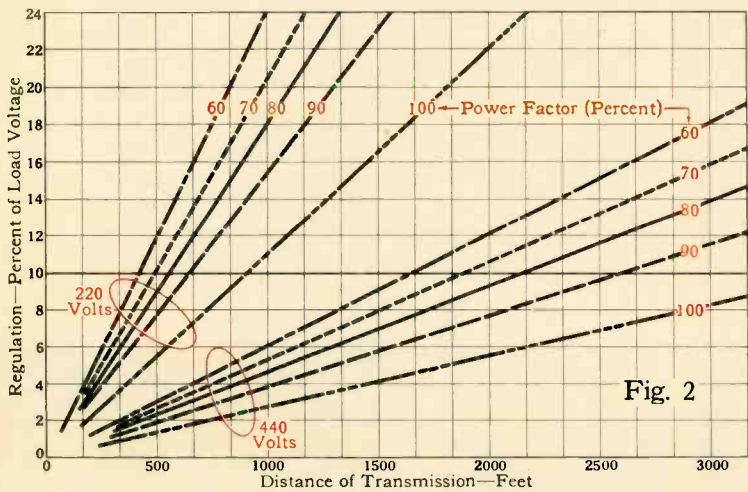

Fig. 2—Transmission distances for a 500 000 circular-mil cable at 220 and 440 volts, for power factors of 60 to 100 percent.

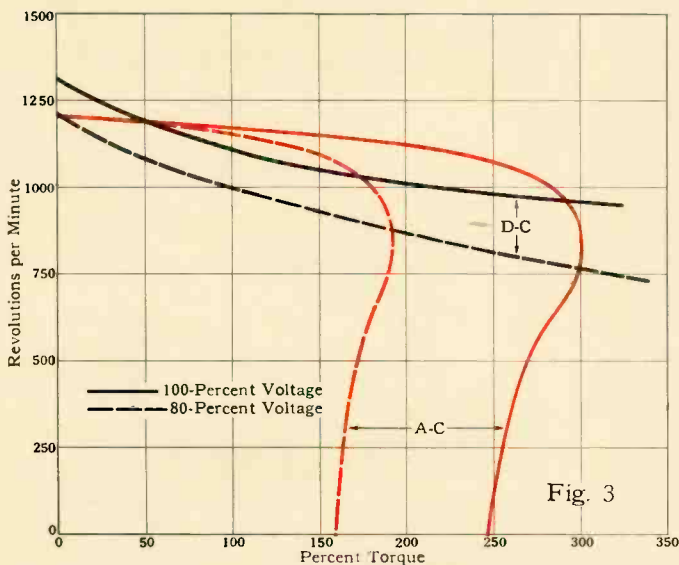

Fig. 3—The speed-torque curves for a d-c compound-wound motor, and those of a low-slip, squirrel-cage induction motor.

factors (i.e., power factor, etc.) inherent in a-c systems.

The greatest problem in a-c regulation occurs during the motor start-up, and, as a result, the a-c conductor choice is determined chiefly by the motor-starting current and torque demand, plus the added factor of a-c contactor drop-out ratings.

For approximately equal torques of 200-percent full-load ratings, the starting current for a-c motors is approximately two-and-one-half times that for d-c motors. The a-c motor requires a regulation half that for a d-c motor to meet these conditions.

If cable impedance is assumed to be a direct function of cable cross-section, the a-c motor requires approximately 4.62 times more copper at 220 volts than the d-c motor at 230 volts. At 440 volts this figure is 1.15. However, because of the effect of cable reactance and power factor, these ratios are not actually true, but rather vary from a fraction of, to a larger figure than 4.62. A proper selection of conductors will keep this ratio at a minimum.

For a fully loaded motor the copper required for a 440-volt cable is approximately one-fourth that for a 220-volt cable for equivalent regulation, while for a motor-starting load, the 440-volt cable may require as low as one eighth the copper of a 220-volt cable for the same regulation. Since it is obvious that the first case will be the limiting factor, the 440-volt cable can be one fourth the size of a 220-volt cable for equivalent regulation; likewise, the starting regulation at 440 volts may be half that at 220 volts.

The relative distances that a load of 200 kw can be transmitted over a cable (4/0) at 220 volts a-c and 440 volts a-c are shown in Fig. 1 for power factors ranging from 60 percent up to 100 percent. A line is drawn across the chart at the ten-percent regulation level, tentatively set as the desired maximum. Note that the transmission distance at 440 volts is four times that for 220 volts; and that the lower the power factor of the load, the shorter the possible transmission distance for the same percent regulation.

The transmission distances for the same considerations except for a 500 000 circular-mil cable are shown in Fig. 2. Again a straight line drawn across the chart at the ten-percent level shows the transmission distance at 440 volts to be four times that at 220 volts for the same regulation. As before, the lower power factors greatly reduce the transmission distance possible for a given voltage regulation.

These comparisons graphically illustrate the saving in copper, which is an item of tremendous importance; from a safety angle the line-to-ground voltage is only 256 in the 440-volt system, as compared with a voltage of 275 on d-c systems. In addition, a safer grounding method is possible with the a-c system than has yet been devised for direct current.

The minimum power factor always present during a motor start-up causes the line reactance to take precedence over the line resistance in the determination of voltage drop. Reduction of line reactance is better accomplished by a minimum conductor spacing and the use of paralleled three-conductor cables, since reduction of conductor size in a cable produces very little if any increase in reactance.

In the solution of the regulation problem, two choices are available: either increase conductor sizes and num-



bers, or use power-factor correction to minimize the effect of motor-starting currents or line reactance, or both.

Consider a typical case. A continuous-mining machine 1000 feet from the low-voltage transformer, with one 50-hp traction and two 70-hp cutter motors, imposes a 25-percent traction-motor load and a starting load for both cutter motors, which is the worst condition that could be experienced. Assuming a 35-percent and 85-percent power factor for starting and running power factors, the line currents would be 1800 and 475 amperes, respectively.

Assuming unloaded starting for the cutter motors, a maximum regulation of 20 percent can be chosen as practical from contactor drop-out considerations. Such a regulation reduces the starting current to 1440 amperes.

A 1 500 000 circular-mil cable would give 24-percent regulation, but would not achieve a 20-percent regulation since further increase in conductor size serves to produce a net increase in conductor spacing and reactance. Quite obviously, too, a cable of such large size is impractical from a weight and handling standpoint.

The use of two paralleled three-conductor cables would permit 300 000 circular-mil conductors to give 20-percent regulation, or three paralleled three-conductor cables with 2/0 conductors can be used. The important point is the total copper cross-section of the three 2/0 cables, which is less than one-third of that of the 1 500 000 circular-mil cable and is made possible by closer spacing. Again, line reactance is a most important factor in a-c voltage regulation.

Now consider power-factor correction as a means of improving regulation. To avoid the necessity of additional kva capacity in the system feeding the load, the total line current with capacitors added must be no greater than before. The capacitor will therefore be 190 kva and the full-load line power factor will be 85-percent leading instead of lagging.

Such a capacitor allows the two paralleled cables to be reduced from 300 000 circular mils to 4/0 conductors for the same 20-percent regulation, while the three paralleled 2/0 cables could not be reduced to 1/0 conductors without increasing the regulation to 21 percent. It is interesting to note that only 95-kva capacitors, which would give a full-load power factor of 100 percent, would require 250 000 circular mils for two cables and the same 1/0 for three cables with 22-percent regulation. In all the above cases, the full-load regulation is less than 11 percent. Reduction of line reactance is more beneficial than the addition of capacitors.

The discussion of shunt capacitors thus far has assumed them as connected continuously to the line. However, they can be in-

stalled such that they can be switched from the line with the motors. The disadvantage of this method is the possibility of overvoltage from self-excitation unless the capacitor size is limited to a kva rating approximately one fourth of the connected motor horsepower. The maximum capacity possible with two 70-hp motors would then be about 35 kva. Since the small benefit of the 95-kva capacitors has already been shown, this method also would be unsatisfactory.

The addition of capacitors does, however, correct power factor and reduce voltage drop throughout the feeder system. Therefore, some combination of capacitors and cable division gives the best answer in the problem of voltage regulation, but shunt capacitors cannot do the job alone.

Compare the characteristics of a-c and d-c motors. Over the normal operating range of voltages, the d-c motors maintain essentially the same peak value of torque, while reducing speed approximately in direct proportion to reduction in line voltage. The a-c motor-starting and maximum available torque varies as the square of the line voltage, while maintaining an essentially constant speed. In addition the starting current is approximately five times normal running current and the starting power factor is very low. The d-c starting current is in direct proportion to the torque required and is usually limited by a starting resistance. Loss of torque in the a-c motor can be compensated to some degree by the use of a motor design such that the high starting torque more closely approaches the pullout torque values; also the low starting current aids in keeping the line loss at a minimum.

Consider the speed-torque curves for a d-c compound-wound motor and a low-slip, high-pullout and starting torque, a-c squirrel-cage induction motor, as shown in Fig. 3. The stalled torque or zero-speed torque of the d-c motor is not shown, since this is not considered to be a safe operating point; the resultant high current can cause a commutator flashover.

Factory-assembled units simplify the installation of underground substations.

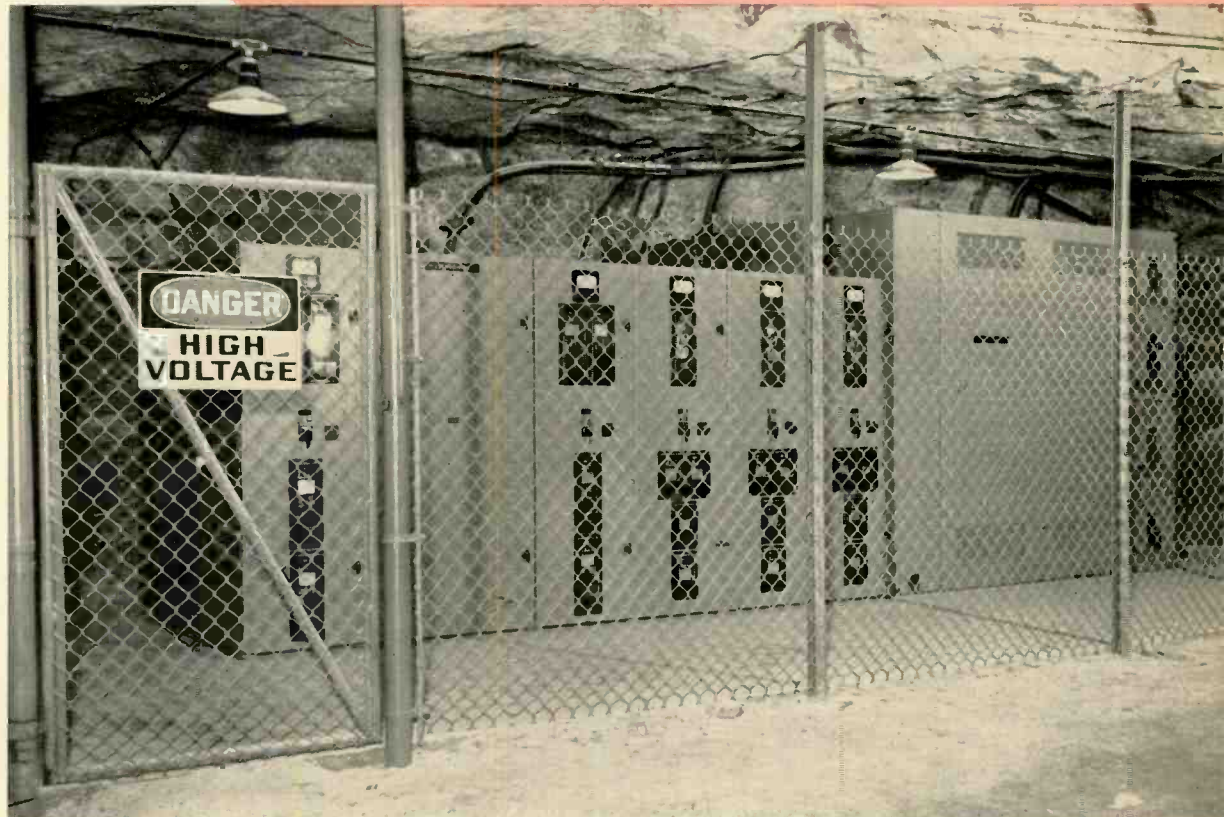

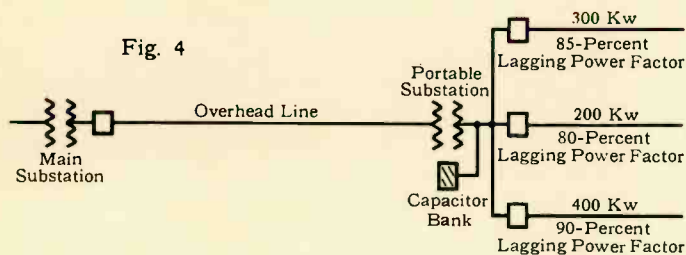

Known Constants  
 Voltage at load ..... 4000 or 6900 volts  
 Total load ..... 900 kw  
 Power factor of load ..... 86 percent  
 Voltage drop to load ..... 5 percent of load voltage  
 Conductor spacing of feeder. Aerial line, 34 inches  
   Cable, 10/64 inches conductor insulation  
 Length of feeder ..... 8000 feet

**CONDUCTOR SIZES DETERMINED FROM CURVES**

Voltage	Conductor Size	Power-Factor Correction	Type of Line
4000	300 000 cm	None	Aerial
4000	4/0	95% Lagging	Aerial
4000	1	97% Leading	Aerial
4000	3/0	None	3-Conductor Cable
6900	2	None	Aerial
6900	2	None	3-Conductor Cable

While all but the smaller sizes of d-c motors are started in series with a current-limiting resistor, a-c motors are usually started directly across the line. While the a-c motor develops full starting torque at once, a voltage reduction to 80 percent normal reduces the starting torque to 64 percent, while the d-c motor under the same conditions merely suffers a reduction in speed. In short, a serious reduction in line voltage can cause the a-c motor to fail to start, while causing only speed reduction in the d-c motor.

**Solution of A-C Distribution Systems**

Alternating-current systems involve several considerations not present in d-c systems, which tend to complicate the calculations of an a-c line. However, two easy and fairly accurate methods are available to solve a-c distribution systems, at either primary or utilization voltages.

For example, taking a small section of an a-c distribution system, as shown in Fig. 4, the problem is to determine the conductor size required to maintain a five-percent voltage regulation, and the best transmission voltage.

The first step is to determine the total load and combined power factor appearing at the low-voltage substation. Adding the kilowatt loads directly, the total is found to be 900. Using Fig. 5 to determine the kvars of each load, the total is 525 kvar for the 900-kw load, and from Fig. 5 again, we see that this represents a power factor of 86 percent lagging. Now a conductor size can be chosen.

The conductor sizes as a function of power factor and "kwd" for one-percent voltage regulation are shown in Fig. 6. The term kwd is the product of kilowatts load and feeder length in thousands of feet for a nominal mean conductor spacing of 34 inches. The 900-kw load for a distance of 9000 feet at five-percent regulation, then, represents 1620 kwd. At a transmission voltage of 2300 volts, at 86-percent power factor, there is no conductor curve, which means this voltage is unsatisfactory. Checking a voltage of 4000 volts, we find a

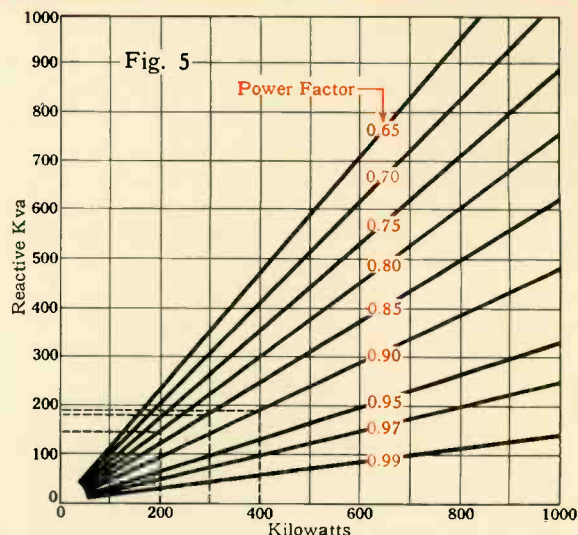

Fig. 5 — Relationship of kvars to kw at various power factors.

400 000 circular-mil conductor to be satisfactory. If this is too large, either a higher voltage or power-factor correction can be tried.

Trying a voltage of 6900 volts first, a No. 2 conductor appears satisfactory. If power-factor correction is used, a 4/0 conductor at 2300 volts would require a leading power factor of 97 percent, while at 4000 volts it would require a lagging power factor of 95 percent.

Referring to Fig. 5 again, observe that a power factor of 95 percent lagging shows 300 kvar for 900 kw, leaving 225 kvar to be compensated for by capacitors. By a similar method note that 750 kva of capacitors would be required for a 97-percent leading power factor. The cost of a capacitor installation can then be balanced against the cost of conductors and the higher transmission voltages.

Now check the same problem, using a three-conductor cable. Referring to Fig. 7, which is a duplicate of Fig. 6 but is for cable spacings, we find again that 2300 volts is not a suitable transmission voltage, that 4000 volts requires a 3/0 conductor, and that 6900 volts requires a No. 2 conductor.

If the power factor is to be improved, the same procedure would be followed as before, but a closer look at the slopes of Fig. 7 curves shows that little reduction in conductor size can be achieved. As an example, to reduce the conductor size from 3/0 to 2/0 we must improve the power factor from 85 percent lagging to 98 percent lagging, and to reduce to the next conductor size of 1/0 requires an improvement to 85-percent leading power factor. Here again the importance of a small line reactance is apparent, as is the small gain derived from shunt capacitors, where cables are used.

These curves can be used for voltages of 230 or 460 by taking the square of the voltage ratios as a multiplier. For example, 2300 volts is ten times 230 volts, and the square of this ratio is 100. Ten kwd at 230 volts is thus read as 1000 kwd on the 2300-volt scale.

The last check is the thermal capacity of the conductor sizes chosen. Referring to Fig. 8, at 4000 volts and 85-percent lagging power factor, a No. 4 conductor is adequate for the pole line, and a No. 1 conductor is adequate for the cable. Since these sizes are smaller than those chosen from Figs. 6 and 7, it is obvious that the condition of thermal capacity is fully satisfied.

There are occasions where conductor spacings, other than

those discussed so far, are required. For this reason an alternate method is sometimes used for a-c line calculation; this method is also advantageous in that it can easily be jotted down in a pocket memo or diary, and the calculations involved are very simple.

The complete method is shown in Fig. 9, which is more accurate than many short-cut methods. These formulas can be worked in either direction, in that a conductor size can be assumed, as well as all but one of the other variables, and the last variable determined; or a load and all but one of the other variables can be assumed and the remaining variable determined.

The term kwd, as before, represents the load in kw per one-percent regulation per 1000 feet of line one way. Should it be desired to use  $R$  and  $X$  as the resistance and reactance, respectively, per mile of line instead of per 1000 feet, then the kwd will be per mile of line instead.

If trigonometric tables are not available to determine the term "tan  $\theta$ " from the power factor, it can easily be calculated from the power factor as shown.

Lagging and leading power factors are taken into consider-

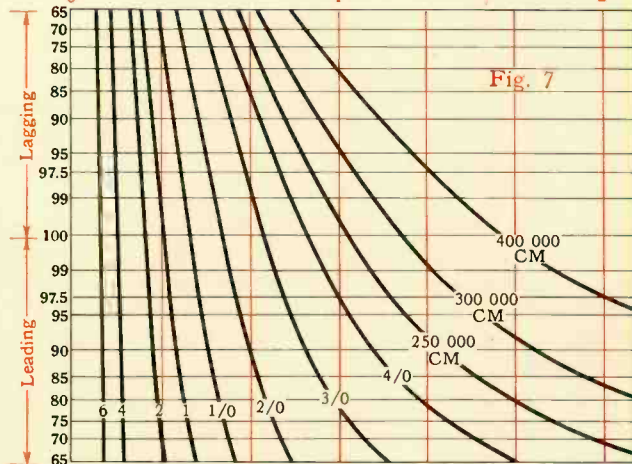
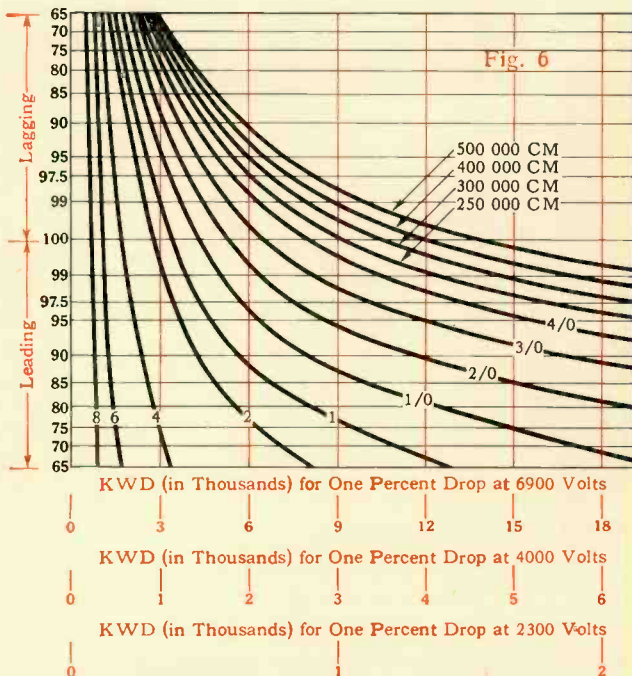

Figs. 6 and 7—Conductor and cable sizes as a function of power factor and "kwd" for one-percent voltage regulation. Top diagram is for conductor sizes, lower for cable spacings.

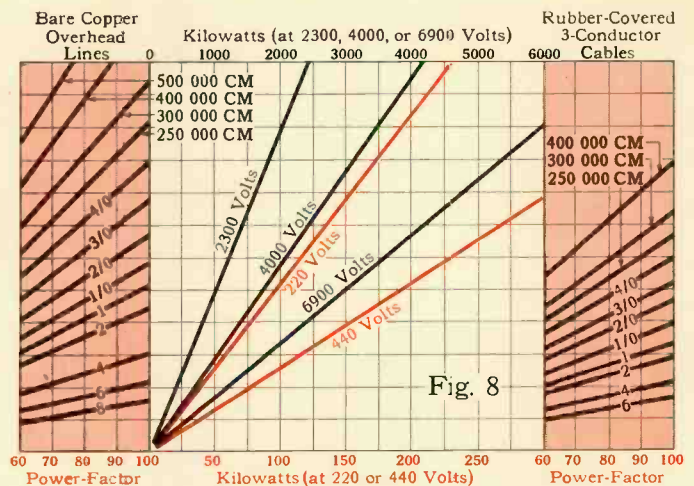

Fig. 8—The adequacy of the conductor and cable sizes can be determined from this group of curves. This indicates whether the chosen conductors have sufficient thermal capacity for the required job.

ation by the sign between the  $R$  and  $X$  terms, being plus for a lagging power factor and minus for a leading power factor. Either three-phase or single-phase lines can be calculated. The resultant kilowatts obtained from the formula are for a three-phase line; and dividing this result by two will give the kw for a single-phase line of the same size, length, etc.

Both a-c and d-c motors and distribution systems have their limitations, which are further magnified by laws limiting utilization-voltage maximums; but the trend towards increased mechanization and the increased demand for electric power at points remote from the power sources may gradually force a turning to a-c powered equipment. Also, a revision of mining laws to permit utilization voltages that are best suited to the needs of the industry, as well as to the safety of the equipment-operating personnel, seems to be a necessary requisite for future progress.

Fig. 9—A calculation method for a-c distribution lines. These formulas enable simple solution of system factors.

$$KWD = \frac{E^2 \times 10^{-6}}{R + X \tan \theta}$$

KWD—Load in kilowatts per one percent regulation per 1000 feet of line  
 $E$ —Voltage at the load  
 $R$ —Resistance per 1000 feet of one conductor  
 $X$ —Reactance per 1000 feet of one conductor for spacing used

$$\tan \theta = \frac{\sqrt{1 - PF^2}}{PF}$$

tan  $\theta$ —Trigonometric tangent of angle, the cosine of which is the power factor of the load  
 $PF$ —Power factor of the load

$$KW = \frac{KWD \times \text{Percent VR}}{D}$$

KW—Power in kilowatts to be transmitted  
 Percent VR—Percent voltage regulation desired  
 $D$ —Length of feeder in thousands of feet

1. In the top formula use  $(R + X \tan \theta)$  for lagging power factors, and  $(R - X \tan \theta)$  for leading power factors.
2. For three-phase power multiply kilowatts by 1; for single-phase power divide kilowatts by 2.

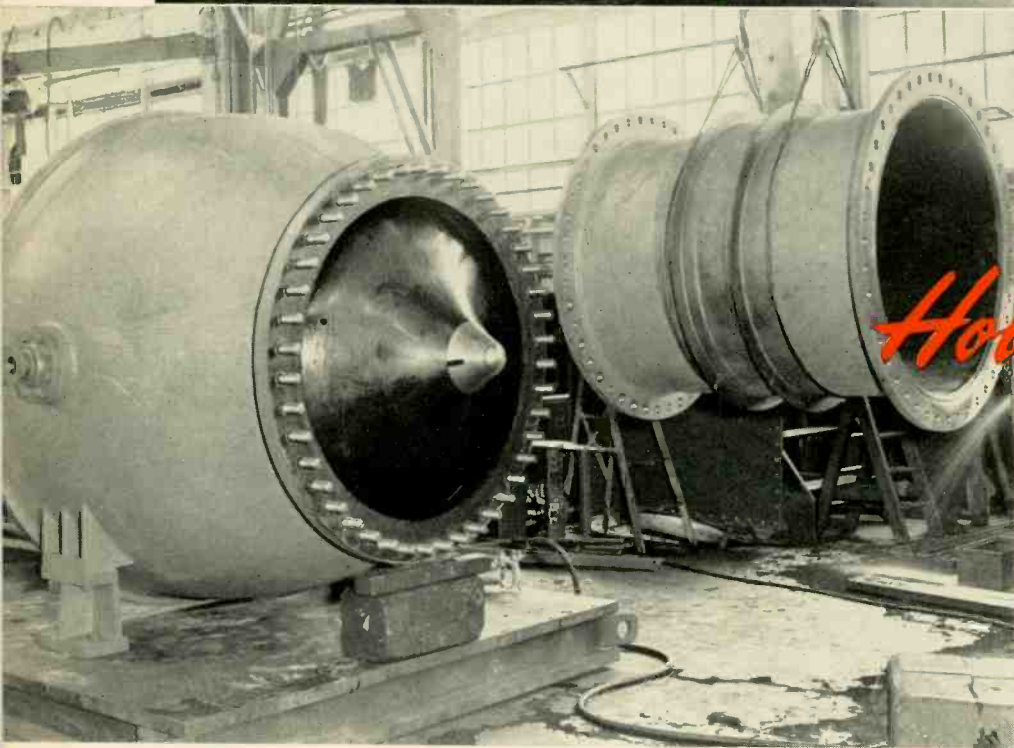
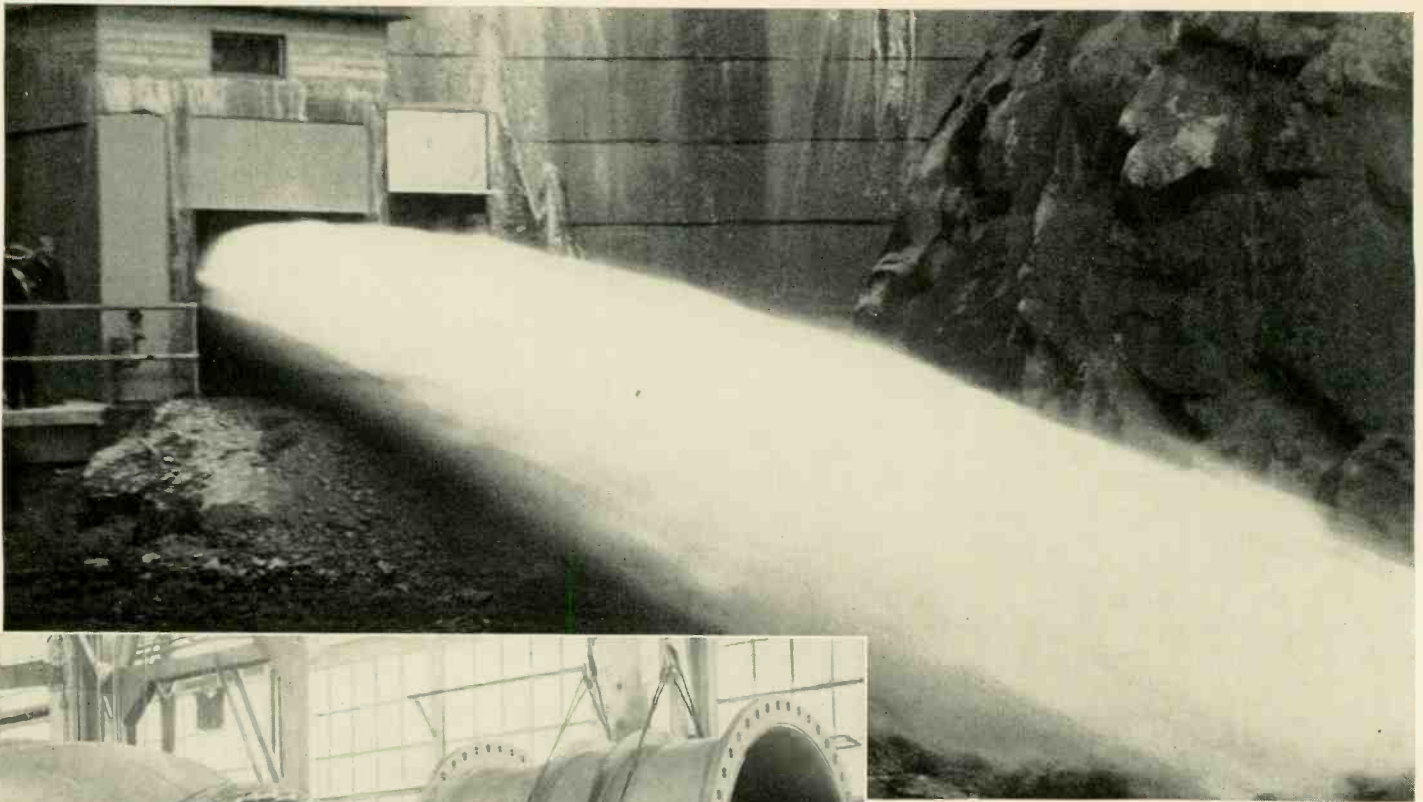

## Hollow Jet Valves

G. H. HEISER

Manager, Mechanical Engineering Division  
Westinghouse Electric Corporation  
Sunnyvale, California

**Mountains of spray and erosion of stilling basins are unwanted by-products caused by the water discharged from storage basins. The hollow-jet valve produces a "soft" aerated stream, reducing these problems.**

**Top photo: The jet produced by a hollow-jet valve. Below: A 48-inch hollow-jet valve. This shows the inlet, i.e., the upstream end.**

**T**HE HOLLOW-JET valve\* is a high-head, free-discharge valve used to regulate and discharge water from storage reservoirs. As its name implies, the valve discharges a jet that is hollow in form. This hollow jet is produced by the shape of the water passage beyond the valve seat. The water is also aerated as it passes through the valve.

This aeration, together with the hollow form of the jet, makes for a soft discharge into the stilling basin or flow channel. Relative freedom from erosive action by the discharge from the valve lowers both original construction and maintenance costs of stilling basins and channels. The absence of

spray and mist is another important advantage of the hollow-jet valve, particularly if highways and electrical installations are located in the vicinity. This feature also prevents icing on nearby areas if the installation is located where freezing temperatures are encountered.

Water flows through the valve without causing partial vacuums that give rise to cavitation, which in other types of free discharge valves can cause serious erosion of metal in contact with the water stream. Also eliminated are the vibration effects of cavitation that can cause damage to the valve and surrounding structure.

Close regulation is readily attained with the hollow-jet valve, making it the ideal selection in applications where this function is important. The jet is constant in diameter and in flow pattern for the same head, throughout the full range of valve openings. The valve always discharges axially regardless of head or opening.

\*The inventors of the hollow-jet valve are B. H. Staats and G. J. Hornsby of the U.S. Bureau of Reclamation.

The inlet diameter of the valves built so far range from 14 inches to 102 inches. Under an effective head of 130 feet, a 102-inch valve can discharge 3650 cubic feet per second. Since 1945, when the first of these hollow-jet valves was tested at Hoover Dam, 43 have been put in operation in the United States and foreign countries.

The hollow-jet valve controls flow by the positioning of a needle. It thus seats in the upstream direction. In the all-cast design of hollow-jet valves, the needle has several holes to admit water to its interior to put the valve in complete balance when fully closed. In open positions, the valve is very nearly balanced, the amount of unbalance being dependent on the diameter and location of the balancing holes and the effective head at the valve. The needle is moved forward and backward by hand or by electric motor, through a gear train and screw. Because of the balance feature, little stem torque is required. Valuable protection to the upstream works is afforded by the fact that the valve cannot slam shut and cause water hammer in the connecting penstock.

In addition to the conventional all-cast construction described above, a hydraulically operated hollow-jet valve has been developed by Westinghouse engineers. This valve has the same flow characteristics and advantages of a soft hollow jet, i.e., freedom from cavitation, erosion, and vibration, and is easily regulated.

This new valve is not balanced by the penstock water pressure, but is operated and balanced by oil pressure. To operate the needle, high-pressure oil is pumped into a cylinder between two cones forming the needle. The oil pressure builds up until the needle just moves. Then a state of equilibrium exists between the water load on the valve and the operating oil pressure. To move the needle further, an Acme-threaded screw, working through a gear train, is moved by hand or an electrical remote control.

This screw controls a variable orifice located between the

needle support cone and the screw end. As the screw is moved to open the orifice, oil flows from the chamber changing the balance, and the needle moves in the opening direction. The needle can be stopped at any position by stopping movement of the screw. The oil under pressure can then be shut off and the needle is supported mechanically on the stem, positively locked by the Acme threading. For closing the valve, the screw is merely turned in the opposite direction. This tends to close the orifice and the pressure is built up to balance the needle. By continuing to move the screw, the needle continues to close in a smooth manner. As with the mechanically operated valve, there is no possibility of slamming and resultant water hammer.

The maximum pressure available within the needle chamber of the mechanically operated valve is the static head of water above the valve at shut-off. For the valve needle to be balanced when shut off, the outside diameter of the needle cylinder must correspond to the seat diameter. Having established a needle-cylinder diameter, the minimum diameter of the outer barrel of the valve becomes fixed. This latter diameter must be large enough to permit discharging the required amount of water, with enough space left between the inner diameter of the hollow jet and the needle cylinder to permit the proper entrance of air into the stream.

By using higher pressures to operate the needle, as can be accomplished with a pressure system independent of the penstock pressure, the needle cylinder can be appreciably reduced in diameter. By changing this dimension, the outer barrel cylinder diameter can also be reduced. In fact, a decrease in diameters all along the valve except at the inlet can be accomplished. About 30-percent reduction in weight results from use of the oil-operated valve, along with a reduction in size of machine tools required to machine the cylinders, and a simplification of the problems usually associated with shipment of larger valves.

## What's NEW . . . . .

### Ozone—Nature's Air Freshener

THE ROOMS of the average home confine so many potential odor-producing elements that it's fortunate they don't all act at once. There are cooking odors, cigarette smoke, food odors, those from soap, perfumes, paint, and ammonia to mention but a few. That the air is bearable most of the time is because the odor-bearing vapors are dispersed, eventually, in the large volume of the house, or are removed by air drafts. Air conditioning helps considerably, but is not a complete answer by any means.

By contrast, outside air usually seems fresher. Again part of the answer lies in better dispersal of the odor vapors. But in addition, nature lends another hand. Ozone—an active form of oxygen that contains three atoms per molecule instead of the customary two—plays a vital role in freshening the outdoor air. Ozone literally “burns up” the odor-carrying vapors, i.e., the extra atom of oxygen combines with and decomposes the odor molecules, thus eliminating the odor.

This being so, many devices and methods of using this principle indoors for odor killing have been devised during the past 50 years. Earlier ozonizers made use of a silent discharge between two electrodes. In this device some of the oxygen atoms in the discharge path are ionized, and recombine to form three-atom molecules of oxygen, or ozone. This same process is also one of

those used by nature in producing ozone; the fresh, clean smell of the air immediately following a storm is partly caused by the creation of ozone by lightning discharges. Most of the ozone in nature is produced by short ultraviolet radiations absorbed by oxygen in the upper atmosphere.

Much confusion, considerable contradiction, and some alarm have surrounded past research on the effects of man-produced ozone devices. Early research seemed to indicate that ozone was toxic to humans in certain concentrations. Later research showed that the oxides of nitrogen, which were produced by the arc discharge concurrently with the ozone (and in varying amounts depending upon the current density in the arc), greatly contributed to the toxicity of ozone.

A means was found, however, to create ozone without producing nitrogen oxides. This was by ultraviolet wavelengths (in the 1849 Å region) from a mercury-discharge lamp, which effectively produces ozone from the oxygen in the air. At the same time, these wavelengths are too long to produce nitrogen oxides, which require less than 1200 Å. The ultraviolet rays can readily be produced by a mercury-vapor lamp. Research at the Westinghouse Lamp Division Laboratories with the Westinghouse Sterilamp discharge device led to the later development of a lamp—the walnut-sized Odorout lamp—specifically for ozone production and odor killing, and suitable for home use. The research was car-

ried even further to determine the oxidizing action on odor molecules and, through the use of newly developed measuring techniques, to measure accurately the extremely small concentrations effective in this application.

Much interesting information has been uncovered regarding the natural production of ozone. Previously ozone was believed to be nonexistent in the air of large cities, i.e., that it was used up as fast as it was produced. However, concentrations of 0.01 to 0.15 parts per million by weight were found over Chicago in the course of a year's tests. Tests in Los Angeles by other scientists revealed up to 0.03 to 0.35 parts per million by weight. Other experiments, conducted over a period of years in various parts of the world, showed that in some sections the normal ozone concentration frequently exceeded one part per million. Based upon these tests and many others, the accepted maximum concentration of ozone is established as 1.0 part per million by weight by the United States Public Health Service. For comparison, the concentrations produced by the Odorout lamp in a fixture are 0.05 parts per million by weight for a 500-cubic foot room, or 0.025 for a 1000-cubic-foot room. Thus the ozone produced by the Odorout lamp is well within the limits of toxicity—if such exist—since nature itself provides outdoor air with 30 to 40 times as much ozone concentration.

The odor of ozone in the air can be detected in concentrations of as little as one part in 500 million. At concentrations of one part in 50 million the odor assumes the pleasant, clover-like aroma common after thunderstorms. When the concentration reaches one part per million a sulfur-like odor becomes apparent.

Ozone is useful for other purposes as well as odor killing, being a powerful germicide. Ozone in amounts larger than those used in deodorization are currently being used in the preservation of meats, eggs, and fruits. It is a strong oxidizing agent and even higher concentrations can be used in bleaching and various chemical reactions. One city goes even further, using tremendous amounts of ozone to sterilize and deodorize its water supply. Although ozone has been known for more than 100 years, we are just beginning to learn of its potentialities.

**This sealed dry-type transformer was over loaded to the failure point. Little change is apparent in the high-voltage coil after tests in which the operating temperature averaged nearly 640 degrees C.**

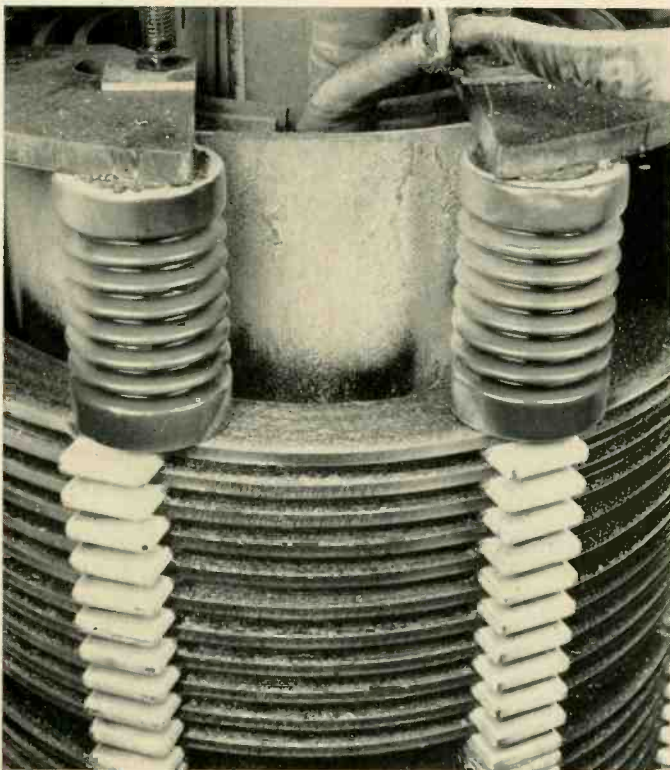

**Final adjustments are made on one of the teletype receiving machines that form part of the new Westinghouse intra-company teletype-relay system. This new system can receive 33 messages at one time; the network contains a total of 98 sending and receiving stations at present, and is expected to expand to about 150 stations.**

### Sealed Dry-Type Transformer Fails Safely

**W**HEN a sealed dry-type transformer was recently overloaded to the point of failure, it simply dropped its load. No fire—no explosion. Designed for installation close to the load, these transformers—introduced by Westinghouse in 1942—do not require fireproof vaults. They use only a small amount of volatile material, and operate in pressure-tight cases under a small pressure of dry nitrogen.

Destructive tests were conducted to find out just what would happen when such a transformer failed under the most adverse conditions. A standard core-and-coil assembly was placed in a tank equipped with thermocouples, thermometer, and a pressure gauge. A spark gap was located above the core and coils in the region where insulation decomposition gases would accumulate. The transformer was sealed in its case under a one-pound pressure of dry nitrogen.

The transformer was excited at normal voltage and a standard temperature test begun. The unit carried 100, 200, 300, 400, and 500 percent of rated load for one hour each, with no cooling period between loads. The gap was flashed every 50 seconds. After carrying 600-percent load for ten minutes, the transformer dropped its load, as indicated by the load ammeter. There was no disturbance. Subsequent examination revealed that the failure resulted from the melting out of a part of the low-voltage winding near the top of the coil.

### A Two-Motor Cable Drive for Ingot Buggies

**A** NEW SOLUTION to the ingot-buggy drive problem has been worked out for two buggies in the new Fairless plant of the U.S. Steel Company. Ingot buggies, which carry 20-ton ingots from soaking pits to roll tables, have generally been driven by motors on the buggies themselves. But the proximity of red-hot steel, and the problem of many current-collector rails, makes it desirable to remove all electrical equipment from the buggy. The

trend is to tow it by cable instead. The ingot-buggy run at Fairless is 650 feet, considered too long for a continuous cable.

In the new scheme the buggy is pulled back and forth by a cable and motor located at each end. The control problem is made difficult by the fact that when the car is being pulled in one direction the "idle" cable must be kept taut. The idle motor

actually acts as a generator during acceleration and running, the generated power being fed back into the system. The system has a d-c generator, a 200-hp motor at each end, with a booster controlled by a Rototrol regulator in series with each motor. With this arrangement the idle motor automatically pulls back a constant amount. The buggy is controlled by pushbuttons.

## Alternating-Current Brakes—Traffic Cops of Industry

**P**RACTICALLY all a-c motor applications that demand start-stop operation or quick deceleration—such as cranes or machine tools—rely upon the a-c brake as a stopping device. One other method, plugging the motor (reversing the field), can be used for quick deceleration but is useless as a holding device. Also, in the case of unusually large applications—above 125 pound-feet continuous torque—the a-c solenoid may be displaced by a hydraulic system, because the brake magnet of the strength required would react too rapidly. But exclude these two minor exceptions, and the a-c brake, essentially without change in design, has been the main motor-stopping device since the introduction of a-c motors more than 50 years ago.

Now a completely new model has been developed. To offset the increasing dearth of skilled maintenance men, the redesign puts paramount emphasis on simplicity of operation and freedom from maintenance. The result is a new single-adjustment a-c brake that combines what were three adjustments: (1) spring

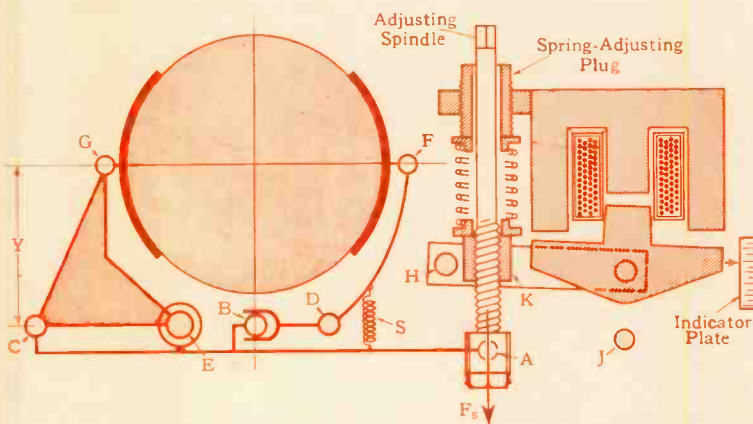
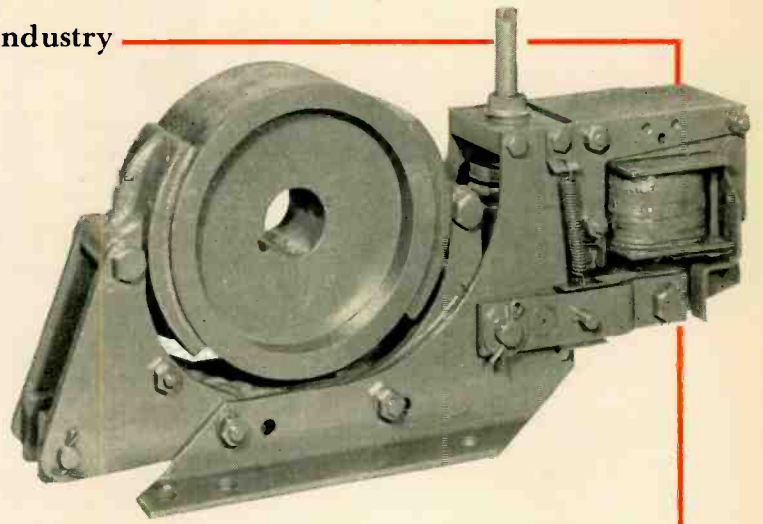

Operation of the brake is comparatively simple and derives its effectiveness from a unique linkage system (see diagram above). The brake arms are pivoted on fixed pins *D* and *E*, while lever *ABC* is pivoted to solid arm *GEC* at point *C* and is connected to arm *FDB* at point *B* by a pin riding in a slot. Because of the geometry of the system, force  $F_s$  presses the shoes against the wheel with equal pressures.

Any misalignment of the wheel center to the right or left of the vertical center line of the brake causes the linkage to pivot about point *A*, but will not change the effect of force  $F_s$  on the shoes. Assuming a vertical movement at point *C*, with point *A* stationary, calculation of the horizontal displacements of points *G* and *F* will show them to be equal and in the same direction.

With the magnet de-energized, adjustment of the spindle raises or lowers the moving part of the magnet. If the spindle is turned counterclockwise until the moving part rests on the retarding bar *J*, any additional turning raises point *A* and frees the shoes from the wheel for maintenance.

With the magnet energized, so that the trunnion pin *K* is stationary, turning the adjusting spindle increases or decreases the amount of shoe clearance. Turning due to vibration is prevented by two spring clips.

Maximum impact area is provided by the short-stroke clapper-type magnet. Backlash due to wear and reversal of thrust in the various joints of the linkage is prevented by tension springs. While normally the brake is mounted on a horizontal plane, any angle of mounting will not affect the operation.

compression—to control brake torque; (2) magnet travel—to control total shoe clearance from the wheel; (3) auxiliary screw adjustment—to equalize the shoe clearances. A visible indicator now tells the maintenance man when to readjust for brake wear, and how much. No longer can lost instruction leaflets or obscured instruction nameplates be the cause of improper adjustments that result in failures.

Another design factor was the tendency of the maintenance man to overlook the brake because of the inaccessibility of the adjustment devices and the general difficulty of making the adjustments. Making one device, an adjustment spindle, the job of three is 90 percent of the answer to this problem. The other ten percent was obtained by locating this spindle at the top of the brake so an ordinary open-end wrench can be used. The adjusting spindle varies the magnet travel, the proper amount of which is shown on an indicator plate. Naturally, as the brake lining wears, the magnet travel increases until finally the marker registers on the *readjust* line. When this occurs, the adjusting spindle is merely turned clockwise until the marker once again registers on the *normal travel* line. Spring compression, which governs the torque and is preset at the factory, is also restored to its original setting by this operation. (The torque rating can be changed if necessary by increasing or decreasing the amount of spring compression, but once a satisfactory setting has been obtained for a particular application, no further torque adjustment is necessary.)

If for any reason the indicator plate cannot be seen, the brake can be adjusted by turning the adjusting spindle clockwise until the shoes touch the wheel, which can be recognized by the suddenly increased resistance to turning, and then backing off one turn. This feature is particularly advantageous on weatherproof brakes because it eliminates the necessity of removing the covers. (It is not necessary to shut down to make this adjustment—the only requirement is that the maintenance man have a wrench and be able to reach the top of the adjusting spindle.)

To eliminate the possibility of making the magnet travel so large that it will not operate, and thus cause a coil burnout, a special retarding bar has been added. This "stop" also makes it possible to use the adjusting spindle as a means of manually releasing the brake, either in an emergency such as a power failure or when it is necessary to remove the shoes for relining, by turning the spindle counterclockwise until the shoes are completely free of the wheel.

This article was written by G. Currie, Motor Engineering Department, Westinghouse Electric Corporation, Buffalo, New York.

## More Room for Generator Production

The continuing growth of the electric-utility industry calls for increased generator production facilities to accommodate both larger sizes and increased numbers. Shown here is one phase of this expansion—a new 100 000 square-foot building at the Westinghouse East Pittsburgh Works. Here turbine generators over 60 000 kw and waterwheel generators are assembled, wound, and then tested.

The photograph at top right shows the East Pittsburgh Works; the new generator building is indicated in color.

At right is an overhead view of a portion of the test area. In the center is the portable, sound-absorbing enclosure for balancing and seasoning large rotors. This enclosure can be used on any of the three test rigs. The concrete-block structure at the upper left houses the three-phase reactors used in full-load testing.

Below, a photograph taken from the test-floor area looking toward the opposite end of the building 1000 feet away. In the background is one of the three 50-ton cranes. Not shown are two 200-ton cranes.

An outstanding feature of the new building is its assembly pits for turbine generators. Actually large jigs, the pits will be used for the complete assembly operation. The finished generator will then be lifted into the test pit. This frees test rigs for their true function, since no generator assembly will take place there.

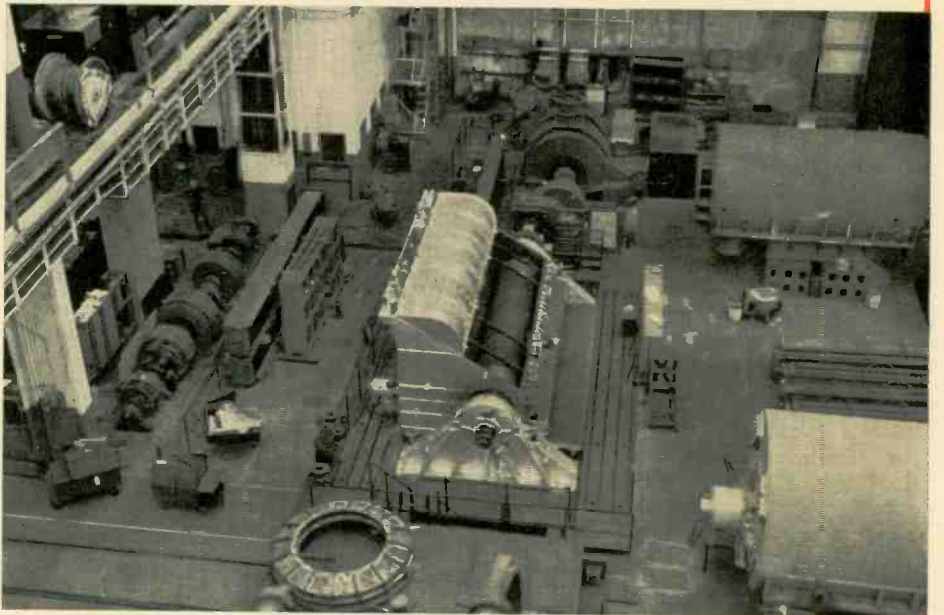
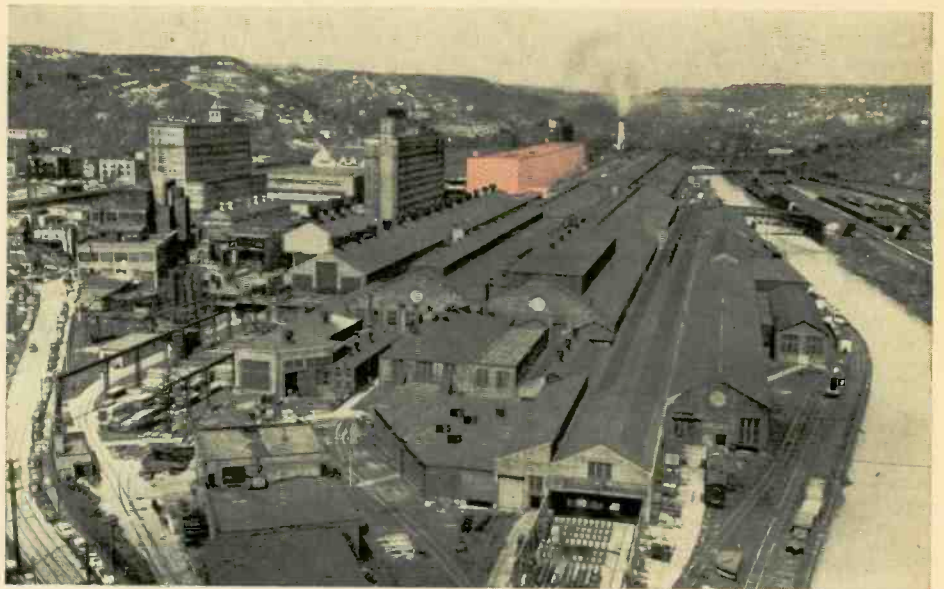



# Personality Profiles

S. A. Haverstick and J. Z. Linsenmeyer, whose profile also appears on this page, were classmates at Lehigh University, but their careers have taken divergent paths. Haverstick has been a marine engineer almost since the time he joined Westinghouse. Two years ago his activities were

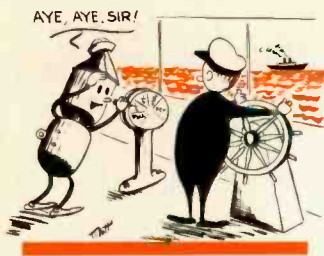

broadened to include aviation, when he was made manager of the Industry Engineering group that handles marine and aviation applications. Regular readers will recall one of his previous marine articles, describing the Navy's high-power testing station.



The distinction of being the first engineer on a new product is an experience that most engineers would relish. Such was the case with W. F. Born. In 1946, Born joined Westinghouse where he became the nucleus of a bus-duct engineering section. He was not without some experience along these lines, however, having worked for a time for a bus-duct firm in St. Louis, where he had attended Washington University. In 1947, as supervisor of bus-duct engineering, he moved with the Standard Control Division to Beaver, Pa., where production was started. A firm believer in the benefits of bus duct, Born has traveled many miles to promote its use, and solve individual application problems in various industries.

J. B. Wallace, Born's coauthor, worked on the design of many of the special fittings described in the bus-duct article. A mechanical engineering graduate (from the University of Pittsburgh in 1943), he joined Westinghouse in 1948 after a four-year stint with the Navy. Two of those four years were spent on sonar design in the Naval Research Laboratory, the other two aboard ship.



C. Perry Croco graduated from the University of California and joined Westinghouse in 1925. After completing the Graduate Student Course, he had successive assignments designing large d-c motors, and working on steel-mill engineering problems. He became an authority on steel-mill electrification, and, in 1939, helped engineer a 2500-fpm skin-pass mill,

at that time a record-breaking speed.

In 1943 he left Westinghouse, but returned a year later as manager of the Welding Department. In 1949 he was named manager of the Project and Application Section, Control Engineering, and in 1952 became engineering manager in



the Pittsburgh Engineering and Service Office, the position he now holds.

Frank Slamar started on the Graduate Student Course immediately after graduating from Newark College of Engineering in 1941. He was then assigned to Control Engineering, in the section concerned with apparatus development; here he helped develop relays and contactors. In late 1942 he entered the Navy, where he spent part of his time instructing at Annapolis and the remainder as engineering officer on a destroyer in the Pacific. When he returned to Westinghouse in 1946, he asked for assignment to the electronic-control section, where he has worked since.

Slamar mentioned in passing that his favorite sport is golf. He wouldn't tell his score, but admitted that a set of electronically controlled clubs would help.



Between them, J. Z. Linsenmeyer and A. G. Owen—coauthors of the mine power systems article on page 135—have worked on problems involving nearly every phase of industrial electrification. Linsenmeyer, for example, came to Westinghouse from Lehigh University in 1937, and after completing the Graduate Student Course and putting in a brief stint on the motor test floor, settled down in the Industry Engineering Department. His first assignment was in the General Mill Section, where he handled, at one time or another, electrical applications in the rubber, textile, food, and lumber industries. Then in 1946, Linsenmeyer moved next door, to the Mining, Petroleum, and Chemical Section, where he worked on numerous applications in these industries. In 1949, he was made manager of this group.

Owen's experience has been almost as varied, but along different lines. While attending the State University of Iowa, he worked as a lineman and serviceman for an electric utility. After graduation in 1931, he worked at various engineering

assignments in the maintenance and construction fields. In 1945 he came to Westinghouse as a design engineer and worked on Precipitron electronic air cleaners for several years. Then for another two years—with another company—he designed



cyclotron controls and specialized power equipment for experimental ultra-high-frequency equipment. In 1950, he returned to Westinghouse in the section now headed by Linsenmeyer. Since then he has worked on various assignments, including electrostatic precipitation, and underground and open-pit mining equipment. Perhaps the most unusual project was one involving a completely automatic a-c underground conveyor haulage system for coal mines.



J. S. Johnson has been referred to as a "dynamo doctor," an apt term in more ways than one. Like his medical counterparts, "Doctor" Johnson is a firm believer in giving check-ups to spot possible trouble and head it off. And, like all doctors, he is constantly on call. As supervising engineer in the Insulation Development Section of the Generator Engineering Department, he spends full time on the maintenance-inspection service of generator insulation. The periodic "physicals" he gives generators in the field keep them in top shape, but when an occasional machine gets "sick," he is Johnny-on-the-spot to nurse it back to health. A graduate of the Newark College of Engineering with a B.S. in E.E. in 1935, he joined Westinghouse in 1941, after service with Weston Electrical Instrument Corporation and the Consolidated Edison Company, New York City. In between calls on generator "patients" all over the country, he recently found time to build a house, in the literal sense of the word.

Johnson is one kind of doctor who doesn't mind being called a butcher; recently he had a side of beef ready for cutting and deep-freezing when hurriedly called out on a case. The extra week the beef hung not only made it better meat, but the additional evaporation saved Johnson money, since he paid for the animal by the pound at the time of processing.

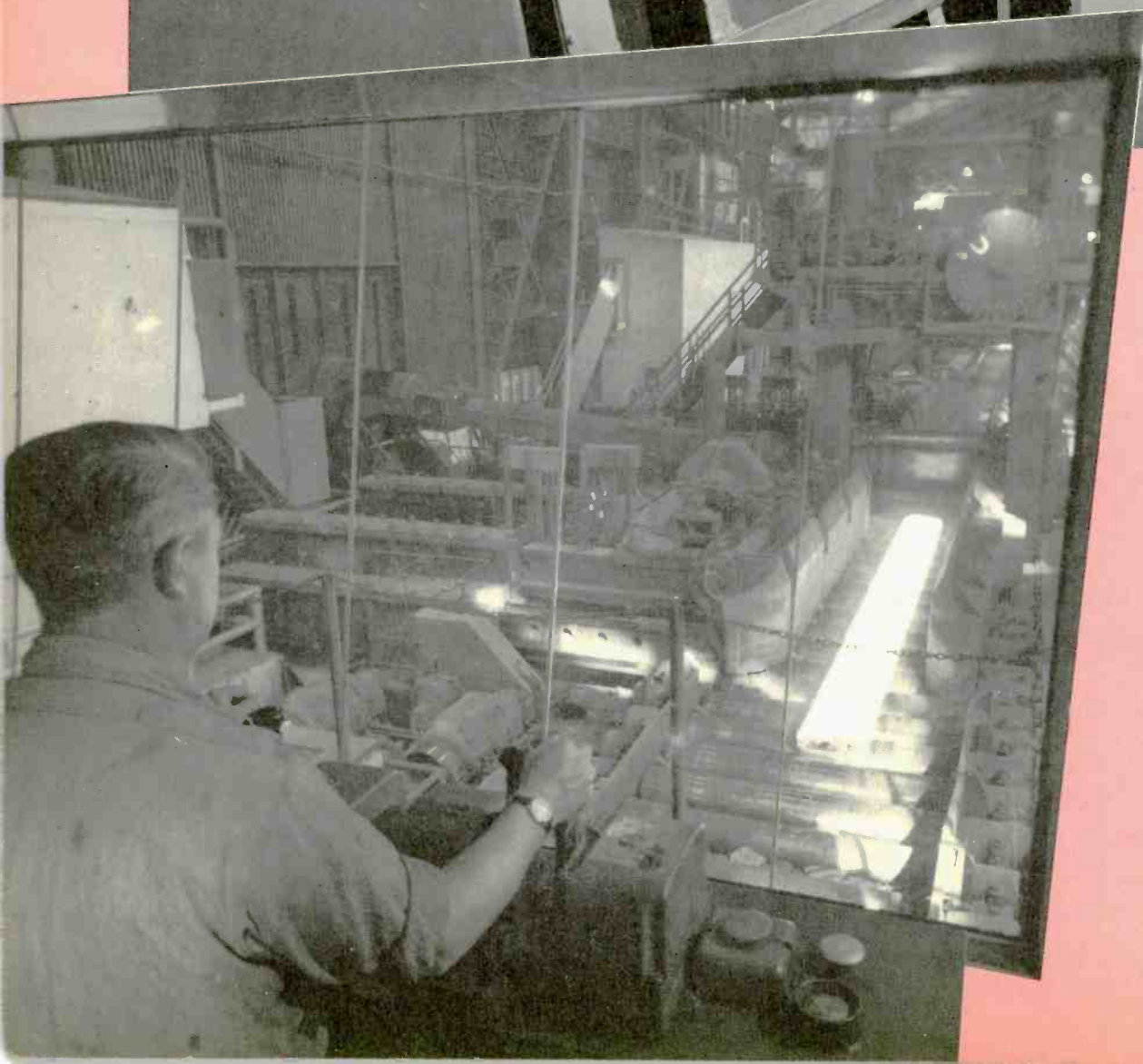
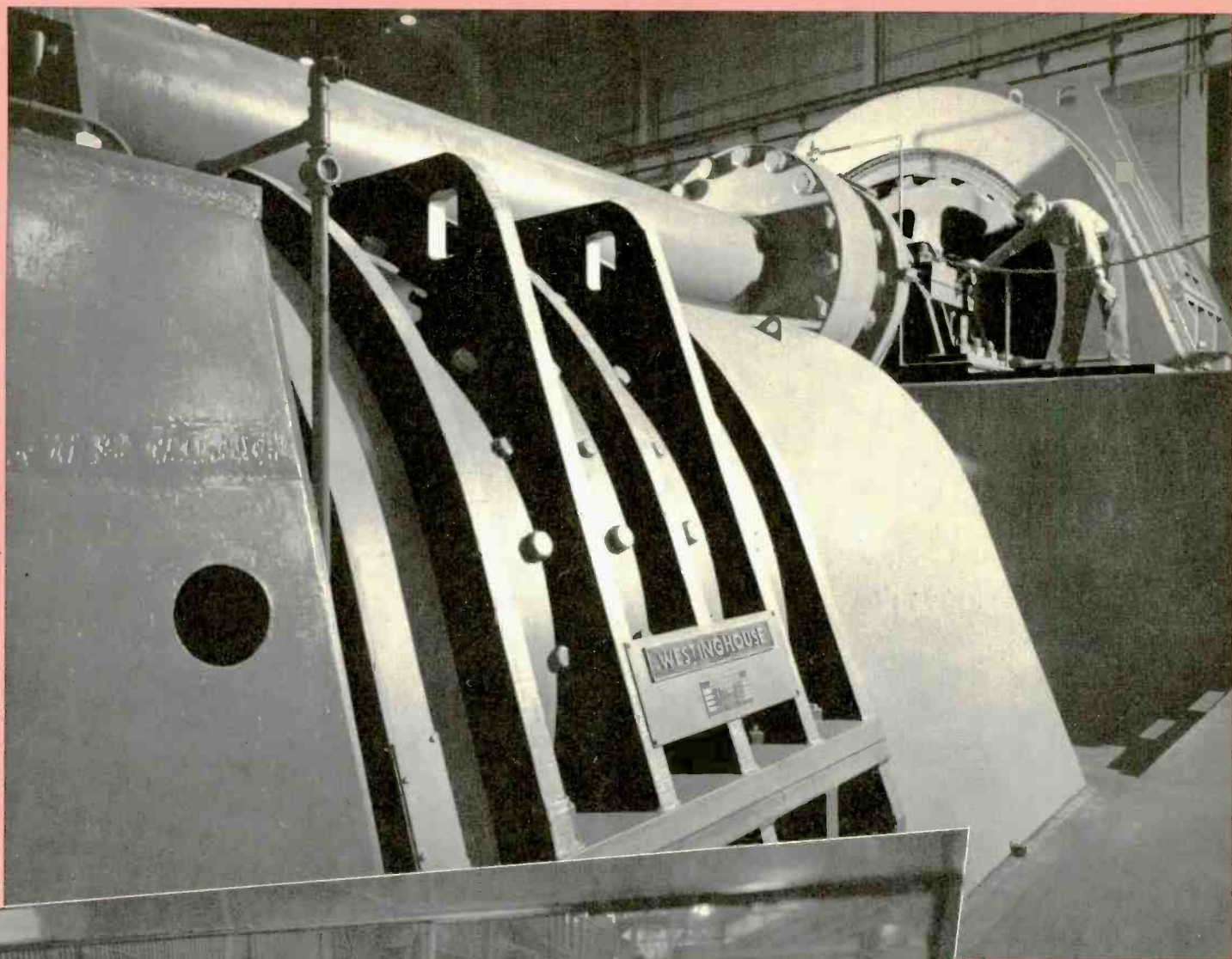

The 10 000-hp twin motor above reverses from 40 rpm in one direction to 40 rpm in the other in just one second; it is the drive motor for the new blooming mill shown from the control-room window in the photograph at left. This extremely high-speed operation is made possible by using Rototrol regulators to provide high forcing voltages to the main machine exciters.