

WESTINGHOUSE

Engineer



February 1943

The Power of the world—

WORLD power! To men of force such as Genghis Khan, Alexander, Caesar, Napoleon, Hitler, these words have meant the ability to enforce their will on other men, which, in the end, is always the power to destroy. But, to men of science and engineering these two words mean the ability of men to enforce their will on their environment. To them, world power provides the forces of construction.

ONE GREAT problem of the world, as Dr. Furnas points out in this issue, is the development of new sources of energy. Radium has intrigued the imagination of many because of its spontaneous emission of energy. The heat obtained from many tons of coal is but the flame of a match compared to the total energy released by a small quantity of radium. A gram of carbon burned with oxygen produces 8000 calories of heat; a gram of radium eventually releases 10 billion calories or 1 200 000 times more.

How fortunate it would be if we had been favored with abundant reserves of radium! Perhaps, but radium in tonnages would not make a very good power plant. Radium, for all its enormous store of energy, would be a poor substitute for coal, because of the slowness with which it releases energy. A gram of radium gives up energy at only about 100 calories per hour; even slowly burning coal releases 80 times as much. Furthermore radium is obstinate. Nothing scientists have been able to do to radium has any effect on it. It cannot be changed chemically; its rate of energy dissipation cannot be speeded up or slowed down. It is immune, thus far, to human interference.

GEORGES CLAUDE, of neon-lamp fame, attempted to utilize the difference in temperature between the surface of sea water and that many feet below as a source of energy. (Heat devices depend on a temperature difference to provide usable power.) However, no one has come forward with any plan to take horsepower out of the much greater temperature difference that exists between the layers of the earth's atmosphere. The temperature of the lower level of the stratosphere (roughly from 10 to 20 miles up) is thought to be nearly constant at about -53°C (-191°F).

Above the stratosphere is a layer about 25 miles thick relatively rich in ozone. This layer is hot. The exact temperature is in dispute, but some scientists believe it is even hotter than boiling water because of the absorption by the ozone of ultraviolet radiation. Here is a temperature difference of possibly over 400 degrees F. A power plant with sky hooks might use such an energy source.

SPECULATION on possible future sources of power seems to have all the allure of the soothsayer's art and at least a dozen suggestions can be garnered at almost any gather-

ing. After perpetual-motion schemes have been relegated to their limbo, we find that the grandeur of display deludes many into thinking that lightning and the aurora borealis should be great sources of energy. Actually they are both minute flashes in the pan. Some long to put the harness on every geyser and hot spring in the world. Why not? The capital of Iceland is largely heated by hot springs. It is a good idea but strictly limited, and in some cases, particularly Yellowstone Park, scenic property rights pre-empt the setup. More vigorous persons would like to harness volcanoes, but the geological temperament in those locations is a little too energetic. Others would make artificial geysers by drilling into the hot layers of the earth. They do not take adequate consideration of the tremendous mechanical difficulties, or how very slowly the visible heat of the rocks would be conducted to the desired small spot.

IN A coal-fueled power plant one carbon atom is combined with two oxygen atoms to form carbon dioxide and heat, the reaction being finished in an instant. In the solar plant, which is the original source of all our energy, a different and much slower process occurs.

The steps of the sun's reactions are not known with finality but the process is generally believed to be a slow combination of four hydrogen atoms to form one of helium. It is possibly a six-stage reaction,* in which carbon is a catalyst. It is transmutation of elements on a stupendous scale. First an atom of hydrogen combines with one of carbon to form an isotope of nitrogen plus gamma radiation. This is a leisurely process, requiring something like two and a half million years. In the next step, finished in ten minutes, the nitrogen becomes a carbon isotope plus a positive electron. The third phase requires about fifty thousand years. In it the new carbon isotope goes back after hydrogen atom number 2 to make nitrogen plus gamma radiation. Step four is the longest of all. The nitrogen plus a third hydrogen atom becomes, in about four million years, an oxygen isotope and more gamma radiation. Steps five and six are speedy by comparison. In a few minutes the oxygen isotope becomes a nitrogen isotope (different from that of step one) and another positive electron. Finally this second nitrogen isotope mates with a fourth hydrogen atom in 20 years to give helium, a final product, and our original carbon atom, which is ready to start over again on another cycle of six or seven million years.

Can such a process of disintegration of matter be speeded up by man? Probably not, but the speculation is made more interesting by the recent phenomenon of the heavens in which the exceedingly bright Nova Puppis suddenly appeared where no star had ever been cataloged. The reaction within this body became accelerated at least six million times in a few weeks. How, no one knows. If we did perhaps. . . .

*See the 32nd Kelvin Lecture delivered by Dr. Sydney Chapman before the Institution of Electrical Engineers, London, May 8, 1941.



THE need for easing shipping burdens, the shortages of man power, and other war-related problems have made it necessary for the Federal Government to reduce the amount of paper used by magazines. The Westinghouse ENGINEER is gladly complying with this wartime measure by making minor curtailments in circulation, by limiting sample copies, by various printing-plant economies, and by other means, none of which affect the size or quality of the publication. It is now all the more necessary that each copy of the Westinghouse ENGINEER receive the widest possible use. Will you please assist in making this copy of the Westinghouse ENGINEER "go farther" by seeing that it is made available to as many of your associates as possible.



Table of Contents

COVER: *Stark and gaunt against the winter sky, the compressed-air breakers stand on guard. The spirit of protection has been caught by the artist, F. G. Ackerson. This type of breaker, new on the utility scene, is described on page eight.*

Power Sources of the Future 2
C. C. Furnas

Outdoor Compressed-Air Circuit Breakers 8
B. P. Baker

Safe Transformer Overloads by Chart Determination 11
R. C. Cheek

Factors in Lightning Protection 15

Stories of Research 16

Limiters in Industrial Networks 18
H. L. Rawlins and C. E. Warren

Increased High-Voltage Power Transmission Via Series Capacitors. 24
R. D. Evans and R. L. Witzke

Cloth Carbonizing, Electrically. 26

Transformer Radiator Mounting Separate from the Tank. 27
R. L. Brown

Mechanics of Steel Hardening 29
T. H. Gray

Supervisory Instruments for Turbines 30

Methods of Grounding Rotating Machines 33
S. B. Griscom

The World's Largest Transformers 39

What's New! 40

Editor—CHARLES A. SCARLOTT • Editorial Advisors—R. C. BERGVALL • T. FORT • R. E. WILLIAMS

PUBLISHED QUARTERLY BY WESTINGHOUSE ELECTRIC & MFG. CO. ANNUAL SUBSCRIPTION PRICE: U.S.A., \$2.00; CANADA, \$2.50; OTHER \$2.25. SINGLE COPIES, 50c. ADDRESS, WESTINGHOUSE ENGINEER, EAST PITTSBURGH, PA.

Future Sources of Power

From the time of the first bonfire, we have been spending our stored-energy riches on the basis that "there is more where that came from." We are still living on the principal; we have not yet learned to live on our income from the sun. Except for energy captured from falling water, from winds, and a few insignificant hot springs, all our energy comes from expendable sources. The day is near when the stocks of some fuels will be gone and the recovery cost of others may start to rise. The situation deserves the attention of all engineers.

CONTRARY to conventional history books, the Industrial Revolution is not something that started about the time of James Watt and then flickered to a standstill in a generation or so. It is a social growth only now really beginning to get under way. It is self-evident that the entire existence of the evolved industrial structure depends basically on the continued availability and utilization of tremendous amounts of inanimate energy. This is probably the most important fact of modern history. Not only is human convenience and the survival of industries at stake; our entire social structure is involved.

Can we count on our present tremendous energy supplies always being available at the flip of a switch or the turn of a

C. C. FURNAS
*Director of Research
Curtiss-Wright Airplane
Division*

energy. Coal and petroleum are solidified sunshine (in the form of the chemical products of photosynthesis) of a few hundred million years ago. Water power comes from the water evaporated last week or last year. Wood represents the energy of leaf-captured

sunshine of a few years' standing.

Coal and petroleum, on which we now put our principal reliance, are irrevocably expendable items. When they're gone, "that's all there is; there isn't any more."

If new deposits are being formed anywhere on the earth's crust at present, it is only at a relatively infinitesimal rate; certainly not rapidly enough to catch up with the fast-moving human race. So, for the bulk of our power we are simply digging into a fossil storehouse—graciously handed to us by chance—and thus far we have made essentially no progress toward replenishing it. Our civilization exists by the process of sponging on the past ages, and that prodigality can't go on forever.

We can ignore the future and assume that there will be plenty for ourselves and our children, perhaps the grandchildren, and let posterity work out the answers when their turn comes to face the technical problems. But that, at its best, is certainly an unsportsmanlike policy, and at its worst, probably a foolish one.

The problem of continuing the energy supply even for the generation now starting is definitely not simple. In the complete world picture it may rapidly become acute, particularly if the suppressed millions of people on the earth should suddenly advance on a wave of industrialism and begin demand-

ing energy supplies per capita comparable with those to which Americans are accustomed. It is hardly too early for the technical experts to ponder the questions, "How long will our present-day energy supplies probably last?" and "What can be done about them?"

How Long Will They Last?

Petroleum is the most critical fuel material in America. In 1941 domestic consumption was about 1400 million barrels. The known, proved petroleum reserve in the country is about 20 billion barrels, depending somewhat on who does



... The total electric energy generated in 1941 in the United States was 168 billion kilowatt-hours. The hydro-electric energy was 51 billion kilowatt-hours, or 30 per cent of the total. ...

valve? If we quickly run through our chance heritage of readily available power, what can we do about the future? No one can give the complete answer yet, but we can consider a few of the salient features.

The Original Source of Our Energy

Our principal sources of energy, in terms of quantity produced, are coal, petroleum (including gas), with water power bringing up the rear. Wood, at one time an important item in the American fuel economy, is now of minor importance. In the last analysis these fuels are all modified forms of solar

the estimating. Thus the petroleum actually in sight is only about a 14-year supply. As new discoveries and improved prospecting techniques are coming forth constantly, most of the people in the petroleum industry say they are not worried about the supply, at least for the present generation. It is a little discouraging to note, however, that new discoveries are not quite keeping pace with use, so the pinch of partial depletion may come sooner than the optimists anticipate.

Possibly extensive fields lie under the ocean next to coastal plains, as along the Gulf of Mexico. Large amounts of petroleum may be hidden at far greater depths than are yet explored. We hope so, but it should be remembered that if recovery is made from the more difficult places, the cost of production is certain to rise and the customer must pay it. It does not take a professional pessimist to visualize that the first half of the twentieth century will soon be looked back upon as the period of the last bonanza of mineral wealth—when oil flowed like water and could be had for the finding and taking.

This should not imply, however, that the petroleum industry has been principally characterized by wild-catting and waste. Actually the opposite is true. Technical advances in refining have greatly extended the range of petroleum resources. Widespread utilization of cracking has more than doubled the yield of gasoline and so has more than doubled the supply of motor fuel. In 1916 the average yield of gasoline per barrel of crude was about 7½ gallons; today it is about 18 gallons per barrel. Now the polymerization of refinery gases into liquid fuels is beginning to come in, and is helping to extend further the life expectancy of petroleum reserves. Through the use of more and larger pipe lines, natural gas is being used much more extensively and relatively little is now wasted. Such technical advances are a great factor in maintaining a liquid fuel supply, but eventually, perhaps distressingly soon, the pinch of depletion will begin to make itself felt. What then? Let's survey the possibilities.

Getting All the Petroleum Out of the Ground

Even with the best production methods, over half the original petroleum deposit is still in the ground after the well has apparently gone dry. The oil fills the interstices between the sand grains, and also clings to the surface of the particles by adsorptive forces. Getting all the oil out of even a limited area is analogous to sucking all the juice out of an orange, concealed in the center of a basket of rocks, with a long hypodermic needle. In the mid-continent fields oil flow is sometimes revived by "repressuring" the wells in which natural gas is forced into overlying strata. The opposite approach, forcing water under the oil layers, has been employed with some success, particularly in Pennsylvania. In some oil sands the structure can be opened up and the rate of oil flow increased by forcing copious quantities of 15 per cent hydrochloric acid solution to the bottom of the wells. All these things help—but not much. Mining the sands appears to be impractical, not to mention being very expensive. If someone will devise an inexpensive means of breaking the adsorptive forces between petroleum layers and

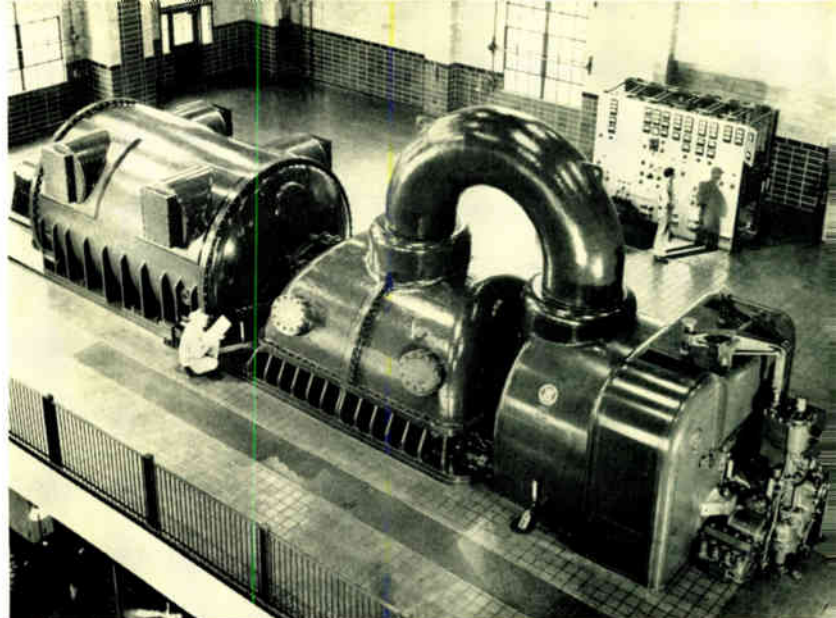

... Energy, mechanical and electrical, consumed in the United States in 1939 amounted to about 9580 billion horsepower-hours, of which 226 billion horsepower-hours was electrical energy. Electric power accounted for only 1/42 of the energy consumed in the United States that year. . . .

the sand grains, he will greatly lengthen the life of our oil resources, not to mention making a fortune for himself.

Shale Oil

In Colorado and other parts of the country are many billions of tons of oil shale, which, when heated, yield from half a barrel to two or three barrels of petroleum-like oil per ton of shale. The estimated United States reserve is 92 billion barrels. The potential supply is equivalent to about five times the liquid petroleum in sight. It is enough to supply our motor fuel for 60 or 80 years, assuming all of the oil could be recovered from the shale and that our needs do not increase. But mining or quarrying the shale, retorting it, and disposing of the waste cost effort and money. If the refinery cost of gasoline should double, shale oil might compete. Thus, we shall get it only by paying higher prices than at present.

Distillation of Coal

The modern by-product coke oven produces two to three gallons of benzol per ton of bituminous coal charged. It is a satisfactory motor fuel, particularly when blended with gasoline, but the supply is not large enough to be significant in motor-fuel production. If all of the benzol produced by all the by-product coke ovens in the world were used for motor fuel, it would supply only about one and one-half per cent of the normal gasoline demand of the United States.

Hydrogenation of Coal

Germany and, to a lesser extent, England are making fairly satisfactory liquid fuels by reacting hydrogen gas with low-grade coal. In the Bergius process, coal is introduced into a retort in the presence of any of several possible catalysts. The retort is heated to about 400 degrees C and hydrogen is pumped in at 150 atmospheres pressure. In a short time the compounds containing oxygen are converted to hydrocarbons, which are liquid at ordinary temperatures and pressures. The yield of liquid fuel of fairly good grade can be as much as 125 gallons per ton of coal processed.

The Fischer-Tropsch process uses producer gas (a mixture of carbon monoxide and hydrogen), which is made by the reaction of steam on coal or coke. At high temperature and

TABLE I—ACREAGE NECESSARY TO PRODUCE ALCOHOL TO SUPPLY UNITED STATES MOTOR FUEL DEMAND

Crop	Yield in Gals. of Alcohol per Acre	Acres Required to Produce 20 Billion Gals. of Alcohol
Corn (average yield).....	75	266 000 000
Corn (good yield).....	150	133 000 000
Saccharine Sorghum.....	300	66 600 000
Sugar Cane.....	500	40 000 000

pressure and in the presence of proper catalysts, carbon monoxide and hydrogen react to give a mixture of various alcohols plus some liquid hydrocarbons to yield a liquid fuel.

By 1939, Germany was producing synthetic motor fuel by these processes at the rate of 200 million gallons annually. That would fill a great many gasoline tanks, but it would supply the United States less than a day and a half.

The experience of these two countries shows that it is possible to produce quantities of motor fuel from coal but at a price. The cost of production is about 20 cents a gallon compared to the American cost of five to six cents a gallon from petroleum. That high cost might be lowered somewhat, but the prospects are that it will not go down materially. At least for a considerable period of time we can continue to drive our cars on motor fuel from coal, but we'll have to pay dearly for the privilege.

Alcohol from the Farm

The production of alcohol from farm products for motor fuel has been a political football all over the world. Thus far it has been unfeasible and uneconomic. The first unfavorable factor is that of cost. Although marvelous claims of low cost ("if we can only get going on large scale") have been made, the evidence thus far is that production costs would be 15 to 20 cents per gallon. If the production cost of petroleum products rises about threefold, then alcohol could come into the race on the price basis, and supply part of the demand, but by no means all of it.

The figures of acreage required, table I, to furnish the necessary fuel casts a pall of discouragement over any hopes of producing all motor fuel from farm crops. The 300 million acres under cultivation in the United States probably cannot be greatly extended without serious injury to our soil. The possibility of growing enough additional corn to meet the thirst of our automobiles seems remote.

High-producing sugar cane might seem to be more in the running—a mere forty million acres of good-yielding cane would satisfy the demand. That's about 30 per cent more land than lies in Louisiana. There isn't that much sugar-cane land in the United States.

Alcohol from farm products is made by the fermentation

of starch or sugar. If the micro-organisms could be induced to ferment the cellulosic waste directly to yield large amounts of alcohol, the picture might be more favorable, but they don't seem to want to work that way. Relatively recent work, particularly at Carnegie Institute of Technology, has shown that by proper control of basicity, temperature, and pressure, cellulosic material can quite rapidly be converted into liquid or solid fuels analogous to petroleum and coal, which nature took millions of years to make. This may be a good lead to follow for part of our motor-fuel supply, but thus far it is only a prospect.

We can have fuel for automobiles for at least several generations, but at a price. The lush days of practically free oil from the ground will begin to end and before long—probably too soon to please us. This generation may feel the pinch of partial depletion. And steps toward economy or conservation are much in order.

Natural Gas

Natural gas is, and will continue to be for several years, a major energy source. United States government estimates in 1939 indicate a reserve of 66 trillion cubic feet, which at the 1939 rate of consumption of two and a half trillion cubic feet will last about twenty-five years. Also, it is possible that new reserves will be located and methods of greater recovery developed, but in general it suffers the same handicaps as its liquid cousin, petroleum. The lowest-cost, most accessible supplies are tapped first, and even with great luck in new discoveries the age of United States gas reserves does not extend much beyond a generation.

Coal, Backbone of Our Energy Supply

In the foregoing, considerable emphasis was placed upon the utilization of coal to produce liquid fuels, so it may be well to inquire: How stands it with our coal supply?

In this category, the United States appears to be the most happily situated country in the world. The United States has 42 per cent of the estimated coal reserve of the world, but only 6 per cent of the world population. This may seem hoggish, but it was chance that did it. Viewing the North American continent as a whole, the picture is even more one-sided, for within the continental boundaries is 69 per cent of the estimated world reserve and only eight per cent of the population.

Since some American first threw a black diamond on a fire down to the present we have consumed only about 0.7 per cent of our estimated reserve in this country. At the present rate of coal consumption, roughly 500 000 000 tons per year, the United States has enough bituminous coal alone

TABLE II—ESTIMATED NET ANNUAL YIELDS PER ACRE FOR VARIOUS CROPS IN THE FORM OF ALCOHOL AND CELLULOSIC MATERIAL

Crop	Yield per Acre	Gals. Alcohol per Acre	Btu* Value per Acre	Cellulosic Waste Tons per Acre	Btu* Value per Acre	Btu* Requirements for Production per Acre	Btu* Requirements for Processing into Alcohol per Acre	Net Btu* Yield of Liquid Fuel per Acre	Btu* Value of Excess Cellulosic Waste per Acre
Wheat.....	30 bu.	82	5 962	2	26 000	760	6 150	5 202	19 850
Rye.....	40 bu.	95	6 907	2	26 000	760	7 125	6 147	18 875
Corn.....	40 bu.	100	7 271	2	26 000	760	7 500	6 511	18 500
Grain Sorghums..	50 bu.	125	9 100	4	52 000	760	9 375	8 340	42 625
Barley.....	40 bu.	80	5 817	2	26 000	760	6 000	5 057	20 000
Sweet Potatoes...	15 tons	500	36 355	1	13 000	1 014	37 500	35 341	-24 500
Sugar Cane.....	20 tons	360	26 058	8	104 000	1 014	22 950	25 044	81 050

*Btu figures given in thousands.

TABLE III—ESTIMATED ORIGINAL COAL RESERVES IN THE UNITED STATES

Type of Coal	Reserve, Short Tons
Lignite	939 584 000 000
Sub-bituminous	996 081 000 000
Bituminous	1 429 895 000 000
Semi-bituminous	56 569 000 000
Semi-anthracite and Anthracite	22 423 000 000
Total	3 444 552 000 000

in sight within the continental boundaries for 3000 years.

This array of data can easily have an enervating influence and lead one to believe that there is nothing to worry about. Who cares about 3000 years from now anyway! There are a few facts, however, that should be scrutinized before lapsing into placidity.

1—The better coal deposits, like the better apples on a tree, are few in number. As we pick the best (we are already past that point in the anthracite fields) the remaining deposits become more and more difficult to work. It will probably never be possible to get all the coal out of the ground, perhaps only a small fraction of it.

2—Coal deposits are localized. Great areas of our country and the rest of the world can be better and more economically served with some energy source other than coal.

3—If the other 94 per cent of the people of the world decide that that 6 per cent block—which is the United States—should give up a substantial portion of the 42 per cent of the coal reserve, then there probably isn't much that we could do about it.

These facts indicate that an adequate coal supply may be ours for a much shorter period than a column of figures might indicate. We have to consider the world-power picture in terms of our own resources. It will be time and effort well spent to look still further into all other possible sources of energy.

Water Power, Important but Insufficient

Practically all the developed water power of the United States goes into the generation of electrical energy. The total electric energy generated in 1941 in the United States was 168 billion kilowatt-hours, of which hydroelectric energy was 51 billion kilowatt-hours, or 30 per cent of the total. Reliable estimates place the feasible harnessing of falling water for hydroelectric energy at 220 billion kilowatt-hours per year in this country from supplies available 90 per cent of the time. This would very handily take care of our present electrical demands if it were properly placed.

Inasmuch as water power is non-expendable this might seem at first glance to take care of most of our demands, but that impression is misleading. A compilation of information on energy used in 1939 indicated that the mechanical and electrical energy consumed in the United States in that year was about 9580 billion horsepower hours, of which 226 billion horsepower hours was electrical energy. Although it is common to think that power and electric power are synonymous, electric power accounted for only 1/42 of the total energy consumed in the United States in that year.

Part of this truly tremendous block of energy went to satisfy the first and second laws of thermodynamics, through the inherent inefficiencies of our heat engines, but much

more went to heat buildings and into chemical and metallurgical processing. Whatever the distribution, it is evident that we must look well beyond hydroelectric power to supply our eventual energy demands.

Miscellaneous Possible Sources

Utilization of Current Vegetation

About 50 times as much energy is stored up in plant life on the earth in one year as man utilizes in that year. It might then appear that we could use the present growing trees, grasses, and shrubs for fuel, and thus solve the problem. Close investigation makes that idea discouraging as far as the United States is concerned. The only annual crop



... The windmills of Holland and the American farm-yard have captured much useful power from the winds, but it is insignificant compared to our needs. On Grandpa's Knob on a Vermont mountain top is this wind-driven power plant, delivering at full load 1000 kw. (Photo courtesy S. Morgan Smith Company.)

available for fuel use in this country would be the cellulosic farm wastes. These wastes total about 260 000 000 tons per year. But to supply our required 25 quadrillion Btu would call for about 1 800 000 000 tons—sevenfold greater than the supply, assuming every bit of the agricultural scrap could be assembled for use.

Bringing the forests into the picture wouldn't help much. The standing timber in the United States totals about 400 billion cubic feet of good, honest wood. If we used it exclusively to supply our energy demands, it would last just about four years and no more. Our present energy require-

ments are of an entirely different order of magnitude than during the Revolutionary period.

Wind

Lots of energy goes to waste in a hurricane or tornado, but you cannot count on it. The winds are not dependable, even in Kansas. Moreover, the average breeze is at a very low potential as far as energy is concerned. In general, however, except for isolated, special cases where a high-cost storage capacity can be provided, wind power seems to be out. A wind-driven generator installed recently on Grandpa's Knob at Rutland, Vt., is an attempt to extract power from moving air on a commercial scale. A pair of 175-foot blades drive a 1000-kw 60-cycle generator. It is expected that the generator can deliver full load about one quarter of the time, and part load for about half the time.

Tides

In a few places, such as Passamaquoddy Bay the use of tidal power may be practicable if a possible market is close at hand. Like the power from falling water, this may help, but it can supply only a small part of our needs. The tides, incidentally, are the only present potential power source not based on energy delivered by the sun. Any energy we get from the tides comes from the kinetic energy of rotation of the earth, which results in a slight retardation of its spin.

Wave Power

Many wave motors have been designed, some of them have been patented. But the item of variability of the source of power seems to relegate this device to the impractical heap.

Direct Utilization of Solar Energy

Our methods of utilizing the energy from the sun are all more or less makeshift adaptations of natural phenomena and are highly inefficient, for efficiency is not one of nature's virtues. Because of this, nature in the long run is going to let us down in the matter of meeting our energy demands. But it would be the greatest bit of irony of all time if our much-vaunted scientific civilization should falter for lack of power, because the sun showers as much energy onto the earth in one minute as the human race utilizes in one year. It can be had for the taking, but the taking apparently calls for a good deal more cleverness than we have yet displayed.

The radiant energy reaching the outer envelope of the earth's atmosphere is 0.168 horsepower per foot of projected area. In the latitude of the temperate zones, with normal weather conditions, about 0.1 hp per square foot should be available. The energy falling on one square yard of roof would more than operate all the electrical household appliances, including light, of the average family—if it could be directly utilized. Most factories have sufficient energy falling on the roof to operate all the machinery in the place—if the management had enough ingenuity to capture it. Enough energy falls on about 200 square miles of an arid region like Mojave desert to supply the United States.

Photo-Electric Cells

One of the obvious possibilities for direct utilization of solar energy lies in photo-voltaic cells such as the type made

of copper-oxide discs or of selenium. Thus far photo-voltaic cells have operated with efficiencies of only about one half of one per cent and have been very expensive. If someone can make revolutionary improvements in them, and can cut the cost of construction sharply, we might have something there. At present the prospects are discouraging but one hesitates to say that such utilization is forever impossible.

Solar Boilers

The simple and obvious device of using focused sun's rays to heat up a liquid has been toyed with for a long time. Solar boilers of various degrees of impracticality have been born in many inventors' minds and have been the subject of many patents. Dr. C. G. Abbot, of the Smithsonian Institution, has a small solar power plant with revolving parabolic mirrors for which he claims an electrical energy production efficiency of 15 per cent. We shall have to do better than that if the sun's rays, which are not of very high intensity to begin with, are to be a practical energy source. It is not likely that the efficiency of a solar power plant, if it operates by steam generation, can be greatly improved.

On the other hand, solar energy may well be on the verge of being practical for heating buildings where a high potential is not important. The storage capacity for such a scheme must be sufficient for weeks or even months of operation. A basement full of hot water, periodically reheated by the sun's rays, might be possible, but it hardly sounds practical. A closed cycle, employing a low-boiling liquid, might better serve for such a storage. First costs would be high but operating costs might be cut to the vanishing point.

Energy by Photosynthesis

The genesis of all our fuels rests on the chemical reaction of photosynthesis, whereby carbon dioxide and water combine, with the aid of solar energy, with chlorophyll as a catalyst, to give the chemical compounds of plants. The exact mechanism, the intermediate products, the mapping of the individual steps of photosynthesis are still matters of scientific dispute, but the effect can be represented by the over-simplified equation:

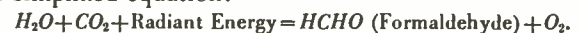

Although it probably is not retained in any part of the process, the simplest possible carbohydrate, formaldehyde (*HCHO*), might be thought of as the building block for all plant structure; whatever the steps, photosynthesis first produces simple sugars, which then serve as the basic material for the complex compounds of the plants.

These compounds are so much solar energy, for they can be burned or otherwise oxidized to release the potential Btu's stored therein. The burning of coal is, in effect, the releasing of a block of some ancient solar radiation.

In nature, the process of photosynthesis is highly inefficient as an energy storing mechanism. Even in the case of the most luxuriant plants, the potential energy of the compounds formed is less than two per cent of the solar energy that fell upon the leaves. The chemists have become so clever in the field of catalytic reactions that they should be able to improve that energy-capturing efficiency by many fold. Perhaps inorganic compounds can be made to be much more efficient reservoirs for energy.

What we should like to do would be to take some such simple compounds as formaldehyde, formed with the help of radiant energy, put it in an electro-chemical cell, expose it to oxygen, and then reverse the above reaction and get back the stored energy as electrical energy. Perhaps all that is needed is a proper catalyst to complete the oxidation to CO_2 and water and get back all the stored energy.

It is a wide open field—this study of photosynthesis and the study of oxidation. That is the reason it is promising. The systems that might be used would not necessarily be limited to organic compounds. It may well be that inorganic compounds offer the most hope. The satisfactory system would need to be one that is as light-sensitive as the chemicals on a photographic film, as easily reversible as a lead storage cell. If such a photo-chemical-electric system can be developed, the problem of energy capture and storage would be solved. The storage of the energy would be simply that of storing chemical compounds. We are accustomed to doing the same thing with coal.

Some day the photo-chemical approach to energy utilization will either be solved or definitely proved impracticable. In view of our own energy resources it may seem foolish to start working on it now. But it may not be too early to start. If we wait too long we may be caught short as energy supplies dwindle. Moreover, many parts of the world already suffer from insufficient energy. Many international problems might disappear if every group of people could fully utilize the energy falling on its rooftops.

Atomic Power, Conversion of Matter to Energy

Nearly all the foregoing discussion has been with eyes to the sun as the original source of our energy, but that is a form of evading the issue. Where does the sun get its energy? From sound theoretical considerations, the answer is found in the conversion of mass into energy.

One of the results of the Einstein considerations was to focus attention on the relation between mass and energy. In the last analysis mass is energy and energy has mass, the one should be convertible into the other. The Einstein relation between mass and energy is the simple equation $E=MC^2$, in which E is the energy in ergs, M is the mass in grams, and C is the speed of light in a vacuum (approximately 3×10^{10} cm. per second).

Each gram of matter is the storehouse of 9×10^{10} ergs, or 2.15×10^{13} gram calories. The energy of combustion of a gram of coal is a mere 7000 calories. Hence, if we could completely annihilate matter we should be able to obtain 3000 million times as much energy as from the burning of the same weight of coal.

The spectroscopic and theoretical evidence establishes with fair certainty that the energy of the sun comes from the conversion of hydrogen into helium (see inside front cover of this issue) with a slight overall loss in mass and the release of tremendous amounts of energy. This cycle of events doesn't happen on the earth. We don't have the energy concentrations of the 20 000 000 degrees C interior temperature and extreme pressures of the sun. At first glance it appears that we are never to have a successful Atomic Energy Development Company on the earth.

But there is a breed of men which thrives on the intricate,

difficult and apparently unsolvable problems. Disintegration of matter intrigues the physicist. He will not let the idea alone. Although he has not yet devised an atomic disintegration process that gives a net yield of energy he knows that nature has provided one on a small scale in the spontaneous but ordered disintegration of radium, which gives an overall, though sluggish, transformation of mass into energy, accompanied by a true transmutation of elements.

... The sun showers as much energy onto the earth in one minute as the human race utilizes in one year. It can be had for the taking, but the taking apparently calls for a good deal more cleverness than we have yet displayed. . . .

By far the greatest stimulus which the search for the key to atomic power has ever received came with the discovery, now a few years old, that one isotope of the element uranium, U_{235} , if bombarded with *slow moving* neutrons (one of the fundamental particles of matter) disintegrates with violence. The U_{235} atom literally splits in two, not in an exact pattern, but roughly to give two smaller atoms of somewhat less than half the weight plus a shower of super-high-speed neutrons that bear the energy resulting from an overall loss in mass. These high-speed neutrons will not disintegrate adjacent U_{235} atoms. They pass through as a fast-moving golf ball skips over the top of the cup instead of dropping in. But, if the high-speed neutrons are slowed down, by giving up their energy to a surrounding absorbing medium, water for instance, they might be able to induce still further disintegrations, in this manner setting up a chain reaction that would be a super-powerhouse.

The missing link thus far in testing the idea is that enough sufficiently pure U_{235} has never been separated from common uranium U_{238} for adequate trial. U_{235} occurs to the extent of 0.79 per cent in all natural uranium and is inordinately capable of resisting separation. In theory the disintegration of a gram of U_{235} would release as much energy as the burning of about $2\frac{1}{2}$ million grams of coal. One pound of this dynamic material would release enough energy, if utilized at 100 per cent efficiency, to drive a four-motored airplane around the world fully five times without refueling.

In the event that U_{235} does submit to the harness of human intentions it may never loom large in the total energy picture. It is a rare element, stubbornly tied to its atomic kin from which separation is extremely difficult. It might forever remain a museum curiosity or an item of very limited use. But progress has a way of not stopping. Will U_{235} be the link which will lead to the ways and means of obtaining energy from the atomic disintegration of more plentiful elements? The well-informed man knows that the odds are much against its success. However, he will remember that some of Jules Verne's wilder fantasies became commonplaces in the early twentieth century, and while he may be content to take his energy where he finds it, he would rather like to be around if atomic disintegration for power production ever does become a practical reality. It would lead to technical and sociological changes which would make all previous events appear to be amateurish rehearsals for the big show.

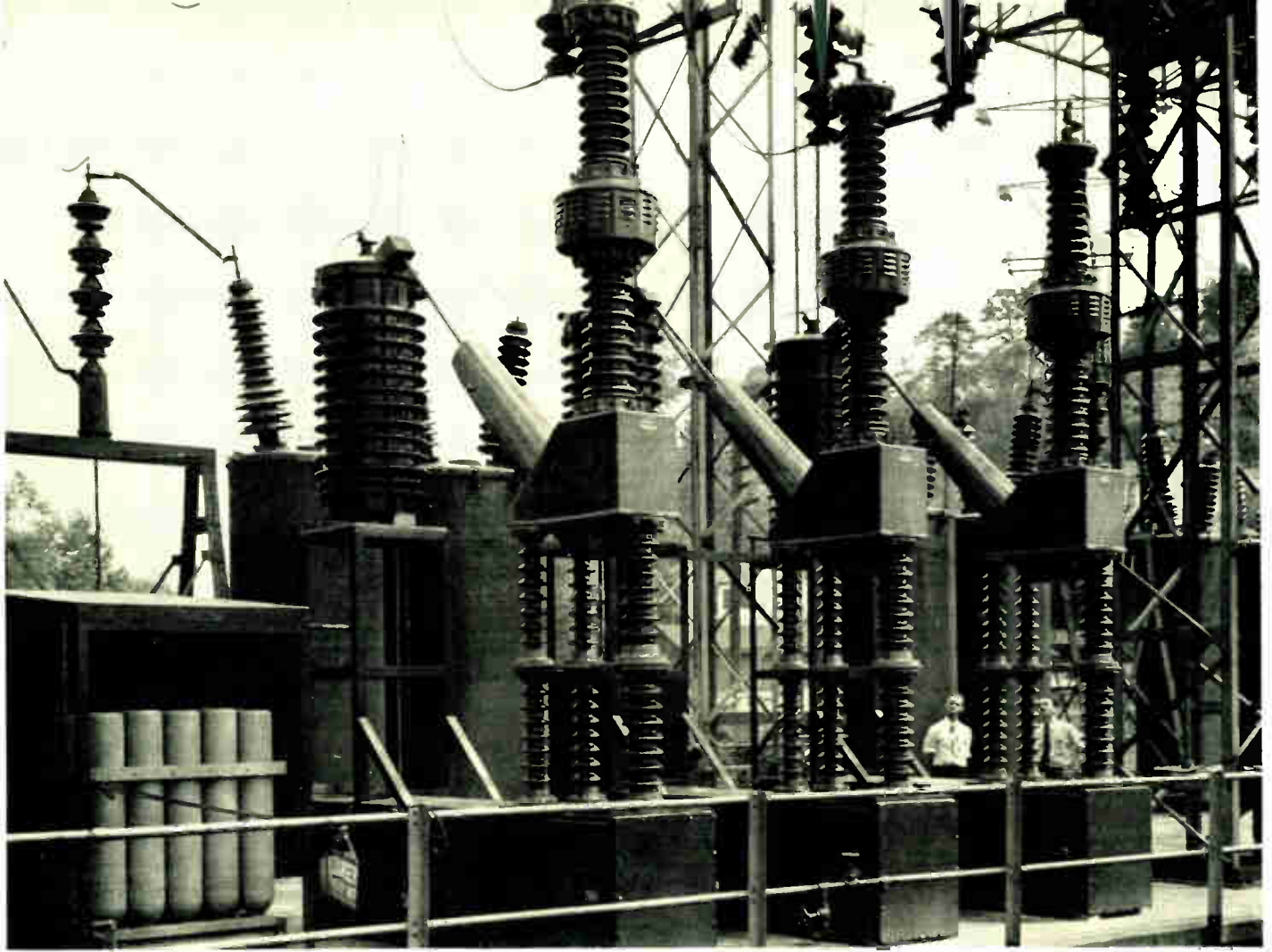

The West Penn Power Company's 138-kv, 1.5 million-kva, compressed-air breaker.

High-Voltage Compressed-Air Circuit Breaker

The circuit breaker protecting a power system is like a municipal fire department; it is infrequently used, yet it must be constantly available and must function immediately in an emergency under all conditions. On duty 24 hours a day, a breaker may be called upon to work less than half a second a year, but in that split second, this protecting giant has in its keeping the full responsibility of the safety of connected apparatus valued in millions of dollars.

THE use of oil as an interrupting medium dates back to the time when an electric arc was first extinguished in a wooden barrel partially filled with oil. From this crude beginning was developed the system which permitted the extended transmission and concentration of electrical power in the United States, unequalled anywhere in the world. For this pre-eminence, the oil circuit breaker is given credit. Because of its insulating properties and remarkable arc-quenching ability, oil has been the interrupting medium in the large, high-voltage units, upon which the breaker art has been based. The flammability of oil and its vapors plus considerations of inspection and maintenance have created a demand for oilless circuit breakers for indoor powerhouse service. To meet this demand compressed-air circuit breakers have been developed

B. P. BAKER
Switchgear Engineer
Westinghouse Electric & Mfg. Co.

for the 15-kv field, covering the one half to two and one half million kva range. Now, compressed-air breakers for high-voltage outdoor service have been built and installed. An experimental single-pole, compressed-air circuit breaker unit rated at 138 kv has interrupted as high as 8900 amperes with full 132 kv across its terminals, on a circuit with a transient recovery rate of 3190 volts per microsecond.¹

The swing in design away from oil began in 1928 to 1930. The first major contribution in the oilless breaker field was the development of the "De-ion" air breakers in 1928.^{2,3} The limitations of this type of self-contained breaker, capable of repetitive service, were about three-fourths of a million kva at 15 kv and one and one half million kva at 24 kv which was inadequate for high-voltage outdoor service.

In Europe, the designing away from oil led to the investigation of compressed-air and water breakers.^{4, 5} Compressed air as an interrupting medium became increasingly popular for both indoor powerhouse voltages and outdoor high-voltage service. These breakers utilized the nozzle type of interrupter (drawing a short arc on a stationary, hollow electrode and blasting it longitudinally through the electrode with compressed air), but they seemed to possess a current limitation at low voltages which limited them to approximately one million kva. At high voltage, the nozzle type seemed better adapted, as current to be interrupted did not exceed 10 000 to 15 000 amperes. This capacity met the demands of European practice but inasmuch as its kva capacity did not go higher than the previously developed De-ion breaker, this development has not been used generally in this country. In 1938 the continued demand for high-power oilless indoor breakers resulted in the development of the transverse flow interrupter, which has been tested to two and one half million kva and shows no limitations to further expansion.^{6, 7}

The water breakers seemed very successful and, in general, met European requirements. Their designs did not have sufficient interrupting capacity for use in this country. The Westinghouse Company developed a 15-kv water breaker which was successfully tested to 1.5 million kva, but this proved impractical for heavy-duty use.

The perfection of the vertical-flow, high-voltage compressed-air interrupter brought about the development of the 138-kv, 1.5 million-kva compressed-air breaker. This interrupter is comprised of insulating discs with centrally located concentric holes through which the arc is drawn. The compressed air blasts the arc from all sides; the hot ionized gases are dissipated through the interrupter chambers out of louvers in the column sides. The enveloping flow of cool air thus prevents reignition of the arc after

current zero due to its intense turbulence at high pressure.

The pole-unit mechanism consists essentially of a vertical cylinder and piston operating the arcing contact and a cylinder and piston mounted at an angle operating the isolating switch. Both switching mechanisms are fast and are pneumatically interlocked so that the circuit is opened by the arcing contact and closed by the isolating switch.

When the breaker is in the closed position, the circuit is from the top of the upper porcelain, through the interrupter to the pole-unit mechanism, thence to the isolating switch blade to the current transformer terminal. After passing through the current transformer the other line terminal is brought out at the top of the current-transformer housing.

When the breaker opens, the arcing contact draws the arc into the interrupter where it is promptly extinguished by the air blast. After the arc is extinguished the isolating switch is opened, thus placing a visible air gap in series with the interrupter. In the West Penn Power Company's 138-kv, 1.5 million-kva three-pole compressed-air circuit breaker, the three poles of the breaker are mounted separately and are mechanically independent. However they are simultaneously electrically controlled from a single housing which contains all relays, gauges, and other control devices. Their operation is synchronized to within one cycle. They can be easily converted to provide high-speed reclosing for segregated phase service.

The air-supply systems for these breakers consist of an insulated, heated, metal enclosure in which two 1000 psi. compressors, driving motors, and control equipment are housed. In the back of this enclosure is a battery of ten, one and one-half cubic foot bottles in which air at 1000 psi. is stored. From these bottles, the air passes through a reducing valve and other protecting devices to the reservoirs of the breaker pole units where it is stored at 350 psi, the normal

Diagram and photograph of vertical-flow interrupter together with one stationary contact with moving contact member protruding through it.

The interrupter consists of two fibre discs with a metal insert in the center of each disc. These inserts have centrally located holes that form the orifices through which the arc to be extinguished is drawn. Between these orifice discs another insulation plate is spaced, which restrains the random motion of the arc in the exhaust gas. The interrupter is symmetrical about this plate, the hollow tulip-type upper stationary contact and the upper orifice forming one interrupting unit, the lower tulip contact and orifice forming the other. The moving contact draws the arc from one stationary contact to the other. The upper stationary contact is suspended from the upper end of the upper porcelain which is the insulation between it and the upper orifice. The lower stationary contact is supported from the lower end of the lower porcelain which provides insulation in a similar manner.

The air blast for interrupting the arc passes through the lower orifice and contact. The remainder passes through the tubes in the interrupter to the upper porcelain from which it escapes through the upper orifice and its adjacent hollow contact. The air, as shown, approaches the arc in a radial direction between the orifice plates and the streamlined shields on the stationary contacts. When it reaches the arcing space, it turns and flows vertically along the arc stream, some of it escaping through the contacts while most of it escapes through the orifice plates. This enveloping flow of high-pressure cool air carries with it the hot ionized gas which is formed while the current in the arc is at, or near, its crest value, so that when the current zero is approached the last little thread of hot, conducting, ionized gas is subjected to an intensely turbulent flow of converging, cool, high-pressure air and reignition is prevented.

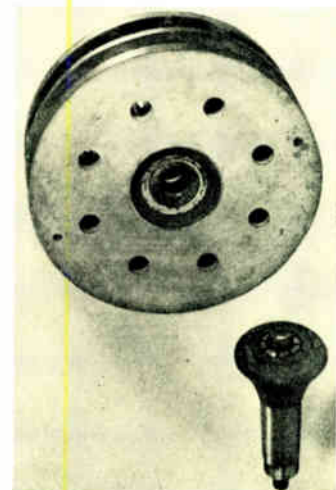
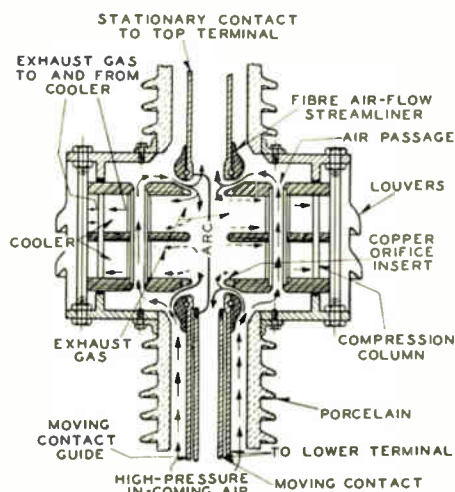

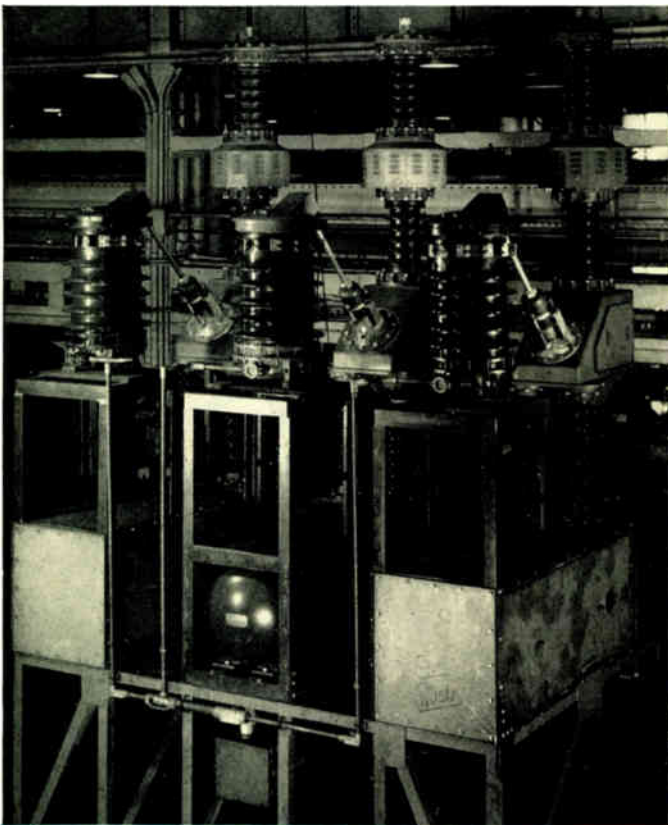

A three-pole, 69-kv, 1.5 million-kva compressed-air breaker in service at the Philadelphia Electric Company's Chester Station.

breaker operating pressure. By compressing to 1000 psi, cooling, and then expanding to 350 psi, dry air is secured for satisfactory operation of the breaker.

The ability of the piston-operated isolating switch to operate under all kinds of weather conditions was proven by placing a pole unit of the breaker in a cold room. Here it was thoroughly sprayed with water and the temperature lowered to -14 degrees F. The breaker was then sprinkled periodically until ice at least one half inch thick covered the entire unit.⁸ Upon energizing the opening coil, the operation of the contacts appeared normal and the isolating blade functioned as though no ice were present.

A pole unit of this breaker was tested in the East Pittsburgh High-Power Laboratory at 5900 amperes with full 132 kv across its terminals.⁸ It was also tested at 7000 amperes at 88 kv with a circuit transient recovery rate of 2600 volts per microsecond.

This breaker was installed at a point where it would receive the most severe service that could be obtained on the West Penn Power System. During the first three months of service, it was given 41 operations, five of which were automatic, resulting from line faults. All operations have been quite satisfactory with no noticeable system disturbance or breaker distress.

A 69-kv 1 500 000-kva compressed-air circuit breaker has been in service on the Philadelphia Electric System for approximately five months. This breaker is similar to the 138-kv breaker except for insulation and a mounting frame which supports the three-

pole units off the ground to prevent employees touching live parts.

Interrupting tests were made on a single-pole unit of this breaker up to 18 700 amperes with full 66 kv applied to its terminals, on a circuit with a transient recovery rate of 2600 volts per microsecond.

The operating experience on the high-voltage compressed-air circuit breaker that is being obtained will properly guide future design and will indicate the relative merits of this type of breaker compared with breakers that depend on the use of oil.^{9, 10}

REFERENCES

- 1—"Vertical-flow Outdoor Compressed Air Breaker," L. R. Ludwig, B. P. Baker, *AIEE Transactions*, Volume 60, No. 5, May 1941, p. 217.
- 2—"Theory of the De-ion Circuit Breaker," J. Slepian, *AIEE Transactions*, Volume 48, 1929, p. 523.
- 3—"Structural Development of the De-ion Circuit Breaker up to 15 Kv," R. C. Dickinson and B. P. Baker, *AIEE Transactions*, Volume 48, 1929, p. 528.
- 4—"The Brown Boveri Air-Blast High Speed Circuit Breaker," *Brown Boveri Review*, November 1935, p. 199.
- 5—"Det Expansionschalter," F. Kesselring, *ETZ*, April 3, 1930, p. 495-508.
- 6—"A New 15 Kv. Pneumatic Circuit Interrupter," L. R. Ludwig, H. L. Rawlins and B. P. Baker, *AIEE Transactions*, Volume 59, September 1940, p. 528.
- 7—"Design and Construction of High-Capacity Air-Blast Circuit Breakers," H. E. Strang and A. C. Boisseau, *AIEE Transactions*, Volume 59, September 1940, p. 522.
- 8—"A Vertical-flow Outdoor Compressed Air Breaker and Its Application on a 132 Kv. Power System," H.A.P. Langstoff and B. P. Baker. To be presented at the 1943 Mid-Winter Convention.
- 9—"The Vertical-flow Interrupter and Its Application to Oil-Poor Circuit Breakers," B. P. Baker, *AIEE Transactions*, June 1941, p. 440.
- 10—"A Multi-orifice Interrupter For High Voltage Oil Circuit Breakers," L. R. Ludwig and W. M. Leeds. To be presented at the 1943 Mid-Winter Convention.

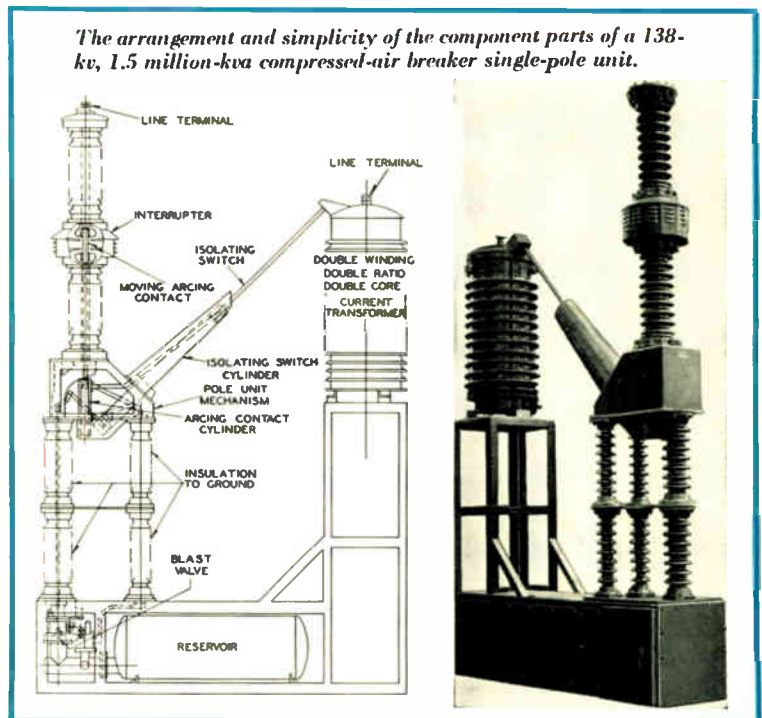

The arrangement and simplicity of the component parts of a 138-kv, 1.5 million-kva compressed-air breaker single-pole unit.

LEAVE SPACE ABOVE THIS LINE BLANK FOR FILING

TO San Francisco WORKS D.O. DATE April 9, 1945
DEPT. Eng. & Serv. MR. J.C. Tietel

Utah Oil Refining Co.
80HP Type C-14 Turbine S[#]2-A-9338-1&2
G.O. 5L-41457-T

1. We have had 4 blade failures on these two 80 HP turbines in each case two to five consecutive blade break off at the root. The first two failures occurred on S[#]2-A-9338-1. These blades were replaced by some the customer made. Recently two ^{more} of the original blades have broken out. These have not been repaired. The other turbine S[#]2-A-9338-2 has recently broken out two blades. In all cases it is the low pressure ~~long~~ blades that have failed.

2. The turbines have been in operation since July 1943. Only one turbine operates at a time. They are coupled to a Westinghouse reduction gear driving a 1770 R.P.M., 1800 G.P.M., 100 ft. head D. Level pump. At the time the turbines were inspecting the pump was discharging 1875 G.P.M. at 70' ft. head. Storm pressure was approximately 130"

FROM _____ NAME _____
DEPT. WORKS OR D.O.

Make it brief; make it clear; make it legible!

LEAVE SPACE ABOVE THIS LINE BLANK FOR FILING

TO _____ WORKS _____ DATE _____
D.O.

DEPT. _____ MR. _____

16.5 ft square inch gage.

3. The turbines are operating at present with two new rotors.

4. We feel that the service from these two turbines has been unsatisfactory and would appreciate your comments as to making a correction.

FROM _____ DEPT. WORKS OR D.O. _____ NAME *O. J. Hanner*

Make it brief; make it clear; make it legible!

Quick Determination of Safe Transformer Overloads

Sage advice has always been to avoid burning the candle at both ends. In times of emergency even this becomes necessary, power-system operators have found. Overloading transformers within the limitations of normal insulation life and other factors has been done successfully through the use of automatic thermal protective devices. Overloading transformers unprotected by such devices, even to the point of slight insulation deterioration, is now sometimes necessary. Standard limitations have been established for this practice, giving a maximum of excess power with a minimum of damage. To use these safety limitations ordinarily involved the solution of equations containing exponential terms and fractional exponents. These are eliminated by the simple graphical method described in this article.

THE WAR has greatly stimulated the interest of power-system operators in the loading of transformers by copper temperature. Increased system demands and the difficulty of obtaining new equipment to supply them have led in many cases to the necessity of operating transformers and associated apparatus for short times at loads considerably above normal. This practice, if followed intelligently, need not result in an undue shortening of the life of a transformer. Most transformers contain a reservoir of capacity in excess of the name-plate ratings, a reserve that can be tapped during emergencies or during peaks of recurrent load cycles and built up again when the load decreases. By utilizing this reserve and any additional capacity provided by low ambient temperatures, many increased load demands can be met safely with existing apparatus, thereby making the purchase of additional equipment unnecessary.

The usual limitation to transformer loading is the temperature of the insulation because deterioration of insulation is a function of temperature and proceeds rapidly at temperatures much above normal. Determination of the ability of a transformer to carry a given overload thus depends usually on two things, a knowledge of permissible insulation temperatures and their duration, and a method of determining the temperatures that result from a given load or load cycle.

Effect of Temperature on Insulation Life

The effect of temperature on the rate of insulation deterioration cannot be exactly calculated because too many factors are involved. For this reason, working figures are necessarily averages based on experience. Definite figures have been suggested as guides by various standardizing bodies,

TABLE I—HOT-SPOT TEMPERATURE LIMITS FOR OIL-IMMERSED TRANSFORMERS
(Suggested by American Standards Association, Standard C-57)

	Hottest-Spot Temperature Degrees Centigrade		
a—Temperature Maintained Continuously	95		
b—Temperature Resulting from Recurrent Short-Time Overload Operation: (a recurrent short-time overload is one of limited duration imposed in accordance with a known schedule; it is regarded as occasional and occurring not oftener than once approximately every 24 hours.)	Time in any 24-hr. Period		
	2 hours	8 hours	24 hours
c—Temperature Resulting from Emergency Short-Time Overload Operation: (an emergency short-time overload is an unexpected overload of limited duration; it is to be regarded as an infrequent occurrence.)	110	105	95
	Time		
	2 hours	8 hours	24 hours
	115	110	105



Charts, a straight edge, and simple addition obviate usual involved calculations as illustrated by the author.

R. C. CHEEK
Central Station Engineer
Westinghouse Electric &
Manufacturing Company

however, and these can be used with the assurance that they are conservative. Certain temperature limits that insure normal life expectancy of insulation have been suggested, as well as other limits that entail a small sacrifice in life. Normal life expectancy is regarded as the useful life of a transformer operated continuously at rated load with a daily average ambient temperature of 30 degrees C.

The suggestions of the American Standards Association for the loading of oil-immersed transformers are contained in table I. The temperature limits are conservative and are based on loading with little or no sacrifice in the normal life expectancy of the transformer.

Emergency Loading with Moderate Sacrifice of Life Expectancy

The life of organic insulating materials is determined mainly by mechanical considerations, i.e., tensile strength, inasmuch as the dielectric strength of such materials is but little affected by mechanical deterioration. It is reasonable to permit occasionally a limited loss of mechanical strength when emergency conditions make it necessary to overload apparatus beyond the temperature limits of table I.

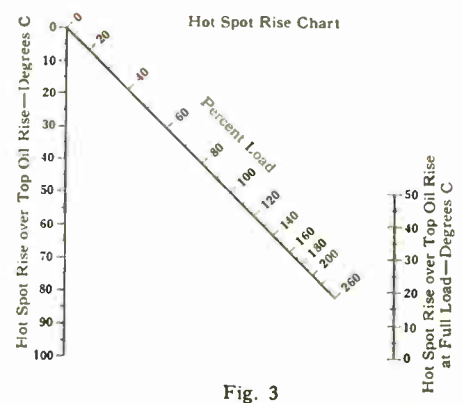
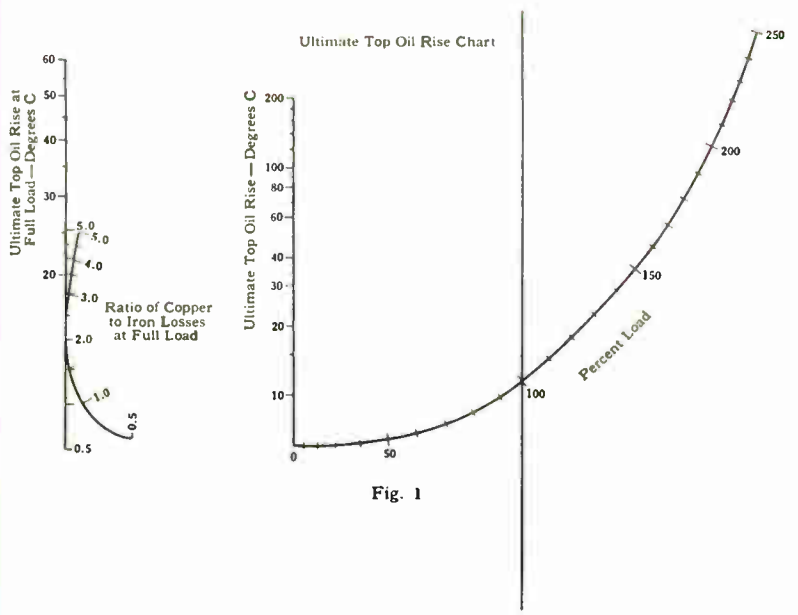
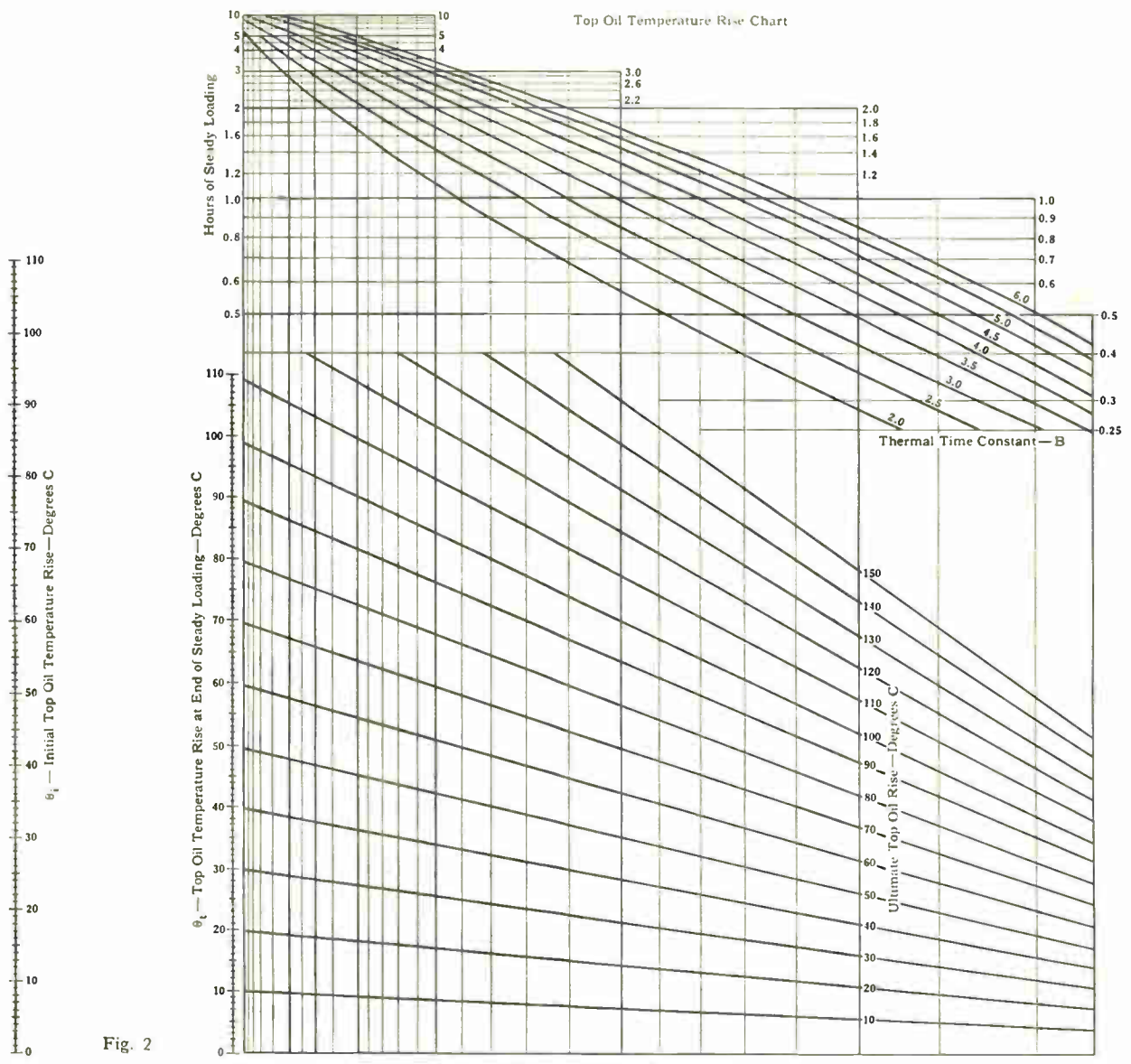

Charts for Quick Determination of Safe Transformer Overloads

USE OF THE CHARTS

TABLE II—SUGGESTED CLASSES FOR TRANSFORMERS FOR CALCULATING EMERGENCY AND RECURRENT OVERLOADS

Class 1—Oil-insulated, self-cooled transformers up to 150 kva, 25 kv, and transformers with windings of all voltage classes rated 15 amperes or less. Class 2—Oil-insulated, self-cooled transformers above 150 kva and up to 69 kv. Class 3—Same as Class 2 except forced air cooled. Class 4—Oil-insulated, self-cooled transformers which include regulating equipment and are used as unit substations. Similar to Class 2 except for longer time constant. Class 5—Same as Class 4 except forced air cooled. Class 6—Large high-voltage power transformers, oil insulated, self-cooled, above 69 kv. Class 7—Same as Class 6 except forced air cooled.							
Class	Average Characteristics						
	1	2	3	4	5	6	7
Hot-Spot Rise Over Top Oil	20°	10°	16°	10°	16°	12°	19°
Top-Oil Rise	40°	50°	47°	50°	47°	50°	46°
Loss Ratio	2.5:1	2.5:1	4.5:1	2.5:1	4.5:1	2.5:1	4.5:1
Time Constant B	3	4	2.5	6	4	4	2.5

IN CALCULATING hot-spot temperatures in a given transformer, it is best to use actual test data showing the full-load loss ratio, ultimate top-oil rise, hot-spot rise, etc., on the unit in question. Where such data are not available, however, the characteristics given in table II for the several different classes of transformers can be used as the average characteristics for each class.⁴

To find the hot-spot temperature at the end of a given load period, first calculate the top-oil rise at the end of the period; then determine the hot-spot rise above top oil temperature (the copper gradient), and add this figure to the top-oil rise; and finally add to this sum the ambient temperature.

Before the top-oil temperature at the end of a given time can be calculated, the ultimate top-oil rise for the load under consideration must be found. The chart of ultimate top-oil rise, Fig. 1, solves eq. 1 for ultimate top-oil rise at a given load for a transformer of any reasonable full-load top-oil rise and ratio of copper-to-iron losses. This chart is used as follows: Lay a straight-edge between the load on the per cent load scale and the full-load loss ratio on the curved ratio scale. This will determine a point on the scale marked "Ultimate Top-Oil Rise." This point is not, however, the ultimate oil rise because the full-load ultimate rise has not yet been taken into consideration. Holding this point move the left-hand end of the straight-edge to the full-load loss ratio on the straight ratio scale. This determines a point on the ungraduated vertical line; holding this point, move the straight-edge to the full-load ultimate top-oil rise on the extreme left-hand scale. The ultimate top-oil rise for the load under consideration can then be read on the scale marked "Ultimate

Top-Oil Rise," Fig. 1.

The top-oil rise chart of Fig. 2 solves eq. 4 for the top-oil rise. Enter the chart at the top, using either the right- or left-hand time scales. Read horizontally along the line corresponding to the time of steady loading to the point at which this line intersects with the line corresponding to the time constant of the transformer, taken from table II, or calculated as shown under eq. 2. From this point read vertically downward to the inclined line corresponding to the ultimate top-oil rise previously calculated for the given load. Between the point thus located and the initial top-oil rise on the θ_1 scale, the top-oil rise at the end of the given time is found on the θ_2 scale.

Whenever the duration of a given load is greater than the time available on the time scale of Fig. 2, the total load period can be broken up into smaller times and the final top-oil rise for each used as the initial top-oil rise for the succeeding period.

Hot-spot rise above top-oil rise is found from hot-spot rise chart, Fig. 3, which solves eq. 5. Laying a straight-edge between the full-load hot-spot rise over top-oil temperature (usually taken as average copper rise

over top oil plus 10 degrees C) and given load on load scale gives the hot-spot rise over top-oil rise on the third scale.

By adding together the top-oil rise, the hot-spot rise over top-oil rise, and the ambient temperature, the hot-spot temperature can be obtained.

Recurrent Load Cycles

On recurrent load cycles the procedure is similar to that just described for emergency loads. The actual 24-hour load curve should be divided into blocks of constant loads of several hours each. The shape of the load curve itself will suggest

the manner in which it should be divided. The constant load for each period should have approximately the same rms value as the actual load curve for the period. This figure usually can be obtained with sufficient accuracy as follows:

$$L_{eq} = \sqrt{\frac{L_1^2 + L_2^2 + \dots + L_N^2}{N}}$$

where L_{eq} is the equivalent constant load for the whole period, L_1, L_2, \dots are the average ordinates of the load curve for the first hour, the second hour, etc., and N is the number of ordinates taken.

In determining the hot-spot temperatures, the final top-oil rise for each period is used as the initial top-oil rise for the succeeding period. It is best to assume an initial top-oil temperature at some point in the load cycle and proceed through the cycle, continuing the calculations until the cycle of hot-spot temperatures begins to repeat itself. The number of times the transformer load cycle must be repeated usually depends upon the accuracy of the initial assumption. Normally it should not be necessary to carry the calculations through the cycle more than two or three times.

EXAMPLE

A TRANSFORMER having the characteristics of class 2 of table II has been operating at 100 per cent load long enough for the top oil to have reached its ultimate temperature rise. An emergency load of 140 per cent is applied and maintained for three hours; then the load is reduced to 90 per cent and held constant for three hours. Determine the maximum hot-spot temperature and the hot-spot temperature at the end of the three-hour 90 per cent load period. Is this emergency loading within ASA limits for normal transformer life? Assume 30 degrees C ambient temperature.

Solution: First determine the ultimate top-oil rise at 140 per cent load from the ultimate top-oil rise chart, Fig. 1. Lay a straight-edge between 140 per cent load and 2.5 loss ratio on the curved ratio scale. This determines a point on the ultimate top-oil rise scale. Disregard the actual scale reading, but hold this point and move the straight-edge to 2.5 on the straight ratio scale. (Since

the curved ratio scale and the straight ratio scale almost coincide at this point, this movement will be slight.) This determines a point on the vertical ungraduated scale. Holding this point, move the straight edge to 50 on the full-load ultimate top-oil rise scale. This gives 73 degrees as the ultimate top-oil rise at 140 per cent load.

To determine the top-oil rise after three hours at 140 per cent load, enter the top-oil rise chart, Fig. 2, at the top, reading horizontally along the line marked three hours to the intersection of this line with the line for $B=4.0$. From this point read vertically downward to the line corresponding to 73 degrees ultimate top-oil rise. Between this point and 50 degrees on the θ_1 scale read 62 degrees final top-oil rise on the θ_2 scale. The initial top-oil rise is taken as 50 degrees because the problem states that the transformer is operating originally at full load with the temperature rises of all the components at their ultimate figures.

Next, determine the hot-spot rise over top-oil temperature at 140 per cent load. The chart in Fig. 3 gives 17 degrees rise for 140 per cent load when the full-load hot-spot rise over top-oil rise is 10 degrees C.

The maximum hot-spot temperature is the sum of the ambient, top-oil rise, and hot-spot rise, or $30+62+17=109$ degrees C.

For 90 per cent load the ultimate top-oil rise is determined to be 43 degrees. Three hours with $B=4.0$, an ultimate top-oil rise of 43 degrees, and an initial top-oil rise of 62 degrees give 52 degrees as the final top-oil rise after three hours at 90 per cent. The hot-spot rise is found from Fig. 3 to be 8 degrees, and $30+52+8=90$ degrees, the final hot-spot temperature.

The ASA Guide permits emergency hot-spot temperatures of 110 degrees C to be maintained for eight hours, and a three-hour load which results in a maximum hot-spot temperature of 109 degrees C is within these permissible limits.

TABLE III—HOTTEST-SPOT TEMPERATURES THAT DECREASE INSULATION LIFE NOT OVER ONE PER CENT

Duration of Load—Hours	Hottest-Spot Temperature Degrees Centigrade
1	137
2	130
4	125
8	120
24	110

The A.I.E.E. Transformer Subcommittee's report on overloading transformers and regulators¹ gives the time and temperature limits, table III, that result in sacrificing not over one per cent in insulation life. Because little is gained by attempting to integrate the curve of rising temperature to get an average value that is slightly below the final value, the temperatures given in this table can be taken as temperatures at the end of a steady load of duration shown. These limits apply to scaled-type transformers in which the oil is effectively protected from air and moisture, and in general only to transformers of modern design, i.e., built since about 1928. Overloads that result in the temperatures of table III should not be allowed to occur more than once in any one day and not more than 25 or 30 times during the life of the transformer. The insulation, windings, and oil are assumed to be reasonably free from excessive amounts of moisture and sludge. In no case, regardless of temperature, should more than twice rated load be carried unless special consideration is given to all factors involved.

The effect of overload on all parts of the transformer and the remainder of the system should always be considered. Such items as oil expansion, bushings, leads, soldered joints, etc., should be checked because limitations other than transformer temperature alone may apply. For example, the load on induction or step-type voltage regulators should never exceed 150 per cent at any time, regardless of temperature, because of the heavier duty imposed upon the associated control and switching devices.

Calculating Hot-Spot Temperatures

With the permissible time and temperature limits established, it is next necessary to determine what hot-spot temperatures result from a given emergency load or recurrent load cycle. This subject has been thoroughly investigated, and empirical laws of temperature variation have been derived that give results sufficiently accurate for practical purposes. Unfortunately, however, the equations expressing these laws are somewhat complicated, involving exponential terms and fractional exponents. Calculations are tedious and require the extensive use of tables of logarithms or a log-log slide rule.

To simplify these calculations the nomographic or alignment charts, Figs. 1, 2, and 3, have been devised. These charts afford a means of solving rapidly and accurately equations based on the assumptions usually made in calculating hot-spot temperatures in oil-immersed, self-cooled or forced air-cooled transformers.

The assumptions are:

1—The hot-spot temperature is the sum of three temperatures: the ambient temperature, the top-oil rise above ambient, and the hot-spot rise above top oil (commonly called copper gradient).

2—The ultimate top-oil temperature rise above ambient varies as the total losses to the 0.8 power. That is,

$$\theta_u = \theta_{FL} \left(\frac{1+RL^2}{1+R} \right)^{0.8} \dots \dots \dots (1)$$

where θ_u is ultimate top-oil rise above ambient, θ_{FL} is ultimate top-oil rise above ambient at full load, R is the ratio of copper losses to iron losses at full load, and L is the per unit load for which the ultimate oil rise is desired.

3—Increasing top-oil rise on transient loads or load cycles follows the exponential law

$$\theta_t = \theta_i + (\theta_u - \theta_i) (1 - e^{-t/B}) \dots \dots \dots (2)$$

where θ_t is the top-oil temperature rise at any time t (hours) during the steady loading in question, θ_i is the initial top-oil rise, i.e., the rise at the start of the loading in question, (this would be the same as the final rise at the end of the preceding loading), θ_u is the ultimate top-oil rise for the new loading (as given by eq. 1), t is length of time in hours that the new loading is to be applied, and B is the thermal time constant for top-oil temperature rise, calculated as follows:

$$B = \frac{C\theta_{FL}}{W}$$

$$\text{where } C = \frac{3.5 (\text{lb core} + \text{lb coils} + \frac{2}{3} \text{ lb tank}) + 90 (\text{gal. oil})}{60}$$

θ_{FL} = ultimate top-oil rise at rated load, and W = total watts loss at rated load.

For steady loads for which the ultimate top-oil temperature rise is lower than the initial temperature rise, the following equation applies:

$$\theta_t = \theta_i - (\theta_i - \theta_u) (1 - e^{-t/B}) \dots \dots \dots (3)$$

This is eq. 2 in slightly different form. Both of these equations give, upon reduction,

$$\theta_t = \theta_i e^{-t/B} + \theta_u (1 - e^{-t/B}) \dots \dots \dots (4)$$

The same equation thus applies for both the heating and cooling parts of a load cycle, assuming that the thermal time constant B is actually constant for all loads and temperatures. This assumption is not strictly correct, but it is commonly made in the calculation of oil temperature rises and gives sufficiently accurate results.²

4—The ultimate hot-spot temperature rise above top oil varies as the 0.8 power of the copper losses or as the 1.6 power of the load. That is

$$T_{HS} = T_{FL} L^{1.6} \dots \dots \dots (5)$$

where T_{FL} is the hot-spot copper rise over top oil at full load, and L is the per unit load.

It has been common practice to take the average copper rise (by resistance) at full load, plus an arbitrary allowance of 10 degrees C, as the full-load hot-spot rise. This practice is conservative because in modern power transformers the difference between the hot-spot and average copper temperatures at full load may be considerably less than 10 degrees C.³

Time constants for copper temperature rises above oil are not considered, because these are of the order of a few minutes. The charts are based on steady-load periods of not less than a quarter of an hour, so that ultimate copper rises can

be used with negligible error in all cases covered by them.

The charts reduce the solution of eqs. 1, 4, and 5 to simple operations that can be performed in a few seconds with a straight-edge. They take into account the ratio of copper losses to iron losses at full load, the division of the hot-spot rise between oil rise and copper rise over oil at full load, and the time constant of the transformer; thus no factor in any of the equations is neglected or approximated, and the results are about as accurate as would normally be obtained by slide-rule calculations, using the equations directly.

Sidetracks for Lightning

Since the days of Benjamin Franklin, lightning rods have been the finishing touch to almost every new barn and farmhouse, as much, we suspect, for decoration as for utility. With the advent of electric power transmission, lightning protection became really serious business. Protective practices now have a scientific background. With the construction of hundreds of new arsenals, powder plants, ammunition dumps, and other hazardous structures the matter of protecting them from lightning becomes a problem of first order of importance. For the solution, architects and Army engineers are borrowing heavily from the experience of the electrical engineer.

When and where lightning will strike is known to no one. But engineers have been counting lightning strokes throughout the country for many years, and now can tell with fair certainty how often a given area is likely to be struck in an average year. In fact, engineers have a curve for it. They have found, for example, that an average-sized structure 25 feet in height may be struck as often as once every 30 or 40 years while one of large extent having an area of say 40 000 square feet about once every 10 years. Some of the modern ordnance plants may have several hundred buildings so that there is a good likelihood of several in each plant being struck each year. The oil reservoirs of tank farms frequently cover as much as 1/10 to 1/5 of a square mile. Thus, there is a probability that one to two direct strokes would occur each year if they were not adequately shielded.

How likely a structure is to be struck by lightning is greatly affected by its height and shape, as has been demonstrated on models subjected to man-made strokes of lightning in Westinghouse high-voltage laboratories. For structures less than 500 feet tall the probability of strokes is about proportional to height. Objects short in relation to the area they cover, such as oil reservoirs,

are not likely to attract strokes from a sky area larger than their own area. The probability of direct strokes is directly proportional to the area of the structure and the number of strokes which emanate per unit area of sky. This has been found to average about 10 strokes per square mile of sky area per year in regions of 25 to 40 storm days, which includes the northern half of the United States east of the Rocky Mountains.

In the days of plenty, the question of wire size for lightning-shield systems was of small importance. One more than sufficiently big was used without question. Frequently No. 2 A.W.G. was chosen. Now with materials scarcity, the matter deserves attention. Lightning-investigation engineers find that a No. 6 A.W.G. conductor, either copper or steel, has more than the necessary current-carrying capacity and sufficient mechanical strength for most applications. As a consequence, considerable saving in material has been made by adopting for many structures the smaller wire. However, all parts of the protective structure that may be picked for lightning to hit should be as

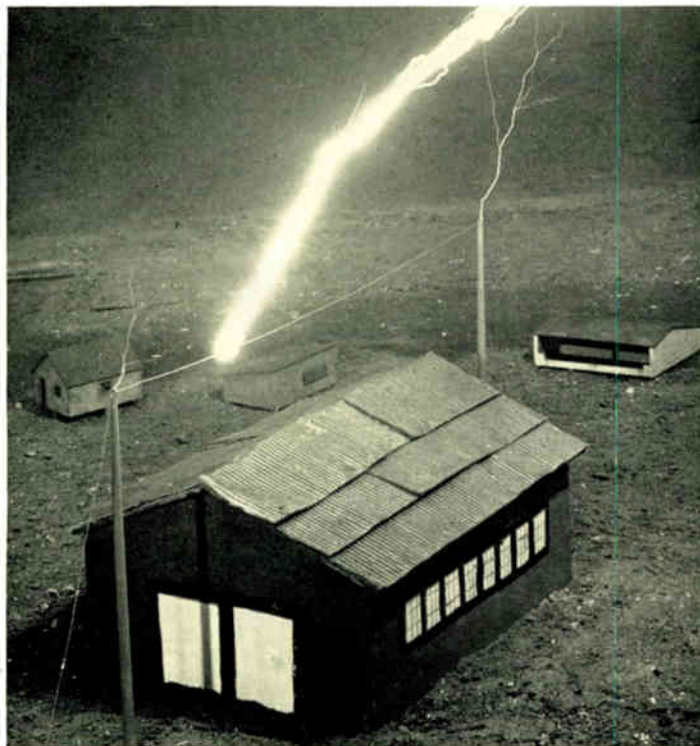

REFERENCES

- 1—"Interim Report on Guides for Overloading Transformers and Voltage Regulators," A.I.E.E. Transformer Subcommittee, *A.I.E.E. Transactions*, September, 1942, p. 692-4.
- 2—"Emergency Overloading of Air-Cooled, Oil-Immersed Power Transformers by Hot-Spot Temperatures," V. M. Montsinger and P. M. Ketchum, presented at the A.I.E.E. Summer Convention, Chicago, Ill., June 24, 1942.
- 3—"Hot-Spot Winding Temperatures in Self-Cooled, Oil-Insulated Transformers," F. J. Vogel and P. Narbutovskih, *A.I.E.E. Transactions*, March, 1942, p. 133-6.
- 4—"Emergency Overloads for Oil-Insulated Transformers," F. J. Vogel and T. K. Sloat, *A.I.E.E. Transactions*, September, 1942, p. 669-72.

large as No. 2 because there is always some burning at the point of lightning contact.

Lightning can strike with safety a metal enclosure filled with gasoline or explosive. Any region completely enclosed by metal surfaces not only is shielded from contact by direct strokes, but also from fields of any external electrical disturbance. It is necessary only that the steel be thick enough that a hole is not burned through it by the stroke. Sheets greater than 3/8-inch thick cannot be appreciably damaged by the most severe stroke.

Lightning, for all its reputation of speed, is not infinitely fast. Some time is required for lightning to travel down a wire. Not much, but perhaps a few microseconds. Considering that current may rise as fast as 40 000 amperes per microsecond, potentials of as much as 16 000 volts can appear across each foot of conductor. For this reason, when shielding a non-metal structure by a metallic "cage," it is important that the wires to ground be far enough removed from all metallic objects so that there can be no possibility of sparkover, which in itself might become a hazard. In many industrial locations such as oil pipeline pumping stations, explosive plants, etc., a spark will cause a devastating amount of damage.

The degree of protection necessary varies with the value and vulnerability of the property to be protected, and the probability of direct strokes. The protection adequate for a barn is not applicable to structures where petroleum products, flammable gases, or explosives are being handled or stored. The importance of such structures cannot be overstressed and the best of protection is the minimum allowable. Preventing direct strokes is not feasible. Shielding with vertical masts and horizontal ground wires answers the requirements of efficacy and minimized use of critical materials.

Stories of Research

A Yardstick for White-Hot Steel

A WHITE-HOT slab of steel ten feet wide is swiftly squeezed out between the rolls of a mill. It is too hot to get near it without an asbestos suit. Obviously any ordinary measuring device is out of the question. Yet the roll operator needs to know quickly and accurately the width of the slab in order that he can adjust the mill to bring it to the desired dimensions with least waste by trimming.

Dr. E. D. Wilson tackled the problem, although his normal activity is with non-optical apparatus, and produced a practical answer in the form of a simple system of mirrors. The image of the hot slab is picked up by a convex mirror and reflected to another mirror for convenient observation by the operator. Superimposed on this image before him is the image of a brightly lighted scale. By a simple adjustment of the mirrors the width of the slab can be read directly on the phantom scale. The width can be read down to units of one-half inch, which is sufficiently accurate to prevent, not only the waste of vital material but also to conserve equally vital time and labor both in the measuring and trimming operations.

This device for remote measurement of hot steel plates has the distinct merit of being non-critical in its installation, maintenance, or repair. In the conditions under which it must operate in a steel plant, this is of great importance. The effectiveness of simplicity is here exemplified.



Glass instrument bearings as seen under a microscope. These "jewels" are so inspected to check depth and angle of the cavity.

Jewels of Glass

THE flow of polished sapphire jewels from Nazi encircled Switzerland has been stemmed. Faced with the augmented demands of our military forces for instruments in great numbers which depend on jeweled bearings, engineers turned to glass as a material for the vital parts. Research has revealed that the glass bearing is not only an acceptable substitute but is a superior bearing. Sapphires, second only to diamonds in hardness, are hand polished for bearing use whereas glass bearings, formed under heat, are flame polished and are much smoother. Glass, being softer, wears more but there is less pivot wear and, most important, the lifetime friction in the bearing is less than with sapphires. Significantly, the future offers a cheaper and better bearing jewel from assured domestic-industry sources.

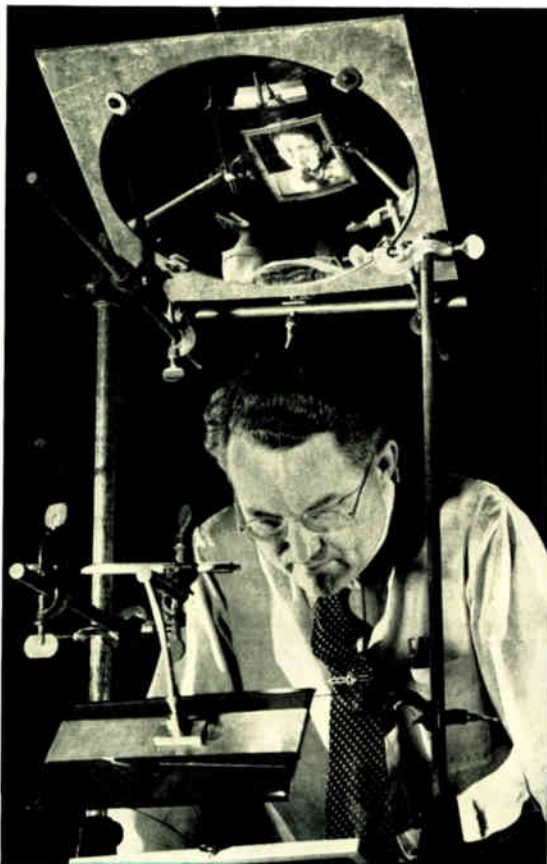

As Dr. Wilson appears to the measured objective.

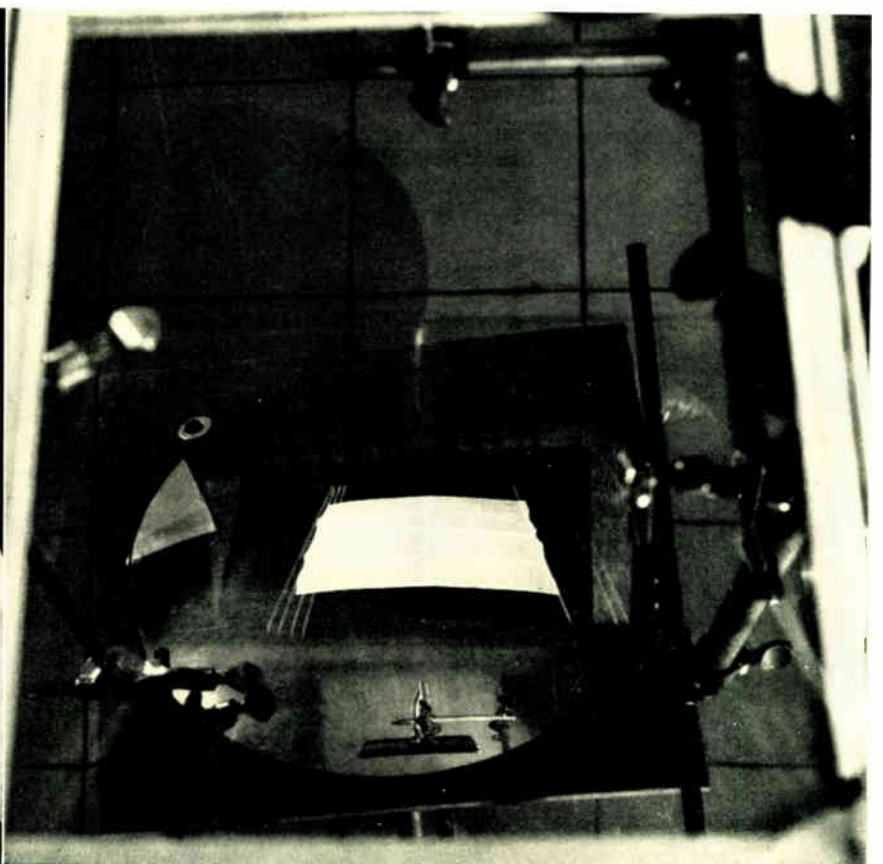

As the operator sees the slab image with the gauge marks superimposed upon it.

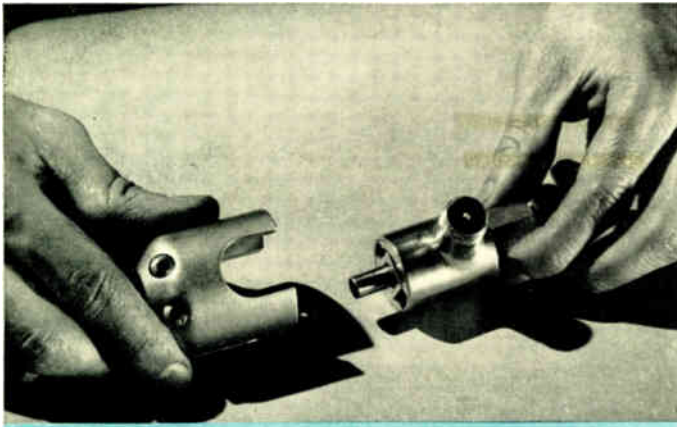

The complete accelerometer is held in the left hand. The right hand holds an additional mass which increases the sensitivity.

Crystals Used to Measure High Accelerations

THE use of quartz spans the entire history of mankind. Among the few remaining artifacts of earliest man are arrowheads of flint, a hard form of quartz; the frequencies of radio-broadcast stations are controlled by quartz crystals. And now an ultra-modern use—the measurement of acceleration—has been made of their fascinating physical and electrical properties.

Quartz has a mysterious ability. When an alternating voltage is applied between the faces of a quartz crystal properly cut, the crystal vibrates mechanically at the frequency of the applied voltage. This is the property utilized in radio-frequency control. But, this action can be worked in reverse. Vibrate the crystal mechanically, and an alternating voltage of the same frequency appears across the faces. This fact has been put to work at the Westinghouse Research Laboratories as a new kind of accelerometer.

This device is intended to measure high rates of accelerations. It consists of a steel case bolted solidly to the object whose acceleration is being measured. On the inside, stacked in line in the direction of motion, are a quartz crystal, a thin layer of copper, another quartz crystal and a small mass all held against the case by a soft spring. When the acceleration occurs, this mass because of its inertia, exerts a force on the quartz crystals. Because of their peculiar ability the crystals translate this force into a charge proportional to the acceleration. This charge is taken off at the copper leaf, led to an amplifying system, and thence to a cathode-ray oscillograph, where it is photographed on moving film. The film speed is such that the events of one thousandth of an inch are spread over an inch of film. The quartz accelerometer faithfully records accelerations of high order occurring at frequencies up to 10 000 per second, which is well below its own natural frequency.

The accelerometer itself is small enough to be carried in a coat pocket, being about $1\frac{1}{8}$ inches square by 3 inches long. Its special merit is ruggedness. While the output of quartz is not as high as some other crystals, it is able to withstand without injury the high forces associated with high accelerations.

Thus far the accelerometer is employed in the study of wartime problems. However, it is a practical tool that will have much use in the improvement of peacetime machines.

Fatigue of Luminescents

PRODUCTIVE effort of a worker tapers off from the first bright, clear-headed energy which he expends at the start of the day to the tired, less efficient pace of the late afternoon. These evidences of fatigue are eradicated, however, by a restful night's sleep and the next day's work tackled with renewed energy. Recent tests conducted by Dr. N. C. Beese, research engineer, reveal that luminescent molecules when exposed to ultraviolet light are similarly affected. There is a definite fatigue effect; the molecules lose their efficiency and tend to slow down in their production of luminescence, but after suitable rest in the dark, fully regain their strength.

In view of the tremendous and continuing growth of fluorescent lighting, factual information regarding this phenomenon became in-

creasingly necessary. Using newly devised apparatus, Dr. Beese, in a series of tests covering both organic and inorganic materials in various forms and operating under different intensities of short wave irradiation, secured interesting and valuable data.

The varying conditions of material and manner of testing made it necessary to resort to several schemes to develop the data needed. In one test, Dr. Beese used a high-speed oscillograph, a light output measuring device to get simultaneous measurements of visible and ultraviolet light with a time component. In order to have a source of ultraviolet light of intense concentration with which to irradiate the materials, the substance to be tested was placed inside a low-pressure mercury-vapor lamp. To achieve the same effect, in another experiment powdered material was painted on the quartz envelope of a mercury-vapor lamp. This lamp had a section of clear quartz tubing through which it was possible to measure the intensity of the ultraviolet rays being developed in the tube. A thorium photocell was used to pick up the ultraviolet radiation that passed through the clear quartz section while a caesium photocell registered the visible light. Amplifiers were used to amplify the photocurrents sufficiently for use with an oscillograph. The two traces were so placed on the film as to obviate interference. The illustration shows Dr. Beese with still another device consisting of a black lamp as source of ultraviolet. These rays are passed through a quartz water cell to remove infrared rays and fall upon material to be tested. Behind this is seen a photocell with attendant battery and microammeter. A stop watch is used for timing readings. In most materials tested, the microammeter readings decrease with the length of time exposed to the ultraviolet rays, showing a decrease in luminous output as a result of the fatigue effect.

Of the great variety of materials tested, only two failed to show marked evidences of molecular fatigue effect. These two were zinc sulfide and zinc-calcium sulfide. Both are, however, too unstable for commercial lamp use. Other materials tested include calcium tungstate, magnesium tungstate, cadmium borate, and zinc silicate, this latter compound showing greatest loss of efficiency of this group. Uranium glass (fluorescent canary glass) and solutions of fluoreocin and anthracene also showed a pronounced fatigue effect.

Dr. Beese's exhaustive examinations developed conclusively a molecular fatigue effect in substances identified with the production of fluorescent light. He feels, however, that further study might reveal methods of overcoming this fatigue effect in fluorescent materials.



From the microammeter reading, Dr. Beese can determine the reaction of the fluorescent canary glass to the ultraviolet rays emitted by the black lamp at the right. A quartz water cell removes the unwanted infrared rays before the light impinges on the photocell.

Use of Limiters in War-Plant Networks

When industrial plants borrowed the secondary-network idea from city distribution systems, along with it came a device called a limiter. It looked like a fuse, and acted like a fuse, but served a different function—to interrupt fault current only. The limiter has proved to be even more important on plant systems than for its original job. In planning a network system using them, not only must limiters of proper rating be selected, but also each limiter must be coordinated with every other circuit-opening device.

THE secondary-network system, long a standard of reliability for low-voltage metropolitan distribution, is being rapidly adopted in industrial plants.^{1,2} The successful operation of any industrial network system depends on the correct functioning of the devices that limit energy flowing into a fault on the cable system. These devices are known as limiters. In a typical industrial-network system, such as shown in Fig. 1, all power supplied by the distribution system can, therefore, be no better than the reliability of its limiters.

Early network systems for city distribution did not use limiters, because cable-insulation failures on 120/208-volt systems generally were self-clearing.³ An arc space recovers a dielectric strength of about 250 volts instantaneously at current zero. This is sufficient to cause automatic interruption of an arc on a 120/208-volt circuit. Experience indicated, however, that further reliability could be obtained if the amount of energy flowing into any cable fault could be limited. Considerations indicating the need for this limitation are:

1—Solid metal-to-metal faults may not be self-clearing.



H. L. Rawlins and C. E. Warren with cutaway-model limiter.

2—Faults, although self-clearing, can persist until heating of the cable results in permanent damage to its insulation.

3—On persistent faults sufficient explosive gases can be liberated from damaged insulation to cause manhole explosions.

4—Faults, if not cleared immediately can spread to adjacent cables, materially increasing the resultant damage.

These factors led to the development of limiters, which consist of fusible links located at the ends of cable runs. They guarantee the clearing of any fault on the cable before its insulation is damaged or before the fault spreads to other cables. The correct analysis and solution of this problem is the work of Mr. C. P. Xenis, of the Consolidated Edison Company of New York.^{4,5,6}

A fuse and a limiter are similar in physical form and in method of operation. However, because a fuse is essentially an overload protective device, and the limiter is intended primarily as a means of fault clearing, the shape of their current-clearing time curves differs.

Until secondary networks were adopted by industrial plants, the application of limiters was confined almost exclusively to 120/208-volt networks for city distribution, in which the requirements of limiters were not severe. The system voltage is low, and short-circuit currents seldom reach 30 000 amperes. Hence, on urban systems the interrupting duty on limiters is moderate. Limiters are usually placed in underground vaults so that restrictions on noise or demonstration are not severe.

Industrial Plants Impose Special Requirement on Limiters

When the network distribution system is applied to an industrial plant new problems arise. Distribution voltages up to 600 volts are encountered, cable runs are considerably shorter, and power concentrations are greater. All of this leads to greatly increased short-circuit currents that must be interrupted at higher voltages where faults are seldom self-

H. L. RAWLINS
Protective Devices Engineer
C. E. WARREN
Central Station Engineer

Westinghouse Electric & Mfg. Co.

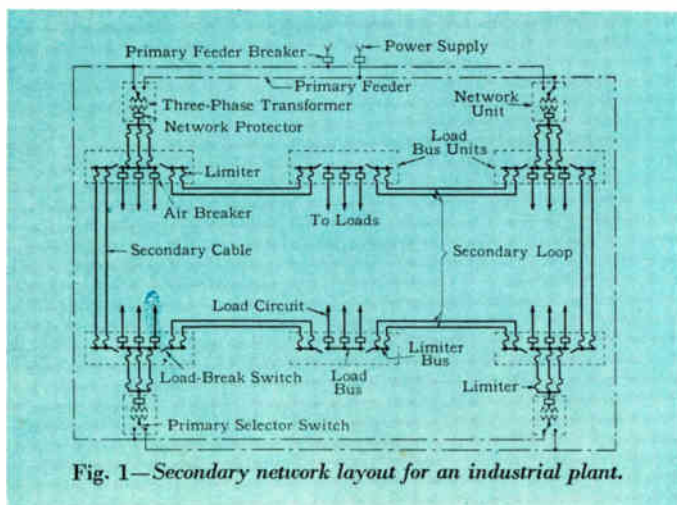

Fig. 1—Secondary network layout for an industrial plant.

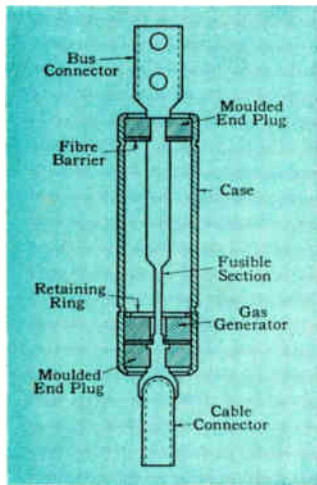

Fig. 2—Limiter in cross section.

The essential parts of the new 600-volt, 60-cycle, 50 000-ampere limiter are: the main conducting element with reduced fusible section, an outer copper shell, and insulating plugs to isolate the conductor from the outer shell. The conducting element is made from copper tubing, around which are molded the end plugs with their retaining rings. Fiber washers adjacent to the end plugs prevent arc flame from burning the molded material, and produce a gas-generating structure. The retaining rings, which fit against embossed shoulders on the outside casing,

prevent the structure from moving under the stress of interruption. The outer copper tube forms the case of the limiter and serves two functions: first, it completely seals the chamber and prevents the emission of hot gases or flame, and second, it furnishes a condensing surface for the metal vapors emitted from the fusible element. The assembly is held rigid by embossing the copper tubing at the retaining rings, and is then sealed by swedging in the ends of the casing.

Current is interrupted by a combination of turbulence resulting from gas emission from the fiber washers and the increase in pressure within the structure. At higher currents, this increase in pressure produces a high arc voltage. This limits the current and shifts its phase relation so that interruption occurs near normal voltage zero.

clearing. Hence, positive interrupting means must be provided to clear faults on systems with voltages above 120/208 volts. The device used to accomplish this on industrial-plant systems must not only be able to interrupt currents up to 50 000 amperes at 600 volts, but also to meet several other severe conditions.⁷ Because they must function close to men at work the noise and demonstration must be strictly limited. The devices must not present any fire hazards. To permit several of them to be mounted in a small space their own temperature rise must be low. Also their time-current characteristics must be such as to permit coordination with other limiters, with cable insulation, and with network-protector fuses. A new, totally enclosed limiter designed by Westinghouse engineers to meet these requirements is shown and described in connection with Fig. 2.

The problem of applying the limiter to an industrial network system can be resolved into two parts:

1—The selection of a limiter that will protect the insulation of the conductors in the network secondary loop.

2—The selection of limiters that can be coordinated with each other and with the network-protector fuses for any fault that may occur on the network system so that no limiter is blown unless a fault appears on the cable associated with it.

Limiters Must Melt Before Dangerous Insulation Temperature Is Reached

The first part of the problem is largely a matter of choosing a limiter with a time-current characteristic slightly faster than the maximum safe time-current curve of the protected conductor insulation. The new limiters, the time-current characteristics of which are shown in Fig. 3, can be coordinated with the damage characteristics of the insulation of rubber-covered conductors ranging in size from 1/0 to 600

TABLE 1—MINIMUM RATIOS OF CURRENT IN PROTECTING LIMITERS AND FUSES TO CURRENT IN PROTECTED LIMITERS AND FUSES NECESSARY TO OBTAIN PROPER COORDINATION

Rating of Protecting Limiters and Fuses	Rating of Protected Limiters and Network Protector Fuses							
	Limiters				Network Protector Fuses			
	4/0	350 MCM	500 MCM	600 MCM	800 Amp.	1200 Amp.	1600 Amp.	2000 Amp.
4/0	1.5	1.1	0.6	0.5	0.6	0.4
350 MCM	2.0	1.5	0.8	0.7	0.9	0.6	0.4	...
500 MCM	3.8	2.8	1.5	1.2	1.4	0.9	0.6	0.4
600 MCM	5.3	4.0	1.9	1.5	1.8	1.1	0.7	0.5
800 Amp.	4.4	3.2	1.8	1.4
1200 Amp.	...	6.5	3.8	2.9
1600 Amp.	5.9	4.7
2000 Amp.	7.7	6.2

MCM. The 4/0 limiter protects all conductors from 1/0 to 4/0; likewise the other limiters in turn protect all conductor sizes between their rating and the next lower limiter rating. The rating of the limiter is obviously fixed by the size of the conductor it is to protect and not by its own current-carrying capacity.

When bus duct (metal-enclosed bus) is used for the secondary loop of the network system, it is not necessary or practical to provide protection because the insulation is composed of inorganic material. In such installations, the limiter functions solely to isolate faults. Limiters should be applied so that their minimum melting current is about twice the normal rating of the bus duct to which they are connected. In other words, they are not overload devices, that being the province of fuses. As shown in Fig. 3, the 750-ampere bus duct with 600-MCM limiters is the largest rating possible.

Limiters Must be Coordinated with Each Other

The second part of the problem, coordination of limiters with each other and with the network-protector fuses for any fault condition, is more involved. Distribution of the fault current in the network circuit elements must be determined. This determination can be done either by calculation or with a d-c calculating board. Because the calculation necessary is laborious, and a calculating board may not be immediately available, general rules for certain assumed limiting conditions can be used as guides in obtaining the solutions to specific coordination problems.

The four fault conditions chosen for the discussion of the coordination problem are discussed in detail and shown schematically in Fig. 4. The fundamental problem of coordination always is to insure that the faulted section of the network secondary loop will be isolated from the remainder of the system by operation of the fewest limiters and fuses,

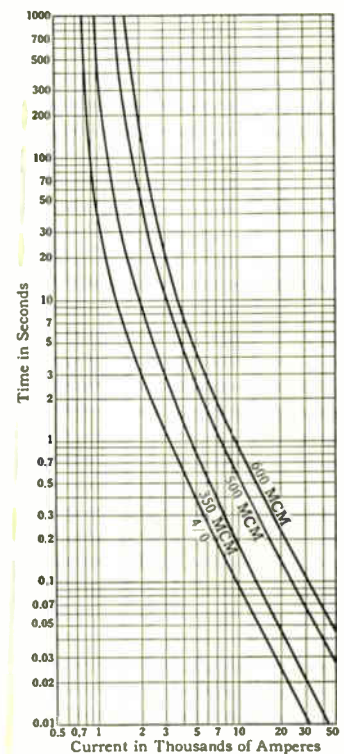

Fig. 3—Limiter melting-time-current characteristic curves.

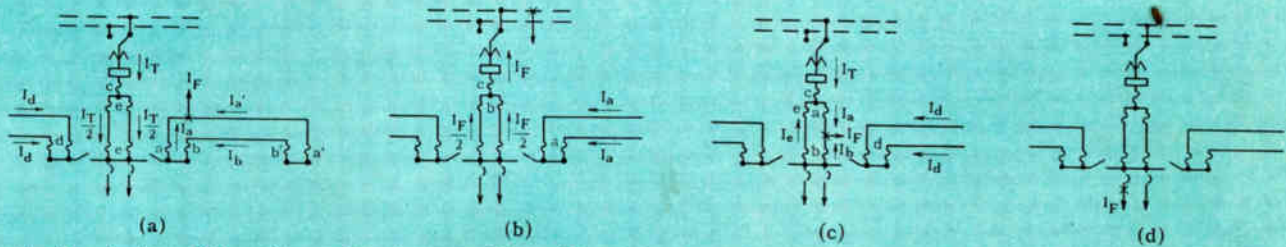

Fig. 4—Four fault conditions discussed in the text. All possible minimum ratios for proper coordination in these faults are listed in table I.

and without damage to any other limiters or fuses in the system. The limiters and fuses for isolating the fault will be designated by the prefix *protecting*; all other limiters and fuses will be designated by the prefix *protected*.

Proper coordination is obtained if the maximum total clearing time of the protecting element be less than the minimum melting time of the protected elements. This condition is always safely met if the current in the protected element does not exceed two thirds of the current necessary to melt it during the time required to melt the protecting element. Stated conversely, the protecting and protected limiters of equal ratings are always coordinated if the current in the protecting limiter is $1/0.66$ or 1.5 times the current in the protected limiter. Where the ratings of the protected and protecting elements are identical, it is merely required that the current in the protected element not exceed two thirds of the current in the protecting element. If the ratings are not alike, the curves of Figs. 3 and 5 should be used. For example, calculate if one 600-MCM limiter carrying 30 000 amperes will protect two 500-MCM limiters carrying 15 000 amperes each. The melting time of the 600-MCM limiter is 0.105 second. The current to melt a 500-MCM limiter in 0.105 second is 24 000 amperes, two thirds of which (16 000) is greater than 15 000 amperes. Therefore, one 600-MCM limiter protects two 500-MCM limiters under these conditions. This rule assumes that the fault current in the protected limiters or fuses does not exceed 25 000 amperes for 500-MCM and 600-MCM limiters and all ratings of network fuses, 20 000 amperes for 350-MCM limiters, and 15 000 amperes for 4/0 limiters. This limitation is automatically satisfied because two or more parallel circuits always feed the protecting element.

Different Criteria Used When Fault Current Is Unknown

This method is satisfactory where the distribution of fault current is known or can be easily determined. For other cases it is necessary to establish different criteria to assist in the coordination of the limiters and the protector fuses.

A general rule can be stated for the

coordination of combinations of limiters of different ratings and for combinations of limiters and network-protector fuses: If the ratio of current in the protecting element to current in the protected element is equal to or greater than a certain minimum, proper coordination is obtained. These minimum ratios are listed in table I for all possible combinations. For example, if a 600-MCM limiter is to protect a 500-MCM limiter, the current in the 600-MCM limiter must be at least 1.9 times the current in the smaller limiter. All ratios are based on the criteria for proper coordination previously stated. In each case the ratio has been determined for the set of conditions that result in the maximum value for the ratio.

Various Alternate Schemes Have Been Proposed

A summary of the discussions of the coordination of limiters and network-protector fuses for all fault conditions discussed in detail with Fig. 4, is given in table II. A network system consisting of at least two conductors per phase in the secondary loop, and at least three conductors per phase in the transformer ties, provides complete coordination for most cases discussed in the above paragraph.

Some have suggested that the load-break switch and secondary-loop limiters be replaced by circuit breakers as shown in Fig. 6(a). One of the coordination problems arising with this arrangement is to obtain selectivity between the radial-load-feeder circuit breaker and the secondary-loop tie circuit breakers for a fault on the radial feeder. If the total fault current is less than the instantaneous setting of the feeder breaker, it is probable that proper coordination is obtained. However, this depends on the relative ratings of the loop-tie and feeder circuit breakers and the division of fault current between the two sections of the network secondary loop. Proper selectivity may not be obtained if the fault currents in the various circuit breakers are within the range where the inverse-time limit characteristic curves of the air circuit breakers are relatively flat.

When the fault currents exceed the instantaneous trip settings of the various breakers, all breakers open. At least four of the loop-tie breakers

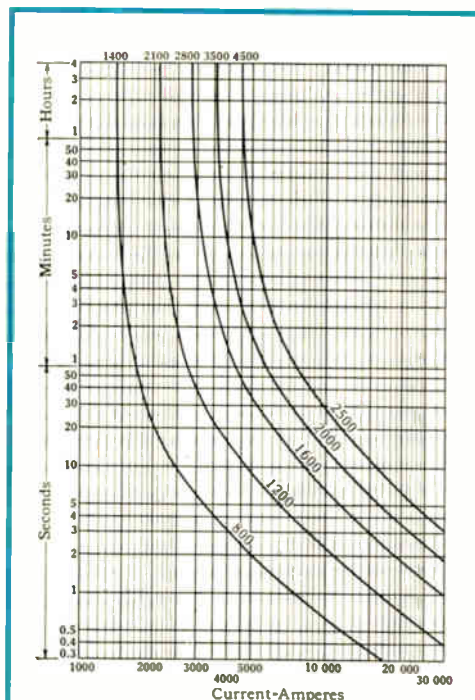
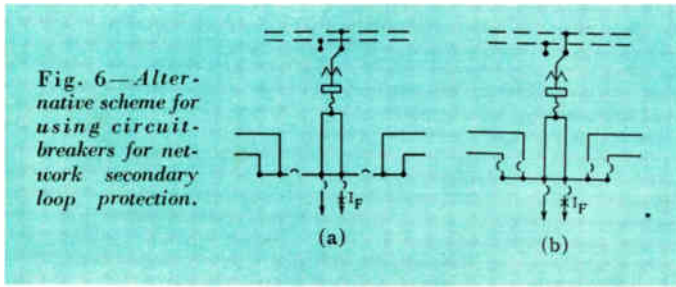

Fig. 5—Melting time-current curves of special-alloy network-protector fuse characteristics for use with data in Fig. 3 for limiter coordination computations.



open, and in many cases six or eight are tripped by a severe fault. When the system has load-bus units not supplied by a transformer, the load at these points is dropped until the loop-tie breakers have been reclosed.

The alternate arrangement shown in Fig. 6(b) has been proposed as an improvement over the arrangement of Fig. 6(a). However, if the rating of the circuit breaker in each circuit of the secondary loop is one-half the rating of the loop-tie breaker in Fig. 6(a), the situation is exactly the same as described above. The fault current through each loop-tie breaker of Fig. 6(b) is cut in half, but because the breaker rating has also been halved the instantaneous trip setting is reduced to one-half that for the breakers of Fig. 6(a). The only difference between the two arrangements is that it is necessary to reclose twice as many loop-tie breakers after the occurrence of a severe fault on the system, when the arrangement in Fig. 6(b) is used.

Some improvement in the arrangement of Fig. 6(b) can be made by using circuit breakers with a rating of about twice the normal capacity of the loop circuit with which it is associated. This doubles the fault current necessary to pro-

Fig. 7—Cutaway view of blown limiter.

This cutaway view of a limiter shows what the interior looks like after the limiter has operated. The condensed metal vapor can be seen as irregularities on the inside surface of the blown limiter. Repeated interruption tests at 600 volts throughout the entire current range, up to the interrupting rating of the limiter, have demonstrated the adequacy of the limiter. In many of these tests, the limiter was completely surrounded by surgical cotton in accordance with the procedure established by the Underwriters Laboratories. In no test was the cotton discolored, thus proving the absence of flame or hot gases external to the limiter. In conjunction with the interruption tests, overvoltage tests on blown limiters have demonstrated the ability of the blown limiter to withstand full voltage in service. In all cases, the limiters withstood more than 2200 volts continuously for several days.

Temperature-rise tests were made with the limiter connected to the supply by eight-foot lengths of the proper size, type-R cable. The limiter was supported in free air, and was shielded from air currents by a canvas screen placed completely around the device. Temperature rises were found to be less than 30 degrees C for all sizes of limiters at the maximum current rating of their respective cables.

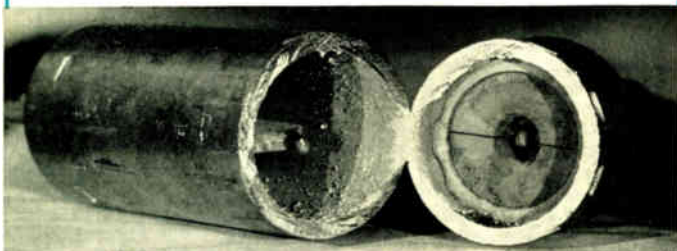
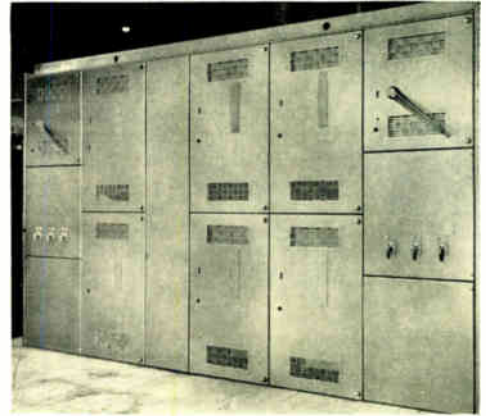

Fig. 8—Load-bus unit with two limiter sections and six drawout-type feeder breakers.



duce instantaneous tripping and, therefore, reduces the number of times that the loop-tie breakers trip. However, this is an expensive and wasteful means for obtaining better coordination, and in addition the breaker does not provide proper protection for the insulation of the conductors in the secondary loop.

As an alternate scheme the loop-tie breakers of Fig. 6(a) can be protected by overcurrent relays. The relays are set so that their inverse-time characteristics give proper selectivity for faults on various parts of the system. This scheme requires the additional initial expense of the relays, and also that they be maintained and adjusted. Therefore, replacing load-break switch and limiters with loop-tie circuit breakers results in an increase in expense and decrease in reliability.

Some of the outstanding advantages of the limiters, as used in the industrial-type network system are:

1—The inverse-time characteristic of the limiter is such that when it is used in a properly designed industrial network system, isolation of all faults is obtained with no interruption of power to the system load.

2—The limiter is a simple, thermally operated, totally enclosed device that requires but little attention and maintenance.

3—The limiter, being a thermally operated device, is well suited to the protection of cable insulation from damage resulting from overheating under fault conditions.

4—The limiter, when clearing a fault on the system, operates rapidly, with no external demonstration to limit the disturbance at the fault to a minimum.

The following two pages contain the presentation and solution of four coordination problems based on Fig. 4.

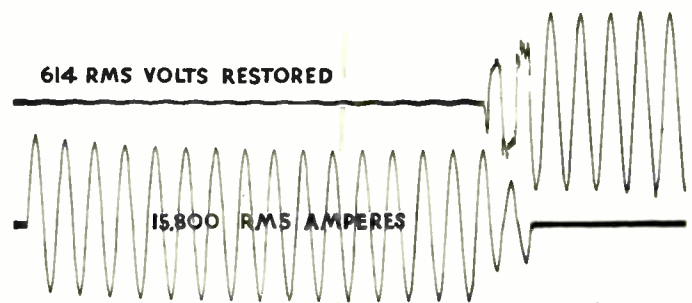

Fig. 9—Oscillogram of the interruption of 15 800 rms amperes.

COORDINATION PROBLEMS

Case A

THE first coordination problem, Fig. 4(a), is for a fault on one of the secondary loop circuits. In this case, the limiters a and a' at each end of the faulted circuit are the protecting elements, and they must clear to isolate the fault from the system. The fault current varies somewhat with the location of the fault on the loop circuit, but a discussion of the coordination of limiter a applies as well to limiter a' . With limiter a the protecting element, the significant current ratios are $\frac{I_a}{I_d}$, $\frac{I_a}{I_T}$, $\frac{2I_a}{I_T}$, and $\frac{I_a}{I_b}$.

In a correctly designed network system, the secondary loop conductors are of equal size. This means that all limiters associated with the secondary loop have the same rating, and that, within an error of one or two per cent, the fault currents through the limiters d will be equal in magnitude.

The minimum ratio of $\frac{I_a}{I_d}$ occurs when the transformer is out of service, and the fault location is near limiter a' . Under these conditions, I_a is equal to I_d , and $\frac{I_a}{I_d}$ equals one, the least possible. However, limiter a' carries more current than limiter a and, therefore, clears first, after which I_a equals $2I_d + I_b$.

A general discussion of this coordination problem is difficult because of the sequential blowing of limiters a and a' . Analysis of particular cases shows that if $2I_d$ is less than three fourths of the total fault current, I_T , proper coordination is obtained. The relative magnitude of $2I_d$ can be easily checked by making an approximate calculation, neglecting all transformers and circuits in the system except those on either side of, and adjacent to, the fault. If a transformer is located at the load-bus unit under discussion, or at the load-bus unit immediately to the right, the above condition is always satisfied.

The closer the fault is to limiter a , the higher the ratio $\frac{I_a}{I_d}$. When the fault is near the point on the loop circuit that results in $I_b = 0$, the ratio

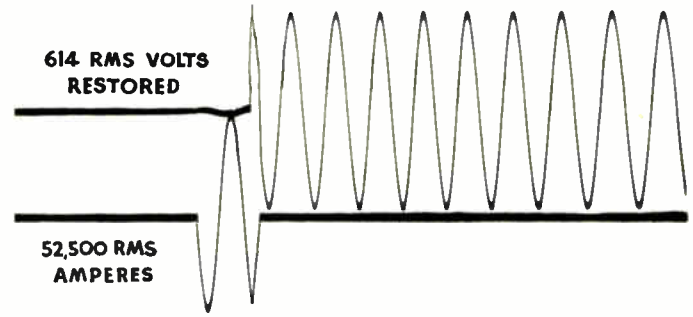

Fig. 10—Oscillogram of the interruption of 52,500 rms amperes. This is five per cent in excess of the rating of the limiter.

is a minimum, two, and coordination is assured. Because most faults occur on the longer central portion of the loop, the probability of obtaining automatic coordination of limiters a and d is high. If the secondary loop has three or more parallel circuits, coordination is obtained for any fault or transformer location. Where the secondary loop consists of only one circuit, limiters a and d will not coordinate unless the fault current supplied by the transformer is equal to or greater than one half the fault current in limiter d . In general, this condition is not always satisfied, and coordination with only one circuit in the secondary loop is doubtful.

Coordination of limiter a with network-protector fuse c depends on the ratio $\frac{I_a}{I_T}$. This ratio has a minimum value of one when I_d and I_b are

zero. In most practical cases, the minimum ratios of $\frac{I_a}{I_T}$ range from 1.25 for network transformer ratings of 1000 kva to 1.75 for transformer ratings of 300 kva. If the network system is designed with two or more parallel circuits in the secondary loop with a combined current-carrying capacity not greater than 100 per cent of the network transformer full-load current, table I shows that coordination is obtained.

The coordination of limiter a with limiter e in the transformer tie circuit depends on the ratio $\frac{2I_a}{I_T}$. If there are three parallel circuits in

the tie, the ratio is $\frac{3I_a}{I_T}$, etc. When the rating of limiter a is equal to or less than the rating of limiter e , and there are two or more parallel circuits in the transformer tie, the limiters always are coordinated.

The ratio of $\frac{I_a}{I_b}$ varies over a wide range, depending on the fault location. If the fault is near limiter a , I_b is in the direction shown, and is approximately equal to I_d' ; however, if the fault is near limiter a' , I_b flows in the opposite direction, and is approximately equal to I_d . For faults between these two points, I_b becomes smaller, and for one particular fault location is zero. The coordination of limiters a and b is difficult when the fault occurs near limiter a' . Proper coordination is obtained for this condition, if $2I_d + I_T$ is greater than one fourth of I_T . This condition is always obtained if a transformer is located at the load-bus unit under discussion. If there are three or more parallel circuits in the secondary loop, coordination results automatically.

Case B

A FAULT on the primary circuits or on the network transformer is normally cleared by the opening of the network protector. However, on the rare occasion when the protector fails to function, it is desirable to have the protector fuse c clear before the limiters in the secondary loop and transformer tie have been damaged or opened. The network protector fuse is now the protecting element, and the minimum ratios necessary for proper coordination with the limiters are given in table I.

The ratio of the current in the protector fuse c to the current in limiter b is two. In general, this ratio is equal to the number of parallel circuits in the transformer tie. When the rating of the network protector and transformer tie circuit limiters has been determined, their coordination can be checked with table I. In some cases, it is necessary to increase the number of parallel circuits in the transformer tie, without decreasing the conductor size, for coordination.

The coordination of the network-protector fuse c with the secondary loop limiter a is determined by the ratio $\frac{I_T}{I}$. This ratio is a minimum

TABLE II—SUMMARY OF DISCUSSION OF COORDINATION OF LIMITERS AND NETWORK PROTECTOR FUSES FOR THE FOUR FAULT CONDITIONS OF FIG. 4

Case	Protecting Element	Protected Element	Minimum* Current Ratio	Remarks
A	Limiter a	Limiter b	See discussion	Coordination will usually be obtained with two conductors per phase in secondary loop, three or more conductors per phase will make coordination automatic.
	Limiter a	Fuse c		Reference to table I shows that coordination will be automatic except for combinations of 800- and 1200-ampere fuses with 500- and 600-MCM limiters.
	Limiter a	Limiter d	See discussion	Two or more conductors per phase in secondary loop will give satisfactory coordination.
	Limiter a	Limiter e	2	If the rating of limiter a is equal to or less than the rating of limiter e , and there are two or more parallel circuits in the transformer tie, proper coordination will be obtained.
B	Fuse c	Limiter a	2	Most combinations of limiters and protector fuses will require three or more conductors per phase in loop and approximately equal division of current between the two sections of loop.
	Fuse c	Limiter b	2	Refer to table I for any particular combination of limiter and protector fuse.
C	Limiter a	Fuse c	See discussion	Coordination will usually be obtained with three or more conductors per phase in tie, with current-carrying capacity not greater than 150% of transformer full-load current.
	Limiter b	Limiter d	2	Three or more conductors per phase will insure automatic coordination.
D	Load Feeder Circuit Breaker	All limiters and fuses		Depends on relative ratings of limiters b and d , but automatic coordination will usually be obtained with two or more conductors per phase in loop.
				Automatic coordination under all conditions.

*Minimum current ratios are based on diagrams shown in Fig. 4.

when all of the current is supplied from one section of the secondary loop. The minimum ratio for the configuration shown in Fig. 4(b) is two, and like the transformer tie, the minimum ratio in general is equal to the number of parallel circuits in the loop. In many cases the ratio given in table I, for the particular ratings of limiters and protector fuses

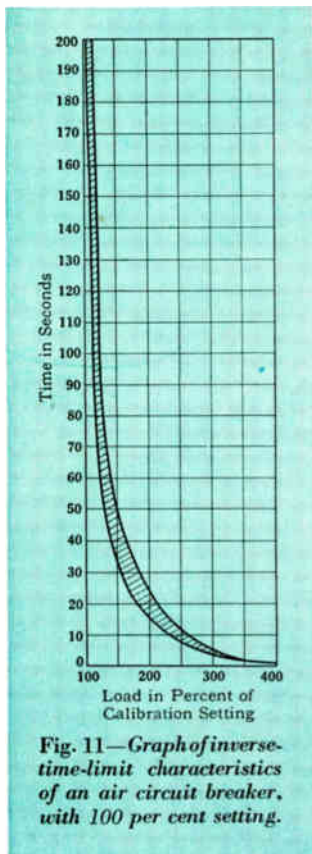

Fig. 11—Graph of inverse-time-limit characteristics of an air circuit breaker, with 100 per cent setting.

commonly used, is greater than the ratio based on the assumption that all fault current is supplied from one section of the loop. In this case, the division of fault current between the two sections of the loop must be estimated. This is done by assuming a solid three-phase fault at the secondary terminals of the transformer and calculating the division of fault current, neglecting all transformers except those at the ends of the two sections of the loop feeding the fault. Assume that such a calculation shows that 60 per cent of the total fault current is supplied from the right-hand section of the loop and 40 per cent of the fault current from the left-hand section. The total fault current I_f is 100 per cent, and I_a is $\frac{60}{2}$ or 30

per cent; therefore the ratio $\frac{I_f}{I_a}$ is $\frac{100}{30}$ or 3.33.

In some cases the protector fuse c does not coordinate with either limiter a or b without the use of a large number of parallel circuits in the transformer tie and secondary loop to insure coordination cannot be justified. When

this situation arises, it is desirable to choose the number and size of the cables in the transformer tie so that their limiters protect the limiters in the secondary loop.

Case C

THE third coordination problem, shown in Fig. 4(c), arises only when it is necessary to locate the transformer some distance from the network load-bus unit (usually 25 feet or more). In these installations, the probability of fault on the transformer tie is usually great enough to justify the use of limiters in the tie circuits. The limiters a and b are the protecting elements, and they must blow and isolate the fault before the protector fuse c and the limiters d and e have been opened or damaged.

The magnitude and direction of the current I_e depends on the location of the fault on the tie circuit. If the fault is near a , I_e is in the direction shown, and is nearly equal to I_b . In this case, the ratio $\frac{I_a}{I_e}$ is not larger than 1.5 unless I_f is equal to or greater than 50 per cent of I_e . Because this relation of I_f to I_e cannot always be assured, the coordination of limiter a with limiter e is doubtful in many cases. However, if the transformer tie consists of three or more parallel circuits, I_e is divided into two or more parts and proper coordination between limiters a and e always results.

With the fault near limiter b , I_e flows in the opposite direction, and is approximately equal to I_a . However, limiter b carries considerably more current than limiter a , and, therefore, clears first. After limiter b has blown, the least value of $\frac{I_a}{I_f}$ is one, but usually it is much larger because I_e again reverses and flows into the fault through limiter a . Because of the sequential blowing of a and b , rules cannot be readily stated for the coordination of limiter a with the network-protector fuse c . However, an analysis of several cases shows that if the transformer tie consists of three or more parallel circuits with a combined capacity not greater than 150 per cent of the transformer full-load current, coordination results.

Coordination of limiters b and d depends on the ratio $\frac{I_b}{I_d}$. The minimum is two, and, in general, depends on the division of fault current between the two sections of the loop. As previously explained, a quick estimate of the division of fault current can be obtained by neglecting the effect of all transformers except those at the ends of the two sections of secondary loop feeding the fault. If b and d have the same rating, and the secondary loop has two or more parallel circuits, coordination is always obtained.

Case D

CASE D involves the coordination of the circuit breaker protecting the radial load feeder circuits with all the limiters in the load-bus unit. The circuit breaker is now the protecting element, and it must operate to isolate the fault before the limiters and fuses in its associated load-bus unit have been opened or damaged. In this problem, the magnitude of the total fault current I_f varies over a wide range, depending on the type and location of the fault on the radial feeder circuit.

For fault currents less than about ten times the normal circuit breaker rating, the tripping of the circuit breaker is controlled by an inverse-time-limit characteristic, Fig. 11. A simple example shows that the limiters coordinate in this range. Assume as an extreme case a 1000-ampere breaker supplied through two 4/0 limiters in parallel. If the fault current is 2000 amperes, the breaker trips in at least 24 seconds, whereas the limiters, which carry 1000 amperes each, have a melting time of about 40 seconds. The fault current usually is divided between four to six circuits and, therefore, proper coordination is assured, as Fig. 4(d) indicates.

When the total fault current exceeds about ten times the normal rating of the circuit breaker, the breaker is tripped instantaneously, that is, with no intentional time delay. Over this range of currents, the total clearing time of the breaker is of the order of two or three cycles. As indicated in Fig. 3, even for currents of 30 000 to 40 000 amperes, melting times of the limiters are of the same order of magnitude. Therefore, if the total fault current is divided between four to six limiters as shown in Fig. 4(d), coordination is obtained.



Fig. 12—Rear view of the metal-clad type of industrial-network load bus unit showing the limiter compartment.

REFERENCES

- 1—"Secondary Networks for Industrial Plants," J. S. Parsons, *Westinghouse ENGINEER*, Vol. 1, No. 3, November 1941, p. 85.
- 2—"Secondary Networks to Serve Industrial Plants," C. A. Powel and H. G. Barnett, *A.I.E.E. Transactions*, Vol. 60, April, 1941, p. 154-6.
- 3—"Arcs in Low Voltage A-C Networks," J. Slepian and A. P. Strom, *A.I.E.E. Transactions*, Vol. 50, 1931, p. 847-53.
- 4—"Short Circuit Protection of Distribution Networks by the Use of Limiters," C. P. Xenis, *A.I.E.E. Transactions*, Vol. 56, 1937, p. 1191-96.
- 5—"Limiters Prevent Cable Faults from Spreading on Networks," C. P. Xenis and E. Williams, *Electrical World*, Vol. 112, 1939, p. 1022-4.
- 6—"Operating Record Proves Value of Limiters," C. P. Xenis and E. Williams, *Electrical World*, Vol. 112, October 21, 1939, p. 1165-6.
- 7—"A 600-Volt Enclosed Limiter for Network Use," P. O. Langguth, H. L. Rawlins, J. M. Wallace, *A.I.E.E. Transactions*, Vol. 61, July 1942, p. 536-8.

Capacitors Let Two Lines Do Work of Three

Good ideas like good men are often ahead of their time. Use of series capacitors to increase the power carried over a transmission circuit has intrigued engineers for half a century, but the idea had to await certain practical developments to be worth while. The necessary reduction in the cost of capacitors, development of fast breakers and relays, and creation of a capacitor protective scheme have been accomplished, bringing this scheme to a practical status.

THE permissible load on high-voltage transmission circuits can be increased, and the cost of power carried can be reduced by the use of series capacitors. A study of a typical 230-kv, 234-mile line shows that a series capacitor has a total cost, including capitalized figures for losses, of one-half the cost of an additional line. The first cost of the capacitor itself is one-fourth of the cost of the additional line. Although large series capacitor banks, say 100 000 kva on a 230-kv circuit, are required, the apparatus has reached a stage of development that such installations can be undertaken. Analytical studies and tests on a miniature system indicate that a power transmission system with such series capacitors will operate satisfactorily.

The series reactance of transmission circuits has long been recognized as one of the factors limiting the amount of power that the line can carry. The use of series capacitors to compensate for this reactance has been a technical possibility for 50 years. However, several practical obstacles stood in the way of this use of capacitors. Developments during recent years that now make these applications practical include:

1—Reduction in cost and increase in reliability of capacitors. Since power capacitors came into use about 15 years ago their cost has been reduced two-thirds.

2—Development of high-speed circuit breakers and relays for transmission circuits. Without them series capacitors are not practical for increasing transient-stability limits.

3—Development of protective equipment that permits the use of capacitors with voltage rating determined by load currents while retaining the advantages of capacitors with voltage rating determined by short-circuit currents. This makes for more economical installation.

This use of series capacitors is on transmission circuits on which the permissible loading is limited by the transient stability. When transient stability was given important consideration several years ago, it was assumed that series capacitors, if effective, had to remain in service during fault conditions, and, therefore, had to be designed to withstand fault voltages. The size of non-protected series capacitors, i.e., not equipped with breakdown gaps to limit voltages under fault conditions, cannot be reduced by decreasing the current-carrying parts. To provide practical amounts of compensation the voltage drop across the series capacitor

R. D. EVANS
Consulting Transmission Engineer
R. L. WITZKE
Central Station Engineer
Westinghouse Electric &
Manufacturing Company



under normal conditions might be about 40 per cent of line-to-neutral voltage. On a 230-kv circuit this is about 50 kv. Thus, if the maximum fault produced a capacitor voltage of three times that permissible for units designed for normal operation, the kva of a non-protected capacitor would be

approximately nine times the kva for normal load. On this basis the series-capacitor scheme is not economical. These views have held until recently when a new protective scheme was proposed. Essentially in this scheme the capacitor is short-circuited during a fault and then quickly restored to service following the fault. With modern, high-speed relays and circuit breakers used in conjunction with this protection system, the capacitor is in service except for six to eight cycles at the time of the fault, which has little effect on the transient-stability limit. By this means it is possible to use relatively inexpensive capacitors of the protected type, and still retain most of the advantages of the non-protected type that remain in the circuit at all times.

One Capacitor Bank Serves Two Lines

A typical circuit arrangement for the utilization of series capacitors to increase the transient-stability limit of transmission systems is shown schematically in Fig. 1. It consists of a double-circuit line with the series capacitor connected between two sections of the bus at an intermediate switching station. Capacitors cost least when so located. If series capacitors were located independently in each line section, additional capacitors would be required to carry the load with any one line section out of service. Locating the series capacitor in this manner is also advantageous in reducing the short-circuit-current voltages at the series capacitor during faults on the transmission system.

Protective Scheme Uses Gap and High-Speed Circuit Breaker

The protective scheme includes a protective gap to short circuit and protect the capacitor against excess voltage. Means are necessary for automatically interrupting the flow of line current through the protective gap in order to return the capacitor to service after the condition that produced the excess voltage has been removed. This is accomplished by a circuit breaker in parallel with the gap. This breaker is mounted on the insulated platform and has the same voltage

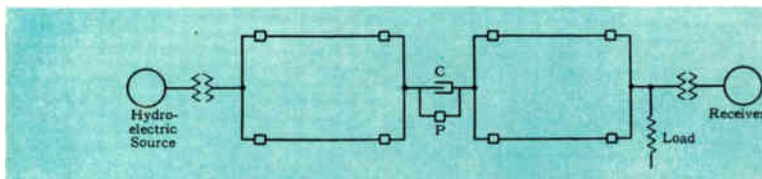
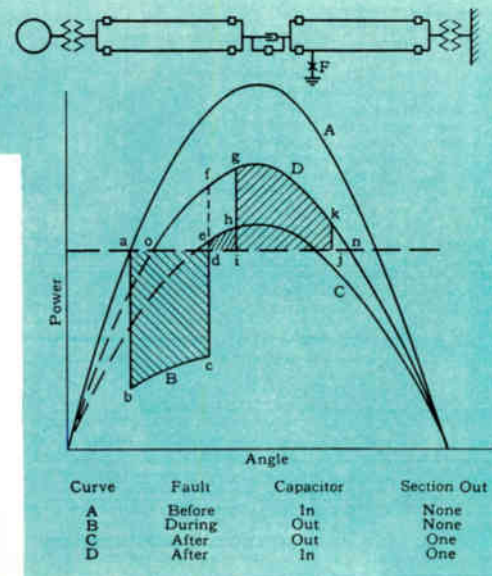

Fig. 1—A series capacitor application to increase power-carrying capacity of a two-circuit transmission line. A single series capacitor (C) and protective equipment (P) are connected between the two bus sections at an intermediate switching station.

Fig. 2—Power-angle diagram for sending end of series-capacitor power system connected to infinite receiver. For stability, area (abcd) is less than or equal to areas (edih) plus (gijk).

ab—fault on one line section, series capacitor shunted; ce—faulted line section switched out; k—point of maximum angular swing. Consider the system shown to be operating at the load and angle corresponding to the point a on Curve A. Upon the application of the fault, the output of the generator drops to the point b on Curve B. The difference in power ab accelerates the generator and increases the angle by which it leads the receiver. At the point c the fault is isolated by the action of high-speed breakers and relays, thus changing the operating point to e on Curve C. Power corresponding to de decelerates the generator, but because

of the accumulated velocity it swings forward along Curve C. At the point h the series capacitor is restored to the circuit by the opening of the shunting path in the protective equipment, and operation proceeds from the point g on Curve D. Because the energy stored during the accelerating period has not been completely absorbed, the system continues to swing forward ultimately reaching point k, such that the decelerating area, area (edih) + area (gijk) equals the accelerating area (abcd). The system is stable for the conditions shown, and will oscillate about the point o and ultimately come to rest at that point. The system would



be unstable for the conditions shown in the event that the series capacitors were not restored to the circuit promptly after the isolation of the faulted line section.

rating as the capacitor. By-pass, isolating, and grounding switches are used for removing the capacitor from service for maintenance. Switches and circuit breaker are all operable from the ground. Motor-operated mechanisms can be used to obtain remote electrical control of all switching equipment, if this is necessary.

Coupling capacitors with special connections can be used to provide remote control of the series capacitor through a carrier-current channel. Such control fits into the general scheme of carrier-current relaying, which is an essential part of the operating combinations.

Improvement in System Stability

The stability problem with series-capacitor systems can be viewed in the same manner as that of other systems by considering only the 60-cycle reactances of the circuit. It is, of course, necessary to consider the change in circuit reactance produced by the series capacitor. A physical picture of the system phenomena during a fault is given in Fig. 2. The system consists of a hydro-electric generator feeding through a series-capacitor transmission system to an infinite bus. The system is subjected to a fault that is cleared by isolation of the faulted line section.

Miniature-System Tests

The general scheme of using series capacitors to increase the transient stability limits of transmission systems was studied by means of miniature-system tests in the Westinghouse Stability Laboratory. Miniature systems were used to simulate the three systems in Fig. 3. The results of these investigations showed that for double line-to-ground faults the transient power limit of the system in Fig. 3(a) was approximately 50 per cent higher than the power limit of the system in Fig. 3(b) and comparable to the power limit of the system in Fig. 3(c). In making these tests the series capacitor was adjusted to compensate for 60 per cent of the line reactance with all line sections in service.

The addition of series capacitors to transmission circuits may introduce new operating problems. Among these would be included the increased tendency toward spontaneous hunting and possible difficulty in induction starting of machines such as synchronous condensers. However, tests in the Stability Laboratory prove that these difficulties are encountered only at light load. Because the series capacitor is not required during periods of light loads, the difficulties can be avoided by removing the capacitor from service when it is not required. Furthermore, the laboratory tests indicate that spontaneous-hunting difficulties will not be experienced

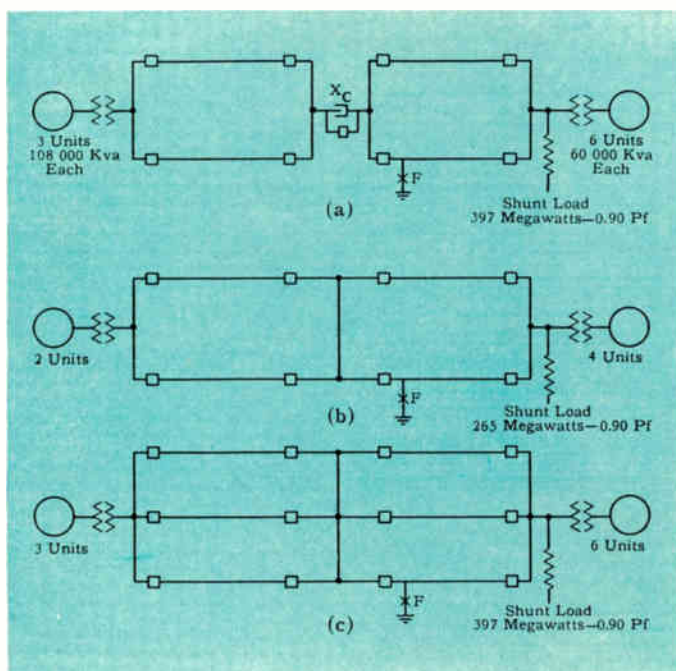

Fig. 3—Typical transmission system and alternatives for a fifty percent increase in loading. (a) is proposed series-capacitor system with two-circuit line; (b) is original system; (c) is alternate with a third circuit.

even at light loads if the generators connected to the system are supplied with damper windings.

Results of Economic Study

An economic study¹ for making a 50 per cent increase in the loading of a typical two-circuit 230-kv transmission system was made on the basis of (1) adding a series capacitor, and (2) adding a third circuit. The systems selected for study are shown schematically in Fig. 3(b) and (c). The cost of 108 000 kva of series capacitor required is about \$1 200 000. The cost of the third line and its switching equipment, estimated conservatively, amounts to \$4 500 000. Thus, the first cost of the series capacitors is about one-fourth of the third line. The series capacitor increases the permissible load per circuit, and, therefore, increases line loss and the synchronous condenser capacity required for maintaining voltage. By adding capitalized figures for the additional line loss and condenser capacity to the cost of the series capacitor itself the total amounts to \$2 100 000, which is approximately one-half

the cost of the third line. These estimates are based on low-cost line construction and high load-factor conditions. The series capacitor shows still larger savings if higher line cost or lower load-factor conditions obtain.

The most promising use of series capacitors is to increase the transient stability limit of multiple-circuit, long-distance, high-voltage lines, with or without intermediate sectionalizing stations. Series capacitors can also be used in single-circuit lines for increasing the steady-state stability limits and for increasing the transient stability limits for faults on connected lines at either end of the system. A further advantage of adding series capacitors is made evident where the desired increase in power limit corresponds to but a fractional part of the increase in power that would be obtained by adding another line to the circuit.

REFERENCE

1—"Series Capacitors for Transmission Circuits," E. C. Starr and R. D. Evans, A.I.E.E. Technical Paper 42-112 presented at Chicago, Ill. June, 1942.

Light Finish on Cloth with Infrared

If you think you are hard on clothing, you should see what happens to the material before the tailor gets it. Woolen cloth is porous as it comes from the loom, so the fibers are crushed together to interlock the wool-fiber scales, matting the strands. Formerly, this was done by hand, pounding with wooden mauls. Now it is done more swiftly by running the cloth through wooden rolls under great pressure. It is run over dryer drums (hot-can dryers), and through an acid bath after which it is heated almost to the scorching point and pounded again. The material is then seized on either edge by needles on two endless chains which act like automatic curtain stretchers, stretching the material to correct width. This is called the tenter range and is possibly the origin of the expression about being kept on tenterhooks. A rotary shear trims the surface, after which galvanized picks on a drum pick up the nap, which is laid in the proper direction by a heavy roll. The cloth is then singed. Worn out before it is used? Not at all. Without these torturous operations rivalling the Spanish Inquisition; without this industrial version of a combination hot-foot, mayhem and commando tactics, the woolens would be porous, sleazy and of poor wearing quality. A miracle in sheep's clothing.

One of the finishing processes in the manufacture of woolen cloth is to dip it into a weak solution of acid, and after being dried, to run it through a carbonizing section. The speed of the cloth through the dryer and the carbonizer depends on the weight of the material (25 yards per minute for 16 oz. Navy Melton). The temperature in the dryer runs from 190°F to 220°F and in the carbonizer ranges from 260°F to 265°F. At this latter temperature, the acid in the cloth reacts with the burrs and vegetable matter in the cloth, forming carbon which is later powdered out of the cloth.

For generations, cloth has been dried and carbonized in steam-heated dryers and carbonizers having air circulators. These are

large and ungainly, occupying extensive floor space. Also, carbonizing by steam heat is inflexible in that it takes considerable time to bring the machine up to the required heat and once in operation, the cloth cannot be stopped even for a few seconds or it becomes scorched. One specific requirement for this method is that the cloth must be absolutely dry. Not the least factor is that a steam heated carbonizer, which is similar in size to the dryer shown in the photograph, costs approximately \$10 000.

The infrared lamp carbonizer is small and compact, occupying space about seven feet by seven feet and seven feet high. Starting cold, it can be raised to operating temperatures almost instantly. In the event of an emergency, the temperature can be as quickly lowered so that the machine may be stopped for any length of time without harm to the fabric. While steam heat causes scorched streaks on material not absolutely dry, infrared lamps do not, and function

just as well as carbonizers when there is some moisture in the cloth.

The infrared lamp carbonizer unit consists of a simple cabinet in which are mounted, with suitable controls, 350 infrared lamps of 250 watts each. The cabinet is lined with a sheet of stainless steel through which the lamps project. This reflector, also covering the inside of the two doors, prevents absorption of the infrared rays by anything but the material passing through the device. The material is threaded over rolls so that first one side is exposed to the lamps and then the other, the carbonizer containing 21 yards of cloth as compared to 100 yards of cloth in the steam type. The cloth is exposed to the rays for about 20 seconds, and to the heat of the old method for about four minutes. The lamps are so arranged in banks that one or more of the banks comprising one-fourth of the lamps can be cut in or out, thereby varying the carbonizing in steps of 25 per cent.

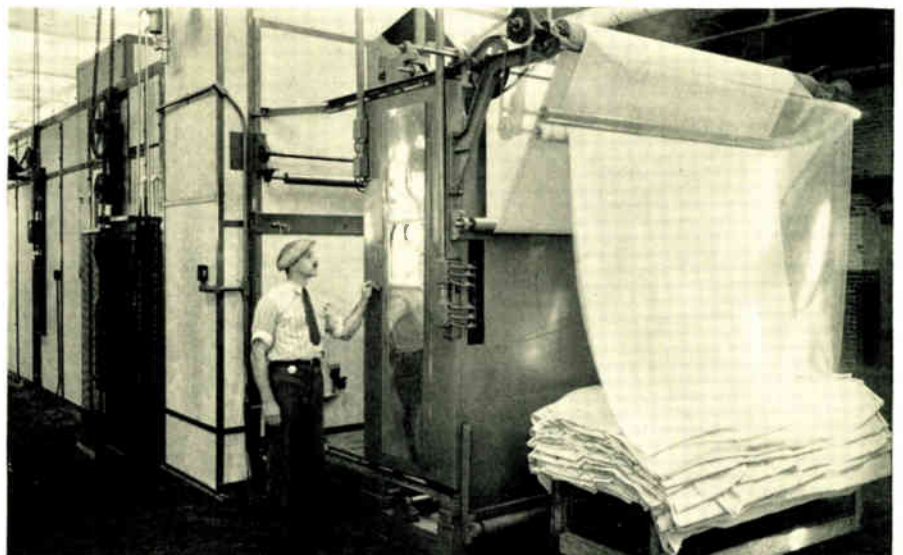

Transformer Radiators Separately Banked

Sometimes an auxiliary or adjunct increases to such size or importance that it outgrows its dependency status. Transformer radiators may be considered such. From humble beginnings, little more than ugly warts on the otherwise smooth surface of transformer tanks, they have become progressively larger, major equipment in their own right. Some are now so big the transformer tank does not have enough surface to support them. The radiators are now installed by themselves at a distance of some feet from the transformer they serve—with little or no loss of cooling effectiveness, and withal the gain of many operating advantages.

A NEW method of mounting transformer radiators solves many of the physical problems encountered in the use of large self-cooled transformers. The banking of radiators separately from the transformer enables the best use to be made of the available space for transformer placement. It presents the means whereby ample radiating surface for transformer cooling can be provided readily, an especially difficult feat physically on the larger transformers. Further, this type of radiator mounting lends itself admirably to forced-oil and forced-air cooling in addition to thermo-syphon cooling action.

The most popular method of cooling power transformers is by means of an external radiating surface added to the tank either in the form of detachable radiators for large units or tubular coolers welded to the tank for smaller units. The reliability of this type of cooling exceeds that of any other method. Oil is circulated by the chimney effect or thermo-syphon head developed by the cooled oil in the radiator and the warmer oil in the transformer tank. Because no artificial means are required to circulate either the oil or the cooling air, constant attention or energy supply are not necessary. Radiator cooling is particularly well suited to unattended and isolated stations.

The weight and losses of a transformer are functions of the cube of the dimensions, whereas the surface area is a function of only the square of the dimensions. The losses, therefore, increase faster than the external surface of the tank and much faster than the perimeter of the tank to which radiators can be attached. On small transformers the tank alone has sufficient surface to dissipate the losses, but as the transformer is made larger, a point is reached where there is insufficient room on the tank wall for the necessary cooling surface. This is particularly true where the radiators must compete for space on the tank wall with auxiliaries such as tap changers, terminal chambers, lightning arresters, etc.

This problem has been solved effectively by mounting the radiators in a bank on their own base as a separate unit and connecting the bank to the transformer by header pipes and valves. Tests have shown that the cooling with this method of mounting the radiators is as good as that obtained with wall-mounted radiators.

The scheme has many inherent advantages, all of which have not been available heretofore. A primary consideration is the saving in cost. The radiator bank can be factory

R. L. BROWN
Transformer Engineer
Westinghouse Electric & Mfg. Co.

assembled, thus saving the field expense incurred when radiators must be assembled on the main tank in the field. The radiator assembly need not be torn down in the event it becomes necessary to repair or replace the transformer. The inspection and repair of

the transformer are facilitated in that it is not necessary to work around or remove the radiators usually mounted on the transformer tank. Should repairs be necessary, valves on either side of the header connections provide means for the retaining of the oil in the transformer tank and the radiator proper. To move either the transformer or the radiator, or both, the only oil that needs to be drained is that between the valves. Each individual radiator is equipped with valves in its connections at the top and bottom so that it can be removed without draining oil from the radiator bank.

Separate banking of transformer radiators aids in the increase of transformer capacity because air-blast fans can

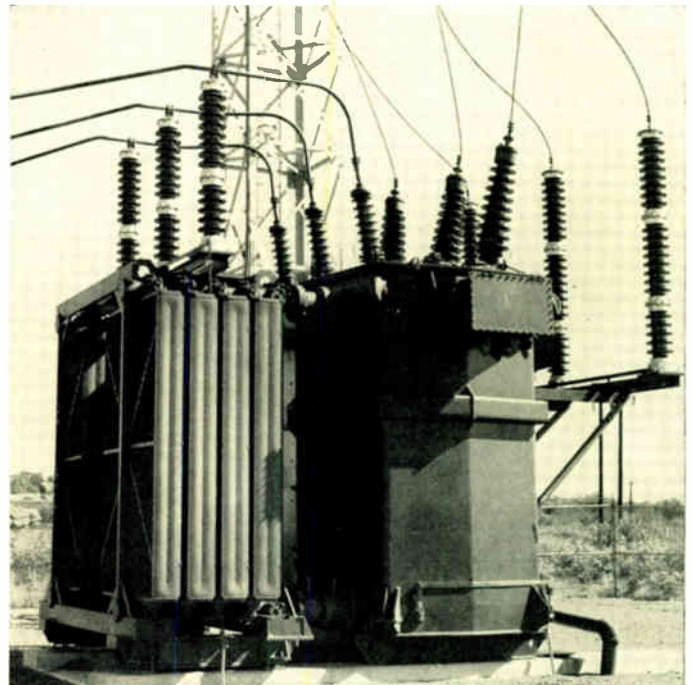

In this outdoor installation, the separately banked radiator at the left is mounted on adjustable jack-plate mountings which facilitate the aligning of the junctions of the coolant headers.

readily be applied to the end of each radiator group to increase the rating of the transformer by as much as one third. Oil pumps can be added to the header connections so that the oil can be circulated rapidly, thus increasing the rating by an additional one third or a total of two thirds above the self-cooled rating.

Space in power installations is often at a premium and the most desirable placement of equipment cannot always be achieved because of its bulkiness. In this type of radiator mounting, the bank or banks can be arranged to suit the space in which they are to be installed. Where it is desirable to keep the units as close together as possible, the bank of radiators can be placed behind each unit. In this way at least ten feet in the center-to-center distance between large units can be saved over the conventional method of mounting radiators. This results in a saving in space as well as in overhead structural steel.

In some cases it is desirable to mount the radiator bank at a distance from the transformer. The bank can be mounted as much as 10 feet from the transformer without appreciable loss in cooling efficiency, and much farther with only slight increase in temperature rise.

The practical size of self-cooled units is no longer limited by the number of radiators that can be crowded onto the tank. Therefore, a transformer of any desired rating can be made self-cooled. Some 75 000-kva self-cooled units have been built recently, using two separately mounted radiator banks. With air-blast fans mounted on the radiator banks, the rating will be 100 000 kva. Because a tap changer and other auxiliary equipment are mounted on the tank walls, it would have been difficult to mount enough radiators on the tank to dissipate the losses on this transformer.

The converse is also true. That is, when the radiators are

mounted in a separate bank, the tank walls are available for the mounting tap changers, terminal chambers, lightning arresters, etc. These devices can be mounted wherever they best suit individual requirements of that unit.

The radiator banks are made of conventional radiators mounted on header pipes. The lower headers are mounted on a base structure and the upper headers supported by structural members from the base, thus keeping mechanical stresses from the radiators during lifting, shipping, installing or repairing.

The radiator bank headers are rigidly bolted to the flanged openings provided on the transformer tank. When two separate assemblies are to be bolted together to make an oil-tight connection, it is necessary that provision be made for an adjustment so that the surfaces to be bolted together can be lined up exactly. This is accomplished by means of jack plates at each corner of the base of the radiator assembly. These jack plates can be raised to prevent interference with rollers or skids while the radiator bank is being moved into position. The jack plates are then lowered and the radiator bank raised by means of the jack nuts. This permits perfect alignment of the flanges before bolting together. Where wheels on the radiator base are desirable, each wheel axle is placed in an eccentric bearing support that can be turned to raise or lower the bank for aligning the flanges to be bolted together.

When first cost and saving in vital materials are important, the size of the transformer can be reduced by forcing the oil through the radiators and through the ducts of the transformer. Separately banked radiators permit the ready installation of circulating pumps in the connection between the header and the tank. This cannot easily be accomplished if the radiators are mounted on the tank wall. A transformer equipped with air-blast fans for blowing air on the radiators

The separate banking of radiators lends itself to conform easily with any type of cooling system. At left is shown a wheel-mounted radiator. In addition, this particular bank has also been equipped for forced-air cooling. At the right is an entirely different arrangement of radiators. Here they are pedestal mounted and the structural strength inherent with separate radiator banking is shown by the transverse and vertical bracing.

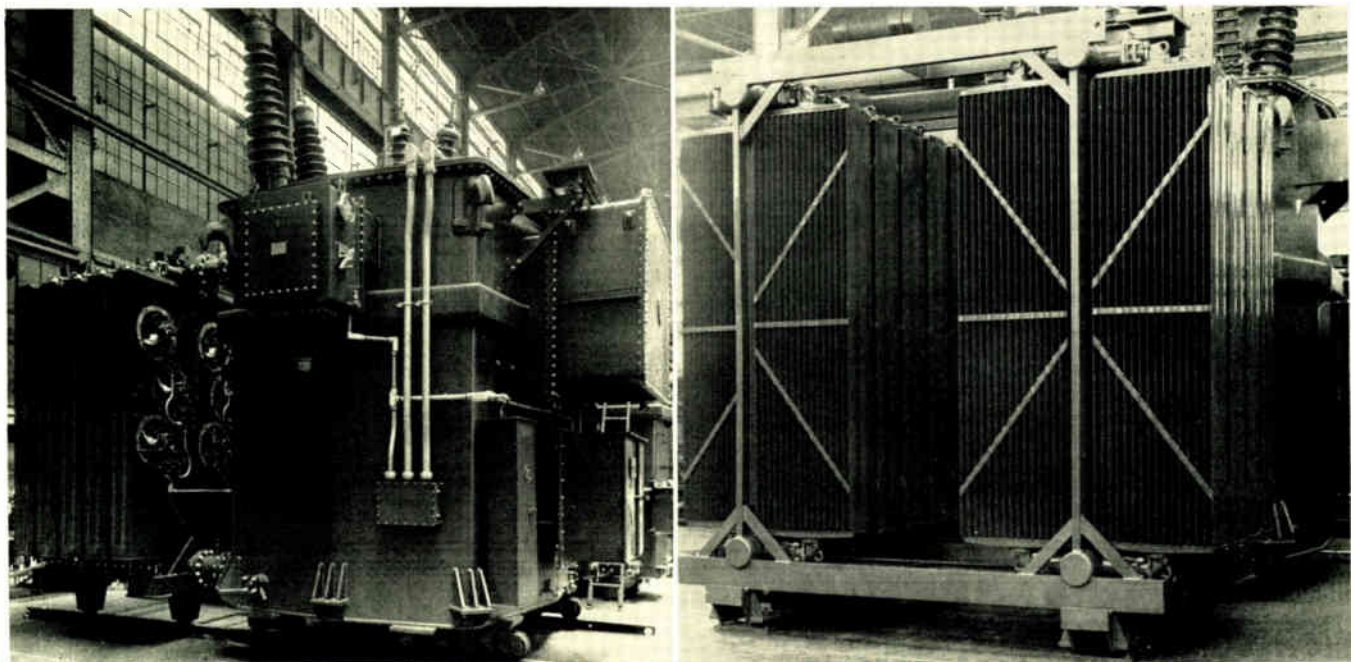

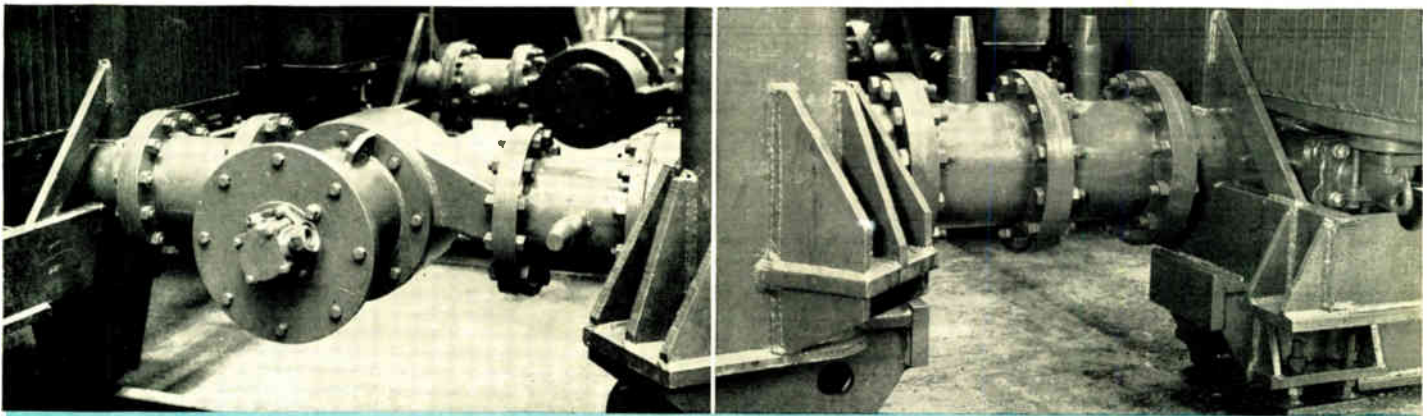

At the right is a thermal-convection cooling system header. The coolant cut-off valves, shown by their stems, permit the separation of the radiator and the transformer for repairs to either, with the minimum handling of the coolant. At the left, a pump and motor unit has been placed between the flanges. By this expedient, the installation has been changed to a forced-cooled unit with a 20 per cent increase in output capacity.

and having pumps for circulating the oil will carry a 60 per cent load without pumps or fans operating, an 80 per cent load with fans, and a 100 per cent load with both pumps and fans. This type of cooling system is particularly well

suited to units that are connected to widely varying loads or to units where the load, at this time, may be high because of the present emergency but having the prospect of substantially lighter loads in the future.

Why Steel Hardens

ALMOST everyone has been exasperated at a railway car windows that refuse to budge. Friction in the sash, largely caused by carbon particles in the guise of cinders, is the usual cause for sticking. This pardonable annoyance, however, is more than compensated by the inestimable value of carbon particles performing the same "braking" actions when interspersed in the atomic lattice of iron and forming the alloy known as steel. These "atomic brakes" resist the movement of the iron atoms by external force and the increase of this resistance to displacement is a measure of the increased hardness of the alloy caused by the carbon.

The ability of iron, unique among metals in this respect, to increase its hardness many times through additions of slight amounts of carbon and suitable heat treatment, makes it one of the most useful alloys. Add to this highly useful attribute of hardness its cheapness and comparative ease of manufacture and we have the reason that this is known as the steel age.

Steel, upon being heated above a certain critical temperature, changes its state of structure by a rearrangement of its atoms. In

this new state, when it is said to be a solid solution, steel is able to dissolve many times the amount of carbon it was capable of dissolving in the original state. Upon being rapidly quenched, the carbon precipitates as many submicroscopic particles of an iron-carbon compound called iron carbide. These particles distributed uniformly throughout the steel act as keys to inhibit slippage or deformation of the sections of metal in their relations one to another. This action is comparable to cinders being thrown upon an icy street to prevent slippage over its surface. Since hardness is defined as resistance to deformation, it is seen that the steel is hardened to the degree that slippage or deformation is inhibited by this treatment.

The degree of hardness is dependent on the proper handling of certain fundamental factors. One factor is the carbon content. For certain degrees of hardness, certain percentages of carbon are necessary. Another prerequisite factor is the heating of the steel above the critical temperature. This critical temperature manifests itself by recalescence (in heating, heat is absorbed without increase in temperature but with a change in the steel

expansion; in cooling heat is given off without any lowering of temperature but with a change in the steel contraction), a phenomenon occasioned by energy expended in a change of state of the metallic crystals. Fast cooling or quenching produces a large number of minute hardening particles, i.e., iron carbide, dispersed throughout the steel, which renders it hard. Slow cooling allows the carbon to come out of solution in comparatively few numbers of large carbide particles, a characteristic of the structure of annealed soft steel. That rate of cooling, above which hardening is obtained and below which steel remains unhardened, is called the critical cooling rate of the steel and this rate varies with the composition of the steel.

Steel hardening therefore is dependent upon heating the steel above the critical or transformation temperature and then cooling it at a rate sufficiently rapid to produce the uniform dispersal of the submicroscopic carbides throughout the lattices of the iron atoms in the steel mass. This treatment plus the introduction of many varied types and amounts of alloying elements give us the great number of steels we now so urgently need.

T. H. GRAY

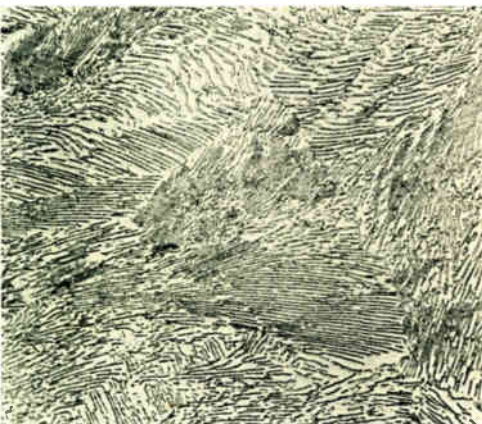
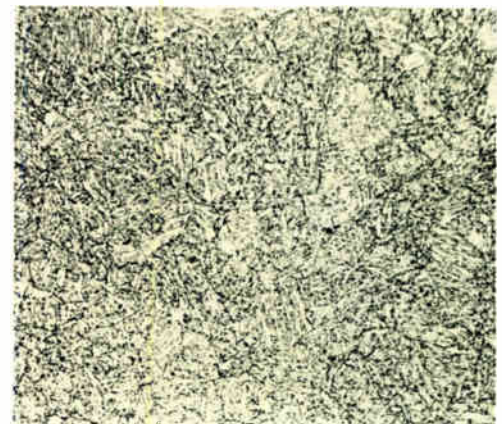

Fig. 1—A photo-micrograph of the surface of polished soft steel.

Fig. 2—A photo-micrograph of the surface of heat-treated steel.

In Fig. 1, the carbides are shown as dark parallel plates surrounded by iron. This type of structure allows the steel to deform in the regions where no carbides are present. Hardened steel, Fig. 2 reveals no such carbide segregation. The carbides are evenly distributed throughout the mass and they are too small to be resolved under the microscope.



Automatic Watchmen for Turbines*

Modern steam turbines have been engineered into huge streamlined affairs whose sleek, all-enveloping sheathing conceals any physical manifestations of internal operations. Abnormal conditions may develop that might cause extensive damage unless detected and corrected. Supervisory instruments make it possible to "look inside" a steam turbine and measure those things which give the best indication of the condition of mechanical operation. These "eyes" not only warn the operator of any developing trouble, but they also write a permanent record of past mechanical performance for future reference.

THE operator of a reciprocating engine did not have many instruments. He depended on his senses to see, feel, or hear parts subject to wear, overheating, or in need of adjustment. On turbines of 20 years ago pressures, temperatures, and speeds were low, and rotating parts were massive. His hand was a fair measure of vibration. His "listening stick" told him if he had a rub and where it was.

The steam turbine is a precision-built machine, as much so as a fine watch or a laboratory instrument. Yet, for a precision machine, the conditions of its operation are extremely difficult. The rotating element of a modern high-speed turbine carries low-pressure blades that move past stationary parts, a fraction of an inch away, at a speed of 850 mph. Clearance must be maintained at all times, while the machine is cold, during starting or stopping periods, as well as during normal operation. The problem can be appreciated when it is realized that temperature difference between the two extremes of cold machine and normal operation may be as much as several hundred degrees. This causes an expansion of approximately an inch in the length of both stationary and rotating parts of large machines.

The operation of these precision machines is materially aided by the use of supervisory instruments, of which several have been developed and thoroughly tried in service. To the credit of turbine builders and operators, serious mishaps to turbines have been extremely rare. However, a turbine failure could be costly, both in money and lost time. Furthermore, slight operating difficulties within the turbine may lead to serious damage if undetected; in fact, cases are on record of serious trouble developing from minor difficulties, the symptoms of which were not noted in time.

In addition to providing a comforting insurance against turbine outages, automatic supervisory instruments of the recording type serve other equally important functions. They definitely improve power-plant operation because the availability of the continuously drawn charts makes possible a complete analysis at leisure of any abnormal occurrence in connection with turbine operation. Also, the instruments provide information that is helpful in the maintenance program by showing the actual condition of vital parts. They provide more certain knowledge of when shutdowns for repairs are really needed. When equipped with signal or alarm

devices they warn the operator of an abnormal condition.

The application of electrical instruments to a steam turbine is a relatively new thing. Steam engineers have not been accustomed to them, but electrical engineers have for many years used electrical devices in the operation of their part of the power plant; they have come to rely upon them with confidence. It is in keeping with the trend of power-equipment operation that the steam end of the generating unit make use of them, too. Better performance is being expected of turbines as it is of other parts of the plant. Crews in the turbine room, if anything, are growing smaller, at least in proportion to their duties, so that these internal turbine "watchmen" come as welcome aides.

In addition to the information available to the turbine operator by the regular instruments and gauges, there are at least four additional facts that are extremely helpful to him. On starting the turbine he should know if the spindle is

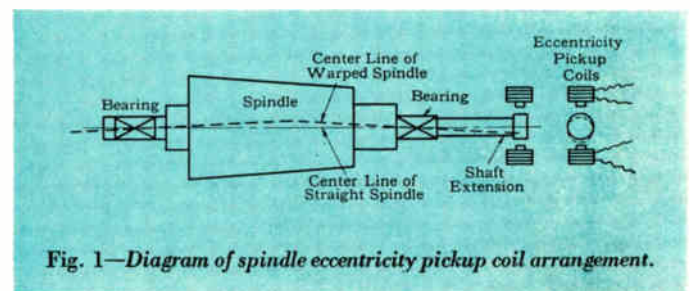

Fig. 1—Diagram of spindle eccentricity pickup coil arrangement.

straight or if it has been warped by uneven cooling. Also, in bringing the turbine up to normal operation, he should be sure that the cylinder or casing is expanding properly. Likewise any undue movement of the spindle (turbine rotor) relative to the thrust bearing indicates that all is not well and that prompt action is necessary. Lastly, the amount of vibration of the spindle is a key fact in judging the behavior of the turbine.

Shaft Eccentricity

If a turbine spindle is allowed to remain stationary after a shutdown, it cools more rapidly at the bottom than at the top, resulting in a warped or bent spindle. To prevent "spindle kink" modern large turbines are provided with a turning gear to rotate the spindle slowly during the cooling period. It is, however, essential for an operator, before admitting steam to the turbine, to determine whether the

*Prepared from data supplied by H. C. Werner, Research Engineer, and G. V. Krenikoff, Steam Turbine Engineer, Westinghouse Electric and Manufacturing Company.

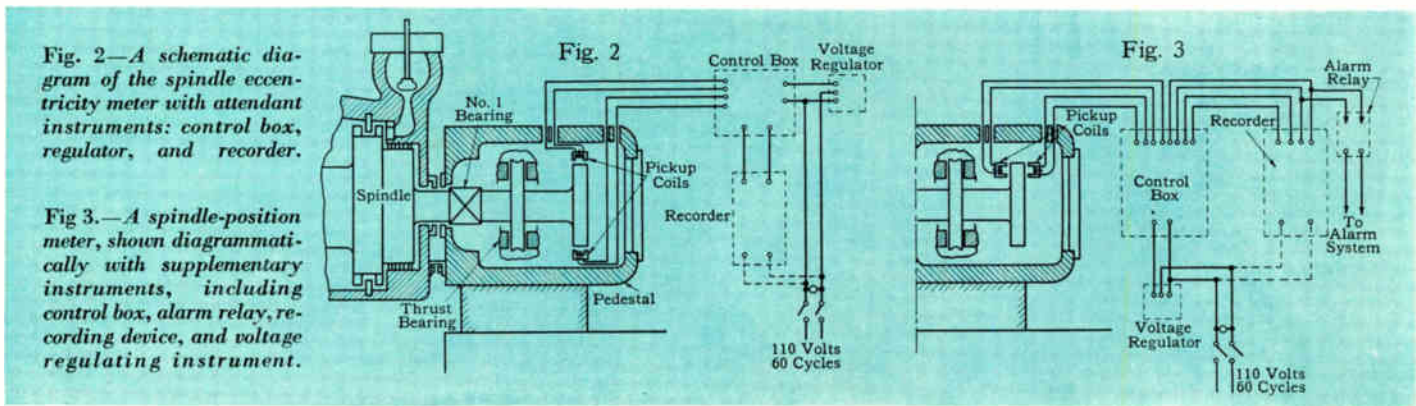

spindle is straight, as even a slight eccentricity in a high-speed turbine results in tremendous unbalanced forces that might cause rubs and injure the bearings, blades, and seals. In a typical 3600-rpm turbine a spindle with a "kink" of only four thousandths of an inch develops a centrifugal force of some 15 000 pounds.

To make automatic determination of spindle eccentricity, an instrument called the spindle eccentricity meter has been devised. This meter indicates and records on a conveniently located instrument board the eccentricity of a turbine spindle at the point on the axis where the meter is applied, usually near the free end of the spindle extension, where the effect of bending is greatest. Its relative position and arrangement are shown diagrammatically in Fig. 1.

The eccentricity meter employs the electromagnetic principle extensively used for accurately measuring small variations in distances, as in strain gauges. Two iron-core pickup coils are located on opposite sides of the turbine shaft, as shown in Fig. 2. When the spindle is straight, the air gaps are equal, and a bridge circuit of which both coils are a part is balanced. When the spindle is bent, one air gap becomes alternately shorter than the other. The result is a periodic variation in the current in the center leg of the bridge circuit which is used to operate an indicating or recording meter to show the outage or eccentricity of the shaft in thousandths of an inch.

Spindle Position

Lengthwise clearances between rotating and stationary

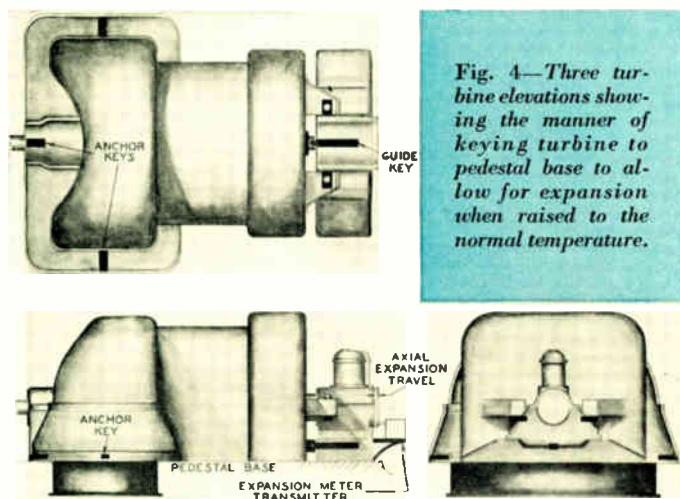

members are provided to allow space for the turbine blades during all conditions of turbine operation. Spindle motion in excess of actual clearance causes rubs with adjacent stationary parts. The thrust bearing holds the spindle within close clearance limits and carries any unbalanced axial load. As the electrical load on the machine varies, the thrust load changes, tending to displace the spindle slightly. Spindle displacements are important in turbine operation because through them any abnormal thrust loading, such as is sometimes caused by the accumulation of foreign matter on the blades, can be detected. Also, this type of displacement indicates wear of the thrust bearing itself.

The spindle-position meter, and the eccentricity meter, operate on the same electromagnetic principle. The pickup coils, Fig. 3, however, are now arranged so as to measure longitudinal motion of the spindle. It is desirable to locate the pickup coils as close to the thrust bearing as possible in order to avoid possible differential expansion errors. A soft-iron disc attached to the shaft rotates between the two coils, and any axial displacement of the rotating disc with respect to the stationary coils is recorded.

Cylinder Expansion

Thermal expansion of the casing or cylinder is another problem of starting and operating a turbine. When steam is admitted to the turbine, the cylinder expands. A large 3600-rpm turbine may "grow" in length approximately an inch and a large 1800-rpm turbine approximately an inch and a half from the cold to the hot conditions.

To permit this necessary expansion one end of the machine is anchored to the foundation, while the other end is allowed to slide, indicated in Fig. 4. To preserve the bearing alignment, the pedestal slides axially along a lubricated key in the base. A smooth, continuous motion of the pedestal as it slides along the base is a good indication that the expansion is proceeding properly. The rotating and stationary parts of the turbine may expand at different rates because the spindle which is surrounded by steam tends to heat first. This differential expansion must not be allowed to eat up the clearance between the stationary and rotating parts as this would result in a rub. At low speeds such rubs can usually be detected with a listening rod. Thus the rate, the extent, and the continuity of the turbine expansion all become important information.

This information can be supplied by a supervisory instrument called the cylinder-expansion meter. The expansion

meter makes a continuous record of the relative displacement of the sliding pedestal with respect to its base, and thus gives the actual overall expansion of the casing during the starting and stopping periods, and the variations in expansion due to load changes. This is a simple instrument, based on the principle of the well-known synchrotie position indicator. It consists of two small polyphase induction motors, with single-phase stators and three-phase rotors. With the rotors interconnected electrically and the stators connected to the same source of single-phase power, the receiver rotor follows exactly any rotation of the transmitter rotor. In the expansion meter, the transmitter is mounted on the pedestal base. By a rack-and-gear device, any relative motion between the sliding pedestal and the base results in a corresponding rotation of the transmitter rotor, as shown in Fig. 5. This rotation, duplicated by the receiver motor located in the recorder, shows graphically this relative motion. Any sharp deviation in the line indicates that the pedestal is binding, or that the expansion is restrained, and this condition indicates a probable distortion to the casing.

Spindle Vibration

Vibration amplitudes that were considered satisfactory on 1200- and 1800-rpm turbines cannot be tolerated on 3600-rpm units. Furthermore, traditional methods of measuring vibration may be misleading. The finger tip held against the bearing pedestal, or better still, a vibration meter set on the bearing housing give a fair indication of the amplitude of spindle vibration for the low-pressure and temperature 1800-rpm turbine; but in high-speed machines operating under high pressure and temperature the spindles are light, and the spindle vibration may not be sensibly transmitted to the massive bearing housings. In 3600-rpm superposed turbines the spindle can be vibrating with an amplitude of several thousandths of an inch with practically no indication of this condition externally.



Also, even when spindle vibration does manifest itself at any of the stationary parts of the turbine, it may not be detected. If a change occurs rapidly, the operator can sometimes detect the change without the aid of an instrument. However, if the change is gradual, the effect may not be noticed by even the most experienced operator. Herein lies the desirability of a continuous recording instrument.

The spindle-vibration meter picks up the vibration where it originates, at the spindle. This vibration meter is shown in Fig. 6. It operates on the well-known principle of a pickup coil located in a magnetic field generating a voltage proportional to the amplitude and frequency of its vibration. The magnet being seismically mounted on the pedestal is not affected by any vibration of its support. If several pickups are used to indicate vibration at different points on the same unit, the record of each station is made on a common chart in successive and periodic intervals, the length and order of which is determined by the setting of a program timer.

Scope of Supervisory Instruments

Quite possibly instruments with different functions or modified functions of these four instruments may be desirable or even needed in the future, and the choice of instruments should be governed by the conditions of service. Considering the needs of an average installation, these four instruments are at present regarded as the most desirable from the standpoint of quick starting and safe operation.

While the addition of supervisory instruments cannot be considered a substitute for intelligent operation, it is a definite step toward a better control. The addition of equipment such as the shaft-vibration meter and spindle-position meter does not presuppose that a failure or accident will develop. On the contrary, the worth of these instruments lies in the fact that another step is being taken in the direction of greater plant reliability, the importance of which is fully appreciated by power-plant engineers.

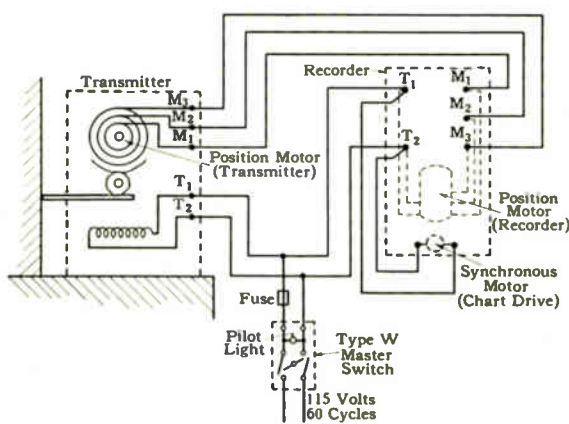

Fig. 5—Expansion meter records the turbine expansion precisely, giving graphical evidence of any irregularities in this motion.

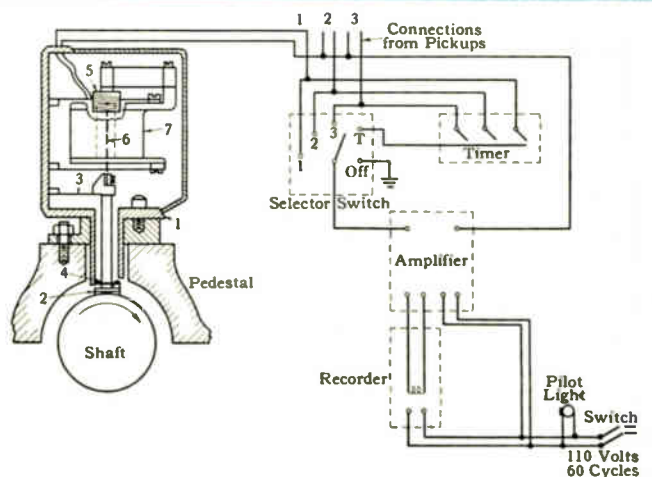

Fig. 6—Diagram of vibration meter with attendant instruments, including a selector switch for monitoring various positions.

Merits and Methods of Generator Grounding

In the electrical industry, perhaps more than in any other, many questions have a clear-cut, mathematically exact answer; relatively few matters must inevitably result in debate. Electrical engineers do, however, have some questions that seem never to be settled. One of these is the grounding of generator neutrals. The problem is as old as the industry, but to this day there is not general agreement, first as to whether the machines should be grounded or ungrounded, and second, if grounded, whether they should be solidly grounded or grounded through a resistor, a reactor, or a combination of the two. This article does not presume to settle the controversy but presents factors involved in selecting the best method of grounding a particular system.

STABILIZING the neutral is a term frequently used to describe a reason for grounding. In the strictest sense, only by solid grounding can the neutral be stabilized with respect to both dynamic and transient voltages, assuming that stabilizing means holding the neutral at or near ground potential, even during a ground fault on a phase conductor. For example, suppose a system is grounded through a resistor capable of passing full-load current. If a ground fault occurs on one phase conductor, that conductor must be at ground potential. The neutral is then above ground potential by the induced voltage minus the reactance drop caused by the fault current. This shift is practically the full phase-to-neutral voltage because the reactive drop is small and in quadrature with the induced voltage. Experience, however, has shown that insulation troubles encountered with ungrounded neutrals have been eliminated by grounding through a resistor. It is apparent, therefore, that some phenomenon other than mere dynamic voltage displacement of the neutral is involved. This condition was recognized years ago and was generally associated with "arcing grounds."

That arcing grounds could give dangerous overvoltages was shown in 1923.¹ Later, extensive tests and field studies indicated that perhaps too much emphasis had been placed on "arcing grounds" to account for the inferior performance of ungrounded systems.² The method (and electrical dimensions) of system grounding influences the degree of overvoltage possible during switching operations as well as during ground faults.³

In the references cited and in many others, the overvoltages discussed, ranging up to five or six times normal, were of a transient nature. Their creation involved the striking and restriking of an arc in a circuit consisting of inductance, capacitance, and resistance. Although the amount of the rms voltage displacement of the neutral is a factor, it is usually less important than the relative amounts of inductance, capacitance, and resistance in the circuit. These latter-mentioned circuit factors and the arc characteristic control the magnitude, frequency, and damping of transient overvoltages. Attempts have been made to translate these theoretical investigations into practical yardsticks by which the neutral-impedance device of proper size to prevent overvoltages can be specified. This is most difficult because,

S. B. GRISCOM
Central Station Engineer
Westinghouse Electric & Mfg. Co.

while theory may show the comparative performance, all phenomena of this kind are of random occurrence. To appreciate the difficulty, it must be realized that overvoltages do not occur unless the system is disturbed, either by a fault or a switching operation.

These involve arcs in air or in oil under widely varying conditions. Thus, a system poorly grounded may have escaped troubles simply because the required arc conditions have not occurred, while another system more adequately grounded may have had several cases of trouble. Therefore, it is unlikely that well-founded boundaries of safe and unsafe amounts of neutral impedance will be available for some time. Reactor grounding is subject to the greatest uncertainty. Various investigators have suggested values of neutral reactance. One form of definition is in terms of generator reactance, that is, the upper limit of neutral reactance is regarded as being one-half the generator subtransient reactance. Others have expressed the neutral reactance indirectly by specifying the ratio of X_0 to X_1 at the terminals of the generator. Here, X_0 is the resultant zero-sequence impedance of the system including the neutral reactor, if any, and X_1 the combined positive-sequence impedance of the system including generator. Upper limits for X_0/X_1 between four and ten have been suggested by different investigators. At present, it is doubtful if one of these criteria can be selected to the exclusion of another, and perhaps the best rule to follow is to make the neutral reactance as low as consistent with satisfying other objectives.

It has frequently been proposed that current-limiting or neutral reactors be shunted with resistors to minimize transient overvoltage. Theoretical study of this arrangement does not indicate the resistor is effective unless its current-carrying capacity nearly equals that of the reactor. Under this condition the parallel connection serves no good purpose. If high impedance is required, the reactor should be omitted and the resistor used alone.

Safety of personnel is not usually considered a factor in the selection of the grounding procedure for generators, not because personnel safety is ignored, but because the choice of grounding scheme has little to do with the hazard to operators. On domestic or industrial lighting circuits, solid grounding is materially safer. This is because the low voltage (about 130 volts rms maximum) is not high enough to be

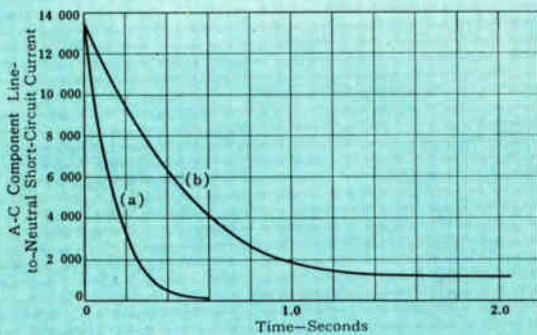

Fig. 1—The calculated decay of a fault current in a solidly grounded synchronous condenser under two conditions.

Time required for symmetrical component of phase-to-neutral short-circuit current to decay in a 30 000-kva, 10 000-volt synchronous condenser, from an initial condition of full load overexcited, when both armature and field circuits are opened simultaneously. Condenser speed assumed to be constant. (a) Condenser field circuit opened on discharge resistor. (b) Exciter field circuit opened.

fatal except in exceptional cases where intimate contact is made with both an energized conductor and ground, and where the body is included in the current path. Solid grounding of lighting circuits removes a worse hazard where 2300 volts or more might be impressed on lighting circuits to ground, in the event of contact with a higher voltage circuit, or through a transformer failure. Generator voltages are usually fairly high, so that capacitive and leakage currents, with the generator neutral ungrounded, result in ground fault currents well above those known to be fatal. Thus, leaving a generator neutral "free" does not materially lessen the real hazard to life. On the contrary, the false sense of security engendered might actually increase the hazard.

Ungrounded Operation

From a broad point of view an "ungrounded" generator is in reality capacitance grounded. Under normal conditions the capacity currents flowing from machine windings, leads, etc., to ground are sufficient to hold the generator neutral point close to ground potential. When a ground fault occurs on a phase conductor, a capacitive current flows, with magnitude dependent upon the size of the generator, length of connecting lines and cables, etc. For an isolated generator (with no leads except those connecting to a transformer) this current is from about ¼ ampere for a 10 000-kva, 2400-volt, 3-phase, 3600-rpm turbine generator to about 12 amperes for a 60 000-kva, 13 800-volt, 90-rpm waterwheel generator. While small, these currents cannot be ignored. They are well above the amounts required to produce lethal shock, and, if allowed to continue, would burn the insulation, and cause transient overvoltages on other equipment.

The transient overvoltages result from alternate extinguishing and restriking of an arc in a circuit containing both inductance and capacitance, the effect being much similar to the oscillations set up in the old 'spark'-type radio transmitter. The overvoltages can be materially reduced by some form of neutral-grounding device.

A potential transformer connected between generator

neutral and ground has sometimes been used as a combined grounding device and ground indicator. A potential transformer is completely inadequate for the purpose of suppressing transient overvoltage. This is apparent when it is considered that at 60 cycles, the effective impedance of the primary of a 13.8-kv potential transformer with 100 volt-amperes burden limits the current to about 0.0125 ampere, whereas the capacity currents to be discharged may be of the order of 12 amperes. Even this comparison is incomplete because, to be effective, a discharge device must be able to function at high frequencies, where the magnetizing and leakage reactances of potential transformers are high.

Another objection to potential transformers between neutral and ground is the possibility of "ferro-resonance." The secondary of the potential transformer is essentially open-circuited with the usual burdens, hence the effective impedance, as viewed from the primary, results from magnetization of the core. This impedance is variable depending upon the degree of saturation, which varies greatly from direct-current transients. There then exists the possibility of series resonance of transformer reactance with the capacitance of the machine, producing high voltages across each element. This phenomenon can be controlled by shunting the secondary with a resistor but the transient-overvoltage problem is not materially benefited thereby because the resistor will of necessity be too small to control the capacitance energy available.

Resistance Grounding

As far as transient overvoltages are concerned, neutral-grounding resistors have a clean bill of health from both theoretical and practical aspects. In a few cases neutral resistors, as originally installed, later appeared to be inadequate as the system expanded in size, and reducing the ohms lessened equipment failure. Other than these, resistors seem unquestionably to have been effective in preventing high transient overvoltages.

The ability of a resistor to suppress excess voltage has no doubt been responsible for the small amount of technical attention given it. Many years ago, W. Petersen gave the formula

$$R = \frac{6.2 \times 10^6}{(L_a + 5 + 25 L_b) \times f}$$

where L_a = miles of overhead lines, L_b = miles of underground cable, f = frequency in cycles per second, and R = neutral resistance in ohms.

This formula is evidently based on a resistor current equal to the capacitive ground-fault current existing without the resistor, in other words, the same resistance as would be used for a ground-fault neutralizer. The constant 6.2×10^6 and the multiplier 25 for L_b were apparently chosen to give a reasonable approximation of those variations caused by the effect of voltage class on conductor spacings. In a report on grounding practice⁴ issued 12 years ago all systems surveyed used grounding resistors lower than required by the formula. This probably results from the desire to stay away from a prescribed upper limit rather than from scientific knowledge that lower resistances are necessary. Such studies as have been made using the transient analyzer indicate that resistances at least as high as those derived by Petersen's formula are permissible.

Practical Considerations of Neutral Grounding

If four-wire systems (those having single-phase loads connected line-to-neutral) are excluded, there are essentially only two reasons for grounding a generator neutral. One is to minimize damage from overvoltage, and, the other, in the event of a ground fault, is to permit accurate detection of the faulty piece of equipment. Different grounding procedures bring in secondary effects, some desirable, some not, requiring a consideration of the pros and cons as applying to the specific case. The following conditions are the most important to be considered.

Dynamic Voltage Neutral Displacement

The maximum normal rms voltage stress to ground of a generator is 58 per cent of the line-to-line operating voltage. The factory insulation test is customarily twice the rated line-to-line voltage plus 1000 volts for one minute. The factor of safety for a machine is therefore about 3.5 to 1 for the "as new" condition of insulation. If the neutral is fully displaced, the factor of safety is reduced to 2 to 1. For machines in the "as new" condition, this is obviously ample margin, assuming the fault condition is removed in a reasonable time. For machines with old insulation it seems reasonable to say that if the insulation cannot withstand line-to-line operating voltage to ground, it is not in fit condition for regular operation. It can be concluded that for a brief period necessary to select and isolate the defective equipment, there should be no objection to a grounding scheme on the basis that it permits neutral displacement.

Mechanical Stress on Windings Caused by Short Circuits

The mechanical bracing of generator windings is based on stresses that result from the currents obtainable through the machine during three-phase short circuits. This current is equal to the internal voltage divided by the subtransient reactance (X_d'') with proper allowance for asymmetry. If a machine is solidly grounded the current through the grounded phase can considerably exceed this amount. To ground solidly under these circumstances is to risk distortion of the generator windings (whether the fault be internal or external to the machine) and requires a method of grounding by which such excessive currents can be avoided.

Burning of Machine from Internal Fault Currents

This is a subject upon which comparatively little statistical data are available. Obviously the particular coils involved in the failure must be replaced in any event. The communication of damage from the point of original failure to other coils, and more particularly to the iron laminations is obviously dependent upon both current magnitude and its duration. It is also apparent that the burning has no particular relation to the full-load current or to the proportion of the total furnished by the generator but to the absolute value in the fault. Of the damage to coils and iron, the latter is much more serious. After a rotor is removed, it makes little difference whether one or a half dozen coils must be replaced. However, there is a large difference in the time and labor involved where the laminations need only to be cleaned up

and mica separators placed between them and where the iron must be unstacked and whole sections replaced. Evidence seems to indicate that currents of several thousand amperes, if interrupted in 0.25 second or less, do not seriously damage the iron, and currents considerably higher can, no doubt, be tolerated if the clearing time is kept low.

Some rough figures in this connection may be of interest. The latent heat of fusion of iron is 60 Btu per pound so that 63.3 kilowatt-seconds of energy are required to melt one pound. If a minimum arc drop of 50 volts and a time of 0.25 second are assumed, the extent of the burning will be directly proportional to the current or one pound for 5000 amperes, five pounds for 25 000 amperes, etc. These figures are too large because, obviously, some heat will be conducted away and some used in vaporizing both copper and iron. They are too small if the minimum arc voltage of 50 is exceeded because of the lengthening of the arc from magnetic or other effects.

It is also of interest to speculate on the other end of the current range. Suppose the machine is "ungrounded" and the capacitance current caused by a ground fault is 10 amperes. Also, it has been reasoned that because the machine is ungrounded a ground fault can be allowed to persist until the load is picked up by another generator, say, in 10 minutes. The 10-ampere arc will be "stabilized" by the high-capacitive impedance in series with it but the arc voltage is likely to be much higher than the 50 volts assumed in the high-current case because of the negative-resistance characteristic of an arc. If 250 volts arc drop is assumed, the arc energy developed in 10 minutes is

$$\frac{250 \text{ volts} \times 10 \text{ amperes} \times 600 \text{ seconds}}{1000} \text{ or } 1500 \text{ kw-seconds.}$$

Not allowing for conduction and vaporization, this could fuse 24 pounds of iron or copper.

It is not expected that the above figures are exact, but they do indicate that high fault currents, promptly interrupted, may be less injurious than very small currents on "ungrounded" generators which are allowed to continue until a course of action is planned.

Relay Selection of Faulty Equipment

This cannot well be discussed without using specific examples. A few generalities can be noted. With the "unit" system but little selectivity is required, the mere existence of a ground being sufficient indication to remove the gener-

Fig. 2—Transformer-resistor scheme of generator grounding on unit system.
Fig. 3—Resistor (or reactor) generator grounding on unit system.

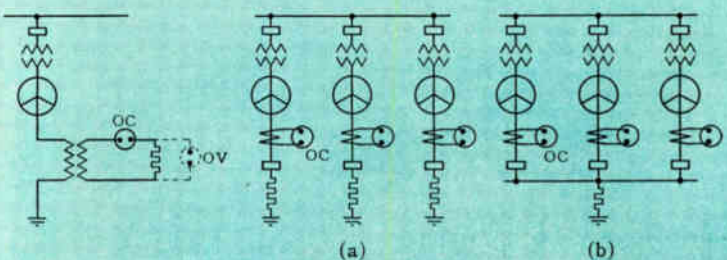

Fig. 2

Fig. 3

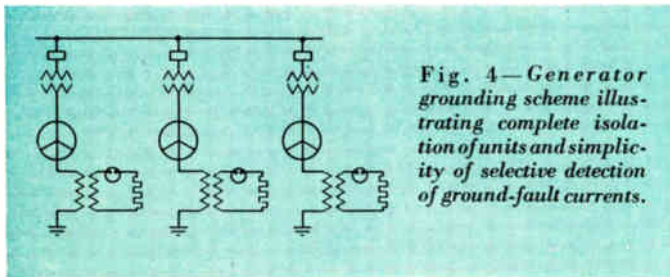

Fig. 4—Generator grounding scheme illustrating complete isolation of units and simplicity of selective detection of ground-fault currents.

ator and associated transformer, leads, etc., from service. With generators paralleled on a common bus, fault current of appreciable magnitude (comparable with full load) is required if differential or "ground" type relays are used. For faults near the neutral of the winding, any neutral impedance materially affects the sensitivity of protection, because both the ground and differential currents are reduced almost directly as the location from the line terminal if there is appreciable neutral impedance. If the machine is solidly grounded, both the differential and ground currents are comparatively much less affected by the location of the fault within the winding.

Neutral Breakers

It is customary to trip the line and field breakers, and to stop the flow of energy to the prime mover upon relay indication that a generator fault has occurred. This still allows some fault current to flow because of the generator's own emf. In Fig. 1 is shown the calculated decay of fault current in a solidly grounded synchronous condenser (a) with main field breaker opened and (b) with the exciter field breaker opened. The difference between these curves results from the influence of generator versus exciter time constant and the residual magnetism in the machines. In either case, the fault current could be terminated by the use of a neutral breaker tripped simultaneously with the line breaker. Whether such a breaker is advisable is an economic question. On small machines it is probably unjustified; on large ones, the cost might easily be dwarfed by prolonged outage.

Adaptation of Grounding Method to Specific Generator Connections

The variations of generator connections with respect to bus arrangements, high- and low-voltage distribution, three wire, four wire, etc., are too numerous for separate consideration here. Only those most frequently encountered will be considered.

Unit System

In most cases of machines solidly grounded, the current through the faulted phase, in the event of a ground fault, exceeds the three-phase current on which the mechanical bracing of the windings is based. Some limitation of fault current is therefore required.

A neutral reactor accomplishes this purpose, and many have been installed. Assuming that the ratio of X_0/X_1 is held to a reasonable figure (4 to 10, depending upon opinion) and prompt tripping is accomplished, all objectives appear satisfactorily met by the neutral reactor.

A neutral resistor passing from $\frac{1}{2}$ to $1\frac{1}{2}$ times full-load

current of the individual generators also meets all objectives. From the point of view of burning on short circuits, it will be relatively better, but probably not significantly so except for large units. Its installed cost, considering space required, will probably be higher. On an average installation, the cost and space do not appear warranted.

Grounding the generator through a potential transformer for ground-fault detection has some objectionable features. There is a good possibility of high transient overvoltages. The possibility of "ferro-resonance" is present, but can be prevented by resistance loading of the secondary. There is some possibility of false tripping because of electrostatic coupling through the main transformer bank.⁵ If the relay operation is used for alarm instead of tripping, there is considerable possibility of destructive burning of the iron laminations. Partially offsetting these disadvantages too is cost, which is a minimum for this scheme.

A grounding procedure used in several installations recently is shown in Fig. 2. It consists of a medium-sized distribution transformer with the primary winding connected between neutral and ground and with the secondary loaded with a resistor. Normally, no current flows in either primary or secondary. When a ground fault occurs, the neutral is displaced and a neutral current flows. Its magnitude depends principally upon the resistance in the secondary and the turns ratio. These are ordinarily chosen such that the neutral current with a ground fault would be equal to the capacitive current that would flow without the neutral device. The resultant fault current is the vector sum of the resistive and capacitive components and, if the two are made equal as suggested above, the resultant will be 1.41 times either component. Burning in the fault will therefore be little increased over the so-called "ungrounded" operation, and negligible compared to reactance or resistance grounding for the same fault duration.

Ground faults can be detected by current or voltage relays, as indicated in Fig. 2. There should be no difficulty in detecting faults within 10 per cent of the machine neutral, and even less with sensitive relays, because harmonic voltages, which can restrict the sensitivity of a potential transformer used as a neutral grounding device are largely overpowered by the resistance load.

Transient-analyzer studies indicate that transient over-

Fig. 5—Four alternative grounding procedures of the semi-unit system.

- (a) Independent generators separately grounded through reactors.
- (b) Single reactor grounding for independent or compound generators.
- (c) Compound generators, transformer-resistor grounded.
- (d) Independent or compound generators on a double-primary transformer with transformer-resistor grounding.

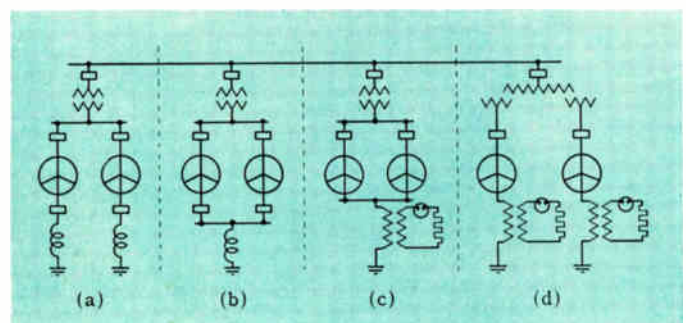

voltages on generators grounded in this manner are well within safe limits. The possibility of ferro-resonance is completely avoided with this combination. There is also little likelihood of false tripping from electrostatic coupling with high-voltage circuits through power transformer windings. The total cost of the scheme is considerably less than either a resistor or reactor, particularly if neutral breakers were used for the latter. Everything considered, this is probably the best scheme for grounding unit generators.

When several unit generators are operated in a given station there is the choice between the connections shown in Fig. 3, if resistors or reactors are used. (Resistors are shown for illustrative reasons only.) From the standpoint of permitting detection of the faulty unit, the uses of a neutral device for each generator or a single neutral device for all machines are similar because moderate to heavy fault currents will flow, and these can be selectively picked up by both ground and differential relays. Equipment cost and space will be a minimum for the single-neutral plan Fig. 3(b) but the neutral bus may be inconvenient to construct, and represents a hazard as it may become grounded accidentally without becoming evident until trouble occurs. When a ground fault occurs upon one unit, the neutrals of all units are displaced, more with the resistor scheme than with the reactor. With insulation in good condition this should not, however, be a hazard. The choice between the plans of Figs. 3(a) and 3(b) depends upon local conditions, with Fig. 3(a) to be favored unless the cost factor is important.

The transformer-resistor scheme as applied to multi-unit stations is shown in Fig. 4. It is obviously necessary to duplicate the equipment for each generating unit, as no fault selectivity between units would otherwise be possible. Because of low cost, this becomes feasible, and the complete independence of one unit from another is quite desirable.

Semi-Unit System

In Fig. 5, two generators are operated from a single transformer bank to effect economy in cost and space of transformers. Because a ground fault on either generator or any connected apparatus tends to displace the neutrals of both generators, it is apparent that fault selectivity must be secured by current and not voltage. This requires either a resistor or reactor grounding device, and either will be satisfactory if properly applied. The reactor is likely to be the most economical of space and cost. A device can be used for

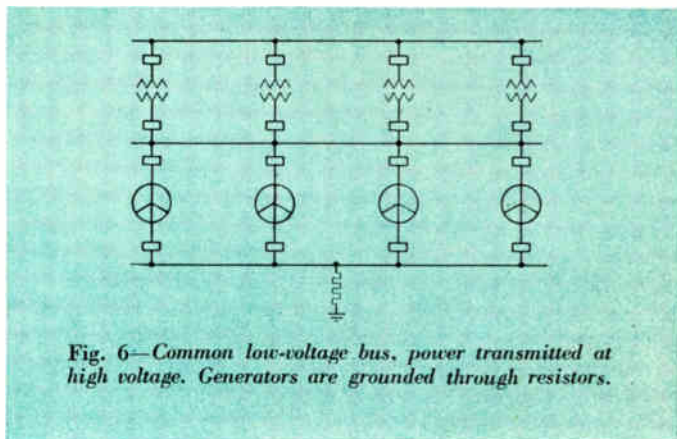

Fig. 6—Common low-voltage bus, power transmitted at high voltage. Generators are grounded through resistors.

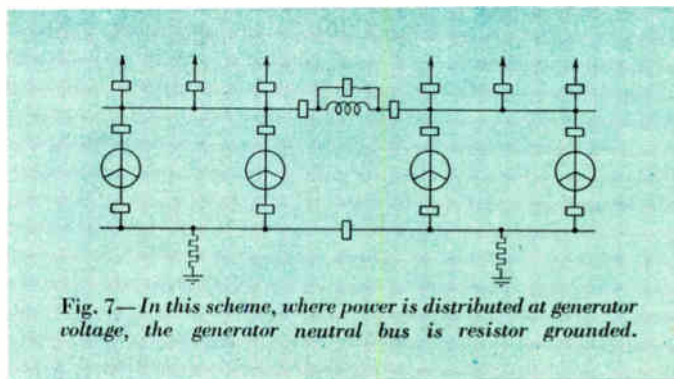

Fig. 7—In this scheme, where power is distributed at generator voltage, the generator neutral bus is resistor grounded.

each unit or each pair, the arguments being similar to those discussed in connection with Figs. 3(a) and 3(b). In this case, the neutral bus is likely to be short, and the economics may favor the connection shown in Fig. 5(b).

When the two generators on a common transformer are driven by turbine elements of a cross-compound turbine where neither element is capable of independent operation, the scheme of Fig. 5(b) is particularly applicable if resistor or reactor grounding is used. However, in such cases, where no selectivity between generators is required, the transformer-resistor scheme shown in Fig. 5(c) is feasible and much cheaper. The transformer bank should also be tripped as the ground fault may be in its low-tension windings.

While the transformer-resistor scheme does not permit selection and isolation of the faulty generator for the directly paralleled connections of Figs. 5(a) and 5(b) (assuming independently operating generators in 5(b)), it is quite suited to the multi-winding transformer connection of Fig. 5(d). Here, the isolation provided by the dual transformer primaries allows relay selection of the faulty generator by neutral displacement. Should the ground fault be in the transformer winding, tripping the generator will not remove it, and the transformer bank must also be tripped.

Common Generator Bus, Power Transmitted at High Voltage

In cases of a ground fault on the system, shown in Fig. 6, discrimination between machines can be made only on a current basis because the neutral shift of all machines would be the same if the machines were ungrounded, potential transformer grounded, or transformer-resistor grounded. This limits the choice to solid grounding, resistor grounding, or reactor grounding. Further, because X_0 for the generators is usually less than X_1 , the requirement of not exceeding the three-phase fault current in any winding generally rules out solid grounding. The choices to be made, therefore, are between reactance or resistance and whether to use one or more devices for a station.

The principal issues are the selective detection of ground faults and the total installed cost, although total magnitude of fault current is also of interest. If a resistor is used, the ohms will usually be chosen so that the fault current is between $\frac{1}{2}$ and $1\frac{1}{2}$ times full load of an individual generator unit. If a reactor is used, the maximum resistance is limited by the prospect of dangerous transient overvoltages. Therefore, the total ground fault current rises with an increase in the number and size of the generating units. This does not ordinarily require any additional provision for the generators,

circuit breakers, etc., but obviously can result in more extensive damage from the short-circuit arc.

With connections as shown in Fig. 6 it is customary to operate with only one generator-neutral breaker closed. With a grounding resistor, no difference exists in total ground-fault current whether one or all of the machines are grounded. With a grounding reactor, the total ground-fault current increases as the number of grounded generators is increased, but not in direct proportion.

As the location of a ground fault approaches the neutral terminal, the sensitivity of relay protection decreases. This effect is more pronounced with resistor grounding than with reactor grounding because of the smaller currents involved. In any case, the degree of protection is likely to be less than can be obtained in the unit system of operation where there is no problem of selection between faulted generators.

In many power plants, particularly those connected to large systems, it is difficult to keep X_0/X_1 sufficiently low to be sure of avoiding excessive transient overvoltages. This fact plus the advantage of avoiding large currents from ground faults gives, in the opinion of most operating engineers, the edge to grounding resistors for generators

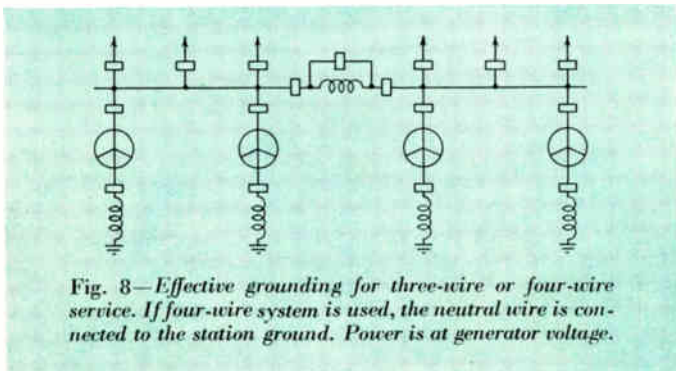

Fig. 8—Effective grounding for three-wire or four-wire service. If four-wire system is used, the neutral wire is connected to the station ground. Power is at generator voltage.

with multiple buses. The advantage of better relaying for faults close to the machine neutral is evidently more of a technicality than a necessity because of the small incidence of faults in that vicinity.

Systems with a Common Generator Bus, Power Distributed at Generator Voltage

This connection must be considered on the basis of whether the distribution system is three- or four-wire, the latter implying that single-phase loads are connected from line wire to neutral wire. If the system is three-wire, it can be "effectively grounded," in which case lightning arresters for grounded-neutral service can be applied throughout the system; or it can be resistance grounded, requiring the use of full-rated lightning arresters. If the system is four-wire, it must be effectively grounded in order to prevent overvoltages on the single-phase loads in case of ground faults.

The potential-transformer scheme of grounding is automatically ruled out by the requirement of obtaining selective relaying of ground faults on generators and lines. So, too, is the transformer-resistor scheme when the resistive component of the ground fault current is made equal to the capacitive component. There have been cases in foreign practice when rather small ground currents (50 amperes for

example) have been used where an adjacent industrial plant is fed directly at generator voltage. This is done in an effort to improve safety to factory workers. Solid grounding of one or more generators will almost invariably cause the current in their windings to exceed their mechanical design strength. These eliminations leave the choice between resistors and reactors. Either is satisfactory; if reactors are used, X_0/X_1 is held low enough to prevent high transient overvoltages.

Opinion differs somewhat as to the permissible maximum value for X_0/X_1 , ranging from 4 to 10. However, if the principal advantage of reactor grounding—use of grounded-neutral arresters—is to be realized, X_0/X_1 must be held to three or less. Considering that a grounding reactor is usually somewhat less expensive than a grounding resistor and that grounded-neutral arresters cost less than full-rated arresters (and give better protection), the cost item is definitely in favor of reactor grounding. One disadvantage of reactor grounding is that the ground-fault currents are quite high and can cause more damage than the moderate currents with a grounding resistor. Another disadvantage arises if the distribution system involves paralleling of feeders external to the generating station, but without grounded transformers at such junction points. Under these circumstances, there is frequently insufficient residual potential during ground faults to polarize directional ground relays, and relaying for the more frequent ground faults is greatly handicapped.

With cable distribution systems there are arguments in favor of both reactor and resistor grounding. With reactor grounding and $X_0/X_1 = 3$ or less, there will be practically no rise in potential of the unfaulted phases during ground faults. With resistor grounding, however, the unfaulted phases rise to full phase-to-phase voltage above ground, exposing the entire connected cable system to this voltage for the duration of the fault. On the other hand, the fault current with the resistor ground is quite moderate, so that the damage should be confined to the faulted cable and restricted to the fault location. With reactor grounding, if the fault is not promptly isolated, the heavy currents may damage the adjacent cables, duct banks, etc. There is thus something to be said on both sides, and the answer to this question can best be found in the accumulated experience of each operating company. Both types of grounding are used extensively.

A generating station with resistor ground is shown in Fig. 7, two grounding resistors being used. This gives somewhat more flexibility and insures the availability of a ground at all times. If reactors are used, a similar connection could be employed. However, complications arise with varying numbers of machines in service, and also because of dissimilarities between machines caused by normal growth in station size over a period of years. For example, suppose the generators have $X_1 = X = 15$ per cent and $X_0 = 3$ per cent. A neutral reactor of four per cent accomplishes the primary purpose of limiting the fault current through the generator to the three-phase figure.

$$I_{3\phi} = \frac{E_n}{0.15} ; I_{LG} = \frac{3E_n}{0.15+0.15+0.03+3 \times 0.04}$$

If the generating station grows to a total of five such units, X_0/X_1 becomes $\frac{0.15}{0.51/5}$ or 5.0, thus exceeding the effectively

grounded classification where grounded-neutral lightning arresters can be used. Similar reasoning can be applied to Fig. 6 if reactors are used instead of resistors as shown.

The same effect is produced by an increase in system generating capacity. If the new machines were larger than those in the initial installations, or their reactances different, a limitation would be reached sooner. For these reasons, the layout of Fig. 8 is preferable to that of Fig. 7 (assuming reactors for Fig. 7), as the reactor can be purchased to fit each generator individually. The size of the system will also exert a minor influence. The neutral breaker need not be opened except by differential relays, so that the operation of the station is simplified. The additional cost of the reactors is somewhat offset by the omission of the neutral bus.

When star-connected transformers are connected to the generating bus it may be possible to use them as a grounding means. If they are sufficiently large that X_0/X_1 is low, their neutrals can be directly grounded and neutral grounding of the generators is unnecessary. If X_0/X_1 is so high that transient overvoltages become a limitation, a resistor between the transformer neutrals and ground can be used. Because the transformers are most likely to be continuously in service, this eliminates neutral switching operations when putting generators in or out of service.

Variations of generating station connections, and offsetting advantages of one scheme over another make generalized recommendations difficult. The following are suggested as probably the best fitted for each of the commonly used generator connections.

Unit system: transformer-resistor combination, Fig. 2.

Semi-unit system, Fig. 5: resistor, reactor or transformer-resistor, depending upon local conditions.

Common generator bus, power generated at high voltage: resistor Fig. 6.

Common generator bus, power distributed at generator voltage: reactor or resistor depending on local conditions.

REFERENCES

- 1—"Voltages Induced by Arcing Grounds," by J. F. Peters and J. Slepian, *A.I.E.E. Trans.*, Vol. 42, 1923.
- 2—"Overvoltages on Transmission Lines Due to Ground Faults as Affected by Neutral Impedance," Engineering Report No. 30, Joint Subcommittee on Development and Research, Edison Electric Institute and Bell Telephone System, November 15, 1934.
- 3—"Power System Transients Caused by Switching and Faults," by R. D. Evans, A. C. Monteith and R. L. Witzke, *Electrical Engineering*, Vol. 58, August, 1939.
- 4—Table II of "Present Day Practice in Grounding of Transmission Systems," *A.I.E.E. Transactions*, Vol. 50, September 1931, Part 3.
- 5—*Electrical Transmission and Distribution Reference Book*, Chap. 17, p. 472, Fig. 25.

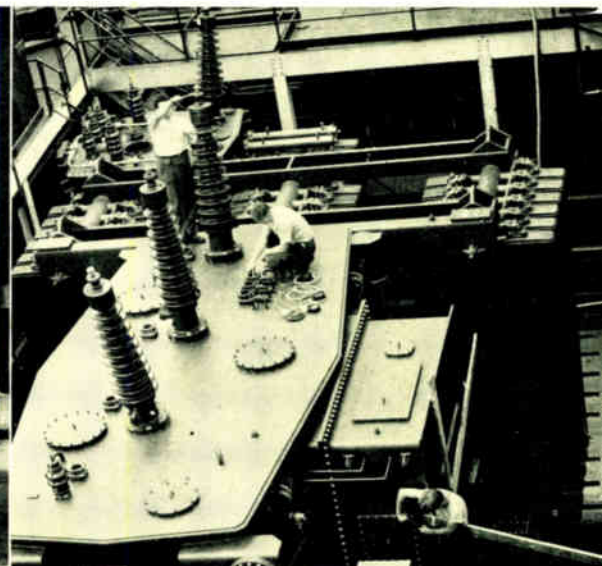
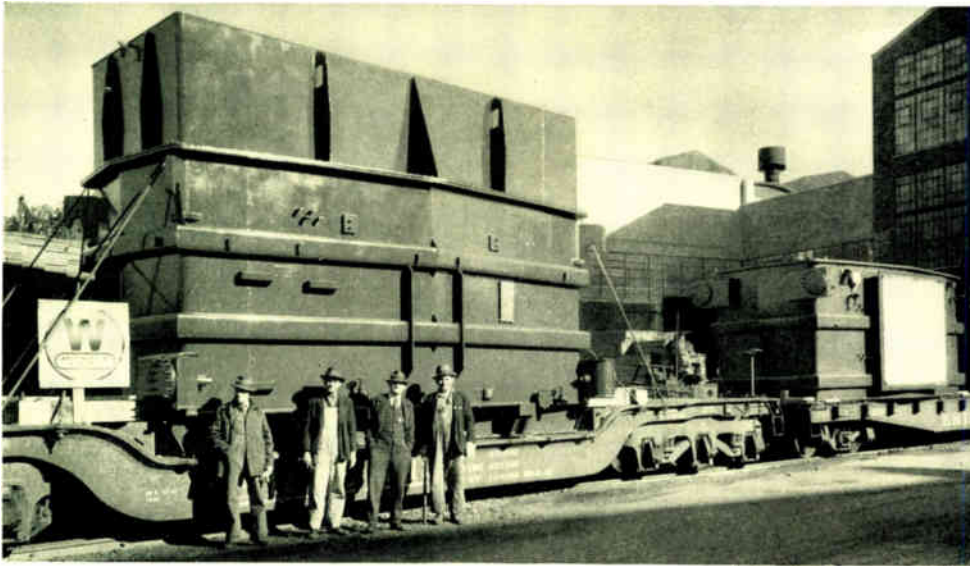

SIZE alone is no longer news. The War has needed manufacturers into making the "largest" of many products. Producing the largest transformer in the world, and at the same time crowding into this "largest" the capacity of an even larger transformer is news.

Two such transformers, rated at 75 000 kva each, supply power to a new war industry from current made available in a metropolitan area by war curtailment of local power consumption. Each transformer is as large as a six-room house. With attendant equipment, each is approximately 39 feet long by 24 feet wide and 25 feet high. Inherent in the design is the ability to withstand a shock of five G's and to withstand a total external pressure of 350 tons.

Their construction required 188 tons of structural steel and 130 miles of copper wire (29 tons). The cores required 111 tons of special core steel, Hypersil, which provides a core of much greater permeability and lessened hysteresis losses. This design brought about a saving of 40 tons of core steel, 10 tons of structural steel, four tons of copper, and over a tank car of cooling oil. Radiators are separately banked, which, with the use of Hypersil, made these transformers possible. Without them, shipping and installation problems would have been insuperable.

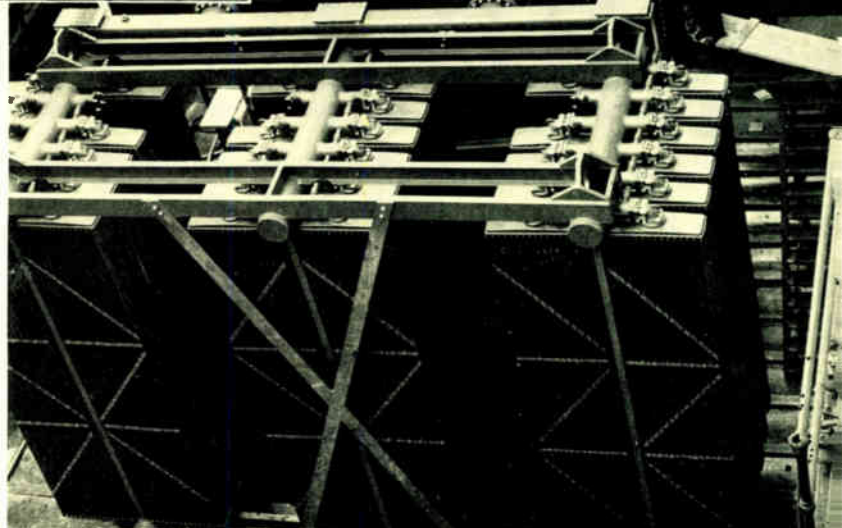

What's New!

New No. 2 Linestarter

IN LINE with the demands of the times, the engineering of the new Westinghouse No. 2 Linestarter centered upon savings—savings in space and materials. Withal, none of the salient features of the previous models were sacrificed and several important new features were incorporated in the new design.

While retaining the De-ion arc quenching and the bi-metal calibrated-disc overload trip, the space needed for mounting the linestarter was reduced over 40 per cent. The contacts are of solid silver which are made oversize to provide extra thermal capacity and eliminate the necessity for shunts. These double-break contacts are operated by a fulcrum-type armature with a knife-edge suspension point. This armature suspension is self-cleaning and has little wear due to relatively small motion.

Though the size was reduced materially, provision has been made for four interlocks and all parts are removable from the front. Special attention was given the necessity for ample "knuckle" space for wiring work. All terminals are clearly marked and easily identified. Mounting space was further saved by using a lift-off cover instead of the ordinary hinge type. By a simple adjustment of a reset button the overload relays can be arranged so that they can be reset by hand or can be automatically reset as the bi-metal disc cools.

Greater Strength for Buried Lamps

THE tremendous growth in size of airplanes has many little-expected engineering ramifications. When airport runway boundary lights (contact lights) were first introduced about seven years ago, seldom was one damaged by a plane landing on the top of one or rolling across it. The ability to withstand a 35 000-pound dead-weight load was ample. Now, should a pilot set down a big bomber or a stratoliner at sixty or eighty miles per hour, directly on top of one of these "button" lighting units, a contact light may be crushed, and all too often is. The greatly increased requirements have been met in striking fashion.

The new contact light has withstood dead-weight loads of 122 000 pounds. The new construction uses the principle of bridge design, all sections being trussed and avoiding any cantilever members.

While the engineers were about it, they improved the whole works. All strategic materials were avoided, saving three pounds of nickel and the weight of the aluminum used previously in the reflector. Rubber gaskets have been eliminated. By using an improved optical system,



These lights, buried along airport runways to mark the runway boundaries, must be unobtrusive physically but prominent optically. Though small, their inherent strength must be great should a plane strike them.

a recent development in shock-resisting glass, and pre-focused lamps, the two-element lens system has been simplified to a single lens, with an eight per cent improvement in light efficiency. These boundary lights can be fitted with shields limiting the angle of visibility.

Oil for the shellac of India: new bushings improved.

Shortages engendered by the global war generally touch off a mad scramble for substitutes. In the case of shellac for condenser bushings at Westinghouse, the only result was an orderly acceleration of a development that had been going on for two years. The outcome of this activity has been the placing in production of an oil-impregnated condenser bushing, superior in many respects to the bushing previously built, with an overall saving of some 40 per cent in shellac. Bushings up to 100 inches are wound with paper of the required size. Larger sizes are spiral wound as shown.

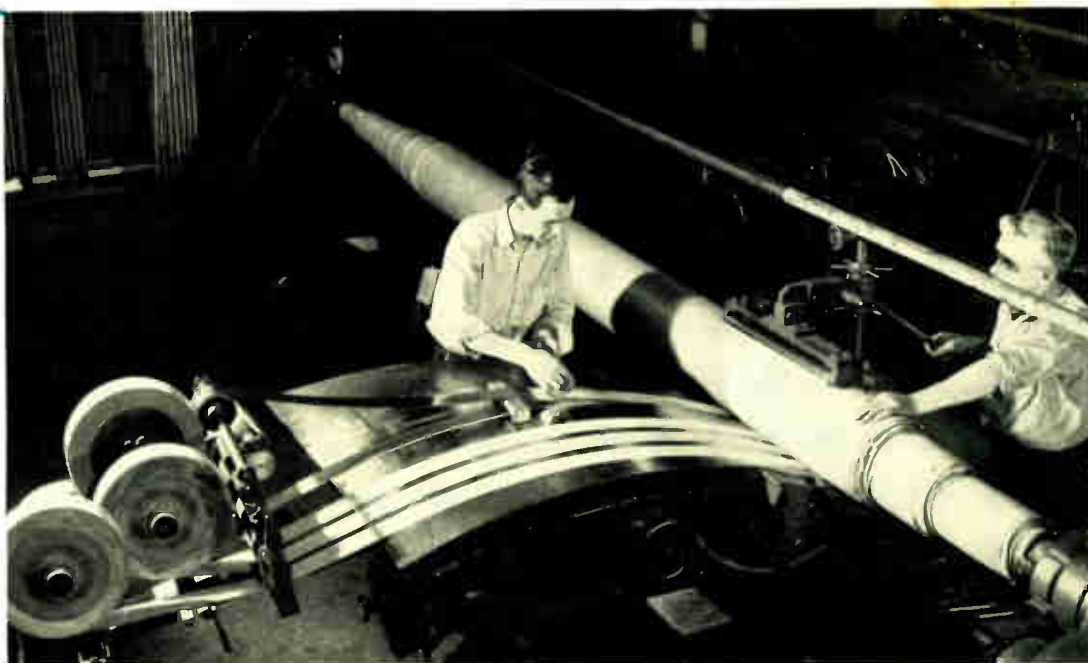

P E R S O N A L I T Y P R O F I L E S

Dr. C. C. Furnas certainly gets over the ground—in more ways than one. While at Purdue he was Big Ten track champion in three cross-country and distance events. In the 1920 Olympics at Antwerp, he represented the United States in the 500-meter race. But more specifically we mean another form of coverage. Since obtaining his Ph.D. at the University of Michigan, he did a turn as professor of Mathematics at Shattuck Military School, served as a physical chemist for the U. S. Bureau of Mines at Minneapolis, and was for ten years Associate Professor of Chemical Engineering at Yale. Normally his home is in New Haven but he swears that in the past year he has been in every Pullman on every railroad in the Dayton, Pittsburgh, Buffalo, Boston, New York, and Washington areas, while supervising various research projects of the National Defense Research Committee. Beginning this month, he is taking charge of the Research Laboratory of the Curtiss-Wright Airplane Division in Buffalo. In his "spare" time he has edited the sixth edition of "Rogers Manual of Industrial Chemistry," written several popular books on science such as "Storehouses of Civilization," "America's Tomorrow," "The Next Hundred Years," and several dozen articles for semi-popular technical publications. He has served on various committees and boards created to interpret and direct technological trends. He has also served as a consultant for the U. S. Steel Corporation at Gary, Ind.

R. L. Witzke has considered transients of more than passing interest. Since joining the Central Station Engineering group of Westinghouse in 1936 he has devoted much time to



this study. Having become an expert in this field he found himself at a loss to demonstrate them and their behavior to fellow engineers, so he devised a means by which one can literally see a transient. With this device, consisting of a commutator, a set of rotating mirrors, and a projector, he has appeared before dozens of technical groups, helping make this difficult subject easy. Witzke also collaborated in the development of a calculator, in which a special transient repeater in the form of a commutator is hitched to the a-c calculating board. Not all of his work by any means is theoretical. Anyone faced with the problem of what to do on long train trips might well ask Witzke's advice. His main occupation at present is helping solve practical power problems in the New England and Pacific Coast areas. Witzke

is a graduate of the University of Iowa (B.S. in 1934 and M.S. in 1936).

Coauthor in this issue with Witzke is R. W. Evans, of symmetrical component fame. A brief account of his background appeared in our February, 1942, issue.

Not often, in these days of specialized engineering, does an electrical engineer less than a year out of school make a contribution to the profession worthy of space in technical journals. R. C. Cheek graduated from Georgia



Tech in 1941 and, after only a few months at Westinghouse, developed a graphical method of solving a problem that has always been considered complicated, that of predicting transformer temperatures under a variety of load and ambient conditions. In between sessions of going to school, Cheek studied and experimented with radio. He served for a time as radio operator on a coastwise oil tanker and later operated a broadcasting station. Unlike most authors, he also has had editorial experience, having edited the *Georgia Tech Engineer* while an undergraduate.

One of those all too few people who know what they want to do and start specializing in that line immediately, R. L. Brown started right in with the Transformer Division at Sharon when he came with Westinghouse in 1922 and has been there ever since. Selected by B. G. Lamme from the 1922 Class at Ohio State where he received a B.S. in E.E., R. L. Brown entered directly into his life work without going through the usual student training course, counting himself fortunate to be in the last design class conducted by Mr. Lamme. His real hobby is devising means of

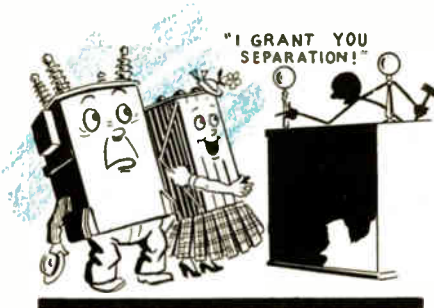

cost reductions which evidences itself in the huge transformers which he "fathers." Indicative of the scope of his activities are his foster children, the world's largest transformers described briefly in this issue.

Westinghouse is further indebted to Ohio State for H. L. Rawlins, B.S. E.E. '26 and C. E. Warren, B.S. E.E. '38. Mr. Rawlins furthered his work there, receiving his M.S. in E.E. in 1927. Coming with the Company in '27, he has advanced through the Switchgear Engineering Department to the position of assistant manager. A specialist in protective devices, he has made fuses and limiters his forte. C. E. Warren forsook Ohio State for his M.S. in E.E., receiving this degree from M.I.T. in '40. Since coming with Westinghouse he has been in the Distribution Section, computing and designing, particularly in connection with industrial networks. The mathematical intricacies of engineering protective devices are his dish, possibly because of his hobbies, which are bridge and chess, or perhaps, vice versa.

Many times we have been asked, "Who drew the little sketches for this issue? They're swell!" Well, if you must know, the artist is Warren Small. When it comes to putting across a technical point with a few well-placed strokes of his pen, bringing to life inanimate

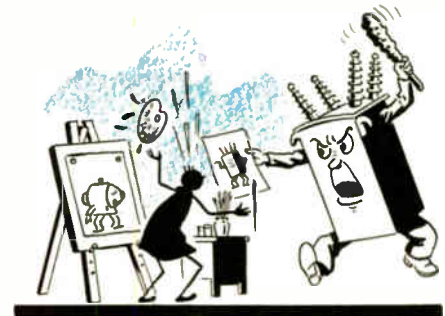

objects such as motors, transformers, electrons, and power houses, Small is tops. Combining action with a touch of humor without technical offense; that is his long suit.

Many times we have called him at some late hour saying in effect, "Warren, we need a sketch to illustrate our write-up of the author of a story on separate-mounting of transformer radiators. We haven't an idea in the world. What can you do for us?" Next day he delivers the completed sketch without further ado (see the sketch at left).

Small is a Westerner from out Oregon way (who but a Westerner could draw a welding generator as a contented cow?) Some 15 years ago he joined the Art Department of Westinghouse; since, he has become a member of the illustrating staff of *Pittsburgh Sun-Telegraph*. As a diversion, during his Pittsburgh sojourn, he has drawn the "pen and inks" for *The Electric Journal*, now for the *Westinghouse ENGINEER*, and for several other local publications. Says he likes to. His work shows it.

Engineering is a seven sided structure — research, design, construction, installation, operation, maintenance, and protection, which is often too lightly regarded. This issue treats particularly of protection: instruments that help detect incipient troubles in steam turbines; the best methods of grounding generators; a new high-voltage circuit breaker; and protection of industrial-plant distribution networks.

