

C 621.38  
W527

R.P.L.

WESTERN  
UNION

# *Technical Review*

**Birth of the Vacuum Tube**

**Switching to Tie-Lines**

**Tape-to-Page Translator**

**Pulse Modulation Systems**

**Rubber Insulators**

**Smoke Detection**

VOL. 3  
APRIL

NO. 2  
1949

# WESTERN UNION

# Technical Review

VOLUME 3  
NUMBER 2

Presenting Developments in Record Communications and Published Primarily for Western Union's Supervisory, Maintenance and Engineering Personnel.

APRIL  
1949

## CONTENTS

	PAGE
THE BIRTH OF THE VACUUM TUBE . . . . . <i>F. E. d'Humy</i>	46
SWITCHING TO PATRONS' TELEPRINTER TIE-LINES . . . . . <i>R. S. Wishart and G. G. Light</i>	51
TAPE-TO-PAGE TRANSLATOR . . . . . <i>A. E. Frost</i>	61
PULSE MODULATION SYSTEMS FOR TELEGRAPHY . . . . . <i>J. R. Hyneman</i>	69
RUBBER INSULATORS FOR POLE LINES . . . . . <i>H. H. Wheeler and W. F. Markley</i>	77
SMOKE DETECTION FOR WESTERN UNION SWITCHING CENTERS . . . . . <i>F. C. Evans</i>	83

*Published Quarterly by*

## THE WESTERN UNION TELEGRAPH COMPANY

### COMMITTEE ON TECHNICAL PUBLICATION

*P. J. Howe*, Development and Research Dept., *Chairman*

<i>F. B. BRAMHALL</i> . . . . .	Development and Research Dept.
<i>I. S. COGGESHALL</i> . . . . .	Internat'l Communications Dept.
<i>W. H. FRANCIS</i> . . . . .	Plant and Engineering Dept.
<i>G. P. OSLEN</i> . . . . .	Public Relations Dept.
<i>S. N. PHILLIPS</i> . . . . .	Commercial Department
<i>M. J. REYNOLDS</i> . . . . .	Patent Department
<i>H. M. SAUNDERS</i> . . . . .	Traffic Department

*NELL ORGAN*, *Secretary*

Address all communications to THE WESTERN UNION TELEGRAPH CO.,  
Committee on Technical Publication, 60 Hudson St., New York 13, N. Y.

SUBSCRIPTIONS \$1.50 per year

PRINTED IN U.S.A.

(Copyright 1949 by The Western Union Telegraph Company)

**WESTERN UNION ENGINEERING HAS BEEN HONORED** in the bestowal, in March 1949, of a Fellowship award by the Institute of Radio Engineers upon Mr. F. E. d'Humy, Vice President in charge of Development and Research. Following closely his election, in January, to the Telegraph Company's Board of Directors, public recognition of his achievements has thus been added to the management's own appraisal of the qualities of leadership and guidance which have largely determined the direction of our technological advancement.

The Institute's citation was "in recognition of his long service in the communication field, and for his pioneering in the application of radio-relays to telegraph message service." This is but the most recent, although one of the more spectacular departures inaugurated by Mr. d'Humy in a long list of instances where he has broken with tradition. Himself the holder of patents for numerous inventions, principally in the telegraph and other electrical fields, his fertile mind has run the gamut of possibilities of improvement of our Company's techniques, and has inspired his co-workers to carry engineering achievement to new heights.

To his associates, "F. E. H." is, in rare degree, philosopher and friend. Since his early days, he has from time to time published valuable writings of scholarly nature, sometimes inspirational, sometimes historical in content, exhibiting an



F. E. d'HUMY

aspect of his nature which may be described as a crystal-controlled carrier of the eternal verities, upon which all innovations are but controlled modulations. Such an historical paper was lately presented by him at Omaha, Nebraska, before the Newcomen Society in North America. In the belief that its readers would find in it much of revelation and enlightenment, **TECHNICAL REVIEW** is pleased to present this example of Mr. d'Humy's writings. "The Birth of the Vacuum Tube", as the leading article in this quarter's issue.

# The Birth of the Vacuum Tube

F. E. D'HUMY

Essentially full text of address delivered to the Newcomen Society in North America, at Omaha, Nebr., in October 1947.

In each and every tool serving mankind, much can be found of deep interest to those who choose to explore their underlying principles and penetrate as far into the unknown as they are permitted by the supreme governing Power. I say this deliberately because I firmly believe that we human beings are permitted to gain understanding only as we fit ourselves for the greater responsibilities.

The tool I have chosen for particular reference this evening, is one of recent birth. It is the Vacuum Tube. Its evolution is a beautiful example of how man has been guided, step by step, by the unseen Power patiently at work disclosing to us on earth, the verities of the infallible and all-prevailing law. This generation has become very familiar with the existence of this new tool through the popularity of the radio. Like the many species of life, vacuum tubes are produced in many varieties. The action which takes place within a vacuum tube is one in which that very tiny something—the electron—plays a very big part.

Since the days when the old Greek philosophers held sway, men of science have studiously tried to discover the nature of matter which makes up our physical universe. They believed by so doing that they would bring to light the laws which govern all existence. Many centuries went by without ought but vague speculation. These valiant searchers were poorly equipped with the kind of tools so essential when exploring such an intricate subject. Gradually new tools were evolved which served to bring their steps closer to the goal of their quest. Since the turn of the present century, a flood of light has been thrown on the nature of the atomic structure and we are

now able, through electronic bombardment, to disrupt the internal pattern of the atom of matter. We have learned to harness the electron and put it to work for many of our especial needs. It is this recent step which has opened so many doors to new scientific activities and which is revealing an heretofore undreamed of new world.

The beginning of this wonderful era is traced to the year 1883. In that year, our tireless and popularly known researcher, Thomas Alva Edison, at the age of 36, while experimenting with his famous incandescent lamp, made the discovery which later was to revolutionize the scientific world and open technical avenues of transcending importance. Immeasurable benefits have since been accorded mankind through this discovery. Its worth was not realized at the time and little was done about it for quite a while. This was to be expected for there were other problems needing immediate solution. Strange as it may seem, it was those problems which led to the great discovery referred to, that temporarily diverted especial attention from the, by far, more important subject. It was while coping with one of the immediate problems that Edison discovered that, if a metallic plate were inserted in the vacuous space of one of his incandescent lamps and electrically connected to the positive end of a glowing filament, a current would flow in the shunt circuit; but if, instead, the plate were electrically connected to the negative end of the filament, no current would flow. It appeared to be a one-sided effect which could not then be explained. But it did arrest the attention of the scientific world and the phenomenon became known as "The Edison Effect".

In the discovery of "The Edison Effect", we are given a striking example of how the development of one tool paves the way for the discovery of another tool. Now, let us see how it happened in this case.

Edison's development of the carbon filament incandescent lamp revolutionized the lighting of the modern world. Those of us who are old enough to have used the carbon filament lamp of early vintage, remember how, after a few hours of burning, the interior of the glass bulbs became blackened. As the blackening grew worse, so did the filament lose some of its carbon and brilliance, and so did the blackened bulb offer greater difficulty to the passage of light radiated by the weakened filament. This was a real problem.

It was quite natural for the inventor of the incandescent lamp to seek a remedy for an inherent defect in the child of his creation. The phenomenon which blackened the inside of the bulb and prematurely ended its useful life, Edison called "carrying". He observed that in many cases there was a narrow strip on the inside of the bulb's surface that showed relatively little blackening. It was clear that this was a shadow area where one leg of the filament shielded the other. Edison observed that the leg of the filament that cast the shadow was always connected to the positive side of the direct current circuit supplying the lamp. By this he readily reasoned that carbon particles were projected in straight lines from the negative leg of the filament. Here was a clue for preventing deposits on the inside of the bulb. Edison thought:—why not place a metal plate in a strategic position inside of the bulb and electrically connect the plate to the positive terminal of the filament? He did this and was rewarded in finding his theory substantiated.

At the same time he observed that an electric current flowed in the shunt circuit thus formed, and that this current flowed across the vacuous space within the bulb. Edison was then and there conscious that there had been disclosed to him, a phenomenon which could be put to good use. It could be used as a regulator or governor of electrical apparatus or dynamos. He was granted a United States patent on

October 21, 1884, in which it was described that the electrical current flowing through the vacuous space could control electrical apparatus. Also in this same month and year the *Electrical Review* of London recorded Edison's British Patent No. 2988 with a full description of the object of the invention. In December of the same year, the *Electrical Review* again found "The Edison Effect" sufficiently important to report Edison's exhibit at the Philadelphia Electrical Exhibition where the strange phenomenon was demonstrated, and to further describe in detail the construction of the lamp and its possibilities. The scientific world had become conscious of an infant of great promise.

Returning, once more, to the month of October 1884, there is to be found in the transactions of the American Institute of Electrical Engineers, "Notes on Phenomena in Incandescent Lamps", presented in a paper by Professor Edwin J. Houston, before that august body at Philadelphia. This is an historical record which scientists will forever cherish. In his opening remarks, Professor Houston said: "I have not prepared a paper, but merely wish to call your attention to a matter which I suppose you have all seen and puzzled over. Indeed, I wish to bring it before the Society for the purpose of having you puzzle over it. I refer to the peculiar high vacuum phenomena observed by Mr. Edison in some of his incandescent lamps". After a description of the lamp and its puzzling phenomena, a discussion followed with Sir William Henry Preece taking part. A few months following this meeting, Mr. Preece presented an interesting paper on the subject which was published in the "Proceedings" of the Royal Society for 1885.

Nearly five years later, February 14, 1890, Professor J. A. Fleming, who became intensely interested in "The Edison Effect", gave an engaging discourse before the Royal Institute of England and at that meeting presented a series of interesting experiments including one which, quoting Professor Fleming, ". . . will show you that a high vacuum, or, indeed, any vacuum, is not necessary for the production of the 'Edison Effect'. Here is a carbon



horseshoe-shaped conductor, not inclosed in any receiver. Close to the negative leg or branch, yet not touching it, we have adjusted a little metal plate. The sensitive galvanometer is connected between this plate and the base of the other, or positive leg of this carbon arch. On sending a current through the carbon, sufficient to bring it to bright incandescence, the galvanometer gives indications of a current flowing through it, and as long as the carbon endures, which is not, however, for many seconds, there is a current of electricity through it, equivalent to a flow of negative electricity from the plate through the galvanometer to the positive electrode of the carbon. The interposition of a thin sheet of mica between the metal plate and the negative leg of the carbon loop, entirely destroys the galvanometer current". Mr. Fleming gave credit to his assistant, Mr. A. H. Bate for this experiment. This experiment is of interest, not alone because it demonstrated that "The Edison Effect" may be produced in open atmosphere or without the aid of an evacuated chamber, but more especially because, as we review the history of the discovery, it is obvious that the Bate experiment could not have been conceived without the prior disclosure which resulted from an analysis of the cause of blackening of Edison's incandescent lamps. It was this blackening phenomenon which pointed the way so forcibly to the step which through Edison's receptive mind led to the birth of the vacuum tube.

As we look back on history, how clearly we are able to realize that Edison was guided in his work. His receptive mind responded to Divine impulses. We cannot help but see in this illustration, the evolutionary enlightenment of man following a scientific pattern laid out by the all-encompassing Power which governs the universe.

Without the incandescent lamp, which in itself did so much for the economic advances of civilization, it is quite certain that the electronic tube would have been greatly delayed and it is not unlikely that its arrival would still be in the future. A glowing filament in an evacuated chamber was essential in the make-up of the

incandescent lamp. This combination or equivalent combination, plus another element in the form of a metallic plate, was and is essential to produce "The Edison Effect". Yet, the two entities widely differ in their respective services.

What actually was discovered was a device which functions as a check-valve. That is, it allowed electricity to flow in one direction and permitted no flow in the opposite direction. It was not long before this principle was gainfully used for rectifying alternating currents. Through the conversion of alternating current into direct current, we were given this simple means of using alternating current for operating direct current equipment and apparatus and for charging storage batteries. The ability to rectify alternating currents, including those of ether waves infinitely small in value, and ranging from low frequencies to those infinitely high, such as those with which we are familiar in radio and television working, has opened an entirely new vista of research and development of transcending importance. We are now dependent upon it in the functions of many industries. Without it, radio would be impossible, flight control would be most seriously handicapped and we would not be enjoying many other advantages accorded present day life which electronics are now providing.

Although that great English physicist, Professor J. A. Fleming, studied "The Edison Effect" seven years after its discovery, it was not until 1899 when another Englishman, Sir J. J. Thomson, showed that the phenomenon was the result of negative electricity given off from the hot filament in the form of electrons. At the time of Thomson's experiment there was no doubt in the minds of physicists that carriers of electricity emitted from a hot filament were electrons, but the mechanism of emission was not known until O. W. Richardson, a winner of the Nobel Prize, showed in 1901 that the electrons were emitted solely by virtue of their kinetic energy. He assumed that the electrons in a metal which are free to move under the influence of an electric field, behave like the molecules of a gas. The number of electrons which are naturally

emitted at atmospheric temperatures. is extremely small, but if the temperature were raised, the number would increase rapidly. Thus, there was an elapse of 18 years before a true understanding was evolved of what was taking place in "The Edison Effect".

Tracing the progress of "The Edison Effect" further, we find J. A. Fleming in 1905 still intrigued with the phenomenon. It was at that time that he concluded that such a device could be employed to convert alternating currents into direct currents. He modified Edison's experiment by placing a circular copper plate around the filament and added a local battery with head telephone. He termed this device a rectifying "valve", and demonstrated that this valve when placed in a radio receiving circuit would convert the high frequency currents into direct currents which would operate the head telephone. Marconi used this device as a radio detector in his circuit.

Step by step we witnessed "The Edison Effect" emerging from its swaddling clothes into a sphere of usefulness of stupendous importance. Dr. Lee DeForest made one of the most telling contributions in 1907 when he added to Fleming's rectifying valve, a third element, called a "screen" or "grid", which he placed between the hot filament and the cold plate. By introducing the third element, DeForest provided a means for controlling the strength of current flowing between the plate and filament. He was able to cause a tiny current applied to the grid to control a much stronger flow of current from the plate. An infinitesimal amount of energy applied to the grid circuit would release hundreds of times more energy through the plate circuit.

By adding the third element or grid to the two-element tube of "The Edison Effect" or to the Fleming detector or valve, it became possible to put electrons to work for man's benefit in still another channel of utility. We were then able to amplify the effect of minute electric currents to currents of enormous proportions. The whole vista of wireless telegraph and telephone, and radio broadcasting was, at last, opened to practical application. The

path was not easy, for much still remained to be done to render the vacuum or electronic tube commercially practical. Diligent work continued for several years and a most rigorous analysis and research were pursued by many able engineers. No stone was left unturned to learn all possible about this most remarkable tool. In the years immediately following, the use of electronic tubes by radio amateurs grew apace although the tubes could not at that time be depended upon to give reliable and uniform operation. Much experience was thus gained and various circuit arrangements for coupling vacuum tubes were devised. E. H. Armstrong observed that high frequency currents impressed upon the grid circuit were reproduced as high frequency currents in the local circuit and further discovered that the plate and grid circuits could be electrically coupled in a way that the received radio signals would be amplified hundreds of times beyond the gain which otherwise could be obtained from a single tube.

Pyramiding or cascading the actions of tubes, one upon another, as a means for obtaining a succession of stages of amplification, was resorted to in the early experiments of the three-element tubes. As experiments went forward, needs were found for variations, not only in the circuit arrangements but, as was to be expected, step by step the tubes themselves were progressively improved and modified for specific performance. In addition to the two- and three-element tube, a need was found for four- and for five-element tubes and these were developed in selective varieties. Electronic tubes are now to be found in all dimensions and for manifold purposes. Some are enclosed in glass envelopes and others in metal envelopes. Small tubes, no larger than a peanut, are capable of passing and amplifying ether waves oscillating in frequencies of a very high order such as those serving television. Some of the larger power tubes radiate so much heat that it is necessary to water-cool them. There are tubes capable of radiating 50 kilowatts or more of wave energy and no limit can be placed upon form or size of these tools in future development.

As it is the purpose of this paper only to record the gift of those scientists devoted to civilization who evolved that most wonderful tool, the electronic tube, no attempt is made to review in detail the many varieties of tubes which have branched forth from that productive root, "The Edison Effect"; nor is this the place to enumerate the many uses and services in which electronic tubes are playing an important part.

People, in general, are becoming so accustomed to the many wonders brought into daily use through the instrumentality of the electronic tube, that the great majority accept it without question or without knowing what is really transpiring in this economic world of ours. Many are merely satisfied to be entertained by sound broadcast programs and latterly with television, and to know that through radar it is possible for a battleship to locate the range of another ship many miles away (although completely out of sight), and accurately strike the target with long range guns. These actualities, and many others, are usually accepted without pausing to ascertain the meaning of it all.

No longer are we amazed at such marvels as the electron microscope which is fifty times more powerful than the best optical microscope ever made and so acute that by its aid, molecules can be seen.

Even as early as in 1933 during the "Century of Progress" held at Chicago, Illinois, the public accepted, as passing interest, that great demonstration when astronomers, each evening, focused their telescopes in the direction of Arcturus residing in the constellation Bootes, forty light years away, and amplified the energy received from that distant astral body many millions of times so that it could be used to trip the electric light switches and turn on the lighting system of the Exhibition grounds. It was significant that the light ray which tripped the switches each evening during the Century of Progress in the year 1933, started its journey from Arcturus at the time of the Columbian Exposition held in Chicago in 1893, or just forty years before. How many who witnessed that extraordinary feat paused to pay tribute to "The Edison Effect", or even to realize the association? It is, indeed, unfortunate that this great opportunity was not used to promote a public reverence for the discoverer of this renowned phenomenon. Fortunately, some do keenly realize that the laws of the complex universe are being revealed and made use of by men and that we are traveling a path of knowledge which is progressively leading us into closer unity with the supreme guiding Power.



# Switching to Patrons' Teleprinter Tie-Lines

R. S. WISHART and G. G. LIGHT

The mechanization of Western Union offices by the introduction of reperforator switching has made it feasible to relay messages, received in the form of perforated tape, to tie-line teleprinters in patrons' offices by switching means, rather than by gumming the messages on receiving blanks at the main office and then manually transmitting them by keyboard to the tie-line teleprinters, as was previously done.

The method of switching to tie-lines differs considerably from the general switching scheme that has been described in articles on "The Development of Western Union Switching Systems."<sup>1</sup> There are generally many hundreds of tie-lines and consequently they are too numerous to place in the same switching turrets with trunks, tributary and branch circuits. Also, the special instructions pertaining to them are often too bulky to form part of primary switching position route charts. The practice, therefore, is to provide certain jacks or push-buttons in the switching turrets of the main switching aisle by means of which all messages to tie-line patrons are switched cross-office to a group of secondary switching positions dealing solely with tie-lines.

Such secondary switching positions must cope with many situations which differ from those found in trunk, tributary, or branch switching, such as: both tape and page teleprinters are used in patrons' offices while trunk, tributary and branch transmission is tape only; practically all tie-lines are single circuits, hence messages from and to patrons traverse a single path; the opening and closing hours are variable; the patrons are not always prompt in acknowledging receipt of messages. Also, patrons frequently require that no messages be sent to them during their lunch hours, and they often

demand special after-closing-hour handling of messages to individuals in the patrons' offices. These are handicaps that in the past produced low average rates of manual handling of messages to and from patrons' tie-lines, but which had to be overcome to justify tape switching to patrons.

One of the earlier steps in solving this switching problem was made about the time of the installation of the first reperforator switching offices and was limited to switching to tape teleprinter tie-lines. It consisted of providing secondary switching positions for tie-lines. Each position was equipped with a printer-perforator feeding continuous tape into a transmitter. Associated with the transmitter were two monitor teleprinters, two cords and plugs, and a tie-line turret. The operator plugged the first cord into a patron's tie-line jack and allowed the transmitter to send a message. Upon conclusion of transmission, as indicated by the double period termination of the message, the monitor teleprinter was left connected to the patron's tie-line to receive an acknowledgment while the transmitter was switched to the second cord circuit and monitor teleprinter. The second cord was then plugged into another tie-line jack to send the next message, and so on.

This method of switching, while a definite improvement over previous manual relay methods, encountered certain limitations. Situations peculiar to tie-lines, such as slow acknowledgment from patrons, busy tie-line conditions and closure of circuits during patrons' lunch periods, prevented operators from making efficient use of their time, and necessitated the switching of as many as 25 percent of the messages to "hard copy" printers for manual relay in order that the transmitter could be cleared for switching subsequent

messages in the continuous tape. The traffic load that could be fed to a switching position, and obtain reasonable speed of service, was also limited by these circumstances. Inasmuch as the limitations of this method of switching were principally the result of inability to switch messages out of sequence, the development of the system described below was undertaken.

#### Description of System

This new system, now in operation in some of the modernized offices, overcomes the previously mentioned handicaps to switching, by:

(a) Providing means at each tie-line position for switching through translators to page teleprinter tie-

lines, as well as means for switching direct to tape teleprinter tie-lines.

(b) Allowing messages to be separated one from the other before being placed in a transmitter. This permits messages to be sent out of turn if a specific tie-line is busy or temporarily closed.

(c) Providing sufficient transmitters and cord circuits with monitor printers at each switching position so that the operator is seldom without facilities for switching a message.

(d) Only slightly limiting the operator's output by busy tie-line conditions.

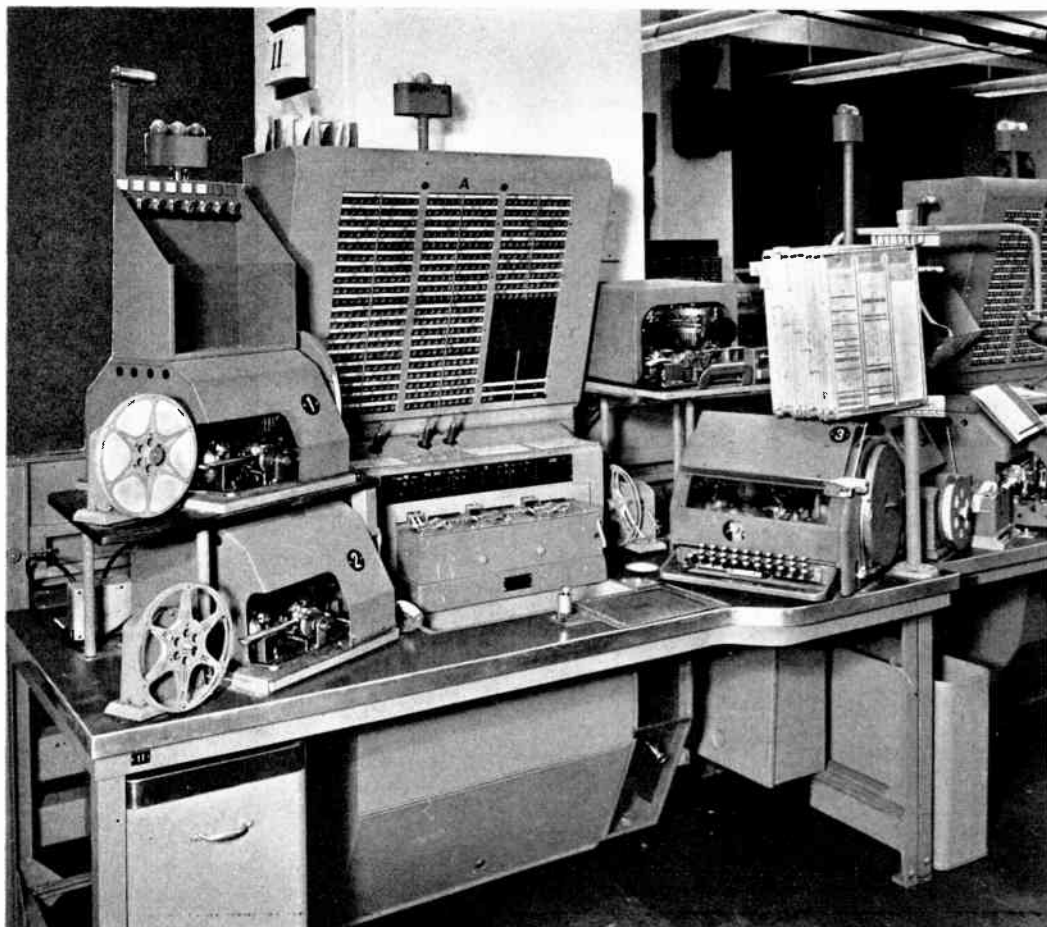

Figure 1. Tie-line switching table 346-A

- (e) Making possible the correction of obvious errors that may appear in the received printed-perforated tape.
- (f) Retaining overnight hold-over messages in tape form for transmission in the morning, thus avoiding conversion to hard copy form.
- (g) Adding the time and date after each message sent.

The new switching positions are of the type shown in Figure 1 and are known as 346-A tables. The turret in the center of the figure has a maximum capacity of 600 double conductor jacks, thus permitting the termination of 600 tie-lines. Below the turret is a cord shelf containing three plug ended cords, and under that is a control panel and a unit of three transmitter-distributors driven by a single motor. To the right of the turret is a 36-A Printer-Perforator. In front of and below the printer-perforator is a 2-B Teleprinter with the keyboard electrically separated

from the printing unit which serves as a monitor. A group of route chart leaves is mounted above this monitor printer. To the left of the turret are two monitor printing units. All monitors have tape windup reels to retain monitor copy for accounting purposes. In front of the transmitters is a retaining trough and a spring clip for holding message tapes which must be temporarily held and sent out of turn because the circuits to which they are destined are busy. In front of the trough is a number sheet holder and an editing punch used in correcting tapes. There is a message tape file box above the left-hand top monitor printing unit for tapes held out during patrons' lunch hours.

All elements in the operation of the 346-A position were arranged to bring them within convenient reach and view of the operator. For instance, the turret leans forward so that the top jacks are within the arc of reach of an average seated operator. Similarly, the monitor tapes, printer-perforator, control panel and transmitters are either at eye height or within reach. Controls in some cases

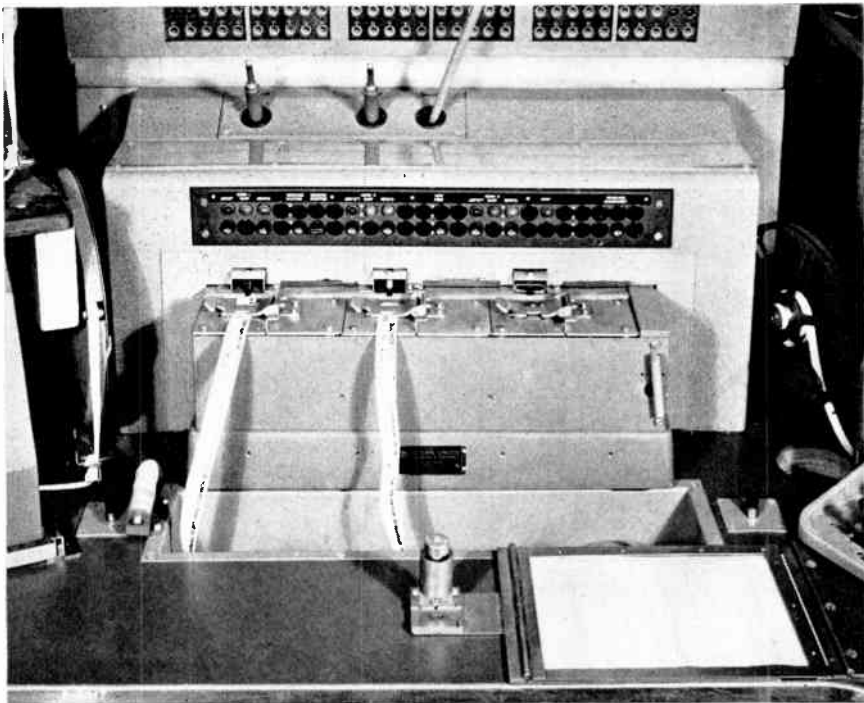

Figure 2. Control panel, transmitters and tape editor on 346-A table

have been duplicated to facilitate operations. For instance, a keyboard inserting push-button in the control panel (see Figure 2), is associated with each transmitter to be used for transmitting corrections. A duplicate push-button is mounted alongside the accompanying monitor teleprinter to be used to insert the keyboard to answer a patron's questions. As a result of this design, averages as high as 80 messages edited, switched and acknowledged, have been reached in a peak hour on a position of this type.

Most of the equipment is of a standard type. The printer-perforator is of the chadless tape type. The monitor teleprinters have period and operating bail contacts for cord circuit control; two of them are without keyboards. The third monitor teleprinter at each position is equipped with a keyboard, which can be introduced by push-buttons into any of the three cord circuits for conversation purposes. The three transmitter-distributors ganged together on one motor drive (see Figure 2) are equipped with a slightly modified form of the usual "tape-out" sensing pin. This

sensing pin serves to stop the transmitter and responds to editing notches punched in the edge of the tape, as well as to the end of the tape. Associated with the switching positions are two newly developed devices that are a necessary part of the tie-line switching system. These are the Automatic Time and Date Transmitter,<sup>2</sup> and the Tape-to-Page Translator.<sup>3</sup>

A complete installation for tie-line switching includes a sufficient number of 346-A positions to handle all the tie-line traffic during the peak hour. The net hourly average of messages per position switched to customers is roughly twice that of the positions originally provided for continuous tape switching to tie-lines.

### Operation

Figure 3 is a theoretical block diagram which shows the flow of tie-line messages through a reperforator switching office. One push-button or jack in each turret in the main switching aisle is labeled "Tie-Line." By means of this push-button or jack, tie-line messages received on incom-

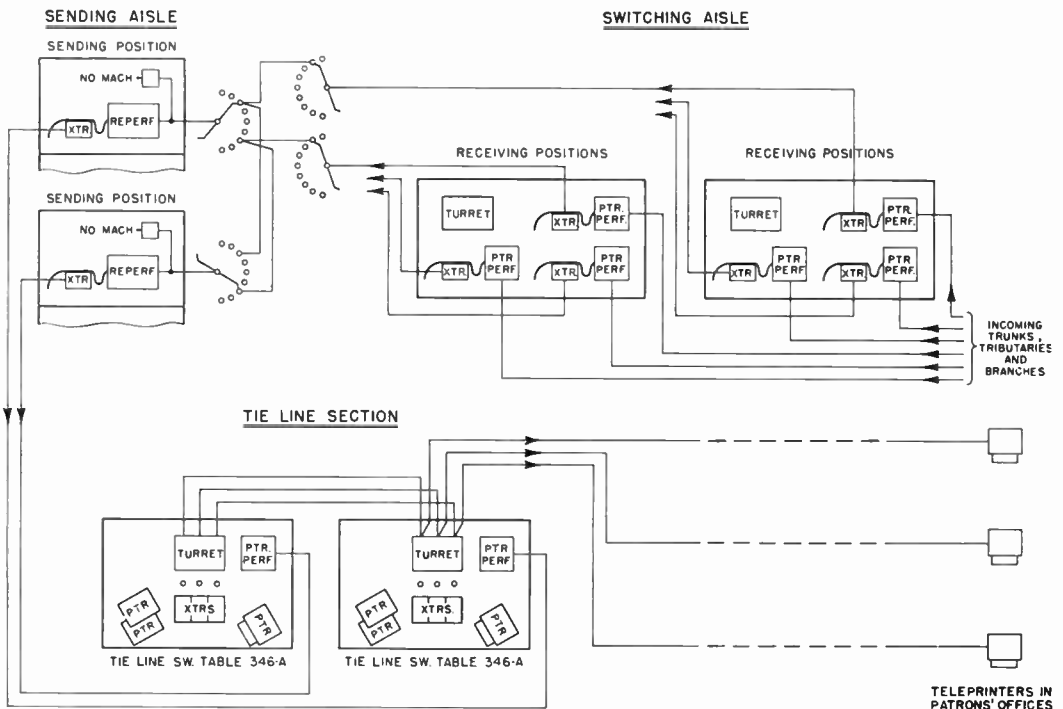

Figure 3. Flow of tie-line messages through a reperforator switching office



ing trunks, tributaries and branches are switched cross-office into reperforator sending positions. One reperforator sending position is required for each tie-line switching table. Tie-line messages flow from each of these reperforator sending positions to the printer-perforator on the associated 346-A tie-line switching table.

Each tie-line message switched cross-office receives an intra-office number from the automatic numbering machine at the sending position. The successive messages, as received on the printer-perforator at each tie-line switching table, are separated by six "blank" characters, a "letters" character, and four or five additional "blank" characters. These characters are automatically punched in the tape at the reperforator sending position following the double period termination of each message.

The operator at each tie-line switching table detaches each message received on the printer-perforator by severing the tape along the "letters" character that is interjected between the blanks at the end of the message. The message tape is then scanned for errors and paste-overs. If any paste-overs or obvious errors are noted, the tape is placed in the Tape Editor. This device, which can be seen in Figure 2 attached to the number sheet holder, is equipped with a plunger which is actuated to cause a half-moon notch to be cut in the upper edge of the tape at the location of each error. The notch subsequently serves to stop the transmitter so that the error or paste-over may be eliminated. After the tape is scanned, the operator marks off the intra-office number on the number sheet and adds the call letters of the patron to which it is destined, using the route chart leaves if necessary to determine handling.

The operator now inserts a transmitter cord plug in the appropriate tie-line jack, and places the edited tape in the associated transmitter by pushing it under the tape lid while the transmitter start lever is held depressed. This lever (located in front of the tape lid and visible in Figure 2) disengages the transmitter feed wheel so that it will spin freely, and also places the transmitter mechanism in condition to

start transmission upon release of the start lever. As previously stated, these transmitters are equipped with a sixth pin for sensing editing notches or the end of tapes.

A cord circuit (Figure 4) as used on these tables includes a transmitter, a monitor printer, a cord and plug, means for introducing a keyboard, means for automatically connecting a translator when required, and means for automatically introducing a time and date transmitter at the end of each message. A cord circuit allotter is utilized to assure that only one cord circuit may be connected to any particular line at any one time.

Double conductor jacks are used in the tie-line turrets. Negative battery is connected to the sleeve circuit of *tape* tie-line jacks, while positive battery is connected to the sleeve circuit of the *page* tie-line jacks. The direction in which the translator request (polar) relay armature (Figure 4) moves under the control of these sleeve potentials when a plug and cord is inserted in the turret jack, determines whether or not a tape-to-page translator will be introduced into the circuit.

*Page Transmission.* The right half of Figure 4 shows schematically the association of a translator between the tape transmitter and a page tie-line connection. Assume that the start lever of a transmitter has been depressed, that a tape has been placed in it, and that the associated cord and plug has been inserted in the jack of a page teleprinter tie-line. The positive potential on the sleeve of the jack causes the armature of the translator request (polar) relay to move to the side that will complete a circuit for the request of one of a common group of translators when the cord circuit obtains a connection to the line. The actual connection to line is controlled by the allotter shown at the bottom of Figure 4, which functions to determine whether or not the line is idle, and then permits only one cord circuit to be connected even though more than one may be seeking a connection to the same line at the same instant.

As the translator is connected, the transmitter on the 346-A table functions to transmit into the reperforator of the translator. At the translator, the tape is



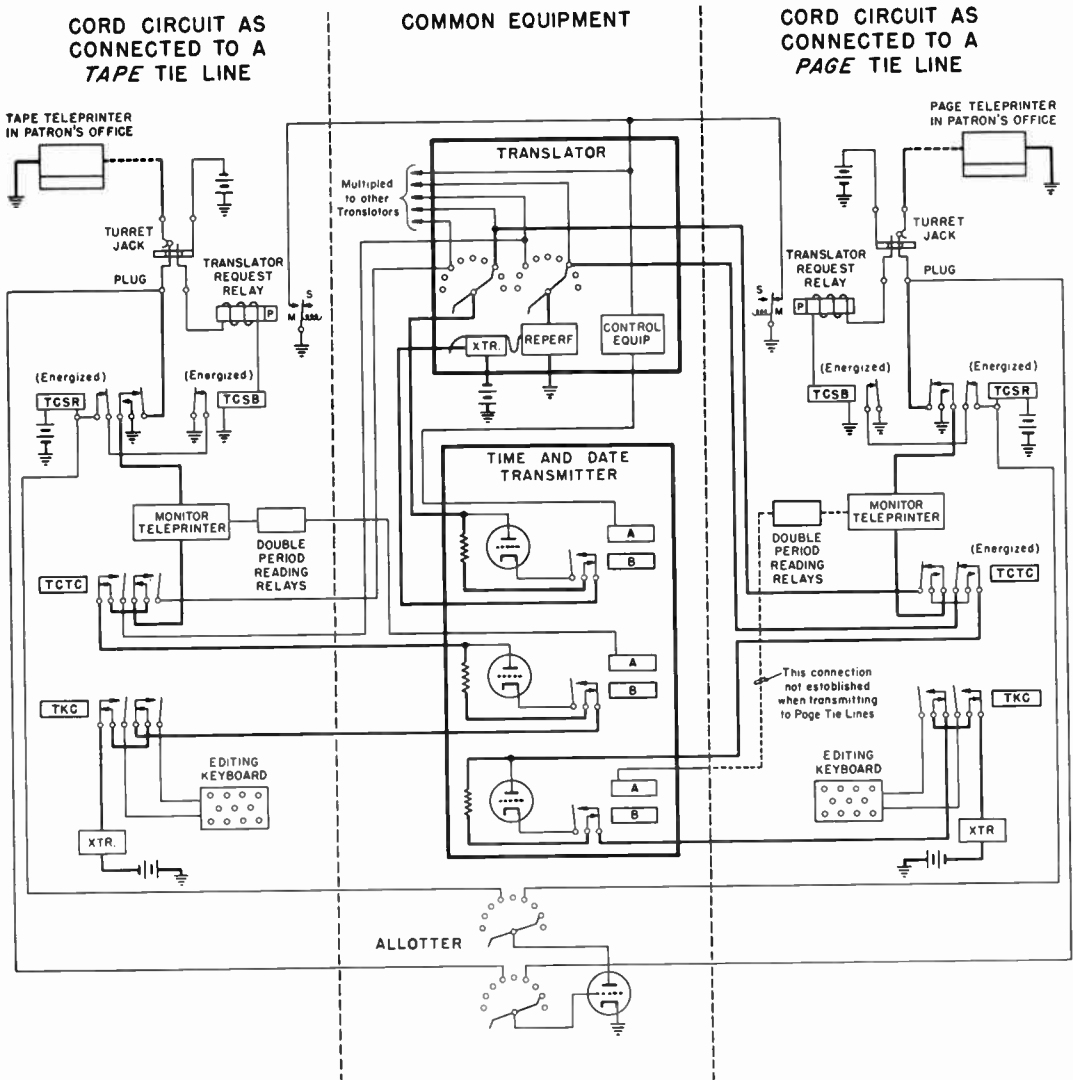

Figure 4. Arrangement of cord circuits for tape and page transmission

automatically read and retransmitted to the tie-line by the transmitter of that unit. A slight delay is introduced before transmission starts to allow the customer's teleprinter motor to get up to speed. The transmitter operates through reading relays and a distributor to send all characters that are common to both tape and page operation directly to the patron's page teleprinter. When the translator transmitter senses a character not common to both types of teleprinter, a rotary switch and relays function to transmit the page equivalent of that character to the line. For example, if the translator trans-

mitter senses a  $\frac{1}{4}$  sign, it stops while the abbreviation *PCT* is sent to the line. When an = sign is read by the translator, it inserts a carriage return and line feed, and so on. Also, the translator counts the number of characters sent to the line and inserts a carriage return and line feed on the first space following the minimum line count (53 characters).

When the double period termination of the message is read, these two characters are translated into upper case *M*, letters (to produce a page teleprinter period), a carriage return and one line feed. The translator then automatically requests the

time and date transmitter. This device starts its transmission as soon as the beginning of a time and date cycle occurs. The time and date will appear as

(1250 PM FEB 15 49) =.

Upon completion of the time and date transmission, the translator functions to send a carriage return and eight line feeds. If at this instant the tape has passed through and out of the transmitter on the 346-A table, the sensing pin will be actuated and the translator will disconnect from the cord circuit. However, if a number of successive messages are being sent to one patron without a break in the tape between messages, the sensing pin of the transmitter on the 346-A table will not be actuated and the translator therefore will remain connected until the last message has passed through.

The message as transmitted to the line is recorded on the associated monitor teleprinter. The sent tape itself is held within reach in the tape chute leading from the transmitter to the tape bin, by the slight pressure of a flat spring in the chute (see Figure 2). It is thus available for reference should the patron ask a question. A following tape inserted in the transmitter pushes the preceding tape into the tape bin.

The bail contacts of the monitor teleprinter close on the first character of a response from the patron and cause the acknowledgment lamp in the control panel to light. The operator observes the monitor tape, and if an acknowledgment was received, inserts the time on the number sheet after the proper intra-office number and then pulls down the cord circuit plug.

If the patron should ask a question, the operator pushes the "keyboard" push-button. As soon as the associated green lamp in the control panel lights, signifying that the keyboard has been cut in and a translator has been reconnected, the operator answers. The translator and keyboard disconnect when the cord circuit plug is removed from the jack, or if the operator terminates her note with a double period.

*Tape Transmission.* The left half of Figure 4 shows schematically the arrange-

ment of a cord circuit when transmitting to a tape tie-line. When a connection is made to a tape tie-line, the negative potential on the sleeve of the patron's tie-line jack holds the translator request relay in a spacing condition and thereby arranges the cord circuit so that a translator is not requested. Also, should it be necessary to introduce the keyboard into the cord circuit, depressing the keyboard push-button inserts the keyboard the same as for page transmission, but in this case a translator is not requested at any time during or after the transmission of the message tape.

From the switching operator's standpoint, the same procedure is followed in switching messages to page and tape tie-lines. The electrical functioning of the circuit arrangements differs somewhat because a translator is included in one case but not in the other.

A tape is placed in the transmitter on the 346-A table, the allotter establishes the connection and transmission starts after about a 3-second delay which enables the motor in the patron's teleprinter to get up to full speed. Now, since no translator is included in the connection to a tape tie-line, the transmission is direct from the transmitter on the 346-A table to the patron's tape teleprinter. Also, local circuits are established wherein the double period termination of a message is read by contacts on the monitor teleprinter and double period reading relays. Reading of the double period serves to stop the tape transmitter and initiate a request for the time and date transmitter. Upon completion of the time and date transmission, the tape transmitter runs out the six "blank" characters following the double period and then stops. The operator holds the connection until an acknowledgment is received, and then pulls down the cord circuit plug.

### Editing Messages

Earlier in this article reference was made to the use of a tape editor for introducing notches in the edge of the tape to cause the transmitter to stop. The editing procedure is as follows: When the tape-out sensing pin is uncovered by an editing notch, the transmitter stops ready to send

the character immediately following the notch. If the error is a paste-over, the operator depresses the transmitter start lever and pushes the tape through until the next good character to be sent is the last wholly visible character before the edge of the tape lid. The start lever is then released and the transmitter restarts and continues to the end of the message or until another correction notch is encountered.

To correct an obvious error, the procedure is similar except that, when the transmitter stops for the correction, the appropriate keyboard push-button in the control panel is depressed to introduce the keyboard into the circuit. The correction is transmitted from the keyboard, and the start lever is then depressed in order that the errored portion of the message may be pushed through the transmitter. Releasing the start lever permits the transmitter to restart. The restarting of the transmitter in turn disconnects the keyboard.

### **Auxiliary Operations**

Occasionally a message is received at one of the tie-line switching positions which, for one of various reasons, requires rerouting to another destination. Each switching position has a jack connection to a circuit over which such messages may be retransmitted to a receiving position in the main switching aisle of the reperforator switching system. This circuit includes an automatic numbering machine in order that a sequence number record may be maintained of such messages.

It is also necessary at times to produce a "hard copy" of a message, i.e., tape gummed on a blank. Therefore a hard copy circuit is made available to all tie-line switching positions. This circuit, which is also equipped with an automatic numbering machine, terminates in a tape teleprinter at a gumming position.

### **Special Arrangements for Handling Night Hold-Over File**

The two circuits just described can be converted by means of multi-pole switches into night hold-over file circuits. This is

done by connecting one of the above circuits to the printer-perforator on one tie-line switching position, and connecting the other circuit to the printer-perforator on a second tie-line switching position. The automatic numbering machines on these circuits are also replaced by numbering machines having special identifying letters for the number series.

After 5 PM the switching positions begin to receive messages that according to customer's instructions are to be held until the next morning. These tapes are assembled in a cabinet having 48 coiled spring tape holders that hold tapes for up to 96 customers, alphabetically listed.

Later during the night, the accumulated messages for each customer are edited and passed through one or the other of the night hold-over file circuits, thereby reperforating the messages into one continuous tape, with each message sequentially numbered. The tape is then placed under a spring clip in the above-mentioned cabinet for transmission to the customer in the morning.

Aside from groups of messages sent to a customer, other individual held-over messages are likewise identified by a separate number series provided by using "Tab Numbering." This consists in making use of a roll of tape at each position, in which is perforated a sequence of numbers. These rolls of tape are held in a small container mounted at the right side of the cord shelf of the 346-A table. A number is separated from the roll and placed in the transmitter ahead of each individual held-over message transmitted.

### **RQ-BQ Positions**

A separate RQ-BQ position (Figure 5) is provided for the correction of tapes that contain doubtful words or in which confirmations of numbers or unusual words differ from the original text. Its appearance is similar to the 346-A table described, except that mounted on the left half of the position is transmission equipment which automatically selects outgoing trunks and sends RQ's (requests for confirmations). This transmission equipment consists of a keyboard printer-perforator,



Figure 5. RQ-BQ table

a transmitter and various automatic controls. The table has a 600-line turret and one cord circuit for switching to tie-lines. The printer-perforator on the right side of the table, which is connected via a sending position to an RQ-BQ jack or push-button in the turrets in the main switching aisle, receives BQ's (answers to the RQ's). Upon the reception of a BQ, the operator verifies the associated tape and transmits it to the customer.

This system of switching to tie-lines is

being installed in large switching centers and will provide improved operation and speed of service.

#### References

1. THE DEVELOPMENT OF WESTERN UNION SWITCHING SYSTEMS, R. F. BLANCHARD and W. B. BLANTON, *Western Union Technical Review*, volume 2, No. 1, January 1948; volume 2, No. 2, April 1948.
2. THE AUTOMATIC TIME AND DATE TRANSMITTER, W. S. W. EDGAR, JR., *Western Union Technical Review*, volume 2, No. 4, October 1948.
3. TAPE-TO-PAGE TRANSLATOR, A. E. FROST, described in this issue of *TECHNICAL REVIEW*.



**THE AUTHOR:** Ronald S. Wishart acquired his education in Scotland, where he was born, and in France, England and the United States. Entering the service of the Postal Telegraph Company in 1907, he served as printer attendant, first on Rowland multiplex printing telegraph, then on Wright and early Morkrum equipment, and later as Automatic Chief Operator in the New York main office, with an intervening period as foreman at the Western Electric telephone repair shop. With the introduction of Morkrum apparatus in the Associated Press, he became Chief Operator in that service. In 1916 he was sent to the Mexican Border with the National Guard, and during World War I he served with the Signal Corps in Europe. After the war, he worked with the Morkrum Company (now Teletype) and represented that company in Europe from 1919 to 1922, when he returned to America to become Assistant Manager Sales Engineering. In 1924, Mr. Wishart returned to the

Postal as Printer and Automatics Engineer, and subsequently held various positions, including those of Central Office Engineer, Inside Plant Engineer and Chief Engineer. Since the merger of Postal with Western Union in 1943, Mr. Wishart has been Assistant New Methods Engineer and Assistant Systems Engineer, in which capacities he has contributed much to the development and expansion of reperforator switching systems, particularly the tie-line switching system described in the foregoing article. He is a Member of the AIEE.



**THE AUTHOR:** G. G. Light joined the Equipment Research Division of Western Union in 1927 following his graduation from Virginia Polytechnic Institute. Except for some time spent in the development of repeaters and terminal sets, he has been engaged exclusively in the design of manual, semi-automatic and automatic switching systems. He did circuit development for all of the major leased reperforator switching systems prior to 1942, at which time he entered upon active military duty. He attained the rank of Major in the Signal Corps while discharging important responsibilities in connection with its research and development program for wire facilities. Since his return in 1946 he has been active in the post-war mechanization program, doing circuit development work for reperforator switching systems for Western Union offices, including the system described above.





# Tape-to-Page Translator

A. E. FROST

A paper presented before the Winter General Meeting of the American Institute of Electrical Engineers in New York, N. Y., February 1949.

The Telegraph Company has recently extended reperforator switching methods to the delivery of telegrams to tie-line patrons. Some of these customers have tape teleprinters in their offices, while others prefer page machines. All business allowed to enter the reperforator switching system is in the form of tape printer copy suitable for reproduction on tape teleprinters. Messages originating on page machines must be manually retransmitted as tape copy for routing through the switching system. Page teleprinters require that carriage return and line feed functions be transmitted and there are many other differences between tape and page printer operation. To avoid manual retransmission to page tie-lines these differences must be reconciled automatically. This is the purpose of the tape-to-page translator.

Figure 1 shows tape and page teleprinter character assignments. Only the differences between them are shown in the page columns. The abbreviations *UC* and *LC* refer to upper case and lower case respectively. The page printer has two of the 32 possible combinations of the five-unit code assigned to carriage return and line feed. The tape printer has four characters assigned to these code combinations, which means that the tape printer has four character assignments that do not appear on the page printer. The omitted characters are: paragraph sign, equals sign, English pound sign, and the percent sign. The paragraph sign is obviously not required, neither is the equals sign, since it is used only as an indication to the tape printer gumming operator that a new line should be started. The English pound and the percent must be written out in page printer operation. The translator performs

a conversion for the percent sign but the pound sign is ignored.

The translator requirements may be summarized as follows: Insert carriage return and line feed at appropriate intervals; convert the equals sign into carriage

CHARACTERS				CODE SIGNALS				
PAGE		TAPE		1	2	3	4	5
UC	LC	UC	LC					
		-	A					
		?	B					
		:	C					
		\$	D					
		3	E					
			F					
		&	G					
#		£	H					
		8	I					
		BELL	J					
		(	K					
		)	L					
.		%	M					
,		'	N					
		9	O					
		0	P					
		1	Q					
		4	R					
'		9	S					
		5	T					
		7	U					
		;	V					
		2	W					
		/	X					
		6	Y					
		"	Z					
			SPACE					
CAR. RET.	,		.					
LINE FEED	#	=						
		FIGURES						
		LETTERS						
		BLANK						

Figure 1. Tape and page printer character assignments showing only the differences in the page columns

return and line feed; perform conversions for the number sign, period, comma, apostrophe, percent sign and paragraph sign. Also, at the end of a message, in response to the double period end-of-message signal, transmit carriage return and line feed; initiate a request for time and date; and, upon completion of the transmission of time and date, end the message by transmitting a carriage return and eight line feeds to provide well defined separation between messages.

### Translator Plan

Figure 2 shows a block diagram of the translator components and illustrates the plan chosen to effect translation. Tape teleprinter signals are received and perforated by the reperforator. The perforated tape passes through the tape transmitter, which sets up the code combinations punched in the tape, character by character, on five reading relays. The reading relays carry several sets of contacts for reading the character and an additional set of contacts from which the selection may be transferred to the storing relays, should no translation be required. Associated with the storing relays is a sending distributor for transmitting the signals to a page teleprinter circuit.

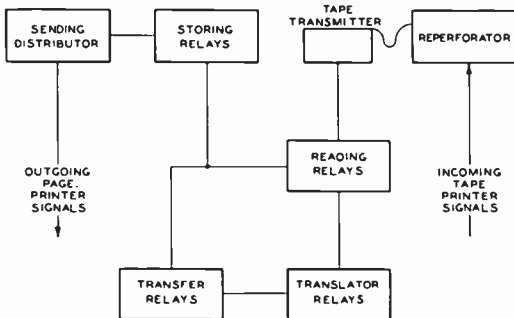

Figure 2. Block diagram of translator

Should a character requiring translation be set up on the reading relays, a circuit is established to energize one of the translator relays. One translator relay is required for each of the nine functions and, when operated, it sets up the conditions required for the particular translation. Since most of the conversions require that

more characters be transmitted than are received, it is necessary to establish a condition whereby a succession of conversion characters may be transferred, one at a time, to the storing relays. This is the purpose of the transfer relays. Operation of a translator relay immediately causes the operation of an appropriate transfer relay which carries contacts for the transfer of the first conversion character to the storing relays. Provision is made that this transfer shall take place from transfer relays and not from the reading relays; that is, the first conversion character is transferred to the storing relays in place of the character requiring translation. Then a second transfer relay is operated and the first one released to effect the transfer of the second character to the storing relays. This process is repeated as many times as is required. The operation of the last transfer relay establishes circuits for the restoration of normal transmission.

It is fundamental that transmission to the translator must be stopped during the transmission of additional conversion characters. The perforated tape furnishes the necessary loose coupling between the originating transmission and the translator. The tape transmitter is stopped and started again by the translator as required.

The translator is provided with two items not shown in this diagram. One is a counter to count the number of characters in each line of page copy, to indicate that a carriage return and line feed should be inserted upon the reception of the following word space; the other is a rotary switch used to effect the transfer of the conversion characters for the paragraph sign, and also the carriage return and eight line feeds at the end of a message.

### Transfer and Storing Relay Circuits

All of the events required by translation are timed from local rings on the sending distributor shown in Figure 3. The distributor brushes are continuously rotating. Local segments are shown in proper relation to the sending segments. Stepping of the transmitter takes place during the transmission of the start impulse. An auto-stop relay, differentially wound, is in-

cluded in the circuit to stop the transmitter and hold its contacts to spacing when the auto-stop circuit is opened due to tight tape or because additional characters need to be inserted for a translation. The count pulse steps the counter, resets it and releases certain transfer relays. The following segment is used to operate and release relays. The read pulse seeks a path through contacts of the reading relays to operate translator relays. The switch step segment steps the rotary switch for the conversion of the paragraph sign and for the message ending characters. Timing of the transfer of a character to storing relays is done by the transfer segments.

merely necessary, at the time of transfer, to insure that only the desired circuits are closed.

The operating circuit of the fifth storing relay is shown. When any one of the fifth pulse transfer points is closed, the relay is energized as the local brushes pass over the fifth transfer segment. The relay locks up to negative battery, and during the following revolution of the distributor a marking fifth pulse signal is transmitted to line. Should the next fifth pulse signal be spacing, all of the transfer points would be open as the brushes pass over the transfer segment in this revolution. Positive battery, through the transfer segment, is

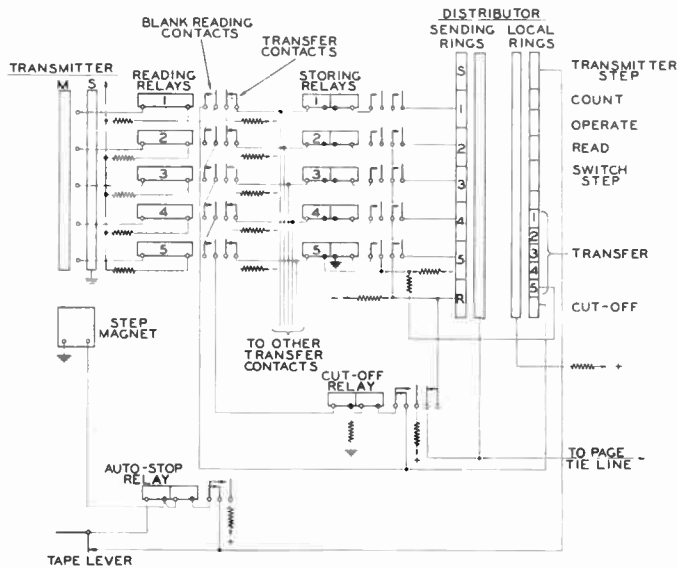

Figure 3. Transfer, auto-stop and cut-off circuits

Because of the number of conversions required in translation, the transfer of the desired selection to the storing relays was kept as simple as possible. The storing relays must be capable of responding to any one of 13 transfer relays and to 16 positions of the rotary switch in addition to the reading relays. The circuit is arranged so that a closed circuit to battery from any of the transfer points will prepare for the transfer of a marking signal to a storing relay, and that an open circuit at all of the transfer points will effect the transfer of a spacing signal. This allows all of the transfer points to be paralleled. It is

applied to the locking circuit in opposition to the negative locking battery, and the relay releases. On the following revolution of the distributor a spacing signal is transmitted to line. The location of the transfer segments is such that a storing relay will not be disturbed during transmission from its contacts.

Since the distributor brushes are continuously rotating, it is desirable to short out the distributor when no intelligence is being transmitted. This, and to prevent the counter from stepping on blank characters, are two of the reasons for providing the cut-off relay. The cut-off pulse

occurs during the transmission of the rest pulse, an essential requirement to avoid mutilating a character. Blank reading contacts determine the position of the cut-off relay.

Two of the more simple conversions have been chosen to be described in some detail. They are representative of the translator functions.

the upper case relay. When the transfer takes place, the fourth storing relay is operated from contacts on the carriage return transfer relay. It will be noted that the second pulse set up on the reading relays is open at contacts of the equals sign relay. On the following revolution of the distributor, a fourth pulse for carriage return will be transmitted to the page tie-

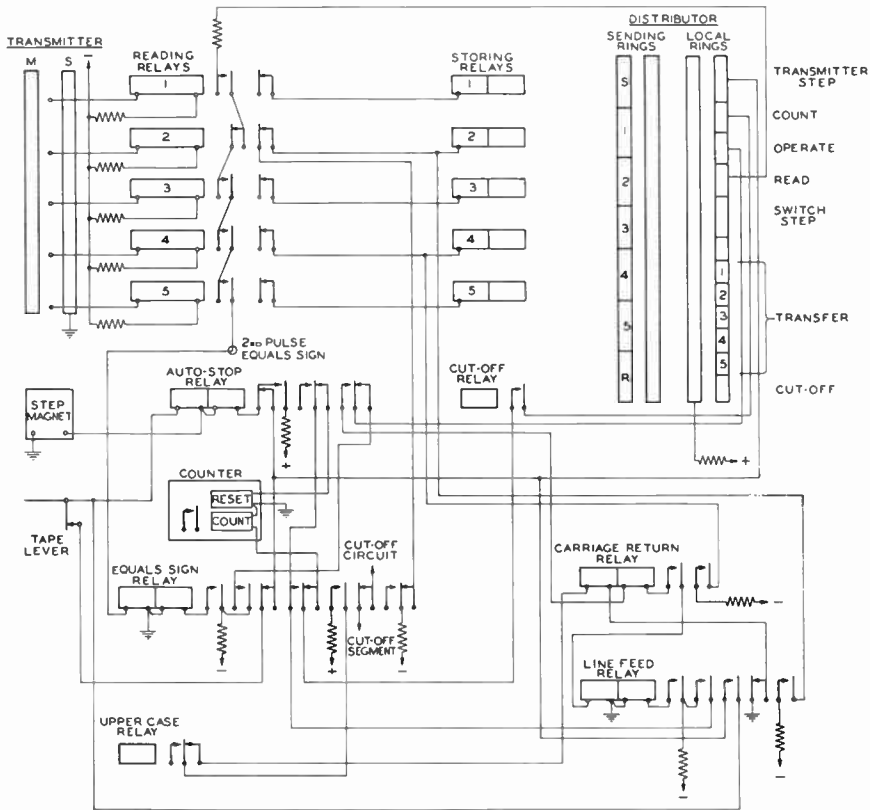

Figure 4. Conversion of equals sign to carriage return and line feed

Figure 4 shows the circuits involved in converting the equals sign to carriage return and line feed. When an equals sign is stepped into the transmitter, a marking second pulse is set up on the reading relays. This occurs at the beginning of transmission of the previous character to the page tie-line. The second pulse is read through contacts of the reading relays, operating the equals sign relay, which locks. The carriage return transfer relay is immediately operated from contacts of the equals sign relay through contacts of

line. While the carriage return character is being transmitted, the auto-stop relay is operated by the transmitter step pulse because the auto-stop circuit is open at the equals sign relay. The transmitter magnet is energized, holding the transmitter contacts to spacing. The operate pulse operates the line feed relay which locks and releases the carriage return relay. When the local brushes pass over the transfer segments, the second storing relay is operated and the fourth is released. On the next revolution of the distributor, a sec-

ond pulse for line feed is transmitted. During this revolution it is desired to reset the counter and restore the circuits to normal. Operation of the line feed relay closed the auto-stop circuit which was opened by the equals sign relay. The transmitter pulse now releases the auto-stop relay and the transmitter steps the tape to the following character and sets it up on the reading relays. The count pulse resets the counter and also releases the line feed transfer relay. The operate pulse releases the equals sign relay, thus completing the conversion and the restoration of the circuits to normal.

For the natural end-of-line conversion, when the counter contacts close and the following word space is read, the same carriage return and line feed transfer relays are used.

Whenever a second pulse is read, whether upper or lower case, the equals sign relay responds. In the lower case the

conversion of equals sign to carriage return and line feed takes place as described. In the upper case, however, the upper case relay is operated and, instead of operating the carriage return relay, the circuit is directed to another transfer relay for the conversion of the number sign.

Figure 5 covers the conversion of the paragraph sign into carriage return, line feed and five word spaces. The paragraph sign is upper case S. Therefore an upper case signal must have been received and read and the upper case relay operated and locked up. This completes the circuit for the operation of the paragraph relay when a 1, 3, marking combination is read. When the paragraph relay is operated, the 1 and 3 transfer circuits from the reading relays are opened. The rotary switch step circuit is closed; the switch is stepped from the switch step segment, and through level 2 a fourth pulse for carriage return is transferred to storing relay #4 in the

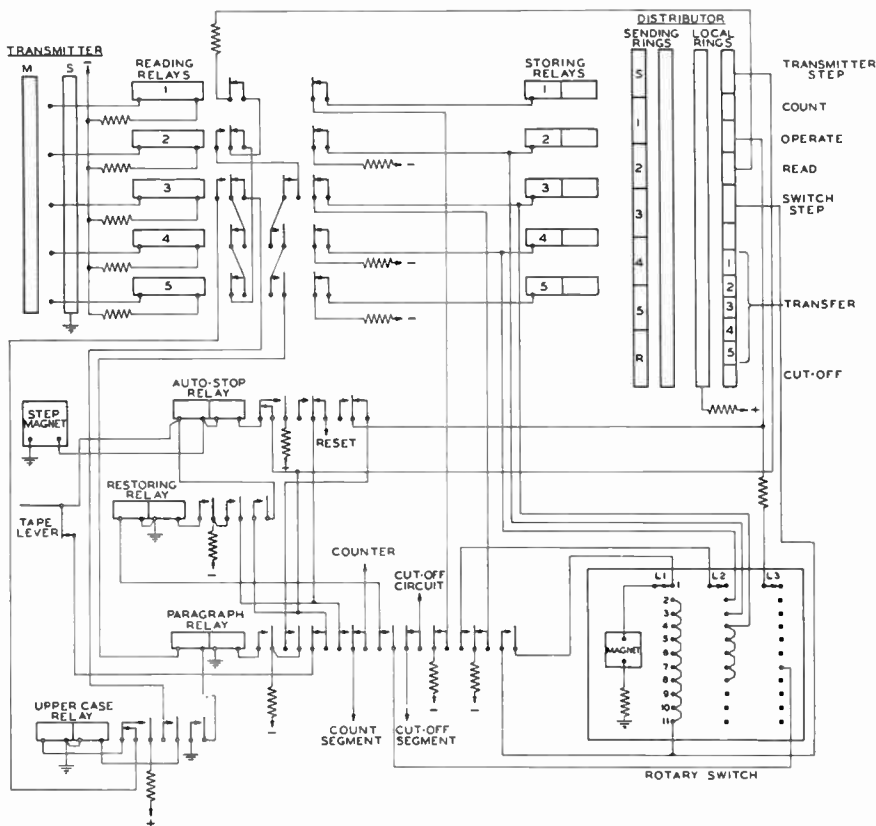

Figure 5. Conversion of paragraph sign to carriage return, line feed and five space characters



same revolution in which the paragraph sign is read. On the following revolution the transmitter is auto-stopped; the switch steps again and then a second pulse for line feed is transferred to storing relay  $\neq 2$ . On each of the following five revolutions a third pulse for "space" is transferred to storing relay  $\neq 3$ . On the next to the last of these steps a circuit is established through level 3 of the switch to prepare for the resumption of normal transmission. The restoring relay is operated by the operate pulse on the next revolution. This closes the auto-stop circuit so that on the following revolution the auto-stop relay releases and the transmitter steps. The count pulse releases the restoring relay and resets the counter. The operate pulse releases the paragraph relay, which completes the translation.

The application of the rotary switch for this translation is simplified because the conversion characters have a single marking impulse code. A fourth level on the same rotary switch is used for the end-of-message translation.

Figure 6 shows the front view of the tape-to-page translator rack. Each rack accommodates three translators. Each of the three shelves shown carries a reperforator, a transmitter and a monitor unit. The monitor unit houses the counter for indicating the end of line, signal lamps, and a monitor jack. The relay banks, distributors and rotary switches are mounted on the rear of the rack.

### Application

In practice, a tie-line sending installation may involve as many as 20 or 25 tie-line transmitters, any one of which can transmit to any one of a maximum of 600 tie-lines served by a central office. The division of the tie-line traffic load between tape teleprinters and page teleprinters varies in different localities. The average is about half and half. Therefore, only about one-half as many tape-to-page translators are required as there are tie-line transmitters. The translators are installed on a concentrator basis in such a manner that when a transmitter has a message for

a page tie-line it will obtain the connection through an idle translator. The request for a translator is wholly automatic and the tie-line operator need not know to which type of teleprinter the message is being transmitted. The operator places the mes-

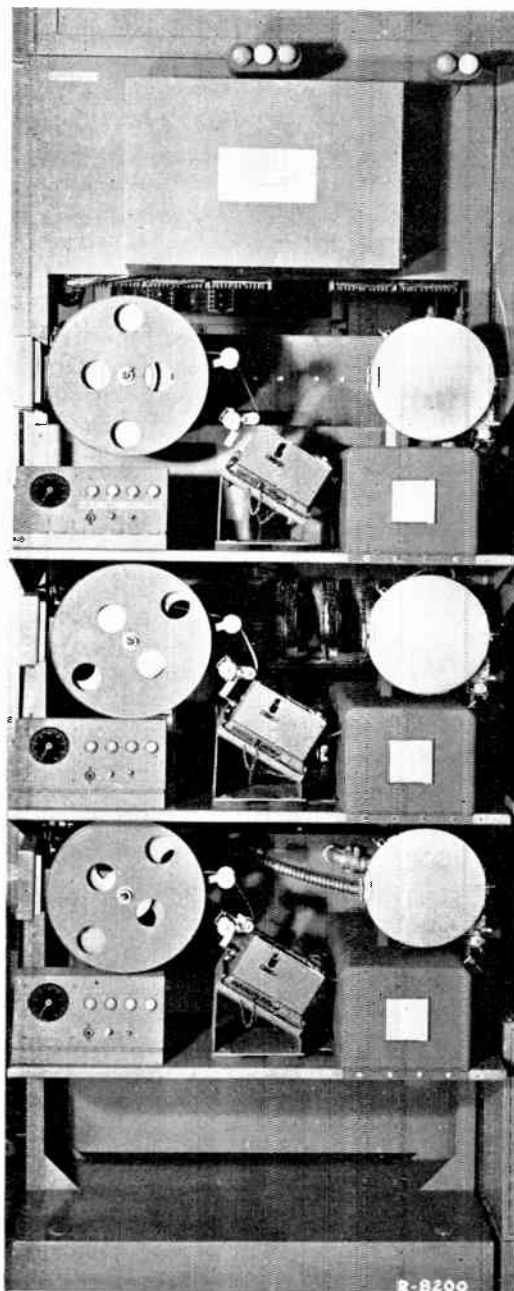

Figure 6. Tape-to-page translator rack for three translators

sage, in the form of printer-perforated tape, in the transmitter. After noting the address, she cords the transmitter into the tie-line jack corresponding to the address. Should the patron have a page teleprinter, the circuits established will request a translator, and when the connection is obtained the transmitter will start. This transmitter at the sending position sends to the reperforator on the translator rack.

The output of the translator transmits directly to the page tie-line.

The first application of the tape-to-page translator is with the new tie-line sending installations, beginning with those in the Boston office of the Telegraph Company. It is found to be very effective in improving the speed of service and efficiency in the delivery of telegrams to patrons' offices equipped with page teleprinters.



**THE AUTHOR:** A. E. Frost has been associated with the Engineering Department of Western Union since immediately after his graduation from the University of Vermont in 1924. For about 15 years he was engaged in the development and design of multiplex printing telegraph equipment for submarine cables, and supervised installation and training for the operation of systems in England and Newfoundland. Since 1939 he has done development work on the varioplex, regenerative repeaters, start-stop systems, and reperforator switching equipment. During World War II he was assigned to the development of special printing telegraph systems for the armed services, and participated in the initial operation of a system in Alaska. He also collaborated in the design of perforated tape storage equipment for a large-scale computer developed under government contract. Mr. Frost was appointed Assistant Automatics Research Engineer in 1947. He is an associate member of the AIEE.

## Western Union's Desk-Fax Program Gets Under Way



**Telefax Concentrators** recently placed in operation in the Central Office in New York. Units like this will serve Desk-Fax patrons in many cities throughout the nation. They will be described in subsequent issues of *TECHNICAL REVIEW*.

# Pulse Modulation Systems for Telegraphy

J. R. HYNEMAN

In order to understand the place of pulse modulation systems in modern telegraphy a few words are necessary for background. Great progress has been made in the multiplexing of circuits through processes of frequency division; that is, the division by means of filters of an available frequency range as provided by an available circuit facility into a number of blocks, or channel groups, with further subdivision into individual channels. Frequency division systems reached their highest development in the wire line field where usable frequency spectrum possessed definite boundaries and, further, the cost of a projected expansion was definitely measurable. This latter followed from the fact that width of frequency band was directly related to the number of loading coils, transpositions and repeaters per mile of circuit length, and care in construction and maintenance was generally a function of the top line frequency. Progress along these lines has now levelled off and it is unlikely that further significant advances can be achieved by present techniques.

A minor revolution in the thinking of communication engineers has been brought about by two major war time developments; first, new knowledge of radio propagation factors which has led to the adoption of super-high-frequency (s.h.f.) radio for commercial communication purposes, and second, the development of techniques for the generation, transmission, modulation and reception of pulses, or bursts, of radio frequency energy at very rapid rates. Advances in these two fields and in contributory techniques have brought high-capacity radio pulse transmission systems much nearer to commercial practicability. The advantage of pulse systems generally is that by limiting transmission to very short periods instead of having continuous transmission,

much higher signal levels can be transmitted within the energy dissipation limits of the tubes and other apparatus; yet if the receiver is activated synchronously with the incoming pulses, but is inactive at all other times, it will in effect be operating at a high signal power level and will also be immune to the noise occurring during the silent intervals. Another advantage is that since only one channel is transmitted at one time, there is considerable reduction in the tendency for channels to mix, or intermodulate, in common apparatus such as repeaters.

Signaling methods which may be classified as pulse types are numerous. It is possible to cover only a few of them here, and consideration will be limited to the more important types.

## Types of Pulse Modulation Systems

A type of pulse modulation system familiar to telegraph men is the time division multiplex long used on wire lines at speeds up to 60 or 70 cycles per second. These speed limits have prevailed for many years because of the adverse transmission characteristics of wire lines and the lack of satisfactory high speed distributors and synchronizing systems. Also additional leg extension equipment was necessary if the channels were to be extended to distant offices or operating positions. The nearest existing analogy here to a high-speed pulse system is the 100-cycle, 8-channel, 400-wpm multiplex which now operates over one of Western Union's loaded transatlantic cables. The mechanical distributors for these terminals are 24 inches in diameter, employ silver segments and pose a considerable maintenance problem.

The characteristics of s.h.f. radio invite a somewhat different approach from what



has been the case with wire lines. Radio frequency wave lengths as allocated by the FCC in the range under consideration comprise bands millions of cycles in width because it is not technically feasible to separate these wave lengths when they are closely spaced. In consequence, economy of spectrum is not so pressing as in the case of wire lines, and relatively wasteful channelizing methods may be tolerated if apparatus economies or other advantages are thereby brought about. Hence, on a radio relay circuit which links large cities and requires large numbers of channels, the efficient but more expensive frequency division method of channelizing may be warranted. However, on radio circuits linking lesser centers, the small number of channels needed may be obtained more cheaply by a less efficient but entirely satisfactory pulse system.

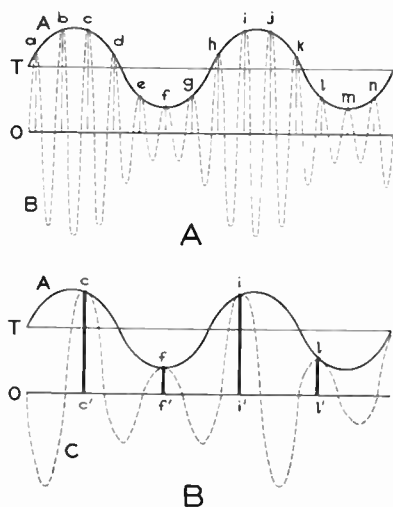

Figure 1. Carrier modulation and sampling processes

The basic characteristics of pulse systems will now be developed with the aid of Figure 1A. Let the full line curve A represent two cycles of a signaling wave located on a time axis T, and bearing a series of 14 points designated by the letters a to n spaced at equal distances in time thereon. It is obvious that these points define the wave with considerable accuracy, and that if the coordinates of the points were transmitted to a suitable re-

ceiver, the receiver would reproduce the signal wave A. Proceeding further, a second sine wave has been delineated by the dotted line B which has positive half wave peaks coincident with the points a to n. It is apparent now that the outline of the first wave could be transmitted over a circuit by transmitting in carrier fashion the amplitude-modulated dotted line wave B; in fact, only the positive half cycles of this wave need be transmitted.

To delineate the curve A, seven points per cycle have been indicated and the frequency of wave B is therefore seven-fold that of wave A. Surprisingly, however, it has been found that only two points per cycle are actually necessary to reproduce a sine wave of given frequency, and consequently the frequency of wave B need be only twice that of wave A. Such a wave has been drawn at C in Figure 1B to embrace the points c, f, i, and l only, thus having a frequency  $2\frac{1}{3}$ -fold that of wave A. To transmit the points c, f, i, and l neither is it necessary to transmit the entire half cycles of the wave C, but merely short pulses having the proper position in time, and of an amplitude corresponding to the height of the respective points above a base line. The pulses occurring at c', f', i', and l' having the repetition rate, or frequency, of wave C completely represent the wave A, and this is the foundation upon which modern pulse transmission systems rests.

In the illustration, a simple sine wave (wave A) only has been considered, whereas it is known that a speech signal or a voice-frequency band containing 18 telegraph channels may be a very irregular wave. Such a wave, however, may be resolved into a series of sine waves, and so long as the pulse frequency is at least twice the frequency of the highest component in the complex signal wave, it will accurately represent the signal.

These short pulses may be transmitted over any suitable medium and at the receiving end, if they traverse a low-pass filter of suitable design, the spaces between the pulses are filled in, or bridged over, to form a replica of the original wave. It goes without saying that the amount of signal energy received in the



short pulses is very minute, and considerable amplification is required to bring the final signal to a suitable level.

The process just described is known generally as sampling and is a primary step in all pulse transmission systems. Once the samples representing the intelligence have been obtained, they may be transmitted by any one of a number of different methods. If transmitted in their original variable amplitude form, the method is known as pulse amplitude modulation, or *PAM*. In another common method, the transmitted pulses are displaced in time of occurrence from their mean position according to the amplitude of the successive samples. This method is known as pulse time modulation (*PTM*) or, alternatively, pulse position modulation (*PPM*). In a third method, respective amplitudes of the pulses may be represented by a series of code combinations of pulses of constant amplitude, but of marking or spacing character, such as the letters of the alphabet may be represented by the 5-element Baudot code. This method of transmission is known as pulse code modulation or *PCM*. Under another method, the pulses are modulated as to

duration, or width, in accordance with the instantaneous signal amplitudes, (*PDM*). Still other methods have been proposed, but those above named are the most practicable and have now been rather thoroughly explored.

### Multiplexing

If a 3000-cycle speech wave is sampled at an 8000-cycle rate, the time between samples is  $1/8000$  second, or 125 microseconds (*msec*). But techniques are available for generating, transmitting and utilizing pulses of the order of 1 microsecond length, or even less. Consequently, it has been proposed to subdivide the 125-*msec* period into a number of smaller intervals and to transmit additional channels during each interval.

Figure 2 illustrates how samples from seven additional channels may be added to those of channel 1, in order, along with a marker or synchronizing pulse, to produce a "frame" for multiplex transmission. The pulses numbered 2 to 8, respectively, represent samples from seven other channels each identical to channel 1. This is a time-division type of multiplex and, in a manner analogous to the segments of a mechanical rotating distributor, vacuum tube "gating" circuits, one for each channel, are rendered conductive in order, in synchronism with the incoming pulses, to select each pulse into its assigned channel circuit. For the purpose of maintaining synchronism, a marker pulse having a distinguishing characteristic such as added length or amplitude is introduced as the initial pulse of each frame. The figure shows time allocations for a typical 125-*msec* frame in which the channel pulses are 1 *msec* in length and are separated by spacing intervals of 13 *msec*. The marker pulse is 4 *msec* long. With a pulse being transmitted approximately every 14 microseconds, the fundamental rate will now be 72,000 per second, and this signal can be transmitted over any suitable transmission path having the necessary band width. For such a band width a radio circuit is preferable and, if the 72,000-cycle signal modulates the amplitude of a radio frequency carrier, the double sideband out-

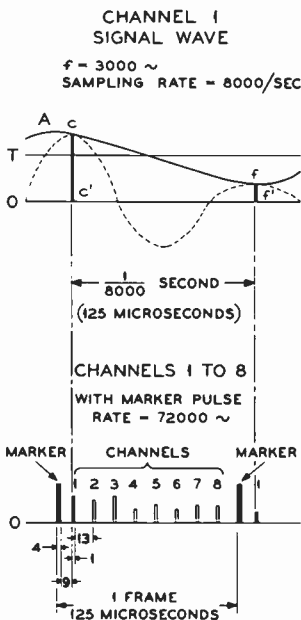

Figure 2. Combining channel samples for multiplex transmission

put will require a slice of radio frequency spectrum of the order of 160,000 cycles; the same will in general be true of frequency modulated radio.

### Pulse Time Modulation

In the multiplex system just illustrated, the pulses are the samplings as taken directly from each of the eight channels and these pulses could be transmitted without modification from a PAM system. A drawback of amplitude modulated methods of signaling is that it is the signal amplitude which conveys the intelligence, and amplitude is very susceptible to noise influence. Hence the PAM system is particularly subject to interference. It is much preferred to use a method in which intelligence is independent of pulse height so that all pulses, both channel and marker, can be of the same height, thus permitting the use at the receiver of amplitude limiters and certain other specialized interference suppressing devices. Of these methods, probably PTM is the most simple and the spacing on Figure 2 is laid out to accommodate this method.

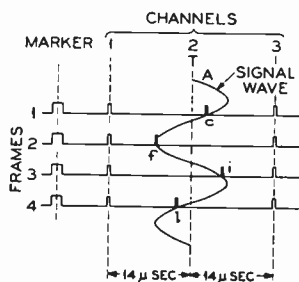

Figure 3. Pulse time modulation of one channel, with adjacent idle channels

Figure 3 illustrates in further detail the principles of PTM. Portions of four successive frames of a multiplex signal are shown in vertical order, and it is assumed that the signal wave of Figure 1 is applied to channel 2, the adjacent channels being idle. It will be noted that the channel 2 pulses are advanced or retarded in time from the mean or zero position in accordance with signal polarity, and to a distance which depends upon the instantaneous

signal amplitude at the moment of sampling. The channel pulses are 1 msec in width, hence allowing for a plus or minus deviation of 4 msec between the extreme positions for the channel pulses. This guard time is essential because in passing through the necessary tuning and other circuit elements of the receiver, the short pulses do not remain sharp but are somewhat smoothed or spread out, and some time must be allowed for the pulses to build up and decay.

As previously stated, it is a feature of pulse systems that for fixed average power at the transmitter, the peak power can be increased if the pulses are at the same time shortened, hence obtaining considerable advantage in signal-to-noise ratio. However, if the same amount of spreading, or overlap, is to be preserved, the necessary band width for transmission is increased proportionately. In some types of pulse systems it has been found possible, by means of "cross-talk balancing" at the receiver, to neutralize to some extent the overlapping of the pulses and thus secure substantial reductions in the band width requirements.

### Pulse Code Modulation

The operation of a PCM channel will now be explored somewhat further. Referring back to Figure 1B, it will be noted that the amplitude of the samples over the range from the shortest at  $f'$  to the largest at  $c'$  may have a very wide range of values. Since these amplitudes must be transmitted and ultimately reproduced with considerable accuracy if ultimate signal distortion is to be avoided, any system of code transmission will require a large number of code combinations, corresponding respectively to definite values in the range of amplitudes of the samples. The Baudot code is one instance of a binary, or two-position, code of five digits and it will provide  $2^5$  or 32 combinations. In the example to be considered a 7-digit binary code producing  $2^7$ , or 128 combinations is used, so that in any particular sample the amplitude error will not exceed  $1/256$ , or .39 percent. This process of representing a continuous amplitude range by a finite

number of discrete steps is known as "quantization" and each step is known as a "quantum".

The code groups for a number of channels may be combined in sequence for multiplex transmission, but since there are now seven pulses where there was but one before, the time allotted to each pulse is much less. For example, to accommodate the eight channels previously referred to,  $8000 \times 8 \times 7 = 448,000$  pulses per second

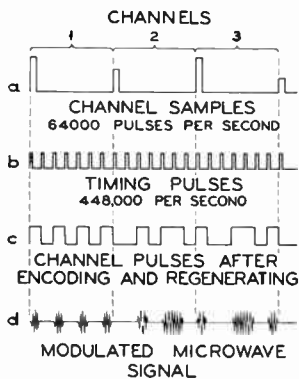

Figure 4. Pulse code modulation—Conversion of signal samples to coded radio pulses (8-channel group)

will be needed. It is not feasible to handle a very large number of channels in one group by this method because as the pulses are shortened the difficulties of generating and timing increase. It is preferred, therefore, to form groups of 8 to 12 code modulated channels and then to arrange these groups one above the other in a wide frequency band by a frequency translating process.

Figure 4 will make clear the conversion of the original signal samples into 7-unit

on-off code representations under the control of accurately regulated timing pulses. The code pulses may then modulate a microwave transmitter directly, or may modulate an intermediate frequency which accommodates this single group. Each pulse of the code starts at precisely timed intervals but continues without interruption until an opposite pulse occurs. For purposes of synchronization, a pulse of distinguishing character may be substituted for the first pulse of channel 1 in each frame of 8 to 12 channels. Channel 1 then becomes, in effect, a 6-pulse code channel and its quality will accordingly be degraded somewhat below that of the other channels.

Figure 5 illustrates in very schematic fashion the principal elements of one 8-channel group of an 80-channel PCM terminal arranged for microwave radio transmission. The eight primary voice-frequency bands, each accommodating, as desired, telephone, facsimile or carrier telegraph signals, first traverse respective low-pass filters and peak voltage limiters, so as to limit the channel frequency and voltage to the capacity for which the system is designed, and then connect to segments of a distributor which sample each channel at the rate of 8000 per second. While for this and subsequent distributor devices of the system, mechanical distributor devices have been illustrated, these are in practice electronic types. The output of this distributor has the form illustrated in Figure 4a. The channel samples of various amplitudes are then conveyed to a second distributor which admits the channel pulses to the coders. Two coders operating alternately are provided in order to allow ample time for clearing out

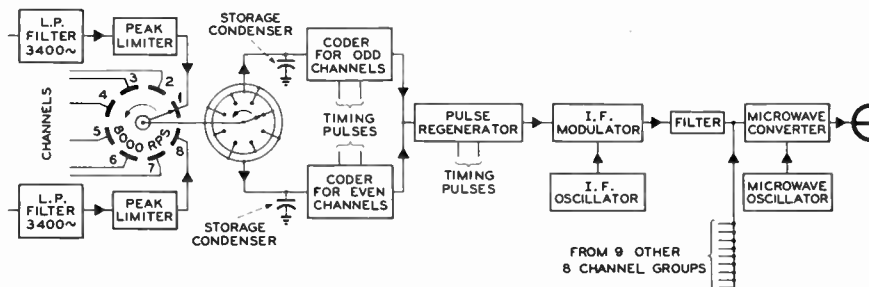

Figure 5. Transmitter for pulse code modulation system

and restoring to zero position following each coding process, thus to prevent cross-talk. At the input of each coder is a storage condenser which is charged by the alternate samples during the very brief period of closure, and which functions during the selecting period to maintain across the coder input a voltage which is proportional to the sample, thereby to select the appropriate one of the possible 128 code combinations.

For the coder a unique cathode ray type of device has been developed. The fundamental element of this device is the "aperture plate," with a backing output plate, which together replace the usual screen of a cathode ray tube. This aperture plate bears a group of seven vertical rows of holes located alongside each other, the holes in each row having differing vertical dimensions and arranged to be swept horizontally by the electron beam so that as the beam sweeps across the plate, when it strikes the holes it is allowed to pass through to the output plate to initiate a signal pulse. The total height of the aperture plate is divided into 128 parts, or steps, and by means of a grid composed of horizontal strips which fronts the plate, the beam is guided horizontally across the plate in any one of 128 horizontal positions as selected by the amplitude of the signal sample. The holes of the seven vertical rows are so arranged relative to each other that in sweeping across them the beam will generate a series of seven marking or spacing signal pulses which differs for each of the 128 sweep positions. Hence signal samples measured by a scale of 128 units each initiate the transmission of a 7-pulse combination unique to the amplitude of the sample.

The signal output current of the coders is very minute and the wave shape is imperfect, accordingly the two coders in turn send their pulse combinations into a pulse regenerator which not only amplifies the pulses but reconstructs them into square top signals in orderly sequence illustrated ideally in Figure 4c. The signals at this stage have the rate of 448,000 per second (224,000 cycles) and could be transmitted over a circuit which would accommodate a frequency range of the order of 500,000

cycles. Ten of these 8-channel groups could be joined on a single circuit by shortening the individual pulses and interlacing them in a manner analogous to that already illustrated in Figure 2. The pulse rate would then be 4,480,000 per second. At such high pulse rates the problems of generating, synchronizing and selecting become quite severe, so it is preferred at this point, by resorting to frequency translation techniques, to modulate separately intermediate frequency carriers in the neighborhood of 65 mc by each channel group to produce bands located one above the other. This composite band accommodating, in the system here described, 80 voice bands, or as many as 1440 telegraph channels, may then be transmitted over a microwave radio relay system.

The receiving end of a PCM system is quite similar to the sending end but functions in reverse. In the radio system previously referred to, the output of the microwave receiver is first divided into the ten 8-channel groups by means of frequency division methods, and then directed to the PCM receiver for each group. The received signals are more or less distorted by transmission defects and

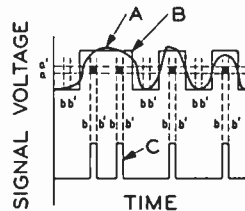

Figure 6. Operation of slicing and gating circuits

interference but short of the severest kind of distortion they may be regenerated to substantially their original form. The regenerative process here employs two rather unique devices, a "slicer" and a "gater," the functions of which will be explained by reference to Figure 6. Let A represent a distorted 7-pulse received wave, the original ideal shape being indicated in curve B. If this wave A is impressed upon the input of a suitable slicing circuit, current will be passed only when



the input voltage lies between the values  $a$  and  $a'$ , but remains zero at all other input voltages. This sliced signal is now impressed upon a synchronized gating circuit which is adapted to pass current only during the short time intervals  $b$ - $b'$  and is blocked at all other times. In effect, therefore, a signal will be registered if, and only if, a voltage slightly greater than half signal voltage is present during a short interval at the center of the pulse period. In the present case, pulses will appear in the output circuit to correspond to the periods designated by the shaded areas so that when amplified the pulses will have been regenerated into the short, sharply formed, uniform height pulses of curve  $C$  ready for delivery to the two decoders operating alternately.

The decoder is a device which upon receipt of any code combination interprets the combination into a signal amplitude which must correspond to that which was originally impressed upon the sending coding tube. It should be pointed out first that the coder and decoder used in a particular system must be designed to cooperate with each other; in particular, the coder must lend itself to the generation of code combinations which can be readily reconverted to amplitudes by the decoder. In the present case, the decoder is of a type which in response to signals transmits a fixed increment of charge to a leaky condenser, and the code combinations are such that the charge remaining on the condenser at a specified time shortly following the 7th pulse is different for each of the 128 different code combinations. It can be seen that the charge remaining on the condenser will be largest for the 7th pulse and smallest for the 1st pulse, and that maximum charge will result when all seven pulses are marking, while all other combinations produce a charge of intermediate value. The holes in the aperture plate of the coder tube have therefore been laid out so that the highest amplitude sample, reaching to the top of the plate, will send seven marking pulses; the next highest sample will send marking pulses in positions 2, 3, 4, 5, 6, 7; the third in positions 1, 3, 4, 5, 6, 7, and so on according to a selected schedule until for the

smallest sample the No. 1 pulse only is sent. The output circuits of the two decoders are alternately connected through a distributor to amplifier and shaping devices, and thence through an 8000-rps 8-segment distributor to the receivers for the eight channels. The pulses from the output distributor have a form analogous to those of Figure 1B. In order to derive intelligible speech from these, each distributor segment is connected to a holding condenser located across the input of an amplifier. The amplifier output current is thus maintained for the length of the sampling period at a voltage proportional to the height of the sample, and a succeeding low-pass filter smooths the resultant stepped wave into a signal wave which very closely resembles the original speech wave.

The PCM system has certain marked advantages and disadvantages. Principal advantage follows from the fact that the on-off pulses have a standard height and a standard location so that they can be received and regenerated for retransmission indefinitely, so long as the pulses are not mutilated beyond a threshold value which in practice approaches 40 percent. Such systems therefore offer the promise of good quality, very long-distance transmission under conditions of severe interference. On the other hand, a 7-unit code means a 7-fold multiplication of transmission band width, hence the system in effect trades freedom from interference for band width. In common with other pulse systems, it bears the requirement that double sidebands must be transmitted, whereas in frequency division methods single sideband transmission is feasible.

In the foregoing rather brief descriptions, a number of apparatus items and functions were described in connection with particular systems. These, however, are of more general application and may find use in any of the pulse systems described or others not referred to here. This general mode of communication has successfully filled a number of radio applications, and is now undergoing development as an alternative to frequency division processes in the design of terminals for radio relay telegraph systems.



There is promise that as development progresses, the present penalty of excessive band width will be so reduced that pulse systems will be able to compete with frequency division systems on the basis of first cost and reliability alone, particularly for certain applications.

## References

1. THEORETICAL ASPECTS OF VARIOUS SYSTEMS OF MULTIPLEX TRANSMISSION, V. D. LANDON, *RCR Review*, volume 9, June 1948, pages 287-351.
2. PULSE TIME MODULATION, E. M. DELORAINE and E. LARIN, *Electrical Communications*, volume 22, Nov. 2, 1944, pages 91-98.
3. A MULTICHANNEL MICROWAVE RADIO RELAY SYSTEM, H. S. BLACK, et al. *Electrical Engineering Transactions*, volume 65, Dec. 1946, pages 798-806.
4. MULTIPLEX BROADCASTING-PULSE TIME MODULATION AND ITS APPLICATION TO RADIOBROADCASTING, F. ALTMAN and J. H. DYER, *Electrical Engineering*, volume 66, April 1947, pages 372-380.
5. DISTORTION AND BAND-WIDTH CHARACTERISTICS OF PULSE MODULATION, H. L. KRAUSS and P. F. ORDUNG, *Electrical Engineering Trans.*, volume 66, 1947, pages 984-988.
6. TELEPHONY BY PULSE CODE MODULATION, W. M. GOODALL, *Bell System Technical Journal*, volume 26, July 1947, pages 395-409.
7. A 96-CHANNEL PULSE CODE MODULATION SYSTEM, C. B. FELDMAN, *Bell Laboratories Record*, volume 26, Sept. 1948, pages 364-370.
8. BEAM DEFLECTION TUBE FOR CODING IN P.C.M., R. W. SEARS, *Bell Laboratories Record*, volume 26, Oct. 1948, pages 411-415.
9. DECODING IN P.C.M., L. CARREY, *Bell Laboratories Record*, volume 26, Nov. 1948, pages 451-456.
10. AN EXPERIMENTAL MULTICHANNEL PULSE CODE MODULATION SYSTEM OF TOLL QUALITY, L. A. MEACHAM and E. PETERSON, *Bell System Technical Journal*, volume 27, Jan. 1948, pages 1-43.
11. ELECTRON BEAM DEFLECTION TUBE FOR PULSE CODE MODULATION, R. W. SEARS, *Bell System Technical Journal*, volume 27, Jan. 1948, pages 44-57.
12. P.C.M. DISTORTION ANALYSIS, CLAVIER, PANTER, GRIEG, *Electrical Engineering*, volume 66, Nov. 1947, pages 1110-1122.
13. PULSE MODULATION: "THE DOTTED LINE SYSTEM," F. B. BRAMHALL, *Western Union Technical Review*, volume 2, No. 4, October 1948, pages 155-160.



**THE AUTHOR:** J. R. Hyneman graduated from Purdue in 1921, after a two-year interruption due to World War I, and joined the staff of the Apparatus Engineer in June of that year; he transferred to the Research, later Transmission Research Division, in 1926. Since that time, Mr. Hyneman has specialized in patent engineering, handling a variety of work which is normally the joint responsibility of the designing engineers and the patent attorneys. Such work has covered many fields, such as: preparation of patent applications; studies to determine restrictions or freedom under existing patents; licenses and agreements with other organizations granting, securing or interchanging patent rights. The article published in this issue is a natural result of the perspective gained from such a career. He is a Member of the AIEE.

# Rubber Insulators for Pole Lines

H. H. WHEELER and W. F. MARKLEY

A paper presented before the Winter General Meeting of the American Institute of Electrical Engineers in New York, N. Y., February 1949.

Like so many modern developments, the use of rubber insulators on pole lines is the unexpected outcome of research originally started in a somewhat different direction. Observations over many years had shown that substantial annual sums were spent in replacing glass insulators mischievously broken, and that such breakage was largely confined to specific and well-recognized locations which seemed especially to lure children or hunters to destructive activities; sometimes one or two poles in a particular area required insulator replacements almost weekly. Figure 1 shows an example of such mischievous breakage.

surprising degree of protection, it was not entirely satisfactory.

The next device that was tried was a moulded rubber shroud over a small glass insulator of the pony type. This too developed a satisfactory degree of protection against blows, but was rather costly because of the volume of rubber required. It became obvious at this point that the real solution of the problem was to make the insulator itself of rubber. Although it was felt at the time that a suitable rubber compound could be developed possessing adequate physical characteristics and insulating properties, there was some ques-



Figure 1. Illustrating mischievous damage to glass insulators

In the initial consideration of this problem, some thought was given to the idea of improving the glass itself; that is, making the insulator from tempered or shatter-proof glass in order to improve its resistance to breakage, but it was found that such a design was impracticable. Thought was also given to the idea of surrounding the glass petticoat with an outer metallic skirt and although this attachment gave a

tion whether any such compound would have a useful life outdoors of more than three or four years.

Mechanically, the rubber composition had to be strong enough to carry the load of a telephone or telegraph wire and yet be sufficiently resilient so as not to crack when struck; it was also important that the insulator maintain its resilience and not crack or check for a reasonable period

when subjected to the heat and ultraviolet rays of the sun.

Considering electrical qualities, surface leakage obviously accounted for so large a fraction of the current losses that high volumetric resistivity of the material was not a necessary requirement. In a dry atmosphere, the surface leakage over any insulator is negligible, but in the presence of moisture two major conditions affect leakage. The first is the specific heat conductance of the material, or in popular expression, whether it feels cold or warm to the touch. On good heat conductors, water precipitates out of the atmosphere more freely and at smaller temperature differences than on poor heat conductors. The other condition has to do with the interfacial tension between water and the insulator surface, or more popularly, whether or not water "wets" the surface. A small quantity of water on a surface with which it has a high interfacial tension, tends to draw itself up into a series of discrete globules, not touching each other and with dry surfaces between. Such a condition is conducive to low electrical leakage over the surface. If, however, the interfacial tension is low, the water "wets"

the surface, and it tends to spread out in a more or less continuous film over considerable areas and this gives rise to high electrical leakage.

It was found that almost any rubber composition had an adequately low factor of heat conductance, but that extremely few compounds possessed the required inherent "non-wetting" surface characteristic desired for good insulating efficiency under conditions of rain or heavy fog.

Ultimately, a vulcanized rubber compound was developed having a reasonably satisfactory combination of essential qualities. This rubber compound was of the wax-bearing type, and the composition and extent of the wax ingredient and the technique of compounding were important characteristics in its manufacture. The wax component of the mixture blooms, or migrates to the surface continuously for years, thereby maintaining in service high interfacial tension with water and insuring the desired "non-wetting" characteristic of the insulator; in addition, reasonable self-cleaning characteristics are afforded, and almost complete freedom from surface checking under prolonged sun exposure. This wax component of the rubber compound represents one



Figure 2. Left to right:

- Standard double petticoat glass insulator;
- R-4 Rubber insulator for use on wood pin;
- R-3 Rubber insulator for mounting on spindle of steel pin;
- R-5 Rubber insulator for use on telephone-type short shank transposition pin;
- RC-1 Rubber insulator for use with Case span-type transposition bracket.

of the principal features of Western Union patents' covering the product.

Two styles of single petticoat rubber insulators, designated as Types R-1 and R-2, were designed for force-fit mounting on the spindle of a steel pin. A field trial of the R-1 insulators showed the desirability of reinforcing the wire groove, while laboratory studies of the R-2 insulator, which was designed to contain a minimum amount of rubber, indicated that the reduction in size was carried too far. The essential details of these two designs were combined in a third design, called Type R-3, which is now standard for use with steel pins. A fourth design was tried, moulded so as to provide an inner petticoat, but moulding difficulties were encountered which made the cost of manufacture prohibitive.

The design of the Type R-3 insulator is shown in Figure 2, along with other styles of rubber insulators that were subsequently developed for specific purposes. The Type R-4 insulator shown was designed with an inner thread for use on wood pins, and is currently being employed in considerable quantities in the telephone industry. The Type R-5 insula-

tor, designed for use on telephone-type short-shank transposition pin, was developed to meet requirements of two Canadian railroads. The Type RC-1 insulator was designed for use on the Case span-type transposition bracket where the expense of replacing a broken glass insulator is sometimes prohibitive. The compound used in the Type R-5 and Type RC-1 insulators had to be modified somewhat to improve its toughness, in order to enable the insulators to withstand the continuous severe stresses encountered in service.

This latter compound was subsequently adapted for use as bushings<sup>2</sup> in various types of glass insulators, as shown in Figure 3. It was found that this rubber composition not only provided adequate resilience for the assembly, but materially improved its overall electrical efficiency. The RB-1 flange-type rubber bushing shown was designed for use with the glass insulator on the Case span-type transposition bracket. The RB-2 straight-type rubber bushing was designed for the shackle-type glass insulator to replace the lead bushing which was normally used, but which was not entirely satisfactory. The RB-2 bushing is also shown in position in



Figure 3. Left to right:

- RB-1 Flange-type rubber bushing;
- RB-1 Rubber bushing in position in glass insulator, used on Case span-type transposition bracket;
- RB-2 Straight-type rubber bushing;
- RB-2 Bushing in position in dead-ending glass insulator;
- RB-2 Bushing in position in power insulator.

a glass insulator for use in power work; this combination of rubber bushing and glass insulator is being used to replace porcelain insulators and is an entirely new development in the power industry.

Rubber insulators moulded with these approved compositions have definitely solved the breakage problem, not only in service but also in shipping and handling. In actual tests, with insulators mounted on steel pins, loads that resulted in bending the pins left the rubber insulators unmarked. One such insulator, dropped from a 12-story window to the concrete pavement, was entirely unaffected. Bullets would pass through, but would not shatter the insulators. The smaller projected area made hits less likely, and the lack of any visible evidence on the insulator when struck discouraged its use as a target for marksmen.

The first extensive field installations of rubber insulators on steel pins were made in 1939 and 1940 in a wide variety of areas including Florida, representing severe sunlight exposure; the West Coast along San Francisco Bay, representing a difficult fog area; Nebraska, a heavy wind exposure; and the New York-Philadelphia area, representing a wide diversity of weather conditions varying from dry to fog and heavy rains. Numerous small installations were also made in locations where the breakage of glass insulators was a major consideration.

After six years' service, a number of these insulators were removed from the various areas for rigorous laboratory inspection, and it was generally observed that the insulators were practically as good as new, except those from the Florida area which showed a slight superficial checking of the rubber. All of these insulators continued to maintain their original toughness and elasticity, as well as their self-cleaning and water-repellent characteristics.

In the heavy wind exposure in Nebraska, it was found that the rubber insulators are capable of satisfactorily supporting the relatively heavy loads resulting from large gage iron wires. Where the rubber insulators supported No. 9 copper wire in this area, the resilience of

the rubber materially reduced tie-wire breakage and resulted in fewer fatigue breaks of the line wire.

In the New York-Philadelphia and the West Coast areas, the rubber insulators at critical points of support, such as at corners and terminals, showed no weakening under the severe mechanical strain encountered.

Because the line sections most vulnerable to insulator damage were initially selected for rubber insulator installations, the field reports indicated that the saving in broken glass insulators for the first year more than paid for the rubber insulators, and resulted in reduced material and labor costs. In addition, by eliminating the broken insulators which ordinarily caused increased leakage and wire trouble in wet weather, sustained line insulation was achieved, with consequent increased operating efficiency of the circuits.

The electrical performance of rubber insulators in the various classes of service has considerably exceeded original expectations. Relative insulation resistance characteristics determined from d-c leakage measurements on circuits insulated with rubber and with glass, respectively, are shown by the curves in Figure 4.

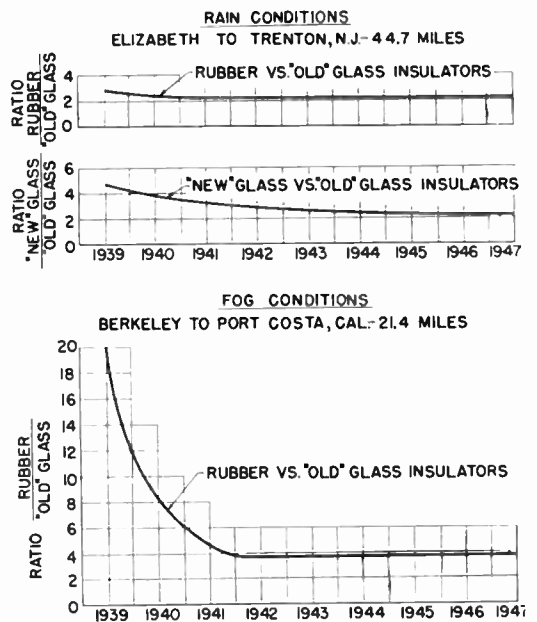

Figure 4. Relative insulation resistance of open wire circuits



In Figure 4, the curves representing Elizabeth-Trenton circuits comprising about 45 miles of open wire (approximately 3100 insulators per circuit), indicate the average performance, during periods of heavy rain, of two rubber-insulated circuits and two glass-insulated circuits, all installed at the same time, as compared with old glass-insulated circuits that have been in service for 30 years or more.

These curves show that after the first few months the rubber-insulated circuits develop and maintain about a 100-percent improvement over "old" glass-insulated circuits in insulating properties. On the other hand, while the new glass-insulated circuits appear to be nearly five times as good as the old glass-insulated circuits, and almost twice as good as the rubber-insulated circuits in the early stages of exposure, they deteriorate more rapidly in insulation resistance so that after the first three or four years on the line, they approach the rubber-insulated circuits in insulating characteristics and maintain this equivalent electrical performance on further exposure. Although these curves reveal that the circuits insulated with rubber and "new" glass maintain, on prolonged exposure, a two-to-one superiority over "old" glass-insulated circuits, field reports show no noticeable difference, under normal weather conditions, in the operating performance of any of these circuits, indicating that the old glass insulators still possess adequate insulation.

In Figure 4, the curve representing Pacific Coast circuits along San Francisco Bay comprising about 22 miles of open wire (approximately 900 insulators per circuit), shows the average performance of two rubber-insulated circuits as compared with old glass-insulated circuits that have been in service for 30 years or more; no "new" glass-insulated circuits were erected in this section when the rubber insulators were installed. This curve indicates that during periods of widespread fog, the rubber-insulated circuits during the first two years of service are 8 to 20 times as good as the old glass-insulated circuits from the standpoint of insulation resistance, and then reach a stage of equi-

librium in which they appear to maintain a line insulation practically four times as good as old glass-insulated circuits. This relative performance in this area is also confirmed by current field reports which indicate that during periods of adverse weather, when all of the glass-insulated circuits are completely "fog-bound," the rubber-insulated circuits provide reasonably satisfactory operation.

These relatively extensive field tests with the steel pin type rubber insulators indicate generally that in normal telegraph service, the electrical efficiency of rubber-insulated circuits in heavy rain exposure can be expected to be about on a par with that of glass-insulated circuits of the same age, and superior to glass-insulated circuits in an area where heavy fog and high humidity are encountered. Similar results have been reported on the use of the wood pin type rubber insulators by the telephone industry.

Although no carrier circuits have as yet been insulated exclusively with rubber, short sections have been so equipped, with no apparent change in operating efficiency. Limited laboratory studies on the relative transmission efficiency of rubber- and glass-insulated circuits at various frequencies indicate that the a-c wet weather losses for both types of circuits are about the same for frequencies up to, and somewhat beyond 30 kc. Because of limited experience with rubber insulators at frequencies appreciably higher than 30 kc, and the fact that at these frequencies electrical losses mount rapidly, it is not possible to say at this time whether a circuit insulated entirely with rubber in this higher frequency range would provide acceptable operating efficiency, but it is believed that a small percentage of rubber insulators in such a circuit would not adversely affect its overall transmission characteristics.

Rubber insulators will never equal in lasting qualities the more fortunate glass insulators, many of which in their 50 or more years of existence have out-lived not only the original crossarm on which they were mounted but also its replacement. However, it is anticipated that the average life expectancy of rubber insula-

tors will be 15 years or more, judging from their performance during the past nine years. Furthermore, their outstanding record of durability and overall electrical and mechanical efficiency during these nine years warrants their continued use, even if it were not for the determining

factor—that rubber insulators are without question the answer to the problem of mischievous breakage.

#### References

1. U. S. Patents No. 2,218,497; No. 2,304,483; Canadian Patent No. 421,697.
2. U. S. Patent Application Serial No. 12571.



**THE AUTHOR:** H. H. Wheeler, Lines Engineer, of the Plant and Engineering Department, received his Engineering Degree from the University of Minnesota in 1917 and shortly thereafter became an Engineering Assistant under the Construction Engineer. He has been closely and continuously identified with pole line and other outside telegraph plant construction problems and has participated in, or supervised the preparation of all of the Company's present construction standards for such plant. In 1929, the group headed by Mr. Wheeler undertook the investigation of means for reducing the leakage of current from line wires, and one of the results of this work was the development of practicable non-breakable rubber insulators. He has continued to direct the development of these insulators whose applications have expanded quite rapidly since the end of the war. In 1942, he became Assistant to the Engineer

of Lines, and assumed his present position the following year. In 1947, Mr. Wheeler headed a Commission of American Communication Engineers who, at the invitation of the Government of Colombia, South America, made a survey of the trunk telegraph and telephone systems of that country and submitted to the Minister of Posts and Telegraphs a plan which is now being followed for the expansion and modernization of these facilities.

**THE AUTHOR:** W. F. Markley, Assistant Lines Engineer of the Plant and Engineering Department, was graduated from Stevens Institute of Technology in 1917, and immediately joined the Engineering Staff of Western Union as an Engineering Assistant in the Construction Engineer's Division. He was made Assistant to Engineer of Lines in 1941 and appointed to his present position in 1943. He developed the first thermoplastic insulated weatherproof wire ever employed for outside service in the communication industry, initiated major improvements in the design of equipment and switchboard wire and cable, and directed the development of polyethylene insulated multiple conductor office cable. As one of his activities, Mr. Markley conducted the performance studies of field installations of rubber insulators and supervised the design, development and testing of the newer types of insulators and the bushings referred to in the paper. He was a member of a Commission of American Communication Engineers that was invited in 1947 by the Colombian Minister of Posts and Telegraphs to inspect the main trunk telephone and telegraph lines of the Colombian National Government. He is active in the work of the American Society for Testing Materials, being First Vice Chairman of the Technical Committee on Corrosion of Iron and Steel, a member of the Advisory Committee on Corrosion and on the Advisory Board of the Technical Committee on Wires for Electrical Conductors.



# Smoke Detection for Western Union Switching Centers

F. C. EVANS

An electronic smoke detection and alarm system will protect each of the automatic selective switching centers in the new mechanized national network Western Union is establishing to improve the speed and efficiency of telegraph service. Each of these high-speed communication centers contains upward of 3,000 miles of wire conductors and more than 1,000,000 intricate wire connections. Obviously a fire of any size would cause considerable damage to such equipment.

Considering this hazard, the Telegraph Company engineers, collaborating with insurance and fire protection engineers, consulted the American District Telegraph Company on the subject of providing a system for the detection of incipient fires. The result was an adaptation of the highly successful electronic smoke detection system which ADT provides for the protection of fur storage vaults and similar enclosures containing highly-concentrated valuables, and which is now used extensively throughout the country.

Since electrical equipment, like fur coats, usually gives off smoke before it bursts into flame, the solution to both problems obviously is akin. ADT engineers, pioneers in the development of photoelectric protection devices, therefore were able to adapt their Smoke Detection and Alarm System, which has been tested and approved by the Underwriters' Laboratories, Inc., to meet the specific requirements of Western Union's switch rooms.

Based on the principle of the electric eye, the system operates to give an alarm whenever smoke penetrates a beam of light projected across the protected area. The light-source and light-receiver units usually are mounted just below the ceiling. The light-source unit, installed at one

end of the room, projects a constant beam of light to a shielded light-receiver unit at the opposite end of the room. To guard against accidental interference, the beam is protected by a prefabricated, perforated metal cage. The light-receiver unit contains the photoelectric cell which is sensitive to changes in the intensity of light. A decrease in the amount of light falling on the cell when smoke enters the beam initiates an alarm signal.

Full-scale tests of this system, modified to meet the specific requirements of Western Union, were conducted in the switching center at Philadelphia. Employing one light beam per aisle and with highly sensitive settings, the system proved capable of detecting an exceedingly small amount of smoke. One of the tests consisted of placing a small-gauge synthetic insulated switch-room wire about 1½ inches long against a hot soldering iron. The smoke was detected in less than a minute after the small piece of wire was placed in contact with the heated iron, no matter where in the room the smoke was generated and despite the forced circulation of air in the switch room. Each smoke detection system installation must successfully undergo such tests before it is put into service.

This remarkable performance conclusively proved the ADT Smoke Detection System ideal for the desired purpose. As a result, Western Union and ADT have contracted for installations as each new switching center has been established.

Operation of the smoke detection system results in the sounding of one or more smoke alarm bells in the Western Union office and the automatic shutting down of air circulating fans. The alarm also is transmitted to the local ADT Central Station, and the municipal fire department is



*Figure 1. Switch room at Syracuse, N. Y., showing light beams of smoke detection system shielded by perforated metal cages*

dispatched when the automatic smoke alarm is followed by an alarm from a manually operated fire alarm box located in the Western Union office as a part of the smoke detection and alarm system.

Figure 1 is a photograph of the Western Union switch room at Syracuse, showing the smoke detection installation. Although two beams appear to be protecting a single aisle, each beam continues individually down an offset aisle.

Figure 2 shows five of the smoke detector light-receiver units at the ends of the aisles. The light-receiver unit contains a photocell of the photovoltaic type. Light impinging directly upon the cell generates a small current at low voltage. The output of the cell is fed into a balanced "zero load" type of circuit, the compensating current being supplied by a dry cell. A sensitive contact-making galvanometer, connected across the balancing circuit, responds to current changes in the circuit, thereby measuring any light changes caused by smoke penetrating a light beam.

With this balanced arrangement, equip-

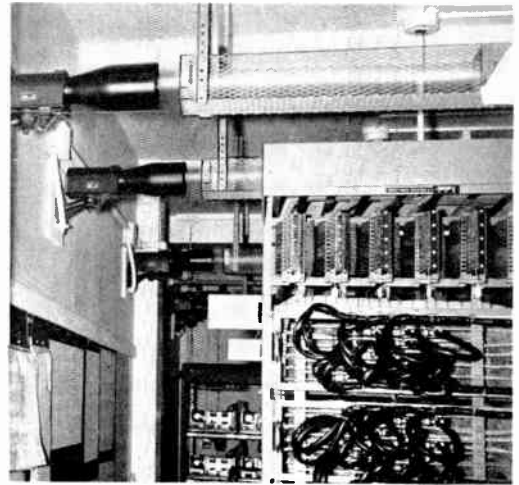

*Figure 2. Light-receiver units at ends of aisles in Syracuse switch room*

ment failures cause a directional change opposite to that caused by smoke, thereby initiating distinctive trouble signals. The contacts of the galvanometer are so arranged that when the contact needle deflects to a preset index, a small per-



manent magnet draws the moving contact against a fixed contact member, thereby solidly establishing an electrical circuit despite the very small currents and voltages which the galvanometer measures.

The light-source unit is of a low-voltage, prefocused filament type, run at a voltage considerably under its rated voltage in order to give the filament extra-long life.

The filament and the filament current are electrically supervised. Any failure causes a distinctive trouble signal to be transmitted to the ADT Central Station. All other wiring interconnecting the various elements of the system is similarly supervised. Usually it is arranged so that two smoke detector beams aid each other by being connected to a single control unit.

**SCHEMATIC DIAGRAM OF  
#B3501 SMOKE DETECTION SYSTEM**

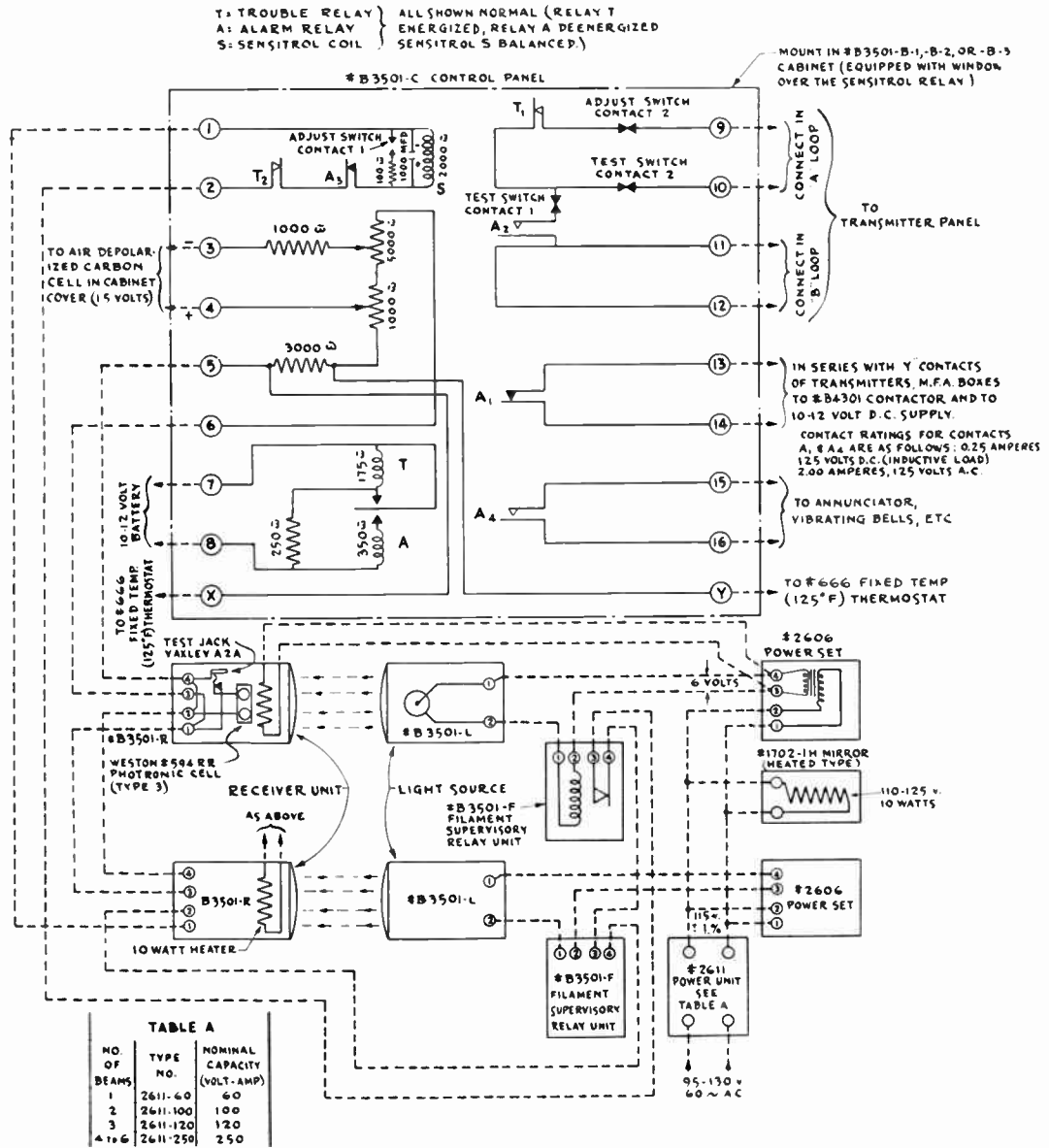

Figure 3. Schematic diagram of ADT Smoke Detection System



As many control units are provided as are necessary to handle all of the beams in a particular switch room. All of the control units are connected to a single smoke alarm transmitter for signaling the ADT Central Station.

Current for the light beams is taken from the commercial a-c supply through a voltage-stabilizing transformer so that moderate voltage fluctuations will have no effect upon the smoke detection system. Any voltage drop beyond the compensating capacity of the transformers, and persisting for three seconds or more, causes a trouble signal to be transmitted to the ADT Central Station. Current for the transmitter and for the pilot circuit of the contactor unit is supplied by a trickle-charged storage battery. This battery also supplies the current for the vibrating type alarm bells.

The manually operated fire alarm box in the Western Union office is so connected that in addition to signaling the ADT Central Station it also operates the same contactor unit that shuts down fans when the smoke detection system operates. In those switch rooms where the filters of the air conditioning system appear to require it, fixed-temperature fire detecting thermostats of 125° F rating are installed near the filters. In case of fire in the filters these thermostats operate the system in the same manner as a smoke alarm.

Figure 3 is a complete schematic diagram of the Smoke Detection System.

Each switching center is equipped with suitable first-aid types of fire extinguishers. It is expected that with the speedy detection and alarm obtained from the smoke detection system, any outbreaks that may occur can easily be handled without outside aid or the use of fire extinguishing media that might cause unnecessary damage to the delicate communication devices.

The switch rooms are kept exceptionally clean and free from dust, and access to them is restricted. A positive air pressure is maintained so that no dust or dirty air leakage into them can take place. Because of these controlled conditions, it is possible to operate the smoke detection system at a much higher sensitivity than in other types of installations. In tests, the system operated when smoke introduced into a light beam caused a reduction of less than one percent of received light.

The smoke detection systems are being installed under the supervision of ADT plant department representatives, in accordance with standards jointly worked out by Western Union and ADT engineers. Supervision, inspection, tests and maintenance of the equipment will be provided by ADT.



**THE AUTHOR:** Francis C. Evans is Engineering Supervisor in charge of Automatic Fire Alarm Services and Supervisory Services Division of the Engineering Dept. of the A.D.T. Company, Inc., a Western Union subsidiary. He has been with that company since shortly after his graduation in Mechanical Engineering from Harvard University, in 1931. His work includes engineering responsibility for the ADT's automatic fire alarm, smoke detection, sprinkler system supervisory and waterflow alarm services, and industrial supervision services. Mr. Evans has taken out numerous patents and written various technical articles in connection with his work. He is a Licensed Professional Engineer of the State of New York, a Junior Member of the ASME, and a member of the NFPA and the Harvard Engineering Society.







