

# UHF CONVERTERS

By P. R. Simon

Advanced Application Engineer

To receive u h f television signals on the standard v h f television set, the only addition necessary, except for the antenna, is a frequency converter. This is a device which transforms the ultra high frequency signals (470-890 mc) to either a very high frequency that the set normally receives (low channels 54-88 mc, high channels 174-216 mc), a special converter frequency (usually 130 mc), or converts directly to the receiver's i f frequency. Remote antenna distribution systems, either commercial or private, often convert the signal at the antenna because of the large cable losses at u h f, thereby making converters at each receiver unnecessary.

There are two general classes of converters—the fixed-tuned, single channel unit and the all-channel tunable unit. Both single and double conversion are used. In double conversion, the u h f is reduced to v h f which is in turn converted to the i f by the v h f mixer. Turret tuner strips are in the fixed-tuned category. These coil strips are available for all channels. Any of the original v h f strips can be replaced with a u h f

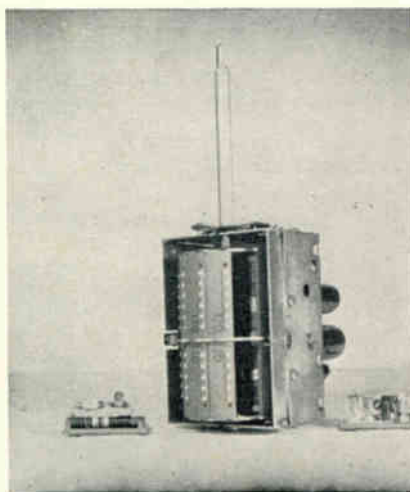

Figure 1. Turret tuner showing u h f tuning strips removed.

unit as described immediately below (See Figure 1).

Most turret tuners use two strips per channel for the oscillator and antenna systems, respectively. The u h f strips usually contain two crystal diodes. One diode accentuates the oscillator harmonic content while the second diode is the u h f crystal mixer (See Figure 2).

Another single channel type is the complete external unit containing oscillator and mixer, fixed-tuned coils, and a u h f-v h f switch. Some of these converters obtain power from the set, and some have a self-contained power supply.

In a converter using a Sylvania Type 6AN4 tube as a mixer with a Type 6T4 oscillator, it is possible to achieve improved conversion efficiency. The addition of an r f amplifier stage using a 6AN4 tube will provide additional gain which is useful in weak signal areas.

The advantage of any fixed-tuned type is its simplicity and lower cost. Some limitations of the fixed-tuned converter are the number of channels available and the sacrifice of a v h f channel in the turret type. Also, they must be readjusted or replaced by a technician if a different channel is to be received. The unit that is fastened to the back of the set has a physical disadvantage in that the person tuning the set must reach behind it to switch from u h f to v h f.

Several experimental single channel converters were constructed in the Advanced Application Laboratory of Sylvania's Receiving Tube Division for the purpose of u h f tube development. It is interesting, as representative of the fixed-tuned converter unit, to study their u h f circuitry.

A converter using two Sylvania Type 12AT7 tubes (a twin triode widely used at lower frequencies) operated successfully on Channel 22.

# TECHNICAL SECTION

JUNE 1953

Vol. 20, No. 6

William O. Hamlin, Technical Editor

This information in Sylvania News is furnished without assuming any obligations

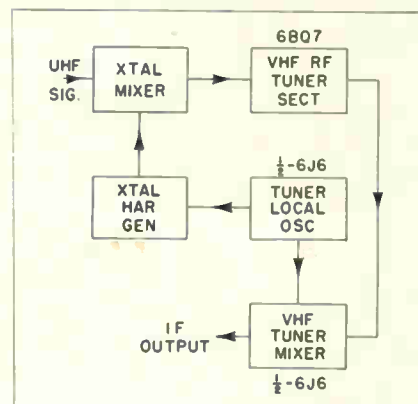

Figure 2. Block diagram of turret tuner strips used in standard coil tuners.

It contains a grounded grid r f amplifier and a grounded grid mixer in one tube; a Hartley oscillator, using a "hairpin loop" for the coil, and an i f preamplifier were contained in the other tube. The result was an efficient converter, but it had a poor noise factor which becomes objectionable in weak signal areas.

The same type of circuit using the Sylvania u h f tubes, Types 6AN4 and 6T4, gives greater gain and less noise (See Figure 3). A single Type 6AN4 grounded grid r f amplifier performs remarkably well at u h f, as compared to ordinary tubes. This type has a high voltage gain and low noise figure. By using it as an r f amplifier, the overall noise of a converter can be reduced and additional gain obtained.

The majority of commercial tuners are in the variable tuned category which can receive all the ultra high frequency television channels. The main advantage is that special channel adjustments are unnecessary. Secondly, they can be installed by anyone, unless a special u h f antenna installation is needed. The channel used for the second conversion frequency is at the discretion of the manufacturer. For this purpose,

(Continued on page 6)

## Book Review

# HOW TO UNDERSTAND AND USE TV TEST INSTRUMENTS

By Milton S. Kiver,  
Published by Howard W. Sams & Co., Indianapolis 5, Indiana. 1953.  
147 pages, \$3.00

Mr. Kiver's preface summarizes the philosophy of the book very well. His point that the test instrument cannot think for itself, but must rely on the serviceman to do its thinking for it, is worth repeating. He then proceeds to do an excellent job of presenting material designed to increase the serviceman's knowledge and ability.

As the title indicates, the primary concern is "to understand and use," but sufficient basic diagrams and circuitry are presented to facilitate the understanding phase. The entire book is well illustrated with a variety of types of test equipment.

The Vacuum Tube Voltmeter section contains an excellent basic discussion on how to read meter scales, linear and non-linear, which may appear elementary but is well worth the space. Along similar lines, the A.M. Signal Generator section discusses vernier dials. Sweep Signal Generators are well covered, as are Oscilloscopes and their accessories including several types of voltage calibrators for 'scopes.

The heading "Special Television Test Instruments" might have been expanded to indicate the excellent material actually contained in this section. Horizontal, vertical bar, cross hatch, and dot pattern methods are illustrated. "Linearity Checks" starting on page 98 would probably be of interest to most servicemen.

The portion on TV Field Strength Meters contains several good suggestions on using such instruments.

This book would be very useful for a serviceman who wishes to improve his ability to use his instruments for maximum benefit; and would be excellent for newer servicemen who have a knowledge of fundamentals but lack proficiency in using equipment.

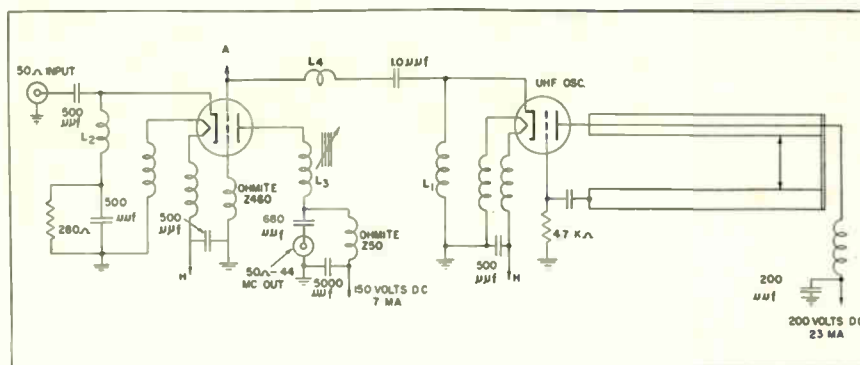

Figure 3. Schematic of 6AN4-6T4 in a grounded grid u h f mixer and local oscillator circuit.

(Continued from page 5)

some sets have been provided with a special frequency which is not used for television broadcasting. Converters are available with this special if output, generally a frequency around 130 mc (between the fm broadcast band and Channel 7).

The external variable tuned converter is represented by the Sylvania Models C31M, C32M and the C33M. In these converters, the antenna input, mixer and oscillator stages are tuned by shorted quarter-wave lines which give stability and a higher "Q" than is obtainable in ordinary inductance coils.

The Models C31M and C32M can use either the Sylvania Type 6T4 or the Type 6AF4 as the oscillator. The crystal mixer can use either the Type 1N72 or 1N82. The if preamplifier is a 6BQ7 in a low-noise, cascode circuit. The C33M is identical except for the if amplifier which is a Sylvania Type 6CB6. The output of these converters is broadbanded on Channels 5 and 6 so that either channel can be used.

The trend in the tunable converter field is to make the unit an integral part of the television receiver by placing it in the cabinet so that the v h f-u h f tuning can then be combined physically in a single tuning and channel switching mechanism on the front panel of the receiver. With the advent of the Sylvania Types 6AN4 and 6T4, it is now possible to use the same r f amplifier, mixer and oscillator stages to tune the v h f band as well as the u h f bands. These types will appear in new set designs in the near future.

The new Sylvania television receivers are optionally equipped with a u h f tuner that operates in conjunction with the v h f unit. The very popular 1-508-2 Chassis is equipped with a u h f tuner using a 6J6 for the oscillator and two 1N82 silicon crystals. The 1-510-2 Chassis employs a u h f tuner using a Type 6AF4 or Sylvania Type 6T4 oscillator and a Sylvania Type 6AN4 as a mixer.

As the v h f turret tuner is rotated to the u h f position, the v h f-r f amplifier and mixer become an if preamplifier at 40 mc. An actuating lever turns on the u h f tuner power, turns off the v h f oscillator, switches the u h f output to the v h f input terminals, and the u h f channel numbers appear in a window on the dial. The v h f fine tuning control becomes the u h f continuous channel selector. This all takes place in one turn of the v h f channel selector switch!

The u h f tuner employs double-tuned preselector circuits, a local oscillator at one-half the injection signal frequency, and an oscillator doubler circuit. The r f tuned circuits are of the transmission-line type consisting of quarter-wave coaxial lines, end tuned by a capacitor. The entire unit is silver plated (See Figure 4).

## REPAIR

Silicon crystal diodes are commonly used as mixers at ultra high frequencies. Many converters on the market today use the Sylvania Type 1N82. In converters using crystal mixers, some improvement in signal-to-noise ratio in weak signal



areas may be achieved by selecting crystals, since some diodes are less noisy than others. In strong signal areas the noise factor would not be a problem, almost any silicon crystal with a good forward-to-reverse current ratio would work satisfactorily.

An ohmmeter is the only equipment needed to check a crystal diode for burnout. Put the test leads across the crystal and take a reading; reverse the leads and take another reading. One of the resistance values should be at least ten times greater than the other for the crystal to be good.

Optimum performance of a 1N82 silicon crystal diode mixer is obtained at a d c current of 0.5 ma. This value gives the lowest noise level with a high conversion efficiency. The d c current, caused by the oscillator injection voltage, is adjusted by varying the oscillator coupling to the mixer. Many converters have some provision for easy insertion of a milliammeter for the adjustment.

When soldering to crystal diodes, precautions should always be taken to prevent overheating them. For this reason, most applications use a clip-type crystal holder that sometimes becomes loose and is a source of noise to the converter. If soldering is done to the pigtailed of the crystals, a pair of pliers should be held on the lead between the crystal and the soldering iron to conduct heat away from the crystal.

When servicing a converter, it can be ascertained in several ways that the oscillator section is working: first, the presence of crystal current as previously mentioned; second, the use of an absorption type wavemeter in the u h f spectrum; third, measuring the d c grid bias on the oscillator tube which should be from -4 to -8 volts with respect to ground. A calibrated u h f wavemeter would also be useful in checking the tuning range of the oscillator; this is important because the other tests only indicate the presence of oscillation but not the frequency. It is conceivable that the malfunctioning of certain components could change the

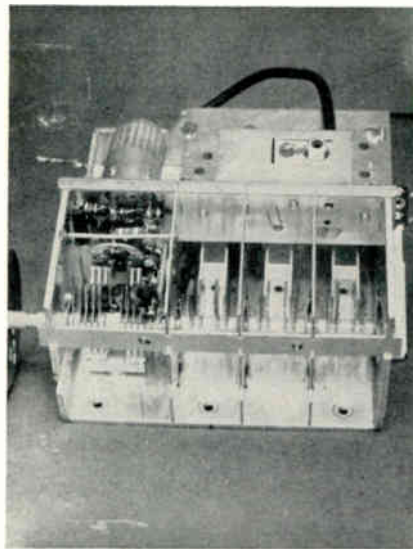

Figure 4.

The u h f converter which is optional equipment for the Sylvania 508 chassis.

frequency of oscillation and still give the normal indications of bias and crystal current.

Because of the extremely high frequency, replacement of components and tubes of the r f section presents problems not usually encountered in conventional radio and television service. The length of leads, lead dress, and placement of parts is quite critical.

## SYLVANIA TYPE 6BQ6G

The Sylvania Type 6BQ6G is a beam power amplifier designed for use as a driver tube in horizontal deflection circuits. It is identical to the popular Sylvania Type 6BQ6GT except for bulb size.

The trend toward larger screen television receivers has placed heavier demands on deflection circuits, with the consequent increase in heat dissipation. Tubes with the suffix "G" use the ST type of bulb, which has a larger surface for heat radiation than the "GT" or glass tubular type.

For this reason, the Type 6BQ6G was developed which will operate at a lower bulb temperature than the "GT" version for the same operating conditions. The "G" and "GT" styles are interchangeable where physical space is adequate.

## SYLVANIA TYPE 6V3

The Sylvania Type 6V3 television damper tube, unique in its physical construction, aids greatly in flyback circuit design.

The cathode, which is normally connected to a base pin in other tubes, connects to the top cap in the 6V3. Thus, when the cathode is operated at high peak voltages, such as those occurring in flyback circuits, there is less danger of voltage breakdown between base pins. The bulb also acts as a stand-off insulator for the cathode-to-flyback transformer lead. In addition, the high voltage lead is kept short and above the chassis which eliminates the need for a feed-through insulator, a source of high voltage breakdown.

The Sylvania 219/220 Tube Tester is designed so that each pin is brought out to a corresponding switch number. This feature is very valuable in that it enables the operator to know exactly which element is faulty on shorts tests. A slight disadvantage of this arrangement, due to the straight through connections, is the necessity of using an adapter to test the 6V3. This adapter is very easily constructed from an octal tube base and a top cap connector (See SYLVANIA NEWS, Technical Section, April, 1953).

The Sylvania 139/140 Tube Tester uses a different circuitry which does not have the pin number to switch correlation. On this instrument the 6V3 can be tested without an adapter.

## CORRECTION

We wish to correct an error which appeared in the April Issue of SYLVANIA NEWS. The third column listed under the "Model 219/220 Tube Tester Settings for Type 6V3" should read

C  
579  
259  
257

The heading should read "Settings and Adapter for Type 6V3 Sylvania Model 219/220 Tube Tester."

# Service Hints

**NOTICE:** Due to International Exchange restrictions on promotional items, we can no longer accept Service Hints from countries other than the United States and Canada. We wish to thank our foreign readers who have submitted "Service Hints" in the past. It is with sincere regret that this notice has to be published.

**USING OLD PLASTIC CABINETS**—Old bakelite plastic radio or tv cabinets can be sawed into "boards" for insulating material. Most cabinets have a very high dielectric rating. I have found that most of them will stand about 20,000 volts per 1/8 inch thickness.

These "boards" could then be used as high voltage terminal strips, feed through insulators, rectifier socket mounts, etc., in tv and similar cathode-ray tube equipment, and for a hundred and one other uses around electronic equipment. In addition, they cost nothing.—Harold J. Weber, Sparta, Illinois.

**CHART RACK**—Today there are many charts of all kinds available to the serviceman by the manufacturers. Most of the time the small radio shop is not equipped with suitable space to properly hang them on the wall and make use of them. This

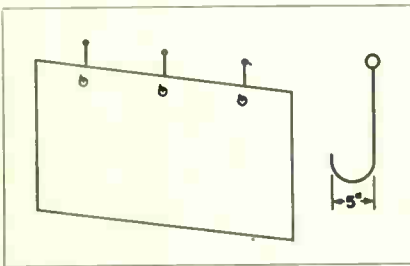

is what I do to remedy the situation. First, the chart is pasted to any kind of cardboard. Old boxes will do. Use linoleum cement, it does a neat job. Next, make several eyelets, spacing them evenly along the top of the charts. Fashion the hooks with any kind of wire and screw on the wall. The charts can be kept neat and always available this way. Donat A. Duquet, Waterville, Maine.

**SYLVANIA 139-140 TUBE TESTER LINE VOLTAGE CALIBRATION**—I always take my tube tester on calls but not always my VTVM. Sometimes I have reason to suspect low line voltage and wish to check it. This can be done by recording meter readings for each line voltage on a card and gluing it to the inside lid of the tube tester. I set the line voltage adjustment switch on #1 position and recorded the reading on the lowest meter scale for voltages from 60 to 130 volts in five-volt steps.

Voltage Control Position #1	
Meter Read On Lower Scale	Indicated Line Voltage
30	60 Volts
32	65
34	70
—	—
—	—
56	125
58	130

—Shott's Radio and Television Service, Burbank, Calif.

**ELECTRICIAN'S SCREWDRIVER**—This screwdriver loop maker will be found very handy for the electrician especially where pliers are hard to use. As the sketch shows, it can be made easily with any straight blade screwdriver. The added piece can

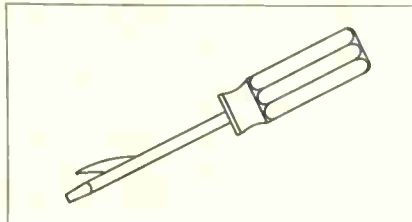

be set any place along the blade to suit one's purpose. Solder this piece or braze according to the equipment

available. Use an old plier jaw for the extra piece. To use, insert the wire in the slot and turn the screwdriver to the right or to the left and the loop is made. Then pull back the screwdriver and use this same tool to tighten the screw.—D. A. Duquet, Waterville, Maine.

**ELECTROFLASH UNITS—SAFETY FIRST**—I was reading your Technical Section the other day about the electroflash unit and some of the safety precautions to be observed. I have a little more to add about safety, etc., since I did quite a bit of service and rebuilding on this type of equipment. As for safety, it isn't any joke and must be observed. Also, the repairman should fully contemplate his repair actions beforehand in regard to the safe discharge of the high voltage condenser because it is possible to get badly stung from the flash gun even though the high voltage condenser was originally discharged. Moreover, if you do any work on these units, be sure that you are not unduly tired and hazy on what you are doing.

One night last summer when I was perspiring freely and dog-tired, I worked on the gun section of the flash unit. The unit was pulled from the a c line and the high voltage condenser discharged by first triggering the gas tube, by resistance, and then by the interlock switch. The flash unit had an interlock switch that shorted out the high voltage condenser when the unit was pulled from the carrying case, but when it was set on the bench the interlock switch opened up. I pulled the gun unit from its casing and picked up what I thought was an insulated section and received a hard jolt. The high voltage condenser had enough residual charge to build up voltage and I had touched a broken piece of insulation around the high voltage resistance string. A high voltage oil-paper condenser of high microfarad rating can also build up a voltage by just setting in a place where there are high temperature fluctuations. As a precaution against bad shocks, work with just one hand when possible.—J. Perkinson, Jr. Miami, Florida.



Vol. 1: \$1.00—Vol. 2: \$1.00—Vol. 3: \$1.00—Vol. 4: \$1.00

Binders With Complete File of Technical Sections:

# ION TRAP MAGNETS

By G. E. Fogg, Field Engineer  
Television Picture Tube Division

One of the very important factors in servicing tv sets is use of the correct ion trap magnet and its proper adjustment.

The mere presence of raster on the tube is no indication that the magnet has been properly adjusted. Operation of the set for even a few seconds with the magnet incorrectly adjusted may permanently damage the picture tube. Hence, it is of utmost importance that the magnet be correctly adjusted immediately.

There are two general classes of ion trap magnets—double and single field types (See Figure 1). Each type of magnet is used with a specific electron gun structure and in most instances, a particular tube type.

The physical construction of ion trap magnets varies considerably. The double field type always has two pairs of pole pieces or two ring magnets; the single field type has only one magnet.

The proper field strength of an ion trap magnet is dependent on several factors; the most important being the gun design and the high voltage ( $A_2$  Voltage) on the picture tube.

In the case of a double field ion trap magnet, a field strength of 35 gauss in the main field will usually be satisfactory. For tube types requiring single field magnets, two strengths—35 gauss and 45 gauss, will be adequate for practically all applications. In general, the higher operating voltages will require stronger magnets.

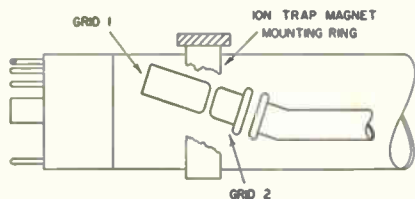

Figure 2. Approximate Placement of Ion Trap in Relation to Electron Gun.

A good method of adjusting an ion trap magnet is as follows: Locate the ion trap magnet approximately at the slant cut or anode bend, which is visible through the neck (See Figure 2). In the case of double magnet ion traps, place the smaller (weaker) magnet toward the tube face. With the brightness and contrast controls turned to minimum, turn the set on and allow it to warm up for about a minute. Turn the contrast and brightness controls about half way on. Move the ion trap magnet back and forth along the neck and around it until the picture is brightest. Now, readjust the contrast and brightness controls for proper contrast and brightness level used by the customer. Readjust the ion trap magnet position for maximum brightness. The ion trap *must never* be used to center the picture on the tube.

In the case of the split ring double

field ion trap magnet, some rotational adjustment of the weaker magnet with respect to the stronger magnet may be required for pattern centering. After final adjustment, the ion trap magnet should be within  $\frac{1}{4}$ " of the slant cut between second grid and anode or the bend in anode on guns having a bent anode structure. If the magnet is beyond this range, a magnet of different field strength should be used.

If, after the correct set up of the ion trap magnet has been made, the magnet is too close to, or on the tube base, a magnet of lower field strength should be used. The reverse is true if the ion trap magnet is too close to the face end of the tube.

The table lists the types of ion trap magnets to be used with the various types of picture tubes.

(Continued on page 6)

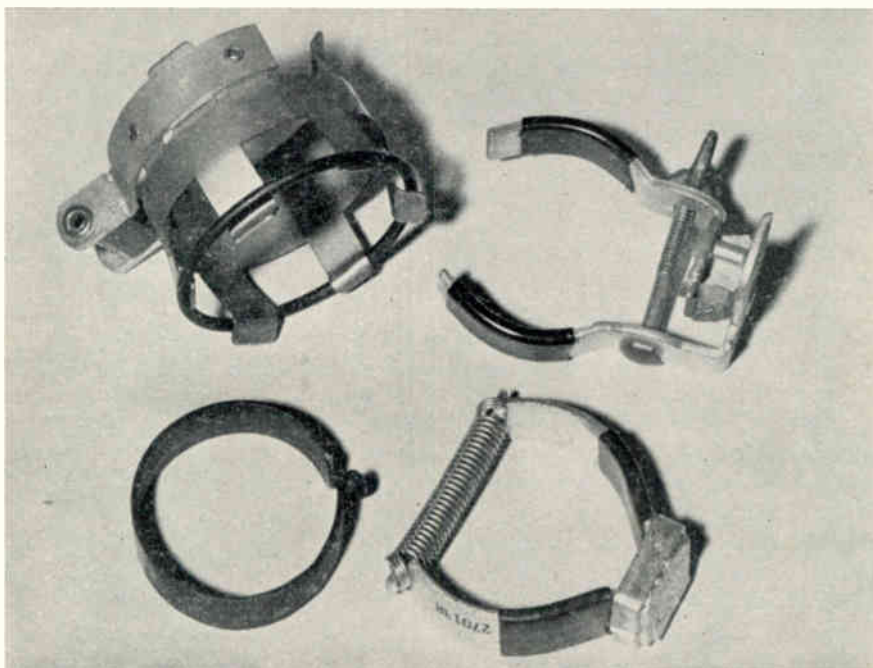

Figure 1. A Selection of Common Ion Traps, a Double Magnet Type in the Upper Left.

This information in Sylvania News is furnished without assuming any obligations

## PRECAUTIONS IN USING "UNUSED" TUBE PINS AS "TIE-POINTS"

It is a common practice in the electronics industry, home construction and in service shops to utilize the "unused" socket pin lugs as "tie-points" to mount other components.

If this practice is to be used proper precautions must be observed.

If the tube basing diagram gives a certain pin number followed by NC, it means that no internal connection has been made to this pin and hence, the corresponding lug is available for use as a "tie-point."

If, however, the basing diagram gives a pin number followed by IC, it means that this pin is internally connected to some part of the tube structure and is NOT available for use as a "tie-point." Such internal connections may be made by the tube manufacturer for a number of reasons of a mechanical or electrical nature. Therefore, connections should NOT be made to any pin marked IC.

## NEW MINIATURE UHF TRIODE OSCILLATOR

A new miniature 7-pin medium mu triode, designated the 6T4, has recently been released by the Radio Tube Division of Sylvania Electric Products Inc.

The Sylvania Type 6T4 was designed for service as an oscillator in television tuners or converters covering the new u l f bands. The tube features short bulb, T-5½ construction, having a maximum overall length of 1¾ inches, and a maximum seated height of 1½ inches. The Sylvania 6T4 also features double plate and grid connections to reduce lead inductance. In circuits designed for its use the 6T4 is capable of operation up to 1000 mc.

When operated with 80 volts on the plate and a plate current of 18 ma, the Sylvania Type 6T4 has a transconductance of 7000 umhos, an amplification factor of 13, and a plate resistance of 1860 ohms.

# ION TRAP MAGNET TYPE

D-Double		S-Single	
Tube Type	Trap	Tube Type	Trap
7DP4.....	D	17AP4.....	S
7QP4.....	S	17BP4/A/B/C.....	S
		17CP4/A.....	S
8AP4.....	S	17FP4.....	S
8AP4A.....	S	17GP4.....	S
		17HP4.....	S
10BP4/A.....	D	17JP4.....	S
10MP4/A.....	D	17KP4.....	S
		17LP4.....	S
12LP4/A.....	D	17QP4.....	S
12QP4/A.....	S	17RP4.....	S
12RP4/A.....	S	17SP4.....	S
12TP4.....	D	17TP4.....	S
12UP4/A/B.....	D	17UP4.....	S
12VP4/A.....	D	17VP4.....	S
12WP4.....	S	17YP4.....	S
12YP4.....	S		
14BP4/A.....	S	19AP4/A/B/C/D.....	S
14CP4.....	S	19DP4/A.....	S
14DP4.....	D	19EP4.....	D
14EP4.....	S	19FP4.....	D
14GP4.....	S	19GP4.....	S
14HP4.....	S	19JP4.....	S
		19QP4.....	S
15CP4.....	D	20CP4/A.....	S
15DP4.....	S	20DP4/A.....	S
		20FP4.....	S
16AP4/A.....	D	20GP4.....	S
16CP4.....	D	20HP4.....	S
16DP4/A.....	D	20JP4.....	S
16EP4/A/B.....	D	20LP4.....	S
16FP4.....	S	20MP4.....	S
16GP4/A/B.....	S		
16HP4/A.....	D	21AP4.....	S
16JP4/A.....	D	21DP4.....	S
16KP4/A.....	S	21EP4/A.....	S
16LP4/A.....	D	21FP4/A.....	S
16MP4/A.....	D	21KP4.....	S
16QP4.....	D	21MP4.....	S
16RP4.....	S	21WP4.....	S
16SP4.....	D	22AP4/A.....	S
16TP4.....	S		
16UP4.....	D	24AP4/A.....	S
16VP4.....	S	24BP4.....	S
16WP4/A.....	D		
16XP4.....	D	27AP4.....	S
16YP4.....	S	27EP4.....	S
16ZP4.....	D	27GP4.....	S
16ABP4.....	S	27LP4.....	S
16ACP4.....	S		
16AEP4.....	S	30BP4.....	S

# PICTURE TUBE PICTURE

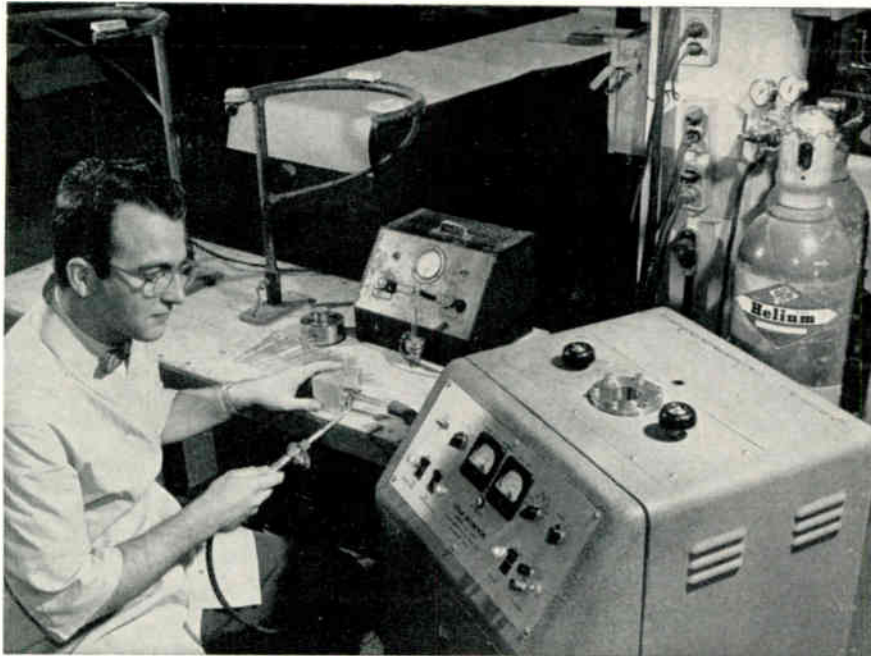

This month's picture illustrates one of the more unusual tests employed to maintain the high quality of Sylvania Picture Tubes.

The seal between the base connecting wires (stem leads) and the glass wafer end (header) is critically important in cathode ray tube construction. Seals must be faultless to assure the constant high vacuum necessary to peak performance and long life.

Sylvania uses Consolidated Engineering Corporation Helium Leak Detectors with Sylvania - designed fittings, for inspection of these seals. The glass wafer is mounted vacuum

tight onto the "Sniffer." The "Sniffer" is attached by special hose to the detector console which contains pumps, amplifiers, calibration circuits, and the leakage indicator.

Helium gas from the cylinder is passed over the exposed side of the wafer. If there is a leak the "Sniffer" will relay the condition to the console and the indicator will respond.

The Helium Leak Detector shown is a very sensitive instrument. The elimination of wafers evidencing even minute leakage is one of the more important Sylvania manufacturing steps that assures prolonged picture tube life.

## PEAK-TO-PEAK TV VOLTMETER PROBE

In servicing television receivers it is often desirable to measure the amplitude of complex waveforms. When an oscilloscope is not available the technician may wish to do this on his VTVM by using a crystal probe.

The probe shown in Figure 1 is a full-wave doubler circuit. The Sylvania Type 1N58 Germanium Crystal ( $D_1$ ) conducts whenever its cathode is negative. This causes the  $0.5 \mu\text{f}$  capacitor ( $C_1$ ) to charge in a negative polarity across the 10 meg-

ohm resistor ( $R_1$ ), producing a negative d c voltage at the terminals. The other 1N58 crystal ( $D_2$ ) is connected in opposite polarity and produces a positive d c voltage across its 10 megohm load ( $R_2$ ). These two voltages add in series across the resistors so that the VTVM will read peak-to-peak values on the d c scale.

This crystal probe will be a handy accessory to the Sylvania Polymeter when making home service calls.

# TESTING TELEVISION PICTURE TUBES

In response to numerous requests, the list of picture tubes which may be checked using the Sylvania 228 Adapter has been greatly enlarged.

Using the Sylvania 228 Adapter in conjunction with a Sylvania Tube Tester Model 139, 140, 219 or 220, practically all the commonly used 10 to 30 inch magnetic types may be checked. In many instances it will not be necessary to remove the tube from the set, thus saving valuable time. Be sure the set is turned OFF before attaching the Adapter to the picture tube! Make the settings according to the tube type being tested, and plug the Adapter into your Sylvania Tube Checker.

The numerical scale readings on the Tube Checker are used, rather than the Good-Bad scale. This is due to the difference between the low tube tester voltages and the high tv receiver operating voltages for the CRT.

There are only a few defects, such as gas, which show up only with a very high voltage applied to the tube. Using the Sylvania 228 Adapter with one of the Sylvania Tube Testers will detect 80-85% of the defective picture tubes.

The settings listed below apply to any A, B, C or D version of these types.

(Continued on page 8)

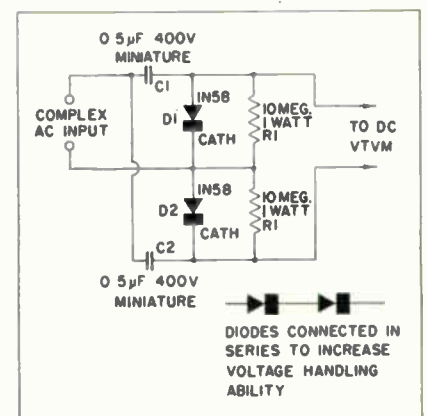

Figure 1. A. Crystal Diode Voltage Probe.







# SERVICING THE ELECTROFLASH

# SYLVANIA NEWS TECHNICAL SECTION

## PART I (WABASH MODELS R-1140 AND R-1142)

JULY AUGUST 1953 Vol. 20, No. 7  
 William O. Hamlin, Technical Editor

By J. H. MINTZER, Supervisor of Factory Service Stations

This information in Sylvania News is furnished without assuming any obligations

A considerable amount of correspondence is received by the Company regarding the servicing of electroflash equipment. A typical query in a large percentage of the letters received is, "Will you please advise where I can send my electroflash for repairs? Our local radio technicians cannot repair this type of equipment." Actually, there is no reason for a serviceman to doubt his ability to understand and repair electroflash equipment. The circuit theory is fundamentally simple and the only factor which should be of any concern is safety. This cannot be stressed too greatly. However, it is felt that the average present-day technician, with his knowledge and experience in television, is well aware of the danger involved when working with lethal voltages.

### THEORY OF OPERATION

We feel that a brief introduction to the theory of electroflash operation and some trouble-shooting kinks on the Wabash portable models, will enable many servicemen to pick up a few dollars which would have ordi-

narily slipped through their fingers. Fundamentally, all that is required to fire the Sylvania Type R-4330 flash tube is a high voltage supply capable of a fairly heavy instantaneous current. Secondly, a method is required to trigger this energy through the tube. The power supply is a conventional voltage doubler circuit. The transformer secondary voltage, approximately 900 volt r m s, is doubled and rectified with a pair of half-wave rectifier tubes which charge a heavy storage capacitor, usually 25 to 35 microfarads. After the unit is turned on for approximately 20 seconds, a charge is built up in the capacitor to maximum value necessary to obtain the required watt seconds of energy. This energy is fed to the gun or flash tube assembly by means of a high voltage cable.

To properly trigger or ionize the gas in the flash tube, the energy supplied from the power supply must discharge through the flash tube and be converted to light energy at the required instant. The voltage supplied by the power supply (above

2000 volts) is not of a sufficient potential to ionize the flash tube gas; therefore, ionization must be accomplished by an external triggering circuit. The triggering circuit of the gun assembly in Figure 1 consists of: the trigger transformer T-102; Sylvania Type OA5 (X-7027) thyatron trigger tube; fixed capacitors C-104 and C-105; and the voltage divider resistor network totaling about 10.8 megohms. The voltage from the power supply applied to this divider network supplies about 40 microamperes of current between the cathode and the "keep alive" grid of the Sylvania Type OA5 (pins 3 and 4). Capacitors C-104 and C-105 charge during this period.

(Continued on page 8)

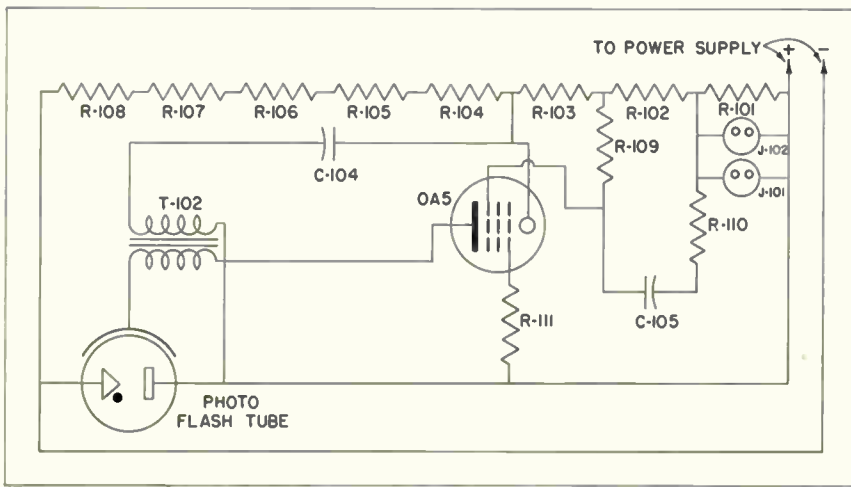

Figure 1. Gun assembly of photo flash unit.



J. H. MINTZER

Mr. Mintzer is Supervisor of the Factory Service Department for Test Equipment. He joined Sylvania in 1946, after leaving the Army and became a specialist in repairing servicemen's and laboratory test equipment. In 1932 he received an amateur radio license; his call letters are now W3LFU. His Army experience included three years overseas duty with the AACs. He served as Chief Operator, maintenance technician and instructor in direction finding, radio teletype, heavy transmitting, ground-to-air and instrument landing equipment.

# MECHANICAL PRESSURE TESTING TV PICTURE TUBES

By G. D. Ostrander, Television Picture Tube Division

Previously published articles have pointed out many of the important factors which must be considered in the production of Television Picture Tubes. Pictures and articles have been published concerning the importance of thorough testing and the many precautions necessary in manufacturing screens. Maintaining control of the critical spacings in the electron gun has been emphasized as well as the absolute necessity of insuring leak-proof seals in the base. All these precautions, however, are of no avail if the bulb is not of the same high quality and built with the same care.

Much research in this basic field has been done by the bulb manufacturers. A well designed bulb is also important from the standpoint of safety in handling, both during production and during installation. Since the tubes are rigidly inspected for physical flaws and imperfections, it is also advantageous to have the best bulb possible to reduce the number of rejects during the manufacturing process. These factors become increasingly more important as the size of the bulb is increased.

The present trend toward larger television picture tubes, and Syl-

vania's policy of building the highest possible quality into its products, makes it necessary to obtain more and more information as to the strength and behavior of both glass and metal bulbs under the stresses created by the high vacuum in the tube. Faced with the need for information, methods have been devised to mechanically test such tubes under pressures greater than one atmosphere, (approximately 15 pounds per square inch). Such methods may use either air or liquid (water) pressure systems. Both systems are used by Sylvania's Television Picture Tube Division. Each method has its own advantages and limitations.

In using the liquid system, the tube is enclosed in a screen cage (See Figure 1) and is lowered into a tank which is filled with water at a known temperature. The tank is then sealed off and a controlled cushion of air is allowed to enter the tank to build up the pressure to any desired value. (See Figure 2). Due to the incompressibility of water, the pressure is transmitted equally over the whole surface of the tube, and the pressure is built up until the tube is broken at some indicated gauge pressure. Tubes to be tested in this manner may be first abraded, (or scratched) using 150 emery grit, around the four sides and corners of the faceplate to simulate any desired degree of abrasion encountered in handling. The water tank setup is quite flexible, requires a minimum of space, and

enables rapid testing at a moment's notice.

Occasionally it may be desirable to pressure check bulbs before they are made into tubes and exhausted. This is done simply by inserting a rubber stopper into the flared end of the neck and subjecting the bulb to pressure as before. The applied pressure in this case (since the bulb contains air at atmospheric pressure and not a vacuum) will be read directly as gauge pressure, whereas tubes already exhausted are actually under a pressure of 15 pounds per square inch due to the vacuum, plus the indicated gauge pressure. To eliminate any confusion which might exist when referring to the test results, all pressures are recorded as absolute readings and refer to actual pressures exerted upon the tube or bulb body whether the tube is under a vacuum or stoppered to air.

This liquid system is very useful in obtaining data quickly to detect any flaws in bulb construction or defects due to scratches, chips or imperfections in glass quality. Much useful information may be obtained from the remains of the tube, by examining the fracture patterns of the glass chips.

It may also be of interest to subject bulbs to pressure for longer periods of time to determine glass or metal fatigue effects occurring over a period of days. Any such setup which must run continuously, twenty-four hours a day for a week or so, must be care-

Figure 1. A tube being placed in the case preparatory to being lowered into the water pressure tank.

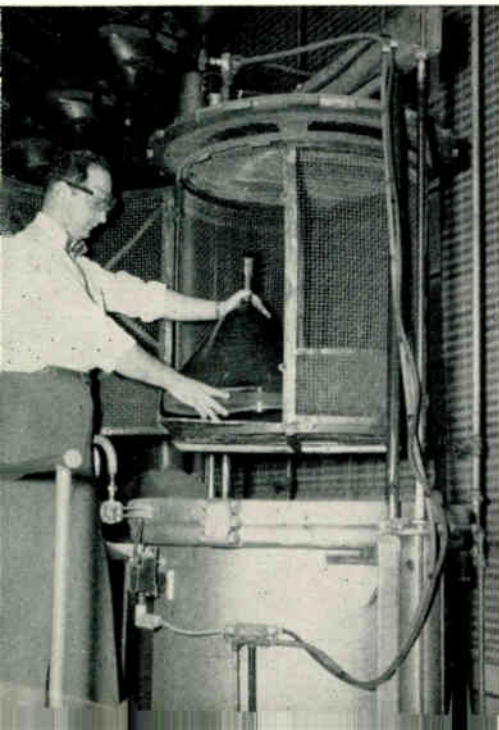
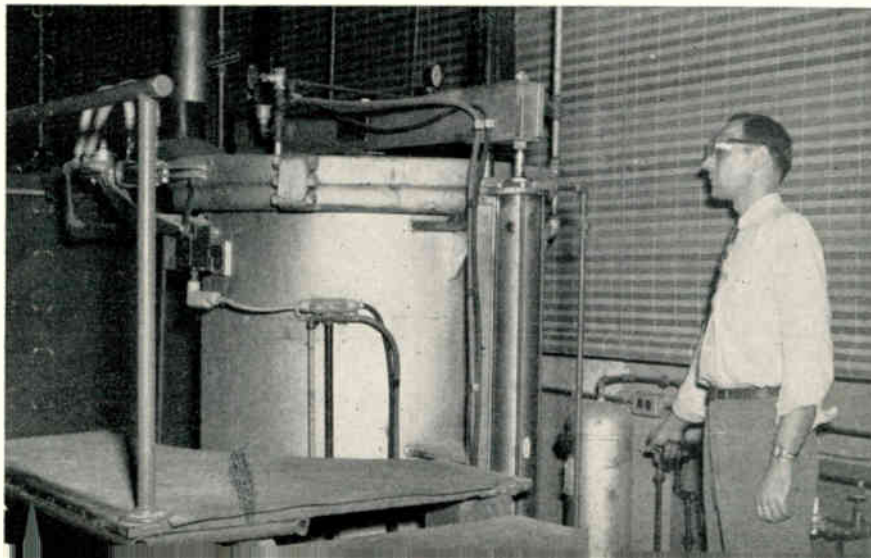

Figure 2. Applying pressure after tube is lowered into water pressure tank.





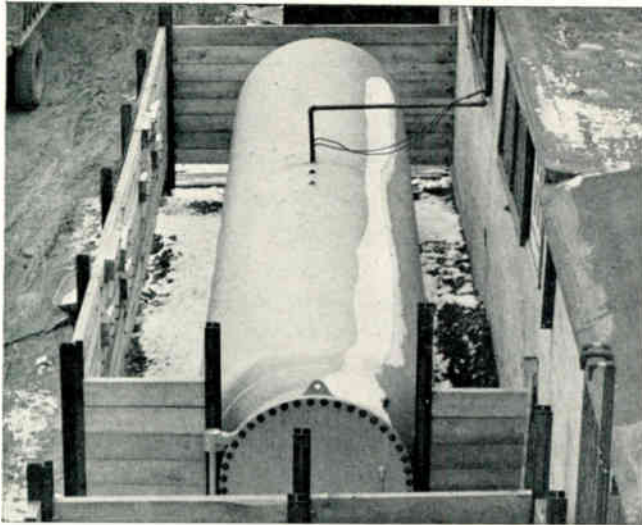

Figure 3. Air pressure tank with its gasketed cover in place.

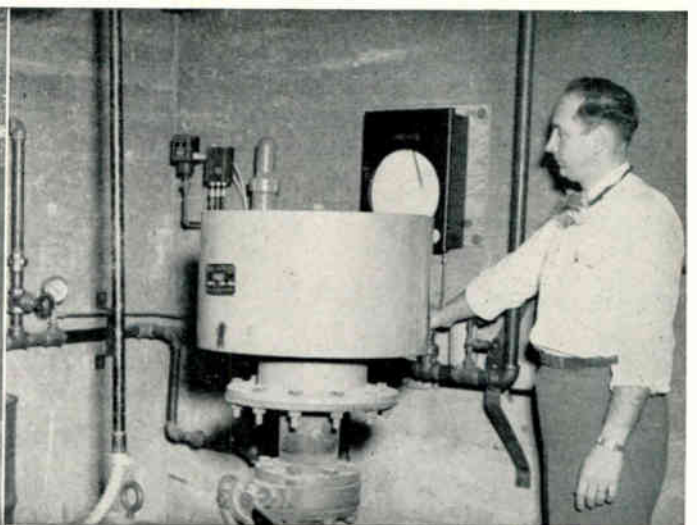

Figure 4. Recording and control position for air pressure tank.

fully controlled as to pressure. A means must also be devised to monitor the tubes under test and indicate their condition. Such a testing system has been set up and is now being used by Sylvania's Television Picture Tube Division General Engineering Department at Seneca Falls. Consistent and reliable data cannot be obtained by tests of one or two tubes since they represent too small a sample. The pressure tank must be large enough to accommodate a number of tubes at one time, thus allowing tests to be conducted on a group of tubes to obtain more reliable data.

The tank now in use for this purpose has a capacity of 800 cubic feet and is 27 feet long by 6 feet in diameter. One end of the tank has a gasketed cover which is sealed airtight by 44 one inch by six and one-half inch long steel stud and nut assemblies. (See Figure 3). The maximum allowable working pressure of the tank is 60 pounds per square inch. Safety valves, or "pop-off" valves are set at the maximum working pressure of the tank. An automatic controlled air pressure system is provided, together with continuous seven-day pressure recorder. (See Figure 4). Once the system is put into operation at the desired pressure, the tank may be left unattended except for regular checks on the progress of the test.

Tests are usually conducted on groups of ten or twelve tubes at a

time. Each tube is placed in a cardboard carton to protect it from flying particles in case a nearby tube fails. In order to monitor each tube from outside the tank and to make a daily check on tube failures, electrical cables are connected to the filament of each tube. These cables are then passed through a pressurized fitting in the tank and finally terminated at an indicating device. This consists of a transformer in series with a group of microswitches. Each switch, when depressed, isolates that tube being monitored and checks for continuity of filament by means of a current meter. If the tube has failed there will be no current indicated on the meter.

When tests are conducted in the air tank upon bulbs which have no filaments, i.e. unfinished tubes, a trigger mechanism is attached to the bulb. This closes the circuit in the event of tube failure and records it at the outside control position.

Tests are being run continuously in this tank on all types of glass and metal bulbs and tubes. The data compiled has yielded valuable information on the mechanical properties of picture tubes. This is yet another example of the "Applied Research" conducted by Sylvania Electric Products Inc. to ensure the highest possible quality tubes.

## Vertical Line Troubles

Various vertical lines can be observed on television screens which indicate different conditions. The most familiar of these is the straight black line on the left caused by either "Barkhausen Oscillations" in the horizontal output tube or a defective horizontal output tube.

A vertical white bar on the left is usually caused by insufficient damping due to a weak damper tube, defect in the voltage boost system or defect in horizontal sweep output.

A white vertical bar near the center of the picture indicates either a mis-adjusted drive control, defect in the horizontal discharge circuit, hori-

zontal amplifier circuit, or a defect in the voltage boost system.

A black narrow vertical band with ragged edges very close to the left hand edge of the raster, which changes to small crawling diagonal lines when a strong signal is received, is termed the "spook." The spook originates by radiation from the horizontal deflection circuits and is picked up by the rf and if stages. This new type of interference is reduced by better shielding between these circuits and placing 1-5  $\mu$ h chokes in the damper tube plate and cathode leads.



## SERVICING THE ELECTROFLASH

(Continued from page 5)

When a gun is triggered, either by the manual push-button switch or by the camera shutter switch (connected by plugs to J-101 and J-102), R-101 is shorted out. The result is that a sharp positive rise in potential appears on C-105 and, therefore, at the grid of the OA5 (pin 2). Ionization takes place and allows a heavy current flow through the OA5, discharging C-104. The primary of the trigger transformer T-102 is energized by this current causing a potential of 15 kv peak volts across the secondary. This voltage is applied to the R-4330 flash tube trigger grid and is sufficient to cause ionization. This allows the stored-up energy of the power supply storage capacitor to be discharged through the tube, resulting in an instantaneous flash of light.

The Wabash portable electroflash (R-1140 and R-1142) can be studied as typical units even though they are no longer manufactured. They differ only in their method of obtaining flashing power. The gun is essentially the same for both units. Some guns use slightly different values of resistors in the divider network, but they still total about 10.8 megohms. The R-1140 is designed to operate only from a 110-125 volt a c, 60 cycle line source. Its circuit appears in Figure 2. Rated flash figures in watt-seconds are based on an input line

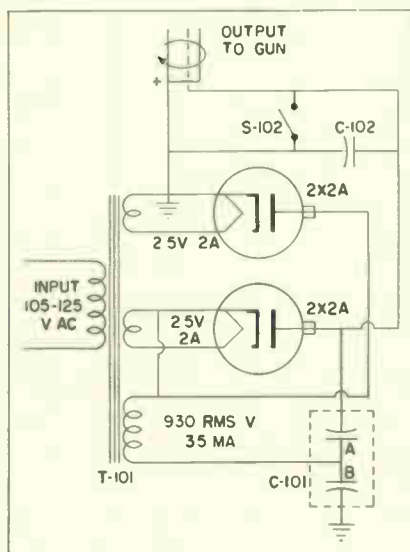

Figure 2. 110 volts a c power supply for the R-1140 photo flash.

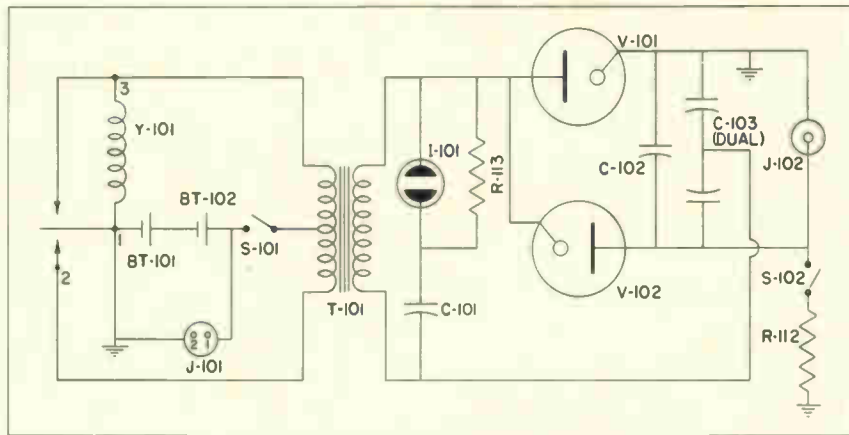

Figure 3. Battery operated power supply for the R-1142 photo flash.

voltage of 117 volts; but, providing the gun is in good condition, the line voltage can vary considerably in either direction before erratic flashing can be expected. The R-1140 power supply uses a conventional voltage doubling system consisting of a power transformer (T-101), a pair of Type 2X2A rectifier tubes, doubling capacitor (C-101) and storage capacitor (C-102). It operates as described in the third paragraph.

The R-1142 model, Figure 3, is designed for battery operation. It is a battery-vibrator type supply operating on a 4 volt system. Components

making up this supply are: a pair of 2 volt wet cells (BT-101 and BT-102), vibrator (Y-101), power transformer (T-101), two Type CK-1013 or CK-1027 rectifier tubes, doubling capacitor (C-103) and storage capacitor (C-102). A resistor (R-112) is used to discharge the storage capacitor when the safety switch (S-102) is closed. The neon lamp (I-101) merely acts as a pilot lamp. Operation is similar to the R-1140 except for the power source.

To be continued next month with a discussion of servicing procedures for the Electroflash.

## Service Hints

**DUMONT MODEL RA112**—Serial numbers below 123594.—Symptoms were static in the sound with video normal.

Sound channel tubes proved to be ok. The 1000 ohm resistor to the 2nd sound i f tube was overheating but the ceramic bypass capacitor was not shorted.

I replaced the Discriminator Transformer (DuMont Part No. 20004411) and the trouble was cured.

Later, examination of the old transformer showed that the mica sheets of the capacitor inside the transformer had broken down. The circuit was changed in later models to prevent this from occurring.—Vincent Cama, Brooklyn, New York.

**WESTINGHOUSE MODEL H710T.**  
2 Chassis 2217-5 — Picture three fourths normal size and width of picture changes with Horizontal Hold adjustment. The 6BQ6 Horizontal Amplifier Plate was slightly red. The d c voltages checked approximately correct and all sync pulses and horizontal drive were normal.

When checking the d c voltages on the 6BQ6 it was found that the plate load resistor R-438 (33K) was missing from the circuit. Replacing this resistor effects a complete cure. I had one more set with the same trouble.—J. Nolter, Mahanoy City, Penna.

# ALUMINIZED SCREENS FOR BRIGHTER PICTURES

SYLVANIA NEWS

## TECHNICAL SECTION

By P. M. Reinhardt - Technical Publications Section

MARCH 1954

Vol. 21, No. 3

William O. Hamlin, Technical Editor

This information in Sylvania News is furnished without assuming any obligations

The problem of obtaining brighter pictures from television picture tubes has received considerable attention for a number of years. Many improvements have been made in the past which have increased the electron beam power, and thus increased the picture brightness. Much has been gained by increasing voltages, and by new developments in electron optics which have served to increase the beam power. Such improvements, however useful, were directed only toward increasing the amount of power beamed at the screen.

Another avenue of approach to the problem of increasing picture brightness is to improve the efficiency of conversion of beam power into useful light output on the face of the tube. Considerable research and development work has been done to produce the most efficient phosphors possible for each desired application.

In addition to improvements on the phosphors, a considerable gain in the light output may be obtained by applying a mirror-like metal backing upon the phosphor screen. Since aluminum is the metal usually used, such tubes are commonly termed Aluminized Tubes.

This aluminum film greatly increases the useful light output and also produces a number of other useful effects. The mirror-like metal film improves contrast by reducing the amount of light which normally goes back into the tube, away from the viewer. Such lost light is usually reflected from the inside of the tube back through the screen, thus degrading the contrast in a non-aluminized tube.

The highly conductive metal film improves the secondary emission characteristic of the screen by providing an easier path for removing electrons from the screen. Thus, the

screen phosphors can convert more of the beam power into useful light.

Aluminizing becomes increasingly more important as the trend continues toward higher anode voltages. This is one of the reasons that aluminizing was, and still is, employed in many 5- 7- 10-inch projection and special purpose tubes. Such tubes were operated at anode voltages very much greater than directly-viewed television picture tubes of comparable screen sizes. With the present demand for larger and larger tubes, which require higher anode voltages, it is evident that aluminizing is an effective method of producing brighter pictures.

Let us now examine some of the requirements of this metal coating. One important factor is that the metal layer must be sufficiently thin to enable the beam electrons to penetrate it and excite the phosphors to produce light. This requires precise control over the process of depositing the metal. The metal film, in spite of its extreme thinness, must be opaque, smooth, and have a high reflectivity. Strength and durability are especially important, since the metal film must

be very thin. The electrical conductivity should be rather high to provide the easy path for removing electrons from the screen, as mentioned above.

Finally, the metal should be chemically inert with respect to the materials and phosphors used in the screen, and should be such that it may be readily deposited upon the screen.

Aluminum fulfills all these requirements, being strong, durable, highly conductive, and having a highly reflective, mirror-like surface. In addition, it may be easily deposited by a vaporization process in a vacuum. Now that we have discussed the reasons for, and factors involved in aluminizing picture tubes, it is of interest to see how the process is accomplished.

Each bulb is carefully inspected to ensure that both the bulb and faceplate are free from imperfections in accordance with Quality Specifications. The bulb, on a vibration-free moving belt, then passes underneath a station where the screen solution is injected into the bulb.\* See Figure

(Continued on page 6)

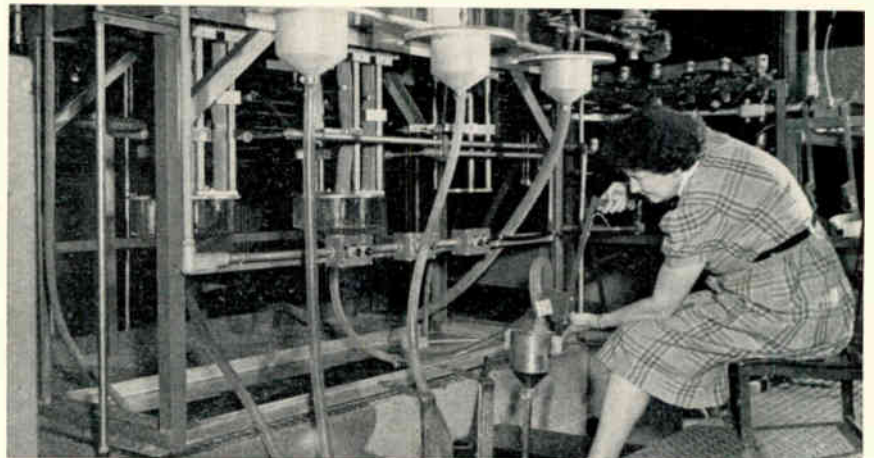

Figure 1. Screen solution being injected into bulb as it passes beneath the operator on a vibration-free moving belt.



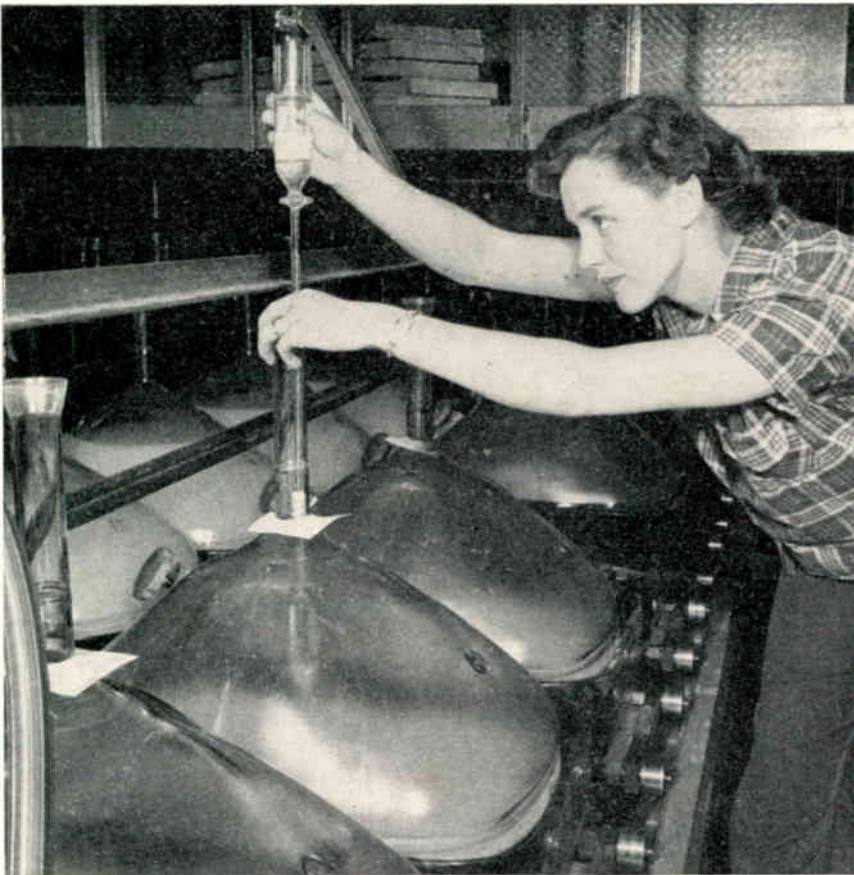

Figure 2. A controlled amount of lacquer is deposited upon the water cushion as the tube passes by on the belt.

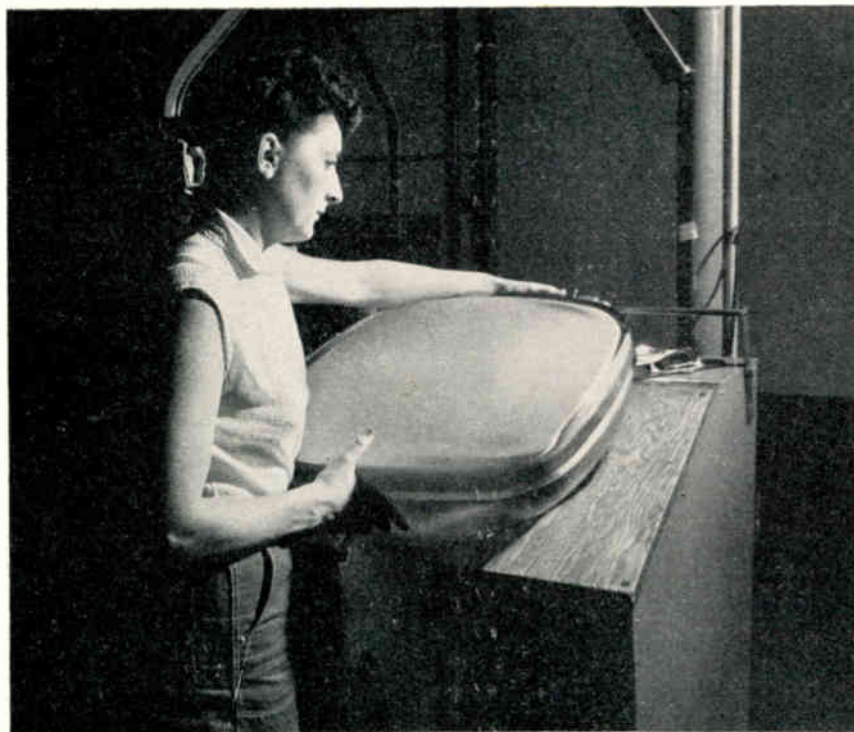

Figure 3. Inspecting lacquer-covered screen prior to application of the aluminum film.

## ALUMINIZED SCREENS

(Continued from page 5)

1. After the fluorescent screen has been settled and dried, a water cushion is put into the bulb. This water cushion is necessary to provide a very smooth surface upon which a film of lacquer may be deposited. An operator then deposits a controlled amount of lacquer onto the water cushion, as shown in Figure 2. The water cushion, having accomplished its purpose of forming a smooth surface for depositing the lacquer film, is then carefully and gently poured off. The extremely smooth lacquer layer upon the screen is then dried to form the surface upon which the aluminum film is to be deposited. This lacquer layer is required because depositing the aluminum directly upon the rough, crystalline screen surface would result in a non-reflective, black screen rather than the shiny mirror-like surface which is desired.

The bulb containing the lacquer-covered screen is carefully inspected before the tube is approved for the next step in aluminizing. See Figure 3. The lacquer film is burned out later in the process, after it has served its purpose.

A small amount of aluminum wire is attached to a tungsten wire filament, mounted on electrodes inside the bulb. The air in the bulb is then exhausted so as to create a vacuum in the bulb. This is done to make possible the vaporization of the aluminum. It is necessary to maintain a very high vacuum to ensure vaporization of the aluminum, rather than oxidation of the aluminum and tungsten which would result in undesirable black deposits inside the tube. As the operator at the control

(Continued on page 8)

At 1½ cents per prospect per month, the 1955 Sylvania Service Dealer Calendar is the best, low-cost, direct mail advertising you can use. Ask your Sylvania Distributor for a free copy and full details, or write to Sylvania, Advertising Distribution Department, 1100 Main Street, Buffalo 9, N. Y.



# CROSS COMPARISON OF DUO-TRIODE TYPES USED FOR CASCODE AMPLIFIERS

This table has been compiled as a comparison guide for tubes in cascode amplifier or push-pull neutralized amplifier service. They are arranged from left to right by increasing amplification factors. It is sometimes desirable in fringe areas to replace a

tube with one having a higher gain; in addition, some types are more readily available than others.

The comparison chart makes it apparent that for most circuits the 6BQ7, 6BQ7A and 6BZ7 may be interchanged without circuit changes. The

same is true for the 6BK7 and 6BK7A. To interchange the first group one of the second group, it is with mandatory to change the cathode resistor. Also, a slight alignment touch-up is necessary for best performance.

	6BQ7		6BZ7		6BQ7A		6BK7		6BK7A	
<b>MECHANICAL DATA</b>										
Bulb	T-6½		Same		Same		Same		Same	
Base	Small Button 9-Pin		"		"		"		"	
Cathode	Unipotential		"		"		"		"	
Mounting Position	Any		"		"		"		"	
Basing	9AJ		"		"		"		"	
<b>ELECTRICAL DATA</b>										
<b>Heater Characteristics</b>										
Heater Voltage	6.3		6.3		6.3		6.3		6.3	
Heater Current	400		400		400		450		450	
<b>Direct Interelectrode Capacitances*</b>										
	Sec. I	Sec. II	Sec. I	Sec. II	Sec. I	Sec. II	Sec. I	Sec. II	Sec. I	Sec. II
Grid to Plate	1.15	1.15	1.15	1.15	1.15	1.15	1.9	1.9	1.8	1.8
Input	2.55		2.5		2.85		3.0	3.0	3.0	3.0
Output	1.30		1.35		1.35		1.1	1.0	1.0	0.9
Input (Grounded Grid)		4.75		4.95		4.75	5.0	6.0	6.0	6.0
Output (Grounded Grid)		2.40		2.27		2.27	2.8	2.6	2.4	2.4
Plate-Cathode	0.12	0.12	0.15	0.15	0.15	0.15				
Heater-Cathode	2.3	2.3	2.6	2.7	2.65	2.70	3.2	3.4	2.8	3.0
Plate-Plate (Max.)		0.006		0.010		0.010		0.075		0.075
Grid-Grid (Max.)		0.014		0.024**		0.024**		0.003		0.004
Plate-Cathode (Grounded Grid)							0.24	0.24	0.22	0.22
<b>RATINGS (Design Center)</b>										
Plate Voltage	250		250 <sup>1</sup>		250 <sup>1</sup>		300		300	
Plate Dissipation	2.0		2.0		2.0		2.7		2.7	
Heater-Cathode Voltage	200		200		200		90 <sup>2</sup>		90 <sup>2</sup>	
Cathode Current	20		20		20					
<b>CHARACTERISTICS</b>										
Plate Voltage	150		150		150		100		150	
Cathode Bias Resistor	220		220		220		120		56	
Plate Current	9.0		10		9.0		9.0		18	
Transconductance	6000		6800		6400		6100		8500	
Amplification Factor	35		38		39		37		40	
Plate Resistance	5800		5600		6100		6100		4700	
Grid Volts for 10 $\mu$ a I <sub>b</sub>	100 $\mu$ a I <sub>b</sub> at -10 V E <sub>c</sub>		-11		-10		-9		-12	
* External Shield No. 315 connected to cathode.										
** Plate 2 to P1 and G1.										
<sup>1</sup> May be as high as 300 volts under cutoff conditions in grounded grid circuits with direct coupled drive.										
<sup>2</sup> When operated as a cascode amplifier and the two sections are connected in series, the heater-cathode voltage of the grounded grid stage may be as high as 250 volts maximum with the heater negative with respect to the cathode.										

## ALUMINIZED SCREENS

(Continued from page 6)

panel increases the current through the tungsten wire filament, the pure aluminum melts and then vaporizes inside the tube. See Figure 4. This aluminum vapor condenses on the inside walls of the tube, becoming the conductive and mirror-like aluminized backing for the screen.

The bulb is then gently "let down" to atmospheric pressure and continues on its way through the processing cycle, finally emerging as one of the best picture tubes available—a Sylvania Aluminized Picture Tube.

\*SYLVANIA NEWS, December, 1952.

## SYLVANIA 132Z OSCILLOSCOPE AGAIN AVAILABLE

Industry and service-dealer acceptance of the 132Z Oscilloscope has resulted in production of a limited number of these fine instruments.

At its very attractive price of \$169.50, Sylvania offers these features:

A BIG 7-inch screen for easy viewing . . . and . . . a window graph for reading your wave forms to scale. Rugged performance.

Protection . . . with the Sylvania safety glass shield.

Sensitive response . . . only one tenth of a volt will cause a full one inch of height deflection.

Saves time and makes easier the servicing of television in today's highly competitive service business.

## UHF STRIP CONVERSION

Our attention has been called to statements previously made in SYLVANIA NEWS on u h f strip conversion which are misleading because the comments were not adequately clarified in regard to different types of channel strips and the quality of reception expected from them. The strips actually referred to in the articles "U H F Converters," June 1953 and "What's the Answer," January 1954 are the double conversion type, where a crystal is substituted for two tubes in the converter.

There are other types of strip converters used by some manufacturers in their 1954 sets which have superior arrangements to provide good receiver gain at u h f.

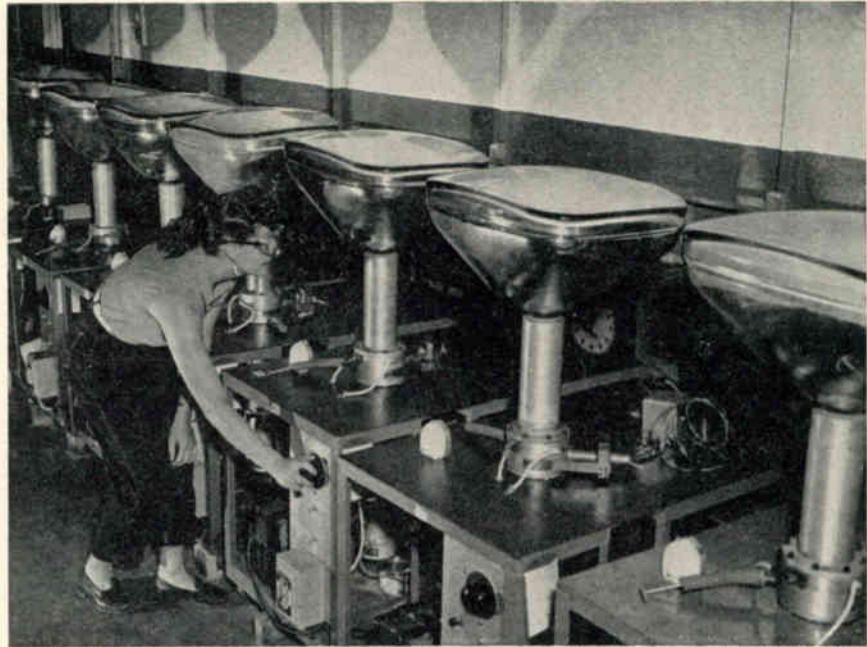
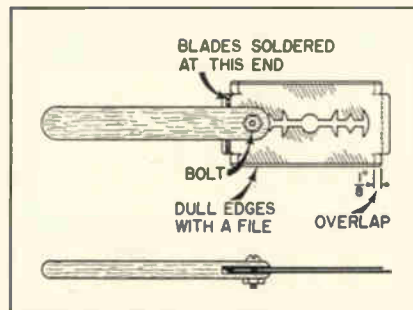

Figure 4. Pure aluminum is vaporized inside the tube.

# SERVICE HINTS

### HANDY RAZOR BLADE TOOL—

A handy tool for cleaning, scraping or bending variable capacitor plates may be made from two double edged razor blades. Solder the two blades together at one end with the blades positioned so that one extends about  $\frac{1}{8}$ " beyond the other. Next fasten a handle by means of a bolt to the end



Razor Blade Scraper for Variable Capacitors.

that was soldered. The drawing shows more clearly how it is constructed. Run a file over the sharp edges to remove the possibility of being cut.

By straddling the blades over a capacitor plate, it can be positioned or

cleaned. The thin blades make a tight width gauge on small variables of the broadcast set variety without undue pressure on adjacent plates.—John A. Irwin, Wethersfield, Conn.

**GROUND STRAP RIVETS ON SOCKETS** do not always make a low resistance contact to the chassis. In some instances, I have found that the poor contact caused intermittent reception and oscillation. This is especially true where wafer sockets are used with a center shield and ground strap.

When working on a Silvertone portable radio with this condition, I checked the resistance with an ohmmeter between the center shield and ground on each socket. Three out of five of the sockets had 15 to 20 ohms resistance as the set was jarred or chassis twisted.

To cure this type of trouble, solder a short lead between the center socket shield and chassis.—Adams Radio Service, Williamsport, Penna.

# SYLVANIA MODEL 404 OSCILLOSCOPE

By R. E. Grow—Test Equipment Department



Figure 1. Sylvania Model 404 Laboratory Oscilloscope. This instrument is particularly suitable for use in observance—without distortion—the sawtooth, square-wave, and other pulses found in television equipment.

The new Sylvania Television Laboratory Oscilloscope, Type 404, is designed to meet advanced television service, production and general laboratory requirements. It features a wide frequency response, with freedom from transients, overshoot, and phase shift, which makes it useful where it is necessary to observe pulse waveforms without distortion.

All waveshapes are accurately displayed on a large, eye-saving 7-inch screen. An important feature is the safety shield in front of the cathode ray tube to protect the operator and the tube. An exclusive rubber mount is used to cushion the cathode ray tube. The rubber mount extends out from the screen and the inside surface is cylindrical so that a paper mask can be used to shield the screen in very bright locations. A cross-hatched

screen is provided which may be placed directly in front of the cathode ray tube for convenience in measuring the pattern deflection and for crayon marking. This clear plastic screen is easily removed, since it is mounted in a round piece of spun aluminum which is shaped to fit exactly over the rubber bezel on the oscilloscope.

One of the essential features of a good oscilloscope is the freedom from response to extraneous electromagnetic fields. An oscilloscope with limited shielding may have a distorted trace when the instrument is alongside a piece of electrical apparatus generating a strong electromagnetic

field. The Sylvania Model 404 is well shielded and may be operated in these fields without such distortion.

## Vertical Deflection Amplifier

The vertical sensitivity of the Model 404 is 10 millivolts r m s sine wave input for one inch peak-to-peak deflection. This sensitivity will provide large pictures from small waveform voltages such as individual stages in tv sets and present complete patterns of the television video signal in its entirety. The response of the amplifier is uniform over the frequency range from 10 cycles to 2 megacycles and is usable up to 4

(Continued on page 6)

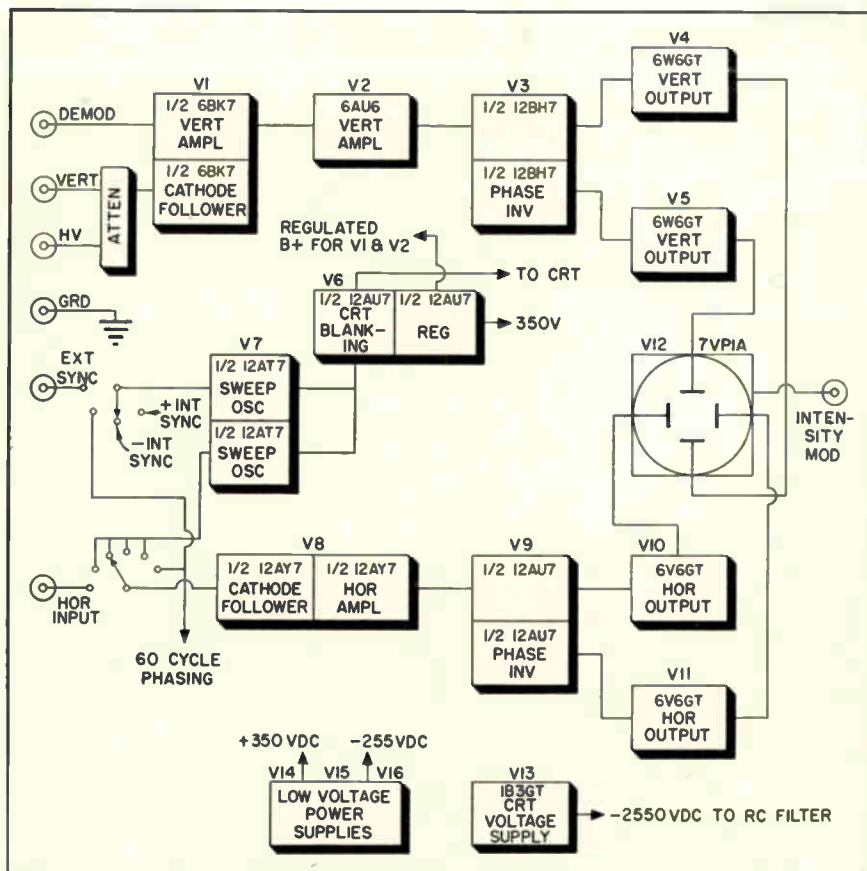

Figure 2. A block diagram of the Model 404 Oscilloscope.



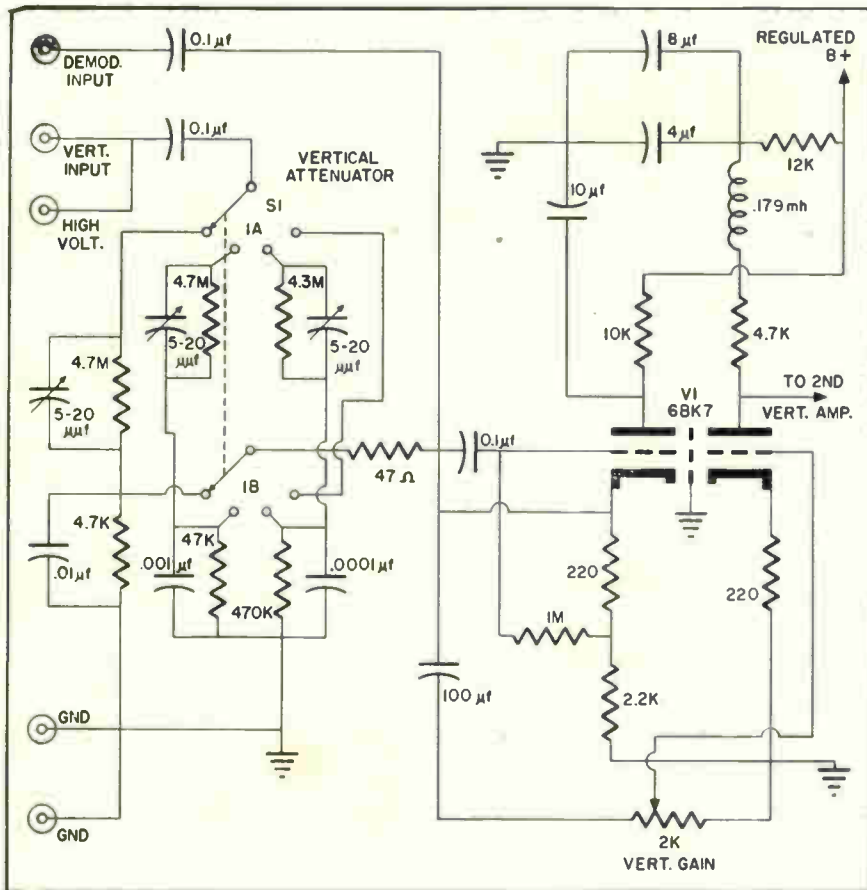

Figure 3. Schematic of the vertical input cathode follower and first amplifier stage, and showing the input attenuation network.

## SYLVANIA MODEL 404 OSCILLOSCOPE

(Continued from page 5)

megacycles with an attenuation of 6 db. The input impedance is high across the entire band. The vertical input circuits are shown in Figure 3.

The cathode follower circuit used in the first stage has a very high input impedance of 5 megohms shunted by  $26 \mu\text{f}$ . The purpose of this stage is to match the high impedance input to the low impedance gain control and to reduce input capacitance. The vertical gain control is in the cathode circuit where it has negligible effect on the frequency response. The signal is amplified by a triode and a pentode which drives the vertical deflection phase inverter. Extra stability is obtained in these stages by using a triode regulator in parallel with the voltage supply. It prevents bounce or flutter caused by extraneous disturbances in the B+ voltage line.

The vertical deflection phase in-

verter utilizes a Type 12BH7 duo triode tube. The cathodes are tied together and one section operates as a grounded-grid amplifier so that the plate signals applied to the push-pull 6W6 vertical deflection output tubes are equal and 180 degrees out of phase with each other. The two output tubes have sufficient output to produce full deflection without distortion. The observed pattern may be inverted by means of a switch.

The total phase shift of both the vertical and horizontal amplifiers does not exceed 10 degrees at any frequency from 10 cycles to 2 megacycles. High frequency response is accomplished by using peaking coils connected in series with the plate load resistors. Several of the stages also have low frequency boost networks to make the response uniform at very low frequencies.

### Horizontal Deflection Amplifier

The horizontal sensitivity is 150 millivolts per inch. The horizontal

base line may be expanded so that its total effective length is 21 inches—enough to facilitate detailed examination of small portions of waveforms. The response of the horizontal amplifier is flat between 10 cycles and 600 kc and the multivibrator sweep generator provides a linear time base from 25 cycles to 50 kc with a usable sweep up to 130 kc.

The horizontal sweep may be a sawtooth wave from the internal sweep generator, a 60-cycle sine wave whose phase may be varied by the phasing control, or a sweep voltage from an external source. The sweep generator may be synchronized to either a positive or negative reference signal which is applied to a 12AT7 sync amplifier. The input impedance is 5 megohms shunted by  $31 \mu\text{f}$ .

The first horizontal amplifier stage utilizes a cathode follower circuit which is similar to the first vertical amplifier stage described in the vertical deflection amplifier section.

A 12AU7 in a phase inverter circuit drives the final push-pull stage which is coupled to the horizontal deflection plates of the cathode ray tube.

(Continued on page 8)

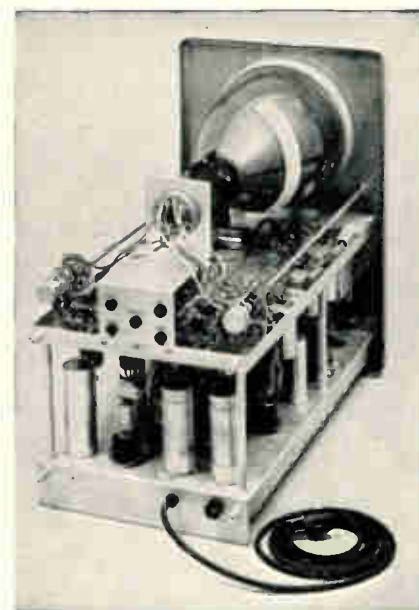

Figure 4. Internal view showing location of the various components. Notice the heavy, rigid construction and the "two floor" shielding of circuits which are of great importance for insuring long and satisfactory service.

# TECH TOPICS

## RADAR

The term "Radar" is a coined word meaning *Radio Direction and Ranging*. Radar is a device that will tell the direction and distance an object is from the instrument by the means of radio waves. It is used in civilian or peaceful purposes for marine navigation and aircraft control. The military uses it for gun control, locating the enemy and attack warning in addition to its peaceful uses.

The fundamental principle of pulse type radar is fairly simple.\* A very short pulse of radio energy is beamed in the desired direction. If this energy strikes an object more solid than air, some of this energy will be reflected back toward the radar station in the same manner that a mirror reflects light. It will return along the same path as the out-going signal and eventually be picked up by the radar station's receiver. Because radio waves always travel at the same speed and the time from sending to receiving can be measured on a 'scope, the distance of the object can be easily measured. (See Figure 1).

The direction of the object is indicated by the position of the antenna

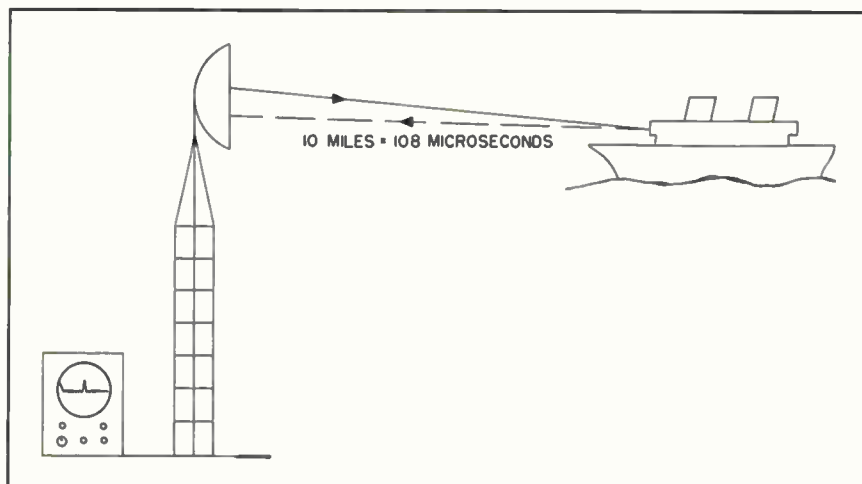

Figure 1. An illustration of the principle of RADAR. The solid line extending from the antenna represents the transmitted microwave radio beam and the dashed line is its reflection from the object under observation.

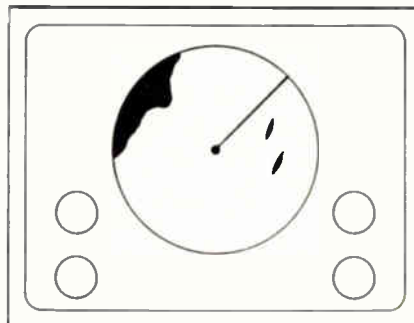

Figure 2. Plan Position Indication (PPI) pattern at a RADAR observation post.

at the time the reflection was received.

The frequencies for radar are so high (often well above the u h f tv frequencies) that great accuracy can be achieved. At very short wavelengths down to fractions of an inch it is possible to use antennas similar to searchlight reflectors.

For marine navigational purposes the radar 'scope presentation is usually circular to show the area surrounding the ship on all sides. The sweep in the cathode ray tube starts in the center and travels outward as each signal is sent out. Simultaneously, the sweep rotates around the tube in synchronization with the antenna.

As an echo is received, the sweep brightens and leaves a radar picture

of the area. (See Figure 2). The dark area at the upper left indicates land, the other dark areas are ships.

The cathode ray tubes used for radar plan position indicators are different from those in ordinary oscilloscopes. They have long persistence screens so that the picture remains long after the sweep has gone by.

Radar, the eyes that see in the dark, protects our coastline from enemy attack, protects our ships from collision with icebergs and other ships, lands airplanes in "visibility zero" conditions, and saves lives of our fighting men in war.

The Federal Communications Commission now has a special Radar Endorsement for Commercial Operator Licenses.

\*Other types of radar may use CW, A M and F M.

### SYLVANIA TUBE TESTER SETTINGS

We have recently instituted a new system for bringing you Sylvania Tube Tester Settings for tubes which have not yet appeared on the Roll Chart. They will be listed at the bottom of the Technical Manual supplement for the tube type to which they apply. This allows quick and ready reference when needed.

The settings will be listed only for tubes not on the chart, and they will be removed at each Technical Manual revision. This system was begun with the January 1954 issue for the Sylvania Type 6CM6.

### TV CRYSTAL REPLACEMENT GUIDE

When	Use
<i>The Set Lists</i>	<i>Sylvania Type</i>
1N64	1N132
CK706	1N132
1N65	1N34A
1N72	1N82, 1N82A
CK710	1N82, 1N82A

### NTSC COMPATIBLE COLOR

#### TV APPROVED

Last month, the FCC put its stamp of approval on the NTSC compatible color television system. Now the way is clear for the networks to broadcast in color, and for the manufacturers to sell color television sets.

At the present time, color television  
(Continued on page 8)

# Sylvania Model 404 Oscilloscope

(Continued from page 6)

## Sweep Generator

The sweep generator produces a linear sweep from 25 cycles to 50 kc. It may be synchronized with either the signal applied to the vertical deflection amplifier, the 60-cycle line voltage, or an external source. Synchronization sensitivity is such that 100 millivolts peak-to-peak amplitude will effect positive lock-in.

## Voltage Supplies

The 1900 volt cathode ray tube accelerating potential insures a bright and well-focused trace. The high voltage supply uses a Type 1B3GT half-wave rectifier tube and a resistance-capacitance filter. The other voltages for the cathode ray tube are obtained from the high voltage divider which improves stability. A 350 positive d c voltage is supplied by a Type 5V4G full-wave rectifier. A negative d c voltage of 255 volts is supplied by a full-wave rectifier circuit using two Type 6X4 tubes.

## Accessories

The Model 404 Sylvania Oscilloscope is new and modern in circuitry. The controls on the front panel are of the latest concentric type and are conveniently grouped by function. Accessories included as part of the instrument are a high voltage probe and a demodulator probe. The demodulator probe has a flat response from 20 cycles to 3 mc and will pass a 30 cycle square wave with less than 2 degrees of tilt. The high voltage probe has a dividing ratio of 50 to 1 and has a maximum input voltage level of 25,000 volts.

A wide variety of measurements in television receivers and other types of electronic equipment may be made with the new Sylvania 404 Oscilloscope. This instrument with its modern styling, eye appeal, and sound engineering, will prove invaluable for service, laboratory and industrial applications.

# SERVICE HINTS

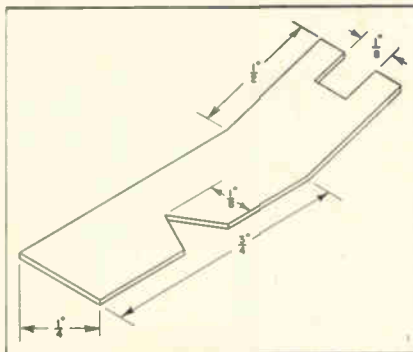

1. Drawing for "Connecting antenna Clips" showing rectangular strip of metal with notches and dimensions.

## CONNECTING ANTENNA CLIPS

—When installing a TV set, I furnish the customer with a set of antenna clips for his own use when it is required to disconnect the set. I have found that by connecting the clips directly to the antenna screws on the set, it is hard to get a good connection. To remedy the situation, I attach to the existing antenna screws a set of home-made terminals, and then connect the antenna clips to these terminals. Material: brass or copper about  $\frac{1}{32}$ " thick.

—Donat A. Duquet, Waterville, Maine.

## Sylvania Television Oscilloscope—Type 404

### Specifications

Power Line: 105/125 volts, 50/60 cycles  
Amplifier frequency response: Vertical, 10 cycles to 2 Mc. within 3 db (sine wave), to 4 Mc. within 6 db.

Horizontal, 10 cycles to 600 Kc. within 3 db (sine wave).

Sensitivity: Through vertical amplifier, 10 millivolts (0.010 volt) rms sine wave for 1 inch of deflection (peak to peak). Through horizontal amplifier, 150 Mv, rms sine wave for 1 inch of deflection (peak to peak). Direct to vertical plates (D3 and D4), 24 volts rms sine wave for 1 inch of deflection (peak to peak). Direct to horizontal plates (D1 and D2), 26 volts rms sine wave for 1" deflection (peak to peak).  
Input Impedances: Vertical amplifier, 5 megohms, 26  $\mu$ f. Horizontal amplifier, 5 megohms, 31  $\mu$ f. Deflection plates, 4.7 megohms, 16  $\mu$ f.

Sweep synchronization: Phase inverter type, variable in amplitude & polarity. Maximum vertical and horizontal input terminal: 1000 volts peak combined ac and dc.

Sweep Frequency: 15 cycles to 50 Kc.  
Tube Complement:

- 1 Sylvania Type 7VP1
- 1 Sylvania Type 12AT7
- 1 Sylvania Type 6BK7
- 1 Sylvania Type 6AU6
- 1 Sylvania Type 12BH7
- 2 Sylvania Type 6W6GT
- 1 Sylvania Type 12AY7
- 2 Sylvania Type 12AU7
- 2 Sylvania Type 6V6GT
- 1 Sylvania Type 5V4G
- 1 Sylvania Type 1B3GT

Power consumption: 230 watts at 117 volts, 60 cycles.

Cabinet size: 17 $\frac{1}{16}$ " high, 11 $\frac{1}{8}$ " wide, and 17 $\frac{1}{2}$ " deep.

Weight: 55 pounds.

## NTSC COMPATIBLE COLOR

(Continued from page 7)

is very much in the experimental stage. The first receivers will be few in number and quite expensive, and several years will pass before color television will be available for the millions.

The television serviceman can prepare for color television in his town by reading the many articles on the subject, which are appearing in the national radio and television magazines. Color television is inherently more complicated and proportionately more difficult to service than black and white television; and it behooves every television technician, worthy of the name, to give the public competent color television service. Waiting until a color set appears at the shop which needs repairing is too late for learning the whys and wherefores of color. Begin your color television education now by strengthening your foundation in black and white television and studying whatever color material comes your way.

The SYLVANIA NEWS Technical Section will bring you articles on the complete color television system soon. The entire Sylvania engineering staff is backing this project, so that no phase of this new medium of entertainment will be overlooked.



# INSTALLING UHF ANTENNAS

By P. R. Simon  
Advanced Application Engineer

The foremost television problem in the American communities this year is the arrival of u h f, either in competition with existing v h f stations or as the only station. Attention is focused on the u h f antenna and converter because they are the only salient features at the receiving end of u h f tv that are different from v h f. The problem is so new that servicemen with u h f installation experience are woefully lacking in most communities. However, here at Emporium, the Sylvania Experimental Station KG2XDU (Channel 22) has provided a proving ground for u h f reception.\*

Almost all conditions of reception are found in Emporium. Line-of-sight locations receive a signal up to 30,000 microvolts per meter, and unfavorable locations receive little or no signal with multiple out-of-phase reflections from the hills. Some of the ghosts due to these reflections are equally strong as the true signal.

Over flat terrain, distant u h f reception is possible with elaborate fringe area type of antennas. How-

\*J. B. Grund—EXPERIMENTAL U H F STATION KG2XDU — SYLVANIA NEWS, December, 1952 and February, 1953.

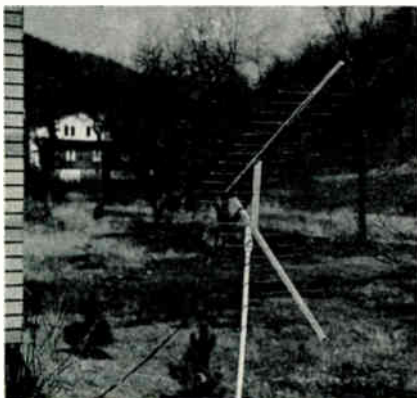

Figure 1. A corner reflector for the reduction of ghosts on u h f.

ever, because of the narrow, irregular valley, Emporium had the additional problem of eliminating ghosts. In fact, the reflections were used for reception in many instances.

Ghosts are caused by reflected signals which have travelled over a different and longer transmission path and are picked up by the receiving antenna. They usually travel over a different path than the true signal and thereby make it possible to eliminate them. The characteristics of the antenna under these conditions should include a high front-to-back ratio. This is the ratio of the signal received with the antenna directed toward the station to the signal received with the antenna directed away from the station.

One of the best antennas we found for exclusion of ghost signals was the corner reflector (See Figure 1). This antenna virtually shuts out all the signals arriving from the rear. Ghost-free reception was obtained where previously annoying double and triple images prevailed.

U H F has the advantage of smaller antenna dimensions than v h f television. Multiple stacked arrays that are cumbersome when built for v h f become small, easily managed units at ultra high frequencies (See Figure 2). These high gain antennas have the inherent property of a very narrow lobe in their field patterns. There is a direct relationship between antenna gain and the main lobe width (See Figure 3). The sharp directivity of this type of antenna makes the azimuth adjustment critical when installing it. Location and height adjustments are critical at u h f due to reflection and attenuation of the signal by interfering bodies which increase with increasing frequency.

This information in Sylvania News is furnished without assuming any obligations

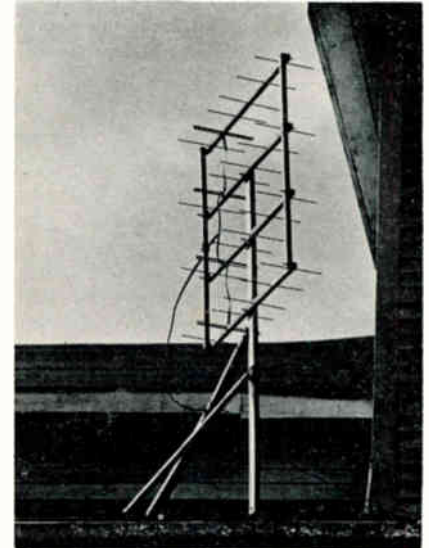

Figure 2. V H F stacked Yagi antennas for high gain in fringe areas.

A v h f installation was easily made by choosing a convenient chimney mount and approximately orienting the array toward the station. Our experience with u h f has been that moving a Yagi beam up, down, or to either side only three feet varied the field strength to double or triple its previous value. An ultra high frequency field strength meter proved invaluable in this process. We improvised one in the laboratory by converting a commercial v h f field strength meter which uses a Standard Coil Turret Tuner. The plug-in strips allowed us to simply replace one of the unused v h f strips with one for the u h f channel desired. It was also necessary to add a 300 ohm shielded lead from the meter terminals to the tuner input to prevent oscillation or a spurious reading when no signal is present.

As there is probably more than one unused v h f channel in most areas, new u h f stations can be received

(Continued on page 6)

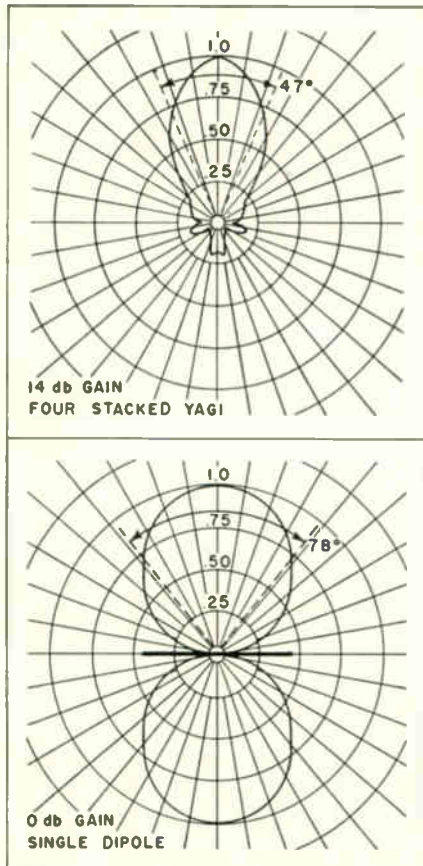

Figure 3. Horizontal field patterns of a four stacked Yagi and dipole antennas.  
25,250

Power gain over dipole =  $\frac{\text{Angle A} \times \text{Angle B}}{25,250}$   
Angles A and B are in planes at right angles to each other; e.g. horizontal and vertical.

### UHF ANTENNAS (Continued from page 5)

with the appropriate strip without reducing its use as a vhf field strength meter.

With this meter in view of the person installing the antenna, the location of the highest field strength can be ascertained with a few trials. The usual roof-to-set communication practice of aligning a tv antenna includes a delay of observer response which results in a long chore. Thus, the use of a portable field strength meter shortens the job considerably.

Television viewers in fringe areas may shy from the thought of adding more antennas to the already crowded roof-top apparatus where vhf has been received. Many will try to receive uhf on their present arrays. For strong signal strength areas, they may be adequate for good reception. We used an all-channel vhf conical mounted on the laboratory roof to successfully receive the KG2XDU (Channel 22) signal at a distance of 1.5 miles from the transmitter. In other nearby line-of-sight locations satisfactory pictures were obtained by using the antenna built into the converter or set. The built-in type of antenna is usually a folded half-wave dipole or triangular fan which is considered to have little or no gain.

In weak signal areas special high gain uhf antennas are necessary. There are a wide variety of this type of antenna; just about every type of beam known is practical at these frequencies. However, the wide frequency span covered by uhf tv (470 to 890 mc) makes the construction of an all-channel high gain antenna difficult. The inverse relationship between gain and bandwidth necessitates a sacrifice in gain to achieve a bandwidth adequate to cover all the desired channels. Television owners in ultra-fringe areas require single channel, extra high gain type of arrays for each channel to be received. This is not too great a trial when the small size of the uhf array is considered.

Although the KG2XDU transmitter is of the experimental low power class, with a maximum e.r.p. of 300 watts visual and 100 watts aural, we have been successful in receiving a picture at a distance of 10 miles. In this test, over a theoretical line-of-sight, a single Yagi antenna was used which had a gain of 9 db.\*

We will continue this series with a discussion of ultra high frequency converters next month.

\*P. R. Simon—A HIGH GAIN YAGI ANTENNA, SYLVANIA NEWS, January, 1953

## A HORIZONTAL DEFLECTION STABILIZER TUBE

For many years, the television receiver manufacturer has been forced to allow a generous safety margin in the design of the horizontal deflection

circuit in order that tube ratings would not be exceeded at high line voltage. Such a design requirement made it difficult, at times, to obtain

full scan at low voltage even with maximum settings of the horizontal controls.

A relatively low cost solution to

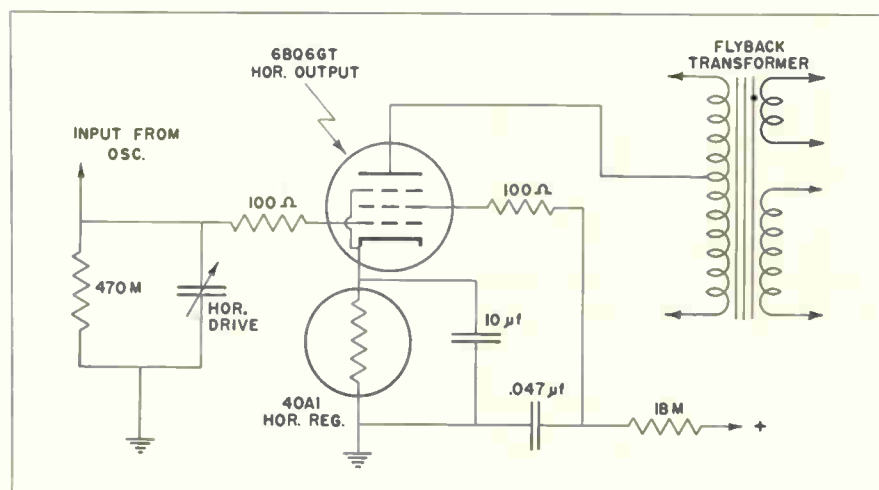
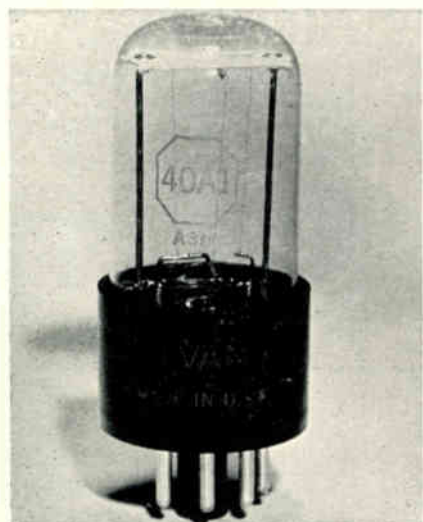

Fig.1. A typical circuit using the Sylvania type 40A1.



the problem is supplied by Sylvania Type 40A1 Horizontal Deflection Stabilizer Tube. This is a filamentary type ballast tube having an average voltage current characteristic as shown in the Sylvania Technical Manual Supplement. The Type 40A1 is used as the cathode resistor of the horizontal output tube in receivers specifically designed for its use (See Figure 1). Because of the non-linear resistance characteristic, variations in anode voltage, picture width, output tube cathode current and damper diode current with line voltage are considerably below that which result from using a fixed cathode resistor. It becomes possible, therefore, to operate the horizontal output tube near full scan capabilities at low line voltage without subjecting it to operating conditions which exceed the maximum ratings at high line voltage. This insures greater reliability and trouble-free operation.

In Table I are given figures which illustrate the desirable effects of using the Type 40A1 in television receivers. The figures of Table I (B) were obtained by substituting a variable cathode resistor for the Type 40A1 and adjusting it so that at 117 volt line, operating currents and voltages were identical to those obtained with Type 40A1 at 117 volt line. The stabilizing effect of the Type 40A1 is apparent at once. Of special interest is the greatly reduced variation in output tube cathode current and damper current.

While it is not a complete solution to the problem of scan changes with line voltage, the Sylvania Type 40A1 Horizontal Deflection Stabilizer is of considerable value in maintaining less variant values of horizontal output tube cathode current, damper current, anode voltage and scan width with varying line voltage than would be the case with the use of a fixed cathode resistor.

The Sylvania Type 40B2 has recently been announced. The addition of this tube allows more flexible circuit design.

TABLE I

Percentage Variation of Operating Currents and Voltages with Respect to 117 Volt Line Conditions — Line Voltage Varied From 105 to 130 Volts.

	Output Tube $I_k$	$I_{\text{damper}}$	Second Anode E	Scan*
A—With 40A1	10.7%	9.5%	15.7%	6.6%
B—With $R_k$	28.6%	25.9%	27.5%	15.8%

\* Scan measurements made using large circle of "Indian Head" test pattern.

## AN EASILY BUILT UHF TV CORNER REFLECTOR ANTENNA

By P. M. Reinhardt—Technical Publications Section

The 90° corner reflector antenna for u h f tv, shown in the accompanying figures, is relatively simple to construct, since it contains fewer critical dimensions than a Yagi of comparable gain. The antenna described in this article has a gain of about 10 db, or slightly better than a single six element Yagi. The corner antenna provided a better picture than a pair of 6 element stacked Yagi antennas, since it appears less susceptible to ghosts, due partly to its better front-to-back ratio. Our location is such that we receive the signal down in a valley solely by reflection from a nearby hill, thus our antenna points away from the transmitter. In this location the corner antenna provided better results than either a single, or a two stack Yagi. The antenna may be built for any of the u h f channels by laying out the dimensions in terms of the wavelength, and then converting these to inches.

The only dimensions which are somewhat critical are those involved in the construction of the dipole and its matching section, and the spacing (D) of the dipole from the vertex element. While it is possible to match 300 ohm line directly to the dipole, this is not recommended since it requires a considerable increase in dimension D. If D is increased too

greatly, the field pattern may change from a single lobe to one having several major lobes unless the length of the sides (W) is increased. Thus to have a physically compact antenna with a single major lobe and to keep the size reasonable, D was made a quarter wavelength long and a matching section included. The dipole element is a half wave, shortened due to the tubing diameter, and the presence of the matching section.

Once dimensions A and D are chosen (depending upon the channel desired), the other dimensions are simple. The length of the reflector elements L are not critical since they are not parasitically excited. They should preferably be at least the length of the dipole A plus D, ( $\frac{3}{4}$  of a wavelength), which is another reason for keeping D reasonably small. These reflector elements are not cut to any particular frequency but are merely greater than A so that they may approximate the effect of a solid sheet. By the same token, the spacing S is not critical so long as it is somewhat less than D, so it was made a tenth wavelength.

The length of the reflector sides then determines the number of reflector elements required. The lengths of the sides are not especially

(Continued on page 8)





# EXPERIMENTAL UHF TELEVISION STATION KG2XDU - PART II

By J. B. Grund - Advanced Application Engineer

## TRANSMITTER SITE

Emporium, the headquarters of the Radio Tube Division of Sylvania, is situated in the Allegheny Mountains of Northwestern Pennsylvania. The elevation of the town proper is from 1020 to 1070 feet above sea level and the surrounding hills rise sharply to 1200 feet above the valley floor. Television signals are received in the valley occasionally, but on the hill tops consistent reception of several vhf tv stations is possible.

It was desirable to choose a site which would overlook the town, allow good reception of v h f signals, and be accessible by road. A site 1100 feet above and 1.7 miles south-east of the center of Emporium was selected (See Figure 1). This location overlooks more than half the homes in town and is of sufficient elevation to be a good receiving point for v h f television stations.

The hill summit was cleared of trees and a small concrete block, fire-proof building was erected to house the transmitter and associated equipment. Because of its isolated location, no windows were included in the building; therefore, air vents and exhaust fans were necessary to supply ventilation.

## THE TRANSMITTER

Sylvania tubes were used throughout the transmitter (See Figure 2) except for the u h f transmitting type used in the last tripler and final amplifier.

The sound and picture transmitters are nearly identical, the main difference being in the modulation circuits. Oscillator stages are followed by two buffer-amplifiers, two triplers, and a 4X150A final amplifier. The outputs are combined and fed to a high gain antenna system.

In order that tv receivers of the inter-carrier sound type will operate properly, it is necessary to maintain an exact 4.5 mc between the sound and picture carriers. Therefore, station KG2XDU in addition to maintaining the frequency of the picture carrier within the frequency tolerances required by the terms of the license, maintains a continuous check of the sound and picture carriers so as to maintain a constant 4.5 mc difference.

The station identification signal on the picture carrier is provided by a video test pattern generator utilizing a custom-built monoscope tube which produces a test pattern with the station call letters superimposed thereon.

An audio amplifier supplies the frequency modulated sound transmitter with signals from the tv receiver, a tone oscillator, tape recorder or microphone.

Various other monitors and meters are used, including an on-the-air picture monitor, and a Sylvania Model 400 'Scope to show percentage of visual modulation.

The video test pattern generator runs all the time; the rest of the equipment operates from time clocks. One time clock turns the transmitters on and off at preset times. Another time clock controls a Sylvania Model 508 tv receiver. The low noise cascode input of this receiver makes a booster unnecessary. Signals from WJAC-TV Johnstown, Channel 6, 88 miles away are received snow-free. A third time clock switches in the KG2XDU test pattern and aural announcement every 15 minutes to automatically delete the station identification from WJAC-TV as required by the

FCC. A tape recorder makes the aural station announcement.

Because of the satellite operation, eight of the twelve transmitter power supplies are voltage regulated to maintain constant transmitter power input under varying line voltage. There is an overload relay on each power supply in addition to the line fuse. These overload relays in conjunction with time delay tubes and relays on the control panel of each transmitter automatically switch off the whole transmitter if a short circuit or other malfunction is not cleared within ten seconds. When the transmitter is again switched on (manually) pilot lamps show where the fault occurred.

A 98 foot guyed tower, strong enough to withstand the severest storm, was erected on the hill at the highest elevation. The terms of the construction permit required the tower to be painted with alternate orange and white bands and surmounted with red beacon lights (See Figure 3).

It was decided that a directional antenna should be used to take advantage of its power gain and concentrate the signal over Emporium. The antenna originally consisted of two sections of eight half-wave dipoles in phase with reflectors. The two sections were mounted 60 degrees apart so that between the half power points the horizontal radiation pattern

(Continued on page 6)

Figure 1. The transmitter site from the air.





Figure 2. The KG2XDU transmitter racks.



Figure 3. The KG2XDU tower and station building.

## Experimental UHF

(Continued from page 5)

covered a 110 degree arc. The antenna has been recently changed with a view to improving the vertical radiation pattern. Andrew Type 738 seven-eighths inch semi-flexible air dielectric coaxial cable feeds the signal from the transmitters to each section of the antenna. Transformers are used to match the 52 ohm unbalanced cable impedance to the 300 ohm balanced input sections of the antenna. The signal attenuation in these 100 foot feedlines is negligible and the V S W R of the completed system is low, about 1.2 to 1.

### RECEPTION

With no obstructions between transmitting and receiving antennas,

a dipole will supply a satisfactory picture to the u h f receiver or converter. However, Yagi antennas cut to Channel 22 or corner reflectors are usually necessary to eliminate "ghosts" caused by reflected signals. A satisfactory picture has been obtained 10 miles from the transmitter, yet in the southeast section of Emporium, less than two miles from the transmitter, but shadowed by a hill, only weak, multipath signals reflected from another hill north of town are received. These signals give a weak and snowy picture with from two to five "ghosts". It is hoped that station KG2XEL, on Channel 82 located in Emporium will give better signal coverage and supply a signal to sections thus shadowed from KG2XDU by hills.

KG2XDU signals can be received throughout most of the town by converters installed on v h f tele-

vision receivers. Antennas required vary from dipole where the signal is strongest to four stacked 6-element Yagi arrays in weak signal areas. The corner reflectors are more effective than the 6-element Yagi in areas where reflections cause multiple ghosts.

KG2XDU is operated daily to supply a u h f signal for the Sylvania Engineering Laboratories. The test pattern and tone and program material from WJAC-TV are broadcast with the transmitter unattended but closely monitored. The broadcasts have proved very helpful in carrying out tube development in u h f tuners and converters. Other manufacturers have also been aided by the signals in the development of v h f—u h f tuners built around Sylvania tubes. This is another segment of the Sylvania program to bring better radio and television to the public.

### Additions and Corrections for Type 139-140 Tube Testers

Type	A	B	C	D	E	F	G	Test
6BK7	6.3	0	—	0	1 3	3 7	18 18	W W
6X8 (Correction of G Setting Only)							48 37	
5608 (Correction of G Setting Only)							46 46	
5670	6.3 6.3	1 1	58 58	3 3	7 3	6 7	30 30	U U
5687	12.6 12.6	0 0	9 9	0 0	1 4	3 7	19 19	X X

### Additions and Corrections for Type 219-220 Tube Testers

	A	B	C	D	E	F	G	K
6BK6	Change last two tests from U to T							
6BK7	6.3 6.3	4 4	58 35	25 25	5 5	2X 7X	1 6	3 8
6X8 (Correction of D Setting Only)				38				
12L8	12.6 12.6	6 6	7 7	40 40	7 7	15X 35X	8 4	2 2
5608A	2.5 2.5	1 1	7S 7S	48 48	7 7	3Y 5Y	2 6	4 4
5670	6.3 6.3	1 1	89 29	25 25	9 9	3X 7X	4 6	2 8
5687 (Correction of First K Setting Only)								3



## PICTURE TUBE PICTURES



During the next few months we plan to devote this spot to a picture and a short description of an unusual test, process or method used in the manufacture of Sylvania Television Picture tubes.

This month's picture depicts an air comparator being used to test the vitally important grid-to-cathode spacing in constructing the electron gun. A stream of pure, clean air is directed through the opening between the grid and cathode. The comparator then measures the resistance to the air flow. If the spacing is too great the resistance will be low, while close spacing will yield too high a resistance. The instrument may then be

calibrated to the production limits desired. This enables the operator to adjust this grid-cathode spacing to within 5/10,000 of an inch.

In addition to its convenience, this method also has another important advantage in that no gauge or other tool comes in contact with the surface of the cathode. This eliminates the possibility of chemically contaminating the cathode. Notice that the operator is wearing finger-protectors. This is done to prevent contaminating the gun structure by body salts due to perspiration.

These are but a few of the many precautions to ensure the high built-in quality of Sylvania Picture Tubes.

## A Powerful UHF TV Station

A high power uhf tv station will soon go on the air in Reading, Pennsylvania. WHUM-TV is a uhf station on Channel 61 with 250,000 watts effective radiated power.

It is important to us because it is a prototype of other stations that will cover the United States with tv signals not too far in the future. The power radiated by this station at a frequency of 755 mc was impossible not very long ago, but a new klystron tube was developed that will do the job.

A helical head antenna mounted atop a 1,036 foot guyed tower confines the signal to low angles of radiation and thus increases the effective power radiated. The tower is located on a 1,600 foot mountain which raises the antenna elevation to over 2,600 feet. It is expected that the service area will cover a 62 mile radius from the tower because of the high power and height.

The servicemen in the Reading area were prepared for the advent of u h f by various group service meetings where they were told about u h f converters and antennas. Not all new u h f areas will get this personal u h f instruction. Keep posted with the SYLVANIA NEWS, Technical Section for the latest developments.

---

## Your SERVICE HINT Is Worth \$5.00

Sylvania will send you a certificate worth five dollars towards the purchase of any advertising item listed in our "Multiplying Pennies" booklet for your latest service hints.

All you have to do is send us your solution to a servicing problem—a

solution that's novel or more efficient than the ordinary method. If the editors of SYLVANIA NEWS find it acceptable for publication, you'll receive your five dollar certificate in the next mail! Please do not send routine or generally known infor-

mation.

Send your service hints to:

SYLVANIA ELECTRIC PRODUCTS INC.  
*Technical Publications Section*  
EMPORIUM, PENNSYLVANIA

# Service Hints

**STANDARD COIL TUNERS**—A plate bypass of 10  $\mu\text{f}$  opens in the rf section, 6AG5-6CB6 or 6BC5, causing a condition of weak reception on some channels only. No amount of oscillator tuning will bring in these weak channels. This capacitor is easily accessible and is a Ceramicon mounted on the side rf plate to ground.

This is also true of the GE continuous type tuner, but here they utilize 3 tubes, two rf stages with 1 to 3  $\mu\text{f}$  screw type trimmers mounted on the top of tuner for plate bypassing. A cold solder connection or corrosion breaks down and opens trimmer. Seashore salt air and atmospheric conditions will have a terrific effect on these trimmers causing weakness on some channels and no reception at times. Place a hot lamp over section after cleaning with carbon tet.—Harry Ringel, New York City.

**ANTENNA CONNECTIONS—INSTALLATION**—Permanent and rust-free connections for antennas and lighting arrestors can be made by applying roof patching cement on the connection after the nut has been tightened. Rust will not form and it will make for a better installation with less call-backs. Also if you install open-end antennas this compound on the end of the rods will reduce the loss considerably.—Donat A. Duquet, Waterville, Me.

**SOLDERING IRON TIPS**—Tips of soldering irons eventually become corroded from the heat and are almost always impossible to remove when a replacement is necessary. In order to avoid this, graphite powder dusted onto the portion of the threaded tip and on the threads of the soldering iron chamber will permit

the tip to be removed easily at any time.—Norman Deschambault, P. Q., Canada.

**PHILCO MODEL 49-1278**—This set had a loss in sound and snow in the picture of channel 1 which was not caused by external factors such as the antenna system. On examining the tuner, it was found that contact finger number 1 of terminal board number 7 was broken and not making contact from the antenna to the rf coil. To repair this mechanical failure, I used a strip of thin gauge spring brass and soldered it over the full length of the contact finger. It is a good practice to check all turret type of tuners for this sort of trouble.—Louis E. DelColle, 3404 Taylor Terrace, Philadelphia 45, Pa.

**CIRCUIT BREAKERS**—It is a good idea to install 5 to 6 amp. circuit breakers on the power outlets of the service bench, one breaker for four outlets. Generally not more than two breakers are needed for the average service shop. They are not expensive and pay for themselves in saving fuses and lost time. The breakers operate instantaneously on direct shorts in test instruments, and radio and television sets and are easy to reset. Being connected in only one side of the line to the outlets, they are easy to install.—James P. Torre, 57 St. Nicholas Ave., Brooklyn 27, New York.

**REPAIRING PHONO DRIVE WHEELS**—For emergency repairs on worn phono drive wheels which do not have any holes or dents in the rubber rim, but are worn sufficiently to slightly change the speed of the turntable, or if worn where insufficient drive pressure is maintained, the following tip may be worthwhile. We have found some of them going strong a year after this "temporary"

repair is made. Carefully "peel" the rubber from the rim of the wheel and cut a narrow piece of white physicians tape just long enough to reach around the periphery in the slot without overlap, and with the sticky side toward the wheel. Then replace the rubber ring in its original position on the wheel smoothing it down carefully and evenly. This will increase the diameter very slightly and also the pressure against the driven turntable. This stunt can be used in recorders and other units using the same type of drive.—M. G. Goldberg, St. Paul, Minnesota.

**RIGHT ANGLE SOLDERING IRON**—What to do with old soldering irons having either broken tips or frozen in tips has been a problem for some time. Provided the element and cord are otherwise in good condition, drill a quarter inch hole through the end of the iron as close as possible to the end. Now secure a piece of copper rod about a quarter inch in diameter and over two inches long, then force this copper rod through the iron. One end of the copper rod should be beveled and then tinned for correct soldering. Now with the rod forced into the iron you have an efficient right angle soldering iron which is excellent for use in present day servicing, particularly when working in tight corners and on tv tuners.—Seymour Greenberg, Whitestone, L. I., New York.

**6 VOLT PHONO MOTOR**—Being called upon for a PA system for mobile use in a political campaign, I needed a phonograph to operate from 6 VDC IMMEDIATELY! So, since I didn't have time to produce an inverter, I took a standard phonograph assembly, removed the motor, which had a  $\frac{1}{4}$ " driveshaft, and substituted a 6 VDC PARALLEL WOUND fan motor with a  $\frac{1}{4}$ " shaft. It had the same speed as the original motor (usually 1750 rpm) so everything worked fine! Do not use a series motor though, as every increase in gas feed causes the generator voltage to increase, and produces "WOW".—Harold J. Weber, Sparta, Illinois.



# BANDPASS AND THE TV PICTURE

By W. O. Hamlin - Technical Publications Section

The bandpass of a television receiver is of prime importance for sharp, clear, good contrast television pictures. The typical overall video bandpass of a tv receiver should extend from 60 cycles to over 2 mc. Better receivers have bandpass frequencies up to 3.5 mc. Loss of the proper video bandpass due to serious misadjustment of tuned stages or defective parts in video stages will produce a very inferior picture. The effect of the poor bandpass can be readily detected by viewing a test pattern but is more difficult to see in the usual television program. For this reason, many television viewers will continue to use their tv receiver unaware that the picture could be better if the set were realigned or repaired.

Poor high frequency response gives the picture a washed out appearance and lack of picture detail. It is easy to see in the vertical wedges of a test pattern (See Figure 1). Notice that the fine lines are practically invisible. This effect is explained by considering what happens when the modulated electron beam sweeps across the face of the picture tube.

The beam sweeps across the picture tube at a great rate of speed; it takes only 63 microseconds (63 millionths of a second) to scan one complete

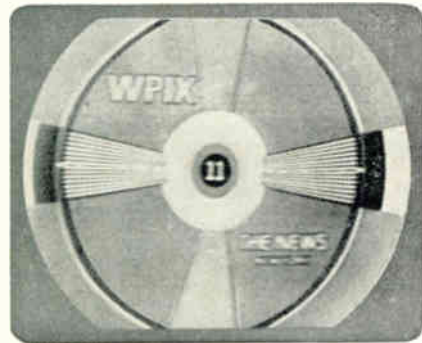

Figure 1. Inadequate high frequency video response.

line. As it produces the light area of the test pattern there is little change in beam modulation, which is represented as B in Figure 2, and it is unaffected by the narrow bandwidth. However, when the incoming signal changes to black, in a split microsecond, which is represented as A in Figure 2, the video amplifier cannot amplify the high video frequency component. The edges of black areas are not sharp and small details and lines such as the vertical wedges may not show at all.

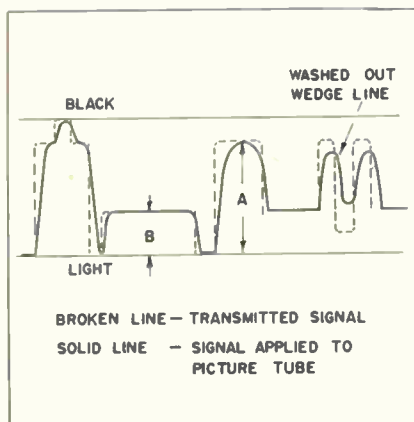

Figure 2. Part of scan line with inadequate high frequency video response.

Some of the causes for poor high frequency bandpass are defective peaking coils in the video amplifiers or serious misalignment of rf or if sections. Also, excessive capacitance between video circuits and ground will reduce high frequency response. It may be improved by dressing leads in the video amplifier circuits and the video lead to the picture tube.

Poor low frequency response causes large dark areas to be non-uniform in brightness and have trailing edges. Vertical blanking will not be effective and it may be difficult to keep the picture in sync if the trouble is ahead of the sync take-off point.

This information in Sylvania News is furnished without assuming any obligations

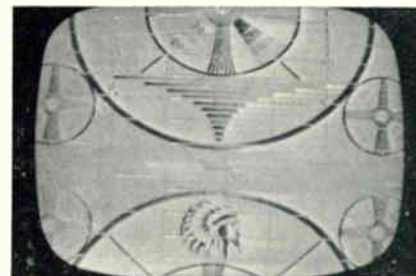

Figure 3. Inadequate low frequency video response.

Figure 3 shows a test pattern on the screen of a tv receiver that has poor low frequency response. The picture was deliberately moved off center to show the absence of the usual blanking bar between pictures. Notice how the horizontal dark bars in the lower center fade out toward the right.

The most likely cause of this condition would be an open video coupling capacitor which, due to sheer bulk, would allow high frequency components of the signal to leak through but effectively blocks the lows. This coupling capacity must be large to pass the low limit of 60 cycles. To eliminate this critical part many manufacturers have used direct coupling between the video amplifier and the picture tube cathode. This eliminates one cause of trouble with low frequency response.

Probably the most common cause of narrow or non-uniform bandpass is improper alignment of rf or if stages which is quite critical, especially in fringe area reception. Amplification over the video bandwidth should be uniform to conform with the bandwidth of the transmitted signal, and proper alignment is necessary to achieve this. The typical bandpass waveform of a

(Continued on page 7)

# A Yagi Antenna For The UHF TV Channels

By P. R. Simon  
Advanced Application  
Engineer

A Yagi type of antenna is one of the simplest high gain antennas to build for reception of one particular channel. Such an antenna using No. 8 aluminum wire as directors and reflector and a dipole constructed of  $\frac{1}{4}$ " and  $\frac{1}{8}$ " brass tubing was optimized dimensionally to achieve the greatest gain on channel 22 or 521 mc.

A gain of 9 db was measured and a good front to back ratio and a good match to 300 ohm twin line was obtained. The dimensions of the antenna are shown in Figure 1. The boom was made of a wax impregnated

oak strip  $\frac{3}{4}$ " x  $\frac{3}{4}$ " x 32" and mounted to its support at the end beyond the reflector. This type of antenna should find wide application for other u h f channels as u h f stations come on the air in the future. To facilitate the construction of antennas for other channels, in Table I are shown all the dimensions that change with frequency converted to fractions of a wavelength. The symbols L and S refer to the element length and spacing as described in Figure 1 with all other dimensions remaining the same as specified. For further convenience in finding the center wavelength of the u h f channels from No. 14 to 83, the formula below was derived:

$$\text{Wavelength (inches)} = \frac{11800}{6 (\text{u h f channel number}) + 389}$$

Dimension	Wavelengths
S <sub>1</sub>	0.215
S <sub>2</sub>	.240
S <sub>3</sub>	.200
S <sub>4</sub>	.290
S <sub>5</sub>	.285
L <sub>1</sub>	.495
L <sub>2</sub>	.450*
L <sub>3</sub>	.430
L <sub>4</sub>	.430
L <sub>5</sub>	.420
L <sub>6</sub>	.415

\*L<sub>2</sub> is overall length of the  $\frac{1}{4}$ " diameter element of the dipole.

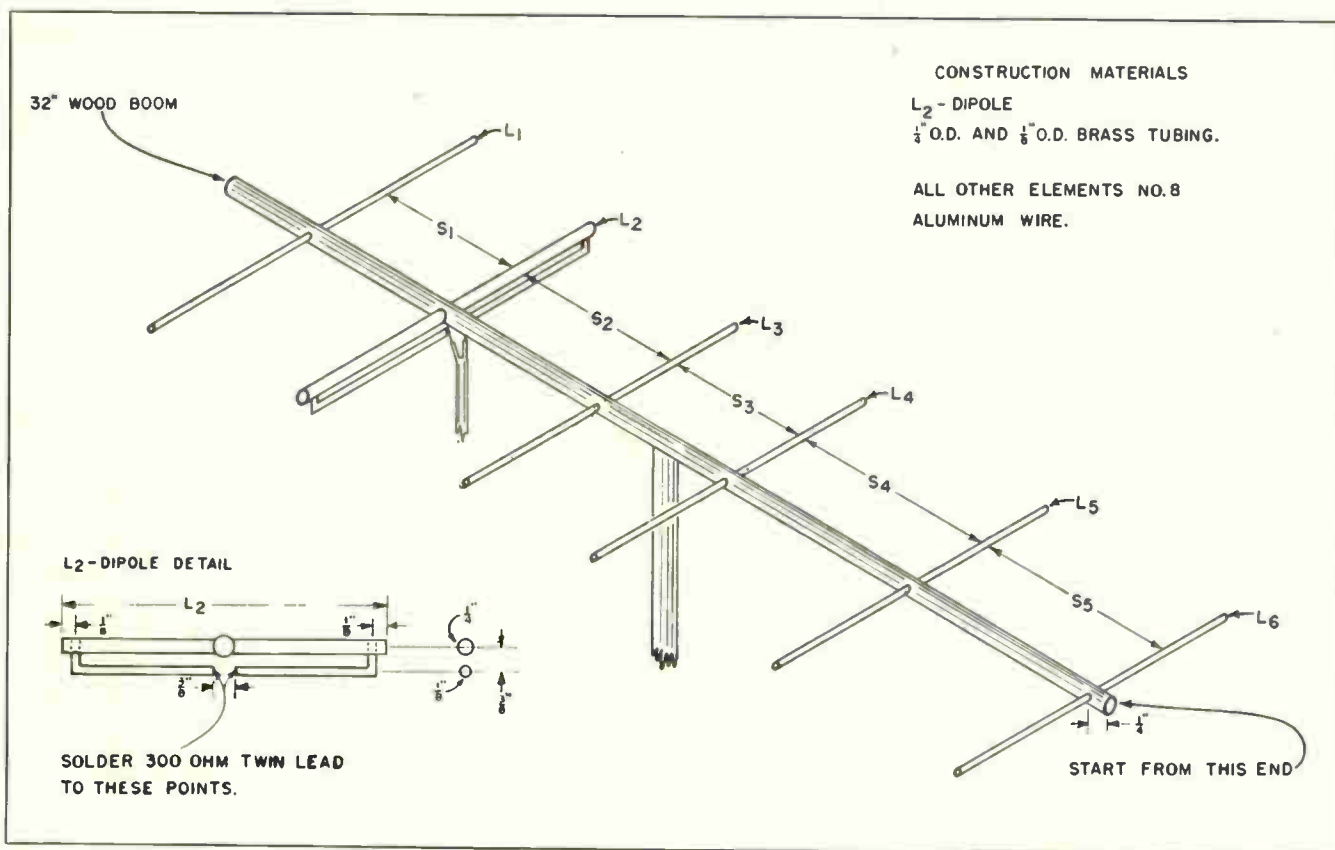

Figure 1. A UHF Yagi Antenna



# THE NEW UHF TV CHANNELS

Channel	Freq. MC	Channel	Freq. MC	Channel	Freq. MC
14.....	470-476	37.....	608-614	60.....	746-752
15.....	476-482	38.....	614-620	61.....	752-758
16.....	482-488	39.....	620-626	62.....	758-764
17.....	488-494	40.....	626-632	63.....	764-770
18.....	494-500	41.....	632-638	64.....	770-776
19.....	500-506	42.....	638-644	65.....	776-782
20.....	506-512	43.....	644-650	66.....	782-788
21.....	512-518	44.....	650-656	67.....	788-794
22.....	518-524	45.....	656-662	68.....	794-800
23.....	524-530	46.....	662-668	69.....	800-806
24.....	530-536	47.....	668-674	70.....	806-812
25.....	536-542	48.....	674-680	71.....	812-818
26.....	542-548	49.....	680-686	72.....	818-824
27.....	548-554	50.....	686-692	73.....	824-830
28.....	554-560	51.....	692-698	74.....	830-836
29.....	560-566	52.....	698-704	75.....	836-842
30.....	566-572	53.....	704-710	76.....	842-848
31.....	572-578	54.....	710-716	77.....	848-854
32.....	578-584	55.....	716-722	78.....	854-860
33.....	584-590	56.....	722-728	79.....	860-866
34.....	590-596	57.....	728-734	80.....	866-872
35.....	596-602	58.....	734-740	81.....	872-878
36.....	602-608	59.....	740-746	82.....	878-884
				83.....	884-890

## Bandpass & The TV Picture

(Continued from page 5)

television receiver, which you have seen so often in servicing manuals, is designed to give just the right amounts of sound and picture carrier with wide band video modulation for best reproduction of the transmitted signal. The set should be aligned to this waveform by use of a tv signal

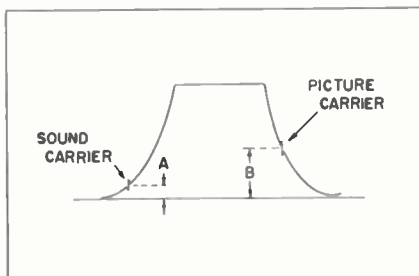

Figure 4. Typical intercarrier bandpass.

generator and an oscilloscope.

In an intercarrier receiver it is important that the sound carrier level does not become greater than 10% of the picture carrier at the video amplifier. This is because greater amplitudes will cause distorted sound due to video modulation of the 4.5 mc beat note sound signal. Amplitudes much less than 3% of the picture carrier would not give a high enough sound level. The optimum ratio of sound to picture is depicted in Figure 4. A—the sound carrier level is 3% of B—the picture carrier level. B is about 50% down the slope from maximum video frequency amplification to match the vestigial side band signal received from the station.

Misadjustment of the if stages that raises the sound carrier up the

slope may cause distortion of the sound and/or bands in the picture. Bands in the picture are more commonly caused by misadjustment of the sound take-off trap (See Figure 5). Improper bandpass in

(Continued on page 8)



Figure 5. Sound in video applied to picture tube.

(Continued from page 7)

the other direction (raising the picture carrier up the slope) will accentuate the low frequencies and reduce the higher video frequencies.

Sometimes in fringe area reception the technician will deliberately distort the bandpass waveform in order to get more gain from the if stages. This reduces the high frequency video response as was mentioned, but the theory is that a poor picture is better than none. There may be some merit to this procedure if care is taken that the sound carrier strength has the proper ratio to the video carrier. In this respect the separate sound channel set has an advantage because peaking the video will not affect the sound.

Peaking the if's for ultra fringe area reception can be done scientifically by two different methods. An oscilloscope and sweep frequency generator must be used for both. The first method is to peak up the normally flat portion of the bandpass curve until the video carrier marker rides close to the top (See Figure 6A).

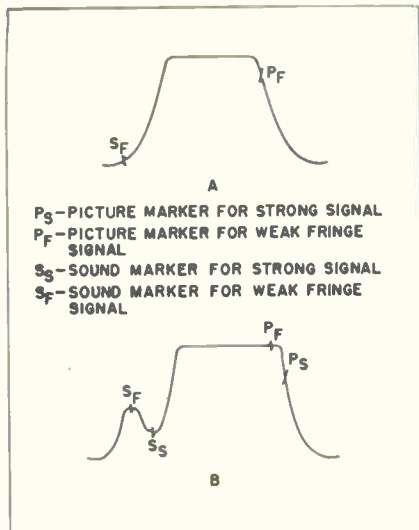

Figure 6. Peaked video bandpass for fringe areas. A—Ordinary peaked if bandpass. B—Peaked if bandpass by using special traps.

The left hand slope is adjusted so that amplification of the sound carrier marker is about 3% of the video carrier.

An improved method that gives a better wave shape is to peak the right hand video portion of the waveform and set the sound carrier marker on

top of a minor peak (See Figure 6B). The minor peaks occur in most wide band amplifiers and can be made to coincide with the sound marker by adjusting various traps in the receiver.

Today it is possible to achieve the same high gain without distorting the wave shape by the use of a low noise, high gain booster between the antenna and the receiver. Remember that you cannot get clear and detailed pictures without amplifying almost all the video frequencies.



## HIGH VOLTAGE PROBE FOR THE POLYMER

Often the television service technician has a need to measure the extremely high voltages found in television receivers.

A dim picture on the CR tube may be caused by trouble in the flyback high voltage supply. The trouble is most easily located by checking the d c voltages throughout the circuit (filter capacitor, voltage doubler or tripler capacitors, rectifier tubes). A low voltage reading will help find which part or tube is at fault or indicate that there is trouble in the horizontal deflection circuit.

You can measure these high voltages, ranging from 6 KV to 30 KV, on the Polymer by using the high voltage probes that are sold as accessories to the meter. The probes are designed for low leakage, high breakdown voltage, and safety to the user.

The Sylvania Type 222 High Voltage Probe will multiply the Polymer ranges by 10 allowing a maximum reading of 10,000 volts d c. The Sylvania Type 225 probe multiplies the ranges by 30 permitting a reading up to 30,000 volts. Since the resistors in the probes are adjusted for use with the Sylvania Polymer, the probes will not function correctly with other makes of instruments.

## Service Hints

**DUMONT RA 112, 133**—Have had numerous complaints about tuning indicators sticking. Many hours may be spent in the shop, checking these units, to no avail, for the trouble is *not* in the chassis. The trouble stems from the fact that the celluloid window (in the cabinet) warps in towards the indicator needle. There are two remedies: First, the celluloid may be reversed in the holder. Secondly, the chassis bolts may be loosened and the chassis pulled back as far as possible. The knobs will still hold securely.—H. Melnick, Elmont, New York.

**TO AVOID LOSS OF TV LINE CORDS** through forgetfulness and to save having to grope for hard-to-reach wall or floor receptacles, make a tv

line connector as follows: Cut off receptacle plug from a tv connector and replace with a male connector which will fit into the tv back cover plug. Cover exposed part with tape. Then simply plug into back cover (with cover removed from set) and other end into receiver as usual.—Leo A. Beck, Butler, Pennsylvania.

**EMERSON 124B, 669B, 675B**—In all sets feeding back a portion of the vertical retrace, check for an open coupling condenser from vertical output section to brightness control. Complaint for this is white retrace lines in pix when brightness is brought up to viewable level. (On Emerson 124B series, Emerson 669B, and Emerson 675B.)—Harry Ringel, New York City.



# PIN CUSHION MAGNETS

By C. A. Peterson - Tube Application Section

## TECHNICAL SECTION

Modern television receivers employ fixed-strength magnets to perform a variety of functions in the operation of the picture tube. Most servicemen are familiar with the adjustment of the ion-trap magnet\* and the focalizer, or permanent focusing magnet. However, little information is available concerning the adjustment of the relatively new pin cushion magnets.

The ion-trap magnet serves to separate the heavy ions from the electron beam, thereby preventing damage to the picture tube screen. The focalizer serves to focus the electron beam to a pin-point spot to give clear, sharp pictures.

The pin cushion magnets were designed to correct for an effect known as pin cushioning, which became prevalent with the advent of the cylindrical picture tube and the cosine yoke. This pin cushion effect may be seen in Figure 1A. It is characterized by a squeezing in of the sides of the raster which results in very pointed corners. As the name implies, the overall shape of the raster is that of a pillow, or pin cushion.

The pin cushion magnets may vary in size but they are usually in the form of a bar. They are mounted on, or near, the yoke and on the side towards the picture tube screen. The mountings are such that the magnets themselves extend over the glass portion of the picture tube in front of the yoke. They are always found in pairs, mounted above and below or on each side of the yoke. In some cases magnets are used on all four sides.

Since the entire raster assumes the pin cushion shape, the defect is most easily seen by decreasing the height and width of the raster until all four sides are visible. The photographs in

Figure 1 were obtained under these conditions. Referring to Figure 1A, it is easy to see where the corrections need to be made. Although all four sides are curved, only two pin cushion magnets are used, and these are mounted on the top and bottom of the yoke in this particular instance. The picture tube here is a 17-inch cylindrical model.

In many cases the pin cushion magnets are mounted with a non-magnetic strap which can be easily bent, so that no tools are necessary in making the adjustments. The magnet is tipped toward or away from the picture tube by bending the strap until the proper straight-sided raster is obtained. It may be necessary to rotate the position of a magnet slightly to achieve the end result. It must be remembered that the closer the magnet is to the picture tube, the more pronounced is its effect. Some

receivers do use a type of rigid mounting with which it is necessary to loosen a screw before the magnet can be moved. The end result, as far as the correction of the pin cushioning effect is concerned, is shown in the Figure 1B.

It is fairly common to find one or two pairs of pin cushion magnets on spherical picture tubes in the 24 and 27-inch sizes. Although the pin cushioning is slight, the magnets are very useful in obtaining better horizontal linearity. Some sets have been found to employ no horizontal linearity control, in which case corrections to horizontal linearity can be made with the pin cushion magnets.

Figure 2A shows a condition of horizontal non-linearity existing in a 24-inch spherical picture tube. This

(Continued on page 7)

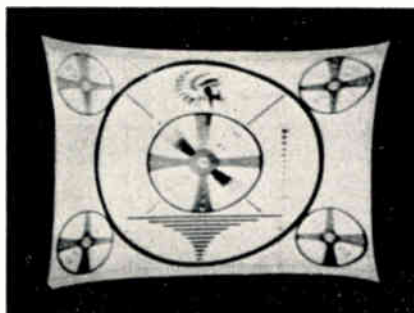

Figure 1A. Height and width reduced to show bad pin cushioning. This set needs magnet adjustment.

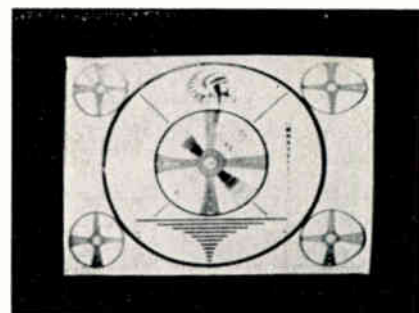

Figure 1B. Pin cushioning corrected after magnet adjustment.

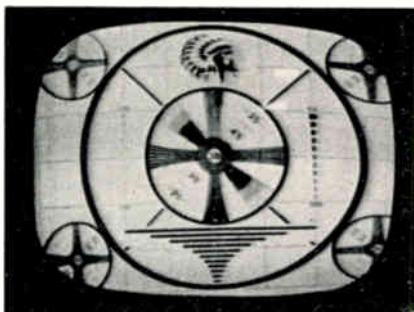

Figure 2A. Horizontal non-linearity in a 24 inch spherical picture tube.

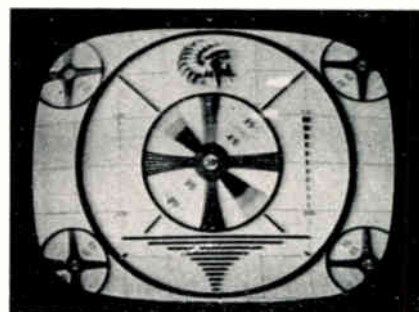

Figure 2B. Non-linearity corrected by magnets.

\*"Ion Trap Magnets" G. E. Fogg, Sylvania News, March, 1953 Vol. 20, No. 3.

# TV ALIGNMENT ACCURACY

By G. M. Lankard - Test Equipment Department

The television technician desires to equip his shop with test instruments which do the best job at a reasonable cost. The first requirement for the service bench is a good Vacuum Tube Voltmeter, such as the Sylvania Poly-meter. Secondly, alignment equipment is a necessary adjunct in trouble-shooting and is also used to put the receiver in good condition after r f or i f parts replacement.

In purchasing the alignment instruments to be used, the decision should be based upon ease of operation, quality of performance, construction and cost. Obviously, it would not be economical to buy expensive laboratory equipment because of prohibitive prices; also the purchase of inferior equipment is uneconomical because of unsatisfactory service and life. A compromise must be reached which will produce happy customers from satisfactory tv repairs and a happy pocketbook for the repairman.

Television receivers today are produced by mass production methods using standard components and definite limits of tolerance. This means that highly precise laboratory standards of measurement are not necessary for the service shop whose foremost consideration is satisfactory restoration of tv receiver operation. Simple, easily adjusted equipment, within the prescribed accuracy determined by set manufacturers, will best meet the aforementioned requirements.

The design engineers, complying with RETMA standards, have set the tolerance for r f and i f alignment at five per cent. Since a primary standard used to calibrate a secondary unit should have an accuracy of at least five times the accuracy of the secondary unit, an accuracy of one per cent is used for tv alignment equipment. Instruments of greater precision for this type of work add negligible improvement to the results and can be difficult to set up.

With the alignment tolerance of one per cent (generally used), any

discrepancy between oscillator and i f frequencies is corrected by the fine tuning control on turret tuners or by the main tuning control on continuous-tuning-type tuners. This adjustment for best picture and sound optimizes the relationship of oscillator to received signal to produce the proper mixer output for i f amplification. The r f stages are relatively unaffected since the bandwidth of the average receiver r f stage is usually six to eight megacycles which allows an even larger variation than the previously specified one per cent.

However, large inaccuracies of alignment may result in a poor picture due to several factors. First, the fine tuning oscillator adjustment may not have sufficient range to bring in the clearest possible picture. Secondly, large errors, especially in continuous tuners, may cause the r f signal to fall outside the tuner passband which will result in either poor sound and picture detail or sync pulse difficulties, depending on which side of the signal receives poor amplification. Well equipped service shops have accepted the practice of using alignment instruments with one per cent accuracy because of these considerations.

Bearing in mind the service shop's needs, the Sylvania Electric test equipment department offers only instruments of the finest quality

within the accepted standards for television and radio servicing. The Sylvania Model 500 Sweep Generator and the Model 501 Marker Generator are a well-known pair of complementary units because of their accuracy, neat matching appearance, convenient size, and solid construction.

The prime requisites of a sweep generator are a wide sweep to cover the complete bandwidth under test and an absence of amplitude modulation to preclude the possibility of an erroneous passband waveform.\* The model 500 not only meets these requirements, but also provides the additional features of phasing control, good linearity, and low leakage from the cabinet which is often important.

The Model 501 Marker Generator has the accuracy necessary for overall alignment and a crystal may be used where greater accuracy is desired. In television inter-carrier sound receivers the 4.5 mc sound channel is accurately defined by the difference between the picture and sound carriers; therefore, it should be aligned with special care. It is recommended that the Sylvania Type 229, 4.5 mc crystal be plugged into the convenient front panel socket of the Model 501 for this operation.

Be economical by buying SYLVANIA.

\*If the response is not flat but the variation is known, it can be compensated for in the alignment procedure.

Figure 1. TV alignment set up. From left to right is the Sylvania 500 sweep generator, 501 marker generator, Sylvania TV set and Sylvania 400 oscilloscope.





## PIN CUSHION MAGNETS

(Continued from page 5)

particular receiver has one set of pin cushion magnets mounted on the sides of the deflection yoke. By simply adjusting these magnets with respect to the picture tube, the linear pattern in Figure 2B was achieved.

In sets employing both pin cushion magnets and a horizontal linearity control, the pin cushion magnets should either be removed, or positioned as far from the picture tube as possible. The horizontal width and linearity controls should then be adjusted for as linear a picture as possible. Once this has been done, the pin cushion magnets may be used to obtain the final corrections, either to the linearity or for the pin cushioning effect.

A bar generator may be used to detect conditions of picture non-uniformity without altering the size of the raster. The relative spacing between bars indicates the degree of non-linearity while the curvature of the bars toward the edges of the raster indicates the degree of pin cushioning. Figure 3 shows a bar pattern on a 21-inch cylindrical tube in which non-linearity and pin cushioning were purposely introduced. The conditions are evident.

Since the pin cushion magnets are fixed in strength, they require little attention once adjusted. When setting up a new receiver for the first time, or after replacing the picture tube, these magnets should be checked for correct adjustment. A few minutes spent in this manner may add that extra quality which makes a good picture almost perfect.

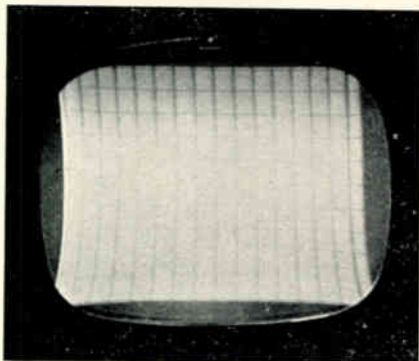

Figure 3. Bar pattern readily shows up non-linearity and pin cushioning.

## WHAT'S THE ANSWER

**CUSTOMER:** How much will it cost to add u h f to my present v h f set?

**SERVICEMAN:** Your set can be easily converted by the addition of an external unit or u h f channel strip. The antenna necessary for u h f depends entirely on the signal strength and local conditions.

TV receivers with turret tuner inputs may receive the local u h f channel by substituting the appropriate u h f tuning strip for one of the unused v h f channel strips in the set. However, this method limits you in the number of channels received and does not give additional gain that may be necessary in weak signal areas, but it is the least expensive method of conversion.

Converters sell from \$29.95 to over \$50.00, your choice depending on the quality and style desired. Practically all of them will work satisfactorily in converting u h f to the v h f input of your present re-

ceiver. The low or medium priced models give you the best dollar value and the higher priced units should give slightly better performance in fringe areas, better cabinetry and construction. One of the higher priced models even includes a tunable v h f booster.

U H F antennas come in all sizes, shapes, configurations and performance specifications. Prices range from \$6.00 to \$20.00—stacked antennas being approximately double this. Some of the higher priced models are designed for both u h f and v h f reception. In very strong signal areas the build in antenna of the booster should be satisfactory, if one is included.

Therefore, the cost of obtaining satisfactory u h f reception could be anywhere from \$10.00 to \$100.00 plus installation fee, depending upon the previously mentioned factors and your personal preference.

### SYLVANIA TYPE 6BQ7A

The Type 6BQ7A has recently been announced by Sylvania Electric Products Inc. This is another of the v h f cascode amplifier tube series with higher gain than its prototype, the 6BQ7.

The 6BQ7A has a  $g_m$  of 6400  $\mu$ mhos and an amplification factor of 38 with 150 volts applied to the plate. It can be used as a replacement for the 6BQ7 with slight realignment of the tuned circuits.

In addition to cascode amplifier use, it is ideally suited to grounded grid balanced amplifier service for frequencies up to 300 mc.

### SYLVANIA TYPE 6CS6

The Type 6CS6, a new tube designed for combined sync separator—noise suppressor use, has recently been announced by Sylvania Electric Products Inc.

It is designed to be used in circuits that accomplish sync separation by feeding the video signal extending in a positive direction to grid three

where the negative grid leak bias development automatically adjusts the clipping level.

Noise suppression is obtained in the 6CS6 by applying a video signal extending in a negative direction to grid one. Strong noise impulses will cause tube cut-off momentarily and thus reduce the harmful effects of noise on picture tube sweep circuits.

The 6CS6 grid number three has a sharp cut-off characteristic to facilitate the clipping action which removes picture information from the sync pulses.

This tube is in the T-5½ bulb style and has a 6.3 volt heater.

### REVISED SYLVANIA 219/200 TUBE TESTER SETTINGS FOR TYPE 1B3GT

	A	B	C	D	E	F	G
Old	1.25	2	13578	14	7	U	9*
New	1.25	2	13578	63	7	T	9*

# SERVICE HINTS

**REMOVING PICTURE WINDOWS ON ADMIRAL RECEIVERS**—All late model Admiral TV receivers have removable picture windows so that the picture tube and safety glass can be cleaned.

When the retaining pieces (either wood strips or a snap in channel) are removed, the picture window is free to be removed. Usually, the window does not fall out and there is no room to get behind the glass with the hand. A sharp tool is dangerous because it may scratch the cabinets.

A suction cup, made of an old high voltage cap with a lead pencil run thru it serves very nicely to pull the glass forward or to re-position it. —Herb Bowden, Chicago, Illinois.

**G. E. 17C113**—Intermittent loss of vertical sync, unstable horizontal sync, too much contrast, with no control were the symptoms.

The tubes checked good and the clipper grid capacitor was not at fault.

Slow warm-up time suggested that the globar resistor in series with the tube filament needed to be replaced. Replacing the resistor restored the set to normal operation.

It was concluded that the filament voltage of the sync clipper tube was so low that it was inoperative. The strange part of it all was that the picture width was nearly normal.—George's Radio, Santa Ana, California

**SECONDARY EFFECTS OF DEFECTIVE COMPONENTS** — When making a repair such as replacing a defective tube, it is a good idea to check associated components even though the set works properly. This prevents call backs due to weakened parts giving out.

A Motorola 9VT1, Chassis TS-13 which had insufficient width, contrast and volume, was in the shop for repair. The 25L6 audio output tube was shorted. Replacing the shorted tube cleared up the insufficient width and contrast but not the volume which was still weak.

Further checking showed that this sequence had occurred:

1. the tube shorted.
2. cathode resistor burned out.
3. this placed a high voltage across the low voltage cathode electrolytic bypass capacitor which caused it to break down. The new tube worked because of the capacitor short.

Replacing the parts restored the set to normal operation.—Samuel R. Craig, Fraser, Michigan.

**PANEL LIGHT FOR SYLVANIA TUBE TESTER**—I installed a 6 watt 120 volt bulb and socket underneath the panel of my Sylvania 140 Tube Tester in order to illuminate the chart. It was placed in the center to give even lighting. The glare is cut down by wiring a narrow strip of metal lengthwise on the bulb and adjusting for best effect on the illumination. A switch can be mounted on the top panel to turn off the light when it is not needed.—Daniel H. Webster, Dubuque, Iowa.

EDITOR'S NOTE: Keep bulb far enough away from chart to prevent scorching.

**GENERAL ELECTRIC TV RECEIVERS, EARLY PRODUCTION "A" CHASSIS** — When servicing these 14" to 17" sets using selenium rectifier power supplies and series filament strings, look for the following defects:

1. Poor sync with no control of contrast and picture (overdriven)—leaky .01  $\mu$ f capacitor at clipper grid. (ED. NOTE: replace with 600 volt molded type.)
2. No picture—shorted .05  $\mu$ f capacitor at cathode of video output tube which removes plate voltage to first video amplifier. (ED. NOTE: replace with 400 volt unit.)
3. No high voltage—open 4000 ohm resistor in 25BQ6 screen circuit. (ED. NOTE: replace 7 W units with 10 W units.)
4. Intermittent picture or poor vertical sync—check germanium diodes.

5. Lack of width—check voltage across selenium rectifiers.

—George's Radio Service, Santa Ana, California.

**DO NOT USE SCREWDRIVER OR NEON BULB** to check the picture tube high voltage. This method will not always show up the trouble and there is danger of bodily injury. Use a High Voltage Probe on your V.T.V.M.

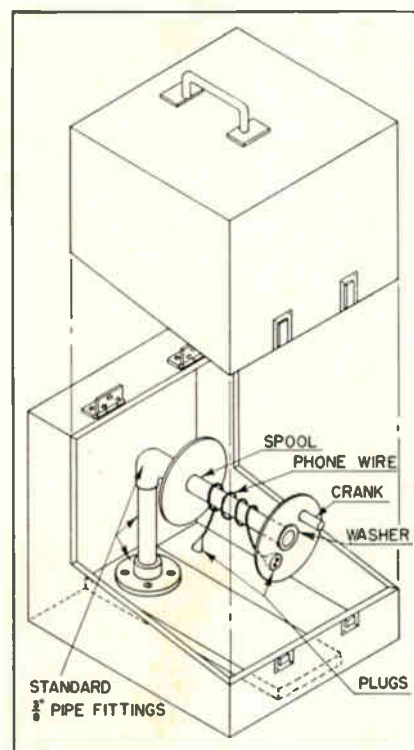

**TELEPHONE BOX**—I use a set of Wheeler Sound Powered Phones when checking antenna installations. I have arranged them in a special box on a reel and crank assembly. This allows me to roll out the wire and reel it in conveniently and fast.

The reel will hold about 200 feet of wire and is very easily constructed from common pipe. The box itself is so constructed that the wire roll and its stand are accessible when the lid is lifted. There is enough room on each side of the roll to hold the two phone sets. —Donat A. Duquet, Waterville, Maine.

A complete exploded view construction diagram of Mr. Duquet's carrier is shown above.

# SERVICING THE HORIZONTAL SWEEP MULTIVIBRATOR

By G. L. QUINT -- Technical Publications Section

The multivibrator is another of the relaxation oscillator "family" that is sometimes used in television receivers to generate the sweep voltages.

The multivibrator can be designed to operate as a *free-running* oscillator at a frequency determined by its circuit parameters, or it may be made to operate in synchronism with an external signal at a given frequency or some submultiple of the given frequency. It can also be designed to operate as a single-shot device requiring an external trigger signal to initiate and/or terminate its operation.

There are many forms of the multivibrator, depending upon the function that it is to perform. This article will deal with only the typical circuits which the television serviceman is likely to encounter.

### CATHODE COUPLED MULTIVIBRATOR

In Figure 1 is shown a typical cathode coupled multivibrator horizontal sweep oscillator. The feedback necessary to produce oscillation is supplied via C<sub>256</sub>, from the plate of the first stage to the grid of the second stage and by R<sub>258</sub>, the common cathode resistor. The trapezoidal voltage necessary to produce a sawtooth current in the deflection coils is developed across C<sub>257</sub> and R<sub>260</sub>. The peaking resistor, R<sub>260</sub>, is necessary to produce proper linearity of the sweep current in the deflection coil.

The LC circuit (L<sub>68</sub> and C<sub>255</sub>) is shocked into oscillation by the multivibrator action and oscillates at a frequency close to 15,750 cycles per second to increase the stability of the

oscillator. It is called by various names depending on the manufacturer such as, ringing coil, horizontal stabilizing control, horizontal frequency control or horizontal lock adjustment. Sometimes a resistor is shunted across the LC circuit to decrease the amplitude of the oscillation developed by the circuit to the value for best stability and to broaden the response of the circuit.

Note in Figure 2 that there are no waveforms shown for the grid of the first stage. This is because the grid of this stage has no periodic waveform developed on it due to the basic multivibrator action, but rather is held at ground potential or at some d c voltage, depending on the type of AFC circuit used. When the oscillator tends to drift off frequency, the

(Continued on page 6)

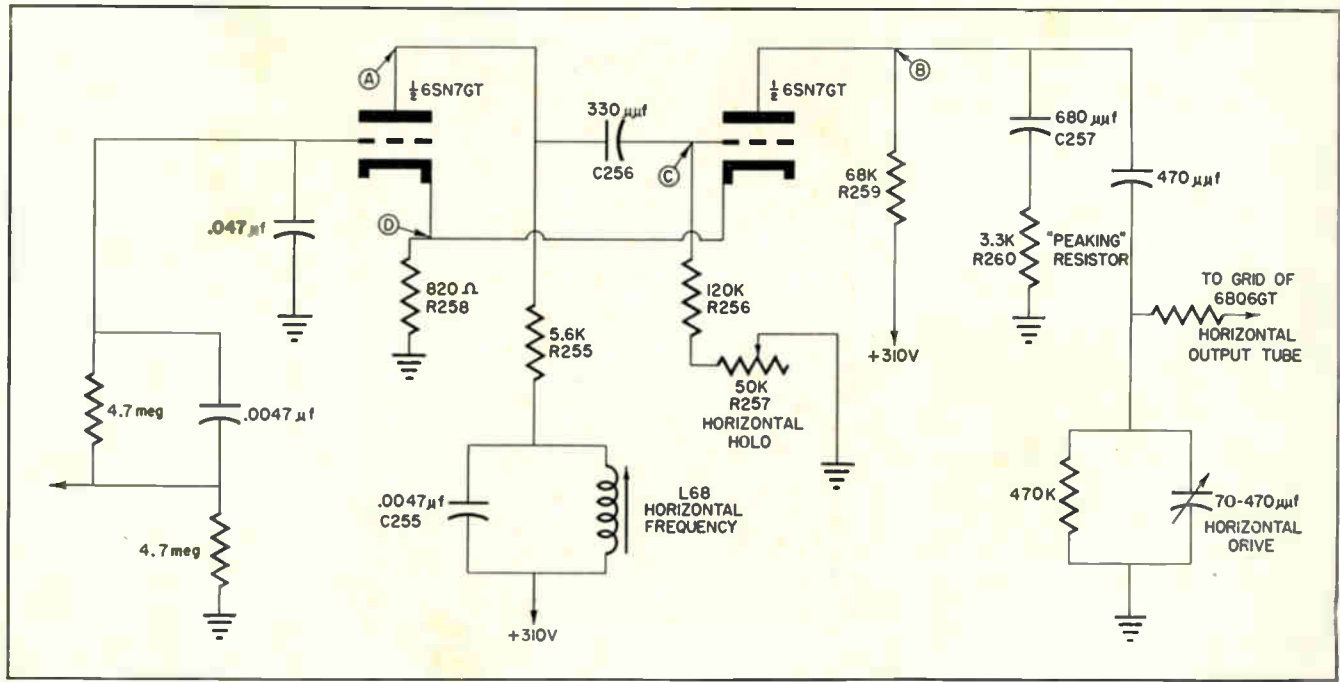

Figure 1. Cathode coupled multivibrator horizontal oscillator used in the Sylvania Chassis 510 (change C08) and 504 (change C02).

Vol. 1: \$1.00—Vol. 2: \$1.00—Vol. 3: \$1.00—Vol. 4: \$1.00

Binders With Complete File of Technical Sections:



# SERVICING THE HORIZONTAL SWEEP MULTIVIBRATOR (Cont.)

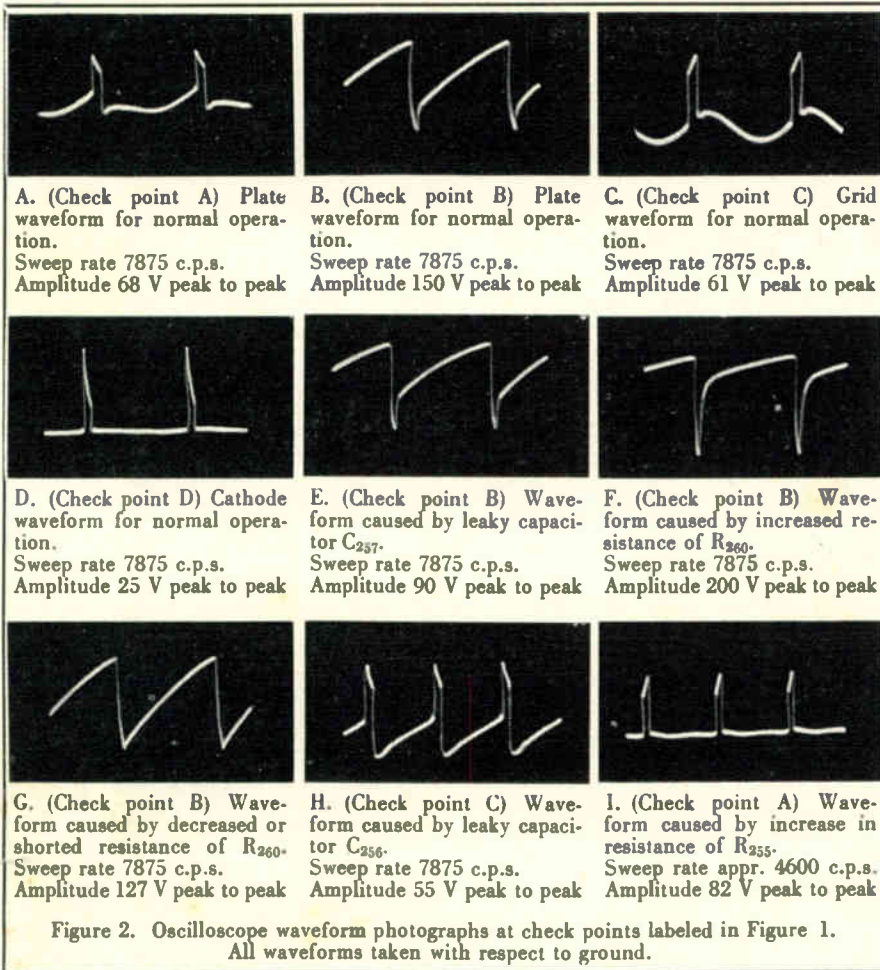

(Continued from page 5)

AFC circuit applies voltage of proper polarity and amplitude to bring the oscillator into sync.

## SERVICING THE MULTIVIBRATOR

According to the well known ancient proverb "that one picture is worth a thousand words," we will show actual oscilloscope pictures of how defective circuit components effect the normal multivibrator function and its waveforms. If the sweep capacitor  $C_{257}$  should develop leakage, the waveform at point B of Figure 1 will be approximately as shown in Figure 2E. It is impractical to discuss the effects of various amounts of leakage current. Therefore, we will show only a representative example. Note in Figure 2E how the *sweep voltage* has started to curve as com-

pared to the normal waveform of Figure 2B. The effects on the picture may be, decreased brightness, decreased width or picture non-linearity. If  $C_{257}$  shorts, which is an example of extreme leakage, the oscillator will cease to function and loss of high voltage will result. Checking the d c voltage at check point B of Figure 1 is also a helpful double check. If  $R_{259}$ , the plate load resistor of this stage, should increase in value it will also cause the d c plate voltage of this stage to be lower, but will not cause the sweep to be non-linear. Therefore, proper interpretation of the waveform as shown on the oscilloscope will greatly reduce the time needed to locate the defective components.

In the event that  $C_{257}$  was found defective, there is the possibility that the set will still not be normal after  $C_{257}$  is replaced due to other mal-

functioning components. A defective capacitor often will cause overload and possible change in value of an associated component, in this case  $R_{259}$  and  $R_{260}$ . This is indicated by one or more of the following symptoms; picture crowded at the right, decreased width, raster off center, insufficient brightness, multiple pictures and loss of horizontal sync. To localize the trouble to the multivibrator circuit, check the waveform at point B in Figure 1—the normal waveform is shown at Figure 2B. Figure 2F shows the abnormal waveform resulting from an increase in  $R_{260}$ . Figure 2G shows the abnormal waveform resulting from  $R_{260}$  decreasing or shorted out, which would cause the picture to spread out at the right and a white vertical bar to appear down the center of the raster. When replacing these components, exact replacements or components having the same characteristics should be used.

If the coupling capacitor  $C_{256}$  should develop leakage, the following symptoms might occur; instability of the horizontal oscillator, loss of sync, picture overlap, hold control becomes ineffective or effective only at extreme settings producing a multiple picture or decreased brightness. Should  $C_{256}$  be shorted or have very high leakage, loss of high voltage will result because the oscillator cannot function. Examination of the waveform at point C of Figure 1 will help to localize the trouble. The normal waveform at this point is shown in Figure 2C and the abnormal waveform is shown in Figure 2H. Comparing the two waveforms, note the change in shape and frequency. The oscilloscope sweep is set at 7,875 cycles per second and with normal conditions we observe two cycles of operation. The abnormal waveform shows three cycles of operation for the same sweep frequency, indicating that our oscillator is running too fast. If the serviceman would put a mark on his scope sweep frequency controls at points where 30, 60, 7,875 and 15,750 cycles

(Continued on page 8)



# SERVICE HINTS

**TEST SPEAKER CONNECTOR**— Many of the auto radios have separate speakers, which are often left in the car as the radio is removed for repair. The problem on the test bench is to wire in the test speaker. I have found that 90% of the auto radios can be serviced with this gimmick.

Take one small pin from a vibrator or type 80 tube and one pin from an octal tube. Connect them as shown

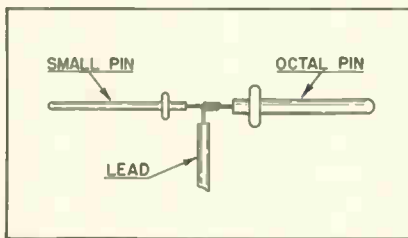

in the picture. Fasten one lead to the center of the pins. Fasten an alligator clip to the other lead for a ground connection. You insert the proper pin into the radio socket; the small on Ford, Mercury etc., the large on Motorola, Philco, Hudson, Kaiser Frazer, etc.—Frank T. Kurowski, New Hartford, N. Y.

**SOLDERING AID** — There are many soldering aid tools on the market, however a home made tool is easily constructed.

Before you discard that old auto antenna rod, cut off the top section with the red ball (about 8"). Then grind down about 1/2" of the end to a fine tip and bend over into a hook (see picture). You can tape over the rod for insulation.

It can be used for an exploratory probe and soldering aid or as a tapper

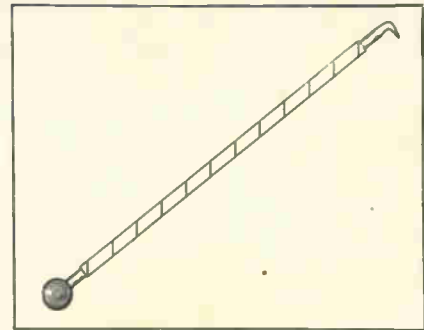

for microphonic tubes by using the plastic ball.—Frank T. Kurowski, New Hartford, N. Y.

**TROUBLESHOOTING LIGHT** — Sometimes I have trouble getting into dark corners when on a service call. I remedied the difficulty by unscrewing the tip of my Ungar soldering pencil and replacing the tip with a 7 watt candelabra bulb. Now I get all the light I need.—Stephen Goch, Bronx, New York.

## SERVICING THE HORIZONTAL SWEEP MULTIVIBRATOR

(Continued from page 6)

per second sweep occur, he will provide himself with a quick method of comparing operating times in various television sweep circuits and thus be able to determine if the circuits are operating too fast or too slow compared with normal operation.

If  $R_{255}$ , the common cathode resistor, should happen to become shorted, from a heater-cathode short for instance, the oscillator will become inoperative causing loss of horizontal sweep and high voltage. Replacing the tube will correct the situation if the trouble is from a heater-cathode short. If heater-cathode leakage exists, but not to the extent to make the oscillator inoperative, the following symptoms might be indicated; loss of horizontal sync, hold control ineffective, raster dim, brightness control ineffective, decreased width and varying the horizontal hold control causes picture brightness to vary. The waveform at point B in Figure 1 will be similar to that of Figure 2F.

$R_{255}$  and  $R_{259}$  may increase in value if their rated wattage is exceeded as might be caused by one of the following: A leaky or shorted  $C_{256}$ ,  $R_{258}$  shorted as previously mentioned, or if the oscillator frequency becomes so high that the oscillator tube's average plate current increases. Figure 2A shows the normal waveform at Check point A of the 6SN7GT horizontal oscillator tube and Figure 2J shows the abnormal waveform resulting from increased value of  $R_{255}$ . Note the change in shape and frequency of the abnormal waveform. The frequency of the multivibrator is lower, the sinusoidal variations so clear in Figure 2A are flattened off in Figure 2J and the ratio of trace to retrace time has increased.

### REPLACING COMPONENTS

Since the proper operation of the sweep circuit is affected to a very great extent by its component values, it should be emphasized that defective components be replaced with exact duplicates. For instance, the coupling capacitor  $C_{256}$  should have very little leakage current for proper operation. If this capacitor is re-

placed by one whose dielectric has very poor insulation quality, normal operation may exist when the chassis is out of the cabinet, but when the chassis is placed in the cabinet the temperature rise of this component may cause erratic operation due to the leakage current increasing as the temperature increases. This fact not only applies to this circuit but to other circuits where the temperature rise effects the components in critical functions. Also, the tolerance of the resistors must be the same as specified by the set manufacturer or proper operation will be impeded. Since the frequency of a multivibrator is critical with respect to the cut-off characteristic of the tube(s) used, the slight variation in characteristics between tubes of the same type may necessitate readjustment of the hold control for most stable operation after a replacement is made.

The author wishes to express his thanks to Mr. Carl A. Peterson of the SYLVANIA Commercial Engineering Laboratories for his assistance in taking the photographs which appear.



# TWIN LEAD "SPRIGS" FOR CONNECTING TWO TV ANTENNAS TO ONE FEED LINE

BY W. P. MUELLER - SECTION HEAD ADVANCED APPLICATION SECTION

In many instances, the fringe area television viewer is faced with the problem of having two stations that can be received, but only the use of separate high gain antennas will give satisfactory reception. There are several ways of solving this problem.

One solution is the use of a broad-band antenna, such as a conical, or bowtie, in conjunction with a rotator. However, this method usually produces a less satisfactory picture than the use of a single-channel, high gain antenna. Also, the rotator installation approximates the cost of an additional antenna.

Another method often used is reception on separate high gain, single-channel antennas, which are selected by a switch or simply by clipping the appropriate feeder to the antenna terminals of the receiver. The goal of better picture quality is accomplished, yet the inconvenience of changing feeders for each channel is enough to plague any housewife who is already confused by the number of controls on her tv set.\* The problem can be solved conveniently and efficiently by means of a simple filter circuit in the feed line to each antenna, thus avoiding the need for any additional switches.

The filter functions on the principle that a signal traveling down a transmission line will not be affected by another line across it if the second line presents a high impedance at the signal frequency.

Such a filter can be constructed with inductance coils and capacitors tuned to the channels being received. However, the use of twin lead stubs

\*A mixing transformer eliminates these difficulties, but it inserts additional loss in the line which may be detrimental to a weak signal.

is somewhat cheaper and more convenient, particularly if the filter is outdoors where it would be necessary to weatherproof the coils and capacitors. Placing the network at the antennas allows one feeder to bring both signals to the receiver without the use of a remote switch. We shall call these tuned stub filters *sprigs* from their physical appearance.

### Theory

Two basic circuit types are required. The first must reject the lower frequency channel and pass the higher frequency channel, while the second must pass the lower and reject the higher frequency channel. These two basic filter types are presented in Figures 1 and 2; their reactance vs. frequency characteristic and two possible forms of the physical arrangement are shown.

Figure 1 shows the filter which is used on the line from the low frequency antenna. Figure 1A represents graphically the reactance characteristic plotted against frequency. Figure 1B is the equivalent

L-C circuit and Figure 1C its equivalent twin lead stub or *sprig* circuit.

Additional isolation between the two antennas is secured by connecting them together in such a way as to make use of the principle that a short circuit across a transmission line will look like an open circuit at a distance of a quarter wavelength away.

For example, the high channel series resonant circuit is placed a quarter wavelength at the high channel from the common junction of the two antennas. Similarly the low channel series resonant circuit is placed one quarter wavelength at the low channel from the common junction. This transforms the short circuits to high impedances across the opposite antennas. A study of Figure 3 will explain the operation of the filter more clearly than a lengthy word description.

Figure 3 gives the dimensions of stubs 1 and 2 in terms of wavelength. To obtain the length of twin lead, the electrical length in space must be multiplied by its propagation factor, (Continued on page 6)

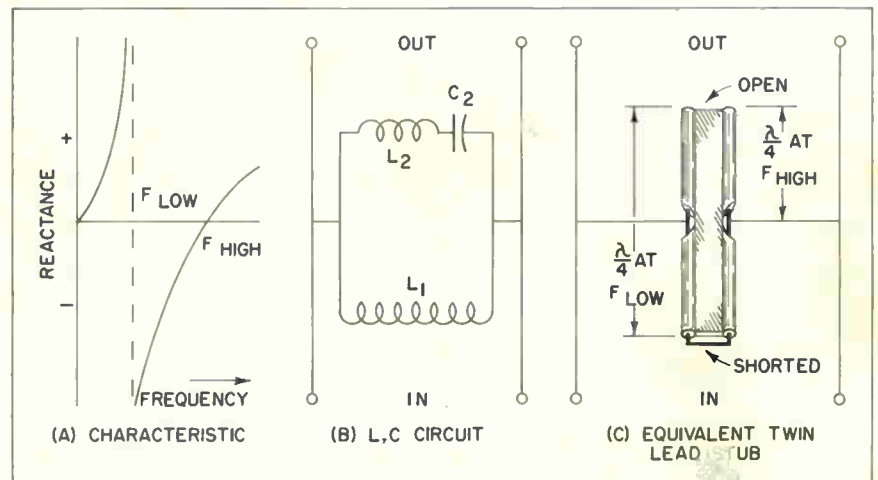

Figure 1. Filter for use on the lower channel tv feeder to reject the higher frequency channel

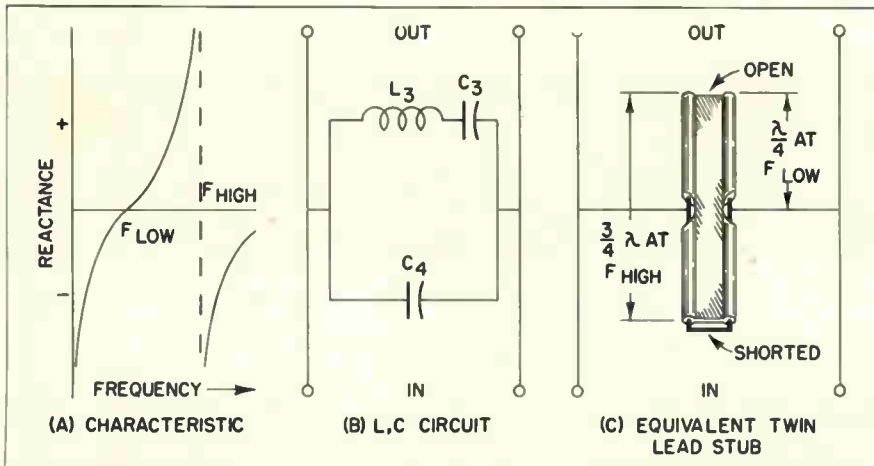

Figure 2. Filter for use on the higher channel tv feeder to reject the lower frequency channel

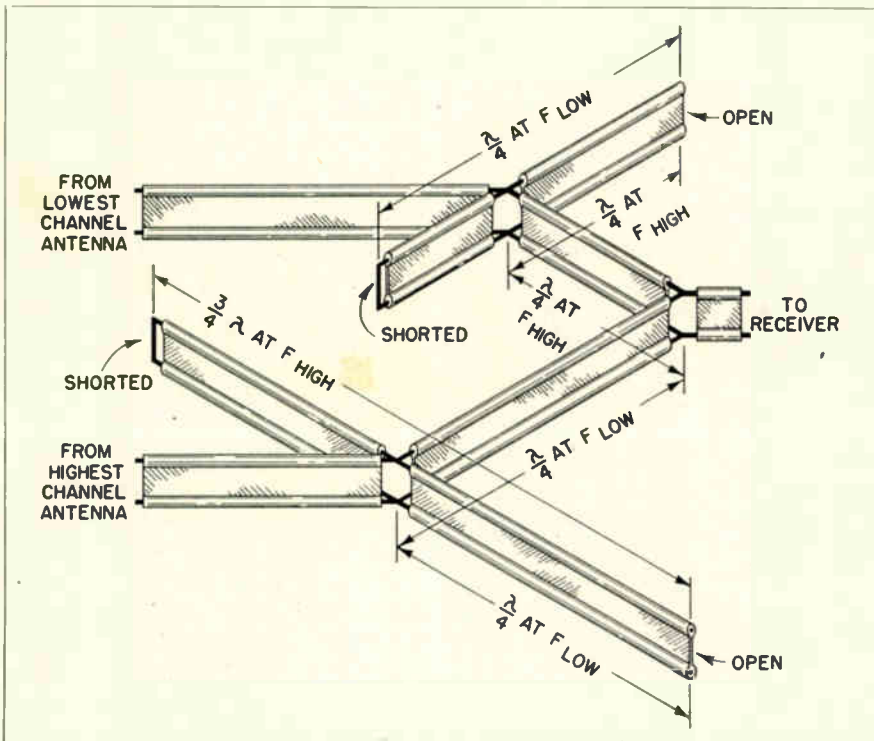

Figure 3. Twin lead sprigs for connecting two television antennas to one feed line.

(Continued from page 5)

which is about .82 for most flat twin lead or use the twin lead length equaling one-quarter wavelength for each tv channel which is given in the TV Channel Table elsewhere in this issue. Multiply this length at the high frequency channel by three to obtain the sprig length for the higher frequency antenna line.

An added advantage of using sprigs is that lightning protection may be achieved by connecting a ground wire to the center of the shorted ends shown in Figure 3. This does not affect the efficiency of the system

because the short is "cold" to rf at these frequencies.

At ultra high frequencies the stubs also provide additional rejection of if interference pickup, because the shunting stubs are so short that they represent only 10 to 20 ohms at the if frequencies.

There is one limitation in using sprigs. They will not work properly on harmonically related frequencies because tuned lines will show resonance on any number of quarter wavelengths. Fortunately, most tv frequencies are not harmonically related.

## AGC BIAS

The Sylvania Chassis 502, 507 and 508 use an agc bias cross-over network in conjunction with a keyed agc amplifier tube. The purpose of this network is to allow the rf tuner section to operate with 0 bias when no signal or very weak signal is present and switch to large agc bias control when a normal signal is received. At the same time, the agc bias to the if amplifiers is permanently divided down to a lower value. This system results in the best noise figure in the tuner when it is most needed and prevents overloads, with attendant wash out of picture, on very strong signals. The agc switching or cross-over control tube is termed—agc clamper.

## FIELD STRENGTH METERS

An indispensable instrument for the TV serviceman is a field strength meter. It will save time both in repairing and installing antenna systems. You can increase customer satisfaction by showing him that the choice of antennas for him was done scientifically rather than the "by guess or by gosh" system. Also time is saved, resulting in more money for your pocket, by quickly orienting the antenna from the roof top. The field strength meter is invaluable in checking transmission line losses and determining the cause of transmission line and antenna troubles.

## NOISE IMMUNITY CIRCUITS

The trend in better, more stable, fringe area television receivers continues in this year's models by the addition of noise immunity or noise suppression circuits. They are principally designed to prevent the sweep oscillators of the receiver from being affected by strong noise pulses.

There are a great variety of circuits to perform this function. They are usually a part of the sync separation or sync amplification circuits and go by many names such as noise gate, noise canceller, noise suicide, noise clipper, etc.

# TV CHANNELS TABLE

Frequency, Quarter Wave Length, and Quarter Wave Length of Twin Lead for determining antenna dimensions and twin lead stub lengths. (Wave length is to the nearest  $\frac{1}{32}$  inch.)

Channel No.	Freq. Range	$\frac{1}{4} \lambda$ in in.	$\frac{1}{4} \lambda$ Twin Lead in in.	Channel No.	Freq. Range	$\frac{1}{4} \lambda$ in in.	$\frac{1}{4} \lambda$ Twin Lead in in.
<i>VHF</i>				<i>UHF</i>			
2	54-60	$51\frac{13}{16}$	$42\frac{13}{32}$	42	638-644	$4\frac{5}{8}$	$3\frac{25}{32}$
3	60-66	$46\frac{29}{32}$	$38\frac{15}{16}$	43	644-650	$4\frac{19}{32}$	$3\frac{3}{4}$
4	66-72	$42\frac{13}{16}$	$35\frac{3}{32}$	44	650-656	$4\frac{17}{32}$	$3\frac{23}{32}$
5	76-82	$37\frac{13}{32}$	$30\frac{21}{32}$	45	656-662	$4\frac{1}{2}$	$3\frac{11}{16}$
6	82-88	$34\frac{3}{4}$	$28\frac{1}{2}$	46	662-668	$4\frac{15}{32}$	$3\frac{21}{32}$
FM-98 mc	88-108	$30\frac{5}{32}$	$24\frac{23}{32}$	47	668-674	$4\frac{13}{32}$	$3\frac{5}{8}$
7	174-180	$16\frac{21}{32}$	$13\frac{21}{32}$	48	674-680	$4\frac{3}{8}$	$3\frac{19}{32}$
8	180-186	$16\frac{3}{32}$	$13\frac{3}{16}$	49	680-686	$4\frac{5}{16}$	$3\frac{17}{32}$
9	186-192	$15\frac{19}{32}$	$12\frac{13}{16}$	50	686-692	$4\frac{9}{32}$	$3\frac{17}{32}$
10	192-198	$15\frac{7}{32}$	$12\frac{13}{32}$	51	692-698	$4\frac{1}{4}$	$3\frac{1}{2}$
11	198-204	$14\frac{23}{32}$	$12\frac{1}{16}$	52	698-704	$4\frac{7}{32}$	$3\frac{15}{32}$
12	204-210	$14\frac{1}{4}$	$11\frac{23}{32}$	53	704-710	$4\frac{3}{16}$	$3\frac{7}{16}$
13	210-216	$13\frac{27}{32}$	$11\frac{11}{32}$	54	710-716	$4\frac{5}{32}$	$3\frac{13}{32}$
<i>UHF</i>				55	716-722	$4\frac{3}{32}$	$3\frac{5}{8}$
14	470-476	$6\frac{1}{4}$	$5\frac{1}{8}$	56	722-728	$4\frac{3}{32}$	$3\frac{11}{32}$
15	476-482	$6\frac{3}{16}$	$5\frac{1}{16}$	57	728-734	$4\frac{1}{16}$	$3\frac{5}{16}$
16	482-488	$6\frac{1}{8}$	$5\frac{1}{32}$	58	734-740	$4\frac{1}{32}$	$3\frac{9}{32}$
17	488-494	$6\frac{1}{32}$	$4\frac{31}{32}$	59	740-746	$3\frac{31}{32}$	$3\frac{1}{4}$
18	494-500	$5\frac{31}{32}$	$4\frac{29}{32}$	60	746-752	$3\frac{15}{16}$	$3\frac{1}{4}$
19	500-506	$5\frac{7}{8}$	$4\frac{13}{16}$	61	752-758	$3\frac{29}{32}$	$3\frac{7}{32}$
20	506-512	$5\frac{13}{16}$	$4\frac{25}{32}$	62	758-764	$3\frac{29}{32}$	$3\frac{3}{16}$
21	512-518	$5\frac{3}{4}$	$4\frac{23}{32}$	63	764-770	$3\frac{7}{8}$	$3\frac{5}{32}$
22	518-524	$5\frac{11}{16}$	$4\frac{21}{32}$	64	770-776	$3\frac{27}{32}$	$3\frac{1}{8}$
23	524-530	$5\frac{5}{8}$	$4\frac{19}{32}$	65	776-782	$3\frac{13}{16}$	$3\frac{3}{8}$
24	530-536	$5\frac{9}{16}$	$4\frac{9}{16}$	66	782-788	$3\frac{25}{32}$	$3\frac{3}{32}$
25	536-542	$5\frac{1}{2}$	$4\frac{1}{2}$	67	788-794	$3\frac{3}{4}$	$3\frac{1}{16}$
26	542-548	$5\frac{7}{16}$	$4\frac{7}{16}$	68	794-800	$3\frac{23}{32}$	$3\frac{1}{32}$
27	548-554	$5\frac{3}{8}$	$4\frac{3}{32}$	69	800-806	$3\frac{11}{16}$	$3\frac{1}{32}$
28	554-560	$5\frac{5}{16}$	$4\frac{3}{8}$	70	806-812	$3\frac{21}{32}$	3
29	560-566	$5\frac{1}{4}$	$4\frac{5}{16}$	71	812-818	$3\frac{5}{8}$	$2\frac{31}{32}$
30	566-572	$5\frac{3}{16}$	$4\frac{1}{4}$	72	818-824	$3\frac{19}{32}$	$2\frac{31}{32}$
31	572-578	$5\frac{5}{32}$	$4\frac{7}{32}$	73	824-830	$3\frac{9}{16}$	$2\frac{15}{16}$
32	578-584	$5\frac{3}{32}$	$4\frac{3}{16}$	74	830-836	$3\frac{9}{16}$	$2\frac{29}{32}$
33	584-590	$5\frac{1}{32}$	$4\frac{1}{8}$	75	836-842	$3\frac{17}{32}$	$2\frac{7}{8}$
34	590-596	5	$4\frac{3}{32}$	76	842-848	$3\frac{1}{2}$	$2\frac{7}{8}$
35	596-602	$4\frac{15}{16}$	$4\frac{1}{16}$	77	848-854	$3\frac{15}{32}$	$2\frac{27}{32}$
36	602-608	$4\frac{29}{32}$	4	78	854-860	$3\frac{7}{16}$	$2\frac{27}{32}$
37	608-614	$4\frac{27}{32}$	$3\frac{31}{32}$	79	860-866	$3\frac{7}{16}$	$2\frac{13}{16}$
38	614-620	$4\frac{13}{16}$	$3\frac{15}{16}$	80	866-872	$3\frac{13}{32}$	$2\frac{25}{32}$
39	620-626	$4\frac{3}{4}$	$3\frac{29}{32}$	81	872-878	$3\frac{3}{8}$	$2\frac{25}{32}$
40	626-632	$4\frac{11}{16}$	$3\frac{7}{8}$	82	878-884	$3\frac{3}{8}$	$2\frac{3}{4}$
41	632-638	$4\frac{21}{32}$	$3\frac{13}{16}$	83	884-890	$3\frac{11}{32}$	$2\frac{23}{32}$



# SERVICE HINTS

**A SIMPLE WATTMETER SUBSTITUTE** can be rigged up cheaply in the following manner: Use a one ohm, heavy wattage resistor and connect it as shown. An ordinary AC voltmeter connected across A and B permits a wattage check accurate enough for service applications. For example, if the voltmeter reads three volts, then since  $I$  equals  $E/R$  that is  $3/1$  or three amperes, then  $W$  equals  $3 \times 120$  or 360 watts. In practice, all that needs to be done is to multiply the voltmeter reading by 120 (the line voltage). Thus two volts means  $2 \times 120$  or 240 watts—five volts means  $5 \times 120$  or 600 watts, etc. A 25 watt resistor permits loads up to 600 watts to be checked—a 50 watt resistor will handle up to 850 watts—a simple ohms law calculation will indicate any higher reading values desired.

The strategic uses of a wattmeter for servicing are too numerous to mention here, but will certainly suggest themselves to the enterprising serviceman. Total cost (less voltmeter, which it is devoutly hoped we all possess) less than a dollar.—H. L. Solomon, Brooklyn, N. Y.

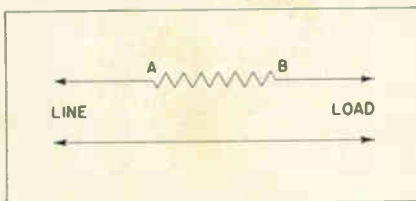

**MOTOROLA MODEL 21T2 Chassis 351-A—Intermittent Reception.**—This set would play for hours, then suddenly cut off. It finally cut off in the shop after playing 15 hours, so that I was able to track down the trouble. By using a signal generator to inject a signal, I worked back toward the front end and located the trouble in the antenna coil. A new antenna coil wound with No. 30 enamelled wire worked perfectly. The old coil apparently had shorted turns causing a bad mismatch at the input.—J. Nolter, Mahanoy City, Pa.

**POWER LINE FILTER BY-PASS IN TV RECEIVERS**—Working on an RCA Television Model 9TW309 with a snowy picture and normal sound, I found that the antenna transformer was burned open.

First, suspecting lightning damage, I examined the lightning arrestor and found it correctly installed.

The antenna contained a folded dipole which had a dc connection to the mast. The mast was grounded through the lightning arrestor strap.

The ac potential between the antenna lead and the chassis was measured and found to be approximately line voltage. Reversing the ac plug lowered the potential considerably. Checking the line bypasses showed one to be shorted which made the chassis "hot" with a c.

This trouble would not have shown up in other than a properly grounded antenna system. It is easy to realize the importance of such a situation since the chassis floats at line potential.

If the antenna transformer had been replaced without replacing the capacitor, it would have burned out also. Therefore, it is a good policy to check these capacitors on all sets.—Adam Zelinski, Jersey City, N. J.

**ROSIN SOLUTION**—About one ounce of rosin is dissolved in 3 ounces of alcohol by allowing it to stand at room temperature in a glass-stoppered bottle. The final solution has several excellent uses around the service shop, such as:

Non-corrosive soldering-flux for litz and other fine wires.

Prevent slipping of dial cords after the cord has been moistened with the solution and dried.

Cement for holding screws in wood, etc.

Violin-bow rosin is the best grade for this purpose. 180-proof denatured alcohol is suitable if pure grain alcohol is not obtainable.—Irvin Levin, Hyattsville, Maryland.

**CLEANING TV TUNERS**—Wafer-Tier Type TV coil switches such as used in RCA models 721TS, 621TS, 630TS become noisy and make poor contact after being used for some time. It is hard to reach the contacts for cleaning by ordinary methods. It was found that a flit gun filled with carbon tetrachloride could be used to spray the fluid directly onto the contacts.

Tuner contacts oxidize after being in use for some time, poor contact results which may cut off reception altogether. The use of a good silver polish will clean them up very nicely.—C. L. Mintzer, Brooklyn, New York.

**EDITOR'S NOTE**—Carbon tetrachloride leaves a slight film when it dries. Do not spray it in the tuner indiscriminately.

**SILVERTONE 101-867TV**—Intermittently the picture would lack contrast, go out of focus, and sound would become weak. The set worked fine at the shop and no amount of tapping, heating or change in position caused the intermittent condition.

Since the trouble occurred at the customer's home, we suspected the voltage supplies; therefore, we made a list of voltages across the voltage dividers. Two weeks later the set began acting up in the customer's home and we made another voltage list while the set was in this condition.

Comparing the readings and checking against the schematic showed the trouble to be in the Candohm resistor R67318 located inside the high voltage cage. It had shorted between the resistance element and metal case of the resistor which lay against the chassis. Replacing it cured the trouble.—George's Radio, Santa Ana, California.

## HANDLING PLASTIC CABINETS

—The new plastic cabinets are hard to handle, especially the 21" table models. A suction cup device used by people who handle large sheets of plate glass for store fronts works like a charm and provides a real hand hold for safe and convenient handling. They may be obtained from suppliers of glass equipment.—H. H. Heinrich, New London, Wisconsin.



(Continued from page 5)

rate of oscillator blocking may cause this condition. If  $C_1$  is leaky it will not hold the cut-off bias a sufficient length of time to give a 60 cycle frequency at any setting of the vertical hold control. Because of the nature of the condition, the frequency would be higher than 60 cycles which may make it impossible for the sync pulses to lock in the picture.

A change in value of  $R_1$  or  $R_2$  will either increase or decrease the frequency of oscillation; an increase in resistance will decrease the frequency and vice versa. If the vertical hold adjustment locks in the picture at the extreme end of its range it would be wise to change  $R_1$  to a value that allows adjustment near the center, if you are sure that a defective part is not involved. Add resistance to  $R_1$  if the control adjusts at maximum resistance, subtract resistance from  $R_1$  if it adjusts at minimum resistance.

In some sets a long warm-up time is required for stabilization of the oscillator developed grid bias which determines operating frequency. This initial warm-up time is usually in the order of 25 seconds and may take as long as 60 seconds. If this time is excessive, another tube will probably reduce it.

In servicing television circuits there is no more valuable aid than a good 'scope and a voltage calibrator which will save hours of unsuccessful troubleshooting. Also, an analysis of circuit operation will save time and make more money for you in tv.

Your questions on blocking oscillator problems are invited. Those of greatest merit will be published with the answer.

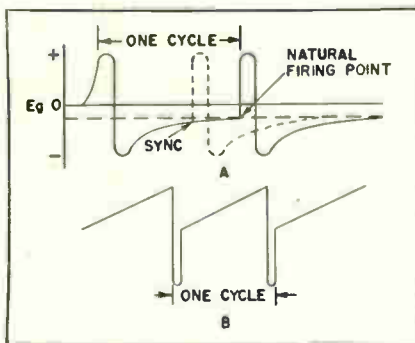

Figure 2. Blocking oscillator waveforms.

## PICTURE TUBE PICTURES



This month's Picture Tube Picture concerns another of the many exacting tests which Sylvania Picture Tubes must undergo to ensure the highest quality available.

A minimum of three gas checks, in addition to many other tests, are run before the tube leaves the factory. The final gas check is compared with records of several previous gas checks

made along the production line.

If any indication is given that even a minute amount of gas has been generated inside the tube or has leaked in after evacuation, the tube is promptly rejected.

This is another example of how carefully Sylvania Picture Tubes are built to give their long, trouble-free life.

## NEW CHARTS FOR SYLVANIA TUBE TESTERS

New Roll Charts are now available to all owners of Sylvania 139/140 and 219/220 Tube Testers. Copies may be obtained at \$1.00 each from Sylvania Electric Products Inc., 1221 West Third Street, Williamsport, Pennsylvania. Attn: Mr. Jack Mintzer.

Revised roll charts for Sylvania tube testers are prepared as a service to users of Sylvania equipment. Between revisions, supplemental settings are published in SYLVANIA NEWS as soon as available.



# High Electrostatic Picture Tube Substitution

By F. L. Burroughs - Picture Tube Division

Several electrostatic-focus picture tubes introduced two years ago were of the high voltage focus type. They were never widely used in television receivers. The high voltage electrostatic focus types listed in Table I may be replaced with some advantage by the suggested low voltage electrostatic-focus tubes more readily available. The basing arrangement on the newer low voltage focus tubes is the same as for the ones they replace, so it is only necessary to connect the number 6 pin to a new focus voltage point in the tv receiver.

The first step in substituting a low focus voltage tube in place of one operating at the higher focus voltage is to disable the existing focus voltage supply. This supply operates at several thousand volts so the usual precautions in dealing with high voltage should be followed.

Then the lead from the low voltage focus pin should be connected to a variable voltage source of a few hundred volts. The best voltage supply to use in most television sets is the picture tube's G2 supply. A potentiometer may be connected as shown in Figure 1, or, if preferred, a simple voltage divider consisting

of three or four one megohm resistors is satisfactory.

When the changes in the set wiring are completed, the focus voltage should be set at the proper point. Before the focus voltage adjustments are made, the ion trap should be moved along the neck to the point where the brightest picture is obtainable. Then the brightness and contrast controls should be set so that a picture of the desired brightness is being viewed.

In adjusting for best focus it will be necessary to change the focus voltage about 100 volts at a time to notice an appreciable change in focus on the tube. Moving the potentiometer arm quickly through its entire range will show changes in tube focus most clearly, and then the point of best focus can be promptly determined.

In similar fashion, if a voltage divider having several taps is used, it is best to move the connecting wire rapidly from one tap to another until the best focus point is found. Once the proper focus voltage is selected, it will not usually be necessary to make further adjustments during the life of the tube.

Table I

High Voltage E <sub>s</sub> Focus	Suggested Low Voltage E <sub>s</sub> Focus
Type	Replacement
17FP4A	17HP4/17RP4
20FP4	20HP4
20GP4	20HP4A

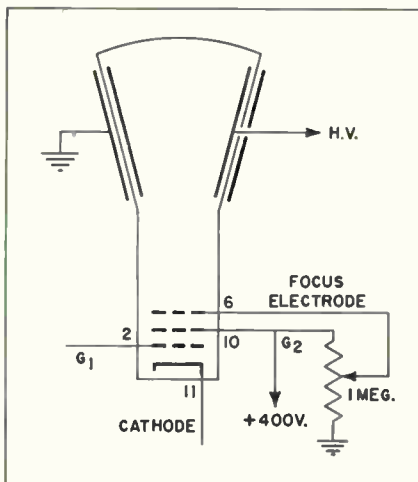

Figure 1. Adjustable focusing voltage

## SETTINGS AND ADAPTER FOR TYPE 6V8 SYLVANIA MODEL 219/220 TUBE TESTER

Using the settings listed below, set the Tube Tester in the usual manner. Plug the Type 6V3 into the nine-pin socket. Plug the adapter into the octal socket. Connect the top cap connector from the adapter to the top cap of the type 6V3. Read the meter in the regular manner.

### MODEL 219/220 SETTINGS FOR TYPE 6V3

A	B	C	D	E	F	G	K
6.3	4	579	10	5	Z	2	
6.3	4	579	10	5	Z	7	
6.3	4	579	10	5	Z	9	

Note: The 139/140 Tube Tester will check the 6V3 without the adapter. Settings are included in the new roll chart (see chart announcement on Page 6).

Adapter for type 6V3 to be used in conjunction with Sylvania Model 219/220 Tube Tester is shown to the right.

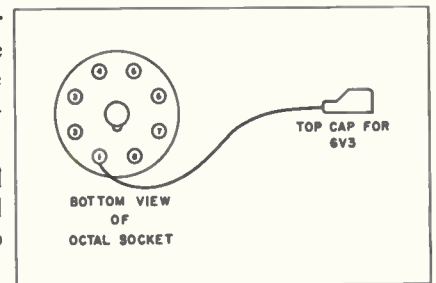

# Service Hints

**PERIODIC CLEANING OF CONTACT POINTS** on turret type tv tuners is a must for efficient reception. Carbon tetrachloride and numerous other cleaning fluids are not recommended, due to their leaving a film when dry. A corrugated rubber wedge (type used to prevent car windows rattling) may be used to remove corrosion by rubbing against contacts. Contact should then be brushed off with a completely dry typewriter brush.—Seymour Greenberg, Whitestone, L. I., N. Y.

**Editor's Note**—Not practical for all turret type tuners without disassembling.

**EMERSON 629, B SERIES TV**—No picture, no raster; high voltage dropped from 14,000 volts to less than 2,000 volts. The 2 megohm resistor in the high voltage doubler supply dropped in value from 2 megohms to less than 800,000 ohms. It is advisable that this resistor be replaced with a 4 watt resistor to prevent future recurrence of this condition.—S. Plauski, New York, New York.

**SILVERTONE MODELS 1162, 1117 AND 1172**—made by Air King Company (CBS). These models had cases of horizontal double pulsing. This was caused by incorrect resistors and resistors changing value with use. To correct this condition, change the 270K ohm resistor (from Pin 6 to B+ of the 12BH7 horizontal oscillator tube circuit) to 220K ohms. This must be done without changing any other resistance value.—Joseph P. Lopardo, Jr., Philadelphia, Pa.

**ENLARGED SCREW HOLES**—To repair enlarged screw holes for holding backs or lids on radios, I stick a piece of solder in the hole and cut off flush with the cabinet surface. When the screw is reinserted the solder leads up the hole and makes the screw fit firmly.—Gilbert H. Doty, Dayton, Ohio.

**TEST PROBE ADAPTERS** — A chuck type test probe tip can be made to accommodate banana plugs by drilling out the end with a No. 24 drill. Either a banana plug or an alligator clip will slip into the hole.

A banana plug wound over with insulated wire with one end bare will make a condenser probe tip. I used a 4" banana plug socket with a 100K resistor inside for an isolation resistor tip which fits over the banana plug.—Maury Kerr, Redondo Beach, Calif.

**CROSLEY MODELS EU-21COL, EU-21COL-BD** — The picture first appears normal and then turns negative after five minutes and very faint after ten. All voltages are normal except for the last video (6AH6) which is slightly higher.

Checking with a 'scope shows high distortion on the plate of the 6AH6 and no gain. By using a VTVM I discovered that the picture control in the cathode circuit had high resistance. It checked good when cold. The carbon disc was cracked which would open up from heat after the set had been on for awhile.—Joseph Nolter, Mahanoy City, Pa.

**ARCING CLIP TYPE TERMINALS** —All TV Receivers. In tv sets with 1B3, 6BG6 or 6BQ6, the arcing causes bright intermittent flashes on the screen. It can be remedied by changing clips with ceramic caps.—Signal Radio, New Haven, Conn.

**HIGH VOLTAGE CABLES**—All TV Receivers. Intermittent snaps of high voltage in the high voltage supply indicates installation breakdown. This can be remedied by replacing cables with high tension auto ignition type. Thereafter, there is no trouble if the cable touches the chassis.—Signal Radio, New Haven, Conn.

**REMOVING OR REPLACING PICTURE TUBES**—Before tube is removed from set place a straight edge (ruler or pencil) as a guide from

the tube flare to socket. Place a drop of red nail polish on each unit on tube neck (yoke, focus coil, ion trap and tube socket). When the tube is replaced these adjustments can be lined up with ease.—J. P. Torre, Brooklyn, New York.

**PROTECTING PHONO CARTRIDGES**—Remove the soft rubber liner from a defective vibrator. When servicing record players, slip this liner over the cartridge. This will prevent injury to pickup or needle from "banging around" during examination or repair operations. It can also be used when delivering set to owner.—Radio Hospital, Los Angeles 33, California.

**TEST LEAD RACK**—Save time and improve the appearance of your shop by storing test leads on this easily constructed rack. The rack shown below can be made longer if necessary but the size shown here is ample to take care of an ordinary service shop.

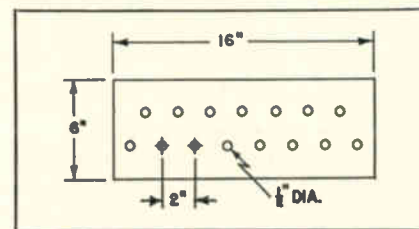

This rack is made from a board 16" x 6" x 3/4". Drill holes across the board 2" apart (see sketch above). Insert ordinary clothespins into these holes. A small amount of glue applied to the head of the clothespin will hold them secure.

Test leads can be inserted into, over or between the clothespins.—Donat A. Duquet, Waterville, Maine.

**HANDY TEST PROBE TIP INSULATOR**—Many times I have had trouble watching the test probe contact and Polymeter at the same time. I have made testing easier by slipping a piece of rubber wire insulation over the tip of the test probe, letting it extend over the end of the tip by about 1/2". By placing the end of the rubber on the point of contact, I can take a reading by exerting slight pressure on the probe while watching the meter.—Daniel H. Webster, Dubuque, Iowa.

# SERVICING THE ELECTROFLASH

## PART II (WABASH MODELS R-1140 AND R-1142)

By J. H. MINTZER, Supervisor of Factory Service Stations

When servicing electroflash units, the first thing to be determined is the location of the source of the trouble. In most cases, you can assume that if the "keep alive glow" is visible in the Sylvania Type OA5 trigger tube, the power supply is operating normally. The OA5 tube can be seen by unscrewing the bottom end cover on the base of the gun on Wabash models. The "keep alive glow" appears as a small lighted violet spot at the base of the tube elements. If the glow is not visible, it could, of course, be a gun defect such as a defective OA5 or an open resistor R-111, in Figure 2 (1)\*; but, as stated previously, the chances are that it is power supply trouble. Therefore, checking the power supply should be the next logical step. The power supply should be removed from the cabinet to be sure that the storage capacitor is discharged before any attempt is made to measure voltages. The case should never be removed from the gun before it is detached from the power supply.

To remove the Wabash R-1140 model from its cabinet, first remove the two chassis mounting screws located on the bottom of the cabinet. The power supply can then be lifted out. If the storage capacitor is in a charged condition, a loud pistol-like report will be heard as the safety switch shorts out the terminals of the capacitor. If this report is not heard, proceed with extreme caution as the shorting switch spring may have been bent in a previous repair and is not making contact. Lay the supply on its side and, with a piece of

\*Numbers in parentheses refer to circled numbers on the drawing indicating various trouble points.

good insulating material about a foot long, close the shorting switch contact. It is located directly over the ungrounded terminal of the storage capacitor. Before making any measurements, be sure that this switch is closed and in proper working condition. These capacitors can build up a residual charge even though no voltage is being applied. They have been known to lay on a shelf for months and then surprise a careless handler with a "teeth shaking jolt." It is a good idea to short the terminals out when storing them.

After all precautions have been taken with the capacitor, a voltage reading should be taken of the output. The meter should be switched to its high range and connected to the circuit before the supply is turned on, bearing in mind that all Wabash electroflash equipment use a positive ground. Before turning the power supply on, set it in an upright position so as to disengage the shorting switch contact. The voltage reading obtained should be approximately 2350 volts, in Figure 2 (2), at a normal line voltage of 117 volts a c input in units using either Sylvania Type R-4330 or R-4340. Should the output reading obtained be much less than this figure, normal power supply service procedure can be used in checking out the components.

The Wabash R-1142 power supply is a battery-vibrator type which may be removed from its cabinet in the following manner. First, remove the four screws located on the top and carefully lift the top cover off. The safety switch on this model is held open by means of a small bakelite rod seated against this top cover. If care is not used, the rod can be broken or

fly out and become lost due to the tension exerted on it by the safety switch spring. Be sure that the switch is closed. Use a piece of insulated material and push the contacts together if necessary. The two cabinet ends can be removed by inserting a knife under the heads of the casing rivets and prying them out. Four Phillips head countersunk screws hold the chassis to the main body of the cabinet. Servicing this supply is the same as the R-1140 previously mentioned, except that the battery and vibrator should be checked.

Should the power supply prove to be in normal working condition, the next step is testing the gun. Figure 1 shows front and back internal views of the two Wabash gun models. Again, a word of caution: always disconnect the gun from the power



Figure 1. Two types of photo flash guns using SYLVANIA tubes. The SYLVANIA Type OA5 trigger tube can be seen on the lower end.



## SERVICING ELECTROFLASH PART II

(Continued From Page 5)

supply before removing the case and attempting measurements. Safety is the primary consideration, although erroneous resistance readings would result were it not disconnected. The gun can be removed from its case in the following manner. Remove the flash tube and reflector. In the Wabash models, the reflector mounting bracket is held in place by two No. 4 self-tapping screws; the retaining band and tube clamp encircling the top of the gun are held in place by one No. 4 machine screw. Insert the forefinger under the flash tube socket and pull; at the same time, grasp the gun with the other hand and push the bakelite connector strip upward with the thumb. There is danger of breaking wires if this procedure is not followed.

The first check should be a resistance reading of the voltage divider network made up of resistors R-101 to R-108 in Figure 2 (3). This can best be done by measuring between pins 3 and 5 of the flash tube socket or between pin 5 and the exposed shield of the high voltage cable. The reading obtained should be approximately 10.8 megohms, plus or minus five per cent. If the variation exceeds five per cent, check each resistor in the divider individually and replace if necessary. Special attention should be given to the value of R-101 to see that it is within its five per cent tolerance; intermittent operation may result if it is not. The unit will flash automatically without being triggered or will not flash at all, depending on whether R-101 is excessively above or below its specified tolerance. Should the divider resistors check okay, a check should then be made of the values of the trigger tube supply resistors, R-109, R-110 and R-111. Again, if any exceed their tolerance they should be replaced.

This is probably the best time to explain why new batteries are installed in portable units when, in many cases, it is not the batteries that are at fault. All conditions in the gun being normal, a total of about 180 flashes can be expected out of a

set of fully charged batteries in good condition. This figure is based on factory tests, flashing the unit every consecutive 20 seconds. However, flashing at longer intervals will reduce the number of available flashes proportionately. Certain conditions in the gun will alter those figures. A gun in good electrical condition will fire at a minimum voltage of 1750 volts. If the trigger supply voltages were not correct or the oscillatory trigger capacitors had over the nominal amount of leakage, the minimum flashing voltage would increase. Therefore, even if the batteries were in a fully charged condition, fewer flashes would be obtained, sometimes reducing to almost one-half the normal number. One of the most common causes of this reduced flashing voltage range is the condition of the capacitors C-104 and C-105 in Figure 2 (4). If a capacitance tester is not available, we suggest the replacement of these capacitors rather than relying on the familiar ohmmeter "kick" test. Ordinarily not much trouble should be encountered with the triggering transformer (T-102). Excessive moisture will affect its operation; therefore, the rubber weather-proofing band should always be replaced around the top of the gun and flash tube. The primary of the trigger transformer will

measure practically a short circuit on most ohmmeters. The secondary will measure about 20 ohms and will occasionally open up, but these cases are rare.

Ordinary tube failures can be just as troublesome in this type of unit as well as in radio and tv servicing. The R-4330 and OA5 characteristics can result in delayed or advanced firing time due to a change in ionization voltage requirements resulting from any of the common defects to which all tubes are subject. For instance, the complaint could be intermittent or erratic firing. If the supply voltages build up to a peak maximum over a long charging time, the flash tube will fire. After once being fired and heated, it will continue firing at 200 or 300 volts less with normal triggering voltages. The serviceman should bear in mind that consecutive firing of the equipment in this manner can give a false impression that the equipment is operating properly. A professional photographer, however, may need the flash in fifteen seconds after turning the unit on, which is insufficient time for the peak voltage build-up necessary to fire the faulty gun. A normally working gun should fire within 15 seconds of "power on"; if it does not, the customer's complaint of erratic firing is probably justified.

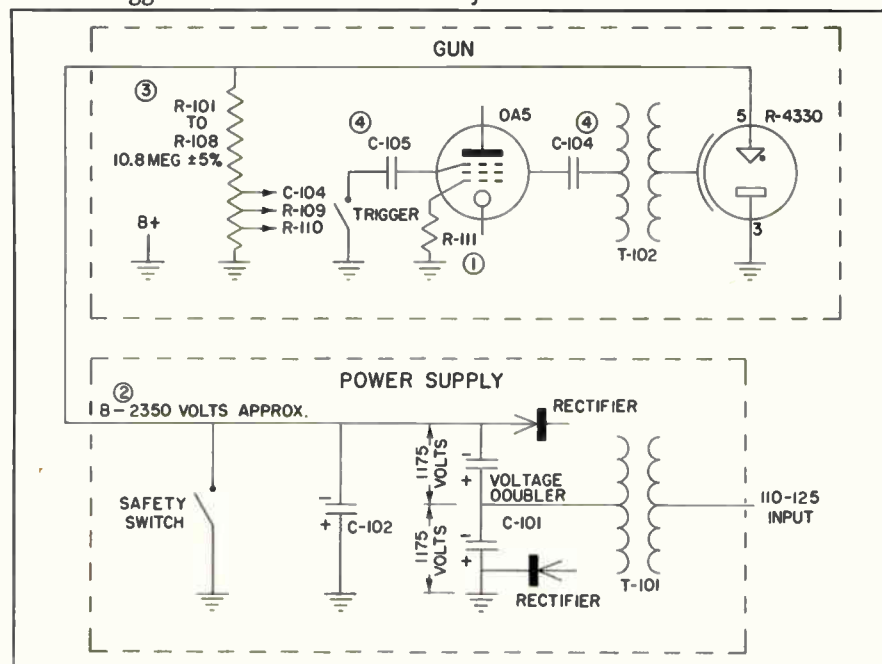

Figure 2. A partial single line schematic of a photoflash unit to aid in trouble shooting. Circled numbers indicate trouble points mentioned in the article.

# TECH TOPICS

## TRANSISTORS

BY W. O. HAMLIN

The transistor is a semi-conductor\* amplifying device which came to the public's attention five years ago when it was announced that operative units had been constructed.

Since then, considerable progress has been made in the methods of constructing transistors; so that today, the experimental laboratory model is emerging commercially. Investigations and experiments continue in the semi-conductor field so that large quantities will be available for general use by the public.

The transistor has several features which are a definite advantage over vacuum tubes in certain types of electronic equipment and devices. They are small in size—the average unit being from ½" to 1" high; power requirements are low—many tran-

sistor circuits have been designed to run from ordinary flashlight cells; their life is extremely long—predicted to be 70,000 to 100,000 hours; and a reduction in size and number of associated circuit components is usually possible.

In this early stage of transistor development, there are numerous problems concerning their manufacture and application of them. One of the subjects of investigation, which engineers expect to solve shortly, is production methods that will make transistors with uniform and dependable electrical characteristics equaling the quality that has been achieved over the years in vacuum tubes.

Transistor circuits are different than those for vacuum tubes. Current flow, circuit voltage polarities, input impedance, and output impedance seem odd when first viewed by one

\*A semi-conductor is material having a conductivity lower than metals, but higher than that of insulators.

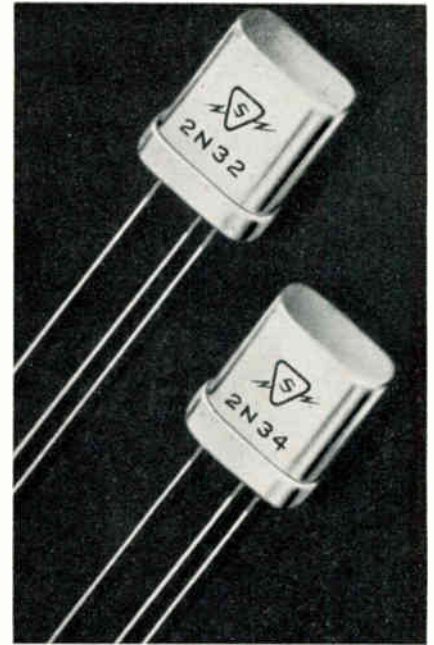

Figure 1. Two hermetically sealed SYLVANIA triode transistors.

familiar with vacuum tube circuitry. However, a comparison between the familiar tube and the unfamiliar transistor may aid in understanding the characteristics of the new device. (See Table I).

Figure 2 shows a cross-sectional diagram and proper biasing polarities for the four types of transistors that have been developed. It can be seen that the polarities of the supplies for the N-P-N junction and the P type point-contact transistors are similar to those used for vacuum tubes.

For the purpose of illustrating their functions, an analogy can be made between the vacuum tube grid to the transistor base, cathode to the emitter and plate to the collector. But, due to the different approach in transistor theory, such an analogy may result in erroneous conclusions. Therefore, caution must be exercised in this comparison.

They are similar to the triode vacuum tube in the number of its elements and can be connected in various configurations such as a grounded emitter amplifier with base input, grounded base amplifier with emitter input, or a grounded collector amplifier with base input.

The points which are usually confusing to the serviceman, when first

(Continued on page 8)

TABLE I  
COMPARISON OF TRANSISTORS AND VACUUM TUBES

Criteria	Transistors	Tube
Gain/Stage	0-40 db	0-40 db
Noise Figure at 1000 c p s, BW = 1 c p s	10-50 db	0-30 db
Freq. Limit as an Amplifier	0-30 mc	0-60 k mc
Freq. Limit as an Oscillator	300 mc	0-60 k mc
Output Power (Po)	0-200 mw †	0-kilowatts
Class A Efficiency	Point Contact 35% Junction 35-49%	35%
Class B Efficiency	>80%	79%
Class C Efficiency	99%	85%
Oscillator Efficiency	>70%	60-70%
Total Power Required	Point Contact 4-50 mw Junction 1-100 μw	50 mw to 2 w
Physical Volume	0.0005-0.02 in. <sup>3</sup>	0.125-1.0 in. <sup>3</sup>
Temperature Limitations	-60°C to 80°C	-60°C to 200°C
Shock Limitations	20,000 to 30,000 G	750 G
Life	>70,000 hours	0-5,000 hours

† Laboratory experiments have indicated that transistors designed with 200 watt ratings are possible.

## TECH TOPICS

(Continued From Page 7)

encountering transistor circuits are:

1. the conflict in voltage polarity between conventional vacuum tube circuitry and P-N-P junction and N type point-contact transistor circuitry.
2. the change in biases from constant voltage to constant current sources.

The transistor is biased from a constant current source in order to insure a stable operating point. It is obtained by making the source impedance large in comparison with the load impedance. One way of doing this, is to place a large resistance in series with a voltage source so that the effective source impedance is at least ten times greater than the load impedance.

As shown in Figure 2C and 2D, the point-contact transistor employs two pointed wire contacts which are similar to the rectifying contacts in crystal diodes and the *cat-whisker* in the old-time galena crystal radios. The junction type of transistor of Figure 2A and 2B depends upon the barrier formed by the junction of two dissimilar types of germanium (N type and P type). N type of germanium has an excess of available electrons (negative charges), while the P type has a deficiency of electrons (holes or positive charges). The amplifying nature of a transistor depends upon the emitter terminal introducing minority carriers (holes for N type of germanium and electrons for P type germanium) into the semi-conductor material.

Typical characteristics for the Sylvania Type 2N32 point contact transistor and the Sylvania Type 2N34 P-N-P junction transistor are given in Table II. These new hermetically sealed transistors are pictured in Figure 1.

The majority of the transistors now commercially available are of the junction type. The junction transistor, because of its low noise figure (10 db), will generally be used for small signal linear applications. The point-contact transistor, because of

Typical Values	TABLE II	
	2N32 Grounded Base Amplifier	2N34 Grounded Emitter Amplifier
Input Impedance	300 ohms	600 ohms
Output Impedance	20,000 ohms	60,000 ohms
Emitter Bias Current	0.5 MA	1 MA
Collector Voltage	-25 volts	-6 volts
Operating Power Gain	21 db*	40 db†

\*Measured with a collector load resistance of 10 k ohms, and a generator impedance of 500 ohms, and a signal frequency of 270 c p s.  
 †Measured with a collector load resistance of 30 k ohms, a generator impedance of 500 ohms, and a signal frequency of 270 c p s.

its negative resistance characteristics, will find wide applications in non-

linear circuits, such as computer and switching applications.

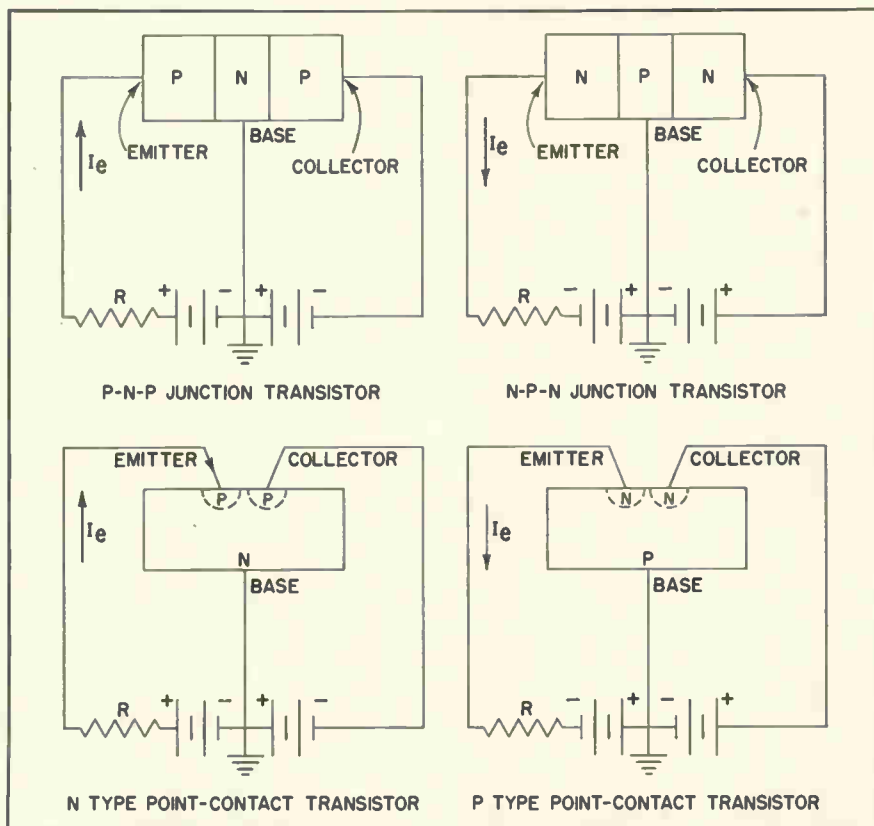

Figure 2. Four types of triode transistors connected in equivalent circuits.

## SERVICE HINTS

**RCA TV SETS**—On any RCA television set using a 6BQ7 and 6X8 in the tuner, there is a condenser marked C5 in the schematic that is 22  $\mu\text{f}$ . This condenser sometimes cracks open in the summer months because of the expansion of the metal

plate that it is bound to. The symptoms are that channel 2 will intermittently appear on channel 4, etc. Replacing this condenser usually will clear up this trouble.—Murray Gellman, Brooklyn, New York.



## CHECKING FLYBACK CIRCUITS WITH A 'SCOPE

By H. A. White — Sales Service Engineer

Many technicians have bought cathode ray oscilloscopes (usually called 'scopes), knowing they must be valuable instruments, yet not knowing exactly how to use them. In reality, the 'scope is such a versatile instrument, that a good technician never ceases to find new ways to use it in isolating troubles and ferreting out defective components.

The following is a typical example of the way in which this versatile instrument may be used to good advantage.

Figure 1 may be considered to be representative of the horizontal flyback circuit in a typical modern tv set. A set developed trouble, which may be described as follows:

1. When brightness was increased,
  - a. Picture elongated in the vertical direction indicating possibility of more vertical sweep voltage,

- b. Picture decreased or shortened in the horizontal direction indicating less horizontal sweep voltage,
- c. Picture went out of focus when maximum brightness was used,
- d. Brightness did increase to some extent, but not as much as expected.

Of course, the typical television set contains many circuits, which may or may not interact, and this, precisely was the problem here, "How can the brightness control influence vertical height, horizontal width and focus?"

A quick check with a voltmeter at B+ showed no fluctuation of power supply voltage with varied brightness setting.

The voltmeter was next connected to the cathode of the 6W4 to read boost voltage, and again little fluctua-

tion was noticed as the brightness control was again varied.

Something about brightness variation was affecting the horizontal width, and the chief diagnostician—the Sylvania 400 'Scope — was wheeled alongside.

The 'scope was grounded to chassis, and an alligator clip lead, connected to the vertical input, was clipped around the insulation of the plate lead to the 6BQ6. **DO NOT MAKE A CONNECTION TO THE PLATE ITSELF!** The alligator clip picks up enough signal by capacity coupling through the insulation to drive the 'scope. A direct connection to the plate would apply peak positive pulses of several thousands of volts to the 'scope's input blocking capacitor, and would surely puncture its dielectric which is rated at 600 volts.

Figure 2-A shows approximately the waveform viewed with the 'scope sweep set to 7,875 cycles per second, and brightness at the right point to get a fair picture. When the bright-

(Continued on page 8)

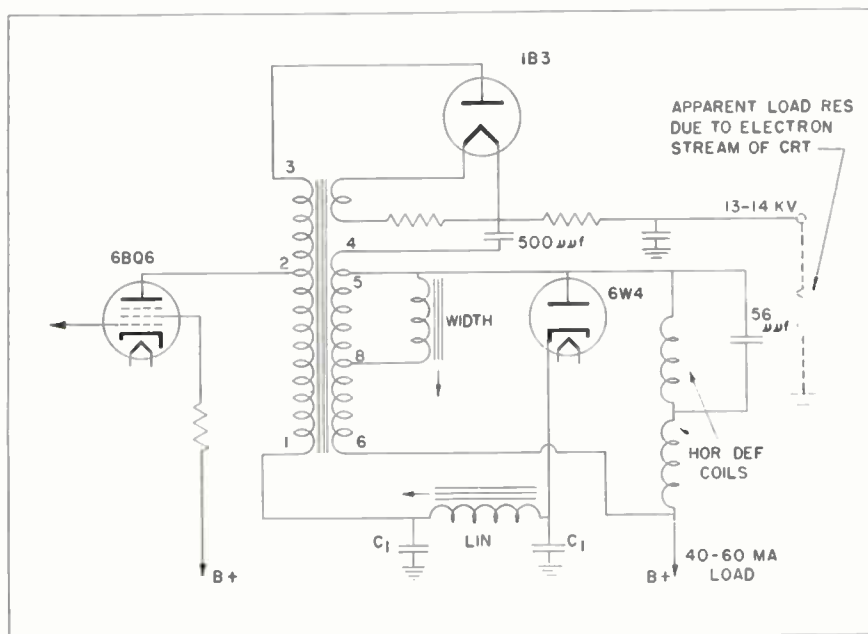

Figure 1: Typical Flyback Circuit

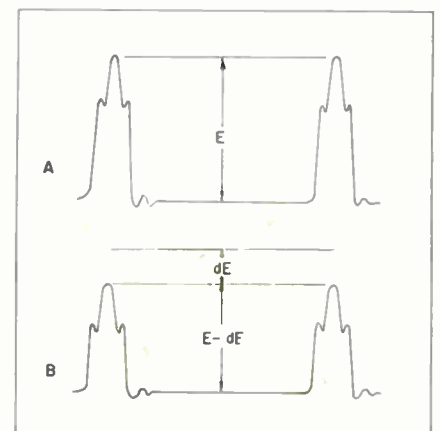

Figure 2: Waveform on 6BQ6 Plate  
 A—Horizontal Flyback Pulse With Brightness Retarded  
 B—Horizontal Flyback Pulse With Brightness Advanced

Binders With Complete File of Technical Sections:

Vol. 1: \$1.00 — Vol. 2: \$1.00 — Vol. 3: \$1.00 — Vol. 4: \$1.00

# BY-SERVICE CLASSIFICATION—PART III

The following *BY-SERVICE* listing of tubes has been prepared to assist the service technicians and engineers in selecting suitable substitutions for types not listed in charts or when a major change in power supply is undertaken. Although only the basic characteristics are listed these are sufficient to eliminate the majority of tubes not suitable for the particular application. Thus, the user can quickly select a group of possible tubes and then eliminate, by individual examination, those which for other reasons may be undesirable.

<b>INDICATORS</b>									<b>Power Output</b>	
Type	E <sub>f</sub>	I <sub>f</sub>	Style	Target Current Ma.	Type	E <sub>f</sub>	I <sub>f</sub>	Style	Mw.	
2E5	2.5	0.80	T-9	1.0 4.0 2.0	1AC5	1.25	0.04	T-3	450 600 700 200 240 575 310 310 250 675 575 2100 1900 1600 100 115 35 200 270 65 270 170 35 90 100 200 3500 3200 4800 11000 18000 600 700 170 180 1550 1450 600 1400 100 200 90 175 300 325 250 270 240 270 230 330 250 270 240	
6AB5/6N5	6.3	0.15	T-9		1C5GT	1.4	0.10	GT		
6AD6G	6.3	0.15	T-9		1E7G	2.0	0.24	ST-12		
6AF6G	6.3	0.15	T-9		1F4	2.0	0.12	ST-12		
6AL7GT	6.3	0.15	GT		1F5G	2.0	0.12	ST-12		
6E5	6.3	0.30	T-9	1.0 4.0 3.0 1.0 4.0 1.0 4.0	1G5G	2.0	0.12	ST-14		
6T5	6.3	0.15	ST-12		1G6GT	1.4	0.10	GT		
6U5	6.3	0.30	T-9		1J5G	2.0	0.12	ST-14		
1629	12.6	0.15	GT	1.0 4.0	1J6G	2.0	0.24	ST-12		
<b>MULTI-PURPOSE TUBES</b>					1LA4	1.4	0.05	Lock-in		
Type	E <sub>f</sub>	I <sub>f</sub>	Style	Gm	Class	1LB4	1.4	0.05	Lock-in	
1B8GT	1.4	0.10	GT	275 1150	1	1Q5GT	1.4	0.10	GT	
1D8GT	1.4	0.100	GT	325 925	1	1S4	1.4	0.10	Min.	
2B7	2.5	0.80	ST-12	950 840 1000	2	1T5GT	1.4	0.05	GT	
3A8GT	1.4	0.10	GT	325 750	1	1W4	1.4	0.05	Min.	
6AD7G	6.3	0.85	ST-14	325 2500	2	2A3	2.5	2.50	ST-16	
6B7/S	6.3	0.30	ST-12	950 840 1000	2	2A5	2.5	1.75	ST-14	
6U8	6.3	0.45	T-6½	5200	2	3A4	1.4	0.20	Min.	
7C8	6.3	0.30	Lock-in	2100	3	3B5GT	2.8	0.10	GT	
12B8GT	12.6	0.30	GT	1800 2400	2	3C5GT	1.4	0.10	GT	
25A7GT	25.0	0.30	GT	1800	4	3D6	2.8	0.05	Lock-in	
25B8GT	25.0	0.15	GT	2000 1500	2	3E5	2.8	0.110	Lock-in	
25D8GT	25.0	0.15	GT	1100 1900	2	3E5	1.4	0.220	Min.	
28D7/W	28.0	0.40	Lock-in	3400	3	3E5	1.4	0.050	Min.	
32L7GT	32.5	0.30	GT	6000	5	3E5	2.8	0.025	Min.	
70A7GT	70.0	0.15	GT	5800	5	3LE4	2.8	0.05	Lock-in	
70L7GT	70.0	0.15	GT	7500	5	3LF4	1.4	0.10	Lock-in	
117L7/M7GT	117.0	0.09	GT	5300	5		1.4	0.10	Lock-in	
117N7GT	117.0	0.09	GT	7000	5		2.8	0.05		
117P7GT	117.0	0.09	GT	5300	5	3Q4	1.4	0.10	Min.	
1 Diode-Triode Pent.						3Q4	2.8	0.05		
2 Triode Pentode						3Q5GT	1.4	0.10	GT	
3 Dual Tetrode						3S4	2.8	0.05	Min.	
4 Rectifier-Pentode						3V4	2.8	0.05	Min.	
5 Rectifier-Beam Amp.						3V4	1.4	0.10	Min.	
						3V4	2.8	0.05		
<b>POWER AMPLIFIERS</b>						4A6G	2.0	0.12	ST-12	
<i>Triodes—Pentodes</i>						5A6	4.0	0.06		
<i>Beam Amplifiers—Tetrodes—Class B Duo Triodes</i>						5A6	5.0	0.230	T-6½	
Type	E <sub>f</sub>	I <sub>f</sub>	Style	Power Output Mw.		5A6	2.5	0.460		
1A5GT	1.4	0.05	GT	100 115					1000 2800 3100	

Type	E <sub>f</sub>	I <sub>f</sub>	Style	Power Output Mw.	Type	E <sub>f</sub>	I <sub>f</sub>	Style	Power Output Mw.
6A3	6.3	1.00	ST-16	3200	10	7.5	1.25	ST-16	400
				1500					900
				1000					1600
6A4/LA	6.3	0.30	ST-14	700	12A5	12.6	0.30		800
				1500		6.3	0.60	ST-12	3400
6A5G	6.3	1.25	ST-16	3750	12A6	12.6	0.15	Metal	3400
				15000	12A6GT	12.6	0.15	GT	3400
6A6	6.3	0.80	ST-14	10000	12A7	12.6	0.3	ST-12	550
6AB6G	6.3	0.50	ST-12	3500	12L8GT	12.6	0.15	GT	300
6AC5GT	6.3	0.40	GT	3700					1000
				8000	14A5	12.6	0.15	Lock-in	2800
6AC6GT	6.3	1.1	GT	3600	14C5	12.6	0.15	Lock-in	2000
6AG7	6.3	0.65	Metal	3000					4500
6AH5G	6.3	0.9	ST-16	10800					5500
6AK6	6.3	0.15	Min.	1100					10000
6AK7	6.3	0.65	Metal	3000					14000
6AL6G	6.3	0.9	ST-16	10800	18	14.0	0.30	ST-14	4800
6AM5	6.3	0.2	Min.	1400					11000
6AN5	6.3	0.45	Min.	1300	19	2.0	0.26	ST-12	18000
6AQ5	6.3	0.45	Min.	4500					2100
				2000					1900
6AR5	6.3	0.40	Min.	3200					1600
				3400	19BG6G	18.9	0.30	ST-16	
6AS5	6.3	0.80	Min.	2200	20	3.3	0.132	T-8	50
6AS7G	6.3	2.5	GT						130
6B4C	6.3	1.00	ST-16	3200	25A6/GT	25.0	0.30	Metal/GT	900
				1500					2000
				1000					2200
				4000	25A7GT	25.0	0.30	GT	770
6B5	6.3	0.80	ST-14		25AC5GT	25.0	0.30	GT	2000
6BF5	6.3	1.2	Min.		25B5	25.0	0.30	ST-12	2000
6BC6G	6.3	0.90	ST-16						3800
6CD6G	6.3	2.5	ST-16		25B6G	25.0	0.30	ST-14	2400
6E6	6.3	0.60	ST-14	750					7100
		0.70		1600	25C6G	25.0	0.30	ST-14	3600
6F6	6.3		Metal	3200					6000
6F6G/GT	6.3	0.70	ST-14/GT	4800	25L6	25.0	0.30	Metal	2100
				11000					4300
				18000	25L6GT	25.0	0.30	GT	2100
6G6G	6.3	0.15	ST-12	600					4300
				1100	25N6G	25.0	0.30	ST-12	2000
6K6GT	6.3	0.40	GT	350					3800
				3400	26A7GT	26.5	0.6	GT	5500
				4500	31	2.0	0.13	ST-12	185
6L6	6.3	0.90	Metal	6500					375
6L6G	6.3	0.90	ST-16	10800	32L7GT	32.5	0.30	GT	1000
6L6GA	6.3	0.90	ST-14	17500	33	2.0	0.26	ST-14	70
				26500					90
				47000	35A5	35.0	0.15	Lock-in	1500
6M5	6.3	0.71	T-6½	3900					1300
6N6G	6.3	0.80	ST-14	4000	35B5	35.0	0.15	Min.	1500
6U6GT	6.3	0.75	GT	2000	35C5	35.0	0.15	Min.	1500
				5500	35L6GT	35.0	0.15	GT	1500
6V6/GT	6.3	0.45	Metal/GT	2000					3300
				4500					925
				5500	38	6.3	0.30	ST-12	1050
				10000					1200
				14000	41	6.3	0.40	ST-12	350
6W6GT	6.3	1.20	GT	2100					3400
				3800					4500
6Y6G	6.3	1.25	ST-14	3600	42	6.3	0.65	ST-14	4800
				6000					11000
6Y7G	6.3	0.60	ST-12	5500					18000
				8000	43	25.0	0.30	ST-14	900
6Z7G	6.3	0.30	ST-12	2500	45	2.5	1.50	ST-14	830
				4200					1600
7A5	6.3	0.75	Lock-in	1500					2000
				2200	46	2.5	1.75	ST-16	1250
7B5	6.3	0.40	Lock-in	350	47	2.5	1.75	ST-16	2700
				3400	48	30.0	0.40	ST-16	2000
				4500					3000
7C5	6.3	0.45	Lock-in	2000	49	2.0	0.12	ST-14	170
				4500					3500
				5500					
				10000					
				14000					



## CHECKING FLYBACK (Continued from page 5)

ness control was advanced, Figure 2-B resulted, showing that horizontal drive had decreased by about 25%. This explained the symptoms described in the second paragraph.

The same percentage decrease in the peak positive pulse would occur at the plate of the high voltage rectifier, and high voltage would drop to about 75% of normal. This explained the loss of focus and the expansion of the picture in the vertical direction, since a slower electron beam is deflected more than is a fast beam as it moves through a magnetic field. The decrease in horizontal drive more than compensated for the decrease in the picture tube anode voltage so that some squeezing was noticeable.

Of course, all the above symptoms may indicate to the good technician just what the trouble was, but what if they did not? He must then use his instruments to isolate one circuit, and then find a specific component. The 'scope was used to do this quickly.

Variable output from the 6BQ6 might be caused by variable drive on the grid of this tube, but a quick check showed no change in the grid waveform with a change in brightness adjustment. This conclusion could then be reached; there was nothing wrong with the horizontal oscillator, control circuits or their components. This is important, since the serviceman's problem is one of finding what to fix, and the more possible sources of trouble he can eliminate, the faster and more profitable his work will be.

Changing the three tubes in Figure 1 failed to make any difference. Next, it was decided to learn whether the variation in brightness control caused appreciable loading of the 6BQ6 and flyback transformer, as brightness varied. By removing the plate lead to the 1B3, it was inactivated, and it was seen that the fluctuations in horizontal drive, as indicated on the Sylvania 400 'Scope, no longer occurred when the brightness control was advanced.

It was decided that a cracked iron core in the flyback transformer itself

POWER AMPLIFIERS					
Triodes—Pentodes—Beam Amplifiers—Tetrodes					
Class B Duo Triodes					
Type	E <sub>f</sub>	I <sub>f</sub>	Style	Power Output Mw.	
50	7.5	1.25	ST-16	1600	2400
				3400	4600
50A5	50.0	0.15	Lock-in	2100	4300
50B5	50.0	0.15	Min.	1900	
50C5	50.0	0.15	Min.	1900	
50C6G	50.0	0.15	ST-14	3600	6000
50L6GT	50.0	0.15	GT	2100	4300
VT52	7.7	5.0	ST-17	1000	
53	2.5	2.0	ST-14	10000	
59	2.5	2.0	ST-16	1250	3000
71A	5.0	0.25	ST-14	125	400
				790	
79	6.3	0.60	ST-12	5500	8000
89	6.3	0.40	ST-12	300	1500
				3500	
182B/482B	5.0	1.25	ST-14	1350	
183/483	5.0	1.25	ST-14	1800	
210-T	7.5	1.25	ST-16	400	900
				1600	
950	2.0	0.12	ST-14	1000	
1276	6.3	1.00	ST-16	3200	1500
				1000	
5686	6.3	0.35	T-6½	2700	
5824	25.0	0.30	ST-14	4300	
5932	6.3	0.90	T-12	10800	
SPECIAL PURPOSE TUBES					
Type	E <sub>f</sub>	I <sub>f</sub>	Style	Use	
6AE6G	6.3	0.15	ST-12		
6BN6	6.3	0.3	Min.	Limiter-Disc'r.	
12BN6	12.6	0.15	Min.	Limiter-Disc'r.	
5722	4.9	1.6	Min.	For Noise Gen.	
X6030	3.0	0.6	Lock-in	For Noise Gen.	

(Concluded)

would prevent adequate induced power between taps 2 and 3 even though current flow between taps 1 and 2 were normal. The fact that the filament of the 1B3 was not lighted sufficiently further indicated a lack of energy in the upper section of the core.

Changing the transformer restored the set to normal.

This article is intended to encourage the use of your oscilloscope. Too many of these valuable servicing aids collect dust while a technician tries to use other much less effective means of analysis. Naturally, he tries to avoid changing a transformer

as long as possible, but if it can be definitely determined within a short time of five to twenty minutes that such a change is necessary, then the job can be done, the ticket written, and the set delivered.

Remember too, that you rate as much for your twenty minutes of skilled work as another man would with three hours of hit or miss checking and changing of components.

Again, CAUTION! Do not connect any instrument directly to the plate of the 6BQ6.

Use your 'scope for faster, more profitable servicing.



## SERVICING SWEEP MULTIVIBRATOR

(Continued from page 5)

use of a voltage divider that will not distort the waveform in order to keep within the input voltage rating of the oscilloscope. A more convenient method of checking the output waveform of this stage is to observe the waveform at the tap of the vertical output transformer which feeds the vertical deflection coils. The pulse amplitude here is usually of the order of 100 to 200 volts, eliminating the need for a voltage divider.

R8, the vertical size or height control, and R88 form the plate load for the 12AX7. These high values assist in producing better sweep linearity because the RC time constant of the sweep interval for C73, the sweep capacitor, is very long compared to the duration of the vertical sweep time interval. Thus, the charge of C73 is confined to the time during which the charging portion of the exponential curve is fairly "linear." R8 functions as a height control by varying the amplitude of the charge on C73.

The "trapezoidal" voltage necessary to produce a linear current in the deflection coils is produced across R92 and C73, which in turn is amplified in the vertical output stage.

R3 and R6 in the cathode circuit of the 12AX7 vary the bias of this stage and thus control the frequency of the oscillator. R5 in the cathode of the 6AH4GT output stage functions as a linearity control by adjusting the operating point of this stage in such a manner that the non-linearity of the tube characteristics helps to overcome the inherent non-linearity of the sweep voltage developed across R92 and C73.

### TROUBLE SHOOTING

The waveforms shown in Figures 2A, B, C and D show the waveforms at the check points indicated in Figure 1 under normal operating conditions. The other waveforms show how malfunctioning components affect multivibrator action, thus producing poor scanning signals with attendant distortion of the picture dimensions and/or linearity.

The troubles discussed do not include tube defects since this is one

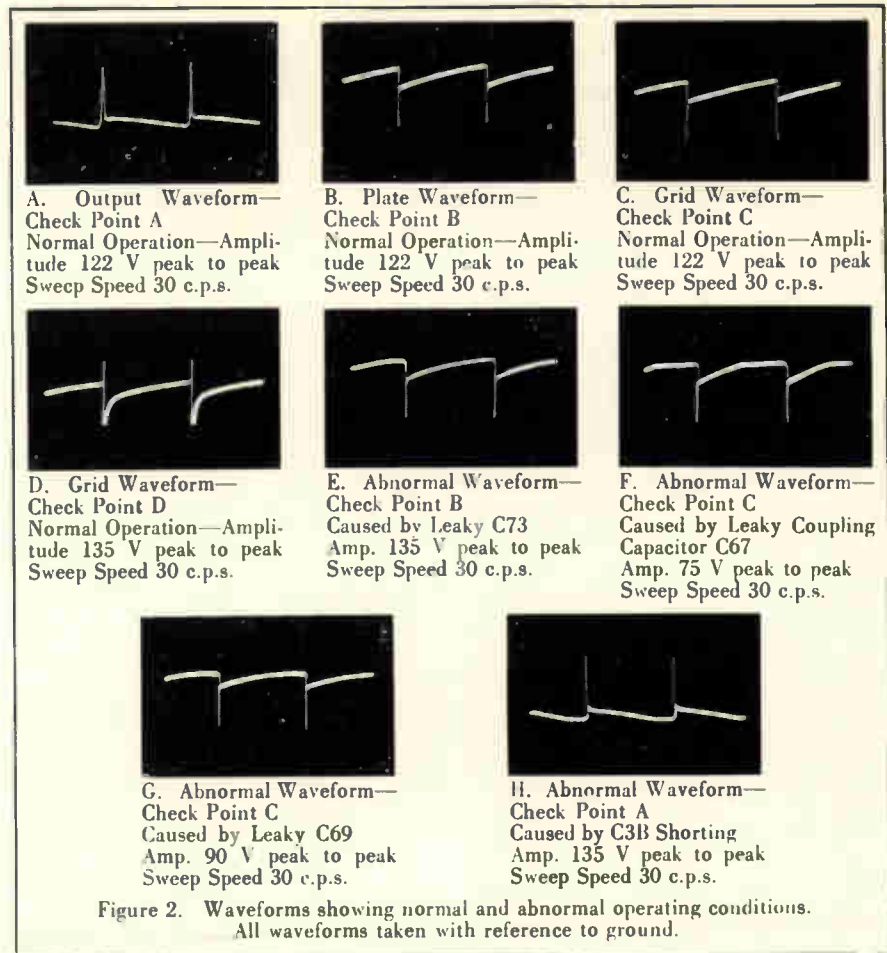

of the first things the serviceman checks in normal service procedure.

If C73, the sweep capacitor, should develop leakage, one or more of the following symptoms may show up in the picture: decreased height, picture flattened on the bottom, height and/or linearity controls cannot be adjusted to produce normal picture. This trouble may be localized by examination of the waveform at check point B in Figure 1. The waveform under this condition is shown in Figure 2E. Note how the sweep voltage has started to curve compared to the normal waveform of Figure 2B. The amount of curvature will depend upon the amount of leakage current present in the capacitor. Figure 2E indicates the effect when the capacitor had a leakage resistance of one megohm.

Figure 2F shows the waveform at check point C which results when C67, the coupling capacitor from the plate of the 12AX7 to the grid of the

6AH4GT, becomes leaky. This condition may show up as picture folded over at the bottom, poor linearity, raster may not fill screen, linearity and height controls ineffective, or vertical hold may become very unstable. Note in Figure 2F the obvious distortion of the signal compared to the waveform of Figure 2C for normal operation. High leakage or a short of C67 will cause the oscillator to become inoperative and loss of sweep will result.

Figure 2G shows the waveform at point C which results when C69 becomes leaky. This condition may show up as one or more of the following symptoms on the picture: picture flattens off at the bottom, poor linearity, raster will not fill screen, height and linearity controls cannot be adjusted to produce proper raster, vertical hold unstable, or intermittent vertical scan. Comparison of the normal waveform (Figure 2C) with the abnormal waveform (Figure 2G)

(Continued next page)



# NOTES ON USING TWIN LEAD SPRIGS

We have had a number of inquiries for further information on the article "Twin Lead Sprigs for Connecting Two TV Antennas to One Feed Line." Reiterating a statement in the article, the one primary limitation of sprigs is that they will not work properly if the high frequency is an odd harmonic of the low frequency. The question then arises as to how close the high frequency channel can be to an odd harmonic frequency for proper operation.

There is no general rule to cover this problem, because it depends upon the 'Q' of the sprig and the distance from the junction to the short in terms of wave length at the higher channel. In general, if the high frequency v h f channel is two channels removed from the low channel harmonic, operation will be satisfactory. Combinations that will not work are listed in the table. Channels on either side of the listed ones are in the doubtful range, especially in the u h f region where a margin of several channels from the harmonic

TABLE 1

Low Channel	High Channel
2	7, 21, 40, 59, 78
3	9, 30, 51, 72
4	12, 16, 39, 62
5	27, 54, 80
6	34, 63
7	24, 83
8	27
9	30
10	33
11	36
12	39
13	42

Channel combinations to avoid. Adjacent channels will also be troublesome, especially at the higher frequencies.

is necessary. The harmonic limitation does not apply if coils and capacitors are used to construct the filter traps.

One anomalous factor which was not clearly explained in the article is the instance where a quarter wave at the low frequency is longer than three quarter wave lengths at the high frequency, so that it is impossible to construct the high frequency feeder stub as shown in Figure 3. This is easily rectified, as this stub can be any odd multiple of a quarter wave length such as,  $3/4$ ,  $5/4$ ,  $7/4$  etc. If the short across the sprig comes very close (in terms of wave length) to the feeder, it is an indication that a harmonic of the low frequency is being approached and the system might not work properly.

Another use for sprigs is at the receiver end of the feeder from a combination u hf-vh f antenna. If the frequency relations are right, you may use them in reverse and connect them to separate receiver inputs for u h f or v h f.

## SERVICING SWEEP MULTIVIBRATORS

(Continued from page 6)

shows a curvature and flattening off of the sweep voltage.

Figure 2H shows the waveform at check point A of Figure 1 when C3B, the cathode bypass capacitor for the vertical output stage, develops a short or very high leakage. One or more of the following symptoms may show up in the picture: linearity control ineffective, poor linearity, raster lacks normal brightness except at extreme setting of brightness control. The reason for the decreased brightness may be explained by the fact that should the cathode bias resistor short out due to C3B shorting, or a heater-cathode short, the gain of the vertical output stage increases resulting in a greater sweep current amplitude in the deflection coils. This causes a greater vertical sweep and the raster now covers more area; therefore, the brightness control has to be advanced to obtain normal brilliance. In other words, for a given setting of the

brightness control and a normal size raster, the screen exhibits a given amount of light—if we keep the brightness constant but increase the "size" of the raster it is obvious that the brightness will decrease. This same effect may result due to a lowering of the high voltage output of the flyback supply for the CRT anode, in which case the picture is said to "bloom." If this condition exists it may also be accompanied by a shortened horizontal scan.

It should be emphasized again that defective components should be replaced with exact duplicates as far as electrical characteristics, tolerance, etc., are concerned.

### Correction For "Servicing The Horizontal Sweep Multivibrator"

This article appearing in the November issue of the SYLVANIA NEWS, Technical Section, had an error in Figure 2.

To correct this error, simply interchange waveform photographs over the caption labelled 2A and 2C.

## TUBE TYPES ADDED TO NEW ROLL CHARTS

(See announcement on page 8)

Tester 139/140

6AJ4	6AN4	6V4	12B4
6AM4	6CL6	12A4	12BZ7
5726			

Tester 219/220

1AG5	6CL6	12BZ7	5881
6AJ4	6V4	5703	6111
6AM4	12A4	5726	6112
6AN4	12B4		

### ROLL CHART CORRECTION FOR 228 CR TUBE

#### ADAPTER SETTINGS

219-220 pc No. 18325E roll chart emission reading for 228 adapter should read:

10                      15

Bad | Doubtful | Good

139-140 pc No. 15845-H-1-53 roll chart emission reading for 228 adapter should read:

8                              12

Bad | Doubtful | Good

# SERVICE HINTS

**OPEN HORIZONTAL SYNC GUIDE TRANSFORMER**—Raster shrinks and shifts to upper right of picture tube, dims and defocuses, and goes out of horizontal sync.

When defect occurred the voltage on the horizontal oscillator tube decreased noticeably. It seemed as though the horizontal sync guide transformer was open yet it showed continuity with the set off.

The defect was finally located as an unsoldered lead on the horizontal sync guide transformer. (See Figure below).—William Miller, Pittsburgh, Penna.

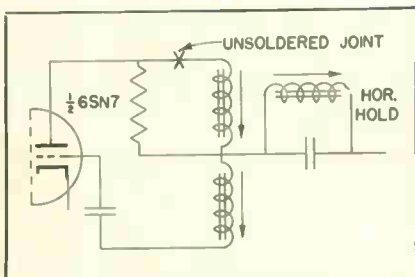

**TESTING FOR SHORTS IN TV VOLTAGE SUPPLIES**—An indispensable gadget for discovering the cause of burned out fuses in TV sets can be made by soldering a 1/2 to 2 ampere automobile light bulb across a burned out fuse and inserting same into the TV fuse clips. Intermittent shorts can be located by watching bulb while jarring suspected components.—Blue Radio & TV, Hartford, Connecticut.

When a set has blown a fuse we connect two 120 volt, 40 watt lamps in series across the fuse clips. The lamps light up and don't burn out which gives us a chance to test for shorts. — Jopp Electrical Works, Princeton, Minnesota.

**EDITOR'S NOTE**—Useful for trouble causing fuses to blow. Lower voltages caused by bulb resistance may prevent the trouble from showing up.

**CATHODE TO FILAMENT SHORT IN PICTURE TUBE**—The complaint was an intermittent picture on an Emerson Model 690B.

Upon loss of picture there were the symptoms of poor a c filtering—a dark screen except for a 3 inch band of white across it.

By checking with a scope, I found video at the grid of the 6AC7 video amplifier but none at the plate. Pulling the socket off the picture tube made the signal appear at the video amplifier plate.

The trouble was a cathode to filament short in the 19AP4 picture tube.—William Miller, Pittsburgh, Penna.

**MOTOROLA MODEL 5A5 PORTABLE RADIO**—The rectifier tube in this set is the type 117Z3. Normally the plate lead of this tube, as given on the standard tube basing diagrams, is connected to pin 5. This receiver is wired with the plate lead to pin 1, which is an internal connection that may or may not be to the plate, depending on the manufacturer.

To allow replacement with any 117Z3, simply move the plate lead from pin 1 to pin 5.—Bob and Mary Bair, Hood River, Oregon.

**TRAV-LER, MODEL 12T**—At first there was an annoying crackling sound. Then it was observed that there were sparks between ground clip and outside of cathode ray tube.

Improving the ground did not eliminate the sparking. Shortly after that the picture would go on and off. Next, no picture and no raster.

Replacing the 500  $\mu$ fd 20KV condenser cleared it all up and restored the picture, and eliminated the sparking.—S. J. Manson, Mattapan, Mass.

**AUDIO TEST UNIT FOR HOME SERVICE CALLS**—In order to eliminate removal of a chassis from a customer's home for minor audio repairs, I have constructed a portable audio test unit as shown in the diagram below, to diagnose troubles quickly.—F. Boettinger, Easton, Pa.

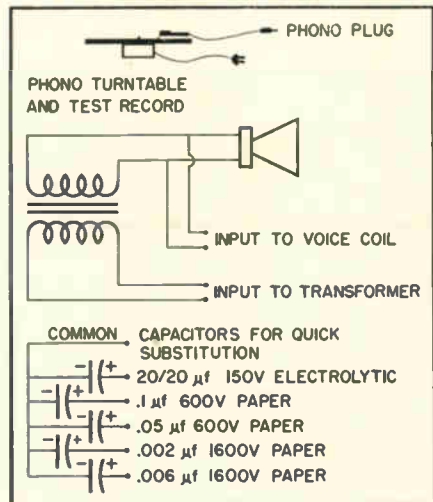

## NEW CHARTS FOR SYLVANIA TUBE TESTERS

New Roll Charts are now available to all owners of Sylvania 139/140 and 219/220 Tube Testers. Copies may be obtained at \$1.00 each from Sylvania Electric Products Inc., 1221 West Third Street, Williamsport, Pennsylvania. Attn: Mr. Jack Mintzer.

New tube types added to the chart are listed on Page 7. Between revisions, supplemental settings are published in SYLVANIA NEWS as soon as available.