



Copyright 1944, Sylvania Electric Products Inc.

January, 1944

EMPORIUM, PENNA.

Vol. 10, No. 11

Dr. Ben Kievit who has recently been assisting Mr. Walter Jones in editing the Technical Section of the News, has been transferred to the New York Office where he will devote all of his time to field engineering.

Quality and Life Proved By Over Decade Of Service

An interesting letter came into the office the other day from one of our friends, Mr. Thomas Fay of Pilsudski Way, South Boston, Massachusetts. He included an old Sylvania Type SX-280 which had been operating regularly in his set for twelve or thirteen years. We can tell from the internal construction that this is not an exaggeration because slight changes are occasionally made as improvements in assembly or processing are found, and no tubes have been built like this for twelve years.



This SX-280 has given regular and faithful service for twelve or thirteen years — can still take it and dish it out.

The research carried on since then has made it possible for Sylvania engineers to build tubes having improved performance, smaller in size and weight, and at much lower cost than was possible then. Sylvania customers now, as in the past, are assured the ultimate in tube life, performance and high quality standards as a result of our progressive engineering.

It is even more interesting to note that instead of being worn out after this long service the tube had merely developed a loose connection in the soldering at one of the pins. We corrected this condition and now the tube tests perfectly. We are sending it back "home", and can see no reason why it should not give its owner many more years of service.

The type 280 was designed years ago when much less was known about tube life than our engineers know now.

Do You Have All Three Of These?



IF NOT -- ORDER YOUR FREE COPIES NOW

When the series of Hints booklets illustrated here were first printed, little did we think that their popularity would reach such heights. Time and again we have had to replenish our stocks, but still we continue to distribute them free of charge. Our satisfaction comes from the many letters we receive indicating that thousands of dollars and thousands of hours of valuable time have been saved for servicemen through the use of this information.

If for any reason you do not have copies of each of these booklets, get them at once. They are available, free, from your Sylvania Distributor or directly from us. Simply address a post card to: Advertising Department, Sylvania Electric Products Inc., Emporium, Pennsylvania.

SYLVANIA TYPE 28D7 RECTIFIED POWER OSCILLATOR

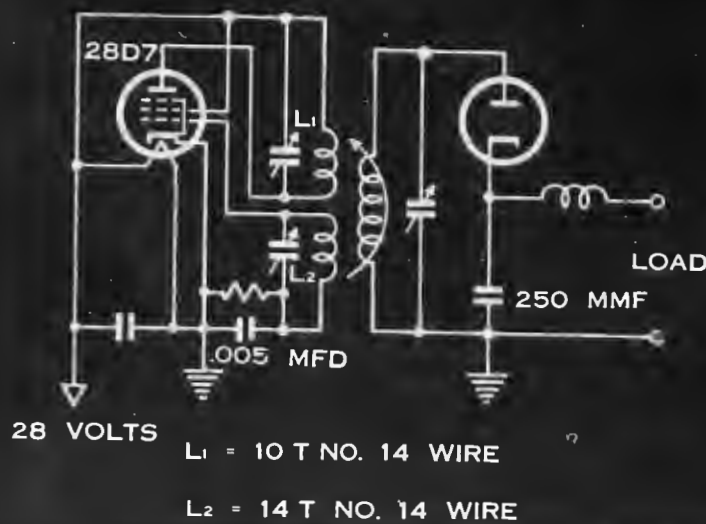

FIG. 1

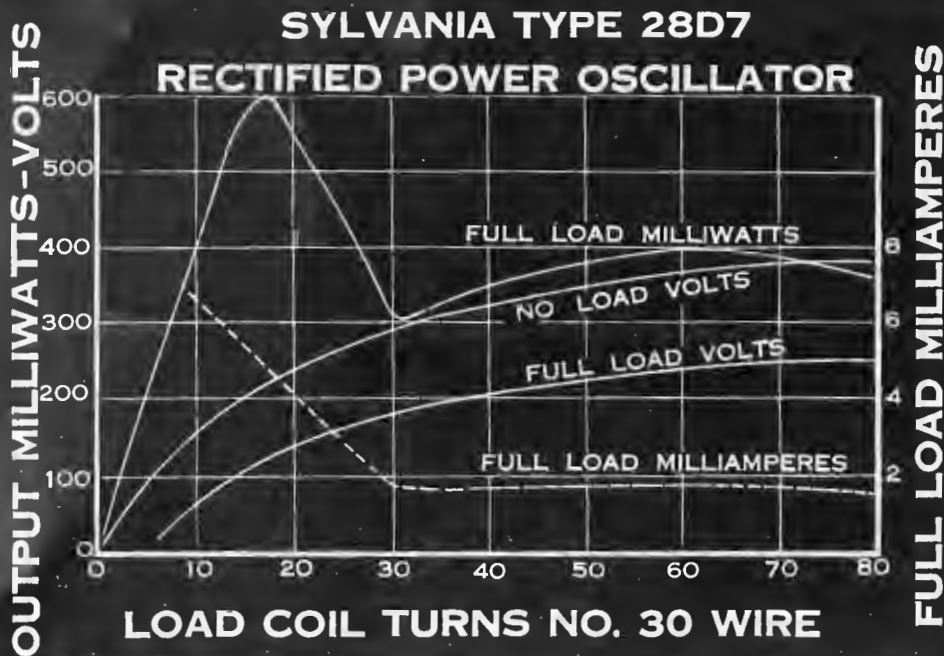

FIG. 2



FIG. 3

INTERESTING APPLICATION

EDITOR'S NOTE: Two preceding issues of Sylvania News described the Sylvania Type 28D7 and the use of several standard receiving tubes with 28 volt supply. We resume the series this month with circuit and design data for use of the Type 28D7 tube as a voltage booster.

The preceding articles of this series have featured the new power output tube, Sylvania Type 28D7, and a selection of standard tubes having characteristics for 28 volt operation comparable to tubes normally used at much higher voltages. A complete set can therefore be designed which will operate from a single 28 volt source. In cases where the 28-volt supply may drop too low under some conditions to operate certain stages or services having a critical minimum voltage (such as high frequency converters or oscillators) the Sylvania Type 28D7 makes possible a very compact booster source. This is done by coupling the Type 28D7 as an oscillator to a load coil of the required characteristics and rectifying the output with a diode. The output will require very little filtering and can if desired be added in series with the 20 to 28 volts already available to get power outputs up to 725 milliwatts at medium voltages of 50 to 250 volts. Output voltages of 500 to 600 volts for lower power requirements can readily be obtained. This is added in series with the 28 volt source for the maximum values given or can be used as an isolated source if required.

The frequency employed in taking these data was between 4 and 10 mc., depending upon the load coil. The circuit is shown in Figure 1, the grid and plate coils being the same for all the curves taken. Changes were made in the load coil which slides inside L_1 , L_2 and in the tuning condensers to obtain different output currents and voltages. The optimum value of the grid leak must be found experimentally for each coil and also varies slightly with the load, generally being between 200 and 5000 ohms.

The curves of Figure 2 show the effect of varying the number of turns of the load coil using just one size of wire. Curves for no load volts, full load volts, maximum milliwatts output and the current at maximum output are shown. The peak output at 18 turns is quite critical, 20 turns giving noticeably less output. This curve is typical of those obtained with other sizes of wire and the trends of peak milliwatts output are shown in Figure 4, which can be used to estimate the wire size required for other loads. For the particular set of grid and plate coils used for these data the peak output is obtained for some other sizes of wire approximately as follows:



OF SYLVANIA TYPE 28D7

No. Wire	Turns for Max. Milliwatts
20	12
24	13
27	15
30	18
33	20

As shown by Figure 4, the full output of 600 milliwatts or more can be obtained over quite a useful range of voltage by proper choice of wire size. In cases where all this power is not required, it is equally satisfactory to design for higher voltage by using the broad hump of the curve (Figure 2) which occurs around 60 turns. Regulation curves have the same slope as that shown in Figure 3 which is a typical curve obtained with the 18 turn coil of No. 30 wire.

When designing for a service in which the 28 volt supply may drop considerably in actual operation the curves of Figures 5, 6 and 7 will be of assistance. Design must be based on the lowest voltage to be encountered, and Figure 5 shows the power available at various supply voltages from 19 to 28 volts. A coil can be estimated from data on the 18 turn No. 30 wire coil shown in Figure 5 using the percentages of output obtained in conjunction with the coil design curve of Figure 4. Once a coil has been selected to meet the minimum voltage condition, the voltages and currents available with other supply voltages can be obtained from Figures 6 and 7 showing output volts and current for several values of fixed load resistance. (The values obtained by using a self bias tube as the load differ so slightly from the curves for resistance that they have been omitted). Figures 6 and 7 show that the tuning and coupling adjustments are non-critical. Each curve was taken with the adjustments optimised and permanently set at the point marked by the arrow and then the supply voltage was varied from 19 to 32 volts. The voltages are shown for six different loads in Figure 6 and the corresponding currents for these loads in Figure 7. Voltage curve "A" is used with current curve "A". The difference between the curves for an adjustment at 19 volts and one at 28 volts is almost negligible showing as a slight drop at 32 volts when optimised at 19 volts.

Each particular application making use of this circuit will probably require special design of the oscillator coil assembly. This necessarily condensed account is given here as an interesting example of the increasing use of electron tubes in low voltage services and because some of our reader-servicemen in the armed forces may be required to service such equipment. It is hoped that the others will find it interesting even if not immediately applicable under present conditions.

TYPE 28D7 POWER OSC.

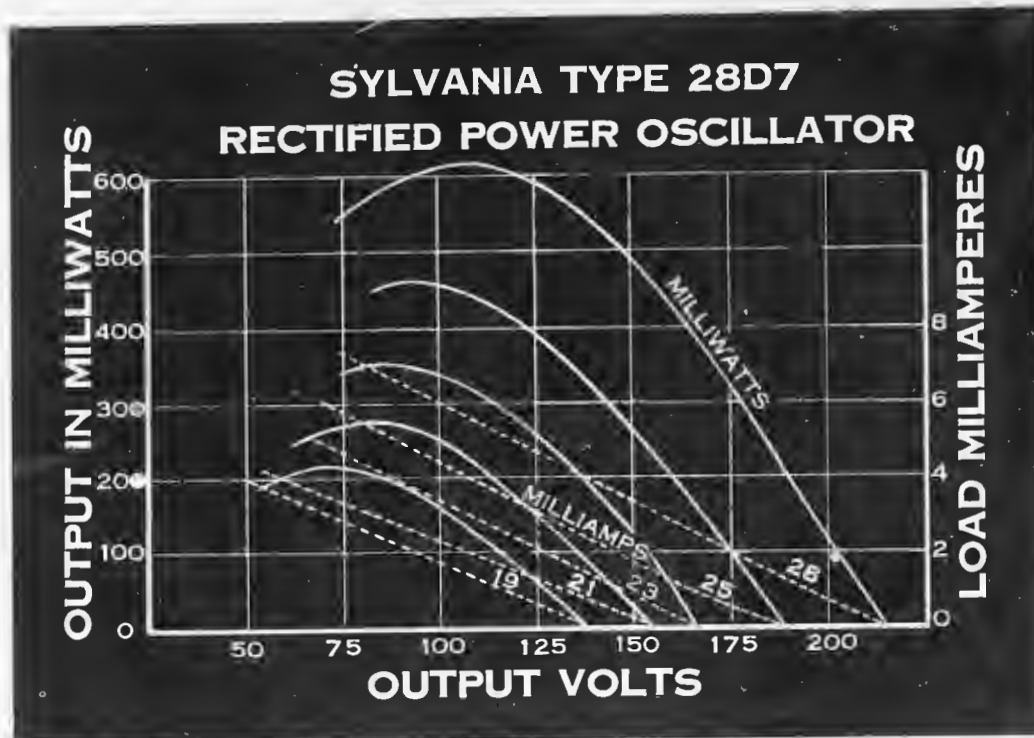

FIG. 5

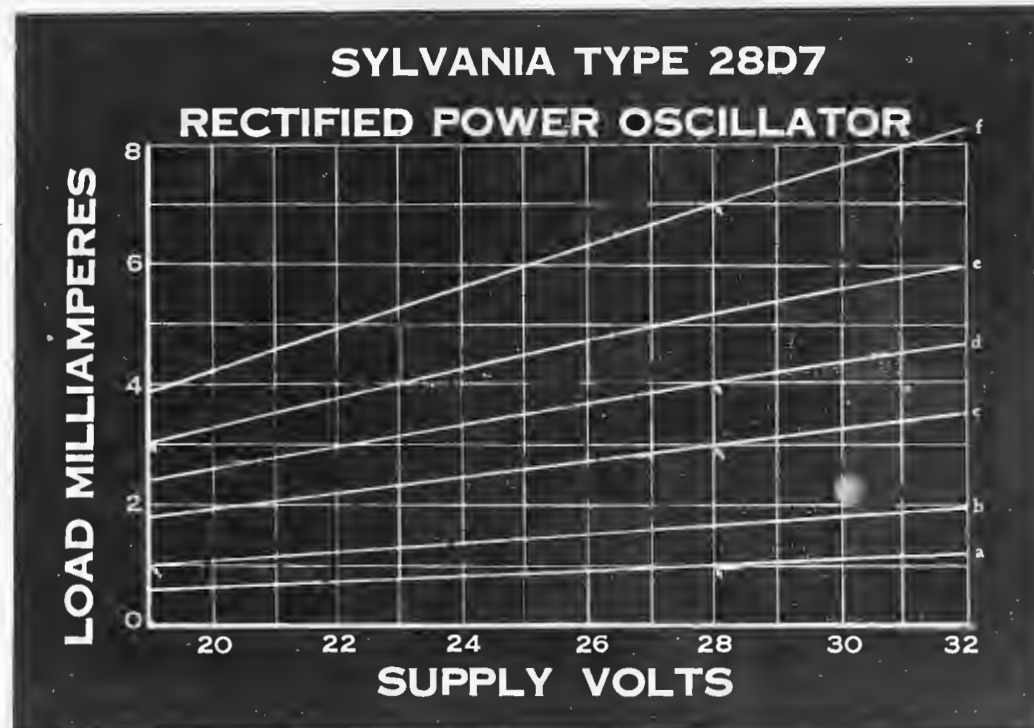

FIG. 6

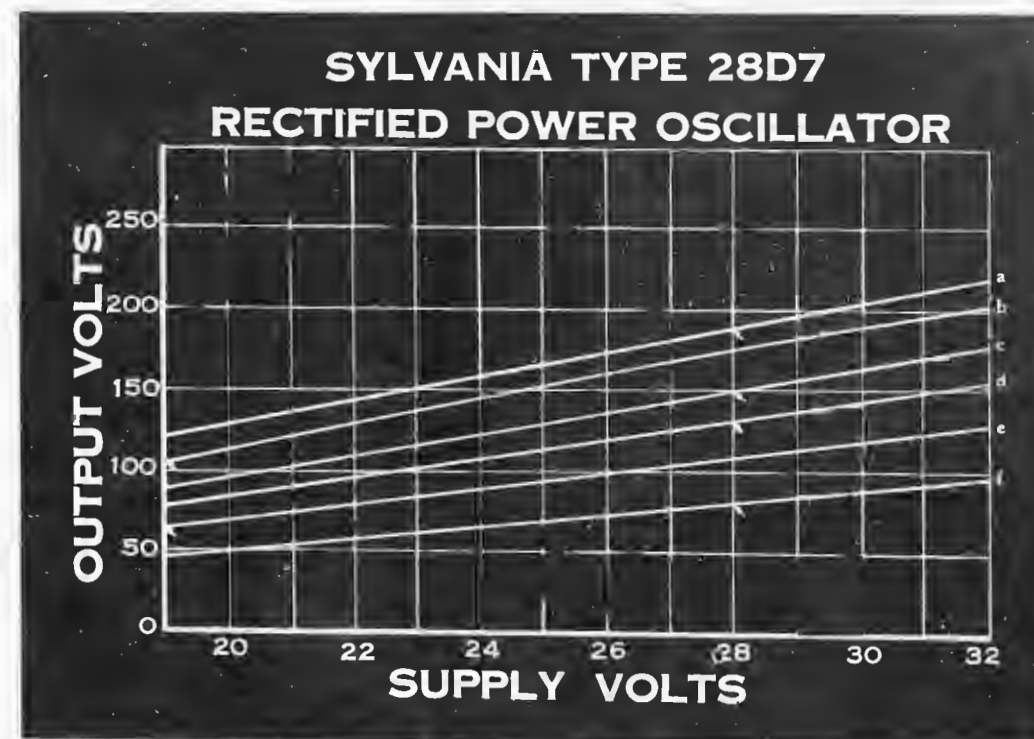
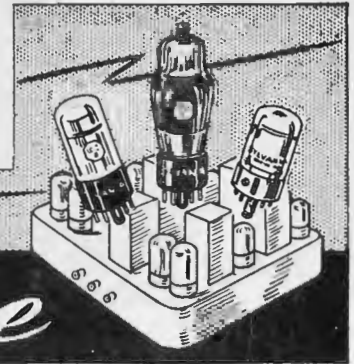
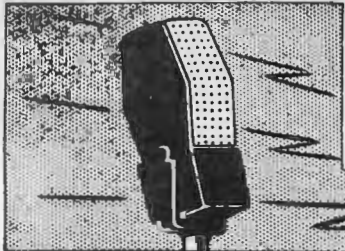

FIG. 7

THE information presented in the Sylvania Service Exchange is contributed by servicemen as the result of practical experience. It is very carefully considered before being accepted, and we believe it to be correct and authentic. However, we assume no responsibility for results. Please do not send routine or generally known information.



THE Service Exchange

Wards Airline Model 04BR512A. On this set the aerial consists of a small tin plate which fastens to the set with four cinch buttons. A small spring clip lays against this plate and is connected to the antenna coil of the set. If weak or no reception is found, remove the tin aerial plate and thoroughly clean with fine sandpaper the part which touches the aerial connection spring and also the spring proper. — Marion L. Rhodes, Knightstown, Indiana.

* * *

J. P. Seeburg Corp. Model B. Two troubles encountered with this changer. In one, the switch control-knob (67) would fail to operate the reject function. After a good deal of hunting, a small lump of solder was found under the switch knob, between the escutcheon plate and control-lever assembly (36). This would shift around and now and then get into such position as to prevent full travel of the control-lever. The solder was no doubt dropped from the iron while the A.C. switch (34) was being connected in.

A second trouble is excessive backlash between the two selector-arm and blade assemblies (54). When one was held stationary, the other could be rotated through an arc of 35 or 40 degrees. This made adjustment of the assemblies impossible. If adjusted so that the receding assembly would clear the edge of the record so as to permit it to drop, then the advancing assembly failed to come forward far enough to reach the record. The backlash was the result of manufacturing tolerances at the rollers, bearings, cams, etc., and a certain amount is desirable. It was found possible to reduce it to an unobjectionable amount by fitting new pins into the selector shafts (15). The original pin was a round pin about one-eighth inch in diameter, engaging a notch in the hub of selector-arm assembly (55). The pin made only line-contact with the walls of the notch, and the fit was very loose. The backlash at this point was greatly multiplied at the ends of the selector blades. New pins were turned up, and flattened on opposite sides. This eliminated all play at the selector-arm assemblies, and the changer then functioned properly. The new pins were of two diameters, so as not to have to alter the size of the hole in shaft (15).—W. S. Arns, Kenmore, N. Y.

Thank You, Charles Walker

Right out of a clear sky comes this letter from serviceman Charles Walker of Detroit, Michigan. It is indicative, we think, of servicemen's appreciation for the continuous flow of helpful material which it is Sylvania's established policy to supply.

"Dear Sirs: I am enclosing a service hint which you may be able to use in your Service Notes.

"I am going into the Air Corps shortly and will have to discontinue servicing, of course. I wish to commend the Sylvania people for all the time, effort, and skill they have put into publishing aids for the radio serviceman; I think that they have far exceeded the work done by any other tube company. I have found the News to contain more practical, usable material for its size than any other service paper.

"After the war, if I return to this type of work, I am certainly planning to use Sylvania products which have done the job for me in the past six years."

RCA 9K and K80. If set is intermittent, it is due to defective .01 Mfd. coupling condensers.—Henry Hudson.

* * *
Zenith Chassis 5666. Intermittent loss of signal, accompanied by strong 60-cycle hum. Caused by the rubber insulation on the yellow lead of dial-lamp melting and permitting the lead to short to the chassis frame. The short occurs at the point where the lead passes over the edge of the chassis, and is not readily detected by inspection, as the rubber on top may look all right. Lifting up on the lead clears the hum and brings in the signal. The other lead to the dial-lamp (black rubber) seems to be unaffected by the heat; the yellow rubber melts and runs. There isn't much slack in the leads to the lamp; repair is possible, but I found it desirable to run a set of new lead wires, from the rectifier-socket to the lamp-socket.—W. S. Arns, Kenmore, New York.

* * *

RCA BP10. Oscillation caused by defective 10 mfd. 60-volt (C17) electrolytic condenser in screen grid and plate circuit.—Henry Hudson.

Philco Models 16-X 29 etc. Lately I have run across a number of these sets with the same complaint. The sets were dead but all voltages were normal. On checking them very carefully, however, I found that the grid lead of the second Detector tube had been changed so that instead of running to the grid cap of the tube inside the tube shield it was passed under the tube shield and run up the outside with the result that when the tube shield was pressed down the grid lead had been shorted to ground by the shield. The trouble is readily cured by running the lead inside using a new wire if the original one is badly cut.—D. B. MacGregor, Cleveland, Ohio.

* * *

Scratchy Noise and Interference in any radio or record player. This type of trouble is very annoying and sometimes quite difficult to locate. It is a well known fact that any metal parts that are free to move against another, or against the grounded chassis will cause interference. All such parts should be bonded to ground and chassis. My method for locating these parts causing interference is to connect a test wire to the chassis, then touch it to all the various parts around the instrument including speed control adjustment on the phonograph. Any part or parts that can cause interference will make a noise in the speaker. I have found that even a loose screw can be easily located by this method, and to correct it when found is a simple matter. Remember also that poor contacts on tone and volume controls may cause noise when the vibration from the speaker disturbs the contacting arm.—Edgar Landon, Oakland, California.

* * *

Interchanging 5X4G and 5U4G Tubes. To make a conversion from 5X4G to 5U4G types, or vice versa, rewire the socket as follows: connect a jumper from pin connection No. 2 to pin No. 7; connect another jumper from No. 3 to No. 4; connect a third jumper from No. 5 to No. 6. This wiring will enable a serviceman to insert either a 5X4G or a 5U4G at any time in the future, without making any further changes. Caution: Be sure that none of the unused pin connections in the original wiring are being used as tie points for other circuit wiring.—Charles Walker, Detroit 2, Michigan.



Copyright 1944, Sylvania Electric Products Inc.

February-March, 1944

EMPORIUM, PENNA.

Vol. 10, No. 12

CHEMICAL HIGHLIGHTS OF TUBE MANUFACTURING

Most people may not realize that the chemical purity of the various metals, insulators, and ceramic coatings used in vacuum tube manufacture is of the greatest importance in making tubes that will operate satisfactorily for hundreds of hours. A brief description of some of the chemical and physical considerations involved in vacuum tube design will explain how they function, and account for changes in characteristics that may take place over long periods of time.

THE EMITTER

Probably the most important part of a tube is the emitter. In all modern receiving tubes this is either a wire or a cathode sleeve coated with a mixture containing barium and strontium salts which when properly processed form the critical mixture of alkaline earth metals and their oxides, which are responsible for the actual emission. This coating is very susceptible to "poisons," particularly sulphur and iron oxide. Very little of these in the base metal or in the spray

will spoil the tube initially, and if the bulb or outer elements contain these "poisons" they eventually reach the cathode coating and impair tube performance or life. Platinum and its alloys were used early in the industry but eventually nickel of sufficient purity became available which together with a few nickel alloys for special tubes is almost universally used today.

THE GRIDS

The materials used for the small grid

(Continued on page 2)

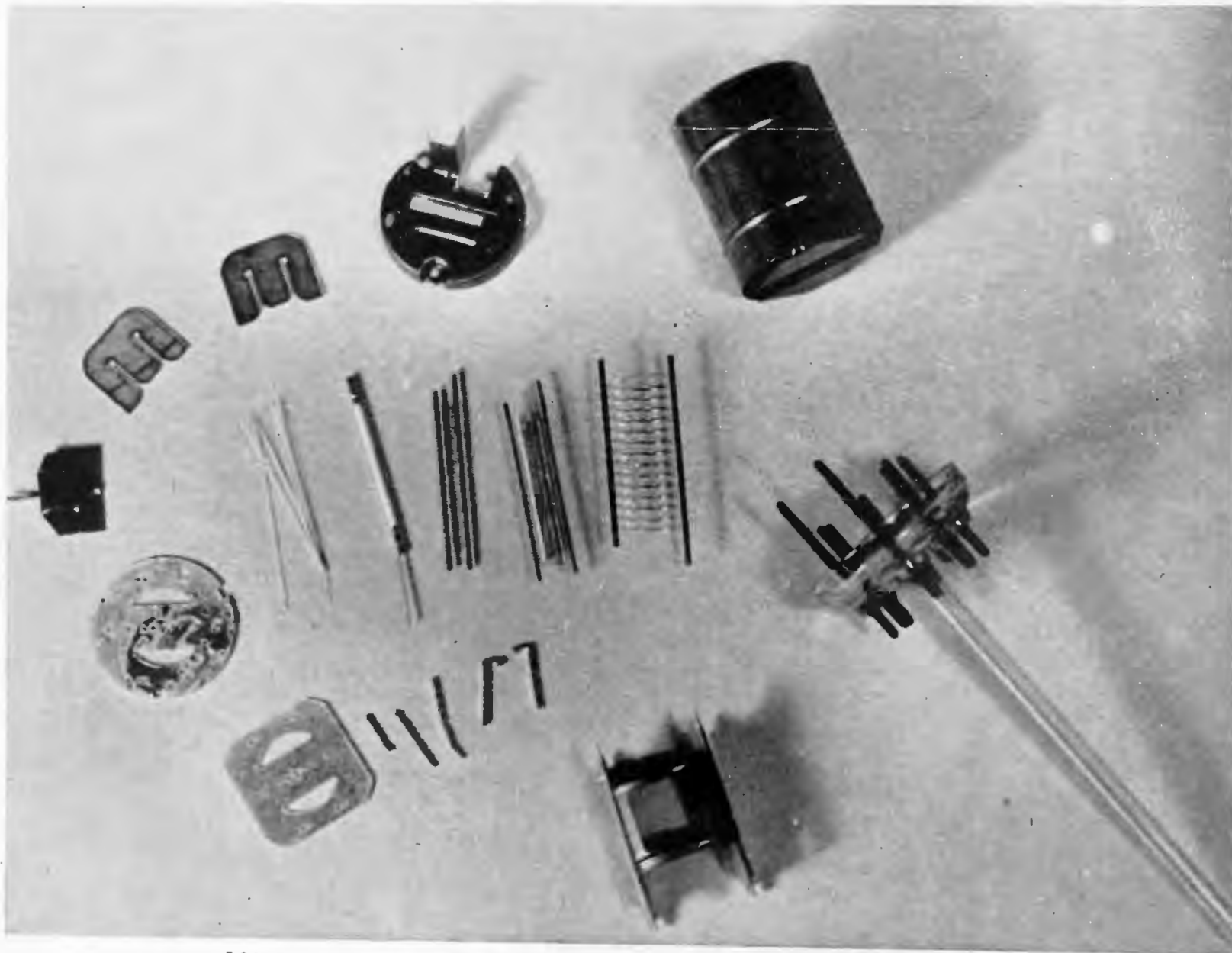

LOCK-IN TUBE PARTS. Illustrated here are the basic parts required to make a 7A7 tube. Bulb and base are not shown and the header on the right is already assembled from 10 parts.

CHEMICAL HIGHLIGHTS OF TUBE MANUFACTURING

(Continued from page 1)

wires are molybdenum or one of the various nickel-chrome-iron alloys. The side rods are generally nickel or copper. Emission from the grid would give undesired characteristics so that in tubes which may have the grids operating at a fairly high temperature it is necessary to "poison" the surface without using a material which would eventually drift over to the emitter. Manganese alloyed with the nickel is one such way, a carbon coating another, and for some types gold-plating has even been resorted to.

THE PLATES

The plates and larger sheet metal shields, beam confining plates, etc., have commonly been made of nickel because of its purity and ease of processing without introducing impurities. Recently, however, the high production schedules for tubes and the scarcity of nickel have forced the development of iron pure enough for the purpose. This is protected while in stock by nickel plating or a coating of specially purified oil which has to be removed before use by thorough washing with chemicals. With this material, the closest possible control of all manufacturing processes is even more necessary than before. The use of iron or nickel plated iron is still unsatisfactory for cathodes.



WIRE COATING MACHINE. This machine is used for coating heater wire. The wire is drawn through the mixture of insulating oxides and the coating is baked on in passing through the electric oven.

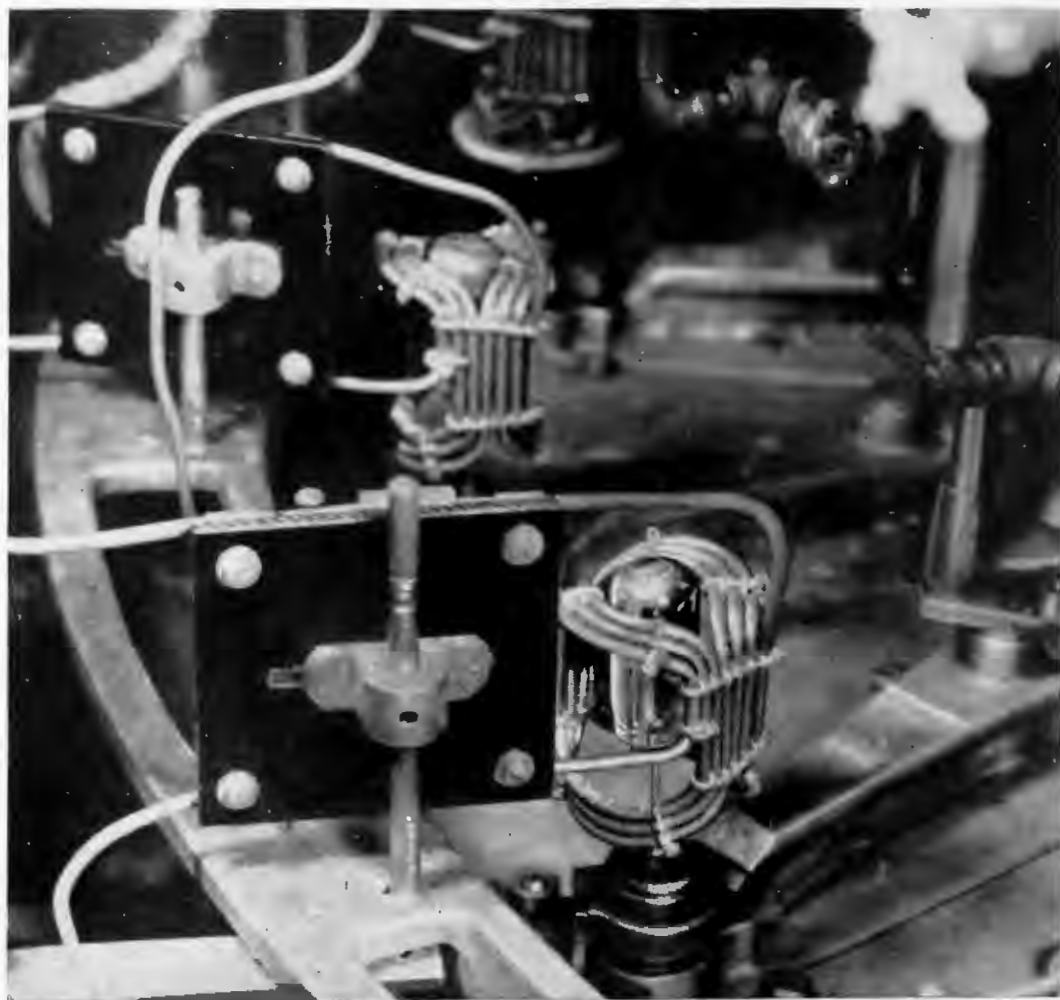

HEATING THE PLATE ON THE EXHAUST MACHINE. The water-cooled copper coil shown around the tube carries the high frequency current to make the plate red hot.

THE HEATER

In Sylvania cathode type tubes the heater wire is usually tungsten. No other metal or alloy has yet been found having better characteristics for this application. The insulating coating used to keep the heater from shorting to the cathode sleeve is critical as to purity also, but for a different reason. In the exhaust process the high temperature of the tungsten will cause it to react chemically with all but a very few of the usual ceramic materials. Quartz was originally used but was discarded in favor of very finely ground aluminum oxide. This is generally mixed with a binder and the wire is passed through the mixture by machine and the coating is baked on. The binder is later broken down chemically and driven off, leaving a sintered coating of the oxides to form an insulating layer.

MICAS AND MISCELLANEOUS PARTS

Before the war all Sylvania tubes used the best grade of India mica, but, now that this cannot be obtained in quantity, special procedures have been found that enable American and Brazilian micas to be used with equal satisfaction. For many tubes it is necessary to apply a roughening surface coat of an insulating spray in order to reduce the effect of metal vapors that may condense upon the mica surface. Getter tabs, hook

wires, support rods, and connectors all have their own particular problems. The getter itself is an interesting chemical problem. In incandescent lamps, phosphorus is used as a getter because of its affinity for oxygen, but in tubes with coated emitters phosphorus is a poison, and besides, a more active material which will combine with gases other than oxygen is necessary. Magnesium was the first material used. It is well known as the material used for flash powder and photo flash lamps. A small piece of the metal is fastened on some part where it can be vaporized later. In recent years a better getting action has been obtained by using a mixture of magnesium, aluminum and barium, the exact proportions varying with the requirements of the tube. The mixtures containing more barium give a darker color deposit and do not spread over the bulb as much as those with more magnesium. These getters of course must be kept stored in vacuum or they will be worthless and the tubes which have had the getter applied may only be allowed to stand a limited time before exhausting or the air will have destroyed the getter.

THE EXHAUST PROCESS

The exhaust process is much more than just sucking the air out of a bulb, for that is just to prepare the ground, as it were, for the necessary chemical changes which will make it into an operating radio tube. After most of the air has been pumped out, the heaters are connected to something more than normal voltage. The binders are first broken down chemically into gases which are then pumped out. A good pump is necessary because if these gases are not removed as fast as released they will cause undesirable interactions to occur and might also cool and condense on the other parts to cause trouble later. The barium and strontium carbonates on the cathode coating, now free of binder, give off carbon dioxide and are converted into the oxides required for emission. About this time a high frequency oscillator is used to make the metal plates red and sometimes even white hot. To most people a piece of metal is "all metal" but to a tube man it is as full of air as a porous brick. Heating these parts red hot drives out the air, but it comes out so slowly that for some high voltage transmitting tubes the exhaust process may last several hours. Careful control of this

heat is important because too much will vaporize the metal which would be deposited on the insulation causing leakage and possibly noise. Following this, the heater coil is moved closer to the getter which flashes and deposits active material on the bulb to react with any gas subsequently released.

AGING AND TESTING

When tubes are taken off the exhaust machine they are sometimes usable as they are, but the characteristics are not very stable. The ageing process consists of operating the tube at higher than normal current long enough to be sure that all the emitter coating is chemically changed and to permit gases and impurities still present to come out of hiding. An average time of about half an hour is required for this process in order to be sure that the whole surface of the cathode contains active electrons and that all traces of gas have been cleaned up by the still active getter. Tubes testing good after this are reasonably sure to give the required service, but regular tests are taken and put in operation at full rating for 1000 hours to assure high quality and to give warning in case the chemical or electrical properties of some material has changed.

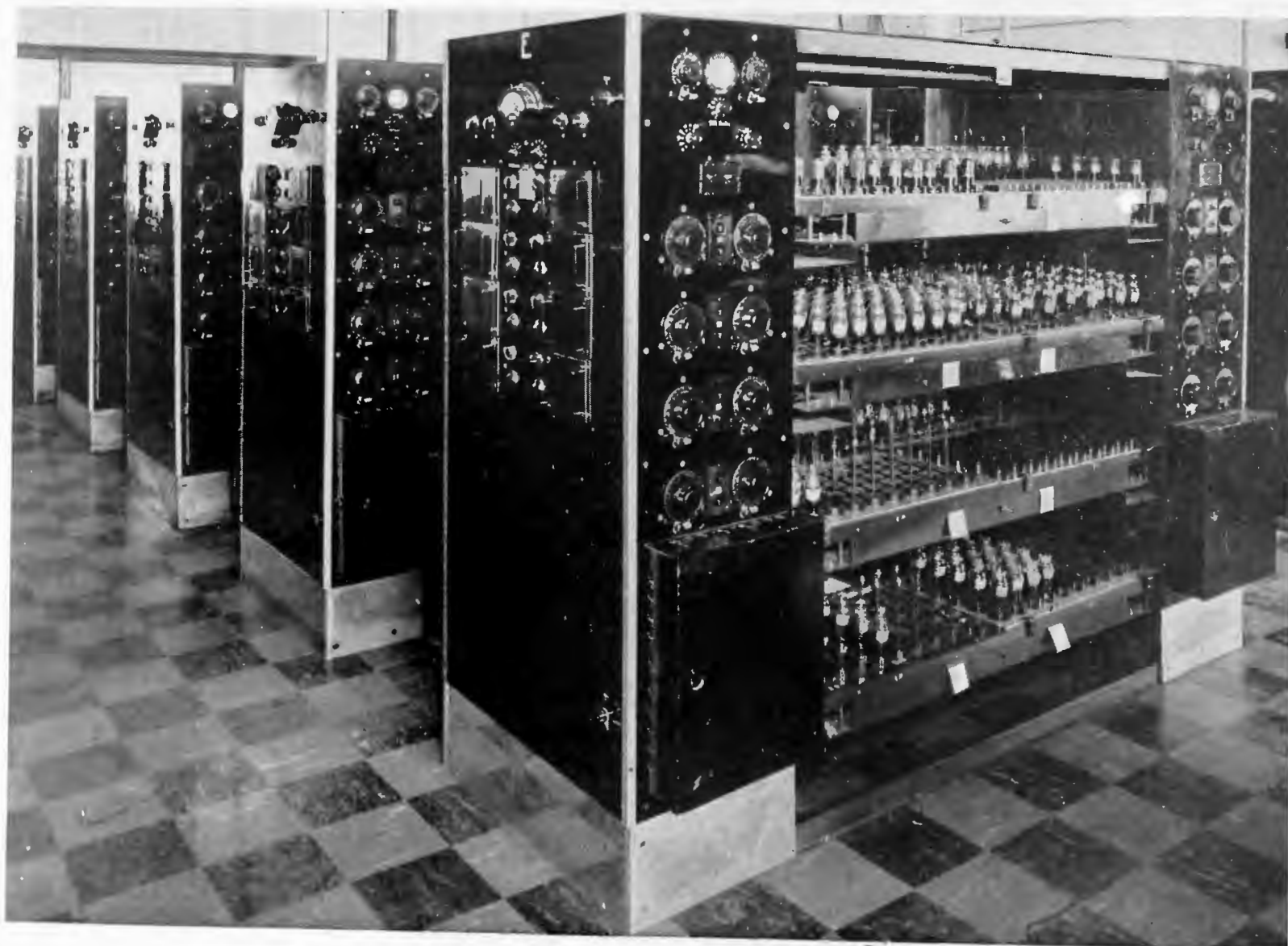

TYPICAL LIFE TEST RACK. This shows one of the many life test racks as used in the Salem Receiving tube plant. Each rack has a capacity of 800 tubes of 16 different kinds.

THE information presented in the Sylvania Service Exchange is contributed by servicemen as the result of practical experience. It is very carefully considered before being accepted, and we believe it to be correct and authentic. However, we assume no responsibility for results. Please do not send routine or generally known information.

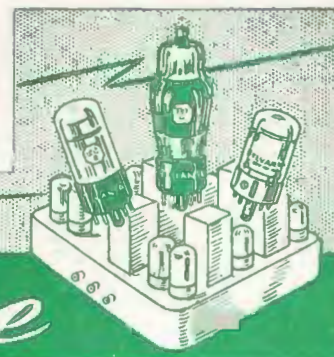

THE Service Exchange

Zenith Model 6D10 W. On this particular model, the dial often turns hard due to the rotor becoming tight in the tuning condenser. As there is no end play adjustment, the best solution is to cut a piece of bakelite rod and slip between the end sections of the stator. This small rod should lay on top of the condenser and should be slightly notched to slip over the center section. The tightness is apparently due to contraction and expansion of the metal. A little sanding on one end of the rod may be needed to get just the correct looseness of the condenser. Have used this method when all other remedies have failed.—Marion L. Rhodes, Knightstown, Indiana.

Philco 40-130. In cases where the set is noisy and often cuts off completely the trouble has been traced to the Antenna Trimmer condenser (1A on the schematic) located on the loop. The metal washer under the adjusting screw shorts to the metal eyelet used to rivet the opposite plates. By removing the screw and metal washer and inserting a small piece of mica, such as is found in the Sylvania Mica Kit, between the plates of the trimmer and the metal washer a permanent cure is accomplished.—Walter D. Cummings, Pittsburgh, Pa.

RCA Victor 1942 Record Changer. On the 1942 RCA Victor standard changer, if the clicking sound of the clutch is heard and the arm moves very slowly when in cycle even when no records are on posts, remove the center post and clutch; remove all oil from the surface of the clutch so that the lever moves back and forth freely on it. If necessary, polish lever and plate with crocus cloth. Leave it dry—do not oil and reassemble.—Sam Slymen, Los Angeles, California.

Philco Model 37-116 Code 122. For intermittent operation when loss of signal occurs and there is also oscillation which increases as the I.F. control is turned to the fidelity position, look for the following—A signal voltage will be evident at the second detector disappearing as the tuning condenser is turned to the closed position. The remedy is to replace the filter condensers in can (8-3-2 mfd). They sometimes check OK for leakage but have poor power factor.—Marion L. Rhodes, Knightstown, Indiana.

In the November, 1943 (Vol. 10, No. 9) issue of Sylvania News there is a Service Exchange note by Don Blair of Franklin, Pa. to which I would like to take exception. The practice of connecting an ohm-meter and especially a low range ohm-meter across a dynamic microphone should absolutely be avoided. The relatively high current of a low range ohm-meter (frequently about 100 ma.) will cause a violent movement of the diaphragm frequently rupturing the same. Generally speaking the better the quality of the microphone the more dangerous is this practice. Your correspondent evidently does not realize the fragility of a high fidelity microphone; the diaphragm of one should never be touched with the fingers, thumped, or acoustically excited to the extent that would be necessary to produce an appreciable deflection of the meter. Walter N. Pike, North Beach, Md.

Zenith 6 D 311. I have found that replacement of bad filter condensers in this model with new ones of the same capacity does not always cure objectionable hum. By connecting a 40 mfd 150 volt electrolytic condenser from the screen grid (+) of the 25L6G to the (-) 40 mfd condenser (C9) and omitting the 16 mfd condenser (C10) altogether the hum was completely cured.—D. B. MacGregor, Cleveland, Ohio.

Crosley 52TD-U. I have had three of these sets in lately, with the same trouble. The set will operate on short wave band but will work for a few minutes or intermittently on the broadcast band. The oscillator coil was found to have a very poor soldered connection on the 12SA7 cathode winding. This is on the under side of coil and coil must be loosened from chassis and tipped up to get to it.—C. F. Carrick, Coeur D'Alene, Idaho.

Noise Elimination in Auto Radios. There is sometimes a rasping noise in the older type auto radios while tuning. This is usually caused by ratio gear on condensers becoming worn. Graphite lubricant such as used by some of the music box companies spread on the teeth of this gear will stop noise every time.—J. Leo Robey, Waldorf, Md.

Philco 1942 Automatic Record Changer. The selenium cell used in 1941 and 1942 Philco changers can be tested by connecting directly to a 250 millivolt meter or a 1 milliamper meter which is more common. Under a strong light or direct rays of the sun, a good cell will go close to full scale on 250 millivolt meter.—Sam Slymen, Los Angeles, California.

Tube Substitutions. Our shop happens to have an ample stock of 12K8's and few 12K8 jobs. When a 12SA7 needs replacement, we use a 12K8 with the triode plate grounded, if convenient. For awhile we used 12A8's for this job, as Mr. Auringer suggested in the News. However, we find that an electrode in the electron stream goes negative if it is not connected to cathode, reducing gain. On a VTVM this voltage reached -1.5 volts, gain going down appreciably. When substituting for a 12SK7, triode plate and grid are grounded. Changing over from a 12K7 is similar, but simpler since the 12K7 has the grid connection brought out on top.

Another thing we often do is to change the pilot light circuit. When a 35Z5 pilot section burns out, change the #2 to #5 lead from #5 to #3 terminal. Then change the #2 or #3 pilot lead to #5. Plate current on even a 4-tube set lights the pilot lamp satisfactorily. Often we have to cut down a resistance line cord for a set and frequently there is no pilot section on the replacement. It is really a simplification of the original circuit to connect the pilot lamp in series with the rectifier tube plate supply.—Charles McCleskey, Jr., San Antonio, Texas.



If You've Hit The Jackpot with a new solution to some service problem, won't you please share it with others in the radio service business by sending it to us for publication in these columns? Hints resulting from your personal experiences are invaluable to other servicemen, and your willingness to share them is more commendable than ever during these difficult times.



Copyright 1944, Sylvania Electric Products Inc.

APRIL, 1944

EMPORIUM, PENNA.

Vol. 11, No. 1

EMERGENCY OHMMETER CIRCUIT DESIGN

During the last few months we have had a large number of requests for ohmmeter data from servicemen. This may be caused by the scarcity of good meters and the large number of new recruits starting out in the radio service field. Perhaps too, some of the "retired" fraternity have started work again as

resistors which may be on a meter. Most meters will not have all these, the simpler and cheaper the meter, the fewer of them there will be. In general only moving-coil (D'Arsonval movement) meters are considered good enough for such work; so the procedure given here will be based on that, but should work equally well for

meters), zero adjustment and magnetic shunt. The average inexpensive voltmeter will have R_s open, R_1 and R_2 combined into one spool which would be tapped if it were from a voltmeter with more than one range. The magnetic shunt, one form of which is shown as Figure 1A, is used only on recent models of very good meters to bypass some of the magnetism so it does not go through the coil. On the cheaper models the magnet is reduced in strength by putting it in an A. C. field until the required calibration is obtained. The zero adjustment of the hairspring should be familiar to everyone. The balance weight opposite the pointer should be checked for adjustment if it is desired to use the meter in any other position than horizontal. This adjustment is described later:

MECHANICAL CHECK

Before starting on any measurements it would be best to check the meter mechanically. Put a strong light behind the meter, or a piece of white paper in a strong light and look through the air gap for filings, dirt, etc. Clean out as well as possible with a pipe cleaner and finish by blowing quite hard while holding the coil from slamming. The coil should be loose in its bearings and should not stick anywhere when moved slowly over the scale. Check the pointer for straightness, using tweezers if necessary to straighten it. If it is desired to check the balance this is done by holding the meter vertically with the zero mark directly above the pivots, adjust the hairspring until the pointer is on zero in this position. Then hold the meter, still in the vertical position, but with pointer approximately horizontal. If the meter does not still read zero the weight requires adjusting. Move the weight towards the light side. If there is no adjusting weight a match stick can be used to put a small dab of hot wax or quick drying lacquer on the light side. Do not put any on the coil, just on the pointer or its extension on the opposite side.

METER SENSITIVITY

Now that the meter has passed its "physical" we are ready to start on the electrical tests. If you have or can borrow a milliammeter the work will be greatly simplified, just use the circuit of

(Continued on next page)

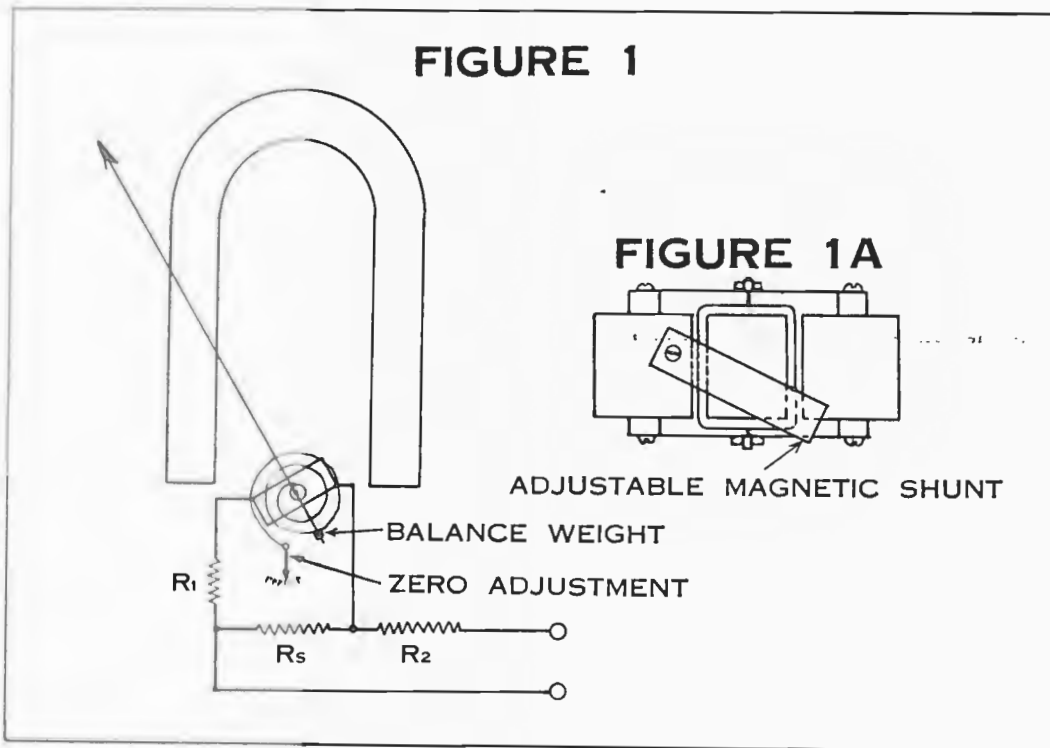

a favor to their friends since there is more service work to do than can be done by the remaining civilian servicemen. In many of these cases they have a meter of more or less unknown value which they hope to make into an ohmmeter. Any ohmmeter information we have seen in magazines or books starts with a known meter and all the values of resistance etc., are already worked out. In this article, however, we will try first to show how to determine the essential electrical constants for any meter; second, how to estimate the range of values over which the meter will be useful in any one of the simpler circuits; and third and last, to show how to calculate the resistors required.

All servicemen know how meters work, but may not be familiar with all the confusing little details that show up when a meter is removed from the case. Figure 1 shows the possible adjustments and

any other meter having a sensitivity sufficient to be useful to a serviceman. Even an A. C. voltmeter will make an ohmmeter of sorts, though the range may be quite low. Some A. C. meters consist of regular D. C. movements with either a rectifier or thermocouple connected to the terminals with leads going to the moving coil. These will be very good meters, indeed, as they are quite sensitive. Disconnect the rectifier or thermocouple and wire directly to the moving coil. Dashboard ammeters of the type used in cars to indicate charge and discharge of the battery should be given up at the start. They are in general unsuitable for any kind of test work, and so also are the dynamometer type meters occasionally found in some tube checkers.

ADJUSTMENTS

The adjustments shown in Figure 1 are, shunt resistor R_s , series compensating resistor R_1 , series resistor R_2 (in volt-

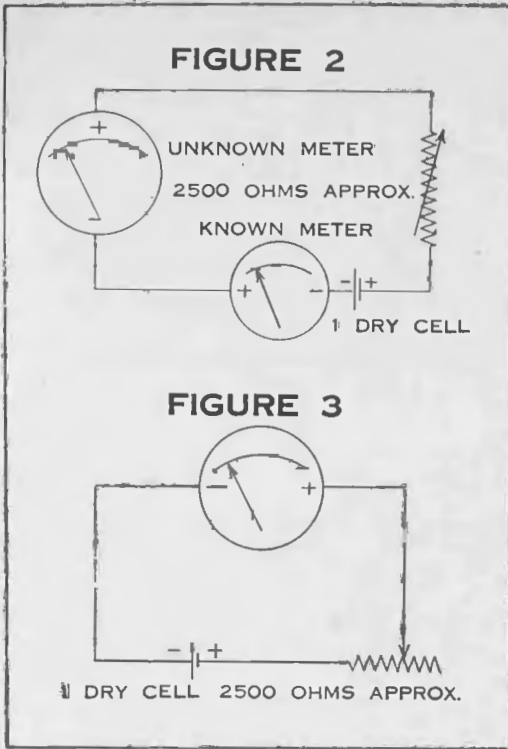

Figure 2 adjusting R until the unknown meter deflects full scale and read the current on the good meter. Any resistor in the position of R2 of Figure 1 should be shorted and R_s open circuited for this test. Let us call this figure the "current for full scale deflection," cfs for short. In case no milliammeter is available we can get this approximately as follows: Mount a good grade of wirewound potentiometer on a panel with a pointer and paper scale. Do not use one of the special tapered potentiometers. For meters in the range of 1 ma to 10 ma a value of 2,000 ohms will be satisfactory. For better meters it may be necessary to use 10,000' ohms. Mark off the scale evenly in hundreds of ohms with dividers, from resistance all-in to resistance all-out. Connect as in Figure 3, being sure to use the right two terminals so that when set for 2,000 ohms it isn't 0 ohms. Meters are scarce, so check this point carefully. Use a new dry cell so that an assumed value of voltage will not be far off. When all is ready, touch the last wire connection quickly to see that the meter does not deflect off scale. If it does, find a value of R which will keep the meter on scale, this can be a known fixed value in series with the potentiometer, or it may require calibration of a larger potentiometer. Adjust until full scale deflection is obtained. To get the cfs we will assume a value of 50 ohms resistance in the meter (we will check it later and correct the cfs if necessary)

$$cfs = \frac{1.55}{50 + R1}$$

The 1.55 volts is a good average for a new dry cell but if you have a more accurate figure it should be used. The 50 ohms estimated for the meter resistance is about what the usual 3" or 4" meter runs, but may be anywhere from 10 to 1000 ohms.

Table 1 will give some idea of the range of resistance covered by meters for

different values of cfs, and battery voltage in the usual circuit. The maximum and minimum values of ohms readable are taken at 1/50 and 49/50 of full scale for the circuit shown at the head of the

TABLE 1

C F S	Circuit Fig. 4		Circuit Fig. 5	
	Max. Ohms	Min. Ohms	Max. Ohms	Min. Ohms
10 Ma.	7,500	750	1/2 Meg.	50,000
9	9,000	900	555,000	55,500
8	10,000	1,000	625,000	62,500
7	11,500	1,150	715,000	71,500
6	13,000	1,300	835,000	83,500
5	15,000	1,500	1 Meg.	100,000
4	18,000	1,800	1 1/4 Meg.	125,000
3	25,000	2,500	1 2/3 Meg.	166,700
2	37,500	3,750	2 1/2 Meg.	250,000
1 1/2	47,500	4,750	3 1/3	333,000
1	75,000	7,500	5 Meg.	1/2 Meg.
1/2	150,000	15,000	10 Meg.	1 Meg.

column. Ohmmeter scales are badly crowded at the high resistance end, so do not count on accurate readings over more than two-thirds of the total scale.

You may or may not wish to use the scale which is on the meter. If it is now marked in volts, milliamperes or in any other unit that gives nearly uniform divisions, it will be easiest to make a table or graph showing the ohms corresponding to each scale division. It will be more convenient to use if you are handy with a small pen and can draw in a special scale for ohms above or below the present scale.

Ohmmeter scales are not uniform, so every point must either be calculated or determined experimentally as shown later. Sometimes the old scale may only have a few marks on it, for example, good, weak and bad, if from an old tube checker. In this case probably the best thing to do is to cut a small card to fit the scale and

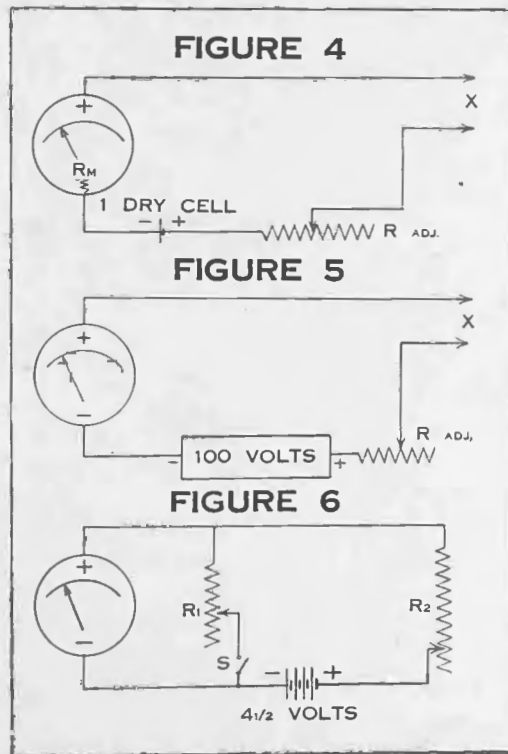

fasten it on with rubber cement. The zero, full scale and approximate position of the arc can be penciled in. If the scale is taken off the meter and tacked to a board these lines can then be drawn in

more accurately with pen and ink. The divisions can either be put in uniformly and a calibration curve used or the calibrating points may be determined before finishing the scale.

USE AS A VOLTMETER

Before describing the calibration in detail it would be best to find the other important meter constant and show how the meter could be used as a voltmeter if desired. In Figure 1 the resistance R_s; which was disconnected while getting the cfs (the greatest possible sensitivity of the meter) can be used to adjust the meter to any sensitivity poorer than the cfs figure obtained. One of the most used sensitivities is 1000 ohms per volt, which corresponds to a cfs of 1 milliampere. If at all possible to get this sensitivity by adjustment of the magnetic shunt, or if the meter is quite old, by remagnetizing the magnet, it should be done. If the sensitivity is better than 10 ma (cfs) you probably will wish to use it as a voltmeter also. It will make the resistors much easier to obtain if the value of R_s is adjusted carefully so as to get a cfs of 1.0, 2.0, 5.0, or 10.0 milliamperes, corresponding to 1000, 500, 200, or 100 ohms per volt respectively.

METER RESISTANCE

In order to get the actual meter resistance as a check on the assumed value of resistance used in calculating the cfs and needed in order to know the value of series resistor required for low range voltmeters a circuit like Figure 6 should be set up. R1 should be a calibrated potentiometer as made for use in Figure 3 but of about 100 ohms. R2 can be any adjustable resistor for which the calibration is not required. First, leaving R1 disconnected, adjust R2 until full scale deflection is obtained. Then connect R1 and adjust it until the deflection is half the first deflection. If this point cannot be obtained a larger value of R1 may be required. The value of R1 obtained is then the resistance of the meter since it now takes half the current that formerly passed through the meter. If this figure is greater than the 50 ohms previously estimated, correction for the value in the equation for cfs should be made. There is a possibility of its being less, in which case add enough series resistance to get 50 ohms or some simple multiple, so that a standard resistance for the first resistor of the voltmeter circuit can be employed.

VOLTMETER CIRCUIT

Figure 7 shows the circuit diagram for a voltmeter (multirange) up to 1000 volts and the table under it shows the value of each resistor for the preferred adjustments of C.f.s. These are all based on 50 ohms in the meter, but in case yours is greater than 50 ohms deduct the difference from the value of R1 only. The formulae shown in the bottom line of the table will make possible the calculation of these resistors for other ranges and other sensitivities.

FIGURE 7

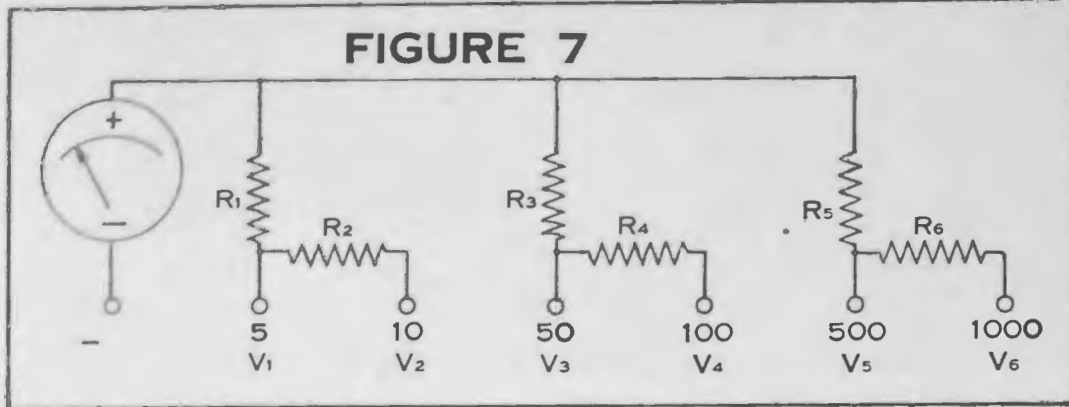

Ohms per Volt	CFS	R1	R2	R3	R4	R5	R6
1000	1.0 Ma.	4050	5,000	50,000	50,000	500,000	500,000
500	2.0	2450	2,500	25,000	25,000	250,000	250,000
200	5.0	950	1,000	10,000	10,000	100,000	100,000
100	10.0	450	500	5,000	5,000	50,000	50,000
$\frac{\omega}{V}$	N	$V_1 - \frac{\omega}{V} - 50$	$(V_2 - V_1) \frac{\omega}{V}$	$V_3 \cdot \frac{\omega}{V}$	$(V_4 - V_3) \frac{\omega}{V}$	$V_5 \cdot \frac{\omega}{V}$	$(V_6 - V_5) \frac{\omega}{V}$

If these tests have been followed through we now have sufficient data to determine the ohmmeter and voltmeter scales to be used. Note that if it is decided to use the circuit of Figure 5 it will require a voltage of 100 volts; 150 volts might be used, in which case the values of resistance in Table 1 will be 100 times the value shown for Figure 4. It is probably inadvisable to use a higher voltage than this. No circuit is shown for obtaining this voltage because anyone can throw together some parts from the scrap box. A really good one using a Sylvania VR90, VR105 or VR150 might be worthwhile if the parts are available and if you think the accuracy of the rest of the ohmmeter justifies this. A switch to use either 1½ or 100 volts would be good but different values of adjusting resistor will be required.

CALIBRATION

By using Ohms law we can find the resistance corresponding to any given point on the scale. Suppose there are N scale divisions then the current at any particular point p will be

$$\frac{p}{N} \times cfs.$$

Since you know the battery or supply voltage being used then in Figure 4

$$I = E/R \text{ Becomes}$$

$$\frac{p}{N} \cdot cfs = \frac{E}{R_x + R_{adj} + R_m}$$

In setting up the zero adjustment by varying R_{adj} so as to give full scale deflection with R_x = 0 we know

$$R_{adj} + R_m = \frac{E}{cfs}$$

Repeating the calculation for a large number of points will enable the graph to be drawn or the scale marks to be inked in if that has been decided upon.

If a selection of resistors of 10 per cent accuracy or better is available a quicker method is to mark the scale at these known values.

OHMMETER CIRCUITS

In addition to Figures 4 and 5 other circuits which may be used are shown in

Figures 8 and 9. These have the advantage that they do not require calibration of the meter but they do make a much more bulky set-up and also require one or two known standard resistors. Figure 9 is particularly bulky because it is built

FIGURE 8

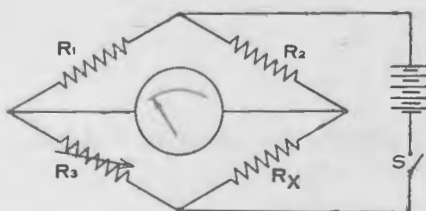
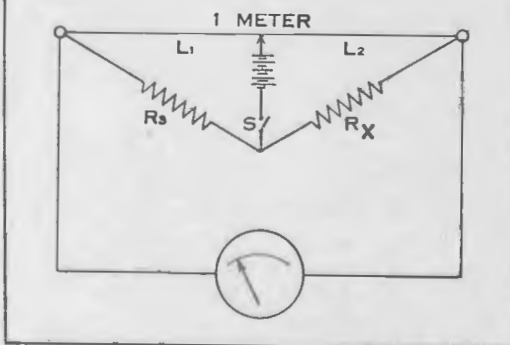

FIGURE 9



around a meter stick. The bridge circuit is, we hope, familiar, but for those who have forgotten

$$R_x \text{ (ohms)} = \frac{R_3 \cdot R_2}{R_1} \text{ (Figure 8)}$$

$$R_x \text{ (ohms)} = R_3 \cdot \frac{L_2}{L_1} \text{ (Figure 9)}$$

(When balanced so that no current flows through the meter).

For use in these circuits it is best to change the position of the needle sufficiently up-scale to allow a deflection in the opposite direction to be clearly visible. Any meter, no matter how poor the sensitivity, can be used in these circuits, the loss in sensitivity being made up by increasing the battery voltage, if necessary right up to the point where the resistors get hot.

If the meter is a voltmeter its series resistor should be shorted out for this service. No switch is shown in the meter circuit but when measuring the D. C. resistance of chokes or transformers one should be added and not closed for a few seconds after closing the switch in the battery circuit, so as to avoid the inductive effect. If the balance does not stay constant but drifts, it is due to the fact that the current is high enough to cause some heating. In using this method, therefore, it is best to start with a low voltage until a rough balance is obtained, then increase until the desired accuracy is reached.

The accurate resistors for R₁, R₂ and to a lesser extent R₃ could be precision resistors if available, if not, it would be well to have these measured on a Wheatstone bridge. Many distributors have these and if specially requested to pick out two resistors having the same value for this purpose would probably oblige. The actual value does not matter as long as both are the same, but they should be wirewound. A value anywhere from 200 to 2000 ohms would give good results. In the circuit of Figure 8 R₃ must be variable over the range of resistors being measured. Two or three potentiometers calibrated as described earlier in this article will give approximate results, perhaps good enough for most service work. If greater accuracy is desired the potentiometers could be measured on a bridge, (most high schools have one) or some multipoint switches could be arranged to connect accurate or previously measured resistors arranged to form decades over the desired range. The resistor R₃ of Figure 9 should for greatest accuracy be between 1/10 and 10 times the unknown value so a selection of measured resistors covering the usual values will be most useful, and could be arranged on a selector switch. The wire L₁ and L₂ can be any resistance wire available, or in a pinch, even piano wire about .030" diam. will serve.

Before closing it would be well to mention a method which requires no meter at all. This can be done in the circuit of Figure 9 by substituting a pair of phones for the meter and a transformer for the battery. A doorbell transformer would probably be satisfactory, or even an old radio power transformer with enough low voltage windings to add up to 15 to 20 volts when connected in series.

Since this article is intended to enable servicemen to get passable measurement of resistance with minimum equipment no mention has been made of the more complicated circuits using vacuum tube voltmeters. It is our hope that all servicemen will have such an instrument as soon as it is possible to get them, or the parts to make them, but if this article enables a few servicemen to "get by" with their present equipment for the duration it will have served its purpose.



THE information presented in the Sylvania Service Exchange is contributed by servicemen as the result of practical experience. It is very carefully considered before being accepted, and we believe it to be correct and authentic. However, we assume no responsibility for results. Please do not send routine or generally known information.

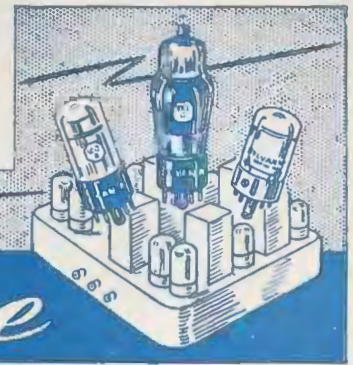

THE Service Exchange

Atwater Kent Model 317. When this model is noisy and reception is intermittent especially when set is jarred, examine the leads which go from the top of the tubes into the coil cans. The rubber insulation here often rots completely or partially away and causes the trouble. Unsolder the grid cap and slip new insulation over the entire lead and resolder the grid cap.—Marion L. Rhodes, Knightstown, Indiana.

* * *

Philco 1942 Automatic Record Changer. The selenium cell used in 1941 and 1942 Philco changers can be tested by connecting directly to a 250 millivolt meter or a 1 milliamp. meter which is more common. Under a strong light or direct rays of the sun, a good cell will go close to full scale on 250 millivolt meter.—Sam Slymen, Los Angeles, California.

* * *

RCA Model 8M Auto Set. A sudden drop in volume may be caused by oxidation between the trimmer screws and spring plate. Cleaning the screw and plate and increasing spring tension cures this. Don't overlook checking the trimmer located between the condenser and chassis and reaching through the small hole on the underside of the chassis.—S. J. Stansfield, Farmington, Mich.

* * *

Stromberg-Carlson 935. Inoperative sets are sometimes caused by the dual .05 mfd. condenser C93-94 shorting. This is a common trouble with these sets and I replace with individual condensers with a 600 volt rating.—Leonard D. Chroma, Tarrytown, N. Y.

* * *

Zenith Combination Battery AC-DC Portables. Frequently these sets come into the shop and do not play at all. Voltages on all the plates usually check OK but a check on the filament shows a drop of from half-volt to a volt. This is in circuits using the cathode circuit of the rectifier tube to supply the filament voltage for the other tubes. An additional 16 mfd. filter condenser added from the cathode of the rectifier tube to the negative return will remedy this trouble which seems to be caused by a weak rectifier tube for which replacements are not available right now.—J. W. Tantaske, Verona, Pa.

Substitute for 12SA7. Since the Type 12SA7 is so difficult to get and so often needed for replacement, a Type 12K7 may be substituted. The following steps are taken: Disconnect the wire from pin No. 5 and connect to top cap. Take wires from pin No. 8 and connect to pin No. 5. Tie a jumper from pin No. 8 to pin No. 6. Little realignment is necessary.—J. F. Ewald, Clovis, Calif.

Editor's Note: We publish the above with reluctance because it will not always give a satisfactory repair. It was tried on a Zenith set in the Laboratory and the sensitivity was reduced by a ratio of 20 to 1. In areas of high signal strength it may be passable but you may get some complaints.

Serviceman Tom Davis Wants Your Help

Tom Davis of Cave Spring, Ga. has written us to ask why we don't let you servicemen describe the symptoms of those sets you can't fix so that anyone who has solved that same problem can suggest the solution. He needs help to stop oscillations on the following sets:

'39 RCA Model

'41 Philco Model

'42 Motorola 4-tube battery set

Can you help him? Whether you can or not, would you like to see this feature continued? Will you help to make it a success?

Silvertone #110.391-1. This portable battery AC-DC has an unusual circuit. On AC-DC the filament voltage for the four 1.4 volt tubes is taken from the hi-voltage circuit of the 35Z5GT. Low voltage on these filaments may be caused by a partially open 70 mfd. 150 volt tank condenser between cathode and ground.—H. F. Hamilton, Findlay, Ohio.

* * *

Amrad Model 81. If set hums check the four anode 52 mfd. mershon condenser. Disconnect each wire separately from each anode of mershon, inserting in series a 0 to 10 milliammeter. If meter registers over 4 mils leakage per 8 mfd. section replace with a 2 mfd. 400 volt condenser. If meter registers over 10 mils for 18 mfd. section replace with a 4 mfd. 400 volt condenser.—Geo. Baer, Roslindale, Mass.

Sentinel Radio Model 275. Audio stage passed signals. I.F. transformers and tubes tested OK. All tube voltages OK and resistance of transformers OK but set dead. Tried inserting new tubes, still no signal. Finally I inspected the tube socket and found that the 2nd I.F. tube was not inserted correctly. The molded bakelite rim of the socket had become chipped allowing the centering lug to enter in another place. A new socket was installed for a permanent repair.—T. B. Lee, Louisville, Alabama.

* * *

Field Coil Burnouts. I spent much time on a Crosley Model 58 trying to increase the volume to normal, but nothing seemed to help much. Finally, another dynamic speaker was plugged in in place of the regular speaker, and the volume appeared to increase. Checking the regular speaker, I found that at some time in the past the field coil had apparently burned out, and instead of repairing it, or replacing it, the connections from the speaker to the plug had been rearranged so that the 45 output tube plate received its positive voltage through the output transformer primary, but no current flowed through the field coil to energize the speaker.

A quick and entirely satisfactory repair was made on the field coil, by checking it with an ohmmeter to discover where the circuit was broken, which in this case was very near the core end of the winding. Then by scraping the enamel insulation from a few turns of the winding along the outside of the coil, near the core, and tapping it, the entire winding from that tap to the outside of the coil was OK, and when the speaker connections were returned to normal, the radio performed normally, with very good volume and tone. The few turns at the inner end of the field coil that were by-passed in this way, have no affect, and the slight change in resistance is not noticeable. To check the coil for the break, I connected ohmmeter to one end of winding, and using a sharp prod, scraped through insulation along side of windings until point was reached where indication changed. Repairs could also be made near center of coil, simply by shunting the break along the edge of the coil, after which the coil is retaped.—Paul L. Graham, Belgrade, Nebr.

Sylvania News

Copyright 1944, Sylvania Electric Products Inc.

May-June 1944

EMPORIUM, PENNA.

Vol. 11 No.2



Many of the parts used on the diffusion type exhaust pumps are complicated examples of the glass blower's art. These pictures show several steps in the process as Mr. Maiolatesi makes a new part for a diffusion pump.



COMMENTS ON TUBE SUBSTITUTIONS

Naturally, we, as tube manufacturers, should know a little about the proper ways to use tubes. We have tried to pass this information along to our customers and to servicemen in particular, by publishing manuals, correlation charts, characteristic charts and quite recently, tube substitution charts. A very common cause of bad headaches for tube engineers is to see the circuits or conditions under which their favorite tube gets used in the field.

HIGH PRICED SUBSTITUTION CHARTS NO BARGAIN

One similar item has come to our attention quite recently. You have probably noticed ads for tube substitution lists prepared by various organizations where they offer lists of 100 to 300 substitute types for anywhere from 25c to \$3.00; sometimes additional useful servicing articles are included. We have had opportunity to look over several of these replacement charts, and in general, we find that those supplied (usually free) by tube manufacturers are substantially correct and that many of those sold to the innocent serviceman may be quite likely to cause him, and perhaps his customer, plenty of trouble.

MANUFACTURERS' SUBSTITUTION CHARTS ARE DEPENDABLE

The replacements that have been recommended as a war-time expedient in the form of charts or otherwise by the various tube manufacturers are the results of probably the best engineering advice that could possibly be procured on this subject. It is assumed that these recommendations will only be tried by those individuals who are familiar with radio servicing theory. Blindly following substitution rules is sure to get you into trouble sometimes; there are so many circuits, and besides someone else may have already made some war-time substitutions. You can't service sets these days unless you know what it's all about. We hesitate to say that any given substitute will never work—perhaps it will work fine in some unknown set made

(Continued on Page Five)



Picture number five shows new part in place.



SYLVANIA'S Williamsport Plant is proof of women's place in industry. The intricate and exacting work involved in the manufacture of transmitting tubes takes

dexterity and patience, and shows women's superiority in this field. Several hundred women are now employed at Sylvania's Williamsport Plant with gratifying results.

Below are shown a few of the operations.

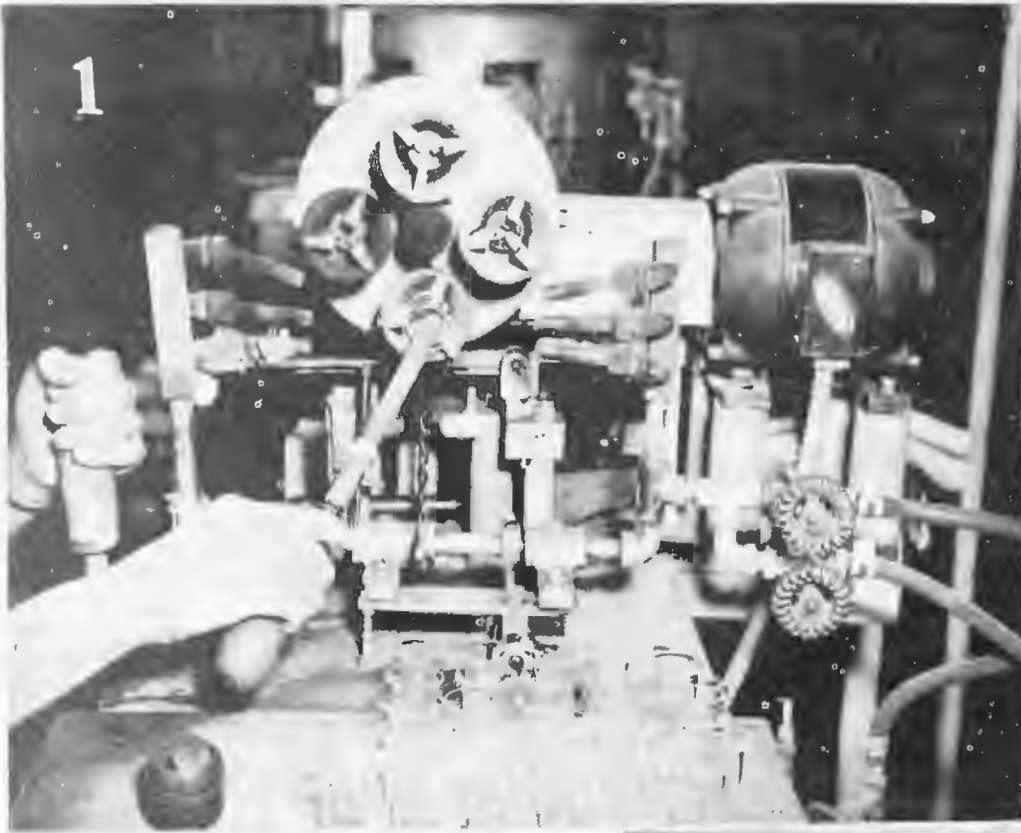

1. This hand type flaring machine is still in use for special sizes of flare. Gas flames soften the end of a glass tube which can then be stretched with the tool shown, to form the flare.

2. This machine heats the glass on the top of the bulb and then punches a hole for the plate lead connection.

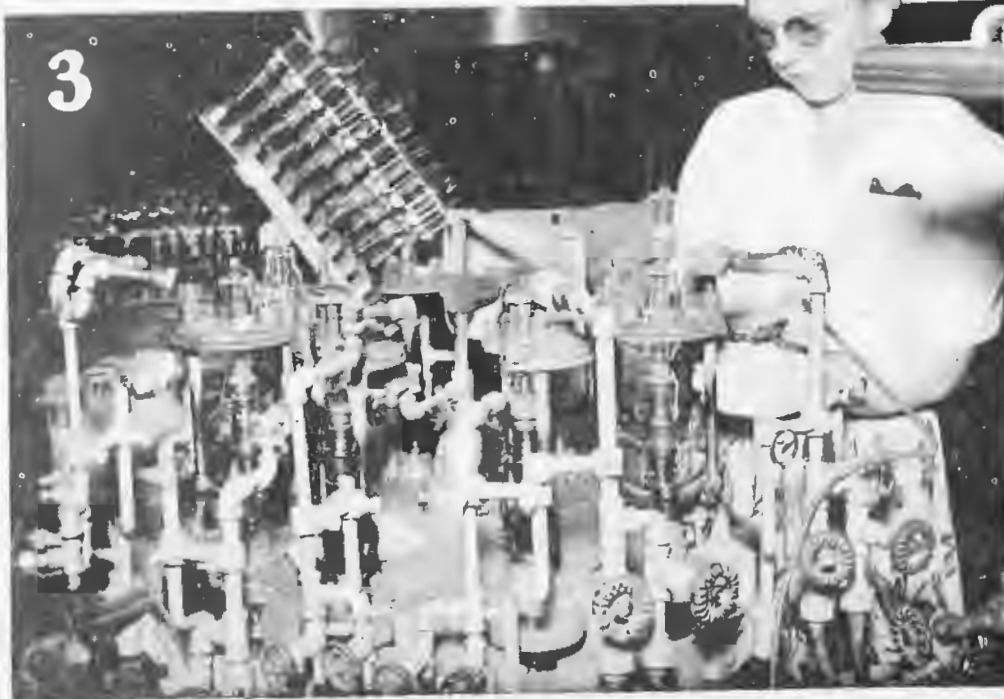
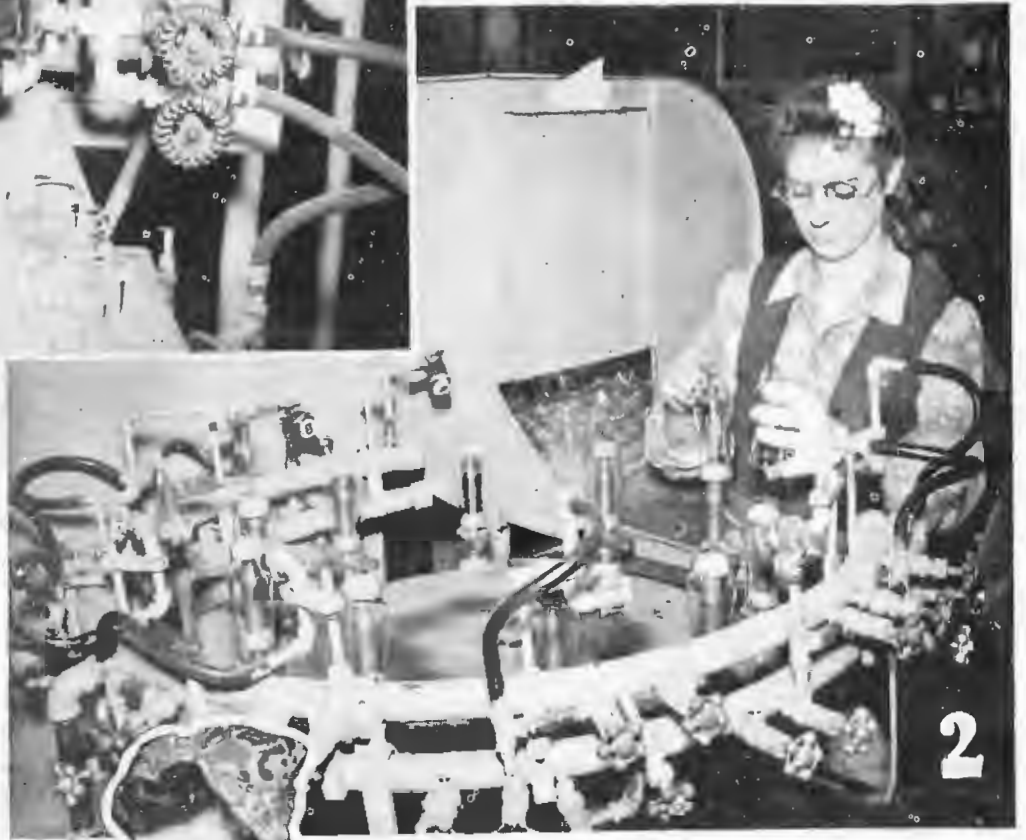

3. On this sealing machine the bulb prepared in the last picture is slipped over the completed mount and fires melt the glass opposite the flare, fusing them together. The glass around the plate connection is also sealed in the same operation.





4. This is the exhaust machine. Tubes go into an oven first to help drive the air out of the glass, after which it goes to the plate treating coils where the metal parts are kept red hot while the gas is being pumped out.



5. This machine keeps the bulb and base in perfect alignment while the cement holding them together is baked on. The operators of this machine also cut off and solder the wires as the tubes are taken off.

6. From left to right this shows a flare; a complete mount, top cap, bulb, base and a completed Sylvania type 807 tube.



COMMENTS ON TUBE SUBSTITUTIONS

(Continued from Page Three)

by John Doe of Podunk, but some will stand so little chance of working satisfactorily that the information is definitely misleading. One such list is before us now and recommends the 1D7G as a substitute for the 1A7G! A 2.0-volt tube in place of a 1.4-volt tube! And it isn't a misprint either because a similar change, and to make it worse the converse (use of a 1.4-volt tube in place of the 2.0-volt tube) has been recommended for the following:

- 1H5G and 1H6G
- 1G4G and 1H4G
- 1N5G and 1D5G

These substitutions are listed in our chart as possible, but with the note that the battery voltage must be changed.

In some recommendations power output tubes have been similarly abused but in this case substitutions are made without change of bias voltage. It is mentioned that the tone may be different but is called "reasonably good." No mention is made that the plate current may be nearly double normal, and in these days of scarce batteries as well as tubes, this point surely would not escape an up-to-date serviceman. We believe that all of you would rather take a few minutes more and change the position of the grid return so as to get a set operating correctly and, incidentally, sounding better. We consider some of the other power output tube substitutions that have been recommended rather questionable too; 6G6G in place of 6F6G; and 6K6G in place of 6L6G.

Surely, there are enough types of tubes available in 6-volt remote cutoff and sharp cutoff classifications so that it is not necessary to put sharp cutoff tubes in remote cutoff sockets and vice versa, but we have seen it recommended. The same error is made for the corresponding 12-volt types. Here again is a case that might conceivably work sometimes, but would you want this in your own set?

Just a few more itemized criticisms to give an idea of the things to watch out for in lists of this nature:

6J5 and 6P5 may substitute for 6L5 in parallel heater circuits only.

6SS7 may substitute for 6K7 in parallel heater circuits, and by use of a 42-ohm resistor across the heaters it may be used in series circuits.

5U4G may substitute for 5Y3 if the heater winding of the transformer will stand an additional ampere.

5W4 may substitute for 5U4 only if the load is reduced to somewhere near the rated load for 5W4 (100 ma.) whereas 5U4 is rated for 225 ma. Very poor life otherwise.

1LC6 may substitute for 1LD5—sometimes, but it may be necessary to add

(Continued on Page Six)

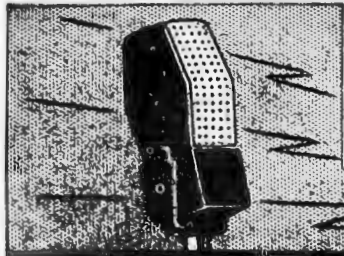

THE information presented in the Sylvania Service Exchange is contributed by servicemen as the result of practical experience. It is very carefully considered before being accepted, and we believe it to be correct and authentic. However, we assume no responsibility for results. Please do not send routine or generally known information.

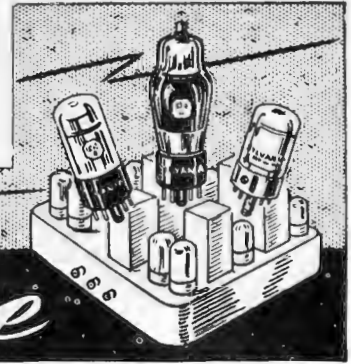

THE Service Exchange

In reference to Tom Davis' oscillation trouble. (See Page 6, April Sylvania News). I can sympathize with him and believe I can help him.

The cure for oscillation in nine cases out of ten is to isolate the plate and grid circuits as much as possible, by (1) dressing all leads, especially the "hot" I.F. and R.F. leads close to the chassis and away from each other.

(2) Filter the d.c. component to these I.F. and R.F. transformers. 1000 ohms and an .05 condenser does the job. (3) Shield any tubes that might be involved. Pass your hand over the tubes in question to locate stage oscillating.

A final, though not recommended method, is to de-tune the offending I.F. stage if that is where the trouble is originating. — Charles V. Matt, Cicero, Illinois.

COMMENTS ON TUBE SUBSTITUTIONS

(Continued from Page Five)

a screen resistor in order to get good sensitivity.

The use of an r-f pentode for a converter of the 6SA7 type by using the control grid for the oscillator grid and the suppressor as the control grid is so likely to give poor sensitivity that we cannot recommend it for general use.

The substitution of the high- μ diode triodes 6T7G, etc. for the low- μ diode triodes, 6V7G, etc. and vice versa, will also give poor performance in many cases.

In conclusion, we can only repeat that the Sylvania substitution chart is still available free to servicemen on request and that we are glad to help out in any cases you find difficult. We will print your "discoveries" in the Service Exchange and include any substitution you propose in future editions of the chart if, in our opinion, the change would work in the majority of receivers.

Majestic Model 330. The bypass condensers of this model are contained in two cans—part numbers 8731 and 8704. The color coding of the leads is not given in the usual set diagram so it is quite a nuisance to locate a defective unit. The illustrations give the color coding and size of each component and have been a great help to me since I made them up.—Henry Bollmann, Berkeley Heights, New Jersey.

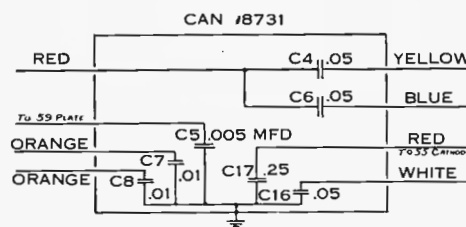
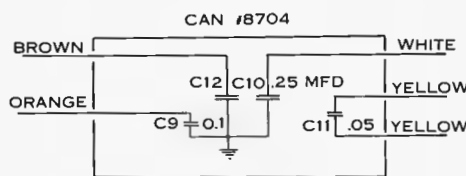

Using 3A8 in Place of 1N5 and 1H5. In case you need Types 1N5 and 1H5 you can replace both with a Type 3A8 in most portables having the tubes in series as follows: Put the Type 3A8 in the 1N5 socket making sure that contacts No. 1, 8, 6 and 5 are clear. Now connect wires from grid, plate and diode of 1H5 socket to No. 5, 6 and 8 of the 1N5 socket. Short pins 2 and 7 on the 1H5 socket to complete the filament circuit. I use a tube base with a link in place of the filament so that rewiring will not be necessary when tubes are more readily available. It is easy to put the filaments in parallel in sets requiring it.—Ray Moore, Salem, Oregon.

Silvertone Models 7252, 7251, Chassis No. 110.988. Quite a number of these sets have come into the shop with the same complaint, that of loss of sensitivity over the entire broadcast band. After considerable checking I found that the small fixed padder condenser (.000425 mfd.) in the low frequency section of the oscillator circuit had changed in value due to temperature changes and moisture absorption. Replacement with a variable or adjustable padder and realignment of low end of band will work

wonders with the gain and overall sensitivity of this set.—Arthur L. Johnson, Hutchinson, Kansas.

Philco Auto Radio Models AR6. Intermittent operation and noise in these models can almost always be traced to the flexible shielding used as a bond between the tuning mechanism housing and ground. I replace these bonds with a small but fairly sturdy dial drive spring which when soldered from the condensers frame to ground gives a permanent flexible repair, and will never break, regardless of vibration or condenser movement. Realign the set and check for condenser plate clearance over entire broadcast band.—Arthur L. Johnson, Hutchinson, Kansas.

Solar CB-1-60 Condenser Analyzer. When the high resistance range, R-1 (5M ohms to 2 meg.) is inoperative, the probable cause is an open wire-wound resistor, CB-37, (the larger of the two flat resistor strips). Repair of this resistor is inadvisable due to the small size of the resistance wire.

If an exact duplicate part is not available, use a precision 100,000 ohm wire-wound resistor, and if this is unavailable, use a standard 100,000 ohm, carbon, one watt. As a matter of interest, the smaller flat wire-wound resistor, CB-31, is a 1,000 ohm unit.—Joseph S. Napora, Dayton 3, Ohio.

Substitution. Type 12A8GT may be substituted easily for Type 12SA7GT. The number 8 terminal goes to grid cap naturally. Number 6 to number 8 for correct cathode connection, number 6 which is vacant (then) is now connected to number 4. This is the simplest substitution I know of and realigning is slight.—Bert Felsburg, Frackville, Pa.

Dial Drive Belts. We get long heavy leather boot laces the kind that are rough on each side and cut them to the right length and fasten them together with hookup wire dropping a little solder on the connection to make them like sewing machine belts. We have had some of these out in sets for as long as four years and they are still going.—C. C. Dibrell, Ardmore, Okla.



Copyright 1944, Sylvania Electric Products Inc.

July, 1944

EMPORIUM, PENNA.

Vol. 11 No. 3

EXPLANATION OF THE RADIO TUBE NUMBERING SYSTEM

Servicemen who have been in the business for many years and have grown up with the various tube nomenclature systems have little trouble keeping the numerous types straight in their minds. It may appear almost hopeless, however, to those who are just starting to work with tubes.

An explanation of the systems employed will probably be a big help to many of our readers and we hope that even those of you who don't need this will find a few interesting points.

PRIOR TO 1933

Originally, of course, tubes were assigned numbers like 201, 235, 246, etc., with certain companies distinguishing their products by calling theirs 301, 401, etc. This eventually became confusing so the figure in the hundreds place was dropped and those types became '01, '35, and '46, etc. These numbers had no connection with the tube characteristics. Type 35 was a 2.5 volt R-F tetrode; Type 36 was a 6.3 volt R-F tetrode and Type 37 was a 6.3 volt triode. Obviously some better arrangement was needed so a systematic method of numbering was worked out.

1933 TO 1944

The type number assigned to any tube in this system consists of 3 or 4 groups as follows:

- | | | | |
|-----------------------------|----|-----|----|
| 1. A figure group..... | 1; | 1; | 1 |
| 2. A letter group..... | A; | LN; | T |
| 3. A figure group..... | 1; | 5; | 5 |
| 4. One or more letters..... | | | GT |
- (sometimes)

In the above examples 1-A-1, 1-LN-5 and 1-T-5-GT the first figure 1 means that the filament voltage is around 1.0 volts. The figures 1 or 5 in the third group indicate the number of useful elements. The letters in the second group are generally assigned in order as the types are brought out but may have a special meaning as described later. The final letters generally describe the mechanical construction or size which is also described later.

Similarly Type 6A3 is a 6 volt tube having 3 useful elements, in this case a power output triode. Type 6A4 is similar with one more grid terminal; it also has a third grid connected internally, but this is not counted as no connection to it is brought out.

This seems fairly simple, so far, but it started to get confusing when metal tubes were added. These have a terminal for the metal shell; therefore, this had to be counted, as it was useful for shielding, so a simple cathode-type triode became Type 6F5. In order to prevent confusion when a tube similar to Type 6F5 but in the glass bulb was announced, it was called Type 6F5G, although there really are not 5 useful elements. The G indicates a glass bulb on the recent types only (having the octal base). Unfortunately, there is no designation to distinguish the old glass types from the metal types. They have to be remembered or looked up. Type 6E5 is an indicator tube in a glass bulb with 5 useful elements. Type 6F5 is a metal triode with 4 useful elements plus a metal shell.

LOCK-IN TYPES ADDED

The next additions were the Lock-In types in which the 6.3 volt tubes can be distinguished from the other construction by being called "nominal" 7.0 volt tubes such as Types 7A4, 7B8, etc. Similarly, the 12.6 volt tubes with nominal ratings of 14.0 volts are called Types 14A4, 14B8, etc. On some of the low voltage tubes, the Lock-In construction is indicated by the letter L as first letter of the second group such as Type 1LN5, which is similar to Type 1N5, but of Lock-In construction (exceptions are listed later). This is not a general rule, however, because Types 1LN5 and 1N5, while very similar, differ in that the suppressor grid of Type 1LN5 is brought out to a terminal while in Type 1N5G, it is tied internally. Lock-In Type 1LH4 is similar to Type 1H5G, so it is difficult to see similarities between these groups. Exceptions; Lock-In Types without either "L" or "Nominal" Volts rating 1AB5, 1R4, 3D6 and 3B7.

The next development was the introduction of a single-ended metal and glass tube to compete with the convenience of the Lock-In types which have no top cap. Thus, Type 6SK7 is similar to Type 6K7 except that the S indicates that the basing has been changed to allow all connections being made on the bottom. Similarly, Type 6SJ7 and 6J7; 6SS7 and 6S7. There are exceptions here too; Type

6SA7 is not like Type 6A7 because Type 6A7 has the old base, and no metal type with a top cap has been made similar to Type 6SA7. Converters formerly required one more connection than the eight available in single-ended construction, so a new style of converter had to be invented. It has 7 elements, including shell, and the S was added to show that it belonged in the group with the other single-ended types.

The next major change was the reduction in size of the bulb on many types like 6J7G. This was done just to get a smaller tube, and since the characteristics were the same, it was called Type 6J7GT, the "T" standing for tubular bulb. This resulted in a tremendous number of types and to reduce the number required in stock, it was decided to mark the small tube Type 6J7GT/G, meaning that it could be used in place of either Type 6J7G or 6J7GT.

FIRST NUMERAL GROUP OF TYPE DESIGNATION

In assigning these numbers to tubes, it was hoped that certain letters would be associated with particular characteristics, but as more and more tubes were brought out, exceptions were found necessary. A few of the rules with their exceptions are:

- 0—Cold Cathode—or requiring no heater supply.
Exception: 01A (contracted from 201A).
- 1—Filament volts between 0.1 and 2.1 volts.
Exception: 1V. (from the earlier system)
- 2—Filament volts between 2.1 and 2.9.
Exception: 2.8 volt battery tubes were marked 3A8, 3LF4, etc.
- 3—Filament volts between 3.0 and 3.9.
- 5—Filament volts between 5.0 and 5.9.
- 6—Filament volts between 6.0 and 6.9.
- 7—Filament volts between 7.0 and 7.9.
etc., after 25 volts actual value given.

Note (1): When heater or filament is center tapped for use on two voltages, the higher voltage number is used. Exception: Type 6Z5 may be connected for 12 volts also.

Note (2): On Cathode Ray types this first number refers to the screen diameter in inches.

Note (3): 7 and 14 are "nominal" ratings; operation should be at 6.3 and 12.6 volts.

EXPLANATION OF RADIO TUBE NUMBERING SYSTEM

(Continued from Page Three)

THE FIRST LETTER GROUP

The letters U, V, W, X, Y, Z—commonly are used to indicate rectifiers.

Exceptions: Type 6U7G, 6U5, 6U6GT, 6V6G, 6V7G, 6W7G, 6Y6G, 6Y7G, 6Z7G, 7V7, 7W7 and 14W7.

S—as first letter of the letter group indicates single-ended tubes, related to grid-cap types.

Exceptions: Type 6S7, (but 6SS7 is single-ended), 1S4, 1S5, 7S7, these are single-ended but could by their construction be no other way.

THIRD GROUP OF TYPE DESIGNATION

Numbers 1 to 8 designate number of useful elements brought out to terminals.

Notes: (1) In metal tubes, the shell counts as one element.

(2) In Type 6A5G, heater and cathode are tied internally, as well as brought out, counting as two elements.

(3) Shielding by or in base does not count as an element.

Exceptions: On some types the heater tap or the shielding lug has been counted as an element—Examples 7G8, 28Z5, 3D6, 7C4, 7E5, 3B7, 7V7, 7W7, 7A8, 35Z5GT, etc. The reason this rule has so many exceptions is that there has been no general agreement on the inclusion of filament center taps, shielding lug, suppressor grids when tied internally, and split screens as useful elements.

DOUBLE LETTERS IN SECOND GROUP

Combinations like AB, AC, AD, and AE were used when all the single letters were used up.

Rules: L preceding another letter means Lock-In construction—Example 1LN5.

S as second letter of the group indicates single-ended construction previously explained.

P as second letter of the group is for cathode ray types—Example 3BP1.

FINAL LETTER GROUP

A—Quick Heating—Old types like 24A. Reduced filament current as in 01A, 112A, 01AA. Smaller bulb size—as in Type 6L6GA. Also used for other minor changes which in general do not affect interchangeability.

E—Minor construction change to make tube suitable for export. (Seldom encountered in American sets).

G—Glass bulb ST-12 size to ST-16.

GT—Glass bulb T9 size.

GT/G—Glass bulb T9 size. Interchangeable with G and GT types.

H—Horizontal assembly—example 1F7GH.

H—Heater type construction when originally made as a filament type—as 2A3H.

L—Lock-In construction but with octal base and standard octal connections.

LA—Not really a final letter group as the tube was originally called LA.

LT, ML, LM—Glass or metal tube fitted with a Lock-In type base.

MG—Metal-glass construction—a glass tube enclosed in a metal shell.

P—Pentode Construction—as in 1B4P.

S—With shield sprayed or soldered on. (Generally as supplied for Majestic replacements).

T—Tetrode Construction—as in 1B4T.

T—Special construction for use in transmitters—as in 210-T.

V—Vacuum—example 88V (As different from mercury vapor).

V—Vertical Assembly—example 1F7GV.

X—Low Loss base for H-F use(Ceramic).

Y—Low Loss base for H-F use(Phenolic).

Whenever possible, the 12 volt equivalent of a 6 volt tube has kept the same letters. For instance, Types 6A8GT and 12A8GT are identical except for heater rating. There are a few exceptions to this:

7C7—14C7—Similar but not exactly the same.

7A5—14A5—Similar but not exactly the same.

6A7—12A7—Nothing similar.

6A5—12A5—Nothing similar.

6B8—12B8—Nothing similar.

6C8—12C8—Nothing similar.

6B7—12B7—Nothing similar.

THIRD SYSTEM—1942

A third system has been added recently due to the large number of new types developed for military purposes. Complete details of this cannot be listed since the system includes a letter which indicates the purpose or classification of the tube. These new designations all take the form of 1-T-21 in which the initial figure 1 shows that the input wattage to the cathode is between the minimum and maximum values of 0 and 10 watts. The T designates whether the tube is an oscillator, power amplifier, etc.

The following letters have been assigned so far:

A—Single element tubes—ballasts, etc.

B—Rectifiers—full and half wave Regulators—spark gaps, etc.

C—Triodes—including three element gaseous tubes.

D—Tetrodes—including four element gaseous tubes.

E—Pentodes.

F—Hexodes.

G—Heptodes.

H—Octodes.

L—Vacuum sealed capacitors.

N—Crystal detectors and rectifiers.

P—Photo emissive tubes.

R—Mercury pool rectifiers.

S—Vacuum sealed contactor type switches.

Some letters are also reserved for groups of tubes which at present are only made for military use. Originally this system was set up by the RMA to

take care of transmitting and special purpose tubes but the dividing line is not very sharp so we can expect that some tubes from this series will eventually be used in receivers. Where new receiving types can be fitted into the older system they will of course be added.

The final numerals start with 21 and go on up as more types are developed. This number (21 or higher) serves to distinguish tubes of this nomenclature system from the preceding groups and also provides all the room for expansion that should be required for some years to come.

This article can not be considered as absolutely complete and accurate because of the number of exceptions that have been made and the length of time covered. We believe, however, that the most important rules and exceptions are correct and will be of assistance to servicemen in understanding tube type numbers.

RELEASED DATA ON THREE NEW RADIO TUBE TYPES

This month Sylvania is releasing data on three new types: OC3/VR105; 1L4 and 6J6.

In "Sylvania News" of January-February 1943 is a complete description of the other Sylvania regulator tubes: types OB3/VR90 and OD3/VR150. Shown below is a curve giving, for comparison purposes, the typical regulation of all three regulators. Description of the

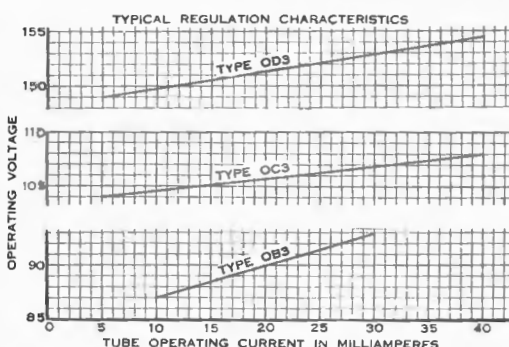

newly announced OC3/VR105 is as follows:

TYPE OC3/VR105 VOLTAGE REGULATOR PHYSICAL SPECIFICATIONS

Style.....	Glass
Base.....	Small Octal 6-Pin
Bulb.....	ST-12
Diameter.....	1 1/16" Max.
Overall Length.....	4 1/8" Max.
Seated Height.....	.39 1/16" Max.

BASE PIN CONNECTIONS

Pin 1.....	No Connection
Pin 2.....	Cathode
Pin 3.....	Jumper
Pin 4.....	Omitted
Pin 5.....	Anode
Pin 6.....	Omitted
Pin 7.....	Jumper
Pin 8.....	No Connection

CHARACTERISTICS

Starting Supply Voltage.....	127 Volts Min.
Operating Voltage (Design Center).....	105 Volts
Operating Current Range*.....	5 Ma. Min. 40 Ma. Max
Regulation over Operating Current Range†.....	4 Volts Max.

(Continued on Page Five)

RELEASED DATA ON THREE NEW RADIO TUBE TYPES

(Continued from Page Four)

Max. Peak Current—5 to 10 sec. starting cycle..... 100 Ma.
 * Adequate resistance required in series with tube to limit tube current to 40 ma.
 † See Circuit Application.

CIRCUIT APPLICATION

Sylvania Type OC3/VR105 is a gas filled, cold cathode voltage regulator. It is characterized by a practically constant internal voltage drop across which a load requiring good voltage regulation may be connected.

The OC3/VR105 is mounted in an ST-12 bulb with a standard small, 6-pin octal base. The outside, cylindrical electrode is the cathode and is connected to base pin No. 2. The inner electrode is the anode and is connected to pin No. 5. The jumper within the base serves as a switch to open the power supply circuit when the regulator tube is removed from its socket, providing the proper socket connections are employed.

A current limiting resistor should always be used in series with the OC3/VR105 and the supply voltage. The amount of current drawn by the load will of course determine the size of this resistor, but it should be such as never to allow an operating current of more than 40 milliamperes to flow through the OC3/VR105 in case the load is disconnected.

To start the tube operating some definite d-c voltage must be applied to ionize the gas in the tube. This voltage is approximately 115 volts but should never require more than 127 volts. Once started, the tube continues to operate at some voltage within the operating range of 105 to 112 volts. The operating voltage will also be dependent upon the current passing through the tube, generally being several volts higher at 40 milliamperes than at 5 milliamperes. This difference in operating voltage on any particular tube is a measure of the regulation for that tube. For Type OC3/VR105 the maximum regulation is 4 volts over the operating current range. On an ideal tube the regulation would have a zero slope and the operating voltage would be constant over the operating current range. This condition is rarely obtained in actual practice. The regulation tends to improve during the life of a tube. It is important to note that individual tubes may not deliver identical voltages to the load. Nevertheless, the voltage should always be within the specified limits for operating voltage and the regulation will be 4 volts or less.

Two or more OC3/VR105 tubes may be connected in series to obtain higher voltages which are multiples of the drop for a single tube. Voltage taps may be

taken from the junction points of the regulator tubes.

TYPE 6J6 HIGH-FREQUENCY TWIN TRIODE

PHYSICAL SPECIFICATIONS

Style..... Miniature
 Bulb..... T-5½
 Diameter..... ¾" Max.
 Overall Length..... 2½" Max.
 Seated Height..... 1⅞" Max.
 Mounting Position..... Any

PIN CONNECTIONS

Pin 1..... Plate T2
 Pin 2..... Plate T1
 Pin 3..... Heater
 Pin 4..... Heater
 Pin 5..... Grid T1
 Pin 6..... Grid T2
 Pin 7..... Cathode
 Basing..... 7BF-0-0

RATINGS AND CHARACTERISTICS

Heater Voltage..... 6.3 Volts
 Heater Current..... 450 Ampere
 Maximum Plate Voltage..... 300 Volts
 Maximum Plate Dissipation (per plate)..... 1.5 Watts
 Maximum Grid Resistor (self bias connection)..... .5 Megohm
 Heater Cathode Voltage (Max.)... 90 Volts
Direct Interelectrode Capacitances*
 Grid to Plate..... 1.6 μf.
 Grid to Cathode..... 2.2 μf.
 Plate to Cathode..... 0.4 μf.

*Each unit—with no external shield, other section grounded.

OPERATING CONDITIONS AND CHARACTERISTICS

	Class A ₁ A-F Amplifier	Class C R-F Oscillator and Power Amp.
Plate Voltage.....	100 Volts	300
Amplification Factor..	38	
Plate Resistance.....	7100 Ohms	
Transconductance....	5300 μmhos.	
Plate Current (per plate).....	8.5 Ma.	8.0 Max. Ma.
Grid Voltage (50 Ohms cathode bias-both sections used) Note (1)		
D-C Plate Current (per plate)	15 Max. Ma.	
D-C Grid Current (per grid)	8.0 Max. Ma.	
D-C Plate Input (per plate)	4.5 Max. Watts	
Driving Power (Approx.)	0.35 Watts	
Power Output (Approx.) (see circuit application)	3.5 Watts	

Note (1) Normal value - 10 volts, obtained from 220 ohm cathode resistor, 625 ohm grid resistor or fixed supply. Maximum value - 40 volts.

CIRCUIT APPLICATION

Sylvania Type 6J6 is a miniature low capacity twin-triode designed particularly for use at ultra-high-frequencies. Its small size and high efficiency make it particularly useful in compact, light weight portable equipment.

The 3.5 watts output rates above may be obtained at moderate frequencies decreasing at higher frequencies, but at 250 Mc: the output is still 1.0 watt as a push-pull oscillator with a plate voltage of 150 volts and a grid resistor of 2000 ohms common to both units.

This tube may also be used as a mixer at frequencies up to 600 megacycles.

TYPE 1L4 R-F AMPLIFIER PENTODE

PHYSICAL SPECIFICATIONS

Style..... Miniature
 Bulb..... T-5½
 Diameter..... ¾" Max.
 Overall Length..... 2½" Max.
 Seated Height..... 1⅞" Max.
 Mounting Position..... Any

PIN CONNECTIONS

Pin 1..... Neg. Fil. Sup. and Internal Shield
 Pin 2..... Plate
 Pin 3..... Screen Grid
 Pin 4..... No Connection
 Pin 5..... Neg. Fil. Sup. and Internal Shield
 Pin 6..... Grid
 Pin 7..... Pos. Filament
 Basing..... 6AR-O-1&5

RATINGS AND CHARACTERISTICS

Maximum Filament Voltage
 D-C Battery Operation—must never exceed..... 1.6 Volts
 AC/DC Power Line Operation—design center..... 1.3 Volts
 Maximum Plate Voltage..... 110 Volts
 Maximum Screen Voltage..... 90 Volts
 Maximum Total Cathode Current... 6.5 Ma.
 Minimum Grid Bias Voltage..... 0 Volt
Direct Interelectrode Capacitances:*
 Grid to Plate..... 0.010 μf. Max.
 Input..... 3.6 μf.
 Output..... 7.5 μf.

*With no external shielding.

OPERATING CONDITIONS AND CHARACTERISTICS

Filament Voltage D-C..	1.4	1.4 Volts
Filament Current.....	0.050	0.050 Ampere
Plate Voltage.....	90	90 Volts
Screen Voltage.....	67.5	90 Volts
Grid Voltage.....	0	0 Volt
Plate Resistance.....	0.6	0.35 Megohm
Transconductance....	925	1025
Plate Current.....	2.9	4.5 Ma.
Screen Current.....	1.2	2.0 Ma.
Grid Bias for 1b = 10 μamp.....	-6.0	-8.0 Volts

CIRCUIT APPLICATION

Sylvania Type 1L4 is an RF-IF sharp cutoff pentode of the miniature style of construction. It is especially designed for radio frequency or intermediate frequency amplifier service in compact, light weight, portable equipment. The high operating efficiency allows the tube to be used with extremely low B supply voltages. The construction incorporates internal shielding which is connected to minus filament, and eliminates the need for an external bulb shield in most applications. A shielded socket should be employed to obtain the minimum grid-plate capacity. The circuit applications are the same as those for Sylvania Types 1LC5 and 1N5GT/G.

**BACK THE ATTACK
 BUY WAR BONDS
 AND STAMPS.**

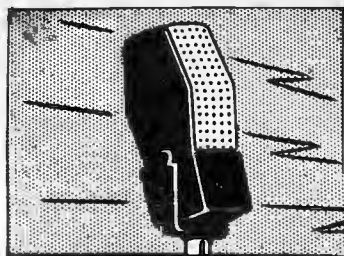

THE information presented in the Sylvania Service Exchange is contributed by servicemen as the result of practical experience. It is very carefully considered before being accepted, and we believe it to be correct and authentic. However, we assume no responsibility for results. Please do not send routine or generally known information.

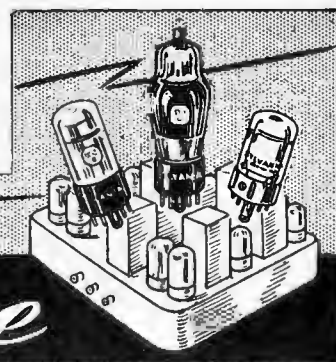

THE Service Exchange

Philco 1937-38-39 Models. If the receiver operates normally for about five minutes then gradually loses its sensitivity until only the strongest local can be heard, try replacing the 6K7G i-f tube before checking filters, by-passes, etc. We had two Philco models and one other make of receiver with this type of complaint and in each case the 6K7G tube was at fault. Also in each case the tube tested OK on two different tube testers. It is our belief that the tubes had a small gas content that was detrimental to satisfactory performance.

To localize the offender, feed a wobbled i-f signal into the first detector grid and note the size of the image on the screen of the oscillograph. In a short while the image will decrease until practically no signal will come through. Replacement of the i-f tube will restore the original image size.—Joseph S. Napora, Uniontown, Pa.

★ ★ ★

Philco Model 38. Noisy volume control caused by poor contact through wiper arm. A slight wiring change helps out a great deal. Disconnect condenser #40 from the top of the volume control and connect to the wiper (center) arm contact. Disconnect resistor #39 from the bottom of the primary and secondary of the antenna transformer #2 and connect to the top of the volume control.—M. S. Planovsky, Cleveland, Ohio.

★ ★ ★

Aetna Receivers. In Aetna models using a 6D6 as i-f amplifier or first detector, the tubes may check OK but a whistling may be present due to a poor tube. Realign the receiver and change either of the 6D6 tubes for a new Sylvania and like magic the whistling will cease.—Royal Radio Repair, Royal, Utah.

★ ★ ★

Philco Models 37-38, 37-623. The output transformer used in these models is a frequent offender in that one or both sections of the primary opens up due to corrosion. When one section opens, one-half of the type 1J6G tube receives no plate voltage, with resultant distortion on loud passages. When both sections open the symptom is obvious. Replacement with Philco part No. 32-7638 is recommended since the new unit is impregnated in a moisture proof compound.—Joseph S. Napora, Uniontown, Pa.

RCA Model M34 Auto. The above model was dead. Tubes and voltages OK, except on the plate of the 6B7 triode section. I-f transformer and interstage transformer windings OK. The set draws about 14 amps. current. Vibrator OK. The trouble was finally located in the blue lead from the i-f transformer to the plate. The insulation had been cut by the shield can of the i-f grounding the plate lead and cutting out the 1st. audio stage. This trouble is quite elusive and you must look closely to find it. The best bet is to replace this lead with lacquered wire when you have this set in your shop.—M. Planovsky, Cleveland, Ohio.

Acceleration Chart for Asking

This month Sylvania is distributing copies of an Acceleration Chart. This is a nomograph constructed to simplify calculation of the third quantity when two of the following are known: Acceleration in G's; vibrations per second and amplitude of vibration in inches. It can also be used similarly in connection with centrifugal force with revolutions per second and rotational radius.

Sylvania will be glad to send a copy of this Acceleration Chart on request to anyone whose work deals with vibration problems. It will be of little use to the average serviceman but is noted here because many engineers on our mailing list can no longer be reached at their old addresses. If you can use the chart, send your request to News Letter Number 79, Sylvania News, Emporium, Penna.

Antenna Leads. In replacing the antenna leads on small portables with the antenna in the lid, I use a piece of the old dial belt from an Atwater-Kent. These are usually the desired width and stand up very well in this service.—John R. Dahlgren, Denver, Colo.

★ ★ ★

Stromberg-Carlson 240 M Series. Distortion in these models may be caused by resistor R32, 25,000 ohms dropping in value to about 9000 ohms. I replace this with a good 10 watt resistor and also the cathode resistor of the 6F6 which usually gives trouble too.—Leonard D. Chroma, Tarrytown, N. Y.

Zenith Chassis No. 12A3. In a great number of these sets a very noticeable, hard to find hum is caused by the 6J5 tube in the first audio socket. In case of hum, try a Sylvania first.—George C. Blisard, Waco, Texas.

★ ★ ★

Zenith "Camera Type" Battery Portable. When you have a Zenith camera type portable in the shop for repairs, carefully inspect the fiber insulation on the "A" battery clamping device. Measure the resistance across the fiber. When batteries are left in the set for quite a while the electrolyte from the dead A cells will impregnate the fiber and cause a low resistance circuit across the "A" battery terminals. Batteries will not last 24 hours. Remedy is to either order a new clamping device or better still, change from the fiber to another type of insulation that will not absorb the electrolyte.—Neill G. Carpenter, Lake Charles, La.

★ ★ ★

Zenith Model 9-S-263. The voice coil in the speaker opens, but before tearing the cone out for a replacement, carefully remove the two $\frac{3}{8}$ " round paper tabs near the apex of the cone and there you will probably find the open. Resolder the connection and re-cement the tabs and the job is done.—Joseph S. Napora, Uniontown, Pa.

★ ★ ★

Zenith Model 7-S-363. Carrier hum in this model can be eliminated by installing an 0.05 mfd. 600 volt condenser from a-c line to chassis.—Joseph S. Napora, Uniontown, Pa.

★ ★ ★

Scratch Remover. To remove scratches on receiver cabinets, roll a few pecan meats in a cheesecloth holder. When you come across a scratch, rub the pecan oil over it and when dry polish with a soft dry cloth. If this scratch remover is kept in a jar or can it will last for months.—Arvid W. Berger, Neillsville, Wisconsin.

★ ★ ★

Stewart Warner Model R-110. The performance of this 10 tube super-het. can be greatly improved by replacing the original intermediate frequency transformers with Meissner dual-tuned units; Meissner Stock No. 16-700 and 15-5702. Complete realignment is obviously necessary.—Joseph S. Napora, Uniontown, Pa.

Sylvania News

Copyright 1944, Sylvania Electric Products Inc.

August-September, 1944

EMPORIUM, PENNA.

Vol. 11 No. 4

GOVERNMENT WILL RELEASE SURPLUS TUBE STOCKS

Orderly Distribution Through Tube Manufacturers Planned

By **BOB ALMY**

Manager Sylvania Distributor Sales



BOB ALMY

The first lot of radio tubes which has been declared surplus by the government will soon be released. The exact quantities which are included in this first lot are not definitely known. We understand that there are substantial quantities of receiving tube types in addition to transmitting and special purpose types. It is believed that the majority of receiving types can be absorbed quickly in the civilian market, if they are not required for war orders. Unfortunately, there are not large quantities of the really "hot" numbers such as 12SA7GT/G.

For some time the tube manufacturers have been negotiating with government agencies with the purpose of obtaining an orderly disposition of these stocks through normal trade channels. This is in accord with the policy of the Office of War Surplus Administration, who agree that normal distribution methods and trade practices should not be disrupted and that the government should realize as large a return as possible on salable merchandise, to help defray the costs of war.

Radio tubes are one of the first items in the electronic classification which the government has listed for disposal. Radio tubes were selected because there are relatively few manufacturers and a critical civilian shortage exists. In fact, radio tubes might be considered something in the nature of a guinea pig for experimentation and the method devised may very likely provide the pattern for disposal of other surplus electronic items.

While this first release will be very welcome and will help to relieve the general shortage, yet we question if it will make an appreciable dent in the overall shortage condition and when distributed nationally will not be particularly noticeable to individual radio service dealers and their customers.

Under the proposed arrangements, the several manufacturers will be appointed as agents of the Defense Supplies Corporation. The tubes will be distributed among the manufacturers on a pro rata basis by type. The manufacturers will inspect the tubes, place them in standard cartons and distribute them to their regular customers on an equitable basis, marked "MR" when sold for replacement use. Some of the stock may be sold against war orders for equipment, so the military has first call before "MR" distribution can be made. The contract requires that the tubes shall be sold by the manufacturers subject to all OPA and WPB regulations. Sylvania customers can be assured that any tubes received of this lot have passed Sylvania's rigid quality specifications and are subject to our standard guarantee.

Although there is considerable detail involved, it is hoped that the tubes available for "MR" distribution will soon be flowing through to the trade. The distribution of this first lot should be completed within a reasonable time, following receipt of shipments from the government depots.

Whether or when additional lots will be released or the quantities is not known at this time. This will be contingent on the progress of the war. We shall report to you in subsequent issues of Sylvania News.

In the July issue of Sylvania News, type 2A3 was priced at \$1.90. This is in error and should be priced at \$1.95.

CIVILIAN "MR" TUBE SUPPLY GENERALLY IMPROVED

Reports from the field indicate that deliveries of "MR" tubes have generally improved during the past sixty days. Certain types such as the 12SA7GT/G and the battery types continue on the "acute" list.

In the first seven months of this year the tube manufacturers delivered slightly more tubes for civilian use than for the corresponding period last year.

As a result of the WPB Civilian Tube Program, production has been concentrated, as far as possible on the important civilian types. Also the industry interchange program has made it possible for each manufacturer to supply a more rounded out line.

Last month we told you that the WPB had again scheduled approximately 4,500,000 "MR" tubes for the third quarter. However, due to technicalities in the "directives" which provided that rated orders for equipment must be given preference, it is doubtful if the goal of 1,500,000 per month will be exceeded appreciably.

(Continued on Page Eight)

ESTHER WILLIAMS

*Metro-Goldwyn-Mayer
Screen Star*



SYLVANIA NEWS TO HAVE IDEA DEPARTMENT

★ Your Ideas May Win A FIVE Dollar Advertising Material Certificate For You ★

Sylvania News' Idea Department is aimed at providing new ideas that the servicemen can use in their shops. We want ideas that will save steps, provide shortcuts, streamline radio repairing, and in general, help servicemen make their endeavor pay bigger dividends. These ideas must be tested and proven, and obviously must come from servicemen themselves.

That shop idea you are so proud of may help some serviceman reduce his operating cost by cutting down the time spent on each set. His idea, in turn, may be the very idea that will change your entire approach to a quick re-wiring job.

Sylvania News will make these ideas available to its thousands of readers by devoting a full page to the new de-

partment in every issue. And, as an inducement for servicemen to send in ideas, Sylvania News offers a Five Dollar Advertising Material Certificate for those selected for publication.

The five dollar certificate entitles the serviceman to select merchandise from Sylvania's "Multiplying Pennies" folder. This little four page folder is crammed with illustrations and descriptions of merchandise that is in constant demand by Sylvania servicemen. Its purpose is to give the best values at a non-profit figure, and is a service directed at making radio repairing a more profitable business. If you don't have a copy of the "Multiplying Pennies" folder ask your jobber for one or write to Advertising Department, Sylvania Electric Products., Emporium, Pennsylvania.

FIVE DOLLAR ADVERTISING MATERIAL CERTIFICATE AWARDED FOR IDEAS

Shown at right is a facsimile of the Five Dollar Advertising Material Certificate which is to be awarded for ideas published in Sylvania News. This certificate will be accepted in exchange for advertising material not in excess of five dollars.

You simply select merchandise from the "Multiplying Pennies" folder, fill in the order blank provided with the folder, attach signed Five Dollar Advertising Material Certificate, and mail to the Advertising Department, Sylvania Electric Products Inc., Emporium, Penn-

sylvania. Your selected items will be on their way to you in a few days.



500 PENNIES GO A LONG WAY WHEN YOU READ "MULTIPLYING PENNIES"

Divided under five headings in the "Multiplying Pennies" folder is illustrated and described material used by servicemen in their every day work. Store identification, sales promotion material, technical literature and store service aids make interesting reading for busy servicemen who know the value of store helps. A few items, taken at random that should catch your attention are: technical manual, service stickers and weatherproof service banners. There are also durable

shop coats, and tough service kits to name only a few. Values are all rock-bottom and cannot be matched elsewhere.

A signed Five Dollar Advertising Material Certificate, accompanied by a filled-in order blank (the order blank is inserted in "Multiplying Pennies" folder), mailed to the Advertising Department, Sylvania Electric Products Inc., Emporium, Pa., will deliver to you merchandise that, penny for penny, is an unbelievable value.

HOW TO WIN THE FIVE DOLLAR ADVERTISING MATERIAL CERTIFICATE

The two simple sketches shown on this page clearly illustrate the type of ideas that may help you win a Five Dollar Advertising Material Certificate. Time-saving equipment that will be simple to construct, original in design and give a maximum of efficiency, will be the important factors in awarding certificates.

In submitting the sketches of your ideas to Sylvania News, draw them as clearly as possible with sufficient notes to make the material coherent. Drafting technique will have no bearing on the acceptability of the ideas, as all used

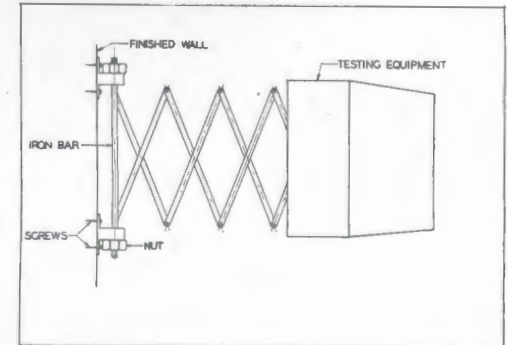

Wall pull-out support for facilitating equipment movement.

material will be re-drawn for publication to give a uniform effect. Merely make the sketches legible and complete.

In our two illustrations we have used completely manufactured parts and have put them into shop use. However, it is not our aim to limit the contender by specifying manufactured parts. If, instead, the serviceman feels that his idea would not work under these conditions, he is free to use any approach he cares to.

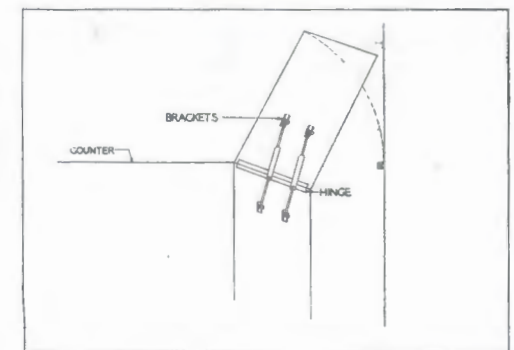

Counter flap with slow closing door stops.

Easily constructed, time-saving practical ideas that are applicable to every day shop operation are what we want, and on these points we will award the Five Dollar Advertising Material Certificate for all published ideas.



Copyright 1944, Sylvania Electric Products Inc.

August-September, 1944

EMPORIUM, PENNA.

Vol. 11 No. 4

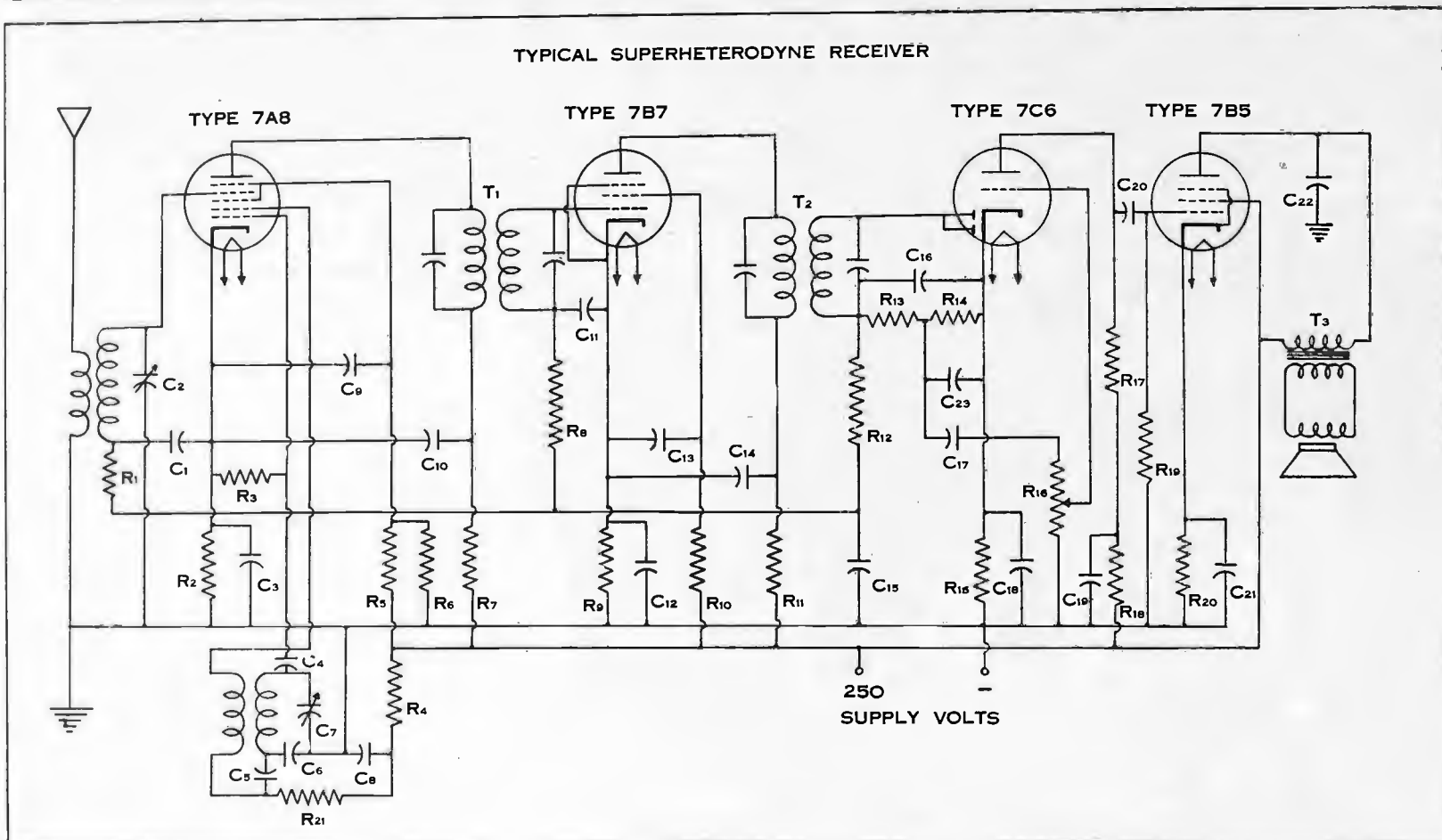

CAUSES AND CURES FOR OSCILLATIONS

Our regular readers will remember that in the April issue, a suggestion was made to extend the scope of the Service Exchange to allow servicemen to submit letters describing their unsolved problems in the hope that some reader would have encountered and satisfactorily solved the same problem. Only a few letters were received in support of the suggestion and only two answers offered suggestions to help Mr. Tom Davis with his oscillation trouble.

We believe that the following article compiled by the laboratory staff will be a reference that every serviceman should have available. The subject matter was collected from Service Hints received since the start of the Technical Section, and the experiences of our laboratory staff.

The characteristics of radio tubes which make them good amplifiers are also responsible, in general, for making them good oscillators. Those of you who have

built oscillators will remember that the important requirements are: (1) Grid and plate tuned to the same frequency. (2) Coupling between the grid and plate so that energy transfer can take place. In radio sets the grid and plate are, of course, tuned to the same frequency, or as closely as possible, and oscillation is prevented by reducing, or in some older sets, by neutralizing the energy which is fed back to the grid from the plate circuit. In radio sets it is not enough to worry about the coupling within each individual stage but overall coupling also is very important. If you realize that when the overall gain of an amplifier is 100,000, it also means that if the phasing is right, 1/100,000 of the output energy coupled back to the first tube will cause oscillation. It is obvious that in the higher gain amplifiers it is quite likely that some little defective part might set them into oscillation.

If you have built any sets, you will

know too that a little coupling (regeneration) is a good thing sometimes. It will greatly improve the selectivity and sensitivity of the set and if it can be made nearly uniform over the whole band, it is very desirable. Consequently, many small sets are designed to receive a large part of their gain from the feedback which has been controlled only sufficiently to prevent oscillation. It is easy to see, therefore, that oscillation trouble with some sets is actually the result of close design since normal tolerance in the value of some replacement component may be sufficient to cause trouble.

MECHANICAL CAUSES

The few cases of purely mechanical feedback such as vibration of the condenser plates on loud signals, probably will not give servicemen much trouble. However, we will include here, for simplicity, those obvious mechanical

(Continued on Page Four)

CAUSES AND CURES FOR OSCILLATIONS

(Continued from Page Three)

changes which cause oscillation by altering the electrical characteristic which is responsible for the trouble. Perhaps the most common cause of this nature is poor bonding of the variable condenser to the chassis. In some sets the common "bathtub" for all the tuning condensers is carefully insulated from the chassis and then bonded by a flexible lead at one point only. This can give trouble only when looseness or oxidation increase the resistance at that point. The really hard ones to find are those which have each tuning condenser separately grounded. Here, oxidation changes the distribution of the return currents to ground so that two stages may then have a common return path with the well known result. Somewhat similar is a poor connection in which the condenser rotor shaft makes contact with the spring which is supposed to ground the shaft between the two sections of the condenser. The cure is obvious and there are several ways of correcting the trouble. Running a No. 14 copper wire from one end of the set to the other and tying all the r-f grounds to it is one good way. To digress a moment, suppose that this added coupling instead of being in the correct phase to cause oscillation were of the opposite phase, what would happen? Could this be the cause of poor sensitivity in some older receivers by causing degeneration and defying even the best servicemen to find it?

Among the mechanical causes, we must list also poor contacts between tube shields and ground, lost shields or parts of them, and changes in the placing or angles of the r-f coils with respect to each other. If a set is designed for use with a 50 ft. antenna and your customer only has 10 ft. of wire dropped out the window, it may not load the first stage sufficiently to prevent oscillation. Similarly, a poor ground or even too long a ground lead can cause trouble. Acoustic feedback, at times, can also cause a squeal. This may be the result of hardening of the rubber speaker mountings, or perhaps someone has rebuilt the set into a new cabinet in which the speaker is placed closer to the tubes than before.

BYPASSING TROUBLES

The diagram, accompanying this article shows a typical radio with one i-f stage and A.V.C. to illustrate most of the points where bypassing is required. Notice that there is a bypass at every screen grid, every plate supply, every cathode resistor and in several places on the A-V-C circuit. Some special circuits which do not require the cathode resistor to be bypassed are push-pull amplifiers,

some inverters and some types of degenerative amplifiers.

It is important that servicemen note that the circuits are really filtered not just bypassed. The resistors, R5, R7, R11 and R18 are there for two purposes. They drop the screen, or the plate voltage to the required value and also add series impedance so that the bypass condensers C9, C10, C13, C14 and C19 can be of practicable size. This is mentioned here because when tubes are substituted which have different screen voltage or current requirements, someone is quite likely to change the resistor in order to get the required voltage but forget all about the change in filtering incidental to this change. Of course, an increase in the resistor will not matter as this only increases the effectiveness of the filter. In design work the bypass condenser for use in the R-F stages is selected to have one percent of the impedance of the series resistor used. In audio circuits where the gain is much lower, a ratio of 10 to 1 should prove generally satisfactory.

Squeals all sound the same, no matter what the cause, but we can localize the "put-put" type of oscillation which occurs in the audio stages only. This has been reported occasionally as due to defective tubes but usually in battery sets it comes from a combination of low "B" batteries and inadequate bypassing. In these days of scarce batteries, it may be necessary to increase the size of the bypass condenser above the usual design value to get longer life even if the volume is down. In A-C sets a defective filter or an audio bypass condenser is the usual cause.

TRICKS IN DIAGNOSIS

It would be of great help if some simple way could be described to determine which stage is doing the oscillating. Some people recommend holding a hand near each tube in turn and claim that when close to the oscillating tube, the oscillation will stop. This does not always work. Touching the grid terminal lightly with a finger is a time-honored method; if the tube is oscillating, two pronounced clicks should be heard as the finger touches and leaves. Both of these methods upset the capacity and loading of one stage so much that it affects other stages too, and so it also does not always work. A suggested method is to hold a 10,000 ohm resistor or .1 mfd. condenser by one terminal and touch the grid terminals in turn with the other. This introduces a loss with the minimum of detuning and will stop many oscillations. It may not work with a very strong oscillation, however. A pair of phones connected to the detector output will indicate whether the cause is before or after the detector; similarly disconnecting the screen voltage of each r-f or i-f tube in turn will indicate approximately where the trouble is unless this slight disturbance

in load and capacity is too great. As a last resort, the voltage across the signal grid resistor of each likely stage can be read with a high resistance meter. Any voltage greater than a volt is abnormal and may indicate the oscillating stage.

Assuming that we have found which stage is oscillating, we can now connect a condenser of approximately the same size across each bypass condenser in turn. We say approximately the same size so that a very large condenser will not be placed in a position like C22 where it could bypass all the energy before it gets to the speaker without curing the trouble at all. As condensers get old they may become partially or completely open circuited. Double the required capacity in any bypass condenser will not upset the normal operation, so if the oscillation stops, you can be reasonably sure you have found the defective condenser. In many cases, particularly where electrolytic condensers have been used, they seem to lose their efficiency in r-f bypassing with age, and it will be found that small paper condensers connected across one or more of them will restore the set to normal.

The bypass condensers on the A-V-C circuit are almost as critical as the other bypass condensers, even if usually less clearly understood. Condensers C15 and C16 are to prevent the I.F. delivered to the diode from getting back to the I.F., converter, or r-f tube (if any) grids through the A-V-C resistors R12, R8 and R1. The high value of these resistors is of great assistance in filtering this circuit, but trouble still can occur.

It hardly seems necessary to mention that the old style neutrodyne receivers may also oscillate because they need neutralizing. In another type of old TRF set using triodes oscillation was prevented by the use of a 500 to 1000 ohm "losser" resistor in series with and close to each grid connection. Time and occasional grid shorts may have caused this resistor to decrease in value so that it no longer was capable of preventing oscillation of that stage.

Since the mutual conductance of tubes increases as the bias is decreased, it is, of course, advisable to see that the correct bias is applied. Similarly, if the plate and screen voltages are higher than normal for the set, oscillation may be found. The use of a higher powered rectifier tube, or the use of a lower power output tube as a wartime substitute may easily produce this effect.

AUDIO AMPLIFIERS

The circuit shown has only one audio amplifier stage but all the oscillation causes can be described by reference to it. The combination of C23, C16 and R13 becomes a filter whose purpose is to keep the i-f frequency from getting into the grid circuit of the 1st audio tube; in

CAUSES AND CURES FOR OSCILLATIONS

(Continued from Page Four)

this case the triode section of the Type 7C6. Condenser C21 (usually not required in push-pull output stages) prevents degeneration and loss of volume, but probably does not influence oscillation one way or the other except that its removal might change the response enough to mislead someone occasionally. Condenser C22, however, is necessary to lower the effective impedance that the output transformer and speaker offer to the high frequencies in the plate circuit of the output tube, particularly when it is a pentode. A similar condenser or sometimes a resistor, is used to load the secondary of the first audio transformer in sets using that kind of coupling. If these are defective, a very annoying high pitched whistle will be produced. The reversal of the leads of an audio transformer may cause a similar whistle, but

you need expect this only if a transformer has been replaced.

OSCILLATIONS DUE TO SUBSTITUTIONS

The use of substitute tubes in the present emergency also may cause oscillation. Most of the new tubes are higher in efficiency than the older ones. This means that for a given plate current, the mutual conductance is higher. When put in an older circuit, therefore, it probably would have a higher mutual even at the same voltage, but if the current drain is lower, the voltage may be quite a lot higher with correspondingly still higher mutual. The cure in this case is to increase the value of the series dropping resistor until normal operation is obtained which may be at a lower plate (or screen) voltage than for the original tube. Lower the screen voltage on the screen grid tubes and the plate voltage on triodes only. An increase in the cathode bias resistor can be used to advantage in case the operating bias comes out at less than one

volt, but if too much change is made here, it may destroy the effectiveness of the A-V-C system. As mentioned before, any change in rectifier output or total set drain will affect the voltage on the balance of the tubes.

Rewiring changes, the use of adaptors and the use of tubes having different shielding design may also cause oscillation by reason of the change in feed-back capacity. Be sure the grid and plate leads are separated as far as possible and shielded. Adaptors are difficult to shield but as a last resort, the screen voltage may be reduced enough to get proper control. This may not reduce the gain as much as it would seem since enough feed-back can be left to bring the overall sensitivity nearly to normal.

It is our hope that this article will help the serviceman to more clearly understand the intricacies of oscillations and that the information set forth will help the reader in his every-day radio repair work.

TYPE EF-50—HIGH FREQUENCY AMPLIFIER PENTODE

Sylvania Type EF-50 is one of the contributions to the war effort having characteristics which may find many applications in postwar design. It is interchangeable with one of the best European type tubes and is sufficiently like the Lock-In tubes in construction that Sylvania was the only American manufacturer requested to build this type for the armed forces and for lend-lease.

This tube is different from the better known Sylvania Types 7V7, 7W7 and metal tubes like 6AB7/1853 in that it is designed to operate at 250 volts on both screen and plate. This makes possible operation at higher frequencies because of the resulting reduction in input loading. The high mutual conductance and the relatively low capacity and input resistance for such a high mutual conductance also contribute to advantage in its use at high frequencies. The tube has its own external shield grounded through the center lug as well as internal shielding which is brought out on two terminals for better grounding. Since suppressor and cathode are brought out separately, nine pins are required.

At frequencies from 20 megacycles up, it gives particularly good performance in broadband i-f and r-f amplifiers.

PHYSICAL SPECIFICATIONS

Style.....	Metal Glass
Base.....	Special 9-Pin
Diameter.....	1.47" Max.
Overall Length.....	3.0 " Max.
Seated Height.....	2.44" Max.
Mounting Position.....	Any

BASE PIN CONNECTIONS

Pin 1.....	Heater
Pin 2.....	Screen Grid
Pin 3.....	Plate
Pin 4.....	Suppressor Grid
Pin 5.....	Int. Shield
Pin 6.....	Cathode
Pin 7.....	Control Grid
Pin 8.....	Int. Shield
Pin 9.....	Heater

RATINGS AND CHARACTERISTICS

Heater Voltage (Nominal)	7.0 Volts
AC or DC.....	7.0 Volts
Heater Current (Nominal).....	0.320 Ampere
Plate Voltage.....	300 Volts Max.
Screen Voltage.....	300 Volts Max.
Plate Dissipation.....	3 Watts Max.
Screen Dissipation.....	1 Watt Max.
Direct Interelectrode Capacitances*	
Grid to Plate.....	.007 μ f. Max.
Input.....	8.0 μ f.
Output.....	5.0 μ f.

*No additional Shielding.

TYPICAL OPERATING CONDITIONS AND CHARACTERISTICS

Heater Voltage.....	6.3 Volts
Heater Current.....	0.3 Ampere
Plate Voltage.....	250 Volts
Screen Voltage.....	250 Volts
Cathode Bias Resistor.....	150 Ohms
Plate Current.....	10 Ma.
Screen Current.....	3.1 Ma.
Mutual Conductance.....	6300 μ mhos
Plate Resistance.....	0.6 Megohm

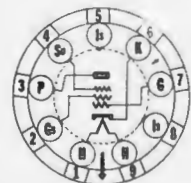

EF-50

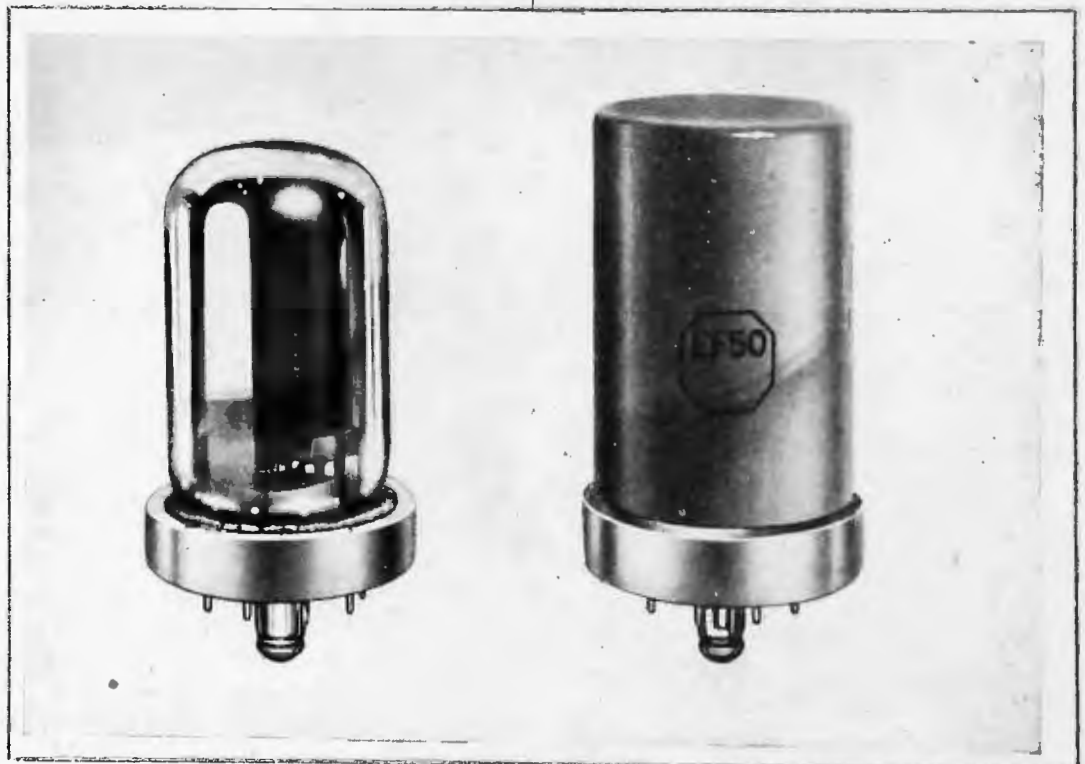



THE information presented in the Sylvania Service Exchange is contributed by servicemen as the result of practical experience. It is very carefully considered before being accepted, and we believe it to be correct and authentic. However, we assume no responsibility for results. Please do not send routine or generally known information.

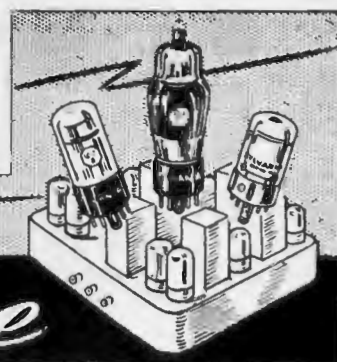

THE Service Exchange

Philco Model 37-690. To eliminate noisy reception due to bad resistor sections in power unit, make these necessary changes. First install a wiring panel under condenser #175 mounting screw, then disconnect the green and white wire from terminal 4 of resistor #177 and connect it to the wiring panel lug. Remove wire between terminal 5 of resistor #177 and terminal 6 of power cable socket and connect a 300 ohm between the terminal panel lug and terminal 6 of power cable socket. Add a 75 ohm resistor and connect it between the terminal panel and terminal 3 of resistor #177. After doing this disconnect the brown wire from terminal 5 of resistor #177 and connect it to any ground on the chassis. This procedure should eliminate resistor #177 on 80 and 325 ohm unit entirely out of the circuit, resulting in quieter reception all around.—M. S. Planovsky, Cleveland, Ohio.

* * *

Philco Model 37-670. When the shadowgraph on this model flickers accompanied by a click in the speaker and the set still plays good, change the 6A8G tubes and the .05 condenser #39 on the diagram. This condenser becomes intermittent making the shadowgraph become

sluggish and effective only on strong locals.—M. Planovsky, Cleveland, Ohio.

* * *

Philco Model 37-660. Excessive hum due to proximity of filament and grid leads, it is necessary to redress the filament leads wiring from the 6K5G to the 6J5G tube as far as possible away from the control grid lead of the 6K5G tube.—M. S. Planovsky, Cleveland, Ohio.

* * *

Philco Model 37-641 (Codes 121, 125). To improve operation of receiver at 18 megs. the following condensers are added: 250 mmfd. condenser from screen of det-osc. to ground, 0.1 mfd. condenser connected from B negative to ground in the I-F unit. Change condensers #21, a .25 mfd. tubular, to a .15 mfd.—M. Planovsky, Cleveland, Ohio.

* * *

All Late Model Sparton Radios. Be sure chassis bolts are loosened before trying to turn dial. Tight bolts cause dial to bind and results in broken cable. This is particularly true of the Model 6521.—George C. Blisard, Waco, Texas.

* * *

Philco Model 37-9. To improve the i-f circuit operation a .1 mfd. condenser is connected from the red primary lead of

the i-f transformer #53 to ground. To prevent distortion at minimum volume, the green and white wire connecting the volume control #67, center lug to the automatic tuning dial audio switch #93, must be kept clear of compensator #54 and the diode circuit of the 6Q7G tube.—M. Planovsky, Cleveland, Ohio.

* * *

Gilfillan Model 5G8. Strong motorboating is usually due to a by-pass condenser from the 78 tube suppressor to ground. Although this condenser checks OK on the tester it opens intermittently under working conditions, thus causing motorboating. This trouble is quite common to these receivers. Replace the unit with a .05 mfd. 600 or 400 volt condenser.—M. Margossian, Oakland, Calif.

* * *

Chevrolet 985695. Dead. No sound and tubes don't light. Moving fuse lead brings set on. You don't have to pull set. Remove two screws on bottom of set that holds fuse and spark plate. Pull out and turn over. Solder end of fuse holder to spark plate. Riveted connection has worked loose.—Clifton S. Krumling, Blue Earth, Minn.

TYPE 7G8/1206 LOCK-IN SHARP CUT-OFF CATHODE-TYPE DOUBLE TETRODE

PHYSICAL SPECIFICATIONS

Cathode.....	Coated Unipotential
Base.....	Lock-In 8-Pin
Bulb.....	Short T-9
Diameter.....	1 1/16" Max.
Overall Length.....	2 1/2" Max.
Seated Height.....	1 1/2" Max.
Mounting Position.....	Any

BASE PIN CONNECTIONS

	Section
Pin 1.....	Heater
Pin 2.....	Plate
Pin 3.....	Screen
Pin 4.....	Control Grid
Pin 5.....	Control Grid
Pin 6.....	Cathode
Pin 7.....	Plate
Pin 8.....	Heater
RMA Basing.....	8BV-L-0

RATINGS AND CHARACTERISTICS

Heater Voltage (Nominal) (AC or DC).....	7.0 Volts
Heater Current (Nominal).....	0.320 Amperes
Maximum Plate Voltage.....	300 Volts
Maximum Screen Supply Voltage.....	300 Volts
Maximum Screen Voltage.....	100 Volts
Maximum Plate Dissipation (Per Section).....	1.5 Watts
Maximum Screen Dissipation (Per Section).....	.1 Watts
Minimum External Control Grid Bias Voltage.....	0 Volt

Maximum Heater Cathode

Potential.....	90 Volts
Direct Interelectrode Capacitances* (Per Section)	
Grid to Plate.....	0.15 μμf (Max.)
Input.....	3.40 μμf
Output.....	2.60 μμf
*With 1 1/16" diameter shield connected to cathode, duplicate tests on each tetrode unit.	

TYPICAL OPERATING CONDITIONS AND CHARACTERISTICS#

(Per Section except Heater)	
Heater Voltage.....	6.3 Volts
Heater Current.....	0.300 Ampere
Plate Voltage.....	250 Volts
Screen Voltage.....	100 Volts
Grid Voltage.....	-2.5 Volts
Plate Current.....	4.5 Ma.
Screen Current.....	0.8 Ma.
Transconductance.....	2,100 μmhos
Plate Resistance.....	225,000 Ohms
Grid Voltage for 10μa. Plate Current -10 Volts	

#To test sections separately apply at least 40 volts negative to control grid of section not under test.

CIRCUIT APPLICATION

Sylvania Type 7G8/1206 consists of two sharp-cut-off tetrodes in the same bulb with common cathode and screen connections. For use as an R-F amplifier at frequencies up to 400 Mc. the push-pull

connection with both units in the same bulb gives improved performance, because of the effectively shorter cathode and screen leads. Currents in these leads are out of phase and effectively neutralize, thus extending the effective frequency range. The push-pull connection made possible by this construction also reduces the effective input capacity to half that of a single tube.

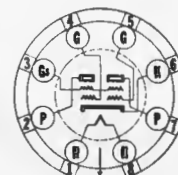

7G8/1206

GREATER DEMAND FOR SYLVANIA TECHNICAL LITERATURE

Second Reprint of Hints Booklets To Fill Thousands of Requests

The many thousand requests for the three "Hints" booklets recently published is typical of the acceptance by radio servicemen of Sylvania's technical material. The picture above illustrates the deluge of requests received by the Advertising Department for these three popular little booklets. Requests actually figured in the thousands and we are now in our second reprinting of the booklets.

If you didn't receive your copies of Radio Circuit Hints, Radio Tube Hints and Radio Equipment Hints, mail your request now for these three helpful little booklets.

Much to our pleasure, Sylvania "Hints" booklets, in big demand among our servicemen, have also been finding wide acceptance in our armed forces. The data in Sylvania's Service Hints booklets have proven useful in simplifying knotty problems confronting servicemen, and now Army and Navy personnel are finding their contents invaluable.

A breakdown of the figures for the first three months of this year shows 79.9 percent of the booklets went to dealers and servicemen, and the second largest figure of 10.8 percent went to the armed



forces. The rest of the booklets went to the following groups: foreign, 2.9 per cent; government .4 percent; schools and colleges 1.7 percent and employees of radio manufacturing concerns 2.6 percent.

As in the past, Sylvania's wartime and postwar policy will be to supply technical help on our products and to clarify

perplexities of radio and radio repair.

We are pleased to offer to our readers other technical data and booklets all of which are described in Sylvania's "Multiplying Pennies" folder. If your Jobber cannot supply you with this folder, write to Sylvania Electric Products Inc., Advertising Dept., Emporium, Penna., and one will be sent you without charge.

ELECTRONIC TUBES HELP TO WIN BATTLES

Naval Warfare Makes Continuous Demands For Electronic Tubes

Electronic tubes—hundreds of different varieties, performing scores of vital and exacting services—constitute the senses which animate our fighting ships and perfect their battle efficiency.

Approximately 1,684 electronic tubes help make a modern battleship the great fighting mechanism she is, and 1,550 electronic tubes keep our greater aircraft carriers always on the alert. More than one American pilot shot down in the sea owes his life to the fact that the tubes contained in his emergency transmitter functioned efficiently, so that he was able to signal our forces and be picked up.

A cruiser has at least 855 electronic tubes. A submarine carries some 200 and the P.T. boat, the terror of the Navy, uses equipment requiring 140 tubes. Aside from the combat ships of the fleet, countless tubes must be supplied for our armada of landing craft.

So it is that on every war front, electronic tubes sink ships, shoot down planes, help to win victories. Unmentioned and unsung, the reliable performance of these tubes is reflected in

every success leading to the final overthrow of the axis.

Sylvania's name is being carried to the four corners of the globe on battleships, cruisers and carriers. Our products have stood the rigors of battle, and a high standard of durability has been maintained only by an exacting check and double-check of all completed electronic tubes.

To date, the bulk of Sylvania's electronic tubes have been directed to our armed forces, leaving but a small percentage available for civilian demands. However, a note of optimism can be expressed at this time as regards increased tubes for civilian consumption in the near future.

But, until cutbacks actually do occur in war orders, Sylvania's electronic tubes will meet the challenge; electronic tubes are needed to keep our great Navy plowing towards its ultimate victory—our victory. And, when V-Day is won, our effort will be to keep your shelves stocked with the same high quality Sylvania electronic tubes that has been our policy through the years.

SYLVANIA'S EMPORIUM PLANT AWARDED ITS THIRD ARMY-NAVY "E" STAR

Sylvania's Emporium, Pennsylvania plant received its third Army-Navy "E" star for excellency in the production of radio tubes for the armed forces.

Gathered at the front of the main building, employees heard Master of Ceremonies, H. Ward Zimmer, General Manager of Operations—Receiving Tube Division, deliver a brief talk expressing the management's deep appreciation for the effort put forth by the Emporium employees in winning this highest of awards. The new three-star flag was presented to the employees who were represented by Agnes Peterson and Sophie Vernesky.

Among those present at the gathering were B. G. Erskine and Major J. T. Rhudy. Mr. Erskine, Sylvania's Chairman of the Board, was doubly proud that the home of Sylvania's first tube should be the first Sylvania plant to receive its third Army-Navy "E" Star.

"E" flags also wave over the Sylvania plants in Salem and Danvers, Mass. and Williamsport, Penna.

SHOP OF THE MONTH

In inaugurating "Shop of the Month," Sylvania News has selected Chris M. Mundt, proprietor of the Mundt Radio Service of 112 West 5th Street, Pittsburg, Kansas as the winner. The selection of the "Shop of the Month" winner was based on a carefully made study of many file pictures and we found the most desirable qualities in Mundt Radio Service Shop. Neatness, attractiveness and a well planned shop layout were the three factors considered in making our selection.

Mr. Mundt has heeded the prime requisite in successful store operation—neatness and cleanliness. Everything



seems to have its definite place; as evidence, note the built-in bins used for keeping small parts in a handy spot instead of scattering them over workbench and counter. As for cleanliness, a well scrubbed effect was our first impression in studying the pictures.

Interest is further aroused in Mr. Mundt's shop by the advertising displays

which are prominently placed, and the many types of merchandise needed for radio servicing are carefully arranged in the glass show case where they will catch the eye of the incoming customer. Glossy paint adds a finishing touch and gives the shop a crisp, clean aspect.

Time-saving and shop layout are synonymous in Mr. Mundt's case, and a consciousness of this fact is apparent. The pictures accompanying this article show the work-bench and testing equipment at the right; along the rear wall are shelves of neatly piled radio tubes, condensers and other necessary replacements. In the foreground is the glass display case and counter. Here we find the three factors within a few steps of each other, thus making the shop so compact that one serviceman can handle the entire operation. Because of its compactness, Mr. Mundt is always before his customers and affords them an opportunity to observe a skilled technician at work, watch tubes being tested and repairs being made. The mysteries of radio repairing, which usually go on behind closed doors are brought out in the open for the customer to see; customers like to watch even though they don't always understand the technical theory of radio repair. It's an interest-builder which never fails to get results—let the customer see what he is getting and he will love it.

We congratulate Mr. Mundt on an outstanding shop; it is clean, attractive



and well planned. Obviously, Mundt's Radio Service is no "hodge-podge" of ideas, but has been planned from start to finish. Such a shop means well executed repair work and as evidence of this fact, Mr. Mundt has been servicing radio sets for fourteen years with continuous success.

SEND YOUR SHOP PICTURES TO SYLVANIA NEWS

In this, and every subsequent issue of Sylvania News will appear an article titled, "Shop of the Month." Accompanied with pictures, "Shop of the Month" is aimed at showing our thirty-five thousand readers where other servicemen do business and under what conditions; it is an effort on our part to arouse servicemen's interest in the shop itself as a business booster.

By showing pictures of radio repair shops from coast to coast, the serviceman will be able to compare his shop with others; he can see where his shop is lacking and where it is superior. In this way we hope servicemen will become more conscious of the importance of store appeal in getting the customer in the shop. We feel that now is the time to make plans for improving the shop of the future.

Sufficient construction data will be incorporated in "Shop of the Month" to enable the reader to duplicate the equipment.

A picture of your shop and sufficient information to make an interesting article would be appreciated by Sylvania News. This is an opportunity for radio repair men to show fellow servicemen their shop and, thereby build a stronger bond and understanding of each other's problems. Send the pictures and shop facts to Sylvania Electric Products Inc., c/o Editor, Sylvania News, 500 Fifth Avenue, New York 18, New York.

CIVILIAN "MR" TUBE SUPPLY GENERALLY IMPROVED

(Continued From Page One)

Our feeling is that the fourth quarter will see gradual improvements in "MR" deliveries in types and quantities. War cutbacks of military orders will be the determining factors. The W.P.B. is reviewing fourth quarter schedules with the view of authorizing additional "MR" production, particularly critical types.

Sec. 562, P. L. & R.
U. S. POSTAGE
PAID
Emporium, Pa.
Permit No. 1

POSTMASTER: If Address has
moved, notify sender on Form 3547,
Postage for which is guaranteed.
When Form 3547 is sent, abandon
this mailing. Return only if no cor-
rect address is available.

Mr. Granville W. Arnold
139 Main St.
Emmaus, Pa.

Published By
SYLVANIA ELECTRIC PRODUCTS INC.
Manufacturers of Sylvania Radio Tubes and Electronics Devices, Sylvania Incandescent
Lamp Bulbs, Fluorescent Lamps and Equipment.
RICHARD G. MACKAY Editor
W. R. JONES Associate Technical Editor

SYLVANIA
ELECTRIC PRODUCTS INC.
Post Office Box 431
EMPORIUM, PENNA.
Return Postage Guaranteed

Your Copy of
SYLVANIA NEWS
August-September, 1944
Vol. 11 . . . No. 3





Copyright 1944, Sylvania Electric Products Inc.

October, 1944

EMPORIUM, PENNA.

Vol. 11, No. 5

FEWER CIVILIAN "MR" TUBES SCHEDULED BY W.P.B. FOR THE FOURTH QUARTER

Military Demand for Receiving Types Increased

By **BOB ALMY**,
Manager Sylvania Distributor Sales

We are continuing to report in this column on the civilian tube delivery situation, since we believe that this is of prime interest to you. After showing a gradual improvement during the last few months, with prospects for increased "MR" production, the picture has suddenly changed. There will be fewer civilian "MR" tubes available. WPB has found it necessary to curtail the industry's "MR" tube production, in both total type and quantity, for the fourth quarter of this year.

As you know, radio tube production is scheduled by the WPB, and tube manufacturers comply with WPB directives. Military requirements must take precedence, for we all realize that radio tubes are playing a mighty important part in winning the war. Perhaps some day the story can be told.

As this is written, the WPB has frozen all "MR" shipments against production for the fourth quarter. The action is considered only temporary, pending issuance of revised directives. Therefore, we do not know definitely just how much "MR" production will finally be authorized. Advance information indicates that no "MR" production will be scheduled for several of the important civilian types. Many of the battery, and A.C.—D.C. group types will probably continue in short supply.

The reason for this action is that military requirements have increased and there is not sufficient tube production capacity in the industry to satisfy the military demands and take care of civilian requirements at the same time, particularly in the fourth quarter.

The WPB will continue to direct the interchange of "MR" tube production between the manufacturers, on a pro rata basis, so that each will have as rounded out a line as far as possible. In a similar manner, the manufacturers are expected

to distribute available "MR" tubes on an equitable basis to their customers. Sylvania will of course continue its allocation plan, which has been so well received.

The full effect of this curtailment of "MR" production may not be noted in October, because of a normal average thirty-day lag between production and shipment. Thus the fourth quarter "MR" reduction will be reflected into January of next year.

Despite these conditions, there is still a possibility the curtailment may not work out to be as drastic as it now appears. Larger quantities of surplus tubes than now anticipated may be received, and military requirements may be reduced. In the next issue of Sylvania News we will report any changes in the status.

Last month we told you about the plan for disposal of government surplus tube stocks. So far only very modest quantities of these tube stocks have actually been delivered to the manufacturers. Because this plan has been slow in getting under way, and because rated orders for war equipment take preference, it is not likely that large quantities of the important types will be made available for civilian use in the immediate future. However, we are hopeful that limited quantities, which will help to relieve the civilian tube shortage to some extent, may be obtained before the end of the year.

Sylvania Electric Products is sponsoring the War Bond Window Display Contest during the 6th War Loan Drive which begins November 20. All retail radio stores and service shops are urged to participate in this Contest to promote the sale of War Bonds, not only with the thought of winning a prize, but also to make the public War Bond conscious.

More than 500 War Bond prizes will be contributed by Sylvania. Complete details on the contest are given in the insert of this issue of Sylvania News. This insert is also being mailed to all known dealers and service shops throughout the country.

CENTURY RADIO CO., INC. MARKS TENTH BIRTHDAY

Sylvania's Philadelphia Distributor Looks Back on a Decade and Forward to Another Bigger Ten.

Century Radio Company Inc. of 401 North Broad Street, Philadelphia, Pa. celebrates its tenth year of active business on the first of November. Starting at the low ebb point of depression years, Century has never taken a backward step in its ten year existence, but has grown steadily until today it holds a position of high esteem, and respect among dealers and servicemen in the Philadelphia area.

Under the able guidance of Mr. Norman M. Sewell, President of the company, and Mr. George B. Scarborough, Vice-President in Charge of Sales, Century has flourished, and since its inception has acted as our distributor in that area, handling countless thousands of Sylvania radio tubes.

Its birthplace was humble; a second floor office and warehouse at 235 South Eighth Street housed the company at the

(Continued on Page Seven)

FRANCES RAFFERTY

*Metro-Goldwyn-Mayer
Screen Star*



GOOD RESPONSE GREET'S IDEA DEPARTMENT

FOUR SERVICEMEN WIN FIVE DOLLAR ADVERTISING MATERIAL CERTIFICATE

HERE ARE YOUR OCTOBER WINNERS!

1. Mr. Samuel Fels of Fels Radio and Appliance
612 Rogers Avenue, Brooklyn, N. Y.

2. Mr. Eric Tallarek
3892 French Rd., Detroit, Mich.

3. Mr. J. Stephen Gold
406 Tyson Ave., Glenside, Penna.

4. Mr. Bob Laemmel
3148 Morganford St., St. Louis, Mo.

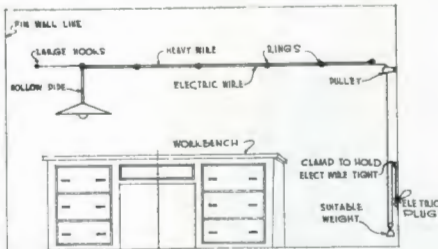

Mr. Eric Tallarek
Drawing No. 1

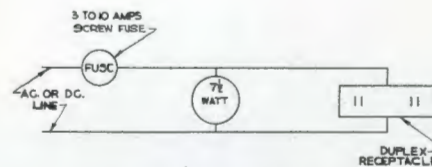

Mr. Samuel Fels
Drawing No. 2

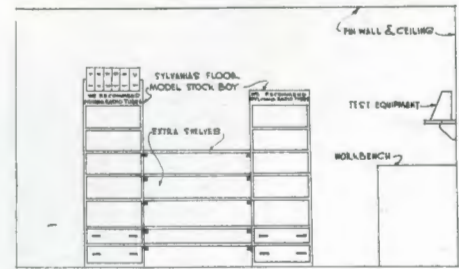

Mr. Bob Laemmel
Drawing No. 3

Response to Sylvania News' Idea Department has been heavy, and the quality of the material so excellent that the judges found difficulty in making up their minds. In some cases there were similar ideas expressed in a slightly different manner and to these contributors also goes a Five Dollar Advertising Material Certificate. The basic idea is our aim and many variations may accompany any one.

Because the ideas were so excellent as a whole, and making a choice of three so difficult, all material on hand and any that comes in from now on will all be reconsidered for the next issue. So those who aren't among the lucky ones this month are still in the running and have a good chance.

OVERHEAD LIGHT CAN MOVE TO EITHER SIDE OF BENCH TO FACILITATE WORK

Mr. Eric Tallarek of 3892 French Road, Detroit 14, Michigan, caught on to the Idea Department and won for himself the Five Dollar Advertising Material Certificate.

The drawing above pretty well tells the story, but of course this idea could be varied in many ways. It so happened that Mr. J. Stephen Gold of Glenside, Pa., had Mr. Tallarek's idea in mind, with a slight variation, so to him we also send Sylvania's Five Dollar Advertising Material Certificate.

The weight indicated would have to be figured so that when the lamp is at the right hand side of the work bench, the weight would still be off the floor. However, this technicality merely involves cord length.

A heavy wire extends across the back wall, or for that matter, could run across the ceiling, and the result would be just as effective. Wire rings or any suitable part could be used to hold the electric cord in position. As for the clamp and pulley, there are too many varieties to mention here, but judgment should guide you in selecting the right one for your shop.

AUTOMATIC ELECTRIC CURRENT TURN-OFF HELPS KEEP BILL DOWN

Mr. Samuel Fels of Fels Radio and Appliance Service, 612 Rogers Avenue, Brooklyn, New York came through with outstanding idea number two.

The story is best told in his own words: "Below is a sketch of a simple device which I use in duplicate places on my work bench. Its purpose is to help prevent leaving the soldering iron on or any other electrical apparatus, and forgetting about them. Also, if anything is plugged in that shorted, the fuse is at my finger-tips, making for easy replacement when it blows.

"I use the ordinary screw type fuse size from 3 to 10 amps, as a switch when current is on, and the 7 watt bulb is lit which attracts my attention."

Here is an idea that can certainly be used in any radio serviceman's shop. It not only keeps the electric light bill down but could prevent a fire from an overheated soldering iron or other appliance. Congratulations to you Mr. Fels for supplying us with this outstanding idea. It should prove useful to radio servicemen who see the value in shop ideas for economy and safety measures.

TWO SYLVANIA "STOCK BOYS" ACT AS SUPPORT FOR EXTRA SHELVES

Bob Laemmel of 3148 Morganford Street, St. Louis, Missouri contributed something that was right under our nose and never occurred to us until we saw it in black-and-white.

Here it is in a nut-shell: by taking two of the Sylvania's "Stock Boys", getting sufficient lumber, a few nails, a saw and a little elbow grease, additional shelves are the results.

As for the construction of the shelves, three or four pieces of lumber, $\frac{3}{4}$ " wide by 6" deep, in any length the serviceman cares to make it—Mr. Laemmel suggests 3'-0" long to be on the safe side—plus wood supports of about an 1" square at either end of the shelves. The supports are fastened to the "Stock Boys" by self tapin screws of sufficient number to give strength. There is no reason why four or more shelves couldn't be used providing they were not overloaded.

Thank you Mr. Laemmel for your excellent contribution. Its simplicity of construction makes it practical, and there is no question that it is usable. We want to hear from you again.



Copyright 1944, Sylvania Electric Products Inc.

October, 1944

EMPORIUM, PENNA.

Vol. 11 No. 5

RESISTANCE-CAPACITY BRIDGE WITH TUNING INDICATOR TUBE

Since servicing equipment and meters are still hard to get, many servicemen will want to make the bridge described this month. If you haven't the necessary parts in your shop, it is assumed that you can get them at your Sylvania distributor as the parts are standard items. We know this will be a very useful piece of equipment to any serviceman who does not already have its equivalent.

ately above it, with the bias adjustment for the "eye" tube at the lower right. On the lower left is the range switch used to select the standard R or C for comparison with the unknown. The On-Off switch, pilot lamp and the three binding posts complete the external layout.

The complete circuit is shown in Figure 3. The part on the left is the bridge, the unbalanced voltage of which is amplified by the first section of the Type 7F7. The

potentiometer R_1 takes the place of the slidewire in Figure 1 and the 40-ohm resistors, R_2 and R_3 on each side of it are added so that ratios greater than 10 to 1 will not be used with consequent inaccuracy. The first section of the Type 7F7 is connected as a resistance coupled amplifier with a gain of between 45 and 60. The amplified signal is rectified by the second triode section used as a diode, and the resulting D-C voltage is available

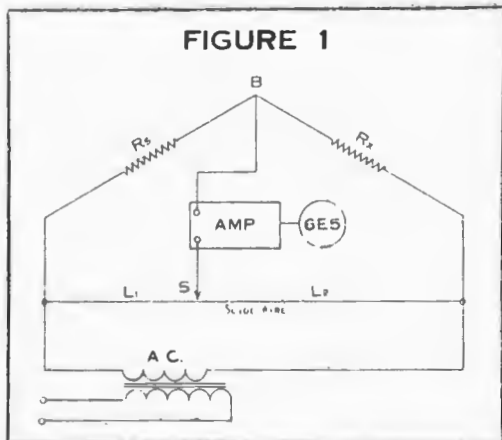

BASIC CIRCUIT

Figure 1 shows the fundamental circuit used. A small A-C voltage is applied across the network $R_s R_x L_1 L_2$. As the slider S is moved along the slidewire to obtain balance there will always be some point which is at the same potential as B. With this point found, the value of R_x (ohms) = R_s Ohms. L_2/L_1 . A known and an unknown condenser can be substituted for R_s and R_x because A-C is used but in that case C_x (mfd.) = C_s (mfd.) $\cdot L_1/L_2$. The reason the ratio is inverted for capacities is that the impedance of the condenser is $\frac{1}{2\pi f c}$ where f = frequency and c = capacity of condenser, the $2\pi f$ cancelling out in the equation.

Figure 2 shows the front view of a completed instrument. The cabinet shown is of standard size, the sloping panel type being used because of its convenience, but any shape desired will serve or it can be built into a rack above the workbench if the portable feature is not required. The large pointer in the center is on the potentiometer which takes the place of the slide-wire in the fundamental circuit. The Type 6E5 indicator tube is immedi-

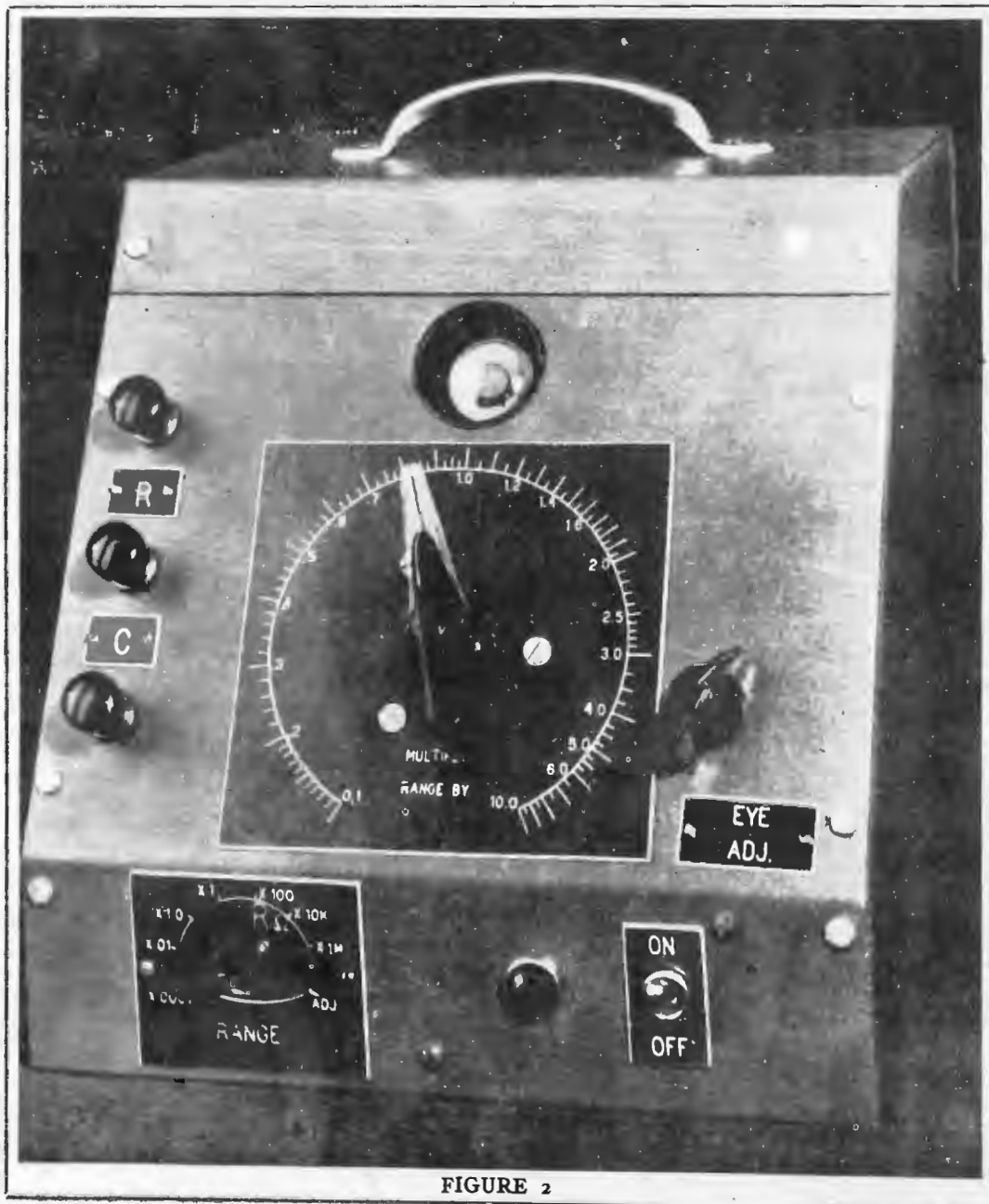
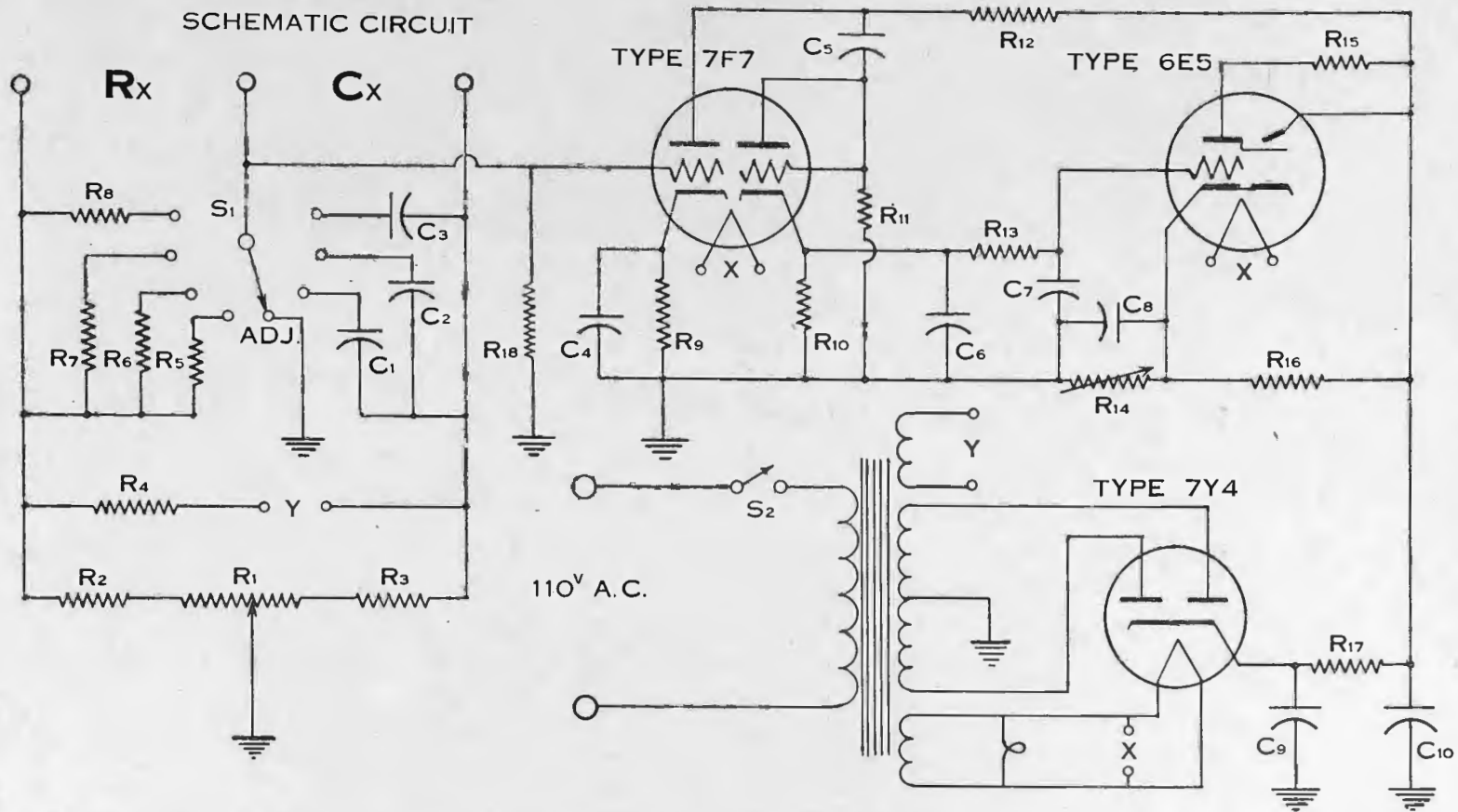

FIGURE 2

FIGURE 3
SCHEMATIC CIRCUIT



PARTS LIST

R ₁	400 Ohms Wire Wound Potentiometer—Uniform	1 Watt	C ₃	100 Mmf	1% Best Obtainable
R ₂ +R ₃	40 Ohms	1 Watt	C ₄	25 Mfd	Low voltage electrolytic condenser
R ₄	5 Ohms	20%	C ₅ -C ₆	.02 Mfd	20% Paper Bypass 400-600 Volts
R ₅	1 Ohm	1%	C ₇	.01 Mfd	20% Paper Bypass 400-600 Volts
R ₆	100 Ohms	1%	C ₈	8 Mfd	Low voltage electrolytic condenser
R ₇	10,000 Ohms	1%	C ₉ -C ₁₀	8 Mfd	400-500 Volt Filter Condenser
R ₈	1 Meg.	Best Obtainable	S ₁	8 Point Selector Switch	
R ₉	5000 Ohms	20%	S ₂	Line Switch	
R ₁₀	10 Meg.	20%	Cabinet	8"x8"x8" (as illustrated)	
R ₁₁	1 Meg.	20%	Transformer	For 3 or 4 tube set, 250 to 350 V. each side of center 1-6.3 Fil. Wdg. 1-5.0 Fil. Wdg.	
R ₁₂	1/2 Meg.	20%	Panel Lamp	6-8 Volt	
R ₁₃	1 Meg.	20%	Sockets	Lock-in (2 req'd.) 6 prong (1 req'd.)	
R ₁₄	5000 Ohms	Wire Wound Volume Control	Binding Posts	with insulated washers	
R ₁₅	2 Meg.	20%			
R ₁₆	1/10 Meg.	20%			
R ₁₇	10,000 Ohms	Adjust for Req'd. Voltage			
R ₁₈	10 Meg.	20%			
C ₁	1.0 Mfd	1% Best Obtainable			
C ₂	10,000 Mmf	1% Best Obtainable			

across the 10 meg. resistor in the cathode circuit. This high resistance in conjunction with the .02 mfd. condenser C₆ makes the peak voltage of the sinewave available for application on the control grid of the Type 6E5. These values for the components result in a time constant which has no noticeable lag between dial adjustment and eye response. The cathode resistor R₁₄ is made adjustable and additional current is bled into it through R₁₆ so that the most sensitive position of the eye (almost closed) can be used for indication on all scales, even when condensers having leakage are being measured. The rectifier and associated circuits are not unusual except for the resistance-capacity filter which is cheaper and good enough for this purpose. The value of R₁₇ should be picked to give an output of approximately 300 volts with the transformer you intend to use. A choke could be used but will not be necessary unless the high voltage winding has an unusually low value of voltage.

CONSTRUCTION

Figures 2, 4 and 5 show enough detail of the model made in the laboratory that any serviceman can adapt the available

components to the cabinet on hand. As far as we know there is nothing critical about the placing of any of the parts, but it would be well, of course, to have a short lead to the first amplifier grid. In case the layout desired requires this lead to pass near the power transformer it should be shielded to prevent pick-up.

The potentiometer R₁ is quite important, linearity, smoothness and reliability being the required characteristics. The calibrated circle illustrated is 3 1/2" in diameter which we believe is the minimum that will be easy to mark and use. The sharpness of the indication is good enough that a larger diameter could be used if desired. Resistors R₂ and R₃ are slightly critical. These values should be exactly equal and between 1/10 and 1/11 of the value of R₁; tolerance of 38 to 42 ohms is suggested when 400 ohms is used for the potentiometer. The values of the standard resistors and capacities are the only other critical components, and are specified as 1% in the Parts List.

Since the unknowns are compared directly with these, the accuracy will also be 1% except for errors in reading. The crowding at the upper end of the scale will make a probable reading error of

± 10%. The scale at the lower end is spread so that values could be read closer than the accuracy of the standard resistors. This accuracy should prove sufficient for most service work, but if your work requires great accuracy near any special value, a standard of that value could be included on the selector switch. A standard megohm is quite expensive but since radio resistor values above a half-megohm or so are not critical, a selected carbon resistor could be used until need for greater accuracy is found.

The accuracy of reading is affected by the gain since this must be high enough to make noticeable difference in the indication of the "eye" for the smallest reasonable change in the resistance setting. Using the Type 7F7 with the circuit values shown seems to give all the gain required. The somewhat unusual values used are because the signal is line frequency whereas most small sets using resistance coupled amplification could cut off at 100 cycles. If sufficient gain is not obtained, the values of the components should be checked, particularly R₉, R₁₀, R₁₁, R₁₂, C₄ and C₅.

Notice that the eye adjust position is

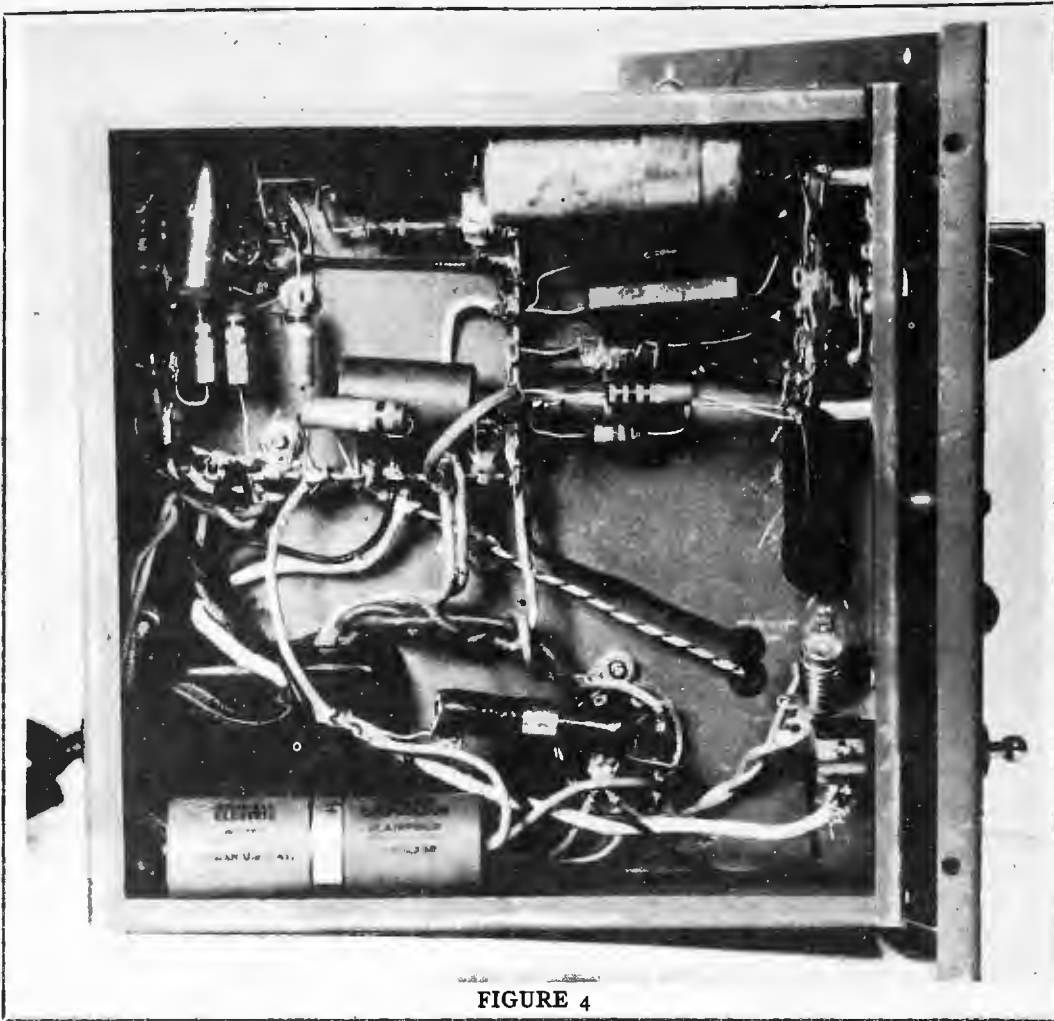

FIGURE 4

shown between the capacity and the resistance switch positions on the circuit diagram but that on the illustration it is shown at one end. Except for this the positions of the standard resistances and capacities will be as viewed from the back of the switch.

CALIBRATION

No matter how accurately you have selected parts and constructed the unit, the final accuracy will be dependent upon how carefully the dial is marked. This operation may be performed most simply by following closely the procedure outlined in the following paragraphs.

Take a piece of moderately stiff glazed white paper and cut to the dimensions you have allowed for the dial. Using a compass, draw the part of a circle corresponding to the amount of rotation of the potentiometer used for R_1 and having the center of the circle at the center of the potentiometer shaft. Next, drill all dial mounting holes and rigidly fasten the dial to the face of the cabinet in the position desired for the final assembly. The potentiometer knob with a pointer of sufficient length to just cover the arc of the circle on the dial should now be installed and orientated on the shaft so that the pointer traverses the full length of the scale arc when the potentiometer is rotated from one extreme to the other. Then mark the position of the knob clamping screw on the potentiometer shaft, remove the knob and file a flat section on the shaft at the mark so that the knob can be reinstalled repeatedly and have the pointer at the same relative position with respect to the potentiometer rotation.

With this preliminary work completed, you are now ready to mark the scale divisions on the dial. If you have used comparison standard resistors and condensers of 1% or better accuracy in the

positions R_5 to R_8 and C_1 to C_3 , it will be necessary to mark the dial on one range only and the other ranges will be correct. Assuming this to be the case, the next step is to secure a standard decade resistor box containing units, tens, and hundreds decades; or tens hundreds, and thousands decades; or perhaps, more available a one-thousand ohm wire wound potentiometer or rheostat which you may have calibrated at a number of points, the more points the better. Assuming that you have a calibrated rheostat, set the range switch to "adj." and adjust the "eye adj." control till a very fine shadow line is visible on the eye tube, and then throw the range switch to R-100 ohms; connect the calibrated rheostat to the R terminals and proceed to mark the dial scale divisions. This is done by setting the rheostat to 10 ohms and then rotating the dial pointer until the eye shadow angle is at a minimum, the "eye adj." control may have to be reset slightly to give a fine line, and mark the position of the pointer on the scale with a sharp pencil. This point should be marked 0.1 since 10 ohms is 0.1 of the 100-ohm standard. Change the rheostat setting and repeat for the number of calibration points desired on the dial. When the rheostat is set at 100 ohms and the point is located on the dial, it should be marked 1.0 and should fall very nearly on the center of the scale arc. When all the points have been located you should have approximately a logarithmic scale reading from 0.1 to 10. This scale will now be correct for the multiplier of each range of resistance and capacity set up on the range switch.

The next step is to ink the scale divisions and numerals and to cover the

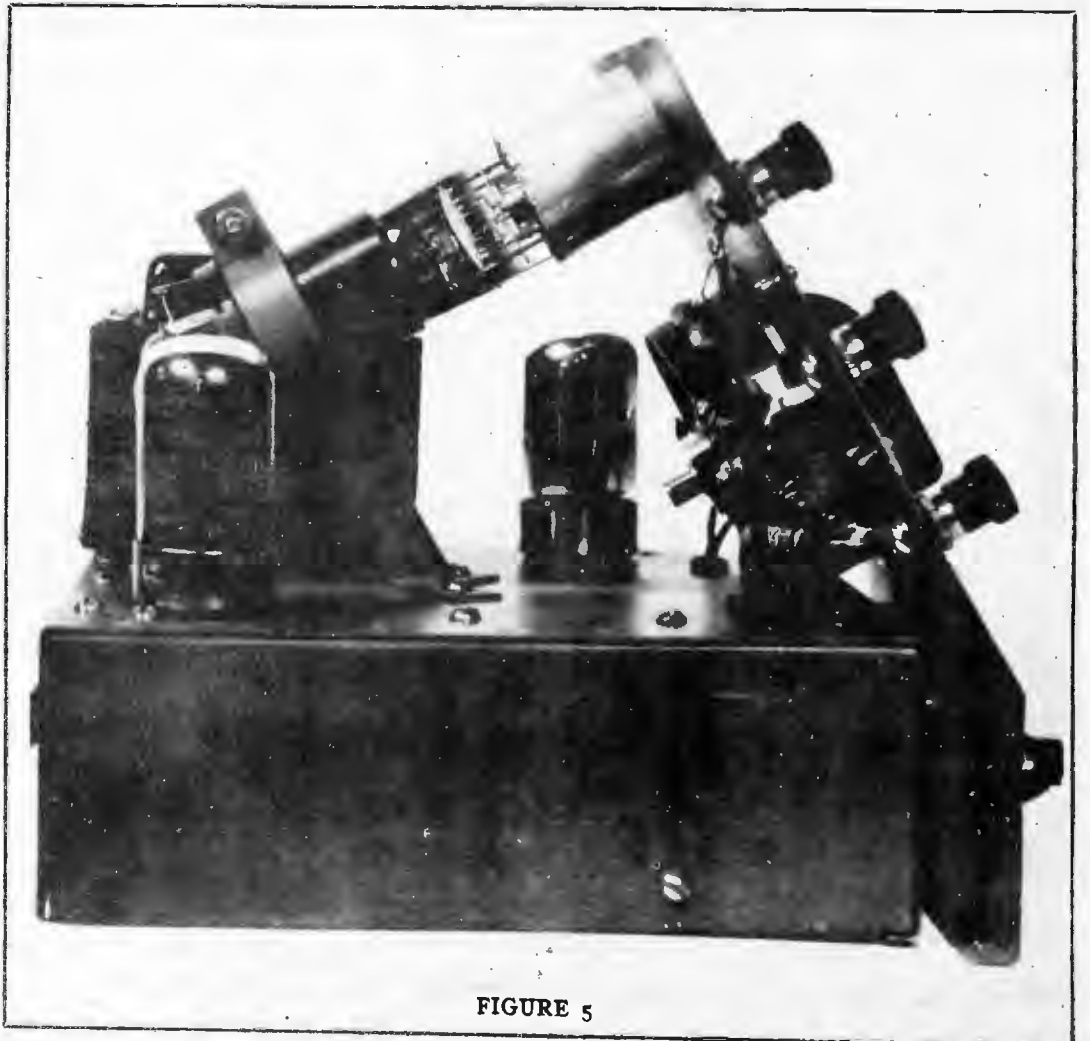

FIGURE 5

paper with a protective coating such as a sheet of clear celluloid or plastic; or the paper dial can be used as a template to make a dial of more durable material. It is also possible to use other material than paper for the dial and engrave or etch the scale directly on it. This calibration can be made by using a series of selected resistors for the unknown but will require a large number of resistors to get sufficient points on the scale.

OPERATION

When everything is all ready to operate, turn it on and set the selector switch S_1 to the adj. position. As soon as the tubes warm up, the green background of the "eye" tube will probably show a V of darker color. Reduce this to a fine line by the "eye adj." control. Any unknown resistance or capacity connected to the proper terminals can be measured by first setting the range switch and then varying the main dial until this minimum shadow line is again obtained. The effect of leakage across condensers is interesting. Suppose you have a good 0.01 mfd. condenser properly balanced to the hair line shadow, and then notice the difference when a 5.0 meg. resistor is placed in parallel with it. This does not change the value of capacity obtained, only widens the hairline to about $\frac{1}{8}$ ". This can therefore be used to estimate the leakage of the condenser being tested. If the leakage is quite bad, you may be unable to get a balance. For other values of condenser, the approximate parallel resistances to widen the shadow to $\frac{1}{8}$ " are as follows:

.01 mfd.	5.0 megs.
.05 mfd.	$\frac{1}{2}$ meg.
.1 mfd.	$\frac{1}{4}$ meg.
1.0 mfd.	30,000 ohms

.5 mfd.	70,000 ohms
10 mfd.	1,000 ohms
5.0 mfd.	3,000 ohms

Readings on electrolytic condensers are not prevented by this action because the capacity is high as compared to the leakage but best results are obtained if condensers having been on the shelf for some time are first reformed by applying approximately their normal working voltage for a few minutes.

PRECAUTIONS AND LIMITATIONS

This bridge will measure resistance and capacity only. Do not expect it to test condensers for breakdown also, although as just explained, it will give a rough indication of the leakage.

We can make use of the out-of-phase component due to resistance across the condenser under test, but the corresponding effect of inductance in a resistor under test is a distinct disadvantage. The D-C resistance of voice coils and iron core chokes cannot be measured on this account.

The amount of current that can flow through the lowest value of resistance being measured is limited by the resistor R_4 to about 1 ampere—for 0 ohms, at 10 ohms the maximum current is down to $\frac{1}{3}$ amp. and for values above that it is quite safe for any radio component. Measurement of very low value wire wound resistors which normally will not pass 1 ampere of current should be performed quickly so as not to overheat them too long. Low resistance voice coils could also be damaged by softening the cement holding the wire in place.

Filter condensers above 10 mfd. can be read approximately by placing them in series with a 10 mfd. condenser and

calculating from the resulting series capacity.

POSSIBLE SUBSTITUTIONS

The basic requirements of this circuit are few, and if any particular component is unobtainable, the following comments will be of assistance.

R_1 —any value from 100 to 5000 ohms should give satisfactory performance, but the values used for R_2 and R_3 should be between one-tenth and one-eleventh of the value used for R_1 .

Type 7F7. A high mu triode—or pentode, with a diode having a separate cathode is required. Two separate tubes may be used if the layout can be changed to get them in the cabinet selected.

Type 6E5. Any of the triode indicator tubes will work. The values of R_{16} and R_{14} may require adjusting to get the correct bias for shadow control.

Transformer. One heater winding is required to light the rectifier, amplifier and indicator tube heaters and another winding of 5.0 to 10.0 volts for the bridge. Adj. R_4 to limit current with 0 ohms in R_x to 1 amp. The plate winding is not critical, 200 to 350 volts each side of center could probably be taken care of by adjustment of resistor R_{17} .

Type 7Y4. Of course 6X5G, 84, 6Y5, 6Z5 and 6ZY5G would give equally satisfactory operation here, and if an additional heater winding is available on the transformer any of the filament type rectifiers could be used.

The only other components which might be hard to find are the standard resistors and condensers. Wirewound resistors and good paper or mica condensers should be used. Your Sylvania distributor may have a bridge or meter to select these values for you.

"TWO CORRECTIONS TO AUG-SEPT. SYLVANIA NEWS"

1. The article titled "TYPE EF-50—HIGH FREQUENCY AMPLIFIER PENTODE", page five, second paragraph, third sentence should read: "The high mutual conductance and the relatively low capacity and input conductance (conductance in place of resistance) for such a high mutual conductance also contribute to advantage in its use at high frequencies."

2. Sylvania's Engineering Dept. has added another paragraph to the article titled "CAUSES AND CURES OF OSCILLATIONS," and it precedes the last paragraph of the article. It reads, "Originally, many tubes for use in r-f circuits were supplied with metal-shell bases which were grounded to pin #1. In some portable sets, this was all the shielding supplied. The tubes you use to replace these may no longer have this metal-shell base so oscillation might result. You may have to provide a shield in these cases. There have been freaks where the metal-shell connection to pin #1 had not been made properly, so this is one more item to check.

SERVICE EXCHANGE

Stewart-Warner, Model R-1425-A. A common complaint on these models seems to be a shorted .005 mfd. condenser between 6F6 plate and ground. As these are only 400 w.v. units, a 600 w.v. condenser should be used for replacement.—Al Santmier, Jr., Dolgeville, N. Y.

General Electric, Model LB-702. (Serial #17203). This is an AC-DC or battery portable and the complaint was hum (general). It sounded like an open filter but when the chassis was removed, the hum stopped. After making the general "tapping" tests, I found that by wiggling the cylindrical metal shield on the bottom of the 1T4 I-F tube, the set would be very erratic, sometimes stopping and going into oscillation. This shield was making poor contact to the chassis and a remedy was effected by soldering a short length of flexible wire from the shield to chassis. Evidently when the chassis was in the cabinet, pressure was exerted which aggravated this poor connection and caused the hum. This repair would be of benefit to any of these

tube sockets regardless of receiver make or model.—Al Santmier, Jr., Dolgeville, N. Y.

TO OUR READERS

It has always been our aim in the Technical Section of Sylvania News to give our readers something a little out of the ordinary in electronic theory. Our main article in this issue follows that pattern, we feel, in attempting to give concrete, helpful information.

If you find "Resistance—Capacity Bridge With Tuning Indicator Tube" gives you information you want and can use, we would appreciate knowing about it. Your comments can help us more readily determine what you want in future issues of Sylvania News' Technical Section.

Drop us a note and express your opinion. If you like it, well and fine; if you don't, let us have the reasons, and we will try to make amends. Address your letter to Richard G. Mackey, Editor, Sylvania News, Emporium, Pa.

PHILADELPHIA RADIO SERVICEMEN'S ASSOCIATION MEETS

"Sound On Wire" And An Open Forum Make For An Interesting And Enlightening Evening



On Tuesday evening, September 19th, The Philadelphia Radio Service Men's Association held a meeting at the Architect's Hall in that city. Well over a hundred members and interested parties listened to an authoritative and enlightening group of electronic experts expound post-war possibilities as it affects the radio serviceman.

First on the program was a confidential Navy Department film covering the invasion of France on D-Day with all its thrilling and dramatic force. Rarely seen by the public, the film met with genuine favor and enthusiasm by the assembled group.

A demonstration of "Sound on Wire" held the attention of the gathering. Under the auspices of General Electric, it proved itself to be an innovation with far reaching possibilities.

The inauguration of an "Open Forum" brought together four leaders in the electronic field. Mr. Norman M. Sewell, President of Century Radio Co. Inc., Sylvania's Philadelphia distributor, Mr.

Harry P. Bridge of Harry P. Bridge Co., advertising, Mr. Allan Mills of R. C. A. and Mr. James M. Skinner, Jr. of Philco Radio and Television Co. who all contributed their time to the forum. Mr. Mal Parks, Editor of Radio Television Journal, a co-sponsor of the meeting, acted as moderator.

Questions to the quartet came thick and fast, with the post-war outlook for radio servicing dominating the forum. An optimistic viewpoint was expressed by all four with stress made on preparedness on the part of servicemen to meet the challenge of television and its many new applications.

Mr. Parks, familiar to Philadelphia servicemen, rounded out the evening's program. Well known in helping to organize servicemen's associations throughout the country, Mr. Parks spoke on the future of radio and television repair, and the serviceman's place in it. The importance of closer cooperation among servicemen through associations was also brought out in his talk.

He warned that competition from many outside sources could be expected. At this time, large and powerful companies seeing the great potentialities in television and its maintenance after the war are training technicians to fill this work. A second group that is certain to come into the picture, said Mr. Parks, is the "combines" which will be made up of specialists in television. Because of their strength in numbers, they will make their presence known in the community through local advertising. Large so called "hard good" stores also will have departments handling television repairs, and the returning service boys who have been exposed to the latest theory in electronics will be keen competition.

"The day of the screw-driver mechanic are gone forever," said Mr. Parks. Competition will be keen and only the skilled, trained technician will find a place in television. Mr. Parks summed up by expressing the importance of further training and closer cooperation, so that the serviceman could maintain his rightful place in electronic industry.

CENTURY RADIO COMPANY INC. MARKS TENTH BIRTHDAY

(Continued from Page One)

start, but two years of growth meant more floor space was needed and new

NORMAN M. SEWELL



President Of Century Radio Company, Inc.

quarters were set up at 120 North Seventh Street. At this time a partnership, Century Radio Company became a Pennsylvania corporation. A period of rapid growth ensued, and again Century had to move to avail itself of added needed space. Offices and showroom were taken at the Terminal Commerce Building from which the company operates at the present time.

Early in 1941, the management, with farsight and vision, widened its line of merchandise to include television equipment, and at the same time other merchandise was weeded out to make room. To facilitate the complexities of volume business, Norman M. Sewell, Inc. was set up to sell all merchandise exclusive of Sylvania radio tubes. This made Century's an exclusive tube distributing operation, selling Sylvania tubes to all types of accounts in the electronic, electrical and industrial trades.

Through the war, Century has done more than its share in helping to expedite tubes for the needs of Army and Navy, and at the same time has made available to its customers a fair share of the tubes allotted to them on a pro rata basis.

Well established after a comparatively short space of time, Century Radio

Company Inc. can look forward to continued success and prosperity in the post-war era. Geared for a big turn-over of sales, and with a following of loyal accounts, the Philadelphia area can look to Century Radio Company Inc. for dependability of electrical and electronic merchandise in the future as in the past.

GEORGE B. SCARBOROUGH



Vice-President in Charge of Sales for Century Radio Co., Inc.

SHOP OF THE MONTH

Mr. Wintermute, proprietor of V. M. Wintermute Radio Service, 132 West Fourth Street, Plainfield, New Jersey sent us a photograph of his work bench that is so outstanding in neatness and compactness that for him and his shop we have nothing but praise. A well thought out piece of work has been done in constructing this work bench, and our opinion is that it justly deserves "Shop of the Month" recognition.

Analyzing the picture uncovers the semblance of a shop that functions on the best business principles. The clean counter and stools provide a resting place for customers, and the use of the counter sales receipt machine at the left makes certain that all incoming sets are tabbed and priced for repairs. The tube checker at the right end of the counter affords the customer the privilege of seeing for himself what tubes need replacing. Behind the checker to the far right are shelves for radio sets and a desk used for general clerical work.

The bench itself seems to include all the principal testing and analyzing apparatus needed to carry on a successful servicing business. Starting in the upper left hand corner we find a condenser checker, and below left is a frequency modulation signal generator. At the center above is a tube checker, while below is an oscilloscope, and below the oscilloscope is a power supply unit. Upper right is the signal generator, and

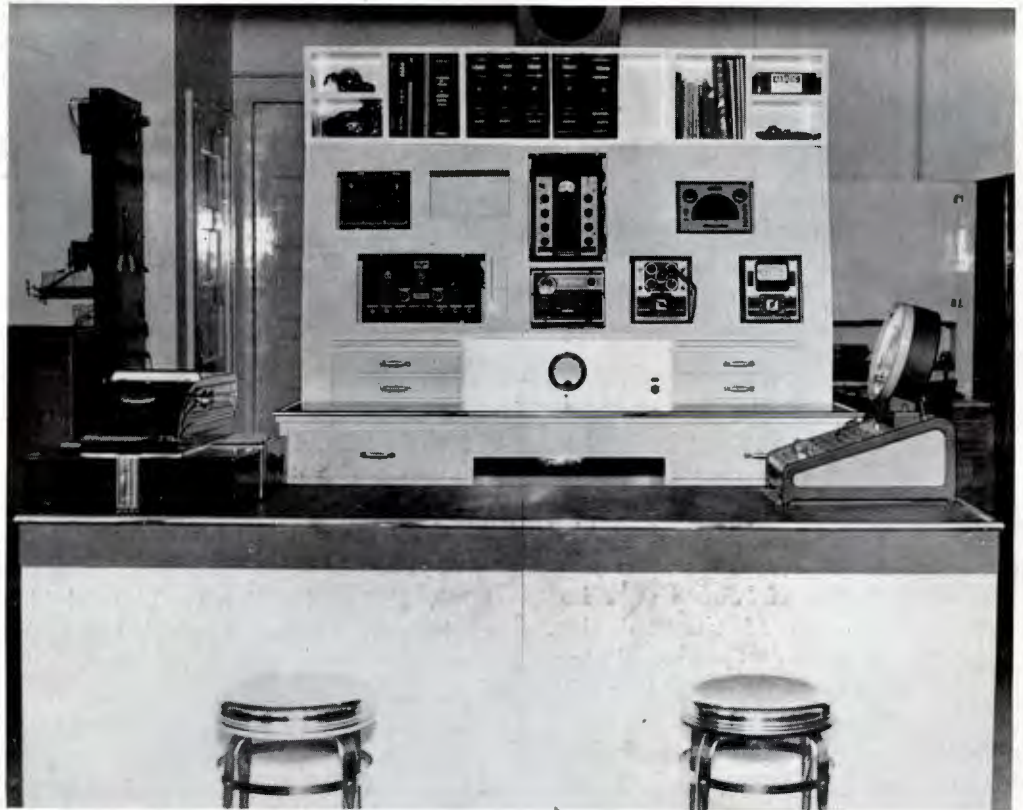

left and right below is an analyzer and volt ohm milliammeter respectively.

Mr. Wintermute has seen the value of a good paint job for his shop—and a high gloss finish at that. Paint acts in two ways; it makes it easier to clean the shop and also snaps up the general appearance.

A dull, dingy store reacts unfavorably on a customer, so a paint investment is always worth while.

A well balanced shop, offering fine and varied testing devices, a good business approach, all with an eye to increased business, gives Mr. V. M. Wintermute a big jump on the post-war radio servicing field. For many years Mr. Wintermute has been a loyal booster and purchaser of Sylvania tubes, and is an active account of Dale Distributing Co. of New York City.

Sec. 562, P. L. & R.
U. S. POSTAGE
PAID
Emporium, Pa.
Permit No. 1

Mr. Granville W. Arnold
139 Main St.
Emmaus, Pa.

POSTMASTER: If Addressee has moved, notify sender on Form 3547, postage for which is guaranteed. When Form 3547 is sent abandon this mailing. Return only if no correct address is available.

SYLVANIA
ELECTRIC PRODUCTS INC.
Post Office Box 431
EMPORIUM, PENNA.
Return Postage Guaranteed



Your Copy of
SYLVANIA NEWS
OCTOBER, 1944
Vol. 11 • No. 5

Published By
SYLVANIA ELECTRIC PRODUCTS INC.
Manufacturers of Sylvania Radio Tubes and Electronics Devices, Sylvania Incandescent Lamp Bulbs, Fluorescent Lamp and Equipment.
RICHARD G. MACKAY • Editor
W. R. JONES • Associate Technical Editor

Radio Servicemen's Survey Reveals Demand For Moderately Priced Television Sets

A survey by the Institute of Radio-Television Opinion clearly shows that radio servicemen are alert to changing conditions, and that 99 percent of those interviewed have already made some post-war plans.

Questions based on sales of radio receivers revealed that a great percentage of the serviceman's income was derived from radio sets before the war. However, the point of price for television sets showed that a desire for sets within reach of the middle-class group was a "must" on their list.

The greater percentage of those servicemen interviewed expressed the same complaints on pre-war radio sets—there were too many useless gadgets, lack of standardization of parts made repairing difficult, and the cabinets were too small.

Sylvania News

Copyright 1944, Sylvania Electric Products Inc.

November, 1944

EMPORIUM, PENNA.

Vol. 11, No. 6

CIVILIAN "MR" TUBE SHIPMENTS RESUMED

Recent Freeze Order Cancelled by WPB
Fourth Quarter Schedule Released

By **BOB ALMY**,
Manager Sylvania Distributor Sales

In the October issue of Sylvania News we told you that there would be fewer civilian "MR" tubes available during the fourth quarter. Now we find that the delivery situation has improved slightly and is not quite as "black" as we painted it last month.

Based on WPB revised schedules, it is possible that the industry will deliver as many civilian tubes during the current quarter as were obtained for the third quarter.

Several of the important demand types on which the shortage has been particularly acute will continue in short supply. Some other types, including a few of the older types, should be available in larger quantities than heretofore.

The temporary freeze order which the WPB placed on "MR" shipments last month has been rescinded. Manufacturers may now make shipment in accordance with the revised directive schedules which were recently issued.

Only a few types and in limited quantities have so far become available for "MR" purposes from the DSC surplus stocks. For the most part the tubes which have been obtained from DSC surplus stocks have been applied against war orders which take precedence over "MR". We believe that larger quantities of surplus stocks and in types most urgently needed for the civilian market will be released for "MR" in the near future.

Whether the "MR" delivery status will improve over the next few months and to what extent, we are not in a position to predict. It is contingent on several factors, such as the release of DSC surplus tubes, the progress of the war on all fronts, and types required by the military. The "MR" schedules for the first quarter of next year will be issued in late December. If at that time additional "MR" production capacity is available we are assured that it will be authorized by the WPB. You may depend on us to keep you posted through Sylvania News regarding any significant trends or developments.

SYLVANIA WINDOW DISPLAY CONTEST STARTS WITH 6TH WAR LOAN DRIVE

Five Hundred And Eighty War Bond Prizes To Be Awarded
For Outstanding Window Displays

Far from being won, the war seems to be entering one of its most critical phases. Despite our progress our enemies persist with relentless fury in an effort to stave off the day of their final debacle. The requirements on the battle front and the home front were never greater.

The 6th War Loan Drive, starting on November 20th, is our way of saying to the boys "over there" that we're behind them, and that their final drive for victory and war termination, will be backed up through the purchase of War Bonds by the American public.

In our October issue of Sylvania News we inserted an extra section announcing the 6th War Loan display Contest with 580 War Bond prizes valued at \$10,500 upon maturity. Clearly stated is the fact that while Sylvania Electric Products Inc. is financing the award of prizes, the product name should not appear in the window displays.

The aim of the contest, however, is to catch the eye of the passer-by and is an effort to keep before Mr. John Q. Public the fact that the purchase of his share of War Bonds and stamps during the 6th War Loan Drive is his duty and privilege.

To you, the radio servicemen and dealers, is given this opportunity to come to the fore and make the 6th War Loan Drive go over the top, and at the same time offers you the opportunity to compete with fellow radio wholesalers for the many War Bond prizes offered by Sylvania Electric Products Inc. A successful completion of the 6th War Loan Drive may mean the saving of thousands of lives, and will certainly be a factor in shortening the conflict.

The blow-up of the \$100.00 War Bond is now available in a limited supply and is 26" x 14". Address your requests for the blow-up to the Advertising Department, Emporium, Pennsylvania.

THIS LITTLE LADY HAS THE RIGHT IDEA



STRAP-LESS AND SMILING! Luscious Dorothy Parkington urges you to hurry and win one of the 580 war bond prizes totaling \$10,500 to be awarded by Sylvania Electric Products Inc., to all retail radio stores and service shops throughout the country participating in a national display contest featuring a \$100 war bond to promote the sale of war bonds during the 6th war loan commencing November 20th. Retail radio



stores will make photographs of their displays and send them to the Sixth War Bond Drive Display Contest Committee, care of Display World, Cincinnati 1, Ohio. All displays will be judged for their originality, sales appeal and attention appeal! Get that war bond window in . . . and cash in! Remember, the first Sylvania prize is \$1000 war bond! 579 other war bond prizes just waiting to be distributed!



IDEA DEPARTMENT

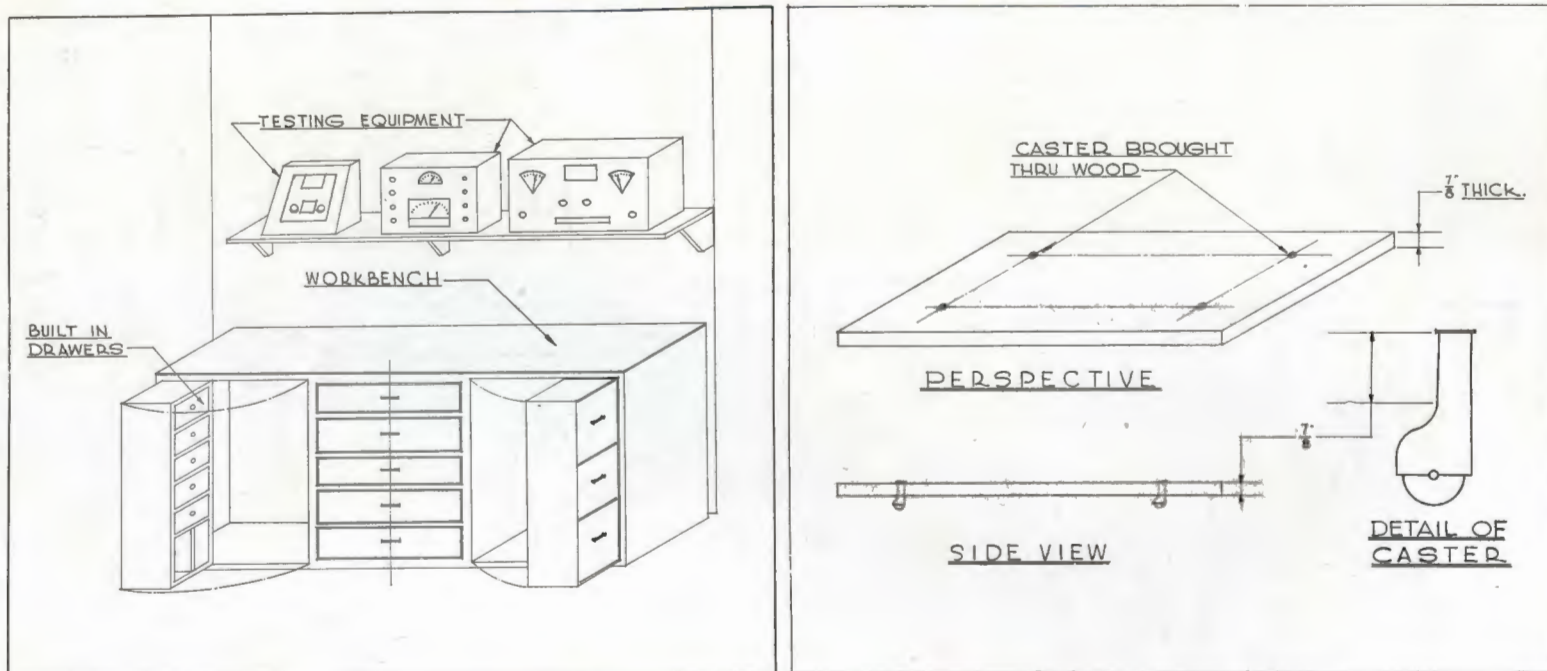

FOR A LIMITED SPACE PART DRAWERS CAN FIT INTO WORKBENCH

"A place for everything and everything in its right place" is an adage which certainly applies to any busy, successful serveshop. Without suitable shelves, and bins for parts, the service shop would soon become a shambles.

Most servicemen have their own little system for keeping replacement parts in their place, but Mr. Robert Freeman of 1030 Beechmont Street, Dearborn, Michigan has incorporated drawers in a unique way. Not only are all parts handy to the workbench, but being on hinges, the shelves can be closed into the bench and are out of the way. The inner part of the workbench, or the part into which the drawers swing, could be lined with shelves used for any purpose.

For a small shop of limited space, a complete unit of bench, parts and testing equipment could be fitted into a comparatively small space.

HELP US TO HELP YOU

Sylvania News functions solely for those interested in electronic theory and information of a general nature to the vocation. In working with this aim in mind, we have found that the best material comes from the serviceman and dealer; material submitted by these two groups has a wide acceptance by fellow readers because the facts given are "down to earth" and factual.

Naturally it is our aim to make Sylvania News interesting to its readers by publishing articles which will be helpful and informative.

Help us to give you the material you want to read; drop us a note covering any phase of your business you care to. If you have a picture of your shop or yourself, send it along and we will see that it is returned to you after using.

A "DOLLY" FACILITATES MOVEMENT OF TESTING EQUIPMENT

When a radio set has been completely dismantled, it is often better to bring the testing equipment to the set rather than the set to the testing equipment.

Mr. A. J. Paddock of Paddock's Radio Service, Warwick, New York submitted a drawing of a "dolly" that could certainly be useful to many servicemen. In his own words Mr. Paddock says: "The idea is simply a 'dolly' constructed of $\frac{7}{8}$ inch stock with four single ball type roller casters. This is made in any size to the users desire, and is used for Chanalyst, Audolyzer, Scope, etc. or any heavy instrument which one wants to move to any position on the bench. Using the single ball type caster is advantageous in that the slightest pull of a test lead or probe will move the instrument to the point of work."

NORTHWEST TERRITORY HAS NEW DIVISION MANAGER FOR TUBES

**Mr. Cortland T. Clark Will Cover
Washington, Oregon, Idaho & Montana
For Sylvania Electric Products.**

Sylvania Electric Products Inc. announces the appointment of Mr. Cortland T. Clark of Seattle, Washington as Northwestern Division Manager of the Radio Tube Division. Mr. Clark's territory will cover the states of Washington, Oregon, Montana and Northern Idaho.

For many years connected with the electrical and electrical appliance field, Mr. Clark comes to Sylvania with a well rounded background and understanding

of sales and merchandising promotion.

After completing his schooling at the University of Washington, Mr. Clark was connected with Industrial Electric Co., electrical contractors in the Seattle area, and in 1936 he took over the duties of Appliance Sales Manager for the North Coast Electric Company, Seattle, later to become the Assistant to the General Manager of that firm, which position he occupied before coming with Sylvania.

Mr. Clark is a veteran of World War II having served in the Navy from which he was honorably discharged. He is a member of the Washington Athletic Club and the I. E. S. Mr. Clark will make his headquarters at the Sylvania Seattle office.

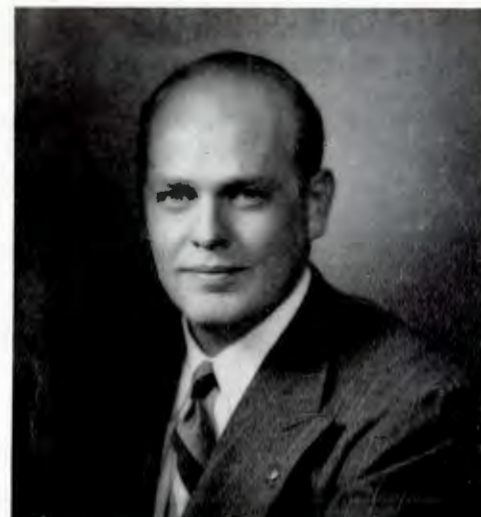



Copyright 1944, Sylvania Electric Products Inc.

November, 1944

EMPORIUM, PENNA.

Vol. 11 No. 6

A BIBLIOGRAPHY OF ARTICLES OF INTEREST TO SERVICEMEN

This month we are printing a bibliography of useful service articles appearing in the last two years of the magazines most likely to be available to the average serviceman and radio experimenter. The magazines are Radio News; Service; Radio Craft; Radio & Television Retailing (formerly Radio Retailing Today) and Radio.

While substitutions are such a large part of the servicing business today every serviceman needs a reference library not only of substitution articles but of the fundamental principles so that if changes in unusual circuits are necessary they can be figured out. It would have been impossible to list in detail all separate substitutions printed but these have been divided into the various major groups so that it will be reasonably convenient to find the required one. Please note the large number of items of service equipment on which construction articles are shown.

In many cases the titles of the articles have been reworded so as to make possible the indexing of the subjects in alphabetical order. No claim is made to completeness, since articles of interest to servicemen only were required, but this was construed broadly so that most radio experimenters will find all the important articles listed. Items that are of news value only, or those articles describing a commercial product have been omitted, since the former are too general, and the latter of interest only to those who have the equipment described.

Every serviceman probably gets about two of these selected magazines and it is hoped that reference can be made to the others in a public library when required.

CONSTRUCTION ARTICLES

Bass & Treble Boost Circuits

L. G. Sands, Radio Craft, July 43, p. 596

L. G. Sands, Radio Craft, August 43, p. 662

Code Practice Oscillators

D. Gnessin, Radio Craft, June 43, p. 543

C. Cool Jr., Radio News, October 44, p. 95

Coil Winder: Homemade

Radio Craft, April 44, p. 430

Etherscope, The (Oscilloscope Band Scanner)

Radio Craft, September 44, p. 727

Horn: How to Make an Exponential

J. Langham, Radio Craft, May 43, p. 464

Interphone Communicators: Simple

A. Blumenfeld, Radio Craft, January 43, p. 216

R. F. Scott, Radio News, March 43, p. 28

J. H. Crescom, Radio Craft, February 43, p. 291

A. Blumenfeld, Radio Craft, April 43, p. 418

Loop Antenna Design & Construction

A. C. Matthew, Radio, February 44, p. 30

Phono Oscillator: Simple

F. E. Marsh, Radio Craft, February 43, p. 286

Power Packs for Portable Receivers

F. Shunaman, Radio Craft, January 43, p. 224

R. F. Converter for Short Wave Broadcasts

W. F. Frankart, Radio News, August 43, p. 29

Receiver: A Compact AC-DC Portable

E. M. Yard, Radio Craft, April 43, p. 409

Receiver: The Simplicity

H. Gernsback, Radio Craft, January 43, p. 220

F. Shunaman, Radio Craft, March 43, p. 342

Transceiver: A 2½ Meter

H. A. Bowman, Radio News, June 44, p. 38

Transformers: Rewinding Burnt Out

J. E. Dolan, Radio News, October 44, p. 32

Volume Expander Circuit

H. Newton, Radio Craft, June 43, p. 548

NOMOGRAPHS

Acceleration Chart

Sylvania News Letter No. 79

Audio Frequency Power Output Chart

Radio News, June 44, p. 40

Capacity Reactance Calculator

Radio Retailing Today, March 43, p. 41

Radio News, March 44, p. 29

H-F to D-C Resistance Chart

R. G. Middleton, Radio, December 43, p. 34

Non Linear Variable Resistances

Radio, October 44, p. 13

R. F. Coil Design Chart

Radio News, December 43, p. 47

Resistance (in parallel) Capacitances (in series)

Radio News, January 44, p. 31

Ripple Factor for 60 cycle Filters

Radio News, May 44, p. 40

Stage Gain of Pentode Amplifiers

Radio News, April 44, p. 45

SERVICING ARTICLES

Aircraft Radio: Maintenance on

G. O. Crowley, Radio, January 43, p. 30

Aligning Aid for Loop Receivers

J. T. Willard, Service, July 43, p. 9

Aligning Superhets (for beginners)

Radio Craft, February 43, p. 282

Amplifier Servicing: Audio

Radio & Television Retailing, August 44, p. 60

Amplifiers: An Analysis of Low Power Phono and Audio

A. A. Ghirardi, Service, July 43, p. 5

Auto Radio Control Cables: Repairing

B. V. Selle, Service, July 43, p. 18

Bandswitches: Servicing

A. A. Ghirardi, Service, February 43, p. 5

Cathode Ray Oscillograph: Servicing with the

Wm. E. Moulic, Radio Retailing Today, June 43, (insert)

A. Ghirardi, Service, January 44, p. 8

Howard & Eddy, Radio News, September 44, p. 28

Color Codes for Resistors, Condensers and Transformers

Radio Craft, February 43, p. 297

Components: Functional Analysis of Radio

Radio News, June 44, p. 46

Condenser (Electrolytic) Replacement Problems: Solving

M. E. Heller, Service, January 43, p. 13

Condensers: Testing

T. R. Cunningham, Service, April 43, p. 20

Condensers: Characteristics of

A. C. Matthews, Radio, June 43, p. 24

Converters: Parastic Oscillations in

Radio Retailing Today, February 44, p. 64

Distortion: Audio

T. Powell, Radio Craft, April 44, p. 409

T. Powell, Radio Craft, May 44, p. 475

T. Powell, Radio Craft, June 44, p. 534

Fidelity Requirements

O. B. Hanson, Radio, October 44, p. 37

Grid Emission: Tracking down

Sylvania Radio Tube Hints, Vol. 1, p. 30

Hum: Causes and Cures of in Amplifiers

Radio Retailing Today, August 43, p. 54

Inductors: Characteristics of

A. C. Matthews, Radio, August 43, p. 36

Interference: Causes and Cures

Service, April 43, p. 25

Radio Retailing Today, February 43, p. 37

H. B. Davis, Radio News, October 44, p. 47

Interference: Eliminating Electric Sign

F. V. Dillion, Service, March 43, p. 10

Interference From Fluorescent Lamps: Reducing

Radio Retailing Today, April 44, p. 65

Interference: Cross Modulation as a Factor in

Ted Powell, Radio Craft, July 43, p. 605

Ted Powell, Radio Craft, August 43, p. 669

A BIBLIOGRAPHY OF ARTICLES OF INTEREST TO SERVICEMEN

- Interference: Filtering Dynamotor**
H. Goldberg, Radio News, March 43, p. 13
- Interference: Reducing Auto Radio Noise**
B. Kassin, Service, June 43, p. 25
- I. F. Transformers: Wartime Servicing of**
A. A. Ghirardi, Service, November 43, p. 5
- Locating Causes of Intermittent Reception**
Y. Gabin, Radio News, September 44, p. 50
- Locating Trouble in Set by Voltage Analysis**
Jack King, Radio Craft, July 43, p. 598
- Locating Defects in Radio Receivers**
D. B. Looney, Radio Craft, November 43, p. 86
J. King, Radio Craft, August 43, p. 669
E. Leslie, Radio Craft, April 43, p. 403
M. Muten, Radio News, November 44, p. 47
- Locating Trouble with the V. T. Voltmeter**
Sylvania Radio Equipment Hints, Vol. 1, p. 15
- Locating Trouble: See also Signal Tracing**
- Locating Trouble: See also Cathode Ray Oscillograph**
- Loud Speaker Response Curves: Understanding**
Radio News, April 44, p. 35
Radio News, May 44, p. 32
- Microphones: Repair and Maintenance of Carbon**
Radio Craft, August 43, p. 670
- Microphones: Attaching to Sets and phono players**
J. King, Radio Craft, February 44, p. 286
- Motors: Testing Small**
J. W. Wodjeck, Radio Craft, September 44, p. 736
- Noise: See Interference**
- Oscillators: Servicing Radio**
J. B. Crowley, Radio News, May 44, p. 26
- Oscillations: Causes and Cures for**
Sylvania News, August-September 44
J. King, Radio Craft, January 44, p. 221
- Portables—3-way: Analysis of Filament Switching in**
B. Kassin, Service, February 43, p. 12
- Portables—3-way: Servicing**
J. Kearney, Radio Craft, June 43, p. 535
- R. F. Coil Design: Wartime**
F. Sunaman, Radio Craft, July 43, p. 607
- Receivers: Modernizing Old**
W. B. Miller, Radio Craft, March 43, p. 345
G. Chase, Radio Craft, June 44, p. 541
F. E. Bartholy, Service, March 43, p. 5
W. Moody, Service, October 44, p. 18
- Receivers: Servicing F. M.**
J. M. Kleinman, Radio Craft, March 44, p. 344
- Record Changers: Tips for Servicing Changers**
Radio Craft, November 44, p. 93
Radio Retailing Today, January 43, p. 38
Service, September 44, p. 11
- Recorder Servicing in Wartime**
A. A. Ghirardi, Service, January 43, p. 14
D. W. Aldous, Service, October 44, p. 14
- Resistors: Calculation of Odd Sizes**
D. Espy, Radio July 43, p. 36
See also Nomographs
- Resistors: Characteristics of**
A. C. Matthews, Radio, June 43, p. 30
- Replacing Screen Grid Tetrodes with Variable mu Pentodes**
F. E. Bartholy, Service, March 43, p. 5
- Signal Generators: Calibrating**
J. King, Radio Craft, April 44, p. 412

- Signal Tracing: Principles of**
N. B. Cook, Radio News, November 44, p. 32
R. E. Altomare, Radio Craft, March 44, p. 343
R. E. Altomare, Radio Craft, April 44, p. 411
R. E. Altomare, Radio Craft, May 44, p. 477
- Signal Tracing with Multivibrators**
M. E. Heller, Service, February 44, p. 10
- Sound Jobs: How to Handle**
Radio Retailing Today, October 43, p. 50
- Sound Installation Suggestions**
S. Harman, Service, February 44, p. 14
S. Harman, Service, March 44, p. 14
S. Harman, Service, April 44, p. 10
D. C. Hoeffler, Radio Craft, June 44, p. 525
- Speakers: How to Service Radio**
F. Shunaman, Radio Craft, December 43, p. 150
B. Kassin, Service, July 43, p. 22
- Substitutions: Adaptors for Tube**
Sylvania News, October 43
W. G. Eslik, Radio Craft, June 44, p. 539
- Substitution Charts: Tube**
Sylvania News, April, May-June, July 43
- Substitutions: Circuit Changes for Rectifier Tube**
Radio Retailing Today, March 43, p. 42
Radio Retailing Today, May 43, p. 48
Radio Retailing Today, July 43, p. 46
- Substitutions: Circuit Changes to Use 6 Volt in Place of 12 Volt Tubes**
H. J. Foht, Service, May 43, p. 12
Radio Retailing Today, July 43, p. 46
Radio & Television Retailing, May 44, p. 72
Sylvania News, July 43
- Substitutions for Battery Types**
Radio Retailing Today, July 43, p. 46
Radio & Television Retailing, Sept. 44, p. 60
Sylvania News, April 43
- Substitutions: General Articles on Tube**
H. Davis, Radio Craft, February 43, p. 278
Radio Retailing Today, March 44, p. 62
Radio Retailing Today, May 44, p. 68
See Also Receivers: Modernizing Old
- Substitution for Types 12SQ7 and 12Q7**
Radio Retailing Today, April 43, p. 36
Radio and Television Retailing, July 44, p. 56
- Substitutions for Converter Types**
Radio Retailing Today, May 43, p. 48
Radio & Television Retailing, Sept. 44, p. 60
Radio Retailing Today, December 43, p. 52
Radio Retailing Today, March 44, p. 62
Radio Craft, May 44, p. 474
- Substitutions for Power Tubes**
M. S. Kay, Radio News, August 44, p. 40
J. King, Radio Craft, May 44, p. 474
- Substitute Power Supplies**
R. F. Scott, Radio News, October 43, p. 42
R. S. Havenhill, Radio Craft, April 43, p. 410
R. S. Havenhill, Radio Craft, July 44, p. 598
- Substitute Power Supply for Battery Portables**
R. S. Havenhill, Radio Craft, April 43, p. 410
R. S. Havenhill, Radio Craft, July 44, p. 598
- Substitutes for Rectifier Tubes**
Radio Retailing Today, March 43, p. 42
Radio Retailing Today, May 43, p. 48
Radio Retailing Today, July 43, p. 46
- Superheterodyne Tracking Problem**
E. Leslie Radio Craft, November 44, p. 85
- Testing Amplifiers with Square Waves**
J. Williams, Radio News, January 44, p. 24
Radio Retailing Today, January 44, p. 48

- Testing: Use of Tungsten Lamp in**
M. Merten, Radio News, November 44, p. 47
- Tube Tester Settings for Type 35Z5GT G**
Sylvania Radio Tube Hints, Vol. 1, p. 25
- Vibrator Operation and Development**
M. E. Heller, Service, August 43, p. 14
M. E. Heller, Service, September 43, p. 12
- Volume Controls: How to Service**
J. Beever, Radio Craft, May 43, p. 467
B. Kassin, Service, May 43, p. 28

SERVICING INDUSTRIAL EQUIPMENT

- Aircraft Radio: Maintenance on**
G. O. Crowley, Radio, January 43, p. 30
- Color Comparators and How they Work**
J. Keating, Radio News, August 43, p. 41
- Crime Detection: Electronic Aids for**
R. P. Turner, Radio News, Sept. 44, p. 20
- Dust Precipitation Electrically**
Radio Craft, June 43, p. 526
- Farm: Electronics Apparatus for the**
S. R. Winters, Radio News, August 43, p. 30
- Industrial Measurements: Electronics used in**
C. E. Jackson, Radio News, August 43, p. 29
- Microvolter for Biological Work**
Radio Craft, May 44, p. 471
- Oscilloscopes Used in Industry**
W. Muller, Radio Craft, October 44, p. 23
W. Muller, Radio Craft, November 44, p. 87
- Photocontrol Equipment: Servicing**
S. J. Murcek, Service, June 43, p. 12
S. J. Murcek, Service, August 43, p. 8
S. J. Murcek, Service, December 43, p. 8
S. J. Murcek, Service, January 44, p. 19
- Photoelectric Alarms**
C. E. Jackson, Radio News, May 43, p. 14
- Piezo Electric Surface Analyzer**
R. S. Sawdey, Jr., Radio, March 43, p. 20
- Receivers: Modernizing Police**
H. L. Lipson, Radio News, Sept. 44, p. 44
- Timer Trouble: Electronic**
S. J. Murcek, Service, September 43, p. 7
- Tubes in Industry: Using**
Radio Retailing Today, November 43, p. 48
S. J. Murcek, Service, July 44, p. 14
- Voltage and Speed Regulators: Electronic**
S. J. Murcek, Service, February 44, p. 22
S. J. Murcek, Service, March 44, p. 22
S. J. Murcek, Service, April 44, p. 22

TEST EQUIPMENT

- Amplifier For Use In Receiver Servicing**
H. F. Loeper, Service, November 43, p. 7
- Analysers for Service Work**
R. F. Scott, Radio News, January 43, p. 24
W. Flaherty, Radio News, January 44, p. 48
C. Fishback, Radio Craft, May 44, p. 481
W. Neelands, Radio Craft, March 43, p. 362
E. Pottruff, Radio Craft, April 43, p. 411
H. L. Jellicorse, Service, June 44, p. 10
R. P. Turner, Radio News, May 43, p. 34
R. P. Turner, Radio News, November 43, p. 35
- Capacity Bridge: Direct Reading**
L. W. Smith, Radio Craft, April 43, p. 412
R. P. Turner, Radio News, Sept. 44, p. 40
H. L. Poling, Radio News, February 43, p. 26
- Capacity Bridge With Tuning Indicator Tube**
Sylvania News, October 44
McMurdo Silver, Radio News, October 44, p. 40

A BIBLIOGRAPHY OF ARTICLES OF INTEREST TO SERVICEMEN

Capacity Meters

I. Queen, Radio Craft, July 44, p. 602
 H. R. Michaelson, Radio Craft, February 44, p. 283

Chanalyst: Circuit and Use of the Audio

Service, October 43, p. 32
 Service, November 43, p. 26
 Service, December 43, p. 28

Chanalyst: A UHF Converter for the

W. Carroll, Service, July 43, p. 10

Distortion Meter for P. A. Work

R. P. Turner, Radio News, April 43, p. 18
 A. A. Bertram, Radio News, January 44, p. 41

Frequency Meter for Audio

Guy Dexter, Radio News, December 43, p. 38

Inductance: Measurement of

Guy Dexter, Radio News, January 44, p. 28
 I. Queen, Radio Craft, August 44, p. 664
 Sylvania News, November 44

Meter Calculation: Simple

Rosenfeld & Howard, Radio Craft, May 44, p. 479

Meter Repair Procedure

A. A. Ghirardi, Service, August 43, p. 5
 A. A. Ghirardi, Service, September 43, p. 10
 A. A. Ghirardi, Service, October 43, p. 13
 F. J. Lingel, Radio Craft, May 43, p. 465
 F. J. Lingel, Radio Craft, June 43, p. 531

Meter Substitutes

R. P. Turner, Radio News, October 43, p. 38

Meters

See also—Capacity Meters
 V. T. Voltmeters
 Tube Tester
 Distortion
 Voltmeters
 Q-Meters
 Power Output
 Frequency Meters
 Ohmmeters

Ohmmeters: Using Old Meters in

J. R. Kearney, Radio Craft, Feb. 43, p. 288
 Sylvania News, April 44
 W. Moody, Service, September 44, p. 12
 F. Shunaman, Radio Craft, March 43, p. 348
 G. L. Manning, Radio News, Feb. 43, p. 36

Oscillator: An All-Wave Test

F. V. Dillion, Service, April 43, p. 18
 McMurdo Silver, Radio News, July 44, p. 30

Oscillator for Testing: An Audio

R. P. Turner, Radio News, May 43, p. 34

Oscillator for Code Practice

R. C. Zaun, Radio News, December 43, p. 25
 Radio Craft, April 43, p. 424

Oscilloscope: Adaptor Unit for Basic

Guy Dexter, Radio News, September 43, p. 40

Oscilloscope: Electronic Switch for use with

S. A. Proctor, Radio News, October 43, p. 35
 R. P. Turner, Radio News, December 43, p. 28

Power Output Meter: An Easily Built

G. Dexter, Radio News, July 43, p. 38

Power Supply: A Versatile

M. E. Heller, Service, October 43, p. 7

Power Supply: An Experimenters

H. L. Davidson, Radio News, January 43, p. 17

Q Meter: A Homemade

R. P. Turner, Radio News, July 43, p. 20
 S. W. Edwards, Radio News, January 44, p. 35

Resistance Capacity Bridge with Tuning Indicator Tube

Sylvania News, October 44
 McMurdo Silver, Radio News, October 44, p. 40

Signal Tracer made from Old Receiver

J. F. Cooler, Radio Craft, July 44, p. 591

Signal Tracer and Handy Tester

E. Pottruff, Radio Craft, April 43, p. 411
 H. L. Jellicorse, Service, June 44, p. 10

Signal Tracer for Audio Amplifiers

R. P. Turner, Radio News, January 44, p. 36

Square Wave and Pulse Generator

W. Miller, Radio Craft, January 43, p. 207
 W. Miller, Radio Craft, February 43, p. 272
 R. P. Turner, Radio News, March 44, p. 30
 J. Kane, Service, November 43, p. 25
 W. P. Bollinger, Radio June 43, p. 21

Tester: Dynamic Tube (Transconductance)

J. A. Dewar, Radio Craft, November 44, p. 94

Tester for Thyratrons: Tube

W. D. Stewart, Radio News, March 43, p. 20

Testers: Uses for Old Tube

G. L. Manning, Radio News, February 43, p. 36

Tester: Handy Radio

W. Neelands, Radio Craft, March 43, p. 362

Test Equipment Maintenance

L. W. Burt, Radio Craft, March 43, p. 380

Vacuum Tube Voltmeters: How to Use

G. Dexter, Radio News, April 43, p. 26

Vacuum Tube Voltmeters: Electric Eye

W. Neelands, Radio Craft, July 43, p. 612
 Sylvania Radio Equipment Hints, Vol. 1, p. 32
 W. Flaherty, Radio News, November 44, p. 48

Vacuum Tube Voltmeters: Laboratory

R. P. Turner, Radio News, July 44, p. 47
 McMurdo Silver, Radio News, Sept. 43, p. 32
 McMurdo Silver, Radio, February 44, p. 23
 R. F. Scott, Radio News, January 43, p. 24
 W. Flaherty, Radio News, January 44, p. 48
 C. Fishback, Radio Craft, May 44, p. 481

Vacuum Tube Voltmeters: Simple

Sylvania Equipment Hints, Vol. 1, p. 5
 H. Davis, Radio Craft, January 43, p. 222
 H. Davis, Radio Craft, February 43, p. 287
 E. Antoine, Radio Craft, May 43, p. 482
 R. P. Turner, Radio News, March 43, p. 32
 Radio Craft, January 44, p. 214
 Radio Craft, October 44, p. 24

Voltmeters: Simple Peak

Sylvania Radio Equipment Hints, Vol. 1, p. 12

Voltohmeters: Simple

Fred Shunaman, Radio Craft, March 43, p. 348
 R. P. Turner, Radio News, November 43, p. 35
 G. L. Manning, Radio News, Feb. 43, p. 36

Voltohmist Jr: High Frequency Adaptor for

G. Dexter, Radio News, June 44, p. 35

Voltmeters

See Also Ohmmeters

(This Article will be continued in the December Issue)

HERE ARE NEW STANDARD CIRCUIT SYMBOLS

Recently, the controversy in the American Standards Association on co-ordination of electrical graphical symbols between the communication and power groups of the industry has been covered in issues of the popular service radio magazines. One magazine went so far as to use the new symbols throughout the article as an example so that the reader could see how it worked out. As far as we can tell, the new standards will cause no confusion among radio technicians as long as they watch out for the old capacity symbols (3 and 4) which now mean contacts. However, the symbol shown as No. 5 will probably be used in radio work in preference to these.

Notice the choice we have now in symbols for resistance and inductance. The new symbols for inductance No. 13,

16 and 17, as compared to the older method which required the use of instruments, shows them to be much simpler. With the exception of this new one all these symbols can be quickly drawn with the aid of the Sylvania Symbol Guide (still available at 25c). If necessary for your work, a sharp knife can be used to straighten out the corners of the 3/4 circles used for drawing inductances. However, since these symbols are optional, and since transformers and chokes are still indicated by adding the straight lines to these symbols, this would not seem to be necessary. Some articles we have seen, however, leave the impression that the symbol for inductance has been changed to 13 and 16 or 17, but this is not stated in the new standard.

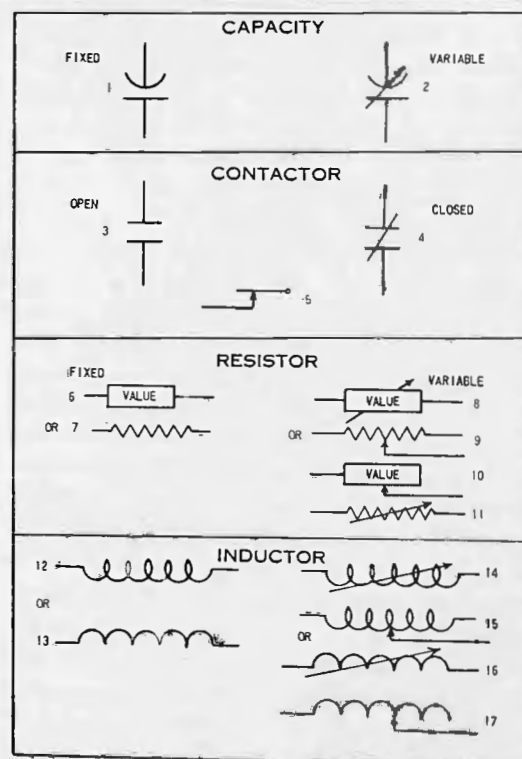

THE information presented in the Sylvania Service Exchange is contributed by servicemen as the result of practical experience. It is very carefully considered before being accepted, and we believe it to be correct and authentic. However, we assume no responsibility for results. Please do not send routine or generally known information.

THE

Service Exchange

Crosley Romeo (Auto). This hint is for the Crosley Romeo auto sets in which the 6D6 audio tube is located very near the volume control switch and incoming battery cable. Sometimes these sets develop a buzz which ordinary methods, such as replacing tubes, vibrators, tightening chassis, etc., do not help. The set may even work OK when removed from the car. If the 6D6 is completely shielded together with the grid lead the trouble will usually clear up completely.—J. Moller, Cincinnati, Ohio.

* * *

Hum in AC-DC Sets. If this is not caused by a bad filter, and it often is not, check for insulation leakage from an AC source, such as the rectifier socket or other point where grid or AVC circuits are tied near AC or raw DC with only fibre or molded paper between. Many so-called insulators absorb moisture and let AC leak over to grid circuits. One other spot is leakage through dial lamp socket to bracket especially in the 1940 Zenith "Advance Design" models. Either unclip the socket from chassis or use high range megohm meter.—Tom G. Davis, Cave Spring, Ga.

* * *

Tube Repair. I have found that it is possible to weld the filaments of tubes such as the 12, 35 and 50 series, by the simple expedient of a Ford spark coil and 6 volt storage battery. While this repair is not sure-fire in all cases, due to breaks occurring near the base of the tube, where the filament is welded to the wire going to the base pins, and breaks that are too far apart, it will be effective in half or possibly more cases. So far, I have performed this operation on a quantity of tubes, and have had good results, and have had very few "kick-backs", and these have been only on 50L6 tubes. Practically everyone knows how to connect a spark coil up, so there would be no need in going into that. However, after hooking it up, the two top wires on the coil should be connected directly to the filament prongs of the open tube, and the juice then turned on. If arcs are visible in the tube base, or within the tube structure, chances are that that tube cannot be repaired due to the breaks being too far apart, however, if there are no arcs visible, with the juice on, the possibilities are good that the tube has been successfully welded together, which can

be checked by a tube-tester, ohm-meter, or insertion in the set. If the first attempt at welding a tube filament checks good, and the filament opens up again, it can be put through the process repeatedly until the weld is complete, or arcs appear, in which case the tube is definitely "open" to stay.

This is by no means to be considered practical, where replacement tubes are available, but, the tube situation being what it is, it will sure help to get these dead sets off the shelves.—J. W. Fantaske, Verona, Pa.

CORRECTION

Our attention has been called to a mistake in the schematic diagram of the Resistance-Capacity Bridge appearing in the last issue. The letters for the binding posts in the upper left hand corner of Fig. 3 are interchanged. That is, in place of Cx write Rx and in place of Rx write Cx. We hope this error has not caused anyone trouble.

General Electric F-75 Receivers. Quite a number of these sets have been brought to the shop lately, and almost all have had the same trouble and complaint. When the chassis is jarred in the cabinet or on the bench a noise is heard which sounds somewhat similar to a shorted tube or intermittent condenser, but which actually is not caused by either of these. After a great deal of testing and examination, I found that the source of the noise was the power transformer. The laminations in this transformer are held together by four corner rivets and two extra rivets in the center on each side of the shell, and the latter were causing the noise, even though they do not seem to be loose. Bonding these two center rivets to chassis will permanently clear up the trouble from this source.—Arthur L. Johnson, Hutchinson, Kansas.

* * *

Microphonism in Zenith Sets. I repaired a microphonic Zenith by cutting rubber washers from an old automobile inner tube. The mounting screws for the loudspeaker were removed and longer ones of smaller diameter were used with two or three of the rubber washers on each side of the speaker. If the same size screws must be used the holes in the speaker rim should be enlarged so that

some of the rubber washer can squeeze in between to prevent contact of the speaker frame and bolt. This prevents vibrations from being transferred to the tubes.—Robert McNutt, Syracuse, N. Y.

* * *

ALL PURPOSE ECONOMICAL UTILITY TESTER

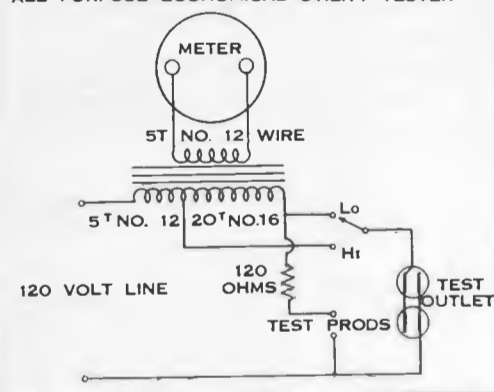

I rewound an old bell transformer with the number of turns and size wire given above and found that the use of it saves guess-work and speeds up repair of all utilities which operate from a fraction of a watt to 500 watts. The meter required is 5 amperes AC.

It can be calibrated in watts or amperes by using known wattage lamps. Two ranges are provided by the tapped primary 1 Amp. (120 Watts) or 5 Amp. (600 Watts). Heater coils, etc., will read above normal if several turns have become shorted out. Transformers will indicate shorted turns immediately so that no waiting is necessary to see if they overheat. Calibration in watts will not be correct for inductive loads but this will be noticeable only on unloaded transformers and motors. Since the bell transformer core saturates with these currents through the windings, it will protect the meter from damage but it will not prevent the line fuse from blowing so one should be provided on the test panel of lower value than the light circuit fuse.

The 120 ohms in series with the test prods allow the instrument to be calibrated as an ohmmeter (for low values) or used as a continuity meter. Use only where one ampere can be carried. Calibration can be calculated since $\frac{1}{2}$ scale will be 120 ohms; $\frac{1}{3}$ scale 240 ohms, etc.

The 120-ohm resistor should be wound on an asbestos form using Nichrome, Chrom-el or Copel wire if possible.—T. T. Czarnecki, Detroit, Michigan.

CHICAGO CONFERENCE DRAWS RECORD CROWD

Radio and electronic parts manufacturers, distributors and representatives from every section of the country invaded Chicago on October 18, 19 and 20th to attend the Electronic Parts and Equipment Industry Conference at the Stevens Hotel. Never before has such a Convention been undertaken in the electronic industry, and the attendance lived up to all expectations.

Some hundred and fifty manufacturers were represented for the three day session. Booths and private suites afforded distributors an opportunity to talk with manufacturers on post-war, and present day problems.

Three general industry luncheons presided over by prominent speakers in the fields of sales, advertising, and electronics featured the Conference. The scope of electronics and its diversified use in the near future high-lighted the many talks.

Sylvania was strongly represented at the Conference by more than thirty company members.

Those in the accompanying picture are Mr. D. G. Mitchell, Vice-President in Charge of Sales, C. W. Shaw, General Sales Manager, H. H. Rainier, Assistant Manager Distributor Sales, P. S. Ellison,



Director Advertising and Promotion, G. R. Holden, Secretary to the Management Committee, R. P. Almy, Manager Distributor Sales, F. W. Mansfield, Manager Sales Research, R. G. Mackey, Editor Sylvania News, H. P. Gilpin, Manager Equipment Sales, T. Harragan

and H. V. Oddquist of Sylvania's Advertising Agency. Division Managers and Salesmen in the picture are G. C. Isham, J. T. Fulwiler, R. H. Henderson, D. C. Patrick, J. T. Millican, G. R. Wannan, C. W. Chapman, J. T. Mallen, W. G. Patterson, and C. T. Clark.

CIVILIAN-RADIO SALES TO TOTAL BILLION ANNUALLY

"The radio industry and trade is now getting ready to produce and sell a billion dollars of civilian-radio products every twelve months, two to three months after Germany falls," declares Dr. Orestes H. Caldwell, former Federal Radio Commissioner, now editor of "Electronic Industries", who for many years has compiled the statistics of the radio industry. Dr. Caldwell's estimates, based upon studies made by his editorial associates on the magazines, "Radio and Television Retailing" and "Electronic Industries", follows:

16 million radio sets.	\$ 733,000,000
60 million replacement tubes.	65,000,000
Repair parts.	90,000,000
Batteries for 3 million portable radios.	12,000,000
Phonograph records, 200,000,000.	100,000,000
Total radio mdse.	\$1,000,000,000

The figures assume that no substantial number of television sets will be distributed during the first sales. Within a few years, however, annual television volume may be expected to duplicate in dollar volume that of radio sets—selling say, one-sixth to one-quarter as many television units at prices averaging six to four times those of present radio sets.

RADIO EXPERTS DEDICATE ELECTRONIC CLUB

On Tuesday evening, September 19, Members of the Radio and Electronic Technicians Association Inc. gathered to hear four speakers at the dedication of the organization's new clubrooms at 528 East Colfax Avenue, South Bend, Indiana.

Speakers included Mr. Harold H. Rainier, Sylvania's Assistant Manager of Distributor Sales from Chicago, Ill., Mr. Claude Gerlock of South Bend,

Indiana who gave a demonstration of the new lip microphone, Mr. Jack Keith and Mr. Russell Schwarzentraub, both of the P. R. Mallory Company of Indianapolis.

The Radio and Electronic Technicians Association Inc. is made up of electronic engineers engaged in radio service in the Southern Michigan and Northern Indiana area.

Officers of the organization are Mr. John Lackman, President, and Mr. John Davies, Secretary-Treasurer.



SHOP OF THE MONTH



Mr. George W. Leffler Jr., owner of Ideal Radio and Television Service at 1827 Seneca Street, Buffalo, N. Y. has proven to all who visit his store that radio repair can be made into a big and profitable business. In four years the shop has expanded to such an extent that today it requires the entire structure and employs eleven skilled technicians. Mr. Leffler, with an eye for increased future business, has recently bought the building.

In the forward part of the shop is the large workbench (as shown in the picture above) which includes the latest testing apparatus. Glass jars seen above the bench are filled with replacement parts and are within easy reach of the technician. The metal cabinets at left and

right contain different types of condensers, sockets, coils, knobs, and resistors. A smaller workbench is on the opposite side of the shop and is used to handle surplus work when the larger bench is being used to capacity.

The rear half of the shop is divided into an auto radio repair service capable of accommodating three cars, and another section is set aside for a stock room.

Several newly constructed shelves have been labeled "Repaired", "Cabinets Removed", "To be Called For", etc., thus breaking up work in the shop under different headings and classifications. All incoming work, whether brought in by the company cars or in person, is given a triplicate card of which one goes to the

owner, one on the set, and the third is filed away for future reference and acts as an ever increasing mailing list.

Mr. Leffler has built his successful business with care, and every detail in the company's progress has been thoroughly thought out before acted upon.

J. T. MILLICAN JOINS SYLVANIA'S SALES FORCE

Mr. J. T. Millican has joined the sales force of Sylvania Electric Products Inc. Radio Tube Division, and will contact Sylvania customers in the East Central territory.

Mr. Millican previously was connected with the Fisher Body Division of General Motors Corp. in Cleveland, Ohio where he handled personnel work of a wide variety.

A graduate of Western Reserve University, Mr. Millican received his B.B.A. degree in June, 1943. He was recently honorably discharged from the Army. He is married and has two sons. His headquarters will be in Cleveland, Ohio.



Sec. 562, P. L. & R.
U. S. POSTAGE
PAID
Emporium, Pa.
Permit No. 1

Mr. Granville W. Arnold
139 Main St.
Emmaus, Pa.

POSTMASTER: If Addressee has moved, notify sender on Form 3547, postage for which is guaranteed. When Form 3547 is sent abandon this mailing. Return only if no correct address is available.

Published By
SYLVANIA ELECTRIC PRODUCTS INC.
Manufacturers of Sylvania Radio Tubes and Electronics Devices, Sylvania Incandescent Lamp Bulbs, Fluorescent Lamps and Equipment.
RICHARD G. MACKAY Editor
W. R. JONES Associate Technical Editor

SYLVANIA
ELECTRIC PRODUCTS INC.
Post Office Box 431
EMPORIUM, PA.
Return Postage Guaranteed



Your Copy of
SYLVANIA NEWS
NOVEMBER, 1944
Vol. 11 . . . No. 6

Sylvania News

Copyright 1944, Sylvania Electric Products Inc.

December, 1944

EMPORIUM, PENNA.

Vol. 11, No. 7

1944 REPLACEMENT TUBE SALES SLIGHTLY EXCEED PREVIOUS YEAR

"MR" Directives are Discontinued for First Quarter 1945. WPB Predicts Shortage Will Continue Until End of War.

By **BOB ALMY**,
Manager Sylvania Distributor Sales

It is estimated that in spite of the October "freeze order" the manufacturers will actually deliver slightly more "MR" replacement tubes for the fourth quarter than for any preceding quarter this year. November and December deliveries improved in both the number of types and total quantities.

Based on incomplete figures, we estimate that the manufacturers will sell in 1944 for domestic civilian replacement approximately five per cent more tubes than were sold in 1943. Compared with 1941, which is considered to be the last normal year, the 1944 figure will approximate 60% of 1941.

In 1941 the industry sold approximately 33,800,000 tubes for civilian replacement. As every serviceman knows, the demand has increased over normal because no new receivers have been manufactured since 1942. Therefore, 1944 deliveries, averaging about 1,700,000 monthly, have been sufficient to satisfy possibly 30% of the potential demand, not including replacement of inventories.

Throughout 1944 the WPB specifically scheduled civilian tube deliveries by directives. It also directed the interchange between manufacturers of such "MR" production. This program will now be discontinued. Only the production for war orders will be specifically controlled by WPB directives. The tube manufacturers may continue to produce tubes for civilian use to the extent that they have capacity over and above war order directives. It is understood that manufacturers will continue to exchange types with one another.

The production capacity available for "MR" in the industry is estimated for the first quarter of 1945 at approximately 15% more than the average monthly sales figure obtained in 1944. Whether this quantity can be obtained depends upon the labor supply and military demands.

The Radio and Radar military program is scheduled to continue at a high level. More and more radio tubes are required

(Continued on page 8)

SYLVANIA TUBES ARE HELPING TO BRING YOUR BOYS BACK SOONER

Those Sylvania Tubes Not On Your Shelves Are Doing A Bigger Job On The Fighting Fronts This Christmas Day.

Those much needed tubes that you could use are overseas guiding a lost pilot to his base, directing the fire of our big guns pounding some far off Pacific atoll. Radio keeps our tanks in close contact with their base of operation and directs the infantry through a maze of thrusts and attacks by means of the "walkie-talkie". Great naval and ground forces move into position relying on radio and radar to give split second accuracy, and lurking submarines are ferreted out through electronic equipment. The entire war machine achieves its striking power through closely knit intercommunications. All of which means that the radio tube is the electronic device that is a major factor in breaking the back of Germany and Japan.

This Christmas, like none other in our time, the peace loving world is in complete unison. We, in the safety of our homes will be thinking of those dear to us who

are scattered over the globe sleeping in fox-holes, mud and filth. They are giving their all for our future security, and are doing it without protest. So, at this time of year when good will toward men personifies the Yule Tide let us think of what those critical type tubes, not in stock, are doing to save a life. We of Sylvania Electric Products feel a warm glow of satisfaction in a job well done, and hope that our effort has helped shorten the conflict.

It hasn't been easy for the civilian radio trade to keep the electronic home front functioning, and to you, our jobbers, dealers and servicemen goes our heart-felt thanks for your splendid cooperation and understanding of a manufacturer restricted by war contracts. Our desire is, of course, to serve you now as in the past, so let us hope that before another Christmas is before us, we are shipping all the tubes you can use.



REMEMBER?

Three Christmases ago—remember! December, 1941. That was the month we "got mad" after Pearl Harbor and bought 341 millions in Series E Defense Bonds; three times the amount we sold during November. That was the year some of the boys still came home from the training camps; that was the year we got our first taste of the war that seemed so very, very far away; something terrible occurring in Europe, in China, in Russia and North Africa. Three years ago and Now!

December 1944. Payroll savings figures show more than 500 millions in Series E War Bonds alone.

Three years of war has brought us up to Christmas 1944 and the eve of a New Year. Today, now is the time to buy and buy and buy War Bonds in still greater quantities until the shear might of America is felt by our enemies.



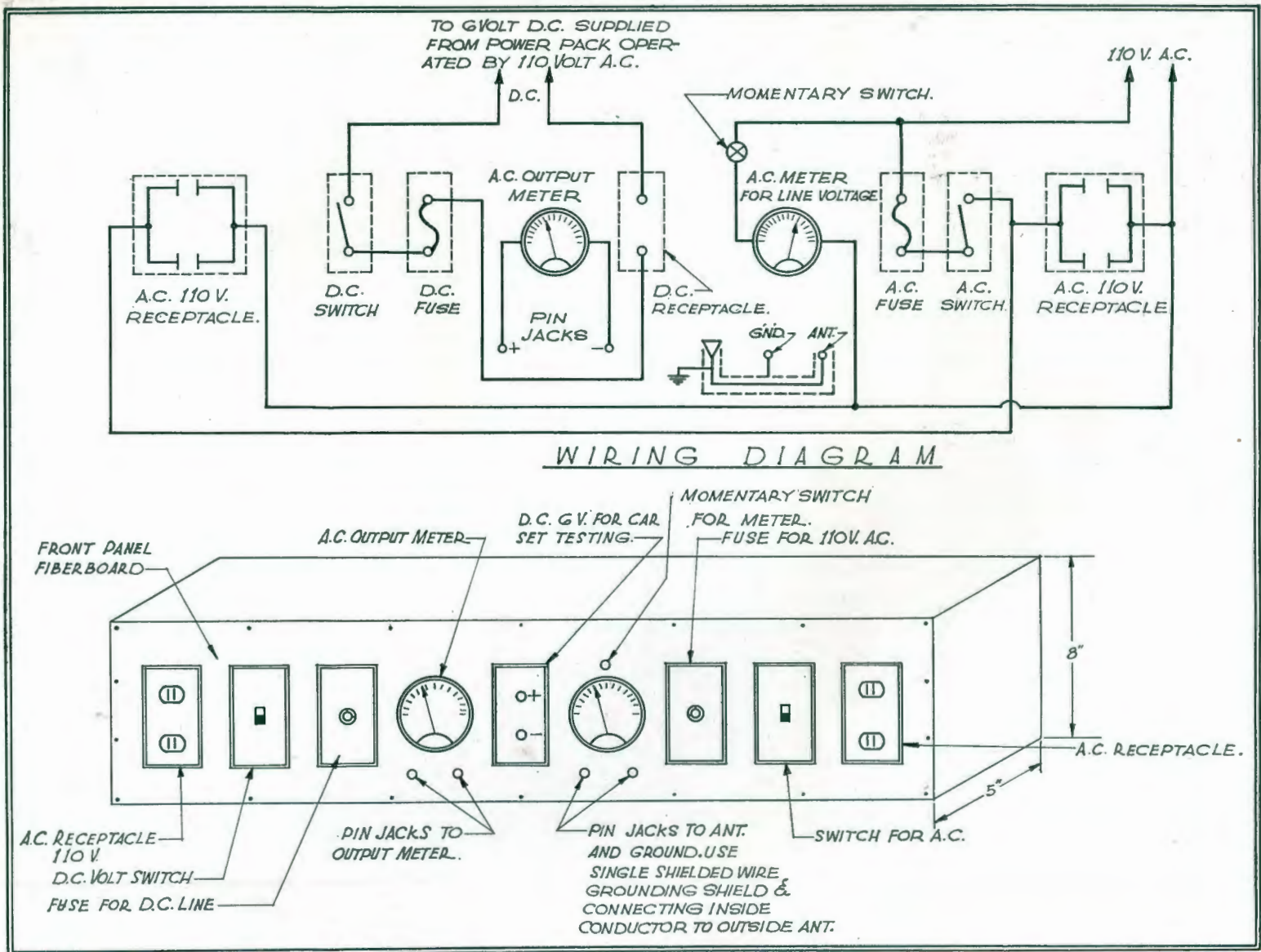

A POWER PANEL FOR YOUR WORKBENCH

To Mr. Philip L. Davidson of 135 Amboy Street, Brooklyn, New York goes the Five Dollar Advertising Material Certificate for his sketch of a power panel. Such a practical idea for the work bench appears to be something that would prove valuable to the busy serviceman.

It is, in general, a flexible idea in that it can be varied to suit the particular needs of the shop. As Mr. Davidson

says: "This panel can be built to fit the individual work bench and other items such as a test speaker, D. C. meter, etc. can be incorporated if the builder desires.

Mr. Davidson goes on to say that "This panel has been a great convenience to me in my radio service work, and I'm sure that many other servicemen will find it worth while building."

HOW ABOUT YOUR IDEA?

A Five Dollar Advertising Material Certificate is yours for one idea that is applicable to the serviceman's shop or workbench.

If your idea is used in subsequent issues of The News, the Certificate will be sent you with Sylvania's "Pennies Folder" to guide your selection of our many useful items.

BOB HENDERSON TELLS A STORY

Bob Henderson, Sylvania Division Manager of the Central Division is well known to the radio tube trade in that area, but of his son Floyd we have heard little until Bob modestly sent us a clipping and letter of the boy's whereabouts and activity.

Home, after completing fifty missions over fortress Europe, Floyd relates stories of encounters with flak, fighter opposition, and near disaster on numerous occasions, but came through it all unscathed, hale and hearty. His citations are many and speak for themselves: the Air Medal and three bronze oak leaf clusters, the European theater of war ribbons with three major battle stars, and a presidential citation.

A side note to the story is a quote from

Bob's letter to us: "Before Floyd left for overseas duty, I gave him a new Sylvania pencil and when he returned from Italy he brought this pencil back and gave it to me as a souvenir. This pencil was used by the radio gunner to write the log on each of the fifty bombing missions Floyd made over enemy territory."

We like to think that more than just lady luck was flying with Floyd on his sojourns over Europe, and that in some small measure Sylvania's electronic tubes gave guidance to this pilot and crew in bringing them back to their home base.

A proud dad is Bob Henderson these days, so give him a hearty hand shake the next time he's out your way.

At right is a picture of Floyd taken upon his return from overseas.





Copyright 1944, Sylvania Electric Products Inc.

December, 1944

EMPORIUM, PENNA.

Vol. 11 No. 7

A BIBLIOGRAPHY OF ARTICLES OF INTEREST TO SERVICEMEN

(Continued from the November Issue)

RECENT ADDITIONS TO LAST MONTH'S BIBLIOGRAPHY

CONSTRUCTION ARTICLES

High Fidelity Speaker for F. M.
W. A. Stocklin, Radio News, Dec. 44, p. 36

Frequency Deviation Meter for Amateurs
R. P. Turner, Radio News, Dec. 44, p. 42

TEST EQUIPMENT

Oscilloscopes: Building or Modernizing your own
A. D. Mayo, Radio News, Dec. 44, p. 48

SERVICING ARTICLES

Substitution Charts: Tube
Radio Service Dealer, November 44, p. 18

Tubes: Repair Process for Burnt Out Radio
Radio Service Dealer, May 44, p. 16

Substitutions for Mica Condensers
Radio Service Dealer, July 44, p. 20

THEORETICAL ARTICLES

Amplifiers: R. F. (for beginners)
Radio Craft, February 43, p. 296

Amplifiers: Audio
Radio Craft, October 44, p. 19
Radio Craft, March 43, p. 360
Radio Craft, April 43, p. 416
Radio Craft, May 43, p. 472
Radio Craft, June 43, p. 538
Radio Craft, November 44, p. 88
Radio & Television Retailing, October 44, p. 66

Amplifiers: Resistance Coupled
C. Radius, Radio, June 43, p. 35

Amplifiers: Push Pull
C. Radius, Radio, August 43, p. 41

Amplifiers: Class C
C. Van Rensselaer, Radio, December 43, p. 30
C. Van Rensselaer, Radio, January 44, p. 33

Amplifiers: Modulating Class C
M. D. Post, Radio News, December 44, p. 38

Amplifiers: Transformer Coupled
C. Radius, Radio, July 43, p. 32

Amplifiers: Wide Band
E. M. Noll, Radio, July 43, p. 23
E. M. Noll, Radio, September 43, p. 37
E. J. Bukstein, Radio News, August 43, p. 21

Antenna Coupling and Switching Methods
M. E. Heller, Service, March 44, p. 10
M. E. Heller, Service, April 44, p. 14

Antenna: The Dispersion
H. W. Kline, Radio News, December 44, p. 28

Bass Boost Circuits: Fundamental
W. Moody, Radio News, November 43, p. 48

Bias Circuits: An Analyses of Grid
A. A. Ghirardi, Service, December 43, p. 5

Crystals (Rochelle Salt) and their Application
R. S. Sawdey, Jr., Radio, September 43, p. 23
R. S. Sawdey, Jr., Radio, October 43, p. 32

Cathode Ray Tubes and How They Work
N. Rhita, Radio Craft, July 44, p. 604

Carrier Communication
W. Muller, Radio Craft, March 43, p. 346
W. Muller, Radio Craft, March 43, p. 475

Detector Operation
Radio Retailing Today I, February 44, p. 60
Radio & Television Retailing II, June 44, p. 64
A. Moore, Service, October 44, p. 11

Detector: Improving the Diode
G. A. Hay, Radio Craft, August 43, p. 663

Dielectrics for Radio & Electronic Applications
A. C. Matthews, Radio, November 43, p. 27

Discharge Tubes: Fundamentals of Gas
C. D. Prater, Radio News, May 43, p. 24

Electrolytic Condensers
Robinson & Burnham, Radio, February 44, p. 17

Electronic Devices: Circuits for
S. J. Murcek, Service, November 43, p. 9

We realize that the selection of magazines used in preparing this bibliography may be somewhat arbitrary and that other technical periodicals could—and perhaps should—have been included. However, before making additions to this bibliography, we would appreciate having comments from our readers so that the arrangement, and magazines covered will be most useful to you.

F. M. Discriminator
J. M. Kleinman, Radio Craft, February 44, p. 278

F. M. Receiver Theory
S. J. Thompson, Service, June 43, p. 5
W. P. Bollinger, Radio, February 43, p. 20
Radio, March 43, p. 26
Radio, April 43, p. 20

F. M. Service: Effect of Channel Width on
F. M. & Television, October 44, p. 28

Gas Discharge Tubes: Fundamentals of
C. D. Prater, Radio News, May 43, p. 24

Hearing Aid Circuits and Data
I. Queen, Radio Craft, October 44, p. 20

Klystrons
Capt. E. E. Skinner, Radio Craft, October 44, p. 17

Light Modulation System: The German
D. Gifford, Radio, November 43, p. 32

Measuring Radio Frequencies: Methods of
R. P. Turner, Radio News, January 43, p. 6

Measurement of Phase Displacement by Oscilloscope
M. Halzman, Radio, September 43, p. 32

Measurement of High Frequency
J. R. Kearney, Radio Craft, March 43, p. 344

Meter Errors and their Causes
A. Ghirardi, Radio Craft, November 43, p. 76
A. Ghirardi, Radio Craft, December 43, p. 142
A. Ghirardi, Radio Craft, January 44, p. 206

Microphones and How to Use them
W. Moody, Radio News, January 43, p. 38
I. Queen, Radio Craft, September 44, p. 723

Microscope: The Electron
E. Leslie, Radio Craft, September 44, p. 728

Neutralization
C. Radius, Radio, March 43, p. 32

Nomographs: Theory and Application of
R. G. Middleton, Radio, November 43, p. 42
R. G. Middleton, Radio, December 43, p. 36
R. G. Middleton, Radio, January 44, p. 36

Oscillator Circuits: Crystal Controlled
J. Anlage, Radio, April 44, p. 25

Oscillator and How it Works
R. F. Scott, Radio Craft, December 43, p. 144
R. F. Scott, Radio Craft, January 44, p. 208
M. D. Post, Radio News, May 44, p. 35

Oscillator Frequency Stability
A. C. Matthews, Radio, December 43, p. 26

Oscillograph Sweep Circuits
Radio Retailing Today, April 44, p. 54

Permeability Tuning: Incremental
Radio, October 44, p. 31

Phonograph Pick-Ups: Crystal
R. Dally, Radio, September 44, p. 38

Photoelectric Phenomena
C. D. Prater, Radio News, July 43, p. 26

Power Supply Systems: Constant Voltage
M. Glaser & E. Glaser, Service, May 44, p. 7

Practical Electronics: Course in
F. Shunaman, Radio Craft, Monthly starting April 44

Practical Radio Course
A. Ghirardi, Radio News, Monthly

R. F. Input Circuits: Analysis of
A. Ghirardi, Service, April 43, p. 5

R. F. Power for Heating Wood
J. P. Taylor, Radio, January 43, p. 23

Radio Tube Numbering System: Explanation of the
Sylvania News, July 44

Resistors and their Behavior
A. P. Howard, Radio, July 44, p. 27
A. P. Howard, Radio, August 44, p. 30

Rectifiers: Controlled
S. J. Murcek, Service, October 43, p. 9

Resonant Impedance Transforming Networks: Geometric Solutions for
R. C. Paine, Radio, October 43, p. 36

(Continued on page 4)

A BIBLIOGRAPHY OF ARTICLES OF INTEREST TO SERVICEMEN

- Resistance Capacity Networks, Graphical Solution of
M. C. Jones, Radio, November 43, p. 35
- Sound Conditioning for Homes
F. M. and Television, October 44, p. 30
- Superheterodynes and How they Work (for beginners)
Radio Craft, March 43, p. 356
- Supersonic Waves
A. Quirk, Radio, May 44, p. 32
- R. F. Yates, Radio Craft, August 44, p. 661
- Timing and Delay Circuits
R. P. Turner, Radio News, August 43, p. 32
- Tuning Devices: A Study of Automatic
A. A. Ghirardi, Service, May 43, p. 5
- Tube Symbols
C. E. Winter, Radio Craft, August 44, p. 673
- Tube Types: Factors Involved in Choosing Radio
A. C. Matthews, Radio, May 44, p. 29
- A. C. Matthews, Radio, June 44, p. 32
- A. C. Matthews, Radio, July 44, p. 38

- Tubes: Fundamentals of Vacuum
A. Ghirardi, Radio News, January 43, p. 30
- A. D. Prater, Radio News, March 43, p. 14
- Tube Plate and Screen Dissipation Ratings
Sylvania News, January-February 43
- Sylvania Radio Tube Hints, Vol. 1, p. 38
- Tube Design Features: Converter
R. L. Stewart, Service, September 44, p. 9
- Sylvania News, March 43
- Sylvania Radio Tube Hints, Vol. 1, p. 5
- Tubes: Constructional Features of Vacuum
Sylvania News, December 43
- Tubes: 28 Volt Operation of Receiving
Sylvania News, November 43
- D. Gnessin, Radio Craft, June 44, p. 540
- Tube Manufacturing: Chemical Highlights of
Sylvania News, February-March 44
- Tubes: Electron Ray (for beginners)
Radio Craft, May 43, p. 486
- Tube Capacities: Explanation of
H. B. Michaelson, Radio Craft, November 43, p. 82

- Tube Operation: Tetrode and Pentode
C. Radius, Radio, February 43, p. 32
- U. H. F. Theory and Application of (Course in)
M. S. Kiver, Radio News, Monthly starting January 44
- Voltage Doubler Circuits
J. King, Radio Craft, September 44, p. 733
- Voltage Dividers: How to Design
Radio Craft, December 43, p. 164
- Voltage Booster: Use of Type 28DT as a
Sylvania News, January 44
- Radio, March 44, p. 30
- D. Gnessin, Radio Craft, August 44, p. 670
- Sylvania News Letter No. 77 and 78
- Volume Expansion
G. E. Otis, Radio, August 43, p. 30
- Radio, April 44, p. 10
- Wave Analyzers: Theory of
R. D. Turner, Radio News, October 44, p. 44
- Wax Impregnation of UHF Coils
S. Young White, Radio, November 43, p. 38

MEASURING INDUCTANCE WITH R-C BRIDGE

As this issue is being prepared it is a little too early for many comments to have been received on the R-C bridge described in Oct. issue. A few favorable comments have been received, however, one of which suggested that the bridge would be much more useful if it could also be used for measuring inductance.

As a matter of fact, it can be used for this. This was realized when it was designed but no reference was made to this fact in the article for two reasons. First, we did not think servicemen would have many inductances to read in the range that could be covered by the 60 cycle supply and second, where can the necessary standard inductance be obtained? Due to the low frequency, the lower limit of inductance measurements would be about one millihenry with no upper limit within the range of probable inductance values. This will limit its usefulness to the measurement of filter chokes and the usual R-F chokes. It cannot be used to read inductance of any ordinary coils used in tuned circuits.

With these limitations in mind those of you who wish to use the bridge this way should proceed as follows: Use additional points on switch S1 for the standard inductances you wish to include and connect the other sides the same as an additional standard resistance. Using the same ratios as before, the standard values should be 10 millihenry, 1 henry and 100 henry but this last value is impractical. If the decimal values above cannot be readily obtained, we would suggest just adding two binding posts for the standard value available and using a multiplying factor. For example, if the best R-F choke you have for a standard is 60 mh. and on measuring an unknown value you get balance on the bridge at .34, then the answer is $60 \times .34 = 20.4$ millihenries.

(Continued on page 5)

TYPE 1AB5

Lock-In Remote Cutoff Filament Type R-F Pentode

CIRCUIT APPLICATION

Sylvania Type 1AB5 is a filament type pentode intended for use as a mixer or r-f amplifier in circuits requiring a tube of greater mutual conductance than the 1LN5. It is particularly designed for use at frequencies of 50Mc. and higher, this combination of characteristics resulting in a higher effective input resistance at these frequencies.

The unusual filament voltage is to allow three tubes of this type to be used in series with a 4½ volt battery and a fixed (or ballast) resistor. They must not be used on a 1½ volt filament supply without a dropping resistor.

PHYSICAL SPECIFICATIONS

Style	Lock-In
Base	Lock-In 8-Pin
Bulb	Short T-9
Diameter	1¼" Max.
Overall Length	2½" Max.
Seated Height	1½" Max.

BASE PIN CONNECTIONS

Pin 1	Filament
Pin 2	Plate
Pin 3	No. 2 Grid
Pin 4	No Connection
Pin 5	No Connection
Pin 6	No. 1 Grid
Pin 7	No. 3 Grid & -Fil.
Pin 8	-Fil. & No. 3 Grid
RMA Basing	5 BF-L-O

RATINGS AND CHARACTERISTICS

Filament Voltage (dc)	1.2 Volts
Filament Current	0.130 Ampere

Maximum Plate Voltage	150 Volts
Maximum Screen Supply Voltage	150 Volts
Maximum Screen Voltage	150 Volts
Maximum Plate Dissipation	1.0 Watt
Maximum Screen Dissipation	0.3 Watt
Minimum External Control Grid Bias Voltage	0 Volt

Direct Interelectrode Capacitances:*

Grid-Plate	0.25 µmf. Max.
Input	2.80 µmf.
Output	4.2 µmf.

With 1¼ diameter shield (RMA Standard M8-308) connected to negative filament.

TYPICAL OPERATING CONDITIONS AND CHARACTERISTICS

Filament Voltage (dc)	1.2	1.2 Volts
Filament Current	0.130	0.130 Ampere
Plate Voltage	90	150 Volts
Screen Voltage	90	150 Volts
Grid Voltage	+0	-1.5 Volts
Plate Current	3.5	6.8 Ma.
Screen Current	0.8	2.0 Ma.
Transconductance	1100	1350 µmhos
Plate Resistance	0.275	0.125 Megohms
Grid Voltage for 10 µmhos		
Transconductance	-14	-23 Volts
Grid Voltage for 725 µmhos		
Transconductance	-3	-6 Volts

*Rg1 should be 1 megohm minimum under conditions of zero bias.

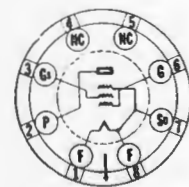

5-BF

Tube and Base Diagram Viewed from Bottom of Base

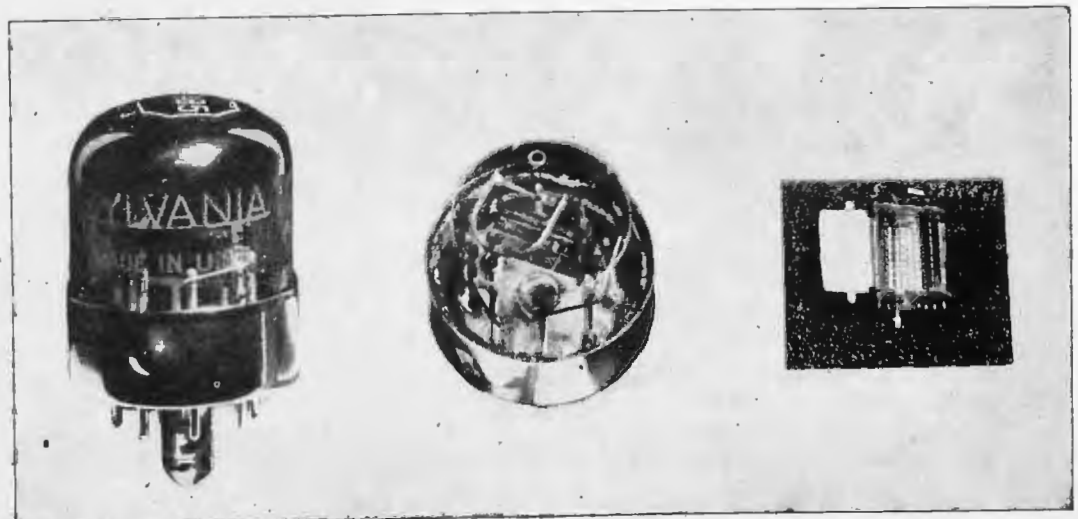

MEASURING INDUCTANCE WITH R-C BRIDGE

In measuring filter chokes having an iron core, another source of error is introduced. Filter chokes of good design are rated for inductance with normal D-C flowing but such a measurement is not practical outside a laboratory. An error is introduced because chokes of different manufacture or design do not have the same relation between inductance with normal D. C. flow and inductance with no D. C. flowing. It may give a rough comparison suitable for picking out "brute force" filter chokes but should not be relied on where resonance is used to get the lowest possible hum level.

(Continued on page 6)

TYPE 3LF4 LOCK-IN BEAM POWER AMPLIFIER

PHYSICAL SPECIFICATIONS

Style	Lock-In
Base	Lock-In 8-Pin
Bulb	T-9
Diameter	1 1/4" Max.
Overall Length	2 1/2" Max.
Seated Height	2 1/4" Max.
Mounting Position	Any

BASE PIN CONNECTIONS

Pin 1	Filament
Pin 2	Plate
Pin 3	No. 2 Grid
Pin 5	No Connection
Pin 6	No. 1 Grid
Pin 7	Filament C.T. & B.P.
Pin 8	-Filament
RMA Basing	No. 6BB-L-O

RATINGS AND CHARACTERISTICS

	Series* Filament	Parallel** Filament
Maximum Filament Voltage		
Dry Battery Operation— Voltage must never exceed	3.2	1.6 Volts
AC-DC Power Line Operation— Design Center	2.6	1.3 Volts
Maximum Plate Voltage	110	110 Volts
Maximum Screen Voltage	110	110 Volts
Maximum Cathode Current (Zero Signal)	6*	12 mA.

OPERATING CONDITIONS AND CHARACTERISTICS

Amplifier Class A₁

	Series* Filament	Parallel** Filament	
Filament Voltage	2.8 dc	1.4 dc	1.4 dc Volts
Filament Current	0.050	0.100	0.100 Ampere
Plate Voltage	90	85	90 Volts
Screen Voltage	90	85	90 Volts
Grid Voltage	-4.5	-5	-4.5 Volts
Peak A-F Signal Voltage	4.5	5.0	4.5 Volts
Plate Current	8.0	7.0	9.5 mA.
Screen Current (Nominal)	1.0	0.8	1.3 mA.
Plate Resistance (Approx.)	80,000	70,000	90,000 Ohms
Mutual Conductance	2,000	1,950	2,200 μmhos
Load Resistance	8,000	9,000	8,000 Ohms
Total Harmonic Distortion	8.5	5.5	6.0 Percent
Power Output	230	250	270 Milliwatts

*A resistor of 270 ohms must be used in parallel with the negative section of the filament (pins 7 & 8) in order to insure that the value of 6.0 ma. total cathode current for each 1.4 volt section of the filament is not exceeded.

**For parallel filament operation connect pins No. 1 and No. 8 to positive voltage supply and pin No. 7 to negative voltage supply.

CIRCUIT APPLICATION

Sylvania Type 3LF4 is a Lock-In beam power amplifier having electrical characteristics identical to Type 3Q5GT. This type is economical of battery power because of the low filament and plate currents for the large power output available. In series operation note the use of a shunting resistor on the negative half of the filament to equalize the current in the two sections of the filament.

TYPE 6AK5 R-E Pentode

CIRCUIT APPLICATION

Sylvania Type 6AK5 is a miniature sharp cut-off r-f pentode in the short bulb, and is designed for use in ultra high frequency equipment. Its small size and high efficiency make it particularly useful in any compact, light weight portable equipment requiring a cathode type pentode.

PHYSICAL SPECIFICATIONS

Style	Miniature
Bulb	T-5 1/2
Diameter	3/4" Max.
Overall Length	1 1/4" Max.
Seated Height	1 1/2" Max.
Mounting Position	Any

BASE PIN CONNECTIONS

Pin 1	Control Grid
Pin 2	Cathode & G3
Pin 3	Heater
Pin 4	Heater
Pin 5	Plate
Pin 6	Screen Grid
Pin 7	Cathode & G3
RMA Basing	7BD-0-0

RATINGS AND CHARACTERISTICS

Heater Voltage	6.3 Volts
Heater Current	175 Ampere
Maximum Plate Voltage	180 Volts

Maximum Screen Voltage	140 Volts
Maximum Plate Dissipation	1.7 Watts
Maximum Screen Dissipation	0.5 Watt
Maximum Cathode Current	12 Ma.
Maximum Heater-Cathode Voltage	90 Volts

Direct Interelectrode Capacitances:*

Grid to Plate	0.01 μf.
Input	3.9 μf.
Output	2.85 μf.

*With 3/4" diameter shield (RMA Std.) connected to cathode.

OPERATING CONDITIONS AND CHARACTERISTICS

Plate Voltage	120	150	180 Volts
Screen Voltage	120	140	120 Volts
Cathode-Bias Resistor	200	330	200 Ohms
Plate Current	7.5	7.0	7.7 Ma.
Screen Current	2.5	2.2	2.4 Ma.
Transconductance	5000	4300	5100 Micromhos
Plate Resistance	0.34	0.42	0.69 Megohms
Plate Current Cutoff (Approx.)	-6.0	-6.5	-6.5 Volts

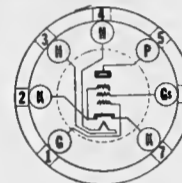

7-BD

Tube and Base Diagram
Viewed from Bottom of Base

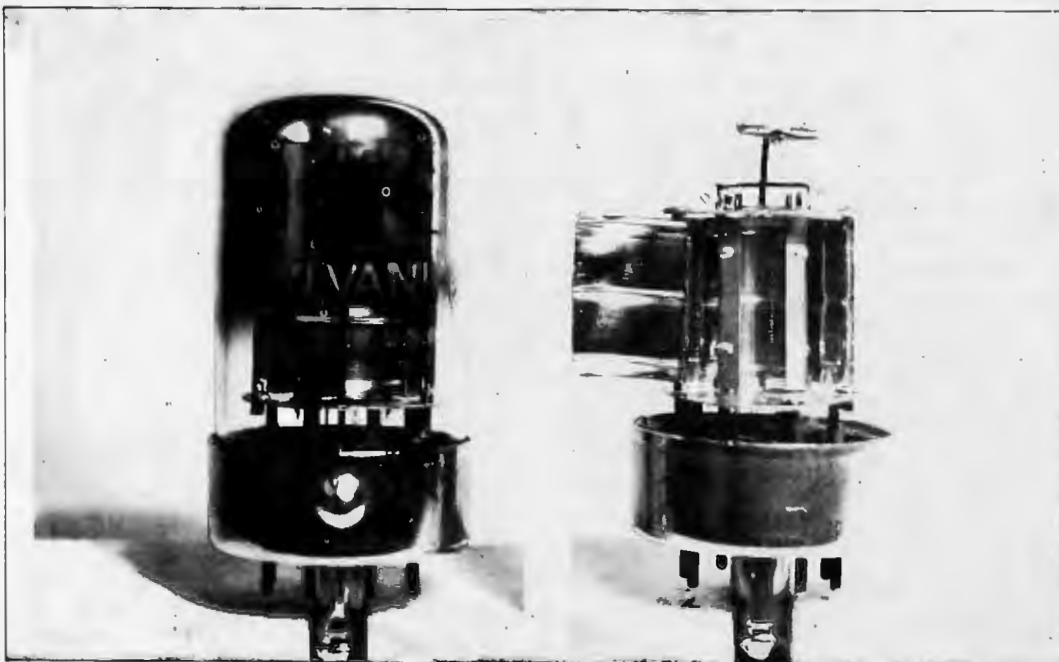
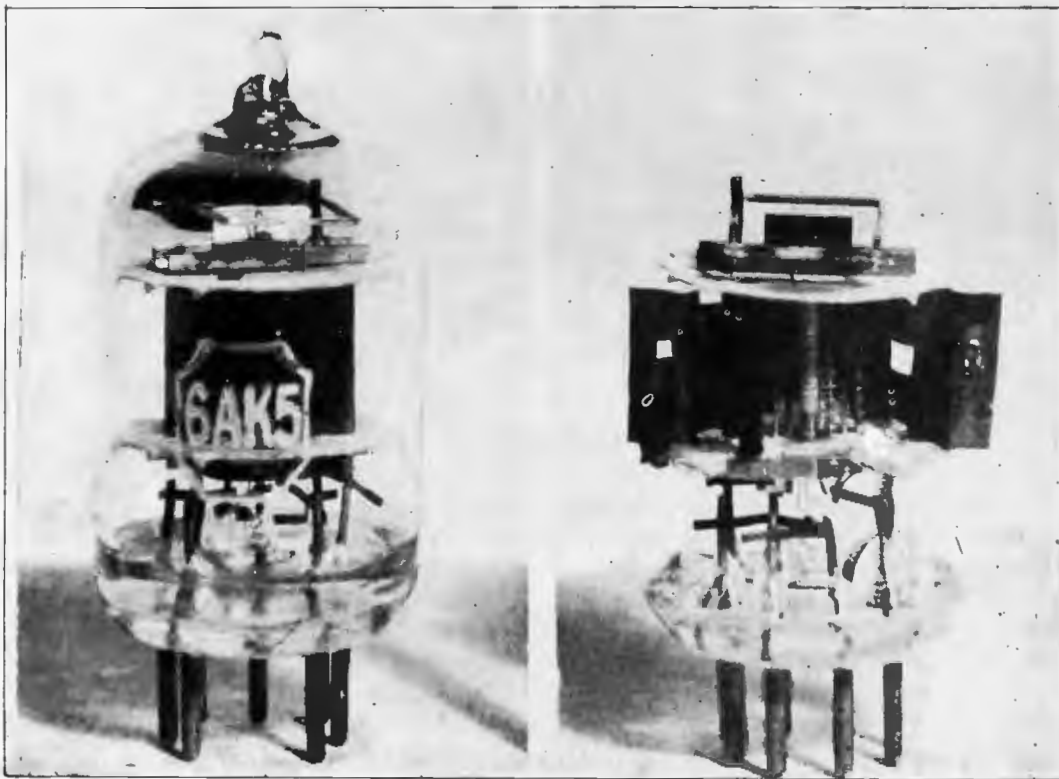

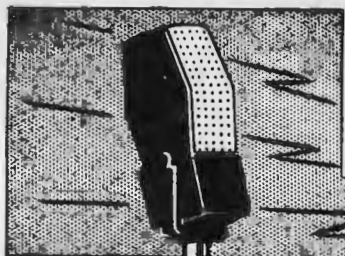

THE information presented in the Sylvania Service Exchange is contributed by servicemen as the result of practical experience. It is very carefully considered before being accepted, and we believe it to be correct and authentic. However, we assume no responsibility for results. Please do not send routine or generally known information.

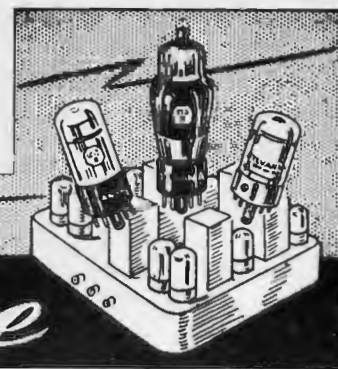

THE

Service Exchange

Philco AR-10 Auto Radio. Intermittent reception in this model may be caused by a defective .004 mfd. condenser (#33) which is connected from the grid of the 7C6 second detector to the volume control.—OK Radio Service, Dover, Pa.

* * *

Grunow 11G Noisy Reception. I have found that in several of this particular model a sporadic noise exists which is very difficult to locate. The noise is especially bad when the 6A8 converter tube is tapped, which would seem to indicate a defective tube. When several new tubes are tried and the trouble persists, replace the socket with a molded type and the noise will be cleared up. It seems that some of the wafer type sockets used in this set are held together by two rivets, and after some time they become conductive sufficiently to partially ground the oscillator grid and other elements through the rivets, thus resulting in erratic and noisy operation.

A similar noise in this set can also come from the r-f transformer. Examine this transformer carefully for indications of electrolysis, which corrodes the winding (primary) and causes the raspy reception. Replace with new coil, or remove old primary winding from coil, carefully clean and rewind with same size wire as removed. A coating of coil dope over and inside the coil will prevent recurrence of the trouble.—Arthur L. Johnson, Hutchinson, Kansas.

* * *

Crosley Models 62TA Chassis 37. I have found in several of these sets that when distortion occurs after a few minutes operation, it is usually caused by leakage between the windings of the 1st I-F transformer, due to heat from the 35Z5 tube located next to it. The best remedy is to replace with a new transformer, but if none is obtainable, remove the coil from the can and coat with several layers of high-Q coil dope. Replace coil, and around the outside of the can, fasten a strip of asbestos with service cement. Allow the set to warm up for a few minutes, realign the I-F's carefully, and the trouble will be permanently eliminated. I have tried several different ways to remedy this trouble, but have found that the above described procedure is best for a permanent and satisfactory repair.—Arthur L. Johnson, Hutchinson, Kansas.

In those cases where the only available substitute tube for use in a 150 Ma. series string is a 300 Ma. type. I have found that a 40-watt bulb in series with the substitute will give the proper operating temperature. The original series string should be corrected by placing a resistor in place of the defective heater. A very neat way to use this lamp without releasing additional heat in the radio chassis is to place it in a small reading lamp which may rest on or beside the radio. Of course, the lamp cord will be connected inside the radio and will operate only when it is on.—Glenn Seaton, Cleveland, Ohio.

* * *

Intermittent Oscillation of 12SK7 I-F Amplifier tube was caused by poor connection between metal shell and #1 pin. Tube tested OK so I put a metal shield (type used on GT bantam tubes) over 12SK7 scraping the metal base if necessary to get a good contact and soldered a lead from the shield to chassis (or B- if chassis is above ground).—Al Santmier, Jr., Dolgeville, N. Y.

* * *

Many times in aligning sets, it is difficult to clip the output meter lead to either the voice coil or to the plate connection of the output tube and still leave the I-F and R-F trimmers readily available. In this case, and also when the clip insists on jumping off the terminal, I use the analyzer plug on my set tester with the output tube in the analyzer. This makes all the terminals available on the pin jacks of the analyzer and since they are numbered there is no reason to get the wrong terminals.—I. Plotkin, Washington, D. C.

* * *

Substitute for 1A7G. I have found that Type 3A8GT may be substituted for Types 1A7GT or 1A7G. This is done by removing the leads connected to pin No. 2 to pin No. 1. If any leads are on No. 1 or No. 8 they are tie points only and must be removed. Connect No. 2 to No. 7. In series circuits it is necessary to clear pins 1 and 8 only and make provision for the additional voltage.—James Reese, Griffin, Ga.

Editor's Note: The filament drain will be increased by 50 ma. on 1.5 volt service.

In servicing AC-DC sets with hot chassis, I have found it difficult to align the sets with my A-C operated signal generator since both sides of the line of the signal generator are bypassed to ground.

One way to get around this is to use the loop from an old battery receiver. This loop has two windings, one of many turns used for the tuned aerial circuit and the other of only a few turns for use with an external antenna and ground. The signal generator is connected to the ends of the loop aerial and the whole thing is placed close to the set to be aligned.

The loop may also be connected as an R-F transformer with the signal generator connected to the coil having only a few turns. Either method saves a lot of time in the alignment of this type of receiver.—I. Plotkin, Washington, D. C.

* * *

G. E. Model L-641 (1942), In this model the 1000-ohm $\frac{1}{2}$ watt filtering resistor in the plate circuit of the 6SK7 I-F tube seems to gradually change its resistance. Eventually this will be shown by an odd type of whistle after the set has been operating for a while. I replace with a 1 or 2 watt resistor.—Ralph M. Johanns, Buffalo, New York.

* * *

Inoperative AC-DC Sets. When testing receivers containing 25Z5 tubes in which all tubes light but no signal, look at 25Z5 tube first. If this tube shows one heater a little brighter than the other heater, disconnect both filter condensers. One will be shorted and the other will not last long. Put in two new filters before trying another 25Z5 tube in set. It will be found that one side of 25Z5 tube is dead, due to shorted filter. If filters are not replaced first before putting in new tube, it will pop one side of tube the instant the current is turned on, every time.—Dan F. Taylor, Hudson, Mass.

MEASURING INDUCTANCE WITH R-C BRIDGE

(Continued from page 5)

The effect of D-C resistance in the choke winding has the same effect on the balance as leakage in a condenser and it is similarly necessary to change the "eye adjust" setting in order to get a chart indication of the null point on inductances having a low Q.

SYLVANIA'S NAME IS PROMINENTLY DISPLAYED AT SPANISH EXPOSITION

Sylvania's name was prominently displayed at the International Supply Fair held at the U. S. A. Hall in Barcelona, Spain. The firm of Vivo, Vidal and Balasch, distributors of many leading American products in the electronic, electrical, and appliance field, have represented Sylvania Electric Products Inc. for several years throughout Barcelona and environs.

With the vast improvements that have occurred in electronics and lighting since the outset of the present conflict, Sylvania's varied electrical devices will find an every growing acceptance in war ravaged Europe. The phrase "Sight, Sound, Sylvania" will be synonymous with the vast reconstruction that lies ahead.



RADIO HEADS LIST OF HOUSEHOLD APPLIANCES IN NEED OF REPAIR

W.P.B. Survey Reveals 15% Of All Radios Are Not In Working Order

The Office of Civilian Requirements, War Production Board has issued figures on repair status, age and quantity in domestic uses of twenty-three household appliances. Among these radios stood at the top of the list for items in need of repair.

Results are based on replies from over four thousand five hundred households, geographically and economically representative of the nation as a whole. In homes having one or more sets, figures reveal that eight percent of this group are completely without reception.

An estimated number of home radios, forty-six million appears to be a close estimate. Of this amount eighty-five percent are in working order, twenty-eight percent have needed some sort of repair since January 1. More than half reported that they had no difficulty in obtaining

repairs, and further figures reveal that over fifty percent of the sets are five or more years old.

A breakdown of the figures is as follows:

1. Radios (excluding auto)—46,275,528
2. Percentages of sets that are less than one year old and over five;
 - less than 1 year..... 1.0%
 - 1 year..... 3.6%
 - 2 years..... 11.6%
 - 3 years..... 16.8%
 - 4 years..... 15.0%
 - 5 or more years..... 52.0%
3. Percentage of sets in working order—85%
4. Percentage of sets out of working order—15%
5. Percentage of Households with one or more radios, but none in working order—8%

HARD HITTING DALE SALESMAN IS NOW HITTING JAPS

To our attention has come the whereabouts of Bob Tremaine, formerly of Dale Distributing Co. Inc. of New York City, and now getting in his swats at the Nips.

Since leaving the "big city", Bob has served eleven months in the Pacific as p.f.c. in the anti-aircraft battalion, and from the accompanying snapshot, he appears to be thriving on his new surroundings.

Always on the lookout for new post-war customers, Bob is making friends with the local inhabitants and in his letter says: "I think I've found a dealer for Sylvania tubes. It ain't gonna be easy 'cause the natives don't speak 'Brooklyn English', but I'll do my best."

Those who know Bob and his fine sales ability hope to see him back "in harness" in the near future selling Sylvania tubes by the carload to his many Dale Distributing customers.



POST WAR ELECTRONIC PRODUCTION FIGURES ESTIMATED AT A BILLION DOLLARS ANNUALLY

Figures compiled by George S. Armstrong & Co., 52 Wall Street, New York, industrial engineers and management consultants, shows that the dollar volume of production by the electronic industry on a wholesale basis may reach and even exceed \$1,000,000,000 annually after the war, or more than three times the pre-war figure. Huge post-war contracts may push the output as high as four billion to fulfill the heavy expected civilian demands.

With the many new applications uncovered through the present war needs, electronics will be invaluable in curing synthetic resins for use in plastic materials, and to dehydrate food instantaneously; radio frequency heating will be used to make tin plate also.

In the field of transportation, radar will be used to aid marine navigation, and improved safety devices will assist railways. Intercommunication between police cars, and various uses of the "walkie-talkie" are other outgrowths of new electronic discoveries.

All of which means that the future of the electronic technician in maintaining and repairing the many electronic devices to be used in industry opens a lucrative and comparatively new field with ever increasing possibilities. Servicemen who are anxious to expand their scope of operations in the electronic field, would do well to lay the ground work now through extensive investigation and study of electronics in its advanced and intricate use.

SHOP OF THE MONTH



On October first, of this year Radio Laboratory of 704-706 North Washington Avenue, Scranton, Pennsylvania celebrated its tenth anniversary in the radio dealer and servicing business.

From its inception Radio Laboratory has used radio repair as its forte with from three to four thousand sets being repaired yearly. Under the able supervision of Mr. Stanley A. Mol, chief mechanic, and Mr. B. Kerrigan, his assistant, the service department manages to turn out the work even with the shortage of critical replacement parts. Excellent cabinet refinishing is another feature of the radio service department;

here the cabinet is sanded, scraped for mars, and refinished in stain and polish by Mr. Frank Kulesa. The customers have come to know Radio Laboratory as not only a fine service shop, but one capable of superior cabinet finishing.

In the ten year span, Mr. Julius Gerson, proprietor of the store, has gradually built and expanded Radio Laboratory into a well rounded organization that, today handles records, phonographs, combination and console sets, (pre-war, of course) needles, and sheet music.

With the non-existence of civilian radio production, Radio Laboratory is

finding a ready market for reconditioned sets, and car radios converted to home use according to O.P.A. ruling number 430. With Radio Laboratory's reputation and name backing every set purchased, Mr. Gerson makes certain that the best of workmanship and available parts go into this work.

1944 REPLACEMENT TUBE SALES SLIGHTLY EXCEED PREVIOUS YEAR

(Continued from page 1)

to meet the demand for original equipment and replacement for our forces and for our allies. A labor shortage, principally female, is still a bottleneck in radio tube production.

WPB, in a recent statement, estimated that after victory in Europe, only a slight reduction in military tube requirements can be expected. Production of tubes for civilian replacement may be increased, possibly doubled, within four months after "Victory in Europe" Day. Even so, the replacement demand will not be satisfied until months after the defeat of Germany and Japan.

This means that radio servicemen can look forward to a continuance of the many wartime expedients, such as using available substitute tubes with adaptors, or rewiring sockets, for several months to come.

It is likely that, although the shortage is now general throughout the line, some numbers will be available in adequate quantities sooner than others. "MR" production will be centered as far as possible in the important demand types. Releases of surplus stock through the Defense Supplies Corporation disposal plan will be helpful, although the quantities made available for replacement use have been very limited to date.

Sylvania will continue its policy of allocating all available tubes among its customers on a pro rata basis, to provide the most equitable distribution. Sylvania distributors are encouraged to allocate to their customers on a similar basis.

Sec. 562, P. L. & R.
U. S. POSTAGE
PAID
Emporium, Pa.
Permit No. 1

Mr. Granville W. Arnold
139 Main St.
Emmaus, Pa.

POSTMASTER: If addressee has moved, notify sender on Form 3547, postage for which is guaranteed. When Form 3547 is sent, abandon this mailing. Return only if no correct address is available.

Published By
SYLVANIA ELECTRIC PRODUCTS INC.
Manufacturers of Sylvania Radio Tubes and Electronics Devices, Sylvania Incandescent Lamp Bulbs, Fluorescent Lamps and Equipment.
RICHARD G. MACKAY Editor
W. R. JONES Associate Technical Editor

SYLVANIA
ELECTRIC PRODUCTS INC.
Post Office Box 431
EMPORIUM, PA.
Return Postage Guaranteed

Your Copy of
SYLVANIA NEWS
DECEMBER, 1944
Vol. 11 - No. 7

