

PHILCO

TECHREP
DIVISION
BULLETIN



DECEMBER
1952



HOLIDAY

GREETINGS

PHILCO TECHREP DIVISION BULLETIN

Published Monthly by
The TechRep Division of Philco Corporation
Philadelphia, Pennsylvania

TEA-4000

Volume II

DECEMBER, 1952

Number 12

CONTENTS

BULLETIN Binders Now Available	2
Editorial	3
By John E. Remich	
Design and Application of the Pi Network	4
By Wallace L. Cook	
Useful Signal Corps Supply Publications	11
By Calvin R. Graf	
Electronic Computers—Part II	16
By Warren Kitter	
Solution to Last Month's "What's Your Answer?"	19
What's Your Answer?	20
Modification of the ID-73/CPS-1 Plan-12 Indicator	22
By B. L. Kortegaard	
Reference List of Schematic Symbols	23
Control Circuits for Tower Installations	28
By M. M. Elson	
Index for Vol. II—Philco TechRep Division Bulletin	36
In Coming Issues	40

Editor
John E. Remich

Managing Editor
Robert L. Gish

Technical Editors
Curtis L. Frantz
Francis R. Sherman
Gail W. Woodward

EDITORIAL OFFICE:
PHILCO CORPORATION
TECHREP DIVISION
22nd and LEHIGH AVENUE
PHILADELPHIA 32, PA.

If any information contained herein conflicts with a technical order, manual, or other official publication of the U.S. Armed Forces, the information in the official publication should be used.

BULLETIN Binders Now Available

The first shipment of binders for the Philco TechRep Division BULLETIN are now in stock at Headquarters, and all readers who completed the binder-reservation cards (distributed in August) may now obtain your binders by mailing us your check or money order for \$1.50 for each binder desired.

Make your check or money order payable to Philco Corporation, and address it as follows:

Philco Technical Publications Dep't.
18th and Courtland Streets
Philadelphia 40, Penna.

Be sure to mail your order to this address rather than to our Headquarters offices at 22nd St. & Lehigh Ave., because all sales of the binders will be handled through our Publications Dep't. offices.

Be very sure that your name and address are printed or typed plainly on your request, and that you clearly indicate that your request is for the binder. (This is very important, because the above office also handles sales of Philco Training Manuals and other technical publications.)

Those readers who did not return their reservation cards in August may also request binders by sending us their check or money order in the same manner, but those orders for which reservations were previously received will, of course, be filled first.

Editorial

ANOTHER YEAR OF PROGRESS

By John E. Remich, Manager, Technical Department

So much has been accomplished in electronics during the past year, that no really adequate review of our progress as an industry could be set down in fewer than many thousands of words. However, a few highlights are too outstanding to be ignored.

One has only to look at the advertisements in any current electronics periodical to appreciate what has occurred in the past year. For example, only months ago, we were marveling at the fact that printed-circuit techniques had been developed to the point where R-C coupling networks could be fabricated into one small ceramic unit. Now, entire multi-stage printed-circuit amplifiers are widely available, and at least one manufacturer is producing a complete printed-circuit broadcast receiver.

The recent advances in the field of solid-state electronics need no comment here, for they have been discussed on this page before. It suffices to say that the laboratory wonder of last year, the transistor, is the commercially available standard production item of today, with the range of potential applications apparently almost unlimited. Such applications of these new devices include a widely publicized television receiver, designed and tested only weeks ago, in which the entire tube complement was replaced by transistor-type amplifiers and rectifiers.

In the field of miniaturization, equally unbelievable advances have been made. Not only have individual circuit components been drastically reduced in size and weight, but at the same time the ranges of operating voltages, currents, temperatures, and accelerations have been radically increased. Similarly, complete equipments have been redesigned into units weighing but a fraction of the originals, yet with greatly improved characteristics.

Typical of the advances in basic circuitry is the recent announcement by the Office of Naval Research that the phenomenally low noise figure of 2.5 db has been achieved in two new microwave triode amplifiers, each of which operate at 225 mc. with gains of 10 db and bandwidths of 70 mc. Only months ago, such a noise figure was considered almost impossible to achieve.

The most spectacular achievements of the year, of course, fall into the category of classified information. However, the data which is available makes it clear that 1952 has seen tremendous advances all across the board—in control and interception of guided missiles by electronics means, in electronic computers, in nuclear instrumentation, in telemetering, and in a thousand other fields.

Truly, the industry can view its accomplishments in 1952 with great pride and with no little enthusiasm, for they represent the doorway to a whole new world.

DESIGN AND APPLICATION OF THE PI NETWORK

by Wallace L. Cook
Philco Field Engineer

A practical discussion of the Pi network employed as an r-f coupling device between an antenna and the output of a transmitter.

(Editor's Note: In November, 1950, the author of this article delivered a series of lectures on the subject of Pi networks to a group of field engineers at Headquarters. The response was so favorable that Mr. Cook decided to present the subject in article form. We believe that this data is very timely in view of the recent increased emphasis on interference reduction.)

FIELD ENGINEERS as well as radio amateurs are often called upon to correct interference problems that result from excessive harmonic radiation. This problem can be greatly simplified by the intelligent use of the Pi network, which, in addition to other advantages, provides a large value of attenuation of harmonic energy. Furthermore, because of its desirable characteristics, the Pi network has found extensive use in commercial equipment. This makes an understanding of the basic principles very useful to the maintenance technician.

APPLICATIONS AND ADVANTAGES

The Pi network is frequently used to couple a transmitter to an antenna, and it can be used to replace the conventional plate tank circuit so often used in the final stage of a transmitter. When used in the latter manner, the output of the network can be coupled directly to the antenna, or, in the case where the antenna is located remotely from the transmitter, the output of the network can be coupled to the input of the antenna transmission line.

When the plate circuit of the r-f stage is coupled directly into the Pi network,

the network transforms the transmission-line surge impedance (or antenna resistance, whichever the case may be) into an impedance much higher in magnitude, the magnitude being the recommended plate-load impedance for the output tube. When properly adjusted, this load exhibits unity power factor.

The Pi network has several outstanding advantages when substituted for the plate tank circuit. Approximately 40 db of second-harmonic attenuation can be obtained with a network used in this manner; it can be used to match a relatively wide range of impedances while still maintaining the desired operating Q, and no mechanical device for coupling variation is required to vary the loading of the final amplifier.

A Pi network may be inserted in an r-f transmission line that is already properly terminated, solely for the purpose of taking advantage of its ability to afford an enormous degree of harmonic attenuation. When this use of the Pi network is combined with its use in the plate circuit, a total second-harmonic attenuation of 80 to 90 db can easily be obtained. (This value meets the usual requirements.)

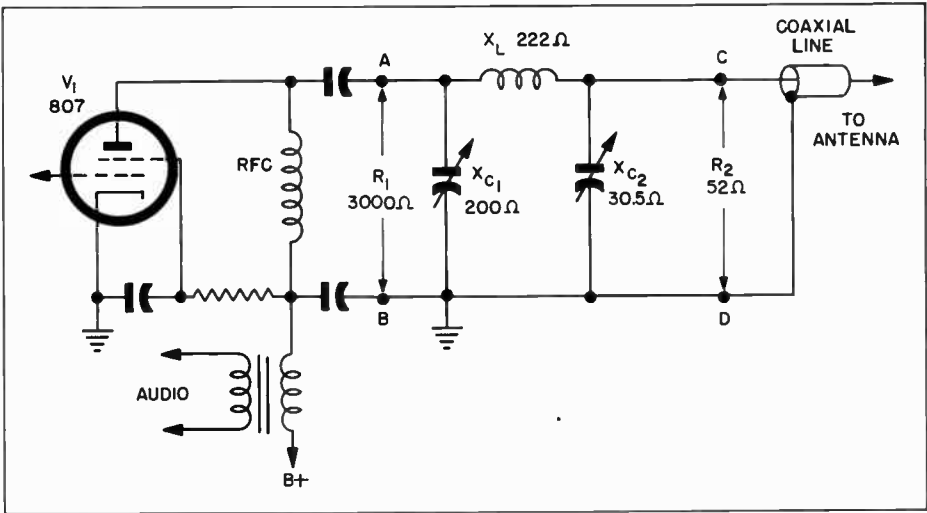

Figure 1. Typical Pi Network

A Pi network can also be employed between the output end of a transmission line and an antenna. Here, in addition to serving as a harmonic attenuator, the network also effects an impedance match between the antenna resistance and the surge impedance of the transmission line. Here, again, a relatively large range of impedances can be matched without disturbing circuit Q, and without employing mechanical methods for producing coupling variations.

THE PROBLEM

Referring to figure 1, suppose it is desired to design a Pi network to couple between an 807 operated as a class-C, plate-modulated r-f stage, and a 52-ohm, concentric, r-f transmission line, as shown in the diagram. The operating frequency of the transmitter is to be 29 mc. A practical step-by-step solution to this problem follows:

CALCULATION OF R_1

In figure 1, R_1 is the impedance between points A and B of the network; this is the impedance the plate circuit of the 807 sees when looking into the network.

The proper plate load impedance for a class-C amplifier can be determined from the following equation:

$$R_1 = \frac{(E_{\text{peak}})^2}{2 \times \text{Eff.} \times I_b \times E_b} \quad (1)$$

where R_1 is the plate load impedance, E_{peak} is the peak plate-voltage swing ($1/2$ the total peak-to-peak plate-voltage swing), Eff. is the plate-circuit efficiency expressed as a fraction, I_b is the d-c plate-current reading, and E_b is the d-c plate-supply voltage.

In normally operated class-C amplifiers, the peak plate-voltage swing (E_{peak}) will range between .85 and .9 times the d-c plate-supply voltage, and the plate-circuit efficiency, Eff., will be between .7 and .8.

For all practical purposes, R_1 may be calculated by the equation:

$$R_1 = R_p / 2 \quad (2)$$

which is simply one half the d-c plate resistance of the tube. Tube-manual data shows that an 807, operated as a plate-modulated, class-C stage, requires a d-c plate voltage of 600 volts, and should draw 100 milliamperes of plate current. The d-c plate resistance in this case will be:

$$R_p = E_b / I_b = 600 / .1 = 6000 \text{ ohms.}$$

Therefore, 3000 ohms will serve as a satisfactory plate-load impedance in this problem.

ABOUT R_2

R_2 is simply the load resistance connected across the output of the network, and all formulas in this article assume R_2 to be a purely resistive component. For satisfactory results, this loading resistance must never be less than R_1/Q^2 . In this problem, R_2 is the surge impedance of the coaxial line, and is 52 ohms.

SELECTING THE PROPER Q

A Pi network may be designed to possess any reasonable Q desired, and in calculating the reactance of the three components, the desired Q of the network must first be determined.

Theoretically, there is no practical limit to the Q of a Pi network designed for use with telegraph transmitters; however, when coupling a voice-modulated wave, heavy distortion of the audio component results if it is attempted to apply and remove power from the circuit at a rate greater than the natural period of buildup and decay of power in the circuit. The Q of a Pi network employed in coupling a voice-modulated wave should be between 12 and 20. A Q of 15 is used in this problem.

CALCULATION OF C_1

C_1 is used in the Pi network for tuning the network to resonance, and the reactance of the capacitor is determined by the formula:

$X_{c1} = R_1/Q = 3000/15 = 200$ ohms. Therefore, in the problem, C_1 must have a reactance of 200 ohms at the operating frequency of the transmitter.

Since C_1 is used to tune the network to resonance, a variable capacitor should be used to provide a means for compensation for any variation in component parts.

$$C_1 = 1/2 \pi F X_{c1}$$

where

F = freq. in c.p.s.

X_{c1} = reactance of C_1 in ohms.

In this case,

$$C_1 = 1/(6.28 \times 2.9 \times 10^7 \times 2 \times 10^2) \\ = 27 \mu\mu\text{f.}$$

Therefore, C_1 must be capable of tuning through 27 $\mu\mu\text{f.}$ for use in this circuit (a value of 50 $\mu\mu\text{f.}$ would be suitable).

C_1 must be able to withstand the maximum, peak, a-c plate voltage developed at the plate of the 807. The plate-input power to the tube will be:

$$W_i = E_b \times I_b = 600 \times .1 = 60 \text{ watts.}$$

Assuming a plate-circuit efficiency of .75, the power output of the stage will be:

$$W_o = W_i \times \text{Eff.} = 60 \times .75 = 45 \text{ watts.}$$

Since approximately 45 watts of unmodulated r-f power will be applied to the input of the network, and the impedance across the input of the network is 3000 ohms, the voltage across C_1 will be:

$$E = \sqrt{WZ} = \sqrt{45 \times 3000} = 367 \text{ volts.}$$

Since this is the r-m-s voltage before modulation, the peak voltage before modulation will be:

$$367 \times 1.414 = 519 \text{ volts.}$$

The peak voltage during 100% amplitude modulation will be:

$$519 \times 2 = 1038 \text{ volts.}$$

This is the maximum peak voltage which will actually be impressed across the input capacitor (C_1) during 100% modulation.

CALCULATION OF C_2

C_2 is used in the Pi network for varying the loading of the final-amplifier stage, and its reactance is determined by the equation:

$$X_{c2} = R_2 \sqrt{R_1/[R_2(Q^2+1) - R_1]} \quad (3)$$

In this case:

$$X_{c2} = 52 \sqrt{3000/[52(15^2+1) - 3000]} \\ = 30.5 \text{ ohms.}$$

Therefore C_2 must possess 30.5-ohms reactance at the operating frequency of the transmitter.

Since C_2 is used to vary the loading

of the stage, a variable capacitor should be used here to permit the loading on the stage to be held at the proper value regardless of variations in component parts.

The capacitance of C_2 is determined by the formula:

$$C_2 = 1/2 \pi F X_{C2}$$

In this case:

$$C_2 = 1/(6.28 \times 2.9 \times 10^7 \times 30.5) = 180 \mu\text{mf.}$$

Since C_2 must be capable of tuning through 180 $\mu\text{mf.}$ for use in this circuit, a 250- $\mu\text{mf.}$ capacitor would be satisfactory.

For calculating the voltage across C_2 , it may be assumed that the 45-watts output of the final stage is reaching the load, R_2 , because the losses in a properly designed Pi network are very small. The r-m-s voltage across the load impedance, without modulation, can be calculated by the formula:

$$E = \sqrt{WZ} = \sqrt{45 \times 52} = 48 \text{ volts.}$$

Therefore, the maximum peak voltage during 100% amplitude modulation will be:

$$E_{\text{peak}} = 48 \times 1.414 \times 2 = 136 \text{ volts.}$$

This is the maximum peak voltage which will actually be impressed across the output capacitor, C_2 .

CALCULATION OF L

The reactance of the inductance is calculated by the formula:

$$X_L = \frac{QR_1 + \left(\frac{R_1 R_2}{X_{C2}} \right)}{Q^2 + 1} \quad (4)$$

In this case:

$$X_L = \frac{(15 \times 3000) + \left(\frac{3000 \times 52}{30.5} \right)}{15^2 + 2} = 222 \text{ ohms.}$$

Therefore, L must possess 222 ohms of reactance at the operating frequency of the transmitter.

The inductance of L is determined

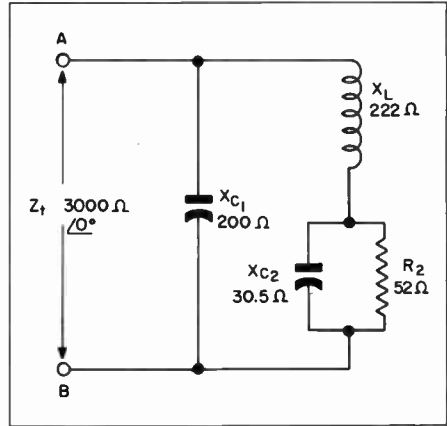

Figure 2. Equivalent Circuit of Pi Network of Figure 1

by the formula:

$$L = X_L / 2 \pi F$$

In this case,

$$L = \frac{222}{6.28 \times 2.9 \times 10^7} = 1.22 \mu\text{h.}$$

A fixed inductor can be used in this problem because the tuning and loading functions are performed by variable capacitors.

PROOF OF IMPEDANCE MATCH

We may check the accuracy of our calculations if we so desire by finding the impedance across the input of the Pi network between points A and B, to see if the plate circuit of the tube actually sees 3000 ohms of pure resistance when looking into the Pi network.

The formula for the impedance across the input of the Pi network can more readily be seen by examining figure 2, the equivalent circuit. The formula for the impedance between points A and B (or Z_L) is:

$$Z_{AB} = \frac{X_{C1} \left(X_L + \frac{R_2 X_{C2}}{R_2 + X_{C2}} \right)}{X_{C1} + X_L + \frac{R_2 X_{C2}}{R_2 + X_{C2}}} \quad (5)$$

In order to calculate the impedance between points A and B, we must, of course, start at the load (R_2) where

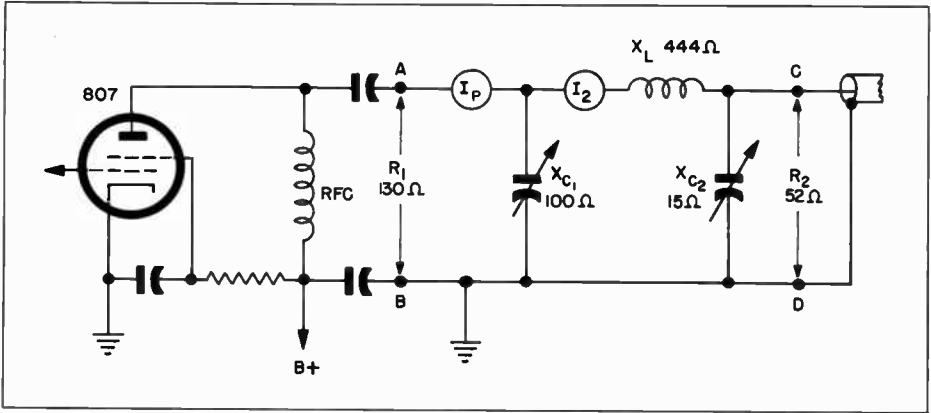

Figure 3. Same Network as in Figure 1, Showing Impedance at Second Harmonic

we have a 30.5-ohm capacitor shunted across a 52-ohm resistor. The impedance of this combination will be:

$$Z_1 = \frac{R_2 X_{C2}}{R_2 + X_{C2}} = \frac{(52/0^\circ)(30.5/-90^\circ)}{52 - j30.5} = \frac{1586/-90^\circ}{60.3/-30.4^\circ} = 26.3/59.6^\circ = 26.3(\cos 59.6^\circ - j\sin 59.6^\circ) = 13.3 - j22.88 \text{ ohms.}$$

This impedance of this parallel combination (Z_1) is in series with the inductance, and therefore must be added to the inductive reactance, which gives us:

$$Z_2 = 13.3 - j22.88 + (0 + j222) = 13.3 + j199.12/+86.2^\circ$$

This impedance (Z_2) is in parallel with the input capacitor, so that the impedance between points A and B of figure 2 will be:

$$Z_t = \frac{(199.12/+86.2^\circ)(200/-90^\circ)}{(13.3 + j199.12) + (0 - j200)} = \frac{39824/-3.8^\circ}{13.3 - j.88} = \frac{39824/-3.8^\circ}{13.3/-3.8^\circ} = 3000/0^\circ \text{ ohms.}$$

HARMONIC ATTENUATION

By making a few simple calculations, we may go a step further in our problem and determine the amount of second-harmonic attenuation obtained by the use of the Pi network.

Figure 3 represents the circuit as it looks to the second harmonic. Since capacitive reactance varies inversely with frequency, X_{C1} and X_{C2} will be half their former values, and, since inductive reactance varies directly with frequency, X_L will be twice its former value. Due to the change in reactance of these components, the impedance offered to the second harmonic (between terminals A and B of the network) will be vastly different from the impedance offered to the fundamental. In calculating this impedance, we must start at the output, where we have a 15-ohm capacitive reactance shunted across a 52-ohm resistor. The impedance of this combination will be:

$$Z_1 = \frac{X_{C2} R_2}{X_{C2} + R_2} = \frac{(15/-90^\circ)(52/0^\circ)}{52 - j15} = \frac{780/-90^\circ}{54/-16^\circ} = 14/-74^\circ = 14(\cos 74^\circ - j\sin 74^\circ) = 3.86 - j13 \text{ ohms.}$$

This parallel combination is in series with the inductance, and must be added to its reactance. This will give us:

$$Z_2 = (3.86 - j13) + (0 + j444) = 3.86 + j431 = 431/\underline{89.5^\circ} \text{ ohms.}$$

This impedance is in parallel with the input capacitor, so that the impedance between points A and B of figure 3 will be:

$$Z_t = \frac{(431/\underline{89.5^\circ})(100/\underline{-90^\circ})}{(3.86 + j431) + (0 - j100)} = \frac{43100/\underline{-.5^\circ}}{3.86 + j331} = \frac{43100/\underline{-.5^\circ}}{331/\underline{89.3^\circ}} = 130/\underline{89.8^\circ} \text{ ohms.}$$

Therefore, the plate-load impedance seen by the second harmonic will be 130 ohms, and, practically speaking, this load will look like a pure capacity.

Getting back to the fundamental frequency temporarily, between points A and B across the input of the network we have 3000 ohms, and the power going into the network is 45 watts. The current input to the network, as represented by I_p in figure 3, will be:

$$I_p = \sqrt{W/Z} = \sqrt{45/3000} = \sqrt{.015} = .122 \text{ ampere.}$$

In a class-C amplifier, the second-harmonic component of plate current is normally considered to be as great in amplitude as the fundamental component; therefore, we will consider I_p to be .122 ampere at the second-harmonic frequency also.

The voltage between points A and B at the second-harmonic frequency will be:

$$E_{AB} = I_p Z = .122 \times 130 = 15.86 \text{ volts.}$$

Since the impedance of the load (the 52-ohm coaxial line shunted with the 15-ohm capacitor) in series with the coil is 431 ohms at the second-harmonic

frequency, the current through the coil, labeled I_2 in figure 3, will be:

$$I_2 = \frac{E_{AB}}{Z} = \frac{15.86}{431} = .0368 \text{ ampere.}$$

Since this current flows through the load (the 52-ohm coaxial line shunted with the 15-ohm capacitor), the voltage across the load resistance will be:

$$E = IZ = .0368 \times 14 = .515 \text{ volt.}$$

At the fundamental frequency, since the load resistance is 52 ohms and absorbs 45 watts, the voltage across the load at the fundamental will be:

$$E = \sqrt{WZ} = \sqrt{45 \times 52} = \sqrt{2340} = 48.4 \text{ volts.}$$

The attenuation to the second harmonic in the above circuit, expressed in db, will be:

$$\begin{aligned} \text{db} &= 20 \log \frac{E_1}{E_2} = 20 \log \frac{48.4}{.515} \\ &= 20 \log 94 = 20 \times 1.974 = 39.5 \text{ db.} \end{aligned}$$

Thus, the Pi network has reduced the level of the second-harmonic component to 39.5 db below that of the fundamental.

In Pi networks designed to have a Q of 15, the second-harmonic attenuation will vary from 38 to 45 db, depending on the impedance-transformation ratio. For a ratio of 1:1, the attenuation will be 45 db, and for an impedance-step-down ratio of 85:1, the attenuation will fall to approximately 38 db.

A calculation of the attenuation offered to the third harmonic by the above network would show an attenuation 12 db greater than that offered to the second harmonic, or, in this case, approximately 52 db. This will always be true in Pi networks, and the attenuation of the fourth harmonic will be 20 db greater than that offered to the second.

TUNING PROCEDURE

In tuning a Pi network as illustrated



WALLACE L. COOK was born on March 29, 1924, at Bethel, Mississippi. After graduating from high school in 1941, he received his first formal training in electronics at the NYA radio school at Tupelo, Mississippi, where he specialized in transmitter and receiver repair.

In 1942, he received a Civil Service appointment as Radio Mechanic, and was assigned in this capacity at Atlanta, Georgia until his entry into the U. S. Army in 1943.

Shortly after his discharge, in 1946, Mr. Cook became an instructor at the Cook Radio School, Jackson, Mississippi, where he attained the status of Chief Instructor. While engaged in his teaching activities, he was also hard at work on the advanced-radio-engineering course presented by CREI. He graduated from this course early in 1950.

Mr. Cook joined the Philco TechRep Division in the latter part of 1950, and has performed field-engineering duties since that time. In addition to holding a radiotelephone first-class license, he has been actively engaged in amateur radio operating for the past seven years, under the call of W5LFB.

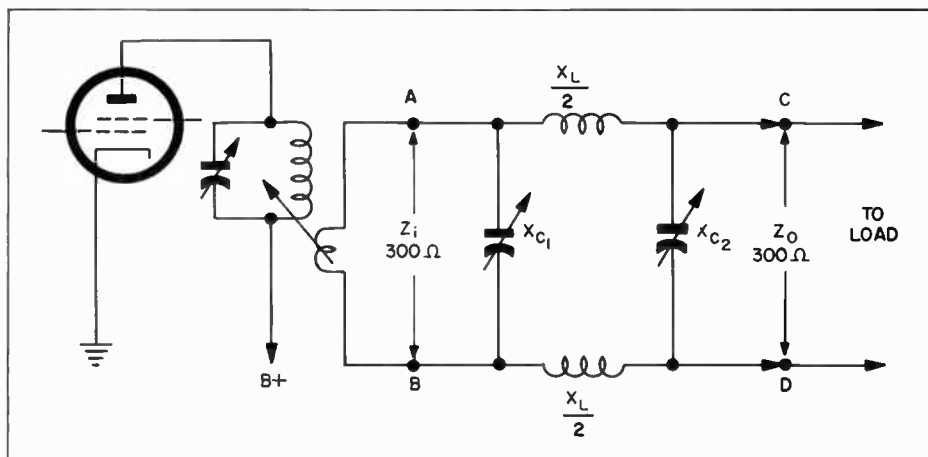

Figure 4. Typical Pi Network Used to Couple into Balanced Transmission Line

in figure 1, means should be provided for applying a reduced plate voltage to the final stage. Before applying plate voltage, connect the load, R_2 , to the Pi network and turn capacitor C_2 to its fully-meshed position. Apply a reduced plate voltage and tune C_1 to resonate the network, as indicated by a dip in plate current. If this dip in plate current is too low (taking into consideration the reduced plate voltage) decrease the capacitance of C_2 and retune C_1 for resonance. Repeat this procedure until a plate current is obtained which is approximately correct for the reduced plate voltage, then apply the full plate

voltage and repeat the procedure until the plate current, at resonance, is proper for the stage.

BALANCED TRANSMISSION LINES

Suppose it is desirable to insert a Pi network into a balanced transmission line, as illustrated in figure 4 (a 300-ohm twin lead for example). R_1 and R_2 will be equal, and, in this case, 300 ohms. Therefore, the transformation ratio is 1:1. All component values are calculated in the manner previously shown; however, when X_L is calculated, insert a coil having half the calculated reactance into each leg of the line.

USEFUL SIGNAL CORPS SUPPLY PUBLICATIONS

by Calvin R. Graf
Farmer Philca Field Engineer

A brief summary of useful data pertaining to Signal Corps supply publications.

SOONER OR LATER there comes the time in the field engineer's life when he has to learn about supply and about supply procedures. If it comes early, he learns the hard way. If it comes later, he still learns the hard way. The engineer that acquires even a limited knowledge of military stock numbering and nomenclature will be much better off than the man without this information, whatever his duty assignment may be.

An old saying goes, "An army travels on its stomach." This statement is supposedly based on the fact that in most cases, an army's rate of travel is limited by the degree to which supplies are able to keep up with it. However, a lot of the slowness traditionally blamed on supply action results from the faulty manner in which supplies are sometimes requisitioned; it isn't all Supply's fault.

A discrepancy occasionally found on requisitions is the use of incorrect nomenclatures and stock numbers. An incorrect nomenclature means that supply does not know what the ordering agency wants. The importance of using correct nomenclature can be seen by the following stock numbers. RADIO SET AN/TRC-1 is carried under stock number 2S5002-1, RADIO TERMINAL SET AN/TRC-3 under 2S5002-3, and RADIO RELAY SET AN/TRC-4 under 2S5002-4. Note that all three are RADIO SETS, that they are all AN/TRC equipment, and that the stock numbers lie in numerical sequence. Considerable confusion could result if any of the three were requisitioned incorrectly. In this

case, the equipment components are the same for each set, except that the quantities of each component issued vary with the stock number.

From the supply viewpoint, if the title is incorrect, then perhaps the stock number is also incorrect, and time must be wasted while these are checked and corrected. The easiest thing to do is use correct stock numbers and nomenclature, and this can be done by consulting the listed books and publications.

As an example of what may happen when an incorrect stock number is given, consider the ordering of quartz crystals used in the T-14/TRC-1 transmitter. Stock number 2X13.1-4 contains 16 crystals in a Crystal Unit Set, while stock number 2X13.1-6 contains 600 crystals in a Crystal Set. At a cost of several dollars each, the difference in price per unit is quite great.

Another discrepancy with requisitions, and probably the most important, is the use of insufficient or incorrect requisitioning authority. (Some try to order four batteries a week when they are authorized only four every two months.) The list showing the different items that are not authorized because of insufficient requisitioning authority could be made quite long. Attempts to order items when there is doubt as to the authority for their issue merely wastes the time of all concerned.

Most organizations are authorized items on Tables of Allowances (TA), Tables of Basic Allowances (TBA),

Tables of Equipment (TE), or Tables of Organization and Equipment (TO&E). The above listed publications show authority for each and every item that an organization is entitled to, not merely signal items alone. When an item is requisitioned, the specific authority under which the organization operates should be listed by number on the requisition form, and thus serves as the basis for requisitioning.

The following list of books should be of use to many of the field engineers working with the ground forces. In addition, although the Air Force is gradually setting up its own stock numbering system, the list should also prove useful to field engineers working with those Air Force units which have not been directly affected by the change. It should be remembered that many of these publications are authorized to the larger depots only, as they are used on the higher levels of supply. Because of this, they may not be available at some of the smaller bases and fields. The descriptions as given here are not complete, and the books themselves should be consulted for further details as to their usefulness.

SIG 3 List of Items for Troop Issue

This handy book lists all items of signal equipment which appear on the above tables, and in addition, includes many components which may be related to the listed items. The items are arranged alphabetically in the catalog by their Signal Corps nomenclature. In the rear of the book is a cross index of all items listed, but arranged alphabetically by type number.

SIG 4-1 Allowances of Expendable Supplies for Tactical Organizations

This title is self-explanatory; the publication lists those items which may be expended by a tactical organization in times of peace or war.

INTRODUCTION TO SIG 5 Description of Breakdown and Use of SIG 5

Included in the front section of SIG 5 is an introduction which shows the classification system used in the book. It lists the classes and subclasses into which all items have been assigned such as Class 1, Wire and Cable, Class 2, Radio Apparatus, Subclass 2A, Antenna Equipment, etc.

SIG 4-2 Allowances of Expendable Supplies for Schools, Training Centers, Boards, and Fixed Installations

This book lists those items which are authorized a non-tactical organization such as those listed in the title.

SIG 5 Official Descriptive Identification Information on Items to which Signal Corps Stock Numbers Have Been Assigned

This book would be about two feet high if all the sections were piled together. It lists numerically, in sequence, all items to which Signal Corps stock numbers have been assigned, and is the bible of supply when it comes to information concerning any signal item. It gives the stock number of an item, its nomenclature, a brief technical description of what it is and what it does, its overall measurements, its unit of issue (whether each, dozen, pound, reel, barrel, etc.), and its expendability. SIG 5 gives a complete description to everything from a washer used in a typewriter to a gun-directing radar set, with numbers ranging from Class 1A, Bare Wire, to Class 9, Pigeon Equipment. The nomenclature used when requisitioning items should be complete as shown in SIG 5, including capitals in the equipment type and any letters and numbers which follow. Thus, the correct nomenclature for the popular BC-610 transmitter should be RADIO TRANSMITTER BC-610-E. The correct stock number and nomenclature greatly aids supply in filling requisitions.

SIG 5 Index by Type Numbers to SIG 5

When only the type number of an item is known, this book will give its nomenclature and stock number, and its description can then be looked up in SIG 5. If we start with Type Number A-55, SIG 5-1 will tell us that it is an antenna, and that its stock number is 2A255. Looking up this number in SIG 5, we find that the antenna is of the phantom type, of 5-ohms impedance at 6200 kc. to 7700 kc., and that it is used with, but is not a part of, RADIO SET SCR-183.

SIG 5-2 Index by Manufacturers' Numbers to SIG 5

This book lists alphabetically those manufacturers who manufacture Signal Corps items. Under each manufacturer's name is a list of all items that he has produced, first by commercial numbers and then by Signal Corps stock number and nomenclature. As an example, the Hallicrafters HT-4 transmitter is RADIO TRANSMITTER BC-610-E (2C6500E). The index comes in two parts, A thru J, and K thru Z.

SIG 5-3 Index to SIG 5 Alphabetical Listing of Signal Corps Equipment

Just as SIG 5-1 is an index to SIG 5 by type number, this book is an index by nomenclature. ANTENNA A-62 would come before ANTENNA AN-29; ANTENNA KIT before ANTENNA MAST, etc.

SIG 5-4 List of Interchangeable and Substitute Items

As its title indicates, this book lists those equipments which can be interchanged directly with other equipments and those items which can be substituted for others, such as rectifier 5T4 for rectifier 5W4. If there are any limitations or slight modifications necessary, these are listed.

SIG 5-5 Pricing Guide for Signal Corps Equipment

Listed by stock number in this large book is the cost of every item that has a Signal Corps number. It lists only the stock number and the cost, whether it be a GCA unit or a washer. This book is often used by those field engineers working in Planning and Engineering, but is not readily available in the field.

SIG 11-1 Parts Control Lists: Procurement and Issue Control List (Major Items Broken Down by Components)

This book is very helpful in determining what items of equipment are covered under a stock number and how they are procured and issued. As an example, it breaks down the AN/ARC-3 into transmitter, receiver, and dynamotors, and then indicates the main items that are provided with the major items of equipment. It shows that a T-17 carbon microphone may be used with the AN/ARC-3 VHF transmitter or the AN/ART-13 HF transmitter; it shows which radar modulators may be used with which radar sets, etc.

SIG 11-3 Parts Control Lists: Components Applications Lists on Non-Type-Numbered Items (and Substitution Information)

Included in this book is a list of items that have not been assigned a type number, and lists of major items of equipment with which these non-type-numbered items may be used. In this book, an item such as SIGNAL SHIFTER is assigned a number which may be looked up in SIG 5 for a complete description.

A little time spent with any of these books will greatly broaden the field engineer's concept of supply. But even better, his overall technical skill will be increased because of his ability to quickly and easily relate various pieces of equipment to the major components of which they are a part. When requisi-

tioning an item, some agencies do not limit their order to the item they desire, but instead, order a complete system. Supply may not have the system, but they may have the component. However, they will have to back-order equipment for the rest of the system before they can forward it to the ordering agency. In such cases, had the agency ordered only what they needed, they would have received it sooner. Much time can be saved by the field engineer if he learns that equipment can be ordered in various ways which are designed to save time for everyone concerned.

To show the classification system used in SIG 5, the following list is given:

Class 1: Wire and Cable

Subclass

- A Bare Wire
- B Insulated Wire and Cable
- C Lead-Covered Cable
- D Armored Cable
- E Switchboard Cable
- F Special Radio Cable

Class 2: Radio Apparatus

Subclass

- A Antenna Equipment
- B Headsets and Microphones
- C Principal Components of Radio Sets
- J Electron Tubes
- S Radio Sets
- T Signal Corps Specification Tubes
- V Commercial Tubes
- X Quartz Crystals
- XA Quartz Crystal Blanks
- XH Crystal Holders and Parts
- Z Miscellaneous Radio Parts

Class 3: Material Common to Radio and Wire Communication

Subclass

- A Dry Batteries
- B Other Batteries and Battery Supplies
- C Coils
- D Capacitors
- E Cords and Cable Assemblies

- F Electrical Test Equipment
- G Insulators and Insulating Material
- H Power Equipment
- K Capacitors, ASA and JAN Mica Types
- RA Variable Wire-Wound Resistors (Lower Operating Temperatures)
- RB Accurate Fixed Wire-Wound Resistors
- RC Fixed Composition Resistors
- RMF External Meter Resistors (High Voltage, Ferrule Terminal Type)
- RP Variable Wire-Wound Resistors (Power Type)
- RU Fixed Wire-Wound Resistors (Low Power)
- RW Fixed Wire-Wound Resistors (Power Type)
- Z Miscellaneous Material Common to Radio and Wire Communication, including Binding Posts, Clips, Electrical Filters, Fuses, Telegraph Keys, Fixed and Adjustable Resistors, Variable Resistors, Shelters, Switches, Terminal Boards, Terminal Lugs, and Studs

Class 4: Wire-Communication Equipment

Subclass

- A Telegraph Equipment
- B Telephone Substation Equipment
- C Manual-Telephone Switchboards and Equipment
- D Central-Office Dial Telephone Equipment
- E Inside Terminal and Protector Equipment
- F Ringing Equipment
- G Sound and Flash Ranging Equipment
- H Time-Interval Apparatus

- T Teletypewriter Equipment
 - Z Miscellaneous
- Class 5: Line-Construction Material**
- Subclass
- A Poles, Crossarms, and Conduits
 - B Line Hardware
 - C Outside Terminal Equipment
 - D Lumber

- Class 6:**
- Subclass
- A Signal Flags and Panels
 - B Signal-Lamp Equipment
 - C Facsimile and Sound Equipment
 - D Printed Matter
 - E Cryptographic Equipment
 - F Boxes, Cases, and Chests
 - G Chemicals, Lubricants, and Paints
 - H Wire and Cable Reels
 - J Vehicle Equipment
 - L Bolts, Hardware Kits, Machine Keys, Nails, Nuts, Pins, Rivets, Screws, Studs, and Washers
 - M Office Equipment and Supplies
 - N Splicing Material
 - Q Tools and Tool Equipment (A-L Inclusive)
 - R Tools and Tool Equipment (M-Z Inclusive)
 - Z Miscellaneous Material Not Otherwise Classified, including Bulk Material

(rods and sheets),
 Conduits, Pipes, Tubing
 and Fittings, Fastening
 Devices, Flashlights and
 Lanterns, Grommets,
 Lamps and Lampholders,
 Plotting Equipment, Rope
 and Twine, Sheet
 Abrasives, and Straps

Class 7: Meteorological Equipment

Class 8: Photographic Equipment and Supplies

- Subclass
- A Photographic Equipment
 - B Photographic Paper
 - C Photographic Chemicals
 - D Film
 - E Photographic Lamps
 - F Film-Library Equipment
 - P1 Maintenance Parts for Bell and Howell Equipment (PH-131)
 - P3 Maintenance Parts for RCA Equipment (PH-398 and 398-A)
 - P7 SVE Parts (PH-222)
 - P8 Folmer Graflex Parts (PH-47)
 - P9 Tool Equipment
 - P10 Maintenance Parts for Bell and Howell Equipment (PH-330-G)
 - P11 Maintenance Parts for Ampro Equipment

Class 9: Pigeon Equipment



ELECTRONIC COMPUTERS—PART II

The Binary Counter

By Warren Kitter

Technical Publications Department

The second of a series of articles discussing electronic computers. This article deals with the basic concepts of a binary-counting-type computer.

THE BASIS OF ANY TYPE of counting device, whether it is mechanical, electrical, or electronic, is a mechanism which is capable of assuming any one of a discrete number of stable conditions. The popular, pocket-type adding machine exemplifies a mechanical counting mechanism which fulfills this condition. This mechanism consists of a series of identical number wheels each of which has 10 gear teeth on the outer periphery so that the wheel can be positioned in any one of 10 stable states. Each state, of course, represents a decimal digit. When the wheel on the extreme right has passed through all ten positions, a cam engages a gear tooth on the second wheel and advances that wheel one position. The adding process that takes place in this device, assuming that 8 and 6 are to be added together, is as follows: The number 8 advances the wheel eight steps; then the number 6 advances the wheel six additional steps, carrying the first wheel four digits beyond position 10. The result of the addition of 8 and 6 is 4, with a carry-over of 1. Therefore, the first wheel indicates the additive value 4, while the second wheel indicates the carry value, (or a total of 14). This process can be expanded to handle sizeable sums by incorporating additional number wheels. This is similar to the process used in the addition of numbers by electronic computers, and is given here in detail so that the process of addition will not appear too confusing when it is accomplished at lightning speed by electronic means.

The type of adding machine described above has limited usage in the scientific and commercial fields because of the time required to feed information into it, and also because of the relative slowness of each individual operation. These characteristics render this type of machine practically valueless (even when electrified and developed into a calculating device) when large amounts of raw data must be handled such as in the analysis of a census or survey or in the compilation of shell trajectories. High-speed electronic computers are ideally suited for these operations. As an example of the high computational speeds available with modern electronic computers, the UNIVAC developed by the Eckert-Mauchly Computer Corporation is capable of the following calculation speeds:

Addition	1900 problems per second
Subtraction	1900 problems per second
Multiplication	465 problems per second
Division	255 problems per second
Comparison	2396 problems per second

The UNIVAC is also capable of reading digits from a magnetic tape at the rate of 10,000 digits per second (sounds impressive, doesn't it). This is equal to approximately 7500 punched cards each minute. It has been said about ENIAC, the 18,000-tube forerunner of

the UNIVAC, that a skilled operator, working with an ordinary desk machine, would require approximately 20 hours to compute a firing table for a 60-second shell trajectory, whereas the ENIAC can produce the same firing table in 30 seconds, or in less time than it takes for the shell to reach its target.

Now that the reader is convinced that he should trade in his old, obsolete "little lightning" adding machine on a more modern electronic computer, it is time to take up the theory of the various circuits which perform these near miracles.

The simplest type of counting circuit would consist of a locking push switch, a lamp, and a battery connected in series, as shown in figure 1. This elementary circuit is an odd-even type of counter, indicating by one of the two stable conditions of the lamp whether the push switch has been pushed an odd or an even number of times. Relay circuits have been devised which can perform counting functions, and entire computers have been based upon relay operations. However, the shortest time in which an ordinary relay can operate is about 5000 microseconds. In contrast to this, electronic counting circuits composed of flip-flop, or decision, oscillators can produce the same result in less than one microsecond. This means an increase in operating speed of 5000 to 1.

The basic flip-flop circuit is shown in figure 2. In this circuit, it is assumed that component values have been selected so that V_2 conducts a trifle more current than V_1 at the instant plate voltage is applied to both tubes. This extra conduction causes a lowering of the plate voltage of V_2 , and the voltage drop is passed on to the grid of V_1 by means of the coupling capacitor and resistor network. The lowering of the grid potential of V_1 causes a decrease in plate current and a resultant increase in plate voltage, which is fed back to the grid of V_2 , further increasing its plate current.

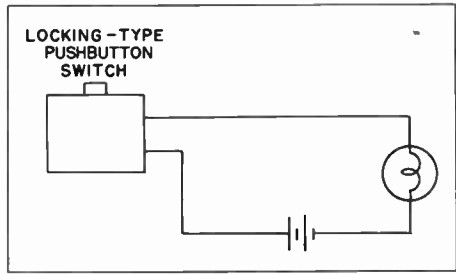

Figure 1. Simple Counting Circuit Which Indicates Whether Button Has Been Pushed an Odd or Even Number of Times

The condition of instability continues until V_2 is conducting heavily at plate-current saturation, while V_1 is held at cutoff because of the large voltage developed across the common cathode resistor (by virtue of the heavy current flow through V_2). This condition is reached practically instantaneously. The neon bulb connected from the plate of V_2 to ground lights only when the tube is cutoff (or during the period of highest plate potential). This bulb provides a visual indication of the condition of the circuit. If the circuit components are chosen so that the positive voltage applied to both cathodes is sufficiently higher than the grid potential of the nonconducting tube, the circuit remains fixed in a stable condition with V_2 con-

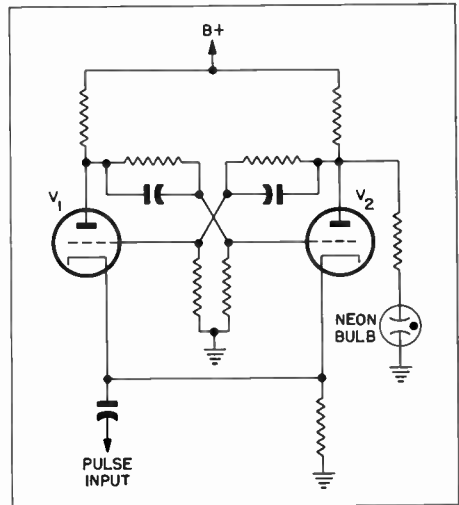

Figure 2. Basic Decision (Flip-Flop) Oscillator Circuit

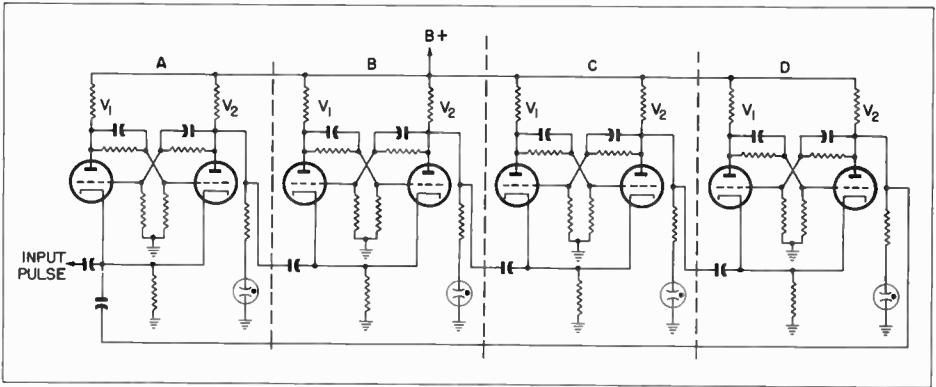

Figure 3. Radix-2 Counter, Capable of Counting to Fifteen (1111 in Binary System) and Resetting to Zero

ducting heavily—the unlit neon bulb indicates the fact that V_2 is operating at saturation. If a negative pulse of correct amplitude is applied to the pulse-input lead connected to the common cathodes, it can have no effect on V_2 , which is already at saturation. However, V_1 is driven into conduction and its plate voltage drops. This reduction in plate voltage is applied to the grid of V_2 , thus tending to lower conduction in V_2 , with the resultant rise of V_2 's plate voltage causing still more conduction in V_1 . This action continues very rapidly until V_1 is operating at saturation and V_2 is operating at cutoff by virtue of the bias conditions produced by the current flowing through V_1 . At this point, the neon lamp lights because of the rise in voltage at the plate of V_2 . A series of negative pulses applied to the input lead will cause the circuit to alternate between its two stable states, while the neon bulb will indicate whether the total number of applied impulses has been odd or even. This type of circuit is known as a modulo-2 counter, since 2 is the standard of measurement in determining odd or even.

If several modulo-2 counters are connected in cascade, the system is known as a radix-2 counter. Figure 3 illustrates a radix-2 counter which, as will be seen, is capable of counting up to 15 and then resetting to repeat the cycle. The four

flip-flop circuits, labeled A, B, C, and D, are identical. The plate lead of tube V_2 in one stage is connected to the cathode-input lead of the flip-flop circuit in the next stage. In all the flip-flops, the circuit constants are such that when the circuit is first energized, V_2 conducts first. Hence, V_2 always goes to plate-current saturation, V_1 is driven to cutoff, and none of the neon lamps is lit when the circuit is first energized. In this condition, the radix-2 counter circuit indicates binary number 0000.*

How the radix-2 circuit counts can be easily understood by following the operation when a series of negative pulses is applied to the common cathode lead of counter A. When the first negative pulse is applied, it causes V_1 , which is at cutoff, to conduct, driving V_2 to cutoff. Since the plate-voltage pulse applied to counter B is in a positive direction, there is no change in state of counter B or any of the following counters. The neon bulb in counter A is now lit, indicating that a binary pulse has been stored in it. If the order of the lamps is transposed from left to right, it can be seen that the lamps now indicate binary number 0001. When the second negative pulse is applied to the pulse-

* Binary notation was discussed in the first article of this series in the October issue of the BULLETIN.

input line, the state of counter A is again reversed, causing the lamp to go out. Inasmuch as the plate voltage of V_2 in counter A has dropped, a negative pulse is transmitted to counter B, creating the condition necessary for a reversal of this flip-flop circuit, and the neon lamp lights as the circuit reverses. The conditions of the lamps in the four counters are now as follows: counter D out, counter C out, counter B lit, and counter A out. This set of lamp conditions indicates binary number 0010, or 2. The third negative pulse again lights the counter A lamp but has no effect on subsequent counters, indicating binary number 0011, or 3. The fourth negative pulse puts out the lamps in counters A and B but lights the lamp in counter C, indicating binary number 0100, or 4. As other negative pulses are applied, the radix-2 counter continues to count until it reaches binary number 1111, or 15. At this point all the lamps are lit; the next negative pulse causes a reversal of the states of all counters (the negative pulse being passed from one counter to the next), so that all lamps go out and

the circuit is returned to its starting, or zero, condition. Counting to higher numbers is possible by adding additional modulo-2 counters. Each additional counter increases the counting range by a power of 2. In a long string of modulo-2 counters, the highest limit of counting is equal to: $(2^n - 1)$ where n is equal to the number of counters in the radix. If it is desired to count in the decimal system, decades of four modulo-2 counters (previously connected so that the 10th pulse restores the circuit to 0000) may be employed. Each decade equals 10, and feeds the 10th, or carry, pulse into the next decade. With this arrangement, six banks of four modulo-2 counters (or 24 flip-flop circuits) are required to count to 1,000,000.

At this point we will temporarily discontinue this discussion, so that the reader can have an interval of time to digest the information already given before taking up logical-and circuits, logical-or circuits, logical-except circuits, adding circuits, memory circuits, and many more of these complex products of our modern electronics era.

Solution to . . .

Last Month's "What's Your Answer?"

In the problem shown last month, the impedance could most easily be determined by comparing turns ratios. For example if 10 turns were used to obtain the 16-ohm output, the 8-ohm tap would locate at 7.07 turns. This is based upon the rule that an impedance ratio is proportional to the square of the turns ratio. Therefore, 2.93 turns would exist between points A and B. If 10 turns represent 16 ohms, 2.93 turns would represent 1.37 ohms. Thus, instead of the more obvious 8 ohms, we find that a rather low value is required. (If you were careless enough to drop the ".07" you would come up with 1.4 ohms.)

The practical value of such an idea is found in extending the range of possible impedance combinations for the indicated transformer.

WHAT'S YOUR ANSWER?

by John Buchanan
Technical Publications Department

THE GREAT JOULE ROBBERY

PROLOGUE

'Twas a dark and stormy night, and around the power house sat the batteries, counting their joules. Twelvevolt, the large one, said to Fourvolt, the small one, "Fourvolt, I just gave you six hundred joules." And Fourvolt, the small one, thus replied, "Twelvevolt, that is the mystery, for four hundred, only, are the joules that I received."

THE STORY

There was a tapping at the electrodes, and the voice of a little demon was heard—but in clever disguise: "Come, come, my faithful stand-bys, this raging night is not the time for quibbling. The commercial line will not survive the evening through, with the elements thus in their present mood. Alertness is the word. A moment now and a call to duty might be heard."

Fourvolt, the small one, then exclaimed, "Woe is me! Six hundred joules more, or my poor relay will be but a passing attraction!"

Bending over Twelvevolt, the large one, the little demon said, "Twelvevolt, six hundred joules is but a pittance to you, but if Fourvolt fails, you will all be dead ere morn. It happens that I have with me a couple of noncoupled chokes with zero resistance, and ideal controls for an exchange of charge. Not a joule will be lost, except for a negligible spark in a fuse that I provide. 'Tis a favor for me, too, for my coils are choking from the sublimate and calcinations of long disuse, though the flushing of a coulomb or two is all that they need to make them again as good as new."

Twelvevolt, the large one, now replied, "Six hundred joules is all I can spare, lest my motor's horsepower be that of a nightmare. But resistanceless coils are not easily found, and so for you, and for Fourvolt, too, I'll discharge this favor of six hundred joules."

"You are kindness, itself," the little demon said; "through this fuse I connect you to choke No. 1; next is switch No. 1; ten seconds later comes switch No. 2, and my coils alone will carry

on; ten seconds again and all will be through. The ammeter is here for you to know that ten amps at most is all that will flow, with nothing remaining by the time I go. Ready now, Fourvolt, here comes the charge of the six hundred!"

Switch No. 1 is closed, and ten seconds later, switch No. 2. Ten seconds again pass, and, true to his promise, the little demon disconnects at 1, 2, and 3, grabs his box, and disappears into the storm.

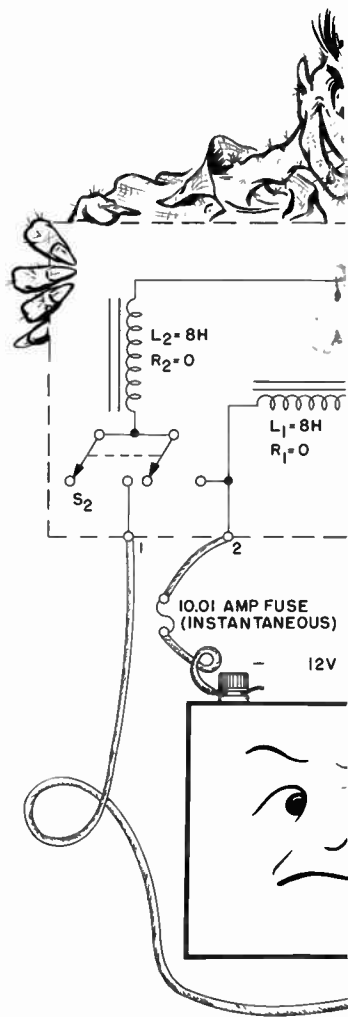

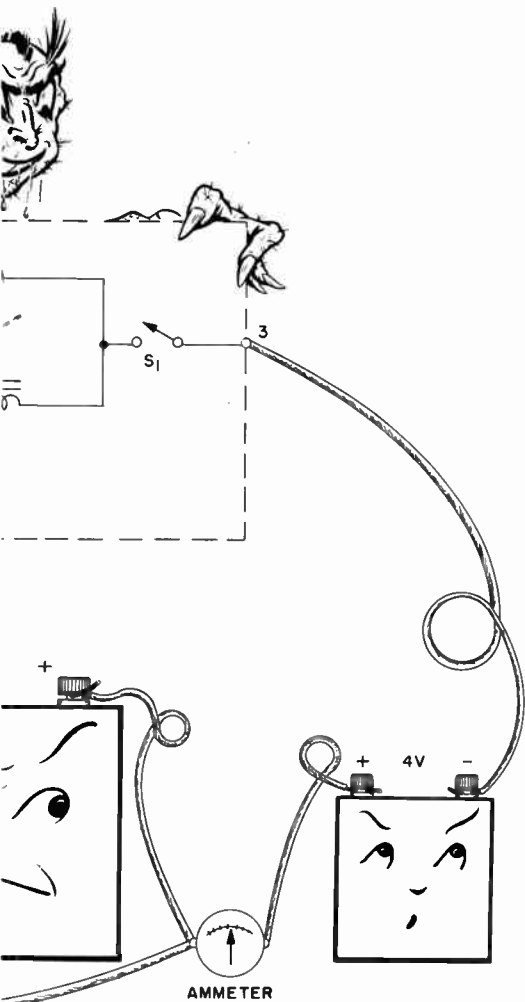

EPILOGUE

Twas a dark and stormy night, and around the power house sat the batteries, counting their joules. Twelvevolt, the large one, said to Fourvolt, the small one. "Fourvolt, I just gave you six hundred joules." and Fourvolt, the small one, thus replied, "Twelvevolt, that is the mystery, for four hundred, only, are the joules that I received."

[Editor's Note: It can be seen that during the first 10-second period after the closing of S_1 , the 12-volt battery is forcing current through both the 4-volt battery and L_1 . Thus, the current starts

at zero and increases linearly (zero resistance) at the rate of one ampere per second to a value of 10 amperes at the end of 10 seconds. This is equivalent to a steady five amperes flowing for 10 seconds. By the formula:

$$J = E \times I \times t$$

where

E = voltage in volts

I = current in amperes

t = time in seconds

J = energy in joules

we find:

$$J = 12 \times 5 \times 10$$

$$= 600 \text{ joules}$$

Thus the 12-volt battery inserts 600 joules into the circuit.

During this time, the four-volt battery received: $J = 4 \times 5 \times 10 = 200$ joules.

When S_2 is closed, the fuse instantly blows, removing the 12-volt battery from the circuit and converting the total inductance to four henries. However, the 10 amperes that were flowing in L_1 will still tend to continue to flow. Now we see that we have a four-volt battery across a four-henry inductance—thus the current flow will now decrease linearly at the rate of one ampere per second. (The decrease occurs because the four-volt battery is opposing the original 10-ampere current flow.) Thus, it will take 10 seconds for the 10-ampere current to reach zero, at which time the circuit is disconnected (by the demon) at points 1, 2, and 3. Thus, the four-volt battery has current forced through it, equivalent to an average of five amperes for 10 seconds. Therefore, during the second 10-second period, the four-volt battery receives: $J = E \times I \times t = 4 \times 5 \times 10 = 200$ joules. Combining this 200-joules charge with the 200-joules charge obtained during the first 10 seconds, it is obvious that the four-volt battery received only 400 of the 600 joules inserted.

Your problem, dear reader, is to find the missing 200 joules.]

(Solution next month)

MODIFICATION OF THE ID-73/CPS-1 PLAN-12 INDICATOR

by B. L. Kortegaard
Philco Field Engineer

Burnout of the cathode resistors in the sweep-output stage has occurred during prolonged operation at short sweep ranges. This article describes a modification designed to alleviate the problem.

(Editor's Note: This article has been approved for BULLETIN publication by Headquarters, Air Research and Development Command, USAF.)

THE PLAN-12 INDICATOR (ID-73/CPS-1) used with the AN/CPS-1 radars is also used with a number of other ground radars. At most installations, this indicator has been modified to include an off-center-scanning function. The off-center feature requires a greater deflection than did the unmodified version, and has necessitated the addition of a second 807 tube in parallel with the original sweep-output tube. A second feature of the modification consists of the simplification of the sweep-gate-width circuit. The modified indicator has a single control that establishes the sweep-gate width at 180 miles for all ranges. Shorter ranges are accomplished by increasing the rate of deflection. For example, if a 20-mile sweep is desired, the slope of the deflection waveform is merely increased to a point where the trace traverses the oscilloscope in the 20-mile time interval. This means that at the end of the 180-mile interval the deflection current is extremely large. In fact, the average current is so large with a 20-mile sweep that each of the two cathode resistors (R_{368} and R_{309}) in the sweep-output stage dissipates about 4 watts. Since the resistors are rated at 2 watts, it is evident that extended operation will result in failure.

Of course, for longer ranges, the rate of deflection is slower and the average power dissipation is correspondingly lower.

Where any off-center-modified Plan-12 indicator is to be used for short-range operation it is highly advisable to make the following additional modification:

1. Remove connections between the S, M, and L positions of S_{302A} .
2. Connect a 1-megohm potentiometer* between the S position of S_{302A} and the cathode of V_{305B} .
3. Connect a 2-megohm potentiometer* between the M position of S_{302A} and the cathode of V_{305B} .

The 1-megohm potentiometer is adjusted, in the S position of S_{302A} , for a 50-mile gate; the 2-megohm potentiometer is adjusted, in the M position of S_{302A} , for a 100-mile gate; and R_{337} is adjusted, in the L position of S_{302A} , for a 180-mile gate.

This modification reduces the sweep time on the short-range and medium-range positions. Since this action also reduces the average power in the deflection system, the power dissipated in the cathode resistors will not exceed rated values, even during short-range operation.

*These potentiometers should be located so as to be inaccessible to operating personnel.)













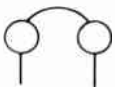

Reference List of Schematic Symbols















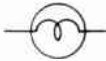

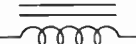
by BULLETIN Staff

A series of circuit-component symbols which will serve as a standard for all schematic diagrams to be published in future issues of the BULLETIN.

(Editor's Note: The following list is by no means as complete as it might have been made, but it does include a sufficient variety of circuit-component symbols to cover the vast majority of those required for illustration of BULLETIN articles.

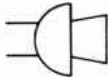
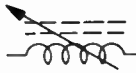
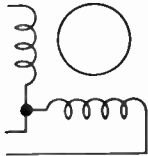
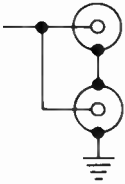
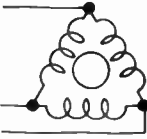
Where a number of variations of a basic circuit element exist, such as in multiple-contact relays, multi-purpose vacuum-tube structures, etc., only the symbol for the basic circuit element has been shown.)

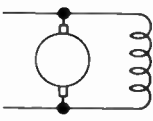
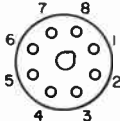
ANTENNA		CRYSTAL, DETECTOR	
ANTENNA, LOOP		CRYSTAL, PIEZOELECTRIC	
ANTENNA, DIPOLE		EARPHONES	
ANTENNA, FOLDED DIPOLE		GAP, ARC	
BATTERY		GAP, HORN	
CAPACITOR, FIXED	OUTSIDE FOIL ON PAPER CAPACITORS 	GAP, SPARK, FIXED	
CAPACITOR, VARIABLE	ROTOR 	GAP, SPARK, ROTARY	
CAPACITOR, ELECTROLYTIC		GENERATOR, A-C	

GENERATOR, D-C		JACK, PHONE (SHORTING-TYPE)	
GROUND		KEY	
GROUND, ALTERNATE (OR COUNTERPOISE)		LAMP, INCANDESCENT	
INDUCTOR, FIXED (AIR-CORE)		LAMP, NEON	
INDUCTOR, FIXED (IRON-CORE)		LIGHTNING ARRESTER	
INDUCTOR, FIXED (POWDERED-IRON-CORE)			
INDUCTOR, VARIABLE (AIR-CORE)		METER	LETTERING DENOTES TYPE
INDUCTOR, VARIABLE (IRON-CORE)		MICROPHONE	
INDUCTOR, VARIABLE (POWDERED-IRON-CORE)		MOTOR, A-C (TWO-PHASE)	
JACK, COAXIAL		MOTOR, A-C (THREE-PHASE)	
JACK, MICROPHONE		MOTOR, D-C	
JACK, OCTAL		PHONO PICK-UP	
JACK, PHONE			

PLUG, A-C

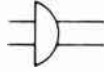

PLUG, OCTAL

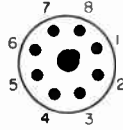

PLUG, PHONE



RELAY

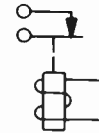

RELAY

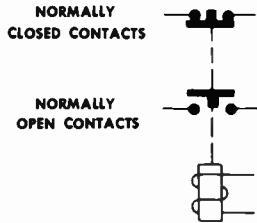

RELAY, POLAR

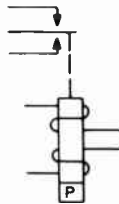

RESISTOR, FIXED



RESISTOR, TAPPED



RESISTOR, VARIABLE (POTENTIOMETER)



RESISTOR, VARIABLE (RHEOSTAT)



SPEAKER, ELECTRODYNAMIC

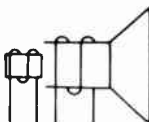

SPEAKER, P-M DYNAMIC

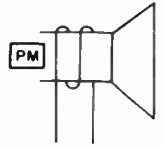

SWITCH, D-P-S-T

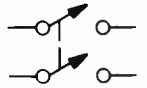

SWITCH, PUSHBUTTON (NORMALLY OPEN)



SWITCH, PUSHBUTTON (NORMALLY CLOSED)



SWITCH, S-P-S-T



SWITCH, SINGLE-POLE, THREE-POSITION



SWITCH, TWO-POLE, FOUR-POSITION

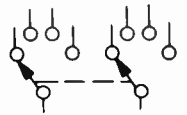

THERMOELEMENT



TRANSFORMER, AIR CORE

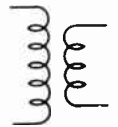

TRANSFORMER, AUTO-

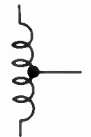

TRANSFORMER, IRON-CORE

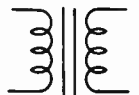

TRANSFORMER, IRON-CORE, CENTER TAPPED

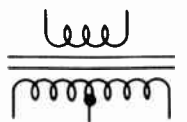

TRANSFORMER, IRON-CORE (WITH FARADAY SHIELD)

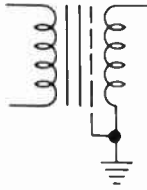

TUBE, V-R (COLD CATHODE)



TRANSFORMER (VARIABLE COUPLING)

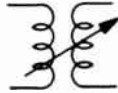

VIBRATOR

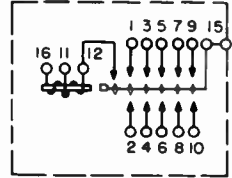

TUBE, DIODE

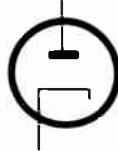

WAVEGUIDE



TUBE, DUO-TRIODE



WAVEGUIDE, APERTURE COUPLING

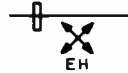

WAVEGUIDE, ATTENUATOR (VARIABLE)

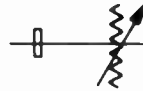

TUBE, PENTODE

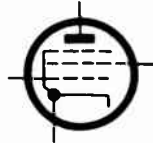

WAVEGUIDE, CAPACITIVE STUB OR IRIS

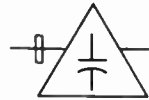

TUBE, REFLEX KLYSTRON

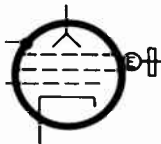

WAVEGUIDE, E-TYPE JUNCTION



TUBE, TRIODE

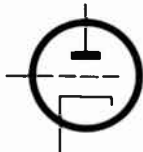

WAVEGUIDE, H-TYPE JUNCTION



TUBE, TRIODE, GAS-FILLED (THYRATRON)

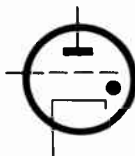

WAVEGUIDE, INDUCTIVE STUB OR IRIS

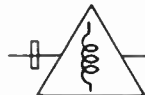

WAVEGUIDE, LOAD



**WAVEGUIDE, PHASER
(VARIABLE)**

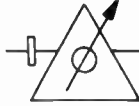

**WAVEGUIDE-TO-COAXIAL
TRANSITION,
INDUCTIVE (VARIABLE)**

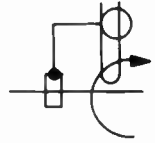

**WAVEGUIDE-TO-COAXIAL
TRANSITION,
CAPACITIVE (OPEN)**

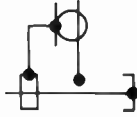

WIRES, CROSSED



**WAVEGUIDE-TO-COAXIAL
TRANSITION,
CAPACITIVE (SHORTED)**

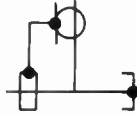

WIRES, JOINED

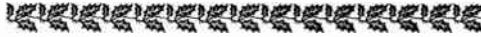

New Dynamotor Power Supply Unit

Typical of recent trends in equipment weight and size reduction, is the new Dynamotor Power Supply DY-88, designed and developed by Lewyt Corporation, of New York. The new unit, already in production, is to replace Vibrator Power Supply PE-237, in various Signal Corps applications.

The unit weighs only 26 pounds as compared to 89 pounds for the unit it replaces, and in addition to saving much critical material, it is superior in performance to the PE-237, and requires considerably less maintenance.

CONTROL CIRCUITS FOR TOWER INSTALLATIONS

by M. M. Elson
Philco Field Engineer

A system for the remote control of multiple transmitter and receiver installations for control-tower and Matcon applications.

(Editor's Note: The author has built several of these control systems, and he states that they are highly dependable, easily constructed, and most important, the required components are usually readily available.)

IT HAS BEEN NECESSARY, several times in the past, to improvise a receiver and transmitter control setup by means of which the operator could rapidly and efficiently control several different radio-communication systems. This is commonly done with control-tower and airways-control installations.

Requirements for such an installation may be listed as follows:

A. Selection of any transmitter by one manual operation.

B. Automatic squelch of receiver in use on selected frequency.

C. A single microphone for use on all channels.

Additional desirable requirements may be listed as follows:

D. Squelch of interfering reception for monitoring of a single channel.

E. Lock-out provisions for transmitters operated from two locations.

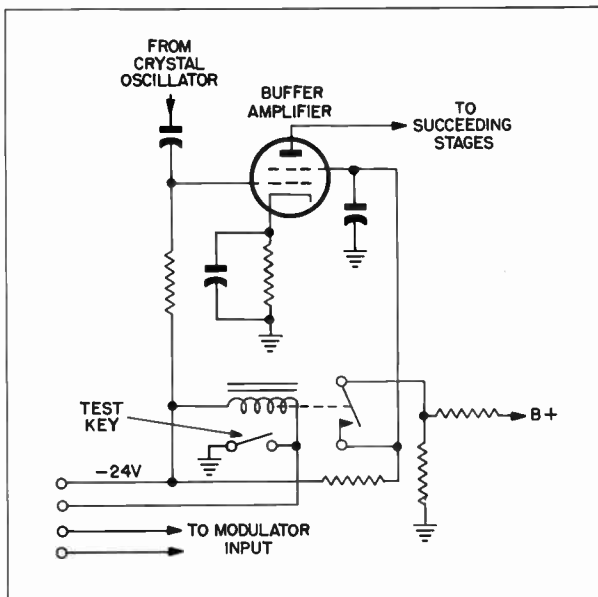

Figure 1. Keying and Modulation Input Circuits of BC-329 (*) Transmitter

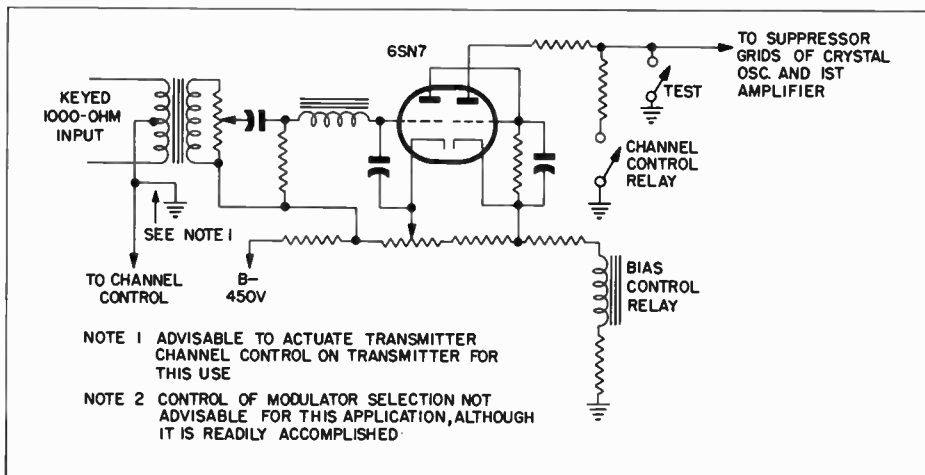

Figure 2. Tone Keying and Modulation Input Circuits of T-158B/FRT Transmitter

Compliance with all of the above requirements sounds rather complicated, but in military applications it may be obtained quite easily. The following paragraphs of this article will deal with each item separately to show how the final typical schematics evolve.

THEORY OF CONTROL CIRCUITS

It should be noted that requirement A above says nothing about *keying* a transmitter. Since it is assumed that the systems outlined will be used for voice transmissions only, microphone keying (press-to-talk) is used. Since one (or more) transmitters may be selected from a multiplicity of transmitters, the operation of the microphone will key all *selected* transmitters.

When only one type of transmitter is used, selection is readily accomplished. When several different types of transmitters are used, unless great care is exercised, selection arrangements can vary so widely as to require excessive equipment and/or maintenance problems. Thus, it is necessary to provide an arrangement which, with minor changes, will operate satisfactorily for any type of transmitter.

Transmitters in common use may be classified into the following groups:

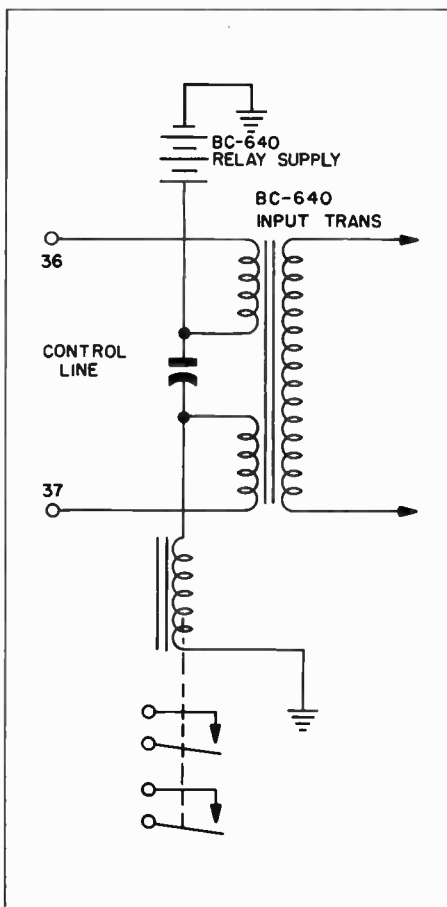

Figure 3. Keying and Modulation Input Circuits of BC-640 Transmitter

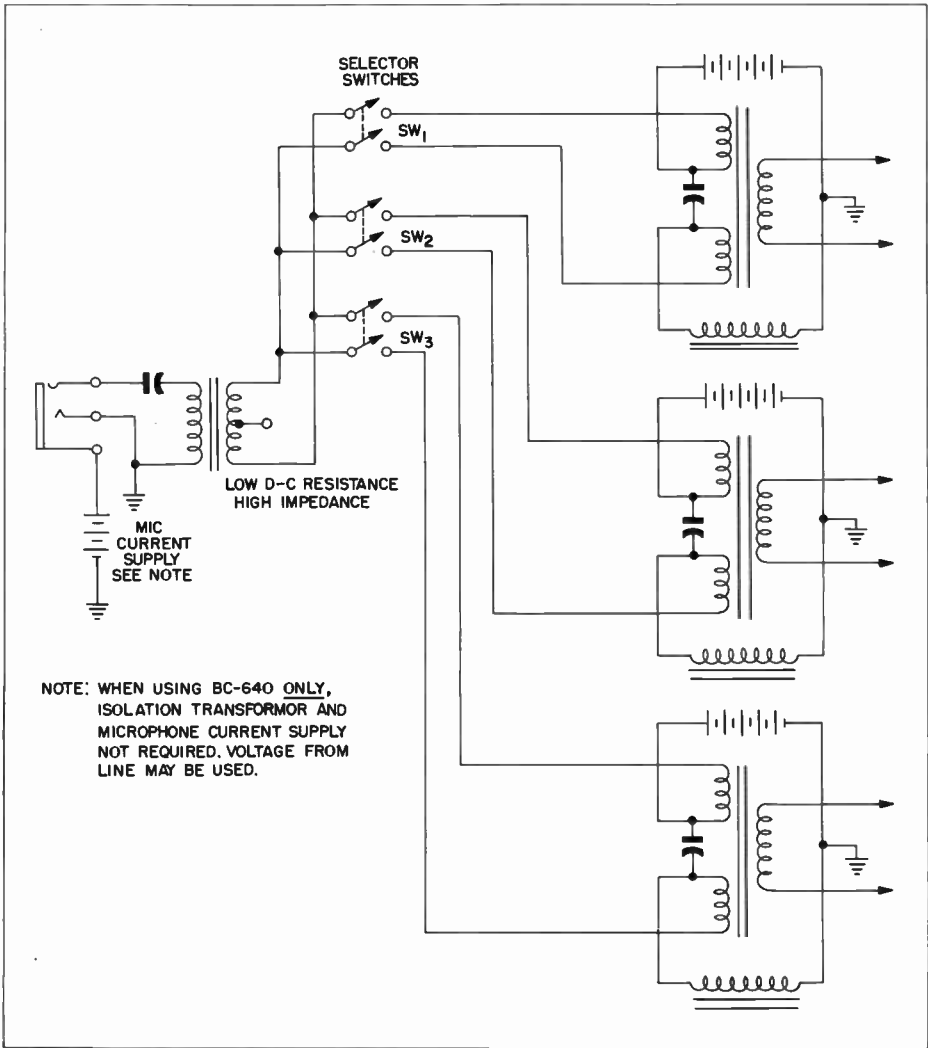

Figure 4. Typical Simplified Selector Bank for BC-640 Transmitters

1. Transmitters which are selected and keyed by d-c voltages.
2. Transmitters which are selected and keyed by a-c voltages.
3. Transmitters which are selected and keyed by either a-c or d-c voltages over a simplexed line.

As typical examples, the BC-329 (figure 1) will be used to illustrate those classed under the first group; the T-158B/FRT (Wilcox 96-C3) (figure 2) will illustrate those in the second group;

and the BC-640 (figure 3) will illustrate those in the third group. It should be noted that these transmitters are used as typical examples only. Methods shown will work equally well for other transmitters of similar types. It should be obvious, also, that the requirements for keying and modulating these typical transmitters will involve three separate problems.

For example the BC-640 (group 3) keying and modulation requirements

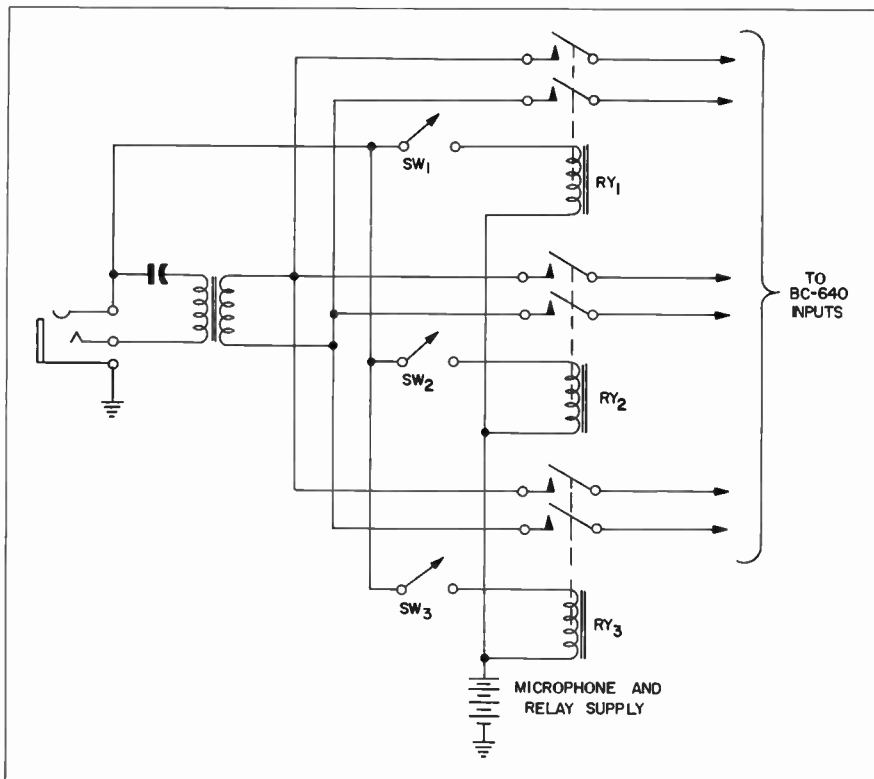

Figure 5. Use of Relays with Press-to-Talk Microphone

are very simple. The only requirements are a low-resistance path between the two sides of the modulation line, and a high-impedance path for the modulating voltage. Then, to provide for selection between several BC-640's, d-p-s-t switches and a microphone power supply are needed. Figure 4 illustrates a simplified version of this. It will be noted that under the circumstances of figure 4, the selected transmitter will be keyed each time a selector switch is actuated. This is an undesirable situation which may be avoided by the addition of a relay in series with each selector switch, arranged so that the desired relay is operated each time the microphone switch is operated. Figure 5 shows a typical circuit which meets requirement A for the "group 3" class of transmitters.

It will be noticed that with the ar-

range of figure 5, operation of the selector switches (SW_1, SW_2 , etc.) merely selects one (or more) of the relays to be used. Operation of the relay does not occur until the microphone press-to-talk switch is actuated.

In order to provide for other types of transmitter control, all that is necessary is the expansion of the same circuit to meet the requirements of the different types of circuits. In each of the other two types of circuits, (groups 1 and 2) two separate lines are in use, one for keying and the other for modulation. In the circuit illustrated in figure 5, the modulation-line requirement may be met perfectly by the use of that line only. Addition of one or two extra contacts to the relay will in each case take care of the keying arrangement for both of the other types. This is illustrated in figure 6.

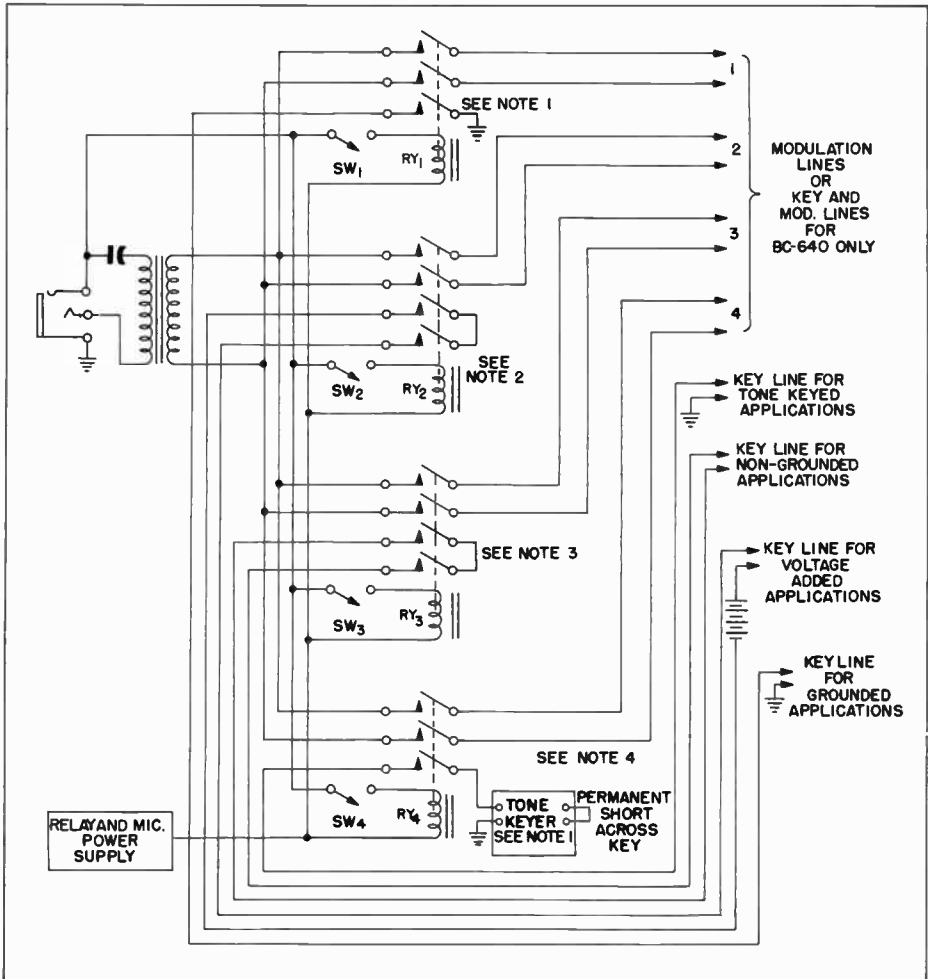

Figure 6. Schematic Diagram Showing a Variety of Transmitter Control Circuits

- Note 1. Use of this type of connection will also key any d-c, grounded-keying type (Opposite side of keying line should also be grounded.)*
- Note 2. Use of this type of connection will key any d-c keyed type of transmitter. Arrange voltage as required for transmitter in use. In addition, this circuit may also be used to overcome excessive resistance in grounded types when keying-line length is excessive.*
- Note 3. This is the preferred type of grounded keying, and should be used in preference to type shown on RY1. Battery may also be inserted in series to overcome excessive keying-line resistance.*
- Note 4. Tone-keyed transmitters use this type of connection. Tone-keying oscillator should be permanently keyed to the relay. Relay selects transmitter to be keyed.*

Close examination of figure 6 will show that as far as transmitter control is concerned, all required functions of the three different types of transmitters have been provided for.

In figure 6, illustrative circuits using relays of the three-pole-single-throw and four-pole-single-throw types have been shown. In three applications of this type

of transmitter-control system, both types of relays have been used without noticeable objectionable features. However, **COMMON GROUNDS BETWEEN MODULATION LINES SHOULD BE AVOIDED — ESPECIALLY WHEN TRANSMITTERS ARE USED JOINTLY BY TWO OR MORE OPERATING LOCATIONS.** In all three

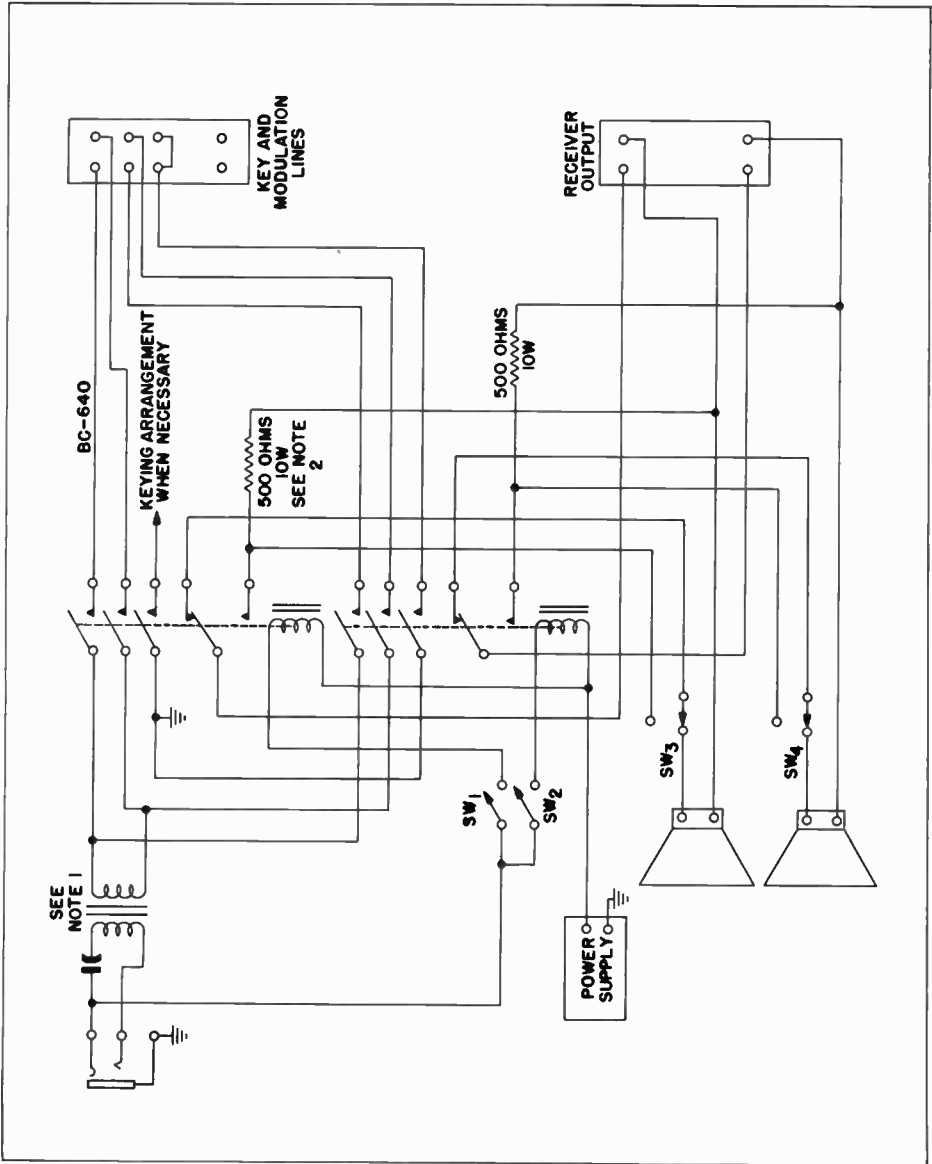

Figure 7. Additional Transmitter Control Circuits, Showing Receiver Squelch Feature

- Note 1.** On long runs of modulation line, insert BC-730D or similar type of constant-output amplifier. Adjust to 0-dbm output and readjust speech amplifiers of individual transmitters accordingly. Use of isolation transformer may be eliminated in this case, but blocking capacitor should be used to prevent d-c saturation of output transformer.
- Note 2.** Use any constant value which will dissipate entire output of receiver.

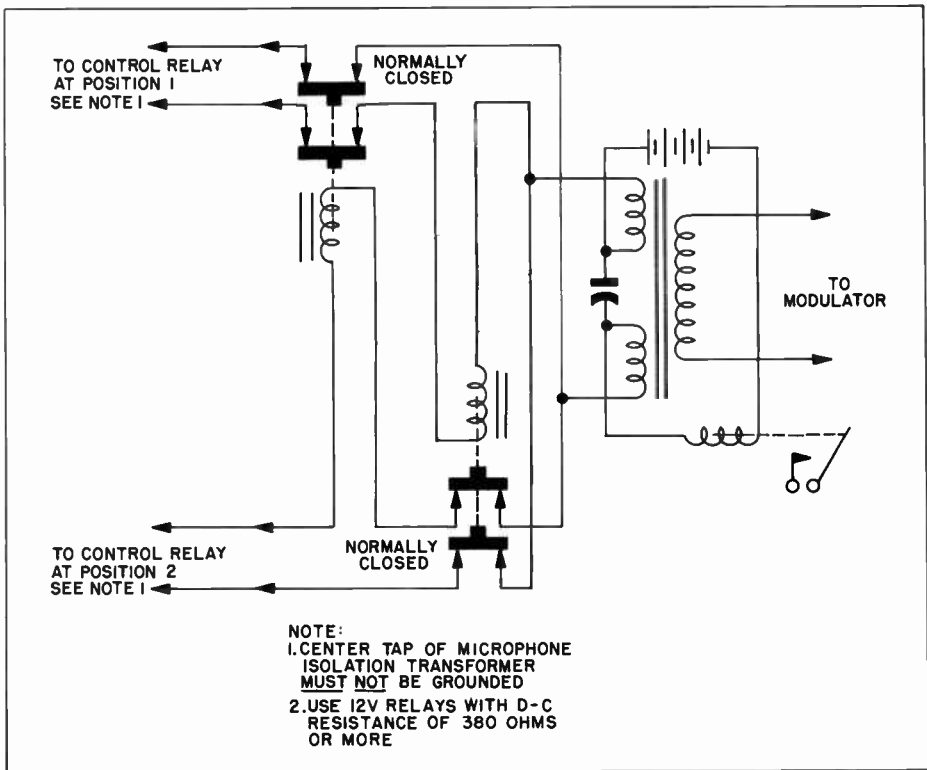

Figure 8. Lock-out Circuits for Dual Control of BC-640 Transmitter

of the installations made by this writer, 3-p-s-t or 4-p-s-t relays were unobtainable. In two cases, two each 2-p-d-t relays were used in parallel, and in the third case one s-p-s-t and one d-p-d-t relay were used in parallel.

Automatic squelch of receiver in use on selected frequency is easily obtainable by the use of a single set of s-p-d-t contacts on the transmitter relay as shown in figure 7. Note that s-p-d-t switches (SW_3 and SW_4) have been inserted in the receiver line with a function identical to that of the relay contacts. These switches provide manual squelch of a particular receiver when operating on another frequency.

Thus, all of the functions that were originally listed have been provided, except item E, "lock-out provisions for transmitters operated from two loca-

tions." Figures 8 and 9 show two typical wiring schematics of this type of circuit.

PANEL CONSTRUCTION

The circuits illustrated in figures 7, 8, and 9 work well and reliably. Construction of any or all of the circuits illustrated may be justified from the standpoint of operator convenience. It is well to note that panel-type construction is the easiest and most convenient. All selector switches and the microphone jack should be mounted on one panel, and all selector relays should be mounted on a separate panel and installed reasonably near the switch panel. The lock-out relays should be mounted on still another panel, and mounted near the transmitters. When constructed, all intra-panel connections should be made by means of terminal strips. Term-

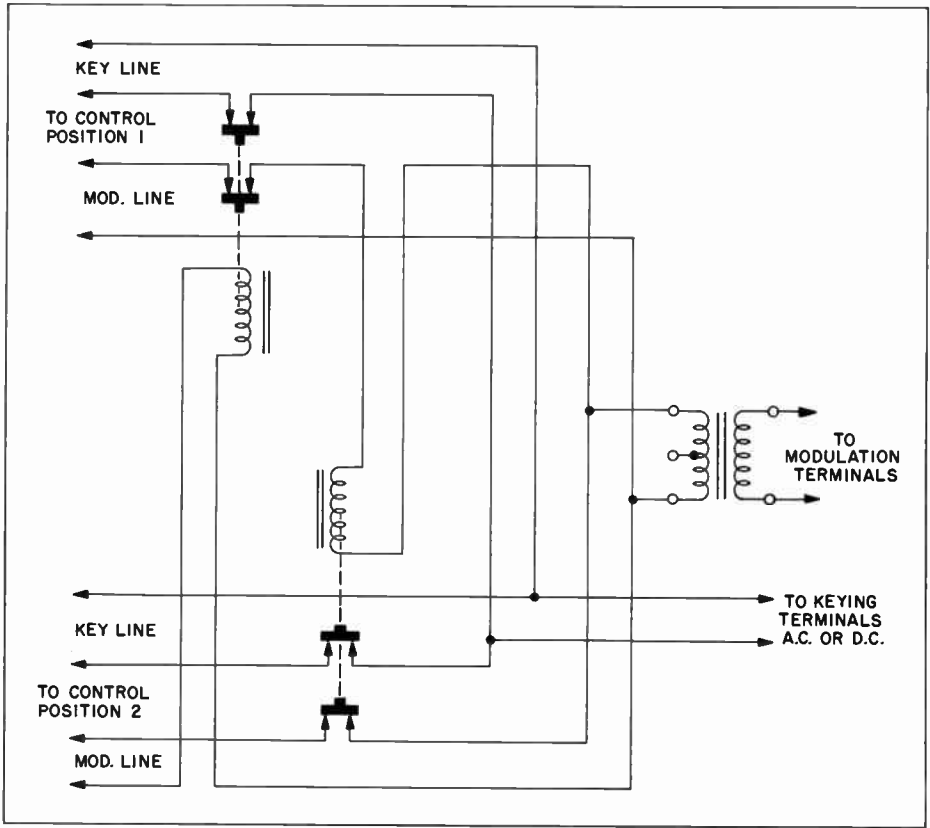
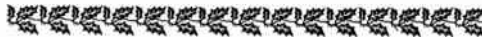

Figure 9. Lock-out Circuits for Dual Control of T-158B/FRT or BC-329 Transmitters

inal strips of the soldering type are preferable; otherwise, lock-washer-type soldering lugs should be used for all cable connections. To simplify maintenance, all relays on either of the relay

panels should be of the same type. The power supply should provide from 25 to 30 volts, when 24-volt relays are used. The microphone should be shunted with a current-limiting resistor, if necessary.



Index for Vol. II—Philco TechRep Division BULLETIN

	Month	Page
A		
AFC Tuning for AN/APQ-13.....	January	32
Airborne IFF Transponders, A Simple, Easily Constructed Unit for Pre-Flight Checking of.....	November	39
Air Force Communications—Electronics Publication, New.....	April	13
Antennas:		
Television Wide-Band Antennas, Physical Constants for.....	July	21
Lightning Protection of Radio Transmitters and Antennas.....	August	20
Radar Antenna Systems.....	November	18
Arc Breaker for R-F Transmitters.....	October	4
Artificial Respiration, Newly Approved Methods of.....	October	16
B		
BC-779 Receiver, Improving Stability of H-F Oscillator in.....	April	31
Book Reviews	March	17
BULLETIN Binders	August	Inside front cover
C		
Cable Connector	February	17
Circuits:		
Circuit Tracing, Aid to.....	March	18
Direct Coupled Amplifiers	April	3
Operational Analysis of a Phase-Modulator Circuit.....	May	11
Constant-Current Voltage Regulation.....	September	3
Construction:		
Screen Room Construction.....	May	3
Frame-Type Building Construction, Some Pointers on.....	November	10
Control Circuits for Tower Installations.....	December	28
Crystal-Diode Tester, A.....	May	47
D		
DBE Loran Equipment, Calibration Adjustments of.....	May	47
Design and Application of the Pi Network.....	December	4
D-C Generators, Increasing Field Excitation of.....	March	14
Direct Coupled Amplifiers.....	April	3
Dynamotor Test Stand, A.....	March	12
E		
Editorials:		
New Series of Articles on Transistors.....	January	3
Patentable Ideas from Field Personnel.....	February	2
New Training—Article Series.....	March	2
The Use of Mathematics in Technical Articles.....	April	2
Specialization Versus Diversification.....	May	2
Growth in the Electronics Industry.....	June	2
Microwave—The “Hybrid” of the Industry.....	July	2
The “Grass is Always Greener . . .” Myth.....	August	2
Training—The Economical Way to Increase the Effectiveness of Electronic Equipment	September	2
You Can Help Solve the Technical Man-power Shortage.....	October	3
The Mounting Cost.....	November	3
Another Year of Progress.....	December	3

Index for Vol. II—Philco TechRep Division BULLETIN (Continued)

	Month	Page
Effects of Electric Shock on the Human Body.....	June	20
Electronic Computers—Part I.....	November	4
Electronic Computers—Part II.....	December	16
“ELI the ICE Man”.....	January	15 <i>Inside back cover</i>

F

FCC Policy, New.....	January	15 <i>Inside front cover</i>
Field Fabricated Two-Path-Polar Line Unit, A.....	February	15
Frame-Type Building Construction, Some Pointers on.....	November	10

G

Gyro Precession and Automatic Gyro Erection.....	February	9
--	----------	---

L

Lightning Protection of Radio Transmitters and Antennas.....	August	20
Line Checking SCR-695, Trigger Device for.....	March	11
LORAC—What It Is and How It Works.....	March	19

M

Magic T, Theory and Application of the.....	July	3
Microwave:		
Model 623B Microwave Test Set, The.....	February	18
New Training Manual—CMT-4.....	March	28
Basic Multiplex Theory.....	August	14
Negative Feedback and Its Application to Philco Microwave Radio Relay Equipment.....	September	10
Miller Effect, The.....	August	3
Modifications of Equipment:		
Modification of the AN/CPS-6B Stalo.....	April	11
Improving Stability of H-F Oscillator in BC-779 Receiver.....	April	31
Modifying the SCR-211(*) to Provide a Frequency-Shifted Test Signal.....	November	8
Modification of the ID-73/CPS-1 Plan-12 Indicator.....	December	22

N

Negative Feedback and Its Application to Philco Microwave Radio Relay Equipment.....	September	10
Non-Magnetic Tools in the Vicinity of a Magnetron, The Use of.....	November	17

P

Phase-Modulator Circuit, Operational Analysis of a.....	May	11
Phase-Sequence Tester.....	February	8
Phasing of Power Transformers, A Quick Method for Determining the.....	March	15
Philco Training Materials.....	March	3
Pi Network, Design and Application of.....	December	4
Popular Misconceptions.....	March	27
Power:		
A Dynamotor Test Stand.....	March	12
Increasing Field Excitation of D-C Generators.....	March	14
A Quick Method for Determining the Phasing of Power Transformers.....	March	15

Index for Vol. II—Philco TechRep Division BULLETIN (Continued)

	Month	Page
Power (Continued):		
Starting and Operating Three-Phase Motors on a Single-Phase Line	August	10
Power-Output Meter for AN/APN-1.....	April	32
Publications, Useful Signal Corps Supply.....	December	11

R

Radar:		
AN/APQ-13, AFC Tuning for.....	January	32
AN/CPS-6B Stalo, Modification of the.....	April	11
Simultaneous Interference—Free Operation of Two Adjacent Radars	June	30
Radar Interpretation in the Northland.....	July	14
Theory and Application of the Magic T.....	July	3
Radar Interference Blanker, A.....	July	17
Radar in E.T.O. Air-Ground Operations.....	October	9
Radar Antenna Systems.....	November	18
Radio-Compass Maintenance, Two Useful Tools for.....	January	34
Reference List of Schematic Symbols.....	December	23
Regulation of Large Power Supplies.....	October	27
Relays, Tester for Octal-Base.....	January	38

S

SCR-211(*) to Provide a Frequency-Shifted Test Signal,		
Modifying the	November	8
Schematic Symbols, Reference List of.....	December	23
Screen Room Construction.....	May	3
Secondary Frequency Standard, A.....	February	3
Shorted Three-Wire Line:		
An Application of Simple Mathematics to a Field Problem.....	May	46
Signal Corps Supply Publications, Useful.....	December	11
Slide Rule for Frequency Calculations, Use of the.....	June	18
Supply Publications, Useful Signal Corps.....	December	11
Sync Separation and the Gated-Beam Vacuum Tube.....	June	3

T

Technical Information Requests.....		
August	13	
Television:		
Intercarrier Television Systems.....	January	4
Television Interference Elimination.....	February	20
TV Tuners, Low-Noise Consideration in.....	May	17
Sync Separation and the Gated-Beam Vacuum Tube.....	June	3
Television Wide-Band Antennas, Physical Constants for.....	July	21
Test Equipment:		
Tester for Octal Base Relays.....	January	38
Secondary Frequency Standard, A.....	February	3
Phase Sequence Tester	February	8
Tester for VB-16 Vibrators, A.....	February	11
Model 623B Microwave Test Set, The.....	February	18
Low Sensitivity Voltmeters, Increasing The Accuracy of Measurements Made With.....	February	27
Trigger Device for Line Checking SCR-695.....	March	11

Index for Vol. II—Philco TechRep Division BULLETIN (Continued)

	Month	Page
Test Equipment (continued):		
Dynamotor Test Stand, A.....	March	12
Power-Output Meter for AN/APN-1.....	April	32
Crystal-Diode Tester, A.....	May	47
Testing 2C39 Tubes for Use in the TDZ Transmitter.....	July	31
Modifying the SCR-211(*) to Provide a Frequency-Shifted Test Signal	November	8
A Simple, Easily Constructed Unit for Pre-Flight Checking of Airborne IFF Transpondors.....	November	39
Three-Phase Motors on a Single-Phase Line, Starting and Operating	August	10
Tower Installations, Control Circuits for.....	December	28
Training Aids:		
New Training Manual—CMT-4	March	28
Philco Training Materials.....	March	3
New Air Force Communications-Electronics Publication.....	April	13
Transistors:		
Introduction to Transistor Electronics—Part 1A.....	January	11
Introduction to Transistor Electronics—Part 1B.....	April	14
A Note on Transistor Development.....	July	32
Introduction to Transistor Electronics—Installment III.....	September	17
Transmitters:		
Testing 2C39 Tubes for Use in the TDZ Transmitter.....	July	31
Lightning Protection of Radio Transmitters and Antennas.....	August	20
Arc Breaker for R-F Transmitters.....	October	4
Trimmer Capacitor, An Easily Constructed.....	June	29
Tools:		
Two Useful Tools for Radio-Compass Maintenance.....	January	34
Non-Magnetic Tools in the Vicinity of a Magnetron, The Use of	November	17
V		
VB-16 Vibrators, A Tester for.....	February	11
Voltage Regulation:		
Constant-Current Voltage Regulation.....	September	3
Regulation of Large Power Supplies.....	October	27
Voltmeters:		
Increasing the Accuracy of Measurements Made With Low Sensitivity Voltmeters.....	February	27
W		
“What’s Your Answer?”:		
“Bright and Dim” Problem.....	January	40
Solution	February	40 <i>Inside back cover</i>
“Identification of Magnetized Bar” Problem.....	February	40 <i>Inside back cover</i>
Solution	March	26
“Connection of Buzzers” Problem.....	March	26
Solution	April	30
Practical Use of January’s “What’s Your Answer?” Circuit.....	March	30 <i>Inside back cover</i>
“RLC Circuit” Problem.....	April	30 <i>Inside back cover</i>
Solution	May	48

“What’s Your Answer?” (continued):

“Resonant Frequency” Problem.....	May	48
Solution	June	19
“Two Lamps and Two S-P-S-T Switches” Problem.....	June	<i>Inside back cover</i>
Solution	July	20
“Farm Wiring” Problem.....	July	<i>Inside back cover</i>
Solution	August	28
“Generators and Selenium Rectifiers” Problem.....	August	19
Solution	September	<i>Inside back cover</i>
“Identifying Wires in a Cable” Problem.....	September	16
Solution	October	32
“What Kind of Tube?” Problem.....	October	26
Solution	November	38
“Impedance Match” Problem.....	November	38
Solution	December	19
“The Great Joule Robbery” Problem.....	December	20

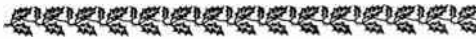

In Coming Issues

At long last, we have an article on Guided Missiles. Many *Bulletin* readers have asked for such an article, but until very recently we had not found anyone who had the required combination of data, experience, and writing ability to prepare it. We are, therefore, very pleased to announce that “Introduction to Guided Missiles,” by Philco Field Engineer Merle E. McDougall, will appear in an early issue.

The author, currently assigned to a guided-missiles training project, has compiled a really impressive volume of material on his subject, and we were most pleasantly surprised to find that all of it could be published without involvement in security problems.

