

PHILCO

TECHREP DIVISION BULLETIN



OCTOBER
1952

PHILCO TECHREP DIVISION BULLETIN

Published Monthly by
The TechRep Division of Philco Corporation
Philadelphia, Pennsylvania

Volume II

OCTOBER, 1952

Number 10

CONTENTS

Editorial	3
<i>By John E. Remich</i>	
Arc Breaker for R-F Transmitters	4
<i>By J. E. Sullenger</i>	
Radar in E.T.O. Air-Ground Operations	9
<i>By Brigadier General E. Blair Garland</i>	
Newly Approved Methods of Artificial Respiration	16
What's Your Answer?	26
Regulation of Large Power Supplies	27
<i>By Gail W. Woodward</i>	
Solution to Last Month's "What's Your Answer?"	32
In Coming Issues	Inside Back Cover

Editor
John E. Remich

Managing Editor
Robert L. Gish

Technical Editors
Francis R. Sherman
Gail W. Woodward

**EDITORIAL OFFICE:
PHILCO CORPORATION
TECHREP DIVISION
22nd and LEHIGH AVENUE
PHILADELPHIA 32, PA.**

If any information contained herein conflicts with a technical order, manual, or other official publication of the U.S. Armed Forces, the information in the official publication should be used.



Vertical Plotting Board in World War II Tactical Air Control Center (This dramatic wartime photograph is from the article, "Radar in E.T.O. Air-ground operations," by Brigadier General E. Blair Garland—see page 9.)

Editorial

YOU CAN HELP SOLVE THE TECHNICAL MANPOWER SHORTAGE

By John E. Remich, Manager, Technical Department

In past editorials appearing on this page, we have commented on the current shortage of trained scientists and engineers. A recent article in the New York Times reported some statements on the same subject by Dr. John R. Steelman, who, until very recently, was Acting Defense Mobilizer. The chief points of the article are worth repeating because Dr. Steelman's message has a direct application to all of us who are engaged in scientific research, development, or technical training of any kind.

Dr. Steelman pointed out that only 1% of the working population of the United States is engaged in engineering and the biological and physical sciences, and that to a large extent, all possibility of future increases in our standard of living, and our national security itself depend upon this 1%. According to Dr. Steelman, scientific research and development during the next few years must, in the interest of national security, be telescoped into about half the time that such programs ordinarily take. The fact that Dr. Steelman is very pessimistic about what can be done to remedy the situation should give us all a mental jolt. He believes that if anything is to be accomplished, it must be done by (1) the full utilization of the abilities of the engineers and scientists now available, and (2) the attraction and training of an increasingly greater number of men and women to the scientific professions.

We who are already in this field are in a position to *do something constructive* about this situation. All of us are in daily contact with persons new in electronics, some of whom may not be in this field by choice. Whether in "on-the-job" training, formal classroom training, or in any other phase of field-engineering activity, our enthusiasm for our own jobs in electronics will do much to help sell engineering as a career to those with whom we work. Every trainee whom we thus persuade to remain in the field of electronics releases an additional engineer for employment at a higher technical level, thus resulting in a double step toward the solution to this urgent national problem.

ARC BREAKER FOR R-F TRANSMITTERS

By J. E. Sullenger
Philco Field Engineer

A simple, thyatron-controlled relay circuit for breaking arcs in the r-f section of a transmitter.

(Editor's Note: This article was received shortly after Bud Compton's article on the same subject had gone to press [August, 1952 BULLETIN]. We feel that this approach will furnish further valuable material on the subject.)

THE NEED FOR A DEVICE of the type described in this article arose from the costly and annoying interruptions to a broadcast transmitter, caused by thunderstorms, and by small winged insects entering the transmitter and flying into the final r-f amplifier tank coil. These conditions were experienced in semi-tropical climate, but they might easily occur in any location where summer thunderstorms are prevalent, or where very small flying insects are common.

These two causes of arcs in the transmitter were overcome with the same piece of equipment. The nature of the arcs was such that once they were started they would not clear themselves. The operator had to remove B+ voltage from the final amplifier, or an overload relay would drop out and the transmitter would then have to be turned on again manually by the operator. This often resulted in damage to the final tubes and rectifiers, loss of revenue to the station because of interruption of paid announcements, and loss of customer good will.

This device will automatically interrupt any arc in the final amplifier or antenna tuning unit of an r-f transmitter, and then return the circuit to normal operating condition

in approximately 1/10 of a second. The circuit operates on the principle that a reduction in carrier strength occurs when there is an arc in the final tank or antenna tuning unit. The device will also provide an external personnel alarm if one is desired.

Although the device was originally designed for use with a broadcast transmitter, it will work equally well with any type of transmitter that has an overload circuit to which it can be attached.

PRINCIPLE OF OPERATION

The principle used is not unique, and has proved very successful in this application. The circuit is shown in figure 1. The input is a tuned r-f transformer (such as is found in receiver antenna circuits) coupled to a diode detector (V_1). The negative voltage developed by the detector is used as bias on a 2050 thyatron (V_2) which has a control relay (K_1) connected in its plate circuit. The plate of the thyatron is supplied with a-c voltage from the power line, and acts as its own rectifier. When an arc occurs in the final tank or antenna tuning unit of the transmitter, the strength of the radiated signal is reduced. This causes the output of the diode rectifier to be reduced, which, in turn, reduces the bias on the thyatron.

The thyatron then conducts, and the relay in its plate circuit is energized. When the relay is energized, the transmitter final amplifier will have B+ removed, and will remain

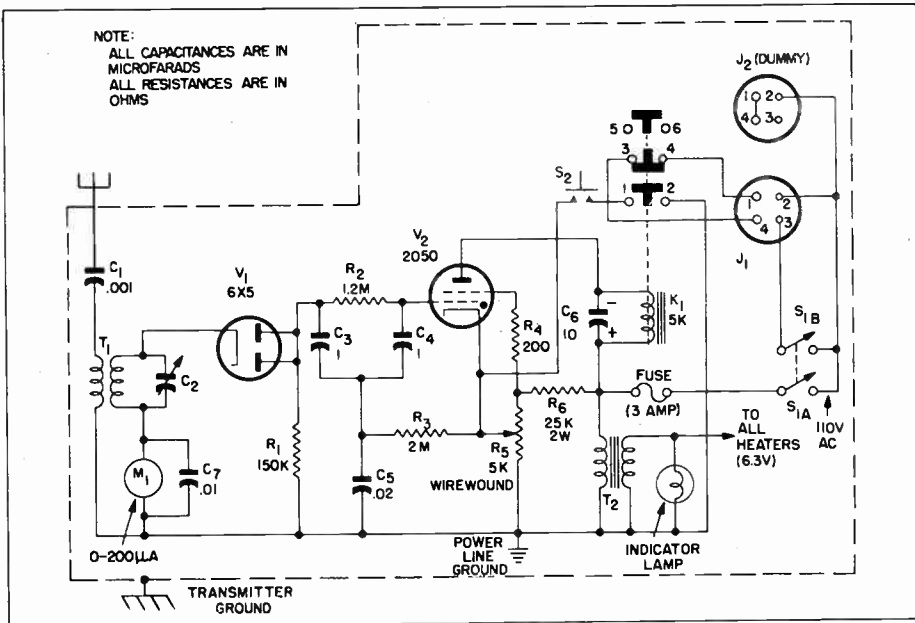

Figure 1. Schematic Diagram of Arc Breaker

off for a period of approximately 1/10 second. This has proved to be sufficient time to quench any arcs, and yet is hardly perceptible to anyone listening to the signal.

The normal transmitter has control circuits built into it to afford protection to the high-voltage-rectifier power supply and tubes (see figure 2). These control circuits function, with slight variations, as follows: One switch on the cabinet (the main line switch) will turn on the voltage to all filaments, as well as the plate voltage to all low-power stages (such as the exciter and buffer), and start the action of a time-delay relay. Sixty seconds after the filaments are turned on, the high voltage may be applied to the final tubes. To apply high voltage to the final tubes, a momentary contact switch, S_3 , is pushed—this causes the B+ contactor, K_2 , to be energized. Once K_2 is energized, it receives power through a set of holding contacts. Connected in series with the relay coil are the

protective relays and the arc breaker contacts (shown in figure 1 as contacts 3 and 4). The protective relays consist of the overload relay, time-delay relay, underload relay, thermal cutout, and any other protective relay or devices, including the arc breaker. If any one of these relays should open, the B+ contactor would open, and thus remove high voltage from the final tubes.

S_{1A} is the power-line switch. It is ganged with S_{1B} which is connected across the TRANSMITTER ON switch (S_3), so that when the arc breaker is caused to cycle and the B+ contactor, K_2 , drops out for 1/10 second, K_2 will again be energized through S_{1B} when relay K_1 is de-energized. Normal operation of the transmitter circuit (without the arc breaker) is such that the TRANSMITTER ON button, S_3 , must be actuated by an operator each time the B+ contactor drops out.

S_2 is provided for the purpose of

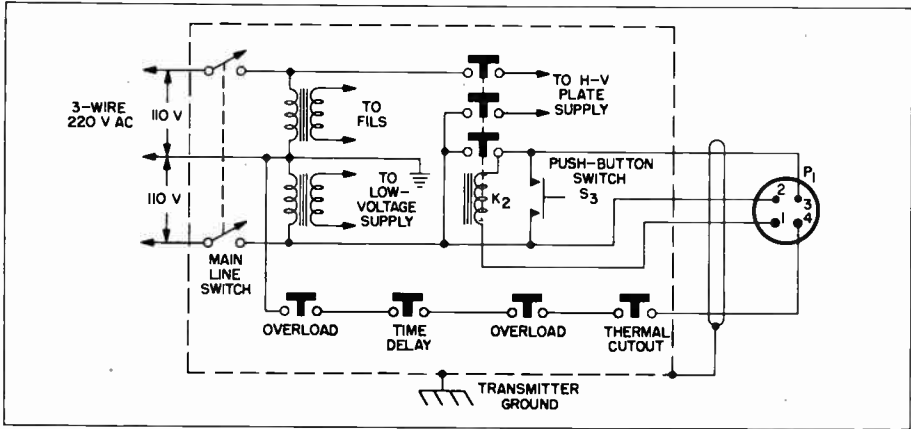

Figure 2. Schematic Diagram of Transmitter Control Circuits

allowing the operator to turn off B+ to the final tubes in the case of excessive recycling of the arc breaker. The action of this switch is as follows: Closing S_2 shorts out cathode resistor R_5 during one of the break periods and causes V_2 to conduct all the time. This causes K_1 to be energized continuously, and hence will keep the B+ contactor, K_2 , open until S_2 is released. This feature allows long-term arcs to be broken manually.

DETAILED CIRCUIT ANALYSIS

R-f energy is picked up by the antenna and coupled through C_1 to the transformer T_1 . T_1 is tuned to resonance by C_2 . (Resonance of the input circuit will be indicated by maximum reading on M_1 , a 200- μ a. movement. The length of the pickup antenna should be adjusted until the maximum reading on M_1 is about midscale.) One end of transformer T_1 is connected to the cathode of V_1 , while the other end is connected through M_1 and a bypass capacitor, C_7 , to the common-ground bus. Energy coupled through T_1 is applied to V_1 where it is rectified. This rectified signal develops a d-c voltage across R_1 , which is applied to the grid of V_2 through the filter network consisting of C_3 , C_4 , C_5 , R_2 , and R_3 .

During the time the transmitter is operating normally, this negative voltage on the grid of V_2 is sufficient to keep it nonconducting; thus, the relay in its plate circuit is not energized, and the transmitter is not affected.

As soon as an arc occurs, there will be a drop (or a complete loss) of radiated signal. This will result in less bias being developed at the grid of V_2 , and the tube will conduct. When V_2 conducts, relay K_1 will be energized, opening contacts 3 and 4. When contacts 3 and 4 open, the coil of the B+ contactor, K_2 , is opened, and the relay drops out, thus removing B+ voltage from the final tubes of the transmitter.

C_6 is an electrolytic capacitor which is connected across relay K_1 to act as a time delay for the operation of relay K_1 , so that when V_2 conducts, K_1 is energized and remains energized for approximately 1/10 second. Thus, the operation of the circuit is such that when the transmitter develops an arc, it will be turned off for 1/10 second, then placed back on the air. (If it is necessary to use a K_1 coil value other than that specified, C_6 can be chosen so as to provide the required time constant.)

As soon as V_2 conducts, grid current will charge grid filter capacitor C_4 . The charge on C_4 is sufficient to cause V_2 to be nonconductive for several cycles of a-c line voltage. The time constant of the filter network in the grid circuit of V_2 is such that V_2 will remain in a nonconductive state for approximately one second.

The foregoing action will be repeated once every second until the arc is cleared. Normally only one cycle is required. If it is desired, a stepping relay can be connected into the circuit, as shown in figure 4, so that the unit will recycle three times and then shut down the transmitter completely. (This feature was not used on the original installation.)

CONSTRUCTION DETAILS

All parts were mounted on a $\frac{1}{8}$ -inch bakelite panel used as a chassis. This simplified the connection of the unit to the a-c line since there was no electrical connection between the electrical ground and the outside cabinet. A copper bus was used to act as common ground for circuit connections. The cabinet used was of metal construction with a hinged lid and a removable bottom plate secured by sheet-metal screws. The cabinet acted as the shield for the unit, and was bonded to the ground system of the transmitter. All outside connections were brought out through plugs and jacks. The jacks were mounted securely on the bakelite chassis, and holes were cut in the cabinet to receive the plugs. No special precautions were required to prevent signal pickup other than the use of shielded cables with the shields brought out of the plugs and secured to the cabinet. The antenna was brought through the cabinet by a feed-through insulator. The antenna proper was a short length of 14-gauge solid copper wire. The proper length will

depend on the field strength present at the transmitter, and is determined by trial and error. (Approximate length in this installation was 18 inches.) A dummy jack was provided on the cabinet to receive the plug coming from the transmitter, so that adjustments could be made on the unit while the transmitter was on the air. This blank jack had pins 1 and 4 shorted so that the transmitter would operate in the normal manner when the cable was removed from the arc-breaker jack and plugged into the dummy jack.

OPERATIONAL ADJUSTMENTS

Insert the plug from the transmitter into the dummy jack. Place the transmitter on the air in the normal manner. Turn on the arc breaker and allow it to warm up. Tune C_2 for maximum reading on the meter. If it reads less than half scale, increase the length of the antenna. If M_1 reads more than half scale, shorten the antenna. Next, adjust R_5 until relay K_1 is clicking on and off, then reduce the setting of R_5 just enough so that relay K_1 is not energized. Reduce the radiated power from the transmitter (by reducing the plate voltage to the final tubes or by changing the coupling or tuning of the antenna) until the radiated power is down 20%. The arc breaker should then be cycling relay K_1 on and off. If it is not, reduce the setting of R_5 until it just starts cycling. Adjustment of R_5 is not critical, but proper setting is very important. Then, bring the transmitter up to normal radiated power. The arc breaker should then stop cycling, and K_1 should remain de-energized. Pull the plug from the transmitter out of the dummy jack (J_2) and insert it in J_1 on the arc-breaker chassis. This completes the adjustments, and the unit is in operation. Any reduction in output power

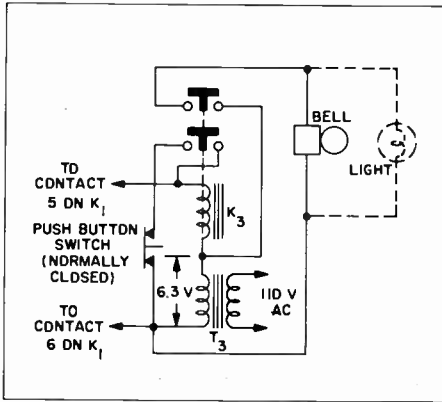

Figure 3. Schematic Diagram of Personnel Alarm

of more than 20% will cause the arc breaker unit to cycle. Normal line-voltage variations will not cause the unit to cycle.

SUGGESTED CIRCUIT ADDITIONS

Personnel Alarm

A personnel alarm could prove to be a valuable addition to this unit in some installations. It can be connected easily. The only modification required is an additional pair of normally open contacts on relay K_1 (5 and 6) and an additional plug to make these contacts available outside of the arc-breaker unit (see figure 3).

Relay K_3 will be energized on the first cycle of arc-breaker operation, and will remain energized until the operator resets it by pushing S_4 . Of course, the bell and/or lights will remain on until reset switch S_4 is pressed.

The personnel alarm and bell may be mounted at any convenient location within wiring distance, and as many bells or lamps as required may be connected in parallel, within the limits of power transformer T_3 .

Three-Cycle Cutout

A stepping relay may be con-

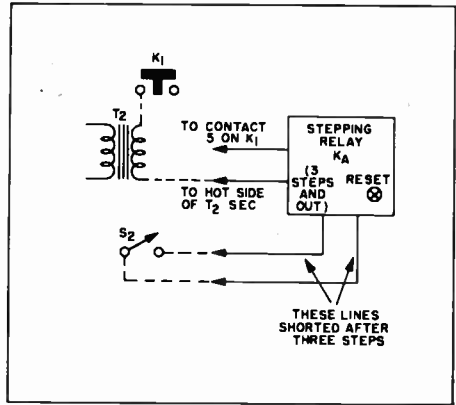

Figure 4. Method of Connecting a Three-Cycle Cutout to Arc Breaker

nected in a similar manner to the arc-breaker unit. The suggested location would be on the arc-breaker chassis, and it could be powered from filament transformer T_2 . When connected as shown in figure 4, relay K_4 , the stepping relay, would receive an impulse each time relay K_1 was energized. As soon as relay K_1 cycles three times, a pair of contacts on K_4 would close and short out S_2 . This would take the transmitter off the air until the operator corrected the trouble and reset the stepping relay, K_4 .

CONCLUSION

The arc breaker has been successful in accomplishing its objective, which was to lessen the noticeable effects of the arcs, and to eliminate manual restarting of the transmitter when arcs occurred. The only preventive maintenance required has been periodic cleaning of the relay contacts. No parts failures have occurred to date. The unit has been in successful operation for the past 18 months.

The author wishes to acknowledge the valuable assistance of Philco Field Engineer, Ernest Weinberg in the preparation of this article.

RADAR IN E.T.O. AIR-GROUND OPERATIONS

By Brigadier General E. Blair Garland

Commanding General, A.A.C.S.

A historical summary of the development of the forces responsible for aircraft control and warning, and for tactical control of Allied offensive aircraft during the European "second-front" invasion and the subsequent campaigns of World War II.

(Editor's Note: This article first appeared in the March-April, 1949, issue of SIGNAL magazine, and appears here through the courtesy of the Armed Forces Communications Association, publisher of SIGNAL. This is the first article of its type to be printed in the BULLETIN. Additional articles providing historical data on present-day communications and electronic systems and equipments are invited, and will be published from time to time.)

As the key to the success of all tactical air operations is the effective flight control of fighter aircraft in one form or another, it was the evolution of such a control system that loomed as the major task facing the tactical air forces in Europe in World War II. Here for the first time an attempt was being made to use a complete aircraft warning and fighter control network as an integral part of a tactical air force working in close cooperation with ground forces.

The primary requisite of such a system was the immediate knowledge of its own aircraft as well as that of the enemy. With little or no existing precedent the whole had to be molded from a heterogeneous welter of personnel originally trained for purely defensive operations, and from whatever equipment could be made available. As it turned out, the radar sets were mostly British with a sprinkling of American. As to the mode of operation, there was still less of a precedent.

ANY STORY OF RADAR in air-ground operations in Europe must go back to the winter of 1942-1943 and the Eighth Air Force in England. At that time a board of officers headed by General Follett Bradley, Inspector General of USAAF (not Gen. Omar Bradley), came to the European Theater primarily to determine the Air Force personnel requirements for the strategic air force, and secondarily, the personnel requirements for a tactical air force. The tactical air force would be the one to cooperate with the American ground forces when

they opened a second front by invading the Continent.

The signal section of the Eighth Air Force was working on plans for the procurement and installation of the British H₂S¹ airborne radar in American Pathfinder airplanes, and on the training of air crews for these airplanes, in an effort to defeat the notoriously bad European weather.

¹ Code name for British blind bombing radar set, later replaced by American H_X radar set (AN/APS-15).

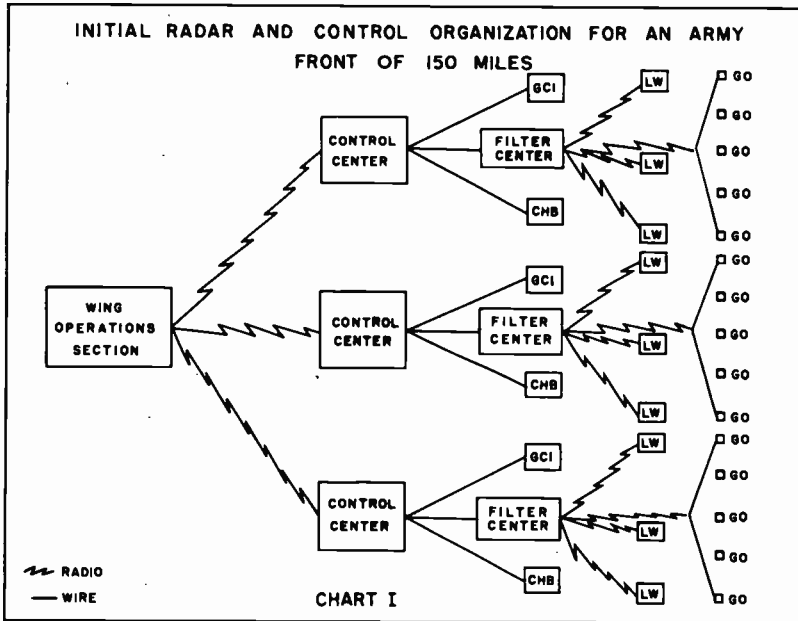

It was therefore natural that Gen. Bradley turned to this section for help in establishing the personnel requirements for radar and communications personnel for such a tactical air force.

It must be borne in mind that very few people at the time had any real conception of what the radar organization of a tactical air force should look like, or what its capabilities and limitations might be. The USAAF had had no combat experience with tactical radar units in the field, while the RAF had had some slight battle experience with such a unit in Africa.

Exact information as to the composition of the ground forces and in what numbers they would make the assault on the fortress of Europe was also extremely hard to pin down, which further hampered the planners. The estimate indicated that there would be two American armies covering a front of 150 miles. Why a 150-mile army front was suggested and used by the Americans in planning has always been a mystery, although

in reality it was fortunate in that it did insure that sufficient personnel and equipment would be made available. The British, on the other hand, based their plans on an army front of 50 miles, exactly the total initial front established, which was more realistic in view of the range of the radar sets available to them. However, what was most important was the official acceptance of a plan. Whether or not it changed the next day would in no way detract from it.

The initial organization proposed for an army front was designated an air defense wing, simply for the lack of a better title. The wing (Chart 1) included an operations section and three control centers, each with a filter center similar to the familiar sector plan for a fixed installation. Each filter center had five GO² posts and a maximum of three LW³ radar sets

²Ground Observer (an individual who reported aircraft from visual observation).

³Light Warning (a small, lightweight radar set).

reporting into it. Each control center had a GCI⁴ radar set and CHB⁵ radar set reporting directly to it. Such a scheme was not difficult to trace back to the elaborate fixed British home air defense system, and would obviously have been as unwieldy as it was complex.

Inquiry was made to the United States as to the availability of mobile radar equipment of such ruggedness as to be suitable for a ground radar organization in a moving situation. Word came back that no equipment of the type required was available. By now it was summer of 1943, and the Signal Officer, cognizant of the fact that an ultimate invasion would take place and that it might be soon, decided that immediate action was necessary. Time could not be wasted in waiting for new equipment to be developed and manufactured in the States.

The British, from their limited air-ground combat experience in the African desert, had done considerable experimenting with mobile-type radar, and with various types of organizations to operate them. In fact, they had by this time settled on an organization (RAF 83 and 84 groups) and on the types of radar sets to be used with the organizations, and were in the process of manufacturing the sets in quantity. Arrangements were made through the Air Ministry to see the finished sets in action.

BRITISH SETS PROCURED

The sight of RAF 83 Group actually conducting intensive commando-type training in the field in preparation for the invasion, while the Americans

were still making plans on paper, caused no little concern. Although the sets appeared to require an overwhelming number of vehicles for operation, and were subject to jamming because of their low frequency, it was decided that they would fill the immediate requirement. Since the British could produce sufficient sets by December, 1943, for both the Americans and themselves, an order was placed for enough sets to equip five of the "paper" aircraft warning units. This decision on the part of the Signal Officer seems questionable, based on hindsight. It must be remembered, however, that the commander and the staff of the Eighth Air Force at the time were completely engrossed in their own plans for the immediate strategic situation. They could hardly be impressed by the future requirements of an unknown tactical air force for a land action that might or might not take place at some indefinite date.

With the radar equipment arranged for, radar and communications personnel based on the Bradley board report were ordered from the States. These included signal battalions, air support command; signal construction battalions, heavy; fighter control squadrons; tactical air communication squadrons; aircraft warning battalions; and wing signal companies sufficient for two tactical air forces of five fighter wings. At the same time, communications equipment to tie these organizations into workable control systems was requisitioned. It was not a small undertaking.

THE MEW

One other incident that was to have considerable bearing on future radar operations on the Continent was the arrival in England of the American radar set familiarly known as the

⁴Ground Control Intercept (a radar set used for control of interception of enemy aircraft by friendly aircraft).

⁵Chain Home Beam (a radar set used for reporting only).

MEW⁶. This set, which had recently arrived from the States, had been obtained by the Eighth Air Force at the request of the RAF, for use on an experimental basis in directing and controlling long-range fighter sweeps from the south coast of England. It had been installed in an advantageous spot on the coast, overlooking the English Channel and the coast of France, and both the Americans and the British shared in controlling missions and sweeps from it.

Among the senior controllers was Capt. Edwin Andrus, an American electronics group officer who had had considerable success, while with the British, in experimenting with the controlling and directing of day fighters by means of long-range radar. His was to be an important role in the future development of the radar organizations used by the Americans.

The MEW set, weighing 66 tons, and installed in permanent buildings at Start Point, Devon, England, amazed those responsible for it by its fine definition and extremely long range. It gained immediate publicity by a thrilling episode in which it picked up 14 Fortresses flying out over the Atlantic on their return from a mission over Germany. Because of faulty navigation they thought they were leaving the coast of Belgium, when actually they were leaving the Brest peninsula. As their fuel was low and they failed to see the coast line of England, the leader gave the order to ditch, and radioed to that effect. At that moment, the MEW picked them up on its scope 170 miles away. By quickly identifying them by D/F radio, the controller talked all 14 of the planes back to England. Although

several had engines out and several were on fire, they all touched down safely.

As the aircraft warning units arrived from the States they were quartered in the field in tents, and preparations were made to initiate them into the intricacies of the British radar sets they were going to use in combat on the Continent. With the increased influx of personnel, one unit after another was sent to the very fine British radar training center at Renscombe Downs. Here they received their sets and equipment, and went into the field to operate as small, separate units rather than as a part of any organized reporting and control scheme.

The organization of each battalion as it completed its training varied but slightly, depending on whether it was intended for the role of operating with the tactical air commands or for the role of air defense of the rear areas. Each battalion took its place in the field with its fighter wing and its associated fighter control squadron⁷. Constant field exercises involving sudden moves without advance notice were held to test mobility and improve operations.

FIRST ACTION

The 555th Signal Aircraft Warning Battalion and the 327th Fighter Control Squadron were assigned to the 70th Fighter Wing. They were immediately deployed in the area about Colchester, and were the first to receive their baptism of fire when German planes made a night air raid on the town. There they began to operate as an integrated control and warning unit of the 70th Wing's fighters, who

⁶ Microwave Early Warning (AN/CPS-1, operating on 3000 mc., with a range of 200-250 miles on a bomber formation at 30,000 ft.).

⁷ The unit which maintained and operated the air-ground radio channels and the radio direction-finding system.

Figure 1. Controllers and Plotters Grouped Around Plotting-Board at IX Tactical Air Command Fighter Control Center, Verviers, Belgium (Joint TAC-Army operations room may be seen through rear window)

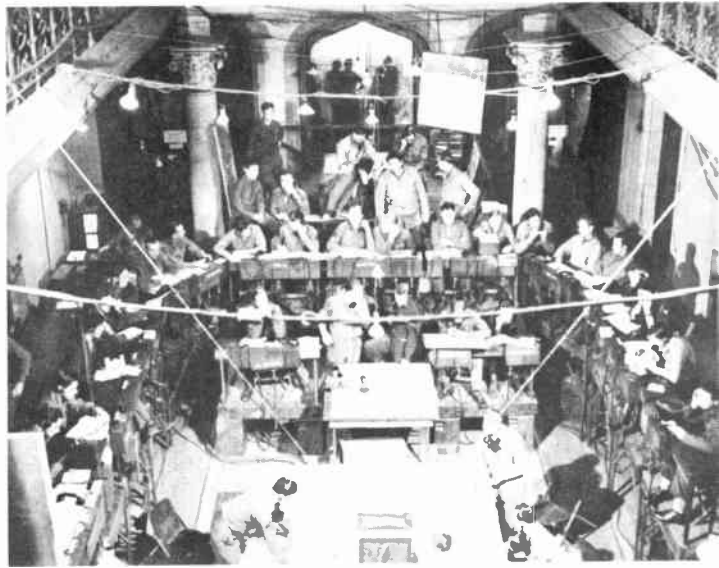

were assisting the Eighth Air Force as escort, and were flying independent fighter sweeps in training for the invasion. Their point-to-point and air-ground radio equipment had not yet arrived, and it appeared, among other disappointments, that keyed radio would be used for reporting. This bit

of gloom was shortly dispelled by the arrival of fine new VHF FM⁸ 30-40-mc. and 70-100-mc. voice radio equipment from the States.

⁸Very-high-frequency frequency-modulated radio which is less susceptible than ordinary amplitude-modulated radio to disturbance from static and noise.

Figure 2. Plotting Board at FDP where Maximum Filtering Possible Was Accomplished



TYPICAL CONTROL AND WARNING ORGANIZATION AS DEVELOPED IN COMBAT IN EUROPE FOR AN ARMY FRONT OF 50 MILES

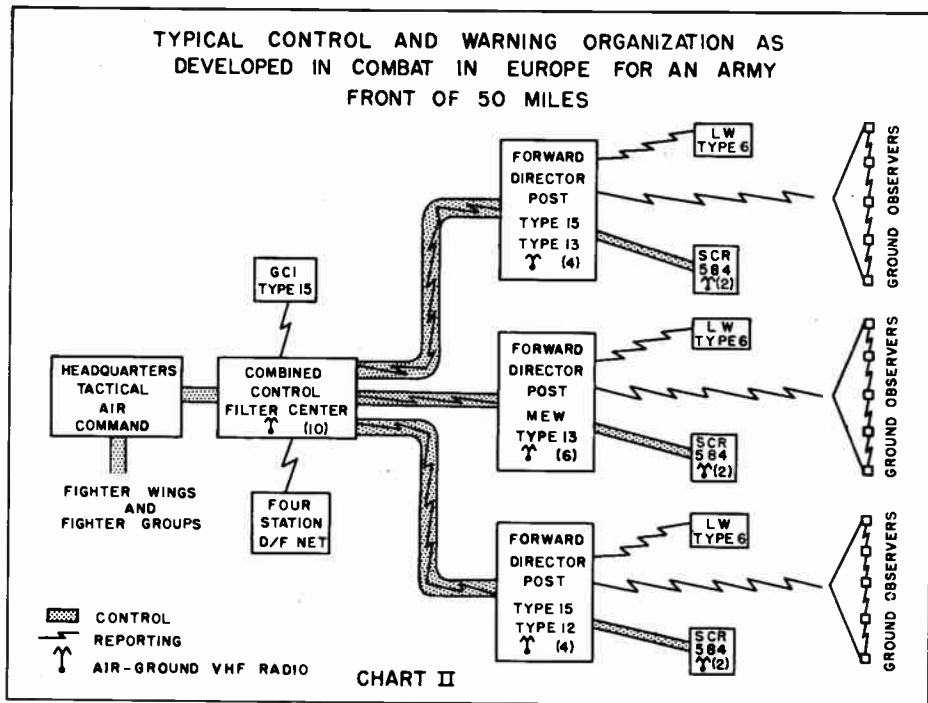

CONTROL IMPROVES

From here on until "D" Day, constant improvements and revisions were made in the organization and operating procedures of the radar battalions, and their equipment was mobilized to the maximum extent possible in trucks and trailers. By now the initial complex control organization had been simplified so that each fighter wing had a combined control-filter center with VHF air-ground channels (Chart II), a four-station VHF fixer net, and a type-15⁹ radar set for early warning and GCI control. Reporting to the center were three forward director posts, each consisting of a miniature combined control-filter center with its VHF air-ground channels, a type-15 and a type-14¹⁰ early warning radar



Figure 3. Controller Briefing Himself on the Latest Ground Situation and Bomb Line Prior to Going on Duty

⁹ British set operating on 209 mc., with a range of approximately 90-100 miles.

¹⁰ British set operating on 600 mc., with a fairly narrow beam. Approximate range: 100 miles.

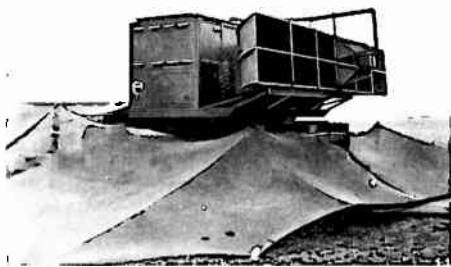

Figure 4. MEW Antenna Mounted on a Trailer Chassis for Rapid Transportation

set, and a type-13¹¹ radar set for height finding. A ground-observer net of five observer posts and a type-6¹² light warning radar set reported to each forward director post. The LW set was intended to cover any blind spots suffered by the FDP because of rough terrain.

BRITISH HIGH CHASSIS

The British radar vehicles with their high chassis and lack of four-wheel drive struck a sour note with the Americans, who took for granted the utility of American trucks. A landing exercise simulating the actual landing of vehicles on the beaches of Normandy was carried out in April. The Signal Officer, with members of the aircraft warning battalions, attended the practice landing; when the few radar vehicles in the test stalled in the surf and were left to the mercy of the rising tide (a passing American standard six-by-six truck with a winch finally pulled them out), a decision was made that every radar vehicle participating in the invasion must have its British chassis replaced by an American standard six-by-six

¹¹ British set operating on 3000 mc., with a narrow vertical beam for reading accurate elevations. Approximate range: 60-70 miles.

¹² British set operating on 212 mc., with a range of 40-50 miles.

or cab-over-engine type of chassis. With great energy, and aided by the closeness of D-Day and the all-out backing of the commanding general, an enterprising ordnance company performed this unbelievable task in a matter of days.

Still another haunting fear brought about a last-minute change in plans. The constant nightmare that the Germans might jam the low-frequency British radar sets, coupled with the phenomenal success of the MEW fixed radar station at Start Point, caused the planners and the commander to pause a moment and consider. A second MEW set had just arrived in England, and was being set up for testing. The operating characteristics of these sets far exceeded those of any known set at the time, but the great question was whether sixty-six tons of delicate technical equipment could be mobilized sufficiently to permit its use in an invasion, and whether it would remain operable

(Continued on Page 18)

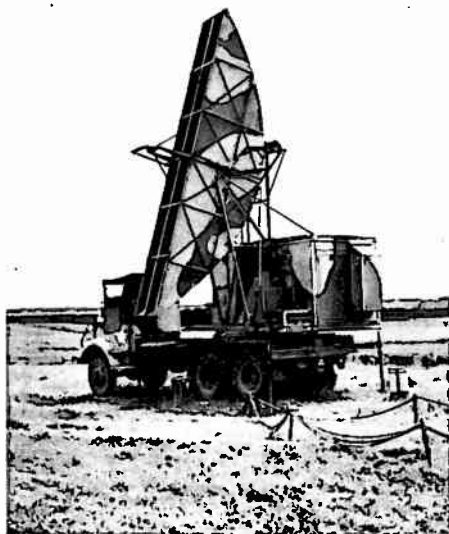

Figure 5. Type-13 Height-Finding Radar (Note American cab-over-engine chassis.)

NEWLY APPROVED METHOD OF ARTIFICIAL RESPIRATION

A Step-by-Step analysis of the Holger-Nielson method of artificial respiration.

(Editor's Note: The Holger-Nielson method of artificial respiration has been adopted by the Armed Forces and by the Red Cross as the most efficient of the many resuscitation methods now in existence. Therefore, in view of the possibility of accidents involving electric shock among electronics personnel, we believe that this material will be of considerable interest and value to our readers.)

The text of the article originally appeared as an American Red Cross publication (#ARC-1086), and is reprinted by permission of the American National Red Cross. The drawings were prepared by our own staff artist, Mr. Adolph Heinrich.)

POSITION OF THE SUBJECT

Place the subject in the face-down, prone position. Bend his elbows and place his hands one upon the other. Turn his face to one side, placing his cheek upon his hands.

POSITION OF THE OPERATOR

Kneel on either the right or left knee at the head of the subject, facing him. Place the knee at the side of the subject's head, close to his forearm. Place your opposite foot near his elbow. If it is more comfortable, kneel on both knees, one on either side of the subject's head. Place your hands upon the flat of the subject's back in such a way that the heels lie just below a line running between the armpits. With the tips of the thumbs just touching, spread the fingers downward and outward.

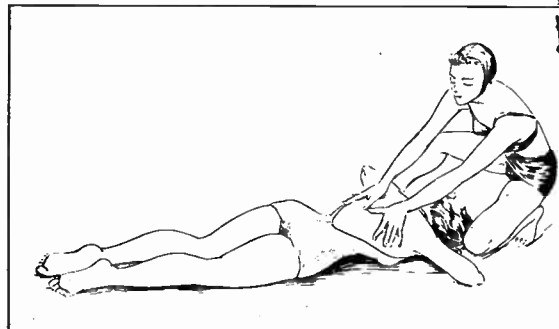

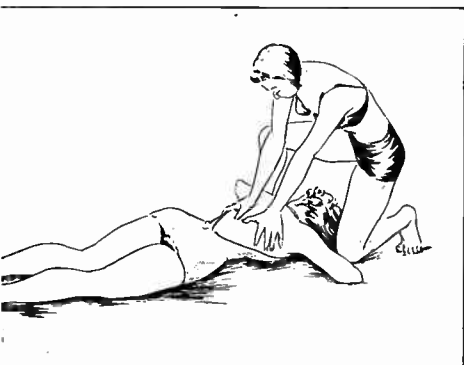

COMPRESSION PHASE

Rock forward until your arms are approximately vertical, and allow the weight of the upper part of your body to exert slow, steady, even pressure downward upon the hands. This forces air out of the lungs of the subject. Your elbows should be kept straight, and the pressure exerted almost directly downward on the back.

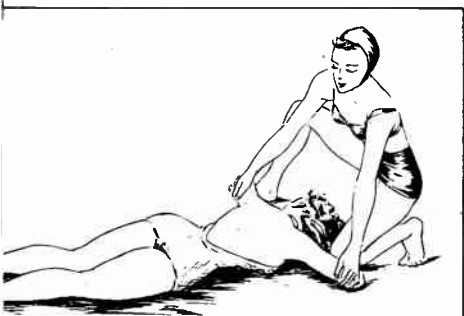

EXPANSION PHASE

Release the pressure, avoiding a final thrust, and commence to rock slowly backward. Place your hands upon the subject's arms just above his elbows, and draw his arms upward and toward you. Apply just enough lift to feel resistance and tension at the subject's shoulders. Do not bend your elbows, and as you rock backward, the subject's arms will be drawn toward you. Then drop the arms gently to the ground. This completes the full cycle. The arm-lift expands the chest by pulling on the chest muscles, arching the back, and relieving the weight on the chest.

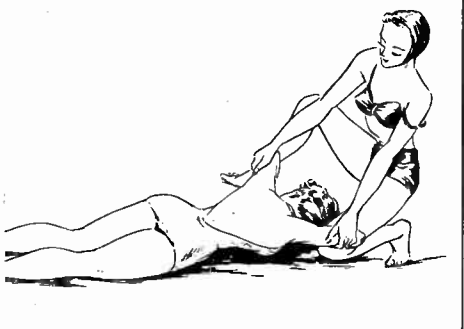

The cycle should be repeated 12 times per minute at a steady, uniform rate. The compression and expansion phases should occupy about equal time; the release periods being of minimum duration.

ADDITIONAL RELATED DIRECTIONS

It is all important that artificial respiration, when needed, should be started quickly. There should be a slight inclination of the subject's body in such a way that fluid drains better from the respiratory passages. The head of the subject should be extended, but not flexed forward, and the chin should not sag lest obstruction of the respiratory passages occur.

A check should be made to ascertain that the tongue or foreign objects are not obstructing the passages. These aspects can be cared for when placing the subject into position or shortly thereafter, between cycles.

A smooth rhythm in performing artificial respiration is desirable, but split-second timing is not essential. Shock should receive adequate attention, and the subject should remain recumbent after resuscitation until seen by a physician, or until recovery seems assured.

RADAR IN . . .

(Continued from Page 15)

throughout the continuing campaign. The antenna itself weighed six tons, and was engineered for mounting on a concrete base. How could it possibly be hauled across a beach and then through Europe?

A hasty trial was held in which expert linemen of a signal construction battalion laid down a temporary base of twelve-by-twelve timbers in place of concrete. The little time consumed in laying the base and raising the antenna, as well as the steadiness of the base, were so impressive that it was decided the mobilization could be accomplished. Orders were given at once to mobilize the second MEW set in 2-1/2-ton, six-by-six Ordnance M-7 type trucks, and a new combat loading plan was approved by the Army for placing it on the landing craft in place of one of the 555th's type-15 sets. Work began on April 15, after much scurrying for equipment by British Branch Radiation Lab,¹³ which had accepted in its stride this last-minute job, and eleven days later the MEW was on wheels and ready to roll.

Time was short for anything more than a cursory trial on the south coast near Exeter, but indications pointed to tremendous possibilities. The operations room, the control room, the test and maintenance equipment, the power and communications facilities, and the antenna were installed or carried in five M-7 type vans and five standard 2-1/2-ton trucks.

Although this was an amazing step forward, it was far cry from the elaborate field installation which included Jamesway shelters that the MEW was to grow into as it attained new heights in controlling aircraft on the Continent. The third set that ar-

rived in England shortly afterward was speedily mobilized by BBRL.

As D-Day approached, more and more simulated landing exercises such as Duck, Tiger, and Beaver were held by the Army. Landing on the wrong beach, arrival at the wrong time, and discovery that many of the radar vehicles with their unwieldy antennae could not board the landing craft for which they were scheduled, all pointed toward the care and detail that had to be put into such operations, and gave those involved many headaches along with much needed experience.

Meanwhile, Neptune, the implementing plan for the real thing, was taking form. Unit commanders were brought in, cleared for TOP SECRET, and briefed on their exact role in the detailed plan. Aerial photographs were studied, and a model of the beachhead was constructed to show the contour of the ground behind the beaches, in order to assist in the selection of the initial radar sites and to indicate the nearest exits from the beach.

Briefly, the plan was this: The fixed radar screen on the south and south-east coast of England was to do the reporting, controlling, and vectoring of fighter aircraft during the assault phase, assisted by radar sets mounted on fighter direction ships just off the hostile shore. The first control and radar equipment ashore in the American sector was to be a GCI set from the RAF 85 Group, since this Group was charged with the air-defense of the beachhead, and was to remain there in an air-defense role as the battle moved forward. American controllers were assigned to control American aircraft flying over the beachhead. Two light warning sets of the 555th were to follow the British ashore, to act as early warning for the GCI fighter control set, followed immediately by the 70th

¹³A branch of Radiation Laboratory at M.I.T. which built the first MEW sets.



Figure 6. Plotters Behind Vertical Plotting Board, Tracking Aircraft (Writing is done backward so as to be correct when viewed from front.)

Fighter Wing components. As soon as the 70th Wing had its control center set up on the beachhead, the fighter direction ships were to pass control to it. Needless to say, this plan required the most minute detailing so that the proper echelons would be put ashore in the proper order to insure a balanced buildup of radar and control equipment, and of communications and radar operating personnel to do the task at hand.

ON OMAHA BEACH

The story of what actually hap-

pened is of interest. The radar vehicles and men of the first echelon arrived off Omaha beach at approximately 5 o'clock in the afternoon of D-Day to find the beach a shambles of dead and wounded assault troops and blasted equipment, not yet entirely cleared of obstacles and the enemy. The tides had run so strong earlier in the day that the 16th Infantry's regimental combat team had landed east of their beach, Easy Red covering exit E-1, and after heavy losses and hard fighting were still in the process of clearing the beach of German defenses.

The radar teams were caught in a stream of ground units too late to turn back. The radar vehicles were landed in the sand amid continuous fire from mortars, machine guns, and small arms. Many of the men and officers were badly wounded, including the wing commander in charge, and many of the vehicles were damaged so badly that they were permanently out of commission. The unwieldy vehicles, by dint of great heroism and leadership on the part of several of the officers and men, including those Americans present, were finally driven off the beach and up a draw to the east of the village of St. Laurent Sur Mer, where they were out of the immediate gunfire.

Early the following day the light warning sets were on the air reporting aircraft. By D + 2 the commanding officer of the 70th Fighter Wing arrived with the first increment of the fighter control center. They at once moved into Griqueville and assumed control of aircraft from the fighter direction ship off Omaha beach. Simultaneously, the first elements of Headquarters IXth Tactical Air Command and the Headquarters of the First Army landed and set up¹⁴ near Grand Camp. The Air Force was ashore. Gradually the remaining elements of the Wing, the IXth TAC, and the fighter groups themselves came ashore. Many of them were so close to the front that at various times they were under fire by German troops and artillery.

The 84th Fighter Wing followed by the 100th Wing landed over the Utah beach, and took their positions in the Cherbourg peninsula to assume control of their fighter-bombers. By

¹⁴The close liaison necessary between a tactical air command headquarters and an army headquarters requires that the two headquarters be established in close physical proximity to each other.

D + 6 the MEW was ashore, and in four more days was on the air controlling the first of the thousands of missions it was to control. As the ground troops fought their way slowly through the hedgerows, and the Allied landing became a certainty, control of American aircraft was taken over completely by the units in Normandy. The radar sets themselves edged forward as fast as the front permitted, and were of tremendous value in assisting the fighters in support of the ground troops. No longer were they training for the battle to come—they were now in it, and playing for keeps.

RADAR SCREEN MOVES FORWARD

It is well to pause here and review what has gone before in order to examine the method by which the air cooperated with the ground through the use of radar and the communications available. As far as the radar itself was concerned, it had developed through various stages—from the fixed chain of home beam stations surrounding the British Isles to the mobile type-15 early-warning sets, and then to the addition, at the last moment, of the American MEW. During the preinvasion period all warning and control functions were performed from the combined British-American control center at Uxbridge, just outside London, and from sectors such as Tangmere, Middle Wallop, and Biggin Hill. During the assault phase, the fighter direction ships lying off Normandy beach had acted as forward direction posts, and had assumed control of the aircraft over the invasion area. Then as the first radar sets became operational ashore, the radar screen was pushed forward and gradually severed from the rear tie to become a separate warning and control scheme. So much for the radar itself. Now, how did it fit into the tactical air force plan of operation?

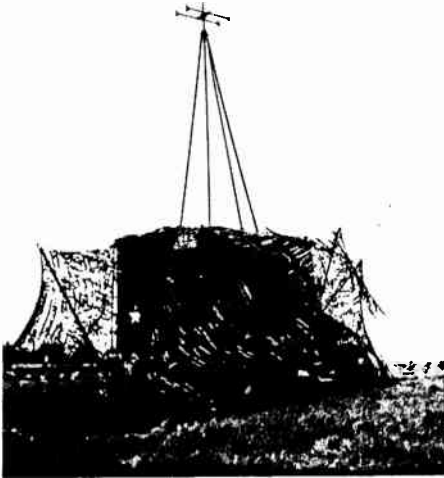

Figure 7. Antenna of Type-14 Radar Set

The initial plan of operation had its origin as far back as November, 1943. It had developed during the following months as equipment and facilities were improvised or became available from the States, and did not change materially during the campaign in Europe. It was visualized that requests for air support would originate at the division and corps levels through air liaison officers acting as air advisors to the commanders at each level. These requests would be transmitted by radio directly to the Tactical Air Command-Army Joint Operations Center, where the G-3 (Air) of the Army and the A-3 of the Tactical Air Command would approve or disapprove them. If approved, the A-3 would pass them on to the fighter wing for execution by its fighter-bomber groups. The wing control center was delegated the task of controlling and directing the mission as soon as it became airborne, and of assisting it in the location of its target by means of radar and radio D/F equipment. In addition, it was

responsible for warning of enemy aircraft, and for controlling interceptions of enemy aircraft both day and night.

This basic plan did not change. Its spectacular success in support of the ground armies was the criteria. Each of the tactical air commands followed this plan in general, although many variations and refinements occurred as the battle situation demanded. For example, following the breakout of the First Army at St. Lo, the rapid advance to the Seine River, and the continuing drive into Belgium, the control elements of the 70th Fighter Wing were taken over by IX Tactical Air Command Headquarters. The wing continued to retain command of the fighter-bomber groups, and became in effect the communications switching central of the Tactical Air Command.

LONG-RANGE RADAR CONTROL

Returning for a moment to the 555th Signal Aircraft Warning Battalion as a typical battalion, it is interesting to trace its progress across the Continent after the breakout in the beachhead. The two type-15 FDP's had come ashore and quickly gone into action. The sites had already been selected by ORS (Operational Research Section, composed of civilian scientific experts) personnel from studies made of aerial photographs and maps of the terrain. Such individuals as Mr. Arnold C. McLean, Mr. Roland W. Larson, and other personnel, under the direction of Mr. Carroll L. Zimmerman, performed little publicized but highly valuable work. The MEW arrived at its first site four miles east of Isigny on D + 7, and four days later introduced Allied pilots to long-range control. Though a bit skeptical at first, the pilots soon found themselves being led to their targets as far as 75 to 100 miles away, and were readily convinced that this was something not

only desirable, but actually necessary. The popularity of radar was at last established, and from then on the pilot could be certain that no matter where he was or where his target was, they could be brought together by this control agency. As the ground situation progressed, so did the experience of the fighter-bombers and their ground control. It soon became evident that the fighter control center, which was operating under the wing, could be more efficiently operated under the command. As the ground forces moved forward the TAC-ARMY headquarters moved directly behind the corps. The fighter-bomber groups, on the other hand, could not move as rapidly since it took time to prepare their strips and runways for them. This meant that the wing headquarters and its radar unit moved forward in order to look as far out as possible over the front lines, and in doing so the communication lines between the wing and its groups were extended beyond control. It was therefore decided that the radar and control units would be assigned to the command headquarters, thus requiring communications only from headquarters directly forward to the radar units. The wing would be located strategically in the center of the cluster of airdromes, permitting fairly short communication lines to the groups. The wing and the command could then be tied together by a single axis. This resulted in considerable saving in the communications requirement, and the fact that the very closest cooperation and liaison in planning between the TAC and Army was necessary, clinched the decision.

FORWARD POST EXPANSION

Greater emphasis was placed on the forward director posts, and each was given additional equipment to carry out its increased functions of control. The MEW whose FDP had

become the most important of the three FDP's expanded its operation room into a 24' x 24' Jamesway shelter, and its vertical plotting board was enlarged to 8' x 10'. More controllers were added to each FDP, more VHF air-ground channels were made available, the number of land-line circuits was increased to include teletype for transmitting the daily field order, and each FDP was given a type-13 height finder and two close-control SCR-584 sets. The function of the FDP's now included reporting all aircraft movements, controlling all local air patrols, positioning aircraft over targets, vectoring fighters home, assisting fighters in rendezvousing with bombers, directing fighters on sweeps after they had accomplished their dive-bomb missions, controlling both day and night reconnaissance missions, and lastly controlling night fighters in the interception of enemy aircraft and in night-intruder work.

EFFECTIVENESS OF SCR-584

The SCR-584 set mentioned above came on the radar scene in July, 1944, while St. Lo was still in the hands of the Germans. An operating crew had been trained on this American precision radar at Middle Wallop, under the auspices of BBRL. Originally designed for antiaircraft gun-laying, the set was a microwave radar used in precision control of aircraft. Its unusual feature was that once it picked up an aircraft, its beam could lock onto it and track it automatically. It had a plotting board with a 1:100,000 scale map, under which a tiny spot of light represented at any instant the exact position of the aircraft over the terrain. The movement of the aircraft was exactly followed by the movement of the spot of light on the map. By watching the spot of light and giving directions to the pilot by voice radio, the controller could direct the aircraft to its exact target.

The initial results were so extremely gratifying that additional sets were remodelled at once for the battalions of the other tactical air commands. These close-control radars came to play a decisive role in the radar screen. Located from four to ten miles behind the front, they controlled fighter-bombers to their targets, provided navigational aid to lost pilots, controlled blind-bombing through the overcast, controlled night fighters on night-bombing missions, and aided reconnaissance planes in photographing large areas. An interesting story that is typical of the experiences of the 584's is that of a flight of fighter-bombers that knocked out a beautifully camouflaged German gun battery. This particular gun battery was firing on a number of American tanks with devastating effect. It was finally located by sound detectors, and its position was sent to the fighter control center with a request that it be destroyed. A flight of fighter-bombers was vectored to the vicinity of the battery by the MEW, but the weather was so bad that the flight was turned over to the 584 for closer control. After several passes over the area the pilots still could not find the well-concealed battery. Finally, as they were about to leave, one of the guns fired and the flash was seen by the flight leader. The flight immediately dived on the battery and quickly destroyed it, to receive the hearty thanks of the tank commander and his tankers.

WITHDRAWAL IN THE BULGE

Many other spectacular stories could be told of radar operations as the battle progressed forward, became stationary, and then with the battle of the Bulge made a complete about face. No particular unit accomplished any more outstanding feats than any other. They all faced hardships,

heavy work, and even death in accomplishing their mission.

One story of interest concerns the 555th during General von Rundstedt's great counteroffensive in December, 1944. The 555th had its FDP's with their 584 sets deployed on a generally north-south line from Aachen, Malmedy, St. Vith, and Bastogne, which was directly in the path of the German drive. The IXth Tactical Air Command Headquarters with its fighter control center was occupying the Palais du Justice building in Verviers, Belgium, with a view to remaining there for the winter.

The ground forces had decided, because of a shortage of supplies, not to start a new offensive until the spring of 1945. The 70th Wing was at Liege and had its groups deployed in the area of Charleroi-Liege. The MEW, which had been destroyed in late November by a fire caused by an exploding gasoline stove, had been restored to its original state by new equipment hurriedly flown from the States.

Then on the fateful morning of December 16th, word filtered back that the Germans were on the move and in sufficient number to prove that it was an all-out attack. There is no need to repeat what happened on the ground as far as the courageous American doughboys are concerned. As soon as the attack began to firm up, orders were given by the air operations officer to withdraw all radar equipment to the west of the Meuse River. In spite of heroic action under small-arms fire by the crew of the FDP at St. Vith, two radar sets were lost and three men were taken prisoner. No one will deny that except for their unselfish perseverance under conditions of ice, snow, and mud, much more equipment would have been lost to the enemy. The MEW,

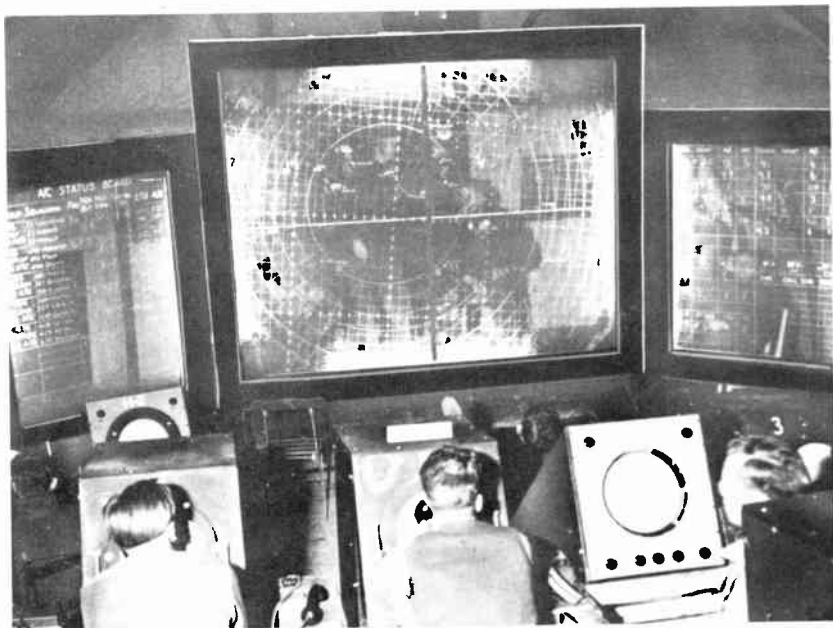

Figure 8. Vertical Plotting Board of MEW, and Remoted Height-Finder Scopes (H-1 and H-2)

which was sited near Eupen, held its position until a German paratrooper captain was killed by a crew member as he was about to attempt the destruction of the set with TNT charges.

RADAR CONTROL'S RECORD

A new ground line was established generally east-west from Aachen, Liege, Namur, and Charleroi, which shifted the radar screen from looking east to looking south over the right side of the German spearhead, and covering the First Army's area. After the paratrooper incident the MEW moved into a new position just north of Liege, and was on the air again within forty-eight hours controlling fighter-bombers under the most difficult weather conditions. The planes played a major part in stopping the German advance by bombing and strafing the tank and motorized columns on the ground. In its new location the MEW was constantly

harassed by buzz bombs, as it was unfortunately in a direct line of the buzz bombs intended for Antwerp and Brussels.

In spite of this, the record shows that for December the MEW-controlled fighter-bombers destroyed 161 German aircraft and damaged 72, with 11 probables. On one outstanding day a controller was credited with 12 kills and 11 damaged. As soon as the ground-battle situation improved, the radar sets were back again on the offensive, following the First Army front as it moved across the Rhine and deep into Germany. By this time German aircraft were a rarity, and the air battle became one of exploitation. The final days of the war found the IXth Tactical Air Command Headquarters at Weimar, the seat of the onetime German Republic, and presently the site of the notorious Buchenwald concentration camp.

The use of radar in mobile air-ground operations came into its own

in the battle of Europe. It began more as a reporting facility, but like a flash it became an indispensable part of tactical air operations. The art of controlling tactical air missions was learned the hard way—in actual combat. Today that art is being perpetuated by the Tactical Air Command. The signal aircraft warning battalion and the fighter control

squadron have been integrated into a single, streamlined, efficient organization, which performs the duties of the old organizations with greater ease and smoothness. The new organization is officially designated a Tactical Air Control Group, T/O & E 1-600, and is fully described in War Dept. Field Manual FM 31-35, "Air-Ground Operations."



BRIGADIER GENERAL E. BLAIR GARLAND was born in Philadelphia, Pennsylvania, November 29, 1903. After graduating from high school at Rochester, New York, in 1922, he attended the University of Rochester for a year, and then entered the U.S. Military Academy at West Point, New York. He was graduated from the Academy and commissioned a second lieutenant in the Signal Corps on June 14, 1927.

General Garland received his Master's degree in electrical engineering from Yale University, New

Haven, Connecticut, in June, 1928, and a year later was graduated from the Signal School at Fort Monmouth, New Jersey. He then became athletic officer at the summer training camp at Fort Monmouth, and in September, 1929, was named post signal officer at Fort Jay, New York. In August, 1932, he entered the Telephone School of the American Telephone and Telegraph Company, in New York City, from which he was graduated in June, 1933.

General Garland then became assistant signal officer of the Hawaiian Department, at Fort Shafter, Hawaii. In May, 1935, he was named an instructor in the Department of Chemistry and Electricity at the U.S. Military Academy, West Point, New York, and five years later became a company commander and then a battalion commander at Fort Monmouth, New Jersey. He was transferred to the Office of the Chief Signal Officer, Washington, D. C., in September, 1941, for duty as executive officer of the Materiel Branch.

In March, 1942, General Garland was appointed signal officer of the Eighth Air Force, with which he moved to England in July, 1942. In November, 1943, he was named signal officer of the Ninth Air Force Fighter Command, which became the Ninth Tactical Air Command, with which he served in France and Germany.

General Garland returned to the United States in June, 1945, and the following month went to the Pacific theater for temporary duty with the Far East Air Forces. In November, 1945, he returned to the United States to become an advisor on the War Department Equipment Review Board, at Washington, D. C. In January, 1946, he was named advisor in aircraft warning activities at Continental Air Force Headquarters, Bolling Field, D. C., and the following April was appointed communications officer of Tactical Air Command, at Langley Field, Virginia.

On May 1, 1947, General Garland was transferred to the Air Force.

The following August, General Garland entered the Air War College at Maxwell Air Force Base, Alabama, and upon graduation in June, 1948, returned to Tactical Air Command Headquarters as Director of Communications.

General Garland went to Germany in September, 1949, to become com-

mander of the 1807th Airways and Air Communications Service Wing in Wiesbaden.

He assumed command of Headquarters Airways and Air Communications Service at Andrews Air Force Base, Maryland, on September, 28, 1951.

General Garland has been awarded the Legion of Merit, Bronze Star Medal, Air Medal, and French Croix de Guerre with Palm. While serving with the Eighth Air Force, he flew combat missions in B-17's testing and using radar equipment.

He was promoted to first lieutenant (permanent) December 18, 1932; to captain (permanent) June 14, 1937; to major (temporary) January 31, 1941; to lieutenant colonel (temporary) February 1, 1942; to colonel (temporary) July 9, 1942; to major (permanent) June 14, 1944; to colonel (permanent) April 2, 1948; to brigadier general (temporary) July 28, 1951, with date of rank from June 30, 1951.

What's Your Answer?

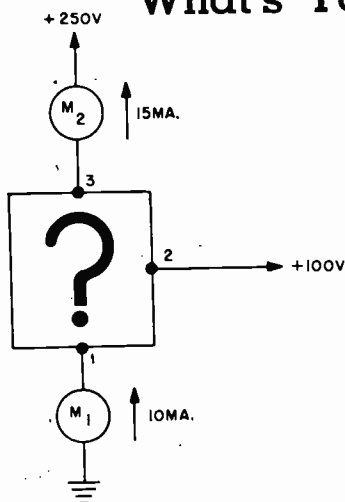

A technician is confronted with a single vacuum tube as indicated by the box in the drawing. He knows that the tube contains only one indirectly-heated cathode which is indicated by pin 1. Pin 2 is connected to a 100-volt supply, and pin 3 is connected to a 250-volt supply (very conventional so far). Two meters, connected as shown, indicate currents as specified in the drawing.

What kind of tube is being used, and how can the plate current exceed the cathode current?

Solution next month.

REGULATION OF LARGE POWER SUPPLIES

By Gail W. Woodward
Headquarters Technical Staff

The use of the saturable-core reactor provides efficient regulation of large power supplies. This article presents a method of regulation that has proved very satisfactory. (This article is based on data supplied by Sorenson and Company Inc., Stamford, Conn., manufacturers of the regulators described.)

ELECTRONIC regulation of a power supply involves three actions: a reference or comparison circuit, an amplifier, and a control circuit. Conventional circuits follow this pattern by using electron tubes for all of these functions. Of course, the control-circuit tubes must be able to withstand the entire current capabilities of the supply. This system works out very nicely until it is applied to a high-current system. (It should be understood that when we refer to a high-current system we mean one whose output is in the order of amperes. For industrial power systems using hundreds of amperes, the ignitron tube or some similar device is often used.) In some high-current regulators, as many as 15 or 20 power-amplifier tubes may be paralleled in order to obtain the required current rating. This method is expensive as well as somewhat inefficient.

The saturable-core reactor has provided the means for an excellent control device. If transformers or reactors are used as the control element, very efficient operation can be expected because of the low losses involved. Furthermore, transformers and reactors lend themselves more readily to large power capabilities.

A-C VOLTAGE REGULATOR

A relatively recently designed volt-

age regulator for a-c power systems is shown in figure 1. The heavy lines indicate the basic power circuit. T_1 is an autotransformer which provides the proper step-up ratio for the desired output voltage. T_2 is a saturable-core reactor. Since T_2 is connected in series with T_1 , the input voltage will be divided between them, with the relative voltages determined by the impedances presented by T_1 and T_2 . This action is shown in figure 2, which shows the equivalent circuit. For a given load, Z_{T_1} will remain constant—if the a-c input varies, it is only necessary to vary the inductance of T_2 to maintain a constant output voltage. Also, it can be seen that if the a-c input remains constant and Z_{T_1} varies, changing the inductance of T_2 will again allow compensation. Actually, variation of both the a-c input and Z_{T_1} could be compensated for by the action of T_2 .

The effective inductance of T_2 is varied by means of a d-c winding which controls the degree of core saturation. Large values of d.c. will result in a small value of inductance in T_2 .

DIODE VOLTAGE AMPLIFIER

Few people consider the diode tube as an amplifier. However, considerable gain can be obtained with a simple filament-type diode. For ex-

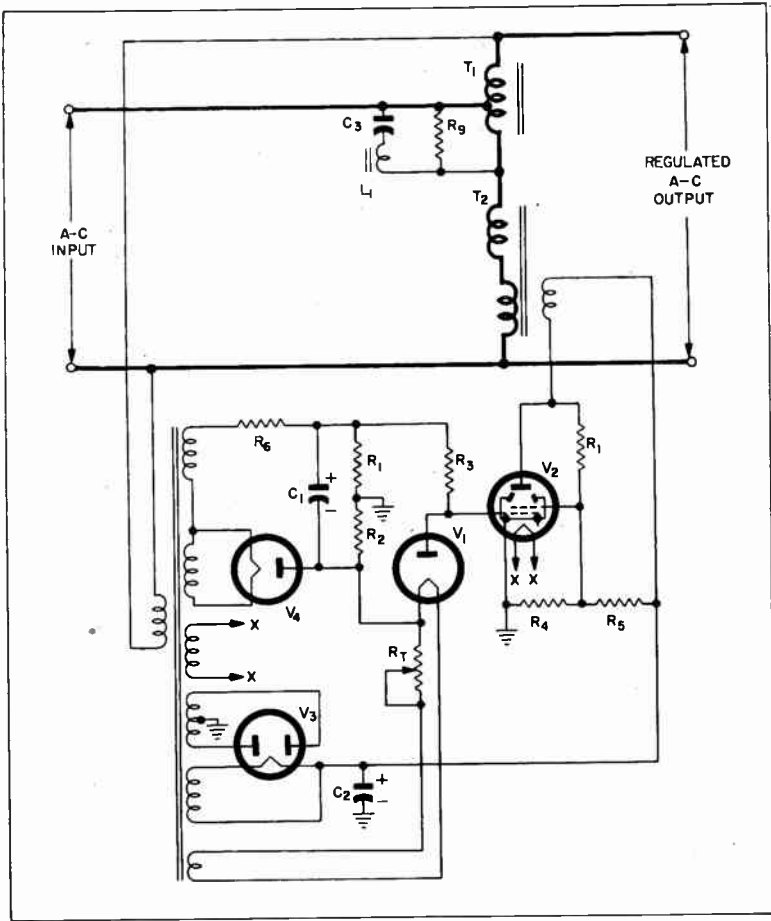

Figure 1. A-C Voltage Regulator Utilizing Saturable-Core Reactor as Regulating Element

ample, assume a temperature-limited diode connected as shown in figure 3. If the filament voltage is varied, the d-c resistance of the diode will also

vary. Thus, the voltage at the diode plate will change as the filament voltage is changed, and, since small

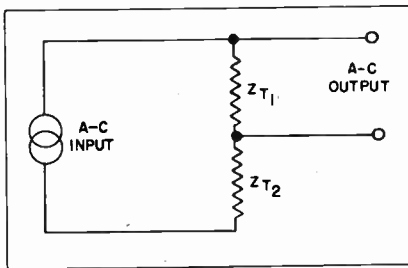

Figure 2. Simplified Equivalent Circuit of Figure 1, Showing Effective Impedances Involved in Regulator Action

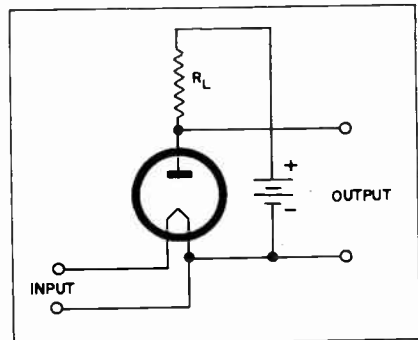

Figure 3. Basic Diode-Amplifier Circuit

changes in filament voltage produce large changes in plate voltage, gain (or amplification) is available.

CIRCUIT ANALYSIS

In figure 1, diode V_1 , in combination with R_1 , R_2 , and R_3 , forms a bridge circuit. The diode filament is heated by means of a transformer winding which derives its source from the regulated output. Two power supplies provide power for the regulator.

If the output voltage were to increase, the filament of V_1 would receive more voltage, thus increasing conduction through V_1 . This would cause the grid of V_2 to be driven more negative, thereby reducing the direct current through T_2 . The reduced current through T_2 would result in an increase in inductance, which would cause more of the a-c input to appear across T_2 and less of the a-c input to appear across T_1 . Less voltage across T_1 means reduced output. Thus, the action of the circuit insures that any change in output voltage will be cancelled.

The degree of regulation is determined by the effective gain of the system. In this circuit, the gain is considered to be the change in d-c voltage across T_2 , divided by the change in output voltage. The circuit in figure 1 has a gain of about 50,000, and the regulation obtained is $\pm 0.1\%$ over a wide range of input and load conditions.

R_T provides a means of adjusting the output voltage to a precise value. Since this control varies the diode filament current, it can produce a wide variation of output voltage without materially altering the efficiency of regulation.

WAVEFORM

Since the saturable-core reactor is

used to determine the output voltage, it is evident that saturation will result in distortion of the a-c waveform. This distortion is of the harmonic type, and can therefore be filtered. This function is accomplished by the filter composed of R_0 , C_3 , and L_1 , which can be made to hold the overall distortion to less than 3%.

RECOVERY TIME

The recovery time of a regulator is defined as the time required to recover from a sudden change (transient) in line voltage or load conditions. The actual value is taken at 63% recovery.

Regulators using electron tubes as control elements have very rapid recovery—so rapid that this factor is seldom considered. The regulator circuit in figure 1 has two sources of delay. The diode filament must heat and cool to effect regulation, and T_2 has an inductive-lag effect which tends to prevent changes in the value of d.c. In practice, it has been found that the T_2 is the limiting factor because the diode filament can be made to change temperature very quickly. A typical value for recovery time is about 0.1 second under the most adverse conditions.

Figure 4 shows a typical 1000-v-a. regulator. The overall size provides a graphic example of space economy.

LINE-DROP REGULATION

If the line between the regulator and the load is long, the line drop under varying load conditions can result in poor regulation even though the regulator itself delivers a constant voltage. The circuit which has been discussed lends itself very readily to compensation for line drop. Figure 5 shows a circuit modification to correct for this factor. Transformer T_3

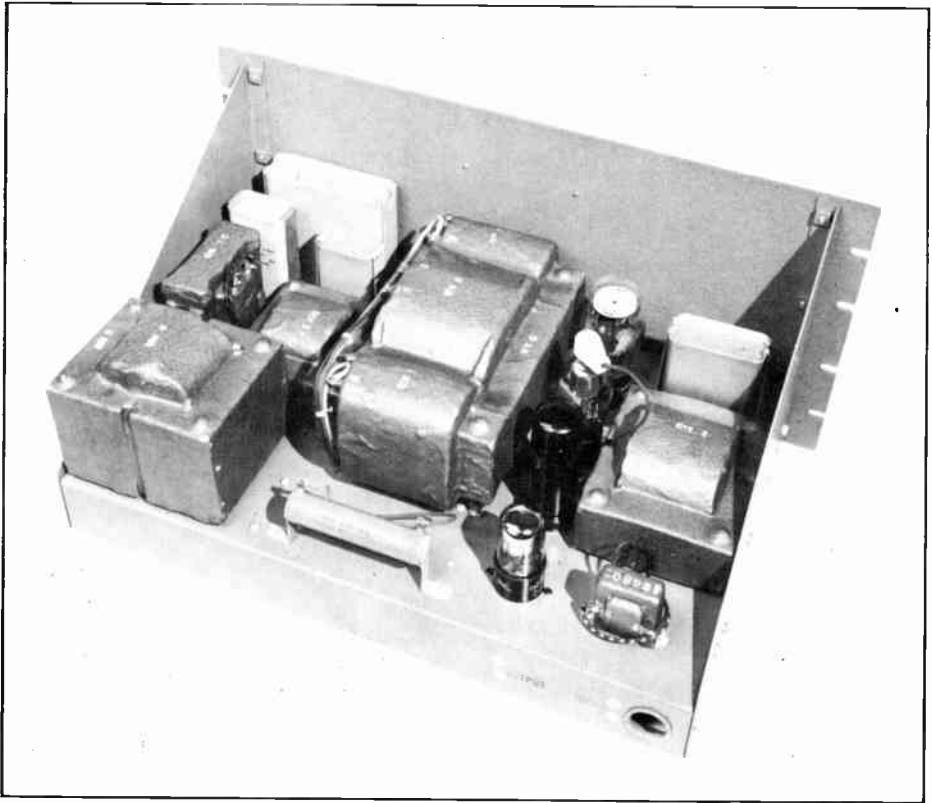

Figure 4. Typical 1000-V.A. A-C Voltage Regulator (This is the Model-1000-SF regulator produced by Sorensen and Company, Inc., Stamford, Conn.)

is connected across one line, so that any line-voltage drop will cause a current to flow in the primary of T_3 . The secondary of T_3 is connected in

series with the filament circuit of V_1 (figure 1). T_3 is phased to oppose the voltage normally supplied to V_1 . Thus, as the line drop is increased, the regulator output is raised sufficiently to provide exact compensation. R_8 is adjusted for a specific line-resistance value.

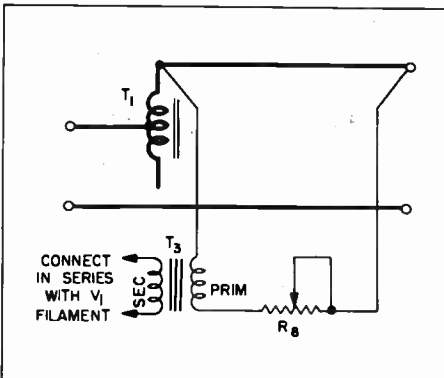

Figure 5. Schematic Diagram of Circuit Which Corrects for Changes in Line Drop under Conditions of Varying Load

D-C VOLTAGE REGULATION

High-current, low-voltage d-c power supplies can also be regulated in much the same manner as the a-c supply shown in figure 1 is regulated. Figure 6 shows a simplified schematic for a d-c regulator. The method of regulation is very similar to that used for a.c. except that the diode is operated from the d-c output and the output of T_1 now feeds T_3 , which is a

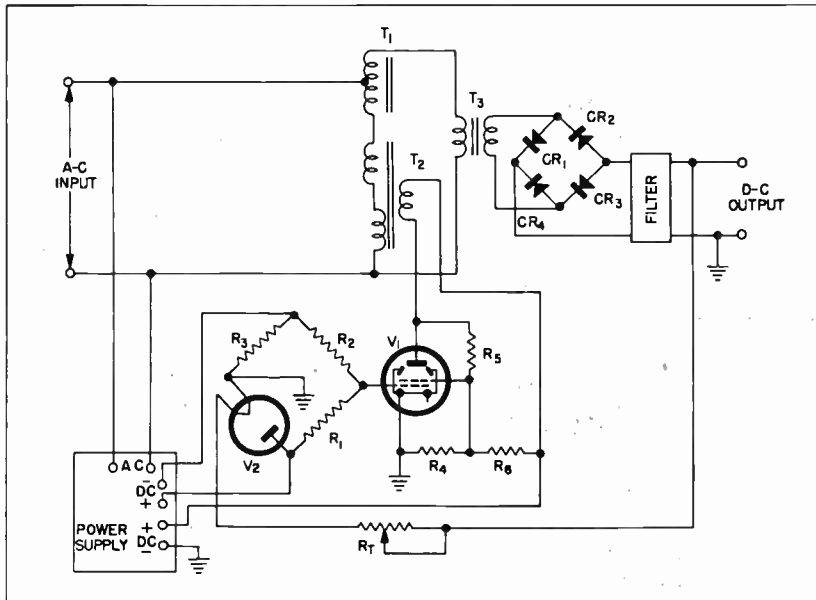

Figure 6. Simplified Schematic Diagram of D-C Voltage Regulator Utilizing Saturable-Core Reactor as Regulating Element

stepdown transformer designed to provide the proper voltage for the bridge-type selenium rectifier. As before, R_T provides the means for vernier adjustment of the output voltage. The regulation accuracy for such a circuit from one-tenth load to full load is $\pm 0.2\%$, and the time constant is about 0.2 second.

CURRENT REGULATION

The regulator circuits which have

been discussed are readily adaptable to constant-current applications. The d-c circuit could be made into a current regulator by energizing the diode filament from a small resistor in series with the load. In the a-c circuit, current regulation could be obtained if the diode filament were energized from a current transformer which is connected in series with the load circuit.

ERRATA

August issue, page 12—the fifth schematic in figure 3 should show a connection from the third phase winding to the junction of L and R.

Same issue, page 19—the BIBLIOGRAPHY should have appeared on page 9 as a part of the article titled "The Miller Effect."

Solution to . . .

Last Month's "What's Your Answer?"

The solution to the problem is outlined in step form for simplicity, and is as follows:

1. Connect the wires in pairs at one end, and ground one pair.
2. Cross the river.
3. Locate the grounded pair by ringing to ground, label these wires 1 and 2, and ground 1.
4. Locate the other 49 pairs of wires with the ringer.
5. Label the second pair of wires 3 and 4, the third pair 5 and 6, and so on until all of the wires are labeled.
6. Connect wire 2 to wire 3, wire 4 to wire 5, and so on until the 100th wire is left open.
7. Cross the river (this completes the round trip).
8. Remove all connections, keeping track of which are the paired wires.
9. Locate the number 1 wire by ringing to ground. The other wire of this pair is wire 2.
10. Connect one side of the ringer to wire 2 and locate the wire which shows continuity—this will be wire 3.
11. Connect one side of the ringer to wire 4 (the wire that is paired with wire 3) and find the wire showing continuity—this will be wire 5.
12. Continue the foregoing procedure until one wire is left—this is wire 100.

In Coming Issues

A wide variety of subjects is covered in the articles now being processed for future issues, among them being "Electronic Computers," (an entire series by Warren Kitter), and "Simultaneous Transmission Systems," by Francis R. Sherman.

Also, several additional installments of John Buchanan's "Introduction to Transistor Electronics" are in various stages of preparation; therefore, these will now appear at more frequent intervals than has previously been possible.



