

PHILCO

SERVICE and ACCESSORY

Merchandiser



VOL. 2

MAY, 1950

No. 10

Spring Time Is Battery Time

Harken unto me, O my brothers in Philco Service and Accessories, harken unto me. Pause for a moment in thy mad whirl of daily bread-winning and listen to my strange tale of fantastic happenings in that great land of free peoples, in the year known as Fabulous Fifty, during the administration of the Truman known as Harry.

Allah in his wisdom rotated the seasons until that portion of the year known as spring came 'round, and as the populace bestirred itself after the long drab days of winter, many unusual things began to happen.

Lovers walking hand-in-hand down shady lanes—as they are wont to do at this season—carrying that descendant of Marconi's marvel, the portable radio, no longer whispered sweet nothings, but spent their precious moments together frantically twisting dials on the portable. Residents throughout the vast rural areas sitting before their home radios no longer relaxed and listened to the news about crops and weather, but spent their time twisting dials and muttering in language unseemly. Small boys, normally happily prepar-

ing for outdoor activities and camping trips, now vainly thumbed their flashlights and waited for the light. And many others were, as the Occidentals say, in the same boat.

And there arose a great cry throughout the length and breadth of the land, and the people rose up in indignation and demanded, "Deliver us from this accursed condition—GIVE US BATTERIES!"

Heed their cry, O my brothers, and remember that it means that you must be ready to meet this huge demand from your customers. But, beware, do not betray them by selling inferior merchandise, for surely the wrath of consumers turned against you can do much harm. Your Philco Distributor has the answer—fresh power-packed Philco Batteries for all types and makes of portable, farm, and any other battery-operated radios, and for flashlights of all kinds and sizes. And he also has a reward for dealers that are really in there pitching—ask him about it.

Yea, verily, **SPRING TIME IS BATTERY TIME—AND TIME TO SEE YOUR PHILCO DISTRIBUTOR!**

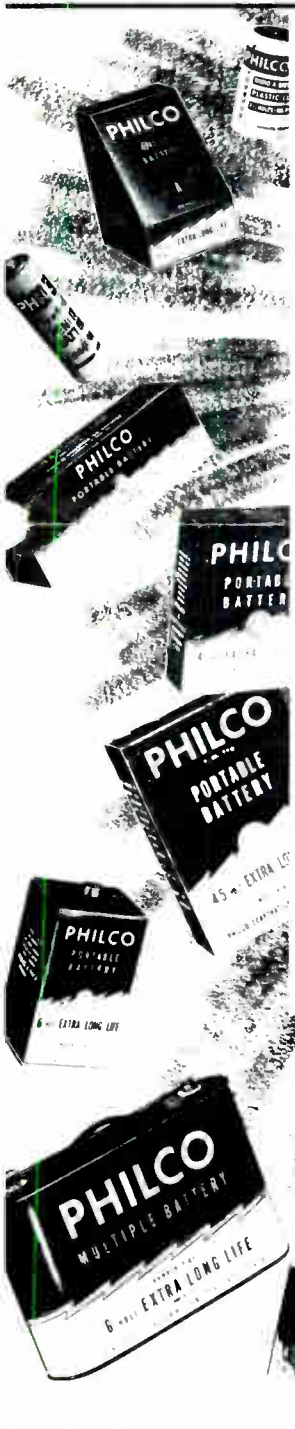

CALL YOUR PHILCO DISTRIBUTOR AT ONCE!

PHILCO BAFFLES AND BAFFLE MODIFICATION KITS AVAILABLE

With the advent of warm weather comes the realization that our refrigerator problems will again be with us. Instead of being a boon, warm weather can be a detriment to the service operation, because in a lot of cases it revives some of the chronic complaints that are prevalent each summer. In the majority of cases the complaints can be resolved to the customer's satisfaction if some time is spent reviewing the problem.

One of the most common summer complaints with refrigerators is higher than normal interior temperatures and excessive internal sweating. The Philco Engineering Department has designed a series of baffles and baffle modification kits which can be used on practically all Philco Refrigerators to solve these problems. On some of the earlier-model Philco Refrigerators, the baffle used under the full-length evaporator has been redesigned to give better results in warm, humid areas.

On the "A" line refrigerators redesigned baffle Part No. 8040-85 for the 7-foot models and Part No. 8040-86 for the 9-foot models, will be a tremendous help in alleviating the excessive sweating and warm temperature condition. The redesigned baffle for the "B" line refrigerators is Part No. 6340-30. On some of the "C" and on the longdoor "D" models, the Engineering Department has designed a modification kit which is very simple to attach to the drain baffle supplied with the refrigerator.

The installation takes but a few models, the Engineering Department kits, which are packed with each kit, are carefully followed.

Now is an ideal time to make these necessary changes to give your customers better service from their Philco Refrigerators. This will not only satisfy your customers, but will boost your reputation in your community.

Locating Intermittent Radio Troubles

The Third Installment of this Practical Series

Forcing the Trouble To Occur

The main problem in the servicing of intermittent sets is getting the trouble to occur. The serviceman can often force the trouble to occur by setting up controlled operating conditions for simulating, or even exaggerating, the actual conditions under which the trouble most frequently occurs.

In some sets, the abnormal condition occurs only in the daytime, while in others, it occurs only at nights. Since it is usually true that the line voltage is higher than normal in the daytime, and lower than normal at night, here are the two extremes of line-voltage conditions. Without the use of any special equipment, a set that gives trouble in the daytime can be tested at the shop during the daytime, while a set that gives trouble at night can be tested at night, thus taking advantage of the usual run of line-voltage conditions.

By the use of a suitable auto-transformer type of line-voltage control (such as Variac), it is possible to simulate higher-than-normal or lower-than-normal line voltages, or to exaggerate the condition in either direction, thus shortening the time required for the trouble to occur. It is important, when exceeding the normal line voltage, to avoid operating the set long enough to damage tubes, power transformer, and certain other parts.

Some sets require a long operating time before the operation becomes abnormal. In such cases, when the sets is removed from its cabinet and tested on the service bench, it is likely that, without some means of heat control, it will require a much longer time to make the trouble occur; under these conditions the heat generated by the set is no longer restricted by the presence of the cabinet. Testing time can be shortened, however, by covering the chassis and tubes completely, using a thick material such as a sweater or blanket. The heat should not be allowed to build up excessively, since there may be danger of damaging certain parts.

(Continued on page 6)

TRAINING COURSE Aids Profit Possibilities

In today's fast-moving business world, education and specialization are the keynotes of success. Colleges, universities, trade schools—yes, even high schools—are turning out more trained and educated men along specialized lines.

This is a desirable condition. The more people who enter business with a good foundation in some special field, the better will be our over-all standard of living.

But what about the man who finished his formal education years ago? Who is going to help him keep abreast of new and changing conditions? Is there any way he can get the necessary education and stay in business at the same time?

Philco has paved the way for the specialized education of its independent dealers and servicemen by ar-

ranging for a complete home study course in refrigeration and refrigeration service.

This opportunity has been available for some time, and servicemen and dealers all over the country have been taking full advantage of it.

You need these 62 carefully prepared lessons to be able to compete in this highly specialized field. See your Philco Distributor today! He has all the necessary particulars as to cost, methods, and other information. Or, if it is more convenient, just write directly to Utilities Engineering Institute, 2525 N. Sheffield Avenue, Chicago, Ill. Be sure to mention that you are a PHILCO SERVICE member. That, and only that, entitles you to the special price of \$60.00—\$6.00 down, \$6.00 per month—or \$57.00, cash.

PHILCO LEADERSHIP— A Result Of Planning

To maintain a high level of consumer demand, any large organization, such as Philco, must constantly be on its toes in planning, producing, and marketing its products. Being well aware of this fact, Philco, along with continuous market research, has recently conducted discussion-type forums to help maintain its unusually high level of consumer demand.

An example of this took place a few weeks ago in Kansas City, where Philco held an important forum on radio. The chief topic of discussion was Philco's product design in the light of consumer acceptance.

The forum was attended by more than 25 representatives of the various specialists within the radio industry—distributors, factory representatives, field servicemen, etc. Each of these men carried with him a wealth of radio knowledge and a background of all the problems as they exist in the field.

Analysis

Under the direction of Mr. James M. Skinner, Jr., Philco Vice-President in charge of service, Philco radio products were presented for analysis. Each one was fully discussed as to design, consumer acceptance, overall performance, ease of service, standing with respect to competition, and the desirability of adding new features. All this was accomplished with an eye to ultimate sales and customer satisfaction.

Synthesis

After a lengthy discussion of each product, the conclusions were carefully recorded. In most cases the product was considered satisfactory in design and fully acceptable to the public; however, some improvements were suggested. Philco engineers made notations of these suggestions for subsequent testing and possible incorporation into future products.



Facts Uncovered

Many interesting facts pertaining to the service and sale of Philco products and accessories were uncovered. For example:

1. *Philco Radio Production.* Mr. Skinner, in his opening remarks, reassured those present that the radio industry is staging a very strong comeback. He substantiated his statement by revealing that Philco plans to manufacture an even more complete line of radios than it did last year.

2. *M-20 Record Changer.* Two noteworthy conclusions on the M-20 record changer were drawn. First, the M-20, an all-round performer, is an excellent changer from an operational and service point of view. Second, it is believed that this changer is the only one on the market today which satisfactorily handles all records automatically.

Philco plans to continue including FM in all of its larger radio and TV sets, plus a few table models. This is in keeping with consumer demands. However, it was decided that there is no appreciable market for a straight FM receiver at this time.

Once again, Philco has demonstrated its leadership in the field of product analysis. Because of this type of leadership, Philco is able to manufacture quality products at a price that consumers can afford to pay.

~~~~~  
**Identify yourself with Philco!**  
~~~~~

Power-Supply Circuits

The history of power supplies, which replaced batteries in home radios, is an interesting story which combines engineering developments and manufacturing-cost considerations.

Half-Wave Rectifier

The simplest method of obtaining direct current from the a-c power supply is the insertion of a rectifier in

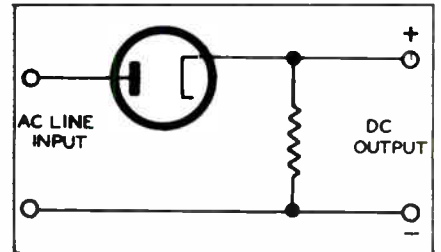

Fig. 1. Half-Wave Rectifier

series with the a-c line. This type of circuit, shown in Figure 1, is still used in many of the less-expensive types of radio receivers.

Full-Wave Rectifier

In order to obtain a smoother output, the idea of using full-wave rectification was proposed and is now extensively used. By full-wave rectification, such as is shown in Figure 2, the ripple frequency is twice that of the circuit of Figure 1; therefore, by using the same filter, a better than two-to-one improvement is obtained in the reduction of hum. The first type of full-wave circuit utilized four rectifiers, arranged in a bridge circuit, but it was soon shown that the same results could be obtained by using a transformer with a center-tapped secondary and only two rectifiers, as shown in Figure 2. For

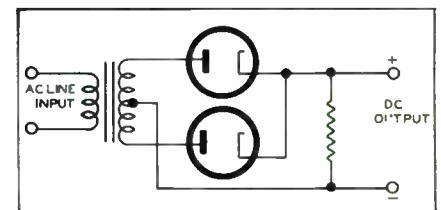

Fig. 2. Full-Wave Rectifier

many years this has been by far the most widely used rectifier circuit for a-c receivers.

Sometimes special circuits, such as a-c/d-c systems with selenium rectifiers, are used. Philco engineers have tested these systems, and use

(Continued on page 6)



Magnecor Antenna Opens New Fields

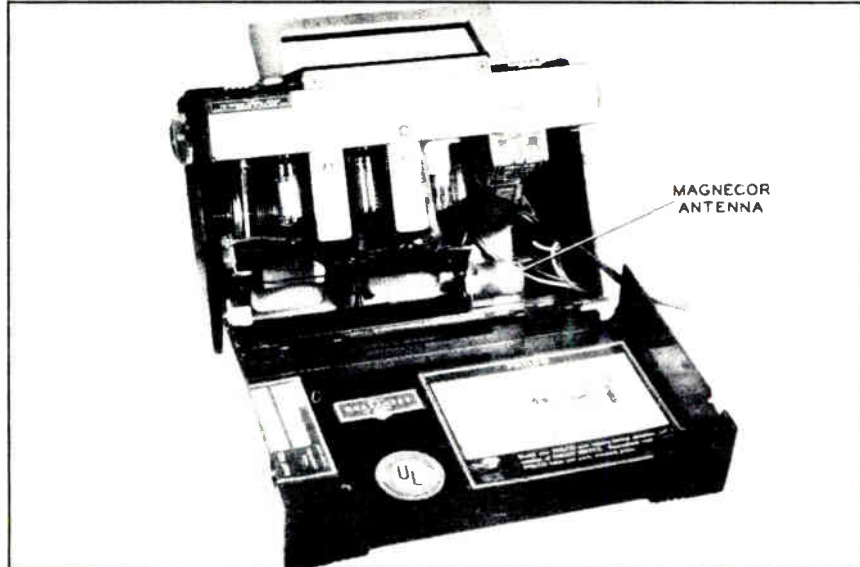

A few weeks ago, Philco released for sale a new AC/DC portable radio set. Its name—the Personal Portable, Model 631.

The biggest feature of this new pocketbook-sized portable, and, incidentally, a terrific selling point, is the new Magnecor Antenna. Cylindrical in shape, and about 7 inches long, it is installed right in the set itself. There are no lids to lift, no aerials to raise, and no buttons to push.

Briefly, the Magnecor Antenna is made as follows: A single-layer coil is wound on a cylindrical core of unusual properties. The core is composed of metallic oxides that are mixed, extruded to the desired shape, and then fired at very high temperatures. The resultant core is physically similar to a ceramic, but at the same time exhibits magnetic properties, including very high permeability and extremely low losses. The finished antenna acts like a high-impedance loop of very high "Q" and low distributed capacity.

Research Proves Desirability

Philco engineers have been working on the Magnecor Antenna for over a year, but they refused to release it until they achieved the

desired "Q" and permeability, and until it was tested under all sorts of adverse conditions.

Results of the extensive tests proved that the Magnecor Antenna is a highly desirable feature in any personal portable radio. Model 631, which uses this antenna, is far better in selectivity and sensitivity than many larger sets. This is a direct result of the high "Q" factor. Signal-

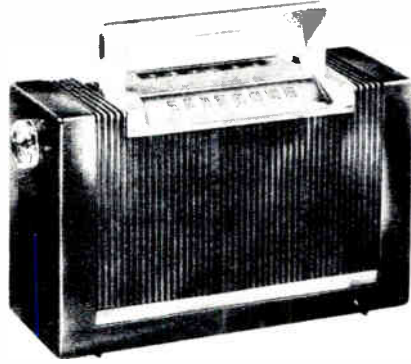

to-noise ratio is up about 2:1 over other sets in the same price range. And lastly, because of its small physical size, the Magnecor Antenna is superior to the average high-impedance loop because of its freedom from local electrostatic noise.

Service No Problem

Service-wise, the Model 631 presents no problems. It has four

easily accessible tubes, and selenium rectifier. It uses two, instead of one, P-35 "D" cell batteries for the "A" supply, and one P-67 (67½ volts) "B" battery. "A" battery life in this set is four times greater with two batteries than with one. But perhaps even more important is the presence of a high-quality audio system and a matched speaker and cabinet assembly. This assembly has been so designed as to eliminate cabinet resonance and speaker buzz.

Tuning Troubles

When aligning a radio receiver, it is sometimes found that the tuning of the set does not follow the dial calibration over the band, or that the sensitivity of the set is not maintained satisfactorily over the band. In such cases, the gang tuning-condenser sections should be very carefully inspected. Turn the

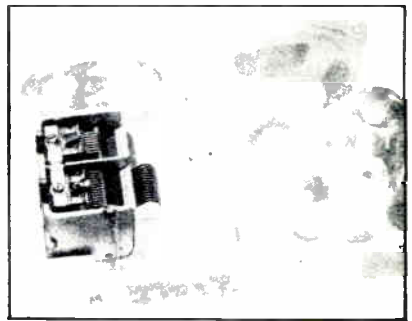

gang to full mesh, and inspect the spacing between the rotor and stator plates of each section, viewing the plates from both sides of the gang. Slowly turn the gang through its range while observing the spacing where the rounded portion of the rotor plates engages the straight edges of the stator plates. Wear, damage, or mechanical distortion of the gang may result in improper spacing in one or more sections of the gang. A set having a gang condenser with this defect cannot be calibrated or tracked correctly.

In many cases a mechanical correction can be made to overcome the trouble. If all sections show a simi-

(Continued on page 7)

Philco Pocketlites



Shine As Money Makers

Last month we introduced you to the new member of the Philco family of fine flashlights, the Imperial Pocketlite. As predicted, it has been breaking sales records all over the country. And this is not surprising in view of its fine construction, convenient size—it's only 5 inches long—low price, and universal appeal. Because it throws a brilliant white spot of light, the Philco Imperial Pocketlite has been an instant hit with professional people such as doctors, nurses, and dentists, as well as electricians, locksmiths, mechanics, and anyone else who needs a great

deal of light from a small, compact device. Its size and weight allow the Pocketlite to fit easily into pocket or purse.

You can't go wrong with this money-making merchandise. Be sure to ask your Philco Distributor about the new Philco Imperial Pocketlite, Part No. 45-6611, suggested list price 79¢ less batteries. Oh yes, don't forget those new Philco "K" cells for this light too. With every Pocketlite sale you have an immediate need for at least two Philco batteries—a ready-made demand if we ever saw one.

PHILCO OUTDOOR AERIAL AIDS RADIO RECEPTION

Here, with the coming of the summertime slack period, is a wonderful opportunity for dealers and servicemen to check up on old customers. Undoubtedly many of them, even those you haven't seen for some time, are now in the market for some of your profitable Philco Accessories.

In addition, this is the time of the year when spring repairs in the home are in order. Winter months, no matter how mild, take their toll on everything that has been exposed to the elements. This goes for radio aerials too. Stretched wires, broken insulators, and other damage caused by the wind, snow, and ice may cause faulty, weak, or noisy radio performance.

Look around your neighborhood. See how many radio owners could improve their reception with the installation of a Philco Outdoor Aerial. Show them how they can increase volume and range with less noise and distortion, and how their favorite programs can be heard more clearly.

This Philco Aerial Kit, Part No. 45-1494, with a list price of \$2.50,



come complete and ready to install. Packaged in an attractive counter display box, the kit includes 60 feet of aerial wire, and 40 feet of lead-in wire. The aerial wire, incidentally, is the same "tough stuff" that was used in thousands of military planes during the War. Also included are insulators, a lightning arrestor, a window lead-in strip, and a ground clamp and hook-up wire.

You can substantially increase your summertime business with the Philco Outdoor Aerial. Place your order today with your Philco Distributor for your share of this business.

Counter Display Ups Sales of 45-RPM Adapters

Philco's 45-rpm record Adapters are a natural for a quick turnover, since all makes of three-speed automatic record changers must use them to play the large-center-hole records. In addition, reports have been coming in from the field which indicate that you can sell even more Adapters with the Philco two-color counter merchandising card which we introduced in the February issue of the Merchandiser.



This display has the advantage of being small enough that it takes up little of your counter space, and yet large enough and sufficiently attractive to really get the customer's attention. The card holds six cellophane packages of six Adapters each, and not only displays the merchandise in such a way that the customer can't possibly miss it, but also clearly illustrates the manner in which the Adapters are to be used.

Another feature of this attractive display is the fact that it also puts in a plug for the Philco Non-Slip Driver, which fits over the standard spindle on the changer and prevents 45-rpm records from slipping. Although there is no sample Non-Slip Driver on the counter card, you'll find that it pays to have one handy to show the customers. Every Adapter sale is a natural lead for a sales pitch on the Non-Slip Driver.

And look at the prices: The Adapters, Part No. 54-4744, have a suggested list price of six for 25¢, while the Non-Slip Driver sells for 20¢. No wonder they are supplementing the income of many progressive dealers. Don't you miss this opportunity—see your Philco Distributor as soon as possible.

Power-Supply Circuits . . .

(Continued from page 3)

them only where they prove as effective and dependable as conventional a-c supplies.

Cost is a constant consideration in every manufacturing operation, just as it is in other types of business. Philco has years of solid reputation for effective cost control with ever-increasing quality.

For instance, there is a normal fluctuation in the cost of the basic materials, and in recent years we have seen the cost of such materials as copper, lead, zinc, etc. increase out of proportion to the cost of other materials. For many years it was the practice of radio-receiver manufacturers to utilize either electrodynamic speakers or permanent-magnet speakers, depending upon the relative cost of copper wire and permanent-magnet material (cobalt steel, alnico, etc.). As far as the receiver is concerned, it cannot tell whether the required magnetic flux is obtained from an electromagnet or a permanent magnet; therefore, it became a matter of economics as to which type of field to use.

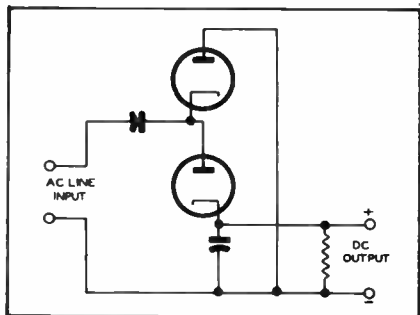

Fig. 3. Voltage Doubling Rectifier

Voltage-Doubling Rectifier

The same force has caused a recent trend in power supplies. Since it is very desirable in the better-class radio receivers to have a full-wave rectifier, it becomes a matter of economics as to how this can best be obtained—whether by the use of a transformer or by means of a voltage-doubler circuit such as that shown in Figure 3.

Voltage-doubler circuits were first developed with the idea of obtaining more voltage from a given source.

Outdoor Advertising Proves Most Effective in Summer Time



In the good old summertime most advertising tapers off. But, when newspaper and magazine ads dwindle and the big radio and TV shows take a vacation, outdoor advertising comes into its own.

Since people spend more time outdoors during the summer, it is natural for costly painted signs and big, fancy billboards to pop up out of the ground as fast as the flowers.

Cost Factor

As dealers and servicemen, you probably know all this. But perhaps the cost of outdoor advertising is more than you can afford. Your Philco Distributor is fully aware of this possibility. That is why he has stocked the Philco Service Decal-

comania, which you can get for only 30¢.

Yes, with the Philco decal, you can have an attractive but inexpensive display on your truck or car for people to see and remember. This same waterproof decal can be attached on your store window, either inside or outside. It comes in three eye-catching colors, too.

And don't forget—the user's instructions which accompany every Philco product remind the customer to "Look for this Emblem in your Neighborhood."

Take advantage of the decal (PR-1553), an effective, low-cost means of displaying the PHILCO SERVICE emblem. Order it from your Philco Distributor today.

This is only one of their good points. In effect, they give you a higher ripple frequency, which is easier to filter. This type of circuit has become increasingly popular, and it has been the fundamental laws of economics that have governed the whole matter. It is just another change similar to those that can be seen repeatedly in the radio industry. We started out by using paper-dielectric condensers in the "B" filter; due to cost, the capacity of these condensers had to be small; therefore, expensive chokes had to be used to obtain proper filtering. With the increasing cost of copper, the development of the electrolytic condenser was accelerated, and modern filters often use capacities ten times as great as those used formerly.

Locating Intermittent . . .

(Continued from page 2)

Some sets are in the abnormal condition when cold, and may suddenly resume normal operation after warming up for a few minutes. For such cases, it may be necessary to resort to artificial cooling in order to make the trouble recur. If the cause is not located on the first try, the set should be turned off, and an electric fan placed so as to direct a cool stream of air on the tubes and chassis, until the temperature is brought down again.

The next installment will describe various test methods for locating the trouble in the more difficult cases. A unique double-signal method employing ordinary test equipment will be of special interest to every serviceman.

Keep your Library of PHILCO SERVICE MANUALS



Up To Date In A

PHILCO SERVICE BINDER

You've Never Had A Deal Like This One



**Find Out From Your
PHILCO DISTRIBUTOR**

**How You Can Get This
Beautiful New Wm. Rogers
& Son "APRIL" Pattern**

**SILVER SERVICE FOR SIX, IN A NEW
MOLDED LUXURY CHEST. (Open Pattern)**

**Modification Of
Attachment Plug
Rates \$10.00 Award**

from an ordinary rubber attachment plug cap with tension prongs. It fits most all sets. is easy to clip on, and holds surprisingly well. The rubber body has enough flexibility to maintain pressure on the prongs against

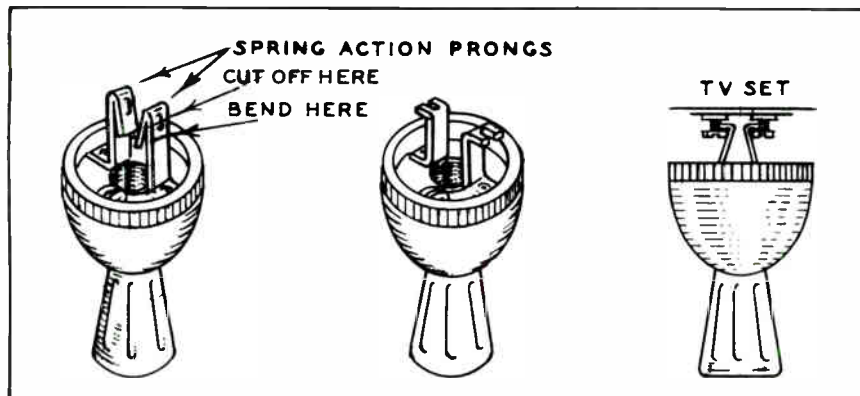

The Merchandiser \$10.00 Idea Award for May goes "Down East" to Walter A. Blau, Jr., vice-president of Blau's Electric Shop, Inc., 237-241 Main St., Middletown, Connecticut. It clearly illustrates how a little ingenuity can save you a great deal of time and effort. Walter Blau writes as follows:

"We have several TV sets lined up in our Display Room all connected at the same time with separate leads of 300-ohm wire. At the ends of these leads we used little alligator clips with insulators to snap onto the terminal screws of the TV sets. We experienced great difficulty with them trying to keep them connected. The screws being so close together made it very difficult to keep the leads secure, so I devised this connector

the screws after they have been adjusted by bending with the fingers for proper spacing to fit the set's terminal screws.

"Because of the great activity in television during recent months. we have been connecting and disconnecting these sets continually with much discomfort. These new connectors have proved to be a big help and saved a lot of 'cuss' words."

Our thanks and a \$10.00 check to Walt Blau for his suggestion that should be a boon to many a dealer with this same problem.

We're still looking for those service hints and promotional ideas; we have a big batch of \$10.00 checks just waiting for your prize-winning letter. Let's hear from you.

Tuning Troubles . . .

(Continued from page 4)

lar displacement of the plates, in the same direction, it is likely that the cause is end play, or endwise shifting, of the main shaft that carries the rotor plates. The remedy is to adjust, if possible the shaft bearings at the end of the gang.

If all sections are not displaced, the individual sections which are displaced must be corrected. This is easily done, of course, if the stator assemblies are mounted by means of machine screws. If they are mounted by means of rivets through the fibre or bakelite pieces at the ends of the plates, it is sometimes possible to drill off the heads of the rivets, remove them, and replace with #4 or #6 machine screws and nuts. With the machine screws in place, it is a simple matter to adjust the stator assemblies to obtain proper spacing of the plates. If the gang is so constructed that no mechanical corrections can be made, it will have to be replaced. It is not practical to attempt to correct a general displacement of plates by bending individual plates; this method is only satisfactory in cases where two or three plates have been accidentally damaged.

**Your \$10.00 Check
Is Waiting Here**

That's right! If you're a dealer or serviceman, and if you've used any successful idea for promoting more business or speeding up service work, we want to hear about it. And for \$ \$ \$, too.

We're particularly interested in hearing about any promotion for selling Philco parts or accessories, such as tubes, batteries, aerials, and so on, or any gadget or system you've used in your service work that has really proved helpful.

Every letter or photograph printed rates \$10.00. Material submitted becomes the property of Philco Corporation. If you can use a \$10.00 bill, think hard! Come up with a good idea, and then send your letter to us, right away! Address all mail for the Philco Service and Accessory Merchandiser to:

PHILCO CORPORATION
P. O. BOX 6738
Philadelphia 32, Pa.



MIKE FARAD sez:

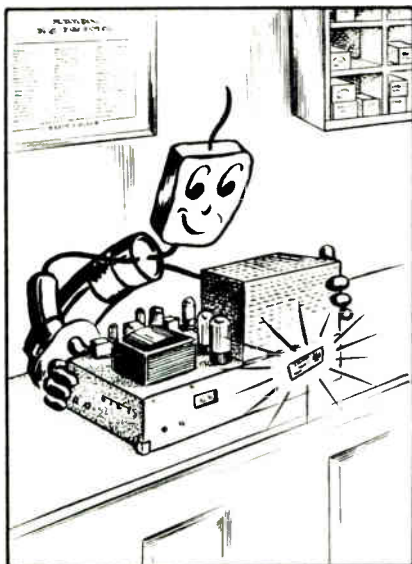

Chassis Stickers (PR-1535) are another sure way to remind your customers that they can count on you for **AUTHORIZED PHILCO SERVICE** which is Expert, Reliable, and Guaranteed. Only \$4.40 per thousand or \$2.75 for five hundred, with your personal imprint, from your Philco Distributor.



IDENTIFY YOURSELF WITH

ORDER

YOUR SIGNS

STATIONERY

AND SALES HELPS NOW

Questions and Answers

- Q. I have had three Model 49-900 radios in my shop for servicing, and all three have had the same trouble—a form of oscillation. By making a slight change in the i-f alignment I am able to eliminate the oscillation temporarily, but after about two months the trouble returns, and the alignment must be changed again. How can I correct the trouble permanently?
- A. Try replacing the condenser-and-choke assembly (C304) with a plain, .2- μ f. condenser, Service Part No. 45-3500-3.
- Q. Although my service area is beyond the range of present television reception, I am interested in learning as much as possible about the theory of operation. Can you tell me how to determine the height of the receiving antenna when the line-of-sight distance and the height of the transmitting antenna are known?
- A. The height of the receiving antenna may be found by using your known information in the following formula:
- $$H_r = \left(\frac{d}{1.23} - \sqrt{H_t} \right)^2$$
- where d = line-of-sight distance in miles; H_t = height of the transmitting antenna in feet; and H_r = height of the receiving antenna in feet.
- Q. I have had several cases of noisy reception in auto radios, which I have traced to vibration of the telescope sections of the aerial. Is there any easy way to remedy such troubles?
- A. If the aerial is not damaged physically, this trouble is usually caused by oxidation of the contact surfaces between the sections of the aerial. The noise occurs when one or more sections are extended. The easiest method of restoring the contact is to work some good contact lubricant, such as Philco All Purpose Lubricator, Part No. 45-2806, into the aerial. To do this, extend the aerial fully, saturate a small tuft of cotton with the Lubricator, and wipe the extended sections. Then work the sections in and out of the aerial a number of times. In cases where the customer has used machine oil on the aerial, the oil should be washed off with a generous application of carbon tetrachloride. Work this cleaning fluid down inside the aerial by running the sections in and out. After waiting about 15 minutes, wipe the sections clean, and use the All Purpose Lubricator treatment described above.

Any questions? Send them in. We'll do our best for an answer. Our address is just below to the left.

PHILCO CORPORATION
P. O. BOX 6738
PHILADELPHIA 32, PA.
RETURN POSTAGE GUARANTEED

Sec. 562, P. L. & R.
U. S. POSTAGE
PAID
PHILADELPHIA, PA.
Permit No. 655

FOR:

Glen Pallo Electronic Ser.
1301 Texas Ave.
Shreveport, La. 4

POSTMASTER: If addressee has moved, notify sender on Form 3547, postage for which is guaranteed. When Form 3547 is sent, abandon this mailing. Return only if no correct address is available.