

Mullard

Outlook

Australian Edition

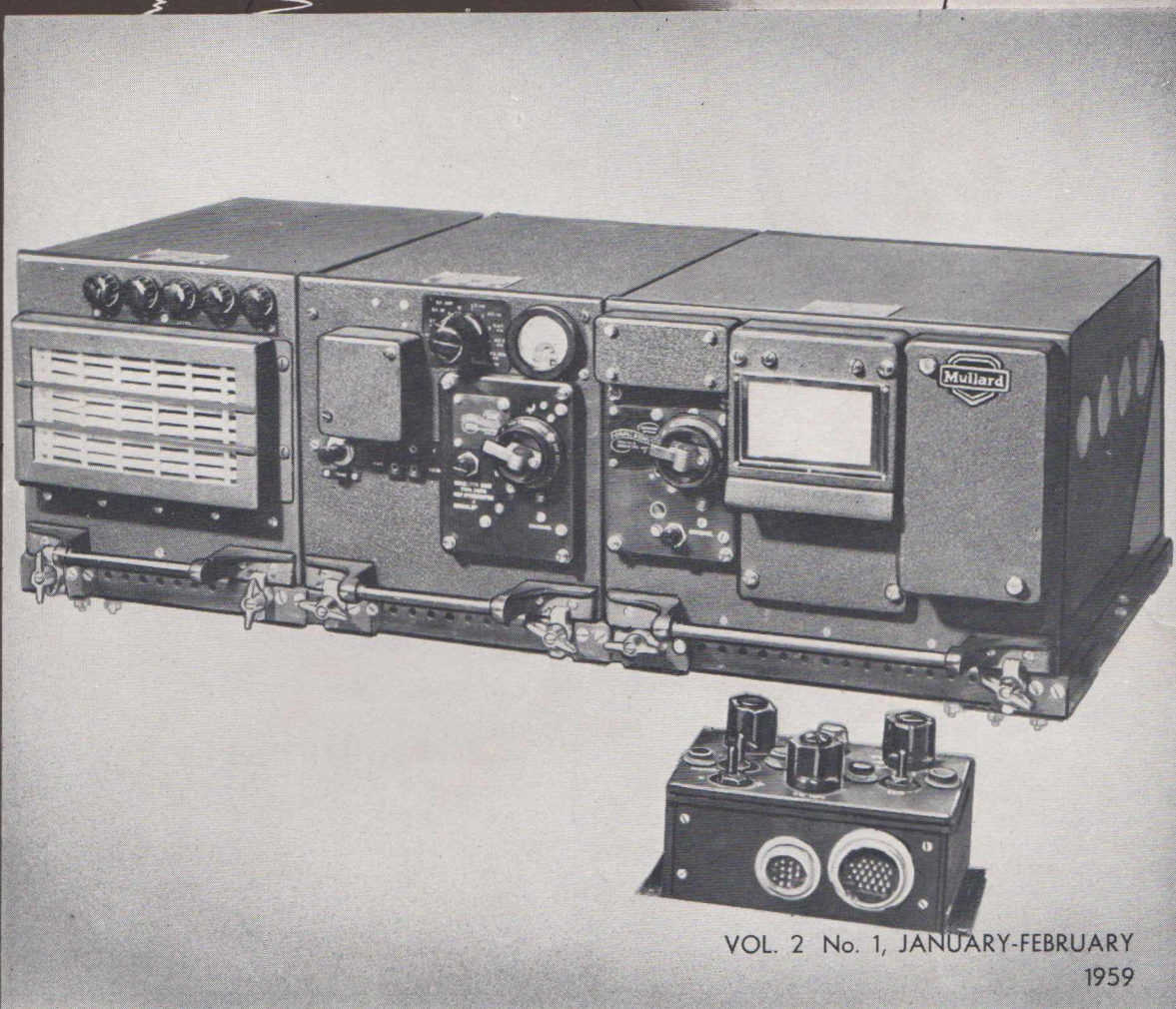

VOL. 2 No. 1, JANUARY-FEBRUARY
1959



MULLARD - AUSTRALIA PTY. LTD.



VOL. 2 - No. 1 JANUARY-FEBRUARY, 1959

Editorial Office:
35-43 Clarence Street, Sydney.
Telephone-BX 2006.

Editorial Staff:
B.P.A. BERESFORD, A.M.I.R.E. (Aust.)
JOERN BORK

All rights reserved by Mullard-Australia Pty. Ltd. Sydney. Information given in this publication does not imply a licence under any patent. Original articles or illustrations reproduced in whole or in part must be accompanied by full acknowledgment: Mullard Outlook, Australian Edition.

CONTENTS :

| | |
|---|----|
| Editorial | 2 |
| Viewpoint with Mullard | 3 |
| Design for Transistor A.F. Power Amplifiers | 4 |
| Airborne S.S.B. Transmitter-Receiver Type X.7443 | 11 |
| One Year of Outlook Publication..... | 12 |

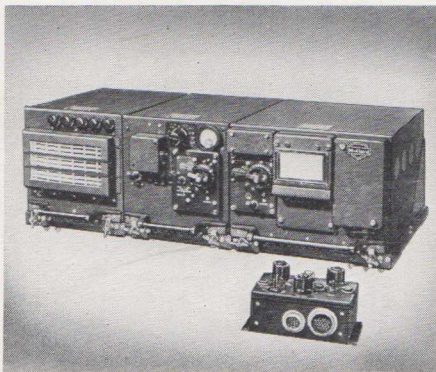

Front Cover: The newly developed Single Side-band Transmitter-Receiver X.7443. The equipment has been designed to fulfil the need for a long range, pilot operated, radio-telephone set in aircraft. More detailed information may be found on page 11 in this issue.

MULLARD-AUSTRALIA PTY. LTD.

35-43 CLARENCE STREET, SYDNEY
Phone: BX 2006

592 BOURKE STREET, MELBOURNE
Phone: MU 2366

Associated with
MULLARD LTD., LONDON
MULLARD EQUIPMENT LTD.
MULLARD OVERSEAS LTD.



It is perhaps significant that

our first birthday issue is

devoted to an application of transistors. In the constantly expanding electronics field the scope of electronic valves and semiconductor devices widens almost hourly, and the transistor relieves the electronic valve of some of its more mundane tasks.

This then is the trend for audio frequency amplifiers and any approach which leads to simplification of design procedures for transistorised equipment is surely worthy of our consideration.

"It is to be noted that when any part of this paper appears dull, there is a design in it."

RICHARD STEELE (1671-1724)

"The Tatler", No. 38.

MULLARD DISTRIBUTORS:-

NEW SOUTH WALES

Martin de Launay Pty. Ltd.
287 Clarence Street,
Sydney. Telephone BX 5834
Cnr. King & Darby Streets,
Newcastle. Phone BM 4741

VICTORIA

Howard Electrical & Radio
Company,
Vere Street,
Richmond. Phone JB 4716
and all leading wholesalers throughout the Commonwealth

QUEENSLAND

B. Martin Pty. Limited,
35 Charlotte Street,
Brisbane. Telephone B 1744

SOUTH AUSTRALIA

Agents: Woollard & Crabbe
Limited,
180 Wright Street West,
Adelaide. Telephone LA 4713

TASMANIA

Medhursts Wholesale Ltd.,
163 Collins Street,
Hobart. Telephone B 2911.
136 Wellington Street,
Launceston. Phone B 2091.

WESTERN AUSTRALIA

Harris, Scarfe & Sandovers
Limited,
691 Hay Street,
Perth. Telephone BF 0131

VIEWPOINT WITH MULLARD

COMMONWEALTH JOINT SIGNALS CONFERENCE



Late last year the Commonwealth Joint Signals Conference was held in London. On this occasion a Meeting was held at Mullard House and Mr. Peter Jago, of Mullard Research Laboratories at Salfords, demonstrates some newly developed electronic apparatus to Wing Commander R. Walker (centre), Staff Officer, Radio, Royal Australian Overseas Headquarters, London, and Group Captain A. G. Pither, C.B.E. (right), Director of Telecommunications, Department of Air, Victoria Barracks, Melbourne, Victoria.

MULLARD DROP CLOTH FOR TELEVISION SERVICE ENGINEERS



The new aid illustrated above is primarily intended for television service engineers engaged on outside duties. Made of good quality material, silk screen printed in attractive colours the Mullard drop cloth is intended for use in the customer's home in order that carpets, etc., may be fully protected when television repairs are being effected.

Supplies are restricted for the time being to television territories, namely New South Wales and Victoria and are available to accredited service engineers on request to the Maintenance Valve Sales Department, Mullard-Australia Pty. Limited, Sydney and Melbourne or through local Mullard Distributors.

five million degrees centigrade — this is how the sun produces its heat, and fusion may be our future source of power.

MODERN MAGNETIC MATERIALS (Running Time 16 minutes)

Over 2000 years ago man was using the magnet in a form of compass. Today the magnet is being used in many hundreds of applications ranging from toys to television sets, from electric bells to complex communications equipment.

The film shows in detail the processes involved in the production of both hard and soft magnets. It also gives some indication of the research that is being carried on to open up even more fields of application for this "maid of all work", the magnet.

TWO NEW MULLARD FILMS

CONQUEST OF THE ATOM (Running Time 22 minutes)

This educational colour film begins with the opening of Calder Hall, Britain's first Atomic Power Station, in October, 1956. It then goes back to 1897 when J. J. Thomson was experimenting with discharge tubes in the Cavendish Laboratory. At this time the atom was believed to be a solid, indestructible sphere, the smallest particle of matter. The film shows how Thomson proved that the atom could be separated into electrons and positive particles. Next we see a reconstruction of Rutherford's experiment which proved that the atom consisted of a central core — the nucleus — with one or more electrons circulating round it. Then in 1919 Rutherford split the nucleus turning nitrogen into oxygen — the first artificial transmutation of one element into another.

In the next section of the film, Sir John Cockcroft explains how in 1932 he and his colleague, Dr. Walton, succeeded in splitting the lithium atom by proton bombardment. We then see

how Sir James Chadwick in the same year discovered the neutron. The atom could then be visualised as consisting of a nucleus of protons and neutrons with electrons in orbit. But the neutron not only explained the structure of the atom, it also provided a new and powerful bullet for atom splitting. In 1938 Hahn and Strassmann split the uranium atom by neutron bombardment; in this process, called nuclear fission, energy was released. For each nucleus split, two or three neutrons were also released which in turn could split further nuclei; in other words they produce a chain reaction. This film shows how in an atomic pile the chain reaction is controlled so that a continuous supply of energy is produced. In the final section it compares the simple, home-made equipment by which Thomson, Rutherford and Chadwick made their momentous discoveries with today's research equipment. It shows that research into fission continues but is also now concerned with Zeta, an equipment designed not to split atoms but to fuse hydrogen atoms with helium at temperatures of over

DESIGN FOR TRANSISTOR A.F. POWER AMPLIFIERS

SYNOPSIS

Much has been published on the design of transistor amplifiers, but all too frequently the information is in a form not readily assimilated by the practical engineer. This paper puts forward a number of premises and concepts which permit the rapid design of audio frequency power amplifiers of outputs ranging from 200mW to 100W. As examples of this design method three practical amplifiers are described of 250mW, 10W and 40W power output.

INTRODUCTION

The design of transistor power amplifiers is in many respects parallel to the design of valve amplifiers but because the active element (the transistor) is a current rather than voltage amplifying device and its characteristics may vary widely with changes in ambient temperature, these additional factors must be taken into account. Similarly, circuit impedances are considerably different in magnitude for transistor equipment but once the designer becomes accustomed to this new order of values, initial design to specific requirements may be considerably simplified. The procedure to be described does not necessarily represent an optimum design but rather a conservative one with emphasis placed on temperature stability rather than the achievement of high individual stage gains.

I (1) The Output Stage.

Although all the classes of operation possible with electronic valves apply equally to transistor output stages by far the most common are single class A and push pull class B. As international standards do not as yet fully cover the definition of class B transistor operation we define it in this paper as "operation in such a manner with respect to bias and signal drive that the quiescent collector current is but a small fraction of the collector current at maximum power output, and the angle of collector current flow is approximately 180°."

The single class A stage has found application in low powered equipments such as hearing aids, personal radio receivers, etc., where power output below 100mW is adequate and in the output stage of automobile radios—power output approximately 3 watts. Techniques have been developed to increase the efficiency of the class A stage in this application (a) but for large power outputs at increased efficiency push pull class B operation is preferred. Push pull class A operation may be desired where the requirements of linearity are particularly stringent but the efficiency is, of course, only the same as for a single class A stage. As a consequence, by far the most common class of operating condition for the output stage is push pull class B. The design principles put forward are, however, just as adaptable for any class of output stage operation.

I (2) In electronic valve circuits the push pull amplifier is most commonly arranged symmetrically with respect to the power supply although the asymmetrical or single ended push pull configuration has been used (b). For transistor output stages we have a choice of either the symmetrical or asymmetrical arrangement and figures 1A and 1B are electrically equivalent practical circuits of these two methods of connection. It should be noted that the conventional push pull circuit (figure 1A) is symmetrical about

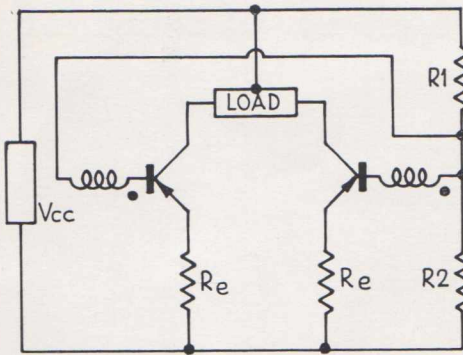

Fig. 1A and 1B.

Practical Push Pull Output Circuits
(a) Conventional Symmetrical.
(b) Single Ended or Asymmetrical.

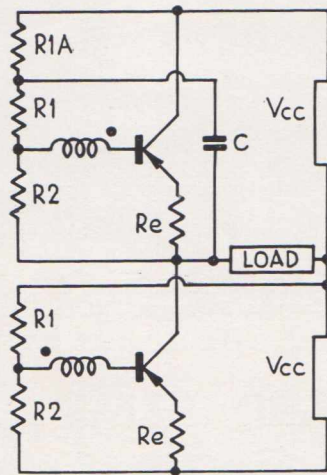

Fig. 2.

A load line plotted on a typical collector family illustrating the "half voltage" principle.

and the single ended or asymmetrical push pull configuration.

To gain an appreciation of the merits of asymmetrical push pull circuits it is necessary to examine a specific design. Let us assume we wish to design an amplifier around a pair of power transistors whose peak collector current $I_c(pk)_{max}$ is say 3 amperes. In the interests of linearity we would design the output stage for only half this peak current, that is $I_c_{max} = 1.5A$ (c). Such transistors in a conventional symmetrical class B stage operating from a 14V supply would yield 10W with a collector to collector load impedance of 32 ohms. In this configuration we require therefore an output transformer of suitable turns ratio to match a 32 ohm collector to collector impedance to that of the loud speaker load and because of the high peak currents flowing and the necessity for a low D.C. primary resistance if the insertion loss of a transformer is not to be excessive—not to mention the normal design requirements of an output transformer to cover the full audio spectrum—such an output transformer is both bulky and costly. An alternative would appear to be a loud speaker of suitable impedance with a centre tapped voice coil. It can be shown, however, that the acoustic efficiency of a centre tapped loud speaker in this arrangement is only 50% (d) and so if we are striving for overall efficiency in the design this technique is precluded.

If we now examine the equivalent asymmetrical circuit assuming that double the collector voltage supply is available we find that the optimum load impedance is 32

$\frac{1}{4} = 8$ ohms and the load is only a two

terminal device. A standard 8 ohm loud speaker can thus be coupled directly to the output stage, overcoming the frequency limitations of the output transformer, reduc-

the supply V_{cc} as is the load, whilst for the asymmetrical or single ended arrangement the positions of the load and power supply are interchanged.

For the same transistor operating conditions double the supply voltage is required for the asymmetrical arrangement but the optimum load impedance is only one quarter the value required for the electrically equivalent symmetrical configuration. It should be noted that $R1A$ and C in the asymmetrical circuit (figure 1B) are necessary to prevent the signal component flowing in the base divider network but as this amounts in practical circuits to only a dB or so of localised feedback these additional components may be omitted. As shown, the circuits of figure 1A and 1B are equivalent—each transistor is supplied from the same voltage, forward biased to the same quiescent current and handling alternate half cycles to the same extent. Peak collector currents are the same, drive power is identical for both systems but for the asymmetrical arrangement the battery must have twice the voltage but need only have just over half the ampere-hour capacity for the same life. This slight increase in capacity or alternatively the slightly shorter life is because of the power dissipated in the extra bias potentiometer network. In any practical push pull class B output stage design we therefore have a choice between the conventional or symmetrical push pull stage

ing the volume and weight of the equipment and permitting lossless coupling between the output transistors and the loud speaker. For these reasons the asymmetrical push pull configuration has been chosen as the basis of unified design for a number of transistor power amplifiers.

II (1) The Driver Stage.

For any transistor amplifier the driver stage poses difficulties somewhat different from the analogous problem with electronic valves. Although it is possible to have a class B push pull driver stage for the class B output transistors practical considerations of linearity and decoupling preclude this arrangement except for equipments such as public address amplifiers where the frequency response is restricted to say the speech range and distortion is not of paramount importance. We are left then to consider a single class A stage and, of course, integral with this problem techniques for stabilising the stage against variations in ambient temperature. Many standard texts cover this subject in detail but a recently evolved technique (e) considerably simplifies design, ensures thermal stability and so enables higher collector dissipation and improved power output from a specific transistor.

If we feed the transistor from double its normal supply voltage through a resistor of value such that at normal collector current half the supply voltage appears across the transistor, then the collector dissipation of the transistor will be a maximum at this operating point. Figure 2 shows the collector family of a typical transistor upon which a D.C. load line has been plotted conforming to these principles. It will be noted that the operating point representing half the supply voltage at the collector results in maximum dissipation and any change in transistor characteristics with changes in ambient temperature will result in the operating point being displaced along the load line to a point of lesser dissipation. By this means stability—that is freedom from thermal runaway effects—may be assured. The foregoing does not mean that the stage will be free from “bottoming” with increase in ambient temperature, but this problem can be considerably eased by ensuring a voltage feed to the base.

II (2) It should be noted that this technique is compatible with the asymmetrical push pull output configuration as with both arrangements we need a supply voltage twice that appearing across the transistors. It is imperative, of course, if we are to gain the maximum value from the half voltage technique to ensure that an adequate heat sink is available for the class A driver but good mechanical practice is all that is usually required. As the series resistor is decoupled no restrictions are placed on the A.C. load impedance of this stage which may be arranged for either maximum power output, minimum distortion or a compromise as is more common in a practical case. Likewise, the “half voltage resistor” may be in either the collector or emitter feed depending on associated circuit requirements. Figure 3 shows the practical circuit of a driver using this principle complete with circuit voltages and currents.

III (1) The Pre-Amplifier.

The pre-amplifying stage of equipment of this nature is invariably of the class A resistance coupled configuration. Decoupling of the supply to this stage is necessary to prevent positive feedback voltages being transmitted along the supply rail and it is possible by a choice of supply voltage for

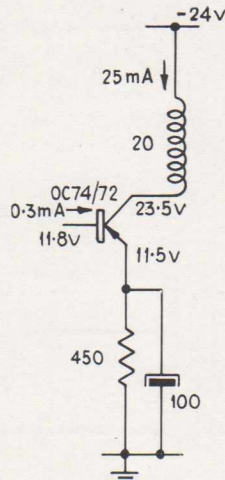

Fig. 3.

Typical “half voltage” driver stage.

this stage to again employ the “half voltage” principle. Indeed, a saving in components and elimination of a coupling network is possible by arranging a direct connection between the collector of the pre-amplifier stage and the base of the driver stage. A configuration of this type can be combined with a D.C. feedback path which can further stabilise the circuit against spreads in transistor static characteristics. Figure 4 illustrates these principles with circuit voltages and currents shown. In this design the emphasis is on temperature stability and circuit simplification rather than in achieving the highest gain stage by stage. As a consequence, the desirability of a direct coupling between the pre-amplifier and the driver stage is considered more important than the power mismatch which this connection entails.

III (2) Analysis of figure 4 will show that both the driver and pre-amplifier stages are designed on the half voltage principle and that the base divider for the driver stage is composed of the pre-amplifier load resistance and the collector-emitter resistance together with the emitter resistor of the pre-amplifier stage. As the collector to

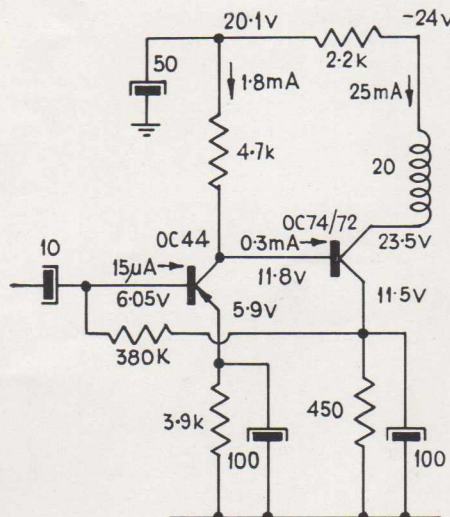

Fig. 4.

The addition of a pre-amplifying stage to produce the “half voltage” stabilised direct coupled pair.

emitter resistance of the pre-amplifier is dependent upon the base bias of this stage which is derived from the emitter resistor of the driver stage, i.e., is dependent upon variations in the emitter (approximately equals collector) current of the driver stage it may be shown that this D.C. coupled pair is not only temperature compensated but also each transistor exerts an extra stabilising action on the other. The elimination of the coupling capacitor removes one low frequency roll-off characteristic from the design and so facilitates the application of negative feedback over the amplifier as a whole. If it is desired to have further pre-amplifying stages to enable the amplifier to operate from sources such as a low level microphone then direct coupled resistive loaded pairs may be designed utilising these principles with the minimum of design effort.

IV (1) Temperature Compensation.

Whilst thermal stability has been considered for both the driver and the pre-amplifying stage no mention has been made so far of stabilisation for the output transistors. Tedious calculations involving mean collector dissipation, the values used for the base voltage divider and the thermal constants of the heat sink will prove the upper temperature limit of the stage (f). However, it is necessary for the designer to check this point practically by subjecting the complete equipment to high ambient temperatures to prove the overall design. Practical results based on a series of amplifiers using these unified design principles have shown that for a power transistor such as the OC16 a base return resistor of 3.9 ohms and an emitter resistor of 0.9 ohm results in practical equipment with upper temperature limits of between 57°C and 68°C provided that an adequate heat sink is employed. These basic values have been standardised in equipment constructed to these unified principles as has a quiescent collector current of 30mA per OC16 at 25°C.

V (1) Design Examples.

Three basic practical amplifier designs have been evolved and constructed to these principles. The first employs a pair of OC72 transistors in the output stage and supplies 250mW to a loud speaker of voice coil impedance 33 ohms. The second has a pair of OC16 transistors supplying 10W direct to a standard 8 ohm loud speaker. The third amplifier was developed as a good quality high power amplifier capable of operating from both pick-up and microphone and supplies 40W direct to a standard 8 ohm loud speaker load. It uses OC16 power transistors in the output stage and the principles of the circuit configuration employed are the subject of a patent application. The similarity between the circuits of the three amplifiers is a direct result of unified procedure which enables the designer to speedily develop amplifiers, within these power ratings, for a specific purpose.

V (2) 250mW Amplifier. This unit is designed for operation from a crystal pick-up and feeds directly into a loud speaker of 33 ohms impedance. The schematic is shown in figure 5, and figure 6 is a photograph of the prototype constructed for novelty around the magnet assembly of a loud speaker.

V (3) 10W Amplifier. Designed with an asymmetric push pull OC16 output stage, this amplifier is intended for good quality reproduction of gramophone records. It is constructed to be complete with its own dry batteries in a case measuring only 11in. x 4in. x 3in. including level indicator and monitoring facilities for the internal batteries. The output couples directly to a

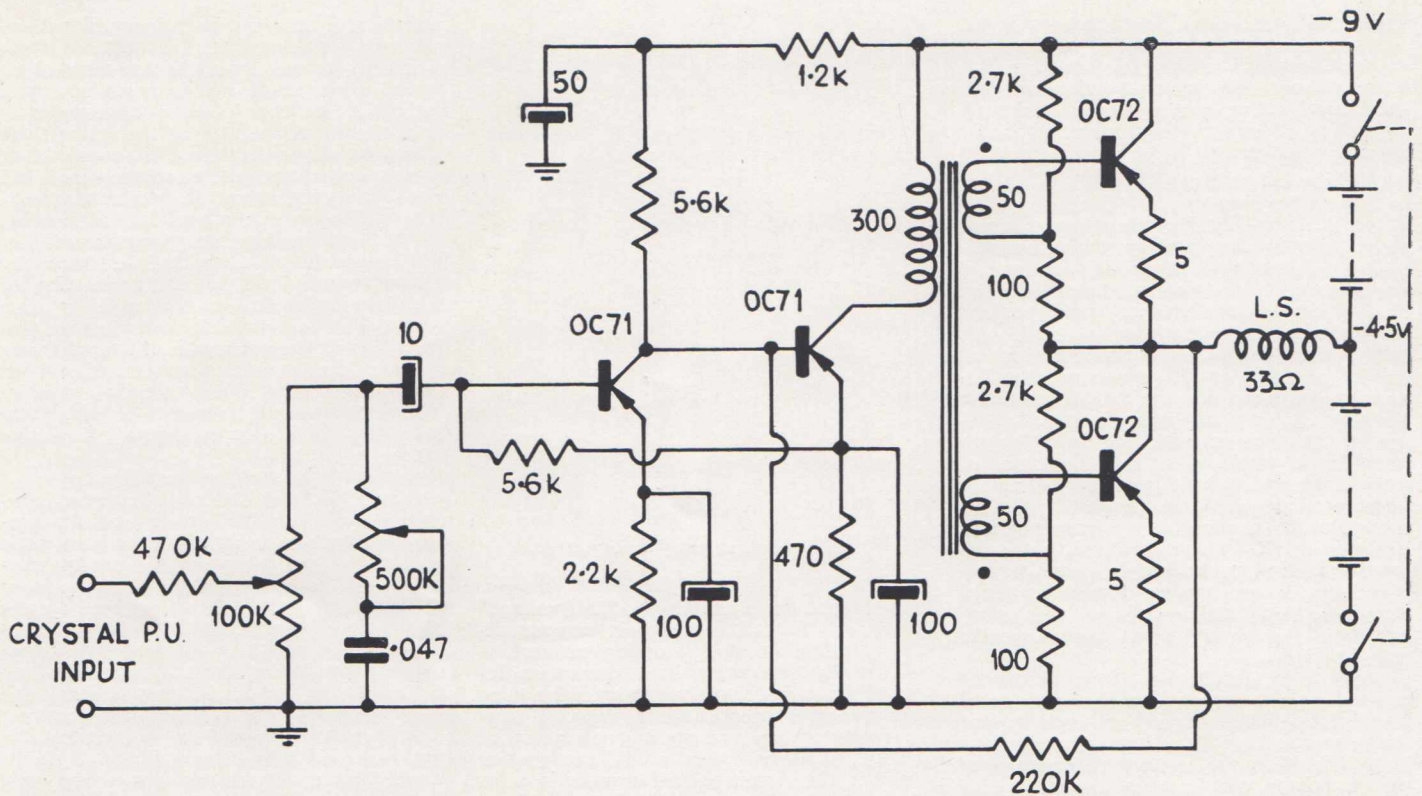

Fig. 5.
Schematic of 250mW amplifier.

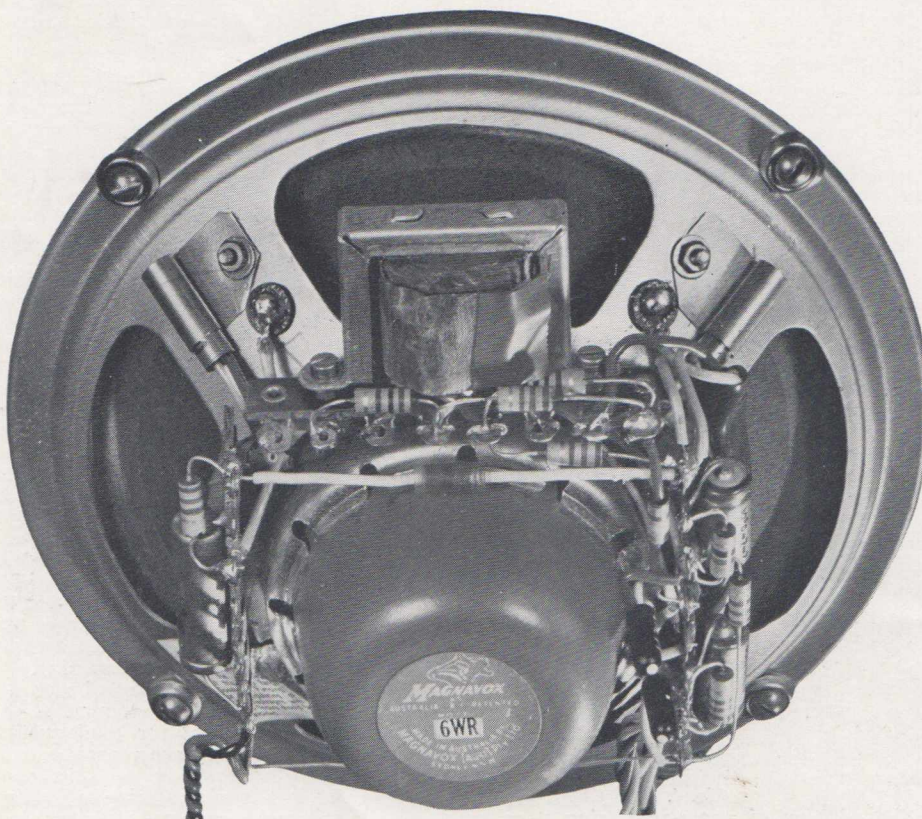

Fig. 6.
Prototype 250mW amplifier.

normal 8 ohm loud speaker. Figure 7 is the schematic of this unit and figures 8A and 8B show the external appearance and internal construction of the amplifier.

V (4) 40W Amplifier. Identical in physical dimensions to the 10 watt unit, this amplifier because of its higher primary input power is best operated from a 24V accumulator. The output again couples directly to an 8 ohm load—the selection of this value being governed to some extent by the impedance of horn loaded driver units because of the potentialities of this equipment for public address applications. Similar monitoring facilities to the 10 watt amplifier are included and the programme input may be from either crystal pick-up or magnetic microphone. A constructional view of this amplifier is shown in figure 9.

Identical design procedure is employed for all three amplifiers.

V (5) It is of interest, however, to examine the design considerations of the output stage for a 40W amplifier. We have seen that a pair of OC16 may yield some 10 watts from a 12 + 12V supply into an 8 ohm load. It would appear therefore that if we could successfully parallel transistors of the OC16 class we could have (operating from a 12 + 12V supply in the asymmetrical configuration)

- 10 watts into an 8 ohm load—single OC16 pair
- 20 watts into a 4 ohm load—parallel OC16 pair
- 40 watts into a 2 ohm load—4 x OC16 pair

This technique would have the obvious disadvantage that with increasing power we have a reducing load impedance and from the practical viewpoint of power loss in loud speaker leads would be precluded for public address or other applications where the loud speaker leads are of reasonable length.

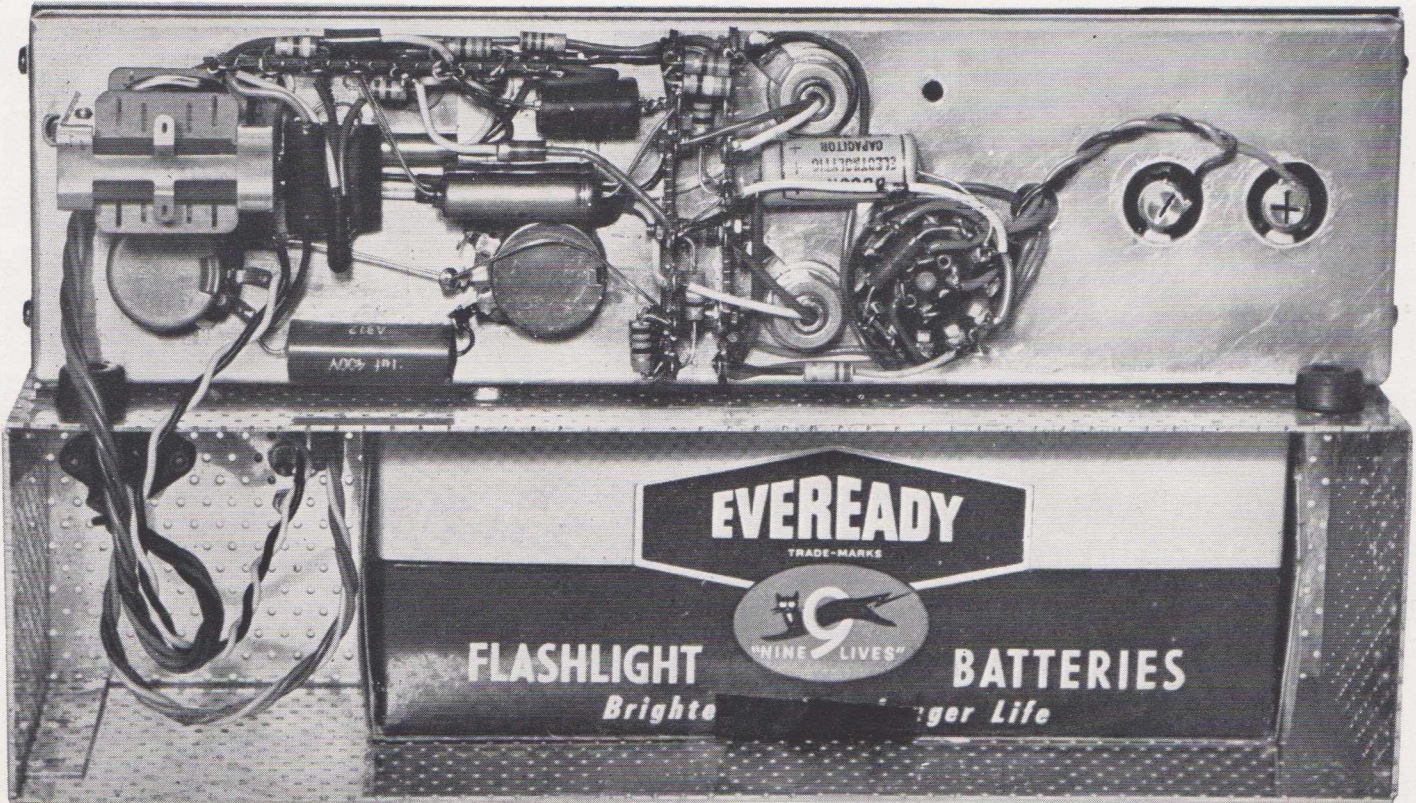

Fig. 8B.
Internal appearance of 10W amplifier.

Note.—With a total thermal resistance of $7^{\circ}\text{C}/\text{watt}$ —a typical value mounted on a practical chassis with mica insulating washers—the above conditions ensure thermal stability at ambients to 60°C .

(b) Driver stage.

Transistor type OC74 (with caution OC72).
Half voltage stabilised Class A.

Collector supply voltage V_{cc} 24V
Collector Current I_c 25mA
Peak collector current $I_{c(pk)}$ 50mA
Stabilising resistance 12×10^3
($R_e + r_p$) $\frac{25}{10^3} = 480$ ohms

Selected load impedance 480 ohms
Standing collector dissipation $P_{c(o)}$ $\frac{12 \times 25}{10^3} = 300\text{mW}$

Assuming collector circuit efficiency $\sim 50\%$
Max. signal collector dissipation $P_{c(max)}$ $\frac{300 \times 10^{-3}}{2} = 150\text{mW}$

Base input current I_b $\frac{I_c}{\alpha'} = \frac{25 \times 10^{-3}}{70} = 0.3\text{mA}$ approx.

Driver transformer impedance ratio $\frac{480}{120} = 4:1$

Driver transformer turns ratio $\sqrt{4} = 2:1$
or more explicitly $4:1 + 1$

For good low frequency performance $L_p = \frac{Z_p}{200} = \frac{480}{200} = 2.4\text{H}$
(-3dB @ 32 c/s)

A practical transformer for this design—secondaries wound bifilar—has a primary resistance $r_p = 20$ ohms.
Collector voltage $V_c = V_{cc} - I_c r_p = 24 - 0.5 = 23.5\text{V}$

Emitter resistor R_e is thus $480 - 20 = 460$ ohms
say 450 ohms

Emitter decoupling capacitor C_e (designed for $\frac{\omega}{10}$)

$$C_e = \frac{10^6}{20 \times 480} \sim 100\mu\text{F}$$

Emitter voltage $V_e = (I_c + I_b)R_e = 25.3 \times 10^{-3} \times 450 = 11.5\text{V}$

Collector to emitter voltage $V_{ce} = V_c - V_e = 23.5 - 11.5 = 12\text{V}$

which satisfies the half voltage principle.

For $I_b = 0.3\text{mA}$ V_{be} for OC74/72 $= 0.3\text{V}$ approx.

Thus the base voltage $V_b = V_e + V_{be} = 11.5 + 0.3 = 11.8\text{V}$

(c) Pre-Amplifier.

Transistor type OC44—chosen to stagger the high frequency roll-off of individual stages.

As the collector of this stage is directly coupled to the base of the driver Collector voltage $V_c = V_{b(driver)} = 11.8\text{V}$.

This voltage is sensibly independent of temperature because of the half voltage principle and the direct coupled pair configuration. To ensure adequate base current swing for the driver, good thermal stability and reasonable stage gain the collector current I_c of the pre-amplifier should be designed approximately five times the base input current of the driver stage.

Thus the collector current

$$I_c = 5 \times 0.3 = 1.5\text{mA}$$

$$I_c + I_{b(driver)} \text{ is thus } 1.5 + 0.3 = 1.8\text{mA}$$

$$R_e \text{ (total) is thus } \frac{V_{cc} - V_c}{I_c + I_{b(driver)}} = \frac{24 - 11.8}{1.8 \times 10^{-3}} = 6.8 \text{ k}\Omega$$

As decoupling is necessary in the collector supply to this stage to prevent a positive feedback voltage being injected via the supply rail, R_c (total) may conveniently be formed of the

Collector load $R_c = 4.7 \text{ k}\Omega$
and the decoupling resistor $R_d = 2.2 \text{ k}\Omega$

The decoupling capacitor C_d (designed for $\frac{\omega}{25}$)

$$C_d = \frac{10^6}{8 \times 2.2 \times 10^3} = \frac{10^3}{17.6} \sim 50\mu\text{F}$$

Base input current $I_b \sim \frac{I_c}{\alpha'} = \frac{1.5 \times 10^{-3}}{100} = 15\mu\text{A}$

Emitter current $I_e = I_c + I_b = 1.5 + 0.015 = 1.515\text{mA}$

For this stage V_e may be 0.5V
i.e. $V_e = \frac{11.8}{2} = 5.9\text{V}$

Emitter resistor $R_e = \frac{V_e}{I_e} = \frac{5.9 \times 10^3}{1.515} = 3.9 \text{ k}\Omega$

Emitter decoupling capacitor C_e (designed for $\frac{\omega}{50}$)

$$C_e = \frac{10^6}{4 \times 3.9 \times 10^3} = 64 \text{ say } 100\mu\text{F}$$

As V_{be} for small signal amplifying stages $\sim 150\text{mV}$

The base voltage

$$V_b = V_e + V_{be} = 5.9 + 0.15 = 6.05V$$

We may thus calculate the base resistor R_b

$$R_b = \frac{V_{e(\text{driver})} - V_b}{I_b} = \frac{11.5 - 6.05}{15 \times 10^{-6}} = 380 \text{ k}\Omega \text{ approx.}$$

As some spread in transistor characteristics is to be expected R_b is composed of 270 k Ω resistor in series with 250 k Ω variable resistor. To adjust this direct coupled pair so that the transistors are at their respective operating points it is only necessary to connect a voltmeter to the collector and emitter of the driver stage and adjust R_b (of the pre-amplifier) until half the supply voltage, i.e., 12V is indicated. With this design procedure the desired thermal stability is obtained if an adequate heat sink is provided for the driver.

B. A.C. Conditions.

The power gain and input sensitivity of the amplifier may now be calculated. The power gain of the output stage is already known from the published data, and here we will assume lower limit transistors.

$$G_p = \frac{P_{out}}{P_{drive}} = \frac{10}{0.15} = 66.6 \text{ times} = 18.3\text{dB approx.}$$

Assuming a driver transformer primary efficiency 95% the power gain G_p reduces to 18dB approx.

For the driver stage we have

The load impedance R_L = 480 ohms

Reference to the data shows that under the operating conditions selected the input impedance r'_{in} ~ 470 ohms.

Power gain G_p is thus

$$(\alpha')^2 \frac{R_L}{r'_{in}} = (70)^2 \frac{480}{470} = 5000 \text{ times} = 37\text{dB approx.}$$

For the pre-amplifying stage we have

The load impedance

$$R_L = r'_{out} // R_c // r'_{in} (\text{driver})$$

Reference to the data shows that under the operating conditions selected the output impedance r'_{out} ~ 18 k Ω and the input impedance r'_{in} ~ 2 k Ω . The load impedance for this stage R_L is thus 18k//4.7k//470 ohms ~ 418 ohms

The power gain G_p is thus

$$(\alpha')^2 \frac{R_L}{r'_{in}} = \frac{(100)^2 \cdot 418}{2 \times 10^3} = 2080 \text{ times} = 33\text{dB approx.}$$

Overall power gain

$$P_g(\text{total}) = 18 + 37 + 33 = 88\text{dB approx.}$$

For a 10 watt power output this gain corresponds to a power input

$$P_{in} = \frac{P_{out}}{6.31 \times 10^{-8}} = 1.58 \times 10^{-8} \text{ watts}$$

As r'_{in} ~ 2 k Ω

$$e'_{in} = \sqrt{P_{in} \cdot r'_{in}} = \sqrt{1.58 \times 10^{-8} \times 2 \times 10^3} = 5.6 \times 10^{-3} = 5.6\text{mV}$$

To match the input of this amplifier to a crystal pick-up cartridge a series resistor of not less than 330 k Ω is necessary. This will produce a voltage division of 166 times.

The initial input voltage sensitivity of the amplifier is thus

$$E_{in} = 5.6 \times 10^{-3} \times 166 = 930\text{mV approx.}$$

It must be recalled that the overall gain calculation of the amplifier was based on nominal transistors in the driver and pre-amplifying stages. Allowance should be made at this stage for transistor spreads so as not to limit the design to "above nominal" types.

The calculation of the effect of parameter spreads is tedious to say the least and is a factor which it is necessary for the designer to satisfy for himself. Nevertheless, for a two stage direct coupled pair such as we have employed having a power gain of 70dB and no gain stabilisation a variation in overall voltage sensitivity of at least 10dB could be expected.

Assuming a negative feedback path in the amplifier to provide 6dB of feedback with lower limit transistors (more with "normal" and "upper limit" spreads) we have an input sensitivity of

$$E_{in}' = 930 \times 2 = 1860\text{mV} = 1.8V$$

This is barely adequate for drive from a crystal pick-up and hence we either require an additional stage or some localised positive feedback around the first stage. It is not the intention of this paper to examine these factors in detail as they could be the topic of a paper in its own right. However, it is apparent that with suitable phasing of the driver transformer very little restriction is placed on where a feedback voltage may be introduced into the D.C. coupled pair.

For simplicity in this design negative feedback has been applied to the base of the driver stage (r'_{in} ~ 470 ohms) requiring a

series feed resistor of 270 k Ω for 6dB gain reduction. As the difference in D.C. levels between the two points of connection is small (~ 0.2V) which will result in a direct current of less than 1 μ A, the D.C. blocking capacitor in the feedback loop may be dispensed with.

VIII. Performance Summary of Practical Amplifiers.

250mW unit.

| | |
|---|----------------|
| Input Sensitivity (Z _{in} 470 k Ω) | 500mV |
| Frequency Response (-3dB points) | 60 c/s—17 kc/s |
| Total Harmonic Distortion @ 400 c/s | 4.7% |
| Total Harmonic Distortion @ P _{out} 100mW | 2% |
| Total Harmonic Distortion @ P _{out} 50mW | 1.3% |
| Zero signal current drain | 7.5mA |
| Max. signal current drain (sine wave) | 43mA |
| Max. signal current drain (speech and music) | 26mA approx. |

10W unit.

| | |
|---|----------------|
| Input sensitivity (Z _{in} 330 k Ω) | 900mV |
| Frequency Response (-3dB points) | 35 c/s—20 kc/s |
| Total Harmonic Distortion @ 400 c/s | 10% |
| Total Harmonic Distortion @ P _{out} 7W | 3% |
| Total Harmonic Distortion @ P _{out} 2W | 2% |
| Zero signal current drain | 120mA |
| Max. signal current drain (sine wave) | 600mA |
| Max. signal current drain (speech and music) | 360mA approx. |

40W unit.

| | |
|---|----------------|
| Input sensitivity (Z _{in} 330 k Ω) | 500mV |
| Frequency Response (-3dB points) | 35 c/s—12 kc/s |
| Total Harmonic Distortion @ 400 c/s | 10% |
| Total Harmonic Distortion @ P _{out} 35 W | 6% |
| Total Harmonic Distortion @ P _{out} 30W | 4% |
| Total Harmonic Distortion @ P _{out} 20 W | 3% |
| Total Harmonic Distortion @ P _{out} 10W | 2% |
| Zero signal current drain | 700mA |
| Max. signal current drain (sine wave) | 2.6A |
| Max. signal current drain (speech and music) | 1.6A approx. |

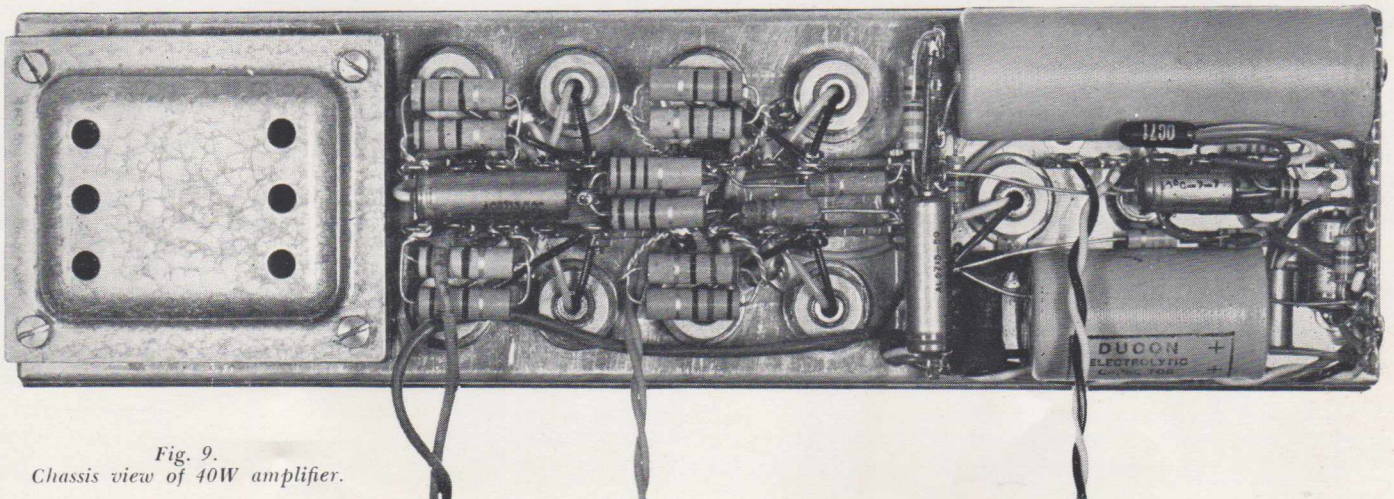

Fig. 9.
Chassis view of 40W amplifier.

IX. Conclusion.

The design considerations co-ordinating the asymmetrical push pull output stage with "half voltage" stabilised driver and direct coupled pre-amplifier facilitate the design of transistor audio frequency power amplifiers. Unification in this manner can lead to considerable simplification of the task befalling the design engineer. It is hoped that this paper may serve as a stimulus to practical engineers in this field to evolve even simpler and more forthright approaches to such a mundane task.

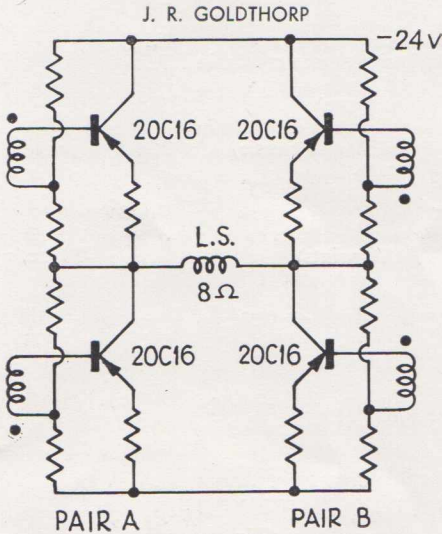

Fig. 10.
Basic circuit of 40W output stage.

BIBLIOGRAPHY AND APPENDIX

- (a) Sliding Bias for Power Transistors in Auto Receivers. "Hybrid Car Radio Sets" Philips 20/456/D/E.
- (b) "Single Ended Push Pull Audio Amplifier", Sinclair & Peterson. Proc. I.R.E. No. 40 (1952 No. 1). "Single Ended Push Pull Output Stages". Electronic Applications Bulletin, Vol. 17, No. 3.
- (c) "Principles of Transistor Circuits"—R. F. Shea. "Transistor A.F. Amplifiers"—D. D. Jones & R. A. Hilbourne. "Transformatorloser NF-Leistungverstärker mit Transistoren". Telefunken Sonderdruck 458.
- (d) For a given supply voltage V_{cc} the maximum power output in a push pull Class B system occurs where the load impedance for each transistor $Z = \frac{V_{cc}^2}{\pi^2 P_c}$ where P_c is the collector dissipation rating of the transistor. Loading of the output stage can thus be effected either by the direct connection of a centre tapped loudspeaker of impedance $Z + Z$ ohm, or by the same speaker of impedance $2 Z$ ohm matched to the collector-collector impedance of $4Z$ through a transformer of impedance ratio $1 + 1:1$ or turns ratio $1 + 1:\sqrt{2}$. Let us

assume that each half of the speaker voice coil has "n" turns and the peak collector current of each transistor is $i_c(pk)$.

Direct Connection.

Mechanical force on voice coil = $i_c(pk)n$
 \therefore Acoustic power output \propto Force²
 $\propto i_c^2(pk)n^2$.

Transformer Coupling.

A primary current of $i_c(pk)$ results in a secondary current of $\frac{i_c(pk)}{\sqrt{2}}$ which of course flows through $2n$ turns. Mechanical force on voice coil = $\sqrt{2} \cdot i_c(pk)n$
 \therefore Acoustic power output \propto Force²
 $\propto 2i_c^2(pk)n^2$
 i.e., Twice the acoustic output of the direct connection.

- (e) "Temperature—Stable Transistor Circuit based on the Half Supply Voltage Principle." Electronic Applications Bulletin Vol. 18, No. 1.
- (f) "Heat Sink Design" and "Temperature Stability of Transistor Class B Amplifiers". Mullard Technical Communications Vol. 3, No. 29.

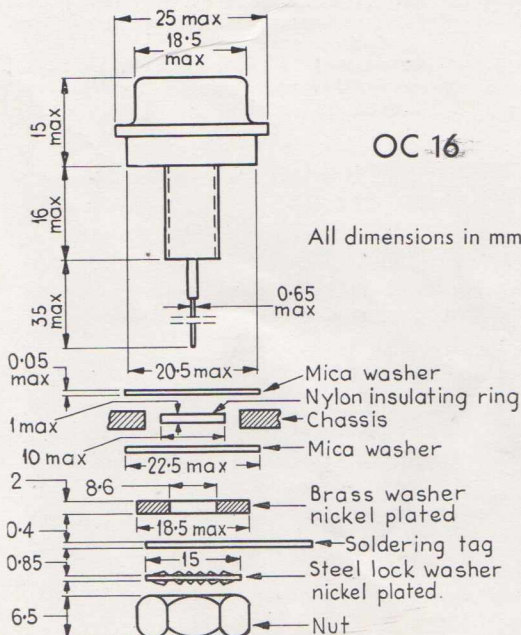

OC 16

All dimensions in mm

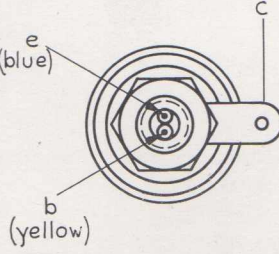
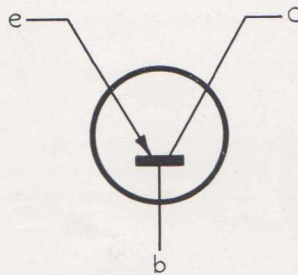

OC 72

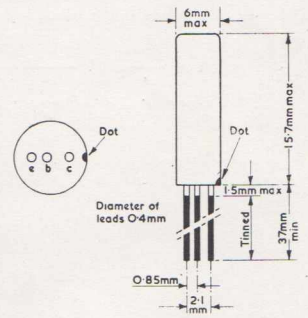
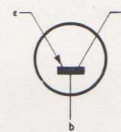

OC 44
OC 71

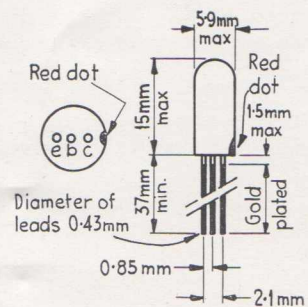
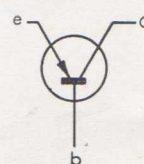

AIRBORNE S.S.B. TRANSMITTER-RECEIVER TYPE X.7443

DESCRIPTION

The three main units can be mounted in either civil or Service-type racking; they are normally supplied mounted side by side on a composite rack, as shown on the cover of this issue. From left to right the units are: Power Supply Unit; Power Amplifier; S.S.B. Unit. The Junction Box is mounted on the left-hand end of the racking and the Remote Control Unit is shown to the right of the main equipment. Full remote control on 12 preset crystal-controlled channels is provided, the operator's controls comprising:

| | |
|-------------------------|--------------------|
| Off—warm up—standby | |
| —operate | switch |
| Send—receive | pressel switch |
| Channel selector | 12-position switch |
| Receiver gain | control |
| Speech clipper (in—out) | switch |
| A.F.C. (in—out) | switch |

The S.S.B. Unit comprises the complete receiver and the low power portion of the transmitter, some sub-units, such as the oscillators, being common to both receiver and transmitter. Nine separate plug-in sub-units comprise the S.S.B. Unit:

| | |
|----------------|-------------------------------|
| A.F. unit | I.F. unit |
| Modulator unit | Carrier oscillator |
| A.F.C. unit | R.F. oscillator (12-channels) |
| Crystal filter | |
| R.F. unit | Tuning mechanism |

Discrimination against the unwanted sideband is obtained in both the receiver and transmitter by four-phase modulators and crystal filters. By this means, a high value of unwanted sideband rejection is obtained without unduly critical circuit adjustment. Although a rejection of 40 dB is specified, the units are initially adjusted for more than 50 dB, thus leaving a wide margin for deterioration due to component ageing, etc.

Both the first (r.f.) and second (carrier) oscillators are crystal-controlled, the crystals for each oscillator being contained in separate ovens. The design of the ovens is such that the equipment can be operated in less than 10 minutes after switching on at an ambient temperature of -40°C . The i.f. is 1.5 Mc/s and the equipment is normally supplied to work on upper sideband on channels above 10 Mc/s and lower sideband below 10 Mc/s; by minor adjustment however, the choice of sideband can be changed to meet other systems requirements, such as

that proposed by I.A.T.A. Speech clipping of 15 dB may be inserted in the transmit path, thus considerably improving the intelligibility of the transmissions under certain conditions of propagation.

The r.f. unit is tuned by a 12-spot mechanical click mechanism and the range and crystal are selected by Ledex switches.

The output from the S.S.B. Unit is fed into the Power Amplifier which is capable of supplying a peak envelope power of 200-300 watts into a 50 ohm load. Tuning of this unit is by 12-spot mechanical click mechanism and Ledex range selector. Two separate a.g.c. systems are employed in the transmit path to maintain the output reasonably independent of microphone input level and change in r.f. gain with frequency.

The Power Supply Unit provides all the power requirements for the S.S.B. Unit and Power Amplifier from a 28V d.c. source.

An air supply of approximately 20 cu ft/min is required for the Power Amplifier; the supply is plugged into the back of the unit in the same manner as the electrical connections. Where an air supply is not obtainable from other sources, a separate blower is available for mounting near the racking. Operation of the complete equipment up to 60,000 feet unpressurised is permissible.

The complete equipment is very small and compares favourably in size and weight with existing d.s.b. equipment.

TECHNICAL SUMMARY

Modulation system. Controlled carrier single sideband.

Frequency range. 2.5 to 20 Mc/s.

Input power. 900 watt maximum from 28V d.c. supply when transmitting on full modulation. 300 watts on receive.

Transmitter power. 200 to 300 watts peak envelope power and 120 watts carrier power into a 50 ohm load.

Channels. 12 preset crystal-controlled channels. No restriction on location of the channels within the frequency range.

Average time to select channel:

15 seconds.

Maximum time to select channel:

30 seconds.

Frequency stability. Approximately ± 1 part per million for normal input

voltage and ambient temperature variations.

Sidband attenuation. Greater than 40 dB on both transmitter and receiver.

A.F. response +1 dB to -3 dB, 500 c/s to 3 kc/s (response at 1000 c/s = 0 dB).

40 dB down at 250 c/s and 5 kc/s. These figures apply to both transmitter and receiver separately.

Meters and indicators. Built-in meter for aligning channels and checking operation.

Lamp indicator on remote control unit to show when equipment is not operational due to ovens not being warmed up or channel not selected.

Transmitter linearity and harmonics. Third order products more than 25 dB down. Harmonics more than 40 dB down.

Speech clipping. 15 dB clipping may be inserted by operating a switch on the remote control unit.

Receiver sensitivity. 1 μV for 20 dB signal-to-noise ratio.

Receiver adjacent channel rejection. 6 dB bandwidth less than 8 kc/s.

A.F.C. sensitivity. Errors up to 160 c/s corrected in less than 2 seconds for carrier input of 2 μV .

Receiver image and I.F. rejection. Image: more than 60 dB down below 8 Mc/s. more than 40 dB down above 8 Mc/s.

I.f. breakthrough: better than 60 dB throughout the range.

A.G.C. characteristic. Audio output varies less than 4 dB for inputs from 1 to 10 μV , and less than 3 dB from 10 μV to 1.0V.

Audio output. Up to 300 mW into 50 ohms load. When output load is changed from 50 to 150 ohms (equivalent to changing number of headsets from 3 to 1), output voltage changes less than 2 dB.

Permissible duty cycle. Capable of continuous operation on a duty cycle of 5 minutes transmit and 10 minutes receive at ambient temperatures from -25°C to $+55^{\circ}\text{C}$.

Capable of working unpressurised at 60,000 ft.

Size and weight. Overall size and weight of the three main units when mounted in a composite civil aircraft rack complete with junction box and interconnecting cables:—

Height: $9\frac{1}{2}$ in (24 cm); Width: 30 $\frac{1}{2}$ in (77.5 cm); Depth: 15 in (38 cm); Weight: 85 lb (38.6 kg).

OUTLOOK

ANNIVERSAR

Mullard
Outlook
Australian Edition



Mullard
Outlook
Australian Edition



1
YEAR

Mullard
Outlook
Australian Edition

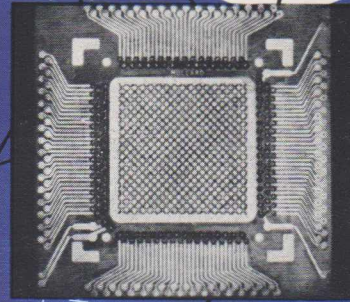

Mullard
Outlook
Australian Edition



Mullard
Outlook
Australian Edition

Mullard
Outlook
Australian Edition

