

MACHLETT

CATHODE PRESS



VOL. 19 • NO. 1 • 1962

UHF

Frequency
Stable

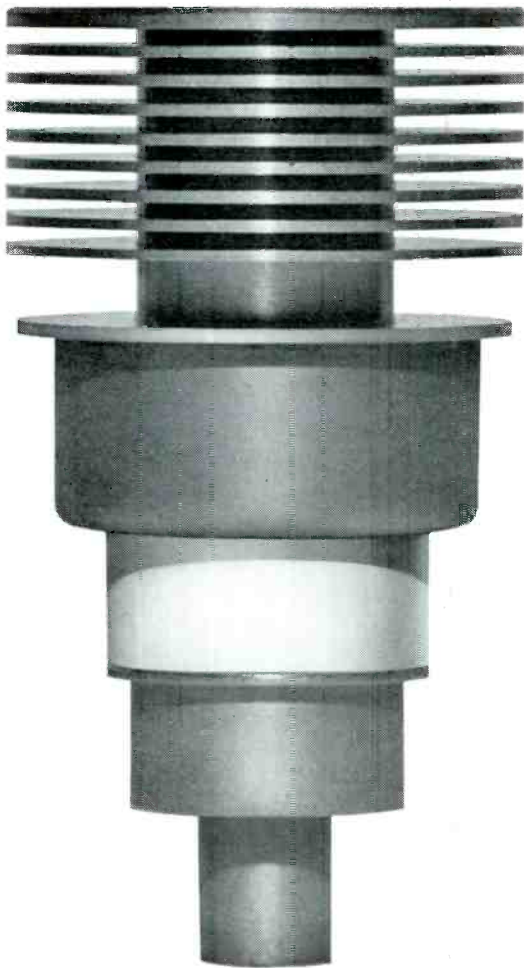

CW or Plate-Pulsed **ML-7855**

Special anode design of ML-7855 permits frequency stable operation within 10-15 seconds after application of high voltage. (Frequency change during this initial period is within 1 mc).

ML-7855 provides frequency stable operation with unregulated supply, as change of plate dissipation has no effect on change of frequency.

CW operation to 2500 Mc, with 1000 V Ebb, 100 ma Ia.

Plate-pulsed to 3000 Mc, with 3500 v eb, 3.0 a ib, with a tp of 3 usec at 0.0025 Du.

Send for Machlett UHF Planar Tube Brochure

An Affiliate of Raytheon Company

MACHLETT

The Machlett Laboratories, Inc.
Springdale, Connecticut

CATHODE PRESS

Vol. 19, No. 1, 1962

Editor, *Richard N. Rose*

Art Director, *Edward J. Bulger*

IN THIS ISSUE

Development of a Hard Tube for High Power Pulse Switching at 180 kV	2
Hard Pulse Modulator Test Facility: 200 kV, 200 mA Capability	6
KGEI Converts to ML-356's in PA and New Modulator	11
Partial Pressure Gauge Tubes	16
Vapor Cooling: Its First Major American Installation in the New 250 kW Voice of America Transmitter	26
The ML-8087, a New Tube for Scan Conversion	35

Cathode Press reports developments of interest to the Electronic Industry at large through its coverage of the latest advances in the design, manufacture and use of electron tubes — with specific reference to their use for x-ray, communication and industrial purposes. Particular emphasis is placed on the role of The Machlett Laboratories in the development of new electron tube products, improvement in current types and in their application.



Development of a Hard Tube for High Power Pulse Switching at 180 kV

Introduction

The commercial market contains a number of power tubes capable of emission in the order of hundreds of amperes. In the development of new tubes for pulse generator service, therefore, most of the emphasis at Machlett has been on designs for higher voltage. Operation of tubes in parallel, moreover, has been generally more satisfactory than series stacking, so there has been more incentive to work towards higher hold-off voltage capability in a single device.

The DP-18 has been developed to operate at dc hold-off voltages up to 180 kV. The thoriated-tungsten filamentary cathode has been conservatively designed to provide at least 225 amperes pulse cathode current. Through careful design of the active electrode geometry, the DP-18 is able to switch 20 megawatts of pulse power at a plate efficiency of nearly 90 per cent and with less than 50 amperes pulse drive current. Ample electrode dissipation capability permits full power operation at duty factors up to 0.005 and higher, unless there is appreciable power dissipated in the anode due to stray capacitance charging at high pulse repetition rates.



by C. V. WEDEN, Product Engineer, The Machlett Laboratories, Inc.

Electrode Design

The electrode geometry of the DP-18 is that of a high- μ triode. The cathode, as mentioned above, is thoriated-tungsten, in a self-supporting filamentary structure. Cathode heating characteristics are 11.5 volts, 360 amperes. This choice of emitter was made because of a desire for long life, high plate efficiency, and long pulse duration.

Plate efficiency is a consequence of grid-anode spacing: the closer the spacing, the lower the tube drop and the higher the efficiency at a given dc plate voltage. It has been found that tubes with metallic cathodes will support field gradients in the grid-anode region about twice as high as tubes with oxide cathodes. With a thoriated-tungsten cathode, therefore, a closer spacing can be tolerated, resulting in higher efficiency.

The pulse duration with metallic cathodes of this type is restricted only by electrode temperatures. Grid dissipation is usually the limiting factor due to its relatively low thermal time constant. In general, pulse durations of several milliseconds can be handled, longer at lower peak power.

The grid has been designed as a compromise between low field gradient and low screening fraction. Special surface treatment based on the emission-inhibiting properties of platinum results in low thermionic grid emission. The overall tube design, furthermore, results in a favorably low yield of secondary grid emission to the extent that negative grid current is virtually eliminated. This is an important feature, since an arc in the load tube puts the power supply voltage on the switch tube when its grid is probably at a high positive voltage. Under these conditions many triodes and tetrodes exhibit negative grid current due to secondary grid emission, in which case the grid loses control unless compensation is provided in the circuitry.

The anode is a high-density copper forging. Longitudinal fins are machined on the exterior to provide sufficient heat transfer area to circulating oil.

Shielding and Envelope Design

One of the most important considerations in high-voltage tube development is proper design of the envelope insulator. The glass or ceramic must be shielded from direct filament radiation, and the shields themselves — and electrode supporting members — must not be sources of field emission. In Figure 1 the internal shields can clearly be seen through the glass bulb. The negative electrode terminal (grid or cathode, as the case may be) is covered by a smooth external shield. This combination puts the glass-metal seal in a virtually field-free region, thereby minimizing the chance of electron emission from this negative junction.

Regarding the choice of insulator, Machlett Laboratories is presently investigating several glasses and high-alumina

ceramics. At this point it is impossible to say that any one material is clearly superior to all others. In the size necessary for the DP-18 (nominally 16 inches in diameter, 13 inches in length), glass required a much shorter lead time for delivery, and it simplified fabrication of the mating kovar collars.

Anode Cooling

The tube is designed to be immersed in mineral oil or equivalent dielectric medium during operation. The anode is designed for cooling by a forced flow of the insulating oil upwards over the anode surface. This surface has been extended by the formation of 240 fins approximately 1 mm thick, 5 mm deep, and 2 mm apart. The fins can be seen in



Figure 1 — Machlett DP-18 high vacuum high power pulse switching tube with anode jacket removed.

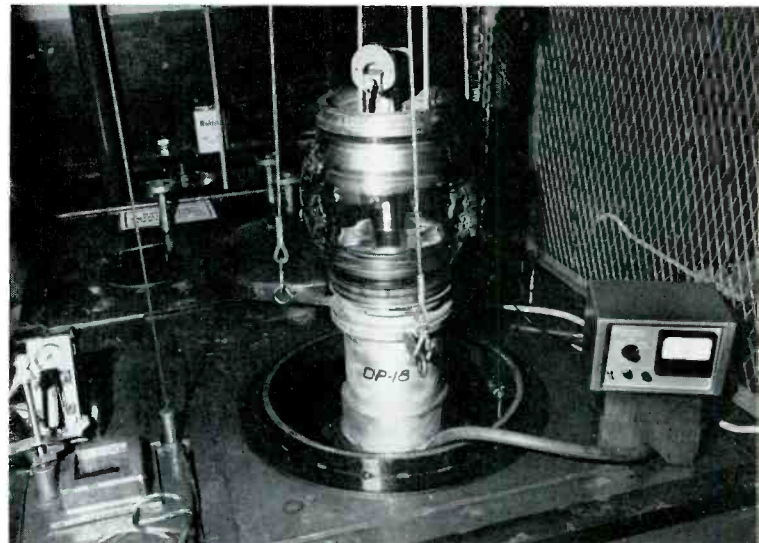

Figure 2 — The DP-18 is shown here being lowered into the Machlett 200 kV, 200 mA hard pulse modulator test facility.

Figure 1.

In operation a close fitting jacket is attached to the anode, and cooling oil is forced through the channels formed between fin pairs. The circulating oil typically enters coaxially at the bottom and discharges near the top of the anode into the bulk oil in the high-voltage tank. Figure 2 shows the tube, with cooling jacket attached, being lowered into the Machlett 200 kV modulator test set (described in another article). While *most* of the heated oil discharges directly into the tank, some of it passes through the large holes in the lifting flange to cool the anode seal and bulb. In addition, a small flow of oil is promoted in the grid-cathode terminal region to cool these seals.

Operation

DP-18 tubes have been operated into a 1000-ohm resistive load at hold-off voltages up to 180 kV and pulse plate currents up to 150 amperes. In a typical test these conditions were obtained at pulse durations of 3-5 microseconds and 200 mA average plate current, which is the rating of the test equipment.

Plate leakage current (field emission) averages well under 1 mA at 180 kV. High voltage stability at 180 kV has been checked by operating the tube with a series resistance as low as 125 ohms.

For bringing this development of a 180 kV switch tube to successful realization, credit is due to Helmut Langer, Development Engineer, and to Barry Singer, Mathematician, working under the direction of Dr. H. D. Doolittle.

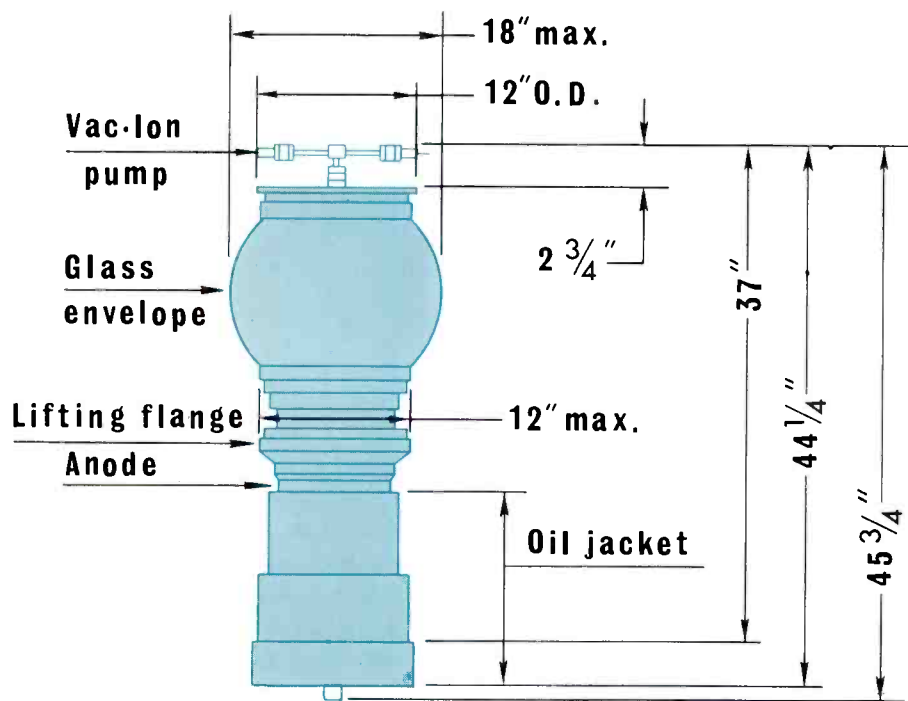
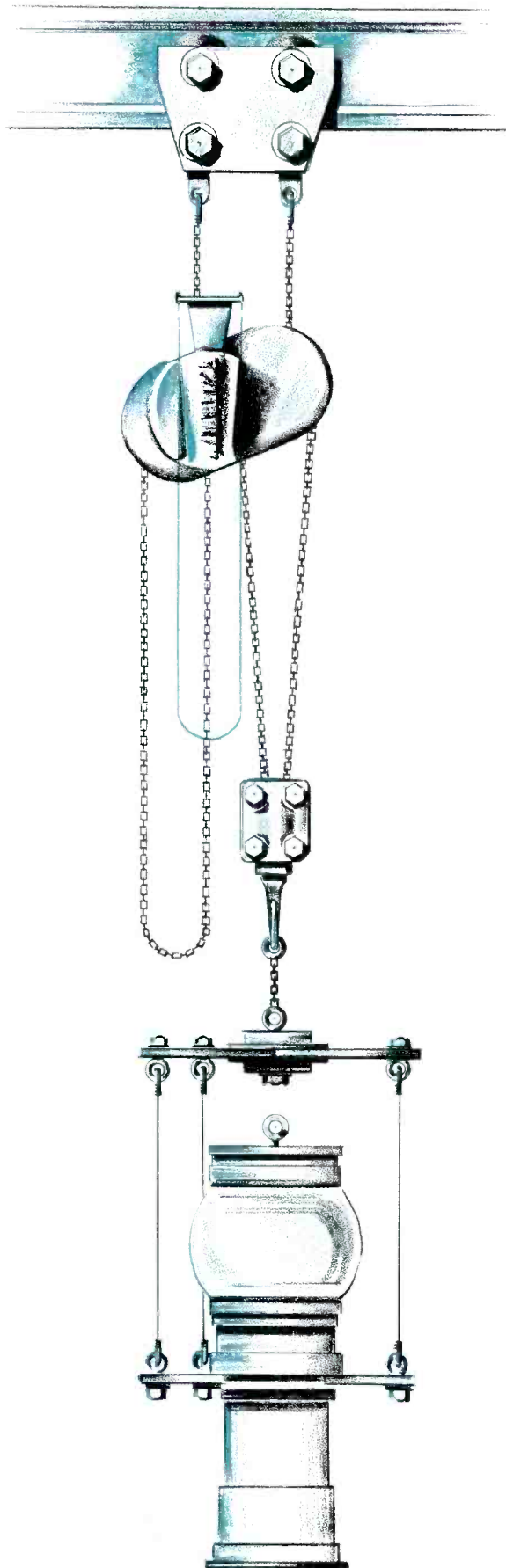

Figure 3 — Outline dimensions DP-18.



Hard Pulse Modulator Test Facility: 200 kV, 200 mA Capability

Editor's Note

During the past six years The Machlett Laboratories has been active in the development of two lines of vacuum tubes specifically designed for pulse modulator service. A series of oxide-cathode shielded-grid triodes has been developed for operation up to 75 kVdc and 5 megawatts pulse switching power. In addition, thoriated-tungsten filament triodes have been developed for operation up to 200 kV hold-off and 20 Mw pulse power. Development is continuing to extend the range of oxide-cathode tubes to 200 kV, and thoriated-tungsten tubes to 400 kV. An important part of this development program has been the design and construction of an engineering facility with provision for making simulated operational tests on these high power, high voltage tubes. A 200 kV, 40-kilowatt average power pulse test set, the subject of the following article, is now engaged in testing a broad spectrum of Machlett switch tubes.

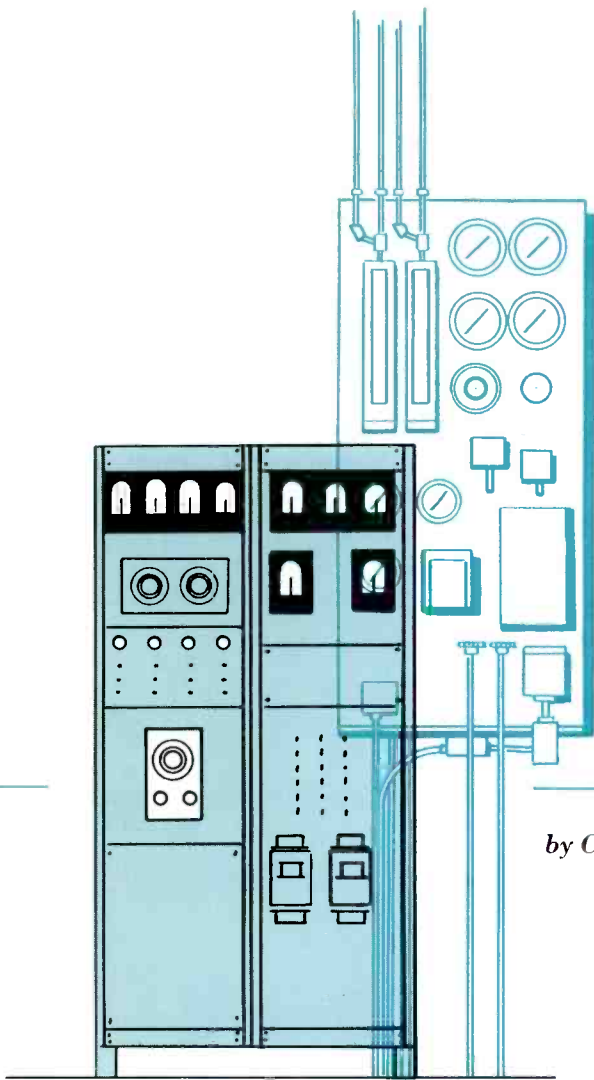

by C. V. WEDEN, Product Engineer, The Machlett Laboratories, Inc.

The importance of operational test equipment in the evaluation of pulse modulator tubes cannot be overemphasized. Static end-of-load-line checks are essential to monitor electrode spacings, and high-voltage hold-off testing is a useful preliminary in the aging schedule. But to be assured that a tube will do the job for which it is designed, it is necessary to test it under operating conditions. Ideally, this means using the tube in a modulator to deliver pulse power to a typical load tube, i.e., magnetron, amplatron, klystron, etc. The cost of simulation to this degree at high power levels would be unwarranted, but a reasonable compromise is to use a resistive dummy load. The important point is to check high-voltage stability of the modulator tube under operating conditions preferably somewhat beyond the required hold-off voltage, pulse current, and stored energy. Experience has shown that the static hold-off capability of a tube does not permit one to predict its performance under normal drive conditions.

A general view of the 200 kV test facility is shown in Figure 1, and a simplified circuit diagram is shown in Figure 2. The diagram also shows the relative physical layout of the major components. The main high-voltage oil tank is divided into quadrants, housing (1) the tube under test, (2) the plate voltage supply, (3) the storage capacitor bank, and (4) the load resistor bank. The pulse driver and control circuitry are housed in the adjacent cabinets.

The tank is half below grade level, providing head room for hoisting heavy tubes into position and simplifying the x-ray shielding. The hoist is arranged so that it serves also to lift the major high-voltage components out of the tank for maintenance.

High-Voltage Power Supply

The dc plate power supply has been designed conservatively for continuous operation at 200 kV, 200 mA. To date the equipment has been limited to operation at 180-185 kV by the specially selected and aged ML-6908 rectifiers. This type is normally rated for 150 kV peak inverse voltage. A set of modified ML-6908's is being built which will permit operation at the full 200 kV in the near future. A standard three-phase, full-wave rectifier circuit is used.

The energy storage capacitance is made up of two 0.5- μ f banks in series, giving a total capacitance of 0.25 μ f. Each bank consists of five 0.1- μ f, 125 kV units connected in parallel.

Load Resistors

A series-parallel bank of resistors is mounted in the oil tank with manual switching accessible above the cover. Load resistance of 250, 500, 750, 1000, 5000, or 40,000 ohms may be selected. In addition, a direct connection (zero load)

is available for making static end-of-load-line and current-division checks.

Tube Under Test Compartment

The tube under test is connected to a socket which is mounted on an elevating platform. A close-up of the tube under test quadrant is shown in Figure 3, wherein a developmental 180 kV switch tube, type DP-18, is being installed.

The operator may raise the platform to a convenient height with a hand crank, and place the tube in its socket. For tubes requiring a forced flow of oil over the anode, the tube is automatically connected to the high-pressure oil supply line. (The oil systems will be described later in some detail.) Electrode connections can be made at convenient levels before the tube is completely immersed in the oil.

During operation, the tube may be observed through the lead-glass port by manipulating a submerged mirror. The observation port is shown in Figure 3 just to the left of the tube, and the mirror adjusting rod is immediately to the left

Figure 1 — General view of 200 kV test facility.

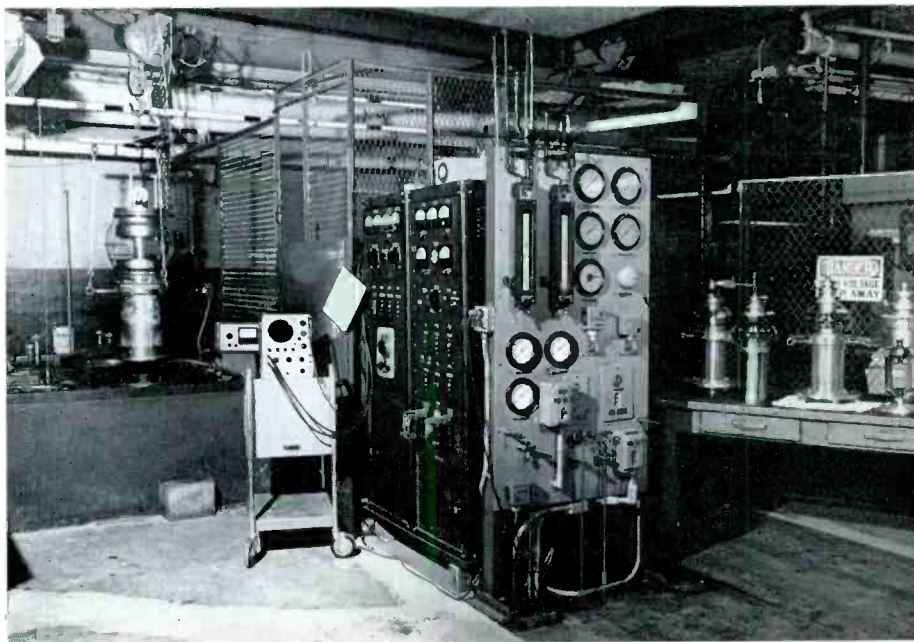

of the port.

The single-phase, ac filament supply is capable of providing up to 20 volts and 500 amperes.

Monitoring jacks are provided for viewing the pulse plate current (up to 500 a), grid drive current (up to 100 a), and grid drive voltage (from bias level up to 3000 volts positive, for a typical switch tube).

Pulse Driver

The tube under test is driven by a hard tube modulator using the ML-6544 shielded-grid triode. The pulse duration is variable from 1- to 10-microseconds, and the pulse repetition rate can be varied from 20- to 5000-pulses per second. A view of the driver cubicle with access panel removed is shown in Figure 4. The ML-6544 is at left center on the ceramic support, connected by flexible duct to a blower. At the upper right is an air cooled dummy load used in making preliminary adjustments on the driver. The ML-6544 is driven by a standard pulse generator and amplifier stages.

Cooling and Filtering Systems

The tank is approximately 9 x 15 x 6 feet deep, and its capacity is some 5700 gallons. The insulating oil used is Esso Special Marcol, a high-purity, high-dielectric-strength oil, and this oil is circulated by two separate systems through an external heat exchanger and filter. The total heat load is 45 kW, divided roughly between the tube under test (22 kW total, plate dissipation plus filament power) and the load (20 kW), with the remainder charged to losses in the high voltage power supply and miscellaneous components.

A "high-pressure" pump system is used to supply a forced flow of oil to the anode of the tube under test. The flow rate can be adjusted up to 30 gpm with a back pressure up to 30 psi. The supply pipe is connected to a short flexible line which connects coaxially with the elevating platform. When a tube is placed on the platform the inlet nipple on the tube socket engages an O-ring in the platform connection, thereby coupling the tube to the high pressure oil supply. In opera-

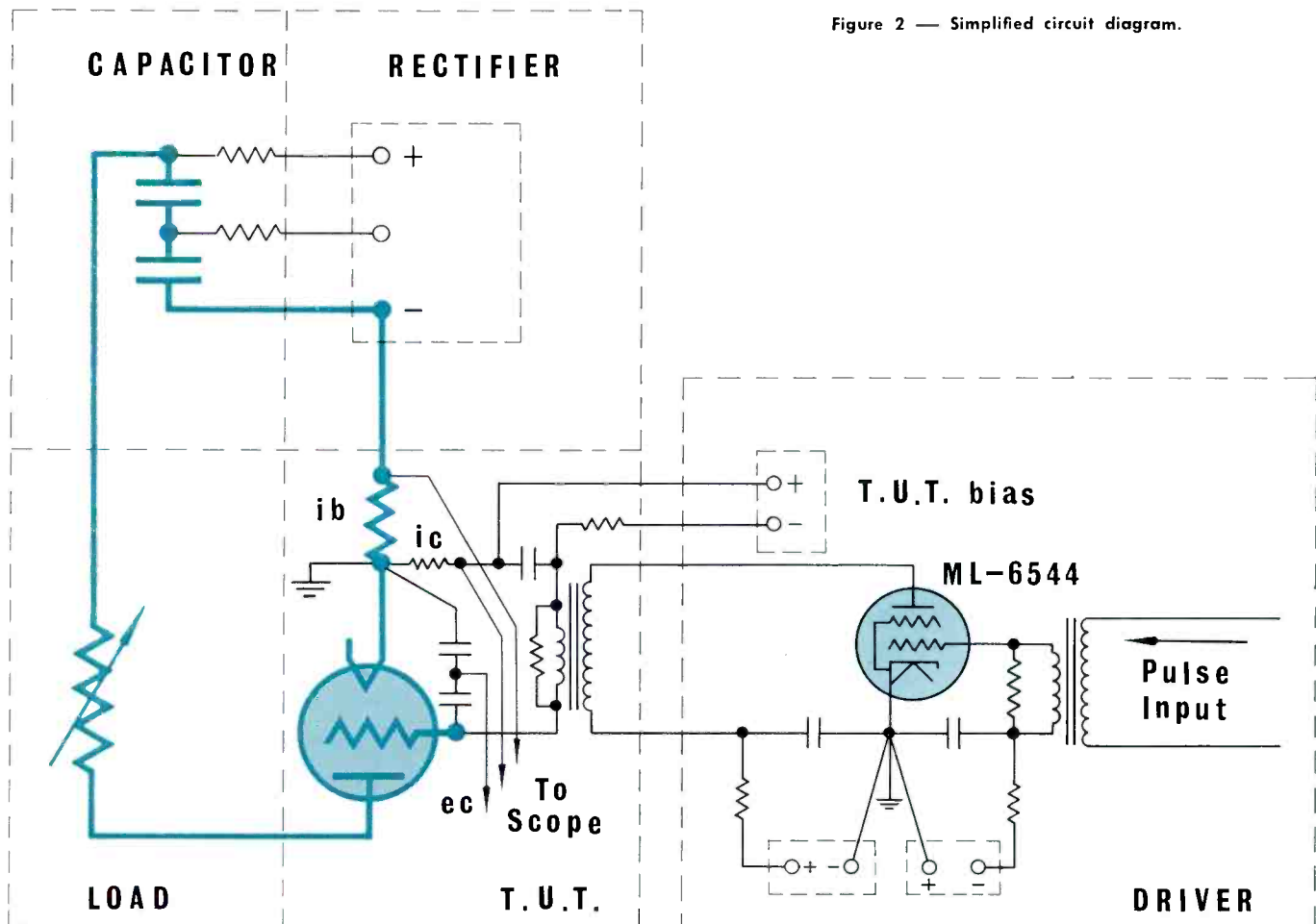

Figure 2 — Simplified circuit diagram.

tion, oil is directed upward over the anode surface, discharging into the bulk oil in the tank.

A common return system draws the heated oil through perforated pipes located just below the oil level in the tank. This system has a capacity of 100 gpm. After passing through the heat exchanger, about one-third of the cooled oil passes through a booster pump of the "high-pressure" system. The remainder flows directly to the tank where it is distributed by perforated pipes located near the bottom.

The heat exchanger is water cooled. It has been designed to maintain a mean bulk oil temperature of 38°C (100°F).

The filter system has a capacity of 15 gpm, retaining particles up to 5-10 microns and up to a pound of water. The system can be operated whether or not the test set is in use, and the total supply of oil will pass through the filter every 6½ hours.

The oil system control panel is adjacent to the driver section and is shown in the foreground of Figure 1. It has

been arranged so that all switches, control valves, pressure gages, flowmeters, and the thermometers are conveniently accessible and visible to the operator.

• • •

The continued expansion of Machlett's line of high power tubes has created a need for advanced facilities to provide adequate evaluation of tubes under realistic load conditions. The extent of the Machlett capability in this field is now demonstrated not only by the breadth of pulse types available but by the depth of the supporting equipment.

The author wishes to acknowledge the contribution of the Machlett equipment engineering and construction groups in bringing this project to successful fruition; in particular, that of D. C. Kudola for the electrical layout, W. A. Bulger for the oil circulation systems, and C. A. Simpson for the overall mechanical layout and design of the tube under test mounting and handling facilities.

Figure 3 — Tube-under-test quadrant.



Figure 4 — Driver cubicle with access panel removed.



KGEI Converts to ML-356's

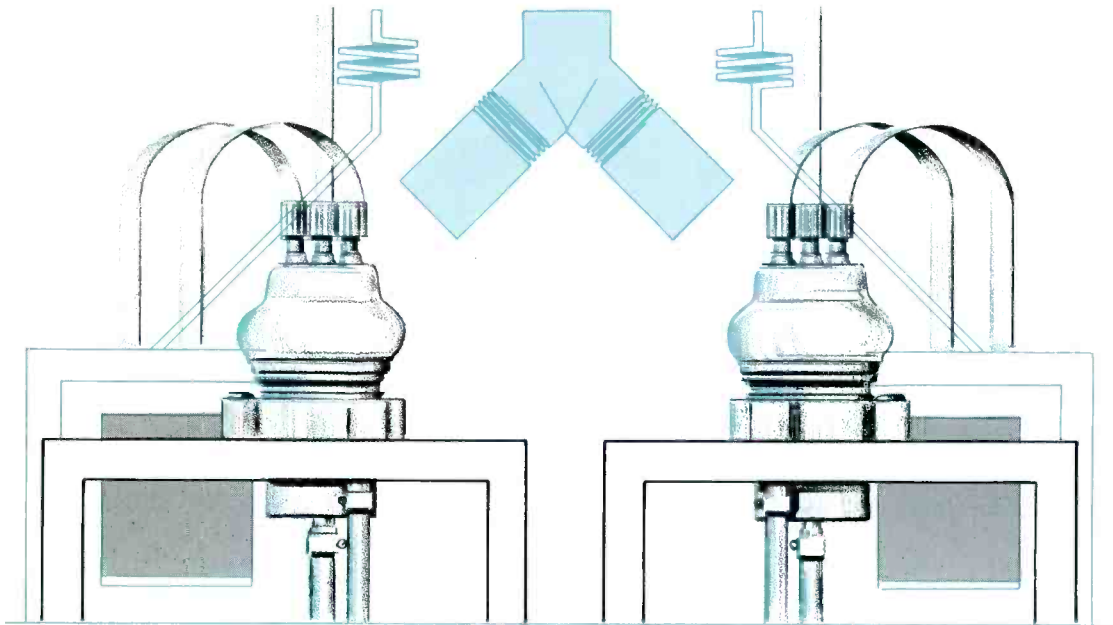

in PA and New Modulator

by *DON C. SMITH, Chief Engineer, KGEI*

The Far East Broadcasting Company broadcasts the Christian message of truth and freedom in 36 languages and dialects from its national and international broadcast facilities, located in the Philippines, Okinawa, and Belmont, California. Transmitter powers range from 1,000 to 100,000 watts.

The latest acquisition is 50,000-watt KGEI near Belmont, California, on the San Francisco Bay. Formerly owned by General Electric, the present schedule consists of 6 hours each evening directed to Latin America in English, Spanish, Portuguese, Chinese and Russian. The response to this programming has been gratifying, and an expanded schedule is anticipated.

The 1939 vintage G.E. transmitter utilized a pair of 880's in the rf and 893's in the modulator power amplifier. Past experience over several years indicated life averages of 3,680 and 5,800 hours respectively. The filament power consumption is quite high since both these have pure tungsten filaments. Modern thoriated-tungsten filament tubes are available which should render much longer life with lower filament power consumption for approximately the same price per tube.

Consideration was given to the possibility of converting to another type. For the rf section, the choice was obvious. The ML-356 is a thoriated-tungsten version of the 880, identical mechanically and electrically except for filament voltage and current requirements. The required filament power of the ML-356 is only 1,275 watts, less than $\frac{1}{3}$ that of the 880.

Before ordering new filament transformers, consideration was given to what might be done to use the existing 880 transformers. Calculations and measurements of the purposely high leakage inductance and comparison of the two loads indicated the 7.5 volts at 170 amperes required for the ML-356 should be obtained by using approximately 107 volts on the transformer primary instead of the 230 volts required for the 880's. Since a combined Variac and buck-boost transformer arrangement was used for varying tube filament voltage, it was felt that the 107 volts could be obtained by feeding from 120 volts. This was cautiously tried when the first ML-356 was on hand and worked exactly as anticipated. The 880's were then

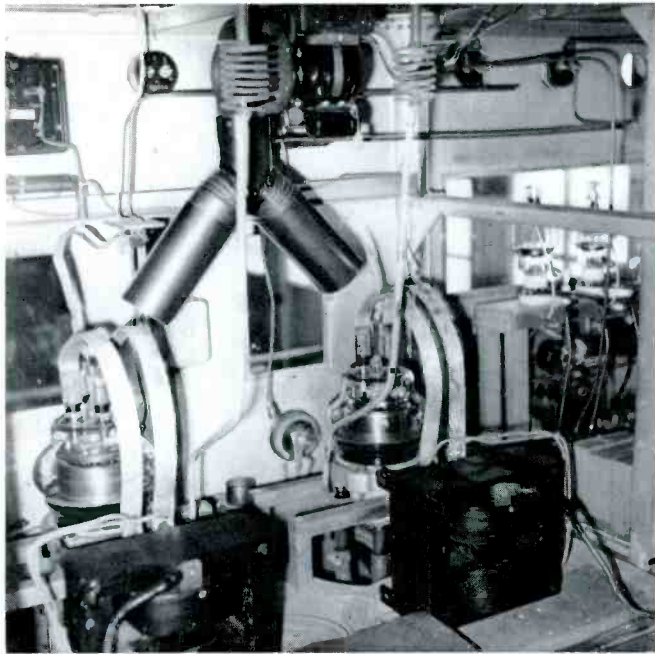
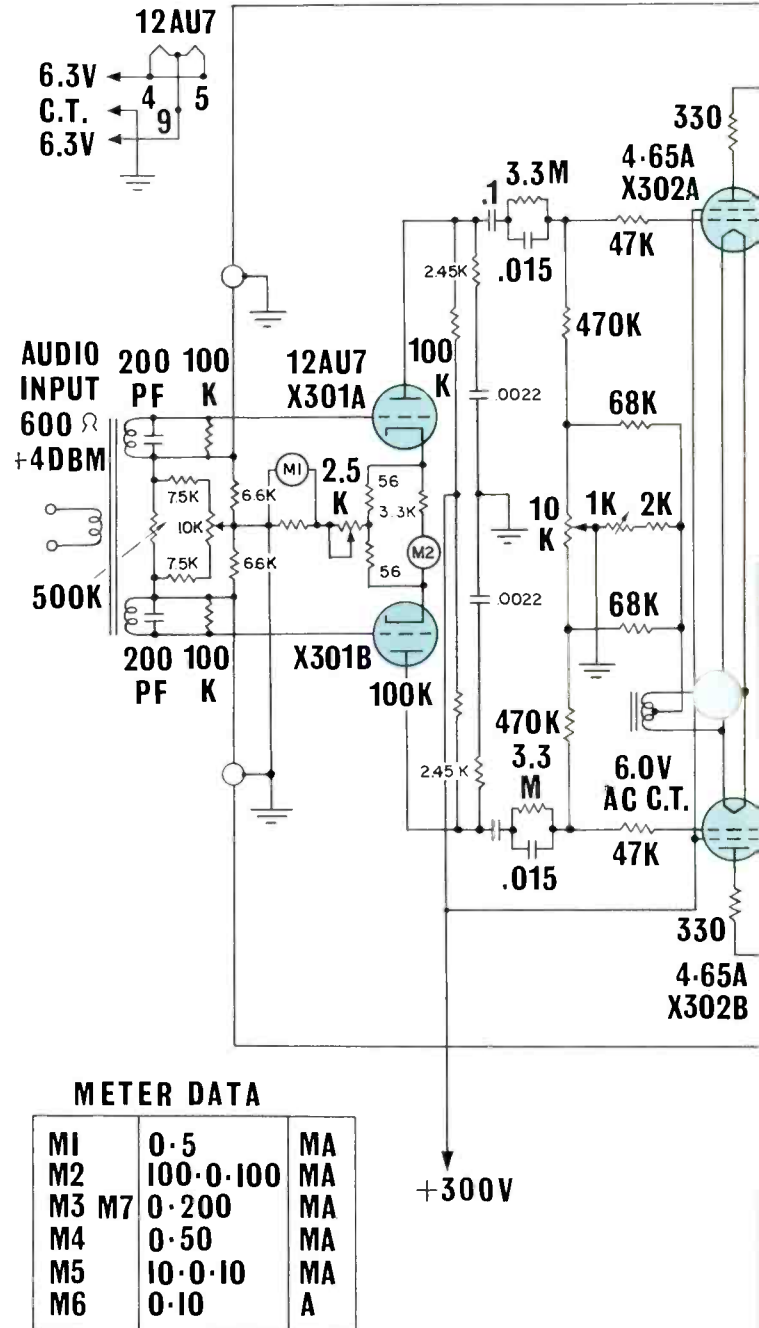

Figure 1 — Rear view of modulator showing completed conversion.

replaced one at a time when they breathed their last. There is now about 5520 hours on the oldest ML-356 with no noticeable change in characteristics. The transformer hardly heats at all, and the filament connectors run cooler. We are completely satisfied with the change.

For the modulator the change was not so simple. There is no thoriated-tungsten equivalent to the 893A available, but there was more to be gained here by conversion to a thoriated-tungsten filament tube. After considering several possibilities it was concluded that conversion to ML-356's here also would be the best solution (see Figure 1). Another problem immediately arose. The ML-356's require about 1.3 amperes each peak grid current at the required power output, whereas the 893A's require less than one ampere. The 849 drivers could not supply this in an AB₁ cathode follower circuit without a step-down transformer. This, added to the fact that the 849 is expensive for its size, nearing obsolescence and a little difficult to obtain, led to the decision to redesign and rebuild the entire electronics of the modulator using ML-356's. The existing modulation transformer and plate supplies were retained.

Type 304TL drivers were chosen because of their ability to produce the required ML-356 grid current operating class B₁ (Figure 2). It is a preferred type and the cost is about 1/3 that of the 849. Table I shows an operating cost comparison of the old and the new. Experience reported from ML-356's used in similar transmitters indicates an average life of at least 10,000 hours can be expected.



NOTES:

Unless otherwise specified, All Capacitances are Micro-Farads; All Resistances are Ohms.

Figure 3 — Schematic drawing of modified modulator section.

tube. The grid current peaks are carried by the 304TL 1,500 volt supply. This resulted in replacing the old 3-phase heavy duty mercury-vapor bias supply with a much smaller single-phase supply using silicon rectifiers.

In order to minimize loss of air time, the entire driver unit was built on a 24" by 35" plate mounting a smaller deck on which the tubes were placed. This unit when completed and tested was placed temporarily behind the existing driver and temporary connections were made to use the new unit driving the 893's. The transmitter was actually operated about ten days like this with testing going on between broadcast schedules. The old driver was then removed, and the new slid into place with no loss of air time. Later the 893A's were replaced by ML-350's after all possible preliminary preparations were made. Five hours air time were lost here, but it was due to complications arising from inexperience in sweat-joint plumbing. About two hours air time were lost on other occasions due to troublesome things like VHF parasitics causing hot spots in neoprene water hose! (It was decided to replace the old porcelain water coils and connecting copper pipes with hose. High-priced hose with a neoprene core was tried, but this ruptured

Figure 4a — Audio frequency response 50% modulation. 27 db feedback.

TABLE I OPERATING COST COMPARISON

Reduction in plate and filament power = 13.42 kW
(Reduction in filament power alone = 12.74 kW)
@ 1.5¢/KWH = \$0.201/ hour saving

Tube costs per 10,000 hours:

Old	New
\$6,668.00	\$2,877.25
or \$0.667/hour	or \$0.288/hour
a saving of \$0.379/hour	
Total saving: \$0.58/hour	

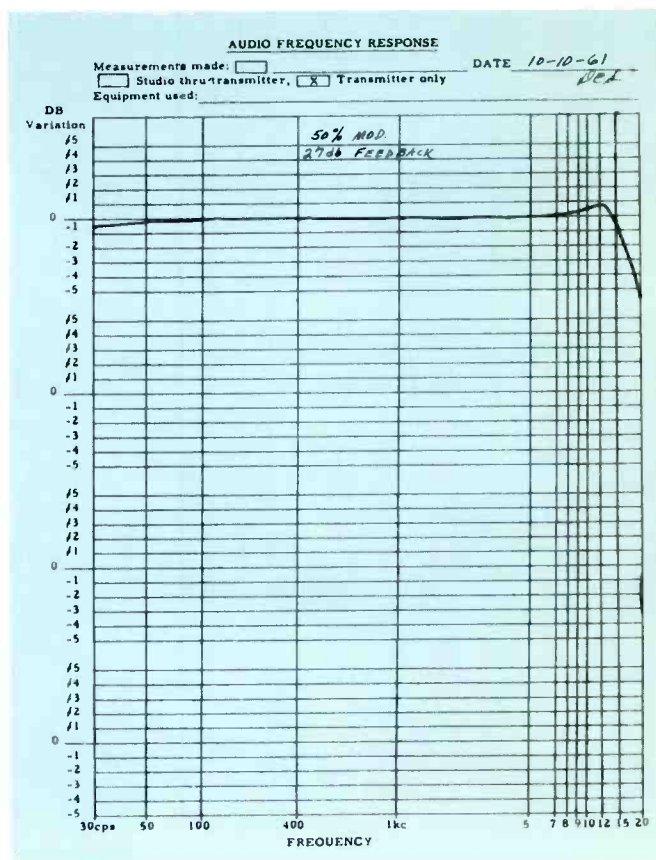

when a mysterious VHF parasitic which occurred under high percentage modulation caused hot spots. Three-quarter inch heavy-duty vinyl garden hose was obtained quickly and has proved very satisfactory.)

All bugs were finally eliminated bit by bit, and the modulator now performs very satisfactorily in every respect. In an effort to reduce construction costs as much as possible, surplus components were used where suitable. Also, thanks is due Eimac, San Carlos, California, for supplying engineering sample 304TL's.

Ideas for the basic circuitry were borrowed from an article, "Modulators For High Power Transmitters", by H. A. Teunissen, which appeared in the June, 1949 issue of *Communication News*, published by the Philips Telecommunication Industries, Hilversum, Holland.

Credit is due to Don Johnson, electrical engineer with Western Electric Company, Winston-Salem, N. C., for much of the basic design work and helpful consultation during testing; to Jim Barham of the KGEI staff for most of the construction and many hours of assistance during testing; to Bill Luck of Varian Associates, Palo Alto, California, for material assistance in various ways; and to K. G. Morrison, Western District Manager for Machlett Labs for the use of an HP-330B Distortion Analyzer.

Figure 4b — Audio frequency harmonic content.
95 % modulation.
27 db feedback.

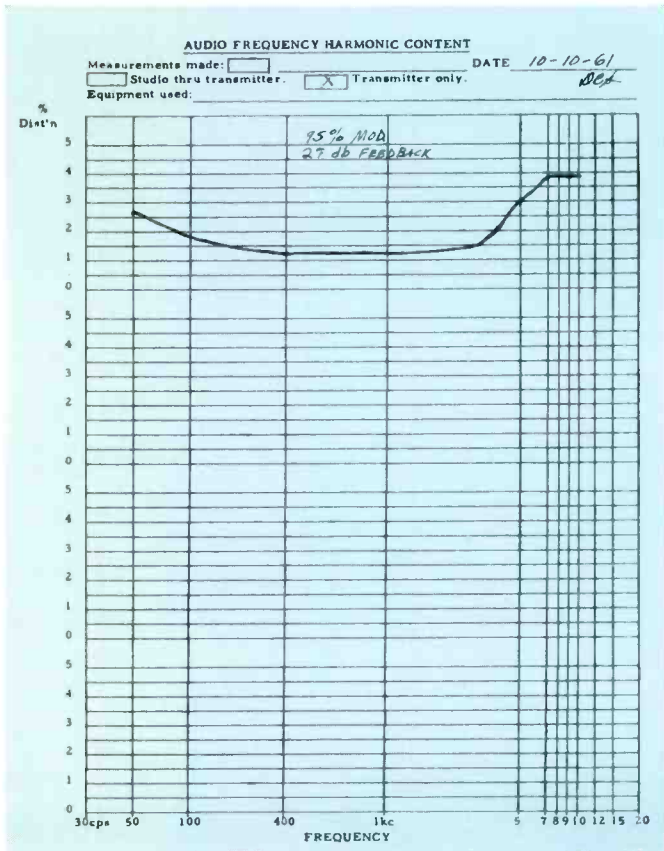

Figure 5 — ML-356

Introduction

Ionization gauges are extensively used today for pressure measurements in a very wide pressure range (10^{-1} to 10^{-13} Torr). They are utilized in research as well as in production. The pressure measurement with all types of ionization gauges is based on a relation which exists between the measured ion current and the pressure in the system. This relation must be determined for each gas type by calibration. If a mixture of various gases or vapors is present in the vacuum system, the "total pressure" readings obtained by an ion gauge are approximate and can be expressed only in terms of "equivalent nitrogen pressure". It is well known that vacuum systems usually contain an unpredictable mixture of the different gases and vapors. "Total pressure" information given by an ion gauge is invaluable — which can be seen from the popularity of these gauges — but it does not reflect the true picture of the "vacuum".

In many applications, however, it became more and more recognized that the amount and nature of different compounds present in this "total pressure" must be known. The knowledge of the gas composition and the partial pressure of the components is of great help in solving various problems. The need for such partial pressure gauges can be shown in many examples: e.g., in a continuously pumped vacuum system a partial pressure gauge indicates readily whether the obtainable minimum pressure is limited by leaks, by the pump, or by improperly degassed parts. Other examples are: e.g., controlling the composition of all the residual gases in vacuum devices, ultra-high vacuum chambers in experimental work or in production, and measuring composition and purity of gases both in laboratory devices and in the upper atmosphere, etc. The demand for instruments to be used for partial pressure gauges for vacuum systems resulted in the development of a variety of such devices. The trend is to use partial pressure gauges in research and also in production where vacuum is utilized as an environment. Machlett Laboratories has selected two types of experimental partial pressure gauge tubes to introduce as production items.

The two selected partial pressure gauges are the rf type non-magnetic mass spectrometer tube and the omegatron tube.

They were selected because the rf mass spectrometer tube measures pressures in the high vacuum range from 10^{-3} Torr to 10^{-8} Torr, and the omegatron gauge supplements this by covering the ultra-high vacuum range from 10^{-5} Torr to 10^{-11} Torr. Their selection was based on the fact that both gauges have been tested and used in research in the last decade, and they have proved useful and reliable.

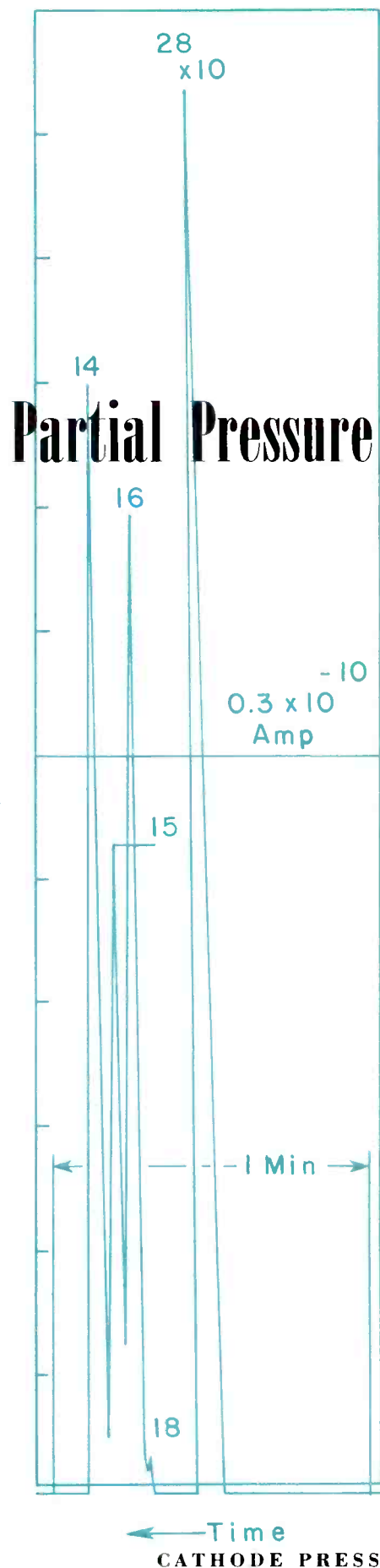

Gauge Tubes

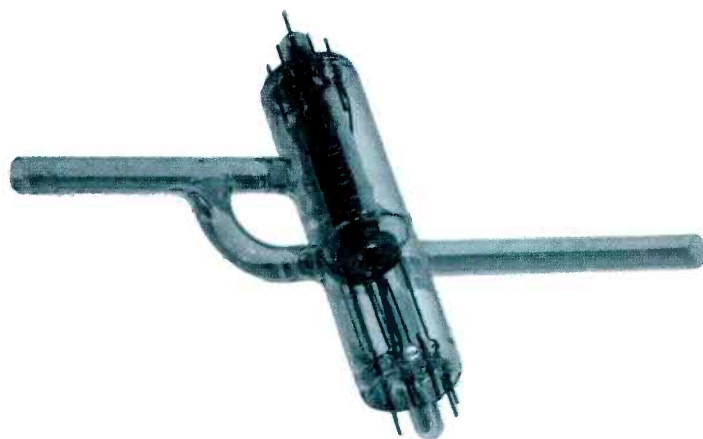

by DR. PETER F. VARADI, The Machlett Laboratories, Inc.

I. RF Mass Spectrometer Tube ML-494 — Total and Partial Ion Gauge

The ML-494 non-magnetic type mass spectrometer tube with associated control circuits can be used for the simultaneous determination of total pressure of a gas mixture as well as determination of the partial pressure of the molecular species present. The sturdy and relatively simple gauge tube shown in Figure 1 was designed to operate in a wide pressure range as high as 10^{-3} Torr and down to 10^{-8} Torr. These features together with the fact that it operates without a magnet make this total and partial ion gauge suitable to replace the conventional ion gauges which are capable of measuring only total pressure. The importance of measuring gas composition in a vacuum system, beside monitoring the total pressure, is well established today, e.g., in the electron tube industry, vacuum evaporation and metallurgy, and in semi-conductor and thin film research.

The ML-494 is a radio frequency mass spectrometer tube (Figure 2). In this system gas molecules are ionized by an electron beam in the ion source of the tube. A part of the ions produced enters the analyzing chamber and is collected on the first grid (G 1). Similar to an ion gauge, the ion current measured here corresponds to the total pressure. Other parts of the ions produced travel through a grid system where ac and dc fields are used to identify ions having different masses.

Principle of Operation

The schematic drawing of the rf mass spectrometer (total and partial pressure) gauge tube is shown in Figure 2. The principle of the rf mass spectrometer is similar to that of the linear accelerator and utilizes only electric fields for mass separation.

Ion Source

The ion source of the tube is located in Chamber 1. It consists of ThO₂ coated tungsten spiral filament (F) as a cathode and a box-shaped anode assembly (A). The ThO₂ coating on the filament enables one to operate the cathode at a low temperature, and delivers 10 mA of electron current at 1300°C. The electrons emitted are accelerated towards the positive potential anode box (A). The gas atoms or molecules present are ionized in this box by the accelerated electrons. The ions formed here are then attracted towards the first negatively charged grid (G 1) into the analyzing chamber. Some of the ions flying into the analyzing chamber are trapped at this first grid, but others fly through this grid and travel through the analyzing grid system. It is interesting to mention that in this unique ion source for higher ionization efficiency, the direction of the electron and ion beams is the same. The complete elimination of the electrons from the ion beam produced is achieved by electric fields and a suitable tube geometry.

Total Pressure Measurement

Ions collected at the first grid (G 1) are used for total pressure measurement. The filament cathode (F), the box anode (A), and the negative potential grid (G 1) can be considered as a conventional ion gauge. Ion current I⁺ measured at this grid is proportional to the total pressure,

$$p = S I^+ \quad (1)$$

Partial Pressure Measurements

Ions not trapped at this grid (G 1) travel through the analyzing grid system. This part of the tube consists of 13 equally spaced grids. Grids G-2 through G-12 are all at the same negative dc potential, and between each alternate grid an rf voltage is superimposed. The rf voltage can be connected to each alternate grid only, the in-between grids being at rf ground, or a push-pull amplifier system may be employed. Ions traveling through this grid system gain energy from the rf field only if they have the proper velocity, *v*, to clear a grid distance, *s*, during a half period of the radio frequency, *f*:

$$\frac{s}{v} = \frac{1}{2f} = \frac{s}{\sqrt{\frac{2e_1}{m_1} V_0}} \quad (2)$$

Here *e*₁ and *m*₁ denote the charge and mass respectively of the ions, and *V*₀ is the ion accelerating voltage. Other ions not having the proper mass lose or do not gain energy while traveling through this grid system.

The wanted ions, having gained energy, and the ones not wanted are separated by the next to the last grid (G 13), on which a high positive "stopping" potential is applied. The positive potential of this grid is selected to repel all ions except those having gained the maximum energy from the rf field. The relation between the radio frequency, *f*,

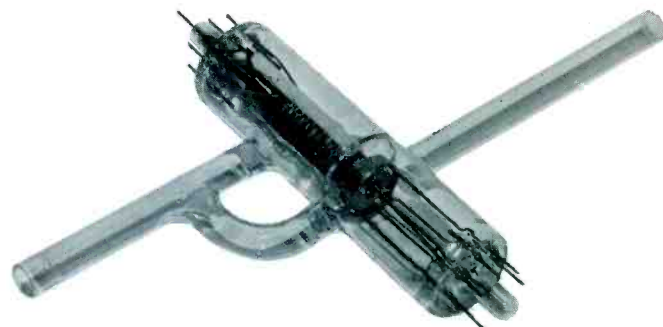
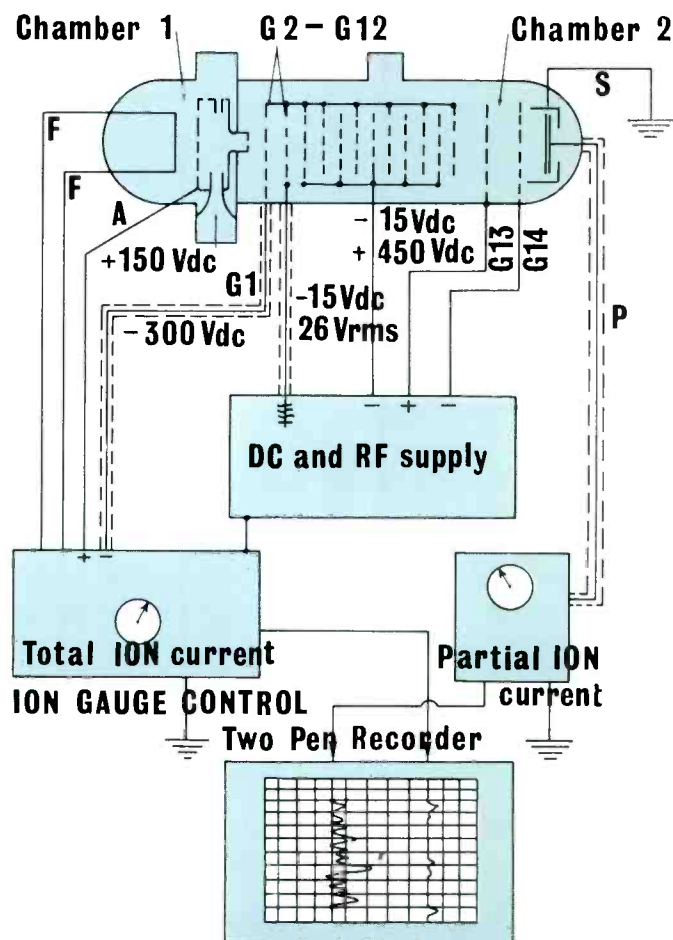

Figure 1 — RF Mass Spectrometer Tube.

Figure 2 — Schematic drawing of the RF Mass Spectrometer Tube and its Electrical Control System.



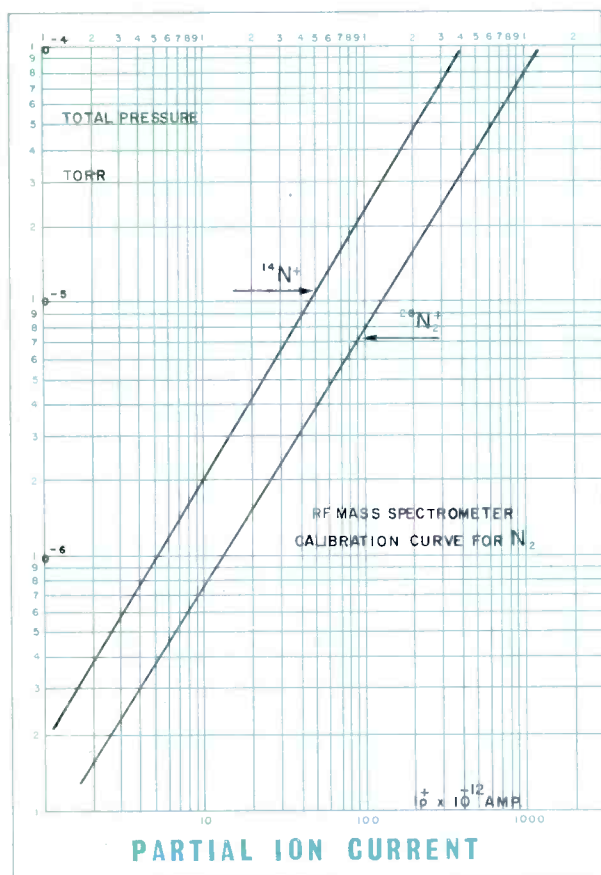
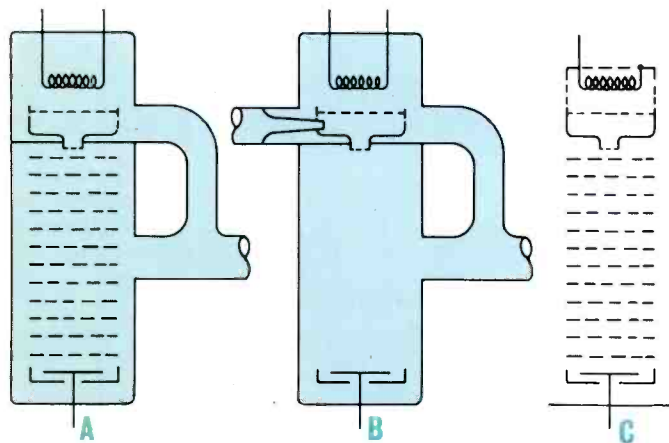

Figure 3 — Calibration Curve Plotted for Nitrogen.

Figure 4a — ML-494 Gauge Tube.

Figure 4b — ML-494A Throughput Gauge Tube.

Figure 4c — ML-494B Nude Gauge.



(Mc/sec.) at which a molecular species, M (atomic mass unit AMU), gains maximum energy can be derived from Equation 2 and written as:

$$M = \frac{K}{f^2} \quad (3)$$

Here K denotes a constant, depending on voltages and tube geometry.

Only the ions wanted are able to pass the energy selector grid, G-13, and are collected on plate C. The resulting ion current is a measure of the abundance of this component in the gas mixture. G-14 and electrode S are for shielding the collector plate. Typical voltages used in this system are indicated also in Figure 2.

The importance of the high rf voltage has to be emphasized. High rf voltages (e.g., 25-40 V rms) are important to achieve high resolution and reliable operation of the system.

The partial pressure measurement in a system combines two tasks: (a) to identify the quality of the compounds, and (b) to determine their abundance. Quality identification is performed by scanning the mass spectrum and determining the components present. The scanning of the mass spectrum is performed by changing the radio frequency. To determine the mass number of the peaks in the mass spectrum, Equation 3 can be used. Having one reference mass, the equation can be written

$$M_x = M_o \left(\frac{f_o}{f_x} \right)^2 \quad (4)$$

where M_o — AMU of the reference ion, M_x = AMU of the unknown ion, f_o and f_x are the frequencies respectively. The mass range in which this rf mass spectrometer tube can be used is $M = 1$ to $M = 250$ AMU. The accuracy of mass determination, based on Equation 4, is better than $\pm 0.5\%$.

Partial Pressure Determination

Partial pressure determination of the gas components is based on a calibration similar to that described for the total pressure measurements:

$$p_x = C - I + M_x \quad (5)$$

Here p_x is the partial pressure of the gas component, $I + M_x$ is the partial ion current of the component of mass M_x at a frequency of f_x , and C is a constant which has to be determined for each gas or vapor individually. The calibration curve for gases is linear up to 5×10^{-4} Torr, and measurements can be carried out as high as 10^{-3} Torr.

Calibration of the Total and Partial Pressure Gauge

The gauge has the feature that it measures total and partial pressures from the same ion beam. This makes its calibration extremely easy. The mass spectrometer system can be calibrated against its "built in" ion gauge. A calibration curve for nitrogen gas is shown in Figure 3.

Tube Design

The gauge tube can be made in three different forms, as is shown in Figure 4a, -b, -c. These are:

- As a regular gauge tube to be affixed to glass or metal systems (replacing ion gauges) ML-494.
- As a through-put gauge, in which case the gases enter the ion source of the tube through a capillary thereby enabling measurement of the flow rate (ML-494A).
- As a nude gauge (ML-494B) which has no envelope and can be immersed in metal or glass systems.

The rugged and simple tube structure withstands shock (10 G in each direction) and vibration. Its features are: (a) the ion source can be degassed by electron bombardment; (b) it is bakable at temperatures up to 450°C; (c) the grids are mesh grids and are mounted under tension on a ring washer, resulting in a reproducible tube structure.

The performance and reliability of this mass spectrometer tube and system are based on our tube geometry and on the dc and rf voltages used. The equally spaced grid system and the high rf and dc voltages utilized make this mass spectrometer system a reliable gauge.

Mass spectra of gas mixtures containing N₂ and CH₄ and N₂ and CO₂ are shown in Figure 5, demonstrating the performance of the tube. Data were taken by a two-pen recorder and the voltages used were as indicated in Figure 2.

Scanning Speed

As can be seen from Figure 5, the scanning of the mass range $M = 10$ to 70 AMU was performed in these measurements in 60 seconds. The scanning speed of this total and partial pressure gauge can be varied, and also oscillographic recording may be utilized. The maximum scanning speed of this instrument is given by the electronics utilized. Fast scanning (sec./range) can be used if fast changes in the vacuum system must be recorded; while low speed (1 min.) can be used in most of the routine work. Slower scanning of the mass range can also be applied; however too slow scanning is not advantageous for the routine vacuum analysis. It is important to mention that the observation of a single component in the system is also possible by tuning the unit to the peak of the component. This is a feature if the changes in total pressure, and also the changes in the pressure of a single component, must be followed.

Electronics

The required control units are schematically shown in Figure 2. Typical electrical data of the tube are given below. The main units are the following.

Ion Gauge Control. Supplying filament current electron current stabilizer, positive anode and negative grid voltage and a dc amplifier for measuring the total ion current. The tube design is such that it enables the use of most of the commercial ionization gauge supplies available.

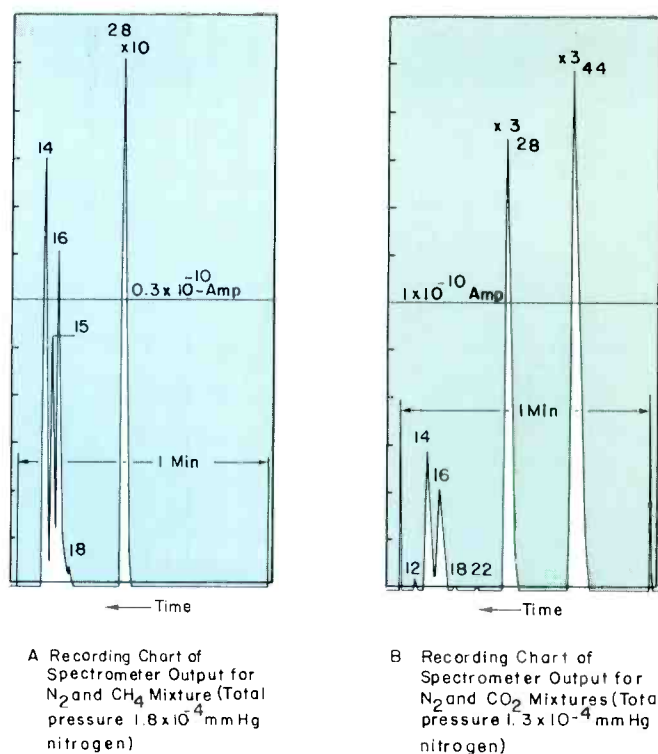

Figure 5 — Mass Spectra of Gas Mixtures.

DC Voltages. May be obtained from batteries or any regulated power supplies.

RF Voltages. The frequency range and the required voltage is indicated in the specifications.

DC Amplifier. For the partial pressure measurement; must have sensitivity of 10^{-12} to 10^{-13} amp. if 10^{-8} mm Hg. partial pressures have to be measured.

The accuracy and sensitivity of the rf mass spectrometer tube depend on the stability of the voltages and on the sensitivity and response of the dc amplifiers used.

General Characteristics

Filament voltage, ac or dc	3 to 5 V
Filament current	2.5 to 3.5 A
Electron emission current (according to application)	0.1 to 10 mAdc
Electron current, maximum (for outgassing)	50 mAdc
RF voltage	25 to 50 Vrms
Frequency range	2 to 32 Mc/sec.
Corresponding to a mass range of	250 to 1 AMU
Resolution, manual scanning	60
Resolution, ½ min. automatic scanning (10 to 65 AMU)	35 *
Pressure range, total and partial	10^{-3} to 10^{-8} mm Hg.
Linear pressure range	5×10^{-4} to 10^{-8} mm Hg.
Sensitivity (depending on the gas type) approximate value	10^{-5} A/mm Hg. for N ₂ ²⁸ peak
Mounting position	Any
Envelope	7052 Glass**



Figure 6 — Applications of the RF Mass Spectrometer Tube.

Applications

The ML-494 tube is equally suitable for scientific and industrial applications. This tube type was reported to be used successfully in a variety of such applications as:

- a. *Gas analysis* during a pump process in conventional vacuum systems.
- b. *Residual gas measurements* in sealed off vacuum devices (e.g., electron tubes).
- c. *Studies on degassing* of materials, or gas permeation.
- d. *Leak detection* in vacuum systems.
- e. *Chemical gas analysis*.
- f. *Space research*.

In the Machlett Laboratories these types of total and partial ion gauges have been used for years for controlling pump processes and improving the quality of power and x-ray tubes by measuring the residual gas composition in these tubes, Figures 6 and 7. This was possible because the ML-494 gauge tube does not require shielding, magnet, or any special adjustment. It can be used in power tube test sets without disturbing the operation of the tested tubes.

*Depending on the dc amplifier used.

**Graded or glass-to-metal seals available on request.

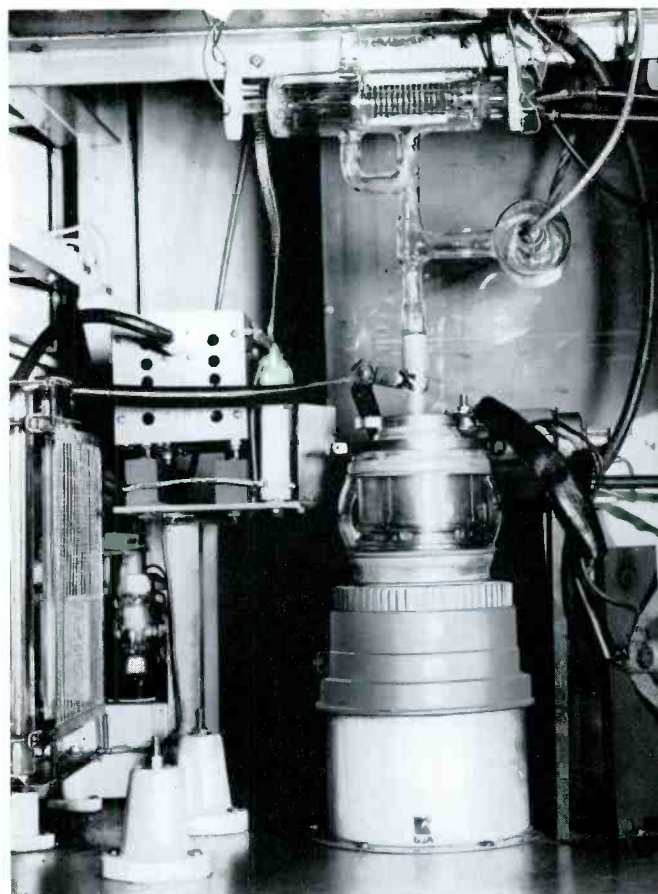

Figure 7 — Applications of the RF Mass Spectrometer Tube.

REFERENCES

General Description

¹Váradi, P. F., Sebestyen, L. G., and Rieger, E.: R.f. Mass Spectrometer, *Vakuum Technik*, 7, 13-16, 1958.

Theory

²Bennett, W. H.: R.f. Mass Spectrometer, *J. Appl. Phys.*, 21, 143-149, 1950.

³Redhead, P. A., and Crowell, C. R.: Analysis of the Linear r.f. Mass Spectrometer, *J. Appl. Phys.*, 24, 331-337, 1953.

⁴Kerr, L. W.: Non-magnetic Mass Spectrometers, *J. Electronics*, 179-198, 1956.

Applications for Electronic Device Research

⁵Bennett, W. H.: Method for Investigating Tube Degassing and Gettering, 13th Annual Conference on Physical Electronics, 143, 1961.

⁶Váradi, P. F.: Gas Composition During Pumping and in Sealed Off Power Tubes, ASTM Symposium on Materials for Electron Tubes and Semi-conductor Devices, 1961.

⁷Hollister, H.: Long Pulse Diode Study, Contract No. AF 30(602)-1696, Rome Air Development Center, Griffiths Air Force Base, New York.

Applications for Space Research

⁸Townsend, J. W., Jr.: Radiofrequency Mass Spectrometer for Upper Air Research, *Rev. Sci. Phys.*, 23, 538-541, 1952.

⁹Meadows, E. B., and Townsend, J. W., Jr.: I G Y Rocket Measurements of Arctic Atmospheric Composition Above 100 Km, Space Research, North Holland Publishing Co., Amsterdam (Holland), 175-198, 1960.

¹⁰Taylor, H. A., Jr., and Brinton, H. C.: Atmospheric Ion Composition, *J. Geoph. Res.*, 66, 2587-2588, 1961.

The above cited references are only a part of the more than ninety scientific papers published on the subject up to this time.

A complete listing of these papers may be obtained by writing to The Machlett Laboratories, Inc.

Partial Pressure Gauge Tubes

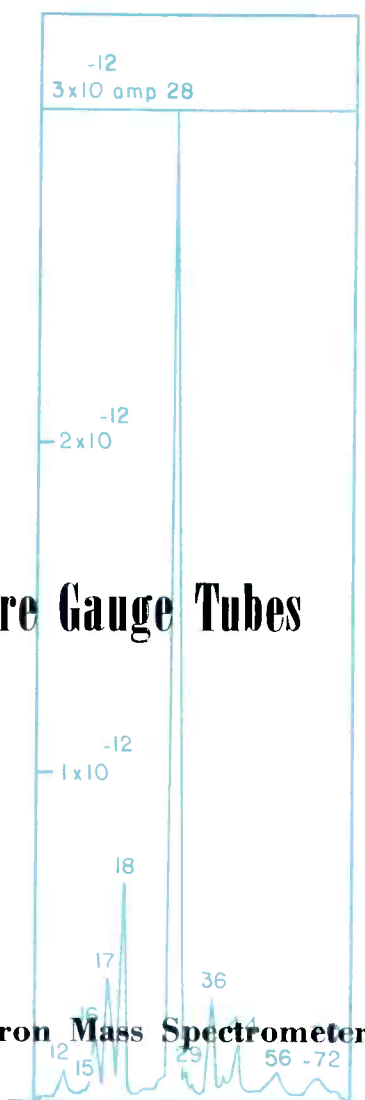

II. ML-573 Omegatron Mass Spectrometer High Vacuum and Ultra-High Vacuum Analyzer Tube

The ML-573 high vacuum (HV) and ultra-high vacuum (UHV) analyzer tube, generally called "omegatron", with associated control circuits, is a convenient, reliable tool for analyzing residual gases in vacuum systems in the pressure range of 10^{-5} to 10^{-11} mm Hg. The partial pressure gauge was developed primarily for ultra-high vacuum applications and was successfully used in solving a great number of analytical problems in vacuum technology in electron tubes, semi-conductors, and also in thin film research. Many types of ultra-high vacuum mass spectrometers were invented in the past decade, but among them the omegatron was chosen most frequently by leading scientists for their studies because of its many features. The main advantage of the omegatron is that, because of its extended use, its characteristics and operation are well established.

Operating Principle

The principle of operation of the omegatron is similar to

that of the cyclotron. The omegatron tube Figure 8, is shown schematically in Figure 9. Gas molecules or atoms are ionized by an electron beam. The ions formed are subject to crossed magnetic and high frequency electric fields. Ions of a selected e/M ratio will move on a spiral path in the shielded volume until trapped by a suitably placed and shielded collector (C). The selection of an ion having a given e/M ratio may be accomplished by changing either the frequency of the applied electric field or the strength of the magnetic field. The relation between the mass number (M) of the selected ion, the rf frequency (f), and the magnetic field (B) can be given by the ion cyclotron frequency (f_c).

$$f_c = 1,525 Bn/M \quad (6)$$

where B is the magnetic field in kilogauss, f_c is the cyclotron frequency in Mc-sec^{-1} , n is the multiplicity of the electronic charge, and M is the mass number of the ions in atomic mass unit (AMU).

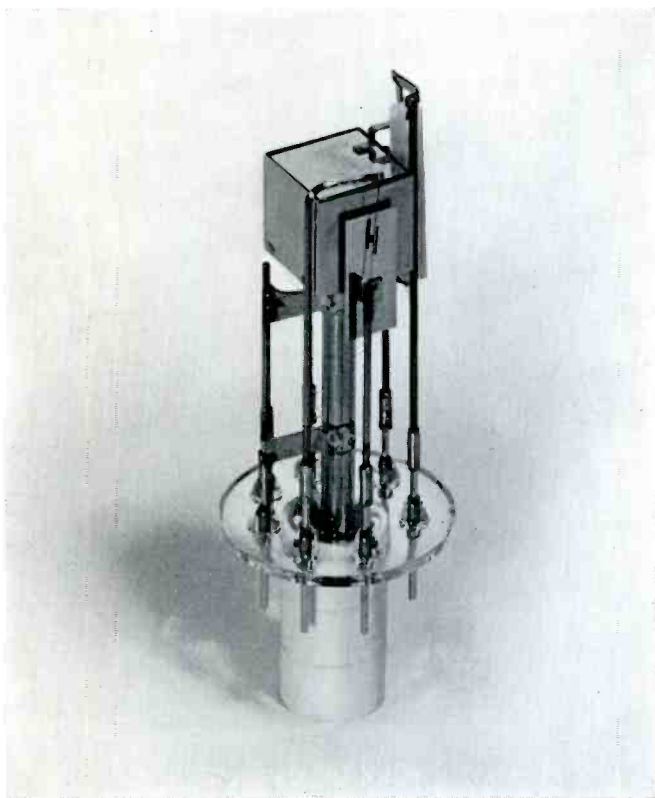

Figure 8 — Omegatron Tube.

Ions having the proper ne/M ratio for a particular rf applied frequency receive energy "kicks" with each revolution and travel in an expanding spiral and finally reach the collector. Other ions having unsuitable ne/M ratio, tending to lead or to lag in the rf field, lose energy after a small number of revolutions and remain close to the point of their origin near the electron beam.

The resolution of an omegatron can be given by the equation:

$$R = \frac{M}{\Delta M} = 96 B^2 r_0 / ME_0 \quad (7)$$

where r_0 denotes the distance from electron beam to the collector in cm, and E_0 is the amplitude of the electric field in volts per cm, and the other symbols are in the above-mentioned units. An experimental value of the resolution may be obtained from scanning the mass spectrum.

The schematic drawing of the omegatron tube and its

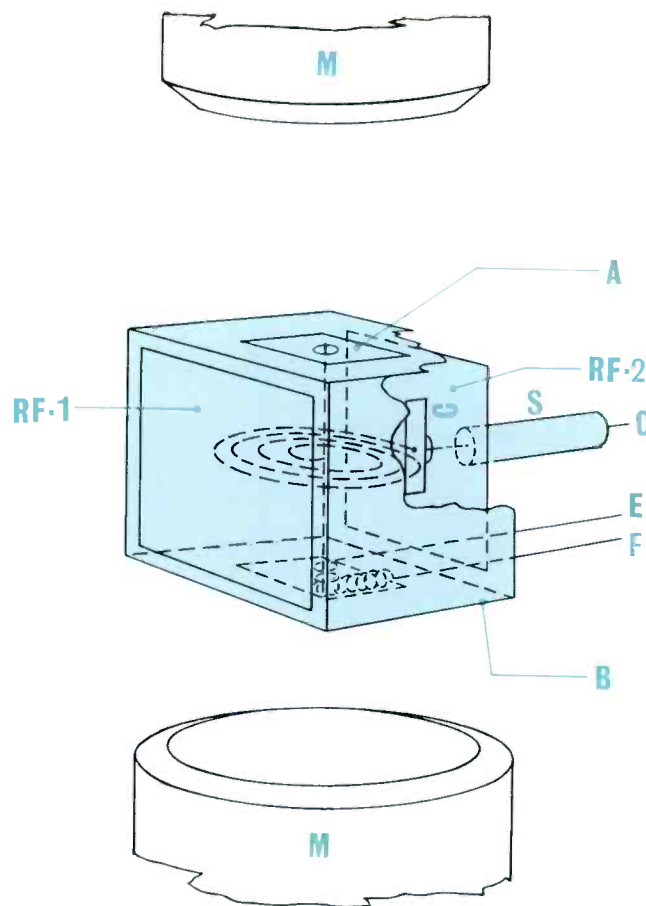

Figure 9 — Schematic Drawing of the Omegatron Tube.

electrical supply units is shown in Figure 10. It consists of a spiral tungsten filament (F). The use of a spiral filament minimizes mechanical failures and makes the system more reliable and assures longer life. The tungsten filament at 5 volts ac operates at 1650°C. The cathode is usually at a negative potential with respect to the box-shaped structure (B), which structure can then, for convenience, be kept close to ground potential. Electrons emitted from the hot filament are accelerated toward the box and fly through the hole which is located in the side of the box opposite the filament. In order to avoid high and useless electron currents from the filament to the box, a cathode potential electrode is mounted between the filament and the accelerating box-shaped electrode. This electrode (E) has a hole in the center and focuses the electrons accelerated by the box into the hole in the box. The electron beam flying into the box can leave the box through a second hole opposite to the first, and reach the electron collector anode (A). This anode is

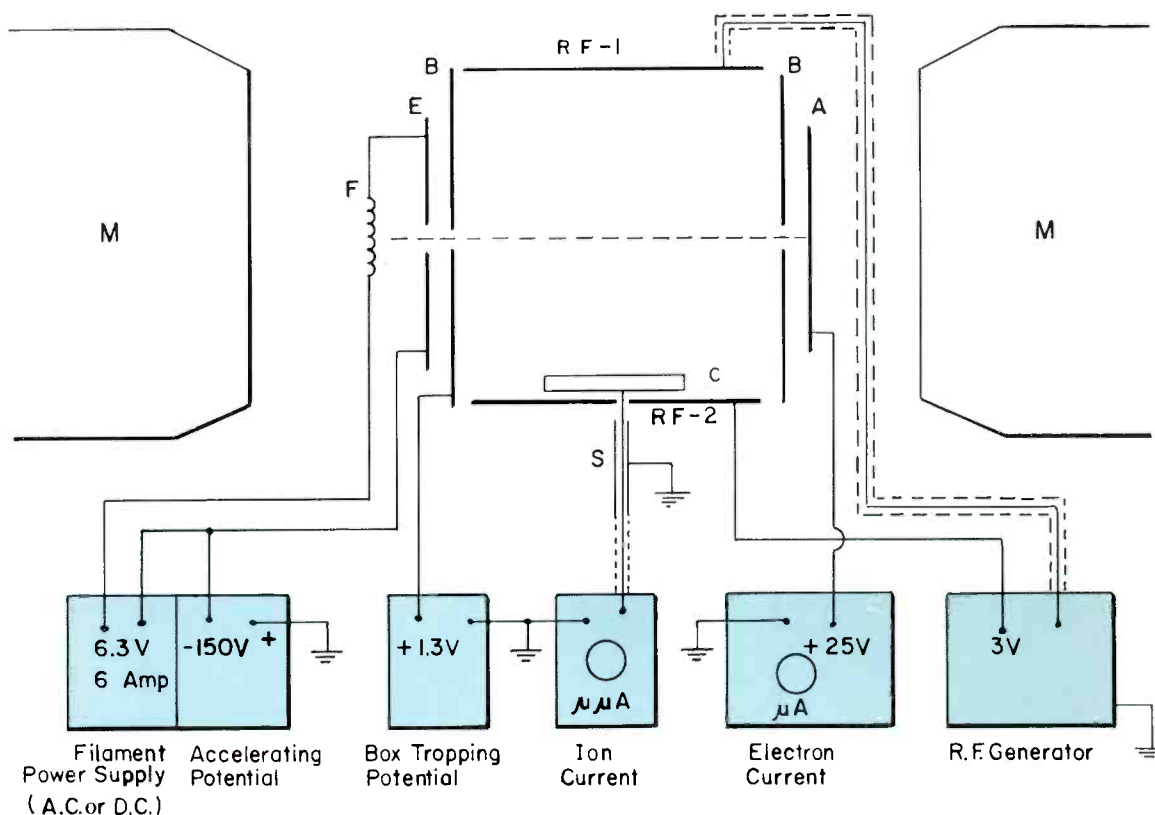

Figure 10 — Schematic drawing of the Omegatron Tube and its Electrical Control Units.

at a positive potential with respect to the box. The tube operation requires a homogeneous magnetic field. The direction of the magnetic field is parallel to the electron beam described above. The magnetic field can be produced either by a permanent or by an electromagnet as specified below, in order to get the electron beam through.

The top and bottom of the box are isolated rf electrodes. They are denoted in Figure 10 as RF-1 and RF-2 electrodes. Usually RF-1 electrode is connected to the rf voltage, while RF-2 is at ground or the two electrodes can be driven in push-pull. The selected ions produced by the electron beam are collected on a collector electrode (C), which is mounted inside the box, and has a shield (S) outside of the box.

The scanning of the mass spectrum is performed by changing the radio frequency. Mass spectra of residual gases are shown in Figure 11.

Design Features

The gauge tube is of a sturdy and relatively simple construction. It has a plug-in type socket and a small volume. The hard glass envelope permits bake-out at temperatures up to 450°C. The glass envelope fits perfectly in the magnet and minimizes the necessary adjustments. The tube structure

is made of a special platinum-iridium alloy which can be degassed without causing changes in its shape or in the spacings and will not influence tube characteristics due to minor surface contaminations.

A picture of the ML-573 omegatron tube is shown in Figure 8.

Electronics

The control units required are shown schematically in Figure 10. Typical electrical data of the tube are given below. The main units are the following.

Filament Power Supply requires a unit delivering maximum 6.3 volts and 6 amperes ac or dc. The electron current can be selected according to the analytical application of the tube normally in the range of 1 to 15 μA . Because the electron current is limited by the filament temperature, the filament voltage must be either manually or electronically controlled to keep the electron current on a preselected value.

DC Voltage may be obtained from batteries or any regulated power supply. Three different dc voltages are required: the accelerating voltage, box trapping potential, and

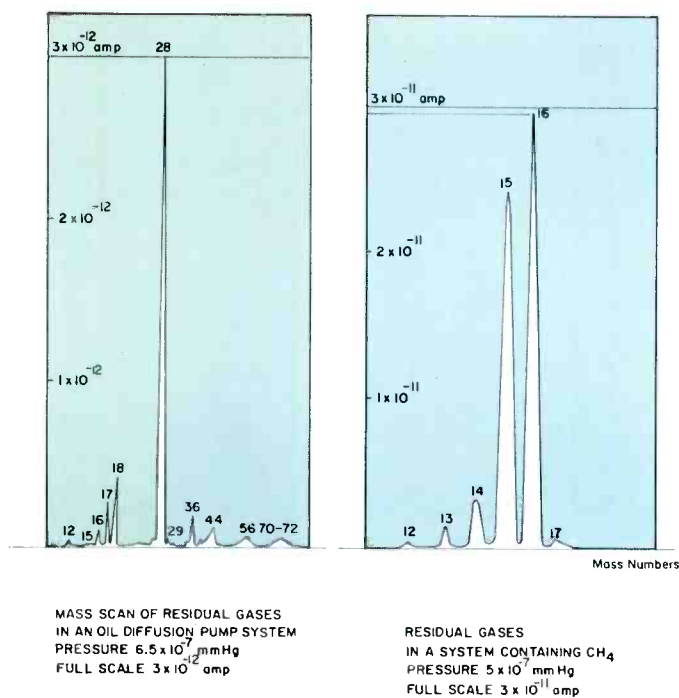

Figure 11—Mass Spectrum of Residual Gases (Analyzed by Omegatron).

anode voltage. These voltages are preferably adjustable to suit the different applications of the omegatron tube.

RF Voltage. The frequency range and the required voltages are indicated in the specifications.

DC Amplifier. The dc amplifier must have a sensitivity of 1×10^{-11} A, for use in the UHV region.

The accuracy and sensitivity of the omegatron tube depend on the stability of the voltages and on the sensitivity and response of the dc amplifier used.

Magnet. The magnet should produce a uniform field of about 3400-4000 G over an area of about two inches in diameter, inside of a 1.5-inch air gap, for optimum resolution. A suitable magnet may be obtained from The Machlett Laboratories.

Adjusting the Magnet. The magnet has to be positioned so that the magnetic field aids the electron beam in travelling through the box. This can be achieved by positioning the magnet while the tube is in operation. The magnet is in position when we obtain maximum electron current on the anode (A) of the tube. The positioning of the magnet is easily achieved by a suitable adjusting table.

General Characteristics

Filament voltage, ac or dc	3 to 6.3 volts
Filament current	1.8 — 2.3 A
Electron emission current (according to application)	1 — 15* μ A
RF voltage	0.5 — 3 Vrms
Frequency range	40 Kc — 6 Mc/sec.
Corresponding to a mass range of	100 — 1 AMU

*Higher electron current may be obtained, but proper care must be taken to avoid burning out of the filament.

Resolution	40†
Pressure range	5×10^{-5} to 10^{-10} mm Hg.
Linear pressure range	10^{-5} to 10^{-10} mm Hg.
Mounting position	Any
Envelope	7052 Glass**

Maximum and typical voltages are as follows:
(All voltages given with respect to ground)

	Maximum	Typical
Filament	-150 Vdc	-100 Vdc
Box (trapping)	+ 1.5 Vdc	+ 1.0 Vdc
Anode	+ 45 Vdc	+ 15 Vdc
RF 1	3 Vrms	2 Vrms
RF 2	3 Vrms	Grounded
Ion collector	Grounded	Grounded
Shield	Grounded	Grounded

A typical mass spectrum is shown in Figure 8.

†Resolution of the omegatron changes over the mass range. The resolution can be selected by the rf voltage applied. The theoretical resolution of this tube for $M = 28$ ions at 0.2, 1.0, and 2.0 Vrms are 200, 40, and 20 respectively (1).

**Graded or glass-to-metal seals available on request.

REFERENCES

General Description

¹Zdanuk, E. J., Bierig, R., Rubin, L. G., and Wolsky, S. P.: An Omegatron Spectrometer, Its Characteristics and Application, *Vacuum*, 10, 13-21, 1960.

Ultra-High Vacuum Research

²Alpert, D., and Buritz, R. S.: Ultra-High Vacuum. Limiting Factor on the Attainment of Very Low Pressure, *J. Appl. Phys.*, 25, 202, 1954.

³Baker, F. A., and Giorgi, T. A.: The Application of the Omegatron to Continuous Analysis of Residual Gases, *Vacuum*, 10, 58-63, 1960.

Applications for Semi-conductor and Thin Film Research

⁴Wolsky, S. P., and Zdanuk, E. J.: The Investigation of Residual Gases in Vacuum Systems, *Vacuum*, 10, 13-21, 1960.

Applications for Electronic Device Research

⁵Wolk, B.: The Breakdown of Cathode Coatings, *The Sylvania Technologist*, 10, 1957.

⁶Klopfers, A., Grabe, S., and Schmidt, W.: Residual Gases in Vacuum Systems, *Vacuum*, 10, 7-12, 1960.

⁷Lichtman, D.: Use of the Omegatron in the Determination of Parameters Affecting Limiting Pressures in Vacuum Devices, *J. Appl. Phys.*, 31, 1213-1221, 1960.

⁸Francken, J. C., and Van der Waal, J.: Residual Gases in Picture Tubes, *Vacuum*, 10, 22-30, 1960.

Chemical Reaction Study

⁹Garbe, S., Klopfers, A., and Schmidt, W.: Some Reactions of Water in Electron Tubes, *Vacuum*, 10, 81-85, 1960.

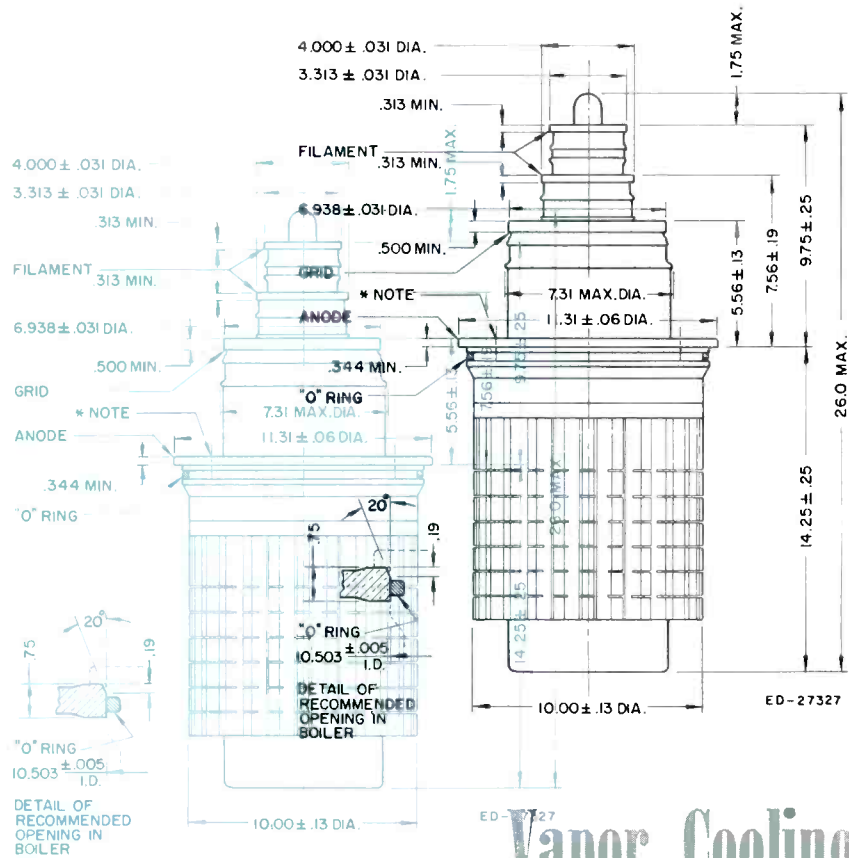

Vapor Cooling:

Its First Major American Installation in the

Introduction

On December 1, 1959, the United States Information Agency issued an invitation to Contractors to submit bids to the Agency for work on new facilities to be constructed in Greenville, N. C. The project was to be a major one; equipment would be used to broadcast Voice of America programs to the Voice's overseas installations for rebroadcast to the Communist countries. The General Electric Company was the successful bidder for the 250 kW transmitters called for by the Agency and The Muehlett Laboratories is proud to have had its ML-7482 vapor-cooled triode chosen for use in these transmitters. Acceptance tests have been satisfactorily made and the new transmitters are scheduled for operation late this year.

Figure 1 — Model of one of the Voice of America transmitting stations being constructed at Greenville, North Carolina. The Voice of America is the radio service of the U. S. Information Agency. *(Photograph courtesy of U.S.I.A.)*

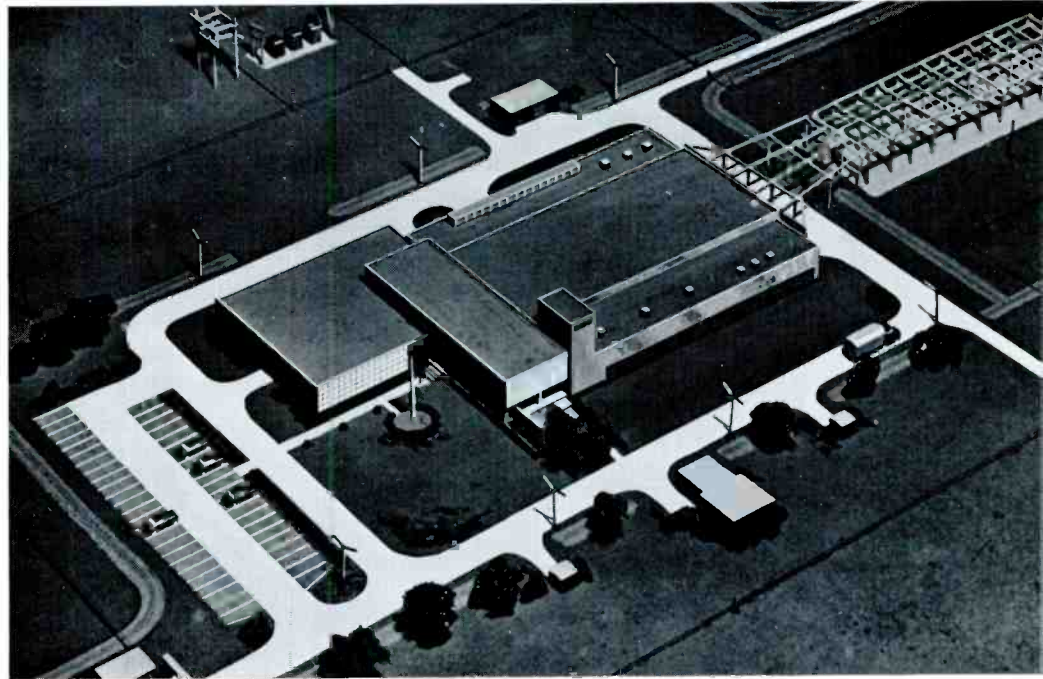

New 250 kW Voice of America Transmitter

Voice of America

The global radio network of the United States Information Agency is the Voice of America, the official radio of the United States. By direct transmission it speaks in 36 languages a total of 103 hours a day to an estimated audience of over twenty million people. (Through taped programs, used by local radio, the audience is nearly tripled.) Eighty-seven large transmitters now carry the "Voice" programs to Communist countries. Ranging in magnitude to one million watts carrier power, the transmitters of the U.S.I.A. use Machlett transmitting tubes in most of the key installations.

In operation since 1953, the megawatt transmitters have logged hundreds of thousands of air hours with the ML-5682 coaxial terminal triode. As it was the leading "communications band" triode of its time so now is the ML-7482, vapor-cooled coaxial terminal triode, employed in the six 250 kW transmitters of the Greenville facility (Figure 1). When completed this operation will consist of six 500 kilowatt, six 250 kilowatt and six 50 kilowatt transmitters. It will be the largest and most powerful broadcasting station complex in the world.

The basic technical purpose of Greenville will be to deliver a stronger signal to Europe, Africa, the Middle East and South America. It will provide a flexible relay system to overseas bases; direct short wave to specified areas; function, if necessary, as an emergency communications system and will replace outmoded installations elsewhere. Having a total

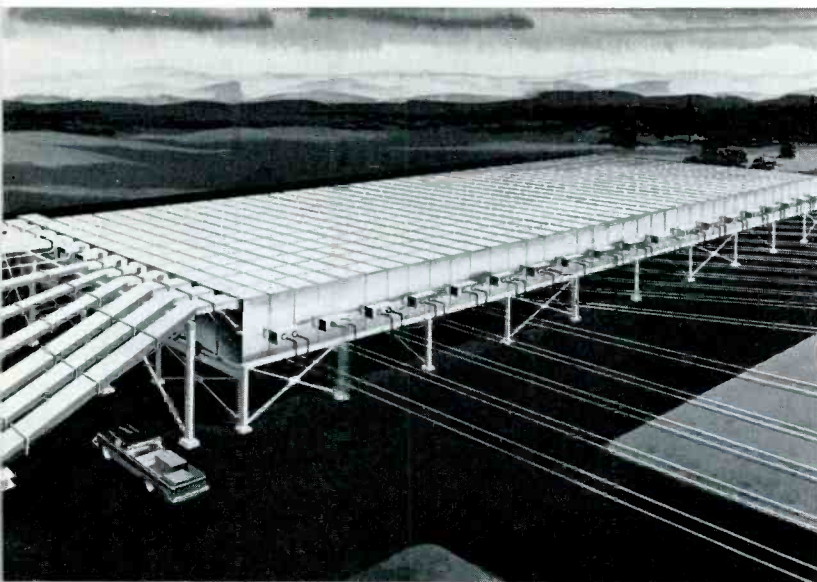

Figure 2 — Artist's conception of switchgear facility at Greenville, North Carolina, transmitter stations now under construction. Through this electronic mechanism, Voice of America programs from 22 transmitters can be beamed to East and West Europe, Africa, Latin America, and VOA relay stations around the world.

(Photo courtesy of U.S.I.A.)

Figure 3 — Front view of the new 250 kW AM transmitter manufactured for the Voice of America by the General Electric Company.

(Photo courtesy of General Electric Company)



installed capacity of 4820 kW carrier power the facility will transmit within the frequency ranges of 4 to 30 Mc. All transmitters, except for low powered units, will be amplitude modulated.

Two major transmitting sites, situated approximately 18 miles apart, have been established for the location of the various transmitters which will be equally divided in numbers and power between the two areas. Each installation is to be complete including all audio and program switching equipment, monitoring and frequency checking, transformer vaults, primary power distribution and so on.

A radio receiving unit will also be part of the facility, it too, will be located 18 miles from either transmitting site. This unit will serve for program, communications, miscellaneous reception and search as required.

Transmitting antennas are on a scale appropriate to the massive undertaking: one site employs 964 acres for the erection of thirty-seven h.f. transmitting antennas, the other 840 acres for erection of thirty-six antennas positioned with reference to a large number of bearings. The antennas themselves will be of the curtain and the rhombic type; the curtain antennas being used for the higher powers. The curtains at either site will be supported by 112 guyed steel towers ranging in height from 154 to 312 feet (Figure 2). Some rhombic antennas will also be used at the higher powers.

Complete antenna flexibility is provided. Any transmitter at the site will be capable of connection to any site antenna; all transmission line runs from each antenna farm will terminate at a transmission line switching bay located adjacent to the related transmitter building.

The New 250 kW Shortwave Transmitter

The General Electric 250 kW shortwave broadcast transmitter (Figure 3) is a high level modulated unit employing five ML-7482 tubes, two in the final position, two as modulators, and one driver. The transmitter is continuously tunable over a range from 3.9 to 26.5 Mc. Vapor-cooling, with forced-air-cooling for tube terminals and condenser unit, is employed for the high power electron tubes.

Transmitter Circuits

A block diagram of the high power stages of the transmitter is shown in Figure 4.

RF Final Stages

Two ML-7482 tubes are used in parallel in a grounded grid-circuit providing 250 kW transmitter output power. 25 kW of this power comes from the driver stage (also a grounded-grid configuration). Conservative tube operation is evidenced here by the fact that one tube alone could produce nearly the entire required output. Radio frequency output is pi-coupled to a harmonic filter consisting of five fixed-tuned filters.

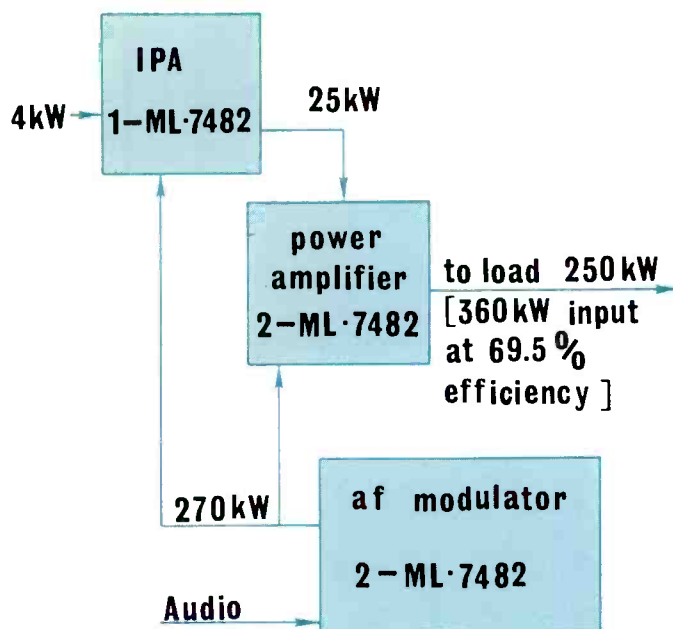

Figure 4 — Schematic diagram of the high power sections of the 250 kW transmitter.

By modulating both driver and final stages linearity is improved, grid heating of the output stage is reduced and negative modulation may be obtained without neutralization. By employing a grounded-grid cavity, circuit tuning stability under all conditions is achieved. The entire rf circuit configuration is clean and is easy to tune; only three variable components are found in each stage, these components being in the pi-coupled tank circuit.

The measured performance of the output and driver stages is as follows. This data represents the meter readings at the transmitter.

	Driver Tube	2 Output Tubes
DC Plate Voltage	12 kV	12 kV
DC Plate Current	3.5 A	26.5 A
DC Grid Current	1.0 A	7 A
Grid Resistor	300 Ohms	75 Ohms

The measured output into the load is 250 kW.
The input power to the two final stages is 360 kW.

The overall efficiency of the final rf amplifier chain including losses in the harmonic filter is 69.5%. This efficiency remains substantially constant throughout the frequency range.

Physical Construction Simplified — RF Amplifier Plate Circuit

The two ML-7482 final tubes, each mounted in a "boiler", are both encased in a large drum as shown by Figure 5. The drum, 32 inches in diameter, is the plate connection; 4 vacuum capacitors between the cavity walls and the drum

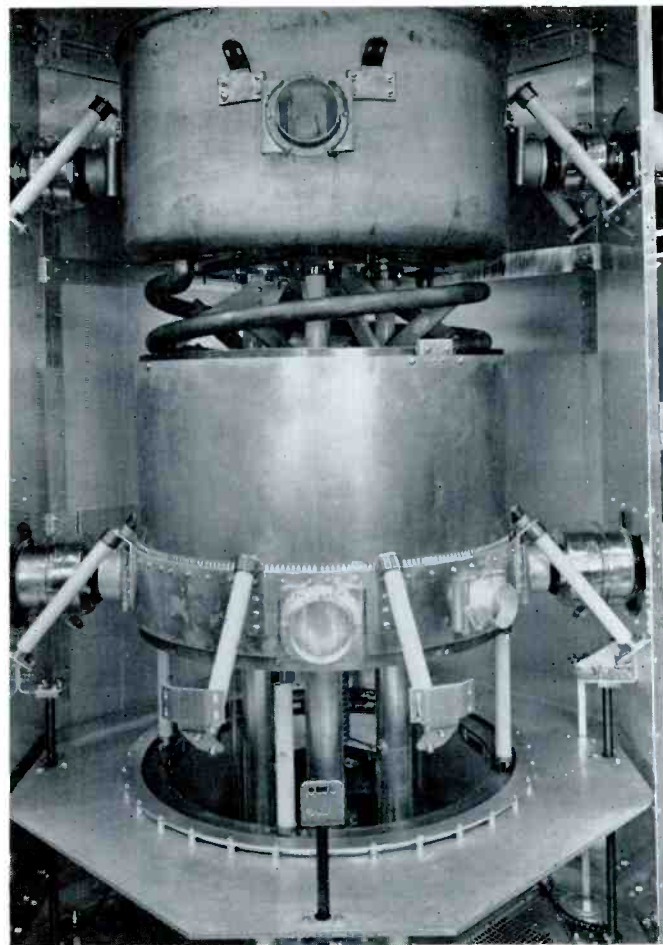

Figure 5 — Detail view of the final amplifier section. Two ML-7482 tubes each mounted in a "boiler", are both encased in a large drum. The drum forms part of the cavity-tuning system.

(Photo courtesy of General Electric Company)

are for plate tuning. The tank coil (a bi-filar helix of 2" diameter copper tubing) carries incoming water to the boilers. The tank coil inductance continuously variable; two contacts, mounted on opposite sides of a large cylinder surrounding the coil, progressively short out the coil as the cylinder is rotated in a helix. The opposite terminal of the coil is formed by a 200 contact-finger band around the plate "cylinder"; four loading capacitors are connected to this band.

A clean plate circuit configuration is achieved by the cavity type grounded grid circuitry. As a result complete stability is achieved under all tuning conditions.

RF Amplifier — Cathode Current

The cathode circuit of the power amplifier is shown in Figure 6. The grids are rf grounded by a ring of ceramic capacitors. Two high current capability bi-filar chokes carry filament heating power. The pyrex glass insulating tubes seen in Figure 7 carry the steam from the boiler to the condensers.

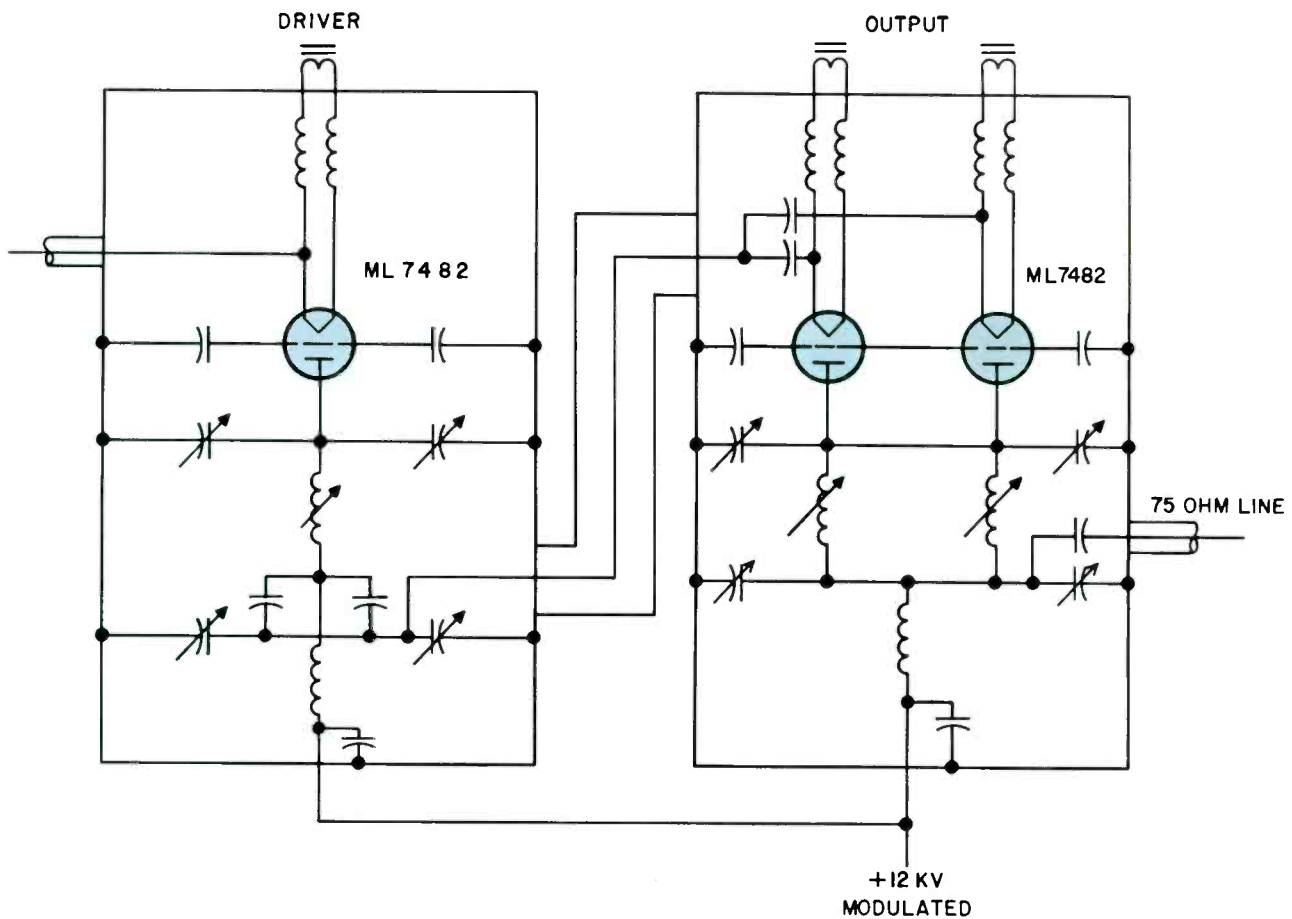

Figure 6 — Cathode circuit schematic of the final rf amplifier. Grounded grid circuitry is employed.

Simplicity of configuration also described the cathode circuit; no adjustments of any sort are required.

Modulator Circuitry

Design requirements for the transmitter specify heavy clipping of the program. The special VOA audio peak-clipping amplifiers are designed to improve intelligibility and to increase the average speech power without exceeding acceptable peak modulation percentages.

Because of this and the trapezoidal waveform needed to effect its accomplishment, the modulator power is 270 kW and not 180 kW, which would normally be required for 100% sinewave modulation of the 372 kW developed by the rf stage (372 kW at 67% gives 250 kW to the load.)

Additional audio requirements are also of a stringent nature; 100% sinewave modulation is required at frequencies from 50 to 10,000 cps and 100% trapezoidal modulation from 100 to 3000 cps with the trapezoid flat-top "tilt" less than 5%. This "tilt" requirement results in a need for an extended low-frequency response to a few cps. The fre-

Figure 7 — Upper section of rf amplifier showing cathode connections and Pyrex tubes which carry off steam created in anode "boiler".
(Photo courtesy of General Electric Company)

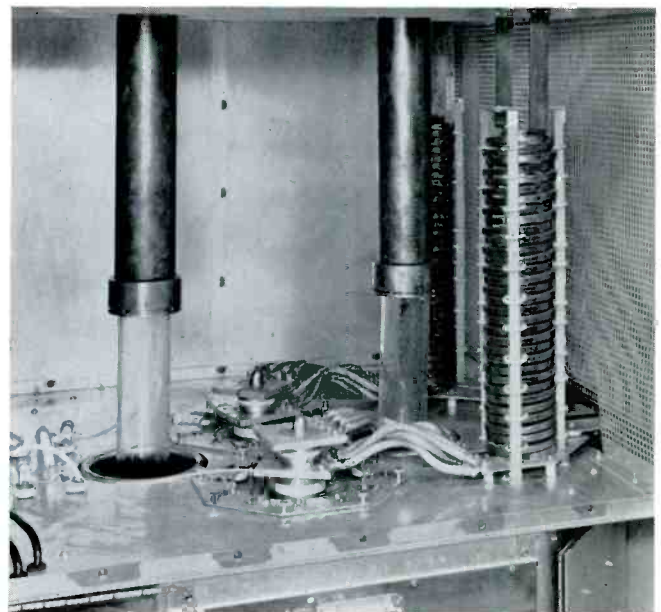

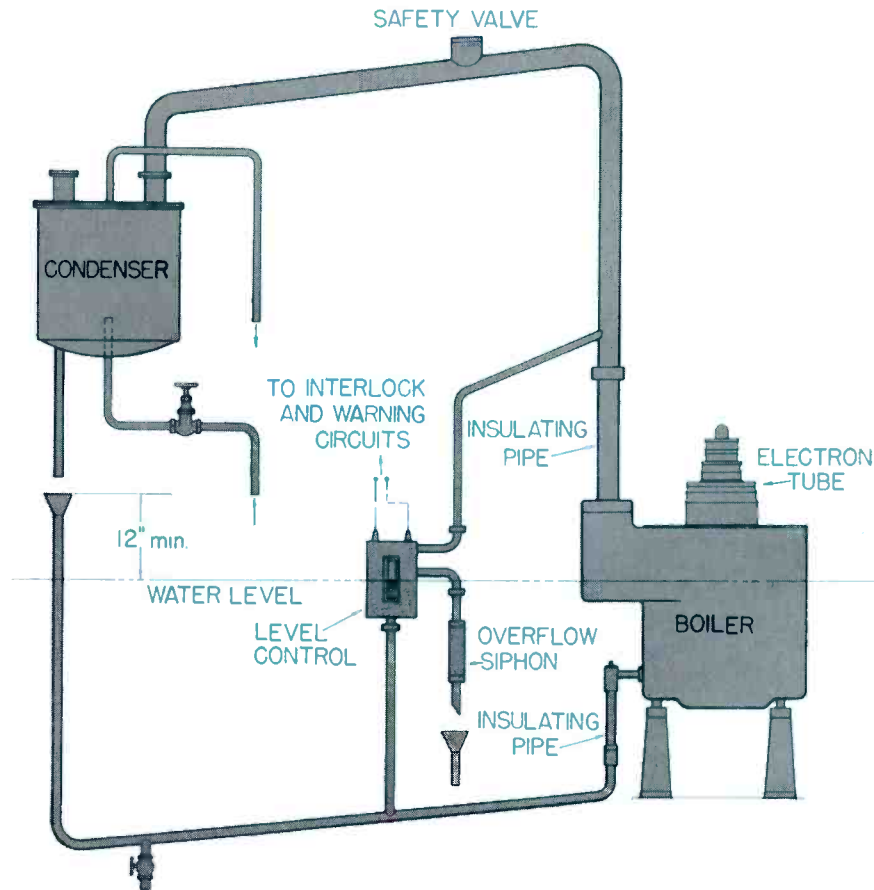

Figure 8 — Vapor Cooling, a schematic representation of the classic system.

quency response is to be flat to 3 cps.

An unusual 2-winding modulation transformer, center-tap grounded, is employed to provide maximum audio bandwidth. By omitting the conventional 3rd transformer winding a high inductance is achieved together with a small leakage inductance. The grounded center-tap circuitry aids low frequency response by eliminating the modulator plate supply filter from the path of the audio power from the modulator to the rf amplifier.

A low frequency boost prior to the modulator tubes was employed to compensate for the modulation transformer and coupling condenser droop, and therefore to achieve a flat response below ten cps. This compensation results in the requirement for an increased modulator tube plate voltage swing at low frequencies bringing the modulator stage dc plate voltage requirements to 15 kV.

The modulator performance data is tabulated below:

	100% Sine	100% Trapezoidal
DC Plate Voltage	16 kV	16 kV
DC Current (per tube)	9.5 A	12.5 A
DC Grid Current (per tube)	0.5 A	2 A
Circuit Efficiency	59.2 %	67.5 %

Vapor Cooling — Basic Principles

In conventional water-cooled power tube systems, the thermal energy of the anode is transferred to the circulating coolant, which subsequently exhibits an increase in temperature. With vapor cooling, however, a fundamental departure in principle is involved: thermal energy is absorbed by a change in the physical state of the coolant, rather than an increase in its temperature. The key to the efficiency of this system lies in the ability of vaporizing water to absorb huge quantities of heat. In a typical water-cooled installation, the coolant experiences a 20°C rise in temperature; thus, each gram of the water absorbs 20 calories of heat. In a typical vapor-cooled installation, water at 95°C is converted to steam at 100°C and 545 calories per gram of coolant are absorbed. The greater thermal capacity of the coolant under these conditions will support anodic dissipation 10-20% higher than other systems, and offers enhanced protection against thermal overloads.

In operation, the rugged copper anode of the vapor cooled tube is immersed in the distilled water within the

boiler. The heat generated within the anode is absorbed by vaporization of the water. The diagram of Figure 8 illustrates the classic system.

As the water experiences a 2000-fold increase in volume during vaporization, a powerful turbulence is created within the coolant. The heavy ribbed anode fins of the vapor cooled tube are designed to take advantage of the turbulence to achieve a vigorous "cleansing" action, precluding the formation of an insulating vapor film on the anode which could lead to excessive local heating.

Steam generated in the boiler is conducted to an air-cooled heat exchanger and the resulting condensate is returned to the boiler. No water pump or external source of energy is normally necessary to circulate the coolant. A density gradient of the coolant within the boiler is established in the process of absorbing anode heat, resulting in a thermo-syphon effect sufficient to insure proper coolant circulation over the whole range of possible operating conditions.

Proper coolant level within the boiler is usually maintained by a feed tank arrangement that capitalizes upon the natural tendency of water to seek its own level. Continued function of this inherent regulatory mechanism is provided by the closed cycle nature of the design which insures that the quantity of coolant in the system remains constant.

The boiler, at anode potential, is electrically isolated from the rest of the cooling system by short lengths of insulated tubing. The use of short, mechanically stable insulators is permitted by the low flow rate requirement (about .09 cu. ft./min. for 100 kW), and the excellent dielectric properties of steam.

Vapor Cooling System — 250 kW Transmitter

The vapor cooling system of the 250 kW transmitter operates at a pressure of 6" of H₂O; tube weight alone (130 pounds) maintains the tube in proper position in the boiler, the system being sealed by an "O" ring gasket located on the tube just below the upper flange on the anode.

Figure 9 — Vapor Cooling system employed by the 250 kW Voice of America transmitter.

(Photo courtesy of General Electric Company)

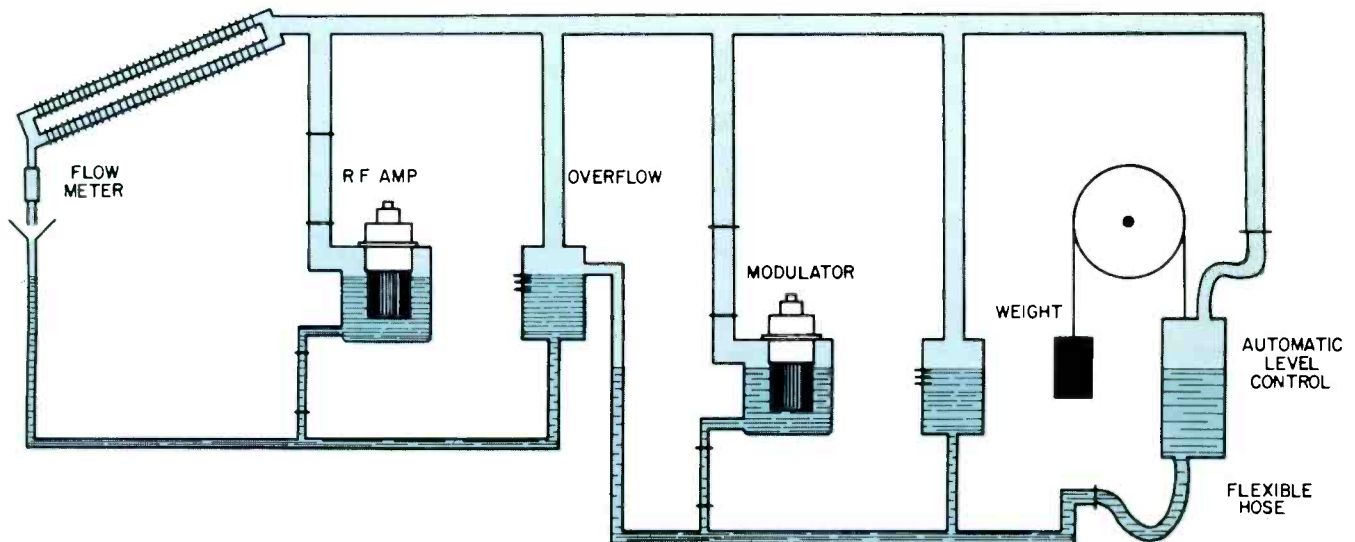

Since, for electrical and physical reasons, the rf amplifier tubes and boilers are located above the level of the modulators, and since a common cooling system was desirable, two water levels are required in the 250 kW transmitter, as shown by the schematic diagram, Figure 9. Salient features of the system are as follows:

- 1) A common condenser is used for the entire transmitter. This arrangement is more efficient than use of separate condensers. This is because the rf and modulator tubes exhibit maximum anode dissipation at 100% and 60% modulation, respectively.
- 2) RF tubes are connected according to the classical system; excess water from condensers returns to the modulator system.
- 3) Modulator system provides for an automatic water replenishment to accommodate delay in production of steam and return of water. Automatic level control is provided by counterweighted tank (See Figure 10). Should the boiler level drop, the

level of water in the tank drops making the tank lighter and permitting it to be lifted and therefore to restore water to the boiler via a flexible hose.

- 4) Condensers are forced-air-cooled using same blower system employed to cool tube terminals and transmitter cabinets.
- 5) System Capacities:

Water	26 gallons
Power Dissipated at 100% Modulation320 kW
Water Flow at 100% Modulation2¼ gpm
Steam Pressure1 p.s.i.
Total Area of Heat Exchanger Tubes112 sq./ft. (4 rows each 28 sq. ft.)
Air Flow through Heat Exchangers20,000 cfm
Air Temp. Rise55° F.

ML-7482

Of conservative and proven design, the ML-7482 triode, Figure 11 (and its water-cooled counterpart, the ML-7560) provides a coaxial terminal construction (such as introduced

Figure 10 — The ML-7482 employs ceramic insulation and uses coaxial terminal construction.





Figure 11 — ML-7482: Massive components of the anode assembly achieve a rugged efficient structure.

by the ML-5681) together with high alumina ceramic cylinders for insulation. Manufactured with a technique proven by the ML-7007 (a highly popular VHF television tetrode) the ML-7482 terminal section is fabricated in a "hydrogen furnace". The reducing atmosphere of the furnace ensures parts cleanliness and obviates the need for subsequent cleaning.

In addition to its advantages in fabrication, the high-alumina ceramic permits high outgassing temperatures, exhibits a lower rf loss factor than glass, and demonstrates a low gas level as indicated by excellent stability under high voltage. The cleanliness of the tube interior is conducive to longer cathode life — a fact amply demonstrated by the comparative life figures of the ceramic envelope ML-7007 and the glass tube it has replaced: tube life has been increased on the average by a factor of two to three times.

The anode of the ML-7482 is made from heavy wall copper tubing. It is fabricated by brazing a bottom plate, heavy notched ribs, top flange and kovar final seal to the tube (Figure 12).

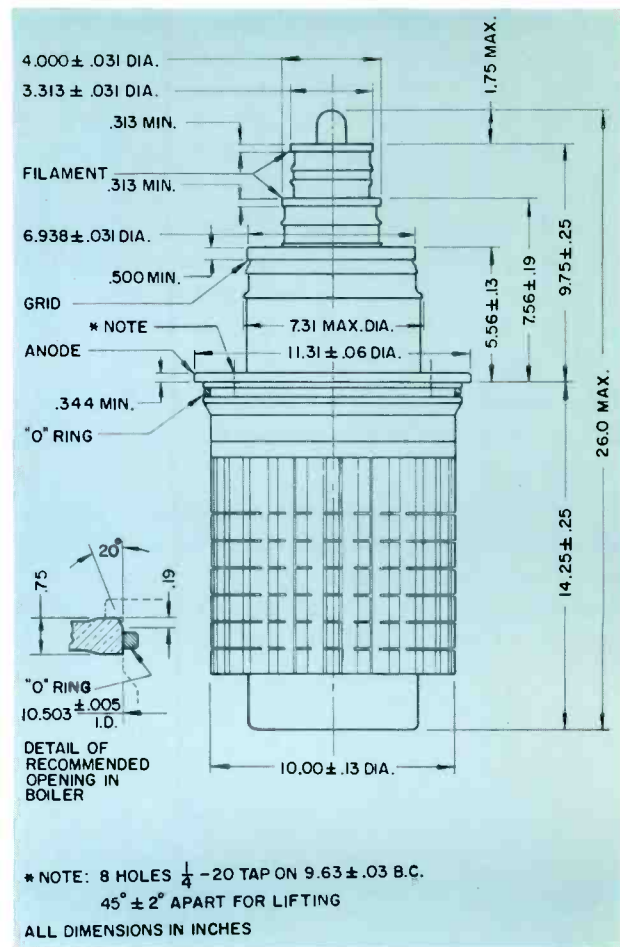

Figure 12 — ML-7482 Outline Dimensions.

Electrical characteristics and maximum ratings for the ML-7482 are given in Table I.

TABLE I

Electrical Characteristics:	
Filament Voltage	16.5 volts
Filament Current	450 amperes
Amplification Factor	45
Maximum Ratings — RF Amplifier — Oscillator (Class C Telegraphy)	
DC Plate Voltage	20,000 volts
DC Grid Voltage	-1,500 volts
DC Plate Current	30 amps
DC Grid Current	4.0 amps
Plate Input	600 kW
Plate Dissipation	200 kW

• • •

The Machlett Laboratories' continuing participation in programs of national interest and importance — such as the Voice of America Greenville project — is a source of great satisfaction to the Company and provides also, a demonstration of the quality and reliability of its products.

The ML-8087, a New Tube for Scan Conversion



by SAMUEL T. YANAGISAWA, Manager Photosensitive and Storage Display Tube Division

Introduction

Several years ago, electrical-signal storage tubes were developed that made possible a large variety of signal and information processing techniques. These tubes were called "scan converter tubes" when constructed with two electron guns that could simultaneously write and read stored information independently of each other. As with most first production models, these tubes had their limitations and in time, the performance requirements of new applications became increasingly varied and more demanding. The Machlett Laboratories, together with the Compagnie Generale de Telegraphie Sans Fil of France, anticipated many of these requirements and developed a new tube. The ML-8087 has features not available heretofore with the result that both equipment manufacturers and users can now enjoy a simplicity of design and usage with high performance capabilities.

Applications

The use of scan converter tubes has spread so rapidly into many fields that it is of interest to review some of the present applications.

The first in point of time and the largest use at present is in radar bright display equipment for the surveillance and control of aircraft while en route between airports and during the approach and departure phases of traffic control. PPI radar information is fed directly into a scan converter and is

converted to be displayed as a bright, flicker-free television type of display on several consoles. Fully controllable storage of this information enables the observer to see the aircraft as bright dots with fading trails that, in themselves, indicate the heading, the paths followed, and also the relative speed by the length of the trail and by the distance between successive past positions. This technique eliminates the need for remembering and tracking successive radar returns as was formerly necessary. It also immediately differentiates between moving aircraft and stationary clutter. The ease of observation greatly relieves the viewing tension and increases observer efficiency. The storage of these returns also aids in the display of airborne beacon returns for identification and control. The same advantages of scan conversion and storage are used in other radar applications wherever detection efficiency and operator fatigue are concerned.

Scan conversion tubes are being used to transform from one set of television standards to another, such as in the case of European or British programs that are to be rebroadcast in the United States or vice versa. Video tape can now be scan converted to be reused on any local standards. The problems of network synchronization can also be eliminated by rebroadcasting at the local line and frame rates.

Band compression to reduce video or informational bandwidth can be accomplished a number of ways; i.e., readout by a slow spiral scan, by slow television raster scan, or by a reduced sampling scan. Conversely, low frame rate information can be converted into a flicker-free rapidly scanned visual display.

An interesting application in astronomical observation is the

improvement of signal to noise ratios by ability to integrate video signals over a number of scans to enhance the contrast over the existing noise level.

With the scan converter, analogue information on a given time base can be changed to a variable time base with or without a controllable delay. This finds application in some types of signal simulation equipment.

Sonar displays are improved with the storage capabilities and flexibility of operation being important factors.

In more complex equipment, three scan converters can be used, each to store a separate color. Readout into a color television tube produces a display with fading storage in which color signifies a fourth parameter such as altitude or identification of stored information.

Three dimensional radar displays are proposed showing the illusion of height so that aircraft trails may be observed in the vertical dimension.

Another application that has been discussed recently is the correlation of statistical data through signal processing and storage in scan converter tubes.

The applications of signal and information processing with these tubes are still increasing as circuit and equipment designers continue to explore the possibilities.

Features of the ML-8087

Intensive and continued development of the storage target and both the writing and reading electron guns have culminated in this new tube which has no crosstalk, high resolution, a fast and complete erase cycle, and a wide storage range.

Until the development of the ML-8087, scan converter tube types had "crosstalk". This was undesired feedthrough of the written signal directly into the reading circuit where it was displayed as unsynchronized background noise. Various methods to circumvent this crosstalk have had to be used, such as rf modulation of the reading beam or video cancellation circuits. Rf carrier techniques entail a loss of signal power during the process of detection in the reading circuit and thus lower the signal to noise ratio. Extensive rf shielding is necessary to avoid undesirable parasitic effects, in addition to the required rf circuit. Video cancellation techniques are simpler but require additional internal tube shielding to avoid undesired effects during intentional write sweep overscanning or offcentering. Now, with the precision ML-8087, the circuit and equipment design is simple and straightforward since no crosstalk exists.

Both writing and reading guns have been designed to give wide dynamic range and high resolution. The tube when used in PPI to television scan conversion will resolve a minimum of 170 range rings at 50% modulation and an ultimate resolution of over 200 range rings when used with a 945 line raster on the read scan. The resolution when used in orthogonal television raster conversion is up to 1000 TV lines. To obtain the full benefit of the resolution capability of this tube, electrostatic dynamic focussing of the read

electron beam must be provided and the bandwidth of the video circuits must be sufficient to pass all the information.

The stored information can be erased in a maximum cycle time of 2 seconds at the long storage setting. In the usual case, the erase time can be much less. The reading process in this, as in all bombardment induced conductivity tubes, also acts to slowly erase the stored information. Normally, the greater the beam current, the shorter the storage. The wide storage range is obtained by varying the collector voltage and the beam current, usually between 0.5 to 5.0 microamperes. During the erase cycle, the beam current is increased by an erase electrode to over 100 microamperes. This greatly increased beam and an erase cycle procedure to the storage target backing plate quickly erase all the stored information down to the noise level. Information can be written and read at full amplitude immediately after the erase cycle is completed without the use of any special writing intensification circuits.

The wide storage capability of the ML-8087 enables it to read information continuously for minutes or it can read and erase information in one television frame scan. This latter short storage ability allows the tube to scan convert between television standards perfectly with no lag or drag of one picture frame into another which would tend to blur fast motions. No other scan converter tube can do this particular task as well.

The principle of bombardment - induced - conductivity makes possible very fast writing rates and allows the use of very short time base sweeps. In addition the response from large and small areas are of uniform amplitude so that intensities corresponding to the original written information are preserved. The level for the Minimum Detectable Signal does not change at a given setting.

The dynamic range is such that noise or "grass" may be written and read without being swamped by the highlights.

There are no collimation problems as both writing and reading beams strike the target at high velocity and are not decelerated. This also results in high linearity of transformation, no pattern distortion, high accuracy of registration, and eliminates any drift stability problems.

Conclusion

The Machlett Laboratories has developed the ML-8087 as a precision scan conversion tube. Its application is simple and reliable. Its adjustments are few and it can be changed in the equipment in less than five minutes.

In a succeeding issue of CATHODE PRESS a detailed technical article about the ML-8087 and its application data will appear. In the meantime, the Engineering Department will be most happy to answer any inquiries.

*The impact of high speed writing electrons, in this instance, causes conduction within the dielectric storage medium in accordance with the stored pattern created by the electron bombardment.

DVST

Announcing Machlett

Direct View Storage Tubes

ML-8130 ML-8139



Brightness: Over 2000 foot lamberts — ML-8130
Over 1500 foot lamberts — ML-8139

Writing Speed — at full brightness:
Over one half million inches per second — ML-8130
Over 150,000 inches per second — ML 8139

Storage: Uniform Storage Characteristics

Resolution: To 80 written lines per inch at optimum brightness

Focus: — both tubes: Electrostatic

Deflection: ML-8130 — Electrostatic
ML-8139 — Magnetic

The Machlett Laboratories, Inc. announces the availability of two new Direct View Storage Tubes, ML-8130 and ML-8139. (Available also in non-shielded versions as ML-7222 and ML-7033). Ruggedized and reliable, these tubes are particularly suited for these typical applications:

Airborne
Weather radar
Search Navigation
Terrain Avoidance

Shipboard
Sonar long-memory displays
Marine displays
Sonar devices displays

Ground
Slow-scan television
Storage instrumentation

Write today for complete data on these new Machlett Direct View Storage Tubes.

MACHLETT

The Machlett Laboratories, Inc. Springdale, Connecticut

a subsidiary of Raytheon Company

ML-8087

Precision

Scan Conversion Tube Fast Erase – High Resolution



The Machlett Laboratories, Inc. announces a new precision manufactured Scan Conversion Storage tube, the ML-8087. Successor to the Machlett made 403X type tubes, which have seen over one million hours use in airways control service, the ML-8087 provides these principal advantages and important features:

- 1 High resolution: a minimum of 180 range rings/diameter at 50% amplitude modulation; equivalent to 900 TV lines.
- 2 Fast erase: less than 2 seconds erase cycle to reduce stored information to noise level.
- 3 Wide storage range: to meet FAA 1213b specification and beyond.
- 4 High signal/noise ratio, typically 80:1 (peak signal to rms noise).
- 5 Rapid set-up time: A few minutes installation is all that is required to adjust tube for optimum operation. No need for critical dynamic focussing of electron beams.
- 6 No variation of output signal with size of written area.
- 7 Only simple video circuits are needed for readout.

Available now from The Machlett Laboratories, Inc. . . . send for complete data on the ML-8087.



The Machlett Laboratories, Incorporated

A division of Raytheon Company

Springdale, Connecticut