

DECEMBER 1978

HEWLETT-PACKARD JOURNAL



Easy-to-Use, High-Resolution Digitizer Increases Operator Efficiency

This advanced new microprocessor-controlled digitizer provides an accurate, speedy, and convenient method for entering position information from maps, slides, x-rays, photographs, and other media into a computer for analysis.

by Frank P. Carau

HAVE YOU EVER NEEDED to enter coordinates from an oscilloscope photograph into a computer for analysis? Or if not from a photograph, perhaps from a map, a graph in a book, a strip chart recording, a 35-mm slide, a mechanical drawing, or a schematic? In any case, what you needed to perform that task was a digitizer.

A digitizer is a device that transforms graphical data into planar coordinate information that can be read and understood by a computer. These coordinates are usually presented as X and Y coordinates based on the position of a cursor on the surface, or platen, of the digitizer. The cursor has a viewing area with a crosshair for alignment with the point of interest on the document, and is coupled either mechanically or electrically to a position sensing device that provides the positional information to the computer.

Advanced Digitizer

Model 9874A Digitizer is a powerful new portable digitizer that offers significant increases in performance and reliability, and simplified operation through 'work-station' design and human engineering. The 9874A (Fig. 1) is designed to provide flexibility, high resolution, and simplicity of use in a wide range of applications using different source media. It has many new features, including a tiltable working surface, rear projection capabilities, a cursor vacuum system, built-in self test, HP-IB* interfacing, automatic document alignment and axis extension, microprocessor control, and a multiple-function user keyboard.

The HP 9874's capabilities are matched to a number of industrial applications, such as a local utility developing a computer model of a pipeline network, a government agency recording data on crop acreage, or a lumber company estimating harvest yields. Other applications include clinical medicine and electronic design. Present digitizer users who would find the 9874A of particular interest include hospitals and

clinics, the military, surveying and mapping firms, manufacturers of electronic equipment, agricultural and forestry services, universities, and research and development laboratories.

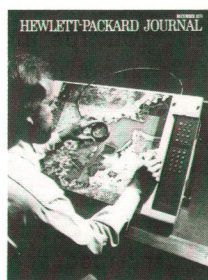

Cover: Model 9874A Digitizer transmits coordinate data to an on-line computer. Its tiltable, translucent platen adapts to a variety of media, including backlighted and rear-projected images. An EXTEND mode is provided for digitizing media larger than the platen. (Aerial photo courtesy of the U.S.A. National Aeronautics and Space Administration).

In this Issue:

- Easy-to-Use, High-Resolution Digitizer Increases Operator Efficiency*, by Frank P. Carau **page 2**
- Cursor Technology*, by Henry T. Hetzel, **page 4.**
- Glass Platen Technology*, by Lawrence E. Brown, **page 8.**
- Annual Index* **page 14**
- 1-MHz-to-50-MHz Signal Source Combines Synthesizer Accuracy, Multi-mode Operation, and Easy Programming*, by Tilman Schad, Dieter Kible, and Peter Brünner **page 19**
- A Compact Logging Multimeter that Can Manipulate Data*, by John E. Scruggs, Marsh L. Faber, and David L. Wolpert **page 28**

*Hewlett-Packard Interface Bus (IEEE-488, ANSI MC1.1)



Fig. 1. Model 9874A is an advanced microprocessor-controlled digitizer that provides 25- μm resolution and $\pm 125\text{-}\mu\text{m}$ accuracy. Its adjustable glass platen accommodates a variety of media. The keypad helps the operator control the digitizer/computer system.

Problems of Digitizing

Many digitizing difficulties arise because digitizing is an operator-intensive function. It requires the user to perform a mechanical control function at the digitizer and maintain control of the computer system at the same time, without removing attention from the digitizing unit.

The primary problem of digitizing is user fatigue. The process of spending hours bending over the digitizing surface accurately positioning the cursor can cause severe problems in operator attention and fatigue. The new HP 9874A digitizer incorporates several features that help reduce these problems.

A major feature is the tiltable platen. By allowing the operator to position the platen anywhere between 17 degrees and vertical, a significant comfort factor can be achieved that would not be possible on other digitizers without special props or mechanical supports.

A second significant feature is the design of the cursor, which incorporates several enhancements that help reduce operator fatigue and reduce error in the digitizing process. The first is an operator controlled vacuum system that allows the operator to cease digitizing and lock the cursor to the platen while answering the phone, checking progress, or simply resting arms and eyes for a while. Another enhancement is the design of the crosshair. The usual digitizer crosshair consists of intersecting lines of approximately 250-micrometre width (see Fig. 2a). With the resolution and accuracy of the 9874A (25 micrometres and ± 125 micrometres respectively)

crosshairs of this design would entirely cover the accuracy window. The 9874A crosshair provides a doughnut target of 375-micrometre outside diameter with a center hole of 250-micrometre diameter (Fig. 2b). Tests have demonstrated that an operator can repeatedly position this crosshair design within 50 micrometres of the known position. Thus the digitizer can be used up to its full specified accuracy limits.

A third feature of the cursor is the fact that the crosshairs are edge lighted for greater visibility. This can be of significant value when digitizing documents with a dark background, or in which there are multicolored lines and high-density information. Increasing the visibility of the crosshairs reduces operator eye fatigue and increases the accuracy of the positioning process.

The second major problem faced by a digitizer user is that of controlling the computer system. Since the user is stationed at the digitizer, it is inconvenient to move to or reach the computer keyboard to enter numeric parameters, see cues, or change program modes or functions. This can be especially inconvenient in situations where significant interaction or frequent mode changes are required. The 9874A makes a significant contribution to user control of the digitizer/computer system by using a work station concept, in which control of the entire computer system is available from the digitizer. Thus the problem of the user's transferring attention from the digitizer to the computer is alleviated. The work station con-

Cursor Technology

by Henry T. Hetzel

In the new Model 9874A Digitizer, the cursor acts as the second plate of a capacitor formed between the platen traces and the cursor pickup. The simplest type of cursor pickup is an open plate, as shown in Fig. 1a. This design has certain drawbacks, the primary drawback being sensitivity to stray electrical fields from outside sources. These stray fields can cause severe errors in the digitized data.

To eliminate this problem in the 9874A, an aperture technique for capacitive pickup was developed. In the aperture technique an electrically grounded flat conductive sheet with a hole in it defines the area from which electric fields are allowed to pass to the collecting, or pickup plate. The top of the pickup plate is also protected by a solid grounded sheet (see Fig. 1b).

This scheme is incorporated into the glass viewing area of the 9874A cursor. What appears to be a single layer of transparent glass is actually a composite of three layers of glass bound together with optical cement. Each layer is coated on its top surface with a thin film of transparent indium oxide, which is electrically conductive. Crosshairs are etched into the bottom surface of the bottom layer and filled with orange epoxy paint. An 18-mm-diameter hole is etched through the indium oxide film on the top surface of this same layer of glass. This aperture hole is concentric with the crosshairs within 12 micrometres. The indium oxide layer on the top of the middle layer is the signal collecting plate, and is shielded from above by a grounded indium oxide film on the top layer of glass. These three layers are then cemented together into a single unit (Fig. 2). Electrical

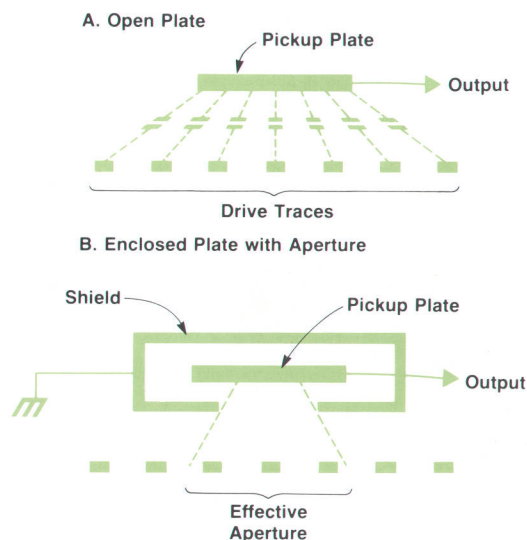

Fig. 1. Open plate pickup design (A) is sensitive to stray fields. 9874A cursor (B) uses an enclosed plate with an aperture.

connections to the layers are made at their edges inside the doughnut-shaped body of the cursor.

Since both the top and bottom layers are grounded, signal fields entering the hole in the bottom indium oxide layer are well protected from external influences, such as the operator's hands, which could distort the field or inject spurious signals.

Transparent indium oxide films were necessary to keep the cursor viewing area open. An alternative would have been to use a large signal collecting ring near the circumference of the cursor. This would have allowed unobstructed viewing without the need for transparent films, but because the entire ring would have been required to stay within the active area of the platen, the digitizing area would have had to be reduced by a large border corresponding to the ring's radius.

Another feature of this cursor construction is the accuracy with which the hole defining the signal area is aligned to the crosshairs. A standard photolithographic process is used to etch the indium oxide, but the critical step of masking the hole onto the photoresist-covered part is done on a precision spindle that rotates the work under a high-power microscope. Adjustments are made to center the crosshairs and the mask on the axis of rotation. The procedure eliminates parallax in the aligning process, which could otherwise have developed through the glass thickness. Once etched into the indium oxide, the hole is permanently fixed relative to the crosshairs because they are both on the same piece of glass. Thus the accuracy of the cursor cannot be changed through mishandling, short of destruction of the cursor lens.

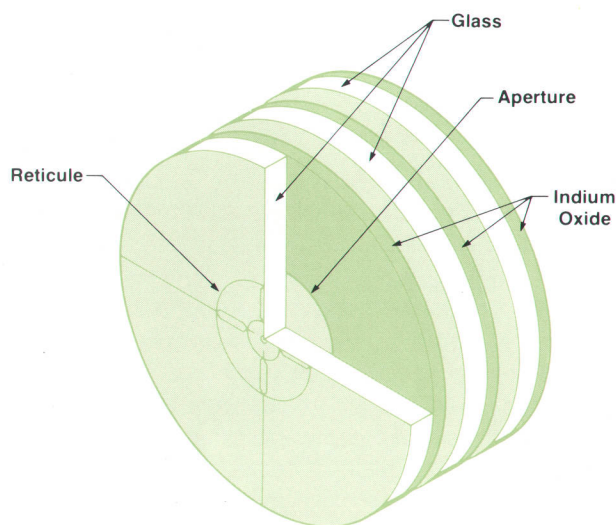

Fig. 2. 9874A cursor consists of three layers of glass with conductive indium oxide layers for the pickup plate and shield.

cept is implemented by means of a multipurpose keypad and display on the right side of the 9874A. This keypad allows the user to select the digitizer mode and enter numeric data, and provides for feedback via the computer-controlled display functions. User control of the computer is facilitated by the special function keys, which can be programmed to provide a high degree of interaction between the user and

the computer.

Another digitizing problem is media compatibility. Digitizing media come in all shapes, sizes, and types, from maps to strip charts to photographs to 35-mm slides. The 9874A provides maximum built-in flexibility to allow the user to interface simply to various media. The adjustable working surface is ideal for flat documents. An optional strip chart box and a slot

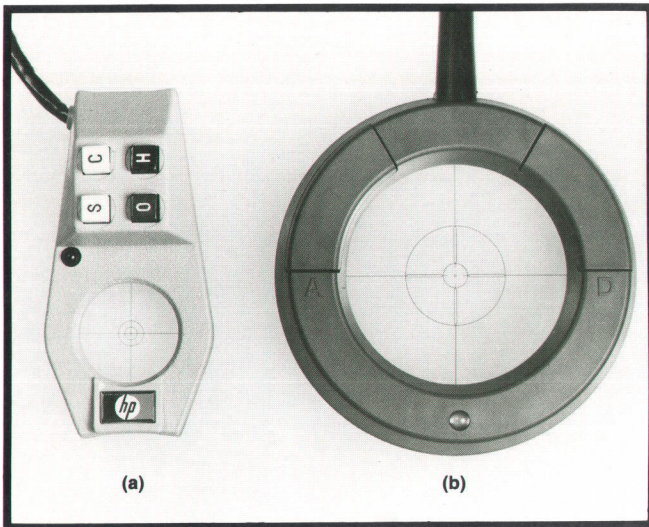

Fig. 2. Old digitizer crosshair design (a), with intersecting lines $\sim 250 \mu\text{m}$ wide, would cover the entire accuracy window of the new 9874A Digitizer. New 9874A crosshair design (b) provides a doughnut target with a $250\text{-}\mu\text{m}$ center hole.

under the keypad can be used for very long strip charts. The EXTEND mode allows very large documents to be moved across the platen while maintaining the coordinates established on the document. The glass platen allows the digitizing of projected transparencies directly, and the user can set up a lamp behind the platen to digitize documents requiring backlighting, such as x-rays.

To provide feedback to the user about present position, mode of operation, error conditions, and commands for user operations, the 9874A has multiple feedback modes. These improve the user's efficiency by more tightly closing the loop between the user and the computer. The programmable display can provide positional feedback, numeric cues, and a limited alpha capability. A more significant feedback mode is achieved with a variable frequency tone that can be programmed to provide many types of information. Some examples are: various tones to specify which point in a sequence the user has digitized, tones with frequency proportional to distance to guide the user to a point or line on the digitizing surface, multiple-frequency error tones to signal various error conditions of greater and lesser importance, and different tones for cueing various tasks. Since the user's attention is normally focused on the digitizer surface, this feature can be very valuable, in that the user can be provided feedback or instructions without removing visual attention from the document surface. This reduces fatigue and increases operator efficiency.

Hardware Design

It took a significant technology effort to develop the 9874A to meet the stringent accuracy and environmental specifications. This effort centered on three

major areas: the digitizing technique, the platen construction, and the cursor construction.

For the digitizing technique there were four major design goals: achieve the required resolution and accuracy, minimize environmental effects, minimize the complexity of the platen construction, and provide an absolute coordinate system, a system in which the cursor can be removed from the platen and still know its position relative to the origin when it is replaced.

The first decision was to use a capacitively coupled or electrostatic drive technique. The platen contains a grid of closely spaced horizontal and vertical conductive traces. These are driven with a voltage signal, and this signal is coupled from the platen traces to the cursor pickup by a small equivalent capacitor formed between the trace and the pickup disc (Fig. 3). The pickup from each trace is related to the effective capacitance between the trace of interest and the pickup plate within the cursor. This capacitance is a function of the distance from the cursor to the trace. Thus traces close to the cursor have relatively large coupling capacitances while traces farther away have lower coupling capacitances. If the cursor pickup is terminated in a capacitive load and a high-input impedance amplifier, a weighted sum of the drive signals from the various traces can be obtained (Fig. 4). If C_L is the load capacitance and if $C_L \gg C_1, C_2, \dots, C_N$, this sum can be computed as:

$$V_o \approx [(C_1/C_L)V_1 + (C_2/C_L)V_2 + \dots + (C_N/C_L)V_N] \quad (1)$$

This can be reduced to:

$$V_o \approx [C_1V_1 + C_2V_2 + \dots + C_NV_N]/C_L \quad (2)$$

Equation 2 shows that the cursor voltage resulting from a particular trace is directly proportional to both the drive voltage and the coupling capacitance between the cursor and that trace. Thus the total resultant output voltage is a weighted sum of the various trace drive voltages based on the distance from the cursor to the individual traces.

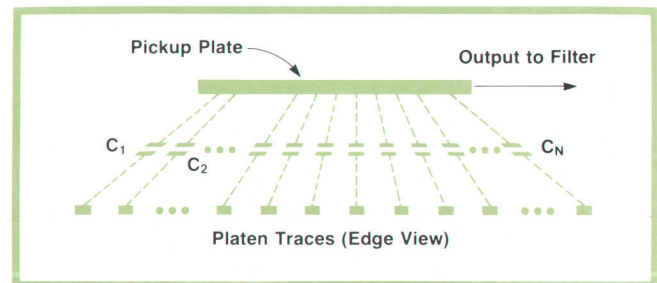

Fig. 3. 9874A platen contains closely spaced traces driven by a voltage signal. Trace signals are coupled to the cursor pickup by the trace-to-pickup capacitances.

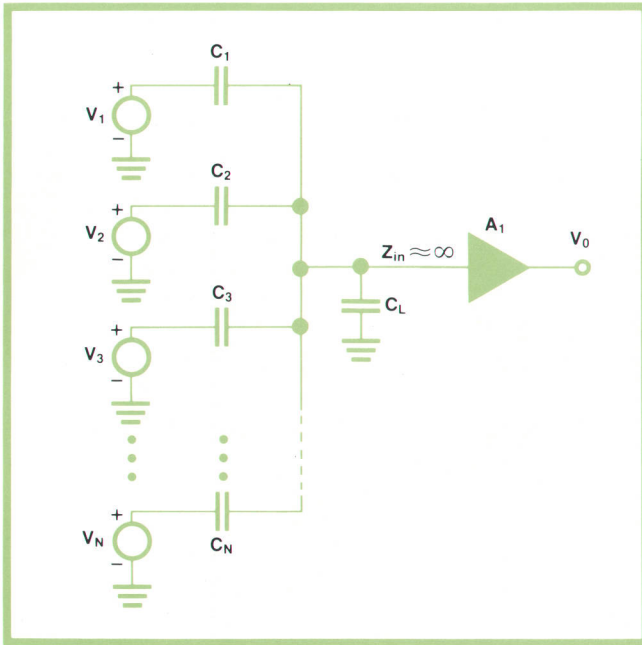

Fig. 4. Equivalent pickup circuit showing trace drive signal sources, equivalent pickup capacitances, and the cursor equivalent load capacitance. C_L is the sum of parallel parasitic capacitances and a fixed capacitor put there to guarantee that $C_L \gg C_1, C_2, \dots, C_N$.

The next step is to create a technique for driving the individual traces that takes advantage of this coupling process. If we sequentially drive each line high for a short period of time and then drive it low we will see a series of weighted pulses coming out of the cursor pickup such that the closest trace has the maximum pulse amplitude. However, dealing with a sequence of amplitude-weighted pulses is difficult and a more convenient technique is desirable. If we drive each trace high and hold it high while subsequent traces go high we will see an output that is a weighted series of steps up to the final, maximum level (Fig. 5). Knowing the velocity with which the wave is travelling across the platen we can measure the distance to the cursor from the first trace on the platen by measuring the time between the start of the wave on the first trace and the midpoint of the rise of the cursor signal. This edge measurement is much simpler to deal with than the pulses. However, another refinement significantly aids the system design. If after driving the traces high we later bring the traces low sequentially such that the drive signal becomes a cyclic wave we can create a cyclic output wave that contains the positional information in its leading and trailing edges. We can then simply measure the distance from the first trace to the cursor by measuring the phase difference from the first-trace drive signal leading edge to the cursor signal leading edge. This is the method used.

Implementing the Digitizing Technique

The easiest way of generating time-delayed cyclic signals is to use a shift register. The desired cyclic signal is fed into the input of the first stage, and the clock frequency determines the delay between the various stages. Thus, for the design discussed above, a square wave of suitable frequency (in our design $f=5$ kHz) is fed into the shift register input and clocked across at a clock rate that makes the wavelength longer than the platen size. This is to avoid phase ambiguity that would occur if more than one cycle appeared on the platen.

The cursor signal is buffered by a high-impedance amplifier and then fed into a bandpass filter. This filter removes the higher-order harmonics in the pickup wave and provides a sine wave output. Because of the effect of summing many weighted signals from the traces, the phase of the filtered pickup signal provides a smoothly varying representation of the cursor position. This makes it possible to interpolate between trace positions and realize system resolution much finer than the trace spacing. The filter output is then run through a zero-crossing detector that produces a square wave output with the phase information of the pickup wave contained in its transition points. Position information is then obtained by

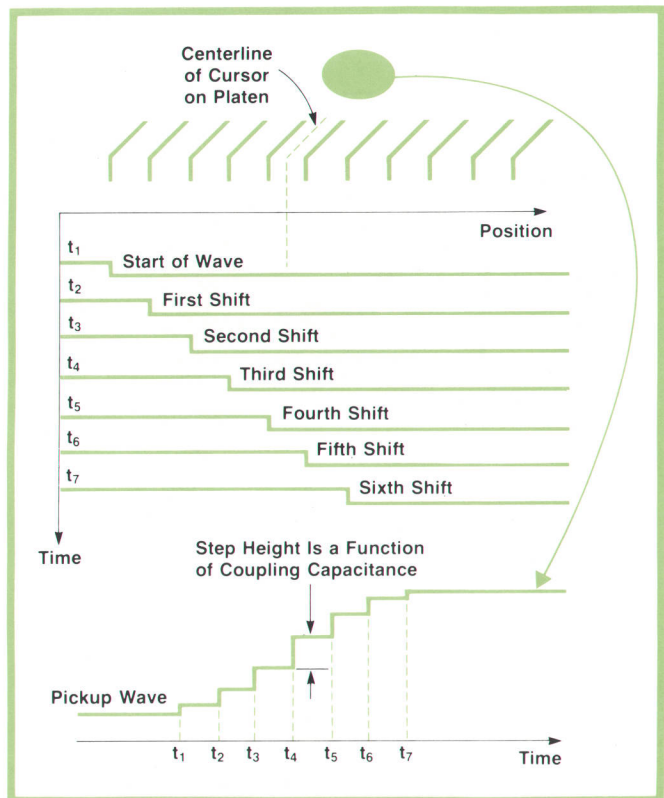

Fig. 5. If each platen trace is driven high and held there while subsequent traces go high, the pickup wave at the cursor output is a weighted sum of step functions. Distance of the cursor from the first trace is proportional to the time from the first-trace step to the midpoint of the rise of the cursor signal.

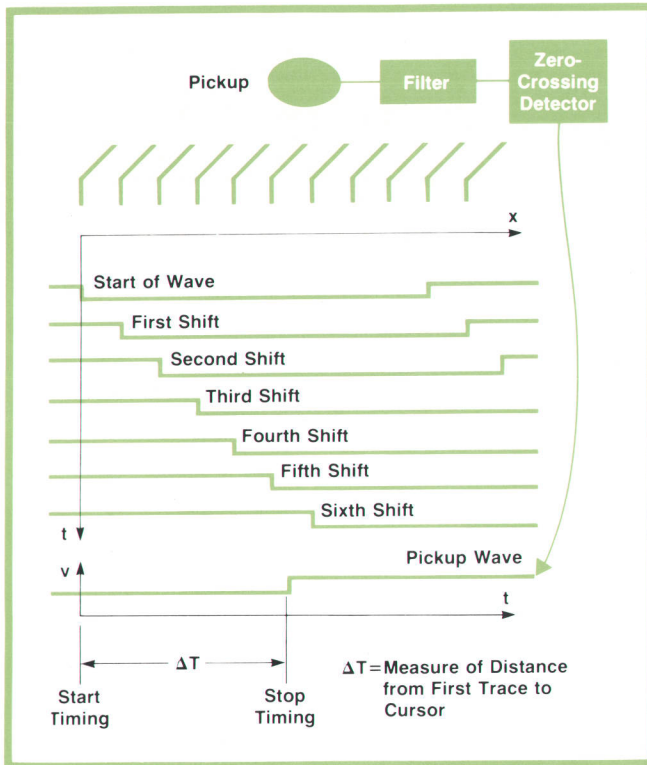

Fig. 6. In the 9874A Digitizer the platen traces are driven high sequentially and later driven low sequentially, creating a cyclic cursor output signal. This is filtered to produce a sine wave, from which a zero-crossing detector extracts the desired phase information.

measuring the time delay (or phase difference) between the rising edge of the first-trace waveform and the rising edge of the processed cursor pickup waveform (Fig. 6).

One problem frequently encountered in electronic systems is drift. This is a variation of a parameter or a component value caused by changes in temperature, humidity, or aging. In the system described above drift comes primarily from changes in the filter phase delay and in the zero-crossing detector error. One useful way to minimize the effects of drift is to make the measurement differential rather than absolute, that is, to make a measurement that represents only those parts of the measurement that may include drift, and then subtract that measurement from the measurement of the total system. In the 9874A we do this by performing a second measurement that we call the reference measurement. In the reference mode the output of the shift registers that drive all of the platen lines are all shifted high or low at the same time. Thus the time delay measured is the same for any cursor position on the platen, whether the cursor is over the first trace, the last trace, or in the middle of the platen. This measurement is retained in the processor, and when a real position measurement is made with the shift register outputs time delayed across the platen, the reference measurement is subtracted from the

position measurement to obtain a differential result with all components that may contain drift cancelled out.

Increasing Resolution

A limitation of the digitizing technique described above is the resolution with which the phase delay between the first-trace wave and the cursor pickup wave can be measured. Practical considerations limit the phase resolution of the system to 0.1 degree or 1/3600 of a cycle. With the size of the platen set at 430 mm the positional resolution of the system is:

$$(430 \text{ mm})(1/3600) = 0.1194 \text{ mm} = 119 \text{ micrometres.}$$

The desired positional resolution of the system is 25 micrometres, or about 1/5 of that provided by this drive technique. This could be overcome by increasing the phase resolution of the system. However if it ever becomes desirable to expand the platen area this limitation will become severe. Fortunately, the drive as described provides enough flexibility to overcome this problem. The approach is simply to keep the shift register input frequency (which establishes the center frequency of the filter) constant, but to decrease the frequency of the shift register clock (which establishes how rapidly the wave moves across the platen). This has the effect of creating multiple cycles of the drive waveform on the platen surface (Fig. 7). By physically shrinking the size of the waveform, but keeping the phase resolution the same, we increase

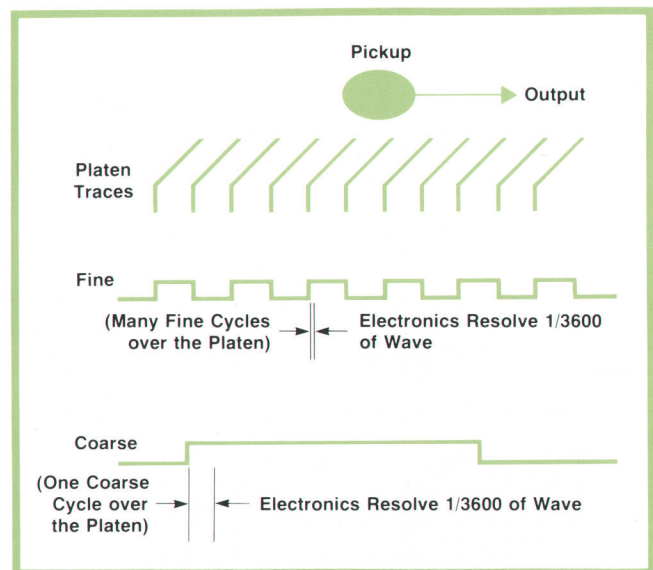

Fig. 7. To attain the desired resolution the 9874A makes fine measurements with multiple cycles on the platen. A coarse measurement with only one cycle on the platen is made to determine which of the fine cycles coincides with the cursor position. A third measurement is used as a reference to eliminate the effects of drift.

Glass Platen Technology

by Lawrence E. Brown

The glass platen of the 9874A Digitizer needs low-resistance, accurately positioned, environmentally stable X and Y circuit patterns to perform the digitizing function. The platen must also provide the user with a usable working surface, the ability to rear-project high-resolution images, and a delineation of the active digitizing area, all within a safe, reliable package.

To attain these objectives, glass was chosen as the substrate material. Two mirror-quality glass plates, called "lites", are used in the platen. The lites are specially ground, patterned, and laminated together to form the platen (see Fig. 1).

The top lite is lapped with an aluminum oxide paste on the upper surface. This frosted finish provides a sharp focal plane for rear-projected images.

Using special HP-developed tooling, a numerically controlled mill grinds the active area delineators in the lapped surfaces and the outside edges of the top and bottom lites. The machine produces smooth edges for safe handling and tightly controlled dimensions for accurate circuit pattern positioning. The ground lites are thoroughly washed and treated with an ammonium bifluoride solution to complete their preparation for the circuit patterns.

The production of the grid lines on each lite is a proprietary photolithography process. Three material layers are successively laminated to the circuit side of each prepared lite. These,

in order, are: photosensitive adhesive, treated copper foil, and photosensitive film. The upper layer of photosensitive film is positively imaged using standard photoetch techniques and glass artwork masters to insure accurate grid lines, exposing the copper foil layer beneath. Using the now imaged top film layer as a resist, the copper layer is then etched away, exposing the photosensitive adhesive. The adhesive layer is then etched with the copper foil acting as a resist. This leaves a full pattern of three-layer grid lines. As a final step, the photosensitive adhesive layer, up to now unpolymerized, is exposed through the glass to be transformed into a hard polymer that permanently secures the foil to the glass. The grid lines have superior electrical resistance values similar to normal printed circuit traces.

The top film layer is removed only at the ribbon connector pads, and ribbon connectors are soldered to each lite. An X and Y pair of lites, complete with ribbon connectors, is tested electrically and then laminated together with transparent polyvinyl butyral resin, used to make auto windshields, as the center adhesive layer. This lamination step seals all the circuitry in the vinyl resin and creates a safety-glass platen.

Aesthetic embellishment is the final step in the platen process. Epoxy inks are screened on both lites to produce borders that mask the ribbon connector joints from the user.

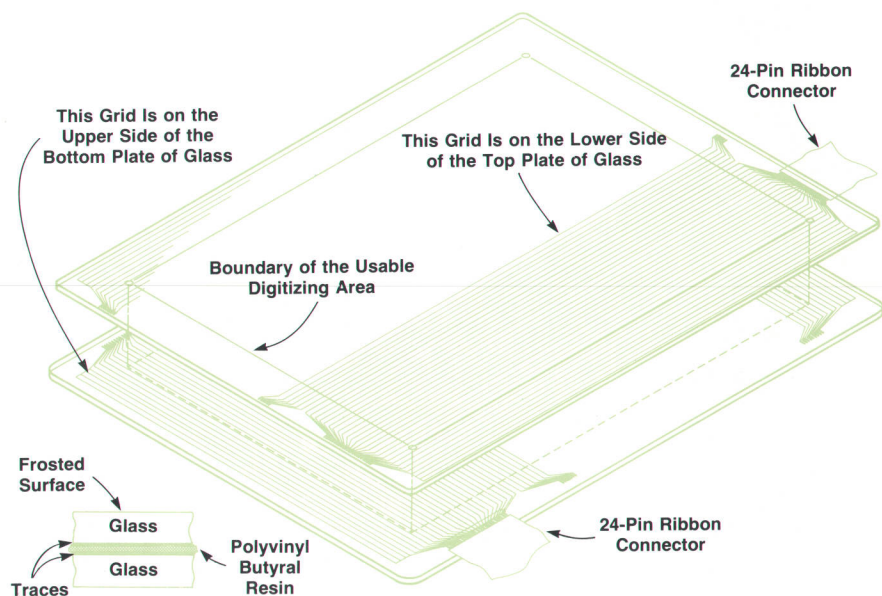

Fig. 1. 9874A platen consists of two mirror quality glass plates (lites) that are ground, patterned, and laminated together.

the physical resolution of the system by the ratio of the spatial wavelengths of the two waveforms. For example, if the waveform that covers the surface has a wavelength of 430 mm, and the compressed waveform has a wavelength of 86 mm, the physical resolution of the compressed drive becomes

$$R = (86 \text{ mm}/430 \text{ mm})(0.1194 \text{ mm}) = 23.89 \text{ } \mu\text{m}.$$

This does present an ambiguity problem, in that com-

pressing the waveform creates several positions on the platen where the measured phase is the same. This is resolved by driving the platen sequentially with both the full-platen-width wave, called the coarse wave, to establish the gross position of the cursor on the platen, and then with the compressed wave, called the fine wave, to provide the ultimate positional resolution.

This technique of coarse, fine, and reference measurements results in a system that provides absolute

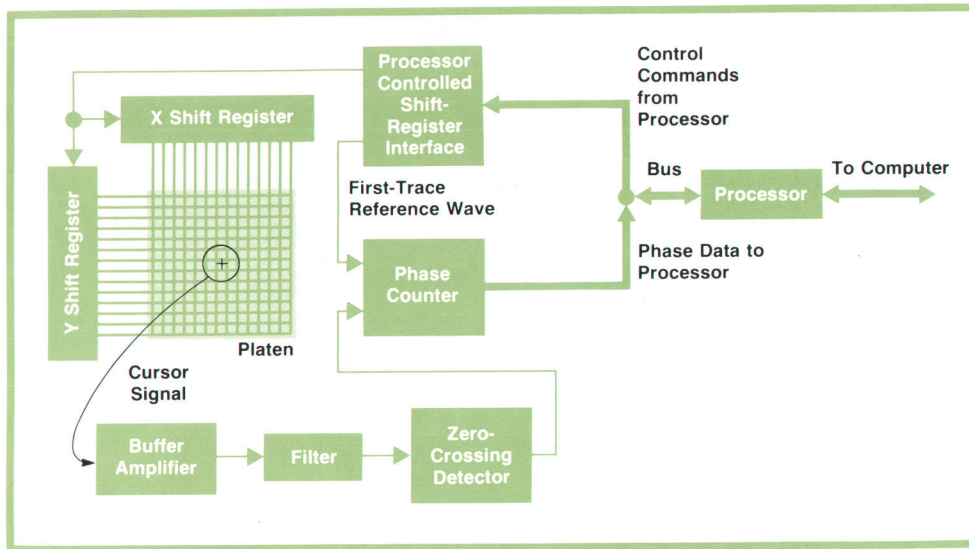

Fig. 8. Model 9874A Digitizer block diagram. Shift registers produce the sequential platen drive signals.

coordinates (the ability to lift the cursor and replace it without losing the origin), excellent environmental stability, and flexibility for later variations in platen format.

System Organization

Fig. 8 is a block diagram of the 9874A digitizing electronics. The shift registers are controlled by an interface unit that transforms commands from the internal processor into the correct drive waveforms for the drive mode selected. The cursor waveform is filtered and sent through the zero-crossing detector and on into the phase counter, which provides a digital word to the processor representing the phase difference between the leading edge of the first-trace reference signal and the processed cursor signal. The processor performs the algorithms required to sequence the digitizing process, interface to the other electronics (keypad, display, beeper, etc.), and communicate with the host computer.

Operation of the stylus, an alternative pickup device, is identical to that of the cursor. The tip of the pen cartridge, which extends beyond the stylus barrel, is used as the electrical pickup, equivalent to the pickup disc of the cursor. The waves are sensed and processed in the same way as the cursor, except that the equivalent pickup area of the stylus is much smaller than that of the cursor, so the signal strengths are greatly reduced. This increases noise effects in the resulting data, and parasitic media effects (see Inherent Problems of Digitizing, page 12) have a proportionally greater impact on the system accuracy.

Microprocessor Power

The digitizing technique and all of the user features were designed around the fact that a microprocessor would be used to make the 9874A a smart peripheral. The digitizing technique makes a single-axis position

measurement that requires three distinct steps to obtain the final coordinate position. The power of the processor is used to perform these measurements for both the X and Y axes, and to minimize complications caused by this sequential measurement. The sequential technique significantly lowers the hardware cost of the system. However, measurement error is introduced if the cursor is moving during a measurement (Fig. 9a). This error is minimized by setting up the software to make the time difference between the X-fine measurement and the Y-fine measurement a minimum, since the X-fine and Y-fine measurements actually establish the system measurement performance. The software cycle for a full X and Y measurement is as follows:

- X-coarse
- X-reference
- X-fine
- Y-fine
- Y-reference
- Y-coarse.

Thus minimum time is spent between the X-fine and Y-fine measurements, and the appropriate reference measurement is made adjacent to each axis' coarse and fine measurements.

This technique minimizes cursor movement error, but there is still an error component present. The solution is to have the software compute the velocity of the cursor and offset the measurement to correct for the error caused by that velocity. The hardware measures the time between the previous point and the present point, t_1 , and the time, t_2 , from the measurement of the present Y coordinate, Y_2 , to the present X coordinate, X_2 (Fig. 9b). By establishing the Y_2 coordinate as the reference to which the X_2 coordinate will be transformed we need only compute the X velocity to determine how much to shift the X_2 point to correct for the cursor motion. The X velocity

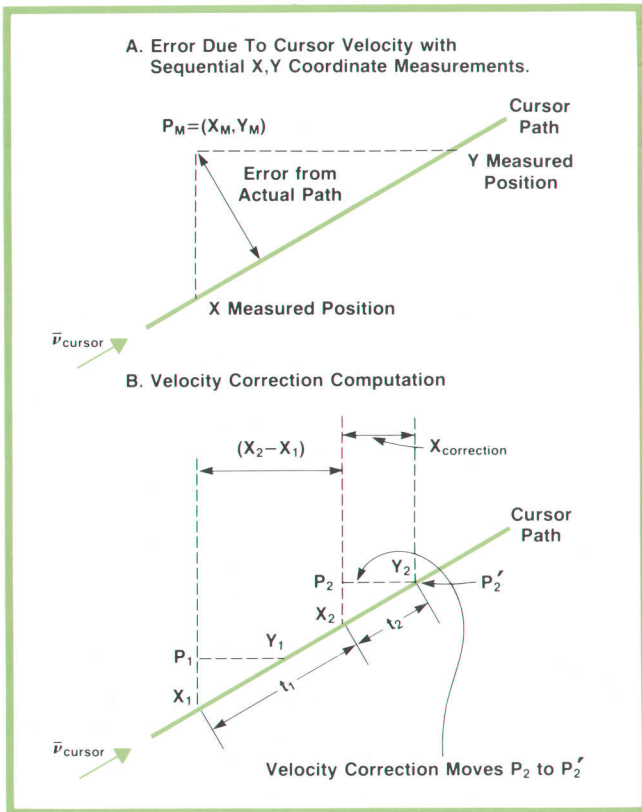

Fig. 9. To compensate for cursor movement during a measurement, the microprocessor computes the cursor velocity and offsets the measurement accordingly.

can be computed from the change in the X coordinate since the last X measurement, and from the time between measurements. The correction can be computed from the X velocity and the time from the X coordinate measurement to the Y coordinate measurement. Thus the X correction is found to be:

$$X_{\text{correction}} = (X_2 - X_1)(t_2/t_1) \quad (3)$$

and the corrected point P_2 is:

$$P_2 = ((X_2 + X_{\text{correction}}), Y_2). \quad (4)$$

This is only a first-order correction, that is, the correction will not be valid during acceleration. It has been found that when an operator is attempting to follow a line accurately by hand the acceleration and velocity levels are low enough that this correction factor produces an overall system error well below the position errors introduced by the operator in the digitizing process.

Another significant contribution of the processor is averaging of the signals during the digitizing process. This averaging takes place during each drive mode, that is, in the X-fine mode, many X-fine measurements are made before the mode is changed to Y-fine.

In the 9874A each coordinate returned to the user is an average of 80 individual measurements. This reduces noise in the measurement process without a corresponding increase in hardware complexity.

Accuracy Results

The accuracy specification of the 9874A is ± 125 micrometres over the platen surface. This is a composite that includes the accuracy of the drive system, the platen, and the cursor. Our tests of actual production machines show that typical accuracy in production units is running between ± 62.5 micrometres and ± 75 micrometres (see box, page 11). Final tests are set to a limit of ± 75 micrometres to assure the user that the system will indeed meet the specifications of ± 125 micrometres. Fig. 10 shows a typical accuracy plot of a production digitizer at 25°C and 50% relative humidity.

Software Enhancements Aid User

Another real contribution of a smart peripheral is its ability to aid the user in solving problems that are specific to that type of peripheral. The 9874A takes full advantage of the available processing power to provide simple solutions to several problems that can impact digitizer users.

The first of these problems is the alignment of the axes of the user's source document to the coordinate axes of the digitizer. In the past this has required either a long setup process or the generation of a computer program to transform the coordinates returned by the digitizer into the user's system. The 9874A performs these calculations internally. The user merely places the document on the platen, presses the AXIS ALIGN key, and digitizes the origin of the document coordinate system and a point lying on the X axis of the document. The internal processor then computes the transform matrix to go from the digitizer coordinate system to the user's coordinate system. All digitized points are then processed through that transform before being sent to the computer so that all points come to the computer in the user's coordinate system.

Another problem the user may encounter is a document too large for the platen of the 9874A. In this case the user can press the EXTEND button on the 9874A, and then digitize two points on the document that lie on the digitizer platen. The user may then move the document to any other position, including translation and rotation, as long as the two previously digitized points are on the platen after the motion is completed. The user then redigitizes the two reference points in the same order as they were initially digitized, and the processor calculates a new transform matrix that includes both the initial AXIS ALIGN and the later translation and rotation of the document.

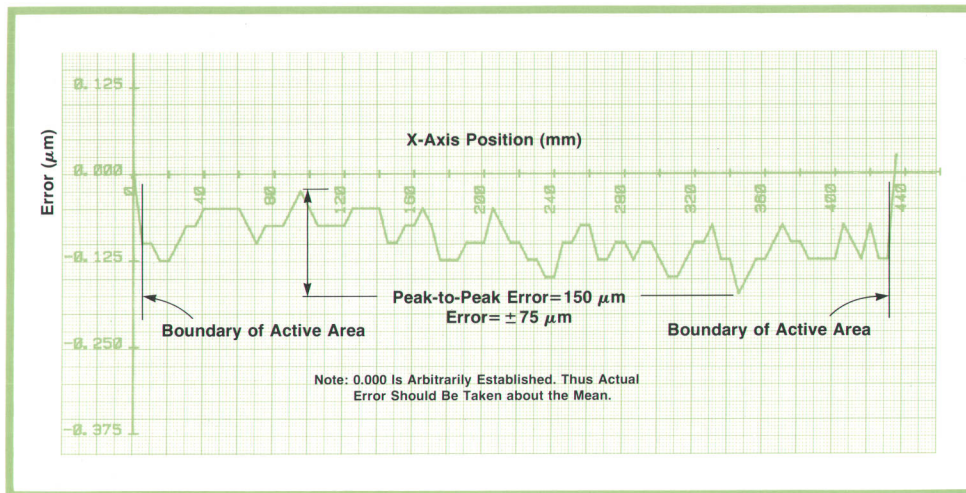

Fig. 10. Typical production digitizer accuracy plot. Maximum acceptable error is $\pm 75 \mu\text{m}$, assuring that the accuracy specification of $\pm 125 \mu\text{m}$ is met.

Points digitized on the document in its new position on the platen are then automatically referenced to the user's coordinate system.

Digitizing is frequently done in a continuous mode, in which the user traces the line of interest and points are sent from the digitizer at a preset rate. In a real digitizing process, the user typically wants to select a new point a certain distance from the last point rather than a certain time after the last point. The 9874A provides the user with a choice of parameters, either time from the last point, or the vector distance from the last point to the next point. Both parameters may

be specified by the user, with time variable from 20 ms to 32,000 ms in 1-ms steps, and distance variable from 100 micrometres to 514 mm in 100-micrometre steps. This eliminates the generation of a multitude of unwanted coordinates, and more closely ties the operation of the system to the user's desired result.

Another software enhancement for the user is the ability of the 9874A to understand a high-level graphics language on the HP-IB (IEEE 488). This provides the user with very flexible high-level commands to perform functions such as computer setup of the digitizer configuration, interrupt of the

Accuracy Testing

The 9874A Digitizer undergoes several levels of accuracy testing before being shipped. The first level of testing is at the assembled printed circuit board level. At this level all of the PC boards that impact system accuracy (including the platen drive boards, the filter board, and the phase counter board) undergo rigorous testing that guarantees that their operation will be within the limits required to provide the specified accuracy. The platen also undergoes electrical testing that ensures that each trace is electrically continuous.

When a digitizer has been assembled, another level of testing takes place. Four functional tests are run on each machine to ensure its operation within the specified limits. First, a repeatability test is run to ensure that the system noise is within the specified bounds. Next an axis skew setup procedure is run. 200 points are taken in a straight line along both axes. These points are fit to a straight line equation and the equations for each axis are compared to generate a correction for the skew, or lack of perpendicularity, between the two axes. This correction factor is set on the processor board and the test is repeated at a different platen location to verify that the correction is within the specified bounds. This correction sets the equivalent angle between the digitizer axes to within ± 0.006 degrees. The next test is an absolute distance test. An F-shaped bar is used; the distance between the intersection points is approximately 250 mm and the actual distance between points is known within 2.5 micrometres. Ten point pairs are taken on each diagonal of the platen. These point pairs must be within ± 75 micrometres of the

known length of the bar to pass the test. This establishes that there is no scale error on the platen surface. The final test run on each machine is a point-by-point accuracy test in which 250 points are taken along a diagonal using a straightedge known to be straight within 5.0 micrometres. A best-fit straight-line approximation is then calculated based on the measured points. The data points are then compared to this straight-line equation and all must fall within ± 75 micrometres of the calculated position. This test uses the previously established fact of correct scale across the platen to test the accuracy of one axis against another. Given the previous testing undergone by the subsystems, the likelihood of both axes having errors that offset and allow a bad unit to pass this test is negligible.

These system tests give a high degree of confidence that each 9874A shipped falls well within the specifications shown on the data sheet. As a second confidence check, random units are pulled from the production line at intervals that are statistically determined to give an acceptable confidence level for the sample size. These units are run through a full accuracy test in which the cursor is positioned on the platen at 200 to 300 points using a machine that provides the location with respect to the given origin to within ± 5.0 micrometres. The typical machine run through this test is achieving accuracies of ± 62.5 micrometres with the worst-case machine achieving ± 75 micrometres accuracy. We are thus assured that the production process is repeatably producing machines that provide the user with the specified accuracy.

computer on specified conditions, interaction with the display and keypad, and error recognition. This is the same language used by many HP computers, including the 9825A, the 9835A/B, the 9845A, and the HP 1000, and by the 2647A intelligent graphics terminal, to communicate with graphics peripherals. This means that many of the BASIC and HPL language commands included in these machines for graphics are compatible with the 9874A Digitizer. These include commands for scaling to user units, setting windows on the available active area of the digitizer, and the function of digitizing itself.

Inherent Problems of Digitizing

The 9874A Digitizer provides a highly accurate, stable digitizing unit with powerful features to allow the user to solve digitizing problems rapidly. However, there are inherent problems that affect the overall accuracy of the system but are beyond the capability of the digitizer to solve. The first is media compatibility. Since the 9874A Digitizer works on a capacitive technique, materials placed between the cursor and the platen that act to modify the electric field established by the platen traces may cause errors in the position measured by the cursor. These media fall into two categories: conductive media and media with dielectric constant variations. Conductive media can significantly alter the position measured by the cursor, and digitizing of conductive material such as metal sheets will not work. Also included in the category of conductive media are nonconductive materials with moderately conductive surface effects. This category includes paper with graphite pencil markings. These markings can range from high impedance to fairly low impedance, depending upon the hardness of the graphite lead, the width of the line, the length of the line, and the area covered. Tests have shown that a normal-weight line using an H pencil lead can cause up to 250 micrometres of error on the digitized point. This effect is accentuated with the stylus because of its significantly reduced pickup dimensions. We recommend that the stylus not be used with documents drawn with graphite lead pencil. Also in this category is a document with surface conductivity caused by moisture and humidity. Moisture and humidity can cause a significant reduction in the sheet resistivity of the surface of materials such as paper. The complete operating specifications provided in the 9874A manual are designed to take into account typical media conductivity increases in humid environments. If the digitizer is to be used in humid environments these specifications should be closely analyzed to establish the actual operating specifications that will be encountered by the user.

Besides being nonconductive, media being digitized must also have a homogeneous dielectric con-

stant. This is the constant that determines the strength of the electric field at the cursor that results from the drive of one line. In effect, it acts to modify the effective coupling capacitance between the cursor and the line of interest. As we can see from equation 2, if the equivalent coupling capacitances from the various lines are not dependent solely on the distance from the platen line to the cursor, but also depend on the variations of dielectric constant of the media across the platen surface, then the pickup wave will also be affected by this variation, and the positional output may be affected. In normal operation, single sheets of paper or other material are usually well within the bounds of the required homogeneity. However, thick pads of paper or paper with different material on its surface (such as a piece of paper with a strip of adhesive tape on the surface) can cause positional errors of up to 125 micrometres.

Even more significant than the electrical properties of the material are limitations imposed by the document material, which can range from paper to mylar to 35-mm slides. Documents all have one general characteristic: they are sensitive to variations in temperature, humidity, and aging. In fact, this sensitivity may not be homogeneous over the surface of the material, especially in cases where a specific grain direction exists. Variations of this type can range up to several percent for certain types of paper. Thus a variation of over 1.25 mm can be seen for slight variations around standard room temperature and humidity. Another significant effect is dimensional variations caused by bending or folding of the source document. Even for mylar, the variation from a 90° bend of small radius (2.5 mm or less) can be as much as 100 to 150 micrometres.

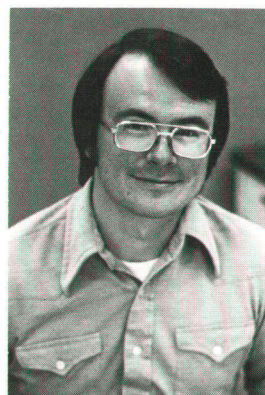

Lawrence E. Brown

Born in Albany, New York, Larry Brown received his BSME degree in 1968 and MSME degree in 1971 from Rensselaer Polytechnic Institute. After graduation, he worked as an emissions test engineer for an automobile manufacturer and did a year of postgraduate work at Rensselaer before coming to HP in 1973. As lead engineer for the product design of the 9874A Digitizer, Larry was responsible for its platen and platen process design. He also designed the four-pen "stable" mechanism concept for the 9872A Plotter. A real downhill and crosscountry skiing enthusiast, Larry has a patent on a ski and pole carrier and for eight years was a semipro ski instructor in Vermont. When not "schussing the slopes," he enjoys hiking, camping and remodeling his home. The Brown family—Larry, his wife, three cats and two dogs—lives in Loveland, Colorado.

Acknowledgements

I would like to thank all of the members of the project team who contributed to make the 9874A the product it is. Worthy of particular note are: Geoff Chance, who was the project manager during the initial definition phase of the project, Alan Richards, who took over as project manager following Geoff's promotion and guided us into production, Larry Brown, who was responsible for the platen process and was project leader on the mechanical side, Jerry Nichol, who did the overall mechanical design, Bill Dalebout, our industrial designer, Henry Hetzel, who was responsible for the cursor design, Mike

Tremblay, who wrote all of the software for the internal processor, Mark Trasko, who designed the processor and interface electronics, Dave Chamness, who did the preliminary design of the stylus, Tony Mallon, who provided valuable help in the testing and EMI design, Paul Bonomo, who set up the manufacturing processes to build the unique parts of the unit, and finally Dave Kinsell, who came in toward the end of the project and helped solve the usual problems that threaten to hold up the final release. 



Henry T. Hetzel

Responsible for the design of the cursor and vacuum system for the 9874A Digitizer, Henry Hetzel received his BS degree in physics from Haverford College in 1961 and MSEE degree from Colorado State University in 1970. Henry has been an HP employee since 1965 and is named inventor on three patents relating to the 9874A Digitizer. He also helped design the 11100 Series Transfer Standard Resistors, and did thermal printhead analysis for the 9800 Series Desktop Computers. Before coming to HP, he was self-

employed, converting old mechanical adding machines to instruments that could be used by the blind. Henry lives on a farm in Loveland, Colorado, and spends much of his leisure time riding and caring for his two horses.



Frank P. Carau

A 1971 BSEE graduate from Virginia Polytechnic Institute and State University, Frank Carau was lead engineer for the electronic design of the 9874A Digitizer, and was responsible for its drive technique, keypad, display, beeper and power supply design. Prior to working on the 9874A, Frank did the preliminary work on the processor design for the 9872A Plotter, and he is now project manager in HP's Desktop Computer Division peripherals lab. Born in Washington, D.C.,

Frank worked as an electronics engineer with the federal government after graduation until he joined HP in 1974. He is a member of IEEE and is named inventor on a patent on the 9874A digitizing technique. A resident of Loveland, Colorado, Frank is married, has two children (ages eight and four) and is expecting his third child in March. Camping, hiking, jogging, reading, photography, skiing and church activities keep Frank busy during his off hours.

SPECIFICATIONS

HP Model 9874A Digitizer

Instruction Set

An easy-to-use, two-letter mnemonic graphics language drives the 9874A. The interface code is given to the 9874A through the HP-IB interface card. Following is a listing of the commands.

DIGITIZE MODES

- SG - Sets the Single Sample Mode
- CN - Sets the Continuous Mode
- OD - Output Digitized Point
- OC - Output Current Cursor Position
- OA - Output Actual Cursor Position
- RC - Read Cursor Position
- ON - Output Annotation
- AA - Sets the Axis Align Mode
- AE - Sets the Axis Extend Mode
- PO - Sets Point One Mode
- PT - Sets Point Two Mode
- IP - Input Scaling Points (P₁, P₂)
- OP - Output Scaling Points (P₁, P₂)
- WO - Sets Window One Mode
- WT - Sets Window Two Mode
- IW - Input the Window Coordinates
- OW - Output the Window Coordinates

DIGITIZE SWITCH MODES

- SN - Switch Normal
- SF - Switch Follow
- TP - Take Point

AIR SWITCH MODE

- AN - Sets the Air Normal Mode
- AT - Sets Air Toggle Mode
- AV - Activate Vacuum
- RV - Remove Vacuum

SPECIAL FUNCTION KEYS

- SK - Set Special Function Key
- OK - Output Special Function Key

ADDITIONAL COMMANDS

- BP - Variable Frequency Beep
- DD - Display Driver
- LB - Label the Display
- OR - Output Resolution
- OI - Output Identification
- OF - Output Factor
- CC - Compatibility Command
- TD - Digitizer Self-Test

CONFIGURATION STATUS

- DF - Default
- DC - Digitizer Clear
- IN - Initialize
- OS - Output Status
- OE - Output Error
- IM - Input Masks

COMPUTER REQUIREMENTS

Computer/Controller	9815A Opt. 002	9825A	9830A/B	9835A/B	9845A/S	HP 1000	2647A
ROMs or software	Built-in	Gen. I/O 98212A	Ext. I/O 11272B/F	I/O 98332A	I/O 98432A	RTE-M/IV 92840A	BASIC Subroutine
HP-IB Interface (IEEE Std 488-1975)	98135A	98034A	59405A	98034A	98034A	59310B	13296A

Specifications

RESOLUTION: 0.025 mm (.000984 in).

ACCURACY

CURSOR: ±0.125 mm (.00492 in) from 0°C to 40°C.

±0.200 mm (.00787 in) from 0°C to 55°C.

STYLUS: ±0.500 mm (.01969 in) from 0°C to 40°C.

±0.600 mm (.02362 in) from 0°C to 55°C.

ACTIVE DIGITIZING AREA: 435 mm × 315 mm (17.13 in × 12.40 in).

AXIS EXTENSION (EITHER AXIS): ±53.69 mm (±33.36 miles).

CURSOR/STYLUS DOCUMENT THICKNESS: full accuracy maintained digitizing through 4 mm (0.1575 in) thick paper.

DOCUMENT MATERIAL: nonconductive.

COORDINATE SYSTEM: Absolute; reference system is unaffected if cursor is removed.

POWER REQUIREMENTS

SOURCE (+5%, -10% (switch selectable): 100V/120V/220V/240V.

FREQUENCY: 48 Hz to 66 Hz.

CONSUMPTION: 1.75A @ 100V, 1.43 A @ 120V, 760 mA @ 220V, 730 mA @ 240V.

SIZE/WEIGHT

HEIGHT

PLATEN LOWERED: 203.2 mm (8.00 in)

PLATEN EXTENDED: 546.1 mm (21.50 in)

WIDTH: 850.9 mm (33.50 in)

DEPTH: 520.7 mm (20.50 in)

WEIGHT: 27.4 kg (60.5 lb)

PRICE IN U.S.A.: \$6200.

MANUFACTURING DIVISION: DESKTOP COMPUTER DIVISION

3400 E. Harmony Road

Fort Collins, Colorado 80521 U.S.A.

HEWLETT-PACKARD JOURNAL

Index

Volume 29 September 1977 through December 1978

Hewlett-Packard Company, 1501 Page Mill Road, Palo Alto, California 94304 U.S.A.

Hewlett-Packard Central Mailing Department, Van Heuven Goedhartlaan 121, Amstelveen-1134 The Netherlands

Yokogawa-Hewlett-Packard Ltd., Shibuya-Ku, Tokyo 151 Japan

PART 1: Chronological Index

September 1977

A New Family of Intelligent Multicolor X-Y Plotters, *Lawrence G. Brunetti*

Easy-to-Use Interface Language Controls HP-IB Plotter, *Thomas H. Daniels and Larry W. Hennessee*

Remote Terminal Plotter Offers Simple Programming and Efficient Communications, *David A. Bones and Marvin L. Patterson*
Speed, Precision, and Smoothness Characterize Four-Color Plotter Pen Drive System, *Marvin L. Patterson, Robert D. Haselby, and Richard M. Kemplin*

Pen and Ink System Helps Assure Four-Color Plotter Line Quality, *Leonard P. Balazer, George W. Lynch, Richard M. Kemplin, and Larry W. Hennessee*

A Battery-Powered ECG Monitor for Emergency and Operating Room Environments, *Sherry R. Grobstein and Ronald D. Gatzke*

October 1977

Advanced Digital Signal Analyzer Probes Low-Frequency Signals with Ease and Precision, *Richard H. Grote and H. Webber McKinney*

Front End Design for Digital Signal Analysis, by *Jean-Pierre Patkay, Frank R.F. Chu, and Hans A.M. Wiggers*

Display and Storage Systems for a Digital Signal Analyzer, *Walter M. Edgerley, Jr. and David C. Snyder*

Digital Signal Analyzer Applications, *Terry L. Donahue and Joseph P. Oliverio*

Printing Financial Calculator Sets New Standards for Accuracy and Capability, *Roy E. Martin*

November 1977

Expanding Synthesized Signal Generation to the Microwave Range, *James L. Thomason*

Frequency Synthesis in a Microwave Signal Generator, *Kenneth L. Astrof*

Signal Generator Features for a Microwave Synthesizer, *Bradley C. Stribling*

Personal Calculator Algorithms III: Inverse Trigonometric Functions, *William E. Egbert*

Viewpoints—Tom Hornak on Fiber-Optic Communications

An NMOS Process for High-Performance LSI Circuits, *Joseph E. DeWeese and Thomas R. Ligon*

December 1977

Wrist Instrument Opens New Dimension in Personal Information, *André F. Marion, Edward A. Heinsen, Robert Chin, and Bennie E. Helms*

Higher Precision in Oscilloscope Measurements of Very Short Time Intervals, *Ronald C. Westlund*

A Wide-Ranging, Automatic LCR Meter for Stand-Alone or Systems Applications, *Masahiro Yokokawa and Keiki Kanafuji*

January 1978

Versatile Low-Cost Graphics Terminal is Designed for Ease of Use, *Peter D. Dickinson*

Raster Scan Graphics with Zoom and Pan, *Otakar Blazek and Michael B. Raynham*

Firmware Control of a Microprocessor-Based Graphics Terminal, *John J. Moyer*

Add-On Digital Signal Processing Enhances the Performance of Network and Spectrum Analyzers, *Mark D. Roos, Jacob H. Egbert, Roger P. Oblad, and John T. Barr*

February 1978

A Logic State Analyzer for Evaluating Complex State Flow, *George*

A. Haag

Viewpoints—Chuck House on the Ongoing Revolution in Digital Testing

Interactive Logic State and Timing Analyses for Tracking Down Problems in Digital Systems, *John A. Scharrer, Robert G. Wickliff, Jr., and William D. Martin*

Entry Level Logic State Analyzer Has High-Level Capability, *Charles T. Small and Alan J. DeVilbiss*

Adapting the 1611A Logic State Analyzer to Work with the F8 Microprocessor Family, *Deborah J. Ogden*

March 1978

The Hewlett-Packard Distributed System Network, *André O. Schwager*

Distributed Systems/3000, *Philip M. Sakakihara*

Distributed Systems/1000, *Robert R. Shatzer*

Data Entry and Communications Systems Have Network Capabilities, *John R. Nielsen and David S. Kaplan*

Experimenting with Satellite-Linked Computer Networks, *Rita W. Williams*

April 1978

A Highly Integrated Desktop Computer System, *William D. Eads and Jack M. Walden*

System 45 Hardware Design, *John C. Keith, Ansel K. Vogen, and Louis T. Schulte*

System 45 Product Design, *Ray J. Cozzens*

Advanced Thermal Page Printer Has High-Resolution Graphics Capability, *Ray J. Cozzens*

New Printhead Technology Developed for System 45, *Eugene R. Zeller*

Personal Calculator Algorithms IV: Logarithmic Functions, *William E. Egbert*

May 1978

Microprocessor-Controlled Harmonic Heterodyne Microwave Counter also Measures Amplitudes, *Ali Bologlu and Vernon A. Barber*

A Technique that Is Insensitive to FM for Determining Harmonic Number and Sideband, *Luiz Peregrino*

Generating High-Speed CRT Displays from Digital Data, *Arnot L. Ellsworth and Kunio Hasebe*

Laboratory Notebook—Swept-Frequency Measurements of High Levels of Attenuation at Microwave Frequencies

June 1978

The Next Generation RF Spectrum Analyzer, *Steven N. Holdaway and M. Dee Humpherys*

A Precision, Digitally-Controlled Spectrum Analyzer for the 20-Hz-to-40-MHz Frequency Range, *Robert Temple*

Signal Processing in the Model 8568A Spectrum Analyzer, *Steven N. Holdaway, David H. Molinari, Siegfried H. Linkwitz, and Michael J. Neering*

Enhanced Digital Storage in the Model 8568A Spectrum Analyzer, *Michael J. Neering and Larry O. Bower*

Developing the Digital Control System for the Model 8568A Spectrum Analyzer, *Michael S. Marzalek and Lynn W. Wheelwright*

Control of Model 8568A Spectrum Analyzer through the HP Interface Bus, *Rex Bullinger*

Designing Serviceability into the Model 8568A Spectrum Analyzer, *David D. Sharrit*

Computer-Based Production-Line Testing of the Model 8568A Spectrum Analyzer, *John Faick*

Part 1: Chronological Index (continued)

July 1978

An Intelligent Peripheral for Measurement and Control, *Ray H. Brubaker, Jr.*
 Measurement and Control Processor Monitors HP Facility, *Robert B. Grady*
 Firmware Intelligence for Measurement and Control Processing, *Donald E. Klais*
 Analog Input Card Calibration, *Vincent J. Dauciunas*
 PHI, the HP-IB Interface Chip, *John W. Figueroa*
 An Easy-to-Use Data Capture Terminal for Industrial Operations, *Jacques A. Ripert, Daniel C. Berthier, and Michel E. Bernard*

August 1978

Universal Counter Resolves Picoseconds in Time Interval Measurements, *David C. Chu, Mark S. Allen, and Allen S. Foster*
 The Triggered Phase-Locked Oscillator, *David C. Chu*
 Time Synthesizer Generates Precise Pulse Widths and Time Delays for Critical Timing Applications, *Keith M. Ferguson and Leonard R. Dickstein*
 Remotely-Controlled RF Switch for Multipoint Tests in Communication Systems, *Kevin J. Bradford*
 Laboratory Notebook—A High-Level-Language Microprocessor Prototyping and Debugging System Using a Desktop Computer

September 1978

A High-Resolution, Low-Frequency Spectrum Analyzer, *Nixon A. Pendergrass and John S. Farnbach*
 Window Functions for Spectrum Analysis, *Roger G. Cox*
 Designing Programmable Digital Filters for LSI Implementation, *Lynn A. Schmidt*
 Desktop Plotter/Printer Does Both Vector Graphic Plotting and Fast Text Printing, *Majid Azmoon, Jaime H. Bohorquez, and Rick A. Warp*
 Plotter/Printer Interface Languages: HP-GL and ASCII, *Michael P. Trego*

October 1978

Higher-Performance HP 1000 Computer Systems, *Rodney K. Juncker*
 RTE-IV: The Megaword-Array Operating System, *Eugene J. Wong and C. Michael Manley*
 F-Series Extends Computing Power of HP 1000 Computer Family, *Julia A. Cates*
 Microcoded Scientific Instruction Set Enhances Speed and Accuracy of F-Series Computers, *Charles R. Geber*
 New Memory Systems for HP 1000 Computers, *Alan H. Christensen and David C. Salomaki*
 Multipoint Terminals for HP 1000 Systems, *Denton B. Anderson, Mitchell B. Bain, and Gary W. Johnson*

November 1978

Printer and Printing Terminal Gain Versatility and Mechanical Simplicity with Microprocessor Control, *Todd M. Woodcock*
 Managing Dot-Matrix Printing with a Microprocessor, *John J. Ignoffo, Jr., Michael J. Sproviero, Phillip R. Luque, and Kenneth A. Wade*
 Versatile 400-lpm Line Printer with a Friction-Free Mechanism that Assures Long Life, *F. Duncan Terry*
 Optimizing the Performance of an Electromechanical Print Mechanism, *Everett M. Baily, William A. McIlvanie, Wallace T. Thrash, and Douglas B. Winterrowd*

December 1978

Easy-to-Use, High-Resolution Digitizer Increases Operator Efficiency, *Frank P. Carau*
 Cursor Technology, *Henry T. Hetzel*
 Glass Platen Technology, *Lawrence E. Brown*
 1-mHz-to-50-MHz Signal Source Combines Synthesizer Accuracy, Multimode Operation, and Easy Programming, *Tilman Schad, Dieter Kible, and Peter Brünner*
 A Compact Logging Multimeter that Can Manipulate Data, *John E. Scruggs, Marsh L. Faber, and David L. Wolpert*

PART 2: Subject Index

Month/Year	Subject	Model	Month/Year	Subject	Model			
A								
Aug. 1978	Access switch for testing communications systems	3754A	May 1978	Counter, microwave	5342A			
Nov. 1977	Algorithms, personal calculator inverse trig.	—	Aug. 1978	Counter, universal time interval	5370A			
Apr. 1978	Algorithms, personal calculator, logarithms	—	May 1978	CRT displays, translator for	1350A			
May 1978	Amplitude measurements, microwave	5342A	Jan. 1978	CRT terminal, graphics	2648A			
Oct. 1977	Analyzer, digital signal	5420A	D					
Feb. 1978	Analyzers, logic state	1602A, 1610A, 1611A/0F8, 1615A	Oct. 1978	Data arrays, megaword (RTE-IV)	92067A			
May 1978	Attenuation, measuring at microwaves	—	July 1978	Data capture terminals	3070B			
B								
Oct. 1977	Bond calculations	HP-92	Mar. 1978	Data entry and communications systems	2026			
C								
Nov. 1977	Calculator algorithms, inverse trig.	—	Aug. 1978	Delay generator	5359A			
Apr. 1978	Calculator algorithms, logarithms	—	Dec. 1977	Delta-time oscilloscope	1743A			
Oct. 1977	Calculator, printing financial	HP-92	Apr. 1978	Desktop computer system	9845A			
Oct. 1977	Coherence measurements	5420A	Oct. 1977	Digital filter design	5420A			
Sept. 1978	Coherence measurements	3582A	Sept. 1978	Digital filters for a spectrum analyzer	3582A			
Apr. 1978	Computer, desktop	9845A	Oct. 1977	Digital signal analyzer	5420A			
Mar. 1978	Computer networks	—	Jan. 1978	Digital storage for network and spectrum analyzers	8501A, 8750A			
Oct. 1978	Computer systems	HP 1000	June 1978	Digitally-controlled spectrum analyzer, to 1.5 GHz	8568A			
Nov. 1978	Computer terminal, printing	2635A/39A	June 1978	Digitally-controlled spectrum analyzer, to 40 MHz	3585A			
May 1978	Computer-to-CRT interface	1350A	Dec. 1978	Digitizer	9874A			
Oct. 1978	Computers	HP 1000 F-Series	May 1978	Displays, CRT, translator for	1350A			
July 1978	Control and measurement processor	2240A	Mar. 1978	Distributed systems	HP 1000			
Oct. 1977	Correlation measurements	5420A	Mar. 1978	Distributed systems	HP 3000			
Dec. 1977	Counter circuits in an oscilloscope	1743A	Mar. 1978	Distributed systems network (computers)	—			
E								
Sept. 1977	ECG monitor, portable, for hostile environments	78333A	Oct. 1978	Dynamic mapping system	—			

Part 2: Subject Index (continued)

Sept. 1977	Electrosurgery interference	78333A			
July 1978	Energy management	2240A			
Oct. 1978	Extended memory area (RTE-IV)	92067A			
F					
July 1978	Facility monitoring	2240A			
Oct. 1977	Fast Fourier transform analyzer	5420A			
Sept. 1978	Fast Fourier transform in a spectrum analyzer	3582A			
Oct. 1978	Fault-control memory	HP 1000 F-Series			
Nov. 1977	Fiber-optic communications	—			
Oct. 1977	Filters, analog, FDNR	—			
Sept. 1978	Filters, digital, LSI implementation	3582A			
Oct. 1977	Financial calculator	HP-92			
Oct. 1978	Floating-point processor	HP 1000 F-Series			
Sept. 1977	Four-color X-Y plotters	7221A 9872A 5342A			
May 1978	Frequency conversion, harmonic heterodyne	5342A			
Oct. 1977	Frequency-dependent negative resistance (FDNR)	5420A			
Aug. 1978	Frequency measurements	5370A			
May 1978	Frequency measurements, microwave	5342A			
Nov. 1977	Frequency synthesizer, microwave	8671A/72A			
G					
Nov. 1977	Generator, microwave signal	8672A			
Dec. 1978	Generator, waveform, 1 mHz to 50 MHz	8165A			
Sept. 1978	Graphic plotter/printer	7245A			
Apr. 1978	Graphics, CRT	9845A			
Sept. 1977	Graphics Language, HP-GL	—			
Sept. 1978	Graphics language, HP-GL	—			
Nov. 1978	Graphics printers, dot-matrix	2608A 2631G			
Jan. 1978	Graphics terminal, CRT	2648A			
Apr. 1978	Graphics, thermal-printer	9845A			
May 1978	Graphics translator for CRTs	1350A			
H					
May 1978	Harmonic heterodyne frequency conversion	5342A			
May 1978	Harmonic number determination	5342A			
Mar. 1978	HP-DSN	—			
Sept. 1978	HP-GL graphics language	—			
July 1978	HP-IB interface chip (PHI)	—			
July 1978	HP-MCL, measurement and control language	2240A			
Oct. 1977	Histogram measurements	5420A			
I					
Oct. 1977	Interest calculations	HP-92			
May 1978	Interface, computer to CRT	1350A			
Sept. 1977	Interference caused by electrosurgery	78333A			
Oct. 1977	Internal rate of return (IRR)	HP-92			
Nov. 1977	Inverse trig-function algorithms	—			
J					
K					
L					
July 1978	Laboratory automation	2240A			
Sept. 1977	Language, graphics (HP-GL)	—			
Sept. 1978	Language, graphics (HP-GL)	—			
July 1978	Language, measurement and control (HP-MCL)	2240A			
Oct. 1978	Large program capability, RTE-IV	92067A			
Dec. 1977	LCR meter, automatic wide-range	4262A			
Feb. 1978	Logic state analyzers	—			
Sept. 1978	Long-axis plotter	7245A			
Oct. 1977	Low-frequency signal analysis	5420A			
Sept. 1978	Low-frequency signal analysis	3582A			
Nov. 1977	LSI circuits, NMOS II	—			
M					
July 1978	Measurement and control language (HP-MCL)	2240A			
July 1978	Measurement and control processor	2240A			
Oct. 1978	Memory systems	HP 1000 F-Series			
Nov. 1977	Microprocessor, NMOS II	—			
Aug. 1978	Microprocessor prototyping system	—			
Sept. 1977	Microstep control system	7221A 9872A			
May 1978	Microwave counter	5342A			
Nov. 1977	Microwave signal generator	8672A			
Sept. 1977	Multicolor X-Y plotters	7221A 9872A			
Dec. 1978	Multimeter, 4½-digit, logging	3467A			
Oct. 1978	Multipoint terminals for HP 1000 computer systems	12790A			
Oct. 1978	Mother partitions, in RTE-IV	92067A			
N					
Mar. 1978	Networks, computer	—			
Nov. 1977	NMOS II LSI circuits	—			
O					
Oct. 1978	Operating system, RTE-IV, for HP 1000 systems	92067A			
Aug. 1978	Oscillator, triggered phase-locked	—			
Dec. 1977	Oscilloscope, delta-time with counter	1743A			
P					
Sept. 1978	Paper drive, bidirectional	7245A			
Sept. 1977	Patient monitoring, hostile environment	78333A			
Aug. 1978	Period generator	5359A			
Aug. 1978	Period measurements	5370A			
July 1978	PHI (HP-IB interface chip)	—			
Sept. 1978	Plotter/printer	7245A			
Sept. 1977	Plotters, X-Y, four-color	7221A 9872A 2608A			
Nov. 1978	Printer, 400 lines per minute, dot-matrix	2608A			
Nov. 1978	Printer, 180 characters per second, dot-matrix	2631A/G			
Sept. 1978	Printer/plotter	7245A			
Apr. 1978	Printer, thermal, for 9845A	9845A			
Nov. 1978	Printing terminal	2635A/39A			
Sept. 1978	Printhead, thin-film thermal	7245A			
July 1978	Process control	2240A			
Mar. 1978	Program-to-program communication	HP 1000 HP 3000 2026			
Mar. 1978	Project Prelude	—			
Nov. 1977	Pulse modulator, microwave	11720A			
Aug. 1978	Pulse width and delay generator	5359A			
Q					
R					
Jan. 1978	Raster scan graphics	2648A			
Apr. 1978	Raster scan graphics	9845A			
July 1978	Reader, card, multifunction	3070B			
Oct. 1978	Real-time executive system (RTE-IV)	92067A			
Sept. 1977	Recorders, X-Y, four color	7221A 9872A			
Mar. 1978	Remote command processing	HP 1000 HP 3000			
Mar. 1978	Remote data base access	HP 3000			
Mar. 1978	Remote file access	HP 1000 HP 3000			
Mar. 1978	Remote job entry	2026			
S					
Sept. 1977	Safety problems in battery-powered medical instruments	78333A			

Part 2: Subject Index (continued)

Mar. 1978	Satellite-linked computer networks	—	July 1978	Terminal, multipoint for industrial use	3070B
Oct. 1978	Scientific instruction set	HP 1000 F-Series	Nov. 1978	Terminal, printing	2635A/9A
Nov. 1977	Semiconductor processing, NMOS II	—	June 1978	Test of a spectrum analyzer, automatic	8568A
July 1978	Serial link, terminals for	3070B	Apr. 1978	Thermal page printer for 9845A	9845A
Nov. 1977	Signal generator, synthesized, microwave	8672A	Sept. 1978	Thermal plotter/printer	7245A
Dec. 1978	Signal source, programmable, 1 MHz to 50 MHz	8165A	Aug. 1978	Time interval counter	5370A
May 1978	Signature analysis, application of	5342A	Aug. 1978	Time synthesizer	5359A
July 1978	Silicon-on-sapphire (SOS) chip family	—	Dec. 1977	Timing measurements, delta-time oscilloscope	1743A
Dec. 1978	Source, signal, programmable 1 MHz to 50 MHz	8165A	Oct. 1977	Transfer function measurements	5420A
June 1978	Spectrum analyzer, 20 Hz to 40 MHz	3585A	Aug. 1978	Triggered oscillator	—
June 1978	Spectrum analyzer, 100 Hz to 1.5 GHz	8568A	Nov. 1977	Trigonometric function algorithms, inverse	—
Sept. 1978	Spectrum analyzer, 0 to 25.5 kHz	3582A	U		
Oct. 1977	Spectrum measurements	5420A	Aug. 1978	Universal time interval counter	5370A
Aug. 1978	Startable oscillator	—	V		
Sept. 1977	Step motor control	7221A 9872A	Oct. 1977	Vibration measurements	5420A
Jan. 1978	Storage Normalizer	8501A 8750A	W		
Mar. 1978	Store and forward	HP 1000	Dec. 1978	Waveform generator, 1 MHz to 50 MHz	8165A
Aug. 1978	Switch, RF for testing multiplexed communications systems	3754A	Sept. 1978	Window functions for spectrum analysis	3582A
Nov. 1977	Synthesizer, microwave	8671A	Dec. 1977	Wrist instrument	HP-01
Nov. 1977	Synthesized signal generator, microwave	8672A	X		
Aug. 1978	Synthesizer, time	5359A	Sept. 1977	X-Y plotters, four-color	7221A 9872A
Oct. 1978	Systems, RTE-based	HP 1000	Y		
T			Z		
Aug. 1978	Telephone testing, switch for	3754A			
Jan. 1978	Terminal, CRT, graphics	2648A			

PART 3: Model Number Index

Model	Instrument	Month/Year	Model	Instrument	Month/Year
RTE-IV	Operating System	Oct. 1978	DS/3000	Distributed Systems/3000	Mar. 1978
HP-01	Wrist Instrument	Dec. 1977	3070B	Terminal	July 1978
HP-92	Printing Financial Calculator	Oct. 1977	3467A	Logging Multimeter	Dec. 1978
1000	Computer Systems	Oct. 1978	3582A	Spectrum Analyzer, .02 Hz to 25.5 kHz	Sept. 1978
DS/1000	Distributed Systems/1000	Mar. 1978			
1000 F-Series	Computers	Oct. 1978	3585A	Spectrum Analyzer, 20 Hz to 40 MHz	June 1978
1350A	Graphics Translator	May 1978			
1602A	Logic State Analyzer	Feb. 1978	3754A	Access Switch	Aug. 1978
1610A	Logic State Analyzer	Feb. 1978	4262A	LCR Meter, Automatic	Dec. 1977
1611A	Logic State Analyzer	Feb. 1978	5342A	Microwave Frequency Counter	May 1978
1615A	Logic Analyzer	Feb. 1978	5359A	Time Synthesizer	Aug. 1978
1743A	Oscilloscope, 100 MHz, Δ time	Dec. 1977	5370A	Universal Time Interval Counter	Aug. 1978
2026	Data Entry/Communications System	Mar. 1978	5420A	Digital Signal Analyzer	Oct. 1977
			7221A	X-Y Plotter	Sept. 1977
2102E	High-Performance Memory	Oct. 1978	7245A	Plotter/Printer	Sept. 1978
2102H	High-Performance Fault-Control Memory	Oct. 1978	8165A	Programmable Signal Source	Dec. 1978
			8501A	Storage Normalizer	Jan. 1978
2111F	HP 1000 F-Series Computer	Oct. 1978	8568A	Spectrum Analyzer, 100 Hz to 1.5 GHz	June 1978
2117F	HP 1000 F-Series Computer	Oct. 1978			
2170A/71A/72A	HP 1000 Model 30 Computer Systems	Oct. 1978	8671A	Synthesizer	Nov. 1977
			8672A	Synthesized Signal Generator	Nov. 1977
2174A/B	HP 1000 Model 20 Computer Systems	Oct. 1978	8750A	Storage Normalizer	Jan. 1978
			9845A	Desktop Computer System	Apr. 1978
2175A/B	HP 1000 Model 25 Computer Systems	Oct. 1978	9872A	X-Y Plotter	Sept. 1977
			9874A	Digitizer	Dec. 1978
2176A/B	HP 1000 Model 40 Computer Systems	Oct. 1978	11720A	Pulse Modulator	Nov. 1977
			12790A	Multipoint Interface for HP 1000 Computers	Oct. 1978
2177A/B	HP 1000 Model 45 Computer Systems	Oct. 1978			
			32190A	DS/3000 Software	Mar. 1978
2240A	Measurement and Control Processor	July 1978	78333A	ECG Monitor, Portable	Sept. 1977
			91730A	Multipoint Driver for HP 1000 Computers	Oct. 1978
2608A	Printer, 400 lines per minute	Nov. 1978			
2631A/G	Printer, 180 characters per second	Nov. 1978	91740A/B	DS/1000 Software	Mar. 1978
2635A/39A	Printing Terminal	Nov. 1978	91741A	DS/1000 Software	Mar. 1978
2648A	Graphics Terminal	Jan. 1978	92067A	RTE-IV Operating System	Oct. 1978

PART 4: Author Index

- A**
- Allen, Mark S. Aug. 1978
Anderson, Denton B. Oct. 1978
Astrof, Kenneth L. Nov. 1977
Azmoon, Majid Sept. 1978
- B**
- Baily, Everett M. Nov. 1978
Bain, Mitchell B. Oct. 1978
Balazer, Leonard P. Sept. 1977
Barber, Vernon A. May 1978
Barr, John T. Jan. 1978
Bernard, Michel E. July 1978
Berthier, Daniel C. July 1978
Blazek, Otakar Jan. 1978
Bohorquez, Jaime H. Sept. 1978
Bologlu, Ali May 1978
Bones, David A. Sept. 1977
Bower, Larry O. June 1978
Bradford, Kevin J. Aug. 1978
Brown, Lawrence E. Dec. 1978
Brubaker, Ray H., Jr. July 1978
Brunetti, Lawrence G. Sept. 1977
Brünner, Peter Dec. 1978
Bullinger, Rex June 1978
- C**
- Carau, Frank P. Dec. 1978
Cates, Julia A. Oct. 1978
Chin, Robert Dec. 1977
Christensen, Alan H. Oct. 1978
Chu, David C. Aug. 1978
Chu, Frank R.F. Oct. 1977
Cox, Roger G. Sept. 1978
Cozzens, Ray J. Apr. 1978
- D**
- Daniels, Thomas H. Sept. 1977
Dauciunas, Vincent J. July 1978
DeVilbiss, Alan J. Feb. 1978
DeWeese, Joseph E. Nov. 1977
Dickinson, Peter D. Jan. 1978
Dickstein, Leonard R. Aug. 1978
Donahue, Terry L. Oct. 1977
- E**
- Eads, William D. Apr. 1978
Edgerley, Walter M., Jr. Oct. 1977
Egbert, Jacob H. Jan. 1978
Egbert, William E. Nov. 1977
Apr. 1978
Ellsworth, Arnot L. May 1978
- F**
- Faber, Marsh L. Dec. 1978
Faick, John June 1978
Farnbach, John S. Sept. 1978
Ferguson, Keith M. Aug. 1978
Figueroa, John W. July 1978
Foster, Allen S. Aug. 1978
- G**
- Gatzke, Ronald D. Sept. 1977
Geber, Charles R. Oct. 1978
Grady, Robert B. July 1978
Grobstein, Sherry R. Sept. 1977
Grote, Richard H. Oct. 1977
- H**
- Haag, George A. Feb. 1978
Hasebe, Kunio May 1978
Haselby, Robert D. Sept. 1977
Heinsen, Edward A. Dec. 1977
Helmso, Bennie E. Dec. 1977
Hennessee, Larry W. Sept. 1977
Hetzl, Henry T. Dec. 1978
Holdaway, Steven N. June 1978
Hornak, Tom Nov. 1977
House, Chuck Feb. 1978
Humpherys, M. Dee June 1978
- I**
- Ignoffo, John J., Jr. Nov. 1978
- J**
- Johnson, Gary W. Oct. 1978
Juncker, Rodney K. Oct. 1978
- K**
- Kanafuji, Keiki Dec. 1977
Kaplan, David S. Mar. 1978
Keith, John C. Apr. 1978
Kemplin, Richard M. Sept. 1977
Kible, Dieter Dec. 1978
Klaiss, Donald E. July 1978
- L**
- Ligon, Thomas R. Nov. 1977
Linkwitz, Siegfried H. June 1978
Luque, Phillip R. Nov. 1978
Lynch, George W. Sept. 1977
- M**
- Manley, C. Michael Oct. 1978
Marion, André F. Dec. 1977
Martin, Roy E. Oct. 1977
Martin, William D. Feb. 1978
Marzalek, Michael S. June 1978
McIlvanie, William A. Nov. 1978
McKinney, H. Webber Oct. 1977
Molinari, David H. June 1978
Moyer, John J. Jan. 1978
- N**
- Neering, Michael J. June 1978
Nielsen, John R. Mar. 1978
- O**
- Oblad, Roger P. Jan. 1978
Ogden, Deborah J. Feb. 1978
Oliverio, Joseph P. Oct. 1977
- P**
- Patkay, Jean-Pierre Oct. 1977
Patterson, Marvin L. Sept. 1977
Pendergrass, Nixon A. Sept. 1978
Peregrino, Luiz May 1978
- Q**
- R**
- Raynham, Michael B. Jan. 1978
Ripert, Jacques A. July 1978
Roos, Mark D. Jan. 1978
- S**
- Sakakihara, Philip M. Mar. 1978
Salomaki, David C. Oct. 1978
Schad, Tilman Dec. 1978
Scharrer, John A. Feb. 1978
Schmidt, Lynn A. Sept. 1978
Schulte, Louis T. Apr. 1978
Schwager, André O. Mar. 1978
Scruggs, John E. Dec. 1978
Sharrit, David D. June 1978
Shatzer, Robert R. Mar. 1978
Small, Charles T. Feb. 1978
Snyder, David C. Oct. 1977
Sproviero, Michael J. Nov. 1978
Stribling, Bradley C. Nov. 1977
- T**
- Temple, Robert June 1978
Terry, F. Duncan Nov. 1978
Thomason, James L. Nov. 1977
Thrash, Wallace T. Nov. 1978
Tregoe, Michael P. Sept. 1978
- U**
- V**
- Vogel, Ansel K. Apr. 1978
- W**
- Wade, Kenneth A. Nov. 1978
Walden, Jack M. Apr. 1978
Warp, Rick A. Sept. 1978
Westlund, Ronald C. Dec. 1977
Wheelwright, Lynn W. June 1978
Wickliff, Robert G., Jr. Feb. 1978
Wiggers, Hans A.M. Oct. 1977
Williams, Rita W. Mar. 1978
Winterrowd, Douglas B. Nov. 1978
Wolpert, David L. Dec. 1978
Wong, Eugene J. Oct. 1978
Woodcock, Todd M. Nov. 1978
- X**
- Y**
- Yokokawa, Masahiro Dec. 1977
- Z**
- Zeller, Eugene R. Apr. 1978

1-mHz-to-50-MHz Signal Source Combines Synthesizer Accuracy, Multimode Operation, and Easy Programming

Offering features not previously available in a single instrument, this new programmable signal source provides many kinds of test stimuli for either automatic or bench test applications.

by Tilman Schad, Dieter Kible, and Peter Brünner

SOFTWARE AND HARDWARE COSTS of automatic and bench testing can be reduced if a single source can provide all the stimuli required to test any given device. While no such universal source yet exists, the new Model 8165A Programmable Signal Source (Fig. 1) is a step in that direction, having most of the capabilities needed for the majority of today's automatic, semiautomatic, and manual test setups.

The new source offers an extensive catalog of features not previously combined in a single instrument. Helpful in testing logic families such as TTL and MOS are its fast-transition pulses, variable offset and amplitude, and dc capability for threshold testing. For linear circuit testing, the 8165A has logarithmic sweep, FM and AM, and sine, ramp and square waveforms. It also has a single-shot trigger for response time measurements, and a counted burst capability for clocking digital circuits to a particular state. The accuracy of manual and programmed set-

tings is such that no external equipment or setup loops are required.

To simplify software requirements for both system integration and daily operation, the 8165A offers full programmability of all modes and parameters, identical syntax for front-panel and remote operation, handy mnemonics reproduced on a logically arranged front panel, and detailed diagnostic information for debugging in the event of a program error. Operating parameters can be transferred from the source to the system controller so the controller can learn manual settings made to establish critical values. Further, to save system controller memory, the source itself can store ten complete sets of operating modes and parameters, so a new operating state can be brought into effect by a single program statement. This also saves time in bench applications because entire operating states can be recalled by two front-panel keystrokes. Built-in batteries maintain data storage when the instrument is turned off.

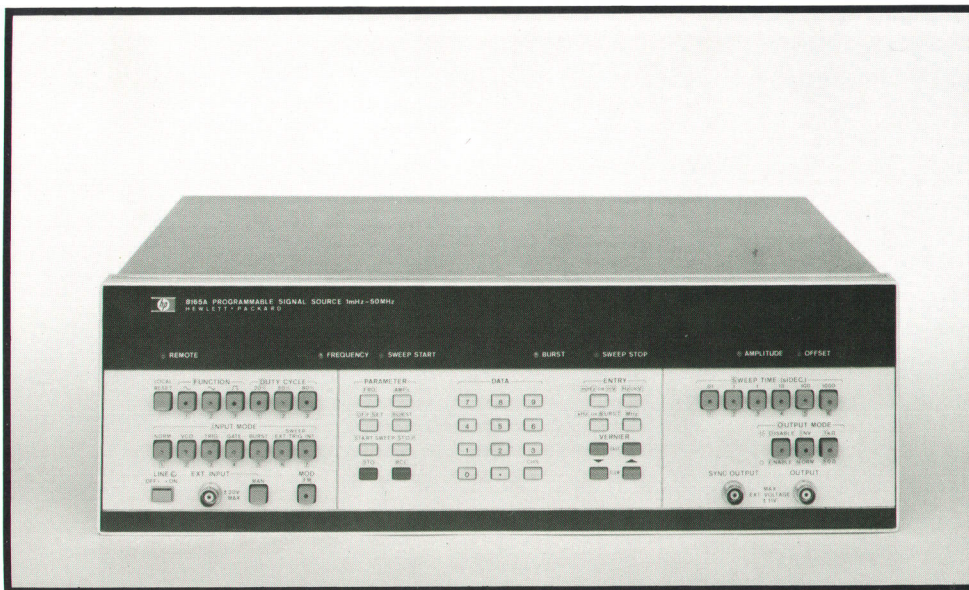

Fig. 1. Model 8165A Programmable Signal Source produces sine, triangle, and square waves in a frequency range of 1 MHz to 50 MHz. It also generates pulses or ramps with 20% or 80% duty cycles in a range of 1 MHz to 19.99 MHz. For stability, the output is phase-locked to a quartz crystal oscillator. HP-IB input/output is standard. An option provides logarithmic sweep and AM.

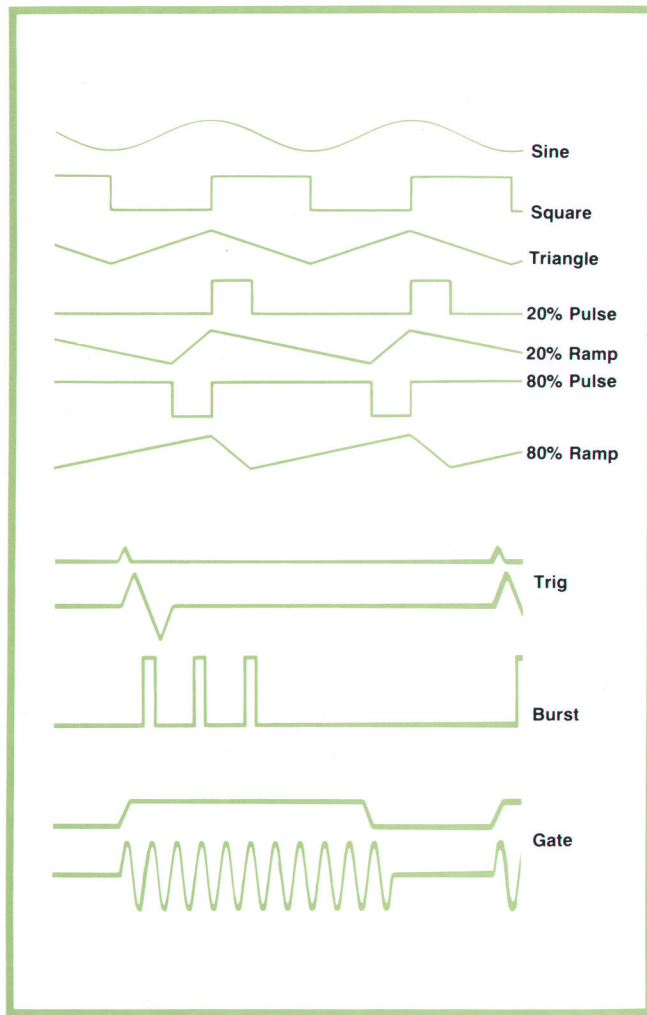

Fig. 2. Typical 8165A output waveforms.

Sine, triangle and square waves are generated in the frequency range from 1 millihertz to 50 megahertz. Sweep is available as an option. Pulses or ramps with 20% to 80% duty cycles are generated in the range from 1 millihertz to 19.99 megahertz. Pulse transition times are less than 5 nanoseconds. Source impedance can be set to 50 or 1000 ohms.

A precision 10-MHz quartz crystal oscillator is used as a frequency reference. Phase locking to the reference achieves output frequency stability of $\pm 1 \times 10^{-5}$ of the programmed value. Frequency resolution is four digits, which provides a resolution of 1 microhertz in the 1-9.999 millihertz range.

Fig. 2 shows various types of 8165A output waveforms.

Design Philosophy

Some challenging engineering problems had to be solved to make the 8165A a reality. One major problem is that, with a frequency range of more than ten decades, amplifier circuits must be designed without ALC loops to keep the settling time short. This re-

quires exceptional gain and dc stability in all circuits. Also, high-speed amplifiers are mandatory to achieve output signals with transition times faster than 5 ns.

Another problem stems from the fundamental difference between conventional and fully programmable instruments. In bench instruments, dial settings are stored by the dials and pushbuttons themselves, and can be checked and changed even when switched off. To provide a similar feature in a fully programmable instrument, the settings must be stored and rechecked automatically without enabling the output. So that power interrupt does not mean that the instrument must be reprogrammed, a non-volatile memory for the operating parameters must be included. An added advantage of the 8165A is that no measuring instruments are necessary to verify the microprocessor-controlled parameters.

To meet these and other requirements the design concept is as shown in the block diagram, Fig. 3. A 1-kHz-to-50-MHz oscillator (HF VCO in Fig. 3) generates a triangle output that may be used directly or fed to a sine shaper. The square wave is derived from the HF VCO's current switch drive voltage. Changing from triangle to ramp form, and consequently changing the square wave duty cycle, is achieved by varying the charge and discharge rates of the HF VCO's ramp capacitor. Duty cycles and ramp symmetries of 20%, 50%, and 80% are available. For high stability in continuous operation, the HF VCO can be phase-locked to an internal or external 10-MHz frequency reference.

Signals below 1 kHz are generated by a low-frequency generator (LFG). Simplified, it consists of an up-down counter (to divide the frequency) followed by a digital-to-analog converter (to synthesize a triangle). The counter is clocked by the HF VCO at a frequency 10,000 times higher than the output frequency of the D/A converter. This allows the HF VCO to run continuously in the phase-lock mode even when a triggered low-frequency signal is required. Consequently, the basic crystal accuracy and stability of the output are preserved in all operating modes.

Microprocessor Control System

To control a multi-capability, flexible instrument like the 8165A, such a vast amount of data has to be processed that a microprocessor is essential. Typical tasks handled by the 8165A's microprocessor are manual data entry via the keyboard, preparation of data to set up the generating circuits, data checking, data reporting, and remote data entry via the HP-IB.* Data is stored by the microprocessor so that information about operating states or errors can be recalled or sent over the HP-IB.

*The Hewlett-Packard Interface Bus is HP's implementation of IEEE Standard 488 and identical ANSI standard MC1.1.

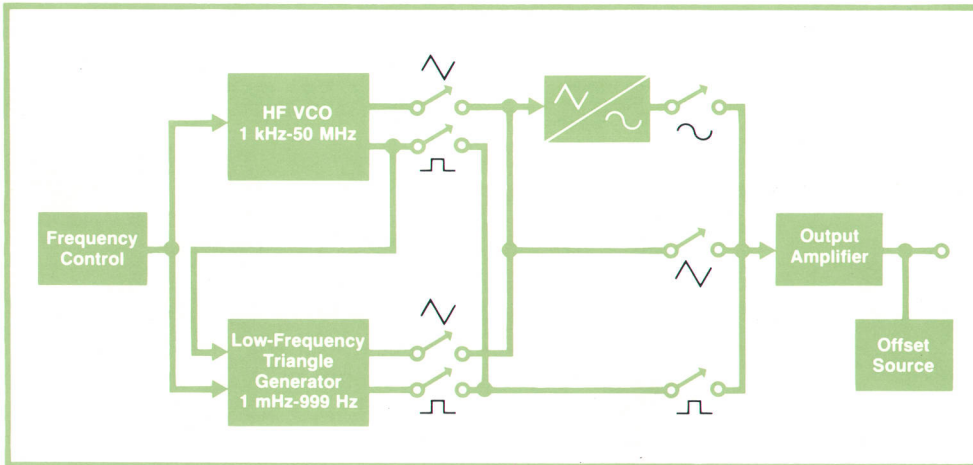

Fig. 3. 8165A basic block diagram. For frequencies above 1 kHz the HF VCO generates a triangle output that is either used directly or fed to a sine shaper. For output frequencies below 1 kHz, the low-frequency generator divides the HF VCO output frequency. The operation of each block is controlled by a micro-processor (not shown).

Communication from the microprocessor to the analog circuits is conducted over an internal bus that works into an acceptor for each controlled analog circuit. Fig. 4 shows the microprocessor bus structure. The acceptor has the function of storing just the information intended for its particular analog circuit, and to do this, each acceptor has a unique address.

The internal bus consists of 16 data/address lines and three handshake lines. The handshake lines define whether data or an address is being transmitted and coordinate the information transfer. The HDAT (high data) line is high when data is transmitted and

low when an address is transmitted. The NDDV (device data valid) line provides a positive transition to signify that the data or address on the bus is valid. The HINH (high inhibit) line goes high to terminate a transmission.

A typical acceptor consists of a latch and a latch-enabling circuit, the latter reacting when the appropriate address appears on the bus. There are seven different addresses for the seven functions: frequency, input mode, waveform, burst count, amplitude, offset, and sweep start-stop frequencies. Circuit configuration and timing of a typical acceptor

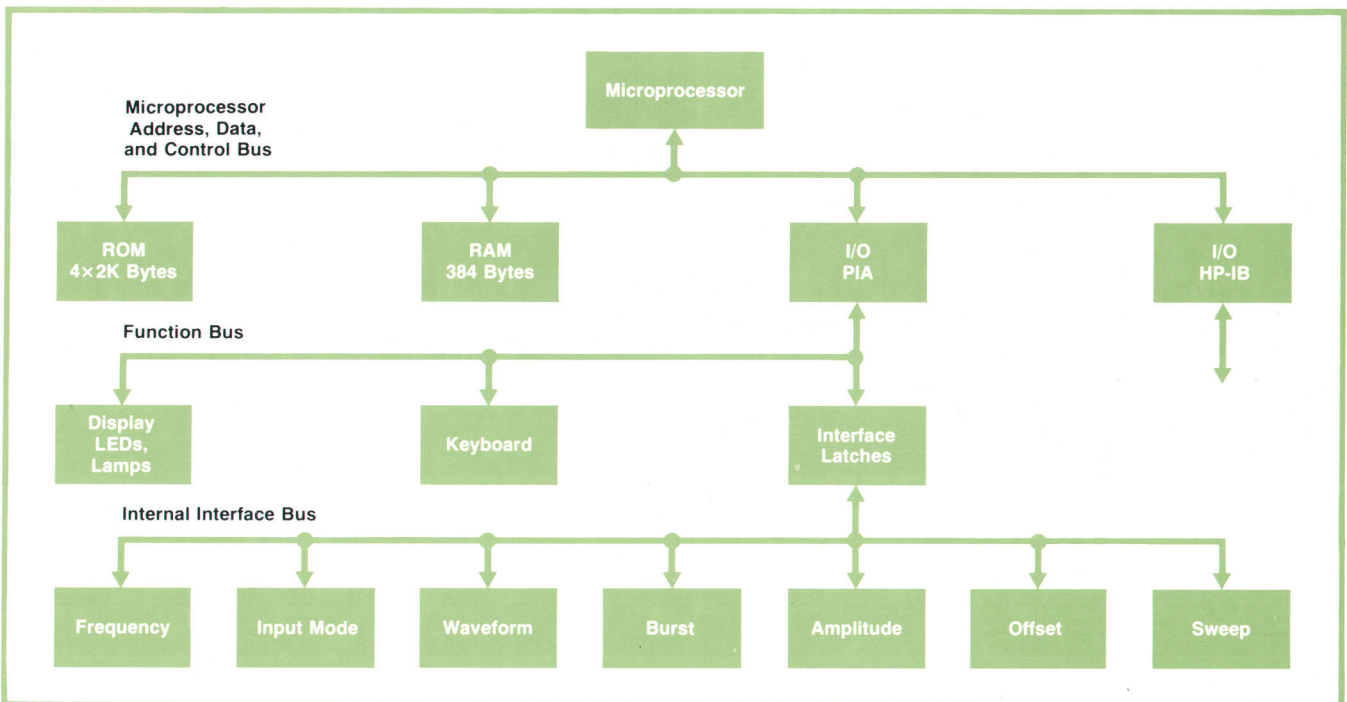

Fig. 4. 8165A microprocessor bus structure. To control the instrument's seven functions, the microprocessor communicates by means of a peripheral interface adapter (PIA) and an internal bus. The bus, consisting of 16 data/address lines and three handshake lines, works into seven acceptor circuits, one for each controlled analog circuit.

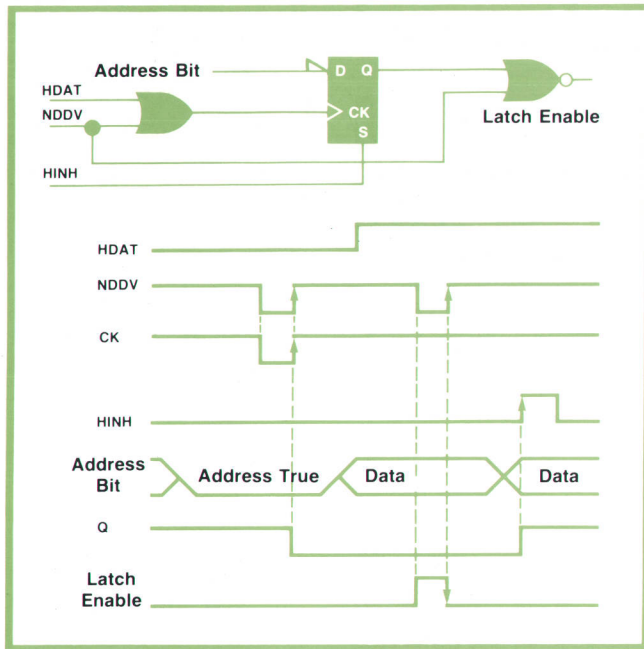

Fig. 5. Typical acceptor circuit consists of a latch and a latch enable circuit, the latter shown here. When the appropriate address line of the internal bus goes low, the latch enable signal is generated, allowing data to be clocked from the bus into the corresponding latch.

are shown in Fig. 5.

The flip-flop, normally with Q high, is clocked by NDDV when HDAT is low. If the latch's address bit is active (low), Q will then go low and permit the next NDDV pulse to enable the latch. When the data is terminated, the HINH pulse returns the flip-flop to its normal state. Data transmitted over the line used by the address bit has no effect on the flip-flop when HDAT is high. If the data for the acceptor consists of more than one 16-bit word, the words are transmitted serially and stored in a corresponding number of latches. Separate enable signals for each latch are generated by a master/slave flip-flop arrangement. Some acceptors in the 8165A use two address bits: in these cases the appropriate lines are applied to an OR gate to supply the flip-flop's D input.

The M6800 microprocessor with 4×2K-byte read-only-memory (ROM) and 384-byte CMOS read/write random-access memory (RAM) controls the input/output section including the HP-IB interface. One M6820 PIA (peripheral interface adapter) performs interfacing between the microprocessor bus and the peripherals, which include the display, the keyboard, and the interface latches.

Operating the 8165A

A disadvantage of many digital instruments is volatility of data after a power interrupt. The 8165A's CMOS RAMs with battery backup are able to store the data approximately four weeks. When the instrument

is switched on, the output is automatically disabled to prevent possible damage to a device under test. A complete error test is also performed. Ten registers are provided to store ten complete operating states. This is very convenient on the bench as well as for systems applications, when rapid and repetitive changes of parameters are required.

An important design goal was to give the user maximum flexibility in setting up. Data loading is simple: select the parameter, and enter the value followed by a delimiting unit key. Simple task pushbuttons (e.g., waveform, input mode) may be pressed at any time during programming. A complete error test is performed after the change of any parameter. The error routine starts by verifying overrange or under-range of entered data. It continues by testing the compatibility of existing data with data just entered. After this sequence, data is stored and processed and the instrument updated.

If an error occurs, the keyboard is locked so the only keys that will operate are those that allow the elimination of the error. As shown in Fig. 6, the keyboard, organized as an 8×9 matrix, is scanned serially by the processor. One-half of the PIA, in conjunction with a multiplexer and a demultiplexer, is responsible for the keyboard matrix. When a changing key status is recognized, key bounce effects are eliminated by reading the status again after a few milliseconds. If there is no further change, the new status is accepted by the control system.

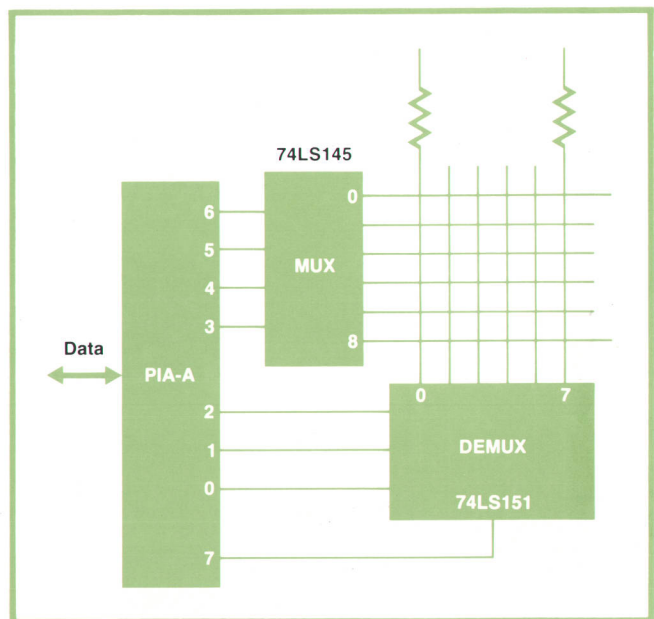

Fig. 6. The keyboard is organized as an 8×9 matrix and is scanned serially by the processor. Half of the PIA, a multiplexer, and a demultiplexer form the microprocessor/keyboard interface.

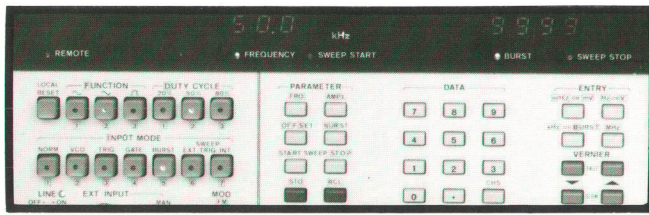

Fig. 7. Mnemonics, indicated on the front panel by framed letters, specify the HP-IB commands necessary to program the corresponding functions.

HP Interface Bus

Remote programming is via the HP-IB and uses the same strategy as manual data entry. Two PIAs and some additional logic perform interfacing between the HP-IB and the 8165A. HP-IB service is controlled by the microprocessor. For example, it interprets universal and addressed commands, and supervises handshake and data reception. To simplify data handling, the interface system operates on an interrupt basis.

Mnemonics, indicated on the front panel by framed letters, specify the system controller keystrokes necessary to program the corresponding functions via the HP-IB (see Fig. 7). For example: "I1 F1 FRQ 1.23 MHz" sets the 8165A to normal mode, sine waveform, and a frequency of 1.23 MHz. For better readability of a written program, blanks and commas can be used in any number within the command strings. They are ignored by the 8165A.

As talker on the HP-IB, the 8165A is able to transmit a complete set of data on request, including its current

operating modes and parameter settings. Thus the system controller can learn manual settings. The set of data consists of eight-character strings, ASCII coded, with a maximum of 16 characters per string. Each string is terminated by a carriage-return/line-feed. Data is received by the 8165A using the same syntax as for sending.

Frequency Generation 1 kHz to 50 MHz

The 8165A uses a phase-locked loop (PLL) method of indirect frequency synthesis that gives the advantage of transferring the accuracy and stability of a crystal source to the variable-frequency output. In a basic PLL frequency synthesizer, a voltage-controlled oscillator (VCO) is tuned roughly to the required frequency by a tuning voltage. A known portion of the output signal is compared with a stable reference frequency, and any phase difference appears as a voltage at the output of the phase detector. This signal is smoothed and applied to the VCO to correct the output frequency. Variable frequencies are generated by inserting a programmable $\div N$ divider between the VCO output and the phase detector.

The 8165A uses two other loops in addition to the main reference loop (Fig. 8). This reduces settling time by keeping the division factor smaller and loop reference frequencies higher. These extra loops effectively provide the $\div N$ function. The output frequency, f_{out} , is divided by a factor R so that the main reference loop operates only in the frequency range 1-10 kHz; this also contributes to short settling times.

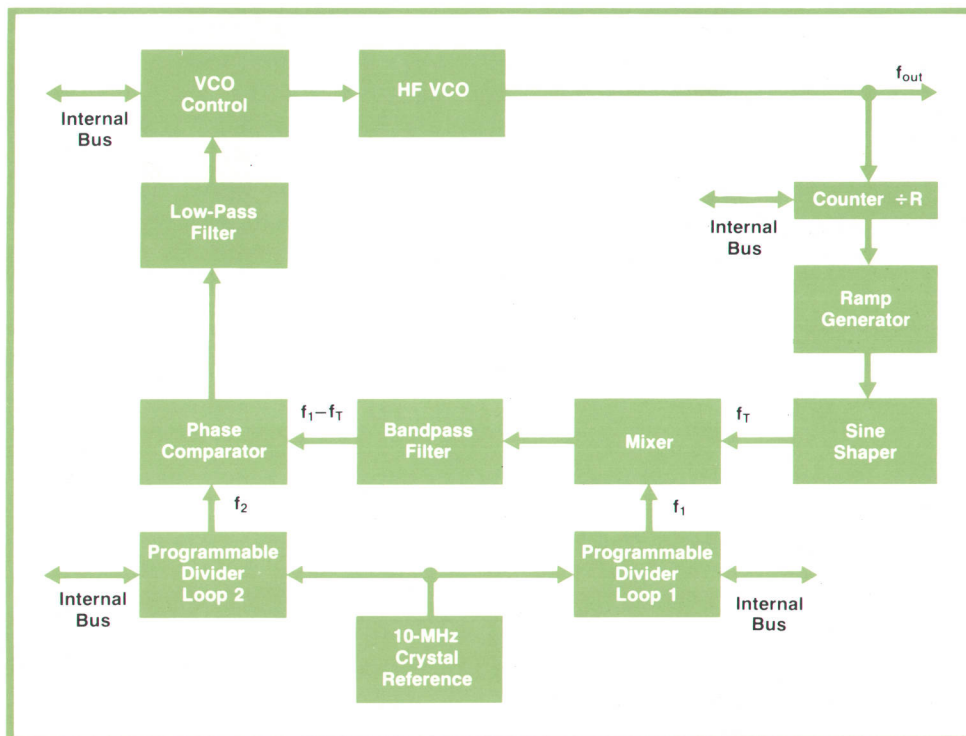

Fig. 8. Phase-locked loop method of indirect frequency synthesis is used in the 8165A. Two divider loops (shown here as single boxes) in addition to the main loop help keep the main loop division factor smaller and loop reference frequencies higher. The main loop operates in a range of only 1-10 kHz; this helps shorten the settling time.

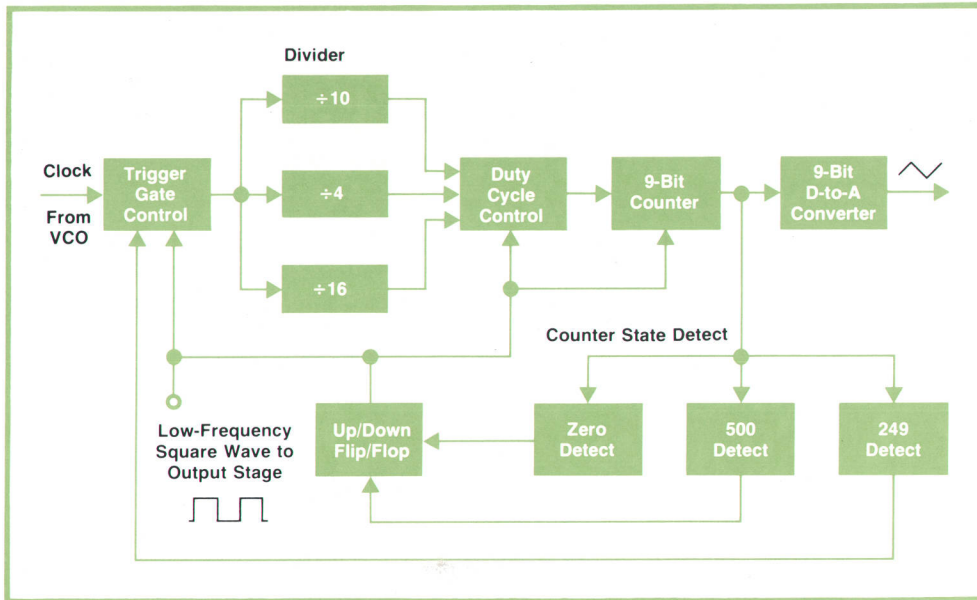

Fig. 9. Low-frequency generator (LFG) divides the HF VCO output frequency to generate output frequencies below 1 kHz. The division factor ranges from 10^4 to 10^6 . Because the LFG runs continuously, crystal accuracy is retained for the triggered and gated modes as well as for the normal mode.

The divide-by-R counter output is applied to a ramp generator and a sine shaper to provide a sine wave that is mixed with the output of the first loop. Use of a sine wave instead of a square wave or ramp helps keep spurious products of the mixer small. These products can cause low-frequency jitter.

The difference frequency is filtered from the mixer output and compared with the second loop's frequency. If f_{out} is accurate and the phase detector output is zero, then

$$f_1 - f_t = f_2,$$

and hence

$$f_{out} = R \times f_t = R \times (f_1 - f_2)$$

This means narrow tuning ranges for f_2 (900-801 Hz) and f_1 (1.9-10.8 kHz). At frequencies above 1 kHz, the PLL is disabled in gate, trigger, and burst modes. In normal mode above 1 kHz, the PLL is enabled and the control voltage to the main VCO is modified by the modulating signal so that the deviation is constant as a percentage of the output frequency.

Frequency Generation below 1 kHz

Frequencies below 1 kHz are obtained by dividing the output of the main VCO (see Fig. 9). The VCO clocks an up/down counter whose count direction is determined by a flip-flop. At counter states of 0 and 500, the flip-flop changes its status and reverses the count direction. The parallel counter outputs are applied to a nine-bit digital-to-analog converter, which generates an approximation to a triangle wave consisting of 1000 discrete voltage levels, or steps, per cycle.

In trigger, gate, or burst mode, counter state 249, which represents the baseline, is detected for gating, synchronization, and cycle counting. For symmetrical waveforms, the duty cycle control divides the

clock by a factor of 10. In the 20/80 mode the division factor is four for the shorter flank and 16 for the longer, the period remaining constant. In the low-frequency range from 1 mHz to 999.9 Hz the 8165A's phase-locked HF VCO runs at frequencies 10^4 to 10^6 times higher than the output of the low-frequency generator. This guarantees high accuracy in the low-frequency output. Because the low-frequency generator runs continuously, crystal accuracy is retained for the triggered and gated modes as well as for the normal mode.

HF VCO

The HF VCO generates a triangular voltage in the range 1 kHz to 50 MHz by charging and discharging a capacitor at a constant rate (see Fig. 10). This is done using a switchable positive current source, I_x , and a smaller negative current source, I_y . When the positive current source is on, the capacitor charges at $I_x - I_y$. When the positive current source is off, the capacitor discharges at I_y . The positive source is switched by a pair of transistors controlled by a Schmitt trigger driven from the ramp voltage.

Frequency is determined by the time taken for the ramp voltage to reach the Schmitt trigger thresholds. Consequently, it is dependent on the ramp capacitor value and the charge and discharge currents. These are varied according to the frequency range and the selected output frequency. Symmetry depends on the ratio of charging current ($I_x - I_y$) to discharging current (I_y). In the range 1 kHz to 19.99 MHz, symmetry is selectable (20%, 50%, 80%). At 20 MHz and above it is fixed at 50%.

One of the main problems in generating a clean triangle with this technique at high frequencies is caused by the parasitic inductance (L) and resistance

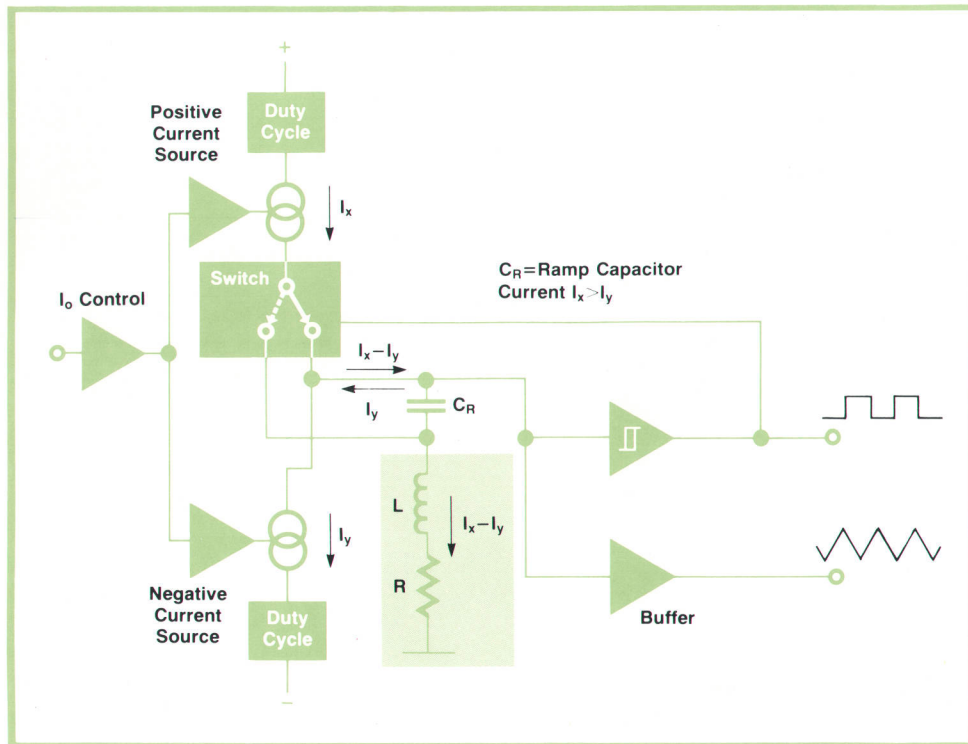

Fig. 10. The HF VCO (voltage-controlled oscillator) generates a triangular voltage in the range 1 kHz to 50 MHz by charging and discharging a capacitor at a constant rate determined by two current sources. A switching arrangement compensates for the effects of stray inductance (L) and resistance (R).

(R) of the ramp capacitor and the range switching circuitry. If L and R are not equal to zero, a spike and a step, respectively, occur on the triangle at the switching point. To compensate for this, a virtual ground is generated by switching the current I_x to either end of the appropriate ramp capacitor directly via an additional switching circuit. For the same reason the ramp capacitor for the highest frequency range is printed directly on the circuit board.

Function and Pulse Generation

In sine operation, a triangle waveform from the VCO or LFG goes to a sine shaper, the sine amplifier, the buffer, and the output driver. Sine shapers in function generators usually consist of a set of diodes. These are connected to voltage sources with defined source resistance and are fed by a source with defined resistance. Although these shapers are valuable in the frequency range up to 10 MHz, even the use of diodes with very low storage times cannot increase the frequency range significantly. The sine shaper concept used in the 8165A, therefore, is different. The basic cell is shown in Fig. 11. It consists of a differential amplifier whose gain is determined only by the resistors R_N . The breakpoints are determined by the current I_N . The shaper circuit consists of five cells connected in parallel (i.e., $N = 1, 2, 3, 4, 5$). An advantage of this approach is that the gain is determined by resistors and is therefore independent of temperature variations. However, the input amplitude and offset must be very stable, since an amplitude drift would cause odd harmonic generation, and an offset drift would

cause even harmonic generation. In triggered mode an offset drift cannot be compensated. At high frequencies and continuous waveforms, automatic compensation is switched on.

The pulse waveform is converted from the ramp by means of a Schmitt trigger. To obtain a pulse with a zero-volt baseline, an offset is added to the pulse amplifier output. For frequencies above 1 kHz, the VCO ramp is switched to the output driver directly.

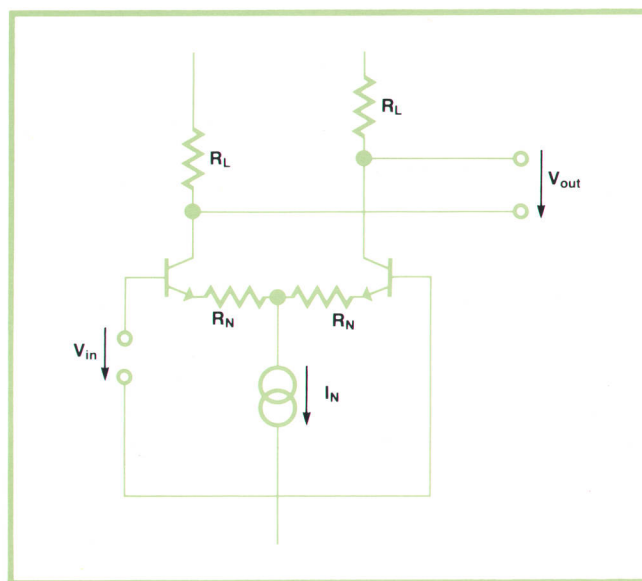

Fig. 11. Sine shaper consists of five of these basic cells connected in parallel. Gain is determined by resistors and is independent of temperature variations.

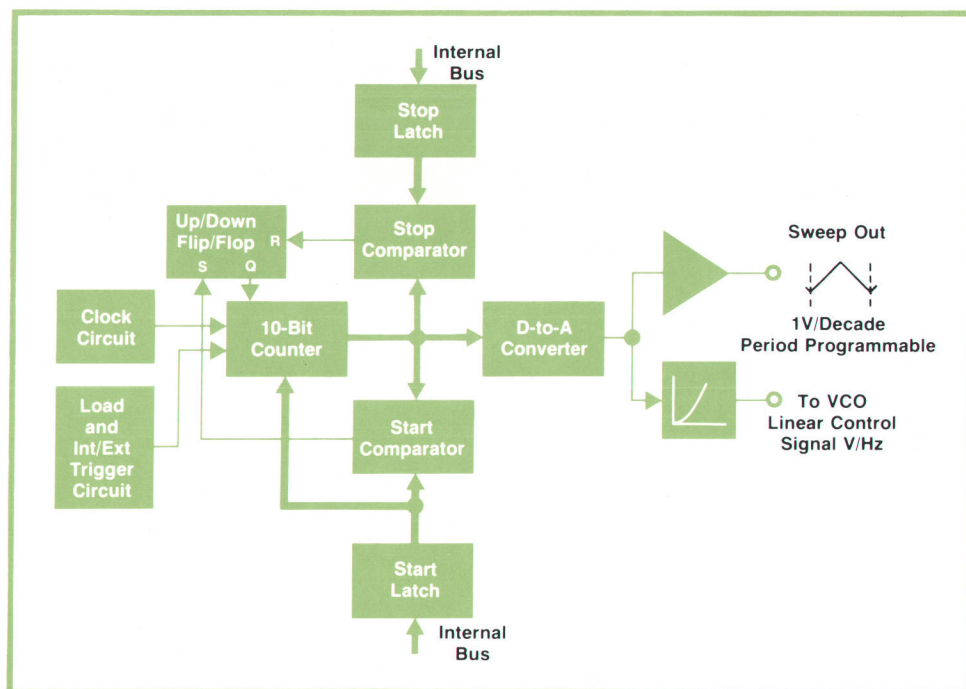

Fig. 12. Optional logarithmic sweep generator is based on an up/down counter and a digital-to-analog converter. Sweep can cover up to three decades.

For lower frequencies, the ramp waveforms from the low-frequency generator are provided to the output driver.

Counted Burst Capability

The 8165A has a counted burst capability, which means that, after a trigger signal is applied, a preprogrammed number of cycles are generated. The technical problem of designing a high-speed programmable counter with common ECL and TTL technology is solved in the usual way: A programmable up-counter is preset to a number $Y - (N - 1)$, where Y is the upper limit of the counter and N is the required number of output cycles. The counter is monitored, and when the state Y is detected, the next output cycle of the HF or LF oscillator is stopped. The value of $N = 1$ is treated as a one-shot trigger, as in external trigger mode, and the value $N = 0$ disables the trigger input and allows the 8165A to be used as a dc source (signal off, offset variable). Thus the full range of 0 to 9999 cycles per burst is available.

Optional Sweep/AM

Option 002 provides the 8165A with logarithmic sweep and amplitude modulation capabilities.

Logarithmic sweep output allows the user to sweep logarithmically between two frequencies as an alternative to the linear sweep available in the VCO mode. A range of three decades can be covered. Unlike some sweep circuits, a triangle instead of a sawtooth is generated. The advantage of this waveform is that there is no need for a blanking stage in an oscilloscope or for a pen lift circuit in an X-Y recorder. The sweep generator is based on an up/down counter and a digital-to-analog converter (see Fig. 12).

After the start frequency has been entered, the stop frequency is checked against the total available sweep range. Following this, the logarithm of the start frequency is automatically stored by the start latch and is subsequently loaded into the 10-bit counter. After the external trigger, the counter accumulates the pulses generated by the clock generator until the stop frequency has been reached. The flip-flop then reverses the counter. The counter's output is converted to a triangular waveform by a 10-bit digital-to-analog converter (DAC). The DAC's output is converted by an antilog amplifier to produce a voltage for controlling the HF VCO. A signal for external deflection purposes (1V per swept decade) is made available by buffering the DAC's output.

Besides sweep, 8165A Option 002 also provides amplitude modulation. The standard instrument has an FM mode, and PCM can be carried out in the gate mode. Because there are no restrictions on selecting the input mode in conjunction with AM, complex waveforms can be generated. Amplitude modulation indexes between 0 and 100% are possible, independent of the programmed amplitude.

The AM stage is based on an electronic attenuator IC, similar to those used in the 8082A 250-MHz Pulse Generator.¹ In this application two basic cells are connected in parallel. The contribution of this arrangement is that the envelope distortion of the modulator is better than -60 dB for frequencies up to 1 MHz.

Acknowledgments

For their very significant contributions, we'd like to thank: Georg Heier for the design of the HF VCO and

A Compact Logging Multimeter that Can Manipulate Data

By combining the attributes of a 4½-digit multimeter, a thermometer, a 4-channel scanner, a printer, and a microprocessor, this versatile instrument can be a time-saver for the design engineer.

by John E. Scruggs, Marsh L. Faber, and David L. Wolpert

TIME IS VALUABLE—just as much so in the design lab as anywhere else. That provided the motivation for a project that culminated in the Model 3467A Logging Multimeter (Fig. 1). The goal was: develop an instrument that saves design time.

Capable of handling a major part of the measurements required during the course of a typical electronic design effort, this self-sufficient instrument measures ac and dc voltages, resistance, and, with external thermistors, temperature. It has a four-channel scanner, a thermal printer for permanent records, and an internal timer that allows unattended measurements. The instrument requires no external control or I/O, yet it can perform computations on measurement data under pushbutton control.

The nucleus of this instrument is a 4½-digit, autoringing multimeter, basically similar to the HP

Model 3466A Digital Multimeter. The printer is a compact, moving-head, dot-matrix, thermal printer similar to those used on the HP-91 and HP-97 Calculators.¹ Scanning is by means of reed relays. A microprocessor provides the communication between the multimeter, scanner, timer, and printer, as shown in the block diagram of Fig. 2.

Data Manipulation

Inclusion of a microprocessor allowed math operations to be implemented. Among other things, these make it possible to linearize and convert readings of thermistor resistance measurements to readings of temperature in °F or °C.

Other operations performed with the math functions involve the use of channel 4 as a reference, designated "Y." Any of the other three channels, de-



Fig. 1. The Model 3467A Logging Multimeter is basically a 4½-digit multimeter with a built-in four-channel scanner and a printer, all controlled by an internal microprocessor. The microprocessor can also translate raw measurement data into more useful forms, such as linearizing and converting thermistor measurements to give readings directly in °F or °C.

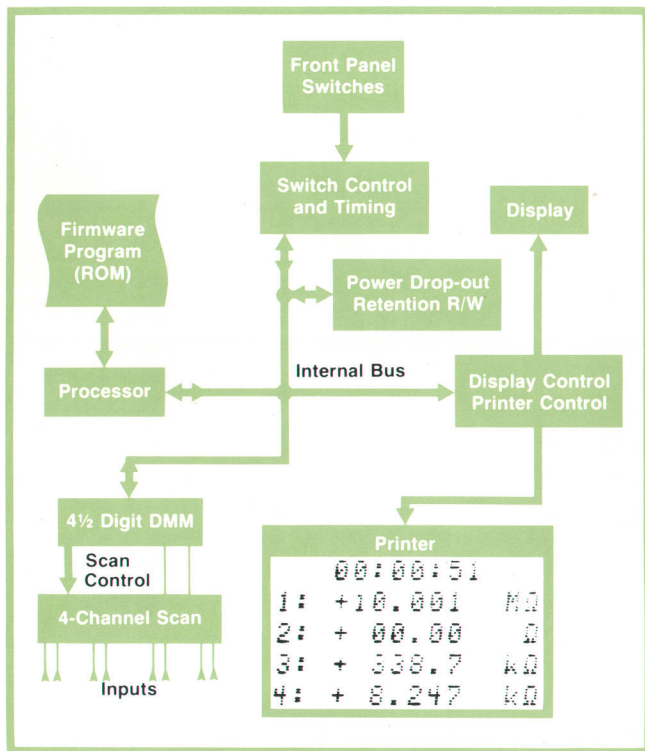

Fig. 2. Organization of the Model 3467A Logging Multimeter.

signed "X," may then operate on the reference so measurement results can be presented in the most useful form. The possible operations are:

$$\Delta \quad (X-Y) \quad \div \quad (X/Y)$$

$$\Delta\% \quad \left(\frac{X-Y}{Y}\right) \times 100 \quad \text{dB} \quad 20\log|X/Y|$$

$$* \quad XY$$

Besides using measurements made on the Y channel as the Y reference, arbitrary values of Y can be entered and stored for use as constants for the math functions. The MATH pushbuttons normally are interlocking so only one at a time can be depressed, but the switch assembly has been modified such that when the Y pushbutton is depressed, the MATH buttons function as momentary contact switches. Each of these can then be used to step one of the display digits to any desired value. The dB pushbutton steps the decimal point to the desired position. Releasing the Y pushbutton stores the displayed number for subsequent use as the Y reference.

Additional uses of the math capability involve offsets. With the input leads shorted, usually at the point of measurement, pressing the $\mu\text{V}, \Omega$ ZERO pushbutton stores any residual voltage or resistance reading as an offset for that channel. This offset, which can be as high as 2 mV or 20 Ω , is then automatically subtracted from subsequent measurements.

Applications

Of what use are these capabilities to the engineer on

the bench? Characterizing amplifiers and filters directly in dB units is one example. With channel 4 measuring the input to the device, any of the other channels measuring the output, and the dB button pressed, readings will be given directly in dB units.

With the appropriate value entered as the Y constant, measurements on channels 1, 2, and 3 can be made in dBm referred to any impedance desired. For example, the voltage V for 1-mW dissipation in a characteristic impedance R_c is derived from the relationship: $V^2/R_c = P$, where $P = 1\text{mW}$. For a 600 Ω impedance, V is 0.7746 volts. With this value entered as the Y reference and the dB button pressed, the results of voltage measurements will then be displayed in dBm referenced to 600 Ω . Obviously, this kind of capability makes the instrument as useful on the production line as on the designer's bench.

When the TEMP function button is pressed at the same time as one of the other functions ($\text{---}V$, $\sim V$, or $k\Omega$), temperature can be measured on channels 1 and 2 while channels 3 and 4 measure the other function. An example of how this "mixed" mode can be used is shown in Fig. 3. Here, the effectiveness of the heat sink used on a power supply regulator is being evaluated. A thermistor is cemented to the case of the regulator transistor and the temperature there is measured on channel 1. Channel 3 monitors the voltage drop across the transistor while channel 4 measures the current ($A \times 1\Omega = V$). With the * MATH button

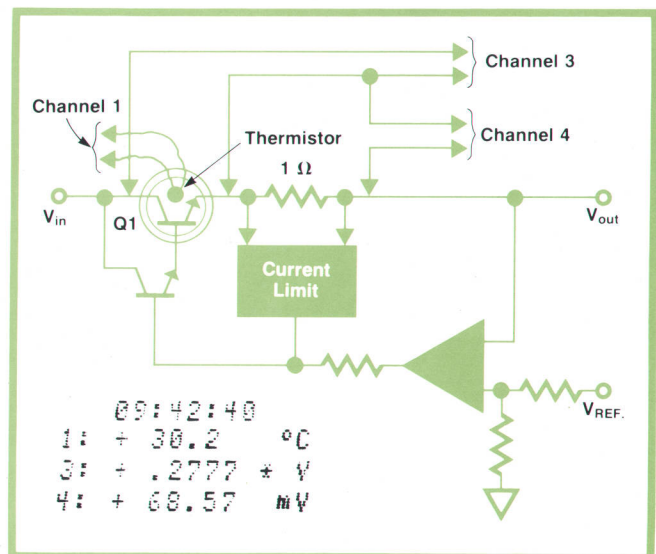

Fig. 3. The thermal performance of a heat sink for a series-regulator transistor is evaluated with the help of the logging multimeter in the setup shown here. The printout shows temperature at the surface of the transistor (channel 1), the power dissipated by the transistor (channel 3), and the load current (channel 4). The instrument multiplies the voltage measured on channel 3 by the channel 4 current reading ($\text{mV} = \text{mA} \times 1\Omega$), which functions as the Y reference, to give the transistor power dissipation (0.2777 W).

depressed, the logging multimeter multiplies the channel 3 reading by the channel 4 reading to give the power dissipated in the transistor. The power supply load can then be varied and a printout obtained by manual pushbutton each time the temperature stabilizes at a new value. Note that the load current (channel 4) is also printed. A second thermistor could be connected to channel 2 to give a simultaneous record of ambient temperature.

With the internal timer, up to four measurement points can be scanned and the results printed at specified time intervals. These intervals range from less than ten seconds up to three hours. This enables unattended monitoring of such quantities as voltage drift versus time during device warmup, and battery charge/discharge characteristics.

Power Drop-Out Protection

With offsets and/or a Y constant stored, it would be at least disconcerting and possibly even disastrous if a power-line transient or momentary power loss caused these constants to be lost, especially if the instrument were operating unattended. To guard against this, the Model 3467A has a power dropout protection circuit that saves entered constants for at least five seconds in the event of a power loss. The circuit is shown in Fig. 4.

While the system is running, data such as the Y reference, offsets, elapsed time, and the next print time are read from the microprocessor memory and stored in a low-power CMOS read-write memory (RAM) each time the display is updated. If line power fails sufficiently long for V_{CC} to fall below 4.83V, the processor system will be disabled, but the data in the low-power RAM will be retained by the voltage on a capacitor (voltage V_C on capacitor C_A). When power returns, the processor, upon resuming operation, first

checks the output of the stored-voltage comparator. If this indicates that the voltage V_C on capacitor C_A is still greater than 2V, it loads the data stored in the low-power RAM into the corresponding locations in its own memory. Instrument operation then continues as before. The printer, however, inserts an extra line feed before the next printout to indicate that a power drop-out occurred.

If V_C is less than 2V when power is restored, the processor initializes the stored Y constant to +1, and the other constants, offsets, and times are set to zero.

The circuit shown in Fig. 4 includes two safeguards. Switch Q1, a transistor, is controlled by the power-on reset signal, a delayed version of the power-valid signal. This allows capacitor C_A to charge only while the processor is operational and data in the CMOS memory is valid. The front-panel line power switch has an additional pole that provides a discharge path for capacitor C_A when the power is switched off. Whenever this switch is toggled, the stored values are reinitialized as above.

Scanning High Voltages

One problem that was resolved during the design of this instrument was the deleterious effect that high voltages can have on scanner relays when floating measurements are made. Fig. 5 illustrates this.

If one side of a voltage source ($\pm 350V$ dc max.) is connected to safety ground and the other is connected to a channel's input Lo (Fig. 5a), a large charging current is switched by the scanner relay S1. This is because the distributed capacitance on the LOW side is relatively large (500-1000 pF), a result of the large area of sheet metal connected to circuit LOW. If switched repeatedly, which would be the case when scanning, this current would eventually pit the relay contacts and cause erratic operation.

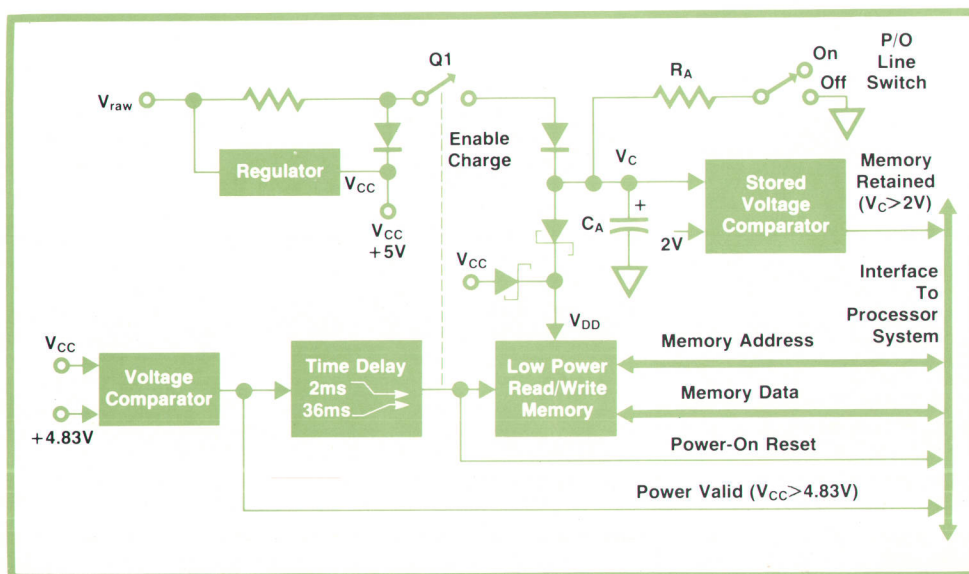

Fig. 4. Power dropout protection circuit retains math constants and other data in a CMOS memory powered by the charge on capacitor C_A . Data is retained for at least five seconds if line power fails.

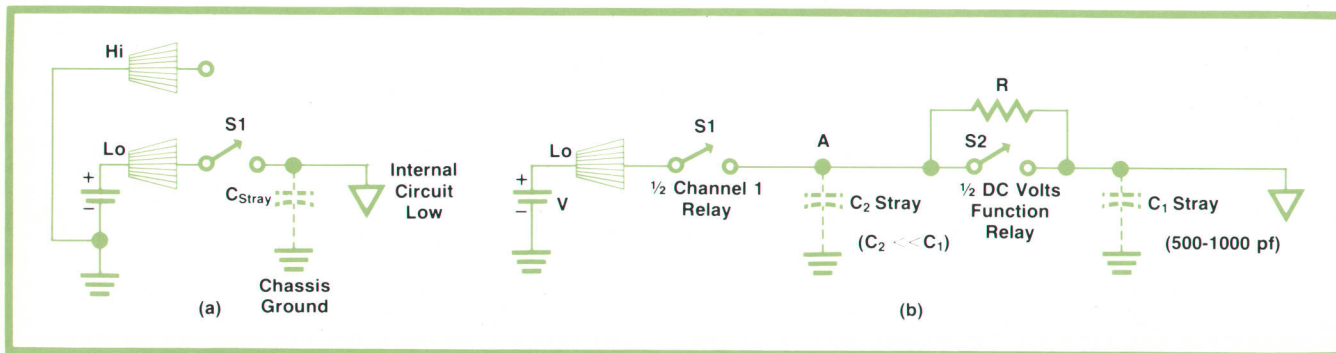

Fig. 5. Relay closings are sequenced (*S1* before *S2*) so neither relay has to switch the full current that charges stray capacitance *C1*. This avoids the damage to the relay points that repetitive switching of high currents can cause.

The solution was to sequence the relays so the scanner relay (*S1*) closes before the function relay (*S2* in Fig. 5b). Point A in Fig. 5b is not connected directly to the floating chassis sheet metal so the distributed capacitance at that point is very small. When *S1* is closed, this small capacitance (*C2*) charges very quickly while *C1* charges relatively slowly through resistor *R*. *S2* is timed to close after *C2* is fully charged. Thus, neither switch is required to switch any appreciable current, resulting in much better reliability in high-voltage measurements.

In the event that a scanner relay should fail in a closed position, it is possible that two measured sources would be connected together when the next channel relay closes. To prevent damage to the sources, a fuse is placed in series with each channel's input. This adds series resistance, but this resistance is effectively "nulled out" of resistance measurements by the zeroing and offset storage procedure.



David L. Wolpert

Dave Wolpert joined HP Loveland Instrument Division in 1972, immediately after receiving his BEE degree from the Georgia Institute of Technology. He was initially involved in several lab investigation projects and subsequently became a designer for the 3495A Scanner. Responsible for the digital hardware and software for the 3467A Logging Multimeter, Dave now works in LID production engineering. A resident of Loveland, Colorado, Dave has also taught electronics technology classes at a local community college. Dave's interest in electronics extends beyond the regular workday. He is currently writing a cassette tape operating system and a business-oriented software supervisor for his home computer system. Dave also enjoys photography, drama, playing guitar and piano, and working at a local recording studio.



John E. Scruggs

Born and raised in Dallas, Texas, John Scruggs is a 1964 New Mexico State University graduate with a BSEE degree. He worked for five years on Apollo and Mariner spacecraft electronics while taking night classes at Arizona State University, where he eventually received his MSEE degree. After another three years as a control systems designer for a monorail vehicles company, he joined HP in 1973. John was initially project manager on a computer-based LSI test system in the Loveland integrated-circuit department. He then transferred to the research and development lab where he worked in several investigations before becoming project manager for the 3467A Logging Multimeter. John, his wife and three daughters, ages seven, ten and thirteen, raise and show quarter horses. John also enjoys playing the guitar and participating in competitive sports such as basketball and tennis.



Marshall L. Faber, Jr.

Marsh Faber joined HP in 1966, shortly after receiving his BSEE degree from the University of Denver. He began work as production engineer on DVMs while studying toward his master's degree at Colorado State University in the HP Honors Coop Program, receiving his MSEE degree in 1971. More recently, Marsh contributed to the design of the 3435A DVM and the 970A Probe Digital Multimeter. At the 1974 IEEE electronic components conference, he received best paper award for his paper entitled "Algorithmic Trimming on Active Circuitry." Born in Washington, D.C., Marsh is married with two children, ages three and five. He enjoys fishing, home improvement, skiing, tennis, racquetball and charcoal sketching. Marsh is also a guitarist and enjoys composing songs as well as playing.

SPECIFICATIONS
HP Model 3467A Logging Multimeter

DC Voltmeter

Range	Maximum Reading
20mV	19.999mV
200mV	199.99mV
2V	1.9999V
20V	19.999V
200V	199.99V
350V	349.9V

MAXIMUM INPUT: ± 350 V from any terminal to ground and between any two terminals.

RANGING: Automatic or Hold/Step.

SENSITIVITY: $1 \mu\text{V}$ on 20mV range.

POLARITY: Automatically sensed and displayed.

ZERO ADJUSTMENT: Front-panel pushbutton compensates for up to ± 2 mV offset for each channel.

ACCURACY (6 months, 18°C to 28°C):

Range	=(% of reading + number of counts)
20 mV	0.05 + 10
200 mV	0.04 + 2
2V-200V, 350V	0.03 + 1

TEMPERATURE COEFFICIENT: (0° to 18°C, 28° to 50°C): $\pm (0.003\%$ of reading + 0.15 counts)/°C.

INPUT RESISTANCE: 10 M Ω $\pm 5\%$ on all ranges.

NORMAL MODE REJECTION: >60 dB at 50/60 Hz $\pm 0.1\%$.

EFFECTIVE COMMON MODE REJECTION (1 k Ω unbalance): >120 dB at 50/60 Hz $\pm 0.1\%$.

SINGLE CHANNEL RESPONSE TIME (without printing): <0.7 seconds to within 1 count of final value on one range. Add 0.8 seconds for each range change.

Ohmmeter

Range	Maximum Reading	Current Through Unknown
200 Ω	199.99 Ω	5mA
2k Ω	1.9999k Ω	1mA
20k Ω	19.999k Ω	100 μA
200k Ω	199.99k Ω	10 μA
2M Ω	1.9999M Ω	1 μA
20M Ω	19.999M Ω	100nA

INPUT PROTECTION: 250 V rms or 350 V (dc + peak ac).

RANGING: Automatic or hold/step.

SENSITIVITY: 10 m Ω to 200 Ω range.

CONFIGURATION: 2-wire with front-panel pushbutton zero adjustment. Lead resistance of up to 20 Ω can be nulled out for each channel.

ACCURACY (6 months, 18°C to 28°C):

Range	=(% of reading + number of counts)
200 Ω	0.08 + 10
2k Ω	0.03 + 3
20k Ω - 200k Ω	0.03 + 1
2M Ω	0.04 + 1
20M Ω	0.15 + 1

TEMPERATURE COEFFICIENT:

Range	(0°C to 18°C, 28°C to 50°C)
200 Ω	$\pm (0.002\%$ of reading + 1 count)/°C
2k Ω - 2M Ω	$\pm (0.002\%$ of reading + 0.1 count)/°C
20M Ω	$\pm (0.01\%$ of reading + 0.1 count)/°C

OPEN CIRCUIT VOLTAGE: <5 V.

SINGLE CHANNEL RESPONSE TIME (without printing): <1.1 seconds to within 1 count of final value on one range. Add 0.8 seconds for each range change.

Diode Test

FUNCTION: k Ω \rightarrow

RANGE: 2k Ω

CURRENT SOURCE: 1mA $\pm 4\%$

DIODE VOLTAGE DROP DISPLAYED IN VOLTS: 1.9999 volts maximum measurable voltage.

AC Voltmeter

AC CONVERTER: True rms responding and calibrated in true rms; ac coupled.

Range	Maximum Reading
200mV	199.99mV
2V	1.9999V
20V	19.999V
200V	199.99V
250V	249.9V

MAXIMUM INPUT: ± 350 V (dc + peak ac), 10⁷ V/Hz from any terminal to ground and between any two terminals.

RANGING: Automatic or hold/step.

CREST FACTOR: 4:1 at full scale.

ACCURACY:

Accuracy applies with readings of $\geq 9\%$ full scale (≥ 1800 counts on 250V range); 6 months, 18°C; sinusoidal waveform.

Frequency	=(% of reading + number of counts)
45Hz - 100 Hz	1 + 40
100 Hz - 10 kHz	0.2 + 40
10 kHz - 20 kHz	1 + 40
20 kHz - 100 kHz	2 + 200

TEMPERATURE COEFFICIENT:

Frequency	(0°C to 18°C, 28°C to 50°C)
45 Hz - 100 Hz	$\pm (0.05\%$ of reading + 2 counts)/°C
100 Hz - 10 kHz	$\pm (0.03\%$ of reading + 2 counts)/°C
10 kHz - 20 kHz	$\pm (0.05\%$ of reading + 2 counts)/°C
20 kHz - 100 kHz	$\pm (0.06\%$ of reading + 15 counts)/°C

INPUT IMPEDANCE: 2 M Ω $\pm 5\%$ in parallel with <100 pF.

SINGLE CHANNEL RESPONSE TIME (without printing): <2 seconds to within 4 counts of final value on one range. Add 1.2 seconds for each range change.

Temperature Measurement

TECHNIQUE: Temperature measurements using thermistors can be made directly in °C or °F, selectable by an internal switch. Thermistor linearization is included for the following thermistors: Yellow Spring 44007, Omega UUA 35J3, Fenwal UUA 35J1 or equivalent. (One thermistor is furnished with each 3467A).

ACCURACY (includes ohmmeter accuracy, thermistor curve fit accuracy, and thermistor self-heating):

-80°C to +80°C	$\pm 0.3^\circ\text{C}$
+80°C to +110°C	$\pm 0.5^\circ\text{C}$
+110°C to +150°C	$\pm 1.3^\circ\text{C}$

Four-Channel Scanner

TYPE: One 2-pole, low-thermal, dry-reed relay per channel.

INPUTS: Floating inputs. Any combination of four channels may be selected to measure one of the following functions: dc volts, true-rms-ac volts, resistance, or temperature. Measurements of temperature on channels 1 and 2 and either dc volts, ac volts, or resistance on channels 3 and 4 can also be made.

CHANNEL-TO-CHANNEL ISOLATION:

Source Impedance	Up to 1 kHz	Up to 100 kHz
600 Ω	>100 dB	>60 dB
10k Ω	>80 dB	>40 dB

Printer and Timer/Pacer

TYPE: Thermal Printer.

PRINT MODES:

MANUAL: Initiates a printout of selected input channels.

AUTOMATIC: Scans, measures and prints selected input channels at preset time intervals.

TIME INTERVAL: 1, 3, 6, 10, 18, 30, 60, or 180 seconds or minutes interval selectable via front-panel pushbuttons.

TIMER: Internal 24-hour crystal controlled interval timer. Timer starts at 00:00:00 (HH:MM:SS). Time offset can be manually entered to synchronize timer with the time of day.

TIMER ACCURACY: Within 1 minute in 24 hours.

POWER FAILURE PROTECTION: Should a power failure occur, the 3467A will retain the math constant, elapsed time, offsets, and ranges for up to 5 seconds.

*Time intervals ≤ 10 seconds may be shorter than actual time required to completely measure and print selected channels. In these cases, next printout will be initiated upon completion of present scan sequence.

General

READING RATE: Depends on input signal level. 2 to 4 1/2 readings/second.

OPERATING TEMPERATURE: 0°C to +50°C.

HUMIDITY: 95% R.H., +15°C to 140°C without thermal paper. 60% R.H., +15°C to +30°C with thermal paper.

POWER: 100/120/220/240 + 5%, -10%, 48 to 440 Hz, <25 VA.

DIMENSION: 190.5 mm H x 212.9 mm W x 304.8 mm D (7 1/2 x 8 3/8 x 12 in.).

WEIGHT: 4.77 kg (10.5 lb).

PRICE IN U.S.A.: 3467A (including 1 roll of thermal paper and 1 thermistor): \$2200.

MANUFACTURING DIVISION: LOVELAND INSTRUMENT DIVISION
 P.O. Box 301, 815 Fourteenth Street, S.W.
 Loveland, Colorado 80537 U.S.A.

Acknowledgments

Ed Pennington and Mike Williams were responsible for the product design and Ralph Swanson handled the industrial design. Ron Firooz contributed to the software. A special thanks to Dave Palermo and Roy Barker who fathered the idea for the project. Thanks also to Bob Hetzel, Lois Bryan and Dave Connell for their support during release to production.

Reference

1. B.E. Musch and R.B. Taggart, "Portable Scientific Calculator Has Built-In Printer," Hewlett-Packard Journal, November 1976.

Hewlett-Packard Company, 1501 Page Mill Road, Palo Alto, California 94304

HEWLETT-PACKARD JOURNAL

DECEMBER 1978 Volume 29 • Number 16

Technical Information from the Laboratories of Hewlett-Packard Company

Hewlett-Packard Company, 1501 Page Mill Road Palo Alto, California 94304 U.S.A.

Hewlett-Packard Central Mailing Department Van Heuven Goedhartlaan 121

Amstelveen-1134 The Netherlands

Yokogawa-Hewlett-Packard Ltd., Suginami-Ku Tokyo 168 Japan

Editorial Director • Howard L. Roberts

Managing Editor • Richard P. Dolan

Art Director, Photographer • Arvid A. Danielson

Illustrator • Susan E. Wright

Administrative Services, Typography • Anne S. LoPresti

European Production Manager • Dick Leekmas

Bulk Rate
 U.S. Postage
 Paid
 Hewlett-Packard
 Company

0200032502&&&BARHERL00
 MR R L BARHAM
 GULF POWER CO
 PO BOX 1151
 PENSACOLA

FL 32502

CHANGE OF ADDRESS: To change your address or delete your name from our mailing list please send us your old address label (it peels off). Send changes to Hewlett-Packard Journal, 1501 Page Mill Road, Palo Alto, California 94304 U.S.A. Allow 60 days.