

DECEMBER 1971

HEWLETT-PACKARD JOURNAL

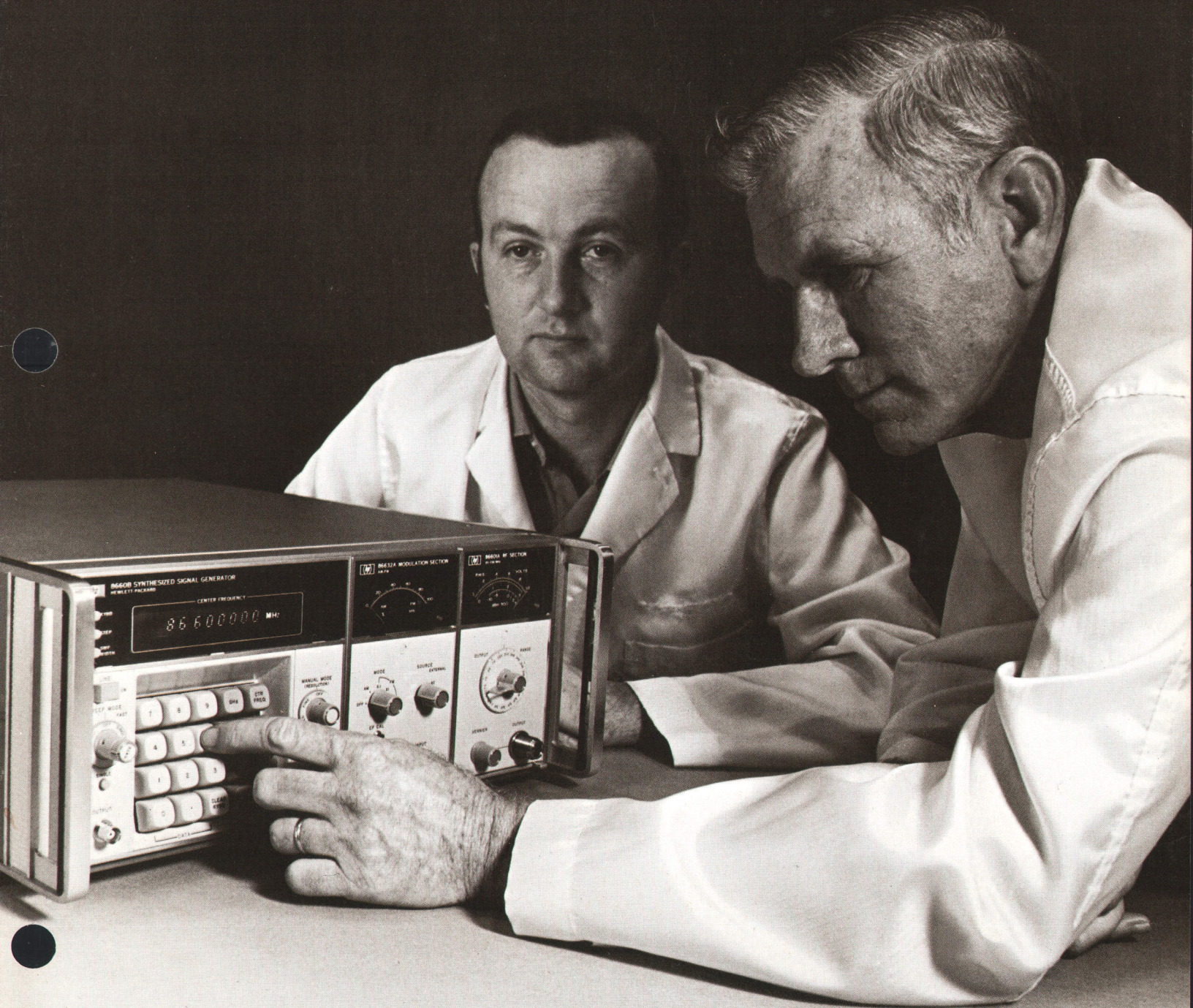

Uniting Signal Generation and Signal Synthesis

A simultaneous solution is devised to the problems of signal generation and signal synthesis, while optimizing both for bench and automatic use.

By John C. Shanahan

OVER THE PAST DECADE there have been two distinct types of signal sources in the market place, each fulfilling a specific range of applications. One of these is the familiar signal generator (e.g. HP 606, 608, 612, etc.), and the other the synthesizer (e.g. HP 5100, 5105, etc.). In many cases both are necessary even in the same test set-up. Hewlett-Packard's 8660A/B Synthesized Signal Generator family is a new solution to this hybrid application. It combines the stability, programmability and frequency resolution of a synthesizer with the modulation and voltage calibration of a high-quality signal generator. This compact, all solid-state system has the versatility of plug-in modulation and RF sections and features directly computer-compatible programming of frequency, voltage level, and modulation.

To accomplish the synthesized aspect of this generator's performance, the indirect synthesis approach has been used.¹ There are seven L-C tuned oscillators, each phase locked for stability and accuracy. A crystal oscillator at 10 MHz is the ultimate source, and all internal signals are referenced to it. Fig. 1 outlines the 8660 family. There are two mainframes, each fulfilling separate requirements. The 8660A with a minimum of front panel controls is suited for systems applications; the 8660B with many new front panel features is a powerful bench instrument. Besides these different mainframes and plug-ins, there are other options available (see specifications) to narrow the choice of instrument further toward a specific application. Higher frequency plug-ins will follow. One common concern with any piece of test equipment is obsolescence.

Hewlett-Packard has tried to minimize this concern with the Synthesized Signal Generator family.

Mechanical Design

Among the unique characteristics of the 8660A/B mainframe is its mechanical design. To insure excellent signal purity and ease of servicing it was necessary to develop efficient shielding techniques that would nevertheless allow access to every electrical and mechanical part that could need replacing



Cover: *Seriousness of intent is visible as John Shanahan (center), project leader, and Hamilton Chisholm, digital controls designer, present a new signal generator that's also a versatile synthesizer. Its two differing mainframes and its two-drawer architec-*

ture form a family of precision signal generators with basic and add-on capabilities to serve not only past and present needs, but also those of the future.

In this Issue:

Uniting Signal Generation and Signal Synthesis,

by John C. Shanahan page 2

Remote Laser Interferometry,

by Richard R. Baldwin, Gary B.

Gordon, and André F. Rudé page 14



Fig. 1. The 8660 system poses for a family portrait. 8660A (left rear), 8660B (right rear), are basic mainframes. Modulation facilities are added with 86632A Modulation Section (near left) in central plug-in position, or 86631A Auxiliary Section (near right) is substituted. Near center pair of plug-ins are RF Sections, 86601A for 0.01–110 MHz, 86602A for 1–1300 MHz.

in the field. The compactness of the packaging brought with it both magnetic and electrostatic coupling problems which could easily have ruined the spectral purity of the signal output. To eliminate these potential problems, many hours of engineering were spent analyzing coupling effects and desensitizing critical circuits.

Because the 8660A/B mainframe will have to accept plug-ins which are presently being developed and also some which haven't been started, extra capability, particularly in the power supplies, has been designed in. Additional mechanical and electrical flexibility has been included so special programming formats can easily be handled by changing one or both interface cards. Also, one of the major objectives was to be able to manufacture a major portion of the mainframe and then make it an 8660A or 8660B by simply inserting the appropriate Digital Control Unit (DCU) as the last sub-assembly during manufacturing. Extensive shock and vibration tests have been conducted on the package to make it as sturdy as possible without hazard to portability.

How Does it Operate?

The front panel controls of the 8660A are self-explanatory, but those of the 8660B are unique and offer new capability in a synthesized signal generator (Fig. 2). A keyboard is composed of twenty keys; it is of altogether new keyboard design.² This front panel control allows direct pushbutton entry of the desired frequency to an accuracy determined by the crystal oscillator. For example, the frequency 36.45 MHz can be obtained by pressing seven keys. First the (3) is pressed, the (6), the (.), the (4), the (5), the (MHz), and finally the (Cent/Freq) key. If a mistake is made during the entry there is a (Clear/Kybd) key. Two 'step' keys are included which cause a frequency increment of any size to be added to, or subtracted from the present frequency. For example, if the previous frequency of 36.45 MHz is one of a number of receiver channels separated by 50 kHz, then the 50-kHz increment can be entered on the keyboard and each time the (Step) key is pushed, the frequency will increase by 50 kHz. Internal registers store the increment so that only one key, (Step), need be depressed to move to the



Fig. 2. Complete instrument with 8660B keyboard-controlled synthesized generator, 86601A 110-MHz rf section, and 86632A modulation section.

next channel. There is also a (Step) key to move frequency lower in successive steps. Besides (MHz), three other keys, (GHz), (kHz), and (Hz) are also present for greater flexibility. The last key is (Swp/Width). This key will allow any frequency span to be entered as a sweep width to be centered on the center frequency shown in the readout area. The output, however, will not actually sweep until the SWEEP MODE switch is set in its appropriate position.

Readout

The solid state numeric readout is designed normally to read the actual frequency at the output connector at all times. However, there are three momentary switches that command the readout to display the registers storing 1) the keyboard infor-

mation, 2) the step information, or 3) the sweep width information. When these momentary switches are released the readout again displays the output frequency. Within the display area is a series of readouts which help the user while performing tests. These annunciators (REMOTE, SWEEP, OUT OF RANGE, OVEN and FM MODE) indicate the status and mode of operation at a glance.

Manual Mode

The manual mode comprises two controls, the resolution switch and the tuning knob. The tuning knob is attached to a rotary shaft encoder that generates pulses as it is rotated. As this control is rotated in a clockwise direction, the frequency at the output is increased in steps determined by the resolution switch. As the tuning control is rotated in a counter-clockwise direction, the frequency decreases. This feature can be likened to the familiar search mode of a synthesizer with one significant difference. This control allows the frequency to be changed without loss of accuracy or stability. Its applications are numerous and yet this control is exceedingly simple to operate.

Sweep Mode

This is another feature new to synthesized signal generators. It is the capability of digital sweep. Incorporated within the 8660B is a sweep control which changes the output frequency in 1000 discrete steps, precisely following a sawtooth pattern. The number of steps is enough to make the swept output appear continuous. In actual operation, all frequencies between the upper and lower limit are generated. However, only 1000 of these frequencies

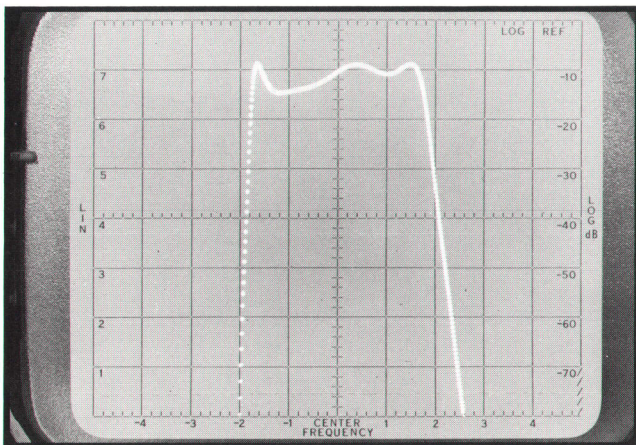

Fig. 3. 8660B/86601A is digitally swept in 10-Hz steps through narrowband crystal filter centered on 2.1145 MHz; resolution is maintained. Scale is 2 dB/cm vertical, 2 s/cm horizontal.

remain at the output for a discrete period of time. Fig. 3 shows the 8660B/86601A being swept through a narrowband filter with no loss in resolution. In fact, the exactness of this particular type of sweep is an asset when precise filter cutoffs are called for. There are three different sweep speeds and three modes of sweeping. The first mode is *AUTO*. It will continuously sweep the output at any one of three rates, slow (10 s), medium (1 s) and fast (100 ms*). The second mode is *SINGLE*. In this setting the instrument will sweep just once when the button is pushed. The third mode is *MANUAL*. It works in conjunction with the *MANUAL TUNING* control mentioned earlier. This mode of operation is unique in that as the *MANUAL TUNING* knob is rotated the readout follows the output frequency. When the frequency reaches the output of the two limits determined by the *SWEEP WIDTH* setting, the *MANUAL TUNING* knob will cease to function. This is a particularly powerful capability when one is analyzing the response of a filter or setting up an X-Y recorder. In all of the above cases, the sweep output (BNC) gives a ramp voltage between zero and +5 volts. This signal can be used to sweep an oscilloscope horizontally or sync external equipment as desired.

In the remote mode, the operator can control frequency, voltage level and modulation just as with the 8660A. However, one other feature of the 8660B is the capability of stepping or incrementing the frequency by simply commanding the (Step) or (Step) function. This then allows the instrument to be swept at the rate and sweep width determined by the remote controller.

Other features of this front panel include:

- Readout blanking of unnecessary zeroes
- Automatic entry of least significant zeroes
- Moving decimal point for ease of reading
- Automatic rejection of illegal entries
- Decimal need not be pushed
- Readout while under remote control

System Concept

As previously stated, an 'indirect synthesis' approach has been used, and all mainframe frequencies originate from seven separate phase lock loops (Fig. 4). One of these, the reference loop, generates a series of fixed frequencies from which the remaining six loops get their stability and accuracy. The most critical of the loops, with respect to spurious signals and phase noise, is the reference loop.

* When sweeping the output at the fast rate, the number of discrete steps is reduced to 100.

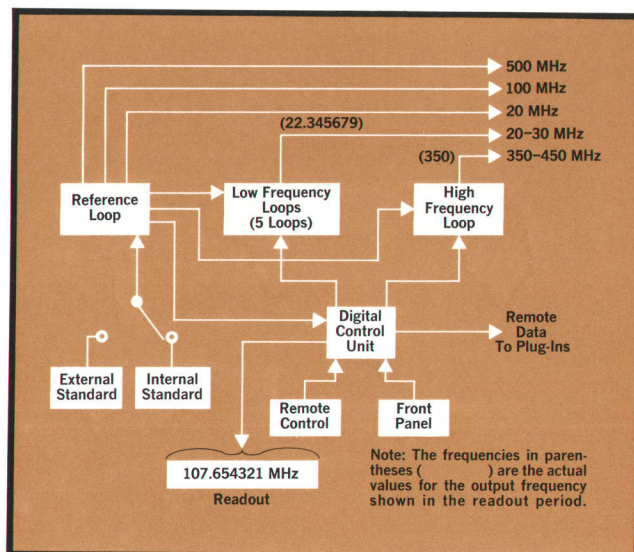

Fig. 4. Block diagram illustrates system concept.

Any spurious signal on the 100-MHz output (typically spurious signals are 100 kHz, 200 kHz, 400 kHz, and 1 MHz) will be multiplied by approximately 20 in future plug-ins, so they must be at least 106 dB down from the 100-MHz signal level; indeed for some margin of safety on an output spec of 80 dB they should be more like 112 dB down. Those spurious signals further away from the carrier (10 MHz and 20 MHz) will be filtered sufficiently by a phase lock loop before reaching the output. The reference loop's master oscillator (100 MHz) can be phase locked either to the internal 10-MHz crystal oscillator or to an external standard. When an external standard is used, its frequency must be within 1 part in 10^{-3} of that specified. Unlike direct synthesizers, the 8660A/B will have an output frequency at all times whether a reference source is used or not. The reason, of course, is the 100-MHz oscillator, and the user should be aware that an unstable frequency at the front panel may simply mean the reference switch is in *EXTERNAL* but an external reference is not connected.

Low-Frequency Loops

The low-frequency section consists of five phase lock loops. Three of these are $\div N$ type, and the other two are summing loops. The resultant frequency, when these five loops are summed together, is a single output covering the range from 20.000001 MHz to 30 MHz in steps as small as 1 Hz or as large as 1 MHz (Fig. 5). These five loops are housed in aluminum extrusions and interconnected by one large multilayer printed circuit

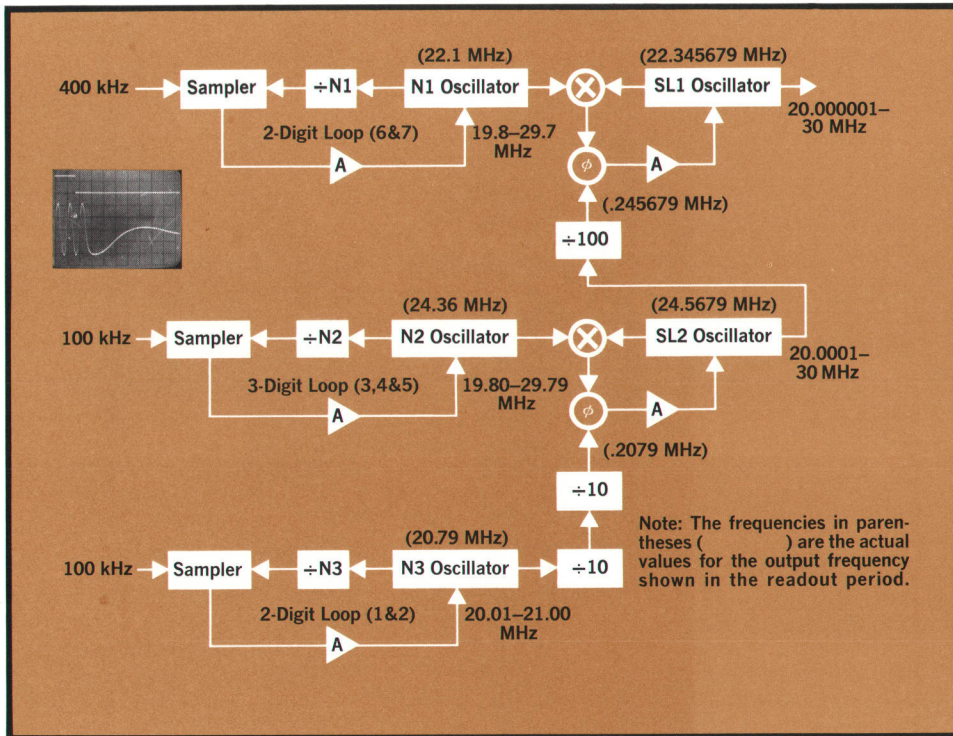

Fig. 5. Five phase lock loops interact in low-frequency section, yet retain 80 dB signal-to-spurious ratio.

board. One of the more significant engineering accomplishments was combining these five loops while still maintaining an 80 dB spec on spurious signals. The number of potential spurious signals is staggering at first glance, but in actual practice has been kept to a level consistent with specified signal purity.

The speed with which the frequency of the 8660A/B can be remotely programmed depends solely on these low-frequency loops. In some cases, the settling time is quite short (100 μ s); but when one of the five phase lock loops is programmed over its complete range, the time to settle can be as long as 5 ms. The worst-case condition occurs when the output frequency changes from nines to zeroes or vice versa. Under this condition all five loops change from one end of their frequency range to the other end. Fig. 5 shows typical switching times for the low-frequency loops and these will be the same as those measured at the front panel output. It is possible that a frequency transient as large as 10 MHz could be generated even though the actual frequency is moving only 1 Hz. This would be rare, but nevertheless it can occur.

The most common spurious signals generated within these low-frequency loops are at 10 kHz, 100 kHz and at the IF of both summing loops. Because there is no multiplication of the 20–30 MHz output, spurious signals at least 80 dB down from the signal level will also be 80 dB down at the

front panel output. Special designs had to be used to minimize both electrostatic and magnetic pickup to assure the 80 dB signal-to-spurious ratio.

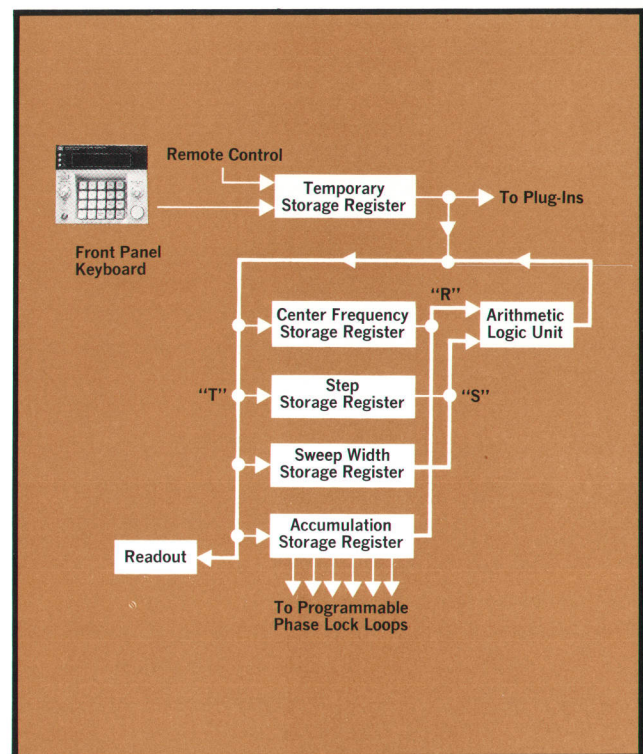

Fig. 6. Block diagram describes function of 8660B Digital Control Unit.

The Indirect Synthesis Approach

There are many advantages but some disadvantages.

When a synthesizer has just one oscillator, from which all other frequencies are arithmetically generated, usually by mixing, multiplying, and filtering, it is ordinarily referred to as a direct synthesizer. The indirect synthesizer usually is taken as one which has at least two oscillators, and often many, which are phase-locked to a reference source.

One such example of a phase-locked oscillator used in an indirect synthesizer is shown in the diagram here. Its block diagram is identical to that of the $\div N2$ loop used in the 8660A/B, and has three digits (1000 discrete frequency steps) controlling it. BCD digital information is sent to the $\div N$ digital divider and also to the digital-to-analog converter, the latter for pretuning the oscillator close to the frequency called for by the digital data. The oscillator's frequency is divided by a number between 1980 and 2979, resulting in a 10-kHz signal at the divider's output. This 10-kHz signal becomes the sampling signal and harmonically samples a 100-kHz signal (harmonic number $M = 10$) from a reference source. The sampler generates a voltage proportional to the phase difference between these two inputs. This error voltage is fed back to the oscillator to close the loop. The shaping amplifier helps to remove the non-linearity caused by the voltage-variable capacitor that tunes the oscillator. The bandwidth of this loop is about 1 kHz and the capture range is 2000 to 3000 times larger because of the division.

To help insure good spectral purity, a sampler is used for the phase detector, yielding increased gain because of the harmonic multiplication.

Some of the distinctions between 'direct' and 'indirect' can now be seen. Large multiplying numbers, like 3000 shown above, are common in indirect synthesizers but in a direct synthesizer the filtering would not be possible to accomplish. When a frequency is multiplied, so is the phase noise. To reduce this multiplied noise a filter is needed either between the multiplier and the newly-formed output or at the output. But when a phase lock loop is used, as in the 'indirect' method, the filtering is accomplished automatically by the inherently narrow loop bandwidth. Indeed,

the bandwidth of the loop can be optimized for best noise performance. At frequencies below the loop's bandwidth, the noise can be determined by the reference source. And at frequencies above the loop's bandwidth the noise will be determined by the resonant oscillator.

In the 'indirect' approach, some degree of phase continuity is attained because the output comes from an oscillator which by necessity must slew from one frequency to another. Also, it is not necessary to amplify the synthesized signal when the 'indirect' method is used, since the locked oscillator can normally supply adequate signal level.

There is at least one drawback, however, to the 'indirect' method and that is the switching speed. In many cases, there is one order of magnitude difference and sometimes more. Instead of switching in periods from $10\mu\text{s}$ to $100\mu\text{s}$, the 'indirect' approach typically requires as much as 1 ms. For many applications this is not much of a problem, and when the cost of the two techniques is compared, a saving is realized by using the indirect approach.

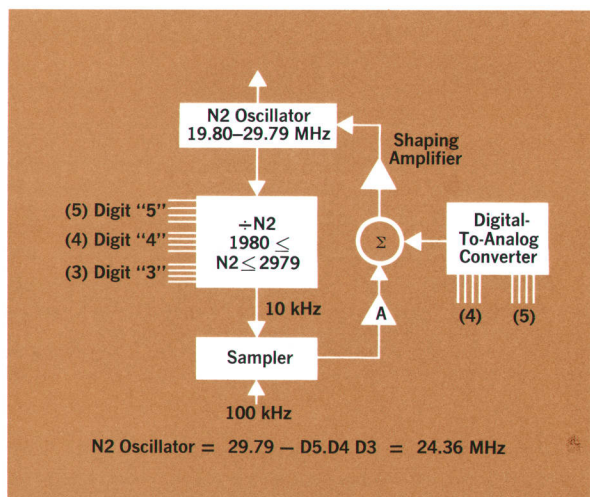

High-Frequency Loop

This loop generates eleven discrete frequencies from 350 MHz to 450 MHz in 10-MHz steps, which are then translated to the front panel output. The loop is of the harmonic sampling type with 10 MHz as its reference source. The loop bandwidth is very wide, approximately 500 kHz; its switching time thus is negligible when compared to the low-frequency loops (Fig. 10). The only spurious signal of any consequence is the 10-MHz sideband, and because there is a direct translation and no multiplication, the 80-dB signal-to-spurious level applies here also.

One of the limiting sources of phase noise in the 8660A/B comes indirectly from this loop. Noise generated in the reference loop is passed through

the HF loop (Fig. 4) with its wide, 500-kHz bandwidth, and is multiplied 35 to 45 times before reaching the output. Some reduction of this noise would normally be expected as a result of correlation with the fixed 500-MHz signal. However, the bandwidth of the reference loop, being 50 kHz, prevents noise correlation. Thus the output signal's purity suffers slightly between 50 kHz and 500 kHz.

Digital Control Unit

The DCU is the brain of the 8660A/B mainframe. It receives digital information from either the front panel controls or a remote source (computer, card reader, tape, etc.) and processes this data for the appropriate subsection. Fig. 6 shows a simplified block diagram of the 8660B digital unit. When a

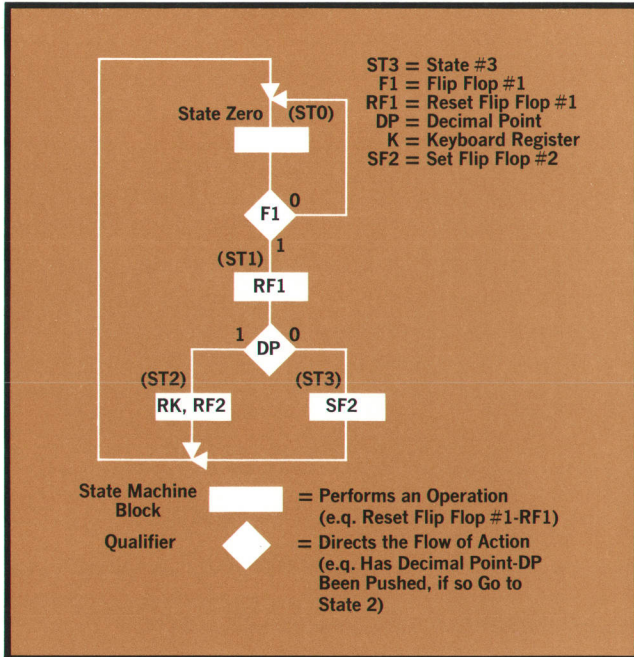

Fig. 7. Algorithmic state flow chart diagram shows digital control unit's logic design.

frequency has been typed on the front panel keyboard the digits are transmitted to the temporary storage register in a character-serial (4 bits), bit-parallel format. The data will remain in this temporary register until one of the four ENTER keys is pushed. Assuming the CENTER FREQUENCY key has been pushed, the data in the temporary register is bussed (4 bits at a time) along the T buss to the center frequency storage register and also to the accumulation (A) storage register. From the A register the data is sent to the phase lock loops discussed earlier. If the (Step) key had been pushed, the data in the temporary register would have been bussed to the step storage register via the T buss. From there the center frequency and step registers are added together in the arithmetic logic unit (ALU) via the R and S busses respectively. The sum of these two registers is transmitted back to the center frequency and A registers along the T buss to complete the (Step) instruction. If the (Step) key had been pushed, the same process would take place with the ALU performing a subtraction instead of an addition. If the SWEEP WIDTH key had been pushed, the data in the temporary register would have been bussed to the sweep width storage register via the T buss.

The sweep operation is a general form of the STEP mode. When the Sweep Mode switch is set for AUTO, the data in the sweep storage register is first divided by 1000 (or 100 in the fast mode)

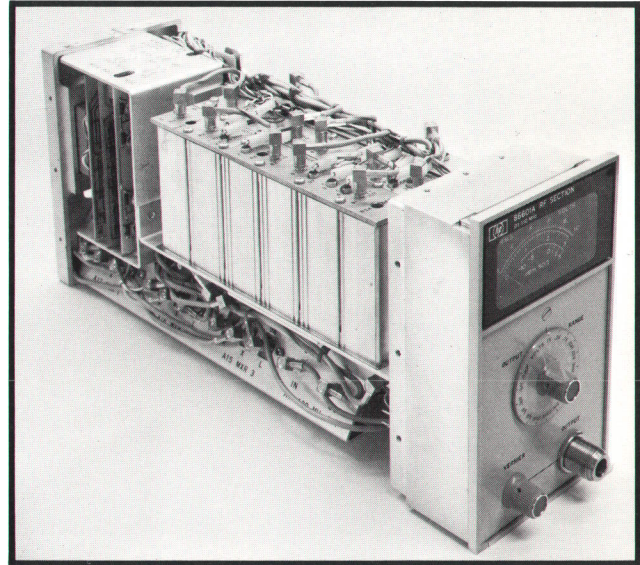

Fig. 8. Each electrical and mechanical assembly of 86601A RF Unit is individually removable.

and then processed through the ALU and back to the A register via the T buss. This operation is performed 1000 times, thereby generating 1000 discrete frequencies in the A register. Now the process starts all over again. The sweep waveform is a simulated sawtooth, symmetrical about a center frequency. The center frequency is displayed on the solid-state readout at all times.

Remote Control

When the 8660 is under remote control, the operation is the same as above for control of frequency. However, if either of the 8660's plug-ins are being programmed, only the temporary storage register is used and data is fed serially (4 bits at a time) from it to the appropriate plug-in.

The 8660A DCU is simpler in its operation because only the center frequency can be controlled. It also has a temporary storage register but only one other register is needed and it is similar to the A register shown here.

The logic design for the 8660B's DCU is based on the use of algorithmic state machine theory (Fig. 7).

Although the 8660A/B mainframes contain the circuits which generate and control items like frequency switching speed, phase noise, frequency stability and accuracy, remote programming times and frequency resolution, each RF section will ultimately determine the performance specifications at the front panel output connector. Because of this, many of the mainframe's specifications are tied to the RF section.

10 kHz - 110 MHz PLUG-IN

The first RF section plug-in designed for the 8660A/B mainframe is the 86601A, covering the frequency range 0.01 to 110 MHz. To function, this plug-in requires a mainframe. It performs two essential operations: 1) it translates the mainframe frequencies to cover the specified range and 2) it amplifies and levels the output voltage. The frequency range is more than four decades, which makes the 86601A useful for applications ranging from component testing to local oscillator simulation. Many of the signal characteristics are determined by the 8660A/B mainframe, but because the signal output is ultimately generated in the plug-in, the important performance details are discussed here.

The 86601A is compact (Fig. 8), and yet each electrical and mechanical assembly can be removed directly. The front panel controls are self-explanatory—only the voltage level is adjusted here. The output signal level can either be controlled manually from the front panel or programmed via the rear panel multi-contact connector. Any or all of the signal's characteristics (frequency, voltage level or modulation format) can be remotely controlled. The voltage attenuation range is extremely wide (159 dB) with a maximum of +13 dBm (1 volt).

The 8660 system certainly is considered both a synthesizer and a signal generator. Synthesis techniques are used in the output circuitry to achieve wide frequency range. So signal purity of this particular plug-in leans more towards synthesizer performance. The output signal is developed through a mixer and amplified to the desired level by a wide-band amplifier of 40 dB gain.

Block Diagram

Fig. 9 shows the system concept in simplified form. Mixer #1 generates 480 MHz, the difference between its two inputs. Both inputs come from the reference loop in the 8660A/B mainframe, but the 500-MHz signal is first filtered to reduce unwanted sidebands (10 MHz, 20 MHz, and 100 MHz). The 500-MHz filter, a stripline design, is about 3-MHz wide with 2 dB insertion loss. Mixer #2 generates a signal covering the range 450-460 MHz, the difference between its two inputs. One of the inputs, 480 MHz, is both amplified and filtered to assure enough level to act as the LO for the mixer and to suppress unwanted mixing products and LO feed-through. This bandpass filter is also a stripline design with a sharp, 4-pole roll-off. The mixed output (450-460 MHz) is filtered before being processed by the modulator. The output of mixer #3 covers the range 0-110 MHz, the difference between its two inputs. This signal is amplified and fed through a 150-dB, 10 dB/step attenuator to the output at the front panel. The amplified signal is also peak-detected and compared to a reference dc voltage in a feedback amplifier. The error voltage from this feedback amplifier is fed back to the modulator to complete the leveling loop. To assure low spurious generation, all mixers are filtered at both inputs and outputs. Amplifiers are also used where necessary to bring a signal voltage up to the level required for a mixer LO.

How Well Does It Perform?

With the operation of both plug-in and mainframe now in mind, an example of an actual synthesized frequency can be discussed. The plug-in

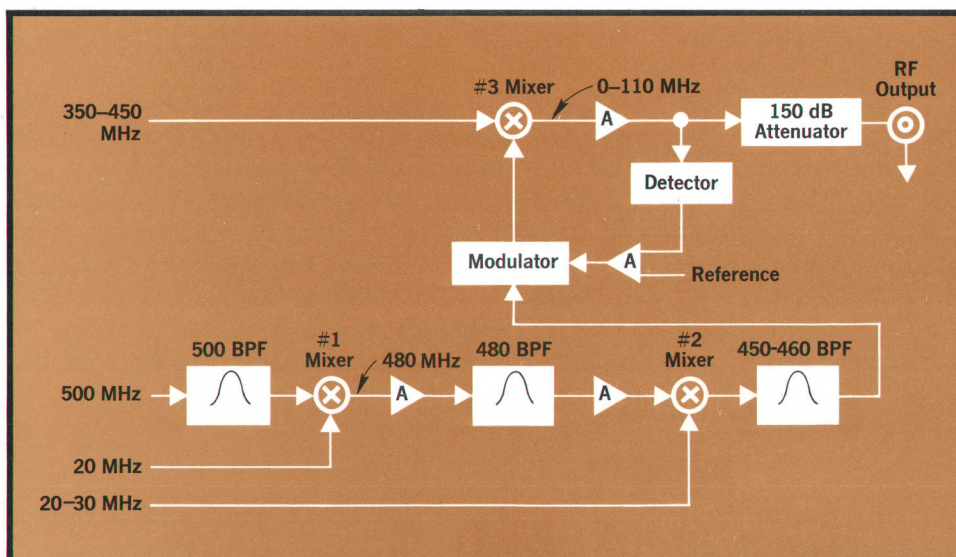

Fig. 9. Block diagram shows rf system concept.

requires four separate frequencies from the mainframe to generate an output. Two of these, 500 MHz and 20 MHz, are fixed and never change. The other two, 350–450 MHz and 20–30 MHz, are variable and depend on the output frequency being asked for. Assuming an output at 107.654321 MHz is desired, we see that the 20–30 MHz signal is set to 22.345679 MHz (Fig. 4). When this frequency is subtracted from 480 MHz in mixer #2, the resultant signal is at 457.654321 MHz. This frequency is then mixed with 350 MHz (from Fig. 4) in mixer #3 giving the expected output at 107.654321 MHz. As the 350–450 MHz and the 20–30 MHz oscillators vary over their complete range, the output will change from 0–110 MHz.

Depending upon the application, some generator/synthesizer performance characteristics are more significant than others. Fig. 10 presents a gallery of performance data typical of the 8660/86601 combination.

One of the design tradeoffs that had to be made with the 86601A relates to AM bandwidth. It becomes necessary to reduce the AM bandwidth as the output frequency is lowered, to prevent the output signal harmonics from rising. Also, the flatness of the signal voltage is degraded to some extent when the frequency is lowered and approaches the bandwidth of the leveling loop. To minimize these problems, the 86601A will automatically change the bandwidth of the leveling loop as the output frequency is varied. A different loop bandwidth is used for each of three frequency regions. Region I is from zero to less than 400 kHz. Region II is from 400 kHz to less than 4 MHz. Region III is from 4 MHz to 110 MHz. The effect of bandwidth switching can be seen in Fig. 10, particularly in the flatness curve. The AM response is also changed because the leveling loop is used to generate this form of modulation.

Modulation

Modulation capability is implemented with an optional plug-in (Model 86632A, Fig. 1) which will be treated in detail in next month's Hewlett-Packard Journal. This unit processes the modulating signal and precisely controls the modulation process. Amplitude modulation is not accomplished within the plug-in, however, but instead by applying the processed modulating signal to the leveling loop of the rf plug-in. Frequency modulation is performed by applying the processed signal to a 20-MHz oscillator within the modulation plug-in. The output of this oscillator, now a frequency-modulated signal, is substituted for the 20-MHz synthesized signal in the

rf plug-in and directly mixed into the output frequency.

Spectral Purity

At the top of the desired performance list for practically all signal generators is a noise-free signal. One of the more important accomplishments was finding the causes of phase noise and then minimizing or removing the noise sources. Fig. 10 shows actual plots of both amplitude and phase noise with respect to the calibrated output signal. Phase noise originates in more than one source. Below 50 kHz, the 20–30 MHz signal (SL1 output) is the determining source. From 50 kHz to 500 kHz, the performance-limiting noise originates in two digital dividers in the reference loop, noise that does not correlate out at the output. And finally, the noise from 500 kHz on is generated by the output amplifier which amplifies thermal noise at its input and which also has a noise figure of its own (6 dB).

Amplitude noise can be just as harmful but, as Fig. 10 shows, this noise is lower than the phase noise. The amplitude noise has many sources also, but only two directly determine the output performance. From zero to around 50 kHz, the feedback amplifiers in the leveling loop contribute noise; and from 50 kHz up the output amplifier is the source of noise. These noise sources have all been painstakingly reduced.

Switching Speed

It isn't very surprising to discover that the 8660 system is capable of being remotely programmed at rates much faster than the response time of the output signal. The digital circuitry that interfaces with the external programming device can function at rates approaching 1 MHz, which becomes insignificant when compared to the millisecond settling time for a change in output frequency or voltage. Fig. 10 demonstrates the switching capability of the 8660 system. For applications where absolute accuracy is not important, the frequency can be changed over 200–500 μ s. But when the output frequency must be within 100 Hz of its programmed value, the user must wait 2–5 ms before asking for another frequency. One of the subtle hazards that most synthesizers have, including the 8660, is the occasional possibility of a large frequency transient even though the output is changing only 1 Hz. As stated earlier, when the frequency is changing from nines to zeroes or vice versa, a transient of many kHz can exist for 200 μ s or so.

Switching Characteristics

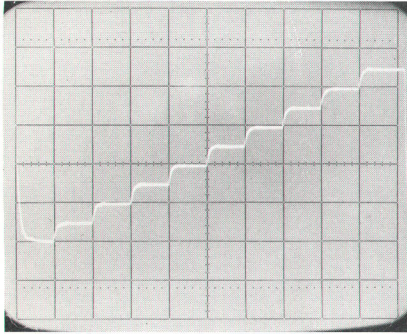

500-kHz steps from 40 MHz to 44.5 MHz (1ms/cm).

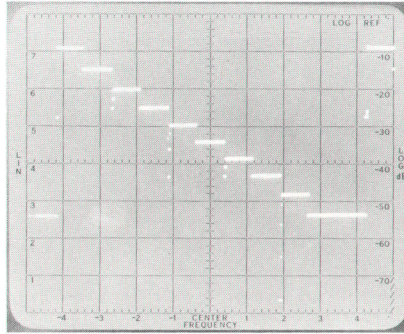

1-dB steps from +13 dBm +4 dBm (2 dB/cm vertical, 5 ms/cm horizontal).

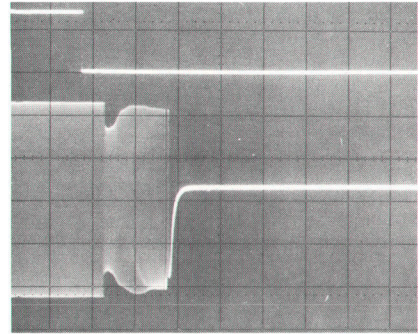

10-MHz step from 30 MHz to 40 MHz (50 μ s/cm). Switching signal is above. Output is mixed against another 40-MHz signal for resolution.

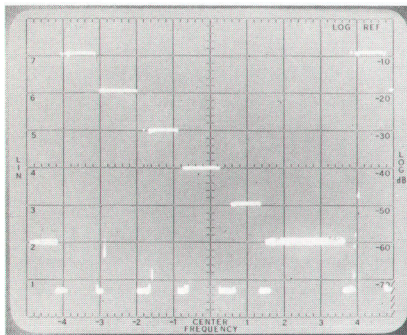

10-dB steps from +13 dBm to -37 dBm (50 ms/cm).

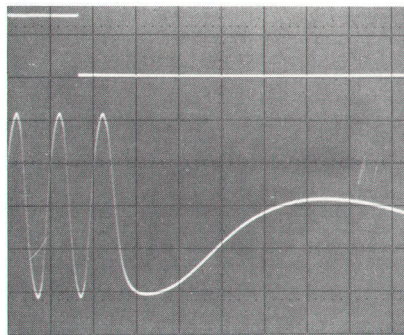

20-kHz step from 30 MHz to 30.02 MHz (50 μ s/cm). Again, switching signal is above and output is mixed against another 30.02-MHz signal for resolution.

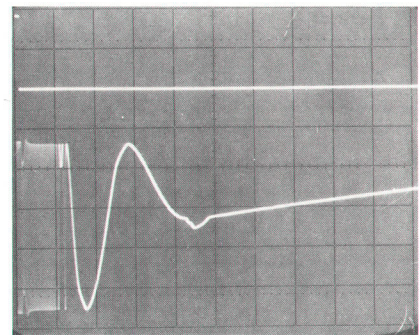

Worst-case condition: 9.999999-MHz step from 30 MHz to 39.999999 MHz (1 ms/cm). Switching signal shown, and output mixed, as before.

Output Voltage

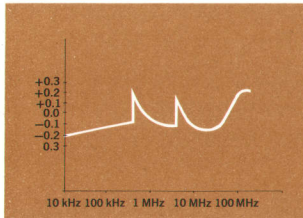

Output voltage vs frequency in relative dB (0 dB = 1 V).

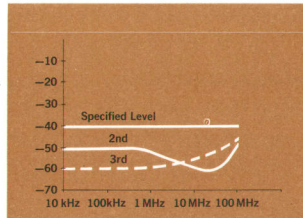

Harmonics, in dB below the carrier at 1 V output. All other harmonics typically below -60 dB.

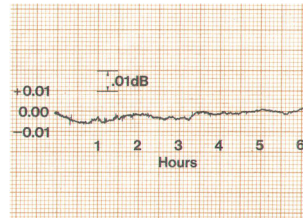

Output voltage vs time

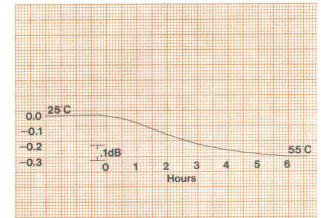

Output voltage vs temperature

Modulation

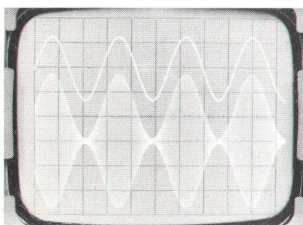

Modulation distortion characteristics. 20-MHz carrier with AM >90% at a 2-kHz rate. Carrier and detected envelope shown.

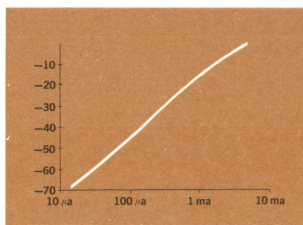

Dynamic range of 86601A modulator, relative attenuation (dB) vs bias current.

Spectral Purity

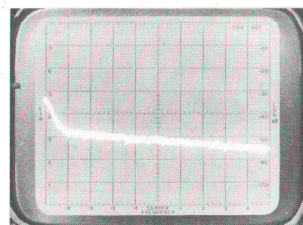

Phase noise in a 1-Hz band (SSB) referenced to carrier. Reference (top graticule line) is -70 dB (20 kHz/cm, carrier = 30 MHz).

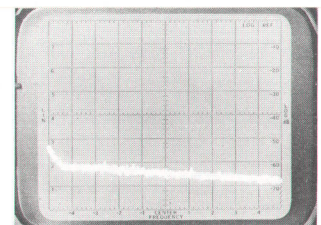

Amplitude noise in a 1-Hz band (SSB) referenced to carrier. Reference is -70 dB (20 kHz/cm, carrier = 30 MHz).

Fig. 10. A gallery of 8660/86601A performance data.

Remote Programming Format

The 8660 system uses a serial entry method for programming because of the number of lines that would be required to control all of its modes in parallel. The rear panel connector can accept two full digits of information (8 lines) at a time. Each set of digits can be transmitted into the 8660A/B mainframe every $1.25 \mu\text{s}$ and each address requires $5.5 \mu\text{s}$. The procedure for programming is first to tell the 8660 what the digits are and then to inform it what is being programmed—frequency, voltage, or modulation. This latter instruction is in the form of an address. The programming interface is fairly easy and for some simple applications can be done in seconds with a card reader (Fig. 11).



Fig. 11. Synthesizer can be programmed with Model 3260A Marked Card reader.

References

1. Victor E. Van Duzer, 'A 0-50 Mc Frequency Synthesizer with Excellent Stability, Fast Switching, and Fine Resolution,' *Hewlett-Packard Journal*, May 1964.
2. Roger D. Story, "Look, No Contacts," *EDN/EEE*, Oct. 1, 1971, pp. 33-34.

Acknowledgments

I am happy to acknowledge the invaluable contributions of the 8660 design team and their persistence and individual commitment.

Hamilton Chisholm—for his work on the 8660B digital control unit and his guidance through the programmable dividers for the phase lock loops. He mastered the algorithmic state machine methods which ultimately resulted in an optimized design for the digital control unit.

Charles Cook—for his work on many of the

mainframe sheet metal parts and his ability to bridge that gap between the lab and production. He stepped in and did a thorough job when it was needed most.

Bob Gallien—for his work on the 86601A RF Section plug-in. He covered the electrical design and development as a one-man project and did excellent work in his first assignment. He is presently supporting the production area with technical backup and helping to develop cost saving methods of manufacturing the product.

John Hasen—one of the experienced designers who carried a major portion of the electrical responsibility. His persistence and insight into problem solving were major factors in attaining the specification objectives. He was directly responsible for the low-frequency loops and performed many system evaluations to assure a sound product.

Roland Hassun—another experienced designer who along with developing the critical reference loop also supplied technical guidance to some of the newer engineers. His background in noise and spectral purity of oscillators and frequency standards brought an important dimension to the project team.

Rich Krueger—for his work on the mechanical designs of the 86601A. This was his first project and he succeeded in developing a serviceable package within the boundary conditions of a plug-in. His latch design is particularly noteworthy.

Michael Marzalek—for his work on the 8660A digital control unit and the remote control interface circuitry. He brought many unique ideas and designs into the digital workings of the 8660. His programs to exercise the 8660 in remote have proven to be essential.

Brad Stribling—for his work on the high frequency loop. Developing a wide range, tunable oscillator at 400 MHz was a major contribution. His thoroughness has resulted in a reliable and optimized phase lock loop.

Bob Waldron—for his work on many of the mechanical designs of the mainframe and especially the die casts and plastic molds. His tenacity is beyond description. He developed mechanical parts which allowed common usage for both the 8660A and 8660B.

There were many other people who helped along the way. Ali Bologlu, Ben Helms and Jerry Merkelo were early contributors. Dick Shores and our illustrious 'Sprint' group made sure that proper documentation was generated for use in production. Bob Giusto coordinated the tooling and Bill West helped to make the new keyboard producible.

Jim McGrath handled the servicing aspects of the program and Jim Paul developed an excellent set of instrument manuals. Dan Derby did most of the industrial design and gave us the keyboard slope

concept. My thanks also to Wally Rasmussen for many helpful suggestions and in keeping the project on the right track. 🍷



John C. Shanahan

John grew up in Omaha, Nebraska, took his BSEE at Iowa State, and came straight from there to work at HP, Palo Alto, in 1960. He's been steadily on Microwave Division engineering projects, including the 8403A modulator, the 8708A synchronizer, the 608E/F and 606B signal generators. With all that, and raising a family, he still found time to take a Master's in EE at Stanford under the HP Honors Program. John is a 15-handicap golfer and an ardent student of U.S. military history. He lives in Sunnyvale with his wife, a daughter, and two sons.

PARTIAL SPECIFICATIONS HP Model 8660A/B Synthesized Signal Generator

MAINFRAMES

FREQUENCY STABILITY:

Internal 10 MHz Oscillator $\pm 3 \times 10^{-8}/24$ hrs., or
Option 001: $\pm 3 \times 10^{-9}/24$ hrs.

External Oscillator: May be 1.0, 2.0, 2.5, 5.0 or 10.0 MHz at 0.2 to 2.0 V into 170 Ω .

REFERENCE OUTPUT: 0.5 to 1.0 V into 170 Ω .

SYNTHESIZED SEARCH (8660B only):

Search dial changes frequency 200 steps/revolution, i.e. 200 Hz, 200 kHz, or 200 MHz per revolution, depending on switch position. Dial tunes entire range of rf section installed.

DIGITAL SWEEP (8660B only):

Symmetrical about center frequency in 100 steps (for fastest sweep) or 1000 steps. Width adjustable over entire range of installed rf section.

Manual Sweep: Dial sweeps selected width in 1000 steps.
Single Sweep: Manual pushbutton.

REMOTE PROGRAMMING:

8660A: All front-panel frequency, output level, and modulation functions.

8660B: CW frequency, frequency stepping (see text), output level, and modulation.

Frequency: 1-Hz or 10-Hz resolution, determined by installed rf section.

Output Level: 1-dB steps over range of installed rf section.

Logic: TTL-compatible (negative true); "0" logic state > 2 V, "1" logic state < 0.8 V.

GENERAL:

Operating Temperature Range: 0° to +55°C.

Power: 115 or 230 volts $\pm 10\%$, 50 to 60 Hz.

Approximately 200 watts.

Size: 16 $\frac{3}{4}$ in. wide x 7 in. high x 21 $\frac{1}{2}$ in. deep (426 x 178 x 547 mm); 19 in. deep behind rack mounting surface.

Weight: Net, 48 lb. (21.6 kg.). Shipping, 58 lb. (26.1 kg.), (8660A or 8660B Mainframe only).

RF SECTION (86601A installed in 8660A or 8660B Mainframe)

FREQUENCY CHARACTERISTICS

Frequency Range: 0.01 to 109.999999 MHz in 1-Hz steps.

Frequency Accuracy and Stability: Determined by oscillator in or connected to mainframe.

Switching Time: < 5 ms to be within 100 Hz of any new frequency selected; < 100 ms to be within 5 Hz.

Harmonic Signals: > 40 dB down.

Spurious Signals: > 80 dB down.

Signal-to-Phase Noise Ratio: > 50 dB in a 30-kHz band centered on the signal, excluding a 1 Hz band so centered.

Residual FM: < 1 Hz rms in a 2 kHz bandwidth centered on carrier.

Signal-to-AM-Noise Ratio: > 70 dB in a 30-kHz band excluding 1-Hz band centered on carrier.

OUTPUT CHARACTERISTICS

Output Level: +13 to -146 dBm into 50 Ω .

Output Accuracy (local and remote modes):

± 1 dB from +13 dBm to -66 dBm, ± 2 dB from -67 to -146 dBm.

Flatness: ± 0.5 dB across entire frequency range.

Output Level Switching Time: Worst case < 50 ms; any change to another level on same attenuator range 5 ms in REMOTE mode.

Impedance: Nominal 50 Ω .

MODULATION CHARACTERISTICS (with 86632A Modulation Section)

AM Depth: 0 to 99% on all output ranges.

AM On/Off Ratio: At least 25 dB with meter at 0 dB or more.

AM Carrier Envelope Distortion: With modulating signal distortion $< 0.3\%$, $< 1\%$ @30%, $< 3\%$ @70%, $< 5\%$ @90%.

Incidental PM: < 0.2 radian peak @ 30% AM.

Incidental FM: $0.2 \times f_{\text{mod}}$.

FM Rate: dc to 1 MHz.

Max. Deviation: 1 MHz.

Incidental AM: With 75 kHz p-to-p deviation at 1 kHz rate AM sidebands > -60 dB.

GENERAL

Size: Plug-in to fit 8660A or 8660B Mainframe.

Weight: Net, 11 lb. (5 kg.). Shipping, 15 lb. (6.8 kg.).

PRICES

Model 8660A Mainframe, \$4900.

Model 8660B Mainframe, \$6000.

Option 001 high-stability oscillator add \$300.

Option 002 no internal oscillator subtract \$350.

Option 003 operate from 400 Hz power add \$50.

Option 004 100 Hz frequency resolution subtract \$500.

8660A only, Option 009 solid-state front-panel frequency display in 1-2-4-8 BCD code add \$200.

Model 86601A RF Section, \$1975.

Option 001 no output attenuator, subtract \$600.

Model 86632A Modulation Section, \$900.

MANUFACTURING DIVISION: MICROWAVE DIVISION

1501 Page Mill Road
Palo Alto, California 94304

Remote Laser Interferometry

This unique remote interferometer, affectionately dubbed The Magic Cube, significantly improves the stability, accuracy, and scope of laser interferometer measurements

**By Richard R. Baldwin, Gary B. Gordon,
and André F. Rudé**

THE DEVELOPMENT OF THE LASER INTERFEROMETER was a major step forward in man's ability to measure distance easily and precisely. Laser interferometers can measure distances up to hundreds of feet with a resolution of a millionth of an inch. They do it by using the wavelength of laser light as a length standard. This wavelength is known precisely enough to make laser interferometers inherently accurate within a few parts in ten million.

In measuring short distances, however, this high inherent accuracy has been difficult to realize. The reason is the laser itself. It generates heat, and even a little heat can cause objects to expand enough to affect the accuracy of an ultraprecise measurement to a significant extent.*

The solution to this problem was hinted at several years ago by a well-known metrologist. After waiting several frustrating weeks for the thermal transients induced by an early oven-stabilized laser to reach equilibrium in his writhing granite surface plate, he ruefully offered this advice to prospective interferometer builders: 'Make one that is small, has no wires, and generates no heat'. It seemed impossible at the time.

As the saying goes, the impossible just takes a little longer. The HP 10565A Remote Interferometer is small, has no wires, and generates no heat. It's completely passive. There's still a laser/electronics package, but the only connection between it and the interferometer optics is the laser beam. Fig. 1 shows the elements of the system.

The difference between this system and previous interferometers is that the distance measured is the displacement of the reflector (at right in Fig. 1),

relative to the remote interferometer (center of Fig. 1), rather than the displacement of the reflector relative to the laser head (at left in Fig. 1). Thus the laser head can be placed far away from the measurement setup. It will still generate heat and its position will still change due to thermal expansion of whatever it is sitting on, but this motion isn't measured. The zero point of the measurement is the remote interferometer, not the laser head. Since the remote interferometer generates no heat, it can be placed close to the measurement setup without introducing error. The improved stability is evident in the drift records shown in Fig. 2.

But improved stability and accuracy are only the beginning of the remote interferometer story. A family of modules has also been developed to be used with the remote interferometer to make a variety of linear and angular measurements, including pitch, yaw, and flatness. Non-contacting linear measurements are possible, too. The remote interferometer expands the scope of laser interferometry to such a degree that its designers like to call it 'the magic cube'.

How It Works

The remote interferometer is essentially the same type of optical system used by A. A. Michelson in the 1890's to measure the meter bar. It consists of a beam splitter and two retroreflectors, one fixed as a reference and one movable. The retroreflectors are glass trihedral prisms, or 'cube corners', which reflect light so the reflected beam is parallel to the incoming beam. The reference cube corner is attached to the magic cube. Fig. 3 shows the optical schematic.

The magic cube is designed to work with the HP

* HP's ovenless laser generates only a fraction of the heat of more conventional oven-stabilized lasers, but in some measurements it's still too much.

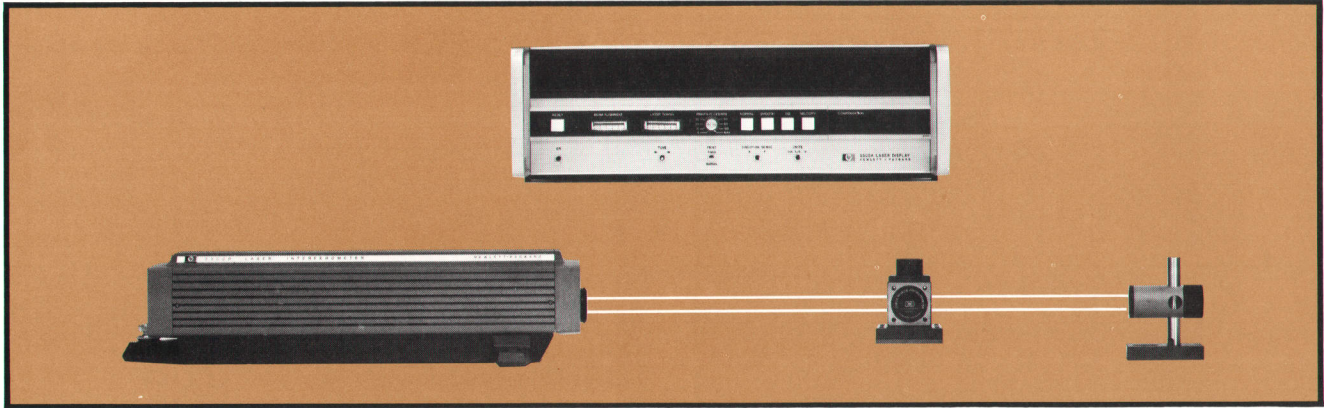

Fig. 1. When Model 10565A Remote Interferometer (cube) is used with Model 5525B Laser Interferometer, the displacement of the reflector (right) is measured with respect to the remote interferometer instead of the laser head (left). The cube eliminates heat and deadpath, two major sources of error.

5525B Laser Interferometer system. Earlier 5525A systems can also work with the cube—a simple factory modification is required. These systems are ac interferometry systems using an HP-developed two-frequency laser. Their principle of operation and their advantages over dc single-frequency interferometers are discussed in Reference 1.

As Fig. 3 shows, the light from the laser head has components at two frequencies, f_1 and f_2 . The f_1 component is linearly polarized in the plane of the drawing and the f_2 component is linearly polarized perpendicular to the plane of the drawing. Upon reaching the beam splitter, which is a specially designed optical glass plate with a multilayer dielectric coating, f_1 passes through with virtually 100% efficiency, while f_2 is just as efficiently reflected. Each frequency travels down a different leg of the interferometer and is reflected by the cube-corner

in that leg back to the polarizing beam splitter. There the two frequencies are recombined, again with near 100% efficiency.

After the laser beam has been divided and recombined in the remote interferometer, it contains relative phase information which can be used to measure any change in the length of either leg of the interferometer. It's important to note here that any changes in the optical path which occur before beam division and after beam recombination—that is, while the two frequency components are coaxial—don't affect the measurement, since these changes affect both frequencies equally. Since beam division and recombination both occur within the remote interferometer, any motion of the laser head relative to the remote interferometer isn't measured at all. In metrological terminology, deadpath error is completely eliminated.

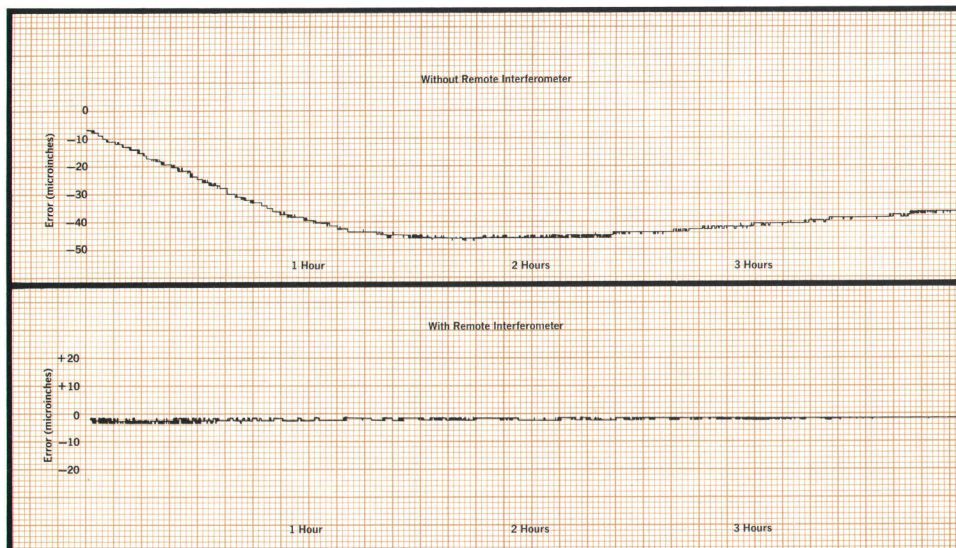

Fig. 2. Stability of laser interferometer measurements is much improved by the remote interferometer because, unlike the laser head, it generates no heat. Improved stability makes the system's sub-microinch resolution usable in a much wider range of applications.

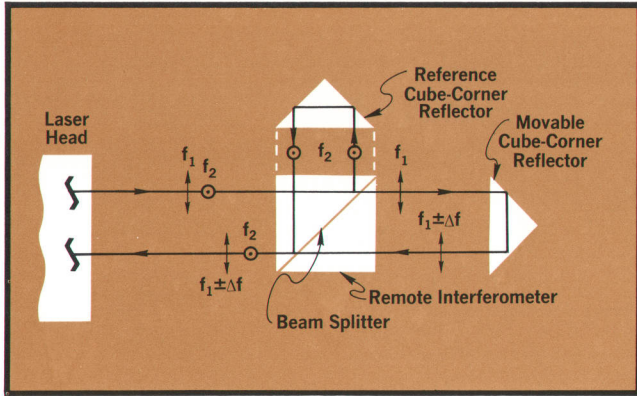

Fig. 3. Remote interferometer is designed for use with HP's two-frequency interferometer systems. It's basically a Michelson interferometer with a polarizing beam splitter and cube-corner reflectors. Changes in the optical path to the left of the beam splitter don't appear in the measurement since both frequencies are affected equally.

Magic Cube and Modules Make Many Measurements

The remote interferometer and its accessory modules take laser interferometry out of the category of a single-purpose measuring technique. Here are the measurements that can now be made and the accessories needed to make them.

Linear Measurements

Simple linear measurements are made with just the magic cube, the 10565A Remote Interferometer, which consists of a base (10565-20004), a remote interferometer assembly (10565-60001), and a reflector assembly (10565-60002). Also needed, of course, is the 5525B system, which includes the laser head, display, and the standard 10550A reflector.

For right-angle linear measurements, the reflector assembly is switched 90° to an adjacent side of the remote interferometer assembly.

Non-Contacting Linear Measurements

Accessories needed are a lens holder and one of three lenses of different focal lengths selected from accessory kit K01-10565A. The lens holder is mounted on the exit port of the remote interferometer assembly to focus the beam on a reflective surface. A telescope (K02-10565A) can be added to the incoming port of the remote interferometer to get a larger spot which is less sensitive to surface defects, or to increase the measurement range.

Angular Measurements

Removing the reflector assembly from the top of the remote interferometer assembly and replacing it with a beam bender (10558A) makes the reference and measuring beams parallel and makes it possible to measure pitch, yaw, and flatness. Also needed are an additional reflector (10565-60002) and a reflector mount (10559A). The reflector mount has small feet with spacing equal to that of the two beams. This gives direct readout in arc-seconds on the interferometer display.

What It's Used For

Since the remote interferometer can make measurements which are immune to relative movement of the laser head, it has found many applications in ultraprecise measurements over small distances, such as the positioning of integrated-circuit stages. The remote cube has advantages that aren't found in other interferometer systems. Due to its small size and weight, it is easily fixtured and is less likely to disturb the system being measured. It also offers more versatility in fixturing than was possible with larger interferometers. The user can mount the interferometer where the measurement is being made, instead of being restricted to the nearest spot big enough for the laser head.

Ease of fixturing, light weight, and good thermal characteristics make the remote interferometer useful for calibration of x-y stages, microcomparators, height gages, and even gage blocks. A good example of the accuracy which can be attained through proper use of the remote interferometer is shown in Fig. 4. The two plots shown in the figure represent the total indicated error over the full travel of a micro-displacement calibrator. The upper plot was taken with the calibrator in a vertical position and the bottom plot was made with the calibrator horizontal. The specified accuracy of the micro-displacement calibrator was 5 microinches, and both plots show the calibrator to be within tolerance. Since the interferometer's one-microinch resolution wasn't adequate, the K02-5525A Resolution Extender was used to extend resolution to 0.1 microinch. The remote interferometer assured the stability needed to make this resolution meaningful.

Angular Measurements, Too

If the remote interferometer is used with the HP 10558A beam-bender attachment the incident and reflected beams are brought out parallel and the interferometer can be used to measure quan-

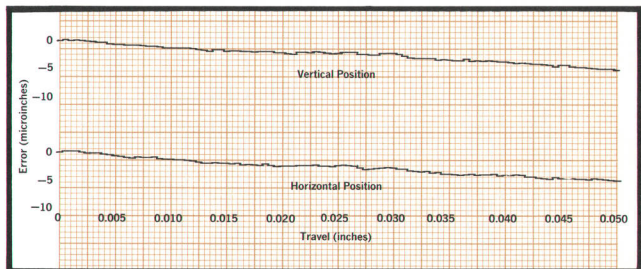

Fig. 4. Using the remote interferometer and a K02-5525A Resolution Extender, a micro-displacement calibrator was checked to within 0.1 microinch. Test showed it to be within its 5 μ in tolerance.

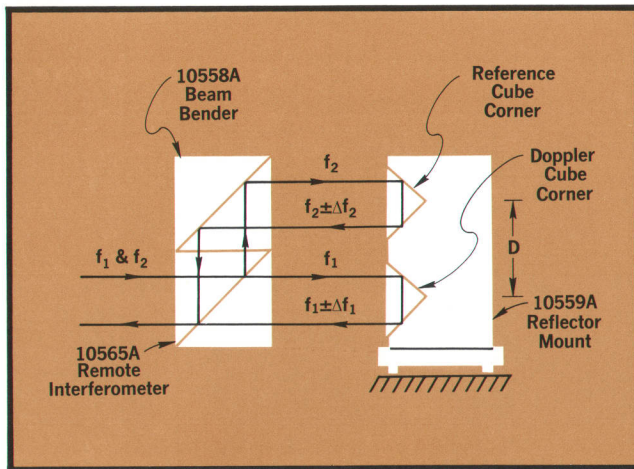

Fig. 5. With Model 10558A Beam Bender attachment and two cube-corner reflectors mounted in a Model 10559A reflector mount, angular pitch and yaw measurements can be made. Translation of the two reflectors isn't measured, but rotation of the reflector assembly is.

ties that no interferometer could easily measure before—angular pitch and yaw. In this configuration the reference cube corner is mounted in a common holder (Model 10559A) with the other cube corner as shown in Fig. 5. Translation of the assembly will not be measured by the interferometer since both cube corners move in the same direction by an equal amount. However, if the assembly is rotated about an axis perpendicular to the plane of the figure one cube corner will move relative to the other and this relative motion will be measured by the interferometer. The separation (D in Fig. 5) between the nodal points of the two cube corners is chosen so the display for small angles reads out directly in seconds of arc. This capability is particularly useful in machine tool certification, since most machine tools have fairly tight tolerances on allowable angular pitch and yaw. *The same interferometer can be used to certify angular pitch and yaw as well as positioning accuracy on a machine tool.*

The angular measuring capability of the remote interferometer is also useful in measuring surface plate flatness. The dual cube-corner assembly is mounted on feet as shown in Fig. 5, and the foot spacing is equal to the cube-corner spacing. Thus any change in elevation of one foot relative to the other will cause the same relative change in the position of the two cube corners, and this can be read directly on the display. If the dual cube-corner assembly is stepped along a surface plate using conventional autocollimator techniques*, the resulting

* This involves stepping the cube-corner assembly along the measurement path and adding incremental changes of elevation to determine the total elevation profile.

readings can be used to give a plot of surface-plate flatness. A typical plot is shown in isometric form in Fig. 6. All data for this plot were obtained using the remote interferometer.

The principal advantages of the remote interferometer over the autocollimator for this application are that the data are available in the proper units (English or metric), the data can be obtained more quickly (especially with an optional digital printer—option 20), and the remote interferometer occupies only four square inches of the surface plate.

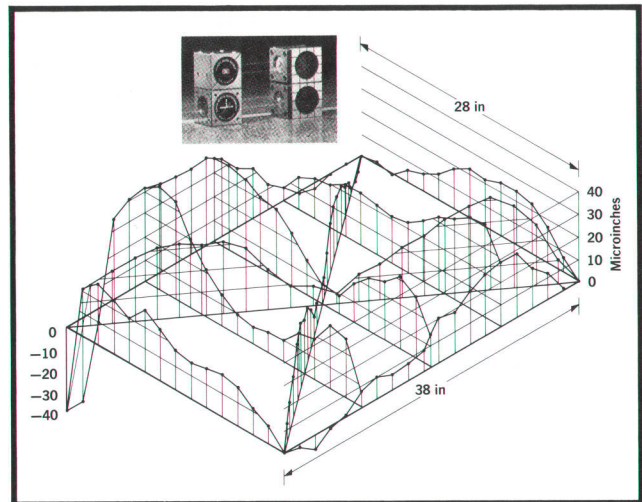

Fig. 6. Minute variations in the flatness of a granite surface plate look like mountains when measured using the angular measurement capability of the remote interferometer.

Non-Contacting Measurements

In all measuring processes where physical contact is employed, a small force is necessary to make certain that the measuring tip or anvil bears firmly against the component or gage surface. In precision measurements this force has to be closely controlled so the elastic distortions it produces are kept within acceptable limits. To maintain a constant measuring pressure, even with a constant measuring force, there must be no change in the area of contact, and this means the geometric form of the surface finish along the path of measurement mustn't vary. Because this is a difficult requirement to meet, non-contacting measurement is a highly desirable alternative. In dynamic measurements, non-contacting measurement is even more desirable, since the mass of any contact mechanism will always affect the dynamics of the measured system to some extent.

In many cases, non-contacting measurements can be made with the remote interferometer. A lens placed on the exit port of the magic cube focuses

Angstrom Measurements with Velocity-of-Light Compensation, the Remote Interferometer, and a Simple Electronic Resolution Extender

The 5525B Laser Interferometer has a basic resolution of one-quarter wavelength, or 6 microinches. In the standard instrument this is extended electronically to one microinch (or 10^{-6} m when displaying in metric units). In practice, however, this extended resolution may not be usable because of instabilities. Some major sources of instability are thermal gradients caused by the heat generated by the laser, variations in the speed of light in air caused by changes in temperature, pressure, and humidity, and variations in the dimensions of the measured part caused by changes in its temperature. Velocity-of-light variations may cause errors out of proportion to their magnitude, particularly for small measurements where there is a large 'deadpath' between the interferometer optics and the zero point of the measurement.

It's now possible to eliminate most of these instabilities. The 10565A Remote Interferometer generates no heat to cause thermal gradients. It's also small enough to be mounted close to the measured part, thereby eliminating deadpath and its associated problems. Changes in the velocity of light and in part temperature can be prevented from affecting the measurement, too. Another accessory for the 5525B Laser Interferometer, Model 5510A Automatic Compensator, is an electronic weather station which corrects all measurements for variations in the velocity of light and the temperature of the measured part.

With the remote interferometer and the automatic compensator, measurements are so stable that resolution of 0.1 microinch can be consistently realized and 0.01 microinch may even be meaningful. Model K02-5525A Resolution Extender electronically extends resolution by a factor of 10. It's a real-time system, much faster than the algorithm built into the standard 5525B system, so it can be used instead of the built-in extension circuitry for applications which require a high data rate and one-microinch resolution, such as vibration analysis or fast control loops. Used in conjunction with the built-in algorithm it gives 0.1 microinch resolution, and two K02-5525A extenders can be cascaded if 0.01 microinch resolution has meaning. When displaying in metric units, two cascaded extenders give a resolution of 10^{-10} m or one angstrom!

How the Resolution Extender Works

HP's two-frequency ac heterodyne interferometer system lends itself to a form of real-time resolution extension that isn't practical with conventional interferometers. The extender is inserted in the cable that connects the interferometer head to the laser display. At this point the distance information is contained in the difference frequency (about 2 MHz) between two high-frequency signals. This difference frequency corresponds to the doppler shift caused by moving one of the cube-corner reflectors. An increase in resolution results from multiplying this difference frequency by the desired resolution extension factor. Model K02-5525A can be programmed for a resolution extension factor of either 6 or 10.

Shown here is the block diagram of the extender. The doppler channel is multiplied by the desired resolution extension factor in a phase-locked loop and then heterodyned back down to the original carrier frequency, thus multiplying only the doppler shift. Another phase-locked loop multiplies the reference channel by one less than the resolution extension factor to create a local-oscillator signal for the double-balanced mixer.

With the extender inserted, the display operates normally in all modes including $\times 10$ and velocity, except that all displayed readings must be multiplied by the resolution extension factor.

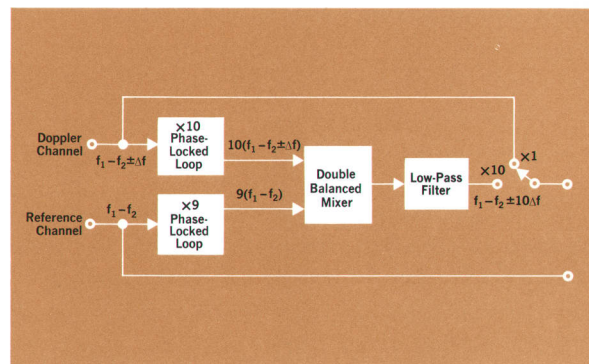

the beam onto a sufficiently reflective surface of the element under calibration. The K01-10565A non-contacting kit contains three lenses of different focal lengths (5 in, 10 in, 30 in). These are adequate for measurements from a microinch to 0.100 in (2.5 mm) with an unusually small spot size of less than 100 microinches (2 μ m). The K02-10565A telescope expands the range of measurement by a factor of a hundred. For example, a 5-in lens with a depth of field of 0.0005 in (0.12 mm) will have with an added telescope a depth of field of 0.500 in (12.5 mm). This depth of field is particularly suitable for measuring

the uniformity of reflective coatings on mirrors, magnetic tape, or parts with a lapped finish such as memory discs.

Vibration analysis is another field where non-contacting measurements are useful. Users may range from the machine tool designer trying to eliminate sources of systematic error to the civil engineer evaluating resonances and damping factors of large buildings or other structures. Like the electronic engineer using an oscilloscope, the mechanical engineer can often use a Fourier analyzer (HP 5450A, 5451A, or 5452A)², to obtain accurate and copious

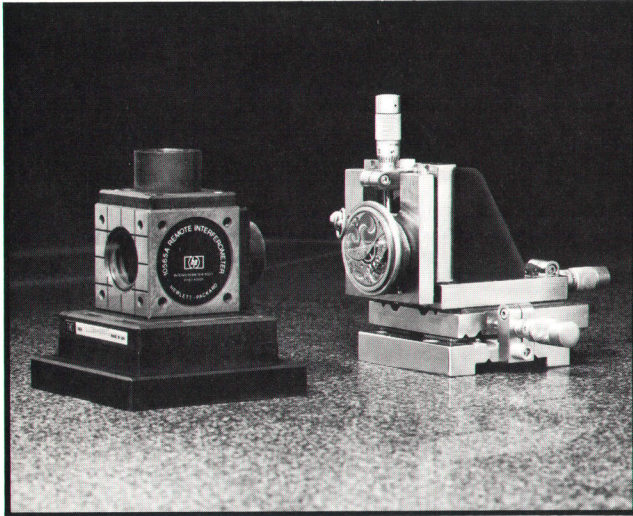

Fig. 7. Non-contacting measurements can often be made with the remote interferometer by focusing the beam on a reflective surface. Illustrated is a vibration measurement on a watch. Model 5450A Fourier analyzer was used for vibration analysis. Model K02-5525A Resolution Extender was used to give sub-microinch resolution.

information from transducers such as accelerometers, strain gages, or the laser interferometer.

Figs. 7 and 8 illustrate two extreme cases. One is a non-contacting measurement on a watch. The beam was focused on the ground-finish head screw of the escapement frame. A root-mean-square displacement of 5 angstroms (2×10^{-8} inches) at the resonant frequency was measured using the laser, a Fourier analyzer, and a resolution extender. The other case is a resonance and damping-factor measurement of a large office building in San Francisco. In this case the cube-corner reflector was placed on the 41st floor of the building (a slant distance of 635 feet = 195 meters). The fundamental resonance is about 1 cycle every 5 seconds.

How the Magic Cube is Built

For surface plate work and machine tool evaluation it is desirable that the remote interferometer maintain a fixed zero point over large distances of travel when measuring pitch and yaw. The design objective is that the maximum zero-point offset be less than 0.1 arc-second per 100 inches. This requires that differences in cosine error between the two beams be less than 1 microinch per 100 inches ($0.01 \mu\text{m}$ per meter) or one part in 10^8 . This in turn requires beam parallelism better than 30 arc-seconds. To get this degree of parallelism, critical lapped faces of the remote cube have to be perpendicular within about 12 arc-seconds, and other tolerances are equally tight.



Fig. 8. Another vibration measurement using the interferometer and the Fourier analyzer. This one measured the resonances of a large office building.

How can an electronics company build parts with this kind of accuracy? HP experience in crystal manufacturing for more than ten years was a strong asset. To have a crystal oscillate within one part in 10^9 or so requires flatness of $1/4$ wavelength over one inch, orientation accurate within 10 arc-seconds, and diameter accurate within 50 microinches. This capability was used in machining the magic cube.

Dominant requirements in the mechanical design are rigidity and stability. The optical system must maintain alignment and the mounting of the component must not distort the optical surfaces. Small-area glass-to-metal bonds were used; they provide enough flexibility to accommodate differential thermal expansion while reducing complexity and space requirements.

Acknowledgments

It's a pleasure to acknowledge the many contributors who participated in the remote interferometer project. Jobst Brandt pioneered many new optical mounting and mechanical assembly techniques. Jim Collins, drawing on his quartz crystal grinding expertise, solved the tight angular tolerance problems. Early prototypes were evaluated by Glenn Herberman and Ed Duzowski of HP's dimensional metrology laboratory. Finally, Carl Hanson and Mark Skrzyzinski smoothed the road to production.

The resolution-extender accessory, a separate project, was designed by Lynn Weber. 

SPECIFICATIONS

HP Model 10565A Remote Interferometer

DIMENSIONS: See drawing.

LINEAR MEASUREMENT ACCURACY: Same as that of the 5525B Laser Interferometer.

ANGULAR MEASUREMENT ACCURACY: (With 10558A Beam Bender) Resolution: 0.1 arc-second (0.01 with K02-5525A Resolution Extender).

Linearity: ± 0.1 arc-second over an angular displacement of 3000 arc-seconds.

Accuracy: ± 0.1 arc-second up to ± 1000 arc-seconds; ± 1 arc-second per degree up to 10 degrees using sine table.

BEAM ALIGNMENT: Exit beam parallel to incoming beam to within ± 30 arc-seconds. Reflected beam perpendicular to exit beam to within ± 30 arc-seconds, provided exit beam is perpendicular to exit face.

OPERATING RANGE: 65 feet (20 m) between Laser Head and Retro-reflector in typical machine shop environment.

WEIGHT: 2.7 lb (1.1 kg) with mounting plate.

ENVIRONMENT:

Temperature: -20°C to $+65^{\circ}\text{C}$.

Relative Humidity: 0% to condensation.

Vibration: 10-55 Hz at 0.1 inch displacement.

Shock: 30 g for 11 milliseconds.

PRICE: Model 10565A, \$2450.00.

MANUFACTURING DIVISION: SANTA CLARA DIVISION
5301 Stevens Creek Boulevard
Santa Clara, California 95050

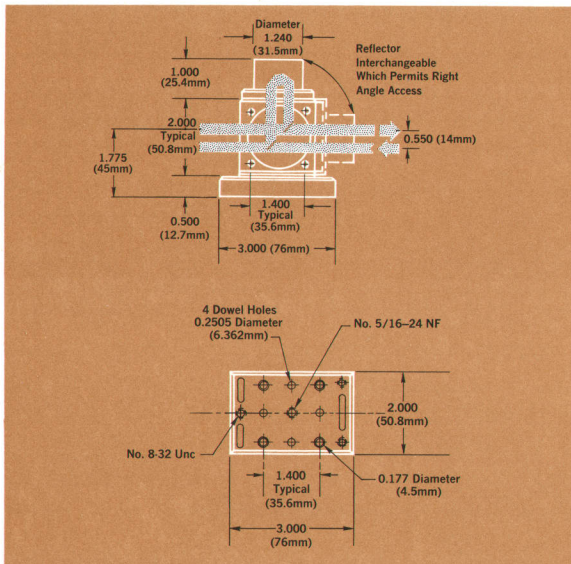

References

1. J. N. Dukes and G. B. Gordon, 'A Two-Hundred-Foot Yardstick with Graduations Every Microinch,' Hewlett-Packard Journal, August 1970.
2. A. Z. Kiss, 'A Calibrated Computer-Based Fourier Analyzer,' Hewlett-Packard Journal, June 1970.

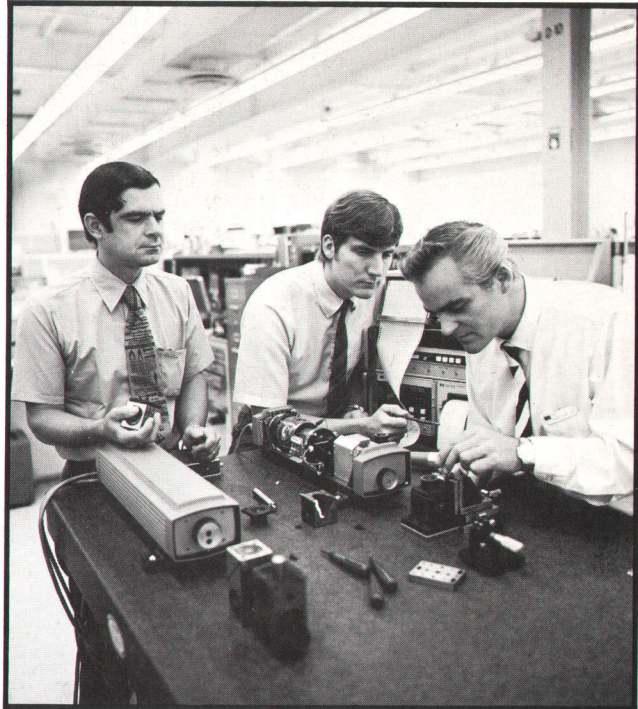

Richard R. Baldwin

Dick Baldwin (left) is the expert on precision optics in HP's laser measurements design section. He's also an expert on precision machining and has written several papers on that subject and on laser interferometry. He's been with HP for two years. Dick holds a B.S. degree in engineering physics from Ohio State University and is a member of the Society of Manufacturing Engineers.

André F. Rudé

André Rudé (right) was project leader for the 10565A Remote Interferometer. He's been with HP since 1966 and was responsible for the product design of HP's laser interferometer system. A member of ASME, André holds a degree in mechanical engineering from Ecole Supérieure de Micromécanique et Chronométrie in France, which may explain why he likes to collect and repair old clocks. Mountains are another of his passions, both for climbing up and for skiing down.

Gary B. Gordon

Gary Gordon (center) is manager of HP's laser measurements and logic test design section. Before becoming laser section manager, he was project leader for the 5525A Laser Interferometer. Gary holds a B.S. degree in electrical engineering from the University of California and an M.S.E.E. degree from Stanford University. His design abilities don't stop at electronics; he also turns out contemporary furniture. When he's feeling nonproductive, he likes to go sailing.

HEWLETT-PACKARD JOURNAL  DECEMBER 1971 Volume 23 • Number 4

TECHNICAL INFORMATION FROM THE LABORATORIES OF HEWLETT-PACKARD COMPANY 1501 PAGE MILL ROAD, PALO ALTO, CALIFORNIA 94304 U.S.A.
Hewlett-Packard S.A. 1217 Meyrin—Geneva, Switzerland • Yokagawa-Hewlett-Packard Ltd., Shibuya-Ku, Tokyo 151 Japan

Editor: R. H. Snyder Editorial Board: R. P. Dolan, H. L. Roberts, L. D. Shergalis Art Director: Arvid A. Danielson Assistant: Maridel Jordan