

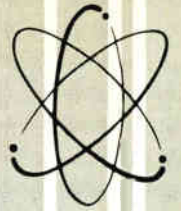

# Techni-talk

COMPLETE ELECTRONIC SERVICING INFORMATION  
radio • tv • hi-fi



VOL. 12, No. 5

OCT.-NOV., 1960

## UNIVERSAL TV SERVICING BIAS SUPPLY

### An Easy-To-Build Supply For All Types Of Servicing

The bias supply shown in Fig. 1 can be built with all new parts for less than ten dollars. Many of the components can probably be found in your stock of surplus parts. Since the circuit in Fig. 2 is relatively simple the complete assembly can be made and wired in a very short time.

#### Adequate Voltages

This unit has been designed to provide a bias supply with sufficient range to be used on all types of TV sets. Adequate voltages are available to bias both horizontal and vertical output tubes while making alignment adjustments. At the same time a bias voltage is also available for the r-f, i-f and tuner AGC circuits. Most commercial bias supplies only have a single voltage available and this is too low to bias horizontal or vertical circuits. The "hi bias" can also be used on color TV circuits.

This supply is a-c operated and completely eliminates the need for separate battery bias packs. It can be used on the shop bench or on outside service calls. The power transformer provides isolation from the a-c line.

The "lo-bias" terminals provide a voltage range from zero to approximately 20 volts. The "hi-bias" voltage range is from about 20 to 100 volts. Both voltages are variable and controlled by individual potentiometers. Obviously by reversing the polarity of the leads the same *positive* voltages are available if needed. Both output voltages have less than 0.1 percent ripple.

The power transformer has a 6.3 volt winding which is used for the pilot lamp. This voltage is also available at the two tip jacks on the front panel for whatever use it might have.

#### Two Jacks For Each Voltage

Two tip jacks are provided for the "hi-bias" voltage and two for the "lo-bias" voltage. The second jack can be used either as a voltage source or to connect a VOM while setting up the required bias voltages.

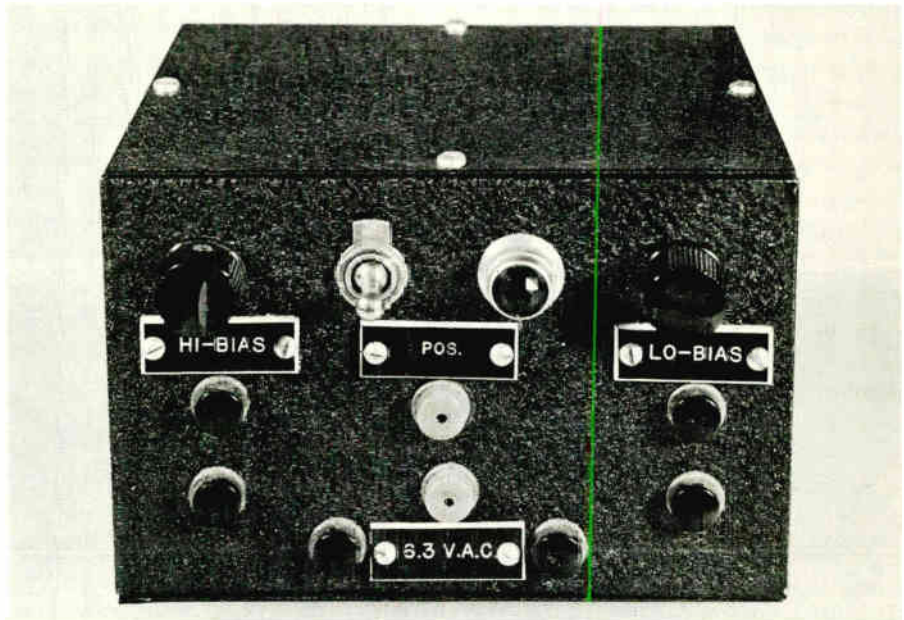

Fig. 1 Complete universal bias supply assembled in 4" x 5" x 6" utility box.

It should be kept in mind that if one positive connection is made to the receiver ground all four negative tip jacks can be used to bias individual circuits. The two "hi-bias" connections can be used on the horizontal and vertical output tubes and

the two "lo-bias" connections on the tuner and i-f AGC circuits.

Some manufacturers recommend that the bias voltage be adjusted to give a certain amplitude signal on the scope. This presents somewhat (Continued on page 6)

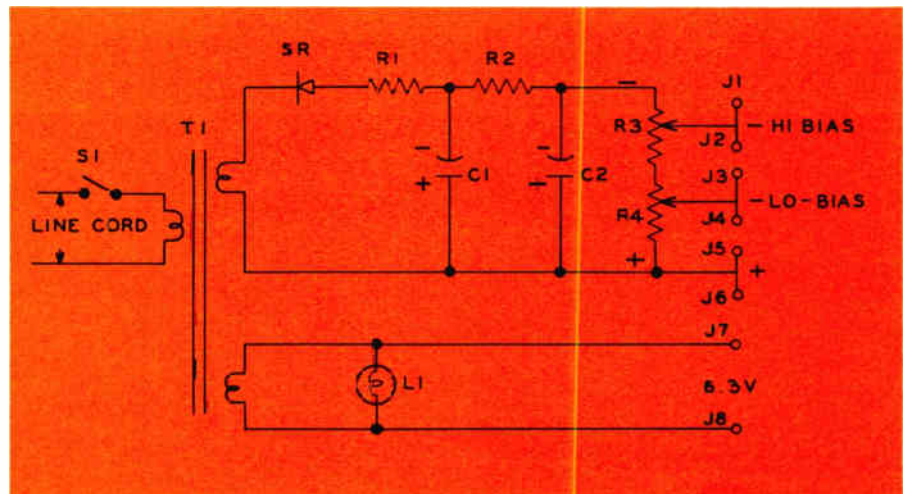
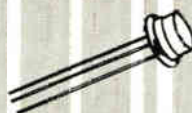

Fig. 2 Schematic diagram for universal bias supply.





## SUCCESSFUL SERVICE MANAGEMENT

# THE FOUR C'S OF CREDIT

By K. E. Kenny

Manager, Credit and Collections  
G-E Electronic Components Division



At a very early stage in human history, primitive people adopted the practice of trading with one another. But the idea of transferring goods and services in exchange for a promise of future payment did not develop for many centuries, since money and credit were still unknown. The simpler method of barter was, in fact, the only feasible method of exchange for primitive man. Sheep were exchanged for oxen, corn for hides, cattle for wives. And the modern American, not to be outdone, resorts to barter, at least in part, when he turns in last year's car for the latest model.

All of us are familiar with the expression, the three R's of education: reading, 'riting, and 'rithmetic. Similar to this, those of us who specialize in credit operations have our four C's of credit. A review of the four C's, like a review of the three R's, is always helpful.

### CHARACTER

Character is rightly considered first. Webster defines it as "the peculiar qualities impressed by nature or habit on a person, which distinguish him from others." In Europe and South America, character alone is considered a sufficient guide to credit and is zealously safeguarded. In Egypt, the entire family is disgraced for life when one of the family reneges on his debts. Honesty, reliability, fairness, sobriety — these are all attributes desirable in a credit risk. Character, however, is not necessarily a surface quality, so that the credit man's problem resolves into judging on the basis of external behavior the internal personal qualities of his customer.

You can arrive at some estimate of a customer's character through your own association with him in church, at community and social events, in clubs, etc. But as it is hardly probable that you will have such associations with everyone seeking to do business with you on a credit basis, you must employ a more usual yardstick. This yardstick is his reputation, that is, what the people who have personal associations with him think of his character. Your reliance upon reputation as a yardstick, however, should not be absolute. You must always weigh just how much of a man's reputation is built on rumor among neighbors who have prejudiced or false views on his behavior.

### CAPACITY

Capacity, the second of the four C's of credit is concerned with the ability of a customer to make good his promise to pay. With the best intentions in the world, a customer may not be able to pay when he is sick or out of work. A practical businessman generally checks such important facts as a customer's age and state of health, and usually he tries to learn something about that person's aggressiveness and outlook on life in general. Not only the chronically sick, but also the tired and the beaten are seldom good credit risks. In this phase of his investigation, the credit man merely couples the physical and financial ability to pay with the general attitude of the customer.

### CAPITAL

Capital is usually the easiest of the four C's to determine. It is tangible and largely impersonal. The credit man has only to learn how much money and other assets his customer has. There are, however, instances in which this information is not readily available in detail. In such cases the credit decision must rely heavily on other factors.

### CONDITIONS

Conditions, the last of the four C's, refers to the economic ambient of the country as a whole and particularly to the industrial and business conditions prevailing in your community. Are people working or not? Is unemployment increasing or decreasing? Is the community undergoing a readjustment or a recession? How long may any of these conditions continue?

A recent study of business failures revealed that 90 percent of the failures were due to two of the four C's: CAPACITY AND CONDITIONS. A further breakdown of this 90 percent revealed the following causes:

- inadequate sales
- heavy operating expenses
- receivables difficulties
- inventory difficulties
- excessive fixed assets
- poor locations
- competitive weaknesses

This may cause you to think that "cash and carry" would be the best way to do business. But stop and

consider a moment the importance of credit to this country and to you personally. Over 52 billion dollars worth of consumer credit is now outstanding. People owning automobiles, for example, owe more than 17 billion of it. You may have bought your own car on time. So did some 70 percent of all recent car buyers.

Many Americans purchase what they want without putting down the cash. This doesn't mean that these people are broke. Most people who buy on credit, are in a financial situation similar to your own when you promise to pay for products you use in your business in the month following their delivery. Most suppliers are satisfied that you will have the cash later and that you have an intention of paying.

Without credit, large corporations couldn't hire thousands of employees, and many people couldn't buy TV sets or radios or anything else. Imagine the things your family enjoys, which you couldn't have bought, were you required to put the money on the seller's counter.

Well managed credit is a vital asset to American business. Without the bridge of credit, there would be a serious gap between production and consumption. Because our credit system is flexible and strong, the American economy can operate at a high level of efficiency, with maximum production and profitable distribution assured.

### ETR-2089 Rear Control Extension

- Permits adjustments of TV controls without removing back of set.
- Tapered to fit snugly over control shafts.
- Can be used on knurled or slotted shafts and will not slip off as screwdrivers do.
- Ask your distributor for ETR-2089 or use order coupon on Page 9.

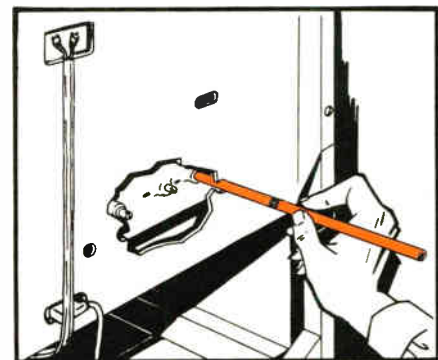

*"Here's the slickest reminder board I've ever used!"*



**\$10.95  
VALUE**

- **Shows what's happening — at a glance!**  
This G-E Service Call Board makes it easy to keep track of jobs. You see at a glance what calls, pick-ups and deliveries are to be made — when and where.
- **It is so easy to use!**  
Entries are written on a rotating plastic sleeve with a marking pencil and erased or changed with the wipe of a cloth.
- **It is always up-to-date!**  
The rotating plastic sleeve is the real feature! As you turn it each day, all deadlines move up so nothing can be overlooked.

**SCHEDULES**

**SERVICE CALLS • PICK-UPS  
DELIVERIES • BACK ORDERS  
INVENTORIES  
WORK SCHEDULES  
SALES**

**ORDER YOURS TODAY**

Because the G-E Service Call Board can be used for so many things, you'll want more than one.

**Only \$5.00 each**

Available from G-E tube distributors or direct from the General Electric Regional Warehouse in Chicago. Use coupon below for warehouse order.

General Electric Company  
Department "B"  
3800 N. Milwaukee Avenue  
Chicago 41, Illinois

*Enclosed is check or money order, including any applicable sales or use tax, payable to General Electric Company for:*

.....G-E Service Call Boards    \$5.00 each

Name .....

Street .....

City.....Zone.....State.....

**G-E SERVICE CALL BOARD — ETR 2144**



# A NEW G.E. DEVELOPMENT— THE ONE-PIECE 23" PICTURE TUBE

A Pioneering Effort In Tube Engineering. The Result—Improved Styling, Larger Picture, Combined With Better Performance. The New G.E. 23" Picture Tube Offers Increased Customer Appeal and Satisfaction.

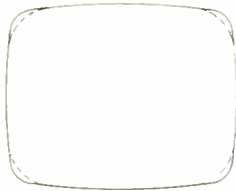

LARGER SCREEN AREA

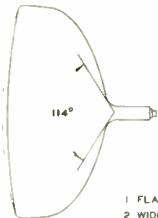

1 FLAT FACE  
2 WIDER ANGLE  
3 EQUIVALENT WEIGHT

## DESIGN FEATURES

Squared corner design incorporates added features of (1) 20 sq. in. additional viewing area and (2) improved styling. Increased radius design of tube face promotes "movie screen" concept and retains ultra-vision glare resistance. The 114° channeled yoke area provides a shorter tube length compared to 110°-23" tube versions and sharper contrast ratio and tube focus. Also, the one-piece bulb design results in *much lower replacement cost* as compared to 23" lamination types. Finally, the tube weight is 8 lbs. less than the 23" 110° type and only 4 lbs. greater than the popular 21" size.

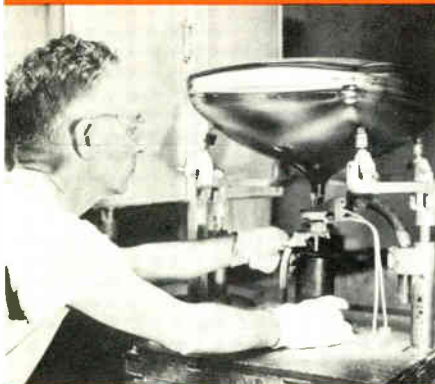

## TUBE DEVELOPMENT

A technician utilizes laboratory evacuation equipment required in tube development activities. New tube types receive carefully controlled thermal and electric processing. RF heating of gun parts and cathode activation are applied to conform with rigid engineering schedules.

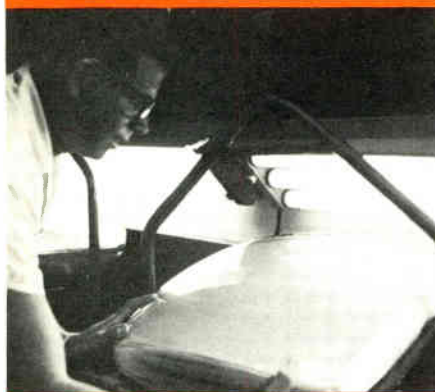

## MANUFACTURING EQUIPMENT

The operator positions the tube on the inline exhaust machine to perform final tube evacuation. All air and gases are removed from the bulb by simultaneously subjecting it to a pumping, heating, and activation cycle. Pressure levels inside the tube after evacuation are equivalent to 10<sup>-6</sup> mm Hg. The tubes reach a peak temperature of 780°F and gun parts are subjected to RF heating to 1470°F.

## QUALITY CONTROL

Statistical quality control inspection and test stations between final test and packing help maintain the quality level required in this highly competitive field. In addition, the product is life tested on expensive, carefully maintained equipment to assure shipment of products consistent with General Electric Company's high quality standards.

General Electric has again lived up to its promise that "Progress is Our Most Important Product." The new, one-piece 23" picture tube incorporates the features of this slogan. Here are embodied new styling, engineering, and manufacturing techniques which combine to offer the customer a progressive product with additive sales features. This article will recount the development of the 23" one-piece television picture tube at General Electric Company in Syracuse.

The development began in March 1959 a uniquely shaped 23" square-cornered bulb which would not require an attached safety plate. Important too, was the fact that the one-piece tube would permit retention of the dark safety glass which General Electric markets under the name "Ultra-Vision."

In addition, it was realized that if the inside glass yoke area could be channeled into four (4) diagonal grooves, several tube improvements would be gained. Namely, the diagonal sweep would be improved which would result in two advantages; (1) improved contrast ratio and (2) the tube length would be shortened due to the wider sweep angle which would result. To complement these features would be an increase of approximately 20 sq. in. of viewable screen area when compared to the popular 21" size.

The tube design program was divided into two simultaneous phases: (1) glass bulb design and (2) electron gun design. Photoelastic studies were made to evaluate "hoop and bending" stresses of bulbs subjected to atmospheric stress loading. Glass strength was measured using strain gauges and hydrostatic pressure tank equipment.

Electronic gun design proceeded with the aid of beam plot studies utilizing electronic computer equipment. Special gun shielding was added to prevent yoke back-flux distortion to the electron beam. Prototype guns were developed to allow study of pin-cushion distortion and center-to-edge focus quality.

Subsequently, sample bulbs were received which had passed through all phases of critical strength studies. The bulb weight was found to be only 4 lbs. heavier than the 21" size and 8 lbs. lighter than the laminated 23" tube. General Electric's persistence that a one-piece 23" tube could be made finally became a reality.

Thus, today the development is completed. General Electric now offers a new product which is more compact, lighter weight, and lower cost.

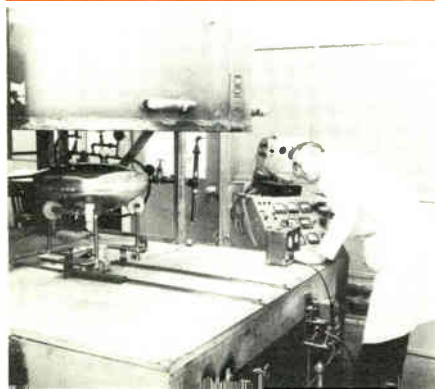

# What's new!

## tubes



### 6FV8 TRIODE-PENTODE



The 6FV8 is a 9-Pin miniature tube that contains a sharp-cutoff pentode and a medium-mu triode in one envelope. The triode section is designed for use as a vertical deflection oscillator, while the pentode section is designed for IF amplifier or general purpose use.

Heater Voltage, AC or DC.....6.3 Volts  
Heater Current.....0.45 Amperes

#### AVERAGE CHARACTERISTICS

	Pentode Section	Triode Section	
Plate Voltage.....	125	125	Volts
Screen Voltage.....	125	...	Volts
Grid-Number 1 Voltage.....	-1.0	-1.0	Volts
Amplification Factor.....	...	40	
Plate Resistance, approx.....	200000	5000	Ohms
Transconductance.....	6500	8000	Micromhos
Plate Current.....	12	14	Milliamperes
Screen Current.....	4.0	...	Milliamperes
Grid-Number 1 Voltage, Approx. Ib = 20 Microamperes..	-9	-9	Volts

### 6FG7 TRIODE-PENTODE

For VHF Converter Applications



The 6FG7 is a 9-Pin miniature tube that contains a medium-mu triode and a sharp-cutoff pentode in one envelope. Designed primarily for use as a combined triode oscillator and pentode mixer in VHF television receivers, the tube features two cathode leads connected to separate base pins to reduce the effective cathode lead inductance.

Heater Voltage, AC or DC.....6.3 Volts  
Heater Current.....0.45 Amperes

#### AVERAGE CHARACTERISTICS

	Pentode Section	Triode Section	
Plate Voltage.....	100	125	125 Volts
Screen Voltage.....	100	125	... Volts
Grid-Number 1 Voltage.....	0	-1.0	-1.0 Volts
Amplification Factor.....	...	...	43
Plate Resistance, approx.....	180000	5700	Ohms
Transconductance.....	7400	6000	7500 μmhos
Plate Current.....	...	11	13 ma
Screen Current.....	...	4.0	... ma
Grid-Number 1 Voltage approx. Ib = .30 μa.....	...	-7.5	-6.5 Volts

### 6FW5 BEAM PENTODE

For TV Horizontal-Deflection Amplifier Applications

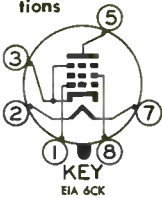

The 6FW5 is a beam-power pentode primarily designed for use as the horizontal-deflection amplifier in television receivers.

Heater Voltage, AC or DC.....6.3 Volts  
Heater Current.....1.2 Amperes

#### AVERAGE CHARACTERISTICS

Plate Voltage.....	250	Volts
Screen Voltage.....	150	Volts
Grid-Number 1 Voltage.....	-22.5	Volts
Plate Resistance, approx..	20000	Ohms
Transconductance.....	6600	Micromhos
Plate Current.....	75	Milliamperes
Screen Current.....	2.4	Milliamperes
Grid-Number 1 Voltage, approximate Ib = 1.0 Milliamperes..	-46	Volts
Triode Amplification Factor #.....	4.1	
#Triode connection (screen tied to plate) with Eb = Ec2 = 150 volts and Ecl = -22.5 volts.		

### 12FX8-A TRIODE-HEPTODE

The 12FX8-A is a 9-Pin miniature triode-heptode designed for use in automobile radio receiver service where plate and screen voltages are supplied directly from a 12-volt storage battery. The triode section is intended for RF amplifier use and the heptode section for frequency converter use.



The 12FX8-A is unilaterally interchangeable with the 12FX8 and differs only in having an additional control on the conversion conductance cutoff characteristic of the heptode section.

Heater Voltage, AC or DC.....12.6 Volts  
Heater Current.....0.27 Amperes

#### AVERAGE CHARACTERISTICS

	Heptode*	Triode	
Plate Voltage.....	12.6	12.6	Volts
Screen Voltage.....	12.6	...	Volts
Grid 3 Voltage.....	0.5**	...	Volts
Grid 3 Resistance.....	2.2	...	Megohms
Grid 1 Voltage, RMS	1.6	...	Volts
Grid-Number 1 Resistance.....	0.033	2.2	Megohms
Grid Voltage.....	...	0.8#	Volts
Plate Resistance, approximate Conversion	0.5	...	Megohms
Transconductance	300	...	Micromhos
Transconductance.....	...	1400	Micromhos
Amplification Factor	...	10	
Plate Current.....	0.29	1.3	Milliamperes
Screen Current.....	1.25	...	Milliamperes
Grid-Number 3 Voltage, approx. Gc = 10 Micromhos..	-3.0	...	Volts
Gc = 1.0 Micromho..	-8.0	...	Volts
Grid Voltage, approximate Ib = 10 μa	...	-3.2	Volts
*Self-excited converter service			
**Voltage developed across 2.2 megohm grid-number 3 resistor.			
#Voltage developed across 2.2 megohm grid resistor.			

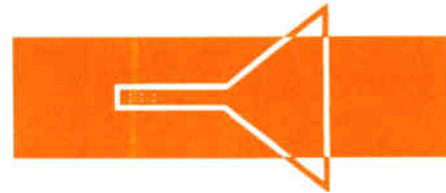

### SIX NEW GENERAL ELECTRIC BLACK-DAYLITE PICTURE TUBES

Listed below is a summary of significant characteristics for each of the new General Electric Black-Daylite picture tubes. All of these tubes are magnetic deflection with electrostatic focus.

#### 14ATP4

90° 450 Ma Heater

Construction...14" Rectangular Glass  
Length.....Overall 13¼", Neck 5½"  
Heater .....8.4V., .45A  
Gun .....Non Ion-Trap  
External Conductive Coating  
500-1000 mmfd  
Anode Voltage.....14KV Max.

#### 14WP4

90° Non Ion-Trap

14WP4.....  
Construction..14" Rectangular Glass  
Length.....Overall 13¼", Neck 5½"  
Heater .....6.3V., .6A  
Gun .....Non Ion-Trap  
External Conductive Coating  
500-1000 mmfd  
Anode Voltage.....14KV Max.

#### 17BJP4

90° Non Ion-Trap

Construction ..17" Rectangular Glass  
Length .....Overall 14⅝", Neck 5½"  
Heater .....6.3V., .6A  
Gun .....Non Ion-Trap  
External Conductive Coating  
12-1500 mmfd  
Anode Voltage.....16KV Max.

#### 17BWP4/17CSP4

110° Five and one-quarter inch neck  
Construction ..17" Rectangular Glass  
Length.....Overall 12¼", Neck 5¼"  
Heater .....6.3V., .6A  
Gun .....Non Ion-Trap  
External Conductive Coating  
1000-1500 mmfd  
Anode Voltage .....16KV Max.

#### 17CDP4

110° 450 Ma Heater

Construction ..17" Rectangular Glass  
Length .....Overall 12½", Neck 5½"  
Heater .....8.4V., .45A  
Gun .....Non Ion-Trap  
External Conductive Coating  
800-1500 mmfd  
Anode Voltage .....16KV Max.

#### 17DKP4

110° Three and one-half inch neck.  
Construction 17" Rectangular Glass  
Length .....Overall 10⅝", Neck 3½"  
Heater .....6.3V., .6A  
Gun .....Non Ion-Trap  
External Conductive Coating  
1000-1500 mmfd  
Anode Voltage .....16KV Max.



# BENCH NOTES

## SMOG REMOVAL

I use Radio Service Solvent to remove grease, smoke and dirt from picture tubes that have been in sets a long time. This dissolves the accumulation and makes it easy to clean. Then I apply glass cleaner. This has saved me considerable time and results in a perfectly clear picture tube.

*John H. Cotton  
Johnnie's Radio & TV Service  
2452 Forest Lane  
Dallas, Texas*

## SEPARATORS FOR SERVICE CASE

Tubes in a tube caddy can be kept in their respective places, even though you remove one or more for sale. Many technicians use the empty box to keep inventory and to keep other tubes from falling all over in the caddy. I like to leave the empty box to show my customer that I am using first quality G-E tubes, so to prevent the tubes from scrambling, you can now get separators from your G.E. distributor (ETR-2039-42). Cut these down to size and fit them in your caddy. Instant inventory is

provided by stapling the appropriate G.E. box top with the tube number on it to the bottom of the case. When refilling the tube caddy, simply look into the empty hole to see what number tube you need.

*Joseph F. DeBiak  
Oakfield TV Service  
Three Oaks, Mich.*

## REMOVAL OF IRON TIP

When it's necessary to remove a stubborn copper tip on a soldering iron, squirt a bit of ordinary household ammonia around the tip and in the recess around it, and the tip will come out easily after a few seconds' soaking.

*Harvey Muller  
Muller's Mart  
Box 6  
Danboro, Pa.*

## REPLACING IRON TIP

Before installing a new tip in a soldering iron, blow a little graphite into the recess in the iron, and the tip will remove easily when it has to be replaced.

*Harry J. Miller  
991-42nd St.  
Sarasota, Florida*

## YOKE REMOVAL

Disconnect the yoke leads and connect an A.C. cord to terminals 1 and 3 (horizontal coil). Plug cord into A.C. socket for a few seconds at a time, checking the temperature of yoke so not to overheat same. The yoke can then be removed without damage to either the picture tube or the yoke.

*Al Collar  
Rt. 8, Box 241  
San Antonio, Texas*

**EDITOR'S NOTE:** A slightly slower, but somewhat safer method would be to connect 100 or 150-watt bulb in series with one side of the a-c lead.

Those desiring to have letters published in this column should write the Editor Techni-Talk, Electronic Components Division, General Electric Company, Owensboro, Kentucky. For each such letter selected for publication you will receive \$10.00 worth of General Electric tubes. In the event of duplicate or similar items, selection will be made by the Editor and his decision will be final. The Company shall have the unlimited right without obligation to publish or otherwise use any idea or suggestion sent to this column.

**Caution:** The ideas and suggestions expressed in this column are those of the individual writers. These ideas and suggestions have not been tried by the General Electric Company and therefore are not endorsed, sponsored or recommended.

## UNIVERSAL TV SERVICING BIAS SUPPLY

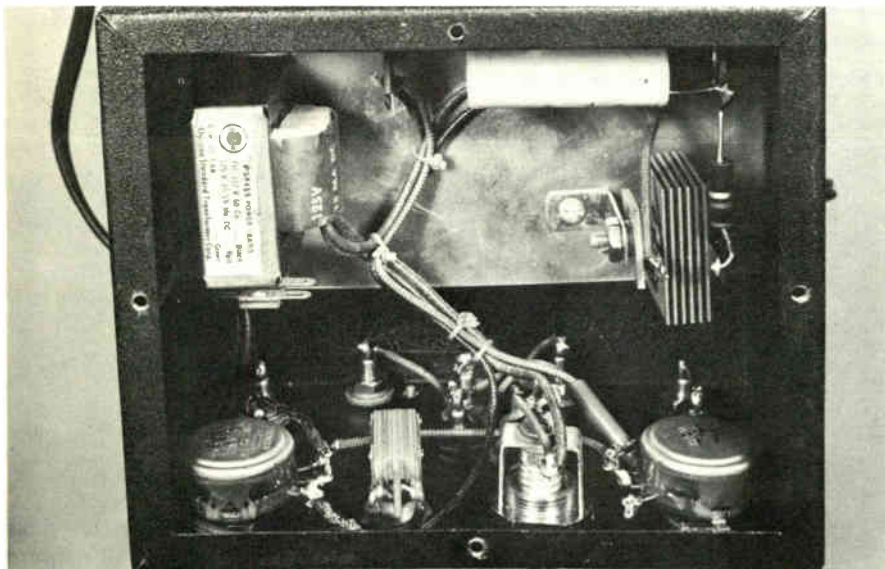

**Fig. 3** Inside view showing placement of parts.

made from a piece of aluminum  $2\frac{3}{4}$ " x  $7\frac{3}{8}$ ". A  $\frac{3}{4}$ " right angle bend was put in each end which was used to mount the sub-chassis to each side of the cabinet.

The sub-chassis is not necessary since the components can be mounted directly to the sides of the utility cabinet. Use of the sub-chassis reduces the number of holes drilled in the cabinet and thereby improves its appearance.

### Additional Voltage Ranges

It should be pointed out that the voltage ranges available at the "hi-bias" and "lo-bias" terminals can be varied by changing the value of variable resistors R3 and R4. If an additional low-bias voltage in the 0-20 voltage range is needed it is only necessary to use two 5000 ohm controls connected in parallel in place of R4. The center control terminal of the additional control would of course go to a new added tip jack. Three separate individual low bias voltages would require three 7500 ohm controls connected in parallel and two additional tip jacks each one wired to the center control terminal.

Pointer knobs can also be used with paper scales pasted to the cabinet under each knob. This scale can then be calibrated in volts which will eliminate the use of a VOM everytime the supply is used. Line voltage variations will, however, affect all bias voltages. Whenever exact bias voltages are required it will still be necessary to use a VOM to establish the correct setting particularly on the lo-bias voltage.

(Continued from page 1)  
of a problem when batteries are used but it is readily accomplished with this bias supply.

The following is a list of parts required:

- 1 T<sub>1</sub> Stancor PS 8415 or Equivalent Power Transformer
- 1 SR 50 or 100ma, 130 V. Selenium Rectifier
- 1 R<sub>1</sub> 100 ohms, 1w. 10% Resistor
- 1 R<sub>2</sub> 5,000 ohms, 5w. 10% Resistor
- 1 R<sub>3</sub> 10,000 ohms, 2w. Control (AB Type)
- 1 R<sub>4</sub> 2,500 ohms, 2w. Control (AB Type)

- 1 C<sub>1</sub>, C<sub>2</sub> Dual 20 Mfd., 150V. Electrolytic Capacitor
- 1 S<sub>1</sub> SPST Toggle Switch
- 8 J<sub>1</sub> to J<sub>3</sub> Insulated Tip Jacks (6 black and 2 red)
- 1 L<sub>1</sub> Miniature Type Pilot Light Assembly
- 1 6" x 5" x 4" Metal Utility Cabinet — Mfrs' Type CU729
- 1 6 Foot Line Cord Set
- 3 Bakelite Tie-Points (2 terminal)

Fig. 3 shows an inside view of the completely assembled unit. An additional sub-chassis was used to mount the tie-points, transformer, capacitor and selenium rectifier. This was

## SERVICE NOTES

### TELEVISION — Intermittent Channel Selection — "M6" Power Tuning

In some "M6" power tuning sets the motor pinion gear may not always engage the selector gear. This shows up as a rasping sound when the channel select button is pushed, and the channel does not change. It happens infrequently, perhaps two times out of ten.

When the power tuning motor is energized, its rotor has a solenoid action which thrusts the pinion gear out to the selector gear at the same time it starts rotating. If the solenoid action is too slow, the rotor speed may be too high for engagement of the pinion gear and the selector gear. This could result in "face mating," with an accompanying grinding noise.

While "face mating" will not result in damage to either gear, too frequent occurrence will cause customer complaint and the condition should be corrected to insure proper operation every time.

The cause of the slow solenoid action is an incorrectly positioned actuating arm of the rear switch contacts. When this actuating arm rests against the rear shaft flange, the rotor must pull against it right from rest. With a spacing of approximately 1/32" between actuating arm and the flange the rotor will have some forward thrust speed before it hits the actuating arm and allow the pinion to engage.

This symptom may occur on some of the 19" receivers, although it could happen on any M6 using the G.I. motor

(vendor code 190). The adjustment is being especially made in our factory and all sets packed from July 25th will be free of this symptom.

Incidentally, an occasional facemate is normal for any M6, about once in 25 or more operations.

To adjust the gap between the nylon actuating arm and the rear motor flange, use a slotted relay adjusting tool (there are many such tools on the market) to bend the nearest phosphor bronze contact spring right at the edge of the nylon. This gap should be approximately 1/32".

This should not disturb the switch contacts, but check to make sure that at rest, the muting contacts are closed and the motor contacts open; and when energized, the muting contacts are open and the motor contacts closed.

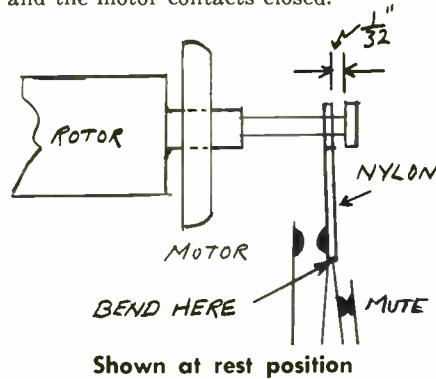

### RADIO — Models C435 and T125 — No Audio

"No audio" may be caused by an "open" conductor circuit in the vicinity of the tuning capacitor mounting lugs. When troubleshooting for "no audio," check for continuity between tuning capacitor mounting lug and conductor

circuit in which lug is mounted. On receivers that measure "open," solder capacitor mounting lug firmly into place to make sure good contact is made between lug and conductor circuit.

If you would like to receive additional information on some specific G-E Electronic Component, just clip out this coupon, write in the material desired, and send it to the Editor. Information, if available, will be sent to you by return mail.

Please check your name and address on the reverse side. Make any necessary corrections below.

(Please Print)

Name.....

Street Address.....

City, Zone No. and State.....

If you expect to move within next two months, please print new address above. If you are receiving duplicate copies, please check this box  and indicate mailing list number which appears at lower left corner of the address area on each copy you receive.

#### ORDER COUPON for Service Light and Complete Tele-Clue Binder

General Electric Company  
Department "A"  
3800 N. Milwaukee Ave.  
Chicago 41, Illinois

Enclosed is money order or check payable to General Electric Company for:

.....ETR-1469 Picture Tube Pillow.....	\$0.50
.....ETR-1095 Complete Tele-Clue Binder.....	\$3.25
.....ETR-2089 Rear Control Extension.....	\$0.50

Total Amount of Check or Money Order.....

PRINT YOUR COMPLETE ADDRESS ON OTHER SIDE

## G-E WIRELESS REMOTE CONTROL SYSTEM V

### Transmitter Adjustments

The complete transmitter chassis is assembled in a two piece plastic case. The bottom half of the transmitter case is removed by taking out the two slotted head screws from the bottom of the case. Lifting the bottom half exposes the battery and most of the circuitry necessary for servicing the unit.

Refer to Fig. 2 in Vol. 12, No. 1 for a complete electrical schematic of the transmitter.

### Shifting the R.F. Carrier Frequency

With this procedure, the radiated harmonics from the television receiver are used to adjust the remote transmitter and the transmitter is then used to align the remote receiver.

When the remote transmitter R-F carrier frequency is activated and the unit is brought within the field of the television horizontal system, harmonics from the horizontal are mixed with the transmitter frequency, and the resulting beat note is within the audio spectrum.

As the transmitter is adjusted so that its frequency approaches that of a given harmonic, the beat note will decrease in frequency until the two frequencies are the same, then the result will be a zero beat or a null. In this manner each of the harmonic peaks within the frequency spectrum of the wireless remote system can be counted as the transmitter antenna trimmer is turned. And since the 3 selected R-F Carrier frequencies for the remote system (291.2, 322.7, & 354.2 KC) were carefully chosen so that they would fall between horizontal harmonics, (Fig. 1) the proper setting of the antenna trimmer is exactly midway between the zero beat point.

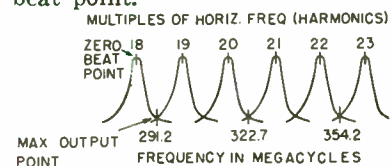

Fig. 1 Harmonic Relation

Therefore, when shifting the frequency of the transmitter, from 322.7 KC to 354.2 KC, two points of zero beat will be heard (21st, 22nd harmonics). The proper setting (354.2 KC) is midway between the 22nd & 23rd harmonic zero beat points.

The same is true when going in the opposite direction from 322.7 to 291.2 KC; however, here the 20th and the 19th harmonics are heard as zero beats.

NOTE: When adjusting the transmitter antenna trimmer, extreme care must be exercised not to turn the adjusting screw too rapidly. Since it only requires 1/2 - 3/4 turn of the trimmer adjusting screw to cover the complete range of 63KC (291.2 to 354.2 KC), it therefore becomes apparent that the zero beats are quite close together.



# ORIGINAL G-E SERVICE AIDS

## PICTURE TUBE PILLOW ETR-1469

In the last two issues we have announced the availability of the Fuse and Heater Checker ETR-981-A and the Magnetic Swing-Beam Service Light ETR-1593 from our Chicago Warehouse. In this issue another G-E Service Aid, the Picture Tube Pillow ETR-1469 will be made available in the same way. ETR-1469 is made of foam plastic 15" x 15" x 1/4".

Here is a service aid that can be used in numerous ways some of which are illustrated at the right.

Probably the most important use for ETR-1469 is to protect the face and edges of a picture tube. A Picture Tube Pillow used for this purpose could save you time and money and in addition help prevent possible injury due to an implosion. Scratches on the faceplate of a picture tube may cost money because any scratch ordinarily makes the tube unacceptable for glass allowance when a new tube is purchased. In addition these scratches weaken the tube and thereby make it susceptible to implosion.

Scratches around the periphery of the faceplate are even more hazardous because the glass in this area is

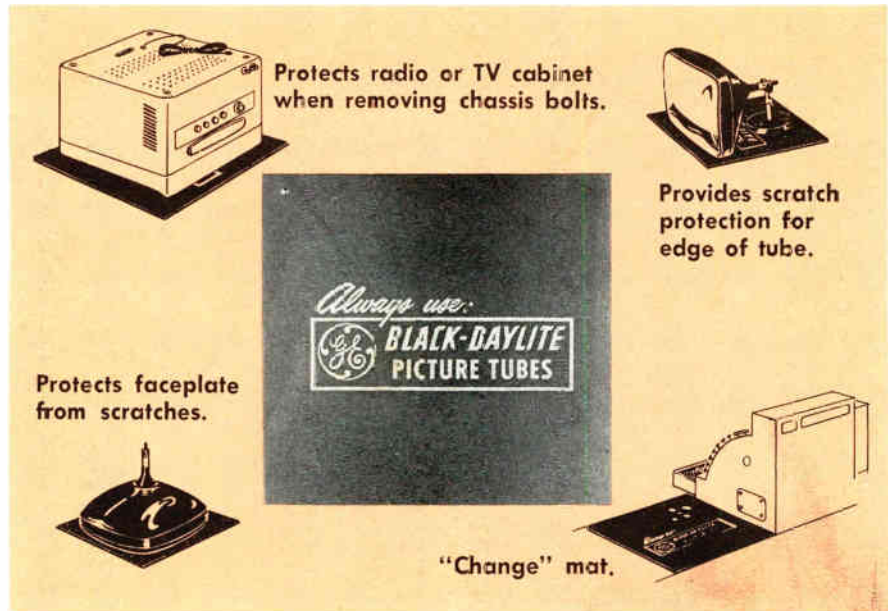

considerably thinner than across the faceplate. Picture tubes should *always* be protected from scratches. Use a G-E Picture Tube Pillow whenever a picture tube is placed on a hard flat surface.

The G-E Picture Tube Pillow ETR-1469 can be obtained from your G-E tube distributor or from our Chicago Warehouse. Use coupon at bottom of page 9 for warehouse order.



### Techni-talk



TECHNI-TALK DISTRIBUTION OFFICE

**GENERAL ELECTRIC**

SCHENECTADY, NEW YORK

**BULK RATE**  
U.S. Postage  
**PAID**  
Schenectady, N.Y.  
Permit No. 148

VOL. 12, No. 5 OCT.-NOV., 1960

### In this issue:

	Page
Universal TV Servicing Bias Supply....	1
The Four C's of Credit.....	2
"Here's the Slickest Reminder Board I've Ever Used".....	3
The One Piece 23" Picture Tube.....	4
What's New!.....	5
Bench Notes.....	6
New "U5" Schematic.....	7 & 8
Radio and TV Service Notes.....	9
G-E Wireless Remote Control System V.....	9

Techni-talk on AM, FM, TV Servicing, published by-monthly by ELECTRONIC COMPONENTS DIVISION, GENERAL ELECTRIC COMPANY, OWENSBORO, KY. In Canada: Canadian General Electric Co., Ltd., 189 Dufferin St. Toronto 3, Ontario. R. G. Kempton, Editor. Copyright 1960 by General Electric Company.

Mr. Thomas Boyd  
1413 North McCollough  
San Antonio, Texas  
Z-7-804

Form 3547 Requested

This copy of **Techni-talk** comes to you through the courtesy of your General Electric tube distributor.

NOTE: The disclosure of any information herein conveys no license under any General Electric patent and, in the absence of an express written agreement to the contrary, the General Electric Company assumes no liability for patent infringement (or any other liability) arising out of use of such information by others.