

THE GENERAL ELECTRIC UHF-103 TUNER—I



Techni-talk on AM, FM, TV Servicing

Copyright 1953 by General Electric Company

A considerable number of UHF tuners are currently available for use with TV receivers. Most of these are separate self-contained units which may be placed on the top or somewhere near the TV receiver. Units are also available which can be mounted inside the cabinet of the receiver. Some of these are in the form of "strips" which become a part of the present VHF tuner and others are in the form of self-contained units which are similar to the type first mentioned except that they must be mounted inside the cabinet. One such unit is the General Electric Model UHF-103 shown in Fig. 1.

This is the basic unit known as "Part A" and has been designed for installation inside the cabinet of any receiver which has adequate space. In most cases, this unit is mounted on the side of the cabinet just above the VHF tuner. There are three parts to the UHF-103 as can be seen in Fig. 1. The tuner unit is shown on the left, the plug-connected power supply on the right, and the control knob near the center.

SIDE MOUNTING TEMPLATE

The template shown as Fig. 2 on page 2 is placed over a suitable area on the side of the cabinet and the six holes drilled as shown. Be sure that there is adequate room inside the cabinet to accommodate the unit before either marking or drilling the cabinet. The tuner is fastened to the cabinet by means of three self-tapping screws and the power unit by means of two wood screws. All of these screws are supplied with the unit. A typical installation is shown in the Fig. 3 drawing. The transmission lines should

be dressed away from any metal objects as indicated in the note near the top of Fig. 3.

Since this unit was designed for installation in a receiver with a controlled a-c outlet, no provision has been made for a separate on-off switch. If an installation is made in a receiver which does not have a controlled outlet, either a separate on-off switch or a controlled outlet should be wired into the circuit.

CIRCUIT DESCRIPTION

A schematic diagram of the Model UHF-103 Tuner unit is shown in Fig. 4. In this unit, conversion of UHF to VHF is achieved by mixing the incoming UHF signal with a signal which is generated by the 6AF4 oscillator. This mixing takes place in the 1N72 crystal diode, the output of which is amplified by the low-noise 6BK7-A cascade amplifier. The output of this amplifier is then link-coupled to the television receiver antenna terminals.

Two antenna inputs are provided; one for the VHF antenna and one for the UHF antenna. Switches S1 and S2 are mechanically ganged with the UHF coil plate. The switch, S1, permits switching of the receiver antenna input lead to either the VHF antenna directly, or to the Tuner output link.

In all UHF positions R11 is shorted out. On the VHF position, switch S2 un-shorts R11. Thus, a small amount of current is permitted to flow through the tubes, even while on the VHF position.

In the UHF-I position, as shown, the signal is fed into the input circuits consisting of C1,

C2, C3, C4, and L1. L1 is a $\frac{1}{4}$ -wave shorted line, the electrical length of which is varied by adjustment of the shorting core. For mechanical convenience, this $\frac{1}{4}$ -wave line is wound into a spiral form and should not be considered as a conventional "coil."

The values of C1, C2, C3, and C4 are chosen so that the input circuit impedance closely approximates 300 ohms across the UHF band, while the impedance at the junctions of C1 and C4 and the ends of the transmission line L1, is very high—in the order of several thousand ohms. C7, C8, L7 and L8 maintain accurate balance of the input circuits. C9 and the 1N72 diode are tied in series across the line. Their midpoint is used for extraction of the VHF converted signal as well as for injection of the local UHF oscillator signal. C9 is critical in value since together with the diode it also affects the balance of the line.

The oscillator, a 6AF4 tube, is connected in an ultra-audio oscillator circuit. Its plate voltage is "shunt-fed" through L17 which presents a high impedance at frequencies above approximately 250 mc. The oscillator tank circuit, L2, is also a tunable shorted $\frac{1}{4}$ -wave line. Oscillator output is taken from the cathode circuit across L14 and coupled through C11 into the 1N72 diode.

L9 furnishes the d-c return path for rectified diode current, while C18 resonates with other circuit constants to the VHF output frequency. The converted UHF signal is coupled through C19 into the cascade 6BK7-A amplifier.

This amplifier consists of two stages. The first stage is a conventional triode, grounded-cathode stage, whose input circuit is tuned to the VHF



Fig. 1. Photograph of the General Electric Model UHF-103 Tuner.

TECHNI-TALK

on AM, FM, TV Servicing

Published by
TUBE DEPARTMENT

GENERAL  ELECTRIC

SCHENECTADY 5, N. Y.
R. G. KEMPTON—Editor

frequency. The plate circuit of the second stage is also tuned to the VHF frequency and its output signal is link-coupled to the VHF receiver. The bandwidth, as measured at half-power points, is approximately 8.0 megacycles which is much wider than the associated television receiver response. This permits greater flexibility of Tuner i-f adjustment should such an adjustment be required in the field in the absence of test equipment.

I-F ALIGNMENT

The General Electric Tuner like most other UHF tuners is set by the factory for Channel 5 operation. If there is a Channel 5 station operating in your area, there is a good possibility that enough of this signal will be picked up by the connecting leads to interfere with the converted UHF signal and produce an inferior picture. In this case, the i-f frequency should be shifted to Channel 6. This can be accomplished by turning core "A" in Fig. 5 approximately three counterclockwise. Then turn core "B" about two and a half turns counterclockwise.

If a 400-cycle amplitude modulated signal generator is available which covers the 75 to 90 mc range, it can be used for adjusting the i-f frequency. The unit is connected as shown in Fig. 3 but should not be mounted to the cabinet until after the i-f adjustments are made. The following procedure should then be followed:

1. Turn the receiver and UHF tuner on. Then set the tuner to any one of the UHF positions. If the tuner is set on a UHF position, the adjustment screws will be *directly* in the center of the UHF adjustment holes shown near the top of the lower drawing in Fig. 5. If the tuner is set on the VHF position, the adjustment screws will be *off-center* in these same holes.
2. After determining which channel (either #5 or #6) the i-f transformers should be aligned to, set the signal generator at the proper frequency—i.e., Channel #5—79 mc, Channel #6—85 mc.
3. Adjust the controls on the signal generator to provide the usual 400-cycle, 30% amplitude modulation with an output level of approximately 500 microvolts. If the output level cannot be easily determined, set the contrast control on the receiver at about the mid-point. Then adjust the output control of the signal generator so that the horizontal bars produced by the 400-cycle modulation are medium gray in color.
4. Insert the output of the signal generator between either of the two UHF antenna terminals and the chassis of the UHF tuner.

5. Peak the i-f tuning cores of T1 and T2 (see Fig. 5) for maximum darkness of the bar pattern as observed on the screen of the picture tube. Reduce the output of the signal generator to maintain the medium gray level as the circuits approach optimum.

UHF ADJUSTMENTS

The UHF tuner is now ready to be mounted to the cabinet as shown in Fig. 3. Now proceed with the UHF tuner adjustments as follows:

1. Turn the receiver and the tuner "on." Set the tuner control knob to the "UHF-1" position. If the switch positions do not appear at the proper point on the control knob or if they appear at a point which is not clearly visible when facing the front of the cabinet, just lift one end of the removable plastic liner on which these positions are printed and move the liner to the correct point. Allow approximately 15 minutes warm-up time before proceeding with the adjustments.
2. Set the channel selector on the receiver to either Channel #5 or #6 according to the preceding information. Set the Fine Tuning control to about the middle of its range.

3. Turn the UHF oscillator tuning core in Fig. 5 counterclockwise until the slot is about level with the inside brown plastic plate. *Do not continue turning beyond this point or the core will drop out.*
4. From this starting point, *slowly* turn the oscillator tuning core clockwise into the coil until a UHF picture and accompanying sound signal are received. Keep in mind that it is the *first* good signal noted while turning the core clockwise from the starting position that is the one to be used. The proper oscillator adjustment can be quickly checked if a VHF signal is available by noting the direction in which the fine tuning control is turned to produce audio bars or beats in the picture. This direction should be the same for both VHF and UHF. If the direction is not the same, slowly turn the oscillator core counterclockwise until the proper signal is received. *Do not permit the tuning core to exert undue pressure when turning the core into the coil because coil damage might result.*
5. Adjust the r-f tuning core in Fig. 5 for maximum picture signal.

(Cont'd on page 5)

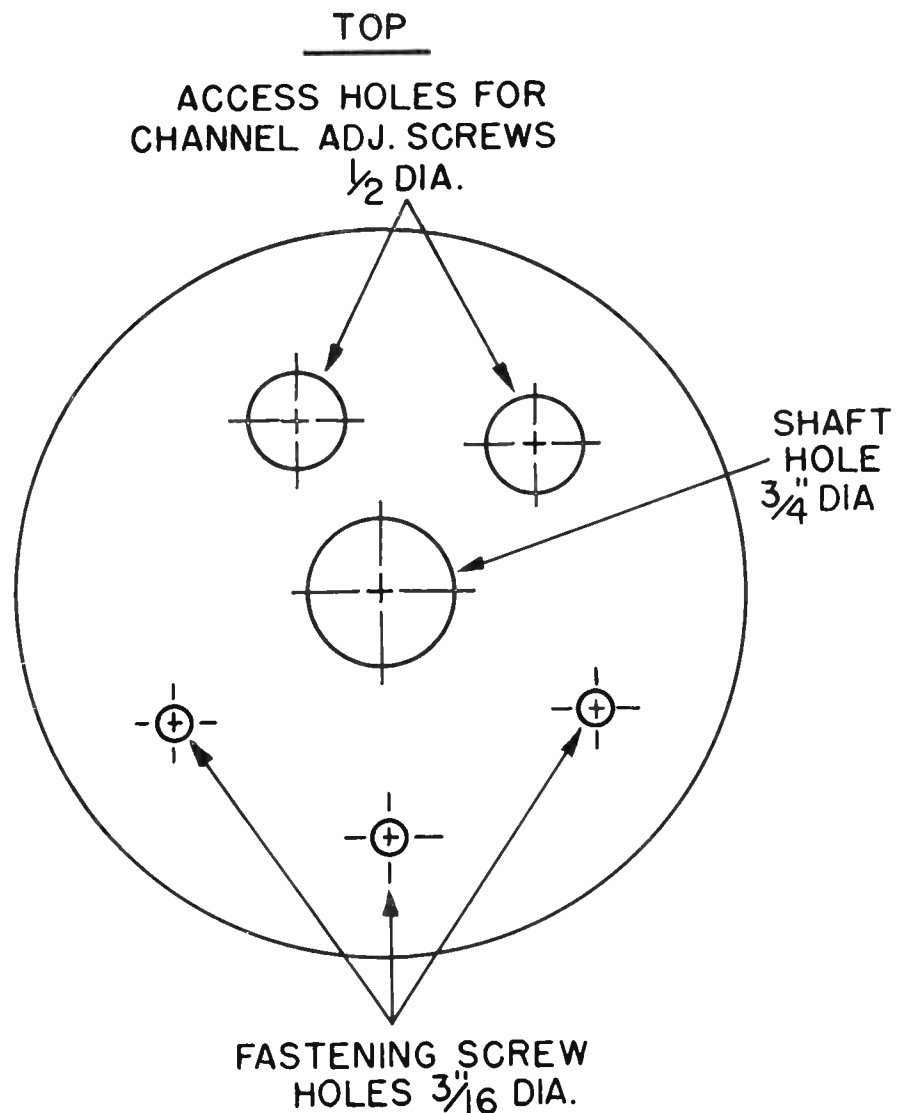

Fig. 2. Template for side mounting the UHF-103 Tuner.

6. Now readjust the oscillator core so that the Fine Tuning control on the receiver will permit tuning slightly into the audio bars or "beats." Also be sure that any adjacent channel interference can be tuned out.

7. The tuner is now aligned for operation on one UHF channel indicated by the UHF1 position on the control knob. Repeat steps 3 through 6 for the UHF2 and UHF3 positions if and when a second or third UHF channel is available in your area.

This part has only described the installation of the basic UHF-103 unit. The next issue will contain a description of the installation of this same unit with accessory kits. If these kits are used, a considerable number of different model General Electric receivers can be adapted for UHF reception from a single control knob mounted on the present control shaft.

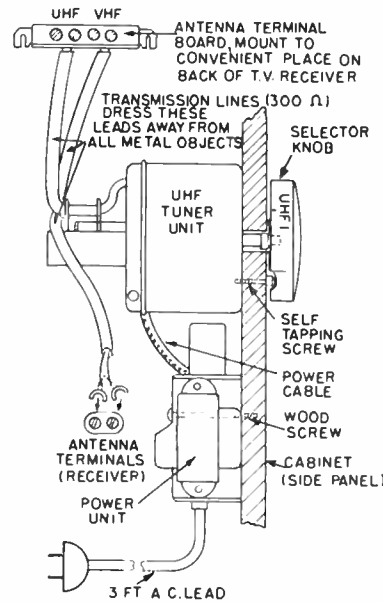

Fig. 3. Relative position when mounting the UHF-103 Tuner to the side of a cabinet.

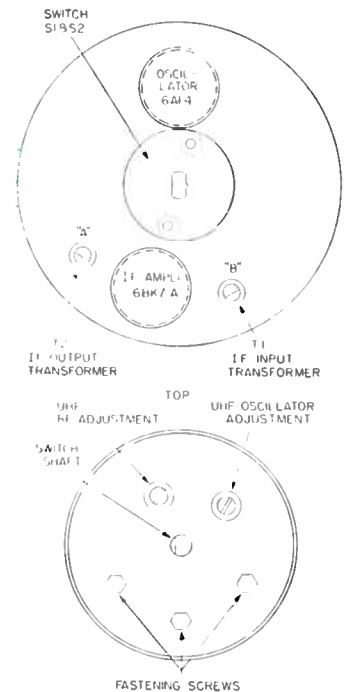

Fig. 5. Location of R-F, Oscillator and I-F adjustments on UHF-103 Tuner.

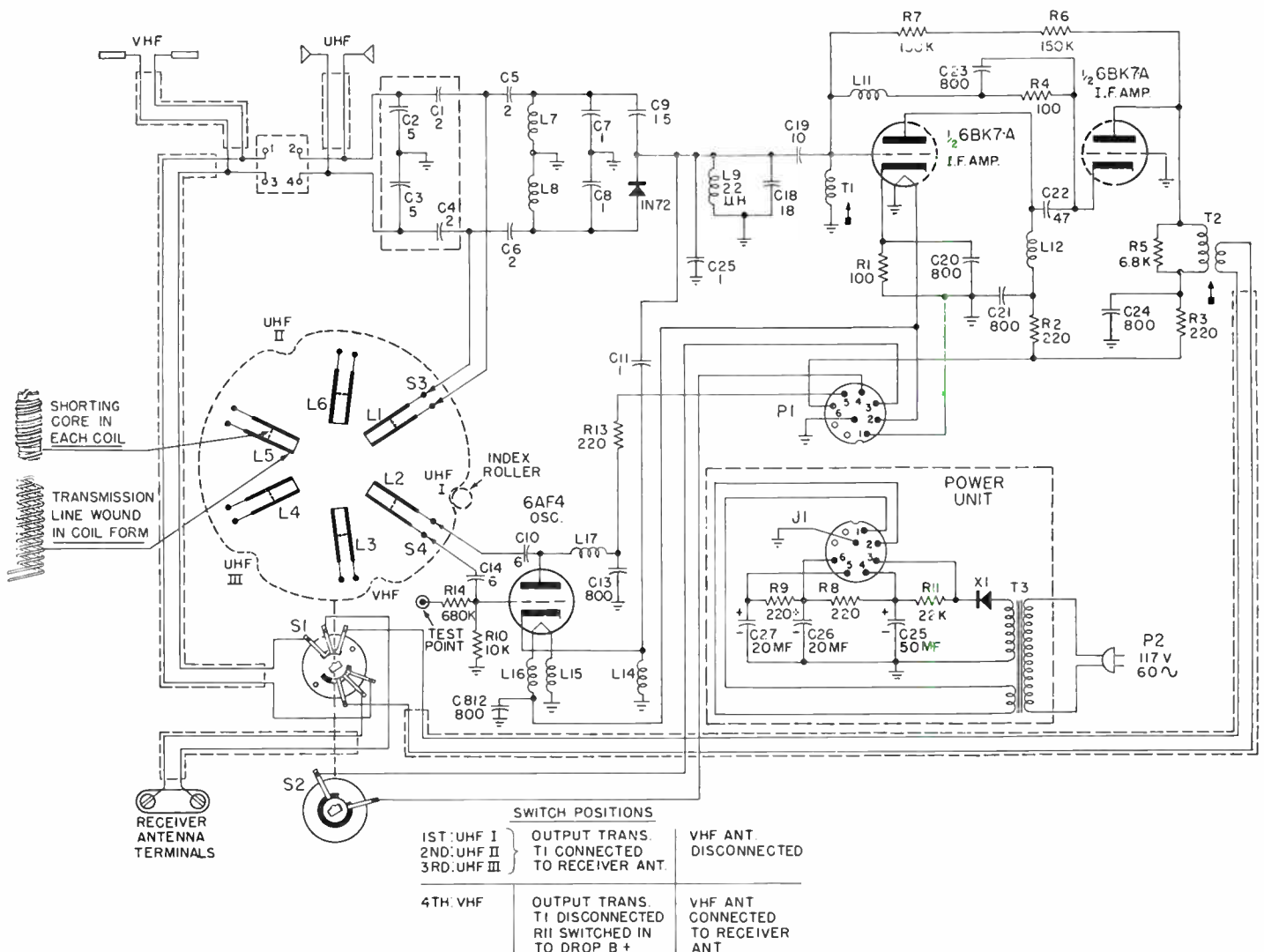

Fig. 4. Schematic diagram of the UHF-103 Tuner.

BENCH NOTES

Contributions to this column are solicited. For each question, short-cut or chronic-trouble note selected for publication, you will receive \$10.00 worth of electronic tubes. In the event of duplicate or similar items, selection will be made by the editor and his decision will be final. The Company shall have the right without obligation beyond the above to publish and use any suggestion submitted to this column. Send contributions to The Editor, Techni-talk, Tube Department, General Electric Company, Schenectady 5, N. Y.

SERVICE HINTS

While out making service calls, I always carry a TUBE CADDY in which I have installed a small test speaker. The leads are long enough to reach the chassis after removal from the cabinet. In this way I can check the sound output.

I always carry an old or used 5U4-G rectifier tube for checking low-voltage supplies. As an example, suppose I find a rectifier tube that is burned out. Since I am not sure the B+ supply is shorted, I slip in the spare tube. If the B+ is shorted, out goes the test tube. I then pull the chassis and start to work. If the test tube lights, I know it's safe to install a new tube and go ahead.

*Robert J. Strong
136 B Danbrook Dr.
Whittier, Calif.*

HUM IN PICTURE

In the past months we have had in our shop a number of 16-in. Emerson television receivers such as Models 629D, 651C, etc., which have had a similar troublesome condition. On all of these sets a 60-cycle hum was visible on the raster. Although the hum was not too predominant, with a picture on the screen, it was noticeable that the top half was darker than the bottom and would require additional increase of brightness with the control in order to overcome this shading of the top half.

After checking all tubes for cathode-heater shorts, including the CR tube, it was found in all these sets that a leaking condenser, .002 mfd. vertical coupling condenser to the cathode of the CR tube (vertical retrance circuit), was the cause creating this 60-cycle hum effect.

*Martin Stein
1616 N. 29th Street
Philadelphia 21, Pa.*

SHORTED DAMPER WINDING

A blown fuse in the high-voltage section of an RCA Model 8TC120 started the normal service procedure of H.V. trouble diagnosis. A fruitless search through the complete high-voltage section finally boiled down to the filament circuit of the 6W4-GT damper tube. Checking the 6.3-volt filament winding on the low-voltage transformer disclosed this winding to be shorting to ground when under the high-voltage load of damper operation. This high-voltage arc-over resulted in high current through the fuse causing it to blow.

Isolation of the 6.3-volt secondary winding on the low-voltage transformer and the substitution of a separate 6.3-volt filament transformer for the 6W4-GT resulted in an economical and speedy repair.

*Willard B. Yorgey, Jr.
386 N. Godfrey St.
Allentown, Penna.*

FLOATER AND WIRING ERROR

Recently I had a G-E Model No. 17C110 which caused me a lot of trouble. Vert., sync. and sound were okay, but hor. sync. was intermittent. The pix would lock in then lose sync and float across the pix tube. I changed the 6AQ7-GT hor. phase det. but soon the pix would begin to float first to one side then to the other. Sometimes the pix would lock in.

This trouble was traced to C352, a 120 mmfd. capacitor from the plate of the triode section of the 6AQ7-GT to the cathodes of the hor. phase det. section of the 6AQ7-GT. This capacitor was intermittently leaky.

I have had several new Philco TV sets with no/or distorted sound after being played for a few hours. A new 6T8 apparently fixed the set only to get a callback in a few days. Since the first one with this trouble. I pull the audio-RF-IF chassis and install a grid resistor for the audio output tube, and clip loose the 470K res. from screen grid to chassis. Whoever wired these sets put the res. on pin 4 (screen grid of the 6V6) instead of the control grid pin #5.

*L. B. McIntyre
Mac's Radio & TV Service
Norwood, N. C.*

FRINGE AREA AGC

One of the standard procedures for improvement of fringe area reception is to remove AGC from the RF stage. This gives good results in most cases. In one case, however, it produced difficulties. Reception was remarkably improved on the high channels due to regeneration. When tuning low channels, however, regeneration developed into oscillation and motorboating which made reception impossible. The only way to eliminate this was to tune the RF stage to a very broad response. This reduced gain and increased snow and made reception worse than with AGC.

To kill two birds with one stone, I decided to take advantage of the inherent property of regeneration. I installed a one meg. pot. from the AGC bus to ground and took RF bias from the arm. With this arrangement, BIAS may be adjusted to give maximum regeneration and, therefore, exceptional improvement in reception. All channels should be checked at maximum contrast to be sure there will be no regeneration. Remove the pot. and wire the correct resistors into a voltage divider. However, I left the pot. in the circuit so that when the set comes back for alignment in the future, it may be adjusted again for maximum performance.

*G. E. Withers
3394 Bagley Dr.
San Diego 10, Calif.*

HAVE YOU ENTERED?

It's ABC-easy

WRITE YOUR OWN TICKET CONTEST

Over 7000 Dollars in Prizes

SEE YOUR G-E TUBE DISTRIBUTOR

TUBE DEPARTMENT
GENERAL ELECTRIC
Schenectady 5, N. Y.

Boyd's Radio Service
411 Fredericksburg Rd.
San Antonio 1, Texas
E-223/J-75

6-13-49

SEC. 34.66 P. L. & R.
U. S. POSTAGE
PAID
Schenectady, N. Y.
Permit No. 148