

# SPECIAL REPORT ON VHF SSB

PART II . . . In This Issue:

## A 144 - MC. DIRECT SSB GENERATOR

By James V. O'Hern, W2WZR

**PART I** — In the July-August, 1962 issue, described a complete 20-watt exciter, with a phasing-type generator on 25 megacycles, and heterodyned to 144 megacycles.

**MOST VHF SSB EQUIPMENT** utilizes the principle of generating the single sideband signal at a lower frequency — either by the filter or phasing method — and then heterodyning it once or twice to the 144-megacycle band. Seeking a simpler approach, W2WZR has developed a method of generating a good quality single sideband signal directly at 144 megacycles using the phasing method. In addition to simplicity, it avoids the spurious signals and "birdies" that can occur in heterodyning type systems.

**NUMEROUS EXPERIMENTS** conducted at W2WZR in the fine art of generating a phasing type single sideband signal on the 144-megacycle band have been mainly devoted to solving these three basic problems:

1. A simple and accurate 90-degree phase shift network for the RF signal from the carrier generator;
2. A stable double balanced modulator at 144 megacycles;
3. Maintaining frequency stability within 100 cycles.

This article reports on the methods and circuits used to solve these problems. They have resulted in a phasing type single sideband generator at 144 megacycles which provides signal quality comparable to phasing type exciters operating in the 3 to 30-megacycle range.

The overall block diagram of the exciter, Fig. 1, shows the audio section

at the upper left, the double balanced modulator and RF phase-shift system at the right, and the RF carrier generator section across the bottom. Each portion of the circuit will be discussed in detail, with emphasis on solving the problems encountered in designing the unit.

**RF PHASE-SHIFT SYSTEM** — The degree of unwanted sideband suppression that can be obtained in a phasing type generator circuit depends on the accuracy of the 90-degree phase difference of both the RF and audio signals fed into the double balanced modulator, from which the single-sideband, suppressed-carrier signal emerges. Suitable audio-phase-shift networks can be purchased, but 90-degree RF phase shift networks for 144 megacycles are not a catalog item.

The final circuit wasn't found on the first try; it required a bit of evolution.

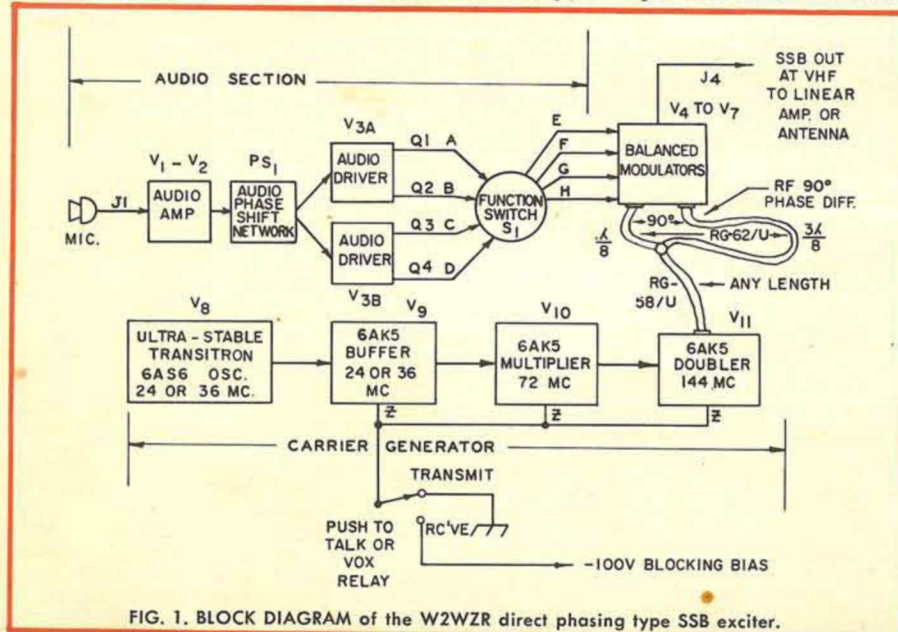

FIG. 1. BLOCK DIAGRAM of the W2WZR direct phasing type SSB exciter.



TUBES

# HAM NEWS

SEPTEMBER-OCTOBER, 1962

The first attempt was a standard R-C, C-R 45-degree-per-leg network, pictured in Fig. 2A, which works fine up to 30 megacycles or so. At 144-megacycles, however, it was too critical due to phase shift inaccuracies from external stray capacitances, and shunt capacitances across the resistors.

The next attempt was using a single  $\frac{1}{4}$  electrical wavelength of RG-58/U 52-ohm impedance coaxial cable as a delay line, as shown in Fig. 2B. This achieved the desired 90-degree phase difference at the terminal points at the right; but, the necessary equalization of RF voltages could not be obtained with this circuit. After reasoning why unbalanced voltages would occur, it was found that input capacitance differed in the two halves of the double balanced modulator to which the RF phase shift network is connected.

The other problem was impedance mismatch. If a high standing wave ratio appears on the  $\frac{1}{4}$ -wave line, a voltage null could occur at the terminal end driving the balanced modulator,

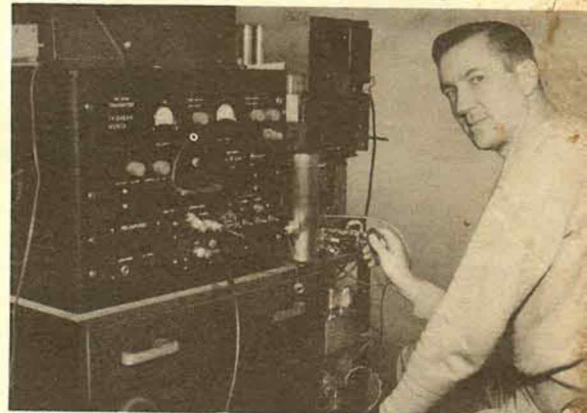

W2WZR DEMONSTRATES the top-notch CW performance of his 144-megacycle single sideband transmitter which contains the direct phasing type SSB generator. Jim really appreciates the advantages of SSB on the VHF bands, since his home location at Nedrow, in Central New York, is surrounded by 1,500-foot high hills! Associated with General Electric for 16 years, W2WZR is an engineering specialist in the Advanced Circuits Section of the Electronics Laboratory at G-E's large Electronics Park operation in Syracuse, New York. He has been a licensed radio amateur as W2WZR since 1947.

## IN THIS ISSUE

Copyright, 1962, by General Electric Company

A 144-MC. DIRECT SSB GENERATOR.....	page 1
A TRIPLE VOLTAGE-REGULATED POWER SUPPLY.....	page 6
PRINCIPLES OF THE TRANSITRON CRYSTAL OSCILLATOR.....	page 7
EIGHTEEN MORE G-E COMPACTRONS ANNOUNCED.....	page 8

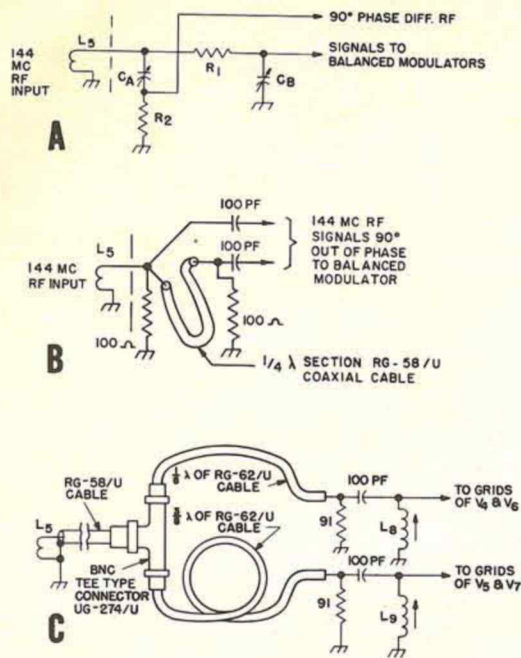

FIG. 2. DIAGRAMS of the RF phase-shift networks tried.

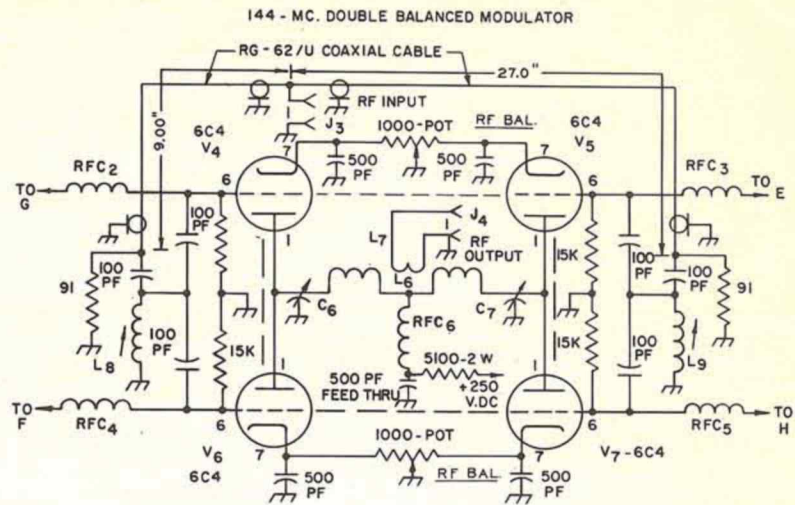

FIG. 3. SSB GENERATOR schematic diagram, showing the lengths of the coaxial cable phasing lines. The 1,000-ohm carrier-balance potentiometers ( $R_3$  and  $R_4$ ) may be located remotely provided the tube cathode pins are bypassed to the chassis with 500-PF disc ceramic capacitors with shortest possible leads.

resulting in much lower RF voltage on the side of the balanced modulator driven from the cable.

In the final circuit, Fig. 2C,  $\frac{1}{2}$  of a wavelength of coaxial cable was inserted to drive one side of the balanced modulator; and,  $\frac{3}{8}$  of a wavelength of cable —  $\frac{1}{4}$ -wavelength longer — was inserted in the other side to maintain a 90-degree phase difference at the terminal ends. In addition, 93-ohm RG-62/U coaxial cable was used as the phasing lines to reduce the mismatch. The 52-ohm RG-58/U coaxial cable through which the 144-megacycle RF signal enters the phase-shift network thus looks into the 47-ohm impedance of the two 93-ohm cables in parallel.

The unbalance due to the difference in input capacitances in the balanced modulator was tuned out with small

slug-tuned coils ( $L_8$  and  $L_9$ ). The RG-62/U coaxial cable has a velocity factor of 0.88 instead of the usual 0.66 factor of RG-58/U and similar cables. Thus the length of the phasing lines is calculated by multiplying the true free-space lengths of  $\frac{1}{2}$  and  $\frac{3}{8}$  wavelengths at 144 megacycles by 0.88 to obtain the correct lengths of the two cables. A design frequency of 145 megacycles also can be used in calculating the lengths, but tests have shown that the carrier frequency can be moved plus or minus one-half megacycle with little effect on the 90-degree phase difference.

**THE DOUBLE BALANCED MODULATOR** problem at 144 megacycles was solved more through careful attention to mechanical details, than by innovations in the electrical circuit. A standard triode type double balanced modulator circuit—

used in some commercially-built SSB adapters—shown in Fig. 3, was found satisfactory. It is capable of much higher output voltage with low input signal levels than a diode type of balanced modulator. The circuit includes the RF phase shift cables just described.

Four single miniature triodes, the popular 6C4, are connected so that one RF signal drives the grids of  $V_4$  and  $V_6$  in parallel; and, the 90-degree delayed RF signal drives the grids of  $V_5$  and  $V_7$ . The four-phase audio signals also drive the 6C4 grids through small RF chokes. The modulation process of addition and cancellation of signals results in a single sideband, suppressed-carrier signal<sup>1</sup> appearing in the plate tuned circuit ( $L_6$ ,  $C_6$  and  $C_7$ ).

Input amplitude balance is achieved by adjusting  $L_8$  and  $L_9$ ; and, capacitors  $C_6$  and  $C_7$  are adjusted to maintain RF balance in the output tank circuit. Current flow balance through the tubes is obtained with the 1000-ohm potentiometers connected between the cathodes of  $V_4$  and  $V_5$ , and  $V_6$  and  $V_7$ .

In order to prevent the 144-megacycle carrier signal from feeding around the balanced modulator, careful shielding is necessary for the output circuit. The mechanical layout sketch, Fig. 4, illustrates how the four 6C4 tube sockets are mounted in a rectangle with the plate pin connections inside a rectangular shield which also houses the output tank circuit.

The rest of the circuit is constructed symmetrically around the shield, using the shortest possible leads on bypass and other capacitors, and the "hot" end of coils and grid resistors, etc. The coaxial cable phasing lines may be rolled up, or run in a loop in a vacant corner of the chassis.

The audio section—and especially the function switch ( $S_1$ )—should be

presents **HOW-TO-DO-IT IDEAS**  
from the 999 radio amateurs at

**GENERAL ELECTRIC**

A bi-monthly publication of the RECEIVING TUBE DEPARTMENT  
Owensboro, Kentucky, U. S. A. • Editor — E. A. Neal, W4ITC

G-E HAM NEWS is available free from authorized G-E Tube distributors. Some distributors mail copies locally to their customers.

A low-cost direct-mail subscription plan is available to persons residing in the United States and its possessions (including APO and FPO numbers).

Subscription rates are:

One Year (6 issues).....	\$1.00
Two Years (12 issues).....	\$2.00
Three Years (18 issues).....	\$3.00
Five Years (30 issues).....	\$4.00

Enclose check or money order for U. S. currency for the proper amount above made payable to "General Electric Company."

Residents of Canada may subscribe to G-E HAM NEWS for \$1.00 per year from the Canadian General Electric Company, Ltd., Electronic Tube Market-

ing Section, 189 Dufferin Street, Toronto 3, Ontario, Canada. Enclose check or money order made payable to: "Canadian General Electric Company, Ltd."

Distribution of G-E HAM NEWS in more than 40 foreign countries is handled through the International General Electric Company. A listing of outlets is available from the G-E HAM NEWS office. Or, write to: Customer Inquiry Section, International General Electric Company, 150 East 42nd Street, 7th Floor, New York 17, New York, U. S. A.

**NOTE:** The disclosure of any information or arrangements herein conveys no license under any patents of General Electric Company or others. In the absence of an express written agreement to the contrary, the General Electric Company assumes no liability for patent infringement (or any other liability) arising from the use of such information by others.



located close to the balanced modulator so that the audio leads running to the grid RF chokes (RFC<sub>2</sub> to RFC<sub>5</sub>) are as short as possible.

This balanced modulator has sufficient power output to drive the small VHF RF pentodes—5686, 6360, 7701, 8156, etc.—as a class AB<sub>1</sub> linear amplifier to several watts peak output. The 5686 is recognized as a superior performer in this service. The output may then be amplified further in linear amplifiers using the 829-B, 5894, 6146-A, 7984 and even larger VHF power tubes.

**FREQUENCY STABILITY** of a single sideband transmitter should be less than 100 cycles for periods of several minutes regardless of the operating frequency. This places a much greater stability requirement percentage-wise on a 144-megacycle transmitter than it does at lower frequencies. Much experimenting was done at W2WZR in achieving satisfactory stability, and the circuits presented here reflect the best results obtained.

Those amateurs who already have a 144-megacycle transmitter which exhibits good stability may use the exciter portion as the carrier generator. It should be run at the lowest possible level and still have sufficient output to feed into the RF phase shift cables and balanced modulator. The main precaution to observe is to isolate the carrier generator carefully from the amplifier stages which follow the balanced modulator. Otherwise, the carrier generator signal can leak around the balanced modulator and cause poor carrier suppression on the sideband signal.

In addition to a frequency stability test on an exciter to be used as the carrier generator, try applying a cutoff bias of minus 100 volts or so on the control grids of all multiplier stages following the crystal oscillator. Then, with just the oscillator running, listen on a 144-megacycle receiver (or converter and communications receiver) for the harmonic of the crystal frequency. Some oscillators have large harmonic output and can put a strong signal into your receiver which prevents your copying stations on that frequency.

If the crystal oscillator has objectional harmonics, it also can be cut off during standby, either with blocking bias, or by removing plate voltage. A check should then be made to see how much the 144-megacycle harmonic of the oscillator frequency shifts each time it is turned on. If more than a few cycles shift is measured, the stability is not suitable for voice-controlled break-in (VOX) operation on single sideband. Otherwise, an annoying slur in voice pitch will occur each time the VOX circuit turns on the transmitter, and oscillator.

If the oscillator frequency shifts with keying, added shielding in the existing exciter can sometimes reduce the crystal oscillator harmonic signal to the level which, with the multiplier stages cut off with blocking bias, will not QRM incoming signals in the station receiver.

Unless the existing exciter really measures up to the performance requirements just outlined, it probably is better to modify it to incorporate the features of the carrier generator developed for use at W2WZR. In this unit, shown in Fig. 5, a transitron type

crystal oscillator—similar to that used by K2LMG in his 144-megacycle SSB transmitter in the last issue of G-E HAM NEWS—operates at either 24 or 36 megacycles.<sup>2</sup> A discussion of transitron oscillators appears on page 7 of this issue. Since its output is very low, and has very little harmonic content, simple shielding will prevent its harmonics from appearing in the 144-megacycle receiver. The 6AS6 pentode tube (V<sub>8</sub>) is used in the circuit.

A 6AK5 miniature pentode tube (V<sub>9</sub>) builds up the output signal to the level needed to drive the multiplier stages, two more 6AK5's. The first multiplier (V<sub>10</sub>) triples to 72 megacycles with a 24-megacycle crystal in the oscillator; or, doubles with a 36-megacycle crystal in the oscillator.

The 144-megacycle final carrier generator frequency is obtained from the second doubler, V<sub>11</sub>, and runs through 52-ohm coaxial cable to the double balanced modulator previously described. This oscillator-multiplier can often be adapted to this portion of an existing VHF transmitter, thus making it a stable carrier generator.

A variable crystal oscillator (VXO) of the type used by K2LMG in his 144-megacycle SSB transmitter also could be used in place of the transitron crystal oscillator. This circuit is repeated here in Fig. 6, and permits operation over a 200-kilocycle range at 144 megacycles. Fundamental type crystals of frequencies between 7.205 and 7.400 megacycles are used, and the plate circuit coil is tuned to the 5th harmonic, or 36 to 37 megacycles. The same two multiplier stages in Fig. 5, (V<sub>10</sub> and V<sub>11</sub>), are then used to obtain the 144-megacycle carrier frequency.

Regardless of the type of crystal oscillator circuit used in a VHF transmitter, steps should be taken to protect the crystal from temperature changes which cause frequency changes due to the temperature coefficient of the crystal. The crystal should be mounted in a location where it is not exposed to heat from other components. An insulated compartment for crystals like that used in K2LMG's SSB transmitter in the last issue is recommended.

All the foregoing comments on improving the frequency stability of VHF carrier generators apply equally to transmitters which are used for CW operation on 144 megacycles. It can make the note sound more like those heard on the 7-megacycle CW band, instead of the shaky, chirpy notes sometimes heard from 144-megacycle CW stations.

**AN AUDIO SYSTEM** is an integral part of single sideband transmitters. Since only a few volts of audio is required for modulation of the balanced modulators, only two or three low-level stages are necessary. In the audio system for the W2WZR transmitter, shown in Fig. 7, a 12AX7 twin triode (V<sub>1</sub>) serves as a cascade audio voltage amplifier. A 6AB4 triode (V<sub>2</sub>) drives a VOX circuit, if used, and the audio phase shift networks through a step-down transformer (T<sub>1</sub>). A commercially-made audio phase-shift network unit (PS<sub>1</sub>—a B&W type 2Q4, Model 350) was used to avoid assembly and adjustment of home-made networks. A 12AT7 twin triode (V<sub>3</sub>) in a push-pull audio amplifier serves as the modulator.

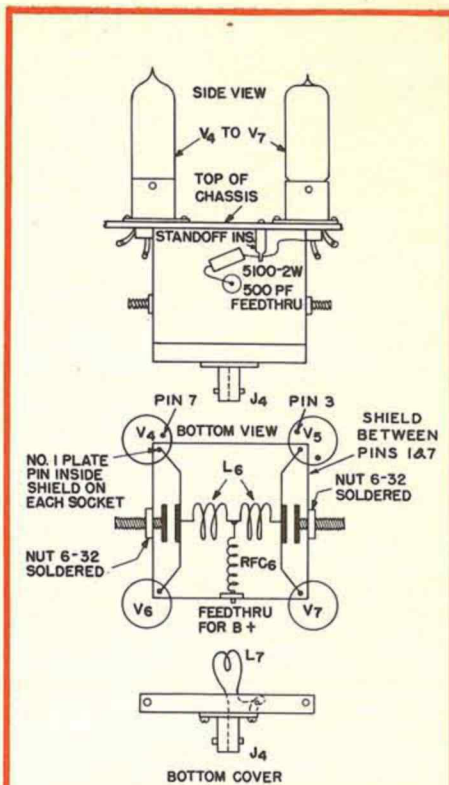

FIG. 4. MECHANICAL DETAILS of the 144-megacycle SSB generator, showing the output circuit and plate connections on the 7-pin miniature tube sockets housed within a shield box made of 1/32-inch thick sheet copper. In the bottom view plates of C<sub>6</sub> and C<sub>7</sub> are made from 1/16-inch copper disks the size of a penny soldered to 6-32x1-inch long brass machine screws. Side view of bottom cover shows output link coil (L<sub>7</sub>) positioned to be fit in the center of L<sub>6</sub>. Complete shielding of output circuit prevents carrier signal leakage around balanced modulator. Contact for pin 2 on the 7-pin miniature sockets is removed to allow room for shield.

Choice of upper or lower sideband modes of transmission, or double sideband, is made through the function selector switch (S<sub>1</sub>) circuit shown in Fig. 8. This switch reverses the audio leads to V<sub>4</sub> and V<sub>5</sub> in the balanced modulator to change from lower to upper sideband. For double sideband, audio lead "D" is connected to V<sub>6</sub> and V<sub>7</sub>, and lead "C" is not connected to any balanced modulator grid.

#### FOOTNOTES

<sup>1</sup>A comprehensive discussion of the theory of the phasing method of generating and receiving single sideband is contained in the article, "A New Approach to Single Sideband," by D. E. Norgaard, QST, June, 1948, page 36; also reprinted in "Single Sideband for the Radio Amateur," by ARRL.

<sup>2</sup>The actual frequency of crystals used in the 6AS6 transitron oscillator should be as follows, allowing for band limits: 24 Mc., 24.001 to 24.665 Mc.; 36 Mc., 36.001 to 36.999 Mc. Crystals should be ordered specifying their calibration at series resonance, which occurs several kilocycles below the parallel resonance at which crystals are usually calibrated.

<sup>3</sup>A good discussion of the subject appeared in "How to Adjust Phasing-Type SSB Exciters," by R. W. Erlich, WJIS, QST, November, 1956, page 16; also in "Single Sideband for the Radio Amateur," by ARRL.

**CONSTRUCTION** of the balanced modulator has already been covered. The audio and carrier generator portions of the exciter should utilize good practice: short leads; input and output sections of each stage well isolated from each other; shielding to prevent radiation of RF signals around the balanced modulator, and into the receiver; etc.

Both the audio and RF sections should be working properly before final adjustment of the balance modulator is attempted. The crystal oscillator in the carrier generator is checked for frequency stability, and the multiplier stages may be tuned up with a grid-dip oscillator. Maximum 144-megacycle output from V<sub>11</sub> can be checked by listening for peak signal strength on a receiver.

The 144-megacycle carrier generator signal is fed into J<sub>3</sub>, and a 50-ohm dummy load is connected to J<sub>4</sub>. Peak up coils L<sub>8</sub> and L<sub>9</sub> and adjust capacitors C<sub>6</sub> and C<sub>7</sub>, for maximum output from the balanced modulator, as indicated by a receiver "S" meter. Next, adjust the 1,000-ohm potentiometers (R<sub>3</sub> and R<sub>4</sub>) to balance out the carrier.

Then, apply an audio tone of about

1,000 cycles at J<sub>1</sub>. The carrier should reappear on the receiver with some tone modulation on it. Adjust the PHASE BAL. (R<sub>1</sub>) and the AUDIO BAL. (R<sub>2</sub>) potentiometers for minimum audio modulation on the carrier.

The final check, of course, is listening to the signal on a SSB receiver while talking into a microphone plugged into J<sub>1</sub>. This exciter is capable of producing the crisp audio quality characteristic of phasing type SSB transmitters. The exciter may be followed by linear amplifiers. At W2WZR, the balance modulator drives a 6360 twin tetrode, which in turn drives a 5894 twin tetrode linear amplifier to about 150 watts peak input.

In several years of operating on 144-megacycles with single sideband, a fixed, crystal-controlled frequency has not been a disadvantage when contacting only one other station at a time. When three or more stations are in a round table QSO using VOX break-in, however, it is more convenient to be able to "zero in" on frequency with a VXO or other tunable oscillator.

Single sideband really shows its advantage for extended ground wave work

when signals are weak. It also makes possible voice contacts during aurora-type propagation when conventional AM voice signals are virtually uncopyable. With a little tuning practice, the ghostly whisper of single sideband signals really stand out, and is almost as easy to copy as single sideband with no aurora flutter.

## 50-MC. DIRECT PHASING TYPE SSB GENERATOR

The fine performance of the direct phasing type double balanced modulator on the 144-megacycle band encouraged W2WZR to try the same circuit on 50 megacycles. Since this is only one-third the frequency, better performance and fewer problems were expected.

A test circuit was constructed using the four 6C4 triode tubes in the same basic circuit as shown for the 144-megacycle balanced modulator in this issue, Fig. 3. It was driven by a stable 50-megacycle RF exciter, and the audio system from the 144-megacycle exciter. The RF phase-shift network cables were made out of sub-miniature coaxial cable and rolled up into coils about 3 inches

**TABLE I — PARTS LIST**

- C<sub>1</sub>.....5-50-pf. midget air variable.  
 C<sub>2</sub>, C<sub>3</sub>, C<sub>4</sub>, C<sub>5</sub>.....3-30-pf. midget air variable.  
 C<sub>6</sub>, C<sub>7</sub>.....home-made 2-plate air variable; see Fig. 4 for details.  
 J<sub>1</sub>.....single circuit shielded microphone jack.  
 J<sub>2</sub>, J<sub>3</sub>, J<sub>4</sub>.....midget coaxial cable chassis connector (BNC series, Amphenol type UG-290/U), or midget phono jack.  
 L.....Coils, see TABLE II—COIL DATA, for details.  
 PS<sub>1</sub>.....Dual 90-degree phase shift networks, packaged in metal tube envelope with 8-pin octal base (B&W type 2Q4, Model 350 network).  
 R<sub>1</sub>, R<sub>2</sub>.....500-ohm composition potentiometer, linear taper.  
 R<sub>3</sub>, R<sub>4</sub>.....1,000-ohm composition potentiometer, linear taper.  
 R<sub>5</sub>.....500,000-ohm potentiometer, audio taper.  
 RFC<sub>1</sub>.....50-uh. midget RF choke (National R-33, 50-uh.).  
 RFC<sub>2</sub> to RFC<sub>5</sub>.....17 turns, No. 30 enameled wire closewound on 100,000-ohm, 2-watt composition resistor.  
 RFC<sub>6</sub>.....1.8-uh. midget RF choke (Ohmite Z-144).  
 S<sub>1</sub>.....3-pole, 3-position, non-shorting rotary tap switch.  
 T<sub>1</sub>, T<sub>2</sub>, T<sub>3</sub>.....20,000-ohm to 600-ohm audio transformer (BC-454 Command Set receiver audio output transformer, marked T<sub>1</sub>, used in W2WZR's model).  
 X<sub>1</sub>.....3rd overtone quartz crystal between 24.001 and 24.665 Mc.; or 36.001 and 36.999 Mc.  
 X<sub>2</sub>.....Fundamental type quartz crystal between 7.201 and 7.400 Mc.

**TABLE II — COIL DATA**

NOTE: All coils wound with enameled copper wire unless otherwise indicated.

- L<sub>1</sub>.....12 turns, No. 28 wire, closewound\*.  
 L<sub>2</sub>.....35 turns, No. 28 wire closewound\*\*.  
 L<sub>3</sub>.....6 turns, No. 28 wire, closewound\*\*.  
 L<sub>4</sub>.....7 turns, No. 20 wire, self supporting, 3/8-inch diameter, spacewound diameter of wire.  
 L<sub>5</sub>.....2 turns, No. 20 wire, self supporting, 3/8-inch diameter, spacewound, located 1/4-inch from bypassed end of L<sub>4</sub>.  
 L<sub>6</sub>.....6 turns, No. 20 wire, self supporting, 3/8-inch diameter, wound in two 3-turn coils, each 1/2-inch long with 3/8-inch space at center; see Fig. 4 for details.  
 L<sub>7</sub>.....2 turns, No. 20 wire, self supporting, 3/8-inch diameter, at center of L<sub>6</sub>.  
 L<sub>8</sub>, L<sub>9</sub>.....3 turns, No. 28 wire, spaced diameter of wire\*\*.  
 \*Use Cambion (Cambridge Thermionic Corp., 445 Concord Ave., Cambridge 38, Mass.) type LS-3 phenolic coil form, 3/8-inch diameter, 1 3/8 inches long, with white-coded iron tuning slug.  
 \*\*Use Cambion type LSM phenolic coil form, 1/4-inch diameter, 3/4-inch long, with white-coded iron tuning slug.  
 NOTE: Cambion ceramic coil forms also can be used for L<sub>1</sub>, L<sub>2</sub>, L<sub>3</sub>, L<sub>8</sub> and L<sub>9</sub>. Obtain PLS-5, 3/8-inch diameter; and, PLS-6, 1/4-inch diameter, both with white tuning slug.

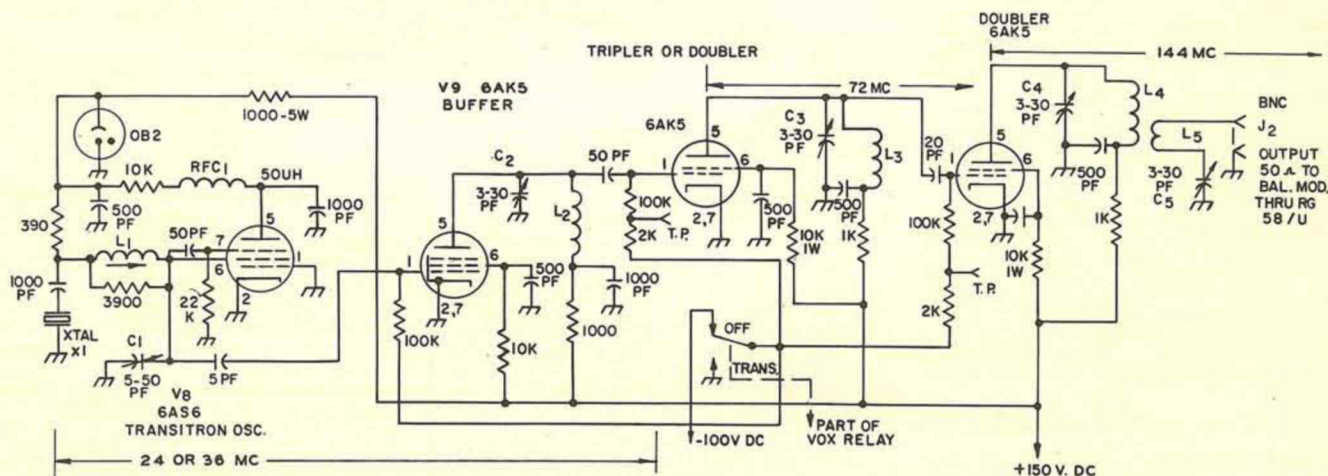

**FIG. 5. CARRIER GENERATOR** schematic diagram, showing the transatron crystal oscillator at left, with buffer and frequency multiplier stages in line toward right. Note that provision is made for applying blocking negative bias through a VOX relay. Coil L<sub>1</sub> is adjusted to tune with C<sub>1</sub> to the frequency of the crystal being used (24 or 36 Mc.).

NOTE: In all schematic diagrams, resistances are given in ohms, 1/2-watt rating unless marked for higher wattage. Capacitances are in picofarads (PF), or microfarads (UF), as marked. Capacitors with polarity signs are electrolytic type of the capacitance and voltage rating specified. Inductances are in microhenries (UH), or millihenries (MH).

in diameter to reduce their bulk and conserve space.

It was found that the box-type shield shown for the 144-megacycle modulator plate circuit was not needed at 50 megacycles to obtain adequate carrier suppression. However, if excess carrier feed-through is encountered by persons who duplicate the 50-megacycle circuit, a shield could be added.

Another double balanced modulator was constructed using two 12AT7 twin triodes. Performance was about the same as for the modulator with the four 6C4 single triodes. One disadvantage of the 12AT7 and other twin triode tubes using the EIA type 9A basing is that the two control grids come out to pins 2 and 7, while the plates are on pins 1 and 6. This makes it difficult to shield the plate circuit from the grid circuit, since one grid pin connection will be located on the plate side of a shield run across the center of the socket.

The 5670 miniature twin triode used by K2LMG in the 25-megacycle double balanced modulator in the July-August issue solves this problem because the 5670 control grids are on pins 3 and 7, and the plates are on pins 4 and 6. A shield can thus be run across the socket to isolate the grid circuit from the plate circuit.

The circuit for the K2LMG 25-megacycle double balanced modulator can be used on 50 megacycles with the same R-C RF phase-shift networks in the grid circuit. The plate circuit can use the same coils and capacitor given in Fig. 9 for 50-megacycle operation of the 6C4 double balanced modulator.

This modulator has sufficient output at 50 megacycles to drive the small RF power pentodes suggested at the top of page 3 in this issue, in a class AB<sub>1</sub> linear amplifier. Power output in the 100-watt class can then be obtained with a linear amplifier using the 829-B, 5894, 6146-A or G-E's new 7984 compactron RF pentode.

The main purpose of this article has been to provide information on how existing transmitters for the 50- and 144-megacycle amateur bands can be converted for operation on single sideband. Construction information on only the critical circuits has been given since the K2LMG SSB exciter in the July-August serves as an excellent guide to the constructional techniques which should be used at these frequencies.

The advantages previously mentioned for single sideband on 144 megacycles also apply to the 50-megacycle band since similar propagation prevails. A number of stations in the Northeast have constructed these direct 50- and 144-megacycle SSB generators and found them easy to get operating correctly. Try converting your present equipment and you'll also be enthusiastic over the improved working range under most conditions.

### COMING NEXT TWO ISSUES —

**THE KCS/COMPACTRON RECEIVER** — a high-performance, double-conversion receiver covering the amateur bands from 3.5 to 30 megacycles — will be described in the November-December, 1962, and January-February, 1963 issues. It contains four of G-E's new compactrons, plus four standard tubes.

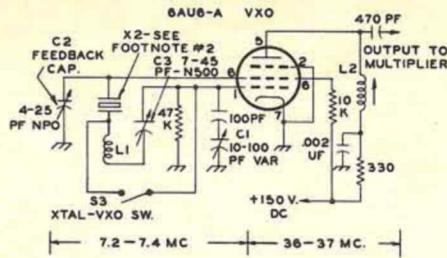

FIG. 6. VXO CRYSTAL OSCILLATOR schematic diagram which can be substituted for the transition oscillator in the carrier generator, Fig. 5.

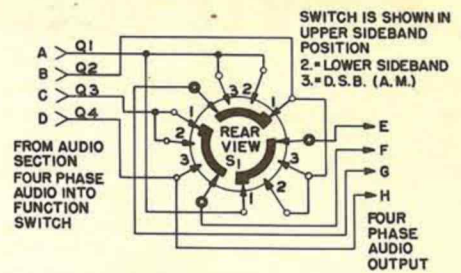

FIG. 8. FUNCTION SWITCH diagram, showing how upper, lower or double sideband output is obtained by changing the phase of audio signals.

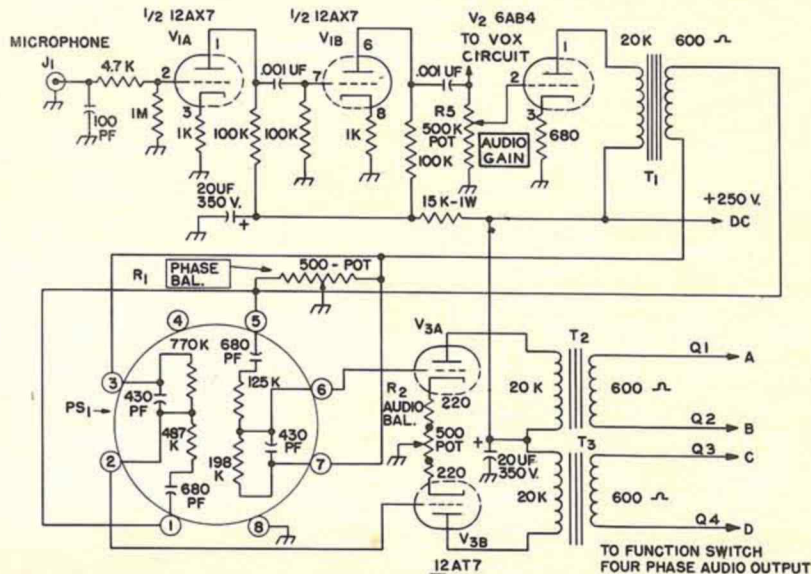

FIG. 7. AUDIO SECTION schematic diagram, showing the basing connections and internal

components of the B&W type 2Q4, Model 350, audio phase shift networks.

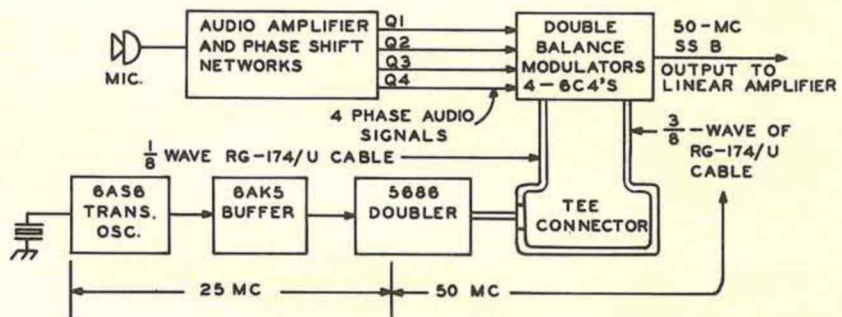

FIG. 9. BLOCK DIAGRAM of a 50-megacycle SSB exciter using the direct phasing type balanced circuit. Sub-miniax type coaxial cable with an impedance of 50 ohms (Amphenol No. 21-598, or Belden No. 8216), and a velocity factor of 0.655, was used for the RF phase-shift network. The  $\frac{1}{8}$ -wavelength section is 19.2 inches long, and the  $\frac{3}{8}$ -wavelength line is 57.6 inches long, using 50.3 megacycles as the design frequency. Other constants for the circuit of Fig. 3 are:

C<sub>6</sub> and C<sub>7</sub>, a 2.8- to 11-pf. per-section miniature butterfly variable. (Johnson type 11MB11); L<sub>6</sub>, 8 turns, No. 20 wire,  $\frac{1}{2}$ -inch diameter, spacewound diameter of wire in two 4-turn coils with  $\frac{3}{8}$ -inch space at center; L<sub>7</sub>, 2 turns No. 20 wire  $\frac{1}{2}$ -inch in diameter at center of L<sub>6</sub>; L<sub>8</sub> and L<sub>9</sub>, 12 turns No. 28 wire closewound on  $\frac{1}{4}$ -inch diameter iron slug-tuned coil form; and RFC<sub>2</sub> to RFC<sub>6</sub>, each 7-uh. single layer midget RF chokes (Ohmite Z-50).

### THREE NEW G-E HAM NEWS HANDBOOKS ARE AVAILABLE

Place your orders now for the three G-E HAM NEWS handbooks announced in the January-February, 1962 issue, on page 7. They are: Third Bound Volume, containing all issues from 1956 to 1960 (ETZ-2620), at \$3.00; Sideband Handbook (ETZ-2973) at \$2.00; and the Supplement to 1956-1960 issues (ETZ-

2911), at only \$1.00. The supplement is bound into the Third Bound Volume too. All books are shipped postpaid. In Canada and foreign countries, add 50 cents to the above prices. Send orders to the address on page 2 which covers your country.

# A TRIPLE VOLTAGE-REGULATED POWER SUPPLY

By David W. Bray, K2LMG\*

The high degree of performance expected from modern electronic circuits often demands constant power supply voltages. This triple voltage-regulated power supply, designed for the 144-Mc. SSB exciter described in the July-August, 1962 issue of G-E HAM NEWS, also can supply power for critical circuits in most any tube type amateur or commercial equipment. It was designed to deliver regulated positive DC voltages of plus 300, 200 and 150 volts simultaneously, and adjustable over a range of 10 per cent above, to 40 per cent below, the design voltages.

Power requirements of the VHF SSB exciter for which this unit supplies power are: plus 300 volts at 70 ma; plus 200 volts at 25 ma; plus 150 volts at up to 155 ma; minus 22 volts for grid bias; two 6.3 -volt, 2.5-ampere AC tube heater supplies.

In the power supply schematic diagram, Fig. 1, a conventional fullwave 5U4-GB rectifier at the left supplies DC power for the regulator section at the right. A 6AS7-GA low-mu twin triode tube acts as a variable resistance in series with the output voltage. When more current is drawn from the power supply, the output voltage tends to go down.

A sensing circuit — the 6AU6-A pentode and the 5651 voltage reference diode — then decreases the effective

grid bias on the 6AS7-GA, reducing its voltage drop and increasing the output voltage of the power supply. The circuit also compensates for increases in line voltage which increase the output voltage from the rectifier. Output voltage is adjusted with the 10,000-ohm potentiometer connected to the control grid of the 6AU6-A.

A second output voltage of 105 volts below the 300-volt regulated supply, or 195 volts, is obtained by using an OC3 voltage-regulator diode as a series dropping resistance. The 300-volt output runs through the jumper connected between pins 3 and 7 in the OC3.

A second 6AS7-GA twin triode in series with the 150-volt output acts as a series resistance from the 300-volt regulated supply. A second 6AU6-A and a 6AB4 triode function as the voltage control and regulating circuit. Adjustment of the 150-volt output is obtained with the 50,000-ohm potentiometer in the control grid circuit of the 6AU6-A.

The negative grid bias supply utilizes a 6.3-volt filament transformer working in reverse, providing 115 volts AC to the 1N93 rectifier, filter and 5651 voltage reference tube. Bias voltage adjustable from 0 to about minus 50 volts is obtained from the 50,000-ohm potentiometer. Grid current flow should be less than 1 milliampere, or the resistance of the potentiometer between the arm and ground will develop additional grid-leak type bias.

\*K2LMG is a consulting engineer in the Advanced Radar and ECM Engineering group of General Electric's Advanced Electronics Center at Cornell University, Ithaca, New York.

(Continued on page 8)

TOP VIEW of the power supply, showing the general layout of the major parts on the chassis.

BOTTOM VIEW showing combination of terminal strip and point-to-point wiring of small parts.

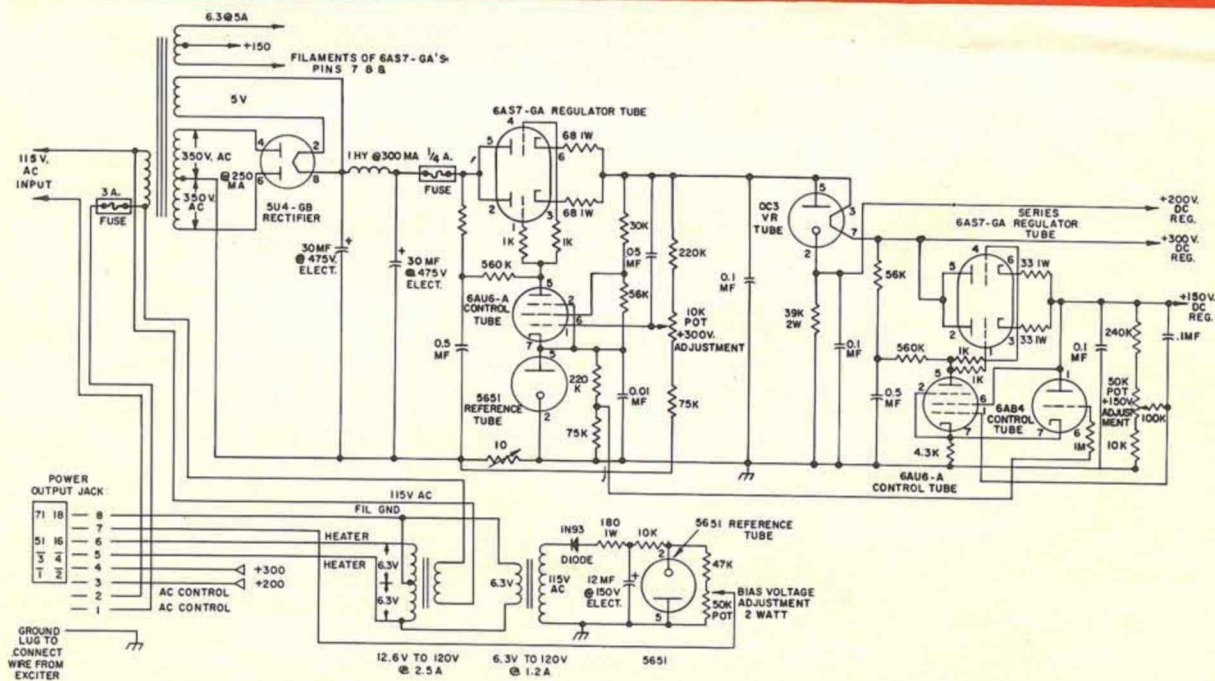

FIG. 1. COMPLETE SCHEMATIC DIAGRAM for the triple voltage-regulated power supply. The power output connector (J<sub>1</sub>) matches the connections in the VHF SSB exciter described in the July-August issue. Resistances are in ohms, 1/2-watt rating unless marked for higher wattage. Capac-

itances are in picofarads (PF), or microfarads (UF), as marked. Capacitors with polarity signs are electrolytic type of the capacitance and voltage rating specified. Output connector (J<sub>1</sub>) is a Cinch-Jones type S-308-AB.

# PRINCIPLES OF TRANSITRON CRYSTAL OSCILLATORS

By James V. O'Hern, W2WZR

**FREQUENCY STABILITY** is all-important in a transmitter being designed for operation in CW and sideband modes on the VHF amateur bands. Even though crystal-controlled oscillators are used, the frequency stability of some circuits is relatively poor. This results in hundreds of cycles—or even kilocycles—of drift at the output frequency each time the oscillator is turned on.

In searching for a crystal oscillator circuit which would introduce practically no additional drift other than that due to temperature changes in the crystal itself, the odd-appearing transitron circuit came to our attention.<sup>1</sup> A test circuit was built up for 24-megacycle third-overtone crystals and was so stable that the crystal could be squeezed with the fingers and cause practically no frequency shift of the sixth harmonic signal at 144 megacycles.

Examining the circuit in Fig. 1, note that the cathode of the 6AS6 pentode tube is grounded, the control grid is grounded, and the screen grid voltage is higher than the plate voltage due to the drop through the 10,000-ohm resistor in the plate circuit. The tube operates as a negative-resistance device in this circuit. It presents a minus  $R$  of about minus 100 ohms. If a tuned circuit which exhibits a positive resistance—but less than the negative resistance presented by the tube—is connected to the screen grid circuit, the circuit will oscillate. If this circuit exhibits positive resistance greater than the negative resistance presented by the tube, it will not oscillate.

To explain the operation of a crystal in this circuit, examine the equivalent circuit of a crystal in Fig. 2:  $L$  is the apparent inductance of the crystal and is very large;  $C$  is the apparent capacitance and is very small; together  $L$  and  $C$  form a series-resonant circuit of extremely high  $Q$ ;  $R_s$  is the apparent resistance associated with the crystal, including contact resistance, etc., and serves to lower the  $Q$  of the series resonant circuit formed by  $L$  and  $C$ ; and  $C_c$  is the external capacitance associated with the crystal, such as to the case, etc. Since it is in shunt with the crystal,  $C_c$  thus is a reactance which forms an undesirable leakage path if the crystal is operated in the parallel-resonant mode.

The transitron oscillator utilizes the crystal in the series-resonant mode; that is, the series resonance of  $L$  and  $C$  determine the circuit frequency. The shunt reactance of  $C_c$  becomes negligible in this configuration, hence the absence of frequency shift when the crystal is touched or squeezed. The series-resonant mode of a crystal is thus the most stable.

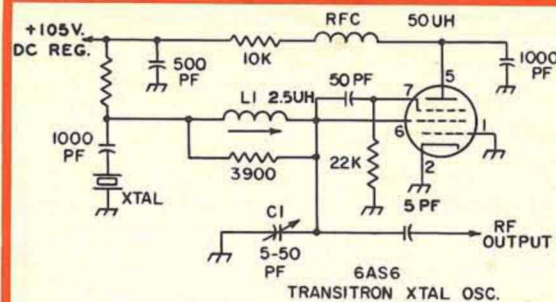

FIG. 1. TRANSITRON crystal oscillator schematic diagram with parts values for the 24- to 40-megacycle range.

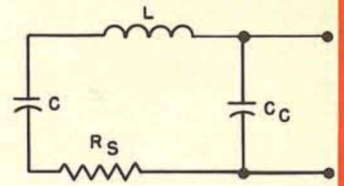

FIG. 2. EQUIVALENT circuit of a quartz crystal.

Turning now to the frequency-determining components in the transitron oscillator, the tube can be identified with just minus  $R$  equals 100 ohms, for example, as shown in Fig. 3. With an  $R$  of 390 ohms positive, the circuit will not oscillate at the frequency of  $L$  and  $C$ , a parallel-resonant circuit in series with  $R$ . If  $R$  can be removed, or made less positive than the minus  $R$  of the tube, the circuit will oscillate.

When a crystal is inserted in the circuit as shown, it forms a high- $Q$  series resonant—or short—circuit at precisely its series-resonant frequency. Since a series tuned circuit presents a short circuit at its resonant frequency, the point "A" in Fig. 4 is at ground only at the series-resonant frequency of the crystal. The resistance  $R$  of the high- $Q$  crystal usually is much less than the resistance presented by the tube, and the circuit oscillates at the series-resonant frequency of the crystal.

If  $L$  and  $C$  are tuned to form a parallel-resonant circuit at the series-resonant frequency of the crystal, the crystal in effect terminates the parallel-resonance of  $L$  and  $C$  at its "cold" end with a very sharp short circuit at only one frequency.

The large  $C$  in series with the crystal is to block the DC screen grid voltage, since the end of  $R$  that is shown grounded in Fig. 4 is actually connected to plus 105 volts in Fig. 1. The  $L$  and  $C$  in Fig. 4 must be resonant at the crystal frequency. In practice, a 3,900-ohm resistance is connected across  $L$  to lower the  $Q$  of the circuit to compensate for aging of components and temperature changes.

To tune  $L$  and  $C$  to the crystal frequency, disconnect the 3,900-ohm resistor and plug a jumper into the crystal socket. With power removed, and with a grid dip oscillator (GDO) set at the crystal frequency held near  $L$ , tune  $C$  until the meter on the GDO indicates that the circuit  $L$ - $C$  is resonant at the crystal frequency. The values of  $L$  and  $C$  shown in the SSB exciter described by K2LMG and W2WZR cover

the range from 24 to 37 megacycles. The values of  $L$  and  $C$  should be scaled up or down in proportion to the desired crystal frequency. If  $L$  is wound on a slug-tuned coil form, the range of adjustment of both  $L$  and  $C$  should permit operation over a frequency range of about 4 to 1.

The transitron oscillator circuit has very low output, and thus should be followed by a sensitive amplifier stage to build up the output signal to sufficient level to drive frequency multipliers, balanced modulators, etc., shown in these exciter. The 6AK5 pentode buffer usually drives another stage, and in the grid circuit of this stage, a test point may be located, as shown in Fig.

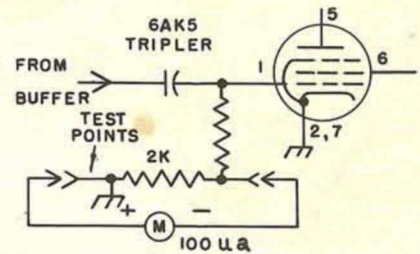

FIG. 5. TEST POINTS in the first multiplier.

5. An indication of grid-current is thus obtained for the final peaking of  $C$ . The meter reading will go through a smooth maximum reading indicating continuous oscillation quite unlike the rapid cessation of oscillation in the usual crystal oscillator circuit when tuned on one side of resonance.

In making tests on the transitron crystal oscillator, it was found that often when using crystals with marked frequencies above 40 megacycles, they would not oscillate in this circuit. Investigation showed that apparently these crystals had a high value of  $R_s$  which prevents the crystal from appearing as a low-resistance to ground at its series-resonant mode frequency. However, practically every crystal below 40 megacycles that was tried made the circuit oscillate readily.

Summing up, if a crystal oscillator of exceptional frequency stability is needed, for the range between 3 and 40 megacycles, try the transitron circuit and be pleasantly surprised at its stability.

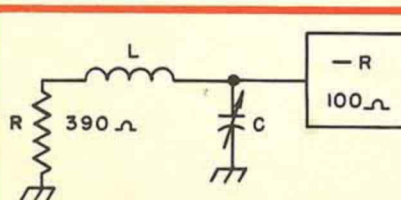

FIG. 3. FREQUENCY-determining components.

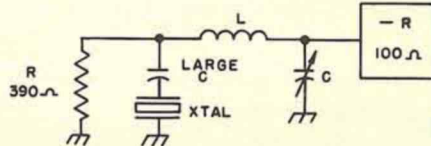

FIG. 4. CRYSTAL added to circuit.

<sup>1</sup>The transitron crystal oscillator circuit is shown in an article, "Mixing for Two-Meter V.F.O., S.S.B. and F.S.K.," by Frank C. White, W3PYW, QST, January, 1960, page 16.



## EIGHTEEN MORE G-E COMPACTRONS ANNOUNCED

THE COMPACTRON line of receiving tubes now being made at General Electric has grown from the sixteen types announced earlier this year in G-E HAM NEWS (January-February, 1962, Vol. 17, No. 1), to a total of thirty-four types. Note in the table below that most of these are multi-function types; or, higher-voltage heater versions of present 6.3-volt heater types. Complete data on specific types of compactrons can be obtained from the Technical Data Unit, General Electric Co., P. O. Box 1009, Owensboro, Kentucky.

### CONDENSED SPECIFICATIONS OF 18 ADDITIONAL G-E COMPACTRON TUBES

TYPE NO.	DESCRIPTION	GENERAL CHARACTERISTICS	BASING DIAGRAM	HEATER VOLTS AMPS.	BULB SIZE	MAXIMUM DIA. "A"	DIMENSIONS HEIGHT "B"
6AF11*	Dissimilar-Double-Triode Pentode	High-Mu Triode Section (Pins 5, 6, and 8) plus 6CX8	12DP	6.3V 1.05A	T-9	1.188	2.000
6AL11*	Dissimilar-Double Pentode	6DT6 (Pins 2, 3, 4, 6, and 7) plus 6AQ5	12BU	6.3V 0.9A	T-9	1.188	2.000
6AR11*	Twin Pentode	Two 6GM6 Pentodes	12DM	6.3V 0.8A	T-9	1.188	1.500
6BE3*	Diode	Damper-Maximum Ratings-Peak Inverse Voltage = 5000 Volts, DC Output Current = 200 Milliamperes	12BL	6.3V 1.2A	T-9	1.188	2.500
6FY7*	Dissimilar-Double-Triode	6DR7 Vertical Oscillator (Pins 9, 10, and 11) and Amplifier	12EO	6.3V 1.05A	T-9	1.188	2.500
11AR11*	Twin Pentode	Same as 6AR11 except heater	12DM	11.2V 0.45A	T-9	1.188	1.500
12AL11*	Dissimilar-Double Pentode	Same as 6AL11 except heater	12BU	12.6V 0.45A	T-9	1.188	2.000
12AX3*	Diode	Same as 6AX3 except heater	12BL	12.6V 0.6A	T-9	1.188	2.250
12BE3	Diode	Same as 6BE3 except heater	12BL	12.6V 0.6A	T-9	1.188	2.500
12G11	Dissimilar-Double Pentode	Same as 6G11 except heater	12BU	12.6V 0.6A	T-9	1.188	2.000
12GE5*	Beam Pentode	Same as 6GE5 except heater	12BJ	12.6V 0.6A	T-12	1.563	2.500
15AF11*	Dissimilar-Double-Triode Pentode	Same as 6AF11 except heater	12DP	14.7V 0.45A	T-9	1.188	2.000
15FY7*	Dissimilar-Double Triode	Same as 6FY7 except heater	12EO	14.7V 0.45A	T-9	1.188	2.500
17AX3*	Diode	Same as 6AX3 except heater	12BL	16.8V 0.45A	T-9	1.188	2.250
17BE3*	Diode	Same as 6BE3 except heater	12BL	16.8V 0.45A	T-9	1.188	2.500
17GE5*	Beam Pentode	Same as 6GE5 except heater	12BJ	16.8V 0.45A	T-12	1.563	2.500
7984	Beam Pentode	R-F Power Amplifier-46 Watts Output (IMS) at 175 Mc	12EU	13.5V 0.58A	T-12	1.563	2.500
8156	Beam Pentode	R-F Power Amplifier-21 Watts Output (IMS) at 175 Mc	12EU	13.5V 0.3A	T-9	1.188	1.938

\*Types presently available from G-E Tube distributors; other types are in production and should be available shortly.

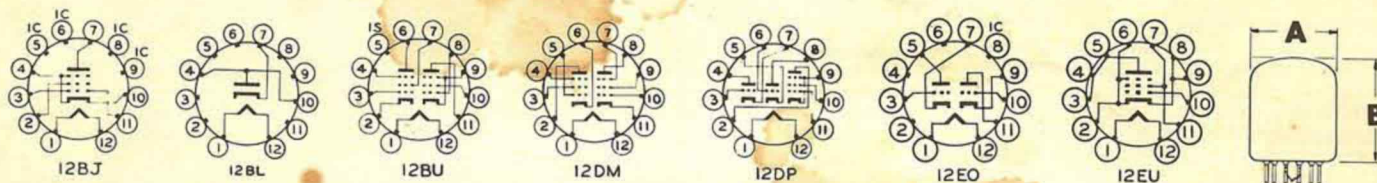

### A TRIPLE VOLTAGE REGULATED POWER SUPPLY (Continued from page 6)

CONSTRUCTION of the power supply was on a conventional 5x10x3-inch aluminum chassis (Bud AC-404, or equivalent). It contains only the 300-volt regulator circuit, plus the 0C3 and negative bias supply. The 150-volt regulator was built separately by K2LMG. It could be included on the main power supply chassis by using a larger 8x12x13-inch chassis (Bud AC-424); or, whatever size is convenient. Placement of parts is

not critical; however, the filter capacitors should be well-removed from heat producing components.

After the power supply is completed and running, the output voltages should be checked with no load, and with full load, to see that the voltage regulators are working correctly. The output terminal marked "200 volts" will have a potential about 105 volts below that of the "300-volt" terminal. The "150-

volt" output should remain constant even when the 10,000-ohm potentiometer controlling the "300-volt" output is varied.

Whenever two or three stable and adjustable DC voltages are needed to power critical circuits, try this conservatively-designed, regulated power supply. Or, build the regulator section alone for use with an existing power supply. It is excellent for utility service.

Available **FREE** from your G-E Tube Distributor

