



**Electronic
TUBES**

G-E HAM NEWS

Copyright 1956, by General Electric Company

JULY-AUGUST, 1956

VOL. 11—NO. 4

ANOTHER LOW-NOISE VHF CONVERTER

144-148 Megacycles

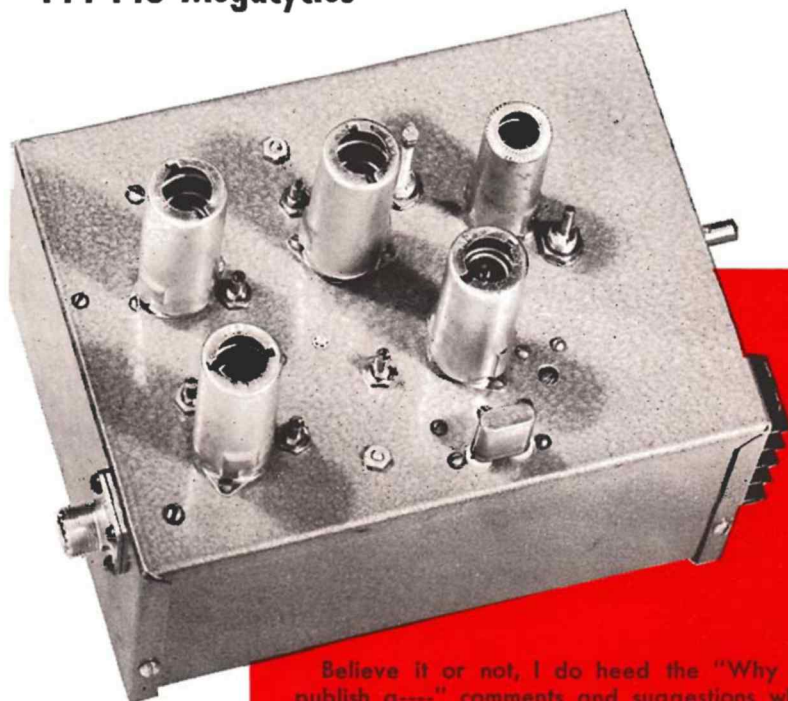

Believe it or not, I do heed the "Why don't you publish a----" comments and suggestions which many fellows write in their letters to me—and here's one result from designer W2RMA—a 144-megacycle model of the excellent low-noise 220-megacycle converter which he originally described in the September-October, 1954 issue of G-E HAM NEWS.

—*Lighthouse Larry*

CONTENTS

144-Megacycle Converter	page 2
Tricks & Topics	page 6
Sweeping the Spectrum	page 7
Technical Information—6AM4	page 8

144-MEGACYCLE CONVERTER

Many requests have been received for information on changes required to obtain 144-megacycle band operation from both the 220-megacycle converter published in September–October, 1954 and the 50-megacycle converter described in the September–October, 1955 issues of G-E HAM NEWS. A consultation with UHF expert Art Koch, W2RMA, indicated that the 220-megacycle converter could more easily be re-designed for the lower 144-megacycle frequency, than adding a multiplier stage (meaning another tube) to the 50-megacycle converter. He concluded that two cascaded 6AM4 grounded grid RF amplifier stages might have a lower noise figure on this band than current twin triode tubes designed for *cascode* circuitry.

Necessary design changes included making larger coils, substituting midsize air variable capacitors for ceramic trimmers, and constructing the converter on a larger *Minibox* type chassis. This open-sided chassis eliminates those *hard-to-get-into* corners encountered in a small conventional chassis, and complete shielding is obtained when the box halves are assembled.

A measured noise figure reading between 4 and 5 db was obtained from this converter after final alignment tests using a laboratory type VHF noise generator. This reading probably is the lowest practical noise figure usable at most urban amateur station locations. Miscellaneous noise (auto ignition, electrical appliances, etc.) picked up by the antenna and feedline in populated areas usually masks weak signals which might be heard on a converter with a lower noise figure. In other words, a *hermit* type station location may be necessary if you wish to take full advantage of a 144-megacycle RF amplifier using an expensive UHF tube.

CIRCUIT DETAILS

The converter circuit, shown in the schematic diagram, Fig. 1, is basically the same as the original 220-megacycle converter, except for the afore-mentioned parts substitutions. Slightly more gain, about 4 db, was achieved by using Type 6AM4 tubes in the two RF amplifier stages in place of 6AJ4's. For an improved impedance match between the coaxial cable antenna lead and the first RF amplifier tube cathode, these connections were tapped onto the input tuned circuit, C_1-L_1 . Otherwise, the fairly low input impedance of the grounded-grid RF amplifier stages would heavily load both this tuned circuit and C_2-L_2 in the plate circuit of the first stage. Coil L_3 provides a direct-current cathode return for the second 6AM4 tube.

Two stagger-tuned circuits, C_3-L_4 and C_4-L_5 , coupled by a 3.3-mmf capacitor, are necessary for proper bandpass between the second RF amplifier plate and the mixer grid circuits. A third 6AM4 triode was selected for the mixer because of quieter operation than multi-grid type mixer tubes. The 134-megacycle mixing signal from the second section of a 12AT7 oscillator-triplexer tube also is coupled to this 6AM4 grid through a small 1.0-mmf capacitor. The first section of the 12AT7 operates as a crystal controlled overtone oscillator on 44.66 megacycles. A Butler type circuit was used to obtain output from overtone crystals ground for this frequency. Most 26.8-megacycle third overtone crystals intended for use with 50-megacycle transmitters, and some active 8,933-megacycle fundamental crystals will operate on their fifth overtone in this circuit when properly adjusted.

The crystal oscillator also may be operated on 67 megacycles by reducing the size of chokes RFC₅, RFC₆, RFC₇ and coil L_9 . Alternate sizes are shown in the

PARTS LIST and COIL TABLE on page 3. Either a special 67-megacycle or a 28.713-megacycle third overtone crystal operated on its seventh overtone is required. However, if you live in the fringe area of a channel 4 television transmitter, radiation of even the small output from this oscillator could cause interference on nearby television receivers tuned to that channel. A TVI-proofing operation on the 12AT7 oscillator section would then be necessary.

A 10–14-megacycle bandpass is achieved in the 6AM4 mixer and 6AK5 intermediate frequency amplifier plate circuits by employing low Q slug-tuned coils, L_6 and L_7 , shunted only by tube and stray capacities. A low impedance 4-turn link coil, L_8 , couples this output to a communications receiver tuning this range through a coaxial cable connected to J_2 . Coils in the oscillator and intermediate frequency amplifier sections may be altered for tuning other output ranges, such as 6–10, 14–18, 26–30, or 30.5–34.5 megacycles, required when the converter is fed into some special *amateur-band-only* receivers.

MECHANICAL DETAILS

A 6 x 8 x 3½-inch Minibox (Bud CU-2109) comfortably houses all components without crowding, although VHF circuit lead lengths were kept very short through careful parts layout. Holes are drilled in the box section having the 6 x 3½-inch ends, according to the chassis drilling diagram, Fig. 2. After drilling, larger parts are mounted on this *chassis* in the locations marked on this illustration. Tube socket pins are positioned in the direction indicated on each socket hole circle and fastened with 4-40 x ¼-inch-long machine screws through holes drilled to match those on the socket. The lugs for pins 3, 4 and 6 on the 6AM4 mixer tube socket were removed to reduce stray capacity between remaining lugs.

Next, the heater and plate voltage leads are run to the tube sockets, mica button capacitors and the six insulated terminal posts, as pictured in the bottom view, Fig. 3. These terminals require little space, but conventional one- or two-lug terminal strips also are suitable. Leads in the VHF circuits are made from No. 16 tinned wire, but insulated hookup wire may be used for all power connections.

Resistors and by-pass capacitors which run between the tube sockets and ground lugs are then assembled. All five control grid lugs on the 6AM4 RF amplifier tube sockets are connected together with short tinned leads and by-passed to ground at pins 4 and 1 in the first and second stages, respectively. All coils and RF chokes, which previously have been wound according to the data in the PARTS LIST and COIL TABLE, are mounted between their associated components with shortest possible leads. Placement of coils and chokes in the RF amplifier stages is shown in the RF amplifier detail view, Fig. 4. Note in Fig. 5 that the connection from plate pin 5 on the 6AM4 mixer tube socket to coil L_6 is made at the chassis end, while the plate lead from pin 5 on the 6AK5 IF amplifier tube socket to L_7 runs to the open end of the coil. This wiring arrangement reduces stray coupling between these coils. By-pass capacitors in this stage should lie flat against the chassis.

Power connections were made through a barrier terminal strip on this model, but most constructors may prefer to substitute a male power receptacle of the type already in use at their stations. Stray pickup of signals in the 10–14-megacycle range is reduced by running the heater and plate voltage leads into the chassis through 0.015-mfd ceramic feedthrough capacitors. Disc ceramic by-pass capacitors wired with shortest possible leads are suitable for other type power connectors. The coaxial input and output connectors are placed on opposite ends of the chassis, also to minimize this signal leakage.

ADJUSTMENT PROCEDURE

All wiring should be rechecked after completing assembly, then heater power may be applied and measured at each tube socket before inserting the 6AK5 tube. The output jack, J_2 , is connected through a coaxial cable to the antenna terminals of a communications receiver covering the 10–14-megacycle range. When plate voltage is applied, increased receiver noise volume should be heard. Coil L_7 is then adjusted for maximum noise with the receiver set at 10.5 megacycles. This stage should not oscillate if the parts layout and wiring instructions have been followed. The 6AM4 mixer tube is now inserted and L_6 is peaked for maximum noise at 12.5 megacycles.

PARTS LIST

- C_1, C_2, C_3, C_4 —2.3–14.2-mmfd midget variable.
 C_5 —4–30-mmfd ceramic trimmer.
 C_6 —2.7–19.6-mmfd midget variable.
 J_1, J_2 —Chassis coaxial connector.
 RFC_1 – RFC_4 —12 turns No. 24 enameled wire wound in threads of $\frac{1}{4}$ –20 bolt.
 RFC_5 —For 44.667-megacycle operation: 32 turns No. 24 enameled wire closewound $\frac{3}{4}$ inches long on a $\frac{1}{4}$ -inch diameter polystyrene rod, or a 1-megohm, 1-watt BTA type resistor. For 67-megacycle operation: 16 turns No. 24 enameled wire, closewound, same form as above.
 RFC_6, RFC_7 —32 turns No. 24 enameled wire closewound, same form as RFC_5 .
 $XTAL$ —Quartz crystal, 44.667 megacycles (26.8 or 8.933 megacycles may work). (For 67 megacycles, see CIRCUIT DETAILS.)
 All capacitors marked "A" are mica or ceramic button.
 All capacitors marked "B" are tubular ceramic.
 All other capacitors are disc ceramic or mica.
 All resistors are $\frac{1}{2}$ watt, $\pm 10\%$.

The 12AT7 oscillator tube and a suitable crystal are next inserted, and a 0–25-milliammeter is temporarily connected in the plate voltage lead to L_9 . Output may be obtained from the oscillator over a wide adjustment range of C_5 , but a sharp dip in plate current should occur when oscillation at the crystal frequency takes place. Oscillator operation should be checked with a receiver tuned to 44.667 megacycles. If a series of oscillations is heard, RFC_5 should be reduced in size a turn or two at a time until a single crystal-controlled oscillation and the sharp plate current dip occurs.

The 6AM4 second RF amplifier tube then is inserted, and a steady, low-level 144-megacycle signal is fed into the antenna jack. Long-winded local amateur

COIL TABLE

- L_1 —4 turns No. 16 tinned wire, $\frac{1}{2}$ -inch inside diameter, $\frac{3}{8}$ inches long, tapped 1.5 and 2.8 turns from grounded end for antenna and 6AM4 cathode, respectively.
 L_2, L_4 —Same size as L_1 , tapped 1.3 turns from grounded end.
 L_3 —13 turns No. 24 enameled wire wound in threads of $\frac{1}{4}$ –20 bolt, then spaced to a $\frac{3}{4}$ -inch length.
 L_0 —4 turns No. 16 wire $\frac{3}{8}$ -inch diameter, $\frac{3}{8}$ inches long.
 L_5 —35 turns No. 30 enameled wire closewound $\frac{1}{2}$ -inch long, then 5 turns spacewound $\frac{1}{2}$ -inch long at open end of a $\frac{1}{2}$ -inch diameter brass slug-tuned ceramic coil form.
 L_7 —43 turns No. 30 enameled wire closewound $\frac{3}{8}$ -inch long at center of $\frac{1}{2}$ -inch diameter iron slug-tuned ceramic form.
 L_8 —4 turns No. 22 insulated wire at chassis end of L_7 .
 L_9 —For 44.667-megacycle operation: 6 turns No. 20 enameled wire $\frac{1}{2}$ -inch diameter, $\frac{3}{8}$ inches long, with $\frac{3}{8}$ -inch leads. For 67-megacycle operation: 5 turns No. 16 enameled wire, $\frac{1}{2}$ -inch diameter, $\frac{1}{2}$ -inch long, with $\frac{3}{8}$ -inch leads.
 L_{10} —3 turns No. 16 tinned wire $\frac{1}{2}$ -inch diameter, $\frac{3}{8}$ inches long with $\frac{3}{8}$ -inch leads, 1.0-mmf coupling capacitor tapped 1.5 turns from by-passed end.

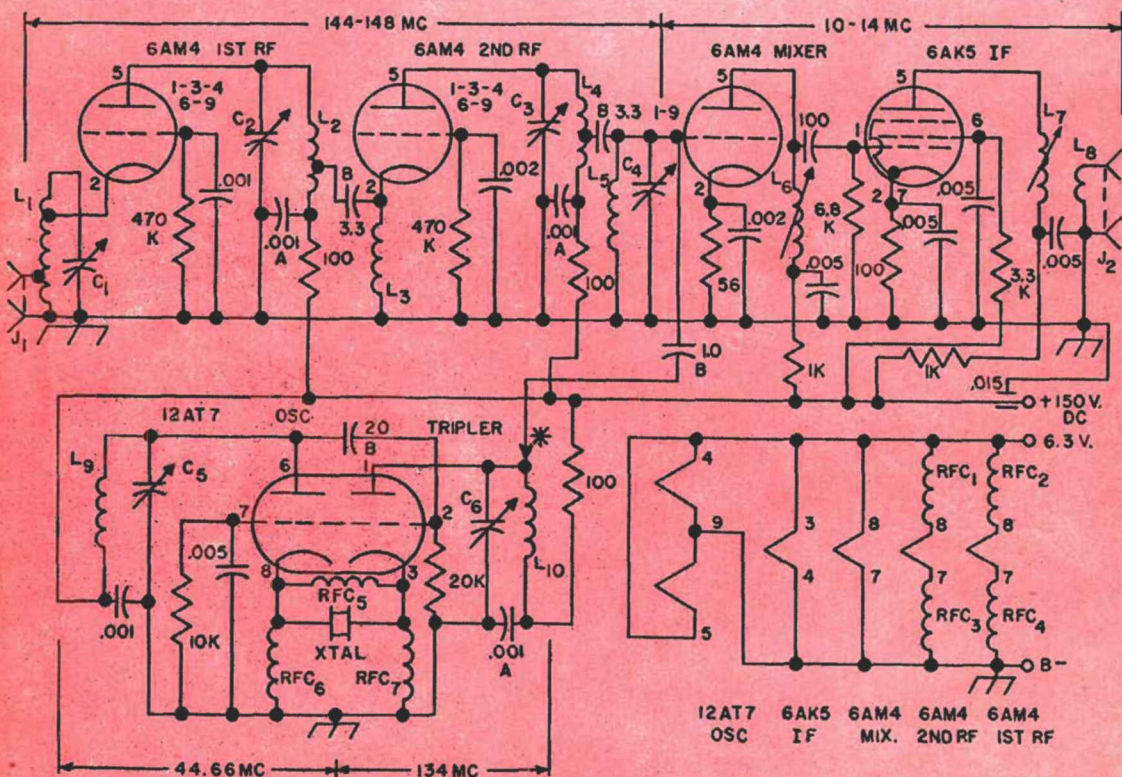

Fig. 1. Complete schematic diagram of the 144-megacycle converter. *The lead from the 1.0-mmf capacitor to L_{10} may have to be tapped down from the top of the coil.

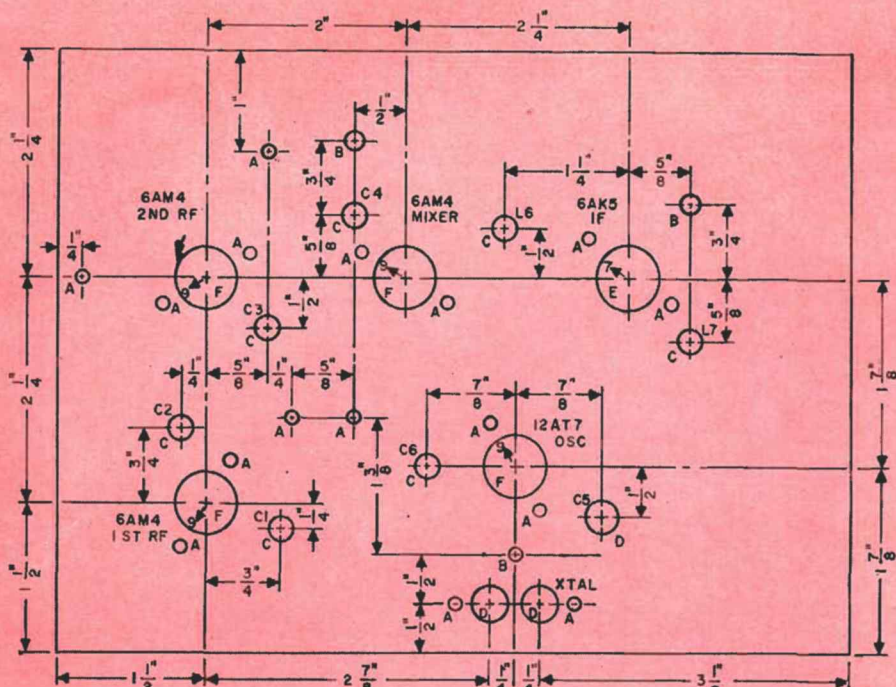

Fig. 2. Chassis drilling diagram. Holes marked "A"—No. 32 drill for tube sockets and terminal posts; "B"—No. 26 drill for ground lugs; "C"— $\frac{1}{4}$ -inch diameter for air variable capacitors and IF coils; "D"— $\frac{3}{32}$ -inch diameter for crystal socket and C_5 ; "E"— $\frac{5}{8}$ -inch diameter socket punch; and "F"— $\frac{3}{4}$ -inch diameter socket punch.



Fig. 4. Close-up view of second RF amplifier circuit in this stage of the center of the p

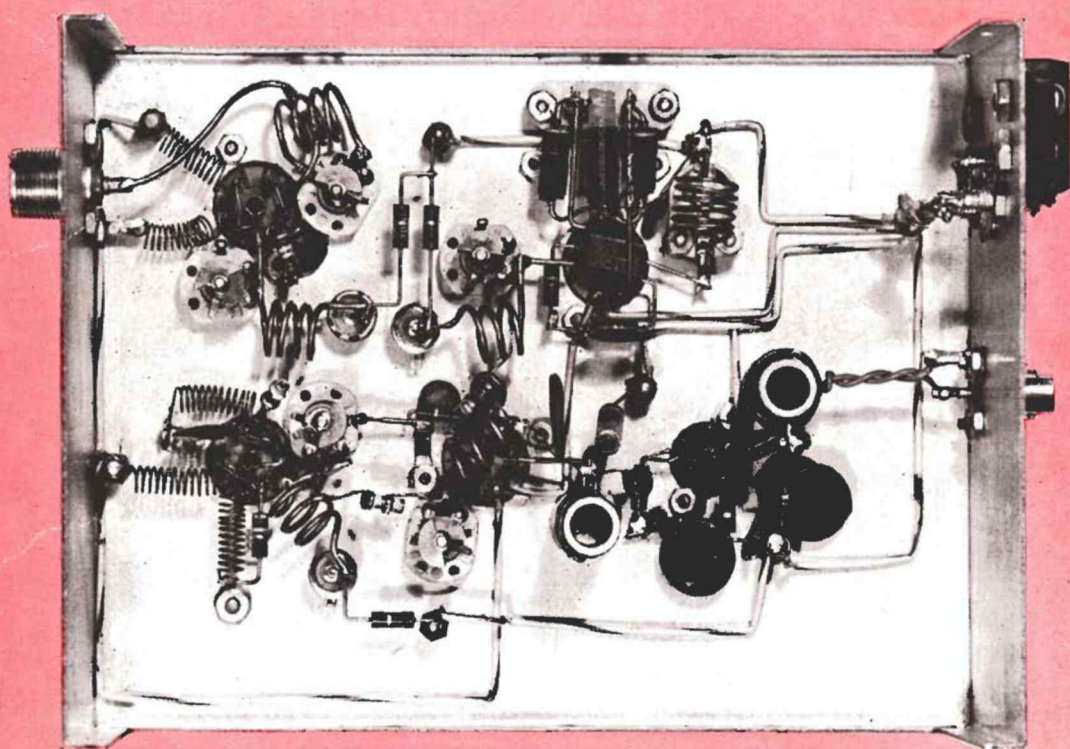
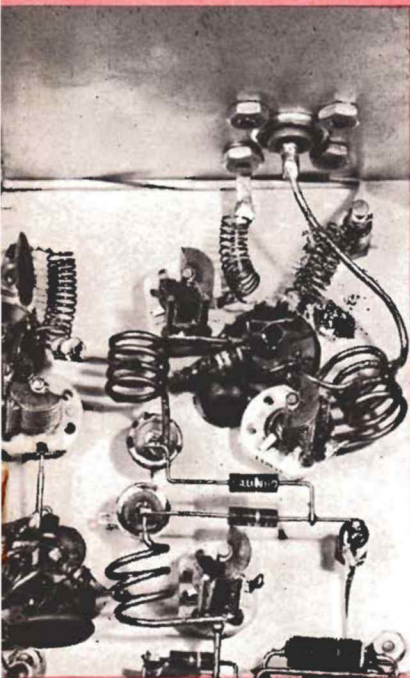

Fig. 3. Bottom view of the 144-megacycle converter showing placement of smaller parts. RFC_6 is shown between RFC_5 and RFC_7 , connected to the crystal and 12AT7 tube sockets. The mica button capacitors double as tie points for L_2 , L_4 , L_{10} and the decoupling resistors.



View showing the vertically-positioned 0.001-mfd grid by-pass capacitor shielding the plate from the small diameter cathode coil, L_3 , near center.

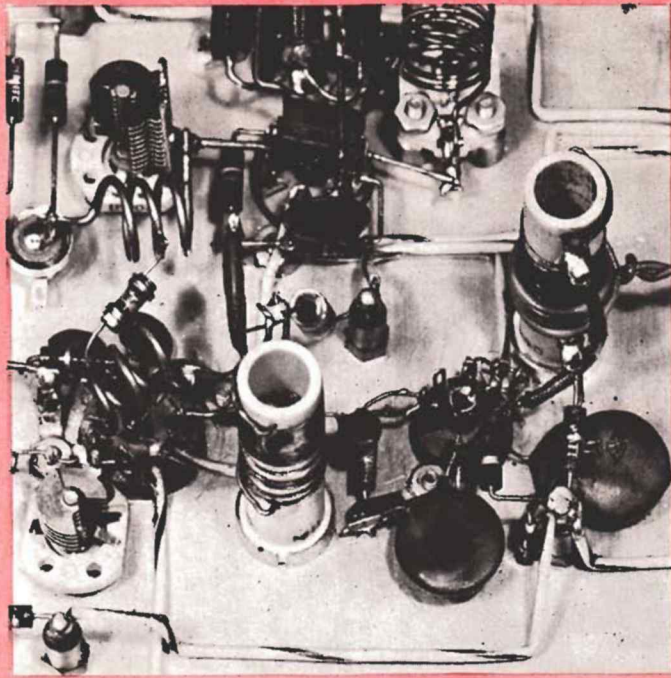

Fig. 5. Detail view of the 6AK5 IF amplifier stage showing by-pass capacitors placed flat against the chassis. A shield between coils L_4 and L_7 is not necessary when the connections are wired according to suggestions in MECHANICAL DETAILS.

stations are a convenient signal source. Tuned circuits C_6-L_{10} and C_4-L_5 are adjusted for maximum signal by spreading or compressing these coil turns for proper frequency coverage, if necessary. If no oscillations are encountered, the 6AM4 first RF amplifier tube may be inserted and circuits C_3-L_4 , C_2-L_2 and C_1-L_1 tuned to resonance. Any oscillations which are found should be eliminated before stages which precede the offender are tested. Additional by-pass capacitors between the other 6AM4 RF amplifier grid pins and ground may help stop an oscillation.

The RF amplifier section may be adjusted either for a nearly flat 144—148-megacycle bandpass, or the 144—146-megacycle portion of the band may be favored. Full bandwidth is obtained by adjusting C_4-L_5 to 145, C_3-L_4 to 146.5, C_2-L_2 to 146, and C_1-L_1 to 144.5 megacycles, respectively. The external signal source, and not the converter noise output, should be peaked at each specified frequency.

When all stages are operating properly, as indicated by the rough tuning adjustments, final alignment may be undertaken. This involves adjusting the taps on coils L_1 , L_2 , L_4 and L_{10} for lowest noise figure, if a VHF noise generator is available. If the generator actually is not calibrated in noise decibels, comparison readings may be taken after each adjustment on the converter until best performance is obtained. The coil-tap positions specified in the COIL TABLE are those which provided lowest noise figure on the test model.

Before attempting noise figure adjustments with the generator, a circuit must be set up to measure the noise output from the communications receiver. An AC or vacuum-tube voltmeter may be connected to the speaker voice coil through an 8- to 500-ohm matching transformer, or to the headphone output on the receiver. The noise generator should have a resistor

connected across its output equal in value to the impedance of the coaxial cable which runs from your antenna or antenna tuner. Turn off the AVC, BFO and noise limiter on the communications receiver and advance the AF and RF gain controls until a one-half scale reading is noted on the output meter. The RF gain control is not moved again during subsequent adjustments.

Next, connect the noise generator to the converter with a short length of coaxial cable and adjust the noise output control until a full-scale receiver output meter reading is obtained. A calibrated dial on the noise output control will be helpful in determining whether the noise figure is improved with each adjustment. The antenna tap on L_1 should be shifted a fraction of a turn from the specified setting, and the noise control reset for a full-scale output meter reading. If the new noise control setting is lower (e.g.; less noise output from the generator is required for the same noise output from the receiver), the tap should be moved a bit further in the same direction. A higher noise control setting indicates that the tap should be moved in the opposite direction. When the best point for the antenna tap has been found, the tube cathode tap on L_1 should be adjusted. Recheck the antenna tap if the cathode tap was changed from its original position.

The same procedure is followed for the taps on L_2 and L_4 , but no change in noise figure may be observed. The 1.0-mmf coupling capacitor between the mixer grid and L_{10} is then connected temporarily to the plate end of L_{10} . If no improvement in noise figure is noted, the capacitor is returned to the original tap. Cross-modulation in the converter resulting from strong local 144-megacycle signals may be reduced by tapping this capacitor further toward the by-passed end of L_{10} . Moving the taps on L_4 and L_2 toward the plate ends of

(continued on page 6, column 1)

VENTILATION FOR UTILITY BOXES

Reading details of recent G-E HAM NEWS equipment which has been constructed inside standard utility boxes having removable front and back panels reminded me of a stunt I've used for ventilating similar equipment in my shack without drilling any vent holes.

I simply place washers on each self-tapping screw which secures these covers, providing ventilation slots which run all the way around the box, both front and back. This system really cools off equipment when the box is not used as a TVI shield.

—Dr. R. G. Minarik, W9GJY

MAKING LONG-LIFE FOLDED DIPOLE ANTENNAS

Breakage of folded dipole antennas fashioned from 300-ohm twinlead, resulting from constant flexing and vibration by the wind, can be eliminated by suspending the twinlead from a "messenger" cable. First, measure a length of plastic clothes line (be sure it has a non-metallic core) about two feet longer than the antenna. Fasten it at a convenient height under slight tension and attach the antenna twinlead to this line every few inches with plastic insulating tape. The lead-in cable also is taped to another length of clothes line tied to the center of the antenna supporting line. Next, tie the clothes line to the insulators on the supporting halyards and haul 'er up.

I have three such antennas, for 80, 40 and 20 meters. One antenna has been up for more than three years with no maintenance or twinlead failure.

—Stanley I. Allen, W7KHZ

144-MEGACYCLE CONVERTER

(continued from page 5)

these coils also may help eliminate this interference, as this reduces the RF amplifier gain slightly. The 56-ohm cathode resistor in the 6AM4 mixer may be changed to 200 ohms to overcome severe cases of cross-modulation.

When the converter is used with a poorly shielded or high-gain receiver, strong signals in the 10-14-megacycle range may be heard if the coaxial cable connection to the receiver antenna terminals is not well shielded. Helpful suggestions for eliminating this interference were described in "Communications Receiver Hints for the V.H.F. Man," by E. P. Tilton, W1HDQ, VHF Editor of QST magazine, on page 36 of their April, 1955 issue. Signals from surprising distances will be heard when a high-gain beam antenna is fed into the converter. If an open wire or twinlead feedline runs from this antenna, the converter may be connected to it through a balun coil designed for this band.

**BASE INSULATORS FOR VERTICAL ANTENNAS**

Discarded high-voltage insulators, of the type used by your local power company on their high-tension transmission lines, are an inexpensive source of base insulators for vertical and ground plane type antennas. They are made in a variety of shapes and sizes and have very high resistance to ground even when wet, due to the construction. Slightly chipped insulators of this type can usually be obtained for little or no cost. The cup shaped insulator (left) is more suitable, but some form of tubing clamp can be fastened with wire to insulators having a "knob" on one end (right).

—Dale Holland, WØRXM

SAVING METER FACES

Whenever a new scale is being added to a panel meter face, such as making a 0-1 milliammeter into a volt-ohm-milliammeter, don't paste the new paper scale over the original. Instead, remove the mounting screws for the face, turn it over, and cement the new scale to the reverse side of the metal backing. When the meter is being restored to its original function, simply turn the scale back again. CAUTION—do not bend the indicating needle—otherwise the meter's accuracy may be impaired.

—Harry J. Miller

TEST PROBES FROM PLASTIC PENCILS

Handy color-coded plastic test probes may easily be fashioned from "SCRIPTO" pencils simply by removing the eraser and soldering a length of flexible test probe wire into the cap and wrapping the exposed metal with plastic insulating tape. A steel phonograph needle which fits tightly into the lead chuck makes a good point that penetrates insulated wire when readings cannot be taken from exposed terminals.

—Gary Davis

PARASITICS

In the schematic diagram, Fig. 3, for the Tri-Range VFO described in the March-April, 1956 issue of G-E HAM NEWS, connect the rotor of C₁₄ directly to the chassis instead of through the 0.01-mfd by-pass capacitor. Then connect this capacitor between the lower end of L₁ and ground. Eliminate the direct connection between L₄ and the rotor of C₁₄. (Circuit as shown would require insulating the rotor and shaft of C₁₄.)

SWEEPING *the* SPECTRUM



A Moscow-published book called "RADIO AMATEUR HANDBOOK" (not ARRL), contains an idea for powering battery-type radio receivers which may seem far-fetched or not, depending on whether you have similar materials available in your junk box.

This suggestion makes use of the voltage difference which appears between certain dissimilar materials in contact with each other when heat is applied, technically called a *thermocouple*. The article described a low-voltage battery, made from two stacks of series-connected thermocouples, heated by the flame of a kerosene lamp. One stack was capable of furnishing 2 volts at 0.5 amperes for a receiver filament supply. The other generated 2 volts at 2 amperes, which was converted into a higher voltage direct current by a special vibrator-type plate supply. The handbook stated that a 6-tube battery-type receiver was completely powered from this *battery*, which mounted on the lamp somewhat like a chimney.

If I have aroused your interest in the thermocouples, a diagram of this unit was published on page 83 of the May 1, 1956 issue of *ELECTRONIC DESIGN* magazine. How about the availability of suitable thermocouples? Your guess is as good as mine!! Anyway, you literally can "burn the midnight oil" during those late evening hamming sessions with portable gear on your next camping trip—and that lamp which powers the receiver also will furnish sufficient illumination for keeping the station log!!

Do you have herringbones on the screen, or your gravelly tones in the sound of the living room television receiver? You can easily listen to the audio when making TVI-elimination tests on your ham transmitter—but how to watch a screen that's usually around a corner—even rooms or floors away from the radio shack? Mirrors? Crane your neck? Appoint a member of the family as "official TVI observer?"

Perhaps you or your local TVI committee already found the answer—a portable television receiver! Several hundred thousand of these handy sets now are in use, but the latest and lightest addition to General Electric's portable TV family is a 9-inch receiver that weighs only 13 pounds! Even frail TVI chasers like me (see top of page, OM, no muscles!) can easily haul this lightweight right into the ham shack.

The new 9QP4 picture tube developed by our Cathode Ray Tube Sub-department expressly for this set has some unique features which distinguish it from other picture tubes. First, a process was devised for fashioning the glass face plate and funnel in one piece on high-speed glass blowing machines similar to those used in glass container manufacture. Most present-day cathode-ray tube bulbs have separate face plates which later are fused to the funnel. Another innovation—bringing the high-voltage lead out through the tube base instead of the funnel wall—was made possible by the relatively low design center anode voltage of 6800 volts, and making the tube neck from glass with high electrical insulating properties.

Newt Kraus, W1BCR, recently became the "middle man" in a unique pole-to-pole QSO between KC4USA at Little America V, Antarctica, and VE8ML. The VE8 station is located at an Arctic weather station on the Northeast tip of Ellesmere Island, one of the Earth's northernmost land masses. VE8ML was having difficulty in properly tuning single sideband transmissions from KC4USA, so W1BCR, transmitting on AM, called in to suggest that he supply the carrier by which VE8ML could copy the SSB. The clocks at all three stations were synchronized and W1BCR set his transmitter frequency precisely to that of KC4USA. KC4USA then transmitted for one-minute periods and W1BCR simultaneously supplied the "remote carrier injection." VE8ML reported that he could read KC4USA with little or no difficulty. The Antarctic station had no trouble copying the AM signal from VE8ML during the QSO, which lasted for about twenty minutes.

What were the main topics of conversation? The weather and *amateur shop talk*!! W1BCR is an old hand at aiding the Antarctic "OPERATION DEEP FREEZE" stations by maintaining two or more traffic-handling schedules each day.

Want to try something different in a program for your local amateur radio club? We recently have prepared a tape recording of the 1955 Edison Radio Amateur Award Presentation ceremony which was held in Washington, D. C., on February 16, 1956. Highlights from the program, including remarks by Herbert Hoover, Jr., W6ZH/K6EV, former Federal Communications Commissioner Edward M. Webster, and 1955 Edison Award winner Robert W. Gunderson, W2JIO, have been edited onto a 7½-inch-per-minute tape which plays for approximately 25 minutes. Your club secretary may request the loan of this recording by writing me at the address shown on the back page. Please allow at least a month before the date of the meeting at which you wish to play this program, so that I can properly schedule shipments. The postage both ways will be paid by me. I simply ask that the tape be returned promptly, so that other clubs can have the tape when they want it.

WHAT'S AVAILABLE? FREE—some back issues of G-E HAM NEWS, 1952 and later—SSB PACKAGES—tube technical data sheets (specify type numbers)—descriptive booklets. AT COST—G-E HAM NEWS mailed to your address by subscription, \$1.00 per year—LOG FORM QSL CARDS, package of 300 cards, \$1.00, postpaid—G-E HAM NEWS Second Bound Volume, containing all issues from 1951 through 1955, plus cross index, \$2.00, postpaid. OH, YES—the banks have suggested that all checks and money orders be made payable to: "General Electric Company."

—Lighthouse Larry

GENERAL DESCRIPTION

NO—the 6AM4 in this photograph (right) definitely does not lie down on the job! A novel horizontal structure, with five grid leads connected in parallel to both ends (for extra low inductance) permits excellent isolation of the input and output circuits in grounded-grid RF amplifier and mixer service. Its sharp cutoff and high transconductance characteristics contribute to efficient performance over the entire range of VHF-UHF television frequencies.

Heater Voltage (AC or DC).....	6.3	Volts
Heater Current.....	0.225	Ampere
Envelope.....	T-6½	Glass
Base.....	E9-1, Small Button 9-Pin	

DESIGN CENTER VALUES MAXIMUM RATINGS

Plate Voltage.....	150	Volts
Positive DC Grid Voltage.....	0	Volts
Plate Dissipation.....	2.0	Watts
Heater-Cathode Voltage*.....	80	Volts

AVERAGE CHARACTERISTICS AND TYPICAL OPERATION

Plate Voltage.....	150	Volts
Cathode Bias Resistor**.....	100	Ohms
Amplification Factor.....	85	
Plate Resistance (Approx).....	9500	Ohms
Transconductance.....	9000	Mmho
Plate Current.....	7.5	Ma
Grid Voltage (Approx) for $I_b = 10$ Microamperes.....	-5	Volts

* When the 6AM4 is operated in series d-c with a second tube, as for example in cascade or direct-coupled circuits, the heater-cathode voltage of the 6AM4 may be as high as 250 volts maximum under cutoff conditions with the heater negative with respect to the cathode.
 **Operation with fixed bias is not recommended.



BASING DIAGRAM



RETMA 9BX

BOTTOM VIEW



G-E HAM NEWS

Available FREE from

G-E Electronic Tube Distributors

published bi-monthly by

TUBE DEPARTMENT

GENERAL ELECTRIC

Schenectady 5, N. Y.

In Canada
 Canadian General Electric Co., Ltd.
 Toronto, Ontario

E. A. NEAL, W2JZK—EDITOR

JULY-AUGUST, 1956

VOL. 11—NO. 4

Printed in the U.S.A.

Des Roberts
 ELECTRICAL SUPPLY CO.
 24-60 MT. VERNON ST., LYNN, MASS.