

THE CROSLEY BROADCASTER

VOLUME 14

NOVEMBER 15, 1935

NUMBER 14



It's a Joyous Thanksgiving
when You're there with a Crosley!

TALKS TO THE TRADE



POWEL CROSLY, JR. SAYS:

PRACTICALLY every home has some rooms that are hard to heat. Particularly is it quite often unpleasantly cool when arising in the morning, when shaving in the bathroom or when giving the baby a bath.

The answer to this problem is the Crosley Temperator with thermostatic control. This is an amazing auxiliary heating device with the features of a central heating plant. With the regulated heat made possible by its thermostatic control, the Temperator gives comforting warmth when and where you want it and at the degree you want it—yet at a surprisingly low cost.

The Crosley Temperator circulates heat so that it is distributed throughout the entire room. It is economical to operate by reason of the thermostat feature. The degree of heat is maintained for whatever temperature the thermostat is set. As soon as the

room reaches the temperature selected, the thermostat switches off the Temperator and switches it on again as soon as the temperature falls below that point.

Consider how many homes in your territory need and want just such an auxiliary heating device. The size of this market will undoubtedly prove staggering.

Then promote the Temperator in every possible way. Display it in your window. Place one on your counter. Demonstrate it to prospects and customers. Here is an efficient, auxiliary heater that is automatic—that defies competition. There is nothing else like it on the market with thermostatic control for such an exceedingly low price.

Give the Temperator a push now . . . and the Temperator in turn will give a big push to your sales and profits.

NO DEALER CAN AFFORD NOT TO HANDLE CROSLY

THE CROSLY BROADCASTER, EARL DITTMAR, EDITOR. PUBLISHED BY THE CROSLY RADIO CORPORATION, CINCINNATI, O. COPYRIGHT, 1935.

ALL PRICES QUOTED HEREIN ARE EASTERN PRICES. ALL PRICES SUBJECT TO CHANGE WITHOUT NOTICE

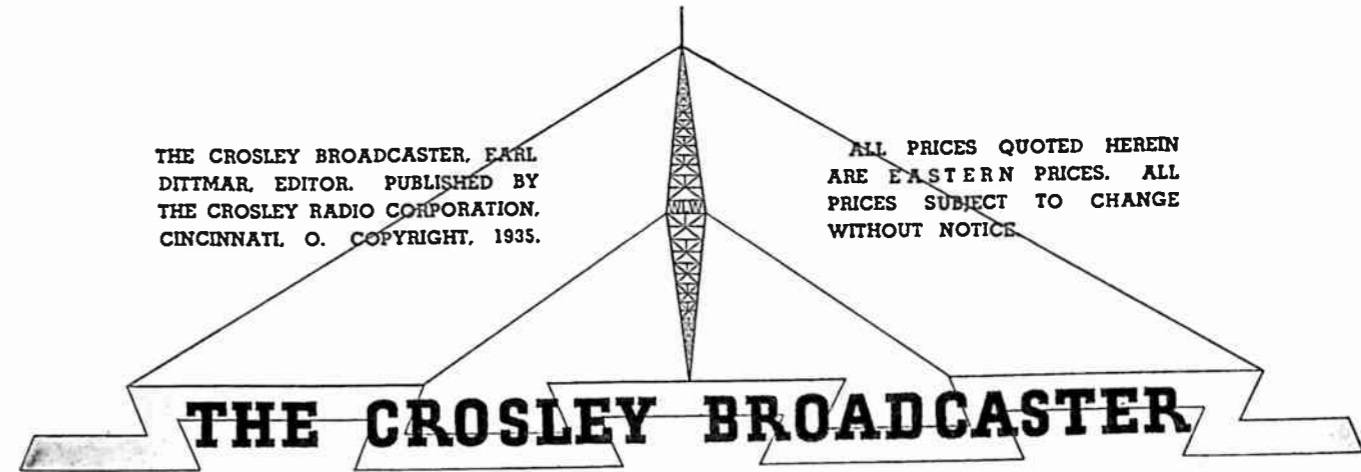

It's Time To Be Grateful . . .

This Thanksgiving, every Crosley dealer has ample reason to be truly thankful. It's a source of pride and a sense of gratification to be selling and deriving profits from such spectacular products. The new Crosley Radios are truly the sensations of the year. The Crosley Shelvador electric refrigerators have made the record of being the fastest growing line of electric refrigerators in public popularity in history. The world's most powerful broadcasting station has brought matchless public acceptance to the products you sell. That's why Crosley dealers everywhere are reaping a harvest of unprecedented sales and profits. That's why, this year, we all have true cause to be grateful.

The Answer To A Sales Problem . . .

No longer need any Crosley dealer lose the opportunity for a radio sale because the prospect has become too greatly attached to his old cabinet to part with it or to sacrifice it for a low trade-in allowance. Now you can turn these prospects into buyers by showing them and demonstrating to them the new Crosley chassis for installation in their present cabinets.

Eight Crosley chassis are presented to help you win profits in this new market. The newest Crosley features are included. Foreign reception . . . metal tubes—perhaps the two biggest factors to cause set owners to want modern radio—are now offered, in addition to innumerable other refinements, to attract this big class of radio prospects.

A large percentage of the ten million obsolete radios in use today be-

longs to this class of people who prize their old cabinets. Go after the business to be had in modernizing these obsolete radios with new Crosley chassis—you'll be surprised at the profits that will come as the result.

Christmas Is Coming . . .

In just a short time, the great yearly buying urge that grips the nation will be here. As soon as Thanksgiving has turned the corner, people everywhere in every walk of life start to concentrate with renewed vigor on that problem of what to give for Christmas.

This year, every Crosley dealer has a golden opportunity to take advantage of this big Christmas buying season, as never before.

First of all, consider the remarkable new 1936 line of Crosley Radios. In these you have everything with which to appeal to every type of Christmas shopper. There are models for every need, taste and pocketbook. There is the choice of metal tube sets or glass tube sets. There are incorporated latest features known to engineering progress to bring added assurance to the life-like reception so vividly dramatized by our slogan, "You're *there* with a Crosley." Each model is a world leader for its particular price class in beauty, performance, value.

Then consider the sensational line of Shelvador and Tri-Shelvador electric refrigerators that have set such a record-breaking pace throughout this year. Their inimitable appeal has earned for them the well merited reputation of being the most sought-after, the most popular and the fastest selling in all electric refrigerator history. The reason for

such spectacular success is not only because of the exclusive and matchless Shelvador feature, but because of the inherent quality built into every model. They are in such demand because of the unusual features, extra usable capacity, additional conveniences, trouble-free and economical operation, distinctive beauty and outstanding value.

That, then, is your opportunity to make this the biggest Crosley Christmas season in history. You have the right merchandise—the time is almost upon you—get started now for the greatest profit season you have ever experienced.

Direct Mail Creates Sales . . .

One sure way of getting more sales is to get more prospects. And an almost sure way to get more prospects is to use the new Crosley radio direct mail campaign. Three mailings are centered around the free offer of a new book by Lowell Thomas, famous world traveler and radio commentator. This highly interesting book gives the answers to questions about foreign lands and foreign broadcasts. Since this is undoubtedly the most outstanding direct mail campaign ever offered in radio history, it is practically certain to connect you with radio prospects and radio sales.

Any dealer who takes advantage of the direct mail campaign in even a limited way can secure additional copies of the Lowell Thomas book.

Complete details for this campaign are in the hands of your Crosley distributor. Insist on having him show it to you so that you can avail yourself of its sales-winning possibilities during that early extra spending period previous to Christmas.



**Miss Radio And Station "Wee"
Feature Of Graybar-Crosley Exhibit At Show . . .**

The two outstanding features of the recent Radio Show at Philadelphia were the crowning of Miss Jean McCool as "Miss Radio 1935," and Station "WEE", world's tiniest radio



**Idaho's Largest Wheat
Farmers Buy Tri-Shelvadors**

"Another Crosley victory" is the way Hirzel's Service of Lewiston, Idaho, terms their recent success in equipping Idaho's largest wheat farmers with Crosley Tri-Shelvador electric refrigerators.

In commenting on the sale, Mr. Hirzel says, "Insisting on the best of everything, the Turner Brothers who own a 4000 acre wheat farm and are widely known throughout this section of the West, choose only by quality. They have only the finest equipment on their farm, such as three Chrysler automobiles and two \$4,000.00 Caterpillar tractors. After carefully considering various makes of electric refrigerators, they have selected two Crosley Tri-Shelvador Model F-70 Electric Refrigerators for their two fine modern homes."

broadcasting station with four one-hundredths of a watt in contrast to WLW's 500,000 watts.

Miss McCool represented Philadelphia in the Atlantic City Beauty Pageant this year. She is the daughter of Jim McCool, Philadelphia's one-time minstrel favorite. The contest was decided on brains as well as beauty, and Miss McCool, who has been blessed with a heritage from her father, sang a cycle of popular songs, broadcasting from Station "WEE", with a 1936 Crosley Constitution console being used for the reception. Miss McCool is shown beside the mike with Andy Stanton, WLW announcer and for seven years manager of the Philadelphia radio show, as master of ceremonies.

The 1935 show was the best attended radio show in years. The radio business in Philadelphia is setting a record pace this season.

**Louisville Reports
Big Gain . . .**

Radio sales to dealers in the Louisville territory for September were 342 per cent ahead of those for the corresponding month a year ago, J. E. Johnson, president, The Cooper-Louisville Co., Crosley distributor in Louisville, reports. "Dealers are all pepped up and this looks like a banner season for us," says Mr. Johnson. "An unusual demand exists for battery sets and Crosley will be the leader in this field."

**Crosley Radio Sales
At All-Time High . . .**

Sales of Crosley radios for the month of October were the greatest in the company's history, Powell Crosley Jr., recently announced.

In his statement Mr. Crosley said, "The month of October just passed was the biggest month for sales of radios in the history of the company. Sales of Crosley radios were 50 percent above those for the corresponding month of 1934 and 20 percent greater than our production for the corresponding month in 1928, which up to this year had been our largest."

Commenting upon business conditions, Mr. Crosley said:

"The outlook for 1935 and 1936 is the brightest in radio history. This is due to improved business conditions and a recognition of the values represented by the 1936 line of Crosley radios. It is another encouraging indication that the economic cycle is again in the ascendancy, and that American business still has its inherent ability to cope with any kind of conditions and rise to new and greater heights. It is also an assurance that the spirit and industry that made America the greatest nation in the world are as much alive as ever in the American people."

It will be recalled that in anticipation of general business improvement, The Crosley Radio Corporation increased its production capacity to 5,000 radio receivers a day and 2,000 Crosley Shelvador electric refrigerators a day earlier in the year.

**None Can Compare
With Shelvador . . .**

After using several makes of electric refrigerators, Mrs. Walter Stock of New Buffalo, Michigan, is convinced that there is none like the Shelvador. She writes of her experience in the following interesting letter:

"Several months ago I purchased a Crosley Shelvador from your dealer, Harold Hard of Three Oaks, Michigan.

"My baby was very ill and I called Mr. Hard at 12 o'clock and at 3:00 p. m., my Shelvador was installed and running.

"I have used several types of electric refrigerators, but none can compare with the Crosley Shelvador."

**Don't Make
Selling Hard, Says This
Crosley 100 Percenter . . .**

"One thought that I would like to stress, particularly to young salesmen, and that is too often overlooked is the simplicity of selling," says Malvin H. Marshall, Crosley 100 Percenter with Anchorlite Appliance Co., Pittsburgh, Pa.

"The younger salesmen coming along," Mr. Marshall said further explaining his statement, "get the idea that the successful salesman is next to super-human. It is natural if we become overly ambitious, to make a hard job out of an easy one.

"Four steps that I try to follow with very little deviation when selling show what I mean:

- "1. A natural and pleasant approach (don't put on and act or overdo yourself trying to attract your prospect's attention;
- "2. Get the prospect seated if possible and intelligently discuss your merchandise;
- "3. Show him that it is profitable to handle; and
- "4. Ask for an order.

"Definitely take a positive stand and don't hesitate because of being afraid the prospect will say 'no'.

"I find it difficult to think of any one special feature in my selling experience. There was one day during the first 100 Percent contest when I closed 11 stores of my largest radio accounts; but that, of course, was due mostly to previous work with those men."

**Proud Owner Of Crosley
Radio And Shelvador . . .**

Mrs. Richard M. Van Riper of Seattle, Washington, writes:

"We have owned a Crosley radio for over six years, and are so thoroughly satisfied not only with its reception and appearance but its economy on tubes.

"We live where clear reception is difficult for some radios, but not our Crosley. So when the need for an electric refrigerator was felt, my husband and I agreed that a Crosley was our choice. No shopping was necessary—it was simply a matter of the type best suited to our needs, and space. So now through our dealer, Protas and Sevvit, we are the proud owners of a Crosley Tri-Shelvador, and are becoming more satisfied and absolutely thrilled with its performance and appearance every day we own it."



Astrology Show Attracts Sales And Prospects . . .

This highly attractive window display was recently used by Wurlitzer's, Dayton, Ohio, to announce a new and novel method that has proven quite successful in attracting prospects and buyers for Crosley Radios and Shelvador Electric Refrigerators. In fact, in about ten days time, Wurlitzers report \$3,000 sales and 3,000 prospects directly traceable to this attraction.

As can be seen, the display announced Madame Alice Richey, world renowned astrologer, who conducted daily demonstrations of as-

trology. With her in the Crosley Little Theater, as the attraction was called, were her son Robert, Albert Kazi, a magician and Captain Roy Edwin, who acted as her "eyes" while she performed behind the scenes. Madame Richey answered any questions, but was not visible to the audience, her answers coming through a Crosley Clipper radio. The new Crosley radios and Shelvadors were demonstrated at the same time. Following her engagement in Dayton, Madame Richey is putting on similar exhibitions in other Wurlitzer stores.



Attractive Exhibit At County Fair . . .

When the Waseca County Fair was recently held, this attractive exhibit was sponsored by the Coast to Coast Store of Waseca, Minnesota.

It displayed Crosley Radios and Shelvadors. This dealer is in the territory of Southern Minnesota Supply Company, Mankato, Minnesota.

The New 1936

CROSLEY RADIOS

● The new 1936 Crosley Radios presented on this and the three following pages have reached new heights in beauty, performance and value. Incorporating the very latest engineering developments, the new Crosley Radios put increased emphasis on that well-known assurance of quality performance—"You're THERE with a Crosley."

No matter what the needs or the purse, there is a new Crosley that is exactly right. Crosley models meet the radio needs of the home, the farm, the camper, the traveler, the business man, the motorist,—in fact everyone.

Here is radio that invites ANY comparison—such comparison will prove that here is the highest possible quality at the most attractive price for everyone.



\$25.00
COMPLETE WITH TUBES
DIMENSIONS:
5 3/4" high,
10 1/4" wide,
7 1/2" deep.

NEW TRAVO
Model 425-II

4 TUBES . AC-DC SUPERHETERODYNE

● Operates on any 110 volt circuit. Has two double purpose tubes. Pilot Light. Attached antenna. No ground required. Attached handle. Full floating moving coil electro-dynamic speaker.



FIVER
Model 515-AC
\$19.99
COMPLETE WITH TUBES

DIMENSIONS:
11 1/2" high,
10 1/2" wide,
7 1/2" deep.

5 TUBES . Two Band SUPERHETERODYNE

● Standard broadcasts 540-1570 Kc. Police, amateur, aviation broadcasts, 1570-4000 Kc. Illuminated, full vision, airplane type dial. 5 to 1 ratio drive. Tone control. Full floating moving coil electro-dynamic speaker.

FIVER CONSOLE
Model 5315-MH
\$37.50
COMPLETE WITH TUBES

DIMENSIONS:
36" high,
21 1/2" wide,
11 1/2" deep.

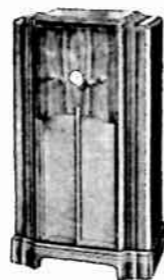

\$25.00
COMPLETE WITH TUBES
DIMENSIONS:
11 1/2" high,
10 1/2" wide,
7 1/2" deep.

PRIVATEER
Model 545-AD

5 TUBES . AC-DC SUPERHETERODYNE

● Operates on any 110 volt circuit. Attached antenna. Full vision, illuminated airplane type dial. 5 to 1 ratio drive. Full floating moving coil electro-dynamic speaker.

A. F. M.
(American) (Foreign) (Metal Tubes)
Model 555-AG



\$29.95
COMPLETE WITH TUBES
DIMENSIONS:
11 1/2" high,
10 1/2" wide,
7 1/2" deep.

5 Metal Tubes . 2 Band SUPERHETERODYNE

● All metal tubes. Standard and police broadcasts 540-1710 Kc. Foreign and police broadcasts 2350-7500 Kc. Illuminated full vision airplane type dial. Tone control. Automatic volume control. Two double purpose tubes. Full floating moving coil electro-dynamic speaker.

A. F. M. CONSOLE
(American) (Foreign) (Metal Tubes)
Model 5555-MK

\$47.50
COMPLETE WITH TUBES
DIMENSIONS:
36" high,
21 1/2" wide,
11 1/2" deep.

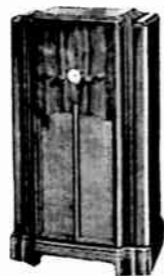

PRICES SLIGHTLY HIGHER IN FLORIDA, ROCKY MOUNTAIN STATES AND WEST

CRUISER
Model 615-C



\$47.50
COMPLETE WITH TUBES
DIMENSIONS:
16 1/2" high,
12 1/4" wide,
8 3/4" deep.

6 TUBES . 3 Band AC-DC SUPERHETERODYNE

● Operates on any 110 volt circuit. Receives standard, foreign, police, amateur, aviation broadcasts. Automatic volume control. Two double purpose tubes. Tone control. Full vision illuminated airplane type dial. 25 to 1 ratio drive. Full floating moving coil electro-dynamic speaker.

CRUISER CONSOLE
Model 615-M
\$59.50
COMPLETE WITH TUBES

DIMENSIONS:
36 3/4" high,
20 3/4" wide,
11 1/4" deep.



BUCCANEER
Model 635-C
\$39.95
COMPLETE WITH TUBES
DIMENSIONS:
16 1/2" high,
12 1/4" wide,
8 3/4" deep.

6 TUBES . 3 Band SUPERHETERODYNE

● Receives standard, foreign, police, amateur, aviation broadcasts. Automatic volume control, Tone control, Full vision illuminated airplane type dial. Full floating moving coil electro-dynamic speaker.

BUCCANEER CONSOLE
Model 635-M
\$54.50
COMPLETE WITH TUBES

DIMENSIONS:
36 3/4" high,
20 3/4" wide,
11 1/4" deep.



OLYMPIA \$45.00
Model 655-C
Same as Buccaneer except employs 6 metal tubes.

Olympia Console \$59.95
Model 655-M
Same as Buccaneer Console except employs 6 metal tubes



CORSAIR
Model 715-D
\$55.00
COMPLETE WITH TUBES
DIMENSIONS:
17" high,
13 3/4" wide,
9 1/8" deep.

7 TUBES . 3 Band SUPERHETERODYNE

● Receives standard, foreign, police, amateur, aviation broadcasts. Automatic volume control. Tone control. Full vision illuminated airplane type dial. 25 to 1 ratio drive. Full floating moving coil electro-dynamic speaker.

CORSAIR CONSOLE
Model 715-N
\$79.95
COMPLETE WITH TUBES

DIMENSIONS:
36 3/4" high,
21" wide,
11 1/4" deep.



MERRIMAC \$65.00
Model 855-D
Same as Corsair except employs 8 metal tubes.

Merrimac Console \$89.95
Model 855-N
Same as Corsair Console except employs 8 metal tubes.



VIKING
Model 725-F
\$65.00
COMPLETE WITH TUBES
DIMENSIONS:
19 1/4" high,
14 1/4" wide,
9 1/4" deep.

7 TUBES . 5 Band ALL WAVE PLUS WEATHER BAND SUPERHETERODYNE

● Five tuning bands, 150 to 22,000 Kc. Receives standard, foreign, police, amateur, aviation, weather broadcasts. Shadow tuning. Automatic volume control. Full vision airplane type dial. Tone control. Two double purpose tubes. Dual ratio tuning control. Full floating moving coil electro-dynamic speaker.

VIKING CONSOLE
Model 725-P
\$85.00
COMPLETE WITH TUBES

DIMENSIONS:
38" high,
22 1/2" wide,
11 1/4" deep.



MONITOR \$77.50
Model 865-F
Same as Viking except employs 8 metal tubes.

Monitor Console \$97.50
Model 865-P
Same as Viking Console except employs 8 metal tubes



CLIPPER
Model 915-EK
\$85.00
COMPLETE WITH TUBES
DIMENSIONS:
19 3/4" high,
15 3/4" wide,
10 3/4" deep.

9 TUBES . 5 Band ALL WAVE PLUS WEATHER BAND SUPERHETERODYNE

● Five tuning bands, 150 to 22,000 Kc. Receives standard, foreign, police, amateur, aviation, weather broadcasts. Shadow tuning. Automatic volume control. Full vision illuminated airplane type dial. Tone control. Dual ratio tuning control. Full floating moving coil electro-dynamic speaker.

CLIPPER CONSOLE
Model 915-EA
\$100.00
COMPLETE WITH TUBES

DIMENSIONS:
41 1/2" high,
25" wide,
12 1/2" deep.

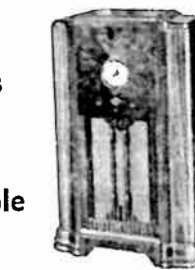

CONSTITUTION \$99.95
Model 1055-EK
Same as Clipper except employs 10 metal tubes.

Constitution Console \$125.00
Model 1055-EA
Same as Clipper Console except employs 10 metal tubes.

PRICES SLIGHTLY HIGHER IN FLORIDA, ROCKY MOUNTAIN STATES AND WEST



\$19.99
COMPLETE
LESS BATTERIES
DIMENSIONS:
8" high,
10½" wide,
5" deep.

BATTERY FOUR
Model 415-AA
4 TUBES SUPERHETERODYNE
BATTERY RECEIVER

● Designed for use with 2 volt air cell "A" battery. Two double purpose tubes. Low battery drain. Pentode output. Permanent magnet speaker.

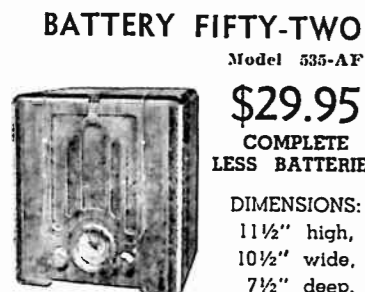

BATTERY FIFTY-TWO
Model 535-AF
\$29.95
COMPLETE
LESS BATTERIES
DIMENSIONS:
11½" high,
10½" wide,
7½" deep.

5 TUBES SUPERHETERODYNE
BATTERY RECEIVER

● Designed for use with 2-volt air-cell "A" battery. Full vision airplane type dial. Combined volume control and on-off switch. New plug-in type battery cable. Permanent magnet speaker.



BATTERY FIFTY-TWO CONSOLE
Model 535-MF
\$49.95
COMPLETE
LESS BATTERIES
DIMENSIONS:
36" high,
21½" wide,
11½" deep.



\$34.95
COMPLETE
LESS BATTERIES
DIMENSIONS:
21¼" high,
18¾" wide,
11½" deep.

BATTERY FIFTY-TWO "A"
Model 535-BH
5 TUBES SUPERHETERODYNE
BATTERY RECEIVER

● Designed for use with 2-volt air-cell "A" battery. Full vision airplane type dial. Combined volume control and on-off switch. New plug-in type battery cable. Permanent magnet speaker. Cabinet will accommodate all batteries.



BATTERY SIXTY-TWO
Model 605-CC
\$39.95
COMPLETE
LESS BATTERIES
DIMENSIONS:
16½" high,
12¼" wide,
8¾" deep.

6 TUBES . 2 Band
BATTERY RECEIVER

● Designed for use with 2-volt air-cell "A" battery. Standard broadcasts 540-1570 Kc. Police, amateur, aviation broadcasts 1570-4000 Kc. Automatic volume control. Manual sensitivity control. Class B power output. Bank wound Litz R. F. coils. Rubber mounted three gang tuning condenser. Airplane type dial. New plug-in battery cable. Permanent magnet speaker.

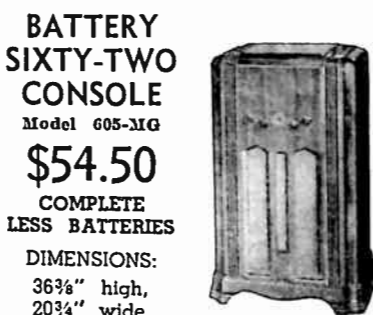

BATTERY SIXTY-TWO CONSOLE
Model 605-MG
\$54.50
COMPLETE
LESS BATTERIES
DIMENSIONS:
36¾" high,
20¾" wide,
11¼" deep.



\$42.50
COMPLETE
LESS BATTERIES
DIMENSIONS:
21¼" high,
18¾" wide,
11½" deep.

BATTERY SIXTY-TWO "A"
Model 605-BG
6 TUBES . 2 Band
BATTERY RECEIVER

● Designed for use with 2-volt air-cell "A" battery. Standard broadcasts 540-1570 Kc. Police, amateur, aviation broadcasts 1570-4000 Kc. Automatic volume control. Manual sensitivity control. Class B power output. Bank wound Litz R. F. coils. Rubber mounted three gang tuning condenser. Airplane type dial. New plug-in type battery cable. Permanent magnet speaker.



BATTERY EIGHT
Model 815-EC
\$59.95
COMPLETE
LESS BATTERIES
DIMENSIONS:
19¾" high,
15¾" wide,
10¾" deep.

8 TUBES . American-Foreign
BATTERY RECEIVER

● Designed for use with 2-volt air cell "A" battery. Receives standard and foreign broadcasts. Automatic volume control. Tone control. Airplane type dial. Moving coil permanent magnet dynamic speaker.



BATTERY EIGHT CONSOLE
Model 815-NC
\$74.50
COMPLETE
LESS BATTERIES
DIMENSIONS:
36¾" high,
21" wide,
11¼" deep.

PRICES SLIGHTLY HIGHER IN FLORIDA, ROCKY MOUNTAIN STATES AND WEST

BATTERY FORTY-SIX



Model 435-AF
\$34.50
COMPLETE LESS
6-VOLT BATTERY
DIMENSIONS:
11½" high,
10½" wide,
7½" deep.

4 TUBES SUPERHETERODYNE
6-VOLT BATTERY RECEIVER

● Operates from 6-volt storage battery. No "B" batteries required. Synchronous vibrator. Illuminated full vision airplane type dial. Rubber mounted tuning condenser. Hi Q Litz wound coils. Permanent magnet speaker.

BATTERY FORTY-SIX CONSOLE
Model 435-MF
\$49.50
COMPLETE LESS
6-VOLT BATTERY
DIMENSIONS:
36" high,
21½" wide,
11½" deep.

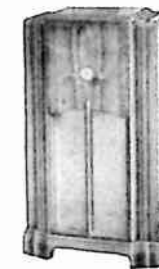

BATTERY SIXTY-SIX



Model 6615-D
\$59.95
COMPLETE LESS
6-VOLT BATTERY
DIMENSIONS:
17" high,
13¾" wide,
9½" deep.

6 TUBES . 3 Band
6-VOLT BATTERY RECEIVER

● Operates from 6-volt storage battery. No "B" batteries required. Weather broadcasts 150-400 Kc. Standard broadcasts 540-1700 Kc. Foreign and police broadcasts 2350-7500 Kc. Automatic volume control. Tone control. 25 to 1 ratio drive. Illuminated airplane type dial. Permanent magnet speaker.

BATTERY SIXTY-SIX CONSOLE
Model 6615-ND
\$75.00
COMPLETE LESS
6-VOLT BATTERY
DIMENSIONS:
36¾" high,
21" wide,
11¼" deep.



32 D. C. SIX
Model 645-CB
\$47.50
COMPLETE
WITH TUBES
DIMENSIONS:
16½" high,
12¼" wide,
8¾" deep.

6 TUBES . 2 Band
32 VOLT DC RECEIVER

● Designed for use with 32-volt DC supply. Receives standard, police, amateur, aviation broadcasts. Automatic volume control. Tone control. Full floating moving coil electrodynamic speaker.

32 D. C. SIX CONSOLE
Model 645-MB
\$64.50
COMPLETE
WITH TUBES
DIMENSIONS:
36¾" high,
20¾" wide,
11¼" deep.

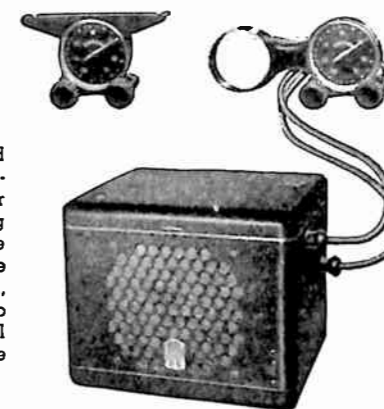
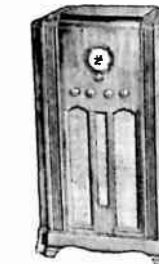

ROAMIO A-156
\$39.95
COMPLETE

● This model is equipped with two remote control adapter panels, so that the user has the choice of mounting the control either under the instrument panel or on the steering wheel. In addition, a special adapter panel to fit in the glove box of several new model cars is available at slight additional cost.

Superheterodyne automobile receiver with seven-tube effectiveness. High gain antenna system. Hi Q Pre-selector circuit with three-gang tuning condenser. Primary vibrator with tube rectification. Tone control. Automatic volume control. Single housing. Full floating moving coil electrodynamic speaker. Remote control illuminated airplane type dial. Remote control adapter.

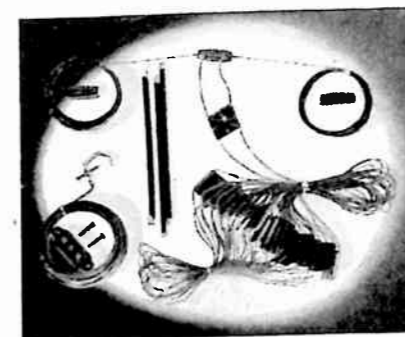

CROSLY COMPLETELY ASSEMBLED ALL-WAVE DUPLEX ANTENNA

For short wave reception, a conventional antenna will give satisfactory results if it is in good condition and the neighborhood in which the set is used is quiet electrically. However, it is especially important that the best antenna obtainable be used.

To get the very best performance possible from any short-wave re-

ceiver, the new Crosley all-wave antenna should be used. It is, without doubt, the most efficient short wave antenna now known for broadcast receiving uses.

Being completely assembled and soldered, the Crosley All-Wave antenna can be quickly and easily installed.

\$5.00

PRICES SLIGHTLY HIGHER IN FLORIDA, ROCKY MOUNTAIN STATES AND WEST











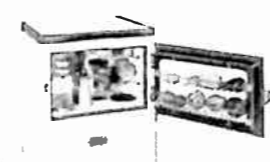

THE OPEN DOOR TO BIG PROFITS!

This Much More

Nowhere else in all the world can anyone find such appealing features as are a part of the new 1935 Crosley Shelvador Electric Refrigerators. Here are features that provide housewives with everything they could desire—that carry with them such an irresistible sales appeal that the Crosley Shelvador has become the fastest growing line of electric refrigerators in America. And these features—this sales appeal is exclusive with Crosley dealers.

"This Much More In A Shelvador" is a phrase that immediately tells everyone here is greatly increased usable capacity and with this feature things are twice as easy to find. The Shelvador and the other exclusive Crosley features are **extra** features—in addition to the outstanding value, dependability, high quality, trouble-free service that characterize every Crosley model—that bring such tremendous pride and satisfaction to every Crosley Shelvador owner.

 FR-20 Table Shelvador has two cubic feet NET capacity; 5.2 square feet shelf space. Two ice trays; uses Rotary compressor. Dimensions: 30" high, 25 1/2" wide, 25" deep. \$79.50	 FR-30 Table Shelvador, 3.1 cubic feet NET capacity; 7 square feet shelf space; 2 ice trays. Uses Rotary Compressor. Dimensions: 30" high, 25 1/2" wide, 25" deep. \$94.50	 FA-35 Shelvador, 3.5 cubic feet NET capacity; 7.5 square feet shelf space. One ice tray and one double-depth tray. Dimensions: 49 11/16" high, 23 1/2" wide, 24 3/16" deep. \$89.50	 FA-40 Shelvador, 4.00 cubic feet NET capacity; 8.6 square feet of shelf space. One ice tray and one double-depth tray. Dimensions: 52 1/2" high, 23 1/2" wide, 25 1/2" deep. \$112.50	 FA-50 Shelvador, 5 cu. ft. NET capacity; 11.3 square feet shelf space. Dimensions: 56 1/2" high, 25 1/2" wide, 24 1/2" deep. \$129.50 Porcelain Exterior (PFA-50) \$132.00
 FA-60 Shelvador, 6 cu. ft. NET capacity; 13.5 sq. ft. shelf space. Dimensions: 59 1/2" high, 30 3/4" wide, 25 1/2" deep. \$149.50 Porcelain Exterior (PFA-60) \$171.50	 FA-70 Shelvador, 7.08 cu. ft. NET capacity; 14.9 sq. ft. shelf space. Dimensions: 57 1/2" high, 32 1/2" wide, 25 1/2" deep. \$169.50 Porcelain Exterior (PFA-70) \$194.50	 F-43 Tri-Shelvador, 4.3 cu. ft. NET capacity; 9.15 sq. ft. shelf space. Dimensions: 54 9/16" high, 23 1/2" wide, 23 1/2" deep. \$139.50 Porcelain Exterior (PF-43) \$139.50	 F-55 Tri-Shelvador, 5.51 cu. ft. NET capacity; 11.0 sq. ft. shelf space. Dimensions: 57 1/2" high, 29" wide, 25 1/2" deep. \$164.50 Porcelain Exterior (PF-55) \$187.00	 F-70 Tri-Shelvador, 7.08 cu. ft. NET capacity; 14.9 sq. ft. shelf space. Dimensions: 57 1/2" high, 32 1/2" wide, 25 1/2" deep. \$189.50 Porcelain Exterior (PF-70) \$219.50

ALL PRICES INCLUDE DELIVERY, INSTALLATION, ONE YEAR FREE SERVICE • PRICES SLIGHTLY HIGHER IN FLORIDA, TEXAS, ROCKY MOUNTAIN STATES AND WEST

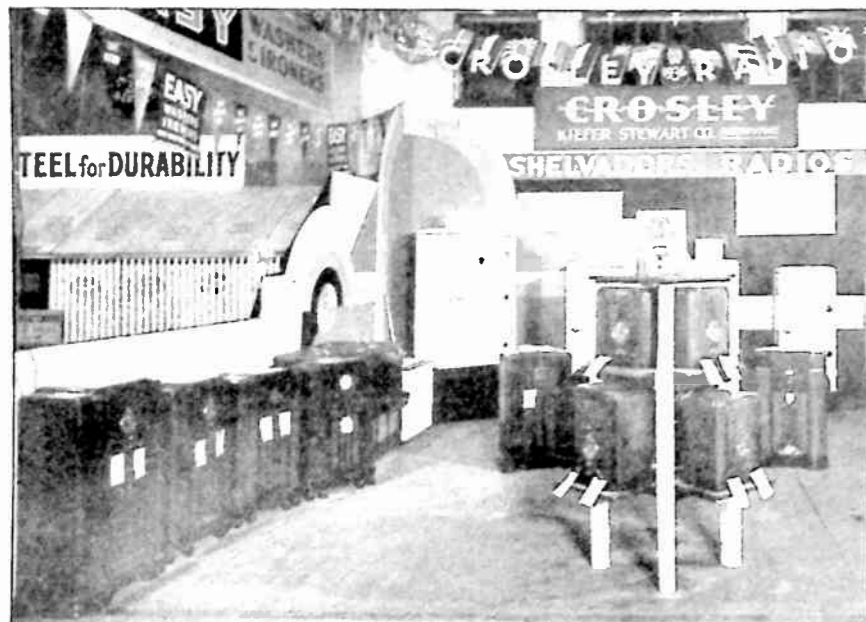

Indiana State Fair Exhibit . . .

During the recent Indiana State Fair, the Kiefer-Stewart Company, Crosley distributors of Indianapolis, Indiana, had this attractive exhibit of Crosley Radios and Shelvador Electric Refrigerators.

New Members Of 100 Percent Club . . .

Crosley distributor Interstate Electric Company, New Orleans, La., has had five new members recently gain entrance into the Crosley 100% club, by reason of their outstanding sales accomplishments. These are: J. F. Wolfe and R. A. Stevenson, Radio and Electric Service, Bay St. Louis, Miss.; Miss Natalie Perkins, and W. H. Perkins, Jr., W. H. Perkins and Son, Baton Rouge, La.; R. H. Cone, Auto Lec Stores, Inc., Baton Rouge, La.

Powerful WLW Broadcasts Feature Crosley Products

500,000-watt WLW—the world's most powerful broadcasting station is carrying these programs, devoted to Crosley radios and refrigerators, into the homes of America to keep the nation ever conscious of Crosley products and to win prospects and sales for Crosley dealers.

(Tune in to 700 Kc.—Eastern Standard Time Listed)

SUNDAY		MONDAY		TUESDAY	
P. M.		A. M.		A. M.	
2:00—Crosley Sunday Concert, Instrumental Trio. (Crosley Radios).	11:00—WLW News Room (Crosley Shelvadors).	6:30—Top O' the Morning, McCormick Fiddlers. (Battery Radios).	11:15—Los Amigos, Virginia Marucel and His South American Orchestra. (Crosley Radios).	6:30—Top O' the Morning (Battery Radios).	6:30—Top O' the Morning (Battery Radios).
3:30—Antonio & His Continentals. (Crosley Shelvadors).	1:30—Moon River, Organ & Poems. (Crosley Shelvadors).	11:30—Arthur Chandler, Jr., Organist (Crosley Radios).	1:30—Moon River, Organ & Poems. (Crosley Shelvadors).	11:30—Arthur Chandler, Jr., Organist (Crosley Radios).	11:30—Arthur Chandler, Jr., Organist (Crosley Radios).
MONDAY		TUESDAY		WEDNESDAY	
A. M.		A. M.		A. M.	
6:30—Top O' the Morning, McCormick Fiddlers. (Battery Radios).	4:15—News and Financial Notes. (Crosley Radios).	6:30—Top O' the Morning (Battery Radios).	4:15—News and Financial Notes. (Crosley Radios).	6:30—Top O' the Morning. (Crosley Radios).	4:15—News and Financial Notes. (Crosley Radios).
11:30—Arthur Chandler, Jr., Organist (Crosley Radios).	4:45—Questions and Answers. (Crosley Radios).	11:30—Arthur Chandler, Jr., Organist (Crosley Radios).	4:45—Questions and Answers. (Crosley Radios).	10:30—The Virginians Male Quartet (Crosley Shelvadors).	4:45—Questions and Answers (Crosley Radios).
				11:30—Arthur Chandler, Jr., Organist (Crosley Radios).	6:15—Sundown Varieties. (Crosley Radios).
MONDAY		TUESDAY		WEDNESDAY	
P. M.		P. M.		P. M.	
4:15—News and Financial Notes. (Crosley Radios).	4:45—Questions and Answers. (Crosley Radios).	4:15—News and Financial Notes. (Crosley Radios).	4:45—Questions and Answers. (Crosley Radios).	4:15—News and Financial Notes. (Crosley Radios).	4:15—News and Financial Notes. (Crosley Radios).
6:15—Sundown Varieties. (Crosley Radios).	11:00—WLW News Room (Crosley Radios).	6:15—Sundown Varieties. (Crosley Radios).	11:00—WLW News Room (Crosley Radios).	6:15—Sundown Varieties. (Crosley Radios).	6:15—Sundown Varieties. (Crosley Radios).
	1:30—Moon River, Organ & Poems. (Crosley Shelvadors).		1:30—Moon River, Organ & Poems. (Crosley Shelvadors).		
TUESDAY		WEDNESDAY		THURSDAY	
A. M.		A. M.		A. M.	
6:30—Top O' the Morning (Battery Radios).	10:30—The Virginians Male Quartet (Crosley Shelvadors).	6:30—Top O' the Morning (Battery Radios).	10:30—The Virginians (Crosley Shelvadors).	6:30—Top O' the Morning (Battery Radios).	10:30—The Virginians (Crosley Shelvadors).
11:30—Arthur Chandler, Jr., Organist (Crosley Radios).		11:30—Arthur Chandler, Jr., Organist (Crosley Radios).		11:30—Arthur Chandler, Jr., Organist (Crosley Radios).	
TUESDAY		WEDNESDAY		THURSDAY	
P. M.		P. M.		P. M.	
4:15—News and Financial Notes. (Crosley Radios).	4:45—Questions and Answers (Crosley Radios).	4:15—News and Financial Notes. (Crosley Radios).	4:45—Questions and Answers (Crosley Radios).	4:15—News and Financial Notes. (Crosley Radios).	4:45—Questions and Answers (Crosley Radios).
6:15—Sundown Varieties. (Crosley Radios).	11:00—WLW News Room (Crosley Radios).	6:15—Sundown Varieties. (Crosley Radios).	11:00—WLW News Room (Crosley Radios).	6:15—Sundown Varieties. (Crosley Radios).	11:00—WLW News Room (Crosley Radios).
	11:15—Dark-Town Meetin' Time (Crosley Shelvadors).		11:15—Dark-Town Meetin' Time (Crosley Shelvadors).		

THE GREATEST SALES HELP YOU HAVE EVER HAD!

Vast Opportunity With New Roamio Automobile Radio . . .

There is an ever-increasing demand for automobile radios that is assuming such tremendous proportions that no Crosley dealer should overlook the profit opportunities existing in this field. Recognizing this fact, Crosley has developed a new Roamio automobile radio that is destined to achieve greater sales records than ever before in history. This Roamio, Model A-156, has many new features and outstanding engineering refinements which take auto radio performance to new heights. It is a superheterodyne with seven-tube effectiveness. Has high gain antenna system, three gang tuning condenser, primary vibrator with tube rectification, tone control, automatic volume control, single housing, full floating moving coil electro-dynamic speaker, remote control illuminated airplane type dial, remote control adapter. This new model has a greatly reduced noise level, improved selectivity and is easier to install since no internal changes are necessary.

You will find a huge market awaiting the sale of this outstanding radio. Go after this business in every conceivable way. One suggestion is that you secure a list of car owners of your territory and wage an active campaign. An attractive and effective circular fully illustrating and describing the Roamio A-156 is available through your Crosley distributor.

Long Service And Complete Satisfaction . . .

Mrs. S. A. McNaughten of Reynoldsburg, Ohio, writes:

"I thought you might be interested to know that we purchased a Crosley radio in November, 1929. I doubt very much if there is a radio in use today that has given as many hours as this one has."

"I am a regular radio fan. Also a stay-at-home. The radio is turned on in the morning about 7 or 7:30 and runs till 10:30 or 11:00 p. m. There have been very few days in that time that it hasn't been used."

"Excepting tubes, I think five dollars will easily cover all repairs."

"I think WLW is a very fine station and certainly is the old stand by with me."



Window Display That Worked Automatically . . .

A very novel window display of kitchen equipment was installed recently by the Union Gas & Electric Co. of Cincinnati. Thousands of people were attracted to the sight by seeing the gas range automatically turn on and off; the water faucets doing likewise and the door of the

Crosley Shelvador electric refrigerator, seen at the extreme right, opening and closing automatically. Outside of the standard cabinets used in the display, it was built entirely and installed by the display department of the Union Gas & Electric Company.



Displays Feature Comparison Of Shelvador With Average Door . . .

Ever alert to the distinctive selling appeal of the Shelvador, Bob Brown, Crosley dealer of Anderson, Indiana, has recently staged a series of window displays that emphatically illustrated Shelvador advantages. Two of these displays are shown above. One dramatizes the extra space of the Shelvador while the other points out Shelvador's heavy insulation. This is undoubtedly an example of the smart promotion stunts that have made it possible for Bob Brown to achieve such outstanding success.

This live-wire dealer is in the territory of Kiefer-Stewart Company, Crosley distributor at Indianapolis,

Indiana.

It's A Wonder . . .

"I was listening to a WLW announcer," writes Harry Gyer of Columbus, Ohio, "and he said, 'when you want to hear a good program you tune in on WLW—why not a Crosley and have both'. So I sent back the radio that I had just bought and ordered a Crosley and I'm mighty glad to say that I did. I have had seven standard makes of radios and can truthfully say that Crosley is the best I ever had. It is more than a radio. It is a wonder."

Model F-70 Tri-Shelvador Delivered For 8 Cents . . .

Ehrlicher Brothers Company of Pekin, Illinois, claim the record for delivering a Crosley Tri-Shelvador model F-70 at the lowest price in history.

Here is the story in the words of this live-wire dealer, "This is how it happened. Last week during the Pekin Street Fair, sponsored by the Pekin Association of Commerce and American Legion, the second award was a Tri-Shelvador Model F-70 furnished by us. Mrs. D. L. Sullivan of this city, purchased a ticket for 8c (the only ticket she had) and won the Tri-Shelvador".

Mrs. Sullivan, highly gratified over her prize, remarked, "I still cannot believe it is mine. It's wonderful. I had often seen them in your window and hoped some day we would be able to have one."

So intense was the local interest in this affair that this Crosley dealer derived untold publicity. "A Crosley Tri-Shelvador that sells for \$189.50 being given for only 8c beats the band" is now a common expression heard on the streets, according to Ehrlicher Brothers Company.



Unique Display . . .

That Crosley dealer Charles Nofrey of Lakeport, California knows how to create out-of-the-ordinary displays that are both unusual and



Large Animated Billboard Keeps Boston Shelvador-Minded

On the top of a two-story building in the heart of Boston is this large 35 by 50 feet billboard to keep the Bostonians conscious of Shelvador. Erected by Crosley Distributor George Collins Company of Boston, in the interests of Morgan Furniture Company, dealer of Boston, this completely illuminated and partly animated billboard is doing an unusually good job in this territory.

This picture cannot begin to do justice to the attractiveness and effectiveness of the billboard. The

effective is proven in the accompanying picture. Nestling in an effective and eye-catching mountain of snow background, the Crosley Shelvador is quite an attraction to the polar bear seeking nourishment from its contents.

It is undoubtedly the use of such effective merchandising stunts that has brought such singular success to this aggressive dealer. Located in a town of only 1250 population, Charles Nofrey has achieved quite an unusual sales record. In a recent three-month period, his sales totalled 82 Crosley Shelvador electric refrigerators.

According to N. J. Etienne of Chanslor and Lyon Stores, Inc., San Francisco, California, Mr. Nofrey has attained this spectacular record in spite of the size of the town "plus the fact that his surrounding territory is very poorly populated and a very poor country generally."

space about ten feet deep across the bottom is animated and is known as a talking sign. A seventy-five word message that is electrically lighted flashes across this sign to point out the dominating features of Shelvador. The illustration of the refrigerator itself stands out in relief.

The sign is positioned at the corner of Fremont and Stuart Streets, which is considered one of the busiest thoroughfares in downtown Boston.

Crosley Performs Excellent In Canal Zone . . .

P. B. Banton of Balboa Heights, Canal Zone writes:

"Our Crosley radio set has now been in operation here two years and seven months and still going strong. It broke down once and that was on account of the insulation on one of the speaker field coils being jammed some way during installation and finally arced through.

"The only thing I did to the set was to install a lamp globe in the bottom of the set which is lighted all the time, and then installed a felt curtain that as soon as I shut down at night is buttoned over the back, to hold the dry air.

"I am mighty proud of my set, and am more than convinced that it brings in a lot that the other sets do not get, and I sure do like the bass notes that the large speaker brings out so strongly."



Here is seen a portion of the attractive and effective floor display used by May-

Stern and Company of Cincinnati to keep their customers Shelvador-conscious.

"No Promotions!" But Does Biggest Refrigerator Business In Cincinnati . . .

No promotions, no unloading of distress merchandise, no contests—but does the biggest refrigerator business in Cincinnati, a city of 451,000 in a trading area of more than half a million.

That in a nutshell is the story of May-Stern & Co., Crosley Shelvador dealer in Cincinnati.

This is a statement just the opposite of most sales successes we hear about. What, then, do they do to acquire and maintain such leadership in a well-known competitive market?

A few facts at the start will help make the story understandable. May-Stern has the largest appliance department within a radius of 300 miles of Cincinnati, a department that includes 10,000 square feet of floor space all on one floor devoted to this purpose. In this department are different sections devoted to refrigerators, radios, and the various appliances carried.

Merchandise is attractively displayed so that customers can readily view all products sold and make their selections by means of convenient comparisons on the floor. Ninety-eight per cent of all refrigerator sales are made inside the store. "We

do not use outside salesmen," said L. H. Wharfield, manager of the appliance department. "The only cases where sales are made outside the store are where the customer coming to the store has requested the salesman to come to the house to talk with other members of the family.

"Our sales are made entirely through our advertising and floor salesmen. Our store uses dominant space in newspapers, running approximately 200,000 lines of advertising in a year for the different departments. In the refrigerator season we predominate in the Cincinnati newspapers in refrigerator advertising. We have a large window devoted to refrigerator displays throughout the entire season.

"We do not use any special sales stunts. We do not use any promotions, sales contests, and we do not sell distress merchandise."

Discussing the May-Stern merchandising policy, Martin Mandelker, general manager, said, "A great deal of our success is due to customer good will. Our customers have the habit of returning to us for their household requirements, and

young people starting out follow in the footsteps of their parents.

Referring to their refrigerator merchandising, Mr. Mandelker said: "In every one of our newspaper advertisements, we emphasize the excellent Crosley Shelvador features. There is no doubt in my mind that our success in selling Crosley refrigerators is due primarily to these novel and practical features. Regardless of what the merchandise is, and no matter in what department in our store it is handled, any particular item that has new features will appeal to the customer. The features embodied in the Shelvador constitute the keynote of the stress used by our sales force in selling Crosley refrigerators."



Shelvador Awarded Prize At European Exposition . . .

The above diploma is an award accorded the Crosley Shelvador for its high quality and general excellence at the recent 1935 Exposition of Hygiene at Strasbourg. Armand Schwab, Crosley distributor for Alsace-Lorraine entered the Shelvador in this exposition. "The Shelvador," Mr. Schwab writes, "was also awarded a prize at the 1934 European Fair at Strasbourg."

Proud Of Shelvador . . .

Mrs. N. C. Hoffman of Chicago, Illinois, writes:

"We like the convenience of the Shelvador and the nice clean-cut appearance of the cabinet. The dealer told us it would not cost much to operate and he was right, as I found that my electric bill increased only a little each month."



Selecting Winner In Davega-Crosley Contest . . .

Here are shown the judges selecting the winner in the Davega-Crosley contest conducted by the Davega

Enthusied Over 1936 Line . . .

It is no wonder that Charles M. Fisher, president of Ownhouse Hardware Company, Bozeman, Montana, is so enthused over the new 1936 Crosley Radios after taking a model home and demonstrating its superior performance to his own satisfaction. An interesting letter recently received from Mr. Fisher follows:

"On a recent trip to Billings, Montana, where the Marshall-Wells Co., had a full line of your 1936 radios displayed, we were indeed pleased with your new setup and placed a nice order with them for a number of your models.

"We have already enjoyed some fine sales and our customers as well as ourselves are highly pleased and very much enthused over your entire line. The writer is using one of your eight tube Monitor consoles and it is unquestionably one of the finest radios I have ever had in my home.

"I want to take this opportunity to express my personal sentiments, along with those of our entire organization, with the new 1936 Crosley models, feeling confident we will all enjoy, not only a fine volume of business, this year, but let the public recognize the fact that Crosley knows how to build radios."

Company, large Crosley dealer in New York and surrounding territory. Left to right are: Manny Roth, sales promotion manager of Davega; Henry Benjamin, vice-president of Davega; Fielding Robinson, manager, Crosley Distributing Corp., New York; and Richard Davega.

The contest was called the "Home Economy Survey." Persons desiring to enter the contest sent in a letter giving the five features which they most preferred in any refrigerator which they purchased, regardless of

Use This New Display For Xmas Promotion

Here is a most striking display that is certain to attract attention during the Christmas selling season. With its metallic blue background, metallic red candle and three carollers in a beautiful color scheme, this display is different from anything you have ever seen. It is designed so that illumination may be obtained if desired. Order this distinctive Christmas display from your Crosley distributor.

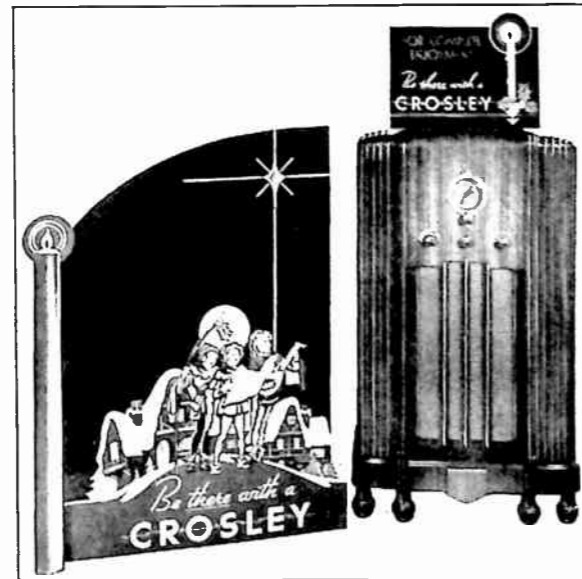

Christmas Ads Are Ready . . .

To help you in the promotion of Crosley Radios and Shelvador Electric Refrigerators as ideal Christmas Gifts, a series of attention-compelling newspaper ad mats has been

Shelvador— The First Choice . . .

That the Crosley Shelvador gives anyone everything they could desire is amply expressed in a recent letter from Joseph M. P. Marvell, Syracuse, N. Y.:

"After months of deliberation and after examining many makes of refrigerators we finally went to see the 'Crosley.' We looked at all the other makes and for the model that fit our requirements we could not find one as low in price as the Shelvador.

"The Shelvador was the most beautiful we looked at—regardless of price. When my wife saw the Shelvador feature and realized what that could do for her, she decided to buy.

"The Shelvador has now been in operation in our home about six months. In the warm weather we have had ice cream daily plus ice cubes and at a surprisingly low cost."

the make. They came into the Davega stores and were shown the various kinds of refrigerators and from their inspection wrote their preferences. By far the most outstanding of all features stressed in the letters was the Shelvador feature which appealed tremendously to the women, said Fielding Robinson, manager, Crosley Distributing Corp., New York.

prepared and is now ready for insertion in your local newspaper. There are one-column, two-column, and three-column ads on both radios and refrigerators. Order these mats now from your Crosley distributor.

CROSLLEY SERVICE SUPPLEMENT

MODEL 555

Tube	Function	TUBE SOCKET VOLTAGE READINGS							
		H	P	S	Su	G	K	Go	Ga
6A8	Osc. Mod.	6.4	295	135	—	0	7.5	-10 to -20	155
6K7	I. F. Amp.	6.4	295	135	10	0	10.	—	—
6J7	Det. & A. F. Amp.	6.4	1	65	4	0	4.	—	—
6F6	Output	6.4	295	295	—	0	20.	—	—
5Z4	Rect.	4.8	—	—	—	—	390	—	—

ALL D.C. VOLTAGES MEASURED TO CHASSIS WITH A 500 VOLT D.C., 1000 OHMS PER VOLT, METER. FILAMENTS MEASURED WITH LOW READING A.C. VOLTMETER. ALL VOLTAGES PLUS OR MINUS 10%. POWER DEMAND 86 WATTS AT 117.5 VOLTS.

PARTS LIST—MODEL 555

Figures in first column refer to parts shown in Diagram on page 18.

Item No.	Part No.	Description	Item No.	Part No.	Description
1A	G6 —27134	Dial Light Assm.	22	—37354	Dial Face only
1B	G6 —27134	Dial Light Assm.	23	B —33906A	A. C. Cord & Plug
2	G82 —32000	Ant. Coil, S. W. B.	24	—5370A	Resistor, 20,000 Ohm
3	G81 —32000	Ant. Coil, B. C. B.	25	—21237	Resistor, 60,000 Ohm
4	G65 —32002	Osc. Coil, S. W. B.	26	—21875	Resistor, 100,000 Ohm
5	G66 —32002	Osc. Coil, B. C. B.	27	—21455	Resistor, 300,000 Ohm
6	G71 —32004	1st I. F. Assm.	28	—33344	Resistor, 400,000 Ohm
7	G72 —32004	2nd I. F. Assm.	29	—37245	Resistor, 1.5 Megohm
8	W —36055	Condenser, 35. Mfd. 400 Volt	30	W —25291	Resistor, 500 Ohm 1½ W. (Flex)
9	W —36057	Condenser, 40. Mfd. 300 V.	31Z	W —28106	Resistor, 500 Ohm ½ W. (Flex)
10	W —36931	Condenser, 12 Mfd. 25 V.	31Y	W —37246A	Resistor, 10,000 Ohm Candohm
11	W —30805	Condenser, 0.01 Mfd. 400 V.	31X	W —37246A	Resistor, 25,000 Ohm Candohm
12Z	W —30322A	Condenser, 0.00017 Mfd. 200 V.	31W	W —37246A	Resistor, 185. Ohm Candohm
12Y	W —30322A	Condenser, 0.006 Mfd. 200 V.	32	G154—36400	Socket, 5Z4
13Z	W —25537A	Condenser, 0.001 Mfd. 400 V.	33	G153—36400	Socket, 6F6
13Y	W —25537A	Condenser, 0.03 Mfd. 400 V.	34	G157—36400	Socket, 6J7
14	W —23191A	Condenser, 0.01 Mfd. 400 V.	35	G151—36400	Socket, 6K7
15AZ	W —28623	Condenser, 0.02 Mfd. 200 V.	36	G156—36400	Socket, 6A8
15AY	W —28623	Condenser, 0.02 Mfd. 200 V.	37	331—CL—9	Speaker, (5555)
15BZ	W —28623	Condenser, 0.02 Mfd. 200 V.		432—CJ—3M	Speaker, (5555) Console
15BY	W —28623	Condenser, 0.02 Mfd. 200 V.		G3 —35696	Speaker Cable (5555)
16	W —27216	Condenser, 0.05 Mfd. 200 V.	38W	W —37247	Band Change Switch
17Z	W —35011	Condenser, 0.006 Mfd. 400 V.	To		
17Y	W —35011	Condenser, 0.03 Mfd. 400 V.	38Z	W —36184A	Tone Control Switch
18	W —36541	Condenser, 0.02 Mfd. 160 V.	40	G1 —26719	Ant. & Grd. Terminal
19Z	W —37241A	4 Section Trimmer Cond.	41	G12 —28500	Power Trans. 60 Cy. 110 V.
19Y	W —37241A	4 Section Trimmer Cond.		G13 —28500	Power Trans. 25 Cy. 110 V.
19V	W —37241A	4 Section Trimmer Cond.		G14 —28500	Power Trans. 25 Cy. 220 V.
20Z	G29 —33006	S. W. Osc. Series Padder	42Z	W —37395	Volume Control A. F. Grid
20Y	G29 —33006	B. C. Osc. Series Padder	42Y	W —37395	Volume Control Output Grid
21Z	G17 —33001	Var. Tuning Cond. Gang	42X	W —37395	On-Off Switch
21Y	—37353C	Dial Assm. Complete	B	—35917	Escutcheon
	—37158	Dial Glass	D	—28	Escutcheon Screws (3)
	—37156	Dial Pointer	W	—31585B	Knob, V. C. & Dial
	—37157	Pointer Screw	W	—36355	Knob, T. C. & Band Change

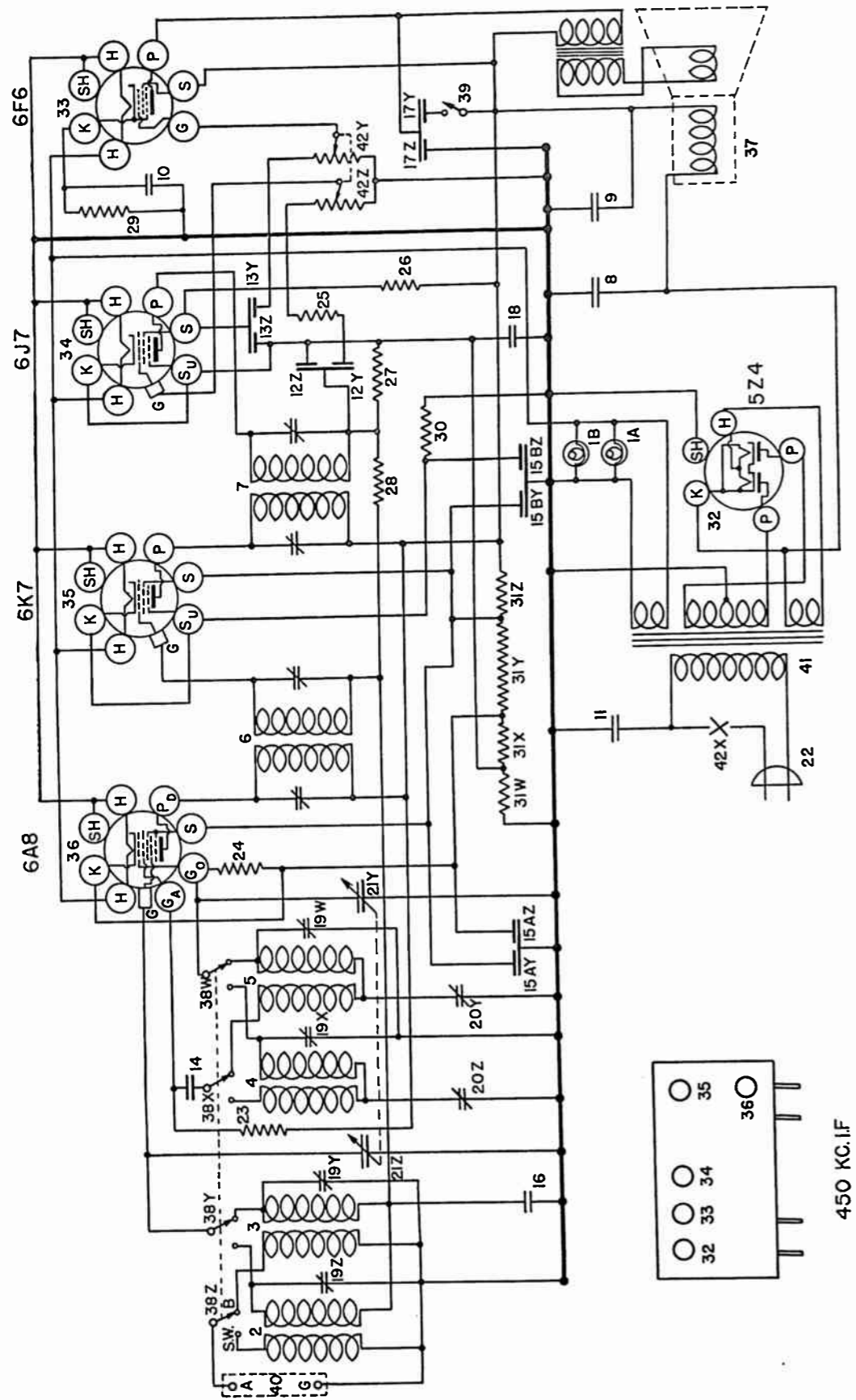

WIRING DIAGRAM—MODEL 555

450 KC.I.F.



What a boon to mothers! Now, with the aid of the Crosley Temperator, baby's bath need cause no worry. No danger of chilling or catching cold—exactly the temperature best for baby, at the touch of a switch.



Now everyone can dress in comfort. The Crosley Temperator will raise the temperature in a room to the desired degree. Just set the thermostat and enjoy the temperature you like best.



The man of the house deserves to shave in comfort. No matter if the rest of the house is cool, the Crosley Temperator will bring comfort and warmth to any room.

THERMOSTATED HEAT is the most Profitable form to sell to EVERYBODY!

HERE is an auxiliary heating device with the features of a central heating plant. Has a thermostat to assure comfort and warmth when and where it is wanted—and at the temperature that is wanted. Just the thing to bring summer comfort to those hard to heat rooms.

Nothing else like it with thermostat at such an amazingly low price. Now is the time to push it—get it on display—advertise it—sell it—and you will be amazed at the profits it will bring in.

\$7.50
Western Price Slightly Higher

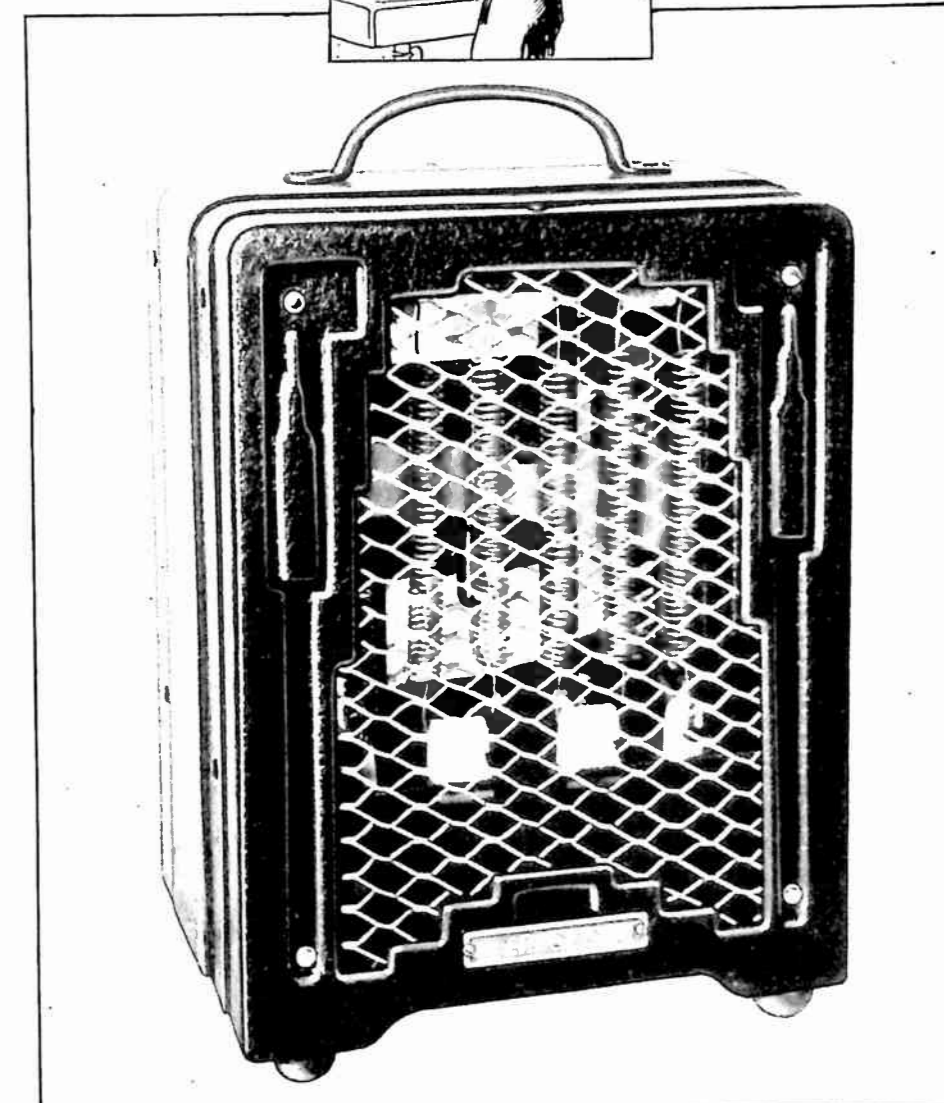

Circulates Thermostatically Controlled Heated Air

- The Crosley Temperator circulates heat so that it is distributed throughout the entire room. It is an economical and efficient method of bringing warmth to any room. By setting the Thermostat to the desired tempera-

ture, that degree of heat will be maintained. The Thermostat switches off the Temperator as soon as the room reaches the temperature selected and switches it on again as soon as the temperature falls below that point.

- Due to the unique design of the Crosley Temperator, its case does not become too

hot to touch. A metal grille at the front and back of the Temperator protects the heating coils and fan.

- The Temperator comes complete with a six foot cord and is ready for operation. Available in two colors—brown or green. Dimensions: 10 1/4" high, 7" wide, 5 1/4" deep.

CROSLLEY TEMPERATOR



Sail the Seas of Profitable Sales

with the



CROSLEY CLIPPER

Nine Tubes . . . Five Bands . . . ALL WAVE PLUS WEATHER BAND



HERE is one of the greatest radios ever built regardless of price. It gets everything—American, foreign, police, amateur, aviation, weather broadcasts. It has everything—distinctive beauty, outstanding performance, latest features, sensational value. It is a big sales and profit maker. Display it—advertise it—sell it—NOW!

● CROSLEY CLIPPER

This superb five-band all-wave model virtually commands the air. The exquisite cabinet has a front panel of center matched stump walnut veneer. Pilasters of California Claro walnut veneer with rosewood caps and reeded corners. Walnut top. Dimensions: 19 $\frac{3}{4}$ " high, 15 $\frac{3}{4}$ " wide, 10 $\frac{3}{4}$ " deep.

CONSTITUTION—Ten metal tubes. Other features and cabinet same as Clipper. **\$85.00**
\$99.95

● CROSLEY CLIPPER CONSOLE

One look at this delightful cabinet and anyone will agree it is one of the most beautiful ever designed. Has a front panel of stump walnut veneer with California Claro walnut on the pilasters. Reeded stiles. Fiddle back walnut on top. Decorative reeded grille. Walnut end panels. Dimensions: 41 $\frac{1}{2}$ " high, 25" wide, 12 $\frac{1}{2}$ " deep.

CONSTITUTION CONSOLE—Ten metal tubes. Other features and cabinet same as Clipper Console. **\$100.00**
\$125.00

All Prices Slightly Higher In Florida, Rocky Mountain States and West

FEATURES

- Nine-tube, Five-band, All-wave Superheterodyne . . .
- Weather Broadcasts 150-400 Kc.
- Standard Broadcasts 540-1500 Kc.
- Police, Amateur, Aviation Broadcasts 1500-4000 Kc.
- Foreign Broadcasts 4,000-10,000 Kc.; and 10,000-22,000 Kc.
- Shadow Tuning.
- Automatic Volume Control.
- Full Vision Illuminated Airplane Type Dial.
- Tone Control.
- Dual Ratio Tuning Control.
- Full Floating Moving Coil Electro-Dynamic Speaker.
- Tubes used are: One type 6D6, two type 76, one type 6B7, three type 42, one type 5Z3, one type 6A7.



Whatever Happens. . . . You're *There* With A Crosley

CROSLEY RADIO