

THE  
GENERAL RADIO

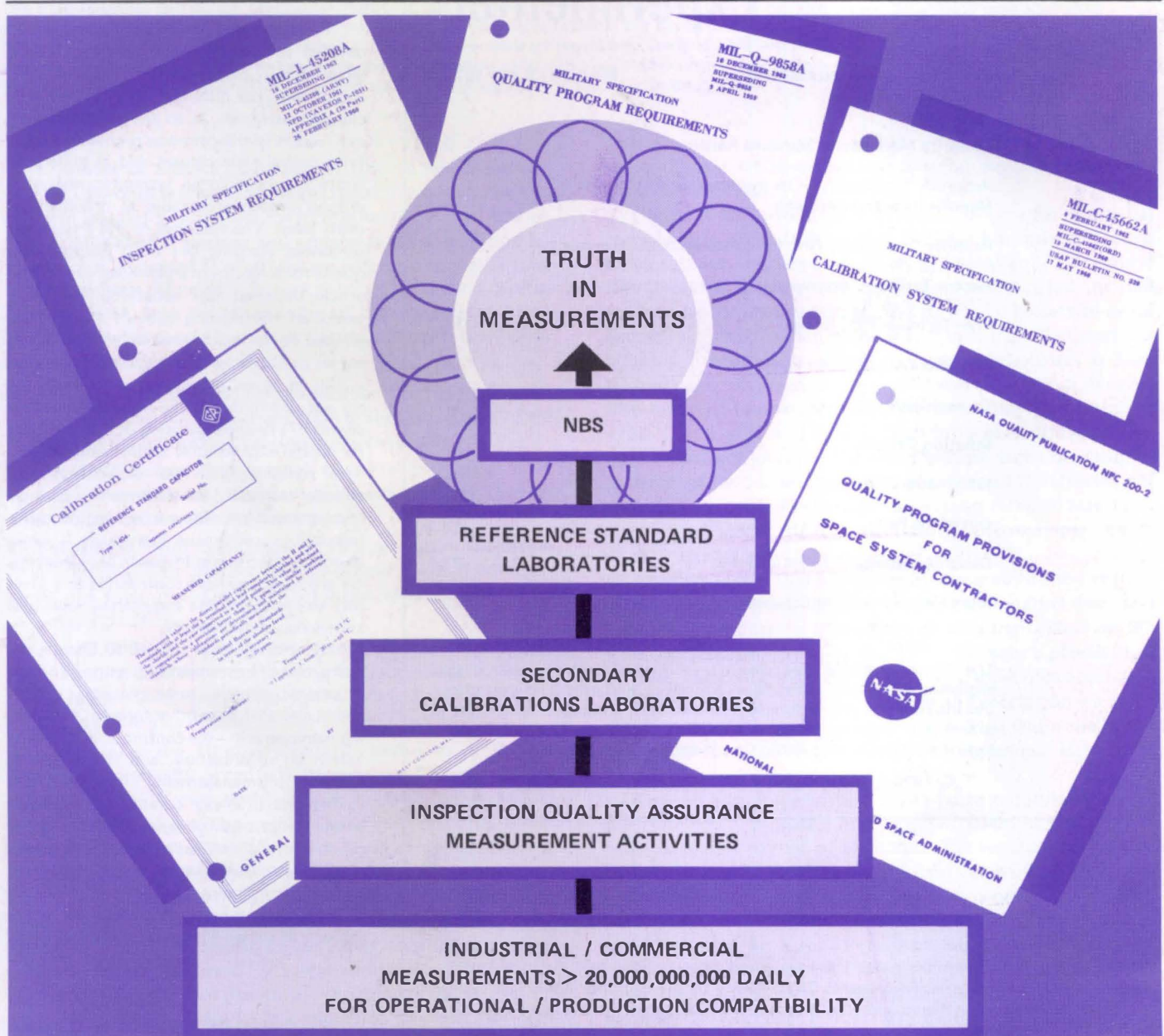

# Experimenter

VOLUME 44  
NUMBERS 3, 4, 5, 6  
MARCH - JUNE 1970



THE  
GENERAL RADIO   
**Experimenter**

VOLUME 44                      NUMBERS 3-6                      MARCH/JUNE 1970

Toward a More Useful Standard Resistor . . . . .	3
Accuracy Traceability — Its Impact upon Instrument Manufacturer and Customer . . . . .	6
Another Traceability Path for Capacitance Measurements . . . . .	8
Recent Technical Articles by GR Personnel . . . . .	10
Five-Terminal RLC Bridge . . . . .	11
Why Make a Five-Terminal Bridge? . . . . .	14
General Radio Expands . . . . .	17
Inflation Deflation . . . . .	18
Information Retrieval . . . . .	18
Out of the Past . . . . .	19
Design Assistance — Noise in Noise . . . . .	21
More Memory — More Convenience . . . . .	22

The *General Radio Experimenter* is mailed without charge to engineers, scientists, technicians, educators, and others interested in the instruments and techniques of electrical and electronics measurements. Address all correspondence to Editor, *General Radio Experimenter*, General Radio Co., West Concord, Mass. 01781.

© 1970 — General Radio Company, West Concord, Mass., USA

**THE COVER** Our government employs a system of measurement-accuracy control expressed in contractual specifications as "traceability to the National Bureau of Standards." It is a philosophy based upon one principle: interchangeability and compatibility of industrial products are attainable through accurate measurements based upon physical standards common to all users. A discussion of the subject appears on page 6.

Our last issue contained a lead article devoted to the economic justification of a large capital investment in automated test equipment. The purposes in writing the article were twofold: 1) to ally ourselves with our readers in the common problem of justifying capital expenditures, and 2) to demonstrate by example an economic reasoning process proven acceptable to one management team. The response to the article was somewhat startling but most pleasing. Requests for a reprint of a talk referred to in the article depleted our supply within three weeks of the mailing date of the *Experimenter*. It has been necessary to make more copies available for the continuing demand.

All of which proves that most engineers are *not* unmindful of the impact upon their company's financial position of their requests for capital expenditures for instrumentation. They recognize that their expenditures are directly related to the profitability of their company and are willing to act as financially responsible, reasonable individuals — when given direction and guidance in procurement. We are happy to have contributed in a small way to increasing the engineering value and knowledge of our readers.

The next logical step is to discuss the economics of instrument utilization. We hope to present, shortly, some thoughts, experiences, and advice on other forms of engineering management — the control of instruments within an organization, and the economic waste of mismanagement. The subject is a vexing one in many companies, large and small. It has been of great concern to our government, which has a tremendous investment in test instrumentation in its own and in its contractors' plants.

Perhaps you have some thoughts on the subject? If so, we'll be glad to hear from you.



C. E. White  
Editor



## Toward a More Useful Reference Standard Resistor

The Electrostatic System of Units and Measurements provides a method of establishing the value of a standard resistor directly from the value of the computable capacitor developed by Thompson-Lampard in Australia. The value for a resistor which more closely approaches the capacitor's impedance reduces the multiplication factor for calibration purposes; the comparison-measurement accuracy is thereby increased up to some definite value for the resistor. For practical reasons, the compromise value of 10,000 ohms has been established recently for a new standard of resistance. Development work by General Radio has produced a resistor with the high stability of the Thomas 1-ohm resistor and with a better temperature coefficient. Our new and different design approach is described in this article.

A number of articles have been written on the advantages of a 10,000-ohm reference standard resistor in comparison to a 1-ohm standard. Some writers have gone so far as to assume that a 10,000-ohm resistor will replace the famous Thomas-type 1-ohm standard. I'm afraid we will have to wait a long time – perhaps 30 years – before this can be proven. But in the meantime, let's see what some of the advantages are to calibration laboratories presently dependent upon the 1-ohm reference standard.

- The 10,000-ohm standard reduces the number of transfer steps required to measure resistors in the range from 1,000 ohms to the highest calibration range required.
- The 10,000-ohm value is much closer to, and can be more easily derived from, the very stable value of the Thompson-Lampard computable capacitor.
- The 10,000-ohm value reduces to a minimum the errors due to lead and contact resistance and thermal voltages, yet the value is not so high that shunt leakage resistance is a major problem.
- The 10,000-ohm value presents a better impedance match to modern null detectors, giving better signal-to-noise ratio, higher detector sensitivity, and reduced power dissipation in the bridge circuit.

What makes the Thomas standard resistor so stable and therefore universally accepted? It consists of a coil of bare, heavy Manganin\* wire that has been heat-treated at 500°C approximately. Next, this coil is placed very carefully on an enameled brass cylinder (any mechanical stress or strain is avoided), then it is hermetically sealed in dry air or nitrogen. This is, of course, a very simple description of the production process; the main point of interest is that the wire is heat-treated at a high temperature *after* it has been formed into a coil. The coil is supported by a heat-conducting form with a temperature coefficient practically the same as the Manganin. There is a disadvantage in this standard, however. Its high

temperature coefficient requires extreme control of the operating environment.

Contrast the production process above with the usual construction of a 1,000-ohm or 10,000-ohm resistor. Here a much thinner, insulated wire is used which cannot be wound into a self-supporting coil. It is necessary to wind the coil upon some form of substrate, and to wind it loosely to avoid excessive stress or strain in the wire. Some manufacturers use bobbins for support, others use cards; every unit is heat treated cyclically in an attempt to relieve any built-in stresses. The range of temperature for treatment may go as high as +150°C and as low as -80°C. This process results in a good resistor but not equal to the Thomas-type, since the temperature range used is not sufficient to relieve all the stresses and strains in the wire. Eventually the stresses retained result in a positive resistance drift with time if, for example, Evanohm\*\* wire is used.

Another factor that affects resistance stability to a certain extent is the coating on thin wire. As the coating dries and hardens it produces a restricting or "choking" effect on the wire, and its resistance increases. When the wire is placed in an oil bath, the coating softens and the wire resistance decreases. Obviously, it is desirable to eliminate the coating on wires if a stable standard is under consideration. This was done in the design of the 10,000-ohm GR 1444 Reference Resistance Standards.

Basic construction of the GR 1444 uses an insulated metal substrate 3½ X 3 inches, having a coefficient of thermal expansion similar to that of Evanohm. The resistors are wound with bare Evanohm wire to a nominal value of 5000 Ω, and heat-treated in an inert atmosphere at approximately 500°C. We find that this treatment gives complete relief from stresses and strains in the wire. There is an additional benefit: the resistor's temperature coefficient can be adjusted to a very close tolerance *after* the resistor is wound. This is possible because the electrical properties of Evanohm change at ele-

\*Registered trademark of Driver-Harris Company.

\*\*Registered trademark of Wilbur B. Driver Co.

1444-B 10-k $\Omega$  standard,  
for use with oil bath,  
shown removed from  
carrying case.

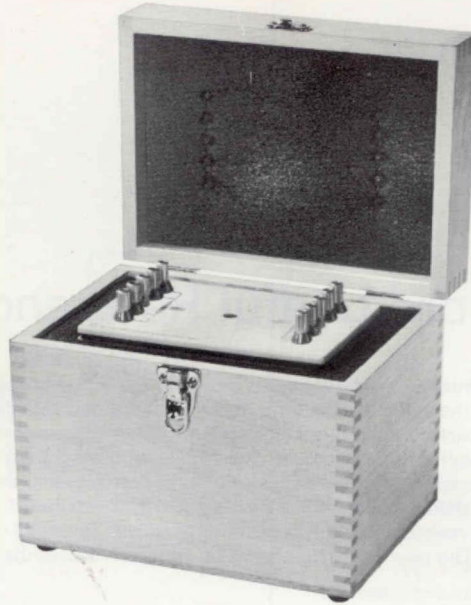
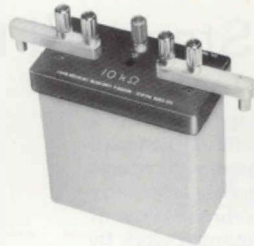

1444-A 10-k $\Omega$  standard  
with temperature sensor,  
shown with carrying case.

vated temperatures as a function of time (refer to note at end of article).

Upon completion of the heat treatment, two of the resistors are mounted upon a heavy brass plate on either side of a center shield, to which is soldered a thermometer well. The GR 1444-A standard includes a 10,000-ohm temperature-sensor resistor network, wound upon the center shield. The network has a temperature coefficient of 1000 ppm/ $^{\circ}$ C and is in close thermal contact with the standard resistor elements. The GR 1444-B standard does not contain a temperature sensor since it is intended for use in an oil bath. An individual temperature-correction chart is supplied for either type standard.

The complete GR 1444 unit is welded into a 1/16-in. stainless steel container, which is evacuated, filled with dry nitrogen, and then sealed. We chose not to use an oil-filled enclosure because no oil is completely free of water. Any water content would cause oxidation of the wire. The effect of oxidation increases with decreased wire diameter. The GR 1444 uses wire of 0.002-in. diameter, and an oxide film of only 1 Å (0.00394  $\mu$ in.) will produce a resistance change of 8 ppm. An extended laboratory test of a GR 1444-A standard demonstrated the stability of the unit over a two-year period (Figure 1).

Since a useful standard of any type ideally should be comparatively unaffected by a hostile environment, we

Figure 1. Typical long-term stability  
of GR 1444 resistors.

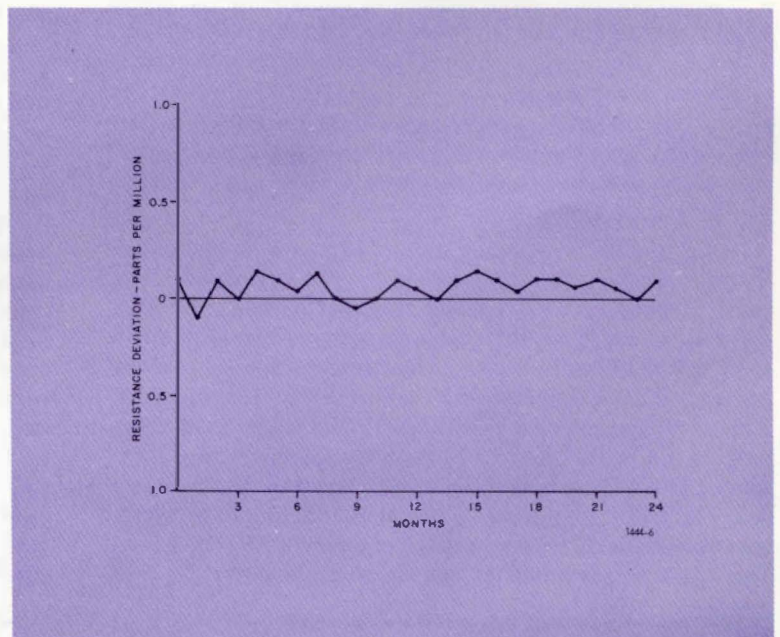



investigated the effect of shock upon the GR 1444-A. The unit was dropped three times, from a height of 36 inches, upon a concrete floor. The result of several tests was a resistance change of  $-0.1$  to  $-0.2$  ppm. Obviously, we don't imagine that you would, in normal practice, deliberately mistreat a standard in this manner. If, however, it were to happen, the value of the standard would not be impaired. By the way, after a two-day rest period the measured change was found to be less than  $\pm 0.1$  ppm. With proper design of transport packaging, the unit will withstand shipment for calibration or any other purpose.

Of interest to specification-minded professional people are two other tests we conducted. The ambient pressure was varied from 1000 microns to 3 atmospheres ( $10^{-3}$  to 2280

mm Hg), and the resistance change was less than 0.1 ppm. Leakage resistance between the resistor and case was measured at  $4 \times 10^{12} \Omega$  at 35% RH and  $2 \times 10^{12} \Omega$  at 94% RH.

—W. J. Bastanier

The author wishes to acknowledge with deepest gratitude the cooperation of Dr. C. D. Starr and of the Wilbur B. Driver Company in permitting use of the heat-treatment techniques developed by them.

Catalog Number	Description	Price in USA
1444-9700	1444-A Reference Resistance Standard, 10 k $\Omega$ , with sensor	\$600.00
1444-9701	1444-B Reference Resistance Standard, 10 k $\Omega$ , without sensor	600.00

Prices subject to quantity discount.

## Some Technical Notes

Starr describes the useful functional changes of Evanohm wire with time as it is exposed to high temperatures.<sup>1</sup> Completely annealed Evanohm wire is commercially available with a temperature coefficient of  $+50$  ppm/ $^{\circ}$ C. During the heat treatment process the temperature coefficient decreases, passes through zero, reaches a maximum negative value of about  $-35$  ppm/ $^{\circ}$ C, and then passes through zero a second time to become positive once again (Figure 2). The first zero-

crossing point is considered to give the most stable condition of the wire.

At the same time that the temperature-coefficient effects are observed, the resistivity of the wire also is changing. Starting at about 730 ohms/cir mil ft, the resistivity rises to approximately 800 ohms/cir mil ft when the temperature coefficient makes the first zero crossing. Continued heat treatment causes the resistivity to reach a maximum value and finally it decreases slightly.

The heat treatment of GR 1444 standards is such as to produce a temperature coefficient of  $\pm 0.1$  ppm and a resistivity of approximately 800 ohms/cir mil ft.

<sup>1</sup>"Properties of Wire for Resistors," C. D. Starr, *Materials Research & Standards*, September 1966.

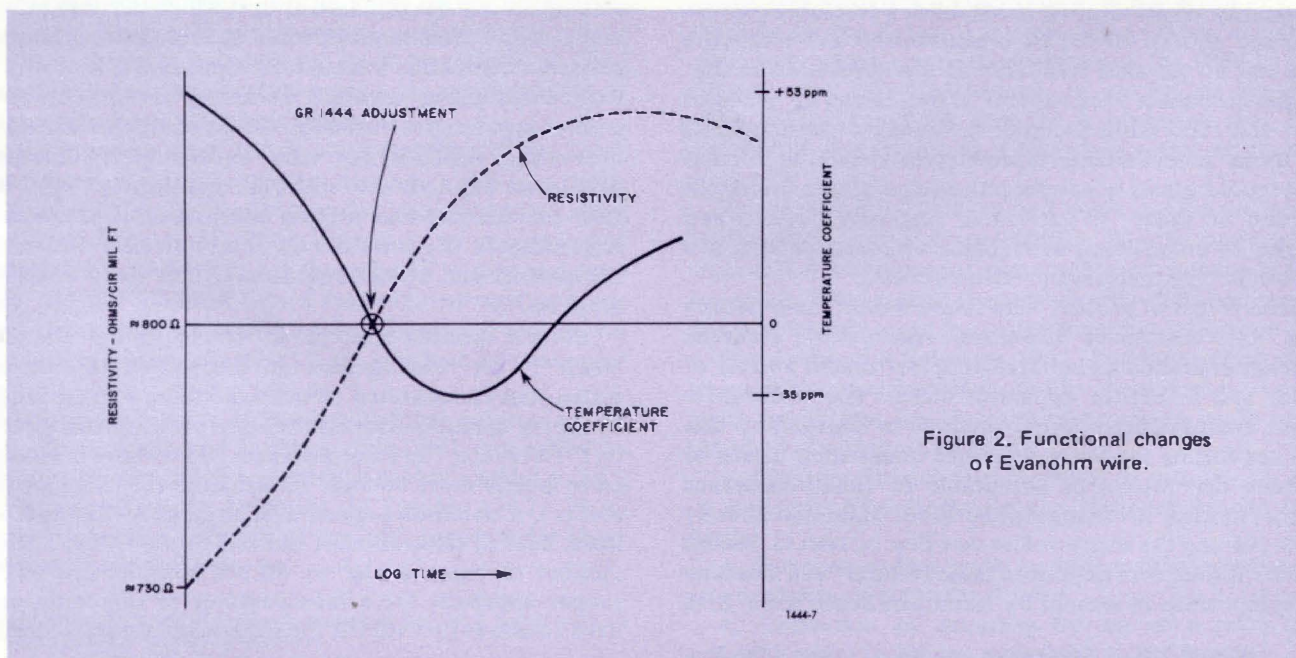

Figure 2. Functional changes of Evanohm wire.

# Accuracy Traceability

## Its Impact upon Instrument Manufacturer and Customer

Dedicated people, experience, and technical knowledge assure operational integrity of measurement standards and calibration activities. These ingredients, however, are not sufficient to assure measurement compatibility with similar activities, nor with the National Bureau of Standards. Required is some sort of measurement interface between production measurements and national standards. The Department of Defense calls this interface "traceability" but does not define it sufficiently or comprehensively. This article relates some background of the traceability problem and our analysis and evaluation of traceability philosophy, and it introduces a fourth path to establishment of traceability.

Shortly after issuance (9 April 1959) by the U.S. Department of Defense of military specification MIL-Q-9858, "Quality Control Requirements," a chorus of voices raising questions was heard. Particularly of interest to all workers in the field of measurement standards and calibration was the clearly expressed requirement stated under the topic heading "Traceability of Calibration:" "In the Zone of Interior, Hawaii and Alaska, measuring and test equipment shall be calibrated with measurement standards, the calibration of which is traceable to the National Bureau of Standards . . ."

Immediately apparent to many metrologists was the impracticality of attempting to establish a traceable pattern of accuracy of state-of-the-art measurements for which the Bureau had no physical standards. It was apparent also that many measurements were capable of evaluation by the ratio type of self-calibration techniques. Finally, measurements based upon independent, reproducible standards derived from accepted values of natural physical constants could gain no further accuracy, if performed originally by qualified personnel, by comparison with similar standards at NBS, and in fact would only increase operational costs.

Official voices of protest were raised within many organizations, e.g., Aerospace Industries Association, National Conference of Standards Laboratories, Instrument Society of America, and Scientific Apparatus Makers Association. Instrument manufacturers found themselves besieged by customers requesting guidance or advice concerning means or techniques that would be acceptable to quality-assurance inspectors in cases involving standards not calibrated directly by NBS. Among the many voices was that of Ivan G. Easton of General Radio, who expressed these feelings<sup>1</sup> at a measurements symposium sponsored by American-Bosch Arma Division:

<sup>1</sup> Easton, I. G., "The Measurement and Standards Problems of Tomorrow," January 25, 1960, unpublished.

"The present hysteria about traceability to NBS is disturbing. The word hysteria is perhaps a bit strong but we have seen situations develop in the past year in which the use of the word does *not* constitute excessive hyperbole. While the intent of the traceability program is crystal clear, the operation of the program needs to be placed in proper perspective. The concept that all calibrations be based ultimately on NBS certification is a commendable one, but the means of achieving this result requires scrutiny. The interpretation of the traceability requirement, in some circles, has led to the demand that a manufacturer state the date of the last NBS certification of the standard against which the item being sold was checked. This request, while at first glance innocent and entirely reasonable, is based on a misconception of a standards structure. A standards laboratory consists of *more* than a set of standards certified by NBS on some particular date. A calibration depends not only on standards, but also on people, on methods and, above all, on integrity . . . I believe that clarification and proper interpretation of traceability requirements is a problem for the immediate future at the commercial and operational level of our national standards program."

Several months later in an article in the *GR Experimenter*,<sup>2</sup> Mr. Easton gave an illustration of one of the difficulties encountered by manufacturers who are requested to supply corroborative information pertaining to "traceability." He wrote, "In a few instances . . . we have been requested to supply more detailed information (pertaining to traceability). A common request in such cases is that we state the latest date of calibration of our standard by NBS. There are a number of reasons why we do not consider this to be the proper approach for a manufacturer of standards, and we have consistently avoided the supplying of such information.

<sup>2</sup> Easton, I. G., "Standards and Accuracy," *GR Experimenter*, June 1960.





Editor White (left) discusses problems of traceability with GR engineers (from left to right) J. Hersh, J. Zorzy, H. Hall, R. Orr, and W. Bastanier who developed the GR 1444 standard resistor described on page 3.

The most significant objection to this procedure is that it constitutes an oversimplification and does not recognize the true nature of a standards structure . . . we believe quality assurance cannot be obtained from any single detail such as the date of an NBS calibration . . . ”\*

Probably the most important point in the consideration of traceability as a required component in a measurement system is the fact that traceability itself does not assure accuracy in measurements. Errors exist within a measurement system because of many reasons, including poor measurement techniques, carelessness or inexperience of measurement personnel, physical changes and consequent drift of instrumentation operating parameters.

We can also consider *degree* of traceability. There is no way in which traceability can be *quantified*. We agree with Lord Kelvin, if you can't put a number on a quantity it can't be measured. True traceability, instead, is an expression of the operating philosophy and integrity of a measurement activity. Its introduction into a measurement system is an attempt to promote honesty in measurements and to supply a base point (an NBS calibration) from which all like measurements can be derived in confidence.

The National Bureau of Standards, focal point of attention by government and industry alike, felt compelled to express its position in the traceability debate and did so. In a presentation at Boulder, Colorado, 23 January 1962,<sup>3</sup> W. A. Wildhack, Associate Director of the NBS Institute for Basic Standards offered these words:

\*Editor's Note: This information is available, however, upon written request to GR's Standards Laboratory.

<sup>3</sup>Wildhack, W. A., "Statement on Traceability," Report of Workshop on Measurement Agreement - National Conference of Standards Laboratories, Boulder, Colorado, 23 January 1962.

"The National Bureau of Standards has received numerous inquiries concerning the meaning of the term 'traceability' as used by Department of Defense agencies in contractual documents and elsewhere, in stating requirements pertaining to physical measurements.

"Without further definition, the meaning of this term is necessarily indefinite as applied to relationships between calibrations by NBS and measurement activities of manufacturers and suppliers. 'Traceability' is not given any special meaning by the National Bureau of Standards, and information as to possible special meanings of the term in military procurement activities cannot, of course, be supplied by NBS. Where questions arise, it is suggested that they be directed to the cognizant military inspection or contracting agency."

Obviously, Mr. Wildhack had made the Bureau's position clear in the matter of traceability, but the position of the manufacturer and user of instruments remained as precarious as before. Fortunately, the specification that had caused the trouble was improved by a supplement specification, MIL-C-45662-A, issued 9 February 1962. Bowing to the logical and technically correct points raised by metrologists, the government agreed that the traceability provision could be established by any of three methods:

- a. Intercomparison directly with, or through, an echelon of standards laboratories to the National Bureau of Standards,
- b. Intercomparison with an independently reproducible standard acceptable to the Bureau,
- c. Derivation of accuracy by use of a ratio type of self-calibration technique acceptable to the Bureau.

The last mentioned method is undoubtedly a most useful tool for any calibration activity. It is recommended by the

Bureau because of its cost-saving features and the reduction of the heavy workload at the Bureau by any work performed by laboratories themselves. Unfortunately, there are many aspects to this method, not known to all measurements workers. Questions raised by General Radio customers continually remind us of this fact. We have been encouraged to present to our readers NBS-acceptable techniques practiced by our engineering staff, which are available to many measurement laboratories.

We approached GR's Henry P. Hall for advice and assurance concerning impedance-calibration techniques that are technically sound and display more than a modicum of common sense. His reaction was immediate and positive. He pointed out the fact that the Bureau itself, possessing a minimum of standards, also faces the problem of traceability on an international scale. Through the years the Bureau has established techniques similar to those listed above as a, b, and c. For more efficient use of its limited budget, facilities, and manpower, it has been forced to develop dependable calibration techniques using other than comparison methods. Most important, techniques so developed are available for use by any technically qualified calibration activity.

From a series of round-table discussions with members of GR's Component and Network Testing Group came information on one of these techniques, technically sound and requiring no recurrent calibration services from the Bureau. Briefly stated, the technique merely involves the application of known frequency correction factors to standards. We think of the technique as Self-Calibration by Frequency Translation. It has been applied vigorously at GR (and NBS) for a number of years. Its use is particularly emphasized in calibration of impedances for one very important reason:

"It has long been known that capacitors are superior to either inductors or resistors for use as impedance standards at high frequencies, because changes in their effective values with increasing frequency can be more accurately and more easily evaluated than such changes in either resistors or inductors."<sup>4</sup>

Some administrative problems of the calibration laboratories emanate from the assumption that all measurements must be *directly* traceable to the Bureau to assure measurement accuracy. Overlooked by many laboratories is the fact that they possess measurement capabilities of such a nature as to provide self-help far greater than they realize. They simply apply known data given them by the standards and instrument manufacturers!

Take, for example, the request by a customer to solve the problem of calibrating a 1-pF capacitor at 1 MHz without the necessity of going directly to the Bureau. He already has a certificate of calibration at 1 kHz, routinely supplied at the time he made the original purchase. Since then, the measurement range in his company's work has expanded into the high-frequency field. His operating budget is nominal and he is interested in keeping his overhead down. The answer he receives from GR is covered in the following article by Mr. Hall.

---

<sup>4</sup> Huntley, L. E., "A Self-Calibrating Instrument for Measuring Conductance at Radio Frequencies," *NBS Journal of Research-C*, April-June 1965.

---

The Editor acknowledges with gratitude the work of Mr. Hall in preparing the above article and is equally appreciative of the constructive discussions with J. F. Hersh, R. W. Orr, and J. Zorzy.

---

## Another Traceability Path for Capacitance Measurements

by Henry P. Hall

The National Bureau of Standards recently announced new services for the rf calibration of impedance standards fitted with precision 14-mm coaxial connectors, like several manufactured by GR.<sup>1,2,3</sup> High frequency bridges and twin-T circuits developed at the Bureau are used for the measurement of resistance, capacitance, and inductance at listed frequencies of 0.1, 1.0, and 10 MHz.<sup>4,5</sup> Anyone who wants direct NBS "traceability" of these standards may send them to NBS for calibration at these test frequencies. This is a significant advancement in the measurement art.

The new service, however, raises an important question: "When are these *direct NBS calibrations* necessary?" This can be considered from two points of view: "When are these calibrations required to obtain a specific accuracy with high confidence?" and "When are they required to prove traceability as defined (somewhat loosely) by the DOD?" The two points of view diverge by varying degrees, unfortunately, particularly when we consider to whom we are trying to prove traceability. We think that the question can be an-

swered satisfactorily for rf-capacitance calibrations, if you are interested in obtaining a *given required accuracy* through use of frequency-correction data. We hope that reason will prevail among metrologists and that the same criteria used in deciding what is sufficiently accurate can also be used to show traceability, for the benefit of quality-assurance inspectors.

The frequency corrections described below were used with apparent acceptance<sup>6</sup> before the new services were available. They still must be used at frequencies between those for which calibrations are now routinely provided.

Actually, all the new NBS rf-impedance calibrations, *R*, *L*, and *C*, are based on the frequency characteristics of air capacitors. While air capacitors vary with frequency in a very simple manner (see below), resistors and inductors vary with frequency in too complex a manner to be as predictably accurate in the rf range. Therefore, these new NBS bridges and twin-T's relate *L* and *R* back to fixed capacitors and capacitance differences in variable air capacitors.<sup>7,8</sup>



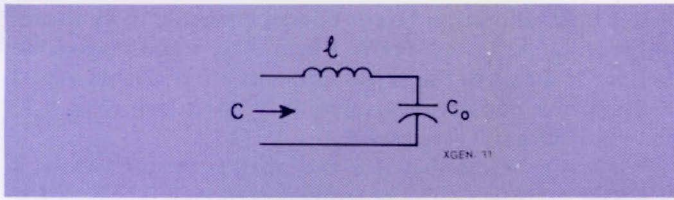

Figure 1. Simple equivalent circuit for two-terminal air capacitor.

### RF Characteristics of Air Capacitors

The simple equivalent circuit of Figure 1 is surprisingly good for representing the effective capacitance of a two-terminal air capacitor. The effective capacitance is

$$C = \frac{C_o}{1 - \omega^2 l C_o} \quad (1)$$

where  $C_o$  is the low-frequency value of capacitance. This equivalent circuit does not include series resistance, which does not appreciably affect the capacitance (even the parallel capacitance) if it is reasonably small. Neither does it include the effects of distributed inductance and capacitance. Also, at high frequencies the skin depth causes a slight reduction in inductance. These effects can be considered as variations in the value of  $l$ , with  $C_o$  being considered a constant (as long as all measurements are made at low humidity, < 40% RH).

The simplest method of establishing  $l$  is to use a grid-dip meter to determine the resonant frequency of the shorted capacitor. This method, together with the above formula, was recommended for many years by NBS<sup>6</sup> to make rf-capacitor calibrations. For capacitors fitted with binding posts or banana-pin terminals, this is very easy to do, although we have to decide how much of the total inductance is in the shorting connection. When coaxial connectors are used, we remove the case to allow coupling to the meter coil.

The value of  $l$  obtained from a resonance measurement differs slightly from a lower-frequency value mainly because of the distributed parameters. The worst case would be that of a uniform line whose effective capacitance could be written:

$$C = \frac{C_o}{\left[ 1 - \omega^2 l C_o - \frac{\omega^4 l^2 C_o^2}{5} - \frac{2\omega^6 l^3 C_o^3}{35} \dots \right]} \quad (2)$$

The derivation is a power series in increasing powers of  $\omega l C_o$ . The first term is the important one for corrections at frequencies well below resonance. When  $\omega^2 l C_o = 10\%$  the next term is 0.2%, and each succeeding term is much smaller still. This effective  $l$  is 1/3 the value of the total inductance. If  $C_o$  is assumed constant, the effective inductance determined by a resonance measurement would be higher than  $l$  by the factor  $\frac{12}{\pi^2} = 1.21$  or 21%.

In large air capacitors (50 pF to 1000 pF) with parallel-plate construction,<sup>1</sup> most of the inductance is in the coaxial

connector and its connection to the "stack" of plates. Most of the capacitance is in the stack itself so that the lumped equivalent circuit is a good approximation. The slight difference between the resonant value of  $l$  and the desired correction value is small, less than the uncertainty of the measurement. Many measurements were made at General Radio to establish this difference so that a more accurate value of  $l$  could be determined.<sup>9</sup> The values obtained agreed closely with NBS determinations (within 10%).

The smaller capacitors (1 to 20 pF) have an appreciable distributed capacitance; consequently, the value of resonant inductance will be in error, but by less than 21%. The effective value for these units was determined by a slotted-line technique.<sup>9</sup> These values, supplied by General Radio for our line of coaxial standard capacitors, are not for use above a specified frequency (250 MHz for the 20- and 10-pF units and 500 MHz for the smaller units). This restriction is mainly because of the variations due to distributed parameters. (Correction curves are supplied with units at higher frequencies.)

An important point, which is verified by the many measurements described above, is that different capacitors of the same value and construction have equal inductance, well within the accuracy of the determinations. This is not surprising. The inductance is mostly in the coaxial line of the



H. P. Hall is a graduate of Williams College (AB — 1952) and M.I.T. (SB and SM in Electrical Engineering — 1952). His first association with General Radio was as a co-op student in 1949, and he assumed full-time duties as development engineer in 1952. He became Group Leader of the Impedance Group in 1964 and presently is an Engineering Staff Consultant. He is a member of Phi Beta Kappa, Eta Kappa Nu, Tau Beta Pi, and Sigma Xi. He is a Senior Member of the IEEE and a member of PMA and has served on several committees.



precision connector, or in the stamped metal pieces that make connections to the plates. Measured variations in  $l_s$ , between similar units, are generally less than 3%, and allowing for a 10% change would be very conservative.

#### When are Calibrations Necessary?

Equation (1) can be rewritten:

$$C = \frac{C_o}{1 - \omega^2(l_s \pm \Delta l)C_o} \quad (3)$$

where  $l_s$  is the specified value of inductance and  $\pm\Delta l$  the possible deviation in this value. This deviation is due to error in determination of the inductance and its changes with frequency or between units. The low-frequency value  $C_o$  can be easily determined to  $0.01\% \pm 0.005$  pF on a GR 1615-A Capacitance Bridge by use of the coaxial adaptor.<sup>9</sup> This value can be used as long as  $\omega^2 l_s C_o \times 100\%$  is less than the accuracy required. Corrections should be used above this frequency, and may be used with confidence as long as  $\omega^2 \Delta l C_o \times 100\%$  is less than the accuracy required. If greater accuracy is required an NBS calibration should be made. Remember, however, that NBS accuracy is based on similar measurement techniques, subject to similar uncertainties.

The question now is: what is the value for  $\Delta l$ ? A value of  $\Delta l = 0.2 l_s$  can be used with confidence as long as the total correction is 10% or less, the maximum frequency for the low values of capacitance is not exceeded, and humidity is reasonably low. Typically, errors will be substantially less. We

suggest that calibration be considered traceable to an uncertainty of  $\omega^2 N l_s C_o \times 100\%$  where  $N$  is some reasonable fraction. If we agree that measurements are traceable, based on some very conservative value of  $N$ , even as high as 0.5, this approach is still very useful.

We wish to stress that it is the small *correction* which is important because  $C_o$  can be easily determined. The high-frequency capacitance value will vary with time, temperature, or shock because  $C_o$  changes with these effects. But unless there is catastrophic damage, the inductance will not change enough to be perceptible. Therefore, *differences* between high-frequency and low-frequency calibrations should be recorded and once made on a given unit need not be repeated. This point should be appreciated also by quality-assurance inspectors.

#### Conclusion

The principle of applying conservative tolerances to frequency corrections has relevance to frequency translation of other types of impedances. Capacitors with dielectric materials other than air have additional sources of deviations, but these can be determined within definite limits and included in the over-all uncertainty. Frequency corrections are significant for larger capacitors at much lower frequencies, and the corrections greatly extend the useful frequency range of the capacitors. This principle may be applied also to inductors and resistors, even though their equivalent circuits are more complex.

#### References

- <sup>1</sup>Orr, R. W., "Capacitance Standards with Precision Connectors," *GR Experimenter*, September 1967.
- <sup>2</sup>Orr, R. W., and Zorzy, J., "More Coaxial Capacitance Standards," *GR Experimenter*, May 1968.
- <sup>3</sup>Orr, R. W., "Stable Series of Coaxial Resistance Standards," *GR Experimenter*, March/April 1969.
- <sup>4</sup>Jones, R. N., and Huntley, L. E., "A Precision High-Frequency Calibration Facility for Coaxial Capacitance Standards," *NBS Technical Note 386*, March 1970.
- <sup>5</sup>Mason, H. L., "Calibration and Test Services of the NBS," *NBS Special Publication 250*, 1968 Edition.
- <sup>6</sup>Jones, R. N., "A Technique for Extrapolating the 1-kc Values of Secondary Capacitance Standards to Higher Frequencies," *NBS Technical Note 201*, November 5, 1963.
- <sup>7</sup>Huntley, L. E., "A Self-Calibrating Instrument for Measuring Conductance at Radio Frequencies," *NBS Journal of Research-C*, April-June 1965.
- <sup>8</sup>Field, R. F., and Sinclair, D. B., "A Method for Determining the Residual Inductance and Resistance of a Variable Air Condenser at Radio Frequencies," *Proceedings of the Institute of Radio Engineers*, February 1936.
- <sup>9</sup>Zorzy, J., and McKee, M. J., "Precision Capacitance Measurements with a Slotted Line," *GR Experimenter*, September 1967.

For more information related to the background of this article, the reader is referred to:

Woods, D., "A Precision Dual Bridge for the Standardization of Admittance at Very-High Frequencies," *IEE Monograph 244R*, June 1957.

Woods, D., "Admittance Standardization and Measurement in Relation to Coaxial Systems," *IRE Transactions on Instrumentation*, September 1960.

Huntley, L. E., and Jones, R. N., "Lumped Parameter Impedance Measurements," *Proceedings of the IEEE*, June 1967.

## Recent Technical Articles by GR Personnel

"Computer-Controlled Testing Can Be Fast and Reliable and Economical Without Extensive Operator Training," M. L. Fichtenbaum, *Electronics*, 19 January 1970.\*

"Using Stroboscopy," C. E. Miller, *Machine Design*, 30 April and 14 May, 1970 (two parts).\*

"How Do You Buy a Counter?," R. G. Rogers, *Electronic Products*, 15 March 1970.

"New Fused-Silica-Dielectric 10- and 100-pF Capacitors and a System For Their Measurement," D. Abenaim and J. F. Hersh.\*\*

"A Four-Terminal, Equal-Power Transformer-Ratio-Arm Bridge," H. P. Hall.\*\*

"Standardization of a Farad," H. P. Hall.\*\*\*

\*Reprints available from General Radio.

\*\*Presented at the Conference on Precision Electromagnetic Measurements, Boulder, Colorado, June 2-5, 1970.

\*\*\*Presented at the Annual Conference of the Precision Measurements Association, Washington, D. C., June 17-19, 1970.



1683-P1 Test Fixture  
for axial leads

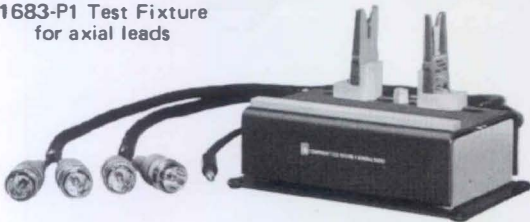

1683 Automatic RLC Bridge

## FIVE-TERMINAL AUTOMATIC RLC BRIDGE

To say that General Radio customers aided in the design of the GR 1683 is an understatement. Virtually all the bridge features are the result of feedback from customers of the earlier GR 1680.<sup>1</sup>

### WHAT YOU ASKED FOR

First and foremost, many of you wanted to measure higher-valued electrolytic-class capacitors, which calls for better bias capabilities, short-circuit protection, and leakage-current mea-

<sup>1</sup>Fulks, R. G., "Automatic Capacitance Bridge", *GR Experimenter*, April 1965.

surements. Some needed to express loss as equivalent series resistance. Still others needed to measure inductors or resistors. All, of course, needed faster measurement rates.

### WHAT YOU'RE GETTING

What you asked for — *plus fast balancing*. Faster measurement rates required a new balancing technique. Many schemes were designed, simulated by a computer model, and analyzed. The rejected methods were either too slow, too complicated, or too expensive. The selected technique (Figure 1)

provides balance time of approximately 100 periods of the bridge test frequency.

### Fast Balancing

We use three techniques — all time savers. The first is an error-counts-controlled clock rate by which the bridge converges at variable rates — quickly for a large unbalance and more slowly for a small unbalance.

The second technique compensates for the time delay in the filter through use of an anticipator circuit. Its operation is illustrated in Figure 2. Assume

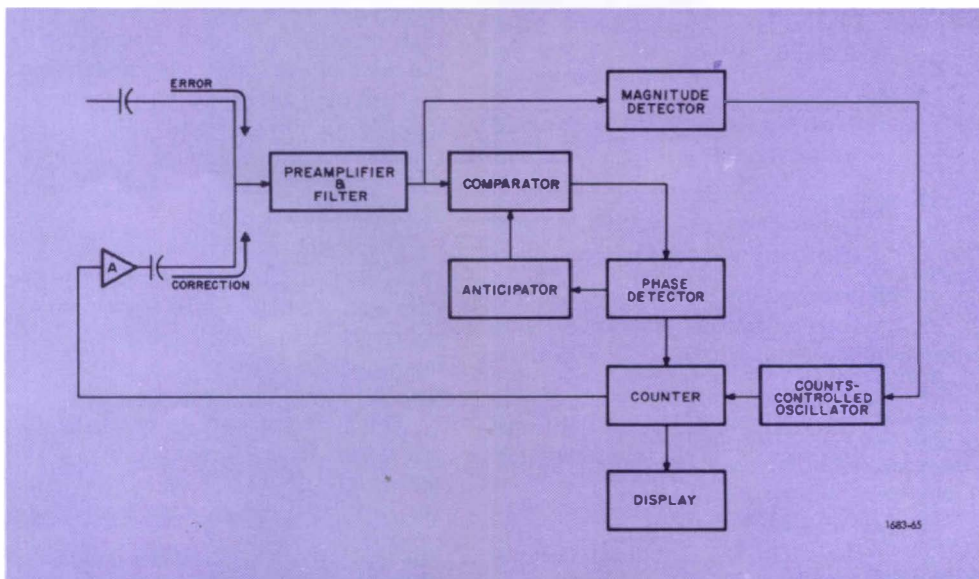

Figure 1. GR 1683 balancing technique.





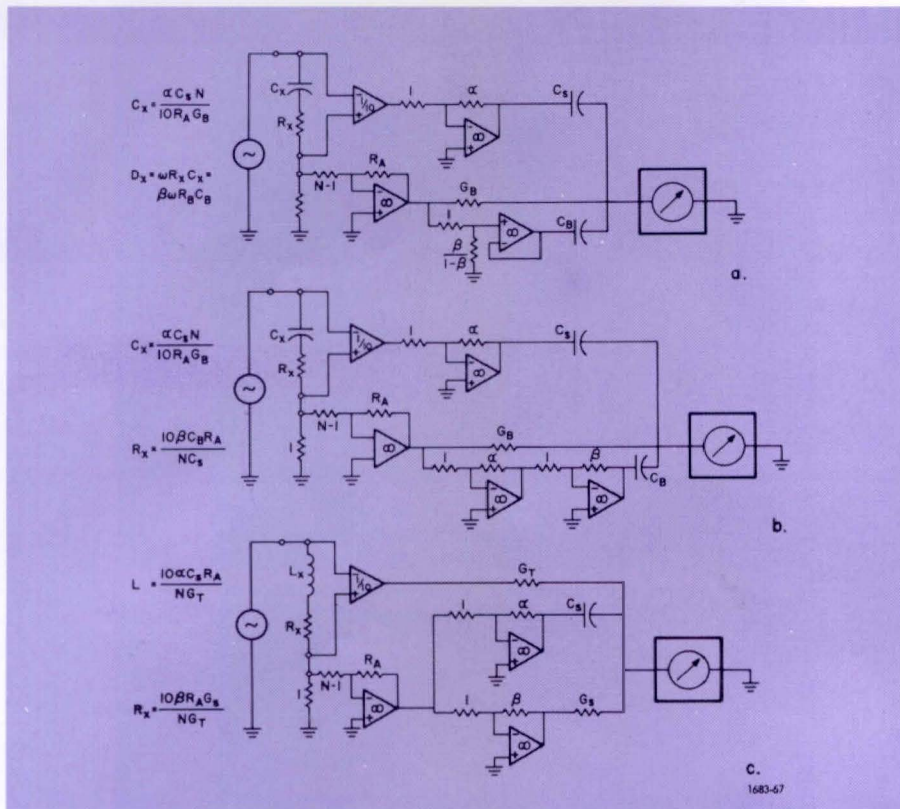

Figure 3. Simplified bridge circuits.

across the current-sensing circuit, when the measurement is made with the 100- $\Omega$  detector and at a frequency of 1000 Hz. This stray capacitance, moreover, causes an error in the quadrature signal ( $D$  measurement) rather than in the in-phase signal ( $C$  measurement), since the undesired current in the stray capacitance on the low side is  $90^\circ$  out of phase with the current into the resistive-current sensor and is usually negligible.

The wide range ( $m\Omega$  to  $M\Omega$ ) of the bridge dictates the characteristics of the input amplifiers. For instance, accurate *low-impedance* measurements require a four-terminal bridge. Two terminals are used to inject and measure current through the unknown, and two terminals to measure the voltage across the unknown. In addition, accurate measurements of higher impedance require a low-impedance source to reduce the effects of stray capacitance, as well as to maintain bridge sensitivity during the measurement of low impedances. To satisfy these constraints, a low-output-impedance signal source and a low-impedance resistance ladder function as

source and detector of the current through the unknown impedance.

A high-input-impedance differential amplifier is used to monitor the voltage across the unknown, making possible four-terminal measurements. In order to reduce stray-capacitance effects to near-zero, a fifth (ground) terminal is provided for a guard circuit.<sup>2</sup> The other amplifiers are precision voltage dividers that supply the current necessary to effect the balance.

<sup>2</sup> See page 16 for a description of the guarding technique used.

## THE FINAL TEST

The degree to which *your* suggestion for improvements has been incorporated within the GR 1683 will be determined at *your* test benches. We look forward to a vote of approval.

— T. J. Coughlin

The GR 1683 was designed by the author; design and technical support were provided by D. S. Nixon, Jr. and A. W. Winterhalter. W. A. Montague was responsible for the mechanical design.

Complete specifications for the GR 1683 are in Catalog U.

Description	Price in USA
<b>1683 Automatic RLC Bridge</b>	
Bench Model	\$4250.00
Rack Model	4215.00
Option 2 Remote Programmability	add 200.00
Option 3 Leakage Current	add 100.00
Option 4 ESR Readout	add 225.00
*Option 5A Low-Level Data Output	add 200.00
*Option 5B High-Level Data Output	add 200.00
<b>1683-P1 Test Fixture for axial leads</b>	165.00

\*Not available together in the same instrument.

PATENT APPLIED FOR

Prices subject to quantity discount.

# WHY MAKE A FIVE-TERMINAL BRIDGE?

Because we want to measure impedances in the milliohm to the megohm ranges accurately. Let's consider two extremes: two-terminal measurements of a 100-mΩ resistor and a 10-pF capacitor. Lead impedances would seriously affect measurement of the resistor; stray capacitances would make measurement of the capacitor fairly meaningless. Our approach to the design of the GR 1683 Automatic RLC Bridge\* included careful consideration of the methods used to connect the component under test to the bridge.

## THE STARTING POINT

Figure 1 demonstrates the effect of connection leads several feet long upon the measurement accuracy of a 100-mΩ resistor. A measurement error of 100% is clearly unsatisfactory. There are several solutions to the problem. A common method is that of substitution: the bridge terminals are shorted and the bridge balance is recorded. Then the unknown unit is connected to the terminals and another reading is recorded. The difference in readings is a measure of the unknown. This method, unfortunately, suffers from several uncertainties such as how close to zero resistance is the short circuit and how repeatable is the contact resistance? A better solution is a four-terminal measurement.

## Four-Terminal Measurements of Low Impedances

From the data on Figure 2, such measurements appear to be perfect – no error! This is not completely true, however, for there are several potential sources of error which will increase measurement inaccuracy. A major error source could be a voltmeter of non-ideal characteristics. If the voltmeter input impedance is 1 MΩ and the voltage-terminal lead impedance is 100 Ω, the resultant error is 0.01%.

Another source of error is the lack of ability of the voltmeter to reject common-mode voltages, particularly if the voltmeter is grounded and has a differential input. This is demonstrated in Figure 3, in which a common-mode gain (rejection) of 10<sup>-6</sup> is assumed. As

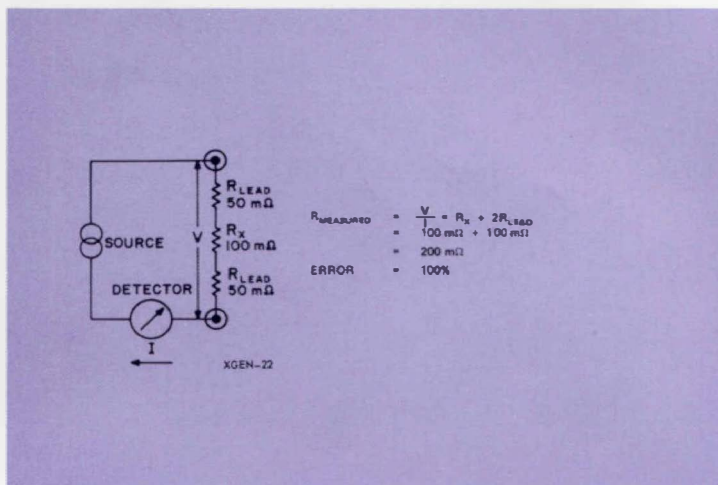

Figure 1. Effect of lead impedance on accuracy of resistance measurement.

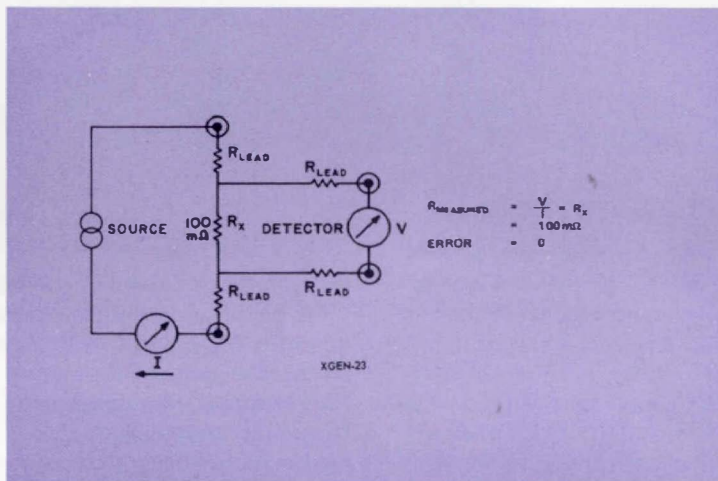

Figure 2. Four-terminal resistance measurement.

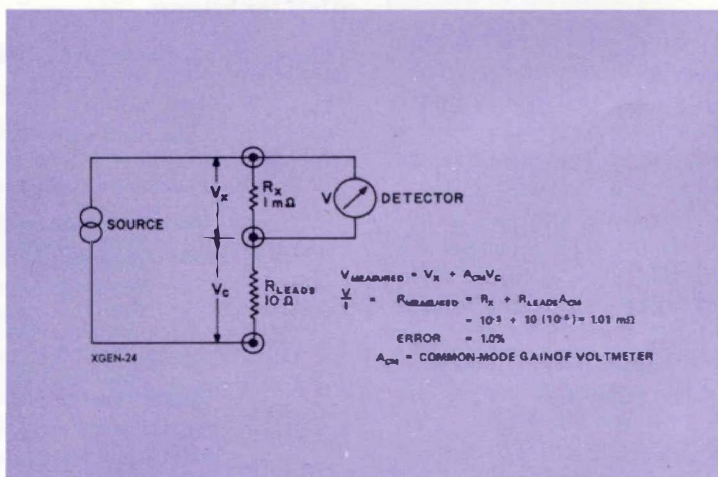

Figure 3. Effect of non-infinite common-mode rejection.

\*See page 11.



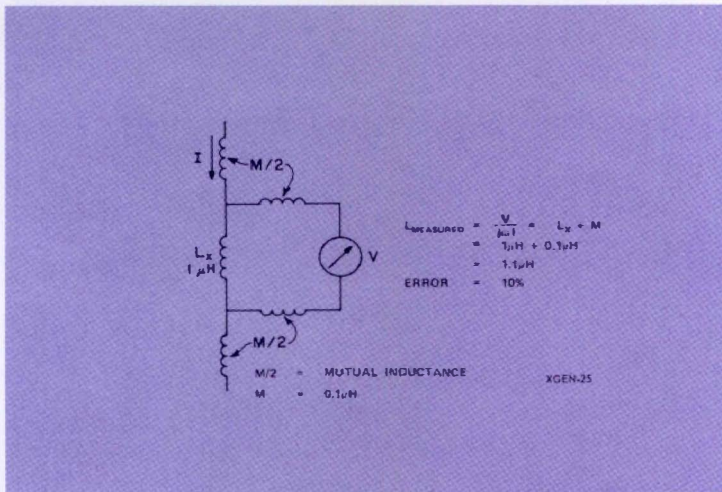

Figure 4. Degradation of inductance measurement by mutual inductance.

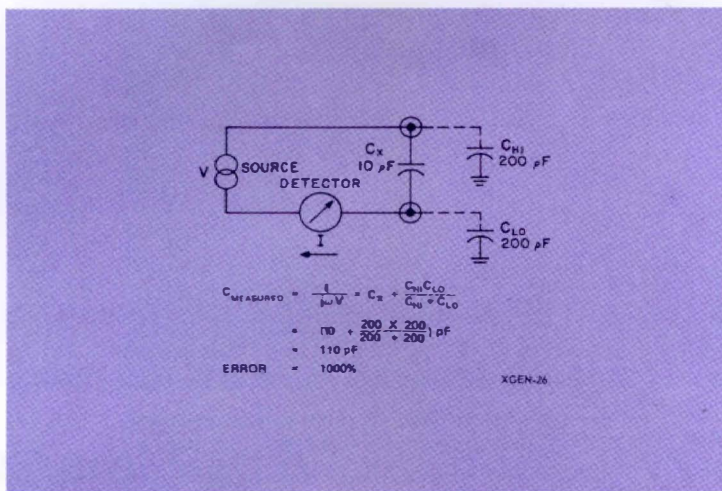

Figure 5. Two-terminal measurement of capacitance.

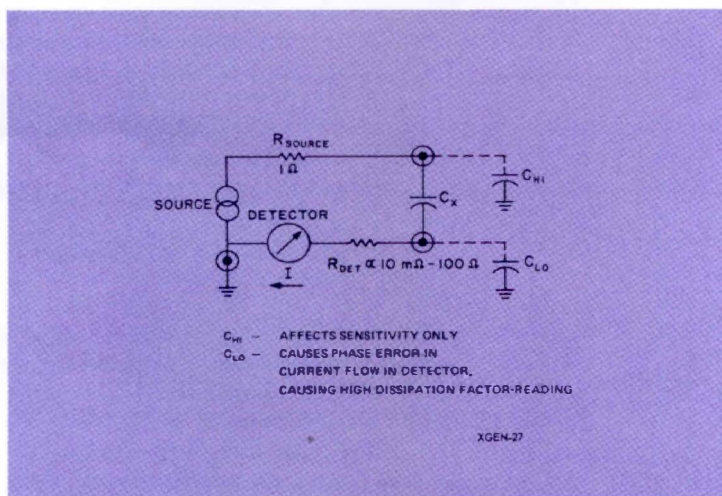

Figure 6. Three-terminal measurement of capacitance.

shown, the measurement error is 1%. Whether this size error is important is, of course, a function of the desired measurement accuracy.

There are more subtle errors in low-impedance measurements. For instance, consider mutual inductance between the current and potential leads.<sup>1</sup> The field induced by the current leads couples to the potential leads, thereby inducing an error voltage. Figure 4 is an example of the way in which an inductor-measurement circuit can be degraded. The solution is simple, if applied logically. Twisting together the current leads reduces the mutual induction by reducing the area of the enclosed field loop. A further improvement is obtained if the potential leads are twisted also and maintained at an angle of 90° from the current leads. If the 90° separation cannot be established, and the twisted pairs are nearly parallel, care must be taken that the pitches of the twisted leads are not made equal. The induced voltage will not be cancelled if the winding pitches are equal.

### Three-Terminal Measurements of High Impedances

As mentioned previously, at the higher end of the impedance spectrum stray capacitance, not lead impedance, is the primary source of error.<sup>2</sup> Consider the two-terminal measurement of a 10-pF capacitor, as shown in Figure 5. Nominal values of stray capacitances have resulted in a measurement error of 1000%!

There are several remedies for this problem, one of which is the substitution method described earlier. The extra measurement is made, however, with the  $C_x$  circuit opened, which may affect the stray capacitances. A second, more preferred way, is to make a three-terminal measurement in which the effect of the stray capacitance is kept to a minimum by use of low-impedance circuitry, with the common source and detector point grounded to form a guard circuit. This is shown in Figure 6.

<sup>1</sup>Hall, H. P., "The Measurement of Electrolytic Capacitors," *GR Experimenter*, June 1966.

<sup>2</sup>Hersh, J. F., "A Close Look at Connection Errors in Capacitance Measurements," *GR Experimenter*, July 1959.

As the impedance of the source or detector circuitry increases, the effect of the stray capacitances on the accuracy of the measurement increases. The most usual form of this guarding technique occurs in a ratio-transformer capacitance bridge (Figure 7). In this case, stray capacitance  $C_{HI}$  is guarded by the low output impedance of the transformer, while the effect of  $C_{LO}$  is eliminated by the fact that at null there is no voltage across the detector terminals and, therefore, no current flows through  $C_{LO}$ .

### THE WHY

We have had several requests for unusual measurements; one was to measure 10,000 pF at the end of 100 feet of cable. Our solution to this problem was a *five-terminal* measurement (Figure 8) made with the GR 1683 Automatic RLC Bridge. The four bridge terminals were connected to the unknown terminals to reduce the effects of the lead impedances to a minimum, and a fifth terminal (or guard) was connected to a common point to minimize the effects of the terminal capacitances. The bridge read  $C_x$  to  $\pm 1$  count both at the bridge terminals and 100 feet away. The  $D$  reading increased by 0.0040 at 100 feet. This was extremely close to the calculated value. In this instance, a two-terminal measurement would have sufficed and the resultant  $D$  error would have been +0.0020, which was the measured value. The circuit error analysis is shown in Table 1.

Another request was to measure a 1- $\Omega$  resistor 25 feet away from the bridge (Figure 9). The reading at the end of the wire was in error by two counts, the calculated error plus the bridge uncertainty ( $\pm 1$  count). Most of the phase error due to the mutual inductance of the leads was eliminated by the twisting of the current leads. The circuit error analysis is shown in Table 2.

### CONCLUSIONS

A wide-range impedance bridge such as the GR 1683 requires three- and four-terminal capabilities. If we apply principles of the new math, adding *three-terminal* capability for higher-impedance measurements to *four-terminal* capability for the lower-impedance measurements results in a *five-*

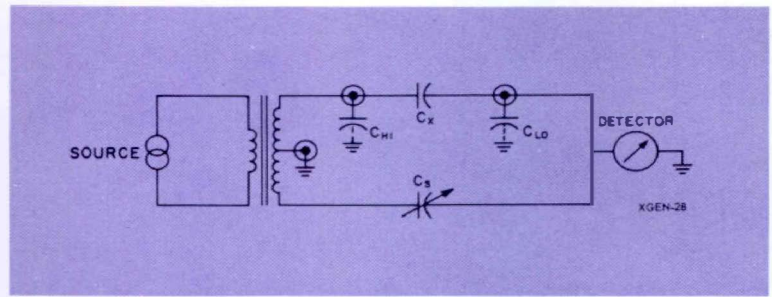

Figure 7. Three-terminal ratio-transformer bridge circuit.

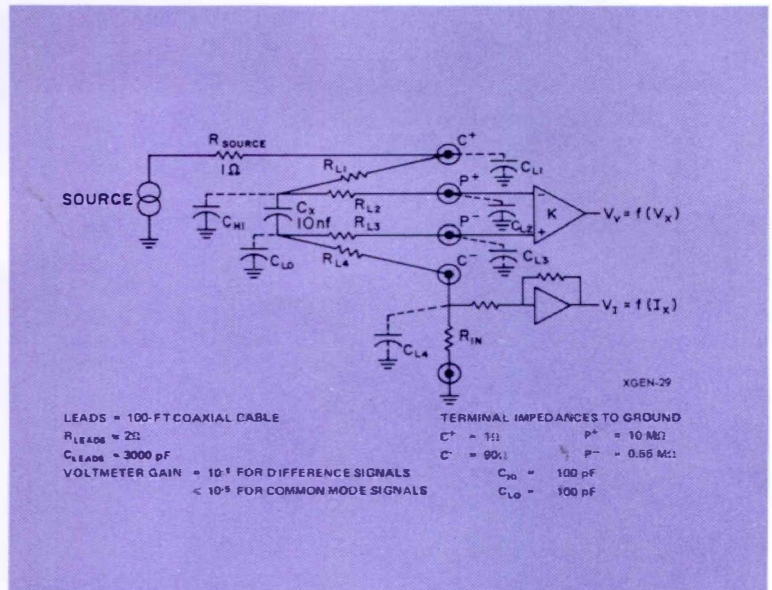

Figure 8. Five-terminal measurement of capacitor 100 feet from GR 1683.

Table 1  
 Error Sources and Resultant Effects for Measurement of 10 nF

Source	Effect		Comments
	%	counts	
$C_{L1}$	0	0	Only affects sensitivity 160 $\mu\text{F}$ reduces sensitivity by 50%
$R_{L1}$ $C_{HI}$	0 0	0 0	Only affects sensitivity
$R_{L2}$ $C_{L2}$	0 0.005	0 0.5	$R_{L2}C_{L2}$ combined cause phase shift of 0.005%, which produces 1/2-count error in the quadrature measurement (D)
$R_{L3}$ $C_{L3}$	0 0.005	0 0.5	Same effect as $R_{L2}C_{L2}$
$C_{L0}$	0.005	0.5	Adds 1/2 count to D reading
$C_{L4}$	0.19	19	Adds 19 counts to D reading
$C_{L3}$	0.19	19	Adds 19 counts to D reading
$R_{L4}$ $R_{IN}(C^-)$	0 0	0 0	$R_{L4}R_{IN}(C^-)$ combined affect sensitivity through common-mode gain of amplifier K. In this case, the effect is negligible.



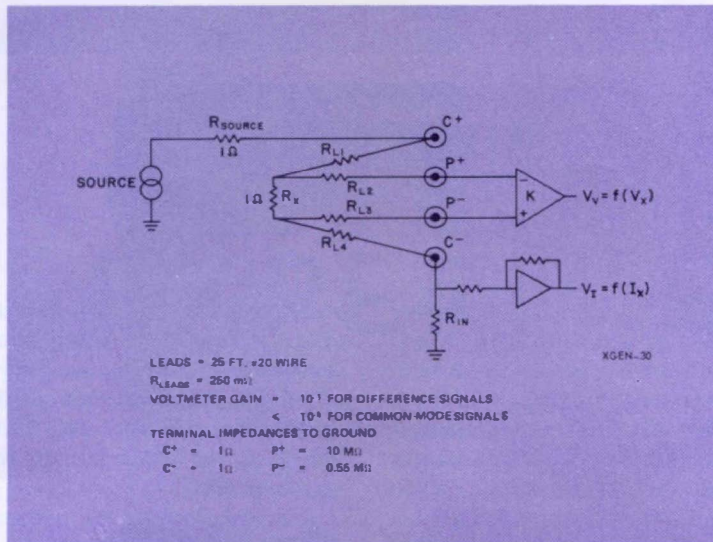

Figure 9. Five-terminal measurement of resistor 25 feet from GR 1683.

Table 2  
 Error Sources and Resultant Effects for Measurement of  $1 \Omega$

Source	Effect		Comments
	%	counts	
$R_{L1}$	0	0	Only affects sensitivity
$R_{L2}$	0	0	Negligible compared to voltmeter input
$R_{L3}$	0	0	
$R_{L4}$	0.0025	0.25	Effect due to common-mode gain of voltage detector K
$R_{IN} (C^-)$	0.01	1	

terminal bridge. If both stray capacitances and lead impedances affect the accuracy of the measurement, a five-terminal measurement will be required.

— T. J. Coughlin



T. J. Coughlin graduated from Northeastern University with the degrees of BSEE (1965) and MSEE (1967). He was a co-op student at General Radio in 1961 and joined GR in 1966 as a development engineer in the Impedance Group, specializing in design of pertinent instrumentation. He is a member of IEEE.

## General Radio Expands

On March 3, 1970, details were completed for the purchase by General Radio of a controlling interest in Time/Data Corporation of Palo Alto, California. Time/Data specializes in development and production of high-speed electronic signal-processing instruments. It is the first domestic subsidiary to be acquired by General Radio in the 55-year history of the company.

Time/Data Corporation, in its four years of operation, has attained a recognized position in its special field of digital signal analysis. T/D's second-generation signal-processing device, the T/D Fast Fourier Transform Processor, was introduced in November 1969 at the Fall Joint Computer Conference. It is designed primarily for high-speed time-series analysis and synthesis under the control of an accessory computer. This permits analysis of electrical signals in real time with a speed and economy not possible with a computer alone. Such systems now are in use in oceanography, biomedical and geophysical research, radar signal processing, speech analysis, environmental science studies, analysis of medical data, and for structural-dynamics investigations that may include the analysis of vibratory characteristics of all types of products.

An announcement on March 3, 1970, designated D. B. Sinclair, GR's President, as President of Time/Data. L. J. Chamberlain has been transferred from General Radio, West Concord to assume the position of Executive Vice President, and E. A. Sloane has been named Vice President and Technical Director.

A second expansion move was made by GR on April 27, 1970, when officials of Grason-Stadler and General Radio signed agreements leading to purchase of all the stock of Grason-Stadler by GR. Grason-Stadler will operate within GR as a wholly-owned subsidiary, under its existing management. Grason-Stadler has been in business about twenty years. It has built a reputation as a leader in the commercial manufacture of precision audiometers and instruments for psycho-acoustics and the life sciences. Its experience and knowledge in these fields mesh with those of GR in the acoustics and signal-processing fields. The combined capability of the two companies is expected to exceed their individual capabilities by a wide margin. In particular, the marketing strength of GR is expected to contribute immediately to increased sales of G-S products. The over-all position of GR as a major source of acoustic instrumentation in the United States is expected to extend and solidify, particularly when taken in conjunction with the high technology of Time/Data's contribution in signal processing.

## INFLATION DEFLATION

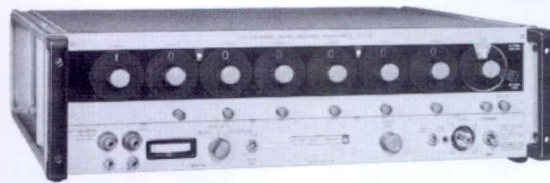

Price of GR instrumentation, as most readers know, is determined in advance of production release and is usually based upon several factors, one of which is anticipated sales. When initial development and other set-up costs have been written off, we are able to consider more favorable prices to the customers. At the same time, changes in design, to reduce manufacturing costs, are considered, but only if there is no reduction in performance.

Customer acceptance of the General Radio line of frequency synthesizers has been most gratifying. Design and initial setup costs have been written off, and the redesign of some modules has resulted in reduced manufacturing costs but, as mentioned above, with no reduction in performance. As a matter of fact, units that are frequency programmable have had switching time reduced

to 200 ms. As a consequence, prices for some models of the GR 1161, 1162, 1163, and 1164 series have been substantially reduced. Readers who have need for synthesizers in applications such as Nuclear Magnetic Resonance, Ultrasonic Studies, Communication Oscillators, Crystal-Filter and Acoustic Measurements, or for incorporation into production test consoles, should review the table of price savings below. They should note, also, that the modular construction of the synthesizer units permits tailor-made resolution to fit the requirements of specific applications,

simply by omitting unnecessary modules. Prices for reduced-resolution synthesizers, for instance, can be computed by the deduction of \$230 for each decade removed and \$300 for removal of the continuously adjustable decade (CAD).

Listed below are the basic specifications for the 7-digit synthesizers with a CAD. Complete specifications and new prices of all models are contained in the catalog pamphlet "Frequency Synthesizers," available upon request to General Radio or at the nearest GR District Office.

	1161-AR7C		1162-AR7C		1163-AR7C		1164-AR7C	
	Old	New	Old	New	Old	New	Old	New
<b>Price in USA</b>	\$6785	<b>\$4990</b>	\$6940	<b>\$4990</b>	\$6920	<b>\$5290</b>	\$7695	<b>\$7195</b>
Frequency Range	0 - 100 kHz		0 - 1 MHz		30 Hz - 12 MHz		10 kHz - 70 MHz	
Resolution	0.01 Hz		0.1 Hz		1.0 Hz		10 Hz	

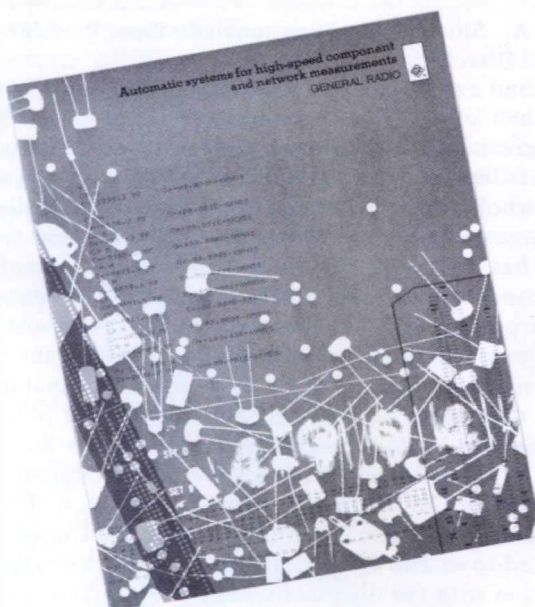

## Information Retrieval

Readers can obtain an index for the 1969 issues of the *GR Experimenter* upon request to the Editor.

For those interested in automatic systems for processing capacitors, semiconductors, resistors, and inductors, a newly-published brochure describing GR's systems capabilities is available. Included in the brochure are systems for measuring  $R$ ,  $L$ ,  $C$ , dissipation factor, leakage current, and other parameters. The examples in the brochure cover bench-top set-ups to multi-bay systems; peripheral equipment such as mechanical handlers and sorters, conditioning chambers, and computers also are included. Most of the systems illustrated will test components and networks to the stringent requirements of military specifications. Your copy of "Automatic Systems for High-Speed Component and Networks Measurements" is free upon request to General Radio.



# The GENERAL RADIO EXPERIMENTER

VOL. VII. Nos. 11 and 12



APRIL - MAY, 1933

## ELECTRICAL COMMUNICATIONS TECHNIQUE AND ITS APPLICATIONS IN ALLIED FIELDS

### THE CONVENIENT MEASUREMENT OF C, R, AND L

**T**HE important considerations in the large majority of bridge measurements made in the average experimental laboratory are the ease and speed of making the readings, and the ability to measure any values of resistance, inductance, or capacitance, as they may exist in any piece of equipment. A completely satisfactory bridge should immediately indicate the answer to such questions as the following:

Is the maximum inductance of this variable inductor at least 5 mh, its minimum inductance 130  $\mu$ h, and its direct-current resistance less than 4  $\Omega$ ?<sup>1</sup>

Has this choke coil at least 20 h inductance and an energy factor  $Q$  of at least 20?

Has this tuning condenser a maximum capacitance of 250  $\mu$ mf and a 20 to 1 range?

Has this filter condenser at least 4  $\mu$ f capacitance and a power factor of only 0.5%?

Is the resistance of this rheostat 200 k $\Omega$ ?

<sup>1</sup> These are the standard abbreviations of the Institute of Radio Engineers. Note that 1 m $\Omega$  is 0.001 ohm and that 1 M $\Omega$  is 1,000,000 ohms.

Is the zero resistance of this decade-resistance box only 5 m $\Omega$ ?

The TYPE 650-A Impedance Bridge will furnish the answers to all these questions and many others. It will measure direct-current resistance over 9 decades from 1 m $\Omega$  to 1 M $\Omega$ , inductance over 8 decades from 1  $\mu$ h to 100 h, with an energy factor ( $Q = \frac{\omega L}{R}$ )

up to 1000, capacitance over 8 decades from 1  $\mu$ mf to 100  $\mu$ f, with a dissipation factor ( $D = R\omega C$ ) up to unity.<sup>2</sup>

These results are read directly from dials having approximately logarithmic scales similar to those used on slide rules. The position of the decimal point and the proper electrical unit are indicated by the positions of two selector switches. Thus the CRL multiplier switch in Figure 1 points to a combined multiplying factor and electrical unit of 1  $\mu$ f so that the indicated ca-

<sup>2</sup> The fact that this bridge is capable of measuring a condenser with large energy losses makes it necessary to distinguish between its dissipation factor  $\frac{R}{X}$  and power factor  $\frac{R}{Z}$ . The two are equivalent when the losses are low.

Since the bridge measures  $R\omega C$  directly, the term dissipation factor has been used, even though the two terms are, for most condensers, synonymous.



capacitance as shown on the CRL dial is 2.67  $\mu\text{f}$ , because the D-Q multiplier switch has been set on C for the measurement of capacitance. It also shows that the DQ dial is to be read for dissipation factor D with a multiplying factor of 0.1 yielding 0.26.

If the condenser had a smaller dissipation factor, this D-Q multiplier switch would have been set for the D dial with a multiplying factor of 0.01. Thus the D dial, as shown in Figure 1, indicates a dissipation factor of 0.0196 or a power factor of 1.96%.

For the measurement of pure resistance the D-Q multiplier switch would be set at R so that the CRL dial indicates a resistance of 2.67  $\Omega$ .

For the measurement of inductance the D-Q multiplier switch would be set at L and the CRL dial indicates 2.67 mh. Using the DQ dial the multiplier is 1 and the energy factor  $Q$  as shown in Figure 1 is 2.6. Had the coil under measurement been a large iron-core choke coil, the CRL multiplier switch might have been set at the 10 h point, thus indicating 26.7 h. Then the D-Q multiplier switch would have been set to indicate the Q dial with a multiplier of 100 and an energy factor  $Q$  of 41 as read on the Q dial.

The ease of balancing the bridge depends on the use of the logarithmically tapered rheostats and the two multiplier switches. To illustrate this, take first the measurement of direct-current resistance.

With the unknown resistor connected to the R terminals, the D-Q multiplier switch is set at R, the GENERATOR switch at DC, and the DETECTOR switch at SHUNTED GALV. The galvanometer immediately deflects, indicating by the direction of its deflection which way the CRL multiplier switch should be turned to obtain approximate balance. The CRL dial is then turned for exact balance, having thrown the DETECTOR switch to the GALV. position.

Because the calibration of the CRL dial extends to 0, the bridge can be balanced for a number of different settings of the CRL multiplier switch. This is very helpful in ascertaining the approximate value of a resistor. Obviously greatest accuracy of reading is obtained when the balance point on the CRL dial

is within the main decade which occupies three-quarters of its scale length.

An inductor or condenser is measured by connecting it to the CL terminals. The GENERATOR switch is set at 1 KC. and the DETECTOR switch at EXT, head telephones being connected to the EXTERNAL DETECTOR terminals. The D-Q multiplier switch is set on L or C as the case demands, pointing to the DQ dial. The CRL dial is swept rapidly over its range to indicate the direction of balance. The CRL multiplier switch is then moved in the direction indicated and balance obtained on the CRL dial. The DQ dial is then turned for

balance. From its setting the desirability of using the D dial or the necessity of using the Q dial will be indicated.

The reactance standards are mica condensers having all the excellent characteristics of the Type 505 Condensers described in the *Experimenter* for January.

The bridge circuit used for measuring condensers is the regular capacitance bridge having pure resistances for its ratio arms. Maxwell's bridge is used for inductors, whose energy factors  $Q$  are less than 10. Above this value Hay's bridge is used. The interdependence of the two balances of these last two

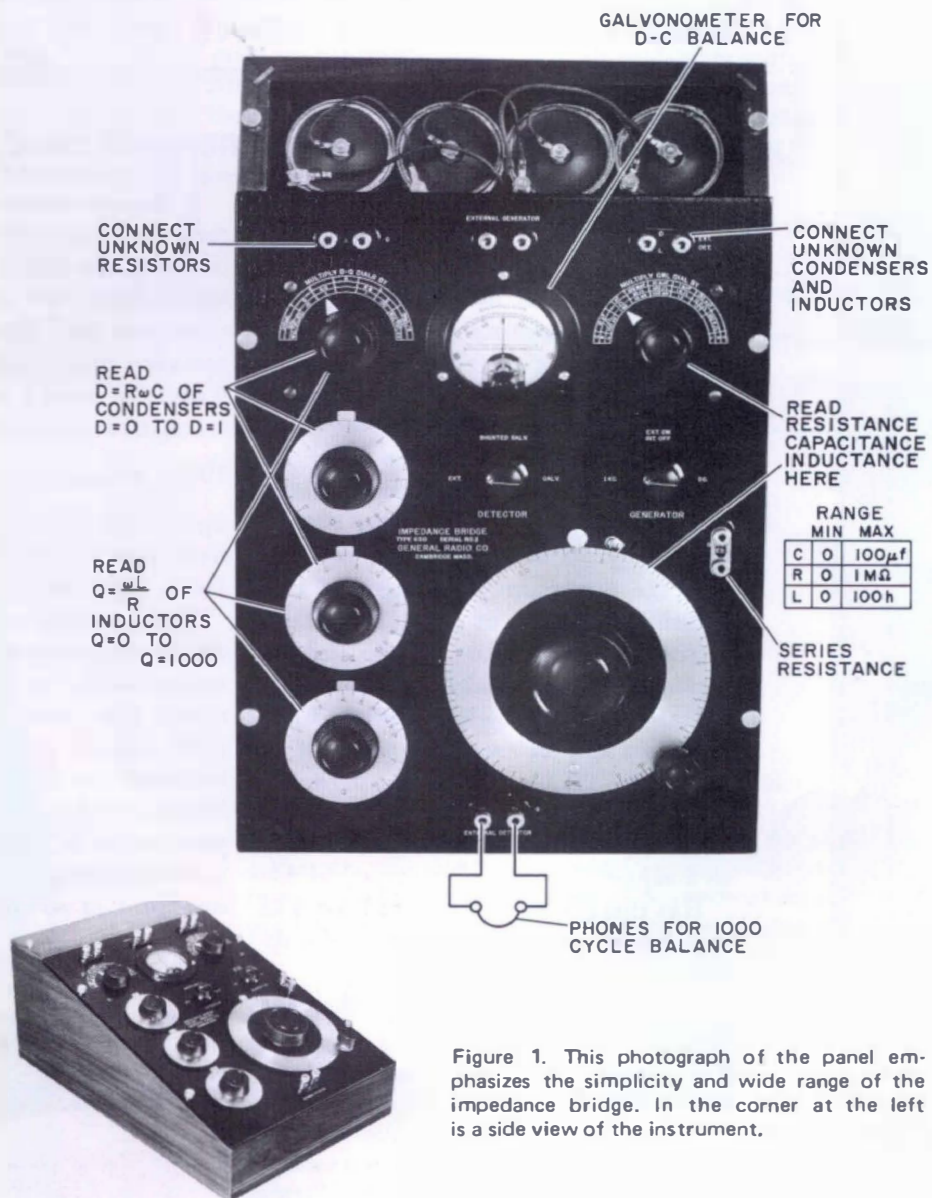



bridge circuits cannot, of course, be prevented, but the use of the logarithmic rheostats for balancing makes it very easy to follow the drift of the balance points.

The accuracy of calibration of the CRL dial is 1% over its main decade. It may be set to 0.2% or a single wire for most settings of the CRL switch. The accuracy of readings for resistance and capacitance is 1%, for inductances 2%, for the middle decades. The accuracy falls off at small values because the smallest measurable quantities are 1 mΩ, 1 μμf, and 1 μh, respectively. Zero readings are approximately 10 mΩ, 4 μμf, and 0.1 μh respectively. The accuracy falls off at the large values, becoming 5% for resistance and capacitance and 10% for inductance. The accuracy

of calibration of the DQ dials is 10%. The accuracy of readings for dissipation factor and energy factor is either 20% or 0.005, whichever is the larger.

The power for the bridge is drawn from four No. 6 dry cells mounted at the back of the cabinet. The liberal size of these batteries assures a very long life. External batteries of higher voltage may be used to increase the sensitivity of the bridge for the measurement of the highest resistances. The internal batteries operate a microphone hummer for the production of the 1-kc current. The capacitance of this hummer to ground is small and has been allowed for in the bridge calibration.

An external generator may be used, though its capacitance to ground may introduce considerable error. Subject to

this limitation, the frequency may be varied over a wide range from a few cycles to 10 kc. The reading of the CRL dial is independent of frequency. The readings of the D and DQ dials must be multiplied by the ratio of the frequency used to 1 kc to give the correct values of dissipation and energy factors, while the reading of the Q dial must be divided by this ratio. For frequencies other than 1 kc the ranges of the DQ dials are altered so that they will no longer overlap. Additional resistance may be inserted by opening the SERIES RES. terminals. The Type 526 Rheostats, described on page 7, are quite satisfactory for this use.

— Robert F. Field

## Design Assistance — Noise in Noise

Noise is a subject so much in the news these days we felt that a bit of information generated by Dr. Gordon R. Partridge, of General Radio, might benefit technical people engaged in noise-reduction efforts. This note simplifies and complements an earlier article in the *Experimenter*.<sup>1</sup>

A problem often encountered in sound measurements is the case of adding a new sound source to an existing background noise and finding the sound-pressure level that the new source *would have added* in the absence of the background. This note explains how to make the conversion from the measured values of background level and background level plus the added source.

Call the background noise signal  $S_1$  and the sum of the background level plus the added signal  $S_1 + S_2$ . Plot both of these measured signals (measured in one-third-octave bands, for instance) on the same graph, as shown in the sketch. Measure the difference in decibels between the  $(S_1 + S_2)$  and the  $S_1$  curves. This difference is tabulated as DIFF in the accompanying table. For the value of DIFF find the correction (CORR). Subtract this value of CORR from the  $(S_1 + S_2)$  curve to find the decibel level of signal  $S_2$  alone.

Example: The sound-pressure level in a room is 40.5 dB in the one-third-octave band centered at 315 Hz. An air-conditioner is turned on, and the sound level rises to 42.5 dB. What sound-pressure level does the air-conditioner alone produce? Solution: The difference is 2.0 dB, so DIFF is equal to 2.0. The corresponding CORR is 4.3 dB. Subtract 4.3 from 42.5, obtaining 38.2 dB. Therefore, the air-conditioner by itself produces a sound-pressure level of 38.2 dB in the one-third-octave band centered at 315 Hz.

<sup>1</sup>Packard, L. E., "Background Noise Corrections in the Measurement of Machine Noise," *General Radio Experimenter*, December 1937.

DIFFerence	CORRection	DIFFerence	CORRection
0.1	16.4	12.0	0.3
0.2	13.5	13.0	0.2
0.3	11.8	14.0	0.2
0.4	10.6	15.0	0.1
0.5	9.6	16.0	0.1
0.6	8.9	17.0	0.09
0.7	8.3	18.0	0.07
0.8	7.7	19.0	0.06
0.9	7.3	20.0	0.04
1.0	6.9	22.0	0.03
2.0	4.3	24.0	0.02
3.0	3.0	26.0	0.010
4.0	2.2	28.0	0.006
5.0	1.7	30.0	0.004
6.0	1.3	32.0	0.002
7.0	1.0	34.0	0.001
8.0	0.7	36.0	0.001
9.0	0.6	38.0	0.000
10.0	0.5	40.0	0.000
11.0	0.4		

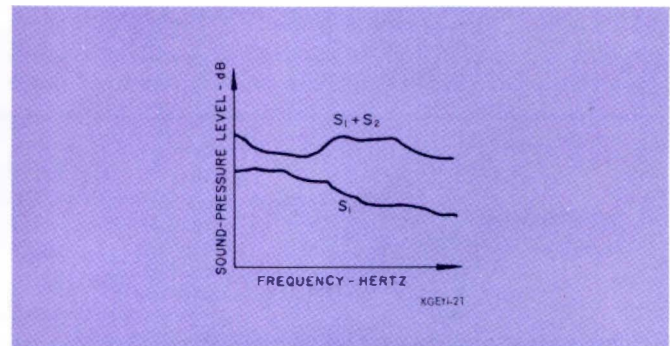

# MORE MEMORY - MORE CONVENIENCE



Further development work on the Option 2 feature of the GR 1790 Logic-Circuit Analyzer<sup>1</sup> has resulted in an increase in the amount of data that can be stored, plus more convenience to the customer. The initial design of Option 2 incorporated a DEC disk with 32,000 words of storage. The improved form includes two cassette-type magnetic-tape transports, which are capable of storing more than 100,000 words per tape and of providing an unlimited program-tape library.

Ability to duplicate tapes is a feature not matched by the disk system. An ad-

<sup>1</sup>"GR 1790 Logic-Circuit Analyzer," *GR Experimenter*, January/February 1970.

ditional feature of the improved option is its physical location within the GR 1790 console in the area previously occupied by two storage drawers.

The ease of preparing programs has been increased. To prepare test programs, type the text on the teletypewriter keyboard or read through the high-speed reader text previously punched in a paper tape. Test programs can be translated and executed without use of paper tape. Source and binary

test programs can be stored, modified, or made accessible by commands typed on the teletypewriter. This feature promotes rapid program preparation and on-line modification of test programs.

The formal presentation of the features of Option 2 is: **OPTION 2, EXTENDED MEMORY.** Two cassette-loaded, magnetic-tape transports, one of which contains the system programs and the other the user programs. The cassettes contain 300 feet of certified tape capable of holding 100,000 words. Data-transfer rate is approximately 330 words per second (5 ips), and access speed is more than 6700 words per second (100 ips) in either direction. Time typically required for access to the entire 300 feet of tape is 30 seconds.

Access to any program on a tape is provided through software. Generation and execution of test programs are accomplished without the use of paper tape. Test programs of over 100,000 words in length are implemented with no support from the operator.

Description	Price in USA
1790 Logic-Circuit Analyzer, console version	\$32,500.00
Option 1 Rack Version	(no extra charge)
Option 2 Additional Memory	add 11,500.00

Prices subject to quantity discount.

GR 1654-Z2 Sorting System

**NEW**

GR 1413 Precision Decade Capacitor

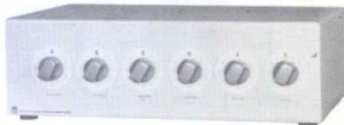

The GR 1413 Precision Decade Capacitor provides, in a single package, a capacitance standard that covers most



widely used values. It was designed principally for use with the GR 1654 Impedance Comparator;<sup>1</sup> the combina-

tion is listed as the GR 1654-Z2 Sorting System. The capacitor ranges from 0 to 1.11111  $\mu\text{F}$  in increments as small as 1 pF and with an accuracy of 0.05% + 0.5 pF. Air capacitors are used for the two lower decades and precision silvered-mica capacitors for the remainder. The unit is provided with three-terminal connections that can be altered easily to two-wire connections. Development was by R. W. Orr.

<sup>1</sup>Leong, R. K., "Impedance Comparison Sprints Ahead," *GR Experimenter*, May/June 1969.

Prices on page 23.

**NEW**



GR 1442 Coaxial Resistance Standard

Availability of the GR 1442-C/D/E Coaxial Resistance Standards, with values of 0.5, 1.0, and 2.0  $\Omega$  respectively, extends the range of GR coaxial resistors from 1,000 to 0.5  $\Omega$ . It is possible to establish very low values of standard dissipation factors for calibra-

tion of impedance bridges when these resistances are used in conjunction with the GR Coaxial Capacitance Standards.

Development of these standards was by R. W. Orr.

Prices on page 23.



GR 1656 Impedance Bridge



**NEW**

An inexpensive 0.1% CRL bridge with fast-balance lever switches, designated the GR 1656 Impedance Bridge.

The basic limitations on the accuracy of our 1% impedance bridge (GR 1650-B)<sup>1</sup> are the resolution and accuracy of the main rheostat and its dial. If a decade resistor were used, it would be relatively easy to tighten the tolerances on the internal standards to get a more accurate bridge. However, decade resistors (with the exception of the new GR 1436) have a row of knobs or concentric knobs which, while satisfactory for occasional adjustment, are tiresome for those who must continually balance bridges. Our most accurate universal bridge (the GR Type 1608,<sup>2</sup> now 0.05%) solves this problem by use of a special 100-position switch, so that only two concentric knobs are needed. This assembly, however, is comparatively expensive. Its use, plus installation of many other measurement and convenience features, results in a relatively expensive general-purpose instrument.

We think we've found the answer to the problem of designing a quickly balanced, high-resolution bridge. Our precision capacitance bridge (GR Type 1615)<sup>3</sup> uses a lever switch with digital readout which we, and our customers, have found very convenient. While this switch design is too expensive for a low-price instrument, we have, with the help of the Oak Manufacturing Company, developed a new lever switch for general-purpose use. This switch is the

<sup>1</sup>Havener, C. D., "The Universal Impedance Bridge - New Face, New Features," *GR Experimenter*, May 1968.

<sup>2</sup>Hall, H. P., "A Precise, General-Purpose Impedance Bridge," *GR Experimenter*, March 1962.

<sup>3</sup>Hersh, J. F., "Accuracy, Precision, and Convenience for Capacitance Measurements," *GR Experimenter*, August/September 1962.

main readout control in the new GR 1656. With it, we have substantially reduced the time required to make a balance and greatly simplified the work required to set several digits to zero - with one sweep of the hand!

The improved readout resolution of the GR 1656, in addition to allowing better accuracy in readings, offers two other advantages. The smallest *C*, *R*, *G* or *L* that can be detected is extended by a factor of ten to 0.1 pF, 100 μΩ, 100 pS (or pico-siemens) and 0.1 μH, respectively, and standards of even-decade values can be compared to 0.01%.

Another important improvement is the sensitive field-effect-transistor chopper-type dc detector that provides good sensitivity over all ranges of the *R* and *G* bridges, from 10<sup>-4</sup> to 10<sup>10</sup> Ω. This wide range, with its basic 0.1% accuracy, makes the GR 1656 a good dc resistance bridge as well as a good ac bridge.

In other respects the new instrument is very similar to the popular GR

1650-B, having in common its six bridges (series and parallel *C* and *L*, plus *R* and *G*), its battery operation, its internal signal source and detector, and its high *D* and *Q* accuracy. The 0.001-*D* accuracy is particularly important in a 0.1% bridge for, in many circuits, such a difference in *D* is just as important as a 0.1% difference in the value of the parameter.

The obvious use of the new bridge is in component measurement, particularly those components of tight tolerance which have come into wide use during the past few years. If the detector sensitivity is adjusted to cause a given meter deflection for a given percent unbalance, it may be used for rapid go/no-go measurements. It can be used also for a variety of measurements on networks and electrical devices.

Development of the GR 1656 was by H. P. Hall, who also contributed the foregoing material.

Complete specifications for the items below are in Catalog U.

Catalog Number	Description	Price in USA
1413-9700	<b>1413 Precision Decade Capacitor</b>	
	Bench Model	\$930.00
1413-9701	Rack Model	950.00
0480-9703	<b>Rack-Adaptor Set</b>	20.00
	<b>Coaxial Resistance Standard</b>	
1442-9702	1442-C, 0.5Ω	80.00
1442-9703	1442-D, 1.0Ω	80.00
1442-9704	1442-E, 2.0Ω	80.00
	<b>1656 Impedance Bridge</b>	
1656-9701	Portable Model	700.00
1656-9702	Rack Model	735.00
1650-9601	<b>1650-P1 Test Jig</b>	35.00
	<b>1654 Impedance Comparator</b>	
1654-9700	Bench Model	1300.00
1654-9701	Rack Model	1250.00
	<b>1654-Z2 Sorting System</b>	
1654-9702	(with decade capacitor)	2230.00

Prices subject to quantity discount.

# GENERAL RADIO

WEST CONCORD, MASSACHUSETTS 01781

617 369-4400

## SALES AND SERVICE

<b>ALBUQUERQUE</b>	505 265-1097	<b>DAYTON</b>	513 434-6979	<b>*LOS ANGELES</b>	714 540-9830
<b>ANCHORAGE</b>	907 279-5741	<b>DENVER</b>	303 447-9225	<b>*NEW YORK (NY)</b>	212 964-2722
<b>ATLANTA</b>	404 633-6183	<b>DETROIT</b>	313 261-1750	(NJ)	201 943-3140
<b>BOLTON</b>	617 779-5562	<b>GREENSBORO</b>	919 288-4316	<b>PHILADELPHIA</b>	215 646-8030
<b>BOSTON</b>	617 646-0550	<b>GROTON</b>	203 445-8445	<b>ROCHESTER</b>	315 454-9323
<b>BRIDGEPORT</b>	203 377-0165	<b>HARTFORD</b>	203 658-2496	<b>SAN DIEGO</b>	714 540-9830
<b>BURBANK</b>	714 540-9830	<b>HOUSTON</b>	713 464-5112	<b>*SAN FRANCISCO</b>	415 948-8233
<b>*CHICAGO</b>	312 992-0800	<b>HUNTSVILLE</b>	800 241-5122	<b>SEATTLE</b>	206 747-9410
<b>*CLEVELAND</b>	216 886-0150	<b>INDIANAPOLIS</b>	317 636-3907	<b>SYRACUSE</b>	315 454-9323
<b>COCOA BEACH</b>	800 241-5122	<b>LONG ISLAND</b>	212 964-2722	<b>*WASHINGTON,</b>	
<b>*DALLAS</b>	214 637-2240			<b>BALTIMORE</b>	301 881-5333

## INTERNATIONAL DIVISION

WEST CONCORD, MASSACHUSETTS 01781, USA

<b>*ARGENTINE and PARAGUAY</b> Cosin S.A. Buenos Aires	<b>HONG KONG and MACAU</b> Gilman & Co., Ltd. Hong Kong, B.C.C.	<b>PERU</b> Importaciones y Representaciones Electronicas S.A. Lima	<b>*GENERAL RADIO COMPANY (OVERSEAS)</b> P.O. Box 124, CH-8034, Zürich, Switzerland	
<b>*AUSTRALIA</b> Werburton Franki Industries Pty. Ltd. Sydney, Melbourne, Brisbane, Adelaide	<b>INDIA</b> Motwane Private Limited Bombay, Calcutta, Lucknow, Kanpur, New Delhi, Bangalore, Madras	<b>PHILIPPINES</b> T. J. Wolff & Company Makati, Rizal	<b>AUSTRIA</b> Dipl. Ing. Peter Marchetti Wien	<b>*FRANCE</b> General Radio France Paris, Lyon
<b>*BRAZIL</b> Ambrlex S.A. Rio de Janeiro São Paulo	<b>*JAPAN</b> Midoriya Electric Co., Ltd. Tokyo	<b>SINGAPORE</b> Vanguard Company Singapore	<b>BELGIUM</b> Groenpol-Belgique S. A. Bruxelles	<b>*GERMANY</b> General Radio GmbH München, Hamburg
<b>*CANADA -</b> General Radio Canada Limited Toronto, Montreal, Ottawa	<b>KOREA</b> M-C International San Francisco, Seoul	<b>TAIWAN</b> Heighen Trading Co., Ltd. Taipei	<b>DEMOCRATIC REPUBLIC OF THE CONGO</b> Desco de Schulthess Zürich	<b>GREECE</b> Marios Dalleggio Representations Athens
<b>CHILE</b> Cosin Chile Ltda. Santiago	<b>MALAYSIA</b> Vanguard Company Kuala Lumpur	<b>THAILAND</b> G. Simon Radio Company Ltd. Bangkok	<b>DENMARK</b> SEMCO Limited København	<b>IRAN</b> Berkeh Co. Ltd. Tehran
<b>COLOMBIA</b> Manuel Trujillo Venegas e Hijo, Ltda. Bogota 2, D. E.	<b>*MEXICO</b> Electronica Fredin S.A. Mexico, 10 D.F.	<b>URUGUAY</b> Cosin Uruguay S.A. Montevideo	<b>EASTERN EUROPE</b> General Radio Company (Overseas)	<b>ISRAEL</b> Eastronics Ltd. Tel Aviv
<b>ECUADOR</b> Suministros Technicos Ltda. Guayaquil	<b>*NEW ZEALAND</b> W. & K. McLean Limited Auckland, Wellington	<b>VENEZUELA</b> Cosin C. A. Caracas	<b>EIRE</b> General Radio Company (Overseas) General Radio Company (U.K.) Limited	<b>*ITALY</b> General Radio Italia S.p.A. Milano
	<b>PAKISTAN</b> Pak Land Corporation Karachi		<b>FINLAND</b> into O/Y Helsinki	<b>NETHERLANDS</b> Groenpol Industriële Verkoop N.V. Amsterdam
			<b>*REPAIR SERVICES ARE AVAILABLE AT THESE OFFICES.</b>	<b>NORWAY</b> Gustav A. Ring A/S Oslo
				<b>PORTUGAL</b> Casa Serras Lisboa
				<b>REPUBLIC OF SOUTH AFRICA</b> G. H. Langier & Co., Ltd. Johannesburg
				<b>SPAIN</b> Hispano Electronica S.A. Madrid
				<b>SWEDEN</b> Firma Johan Lagercrantz KB Solna
				<b>SWITZERLAND</b> Seyffer & Co. A.G. Zürich
				<b>TURKEY</b> Mevag Engineering, Trading and Industrial Corporation Istanbul
				<b>*UNITED KINGDOM</b> General Radio Company (U.K.) Limited Bourne End, Buckinghamshire
				<b>YUGOSLAVIA</b> General Radio Company (Overseas)

GENERAL RADIO

# Experimenter

WEST CONCORD, MASSACHUSETTS 01781

Do we have your correct name and address—name, company or organization, department, street or P.O. box, city, state, and zip code? If not, please clip the address label on this issue and return it to us with corrections or, if you prefer, write us; a postcard will do.

ADDRESS CORRECTION REQUESTED

Mr. Edward F. Sutherland  
14 Firecut Lane  
Sudbury, Mass. 01776

BULK RATE  
U.S. POSTAGE  
PAID  
PERMIT NO. 70  
Scranton, Pa.

PRINTED  
IN  
U.S.A.