



THE GENERAL RADIO

Experimenter

*The New Breed of
Signal Generator*



ALSO IN THIS ISSUE

- New 30-MHz I-F Amplifier
- fastrak Markers for the Graphic Level Recorder

VOLUME 41 · NUMBERS 7, 8 / JULY - AUGUST 1967



the **Experimenter**

© 1967 — General Radio Company, West Concord, Mass., USA

Published monthly by the General Radio Company

THIS ISSUE

	Page
The 1003 Standard-Signal Generator.....	3
New Cartridge Pens for Graphic Recorder	12
A New 30-MHz Amplifier with Two Bandwidths.....	13
GR Product Notes.....	18
NBS to Calibrate Bolometers Fitted with 14-mm Precision Coaxial Connectors.....	20

GENERAL RADIO COMPANY

West Concord, Massachusetts 01781

SALES AND SERVICE

Area	Telephone	Area	Telephone
*Boston	617 646-0550	*New York	(NY) 212 964-2722
*Chicago	312 992-0800		(NJ) 201 943-3140
Cleveland	216 886-0150	Orlando	305 425-4671
*Dallas	214 ME7-2240	Ottawa	613 233-4237
Dayton	513 434-6979	Philadelphia	215 646-8030
Detroit	313 261-1750	San Diego	714 232-2727
Houston	713 622-7007	San Francisco	415 948-8233
Huntsville	205 883-2077	Seattle	206 GL4-7545
Indianapolis	317 636-3907	Syracuse	315 454-9323
*Los Angeles	213 469-6201	*Toronto	416 247-2171
Montreal	514 737-3673	*Washington/Baltimore	301 946-1600
New Haven	203 378-2548		

*Repair services are available at these offices.

GENERAL RADIO COMPANY (OVERSEAS), 8008 Zurich, Switzerland

GENERAL RADIO COMPANY (U.K.) LIMITED, Bourne End, Buckinghamshire, England

REPRESENTATIVES IN PRINCIPAL OVERSEAS COUNTRIES

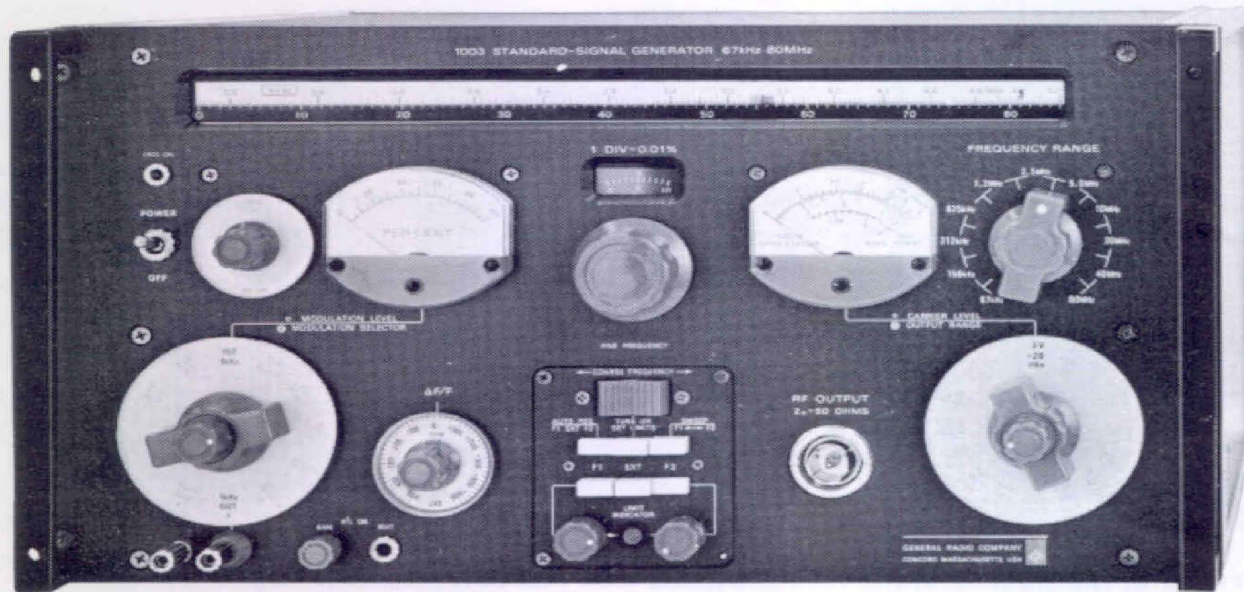

Figure 1. Type 1003 Standard-Signal Generator.

THE 1003 STANDARD-SIGNAL GENERATOR

It is infrequent that one sees major innovation in an art as mature as signal-generator design. Thus the subject of this month's feature is particularly noteworthy, for the 1003 is based on a truly innovative idea for achieving dramatic improvements in frequency stability, resolution, and accuracy. Freshness of approach marked the entire development, and the result is an interesting new chapter in the history of one of the most important of all electronic instruments.

A new generation of GR standard-signal generators began with the introduction, last March, of the 1026,¹ which upgraded many performance characteristics by an order of magnitude or more. Now the 1026 is joined by the lower-frequency (67 kHz-80

MHz) 1003, an all-solid-state signal generator that will probably be the ultimate in this class of instrument for some time to come.

The 1003 is distinctly different from the conventional signal generator. It is different in the way it generates frequencies (by a single-range oscillator, with dividers to produce the lower frequencies) and in the degree to which it maintains frequency, typically within a part per million per 10 minutes. Like the 1026, the 1003 was designed to be the highest-performance signal generator available in its frequency range, and test results indicate that it does in fact enjoy a wide margin over other signal generators now on the market.

¹G. P. McCouch, "A New 500-MHz Standard-Signal Generator," *General Radio Experimenter*, March 1967.

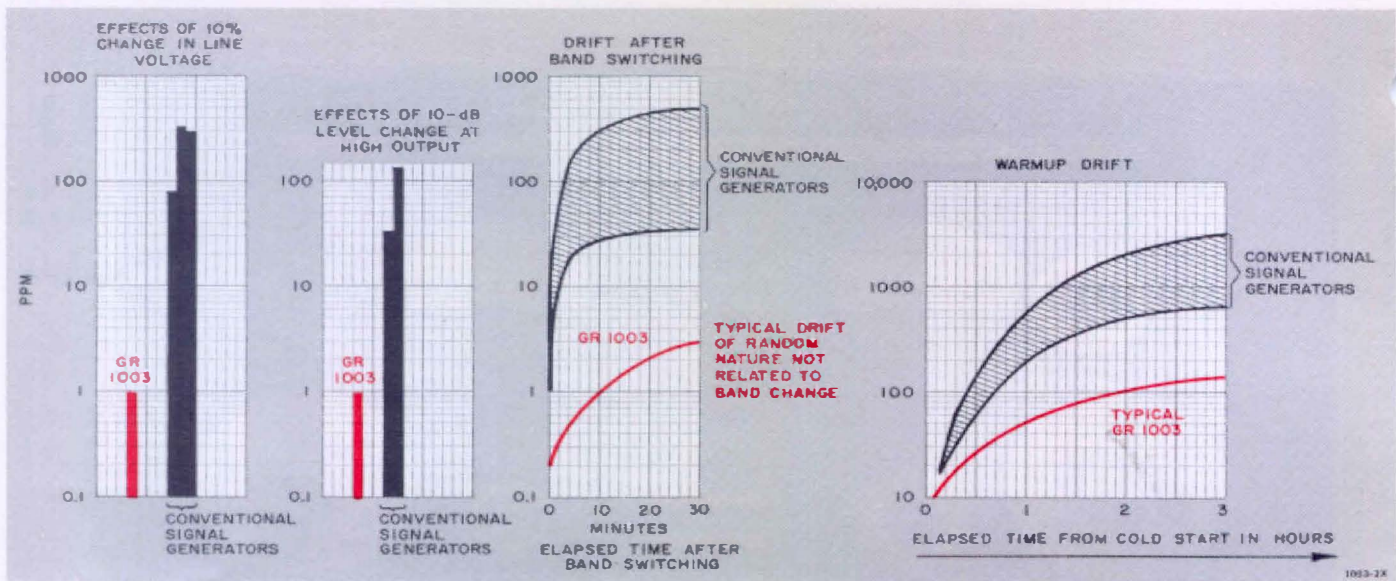

Figure 2. The stability of the 1003 compared with that of typical other signal generators.

For example, Figure 2 illustrates the stability of the 1003 compared with that of typical signal generators of conventional design. One of the chief reasons for the 1003's great advantage in stability is its new approach to frequency generation: Its oscillator is optimally designed for the highest range, and frequency dividers are switched in to produce the lower ranges, imparting the stability of the top range to all other ranges without deterioration. Another result of this approach is a calibration accuracy of $\frac{1}{4}\%$, which is well beyond the reach of other signal generators.

The 1003 uses a motorized dial drive for tuning, sweeping, and programming. For fast, coarse tuning, pushing a rocker switch in the center of the front panel sends the indicator gliding along the slide-rule main frequency dial at about 7% frequency change per second. After using this motor drive to reach the right neighborhood, the user fine-tunes by means of a large rotary control, with each dial division correspond-

ing to 0.01% of the main-dial setting. If this isn't precise enough, the $\Delta F/F$ front-panel control provides electronic, backlash-free settability to a few parts per million over a 1000-ppm range.

Both of the fine-tuning controls are fully calibrated in relative terms, so that the user can detune from a given point by a precisely known amount anywhere on the dial.

It is evident from the foregoing that the frequency stability, calibration accuracy, and resolution of the 1003 permit many more meaningful measurements in very narrow-band systems and devices (e.g., ssb receivers, crystal filters), where older signal generators are either marginal or useless because of resolution and drift problems. In such instances the user has had to use synchronizing schemes or synthesizers to provide a stable enough signal, and in the process he has encountered new problems, such as spurious signals, reduction in shielding efficiency, loss of calibration accuracy, to say nothing of the added tuning inconvenience.

The availability of a motor-driven frequency control presents obvious opportunities for both local and remote automatic tuning, and these are exploited by a programmable automatic-frequency-control device. With this unit, one can sweep between adjustable frequency limits and can automatically tune to preset frequencies. The 1003 can be purchased with or without the auto-control unit installed.

The 1003 has a full complement of auxiliary outputs, including a unique F/N monitor that is a byproduct of the frequency-divider method of rf generation. The F/N output frequency is an exact integral fraction $1/N$ of the actual output, always falling between 67 and 156 kHz. The value of N appears on the dial of the selected frequency range. The constant-level, unmodulated F/N output can be used in many ways, one of which almost suggests itself: measuring or monitoring output frequency indirectly by means of an inexpensive low-frequency counter, even with full modulation.

The main rf output frequency is available at the rear-panel F -monitor connector, which is fully isolated when not in use.

OPERATING CHARACTERISTICS

The 1003 covers its 67 kHz-to-80 MHz range in 10 bands, each somewhat over an octave wide. Over the entire range the instrument can deliver 180 milliwatts of leveled cw power into a 50-ohm load. This is equivalent to 6 volts behind 50 ohms. When the carrier is 95%-modulated, the maximum available carrier level is 3 volts. Envelope distortion and incidental fm are minimized.

The entire warmup frequency drift is typically about 0.01%, and frequency changes due to band switching and to variations in line voltage, load, and level are generally less than 1 part per million (see Figure 2).

The precision 10-dB-per-step attenuator maintains both accuracy and impedance match over the entire 140-dB stepping range. Attenuator error is less than 0.1 dB per step, with a maximum accumulation of 0.5 dB. The attenuator and the continuously adjustable carrier-level control provide an over-all range of 155 dB.

The all-solid-state 1003 draws only 20 watts from the power line. As a result, temperatures are low and components are not under stress. All active devices are operated very conservatively, and the power supplies are short-circuit-proof.

HOW IT WORKS

(See Elementary Diagram, Figure 3)

Oscillator and Power Amplifier

A single-range (34 to 80 MHz) master oscillator is the source of all output frequencies. The key to the instrument's excellent frequency stability is thus the success with which this oscillator was made insensitive to temperature variations and to the influence of the following stages.

A varactor diode permits incremental tuning ($\Delta F/F$) over a limited range. A compensation scheme is used to obtain constant fractional resolution, permitting calibration of the $\Delta F/F$ control in ppm. The electronic tuning circuit is also the means by which the signal generator can be frequency-modulated or phase-locked to an external signal, when the ultimate in accuracy and stability is desired.

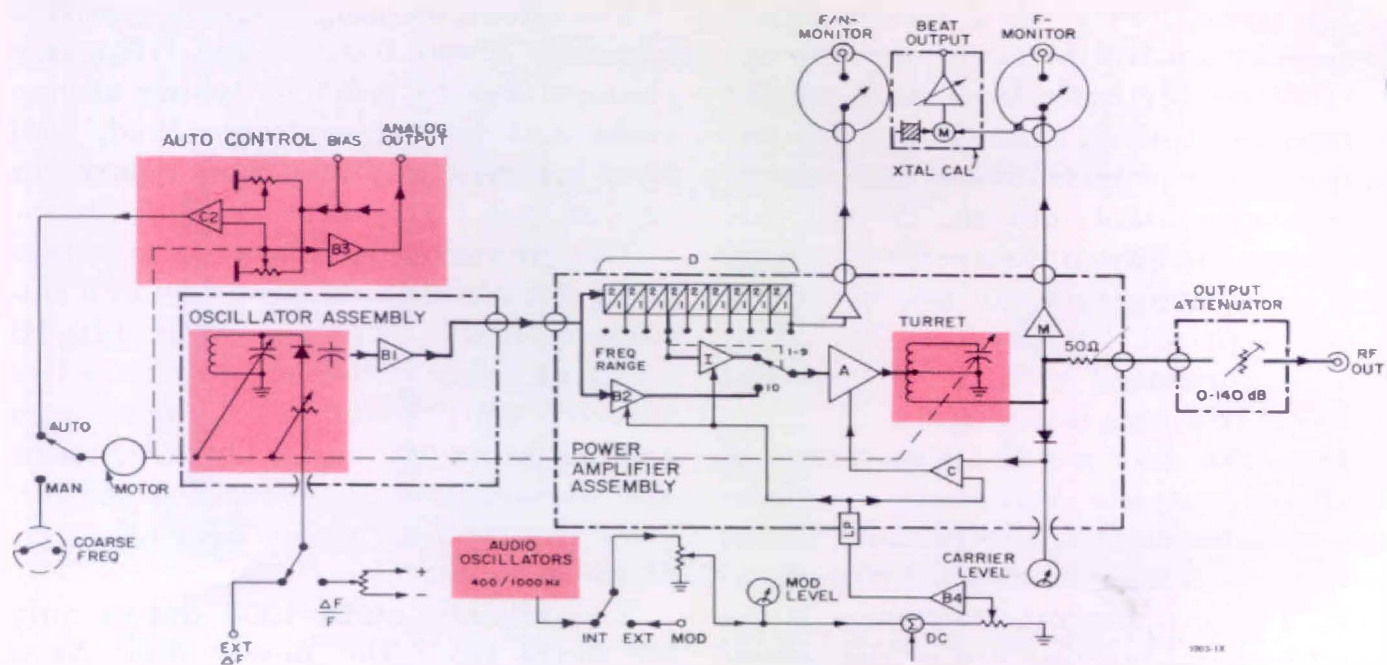

Figure 3. Elementary block diagram.

The oscillator output, after passing through untuned buffer *B1*, enters the power-amplifier unit. On the highest-frequency range (34 to 80 MHz), the rf signal passes through an additional untuned buffer *B2* to the main amplifier *A*. For all lower-frequency ranges, the signal is applied to a series of frequency dividers and thence through untuned buffer (*I*) to the power amplifier. The nine 2:1 dividers give a maximum divisor of 512. Accordingly, the lowest frequency range, produced by the entire cascaded divider chain, is the highest range divided by 512, or 67 kHz to 156 kHz. This low-range output is available as the F/N monitor output, mentioned earlier.

A high degree of isolation between the oscillator and the power amplifier under all conditions practically eliminates all frequency-pulling effects from changes in operating and loading conditions at the output stage. Furthermore, range-switching effects are vir-

tually nil, as Figure 2 shows very clearly, since the same oscillator is used on all bands. Thus no time is wasted in waiting for the frequency to restabilize after band switching, as is typical with other signal generators.

When a particular range is selected, the appropriate number of dividers is activated, and a turret connects the appropriate tank circuit to the power transistor. The tank-circuit variable capacitor is ganged with the oscillator variable capacitor by a non-slip steel cord.

The power amplifier is a 2N3375, whose base voltage controls modulation and output level.

Output System and Leveling

The power-amplifier control voltage is supplied by comparator circuit *C*, which is part of a feedback control system. The other elements of the feedback loop are the tuned amplifier *A* and the detector circuit, whose de-

output is compared against a composite reference signal. Any difference between these two signals generates an amplified correction voltage, which makes the rectified output follow the reference voltage. The regulating action is further enhanced by a secondary control path, which varies the drive level and thereby increases the dynamic range of modulation.

Because the stability of the reference voltage is essential to the maintenance of a constant carrier level, all circuits associated with the generation of this reference voltage are supplied with highly stabilized bias voltages. The results of such careful design are evident in Figure 4, which shows the carrier level varying well under 0.01 dB as the line voltage is swung ± 10 percent.

The detected rf is measured and displayed by the carrier-level meter, which is calibrated in open-circuit volts (i.e., the voltage behind the 50-ohm source impedance) and in dBm of available power. Since the rf level at the sampling point is kept constant by the control circuit, this point can be considered to be a zero impedance source; a 50-ohm series resistor provides the true 50-ohm source impedance.

The carrier-level control varies the reference voltage of the feedback loop and thus provides continuous adjust-

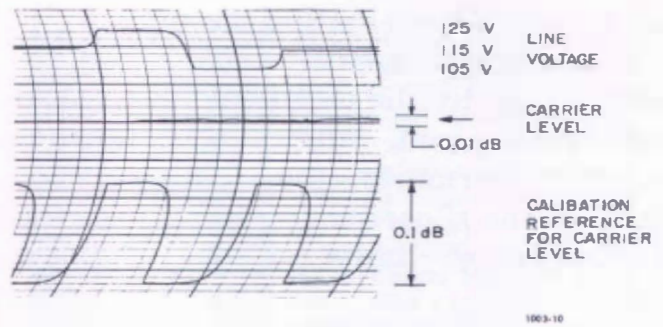

Figure 4. Effects of $\pm 10\%$ line-voltage swing on carrier level.

ment of the leveled output, over a range of 15 dB. The precision step attenuator covers a range of 0 to 140 dB in 10-dB steps.

Modulation

The basic modulating function is performed in the power-amplifier stage by the base voltage on the 2N3375 transistor. This function is linearized through the feedback action, which makes the detected envelope essentially identical to the composite reference signal. In Figure 5, which is an X-Y display of a 90% modulated rf signal vs the modulating signal, one can judge the linearity by observing the straightness of the sloped sides of the trapezoid. Another, novel type of presentation (Figure 6) shows the sum of the modulated and modulating signals. Ideally this should produce a horizontal baseline. Departures from the ideal serve

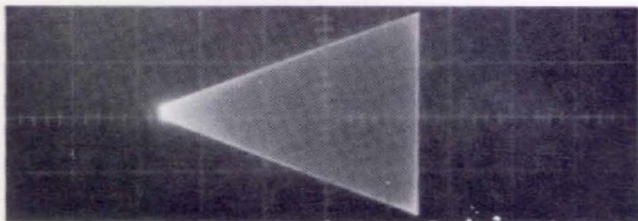

Figure 5. X-Y display of a 90% modulated rf signal (6.5 MHz) vs the modulating signal (400 Hz).

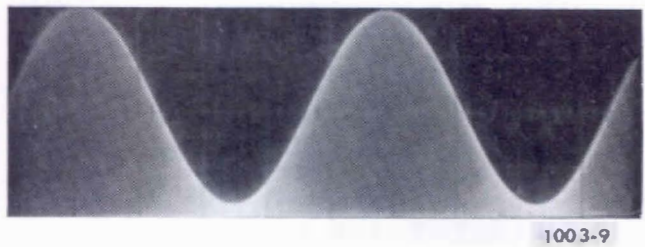

Figure 6. Oscillogram showing addition of modulated (6.5-MHz) and modulating (400-Hz) signals at 90% modulation. Horizontal baseline indicates lack of distortion.

as a basis for evaluating distortion.

The various modes of operation are established by the nature of the applied reference signal, whose instantaneous value determines the instantaneous level of the rf carrier (within, of course, the response limits of the feedback loop).

There are two internal modulating frequencies, 400 Hz and 1 kHz. At either frequency, the modulating signal is highly stable and has very low distortion. The amplitude of these modulating signals can be adjusted by the MOD LEVEL control for up to 95% modulation. The modulation level is monitored in terms of the audio modulating voltage but is calibrated directly in percent. A compensation circuit ensures that a given modulation setting is kept constant over the range of the carrier-level control.

External modulation can be applied with either ac or dc coupling. In the EXT AC mode, any audio-frequency signal can be accepted, controlled, and monitored in the same way as for internal modulation. With sinusoidal waveforms, the modulation passband is flat within 1 dB from 20 Hz to 10 kHz. The ultimate upper limit is the 20-kHz nominal cutoff frequency of the low-pass filter used to feed external signals into the power-amplifier enclosure. On the lower-frequency ranges, however, the rf-amplifier bandwidth also affects the highest usable modulation frequency and percentage modulation.

In the EXT DC mode, the input jack is coupled directly to the amplifier. With no input, the power amplifier is turned off, and a positive-going voltage is required to turn it on. In the off condition, the carrier is down by 50

to 60 dB. Internal limiters protect against excessive modulation input voltages. This mode of operation is particularly useful for remote-control applications and for low-frequency square-wave modulation.

Crystal Calibrator

(See Figure 7)

A 1-MHz crystal oscillator is the basic reference source for the optional crystal calibrator. Two more frequencies, 200 kHz and 50 kHz, are derived by division and are thus coherent with the 1-MHz signal. Even the lowest marker frequency can be used up to the highest carrier frequencies.

Since the rf sample for the crystal calibrator is taken from the F-monitor channel (see Figure 3), a high degree of isolation is realized, providing a reverse attenuation well over 100 dB between crystal calibrator and main output. As a result, the crystal calibrator can be used without fear of contaminating the main output with spurious sidebands.

When the F-monitor output is switched on, it is possible to feed an external reference signal through the F-monitor jack and to use portions of the crystal calibrator circuitry as a

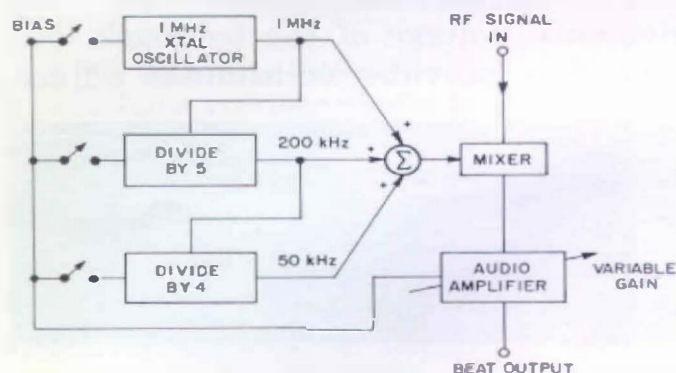

Figure 7. Elementary diagram of the crystal calibrator.

heterodyne frequency meter. In this case, only the mixer-amplifier part of the crystal calibrator is activated.

Auto-Control Unit

The auto-control unit permits a number of automatic tuning operations by either local or remote control. For automatic tuning, the standard frequency-control motor becomes part of a servo positioning system (see Figure 8). An analog dc voltage, proportional to tuning-shaft position, is compared against a reference voltage in a differential amplifier. The amplified error voltage actuates one of two relays, depending on the polarity of the error signal. The appropriate relay energizes the motor to bring the error to zero, and the relay then drops out and turns the motor off. Simultaneously, a dc pulse from a charged capacitor is applied across the motor windings to bring the motor to an abrupt stop. Resolution and accuracy are adequate to permit resettability to within 0.1%.



Rudi Altenbach received his Dipl. Ing. degree in EE from Karlsruhe Technical University in 1948. After three years as development engineer with Siemens and Halske in Germany, he came to Canada, and later to the U.S. From 1951 to 1963 he was engaged in various capacities in the design and development of radar, radio relay equipment and related devices at Canadian Marconi Company, Hermes-Itek Company, and Raytheon Company. In 1963 he joined the GR's Development Engineering staff and has since been working primarily on signal-generator development. He is a member of the IEEE.

The zero-error position is indicated by a neon lamp on the auto-control panel. This lamp is used in the setting of the reference potentiometers to a desired tuning position or limit and also serves as a frequency or position marker. Two internal multiturn high-resolution potentiometers (F1 and F2) permit continuous adjustment of the auto-tune positions or sweeping limits. Many more additional tuning points

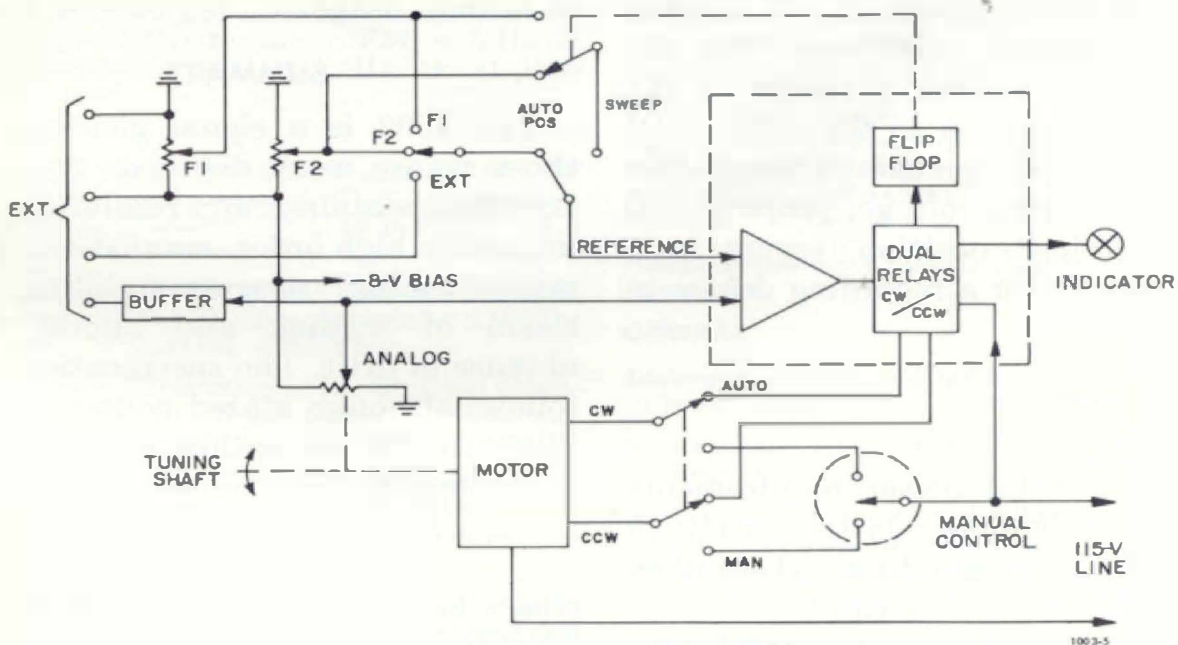

Figure 8. Elementary diagram of the auto-control unit.

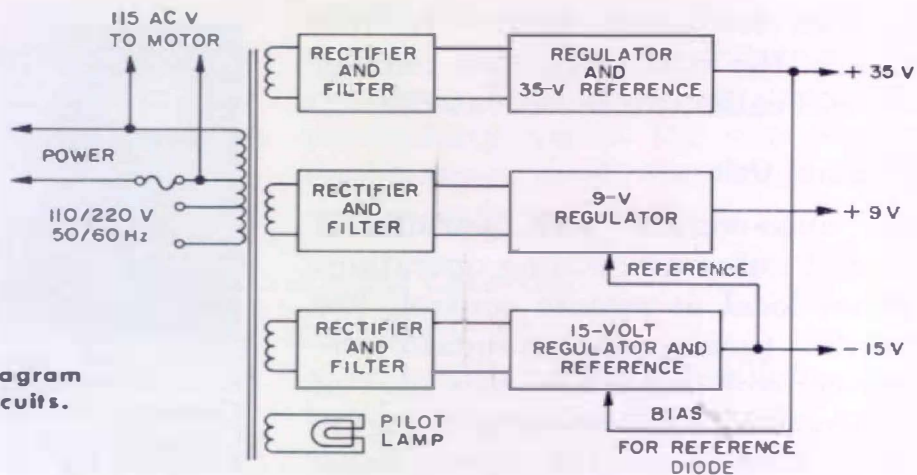

Figure 9. Elementary diagram of the power-supply circuits.

can be added by means of sequentially switched reference signals through an extension socket. An external reference may be either a voltage between 0 and -8 volts or a potentiometer connected to the extension socket. The latter method is preferable for minimum drift. Up to 5 mA can be drawn from the 8-volt bias source, equivalent to over thirty 50-kilohm potentiometers in parallel.

In sweep operation the motor is driven repetitively between the two adjustable limits, F1 and F2. A flip-flop receives a trigger pulse each time the motor reaches a limit, transferring the reference connection to the other limit to actuate the reverse sweep. The analog dc output voltage, proportional to tuning shaft position, serves as a sweep voltage for a recording device in this mode.

Power Supplies (See Figure 9)

Since the total power requirements are very small, it is relatively easy to obtain excellent regulation and stability together with very low ripple.

Especially critical is the regulation of the -15-volt supply that feeds the

oscillator section; variations in this supply are kept to a few millivolts under all adverse conditions by use of a temperature-compensated reference diode in a high-gain series regulator circuit. The other two bias voltages (+9 and +35 V) are also stabilized by series regulators. All active elements are silicon, and protection against accidental damage or burnout is achieved through current limiting. Total dissipation, even under continuous short-circuit conditions, is within safe limits in normal usage.

SUMMARY

The 1003 is a signal generator for those whose work demands frequency accuracy, stability, and resolution of an unusually high order, manual and automatic tuning, programmability, precision of setting, and almost total absence of drift. The specifications that follow, although stated conservatively, illustrate the exceptional performance characteristics that have been achieved.

— R. ALTENBACH

Editor's Note: The basic concept of the 1003 was suggested by A. Noyes, Jr. The instrument was developed by the author, with J. K. Skilling providing the divider circuitry.

SPECIFICATIONS

FREQUENCY

Range: 67 kHz to 80 MHz in 10 ranges: 67 to 156, 135 to 312, 270 to 625, 540 to 1250 kHz, 1.08 to 2.5, 2.16 to 5, 4.32 to 10, 8.64 to 20, 17.28 to 40, and 34.56 to 80 MHz.

Calibration Accuracy: $\pm 0.25\%$, typically $\pm 0.1\%$; scale logarithmic, 140 in. total length. Logging scale with vernier, 8500 div, 0.01% /div.

Crystal Calibrator (optional): Markers at 50-kHz, 200-kHz, and 1-MHz intervals, accurate to 20 ppm.

Mechanical Tuning: Fast motor drive, manually or externally controlled; manual fine tuning, 1% per revolution, calibrated, resettable to 0.01% .

Auto-Control Tuning (optional): 0.1% positioning accuracy. Motor drive sweeps between preset limits or tunes on command to preset frequencies (two internally, additional from external dc voltages or dividers). Sweep rate approx $7\%/s$.

Electronic Tuning: Internal, ± 500 ppm, calibrated, settable to better than 2 ppm; external, approx 60 ppm/volt up to ± 1000 ppm typical, limited fm capability. Max input ± 15 V into 15 k Ω (+ volts increase frequency).

Stability: After warm-up < 5 ppm per 10 min, typically 1 ppm. Frequency will vary less than 1 ppm as a result of $\pm 10\%$ line-voltage changes, range switching (instant restabilization), rf-level adjustments, or load variations. Warmup drift typically 150 ppm in 3 h at 20°C .

Temperature Coefficient: < 20 ppm/ $^\circ\text{C}$, typical.

Carrier Distortion: $< 5\%$, typical.

Noise: A-M, hum and noise sidebands down at least 80 dB relative to carrier. FM, < 3 Hz pk at high-frequency end, < 1 Hz pk at low-frequency end.

RF OUTPUT

Range: CW, $0.1 \mu\text{V}$ to 6 V behind 50 Ω , 180 mW into 50 Ω (-133 to $+22.6$ dBm); modulated, $0.1 \mu\text{V}$ to 3 V behind 50 Ω , 45 mW into 50 Ω (-133 to $+16.6$ dBm).

Source Impedance: 50 Ω . SWR is < 1.02 with attenuator set for 0 dBm or less, < 1.05 for $+10$ dBm, < 1.20 for $+20$ dBm.

Level Control: Total range, 155 dB. Step attenuator, 140 dB in 10-dB steps; continuously adjustable level control, > 10 dB additional.

Accuracy of Leveled Output Power: ± 1 dB at any frequency and termination. Attenuator, ± 0.1 dB per 10-dB step, max accumulated error ± 0.5 dB.

Level Stability: Warmup drift < 0.3 dB, temperature effects < 0.01 dB/ $^\circ\text{C}$, line-voltage variations < 0.02 dB.

Meter: Reads open-circuit volts and dBm.

MODULATION

Level: 0 to 95%, continuously adjustable. Stable within ± 1 dB independent of carrier or modulation frequency (within modulation bandwidth) and output level.

Modulation Band width: At 100-kHz carrier, max modulation frequency is 500 Hz for 95% a-m and 2 kHz for 30% a-m. Above 1-MHz carrier, max is 5 kHz for 95% and 10 kHz for 30%.

Meter: Reads 0 to 100%. Accuracy $\pm 5\%$ of full scale, 0 to 95% to 10 kHz within stated modulation bandwidth.

Incidental Angle Modulation: < 0.1 radian pk at 30% a-m.

Internal

Frequency: 400 and 1000 Hz, $\pm 0.5\%$. Output of 2 V behind 100 k Ω available at panel connector.

Envelope Distortion: $< 1\%$ at 50% a-m, $< 2\%$ at 70% a-m.

External

AC-Coupled: 20 Hz to 20 kHz, 2 V into 2.5 k Ω for 95% modulation.

Direct-Coupled: DC to 20 kHz. Carrier off with 0-V input; 3-V rf output with $+5$ V into 10 k Ω . Max input 10 V peak.

AUXILIARY MONITORING OUTPUTS

Main-Output Frequency: At least 0.5 V pk-pk into 50 Ω (CW) at output carrier frequency.

Subharmonic Frequency: At least 0.3 V pk-pk (approx square wave) behind 150 Ω . Frequency (between 67 and 156 kHz) is coherent with and integrally related to carrier frequency by factor N shown on main dial.

Tuning-Shaft Position (with auto-control option): Analog dc voltage proportional to shaft position and logging number. Approx -7.5 V max behind 7500 Ω , or 90 mV for 1% frequency change.

Range Indicator: Contact closure through rear connector.

GENERAL

Leakage: Effects negligible on measurements of receiver sensitivity down to $0.1 \mu\text{V}$.

Environment: 10 to 50°C ambient for specified performance.

Accessories Supplied: 874-R22LA Patch Cord, power cord, 12-terminal connector for external controls, spare fuses, hardware for both bench and rack mounting.

Power Required: 105 to 125, 195 to 235, or 210 to 250 V, 50 to 60 Hz, 20 W (33 W with motor operating).

Mounting: Rack-bench cabinet.

rack model 19 x 10½ x 12¾ in. (485 x 270 x 325 mm).

Dimensions (width x height x depth): Bench model, 19 x 11 x 15¼ in. (485 x 280 x 390 mm);

Weight (approx): Net, 64 lb (30 kg); shipping, 87 lb (40 kg).

Catalog Number	Description	Price in USA
1003-9701	1003 Standard-Signal Generator	\$2795.00
1003-9704	1003 Standard-Signal Generator Complete with Auto-Control Unit and Crystal Calibrator	2995.00

NEW CARTRIDGE PENS FOR GRAPHIC RECORDER

fastrak recorder marker in place on GR 1521 Graphic Level Recorder.

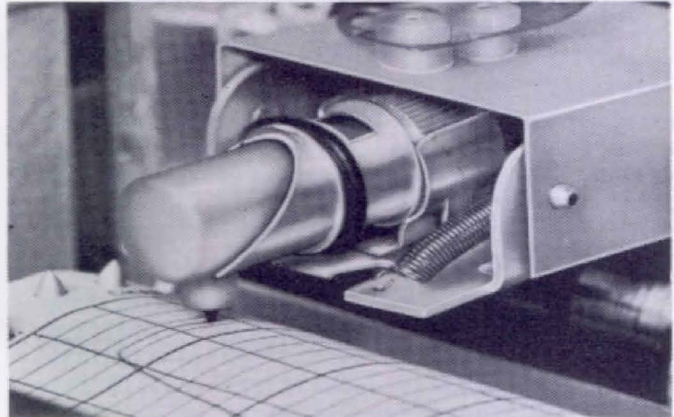

We have developed a new, cartridge-type, disposable recorder pen for the popular TYPE 1521 Graphic Level Recorder. Trade-named the *fastrak* recorder marker, the new pen eliminates the problems of ink loading and tip cleaning.

The tip is specially designed for graphic recording, with only 2 grams of force required for proper operation. Each cartridge has about twice the life of one old-style pen refill and can outlast three rolls of chart paper. When the cartridge is empty, replacement is clean, quick, and easy. The entire

fastrak cartridge, including the writing tip, is disposable. The ink is fast drying, and the marker performs well at all recording speeds. Each marker has a protective cap that prevents drying when the pen is not in use.

fastrak recorder markers are boxed in sets of 12 pens of one color (red, green, or blue) or in an assortment containing four each of the three colors.

The graphic level recorder will henceforth be supplied equipped with *fastrak* markers. A conversion kit is available to adapt existing TYPE 1521 recorders to the *fastrak* marker.

Catalog Number	Description	Price in USA
1521-9439	<i>fastrak</i> Recorder Marker Conversion Kit (includes marker-holder set, installation instructions, and combination marker set)	\$25.00
1521-9449	<i>fastrak</i> Combination Marker Set (includes 4 red, 4 green, 4 blue markers)	15.00
1521-9446	<i>fastrak</i> Marker Set, 12 red markers	15.00
1521-9447	<i>fastrak</i> Marker Set, 12 green markers	15.00
1521-9448	<i>fastrak</i> Marker Set, 12 blue markers	15.00

Figure 1. The Type 1236 I-F Amplifier.

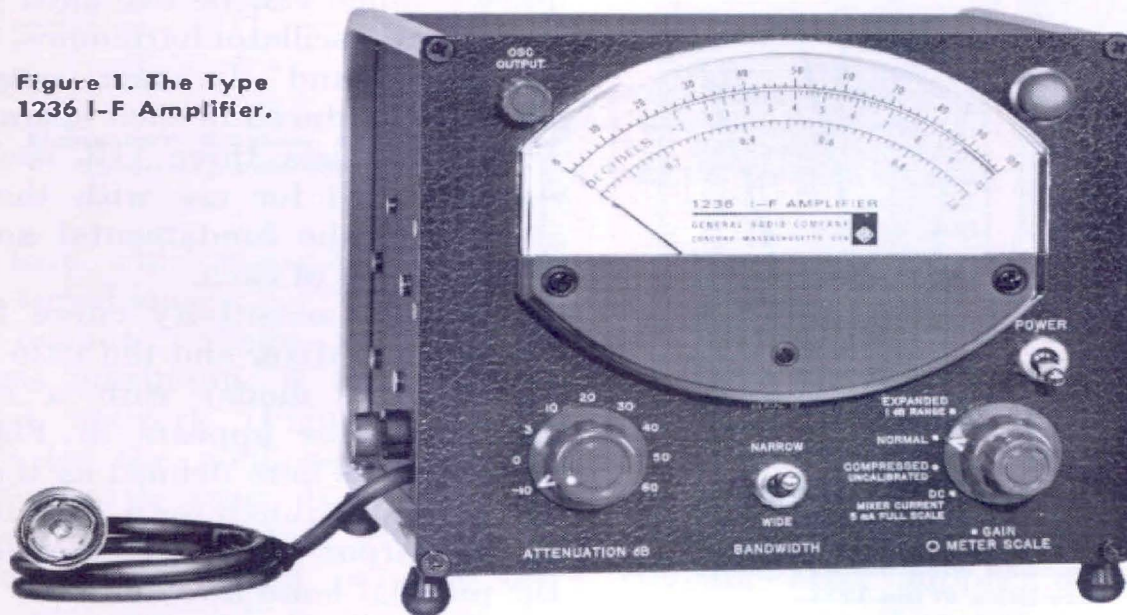

A NEW 30-MHz AMPLIFIER WITH TWO BANDWIDTHS

The 30-MHz amplifier is a popular instrument that goes under a variety of names. It is an important element in a precision heterodyne receiver, and it is sometimes called, somewhat loosely, a receiver. Since it often serves, in combination with a local oscillator and mixer, as a detector for bridge measurements, it is also known as a null detector. No matter what its name, it is practically indispensable for a great many measurements.

The new GR 1236 is a low-noise, high-gain 30-MHz tuned amplifier with two switch-selected bandwidths, giving the user a choice of a "narrow" band of 0.5 MHz or a "wide" band of 4

MHz. One would typically use the narrow band for operation at lower frequencies, switching to the wide bandwidth at higher local-oscillator frequencies where frequency stability is often a problem. The narrow- and wide-band response characteristics are shown in Figure 2.

A six-inch taut-band meter with calibrated linear and decibel scales gives excellent resolution. The top 10 percent of the scale can be expanded to give a full-scale range of 1 dB with a resolution of 0.02 dB per small division. When the meter scale switch is set to COMPRESSED, the agc loop compresses the meter scale to about 50 dB. This feature is almost

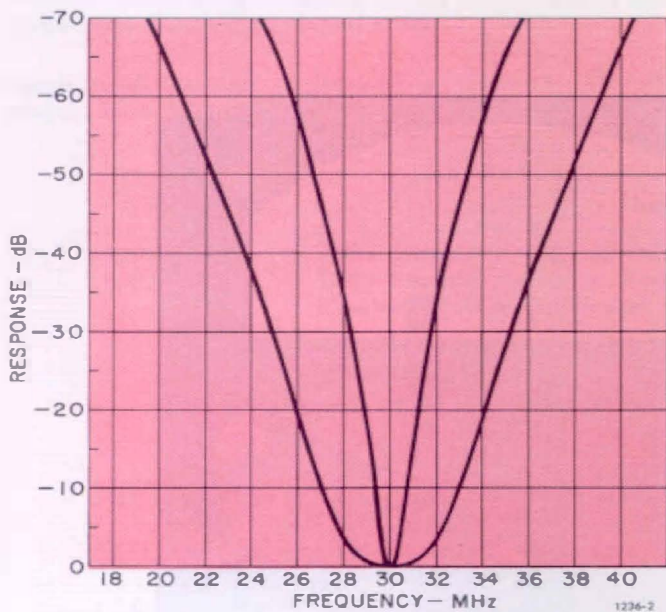

Figure 2. Narrow- and wide-band response characteristics of the 1236.

indispensable when the instrument is used as a null detector in a bridge measuring system.

The attenuator covers a range of 70 dB in 10-dB steps, with an accuracy of $\pm (0.1 \text{ dB} + 0.1 \text{ dB}/10 \text{ dB})$. The accumulated error will generally not exceed 0.3 dB. Because of the excellent repeatability of the attenuator, it is entirely practical to calibrate it against an external standard, thus reducing the attenuator error to that of the standard.

The 1236 combines easily with the new, highly sensitive TYPE 874-MRAL Mixer (see page 19) and one of the GR line of oscillators to form a wide-range measuring receiver. The 1236 includes a separate adjustable regulated power

supply for the local oscillator.

With a given oscillator, the frequency range can be extended by use of the local-oscillator harmonics, though sensitivity and dynamic range are somewhat reduced in such operation.

Table 1 lists three GR oscillators recommended for use with the 1236, along with the fundamental and harmonic ranges of each.

A typical sensitivity curve for the 874-MRAL Mixer and the 1236 (in the narrow-band mode) with a suitable local oscillator appears in Figure 3. Sensitivity is here defined as the input signal level required for a 3-dB increase in the output of the i-f amplifier over the residual noise level.

Circuit

A low-noise preamplifier uses two Nuvistors in cascade in the input stage and a third Nuvistor in the output stage. The heater supply of the Nuvistors is regulated to achieve high gain stability vs line-voltage changes.

The preamplifier output is fed to a ladder-type step attenuator, which covers 70 dB in 10-dB steps. The output meter is used for interpolation between steps.

The postamplifier consists of one untuned and three tuned stages. The gain of the untuned stage is controlled by a front-panel control, with coarse and fine adjustments.

When the METER SCALE switch is in the COMPRESSED position, it activates

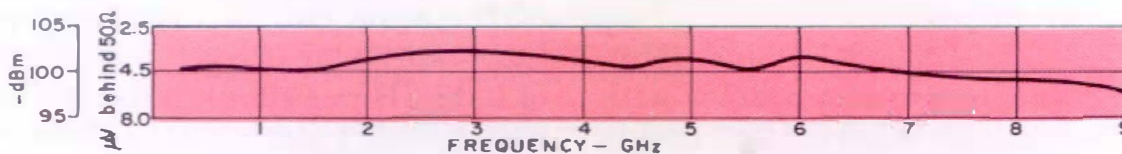

Figure 3. Typical sensitivity curve for receiver system comprising 1236, local oscillator, and Type 874-MRAL Mixer.

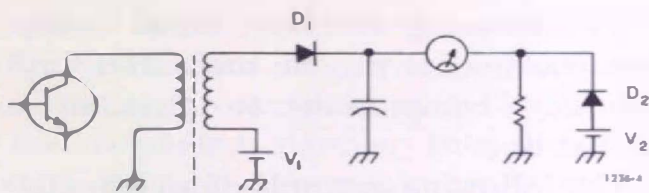

Figure 4. Elementary diagram of the detector linearizing network.

the age loop, which controls the gain of the two tuned stages.

The output voltage is about 2 volts rms maximum. A temperature-stabilized network (Figure 4) compensates for the nonlinear characteristics of the detector diode. In this network, $V1$ is adjusted for a linear response in the upper part of the meter scale and $V2$ is adjusted to optimize the lower part. Figure 5 shows the response with and without compensation.

The measured deviation from a linear response of a compensated detector circuit is plotted in Figure 6. A full-scale meter deflection corresponds to 2 volts rms rf voltage. Point *A* is the reference point, in this case 100% meter deflection, *B* and *C* are points of zero error; their positions are determined by $V1$ and $V2$. The three points of zero

M. Khazam received his degree in Electronic Engineering from the Delft University of Technology, Holland, in 1957, and from 1957 to 1960 was a project engineer with the Laboratory for Electronic Developments for the Armed Forces, in Holland. He joined General Radio in 1962 as a development engineer in the Microwave Group and has since specialized in the development of vhf-uhf instruments and components.



error may be positioned for minimum error over either the whole range or part of the range.

The power supply consists of a Nuvistor plate supply, a supply for the transistors and for the Nuvistor heaters, and a local-oscillator plate and heater supply. All voltages except the local-oscillator heater supply are regulated.

Applications

The 1236 will be widely used with a local oscillator and mixer as a sensitive null detector for bridges, such as GR's 1602 UHF Admittance Meter and 1607 Transfer-Function and Immittance Bridge. Its excellent performance char-

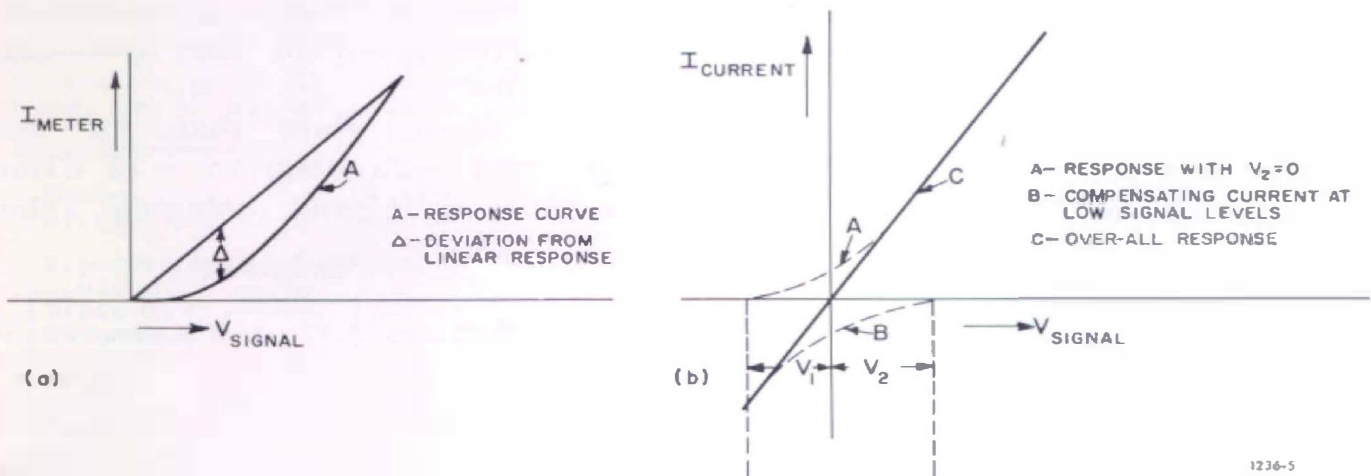

Figure 5. Uncompensated (left) and compensated (right) response of detector circuit.

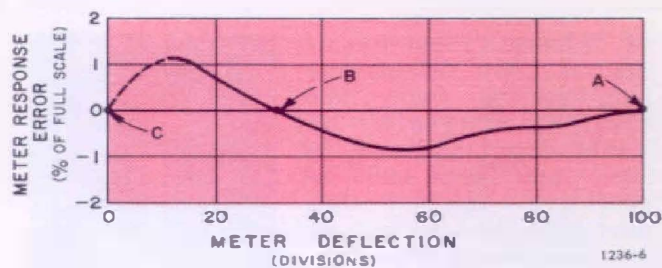

Figure 6. Measured deviation of compensated detector circuit from linear response.

acteristics suggest that it will also be a popular relative-signal-level meter in attenuation measurements, SWR measurements at low signal levels with slotted lines, reflection-coefficient measurements with hybrids or directional couplers, etc. SWR meters consisting of a tuned detector and a high-gain low-frequency amplifier often require a signal level that is too high for measurements on nonlinear devices. The heterodyne detector, with its much higher sensitivity, is the preferred SWR meter in such instances, and it is also recommended in general for precision measurements of both high and low SWR.

Measurements of small reflection coefficients with a directional coupler or a hybrid reflectometer are restricted by the directivity of the coupler or the balance of the hybrid and by the dynamic range and sensitivity of the detector. By the use of precision tuners and such terminations as those available in the GR900 line, the directivity or balance can be made almost perfect at any one frequency. Then, with a hetero-

dyne-measuring receiver, small reflection coefficients can be measured with accuracy comparable to that of a slotted line.

The following example of an attenuation measurement using the i-f series substitution method indicates the accuracy and dynamic range attainable with this system.

The measurement setup is shown in Figure 7. The receiver consists of a 1236 I-F Amplifier, a 1208 Oscillator (40-530 MHz), and an 874-MRAL Mixer. The measuring frequency is 500 MHz.

The 1236 output reading (attenuator setting plus meter indication) is noted with and without the unknown attenuator in the circuit. The difference of the two readings is the measured attenuation. These measurements are repeated at different signal levels to determine the useful dynamic range of the system.

The results appear in Table 2. The top two rows give the 500-MHz signal level at the detector. The third row gives the attenuator values as measured, while in the fourth row the numbers are corrected for the 1236 attenuator errors. The numbers in the fifth row are corrected for the error caused by the residual noise, in accordance with curves given in the operating instructions.

These figures show that, for the range from -73 dBm to -13 dBm (the five right-hand columns), the

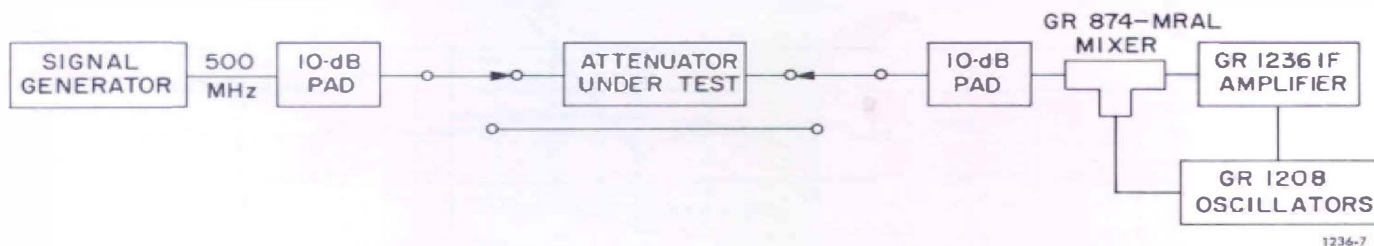

Figure 7. Setup for attenuation measurement described in text.

spread in the uncorrected attenuation figures is 0.19 dB, with a maximum deviation from mean of 0.11 dB. For the corrected figures, the spread is 0.04 dB and the maximum deviation from mean 0.02 dB. With the corrections for residual noise applied, the

spread over the range from -83 to -13 dBm is again 0.04 dB, with a maximum deviation from the mean of 0.02 dB. Here the accuracy is per-chance considerably better than that given in the specifications.

— M. KHAZAM

TABLE 1

Local Oscillator Type	Frequency Range, MHz			
	Fundamental	2nd harmonic	3rd harmonic	4th harmonic
1208-C	40-530	100-1030	165-1530	230-2030
1209-C	220-950	470-1870	720-2790	970-3710
1218-B	870-2030	1770-4030	2670-6030	3570-8030

TABLE 2

Min signal level at detector in dBm	-95	-83	-73	-63	-53	-43	-33
Max signal level at detector in dBm	-73	-63	-53	-43	-33	-23	-13
Measured attenuation in dB	17.2	19.05	19.73	19.69	19.61	19.75	19.80
Measured attenuation corrected for attenuator error in dB	17.4	19.25	19.78	19.76	19.76	19.80	19.79
Measured attenuation corrected for attenuator error and residual noise in dB	20.1	19.8	(noise not a factor)				

SPECIFICATIONS

Center Frequency: 30 MHz.

Bandwidth: Wide band, approx 4 MHz; narrow band, approx 0.5 MHz, selectable by panel switch.

Noise Figure: Typically 2 dB.

Sensitivity: From a 400-Ω source, for a 3-dB increase in meter deflection, < 9 μV (wide band) or < 3.5 μV (narrow band).

Meter Characteristics

Normal Scale: -2 to 10 dB. Linearity ±0.2 dB over 0 to 10-dB range.

Expanded Scale: 1-dB full scale. Linearity ±0.03 dB.

Compressed Scale: 40-dB min range.

Attenuator

Range: 0 to 70 dB in 10-dB steps.

Accuracy: ± (0.1 dB + 0.1 dB/10 dB) at 30 MHz.

Continuous Gain Control: 10-dB min range.

Video Output (Modulation): 1.5 V max; 1-MHz bandwidth.

I-F Output: 0.5 V max into 50 Ω.

Power-Supply Output: 150 to 300 V dc, adjustable, at 30 mA, regulated; 6.3 V ac at 1 A.

Power Required: 105 to 125, 195 to 235, or 210 to 250 V, 50 to 60 Hz, 22 W (without oscillator).

Accessories Supplied: Power cord, spare fuse.

Accessories Available: As local oscillator, GR 1208, 1209-C, 1209-CL, 1215, 1218, and 1361; 874-MRAL Mixer; GR874 low-pass filters, attenuators, adaptors, etc.

Mounting: Convertible-bench cabinet.

Dimensions (width x height x depth): 8 by 7 3/8 by 8 in. (205 x 190 x 205 mm).

Weight: Net, 12 1/2 lb (6 kg); shipping, 14 3/4 lb (7 kg).

Catalog Number	Description	Price in USA
1236-9701	1236 I-F Amplifier	\$675.00

GR Product Notes

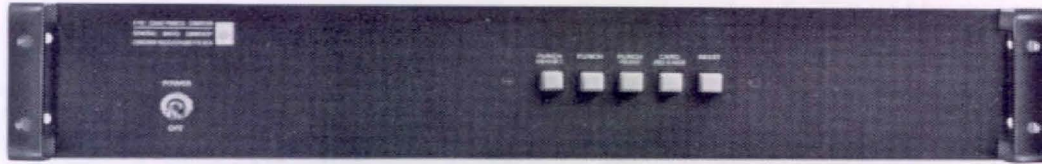

CARD-PUNCH COUPLER

The new 1791 Card-Punch Coupler converts the binary-coded digital output of the GR 1680-A Automatic Capacitance Bridge into the 10-line decimal-coded contact closures required by an IBM 526 Printing Summary Punch. Up to 22 digits of paral-

lel data can be accepted from one or more sources. Since the coupler is a systems component, in some instances requiring custom treatment of connections, price will be quoted on an individual basis.

GR900 ADAPTOR AND AIR-LINE SETS

Now available are complete sets of GR900 precision adaptors and reference air lines, mounted in mahogany cases with foamed-plastic inserts. The 0900-9451 GR900 Precision-Adaptor Set includes all the adaptors needed to mate GR900 connectors with male and female BNC, C, N, SC, OSM*/BRM, TNC, Amphenol APC-7, Precifix 7 mm, and GR874 connectors.

The 0900-9452 GR900 Reference Air-Line Set contains one each of the

six lengths (5, 6, 7.5, 10, 15, and 30 cm) of TYPE 900-LZ Reference Air Lines, plus a 900-WN4 Short-Circuit Termination and a 900-WO4 Open-Circuit Termination, both of which are commonly used with the air lines.

The storage case alone is also available, for those who would like to give their GR900 components the maximum protection against damage and dirt.

*OSM is a registered trademark of Omni-Spectra, Inc.



AMPLITUDE-REGULATING POWER SUPPLY

The TYPE 1263 Amplitude-Regulating Power Supply is now the 1263-C, the new suffix denoting a regulated dc heater supply for improved oscillator performance and a relocated output-rectifier connector for more convenient installation in relay racks.

GR Product Notes

(continued)

GR874 MIXER



The new 874-MRAL Mixer is an improved version of the 874-MR, with significantly better sensitivity and with GR874 locking connectors. Frequency range is 10 MHz to 9 GHz, with a maximum i-f of 60 MHz. A natural partner for the 1236 I-F Amplifier described earlier in this issue.

GR874 ATTENUATORS

The 874-G14 14-dB fixed attenuator described in the October 1965 *Experimenter* is now available in a locking version, the 874-G14L. GR874 single-

section, T-type resistance pads are now offered in 3-, 6-, 10-, 14-, and 20-dB sizes, locking and non-locking.

Catalog Number	Description	Price in USA
0900-9451	GR900 Precision-Adaptor Set	\$1210.00
0900-9452	GR900 Reference Air-Line Set	682.00
0900-9450	GR900 Storage Case	35.00
1263-9703	1263-C Amplitude-Regulating Power Supply	485.00
0874-9561	874-G14L 14-dB Fixed Attenuator	32.50
0874-9947	874-MRAL Mixer	65.00

WESCON

All the new instruments described in this issue can be seen at Wescon, at the Cow Palace, San Francisco, August 22 through 25, 1967. In addition, the GR booth (No. 3015-3018) will feature operating displays of GR frequency synthesizers, automatic component-measuring systems, recording wave analyzers, and the TYPE 1026

Standard-Signal Generator described in the March, 1967 *Experimenter*.

Development engineers from our Concord and Bolton plants will join engineers from our San Francisco and Los Angeles offices in staffing the GR Wescon booth. We look forward to meeting you there.

GENERAL RADIO COMPANY

WEST CONCORD, MASSACHUSETTS 01781

DO WE HAVE YOUR CORRECT NAME AND ADDRESS—name, company or organization, department, street or P.O. box, city, state, and zip code? If not, please clip the address label on this issue and return it to us with corrections, or if you prefer, write us; a postcard will do.

NBS TO CALIBRATE BOLOMETERS FITTED WITH 14-mm PRECISION COAXIAL CONNECTORS

The National Bureau of Standards Radio Standards Laboratory, Boulder, Colorado, announces a calibration service for the measurement of effective efficiency * of coaxial bolometer units fitted with 14-mm precision connectors (e.g., GR900), over a continuous frequency range from 4 to 8.5 GHz. Use of 14-mm precision connectors permits greater accuracy of measurement at radio frequencies than was possible with

the older type N connectors, according to the NBS announcement. At present the calibration service is available for measurement at a nominal power of 10 milliwatts and for bolometer units fitted with thermistor-type elements having a nominal operating resistance of 200 ohms.

* The effective efficiency of a bolometer unit is the ratio of substituted dc power in the unit to the rf power dissipated within the bolometer unit.

GENERAL RADIO COMPANY

WEST CONCORD, MASSACHUSETTS 01781