

# THE GENERAL RADIO EXPERIMENTER

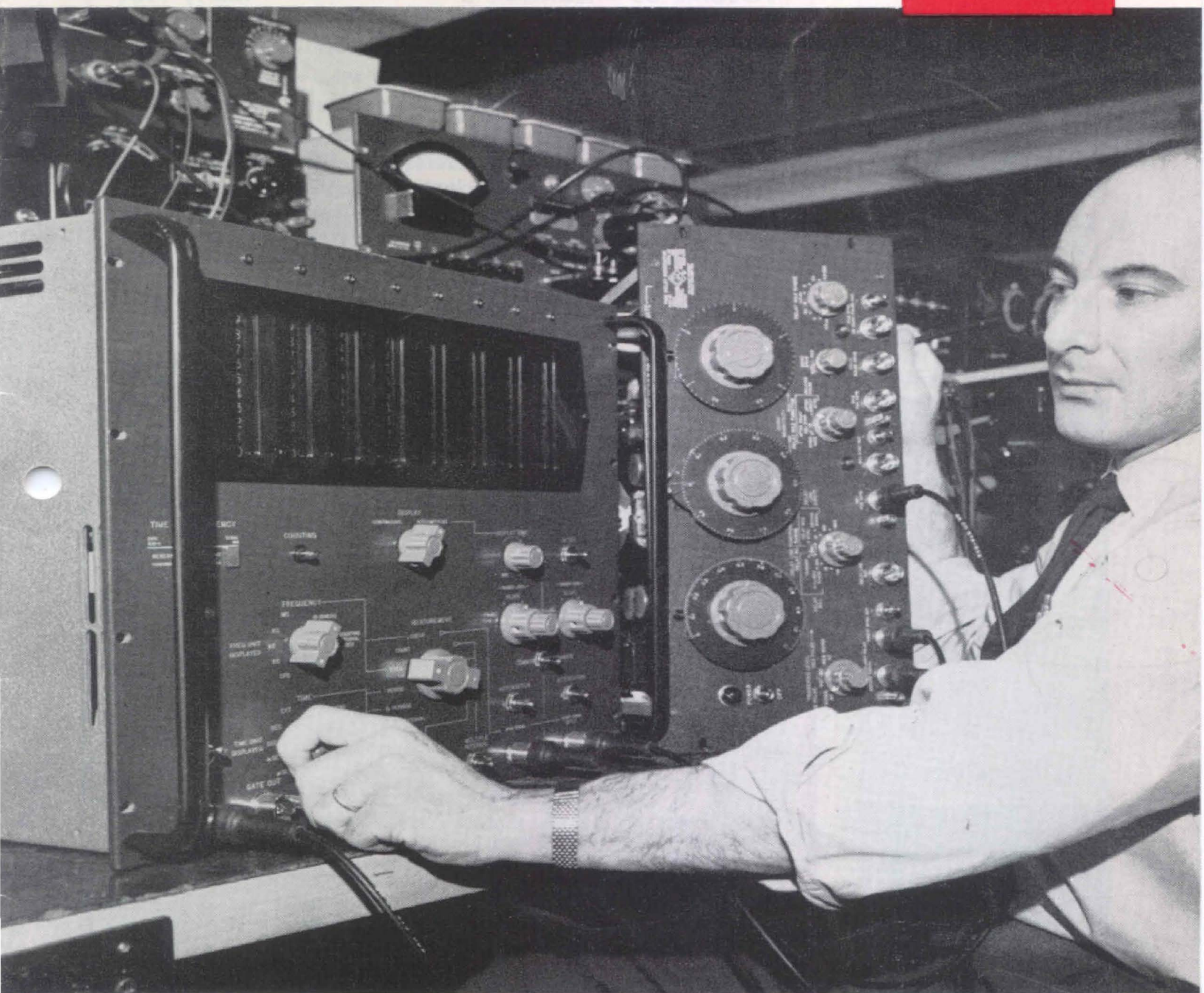

VOLUME 35 No. 5

MAY, 1961

IN THIS ISSUE



Digital Time and  
Frequency Meter



# EXPERIMENTER



©1961—GENERAL RADIO COMPANY, WEST CONCORD, MASS., U.S.A.

Published Monthly by the General Radio Company

VOLUME 35 • NUMBER 5

MAY, 1961

## CONTENTS

	Page
A Frequency Counter with a Memory and with Built-In Reliability . . . . .	3

The General Radio EXPERIMENTER is mailed without charge each month to engineers, scientists, technicians, and others interested in electronic techniques in measurement. When sending requests for subscriptions and address-change notices, please supply the following information: name, company address, type of business company is engaged in, and title or position of individual.

## GENERAL RADIO COMPANY

West Concord, Massachusetts

Telephone: (Concord) EMerson 9-4400; (Boston) MIssion 6-7400

- NEW YORK:** Broad Avenue at Linden, Ridgefield, New Jersey  
Telephone — N. Y., WOrth 4-2722  
N. J., WHitney 3-3140
- CHICAGO:** 6605 West North Avenue, Oak Park, Illinois  
Telephone — VillAge 8-9400
- PHILADELPHIA:** 1150 York Road, Abington, Pennsylvania  
Telephone — HANcock 4-7419
- WASHINGTON:** 8055 13th St., Silver Spring, Maryland  
Telephone — JUniper 5-1088
- LOS ANGELES:** 1000 North Seward St., Los Angeles 38, Calif.  
Telephone — HOLlywood 9-6201
- SAN FRANCISCO:** 1186 Los Altos Ave., Los Altos, Calif.  
Telephone — WHitecliff 8-8233
- CANADA:** 99 Floral Parkway, Toronto 15, Ontario  
Telephone — CHerry 6-2171

### REPAIR SERVICES

- EAST COAST:** General Radio Co., Service Dept., 22 Baker Avenue,  
West Concord, Mass.  
Telephone — Concord, EMerson 9-4400  
Boston, MIssion 6-7400
- NEW YORK:** General Radio Co., Service Dept., Broad Ave. at  
Linden, Ridgefield, New Jersey  
Telephone — N. Y., WOrth 4-2722  
N. J., WHitney 3-3140
- MIDWEST:** General Radio Co., Service Dept., 6605 West North  
Ave., Oak Park, Illinois  
Telephone — VillAge 8-9400
- WEST COAST:** General Radio Co., Service Dept., 1000 North  
Seward Street, Los Angeles 38, Calif.  
Telephone — HOLlywood 9-6201
- CANADA:** Bayly Engineering, Ltd., First St., Ajax, Ontario  
Telephone — Toronto EMpire 2-3741

### COVER



The Type 1130-A Digital Time and Frequency Meter shown in the General Radio Standardizing Laboratory during the calibration of Type 1392-A Time-Delay Generators.

# A FREQUENCY COUNTER WITH A MEMORY AND WITH BUILT-IN RELIABILITY

What, another counter? Yes, the TYPE 1130-A Digital Time and Frequency Meter shown in Figure 1 is a brand-new entry in the field of high-speed counters — new on the scene and new in many important details. Like several others, it is an automatic instrument for the precise measurement of frequency, period, and time intervals. It differs from them, however, in using new circuits and new design ideas to provide unusual features and a very high degree of reliability.

The instrument measures frequencies

from dc to 10 Mc with a maximum precision of  $\pm 0.1$  cps, periods from 10  $\mu$ sec to  $10^7$  sec with a precision of  $\pm 0.1$   $\mu$ sec, and time intervals from 1  $\mu$ sec to  $10^7$  sec with a precision of  $\pm 0.1$   $\mu$ sec. It can also be used to count random events, measure frequency ratios, compute phase shift, and measure characteristics of pulse waveforms.

Digital counters have found increasing application during the past ten years, and several commercial versions have come into wide use. The design of still another, having similar basic charac-

Figure 1. Panel view of Type 1130-A Digital Time and Frequency Meter.

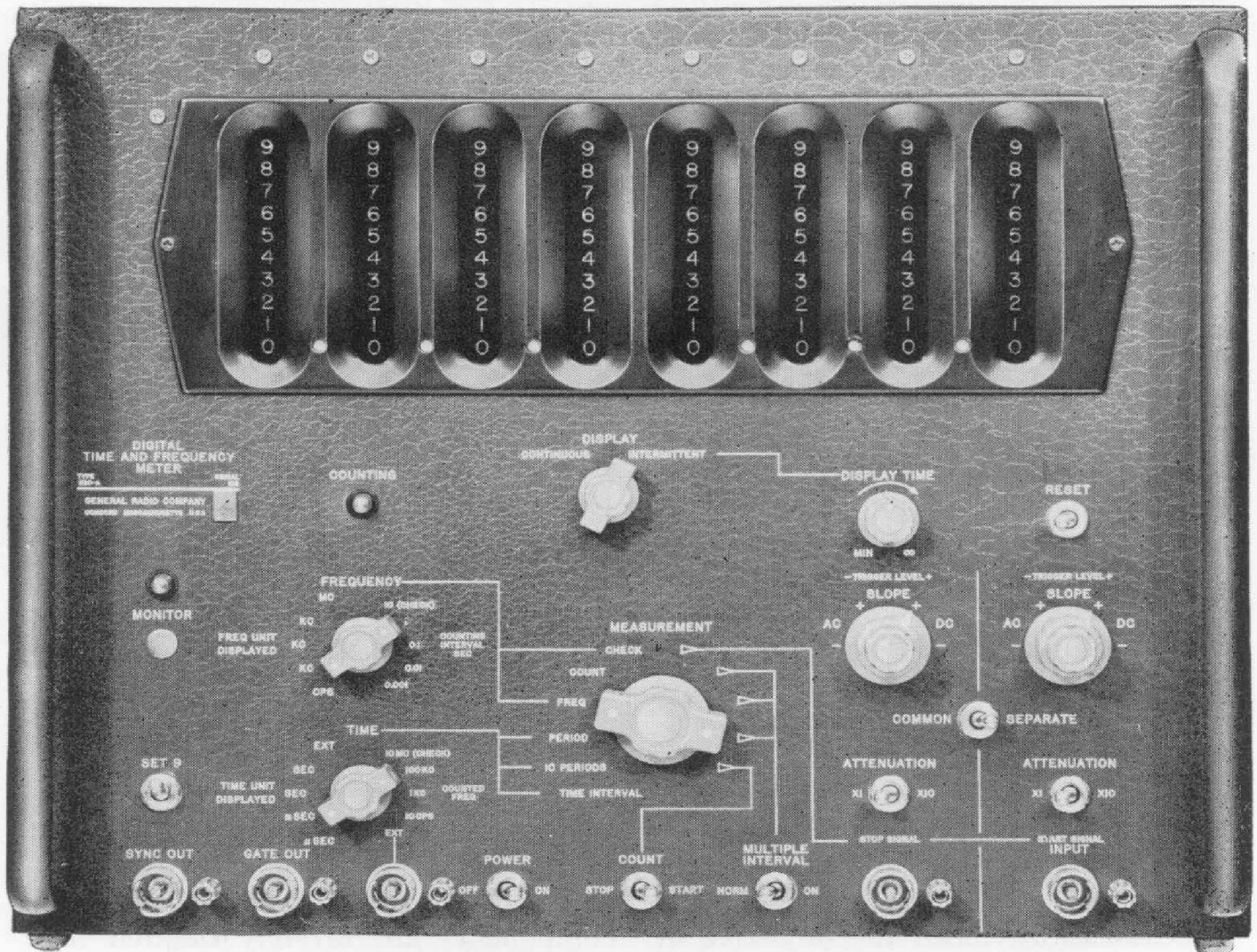



teristics, was undertaken only after thorough study indicated that both performance and convenience of use could be substantially improved.

The TYPE 1130-A is *not* "just another counter." From the start of our development work, we decided that we should design and market such an instrument only if we could make some important new engineering contributions that would have substantial value to most users. Studies of several commercial counters have uncovered inherent shortcomings in existing designs, and field experience has shown that malfunctions arising from these occur often enough to be objectionable and to necessitate extensive maintenance programs.

Further inherent disadvantages in previous instruments have resulted from the nature of the measurement sequence, or program used. The process of alternately counting and displaying has led to the familiar "intermittent" type of presentation, which is not only inefficient but tends to cause operator confusion, fatigue, and annoyance.

To overcome the difficulties stemming from these inherent characteristics and, in general, to build a better counter, we had to design circuits that were not based on traditional ideas. So we made a fresh start. Viewing the instrument as the specialized digital computer it is, we designed the operating system, the new basic circuits, the display and controls, and the mechanical assembly from the ground up. The result is an instrument that we believe represents an outstanding combination of performance and reliability.

## **SPECIFIC GOALS AND ACHIEVEMENTS**

### **Reliability and Ease of Maintenance**

It has always been the objective of

General Radio to produce reliable equipment, and the standards of quality developed in seeking this objective have formed the basis of the company's reputation. This background has furnished a solid foundation from which to work, but it has been buttressed at all possible points by innovation, as well as by the experience of others.

The computer field, in particular, is a rich source of reliability information and ideas, and the design of the TYPE 1130-A Digital Time and Frequency Meter has drawn extensively upon computer techniques and components. A major decision, obviously, has been the selection of vacuum tubes instead of transistors as active components. Progress in the performance of solid-state devices has been continuous, and often spectacular, in recent years. Reliability, on the other hand, takes time both to be achieved and to be assessed. The wealth of proven components and reliability experience for vacuum tubes has therefore, on balance, been given controlling weight in the decision.

To be most useful, an electronic device should operate for a long time without failure and should be easily put back in service in a short time. The first of these characteristics measures reliability and the second ease of maintenance. The GR Counter has been designed to meet both these requirements. Reliability is assured first of all by thorough system design. The counting units described below, for example, use a feedback system not found elsewhere, and the efficiency of the operating program is unique.

Reliability is further assured by painstaking circuit design. Computer-grade tubes (frame-grid types where suitable) are used throughout the instrument. All components are severely derated and





premium-quality connectors are used. Circuits have been designed to operate properly under extensive variations and degradation of tube parameters, and do not require fussy regulated plate and heater power supplies. Only one regulator circuit is used to assure maximum stability of the crystal-controlled time-base oscillator.

Modular construction has been used to simplify maintenance. Every tube circuit is on an etched-circuit board, which can be quickly removed for repair or replacement, and test points are available at marked panels on both sides of the instrument. The etched-circuit boards embody construction techniques that have resulted in a remarkable service record. Since GR began using etched-circuit boards several years ago, we have shipped 14,100 instruments containing 21,300 boards. Among these 21,300 boards only 12 failures have been reported, and the causes for these failures have since been found and corrected.

## Display

The problem of data display was the first to be attacked. The operating program used in most counters produces an inefficient and fatiguing intermittent display. While counts are being accumulated by the instrument, no information is presented to the operator. Conversely, while the result is displayed, no new information is entering the counter. We have developed a storage system that holds a count and displays it continuously while a new count is being accumulated. At the end of each counting interval, the new count is transferred to the display in a brief, 100- $\mu$ sec interval.

Careful attention was also given to the display itself. In-line readouts have been widely adopted for counters but

add considerably to expense, complexity, and maintenance. Thermometer-type displays, on the other hand, have a running-up-and-down appearance that has generally been found objectionable. This objection is completely overcome by the use of storage, and it was therefore decided that the simple, reliable neon-lamp columns offered the best solution for both economy and convenience.

Four decades of the GR counter can be used either as storage or as counting units. Depending upon which function is selected, the operator has the choice of either an 8-digit "intermittent" display of conventional type or a 4-digit continuous display. By proper selection of the counting interval the 4 continuously displayed digits can be any 4 consecutive digits in the 8-digit number. When calibrating variable-frequency oscillators, for example, one is usually interested in only the first few digits. These would therefore be chosen for continuous display. Conversely, in the measurement of frequency drift in very stable oscillators, only the last few digits would probably be significant and chosen for continuous display.

A further unique advantage of internal storage is the inherent availability of voltages suitable for analog graphic recording. The simple TYPE 1134-A Digital-to-Analog Converter accessory, which operates from the storage decades, provides a dc output of 0.1% accuracy and linearity, corresponding to any 3 consecutive digits of the counter display. This output will drive graphic recorders directly without the need of an intermediate, expensive electromechanical storage system. A graphic record is much easier to analyze than a list of numbers, and the results can be just as accurate if the proper digits are selected.

### Decimal-Counting Units

The design of the decimal-counting units, or decades, of the GR Counter has incorporated both optimization techniques and novel ideas. A first step was a detailed study of bistable flip-flop circuits and the interrelations of component values and tube characteristics. Design curves<sup>1</sup> were developed from which optimum values could be determined, depending upon desired repetition rates and available tubes. This was followed by an intensive study of decimal-counting systems.

In operation the flip-flops of a decimal-counting unit are complemented.<sup>2</sup> That is, they reverse state at each input pulse and issue an output or carry pulse for every other input pulse. A single flip-flop, therefore, forms a scale-of-two circuit, producing carry pulses at half the repetition rate of the input. Four cascaded flip-flops form a basic scale-of-sixteen assembly as shown in Figure 2.

Early counters displayed their count directly in binary units and it was customary to refer to them as scale-of-64, scale-of-128 counters, etc., depending

upon the number of flip-flops used. The modern decimal systems stem from the work of I. E. Grosdoff,<sup>3</sup> who showed how to change the scale-of-sixteen system to a scale-of-ten by means of feedback pulses, and how to light ten neon lamps in the now familiar columnar display. Figure 3 shows the two feedback systems described by Grosdoff.

The double-feedback system is best adapted to lighting ten neon lamps in a decimal display because the plate voltages of the four flip-flops can be properly combined in a simple matrix of resistors. The single-feedback system is best adapted to reliable counting.

Because of the ease of obtaining the display, all previous counters have used the double-feedback system in low-speed decades. Such decades, however, are subject to errors in counting caused by the multiple feedback, and failures from this cause have been a frequent source of trouble.

The first feedback signal in the double-feedback system occurs at the count of four. The 0-1 transition of the third flip-flop resets the second flip-flop to 1. This operation causes no difficulty

PULSES TO BE COUNTED	FLIP - FLOP ELEMENTS			
	1st	2nd	3rd	4th
DECIMAL NUMBER	— STATES —			
0	0	0	0	0
1	1	0	0	0
2	0	1	0	0
3	1	1	0	0
4	0	0	1	0
5	1	0	1	0
6	0	1	1	0
7	1	1	1	0
8	0	0	0	1
9	1	0	0	1
10	0	1	0	1
11	1	1	0	1
12	0	0	1	1
13	1	0	1	1
14	0	1	1	1
15	1	1	1	1
16 = 0	0	0	0	0

<sup>1</sup>R. W. Stuart, "Vacuum-Tube Flip-Flop Design for Commercial Instrumentation," NEREM Technical Program, November 19, 1958.

<sup>2</sup>From the concept of complementary numbers. In the binary system two numbers, 0 and 1, form the whole. 1 is therefore the complement of 0 and vice versa, and a flip-flop, in taking on both states, has completed the count of all possible numbers.

<sup>3</sup>I. E. Grosdoff, "Electronic Counters," RCA Review, vol. VII, no. 3, Sept., 1946; pp. 438-447.

I. E. Grosdoff, "Electronic Chain with Decimal Indicators," U. S. Patent No. 2,436,963; March 2, 1948.

**Figure 2. Block diagram of four cascaded flip-flops in a scale-of-16 assembly. Each flip-flop is set alternately to states 0 and 1 by its input pulses. On transition from state 1 to state 0, each flip-flop transmits a carry pulse to the following flip-flop, which in turn takes on states 0 and 1 at half the rate of the preceding flip-flop. The flip-flop states corresponding to the number of input pulses are tabulated below the diagram. Note that the listing of the flip-flop states shows the least significant digit at the left — the reverse of the corresponding binary number.**





since the 0-1 transition of the second flip-flop generates no carry pulse. Consider, however, the transition from 5 to 6. The input pulse first sets the flip-flops to states 0001; the 0-1 transition of the fourth flip-flop feeds a pulse back to the third flip-flop to reset it from 0 to 1; this 0-1 transition of the third flip-flop, however, is the same transition previously used to reset the second flip-flop to 1 in the first feedback operation. With new tubes the unwanted feedback does not occur because the transitions from 1 to 0 and 0 to 1 in the third flip-flop follow each other so closely in time that a full-sized feedback pulse to the second flip-flop is not generated. As the tubes age, however, changes in voltage level and delay time can, and do, prevent this sequence from occurring properly, and the count jumps from 5 to 8 instead of from 5 to 6.

The new GR Counter does not use this system anywhere, but uses instead the foolproof single-feedback system. At the same time, by the use of an addi-

tional neon lamp<sup>4</sup>, the adding matrix for the ten neon lamps is made as simple and economical as the matrix used with the double-feedback system.

Neon lamps are also used in the feedback networks to assure reliable operation<sup>4</sup>, and neon lamps and resistors are used to convert a low-speed counting decade into a combination counting and storage decade<sup>4</sup>.

The problem of tube aging has been greatly reduced in the GR decades. All circuits will operate with half-dead tubes, that is, tubes with half the  $g_m$  or twice the  $r_p$  of a design-center tube, or with any combination of new and aged tubes.

### The 10-Mc Decade

The cascaded time delays involved in the transition from 7 to 8 in the feedback system described above limit its use to input-pulse repetition rates up to about 1 Mc. For operation at faster

<sup>4</sup>R. W. Stuart, "Electric Switching Circuits," British Patent No. 851,652, U. S. Patent Pending. "Counter and Display System," U. S. Patent Pending. "Counting and Storage Systems," U. S. Patent Pending.

**Figure 3. Feedback systems for converting from scale-of-sixteen to scale-of-ten operation. The carry pulses are generated during transitions from state 1 to state 0, the feedback pulses during transitions from state 0 to state 1. The weightings necessary to convert the binary states to a decimal number are listed below the tabulated flip-flop states. The crossed-out binary states do not occur but are bypassed by the feedback reset operations.**

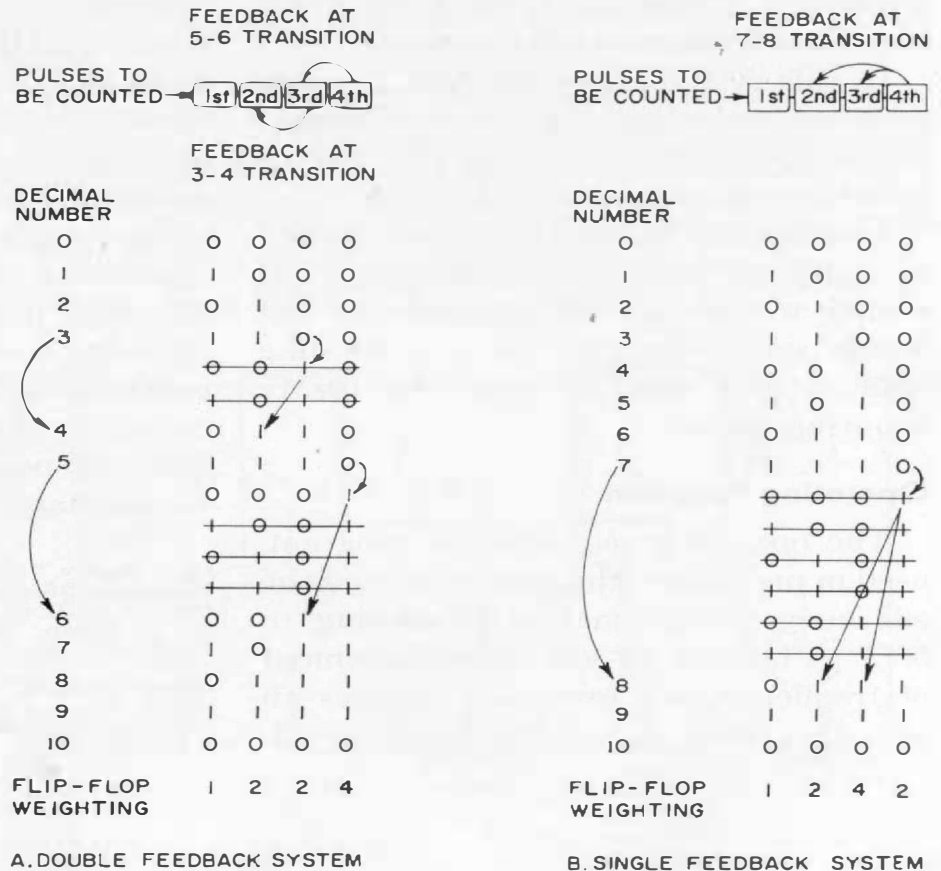

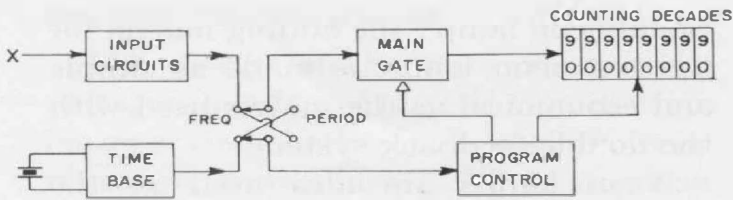

Figure 4. Block diagram of the counter; frequency and period measurement.

rates, high-speed flip-flops and multiple gating systems<sup>5</sup> have been devised to minimize the time delay. In the GR high-speed decade, two novel features have been used that contribute to a degree of reliability comparable to that of the lower speed decades. A block diagram of the gating system used is shown in Figure 6.<sup>6</sup> In this system the 4th flip-flop is a simple set-reset circuit which controls a gate directing the carry pulses from the 1st flip-flop to the 2nd. The count proceeds from 0 to 9 in normal scale-of-sixteen fashion. The transition from 1 to 0 in the 3rd flip-flop at the 8th count sets the 4th flip-flop to the 1 state, closing the gate. The output pulse of the 1st flip-flop at the count of 10 is therefore prevented from triggering the 2nd flip-flop and instead resets the 4th flip-flop to 0, leaving all flip-flops in the 0 state and reopening the gate.

In this system, only the first flip-flop operates at the high-input rate. Current-source coupling<sup>7,8</sup> is used in this circuit to achieve maximum speed.

The decade system described results in a 1-2-4-8 code. This coding is converted to the 1-2-4-2 sequence of the lower speed decades in a four-tube readout unit separate from the 10-Mc counting decade.

**Operating Program**

The operating sequence, or program, used in previous counters has limited the efficiency of information processing to 50% at best. A 10-second measurement of frequency, for example, requires an annoying dead time of at least an ad-

ditional 10 seconds for display before a new counting interval begins. In contrast, the program of the GR Counter is 83% efficient. It is therefore necessary to wait only 2 seconds before a new measurement is begun, irrespective of whether 8 digits intermittent or 4 digits continuous are displayed. For a one-second measurement, the waiting interval is only 0.2 second, for a 0.1-second measurement only 0.02 seconds, etc. The efficiency of the continuous display, on the other hand, is essentially 100% since new answers are transferred in only 100 microseconds.

**Human Engineering**

The positioning and labeling of controls and connectors in previous designs have left much to be desired from the standpoint of the operator. As shown in Figure 1, these components are logically arranged and clearly labeled in the GR counter. The terms used are simple and descriptive. Two-color engraving further simplifies the operation of the instrument. The white engraving indicates information of primary interest to the operator, such as the measurement being made and the units of measurement; the orange engraving indicates secondary or supporting information, such as the counting interval. For example, when the large, centrally located, measurement control is in the Time-Interval position, an orange dot at the rear of the double-bar knob points to an orange line leading to the Start and Stop input connectors.

<sup>5</sup>A. S. Bagley, "A 10 Mc Scaler for Nuclear Counting and Frequency Measurement," *IIP Journal*, vol. 2, no. 2, October, 1950; pp. 1-4.  
<sup>6</sup>E. L. Kemp, "Gated Decade Counter Requires No Feedback," *Electronics*, vol. 26, pp. 145-147, February, 1953.  
<sup>7</sup>Patent Pending.  
<sup>8</sup>R. W. Frank, "An Improved Pulse Generator with 15 ns Rise Time," *General Radio Experimenter*, 33, 2, February, 1959.





## TECHNICAL DESCRIPTION

### Simplified Block Diagram

The simplified block diagram of Figure 4 shows that the TYPE 1130-A Digital Time and Frequency Meter contains five basic circuit blocks: the Input Circuits, the Time Base, the Main Gate, the Program Control, and the Decimal-Counting Units. The Input Circuits are used to generate trigger pulses from the input signal. For frequency measurement the trigger pulses are counted for a time interval derived from the time base; for time measurement (period, 10 period, or time interval), the trigger pulses determine the time interval, during which clock pulses from the time base are counted.

The Program Control opens and closes the Main Gate, controls the display, and handles the various resetting operations.

### Input Circuits

A prime requirement for digital measuring equipment is that it be as nearly automatic as possible. This requirement is put to its most severe test in the input circuits, where the counter system meets the user's system. Highest reliability can be obtained when the signals counted are pulses of constant amplitude and duration; the more nearly constant, the more reliable the counting. Yet this signal must be derived from the user's signal, in which frequency, waveform, modulation, and noise are all variables. To make the counter useful with the widest variety of input signals we have therefore provided:

1. A means for adjusting the input circuit to produce the triggering pulse at some specified input-voltage level. This permits the rejection of some forms of noise in the input signal and adapts the counter to measure the frequency or period of low-duty-ratio pulsed signals.
2. A means for removing dc so that the frequency of an input signal pedestaled on dc can be measured.
3. An attenuator to help reduce the effects of noise and increase the range of the triggering level control.
4. A means for selecting the slope of the input signal which produces the best trigger pulse. This adjustment is particularly im-

portant in period and time-interval measurements where, for maximum accuracy, the most rapidly changing portion of the input signal should be selected.

A simplified schematic diagram of the input circuits of the counter is shown in Figure 5. The two triode sections of the first tube are connected as a push-pull difference-amplifier or "long-tailed pair". The input signal is applied to one grid of the pair and a variable reference voltage, determined by the Trigger-Level control, is applied to the other grid. This reference voltage determines the point on the input-signal waveform at which a trigger pulse is generated by the Input Circuits. For frequency measurement of clean, sinusoidal signals, it is desirable to generate trigger pulses at the zero-crossings of the input signals to obtain maximum sensitivity. However, for frequency measurement of pulse waveforms in the presence of noise which causes multiple zero-crossings, and for period and time-interval measurements and the counting of random events, it is desirable to adjust the triggering level to the cleanest or most significant portion of the input waveform. The Trigger-Level control is a potentiometer with a grounded center-tap covering a broad region of rotation which allows a quick, noncritical return to ground potential. The range of the reference voltage is  $\pm 10$  volts which, in conjunction with the 10:1 input attenuator, provides an effective input-triggering range of  $\pm 100$  volts.

By interchanging the grid connections of the input signal and reference voltage, the Slope Control (not shown in Figure 5) determines whether a trigger pulse is generated at a positive-going or a negative-going crossing of the triggering level. The Slope Control can also connect a capacitor in series with the input signal to block any dc that may be present.

The first amplifier circuit also serves as a stable limiter, since the plate-voltage limits are determined by the plate-supply voltage and the plate and cathode resistors, and are essentially independent of tube characteristics. Because of the symmetrical, balanced nature of

<sup>2</sup>G. E. Valley and H. Wallman, "Vacuum-Tube Amplifier," Radiation Laboratory Series, No. 18, McGraw-Hill Book Company, New York, New York, 1948, p. 411.

Figure 5. Simplified schematic diagram of the input circuits.

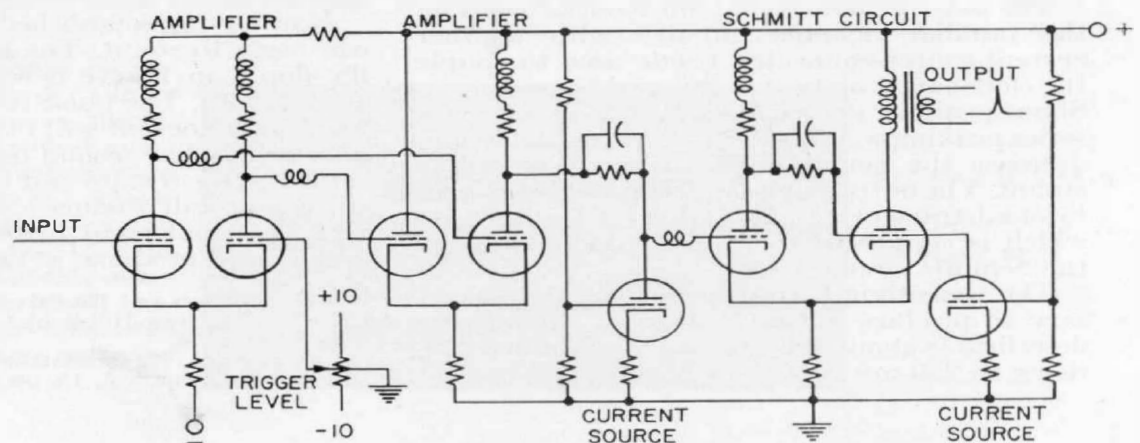

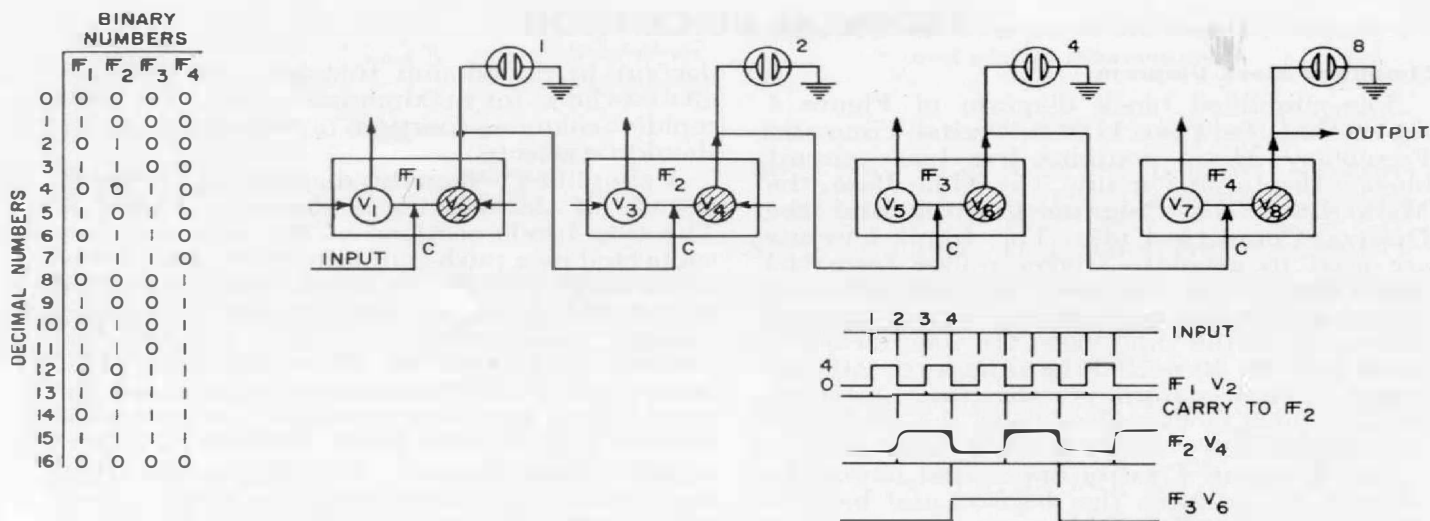

Figure 6. Scale-of-sixteen binary counter and display. The binary numbers represent the states of the flip-flops corresponding to a 1248 weighted code.

the circuit, operation is also essentially independent of plate-supply or filament-voltage variations. Another attribute of this circuit is its very high dynamic range which permits measurement of signals with large amounts of amplitude-modulation or lower frequency noise — since the circuit will not be clamped by the noise or modulation peaks, but will continue to operate at true reference-level crossings.

The output of the first amplifier stage is direct coupled to the second. Both shunt and series-peaking inductors are used to obtain maximum bandwidth. The second stage of amplification is similar to the first except that the push-pull input is converted to a single-ended output. In this connection the circuit is usually referred to as a cathode-coupled clipper.<sup>10</sup>

The output of the second amplifier stage is directly coupled to the following circuit without attenuation by means of a triode connected as a current source.<sup>7,8</sup> Because of the large cathode resistor, the triode draws a constant current through the resistor connected to its plate. With a constant current in the resistor, and therefore a constant voltage across it, any variation in voltage at one terminal of the resistor is transmitted undiminished to the other terminal, but at a different dc level.

The pulse-generating circuit itself is based on the familiar Schmitt circuit<sup>11</sup> with another current-source-connected triode used to couple the left-hand plate to the right-hand grid. Shunt peaking alone is used in this circuit since series peaking would introduce a time delay and decrease the maximum repetition rate of the circuit. The output pulse is generated by a small toroidal transformer, wound on a ferrite core, which is connected to the right-hand plate of the Schmitt circuit.

The sensitivity, (minimum voltage necessary to produce output pulses) of the circuits described is about 100-mv rms from dc to 3 Mc, rising to 250-mv rms at 10 Mc.

Counting Circuits

The general mode of operation of the counting circuits has already been described. The elements of these circuits are "flip-flops," or bistable multivibrators.

Forty of the 87 circuits in the counter are flip-flops. Of these 40 circuits, 36 are used in the Decimal Counting Units, where the binary scale-of-sixteen is permuted to a scale-of-ten for either standard counting or combination counting-storage.

Four cascaded flip-flops forming a scale-of-sixteen are shown in Figure 6.

Let us assume that the circles within the rectangles representing each flip-flop are the two tubes forming the circuit. We define the flip-flop to be in the "0" state with the right-hand tube conducting. Thus, in the figure, the shaded circles represent *on* tubes, and the scale-of-sixteen is in the state 0000. The horizontal line connections represent inputs, say to grids, and a negative pulse placed on the common connection between the tubes will turn off whichever tube is on and will thus complement the state, changing a zero state to a one or a one to a zero. A signal fed to either grid separately will set the flip-flop to the specified state only. If the flip-flop is already in that state, the pulse will have no effect.

Now having established the ground rules, we can begin to count. The first pulse received by flip-flop 1 in Figure 6 will cause it to reverse state (1000). The pulse formed when the right-hand tube goes off will be positive and will not affect FF2. The second pulse will cause FF1 to return to the 0 state and the right-hand tube in turning on will produce a negative pulse causing FF2 to complement (0100). Each 1-to-0 transition will produce a carry pulse and each

<sup>10</sup>Jacob Millman and Herbert Taub. "Pulse and Digital Circuits." McGraw-Hill Book Company, Inc., New York, New York, 1956.

<sup>11</sup>O. H. Schmitt, "A Thermionic Trigger." *Journal of Scientific Instruments*, vol. 15, pp. 24-26, January, 1938.



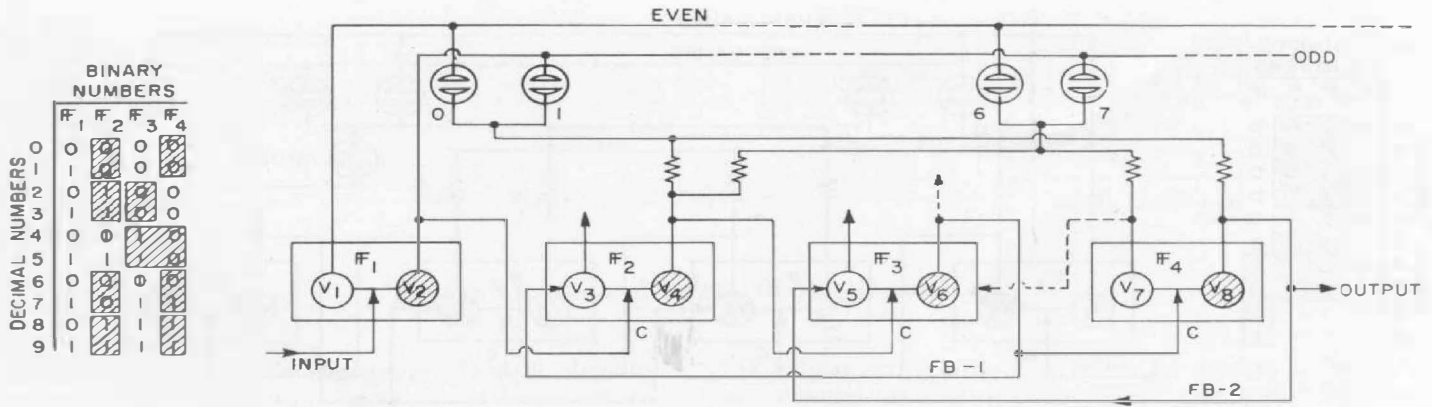

Figure 7. Grosdoff 1224 weighted code showing indicator matrix and feedback paths. The shaded areas designate combinations of flip-flop states that exist uniquely in conjunction with the two states 0 and 1 of FF1 for the allowed states. The neon lamps are connected to the matrix buses.

successive flip-flop will switch at half the rate of the one before it. The simple circuit of Figure 6 therefore produces the conventional scale-of-sixteen sequence.

To make a useful counter, one must add appropriate means to indicate the flip-flop states. This is conveniently done with neon lamps that are operated from combinations of plate voltages in the flip-flop tubes. In Figure 6 four neon lamps are shown, connected to light when the right-hand tube is conducting (state 1). The neon lamps are therefore off for a 0 and on for a 1 in the particular digit (in the binary system) that they represent. These digits are,

respectively, 1, 2, 4, and 8, and the flip-flops are said to be weighted 1-2-4-8 for counting. For example, suppose the counter has received 10 pulses. Flip-flops number 2 and 4 will then be on, and flip-flops 1 and 3 off, yielding a count of  $0(2^0) + 1(2^1) + 0(2^2) + 1(2^3) = 10$ . The first nuclear scalars were constructed in this general fashion, with binary displays.

For convenience and speed of reading in measuring systems it is obviously desirable to count and to display the counted number in the decimal system. I. E. Grosdoff of RCA showed how to construct a decade counter based on

Figure 8a. Plate voltage waveforms at 50 kc of V2, V4, V6, and V8 for 1224 coding. The system operations occurring at pulses 4 and 6 produce the dips in FF2 and FF3 waveforms. These dips, in turn, cause the difficulties inherent in this system. The first feedback is unambiguous; the second, however, requires that the time constant of the feedback path be critically adjusted to be short compared to the time between maximum-rate counts but long compared to the duration of the dips.

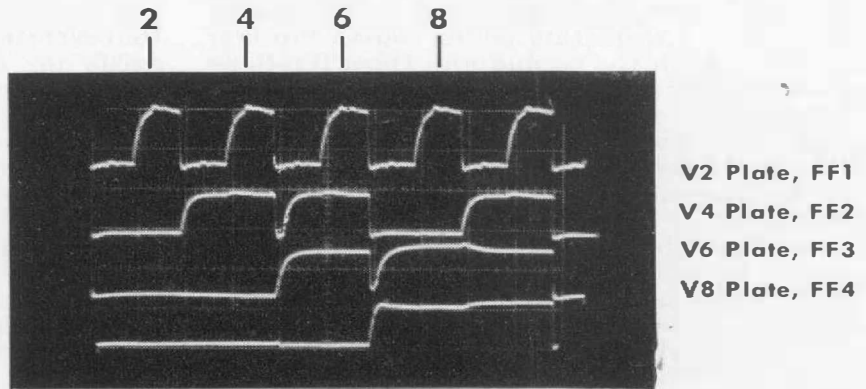
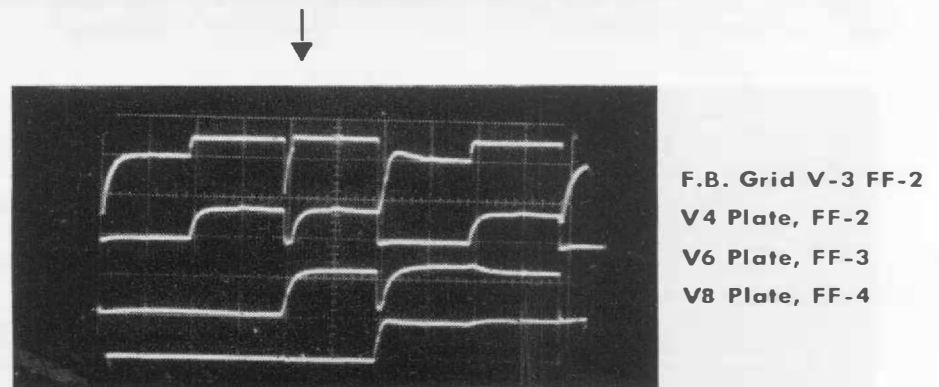

Figure 8b. FF2 grid-voltage waveform. The first feedback shows clearly as an unambiguous signal; the second shows a positive overshoot caused by differentiation of the positive slope of the 0-1 transition in FF3. In this example the grid swings 4 volts above the 10 volts required for cutoff. When this overshoot becomes too large it will produce the commonly observed decade failure of skipping from an indicated count of 5 to 8.



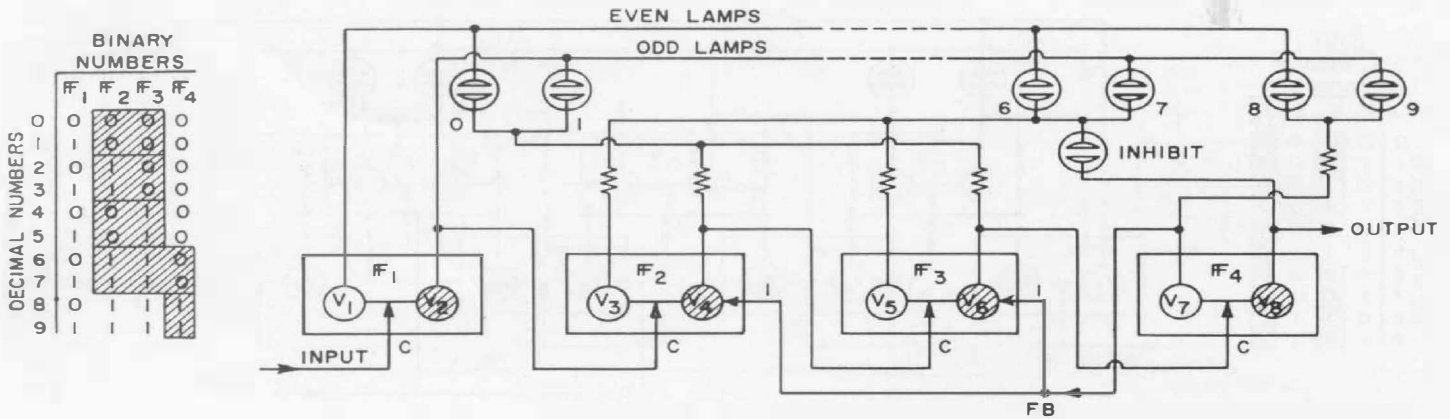

Figure 9. General Radio 1242-weighted code showing feedback and indicator matrix. Shaded areas show neon-lamp matrix connections. For this coding a triple addition must be used. The loss involved in this addition is minimized by the use of INHIBIT lamp instead of a resistor.

permuting the scale-of-sixteen to a scale-of-ten and at the same time connecting ten neon lamps in a simple matrix to display the count as a decimal number.<sup>3</sup>

Figure 7 shows the double-feedback system of Grosdoff. It is the system most commonly used in modern counters because the ten-lamp matrix is the simplest. The general sequence of this coding system has already been described, and the weakness analyzed. The possibility of failure is shown clearly in the oscillograms of Figure 8.

The single-feedback system which Grosdoff suggested does not have this built-in hazard. Its operation has been previously described and the system is shown in Figure 9. In this system the count proceeds normally up to the eighth pulse. The 0-1 transition of the fourth flip-flop then resets both the second and third flip-flops simultaneously to 1, eliminating the 6 scale-of-sixteen binary states 8 to 13 without critical timing. The question immediately arises, why hasn't this more reliable code been used rather than the common one? The answer lies in the indicator-lamp matrix which we shall now discuss. See Figure 10, where this coding system is shown in operation at 50 kc.

Refer again to Figure 7. Assume that a given neon lamp in the indicator will ionize only when it is connected from the potential of an off flip-flop plate to that of an on plate. Now, for example, take the decimal number 1. The 1 lamp is connected from the plate of V2, which

is off (state 1), via two resistors to plates of V4 and V8 which are on (state 0). Thus the 1 lamp will be on. These states in FF2 and FF4 are unique to the digits 0 and 1 in this coding system. In all other allowed states either one or the other flip-flop is in state 1 and the voltage at the neon lamp is  $\frac{1}{2}$  the on-plate voltage, which is not sufficient to light it. Likewise, all shaded state combinations in Figure 7 are unique to corresponding decimal numbers. Note that whether the 0 or the 1 lamp is lighted depends only upon the state of the first flip-flop. The first flip-flop always determines whether the even or odd lamp of a selected pair will light. In this example, therefore, the type of simple resistor matrix shown will unambiguously control the lamps. Now, look at Figure 9. Note that NO such combination of two unique states exists for each pair of decimal numbers. In order to get an unambiguous combination, we must combine at least once the states of three of the flip-flops. The General Radio counting decade uses the combinations shown shaded. It would be possible to continue to use a resistor matrix with a three-resistor addition to control the lighting of the six-seven lamp pair, but the loss in such a resistive adder, when coupled with the fixed ionization-deionization voltage-increment requirements of neon lamps, would call for uneconomically large flip-flop plate swings. We have developed a matrix system requiring the same plate swings as a normal decade by adding one neon lamp to the matrix to prevent

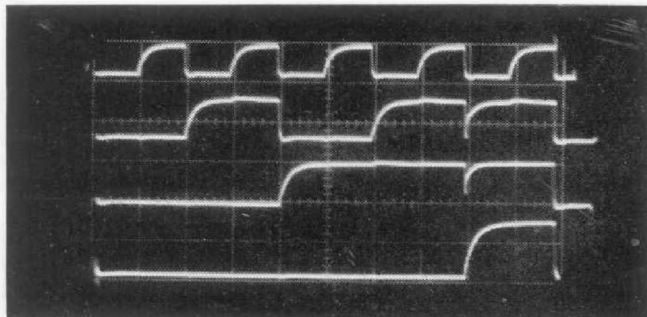

- FF-1
- FF-2
- FF-3
- FF-4

Figure 10. Typical waveforms for the flip-flops in the General Radio 1242 code of plates.





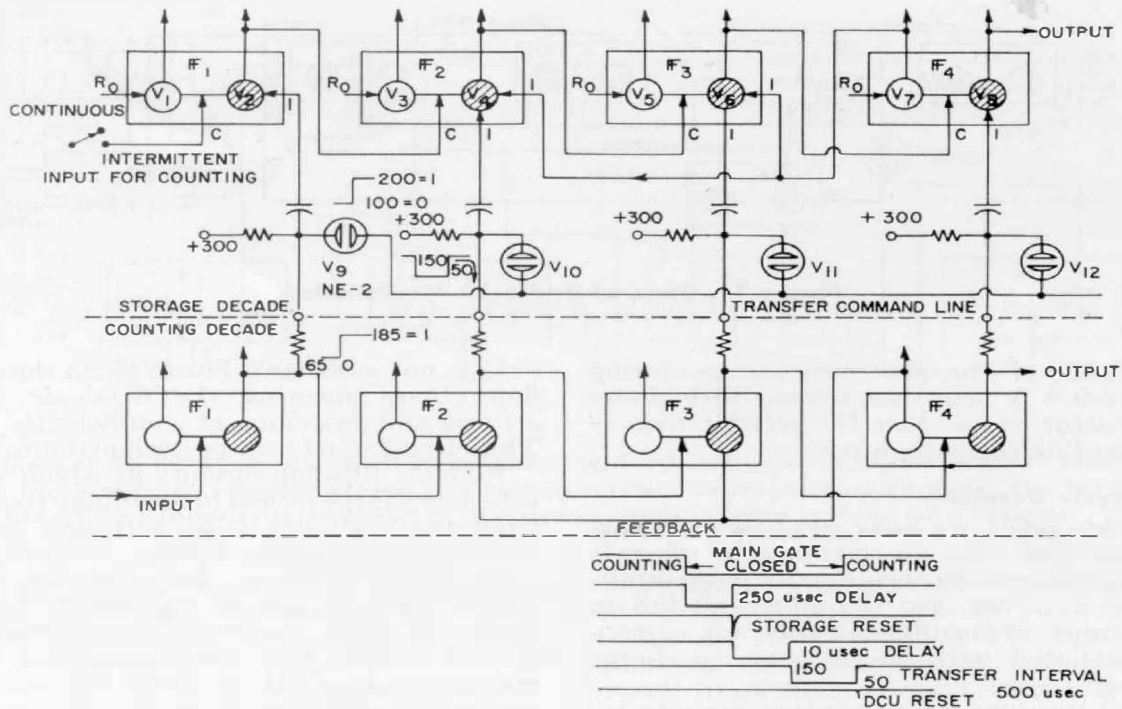

Figure 12. Counting and storage decades for the Type 1130-A.

**Combination Counting-Storage Decade and Storage System**

A decimal counting unit entirely unique<sup>14</sup> to the TYPE 1130-A Digital Time and Frequency Meter is shown in Figure 12. The unit is a combination decade which can either count in the normal fashion at frequencies in excess of 20 kc; or, alternatively, which can store binary data and present it as a decimal number when these data are read in from other General Radio standard 1-2-4-2 coded decimal counting units.

When the counter is used for continuous display of information, the eight dec's are broken into two groups of four each. This is done by interrupting the carry pulse between the fourth and the fifth dec's. (This fifth dec is the first combination unit.) The timing diagram of Figure 12 shows the sequence of events after a counting interval. This sequence is initiated by the closing of the main gate and ended 1000  $\mu$ sec later when the decimal counting units are reset to zero.

During this time interval:

1. The storage units are set to zero, erasing the old data from the last counting interval.
2. After a 100- $\mu$ sec interval to insure that the storage units are at equilibrium,
3. A transfer command pulse is generated on the "transfer" bus lasting for 500  $\mu$ sec. During this interval, any binary 1 in a counting decade will cause the transfer lamp (V9 through V12) to ionize. The resulting pulse will set the equivalent storage flip-flop to the 1 state.
4. 150  $\mu$ sec after the termination of the transfer command, the dec's are reset to zero and the new counting cycle can be started.

When they ionize, the neon lamps themselves

provide pulses which transfer data to the storage units, so that the isolating resistors between the counting and storage units can have very high values. Since the neon lamps, when not ionized, have very small capacitance, the counting and storage units operate independently and no complex switching is required.

At the neon-lamp junctions, the logical 0 and 1 levels from the counting decade provide  $\pm 50$  volts across the bulb which is *not* to ionize and 150 volts across the lamp which must ionize for a 1 transfer. These levels insure that unselected neon lamps can be used with no danger of false transfer or failure to transfer. We have provided a complex, and heretofore unobtainable, function in the combination counting storage decade, by using only four inexpensive neon lamps, eight resistors, and eight capacitors.

**Program**

Figure 13 is a block diagram of the program-control system used in the GR Counter.

Let us assume that the sequence begins with a reset pulse from the Reset Generator. The reset pulse sets all the Decimal-Counting Units and the Program-Control Decade to zero and sets the Main Gate Flip-Flop and the Program Gate Flip-Flop to zero, closing the Main Gate, the Program Gate, the Diode Gate, and the Time Gate. Since the Time Gate is closed, clock pulses from the Time Base cannot activate the Main Gate Flip-Flop and the trigger pulses from the Input Circuits cannot enter the Decimal Counting Units.

<sup>14</sup>Patent Pending.



The reset pulse also triggers the Reset Delay Generator, which produces a pulse 400  $\mu$ sec later and sets the Program Gate Flip-Flop to the "1" state, opening the Program Gate and partially completing the Diode Gate. The Time Gate is still closed, but pulses from the Time base can pass to the Program-Control Decade. The first Time-Base pulse advances the state of the decade to "1", which completes the Diode Gate and causes the Time Gate to open. The next Time-Base pulse, the second, passes through the Time Gate and complements the Main Gate Flip-Flop to "1", which opens the Main Gate and allows pulses from the Input Circuits to enter the Decimal-Counting Units. The second Time-Base pulse also advances the state of the Program-Control Decade to "2," which disables the Diode Gates and closes the Time Gate so that the following Time-Base pulses cannot close the Main Gate. The Main Gate remains open while the Time-Base pulses continue to advance the state of the Program-Control Decade. When the decade reaches "1" again, the Diode Gate is again enabled and the Time Gate is opened, allowing the next Time-Base pulse, the eleventh, to pass through and complement the Main Gate Flip-Flop to "0," closing the Main Gate. Pulses from the Input Circuit have been allowed to pass through the Main Gate into the Decimal Counting Units for exactly ten Time-Base pulse intervals.

The closing of the Main Gate at the end of the measurement interval sets the Program Gate Flip-Flop to "0" and locks out the Program Gate, Diode Gate, and Time Gate so that the Decimal-Counting Units can display their accumulated count. If the Intermittent display mode is used, the Main Gate closing also trig-

gers the Display-Interval Generator. At the end of the desired 0.1- to 10-second display time the Reset Generator is triggered, producing a reset pulse which begins the cycle again.

If the Continuous display mode is used, the Display Interval is disabled and the Main Gate closing triggers the Transfer Unit. This unit causes the count accumulated in the four counting decades to be transferred to the four storage decades. After a 1-msec interval, generated by the Transfer Delay, the Reset Generator is triggered and the cycle begins again. The measurement cycle can be stopped and started again at any point by the Manual Reset, which is controlled by the front-panel Reset switch.

For 10-Period measurements, the roles of the Input Circuits and Time Base are reversed so that the Main Gate remains open for ten input intervals while Time-Base pulses are registered in the Decimal-Counting Units.

The use of the Program-Control Decade in the system provides three advantages:

1. To obtain a 10-second measurement interval the lowest speed Time-Base divider operates at 1 cps rather than 0.1 cps.
2. Ten-Period measurements are easily made.
3. The dead time between measurements is decreased to two-tenths of a measurement interval.

For single-period and time-interval measurements, the Program Gate, Program-Control Decade, and Diode Gate are removed from the system, and the Time Gate operates under the direct control of the Program Gate Flip-Flop or the Input Circuits. The system efficiency is then reduced to 50%, a measurement being made during every other interval at best.

Figure 13. Block diagram of the Digital Time and Frequency Meter for frequency and 10-period measurement.

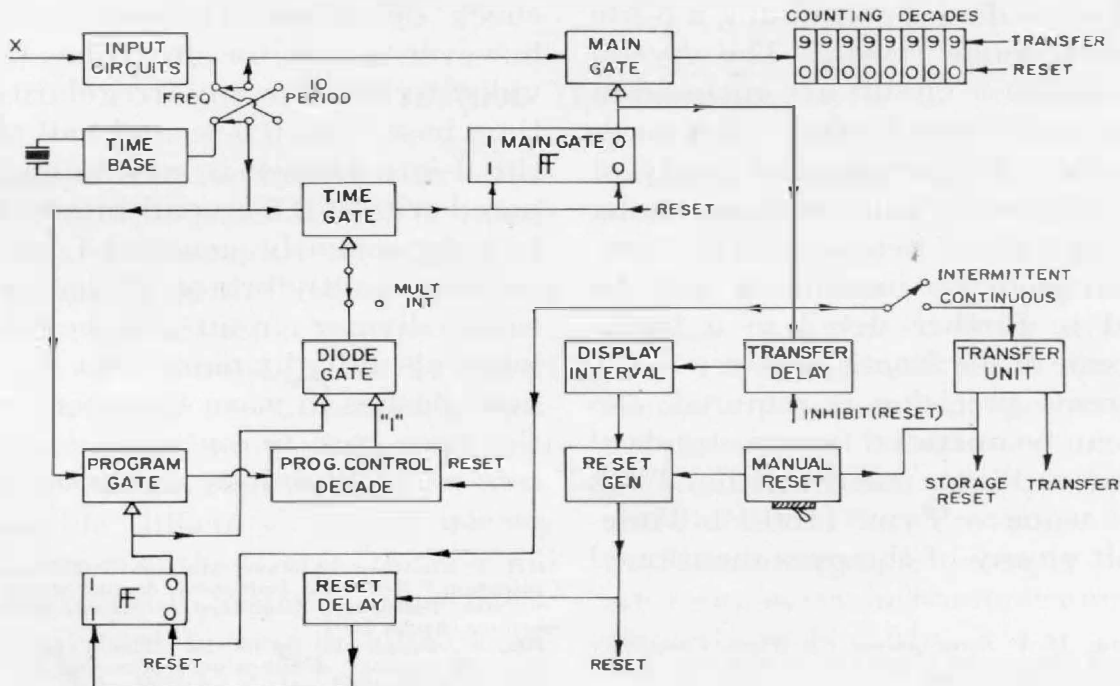

## TIME BASE

### Drive Sources

The time base of the TYPE 1130-A Counter is designed to operate from a 5-Mc source. To suit a wide variety of requirements, several drive sources are available as optional units which can be plugged into the rear of the counter. The TYPE 1130-P2 Oscillator/Multiplier allows operation from external sources of 100 kc, 1 Mc, or 5 Mc, or from an internal 5-Mc oscillator. The internal-oscillator circuit uses a room-temperature quartz crystal of exceptional characteristics<sup>15</sup> with a short-term stability of about  $1/10^8$  per minute and an aging rate of about  $2/10^7$  per week. The multiplier circuit uses novel techniques developed especially for this application.<sup>16</sup>

The TYPE 1130-P3 Oscillator contains the oscillator portion of the TYPE 1130-P2 Oscillator/Multiplier and is recommended for those applications where part-per-million accuracy is sufficient.

The TYPE 1130-P4 Precision Oscillator is a solid-state device containing a 5-Mc fundamental-mode crystal. The crystal and the oscillator circuit are enclosed in a proportional-control oven. This oscillator displays a short-term stability of about  $1/10^9$  per minute and an aging rate of about  $5/10^8$  per week. The time-base drive sources mentioned will be described in further detail in a forthcoming issue of the *Experimenter*.

If extreme precision is required, the counter can be operated from a standard frequency oscillator such as the TYPE 1113-A,<sup>17</sup> using a TYPE 1130-P1 Time-Base Unit or any of the ones mentioned above.

### Time-Base Dividers

The divider circuits are of the proven multivibrator type. The low-frequency dividers use high-valued, plate-load resistors to insure "hard bottoming" and minimize the effect of variations in tube characteristics.<sup>18</sup> The high-frequency, 5-Mc to 1-Mc multivibrator uses a frame-grid double triode in a circuit well stabilized by current feedback.<sup>15</sup> A 100% increase in the plate resistance causes only a 5% change in the free-running frequency of the multivibrators. Because of the exceptional stability of these circuits, no periodic adjustments are required.

### Time-Base Monitor

If the 5-Mc time-base drive signal is absent, the divider chain will operate at a frequency error of about 5%. Similarly, if a failure should occur anywhere in the time base, the 1-cps multivibrator, the last divider in the chain, will be in error. Such an error, of course, will become obvious if the counter is set for self-check operation. In addition to this, however, a monitor circuit has been provided to indicate any irregularity in the time base. The 0.5-second half period of the 1-cps divider is continuously compared with a 0.5-second interval, which is independently generated by a free-running multivibrator of design similar to the divider circuits. If the 0.5-second intervals differ by more than 1%, a panel light flashes to warn the operator. Thus the time base is *continuously monitored even when the counter is making measurements*.

<sup>15</sup>H. T. McAleer, "A Novel Method for Frequency Multiplication," *Electronic Industries*, August, 1959.

<sup>17</sup>"New Frequency Standard," *General Radio Experimenter*, April, 1961.

<sup>18</sup>R. W. Frank, F. D. Lewis, "The Type 1213-C Unit Time/Frequency Calibrator," *General Radio Experimenter*, June, 1956.

<sup>15</sup>R. W. Frank, H. P. Stratemeyer, "A Time/Frequency Calibrator of Improved Stability," *General Radio Experimenter*, October, 1959.





## MECHANICAL DESCRIPTION

The TYPE 1130-A Digital Time and Frequency Meter has been designed to facilitate both the construction of the instrument and the occasional maintenance required. As mentioned above, every vacuum-tube circuit is on an easily removable etched-circuit board plugged into the main structure. The main structure is a rugged framework of cast and machined aluminum, containing the power transformer, some of the power-supply rectifiers and filter capacitors, interconnection cables, plugs, and sockets, some component terminal boards, and the front panel with its switches and switch circuits. Front-panel switches couple automatically to switches on the etched boards without set-screws or critical alignment. Each etched board is securely fastened in the instrument by means of a single screw. Time-Base drive units plug into the rear of the instrument and are held by two panel screws.

Quiet forced-air cooling is used to hold the internal temperature rise to about

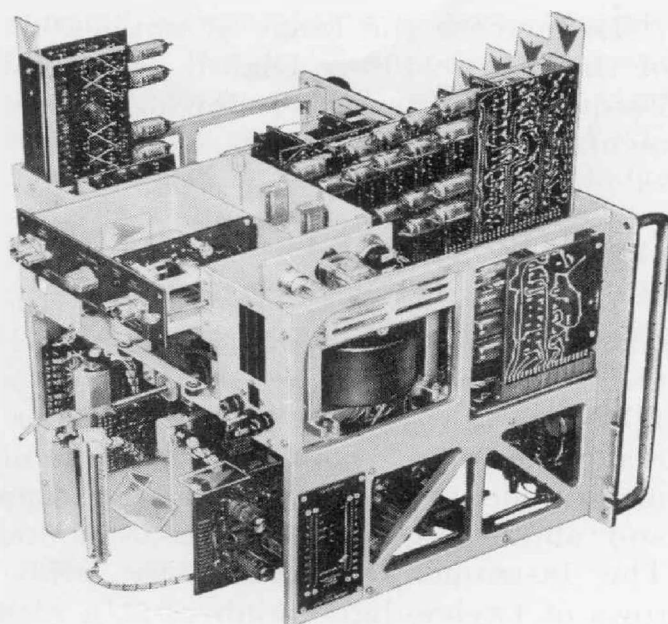

**Figure 14.** Interior view of the Type 1130-A Digital Time and Frequency Meter. Note that the etched-circuit boards (some shown partially withdrawn) are readily accessible.

15 C above the external ambient temperature. The air filter snaps out easily for cleaning.

A view of the instrument with cabinet removed is shown in Figure 14.

## TESTING TECHNIQUES

Because of the modular construction of the Counter, it is possible to test each etched board thoroughly as a unit before installation in the instrument; and the structure itself with its power supply, switches, and components can be tested alone. In addition to subassembly testing, of course, the completed instrument is subjected to over-all testing.

A possible difficulty caused by the wide tolerance of the circuits to tube and component variation is an increase in the probability that a wrong-valued component or a weak tube may go un-

noticed, since the circuit may still function properly. To combat this possibility, the circuits are subjected to marginal testing in which the supply and signal voltages are varied over wide ranges. The Decimal-Counting Units, for example, must operate properly for a plate-supply voltage variation of  $\pm 120$  volts about the nominal value of +300 volts, and the Time-Base unit must operate at half its nominal plate-supply voltage. In addition, every instrument must operate properly to 11.5 Mc.

## ACCESSORY EQUIPMENT

To increase the range of application of the TYPE 1130-A Digital Time and Frequency Meter the following instruments are available:

### **Type 1132-A Data Printer**

Manufactured and serviced by the Clary Corporation of San Gabriel, California, and sold by GR, the TYPE 1132-A Data Printer provides a permanent printed record of the results of measurement on adding-machine tape and allows unattended measurements. The instrument automatically prints rows of twelve-digit numbers at a rate adjustable from one print every twenty seconds to three prints per second. Eight of the twelve digits are obtained directly from the Counter, and the other four digits may be obtained from external sources. A keyboard and print-command bar at the top of the instrument allow numbers to be typed manually between automatic prints. An output for driving an IBM summary punch is available as a special option. The printer is mounted in a bench-type case with the adding-machine tape issuing from the top.

### **Type 1134-A Digital-To-Analog Converter**

Because of the internal storage capability of the continuous display of the TYPE 1130-A Digital Time and Frequency Meter, the task of graphical recording is vastly simplified. The TYPE 1134-A Digital-to-Analog Converter accepts the four-line, 1-2-4-2, binary-coded-decimal outputs of the four storage decades of the Counter and produces a dc analog output of 0.1% accuracy. This accuracy specification includes the effect

of nonlinearity, repeatability,  $\pm 10\%$  line-voltage variations, long-term stability, and ambient temperatures from 0 to 50C. The Thevenin equivalent of the output circuit of the instrument is a voltage source varying from 0 to -30 volts behind a resistance of 30 kilohms. This output will drive 1-ma graphical recorders with input impedances up to 2 kilohms. An internal 100-ohm resistor can be connected in shunt with the output terminals to provide a 100-millivolt signal to drive most voltage recorders, or external resistors can be connected to produce other voltages. The instrument can be switched to operate from any three, or the last two, consecutive digits of the Counter display, allowing a precision of recording as great as that of the Counter itself. The availability of this instrumentation should increase the popularity of graphical recording of frequency stability, drift, etc., because of the ease of interpretation of a graphical record compared with that of a list of printed numbers.

### **Type 1133-A Frequency Converter and Video Amplifier (under development)**

*This instrument increases the sensitivity of the TYPE 1130-A, and increases the frequency range to 500 Mc. The instrument provides a digital display and can be operated either as a wide-band heterodyne converter for clean signals or as a selective converter for noisy signals. The heterodyne-reference signals are derived from the crystal-controlled Time-Base drive source of the Counter and are just as accurate.*

— R. W. FRANK

— H. T. McALEER



## ACKNOWLEDGMENT

The design and development of the TYPE 1130-A Digital Time and Frequency Meter was the work of a development team composed of R. W. Frank, H. T. McAleer, and R. W. Stuart under the leadership of Mr. Frank. The decimal-counting units and the program-control unit were designed by R. W. Stuart, the input amplifiers and time-base unit by H. T. McAleer, and the 10-Mc decade, main-gate system, stop-

channel comparator and power supply by R. W. Frank. The modular concept was developed by R. W. Frank and worked out cooperatively with H. T. McAleer and H. G. Stirling. P. K. Bodge consulted on mechanical-engineering problems, and testing and calibration procedures were devised by W. P. Buuck. G. E. Pilkington was responsible for production engineering.

—EDITOR

## SPECIFICATIONS

### FREQUENCY MEASUREMENT

**Range:** Dc to 10 Mc.

**Sensitivity:** 0.25 volt rms for sine waves, more sensitive at low frequencies; 0.4 volt peak-to-peak for typical pulse waveforms.

**Counting Interval:** 1 msec to 10 sec, extendible by MULTIPLE INTERVAL switch or external connections.

**Accuracy:**  $\pm 1$  count  $\pm$  time-base-oscillator accuracy.

### PERIOD MEASUREMENT

**Range:**  $10\mu\text{sec}$  to  $10^7$  sec — (dc to 100 kc) — for single-period measurement.  $330\mu\text{sec}$  to  $10^7$  sec — (dc to 30 kc) — for ten-period measurement.

**Sensitivity:** 0.1 volt rms for sine waves; 0.3 volt peak-to-peak for typical pulse waveforms.

**Counting Interval:** 1 period, 10 periods, extendible by MULTIPLE INTERVAL switch or external connections.

**Counted Frequency:** 10 Mc, 100 kc, 1 kc, 10 cps, or external (6 volts rms sine waves, or +10 volts peak pulses, 100 cps to 10 Mc).

**Accuracy:**  $\pm 0.1\%$  at 1 volt rms for single-period measurement; better for higher voltage level and good signal-to-noise ratio.  $\pm 0.01\%$  at 1 volt rms for 10-period measurement; better for higher voltage level and good signal-to-noise ratio.

### TIME-INTERVAL MEASUREMENT

**Range:**  $1\mu\text{sec}$  to  $10^7$  sec.

**Sensitivity:** 0.3 volt peak-to-peak.

**Counted Frequency:** 10 Mc, 100 kc, 1 kc, 10 cps, or external (6 volts rms sine waves, or +10 volts peak pulses, 100 cps to 10 Mc).

**Accuracy:** Dependent on slope of input signals at instants of triggering. For steep slopes (e.g., pulses):  $\pm 1$  period of frequency counted  $\pm$  accuracy of frequency counted.

### COUNT MEASUREMENT

**Rate:** Dc to 10 Mc.

**Sensitivity:** 0.25 volt rms for sine waves, more sensitive at low frequencies; 0.4 volt peak-to-peak for typical pulse waveforms.

**Capacity:**  $10^8$  counts.

### TIME-BASE OSCILLATOR STABILITIES

Type	Short-Term	Long-Term
1130-P2	less than $1/10^8$ per minute	less than $2/10^7$ per week
1130-P3		
1130-P4	less than $1/10^9$ per minute	less than $5/10^8$ per week
1113-A (with 1130-P1)	less than $1/10^{10}$ per minute measured with 1 sec sample	less than $5/10^{10}$ per day (10-day average after 60 days' operation)

### GENERAL

**Display:** Neon-lamp columns — 8 digits intermittent, 4 digits continuous.

**Display Time:** Variable, 0.1 to 10 sec, infinite, or continuous display.

**Input Impedance:** 1 megohm shunted by 40 pf.

**Input Attenuator:** x 1 or x 10.

**Check:** 10 cps, 1 kc, 100 kc, or 10 Mc can be counted for 1 msec to 10 sec.

**Monitor:** Flashing lamp indicates lack of time-base drive signal or improper operation of frequency dividers.

**Input Triggering Level:** Variable  $\pm 10$  volts.

**Input Triggering Slope:** Positive-going or negative-going, ac or dc coupling.

**External Outputs — Front Panel:** GATE signal (coincides with counting interval).

SYNC pulses (at start of internal program cycle).





10 cps to 10 Mc (except 1 Mc) standard frequencies from EXT connector, depending on settings of MEASUREMENT, FREQUENCY, and TIME controls.

**External Outputs — At Rear:** MULTIPLE-INTERVAL connections (terminals of MULTIPLE INTERVAL panel switch; “carry” pulse of program-control decade to be counted down by external interval-multiplier circuit for CHECK, FREQUENCY, and 10-PERIOD measurements).

8, four-line, binary-coded-decimal digits (1,2,4,2) (“0” = 185 volts, “1” = 65 volts — 0.5 megohm source impedance — minimum load impedance 1.8 megohm).

**Time-Base Drive Required:** 5 Mc, 1 volt rms into 50 ohms (supplied by 1130-P2, -P3, -P4, 1113-A).

**Power Input:** 115/230 volts, 50-60 cps, 400 watts.

**Dimensions:** Width 19, height 15¾, depth 19 inches (485 by 400 by 485 mm), over-all.

**Weight:** 85 lb. (39 kg).

**ACCESSORY INSTRUMENTS**

**Time-Base Units** (see page 16 and above for description and stability figures).

**Type 1130-P2 Time-Base Oscillator/Multiplier** (rear plug-in) for operation from 100 kc, 1 Mc, 5 Mc or internal 5 Mc.

**Type 1130-P3 5-Mc Time-Base Oscillator** (rear plug-in).

**Type 1130-P4 5-Mc Precision Time-Base Oscillator** (rear plug-in).

**Type 1130-P1 Coupling Unit** for use with external time base, such as TYPE 1113-A Standard-Frequency Oscillator.

**Type 1132-A Data Printer**

**Type 1134-A Digital-to-Analog Converter** for driving graphic recorder.

**Type 1130-P5 Servicing Accessory** — permits operation of any of 11 printed-circuit boards clear of rest of instrument for operational trouble shooting.

Type		Code Word	Price
1130-AM1	(Including Type 1130-P1 Time-Base Unit) Bench Mount.....	LABOR	\$2585.00
1130-AR1	(Including Type 1130-P1 Time-Base Unit) Rack Mount.....	MINIM	2585.00
1130-AM2	(Including Type 1130-P2 Time-Base Oscillator/Multiplier) Bench Mount.....	LAPEL	2750.00
1130-AR2	(Including Type 1130-P2 Time-Base Oscillator/Multiplier) Rack Mount.....	MOCHA	2750.00
1130-AM3	(Including Type 1130-P3 Time-Base Oscillator) Bench Mount.....	LASSO	2670.00
1130-AR3	(Including Type 1130-P3 Time-Base Oscillator) Rack Mount.....	MOGUL	2670.00
1130-AM4	(Including Type 1130-P4 Precision Time-Base Oscillator) Bench Mount.....	LUNER	2950.00
1130-AR4	(Including Type 1130-P4 Precision Time-Base Oscillator) Rack Mount.....	METAL	2950.00
1132-A	Data Printer.....	LILAC	1450.00
1134-AM	Digital-to-Analog Converter (Bench Mount).....	MINOR	595.00
1134-AR	Digital-to-Analog Converter (Rack Mount).....	MOTTO	595.00
1130-P5	Servicing Accessory.....	MOLAR	30.00

U.S. Patents 2,548,457; 2,977,540; and Patents Pending.

**CORRECTION**

The TYPE 1112-A Standard-Frequency Multiplier input specifications given in the April, 1961 *EXPERIMENTER* should be corrected to read as follows:

**Input:** 1 volt, 100-kc sine wave from standard-frequency oscillator. Can also

be driven at input frequencies of 1 Mc (1.5 volts), 2.5 Mc (0.4 volt), or 5 Mc (0.4 volt). Will run free with no input signal, but absolute frequency may be in error by several parts per million.

**General Radio Company**