

Communication *and* Broadcast Engineering

VOL. 2 NO. 2

- Radio Telegraphy
- Radio Telephony
- Wire and Cable Telegraphy
- Wire and Cable Telephony
- Broadcast Transmission
- Carrier Transmission
- Am Transmission
- Marine Radio
- Police Radio
- Aeronautical Radio
- Television
- Facsimile



FEBRUARY, 1935

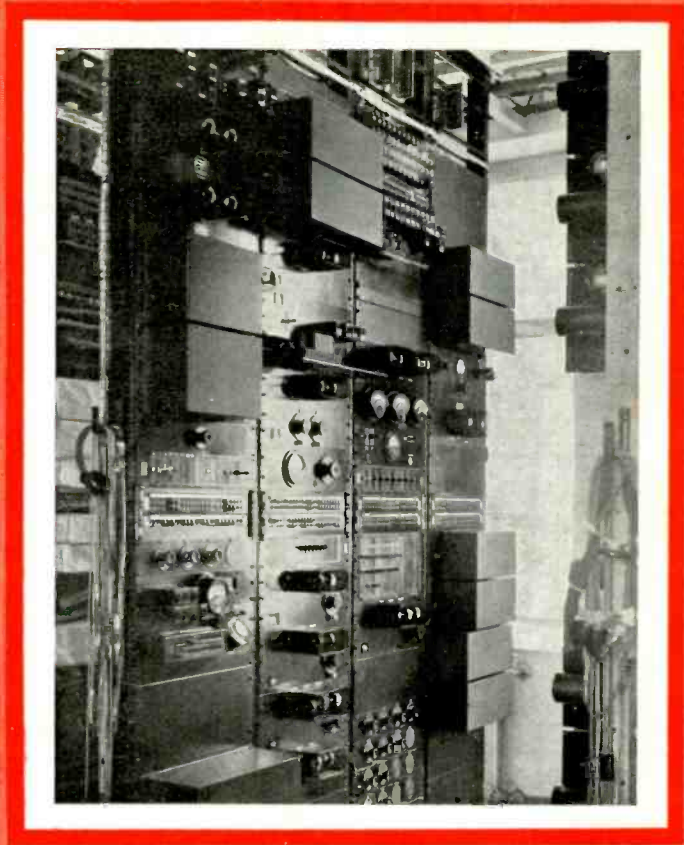

SUBSCRIPTION
\$3.00 YEARLY

The Journal of World Communications



AND NOW THE NEWEST 1935 DEVELOPMENT FROM THE U T C ENGINEERING LABORATORIES

THE VARITONE* AUDIO TRANSFORMER

A universal audio input transformer giving continuously variable low end, high end or low and high end equalization.

VT-1—Designed to work from a single plate or low impedance microphone line to one or two grids.

List price . . . \$8.50 Net to dealers . . . \$5.10

* Patent applied for.

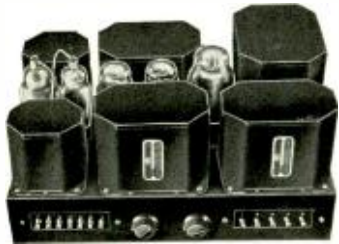

Three stage 45A prime amplifier with VARITONE

The VARITONE is an essential component for High Fidelity theatre and P A amplifiers. Manufacturers of such equipment are invited to write us regarding the application of the VARITONE to their equipment.

Affords 15 D B controllable correction of low frequency response, high frequency response or simultaneous correction of low and high frequency response.

Typical Components for use in a popular priced High Fidelity Receiver Amplifier Using the VARITONE as an input source.

	List Price	Net Price
VT-1 Varitone Input Transformer	\$8.50	\$5.10
PA-132—from single 57 triode plate to push-pull 45 grids	5.00	3.00
PA-245—from two 45 A prime plates to Broadcast and Voice coil lines	7.00	4.20
PA-22 —45 A prime plate and filament supply transformer	10.00	6.00
PA-40 —A prime input choke	4.50	2.70
PA-44 —Output smoothing choke	4.50	2.70
	\$39.50	\$23.70

UTC NIKLSHIELD Audio filter and Power Components are now available in amplifier kits. Quality units that all public address men can afford.

NS-1	1 plate to 1 grid. 3 1/2:1 ratio	\$2.35
NS-2	1 plate to 2 grids, split secondary. 1:1 ratio	2.50
NS-3	Push pull plates to push pull grids. 1.8:1 ratio	2.75
NS-4	Low or high impedance pickup to grid. Pri. 500, 1000, 2000, 4000 ohms.	3.00
NS-5	Single or double button mike to 1 grid	2.50
NS-6	Single or double button mike to 2 grids	3.00
NS-7	Ribbon velocity mike to grid	3.50
NS-8	Ribbon velocity mike to 500 or 200 ohms	3.50
NS-9	Mixing carbon mike. 500 or 200 ohm line to 500 or 200 ohm line	3.50
NS-10	Single plate and carbon mike to one or two grids	3.50

CLASS A OUTPUTS

NS-11	Single 250, 245, 59 triode. TIA to 8, 4, or 2 ohm voice coil	\$2.50
NS-12	Single 18, 20, 33, 41, 42, 47, 2A5, 59 pentode or 89 triode plate to 8, 4, or 2 ohm voice coil	2.50
NS-13	Push pull 250, 245, 59 triode or 71A plates to 8, 4, or 2 ohm voice coil	3.00
NS-14	Push pull 18, 20, 33, 41, 42, 47, 2A5, 59 pentode, 89 triode plates to 8, 4, or 2 ohm voice coil	3.00
NS-15	Push pull 2A3 plates to 8, 4, or 2 ohm voice coil	3.00
NS-16	Push pull 48 plates to 8, 4, or 2 ohm voice coil	3.00
NS-17	Single 250, 245, 59 triode. TIA to 500, 8, 4 or 2 ohms	3.00
NS-18	Single 18, 20, 33, 41, 42, 47, 2A5, 59 pentode or 89 triode plate to 500, 8, 4 or 2 ohms	3.50
NS-19	Push pull 250, 245, 59 triode or 71A plates to 500, 8, 4 or 2 ohms	3.50
NS-20	Push pull 18, 20, 33, 41, 42, 2A5, 59 pentode, 89 triode plates to 500, 8, 4 or 2 ohms	3.50
NS-21	Push pull 48 plates to 500, 8, 4 or 2 ohms	2.75
NS-22	Single 250, 245, 59 triode. TIA to 4000 or 2000 ohms	2.75
NS-23	Single 18, 20, 33, 41, 42, 2A5, 59 pentode or 89 triode plate to 4000 or 2000 ohms	3.25
NS-24	Push pull 250, 245, 59 triode. TIA to 4000 or 2000 ohms	3.25
NS-25	Push pull 18, 20, 33, 41, 42, 47, 2A5, 59 pentode or 89 triode plates to 4000 or 2000 ohms	3.00
NS-26	Single 20, 36, 27, 55, 77 triode or 864 plate to 500 or 200 ohms	3.50
NS-27	Push pull 20, 36, 27, 55, 77 triodes or 864 plates to 500 or 200 ohms	4.50
NS-28	Line to speaker audio matching transformer. Input 4000 ohms and 500 ohms. Output 15, 8, 4 and 0 ohms. Will handle up to 15 watts	4.50



Double push-pull 2A3 amplifier using NIKLSHIELD units

CLASS B INPUT TRANSFORMERS

NS-29	Driver plate to 49, 53, 79 or 89 grids	\$2.75
NS-30	Driver 46 or 59 plate to 46 or 59 grids	2.75
NS-31	Push push 49, 53, 79, or 89 plates to 8, 4, or 2 ohms	3.25
NS-32	Push push 46 or 59 plates to 8, 4, or 2 ohms	3.25
NS-33	Push push 49, 53, 79 or 89 plates to 5000 or 3500 ohms	3.50
NS-34	Push push 46 or 59 plates to 5000 or 3500 ohms	3.50
NS-35	Push push 49, 53, or 89 plates, to 500, 8, 4, or 2 ohms	3.75
NS-36	Push push 46 or 59 plates to 500, 8, 4, or 2 ohms	3.75

FILTER AND AUDIO CHOKES, FILAMENT TRANSFORMERS

NS-37	Filter choke. 25 henrys 30 MA; resistance 900 ohm	\$2.00
NS-38	Filter choke. 15 henrys 60 MA; resistance 240 ohm	2.00
NS-39	Filter choke. 20 henrys 90 MA; resistance 400 ohms	2.50

NS-40	Filter choke. 20 henrys 75 MA; resistance 350 ohms	3.00
NS-41	Filter choke. 10 henrys 150 MA; 95 ohms	3.00
NS-42	Class B input choke. Max. D.C. 175 MA	3.50
NS-43	Center tapped audio for push pull triode plates. Resistance 12,000 ohms	2.25
NS-44	Detector plate shunt choke. Max. D.C. 9 MA	1.75
NS-45	Pri. 115 A.C. Sec. 2 1/2 V.C.T. 6A	2.25
NS-46	Pri. 115 A.C. Sec. 6.3 V.C.T. 3A	2.25
NS-47	Pri. 115 A.C. Sec. 2 1/2 V.C.T. 12A	2.25
NS-48	Pri. 115 A.C. Sec. 5 V. 4 A	2.25
NS-49	Pri. 115 A.C. Sec. 7 1/2 V.C.T. 3A	2.25
NS-50	Plate Transformer for small power tubes. Class A and B. Pri. 115 V. A.C. 60 cycles. Secondaries: 800-0-800 at 75 MA; 5 V.C.T. 3A., 6.3 V.C.T. 2 1/2 A., 2 1/2 V.C.T. 6A	7.00
NS-51	Plate transformer for push pull power tubes Class A and B. Pri. 115 V. A.C. 60 cycles. Secondaries: 400-0-400 at 125 MA; 2 1/2 V.C.T. 5A., 2 1/2 V.C.T. 10A., 5 V.C.T. 3A	9.00

UTC NIKLSHIELD units may be purchased thru your local UTC distributor at regular 40% discounts.

UNITED TRANSFORMER CORP.
Export Division: 15 Laight Street, New York City
264 CANAL STREET NEW YORK CITY

BRUSH MICROPHONES

Six Models Designed for Various Purposes in Recording, Reproduction and Measurement of Sound.

Complete Details on Request

Leading Manufacturers are now offering Public Address and Transmitting Equipment Specially Produced for use in Connection with Brush Soundcell Microphones.

Write us for Information

BRUSH DEVELOPMENT COMPANY

East 40th St. and Perkins Ave., Cleveland, O., U. S. A.
Cable Address: BRUSH, Cleveland

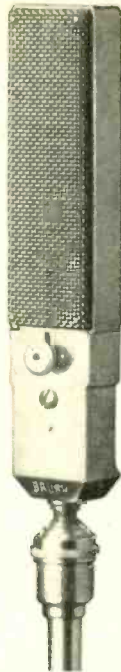

CORNELL-DUBILIER H-Q PYRANOL



Type T-C-30020 shown. 2 MFD 3000v D. C. working voltage. Units of this type can be operated continuously at voltages and ambient temperatures which are destructive to condensers not using the special Pyranol impregnator.

Cornell-Dubilier engineers feel a justifiable pride in knowing that throughout the world their unceasing researches are appreciated in "the finest condenser." Write to them with your problems . . . they are at your service.

Complete range of capacities from 1000 to 100,000 volts. The Pyranol used to impregnate and fill these condensers is non-inflammable, eliminating the fire hazard present in other types of condensers. For use in all commercial radio, telephone, and telegraph transmitters.

These Pyranol heavy duty condensers are part of the most complete line in the world, all featuring the new HIDDEN-QUALITY. Luxuriously dependable operation — specify C-D Pyranols.

CORNELL-DUBILIER CORPORATION
4398 BRONX BOULEVARD
NEW YORK

The New PR-12 PATTERSON

All-Wave Radio

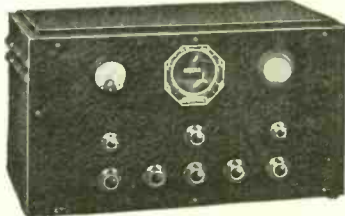

IN STOCK IMMEDIATE DELIVERY

PRICES COMPLETE

(Absolutely nothing else to buy.)

Crackle Cabinet without Crystal. **\$82.00** Prepaid

Crackle Cabinet with Crystal. **\$87.90** Prepaid

Console without Crystal. **\$99.65** Prepaid

Console with Crystal. **\$105.55** Prepaid
Chassis also available.

Built-in Pre-Selector.
12 Matched Sylvania Tubes.
10 1/4-inch Dynamic Speaker.
Modulation Meter.
8 Meter
2-Speed Selector Airplane Dial.
Accurate logging band spread.
Built-in Monitor

Manual and A. V. C. Single Dial Tuning.
3 IP Stages
Duplex operation within 20 kilocycles.
Newly designed Coils.
3 Stages audio amplification.
Self-contained power supply.
Marconi or doublet antenna.
GUARANTEED SIX MONTHS.

SHIPPED PREPAID if Full Purchase Price accompanies your order.

Send for Large Descriptive Catalogue

OUR NEW 100 WATT PHONE C. W. TRANSMITTER NOW READY!
WE ALSO BUILD AMATEUR, POLICE, AND BROADCAST TRANSMITTERS

All Standard Receivers and Pre-Selectors shipped Prepaid at lowest prices—Write for details.

L. I. MARINE & ELECTRIC CO.

163-18 JAMAICA AVE. W 2 60T—W 2 6RQ JAMAICA, NEW YORK
Telephone: JAmalca 6-2925—Cable Address: "ELEC"MARINE, New York

HIGHEST FIDELITY
GREATEST SENSITIVITY
EXTREME RUGGEDNESS

Not only these Outstanding Characteristics, but also the following are features of RADIO RECEPTOR

DYNAMIC (MOVING COIL) MICROPHONES



Radio Receptor Model 6 A



Model 6 A with Plug

1. WEATHERPROOF: Unaffected by excessive heat, cold, moisture, wind, or any climatic conditions.
2. BLASTPROOF: Loud detonations reproduced naturally without injury to diaphragm.
3. WIDE ANGLE PICKUP: Area is uniform over an angle of 135 degrees.
4. BACKGROUND NOISE: All microphone background noise eliminated.
5. CLOSE UP TALKING: No change in frequency response when Model "6" microphones are used.
6. OPERATING CURRENT: No current supply from batteries or other sources required.
7. SIZE: Extremely small and compact.
8. MOUNTING: No delicate spring suspension necessary for P.A. work or close talking.
9. CONNECTIONS: Screw type terminals conveniently brought out on the rear.
10. UNIFORMITY: All Model "6" microphones rigidly tested for sensitivity, uniformity and frequency characteristics.
11. CONVENIENCE: Microphones may be operated one thousand feet from amplifier without appreciable loss.

Complete data gladly supplied on request. Write on your letterhead.

RADIO RECEPTOR CO., INC.

Manufacturers of Radio and Sound Equipment

106 SEVENTH AVENUE

NEW YORK, N. Y.

EDITORIAL

TELEVISION

SIMULTANEOUS ANNOUNCEMENTS to the effect that England and Germany are to institute national television services have created widespread interest in this country. The leading question is whether or not we will follow suit.

The English television system is to be set up by the British Broadcasting Corporation, an institution under the jurisdiction of the British Government. The financial outlay necessary for the establishment of a practical television network will be underwritten by the Government and maintenance costs more than likely will be derived from the radio tax.

The German television system may also be classed as a Government subsidy. The project may be paid for by taxation or through some form of special government appropriation. In any event, the system is presumably not to be supported by private enterprises.

The decisions of the English and German Governments to inaugurate television networks are most certainly not the reflections of radical developments in television design. English and German systems are moderately good but, on the whole, no better than American systems. The reasons, we take it, are much deeper and, surely with regard to Germany, the motive force is more political than social.

There has been offered the excellent suggestion that Federal monies be appropriated for the setting up of a television system of sufficient magnitude to effectively serve the United States. In view of our Government's policies with regard to socialized projects of huge proportions, it would appear that such a proposal might be met with favor in Washington. There is no doubt that such a project would not only provide work for a great number of people, but serve as well to develop an industry—part radio, part motion picture, part theatrical and part advertising—that would assist im-

measurably in healing our financial wounds.

The hitch in such a plan is that, so far at least, our Government is not quite so nationalistic in tendencies as some foreign Governments and has not reached that point of sensitiveness where it would feel impelled to compete with other Governments in the wholesale dispensation of personal propaganda. Moreover, our Government is more inclined to provide financial support to projects that either have more social significance or can in time repay the loans. Television does not seem to be in this class—at least, not so long as it remains the dream of private enterprise.

An English or a German television network would not serve the United States. It might possibly serve one State in the Union, no more. A nation-wide television network would cost at least forty-eight times as much as an English or German chain, and probably more. Our centers of population are widely separated, we have huge areas that, though sparsely populated, must also be served. It has taken us years to build up a national broadcasting network capable of blanketing the country. These stations cannot be used for television broadcasts as they are. The cost of redesigning them would equal, if not exceed, the cost of a new supplemental chain of television stations.

We may assume that were a complete chain of practical television stations made available, the system could support itself very nicely in exactly the same manner as broadcast chains obtain support. We may go even further in this assumption and say that practical television services would overshadow all other mediums of entertainment and advertising. It is a pretty picture and not one which private enterprise wishes to have lost to it. But, television design has not reached that stage where it could compete with the motion picture, the theatre, pictorial advertising in printed form and the newspaper. It is a pretty picture, to be sure, but one that is not as yet complete.

We continue to make advances in television—the special transmission line recently developed by A. T. & T. is a good example. In time we will have developed a system satisfactory for *entertainment purposes*. It will be good from the very beginning.

We have everything to gain and nothing to lose by waiting. We can well afford to do that.

JUST OFF THE PRESS

A new booklet describing the latest developments in Aircraft Radio — Receivers, Transmitters, Radio Direction Finders. We have a limited quantity for free distribution. Please write on your letterhead.

The new Radio Compass Direction Finder designed for the Department of Commerce is fully described.



LEAR DEVELOPMENTS, Inc.

Aircraft Radio Engineers

125 WEST 17th STREET

NEW YORK



WIRE WOUND RESISTORS

Highest Type Obtainable

Our exclusive factory method of reinsulating wire to withstand 180 volt single mercury cup test and automatic winding produces a unit heretofore unobtainable.

100% voltage overload will prove their superiority.

IT TAKES THE BEST TO MAKE THE BEST

WRITE FOR CATALOG

Manufactured by

PRECISION RESISTOR COMPANY

334 Badger Avenue, Newark, N. J.

CLOSED on account of illness!

Did your station shut-down the last time you were home ill? That might sound silly to you . . . but some radio-men think they are indispensable. Of course . . . they're wrong . . . for there's probably another man waiting for your job RIGHT NOW!

There's good money in radio for men who have sufficient technical training. CREI offers you the original home study course in practical radio engineering. There are CREI students and graduates in more than 156 U. S. broadcast stations . . . ask any of them!

★ Write for **FREE 44-Page Catalog** ★

Capitol Radio Engineering Institute

Dept. CB-2

14th & Park Rd., N.W., WASHINGTON, D. C.

HIGH FIDELITY RESULTS!

Our laboratory is one of the most modern and completely equipped in the country. It contains every conceivable piece of apparatus essential for proper

MICROPHONE OVERHAULING
at amazingly low rates

New dry spot diaphragms, highly polished carbon granules replaced and balanced in any type of microphone such as

W.E. 600A }
W.E. 367 } **\$3.50**
UNIVERSAL KK } for complete
AMERICAN S.D. } overhaul.

JEWELL RADIO COMPANY

POWER AMPLIFIERS PACKS SUPPLIES A SPECIALTY

88 Cortlandt St. (Est. 1921) NEW YORK, N. Y.

TRUE "HIGH-FIDELITY"

4 db - 40 to 10,000 Cycles



The new Shure "Wave-Equalized" * Condenser and Crystal Microphones bring you true "High-Fidelity" performance, *guaranteed* uniform response within 4 db from 40 to 10,000 cycles . . . without separate pre-amplifiers or studio wiring changes. Both types may be directly substituted for existing condenser microphones.

New Bullet, Desk Stand, and Direct Floor Stand Models at moderate prices are available for every stage and studio application.

Write today for Bulletin 113C, which gives complete technical data.

*Trade Mark Registered

Established 1925

SHURE BROTHERS COMPANY

"Microphone Headquarters"

215 W. HURON STREET

CHICAGO, U. S. A.



PORTABLE BROADCAST TRANSFORMERS



The ultimate in perfection for those engaged in high fidelity reproduction and sound amplification where durability as well as portability is required. Kenyon portable broadcast units are housed in small aluminum castings. They meet the great demand for portability, high efficiency and low weight. Afford frequency characteristics of ± 1 db from 30 to 15,000 cycles.

KENYON ALL-PURPOSE UNITS

A very reasonably priced high quality line of transformers and reactors ideal for public address, radio receiver, amateur broadcast and speech amplifier requirements. The units are impregnated in varnish under high vacuum, sealed in a moisture-proof compound and are housed in attractive silver finished cases.

SPECIAL UNITS

For those requiring special purpose transformers designed to meet any particular requirement, write us giving the specifications desired or describe your problem and we will gladly cooperate in solving it.

Write for complete new catalog—Now.



"HIPERNIK"

Kenyon Transformers using "Hipernik" are now available under Westinghouse license. (Patent 1277384)

KENYON TRANSFORMER CO., INC.

840 BARRY ST. NEW YORK CITY



THE Group Subscription Plan for COMMUNICATION AND BROADCAST ENGINEERING enables a group of engineers or department heads to subscribe at two-thirds the usual yearly rate.

The regular individual rate is \$3.00 a year. In groups of 4 or more, the subscription rate is \$2.00 a year. (In Canada and foreign countries, \$3.00.) Each subscriber should print his name and address clearly and state his occupation—whether an executive, engineer, department head, plant superintendent, or foreman, etc.

**Possibly your associates
would be interested in this
group plan**

(Communication and Broadcast Engineering)
BRYAN DAVIS PUBLISHING CO., Inc.
19 East 47th Street, New York, N. Y.

COMMUNICATION & BROADCAST ENGINEERING

FOR FEBRUARY, 1935



A DIRECTIVE ANTENNA

FOR WOR

By J. F. MORRISON
Member, Technical Staff
BELL TELEPHONE LABORATORIES

IN THE DESIGN of radio antennas, the primary objective is to radiate the allotted power in such a way that the greatest effective signal strength reaches the point or areas where reception is desired. For the various transoceanic services of the Bell System this has led to the design of antennas that radiate most of their power in one direction. A variety of antennas of this type have been successfully built and operated. They vary in design to accommodate best the wavelengths of the various systems.

WOR SERVICE AREA

Antennas for broadcast stations, on the other hand, have usually been designed to radiate equally in all directions. This is desirable when the population to be served surrounds the station uniformly, but with WOR's new station at Carteret, N. J., the situation is different. The population it serves has centers of greatest density at Newark and New York, lying in a northeasterly direction from the station, and at Trenton and Philadelphia, lying in a southwesterly direction. To the southeast, only a few miles distant, lies the Atlantic Ocean, while to the northwest lies the sparsely populated mountainous territory of northern Jersey and Pennsylvania (See Fig. 1).

WOR's new station employs a Western Electric 50-kw transmitter, and in view of the long experience of the Bell System in the design of directional antennas, they turned to Bell Laboratories to secure an antenna design which taking into consideration the geographical situation, would make their service available to the greatest number of

listeners. There were other restrictions that had to be met, particularly a limitation on the height of the antennas which, because of the proximity of Newark Airport, must not constitute a hazard to aviation. In view of the existing distribution of population, an energy-distribution pattern of hour-glass shape, with its long axis along the line from New York to Philadelphia, seemed most desirable. The calculated distribution is shown in Fig. 2, where the dotted circle gives the distribution that would be obtained from a single non-directional antenna of the same height.



CLOSE-UP OF A SUPPORT LEG OF ONE OF THE TOWERS, SHOWING THE COUPLING HOUSE ABOUT 30 FEET UP WHICH CONTAINS THE TUNING EQUIPMENT FED FROM THE CONCENTRIC TRANSMISSION LINE THAT RISES TO IT FROM THE CATWALK.



CATWALK, 790 FEET LONG, EXTENDING BETWEEN THE TWO ANTENNA TOWERS. THE CATWALK SUPPORTS ELECTRICAL CONDUITS AND THE CONCENTRIC TRANSMISSION LINE WHICH MAY BE SEEN JUST BELOW THE TOP RAIL. THE TRANSMISSION LINE IS ALSO SUPPORTED BY THE RIGHT ANGLE BRACKETS PROJECTING BEYOND THE RAIL.

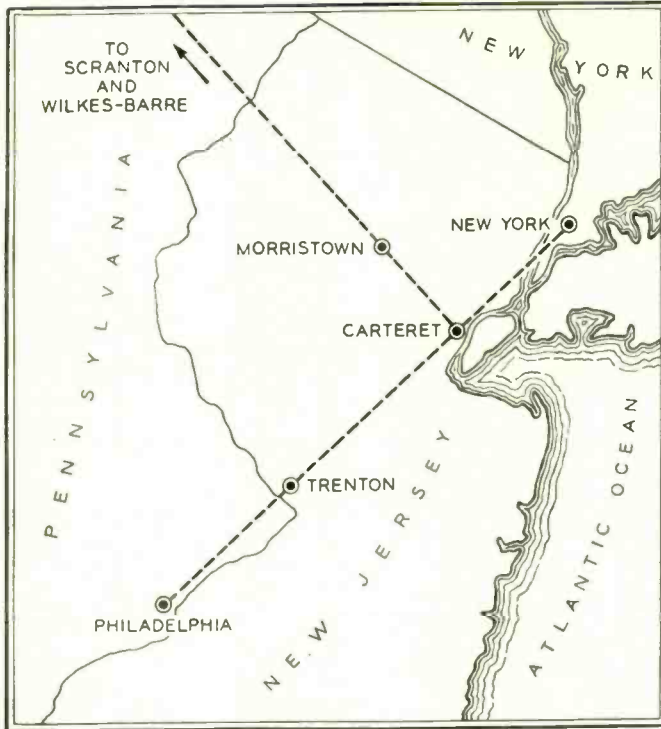

FIG. 1. (LEFT). MAIN COVERAGE AREA OF THE NEW 50-KW WOR STATION.

the new antenna along the major and minor axes of the ground wave is given in Figs. 3 and 4.

A comparison of the curves of Figs. 2, 3, and 4 with the map of Fig. 1 shows the success of the design in covering the desired area. The intensity of the ground wave in the northeasterly direction is adequate to give good reception in all of greater New York, while in a southwesterly direction it is adequate as far as Philadelphia. In a southeasterly direction the comparatively small field strength is sufficient to serve the shore points, only a few miles distant. In a northwesterly direction, a fairly populous suburban area extends about to Morristown. Although the distances relative to the field strength are somewhat greater in this direction than along the major broadcasting axis, the noise level is lower so that a lower level of signal can adequately cover a greater radius. Because of the lower noise level, six millivolts

RADIATION

This curve gives the field-intensity pattern along a horizontal plane. The radiation above the horizontal, however, is also of considerable importance. At broadcast frequencies, radiation at these angles is refracted back to the earth during the night, and—depending on its strength relative to the horizontal field—may either extend the service range of the station, or decrease it by causing areas of interference where reception is poor. The best antenna design, therefore, must consider both the sky wave and the ground wave, and each must be shaped in consideration not only of the population density but of the effect of the two types of radiation on each other. The sky-wave radiation obtained from

FIG. 3. (BELOW). RADIATION FROM THE NEW ANTENNA IN A VERTICAL PLANE ALONG THE MAJOR AXIS OF TRANSMISSION. DOTTED CURVE GIVES THE CHARACTERISTICS OF AN EQUIVALENT NON-DIRECTIONAL ANTENNA.

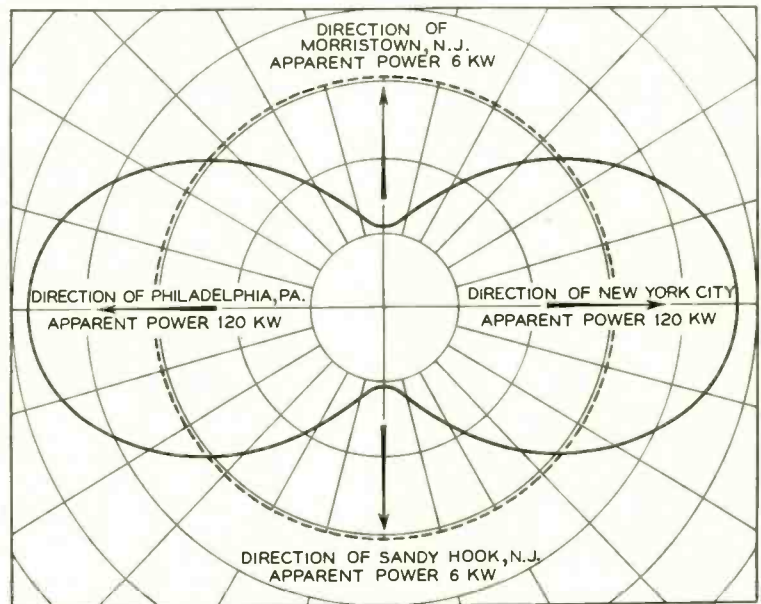
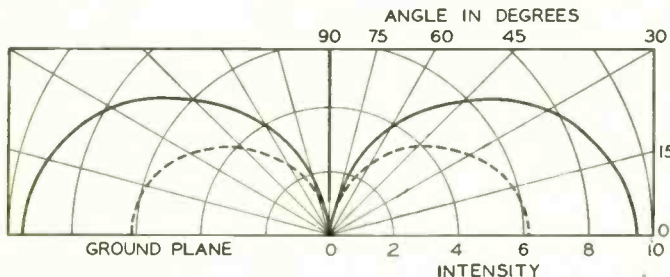

FIG. 2. (ABOVE). FIELD-INTENSITY PATTERN OF THE DIRECTIONAL ANTENNA FOR STATION WOR.

of signal strength in Morristown is as effective as thirty-five in New York.

GROUND AND SKY WAVES

The effects of sky wave, along and across the major axis of the ground wave, and its interaction with the ground wave, are indicated by Figs. 5 and 6.

Southwesterly the sky wave has no appreciable effect until just beyond Philadelphia, while at Baltimore and Washington it is sufficiently greater than the ground wave to dominate the reception. The area of interference lies between Philadelphia and Baltimore, reaching its maximum some forty miles beyond Philadelphia, as indicated by the greatest height of the cross-hatched area of the curve. These distances are not fixed but vary appreciably with changes in the height of the ionosphere, but the average conditions are as shown.

In the northwesterly direction, Fig. 6, the area of greatest interference between ground and sky wave is made to fall in the mountainous districts of north Jersey and Pennsylvania. At Scranton and Wilkes-Barre the sky

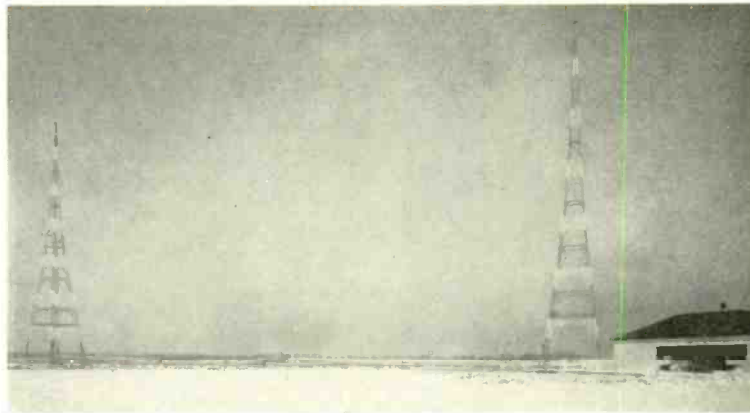

GENERAL VIEW OF THE ANTENNA SYSTEM, SHOWING THE TWO STEEL TOWERS EACH 385 FEET HIGH AND THE WOR TRANSMITTER HOUSE OFF TO ONE SIDE. AT THIS DISTANCE, THE CATENARY AND THE CABLE SUSPENDED FROM IT TO FORM THE THIRD ANTENNA ARE NOT VISIBLE IN THE PHOTOGRAPH.

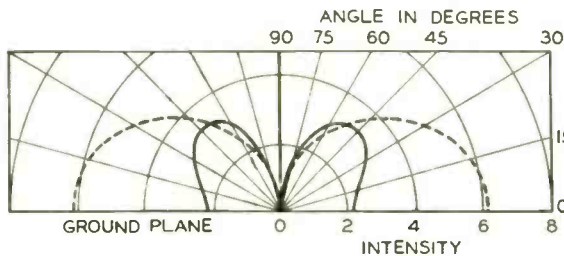

FIG. 4. VERTICAL PLANE RADIATION IN A DIRECTION AT RIGHT ANGLES TO THE MAJOR AXIS. DOTTED CURVE GIVES THE CHARACTERISTICS OF AN EQUIVALENT NON-DIRECTIONAL ANTENNA.

wave predominates, and good nighttime reception will be obtained.

ANTENNA CONSTRUCTION

Such a distribution pattern is obtained by an array of three vertical antennas with their plane in the direc-



CENTER COUPLING HOUSE, MIDWAY BETWEEN THE TWO END TOWERS, WHICH CONTAINS THE PHASE SHIFTING AND TUNING UNITS. THE NETWORK THROUGH WHICH THE MAIN TRANSMISSION LINE DIVIDES THREE WAYS.

tion of minimum radiation. Each antenna radiates uniformly in all directions giving a wave pattern as indicated in Fig. 7. The radiation from the three antennas is alike in magnitude and phase, so that at right angles to the plane of the array the three waves reinforce each other, while along the array they tend to cancel out because of the relationship between the wavelength of the signal and the spacing of the an-

tennas. The use of three rather than two or some larger number of antennas, was decided upon only after considering the distribution pattern of both sky and ground waves and the relative costs of various combinations—all limited by the requirement of keeping the maximum height under the limiting figure.

The physical arrangement of the antennas is indicated in Fig. 8. The antennas at the two ends of the array are 350-foot steel towers manufactured by

the Blaw-Knox Company of Pittsburgh. They are spaced 790 feet apart, and the center antenna is a copper cable suspended vertically from the middle of a steel cable supported by the two towers. Insulators, spaced about twenty-six feet apart sectionalize the messenger cable and thoroughly insulate the three antennas from each other. The end antenna towers are sixty feet square at the base, and each of the four legs is mounted on a single porcelain insulator supported thirty-five feet above the ground by a separate structure. This arrangement reduces the capacitance between the lower part of the tower and the ground, and results in a more desirable distribution of current along the vertical elements.

THE GROUND

A ground grid is formed by No. 10 bare copper wires, each 600 feet long, spaced about every three feet and buried

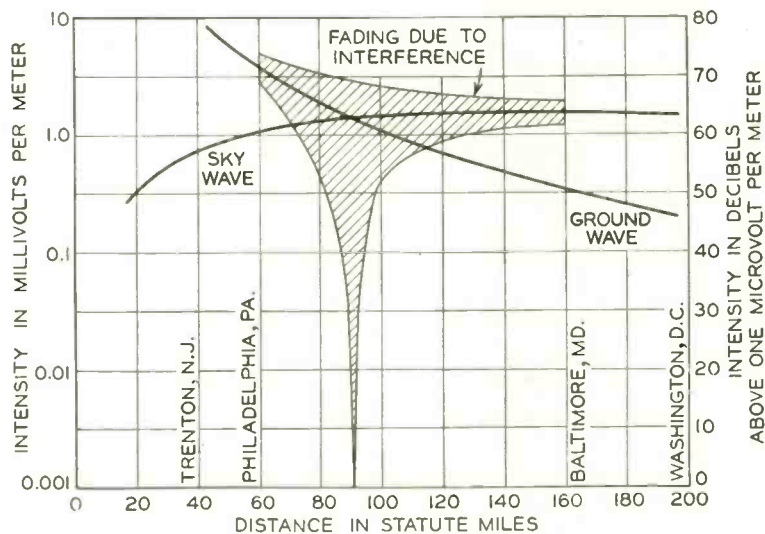

FIG. 5. GROUND AND SKY WAVES ALONG THE MAJOR AXIS OF TRANSMISSION. THIS AREA OF INTERFERENCE IS INDICATED APPROXIMATELY IN POSITION AND MAGNITUDE BY THE SHADED AREA.

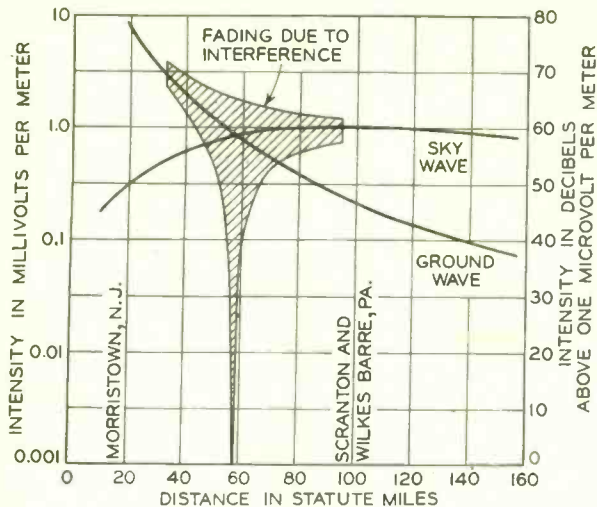

FIG. 6. (ABOVE). GROUND AND SKY WAVES AT RIGHT ANGLES TO MAJOR AXIS, AND THEIR AREA OF INTERFERENCE.

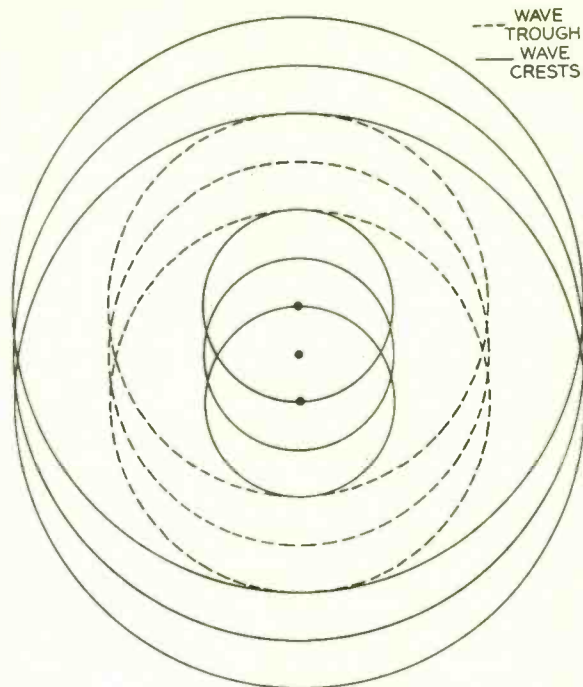

FIG. 7. (RIGHT). WAVE PATTERN OF THREE-ANTENNA ARRAY.

at the depth of a plow furrow. These wires are laid at right angles to, and centered on the axis of the array. Wires of the same size and buried in a similar manner on 10" radii extend 300 feet outward from the end antennas. Nearly forty miles of wire are required for this ground system.

TRANSMISSION LINE

The antenna is connected to the transmitter, several hundred feet away, by a concentric-tube transmission line. While comparatively new in connection with broadcast transmitters, the concentric conductor offers certain advantages over the more commonly used balanced open-wire line. This is particularly true of the WOR installation where radiation from the more usual form of line might distort the directional characteristics of the array. Both inner and outer conductors are of copper tubing, the latter being 2-5/8 inches and the former .7 inch in outside diameter. Insulators between the two tubes are spaced about thirty inches apart, and support the inner conductor concentrically with the outer. The tubes are hermetically sealed and filled with dry nitrogen at about ten pounds pressure. With the aid of pressure gauges, this gas filling gives warning of any openings which might admit moisture, and because of the dry gas employed, minimizes the condensation of moisture inside the tube.

COUPLING AND PHASE-SHIFTING

To secure the desired directional characteristics of the antenna, the cur-

rents in all three—as already noted—must be alike in magnitude and phase. This is made possible by the coupling and phase-shifting units shown in the schematic of the antenna feed system, Fig. 9. There is first a transmission-line coupling unit connecting the transmitter output circuit to the concentric line at the transmitter station. The

transmission line runs to a large box midway between the two towers and under the central antenna. Here is housed a line-branching and amplitude-adjusting unit, a phase-shifting unit, and an antenna-coupling unit for the middle antenna. The line-branching transformer serves to match the impedance of the three branches of the circuit,

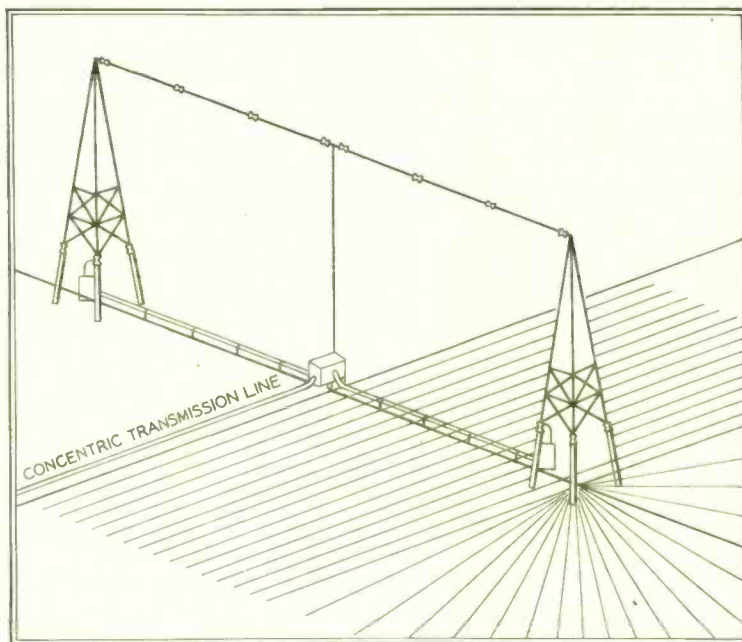

FIG. 8. PERSPECTIVE DIAGRAM OF THE NEW WOR ANTENNA ARRAY.

and also to provide an adjustment for equalizing the current in each. The phase of the currents to the two end antennas is the same because each passes over the same length of line. The phase-shifting unit in the central circuit is employed to make the phase of the current to the center antenna equal to that to the other two. Each antenna has its coupling unit, those for the two end antennas being in similar but smaller boxes at each tower.

CONCLUSION

The new site of WOR at Carteret is some ten or fifteen miles southwest of the site of their present 5-kw station. With the increase in power to 50 kw, and the desirable directive characteristics of the new antenna, radiation in the minimum direction (NW and SE) will be 20% greater than with the old station, while radiation along the New York and Philadelphia line will be twenty-four times greater. Since by far the greatest number of their listeners lie along this direction, it is obvious that the increase in service to the average listener will be much more than is represented by the ten-fold increase in power.

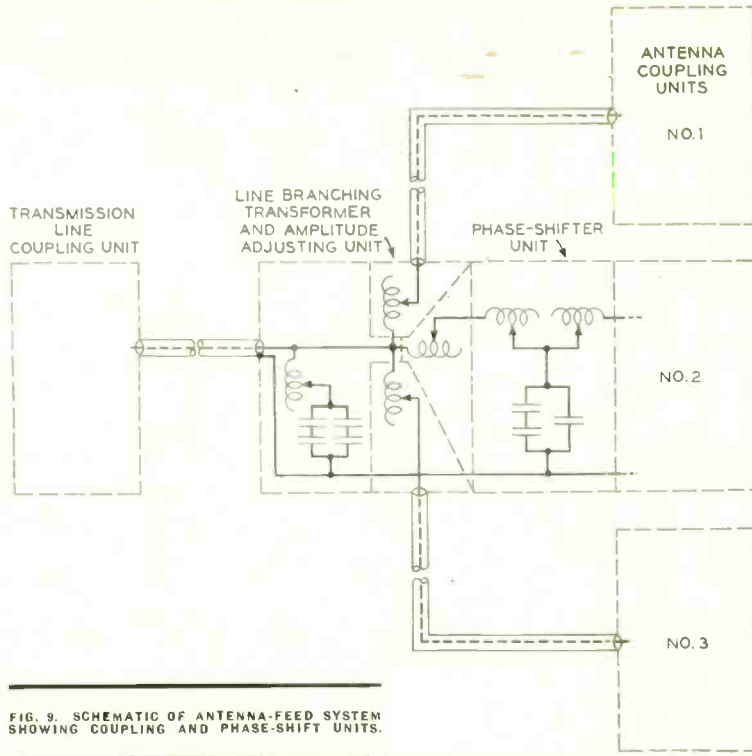

FIG. 9. SCHEMATIC OF ANTENNA-FEED SYSTEM SHOWING COUPLING AND PHASE-SHIFT UNITS.

RECENT ACOUSTIC DEVELOPMENTS

IMPORTANT RECENT developments in the application of acoustics to improving the acoustic qualities of auditoriums, motion picture theatres, and broadcasting studios were discussed (Feb. 5th, 1935) at a meeting of the New York Section of the American Institute of Electrical Engineers at Bell Telephone Laboratories. The speakers were Dr. E. C. Wente, Research Physicist, Bell Telephone Laboratories, and Mr. S. K. Wolf, Acoustic Consulting Manager, Electrical Research Products, Incorporated. The wide variations in sound intensity which occur at any given place in a room as the frequency of a pure tone is slowly changed, was demonstrated to show the interference effects of sound reflected from the walls and ceiling. Also, phonograph and sound picture records of speech, operatic selections, and cathedral choir music were used to illustrate good and bad acoustic conditions in different types of auditoriums.

The recent advent of sound pictures has greatly stimulated acoustic work of this character because they required the reconstruction of many existing theatres and the building of new ones so that speech and music can be satisfactorily reproduced in them. Only 10% of the existing sound picture theatres are entirely satisfactory from the acoustic standpoint, and 25% are excessively

reverberant. The auditor many times realizes that listening conditions are not satisfactory, but is usually not able to tell what is wrong. This can readily be done by the use of acoustic instruments, several new types of which have recently been developed by the Bell Telephone Laboratories.

SOUND INTENSITY RECORDER

One of the most interesting of these new acoustical instruments, a sound intensity recorder, makes a continuous record on a roll of paper of the variations of sound intensity in an auditorium either while a sound is changing, for example, dying out, or when the pitch of a sound is varied. This instrument has a microphone, the input of which after being amplified a million million times is made to operate a moving pointer on wax paper. Each momentary fluctuation of sound intensity—for example, due to the sound reflections from the walls and ceiling of a room—is faithfully recorded on the wax paper as it moves under the pointer. The action is so fast that it can record variations of sound intensity as great as 850 decibels per second and reversals of intensity up to 100 per second. From the record which appears as an irregular line with peaks and valleys, it is possible to determine the acoustical characteristics of an auditorium

much more accurately than by previous methods and so quickly that in two or three minutes as much information can be obtained as could have been gathered in a whole day by earlier workers who had to depend on their ears instead of a microphone for measuring sound.

An interesting local example of the correction of the acoustics of a very large auditorium is that installed in Madison Square Garden on the basis of recommendations by Mr. Wolf and his associates. The construction of a lower ceiling of acoustic absorbing material resulted in so marked an improvement over previous conditions that it is now possible to hear distinctly with the aid of loudspeakers in every part of this great auditorium which, prior to the installing of the acoustic ceiling, had a volume of 6,200,000 cubic feet.

NEW RUSSIAN RADIO STATIONS

TWO THOUSAND new radio stations are being set up on collective and State farms. They will form a network of radio stations, so that the different farms can keep in touch with one another and with headquarters in Moscow. One of the reasons for grain shortages in the past has been the difficulty of maintaining contact with grain-raising farms. (*The Electrical Review*, Nov. 9.)

THE DESIGN OF PADS

By LOUIS W. BARNETT

Studio Engineer

WLW, WSAI, W8XAL

ARTIFICIAL LINES, generally known as "pads," are a combination of resistances arranged so that the ratio of the power leaving at the "receiving" end to the power entering at the "sending" end is determined by the calculated loss required. All pads of this type are constructed so as to have a flat frequency characteristic over the entire audio band desired. Pads are used extensively in transmission networks, sometimes as a means of matching two lines of unequal impedance or to drop the energy level of an incoming signal. Both of the above uses are very common in broadcast work.

The following formulae and tables give the methods in general use in computing the values of the resistance elements of T-type pads and are accurate for the design of any such artificial line which is to have a required loss— L —db—and is to operate between circuits having impedances " S " and " R " of pure resistance.

Before we go farther, however, let us divide artificial lines into two classes, namely; balanced and unbalanced. A circuit, all of whose resistances are symmetrical with respect to ground, is known as a balanced network or pad of the H type. A circuit, which has no impedance on one side is known as an unbalanced network or, T -type pad.

Fig. 1, shows a type T impedance network with S as

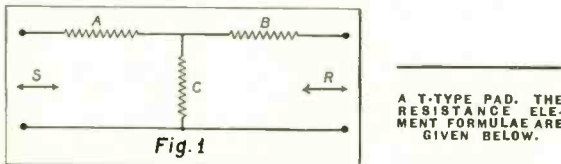

A T-TYPE PAD. THE RESISTANCE ELEMENT FORMULAE ARE GIVEN BELOW.

the input or sending end, R as the output or receiving end, and the two leg resistors A and B and the shunt resistor C .

FORMULAE

In Fig. 1 the resistance elements may be found as follows:

$$A = \frac{S(m^2S + R - 2Rm)}{(m^2S - R)} \quad (1)$$

$$B = \frac{R(m^2S + R - 2Sm)}{(m^2S - R)} \quad (2)$$

$$C = \frac{2mRS}{(m^2S - R)} \quad (3)$$

where m equals the number whose logarithm is

$$\left(\frac{L}{20} - 0.5 \log S/R\right) \text{ or} \quad (4)$$

$$m = \log^{-1} \left(\frac{L}{20} - 0.5 \log S/R\right) \quad (5)$$

All logarithms are to the base 10.

METHODS FOR THE CALCULATION OF THE RESISTANCE ELEMENTS OF PURE RESISTANCE ARTIFICIAL LINES

In the stated equations L is the symbol for the total decibel loss required in the pad under construction.

The value of L is to be used as a positive number in the formulae given. For ease of solution, the larger of the two circuit impedances should be chosen for the S end of the pad.

EXAMPLE

Suppose a pad is to be constructed, and is to be of the balanced H type. A loss (L) of 15 db is required and is to be inserted between a 500-ohm pure resistance circuit and a 200-ohm pure resistance circuit. Then let S equal 500 and R equal 200.

Solving

$$\begin{aligned} \text{The value of } m &= \log^{-1} (15/20 - 0.5 \log 500/200) \\ m &= \log^{-1} (0.75 - 0.5 \times 0.39794) = \log^{-1} (0.55103) \\ m &= 3.5566 \end{aligned}$$

Now that we have solved for the constant m let us continue to solve the equations for the series legs and the shunt leg of the resistance network.

$$A = \frac{500(12.649 \times 500 + 200 - 2 \times 200 \times 3.5566)}{12.649 \times 500 - 200} =$$

416.5 ohms

$$B = \frac{200(12.649 \times 500 + 200 - 2 \times 500 \times 3.5566)}{12.649 \times 500 - 200} =$$

96.92 ohms

$$C = \frac{2 \times 3.5566 \times 200 \times 500}{12.649 \times 500 - 200} = 116.14 \text{ ohms.}$$

Due to the fact that the artificial line is to be of the

balanced *H* type, half of the resistance of the series elements *A* and *B*, as computed above, should be used in each side of the network. Thus, for the example solved, the corresponding *H*-type pad would be as shown in Fig. 2. *A*/2 equals 208.25 ohms, *B*/2 equals 48.46 ohms, but *C* remains the same—116.14 ohms.

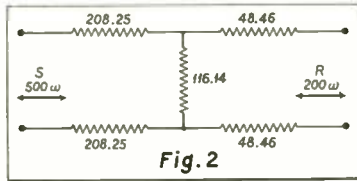

A BALANCED H-TYPE PAD WITH REPRESENTATIVE RESISTANCE VALUES.

MINIMUM LOSS TABLE

Below is shown a table for the minimum loss possible for a T type pad with the given ratio *S*/*R*.

RATIO <i>S</i> / <i>R</i>	MINIMUM LOSS IN DECIBELS
1/1	0.00
1/1.5	5.77
1/2	7.65
1/3	9.96
1/4	11.44
1/5	12.55
1/10	15.79
1/100	26.00

Minimum loss equals

$$10 \cdot \log_{10} S/R \left(1 + \sqrt{\frac{S-R}{S}} \right)^2 \rightarrow 10 \cdot \log_{10} r \left(1 + \sqrt{\frac{r-1}{r}} \right)^2 \quad (6)$$

where *r* equals *S*/*R*.

METHODS USING TABULATED CONSTANTS

Here we have another and possibly more simple method for calculating the resistance legs of pads by using the constants shown in the table following Fig. 3.

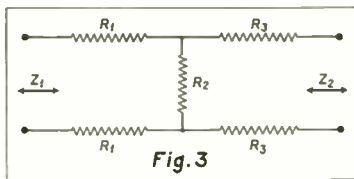

*Z*₁ REPRESENTS THE INPUT IMPEDANCE, *Z*₂ THE OUTPUT IMPEDANCE, *R*₁ THE SERIES INPUT RESISTORS, *R*₃ THE SERIES OUTPUT RESISTORS AND *R*₂ THE SHUNT RESISTOR.

The input impedance *Z*₁ and the output impedance *Z*₂ of a desired pad is known. The decibel loss is also known. With this information mere substitution remains for the desired calculations in the following formula. The formula for finding the shunt resistance *R*₂ is given here.

$$R_2 = 2 K_1 \sqrt{Z_1 \times Z_2} \quad (7)$$

The formulae for finding the series legs *R*₁ and *R*₃ are shown here.

$$R_1 = K_2 Z_1 - K_1 \sqrt{Z_1 \times Z_2} \quad (8)$$

$$R_3 = K_2 Z_2 - K_1 \sqrt{Z_1 \times Z_2} \quad (9)$$

The value of *K* (constant) depends upon the decibel

loss required in each individual pad and is shown in the following table.

DECIBEL LOSS DESIRED	<i>K</i> ₁	<i>K</i> ₂
1	4.34	4.34
2	2.15	2.21
3	1.43	1.51
4	1.05	1.16
5	0.82	0.965
6	0.67	0.835
7	0.558	0.725
8	0.476	0.690
9	0.406	0.645
10	0.352	0.610
12	0.269	0.565
14	0.208	0.540
15	0.184	0.532
16	0.163	0.525
18	0.128	0.515
20	0.101	0.510
25	0.056	0.502
30	0.0318	0.500
35	0.0178	0.500
40	0.0100	0.500
45	0.00565	0.500
50	0.00320	0.500

EXAMPLE

Suppose an artificial line is to be constructed for a loss of 10 decibels when inserted between a 500-ohm pure resistance circuit and a 200-ohm pure resistance circuit. Reference must then be made to the above shown chart for substitution constants. Solving, we find—

$$\begin{aligned} Z_1 &= 500 \text{ ohms} \\ Z_2 &= 200 \text{ ohms} \\ R_2 &= 2 \times .352 \sqrt{500 \times 200} \\ &= .704 \times 316.228 \\ &= 222.624 \text{ ohms} \\ R_1 &= .610 \times 500 - .352 \sqrt{500 \times 200} \\ &= 305.0 - 111.312 \\ &= 193.687 \text{ ohms} \\ R_3 &= .610 \times 200 - .352 \sqrt{500 \times 200} \\ &= 122.0 - 111.312 \\ &= 10.688 \text{ ohms} \end{aligned}$$

Since low-impedance circuits are not rigidly critical as to impedance matching, a slight percentage of error is permissible in the building of pads. Therefore, commercial resistors, which are not very accurately measured, may be used. Their percentage of error may sometimes be as high as 3%. When the values of the calculated resistors, in the above formula, turn out negative in value, the pad combination is impossible. Two pads may be found, however, which will give the desired loss in decibels and also match the input and output impedances.

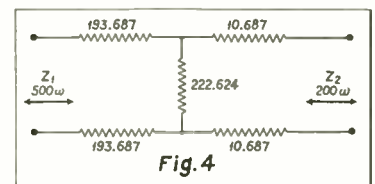

RESULTANT VALUES FOR THE BALANCED H-TYPE PAD TO MEET THE CONDITIONS STATED IN THE EXAMPLE ABOVE.

600-OHM PAD DESIGN

Loss IN DB	CURRENT Ratio K	$\frac{K-1}{K+1}$	$R_0 \times \frac{K-1}{K+1}$ (B ohms)	$\frac{2K}{K^2-1}$	$R_0 \times \frac{2K}{K^2-1}$ (C ohms)
1	1.122	0.0574	34.5	8.65	5190
2	1.259	0.1147	68.8	4.303	2582
3	1.413	0.1712	103.0	2.840	1704
4	1.585	0.2264	136.0	2.098	1259
5	1.778	0.2802	168.0	1.645	987
6	1.995	0.3322	199.0	1.340	803
7	2.239	0.3825	230.0	1.116	678
8	2.512	0.4305	258.0	0.9465	568
9	2.818	0.4760	286.0	0.8410	505
10	3.162	0.5195	312.0	0.7030	422
11	3.548	0.5600	336.0	0.6123	367
12	3.981	0.5934	359.0	0.5364	322
13	4.458	0.6340	380.0	0.4710	283
14	5.012	0.6675	400.0	0.4156	249
15	5.623	0.6980	419.0	0.3670	220
16	6.310	0.7262	436.0	0.3253	195
17	7.080	0.7521	451.0	0.2881	173
18	7.943	0.7766	466.0	0.2558	153
19	8.912	0.7982	479.0	0.2273	136
20	10.00	0.8180	491.0	0.2020	121
21	11.22	0.8360	502.0	0.1797	108
22	12.59	0.8520	512.0	0.1600	96.0
23	14.13	0.8670	521.0	0.1423	85.3
24	15.85	0.8810	529.0	0.1267	76.0
25	17.78	0.8930	536.0	0.1129	67.7
26	19.95	0.9040	543.0	0.1005	60.3
27	22.39	0.9140	549.0	0.0895	53.7
28	25.12	0.9230	554.0	0.0797	47.8
29	28.18	0.9310	559.0	0.0711	42.7
30	31.69	0.9380	563.0	0.0632	37.9

As a final method of selecting the proper resistances for pads, the accompanying table and formulae have been formed for ease in selecting the correct resistive elements to be used in pads of 600 to 600 ohms. For pads having other characteristics than 600 ohms, the resistance values required may be determined by obtaining the product of the characteristic resistance and the constants shown at the left. The values of the resistance shown are to be used in *T*-type pads but may be adapted for *H*-type pads by using half of the value of *B* in each of the four series arms, if the input and

output impedances are the same. Let $K = \frac{I_1}{I_2}$ and R_0

equal the characteristic impedance of the pad. Then

$$B = R_0 \times \frac{K-1}{K+1} \quad (10)$$

$$C = R_0 \times \frac{2K}{K^2-1} \quad (11)$$

The author wishes to express his sincere thanks to Mr. J. G. Harden, Indiana Bell Telephone Co., and to Mr. N. D. Apple, A. T. & T. Co., for their kind assistance in the compilation of the article. Mr. Harden originally derived the first method shown and B. Sachs is responsible for the second formula. The tables have been compiled by the author and others from computation and reliable sources. The author sincerely hopes the article may be of use to a great number of broadcast and audio engineers.

STANDARD FREQUENCY RADIO EMISSIONS

THE NATIONAL BUREAU OF STANDARDS has announced changes in its schedule of standard frequency radio emissions from its station WWV, Beltsville, Md., near Washington, D. C. The changes will substantially increase the service available to transmitting stations for adjusting their transmitters to exact frequency, and to the public for calibrating frequency standards and transmitting and receiving apparatus.

The emissions will be on two days a week instead of one day as formerly, and will be on the three frequencies, 5,000, 10,000 and 15,000 kilocycles per second, instead of the single frequency 5,000. The changes are the result of experimental emissions made by the Bureau on 10,000 and 15,000 kc, with the aid of a large number of organizations and persons who observed the received signals at various places. These tests showed that service could be rendered at all distances in the daytime by the use of the three frequencies. With the use of 5,000 kc alone, it was necessary to have emissions at night in order to give service at distances greater than a few hundred miles from Wash-

ington. With the use of the three frequencies no night emissions will be necessary.

Of the emissions now scheduled, those on 5,000 kc are particularly useful at distances within a few hundred miles from Washington, those on 10,000 kc are useful for the rest of the United States, and those on 15,000 kc are useful in the United States and other parts of the world as well.

Beginning February 1, 1935, and continuing each Tuesday and Friday thereafter (except legal holidays) until further notice, three frequencies will be transmitted as follows: Noon to 1 P. M., Eastern Standard Time, 15,000 kc; 1:15 to 2:15 P. M., 10,000 kc; 2:30 to 3:30 P. M., 5,000 kc.

The emissions consist mainly of continuous, unkeyed carrier frequency, giving a continuous whistle in the phones when received with an oscillating receiving set. For the first 5 minutes the general call (CQ de WWV) and the announcement of the frequency are transmitted. The frequency and the call letters of the station (WWV) are given every 10 minutes thereafter.

The accuracy of the frequencies transmitted is at all times better than a part

in 5 million. From any of them, using the method of harmonics, any frequency may be checked. Information on how to receive and utilize the signals is given in a pamphlet obtainable on request addressed to the National Bureau of Standards, Washington, D. C.

The Bureau desires to receive reports on reception of these emissions, especially because radio transmission phenomena change with the season of the year. The data desired are approximate field intensity, fading characteristics, which of the three frequencies is received best, and the suitability of the signals for frequency measurements. It is suggested that in reporting on intensities, the following designations be used where field-intensity measurement apparatus is not used: (1) hardly perceptible, unreadable; (2) weak, readable now and then; (3) fairly good, readable with difficulty; (4) good, readable; (5) very good, perfectly readable. Statements are desired as to intensity of atmospheric and as to whether fading is present or not, and if so, its characteristics, such as time between peaks of signal intensity. Correspondence should be addressed, National Bureau of Standards, Washington, D. C.

INCREASING POWER OF BROADCAST TRANSMITTERS

Tube Complements for the Various Classes of Modulators and R-F Amplifiers to Obtain Powers from 250 to 5,000 Watts

By R. C. POWELL

WHILE THE TRANSMITTERS used in broadcast stations are of many designs and manufactures the methods of increasing their power output fall within a few general classifications. In many cases the work has been simplified by the development of Class B audio amplifiers. In the revisions suggested below, the output ratings of the existing power supplies have been taken into consideration where possible.

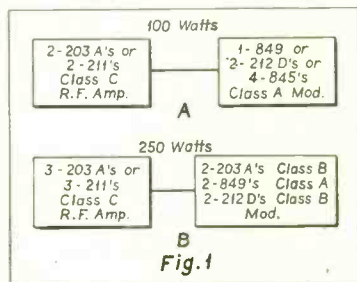

"A" SHOWS TYPICAL 100-WATT LAYOUTS, AND "B" THE CHANGES IN AMPLIFIER AND MODULATOR FOR INCREASING POWER TO 250 WATTS.

100 TO 250 WATTS

The output stage of 100-watt transmitters usually consists either of a pair of 203-A's or 211's operating as Class C amplifiers (see A of Fig. 1), or one type 849 operating as a Class B r-f amplifier. Additions to these two general types required for increasing power to 250 watts are as follows:

The 203-A and 211 are nominally rated at 75 watts output. In carefully designed circuits for broadcast frequencies there is no difficulty in obtaining 100 watts output per tube. Thus by the addition of a third tube of the same type, a carrier power of 250 watts may be obtained.

THE MODULATOR

Modulator systems used in high-level

modulated 100-watt transmitters have consisted either of one 849, two 212-D's or four 845's. In the case of the 849 a second tube of the same type may be used in parallel. Two such tubes will furnish sufficient undistorted power to fully modulate a 250-watt carrier. Two 212-D's may be operated in push-pull Class A Prime or Class B. In the latter case sufficient output can be obtained to modulate a 500-watt carrier.

In the third case where 845's have been used, two 203-A's operated in Class A Prime or Class B will furnish adequate audio power. These arrangements are shown in Fig. 1-B.

The Class B radio-frequency amplifier using a single 849 may be revised to handle a 250-watt carrier by the addition of a second 849, the two operated in push-pull. Some change will be necessary in the modulator and modulated amplifier of this type of transmitter to provide the additional power input to the final stage. These arrangements are shown in Fig. 2.

500 OR 1,000 WATTS

In the infrequent cases where the power of a 100-watt transmitter is to be raised to 500 or 1,000 watts it will be found most economical to add a type 228-A r-f amplifier, as in Fig. 3-A. The output of either the 203-A's Class C or the 849 Class B will be sufficient

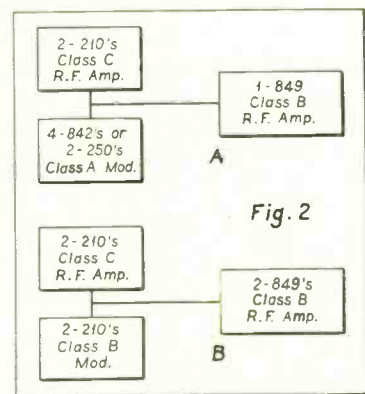

TUBE SET-UPS FOR MODULATOR USED IN CONJUNCTION WITH A SINGLE 849 R.F. AMPLIFIER (A), OR WITH TWO 849'S (B).

to excite the 1-kw power amplifier, as illustrated in Fig. 3-B.

There are in operation a few 250-watt transmitters employing a 204-A Class C amplifier modulated by two 849's Class A (A in Fig. 4). The output of such transmitters can be increased to 500 or 1,000 watts by operating the 849's as Class B modulators and adding the requisite number of 204-A's in the r-f power amplifier, as shown at B in Fig. 4.

INCREASE TO 2,500 WATTS

The output of the latter type of 250-

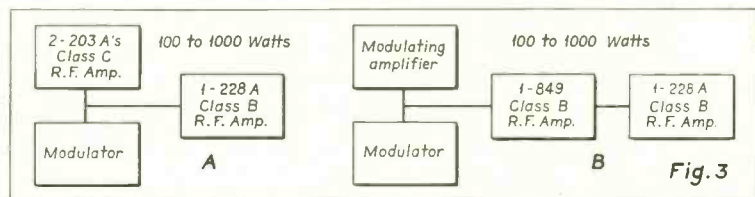

TUBE COMPLEMENT FOR A 1,000-WATT OUTFIT USING A 228-A CLASS B R.F. AMPLIFIER. TWO EXCITATION ARRANGEMENTS ARE SHOWN.

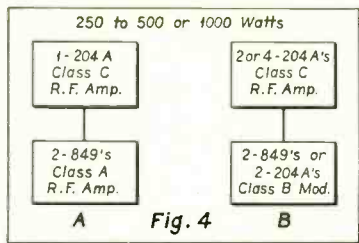

BOOSTING 250-WATTS TO 500 OR 1000 WATTS BY THE ADDITION OF 204-A'S.

watt transmitter can also be increased to 2,500 watts by the addition of two 228-A's operating in push-pull Class B as r-f amplifiers. As an alternative a single 220-B or 207 can be used. The same transmitter can be increased in power to 5,000 watts by adding two 220-B's or 207's operating Class B r-f. Both arrangements are shown in Fig. 5.

Most of the 1-kw transmitters in operation use a 228-A or 207 in the final stage as a Class B amplifier (A in Fig. 6). Such tubes operated as Class C amplifiers will deliver a 5,000-watt carrier. Two similar tubes operated with 5,000 volts on the plates may be used as Class B modulators for a 2,500-watt carrier and with a plate voltage of 7,500 they will supply the power necessary to modulate a 5,000-watt carrier. This arrangement is shown at B in Fig. 6.

GENERAL RULES

With other combinations of tubes and circuits the following general rules may be employed:

FIELD INTENSITY AT RADIO BROADCAST FREQUENCIES

DURING THE PAST three years graphical records of the field intensity of over 300 broadcasting stations in the United States and Territories have been made at the Bureau of Standards' receiving station at Meadows, Md., near Washington, D. C.

The method used for recording the field intensity was developed at the Bureau several years ago.

The data obtained in this way were analyzed to determine the diurnal variations of the received intensity of broadcasting stations at various distances from the transmitting antennas. The data were also analyzed to determine the variation of received intensity as a function of the distance from the transmitter for day-time and night-time transmissions. As reported in RP752 in the December number of the Journal of Research, the maximum sky-wave field intensities at night are received from stations at a distance of about 600 kilometers, or 375 miles. A theory of the propagation of radio waves in the upper atmosphere was developed to explain the data.

The available undistorted audio power for 100 percent modulation should at least be equal to one-half the plate input to the modulated amplifier.

Input power available for the excitation of Class B radio-frequency amplifiers should equal 5 percent to 10 percent of the output power, depending upon the type of tubes used. It is desirable to provide an excess of input power since it can be readily dissipated in the power amplifier input circuit. No correction can be made for conditions where insufficient power is available.

The excitation requirements for Class B audio amplifiers are best enumerated by designating the tubes used in the preceding Class A stage. Two 210's Class A may precede two 203-A's or 211's Class B. Two 845's Class A will excite two 849's Class B. Two 849's Class A will excite two 228-A's or two 207's Class B.

Power transformers used in recti-

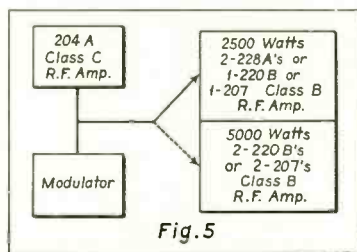

ALTERNATIVE TUBE COMPLEMENTS FOR A 2500-WATT OR A 5000-WATT OUTFIT, BOTH USING CLASS B, R-F STAGES.

The principal conclusion of the paper, aside from the presentation of quantitative data on sky-wave field intensities, is that the variation with distance of the field intensities at night is determined primarily by the radiation characteristics of the transmitting antennas in the vertical plane.

MICROPHONE LEVELS

WE HAVE HAD called to our attention the discrepancies in the voltage gains of various makes of microphones as they appear in the table accompanying the article, "Pre-Amplifier Design," on page 14 of the January issue of COMMUNICATION AND BROADCAST ENGINEERING.

A statement with regard to these values is contained in the third paragraph of the article. It reads as follows:

"It might be well to point out here that this table was compiled from data supplied directly from the manufacturer of the respective input devices listed. Unfortunately all manufacturers of microphones do not employ the same method of calibrating these units, and for that reason this data is not as ac-

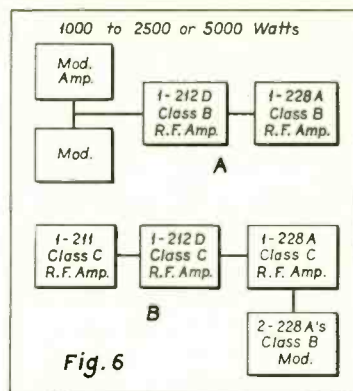

BOOSTING A 1000-WATT JOB WITH CLASS B R-F (A) TO A 2500- OR 5000-WATT JOB BY CHANGING OVER TO CLASS C (B).

fiers supplying Class B r-f amplifiers should have a normal rating equal to 1½ times the non-modulating load and the filter system should be designed to give 5 percent regulation at values between zero and twice the normal load. Rectifiers supplying Class B audio amplifiers should provide 5 percent regulation at loads between zero and four times the plate current drawn when the tube is operated as a Class A amplifier.

When transmitter power is increased it is necessary to replace condensers and inductances in the tank and antenna circuits. These should be of sufficient size to handle twice the non-modulating circulating current continuously at the operating frequency.

curate as it might be if all of these devices were rated on the basis of actual sound pressure measured in dynes per square centimeter required to bring the unit to zero level of .006 watt, or by rating the basis of the amount of amplification required to develop an open-circuit voltage of one volt per bar. Certainly some relationship between the output level of the microphone at various distances from a given and fixed source of sound should be provided. This has been done by the Bell Telephone Laboratories. . . ."

It may be added that high-impedance microphones, such as the crystal and electrostatic types, are usually measured on open circuit, whereas low-impedance microphones, such as the ribbon and dynamic types, are measured on closed circuit. The difference in voltage gain resulting from an open-circuit as against a closed-circuit test, may amount to 6 db.

The voltage gains given in the table can be read more intelligently if this point is kept in mind. Since no indications are given as to the manner of measurement, the correctness of the values cannot be vouched for.—THE EDITOR.

ULTRA-HIGH-FREQUENCY POLICE RADIO SYSTEM

Results and Significance of Field Surveys Made on New- ark Police Radio System

PART II

By PAUL F. GODLEY
Consulting Radio Engineer

THE 500-WATT ultra-high-frequency transmitter of the Newark Police Force, described last month, went into service on the 19th day of November, and some interesting observations have since been made. In certain directions, understandable messages may be had with the car in motion at great distances. The dispatcher's voice from the station has been clearly heard all the way to Trenton, New Jersey—a distance of approximately 50 miles. The country in this direction is essentially flat. To the west of Newark, at a distance of about eight miles, the foothills of the Watchung Mountains begin to rise. After passing a little beyond the top of the first of these, there is a noticeable diminution of the signal, but the signal is not lost. The diminution of the signal

THE STORE ROOM AT NEWARK POLICE HEAD-QUARTERS. FROM TOP TO BOTTOM SHELF ARE STATION-HOUSE RECEIVERS, CAR RECEIVERS, POWER UNITS, AND CAR CABLING.
(Courtesy Western Electric Co.)

after passing over the second range of hills can scarcely be noted. At this time, the distance from the transmitter is approximately twelve miles. The signal is still thoroughly useful. Even though definitely beyond line-of-sight because of the interposition of four-hundred-foot hills, a "commercial circuit" still exists.

NEW YORK SIGNAL LEVELS

In the direction of New York, useful



signals are had all the way to the Hudson River. They are, of course, lost after the car has passed some 60 or 80 feet into the Hudson River tunnels, to be picked up again on the New York City side of the river, as the car emerges from the tunnel. Although the noise levels which obtain throughout New York City are very much higher because of the greater density of motor traffic, it is interesting to note that dispatches from the Newark transmitter are understandable over a considerable portion of the heart of the city. On the other hand, ignition impulses from the city's heavy traffic appear to bound back and forth down the canyons between the tall buildings without as much attenuation as may be observed where traffic of the same density is encountered in open country. In going from lower Manhattan to upper Manhattan, the signal from the transmitter increases considerably as the crosstown streets are approached, and falls away to a minimum about the middle of each block, rising to another maximum as the next cross-street is approached and passed, etc. Frequently, what appear to be dead spots are found in the heart of the city. These are, on the other hand, of no great extent, and except in very rare cases, if one has the patience to wait until the traffic thins out, all messages may be clearly understood. As one nears the northern portion of the city, where the tall buildings begin to decrease in number, and the traffic thins

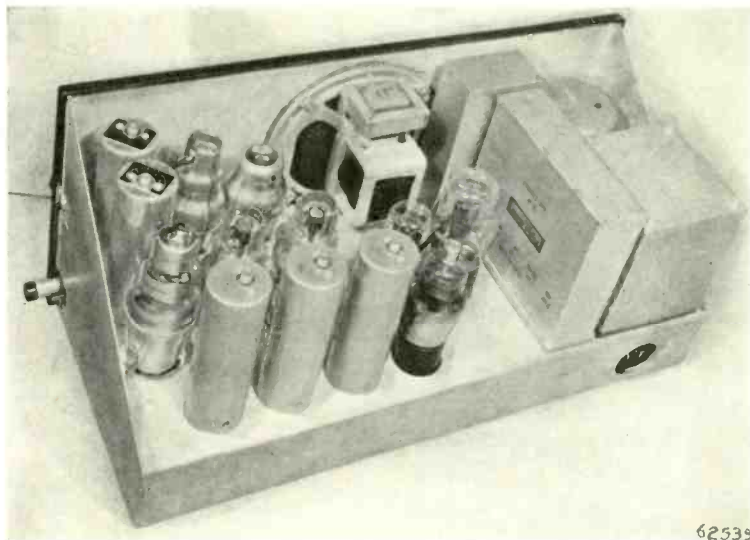

OPEN VIEW OF ULTRA-HIGH-FREQUENCY POLICE RADIO RECEIVER FOR USE AT STATION HOUSES AND OTHER FIXED POINTS. THIS IS THE TYPE OF RECEIVER BEING USED BY THE NEWARK POLICE.

out, the understandability of the dispatches is surprisingly good, in view of the increased distance.

SHADOWING EFFECTS

On the New Jersey side of the river, opposite the northern end of Manhattan, in the northern portion of Englewood, excellent reception is had. Of course, all of the City of Newark and many adjacent municipalities have a signal level sufficient for any practical purpose. Over an extended area, the signal overrides ignition noises of the car, even though the suppressors have been removed. However, throughout that area, including limited portions of Newark itself, there are spots where relatively severe shadowing effects appear to be taking place, and where suppressors are essential. Further afield, satisfactory operation could not be had without suppressors under any circumstances, while still further afield, prime reception is impossible at intersections where a heavy flow of motor traffic prevails at all times.

From all of which, it becomes obvious that the useful service range of a station of this character can be tremendously extended when that day is reached which finds motor manufacturers working a proper shielding of the ignition circuits into the fundamental motor and car designs. From both the motor manufacturers' point of view and the radio engineers' point of view, shielding is the only satisfactory solution for this problem. The use of any type of suppressor in the ignition system of an automobile has a retarding effect upon the ignition currents, for which reason, unsatisfactory motor operation may result where the motor is either not in prime condition, or where it is being operated at very high speeds.

SERVICING

In the preparation of specifications for the Newark system, a considerable amount of thought was given to the service problem. A radio-equipped service car is maintained ready for use. In addition to its own receiver, it mounts spares. The receiver in any one of the patrol cars may be exchanged in a few seconds. Quick exchange for the motor generator is also provided, as well as for the heavy-duty storage battery. Both the latter are mounted in the rear luggage compartment of the coupe, and are readily accessible.

It appears from the experience had to date with this installation that the joint use of some five or six ultra-high-frequency transmitters should provide satisfactory municipal police service for all of the larger towns and cities within the metropolitan area of New Jersey. In



POLICE CAR IN NEWARK, N. J., SHOWING THE ULTRA-HIGH-FREQUENCY RECEIVER JUST BACK OF THE SEAT.

contemplation of the joint use of the Newark plant, it has been recommended that police alarms from the various participating municipalities be broadcast direct from the police headquarters of the individual municipalities. Where a number of police departments are to use one transmitter, occasions would arise, of course, where two or more municipalities might desire at a given instant to broadcast alarms. However, the alarms broadcast are usually of very short duration; even when repeated, they will average, perhaps, less than one-half minute in length, and in case of emergency, the officer in charge at the headquarters dispatching point, can cut an alarm of relatively unimportant character in favor of the emergency alarm, regardless of its source.

COOPERATIVE EFFORTS REQUIRED

Nature appears to have placed definite limits upon some of her resources. In a metropolitan area of this character, a high degree of cooperation is essential to a satisfactory water supply. Nature provides just so much water and there is no more. What there is has to be used with intelligence, and intelligence calls for cooperation. So it is with radio facilities—they are limited. If we are to provide all of the various police groups within a great metropolitan area with the advantages which radio is capable of supplying, we must set up a system which permits of co-

operation. In an effort to cooperate with the Federal Authorities, whose rather vexing problem is to parcel out fairly our radio facilities, the City of Newark has taken a significant and important step in the right direction. There is every indication that the majority of the towns and cities adjacent or contiguous to Newark, appreciate the need for cooperation of this character. It is interesting to note that the City of New York, which has a population of some seven million people, is satisfactorily meeting requirements by the use of three transmitting stations. Here, of course, there is but one police department, and within that department, co-operation.

CONCLUSION

The successful bidder for the Newark system was The Graybar Company. The equipment was designed to meet Newark specifications by the Bell Telephone Laboratories group, and manufactured by the Western Electric Company. The completion of this project was made possible by virtue of the intelligent attack upon the problem by Newark's Director of Public Safety, Michael P. Duffy, and his associates in the department. The plan evolved had the complete support of the entire local press, of the majority of adjacent and contiguous municipalities, and of the Federal Communications Commission.

HIGH-FIDELITY BROADCASTING

Details of the Newly Installed System at WHAM, Rochester

By JOHN J. LONG, JR.
Chief Engineer, WHAM

ANYONE WHO HAS listened consistently to standard broadcasting gets a surprise on hearing a high-fidelity system for the first time. Some are highly pleased with the difference, while others do not like it at first. The usual complaint, from persons not in the habit of listening to the real music as a matter of daily routine, is that it sounds high pitched and stringy. String instruments and muted brass should sound brilliant and piercing if reproduced properly. Broadcast-receiver engineers have supplied tone-control knobs for those who do not wish to hear all that is being transmitted.

HIGH-FIDELITY REQUIREMENTS

There are several parts to a high-fidelity system. All of these parts must be capable of transmitting the original sound to its destination without altering it in any way. These parts are: The studio, the microphone, the studio speech equipment, the telephone lines, the transmitter speech-input equipment, the radio transmitter, the medium of transmission, the receiver, and the loudspeaker. If any of these components are faulty, the whole system will not function properly.

For all practical purposes, at the present time, to operate a high-fidelity system, the noise in the system should be about 60 db below the maximum output desired. The range in volume should be about 40 db, which would leave the noise level 20 db below the softest passage of modulation, if the noise level was down 60 db below the maximum value. The whole system should be capable of reproducing within this range without appreciable frequency or amplitude distortion.

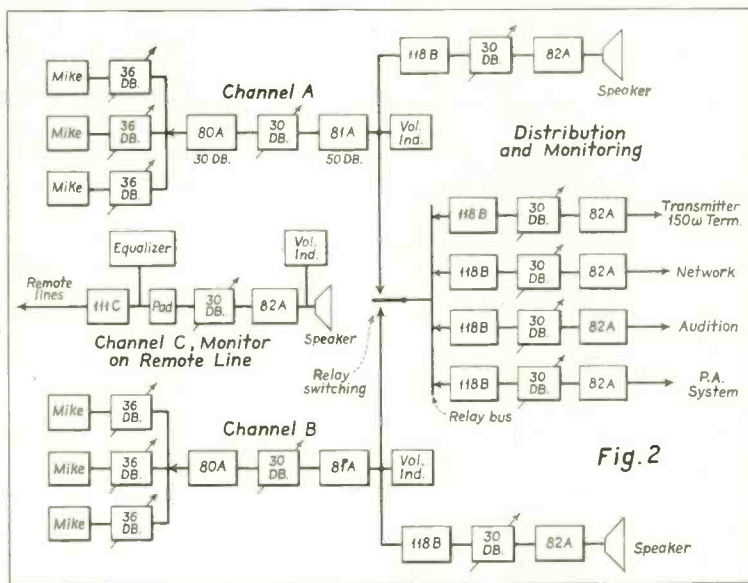

BLOCK DIAGRAM OF WHAM'S CONTROL SYSTEM IN SAGAMORE HOTEL. JACK TERMINATIONS AND EXTRA EQUIPMENT ARE NOT SHOWN.

Studios should be adequately sound-proof and should be designed according to the best available data as to reverberation time, distribution of acoustic treatment, and type of performance to be broadcast.

Studio microphones should have a frequency range flat within 3 db from 30 to 10,000 cycles. The directional effects should be taken into consideration in placing microphones.

Any of the modern microphones can be used, but they all have particular limitations which should be taken into

account when choosing a microphone for a certain type of broadcast. The moving-coil, the crystal, and the ribbon microphones are all capable of high-fidelity transmission. Condenser microphones could also be made to reproduce a wide range faithfully, but this is not common in the average condenser type. The Western Electric moving-coil type is used at WHAM. It is very flexible in operation and can be used under varied and adverse conditions and has reliability, which is a very important item in broadcasting. Its 30-ohm impedance allows the use of long cords without having the pre-amplifier near the microphone. In portable field work this is important, because it permits the operator to have all of his equipment in one spot.

AMPLIFIERS

New Western Electric amplifiers have been installed at WHAM throughout the entire system. The 80A type is used for pre-amplification, the 81A, shown in Fig. 1, is the main studio-channel amplifier, and the 82A is used for distributing the programs to different

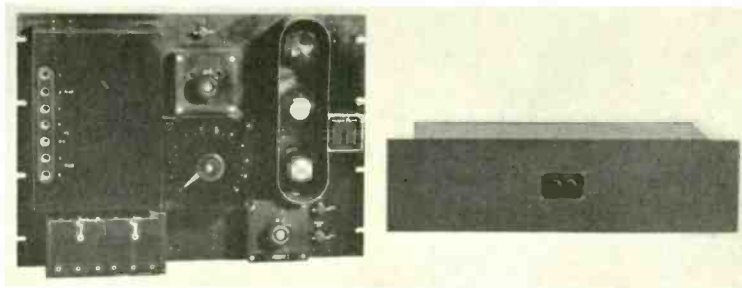

FIG. 1. A COMPARISON OF THE OLD AND THE NEW STUDIO-CHANNEL AMPLIFIERS.

points, and for monitoring. The 82A amplifier is a power amplifier with a gain of 61 db and an undistorted output of plus 24 db. They are coupled to the studio-channel output bus, which operates at "zero level" (6 milliwatts), through a Western Electric 118B bridging transformer, and a balanced ladder attenuator having a maximum attenuation of 30 db and a minimum of 3.7 db. The 118B transformer has an input impedance of 127,000 ohms and an output impedance of 200 ohms. Its loss due to the mismatch is about 30 db. Sixteen of these bridging transformers can be placed across the 500-ohm zero-level bus without dropping the level on the bus over one db. The output range of the bridging circuits is from zero level to plus 24, so that they may be used to feed lines or monitoring speakers. The output impedance of the 82A amplifier is 500 ohms and a Western Electric 119B transformer is used to match it to the dynamic monitoring speaker. All of this equipment is flat within 2 db from 30 to 10,000 cycles.

INTER-CHANGEABLE CIRCUITS

In feeding programs to a national network it is necessary that every precaution be taken to insure uninterrupted service. All of the studio channels are set up the same way, as shown in Fig. 2, and they can be inter-changed in a few seconds in case of equipment failure. These studio channels are either battery or ac operated on the filament circuits, and a B-battery floats on the high-voltage supply so that if a power failure occurs, we can shut down all amplifiers not absolutely essential to putting the program on the air, and monitor temporarily with headphones. Relays to do this switching automatically are to be installed in the future.

In changing our equipment over to high fidelity, we ran into trouble with noise leaking into our circuits. All microphone and other low-level input circuits running to the mixing panels in the studio monitoring positions, and to the 80A pre-amplifiers, had to be carefully shielded with copper-braid wire. On our Eastman School of Music circuits, some of which are 600 feet long, we had to use balanced ladder-type mixing at-

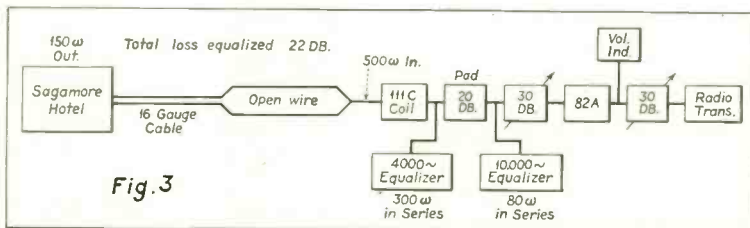

WIRE TERMINATIONS AT WHAM TRANSMITTER, USING UNLOADED CABLE AND OPEN WIRE. THE CIRCUIT IS WITHIN 2 DB FROM 30 TO 10,000 CYCLES.

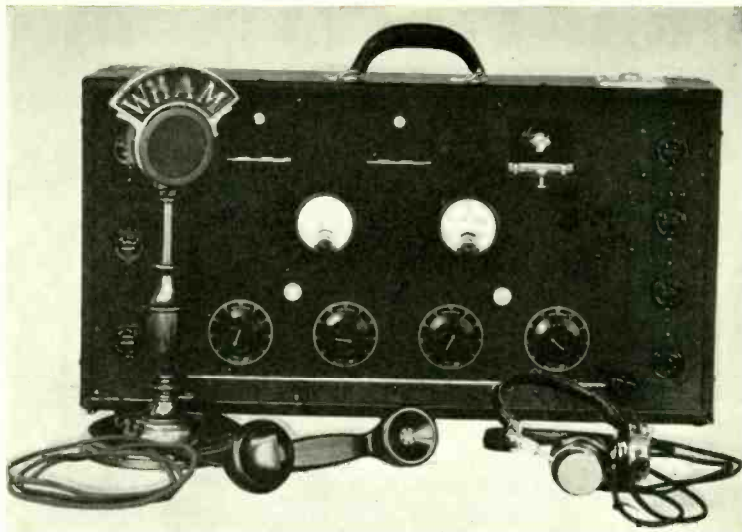

FIG. 4. THE NEW AC-OPERATED REMOTE AMPLIFIER WHICH IS WITHIN 3 DB FROM 30 TO 10,000 CYCLES. MOVING-COIL MICROPHONES ARE USED. THE ORDER WIRE CIRCUIT IS BUILT INTO THE AMPLIFIER.

tenuators to eliminate pickup from other circuits running near the microphone circuits. The amplifiers are very well shielded, but the input circuits running to them should be fairly well balanced to ground and other adjacent circuits.

STUDIO-TRANSMITTER CIRCUIT

At WHAM, the transmitter is about sixteen miles from the studios. As shown in Fig. 3, the programs are sent about halfway on 16-gauge cable and the rest of the way on open wire. The use of a 10,000-cycle terminal equalizer gave us a bad dip in the curve at 4,000 cycles. This was no doubt due to a reflection loss in the circuit caused by the mismatch of the cable to the open wire. We corrected this difficulty by inserting a second equalizer to level off the dip at 4,000 cycles. These equalizers are separated from each other by a 20-db pad, because if they are shunted directly across the incoming circuit, they react on each other so that when one is varied it will upset the other. This circuit can be equalized to within 2 db from 30 to 10,000 cycles with a total loss of 22 db not including the 20-db pad.

SPEECH-INPUT EQUIPMENT

The speech-input equipment at the transmitter consists of two 82A amplifiers, one for operating off the line, and the other for monitoring. Both are connected so that they may be used interchangeably. A cathode-ray modulation indicator is used continuously to keep the level at the point of operation where the greatest coverage can be obtained without running into trouble from over-modulation. Volume-control work has been made more precise by the installation of the new type Weston high-speed volume-indicator meters throughout the system. Overmodulation in a high-fidelity system will show up quickly in the form of a raspy, breaking-up of the modulation. It becomes particularly annoying in the case of a man's speaking voice, or piano music.

THE TRANSMITTER

The new transmitter at WHAM is a Western Electric 306A, 50-kw type. This transmitter is capable of symmetrical modulation to 100 percent within 3 db from 30 to 10,000 cycles. The modulation characteristic is linear within 2 db from 100 percent modulation to 40 db below 100 percent modulation. The noise level is down 62 db below 100 percent modulation. Adjustments of this transmitter to maintain high-fidelity characteristics are more critical than on previous transmitters, and good monitoring equipment is necessary to keep the equipment in proper adjustment. Aging tubes, condensers and resistors will cause marked changes in the fidelity. These conditions can be quickly observed by means of the cathode-ray tube.

REMOTE PICKUPS

On our remote pickup lines we utilize the effect that is obtained when lines are terminated in a lower impedance; the effect of self-equalizing. We terminate the 500-ohm lines in 125 ohms, and by using the regular 10,000-cycle, shunt-type equalizer we are able to flatten any of our local cable circuits from 30 to 10,000 cycles.

The staff has designed and built portable amplifiers with parts now available, which are ac operated, flat within 3 db from 30 to 10,000 cycles and capable of operating into the telephone lines at a minus 4-db level with moving-coil microphones. One of these new units is shown in Fig. 4 and should be compared with the old equipment shown in Fig. 5. A three-channel mixer and main gain is included as well as a volume indicator and built-in order-wire phone. They have three stages of transformer-coupled amplification using the Western Electric 262A vacuum tube which has been especially designed to be used at low audio levels with ac operation. These amplifiers are necessary because we have several broadcasts of the Rochester Civic Orchestra from remote points, mainly from high-school auditoriums in the city. Dance bands and organ programs from theatres are good material for high-fidelity programs, and difficulty often experienced in getting enough high-frequency response on a pickup is eliminated, now that we have a system capable of reproducing these high frequencies faithfully.

BENEFITS OF HIGH-FIDELITY PROGRAMS

Even though the general public cannot at present appreciate the quality of the high-fidelity broadcasts, they will get a benefit in less noise and less distortion. Already there are receivers on the market which have wide audio-frequency ranges. Some of these receivers will not be capable of the wide range

FIG. 5. REMOTE EQUIPMENT USED AT WHAM IN THE EARLY DAYS. NOTE THE MULTIPLICITY OF PARTS AND THE STORAGE BATTERY (THAT WAS ALWAYS LEAKING ONTO SOMEBODY'S RUG!)

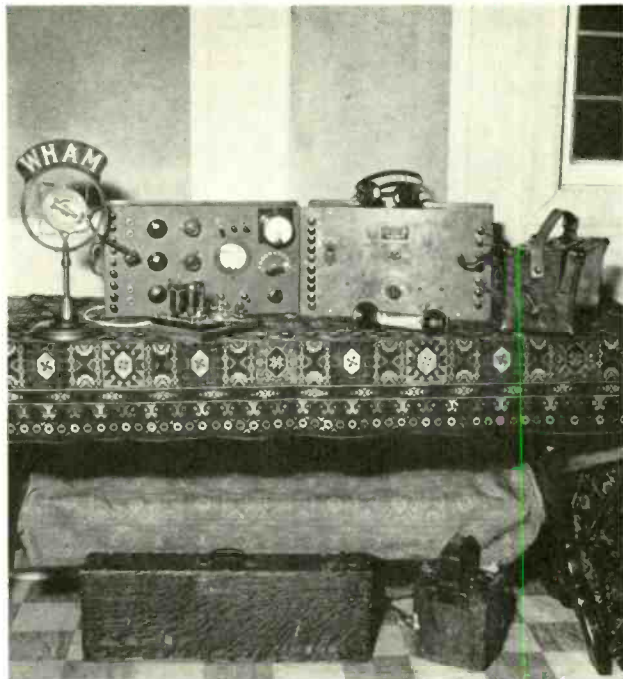

in volume necessary, but there will be a distinct pleasure in listening to wide-range programs even with the volume somewhat compressed. There is a certain strain which comes from listening to a radio which is not reproducing high frequencies. This strain may not be apparent to the listener except that he may tire quickly of listening to radio. This can be demonstrated readily when a quick comparison is made between a standard radio and one which has a wide range. This point, when it becomes generally realized, will go a long way toward building up a greater audience. When people tire of radio due to a technical fault, that fault should be

corrected as soon as is practical. A lost audience means lost business for the broadcast station. The suppression of noise in the broadcasting system is a serious problem, and probably the hardest to combat. Manufacturers of both transmitters and receivers should turn their attention to this point.

Much credit for the installation of the new equipment is due Mr. Gardner, Control Supervisor; Mr. Balling, Chief Transmitter Operator, and for many helpful suggestions, Mr. Ben Olney, of the Acoustical Laboratory. The full cooperation of the management in supplying the necessary equipment of the latest and best design has been appreciated.

PERU SUSPENDS AMATEUR STATIONS

ACCORDING to a report by Julian D. Smith, Commercial Attache, Lima, the following statement was issued relative to amateur transmitting stations:

"It having been proved that there are being transmitted news of an alarming and subversive nature—

"It is resolved:

"1. There are hereby suspended, until further notice, all licenses granted by the office of the Superintendent of Radio for the use of radio transmitting stations called "amateur" in the Republic.

"2. The Superintendent General of the Radio Service shall proceed to confiscate all the installations of such stations which may function contrary to

this disposition, and shall impose upon their proprietors the fines as determined by the General Regulations on Radio." (*Electrical Foreign Trade Notes*, No. 352, Dec. 24, 1934.)

CHINESE WIRELESS STATIONS

AS THE RESULT of the need for greater communication facilities in China, a large order for wireless stations has been awarded Standard Telephones and Cables, Ltd., by the Chinese Government. Under the scheme that is being employed, the larger towns in China will have their own transmitting and receiving stations in order that they may be in constant communication by

telephone or telegraph with other large and important centers.

The wireless links will take the place of costly toll lines for connecting the local telephone networks together. Although the scheme will be on a smaller scale than others, it will be almost identical with the world telephone services between England, America, Africa, Australia, etc., with which Standard Telephones and Cables, Ltd., have been associated. The apparatus will, however, incorporate new features, and careful precautions will be taken to insure absolute secrecy of the telephone side. Facilities will also be provided for high-speed telegraphy. (*The Far Eastern Review*, October, 1934.)

CONCENTRIC TRANSMISSION LINE AT KDYL

By JOHN M. BALDWIN
CHIEF ENGINEER, KDYL

SINCE WLW ADOPTED a concentric transmission line, it has been a pet idea of the writer to try this system of antenna coupling, and see if the resultant improvement was worthwhile. From a theoretical standpoint, any type of transmission-line coupling, properly adjusted, is superior to the old method of directly coupling the antenna to the transmitter, for the losses in the transmitter building are generally much greater than those encountered in a transmission line. In the case of KDYL, we had a tilted wire antenna, 190 feet high at the far end and operated with a series condenser. There was an intense field around the base of the antenna, and special precautions had to be taken to shield the speech equipment and lines from the r-f waves.

CONCENTRIC LINE ADVANTAGES

Inasmuch as the KDYL transmitter is a Western Electric 6B, with capacity coupling to the antenna, the ordinary type of open wire transmission line was out of the question, as it would be impossible to balance the line equally to ground without completely changing the output system of the transmitter. In the case of the concentric line, however, it is not necessary to maintain any balance to ground, and the line can be buried, run overhead, or both, as necessity may require. This made it the ideal type for our needs.

It was decided to experiment with a temporary type of feeder line before going to the expense of a regular in-

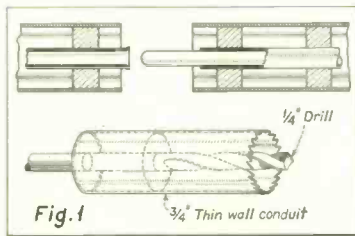

DETAILS OF CONCENTRIC LINE SLIP JOINT AND THE POWER SAW FOR CUTTING THE OAK WASHERS.

CIRCUIT USED IN COUPLING THE TRANSMITTER TO LINE AND LINE TO ANTENNA.

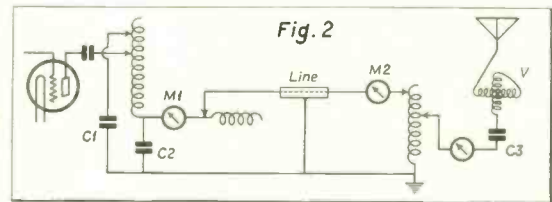

stallation. A line was constructed, using $\frac{3}{4}$ -inch thin wall conduit, with $\frac{1}{4}$ -inch copper tubing for the inner conductor. Oak washers, boiled in paraffin, and held in place on the copper tube by small spots of solder, were used for insulation. (See Fig. 1.) These were perfectly satisfactory for our purpose as they provided ample dielectric strength for the low voltage of the line, and their dielectric constant was not great enough to materially change the line impedance from its calculated value.

ASSEMBLING OF LINE

The line was assembled in ten-foot lengths, with an oak spacer every six inches in the straight portions of the line, and every two inches on the bends. These bends were made with a regular thin wall conduit bender, and were of 7 inches radius; large enough so that little center displacement resulted. Each inner conductor was made with a pin type connector at one end, to slide into the preceding section, as shown in Fig. 1, and the outer conductors were joined with standard connectors used with this type of conduit. Each joint was then taped to keep out moisture, and the line laid upon a series of upright posts, about two feet off the ground in order to clear the heaviest snowfall. In a permanent installation, however, the line should be buried under ground.

COUPLING CIRCUIT

The wiring diagram of Fig. 2 shows the circuit used in coupling the transmitter to line and the line to antenna. This is a simple and easily adjusted circuit and has low losses—at best not over two percent. The ratio of capaci-

ties in the power-amplifier tank circuit is such that the impedance across condenser C-2 matches the surge impedance of the line, although it is possible to operate a short line at an impedance differing from its natural surge impedance by as much as 20 percent without any excessive loss provided, however, that the source and sink impedances are equal. This is easily determined by comparing the readings of M-1 and M-2, which should be equal when the source and sink impedances are matched. The variometer, V, in the antenna circuit has a low range of inductance, and is useful in obtaining exact resonance. Its reactive effect is also necessary to offset the reactance of the fixed antenna series condenser, C-3, which is of .0035-mfd capacity. The antenna itself is very closely one-quarter wave long and is supported vertically between two hundred-foot steel towers.

COMPUTATION OF SYSTEM

The mathematics required for computation of this or any other similar system are rather elementary, and are not gone into here, as the December issue of COMMUNICATION AND BROADCAST ENGINEERING has, on page 14, a very thorough presentation of the problem.

RESULTS OF TEST

In conclusion, the results of a month's test run on the new antenna, together with measurement of the new radiation pattern, show a decided gain in coverage, using the same power as before, and as a result of these tests, KDYL will soon install a permanent concentric line.

TELECOMMUNICATION

PANORAMA OF PROGRESS IN THE FIELDS OF COMMUNICATION AND BROADCASTING

TEN-FREQUENCY TRANSMITTER

SELECTING ANY ONE of ten frequencies by merely twirling a telephone dial, awaiting an instant for it to return and automatically put the carrier on the air, is a feature of the latest radio transmitter designed for aviation ground stations and for coastal and ocean-going vessels. The frequency shifting device resembles a miniature telephone board serving ten dial telephones. Automatic control is so complete that the user's voice may be made to put the transmitter on or off the air instantly or to shut it down completely after an interval of anywhere from one to fifteen minutes.

Any ten frequencies in the range of 2 to 18 megacycles are available and the transmitter is pre-adjusted to those desired. Shifting from one to another merely involves the redialing of a single digit. The dial controls a standard telephone selector switch which closes the proper latching relay on one of ten vertical rods. This rod is then raised by a solenoid relay, closing the circuits to the tuning unit in each amplifier stage which has been pre-adjusted to operate on the desired frequency. The dial can be located at any convenient place, thus providing a simple and effective remote control.

Ten quartz plates, one for each frequency, maintain the carrier within .025

percent of the assigned frequency. The transmitter delivers from 300 to 400 watts depending upon the operating frequency, with a total input power of approximately 3,500 watts and can be operated on CW, MCW or phone with 100 percent modulation.

The system consists of two units. The rectifier unit contains a 200-volt grid-bias rectifier, 800-volt and 2,500-volt plate rectifiers employing mercury-vapor tubes, an audio amplifier and all the control relays. The transmitter unit contains all the radio-frequency generating and amplifying apparatus together with the dialing and switching mechanism. The entire equipment is completely self-contained and employs no rotating machinery, except a small fan which is used for circulating air about the power-amplifier tube in the transmitter.

This equipment has been designed by Bell Telephone Laboratories for Western Electric Company for use at radio stations where it is necessary to operate on a number of different frequencies with a minimum of lost time in changing from one frequency to another. This feature is of great importance in aviation ground stations and ship-to-shore service where transmission conditions require the use of different frequencies for satisfactory communication, depending on the time of day and the distance to be covered.

NEW RADIO DIRECTION FINDER

A NEW TYPE OF radio direction finder for use on both aircraft and on ships has recently been developed which makes it possible to use any standard broadcast station as a directing beam.

EQUIPMENT

The instrument consists primarily of a three-band receiver (Fig. 1) which tunes from 200 to 400 kilocycles, from 550 to 1,500 kilocycles and from 3,000 to 6,200 kilocycles in conjunction with which is a balanced modulator and audio oscillator. In addition to this there is a special loop antenna (Fig. 2) and a small vertical antenna and the sense of direction is shown directly on a zero-center, right-left visual indicator meter. The instrument can be used as both a regular radio receiver on any of the aforementioned frequencies or, by throwing a single switch, the radio di-



FRONT VIEW OF THE TEN-FREQUENCY RADIO QUICK-SHIFT TRANSMITTER FOR COASTAL AND OCEAN-GOING SHIPS AND AVIATION GROUND STATIONS, SHOWING THE RECTIFIER AT THE LEFT AND THE TRANSMITTER AT THE RIGHT.

rection finder properties come into play. Thus, the pilot of plane or ship has a combined radio receiver and homing device in one compact unit both entirely operated from a single remote control head on the instrument panel.

OPERATION

The usual procedure of operation is as follows: Tune in the desired radio station toward which it is desired to direct the course. Turn on the compass switch and then proceed to orient the plane or ship in the normal "sense" of direction until the visual indicator needle reaches mid-scale (on course) position. This will lead directly to the towers of the radio station. When right of course, the meter indicates to the right and when left of course it indicates left.

This instrument makes possible the use of any radio station for showing the course home of plane or ship and with hundreds of stations to choose



FIG. 3. INSTALLATION OF THE RADIO DIRECTION FINDER IN AN AUTOMOBILE. NOTE THE VERTICAL ANTENNA MOUNTED TO THE REAR OF THE LOOP ON TOP OF THE CAR.

from, there never is a lack of directing beams anywhere in the world. The course, with this new radio direction finder, is said to be just as direct and positive as if one were to plot it with pen and rule on a map.

Shown in Fig. 3 is an installation of the radio direction finder on an automobile which is used as a field laboratory and demonstration car by the Lear Developments, Inc., of New York City, who developed this new instrument.

REQUEST TO INSTALL BROADCAST STATION

IN THE "DIARIO OFICIAL" of November 6, 1934, Angel I. Prieto, A. Calle Quillota 214, Vina del Mar, makes application for a concession to install a radio-broadcast station in Santiago. Mr. Prieto states, according to *Electrical Foreign Trade Notes*, No. 351, December 15, 1934, that this station is to have characteristics similar to those of station CE76 now being erected in Valparaiso, which is of the first category, 10,000 watts power. (*Office of Commercial Attaché, Santiago.*)

KFWB USING SOUND-ON-FILM

WARNER BROTHERS' Hollywood station, KFWB, boasts the only piece of equipment that will broadcast sound-on-film-on-air directly from the studio. The equipment was designed and built by the United Research Laboratories and has proven quite a success in recent tests.

Gerald King, station manager of KFWB, is of the opinion that the sound-on-film method of program transcription is superior to the disc recordings. According to reports, the sound-on-film method provides a wider frequency range and is free of surface noise.



FIG. 2. THE SPECIAL LOOP ANTENNA USED WITH THE RADIO DIRECTION FINDER.

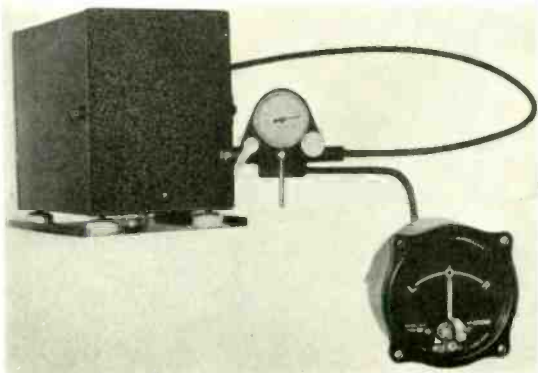
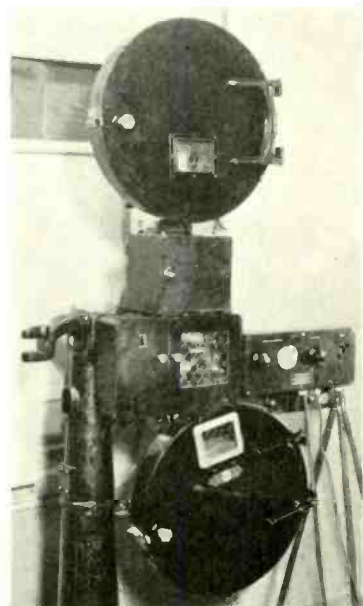

FIG. 1. THE THREE-BAND RECEIVER, REMOTE TUNING CONTROL, AND INDICATOR, USED WITH THE RADIO DIRECTION FINDER.



THE SOUND-ON-FILM EQUIPMENT USED IN THE STUDIOS OF STATION KFWB, IN HOLLYWOOD.

FEDERAL COMMUNICATIONS COMMISSION REPORTS

ACTION ON COMMERCIAL NEWS SERVICE

THE TELEGRAPH DIVISION on January 9 waived the 30-day provision in the matter of inauguration by Western Union of commercial news service at Tucson, Arizona; Peoria, Illinois; Vincennes, Indiana; Fostoria, Ohio; Salisbury, Maryland; Kansas City, Missouri; Cedartown, Georgia; Omaha, Nebraska; Lufkin, Texas; Brockton, Massachusetts; San Francisco, California; St. Louis, Missouri, the rates to become effective January 15, 1935.

CHILLICOTHE TELEPHONE COMPANY

On January 10, the Telephone Division of the Federal Communications Commission considered the request of the Chillicothe Telephone Company to be relieved from compliance with orders of the Commission and of this Division. Upon consideration of the facts in connection with the case, it was ordered that the request be denied.

It was further ordered that the Commission assert its jurisdiction over Chillicothe Telephone Company in its entirety.

AIRCRAFT MARKER BEACONS

The Commission, at a general session on January 11, adopted the following rules:

"247A. The term 'airway radio obstruction marker station' means a station of low power installed in the vicinity of an obstruction to air navigation and operated for the purpose of giving warning of the presence of that obstruction.

"254A. Airway radio obstruction marker stations will not be licensed to use a power greater than 50 watts. The exact power to be authorized is to be determined by the relation between the location of the marker station and the nearest radio-range station operated by the Bureau of Air Commerce.

"260A. Airway radio obstruction marker stations will be licensed for a carrier frequency of 1200 cycles above or below the assigned frequency of the nearest airway radio-range station serving the airway on which the obstruction is located. The marker transmitter carrier shall be one hundred percent modulated at an audio frequency of 120 cycles per second and automatically keyed by continuously successive groups of 5 dashes each. Operation shall be continuous throughout the 24 hours and the assigned carrier frequency will be maintained within .05 percent.

"260B. The Commission may from time to time, in cooperation with the Bureau of Air Commerce, specify radio stations which may be required to install airway radio obstruction marker stations and will specify the conditions under which such installations will be made."

The Commission also modified Rule 229 with respect to the frequencies 2850 kc and 3000 kc so as to read:

"m 2850 kilocycles—fixed
m 3000 kilocycles—fixed

Note: (add) m—temporarily available for fixed service provided no interference is caused to any other service until June 1, 1935."

TELEPHONE DIVISION ORDER NO. 1

The Telephone Division, composed of Commissioner Walker, Chairman, and Com-

¹See *Radio Marker Beacon*, Page 24, December, 1934, COMMUNICATION AND BROADCAST ENGINEERING.

missioners Case and Sykes, on January 17, took the following action:

They decided that the Du Bois Telephone Company of Du Bois, Nebraska, and the Fort Kent Telephone Company of Fort Kent, Maine, are subject to the jurisdiction of the Commission.

To provide a reference file for the general public it was decided to require all telephone companies subject to the jurisdiction of the Commission, to file duplicate copies of their schedules of charges submitted to the Commission in response to Telephone Division Order No. 1.

MISCELLANEOUS TICKER SERVICE

On January 22, the Telegraph Division granted special permission to the Western Union Telegraph Co., to establish New York-New Orleans cotton miscellaneous ticker service to Plainview, Texas, effective on one day's notice.

AMATEUR STATION LICENSES

On January 23, it appearing to the Commission that a number of station licenses were revoked by the Federal Radio Commission and the Federal Communications Commission for violations of the Rules and Regulations of the Commission, and, simultaneously, orders were adopted suspending the operators' licenses of the persons in whose names the stations were licensed:

It was ordered, *That after the period of suspension of the operator's license has expired, the licensee may make formal application to the Commission for station license or licenses, and the same may be handled in routine manner without prejudice.*

APPLICATIONS GRANTED FOR NEW STATIONS

Telegraph Division

December 12, 1934.

MACKAY RADIO & TELG. CO., Inc., Brentwood, N. Y., granted general license to cover construction permit, 5250 kc, 50 kw; also granted license to cover construction permit, 15,675 kc, 50 kw.

L. H. METZGAR, Supt., Alaska Juneau Gold Mining Co., Juneau, Alaska, granted temporary authority to May 1, 1935, subject to filing required amendments for special emergency service to communicate between Juneau and Annex Creek Power Plant, Taku Inlet, which is between main office of applicant and power station near Juneau. Frequency 2726 kc; 25 watts. Same granted to Annex Creek Power Plant, Alaska.

January 2, 1935.

CITY OF DODGE CITY, Kansas, granted construction permit, 2474 kc, 50 watts.

LOS ANGELES COUNTY Flood Control District, Calif., granted construction permit for portable equipment to be used in California, 2726 kc, 50 watts.

BOROUGH OF NORTH PLAINFIELD, N. J., granted construction permit (3 applications) for portable-mobile equipment, 30,100, 33,100, 37,100, 40,100, kc, 3 watts; also authorization to communicate as municipal police station in emergency service on experimental basis only.

January 9, 1935.

STATE OF OHIO, Department of High-

ways, Division of Highway Patrol, Cambridge, granted construction permit for state police station, frequencies 1682 and 1596 kc. The frequency 1596 is assigned on a temporary basis for state police service; subject to discontinuance without hearing; equipment to be maintained at all times capable of operating on 1682 kc, 400 watts. CITY OF ROME, Georgia, granted construction permit for general experimental station, frequencies 30,100, 33,100, 37,100, 40,100 kc, 25 watts.

January 16, 1935.

L. McGEE, Iliamna, Alaska, granted construction permit, frequencies 2922, 2946 kc, 25 watts. The same was also granted for Rainy Pass, Alaska.

PACIFIC ALASKA AIRWAYS, INC., Flat, Alaska, granted construction permit, 3082.5, 5692.5, 5220 kc; 2648, 3082.5, 4125 kc unlimited, 6370, 8015 kc day only; 20 watts.

CITY OF HARTFORD, Conn., granted construction permit, 30,100, 33,100, 37,100, 40,100 kc, 50 watts. Same for portable-mobile equipment (5 applications) to be used within city limits at 25 watts.

CITY OF COLUMBIA, South Carolina, granted construction permit, 30,100, 33,100, 37,100, 40,100 kc, 25 watts. Also authorization to communicate as municipal police station in emergency service on an experimental basis only.

RUSSELL WILLIAM THAW, NC-2111, granted itinerant aircraft station on frequencies, (a) 3105 kc, (b) 2906, 3072.5, 3088, 4937.6, 4952.5, 4967.5, 5672.5, 5692.5, 3062.5 kc (Not to be used west of Kingman or east of Pittsburgh). Power 50 watts; communication: with any ground station with frequency (a) and with Blue Chain station with frequencies (b).

January 23, 1935.

CITY OF SAGINAW, Michigan, granted construction permit for experimental service on frequencies 30,100, 40,100 kc, 100 watts; also granted similar construction permit for mobile equipment (Michigan) at 30,100 kc, 10 watts; same as above except frequency 40,100 kc; and also a similar permit except for frequency 37,100 kc.

EXAMINER PRINTING CO., NC-14250, granted aircraft station license, frequency 3105 kc, 50 watts power, pending receipt and action on formal application.

CITY OF ROYAL OAK, Michigan, granted construction permit, frequencies 30,100, 33,100, 37,100, 40,100 kc, 25 watts, with authority to communicate as municipal police station in emergency service.

Broadcast Division

December 18, 1934.

BAMBERGER BROADCASTING SERVICE, Inc., Newark, N. J., granted construction permit for mobile equipment to operate in broadcast pick-up service on frequencies 31,100, 34,600, 37,600, 40,600 kc, 25 watts.

H. E. STUDEBAKER, Lewiston, Idaho, granted application for construction permit for station to operate on 1420 kc, 100 watts.

January 8, 1935.

WILTON E. HALL, Anderson, S. C., granted construction permit for station to operate on 1200 kc, 100 watts, unlimited time.



VETERAN WIRELESS OPERATORS ASSOCIATION NEWS

W. J. McGonigle, Secretary, 112 Willoughby Avenue, Brooklyn, N. Y.

ANNUAL MEETING

The Annual Meeting of the Veteran Wireless Operators Association, Incorporated, was held at 6 PM on January 11, 1935, at the Hotel McAlpin, Thirty-fourth Street and Broadway, New York City.

The following Officers and Directors were elected for 1935, by sealed ballots which were mailed to the membership following the December meeting and returned to the Secretary before the Annual Meeting: George H. Clark, *President*, Information Department, Radio Corporation of America; Arthur F. Wallis, *Vice-President*, Superintendent, Marine Department, Mackay Radio and Telegraph Company; William J. McGonigle, *Secretary*, Maintenance Engineer, New York Telephone Company; Paul K. Trautwein, *Treasurer*, President, Mariners Radio Service. Board of Directors elected: Fred Muller, Hearst Radio, Inc., subsequently elected Chairman at the first Board meeting; J. A. Bossen, Marine Commercial Manager, Mackay Radio and Telegraph Company; A. J. Costigan, Traffic Superintendent, Radiomarine Corporation of America; W. S. Fitzpatrick, Publicity and Advertising, RCA Institutes; Charles D. Guthrie, Marine Department, Mackay Radio and Telegraph Company; Arthur A. Isbell, Manager Commercial Department, RCA Communications, Inc.; Fred Klingenschmitt, Sales Engineer, Amy Aceves and King; William J. McGonigle, New York Telephone Company.

AWARDS

The Gold Medal of the Veteran Wireless Operators Association for the Year 1934 has been awarded to George W. Rogers, Chief Radio Officer of the ill-fated T. E. L. *Morro Castle* for his outstanding radio work on that vessel in sending distress signals despite the flames and smoke that filled the radio-room, which every moment threatened his life. Mr. Rogers remained in the radio room so long that, unaided, he would have been unable to leave his post. Aided by Mr. Alagna, his First Assistant, he made his way from the smoke-filled, flame-swept, radio room to the fore part of the ship. He remained there until the entire crew remaining aboard the *Morro Castle* was ordered into a lightship tender by the Commander of the Coast Guard cutter, *Tampa*. Upon arrival at Staten Island he was removed to the U. S. Marine Hospital suffering from blistered feet and overcome by his ordeal in the smoke-filled radio-room.

TESTIMONIAL SCROLLS

Testimonial Scrolls have been awarded to the following Radio Officers who have distinguished themselves in the performance of their duties under the most trying circumstances.

George I. Alagna, First Assistant Radio Officer on board the ill-fated T. E. L.

Morro Castle when it was destroyed by fire in September, 1934, off the Jersey Coast. Mr. Alagna was in no small way responsible for the rescue of his Chief, Rogers, from the burning radio-room.

William J. Kirchhoff for meritorious radio service aboard the S. S. *Sea Thrush* which foundered on the rocks off the coast of Washington, and broke into pieces shortly after Mr. Kirchhoff took to a life-boat.

Russel McDonald, Chief Radio Officer on board the ill-fated S. S. *Mohawk* for his excellent radio work in summoning aid which resulted in the saving of a large proportion of the passengers and crew of that vessel. The *Mohawk* sank off the Jersey Coast in January 1935—rammed by the Norwegian freighter *Talisman*.

Ernest H. Cole, Assistant Radio Officer on board the *Mohawk* on its last voyage. Mr. Cole performed his work as a radioman in a most creditable manner.

E. J. Robertson (posthumously) Radio Officer of the British freighter *Usworth* which sank in a mid-Atlantic gale in mid-December. The late Mr. Robertson remained at the key continuously for four days summoning aid. His efforts resulted in the saving of a good proportion of the crew of the *Usworth* by the crews of the Belgian S. S. *Jean Jadot* and the British S. S. *Ascania*. He perished, however, when within but a few feet of the *Jean Jadot*, probably because he was too weak, from his long stay at the key, to grasp a life line thrown to him by members of the crew of the *Jean Jadot*.

Henri Van Den Bussche, Chief Radio Officer and Joe Gately, Second Radio Officer of the Belgian S. S. *Jean Jadot* for their meritorious radio work in maintaining continuous contact with the *Usworth* during the four days the *Usworth* was in difficulty. Such efforts on the part of radiomen aboard rescue craft are truly worthy of recognition.

Jack Dyer, Radio Officer on board the S. S. *Larry Doheney* when that vessel encountered difficulty in a typhoon off Guam. It was due to his outstanding radio work that the *Larry Doheney* was able to make port in Guam.

R. Lilkebakken, Radio Officer on board the Norwegian Motorship *Childar* when that vessel ran aground at the entrance to the Columbia River on May 4th, 1934. Prompt and efficient handling of distress messages resulted in loss of only four men who were washed overboard.

The award of the Gold Medal to Rogers and the Testimonials to George I. Alagna, Russel McDonald, Ernest H. Cole, E. J. Robertson, Henri Van Den Bussche, Joe Gately and R. Lilkebakken, were made at the Tenth Anniversary Dinner-Cruise of the V. W. O. A. at the Montclair Hotel on February 11th, 1935. The award to Jack Dyer was made at the First Annual Dinner-Cruise of the San Francisco Chapter held at the Fairmont Hotel in SF simulta-

neous with the New York Affair. The award to W. J. Kirchhoff was made by Captain Randall of the S. S. *Washington* at sea on February 11th, 1935 at the time our Dinner was in progress in New York. Mr. Kirchhoff is Chief Radio Officer aboard the *Washington*. Messages were exchanged with the *Washington*.

Simultaneous with the New York Tenth Anniversary Dinner-Cruise at the Montclair Hotel and the First Annual Dinner-Cruise of the San Francisco Chapter of the V. W. O. A. in the Army and Navy Club at the Fairmont Hotel, the First Annual Dinner-Cruise of the Chicago Chapter of the V. W. O. A. was held at the Bismarck Hotel in Chicago. Messages were exchanged between each of the Cruises.

PERSONALS

We congratulate Harry Chetham upon obtaining a permanent assignment as Chief Operator of the Somerville Police Radio station, in Somerville, Mass., his home town. HC has been for the past several years acting Chief Operator at that station. . . V. H. C. Eberlin Association Treasurer, formerly Assistant Radio Inspector for Tropical Radio in New York, more recently Chief Radio Officer of the United Fruit S/S. *Ulua*, has been transferred to the Miami station of Tropical Radio as radio-telephone technician. The Miami radio-telephone station is the connecting link between United States and Central American telephone subscribers. We wait, with interest, a description of the comprehensive installation at Miami, VHC.

Arthur H. Lynch, President of the Arthur H. Lynch Manufacturing Company, who saw service as a Commercial radio operator back in 1912, and also in the U. S. Signal Corps during the World War, recently joined the Association as a Veteran member. Welcome AHL! . . . Mortimer O. Smith, formerly of the Engineering Department of NBC, at San Francisco, has been transferred to the Engineering Department of NBC at New York. . . Ray Green of the Radio Staff of the Leviathan is relief operator for the vacation period at Radiomarine's New York Harbor outlet at Bush Terminal. WNY. . . H. H. Parker did an excellent job as Recording Secretary at the last meeting. Think we'll have to give him that as a permanent assignment. . . A. C. Tambourino now selling air-conditioning equipment. . . Sorry to hear of the recent accident in which Peter Podell's son was injured. Hope he's recovered now OK. . . W. C. Simon and J. W. Graham paid for '35. Have you? Contact the Secretary for details of this year's plans.

DON LEE TELEVISION CHANGES FREQUENCY

In anticipation of future television developments, two important changes have been made in the Don Lee television station W6XOA, it was announced by Harry R. Lubcke, director of television for the Don Lee Broadcasting System.

The operating frequency of the station has been changed from 44,500 (6 $\frac{3}{4}$ meters) to 45,000 (6 $\frac{2}{3}$ meters).

The other change is the increase of the radiated power by installation of new radiator equipment to make it possible to send out stronger signals.

OVER THE TAPE . . .

NEWS OF THE RADIO, TELEGRAPH AND TELEPHONE INDUSTRIES

CHINESE COMMUNICATIONS COMMISSION VISITS U. S.

Members of the Chinese Communications Mission, visiting the United States, were entertained at a dinner given in honor of General Fei-Ping Yu, heading the Mission, by General James G. Harbord, Chairman of the Board of the Radio Corporation of America. General Yu is Vice Minister of Communications, Nanking, China, and the members of his Mission are communications experts.

The dinner, in the RCA dining room on the sixty-fourth floor of the RCA Building, followed an inspection by the members of the Mission of the central operating office of R. C. A. Communications, Inc., at 66 Broad Street, where they watched the dispatching and receiving of radiotelegrams and Photograms on the international circuits of RCA.

Following the dinner, the guests inspected the Studios of the National Broadcasting Company in the RCA Building and visited the Radio City Music Hall.

Among those present at the dinner for General Yu were Mr. E. F. Wei, Chief Technical Advisor, Ministry of Communications, Nanking, China; Mr. P. F. Woo, Technical Advisor, Ministry of Communications, Nanking, China; Mr. K. Yih, Chinese Consul General of New York City; Mr. K. C. Li, of New York; Mr. Andrew W. Cruse, Chief, Electrical Division, Bureau of Foreign and Domestic Commerce, Department of Commerce, Washington; Mr. J. F. Sinnott, District Manager, Bureau of Foreign and Domestic Commerce, Department of Commerce, New York; Mr. C. E. Christopherson, United States Trade Commissioner to China, Shanghai; Colonel William Chadbourne, President, China Society of America; Dr. Claudius Murchinson, Director, Bureau of Foreign and Domestic Commerce, Department of Commerce, Washington.

H. K. NORTON WITH RCA

Mr. David Sarnoff, President of the Radio Corporation of America, has announced the appointment of Mr. Henry Kittredge Norton to the position of Assistant to the President of RCA.

Mr. Norton comes to the Radio Corporation from the National Broadcasting Company, the broadcasting member of the RCA family, where he has served as Treasurer and in other important capacities. He brings to RCA a broad knowledge of corporation organization, budgets, and finance and a wide experience in coordinating business activities. Mr. Norton is widely known as an author of books and magazine articles.

VEEDER-ROOT PAMPHLET

Veeder-Root, Incorporated, Hartford, Conn., have a new pamphlet entitled, "To Count is to Control". This pamphlet illustrates and describes some 16 of their general-purpose counters. Especially featured are electrically-operated units, and high-speed resetting units. This bulletin will be sent on request.

COMMUNICATION ELECTRONICS AT COLUMBIA UNIVERSITY

The advanced course in electronics which is offered in the Engineering School at Columbia University has recently been expanded to cover a full year. The first term deals with those aspects of electronics which are of interest chiefly to the electrical engineer, while the second term's work is concerned entirely with communication electronics. Since the two terms may be taken separately, the latter portion is of particular interest to the communication engineer.

Subjects treated in the second half year include resistance- and transformer-coupled audio amplifiers, the output stage, push-pull and Class B amplification, motor-boating, circuit noises, etc. Radio-frequency amplification is also dealt with at length, as are such subjects as waveform distortion, cross-modulation, and the new feedback amplifiers. The theory of linear detectors is developed and consideration is given to exponential conductors and other non-linear circuit elements. Vacuum-tube voltmeters and constant-frequency oscillators are also included in the course.

In addition to providing a comprehensive survey of the fields of communication, the course also gives 3 points of credit towards the Master's Degree.

Meetings are held on Thursday evenings from 7 to 9.

NEW WATER COOLING CATALOGS

Binks Manufacturing Company, 3106 Carroll Ave., Chicago, Ill., offer an 8-page bulletin on indoor forced-draft spray-cooling towers presenting complete information about constructional features, picturing a number of installations, showing typical arrangements, and giving size and capacity data and specifications.

Also a similar 8-page bulletin devoted to atmospheric spray-cooling towers for air conditioning and refrigeration, with complete engineering information and other helpful data is available.

MUTUAL BROADCASTING SYSTEM RE-ELECTS OFFICERS

To Install Permanent Network Lines

The Mutual Broadcasting System held its first annual meeting at the Drake Hotel, Chicago, Thursday and Friday, January 10 and 11, and all officers and directors of the organization with one exception were re-elected.

Officers re-elected were: Chairman of the Board of Directors, A. D. McCosker, of WOR, New York; President, W. E. Macfarlane of WGN; Executive Secretary, E. M. Antrim of WGN; Treasurer, T. C. Streibert of WOR; Auditor, James A. Cotey of WGN. Directors named were: W. E. Macfarlane, E. M. Antrim, Ouin A. Ryan, Edward W. Wood, Jr., of WGN; and Jack I. Strauss, Hector Suyker, A. D. McCosker, and T. C. Streibert of WOR. The directors all were re-elected with the exception of Edward W. Wood, Jr., new commercial manager of WGN, who was

named in place of George F. Issac, who recently resigned from WGN.

Also attending the meeting were: John Clark of WLW, Cincinnati; and George W. Trendle and H. Allan Campbell of station WXYZ, Detroit.

The officers and directors of the Mutual Broadcasting System approved a contract with the American Telephone and Telegraph Company for the rental of permanent lines, sufficient to take care of any commercial program at any given hour required by the advertiser, subject to clearance by stations in the Mutual group.

No changes are to take place in the present sustaining programs of the members of the group, because each member is self-supporting in respect to sustaining shows. This leaves for future consideration the exchange of sustaining programs which would be made between the stations of the group merely for the purpose of gaining a variety of programs. In all respects the Mutual Broadcasting System is to be in actuality a mutual working arrangement between a group of independent stations.

Members of the MBS also approved the establishment in the near future of a traffic department for the network programs and a sales promotion department to furnish market data. Announcement of appointments of heads of these new departments will be made in the near future.

RADIO INSULATION FOLDER

The Synthane Corporation of Oaks, Penna., has issued a new four-page folder on Synthane laminated bakelite radio insulation. The folder, a copy of which will be sent on request, describes the characteristics and standards of quality for Grades X and XX Radioform tubing, coil forms, sheets, rods, tubes and panels. The facilities of the Company for assisting in the design of parts and selection of the proper materials, or in complete fabrication where desirable, are also clearly presented.

NEW PUBLIC-ADDRESS CONCERN

Announcement has been made of the formation of the Morlen Electric Company, Inc., 100 Fifth Ave., New York, N. Y., manufacturers and engineers of public-address amplifiers and accessory equipment.

Morlen Electric Company will carry on the development and marketing of the amplifier products formerly sold by the Simplex Electric Company, Inc.

The new Morlen Professional Line of public-address amplifiers has been designed with a view to meeting the severe operating conditions met in everyday commercial work.

Amplifiers are available in chassis, rack and portable types and in power ranges from 3.2 to 175 watts audio output. In addition there will be a complete line of commercial field exciters, in various current ratings up to one ampere, at 125 volts.

Bulletin No. 4, covering the complete Morlen line of equipment, is now available. Copies may be had on request to the manufacturer.

THE MARKET PLACE

NEW PRODUCTS FOR THE COMMUNICATION AND BROADCAST FIELDS

NEW ERIE INSULATED RESISTOR

The Erie Resistor Corporation, Erie, Pa., has recently placed on the market a new line of 1/4-watt insulated carbon resistors. This new product consists of a molded carbon resistance unit enclosed in a ceramic case. Leads are brought out at the ends to facilitate wiring and insulation with spaghetti, if necessary.

Many features hitherto unavailable in carbon resistors are incorporated in this new product, it is said. The ceramic insulation eliminates entirely the danger of "shorts" even in the smallest spaces. Including the ceramic shell, overall dimen-

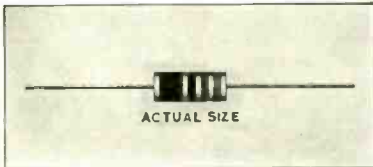

sions are smaller than for the corresponding non-insulated Erie Resistor. Outside dimensions are 11/64" x 7/16". The use of these resistors simplifies many difficult installation problems and in many cases makes relocation possible with greater resultant efficiency. For example, they can be placed inside i-f transformer cans without the addition of further insulation.

These resistors present a distinct improvement in respect to color coding. Difficulty in reading the resistance value when the conventional dot is not in clear view is a common occurrence. This is entirely overcome with the new Erie Resistor as the coding consists of color bands completely encircling the ceramic shell. The widest band, which is at one end, represents the first figure in the resistance value; the band next to it, the second; and the third band, the number of ciphers following the first two figures, in accordance with standard RMA practice. When the set manufacturer desires it, a fourth band specifying tolerance may be added.

The ceramic covering is so designed that it cannot be removed from the resistance pin, although it is purposely made slightly loose to compensate for contraction and expansion of the resistor inside it.

The 1/4-watt unit is now available in production quantities; 1/2-watt and larger sizes will be offered in the near future.

For samples write the Erie Resistor Corporation, 620 West 12th St., Erie, Pa.

NEW "RECEPTOR" DYNAMIC MIKES

The Radio Receptor Co., Inc., 106 Seventh Ave., New York City, have announced their new Series "6" Dynamic Microphones, a cross-sectional view of one of these units being shown in the accompanying illustration. These mikes are designed for public address, broadcasting, studio and

location recording, and all sound-reproduction work. Further, these units are obtainable in three models, namely: 6A, 6B and 6C.

The Model 6A is suitable for both voice and high-fidelity music reproduction; for public address, broadcasting and recording. It covers the widest tonal range, and its sensitivity is said to make unnecessary the amount of amplification required by other types of self-generating mikes. This unit has a response from 30 to 12,000 cycles within plus or minus 1 db. The sensitivity per bar is -65 db, and the sensitivity for normal speech at 3 feet is -55 db. The impedance at 1,000 cycles is 30 ohms.

The Model 6B is especially adapted for public-address work and remote pickup for broadcasting, has a high output, and may be substituted in most cases for a carbon microphone without use of a pre-amplifier. It does not, however, have the response range of the 6A, its range being from 40 to 7,500 cycles within plus or minus 2 db. The sensitivity per bar is -59 db, and the sensitivity for normal speech at 3 feet is -49 db. Its impedance at 1000 cycles, like the 6A and the 6C, is 30 ohms.

The Model 6C is designed for public-address and amateur transmitter work where price is the important consideration. It is not as sensitive as the 6A or 6B but is said to give good results for the use specified. The response of this unit is 40 to 7,500 cycles within plus or minus 2 db. Sensitivity per bar is -69 db, and sensitivity for normal speech at the distance of 3 feet is -59 db.

According to the engineering department of Radio Receptor Co., "The chief consideration in the design of these units was, of course, a uniform frequency response.

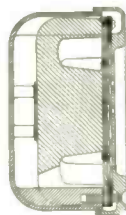

It is essential that the velocity of motion of the coil be proportional to the pressure of the sound wave but independent of its frequency. Now it is obvious that the chief restraint imposed upon such motion at the higher frequencies is the inertia of the coil and diaphragm and at the lower frequencies the stiffness of the diaphragm. Therefore a means of applying friction to this motion was sought so that the motion of the coil over the whole range could be restrained at the high- and low-frequency ends of the frequency range. One obvious method would be the employment of a diaphragm of such material that the friction generated by its flexure would serve the purpose. Celluloid, mica and a

variety of other materials were investigated, such as, paper impregnated with varnishes, and other compounds. Few of these materials introduced this friction to a sufficient degree; and those that did introduced additional mass and stiffness to such an extent that even if these new masses and stiffness could have been compensated for, the sensitivity would have been seriously curtailed. The same experience was had with pads of felt, rubber or similar material resting against the diaphragm.

"For these reasons, an aluminum alloy diaphragm suitably corrugated was chosen and air selected as the damping medium. It was found that the air flowing through the magnetic air gap, in which the coil was positioned, as forced by the motion of the diaphragm, was restrained in its flow and offered considerable restraint to the diaphragm. Unfortunately, however, it was learned that if this path was made sufficiently small and circuitous for our purpose by partially closing the bottom of the gap, the effect of the mass of the air moved was as great as the viscosity at the higher frequencies. This not only reduced the sensitivity of the unit but, in combination with the stiffness of the air cushion between the diaphragm and the pole pieces, introduced undesirable resonant effects at the higher frequencies. This space was, therefore, left comparatively unrestricted so that the mass effect would be negligible. Whatever restraint remains is largely of a frictional nature caused by the turbulence of the air flowing over the round wires of the voice coil.

"This introduces a considerable amount of frictional damping to the motion of the coil but quite insufficient to give the characteristics desired. The remainder is secured as follows: The cap over the front surface of the diaphragm is solid and is perforated with 19 small holes. The space between the diaphragm and the cap is very small so that a very small amount of air flowing into it from the atmosphere will produce a pressure in the space equal to the atmospheric pressure. Therefore, any additional air entering would displace the diaphragm in proportion to the volume of air admitted. Hence considerable resistance is offered to the flow of air by the size and shape of these 19 perforations and the volume of air therefore admitted per unit time is proportional to the pressure and independent of the frequency."

ELECTROSTATIC VOLTMETER

The Ferranti Electrostatic Voltmeter which was introduced in this country some time ago was originally available up to 3000 volts maximum full scale. These instruments can now be had with full scales up to 18,000 volts maximum. These high range meters can be furnished in single-, dual- or triple-range types and have numerous applications in present day testing.

Literature will be gladly sent upon request. Address Ferranti Electric, Inc., 130 West 42nd St., New York City.

NEW GATES SPEECH INPUT EQUIPMENT

The Model 1200B Speech Input Rack, just announced by Gates Radio and Supply Co., Quincy, Ill., is a complete equipment requiring no additions for its opera-

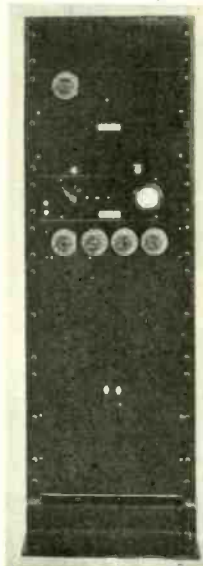

tion other than that of microphones. It is all ac-operated and incorporates every desirable control and feature for high quality, unrepulsive operation, it is said.

The amplifier incorporates type 76 tubes in the first two audio stages and type 2A3 tubes in the output push-pull stage. The

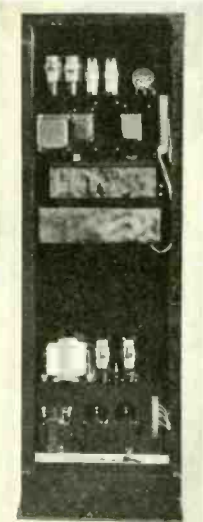

master gain control is calibrated in decibels and pilot light and monitor jack are part of the equipment.

The amplifier is built onto a steel chassis which is fitted against an aluminum panel for rack mounting. The volume indicator consists of a genuine Weston General Purpose DB Meter with pad provided for three 5-db steps of attenuation, giving an actual reading of the indicator meter from negative 10 to positive 26 db.

The mixing panel consists of four channels, the mixing controls being of the constant-impedance type and of latest design, being absolutely noiseless in operation, and they are calibrated in decibels. Input im-

pedances of any standard value can be had.

The rectifier incorporates a pair of 5Z3 tubes, is built onto a steel chassis which is fitted against an aluminum panel for rack mounting.

All panels are finished in baked black, rubbed dull, and special attention should be noted of the rear construction, making accessible within a few seconds every component part of the entire rack.

The frequency response is uniform within 2 db from 30 to 10,000 cycles.

Net price to broadcast stations and recording laboratories, complete with tubes, \$285.00.

NEW MARINE TRANSMITTER

The Long Island Marine and Electric Company, 163-18 Jamaica Avenue, Jamaica, New York, now have available their new "Marine 140-B" 100-watt phone-cw transmitter.

The Marine 140-B is said to have many special features, such as the following: Phone and cw 20-, 40-, 75- and 160-meter bands; visual distortion indicator; modulation percentage indicator; crystal-controlled frequency; permanent neutralization



on all bands; built-in bias supply (no batteries required); designed for use with crystal microphone; self-contained antenna-matching network; and baked wrinkle enamel finished cabinet type rack, 60" high by 19½" wide by 15" deep.

This organization also have available their new PR-12, High-Fidelity, All-Wave Radio Receiver. This unit, shown, covers a frequency range from 8 to 550 meters, and is said to incorporate the following features: Built-in pre-selector, 19 tubes, 10½-inch dynamic speaker, modulation meter, R meter, 2-speed selector airplane dial, manual and ac, 3 i-f stages, and many others.

Only quality equipment is used, it is said. Further information may readily be obtained from the above organization.

NEW SHORT-WAVE DOUBLET ANTENNA

The American Radio Hardware Company, Inc., 137 Grand Street, New York City, have available a new 2½- and 5-meter doublet antenna for use with transceivers. This unit is shown in the accompanying illustration, and it may be noted that this antenna can be mounted either vertically or horizontally.

An adjustment screw permits the locking of this telescoping unit at the desired length, the maximum overall length possible being 60 inches. Further, this unit telescopes to a minimum length of 30 inches, and hence is adaptable to home as well as portable uses.

The following are the desirable features claimed for this unit: Completely insulated,

New American Radio Hardware short-wave doublet antenna.

greater distance and volume, better reception from all directions, durable and compact, easily installed, and requires little space.

AUDAX PICKUPS

The Audax Company, of 500 Fifth Ave., New York has been selected by the American Foundation for the Blind to provide the electric pickup equipment for the Foundation's official apparatus. The Audax



Co. have been creating high quality electrical and acoustical apparatus since 1915 and their advanced engineering facilities is well known throughout the trade.

Audax pickups are said to contain absolutely no Rochelle salt crystals or condenser materials and are unaffected by climatic variations. Special high-fidelity pickup units for use by broadcast stations in transcription work are said to range well beyond the most exacting requirements.

Complete catalog of all Audax models will be supplied on request.

TURNER TYPE G CRYSTAL MIKE

The new Turner Type G Crystal Microphone is a unit designed for public-address and broadcast-transmission work. This unit is shown in the accompanying illustration. It is further said to be a precision-built instrument that is licensed under Brush Development Company patents.

Due to the high impedance of the unit (approximately 80,000 ohms at 60 cycles), this microphone may be connected directly to grid and ground of the amplifier input tube. When so connected it is necessary that a parallel resistance or grid leak of not less than 5 megohms be used. Using a resistance of lower value at this point will reduce the low-frequency response. The Type G Microphone may also be trans-

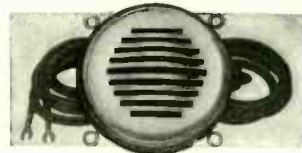

former-coupled to low-impedance circuits.

Further information concerning this microphone will gladly be furnished by The Turner Company, Cedar Rapids, Iowa.

NEW RESISTORS

Now available is an inexpensive extruded resistor capable of a performance equal to that obtained with wirewound units, it is stated. Developed and now offered by Henry L. Crowley and Co., West Orange, N. J., the novelty of the new resistors is said to rest on the production of a solid, homogeneous, full cross-section conduction body.



"Our advertising in your COMMUNICATION AND BROADCAST ENGINEERING has produced gratifying results.

... the results thus far have been satisfactory and far exceeded the results of a trial ad in the competitive publication."

So writes one national advertiser — name furnished on request.

Sales in the broadcast transmission and communication fields are gaining impetus daily—a decided upswing - - - - -

Get your share of this valuable business by advertising in

COMMUNICATION and BROADCAST ENGINEERING

Over 5,000 copies monthly
Guaranteed circulation

NEW A LITTLE VELOCITY
with uniform output!



Output uniform with speaker's head at any angle. Output level equal to large velocity (-38 D.B.). Frequency response 60-7500 cycles. Reproduction life-like. Eliminates audience noise. Transformer included within microphone case. Rugged construction. New chrome aluminum magnets used. Weight only 8 oz. Size 2 1/4" x 1 1/4".
Write for Bulletin CBJ.

AMPERITE Corporation 561 BROADWAY NEW YORK

7-POINT, Jr.
The Little Velocity by AMPERITE

"The Market Place"

Manufacturers are requested to send data on their new products for use in the communications and broadcasting field, promptly, for inclusion in "The Market Place" section.



FREQUENCY MEASURING SERVICE

Many stations find this exact measuring service of great value for routine observation of transmitter performance and for accurately calibrating their own monitors.

MEASUREMENTS WHEN YOU NEED THEM MOST

R. C. A. COMMUNICATIONS, Inc.

Commercial Department

A RADIO CORPORATION OF AMERICA SUBSIDIARY
66 BROAD STREET NEW YORK, N. Y.

28 and 56 M.C. TWIN - TRIODE

- TRANSCEIVERS
- DUPLEX UNIT TRANSMITTER-RECEIVERS



TRANSCEIVERS, each employing push-pull oscillator, Class B modulator. 19 or 53 tubes. 10" x 7" x 5". \$22.50 and \$26.50
COMBINATION-TRANSMITTER-RECEIVER UNITS, each with push-pull oscillator, Class B modulator transmitter and separate receiver employing r.f. stage. Built-in dynamic speaker. 10" x 14" x 5". 19 or 53 tubes. \$36.75 and \$39.75.

Write for Bulletin CBE. It's FREE and chock full of valuable information.

RADIO TRANSCIEVER LABORATORIES
86-27 115th Street Richmond Hill, N. Y.

New American Doublet Transceiver Antennae

2½ and 5 Meters



Recent tests prove conclusively that American Doublet Transceiver Antennae are the most efficient in the field. This new Doublet—either 2½ or 5 meters—with its special forced type locking devices, makes it easy to obtain the proper length for best transceiver reception. Antenna is made of finest hard aluminum tubing, selected and gauged for easy telescoping. Convenient to carry as it telescopes. Closed overall length only 30 inches. Can be extended to 9 feet (108 inches). Supplied complete with all accessories.

Write for catalog illustrating and describing the complete line of American essential parts including vertical transceiver antennae.

American Radio Hardware Co., Inc.

137 GRAND STREET

NEW YORK, N. Y.



UNIVERSAL 5-Meter Hand Set

A new, 9-ounce, compact hand set—Designed for 5-meter transmitters and 5-meter transceivers—Bent Aluminum rubber-covered handle—2000 ohm telephone receiver—High Output, single button Universal Microphone of 200 ohms—6-ft. 4 conductor cord with color-coded phone tips—List Price \$6.00.

UNIVERSAL MICROPHONE CO., LTD.

424 Warren Lane

Inglewood, Calif., U. S. A.

BLILEY CRYSTALS

Supplied to any frequency from 20 Kcs. to 15,000 Kcs.

For Radio
TRANSMITTERS
RECEIVERS
MONITORS
STANDARDS



Write for Bulletin C-4
and price list.

BLILEY ELECTRIC CO.
Union Station Building, Erie, Pa.

EASTERN COIL CO.

Announces a complete line of high grade

MICROPHONE STANDS

for crystal, velocity, dynamic and condenser mikes.

NEW—Heavy telescopic stands ideal for juvenile broadcasts. Special fittings to order. *Catalogue sheets upon request.*

56 CHRISTOPHER AVE. BROOKLYN, NEW YORK
Dikens 2-3538

SAPPHIRE RECORDING NEEDLES!



Type AW—Cut to special angle and radius for satisfactory cutting and recording on Blank Aluminum Discs. Will operate satisfactorily on commercial and home constructed recording machines. \$2.50 each.

\$2.50

Type BW—For recording and reproducing on PRE-GROOVED materials, such as Victor type black composition discs or pre-grooved celluloid. Can also be used on pre-grooved aluminum discs. \$2.50 each.

\$2.50

We manufacture a complete line of cutting, recording and reproducing Sapphire and diamond needles, styluses and shavers. Circular on request.
MEYER KOULISH CO., INC., 64 FULTON ST., NEW YORK CITY

RADIO ENGINEERING



RCA Institutes offers an intensive course of high standard embracing all phases of Radio. Practical training with modern equipment at New York and Chicago schools. Also specialized courses and Home Study Courses under convenient "No obligation" plan. Catalog on Request.

RCA INSTITUTES, INC.

Dept. CB-35.
75 Varick St., New York 1154 Merchandise Mart, Chicago
Recognized Standard in Radio Instruction Since 1909

AMERICAN MICROPHONE CO.

A California Corporation

Microphones of Quality

Condensers, Carbons, Dynamics, and Ribbons

New catalogue available upon request.

1915 South Western Avenue, Los Angeles, Calif.

If it's a CARDWELL there's none better!

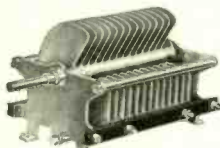

VARIABLE AND FIXED
(AIR-DIELECTRIC) CONDENSERS FOR HIGH AND LOW POWERED TRANSMITTERS

Contract-Manufacturing Service specializing in designing, or manufacturing to specifications, of Inductances, Transformers, Relays, Automatic Telegraph equipment, electro-mechanical devices and instruments and stamped and welded aluminum and duralumin products.

The Allen D. Cardwell Manufacturing Corp. 91 Prospect Street, Brooklyn, New York

THE STANDARD OF COMPARISON

INDEX TO ADVERTISERS

A		E	
American Radio Hardware Co., Inc.	32	Eastern Coil Co.	32
American Microphone Co.	32		
Amperite Corp.	31	G	
B		Gates Radio & Supply Co.	1
Bliley Elec. Co.	32	General Radio Co.	1
Bruno Labs.	1	J	
Brush Development Co.	3	Jewell Radio Co.	5
C		K	
Capital Radio Eng. Institute.	5	Kenyon Transformer Co.	5
Cardwell Mfg. Corp., Allen D.	32	Koulish Co., Inc., Meyer	32
Cornell-Dubilier Corp.	3	L	
		L. I. Marine & Elec. Co.	3
		Lear Developments, Inc.	5
		P	
		Precision Resistor Co.	5
		R	
		Radio Receptor Co.	3
		Radio Transceiver Labs.	31
		RCA Communications, Inc.	31
		RCA Institutes, Inc.	32
		RCA Mfr. Co., Inc.	Fourth Cover
		S	
		Shure Brothers Co.	5
		U	
		United Transformer Corp.	Second Cover
		Universal Microphone Co., Ltd.	32

Yes!

Subscribers may date back their subscriptions to include the first number (October) of Communication and Broadcast Engineering.

A limited number of extra copies have been printed so that files may be kept complete.

The subscription rate is \$3.00 yearly. Foreign and Canada \$4.00 yearly.

Bryan Davis Publishing Co., Inc.

19 East 47th Street
New York City

**THE
TRANSMITTER
OF THE FUTURE**



**—AVAILABLE
TODAY!**

The New RCA Type 5-C High Fidelity 5 K W Broadcast Transmitter . . . Featuring:

1. HIGH FIDELITY performance.
2. All A.C. operation (no motor generators).
3. Automatic line voltage regulation.
4. Wide volume range.
5. At any modulation percentage up to 100, total RMS audio harmonics do not exceed 4%.
6. Weather proof antenna tuning unit, (no tuning house required).
7. Minimum installation cost and building requirements, due to compact design.
8. Hum compensator reduces carrier noise to level even below that of D.C. designs.
9. Double electrostatic shields eliminate RF harmonics.
10. Attractive exterior design for "station display" by John Vassos, the nationally famous authority on engineering art.

The Modern RCA Equipment from Microphone to Antenna is Your Assurance of High Fidelity Performance

RCA Manufacturing Company, Inc.

CAMDEN, N. J.—"RADIO HEADQUARTERS"

**NEW YORK: 153 E. 24th St. · CHICAGO: 111 N. Canal St. · ATLANTA: 144 Walton St., N.W.
DALLAS: Sante Fe Building · SAN FRANCISCO: 235 Montgomery St.**

