

COMMUNICATIONS

INCLUDING "RADIO ENGINEERING" AND "TELEVISION ENGINEERING"

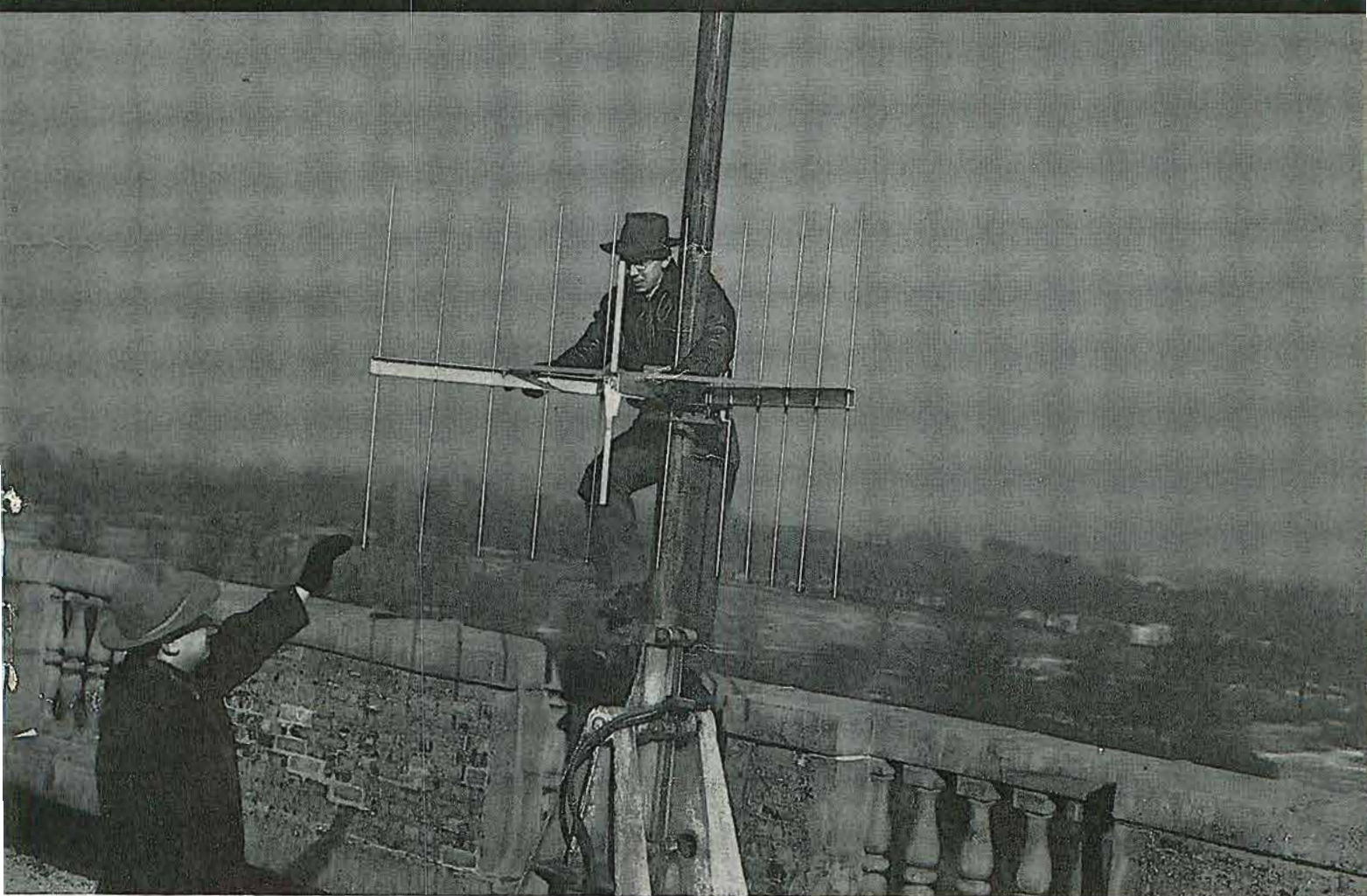

★ THE WMAL-TV MOBILE TELEVISION TRUCK

★ FM PROOF-OF-PERFORMANCE MEASUREMENT TECHNIQUES

★ PROCESSING BROADCAST-QUALITY TELEPHONE RECORDINGS

MARCH

1949

NEW Multi-Channel Radio Transmitter with **INDIVIDUAL OVERLOAD PROTECTION**

INDIVIDUAL OVERLOAD PROTECTION

Advanced electronic design provides each unit with individual protection against overloading—failure of any one channel because of overload does not affect operation of others.

VERSATILE MULTI-CHANNEL OPERATION

Each channel provides up to 3,000 watts for continuous wave or frequency shift transmission—2,500 watts carrier for

phone operation. Three basic units—power supply, transmitter, and modulator—permit a variety of combinations through simple channel switching.

TESTED FREQUENCY STABILITY

Meets rigid F.C.C. requirements for ground station operation. Frequency stability within plus or minus .002% at temperatures ranging from 0 to 45 degrees C.

Channel
Switching
Individual
Overload
Protection
Frequency
Stability

Communication
Fidelity
Inverse
Feedback
High Safety
Factors
Primary
Circuit
Switching
Forced Air
Cooling
Low Operating
Cost, Easy
Maintenance

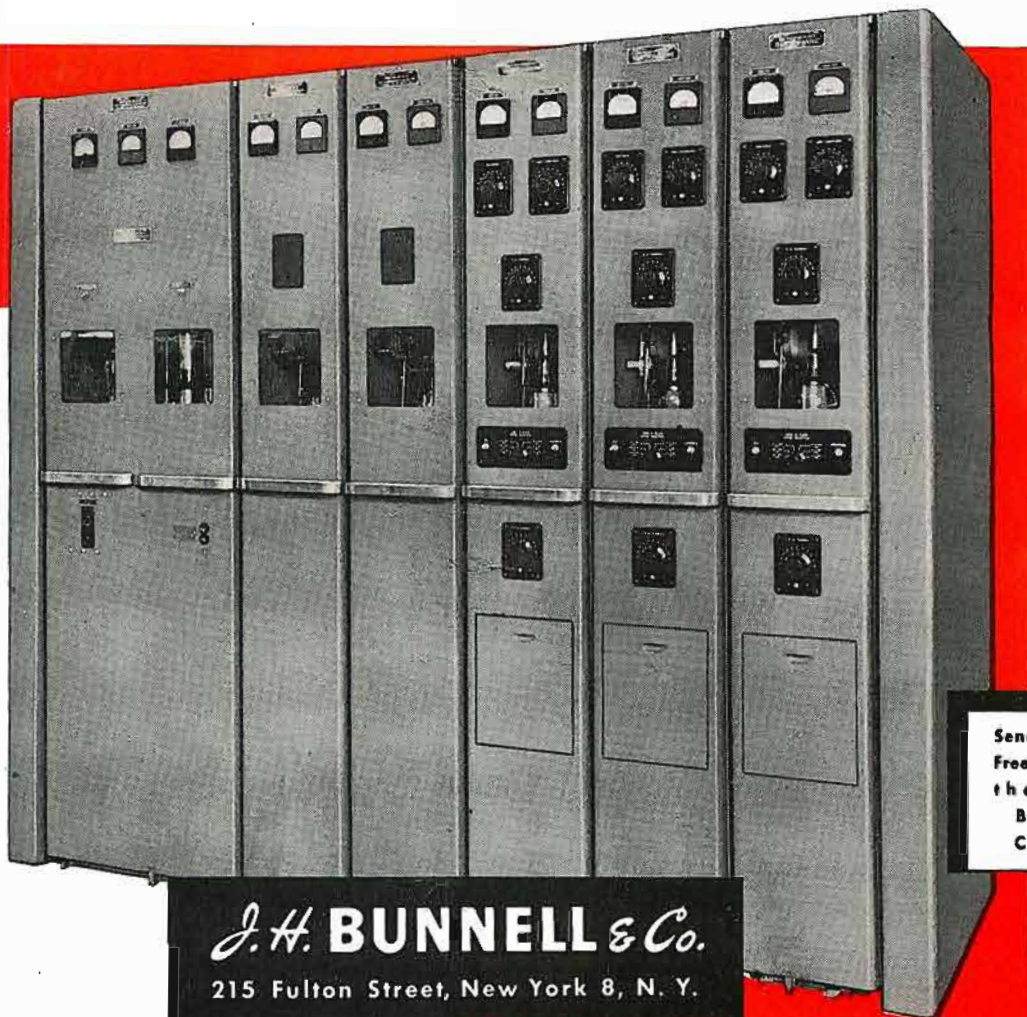

Send for Your
Free Copy of
the **NEW**
Bunnell
Catalog

J. H. BUNNELL & Co.

215 Fulton Street, New York 8, N. Y.

DEPT. 14

BUNNELL -- A Key Word in Communications Equipment

Research, Engineering, Production, and Testing facilities for equipment for: Wire Lines • Submarine Cables • Railroad Communication • Radio Airway Systems • Municipal Signaling • Army and Navy Signaling • Carrier Current • Automatic Telegraph • Facsimile

66-G

Here's the Recorder You asked for!

The best features of Presto's dual motor gear drive with the overhead mechanism and turntable of the famous Presto 6-N.

YES, engineers have often asked us for a compact, economical yet high-quality recorder. Now you may have it in the Presto 66-G for standard and microgroove recording.

Here is a unit ideally suited and priced for the typical broadcast station or large transcription manufacturer. List price, Standard Model, \$996! (\$70 additional for microgroove.)

Here's perfection in total speed regulation and very low mechanical disturbance, thanks to the standard Presto dual motor gear drive. Here's high-quality recording, too, for the 66-G, of course, includes the Presto 1-D cutting head.

You'll find 66-G equal to the most exacting recording tasks when used with suitable amplifiers such as Presto 92-A recording amplifier and 41-A limiter amplifier.



FOR HIGHEST FIDELITY... IT'S PRESTO DISCS

Microgroove, even more than standard recording, demands a perfect disc. The answer is Presto. For, sixteen years ago, Presto made the first lacquer-coated discs... and today Presto discs are first in quality.

PRESTO

RECORDING CORPORATION

Paramus, New Jersey



READY NOW: Magnetic Tape Recorder

You probably saw Presto's new superquality magnetic tape recorder at the I.R.E. Show. If not, be sure to see it in Presto's room at the N.A.B. Convention in Chicago.

Mailing Address: P. O. Box 500, Hackensack, N. J.
In Canada: WALTER P. DOWNS, LTD., Dominion Sq. Bldg., Montreal

WORLD'S LARGEST MANUFACTURER OF INSTANTANEOUS SOUND RECORDING EQUIPMENT AND DISCS

COMMUNICATIONS FOR MARCH 1949 • 1

COMMUNICATIONS

Including Television Engineering, Radio Engineering, Communication & Broadcast Engineering, The Broadcast Engineer, Registered U. S. Patent Office.

LEWIS WINNER

Editor

F. WALEN

Assistant Editor

Bryan S. Davis, President

Paul S. Weil, Vice Pres.-Gen. Mgr.

F. Walen, Secretary

A. Goubel, Circulation Manager

Cleveland Representative:

James C. Mize

2220 Delaware Dr., Cleveland 8, Ohio
Telephone: Erlview 1726

Pacific Coast Representative:

Brent & Brent

1832 W. Sixth St., Los Angeles 14, Calif.
Telephone: Michigan 1732

Suite 1204, Ross Building, San Francisco 4, Calif.
Telephone: BUtter 1-2251

Wellington, New Zealand: Te Aro Book Depot.
Melbourne, Australia: McGill's Agency.

Entered as second-class matter Oct. 1, 1937 at the Post Office at New York, N. Y., under the act of March 3, 1879. Subscription price: \$2.00 per year in the United States of America and Canada; 25 cents per copy. \$3.00 per year in foreign countries; 35 cents per copy.

COMMUNICATIONS is indexed in the Industrial Arts Index and Engineering Index.

COVER ILLUSTRATION

Adjusting Andrew corner-reflector type antenna for communications taxicab service in Chicago.
(See page 14, this issue, for complete analysis of antenna.)

BROADCAST ENGINEERING

The Third Annual NAB Broadcast Engineering Conference..... 7
Program Highlights.

TELEVISION ENGINEERING

The WMAL-TV Mobile TV Unit..... F. W. Harvey and E. D. Hilburn 8
Air-Conditioned Van Has Provision for Two or Three Cameras, Sync Generator, Waveform Monitoring, Microwave Relays, Intercam Links, Test Instruments, Etc.

AUDIO FACILITIES

Producing Broadcast Quality Telephone Recordings..... Adelbert Kelley 12
Telephone Recording System for Tape or Disc Affords High Quality Recording and Permits Rapid Processing of Telephone Interviews and Spot Newscasts.

Monitoring Rectifier for AM Stations... Robert D. Lambert, Jr. 13
System Adapted from Conventional Voltage Doubler Provides Large Audio Output with Relatively Low Distortion.

ANTENNA ENGINEERING

Directional Antenna for the 152-162 mc Communications Band
J. S. Brown and V. J. Moffatt 14
Corner-Reflector Type Vertically-Polarized Antenna Has Gain of About Six db Over Half-Wave Dipole.

TRANSMITTING TUBES

Tube Engineering News..... 18
Microwave Relay Triodes. Power Triodes for 25-110 mc.

FM BROADCASTING

FM Proof-of-Performance Measurement Techniques..... F. E. Talmage 22
How to Use Measurement Equipment and Compile Information for Presentation to FCC.

AERONAUTICAL COMMUNICATIONS

Civil Aircraft Radar..... Samuel Freedman 26
Part II... Equipment Considerations in the 9,000 to 10,000 mc Band.

MONTHLY FEATURES

News and Views..... Lewis Winner 7
Veteran Wireless Operators' Association News..... 21
News Briefs of the Month..... 33
The Industry Offers..... 34
Last Minute Reports..... 36
Advertising Index..... 36

Entire contents Copyright 1949, Bryan Davis Publishing Co., Inc.



Published monthly by Bryan Davis Publishing Co., Inc.
52 Vanderbilt Avenue, New York 17, N. Y. Telephone MUrray Hill 4-0170



QUICK QUIZ

With a Helpful Answer
FOR COMMUNICATIONS MEN

Problem:

A company has a circuit between offices "A" and "B" consisting of 40 miles of No. 12 BB iron wire. Extending from "B" to "C" is another circuit made up of 25 miles of No. 12 BB iron. Changing traffic conditions call for a direct through circuit from "A" to "C". The use of the existing wire facilities does not provide acceptable transmission since the measured loss is 20 db and requirement is for a 5 db to 6 db circuit. How can this requirement be met?

Possible Solutions:

(a) One possibility would be the replacement of the iron wire with .104 copper wire. This would provide a calculated 4.5 db circuit but present day wire and construction costs would require an expenditure ranging from \$12,000.00 to \$18,000.00.

(b) Another solution would be the use of a voice frequency telephone repeater at location "B" capable of a minimum usable gain of from 14 db to 15 db under all ordinary weather conditions. If such a repeater could be found then this, obviously, would be the correct solution since the cost of a repeater is less than 5% of the cost of wire replacement.

The Logical Solution:

Yes—the logical solution is a voice-frequency telephone repeater—if it's a Kellogg Repeater. Here's why—

One of the most important factors in obtaining maximum usable gain in a voice frequency repeater is the limitation of the band of frequencies to be amplified. In the Kellogg repeater this is accomplished in the No. 204 filter which has exceedingly sharp cutoff characteristics outside the voice band, i.e. below 300 cps and above 2700 cps.

Another very important consideration in establishing stable balance at the highest gain is the ability to obtain fine adjustments of resistance and capacity in the balancing net with the maximum of ease. This ideal condi-

tion is provided in the No. 1 balance network of the Kellogg repeater by the use of continuously variable potentiometers (two in each net) and a series of small capacity steps both readily adjustable by hand or screw driver. Thus the time-consuming and comparatively inaccurate method of strapping to adjust for balance is completely eliminated.

Gain adjustments (also screw driver adjusted from the front of the repeater) are accurately calibrated in 1 db steps so that the gain being obtained is always known without the necessity for measurement. Other refinements in Kellogg repeater design include (1) the use of push-pull amplification eliminating harmonic distortion and cross talk or other interference which may be introduced through the power source, (2) the operation of all components at conservative values of current and voltage well below the maximum ratings assuring long, trouble-free life, (3) unit type construction mounting on standard 19" equipment racks thus giving the flexibility necessary for adaption to various circuit requirements, (4) a wide variety of line units for different circuit or signalling functions and (5) provision of test and monitoring jacks for checking tubes and repeater operation.

Kellogg Repeaters are available for operation from either 24 volt or 48 volt battery or from a 105-125 volt 60 cycle AC power source.



SEND FOR OUR REPEATER BOOKLET NOW! ↴

KELLOGG SWITCHBOARD AND SUPPLY COMPANY

REPEATER

3435 SOUTH CICERO AVENUE • CHICAGO

Kellogg Switchboard and Supply Company
4450 So. Cicero Avenue
Chicago 38, Illinois

Please send Repeater Booklet to:

NAME _____

ADDRESS _____

CITY _____ STATE _____



THE FIRST PRACTICAL BOOK
ON THE INSTALLING OF TV and FM RECEIVER ANTENNAS

TV...FM ANTENNA INSTALLATION

OVER 100 PAGES OF PROFUSELY
DIAGRAMMED, PRACTICAL,
UP-TO-THE-MINUTE
INFORMATION COVERING—

by IRA KAMEN
Manager, Television Antenna Dept.
Commercial Radio Sound Corp.

and LEWIS WINNER
Editor, SERVICE and
COMMUNICATIONS

Antenna Tools

(Basic Tools Required . . . Application of the Correct Tools for Specific Types of Installations, Involving Flat-top Roofs, Slate Roofs, Tile Roofs, Chimneys, Etc.)

The TV Antenna Installation Problem

(Fundamentals of All TV Installations . . . Judging Specific Application Features of the Various Types of Antennas Which Can Be Used for TV Work . . . Solving Reflection Problems . . . Improving Signal-to-Noise Ratio.)

Solving the Problems of 12-Channel Reception

(Factors With Which Service Men Must Be Familiar to Accurately Install Antennas For Full-Band Coverage . . . Typical Problems Analyzed.)

High Frequency TV Antenna Installations

(Antennas and Installation Procedures Which Afford Best Results. Solving Major Installation Problems Involving Tuned Indoor and Outdoor Antennas. Application of Stub Filters.)

TV Interference

(Analysis of Nine Sources of Interference and Solutions Which Have Proved Effective.)

Fringe Reception

(Selecting and Installing Antennas for Maximum Reception in Areas Over 45 Miles From Stations . . . Tower Installations . . . Estimating Tower Costs.)

TV Master Antenna Systems

(Typical Multiple Dwelling Antenna Systems for Simultaneous Operation of Many Receivers From a Single Antenna Array and Amplifier Setup.)

FM Antennas

(Analysis of Practical FM Antennas . . . Selecting Proper Antenna for Rural and Urban Jobs.)

The Business of TV Antenna Installations

(How to Conduct Successfully TV Installation and Service Work Today . . . Proper Use of Correct Types of Installation and Servicing Agreements and Warranties.)

TV Antenna Tricks of the Trade

(Antenna Installation Devices Which Will Improve Picture Fidelity.)

(Indexed for Quick Reference)

BRYAN DAVIS PUBLISHING CO., INC., Book Dept.
52 Vanderbilt Avenue, New York 17, N. Y.

Send me a copy of TV . . . FM Antenna Installation, post-paid, for which I am enclosing \$2.00.

(Please Print)

NAME

ADDRESS

CITY AND STATE

● The first edition is limited in quantity. Order Your Copy NOW!

Price \$2 Post Paid

**Reduced studio operating budgets
...expanded program facilities...
with the DU MONT MONOCHROME
SCANNER Model TA-150-A...**

the magic lantern
of TELECASTING!

$$SD+QW = \frac{D}{FWFT}$$

(Simple Translation)

**SUPERIOR DESIGN plus
QUALITY WORKMANSHIP equals
DU MONT**
First With the Finest in Television

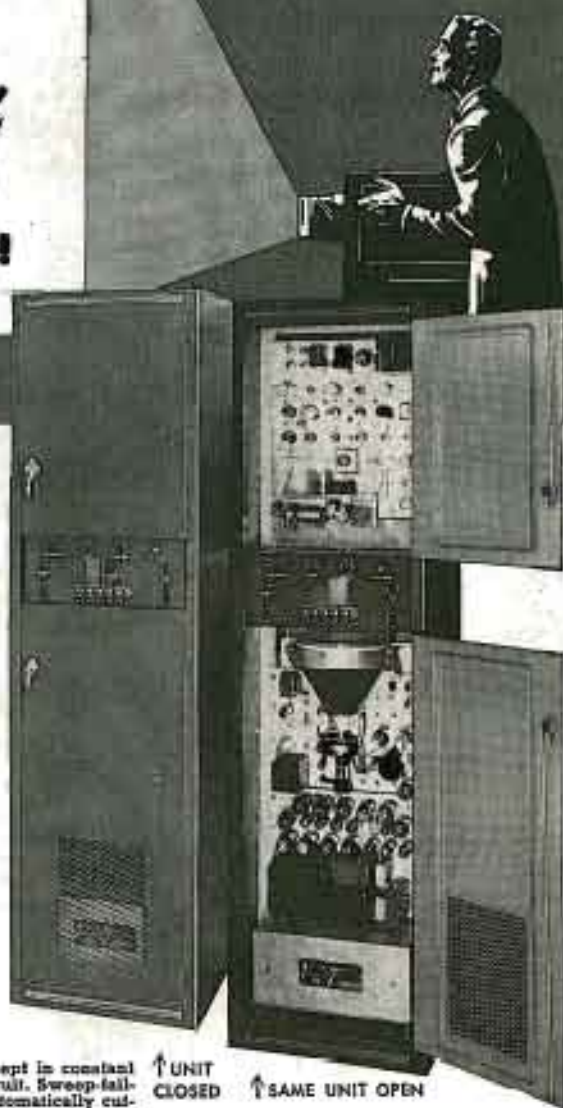

Precisely, this latest Du Mont development, the Monochrome Scanner Model TA-150-A, is virtually "The Magic Lantern of Telecasting." It handles test patterns, commercials, station identification, still photographs, cartoons, graphs—any and all non-animated subjects in the only logical and really economical manner.

When driven from a sync generator such as the Du Mont Model TA-107-B, this unit develops an RMA standard composite signal from standard 2 x 2" glass slides. Still-image pickups become a simple, economical, one-man job. The need for costly film trailers and the operation of movie projectors for short bits, are minimized. The Monochrome Scanner soon pays for itself. Definitely, here's a "must" in the money-making telecast setup.

Early delivery predicated on previous orders

DU MONT MONOCHROME SCANNER Model TA-150-A

A short-persistence Du Mont 10" C-R tube produces a light beam focused by a projection lens on to the glass slide. A condenser lens focuses that light beam after passing through the slide, on to a multiplier-type photo-electric cell. The signal voltage developed is amplified and mixed with blanking and sync pulses, resulting in the RMA standard composite picture signal.

An automatic slide changer handles up to 25 positive or negative 2 x 2" glass slides, operated from local or remote position. The equipment houses the C-R tube and necessary circuits for producing a bright, sharply focused raster on

the tube screen. The raster is kept in constant focus by the focus-stabilizer circuit. Sweep-failure protection is provided by automatically cutting off the high voltage to the tube. The raster is developed by sweep circuits driven by horizontal and vertical pulses.

A switch inserts sync if a composite signal is required, or leaves out the sync if only a video and blanking signal is required for video mixing purposes. Controls to set sync and blanking levels are provided. The control panel carries all necessary switches, fuses and fuse indicators. A teletext switch sets the fading of the sig-

↑ UNIT
CLOSED ↑ SAME UNIT OPEN

nal to black level when slides are changed for slow, medium or fast rate of change.

The unit is complete with its own high and low voltage power supplies. Operates on 115 v. 60 cycles. Approx. 8.0 amps.

Mounted in standard rack measuring 83 1/2" h. x 22" w. x 18" deep.

© ALLEN B. DU MONT LABORATORIES, INC.

DU MONT

First with the Finest in Television

ALLEN B. DU MONT LABORATORIES, INC. - TELEVISION EQUIPMENT DIVISION, 42 HARDING AVE., GLIFTON, N. J. - DU MONT NETWORK AND STATION WARD, 515 MADISON AVE., NEW YORK 22, N. Y. - DU MONT'S JOHN WANAMAKER TELEVISION STUDIOS, WANAMAKER PLACE, NEW YORK 3, N. Y. - STATION WTTG, WASHINGTON, D. C. - HOME OFFICES AND PLANTS, PASSAIC, N. J.

COMMUNICATIONS FOR MARCH 1949 • 5

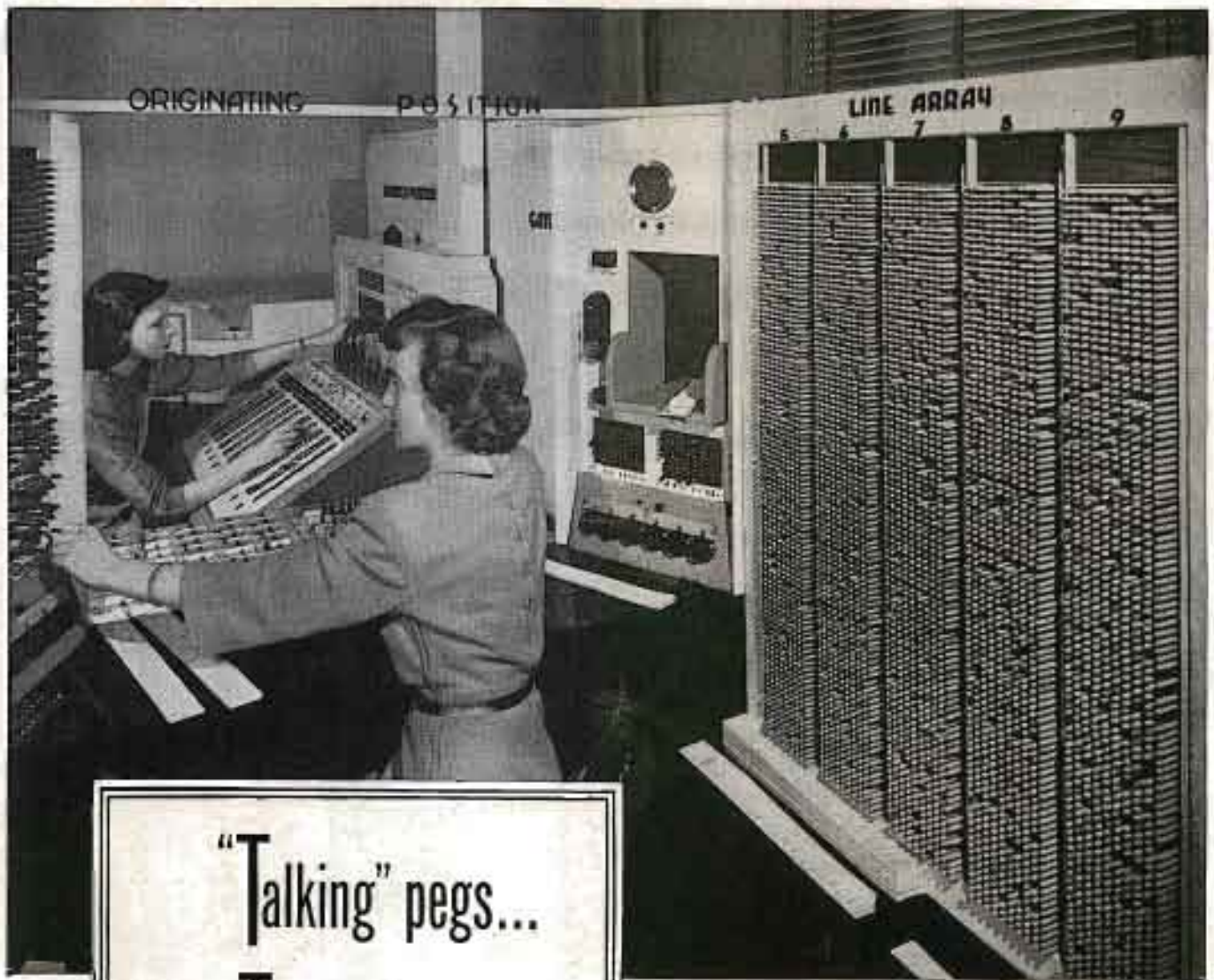

"Talking" pegs... and Talking people

THERE ARE 10,000 pegs in this machine, representing 10,000 subscribers in a crossbar telephone exchange—the latest switching system which handles dial calls with split-second swiftness.

The pegs represent many types of telephone users—two-minute talkers and ten-minute talkers . . . people who dial accurately . . . those who make a false start or two. They are starting a journey through a unique machine which analyzes the performance of dial equipment in a typical central office.

But while an actual crossbar exchange connects your call in a matter of seconds, this counterpart moves far more slowly. It gives the Bell Laboratories engineers who built it time to observe what happens

to each call—where bottlenecks develop, which parts are overworked or underworked, which of the circuits are most used.

In a manual exchange, the number of operators may be changed to meet different traffic conditions. In crossbar, all switching is done by complex electro-mechanical devices, permanently built in. This machine shows how many devices of each kind there must be in a new exchange to give you the best of service with a minimum of expensive equipment.

This traffic-study machine is one of the many ingenious research tools devised by the Laboratories as part of its continuing job—finding new ways to give you better and better telephone service.



BELL TELEPHONE LABORATORIES

EXPLORING AND INVENTING, DEVISING AND PERFECTING, FOR CONTINUED IMPROVEMENTS AND ECONOMIES IN TELEPHONE SERVICE

COMMUNICATIONS

LEWIS WINNER, Editor

MARCH, 1949

The Third Annual NAB Broadcast Engineering Conference

ONCE AGAIN the NAB department of engineering has prepared a streamlined, lively and informative program covering every phase of broadcast engineering for their annual conclave. This year, at a three-day session in the Hotel Stevens from April 7 to 9, twenty-six papers will be read by the country's outstanding specialists in the art.

The meeting will begin on Thursday morning, April 7, with A. James Ebel, chairman, NAB engineering executive committee and director of engineering, WMBD, Peoria, Ill., presiding over a 6-paper session, covering:

A Method of Selecting an FM/TV Transmitting Site; E. S. Clammer, commercial engineer, Engineering Products Dept., RCA Victor.

Clammer will describe an experimental system for evaluating a proposed TV or FM transmitting antenna location. System, which provides information on field strength and incidence of echoes within the proposed service area, employs an airborne transmitter and an antenna radiating pulses of short duration, high peak power and low recurrence rate, and a receiving equipment capable of indicating strength of received pulses and the amplitude of delayed echoes.

The Practical Solutions of TV Installation Problems; Robin D. Compton, technical manager, WOIC (TV), Wash., D. C.

In this paper will be offered the main factors of considerable consequence to the proper performance of the installed equipment, including antenna installation and support design arrangements; transmission line installation for low standing wave ratios; housing, transmitter building design; power requirements for various sections; operating space requirements; testing procedures and equipment different from normal requirements of vacuum tubes for television; operating personnel and training; recommended maintenance procedures; operating costs; studio design and equipment; switching and controls; and TV pickup equipment and methods.

Making and Analyzing TV and FM Field Intensity Measurements; G. P. Adair, consulting radio engineer, Wash., D. C.

Adair will analyze the importance of the TV and FM field intensity survey not only for the FCC records but the operational program of the licensee. The advantages and disadvantages of the many methods available will be covered, and the required equipment will be described.

The Design, Development and Operation of a TV Mobile Unit; Willis L. McCord, manager, TV specialties dept., Allen B. DuMont Labs., Inc.

This paper will cover the design, development and operation of a television mobile unit for use in field operations, and will feature a triple image orthicon camera chain, a full complement of audio facilities, and microwave relay equipment.

Operation of the Image Orthicon Camera; John H. Roe, supervisor, TV systems engineering group, RCA Victor.

Adjustment and operating techniques for obtaining the best possible picture from four types of image orthicon type television cameras will be discussed in this paper. Subjects such as beam alignment, choice of lens and stop, and adjustment of beam current and target potential will be covered in detail.

A 2,000 mc TV Relay Link; Martin Silver, project engineer, Federal Telecommunication Labs.

Silver will describe a link, designed to interconnect television stations in various cities as well as for local portable pickups, which uses a klystron delivering 15 watts, the transmitter being crystal controlled and frequency modulated and the receiver a single superheat. Complete monitoring facilities are provided at each transmitter including power, local picture monitor, frequency monitor, etc.

Afternoon Session, April 8

John H. DeWitt, Jr., member, NAB engineering executive committee and
(Continued on page 28)

Among those who will appear at the NAB Broadcast Engineering Sessions in Chicago.



Royal V. Howard



William L. Everitt



Thomas T. Goldsmith, Jr.



J. E. Young



Robin D. Compton



Howard D. Doolittle



Neal McNaughton

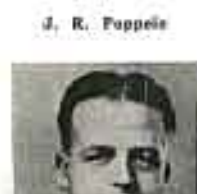

J. R. Poppels



John A. Green



S. J. Begon



M. W. Scheldorf



Martin Silver

The WMAL-TV

Air-Conditioned Mobile Unit, Designed for Speedy Setup, Convenience of Operation and Rapid and Efficient Maintenance, Features Provision for Two or Three Cameras, Sync Generator, Switching Unit to Fade or Switch Between Cameras, Picture and Waveform Monitoring Facilities, and Microphone and Audio Racks, Plus Microwave Relay Equipment, Intercom Links, Test Instruments and Nearly Half Ton of Cables.

by **F. W. HARVEY** and **E. D. HILBURN**

Chief Engineer Assistant Chief Engineer
WMAL, WMAL-FM and WMAL-TV
Washington, D. C.

REMOTE, or special event broadcasting, whereby the viewer is shown an unstaged and unrehearsed event, is one of television's greatest abilities. The immediacy of this type of program makes it of great public interest, and accordingly TV broadcasters make every effort to provide as much of this type of programming as possible. The cost of remote operations has been a limiting factor in the

amount of this type of broadcasting that the average station can provide. Fortunately, due to new techniques, new equipment, and increased experience, the cost of this field operation is being constantly reduced.

The greatest factor in the cost of special event coverage is the time required for the operating crew to prepare for the program. There are the problems of travelling to the scene of

the broadcast, unloading equipment, setting up cameras, providing power and telephone connections, installing microwave facilities, testing and adjusting equipment, etc., all of which consume a great deal of time. Even with the advent of the suitcase type of image orthicon field equipment, this process requires anywhere from one to five hours (for a crew of between five to nine men) depending upon the complexity of the installation. It is evident, therefore, that the mobile control room, or so-called *mobile unit*, must be designed for speed of setup, convenience of operation, and provide for rapid and efficient maintenance of the equipment.

Today's TV broadcaster must either buy or build his mobile unit. A very limited number of different trucks are available as *stock items* from various manufacturers. Because of the limited selection, and the fact that certain additional operating features may be desired, many TV stations have designed and built their own mobile units.

Mobile Unit Requirements

The TV mobile unit is, in effect, a complete TV studio control room on wheels. As such, it must include two or three cameras, with associated power supplies and control units, synchronizing generator, switching unit to fade or switch between cameras, together with picture and waveform monitoring facilities. To handle the sound portion of the program, the unit must carry microphones and audio amplifying equipment. In addition to these obviously essential items, a great number of equally important auxiliary facilities are also required. These include a microwave relay transmitter, intercommunications equipment, telephones for communicating with the studio, test equipment, tools, and last but not least, over a half ton of cables.

While the mobile unit serves to store and to transport all of the aforementioned apparatus, its primary purpose is to provide working space for the operation of this equipment. Therefore, in planning the interior arrangement of the mobile unit, the major consideration is to provide adequate operating space for the equipment and personnel, at the same time making maximum utilization of the storage space. The proportions of the vehicle may be compromised in such

Figure 1

Mobile unit of WMAL-TV set up for a telecast of a football game. Note the roof hatch, tripod mounts and telescopic mast for off-the-air receiver.



MOBILE TV UNIT

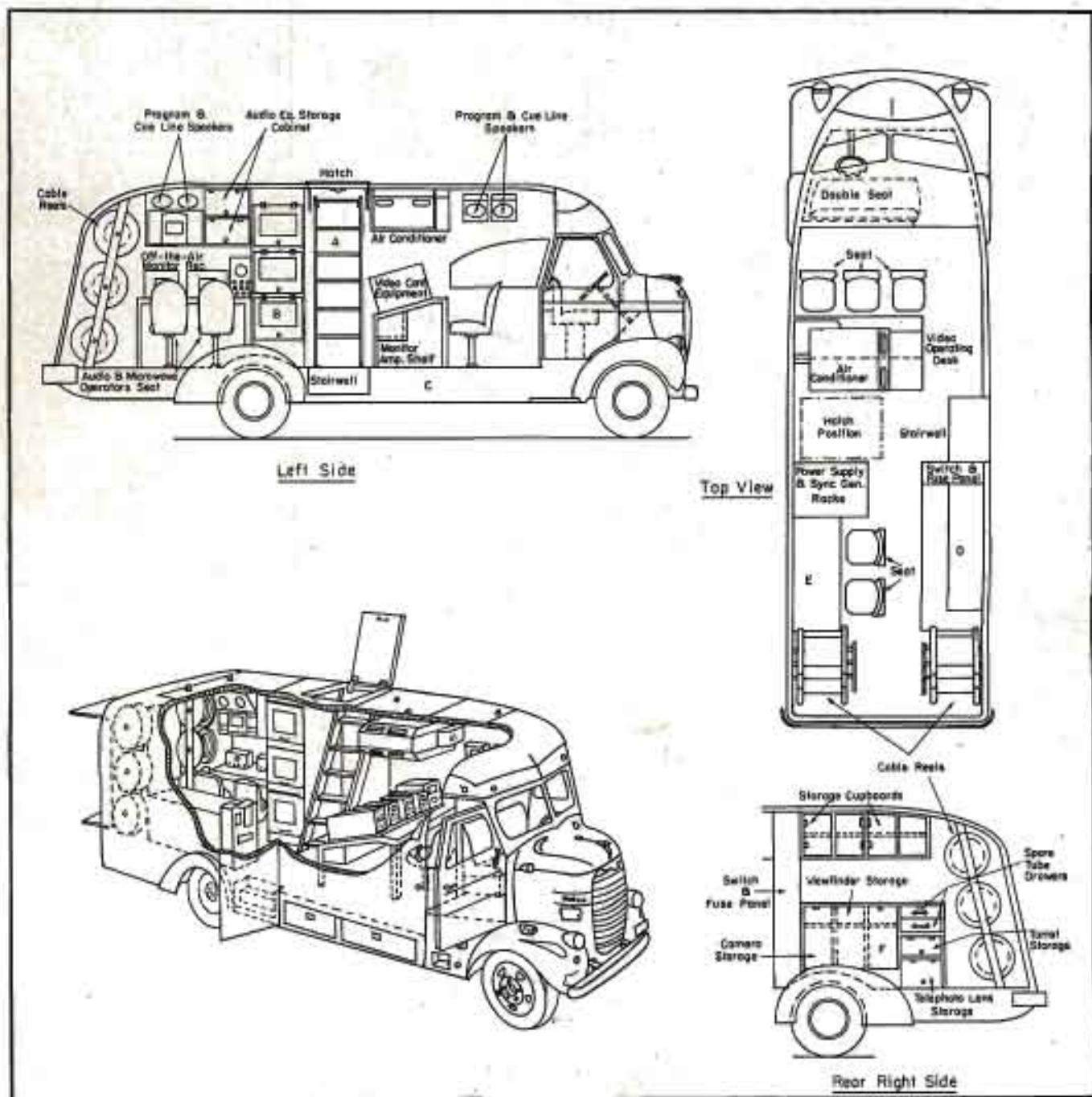

Figure 2

Cutaway views of interiors of the mobile truck. At A is a removable ladder which swings back of the wall when not in use. The power supply and sync generator racks appear in position B. At C are the compartments under the skirts of both sides of the body which are used for the storage of tripods, sound bags, rigs, etc. In position D are the storage cupboards above, the work bench at top, with the camera equipment below. At E is a wall cabinet (above) and an operating bench (below). Removable covers for the camera and viewfinder storage rack are at F.

a manner that sufficient space is allocated for all essentials, without necessarily causing the unit to become unwieldy. Proper treatment of these considerations will result in a unit requiring a minimum of set-up time to get on the air, and providing a maximum of convenience for the operating personnel. This combination is bound to afford the overall result of best pic-

ture and sound quality, at a minimum operating expense.

Typical Remote Operation

In designing our truck, we not only included the aforementioned basic features, but a host of additional items essential to field operations. The need for all of these features becomes quite apparent when on the road, covering

such events as football games, parades, etc.

To illustrate the importance of these features, let us consider a typical football telecast. Two hours before air time, the unit with six technicians arrives at the stadium. The unit is parked in its assigned place behind the grandstand, some 200 feet from the camera positions. In our remote



Figure 4

Rear portion of the mobile unit. The switch and fuse panel are on the left, and power supply and sync generator rack at right. One of the roll-out shelves is shown part way out of the rack.

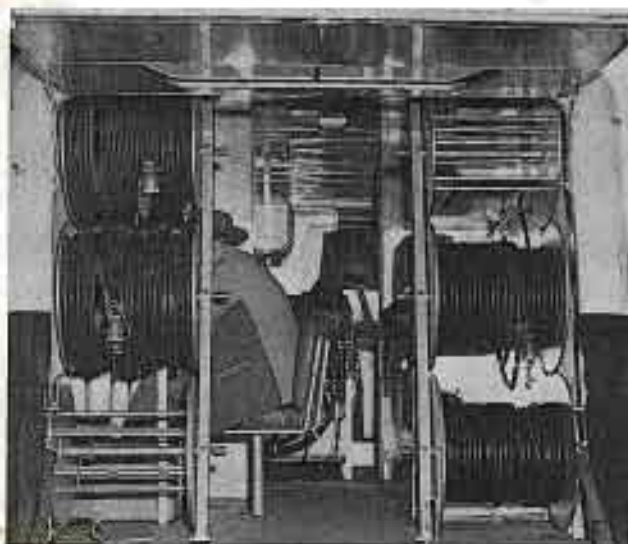

Figure 3

Interior of the mobile unit as seen from the rear. The racks shown carry the normal working complement of 1,800' of multiple conductor cable.

work, our efforts have been organized to the point that individual responsibility has been established for the various operations of setup, and a routine procedure is generally followed.

The rear of the vehicle opens up for rapid unloading. The lower section of the rear door forms an effective working platform, while the upper section affords weather protection. The cameramen remove cameras, lenses and viewfinders from storage cabinets in the rear portion of the truck; tripods are taken from their lockers in the outside skirts of the truck body. This equipment is carried to the camera positions in the grandstand, and set up for operation. The audio operator then takes microphones and audio control amplifier, along with a ten-inch picture monitor which is used by the announcer, to this same vantage point in the stands. Meanwhile, two video control operators have unreeled the necessary lengths of multiple conductor camera cable, and have strung this between the truck and the camera positions. At the truck end, the cables terminate in a connection panel adjacent to the side door. This same panel also accommodates the input power line, audio line and telephone line, as well as a receptacle for connecting the microwave transmitter with its control unit in the truck. This connection panel in the side of the truck serves several purposes; it simplifies the connection of the various cables into the equipment inside the truck, and, being the only terminal point to which external connections are made, permits operation of the mobile unit with all doors

tightly closed against weather or intrusion during the operation.

Power Source and Distribution

Approximately 6 kw of ac power is required to operate the TV unit; this power is obtained from a nearby switchbox which has been installed at this location. The main feeders are connected to the connection panel and the power is then fed to the main power distribution board, located inside, just next to the entrance door. This switchboard provides for the utilization of any of the common, two, three or four wire, single or poly-phase sources of ac power, through the use of a link cross-connect arrangement. On this switchboard are the main disconnect and fuses, branch circuit switches and fuses for lights, convenience receptacles, air conditioning unit, and for all TV equipment. Three voltmeters and three ammeters are installed on the panel for measuring line voltage and current. All power distribution switches are mounted on sub-panels behind the front of the main panel, to prevent accidental brushing of the switches by anyone passing through the doorway.

A group of toggle switches, which control six-volt dc lights inside the truck, are also located on the main power panel. These bulbs are recessed in overhead fixtures, which incidentally are of special design, using both standard 115-volt bulbs for use when such power is available, and six-volt dc bulbs for use whenever the truck is under way, or before external power is connected. Since the dc lighting imposes an additional load on the truck battery, and since the bat-

tery may need an occasional *boost*, a ten-ampere charger is built into the power panel assembly, in order that the battery may be kept charging whenever power is connected to the truck.

Communications to Studio

In remote TV work, it is customary to employ telephone wire circuits to send the sound portion of the program back to the studio. Therefore it is a simple matter to connect the audio output of the mobile unit to the line which has been previously installed between the truck location and the studios. Additionally, in our setup we installed a private telephone line for use in cueing and coordinating the remote operation with the studio. These wire facilities are available at a nominal cost, and upon short notice, anywhere within the field of our operations. For this reason it has not been considered practical to carry radio relay equipment for voice signals.

In contrast, wide-band wire line circuits for video signals are not generally available on short notice, nor are they as economical as the microwave link system. Hence, we use either of two types of microwave relay for sending the picture portion of the program back to the studio. The first is a highly portable, 7000-mc low-powered unit for short distance transmission; the second is a somewhat larger, higher powered, 2000-mc relay for use at more remote locations.

Since, during our football pickup, we are but six miles from the main studios, and we have a line-of-sight transmission path, we use the 7000-

mic transmitter and its parabolic antenna on the roof of the stadium. The transmitter control unit, which is used to control the transmitter frequency and modulation percentage, is operated in the mobile unit, from which point a multiple conductor cable has been strung to the transmitter location on the roof. The transmitter operator, through the use of the telephone communication system to the main studios, checks with the receiver operator to determine exact orientation of the antenna, and provide maximum signal at the receiver.

Equipment Test and Adjustment

With all of the equipment set up, audio and microwave facilities in operation, the crew is then ready to begin adjustment of the camera controls for best picture quality. From this time on, the center of activity is the video operations control area, which is located just forward of the side entrance door. During the time the unit was being made ready for operation, this area was not particularly busy, but now that the mobile unit is ready to start *warning up*, the engineers who are to operate the camera controls, are seated at the video control desk. On this desk are installed two (sometimes three) camera control units, a switching unit, and a master monitor. In addition to the two video control operators, a producer, or program director is seated before the desk. Behind these seats is space for two or three non-operating observers. The producer and the video control operators are in telephone communication with the cameramen, and also with the studio, over the private line.

Initial testing is the next step. The audio operator receives word from the studio that the sound is satisfactory, with regard to level and quality. The cameras then are the critically adjusted for optimum picture quality, and the synchronizing generator phased with the studio generator to minimize *roll-over* when the switch is made to the remote pickup. The waveform of the picture output is then checked for proper sync-to-picture ratio, camera levels matched, and a last minute check of microwave transmitter tuning and power output made. Over the telephone line from the studio comes word that sound and picture are being received in normal fashion. The clock, which is on the power panel is synchronized with the studio clocks and is a key piece of apparatus. In remote work, split-second timing is essential. In our football pickup, for instance, with ten minutes remaining before air time, the



Figure 6
The video control desk. From left to right are the switching unit, two camera controls and space for a third, and a master monitor.

producer calls for a last minute check of lenses, and directs the cameramen to set the opening shots. He also receives word from the audio operator that the announcer is ready to begin his opening salutation upon cue from the mobile unit.

Through the use of a TV receiver mounted in the rear section of the truck, an *off-the-air* picture is being fed to the screen on the master monitor on the video desk. The producer and the engineers observe that the introductory film from the main studio is drawing to a close, and hence, air time for the remote pickup is about due. As the film ends, a station identification is made from the main studio, whereupon the switch is made to the mobile unit. Sound and pic-

ture from the stadium are then on the air. From this time until the end of the game, continuous picture and sound are maintained.

As indicated, most of the area in the after portion of the vehicle has been planned for the storage of equipment, and for the secondary operating functions. However, the control room group are placed forward of this area, where good light shielding is accomplished through the use of tailored snap-on window curtains, and a vinyl curtain, which can be drawn transversely across the truck, to form a reasonably dark enclosure.

In consideration for the long hours of work which the operators of the mobile unit spend in their participa-

(Continued on page 31)

Figure 5
Schematic of the switchboard in the mobile truck.

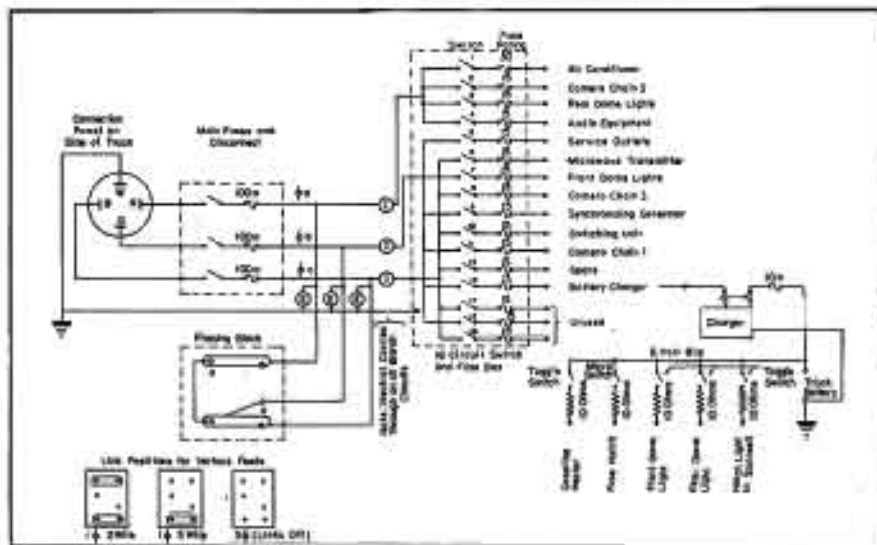

Producing Broadcast Quality TELEPHONE RECORDINGS



Telephone recording system in operation.

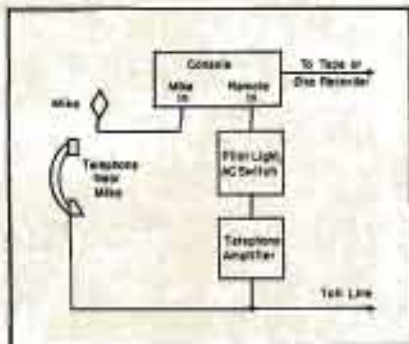

Block diagram illustrating the recorder setup.

How to cut and splice tape in editing.

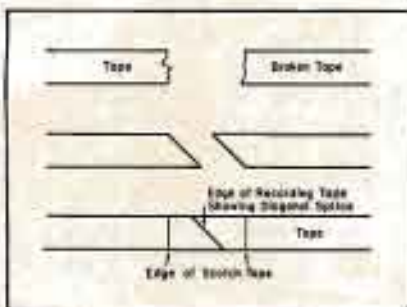

Circuit for optional filter, a Δ -O toroidal inductance with its setting adjustable, which can be used to secure exact resonance.

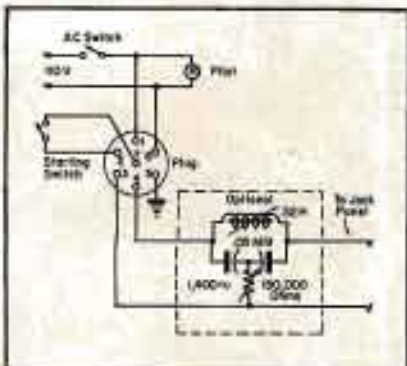

Application of a Telephone Recorder Connector Across Station Trunk Lines and Use of Disc or Tape Recorder Provides High Quality Telephone Recordings, and Permits Rapid Processing of Telephone-Interview Recordings for Spot-News Broadcasts.

by **ADELBERT KELLEY**

Chief Engineer
WINR, Binghamton, N. Y.

IMPROVEMENT OF THE quality of telephone recordings has been a pet project of many broadcast engineers. The problems are many, when you consider the limitations of the telephone carbon microphones and other telephone equipment designed to handle only limited speech frequencies.

During a series of tests at our station, a new type of telephone recorder

¹W.E. 50-A, available through local telephone company.

connector² was tried and found to be quite the answer. With this connector in the circuit, the voice of the newsman in the station making the call is studio quality, while the voice on the other end of the line resembles the quality of the well-known filter mike used in dramas to simulate a telephone. There is no objection to this since it is expected by the station's listeners, who know they are listening to a telephone interview.

The first step in the installation of the system is to order the connector installed across one of the station trunk lines, making provision for an

(Continued on page 32)

Circuit of the recorder connector. Terminals 1 and 6 are for a 120-volt 40 (+5 or -15) or 25 to 60-cycle ac line. Terminals 2 and 7 are for the start recording control; 3 and 4 for recorder connection, and 5 is an electrostatic shield.

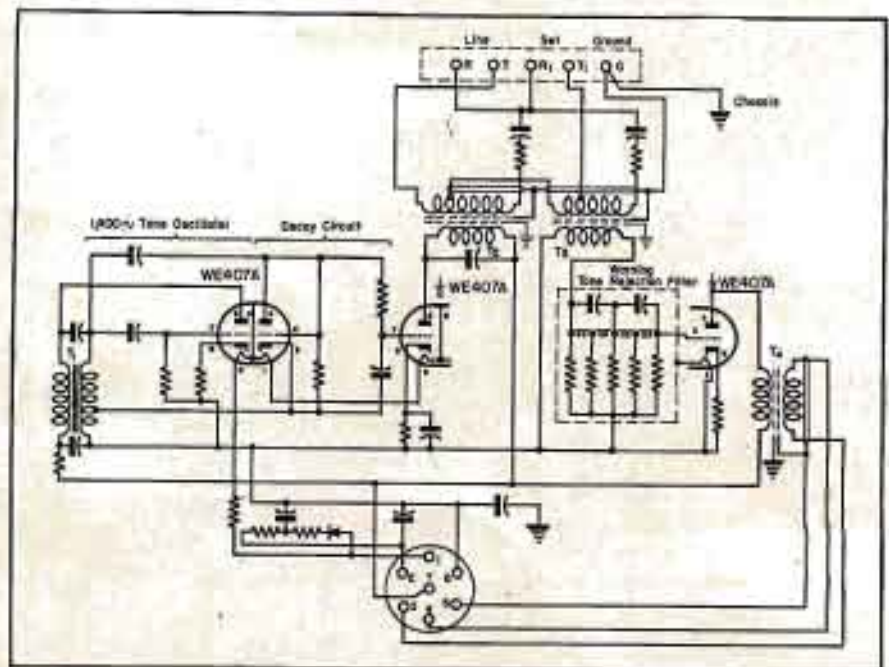

MONITORING RECTIFIER

For AM Stations

MANY AM broadcast station modulation monitor or transmitter facilities do not afford audio output for aural monitoring. This service can be provided by using a monitoring rectifier, adapted from the conventional voltage doubler circuit, as shown in Figure 1.

Balanced Output

This circuit provides *balanced* output, suitable for use with commonly encountered monitoring amplifiers having a *bridging* input impedance of 20,000 ohms, balanced to ground, and adequately large audio output with relatively low distortion.

No RF Wiring

No *rf* wiring is required except a single connection to the *rf* input terminal of the station's modulation monitor.¹

Component Features

To permit adjustment of the *rf* input to the rectifier if desired, C_1 may be made variable. In a typical case, a 250-mmfd fixed mica capacitor was used, providing sufficient *rf* coupling to produce a *dc* voltage of about 40 as measured across points A-B (20,000 ohm-per-volt meter on 50-volt scale). The filter capacitors and the load resistors indicated were chosen to minimize amplitude distortion even at relatively high modulation frequencies, and also to supply a reasonably low output impedance so that the frequency response of the unit would not be adversely affected by the capacitance of a moderate length of shielded cable used to connect it with the station's *patch panel*. No blocking capacitors were installed in the output circuit, since it was found that they

¹It is assumed that this is the usual unbalanced input, with the chassis of the modulation monitor grounded.
 *RCA 66-A.

System, Adapted from Conventional Voltage Doubler, Has a Balanced Output Suitable for Use With Monitoring Amplifier Having Bridging Input Impedance of 20,000 Ohms Balanced to Ground. Provides Large Audio Output With Relatively Low Distortion.

by ROBERT D. LAMBERT, Jr.

WCOS, Columbia, S. C.

were not necessary with the particular monitoring amplifier involved.

Unit Construction

The unit was built up on a small aluminum chassis, and mounted on the side of the rack directly behind the station's modulation² monitor. This permitted a short, direct connection to the *rf* input terminals of the modulation monitor; with little danger of stray *rf* pickup, even with an unshielded lead. Heater supply of 6.3 for the 6H6GT was obtained from an amplifier mounted in the same rack.



Figure 2
 The rectifier unit mounted on side of a rack directly behind the modulation monitor.

Figure 1
 Monitoring rectifier circuit adapted from a conventional voltage doubler.

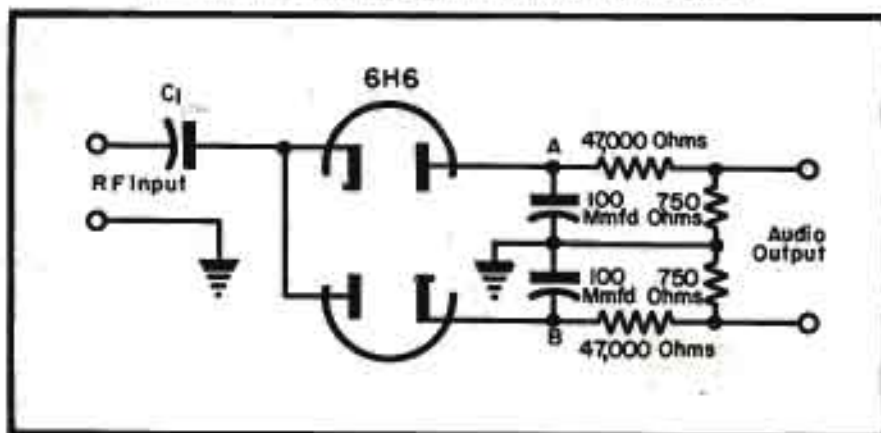

Figure 3

Horizontal radiation patterns for two values of S (major lobes only) where $\phi = 140^\circ$.

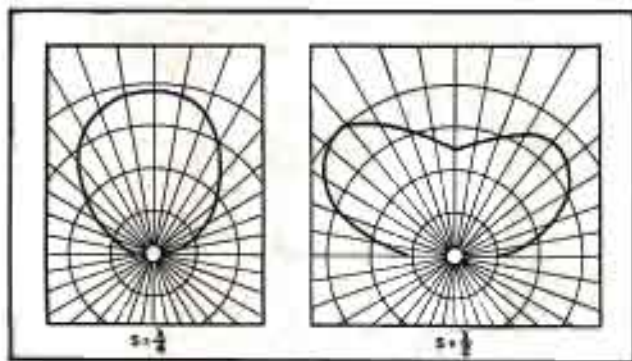
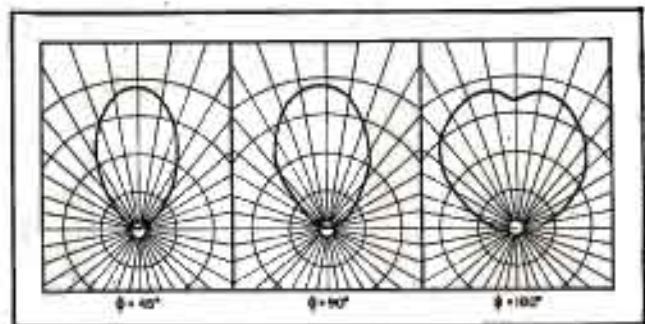

Figure 2

Horizontal radiation patterns for various values of ϕ ; major lobes only.



Directional Antenna For The

Corner Reflector Type Vertically Polarized Antenna Featuring Unidirectional Pattern Has Gain of at Least 6 db Over Half-Wave Dipoles. Can Be Used With 50-75 Ohm Air Dielectric and Solid Dielectric Cables. Performance Is Result of Reflecting Sheet's Action to Direct Radiation from Dipole Along Axis that Bisects Angle Between Reflectors; Theory Based on the Use of Plane Conducting Sheets of Infinite Size.

by **J. S. BROWN** and **V. J. MOFFATT**

Chief Engineer

Engineer

Andrew Corporation

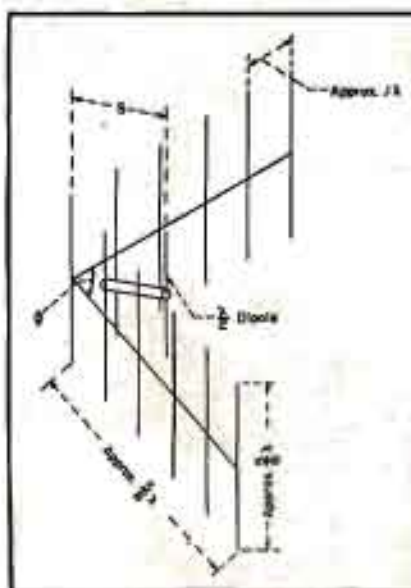

MANY EMERGENCY COMMUNICATIONS systems require directional antennas, for point-to-point relays, for coverage over areas where the antenna is not located in the center of the area to be served, or for suppression of interference between systems operating on the same or adjacent frequencies.

In considering the design features for an antenna adaptable to these conditions, both electrical and mechanical factors were probed. Electrical design objectives were to provide a unidirectional radiation pattern, with a gain of at least 6 db over a half-wave dipole, and to obtain impedance characteristics that would produce a *vswr* of

Figure 1

Simplified drawing of the corner reflector antenna.

less than 1.5. It was felt desirable to develop an antenna type that would be sufficiently broad band to provide this performance over the entire frequency range without adjustment. In order that the antenna might be used with any of several air-dielectric and solid dielectric cables with characteristic impedances falling between 50 and 75 ohms, it was felt desirable to design for antenna impedance characteristics that would meet the *vswr* requirements when the antenna was used with any of the coaxial cables in this impedance range. Mechanical design objectives included adequate strength for wind loading up to 100 mph, suitable mountings for attaching the antenna to a wide variety of supporting structures, and provision for azimuthal orientation of the antenna after mounting.

The corner reflector type of antenna was chosen as the one that would provide the best combination of performance requirements. It is relatively broad band, the feed system is simple, the 6-db gain requirement can be easily met, and it is mechanically simple to construct for the 152-162 mc band.

General Design Criteria

The antenna is used vertically polarized for this application. Its performance, reduced to simplest terms, is a result of the reflecting sheets' action to direct the radiation from the dipole along the axis that bisects the angle between the reflectors. The theory is based on the use of plane conducting sheets of infinite size. It is, of course, necessary to use modified reflectors for practical reasons.

The reflecting sheets may be simulated by using closely spaced rods. This approach is necessary to reduce wind loading. Experiments indicated that spacings of about .1 wavelength

Figure 4
Horizontal radiation patterns of a production design antenna; major lobes only.

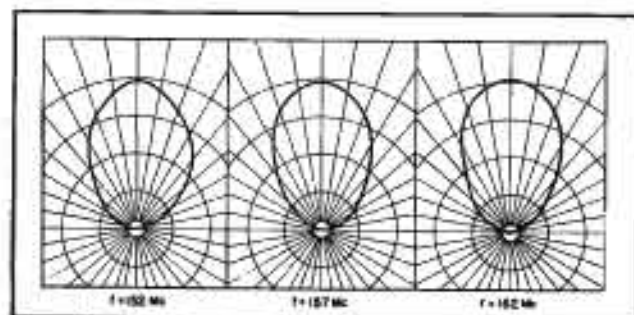
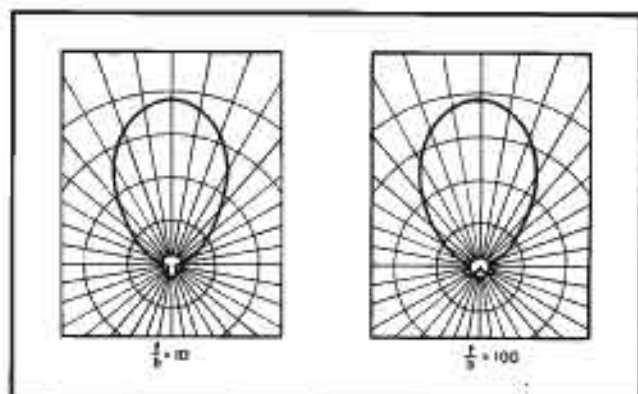

Figure 6
Radiation patterns of two antennas with similar gains but different front-to-back ratio.



152-162 Mc Communications Band

provided a very close electrical equivalent to sheets. The length and number of the rods is also limited by mechanical considerations. It was decided to use reflecting sheets approximately $\frac{3}{8}$ wavelength on a side, or about 4' square. This, of course, reduces the gain below the theoretical maximum, but tests indicated that the reduction was not serious for these dimensions. Reduction in size below $\frac{3}{8}$ wavelength causes a rapid decrease in gain.

Two additional parameters that were found to affect the antenna characteristics are the included angle between the reflectors (θ) and the spacing from the dipole to the apex of the reflectors, (S). Both of these variables were investigated experimentally, and results checked theoretical conclusions. As might be expected, the gain of the antenna is higher for smaller included angles between reflectors. The curves in Figure 2 illustrate relative field patterns for various included angles. As this angle is reduced, however, the radiation resistance decreases and ohmic losses in the antenna cause reduction in gain.

The spacing from dipole to apex was found to be not critical, although there are limiting factors. If this spacing is made large, the main lobe of radiation splits into two lobes. Figure 3 illustrates this effect. If this distance is made too small, the radiation resistance is lowered to a point where ohmic losses limit the gain.

Determination of the final design dimensions was a matter of trial and error. The radiation patterns for the final design are shown in Figure 4, at several frequencies in the band. It can be seen that gain varies slightly over the band.

Accurate determination of the gain of an antenna is not easy, as many

Mc	Gain Calculated by Integration Methods	Gain by Comparison to $\lambda/2$ Dipole
152	8.9	8.3
157	9.2	9.1
162	9.2	10.7

Figure 5
Comparison of gain measurements by two methods; gain in db.

factors in the laboratory setup influence the results. Two different methods of gain measurement were used, to provide a cross-check on results. The first method involved determining gain by integrating the radiation pattern of the antenna, and comparing it to the theoretical pattern of a quarter-wave antenna above a perfect ground. It is necessary, of course, to determine the three-dimensional radiation pattern of the antenna under test. It was found that the main radiation lobe of the corner reflector was essentially elliptical in cross section, which simplified the mathematics of integration.

The second method used to measure gain involved making a direct measurement of antenna performance relative to a test half-wave dipole. A test dipole, acting as a transmitting antenna, was set up and the radiation from it measured by a suitable receiving antenna. A slotted line between

Frequency Mc	152	157	162
Front-to-Back Ratio	23	31	24.3
Major-to-Minor Lobe Ratio	17.8	23.4	22.1

Figure 7
Table of front-to-back and major-to-minor lobe ratios for three frequencies; ratios in db.

the signal generator and dipole was required to measure E_{max} and E_{min} on the coaxial line feeding the dipole. The antenna being tested was then substituted for the dipole and the same measurements made. The power delivered to each transmitting antenna is proportional to $(E_{max})^2$ and from these ratios and the field ratios at the receiving antenna the gain can be determined. One of the disadvantages of this method is the difficulty of constructing a half-wave dipole that produces its theoretical radiation pattern. It is necessary to make extensive measurements of the dipole-radiation pattern before the results from this method may be depended upon. Figure 5 tabulates the gain values obtained by the two methods of measurement.

Front-to-back ratio of directional antennas is often considered a criterion of performance. While it is one factor to be considered in improvement of signal-to-noise ratio, it is not always comparable to the gain of the antenna. This is due to the fact that the minor radiation lobe or lobes may or may not be exactly opposite in azimuth to the main lobe. Figure 6 shows radiation patterns of two antennas with approximately the same gains, but with vastly different front-to-back ratios. Another, and perhaps more suitable measure of performance might be the ratio of major-to-minor lobe field intensity. A tabulation of front-to-back ratios and major-to-minor lobe ratios for three frequencies in the band appears in Figure 7.

Since the antenna is to be used with several types of coaxial cable, each of which requires an end terminal or adapter, impedance measurements were made with end terminals and adapters in place. This was done to insure that the shunt capacities of these fit-

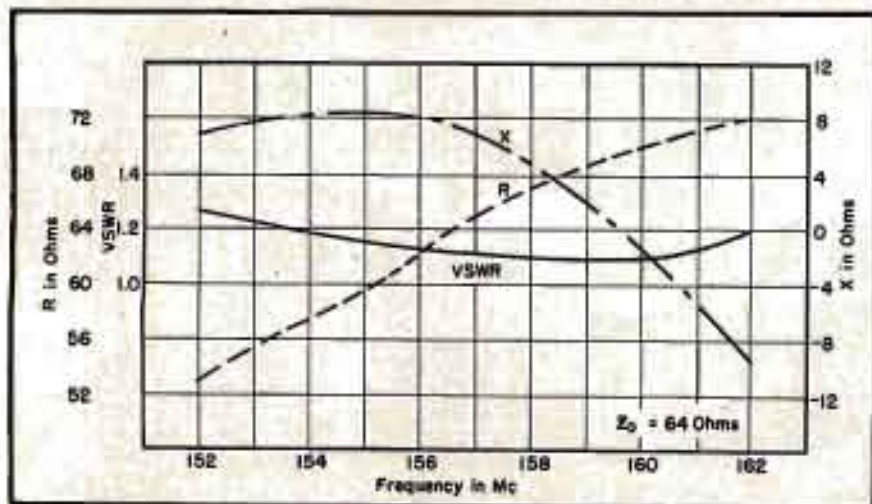

Figure 8
R, X, and *vswr* for a $\frac{3}{8}$ " air-dielectric line, with end-terminal effects included.

tings did not degrade the impedance characteristics of the antenna. Figure 8 shows R, X, and *vswr* with an end terminal for $\frac{3}{8}$ " air dielectric cable in place. This cable has a characteristic impedance of 64 ohms, and the *vswr* is plotted for this impedance. A photograph of the antenna with this fitting in place is shown in Figure 9.

The adapter for RG-8/U and RG-11/U cables is shown in Figure 10, and impedance data appear in Figure 11. The adapter for RG-17/U cable and performance data are shown in Figures 12 and 13. Both of these adapters employ a Textolite 1422 insulator with suitable gasketing to make the back of the connector weatherproof. Although the connector in the RG-8/U and RG-11/U adapter is type UHF, which is not considered weatherproof, this fitting is universally used in emergency communications systems, and was provided to conform with standard practice.

Many types of mounting are required for antennas for this application to accommodate the many types of supporting structures encountered. The antennas can be mounted on a support of circular cross section or on an angle type support. This mount allows azimuthal adjustment of the antenna after it is installed on the tower, and includes a locking device to prevent the antenna

(Continued on page 35)



Fig. 9 (above, left)
View of a dipole feed showing end terminal for a $\frac{3}{8}$ " air-dielectric line in place.



Figure 10
View of a dipole feed with an RG-8/U or RG-11/U adapter.

Figure 12
View of a dipole feed with a RG-17/U adapter.

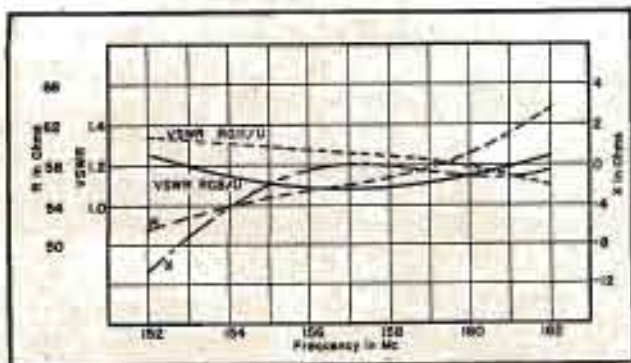
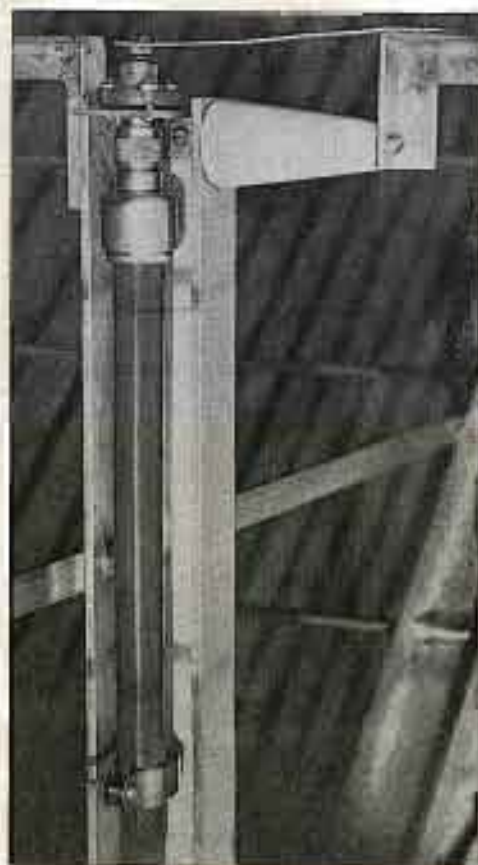
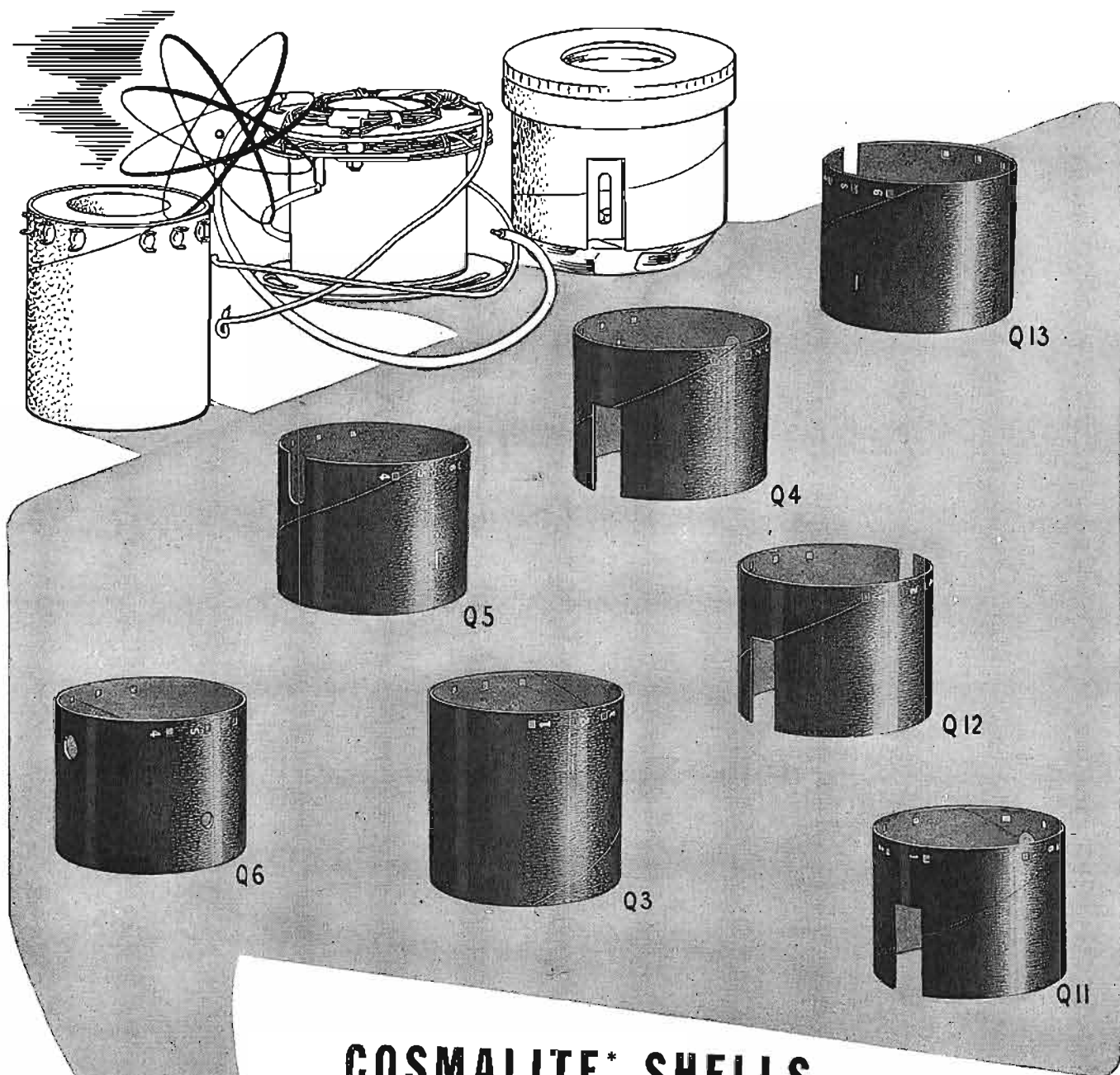

Figure 11 (left)
R, X, and *vswr* for RG-8/U and RG-11/U cables, with adapter effects included.





COSMALITE* SHELLS

for Television deflection yokes
are made to meet your individual needs.

Keep in mind that we have tools available without charge for all Shells shown above. And . . . we can quickly make tools for other punching and notching as may be required.

COSMALITE is known as a quality product. It meets the most exacting requirements.

Inquiries given specialized attention.

DEFLECTION YOKE SHELLS

with black exterior finish, as illustrated above, have 3" inside diameter, 3.093" outside diameter.

Q-3 is 2 31/32" long. The others, Q-4, Q-5, Q-6, Q-11, Q-12, Q-13 are 2 11/32" long.

*Reg. U. S. Pat. Off.

The **CLEVELAND CONTAINER Co.**
6201 BARBERTON AVE. CLEVELAND 2, OHIO

PLANTS AND SALES OFFICES at Plymouth, Wis., Chicago, Detroit, Ogdensburg, N.Y., Jamesburg, N.J.
ABRASIVE DIVISION at Cleveland, Ohio
CANADIAN PLANT: The Cleveland Container, Canada, Ltd., Prescott, Ontario

REPRESENTATIVES

CANADA	WM. T. BARRON, EIGHTH LINE, RR #1, OAKVILLE, ONTARIO
METROPOLITAN	R. T. MURRAY, 614 CENTRAL AVE., EAST ORANGE, N.J.
NEW YORK	E. P. PACK AND ASSOCIATES, 968 FARMINGTON AVE.
NEW ENGLAND	WEST HARTFORD, CONN.



How is YOUR company doing in this "EVERYBODY-BENEFITS" plan?

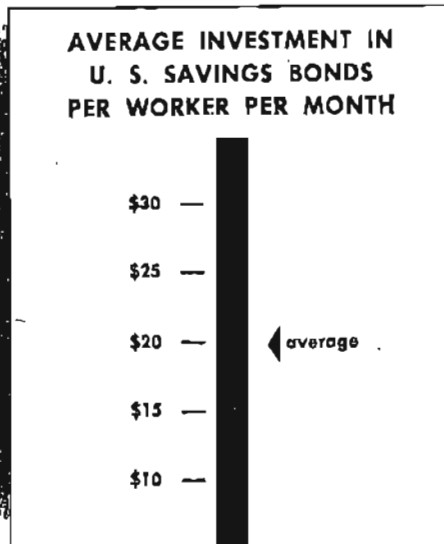
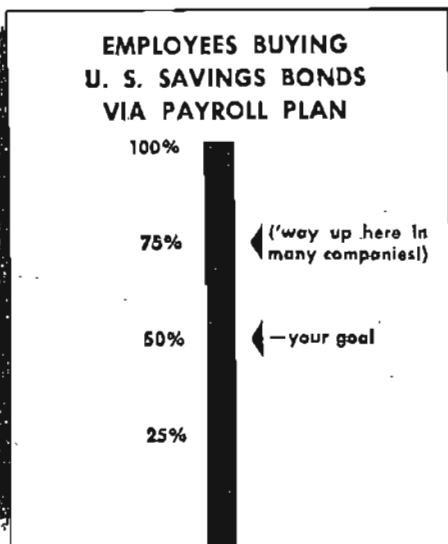

Compare your employee participation with others who have Payroll Savings

If the figures for your company fall below those shown above, you're missing your share of benefits of the Payroll Savings Plan! These benefits are described below. Nation-wide experience proves that when top management puts the "OK" on the Plan, its benefits rise sharply.

BENEFITS TO EMPLOYEES: Every \$3 invested in Savings Bonds pay \$4 at maturity. Workers gain a 33% return on their money—enabling them in the future to buy more of the things they will want—plus the peace of mind that goes with regular saving.

BENEFITS TO EMPLOYERS: The feeling of security that goes with participation in Payroll Savings makes workers more contented. Worrying less, they work better. Among the more than 20,000 large companies with Payroll Savings, records show that—following installation of the Plan—production increased, absenteeism and accidents decreased!

BENEFITS TO THE NATION: The Payroll Savings Plan is a powerful deterrent to inflationary forces. Every Savings Bond dollar built up in the Treasury withdraws a dollar

from the swollen spending stream. The Plan thus contributes to national security—which affects *your* security!

WHAT CAN YOU DO? If your company has the Payroll Savings Plan, make sure it's being adequately promoted—backed by your top executives—to bring your company its full measure of benefits. If you haven't yet installed the Plan, why pass up its benefits any longer? All the help you need is available from your State Director, Savings Bonds Division, U. S. Treasury Department. He is listed in your telephone book. Call him now!

Do You Realize...?

- Over \$75,000,000,000 worth of Savings Bonds have been bought since 1941.
- More than 2/3 of this volume—over \$50,000,000,000—is still held by the purchasers.
- During 3 months of 1948, 1,500 additional large firms installed the Payroll Savings Plan.
- Via this plan, 7,500,000 workers are each investing on the average of \$20 per month of their pay—more than \$150,000,000 per month—in Bonds.

The Treasury Department acknowledges with appreciation the publication of this message by

COMMUNICATIONS

This is an official U. S. Treasury advertisement prepared under the auspices of the Treasury Department and the Advertising Council.





Personals

CAPTAIN A. BEGELMAN, whose service dates back to 1924, is now a master mariner and a pilot out of New York. He reports that he likes to cruise around Long Island Sound in his 18-foot sailboat and to talk with the boys aboard ship in the radio room. He still has his first telephone and telegraph tickets. . . . Ed. Bennett is now in Norfolk, and L. S. Bennett is purchasing agent for the Mass. Radio Telegraph School in Boston. . . . H. K. Bergman writes from WGY, Schenectady, where he is transmitter operator, that he was with St. Lawrence University as operator in charge of broadcasting for 18 years. . . . Eric L. Bisbee, of New York's finest, expects to retire from the police force early this year and would like to return to sea, perhaps on a tanker. . . . G. E. Blum is transmitter engineer at WCFL. . . . Geo. Bonadio owns a retail liquor store in Watertown, N. Y. G. D. did some fine work for Government during the last war and now operates W2WLR. . . . L. C. Brown is with RCAC, Seaford, N. Y. . . . A. W. Burke writes from Boston that news is scarce. . . . H. D. Burman is kept busy as ship inspector with RMCA at Savannah and an occasional trick at WSV. . . . We don't hear from many of our members very often and J. Christianson is one of them. JC is chief radioman at RCAC, Rocky Point. . . . R. J. Cowie sailed on a large number of ships during his time as a radio operator. He is now at WEEI, Boston, as transmitter supervisor. . . . A. M. Da Vico, who lives in the lovely island of Honolulu, has retired. He reports that he still has a great deal of love for radio, his basement workshop being crowded with equipment of his own construction; says that he enjoys reading COMMUNICATIONS. . . . R. K. Davis, Tropical Radio's chief inspector at New York, is busy with ship repair work. . . . G. F. Duvall says that television is here to stay, and from the amount of repair work he does out in Brooklyn he must be right. . . . We're sorry to report that VWOA member William G. Stedman died recently at his home in Brooklyn.

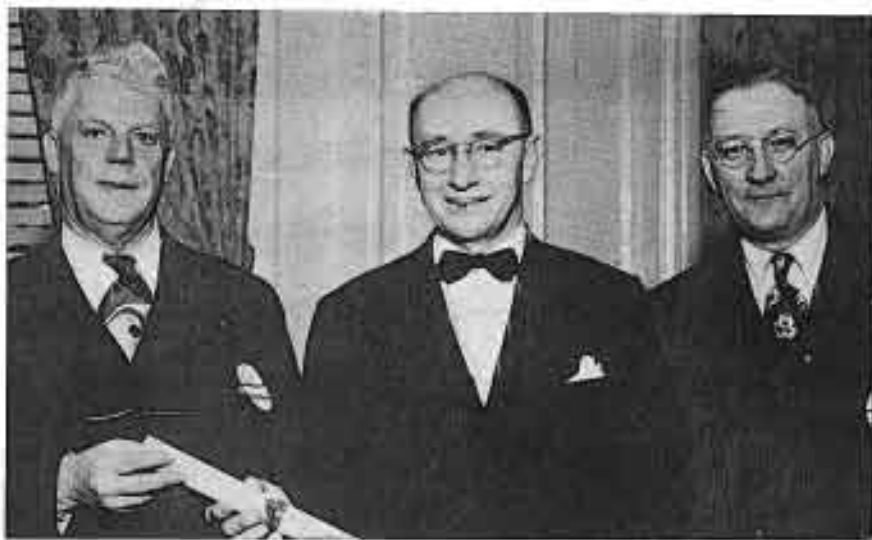

At the 26th annual VWOA dinner cruise which was held at the Hotel Astor, N. Y. City, on February 25. Above: VWOA life member Guy Estwistle, president of the Massachusetts Radio School; VWOA secretary Bill Simon and Larry Bennett, VWOA member from Boston. Below: Capt. George E. Shackles, executive vice president RMCA; VWOA honorary member and FCC Commissioner E. M. Webster and ex presy, W. J. McGoigle.



Below: VWOA honorary member Admiral Joseph R. Redman, vice president of Western Union; Col. Thompson H. Mitchell, executive vice president RCA Communications; VWOA first vice president Arthur J. Costigan and VWOA life member E. H. Rietzka, president Capitol Radio.



FM Proof-of-Performance

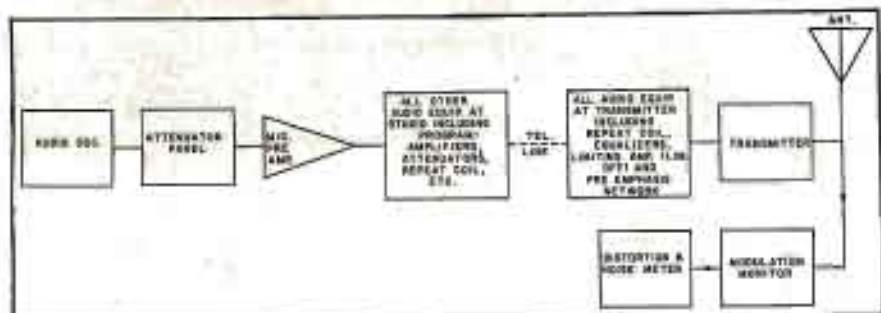

Figure 1a

Arrangement of test equipment which may be used for distortion and PM noise measurements, when transmitter is located remote from studio.

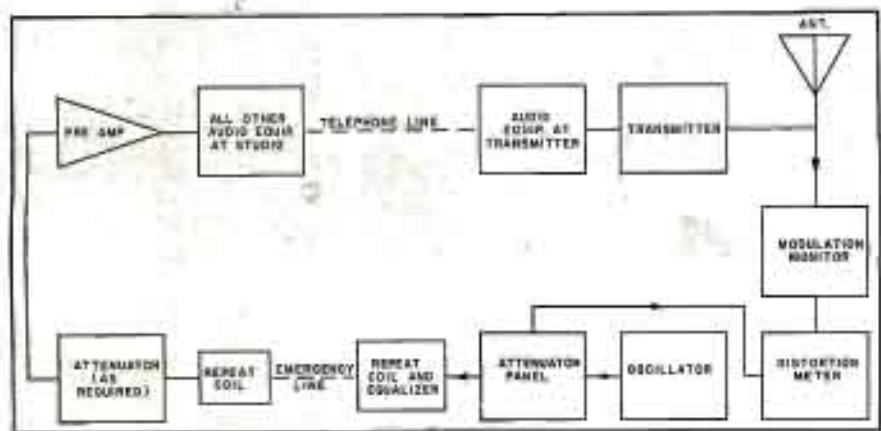

Figure 1b

Equipment setup for measuring distortion, when transmitter is located adjacent to studio.

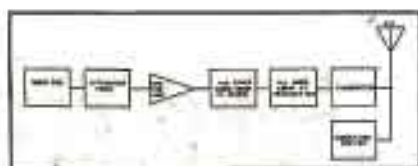

Figure 2

Block diagram of recommended equipment setup for measuring of response.

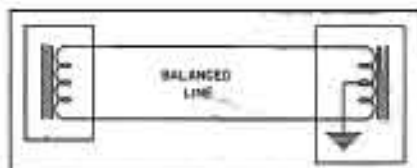
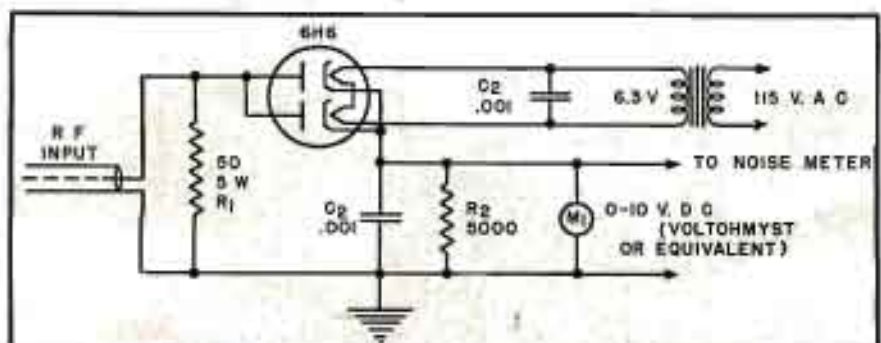

Figure 4

How loop between transformer-coupled units should be grounded.

Figure 3
Schematic diagram of rf rectifier which may be used for AM hum measurements.



PROOF-OF-PERFORMANCE measurements, a basic requirement in licensing procedure, are quite a factor in broadcast engineering operations. Although the FCC has temporarily waived the requirements¹ for these measurements,² it is probable that in the near future this information will become mandatory for all FM stations both when applying for a license and yearly thereafter.

Test Equipment Required

The major items of test equipment required in order to adequately make the measurements are listed below. It is assumed that the station already has a good modulation monitor which provides a low-distortion, de-emphasized audio output with sufficient level for feeding a noise and distortion meter:

1a) Audio Oscillator: Either a continuously variable *bfo*³ or push-button audio oscillator⁴ may be used to make the audio measurements. The push-button frequency system is particularly suited for making the distortion measurements at the FCC specified frequencies. The variable beat frequency oscillator permits response to be measured at additional frequencies, and a more complete response curve plotted.

1b) Attenuator Panel: An accurate attenuator panel and a signal level indicator is required for use at the input of the microphone preamplifier. Because of the preemphasis at the higher frequencies, the input level will change approximately 17 db as the frequency is varied. An additional 12 db of attenuation is required to reduce the modulation level from 100% to 25%. It is therefore recommended that the attenuator panel⁵ be capable of varying the input level at least 35 db.

1c) Noise and Distortion Meter: Two types of noise and distortion meters can be used to meet FCC requirements provided they read harmonics above the 30 kc FCC requirement. One type⁶ can be used at all installations; Figure 1a. Another⁷ can be used only where a second circuit with low noise and distortion level exists between the studio and transmitter locations as indicated in Figure 1b. This instrument requires the transmission of the original signal from the oscillator to the distortion meter in addition to the program circuit path since this instrument utilizes a balancing arrangement for the elimination of the fundamental frequency.

1d) RF Rectifier: Since most commercial FM modulation monitors do not have built-in diode detectors, some form of detector or rf rectifier is required in order to measure the amplitude modulated noise on the carrier. A schematic diagram of a suitable rectifier is shown in Figure 3. Since all of the components of this rec-

¹FCC form 302, section IIB, paragraph 6, specifies the performance measurements. FM stations are required to make when applying for a license. Minimum performance requirements are specified by FCC in section 8A of Standard of Good Engineering Practice Concerning FM Broadcasting Stations.

²List of measurements will appear in appendix 1, next month.

³RCA 68B. ⁴RCA WA-28A.

⁵RCA 89C attenuator panel measures input level and provides variable attenuation up to 75 db.

Measurement Techniques

tifier are readily obtainable from local sources, it is felt that many stations will want to build their own rectifiers. For those who want to go still further, a more elaborate equipment is described in appendix 4. This equipment is much easier to use and will give direct readings when used in conjunction with any noise meter.

Making the Measurements

The FCC specifies that . . . "All measurements shall be made with the equipment adjusted for normal program operation and shall include all circuits between the main studio microphone terminals and the antenna output, including telephone lines, preamplifier circuits and any equalizers employed except for microphones, and without compression, if a compression amplifier is installed."

What is implied by normal program operation is subjected to some interpretation since the level at the microphone input transformer and the resulting overall gain of the system will vary considerably depending on the type of program and the distance the performer is stationed from the microphone, etc. This is an important consideration particularly when making noise measurements, since any hum or noise which originates in the preamplifier will obviously affect the measurements directly in proportion to the overall gain of the system. The RMA has recommended a standard system of gain of 68 db and also specifies the standard output level into the telephone line as +18 dbm and the standard input level as -50 dbm. It is considered that these levels are consistent with the peak readings occurring during a normal broadcast program. The RMA recommendations have now been generally accepted throughout the industry.

Another important item to be kept in mind when setting up the audio system is that the level at all points in the circuit should be kept high enough to override any hum or noise generated in that part of the circuit. As an example, the noise level at the output of one type program amplifier⁶ is less than -82 db below +30 dbm. It follows, therefore, that if the actual output level at which this amplifier is used is 0 dbm, the relative noise level can be as high as -52 db which, of course, will not meet the FCC requirements. In general, the levels should be kept as high as possible without overloading the amplifiers or, in the case of a telephone line, causing crosstalk. In most places, the maximum input level to a telephone line is +18 dbm (level also suggested by RMA); however, it is suggested that this be verified by the local telephone company. In some cases it may be necessary to insert attenuation pads in the output circuit of the various amplifiers in order to raise the amplifier output levels to the proper values.

Another important consideration is the correct use of grounds throughout the audio system. In general, the loop between transformer coupled units should be grounded at only one place, usually at the center tap of the input transformer, as shown in Figure 4.

⁶RCA WM-71A. ⁷RCA 68C.
⁸RCA BA-3C.

How to Use Measurement Equipment (Audio Oscillator, Attenuator Panel, Noise and Distortion Meter, and RF Rectifier) and Secure Required Performance Data for the FCC. . . . How to Enter Information for Presentation to the FCC.

by F. E. TALMAGE

Transmitter Engineer Section
Engineering Products Department
RCA Victor Division, RCA

If a variable-beat oscillator is used, the center tap of the output transformer should be grounded. Likewise, the center taps on the attenuators should be grounded. If a long line exists between the oscillator and the input transformer of the equipment under test, a one-to-one isolation transformer or repeat coils should be used to isolate the grounds—otherwise high noise and distortion may result. The use of shielded patch cords is recommended for all low-level circuits. This is particularly important for the connection between the attenuator panel and the microphone preamplifier.

Output Noise Level (FM)

It is suggested that the FM noise measurements be made first because the noise is mostly likely to affect the final selection of level settings throughout the system. To make noise measurements, the measuring equipment should be set up as indicated in Figure 1a and the following six steps applied.

(1) Audio oscillator is set at 400 cycles.

(2) All attenuators, both the studio and transmitter, are set to their normal setting and audio oscillator and attenuator panel settings adjusted for 100% modulation as indicated on the modu-

lation monitor. (If there is any question as to the accuracy of the modulation monitor, it may be checked using the besel zero system cited in appendix 2.)

(3) Signal level is measured at the input to the microphone preamplifier (this should be -50 dbm). If not, the system gain will have to be readjusted until 100% modulation is obtained with -50 dbm input.

(4) Noise meter is set for zero reference level.

(5) All equipment is disconnected from the preamplifier input and the input loaded with a resistor equivalent to the microphone output impedance.

(6) The FM noise level is measured and recorded as indicated by the noise meter. If the FM noise level is not less than -60 db below the 100% modulation reference level, the best way to proceed is to open up the circuit at successive points starting with the input to the transmitter. At each point the input circuit being opened should be terminated with a suitable load resistance. In this way the source of the hum can be localized.

Audio Frequency Harmonic Distortion

The distortion measurements should be made with the same gain settings and

Figure 5
Block diagram of equipment used for AM noise measurements.

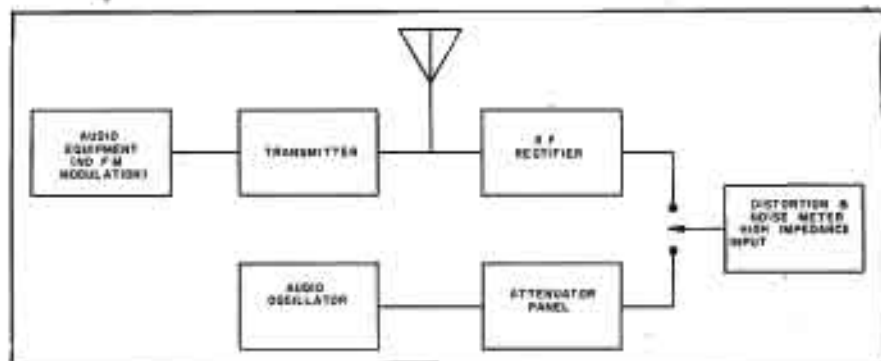

RCA SERVICE COMPANY, INC.
A DIVISION OF GENERAL ELECTRIC COMPANY
CAMDEN 5, NEW JERSEY

F. M.
TEST DATA SHEET

REGION _____
DATE _____

Name of System _____ Location _____ Station Number _____ RCA Service Co. Engineer _____

Title _____ Serial # _____ Original Name _____ Operating Frequency _____ Mod. Frequency _____ Transmitter Location _____ kW _____

Type of Modulation _____ Mod. Rate _____ % Transmitter Line Type _____ Impedance _____

Antenna Manufacturer _____ Type _____ Noise Source _____ Power Level _____

Desired Service by an AM Transmitter _____

STATION EQUIPMENT & MEASURING EQUIPMENT (INFO. & TYPE #)

Equipment and Manufacturer Name _____ Receiver Name _____

Serial Number (Receiver) _____

AUDIO INPUT EQUIPMENT AT TRANSMITTER (INFO. & TYPE #)

Location of Pre-Emphasis Network _____

Figures 6 (above) and 7 (below)
Forms employed to tabulate FM performance test data.

equipment setup as used in making the FM noise measurements; Figures 1a and b. There are six steps in this procedure, too:

- (1) Audio oscillator frequency is set to 50 cycles.
- (2) Audio input (oscillator output and attenuator panel settings) is adjusted for 100% modulation as indicated on the modulation monitor.
- (3) The distortion at the output of the modulation monitor is then measured. Deemphasis should be used and is usually incorporated in audio output circuit of the monitor.
- (4) Steps 1, 2 and 3 should be repeated on at least the following frequencies: 100, 400, 1000, 5000, 10,000 and 15,000 cycles.
- (5) Then steps 1, 2, 3 and 4 should

be repeated, except in each case the audio input adjusted for 50% modulation as indicated by the modulation monitor and measurements omitted at 10,000 and 15,000 cycles.

(6) Finally steps 1, 2, 3 and 4 should be repeated, except in each case the audio input adjusted for 25% modulation as indicated by the modulation monitor and measurements omitted at 10,000 and 15,000 cycles.

The distortion should be less than 3 1/2% at frequencies between 50 and 100 cycles, less than 2 1/2% at frequencies between 100 and 7,500 cycles and less than 3% at frequencies between 7,500 and 15,000 cycles.

AF Response Measurements

To make audio frequency response

measurements, the equipment should be set up as indicated in Figure 2. If the preamplifier response contains compensation to correct for the microphone response and this cannot be easily removed, the preamplifier should be omitted from the circuit. It is recommended that separate response curve be made on the preamplifier. It is necessary to use the same gain settings as were used in making the noise measurements and proceed as follows:

- (1) Audio oscillator frequency should be set to 50 cycles.
- (2) The audio input (oscillator output and attenuator panel settings) should be adjusted for 100% modulation as indicated by the modulation monitor.
- (3) Then the audio level should be measured and recorded at the input of the preamplifier.
- (4) Steps 1, 2 and 3 should be repeated on at least the following frequencies: 100, 400, 1000, 5000, 10,000 and 15,000 cycles in each case readjusting the input for 100% modulation.
- (5) Steps 1, 2, 3 and 4 should be repeated except in each case the input should be adjusted for 50% modulation.
- (6) Then steps 1, 2, 3 and 4, should be repeated except in each case the input should be adjusted for 25% modulation.

These input readings when subtracted from a suitable reference level should be compared with the standard preemphasis curve. To be within the FCC limits it should be possible to plot a curve from this data which, when referred to a suitable reference level, will fall between the standard curve and the lower limit curve shown in Figure 8a.

Output Noise Measurements (AM)

Since it is not practical to amplitude modulate an FM transmitter to obtain a reference level for the AM noise measurement, some other method must be found to establish this reference. In Figure 5 is illustrated a method involving a minimum of equipment. Here, we rectify a known part of the rf carrier, measure the actual noise on the detected voltage, and compare that with the calculated voltage* that would be required to 100% modulate the rf signal at the input of the rectifier. The rf voltage for the rectifier may be obtained from the same source that normally supplies voltage to the modulation monitor. To make the measurement four steps are involved:

- (1) The rf coupling between rectifier and the transmitter must be increased until the rectified dc voltage (M_d , Figure 3) is 4 to 5 volts.
- (2) With the noise meter connected to the rectifier, the noise meter should then be adjusted for a convenient reference reading of the ripple on the rectified dc.
- (3) The noise meter should then be connected to the output of the attenuator panel and the output of the oscillator and the attenuator settings adjusted for the same reading on the noise meter as obtained in step 2. The level indicated by the attenuator panel is equal to the ripple level expressed in dbm.
- (4) The AM noise level referred to level representing 100% modulation* can be calculated by the following formula:

$$\text{AM hum level (db)} = \frac{10 \log_{10} \left(\frac{.707 V_{dc}}{V_r} \right)^2}{.5} + V_r$$

RCA SERVICE COMPANY, INC.
A DIVISION OF GENERAL ELECTRIC COMPANY
CAMDEN 5, NEW JERSEY

AUDIO PERFORMANCE & POWER OUTPUT
F. M. Modulation & F. Mod.

STATION _____ Date _____
Engineer _____

NAME _____
Power _____ Kw, FM level _____ 25 below 1000, Frequency Modulation, AM level _____ 25 below 1000, Amplitude Modulation, 400 cycle ref. AM INPUT for 100% Modulation _____ dbm, measured at _____ 400 cycle ref.

MEASUREMENTS IN PERCENT (See notes above #1)

Dist.	50	100	200	400	800	1000	2000	4000	8000	10000	15000
100% Mod.											
50% Mod.											
25% Mod.											

RESULTS (See notes above #2)

Dist.	50	100	200	400	800	1000	2000	4000	8000	10000	15000
AF, 50-15000 Hz, 100% Mod. (100% Mod. & 100% Mod.)											
100% Mod. (100% Mod. & 100% Mod.)	0	0	0	0	0	0	0	0	0	0	0
25% Mod. (100% Mod. & 100% Mod.)	-10	-10	-10	-10	-10	-10	-10	-10	-10	-10	-10

POWER OUTPUT (dbm)

Antenna Type _____ Gain _____ dBS, Power to Antenna _____ Kw
Length Ft. _____ Ft., T.L. Dia. _____ T.L. Wt. _____ T.L. Loss _____ Kw, T.L. dB
Transmitter Output _____ Kw, P.A. BE (dbm) _____ P.A. Input _____ Kw, Sp. _____

POWER OUTPUT (dbm)

Wave meter # _____ Output _____ Kw, Water Cooled Rectifier _____ dbm T in _____ °C, T out _____ °C
Power at 4000 cps (17 inch T in) _____ Kw, Substrate _____ dbm (reflected) _____ °C, T out _____ °C

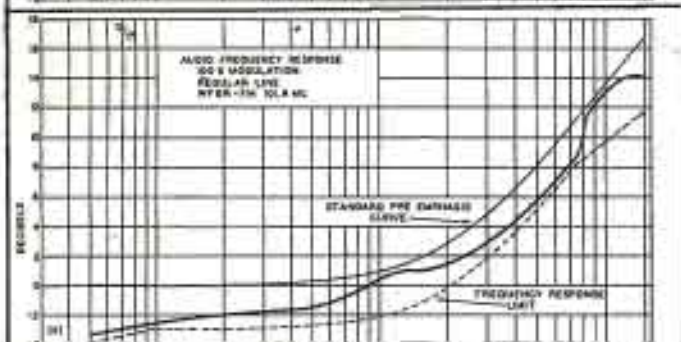
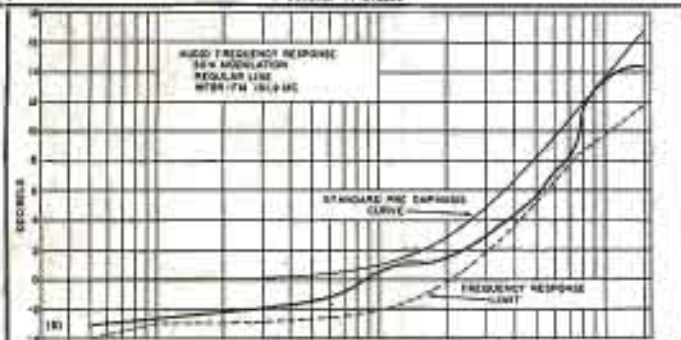
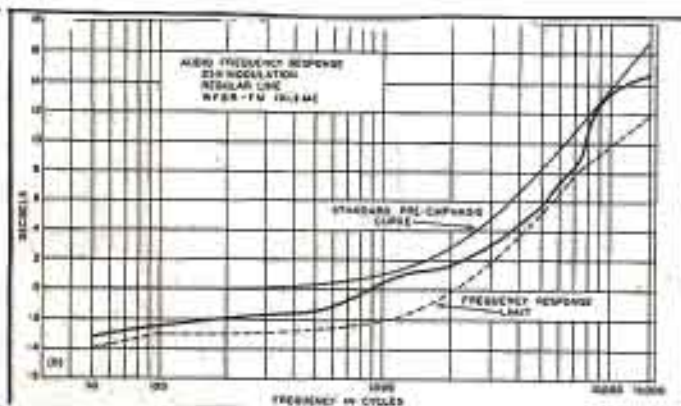

Figures 8 a, b, c and d

Performance curves required by FCC. These are typical curves plotted from measurements taken at WFR-FM, Baltimore, Md.

where: V_{dc} = the rectified dc voltage (M_1)
and V_r = the ripple voltage in dbm

The FCC allows the use of deemphasis between the rectifier and the vu meter.
If there is any appreciable high frequency component to the noise, the use of a deemphasis network will obviously give lower noise measurements, but since

(Continued on page 35)

*The peak voltage required to modulate a carrier 100% is equal to the peak carrier voltage.
**Ref. for Figure 9:
1. RCA WA-26A (RCA 68A oscillator used for response measurements); 2. RCA 89B; 3. RCA 41C; 4. Daven H.; 5. RCA 40 D; 6. Weston 852; 7. RCA 327; 8. Daven; 9. RCA 15B; 10. W. E. 111C; 11. W. E. 12. RCA 86A1; 13. RCA MT-4926A; 14. Daven; 15. RCA BTF-108; 16. G. E. 4 BM-1-A; 17. RCA WM-71A.

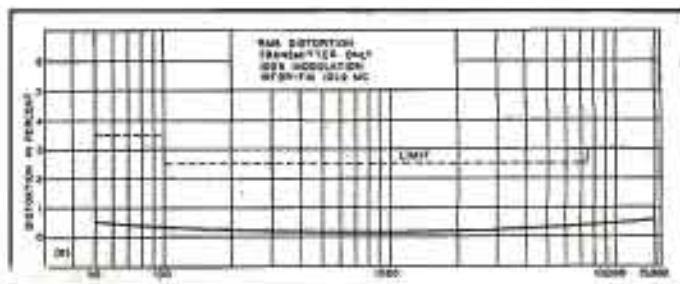
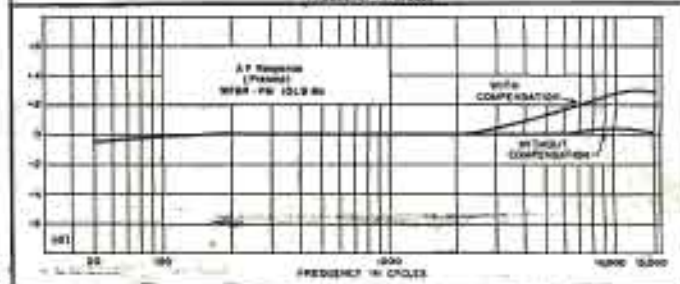
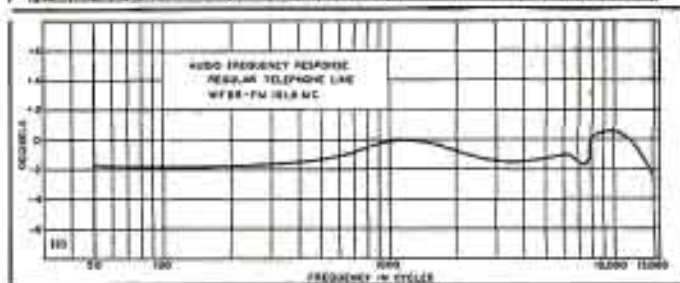
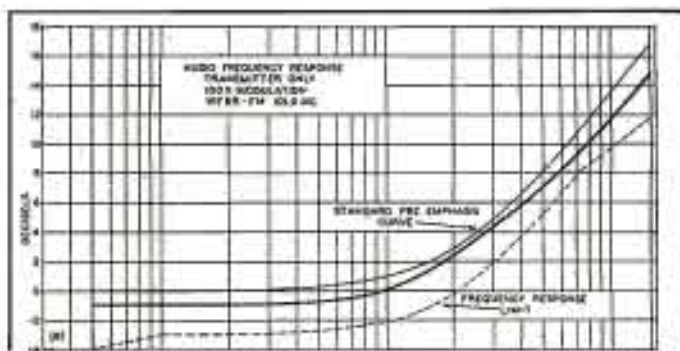

Figure 10 a (above)



Figures 10 b, c and d

Miscellaneous performance curves made from data obtained at WFR-FM. While not specifically required by FCC, similar curves are suggested and should prove useful for station reference purposes at a later date.

Figure 9**

Typical test setup at WFR-FM, including measuring equipment and studio transmitting and audio facilities. Diagrams of this type can be used to report these facilities to the FCC. Item 1 is an audio oscillator; 2, attenuation panel; 3, preamp (studio D); 4, attenuator (studio D microphone, with attenuator set to 10); 5, program amplifier (studio D, with attenuator set to 8); 6, volume indicator meter; 7, bridging coil; 8, attenuator (master gain with attenuator set to 16); 9, line amplifier (No. 3, with attenuator set to 18); 10, Y pad; 11, repeat coil; 12, repeat coil; 13, line equalizer; 14, limiting amplifier (in 18, out 24); 15, pre-emphasis network; 16, attenuator pad (15 db); 17, transmitter; 18, frequency and modulation monitor; 19, distortion and noise meter.

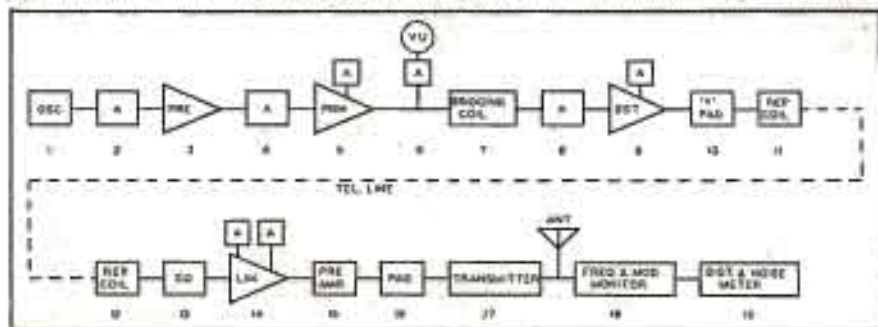

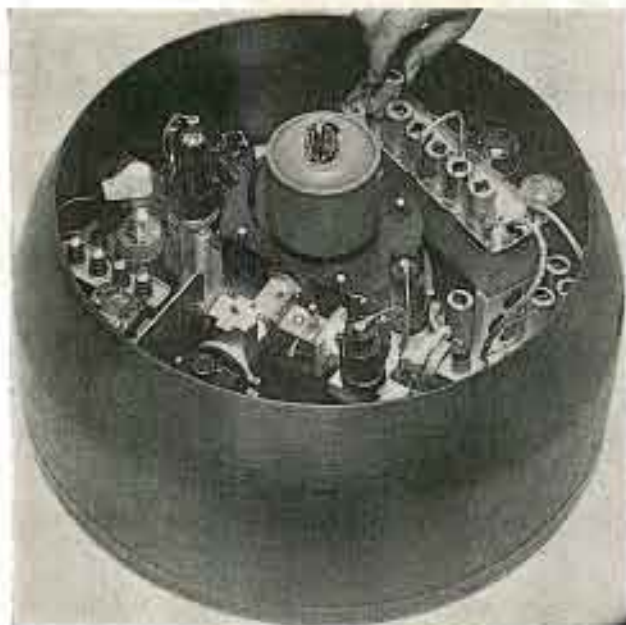

Figure 2
Radar transmitter-receiver unit. (Courtesy Allison Associates)

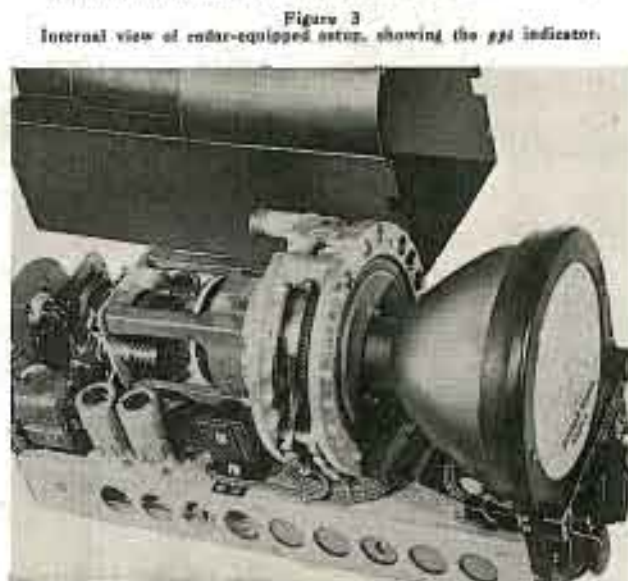

Figure 3
Internal view of radar-equipped astrop, showing the PPI indicator.

Civil Aircraft Radar

ANY RADAR which is to be practical for civil aircraft must of necessity appear to be relatively primitive with respect to the types developed for the military. Instead of a highly precise and complex system costing much payload and high unit cost, the system must be compact, light in weight, dependable in performance by virtue of its relative simplicity and moderate in cost. The initial cost and the loss in payload must be more than met by better and safer navigation and reduced cancellation or deviation in flight schedules.

Basic Radar Characteristics

A typical radar system contains six basic elements (Figure 1):

- (1) *Transmitter* to produce the outgoing signals.
- (2) *Receiver* to receive back the transmitted signals as reflected signals off some distant object.
- (3) *Modulator* to pulse or key the transmitter.
- (4) *Electronic switch* to permit transmission and reception on the same frequency.
- (5) *CRT indicator* to analyze the received intelligence.
- (6) *Antenna assembly* to handle the propagated energy out and back and to control its direction or bearing.

Every radar must comprise a transmitter and a receiver which are tuned to the same-frequency but which are not functioning simultaneously at any instant. The receiver must be inoperative while the short pulse is being transmitted. The transmitter must be inoperative once a pulse (in the order

Part II . . . Equipment Considerations in the 9,000-10,000 Mc Band Where Systems are Extremely Efficient.

by **SAMUEL FREEDMAN**

New Developments Engineer
DeMornay-Budd, Inc.

of a millionth of a second or a micro-second) has been transmitted. Between that time and the beginning of the ensuing transmitted pulse, there must be a sufficient interval to permit the receiver to resume operation and pick up the reflected energy off a distant object. During the relatively long interval between the relatively short

transmitted pulses (a difference of over 1,000 times), the average power of the transmitter (a few watts) can be used to charge a pulsing network so that by breakdown of a high voltage capacitor, a discharge of very high peak power is possible (many kilowatts). The peak power will be equal to the ratio of pulsing interval length to pulsing duration length multiplied by the average power of the transmitter.

Since the wavelength employed is very short (such as 3 centimeters or 1.2") and the antenna is at the focal point of a reflector many times greater in aperture than the wavelength dimensions, the energy is highly concentrated or narrowly beamed. This provides antenna gains in the order of 1,000 times or more for both transmission and reception, since the antenna system is common to both. The result is tremendous instantaneous power equivalence which by conventional radio concepts with non-directive antennas would require billions of watts.

The *minimum range* which a radar can detect cannot be less than the time it takes for a transmitter to send out a pulse and the time that it takes the receiver to get back into operation to receive that pulse. If this consumes

Figure 1
Block diagram of radar setup.
(Courtesy U. S. Coast Guard)

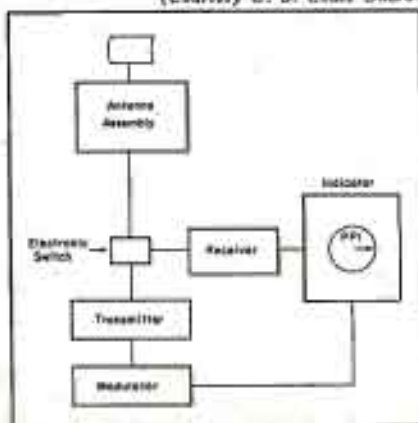

two-millionths of a second (two microseconds), it means that no indication closer than 328 yards can be detected. (The speed of radio or light is 186,000 miles per second or 328 yards per microsecond. Since radar signals are two-way, going out and having to return back, each microsecond of time is considered to be equal to 164 yards. The *crt* indicator is calibrated to show elapsed time between outgoing pulse and returning reflected pulse at 164 yards per millionth of a second.)

The maximum range which a radar can detect is dependent on the transmitter power, amount of antenna beaming, shape and composition of the target and the sensitivity of the radar receiver. Normally, the range is about a full horizon of distance, computing in miles, to 1.4 times the square root of the radar station's antenna elevation in feet plus 1.4 times the square root of the target elevation in feet. In the case of airborne radar, elevations can be very great so that the horizon is not always a limitation. For ranges in the order of 100 miles or more, power of the transmitter, sensitivity of the receiver, reflective qualities of the target and antenna gain become the principal factors.

Civil Aircraft Radar System

In Figures 2 and 3 appear views of a recently developed civil aircraft radar, which features a transmitter, receiver electronic switch and modulator in one housing, located in the upper part of the nose of an aircraft. It connects with a dual rotatable reflector (back-to-back) directly underneath. The reflector system is unique in that two reflectors, instead of the usual one, are employed. This permits scanning detected objects once every 180° of rotation instead of once every 360° of rotation.

The peak power of this radar setup is 35 to 40 kw from a 2J55 magnetron.

Principle of Operation

Since a single repetition rate of 400 pulses of energy at 9,375 mc is used in this system, and the frequency of the input power supply is 400 cycles per second, it is possible to time or synchronize the operation of the entire equipment from the frequency of the input power. The circuit of the modulator which permits such operation is shown in Figure 5. The trigger circuit takes the 400-cycle sine wave and shapes it into a positive trigger pulse for activating the modulator, which utilizes a hydrogen thyatron tube. Since the thyatron is fired in synchronization with the 400 cycles,

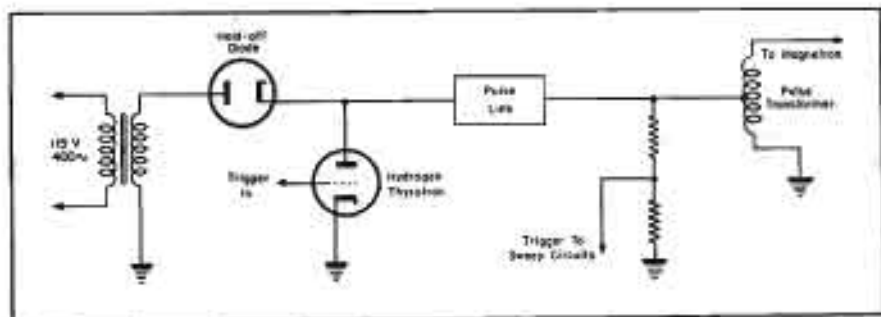

Figure 5
Schematic of the modulator used in the 9375-mc lightweight radar system. (Courtesy Allison Associates)

the pulse line can be charged up on each positive cycle of the power supply and discharged at a predetermined time during the negative cycle. Thus, all high voltage rectifier and filter circuits are eliminated. A hold-off diode tube prevents the charge on the pulse line from leaking off through the power transformer during the negative cycle. When the positive trigger is fed to the thyatron grid, the tube fires and discharges the pulse line. The pulse line thereby delivers a 1.8 microsecond negative pulse to the pulse transformer which steps it up in a ratio of 5:1 and places it on the cathode of the magnetron.

In this civil aircraft radar model, a 2J55 magnetron oscillates at a pulse width of 1.8 microseconds and at a repetition rate of 400 pulses per second. This is achieved at a peak power of about 35 kw at about 9375 mc. This *shf* power is carried from the magnetron through wave guides to the antenna. Since the antenna scanning system consists of two parabolic dishes,

back-to-back, which rotate continuously, an *rf* switch is used to switch the *shf* power so that it is always fed to a dish that is looking at the forward 180°. Thus, a linear scan is accomplished without the use of the common wig-wag type of mechanical motion which causes rapid wear and failure of gears.

Since the same antenna system is used for both transmission and reception, a *duplexer* is inserted in the wave guide to separate the transmitted and received signals. The duplexer consists of two gas switching tubes in a *tr* (transmit-receive) box and *atr* (anti-transmit-receive) box. Both of these tubes are of the broad-band type eliminating many tuning adjustments. The received signals go through the *tr* box into the crystal mixer where they are mixed with a local oscillator signal to produce a 60-mc intermediate frequency. The local oscillator is a reflex klystron tuned to operate 60 mc above the magnetron frequency.

[To Be Concluded in April Issue]

¹Allison.

Figure 4
Block diagram of the Allison radar system.

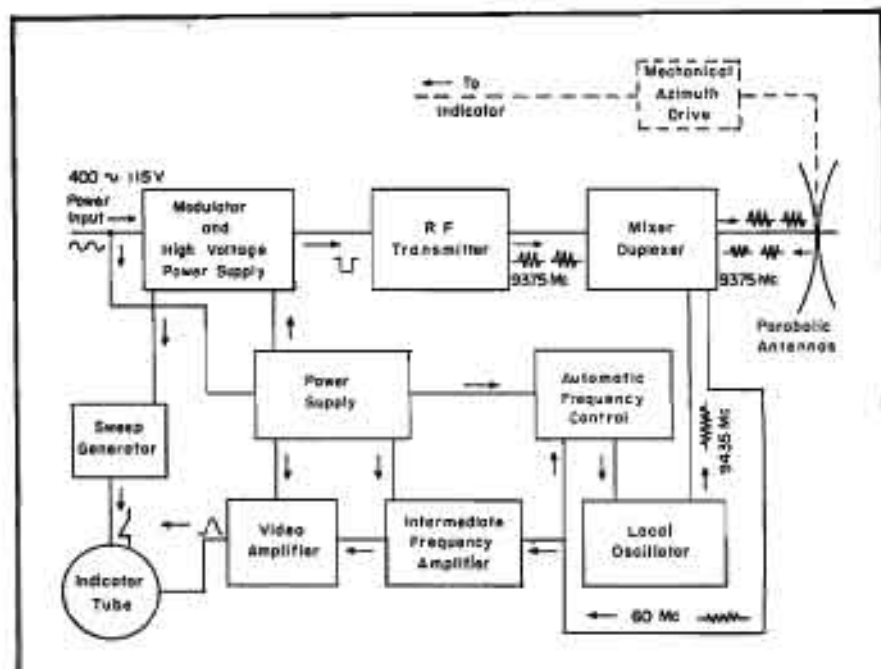

Designed for



Application



74400

The No. 74400
**Shield Can with
Octal Plug-Base**

The versatile No. 74400 unit comprises an extruded rectangular aluminum shield $1\frac{1}{4}'' \times 1\frac{1}{4}'' \times 4\frac{1}{2}''$; a low loss brown phenolic octal plug base to fit, and a base shield to further extend the shielding. Designed for mounting filters, tuned circuits, relays, IF transformers, audio components, complete midge amplifiers or other circuits, etc.

**JAMES MILLEN
MFG. CO., INC.**

MAIN OFFICE AND FACTORY
**MALDEN
MASSACHUSETTS**



NAB Meeting

(Continued from page 7)

president, WSM, Nashville, Tenn., will preside at the pm session on April 7, during which five papers featuring audio will be offered:

AM, FM and TV Audio Measurements; Frank H. McIntosh, consulting radio engineer, Wash., D. C.

Detailed in this paper will be the current FCC audio requirements concerning measurements of gain frequency characteristics, harmonic distortion, and the methods currently used or recommended for their determination. McIntosh will define percentage modulation for both FM and AM transmitters and describe harmonic distortion analysis, both by examination process of individual harmonic components and RMS measurements, using a suitable distortion factor meter and offer practical suggestions for the measurement of these characteristics and requirements for suitable equipment and files to assure acceptance before the Commission.

NAB Recording and Reproducing Standards for Disc and Magnetic Recording; Robert M. Morris, radio facilities engineer, ABC.

This paper will present a brief history outlining the need for and establishment of recording and reproducing standards to facilitate the economical exchange of recorded material among the broadcasters of the United States. Various phases of the problems encountered in arriving at the present standards will be outlined and there will be a discussion of the many yet unresolved problems facing the Recording and Reproducing Standards Committee. The standards thus far agreed upon on magnetic tape and those under consideration also will be discussed.

Magnetic Tape Recording and Reproducing; Dr. S. J. Begun, vice president in charge of engineering, Brush Development Co.

Dr. Begun will analyze the relative performance characteristics of magnetic and disk recording equipment. Reviewed will be fields of application; recording of programs to be transmitted at some later time (time delayed programs); composing a show (editing of programs); and on-the-spot recording (portable equipment).

Properties of Magnetic Tape and Their Relation to Magnetic Recording; Reynolds Marchant, development engineer, magnetic tape equipment, Minnesota Mining & Manufacturing Co.

Marchant will explain the relation of tape properties to recorder design and call attention to the relative importance of various properties. Suggestions will be given for checking the performance of recording equipment, which include, in addition to routine checking of amplifiers and electronic gear checks of head alignment, tape tension, head wear, capstan drive speed, bias adjustment, etc.

A New Portable Audio Amplifier for AM-PM-TV; William W. Dean, audio engineer, broadcast engineering section, G. E.

Described will be a 33-pound ac battery portable remote amplifier, which features a test-tone oscillator for checking line levels.

Friday Morning, April 8

Presiding at this third session will be William B. Lodge, network adviser, NAB engineering executive committee, and vice president in charge of

BIRTCHE
STAINLESS STEEL - LOCKING TYPE

TUBE CLAMPS

Stainless
Steel

Corrosion
Proof



83 VARIATIONS

Where vibration is a problem, Birtcher Locking TUBE CLAMPS offer a foolproof, practical solution. Recommended for all types of tubes and similar plug-in components.

More than three million of these clamps in use.

FREE CATALOG

Send for samples of Birtcher stainless steel tube clamps and our standard catalog listing tube base types, recommended clamp designs, and price list.

THE BIRTCHE CORPORATION
5857 HUNTINGTON DR. LOS ANGELES 32

general engineering, CBS. Featured will be six papers on antennas, tubes, rectifiers and transmitter design:

A Loop-Antenna System for TV Broadcasting; A. G. Kandoian and R. A. Felsenfeld, Federal Telecommunication Labs.

Design of a very broadband triangular stack loop antenna, which features a coaxial diplexing filter which combines the outputs of the transmitters in a single coaxial transmission line, will be described.

A New and Low-Cost TV Transmitting Antenna; M. W. Scheldorf, engineer in charge of research, and Lawrence R. Krabe, engineer, Andrew Corp.

Scheldorf, who will present this paper, will describe a development of a new principle for broadband radiators with elements consisting of multiple rods with a wide variation in lengths assembled in a cone-like shape which uses a single-ended diplexer unit with simple sections of transmission line to interconnect and spaced so to achieve the necessary frequency discrimination with a minimum of physical material and without special intricate features. Krabe will demonstrate the antenna.

Design Problems in Triode and Tetrode Tubes for High Frequency Operation; Dr. Howard Donlitt, development engineer, Machlett Labs.

This paper will detail the adaptation of triode and tetrode switching tubes to power generation in 1000-mc frequency range. The problems of interelectrode capacitance, lead inductance, cathode emission density, and electrode dissipation will be analyzed in relation to fabrication techniques.

Development, Design and Application of Super Power Frequency Modu-

lation; J. E. Young, manager, broadcast transmitter engineering group, RCA Victor.

Young will describe the lab and production design problems which were involved in the processing of a transmitter for operation in the 88-108 mc band. Installation, proof of performance measurements and details of three 50-bw installations which have been completed at WTMJ-FM, WBRC-FM and WMCF will also be discussed.

Automatic Selection of Broadcast Program Circuits; John A. Green, head broadcast engineering department, and Robert D. Essig, engineer, broadcast engineering department, Collins Radio Co.

Green, presenting paper, will describe a new device, *The Autopositioner*, and its relation to broadcast engineering. Green will disclose how fifty program circuits and fifty order wire loops can be switched and controlled from a remote point several miles distant, circuits to be selected can be preset in advance at the control point, and switching occurs when the operate button is depressed. Essig will demonstrate the unit.

High Voltage Metallic Rectifiers Applied to Broadcast Transmitters; Charles K. Hooper, advisory engineer, and Nelson B. Tharp, design engineer, Westinghouse Electric.

Tharp, presenting paper, will reveal the use of metallic rectifiers in AM and FM broadcast transmitters. Data will be offered on the operating characteristics of high voltage selenium rectifiers based on theoretical considerations and actual station experience. Efficiency, regulation, aging effects, operating features and costs of metallic rectifiers as compared with tube rectifiers, will be discussed.

Afternoon Session, April 8

J. R. Poppele, member, NAB engineering executive committee and vice president and chief engineer of WOR, will preside at the second pm meeting, during which film pickup, projector, kinescope recording, video scanners, TV studio lighting and TV receiving antennas will be discussed:

Kinescope Film Pickup Systems; Harry R. Smith, head of special projects group, TV transmitting equipment division, Allen B. Dumont Labs.

Smith will present a description of Dumont film pickup systems starting with the optical image which is projected on the kinescope mosaic and finishing with the video output signal which is sent to the master control equipment.

The Improved 16-MM Synchronite Projector; H. B. Fancher, television engineer, TV engineering section, G. E.

This talk will be concerned with a shutterless projector especially designed for TV service which uses pulsed light from a krypton flash lamp controlled by the sync generator, permitting transmission of single frames at full intensity. Optical system consists of a separate lamp housing with precision mounting and control for the flash lamp reflector and lens system projector head using a standard pull down ratio with an extremely fast starting and stopping time.

Kinescope Recording; Ralph V. Little, Jr., supervisor, theatre TV engineering section, RCA Victor.

Little will describe the film recording camera, which must be specially designed for the purpose because of the difference between the TV system frame frequency of 30 per second and conventional motion picture frame frequency of 24 per second. Discussed will be the

(Continued on page 30)

Broadcast Engineers Helped Design it!

Network Shows Use it!

Now Compare it with any in your Studios!

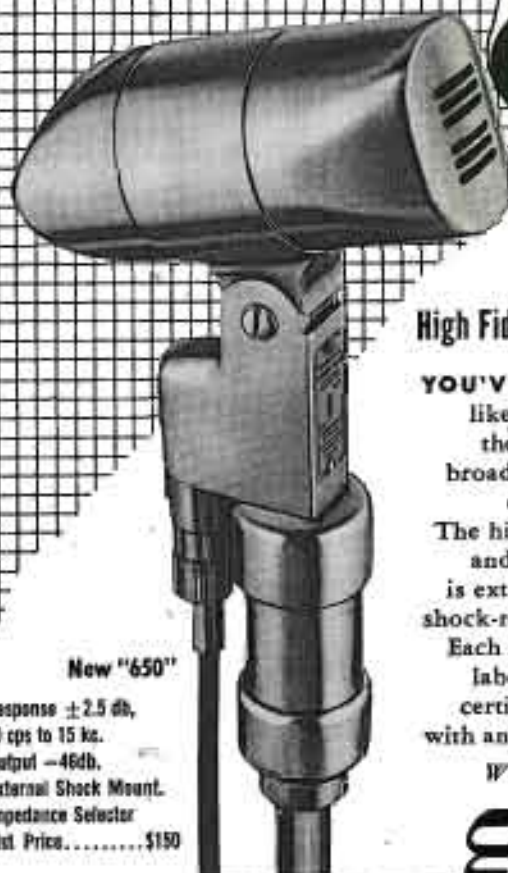

New "650"

Response ± 2.5 db,
40 cps to 15 kc.
Output -46db.
External Shock Mount.
Impedance Selector
List Price.....\$150

Nothing like  High Fidelity Broadcast Dynamics

YOU'VE WANTED microphones like these! Performance meets the highest FM and AM broadcast standards. The bass end is smooth and flat. The highs are particularly clean and peak-free. Construction is extremely rugged and shock-resistant. Omni-directional. Each microphone individually laboratory calibrated and certified. Try one. Compare it with any mike in your own studios.

Write for full facts today!

Electro-Voice

ELECTRO-VOICE, INC., BUCHANAN, MICH.
Export: 13 East 40th St., New York 16, U.S.A.
Cables: Arlab



New "645"

Response ± 2.5 db,
40 cps to 15 kc.
Output -50 db.
External Shock Mount.
Impedance Selector.
List Price.....\$100



The "635"

Response ± 2.5 db,
60 cps to 13 kc.
Output -53 db.
Impedance Selector.
For Hand or Stand.
List Price.....\$80



MAXIMUM PERFORMANCE

Jim Lansing Signature Speakers will provide an almost unbelievable realism. The experience gained through a quarter of a century of leadership in the sound reproduction field has gone into their development and design. For maximum dynamic range and frequency response compare Jim Lansing Signature Speakers before you buy.



MODEL D-133



MODEL D-1002
TWO WAY SYSTEM

Designed especially for FM Monitoring and high quality home sound reproduction. Housed in a beautiful cascade type cabinet.

Write for Descriptive Catalog containing complete specifications.

SEE YOUR JOBBER OR
SEND DIRECT



**JAMES B. LANSING
SOUND INC.**

7801 HAYVENHURST AVENUE
VAN NUYS, CALIFORNIA

NAB Meeting

(Continued from page 29)

means by which the two systems are reconciled and how the equipment may be used in either the single (combined recording) or the double (separate sound recording) methods.

A Cathode-Ray Tube Video Scanner; Roger D. Thompson, project engineer, transmitter division, Allen B. DuMont Labs.

Thompson will analyze the theory of the scanner and a practical approach to circuits for producing the raster, correcting for cut persistence, and gamma correction. Although the unit described was designed to use 2 + 1/2" glass slides, versatility has been achieved by an automatic fade and slide change sequence for artistic transition.

General Purpose Television Studio Lighting; Richard Blount, engineer, lamp department, G. E.

Blount will cover typical equipments suitable for the various lighting tasks, and calculations completed to predict the number of units needed to provide the desired footcandle level. He will show a layout arrangement in a general utility studio.

Television Receiver Antenna Design and Installation; ye editor.

In this paper LW will discuss the importance of the receiving antenna to the broadcaster and how to familiarize the Service Man with the particular types of antennas to use for maximum pickup of TV stations. Also detailed will be circuits and methods to use in eliminating ghosts and interference caused by FM stations, FM receivers, TV receiver local oscillators, TV receiver video circuits, TV receiver sweep circuits, power diathermy equipment, electromedical and industrial apparatus, ham rigs, man-made devices. LW will also analyze fringe-area pickup; applying special types of antennas such as rhombics and yagis; dealer setups using many receivers for demonstrations from a single antenna; tricks of the trade involving correct matching for 75-ohm unbalanced and 300-ohm balanced lines, attenuation pads, divider and decoupling networks for II and III antenna systems, etc.

Saturday, April 9

At this, the fifth and final meeting, will be offered papers on personnel training, facsimile and uhf progress. In addition, there'll be the annual FCC-Industry round-table session. Presiding will be Oscar C. Hirsch, member, NAB engineering executive committee, and owner-manager, KFVS, Cape Girardeau, Mo.:

Training of AM and FM Engineering Personnel for TV Operations; Whitney M. Baston, technical training director, NBC.

This paper will outline a course of instruction designed to train engineers for the practical application of their electronic knowledge. It is based upon the assumption that the individual engineer has completed at least two years of academic study. The methods of instruction, selection of engineers, instructor qualifications and benefits derived will be discussed in some detail.

Recent Advances in Broadcast Facsimile; John V. L. Hogan, president, Radio Inventions, Inc.

Hogan will discuss improvements in facsimile transmission within FCC Standards, and the importance of improved photographic reproduction, high definition and high speed. The latest developments in multiplex facsimile which maintain simultaneous transmission with regular sound programs will be outlined.

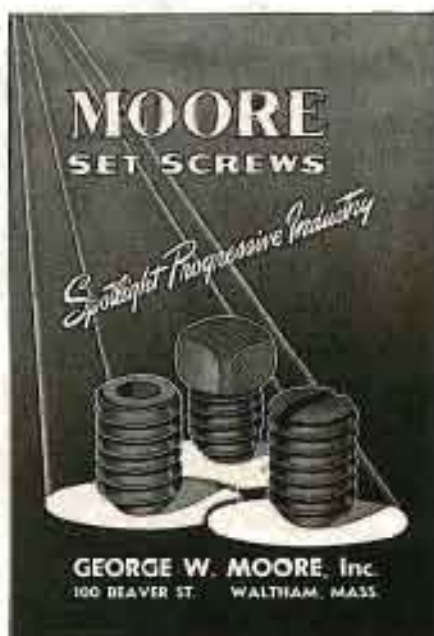

A Progress Report on Ultra High Frequency Television; Dr. Thomas T. Goldsmith, Jr., director of research, Allen B. DuMont Labs.

Dr. Goldsmith will discuss the utilization of the uhf channels extending from 475-899 mc. and detail the propagation problems in the uhf band, possible allocation of frequencies to uhf stations, present status of transmitting and receiving equipment, performance, time schedules and cost, bandwidths, black and white, color, etc.

FCC-Industry Roundtable; Royal V. Howard, NAB, Moderator.

For the Commission

John A. Willoughby,
FCC acting chief engineer
Edward W. Allen, Jr., chief,
Technical Information Division
James E. Barr, chief,
Standard Broadcast Division
Cyril M. Braum, chief,
FM Broadcast Division
Edward W. Chapin, chief,
Laboratory Division
Curtis B. Plummer, chief,
TV Broadcast Division

For Industry

A. James Ebel, WMBD, chairman
NAB engineering executive committee
E. K. Jett, WMAR; K. W. Pyle,
KFBI; and O. W. Townner,
WHAS, members of the NAB
engineering executive committee
E. M. Johnson, MBS, network adviser
NAB engineering executive committee
Frank Marx, ABC, network adviser
NAB engineering executive committee

WMAL-TV Mobile Unit

(Continued from page 11)

tion on remote pickups, every reasonable consideration was given their comfort and welfare. Foam rubber construction chairs are provided for the video operators and the producer. To combat the extremes of weather, a $\frac{3}{4}$ -hp air conditioning unit, and a generous sized gasoline-burning heater are built in. Forced ventilation keeps the air fresh at all times. The interior is lined with fibreglass insulation, covered with perforated aluminum sheets, thus providing some acoustic treatment along with a surface which is easy to keep clean. To eliminate tripping hazards, and provide a clean, durable floor, all interconnecting wiring is concealed in ducts under the asphalt-tiled floor.

Maintenance and Service

It is hoped that we never have equipment trouble while on the air, but occasionally a failure does occur. A number of features to expedite emergency service have been incorporated in the design of the mobile unit.

The power supplies and synchronizing units were mounted in a separately ventilated cabinet rack, with roll-out shelves. Tubes or fuses in any unit can be changed easily in a matter of seconds. A complete set of pre-tested tubes are available in the tube drawers, protected in transit, but ready for instant use when needed. Fuses for the power panel are kept in a compartment above the panel.

For those repairs requiring replacement of component parts, work-bench space is available on top of the compartment where the cameras and viewfinders are stored. Here, test equipment and soldering iron, etc., will be found ready for use.

While the features of our mobile-unit design lend themselves ideally to operating problems encountered in and about Washington, it is realized that other stations in different parts of the country may have problems requiring special treatment. Further, it is felt that a process of development in this field is a never-ending task, which must be pursued until refinements of mobile units and operations reach a stage where more and better *on-the-spot* pickups are economically practical.

In conclusion, we should like to give credit to those members of the WMAL-TV engineering staff, whose previous operating experience and constructive suggestions helped to guide the evolution of this mobile unit from the preliminary design, through to the final interior wiring and outfitting.



New

**Andrew MULTI-V
FM ANTENNA GIVES YOU
GREATEST POWER GAIN
PER DOLLAR!**

Only \$250⁰⁰ side-mounted;
\$435⁰⁰ top-mounted



Here is why the new
ANDREW Multi-V is your
best FM antenna buy:

- ★ Power Gain of 1.6
- ★ 10 KW Power Capacity
- ★ Top or side mounting with equal ease
- ★ Weighs only 70 pounds side mounted; 450 pounds top mounted
- ★ Low initial cost—low maintenance
- ★ Omnidirectional pattern
- ★ Factory tuned to required frequency — no further adjustments required
- ★ Single feed point — single transmission line
- ★ Built to withstand winds of over 100 MPH
- ★ Antenna can be completely assembled on the ground
- ★ Insulation resistance of feed line can be tested without climbing tower

WANT THE MOST EFFICIENT
LOW-COST FM ANTENNA FOR
YOUR STATION? BUY THE
ANDREW MULTI-V!

WRITE FOR BULLETIN 86
for complete details

to-day

Andrew
CORPORATION
111 EAST MAIN STREET, CHICAGO 19

TRANSMISSION LINES FOR AM-FM-TV • ANTENNAS • DIRECTIONAL ANTENNA EQUIPMENT • ANTENNA TUNING UNITS • TOWER LIGHTING EQUIPMENT • CONSULTING ENGINEERING SERVICE

Eastern Office: 421 Seventh Ave., N.Y.C.

Use ICA TELEVISION, RADIO AND ELECTRONIC PARTS FOR PEAK EFFICIENCY



**OVER 2000
TESTED STOCK ITEMS**
RANGING FROM
**CHASSIS, CABINETS
AND ANTENNAS**
To Television Accessories

ICA produces the nation's greatest variety of top quality television, radio and electronic parts. Pioneer and developer of countless standard equipment, ICA's wide range of precision instruments meet almost all needs.

Thousands of industrial manufacturers have found ICA the right answer to their problems. They know that for dependability, quality, price and all-around performance, you can't beat ICA.

If it's a special item, ICA's vast manufacturing facilities are available. Send your specifications for quick estimate.

Catalog available on request.



insuline CORPORATION OF AMERICA

INSULINE BUILDING • 36-02 35th AVENUE • LONG ISLAND CITY, N. Y.
West Coast Branch and Warehouse: 1325 South Flower Street, Los Angeles, Calif.
Exclusive Canadian Sales Agents:
CANADIAN MARCOINI COMPANY • Montreal • Vancouver • Winnipeg • Toronto • Halifax • St. John's (Nfld.)

HERE'S BIG HELP IN TERMINAL WIRING!

The New JONES FANNING STRIP

Connections are made through Fanning Strip, on bench or anywhere apart from barrier strip, and quickly slipped into assembly.

Use with Jones Barrier Terminal Strips, Nos. 141 and 142, for 1 to 20 terminals.

Simplifies soldering. Insures correct connections. Saves time. Ideal for harness or cable assembly. Brass terminals, cadmium plated. Bakelite mounting. Send for complete data.



9-141
Barrier
Strip

9-142
Fanning
Strip. Pat.
applied
for.

The correct wire to
correct terminal
—every time!

HOWARD B. JONES DIVISION

3460 W. GEORGE ST. CHICAGO 18, ILL.

ZOPHAR WAXES COMPOUNDS and EMULSIONS

FOR
INSULATING and WATERPROOFING
of ELECTRICAL and
RADIO COMPONENTS

Also for
CONTAINERS and PAPER
IMPREGNATION

FUNGUS RESISTANT WAXES

ZOPHAR WAXES and COMPOUNDS

Meet all army and navy
specifications if required

Inquiries Invited

ZOPHAR MILLS, INC.
FOUNDED 1846

122-26th ST., BROOKLYN, N. Y.

Telephone Recordings

(Continued from page 12)

extension telephone in one of the studios.

The connector itself is mounted with your other speech equipment, either in the telephone equipment room or near one of the racks. The output of the connector is brought to a special plug,* to which is connected 110 volts ac, the start recording control, and the 600-ohm speech output of the recorder.

The 600-ohm line is about the right level for the remote channel input of the console. This is mixed with the microphone output and fed through the audition channel to the recorder, using the setup shown in the block diagram. Very satisfactory recordings can then be made by leaving the announcer's mike gain at some predetermined level and riding gain by turning down the volume of the remote channel whenever the local announcer is talking. This is simpler than it sounds and eliminates the rasping quality which you would get when you allow the local telephone's output ride through on the recording.

If a tape recorder is used instead of a disc recorder to record the interviews, you have the freedom of rearranging and editing the material with scissors and scotch tape before presentation on the air. This takes a little practice but it isn't too difficult. Pops caused by splices can be eliminated by cutting the tape diagonally while splicing as shown in the drawing.

You will notice a *beep* every fifteen seconds on the recording. This is required by FCC regulations to warn the party on the other end of the wire that he is being recorded. Filters are already incorporated in the connector box but enough of the tone will still leak through to be irritating on the air playback.

The circuit diagram shows the connections to the recorder together with a tone filter which may be used with it. Since this filter has a very sharp rejection slot, it will remove most of the tone without affecting the rest of the connector's output. It will not be entirely effective since the 1,400-cycle *beep* is loaded with harmonics.

Much time can be saved in the initial adjustment of the filter if an audio oscillator is heated with the *beep* of the connector, and then used for subsequent adjustments of the bridge. The output of the oscillator is then inserted at terminals 3 and 4 of the plug and the output of the bridge is connected to a db meter with an amplifier, if necessary, to make the meter more sensitive. The console audition *vw* meter and channel amplifiers are excellent for this purpose.

*Cannon SK-M7-21C— $\frac{1}{2}$ plug

News Briefs

PERSONALS

B. T. Setchell is now president and chief electronic engineer of Setchell Carlson, Inc., New Brighton, Minn. A. P. Setchell is vice president and office manager; D. C. Carlson, secretary-treasurer and chief mechanical engineer; D. L. Johnson, sales manager.

H. E. Taylor is now manager of the Allen B. DuMont Lab. Television Transmitter Division, and E. E. Kessler, assistant manager.

Other appointments in the new division are: Dr. W. H. Mulligan, engineering manager; C. E. Greenwood, manufacturing manager; M. Harris, production control manager; and P. F. Brown, quality control manager.

The Television Transmitter Division occupies its own building at 42 Harding Avenue, Clifton, N. J.



H. E. Taylor

Rogey M. Wise and his staff of Roger M. Wise, Inc., have joined the technical staff of Philco.

The personnel of the Wise organization, formerly located at Rockville Center, N. Y., will occupy new laboratories in the plant of the Lansdale Tube Co.

Among those in the Wise firm who joined Philco are H. Kenneth Ishler, vice president in charge of engineering for Roger M. Wise, Inc.; Joseph J. Grabiec; E. J. Hoffman, formerly manager of a Sylvania subminiature tube plant; and Dr. Philip Hambleton and Stuart L. Parsons.

Harold M. Holmark has been named chief engineer for Doolittle Radio, Inc., Chicago.

Allred S. Gartner has joined Cornell-Dubilier as assistant to Arthur Williams, sales manager of the Capacitor-Manufacturing Division.

LITERATURE

Electro-Voice, Inc., Buchanan, Mich., has released a bulletin, No. 144, with data on dynamic microphones developed for FM and AM broadcast service.

Bulletin also illustrates and describes the E. V. model 425 shock-proof desk stand.

Chicago Transformer Division, Essex Wire Corp., 390 W. Addison St., Chicago 18, Ill., have prepared a 4-page catalog describing a line of television transformers.

Included in the line are television power transformers, vertical blocking oscillator transformers, vertical scanning output transformers, and a horizontal scanning output transformer.

Cornell-Dubilier has released a 36-page motor-starting and motor running capacitor catalog, No. 163.

Eight sections cover: Motor part numbers (alphabetical listing); motor part numbers (numerical listing); cross index of C-D replacements (numerical listing); replacements; technical information; C-D catalog listing; interference filters; service miles.

Kellogg Switchboard & Supply Co., Chicago, have prepared a 204-page general catalog, No. 11, detailing manual and relaymatic switchboards, telephones and associated apparatus, component parts, voice repeaters, carrier systems and supply items ranging from telephone poles, batteries, wire and cable, to linemen's tools. More than 1,000 illustrations are used and the edition is cross-indexed.

The Gates Radio Co., Quincy, Ill., have published a booklet entitled *Standing Wave Ratio in the FM Broadcast Band*.

Prepared by H. E. Parker, the booklet defines standing waves and describes detrimental effects of standing waves, power losses in transmission lines, mismatch, errors introduced in the *rf* output meter reading, antenna terminations and standing wave measuring methods.

Choice of 626 Tubular Resistor Values

IN STOCK

Hundreds of other Stock Types, sizes and values!

**the Variety! . . . the Range! . . . the Quantity!
Ready to Meet Your Needs Quickly!**

More Ward Leonard wire-wound resistors have been produced and used over more years than any other make. And records show that quite often a *stock unit* as the *perfect answer* to many an industrial need . . . for *application*, for *performance*, for *economy*, for *quick delivery*. For example: there are 626 Vitrohm tubular stock values in fixed and adjustable types . . . and many others . . . promptly available! It pays to check into them . . . for *your requirements*.

Contact your local Ward Leonard Authorized Industrial Distributor. Send now for handy Stock-Unit Catalog D-130

Radio and Electronic Distributor Division
WARD LEONARD ELECTRIC CO.
53-M West Jackson Blvd., Chicago 4, U. S. A.



The sign of a Ward Leonard Authorized Industrial Distributor

WARD LEONARD

RESISTORS • RHEOSTATS • RELAYS • CONTROL DEVICES

WHERE BASIC DESIGNS ARE RESULT-ENGINEERED FOR YOU

52 VANDERBILT AVENUE
NEW YORK 17, N. Y.

Group Subscription Plan

Saves Fifty Per Cent of the Yearly Subscription Price if Four or More Subscriptions (Including Your Own) Are Properly Entered on This Form.

1 Year — \$1.00
2 Years — \$2.00



COMMUNICATIONS
A MONTHLY PUBLICATION
OF THE NATIONAL ASSOCIATION
OF BROADCAST ENGINEERS

Please enter annual subscriptions (12 issues) for each of the undersigned for which payment is enclosed at the rate of \$1.00 each. (This rate applies only on 4 or more subscriptions when occupations are given.)

Name

Address

City-State

Occupation

Employed by

Nature of Business

(State if Manufacturer, Broadcast Station, etc.)

Your Title

Your Department

Name

Address

City-State

Occupation

Employed by

Nature of Business

(State if Manufacturer, Broadcast Station, etc.)

Your Title

Your Department

Name

Address

City-State

Occupation

Employed by

Nature of Business

(State if Manufacturer, Broadcast Station, etc.)

Your Title

Your Department

Name

Address

City-State

Occupation

Employed by

Nature of Business

(State if Manufacturer, Broadcast Station, etc.)

Your Title

Your Department

Business or professional classifications are required to complete our records. Each subscriber should write one of the following classifications in space indicated. Use separate sheet of paper for additional names.

CHIEF ENGINEER ENGINEER EXECUTIVE
PURCHASING AGENT DEPARTMENT MANAGER

State your classification if not listed.

This Group Sent In By—

Name

Address

The Industry Offers

HEWLETT-PACKARD MICROWAVE POWER METER

A microwave power meter, model 430A, designed to automatically indicate power developed in a standard barretter, has been announced by the Hewlett-Packard Co., 355 Page Mill Road, Palo Alto, Calif. Power level is read directly on a 4" square meter face.

Meter consists of an ac bridge, one arm of which is a barretter. The bridge is in balance with zero rf power in the barretter. An rf power is applied to the barretter, an equivalent ac (audio) power is automatically removed. Thus the bridge remains in balance. A rotor reads the change in audio power level. This meter, calibrated in milliwatts gives a direct indication of the rf power in the barretter.

The indicating meter is calibrated in dbm in addition to the linear milliwatt calibration.



PRESTO REPRODUCERS

Reproducers for the lp and lateral recordings have been announced by Presto Recording Corp., P. O. Box 500, Hackensack, N. J.

One model, the 153-M, for microgroove recordings consists of the arm, head piece, cartridge, rest, and compensating network with four position switch.

Another model, the 153-R, is identical but is for standard lateral recordings.

The cartridge is a Pliskering with diamond point stylus of either one mil or 1.5 mil tip radius for microgroove or regular type recordings respectively.

Accidental damage to the diamond stylus is minimized by a set screw limiting the downward swing of the arm.

The compensator network and switch provide proper characteristics for reproducing flat recordings, 78 rpm phono records, NAB recordings, and recordings requiring a large roll off at the high end. The frequency response of the compensator in the various equalizer positions is said to be practically unaffected by the value of the terminating load impedance over a range of 100 ohms to high impedance.



G-R POWER SUPPLY, AMPLIFIER, AND OSCILLATOR LAB. INSTRUMENTS

A line of basic, unit-type laboratory instruments has been developed by the General Radio Company, 275 Massachusetts Ave., Cambridge 39, Mass.

Three units are now available: 1-watt amplifier of 45-db gain, covering the range from 20 cycles to 200 kc; oscillator, with plug-in tuning units, operating from 400 cycles to 80 mc; and a small ac power pack that plugs into either the oscillator or the amplifier.

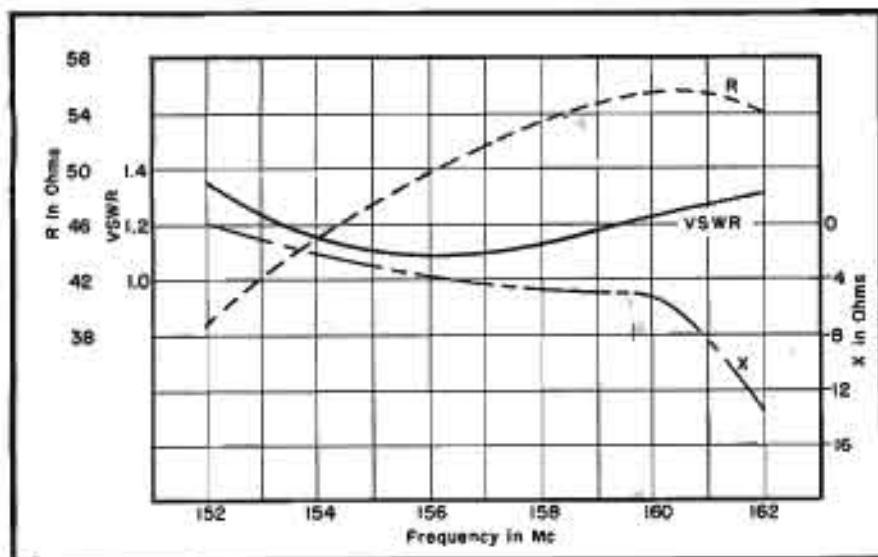

Figure 13
R, X and VSWR for RG-17/U cable, with adapter effects included.

Directional Antenna

(Continued from page 16)

from being swung out of position by wind.

The antenna is constructed almost entirely of aluminum. Reflector elements are $\frac{3}{8}$ " tubing, and are inert-atmosphere arc welded to the supporting aluminum channels. The dipole is made of aluminum angle. The insulator that supports one of the dipole arms is pinned to prevent turning. The other dipole arm is connected directly

to the supporting structure, as it was found unnecessary to make any balance-to-unbalance conversion provisions.

References

- (1) J. D. Kraus, *The Corner Reflector Antenna*, Proc. IRE, Nov. 1940.
- (2) F. E. Terman, *Radio Engineers' Handbook*, First Edition, pp. 818-821; 1943.
- (3) A. H. Ford, Kandoian, *Ultrahigh-Frequency Loop Antennas*, AIEE Transactions; Vol. 59, 1940.

FM Measurements

(Continued from page 25)

the AM noise is normally made up almost entirely of low frequency hum, it will not be affected by the deemphasis circuit. Although the deemphasis is not shown in the circuit of Figure 3, it may be added provided its insertion loss is taken into consideration when making the calculations.

Data Required by the FCC

A copy of the data taken for these measurements, together with curves on distortion and frequency response and brief description of the measuring techniques, should be attached to Form 302 when applying for a license.

There are many ways in which this information can be submitted. The important thing is to make sure that all the data required by the FCC is included. It is suggested that at least the following be included in the report. (See typical forms shown in Figures 6 and 7).

- (1) General information as to the conditions under which the tests were made, such as:
 - (a) Date of making measurement.
 - (b) P_a plate voltage, plate current and grid currents.
 - (c) Transmitter power output.
 - (d) Effective radiated power.
 - (e) Signature of engineer making measurements.
- (2) Data on a_f response measurements.

(3) Data on harmonic distortion measurements.

- (4) Data on carrier noise (FM).
- (5) Data on carrier noise (AM).
- (6) The following curves plotted from the foregoing data (see Figures 8a, b, c and d for a typical set of curves).

- (a) Overall frequency response at 100% modulation.
- (b) Overall frequency response at 50% modulation.
- (c) Overall frequency response at 25% modulation.
- (d) Overall distortion at 100%, 50% and 25% modulation.

(7) Description of measuring equipment, studio and transmitter audio facilities, and measuring techniques. This can best be covered by suitable block diagrams similar to the type shown in Figure 9, together with any explanatory notes which may be required to make the information clear. A block diagram and description of the method used to measure AM noise should also be included.

Although not specifically required by the FCC, it is suggested that, for record purposes, frequency response and distortion measurements be made on the transmitter alone, and that frequency response measurements be made on such items as telephone lines and compensated pre-amplifiers. This information may be very useful at a later date when these proof-of-performance measurements are repeated.

[Appendix data 17, 2, 3 and 4] will appear next month.]

MEASUREMENTS CORPORATION Model 59



2.2 mc.
to
400 mc.

MEGACYCLE METER

Radio's newest, multi-purpose instrument consisting of a grid-dip oscillator connected to its power supply by a flexible cord.

Check these applications:

- For determining the resonant frequency of tuned circuits, antennas, transmission lines, by-pass condensers, chokes, coils.
- For measuring capacitance, inductance, Q, mutual inductance.
- For preliminary tracking and alignment of receivers.
- As an auxiliary signal generator; modulated or unmodulated.
- For antenna tuning and transmitter neutralizing, power off.
- For locating parasitic circuits and spurious resonances.
- As a low sensitivity receiver for signal tracing.

MANUFACTURERS OF
Standard Signal Generators
Pulse Generators
FM Signal Generators
Square Wave Generators
Vacuum Tube Voltmeters
SWR Ratio Meters & Field Strength Meters
Capacity Meters
Megohm Meters
Phase Sequence Indicators
Television and FM Test Equipment

SPECIFICATIONS:
Power Unit: 5 1/2" wide,
6 1/2" high, 7 1/2" deep.
Oscillator Unit: 3 1/2" diameter, 2" deep.

FREQUENCY:
2.2 mc. to 400 mc.
seven plug-in coils.

MODULATION:
CW or 120 cycles; or external.

POWER SUPPLY:
110-120 volts, 50-60 cycles; 20 watts.

MEASUREMENTS CORPORATION
BOONTON NEW JERSEY

GLASOHMS

MIDGET POWER RESISTORS

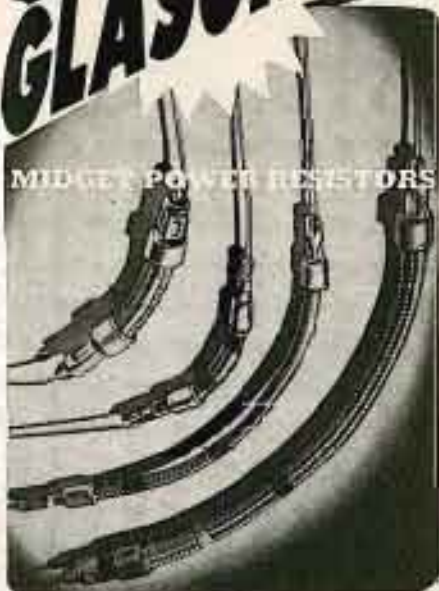

★ Exclusively Clarostat! These flexible glass-insulated wire-wound midget resistors spell tougher components in tighter places.

Fibre-glass core and fibre-glass braided covering. Nothing to char or burn. Ideal for point-to-point wiring. Also used as miniature heating elements in longer lengths.

Series FXG: 1 watt, ¼ ohm to 750 ohms, per winding inch. Series FYG, 2 watts, ½ ohm to 1500 ohms, per winding inch. Patented "Cinch-Grip" ferrules and 2" pigtail leads, standard.

Engineering Bulletin 105 on request. Also sample. Let us quote on your needs!

CLAROSTAT

Controls and Resistors

CLAROSTAT MFG. CO., Inc., Dover, N. H.

In Canada: CANADIAN MARCONI CO., Ltd. Montreal, P.Q., and branches

Last Minute Reports...

A FIVE POINT program to lift the TV station freeze has been submitted by the RMA to the FCC. RMA proposed that, where practical without undue interference, the present twelve *w/f* channels be used in those areas where stations are now operating or are under construction and the use of these channels be extended to other areas as soon as possible; the necessary *w/f* channels (a minimum of four per service area) be utilized so that cities capable of supporting TV and not having any or adequate *w/f* channels could have competitive service; assignments be set up so that *w/f* and *w/f* coverage will provide a minimum of overlap; a *w/f* allocation plan be released promptly to permit establishment of additional *w/f* stations even though the final allocation details for *w/f* may not be complete; and the *w/f* standards be used in the *w/f* band. RMA indicated that propagation data including information on the sync system is adequate for the release of a *w/f* allocation plan. . . . Dr. Frank G. Back has become a consultant for ABC and will assist in the establishment of new standards for TV lighting, lenses, and utilization of camera equipment, with research being conducted at the ABC TV Center at 7 West 66th Street, New York City. Devices developed as a result of Dr. Back's research will be made available first to the ABC network and then to the TV industry generally. . . . E. H. Vogel, manager of marketing for G. E., predicted recently that communications equipment sales in '49 should reach \$23,500,000. . . . The engineering development and model shop facilities of the instrument division of Allen B. DuMont Labs, 1000 Main Avenue, Clifton, New Jersey, have been made available to industry for development, design and construction of special cathode-ray instruments. . . . A TV center is being designed for WBNT-TV in Columbus, Ohio. Center will house studio and transmitter for the TV system and transmitter space for WELD-FM. . . . R. S. Yeandle, G. E. TV engineer, is now on a six week tour of South America to encourage adoption of U. S. television standards. . . . TV reception acknowledgments are being mailed out by KPIX, San Francisco. A card in two colors, the reception report, contains a personalized thank you from Philip G. Lasky, general manager of KSFO and KPIX. . . . NBC has filed an application for a 529-mc transmitter to be erected in the vicinity of Bridgeport, Connecticut, for *w/f* testing. An effective radiated power of between 15 kw and 20 kw is expected to be available. . . . William E. Neill, formerly of WFIL-TV, is now a sales engineer in the television and microwave engineering department of Raytheon. . . . WKTU are the new call letters of the Copper City Broadcasting Corp. TV station in Utica, New York, which will soon be on the air on channel 13. Antenna will be mounted atop a 473' tower on Smith Hill near Utica. . . . The Bureau of Standards have prepared a new international temperature scale, the first revision of the scale since its adoption twenty-one years ago. . . . WHEN, the Meredith Syracuse Television Corp. station in Syracuse, New York, has become a member of the TBA. E. T. Meredith and Bill Eddy are official reps for the station t TBA.

ADVERTISERS IN THIS ISSUE

COMMUNICATIONS INDEX

MARCH, 1949

ANDREW CO.	31
Agency: Huston Brown, Advertising	
BELL TELEPHONE LABORATORIES.....	6
Agency: N. W. Ayer & Son, Inc.	
BENDIX AVIATION CORP. RED BANK DIV.	Back Cover
Agency: MacFadden, John & Adams, Inc.	
BIRCHER CORPORATION	28
Agency: W. C. Jeffries Co.	
J. H. GUNNELL & CO.	Inside Front Cover
Agency: J. H. Tundo	
CLAROSTAT MFG. CO., INC.	26
Agency: Austin C. Leachman & Staff	
THE CLEVELAND CONTAINER CO.	17
Agency: The Heblitz Service Co.	
ALLEN B. DuMONT LABORATORIES, INC.	5
Agency: Austin C. Leachman & Staff	
ELECTRO-VOICE, INC.	29
Agency: Henry H. Tullis, Advertising	
GENERAL RADIO CO.	Inside Back Cover
Agency: The Santa Press	
INSULINE CORPORATION OF AMERICA	22
Agency: S. B. Leon Co.	
HOWARD S. JONES DIV. CIMCH MFG. CORP.	27
Agency: Remondt, MacFadden & Co.	
KELLOGG SWITCHBOARD & SUPPLY CO.	8
Agency: Thrax Associates, Inc.	
JAMES B. LANSING SOUND, INC.	20
Agency: Julian B. Beal & Associates	
MEASUREMENTS CORPORATION	23
Agency: Frederick Smith	
JAMES MILLEN MFG. CO., INC.	25
GEORGE W. MOORE, INC.	20
Agency: Julian Brightman Co.	
PRESTO RECORDING CORP.	1
Agency: Har S. Derstine, Inc.	
U. S. TREASURY DEPT.	23
WARD LEONARD ELECTRIC CO.	23
Agency: Henry H. Tullis, Advertising	
ZOPHAR MILLS, INC.	22
Agency: Goss-Morris Advt. Agency	

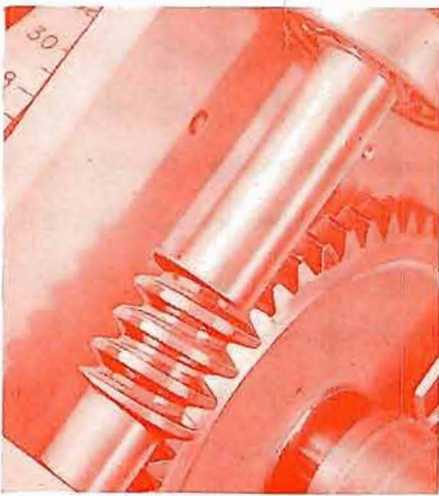

This 50-to-1 worm drive, equipped with a $3\frac{1}{2}$ inch dial, is used for the fine setting adjustment. Backlash is kept very low by spring pressure on the worm shaft. Eccentricity from set screws and misfit is eliminated by cutting the worm and its shaft from an integral steel shafting.

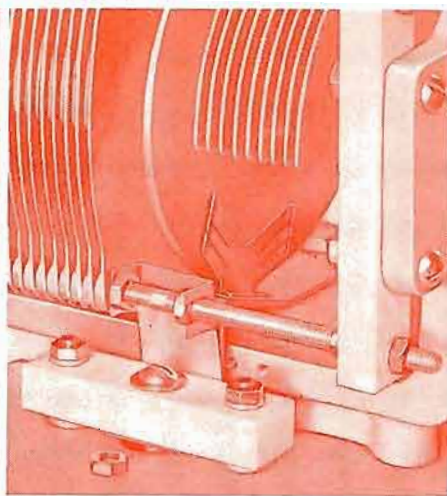

Two small, waxed steelite bars insulate the stator plates. A Figure of Merit (Dissipation Factor \times Capacitance) of $0.04 \mu\text{mf}$ is secured ($0.003 \mu\text{mf}$ with quartz insulators). Connection to the rotor is through spring-tempered silver alloy brushes bearing on a silver-overkey brass disc.

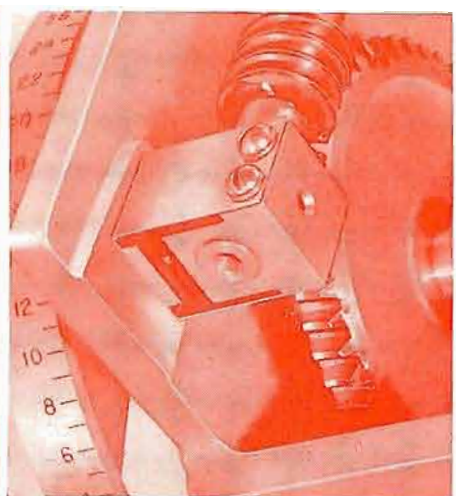

The worm shaft is held to a tolerance of 0.0004 inch radial eccentricity of the worm gear is less than 0.002 inch. The main rotor shaft is held to a tolerance of 0.0005 inch and its bearing surfaces to 0.0002 inch. Ball bearings are used on worm and main rotor shafts.

The STANDARD of Variable Capacitance

Recently the accuracy of the well-known G-R Type 722 Precision Condensers has been increased, making these standards of variable capacitance of even greater use in the laboratory and as the variable element in many instruments such as oscillators and frequency meters.

Typical of the three different models of this condenser is the Type 722-N, with extra low metallic resistance and inductance. This condenser (illustrated) is direct reading to $\pm 1 \mu\text{mf}$. When the corrections (charted on the front panel) are applied to the direct-reading settings the accuracy is increased to $\pm 0.1\%$ or $\pm 0.4 \mu\text{mf}$, whichever is greater, and the corresponding accuracy for capacitance differences is $\pm 0.1\%$ or $\pm 0.5 \mu\text{mf}$.

SPECIFICATIONS

- **CAPACITANCE RANGE:** 100 to 1100 μmf , direct reading
- **STANDARD CALIBRATION:** Direct reading in μmf at 1 kc to $\pm 1 \mu\text{mf}$. Mounted correction chart gives corrections to $0.1 \mu\text{mf}$ at multiples of $100 \mu\text{mf}$.
- **WORM CORRECTION:** For very precise measurements a worm correction calibration can be supplied. When these are applied capacitance can be determined within $\pm 0.1 \mu\text{mf}$ or $\pm 0.1\%$, whichever is greater, and capacitance differences to $\pm 0.2 \mu\text{mf}$ or $\pm 0.1\%$
- **METALLIC RESISTANCE:** Series resistance about 0.008 ohm at 1 Mc
- **SERIES INDUCTANCE:** Approximately $0.024 \mu\text{h}$
- **TEMPERATURE COEFFICIENT:** Approximately 0.002% per deg. C.

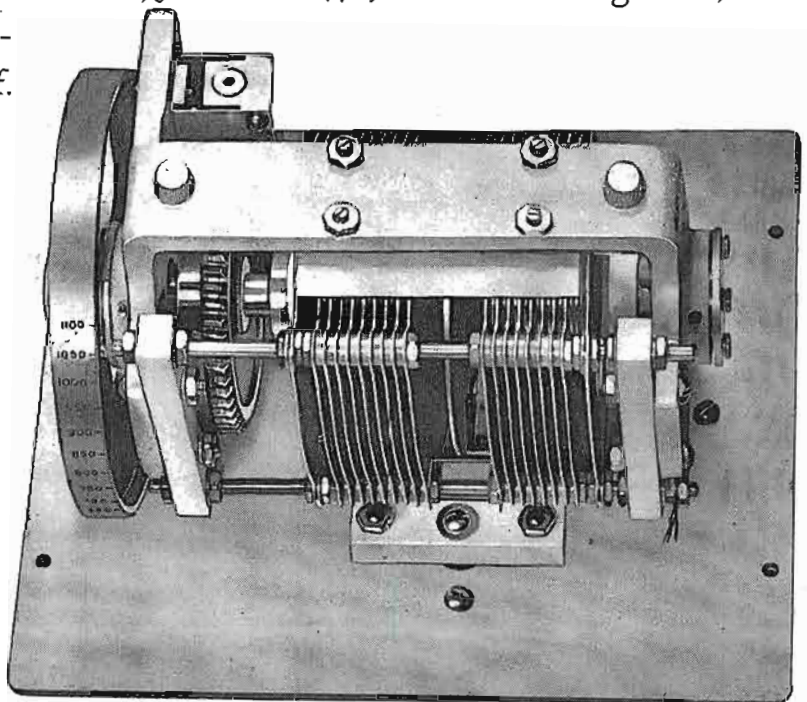

- **TYPE 722-N PRECISION CONDENSER** \$160
- Worm Correction Calibration 50
- Quartz Insulation 85



GENERAL RADIO COMPANY

Cambridge 39,
Massachusetts

90 West St., New York 6 920 S. Michigan Ave., Chicago 5 1000 N. Seward St., Los Angeles 38

What makes BENDIX* dynamotors
SO MUCH BETTER?
For the answers look inside!

END BRACKETS
Die-cast aluminum for strength and light weight.

SHAFT
Precision machined for accurate bearing fit.

BEARINGS
New Departure, SKF, or Fafnir ball bearings, lubricated with government approved lubricants.

BRUSHES
Specially selected for each type of dynamotor to insure greatest brush life and good commutation.

POLE SHOES
Special electric-grade steel with flared tips to smooth out flux changes. Pole assemblies are easily re-usable.

COMMUTATORS
Finest grade, hard-drawn, mica insulated copper, precision machined and undercut for good commutation, long brush and commutator life, and low ripple.

ARMATURE LAMINATIONS
Special electric-grade # steel, random stacked to obtain maximum magnetic characteristics. Slots are skewed to smooth abrupt flux changes.

FIELD COILS
Pre-formed, impregnated, and baked for long life.

ARMATURE
Hand-wound by skilled armature winders with primary winding in bottom of slot to insure guaranteed ripple value of less than 1 per cent. Balanced to .0002 ounce inches.

RED BANK DIVISION		PART—BLACK WRINKLE	
BENDIX AVIATION CORPORATION		QUANTITY	DATE
1. Drawing symbol "B" design (smooth grid)	0001 011	011	RE JUNE
2. All threads must be without free dies S.T.			15.
3. All relationships on drawing must be held as shown.			QTY.
4. References to file of general location are for the user.			APP.
			TELEPHONE

*It Pays to buy Quality . . .
and no finer Quality Dynamotor
is available than a
BENDIX DYNAMOTOR*

Dynamotors • Inverters • Converters • D.C. Motors • Carbon Plate Voltage Regulators

RED BANK DIVISION of

RED BANK, N. J.

Export Sales: Bendix International Division,
72 Fifth Avenue, New York 11, New York



TEMPERATURE RISE—40° C.

STARTING TIME—3 seconds (or less if specified).

VIBRATION RESISTANCE—Will withstand .03 inches (.06 total excursion) between 10 and 60 c.p.s., without special mounts.

TEMPERATURE RANGE—Will operate through ambient range of -55° C to +85° C.

ALTITUDE—Will operate normally to 20,000 feet and higher if special altitude brushes are specified.

CAA APPROVAL—All Bendix dynamotors are capable of meeting Civil Aeronautics Authority type Certification tests and are in use by major, scheduled airlines and government services.

INSPECTION AND TEST—All Bendix Dynamotors are carefully inspected in every step of production. Every unit receives a six to twelve hour run-in, depending on type, to insure proper brush seating.