

COMMUNICATIONS

TELEVISION

NATIONAL
DEFENSE

FEBRUARY

1 9 4 1

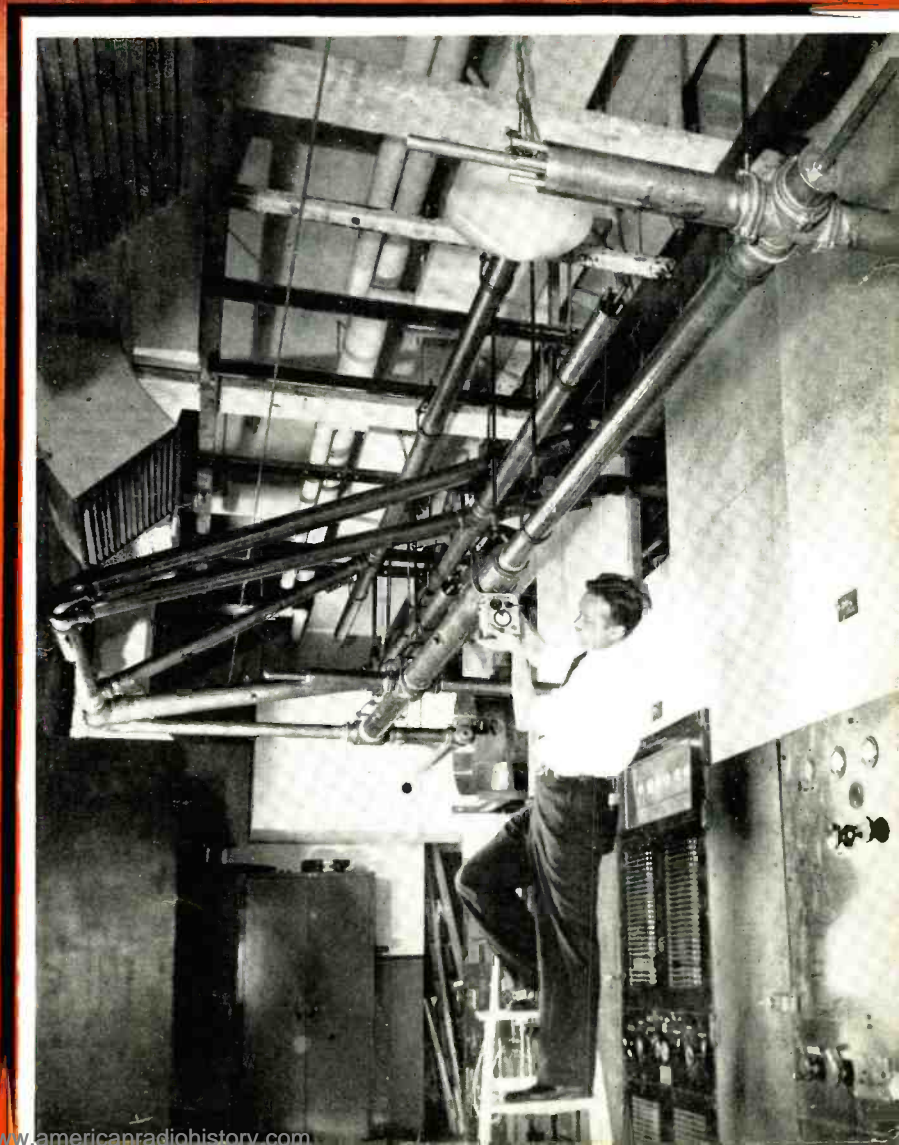

16FA

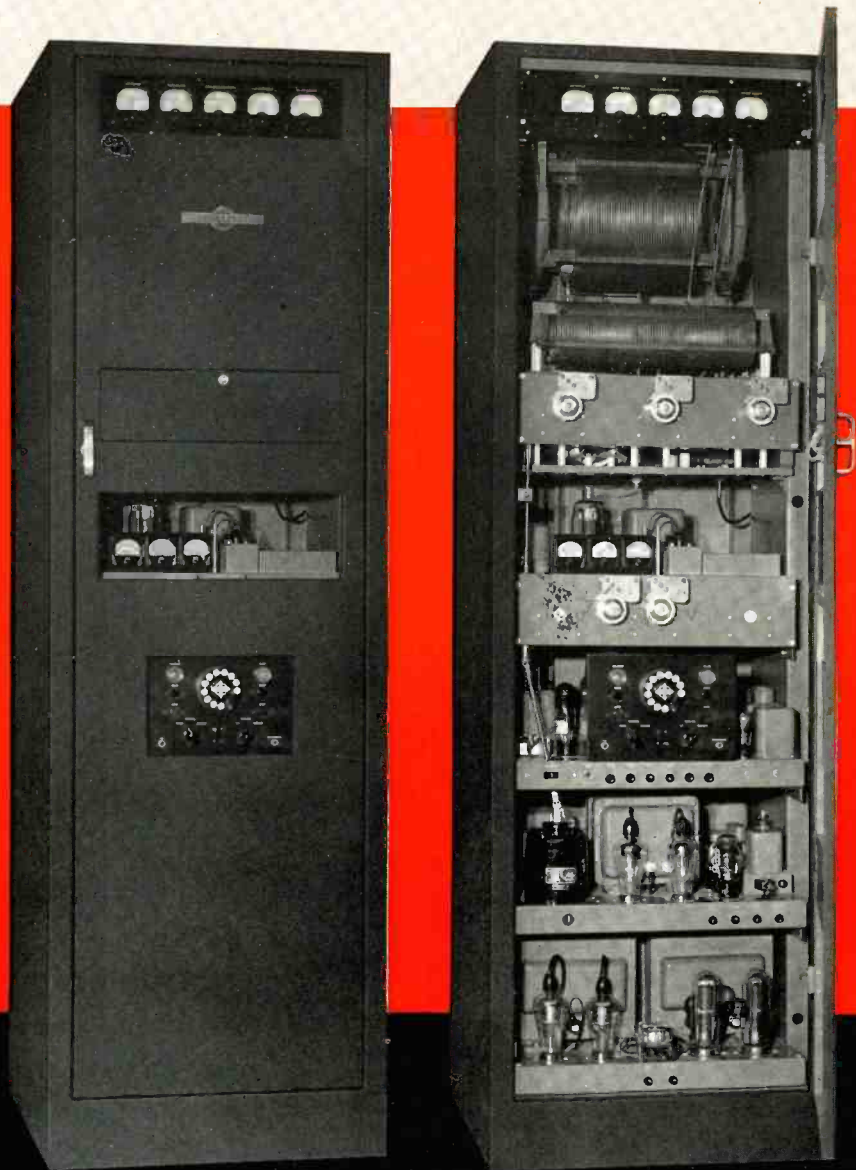

... a new Collins Autotune Transmitter providing automatic multi-frequency operation on both intermediate and high frequencies.

NOMINAL POWER OUTPUT AND FREQUENCY RANGE: 150 watts, 2.5 to 20 mc. 90 watts, 300 to 500 kc.

NUMBER OF FREQUENCIES: 10 with Autotune throughout range.

AUDIO FREQUENCY RESPONSE: Uniform within 3 db from 100 to 5000 c.p.s.

AMPLITUDE DISTORTION: Less than 10% r.m.s. total harmonics at any modulation level measured at 400 c.p.s.

ANTENNA IMPEDANCE: High Frequency — unbalanced antennas of 70 to 600 ohms up to 60° phase angle. Low Frequency — 1 to 10 ohms, 500 to 1500 mmf.

POWER SOURCE: 220 volt single phase 50/60 or 25 cycle.

AMBIENT TEMPERATURE RANGE: 0° C to +50° C.

REMOTE CONTROL: Any of the five standard Collins arrangements can be used.

SIZE: 24"x24"x78". **WEIGHT:** 825 lbs.

NOTE: An output of 300 watts (h-f) and 180 watts (i-f) is available in the 16FA Transmitter which is of similar design.

COLLINS RADIO COMPANY

CEDAR RAPIDS, IOWA • NEW YORK, N. Y.: 11 WEST 42 STREET

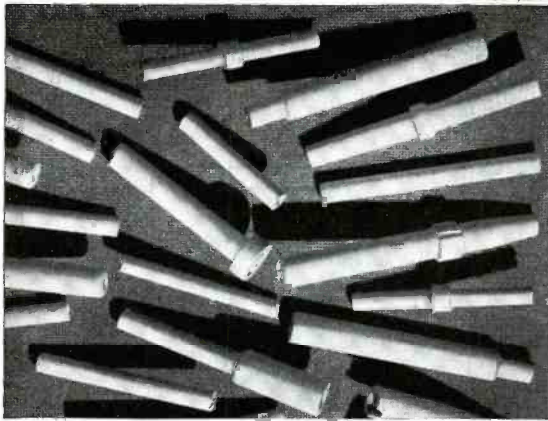

INSULATION HIGHLIGHTS

▲ **OIL BURNER IGNITION** offers an ideal application for Isolantite*. Its high strength minimizes risk of mechanical failure; its non-porosity and high puncture voltage offer equally important advantages from the electrical standpoint. Vitrified at high temperatures, Isolantite is impervious to oil and moisture. In addition to oil burner ignition insulators of the types illustrated, Isolantite supplies complete ignition assemblies, including electrodes, to many of the leading oil burner manufacturers.

▶ **IN FM, TOO**, Isolantite is the logical choice. Typical instance of its use is at W1XOJ, the Yankee Network station at Paxton, Mass., which was designed and built by Radio Engineering Laboratories. Photo shows power amplifier unit, with plate lines supported by Isolantite stand-off insulators. Isolantite engineers will be glad to cooperate in solving your special insulator design problems.

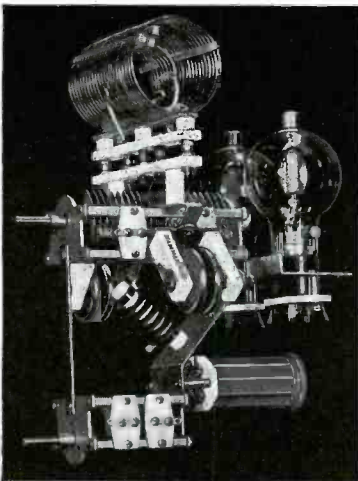
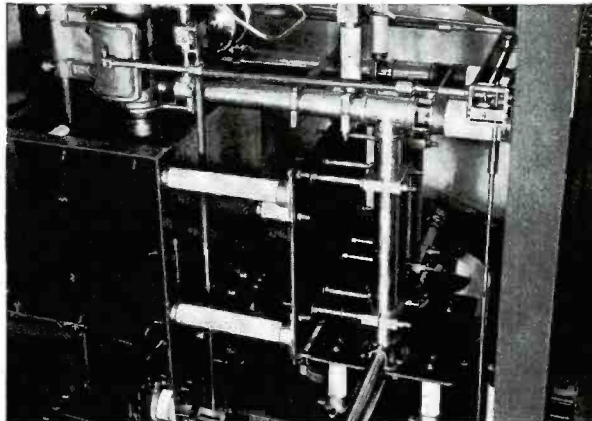

◀ **LIBERAL USE OF ISOLANTITE** in this Hammarlund transmitting kit is typical of its widespread application in progressive design for both amateur and commercial use. Low loss factor, high strength, and close mechanical tolerances are outstanding advantages of Isolantite, and are important factors contributing to its broad, diversified utility.

▶ **VERSATILITY OF ISOLANTITE** is illustrated in this photo of the Western Electric 50 kilowatt transmitter at WJSV, Washington, D. C. Stand-off insulators, coil forms, condenser insulation, notched bars for inductance supports, and lead-in insulators are standard Isolantite insulator designs adaptable to many types of equipment.

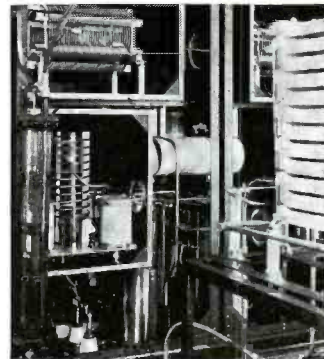

▼ **TRANSMISSION LINES** engineered by Isolantite are made in large and small sizes, with single or double internal conductors. Bulletins describing Isolantite's Transmission Line, solderless fittings, and accessories are available on request. Write us outlining your problem and we will send you complete information. (Isolantite Transmission Lines are sold nationally through Graybar Electric Company.)

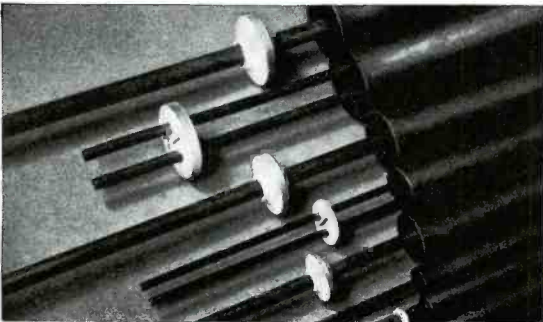

**Registered trade-name for the products of Isolantite, Inc.*

ISOLANTITE

CERAMIC INSULATORS

ISOLANTITE, INC. FACTORY: BELLEVILLE, NEW JERSEY
SALES OFFICES: 233 BROADWAY, NEW YORK, N. Y.

• Contents •

COVER ILLUSTRATION

Making measurements on a wave filter, designed by NBC engineers to make it possible for the main television antenna (atop Empire State Building) to transmit signals from three transmitters simultaneously. Pipes are actually sheaths for smaller copper tubes.

- 5 BRIDGED TEE PADS By Albert Preisman
- 7 MEASURING THE CHARACTERISTIC IMPEDANCE OF LINES By Paul K. Hudson
- 8 TELEVISION OVER WIRE LINES
- 9 COMMUNICATION IN NATIONAL DEFENSE By Donald McNicol
- 10 SOME RECENT TELEVISION DEVELOPMENTS
- 12 NTSC TELEVISION STANDARDS
- 14 MOBILE AIRCRAFT RADIO SERVICE
- 16 VETERAN WIRELESS OPERATORS ASSOCIATION NEWS
- 18 OVER THE TAPE
- 20 DIRECT PICKUP OF COLOR TELEVISION
- 25 BOOK REVIEWS
- 26 AIRLINE ANTENNA COUPLER
- 27 RADIO-CONTROLLED SEADROME LIGHTS
- 28 WMBD TESTS DIESEL-ELECTRICS
- 31 THE MARKET PLACE
- 36 INDEX OF ADVERTISERS

• Editorial Comment •

THE University of Illinois is planning a radio interference conference to be held in Urbana, Illinois, Saturday, May 10. The purpose of the gathering is to inform radio engineers, public service interference trouble shooters, radio amateurs, and service men of the sources of radio interference and their correction. It is hoped through this conference to clear up many misunderstandings in the industry.

Some of the topics to be discussed by outstanding engineers are: the generation of combination frequencies in a non-linear element, diathermy interference, receiver design to minimize strong signal interference, panel discussion on interference between radio amateurs and the broadcast listeners, the adjustment of transmitters to reduce spurious emissions, reduction of airplane interference, and other kindred topics.

It seems to us that this conference is a step in the right direction . . . that it may serve as a stepping stone to the solution of a rather difficult problem facing the radio industry. A program of the gathering will appear in a later issue.

THIS year the National Association of Broadcasters will hold their annual convention from May 12-15 at the New Jefferson Hotel in St. Louis, Mo. This is the nineteenth annual meeting of the NAB, which has among its members 502 of the country's 832 broadcast stations. Further data on the gathering will appear in a later issue of COMMUNICATIONS.

ESTABLISHMENT of the Clear Channel Broadcasting Service with offices in Washington, D. C., has been announced by Edwin W. Craig, of Nashville, Tennessee. Mr. Craig is chairman of a committee of independently-owned radio stations throughout the country, as well as vice-president of WSM in Nashville.

The new service, according to Mr. Craig, is intended to familiarize American radio listeners with the importance of preserving "clear channel" broadcasting primarily as a domestic service, but also in line with the North American Regional Broadcasting Agreement which goes into effect March 29.

Copyright 1941. Bryan Davis Publishing Co., Inc.

BRYAN S. DAVIS
President

JAMES A. WALKER
Secretary

Published Monthly by the
BRYAN DAVIS PUBLISHING CO., Inc.

19 East 47th Street
New York City

New York Telephone: PLaza 3-0483

PAUL S. WEIL
Advertising Manager

A. GOEBEL
Circulation Manager

Chicago Office—608 S. Dearborn Street
Telephone: Wabash 1903



Wellington, New Zealand—Te Aro Book Depot
Melbourne, Australia—McGill's Agency

Entered as second-class matter October 1, 1937, at the Post Office at New York, N. Y., under the act of March 3, 1879. Yearly subscription rate: \$2.00 in the United States and Canada, \$3.00 in foreign countries. Single copies: twenty-five cents in United States and Canada, thirty-five cents in foreign countries.

NOW FLAT TO 15,000 CYCLES!

...Meets Every FCC Requirement
for FM Broadcasting

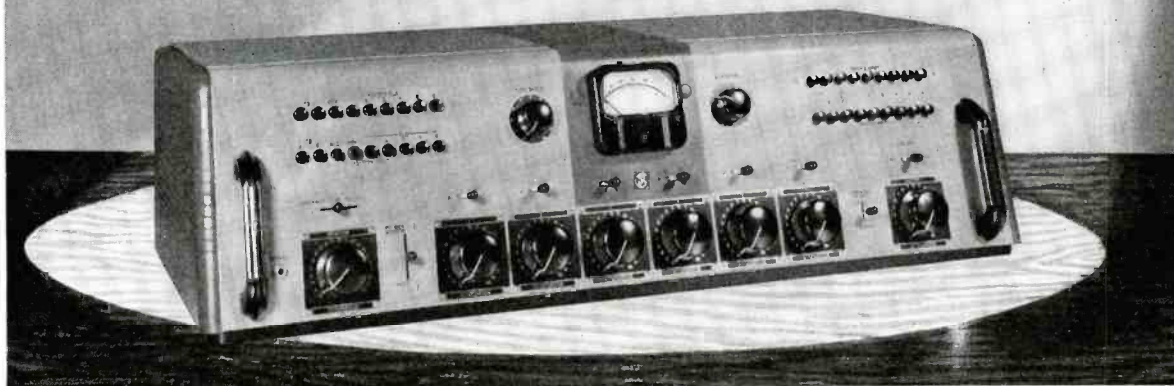

RCA 76-B2 Consolette Speech Input System with Interlocked Push-Button Switching

ALL the features that made the RCA Model 76-B1 known the country over . . . plus an extended frequency response to over 15,000 cycles! That's the new RCA 76-B2, for simultaneous broadcasting and auditioning—with push-button control for more circuit combinations with simpler switching operations.

Monitoring, auditioning, cueing, and talk-back are all under push-button control. The high-fidelity program channel affords 6 mixer controls—4 microphone pre-amplifier input channels with switching control for as many as 6 microphones. Location of control knobs and correct slope of panel give greatest visibility and ease of control. High power output to line and loudspeakers. Hinged top and chassis mounting for instant accessibility of parts.

And all at a price that even the smallest station can afford! Get the facts on RCA 76-B2—write today for complete data.

Use RCA radio tubes in your station
for finer performance

- ★ Frequency Response 30 to 15,000 Cycles
- ★ Independent Auditioning and Program Channels
- ★ Talk-back facilities for two studios and remote lines
- ★ Emergency Amplifier and Power Supply Circuit
- ★ 6 Step-by-step Mixers—Dual Turntable Faders
- ★ 6 Remote Inputs—Push-Button Cueing Control
- ★ New Illuminated Scale VU Meter
- ★ Two Line Repeating Transformers
- ★ Plate Current Meter and Relay Power Supply
- ★ Attractive Appearance—Two-Tone Umber Grey Finish



Broadcast Equipment



RCA Manufacturing Co., Inc., Camden, N. J. • A Service of Radio Corporation of America • In Canada, RCA Victor Co., Ltd., Montreal

New York: 1270 Sixth Avenue

Chicago: 589 E. Illinois Street
San Francisco: 170 Ninth Street

Atlanta: 530 Citizens & Southern Bank Building
Hollywood: 1016 N. Sycamore Avenue

Dallas: Santa Fe Building



OVER 500 JOBBERS CARRY IRC RESISTORS IN STOCK

Why not select a resistor for your development and production program that not only offers assured dependability for defense or industrial needs, but which is also available from a local jobber's stock? When working under pressure, any delay caused by not having the right resistor at the right time may cause unnecessary complications in an already complicated problem.

IRC provides all types of fixed and

variable resistors plus a thorough knowledge of the requirements of the various government services. Thousands of resistors in factory stocks are backed by extensive facilities for large scale production —and still further backed by stocks of many commonly used types maintained by about 500 jobbers throughout the U. S. and Canada.

We will gladly send you names of IRC jobbers in your locality.

GET THESE RESISTOR ENGINEERING DATA BULLETINS

(Please ask for these Bulletins by Number)

- 1—Volume Controls and Potentiometers up to 2 watts and 20 meg. resistance.
- 2—Metallized Type Resistors: Insulated 1/2, 1 and 2 watts; high frequency; high range; high frequency power; high voltage power.
- 3—Insulated Wire Wound Resistors: Type BW from 1/2 to 1 and 2 watts; Type MW, 5 to 20 watts.

4—Power and Precision Wire Wound Resistors: Fixed and adjustable power types from 10 to 200 watts in all shapes, mountings, etc. Inductive and non-inductive. 14 Precision Types to as close as 1/10 of 1% accuracy.

5—Attenuators: 20 to 30 step; ladder, potentiometer or bridged "T" types.

6—Power Rheostats: Quick heat-dissipating all-metal types up to 100 watts.



NEW RESISTOR COLOR CODE CHART

Write direct or ask your local IRC jobber for one of the IRC Resistor Color Code Charts. This is printed on sturdy acetate in vest pocket size and includes both old and the revised RMA color codings, ohms law and a condensed list of IRC Resistor types.



INTERNATIONAL RESISTANCE COMPANY

415 NORTH BROAD ST., PHILADELPHIA, PENNA.

Makers of resistance units of more types, in more shapes, more sizes and for more applications than any other manufacturer in the world.

BRIDGED TEE PADS

I. Introduction—The Tee Pad

THE variable tee attenuation pad has several advantages and disadvantages over many other types of attenuations. The advantages are:

- (1) Perfect impedance matching in either direction on an image basis.
- (2) An attenuation range from zero to infinity, i.e. zero minimum insertion loss.
- (3) The arms of the three rheostats comprising the pad are at one potential, and need not be insulated from one another or the shaft.

The disadvantages are:

- (1) The complexity of three variable resistors or rheostats.
- (2) The noise generated by three sets of contacts.
- (3) The cost of such an arrangement.

Attempts have been made to decrease the number of rheostats required to two, or even one, by the use of circuits known as tapped tee and ladder networks, respectively. As far as noise is concerned it is worthy of note that the reduction of the number of contacts of a device to one-half probably reduces the generated noise power to one-half, which in turn corresponds to a 3 db decrease in contact noise. If we assume an original noise level of -140 db (0 db = 6 milliwatts) then half the number of contacts might be assumed to give rise to a noise level of -143 db. The difference is admittedly of little consequence, so that it is evident that the tapped-tee and ladder networks have little advantage over the ordinary variable tee pad in this respect.

The reduced complexity and cost, however, are of consequence, and merit consideration of these latter two types of pads. But against this is to be noted that they do not match perfectly impedances on an image basis, and also have a certain minimum insertion loss, which may be as much as 6 db or more.

II. The Bridged Tee Pad

There is a form of four-terminal configuration, however, which requires only two rheostats and hence sets of contacts, has zero minimum insertion loss, and

By **ALBERT PREISMAN**
RCA Institutes Inc.

matches impedances perfectly on an image basis. This is known as the bridged tee pad, and is shown schematically in Fig. 1. As may be noted from the diagram, the bridging arm and the shunt arm are the variable resistances, while the two series arms are fixed. It is also to be noted that the two rheostat arms are not at the same potential, and hence cannot be mounted conductively on one shaft, an advantage enjoyed by the variable tee pad, as mentioned above.

For zero attenuation, the bridging arm is short-circuited, and the shunt arm is open-circuited. For infinite attenuation, the bridging arm is open-circuited, and the shunt arm short-circuited. For the former condition, it is evident that the pad acts as a direct connection between the source and the load, and this explains why it has zero minimum insertion loss.

In deriving the formulas for the design of the pad it will be of advantage to derive first those for an ordinary tee pad, and then to obtain those for the bridged tee by means of the delta-star transformation.

III. Analysis of Tee Pad

The formulas for the ordinary tee pad can be derived in many ways, but probably for a resistance network the ordinary algebraic processes are best because of their simplicity and directness.

Schematic of the bridged tee pad.

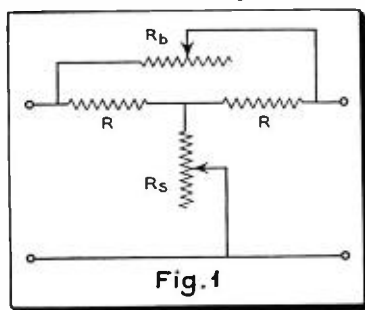

Thus, let the desired loss of the pad at some setting be A db, where A is inherently a negative number, since it represents a loss. Referring to Fig. 2, we note a source on the left-hand side, feeding a load on the right-hand side, through a tee pad whose series arms are X and X, and whose shunt arm is Y. Both source and load have a common impedance Z, and this, of course, accounts for the symmetry of the pad. (It is to be remembered that all impedances are, by hypothesis, resistive in nature).

It is required that the impedance looking into terminals 1—1, when the load is connected, is Z, and that the impedance looking into terminals 2—2, be also Z (with the source connected to terminals 1—1). We make use of a well-known network theorem that the image impedance looking into one end of a four-terminal network is equal to the square root of the product of the open and short-circuit impedances as viewed from that end. Since the pad is symmetrical, this affords but one equation. The open circuit impedance is evidently

$$Z_{oc} = X + Y \dots\dots\dots(1)$$

and the short-circuit impedance

$$Z_{sc} = X + \frac{XY}{X - Y} = \frac{X^2 + 2XY}{X + Y} \dots\dots(2)$$

From these we obtain the image impedance, which is to be equal to Z, namely

$$Z = \sqrt{\frac{(X + Y)(X^2 + 2XY)}{(X + Y)}} \\ = \sqrt{X^2 + 2XY} \dots\dots(3)$$

There are, however, two unknowns, X and Y, so that another equation must be obtained. This can be had from the ratio of the entering current I₁ to the load current, I₂. Let

$$K = \frac{I_1}{I_2} \dots\dots\dots(4)$$

But, for a symmetrical pad, we also have that

$$K = \text{anlg} (-A/20) \dots\dots\dots(5)$$

From inspection of Fig. 2, we also obtain that

$$(I_2/I_1) = K = (X + Z) / \frac{Y(X + Z)}{X + Y + Z}$$

$$= (X + Y + Z)/Y \dots\dots\dots(6)$$

This follows from the fact that the currents are in inverse proportion to the impedances they face, and I_1 faces the impedance of Y and $(X - Y)$ in parallel, while I_2 faces the impedance $(X + Z)$. Since K is known from Eq. (5), we have in Eq. (6) the second equation, for which we have been looking.

Simultaneous solution of Eqs. (3) and (6) yields

$$X = Z \left(\frac{k-1}{k+1} \right)$$

$$Y = Z \left(\frac{2K}{K^2-1} \right) \dots\dots\dots(7)$$

Equation (7) contains the requisite information for the design of a tee pad, and avoids the use of hyperbolic functions, which are of no particular advantage in the case of resistive pads.

IV. Analysis of Bridged Tee Pad

The equivalent bridged tee pad can now be derived. The delta consisting of the two R 's and R_b in Fig. 1 can be replaced by an equivalent star, as shown in Fig. 3. The values of R_1 and R_2 in terms of R and R_b are given by the following formulas:

$$R_1 = (R R_b) / (2R + R_b) \dots\dots\dots(8)$$

$$R_2 = (R^2) / (2R + R_b)$$

As may be noted in the figure, the bridged tee has been replaced by an equivalent tee, whose properties have just been analyzed. Thus $(R_b + R_s)$ correspond to Y , and R_1 to X of Fig. 2. Since, for any value of A , hence k , x and y are determined, R_1 and $(R_b + R_s)$ are thus determined. But, as noted from Eq. (8), R_1 and R_2 are functions of R and R_b , hence these are indeterminate even if R_1 and R_2 are known.

However, another factor enters in, and that is physical realizability. If we substitute the values from Eq. (8), together with R_s , in Eq. (7), we obtain

$$\frac{R R_b}{2R + R_b} = Z \frac{k-1}{k+1}$$

$$\frac{R^2}{2R + R_b} + R_s = Z \left(\frac{2K}{K^2-1} \right) \dots\dots\dots(9)$$

For $A = 0$, or $k = 1$, $R_b = 0$ and $R_s = \infty$ for all values of R . But for $A = K = \infty$, we have

$$\frac{R R_b}{2R + R_b} = Z \dots\dots\dots(10)$$

and

$$\frac{R^2}{2R + R_b} + R_s = 0 \text{ or}$$

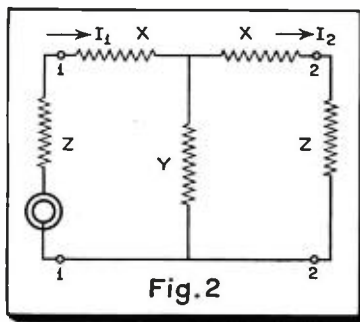

Circuit used for deriving formulas

$$R_s = - \frac{R^2}{2R + R_b} \dots\dots\dots(11)$$

Eq. (11) can be satisfied for positive or zero values of R_s only if R_b is infinite, in which case R_s is zero, a realizable value. But if R_b is infinite, then from Eq. (10), R must equal Z . Hence we conclude that for a bridged tee pad to cover a range of attenuation from zero to infinity, the series arms R must equal the image impedance, Z . In this case the bridging arm R_b must vary from zero to infinity, and the shunt arm R_s from infinity to zero, respectively.

It might appear, however, that if a maximum attenuation less than infinity were desired, other values of R would be possible, as well as of R_b and R_s . While this is true, the departure of all values from those indicated above is small if the maximum attenuation is large, say 40 db, and this latter value is one quite easily demanded in a variable pad. It does not appear, therefore, that any more desirable results will be obtained by assigning to R a value other than Z even when only a finite range of attenuation is desired.

For $R = Z$, we have from Eq. (9) that

$$R_b = (k-1) Z$$

$$R_s = Z / (k-1) \dots\dots\dots(12)$$

Eq. (12), together with $R = Z$, afford the necessary information for the design of a bridged tee pad for any

Equivalent circuit of Fig. 1.

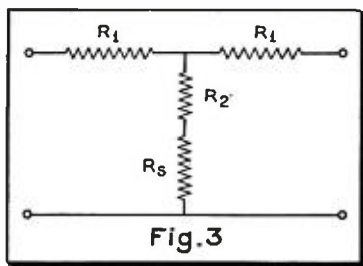

Fig. 3

amount of attenuation as determined by the value of K .

V. Design of Variable Bridged Tee Pad

We can now proceed with the actual design. For the first step, corresponding to $A = 0$ and $K = 1$, R_b is zero, and R_s is infinity. This first contact for R_b is therefore not connected to any other. Let the next step of attenuation be A_1 . Corresponding to this is a value k_1 , by Eq. (5) and the R_b and R_s can be calculated, and let the specific values of the two latter be R_{b1} and R_{s1} respectively. R_{b1} represents the resistance between the first and second contacts of the rheostat R_b , but R_{s1} represents the total resistance from the second contact to the last one of rheostat R_s .

Now let the second step of attenuation be A_2 . Usually this is made equal to twice A_1 , i.e., the pad is designed to have equal increments of attenuation. Corresponding to $A_1 + A_2$ is the value k_2 . This in turn determines R_{b2} and R_{s2} . The next resistance between contacts two and three of rheostat R_b is $(R_{b2} - R_{b1})$. The total resistance between the third contact of rheostat R_b and the last one is R_{s2} , hence the actual resistance between the second and the third contacts of that rheostat is $(R_{s2} - R_{s1})$.

In this manner successive resistors of the two rheostats can be calculated, and the pad designed. For the last step—denote it by n —the last resistor of rheostat R_b is $R_{bn} - R_{b(n-1)}$, and that of R_s is R_{sn} .

VI. Comparison of Two Types of Pads

It is of interest to compare the magnitudes of the variable resistors of the tee and the bridged tee pads. We shall compare the X and R_b arms, and the Y and R_s arms, respectively. From Eqs. (7) and (12) we have

$$\frac{(R_b/x)}{(y/R_s)} = \frac{(k+1)}{2k/(k+1)} \dots\dots\dots(13)$$

It will be observed from Eq. (13) that R_b is larger than x , which means that R_b represents a higher resistance than X . In some cases there is an objection to the use of a high-resistance rheostat instead of a low-resistance unit because of the finer wire required.

On the other hand, y is greater than R_s for values of k greater than unity, which means that the bridged tee enjoys the advantage of a lower resistance rheostat over the tee with respect to this arm. Hence we may finally conclude that the bridged tee is cheaper and easier to build than the ordinary tee.

In the case of a pad for television purposes, the bridged tee enjoys an important advantage over the ordinary tee in regard to the lesser number of arms required. Here each arm has a certain

(Continued on page 22)

Measuring the CHARACTERISTIC IMPEDANCE OF LINES

By PAUL K. HUDSON

A TRANSMISSION line should always be terminated in an impedance equal to the characteristic impedance of the line. There are several reasons for this precaution. (1) A line terminated in its own characteristic impedance acts as an infinite line. (2) There are no standing waves set up on the line. (3) Its impedance at high frequencies will be nearly a pure resistance and therefore it has no natural period. (4) There will be no power loss due to reflection. (5) The current and voltage decay exponentially with length of line.

This article presents two methods of measuring the characteristic impedance of lines. They are named (1) The Ganged Impedance Bridge, and (2) The Three Voltage Method. Each method is based upon a different property of transmission lines. Both methods were used to measure the characteristic impedance of a given line, and the values obtained were compared with the accepted value.

THE GANGED IMPEDANCE BRIDGE¹

Consider a line terminated in its own characteristic impedance. The input impedance will be equal to the characteristic impedance:

$$Z_i = Z_o = Z_R \dots\dots\dots(1)$$

If the terminated impedance differs from the characteristic impedance in either magnitude or angle, the input impedance will not equal the terminated impedance. This principle is the basis for the ganged impedance bridge shown in Fig. 1.

The bridge arms R_1 and R_2 should

¹See also "Ganged Impedance Bridge" by D. B. Green and Paul K. Hudson, p. 20, January 1941, COMMUNICATIONS.

Fig. 3. Circuit of one of 12 equivalent T sections of dummy line.

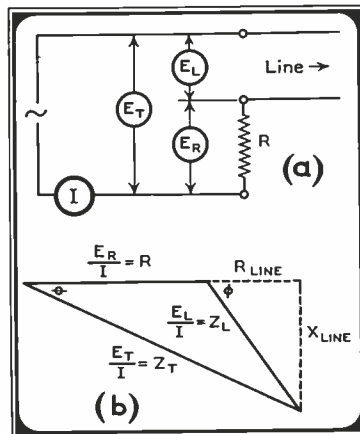
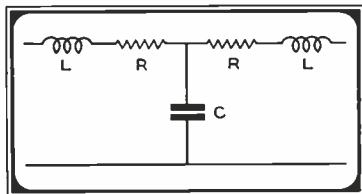
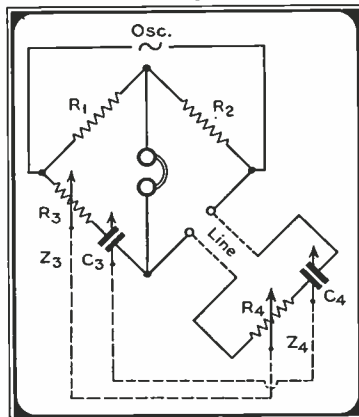

Fig. 2. Illustrating three voltage method for obtaining impedance.

both be set at about 1000 ohms. The resistance and reactance of Z_s and Z_t which are variable, should always be kept equal. This makes $Z_s = Z_t$ for all settings. Ease of adjustment is obtained by mechanically ganging them together, but this is not necessary for accurate measurements. To measure the characteristic impedance of a line the instrument is assembled as shown in the figure. Z_s and Z_t are adjusted by means of R_3, R_4 , and C_3, C_4 , until the signal in the phones is a minimum. Then Z_s (or Z_t) will represent the characteristic impedance of the line measured in terms

Fig. 1. The ganged impedance bridge.



of R and C . This of course can be changed to $R - jX$ or $Z/-\theta$. Inductances were not considered because the characteristic impedance of lines is invariably capacitive.

This bridge can be used only when both ends of the line are available. This condition is met in practice by connecting the distant end of the main line to an auxiliary line. In demonstration laboratories the lines are usually built with both ends available for convenience of measurement.

THE THREE VOLTAGE METHOD*

It can easily be shown that the characteristic impedance of a transmission line is equal to the square root of the product of the input impedance of the line when the far end is open circuited, and again when it is short circuited. That is:

$$Z_o = \sqrt{Z_{oc} \times Z_{sc}} \dots\dots\dots(2)$$

This equation is the basis for the operation of the three voltage method. The circuit diagram is shown in Fig. 2-a. A non-inductive resistance and an ammeter are placed in series with the line and oscillator. A vacuum-tube voltmeter is used to measure the voltage E_r across the resistor, the line voltage E_L , and the total voltage E_t . Values of E_r, E_L, E_t , and I are taken when the line is open and again when it is shorted. These values can be used to calculate the respective impedances of the line by means of the vector diagram shown in Fig. 2-b. The simplest method of procedure is to find the values or R, Z_L , and Z_t . Then θ can be found by the

(Continued on page 30)

*The "Three Voltage Method" was suggested by Dr. Darel B. Green, at The Ohio University.

Comparative results from three voltage method and ganged impedance bridge.

METHOD	CHARACTERISTIC IMPEDANCE
Three voltage method	725 Ω $\angle -8^\circ$
Ganged impedance bridge	720 Ω $\angle -11^\circ$
Accepted value	715 Ω $\angle -9^\circ$

TELEVISION OVER WIRE LINES

TELEVISION over an all-wire circuit had a long-distance public demonstration recently when a program taken from motion-picture films was transmitted from Bell Telephone Laboratories in New York over the coaxial telephone cable to Philadelphia and back to the Hotel Pennsylvania. The demonstration, which was arranged for members of the Institute of Radio Engineers, allowed observers to make a comparison of a scene transmitted over a 190-mile loop of coaxial cable to Philadelphia and back with the same scene locally transmitted across a few miles in New York City. The scenes were reproduced on a special television receiver-tube developed in Bell Telephone Laboratories; and when viewed from the usual distance of five or six feet from the tube the difference between local and long-distance cable transmission was imperceptible.

Motion pictures were scanned at the Bell Laboratories in the Graybar Varick Building and the video signal was transmitted either directly to the Hotel Pennsylvania or to the Hotel after having been sent to Philadelphia and back over the cable. Between Philadelphia and New York there are two coaxial cables inside a single lead sheath. This cable system was installed in 1936 by the Bell Telephone System for use in its experiments primarily on the transmission of speech but also on the long distance transmission of television signals. One of the coaxial cables in the sheath had been used last summer for transmission of television views of the Republican Convention from Philadelphia to New York. In the present demonstration the two cables in the sheath were joined at Philadelphia to form a loop circuit back to New York with a total mileage of about 190. Each of the coaxial cables consists of a copper tube about the size of a lead pencil with a copper wire running through it and held centrally in it by disc insulators three-quarters of an inch apart. About every five miles along the line there is a three-stage vacuum-tube amplifier in each coaxial, making a total of 120 tubes in the loop. So large a number is required, as compared with a voice-frequency telephone circuit which requires six tubes, because the losses in the coaxial are enormous—2,100 decibels for the round trip. That figure means that the signal is reduced in the ratio of one to ten followed by 210 ciphers. If the energy which the

earth receives from the sun were reduced in the same ratio, there would not be enough left to light a flashlight.

From the special transmitter which scans the motion picture at the Graybar Varick Building there emerges a "video" signal current. The components of this signal which were within the range from 40 cycles to 2,700,000 cycles were sent over the coaxial cable to Philadelphia and back, and then, through three intermediate amplifiers to the Hotel Pennsylvania. Because a coaxial cable is not suitable for the transmission of the lower part of this range of frequencies, the signal current was shifted about 300,000 cycles in the frequency spectrum and was transmitted over the cable as a band of frequencies between 300,000 and 3,000,000 cycles. When the signal current arrived at New York on its return trip it was remodulated to occupy again the range about 40 cycles to 2,700,000. A television image corresponding to this video current was then produced at the Hotel Pennsylvania by a special cathode-ray tube. This tube was developed for purposes of testing television transmission by Dr. C. J. Davisson, recent Nobel Prize winner, and his associates in the Bell Laboratories.

In the direct transmission from the film scanner to the Hotel Pennsylvania the entire frequency range of the complex "video" signal was transmitted.

This extends from about 35 to 4,000,000 cycles, and occupies a wider range than was transmitted over the cable system. Despite, however, this difference in range motion picture scenes under the two conditions of transmission were generally agreed to be imperceptibly different.

Both the cathode-ray tube and the transmitter which were used in the demonstration were developed primarily as testing instruments for use in the Bell engineers' study of television transmission since their interest in television is primarily in being able to transmit programs from point to point in the same general way as they provide such interconnecting facilities in radio broadcasting of sound programs. So as to have a wide range of subjects available for their transmission studies motion-picture films are used rather than direct pick-up from a television studio. The film transmitter passes 60 fields a second, corresponding to the conventional television system which transmits 30 pictures a second, each consisting of two "interlaced" fields—i.e., a given strip across the scene is viewed only on alternate fields. Because standard motion pictures are taken at 24 fields a second, it was necessary either to make new films or, as it was decided to do, to use prints from selected negatives, "stretched" by printing alternately two frames and three frames from each frame of the negative. By running the "stretched" film $2\frac{1}{2}$ times as fast as the original, the apparent motion in the picture is left unchanged.

Schematic showing the wire circuits for the long-distance television demonstration conducted by Bell Telephone Laboratories.

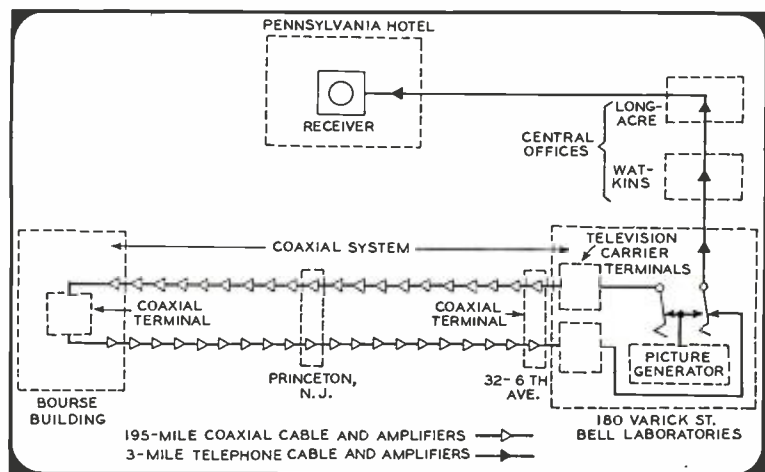

COMMUNICATION IN NATIONAL DEFENSE

IN the present national program looking to national defense, the Government has set up a Defense Communications Board consisting of four main committees—Coordinating, Law, Labor advisory, and Industry advisory committees. The organization of communications, as in all other departments of the national effort, contemplates cooperation for defense against attack. The purpose of the present effort is to provide protection for the citizenry and for American property. Although some of the steps to be taken may parallel those taken beginning in 1917, the conditions are somewhat different from those which obtained following the American declaration of war in 1917.

In 1917, radio had not yet demonstrated its usefulness and dependability for long-distance communication, but in test demonstrations of the national resources, the navy department, in cooperation with the American Telephone and Telegraph Company, over a period of three days maintained telegraphic and telephonic communication between the navy department at Washington and the navy yards and stations in all parts of continental United States. Subsequently, in 1917, the Government, for the period of the war, took over all transmitting radio stations—for operation or abandonment as desired in the national interest. And, on May 21, 1918, a naval censorship was placed over all submarine telegraph communication. On July 5, Congress passed a resolution authorizing the President to direct the operation of all telegraph, telephone and radio systems. It was not until November 2, 1918, that the President directed the Postmaster General to take over the operation of all submarine telegraph stations, to be operated in conjunction with the landline systems previously taken over.

In April, 1917, just prior to the declaration of war against Germany, the Signal Corps of the regular army consisted of fifty-five officers and fifteen hundred and seventy enlisted men, including those stationed in the dependencies. By May, 1918, the force had expanded to seventeen thousand, eight hundred and ninety-two officers, about one hundred and eighty thousand enlisted men, and ten thousand civilians.

The Present Emergency

The Defense Communications Board, referred to in the foregoing, as of 1941, has set up eleven committees represent-

By **DONALD McNICOL**

ing the different fields of communication. These are: Amateur Radio, Aviation Radio, Cables, Domestic Broadcasting, Interdepartment Radio Advisory, International Broadcasting, Radiocommunications, State and Municipal Facilities, Telegraph, Telephone, and United States Government Facilities. This is the national set-up. In addition, and cooperating with the various sections of the DCB, there are being organized Communication Sections as elements of Defense Corps being established in all parts of the country.

The Committee of the DCB, which will be responsible for communication in urban and suburban areas, among the homes, business places and manufacturing plants, is the State and Municipal Facilities Committee. The duties of this committee, as announced, include the study of all phases of state and municipal communications facilities, including state and municipal police radio stations, and state and municipally owned or leased state forestry stations, marine fire radio wire facilities. With the requirements of national defense as a primary consideration, the committee shall recommend plans for the most efficacious use of all those facilities in time of military emergency, giving due consideration to the needs of other governmental agencies, of industry, and of other civilian activities.

Communication in Emergencies

Already the Communication Sections of Local Defense Corps have, through experience, learned something about the requirements when explosions or fires occur in manufacturing plants. When disaster befalls a factory manufacturing war munitions, too often the toll of dead and injured is serious. This, notwithstanding that in all such factories vastly improved precautions are now taken to prevent disaster, and to care for injured persons when explosions or fires do occur. In emergencies, the Communications Section, cooperating with the local Defense Corps, is charged with several responsibilities, such as:

- (1) Communicating with Red Cross and First Aid departments.
- (2) Contacting national and state authorities.
- (3) Communicating with hospitals.
- (4) Communicating with police and fire departments.
- (5) Supplying communication any-

where for all agencies engaged in relief.

Makeup of Communications Sections

Communication Sections cooperating with local Defense Corps must organize and have in readiness for immediate service at all hours a variety of communication services to meet any requirement, and to substitute in case of the failure of commercial services. Obviously, commercial telephone service is the first line of communication, which suggests that local telephone officials be made members of the local Communications Section. Other members of local Communication Sections should be owners of amateur radio stations, telegraph engineers, captains of Boy Scout bicycle corps, and readily available automobile drivers with cars.

Police Radio

In the bulk of the municipalities throughout the country police radio systems are in operation, most of these being two-way systems. To avoid interference, frequencies are assigned so that stations having the same frequencies are not too close geographically. At first sight it may appear that a given police radio has a very limited range of coverage—as to distance. But, in numerous instances it is possible by means of police radio to establish a relay system which in emergency might prove very valuable.

Failure of Established Communication

Commercial telegraph and telephone systems as well as police radio are dependent upon the maintenance of continuous commercial electric power service, except in installations where emergency storage battery power is maintained for interruptions to 110-volt power. It is probable that if the defense emergency continues long, or becomes serious, recourse will be had to the provision of portable transceiver equipment, battery operated, for the use of Communication Sections of local Defense Corps. This is a subject for the FCC to consider in cooperation with NCB. The licensing of such sets to operate on existing police radio frequencies in particular municipalities would provide against power interruptions.

Commercial Service

The American commercial telephone system is the most dependable, and most widely available telephone service in the world. For national defense needs it is immediately available. The two large
(Continued on page 22)

SOME RECENT TELEVISION DEVELOPMENTS

A TELEVISION demonstration was recently conducted for the Federal Communications Commission by the Radio Corporation of America in cooperation with the National Television System Committee. The demonstration consisted of four main parts as follows:

Home receiver—New design of television set featuring pictures 13½ by 18 inches on translucent screen; also 8 by 10 inch pictures on 12-inch kinescope.

Facsimile — Multiplexed with frequency modulation sound broadcast from transmitter atop Empire State Building.

Theatre screen television — Projection of pictures in New Yorker Theatre using a projector in balcony to give a 15 by 20-foot picture on the screen 60 feet away. A new multisonic sound system is used.

Radio relays — Television pictures automatically relayed by radio from NBC mobile television unit at Camp Upton to New York, 68 miles. First relay to Hauppauge, 17 miles distant, and from there to Bellmore, 23 miles, and then to Radio City, New York, 28 miles. Pictures intercepted and transmitted by new horn antennas on relay towers, also received by horn antennas in window on 62nd floor of the RCA Building.

Large Screen Home-Receiver

Introducing a new design of home-television receiver, incorporating numerous developments that make possible a larger picture than heretofore seen on home-receivers, the RCA Laboratories have developed an instrument with a 13½ by 18-inch screen.

This developmental receiver is a

TRK-120 model modified to permit the use of a 5-inch projection kinescope in place of the regular 12-inch kinescope heretofore used to present an 8 by 10-inch picture. The new receiver is equipped with a retractable translucent screen, which slides down into the cabinet when the set is not in use. When in use, the screen is at the top of the set.

The size of the picture on the face of the new 5-inch projection kinescope is 2¾ by 3⅝ inches. The funnel-shaped tube, with its face pointed upward, is mounted on the floor of the cabinet. The picture as it appears on the flat face of the kinescope is enlarged by means of a coated f:2 lens of American design and projected to a mirror on the underside of the uptilted lid of the cabinet, from where it is reflected to the 13½ by 18-inch translucent viewing screen.

Although the projected 441-line, 30-frame picture has 3½ times the area of a regular kinescope receiver, the brightness of the image is the same.

Multiplexed Facsimile and "FM" Sound

Utilizing a single frequency-modulated ultra-short-wave channel to perform two services simultaneously, facsimile and high-fidelity sound, the RCA Laboratories have developed a new method of radio multiplexing.

Microphones in an NBC studio in the RCA Building fed sound over a wire to the f-m transmitter in the Empire State Building, while the facsimile machine operated in a laboratory at

Radio City. A wire line also linked the facsimile scanner with the transmitter. The electrical currents, one carrying sound, the other printed matter or pictures, were combined at the transmitter to modulate a one kilowatt f-m station operating on 45.1 megacycles.

In the demonstration the sound and print signals were detected by a receiver at Radio City. The duty of the receiver was to "unscramble" the sound from facsimile, and reproduce both to correspond with the original transmission. Then the sound was fed into a high-fidelity loudspeaker. The facsimile signals actuate a carbon paper recorder capable of reproducing printed matter, drawings, maps, pictures, etc. The machine, performing this double duty, is about the same size as a standard radio-phonograph console.

The f-m channel is 200 kilocycles wide. For the high-fidelity sound (30 to 15,000 cycles) 150 kilocycles are used. For the facsimile impulses approximately 30 kilocycles of the channel are employed. The remaining 20 kilocycles are utilized as guard bands to keep the sound and facsimile apart.

The facsimile instrument prints on a strip of paper 8 inches wide. Printing speed is 1¼ inches a minute, making it possible to reproduce a message the size of a business letterhead or an 8 by 10-inch picture in less than ten minutes.

Theatre Screen Television

Large-screen television equipment projected a 15 by 20-foot picture on the screen in the New Yorker theatre. There was featured, in addition to new developments in projection, a new multisonic sound system developed by RCA

Left: Depicting theatre television projection. Right: Showing the television relay links.

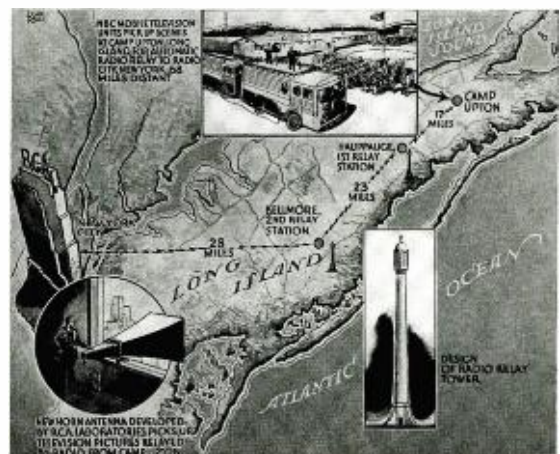
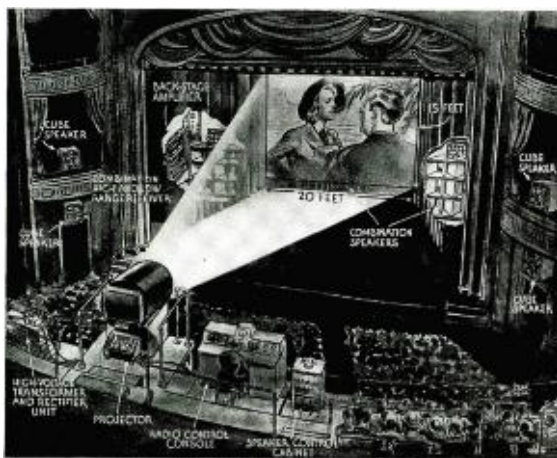

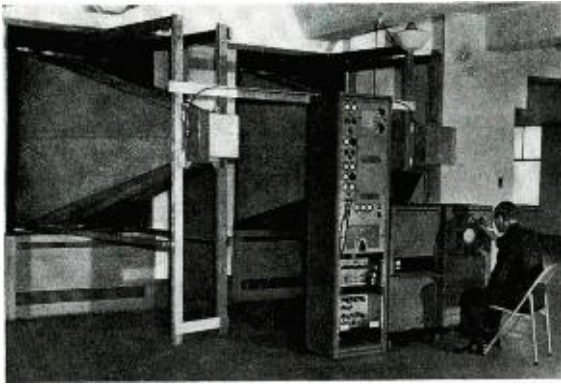

Above: Showing the equipment used backstage in the theatre. Right: Photo of projector and control equipment.

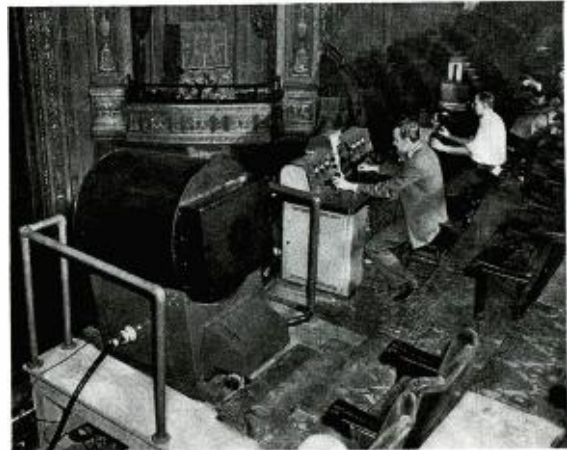

Laboratories for use with the television screen.

A steel-barreled projector pointed over the edge of the balcony casts the television images on the stage screen 60 feet distant. Alongside the projector are control desks at which operators manipulate the knobs that regulate the picture and sound. These operators exercise the same control over faces and scenes as radio control men do over broadcast music and speech. The pictures, as they come over the wire from an outside point, are received first at the control desk to be fed into the projector. In the demonstration the Camp Upton scenes were relayed by radio to the RCA Building, then forwarded from Radio City to the New Yorker Theatre over special wire circuits.

The sound reproduction system used in connection with the theatre television unit is of the extreme high fidelity type, similar in effect and arrangement to the Fantasound¹ used in the motion picture "Fantasia." Differing from Fantasound in that it is manually controlled at the scene of reproduction, the multisonic system permits movement of sound with action on the screen, rotation of sound around the walls of the auditorium, and emanation of sound

¹See "Fantasound," p. 28, Jan., 1941, COMMUNICATIONS.

from any one desired point in the theatre.

The large-screen theatre television system operates on signals delivered to it either by coaxial cable or by special wire circuits.

The installation in the theatre consists of three main units: control, power supply, and optical system.

The control panel gives the operator immediate handling of all controlling, metering, and deflecting elements. He can obtain at any time, every possible check on the operation of the system. Sharpness, brightness, contrast, and size of the image projected may be changed by the turn of a knob. The controls are so simplified that the average motion picture projectionist could operate the unit with but slight training.

The second unit, the power supply for the optical or projection system, is a conventional high-voltage rectifier rated at 70,000 volts. Normally, operation is at 60,000 volts.

The optical, or projection unit, is considered the most important as well as the most complicated of the entire system. For purposes of description, it is possible to divide the unit into three principal elements; that is, the kinescope, or projection tube; the reflecting mirror, and the correcting lens.

The kinescope, built to handle high voltages, is similar in performance to the kinescope used in RCA's standard home-television receivers. The face or diameter of the tube is 7 inches; the tube's length is 14 inches. It is mounted in the center of a hollow steel-shielded cylinder 34 inches in diameter and 34 inches long. The face of the tube is pointed away from the stage screen, and the end of its neck pierces a small hole in the center of the correcting plate of the optical system.

The concave reflecting mirror, 30 inches in diameter, is mounted a few inches in front of the tube's face. The image on the face of the tube is picked up on the concave surface of the mirror, passed through the correcting lens and onto the screen with a magnification of 45 times. The lens corrects for aberrations and passes the image across the auditorium to the stage screen.

The optical system is unique in that it has a speed rating of $f: 0.7$, which surpasses the fastest known projection lens. It was developed by research engineers in the RCA Laboratories, and is a variation of the Schmidt astronomical camera. Optical experts viewed the idea in the beginning as impractical, but one of the engineers, whose hobby is optics, figured out a formula, devised special grinding instruments, and successfully developed the optical system. The first unit required six months to produce, but the technique of grinding the lens was improved to the point where the one used today was ground in six weeks.

The optical unit housing is mounted on a pedestal which contains the video amplifiers and the deflecting output circuits. Because of the optical unit's high efficiency, the screen illumination obtainable in the system is adequate for large-screen pictures in theatres.

Controls for the sound, which accompanies the television projection, are
(Continued on page 23)



The large screen home television receiver. This instrument has a 13½ by 18 inch retractable screen which slides down into the cabinet when the set is not in use. Projection is from a 5-inch kinescope, the size of the picture on this tube being 2¼ by 3⅜ inches.

NTSC TELEVISION STANDARDS

ON January 27 the National Television System Committee submitted its report on television standards to the Federal Communications Commission. Following this meeting the FCC announced that a formal hearing on television would be held on March 20.

Commenting on the March 20 hearing, FCC's Chairman Fly stated that "The Commission will make a broader inquiry at the future hearing, a more thorough examination of the engineering status of the art." Chairman Fly also pointed out that "Another question is that of the availability of materials and machines. You all know that we are engaged in a very broad effort toward national defense. It involves very serious demands on the manufacturer. There is a question when the television industry will be in a position to meet the demands for receiving and transmitting equipment."

Just what form the March 20 hearing will take is not yet known. However, the subjects of color television, syn-

chronization, and national defense will certainly be considered.

The report of the NTSC as submitted to the FCC follows:

Report

The National Television System Committee recommends herewith transmission standards for commercial television broadcasting. The Committee recognizes the coordinate importance of standardization and the commercial application of technical developments now in the research laboratories. These standards will make possible the creation, in the public interest, of a nationally coordinated television service and at the same time will insure continued development of the art.

Monochromatic transmission systems other than those embodied in these standards should be permitted to operate commercially, when a substantial improvement would result, provided that the transmission system has been adequately field tested and that the system is adequately receivable on receivers responsive to the then existing standards.

This Committee believes that, although color television is not at this time ready

for commercial standardization, the potential importance of color to the television art requires that—

(a) A full test of color on the Group A channels be permitted and encouraged, and that

(b) After successful field test, the early admission of color to the Group A channels on a commercial basis coexistent with monochromatic television be permitted employing the same standards as are herewith submitted except as to lines and frame and field frequencies. The presently favored values for lines, frame and field frequencies for such a color system are, respectively, 343, 60, and 120.

These transmission standards are recommended for commercial television broadcasting on the following channels:

No. 1.	50- 56 Mc.
No. 2.	60- 66 Mc.
No. 3.	66- 72 Mc.
No. 4.	78- 84 Mc.
No. 5.	84- 90 Mc.
No. 6.	96-102 Mc.
No. 7.	102-108 Mc.

I: The Television Channel

(1) The width of the standard television broadcast channel shall be six megacycles per second.

(2) It shall be standard to locate the

The television synchronizing wave form. Drawing II.

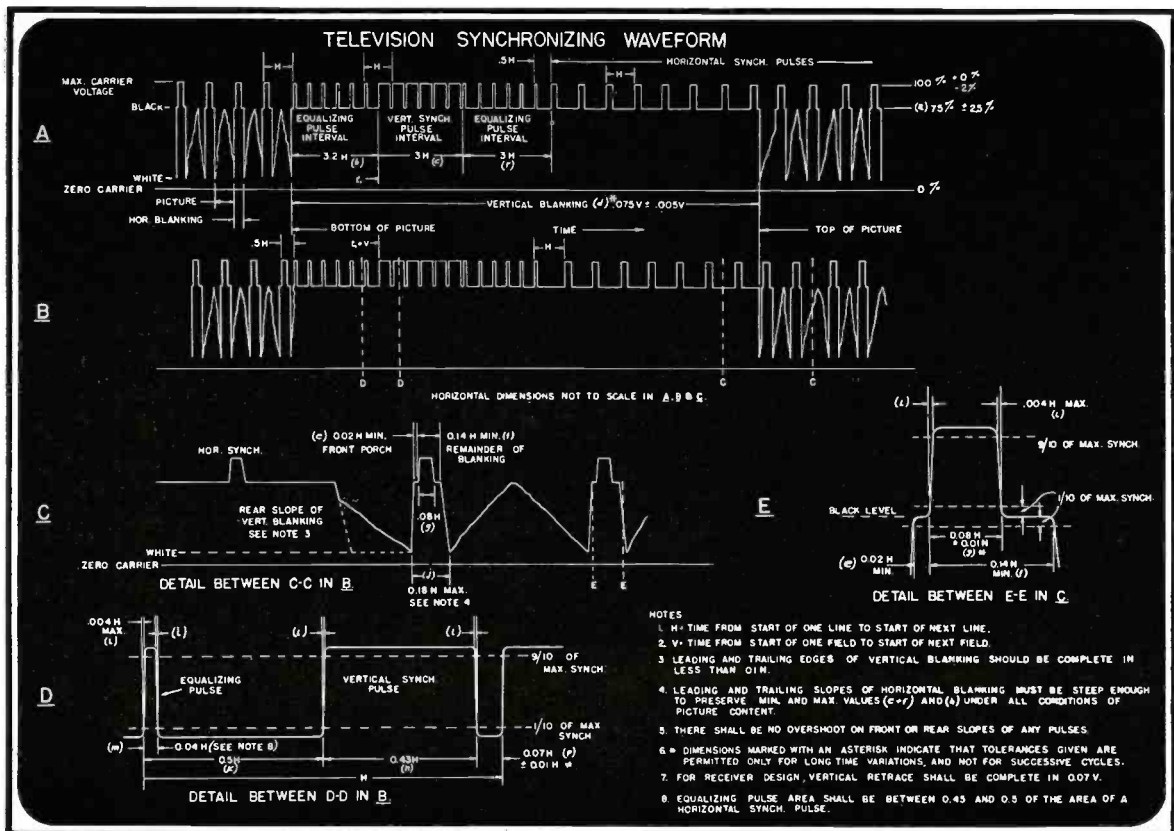

STROMBERG-CARLSON

The PARADE of Leaders in FM

FM and Eimac Tubes have been close companions from the very start. The first public announcement appeared in 1938 when Paul DeMars and the Yankee Network were carrying on their experiments. By the time Major Armstrong had convinced the world that FM was the next great advancement in broadcast transmission, Eimac Tubes were in practically every experimental broadcast station in the country. Stromberg-Carlson, REL, Zenith, The Milwaukee Journal Co. and many others were the leaders in this field and all use Eimac Tubes. There must be a good reason and there is: Eimac Tubes are the tried and proven tube for use in this service. Their unusual performance capabilities, stamina and complete freedom from premature failures due to gas released internally are a few of the good reasons why Eimac Tubes are **FIRST** in most all the important **NEW** developments in radio. Write for information or see the nearest representative.

Eimac TUBES

Eitel-McCullough, Inc.,
San Bruno, California

KSFO-REL
F. M.
DEMONSTRATION

ZENITH

YANKEE NETWORK

MILWAUKEE JOURNAL CO.

CONN. STATE POLICE

R. E. L.

EIMAC REPRESENTATIVES

California, Nevada
HERB BECKER, 1530 W.
104th St., Los Angeles, Cal.
Wash., Ore., Idaho, Mont.
GENERAL SALES CO.,
Verner O. Jensen, 2605-07
Second Ave., Seattle, Wash.
Colo., Wyo., New Mexico,
Arizona, Utah
RICHARD A. HYDE, 4253
Quitman St., Denver, Colo.

Ohio, Mich., Ky., Ind., Minn.,
Mo., Kan., Neb., Iowa
PEEL SALES ENGINEER-
ING CO., E. R. Peel, 154
E. Erie St., Chicago, Ill.
N. Y., N. J., Penn., Md., Del.,
Dist. of Col., Maine, N. H.
R. I., Conn., Mass.
ADOLPH SCHWARTZ,
14726 Elm Ave., Flushing,
New York.

N. Caro., S. Caro., Georgia,
Tenn., Flor., Ala., Miss.
JAMES MILLAR, 316 Ninth
St. N. E., Atlanta, Georgia.
Texas, La., Okla., Ark.
J. EARL SMITH, 2821 Live
Oak St., Dallas, Texas.
Chicago, Illinois, Wisconsin
G. G. RYAN, 549 W.
Washington Blvd., Chicago,
Ill.

picture carrier 4.5 megacycles per second lower in frequency than the unmodulated sound carrier.

(3) It shall be standard to locate the unmodulated sound carrier 0.25 megacycles per second lower than the upper frequency limit of the channel.

(4) The standard picture transmission amplitude characteristic shall be that shown in Drawing I.

II: Scanning Specifications

(5) The standard number of scanning lines per frame period in monochrome shall be 441, interlaced two to one.

(6) The standard frame frequency shall be 30 per second and the standard field frequency shall be 60 per second in monochrome.

(7) The standard aspect ratio of the transmitted television picture shall be 4 units horizontally to 3 units vertically.

(8) It shall be standard, during the active scanning intervals, to scan the scene from left to right horizontally and from top to bottom vertically, at uniform velocities.

III: Picture Signal Modulation

(9) It shall be standard in television transmission to use amplitude modulation for both picture and synchronizing signals, the two signals occupying different amplitude ranges.

(10) It shall be standard that a decrease in initial light intensity cause an increase in radiated power.

(11) It shall be standard that the black level be represented by a definite carrier level, independent of light and shade in the picture.

(12) It shall be standard to transmit the black level at 75 per cent (with a tolerance of plus or minus 2.5 per cent) of the peak carrier amplitude.

IV: Sound Signal Modulation

(13) It shall be standard to use frequency modulation for the television sound transmission.

(14) It shall be standard to pre-empha-

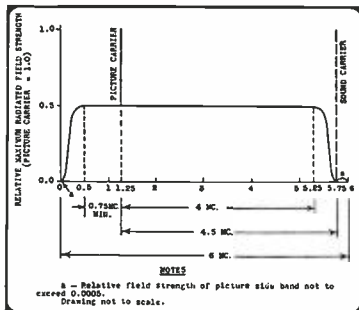

The idealized picture transmission amplitude characteristic. Drawing I.

size the sound transmission in accordance with the impedance-frequency characteristic of a series inductance-resistance network having a time constant of 100 microseconds.

V: Synchronizing Signals

(15) It shall be standard in television transmission to radiate the synchronizing waveform shown in Drawing II.

(16) It shall be standard that the time interval between the leading edges of successive horizontal pulses shall vary less than one-half of one per cent of the average interval.

(17) It shall be standard in television studio transmission that the rate of change of the frequency of recurrence of the leading edges of the horizontal synchronizing signals be not greater than 0.15 per cent per second, the frequency to be determined by an averaging process carried out over a period of not less than 20, nor more than 100, lines, such lines not to include any portion of the vertical blanking signal. (See Note A.)

VI: Transmitter Ratings

(18) It shall be standard to rate the picture transmitter in terms of its peak power when transmitting a standard television signal.

(19) It shall be standard in the modulation of the picture transmitter that the radio frequency signal amplitude be 15 per cent or less of the peak amplitude, for maximum white. (See Note B.)

(20) It shall be standard to employ an unmodulated radiated carrier power of the sound transmission not less than 50 per cent nor more than 100 per cent of the peak radiated power of the picture transmission.

(21) It shall be standard in the modulation of the sound transmitter that the maximum deviation shall be plus or minus 75 kilocycles per second.

VII: Polarization

(22) It shall be standard in television broadcasting to radiate horizontally polarized waves.

Note A: It is recommended that as progress in the art makes it desirable, the maximum rate of change of frequency of the transmitted horizontal synchronizing signals for studio programs be reduced and that limits be set for transmissions originating elsewhere than in the studio.

Note B: It is the opinion of the N. T. S. C. that a picture transmitter not capable of a drop in radio frequency signal amplitude to 15 per cent or less of the peak amplitude would be unsatisfactory since it would not utilize to the best advantage the available radio frequency power. At the same time the N. T. S. C. is aware of the practical situation that it may not be possible for all of the first picture transmitters to meet this standard. It should be possible in picture transmitters for the lower frequency channels in Group A to meet this standard, although it may not be possible for picture transmitters for the higher frequency channels in Group A to meet it at first. After the first operation on the higher frequency channels and as designs progress it should be possible to meet it.

It is requested that the Federal Communications Commission take cognizance of this situation.

Respectfully submitted,

W. R. G. BAKER, Chairman.

MOBILE AIRCRAFT RADIO SERVICE

AN interesting new mobile radio service was recently inaugurated by Lear Avia of California for all airports in the Los Angeles area. When a pilot needs radio service a call brings the radio service truck to any airport in the Los Angeles area within 20 minutes. Manned by aircraft radio service mechanics, the mobile workshop pulls up alongside the airplane and goes to work. If the pilot is in a hurry, the defective instrument is immediately replaced with a new instrument from the stock carried for that purpose in the mobile service shop. No flying time is lost: the faulty apparatus is repaired while the ship is flying, and reinstalled later at the pilot's convenience.

The Learadio mobile workshop is equipped to handle any aircraft radio service problem on the spot. Entirely independent from outside electric power lines, the mobile workshop carries its



Showing the mobile aircraft radio service truck in operation.

own generating equipment for both direct and alternating current of various voltages.

Elaborate test equipment carried in the mobile workshop permits rapid service analysis of any radio trouble. A full complement of tools and spare parts is also included, as well as outside electric power connections for starting airplane motors, floodlights for night work,

fire extinguishers, first aid kit, and many other accessories.

In addition, the mobile workshop is equipped with four Learadio transmitters (UT-6, T-30-AB, AMT-12 and AMT-1), four Learadio receivers (R-3-BB, AMR-12, AMR-1 and APR-A), and four Learadio direction finders (ADF-8, ADF-7, ADF-6 and AMRL). This equipment is available for demonstration or for temporary loan during repairs of any unit. Any airplane, from a Piper Cub Trainer to a trans-Atlantic Clipper, can be serviced or equipped on the spot.

The entire workshop is housed in a speedy 1½-ton cab truck. The low body floor and high cab roof provide full headroom for working at the two spacious workbenches inside the well-lit truck; a third workbench can be slid out at the back of the truck when on location.

Here Is The New, Improved LINGO **FM** TURNSTILE ANTENNA

(PATENTED)

*The Most Awaited FM Development
Since The Introduction of FM Itself!*

Offering These New Features!

1. Antenna radiates a horizontal polarized signal with uniform circular field pattern.
2. Antennas are custom built, and factory adjusted to the operating frequency, making no field adjustments necessary.
3. Design incorporates an improved and greatly simplified method of feeding and coupling.
4. Turnstile elements are fed by coaxial lines, and no open turnstile wires are used.
5. Lighting equipment and climbing steps may be installed without interference to the operation of the turnstile.
6. Heating elements can be used in turnstile arms for sleet melting where necessary.
7. Antennas are available with 2, 4, 6, 8 and 10 layers of turnstile elements, depending upon desired gain.

Now Available for Installation on Towers or Building Roofs

The introduction of this new improved LINGO FM Antenna marks another progressive step in the march of Broadcasting. LINGO has pioneered in the field of Frequency Modulation, and offers this new turnstile antenna as a distinct improvement over all previous designs. This major improvement in FM Antenna design is not an experiment. It has been completely developed, and the performance has been proved by actual tests.

Quotations will be gladly submitted for individual applications only, and will include the essential tubular steel mounting pole, turnstile elements, coupling equipment, transmission lines feeding the elements, etc. Climbing steps, lighting equipment, and sleet melting units, are also available as optional equipment. The erection of the Turnstile Antenna on your supporting tower, or building roof, can also be included.

JOHN E. LINGO & SON, INC. DEPT. C-2 CAMDEN, N. J.

LINGO VERTIC
TUBULAR FEEL
RAD. TORS

**HERE'S THE FM
ANTENNA YOU'VE
BEEN WAITING FOR!**

You'll want to know about this New Lingo Antenna — Write today for complete facts and please indicate your proposed frequency, power and location. Similar Antennas Are Being Developed For Television. Write for Preliminary Information.



VETERAN WIRELESS OPERATORS ASSOCIATION NEWS



W. J. McGONIGLE, President

RCA BUILDING, 30 Rockefeller Plaza, New York, N. Y.

GEORGE H. CLARK, Secretary

Cruise

THE annual Dinner-Cruise of our Association was held at the Hotel Astor, Tuesday evening, January 11, 1941. At this Cruise, devoted to National Defense, our Association celebrated its Sixteenth Anniversary. Simultaneously in other cities throughout the land our Chapters brought together their members in a spirit of camaraderie to lend their efforts in promoting the best possible National Defense. Communications, and especially wireless communication, unquestionably plays a major part in this Defense effort. Our members are well qualified to do their part, and determined to succeed.

We are pleased to acknowledge the following message from Mr. James L. Fly, Chairman of the Defense Communications Board. Mr. Fly greeted us as follows:

"Permit me to extend my congratulations to the Veteran Wireless Operators Association on the occasion of its Sixteenth Anniversary Dinner-Cruise. It seems to me that there is a very tangible and increasingly important function in the radio communications industry to be served by an association dedicated in the main to fostering and extending an esprit de corps in the industry through opportunities for social intercourse. This function has, I believe, been well served by the Association in the past, and my hope is that it may continue its valuable activities in promoting a fraternal feeling within the industry."

Awards

In recognition of their outstanding contributions to the Radio Art and the best possible National Defense the following awards were made:

Marconi Memorial Service Award to Defense Communications Board, James Lawrence Fly, Chairman.

Marconi Memorial Medal of Service to Major General J. O. Mauborgne, Chief Signal Officer, United States Army.

Marconi Memorial Medal of Service to Rear-Admiral Leigh R. Noyes, Director of Naval Communication, United States Navy.

Marconi Memorial Medal of History to George H. Clark, Historian of Radio.

Marconi Memorial Wireless Pioneer Medal to Arthur A. Isbell, Lt. Comdr., United States Naval Reserve (Ret.).

Marconi Memorial Scroll of Honor to David Karp for outstanding radio service.

We were honored by the acceptance of Honorary Membership in our Association by the following:

George W. Bailey, President ARRL and Chairman of the Amateur Committee of the National Defense Board.

James Lawrence Fly, Chairman of the National Defense Board and the Federal Communications Commission.

Major General J. O. Mauborgne, Chief Signal Officer of the United States Army.

Rear Admiral Leigh R. Noyes, Director of Naval Communications, United States Navy.

Niles Trammel, President of the National Broadcasting Company.

We also welcome William J. Halligan, President of The Hallicrafters, into the Association as a Life Member.

The Second Marconi Memorial Scholarship in Radio and Electrical Communication at R. C. A. Institutes was awarded on August 17, 1940, to Robert J. Stahl of Redwood City, Cal., winner of a contest conducted by the American Institute of the City of New York.

Our Association will make Awards in a series of contests designed to stimulate greater proficiency in Communications in connection with National Defense—the first being a Marconi Memorial Award to the winner of the Army Amateur Radio System Code Proficiency Contest.

On behalf of J. R. Poppele, Chairman of our Scholarship Committee, we express our sincere appreciation to Mr. E. H. Rietzke, President of Capitol Radio Engineering Institute, and announce that a scholarship for one year's study at the Capitol Institute will be awarded by our Association in connection with National Defense.

Shrine to Marconi

Although many incidents of heroism by wireless operators at sea occurred during the early days of the art, it was not until the world-startling tragedy of the *Titanic*, on April 15, 1912, and the death of Jack Phillips, who went down with the ship while still sending the call for help (and although rescued later—died from exposure) that the movement arose to commemorate such brave deeds of wireless operators by a monument to their memory.

The plan was initiated in 1912 by C. C. Galbraith, President of the United Wireless Company, together with the heads of several shipping lines. Soon after the preliminary plans had been made, the United was taken over by the Marconi Wireless Telegraph Company of America, and Mr. Galbraith continued his efforts on behalf of the monument when he became an official of the new concern.

Funds were solicited from operators, from passengers at sea, and from the general public. The first contribution was from the *New York Times*, in amount \$100; this was followed by one of \$25 from Harold Bride, who had been Phillips' assistant on the *Titanic*; the Marconi Company gave \$500. In all, several thousand dollars were accumulated.

A committee formed and headed by Mr. Galbraith planned not only to erect a memorial, but also to establish a permanent fund for the relief of the widows and families of wireless men who died in the performance of their duty. Several such charitable donations were made prior to the erection of the monument itself.

The monument design took form, under the creating hands of Hewitt and Bottomley, architects, who submitted the layout

as their donation to the enterprise. It consists of a large granite fountain, behind which rises a granite shaft bearing bronze plates on which are inscribed the names of many wireless men who have given their lives in devotion to duty. The two pieces were erected at the extreme southern part of Battery Park, New York City's outlook to the sea, at the base of the Barge Office tower and against a screen of stately cedars and poplars.

Dedication took place on May 12, 1915, the Honorable George McAneny, acting Mayor of New York City, accepting the memorial on behalf of the city, while the Maritime Association of the Port of New York, in whose hands the administration of the fund had rested, stood in the position of donor. The entire New York force of the Marconi Company was present at the exercises, the Company's offices being closed for this purpose.

The matter of the Memorial being closed, a permanent committee was formed to administer the relief fund. This was headed by J. B. Duffy, C. D. Guthrie, and Benjamin Beckerman. This group of trustees, with changes, has kept in active service up to the present time, one of its duties being to oversee the upkeep of the monument and to take charge of adding new names to the bronze plaques. The present committee consists of George H. Clark, Chairman; J. B. Duffy, Benj. Beckerman, and Sam Schneider.

The Monument Trustees also took to themselves the duty of holding Memorial Day Exercises at the site, but in 1928 this ceremony was voluntarily turned over to the Veteran Wireless Operators Association.

The monument will not remain forever in its present position, for sweeping changes in the topography of Battery Park, undertaken as a part of the beautification of New York's park system by Commissioner of Parks Robert A. Moses, will take away the present site of the memorial. It has been planned and tentatively agreed upon by the Park Department that a consolidation will be made of the present Operators Monument and the proposed memorial to the late Senator Marconi, funds for which have been solicited under the direction of Mr. David Sarnoff, Chairman of the VWOA Marconi Memorial fund. Further impetus to this plan has been given during the past year by the Italian Government, which has presented to the VWOA, through the office of Dr. Constantino, head of the Italian Commission for the New York World's Fair, 1940, a bas relief of the head of the late Father of Wireless together with large black marble slabs enclosing it, the ensemble having formed a part of the Italian Building at the Fair. A combination of the Operators' Monument and the Marconi Pile, with suitable architectural additions to tie the two into a harmonious whole will, according to plan,

(Continued on page 26)

The Monitor

FM HAS WAITED FOR!

Again
G.E.
LEADS THE
WAY



One Unit Provides All These—

- 1 Direct reading of center-frequency deviation (with or without modulation)
- 2 Direct reading of modulation percentage
- 3 Instant calibration against a precision crystal standard
- 4 Adjustable modulation-limit flasher
- 5 High fidelity output for audio monitor

Here's everything you need in an FM broadcast monitor. It's completely self-contained, with built-in voltage-regulated power supply and hermetically sealed precision crystal units. It stole the show at the IRE Convention in New York.

ORDER NOW

... through the nearest
G-E office or direct from
General Electric, Radio
and Television Department,
Schenectady, N. Y.

GENERAL  **ELECTRIC**

160-12-8914

OVER THE TAPE . . .

NEWS OF THE COMMUNICATIONS FIELD

HELT CHAIRMAN NAB ENGINEERING COMMITTEE

Scott Helt, Chief Engineer of Radio Station WIS, Columbia, S. C., has been appointed Chairman of the Engineering Committee of the Fourth District of the National Association of Broadcasters. Appointment was made by John A. Kennedy, of Charleston, West Virginia, Director of the Fourth District, which comprises the States of Maryland, Virginia, North Carolina, South Carolina and West Virginia, as well as the District of Columbia. Helt completed his sixth year of service as Chief Engineer of WIS on January 3, 1941. During that time he has been in complete charge of the WIS transmitter and crew and has supervised all construction and maintenance work.

N. U. INCREASES TUBE PRICES

Because of higher raw material costs, prices of radio tubes, which have been at subnormal levels, have been increased an average of 5 cents each by National Union Radio Corporation, it was announced by S. W. Muldowny, President.

JEFFERSON-TRAVIS EXPANDS

Jefferson-Travis Radio Mfg. Corp. are again expanding. The complete manufacturing, engineering, and office facilities of the organization are now located at 380 Second Ave., New York City. The telephone is GRamercy 3-5493.

SOLAR APPOINTMENT

Solar Mfg. Corp., Bayonne, N. J., manufacturers of capacitors, announces the appointment, as industrial sales engineers for the state of Ohio, of the Ambos-Jones Co., 1085 The Arcade, Cleveland, Ohio.

UNIVERSAL REDUCES RECORDER LINE

Universal Microphone Co., Inglewood, Calif., in January discontinued production on its recorder line with the single exception of the professional model. It will continue to put out the recording chassis for quantity orders to manufacturers and jobbers.

CHANGE OF NAME

On February 1 Goat Radio Tube Parts, Inc., changed their name to Goat Metal Stampings, Inc. The change was made to more accurately reflect their present business, according to E. F. Staver, secretary of the organization. The change accompanied a plant expansion and reorganization. Goat now produces a variety of stampings other than radio tube parts and shields.

HOWARD CATALOGS

Howard announces three new catalogs. One is the 490 technical manual. In addition to full charts and schematics on the Howard 14-tube professional receiver, several pages are devoted to the art of receiver measurements. A good technical book for amateurs, servicemen and sound engineers. The other catalogs are Folder 103, containing data on recording discs and needles; and Folder 104, on the complete line of communication receivers and accessories.

NEW SIGMA PLANT

Sigma Instruments, Inc., have recently moved from the former quarters at 388 Trapelo Rd., Belmont, Mass., to their new home at 76-78 Freeport St., Boston, Mass. The larger quarters have improved facilities for the manufacture of sensitive and semi-sensitive relays, acoustic switches, audio-frequency relays, etc.

JANETTE BULLETIN

Janette has recently issued Bulletin 13-25 which gives rather complete information on their line of rotary converters and dynamotors. Copies of the bulletin may be secured by writing to the Janette Manufacturing Co., 556-558 W. Monroe St., Chicago.

SHALLCROSS BULLETIN

Shallcross Bulletin No. 825 contains a comprehensive listing of resistance decades for almost every need. It also contains information on unmounted decade resistances, wire-wound resistors, rotary instrument switches, binding posts, and decade potentiometer. Shallcross Mfg. Co., 10 Jackson Ave., Collingdale, Pa.

HALLICRAFTERS BULLETIN

A new 20-page bulletin has been made available by The Hallicrafters, Inc., 2611 Indiana Ave., Chicago. Rather complete data is given on their line of communication equipment. Among the interesting new items is a high-fidelity tuner for frequency modulation and amplitude modulation broadcast reception.

FEDERAL BULLETINS

The Federal Telegraph Co., 200 Mt. Pleasant Ave., Newark, N. J., have issued data sheets on the F-343-A and F-343-R transmitting tubes. A price list of transmitting and rectifying tubes has also been made available.

WALCO NEEDLE PRICES

The Electrovox Co., 424 Madison Ave., New York City, have announced a 30% reduction in the list price of Walco sapphire needles. The reduced prices were made possible by production increases and wider use of the needles, it is said. Literature is available from the above organization.

CINAUDAGRAPH CATALOG

A new catalog gives technical and descriptive data on the Cinaudagraph line of speakers. Copies may be secured from Cinaudagraph Speakers, Inc., 2 Selleck St., Stamford, Conn.

VIBRATOR MANUAL

The Turner Co., Cedar Rapids, Iowa, have just issued a vibrator manual which contains considerable technical data. Copies may be obtained by writing for Catalog 1-41.

BOOK CATALOG

The new fall 1940 catalog of technical and scientific books of the Chemical Publishing Co., Inc., 148 Lafayette St., New York, N. Y., contains many new titles. Books in all technical and scientific fields have been added to the previous works.

INTERNATIONAL NICKEL BULLETIN

The Development and Research Division, International Nickel Co., Inc., 67 Wall St., New York City, have made available Bulletin T-19 on "The Deep Drawing, Shearing and Perforating of Monel, Nickel and Inconel." Write to the above organization for copies.

G-E BULLETINS

The General Electric Co., Schenectady, N. Y., have issued two bulletins covering Mycalex insulators (GET-903A) and the Type DO-61 vu volume level indicator (GEA-3145A). Copies may be secured by writing to the above organization.

NEMA BOOKLET

The National Electrical Manufacturers Association issued publication No. 41-63 during January 1941. This booklet covers NEMA Steatite Electric Insulation Standards. Copies may be obtained by writing to the above organization at 155 East 44th St., New York City. The price is 10c.

TUBE CHARACTERISTICS CHART

Complete information on the characteristics, classification, and socket connections of RCA receiving tubes is included in the new edition of the RCA Receiving Tube Characteristics Chart now being supplied through RCA tube distributors. The chart, published in 14-page booklet form, is valuable for engineers and others in constant need of complete information on radio tubes. The chart is printed in easily legible, large-size type. The first two pages are given over to classifying RCA tubes according to their cathode voltages and their functions. It assists the tube user in identifying type numbers and choosing the proper tube type for a given application. The following nine pages make up the characteristics chart. Complete information is given as to dimensions, socket connections, cathode type and rating, use, plate supply, grid bias, screen supply, screen current, plate current, a-c plate resistance, transconductance, amplification factor, load and power output. On the last two pages are shown bottom views of socket connections for 116 types of tubes.

NATIONAL CATALOG

The National Co., Inc., 61 Sherman St., Malden, Mass., have just made available Catalog No. 400. Data is given on dials and knobs, condensers, couplings, coils and chokes, plate and grid grips, shields, cabinets, sockets, insulators, amplifiers and modulators, oscilloscopes, transmitters, and receivers.

SOLAR DISTRICT MANAGER

Solar Manufacturing Corporation, Bayonne, N. J., manufacturers of capacitors, announces the appointment as District Manager for the State of California, of Mr. Harry A. Lasure, 2216 West Eleventh Street, Los Angeles, California.

(Continued on page 20)



★ WESTINGHOUSE

★ WESTERN ELECTRIC

★ RCA

★ RADIO RECEPTOR

★ GENERAL ELECTRIC

★ MARINE COMMUNICATIONS

★ CBS

★ NAVAL RESEARCH LABS.

★ BELL TELEPHONE

★ FEDERAL TELEGRAPH CO.

★ WESTERN UNION



Recognized Quality

The quality of UTC products is well illustrated by the leaders of American industry who have chosen them for use in their equipment.

The UTC research laboratories are doing continuous research and development on special units to fit specific customers' requirements.

May we assist you on your problem?

UNITED TRANSFORMER CORP.

150 VARICK STREET ★ NEW YORK, N. Y.
 EXPORT DIVISION: 100 VARICK STREET NEW YORK, N. Y. CABLES: "ARLAB"

COLOR TELEVISION

THE first public showing of direct pickup of color television was made by the Columbia Broadcasting System before the members of the IRE on January 9. Operation of the direct pickup was explained by Dr. Peter C. Goldmark, CBS's chief television engineer, using slides and actual color television pictures.

The color pictures were picked up by a television camera in the CBS television laboratories on the fifth floor at 485 Madison Avenue, New York, transmitted by coaxial cable under 52nd Street, and reproduced on two different models of color receivers in Studio 21 of the new CBS studio building at 49 East 52nd Street.

Three receivers were used in the demonstration: a standard black-and-white receiver adjusted to receive color pictures in black and white, a standard black-and-white receiver that has been adapted for color, and a compact table model color receiver (which includes a standard broadcast radio receiver) especially designed and constructed in the CBS laboratories. This last receiver illustrates that color need not add bulkiness to the television receiver.

The color pickup is accomplished with an orthicon tube. The level of light

required for direct color pickup is not particularly high by television standards. As a matter of fact, a satisfactory picture can be picked up with a lower level of illumination than is necessary for satisfactory black and white pictures when using the current type of studio pickup tube. Special orthicon tubes are now being developed which are expected to require even less light than the orthicon used in the demonstration.

The small, specially designed and constructed receiver incorporates two important features not previously demonstrated to the public. The first of these is a method of synchronizing the color disk in the receiver with the color disk in the studio by the synchronizing impulses ordinarily transmitted. This means it is not necessary to rely upon 60-cycle current for synchronizing the disks, and permits reception of color pictures when a receiver and transmitter operate from different power supplies.

This receiver also has a simple, ingenious method of phasing the color disk so that the colors shown at the receiver can be "locked" to the colors being picked up. The viewer at home has only to push a button on the cabinet's side

until the picture appears in its proper colors, then release the button. The colors remain properly synchronized with those of the original scenes.

Some of the live subjects shown at the CBS demonstration were the same as those shown IRE during the film demonstration in October to facilitate comparison between film and direct pickup.

One impressive part of the demonstration emphasized dramatic effects possible with color television. Merely by turning a dial, Mr. Goldmark was able to create the effect of moonlight on the face of a girl.

During the demonstration, a new system of low intensity fluorescent lighting was used. These lights eliminate most of the glare from the eyes of the person in front of the camera and are "cold light" so that no discomfort is experienced. They were developed in the Columbia Broadcasting System television laboratories.

The demonstration showed substantial progress along new fronts such as: direct pickup itself; synchronization of color disks; phasing of color disks, and new lighting methods for color television.

Over the Tape —Continued from page 18

WM. H. CAPEN DIES

William H. Capen, Assistant Vice-President and Assistant General Technical Director of the International Telephone and Telegraph Corporation, died at Orange Memorial Hospital, East Orange, N. J., on January 15 after a brief illness. He was fifty years of age.

G-M LABS. MOVES

Fifteen years ago the famous radio scientist, Dr. Lee DeForest, who was then pioneering in his work on "sound-on-film" for movie projectors, delegated G-M Laboratories, Inc., to create a photoelectric cell for this specific purpose. From this auspicious beginning, G-M Laboratories rapidly became one of the foremost concerns in America manufacturing photoelectric cells on a commercial scale.

The steadily increasing demand for its wares made it necessary for G-M Laboratories to enlarge its manufacturing facilities and, in order to provide the maximum of efficiency in plant arrangement, it was decided by the management to erect a new building, purposely planned to serve the exacting needs of precision production. The new building, located at 4314-26 North Knox Ave. in Chicago, in the Montrose Industrial District, is of the modern Daylight type of construction with ample skylight and window areas.

DOOLITTLE BULLETIN

Doolittle Radio, Inc., 7421 S. Loomis Blvd., Chicago, have issued an interesting

bulletin on their line of police radio equipment. This bulletin gives data on both a-m and f-m transmitters and receivers as well as accessories and control units. Copies available on request.

RADIO INSPECTOR POSITIONS TO BE FILLED THROUGH CIVIL SERVICE TESTS

The United States Civil Service Commission has announced examinations to fill the positions of radio inspector in the Federal Communications Commission at \$2,600 a year, and assistant radio inspector in various departments at \$2,000 a year. The salaries are subject to a 3½ percent retirement deduction. Applications must be filed at the Civil Service Commission's Washington office not later than March 6 and March 10, 1941, the extra time being allowed for those sent from Colorado and States westward.

The duties of these positions involve radio inspection work of all kinds, including inspecting radio equipment on ships, aircraft, and at various land stations to determine compliance with government specifications. Applicants must have completed 4 years of college study in electrical or communication engineering, or in physics, except that they may substitute radio engineering experience for part of this requirement. In addition, for radio inspector they must have had experience in working with radio transmitters, or must have completed certain graduate study in communication engineering.

For radio inspector in the Federal Communications Commission, applicants must

also hold a first-class radiotelegraph operator's license, or demonstrate that they can receive and transmit plain text in the International Morse Code at the rate of 25 words a minute.

Further information and application forms may be obtained from the Secretary of the Board of U. S. Civil Service Examiners at any first- or second-class post office, or from the U. S. Civil Service Commission, Washington, D. C.

DRAKE APPOINTMENT

Mr. A. J. Foute, of Drake Manufacturing Co., recently announced the appointment of his son, Kenneth Foute, as Sales Engineer. Ken, a recent graduate of the University of Illinois, brings to the company a likable personality and an understanding of aggressive modern business practices. Drake Mfg. Co. is the largest exclusive producer of dial and jewel pilot light assemblies.

EICOR MOVES

Eicor, well known manufacturers of dynamotors, small aircraft d-c motors, power plants, and converters, are now located in their larger plant at 1060 W. Adams St., Chicago.

DUMONT BULLETIN

The new DuMont type 208 cathode-ray oscillograph is described in considerable detail in a new bulletin. Write to the Allen B. DuMont Laboratories, Inc., 2 Main Ave., Passaic, N. J.



ANNOUNCEMENT
EXTRAORDINARY!

DUAL 24 HOUR **\$840⁰⁰**
RECORDER
FOR SIMULTANEOUS PLAYBACK



SINGLE SPOT **\$540⁰⁰**
RECORDER
FOR INSTANTANEOUS PLAYBACK



PORTABLE **\$300⁰⁰**
FOR INSTANTANEOUS PLAYBACK

**REFERENCE
RECORDING**
*Costs Cut
2 ways!*

for
CONVERSATIONS
CONFERENCES
COMMUNICATIONS
and
VOICE TRAINING

★ **HERE'S NEWS... Real News!** NOW... life-like reference recordings... on paper-thin discs... suitable for filing like a letter... as simply and easily made as using a telephone or phonograph! Revolutionary new equipment costs approximately **ONE-HALF!** Operating costs as low as **10 CENTS PER HOUR!** Sensational savings are now available to airlines, radio stations, schools, police departments and all commercial and industrial concerns. **5 MODELS**... portable and stationary types... ready for immediate delivery. New Functional Assembly to meet your exact requirements. Write, wire or telephone for further information!

**PAPER-THIN RECORDS
-FILE LIKE LETTERS!**

Special plastic material — flexible, tough, nearly indestructible! Unaffected by atmospheric temperature or moisture. Clean, easily handled. Not a fire hazard. Makes no shavings. One stylus serves indefinitely. Easily titled and filed for future reference and playback.

When writing, submit full details of your reference recording problem for complete engineering report. Address
Department E-3.



FRANK RIEBER, Inc.

Main Office and Factory
11916 WEST PICO BLVD.
LOS ANGELES, CALIF.



Licensed by Electrical Research Products, Inc. under Patents of American Telephone & Telegraph Co. and Western Electric Co. Inc.

PRACTICAL DATA
FOR THOSE WHO DESIGN AND BUILD TRANSMITTERS

Transmitting AEROVOX Capacitor Catalog

Reference for the design, construction, testing and maintenance of radio transmitters, electronic and allied equipment. Laboratory capacities. The instruments and smaller tools.

• This new loose-leaf catalog and engineering manual is available to engineers, designers and builders of commercial-grade transmitters, P-A systems, electronic and allied equipment. Contains page after page of listings of extra-quality heavy-duty capacitors of such types as mica, oil, and plug-in electrolytics, of particular interest to those who build to last and to safeguard enviable reputations.

Aerovox has extended its already outstandingly complete choice to include these extra-quality heavy-duty capacitors. What were special types yesterday now become standard Aerovox capacitors today, in taking care of the most critical requirements.

Ask for Your Copy . . .

• If you are engaged in designing and building commercial equipment, write on your business letterhead for a copy, registered in your name.

AEROVOX
 CORPORATION
 NEW BEDFORD, MASS.
 IN CANADA: AEROVOX CANADA, Limited, Hamilton, Ont.

BRIDGED T PADS

(Continued from page 6)

amount of (undesirable) capacity to ground. To avoid as much of this as possible, the arm of either the y or the R_a rheostat—as the case may be—should be grounded, which means that this arm must be insulated from the others. In the case of the bridged tee this insulation is necessary, hence for television purposes the two types of pads meet here on an equal footing as regards construction of the rheostats. But the bridged tee has only one other rheostat arm, whereas the ordinary tee has two additional arms. Consequently the bridged tee is better suited for wide-frequency-range operation, such as in television. A place for its use is in a coaxial cable system, where its excellent impedance matching ability stands it in good stead.

VII. Conclusion

In conclusion it may be noted that the variable bridged tee attenuation pad matches perfectly on an image basis for all values of attenuation from zero to infinity, with a zero minimum insertion loss. It does this by employing two variable resistances and two fixed resistances. For an infinite attenuation range, the latter two resistances should have a value equal to the image impedance of the pad, in order that a negative resistance be avoided for the shunt arm, i.e., in order that the pad be physically realizable.

NATIONAL DEFENSE

(Continued from page 9)

telegraph companies also are well equipped to serve the needs of national defense. Networks provide high-speed written-communication service from Washington, D. C., to industries in every part of the country. Lines extend to army posts and into training camps. The large key industries have been pro-

If your Sound Problem calls for:

- ★ Long Distance Sound Projection
- ★ Large Area Sound Coverage
- ★ Very Clear Voice Reproduction
- ★ Waterproof Construction
- ★ Limited Power Amplifier Wattage

Then Specify
UNIVERSITY REFLEX
 HIGH EFFICIENCY SPEAKERS

UNIVERSITY Reflex Speakers have highest possible efficiency, far greater than any other type of loud speaker. This high efficiency makes it possible for a single Reflex speaker to project sound clearly for over 2 miles with only 25 watts input. Two Reflex High Efficiency Speakers covers an outdoor group of 50,000 people. Only one-half the average power amplifier will be required. Background noise is no longer a problem, due to clarity of high audio output.

If you have a sound problem, write to our engineering department for immediate attention.
UNIVERSITY LABORATORIES
 195 CHRYSTIE STREET - NEW YORK CITY

WHEN YOU CHANGE YOUR ADDRESS

Be sure to notify the Subscription Department of COMMUNICATIONS at 19 E. Forty-seventh St., New York City, giving the old as well as the new address, and do this at least four weeks in advance. The Post Office Department does not forward magazines unless you pay additional postage, and we cannot duplicate copies mailed to the old address. We ask your cooperation.

JONES 140 SERIES TERMINAL STRIPS



140
 3/4" wide by 13/32" high.
 2 to 21 terminals.
 5-40 by 5/16" screws.



141
 1 1/8" wide by 1/2" high.
 2 to 20 terminals.
 6-32 by 1/4" screws.



142
 1-5/16" wide by 3/4" high.
 2 to 17 terminals.
 8-32 by 5/16" screws.

Barrier strip not only makes long leakage path but prevents direct shorts from frayed wires at terminals. Molded bakelite insulation. Ample space on sides for engraving numbers or designations in white. Three sizes as shown. A handy terminal with many applications. Write for prices.

HOWARD B. JONES 2300 WABANSIA AVENUE CHICAGO, ILL.

vided with modern reperforator switching telegraph systems to energize organization and production of war materials, and lines extend to the communication centers of the army, navy, coast-guard and marine corps, and to all key headquarters of national defense.

A census of available communication engineers is now being taken to the end that the Government may know about the experience and availability of competent engineers and technicians. All radio, telephone and telegraph engineers and operators should think constructively about the utility of communication in national defense, and should not hesitate to suggest to the proper authorities any ideas for betterment which occur to them. In no war in which the United States has been engaged in seventy-five years have any explanations or apologies been called for either during the operations or afterward, from men charged with maintaining communications. In the present emergency communications in all of its branches is better prepared than ever before to provide and maintain a high degree of national service.

TELEVISION DEVELOPMENTS

(Continued from page 11)

mounted in a separate console, adjacent to the television control desk. They are linked to 18 high and low-frequency loudspeakers mounted around the auditorium. Wire lines connect the console with the NBC studios and with the central radio receiving point in Radio City. In addition, there are lines which the sound control engineers use for crueing the program.

Three banks of regular RCA Telephone speakers are set up on the stage near the screen. One bank is at the rear of the screen, and the other two are at either side. Beginning at the outer edge of the proscenium arch, other loudspeakers are located at desired points along the side wall and in the rear of the auditorium. One large loudspeaker is suspended from the ceiling.

In installing the sound equipment, engineers incorporated the latest improvements for motion pictures and radio, as well as recent discoveries in the laboratory. Potentially, the equipment is expected by engineers to create a vivid illusion of realism. At present, however, it is viewed as experimental.

The sound control engineer in the theatre, taking his cue from engineers at the pick-up scene, is able to cause the sound to move from left to right or right to left, or to remain stationary in synchronization with the action on the screen. Whenever desirable, he can cause the sound to come from the left

NOW YOU CAN MAKE

ORTHACOUSTIC

PRESTO RECORDINGS

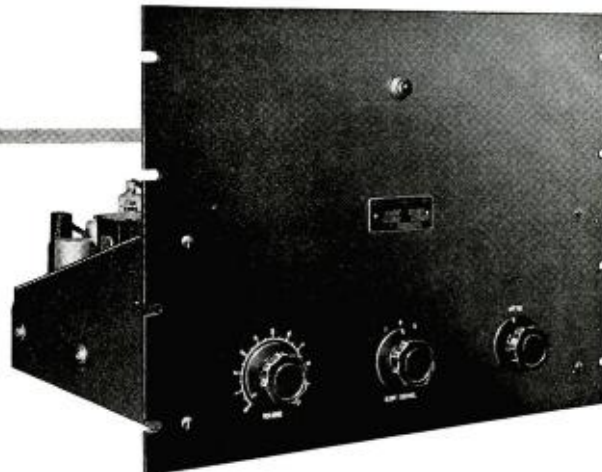

PRESTO 88-A AMPLIFIER

With the development of the new 88-A, 50 watt recording amplifier, Presto offers you for the first time a completely calibrated instantaneous recording system. The frequency response of the 88-A amplifier is matched to the characteristics of both the Presto 1-C cutting head and the Presto recording disc. Changes in response due to varying groove diameter are taken care of by the Presto 160-A automatic equalizer.

Using this complete system you can make Presto instantaneous recordings which will reproduce a frequency range from 50 to 9,000 cycles, uniformly, from start to finish.

A selector switch on the 88-A control panel pre-emphasizes the high frequency response to match the NBC Orthacoustic or either of the two high fidelity lateral reproducing systems now standardized in most broadcasting stations.

The 88-A amplifier has a gain of 85 db providing all the amplification necessary between your program lines or preamplifiers and the cutting head. The power output is 50 watts with 1% distortion. It mounts on a 14" x 19" rack panel and has a built-in power supply. List price is \$250.00.

Add the 88-A amplifier and Presto 1-C cutting head to your recording installation. The results will be a revelation to you. Complete specifications are given in a new Presto catalog sheet just issued.

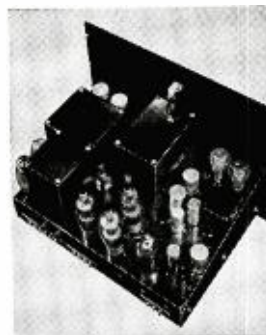

Canadian Distributor: WALTER P. DOWNS, 2313 St. Catherine St. W., Montreal, P. Q.

PRESTO RECORDING CORPORATION
242 West 55th Street, New York, N. Y.

World's Largest Manufacturers of Instantaneous Sound Recording Equipment and Discs

• CENTIMETER RANGE • MULTI-PURPOSE • WAVEMETERS •

MODEL 115 - Price \$150.00

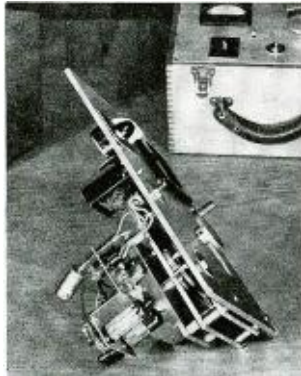

Models 105 - 125
Range 100 cm. to 7 cm.
Accuracy .1 of 1%
Linear wavelength calibration
Transmission line input
Completely shielded
Complete with batteries and tubes
Ready to operate
UHF parts silver plated
Calibration chart supplied

SPECIAL REQUIREMENTS CAREFULLY CONSIDERED
Write for descriptive literature.



LAVOIE LABORATORIES

2534 FAIRMONT AVENUE, DAYTON, OHIO

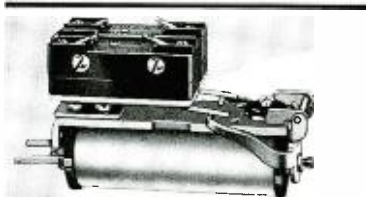

CLARE TYPE "F" Micro-switch • Snap-action Contact RELAY

Operates on a few milliamperes—contacts carry 10 amperes 110 V. a.c. Particularly adapted for machine control, motor and lamp loads, photo electric and similar applications.

C. P. CLARE & CO.
LAWRENCE & LAMON AVES. • CHICAGO
12 EAST 30TH STREET, NEW YORK CITY

CLARE TYPE "FM" RELAY

For slightly heavier loads—contacts rated 15 amperes 110 V. a.c. Operates on low coil current and adaptable to similar applications.

Write for
Clare Data
Book and
Catalog
today

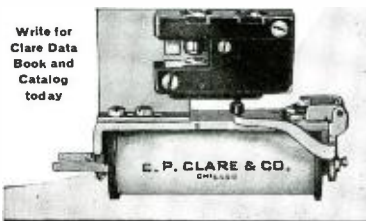

LAMINATIONS

for Output TRANSFORMERS
of Highest Permeability

Standard stocks in a wide range of sizes for Audio, Choke, Output and Power Transformers. Write for dimension sheets.

M permanent MAGNETS

ALNICO (Cast or Sintered)

COBALT-CHROME-TUNGSTEN

Cast, formed or stamped permanent magnets for all purposes. Engineering cooperation backed by 38 years experience in magnet making.

TOOLS • DIES • STAMPINGS
HEAT TREATING

Thomas & Skinner
Steel Products Co.

1113 E. 23rd St. Indianapolis, Ind.

or right of the house, from the rear, and from above. Also, in effect, he can make the sound run around the house.

Radio Relays

The automatic radio relay of scenes from Camp Upton, Long Island, to New York, brought into use the new unattended radio stations. This radio relay system, developed by RCA Laboratories, incorporates a number of engineering features and innovations in communication. The relay towers, as designed for future use, are envisaged dotting the landscape to make possible inter-city television and eventually a television network on a national scale.

Inside the "beacon" on top of the tower is a new horn antenna sharply directional in reception and transmission of ultra-short waves. The towers vary in height, depending upon the terrain and distance to be covered. The automatic apparatus for amplifying and relaying is located in the base of the tower. In a split-second after the pick-up and amplification of the signal, the pictures are "search-lighted" in the desired direction.

The mobile units of the National Broadcasting Company, stationed on this occasion at Camp Upton, televised and flashed the army pictures on the 165 megacycle channel to Hauppauge, 17 miles distant. Hauppauge's automatic relay station intercepted the images and tossed them across 23 miles on 474 megacycles to a horn antenna 200 feet up on a mast formerly used by WEAJ at Bellmore. There again, amplification strengthened the picture-carrying impulses for relay on 506 megacycles to New York, 28 miles beeline.

Protruding from a window on the 62nd floor of the RCA Building at Radio City, two horn antennas with their open mouths pointed in the direction of Bellmore, picked up the incoming ultra-short waves that carried the telepictures. These horns, from their 4 by 6-foot openings, taper along the 8-foot length to an apex about 1½ feet square, where a dipole antenna is located. The impulses were fed into the television sets at Radio City, and also sent over a special wire line to the New Yorker Theatre for projection on the 15 by 20-foot screen. The pictures were 441 lines, 30 frames.

In no instance does the power of the intermediate relay stations exceed 5 watts, an accomplishment attributed in part to the highly directional horn antennas.

Another device of considerable importance to the system was a new RCA tube described as "the inductive output type." With this tube, amplification of the television signals at the relay

stations was effected at radio frequencies instead of the original frequency of modulation. This tube makes possible the streamlining, simplification, efficiency and economy of operation of the radio relay stations.

Taking further advantage of new development in radio tubes, the relay system in the low power stages (receiving circuit) utilizes a new "orbital beam" tube. Operating in general on the electron multiplier principle, this tube is a new means of obtaining high amplification on ultra-high frequencies.

• • •
BOOK REVIEWS

THE MYSTERIES OF TELEVISION, by Arthur Van Dyck, published by The House of Little Books, 156 Fifth Ave., New York City, N. Y., 55 pages. Available from Bryan Davis Publishing Co., 19 E. 47th Street, New York City, price \$1.00 prepaid.

Written primarily for the layman, this excellent little book gives a brief historical review before delving into the underlying principles of television transmission and reception. The author then looks into the future of the television art, as well as facsimile and the broader field of electron optics. This is followed by a dissertation on television studios and programming. Some six pages of questions and answers are also included. Other features of the book include a section devoted to definitions of television terms, and a reading list of books for both the technical and non-technical readers.

Written in a simple, non-technical style, this is an admirable book for the engineer to recommend to his lay friends interested in the television art.

J. A. R.

AN INTRODUCTION TO THE PHILOSOPHY OF SCIENCE, by A. C. Benjamin, published by The Macmillan Company, 60 Fifth Avenue, New York City, 469 pages, price \$3.50.

A superficial glance at the title of this book might create the impression that there is nothing within it to interest the communications engineer. This, indeed, would be quite true if engineers were as incapable of feelings and thoughts as the machines which they create. This, fortunately, is not the case, so that it is highly desirable for the engineer not only to recognize his individual economic and political relationship in society, but also to realize the significance of his work with regard to the scientific structure in toto. Not only will a comprehension of the philosophy of science enhance the engineer culturally, but in addition, a thorough grasp of the nature of the scientific method will actually increase the engineer's efficiency in his specific line of endeavor.

The author has arranged the subject matter of the book into three main divisions. The first deals with "Problems in the Logic of Science." That is to say, it treats the possibility of the logic of science, the nature of symbols, theory of perception and the relation and distinction of descriptive and explanatory sciences. The middle part of the book is devoted to "Analysis of the Concepts of Science." It treats such concepts as numbers, time space, motion, law and cause. The final chapters are headed "Speculative Prob-



Photos show microphone and pickup tests being made after complete assembly and before shipment.

ASTATIC

Crystal Products Must Pass Rigid Inspection Tests Before Shipment



● Volume production has not been permitted to interfere with Astatic's golden rule of "quality first". All Astatic Crystal Products . . . including Microphones, Pickups, Recording Heads and Cartridges . . . are carefully tested to meet Astatic's exacting requirements before being shipped. That's why the name "Astatic" has become synonymous with such phrases as "dependable performance" and "sturdy construction". Consider these points when making replacements or modernizing your present broadcast, public address, amateur or electrical phonograph equipment. See your Radio Parts Jobber. He's handled Astatic Crystal Products for years. He knows and will be happy to explain the long, satisfactory service and excellent performance you will enjoy with any Astatic Product.

ASTATIC

ASTATIC MICROPHONE

IN CANADA: CANADIAN
ASTATIC LTD., TORONTO, ONT.

YOUNGSTOWN
OHIO

Laboratory Inc.

ASTATIC CRYSTAL PRODUCTS LICENSED UNDER BRUSH DEVELOPMENT CO. PATENTS

SHURE CARDIOIDS
 ★
LICK FEEDBACK!
PERMIT
MORE VOLUME!
 ★

In Night Clubs, Theatres,
 Auditoriums, Ballrooms,
 Bowling Alleys, Churches,
 Outdoor Sports and many
 other applications.



UNIDYNE
DYNAMIC



On every job—Shure Cardioids give you better audience coverage—with more volume—free from feedback, reverberation, background noise! These amazing microphones are dead at rear. They simplify microphone placement, solve difficult sound problems on the spot! "Unidyne" Dynamic (illustrated) in high and low impedance models. List Price, \$42.50 and \$45.00. "Uniplex" Crystal (not illustrated), List Price, \$32.50.

See Your Jobber or Write for Catalog 153N.

Shure Patents Allowed. Crystal Microphones licensed under patents of Brush Development Co.



SHURE BROTHERS
 225 W. Huron Street Chicago, U. S. A.

lems" and deal with the "Classification of Sciences," "Human Freedom," and the "Nature of Reality."

The method chosen is one of offering alternative explanations and systems while the author maintains a personal objectivity. Professor Benjamin thought it advisable to permit the reader to choose the "system" which was personally preferable to the reader, without undue influence by the author.

Nevertheless, there does emerge his own definite preference for symbols in scientific inquiry. To these he devotes a large portion of the first part of the book. His analysis of the function of symbols in scientific inquiry is well done.

The speculative problems do not fare so well. They are neither extensive nor conclusive. One could wish that Professor Benjamin had seen fit to elaborate more fully on the problem of human freedom and the nature of reality.

The major defect of the book is the highly pedantic style in which it is written. Surely, in a subject as absorbing as this a little more enthusiasm could have been injected without in any way destroying the objectivity of the exposition.

F. S.

• • •
VWOA NEWS

(Continued from page 16)

grace the center of the planned "New" Battery Park, and even in its first rough layout gives every evidence of being a graceful and beautiful commemorative structure.

Thus through numberless hands has passed the growing idea of keeping alive the memory of heroes of the wireless key, and of the man whose creative genius first gave to the world that instrumentality which was theirs to wield.

Through the courtesy of Dr. Constantino, and the vision of Commissioner Moses, the ensemble bids fair to be a monument of beauty as well as of commemoration.

• • •
AIRLINE ANTENNA COUPLER

A NEW patent in the airline radio field allowing the use of one antenna on several frequencies has been obtained by Howard K. Morgan, superintendent of communications for Transcontinental and Western Air, Inc.

Morgan, who has been experimenting on increased efficiency of antennas for airline use for five years, said that the new patented device will make an an-

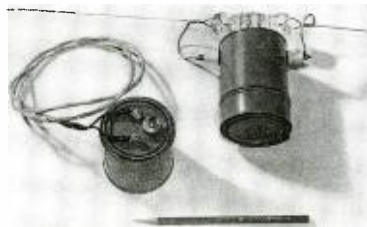

tenna not only very efficient on each frequency, but also the antenna can be used on several frequencies simultaneously.

By the addition of small cans con-

**WON'T DISTURB
 INSTRUMENT
 ADJUSTMENTS**

IDEAL

**"3-in-1"
 JUMBO
 ELECTRIC
 CLEANER**



- Blows—Vacuums—Sprays.
- Super-powered—Full 1 H.P. motor.
- Cleans dirt, dust from electrical wiring, instruments, panels, etc.
- Safe—low pressure air prevents damage to delicate electrical instruments.
- Plugs into any convenient socket.
- Portable—weighs only 14 lbs.
- Blows dry air—won't rot insulation.
- Air Velocity, 24,200 ft. per min. Low pressure.
- Many attachments available to meet your individual requirements.

ASK FOR FREE DEMONSTRATION

IDEAL COMMUTATOR DRESSER CO.

1062 Park Ave. Sycamore, Illinois

SALES OFFICES IN ALL PRINCIPAL CITIES

In Canada: Irving Smith, Ltd., Montreal, Quebec

D.C. Motors



Pincor small motors are especially well adapted for band switching, remote control, etc. for aircraft use or wherever a small, light weight motor is required to give un-failing service. They are available in capacities to meet every requirement. Consult our engineers about your small motor needs.

**PINCOR
 PRODUCTS**

Pincor line includes: Dynamotors, Generators, Converters, Power Plants, Motor-Generator Sets, Pumps. Write for literature.

**PIONEER GEN-E-MOTOR CORPORATION
 CHICAGO, ILLINOIS**

Export Address: 23 WARREN ST., N. Y., N. Y.
 Cable: SIMONTRICE, New York

taining a coupling unit, it has been possible to develop directional antennas showing great efficiency on TWA's two-way frequencies. The device replaces complicated and expensive switches or multiplicity of antennas as at present. By using the new system, antennas can be readily located remote from all interference and can deliver signals to receivers through a single buried wire. Final experimental work of Morgan and TWA communications engineers in the past three years showed the new system to be effective and interference-free when installed almost adjacent to other antennas which were being disturbed by electrical noises.

The new patent is one phase of TWA's large scale experimental program to perfect operational functions in air transportation. Another patent granted to TWA within the past two months involves the construction of the shielded loop antenna, which was developed by TWA under the direction of John C. Franklin. Now company secretary, Franklin was awarded the National Air Board's Safety award for contributing the most to aviation in 1937, as a result of his work on the shielded loop antenna.

• • •

TESTS OF RADIO-CONTROLLED SEADROME LIGHTS

RECENT tests of a short-wave control of fluorescent contact lights mounted on doughnut-shaped rubber floats in the Anacostia River (near Washington) seem to indicate that nearly every ocean harbor, lake port, or river in the United States could be turned into a night landing air-drome for seaplanes.

The development of radio-controlled seadrome contact lights was made jointly by engineers of the Westinghouse Electric & Mfg. Co. and the Firestone Tire & Rubber Co., working closely with the Civil Aeronautics Authority. The three groups are reported to have found the right combination to the correct balance between a battery-operated light, a floating unit not hazardous to navigation, and a light control to turn on lights when needed.

The lights may be strung out in lines on water to light a seadrome exactly as boundary and contact lights do on a land airport. The new lights outline the boundary of the landing lanes and the area in which it is safe for seaplanes to land. For larger seadromes it is planned to make several "runways" on the water so that a plane can always land between these lights and into the wind. The lines of light will define several landing lanes, 500 feet wide, as permanent bases where scheduled or extensive operations are necessary.

For temporary or remote bases where portable equipment will be used, one row of lights is considered enough with the plane being instructed to land always to the left of the line. The spacing between lights making up the line will be about 300 feet. Lanes are planned to be at least 5,000 feet long and twice that if space permits.

Contact lights will be in three colors: red, green and gold. These colors will give the pilot positive indication of his progress

DAVEN PRECISION LEVEL INDICATOR



TYPE 910

This DAVEN Volume Level Indicator is an audio level indicator designed for service in broadcasting, sound recording, and allied fields. The meter is sensitive, rugged and correctly damped for program monitoring.

The meter multiplier is a heavy duty, step type "T" attenuator designed to offer a constant impedance both to the line and to the meter at all steps of control. The zero adjustment provides corrections of ± 0.5 Db. in 0.1 Db. steps. The input impedance of the 910 is 7500 ohms. The reference level is 1 mw. into 600 ohms.



The DAVEN catalog lists the most complete line of precision attenuators in the world; Ladder, "T" type and "Balanced H" networks—both variable and fixed types—employed extensively in control positions of high quality program distribution systems and as laboratory standards of attenuation. Super DAVOHM resistors are precision type, wire-wound units of from 1% to 0.1% accuracy. More than 80 models of Laboratory Test Equipment are listed. Write for your copy of this complete DAVEN catalog.

THE DAVEN COMPANY
158 SUMMIT STREET • NEWARK, NEW JERSEY

down the runway. Two green lights are at the near end, and the remainder of the line will be gold, except two red lights marking the far end.

In addition to the contact lights marking the lanes, seadrome boundary lights which flash red will be floated, about 1,000 feet apart, to warn surface craft that the space inside is restricted for planes. These lights will be kept burning all night for emergency landings.

The light source is a cold-cathode fluorescent lamp about two and a half times as efficient as an ordinary incandescent lamp. It is powered by dry cell batteries which are light in weight and easily replaced. The electrical system has a low battery drain and it is claimed that the steady burning contact light will operate for 60 days, if turned on for a nightly average of five one-hour periods. The flashing red unit, used as a boundary marker, will burn for 2500 hours of continuous operation.

CAA tests of the lights proved that they can be seen from 3 to 4 miles away, depending on the color, on a reasonably clear night. A fresnel lens is used to enclose the bulb and direct the light upwards toward a plane approaching the light. This feature, combined with the stability of the rubber float, makes a light source that does not wink or "shimmy" and appears stationary to the pilot.

The float for the seadrome units is a large rubber doughnut with vertical black and yellow stripes for daytime visibility. Stability of the float in waves up to 6 feet high in practically constant, due to the fact that air pressure is only slightly above atmospheric. The rubber walls are, therefore, extremely flexible, permitting a "jelly-

fish" action; that is, the physical shape of the float changes to match the shifting stress caused by passing waves. Also the soft rubber walls give when struck by watercraft. Small boats were run at high speed directly into the units to test their durability. In some instances the floats were hit so hard that they disappeared under water but bobbed up undamaged 10 or 15 feet away.

Two types of seadrome lights have been developed. The heavier unit has space for three batteries and is designed to be anchored in place at permanent bases. Its fixture may be removed from the float for servicing on shore. The other unit is portable, has but one battery, and weighs

approximately fifty pounds.

Radio control for the lights was perfected after a long period of experimenting. The system developed by Westinghouse radio engineers permits selection of the proper landing lane and the indication of wind direction by the red and green lights. Controls are few and simple so that no technical expert is needed to operate the radio system which is operative up to 6 miles for the seadrome units.

Each light unit has an individual radio receiver mounted inside the metal housing which also includes batteries and control equipment for the fluorescent lamps. Control signals are picked up by a whip antenna also mounted on the unit and similar to that used on many automobiles.



• • •
Showing several of the radio - controlled sea drome lights. Note antenna and lights.
• • •

WMBD Tests Diesel-Electric Set

FOR 53½ station hours January 5, 6 and 7, radio station WMBD at Peoria, Illinois, was entirely operated by a standard 30-kw diesel-electric set.

The test was conducted to determine what difficulties, if any, would be experienced in powering a commercial broadcasting station with a set of this

sort. It proved the ability of the set to accommodate the transmitter load without interfering with the quality of reception, or the normal operation of the station, and to provide a closer voltage control than that possible with purchased power. Electric power was produced at a cost of 1c per kwh with the

set burning 2¾ gallons of 7c fuel an hour.

WMBD operates on a frequency of 1440 kilocycles, with a maximum power output of 5 kw from dawn to sunset and 1 kw during the evening and early morning hours. The transmitter draws 28 kw at .97 power factor, 220 volts, 3-phase, 60-cycle, when delivering 5 kw to the antenna.

The entire station load, including transmitter, incandescent and neon lights, is taken from three 15-kva (13,800-volt primary-delta connected) 220 volts, 3-phase, 60-cycle transformers. Standby service consists of an identical transformer arrangement, but the power is wired to it from the Powerton Station at Pekin, Illinois.

Under normal conditions, the standby service charge is consumed by powering the lighting load, while the local power company (Central Illinois Light & Power) serves only the transmitter.

The standard self-regulating 30-kw, 220-volt, 3-phase diesel-electric set manufactured by Caterpillar Tractor Co., was connected to the transmitter circuit. The set rested on four Fire-

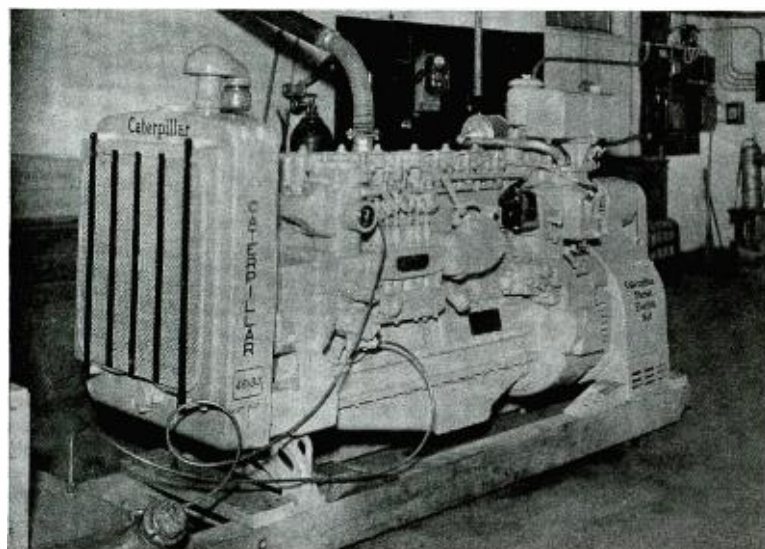

The diesel-electric set tested at WMBD.



AMPEREX
WATER and AIR COOLED
TRANSMITTING and RECTIFYING TUBES

AMPEREX ELECTRONIC PRODUCTS, Inc.
 79 WASHINGTON STREET BROOKLYN, NEW YORK
 Export Division: 100 Varick Street, New York, U. S. A. Cables: "ARLAB"

RADIO OPERATOR

Radio operator with some experience in electrical installation work. Should have at least second class radio telegraph license and first class phone—be able to do own service work. Two year contract—foreign. Reply to Box FP, COMMUNICATIONS, 19 East Forty-seventh Street, New York, N. Y.

CRYSTALS by HIPOWER

The Hipower Crystal Company, one of America's oldest and largest manufacturers of precision crystal units, is able to offer the broadcaster and manufacturer attractive prices because of their large production and the exclusive Hipower grinding process. Whatever your crystal need may be, Hipower can supply it. Write today for full information.

HIPOWER CRYSTAL CO.
 Sales Division—205 W. Wacker Drive, Chicago
 Factory—2035 Charleston Street, Chicago, Ill.

MANUFACTURERS

More than 9000 engineers associated with the radio, television, broadcast, recording and two-way communications fields want to read about your new products in COMMUNICATIONS. Send complete data to "The Market Place" editor.



The best value
in communications
Receivers

MODEL SX-25. Embodies every worthwhile advancement. 12 tubes — 2 stages of preselection — tunes from 540 kc. to 42 mc. in 4 bands — ANL — 6 steps variable selectivity to extreme CW crystal — 10 inch heavy duty PM dynamic speaker — 110 volt 50-60 cycle AC. (DC operation socket provided for battery or vibrapack) Model SX-24 represents the best value in the communications field. 9 tubes — 4 bands — frequency range from 540 kc. to 43.5 mc. Single signal crystal filter equipment. DC operation socket — battery or vibrapack.

the hallicrafters co.
 CHICAGO, U. S. A.

USED BY 33 GOVERNMENTS
SOLD IN 89 COUNTRIES



• To Serve Well •
the Professional Radiomen

An Unending Task



CREI Courses in Practical Radio Engineering Are Under Constant Revision to Meet the Ever-New Developments of the Radio Art

There will never be a "completed" CREI home study course. We will never be content to "let well enough alone." That is why our texts are presented in loose-leaf binders for constant addition and revision. New ideas, new equipment, new methods are constantly changing the radio scene and to keep pace with this progress CREI is constantly revising and modernizing its lesson material.

This is a never-ending task for our competent staff of outstanding engineering instructors, headed by Mr. E. H. Rietzke. Today, Mr. Rietzke is still writing new lessons and revising older ones, assisted by a highly qualified staff of radio engineering specialists. CREI training is built on a sound knowledge of modern radio engineering practice. Behind the scenes, CREI is making a constant effort to improve that which already has proven good. This is slow, exacting and arduous work, but the results are far-reaching in effect, as shown by the accomplishments of our students and graduates.

The entire CREI home study course includes 120 complete lessons. Our schedule requires a thorough revision and new printing of all lessons at frequent intervals. Very rarely does a CREI lesson, when issued, show a copyright date older than two years. ONLY by such methods can radiomen be assured of adequate up-to-date lesson material.

"Since 1927"

CAPITOL RADIO ENGINEERING INSTITUTE

E. H. Rietzke, President

Dept. CO-2, 3224 - 16th St., N.W.
Washington, D. C.

stone vibration dampers, and the exhaust was piped to a Maxim MU2-No. 6 muffler installed outside the building. The attached photographs indicate the simplicity of the installation.

An initial test run was made at midnight, after the station was "off the air", and the distortion and background noises were measured. The distortion varied between .8 to .85 of 1%, whereas the daily log sheets revealed a normal variation of .8 to 1.0 of 1%.

The following morning, the set was pressed into service, and operated continuously for 53½ station hours. The terminal voltage dropped from 221 to 219 volts as the generator heated when carrying full load. The log sheets of the previous week revealed that the transmitter voltage varied from 217 to 224 volts under identical loading.

Several tests were made with a short-wave receiver to determine if any disturbance was being transmitted by the diesel-electric set. Checks were made over the entire short-wave band, but no interference could be detected.

IMPEDANCE OF LINES

(Continued from page 7)

law of cosines. From the vector diagram it is seen that:

$$X_L = Z_T \sin \theta$$

$$R_L = [(Z_T \cos \theta) - R]$$

$$\phi = \tan^{-1} \frac{X_L}{R_L}$$

The values of $Z_{oc}/0_1$ and $Z_{sc}/0_2$ are then used to find the characteristic impedance by means of equation two.

The Transmission Line

The line used for the measurements was a dummy telephone line consisting of twelve equivalent "T" sections. One of the sections is shown in Fig. 3.

Switches were provided to disconnect any section or series of sections from the others. When all twelve sections were connected together this artificial line was equivalent to approximately fifty miles of standard telephone line. The frequency used was 1000 cps. Data is shown in the accompanying table.

Summary

The three voltage method can be used on both audio-frequency and radio-frequency lines, while the ganged impedance bridge is limited to audio-frequency lines. Each method will determine both the magnitude and the angle of the characteristic impedance. The ganged impedance bridge requires more apparatus than does the three voltage method, and it is not as versatile in its adaptation to various lines, yet it has the advantage of determining the answer with less computation.

You and your associates can obtain a year's subscription to **COMMUNICATIONS** (12 issues) for only \$1.00 each by using the Group Subscription Plan.

A regular yearly subscription to **COMMUNICATIONS** costs \$2.00 — but when four or more men sign up at one time, each one is entitled to the half-price rate. (Foreign subscribers on the "G-S-P" only pay \$2.00 each).

COMMUNICATIONS

19 E. 47th St., N. Y. C.

Please enter annual subscriptions (12 issues) for each of the undersigned for which payment is enclosed at the rate of \$1.00 each. (This rate applies only on 4 or more subscriptions when occupations are given.) Foreign Subscriptions are \$2.00 each.

Name

Street

City-State

Occupation or title

Employed by

Nature of business

(State if Manufacturer, Broadcast Station, etc.)

Product

Name

Street

City-State

Occupation or title

Employed by

Nature of business

(State if Manufacturer, Broadcast Station, etc.)

Product

Name

Street

City-State

Occupation or title

Employed by

Nature of business

(State if Manufacturer, Broadcast Station, etc.)

Product

Name

Street

City-State

Occupation or title

Employed by

Nature of business

(State if Manufacturer, Broadcast Station, etc.)

Product

THE MARKET PLACE

BULL SPEAKER

University's new Model 2YR high-power loudspeaker is designed for 50 watts continuous audio input and is of the high-efficiency driver unit reflexed exponential horn type. The speaker is made non-



resonant by means of a rubber tire rim. The driver consists of two standard 24-watt units. The 2YR is supplied complete with driver units and a U mounting bracket. Bell diameter is 24 inches, overall length is 28 inches. Further information may be secured from University Laboratories, 195 Chrystie St., New York City.

CRYSTAL MICROPHONE

Shure Brothers, 225 W. Huron St., Chicago, have announced their 730S "Uniplex" cardioid crystal microphone. This unit is said to combine true cardioid unidirectional performance with high-efficiency speech characteristic. It is suitable for police and commercial communications applications. Complete data from the above company.

OIL-FILLED CONDENSERS

Oil-impregnated oil-filled condensers in handy tubular form are finding many uses in radio assemblies. The 89 series manufactured by Aerovox Corporation of New Bedford, Mass., and now offered as a standard item, has a cadmium-plated brass can



for hermetic sealing, covered by a special varnished-paper jacket with spun-over ends to prevent shorting or grounding. There is a center mounting strap. Available in 400, 600, 1,000, and 2,000 v. ratings, .006 to .5 mfd capacities.

CARRIER-CURRENT CAPACITORS

Recently added to the list of Cornell-Dubilier capacitors were three new units—C-1003, a carrier-current coupling capacitor, and C-1001 and C-1002 capacitors for carrier-current traps. The new type C-1003, a low-voltage coupling capacitor, is available in two sizes, and in all capacities up

OHMITE Ohm's Law Calculator

SEND NOW FOR THIS HANDY, NEW,

Solves any Ohm's Law Problem with one setting of the slide

Everyone's excited about this remarkable Calculator! All values are direct reading. Scales on both sides cover the low current high resistance Radio, Sound and Electronic applications; also the current and wattage range for motors, generators, lamps, electrical apparatus and other applications up to 100 amperes or 1000 watts. Convenient Stock Unit Selector tells the stock number of the resistor or rheostat you may need. Size 4 1/8" x 9". Specially designed by Ohmite Engineers.

Send coupon or write on company letterhead giving name and position. Enclose 10c to cover cost of handling.

OHMITE MANUFACTURING CO.
4870 Flournoy Street, Chicago, U.S.A.
10c in coin enclosed. Send Ohm's Law Calculator. (Please Print Clearly.)

Name

Firm Name

Position

Address

City

State

Comm.-Feb.

Be Right with OHMITE

RHEOSTATS • RESISTORS • TAP SWITCHES

T-PADS

For Speech Input Equipment

A complete line of *speech input controls*, Time tested—second to none—at *Competitive* prices.

Behind our products are years of engineering and production experience. Hundreds of satisfied customers testify to our success. We make no exaggerated claims, but what we make will give you lasting and trouble-free service.

Write for bulletin 411. Complete catalogue upon request.

TECH LABORATORIES

7 LINCOLN STREBT, JERSEY CITY, N. J.

LOOKING FOR A WAY TO IMPROVE YOUR PRODUCTS?

PILOT LIGHT ASSEMBLIES

Better quality, more dependable Pilot Light Assemblies can go a long way toward improving your products. Through skillful design, precision engineering, finest materials and specialization, we've become one of the world's largest exclusive manufacturers of Dial and Jewel Assemblies. Standard and special types in great variety and any quantity available at moderate cost.

Our engineers will gladly assist with your problems. Check up on the exclusive features of our patented units.

WRITE FOR THE DRAKE CATALOG!

DRAKE MANUFACTURING CO.

1713 W. HUBBARD ST. • CHICAGO, U.S.A.

EXPERIMENT WITH THIS MERCURY MIDGET SWITCH!



Here's an opportunity for you to play with—a chance to do some experimenting and whip those "switch" problems you've been up against. The Littelfuse Mercury Midget is designed for low voltage circuits up to 25 volts A.C. or D.C. and currents up to 10 amps at 6 volts and 3 amps at 25 volts. No friction; no wear; no maintenance problem. Positive make and break operation eliminates "flickering."

Two Sizes: 7/16" long and 3/8" in diameter and 7/16" x 1/4" in diameter. List price 15c each.

Some present applications are: thermostat circuits; auto glove and trunk compartments; radio door lights; indicator circuits, etc. What application will your experimenting suggest? Write for full information.

LITTELFUSE, INC.

4751 N. Ravenswood Ave., Chicago, Ill.

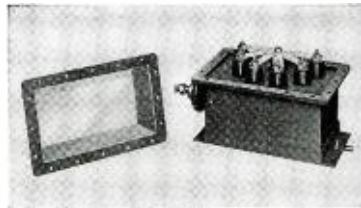

to .075 mfd and voltages up to 15,000 volts. Regarding the Cornell-Dubilier C-1001 and C-1002 capacitors, for carrier-current traps, one is of the fixed capacity type whereas the one illustrated is adjustable over a wide range of values. Descriptive bulletins covering those new capacitors may be obtained by addressing a request to Cornell-Dubilier Electric Corp., South Plainfield, N. J.

COMMUNICATIONS CO. RECEIVER

In the accompanying illustration is shown the Model 82-A receiver of the Communications Co., Inc., 2700 Ponce de Leon Blvd., Coral Gables, Florida. This receiver is designed for airport traffic control towers, airline ground stations, police departments and similar services. It can



be operated either locally or remotely and the necessary control circuits terminate on the plug located on the rear of the unit. The audio output is 500 ohms so that the receiver can be operated directly into the telephone line. It is crystal controlled and can be supplied for any frequency between 1.5 and 12 mc. Further information can be secured from the above organization.

PORTABLE PROFILOMETER

Physicists Research Co., 343 S. Main St., Ann Arbor, Michigan, have made available the Type P portable profilometer shown in the accompanying illustration. This instrument is used for the measurement of surface roughness. The dial is calibrated directly in millionths of an inch,

or "microinches" root-mean-square. It thus measures the average or vertical dimensions of the roughness. This unit should be particularly adaptable to the con-



rol of surface roughness on the shaft of small motors and generators, condenser plates, quartz crystals, cutting styli and the like. Literature is available from the above organization.

RCA MICROPHONE

A new aeropressure microphone whose directional characteristics may be changed at will by the use of a new "paracoustic" reflector baffle attachment, has been announced by RCA Manufacturing Co., Inc., Camden, N. J. The microphone is suited for all types of public-address applications, as well as for amateur radio-telephone transmitters.

Modern in design and of rugged construction, the microphone is designed to



withstand the wind and weather conditions found in outdoor applications. Of course it is equally well suited for indoor use. Frequency response is from 60 to 10,000 cycles. The "paracoustic" baffle changes the directional characteristics of the microphone. With the concave face of the circular, dish-shaped baffle toward the grille, the directional characteristics become sharpened, and feedback is reduced. When the baffle is reversed, so that the convex

PIEZO Electric Crystals Exclusively

- Quality crystals for all practical frequencies supplied SINCE 1925. Prices quoted upon receipt of your specifications.

Our Pledge: QUALITY FIRST
SCIENTIFIC RADIO SERVICE
 UNIVERSITY PARK HYATTSVILLE, MD.

We manufacture a complete line of equipment. Spot Welders, electric, 1/4 to 500 KVA. Standard and Special Transformers. Incandescent lamp and radio tube manufacturing equipment. Glass cutting, slicing, and glass working equipment. College laboratory units, vacuum pumps, and neon sign manufacturing equipment. Wire Butt Welders. A.C. Arc Welders from 100 to 400 Amps. CHAS. EISLER, PRES.

Eisler Engineering Company
 741 S. 13th St. (Avon Ave.), Newark, N.J.

for WIRED MUSIC OPERATORS
 Breastplate "Dispatcher" type. Leaves hands free. Handsome dielectric black finish. Adj. fabric neckband. Choice of single or double headset, high or low impedance. Available total of 12 dif. types and imp. Incl. 7 1/2 ft. flex. cord. Wt. 8 oz. Most attractive lightweight, rugged, practical chest mike yet devised for operators of wired music units. At your dealer or jobber.

UNIVERSAL MICROPHONE CO. LTD.
 INGLEWOOD, CAL., U. S. A.

When You Renew Your Subscription to COMMUNICATIONS
 Remember the Group Rate—\$1.00 a year for four or more subscriptions.
 Regular Rate—\$2.00 a year in U. S. A.—\$3.00 in foreign countries

face is toward the grille, the opposite directional effect is obtained. Without the baffle, the microphone becomes a normal pressure microphone.

TURNTABLE

To meet the demand for recording and high-quality reproduction of records and transcriptions in the home, Presto Recording Corp., 242 W. 55th St., New York City, have released as a separate unit the dual-speed 12-inch turntable formerly sold only as a part of their Model K commercial recorder. This new turntable employs a cast aluminum turntable precision machined to dynamic balance. The table revolves on a single ball bearing at the base of a bronze shaft well. A heavy, live rubber tire is fitted to the rim of the table. A metal pulley on the motor shaft drives directly against the tire eliminating idler wheels, rubber tired pulleys, etc. A slip over pulley is removed to change speed from 78 to 33½ r-p-m. Further information may be obtained from the above organization.

TELEDELTS

Once a closely-guarded secret, Teledelts, the dry, electro-sensitive recording paper used for facsimile telegraphy is now available for public use, the Western Union Telegraph Co., 60 Hudson St., New York City, announces.

Numerous inquiries from manufacturers of recording instruments and from laboratories, colleges and scientists who use automatic recording devices indicate a growing interest in this new recording paper.

Methods in common use employ a recording pen moving across a paper chart, a point vibrating against a carbon paper record, a discoloration of paper by chemical methods, a marking by electrical discharges, and even photographic records made by moving points of light.

Teledelts paper has definite advantages for many purposes because it requires no developing, processing or fixing, and records made upon it are instantly available. It is an electrically conducting sheet of paper coated with material which shows permanent changes of color at any point where an electric current passes through the sheet. The current is applied to the coated side of the paper through a metal stylus and the circuit is completed to a metal cylinder back of the paper. Neither the coating of the paper nor the record is affected by light or atmospheric conditions.

The new paper was developed by Western Union engineers seeking a suitable medium for the facsimile recording of telegrams, pictures, diagrams and other matter transmitted over telegraph lines, without the necessity of developing or otherwise processing the received record. The dry-recorded telegrams received on this paper are ready for immediate delivery on arrival, and this is an important feature of facsimile telegraphy in use today.

The new Automatic Telegraph, using the facsimile process, provides the easiest method known for the transmission of a telegram. The sender presses a button to open a message slot in the telegraph cabinet, and then drops the telegraph blank, on which he has written his message, into the slot, just as he would drop a letter in a mail box. Electricity does the rest: it wraps the message around a cylinder and flashes it to the main office, where it is electrically recorded on a sheet of Teledelts.

COMMUNICATIONS
RADIO CONTROLS
AIRPLANE CONTROLS
STEPPING RELAYS
COUNTING UNITS
REMOTE CONTROLS
CONTACT SWITCHES
INTERLOCKING CONTROLS
LIQUID LEVEL
U. S. GOVERNMENT SPECIFIED CONTROLS
DELAYED ACTION
TIMING CONTROLS
SOLENOIDS

ONE Answer TO 1001 ELECTRICAL CONTROL PROBLEMS



★ Glance at a few of the electrical control applications posted above. Yours may be there. At any rate, it is our purpose here to interpret briefly how Guardian Electric Engineers can quickly transform any of your electrical control problems into a quick solution.

RELAYS by Guardian

Consider that thousands of hours have already been spent designing *7146 Standard Guardian Control Parts . . . that Guardian Engineers encounter thousands of control problems, and in 99 out of 100 times . . . Guardian scores a "bull's eye"!

A production sample finished in sparkling chrome or the conventional dress of strict utility is yours for the asking at Guardian . . . then ONE or MILLIONS . . . simple . . . complex . . . small . . . medium or large . . . delivered AS you want them WHEN you want them with SPEED that excels anything you've ever heard of.

Send Sketch. Initial Your Letterhead for Free Catalog "C" Today

GUARDIAN ELECTRIC

1623 West Walnut Street



Chicago, Illinois



*Inventory Count
Jan. 1, 1941

Series BK-16 Relay. Built to minimum tolerances and the most exacting requirements in production quantities for the U. S. Signal Corps.

Sylvaloy FILAMENT

*Dependability
Uniformity*

"Sylvaloy"
made only by

WILBUR B. DRIVER CO.
NEWARK, NEW JERSEY

Preferred

... BY U. S. GOVERNMENT AGENCIES
IN THE NATIONAL DEFENSE PROGRAM



ATLAS SOUND Equipment is preferred by the U. S. Army, Navy, and Coast Guard for all conceivable applications under the severest operating conditions. Such recognition is outstanding evidence of high quality standards.

★ ATLAS SOUND PREFERRED . . .

by Sound Engineers for the greatest selection of speakers, projectors, baffles, microphone stands, and connectors for all p.a. purposes. You can rely on Atlas Sound for the latest engineering improvements, for rugged construction, and top-flight performance.

★ ATLAS SOUND PREFERRED . . .

by Radio Parts Jobbers for a consistent record of quality and service. Jobbers confidently recommend Atlas Sound Equipment with full assurance of dependability and satisfaction.

★ FREE CATALOG F-40 describes 101 speakers and accessories for every p.a. use. Send for your copy today.



ATLAS SOUND CORPORATION

1449 39th St., BROOKLYN, N. Y.

DIAL

The National Co., Malden, Mass., have recently made available the ACN dial shown in the accompanying illustration. This unit is suitable for use in constructing electron-coupled oscillators, u-h-f receivers,

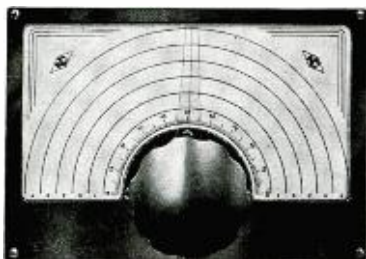

etc. The five-range scale can be calibrated by hand. To facilitate accurate calibration and reading a 0 to 100 division linear range is provided and the transparent lucite pointer has a black etched hairline. A bezel holds the dial scale and its transparent lucite window in place. Two extra dial scales are supplied with each dial. A 5-to-1 ratio vernier drive is employed.

CERAMICON TRIMMERS

Erie Resistor Corp., Erie, Pa., announces that they are in production on a line of ceramic dielectric trimmer condensers known as Ceramicon Trimmers. These units, which have silver electrodes in intimate contact with the dielectric, are inherently stable in capacity with respect to temperature. Made in four styles—three single units and one double unit—they are available in the following temperature coefficients of capacity: 0, $-300 \times 10^{-6}/^{\circ}\text{C}$., and $-500 \times 10^{-6}/^{\circ}\text{C}$. Capacity range is from 1.5 to 45 mmfd in the smaller trimmers and from 4 to 110 mmfd in the largest unit. Change in capacity from minimum to maximum is practically constant per degree of rotor rotation, it is said. As the mounting base of Ceramicon Trimmers is made of a low dielectric-constant steatite,



these units may be mounted flat against a metal chassis with but little increase in minimum capacity.

Ceramicon Trimmers are designed primarily for use in aircraft and mobile transmitters and receivers, and are sturdily constructed to withstand shock and vibration. All internal connections are soldered, with the exception, of course, of the wiping contact with the rotor shaft. Metal parts are of non-ferrous material and are silver-plated to guard against corrosion. The rotor completely covers the entire track on the stator, regardless of the point to which the trimmer is adjusted. Contacting surfaces of the rotor and stator are lapped optically flat. These features prevent dust and other foreign matter from coming in contact with the electrodes and affecting the characteristics of the condenser. The rotor was specially designed with a high torque—averaging 1 inch pound—and due to its circular shape is statically balanced so that vibration will not alter the adjustment.

Copies of a data sheet describing these

Ceramicon Trimmers in detail may be secured by writing the above organization.

LOOP ANTENNA

A new directional loop antenna for civilian planes which makes radio direction finding possible with a conventional aircraft receiver, has been announced by the Aviation Radio Section, RCA Manufacturing Co., Inc., Camden, N. J. Although light in weight, the loop is designed to give long service under severe conditions. The antenna, measuring 12 inches in outside diameter, is provided in both local and

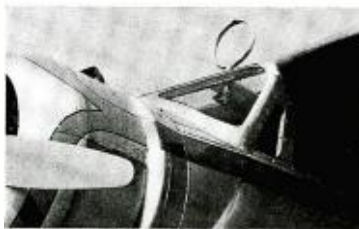

remote control models. It will operate as a direction finder on the beacon (195-420 kc band, or on the beacon and broadcast (195-420, and 495-1400 kc) bands. A high quality, air transport size unit, it combines high electrical efficiency with the rugged construction necessary for passing Civil Aeronautic Authority requirements.

NEEDLES

Howard Radio Co., 1731 Belmont Ave., Chicago, has announced a new low-cost, long-life needle which, it is stated, will cut more than 200 $6\frac{1}{2}$ -inch recordings. The needle has a permo metal tip. Howard has also announced two new playback needles, one for commercial records, the other for home recordings. Literature is available on request.

INSULATING VARNISH

Harvel 612-C insulating varnish is described in a folder just issued by the Irvington Varnish & Insulator Co., 24 Argyle Terrace, Irvington, N. J. Harvel 612-C is a recently developed, internal drying, synthetic resinous phenol-aldehyde type varnish that is said to offer substantial electrical, mechanical, and application advantages as well as more rapid curing. It solidifies throughout by heat-induced chemical polymerization.

PLUGS AND RECEPTACLES

The Pyle-National Company, 1334-58 North Kosther Ave., Chicago, announces a new line of heavy duty plugs, receptacles and cord connectors for use with portable electrical equipment. While this line has the same electrical rating and is approximately the same size as standard attachment plugs and outlet receptacles, it embodies the heavy duty design and substantial construction features of the larger Pyle-National Triploc plugs and recepta-



cles for industrial use. All 2, 3, and 4-pole contact units are interchangeable, to permit using a wide variety of plug shells and receptacle housings to make any desired assembly combination. Contact units are reversible, for safety protection.

PORTABLE SOUND SYSTEM

Erwood Sound Equipment Co., 223 West Erie St., Chicago, have just announced a new 28-watt complete portable system. The case design of this system has provision made for carrying two full-length floor type microphone stands with microphones. A record playing attachment is also included in the case assembly, thus the unit is adapted to general public-address rental work. The loudspeakers are contained in a bias cut front vented type of cabinet which eliminates rear radiation.

CONTINENTAL-DIAMOND LINE

Recognizing the need for faster and more efficient moving of materials and parts in process—the Continental-Diamond Fibre Company of Newark, Delaware, have completely re-designed and re-catalogued their line of Diamond vulcanized fibre hollow ware. This re-design is based on greater standardization, but with sufficient flexibility so that standard equipment can be readily modified to efficiently meet any specific individual material handling problem, and still not penalize the buyer in the way of price for slight deviations from standard specifications. Manufacturers with material handling problems should write for catalog HW.

GENERATOR FIELD RHEOSTATS

In the accompanying illustration is shown a generator field control made available by Ohmite Mfg. Co., 4835 Flournoy St., Chicago. These units are tapered or uniformly wound as required, and de-



signed to provide control for separate or self-excited generators. Small in size, they are particularly useful on portable equipments. The Ohmite field rheostats are available in ten wattage sizes from 25 to 1000 watts and cover the range from 24-32 volts to 320-400 volts. Literature available from the manufacturer.

AUTOMATIC RELAY

Amperite Co., 561 Broadway, New York City, have announced an automatic relay for changing battery sets to a-c/d-c operation. All that is necessary is to plug the regular cord into an a-c or d-c line and turn on the set switch. When the switch is turned on the set operates immediately on battery until the rectifier tube heats up, and then switches automatically to a-c/d-c operation. The relay consists of two single-pole contacts which are placed in the minus A and minus B battery lead.



A CRYSTAL CONTROLLED SINGLE FREQUENCY RECEIVER

for broadcast relays, airlines, police, marine, government service specifications; in fact, any service where a single frequency receiver is required.

We also manufacture a complete line of transmitters and allied communications equipment. The Wilcox standards of operating performance are favorably known the world over.

Submit your specifications to us and ask for complete information relative to our line.

WILCOX ELECTRIC COMPANY

3947 STATE LINE

KANSAS CITY, MO.

Entrance to all Points of Interest

New York's Popular

**HOTEL
LINCOLN**

44TH TO 45TH STS. AT 8TH AVE.

OUR CHOICEST ROOMS From **\$3**

1400 ROOMS each with Bath, Servidor, and Radio.
★ Four fine restaurants awarded Grand Prix 1940 Culinary Art Exhibition.

MARIA KRAMER
PRESIDENT

John L. Horgan
Gen. Mgr.
HOTEL EDISON
SAME OWNERSHIP

Direct Subway

IN THE CENTER OF MID-TOWN NEW YORK

HEAD OF THE
POLICE

CITY OF NATIONAL CITY
POLICE DEPARTMENT
NATIONAL CITY, CALIFORNIA

WE REFERENCE PLEASE GIVE OUR
REFERENCE NO.

October 26, 1940.

Bliley Electric Company,
Union Station Building,
Erie, Pennsylvania.

Gentlemen:

In the past, our greatest difficulty has been in keeping the oscillator section of our mobile police radio transmitters in operation. We have considerable patrolling on dirt roads and that, of course, is hard on any crystals.

Two years ago this month (October 4, 1938), we wrote you an inquiry regarding crystals for the mobile transmitters. Due to continual trouble with the crystals previously purchased, we were desperate indeed for a unit that would function dependably under mobile conditions.

The unit we purchased from you at that time and the subsequent ones ordered during the few months following have all been in constant service to date, and the results have been most gratifying. No transmitter servicing has been necessary as a result of the crystals failing to operate.

Yours very truly,
National City Police Dept.
[Signature]
Communications Officer

Bliley Dependability speaks for itself!

BLILEY ELECTRIC COMPANY
UNION STATION BUILDING
ERIE, PA.

FIXED FREQUENCY CRYSTAL CONTROLLED RECEIVER



MODEL 82-A

Designed especially for Police, Airport Traffic Control, and Airline Ground Stations • Local or remote operation • Compact—Mounted on Standard 3 1/2" Rack Panel • Aligning and Tubes changed from Rear—Unnecessary to remove from Rack • Excellent image rejection, Squelch Circuit, Amplified A.V.C., etc. Supplied for operation on any single frequency between 1.5 to 12 mc. • Moderately priced.

Write for complete information.

COMMUNICATIONS CO., Inc.

2700 Ponce de Leon Blvd. • Coral Gables, Florida

—MICO— ENGRAVER

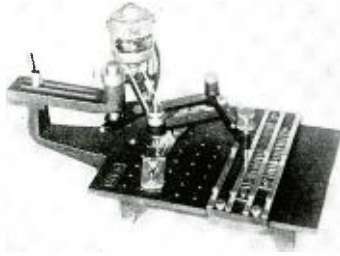

For lettering panels of steel, aluminum, brass, or bakelite, or for marking finished apparatus.

A sturdy machine for routine production as well as occasional engraving.

Attachments increase its versatility to include large work on flat or curved surfaces.

Excellent engraving can be produced by an inexperienced operator.

Prompt delivery. Catalogue on request.

Priced from \$115 with Type

Mico Instrument Co.
18 ARROW STREET
CAMBRIDGE, MASS.

DRAKE

**BREAKS A
PRODUCTION
BOTTLENECK**

**•
REVOLUTIONARY
INDUSTRIAL
SOLDERING IRONS**

**REPLACE THE
ELEMENT
IN 30 SECONDS**

It's no longer necessary to return the iron to the factory when an element burns out. You can replace the element easily and quickly yourself. Irons are available in ratings from 80 to 200 watts.

**SEE YOUR JOBBER OR
WRITE TODAY FOR
COMPLETE INFORMATION**

DRAKE ELECTRIC WORKS, INC.
3656 LINCOLN AVE. CHICAGO, ILL.

Index to Advertisers

	Page
A	
Aerovox Corp.	22
Amperex Electronic Products, Inc.	29
Astatic Microphone Lab., Inc.	25
Atlas Sound Corp.	33
B	
Biley Electric Co.	35
C	
Capitol Radio Engineering Inst.	30
Clare & Co., C. P.	24
Collins Radio Co.	Inside Front Cover
Communications Co., Inc.	35
D	
Daven Co., The.	27
Drake Electric Works	36
Drake Mfg. Co.	31
Driver Co., Wilbur B.	33
E	
Eisler Engineering Co.	32
Eitel-McCullough, Inc.	13
F	
Fairchild Aviation Corp.	Back Cover
G	
General Electric Co.	17
General Radio Co.	Inside Back Cover
Guardian Electric Co.	33
H	
Hallcrafters, Inc., The.	29
Hipower Crystal Co.	29
I	
Ideal Commutator Dresser Co.	26
International Resistance Co.	4
Isolantite, Inc.	1
J	
Jones, Howard B.	22
L	
Lavoie Laboratories	24
Lingo & Son, Inc., John E.	15
Littelfuse Inc.	32
M	
Mico Instrument Co.	36
O	
Ohmite Mfg. Co.	31
P	
Pioneer Genemotor Corp.	26
Presto Recording Corp.	23
R	
RCA Mfg. Co., Inc.	3
Rieber, Inc., Frank.	21
S	
Scientific Radio Service.	32
Shure Brothers	26
T	
Tech Laboratories	31
Thomas & Skinner Steel Products Co.	24
U	
United Transformer Corp.	19
Universal Microphone Co., Ltd.	32
University Labs.	22
W	
Wilcox Electric Co.	35

**YOUR GRACIOUS HOST
FROM COAST TO COAST**



The Gotham



The Drake

The Blackstone



The Town House



Bellevue Biltmore

A.S. KIRKEBY, Managing Director

**KIRKEBY
HOTELS**

A Few Seconds A Year

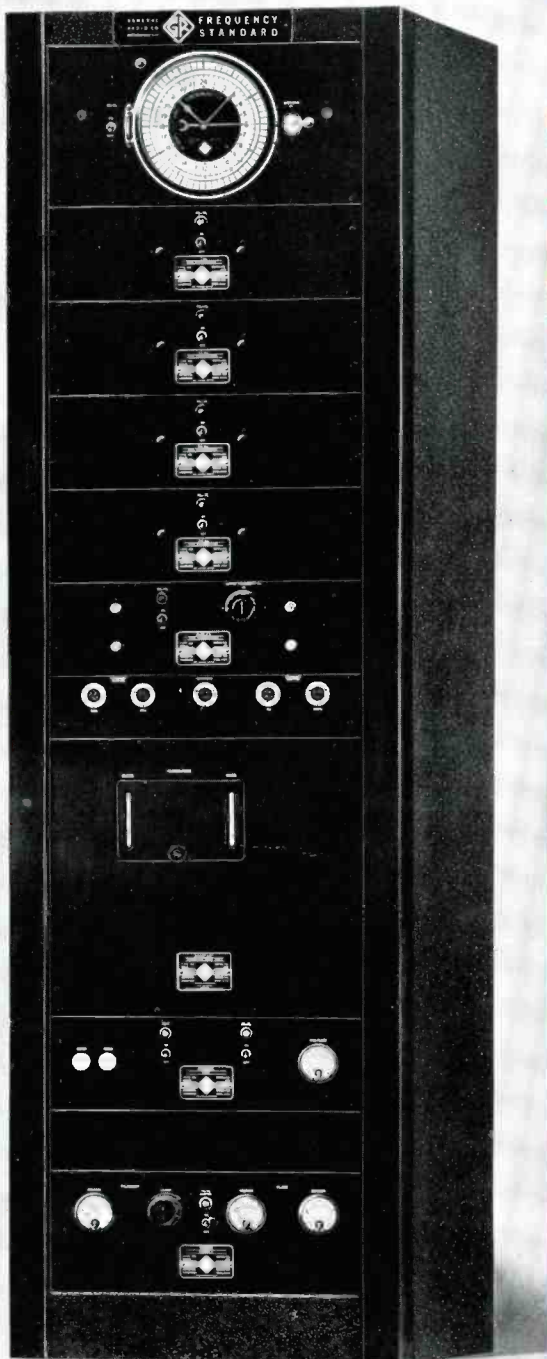

THIS IS THE FACE of the most accurate commercial clock in the world . . . the 1,000-cycle clock controlled by the General Radio Type C-21-HLD Primary Standard of Fre-

quency. This clock is used to compare directly the accuracy of the primary standard with the generally available standard time intervals obtained from astronomical observations and transmitted at frequent intervals by U. S. Naval Radio Stations to all parts of the world.

From these time signals the user of the G-R Primary Standard of Frequency can conveniently and accurately check the operation of the frequency standard.

The G-R Standard, in its elements, consists of a 50-kc piezo-electric oscillator with very accurate temperature control; several frequency dividers controlled by the oscillator; the clock driven at 1,000 cycles; an oscillator control panel; an a-c power supply and a terminal board.

Although the standard is an extremely accurate timekeeper, its primary use is as a generator of radio and audio frequencies that are known with considerable accuracy. With suitable auxiliary interpolation and measuring apparatus, the direct precision measurement of any frequency in the audio or radio-frequency spectrum is possible.

A large number of G-R Primary Standards of Frequency have been sold to educational, commercial and governmental organizations throughout the world. These standards are accurate enough to be used in such delicate scientific experiments as the determination of the force of gravity, the speed of light and the time of flight of bullets where measurements of the highest accuracy are necessary.

In the General Radio laboratories the bench of each engineer is provided with terminals from which the worker may obtain frequencies from a central Primary Standard of Frequency. Use is made of this standard in the design, manufacture and calibration of many G-R instruments.

The G-R Primary Standard of Frequency is not a scientific tool demanding the constant attention of an engineer . . . it is a workaday instrument which runs for years with only slight attention and it can be used for precise frequency measurements by unskilled technicians.

GENERAL RADIO COMPANY
Cambridge, Massachusetts

DESIGNED AND BUILT FOR

PROFITS

FAIRCHILD Precision Sound Equipment

FAIRCHILD'S higher-quality sound equipment is an investment which will *make more money for you.*

You get valuable *flexibility* with dependable Fairchild recording equipment. Fairchild installations bring you these profit-building advantages:

Better-satisfied advertisers . . . Higher-quality recording and transmission . . . Improved "on-location" facilities . . . Less repair expense . . . Double service, as portable and studio equipment.

For a guide to added profits, write for full information on Fairchild equipment to fit your needs.



FAIRCHILD
Sound Equipment Division
AVIATION CORPORATION
88-06 Van Wyck Boulevard, Jamaica, L. I., N. Y.

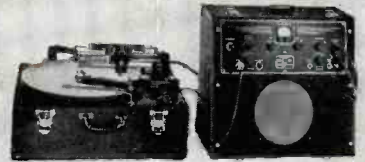

F-26-3—Portable Recorder

Complete portable outfit for the direct recording of voice, music, and sound and for direct play-back. Unit 199-3 Recorder and Unit 219-2 Amplifier.



Unit 227 Transcription Turntable

Eliminates wow, vibration, and speed variation. Dynamically balanced turntable, two-speed adhesion drive. Floating motor assembly.



Unit 199—Recording Mechanism

Extremely flexible equipment, for use indoors or outdoors; easily set up and ready for use in a few minutes. Rugged construction, just recording quality.



Unit 246—Feed-Back Amplifier

Flat within .3 decibel, from 15 to 15,000 cycles. Greater fidelity for broadcasting, recording, play-backs, and laboratory work.

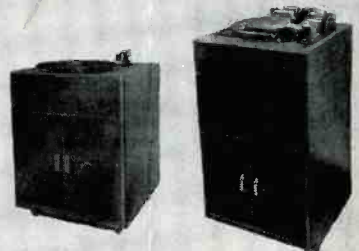

Cabinet Models

F-81—Turntable (Left)
F-79—Recorder (Right)

Ready-to-use equipment—surpasses finest custom-built models. Noise-reducing mountings, all-metal cabinets. Gun-metal finish, chrome trim.