

# COMMUNICATIONS

a merger of  
 RADIO ENGINEERING  
 ...  
 COMMUNICATION &  
 BROADCAST ENGINEERING  
 ...  
 THE BROADCAST ENGINEER

JANUARY  
 1939

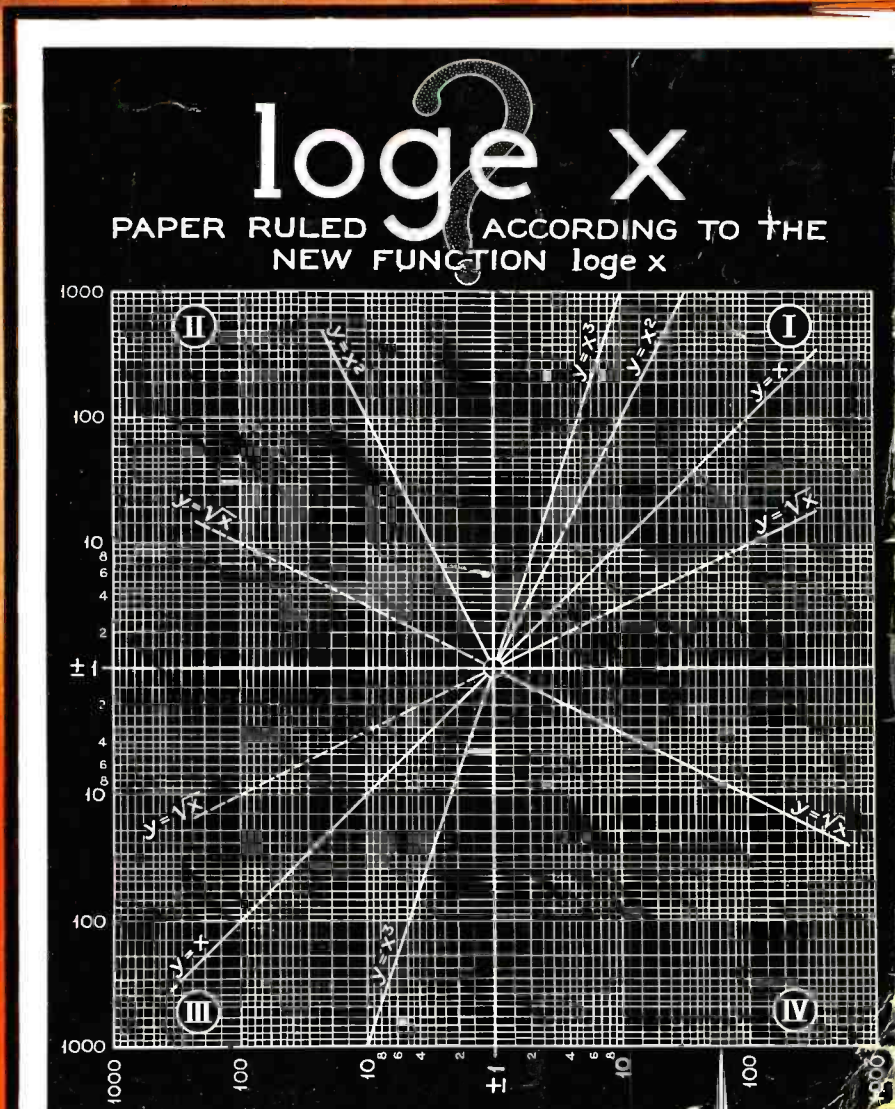

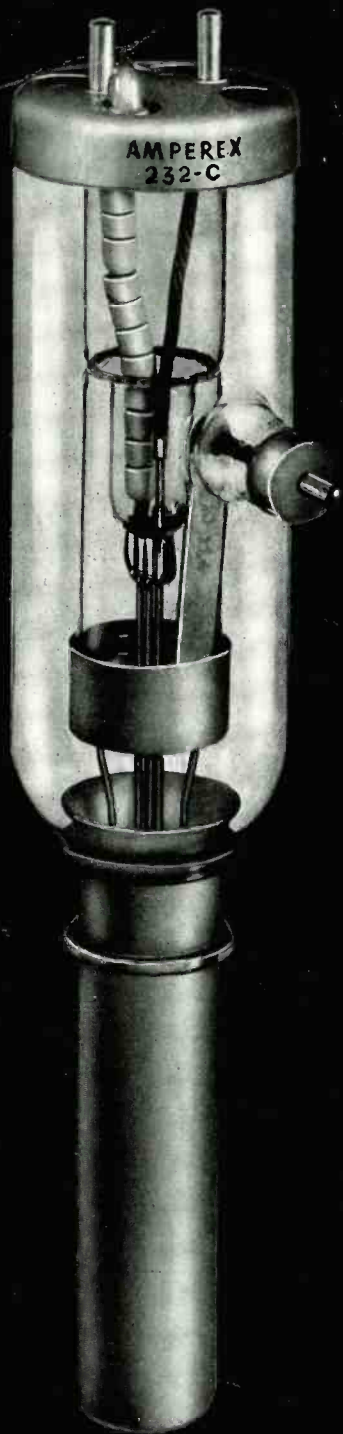

*For the 50 KW station*  
**AMPEREX**  
**HEAVY DUTY TUBES**

**232-C**

The Amperex 232-C, because of its many superior design features, more nearly approaches the ideal for the hard usage imposed upon it in 50 K.W. service.

Its heavy and rugged filament has greater emission capabilities and it is physically so proportioned that it easily withstands the electrostatic strains which it is subjected to.

The Grid is so constructed that primary and secondary emission effects are reduced to a minimum. The supporting wires are notched and the fine cross wires mechanically swaged into the notches. No spot welding is employed. Therefore the brittleness and oxidation of the grid wires is entirely eliminated.

The entire grid structure is solidly bolted to a copper cup which, in turn, is sealed to a glass supporting stem.

The grid seal, as well as the anode seal, is shielded against electrostatic strain.

Rigid alignment of the elements, unvarying characteristics through life, and trouble-proof operation are the results of these structural refinements and design improvements.

**Price \$480.00**

**857-B**

The Amperex 857-B is a mercury vapor rectifier with a filament of high emission efficiency.

A special core material permits the employment of greater areas and the operation of the filament at lower than usual temperatures and consequently at lower current densities per unit area.

This results in a tube of unusual efficiency and extraordinary long life.

**Price \$240.00**



**AMPEREX ELECTRONIC PRODUCTS, Inc.**  
 79 WASHINGTON STREET  
 BROOKLYN, NEW YORK





# COMMUNICATIONS

Registered U. S. Patent Office  
Member of Audit Bureau of Circulations

RAY D. RETTENMEYER  
Editor

## CONTENTS FOR JANUARY

Cover Illustration: Showing various equations plotted on a paper ruled according to the function  $\log_e x$ . Notice that breaks occur along both X and Y axis. See article on page 7.

	Page
With the Editors .....	4
Loge X .....	7
By R. Lorenzen	
New Transmission System .....	9
A Noise Suppressor Circuit for Heterodyne Receivers .....	10
By Olan Richardson	
A Bridge Type Set for Measuring Vacuum Tube Parameters .....	11
By Joseph R. Pernice	
Crystal Control for Portable and Semi-Portable Broadcast Pickup Transmitters .....	14
By S. T. Carter	
Thermocouple Meters .....	15
By J. B. Epperson	
Telecommunication .....	18
Notes and Comment .....	19
Program of the Second Annual Broadcast Engineering Conference .....	20
Veteran Wireless Operators Association News .....	22
Over The Tape .....	30
The Market Place .....	32
Index of Advertisers .....	36

VOLUME 19

Copyright 1939—Bryan Davis Publishing Co., Inc.

NUMBER 1

BRYAN S. DAVIS  
President

JAMES A. WALKER  
Secretary

Chicago Office—608 S. Dearborn St.  
Telephone: Wabash 1903.

Published Monthly by the  
BRYAN DAVIS PUBLISHING CO., INC.

19 East 47th Street  
New York City  
New York Telephone: PLaza 3-0483



SANFORD R. COWAN  
Manager

PAUL S. WEIL  
Advertising Manager

A. GOEBEL  
Circulation Manager

Wellington, New Zealand—Te Aro Book Depot.  
Melbourne, Australia—McGill's Agency.

Entered as second class matter October 1, 1937, at the Post Office at New York, N. Y., under the act of March 3, 1879. Yearly subscription rate: \$2.00 in the United States and Canada, \$3.00 in foreign countries. Single copies: twenty-five cents in United States and Canada, thirty-five cents in foreign countries.

# NOW!

## A TROUBLE-FREE GAS-FILLED CONDENSER

● TO PRODUCE a condenser which we were willing to sponsor as "failure-proof" we found it necessary to adopt a totally new type of design and construction. But Lapp engineers, working in close co-operation with leading radio engineers, have produced such a unit, a condenser which, besides giving you *trouble-free operation*, offers the great advantages of *maximum capacity for given external dimensions* (the unit shown above will replace a whole bank of old-type solid dielectric condensers in series parallel), *practically zero loss, zero change in capacitance with change in temperature*, and a range of sizes that makes this superior new type of unit available for a wide range of applications in your transmitter. For a complete description and technical data, send the coupon below.

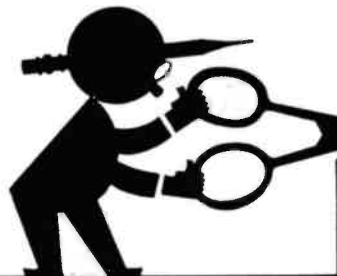
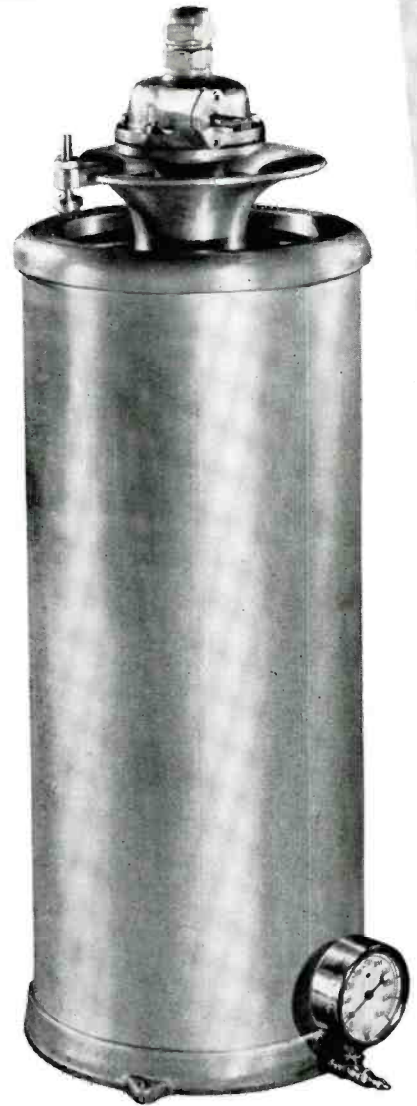

SEND THE COUPON FOR LITERATURE

# LAPP

INSULATOR CO. . .

LE ROY, NEW YORK, U. S. A.

LAPP INSULATOR CO., INC.  
LeRoy, N. Y., U. S. A.

C-3

I want all the facts on the new line of Lapp gas-filled condensers.

Name \_\_\_\_\_

Station \_\_\_\_\_ Street \_\_\_\_\_

City \_\_\_\_\_ State \_\_\_\_\_

# WITH THE EDITORS

---

## BROADCAST ENGINEERING CONFERENCE

THE SECOND ANNUAL Broadcast Engineering Conference is being held at the Ohio State University, Columbus, Ohio, from February 6 through 17. Considerable interest is being evidenced in this meeting and those who can do so are urged to attend. The program of the gathering will be found on page 20. A report of the Conference will, of course, appear in an early issue.

## RMA-NAB MEETING

ADOPTING four factors as the basis of the joint NAB-RMA radio campaign, sub-committees met recently to complete details.

Four fundamentals were regarded as basic to the all-radio campaign which will enlist the cooperation of broadcasters, networks, manufacturers, distributors, and local retailers: "(1) to increase the amount of listening; (2) to improve the quality of home reception; (3) to sell the excellence, variety and extent of American radio program service; (4) to sell the American system of broadcasting and the contributions made thereto by the individual NAB stations."

Underlying the subcommittee's first planning session was the thought that increased listening and an increase in the number of radio sets ultimately showed up in the station rate card, and that on the other hand, a broader public appreciation of the variety and character of program service now being broadcast by radio stations ultimately created a demand for more and better radio sets, a foundation of mutual beneficial interest was established.

An additional consideration, however, was the fact that a program of joint activity which would unite all elements within radio would operate in the more rapid advancement and best interests of American radio.

While details of the campaign are now being prepared, the committee members agreed that it would be administered through the public relations department of NAB for the time being.

For the purpose of organizing every com-

munity behind the campaign, NAB broadcasters will be asked to invite retailers and distributors in their areas to a meeting which will be held either in the station studios or at some other agreeable location. The local broadcaster will be asked to serve as chairman of this meeting, and to present the entire project.

It is estimated that the campaign will be ready for announcement about the third week in February.

Representing RMA were Bond Geddes, Executive Vice President; Sayre Ramsdell, Vice President, Philco; Frank Mullen, Director of Information, RCA. Neville Miller, President, and Ed Kirby, Director of Public Relations, represented NAB.

## IRE-ISRU MEETING

THE ANNUAL joint meeting of the Institute of Radio Engineers and the International Scientific Radio Union will be held in Washington, D. C., on April 28 and 29.

Papers on the fundamental and scientific aspects of radio will be presented. Meetings of other scientific societies will be held in Washington during the same week. S. S. Kirby, National Bureau of Standards, is in charge of the gathering.

## FREQUENCY MODULATION

WHILE VERY LITTLE is being said about frequency modulation, a great deal of work is being done by Major Edwin H. Armstrong and others. Frequency modulation seems to have a number of advantages for use at short wavelengths. Hence, it would not be surprising if considerably more were heard on the subject in the near future.

## AIEE CONVENTION

THE WINTER CONVENTION of the American Institute of Electrical Engineers is being held in New York City from January 23 through January 27. Quite a few sessions during the five days of the meeting will be devoted to communication, instruments, etc. In addition, a number of inspection trips have been planned.



# TRANSMISSION LINE NEWS

## GAS-FILLED ALUMINUM COAXIAL CONDUCTOR

made by ISOLANTITE  
installed at WTAM

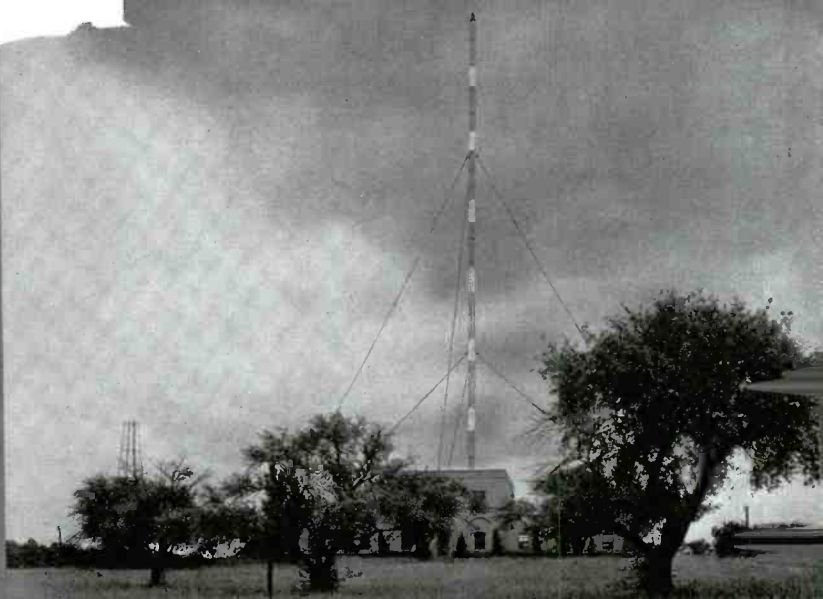

**I**SOLANTITE INC. pioneers again with the introduction of gas-filled aluminum coaxial transmission line for the new 470-foot vertical radiator at Station WTAM, Cleveland.

Light weight and low cost feature this radically new development in transmission line design, while life factor and electrical properties are comparable to those of copper. Solderless connectors make gas-tight joints of high tensile strength by a simple process of tightening bolts. Iso-Q\* low-loss ceramic insulators, shaped to conform with the electrical field, and shielded to eliminate air gap stresses, provide the ultimate in safety and efficiency.

The differential expansion or contraction between the inner and outer tubes is halved by locking the two tubes securely with respect to each other at the middle of the line, so that expansion takes place in both directions from the center point.

Every detail of this new aluminum line is engineered with the same skill that has made Isolantite copper transmission line the choice of more than 100 broadcasting stations throughout the country. Write for information on aluminum and copper transmission lines for broadcast, police radio, airway beacon, and communications equipment.

SOLD ONLY THROUGH GRAYBAR ELECTRIC CO. AND MANUFACTURERS OF TRANSMITTING EQUIPMENT.

\* Registered trade-name for the new lower loss products of Isolantite Inc.



Above: Locking insulator located at center of line allows two-way expansion. Solderless connectors provide gas-tight joints.

Right: Fittings for the line include gas-tight Isolantite end seal equipped with lightning protection gaps and gage for checking gas pressure.

Below, right: A simple tightening operation with a wrench seals the joints in the line against leakage of gas.

Below: A view of the installed line leading from the transmitter to WTAM's tuning tower.

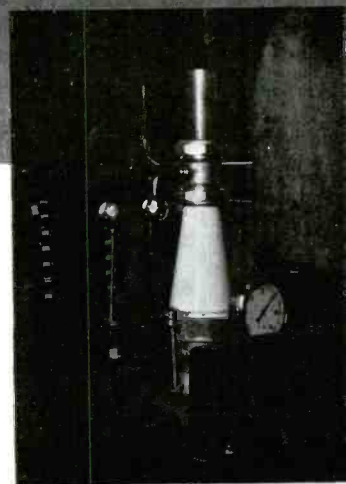

# ISOLANTITE INC.

## CERAMIC INSULATORS

Factory: Belleville, N. J. • Sales Office: 233 Broadway, New York, N. Y.



RCA . . . the name symbolizing creation, progress, achievement in radio! RCA . . . Radio Corporation of America . . . a family of doers writing history with sound in the sky!

Makers of instruments for radio transmission and reception of sound, code messages and facsimile reproduction. Makers of instruments for the recording of sound on records and on motion picture film. Creators of countless radio devices vital to science, industry, medicine, telephony, and public safety.

RCA . . . creator of a nation-wide broadcasting service, The National Broadcasting Co.

RCA . . . creator of a world-wide radio communications system with direct circuits between the United States and 43 foreign countries, and with ships at sea . . . a message service with the speed of lightning.

RCA . . . pioneer in research in radio, sound and television.

RCA . . . truly American, owned by a quarter of a million stockholders in 48 states.

RCA . . . 19 years a name across the sky . . . 19 years of service to all the world.

*Listen to the "MAGIC KEY" every Sunday, 2 to 3 P. M., E. S. T., on the NBC Blue Network.*



## Radio Corporation of America

RADIO CITY, N. Y.

RCA Manufacturing Co., Inc.

Radiomarine Corporation of America

RCA Institutes, Inc. National Broadcasting Company R.C.A. Communications, Inc.



# COMMUNICATIONS

FOR JANUARY, 1939

## loge x\*

By R. LORENZEN

IT IS MATHEMATICALLY impossible to obtain a value for the logarithm of a negative number.<sup>1</sup> A glance at Fig. 1, which is the graph of the equation  $y = \log x$ , shows that, since no part of the curve appears to the left of the ordinate, it is meaningless to consider a quantity such as  $\log(-x)$ .

The engineer, however, although he must bow before ultimate mathematical truths, nevertheless feels that this is a rather unfortunate state of affairs, for, although he has no particular need in his computations for the logarithm of a negative number, he does occasionally have use for a graph paper on which such quantities could be plotted. For example, an electrical circuit of such nature that the positive and negative reactance vary over a very wide range with frequency could usefully employ a ruled paper of this character, as will be shown later in plotting the characteristics of a quartz crystal.

### THE PRINCIPLE

The principle upon which this new paper is based lies in the fact that the limits of accuracy of any physical measurement are such that it becomes meaningless to assign values beyond a certain significant place. Consequently, the first cycle of the logarithmic plot will contain the last significant figure.

Consider the new function  $y = \text{loge } x$  and its representation in Fig. 2. It will be observed that portion *ac* is the upper part of the usual logarithmic curve. The curve *bd* to the left of the

ordinate is an inverted reflection of the portion to the right. All points falling between *b* and *a* are discarded as in-

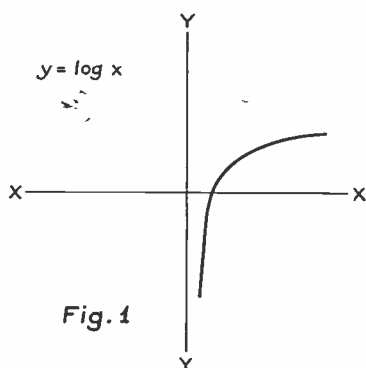

Fig. 1

Above: A plot of  $y = \log x$ .

Below: Plot of  $y = \text{loge } x$ .

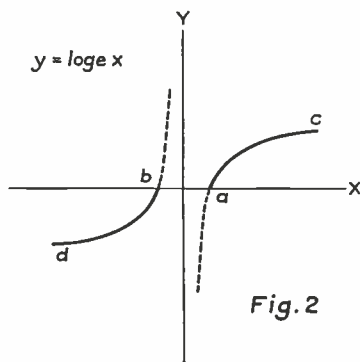

Fig. 2

indicated by the dotted lines. The new function obeys the mathematical laws pertaining to logarithms and differs

chiefly in that  $x$  may assume negative values. Graphically speaking, the significance of  $x$  becoming negative is merely that although it has the same magnitude as  $\log(+x)$  it is plotted to the left of the ordinate.

### DEFINITION OF LOGE X

The function  $y = \text{loge } x$  may be analytically defined as follows:

- where  $y = \text{loge } x$
- (1)  $+\infty \geq x \geq +1$
  - (2)  $+1 > x > -1$
  - (3)  $-1 \geq x > -\infty$

The dash over  $x$  in interval (2) signifies that  $x$  is non-existent in this interval.

Fig. 3 shows the type of paper which results when lines are ruled in accordance with the new function,  $\text{loge } x$ . In this case the break is made along both the X and Y axes thus dividing the paper into four quadrants, the cyclical character of the logarithmic paper in each quadrant consisting of a re-

<sup>1</sup>Strictly speaking, this statement is true only if the domain of discussion is limited to functions of a real variable. If the field is widened to include functions of a complex variable the concept of the logarithm of a negative quantity becomes meaningful. Its significance can be readily understood by an examination of the following demonstration:

ACCORDING TO EULER'S THEOREM

$$r(\cos \theta + j \sin \theta) = re^{j\theta}$$

$$\text{Hence } \log [r(\cos \theta + j \sin \theta)] = \log r + j\theta$$

$$\text{If } \theta = (2k+1)\pi$$

$$\text{then } \cos(2k+1)\pi = -1$$

$$\text{and } \sin(2k+1)\pi = 0$$

$$\log [r(-1+j0)] = \log r + j(2k+1)\pi$$

$$\log(-r) = \log r + j(2k+1)\pi$$

\*Copyright 1939 by R. Lorenzen.

versed reflection of the two adjacent quadrants. The origin is a point which comprises the whole interval from -1 to +1. It should be noted that instead

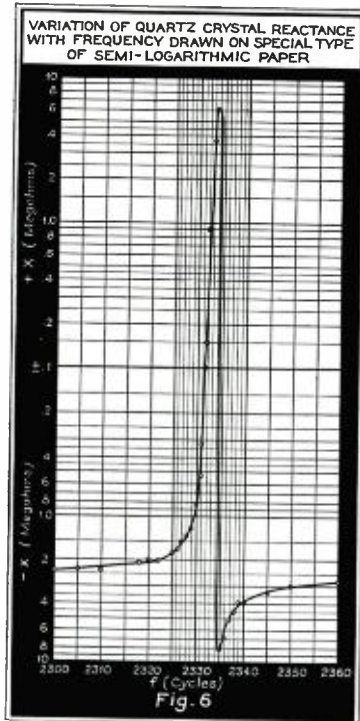

Showing variation of crystal reactance with frequency on special paper (above) and ordinary paper (below).

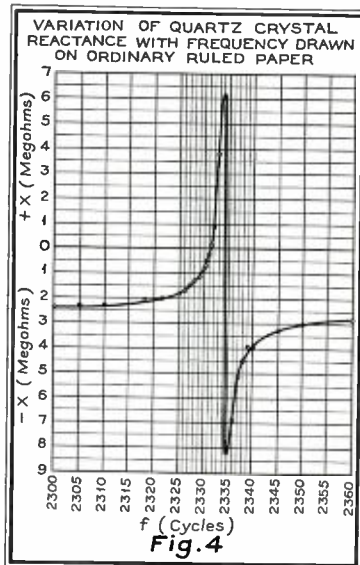

of having the first cycle go from zero to one as has been done here, if it had been desired that the first cycle be comprised of the range 10 to 100, then

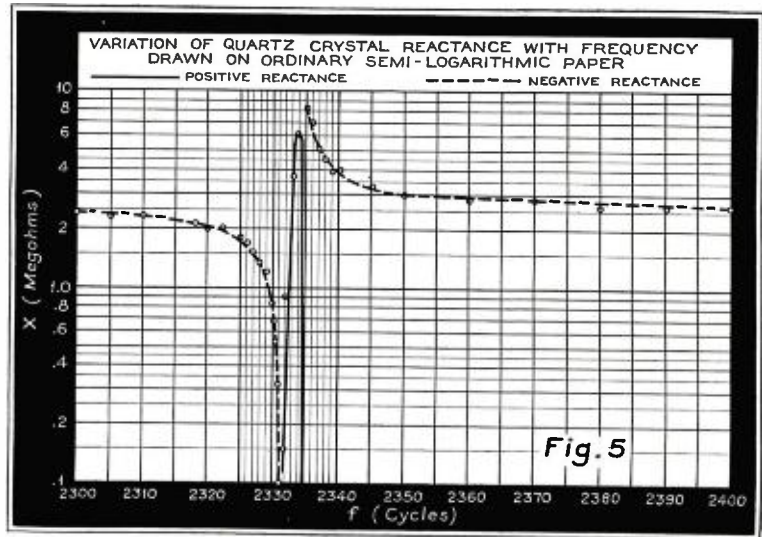

Variation of crystal reactance with frequency on ordinary semi-log paper. Compare with Figs. 4 and 6.

the origin would include the entire region -10 to +10, and similarly for larger or smaller ranges.

#### PLOTTING FUNCTIONS

The functions plotted in Fig. 3 (see front cover) show their behavior when drawn on this type of paper. The functions drawn are typical of those which would appear as straight lines if plotted on ordinary logarithmic paper. The functions are still represented as straight lines but at the origin the direction of the line may or may not undergo a change in direction. If the ordinate is considered to be the  $j$ -axis then the second and third quadrants will contain negative or complex roots of the equation, shown by dashed lines.

#### APPLICATIONS

The author first had occasion to realize the value of this type of paper in 1931. Measurements were made upon a quartz crystal to determine its variation of reactance with change in frequency. It was particularly desired to know the *rate of change* of reactance with frequency. Since the reactance range was very great, plotting the data on ordinary ruled paper, as shown in Fig. 4, was not satisfactory and resulted in unduly cramping the curve, as for example between 0 and -1. Furthermore, rate of variation of a quantity is not indicated with ordinary paper. Consequently, on both counts, a logarithmic paper was called for.

Since it was imperative that logarithmic paper be used, recourse was made

of the customary semi-logarithmic paper, the positive reactance being drawn in full lines and the negative reactance with dashed lines. The resulting curve, which is shown in Fig. 5, does not readily lend itself to physical interpretation.

The new paper was then conceived and the data plotted thereon, as shown in Fig. 6. This solution proved very satisfactory as not only was the rate of reactance change with frequency seen but also the physical interpretation of the phenomena was as easy as when plotted on ordinary quadrille ruled paper. It should be noted that in this instance all values of reactance which fell between +0.1 megohm and -0.1 megohm were plotted as  $\pm 1$ .

Although the break between the positive and negative portions of the chart usually would occur at the beginning of a logarithmic cycle, there are occasions when a break at some other section is found to be desirable. Under such circumstances it is imperative to remember that the portions above and below the break must be symmetrical.

#### THE CHART

In Fig. 7, for example, decibels are plotted against watts. Since 6 milliwatts is here assumed to be the zero reference level it is along this line that the break which separates positive and negative values occurs. The chart is symmetrical about the 6 milliwatt line and the relation between watts and decibels results in a straight line. If, however, the break had occurred at the beginning of a cycle a broken line would have been the outcome.

Whenever the data to be plotted requires the use of a *zero* reference level the break between the positive and negative portions of the chart must occur along this zero reference line and the positive and negative sections must be perfectly symmetrical about this line.

In using this new type of ruled paper or any variant thereof there is one very important point that should always be kept in mind, namely, the first cycle of the logarithmic plot will contain the last significant figure.

The author wishes to express his appreciation for the suggestions and criticisms made by Mr. J. H. Barkey.

### NEW TRANSMISSION SYSTEM

PRELIMINARY INSTALLATION work has been started at Station WHO, Des Moines, in connection with an experimental investigation of a radically new system of transmission. The new system is a development of the Collins Radio Company based principally on an invention due to J. F. Byrne of the Engineering Department of that organization.

Full technical details are not yet available but the new system is briefly described as employing polyphase radiation to accomplish amplitude modulation and normal reception with conventional broadcast receivers. The chief advantage promised by the new development is a realization of the theoretical minimum of power consumption and tube capacity amounting to a substantial reduction in power and tube cost over even the most recent high efficiency systems.

The present WHO transmitter site together with part of the regular WHO radiating system is being utilized for the experiment. Experimental transmissions will be begun in the near future, utilizing the call letters W9XC and a power of 1,000 watts on WHO's regular frequency of 1,000 kc. Transmissions will be conducted between the hours of twelve midnight and the beginning of the normal broadcast schedule and at times when WHO's facsimile experiments are not in progress. Work to be carried out is for the purpose of obtaining engineering data only.

The research program is being conducted by Paul Loyet, Technical Director of the Central Broadcasting Company, its staff and by the engineering staff of Collins Radio Company. No definite predictions are being made at this time by Collins Radio as to the ultimate application of the system beyond the statement that the development when perfected will most likely find its principal application in stations of 50 kw or greater.

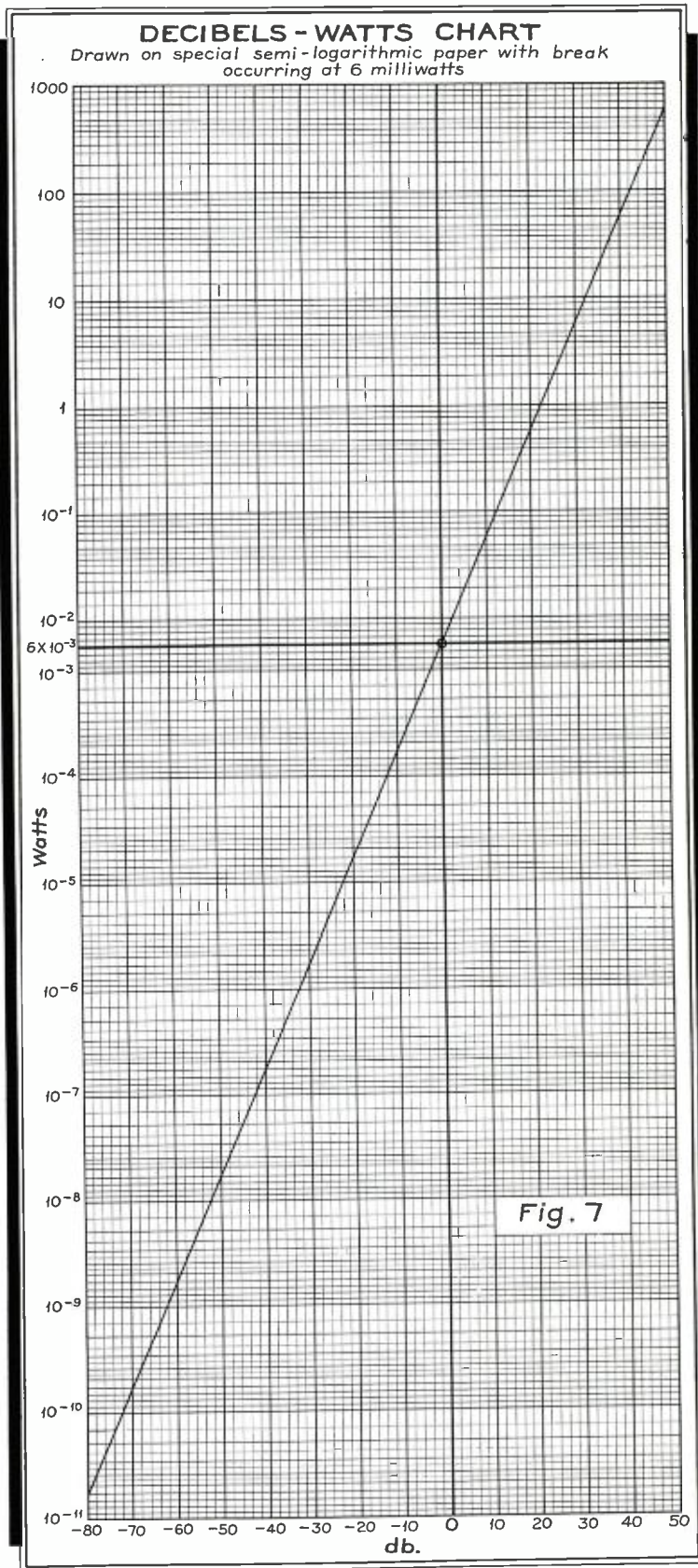



# A NOISE SUPPRESSOR CIRCUIT

## for Heterodyne Receivers

RECENTLY the author prepared an article for COMMUNICATIONS, titled "Carrier Current on Power Systems",\* in which reference was made to a noise suppressing circuit in a heterodyne receiver. Since this circuit presents a novel method of suppression of noise it was thought that a detailed description of it might prove interesting.

The circuit was developed for application to a telemetering system, the receiver of which records changes in the frequency of an unmodulated r-f signal which is transmitted as a carrier frequency on a power system. The receiver is a heterodyne circuit which feeds an audio-frequency-sensitive bridge network which initiates the movement of a recorder. Since the network is frequency sensitive, arcs, due to arrester discharges, insulator flashovers, and such disturbances, common to a power system, would cause frequencies, other than the heterodyne frequency generated in the receiver to register as errors on the recorder. It was therefore necessary to develop a suppressor which would block interfering frequencies from the receiver output. The circuit described here accomplishes this result very effectively.

The accompanying diagram shows the circuit in its simplest form. It consists

of two identical signal channels, each made up of an r-f amplifier, and combination diode detector and pentode

**By OLAN RICHARDSON**

Operating Engineering Department  
GEORGIA POWER COMPANY

audio amplifier with AVC operating from one of the diode plates. These two signal channels (or receivers) are connected to a power amplifier through a push-pull transformer. The output circuits of the two channels are connected to the primary of the push-pull transformer 180° out of phase (differentially). A beat oscillator is connected to the diode detector of one channel. This circuit arrangement accomplishes noise suppression, as can be seen by following its operation under various hypothetical conditions.

Suppose an unmodulated r-f signal is applied to the input circuit of the receiver. The r-f energy will be amplified through the two separate r-f amplifiers equally and passed on to the two detectors. In the detector circuit to which a beat oscillator is connected the signal frequency and the beat-oscillator

frequency will combine generating an audio frequency which will be transmitted through the audio-amplifier element of the tube to the push-pull transformer feeding the power-amplifier stage. In the detector circuit which has no beat oscillator the unmodulated r-f signal naturally will not result in an audio frequency. Hence there will be audio-frequency energy transformed from one-half the primary to the secondary of the push-pull transformer, and through the power amplifier to the receiver output.

Suppose a complex wave, such as results from an arcing ground or lightning arrester discharge is applied to the input circuit of the receiver, the energy is amplified and detected in both of the signal channels and transmitted through the audio amplifiers, arriving at the push-pull transformer in phase and of equal amplitude. Here it bucks out because it is connected to the primary winding differentially (180° out of phase). The result is that no energy is transferred to the power-amplifier stage, and so the complex wave results in no signal at the receiver output.

Now suppose a complex wave and the unmodulated r-f signal wave are applied in combination to the receiver in-

(Continued on page 23)

\*July, 1938, p. 19.

Schematic diagram illustrating the noise suppressor circuit.

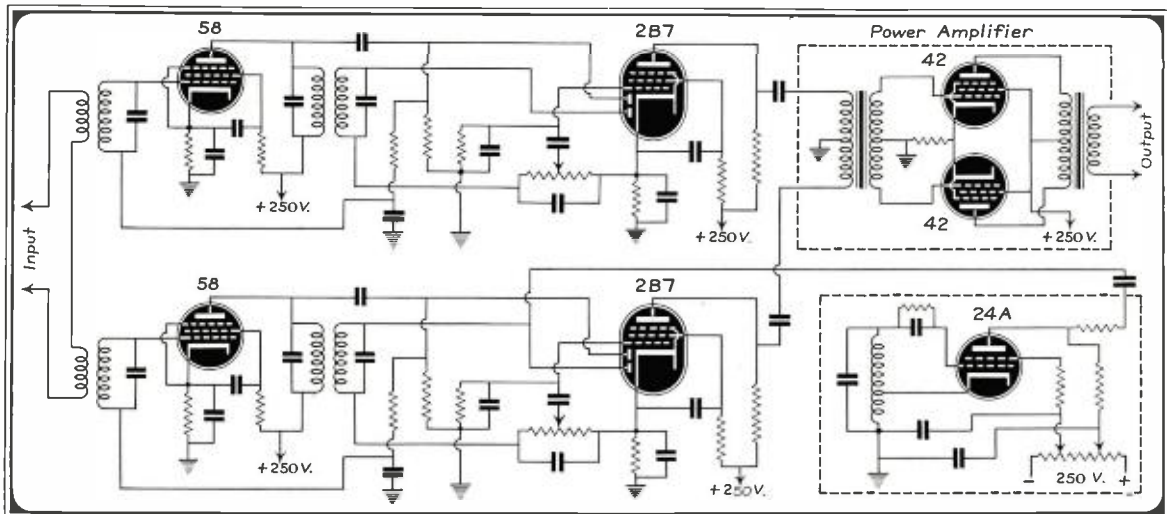

# Bridge Type Set for Measuring VACUUM TUBE PARAMETERS

THE CIRCUIT shown in Fig. 1 is designed to measure under operating conditions the amplification factor  $\mu$ , the mutual conductance  $S_m$  and the plate impedance  $R_p$  for twenty-eight different types of vacuum tubes. This circuit will also permit measurement of the gain  $\mu_g$  of the tube circuit when the tube is working into a nominal load resistance.

The equipment is subdivided into three units: (1) the bridge measuring unit, (2) the tube socket unit, and (3) the power supply and control unit. While this equipment can all be mounted on a panel or chassis as a single unit, it is recommended that, for greater flexibility and better functioning of the circuits, each of these component parts be mounted on separate chassis. Since all the controls must be within reach of the operator, it is suggested that each unit be built as compact as possible and supported on a table with the bridge-measuring unit in the center, the power-control unit to the left and the tube socket unit to the right. If the panel mounting is used, the tube-socket unit should be on top, the bridge-measuring unit in the center and the power-supply and control unit on the bottom.

In Fig. 2 is shown a schematic of the tube-parameter measuring set which is

more readily analyzed and will be used to illustrate the principles on which the circuit of Fig. 1 functions. In order to

## By JOSEPH R. PERNICE

measure the amplification factor the K-1 bridge selector switch is thrown to position 1 and we obtain the well known "Miller" circuit as shown in Fig. 3. The signal source develops a voltage in the grid circuit  $E_g = IR_1$  and a voltage in the plate circuit equal to  $IR_2$  which is in phase with  $E_g$ . The impressed grid voltage causes a voltage  $\mu E_g$  to appear in the tube plate circuit which is 180 degrees out of phase with  $IR_2$ . Hence, if  $R_2$  is varied until no signal is heard in the telephones we know that  $\mu E_g$  must equal  $IR_2$  and we can write

$$\mu E_g = IR_2 \quad \text{or} \quad \mu IR_1 = IR_2$$

$$\text{Therefore, } \mu = \frac{R_2}{R_1}$$

Now, if  $R_1$  is given a fixed value such as 10 ohms,  $R_2$  can be calibrated to show the value of the amplification factor directly without requiring any computation.

In order to measure the mutual conductance the K-1 switch is thrown to position No. 2 and we obtain the circuit shown in the schematic of Fig. 4. Under these conditions the a-c plate current is given by

$$I_p = \frac{\mu E_g}{[R_p + R_L]} \\ = \left[ \frac{\mu}{R_p} \right] E_g \frac{R_p}{[R_p + R_L]} \\ = S_m E_g \frac{R_p}{[R_p + R_L]}$$

When a balance is obtained by varying the  $R_2$  resistor, no voltage appears across the phone circuit since  $I_p R_L$  must equal  $I_n R_2$ . Hence in the above equation we may replace  $I_p$  by  $I_n \frac{R_2}{R_L}$  and since  $E_g = I_n R_1$  we have

$$I_p = I_n \left[ \frac{R_2}{R_L} \right] \\ = S_m (I_n R_1) \frac{R_p}{[R_p + R_L]}$$

$$\therefore S_m = \frac{R_2}{R_1 R_L} \left[ 1 + \frac{R_p}{R_L} \right]$$

If  $R_L$  is very small in comparison with  $R_p$ , then the mutual conductance

$$S_m = \frac{R_2}{R_1 R_L}$$

is given a value of 50 ohms, and if  $R_1$  is given a value such that the product of  $R_1 R_L$  is some power of ten, then the setting of  $R_2$  will give the value of the mutual conductance in mhos. When this value is multiplied by  $10^6$  we obtain the mutual conductance in micro-mhos.

If it is desired to measure the gain  $\mu_g$  of the tube circuit with a specified load on the tube the K-1 switch remains in position 2. However, the strap is removed from the external load binding posts and the load resistor  $R_L'$  is connected to these terminals. Now, a balance is obtained as before by varying  $R_2$  until no signal is heard in the phones. Under these conditions we have that the tube circuit gain

$$\mu_g = \frac{\text{output}}{\text{input}} = \frac{I_n R_2}{I_n R_1} = \frac{R_2}{R_1}$$

For these same conditions of test we have a means of obtaining the amplifica-

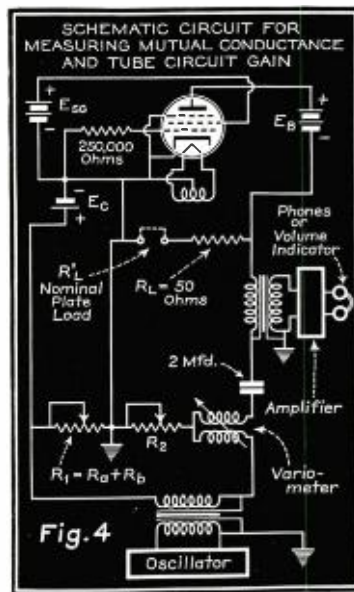
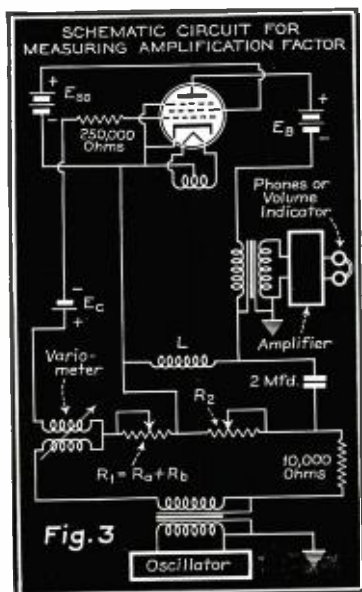

tion factor of the tube since,

$$I_p = \frac{\mu E_g}{[R_p + R'_L]} \quad \text{and} \quad I_p R'_L = I_o R_2$$

or

$$I_p = I_o \left[ \frac{R_2}{R'_L} \right]$$

Hence

$$I_o \left[ \frac{R_2}{R'_L} \right] = \mu I_o \frac{R_1}{[R_p + R'_L]}$$

$$\therefore \mu = \frac{R_2}{R_1} \left[ 1 + \frac{R_p}{R'_L} \right]$$

All the terms of this expression are known except the plate impedance  $R_p$  which can be found by the method outlined in the following paragraph. It should be noted that the 50-ohm  $R_L$  fixed resistor is in series with  $R'_L$  and it should be added to  $R'_L$  in the computation.

To measure the plate impedance of the tube the K-1 switch is shifted to position 3 and the circuit is converted to the bridge shown in schematic of Fig. 5 in which the  $R_a$  and  $R_b$  resistors are the ratio arms, the  $R_2$  resistor becomes the variable standard and in the un-

known arm is inserted the plate-cathode circuit of the tube. In making a measurement  $R_2$  is varied until no signal is heard in the telephones under which condition the bridge becomes balanced. For a resistive balance of the bridge  $R_p R_b$  must equal  $R_a R_2$  and hence the

$$\text{plate impedance } R_p = \left[ \frac{R_a}{R_b} \right] R_2.$$

Then if the ratio of  $\left[ \frac{R_a}{R_b} \right]$  is made

unity or a power of ten, the plate impedance can be read directly from the setting of  $R_2$ .

The equipment included in the bridge measuring unit is shown in Fig. 1 and it consists essentially of the elements of the bridge circuits and the meters necessary for measuring the currents and voltages of the grid, screen-grid and plate circuits. In order to indicate correct operating conditions, the meters should be accurately calibrated preferably after the unit is assembled and wired. The meters will include a multi-scaled voltmeter and microammeter for the grid circuit, a multi-scaled combination voltmeter for the plate circuit

and a similar type meter for the screen-grid circuit. The range of these meters will depend on the respective voltage and current ratings of the vacuum tubes whose constants the set is designed to measure.

In the bridge measuring unit are the  $R_a$  and  $R_b$  resistances which are used to balance the bridge circuits and their total value must necessarily vary widely if the set is to measure a large number of different types of tubes. The arrangement of the individual resistance units which go to make up  $R_2$  will largely depend upon whether the set is designed to primarily measure the constants of triodes, tetrodes or pentodes, or all of these. The lowest value of  $R_2$  will be fixed by the lowest value of  $\mu$  to be measured, keeping in mind that this value will be  $R_1$  times as great as  $\mu$  since it was shown above that

$$\mu = \left[ \frac{R_2}{R_1} \right] \quad \text{and hence } R_2 = \mu R_1.$$

For example the 45 tube has an amplification factor of 3.5 and this being the lowest  $\mu$  to be measured, the " $R_a - R_2$ " resistor combination will have to go as low as 350 ohms if  $R_1$  is adjusted to

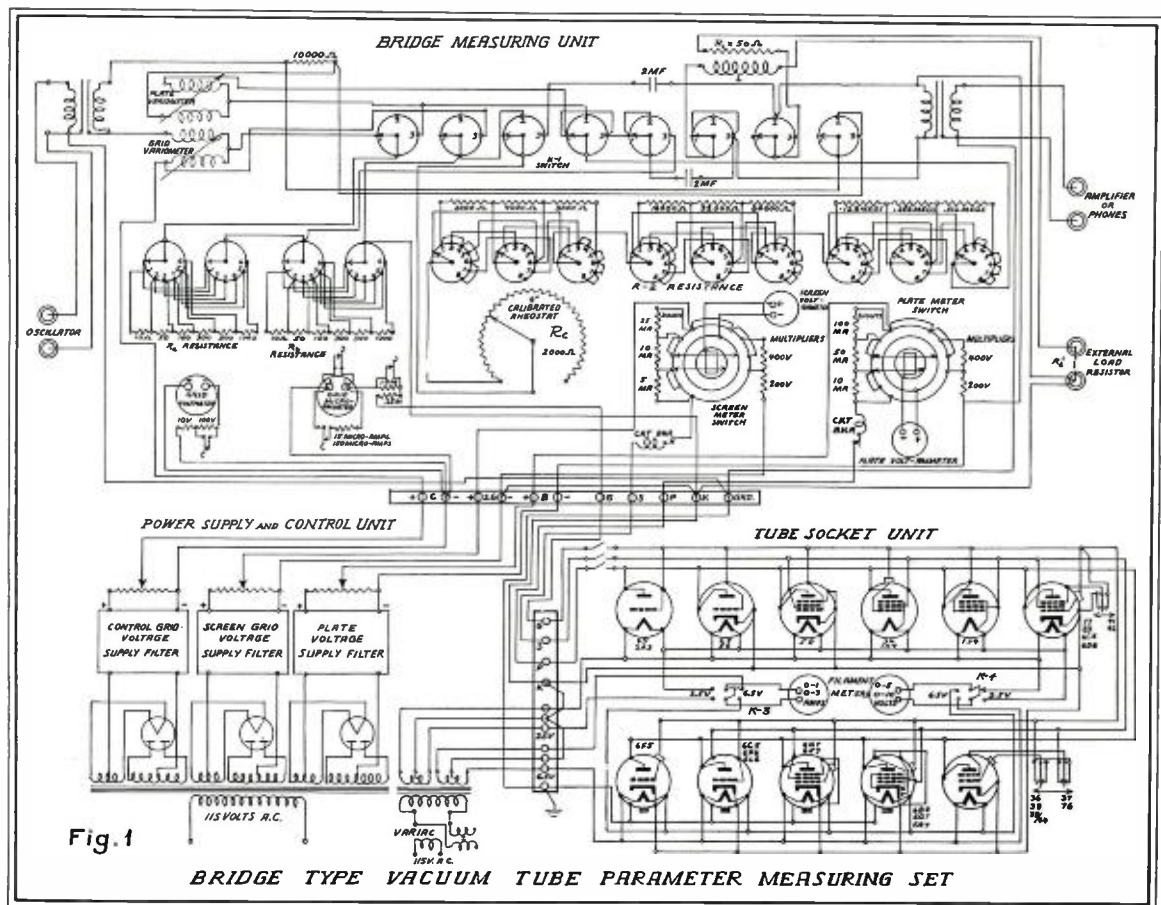



100 ohms. The largest value that  $R_2$  must attain is fixed by the value of the highest plate impedance which must be measured. With few exceptions the plate impedance of triodes is under 30,000 ohms; however for screen-grid and pentode tubes, the plate impedance may be as high as 1.5 megohms such as for a 77 or 6J7 type tube.

In Fig. 1  $R_2$  is made up of three banks of resistors all connected in series with a calibrated 2,000-ohm rheostat  $R_c$ . The calibrated rheostat should not have a diameter of less than five or six inches and it should be readable to an accuracy of about five ohms or better.

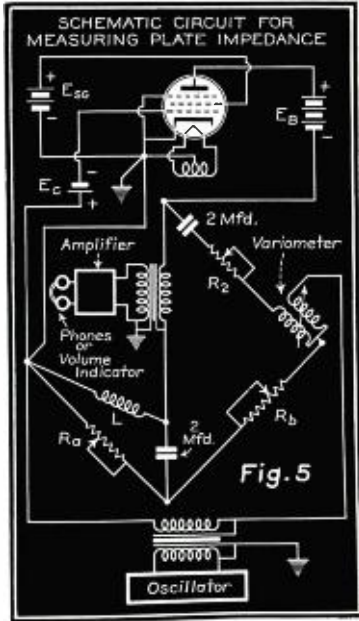

This is necessary because in measuring the lowest amplification factor  $R_c$  will have to indicate a value as low as 350 ohms quite accurately. In each bank of  $R_2$  there are three precision resistors, such as the 500 type which are successively selected by an eight position switch in such a manner that the combination of  $R_c$  and  $R_2$  results in a resistance value which is continuously variable with precision from zero to 1.024 megohms. This arrangement in conjunction with the use of the proper value of the  $R_1$  resistor permits the measurement of the parameters of any vacuum tube.

The  $R_1$  resistor is divided into two equal sections  $R_a$  and  $R_b$  so that it can be used both as a single unit in the measurement of  $\mu$ ,  $S_m$  and  $\mu_e$ , and as a set of ratio arms when measuring  $R_p$ . For greater flexibility each of  $R_a$  and  $R_b$  has six different resistance values controlled through a set of switches as shown on Fig. 1. In making a measure-

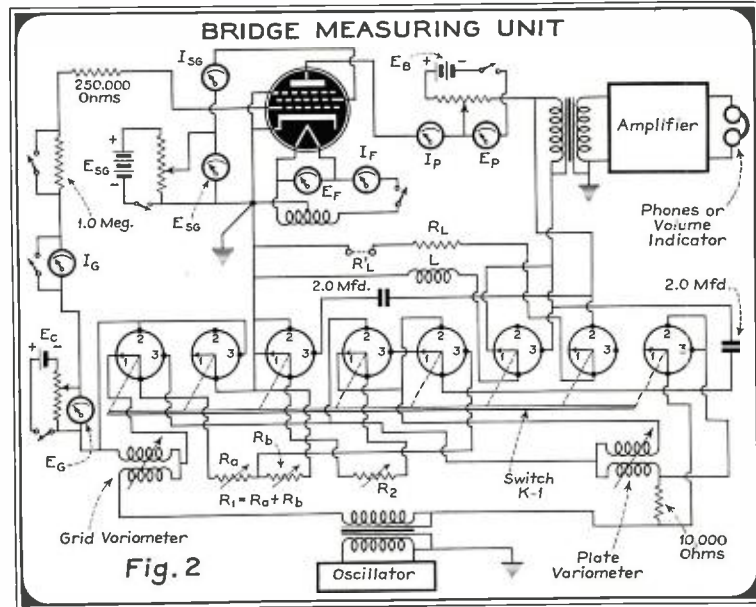

ment  $R_1$  is to be judiciously set at a value for which the bridge is most sensitive and also convenient for computation.

In order to measure the gain  $\mu_e$  of the tube circuit, it will be necessary to remove the strap from the  $R'_1$  binding posts and connect the desired load resistance to these posts as shown in Fig. 1. If it is possible to predetermine the load resistors, these units can be permanently mounted and wired through a selecting switch, otherwise it is necessary to connect these loads externally. It should be noted that the external resistor  $R'_1$ , when connected is in series with the 50-ohm  $R_L$  resistor. When measuring the mutual conductance the strap must be replaced.

In obtaining a satisfactory "null" point balance in the various bridge circuits a variometer is required which corrects for phase shifts in the balancing voltages. When measuring the amplification constant the phase corrector will be found most effective in the grid circuit; however, for the measurement of mutual conductance and plate impedance it is most effective in the plate circuit. In the parameter measuring set two phase correctors are installed only, one of which is in use at a time. This arrangement is desirable because the variometers will in general require widely varying constants and it will no doubt be more feasible to obtain two units within the desired range of inductance required.

It is preferable to determine experimentally the values of the coil inductances and mutual required after the measuring set is constructed. To do this a standard calibrated variometer

should be connected in place of the phase corrector, and parameter measurements taken for a series of vacuum tubes each time noting the amount of total inductance required for the complete disappearance of the signal. In this manner it is possible to ascertain the maximum amount of total inductance required and learning the inductance of each coil from the calibrated variometer, a phase corrector having these desired constants should be constructed or purchased. The constants of the phase corrector can be checked by measuring on an a-c bridge the inductance of each coil separately which may be designated as  $L_1$  and  $L_2$ . Then the coils should be connected first in series "aiding" and then "opposing" and each time denoting the total inductance as  $L''$  and  $L'$  respectively. Then the mutual inductance can be verified from the relation  $M = 1/4 (L'' - L')$  and the coefficient of coupling from  $K = M/L_1 L_2$ .

There are a number of methods for arranging the socket circuits in the tube socket unit. In the arrangement shown in Fig. 1 there are eleven sockets which will permit parameter measurements for twenty-eight different types of vacuum tubes as indicated in the drawing. This unit also includes a multi-scaled voltmeter and an ammeter for the filament or heater circuits, and switches for the grid, screen-grid, control-grid and heater power supplies. Most of the sockets will accommodate more than one tube without the use of keys for switching the tube electrodes. For two of the sockets shown keys are provided which illustrate how the utility of a specific socket can be extended by

(Continued on page 27)

# Crystal Control for Portable & Semi-Portable BROADCAST PICKUP TRANSMITTERS

By **S. T. CARTER**  
WSOC

AFTER TRYING innumerable types of modulated-oscillator and oscillator-amplifier transmitters for portable and semi-portable use at frequencies above 30,000 kilocycles, the need for transmitters of the crystal-controlled type and superheterodyne receivers became very evident. The inherent noise encountered with receivers of the super-regenerative type at any frequency makes their use, except on signals of very strong intensity, impractical. The use of superheterodyne receivers with transmitters using self-excited oscillators does not allow for full use of the modulation capabilities of a transmitter, free from frequency modulation.

The faults of self-excited transmitters was the object of designing the transmitter to be described. At the same time it was desirable that the cost of construction be kept down. Furthermore, the transmitter must be capable of two things that the self-excited transmitter lacked, freedom from frequency modulation and the capability of 100 percent modulation.

The use of frequencies above 30,000 kc allows the added gain to be found in simple beam antenna to be utilized and, because of their physical size, these antenna are thoroughly practical for mobile units. Beam antenna at both the transmitting and receiving end will provide reliable communication up to respectable distances.

The transmitter uses a crystal-controlled oscillator, capable of high-power

harmonic output and a final modulated stage. The oscillator uses a comparatively low-frequency crystal and has sufficient regeneration introduced into the tube's cathode circuit to provide the power necessary at the working frequency without any tendency towards self-oscillation of the tube due to the feedback.

The amplifier uses one of the dual-triode types of tubes, either a 6A6 or one of the octal-base 6N7G tubes might be used. The two triode units are operated as a single push-pull Class C amplifier.

The crystal used is cut for 3884 kilocycles and the plate tank of the oscillator is tuned to the working frequency of 31,100 kilocycles. The crystal itself is housed in one of the variable air-gap type of holders, allowing almost 50-kilocycle frequency variation around 31,100 kilocycles. The oscillator tube used may be either of the power-pentode or beam-types, depending on the amount of power output desired. The metal types of tube are to be preferred over those of the glass type.

Using a 6L6 tube with 350 volts for plate supply and 250 volts for the screen grid, no heat whatsoever was noticed in the crystal itself. No accurate means of measuring the actual crystal current was at hand. However an r-f milliammeter inserted in series with the crystal

showed a reading of 30 ma. This reading was probably high due to the extended leads of the meter in connecting it into the circuit. At any rate the current through the crystal is far below any value that is likely to cause crystal fracture or sufficient heating to cause frequency drift.

Thorough shielding between oscillator and amplifier stage was provided.

The circuit of the oscillator used is not new, however it is believed that the use of such a circuit to provide usable r-f output at harmonic frequencies as high as used here is new.

Contrary to common belief, an oscillator having enough regeneration to obtain good power output at high harmonic frequencies, has nothing tricky about its operation or adjustment. The metal shell of the oscillator tube should be connected to the cathode, at the tube socket, and not to ground.

The r-f chokes used are of the small pi-wound 2.5 millihenry type. The oscillator cathode choke should, if of this type, have one pi removed to provide an inductance of about 2 millihenries. The value of inductance used at this position however is not at all critical. Variations in the value of RFC 2 may be corrected by C 2, its size should not be too small however. RFC 2 may be a small coil of forty or fifty turns of No. 30 wire, bank wound to a diameter of an inch and a half.

The heater terminals of both the oscillator and amplifier stage should be bypassed to ground through a .002-mfd or larger condenser. Either the center tap or one side of the heater circuit should have a direct ground connection.

For the sake of less work in the original unit, the grid circuit of the amplifier was tuned. However, a grid coil with a larger number of turns, resonant at the working frequency could just as well be used as this would eliminate the necessity for one tuning condenser. The oscillator is capable of furnishing far more power than that needed for driving the 6A6 modulated amplifier.

Neutralization of the modulated amplifier is perfectly straightforward in every way. There should be no more trouble from this angle at the higher frequencies than at broadcast frequencies. Common sense in the layout and

(Continued on page 24)

Fig. 1. Circuit diagram showing parts.

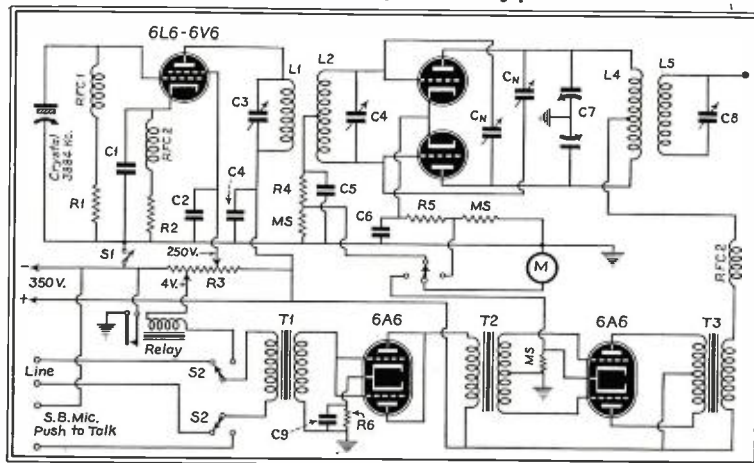

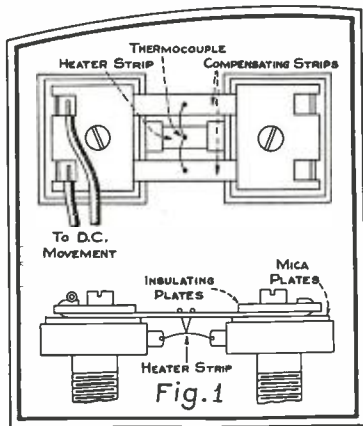

# THERMO- COUPLE METERS

By J. B. EPPERSON

Chief Engineer

SCRIPPS-HOWARD RADIO, INC.

A THERMOCOUPLE METER might be described as a millivoltmeter connected across a junction of two dissimilar metals. When this junction is heated, a voltage is built up across the junction which varies directly as the temperature at the junction. Thus, to use the thermocouple for measuring high-frequency currents it is only necessary to heat the junction with the current to be measured by passing the current through a heater wire placed adjacent to the thermocouple. The millivoltmeter scale is then calibrated as a function of the current through the heater wire.

With a given type heater wire and a given current through this wire, the sensitivity of the thermocouple itself will depend largely upon the materials of the two dissimilar metals and upon the heat dissipation factor at the junction. The more rapidly heat is carried away from the junction, the less sensitive the thermocouple becomes.

In the older forms of thermal instruments large errors were introduced due to ambient temperature variations. To overcome this difficulty, W. N. Goodwin introduced the compensated thermal instrument. This type, as shown in Fig. 1, attains its high accuracy through the use of compensating strips which have the same thermal characteristics as the heater strip itself. The cold ends of the

couple are connected to the compensating strips and the hot junction is connected to the heater strip. Since the compensating strips and the heater strip are thermally equivalent, there is a thermal balance; but when current heats

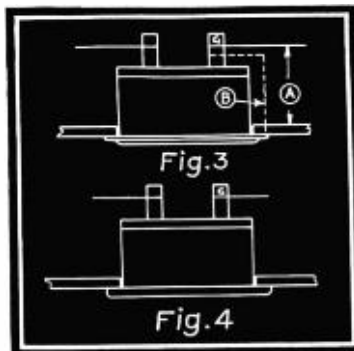
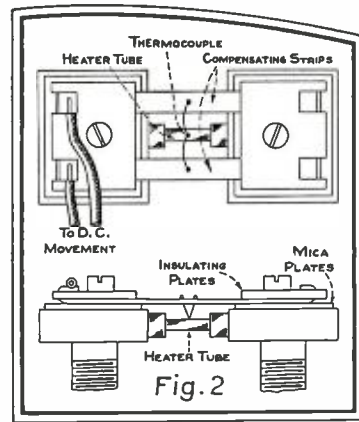

- Notes-**
- (A) If panel is metal, voltage must not exceed 300 Volts
  - (B) If panel is of insulating material, connect case to stud as shown.
  - (C) When metal panel is used and voltage E-O, insulating ring may be omitted.

the heater strip, there is a resultant difference in temperature between the cold and hot ends. This temperature difference produces a thermo-electric voltage which is a result only of the temperature rise in the heater strip. Ambient temperature variations of quite large magnitude are therefore completely eliminated. Some thermal ammeters having ranges of .5 ampere or higher are equipped with compensated thermal converters. The heating elements themselves are made of non-corroding platinum alloy. The couple, usually made of constantan and a platinum alloy is designed to give the highest emf consistent with reasonable overload capacity. Full-scale deflection on the instrument is obtained with only a moderate temperature rise in the heater. Thermo instruments should never be subjected to an overload of more than 50 percent which more than doubles the temperature of the heater, but will not damage it.

Meter ranges below .5 ampere and down to 115 milliamperes are supplied with bridge type couples of special form.<sup>1</sup> Below this value and down to 2 milliamperes, instruments can be obtained with self-contained or vacuum type couples.

<sup>1</sup>See page 193, second edition, "Radio Engineering Handbook," by Henney.

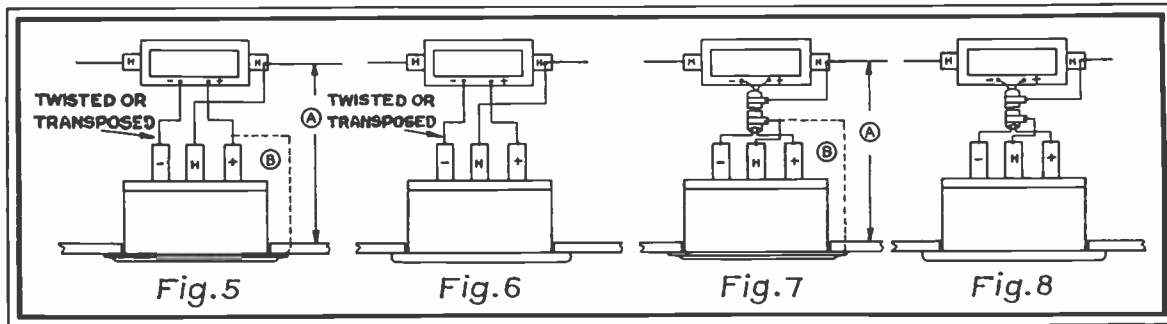



### ERRORS IN THERMOCOUPLE INSTRUMENTS

Standard thermocouple instruments of any type, calibrated correctly on

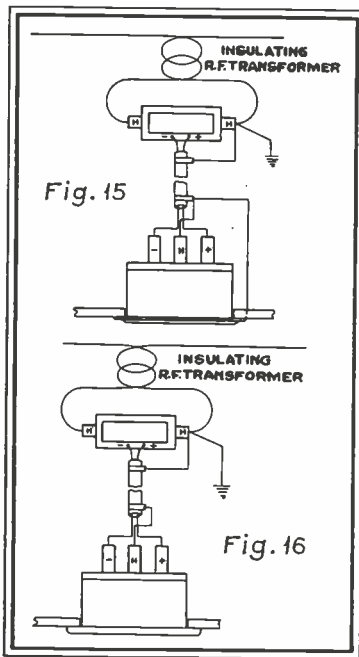

medium frequency, tend to indicate high as the frequency is increased. The reason for this higher indication is due primarily to skin effect in the heater increasing the indication as the frequency is increased. The skin effect is primarily a function of frequency, and the diameter and material of the heater wire. It is an inherent effect and, while minimized through the use of high resistivity platinum alloys, it causes such instruments to read high by an amount depending upon the instrument range and the frequency.

A "Correction Data" chart accompanying this article gives corrections for standard type Weston instruments when used on ultra-high frequency. This correction is given in terms of a multiplying factor to be applied to the reading to get the true current. The data are representative of average values on stock instruments. Due to manufacturing variations the high-frequency corrections vary slightly but may be relied on to plus or minus .02 as applied to the multiplying factor. Note that the chart gives corrections up to 150 megacycles for ranges up to 10 amperes. It will be noted that for low-current instruments corrections are required only at the very high frequencies; within the

broadcast band no corrections whatever are needed.

For use on high-frequency instruments, Fig. 2 shows a newly designed heater in the form of an extremely thin walled tubular conductor. To this heater is welded the thermocouple which in turn actuates the direct-current movement of the meter. A heater of this type has a high-frequency resistance so little different from that at low frequencies, that even at 100 megacycles the error is said to be less than 3.5 percent. Correction curves are not supplied with the ultra-high-frequency type of instrument because of the extremely small errors. These errors, generally speaking, may be taken as well under 5 percent up to 150 megacycles when considering the instrument in free space. The inherent loop of the leads to the instrument, however, may tend to crowd the current to one side of the heating element, which may tend to increase this error slightly, although up to 100 megacycles the error is less than an additional 2 percent. It has been pointed out to the writer that soon nearly all instruments will be of the ultra-high-frequency type and that the older error curves supplied with their standard instruments in the past will no longer apply to instruments pur-

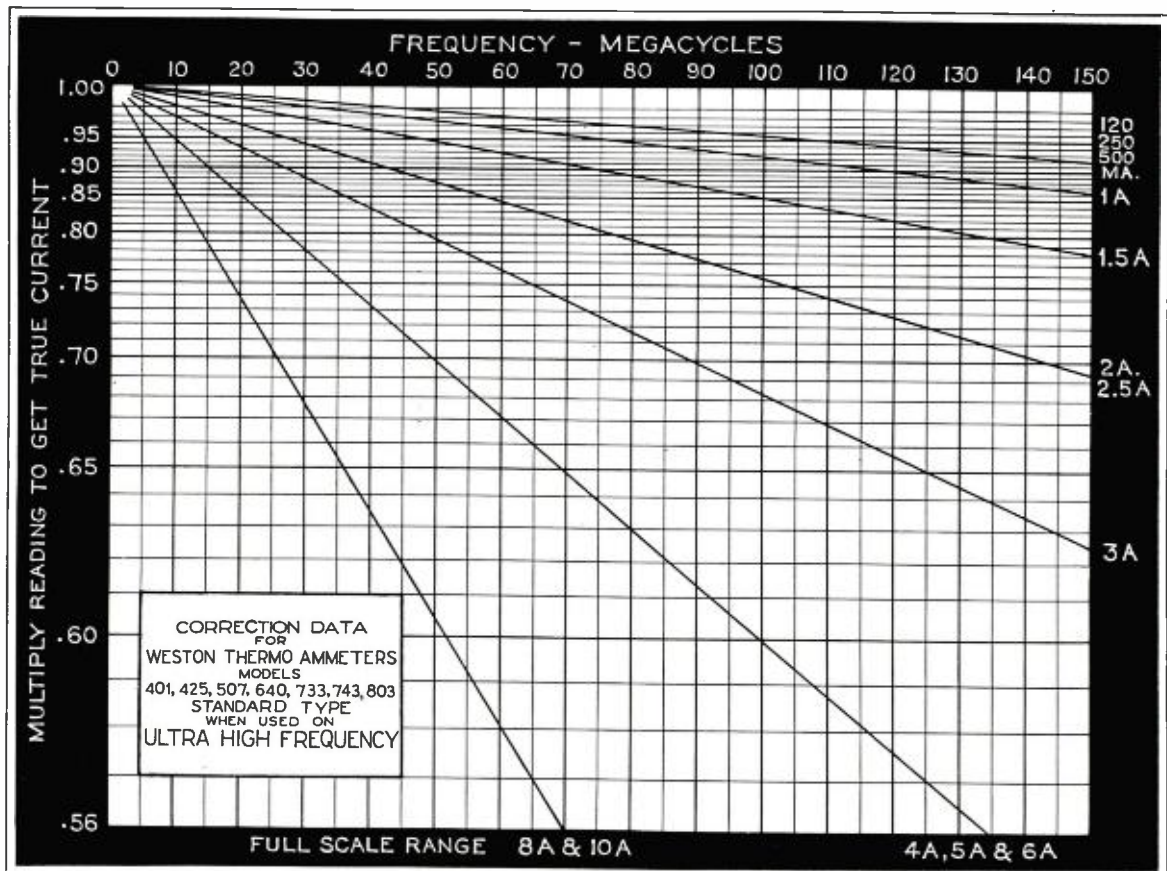

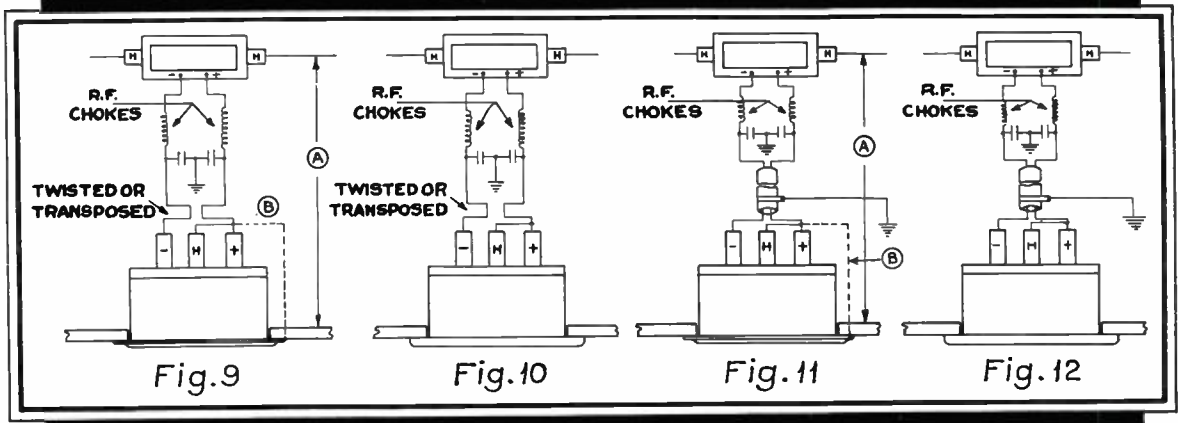

chased in the near future.

For use on the higher frequencies, special acorn-type vacuum couples are also available which are known to be accurate within a few percent up to 200 megacycles per second.

Thermocouple meters may be secured with modified scale characteristics. Through a new design made possible by the use of specially shaped pole pieces and a heavy special alloy steel magnet, it is now possible to obtain a thermal instrument with a linear scale similar to that on any d-c instrument. This meter is spoken of as the "Expanded Scale" type. This new feature will no doubt find use in many applications. It is particularly useful to broadcast stations operating with different day and night powers. Due to the FCC regulations requiring the normal indication of an antenna ammeter to read not less than 1/3 full-scale readings, such stations have had to install separate antenna ammeters for each operating power or provide a suitable switching arrangement to change meter scales with the power change. With the expanded scale meter, however, the normal current readings are permitted to be not less than 1/5 full-scale reading and one meter will usually suffice.

It is desirable that thermocouple type instruments be kept out of strong radio-frequency electrostatic or electromagnetic fields. This can usually be arranged by placing the instrument in a position where these fields are at a minimum, and it is strongly recommended that this be done. Strong fields tend to create eddy currents in the instrument structure and while the internal instrument wiring has been ar-

ranged to present a very small loop area, eddy currents or circulating currents due to strong high-frequency fields may cause damage. To minimize such effects in the ultra-high-frequency instruments which are self-contained, the instrument base is made of low-loss undyed bakelite, yellow in color, and the ultra-high-frequency instruments may be so identified.

If mounted in a metal panel or a metal stand of any sort, a potential of not over 300 volts should exist between such a metal support and one of the instrument terminals. Generally speaking, it is advisable to connect any metal on which the instrument is supported to one of the instrument terminals or else mount the instrument in an insulating panel. Otherwise displacement currents may flow through the small thermocouple, the instrument mechanism, and through the bakelite case to the supporting member, causing damage to the internal structure. The righthand stud, looking at the front of the instrument, is connected to the instrument mechanism and to all metal parts inside the instrument case. This is done to prevent displacement currents from flowing other than through a metallic connection, and also to bring all parts to approximately the same potential to prevent insulation breakdown and electrostatic attraction of the pointer.

Figs. 3 through 18 show connection diagrams of thermocouple type switchboard instruments as used in the more common circuits. Both self-contained and external element applications are shown.

The circuits using external heating

(Continued on page 25)

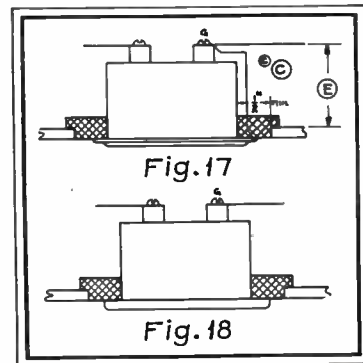
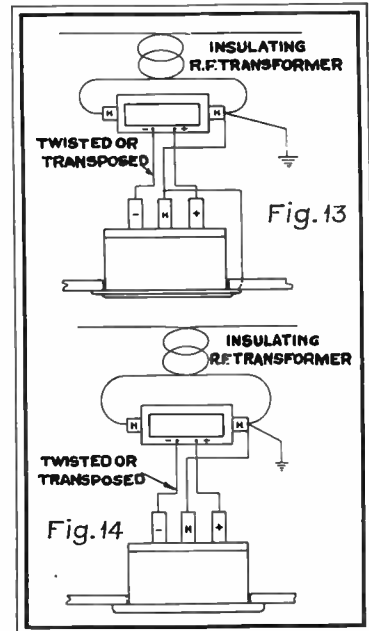

?? ON THE FENCE??? - NO!! →

---

---

# TELECOMMUNICATION

---

---

PANORAMA OF PROGRESS IN COMMUNICATIONS

---

---

## RADIO TOWER LIGHTING CONTROL

A VIGILANT "electric eye" stands guard at the 570-foot tower of Seattle radio stations KOMO and KJR to provide safety for the transport planes and airliners passing in the vicinity. At approaching dusk, as soon as daylight falls below a predetermined adequate level for proper visibility, the "electric eye" unit mounted on the roof of the transmitter building automatically turns on the airways beacon. Similarly, at dawn the control automatically turns off the lighting at the established level for morning.

The photoelectric control unit, which was installed in February, 1936, has never failed in operation nor required adjustment since the time of installation. In addition to eliminating the human element by completely automatic control, the unit has also provided considerable savings, both in lower maintenance costs and more satisfactory operation of the lamps. Replacement costs are naturally high on a 570-foot tower.

The "electric eye" unit, or light collector, consists of three Photronic cells (photoelectric cells of the barrier-layer type) within a weatherproof housing. During daylight the current generated by the cells in the light collector holds open a sensitive "turn on" relay. When the light level falls below the established value, the relay closes, energizing a small synchronous motor which tilts a mercury switch in the control circuit. As the control circuit is closed, the motor also operates a switch, shifting the photoelectric cell circuit to a separate "turn off" relay. At the same time the "turn on" relay is mechanically reset.

In the early morning, as the quantity of light increases, the cell current rises to a point at which the "turn off" relay closes, as soon as the desired illumination level is reached. The small motor energized by the "turn off" relay then opens the lighting control switch, at the same time resetting the relay and shift-

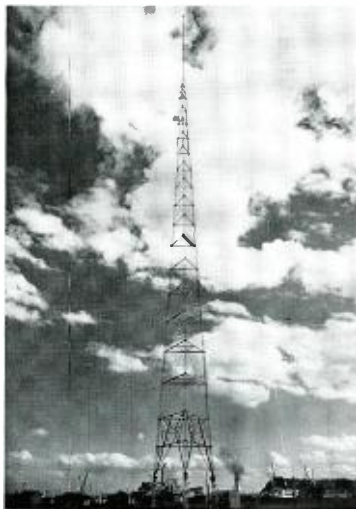

Antenna tower equipped with electric eye light control.

ing the "turn on" relay back into the effective circuit.

Connected across the mercury switch of the relay, a manual switch may be used in the event that a flash of lightning should cause the relay to cycle. An a-c buzzer has been connected across the motor operating circuit of the relay to give an audio signal to the transmitter operator. An exact recording of the turning on and off times of the obstruction lights may thus be kept; the transmitter operator, hearing the audio signal enters the time in the station log book.

Adjustment of the Sensitrol relays has been made for a "turn on" level of 20 foot candles and a "turn off" level of 22 foot candles. These levels, established after tests made over 2½ years ago, have provided quite satisfactory regulation of the obstruction lighting.

The 300 mm airways beacon at the top of the tower contains two 500-watt lamps; and at each one-third height on the tower there are two 100-watt lamps in red prismatic globes. Power for the operation of the lamps is carried across

to tower base insulators by means of a 2½-kw air-gap transformer with 220 volts on the primary and 115 volts on the secondary. Also, on the roof of the transmitter building, a 24-inch rotating beacon is equipped with a 1,000-watt lamp with an automatic lamp changer.

The 220-volt supply to the transformer for tower lighting is controlled directly by the Weston "Photronic" illumination control relay which also operates an auxiliary relay controlling the power to the rotary beacon. The Weston control panel is located on the main power control panel in the transmitter room of the building. The light collector, mounted on the roof of the transmitter building, is set at a 45-degree angle above the horizon, facing the north sky.

F. J. BROTT,  
Chief Engineer,  
Totem Broadcasters, Inc.

## FACSIMILE DEMONSTRATION

AFTER TWO YEARS of practical use in commercial telegraphy, Western Union held its first demonstration of picture transmission by facsimile from Chicago to New York on January 12th.

The system demonstrated makes it possible to obtain a positive and permanent picture immediately ready for use from the receiving machine, and applies to picture transmission the advantages of the Western Union facsimile system in daily use since 1935 for the handling of facsimile telegrams, drawings and other matter.

The new process is an outgrowth of the development by Western Union engineers several years ago of a dry recording paper which records written matter by direct electrical action. This new carbon bearing, fibrous conducting paper is as sensitive to electricity as photographic paper is sensitive to light and makes it possible to receive positive prints which can be used for reproduction purposes.

In an age when the world has become picture-minded, transmission by fac-

*(Continued on page 20)*



# NOTES AND COMMENT

## Design

## Production

### THE RCA-1609 AS A TRIODE

PORTABLE AMPLIFIER designers will be interested in the characteristics of the RCA-1609 tube which has been put on market recently. The tube is a pentode of low microphonic design, and the pentode characteristics are available; but the tube also has interesting possibilities when used as a triode. The triode characteristics have apparently not been published, for they do not appear on the slip accompanying the tubes nor in the usual tube bulletins.

Mr. Wm. Barker, chief operator at WOI, has recently run a complete set of curves on one of these tubes and checked the results against three others. The data, which seems typical of the four tubes, are set forth below.

RCA-1609—Triode Connection (screen grid and plate tied together)			
	90	120	135 v
D-C Plate Voltage.....	3	4.5	4.5 v
D-C Grid Voltage.....	3	4.6	6.2 ma
D-C Plate Current.....	9.1	9.4	9.4
Amplification factor (approx.).....	10,000	10,000	9,500 ohms
Plate Resistance.....	swing to zero)		
Power Output.....	10,000 Ohm Load..... —23 mu		
% 2nd Harmonic.....	20,000 Ohm Load..... 1.5 or less		
% 2nd Harmonic.....	..... 21 mu		
% 2nd Harmonic.....	..... 1.5 or less		

It was found important to make the grid and plate return circuits to the negative filament (which is also the suppressor grid) terminal if low distortion is to be maintained on large grid swings.

W. E. Stewart,  
Chief Engineer,  
WOI.

### DESIGNING BUCKING-OUT SYSTEMS

SOME MEANS for bucking out the steady plate current in vacuum-tube voltmeters, photocell instruments and other measuring apparatus is in almost universal use. When only the change in plate current resulting from a change in grid voltage of interest, such methods permit the use of a more sensitive meter in the

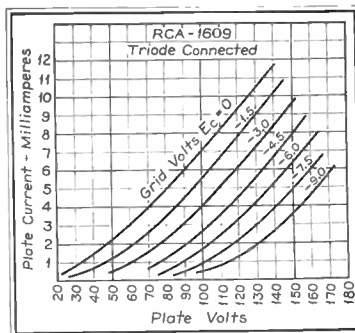

Characteristics of the 1609 triode connected.

plate circuit with resulting greater sensitivity in operation.

At first glance, the matter of selecting the proper values for such a system as is indicated in accompanying diagram seems much too simple to warrant discussion. However, unless certain simple precautions are observed the operation of the entire instrument will become inefficient and unsatisfactory.

One of the commonest faults of such apparatus is zero drift. With no impressed signal on the grid, the current drain on both the plate and bucking batteries is the same when the meter

Circuit showing bucking out system.

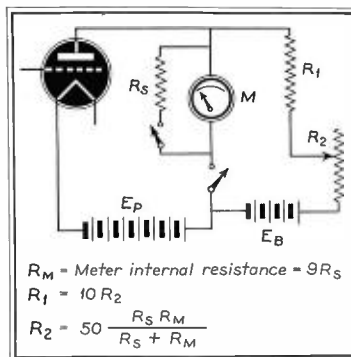

reads zero. If one of these two batteries has better regulation than the other, the zero reading will drift. Therefore it is desirable that batteries of similar characteristics should be used in each circuit. The resistances,  $R_1$  and  $R_2$ , are likewise important. Those of unstable characteristics will cause current fluctuations which will affect a sensitive meter.

In selecting the proper values for the resistors in the balancing circuit, it is best to start with the internal resistance,  $R_m$ , the meter to be used. Since the meter will normally be shunted during preliminary adjustments by  $R_s$  (equal to  $R_m/9$ ) the zero adjustment with the meter shunted will not be the same as that when  $R_s$  is open unless the change in plate current of the tube is of the same magnitude. In tube voltmeters, readjustment will normally be required due to the operating point on the  $dE_p/dI_p$  characteristic which must be employed. In d-c amplifiers, this difficulty may be minimized by working over a portion of the plate characteristic where the slope is straight. In any case, it is advisable to make  $R_2$  large with respect to  $R_m$  in order that the change in circuit resistance be negligible when  $R_m$  is shunted. If  $R_1$  is likewise made large with respect to  $R_2$ , the circuit resistance is kept high, convenience of operation and a factor of safety are introduced in that a wide range of control for a small change in total current will be provided by adjustment of  $R_2$ , while inadvertently moving the adjustment of  $R_2$  will not damage the meter. Typical values which have worked out well in practise are indicated in the diagram.

The voltage of the balancing battery,  $E_m$ , may be determined from the equation

$$E_m = I_p \left( R_1 + \frac{R_2 R_m}{R_s R_m} \right)$$

The voltage thus indicated will make the  
(Continued on page 27)

## Program of the Second Annual

# BROADCAST ENGINEERING CONFERENCE

THE SECOND ANNUAL Broadcast Engineering Conference, which is sponsored by the Department of Electrical Engineering of the Ohio State University, will be held during the period of February 6 to 17, 1939, at Columbus, Ohio. The interest shown by the members of the 1938 conference, who came from 25 states and three Canadian provinces, indicate the need and interest in this gathering.

The primary object of the conference is to establish a common ground for discussion among leaders in the industry and operating engineers. With this in mind the lecturers and discussion leaders have been selected from representative organizations to present some of the more important present-day problems found in the broadcasting field.

That an effort is being made to look into the future is indicated by the sessions devoted to television and facsimile. Also of particular interest will be the panel discussion led by Mr. Ring on the Federal Communications Commission report, "Standards of Good Engineering Practice."

The first week of the conference will be concerned largely with topics centering around the transmitter, and the

FIRST WEEK — FEBRUARY 6 to 11			
Time	9 A.M. to 11 A.M.	11 A.M. to 1 P.M.	2:30 P.M. to 4:30 P.M.
Monday Feb. 6	High-Power Rectifiers E. M. Boone The Ohio State University	Measurements on Broadcast Antennas D. B. Sinclair General Radio Company	Practical Aspects of Radiation Systems and Transmission Lines  J. F. Morrison Bell Telephone Labora- tories, Inc.
Tuesday Feb. 7			
Wednesday Feb. 8	Panel Discussion on "Standards of Good Engineering Practice" A. D. Ring (F.C.C.) J. H. DeWitt (WSM) S. L. Bailey (Jansky & Bailey)	Transmitting Tubes E. E. Spitzer  RCA Manufacturing Company	
Thursday Feb. 9			
Friday Feb. 10			
Saturday Feb. 11	Electromagnetic Waves W. L. Everitt The Ohio State University		

second week with studio and television problems. Each day there will be three one-hour lectures, which will be followed by an hour of group discussion.

The complete program of the gathering will be found in the accompanying tables. Special features include: Tuesday, Feb. 7 (8:00 p.m.)—A lecture-demonstration by Dr. J. O. Perrine, American Telephone and Telegraph Co., on "Waves, Words and Wires"; Thursday, Feb. 9 (6:30 p.m.)—Dinner Fort Hayes Hotel; Sunday, Feb. 12 (10:00

a.m.)—Inspection trip to the WLW transmitter; Thursday, Feb. 16 (6:30 p.m.)—Banquet, Fort Hayes Hotel.

Correspondence regarding the Conference should be addressed to the Director of the Conference, Dr. W. L. Everitt, The Ohio State University, Columbus, Ohio.

### TELECOMMUNICATION

(Continued from page 18)

simile will provide not only an added facility when it is placed in commercial service for publishers and advertisers and others interested in the rapid transmission of pictorial matter, but also for the police.

The demonstration on Thursday marked the 18th anniversary of Western Union's interest in facsimile telegraphy. In 1920 two Englishmen, H. G. Bartholomew and Captain M. D. McFarlane, sent the first pictures ever transmitted across the ocean, using Western Union cables. The pictures were taken at the International Yacht Races and Sir Thomas Lipton was one of the subjects. Other pictures were transmitted in following years and regular picture transmission over Western Union cables between New York and London was

### SECOND WEEK — FEBRUARY 13 TO 17

Time	9 A.M. to 11 A.M.	11 A.M. to 1 P.M.	2:30 P.M. to 4:30 P.M.
Monday Feb. 13	Facsimile C. J. Young RCA Manufacturing Company	Development of the Proposed Standard Volume Indicator R. M. Morris National Broadcasting Company	The Functional Design and the Measurement of Broadcasting Studio Facilities  H. A. Chinn Columbia Broadcasting Company
Tuesday Feb. 14			
Wednesday Feb. 15	Electron Optics V. K. Zworykin RCA Manufacturing Company	The Receiver as Part of the Broadcast System A. Van Dyck RCA License Laboratory	
Thursday Feb. 16			
Friday Feb. 17			

**SEE FEBRUARY COMMUNICATIONS**

established in 1925. A group of newspapers, headed by the New York Daily News, used this system. Its name, the Bartland Process, was created by using a part of the name of each inventor, and it was patterned to coincide with the method of transmission used on the Western Union cable system.

In 1924 and 1925 Western Union cooperated with newspaper interests in the development of a facsimile system known as Telepix, for use between American cities. Slowness of service and lack of great interest on the part of the press or public resulted in discontinuance of Telepix after one year, though at one time some 8,000 miles of wire were used and twenty or more widely separated cities were linked in the service.

### GENERAL ELECTRIC TELEVISION LICENSE

A TELEVISION TRANSMITTER, more powerful than any now in use in this country and designed to broadcast pictures with much improved picture definition, will be put into operation within the next three months by General Electric at Indian Ladder in the Helderberg Hills, 12 miles from Schenectady, N. Y. This announcement was made by Chester H. Lang, manager of broadcasting for General Electric, upon receipt of word from Washington that the Federal Communications Commission had granted the company a license to construct an experimental station.

Built on top of a 1500-foot hill with an antenna strung on 100-foot towers, this station will be at least 250 feet higher than the one atop the Empire State building in New York. To the south are higher hills which, with a directional antenna, will tend to prevent the signal from causing any possible interference with stations in New York City. With a power output of 10 kilowatts, its coverage will be the area comprising Schenectady, Albany, Troy, Amsterdam, and Saratoga, known as the Capital District, with a combined population of more than 500,000.

The television studio will be located in Schenectady, in quarters occupied by WGY until this station moved into its new broadcast home last summer. Its equipment will incorporate many new features developed by General Electric engineers who have spent years in television research. These developments assure a more perfect pickup and broadcast of pictures. At such times as studio programs are not available, motion-picture film will be used much the same as electrical transcriptions now fill-in on broadcast programs.

(Continued on page 26)

## SIMPLIFY 33 1-3 RPM RECORDING WITH THE PRESTO AUTOMATIC EQUALIZER



When you use the new Presto automatic equalizer you can start cutting a 15 minute transcription then forget about it until the end of the program. The equalizer automatically takes care of the frequency response from beginning to end and at the same time holds your audio level absolutely constant.

The equalizer moves with the cutting head carriage. It is always in position to give you a flat response to 6,000 cycles or better, wherever you start cutting.

With the automatic equalizer you can make excellent 33 $\frac{1}{2}$  RPM recordings on the economical 8-inch and 10-inch discs . . . almost impossible with manually operated equalizers.

*A Presto technical representative will give you a demonstration of this new equalizer at your station. He will attach it to your Presto recorder in ten minutes without disturbing your present equipment in any way. Let him show you this amazing new improvement. There is no obligation whatsoever.*

**PRESTO RECORDING CORPORATION, 145 W. 19th ST., NEW YORK CITY**



### Frequency Measuring Service

Many stations find this exact measuring service of great value for routine observation of transmitter performance and for accurately calibrating their own monitors.



**MEASUREMENTS WHEN YOU NEED THEM MOST**  
*at any hour every day in the year*

**R.C.A. COMMUNICATIONS, Inc.**

*Commercial Dept.*

A RADIO CORPORATION OF AMERICA SERVICE

66 BROAD STREET

NEW YORK, N. Y.





# VETERAN WIRELESS OPERATORS ASSOCIATION NEWS



W. J. McGONIGLE, President

RCA Building, 30 Rockefeller Plaza, New York, N. Y.

H. H. PARKER, Secretary

## MEETING

THE FEBRUARY MEETING of the Veteran Wireless Operators Association will be held at the Hotel Astor on Monday evening, February 6th, 1939. This is the Monday preceding our Annual Cruise and it is planned to discuss final plans and to determine the attendance on the 11th. We request all to attend and bring ticket returns. Your cooperation will be deeply appreciated. In the meantime please put forth every effort to insure maximum attendance at the Cruise.

## DINNER-CRUISE

ALL ABOARD! All aboard! For the biggest and finest cruise in the history of our Association to be held in the sumptuous North Ballroom of the newly modernized Hotel Astor, Times Square, New York City, on Saturday Evening, February 11th, 1939. Our committees are laboring day and night to work out the details of the Cruise and your support will help immeasurably in making their job easier and the Cruise a bigger success than any previous association activity. A delicious full-course dinner will be served accompanied by a Martini cocktail to each diner. The cuisine and service of the Astor are internationally renowned and you will definitely enjoy the dinner. There will be dancing during and after the dinner to the scintillating rhythms of Lou Lang and his broadcasting orchestra until the wee sma' hours.

This is an opportunity not to be missed to meet old cronies and reminisce of the early days of radio. You never know who will turn up at these Cruises so it's advisable to attend each and every one of them and have the pleasure of meeting shipmates of days gone by. Call your friends and bring them along. They'll enjoy the proceedings. Delegations are expected from Washington, Camden and from all points of the compass. John Christianson and R. S. Henery, Chairman and Secretary, respectively, of the Port Jefferson Chapter, are expected to lead the delegation from their chapter. A hearty welcome awaits all of you.

Tables of ten may be reserved in advance and the best tables will be held for those purchasing a block of ten tickets early. Get your party together immediately and be sure of an advantageous position from which to observe the proceedings. The tickets are but four (\$4.00) dollars per person and dress is optional. Dress if you wish (there will be many that way) or come as you are.

The presentation of Association awards will be a highlight of the evening and quite likely will be accompanied by a broadcast. There will be many interesting personalities present including some of the award recipients. Attend and aid us in paying tribute to the heroes of the key.

A drama (which may turn out to be a comedy) will be presented by local talent.

Several previous endeavors along this line were well received. It's not the quality of the plot nor the ability of the actors but just that you know them personally and are quite familiar with the absurdity of parts of the play. Come and cheer the Orson Welles on.

Please let us know at the earliest possible moment what your ticket requirements will be—and make them large. Address us at Radio City for additional tickets or contact any officer, director or committeeman. Tickets will also be available at all offices frequented by radiomen, Radiomarine, Mackay, etc. Bring your wife and the family—your friends and cronies—they'll have a splendid time. Write that check out and mail immediately.

We are looking forward to seeing you at the Astor on Saturday Evening, February 11th, 1939. Be there and see for yourself.

## OFFICERS—1939

AT THE ANNUAL MEETING of the Veteran Wireless Operators Association held at the Hotel Astor, Times Square, New York City, on Monday evening, January 9th, 1939, the ballots received from the membership were tallied by a Tellers committee appointed by the President from among the members present and the following results were announced: William J. McGonigle, New York Telephone Company, President; A. J. Costigan, Traffic Manager, Radiomarine Corporation of America, Vice-President; H. H. Parker, Westchester Lighting Company, Secretary; William C. Simon, Chief Radio Inspector, Tropical Radio Telegraph Company, Treasurer.

The following members in good standing were elected Directors: Fred Muller, Sales Engineer, Collins Radio Company; George H. Clark, Information Department, Radio Corporation of America; William J. McGonigle, New York Telephone Company; H. H. Parker, Westchester Lighting Company; Arthur A. Isbell, Commercial Manager, RCA Communications, Inc.; Arthur F. Wallis, Marine Sales Manager, Mackay Radio and Telegraph Company; A. J. Costigan, Traffic Manager, Radiomarine Corporation of America; J. R. Poppele, Secretary and Chief Engineer, Bamberger Broadcasting Service and Radio Quality Group, Inc.

Our congratulations to those elected and our sincere thanks to the Tellers Committee composed of Messrs. Paul A. Girard, T. D. Haubner and W. G. Steadman. The newly elected officers and directors take office immediately.

## AWARDS

AMONG THE NOMINEES for association awards the case of Master Sergeant Stanley Morgan of the United States Army is a most interesting one. We include two of the citations he received for his excellent work on several occasions. The following

citation accompanied the award of the Soldier's Medal to Sergeant Morgan:

"Stanley R. Morgan, Master Sergeant, then Technical Sergeant, 1st Signal Service Company, Signal Corps, United States Army. For heroism displayed during the influenza epidemic at Point Barrow, Alaska, from April 24, 1935, to May 7, 1935. Although seriously ill with the influenza complicated with mild pneumonia, Sergeant Morgan, being the only operator of the radio station, remained at his post transmitting radio appeals for assistance for the natives. By his heroic services, he was instrumental in preventing the spread of this epidemic and bringing quick relief to those already stricken, thereby saving many lives."

For action during Rogers-Post tragedy—

"Radio from Major General James B. Allison, Chief Signal Officer of the Army. Officer in Charge, Washington-Alaska Military Cable and Telegraph System. Chief Signal Officer desires to commend the operator in charge Point Barrow Technical Sergeant Stanley R. Morgan Signal Corps for the high character of services rendered by him incident to the death of Messrs. Rogers and Post vicinity Point Barrow. Sergeant Morgan's initiative, good judgment and strict attention to duty have clearly shown him to be an outstanding soldier of the highest type and as such has reflected great credit on the Signal Corps and the Army. Copy of this commendation will be filed with Technical Sergeant Morgan's record in the War Department."

Two jobs well done and they will be recognized by an award from our Association.

## SAN FRANCISCO

FOR DETAILS of the San Francisco cruise on the 11th of February contact either Gilson V. Willets, Chairman, at 1434 26th Avenue or Stanley W. Fenton, Marine Superintendent of Mackay Radio, Secretary.

A long and interesting letter from Gilson Willets some excerpts from which follow:

"Regards to Poppele, now chief at WOR, a pal of the good old days. I'm glad he nominated Stoddard (for an Award) and I second his motion that Stoddard receive recognition. He did a grand bit of work. I picked him up a few times myself on the trip.

"Since your Marconi Memorial Scholarship will come under the heading of my business here, suppose I am furnished with all the details of the offer. I shall then write it up for my Scripps-Howard newspaper column and for all my 47 different magazine features and columns.

"Parkhurst, originator of the "IP" sets. His has been an eventful career in radio . . . one of great service and many contacts.

"Parachine, for 20 years chief at KPH and now contacting foreign ships in the  
(Continued on page 35)

## NOISE SUPPRESSION CIRCUIT

(Continued from page 10)

put circuit. The complex component of the combination goes through both circuits as described above and is suppressed. The unmodulated signal component goes through and beats with the beat oscillator resulting in an audio signal as described under the case of an unmodulated signal above.

While the above description was stated as briefly as possible to prevent this article from becoming too ramified, there are, however, some points in the adjustment and operation of the circuit which should be brought out. As stated previously it is necessary that the energy to be suppressed, arrive at the push-pull transformer primary undistorted and of equal amplitude and in phase. This of course involves volume control and reactive circuit components. In order to insure uniformity of signal amplitude it is necessary to set up the AVC circuits so that the response of the two circuits is flat, or they operate on identical curves. The flat response is to be desired. By using identical r-f transformers and tuning condensers, there will be little angular difference in the signal energy at the audio amplifier plates when the r-f tuning is peaked in the ordinary manner. This small difference can be reduced to zero as will be explained later.

In making adjustments to the receiver it is necessary to check the operation for conditions of both unmodulated sine-wave and complex-wave signals and both in combination. The method employed on those receivers installed by the author follows. A cathode-ray oscillograph is connected so that the output of the power-amplifier stage is applied to the vertical sweep, the horizontal sweep being operated from an internal timing wave. First an unmodulated signal is applied to the receiver input. The wave form of the beat frequency is then checked for distortion, and if distortion appears, the adjustments necessary to bring the wave to a pure sine wave are made. Next the beat oscillator is shut down and a sine-wave-modulated signal is applied to the input. Now, first one and then the other of the two channels is checked. This is done by removing the control-grid clip of the r-f stage of one of the channels at a time. This permits the remaining channel to operate as a conventional receiver and feed the power amplifier through its half of the push-pull transformer primary. When both channels have been checked for distortion, both channels are then put in operation, and with the beat oscillator again energized, and an unmodulated

## Not The LARGEST... but...



**EVERYTHING You Have a Right to Expect in  
RELAYS by GUARDIAN**

Above—Midget Relays being produced in one of Guardian's highly specialized relay departments. Small compact these Relays by Guardian give maximum control in minimum space. Such efficiency and economy is partly achieved by Guardian's unique arrangement of coil, frame, and contact springs.

Improve your product by eliminating excessive mechanisms make it more responsive more efficient less costly more saleable with Midget Relays by Guardian. Stepping switches, counting units, solenoids, contact switches, overload and time-delay relays by Guardian offer everything you have a right to expect in uniform, faultless, dependable controls.

ANY QUANTITY AS YOU WANT THEM. WHEN YOU WANT THEM. No complaints... no post-mortems... Write for Catalog C Today!



ENGINEERING LAB.—devoted solely to the design of electrical control units from simple to most intricate combinations—uniform in size—space-saving—better and more economical.

# GUARDIAN ELECTRIC

1623C W. WALNUT STREET CHICAGO, ILLINOIS

signal applied to the receiver input, the volume of the beat-frequency output is adjusted to the desired value. After this adjustment has been made the beat-frequency channel is left untouched. The beat oscillator is again shut down and a modulated signal is applied to the receiver input. Now with both signal channels energized the volume of the channel which has no beat oscillator is adjusted until a minimum signal appears on the oscillograph screen. Probably this minimum will not be zero due to the fact that the energy from the two channels is not exactly in phase, and this usually requires close adjustment of the tuning of the two channels. So, after obtaining a minimum signal by adjustment of volume, a still further drop may be obtained by shifting the tuning condenser on the detector input transformer slightly. This will reduce the angular difference in the signal energy to zero and allow a complete cancellation of the modulated signal. With the receiver adjusted in this manner the beat oscillator is again started and the receiver is ready for operation.

In tests run to check the efficiency of the first suppressor circuit installed, the receiver was connected to the recorder, and conditions such as had previously caused large errors in the recorder were

set up on the power system. Arcing grounds which had originally caused the recorder to show a 50% error now caused no error at all. It was found that the r-f signal could be 50% sine-wave modulated without causing an error in the recorder. It was also found that the r-f signal could be modulated normally by voice without causing errors in the recording, thus making it possible to use the same carrier frequency for metering and telephony.

The circuit has also been adapted for use on heterodyne-type receivers which are used for impulse-type signalling and automatic controls. It prevents false operation of impulse-control circuits, or recording circuits. On power systems these include, among others, impulse-type remote-load control for generating stations, impulse-type carrier relaying, and impulse-type telemetering. Of course, the circuit was designed to meet conditions occurring on power systems, but it may also be applied to heterodyne receivers for telegraphic work, both manual and machine, in locations where heavy static, or interference from local electrical equipment is encountered. The author has made no attempt to explore all possibilities of application, but has met with gratifying results in those cases explored.

# Specify LANSING

**IF YOU WANT THE BEST**  
**Monitor Speakers**  
**Public Address Speakers**  
**Radio Speakers**  
**Theatre Sound Systems**  
**Lateral Reproducers**  
**Field Supplies**  
**Dividing Networks**

Ask your local LANSING distributor  
 or write direct to

**Lansing Manufacturing Co.**

6900 McKinley Ave. - Los Angeles, California

the newly developed type 103



## MICROMETER FREQUENCY METER

—an accurate, convenient, economical means for checking transmitter frequencies anywhere from 1.5 to 56 mc.

**ACCURATE:** original developments in circuit, condenser, and dial produce unusual stability and precision. Conservatively rated within 0.01%.

**CONVENIENT:** simply plug in headset, rotate dial for zero beat, and read per cent deviation, + or —, on chart. Individual calibration for each assigned channel.

**ECONOMICAL:** will pay for itself in 18 to 24 months, on one police transmitter. Savings go up with number of transmitters. Practical for U-H-F units.

— Write today for data —



**LAMPKIN  
LABORATORIES**  
BRADENTON . . . FLORIDA

## PICKUP TRANSMITTER

(Continued from page 14)

wiring of the unit are the only requirements.

The circuit diagram, Fig. 1, shows the parts. The circuit diagram, Fig. 2, may be more desirable where more power output is desired and where a higher voltage is at hand. The 807 will operate satisfactorily with plate voltages

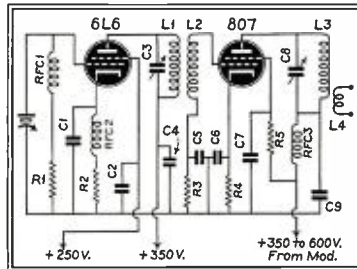

Fig. 2

up to 600 volts and give an output of around 20 watts. If extreme care is used in the layout and if the input circuit of the 807 is very carefully shielded from the output tank circuit there should be no necessity for neutralization. If it is necessary, the tube will neutralize without trouble. A split-stator final tank condenser in cases where neutralization is used is recommended.

The modulator unit shown in Fig. 1 will in most cases be satisfactory for use with an 807 tube in the final stage. However, in cases where full input to the 807 is used, a modulator capable of delivering about 20 watts of audio power is recommended.

The tank coils should be spaced wound to a diameter of about  $\frac{3}{4}$  to 1 inch and should be self supporting. Number 10 soft drawn enameled wire should be satisfactory. All insulation should be of high-quality steatite, isolantite or victron. Keep the neutralizing condensers, metal objects, the tubes and as much as possible all insulating materials out of the concentrated fields of the tank circuits.

Any number of methods of coupling to an antenna may be used. The method illustrated in Fig. 1 may be used to feed a vertical rod connected directly to one side of the tuned tank. A low-impedance untuned line may be tapped across the number of turns necessary for its proper termination or a 1 or 2-turn pickup coil may be used to feed an untuned line.

Power may be from a 6-volt battery and generator or from 110-volt 60-cycle a-c through a step-up transformer and rectifier-filter.

The increased use of the higher frequencies for services other than portable broadcast pickup and amateur and the fact that these signals, even though they

## Dirt Is Destructive to Communication Equipment!

**IDEAL Jumbo Cleaner**

"3-in-1"

**Vacuums—Blows—Sprays!**



Here's a sure way to avoid the ravages of dirt and dust to which sensitive, balanced instruments are otherwise subjected! The Jumbo Cleaner either blows or sucks all dirt and dust from even the most inaccessible places. Reduces "shorts" in wiring and delicate electrical systems!

High velocity, low pressure airstream for vacuum or blowing dry-air. Reduces corrosion and rotting of insulation. Widely used in broadcasting and communication offices. Portable—weighs only 14 lbs.

Ask about Free Trial Offer

**Ideal Commutator Dresser Co.**

1062 Park Avenue

Sycamore, Illinois



## Radio Engineers

who are

**RADIO AMATEURS**

buy a fresh copy today of the

**RADIO AMATEUR  
CALL BOOK**

The CALLBOOK is the only publication that lists all licensed radio amateurs in the United States and over a hundred and seventy-five different foreign countries.

Each issue also contains a world map showing amateur prefixes, press time and weather schedules, amateur prefixes listed alphabetically and by countries and a world time conversion chart.

**Complete . . . Accurate . . . Up-to-Date**

Issued Quarterly

MARCH . . . JUNE . . . SEPTEMBER  
and DECEMBER

Annual subscription \$4.00

Single copies \$1.25

Buy your copy now from your radio jobber  
or direct from:

**Radio Amateur Call Book, Inc.**  
608 S. Dearborn St., Chicago, Ill., U. S. A.



are of very low power, sometimes travel over great distances, makes the use of a crystal-controlled transmitter almost a necessity.

This unit should be of particular interest to both broadcast and police-station engineers having self-excited mobile units. The oscillator shown will deliver usable power when the oscillator tube is one of the small glass pentode types and this should make it of some use for transmitters of the "pack" type. The saving to be made in the use of low-cost low-frequency crystals should be well worth while. The crystal used at WSOC is of the type sold for use on amateur frequencies.

Such a unit as this also should, with plug-in coils or some means of band switching, be of interest to amateurs as an all-band exciter.

Photographs of the original unit, while available, are not shown as it is felt that in cases where construction is contemplated the constructor would use his own ideas as to size and general layout, according to his own requirements.

The actual sizes for the coils are not given. Even minor changes in the wiring from the original will call for changes in the sizes of the coils. They will generally be a cut and try proposition.

The initial adjustment of the unit will require a wavemeter or some other means of determining the proper harmonic frequency to use. A simple coil and condenser type of wavemeter, calibrated against a receiver should be satisfactory.

The oscillator is capable of delivering power on all harmonics up to 124,400 kilocycles with the crystal used, but after the proper harmonic is once determined no further trouble should be experienced.

### THERMOCOUPLE METERS

(Continued from page 17)

elements are shown with two types of cable connections between heating element and instrument. Shielded duplex cable or unshielded triplex cable may be used; whenever possible, however, the shielded duplex cable should be used and the outer shield utilized as the third conductor. If the unshielded triplex wire must be used, the conductors should be twisted together to insure a minimum of r-f pickup.

The writer wishes to acknowledge with thanks the courtesy of Mr. J. H. Miller and the Weston Electrical Instrument Corporation for furnishing much of the material for this paper.

## A MODERN PLANT DEVOTED TO THE MANUFACTURE OF MODERN CAPACITORS



*Capacitors for every radio & electrical use*



A few of the applications for which C-D capacitors are available:

- RADIO RECEIVING
- TRANSMITTING
- TELEVISION
- RECORDING INSTRUMENTS
- PHOTO ELECTRIC CELL APPLICATIONS
- AMPLIFIERS
- X-RAY APPLICATIONS
- THERAPY AND DIATHERMY
- METERS
- HIGH TENSION LINES
- EXPERIMENTAL AND RESEARCH WORK
- LIGHTNING SURGE CAPACITORS
- CARRIER CURRENT WORK, ETC.
- ELECTRONIC APPLICATIONS

Our engineering department will be glad to cooperate with you in obtaining the most economical and efficient type unit for your requirements. Your inquiries are invited. Catalog No. 160 on request.



### "300" SERIES

### A COMPLETE NEW LINE OF SMALL PLUGS-SOCKETS

#### 2 CONTACTS TO 33 CONTACTS

PLUGS WITH CAPS      PLUGS WITH BRACKETS  
SOCKETS WITH CAPS      SOCKETS WITH BRACKETS

Ask for Bulletin 300

**HOWARD B. JONES**

2300 WABANSIA AVENUE, CHICAGO, ILLINOIS

### JARDUR 5 in 1 TIME-STUDY CHRONOGRAPH

NON-MAGNETIC — 15 JEWELS — 1/5TH SPLIT-SECOND TIMING



Send for Catalog

Recommended by leading radio and research engineers who have found this Timer indispensable for their time-study work and for everyday wear. The ideal time-piece for every technician in Broadcasting, Recording Studios and Laboratories.

Actually five precision-built watches in one; Regular Wrist Watch, Stop Watch, (1/5th split second timing), Time-Out Watch, Telemeter (measures the distance from the observer between light and sound from simultaneous sources), Tachometer (indicates the number of miles per hour any aircraft or object is moving over a known distance.)

Enclosed in a handsome stainless steel satin-finish case as thin as a regular wrist watch. Sturdy enough to withstand ordinary rough usage. Leather sweatproof strap.

Guaranteed for one year against any factory defects in workmanship or material.

If Timer does not meet with your entire satisfaction, return it within ten days and your money will be refunded in full.

Send \$5.00 with order and pay the postman balance on delivery.

Regular Price \$51.00. **INTRODUCTORY PRICE \$24.98 DELIVERED**  
JARDUR IMPORT COMPANY, 21 WEST 19th STREET, NEW YORK CITY

## STREAMLINED . . . A NEW STUDIO RECORDER



RADIOTONE PR-20

As streamlined in action as appearance, the Radiotone PR-20 allows every changeover at the flick of a finger—inside-out to outside-in, change from 78 to 33 $\frac{1}{3}$  RPM, lines per inch from 90 to 125. Line spreader and micrometer adjustment of cutting head are extra values. The PR-20 is vibration-free and "wow"-free, because of heavy construction. Specially balanced synchronous motor. This 16" studio recorder offers the maximum of operating ease, plus unbelievable fidelity, at moderate price.

**Radiotone Inc.**

7356 Melrose Ave., Hollywood, Cal.  
620 No. Michigan Ave., Chicago, Ill.



## Announcing

### NEW AMPLIFIER GAIN INDICATOR

MONARCH announces a new Amplifier Gain Indicator to measure the overall gain and frequency characteristics of any power amplifier.

Outstanding features of this instrument include—

1. Reading directly in decibels!
2. No figuring necessary.
3. No accessories required other than a signal source.
4. Guaranteed accurate to within 1 db.
5. Ruggedly built to withstand constant usage.

Ask for Bulletin

**MONARCH MANUFACTURING CO.**  
3343 Belmont Ave. Chicago, Ill.

## TELECOMMUNICATION

(Continued from page 2)

From an ultra-short-wave transmitter on top of the studio building, the images will be relayed over the 12-mile gap on a 1.4-meter band to the main transmitter in the Helderbergs, where they will be broadcast for public reception on a wavelength in the 66-72 megacycle band or on about 4 $\frac{1}{2}$  meters.

## FACSIMILE RECEIVERS

DURING THE past week a facsimile re-

place of the loudspeaker with a throw-over switch. Under this condition, however, attention is required in order to assure proper printing level.

In Fig. 2 is shown a special receiving set especially designed to go with the facsimile receiver. Also available is a timing device which can be used in conjunction with the receiver if desired and which permits the operator to pre-set the receiver. This timing device turns on the mechanism at a predetermined time and shuts off the receiver at the close of the broadcast.

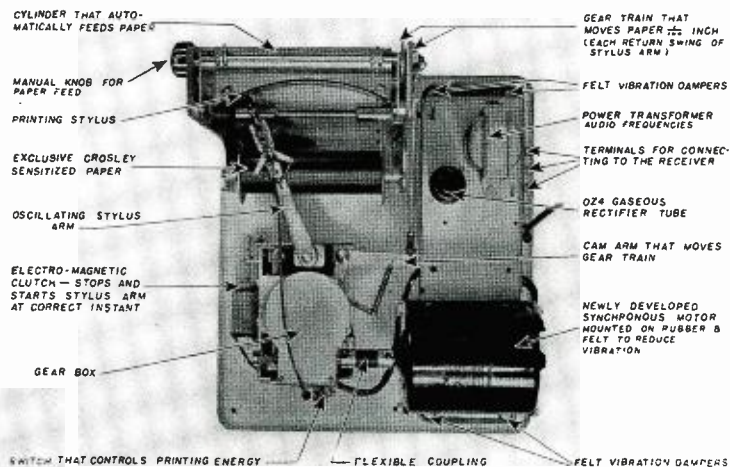

Fig. 2. Showing component parts of facsimile set.

ceiver has been made commercially available by the Crosley Radio Corporation. Known as the Readio printer, these sets are licensed under the patents developed in the laboratories of W. G. H. Finch.

The Crosley facsimile receiver is shown in Fig. 1. According to the manufacturer, it can be used with practically any radio receiver which delivers 5 watts of power, being attached in the

## WHEN YOU CHANGE YOUR ADDRESS

Be sure to notify the Subscription Department of COMMUNICATIONS at 19 E. Forty-seventh St., New York City, giving the old as well as the new address, and do this at least four weeks in advance. The Post Office Department does not forward magazines unless you pay additional postage, and we cannot duplicate copies mailed to the old address. We ask your cooperation.



**HOTEL CHELSEA** RIGHT ON THE BOARDWALK

FOR RECREATION OR RELAXATION  
*Choose the Chelsea*

Here you will find everything to further your comfort and enjoyment—outside ocean-view rooms—wide verandas for lounging—sun deck—beautiful dining room at the ocean's edge—superb cuisine—varied sports and entertainment. You'll like your fellow guests, too, and the delightfully friendly atmosphere of the Chelsea.

SPECIAL WEEKLY RATES

**ATLANTIC CITY**

JOEL HILLMAN • J. CHRISTIAN MYERS • JULIAN A. HILLMAN

FROM  
WITH  
MEALS  
& BATH \$6

ROOM  
ONLY  
& BATH \$3  
Per Person  
2 in a Room





Above: Fig. 1. The facsimile receiver.

Below: Fig. 2. The accompanying radio set.



Examination of Fig. 3 will show the component parts of the facsimile set. A roll of coated paper feeds through the printer a line at a time. This movement synchronizes itself with the transmitter. A stylus moves back and forth across the paper emitting small electrical impulses synchronized with each dot as scanned and transmitted by the broadcast station.

#### NOTES AND COMMENT

(Continued from page 19)

meter read zero when one-half the resistance of  $R_2$  is in the circuit. Cells, when fresh, normally read slightly higher than their rated voltage so this method of computation will take care of the slight excess in voltage provided.

Replacement of batteries will be indicated when zero drift occurs. If the meter pointer drifts up scale, the bucking battery should be replaced; if down scale, the plate battery is unsatisfactory.

J. H. HOLLISTER

#### TUBE MEASURING SET

(Continued from page 13)

the use of a suitable key. With the use of proper switching arrangements, additional sockets could be added to accommodate tubes which are not illustrated. However, care should be taken that no damage will result should the switches be improperly operated. The

tube socket unit will permit only one tube at a time to be inserted in the sockets which is obviously necessary in order to make a measurement.

The voltages for the plate, screen-grid and control-grid may be furnished from rectifiers as shown in Fig. 1 or any other desired source of power may be employed. However, it is essential that a range of variable voltages be available to cover the range of tubes to be measured, and that the voltages be as free as possible from "hums" and interfering harmonics. If the sources of power be rectifiers or small generators it is preferable to remove them from proximity to the bridge measuring unit, but the rheostats for controlling the voltages must be conveniently located near this unit in order that tube operating conditions can be fixed when making a measurement. The best results are obtained when dry batteries are used which will not result in expensive operation if employed in the control grid and possibly screen-grid circuits. On the other hand if individual rectifier supplies are used, the d-c voltage control should be obtained by use of a variac in the a-c supply side rather than a potentiometer in the output of the filter circuit.

A nominal bus voltage of 2.5 and another of 6.5 volts is provided in the circuit of Fig. 1 to accommodate the filaments or heaters of the tubes to be measured and a variac is used for accurately setting the required voltage and current. The K-3 switch closes the filament-ammeter circuit either on the 2.5 or 6.5-volt side and the K-4 switch connects the voltmeter across either of these circuits.

The operation of the tube parameter set is easy and measurements could be made reasonably quick. The tube is inserted in its associated socket and the heater or filament voltage is closed through the K-3 switch. Then the tube electrode switches are closed and all voltages adjusted to their normal operating values. To measure the amplification factor the K-1 bridge circuit selector switch is placed in position 1. Let us say that  $R_a$  is made 100 ohms,  $R_b$  is made zero, and  $R_2$  is varied as a rough adjustment until the lowest signal level is observed in the phones. Then the grid variometer and the  $R_c$  calibrated rheostat are varied until the signal disappears. Under these conditions the amplification factor is given by

$$\frac{[R_c + R_2]}{100}$$

which can be obtained directly from the reading of the dials of the  $R_c$  and  $R_2$  resistors.

For measuring the mutual conductance the K-1 switch is shifted to position 2. Let us say  $R_a$  and  $R_b$  are each

for  
Emergency  
use!

**LINGO**  
**Portable**  
**Dural**  
**Radiators**

■ Made in standard heights up to 100 feet.

■ Erected in less than 15 minutes.

■ Can be stored or transported in sections as short as 6'6".

One of the new Lingo developments is this light-weight Dural Portable Radiator. Compact—it can be stored in as short as 6'6" lengths, if necessary, and erected by two men in 15 minutes, ready for emergency use. This is a worthwhile investment for every broadcast station as a supplement to the permanent antenna in event of failure. It is also useful in testing for new station sites and many other portable purposes. These radiators can be easily transported and set up at any point for instant use. Among the present users are the Pennsylvania State Police, The Canadian National Research Council, The Brazilian Government and the President of Guatemala.

Complete Details  
on Request

Consult us for any technical information regarding your present or proposed antenna system. We have complete expert engineering knowledge as the result of numerous field tests conducted under the supervision of outstanding radio engineering consultants.

Write for illustrated folder on Portable Dural Vertical Radiators. Be sure to state location, frequency and power of station.

JOHN E. LINGO & SON, INC.  
Dept. C-1 Camden, N. J.

**LINGO**  
**VERTICAL**  
**TUBULAR STEEL**  
**RADIATORS**



# COMMUNICATIONS will cost you only \$1.00 for the next 12 issues\*

To the Publisher of  
COMMUNICATIONS  
19 E. 47th St., N. Y. C.

Please enter annual subscriptions (12 issues) for each of the undersigned for which payment is enclosed at the rate of \$1.00 each. (This rate applies only on 4 or more subscriptions when occupations are given.) Foreign Subscriptions are \$2.00 each.

Name .....  
Street .....  
City-State .....  
Occupation or title.....  
Employed by .....  
Nature of business.....  
(State if Manufacturer, Broadcast Station, etc.)  
Product .....

Name .....  
Street .....  
City-State .....  
Occupation or title.....  
Employed by .....  
Nature of business.....  
(State if Manufacturer, Broadcast Station, etc.)  
Product .....

Name .....  
Street .....  
City-State .....  
Occupation or title.....  
Employed by .....  
Nature of business.....  
(State if Manufacturer, Broadcast Station, etc.)  
Product .....

Name .....  
Street .....  
City-State .....  
Occupation or title.....  
Employed by .....  
Nature of business.....  
(State if Manufacturer, Broadcast Station, etc.)  
Product .....

● You and your associates can obtain a year's subscription to COMMUNICATIONS (12 issues) for only \$1.00 each by using the Group Subscription Plan.

Our slogan is "You will read it first in COMMUNICATIONS." Television—radio—facsimile—broadcasting—communications—recording.

This is a fast moving age—this is a fast moving industry! It's passed the billion-dollar-a-year figure and it's still growing. The men responsible for this progress subscribe to COMMUNICATIONS. It is their source for obtaining accurate, complete, technical information *before it is published elsewhere.*

\* A regular yearly subscription to COMMUNICATIONS costs \$2.00—but when four or more men sign up at one time, each one is entitled to the half-price rate. (Foreign subscribers on the "G-S-P" only pay \$2.00 each).

It is easy to get three or more of your associates to join a Group with you. Hundreds of leading engineers and technicians have subscribed year after year on that basis. Use the convenient form on this page. Fill in the names, tear out and mail today with your check or money order. Renewals and extensions are acceptable also.

**COMMUNICATIONS • BRYAN DAVIS PUB. CO., Inc.**

made 10 ohms, and after again making a rough adjustment with  $R_2$ , the plate variometer and  $R_c$  are varied until no signal is heard in the phones. Then, the mutual conductance is given by

$$S_m = \frac{[R_c + R_2]}{R_1 R_L} 10^9$$

$$= \frac{[R_c + R_2]}{[R_a + R_b] R_L} 10^9$$

$$= \frac{[R_c + R_2]}{[10 + 10] 50} 10^9$$

$$= [R_c + R_2] 10^3 \text{ micromhos}$$

Here again the value of the mutual conductance can be read directly from the dials of the  $R_c$  and  $R_2$  resistances.

To measure the plate impedance, the K-1 switch is shifted to position 3. We may make  $R_a$  and  $R_b$  each 100 ohms and then vary  $R_2$ ,  $R_c$  and the plate variometer until the bridge is balanced in which case the plate impedance is

$$R_p = \left[ \frac{R_a}{R_b} \right] [R_c + R_2]$$

$$= \frac{100}{100} [R_c + R_2]$$

$$= [R_c + R_2] \text{ ohms}$$

Again this value can be read directly from the dials.

If the gain of the tube circuit is to be measured, shift the K-1 switch to position 2, open the plate circuit switch and connect the  $R_L'$  load resistance to the external binding posts. Close the plate circuit switch and readjust all the voltages, if necessary. Obtain a balance in the usual manner and then the gain can be computed from

$$\mu_g = \frac{[R_c + R_2]}{[R_a + R_b]}$$

There are certain precautions which might be observed to advantage. For example the value of the inductance  $L$  should not be less than 10 or 15 henries and should not have a d-c resistance of more than 100 ohms in order that the measurements be reasonably accurate. In fact a higher value of inductance is desirable and, if the d-c resistance is such that it causes an appreciable drop in plate voltage it can be compensated by adjusting the plate voltage to a higher value than the nominal value by the amount of the d-c drop in the inductance. A further advantage is realizable if the measurements are made at a frequency of 2,000 cycles as this will give the inductance a greater reactance value. A frequency lower than 1,000 cycles is not recommended.

For greater sensitivity it is recommended that the detector circuit consist of a high-impedance input amplifier hav-

(Continued on page 35)

## FORMED PARTS TUNGSTEN AND MOLYBDENUM

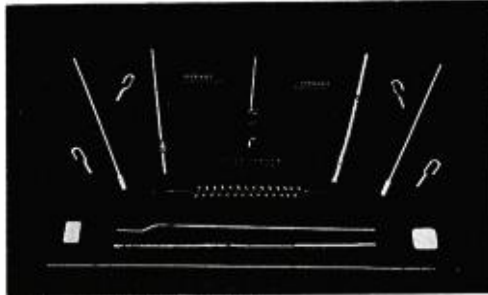

YOU can depend on the name CALLITE for quality in tungsten and molybdenum parts. CALLITE CERTIFIED means uniform, tested, proven quality.

WHATEVER your particular requirements, specify CALLITE. Our engineering staff is ready to assist you with your problems. Special shapes on formed parts made accurately to specifications. Your inquiries are invited. Catalog on request.

GRIDS  
PLATES  
CATHODES  
COPPER-CLAD  
FORMED PARTS  
HOOKS AND  
PIGTAILS  
TRIMET LEAD-IN  
WIRE  
TUNGSTEN FILA-  
MENT WIRE  
MOLYBDENUM  
ANCHOR WIRE  
SPECIAL FILA-  
MENT SPRINGS  
TWO AND THREE  
PIECE WELDS FOR  
HARD AND SOFT  
GLASS  
KULGRID "C"  
TUNGSTEN WELDS,  
ETC.

## CALLITE PRODUCTS DIVISION

EISLER ELECTRIC CORP. • 556 39th ST. • UNION CITY, N. J.

## TUBE SHIELDS TUBE PARTS

- SERVICE
- QUALITY
- PRICE . . .



**GOAT RADIO TUBE PARTS, INC.**

[A DIVISION OF THE FRED GOAT CO., EST. 1893]

314 DEAN ST., BROOKLYN, N. Y.

# OVER THE TAPE . . .

---

---

## NEWS OF THE COMMUNICATIONS FIELD

---

---

### AEROVOX MOVES

The Aerovox Corporation announces the moving of its plant and general offices to larger quarters at New Bedford, Mass. Bought for cash, the group of buildings to be occupied is approximately six city blocks long by two wide, totaling 433,000 square feet or about four times the area of the vacated Brooklyn plant. Aerovox expects the new plant to be in full operation by February 1st.

### IDEAL BULLETIN

The Ideal Commutator Dresser Co. have recently made available literature covering a new wire joint which is said to be safe and cheaper. Write to the above organization at Sycamore, Illinois.

### NEW HADLEY PLANT

Nationwide distribution of Hadley transformers from two complete and strategically located factories is now under way, following completion of a plant of the Robert M. Hadley Company in Newark, Delaware.

The original Hadley factory which will continue operation in Los Angeles, California, has been well-known to the Pacific Coast trade for the past six years. The complete, standard line of Hadley transformers for all radio requirements is now being put into production in the Newark, Delaware, plant, construction of which was completed about a month ago.

### HARRY FOUCH DIES

Harry Fouch, recording engineer with the Universal Microphone Co., Inglewood, Cal., died in the Hollywood Hospital Jan. 3, a few days after a major operation. He had been ill six weeks and was 56 at his death. He was the brother of James R. Fouch, President of the company, and the father of James L., laboratory technician.

### TELEVISION RECEIVER CATALOG

A table and a console model television receiver, providing not only a full 8x10-inch screen image of excellent pictorial detail, but also the synchronized sound for a complete sight-and-sound radio program, are illustrated and described in an attractive two-color catalog just issued by the Allen B. DuMont, Labs., Inc., 2 Main Ave., Passaic, N. J. The catalog also deals with the home entertainment possibilities of television. A copy may be had by addressing the company direct.

### TRIUMPH BULLETIN

The Model 830 oscillograph wobulator is the subject of a bulletin now available from Triumph Manufacturing Co., 4017 West Lake Street, Chicago, Ill. This unit employs a 3-in. cathode-ray tube. Complete data and specifications are given in the bulletin.

### NEW PRESTO PLANT

Expanding for the fourth time in two years, Presto Recording Corporation will move their offices and equipment manufacturing plant on January 24th to 242 West 55th Street, New York City. The space recently leased at this location will be twice the size of the former plant and offices on West 19th Street.

### RCA BULLETINS

A number of new bulletins are available from the RCA Manufacturing Co., Inc., Camden, N. J. The Broadcast Equipment Section have recently released a bulletin describing the new Type 55-B line amplifier, while the Aviation Radio Section has made available data sheets on the AVT-7B transmitter, as well as simultaneous radio range filters. Write to the above organization.

### UNITED CINEPHONE BOOKLET

United Cinephone Corporation, 43-37 33rd St., at Queens Blvd., Long Island City, N. Y., have issued an eleven page booklet entitled "Marvels of the Electric Eye." This booklet is intended to impart a clear conception of this field in terms that the laymen will understand while respecting engineers' appreciation for facts. Copies may be secured from the above organization.

### TELEVISION COURSE

The Newton Institute of Applied Science, 2021 Raymond-Commerce Building, Newark, N. J., have announced a graduate course in television engineering. This home study course is said to be designed to meet the needs of development and research engineers engaged in television work and those wishing to prepare for this field.

### AMERTRAN BULLETIN

The American Transformer Company, 178 Emmet Street, Newark, N. J., have recently issued a 32-page bulletin on the Amertran line of transmitting components. Complete data and specifications are given. Write to the above organization for Bulletin 14-5.

### WESTERN ELECTRIC ORDERS

Orders have been placed by Eastern Airlines with the Western Electric Company for radio telephone equipment to be installed aboard the new Douglas transports now under construction for Eastern. H. N. Willets, radio sales engineer of Western Electric, says the apparatus will be of the standard type now in use by Eastern and will include 50-watt transmitters, beacon, "company," and marker receivers. Mr. Willets also stated his company has completed negotiations with Braniff Airways for the installation of beacon receivers in all un-equipped ships in its fleet.

### CBS ENTERS HOME RECORD FIELD

The Columbia Broadcasting System has purchased the American Record Corporation from Consolidated Film Industries, Inc., according to William S. Paley, President of Columbia. An interesting aspect of the purchase is that the Columbia Phonograph Company, one of the American Record Corporation subsidiaries, some years ago was the owner of the Columbia Broadcasting System. Through the acquisition the Columbia Broadcasting System takes over the manufacture and distribution not only of Columbia phonograph records but also of Brunswick, Vocalion and other well known labels.

### C.-D. CATALOG

Catalog No. 165A has been released by the Cornell-Dubilier Electric Corporation. This catalog consolidates the capacitor listings and descriptions appearing in Catalog No. 161. Copy available free on request at main office of plant at South Plainfield, N. J.

### WILCOX BULLETINS

Wilcox Electric Co., 1014 West 37 Street, Kansas City, Mo., have recently made available two interesting bulletins. One of these bulletins covers the 57-D volume limiting amplifier, while the other one is devoted to the 45-M portable remote amplifier. Descriptions and specifications are given for both units.

### TAYLOR CATALOG-MANUAL

The 1939 Taylor Tube Catalog and Manual is now available from Taylor Tubes, Inc., 2341-43 Wabansia Ave., Chicago, Illinois. This 44-page bulletin covers the Taylor line of tubes and also gives considerable circuit information, as well as descriptions of amplifiers, transmitters, etc. To secure a copy of the bulletin write to the above organization.

### EBY PURCHASES BUILDING

Hugh H. Eby, Inc., has announced the removal of the factory and main office to the company's newly purchased building at 4700 Stanton Ave., Philadelphia, Pa. In addition to the three-story main corner building and adjoining one-story building of 13,000 additional square feet on Abbottsford Ave., was acquired to provide for further expansion.

### BRUSH APPOINTMENT

The Brush Development Co. have recently acquired the services of Dr. S. J. Begun. Dr. Begun, who is well known in the radio field, has been associated with Automatische Telephon, A.G., Ferdinand Schuchhardt, A.G., Echophon Maschinen, A.G., C. Lorenz, A.G., all in Berlin, and with the Guided Radio Co., and Acoustic Consultants, Inc., in this country.



# CERAMIC TUBE BASES

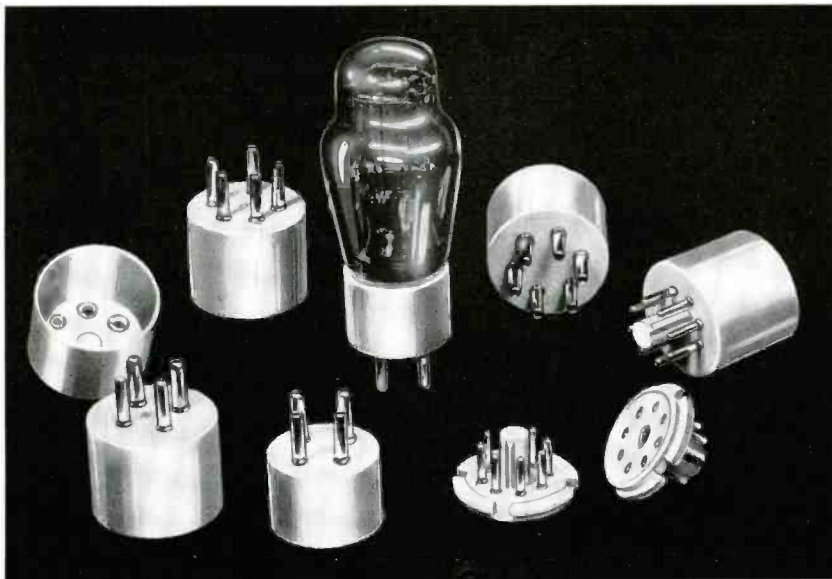

Bases made from low-loss, glazed Alsimag are now available for the usual applications at no extra cost. Television assemblies are also improved by using these same bases.

Quick deliveries can be made as all sizes and combinations are carried in stock. Upon request, literature and prices on given quantities can be supplied.

AMERICAN LAVA CORPORATION, Chattanooga, Tennessee

SALES OFFICES IN PRINCIPAL CITIES

## BRUSH announces MODEL RC-1 RECORD CUTTER

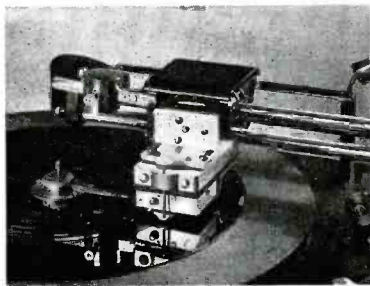

In answer to the widespread demand for a high fidelity, high impedance record cutter at a low price, Brush announces its new model RC-1 cutter. Some of the features that make this instrument outstanding in value are high fidelity plus or minus 3 db. 30-10,000 c.p.s., and no change in quality with depth of cut. The cutter is adaptable to any carriage, and the crystal element is waterproofed in a hermetically sealed case. Net price \$75.00.

• THE BRUSH DEVELOPMENT CO.  
3318 PERKINS AVENUE CLEVELAND, OHIO

# 'PINCOR'

LONG  
LIFE

SMOOTH  
●  
SILENT



# DYNAMOTORS and CONVERTERS



## A Complete Line For Every Purpose

Radio Engineers have learned from experience that Pioneer Gen-E-Motor Corporation's dynamotors, gen-e-motors and converters provide the last word in dependable power supply units for air craft, police, marine and auto radios and public address systems. They are available in a wide range of capacities for every requirement. Designed and constructed to give maximum long life and service. Light weight and compact. For complete information fill out and mail coupon below.

PIONEER GEN-E-MOTOR CORPORATION  
Dept. R-3A, 466 W. Superior Street, Chicago, Ill.

Please send me "Pincor" Silver Band Dynamotor Catalog and Data Sheets.

Name .....

Address .....

City..... State.....

# THE MARKET PLACE

NEW PRODUCTS FOR THE COMMUNICATIONS FIELD

## BEAT-FREQUENCY OSCILLATOR

The Type 700-A wide-range beat-frequency oscillator delivers a substantially constant output at frequencies between 50 cycles and 5 megacycles. Consequently, it can be used to supply a test voltage for measuring the transmission characteristics of wide-band systems such as television amplifiers and coaxial cables. It is an excellent power source for general laboratory measurements, and for modulating standard-signal generators.

The frequency range is covered in two bands: 50 cycles to 40 kilocycles, and 10 kilocycles to 5 megacycles. Both scales on the frequency-control dial are direct-reading.

The maximum open-circuit output voltage is between 10 and 15 volts. The output is taken from an Ayrton-Perry-wound 1500-ohm potentiometer, one terminal of which is grounded. An automatic volume-control circuit holds the output voltage constant within  $\pm 1.5$  db for each frequency range. Because a constant delay voltage is used, the output also tends to remain constant as a function of a-c line voltage.

The oscillator is a-c operated. Power supply may be either 110 to 120 or 220 to 240 volts, 40 to 60 cycles. Normally supplied for table mounting, the assembly is easily adapted for relay-rack mounting.

Further information may be secured from *General Radio Company*, 30 State Street, Cambridge, Mass.—COMMUNICATIONS.

## MARINE RECEIVER

A new radio receiver which covers the long-wave marine and weather report channels as well as the broadcast and short-wave ranges down to 16 meters, has been presented by Hallicrafters, in their "Sky-rider Marine" model. Its tuning range is continuous from 140 kilocycles (2150 meters) to 18.5 megacycles (16 meters) except for a narrow range from 1510 to 1700 kc. It provides reception of code, voice and music. It may be plugged directly into any 110-volt line, either a-c or d-c; or into a converter to draw all its operating power from a marine storage battery.



Further information is available from *Hallicrafters, Inc.*, 2611 S. Indiana Ave., Chicago, Ill.—COMMUNICATIONS.



General Radio oscillator.

IRC resistor.



ELECTROLYTIC CONDENSERS

New high-capacity, low-voltage dry electrolytic condensers in round aluminum cans for use with "A" eliminators, moving-picture sound equipment and other similar



circuits have been introduced by Sprague. Seven units ranging from 500 mfd at 12 volts to 2,000 mfd at 25 volts are now available. These new condensers are known as Sprague Type HLV.

Further information may be secured from the *Sprague Products Co.*, North Adams, Mass.—COMMUNICATIONS.

## ANDREW BULLETIN

"Coaxial Cables" is the title of a new bulletin now available from Victor J. Andrew, 6429 S. Lavergne Ave., Chicago, Illinois. Specifications and descriptive data are given. Write to the above organization for Bulletin 89.

## HIGH-VOLTAGE RESISTORS

IRC resistors for high-voltage protective and measuring devices have recently been developed by employing the metallized type resistance element in a unique spiral formation on a ceramic base. Now available in five standard sizes, these resistors range from the Type MVG, 4 watts, 5,000 d-c volts, 6,000 ohms minimum, 150 megohms maximum on a tube 2" long x 9/16" diameter, to the Type MVR resistor which has a power rating of 150 watts, a d-c voltage rating of 100,000 and a minimum ohms rating of .35 meg. with a maximum of 10,000 meg. The Type MVR is 18 1/2" long x 2" in diameter.

Information will gladly be sent upon request to the *International Resistance Co.*, 401 N. Broad St., Philadelphia, Pa.—COMMUNICATIONS.

## DYNAMOTOR

Model C20, with filter, a new dynamotor just announced by Eicor, Inc., incorporates several new patented features of design.

The brush holder accommodates a brush of longer length and greater cross-section area and has an ingenious method of locking the brush caps. A special device is designed to stop end play in the armature shaft. The manufacturers claim substantial reduction in ripple voltage.

Complete information and specifications may be had free by applying to *Eicor, Inc.*, 515 So. Lavin St., Chicago, Ill.—COMMUNICATIONS.

## KONTAK UNIT

String instruments can now be played through home radio sets with the new Amperite high-output Kontak microphone. All that is necessary is to connect it to the phono input or directly across the volume control—output level —30 db. In spite of the high output, the unit is said to be flat over the entire audio range of 60 to 8000 cps  $\pm 1$  db, and is suitable for not only the popular players but concert artists as well. With the new adjustable clamp shown, the Kontak unit can be readily attached to any instrument without any tools and without marring the instrument in any way. It is adjustable from 1/16 to 1 1/4" and will therefore take any bridge from a small mandolin to that of a double bass.



Further information may be secured from the *Amperite Co.*, 561 Broadway, New York City.—COMMUNICATIONS.





**A COMPLETE LINE  
OF PRECISION  
QUARTZ CRYSTALS  
HOLDERS and OVENS  
20 KC. TO 30 MC.**

*Write for Catalog G-10*

**BLILEY ELECTRIC COMPANY**  
UNION STATION BUILDING  
ERIE, PA.

#### BALLASTRONS

Micamold has just announced a new series of Ballastrons, called types X, Y, and Z. These three universal ballast tubes, with a simple means of adjustment on the base, will replace practically all of the ballast tubes (or plug-in resistors) now in use, it is said.

The X and Y Ballastrons replace both standard and special octal base types, while the Z Ballastrons replace the types having the four-prong or UX base. *Micamold Radio Corporation*, 1087-1095 Flushing Avenue, Brooklyn, New York.—COMMUNICATIONS.

#### DIRECTIONAL MICROPHONE

A new microphone that picks up equally all sounds reaching it from the front but which loses its sensitivity as the source of sound moves to a position behind it has been announced by the Western Electric Company. If a person talking comes closer to the microphone to compensate for this loss in sensitivity, as he walks around from front to back his path will be a heart-shaped curve or cardioid. Because of this pickup characteristic, the device is known as a "cardioid directional" microphone.

The directional properties are said to be equally good for the lowest bass and the highest overtones. Because of the "dead" zone existing behind the microphone, it may be placed near a wall leaving the center of the studio free for use. Reflections from this wall are suppressed and, because of the wide angle of pick-up in front, vertical as well as horizontal, no tilting of the device is necessary.

This cardioid directional performance was obtained by combining the outputs of



Micamold Ballastrons.

Eisler spot welder.



a Western Electric 630-A non-directional pressure unit—the internal mechanism of the well-known "Eight Ball" microphone—with a bi-directional ribbon unit, of new design.

Further information may be secured from the *Western Electric Co.*, 195 Broadway, New York City.—COMMUNICATIONS.

#### ELECTRIC SPOT WELDER

An electric spot welding machine equipped with automatic hydrogen gas economizer is shown here. This type of equipment is employed for welding molybdenum, nickel or other similar metals. In order to prevent oxidation, hydrogen gas is introduced at the time of welding. The flow of hydrogen is directed directly to the spot where the welding takes place. The automatic gas economizer and shut-off valve are so arranged that immediately after the weld is completed the gas is cut out and this gas burns at the spot only during the actual welding operation.

Complete information is available from *Eisler Engineering Co., Inc.*, 750 S. 13th St., Newark, N. J.—COMMUNICATIONS.

#### STANNAGE PTY., LTD

Stannage Pty., Ltd., Sydney, Australia, has been formed to distribute technical radio equipment in the British Empire. Director will be John Stannage, now touring the United States. He is also a stockholder of Stannage Radio, Ltd., of Auckland, and Radio Features, Ltd., of Wellington, New Zealand. Macquarie Broadcasting Services, Sydney, will be affiliated in the new enterprise.



**MADE BETTER TO  
WORK BETTER**



• The combination of high tensile strength that assures a lasting bond and faster, cleaner work made possible by quick acting flux of pure water white rosin, has given Gardiner Rosin-Core Solders an outstanding reputation for efficiency and economy on radio work by expert or amateur. Yet, due to modern production methods and big sales, Gardiner Solders cost less than even ordinary kinds. Made in various alloys and core sizes . . . and in gauges as small as 1/32 of an inch . . . in 1, 5 and 20-lb spools.

Eastern Sales Office and Warehouse: DAVID M. KASSON & CO., 401 Broadway, N. Y.



**Gardiner**  
METAL CO.  
4819 S. CAMPBELL AVENUE CHICAGO, ILL.

# HOTEL DRAKE

SOUTH CAROLINA AVENUE AT PACIFIC  
ATLANTIC CITY, NEW JERSEY

*European Plan Hotel—Moderate Rates*  
• 150 Outside Rooms Beautifully  
Furnished • Also Small Apartments •  
Fully Equipped, including Electric Re-  
frigeration • Convenient to Piers,  
Theatres and Churches • Also Bus  
and Railroad Depot • Garage Ac-  
commodations.

For Literature and Rates, Address  
W. GRAHAM FERRY, Mgr.

## CALLING ALL ENGINEERS

EVERYTHING IN RADIO FOR LABORATORIES  
AND INDUSTRIALS.

We carry a tremendous stock of radio equipment.

**SUN RADIO CO.** 212 FULTON ST. — Dept. C-1  
NEW YORK, N. Y.

PATENTS, TRADEMARKS, COPYRIGHTS

*Correspondence Solicited*

**EUGENE E. STEVENS**

*Registered Patent Lawyer*

Washington Loan and Trust Building Washington, D. C.

We manufacture a complete line of equipment



Spot Welders, electric, from 1/4 to 500 KVA; Transformers, special and standard types; Incandescent Lamp Manufacturing Equipment; Radio Tubes, Ex-Ray, Cathode Ray, Photo Cells, Electronic Equipment Vacuum Pumps, etc. Tungsten Slugs, Rod and Wire Manufacturing Equipment; General Glass Working Machines and Burners; College Glass Working Units for students and laboratory; Photo-Flash Lamp Equipment; Neon Sign Manufacturing Equipment; Thermos Bottle Equipment; Wire Butt Welders. CHAS. EISLER, Pres.



**EISLER ENGINEERING COMPANY**  
739-750 So. 13th St. (Near Avon Ave.) Newark, New Jersey.

### GRADUATE COURSE IN TELEVISION ENGINEERING

The Graduate Division of Newton Institute announces a course in television engineering designed to meet the specific needs of Radio Engineers. Formal study of basic principles and current practice prepares for television development and design. Extensive treatment embraces latest experiments both here and abroad. B.S. in E.E. (or its equivalent) prerequisite to admission. For full details address: Graduate Division, Newton Institute of Applied Science, 2021-Z, Raymond-Commerce Building, Newark, New Jersey.



**TAYLOR**  
VULCANIZED FIBRE  
PHENOL FIBRE  
TAYLOR INSULATION  
TAYLOR FIBRE CO., Norristown, Pa.

## PIEZO Electric Crystals Exclusively

• Quality crystals for all practical frequencies supplied SINCE 1925. Prices quoted upon receipt of your specifications.

**Our Pledge: QUALITY FIRST**

**SCIENTIFIC RADIO SERVICE**

UNIVERSITY PARK HYATTSVILLE, MD.

## "The Market Place"

Manufacturers are requested to send data on their new products for use in the communications and broadcasting field, promptly, for inclusion in "The Market Place" section.

## VWOA NEWS

(Continued from page 22)

harbor for RCA.

"My Morgan Line job was the S. S. *El Oriente* in 1914-1915 and that was followed by 64 ship jobs, many land station jobs including a year as manager at WCI, etc., and then into broadcasting wherein I built, and later was General Manager of WOS, WOC, WRNY, WDBO and KFWI. In 1926 I returned to the ships for a short spell, started writing for a living and retired forever. Since then I've written a lot engineering articles for *Radio Engineering* and other journals.

"I was born, raised and educated in my home town of Mt. Kisco.

"Bill McGonigle, the old so-and-so, owes me a letter since kingdom come—why don't he write . . . new baby or no new baby. (Sorry GVW but they do keep us busy, WJM.)

"Dim in my memory most of the names on the Ballot were familiar to me. I suppose Fitzpatrick has mellowed. Where's Bill Aufenanger? They sent him to WCI to get my 'body' once, New York office thought I'd died.

"Note I've changed the name of my business to "International" because my newspaper and magazine features now appear in 27 countries. (GVW's business is the International Contest Headquarters.)"

### MIAMI

V. H. C. EBERLIN, Secretary of the Miami Chapter, writes: "Was shocked to find VWOA missing in last edition of COMMUNICATIONS. What-sa matter? (Glad to know you read the page "EBBY" and we're sure you saw the explanation in the past issue.) The Miami Chapter is going to get together as soon as the transients return on their "rolling" homes . . . Saw Karl Baarslag the other nite at the Naval Reserve Officers meeting . . . Here is another new member. (Good work, EB.) All goes well with us 'Crackers'. How about yo-all?"

### "DOC" FORSYTH

TO THOSE of you who know Doc Forsyth we appeal to you to drop him a card or pay him a visit at Sailors Snug Harbor on Staten Island. It's a pleasant half hour ride on the ferry from New York and a short bus ride. He is almost totally blind now and your words of cheer would make his daily routine seem less monotonous. He is the only radio operator in the Harbor so he finds little in common to converse with his fellow Harborites. It's a worthy cause so please do your part.

### TUBE MEASURING SET

(Continued from page 27)

ing a gain of about 30 db and the phones connected to the output of the amplifier. The amplifier hum should not be audible at full gain. The detector and oscillator coupling transformers should have electrostatic shields in

order to avoid extraneous capacitive coupling which might prove detrimental in obtaining a satisfactory "null" balance.

If the operator is not skillful in the use of the bridge measuring equipment, the measurement of  $\mu$ ,  $S_m$ , and  $R_b$  for certain types of tubes may not all be obtainable with equal degrees of accuracy. In such cases use may be made of the well known relation that  $S_m = \mu/R_b$  which will serve as a check on any one of the parameters if the other two are accurately measured.

It is of interest to note that with the K-1 switch in position 3 the set can be used for measuring a-c resistance values if the unknown resistance is connected to the plate-cathode terminals. If this feature is desired these terminals can be brought out on a set of binding posts which will make it convenient for connecting the unknown resistances. At the same time this will afford a means for calibrating the parameter measuring bridge since, if a known resistance is connected to the plate-cathode terminals and a "balance" is obtained, the value of the known resistance should equal to the setting giving the value of

$$\frac{R_a}{R_b} = [R_1 + R_2]$$

A microammeter is specified for measurement of the grid current which is an indication of the amount of gas in the tube. An estimate of the relative amount of gas can also be obtained in another way. The 1-megohm resistor in the grid circuit is normally shorted by its associated key, and with this condition, suppose the plate current is measured. Then the short is removed by operating the key and, if the tube shows gas conduction, a grid current will be drawn through the 1-megohm resistor whose IR drop will reduce the effective bias and cause the plate current to increase. Hence the change in plate current is a measure of the gas current.

Extraordinary care should be exercised in the construction of the bridge measuring unit which should be shielded from all extraneous fields. Leakages and capacity effects between circuits and to ground are to be avoided in order that true bridge "balances" are obtained. Many useful suggestions in the construction of the bridge equipment will be found in "Alternating Current Bridge Methods" by B. Hague.

## HOYT METERS



THIS GIANT "CYCLOPS" METER nearly nine inches in diameter is widely used in test equipment where a large and impressive instrument is desirable that can be easily read at a distance. Sensitivity as high as 400 micro-amperes. Resistance: 400 ohms; 3/4" pointer. Sapphire jewelled movement. Made for any panel application as Voltmeter, Ammeter or Milliammeter.

This is one of the many rugged, dependable meters made by Hoyt who has manufactured electrical instruments since 1904. Send for your copy of the new Hoyt reference catalog.

## BURTON-ROGERS

857 Boylston St., Boston, Mass.  
Sales Div.: Hoyt Elec. Inst. Works



# WAXES AND COMPOUNDS

FOR  
INSULATION and WATERPROOFING  
of ELECTRICAL and RADIO  
COMPONENTS

● such as transformers, coils, power packs, pot heads, sockets, wiring devices, wet and dry batteries, etc. Also WAX SATURATORS for braided wire and tape and WAXES for radio parts. The facilities of our laboratories are at your disposal to help solve your problems.

FOUNDED 1846  
*Zophar* MILLS, Inc.  
120-26th ST., BROOKLYN, N. Y.

## Gates Remote Equipment—

"Does a Better Job at a Lower Cost"

GATES RADIO & SUPPLY CO.

Quincy, Ill.



## SHALLCROSS MULTI-PURPOSE ROTARY SWITCH

An inexpensive but high grade instrument switch adaptable to many industrial, radio and laboratory uses. Has low contact resistance and positive setting throughout its 360° swing. Safely carries a 5 amp. non-inductive load up to 2000 volts. Furnished with any number of contacts from 2 to 11.

Write for Bulletin No. 500SD

**SHALLCROSS MFG. CO.**  
Switches -- Resistors -- Instruments  
COLLINGDALE, PA.

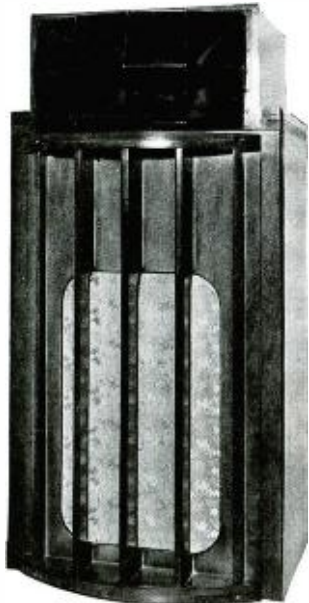

## ANNOUNCING

The most natural sounding loud speaker system ever produced. For program balancing and reproduction purposes wherever really high fidelity is taken seriously.

**SAMUEL A. WAITE**  
506 No. Oakhurst Drive, Beverly Hills, Calif.

## Advertising Index

A	
Aerovox Corp. ....	1
American Lava Corp. ....	31
Amperex Electronic Products, Inc. ....	Inside Front Cover
Amperite Co. ....	36
B	
Biley Electric Co. ....	33
Brush Development Co., The. ....	31
Burton-Rogers ....	35
C	
Callite Products Division ....	29
Cornell-Dubilier Elec. Corp. ....	25
D	
Driver Co., Wilbur B. ....	33
E	
Eisler Engineering Co. ....	34
G	
Gardiner Metal Co. ....	31
Gates Radio & Supply Co. ....	35
General Radio Co. ....	Inside Back Cover
Goat Radio Tube Parts ....	29
Guardian Electric Co. ....	23
I	
Ideal Commutator Dresser Co. ....	24
Isolantite, Inc. ....	5
J	
Jardur Import Co. ....	25
Jones, Howard B. ....	25
L	
Lampkin Laboratories ....	24
Lansing Mfg. Co. ....	24
Lapp Insulator Co., Inc. ....	3
Lingo & Son, Inc., John E. ....	27
M	
Monarch Mfg. Co. ....	26
N	
Newton Institute of Applied Sciences ....	34
P	
Pioneer Genemotor Corp. ....	31
Presto Recording Corp. ....	21
R	
Radio Corporation of America. ....	6
R. C. A. Communications, Inc. ....	21
RCA Mfg. Co., Inc. ....	Back Cover
Radio Amateur Call Book. ....	24
Radiotone, Inc. ....	26
S	
Scientific Radio Service. ....	34
Shallcross Mfg. Co. ....	36
Stevens, Eugene E. ....	34
Sun Radio Co. ....	34
T	
Taylor Fibre Co. ....	34
W	
Waite, Samuel A. ....	36
Wholesale Radio Service Co., Inc. ....	36
Z	
Zophar Mills, Inc. ....	35

*The*  
**AMPERITE**  
**ACOUSTIC**  
**COMPENSATOR**  
*gives you*  
**HIGH OR LOW PITCH**  
**WITH THE SAME MICROPHONE**

With the flip of a finger you can now (1) lower or raise the response of the microphone. . . (2) adjust the microphone for most desirable response for close talking or distant pickup. . . (3) adjust the system to any "taste", room condition, or equipment.

MODELS RBHk, RBMk with Acoustic Compensator, frequency range 40 to 11000 cps, output, -65 db., complete with switch, cable connector and 25' of cable. . . \$42.00 LIST

**NEW! MODEL RSHk (hi-imp); RBSk (200 ohms) Frequency range 60 to 8000 C.P.S. Output -68db. . . Chrome or Gunmetal . . . \$32.00 LIST**

**NEW LOW PRICE CONTACT "MIKE"**  
Model SKH (hi-imp); SKL (200 ohms) \$12.00 LIST

MODELS RAH-RAL, excellent for speech and music. Reduce feedback. . . \$22.00 LIST

Write for Complete Illustrated Bulletins and Valuable Sales Helps.

**AMPERITE CO.** 561 BROADWAY, N. Y.  
Cable Address: Alcom, New York

**AMPERITE** Velocity **MICROPHONE**

**YOUR "STOCKING" FEET**

Those feet of yours work pretty hard just earning your living. Why make them work overtime chasing around in search of some special radio part you happen to need? Your "stocking" feet belong in bedroom slippers. . . not on hard pavements. Smart men do their stocking from our catalog—the comfortable, direct route to everything in radio. Send for your copy.

**WHOLESALE RADIO SERVICE CO. INC.**  
100 SIXTH AVE., NEW YORK, N. Y.  
CHICAGO, ILL. • ATLANTA, GA. • BOSTON, MASS.  
BRONX, N. Y. • NEWARK, N. J. • JAMAICA, L. I.





# RESISTANCE BOXES

*With*

# CONSTANT INDUCTANCE

MANY measurements of impedance at audio and radio frequencies, for precise results, require resistance boxes with very low and constant inductance. The G-R Type 670 Compensated Decade Resistors were designed to fill this demand.

In order to compensate for the inherent changing inductance of decade resistance windings, a double-switch mechanism is provided in these boxes so that when a resistance coil is removed from the circuit, a low-resistance copper coil of equal inductance is substituted. With careful design and workmanship, resistance boxes of constant inductance within 0.05  $\mu$ h result.

When continuously adjustable boxes are desired, the Type 669 Compensated Slide-Wire Resistor is used. Through unique design it has been possible to manufacture this unit with almost constant inductance at any position of the slide.

## FEATURES

- LOW AND CONSTANT ZERO INDUCTANCE
- LOW ZERO RESISTANCE
- ACCURATELY ADJUSTED RESISTANCE VALUES
- LOW TEMPERATURE COEFFICIENT
- LOW FREQUENCY ERROR ... GOOD TO 1 Mc.
- PROTECTED WINDINGS AND SWITCHES
- POSITIVE DETENT MECHANISM
- SHIELDED CABINETS
- THREE SIZES: 0 to 11.1 ohms continuously adjustable: \$60.00; 0 to 111 ohms in 0.1 ohm steps: \$45.00; 0 to 111 ohms continuously adjustable: \$55.00.

WRITE FOR BULLETIN 360 FOR COMPLETE INFORMATION

**GENERAL RADIO COMPANY, Cambridge, Massachusetts**

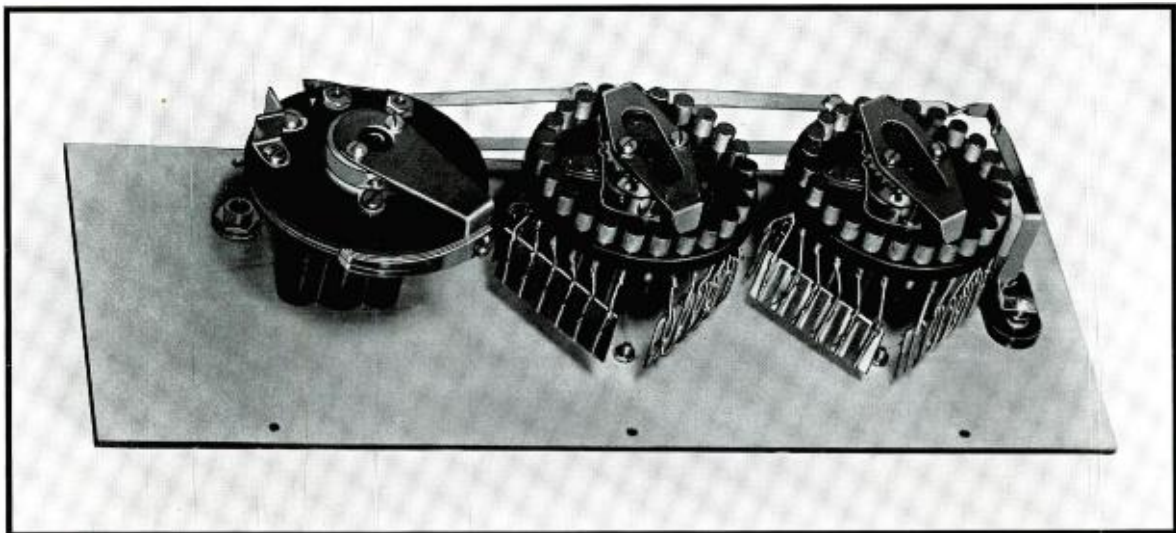

# RCA Introduces

## New WHITE SCREEN

## TELEVISION TUBES

### 906-P4—WHITE SCREEN...\$15.00

Introducing the new RCA-906-P4, a 3-inch television Kinescope. Similar to the present RCA-906 Cathode-Ray Tube, this new tube features a white fluorescent screen—and an unusually low cost! In addition to its

low initial cost, this new tube provides low circuit cost because of its low voltage operation. Has conductive coating which minimizes deflecting-plate loading and prevents drifting of the pattern with changes in bias.

### 1802-P4—WHITE SCREEN...\$27.50

Introducing the 1802-P4, a 5-inch television Kinescope having electrostatic deflection and white screen. This tube provides excellent quality television pictures. The deflection sensitivity is such that the beam may

be deflected across the entire screen with no more voltage than is required for full deflection on 3-inch tube. Separate terminals are provided in the new Magnal 11-pin base for each deflecting plate.

### 1802-P1—GREEN SCREEN...\$24.75

Introducing the 1802-P1, a new 5-inch oscillograph tube which is similar to the 1802-P4 except for its green screen. In oscillographic application the 1802-P1 represents

extremely high quality because it is capable of providing excellent television pictures. For television purposes this tube operates well with an anode potential of 1200 volts.

### NEW RCA MONOSCOPE

The new RCA-1899 Monoscope provides a convenient source of video signal for testing television equipment and for demonstrating television principles. The pattern contains calibrated resolution wedges to indicate the amount of detail the associated equipment can resolve. Other features of the pattern provide tests for linearity of scanning, spot defocusing, amplitude response, frequency response, phase response, and general quality of picture reproduction. Price \$95.00.

*RCA presents the Magic Key every Sunday, 2 to 3 P.M., E.S.T., on the NBC Blue Network*

**RCA Radio Tubes—first in metal, foremost in glass, finest in performance**



for

# TELEVISION

RCA Manufacturing Company, Inc., Camden, N. J. A Service of the Radio Corporation of America