

\$1.00

COMMUNICATIONS

a merger of
RADIO ENGINEERING
...
COMMUNICATION &
BROADCAST ENGINEERING
...
THE BROADCAST ENGINEER

OCTOBER
1937



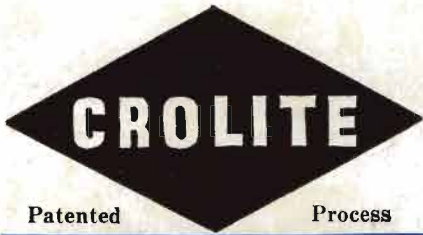

Ahead of the Times!



MAGICORES

offer many engineering possibilities for improvement.

FOR EXAMPLE:



I-F trimming eliminating drift.
Improved gain and Q in Antenna coils decreased noise.



CERAMICS

on new production facilities offer better:

COST
QUALITY

CAPACITIES
DELIVERIES

CONDENSERS

Despite our previous high engineering characteristics and exceptional results, we have been able to importantly increase the quality, an improvement proven by years' tests.

CERAMIC CEMENT

Molded ceramic of real low loss materials. New possibilities. Why not consider them?



LIQUID CROLITE Super Quartz

. . . A liquid for impregnating and covering purposes with losses lower than fused quartz.

Write for Technical Data



HENRY L. CROWLEY & CO.
INC.
1 CENTRAL AVE., WEST ORANGE, N. J.
EXPORT DEPARTMENT: 116 BROAD STREET, N. Y. C.

**Just try to find a program
you can't pick-up better with
the "8-Ball" or the "Salt-Shaker"**



Between them, these two famous Western Electric mikes meet every broadcasting need. Both can be used for non-directional pickups—both can be transformed quickly for directional work by simply putting on their acoustic baffles.

The "8-Ball," which jumped into immediate popularity two years ago, is still being bought in bunches. And

orders for the newer "Salt-Shaker" keep pouring in from broadcasters—and from Public Address operators who find it ideal for their work, too.

At the low prices, you can't afford anything less than the true Western Electric quality these two mikes will give you! For full details: Graybar Electric Co., Graybar Bldg., New York.



Western Electric

Distributed by GRAYBAR Electric Co. In Canada: Northern Electric Co., Ltd.

RADIO TELEPHONE BROADCASTING EQUIPMENT

COMMUNICATIONS

Member of Audit Bureau of Circulations

RAY D. RETTENMEYER • Editors • W. W. WALTZ

CONTENTS FOR OCTOBER

Cover Illustration: G. C. Campbell of WOR at the controls of the transcription equipment in the station's New York studios. Photo courtesy Western Electric Co.

	Page
With the Editors	4
A Five-Kilowatt Air-Cooled Broadcast Transmitter.....By John P. Taylor	7
Television Economics.....By Dr. Alfred N. Goldsmith	10
Linear Amplifier Adjustments.....By A. James Ebel	11
A Simplified Theory of Filter Selectivity.....By Homer Dudley	12
Program of Rochester Fall Meeting.....	14
The Voltage Gain Guide.....	15
Disc Recording—Equipment and Its Quality Requirements..By T. L. Dowey	17
Modern Trends in Cabinetry.....By Lewis Winner	20
An Ultra-Short-Wave Radio Link.....	22
Plate-Resistance Control in Vacuum Tubes as Audio Gain-Control Means By Alfred W. Barber.....	23
Notes and Comment	26
Telecommunication	28
Veteran Wireless Operators Association News.....	33
The Automatic Radio Compass.....	34
The Market Place.....	36
Over the Tape.....	54
Index of Advertisers.....	60

VOLUME 17

NUMBER 10

BRYAN S. DAVIS
President

JAMES A. WALKER
Secretary

Published Monthly by the
BRYAN DAVIS PUBLISHING CO., INC.
19 East 47th Street
New York City
New York Telephone: PLaza 3-0483

PAUL S. WEIL
Advertising Manager
SANFORD R. COWAN
Eastern Advertising Manager
A. B. CARLSEN
Circulation Manager

Chicago Office—608 S. Dearborn St.
Telephone: Wabash 1903.



Wellington, New Zealand—Te Aro Book Depot.
Melbourne, Australia—McGill's Agency.

Entered as second class matter October 1, 1937, at the Post Office at New York, N. Y., under the act of March 3, 1879. Yearly subscription rate: \$2.00 in the United States and Canada, \$3.00 in foreign countries. Single copies: twenty-five cents in United States and Canada, thirty-five cents in foreign countries.

For Quality Styling in Radio Sets

THE universal use of Bakelite Molded for popular-priced radio cabinets indicates how well this material meets the dual requirements of distinctive styling at low manufacturing costs.

Bakelite Molded is available in a wide range of attractive colors and mottles; and may be readily formed into almost any shape or design. Through its use, cabinets often may be designed in one piece, and com-



pletely produced in one operation of the molding press.

In the molding operation, all through-holes, lugs and metal inserts are permanently incorporated, and a final lustre is imparted to all surfaces. The uniform accuracy with which Bakelite Molded cabinets can be produced, and the resulting simplifications in assembly, provide further economies in production.

Other characteristics of Bakelite Molded, that make it highly advantageous for cabinets, are its mechanical strength, lightness in weight, electrical insulation value, and high resistance to marring from abrasion, handling, and furniture polish or soap and water.

Manufacturers and designers of radios are invited to obtain detailed information. Write for comprehensive booklet 50M, "Bakelite Molded."

(Left) 4-tube Emerson Radio with 2-piece cabinet of rich mottled brown Bakelite Molded. (Above) From the same molds, different color-styling is obtained by producing the cabinet body from lustrous black Bakelite Molded. Molder, Associated Attleboro Mfrs., Inc.



BAKELITE CORPORATION, 247 PARK AVENUE, NEW YORK, N.Y.
BAKELITE CORPORATION OF CANADA, LIMITED, 163 Dufferin Street, Toronto, Canada West Coast: Electrical Specialty Co., Inc., 316 Eleventh Street, San Francisco, Cal.

BAKELITE

The registered trade marks shown above distinguish materials manufactured by Bakelite Corporation. Under the capital "B" is the numerical sign for safety, or unlimited quantity. It symbolizes the infinity number of present and future uses of Bakelite Corporation's products.

THE MATERIAL OF A THOUSAND USES

COMMUNICATIONS FOR OCTOBER 1937 • 3

WITH THE EDITORS

PROTECTED INTERMEDIATE FREQUENCY

THE RADIO INDUSTRY, especially the radio receiver manufacturers, should be pleased to learn that the Federal Communications Commission has adopted a request from the Radio Manufacturers Association for the establishment of 455 kilocycles as a protected intermediate frequency. The Commission will endeavor to protect this frequency, set aside in the manufacture of receiving sets, by not authorizing any new frequency assignments in the band from 450 to 460 kilocycles.

Request for the 455-kc band was made last year at the general hearings on allocations through the RMA engineering committee, composed of Dr. W. R. G. Baker, G. E. Gustafson, Dr. C. B. Jolliffe, D. E. Harnett, E. W. Wilby, E. T. Dickey, David Grimes, and Virgil M. Graham.

Although this decision by the FCC may not be all that could be desired, the receiver manufacturers should still welcome it as good news.

ROCHESTER FALL MEETING

THE 1937 Rochester Fall Meeting, sponsored jointly by the Institute of Radio Engineers and the Engineering Division of the Radio Manufacturers Association, will be held on November 8, 9 and 10 at the Sagamore Hotel in Rochester. It promises to be the biggest and best gathering in the history of these meetings. This is especially true of the technical sessions which will include papers on television, receiver design, measurements, etc. The complete program for this convention will be found on pages 14 and 15 of this issue; a detailed report of the meeting will, of course, appear in a later issue.

FCC DIVISIONS ABOLISHED

BY UNANIMOUS VOTE the Federal Communications Commission has adopted an order abolishing the Broadcast, Telegraph and Telephone Divisions. This order, proposed by Chairman Frank R. McNinch, went into effect on November 15. In discussing this change in policy, Chairman McNinch stated:

"Some of the reasons underlying this fundamental change of organization policy are that experience has shown that to subdivide a small Commission has a divisive effect and tends away from cooperation and mutual understanding; the assignment of such important work as has heretofore been handled by divisions theoretically composed of three Commissioners, but in fact functioning with two Commissioners because of the impracticability of the Chairman's keeping himself currently informed and attending meetings, has resulted in two members of the Commission carrying an unnecessary load of responsibility and exercising an undesirably large portion of the power and functions of the Commission, while at the same time denying the other Commissioners any practical opportunity to participate in decisions. When such major phases of the Commission's work, as Broadcasting, Telephone, and Telegraph, have been committed to the handling and decision of only two members, these two members have been denied opportunity to exchange views with and profit by free discussion and expression of opinions by the other Commissioners. Commissioners not on a particular Division have felt a natural reluctance to inquire into the work committed to others, hence, they were denied effective expression of their views upon pending matters. Furthermore, the segregation of Commissioners into units, with power to act, unavoidably requires that they specialize in their thought and action upon limited phases of the Commission's work and this, with other reasons above mentioned, prevents a rounded development of every Commissioner's knowledge of and experience in the whole field of the Commission's work.

"A Commission functioning as such has the benefit of the free discussion and exchange of views, it learns better to cooperate, the Commissioners gain a better understanding of each other, and they influence and share in every important responsibility. The aggregate wisdom and judgment of seven minds is surely greater than any two or three of the seven."

We heartily agree with Chairman McNinch, and believe that the communications industry will profit as a result of the closer cooperation.

A NEW SIMPLIFIED 1KW TRANSMITTER AT LOWEST PRICE IN RCA HISTORY!

This RCA High Fidelity one - Kilowatt Transmitter provides performance which sets a new standard of price value

Modern features of this modern transmitter!

- Low purchase price
- High fidelity
- High efficiency tubes
- High efficiency circuit
- Low operating cost

IT'S HERE—an RCA High Fidelity transmitter offering exceptional performance—at the lowest price in RCA's history.

New, simplified construction is responsible for the extremely low cost of this transmitter—with no sacrifice of performance.

The RCA 1-G has a high efficiency circuit... offers uniform frequency response, low distortion and low hum level. Tubes of brand new design, including the RCA 833, 805 and 802 increase its efficiency and cut operating expenses.

Just as this transmitter is a big money saver in first cost, so it gives you unusual operating economy. Its unusually low power drain averages 4 kilowatts. Audio line amplifier is not required. And a complete set of tubes runs to less than \$500! Further details on request.



Broadcast Equipment

RCA Manufacturing Co., Inc.
Camden, N. J. • A Service of
Radio Corporation of America

New York
1270 Sixth Ave.

Chicago
589 E. Illinois St.

Atlanta
490 Peachtree St., N. E.

Dallas
2211 Commerce St.

San Francisco
170 Ninth St.

**For automatic tuning
without costly changes in chassis design**

YAXLEY JUNIOR TYPE STATION SELECTOR SWITCH

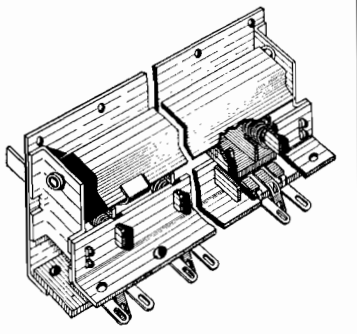
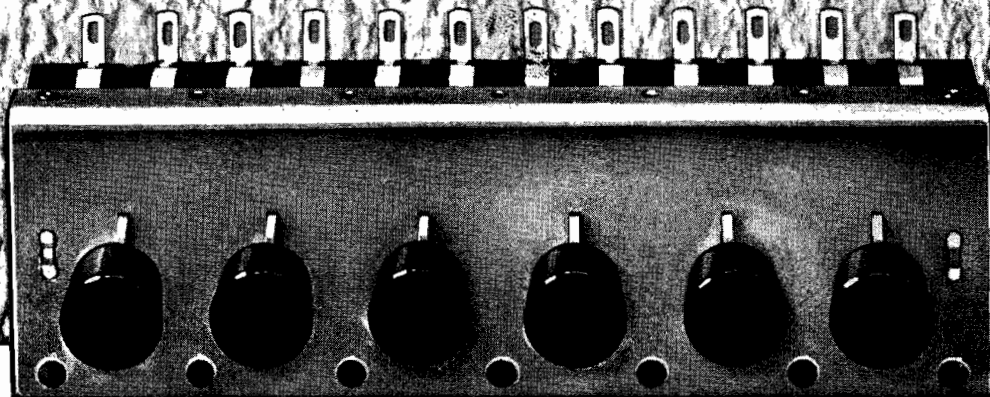

The Yaxley Junior Type Station Selector Switch has been developed in response to the demand for a unit which will occupy a minimum of depth behind the front panel. Engineers contemplating the conversion of current models to automatic tuning without change of expensive chassis dies will appreciate the necessity of this conservation of space between the front of the sub-panel and the cabinet.

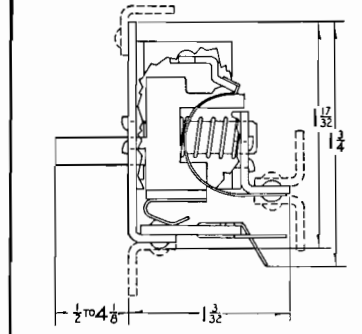

The unit incorporates the same features of dependable mechanical action, quiet operation and long satisfactory life found in the original Yaxley Station Selector Switch and is available with the same terminal arrangements. Flexible tooling permits rapid delivery of units in multiples of from 2 to 12 buttons in a single frame and with variable lengths of actuating

plungers to fit individual requirements.

A newly developed "L" terminal allows series type connection of Yaxley Push Button Station Selector Switches and results in considerable economy of wiring and simplicity of operation.

Write for complete mechanical and electrical specifications covering Yaxley 3-S and 3-SJ Station Selector Switches.



YAXLEY MANUFACTURING DIVISION OF P. R. MALLORY & CO., INC.
INDIANAPOLIS, INDIANA CABLE ADDRESS - PELMALLO

COMMUNICATIONS

FOR OCTOBER, 1937

A Five-Kilowatt, Air-Cooled BROADCAST TRANSMITTER

OUTSTANDING among recently announced broadcast transmitters is a 5-kw model in which all tubes are air-cooled, thereby eliminating the disadvantages inherent in the elaborate water-cooling systems always used in the past with transmitters of this size. The improvements in transmitter design and operation which result, directly and indirectly, from this change have—for medium-power transmitters—an importance comparable to that of the development of the high-efficiency linear amplifier¹ in the high-power field.

Water cooling has always been the bane of engineers invested with the responsibility of transmitter design—and, putting it realistically, “a pain in the neck” to the engineers who must keep them operating. In the early days there were the problems of rotting hose, leaking hose connections, failing flow-interlocks, and electrolysis. In recent years the use of porcelain hose-reels, more reliable interlock systems, and completely non-ferrous circulating systems,² have greatly reduced the servicing problems. However, there still remain the problems of scale formation on tubes, gradual evaporation of water, and necessity of losing time in changing tubes. In addition, there is the question of providing the necessary space and piping external to the transmitter unit. In the case of higher-power transmitters it has seemed—and still seems—that there is no immediate alternative to the use of water cooling. However, for a number of years the possibility of eliminating water cooling in medium-

By **JOHN P. TAYLOR**

power transmitters has been given some thought. The 5-kw broadcast transmitter illustrated in the several accompanying views is the first actual realization of this. The means by which this accomplishment was made possible, and the extent of the practical results, are of interest.

One possible method of building an air-cooled 5-kw transmitter would be



Fig. 2. One of the standard metal-anode type tubes fitted with copper radiating fins for air cooling.

to use a large number of smaller type tubes. Another possibility would be the construction of some radically different type of tube. Both of these would prob-

ably have disadvantages outweighing the possible gain. The more desirable course, and that resorted to in the transmitter shown here, is the use of standard type large-size tubes. These are 891's and 892's respectively—which are regular metal-anode tubes which have been used in standard 5-kw broadcast transmitters for several years, and thus have proven characteristics and life-expectancy. Formerly these tubes were mounted in jackets through which water was circulated—the other parts of the circulating system consisting of a pump, a cooling-radiator and a blower. In the new transmitter shown here, these same tubes are air cooled. The expedient which makes this possible is the addition of a large number of copper radiating fins through which air is blown at a constant rate. These fins are silver-soldered directly to the tube anodes. The modified tubes, which are sold with fins already attached, are specified as 891-R's and 892-R's. One of these tubes is shown in Fig. 2. In Fig. 3, which is a rear view of the modulator and power-amplifier units respectively, the method of mounting these can be seen. The old water jackets are replaced by large porcelain cups into which the tubes, fins and all, are set. Just below each of these tube mountings may be seen the air blowers which force air up through the fins and out the top of the transmitter. These blowers, one for each tube, are of the silent Sirocco type and are equipped with dust filters, so that the constant passage of air will not deposit a film of dust on the tubes and other components. It is interesting to note that these two units of the transmitter are—except for the blower entries beneath, and exits at the top—

¹“A New Power Amplifier Of High Efficiency,” by W. H. Doherty, *Communication & Broadcast Engineering*, May, 1936.

²“Broadcast Transmitter Features,” by John P. Taylor, *Electronics*, Jan., 1936.

power tubes as modulators. In this new transmitter the advantages of high-level modulation definitely outweigh the disadvantage of the additional tube. In the first place, the operation of the modulators Class B, and of the power amplifiers at high efficiency, greatly reduces the amount of heat necessary to be dissipated, and thereby simplifies the cooling problem. In the second place, this method of operation affects a large saving in power consumption. That this latter is not imaginary is indicated by the fact that the total power consumption of this transmitter (average modulation) is only 18.5 kw, whereas linear-amplifier models of recent date require from 28 to 34 kw. With the extended life now being obtained with most tubes, this saving in power consumption is several times greater than the extra tube cost represented by the one additional tube. In addition to these advantages, the use of high-level modulation offers several other advantages. One of these is that it makes possible an improved feedback arrangement. Another is the inherently lower distortion. A third, and not least important, is that the Class C r-f stages are much more easily adjusted than linear stages.

FIXED FEEDBACK

The feedback system made use of in this new transmitter represents something of a new idea, and as such deserves a word of comment. Unlike the feedback circuits which during the past year have been added to most high-power transmitters, this one does not require r-f rectification. This follows from the fact that it operates only from the secondary of the audio-input trans-

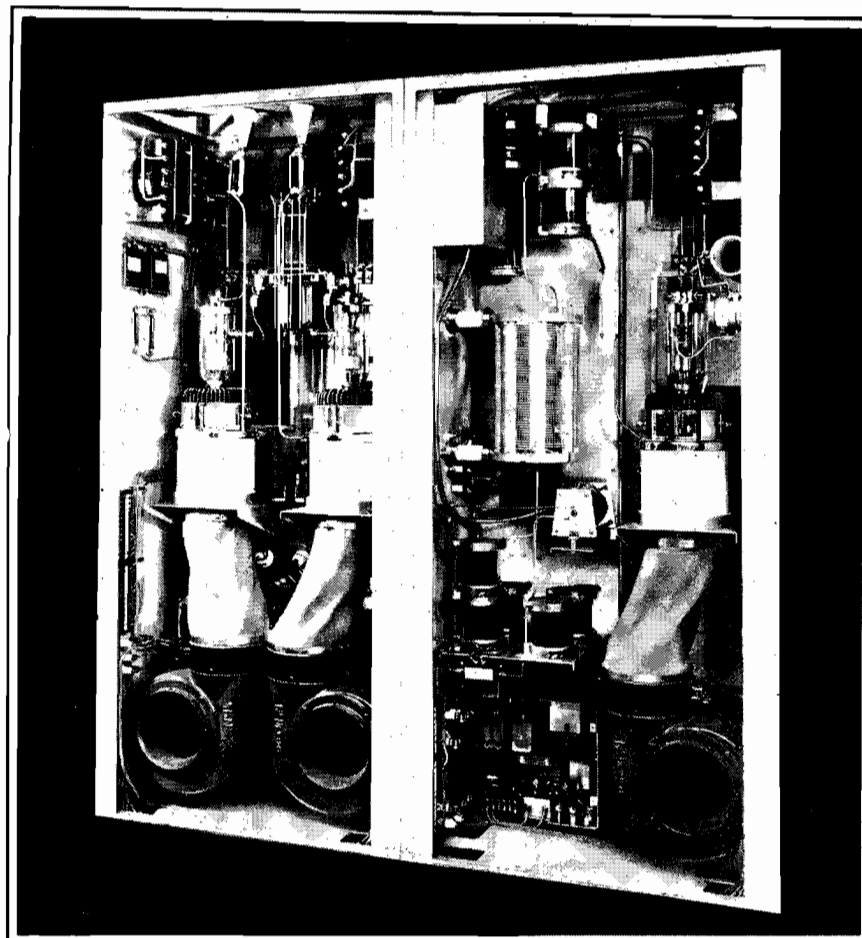
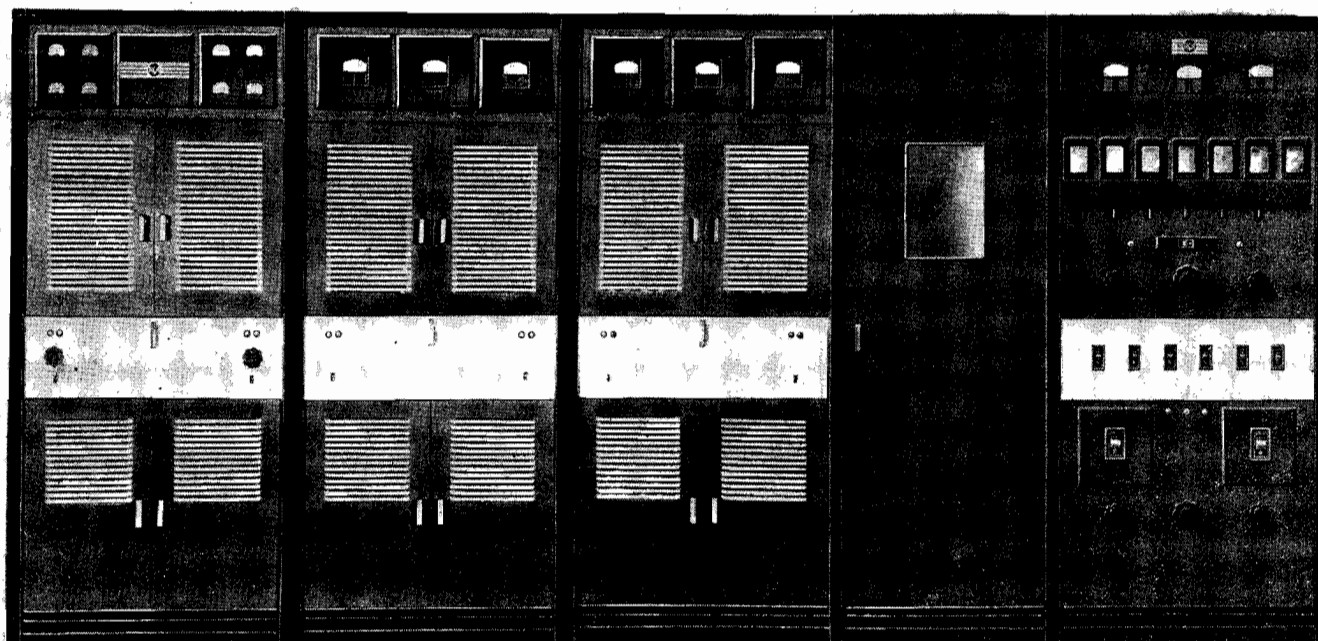

Fig. 3. Rear view of the modulator (left) and power-amplifier (right) units.

former to the primary of the modulation transformer. Reference to the simplified schematic (Fig. 4) will show that the intervening circuits are all push-pull, and due to the use of resistance-coupled audio stages, only one transformer intervenes. This has two important re-

sults: first, together with the elimination of the rectifier, it makes for unusual stability, and second, it reduces phase shift to a minimum. The former is important in that it allows a high feedback ratio (30 db or more being claimed).
(Continued on page 52)

Fig. 1. Front view of the air-cooled 5-kw broadcast transmitter described in the accompanying article.



TELEVISION ECONOMICS

By **Dr. ALFRED N. GOLDSMITH**

Consulting Industrial Engineer

THROUGH AN EXPENDITURE of many millions of dollars here and abroad for research and development, television transmission and reception has become technically possible. Despite the time and money which have already been poured into this work, there are still numerous engineering problems awaiting solution in the television field. Perhaps the most obvious of all is the need for an inexpensive reliable electronic method of producing large and bright black-and-white pictures of minimum optical and electrical errors. Accordingly those planning a television system as distinguished from an individual device for use in that field must allow in their budget for substantial and continued engineering development changes as well as further basic research. The balance sheet of television will therefore include, for many years to come, major expenditures on the engineering side.

Assuming technical development to proceed apace and satisfactorily, the construction, installation, and operation of studio, transmitting, and syndication facilities presents a major financial problem. Television studio design is not sufficiently advanced and standardized at present to permit reliable cost estimating. It is clear, however, that studio facilities for an individual station may well fall in the range from \$50,000 to \$500,000 with correspondingly increased figures for points of major program origination. Individual transmitters are or will be available in due course in the power range from 5 to perhaps 50 kilowatts at costs which may be crudely estimated as between \$300,000 and \$800,000. It must be remembered that television transmitters include sound transmitters as a necessary component. Further, while television transmitters can economize on antenna dimensions, they cannot economize in the least on antenna placement. In a few large cities there are existing buildings of a height adequate for television purposes (500 to 1,000 feet or more) but in many cities it will be necessary to erect heavy towers on existing structures, frequently with additional bracing or reinforcing of the existing building construction. The

costs of such alterations and additions are capable of estimation only in known individual cases.

Television network facilities present an unsolved economic problem. In published statements, it appears that the 90-mile coaxial cable between New York and Philadelphia (which is understood to be fairly suitable for certain television purposes) had a cost of \$540,000 for a 90-mile span. This figure of \$6,000 per mile might be regarded as developmental. Even if reduced substantially, it can readily be seen that the cost of a coaxial cable network paralleling the existing approximately 35,000 miles of telephone broadcasting network would lead to an expenditure running toward \$100,000,000. If this expense were cut down by restricting the length and coverage of the network, the territorial coverage of the connected transmitting stations would be more greatly reduced than in the case of present day broadcasting. It must be remembered that the service range of the ultra-high-frequency television transmitter is far less than that of the medium-frequency radio-telephone transmitter. A compensating circumstance is the fact that the population residing within 30 or 40 miles of the center of a major group of large cities in the United States, though it does not include many large rural areas, nevertheless constitutes a large fraction of the population of the United States and perhaps a correspondingly large fraction of the purchasing power.

Television receivers will require a major expenditure by the American public to justify extensive program transmission which in turn can be sponsored by advertisers only after the looking audience is of satisfactory size. Judging from analysis and commercial experience here and abroad, television receivers will be produced in a number of types and sizes differing mainly in dimensions of the picture, frequency band covered, and certain other points of convenience. Simple receivers may have a small picture for chair-side observation while large receivers may project pictures of a size adequate for viewing throughout an entire living

room. The corresponding range of prices can be very roughly estimated as of the order of \$150 to \$1000, with major acceptable performance for more than one looker embodied in receivers costing several hundred dollars. If a figure of \$250 per receiver is taken as a cross-section average during the first five years of television commercialization, and if it be assumed that there will be 2,000,000 receivers placed in American homes during that period (which figure may be quite wide of the mark), an expenditure by the public of \$500,000,000 for television receiving equipment would be involved.

Program production in the case of television promises to be an even more complicated, demanding, and costly proposition than in the case of sound broadcasting. Every factor of cost bids fair to increase when sight is added to sound. The necessity for providing visual surroundings in the studio (sets, properties, background projection, and the like) leads to major expenditures. The number of actors available for television will presumably be less than those available for sound broadcasting because appearance as well as ability in speaking or musical performance will naturally be required.

It is necessary only to examine the costly facilities and elaborate methods which are used in the motion picture industry to appreciate that somewhat similar elements of cost in the television industry may well impend. Even allowing for the possibility that there is considerable waste in motion picture production, over-elaboration in details, extravagance in the search for spectacular effects, undue inflation of individual returns in certain cases, and a generally lavish method of operation, it must yet be conceded that extraordinary reductions in cost would be necessary if television is to use material even remotely resembling that produced by the leading motion picture studios. No mere minor simplification or economy would meet the requirements.

In round numbers, it may be estimated that Hollywood spends \$150,000,000 per year to produce approximately

(Continued on page 50)

LINEAR AMPLIFIER ADJUSTMENTS

By A. JAMES EBEL

Chief Engineer
WILL

ONE OF THE BIGGEST problems that the transmitter engineer must continually face is that of maintaining the Class B linear amplifier in optimum adjustment. The difficulties surrounding this problem arise from several sources. In the first place, maximum output at carrier level is not consistent with linearity of the amplifier; in the second place, the linear amplifier is not a saturated amplifier, and, therefore, exhibits a high internal resistance. This makes the point of optimum adjustment hard to recognize. And, finally, it reflects a variable load into the preceding stage.

CIRCUIT RELATIONS

Before the engineer can proceed intelligently to tune an amplifier of this type he must have some idea of what the circuit constants and the circuit currents should be. Therefore, preliminary to the actual tuning procedure the various relations which determine the operation of the Class B amplifier will be examined. With the data so obtained it is not necessary to cut and try aimlessly. This reduces the time necessary for tuning and avoids ambiguous results. There is a great wealth of information on linear amplifiers in the literature, so no attempt will be made here to delve into the fundamental theory. Several of the fundamental relations used in this paper have been taken from two of W. L. Everitt's papers on the subject. It is suggested that those wishing to study the subject more fundamentally consult these works. The nomenclature to be used is as follows:

- E_c = absolute value of negative grid bias
- E_g = amplitude of the alternating grid voltage
- E_b = voltage of direct-current plate supply
- I_1 = amplitude of the fundamental alternating-current component of the plate current
- I_T = amplitude of the alternating current in each branch of the tuned-plate circuit
- I_b = average or direct-current component of plate current
- R_L = impedance of tuned load at resonance
- R_T = tank-circuit resistance

θ = one half the angle during which plate current flows.

Fig. 1 is the circuit to be considered. By assuming a linear tube characteristic and that the maximum value of the grid voltage never exceeded the minimum value of the plate voltage, Everitt developed the following equation for all amplifiers regardless of class:¹

$$I_1 = \frac{\mu E_g}{R_L + \frac{\pi R_p}{\theta - \frac{1}{2} \sin 2\theta}} \dots \dots \dots (1)$$

This shows that the fundamental component of the alternating plate current will be linear with respect to the impressed grid voltage if the load impedance, the plate resistance, and the operating angle are held constant. The first two are essentially constant under ordinary conditions. To make the operating angle constant throughout the entire audio swing the value of ninety

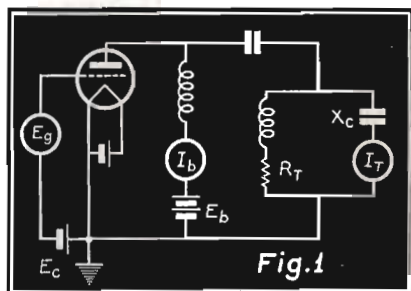

Diagram used to determine circuit relations.

degrees must be selected. Assuming this condition, equation (1) reduces to

$$I_1 = \frac{\mu E_g}{R_L + 2R_p} \dots \dots \dots (2)$$

To establish a ninety-degree operating angle the amplifier must be biased to the cut-off point. This is determined by adjusting the grid bias so that

$$E_c = \frac{E_b}{\mu} \dots \dots \dots (3)$$

¹W. L. Everitt—"Optimum Operating Conditions for Class C Amplifiers"—*Proceedings of the I.R.E.*—February, 1934.

or the grid bias may be adjusted till the plate current drops to zero. Inasmuch as the primary aim in tuning the linear amplifier is to get the maximum output consistent with linearity, the variables that determine efficiency should be examined. The efficiency of a linear amplifier may be given by the following:²

$$\text{Eff.} = \frac{\pi \mu E_g R_L}{4 E_b (R_L + 2 R_p)} \dots \dots \dots (4)$$

In most transmitters E_b and R_p are already determined, leaving E_g and R_L as the only independent variables. An examination of this relation shows that the efficiency of the amplifier is linear with respect to the impressed alternating-current grid voltage. This is true only, however, up to the saturation point; i.e., that point where the maximum grid voltage equals the minimum plate voltage. Beyond this point the amplifier is no longer linear, and, therefore, this is a limit to the value of the a-c grid voltage which can be applied during modulation. From this fact the proper amount of excitation at carrier level may be determined by reducing the value of the excitation voltage at saturation by one-half.

The other variable which can be varied during the process of tuning is R_L . If an attempt is made to maximize equation (4) with respect to R_L the result shows that the efficiency increases with the value of R_L . This does not, however, give maximum output, for as R_L increases the input decreases, and the total result is a reduction in the output. The input must, therefore, remain constant as the efficiency is maximized with respect to R_L . This can be done by expressing the input explicitly in the equation for efficiency as follows:

$$\text{Eff.} = \frac{\pi \mu E_g R_L I_b}{4 E_b I_b (R_L + 2 R_p)} \dots \dots \dots (5)$$

Since $I_b = \frac{2 I_1}{\pi} \dots \dots \dots (6)$

(Continued on page 48)

²W. L. Everitt—"Optimum Operating Conditions for Class B Radio-Frequency Amplifiers"—*Proceedings of the I.R.E.*—February, 1936.

See H. M. Miller.

A SIMPLIFIED THEORY

By HOMER DUDLEY

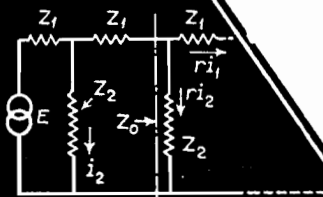

Fig. 1

UNIFORM LUMPED LINE
(LADDER STRUCTURE)

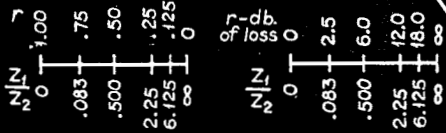

Fig. 2

LOSS WITHOUT PHASE SHIFT

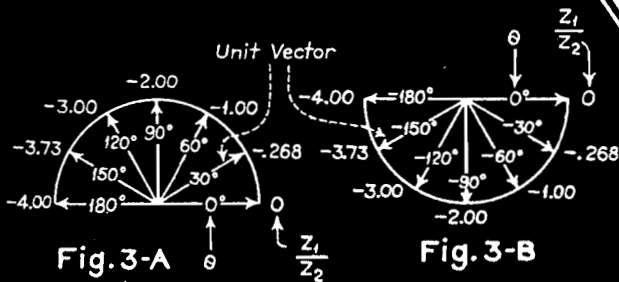
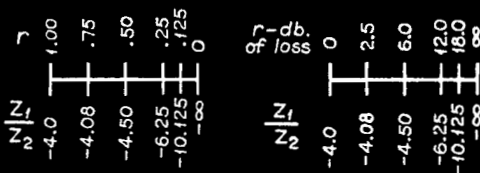

Fig. 3-A

Fig. 3-B

PHASE SHIFT WITH ZERO LOSS.

VALUES OF r vs. $\frac{Z_1}{Z_2}$



LOSS WITH PHASE REVERSAL

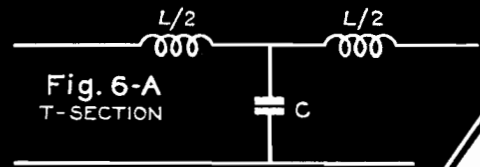

Fig. 6-A
T-SECTION

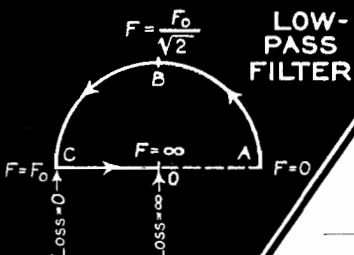

Fig. 6-B

CURRENT RATIO r

ALTHOUGH the literature on filters is extensive, most of the material involves the use of exponential and hyperbolic functions. This mathematics is used to stress the analogy between filters and transmission lines. It also makes for completeness and compactness so that the filter designer can proceed very efficiently when he has the proper mathematical tables at hand.

Such theory, however, contains formulae too difficult for one to visualize readily unless he is quite familiar with these mathematical functions and so it does not give a simple physical picture of the basic filter selectivity*. To give such a picture there is presented herewith an elementary version of filter theory with the use of the simplest possible mathematics to cover the ground gone over. The formulae obtained, while given simpler form, are basically the same as those obtained in such a standard reference work as K. S. Johnson's book "Transmission Circuits for Telephonic Communication."

Consider the general case of a uniform lumped line of series impedance Z_1 and shunt impedance Z_2 as in Fig. 1, starting at the left and extending indefinitely to the right.

Let there be a sinusoidal voltage $E = E_{max} \sin pt$ applied as shown at the left. Currents will flow in all branches. Call the series branch current after the first branch point i_1 and the shunt branch current i_2 .

Next we note that these currents will be reduced from branch point to branch point by the same factor since the line to the right is indefinitely long. Call this factor r . (Note that $-\log r$ is the propagation constant.) With real impedances some dissipation takes place so that the magnitude of r cannot exceed unity but may be anything from 0 up to 1, as the

limit for zero dissipation. The phase of r may be anything from -180° through zero up to $+180^\circ$. The series and shunt branch currents out of the second branch point will be ri_1 and ri_2 respectively. Those out of the third branch point will be r^2i_1 and r^2i_2 and so on down the line.

Next we write the voltage equation for the first complete mesh shown.

$$Z_1 i_1 = (1 - r) Z_2 i_2 \dots \dots \dots (1)$$

Similarly the current equation for the second branch point is written,

$$i_1 = ri_1 + ri_2 \text{ or } i_1 = \frac{ri_2}{1 - r} \dots \dots (2)$$

These two independent equations can be solved for the current ratio r and also for any desired impedances. Thus the impedance of the infinite line to the right as seen from a full shunt termination is given by

$$Z_o = \frac{r_2 Z_2}{i_1} = (1 - r) Z_2 \dots \dots \dots (3)$$

(See Fig. 1.)

The desired formula for r is obtained by eliminating i_1 and i_2 from the voltage and current equations (1) and (2). Doing this gives

$$\frac{(1 - r)^2}{r} = \frac{Z_1}{Z_2} \dots \dots \dots (4)$$

This equation is amazing for its simplicity. Thus each Z appears only once, that to the first power and even then the two Z 's are combined in a single ratio. Yet this simple relation unfolds a complete picture of filtering action. All that remains is to show equation (4) as a graph for various filter conditions.

In ideal filters Z_1 and Z_2 are both pure reactances so that the ratio $\frac{Z_1}{Z_2}$

is a real number in the range from $-\infty$ to $+\infty$. The corresponding values of r are readily found by inspection of (4) and lie in three ranges thus:

*Mention should be made of G. A. Campbell's paper, "Physical Theory of the Electric Wave Filter," *Bell Syst. Tech. J.*, Vol. 1, No. 2, page 1, which gives an analysis that is non-mathematical but not elementary and to T. E. Shea's book, "Transmission Networks and Wave Filters," pp. 209-20, showing a number of graphical representations similar to those given here but with more detail and with allowance for terminal impedances.

OF FILTER SELECTIVITY

BELL TELEPHONE LABS.

Range A, for $\frac{Z_1}{Z_2}$ positive, $+\infty$ to 0,

r goes from 0 to $+1$. This is the case of *loss without phase shift*. It is shown graphically in Fig. 2 with r as a fraction and the same points in db of loss.

Range B, for $\frac{Z_1}{Z_2}$ between -4 and 0,

r has a fixed magnitude of unity but changes in phase from $\pm 180^\circ$ to 0° . This is the case of *phase shift without loss*. The corresponding polar diagram is shown in Fig. 3-A for positive values of θ . Negative values give a downward semi-circle instead of the upward one as shown in Fig. 3-B.

The explanation for this peculiar action of r in changing phase while keeping a constant amplitude is made clearer by rewriting equation (4) thus

$$\frac{Z_1}{Z_2} = \left\{ \frac{1}{\sqrt{r}} - \sqrt{r} \right\}^2$$

For the range of r in question $r = 1/\theta$ so that

$$\frac{Z_1}{Z_2} = \left\{ \frac{1}{1/\theta/2} - \frac{1/\theta/2}{1/\theta/2} \right\}^2 = \left\{ \frac{1-\theta/2}{1/\theta/2} - \frac{1/\theta/2}{1/\theta/2} \right\}^2$$

This can readily be pictured in polar coordinates as in Fig. 4 which shows graphically $1-\theta/2$, $1/\theta/2$, the difference and the difference squared.

For any value of θ from 0 to $+180^\circ$ the value of $1-\theta/2 - 1/\theta/2$ will be a negative imaginary number starting with magnitude 0 for $\theta=0$ and becoming 2 for $\theta=180^\circ$. Squaring this

gives the corresponding values of $\frac{Z_1}{Z_2}$ starting at 0 and going to -4 , always negative and real.

Similarly with negative phase angles for θ values of $1-\theta/2 - 1/\theta/2$ are positive and imaginary starting with magnitude 0 for $\theta=0$ and becoming

2 for $\theta = -180^\circ$ leading to the same $\frac{Z_1}{Z_2}$ range from 0 to -4 .

Range C, for $\frac{Z_1}{Z_2}$ between $-\infty$ and -4 , r goes from -1 to 0. This is the case of *loss with phase reversal* and is shown in Fig. 5.

These are the three basic types of propagation characteristic to be found in filters. They may be combined in various ways and in various amounts to get the specific filter characteristic desired.

The preceding discussion covers completely in a general way the attenuation and phase relations existing in filters built as uniform ladder structures. A common filter form has a T or π network for a section and a repetition of these make up a ladder structure so they are covered here. Furthermore if some other type of network such as a lattice is used then an equivalent T network can be found. To this extent such types are covered.

As a final step polar diagrams of r will be drawn for the simple T-type sections of low, high, band-pass, and of band-elimination filters.

A. *Low-Pass Filter*. The network and polar diagram of current ratio r for the low-pass filter are shown in Fig. 6. Here $\frac{Z_1}{Z_2}$ is negative at all frequencies so there is no OA attenuation range as in the more general case. Point A corresponds to 0 frequency and the arrows represent increasing frequency. The current lags (a positive angle shows lag in these diagrams) as we proceed from section to section away from the starting point. At 180° is the cut-off frequency F_0 . For frequencies above this the loss increases to become infinite at infinite frequency. The impedance ratio

$$\frac{Z_1}{Z_2} \text{ becomes } \frac{j\omega L}{1 - \omega^2 LC} \text{ With subscript 0 at the cut-off}$$

(Continued on page 42)

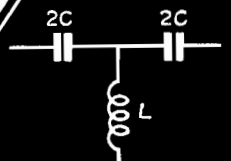

Fig. 7-A
T-SECTION

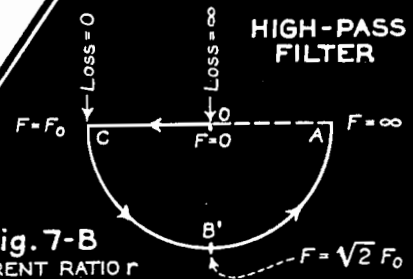

Fig. 7-B
CURRENT RATIO r

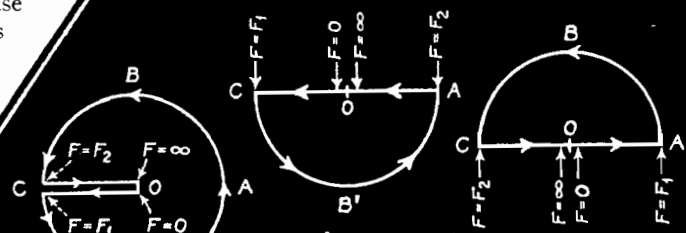

Fig. 8
Fig. 9
CURRENT RATIO DIAGRAMS FOR SEVERAL BAND-PASS FILTERS

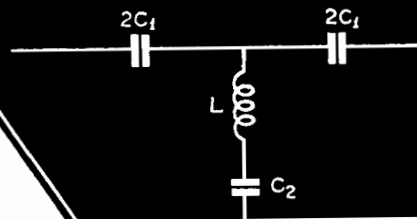

Fig. 11-A
T-SECTION
BAND-PASS FILTER

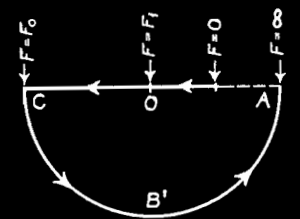

Fig. 11-B
CURRENT RATIO r

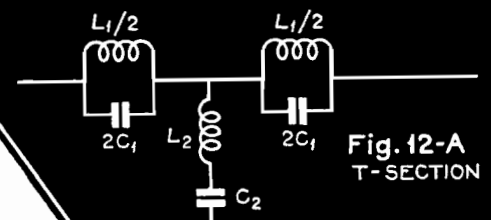

Fig. 12-A
T-SECTION

LOW-HIGH
PASS
FILTER

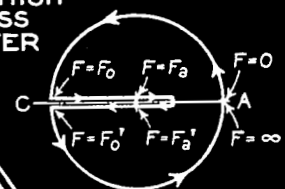

Fig. 12-B
CURRENT RATIO
DIAGRAM

PROGRAM OF ROCHESTER FALL MEETING

APPROXIMATELY nineteen papers will be delivered during the three days of the 1937 Rochester Fall Meeting of the Institute of Radio Engineers and the Engineering Division of the Radio Manufacturers Association, at the Sagamore Hotel, Rochester, N. Y. They will represent to a large extent a gauge of the progress made during the past year in radio and allied research.

A complete listing of the technical papers, with their time of delivery, will be found on the following page. This list includes many subjects of particular interest in respect to television and receiver design as well as standardization.

Last year at the Rochester meeting, A. F. Murray reported on the ten recommended standards then adopted by the RMA Television Committee. At the 1937 gathering he will report briefly on the new standards added to the list, on the trend of standardization, and, if the information is available, on the frequency channels recently set aside by the U. S. Government for experimental television.

In presenting his paper on television synchronization, F. J. Bingley will consider the problems of synchronization in a 441-line interlaced cathode-ray television system. The real test of a synchronizing system is the ability to maintain perfect interlacing at the receiver. The received synchronizing impulses must provide good synchronization of the horizontal deflecting circuits and give perfect interlacing and vertical synchronization which does not fail. Mr. Bingley will discuss the causes for imperfect interlacing and the several requirements which must be fulfilled by the transmitted synchronizing signals. He will also give a comparison of the various synchronizing systems used in the U.S.A. and abroad.

The method of color specification of cathode-ray tubes adopted by the International Commission on Illumination in 1931 will receive attention. R. M. Bowie and G. A. Fink will describe three general methods of obtaining data and will discuss the advantages and disadvantages of each.

In his paper "Figure of Merit for Television Performance," A. V. Bedford will trace the evolution of a sectionalized test chart for measuring resolution, halftones and deformation of television images. Vertical resolution and horizontal resolution are measured in each of twelve sections of the screen and a formula for converting these readings into an over-all resolution figure of merit is given. The figure obtained is equivalent to the total number of black and white dots which could be put in a scene to be transmitted, with random location relative to the position of the scanning lines, and which could

all be separately identified and located in the received picture. The figure of merit may be used as a specification of performance or as a check on developmental progress.

Of special interest will be C. E. Burnett's description of the "Monoscope," a developmental type of tube designed to produce a video signal of the test picture or pattern enclosed in the tube. The high-quality video signal which can be obtained from the Monoscope makes it particularly useful for testing the various units of a television system. Some of these uses are testing studio circuits, receiver circuits, and cathode-ray tubes for television reception.

According to Wm. N. Parker, it is well known that present-day high-definition television requires modulating frequencies from 0 to above 3 mc, so that tube capacities and other difficulties make the handling of such a wide frequency range difficult when using well-known methods of plate or grid modulation. Also, the attenuation of very broad sidebands, when passed through resonant circuits, is serious. To overcome these difficulties Mr. Parker has developed a form of modulation known as "transmission-line modulation." He places the modulator at the end of a $\frac{1}{4}$ -wave transmission line connected at the proper place, to the transmission line connecting the antenna to the power oscillator. This installation is capable of 80% modulation up to 4 mc, and with good plate efficiency.

In the paper entitled "Negative Ion Components of the Cathode Ray," C. H. Bachman and C. W. Carnahan will discuss, in general terms, the presence and detection of negative ions in the beam of a high-vacuum cathode-ray tube. Mass spectrographic analysis has been applied to separate the negative ion components. Their probable sources and effect on the screen will be discussed.

In "Space Charge Limitation on the Focus of Electron Beams," L. B. Headrick and B. J. Thompson will consider the equations for the envelop of electron beams having either rectangular or circular cross section. An idealized focusing field will be assumed in that the initial perpendicular or radial component of electron velocity is assumed to be proportional to the distance of the electrons from the beam axis. The electrostatic force of the electron space charge is the only force considered to oppose the formation of a line or point focus on the beam axis at some distance from the focusing field. The electron density over any cross section of the electron beam is considered to be constant. The axial velocity of beam is assumed to be homogeneous. For the rectangular beam, two cases will be

considered: (1) the electron beam in a field-free space, (2) the electron beam accelerated by a uniform axial potential gradient. The circular beam is assumed to be in a field-free space. The relations between the variables beam current density, voltage, initial angle and the distance between focusing field and the focal point will be shown by curves. In cathode-ray tubes made at present for television and oscillographic purposes, the space-charge limitation on the focus is not of great importance because other factors contribute largely to the spot size. However, as improvements are made in electron focusing systems, the space-charge limitation may account for a large portion of the spot size. Results show that for a circular beam having a given current, voltage, and initial angle, there is a resultant minimum beam diameter at the focal point which can not be reduced by changing the radial component of the focusing field. The value of the minimum beam diameter is nowhere zero and increases rapidly with distance between the focusing field and the focal point. In contrast, for a rectangular beam with one dimension infinite, the minimum beam width depends upon the perpendicular component of velocity supplied by the focusing field. The beam width may be zero up to a given distance from focusing field and beyond this distance the minimum beam width increases with distance from the focusing field.

Also of interest will be the paper presented by J. B. Sherman, describing a method of automatically obtaining frequency-response characteristics of audio apparatus on the screen of a long persistence cathode-ray tube, without mechanical equipment.

D. B. Sinclair's paper, entitled "Parallel Resonance Methods for Measurement of High Impedances at High Frequencies," may be summarized as follows: The use of the ordinary series-resonance methods enables one to measure the effective resistance of a series tuned circuit. The use of parallel-resonance methods enables one to measure the effective conductance of a parallel tuned circuit with equal ease. The duality existing between series and parallel tuned circuits is pointed out and measuring methods described which are the duals of the usual reactance-variation and resistance-variation methods. By analogy these parallel-resonance methods have been named the "susceptance-variation" and "conductance variation" methods. Errors caused by strong coupling to the high-frequency source and by residual parameters inherent in the standard condenser and circuit wiring are discussed for both series and parallel-resonance systems.

A comparison of the ranges, precision and accuracy of the two categories is given. Experimental results are presented for the susceptance-variation method at broadcast frequencies. It is shown that accuracies within 0.25% are obtainable when care is taken with the experimental procedure.

MONDAY, NOVEMBER 8

- 9:00 A.M.—Registration.
- 10:00 A.M.—Technical Session.
Parallel Resonance Methods for Measurement of High Impedances at High Frequencies, by D. B. SINCLAIR, General Radio Company.
- Report of RMA Television Transmission Frequencies and Standards*, by A. F. MURRAY, Philco Radio & Television Corp.
- Vibrational Tube Analysis*, by A. B. OXLEY, RCA Victor Company, Limited.
- 12:30 P.M.—Group Luncheon.
- 2:00 P.M.—Technical Session.
The Problem of Synchronization in Cathode-Ray Television, by F. J. BINGLEY, Philco Radio & Television Corp.
- New High-Efficiency Modulation System*, by R. B. DOME, General Electric Company.
- 4:00 P.M.—Inspection of Exhibits.
RMA Committee Meetings.
- 6:30 P.M.—Group Dinner.
- 7:45 P.M.—Technical Session.

Specification of Screen Color of Cathode-Ray Tubes, by G. A. FINK and R. M. BOWIE, Hygrade Sylvania Corporation.

Figure of Merit for Television Performance, by A. V. BEDFORD, RCA Mfg. Co., Victor Division.

TUESDAY, NOVEMBER 9

- 9:00 A.M.—Registration.
Exhibits Open.
- 9:30 A.M.—Technical Session.
Direct-Viewing Type Cathode-Ray Tube for Large Television Images, by I. G. MALOFF, RCA Mfg. Co., Victor Division.
- Stabilization of Oscillators*, by C. E. GRANQVIST, Stockholm, Sweden.
- A Unique Method of Modulation for High-Fidelity Television Transmitters*, By WILLIAM N. PARKER, Philco Radio & Television Corp.
- 12:30 P.M.—Group Luncheon.
- 2:00 P.M.—Technical Session.
New Projects of the RMA Engineering Division by L. C. F. HORLE, RMA Engineering Division.
- Measurement of Characteristics of Automobile Antennas*, by H. LYMAN, Philco Radio & Television Corp.
- Discussion by H. C. FORBES, Colonial Radio Corp., and D. E. FOSTER, RCA License Laboratory.
- 2:00 P.M.—Physicists' Session.
Space-Charge Limitation on the Focus of Electron Beams, by B. J. THOMPSON

and L. B. HEADRICK, RCA Mfg. Co., Radiotron Division.

Negative Ion Components of the Cathode Ray, by C. H. BACHMAN and C. W. CARNAHAN, Hygrade Sylvania Corporation.

- 4:00 P.M.—Inspection of Exhibits.
RMA Committee Meetings.
- 6:30 P.M.—Stag Banquet.

WEDNESDAY, NOVEMBER 10

- 9:00 A.M.—Exhibits Open.
- 9:30 A.M.—Technical Session.
The Monoscope, by C. E. BURNETT, RCA Mfg. Co., Radiotron Division.
- Further Data on Inverse-Feedback Amplifiers*, by C. B. FISHER, Northern Electric Company.
- Teledynamic Control by Selective Ionization and the Application to Radio Receivers*, by S. W. SEELEY, H. B. DEAL, and C. W. KIMBALL, RCA License Laboratory.
- 12:30 P.M.—Group Luncheon.
- 2:00 P.M.—Technical Session.
Stability of Wide-Band Amplifiers, by E. H. B. BARTELINK, General Electric Company.
- An Audio Curve Tracer*, by J. B. SHERMAN, RCA Mfg. Co., Radiotron Division.
- 4:00 P.M.—Exhibits Close.
RMA Committee Meetings.

THE VOLTAGE GAIN GUIDE*

(See page 16)

THE VOLTAGE GAIN GUIDE is a tabulation of gain values based upon performance of available voltage amplifier tubes and the corresponding operating conditions with which these gain values may be secured. It serves as a companion chart to the power guide¹ for use in the selection of possible tube complements in the design of audio amplifiers.

The gain guide is arranged according to the magnitude of the specified gain. Each value of gain is accompanied by the tube types, operating conditions and circuit constants by which it may be obtained. Where more than one type of tube is listed as giving the same gain they are arranged in the order of the maximum output voltage obtainable. Any tubes which are electrically equivalent to those listed may be considered as having the same gain characteristics under identical conditions.

The maximum signal voltage is expressed in peak volts and not as rms values. An increase in distortion may be expected if these values are exceeded. The signal voltage differs from the bias value because allowance should be made for the effect of contact potential; in some cases the curvature of the dynamic characteristic curves limits the permissible grid-voltage swing. The maximum output voltage is the rms value of the a-c component of the plate voltage when the peak signal is applied.

For plate supply voltages other than those specified in the table, the output voltage and peak signal may be considered as varying in the same ratio as that of the new plate-supply voltage to the voltage listed. This applies only for self-biased operation with the same circuit constants, and for plate-supply voltage changes of not more than fifty percent.

The stage gain for plate resistors other than those given may be obtained approximately by use of the following equation:

$$VG_2 = VG_1 \frac{R_2 (R_p + R_1)}{R_1 (R_p + R_2)}$$

Where: VG_2 = Voltage gain with new plate load resistor

VG_1 = Voltage gain given in chart

R_2 = New plate load resistor

R_1 = Plate load resistor given in chart

R_p = Plate resistance of tube as given by tube manual or characteristic chart

The optimum bias, peak signal, output voltage, bias resistor and plate current as shown in the gain guide do not apply to the new condition if a change in plate load resistor is made to obtain a different gain.

The grid load resistor of the following tube should not exceed the recommended maximum value for that tube. Neither should it be less than twice the value of plate load resistor listed in this gain chart if serious distortion is to be avoided.

*Material prepared by Engineering Department, Hygrade Sylvania Corporation.

¹"Power Guide Chart," *Radio Engineering*, August, 1937, p. 19.

VOLTAGE GAIN GUIDE

(See page 15)

GAIN DB	VOLTAGE GAIN	MAX. OUTPUT VOLTS RMS	TUBE TYPE	PLATE LOAD RESISTOR OHMS	PLATE SUPPLY VOLTS	SCREEN GRID VOLTS	SELF BIAS RESISTOR OHMS	GRID BIAS VOLTS	PLATE CURRENT MA. APPROX.	PEAK SIGNAL VOLTS
16	6	5	1H4G	50,000	45			1.5	0.3	1.2
	6	10	37	50,000	100		2,700	3.0	1.1	2.4
	7	8	1H4G	50,000	67.5			2.0	0.5	1.7
	7	17	1H4G	50,000	100			3.8	0.8	3.5
	7	36	37	50,000	250		2,800	8.0	2.9	7.2
20	7	21	1H4G	50,000	180			5.0	1.8	4.2
	9	24	6J7G*	50,000	250		1,800	4.5	2.5	3.7
	10	6	76	50,000	67.5		2,500	1.4	0.6	0.9
	10	13	76	50,000	100		2,300	2.5	1.1	1.9
	11	13	6R7G	50,000	100		2,100	2.3	1.1	1.7
22	11	44	6R7G	50,000	250		2,700	6.5	2.4	5.7
	11	44	76	50,000	250		2,500	6.5	2.6	5.7
	13	4	6C5G	50,000	45		2,700	1.0	0.4	0.4
	13	9	6C5G	50,000	67.5		4,100	1.6	0.4	1.0
	13	16	6C5G	50,000	100		2,500	2.3	0.9	1.7
26	13	16	6J5G	30,000	100		1,500	2.3	1.5	1.7
	13	16	1H6G	200,000	135			2.3	0.2	1.7
	13	43	6C5G	50,000	250		2,300	5.5	2.4	4.7
	14	2	6J5G	30,000	45		1,100	0.8	0.7	0.2
	15	6	6J5G	30,000	67.5		1,200	1.2	1.0	0.6
	15	50	6J5G	50,000	250		2,300	5.5	2.4	4.7
	21	9	105GP	100,000	67.5	22.5		0.8	0.3	0.6
	21	13	6N7G ⁰	100,000	100		1,900	1.5	0.4	0.9
	24	17	105GP	100,000	100	45		3.0	0.6	1.0
	25	35	6N7G ⁰	100,000	250		1,200	2.8	1.2	2.0
30	27	10	1E5G	100,000	100	22.5		0.8	0.3	0.5
	27	38	6N7G ⁰	250,000	250		2,300	2.8	0.6	2.0
	27	48	105GP	250,000	180	45		3.5	0.4	2.5
	28	6	1E5G	100,000	67.5	22.5		0.5	0.3	0.3
	31	13	1F7G	100,000	180	45		1.4	0.7	0.6
	34	12	6K5G	100,000	100		3,000	1.1	0.4	0.5
	35	10	6Q7G	100,000	100		2,800	1.0	0.4	0.4
	38	27	105GP	100,000	180	45		2.0	1.0	1.0
	39	14	6K5G	250,000	100		5,200	1.1	0.2	0.5
	40	11	6Q7G	250,000	100		5,000	1.0	0.2	0.4
32	40	17	1E5G	250,000	180	45		2.0	0.7	0.6
	42	18	1E5G	100,000	180	45		1.5	1.0	0.6
	42	24	6Q7G	100,000	250		1,500	1.6	1.0	0.8
	43	9	6F5G	100,000	100		2,900	0.9	0.3	0.3
	45	19	1F7G	250,000	180	45		2.0	0.5	0.6
33	45	26	6K5G	100,000	250		1,500	1.6	1.1	0.8
	46	26	6Q7G	250,000	250		2,900	1.6	0.6	0.8
	48	27	6K5G	250,000	250		2,800	1.6	0.6	0.8
	52	22	6F5G	100,000	250		1,700	1.4	0.8	0.6
	53	11	6F5G	250,000	100		5,000	0.9	0.2	0.3
36	63	27	6F5G	250,000	250		3,000	1.4	0.5	0.6
	85	42	6J7G	100,000	250	50	1,100	1.3	1.2	0.7
42	125	44	6J7G	250,000	250	50	2,400	1.7	0.7	0.5

* TRIODE CONNECTION

⁰ ALL DATA EXCEPT FOR SELF BIAS RESISTOR IS FOR EACH SECTION SEPARATELY.

DISC RECORDING

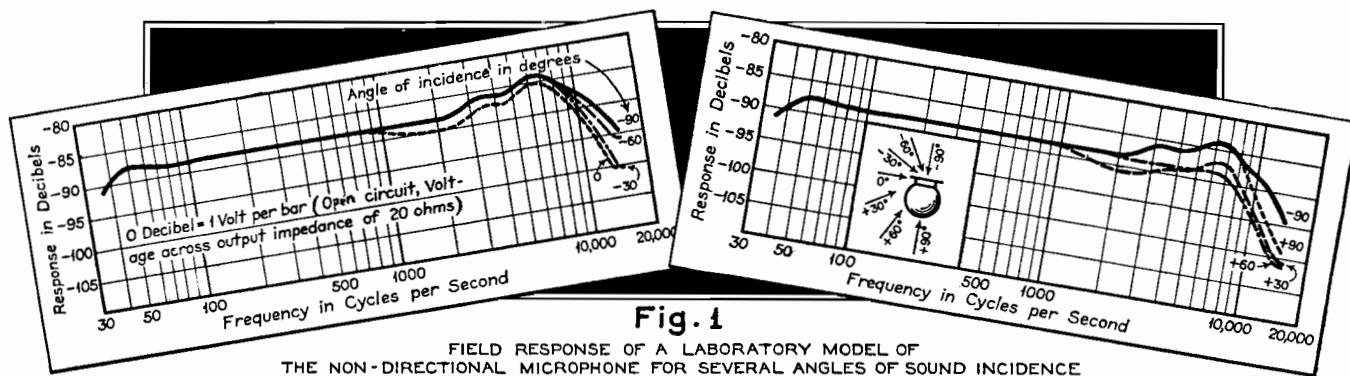

FIELD RESPONSE OF A LABORATORY MODEL OF THE NON-DIRECTIONAL MICROPHONE FOR SEVERAL ANGLES OF SOUND INCIDENCE

Equipment and Its Quality Requirements

By T. L. DOWEY

THE MICROPHONE and amplifier equipment used in transcription recording is closely akin to that used in other high-grade recording work. One of the more recent types of microphone is the Western Electric 630, a dynamic transmitter which is housed in a small spherical casing to overcome diffraction effects and is provided with an acoustic screen in front of the diaphragm to render it non-directional.¹ Fig 1, taken from the article cited, shows its frequency response characteristics with sound coming from various angles of incidence.

Preliminary amplifiers raise the signal coming from the microphone to about zero level at the bridging bus. In one typical transcription recording installation at the present time, this bus may also receive input from wire lines, from disc reproducing machines in the process of re-recording or dubbing, and from a radio receiving set when it is desired to make a record of a program as it is broadcast. Switching facilities are provided, permitting any desired interconnection of studios, amplifier channels, and recorders. A monitoring loudspeaker is provided above each recording machine, with a switch by means of which it may be connected to the studio channel on which the record is being made. Each studio monitoring room also has a monitoring system with high- and low-frequency speakers in a baffle. The various monitors are operated through amplifiers from the bridging bus of each channel. There is also an announcing system which provides communication between each monitoring room and the stage and recording room.

THE RECORDING MACHINE

The recording machine² (Fig. 2) must, of course, be designed primarily with a view to rotating the record at an extremely constant speed. The requirements in this connection are determined for low-frequency changes by the smallest change in pitch the ear will notice when cyclic pitch variation is continuous. It is,

¹A complete description of this microphone is given in the article "A Non-directional Microphone," by Marshall and Romanow, *Bell System Technical Journal*, July, 1936.

²"Machine for Cutting Master Disc Records," by L. A. Elmer and D. G. Blattner—*Trans. Soc. Motion Picture Eng.*, May, 1929.

furthermore, an overall requirement, for it applies to differences between the original and reproduced sound; since both a recording and a reproducing machine intervene between the sounds, variations in the speeds of the two machines are likely to be additive in their effects upon sound pitch, and the sum of the permissible variations must, therefore, not exceed the total permissible variation for the system as a whole. Since the stricter the requirements for constancy of speed the more expensive the machine becomes, and there are comparatively few recorders as compared with the number of reproducers, it is evidently economical to place the severest requirements on the recording machine and to be more lenient with the reproducing equipment. An economical division of the total error between the two machines is probably in the ratio of about 1 to 4. The demand for constancy thus placed upon the recording machine is far higher than can be met by gears and bearings of even the most careful construction, and can be filled only by special means.

Even were it possible to connect the motor directly to the turntable, casual variations in the speed would arise, from varying frictional loads on the turntable and bearings. However, direct connection is unsatisfactory, because the turntable must operate at a lower speed than the motor, and reducing gears must, therefore, intervene. In the actual apparatus the motor drives (through a horizontal coupling) a worm engaging a worm wheel which drives (through a vertical coupling) the shaft to which the turntable is attached.

It is cyclic speed-change that must be guarded against in this mechanism; all such changes with frequencies from about one-half cycle per second up to the higher limit of audibility are to be avoided. Speed changes at audible frequencies introduce extraneous sounds into the records, and speed changes at frequencies below the audible range produce changes in pitch. There are in general two points of origin for these variations: the turntable and its bearings, and the gears. Speed-changing variations in the load on the turntable and bearings are most likely to have the frequency of the

rotation of the turntable (a little more than one-half cycle per second). From the gears three sorts of variation arise—those accountable to inaccuracies in the spacing of the teeth, to errors in the shape of the teeth, and to the successive shifts of load from tooth to tooth.

The fact that a continuous, slightly varying motion of this sort is mechanically analogous to a slightly varying electric current, indicates of course that the solution of the problem lies in the application of electrical filter principles to the mechanical analogies which may be found in the recording machine in the form of masses, springs, and dissipative mediums, such as oil.

A mechanical filter designed by the Bell Laboratories in accordance with these principles is incorporated in the Western Electric Company's commercial disc-recording apparatus. It uses coil-springs as its capacitances, viscous oil for its resistances, and the masses of its moving part as its inductances. The great width of the frequency band to be attenuated, and the number of sources of variation, considerably complicate the problem of determining what values of stiffness, weight, and dissipating ability should be used. For example, variations due to gear inaccuracies are most readily absorbed by very flexible springs, whereas disturbances due to varying loads are best prevented from affecting turntable speed by the use of stiff springs. The filter finally designed embodies a compromise between these conflicting demands. Its general construction is such that the worm-driven gear drives the turntable shaft through the linearly flexible springs, and relative motion of the gear and shaft is damped by the oil.

Irregularities in the shape and spacing of the gear teeth are averaged out by a multiple layer construction of the gear and by having these gear elements drive the turntable through a coupling linkage.

Because the deflections with which this apparatus is expected to operate are very small, it is essential that no motion be lost by "backlash" in pivots. For this reason, and to minimize pivotal friction, flat reed-springs are used for all joints.

Of the velocity variations from the two major sources of error—that is, from varying load at one cycle per

revolution and from varying gear-tooth spacing, at 4 cycles per revolution—the former has been reduced to 0.04% and the latter to a point below the limit of measurement.

It does not seem necessary to dwell at length on the other features and accessories of the recording machine, as they have been more or less standard items for many years. They include the carriage on which the recorder is mounted and which is moved across the record by means of a lead screw; gear shifts for varying the groove spacing and determining whether the cut is to be outwards or inwards across the wax; coarse feed cams for moving the carriage faster than normal when cutting the starting spiral; wax suction apparatus; and an air gun supplied with filtered air or nitrogen for pressure cleaning the wax, just before recording, to remove dust and foreign matter from the surface.

ADVANTAGES OF VERTICAL RECORDING

While vertical movement of the recording stylus was employed 60 years ago by Edison, its modern application has taken place in the past decade.³ Among the advantages accruing from the adoption of the vertical principle are the following:

(1) In extending the frequency range in recording and reproducing, one desideratum is the reduction of the mass of the vibratory system of the reproducer; that is, its mechanical impedance. As a matter of practical design, this was found easier with the vertical type.

(2) Reduction of the mechanical impedance of the reproducer is also desirable as a means of increasing record life. This strengthens the considerations mentioned in the previous paragraph.

(3) It has been found that the reproducing stylus point follows a vertically modulated groove better than a lateral one, resulting in superior high-frequency reproduction in the former case.

(4) Vertical modulation makes it possible to use much closer groove spacings, and hence to greatly increase record playing time.

(5) It was realized that if a consistent all-round improvement was to be made in disc recording, the materials and processing must also be studied. Amongst other innovations which will be described later, this led to the adoption of non-abrasive records. This, in turn calls for a permanently shaped stylus point, which it was found could be provided with less difficulty in the case of vertical modulation.

RECORDERS AND SYSTEM CHARACTERISTICS

While the recorders themselves may be of a type designed for vertical recording only, highly satisfactory results have been obtained by the use of recorders in which a simple mechanical linkage is used to convert the motion of the stylus point from lateral to vertical.

No fundamentally new problem is involved in adapting a lateral recorder for vertical modulation, since with either system the desirable characteristics are about the same. One type of vertical recorder now used approximates constant amplitude characteristics for the lower frequency range from 50 to 300 cycles and constant velocity for the higher range from 300 cycles to the upper cut-off, which is about 9,000 cycles. (In the present instance "cut-off" it taken to be the point at which the response has fallen by 5 db.) In terms of relative

³"Vertical Sound Records" by H. A. Frederick, *Journal of the Society of Motion Picture Engineers*, February, 1932; "Vertically Cut Sound Records," by H. A. Frederick and H. C. Harrison, *Transactions of the A. I. E. E.*, December, 1932.

Fig. 2. The recording machine described in the accompanying text.

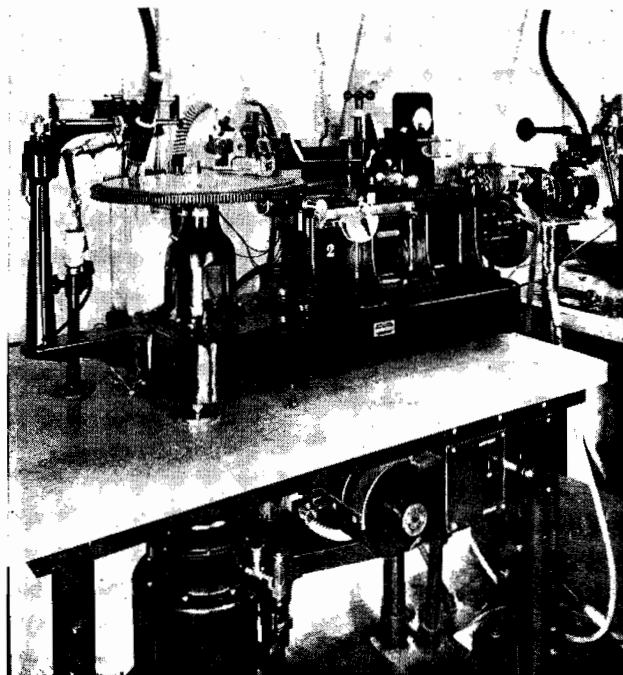

velocity of the stylus the recorders may be said to droop 6 db per octave below 300 cycles (Fig. 3). This arrangement has the advantage of allowing a higher signal-to-noise ratio than would be possible if the response were constant-velocity at all frequencies. It also reduces the danger of cutover at low frequencies of high amplitude. At the same time, uniform response at all frequencies requires that the reproducer (or some part of the reproducing circuit) have a corresponding increase of 6 db per octave below 300 cycles. As the vertical cut reproducer has a very uniform response, it is necessary to provide the low-frequency compensation by means of an electrical equalizer.

It is customary to apply relatively high levels at high frequencies in making vertical-cut records, and to include a corresponding reduction in the reproducing equipment. The result is a flat overall response with a considerable reduction in noise. This is made possible by favorable average amplitude-frequency distribution of speech or music and of surface noise, since most surface-noise energy is at the higher frequencies, whereas peak amplitudes of speech and music decrease above about 500 cycles. A relative increase in the recorded amplitude of the high frequencies, therefore, does not necessitate appreciably reducing the maximum recording level, and a greater signal level can be effectively recorded.

Since the pre-equalizer for obtaining this high-frequency boost in recorded level causes a loss of 18 db at frequencies up to 2,000 cycles, it is most economical from a signal power standpoint to insert it at a point of low level in the system. But since the monitoring circuit branches off after this point, it is necessary to add a post-equalizer in this latter branch in order that the monitoring be representative of normal reproduction. However, in re-recording from one vertical-cut disc to another, it is not necessary to apply post-equalization to the disc reproducer and then pre-equalize again for the recorder. Since these two elements are exactly conjugate, the two together have no effect and may be eliminated.

The recorder is calibrated to work from a 500-ohm resistance circuit and will not give the rated response when operated from any other source. On account of the relatively high inductance of the speech coils of the recorder, its impedance varies considerably with frequency. Consequently, a disc recorder should not be bridged across any other circuit unless the recorder is preceded by an amplifier, since otherwise its variable impedance would affect the frequency response of the other circuit. While it is possible to alter the frequency response of a recorder by operating it from an impedance other than 500 ohms resistance, this method of control is not recommended.

Although the single-frequency overload (at 300 cycles) of a Western Electric disc recorder is about 21 db above 0.006 watt input to the recorder, the maximum safe level for speech or music is about + 8 to + 10 db for a lateral recorder and + 10 to + 12 db for a vertical recorder. These figures also depend on depth of cut and groove spacing as well as the type of sound being recorded. Heavy bass passages, such as drums, may limit the maximum level appreciably, while sound lacking in low frequencies may be recorded at a comparatively high level. Similarly, sound from a "live" room gives greater loudness for a particular maximum level on the record than sound from a "dead" room. From the standpoint of relative signal-to-noise level, each record should be made with as high a level as possible. However, since it is usually desirable to play all records at the same reproducer gain setting, it is best to record only the loud-

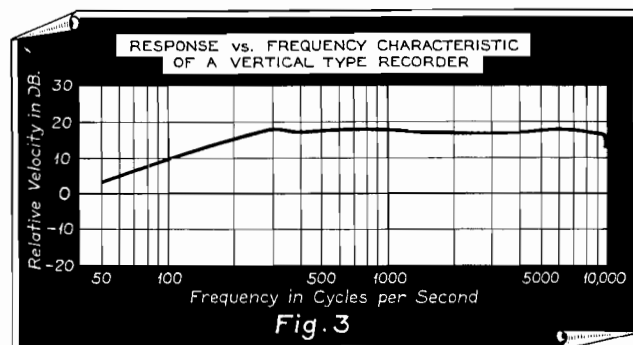

The frequency-response characteristic of a vertical recorder.

est records at maximum level and the others proportionately lower.

For constant amplitude modulation of the sound track groove, the minimum radius of curvature of the groove decreases inversely as the square of the frequency. At very high levels and frequencies, particularly with vertical-cut recording in which pre-equalization is used, it may become comparable with the stylus radius. If so, an appreciable distortion is produced due to inability of the stylus to track properly.

THE MOTOR SYSTEM

No matter how carefully the recording machine may be constructed to avoid contributing velocity variations on its own account, as already described, it is also necessary to insure that it be driven at a highly constant speed if undesirable effects are to be avoided in the record. In order to properly take care of this requirement, the speed regulation or change in speed of the motor-driving system for normal line voltage and load variation must be held within very close limits, and the absolute speed must also be held within 1/2 of 1%, since at the end of a recording it is necessary to switch from one reproducer to another with minimum change in the pitch of sound reproduction. A sudden change in pitch greater than this amount may be clearly noticeable.

The necessity for speed constancy in connection with recording exists both in regard to the speed during the individual "takes" and also in regard to the absolute speed maintained for the different "takes" with any combination of recording machines used within the capacity of the motor system. In the motor interlock system rapid speed variations due to momentary fluctuations in mechanical load, etc., during "takes" are handled automatically in a satisfactory manner by a control cabinet associated with the distributor drive motor and by damping elements associated with the individual recording machines, as already described.

The synchronized motor system makes it possible to start, stop and run the recording equipment in exact synchronism, and, when running, to keep all the apparatus at the exact speed necessary for correct recording of sound.⁴ Each piece of apparatus driven from the synchronized motor system is provided with a separate motor. These are controlled by the motor-driven distributor described below. These motors, which differ only in size and auxiliary details, are especially designed to provide a sufficient starting torque and to insure exact synchronism during starting and running. Each motor has a phase-wound rotor and a phase-wound stator. The

(Continued on page 58)

⁴Further details may be found in the paper "Synchronization and Speed Control of Synchronized Sound Pictures" by H. M. Stoller—*Transactions of the S. M. P. E.*, September, 1928; *Bell System Technical Journal*, January, 1929.

MODERN TRENDS IN

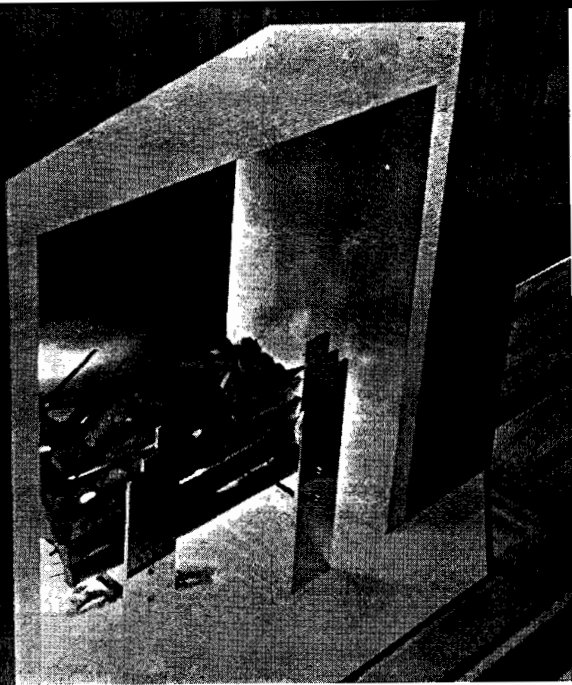

ABOVE: Loudspeaker concealed in modern fireplace. Speaker is mounted on 1" Celotex and suspended at 45° by springs.

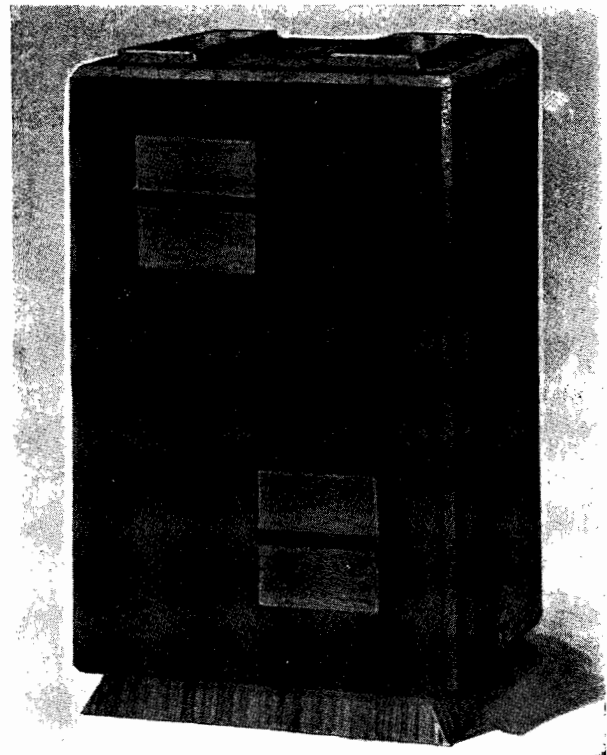

ABOVE: An extremely modern cabinet of early trend. The doors at left permit access to receiver, those at right conceal loudspeaker.

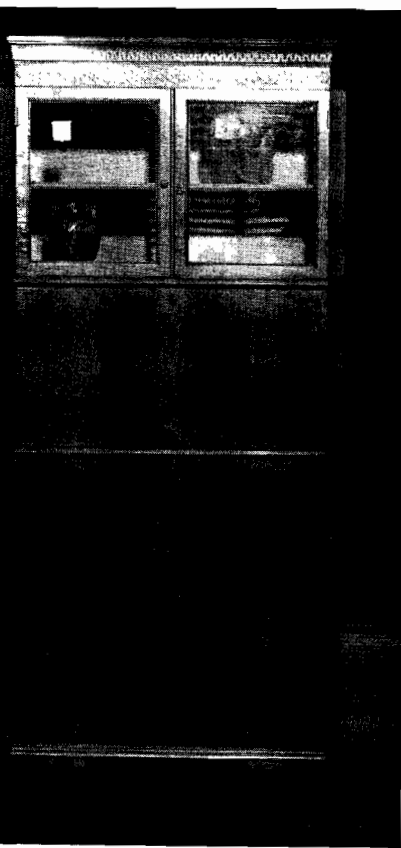

LEFT: An early American cabinet. See illustration at bottom of page.

BOTTOM: Open view of same unit as shown at left. Note receiver in desk compartment and loudspeaker housed behind French doors.

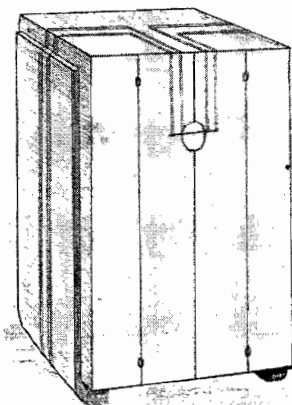

LEFT: Sketch of a modified modern cabinet with French doors.



CABINETRY

By LEWIS WINNER



ABOVE: End piece of early American theme — gumwood finished walnut color. Note inclined panel for easy manipulation.

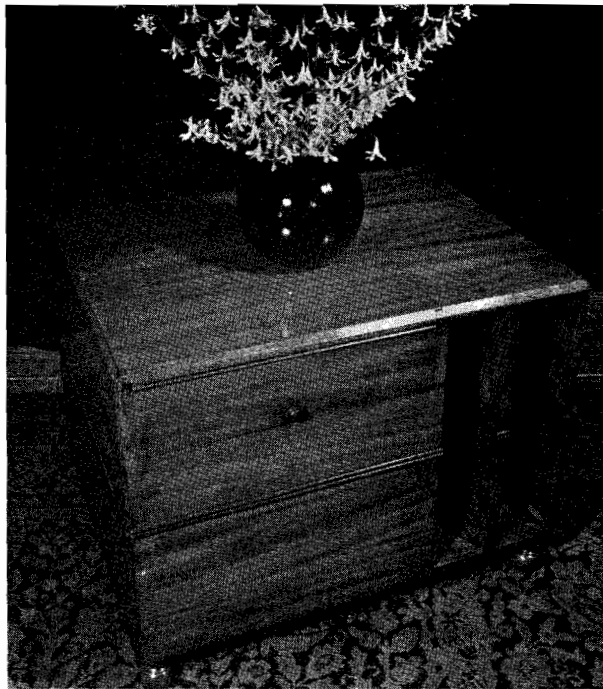

ABOVE: Same unit as at top closed. Note provision for magazine racks.

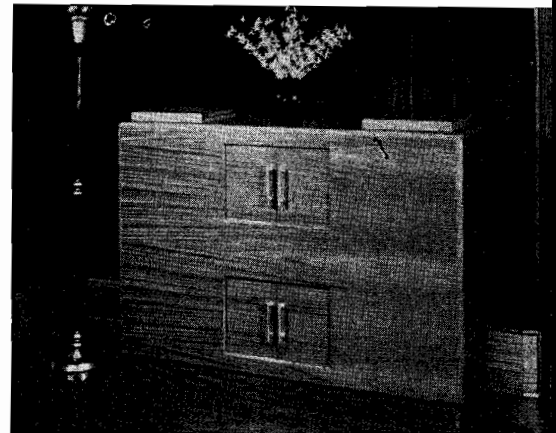

BELOW: The author at a combination bar-radio. The sliding doors are mounted in treated, rubber-fitted grooves.

RIGHT: A closed view of the bar shown below.

BELOW: Illustrating the new Super Pro console as interpreted by Hammarlund.



AN ULTRA-SHORT-WAVE RADIO LINK

THE INAUGURATION, by Sir Walter J. Womersley, M. P., Assistant Postmaster General, of the Belfast-Stranraer 9-channel ultra-short-wave radio-telephone link on August 31st, 1937, marks an outstanding achievement in communications.

Although the use of ultra-short waves for commercial telephony is by no means new, this is the first application in Great Britain, of a system wherein as many as nine telephone channels are passed simultaneously over a single radio link.

This system is the outcome of many years of research by Standard Radio engineers into the technique of ultra-short-wave communication, coupled with long and arduous field trials. It is interesting to note, too, that the ultra-short wave is by no means the limit of wavelength for communication purposes and that the researches of Standard Radio engineers into micro-rays resulted in the design and installation as long ago as 1933 of the Lympne-St. Inglevert micro-ray link¹ used by the Air Ministry, which operates on a wavelength of 17.4 cms over an optical distance of 21.7 miles (35 km).

Foremost among the virtues of the ultra-short waves is the possibility of transmitting wide bandwidths. The width of the band that can be transmitted increases as the wavelength is shortened, and it is for this reason mainly that high-definition television stations all operate in this region, as they require a total bandwidth of as much as 6 megacycles.

The equipment is designed for unattended operation and is capable of complete remote control from the nearest telephone exchange. In addition it is provided with spare equipment, part of which is brought automatically into operation on the occurrence of any abnormal condition. Both transmitting and receiving equipments derive their whole power supply from the public supply mains, the only battery used in the equipment being that for the operation of the relay system. A Diesel electric power plant is arranged so that in the event of failure of the public electricity supply, it will take over the load automatically approximately one minute after such failure and thus avoid serious interruption of the service.

¹"Anglo-French Micro-Ray Link," by A. G. Clavier and L. C. Gallant, *Radio Engineering*, p. 19, February, 1934.

A description of the Belfast-Stranraer 9-channel ultra-short-wave commercial radio-telephone link which was inaugurated August 31, 1937.

TRANSMITTER

In order to understand the operation of the system, let it be assumed that the input of Channel No. 1 is supplied with sinusoidal tone of frequency f_1 kc per second. This input modulates a channel-frequency oscillator having a frequency in the range 150 to 300 kc per second, say, 155 kc, resulting in a carrier frequency of 155 kc together with upper and lower sidebands of $(155 + f_1)$ and $(155 - f_1)$ kc. If Channel No. 2 be supplied with a tone input of frequency f_2 , this will modulate an oscillator having a frequency of, say, 165 kc per second, resulting in a carrier frequency of 165 kc per second and upper and lower sidebands of $(165 + f_2)$ and $(165 - f_2)$ kc. Similarly, Channel 3 may have a carrier frequency of 180 kc per second, and so on to the ninth channel of which the carrier frequency might be 280 kc.

The bands of frequencies derived from the 9 channels are now added together, producing in total a single frequency band extending from $(155 - f_1)$ kc to $(280 + f_9)$ kc. This total frequency band is now used to modulate the output of the ultra-short-wave transmitter having a carrier frequency in the neighborhood of 76,000 kc and to produce by this means a lower sideband extending from $76,000 - (280 + f_9)$ kc to $76,000 - (155 - f_1)$ kc, the carrier wave of 76,000 kc and an upper sideband extending from $76,000 + (155 - f_1)$ kc to $76,000 + (280 + f_9)$ kc. This is the band of frequencies which is radiated by the aerial system.

The band of frequencies radiated by the transmitting system, as described above, is delivered by the distant receiving aerial system to a superheterodyne type of receiver. The second detector of this receiver produces from the above input the original sideband extending from $(155 - f_1)$ kc to $(280 + f_9)$ kc. This band of frequencies is then applied to a bank of 9 selecting circuits which operate as band-pass filters. The currents of frequency $(155 - f_1)$, 155 and $(155 + f_1)$ kc, will

be passed by the first filter to a detector circuit which delivers the original frequency of f_1 kc to the first channel. Similarly, the frequencies $(165 - f_2)$, 165 and $(165 + f_2)$ kc will be passed by the second filter to a detecting circuit which delivers the original frequency f_2 to the second channel. In this manner the whole of the band of frequencies delivered by the second detector of the superheterodyne receiver will be split up, detected and delivered to the appropriate channel.

The carrier frequency of the ultra-short-wave transmitter is held constant within very close limits by a crystal-controlled master oscillator while the beating oscillator of the superheterodyne receiver is similarly crystal controlled. By this means a high degree of selectivity may be attained in the receiver without any necessity of frequent retuning.

The foregoing explanation covers the transmission of 9 channels in one direction on a carrier wave of 76 megacycles approximately. For the reverse direction the circuits of the same 9 channels are transmitted on a carrier wave of 83 megacycles, approximately.

In order to minimize interference between the transmitting and receiving waves, the plane of polarization of the waves emitted by the transmitting aerial is at right angles to that of the waves received by the receiving aerial. At one terminal, therefore, the transmitter is equipped with an aerial system designed for vertical polarization, whereas the receiver is fitted with an aerial designed for horizontal polarization. At the other terminal the receiving aerial is vertically and the transmitting aerial horizontally polarized.

RECEIVER

The receiver is a superheterodyne in the output of the second detector of which the 9 auxiliary carrier frequencies of the distant transmitter are present. Each auxiliary carrier, together with its sidebands, is separated by means of filters, amplified and rectified to reproduce the original speech frequencies corresponding to the channel in question. After amplification these frequencies are passed out to the line at the required level.

It is easy to mix together 9 channels, but to separate them again without no-

(Continued on page 58)

PLATE RESISTANCE CONTROL

in Vacuum Tubes as Audio Gain Control Means

By **ALFRED W. BARBER**

Consulting Engineer

THE MOST flexible tool of the electronic arts, the thermionic vacuum tube, is continually being applied to new uses and to extensions of old uses. In recent months there has been an increasing application of vacuum tubes to audio volume-control circuits. Encouraged by more or less successful automatic volume-expansion systems, tubes are being applied to other automatic audio volume-control functions such as automatic overload prevention, automatic volume contraction and automatic audio volume control. It is, therefore, felt to be timely to point out various methods in which vacuum tubes may be used for these functions, the theory of operation and some practical design limitations in audio volume control by electronic means.

While most electronic volume-control systems depend upon essentially one thing, that of vacuum-tube plate-resistance control, they may be separated into two groups depending upon whether or not the control tube passes the controlled signal from grid to plate or merely acts as an impedance element in a gain-determining network. Assuming that the control grid of the control tube never draws current from a signal-bearing circuit, a primary consideration in design is the curvature of the dynamic plate resistance over the signal voltage excursion in the plate circuit. Two other important factors are range of control and the law of gain control as a function of the control voltage. The last two factors, namely, range of control and law of control may be easily determined from readily available curves of mutual conductance and plate resistance of various commercial vacuum tubes. On the other hand the very practical question of distortion may not be as easily ascertained. The data taken in my laboratory and herein presented may serve to

point out, at least in part, what the distortion limits are in some of the various possible control systems.

Vacuum tubes used as voltage amplifiers are ordinarily operated at a quiescent point mid-way of the linear part of their dynamic plate-current characteristic, especially when maximum undistorted voltage output is required. This mode of operation may be readily determined from a family of plate-current vs. plate-voltage curves taken at various grid-bias voltages and corresponds to the normal mode of operation of amplifier tubes.

Tubes used as plate-circuit rectifiers, on the other hand, may be operated at a point which gives a maximum of second order effect. This calls for a quiescent point such that a large signal passes, more or less completely, through the lower bend of the dynamic plate-current characteristic.

In electronic audio volume-control systems, however, the quiescent point and hence the path of operation is moved over a considerable portion of the tube's plate characteristic and it is at once evident that there are amplitude limitations in such systems if distortionless operation is to be obtained. Actually the distortion will vary considerably with gain but by proper design and operation it may at all times be kept within acceptable limits. The most important restriction is amplitude of operation which will readily be appreciated since the greatest curvature in the path of operation will seem straight if the amplitude of operation used is small enough. The question is, of course, how small is small enough?

Pentodes of low power capacity, such as those used as radio-frequency voltage amplifiers or detectors, are usually selected for volume-control circuits. In general

Illustrating the effect of twenty percent second-harmonic distortion.

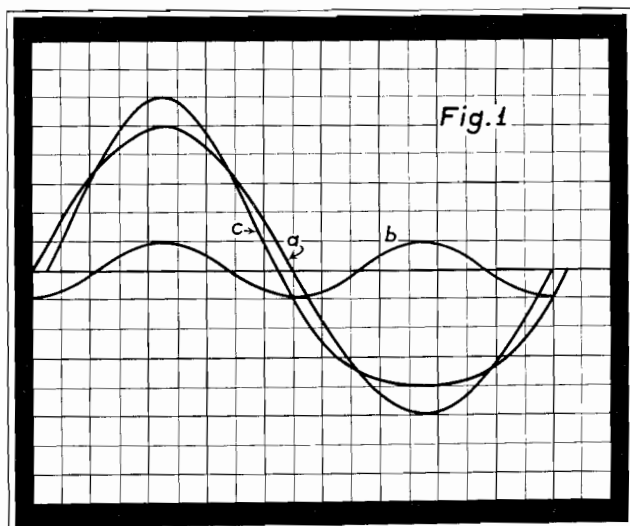

Second-harmonic distortion and control-grid bias plotted against attenuation.

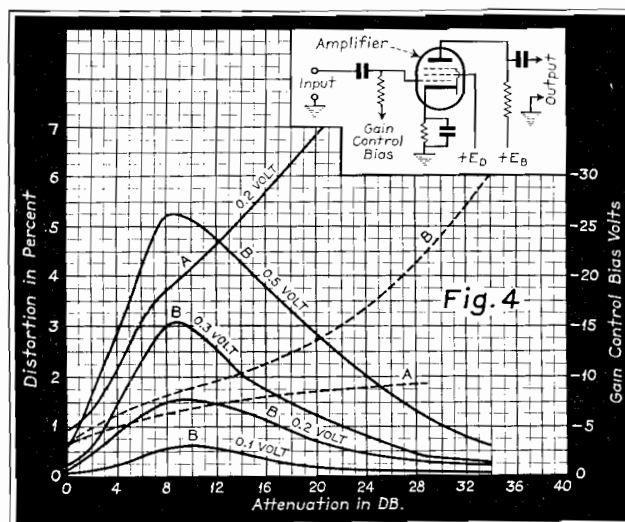

the output is resistance coupled to the next tube and the maximum gain condition is selected to conform to the normal operating conditions of the tube. At this maximum gain point the load resistance may be chosen to minimize second-harmonic distortion by causing the path of operation to bend equally at upper and lower extremes in the same way as for power-output pentodes. The practical advantage of doing this is doubted since even in the case of an expansion circuit where the largest signal produces maximum gain it is impractical to operate too near maximum possible gain and the distortion is not reduced for conditions of less than maximum gain. Also, due to the very high plate resistance of this type of tube, it is impractical to attempt to secure much straightening of the dynamic characteristic by using very large plate load resistances. Thus it is felt to be more important to determine tolerable signal amplitudes without regard to the plate load. In the systems to be set forth a load resistance of 50,000 ohms was used.

The effect of operating over a curved portion of the tube characteristic at greater than normal grid bias is to flatten the upper portion of the waveform corresponding to positively increasing plate voltage or decreasing plate current. Analytically this produces a predominant sec-

bias change. This method has the advantage that considerably higher voltages may be controlled at a given point in the system for a given distortion than can be applied to the grid of a tube used as a gain-control amplifier. One serious disadvantage of this method is that the minimum attenuation is in general high.

A modified form of the plate resistance attenuator gives a wider control and less minimum attenuation and at the same time maintains a large signal handling capacity. If the alternating plate voltage is fed back to the control grid as shown in Fig. 2 the dynamic plate resistance as seen from the plate becomes $r_p/\mu = 1/G_m$ or in other words $1/\mu$ times the normal dynamic plate resistance. Thus a tube varied from a mutual conductance of 2,000 to 2 micromhos may be used as a resistance varying from 500 to 500,000 ohms. Effectively the upper limit of resistance will be determined by the plate load in parallel with this dynamic plate resistance.

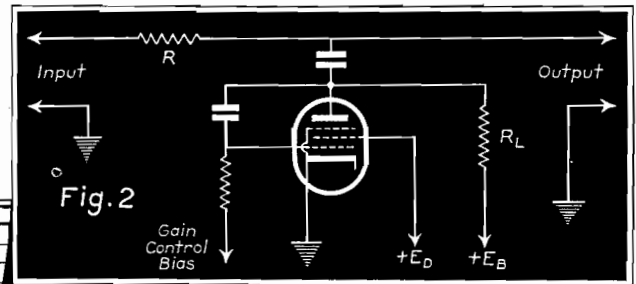
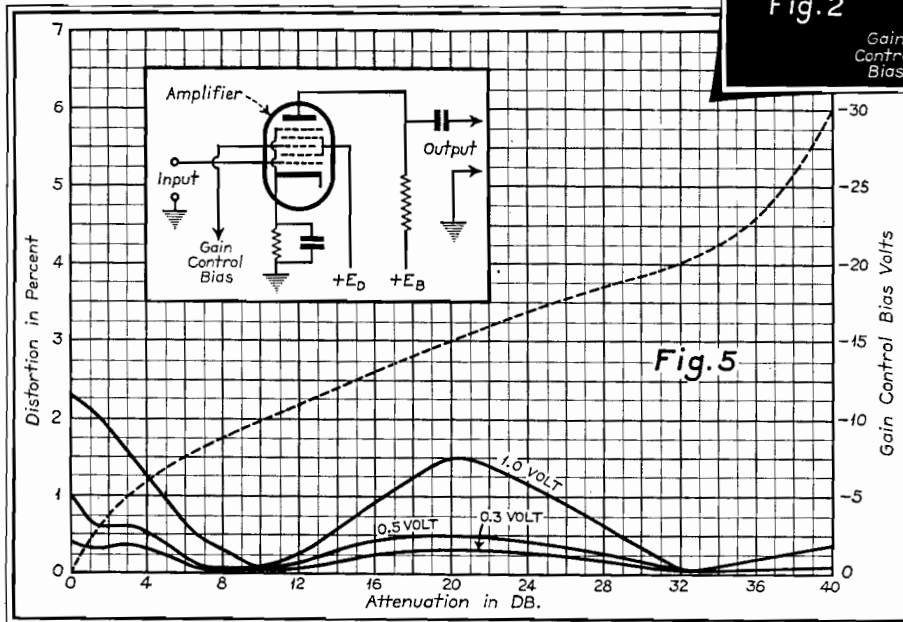

A circuit for feeding alternating plate voltage back to the control grid.

Showing the results obtained with a 6L7 used as a gain-control amplifier. The signal is applied to the first grid and the control bias to the third grid.

ond-harmonic distortion term. As an illustration, Fig. 1 shows at "a" a pure sine wave, at "b" a 20 percent second harmonic and at "c" the resultant wave obtained by adding the fundamental and second-harmonic waves. This resultant waveform will undoubtedly be familiar to those in the habit of observing waveforms by means of a cathode-ray tube.

The most commonly used audio volume-control method consists in varying the plate resistance of a tube used as an amplifier by varying the control-grid bias. In multi-grid special-purpose tubes the bias of a grid other than the normal control grid is often varied for gain-control purposes. The choice of the tube and the grid which is to be controlled will be determined by the signal amplitude on the control grid, the available control voltage and the law of gain variation with bias which is desired.

Another method of control is to use the plate resistance of a vacuum tube as an element in an attenuator and to control the plate resistance by means of a grid-

Actual variations of 500 to 50,000 ohms or 40 db may easily be obtained with a variety of tubes. In the attenuator circuit, as shown in Fig. 2, if the input is placed across resistance R in series with the plate load resistance R_L in parallel with the dynamic plate resistance $1/G_m$ and the output is taken off across R_L in parallel with $1/G_m$ the attenuation between input and output is $R_L/G_m R R_L + R + R_L$. From a distortion standpoint one advantage of this form of tube attenuator is that the signal is reduced in proportion to the attenuation before it reaches the tube.

In Fig. 3 is shown the experimental set-up used to make distortion measurements on the various volume-control systems described. The output of a beat oscillator is filtered to remove harmonics and is fed to a calibrated input attenuator. The known output of the attenuator forms the signal which is to be controlled by one of the methods discussed above. The output harmonics produced by the control system are measured by means of the harmonic analyzer and the results

plotted. The second harmonic only is shown since it predominated in all of the systems measured. The control bias is shown with the results which are shown against attenuation or gain less than maximum so that the law of gain variation with bias may be seen.

Fig. 4 shows curves of second-harmonic distortion and control-grid bias plotted against attenuation or gain less than maximum for two types of tubes gain-controlled by grid-bias variation. The tube circuit is shown along with the results. The solid curve "A" is second-harmonic distortion produced by a sharp cut-off pentode (type 77). The input was 0.2 volt and the bias required to produce the attenuations shown is given by the dotted "A" curve. The solid curves "B" are second-harmonic distortion for a remote cut-off tube (type 78) with signal voltages on the control grid of 0.1 to 0.5 volt. At "B" is shown the bias on the control grid required to produce the attenuations shown. Qualita-

ties from 0.3 to 1.0 volt is shown with full lines. The maximum distortion with this tube was produced at maximum gain with a secondary maximum at a bias of 15 volts or 20 db below maximum gain. If 1 percent distortion is not to be exceeded the maximum signal voltage should never go above 0.5 volt with this tube and mode of operation.

The second method of attenuation, that of using a tube as a resistance equal to $1/G_m$ was investigated and the results are shown in Fig. 6. The solid curves are second-harmonic distortion and the dotted curves are the control bias used. Curves "A" were taken using the circuit shown in Fig. 6-A where the plate resistance of a sharp cut-off tube was used as the plate load of an amplifier tube. The alternating-current plate voltage was fed back to the control grid of the control tube as described in connection with Fig. 2. Curve "B" shows the results of using a remote cut-off tube as the amplifier plate load. Both curves were taken with 0.1 volt on the control grid of the amplifier tube and it will be seen that the remote cut-off tube operates without exceeding 1 percent distortion.

Where large input voltages are to be encountered the circuit shown in Fig. 6-C has a great advantage over the other circuits shown. Several volts can be handled

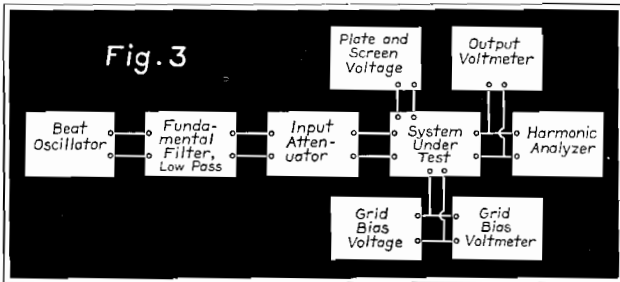

An experimental set-up used in making distortion measurements on various volume-control systems.

Showing circuits and results obtained when a tube is used as a resistance equal to $1/G_m$.

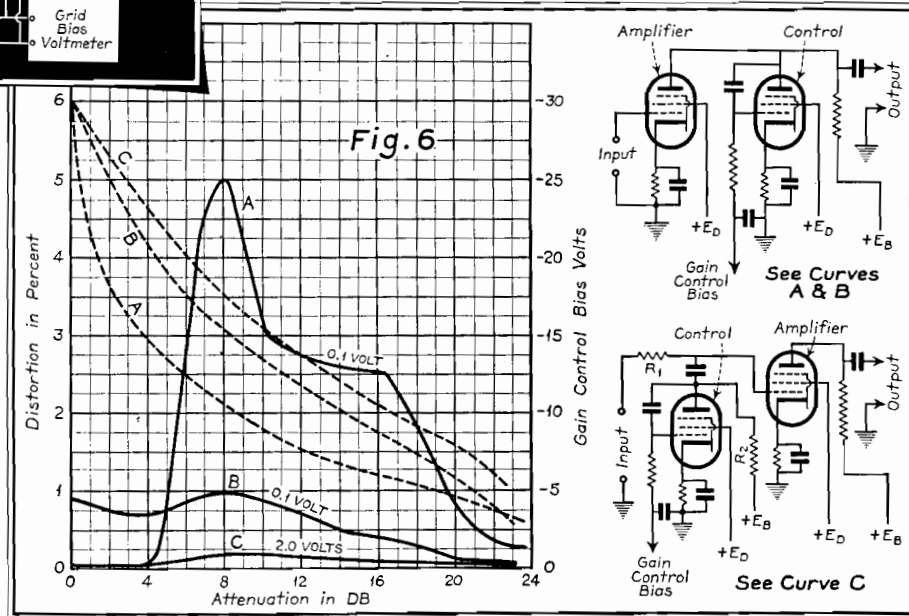

tively these results will fit sharp and remote cut-off tubes having characteristics similar to the tubes actually used. Only a single curve is shown for the sharp cut-off tube since it is evident that its distortion will be excessive except for very small signal voltages. The curves for the remote cut-off tube are characteristic in showing a maximum distortion at a gain somewhat less than maximum, in this particular case at minus 9 db. The bias for this maximum distortion point was about 8.5 volts. For acceptable operation this maximum distortion point must be kept within certain limits. If 1 percent distortion is taken as the maximum to be tolerated, the remote cut-off tube will operate satisfactorily as a volume-control tube if the signal voltage on the control grid is at all times kept below 0.15 volt.

Fig. 5 shows the circuit and results obtained with a type 6L7 tube used as a gain-control amplifier with the signal applied to the first grid and the control bias applied to the third grid. The bias is shown dotted and the second-harmonic distortion produced with signal

by this circuit which is especially useful in cases where the signal is derived from crystal pickups or diode detectors. The circuit is an attenuator essentially as shown in Fig. 2 placed ahead of the amplifier tube. Distortion measurements were made with 2 volts input to the system and the results are shown in the "C" curves of Fig. 6. At no point does the distortion rise above 0.2 percent. With resistors R_1 and R_2 equal, the initial insertion loss of the attenuator is 6 db.

Two general methods of obtaining gain control by means of thermionic vacuum tubes have been described both of which depend on the control of the dynamic plate resistance of a tube. The first method employs the tube to relay the signal. In order to keep the distortion low in this type of circuit the applied signal must be limited to something of the order of 0.1 to 0.5 volt for 1 percent maximum distortion, depending on the type of tube used. The second method employs the tube as a controlled resistance equal to the reciprocal of the mutual conductance of the tube.

MAGNETO MAGNET SELECTS PNEUMATIC TUBE CARRIERS

PNEUMATIC TUBES, such as are used in department stores for transporting cash, are also utilized for speeding telegrams under busy city streets between telegraph central offices and the branch offices where messages are filed.

Frequently two or more branch offices are connected to a single pneumatic tube line, as shown in Fig. 1. For such cases, Western Union engineers have devised an ingenious selecting mechanism for automatically separating the various message transporting carriers sent through the line and discharging them at the proper office.

The carriers destined to branch "X" are constructed of non-magnetic material while those for branch "Y" are of the same construction except that a $\frac{3}{4}$ -inch wide band of steel is attached to the body of the carrier.

Fig. 2 shows a simplified schematic diagram of the selector mechanism.

Just ahead of the terminal at branch "X" a "pickup" or detecting device "A" is mounted astraddle a non-magnetic section of the pneumatic tube. This pickup consists of an automobile magneto magnet around which is wound a coil of very fine wire.

When a non-magnetic carrier passes through the pickup, no effect is pro-

Fig. 2. A schematic diagram of the selector mechanism for the pneumatic tube carriers.

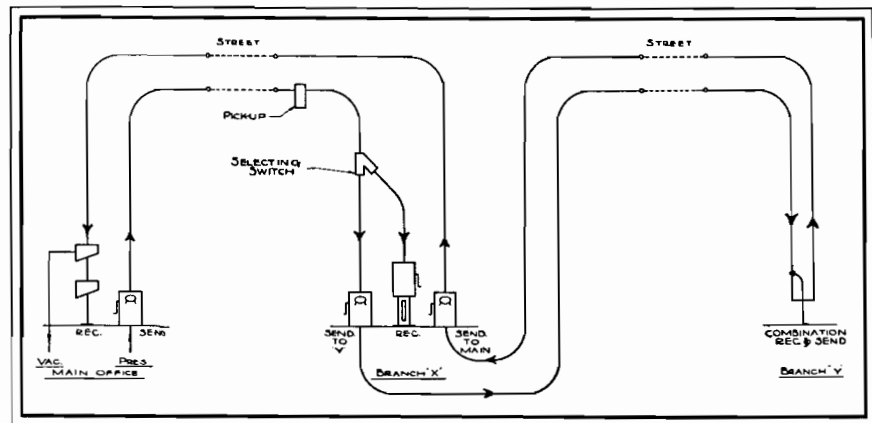
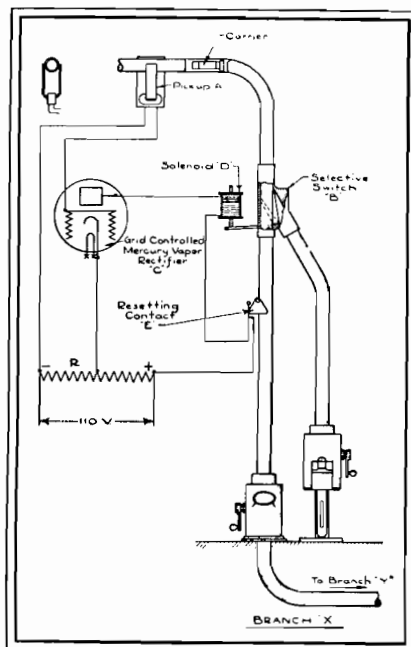

Fig. 1. Showing how branch offices may be connected to a pneumatic tube line.

duced and the carrier is deflected by the tongue of the selective switch "B" and discharged at branch "X." However, when a magnetic carrier passes through the pickup a positive voltage is induced in the pickup coil and applied to the grid of the grid-controlled mercury-vapor rectifier tube "C."

The grid is normally maintained at a negative bias by the resistance "R," thereby preventing current flow through the plate circuit of the tube. When the positive pulse from the pickup is applied it over-rides the negative bias and the tube flashes over, passes current and causes the tongue of the selective switch to be thrown by the solenoid "D." The carrier then passes through to station "Y." The re-setting contact "E," mounted in the tube just below the selective switch opens the plate circuit momentarily, as the carrier passes, thus extinguishing the tube and making the apparatus ready for another selection.

By varying the width of the steel band on the carrier and the negative bias on the tube, selections for several more stations on one line can be made.

OSCILLOGRAPH AMPLIFIER DESIGN

PRESENT demands for sweep circuit simplicity in cathode-ray oscillographs have made it necessary to go to the amplified type of sweep circuit for linear horizontal-deflection voltages. This sweep circuit possesses many advantages in operating flexibility, according to G. Robert Mezger in *DuMont Oscillographer*. The amplitude of horizontal deflection on the cathode-ray tube is di-

rectly controlled by the horizontal gain control. By the simple expedient of overloading the amplifier and driving the overload points off screen on either side of the cathode-ray tube, it is possible to fill the entire screen for fine detail study of a very high-frequency signal. On the other hand, the requirements for amplifying a wave of sawtooth shape faithfully and of maintaining a minimum return trace time impose problems which are of sufficient importance for thorough investigation.

The peculiar waveform of a linear sawtooth causes problems to become much more evident in amplifier design than when the amplifier is designed to carry a pure sine wave. The slow rate of increase of a sawtooth of long period causes it to have much lower frequency components than its period would indicate. At the same time, the return trace is fast and it is necessary that the amplifier have satisfactory high-frequency response. It is also to be noted that the bend from the linear charging cycle to the discharge portion of the wave carries all the frequencies in the middle range. Because of these requirements, a sawtooth is an excellent wave for experimental work in amplifier design.*

Let us consider a sweep circuit of conventional design as shown in Fig 3. It is necessary that this oscillator feed into the grid of an amplifier tube for the amplified sweep circuit demanded in modern oscillographs. The fixed portion of R is of the order of one megohm, while the variable portion is about four

*"A New Method of Testing for Distortion in Audio-Frequency Amplifiers," by H. J. Reich, *Proc. IRE*, Vol. 19, No. 3, pp. 409-15; March, 1931.

COMMENT . . Production

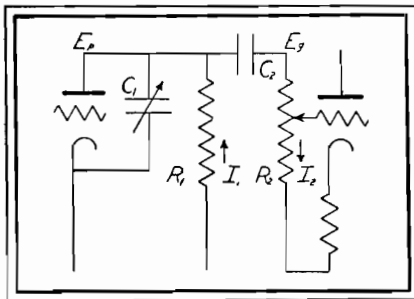

Fig. 4. Circuit used for illustrating the principal causes of plate-current variation.

megohms. This makes the plate load variable from one to five megohms. R refers to the total fixed and variable resistance at any given frequency of operation. In practice, C is usually a stepped capacitor.

The fundamental equation for the frequency of this type of oscillator may be obtained from the fundamental relationship:

$$Q = CE$$

but $Q = \int i dt$

$$\therefore CE = \int i dt$$

integrating, we obtain, since I is maintained essentially constant,

$$CE = It$$

$$\therefore \frac{1}{t} = \frac{I}{CE}$$

or $f = \frac{I}{CE}$

or, expressed in the symbols of Fig. 3:

$$f = \frac{I_p}{CE_p}$$

In order that the sweep signal remain linear with respect to time, and of constant frequency, it is necessary that I_p remain constant for each entire cycle and that E_p may not vary in magnitude due to any external causes such as coupling from other circuits. The principal cause of variation of I_p over one complete cycle can be seen from a consideration of Fig. 4.

Here R_1 represents the plate resistor of the discharge tube, and R_2 is the grid resistor of the amplifier tube. As E_p rises during the forward portion of the sweep, the current I_1 flowing through R_1 must divide inversely as the

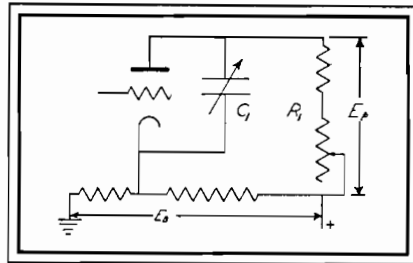

Fig. 3. A sweep circuit of conventional design.

impedances R_1 and $(R_2 + j\omega C_2)$. If $(R_2 + j\omega C_2)$ is small in comparison with R_1 then an appreciable amount of I_1 will flow into the grid resistor R_2 and will cause the sawtooth wave to round off at the top. That is, E_p will decrease due to the poor regulation of the plate-voltage supply circuit, at a rate proportional to the increase in I_2 where

$$I_2 = \frac{E_p}{R_2} \frac{t}{R_2 C_2}$$

In order that the signal be transferred faithfully, it is then essential that

$$I_2 \ll I_1$$

But $E_g = E_p$

where E_g and E_p are the grid and plate signal voltages respectively. Therefore

$$\frac{E_g}{R_2} \ll \frac{E_p}{R_1}$$

$$\text{and } R_2 \gg R_1 \dots\dots\dots(1)$$

This requirement may be set up as our first essential of linear sawtooth amplifier design.

It has been found empirically that in order to maintain E_g equal to E_p at the lowest frequency of operation, the time constant of C_2 and R_2 in combination should be at least ten times the period of the lowest frequency sawtooth signal it is desired to pass.

That is:

$$RC \geq 10t$$

$$\text{or } RC \geq \frac{10}{f_{min}} \dots\dots\dots(2)$$

This equation represents the second essential of amplifier design.

At the point where the gain of the amplifier is determined, another type of distortion enters in the nature of frequency discrimination due to improper

voltage division with respect to frequency across the high and low sections of the gain-control potentiometer. Fig. 5 will show this more clearly. In addition to the pure resistance of the potentiometer, there are also stray capacitances to be considered. C_x is that stray circuit capacity from the input to the potentiometer arm. C_y consists of the input capacity of the tube and other stray circuit capacitances. Since C_x is much smaller than C_y , the greater portion of the high-frequency voltages will be developed across C_x , while C_y shunts these signals to ground. C_y then prevents high-frequency signals from appearing on the grid of the amplifier.

There are two methods of balancing the effect of this unequal potential distribution with frequency. One is by use of a step-by-step voltage divider, using a stepped capacity network placed in shunt with the resistance and of such magnitude as to render the stray and tube capacitances of no importance. The simplest method, and by far the most practical from the cost standpoint, is to

$$\text{make } R_2 \text{ small in comparison with } \frac{1}{\omega C_y}$$

so that the shunt admittance of the tube will be of no consequence. Arbitrarily assuming a ten-to-one ratio, we may write the requirement that:

$$\text{Gain } R \leq \frac{1}{10 \omega C_y} \dots\dots\dots(3)$$

This equation represents our third requirement. (Continued on page 46)

Fig. 5. Circuit illustrating improper voltage division across a gain-control potentiometer.

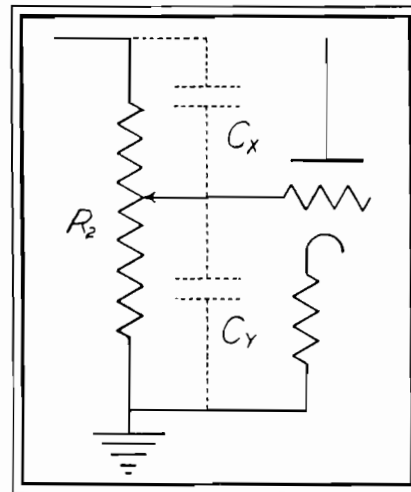

TELECOMMUNICATION

PANORAMA OF PROGRESS IN COMMUNICATIONS

AUTOMATIC TIMER

SPEAKERS at the General Electric Company plant in Schenectady need no longer worry about running over their allotted time. The chairman's problem of handling several speakers on one program has been simplified by an electric time reminder.

The device automatically flashes a warning to the speaker two minutes before he is to finish his address. When this period has elapsed, the word "Finis" is flashed on the reminder and a low toned chime notifies him that his speaking time has ended.

The control device for the reminder is a small portable apparatus with a calibrated dial on the front, which may be set for any duration of time up to 30 minutes. If the speaker is to talk for 10 minutes, the control is readily adjusted and the two-minute warning will flash to the speaker at the end of eight minutes.

A Telechron motor in the control operates a set of switches which in turn operate small relays in the reminder on the speaker's table. The equipment operates on 110-volt, 60-cycle power.

TRANSCONTINENTAL TELEPHONE PROJECT

THE LAST of a line of some 12,000 telephone poles across a 290-mile stretch between Amarillo, Tex., and Albuquerque, N. M., the final link of the fourth transcontinental telephone line, will soon



The automatic time reminder described in the accompanying text.

be set in place by the American Telephone & Telegraph Company. The erection of these poles is part of the largest construction project undertaken by the company since 1930.

While the company has three other transcontinental lines, each providing many communication channels, the steady growth of traffic between points in the East and West has necessitated a substantial addition to intercoastal facilities. The fourth transcontinental parallels the airway across the Texas Panhandle. In general, it follows the same route as the "Will Rogers highway," new transcontinental route from St. Louis to Los Angeles through the famous humorist's home town of Claremore, Okla. The newly-strung wires, spanning a distance of some 1200 miles will be essentially a telephone "express high-

way" for traffic between Eastern points and the Pacific coast.

"THE MANUFACTURE OF VACUUM TUBES"

IN "The Manufacture of Vacuum Tubes," which appeared on page 20 of the September, 1937, issue of COMMUNICATIONS, we unintentionally failed to mention that the photographs had been taken in the vacuum tube plant of the Western Electric Company.—*Editors*

MODERNIZATION OF RADIO-RANGE TOWERS

THE UNITED STATES Department of Commerce has awarded a \$350,000 contract to Blaw-Knox Company for the fabrication of 400 radio-range towers to be erected at various points throughout the country.

The erection of these new towers at needed points, and the modernization of present stations represents a step toward improving air safety by the United States Government.

Modern radio-range stations consist of a group of five towers, four of which form a square with the fifth tower in the center. The towers are about 135 feet high, and the radio impulses go out directly from the tower structure. The four outside towers transmit what is known as the beam course, while the center tower is used to transmit weather reports and other information without interruption of the beam signals.

A typical radio-range station. Note that four towers form a square with the fifth in the center.

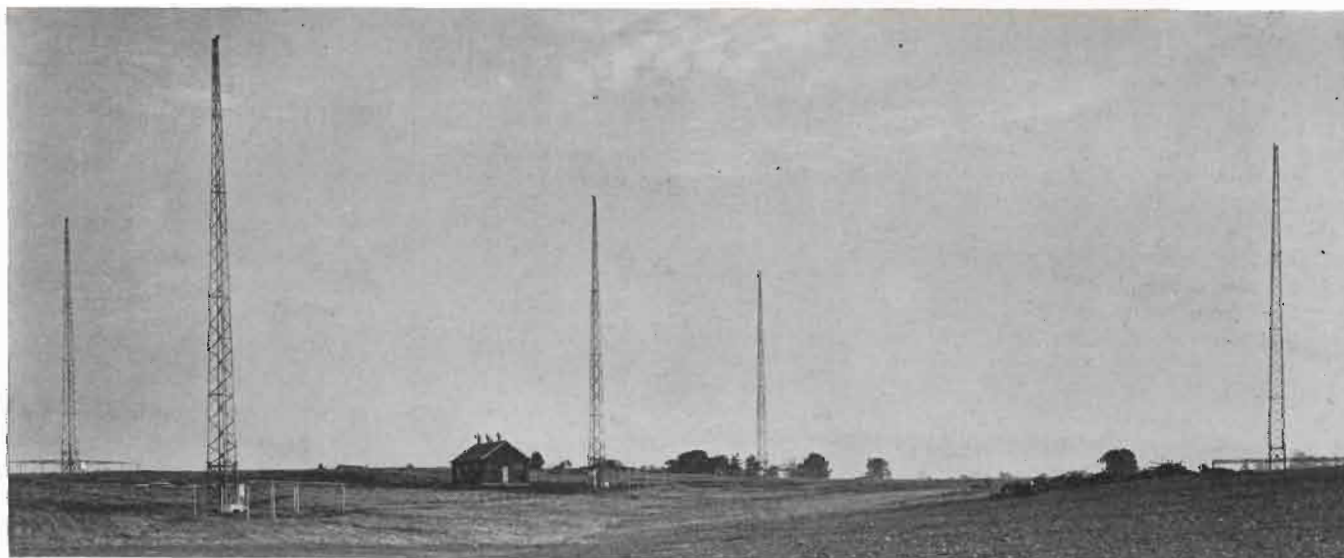

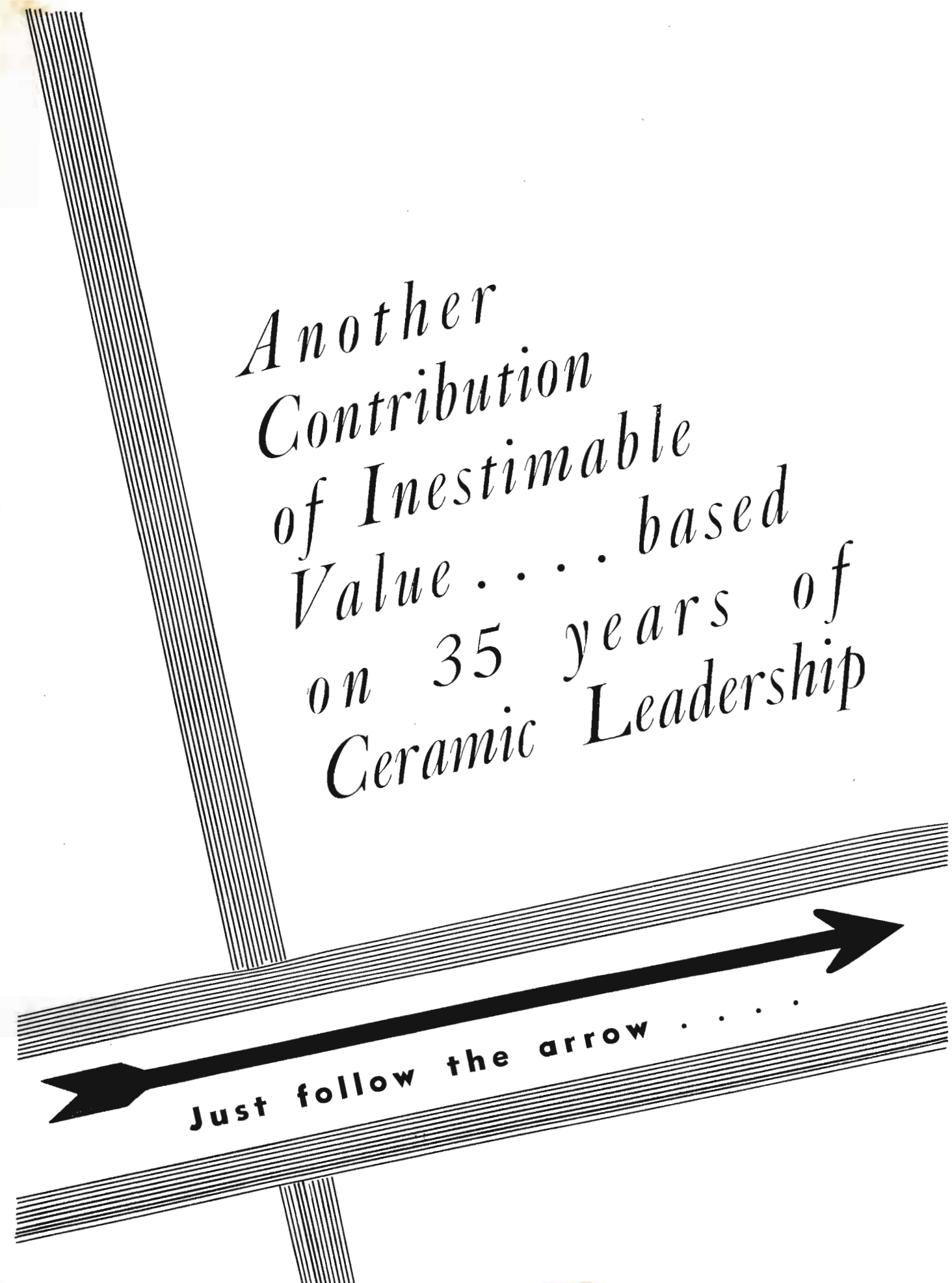

*Another
Contribution
of Inestimable
Value based
on 35 years of
Ceramic Leadership*

Just follow the arrow

Properties of Ceramic Insulating Materials of the American Lava Corporation

The data below represent average rather than optimum values obtained on standard test pieces. While these data are typical, it is well to remember that they may vary slightly, depending upon size, shape, and method of manufacture of the article in question and uses to which put. Values omitted in the table are of no importance considering the technical use of the material.

ITEM	UNIT	TEST METHOD	AlSiMag 35	AlSiMag 196	AlSiMag 197	AlSiMag 211	AlSiMag 72	AlSiMag 202	AlSiMag 203	AlSiMag 190	AlSiMag 192	Lava Grade "I"	Lava Grade "M"	Lava Grade "A"
TYPE OF MATERIAL			Dense steatite materials, consisting chiefly of clinostatite crystals. (MgO-SiO ₂)	Dense steatite materials, consisting chiefly of clinostatite crystals. (MgO-SiO ₂)	High dielectric strength, low dielectric loss, high mechanical strength.	High dielectric strength, low dielectric loss, high mechanical strength.	Expansion, excellent heat shock and electrical properties. Can only be extruded. Low coefficient of thermal expansion, good heat shock and electrical properties. Can be pressed, extruded, and machined by us to close dimensions.	Magnesium-aluminum-silicates, consisting chiefly of cordierite crystals. (2MgO·2Al ₂ O ₃ ·5SiO ₂)	Aluminum silicate, consisting chiefly of rutile crystals (TiO ₂)	Titanium dioxide materials, consisting chiefly of rutile crystals. (TiO ₂)	Natural fired stone magnesium silicate.	Natural fired stone magnesium silicate.	Natural fired stone aluminum silicate.	Natural fired stone aluminum silicate.
PREDOMINANT CHARACTERISTICS			Good electrical characteristics, high mechanical strength, close dimensions.	Low dielectric loss, good electrical characteristics, high mechanical strength.	High dielectric strength, low dielectric leakage at elevated temperatures. High mechanical strength.	Extremely low dielectric loss at both low and elevated temperatures.	Low coefficient of thermal expansion, excellent heat shock and electrical properties. Can only be extruded. Not pressed.	Low coefficient of thermal expansion, good heat shock and electrical properties. Can be pressed, extruded, and machined by us to close dimensions.	Highly refractory body. (3Al ₂ O ₃ ·2SiO ₂)	High dielectric constant, low dielectric loss.	High mechanical strength, great hardness.	Good electrical properties, close dimensions. Limitations on size and form.	Fair mechanical strength. Good heat shock properties.	Available in larger sizes than Grades "I" and "M." Close dimensions.
Specific Gravity			2.5	2.6	2.5	2.6	2.0	2.1	2.1	3.9	4.0	2.8	2.8	2.3
Density	lbs./in. ³		.090	.094	.090	.094	.072	.076	.076	.141	.144	.102	.102	.085
Volume	in. ³ /lb.		11.05	10.65	11.05	10.65	13.85	13.20	13.20	7.10	6.93	9.76	9.76	11.75
Water Absorption	%	A.S.T.M. D1116-34	.08-.03	.05-.02	.30-.10	.08-.03	—	1.0-0.1	12.0	.02-.00	.00	1.5	1.0	3.5
Water Absorption of Impregnated Material	%	A.S.T.M. D1116-34	.00	.00	.00	.00	—	.10	—	.00	.00	—	—	—
Chemical Resistance			At room temperature resistant to all alkalis and acids (excepting hydrofluoric acid.) For special problems consult ALCO.											
Color			White ¹	Cream	White ²	White	Yellow-Tan	Grey-Brown	White	Tan	Tan	Light Brown	Brown	Pink
Softening Temperature	°C. °F.	A.S.T.M. C24-35	1430 2606	1420 2588	1400 2552	1380 2516	1390 2534	1380 2516	1500 2732	1440 2624	1450 2642	1500 2732	1480 2696	1600 2912
Resistance to Heat (Safe limit for constant temp.)	°C. °F.		1000 1832	1000 1832	1000 1832	900 1652	1000 1832	1000 1832	1200 2192	1000 1832	1000 1832	1000 1832	1000 1832	1000 1832
Hardness	Mohs' Scale Talc=1 Diamond=10		7.5	7.5	7.5	7.5	7	7	6	7.5	8	6	6	6
Linear Coefficient of Thermal Expansion	mm./m. per °C.		6.37x10 ⁻⁶ 7.85x10 ⁻⁶	6.34x10 ⁻⁶ 7.62x10 ⁻⁶	7.22x10 ⁻⁶ 8.52x10 ⁻⁶	—	1.80x10 ⁻⁶ 2.59x10 ⁻⁶	1.88x10 ⁻⁶ 2.76x10 ⁻⁶	3.35x10 ⁻⁶ 4.45x10 ⁻⁶	8.10x10 ⁻⁶ 9.34x10 ⁻⁶	8.10x10 ⁻⁶ 9.34x10 ⁻⁶	appr. 9x10 ⁻⁶	appr. 9x10 ⁻⁶	2.80x10 ⁻⁶ 3.84x10 ⁻⁶
Tensile Strength	lbs./in. ²	A.S.T.M. D1116-34	6,500 7,500	8,000 8,500	6,500 7,500	—	—	—	—	—	—	1800	850	1240

Compressive Strength	Unglazed	A.S.T.M. D116-34	75,000 80,000	65,000 75,000	75,000 80,000	65,000 75,000	50,000	40,000	80,000	80,000	20,000	30,000	20,000	10,000	20,000
Modulus of Rupture	Unglazed	A.S.T.M. D116-34	20,000	22,000	20,000	20,000	8,000	6,000	20,000	20,000	4,000	10,000	14,000	10,000	10,000
	Glazed	A.S.T.M. D116-34	23,000	24,000	23,000	23,000	—	—	—	—	—	—	—	—	—
	Impact	A.S.T.M. D256-34T	1.6	1.9	1.8	—	1.0	—	—	1.8	—	1.3	—	—	1.4
Dielectric Strength (step 60 cycles) *3	75° F.	A.S.T.M. D116-34	above 10 ⁸	above 10 ⁹	above 10 ⁸	—	—	—	—	—	—	—	—	—	—
	600° F.	—	11.	—	—	—	—	—	—	—	—	—	—	—	—
	800° F.	—	1.4	—	—	—	—	—	—	—	—	—	—	—	—
Volume Resistivity at Various Temperatures (220 volts AC—60 cycles)	1000° F.	—	.3	110.	40.	25.	25.	—	—	—	—	—	—	—	—
	1200° F.	—	.22	27.	13.	8.8	8.0	—	—	—	—	—	—	—	—
	1400° F.	—	—	8.4	4.6	4.3	3.5	—	—	—	—	—	—	—	—
Dielectric Constant	60 Cycles	A.S.T.M. D150-36T	6.5	6.5	6.5	—	—	—	—	—	—	—	—	—	—
	1000 K. C.	—	6.2	6.0	6.0	5.8	5.0	—	—	—	—	—	—	—	—
	10 M. C.	—	6.0	5.8	5.8	5.0	5.0	—	—	—	—	—	—	—	—
Power Factor	60 Cycles	A.S.T.M. D150-36T	.30	.14	.20	—	—	—	—	—	—	—	—	—	—
	1000 K. C.	—	.20	.06	.12	.03	.40	—	—	—	—	—	—	—	—
	10 M. C.	—	.18	.04	.10	.015	.30	—	—	—	—	—	—	—	—
Loss Factor	60 Cycles	A.S.T.M. D150-36T	1.95	.91	1.30	—	—	—	—	—	—	—	—	—	—
	1000 K. C.	—	1.24	.36	.72	.17	2.0	—	—	—	—	—	—	—	—
	10 M. C.	—	1.08	.23	.58	.08	1.5	—	—	—	—	—	—	—	—
Loss Factor on Impregnated Material After 100 Hours in Water	60 Cycles	A.S.T.M. D150-36T and Navy Spec. RE13A-317F	1.86	.70	—	—	5.5	—	—	—	—	—	—	—	—
	1000 K. C.	—	1.60	.45	—	—	5.0	—	—	—	—	—	—	—	—
	10 M. C.	—	—	—	—	—	—	—	—	—	—	—	—	—	—
Capacity Change Per °C. Between 20-80° C.	—	—	+1.6×10 ⁻⁴	+1.4×10 ⁻⁴	+1.6×10 ⁻⁴	+1.2×10 ⁻⁴	—	—	—	—	—	—	—	—	—
	—	—	—	—	—	—	—	—	—	—	—	—	—	—	—
	—	—	—	—	—	—	—	—	—	—	—	—	—	—	—

*1 Can also be obtained in brown (AISiMag 207) and in grey (AISiMag 206).
 *2 Can also be obtained in brown (AISiMag 210) and in grey (AISiMag 209).
 *3 Test discs 1/4" thick.

Chattanooga, Tennessee - July, 1937
 COMMUNICATIONS FOR OCTOBER 1937

AMERICAN LAVA CORPORATION

35th YEAR OF CERAMIC LEADERSHIP

TENNESSEE

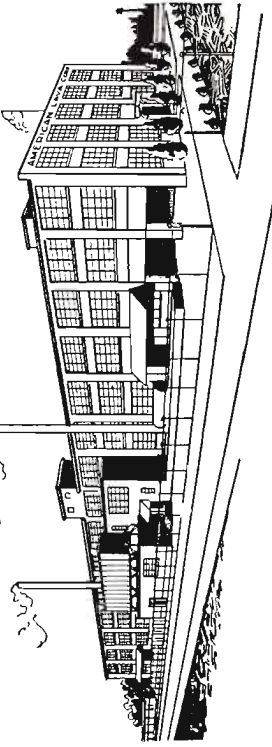

BRANCH OFFICES: (See Telephone Books)
 CHICAGO
 CLEVELAND
 ST. LOUIS
 SAN FRANCISCO
 LOS ANGELES

BRANCH OFFICES: (See Telephone Books)
 NEW YORK
 BOSTON
 PHILADELPHIA
 WASHINGTON, D. C.
 TORONTO, CANADA

STRENGTH Sailed INSULATION

ALSMAG

KNOWN
*For its
Accuracy*



JUST TURN THE PAGE!



The preceding pages show a chart of properties of our various insulating materials. Retain this chart so you may refer to it when specifying your insulating materials. Additional copies available upon request.

AMERICAN
LAVA CORPORATION
Chattanooga,
Tenn.



VETERAN WIRELESS OPERATORS ASSOCIATION NEWS



W. J. McGonigle, President, RCA Building, 30 Rockefeller Plaza, New York, N. Y.

MEETING

THE NOVEMBER meeting of the New York group will be held on Monday evening November 1st, 1937, at a place to be announced on post cards to each member. All are urged to attend this meeting to aid in preparations for our fall activities.

ANNUAL CRUISE

THE THIRTEENTH Annual Dinner-Cruise of the Veteran Wireless Operators Association will be held simultaneously in New York, Boston, Chicago, Miami, New Orleans, Honolulu, San Francisco, London, England, Wellington N. Z., Omaha, Los Angeles, Washington, D. C., and many other cities throughout the country and the world. It is planned that these simultaneous dinner-cruises be dedicated to the memory of, and serve as a memorial to, our late deceased wireless veteran number one, Guglielmo Marconi. Further details will appear in this page in coming issues.

MARCONI MEMORIAL

OUR SINCERE THANKS and grateful appreciation is hereby tendered Mr. Lenox R. Lohr, president of the National Broadcasting Company, for his kind encouragement and splendid support of the Marconi Memorial Fund being sponsored by our Association. Mr. Lohr added his contribution of \$250.00 to our steadily swelling fund.

We invite correspondence and contributions in this regard from all members of the communications industry. Our address is given above.

STATEMENTS

STATEMENTS have been mailed out to those in arrears. Your early reply to the Secretary will be deeply appreciated. We have obtained a new supply of Membership Pins. May we suggest your enclosing an additional dollar with your dues for a pin?

FALL

NOW THAT fall is upon us we look for increased activity in all of our Chapters. We will record from time to time in this page their activities. We suggest you communicate with your local Chairman or Secretary and assist in planning a comprehensive program of events for the coming year.

MIAMI

MIAMI CHAPTER SECRETARY, V. H. C. Eberlin, II, reports: "Down here where the sun is hotter, the 'Sun Worshipers Chapter' has convened and adjourned our meeting of which I report below.

"A goodly crowd of 'Lager-Imbibers' were there, included among whom were our congenial FCC Radio Inspector, Joe H. McKinney . . . Tropical Radio's famous side-swipe King—Mr. Moon . . . Pan Airways representatives, the Messrs. Mackenzie and Harpley . . . Senior Totman,

Department of Commerce Chief, and others.

"Enclosed eight American pesos for dues of Ralph Vern Upp, Mr. Mackenzie, R. D. Phillips and Wiley Paul.

"*Random Notes*—R. D. Phillips, in charge of police radio in Ft. Lauderdale, Fla., showed your correspondent and Wiley Paul around the ultra highs with which Ft. Lauderdale maintains a quick check on happenings in and about that up and coming city . . . Joe McKinney was seen sporting a Lieutenant's regalia out Opa Locka way. Must be 'two weeks Naval Reserve duty time.' . . . Steve Kovacs relieved Alex Vadas on the Yacht 'Mascot' for a spell while Alex vacationed tourist fashion in Europe. (FM take special note.) . . . Senior M. Fernandez relieved F. Dawson as Chief Operator of the Pan Air Dinner Key Radio station. F. Dawson was transferred to the New York station as Chief in Charge. Congrats to both of them . . . C. S. Bodenmann of Mobile, Alabama, requested an application blank. We are temporarily out of them but as soon as we receive some more from you he'll get one and join the ranks.

"That's about all, except that Ye Miami Secretary wishes to report spending a very enjoyable time in the company of President McGonigle whilst sojourning in the northern areas. Regret not having seen Secretary Parker but he can consider this, as can all VVOA members, as a hearty invitation to visit the Miami chapter this coming season."

Thanks lots, Ebby. Keep up the good work and Miami will be largest of the chapters.

HONOLULU

OUR ENTERPRISING Honolulu Chapter Secretary, H. F. McIntosh tells us: "The 'Surf-Board' Chapter of the Veteran Wireless Operators Association held its semi-annual dinner-meeting on July 23, 1937, at the home of Past Chairman George Street, in the beautiful Kahala district of Honolulu. There were representatives of commercial radio companies, the Army, Navy, and Coast Guard radio units of the Island of Oahu.

"George Street, acting chief cook, ably assisted by Messrs. Maddams and Connolly, presided at the outdoor barbecue, turning out barbecued steaks, roast 'Spuds,' etc., voted by all present as 'a mighty swell dish.' Plenty of fresh, tender young coconuts, recently detached from the trees were available for those desiring them. Dinner was served in the spacious, attractive garden with typical Hawaiian coconut oil torches furnishing the light, augmented by the silvery rays of a full moon that only Hawaii knows.

"There were no long drawn out speeches, and by far the principal event of the evening was a one minute's silence when all

hands stood, heads bowed, prayer on lips, in reverent tribute to the memory of the greatest radio man of us all, the late Guglielmo Marconi.

"Altogether the meeting was voted a huge success. The chow was perfect; good fellowship and congeniality abounded in full accordance with the underlying principles and aims of our VVOA. As for the beer—if, at the end of the evening what remained of the original fifteen gallons of beer were auctioned off and you bought it for ten cents, you'd have made a pretty bad deal.

"Enclosed please find Post Office money order for four dollars covering applications for membership of Bennette O'Bannon, who has been in the Army Air Corps since 1932 and is stationed at Wheeler Field, Schofield Barracks, T. H., and Fred M. Mitchem, a member of the Army Air Corps since 1935, also stationed at Wheeler Field."

Splendid work Mac. You've got a fine chapter and a very active one in the "Paradise of the Pacific" and we look for great things from you.

BOSTON

HARRY CHETHAM, Boston Chapter Secretary, reports regarding the meeting of the Boston Chapter in conjunction with the New England Division, ARRL "Hamfest" held at the Bradford Hotel in Boston on Saturday evening, October 2, 1937: "A nominating committee was appointed by Chairman Charles C. Kolster, consisting of Vice-Chairman Guy R. Entwistle, Sam Curtis and Jack Dodge. The date of the next Boston meeting was set for Monday, December 6, 1937, at which time election of officers will take place. Arthur Stockellburg motioned that all members forward their votes to Secretary Harry Chetham. A telegram was received from J. A. Walker, at Thomaston, Maine, expressing his regrets at being unable to attend. Providence, R. I., was represented by Howard Thornley, WPRO, and J. A. Prior, WJAR; New Bedford by our old timer Irving Vermilya who held amateur license IAA. The local police radio groups were well represented—J. G. Barrett, 1906, of Boston police and the general chief operator of Boston police headquarters, Arthur H. Vickerson; the smiling Jimmie Green, Brookline chief radio operator, and Ed Tierney, chief radio operator of the Cambridge police department. Among other old timers present were—I. T. Barnes of Wellesley, Arthur Ridley, Wm. J. Ibach of Marblehead, Commander of the Marblehead Post of the Veterans of Foreign Wars, Sam Curtis, Ted McElroy, Walter Hamilton of Western Union, Arthur E. Ericson of Beverly, and numerous others. Some time we will give you the story of the time Art Ericson was incarcerated in a German prison at Bremerhaven in 1914 and

(Continued on page 46)

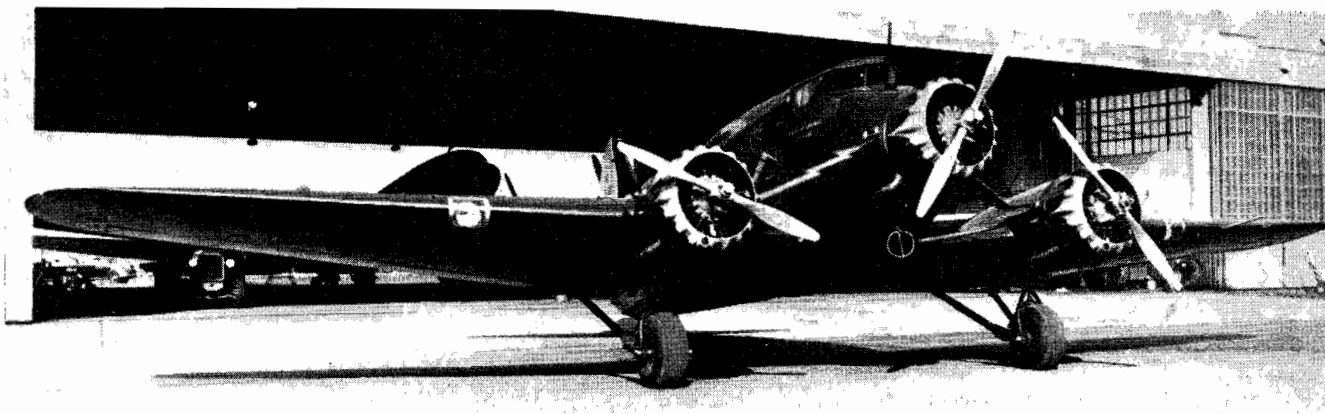

The loop aerial installed in an American Airlines Stinson monoplane.

THE AUTOMATIC RADIO COMPASS

TEN YEARS AGO initial efforts were made to develop a radio compass system, then called "Hertzian compass," in which the angles indicating the position of a radio transmitter appeared automatically on a graduated scale, similar to the scale of an ordinary magnetic compass. Two years later, more complete studies were undertaken and rough models and testing apparatus were constructed. A first working model was then made and the essential principles established. The apparatus described here, therefore, is the outcome of considerable development work by Les Laboratoires, Le Materiel Telephonique, Paris, France, an associate company of the Interna-

The equipment installed in the demonstration plane.

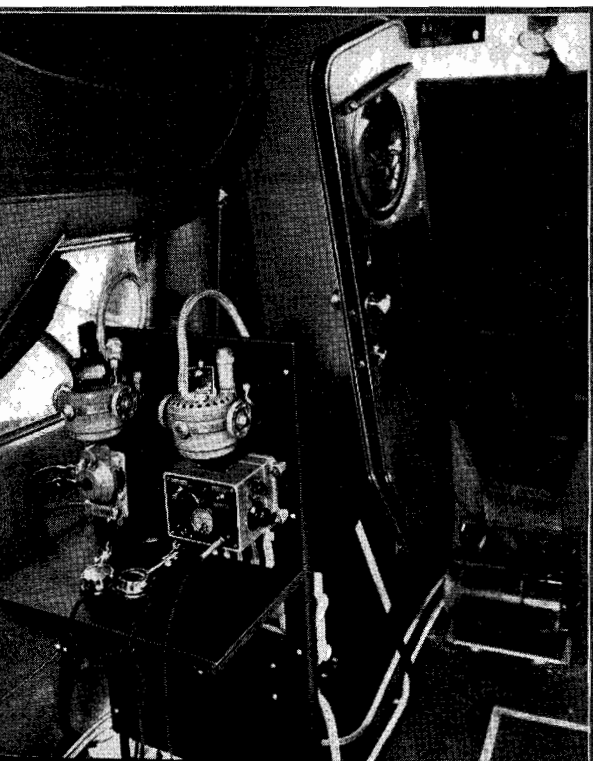

Navigator's indicator complete.

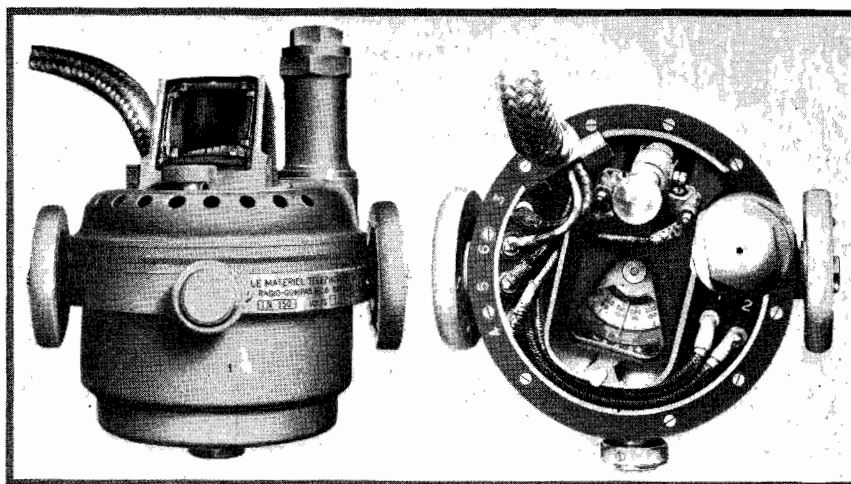

Navigator's indicator, cover removed.

tional Telephone and Telegraph Corporation.

The automatic radio compass has been submitted to numerous tests by both civil and military aviation authorities in France and other European countries, and it has been adopted by several civil as well as government services abroad. This compass, designated as the R. C. 5 E, was recently introduced to American aviation at a demonstration held at Newark airport, Newark, N. J.

The R. C. 5 E automatic radio direction finder can be used readily as a homing device to indicate the deviation to right or left when heading directly toward a radio transmitter, and it also permits cross bearing to be taken during a flight upon radio stations located

to the right or left of the aircraft's course. In other words, the automatic radio compass provides the pilot with a continuous indication of the bearing of any radio station to which it is tuned. This operation is performed by means of a single lever only and involves no more technique than that required to adjust the ordinary domestic radio receiver. The bearings are relative to the longitudinal axis of the aircraft and appear automatically on an indicator similar to that of an ordinary magnetic compass.

By taking advantage of the numerous broadcasting and radio-range stations now in operation, it is unnecessary to use the transmissions from airport ground stations except when the direc-

tion finder is in use as a "homing" device. When homing on any suitable transmitter, due allowance can be made for the angle of drift. Bearings can be taken on any transmitters within range for the purpose of obtaining a line of position; several bearings can be taken in the space of a minute. The bearings so obtained are automatically and continuously registered on an indicator similar in appearance to a magnetic compass, so long as the receiver is tuned to the transmitting station. If simultaneous readings are taken on both radio and magnetic compass, the latter being corrected for magnetic variation and deviation to give the aircraft's true bearing, then the sum of this true bearing and the radio bearing gives the true bearing of the transmitting station from the aircraft, thus enabling the pilot to determine his line of position on a chart.

heterodyne receiver; a remote control head; and a phasemeter-type indicator of bearings. Weight of the complete equipment, excluding battery and electrical cabling, is under 50 pounds. The receiver operates in the range of 200-2000 meters (1500-150 kc), is fed from a 24 or 12-volt power-supply source, and requires 125 watts of current supply.

The rotating loop, about one foot in diameter, is driven through a reduction gear by a small electric motor at a constant speed of 300 rpm. The loop has a drag of about 6 pounds at 150 miles per hour; when the loop is rotating, the drag is increased by 0.2 to 0.4 pounds.

Since a loop receptor is most responsive to signals lying within its plane, and least responsive to those at right angles to it, this rotating loop will give maxima and minima of reception at the



A close-up view of the loop.

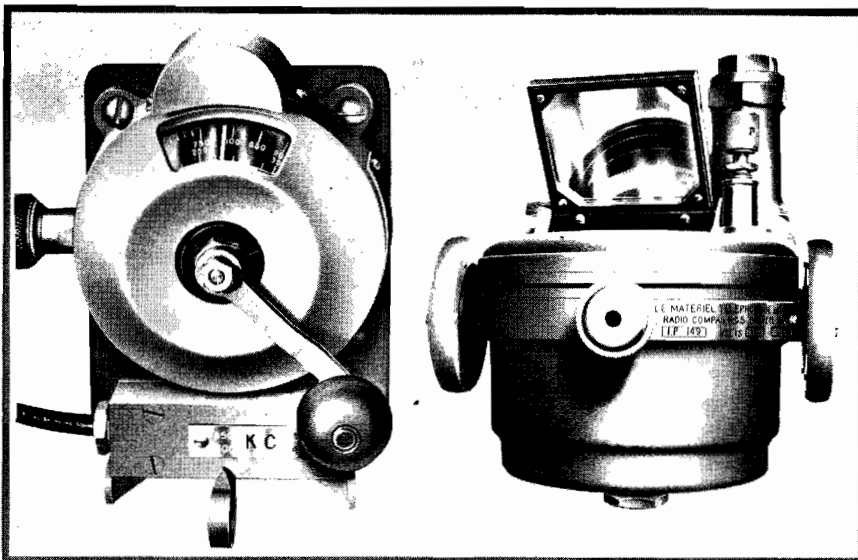

The tuning dial.

The pilot's indicator.

The ease and rapidity with which bearings may be obtained render it practical to obtain numerous intersecting "position lines" and thus fix definitely the position of the aircraft. The whole equipment is remotely operated and can be controlled by the pilot alone if so desired. No trailing aerial is used. The apparatus consists of a small motor-driven rotating loop mounted externally on the airplane; a special 5-tube super-

rate of 600 per minute each. The phase of these maxima and minima, i. e., the moment at which they occur with reference to the signal source, is an indication of angular relationship between the source of signal and the neutral axis; the neutral axis of the instrument coincides with the longitudinal axis of the airplane.

Signals received by the loop are fed through the special receiver, producing a variable current in its output stage in phase with respect to the neutral axis with the received wave. The neutral axis of the instrument to which the phase angle of the loop currents may be compared is obtained by placing on the rotating shaft of the loop a two-phase current generator, the phase of which is adjusted and held constant and coincident with the airplane's longitudinal axis. The variable current from the receiver, representing the maxima and minima of reception, and the two-phase generator current, are compared as to

phase by a special improved phasemeter.

The variable receiver current produces a-c in the armature of the phasemeter, a fixed-phase rotating field is produced in the stator of the phasemeter by the two-phase generator. The magnetic reaction of the fluxes produced by the two currents moves the armature to a position perpendicular to the flux when the current is at its maximum, thus giving constant and automatic indication of the phase angle, and therefore the bearing of the transmitting station in degrees of arc.

Two indicators can be utilized. One is called "navigator's indicator" and the other, "pilot's indicator." In the first, the indication is read on a movable dial graduated in 360° and moving in connection with a fixed pointer. In the second, the indication is limited to $\pm 15^\circ$.

The first is called "navigator's indicator" because it is designed to read bearings directly indicating the position of the plane in relation to any given transmitter located in any quadrant. The second is designed for flying toward any given transmitter, and is useful for this type of radio navigation. It represents an important advantage over the homing systems since it greatly facilitates correction for drift.

The control unit.

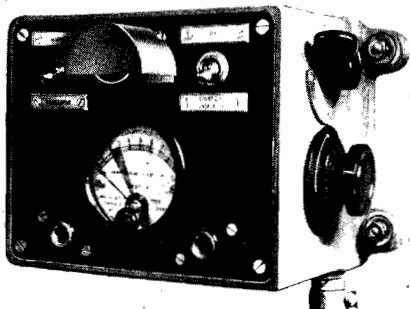

The radio receiver.

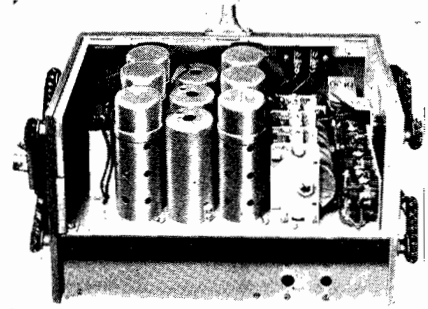

THE MARKET PLACE

NEW PRODUCTS FOR THE COMMUNICATIONS FIELD

UNIVERSAL MICROPHONE

In November a new transmitter-type microphone will be distributed. The new instrument will be an airplane desk type for small transmitting stations such as those for airways or police stations. It will be designed similar to a telephone and will be produced with the switch at the top of the microphone, in the base as a press button, or in the side of the tube. From the base upward the center of the microphone will be ten inches or the standard telephone height. The instrument will be furnished with aeroplane or police type of single-button, high sensitivity carbon microphone, or with Brush crystal unit, or as a dynamic.

This microphone is a product of the *Universal Microphone Co.*, Inglewood, California.—COMMUNICATIONS.

MAGNESIUM DIE CASTING ALLOYS

Doehler has just announced the addition of magnesium base alloys to their list of die casting alloys which include tin, lead, zinc, aluminum and copper base alloys.

Magnesium is the featherweight of the known commercial metals. It is fully one-third lighter than aluminum and on the weight unit basis, is the strongest metal available.

The addition of magnesium to the list of available die-casting alloys combines the labor-saving feature of the die-casting process with the weight-saving feature of magnesium.

The *Doehler Die Casting Co.*, 386 Fourth Ave., New York City, N. Y., will gladly supply additional information.—COMMUNICATIONS.

TRANSMITTING CONDENSERS

Solar has announced that a complete line of transmitting condensers is now ready for trade distribution. The new line embraces oil, paper and mica types in ratings that are said to be suitable for every purpose. A catalog illustrating and describing the Transoil, Solarex and Transmica families which comprise this new line may be secured by writing to *Solar Manufacturing Corp.*, 599 Broadway, New York, N. Y.—COMMUNICATIONS.



The Solar line of transmitting condensers.

Illustrating the wave-expanding feature of the new Du Mont Oscillograph.

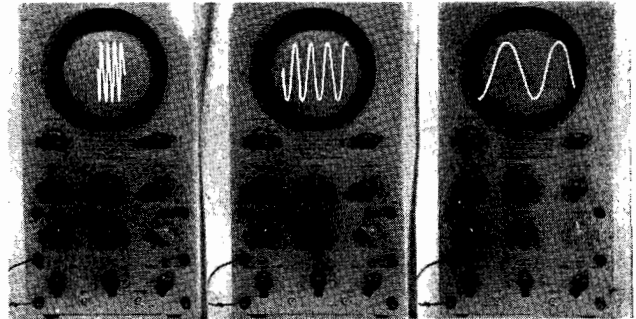

THREAD-CUTTING SCREWS

The development of a screw that actually cuts its own thread in metals and plastics of practically any thickness has recently been announced. Its patented, thread-cutting slot, plus a special hardening process, eliminates the separate tapping operation normally required in the use of standard machine screws. Important production savings in both labor costs and time are assured by the use of this new fastening

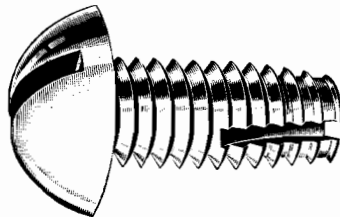

method and, because the screw remains in the threads it has cut, a better fastening is secured, it is stated. Should it ever be necessary to replace the screw, an ordinary machine screw of the same size will fit its threads. A free demonstration kit of Shakeproof thread-cutting screws, including an assortment of different sizes and complete instructions for testing, can be had by writing the *Shakeproof Lock Washer Company*, 2501 North Keeler Avenue, Chicago, Illinois.—COMMUNICATIONS.

WAVE-EXPANDING OSCILLOGRAPH

A wave-expanding feature, incorporated in a new DuMont 5-inch, all-purpose oscillograph, permits the spreading of a small portion of a wave for detailed study. It also allows expansion of waves of much higher frequency than the fundamental frequency of the sweep. Million-cycle waves are said to be observed with good detail, and the return trace eliminator permits the waves to appear only on the forward linear portion of the sweep.

Complete information may be secured from the *Allen B. Du Mont Laboratories*, Upper Montclair, N. J.—COMMUNICATIONS.

6Y6-G

The 6Y6-G beam power tube was recently announced by RCA to radio equipment manufacturers. It is intended for use in the output stage of a-c receivers, particularly those in which the plate voltage for the output stage is relatively low. With 135 volts on plate and screen, it is capable of giving an output of 3.6 watts with a maximum signal input of 13.5 volts. Under these conditions, the total distortion is about 9.5 percent.

Further details may be secured from the *RCA Radiotron Division, RCA Manufacturing Co., Inc.*, Harrison, N. J.—COMMUNICATIONS.

ADJUSTABLE MOTOR DRIVE LATHES

A new design of South Bend back-gear, screw cutting, precision lathes in the pedestal adjustable motor drive has been announced. The new drive is available in the five sizes—9, 11, 13, 15, and 16-inch swing, and in bed lengths from 3 to 12 feet.

The pedestal adjustable motor drive mechanism is a separate unit with the motor and countershaft mounted on a pedestal back of the lathe in a position horizontal with the headstock cone pulley of the lathe. Power is transmitted from the motor to the countershaft by V-belts, and from the countershaft to the lathe spindle by a flat leather belt. This is said to provide a smooth, steady pull, free from vibration and chatter.

The *South Bend Lathe Works*, South Bend, Indiana, will gladly furnish additional information on these lathes.—COMMUNICATIONS.

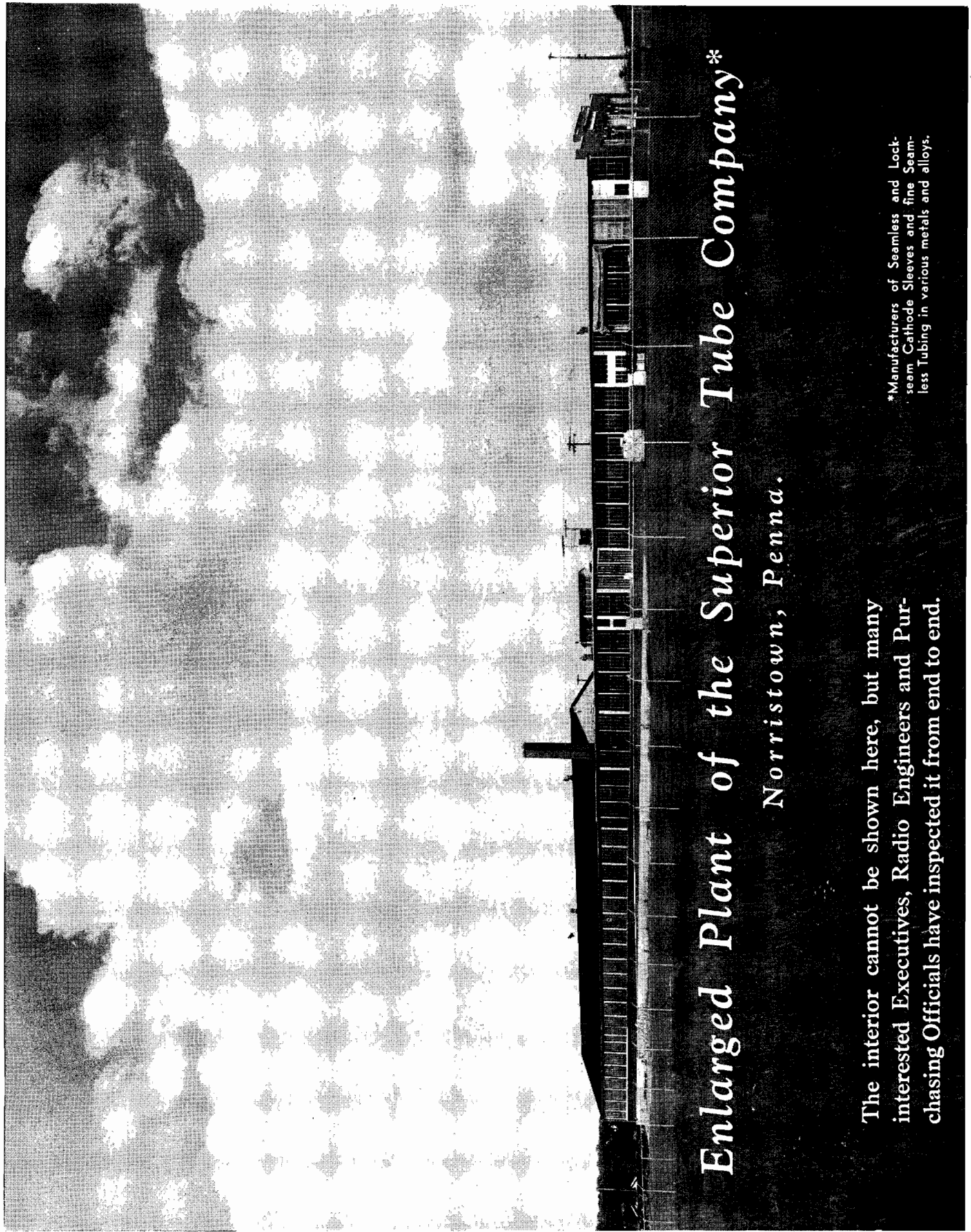

*Enlarged Plant of the Superior Tube Company**

Norristown, Penna.

The interior cannot be shown here, but many interested Executives, Radio Engineers and Purchasing Officials have inspected it from end to end.

*Manufacturers of Seamless and Lock-seam Cathode Sleeves and fine Seamless Tubing in various metals and alloys.

SUPERIOR TUBING

COMMUNICATIONS FOR OCTOBER 1937 • 37

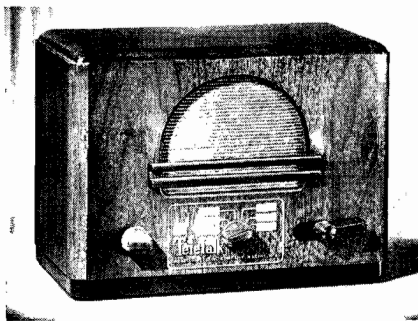

A-C, D-C INTER-COMMUNICATION SYSTEM

The Model 105 Teletalk is a loudspeaker inter-communication system for use in office, factory, home, etc., where inter-communication between one point and one to five remote points is desired either as a group or selectively. A system consists of one master station which is selective and which controls the direction of the conversation and originates the call to the remote speaker stations which can answer the master station only when called. No communication is possible between the speaker units.

Cabinets are solid walnut with a hand-rubbed finish. Communication can be carried on over a distance of 3,000 feet. The Model 105 Teletalk is a product of the *Webster Electric Company*, Racine, Wisconsin.—COMMUNICATIONS.

PHOTOTUBES

The following new photo tubes have just been introduced:

RCA-921, gas phototube (cartridge type); RCA-922, vacuum phototube (cartridge type); RCA-923, gas phototube.

The 921 and 922 are small in size and built in a new way. They have a short double-ended construction which eliminates the conventional base and provides a long insulating path between electrodes. The terminals at either end are in the form of metallic buttons, so designed as to permit inserting each phototube easily and positively in a clip mounting. Features of these new simplified tubes are their lower cost, their low interelectrode capacitance, and their convenience in circuit arrangement.

Although these two new tubes are alike in appearance, the 921 is a gas phototube, while the 922 is a vacuum phototube. These phototubes, because of their high sensitivity to infra-red radiation, are particularly useful in applications where incandescent lamps are employed as light sources.

The new RCA-923 is a gas phototube of the conventional type. It is similar mechanically and electrically to the RCA-918, but has a shorter overall length.

Further details of the characteristics and rating of each of these three types may be secured from the *RCA Radiotron Division*, *RCA Manufacturing Co., Inc.*, Harrison, N. J.—COMMUNICATIONS.

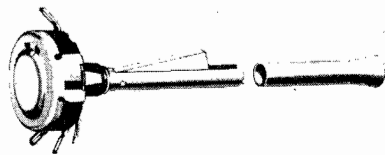
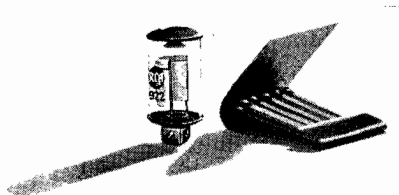

AUTO-RADIO VOLUME CONTROL

The control shown in the accompanying illustration is one of the new type which has been designed to effect speedy replacement in auto radios. These controls are available with or without switch in resistance values of $\frac{1}{4}$, $\frac{1}{2}$, 1, and 2 megohms. All are tapped for tone compensation—the tap can be omitted if desired. All have $\frac{1}{4}$ -inch diameter shafts 3 inches long, slotted for entire length. Hinged shaft insert makes duplication of either slotted or tongue-type shafts easy. The controls without switch are assembled with a slip clutch shaft—an important feature for those cases where the “on-off” switch is in the remote-control head. Switch type units are furnished with double-pole single-throw switch.

Further information may be secured from *Centralab*, 900 E. Keefe Ave., Milwaukee, Wisc.—COMMUNICATIONS.

CATHODE-RAY OSCILLOGRAPH

The Model RFO-4 cathode-ray oscillograph, shown in the accompanying illustration, has a self-contained electronic frequency modulator which simplifies connections and permits selectivity measurements. It has a variable width sweep from 0-30 kc. This modulator permits visual alignment at 665 kc or any harmonic thereof to 5 megacycles, without the use of an external oscillator. With an external oscillator it produces an audio-frequency output continuously variable from 0 to 15 kc. Also permits visual development of audio-frequency response curve.

Among the other features of this instrument are: return trace eliminator (simplifies alignment of a-f and r-f circuits); horizontal amplifier for sweep expansion; high sensitivity horizontal and vertical amplifiers (0.2 volt per inch); trapezoidal patterns permit percent modulation measurements; calibrated screen; cathode-ray tube rotation adjustable by means of flexible mounting.

Complete information may be secured from the maker, *The Hickok Electrical Instrument Co.*, 10514 Dupont Ave., Cleveland, Ohio.—COMMUNICATIONS.

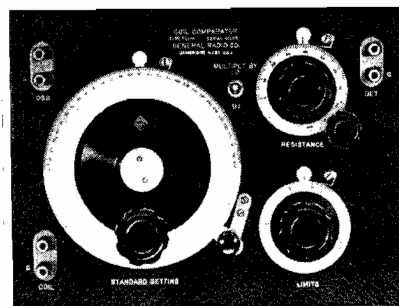
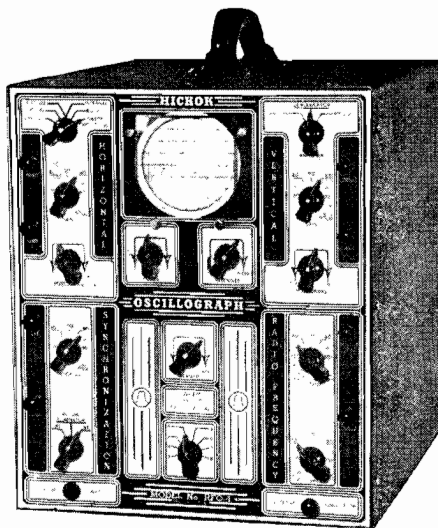

COIL COMPARATOR

The Type 721-A coil comparator is intended for use in the production testing of radio-frequency coils, such as those used in radio receivers. The test is made by comparing the coil with a standard sample.

The coil comparator uses a new measuring circuit which combines the precision of a null method with the simplicity of a resonance method. The circuit is a bridged-T network, which, like a bridge, uses a null point as an indication of balance. The reactance and resistance adjustments are entirely independent, which greatly facilitates balance settings.

In addition to its use as a comparator, direct measurements can be made of inductance and resistance. Capacitance can also be measured if an external coil is used to obtain a balance.

Additional information may be secured from the *General Radio Company*, 30 State Street, Cambridge, Mass.—COMMUNICATIONS.

"PLUGGIN" CONDENSERS

A departure from conventional design in electrolytic condensers is the Tobe “Pluggin” condenser, a newly patented product constructed with a UX 4-prong tube base. With this new unit it is possible to make quick changes. The unit is completely sealed and protected against moisture and high temperatures in a non-corrosive aluminum container. Further information may be obtained from *Tobe Deutschmann Corporation*, Canton, Mass.—COMMUNICATIONS.

CATHODE-RAY TELEVISION TUBES

Two new cathode-ray tubes intended for television reception have recently been made available. They are announced at this time for the convenience of experimenters and amateurs who wish to construct experimental television receiving equipment. Identified by the type numbers RCA-1800 and RCA-1801, these new tubes are known as Kinescopes.

These tubes are of the electromagnetic-deflection type and employ viewing screens on which pictures appear with a yellowish hue. RCA-1800 has a 9-inch screen, while RCA-1801 has a 5-inch screen.

Further information may be obtained from the *RCA Radiotron Division*, *RCA Manufacturing Co., Inc.*, Harrison, N. J.—COMMUNICATIONS.

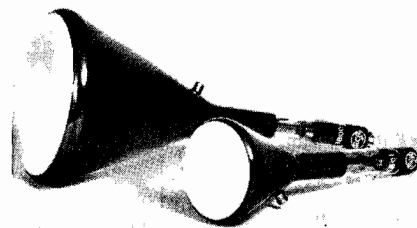

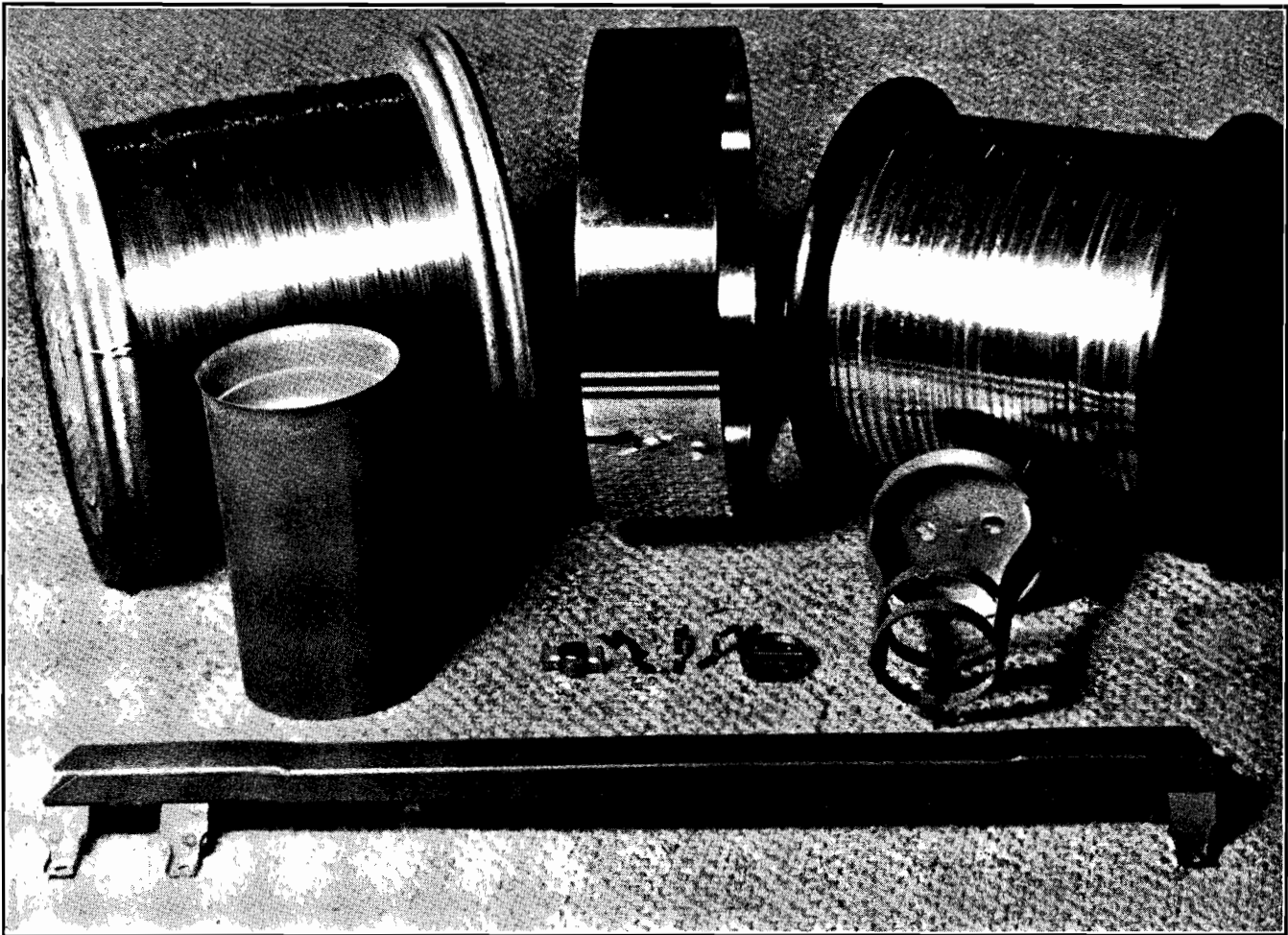

Unretouched photograph

SVEA METAL

In any form, round or flat wire, or strip, the leader for Purity, Quality and Uniformity.

Whether for the smallest receiving tube parts or the large Transmitters and Rectifiers, SVEA METAL is used by makers of Quality Tubes.

Illustrated are collars and shields for receiving and transmitting tubes. Small or large they are just as important and All SVEA METAL for Quality. Also shown are tiny mica straps for receiving tubes in contrast to the large anode support for power tubes.

A QUALITY METAL for a QUALITY PRODUCT

—— SVEA METAL ——

Swedish Iron & Steel Corporation

17 BATTERY PLACE

NEW YORK CITY

RAYTHEON TUBES

Several new Raytheon tubes have recently been announced, among them the 6F8G and the K49CB.

The 6F8G is a tube designed for use as a voltage amplifier and has two independent triode sections, the elements of which are all brought out to separate terminals. Each triode section has the same characteristics as the type 6J5G.

The K49CB is a resistance tube for use in a-c/d-c receivers and is characterized by a ballasting action for the pilot lights not found in the type K49C.

Complete information on these tubes is available from the *Raytheon Production Corp.*, 55 Chapel St., Newton, Mass.—COMMUNICATIONS.

HEAVY-DUTY WELDER

The welder, shown in the accompanying illustration, is of the heavy-duty type and is supplied in capacities from 75 to 250 kva. It is air operated and controlled with magnetic valve, foot-operated switch, and automatic timer and contactor. The welder is supplied with air or water-cooled trans-

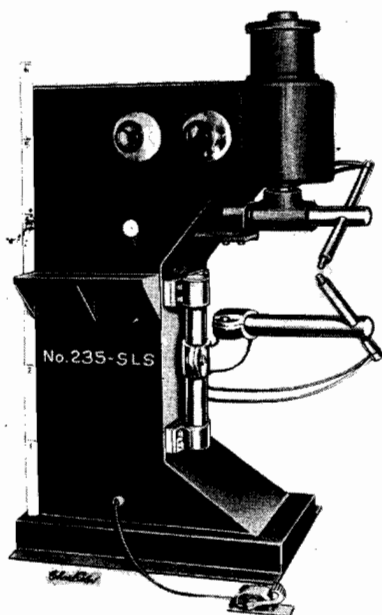

former depending on size. Current changes are obtained by 24-point variable switch. All controls, connections, etc., are completely enclosed in machine body. Bottom arm has vertical adjustment; top and bottom arm can be turned in any position. Electrode holders are water cooled.

This welder is a product of the *Eisler Engineering Co., Inc.*, 750 South 13 Street, Newark, N. J.—COMMUNICATIONS.

TRIADYNE 6AC5G

The Triadyne 6AC5G is a positive-grid Class A power-amplifier triode which is similar to the output section of the type 6B5, and requires a type 76 driver tube to be connected with it in the usual dynamic-coupling type of circuit. The type 76 tube performs the same function as the input section of the 6B5. While the positive-grid characteristic of the 6AC5G suggests typical Class B service, the tube has been designed to give optimum performance in Class A service with the 76 driver.

Complete data may be secured from *Triad Manufacturing Co., Inc.*, Pawtucket, Rhode Island.—COMMUNICATIONS.

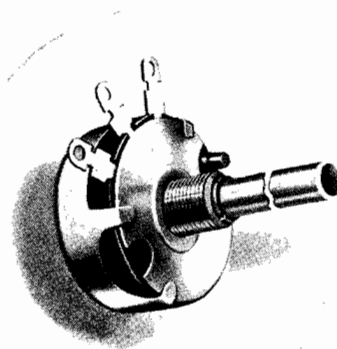

IRC POWER CONTROL

A new IRC metallized-type power control, capable of carrying 2 watts, for plate-circuit tone control and other similar applications, has recently been announced. It is known as the IRC Type CP control. It incorporates all of the well-known features and characteristics of the Type C control, including the metallized-type resistance element permanently bonded to a moisture-proof bakelite base, 5-finger contact, etc. Rapid heat conduction from element to cover and shaft assembly is obtained by an arrangement of a copper heat-conducting plate. This is said to make possible the conservative 2-watt rating as compared to the 1/2-watt rating of standard IRC Type C controls. The size is the same as that of the latter, being small for a power control of this rating.

Complete specifications and samples will be sent upon requests addressed to the *International Resistance Co.*, 401 N. Broad St., Philadelphia, Pa.—COMMUNICATIONS.

VIBRATION PICKUPS

The Brush Development Company recently announced its complete line of vibration pickups. These devices are of typical piezo-electric Rochelle salt crystal design, and are applicable to the study of noises and vibrations in various industrial applications. Three types are now available. Characteristics of the various pickups are such that they cover the complete frequency range. Literature describing these crystal devices is available from *The Brush Development Co.*, 3311 Perkins Ave., Cleveland, Ohio.—COMMUNICATIONS.

TEST-O-LITE

For a number of years the Test-O-Lite has been used for testing electrical circuits. Recently, an improvement has been made

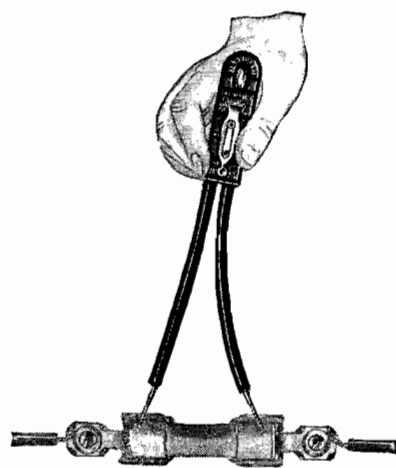

in this product which includes a pocket clip for holding the Test-O-Lite firmly in the pocket. Another improvement is increased sensitivity so that it more easily detects the presence of from 90 volts to 500 volts a-c or d-c by the small neon lamp located in the body of the tester.

The Test-O-Lite is a product of *L. S. Brach Mfg. Corp.*, 55 Dickerson St., Newark, N. J.—COMMUNICATIONS.

LOW-LOSS COAXIAL CABLE

The "CO-X" low-loss coaxial cable is said to have been brought to the market as a result of the development of "Anhygron"—a non-hygroscopic, light-weight, high-strength insulation material. Uses of CO-X are in antenna leads-ins, transmission lines, and feeders; transmission lines between photo-electric cells and amplifiers; in circuits where h-f or leakage losses must be small, and in similar circuits where radiation or pick up must be low. CO-X is comprised of three components, (1) the braided inner copper conductor, (2) the Anhygron separators, and (3) the outer conductor braid.

Complete information may be secured from the *Transducer Corporation*, 30 Rockefeller Plaza, New York City.—COMMUNICATIONS.

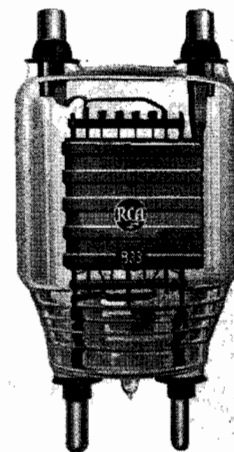

TRANSMITTING TRIODE

A new type of design is featured in the transmitting triode shown in the accompanying illustration. Features of the new design are: a minimum amount of insulation within the tube, low internal lead inductances, and a post terminal construction which makes bases unnecessary. The new tube is designated as RCA-833 and is of the high- μ type for use as a radio-frequency amplifier, oscillator, and Class B modulator.

As a result of its construction, the 833 provides high plate efficiency at moderate voltages. For example, it is said to be capable of giving in broadcast service a carrier output of 635 watts at 2500 volts on the plate, and with this carrier output can be modulated 100 percent. In other services such as police transmitters, aviation transmitters, and experimental ultra-high-frequency transmitters, the 833 also provides good efficiency. It can be operated under conditions of maximum input ratings at frequencies up to 30 megacycles. With reduced inputs its operating range is extended to 100 megacycles.

Further data regarding this tube may be secured from the *RCA Radiotron Division*, *RCA Manufacturing Co., Inc.*, Harrison, N. J.—COMMUNICATIONS.

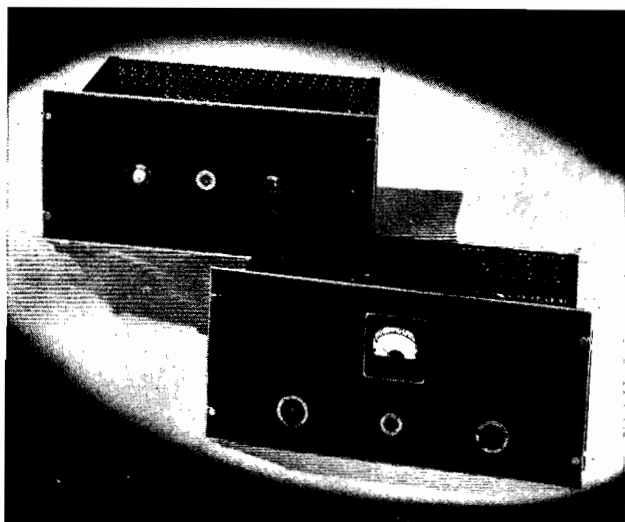

The UTC model 7A-8A studio amplifier has been designed for audition and monitoring service, or for home radio service, where the absolute maximum in fidelity is desirable. It is also suitable for driver service for 100W. or 250W. broadcast stations.

STUDIO MONITORING AMPLIFIER

Three push pull stages are used, all transformer coupled. The first two stages employ 6C5 or 6C6 triode tubes. The output stage can be arranged for either 2A3 or 300A tubes. The power output is 15W. The gain is 85 DB with noise level 60 DB weighted below maximum output. The frequency response is uniform from 30 to 14,000 cycles.

The input transformer used has primary impedances of 50, 125, 200, 250, and 500 ohms. The output transformer can be altered to suit the particular requirements of the user. Standard transformers are available for driver service, for broadcast line and universal voice coils, or for high impedances up to 6,000 ohms, simultaneously with the voice coil windings.

A meter and switch is provided on the audio panel to check the plate current of the first stage, second stage and the individual tubes in the output stage. A control is provided in the output stage to balance the plate current of the output tubes. This is extremely important in high power output stages to effect a minimum of hum and distortion. The power supply panel incorporates a readily replaceable pilot light and fuse. These units are finished in the UTC attractive etched metal panels with dimensions 8 $\frac{3}{4}$ " x 19". The model 7A-8A unit is supplied complete, wired and calibrated. Net. **\$160.00**

EQUALIZER

MODEL 3A—The UTC universal equalizer will equalize telephone lines, recording systems, pickups and cutters, microphones and all other broadcast equipment. It is accurately calibrated and quickly adjustable for both low and high frequency equalization. Low frequency controls permit maximum equalization at 25, 50 or 100 cycles with zero to 25 DB control. The high frequency end permits maximum equalization at 4000, 6000, 8000, or 10,000 cycles with zero to 25 DB control.

Net price to broadcast stations and recording studios **\$85**

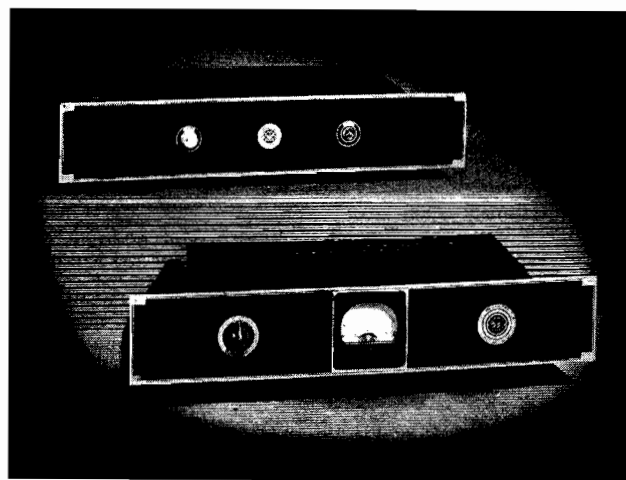
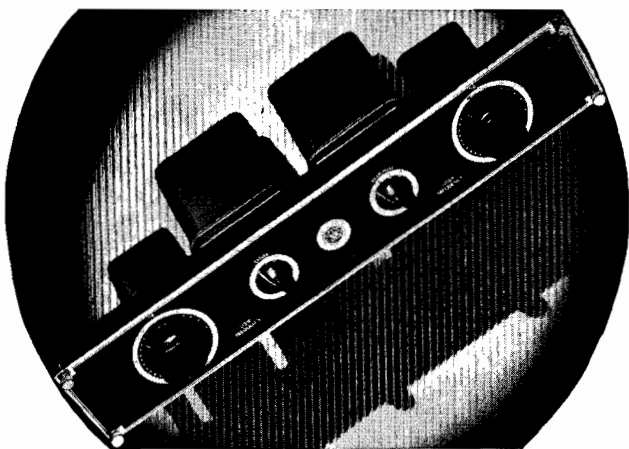

STUDIO PRE-AMPLIFIER

The UTC 5A-6A pre-amplifier is designed to the best broadcast standards for studio service. Input coils are hum-balanced and in addition have quadruple alloy shields. The hum level is practically negligible due to extremely fine filtering in the power supply. The noise level is 60 DB weighted below the maximum output of plus 7 DB. The frequency response is uniform from 30-to-14000 cycles.

Input and output connections will accommodate 50, 125, 200, 250 or 500 ohm lines. The audio amplifier is arranged so that either 1, 2, 3, or 4 stages can be used with respective gains of 25, 50, 73, or 95 DB. Etched panels are used, having dimensions 3 $\frac{1}{2}$ x 19. This unit is supplied, wired, and calibrated. Net. **\$125.00**

UNITED TRANSFORMER CORP.

72 SPRING STREET

NEW YORK, N. Y.

EXPORT DIVISION: 100 VARICK STREET NEW YORK, N. Y. CABLES: "ARLAB"

12H

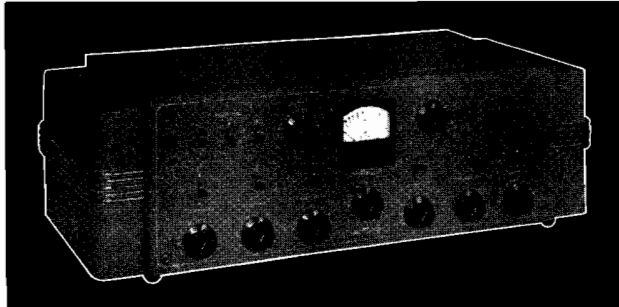

SPEECH INPUT ASSEMBLY

Accepted as the most dependable and finest speech input console, the 12H is being adopted as standard equipment in more and more broadcast stations. 12N and 12Q Consoles (similar to 12H, but modified in circuit and switching arrangement) meet special requirements in large studios.

COLLINS RADIO COMPANY

C E D A R R A P I D S I O W A

NEW YORK, N. Y. 11 WEST 42 STREET

**"ANOTHER CORNELL - DUBILIER
ACHIEVEMENT"**
STATION KGU
H O N O L U L U

KGU has served the islands of Hawaii and the mainland since 1922. Importance of dependability in its broadcast equipment cannot be over-emphasized. To maintain modern standards of radio transmission, every piece of apparatus in this station had to be of the finest.

**That is why KGU engineers selected
CORNELL - DUBILIER CAPACITORS.**

*Just one of the many instances in
which C-D condensers have established
a noteworthy record of dependability.*

**Mica • Dykanol • Paper
Wet and Dry Electrolytics**

For complete details send for Catalog No. 150

*Photo Courtesy Station KGU—Honolulu.

**CORNELL-DUBILIER ELECTRIC
CORPORATION**

WORLD'S OLDEST AND LARGEST
EXCLUSIVE MANUFACTURER OF
CAPACITORS

1005 Hamilton Blvd., So. Plainfield, N. J.

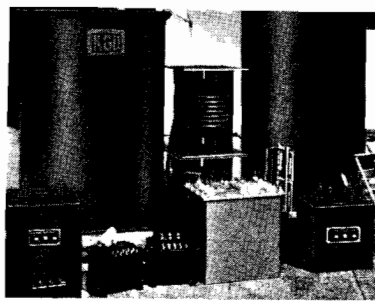

CORNELL - DUBILIER ELECTRIC CORP.

South Plainfield, New Jersey

FILTER SELECTIVITY

(Continued from page 13)

frequency

$$-\omega_0^2 LC = -4 \text{ or } LC = \frac{4}{\omega_0^2}$$

Substituting back we get

$$\frac{Z_1}{Z_2} = \frac{4\omega^2}{\omega_0^2} \text{ or } -\frac{(2F)^2}{(F_0)}$$

where F is the frequency.

B. *High-Pass Filter.* Fig. 7 shows the basic T-structure and the polar diagram of r for the simple high-pass filter. In this case we start at the origin 0 at zero frequency and travel to the left with increasing frequency then swing around the semi-circle at the bottom for here the current leads in the succeeding section. We go around the semi-circle to the end at A corresponding to an infinite frequency.

It is to be noted that in this case $\frac{Z_1}{Z_2}$

approached the range -4 to 0 from the -4 side as against the 0 side in the case of the low-pass filter. It is also to be noted that in both cases θ increased (clockwise rotation) with increasing frequency, a general rule.

C. *Band-Pass Filter.* If in the band-pass filter $\frac{Z_1}{Z_2}$ approaches the range

-4 to 0 from the zero side the resulting r-diagram will be like that for the low-pass filter, Fig. 6, with the range $0A$ added. This is shown in Fig. 8. If the range -4 to 0 is covered by Z_1 in this order, then the polar diagram

of Fig. 9 holds, which is similar to Fig. 7 for the high-pass filter with the range $A0$ added.

It is also possible to get effectively a double pass band by having Z_1 and Z_2 reverse sign at the same instant giving a -4 to 0 and a 0 to -4 adjacent band for a total -4 to 0 to -4 . The polar diagram for this case is shown in Fig. 10. The corresponding case of 0 to -4 to 0 does not exist.

The graphs shown for all the filters so far are for the simplest filter types (those known as the constant-k). In general it is not necessary for the loss bands to have one terminus located at the origin. It may instead be located anywhere in the region $0 < r < 1$. As a simple example a high-pass filter structure is shown in Fig. 11 together with its r-diagram.

Here the zero-frequency point gives r between 1 and 0. With increasing frequency the loss increases in phase to

(Continued on page 44)

Let CLAROSTAT

Solve

YOUR RESISTANCE PROBLEM

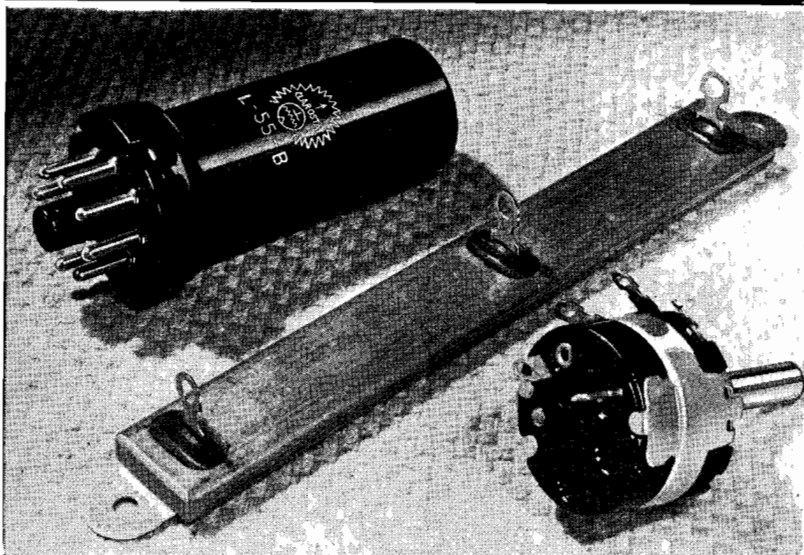

RESISTANCE devices—nothing else, are the sole concern of the CLAROSTAT organization. Its engineers are constantly engaged in developing new products and the further improvement of existing products. Its plant is equipped exclusively for the production of wire-wound and composition-element resistors and resistance devices. Such specialization is bound to be reflected in CLAROSTAT products—and CLAROSTAT quotations.

No matter what your resistance problem may be, it will pay you to submit it to CLAROSTAT for engineering collaboration and quotations.

Loose-Leaf DATA

Complete collection of engineering bulletins, in binder, will be sent if you write on your business letterhead. Meanwhile, don't forget to submit those resistance problems for engineering aid and quotations.



VOLUME CONTROLS

- Composition and wire-wound types, including the new Midget Type just introduced. Widest range of resistance values and choice of tapers and taps, shafts and switches. Maximum immunity to moisture and climatic conditions. Minimum noise. Smoothest mechanical operation.

METAL-TUBE RESISTORS

- Handy voltage-dropping and voltage-dividing resistance networks in metal envelopes similar to metal-type tubes. Compact. Safe. Keep heat above chassis. Hundreds of thousands already in daily use.

ARMORED STRIP RESISTORS

- Metal-clad resistors including latest Molded-Seal Type with bakelite protective jacket inside metal casing for absolutely outstanding service. Doubles wattage rating. Greatest immunity to moisture. Widest range of resistance values and taps.

and OTHER TYPES

- Flexible resistors with braided covering; hum-balancing potentiometers; dual and triple controls for T-pad, L-pad and mixer constant-impedance controls; output attenuators, etc.

CLAROSTAT *Manufacturing Co. Inc.*



285-287 NORTH SIXTH STREET
BROOKLYN, NEW YORK, U.S.A.

• OFFICES IN PRINCIPAL CITIES •

Announcing the NEW PRESTO

Junior
Portable
Recorder



THE lightest . . . smallest . . . least expensive . . . instantaneous sound recorder ever produced. Weight 35 lbs. . . size 20" x 15" x 10" . . . less than half the price of any PRESTO recorder previously offered. The Presto Junior Recorder makes and plays 12" records at 78 RPM . . . cuts at 100 lines per inch on Presto aluminum or cellulose coated blanks . . . gives an amazingly good quality of reproduction.

An ideal machine for out of the studio recording

**ORDER NOW FOR DELIVERY
DURING OCTOBER**

PRESTO

RECORDING CORPORATION
149 W. 19th Street, New York, N.Y.

Export Division (Except Australia & Canada)
M. SIMONS & SON CO., INC.
25 Warren St., N. Y. Cable: Simontrice, N. Y.
Australia & New Zealand Agents & Stockists
A. M. CLUBB & CO., LTD.
76 Clarence St., Sydney, N. S. W., Australia

FILTER SELECTIVITY

(Continued from page 42)

∞ at the resonant frequency F_1 of the shunt branch where the phase reverses and the loss thereafter decreases to zero at the cutoff frequency F_0 after which comes the pass band going up to infinite frequency.

D. *Band-Elimination Filter.* Fig. 12 shows a T-network and a current-ratio diagram for a simple low/high-pass or band-elimination filter.

In this case there is a pass band from 0 where $\frac{Z_1}{Z_2} = 0$ to F_0 where $\frac{Z_1}{Z_2} = -4$

for the first time. Then the loss builds up to an infinite amount whenever Z_1 becomes anti-resonant or Z_2 becomes resonant, whichever happens first. Then there is a region of loss in phase decreasing from an infinite loss to a finite amount and then back to infinity again at the frequency where Z_1 becomes anti-resonant or Z_2 becomes resonant, whichever occurs later. Then the loss decreases with phase reversal to F'_0 the start of the high-pass band above which the pass band to $F = \infty$ is represented by the lower semi-circle.

More filter types could be shown but these are sufficient to illustrate the method of plotting the attenuation and phase-shift characteristics. In a com-

plicated filter section $\frac{Z_1}{Z_2}$ may cover all

or parts of the range $-\infty$ to $+\infty$ many times as the frequency goes from 0 to ∞ . Each time the range -4 to 0 is passed there is a pass band of a type plotted. Similarly the losses outside these ranges are of types plotted so that by assembling such portions of current ratio plots the entire characteristic is readily found.

In conclusion a simple mathematical derivation of the attenuation and phase characteristics of filters has been worked out. The simplicity is obtained first by avoiding the usual derivation of characteristic impedance as the first step, and further by avoiding all hyperbolic functions. A simple equation to give the propagation characteristic as the current ratio is derived and it is then solved "backwards" by inspection to get the required filter theory without solving quadratic functions. It is believed that the utmost simplification has been used while still retaining the basic mathematical theory of filters.

Next examples of simple filter types are given. The results are plotted in graphs of the current ratio to show the attenuation and phase shift from one section to the next.

Looking at how much theory has been developed from so simple an equation

(4) one is amazed, not at the complexity of the filter theory, but rather that so much can be stated in an equation appearing so insignificant.

TELEVISION EXPERIMENTS WITH MOBILE TRANSMITTER

EXPANDING the scope of its experimental television, the National Broadcasting Company will inaugurate outdoor pickups this month, for the first time in America, with an RCA mobile television station. The portable unit, the first to be built in the United States, is now under construction.

The outdoor experimentation will be another forward step in the television field tests. Immediately after the delivery of the new station NBC engineers will begin an intensive schedule of televising outdoor scenes and current events. Football games and other sports, parades and news events are listed in the outdoor schedule. All of the work, however, will be strictly experimental, with a view to improving the equipment and methods.

The new mobile television station will consist of two specially constructed motor vans, each about the size of a large bus. Apparatus for picture and sound pickup will be installed in one, and a video transmitter, operating on a frequency of 177,000 kilocycles, in the other. In the metropolitan area, where many tall buildings make high-frequency transmission difficult, the unit's workable range will be about 25 miles. Ten engineers will be required to operate the two television units. In the experimental field work NBC's present mobile sound transmitter will be included in the station.

The van mounting the video, or picture, apparatus will be the mobile equivalent of a television studio control room. It will be fitted with television and broadcast equipment which will include two cameras, video amplifiers, blanking and deflector amplifiers, synchronizing generators and rectifiers for supplying the "Iconoscope" beam voltages. The principal sound apparatus will be microphones, microphone amplifiers and sound mixing panels. All the equipment will be mounted on racks extending down the center of the van, affording easy access to any part for repairs, and the alterations which will arise from the outdoor experimentation.

Because the transmitting equipment will generate much heat in operation, the interior of the van will be cooled by air drawn through filters at the rear of the vehicle and forced out through the front compartment. A water-cooling system will be installed to maintain tubes at operating temperatures.



“you’re the doctor”

It’s a time-worn expression—that phrase “You’re the Doctor!” It generally means, “I don’t wanna take the advice . . . but I guess I’d better . . . or else sompin’ may happen.”

We, the publishers of the industry’s liveliest, time-liest technical magazine say, “Get yourself signed up to a year’s subscription to COMMUNICATIONS. The 12 issues will only cost you \$1.00 if you use the Group Subscription Plan.

Here is how the “G-S-P” works: A regular yearly subscription to COMMUNICATIONS costs \$2.00—but when four or more men sign up at one time, each one is entitled to the half-price rate. (Foreign subscribers on the “G-S-P” only pay \$2.00 each.)

It is easy to get three or more of your co-workers to join a Group with you. Many hundreds of leading engineers and technicians have subscribed year after year on that basis. Use the convenient form on this page. Fill in the names, tear out and mail today with your check or money order. Renewals and extensions are acceptable also.

You will read it in COMMUNICATIONS first—the important news about all phases of the radio and communications industry. You’re the doctor—sign the prescription—er—we mean subscription, today!!

COMMUNICATIONS • BRYAN DAVIS PUB. CO., Inc.

To the Publisher of
COMMUNICATIONS
19 E. 47th St., N. Y. C.

Please enter annual subscriptions (12 issues) for each of the undersigned for which payment is enclosed at the rate of \$1.00 each. (This rate applies only on 4 or more subscriptions when classifications are given.)

Name
Address
City-State
Classification
Employed by

Name
Address
City-State
Classification
Employed by

Name
Address
City-State
Classification
Employed by

Name
Address
City-State
Classification
Employed by

for Smooth Control of Voltage



To regulate
A. C. Lines
•
Power
•
Speed
•
Heat
•
Light

Use TRANSTAT* REGULATORS

Used for numerous voltage-control applications because of its many advantages over resistive and tap-changing devices. Features are: High efficiency, good regulation, great flexibility. Voltage may be changed gradually, and without interrupting the circuit, from zero to values higher than line voltage. Well suited for large and small voltage-control problems. Equipment available for manual, motor, and automatic control of voltage of any commercial frequency in single-phase or polyphase circuits.

*Patents 1,993,007 and 2,014,570; other patents pending; Transtat trade-mark registered U. S. Patent Office.



Send
for
Bulletin
1176
for
complete
data

**AMERICAN TRANSFORMER
COMPANY**

175 EMMET ST. NEWARK, N. J.

AMERTRAN
QUALITY TRANSFORMERS SINCE 1901

VWOA NEWS

(Continued from page 33)

sentenced to be shot as a spy for having taken photographs.

"Chairman Kolster said he did not care to accept another term as Chairman. We are very sorry to lose his services. Treasurer Trop reports collection of a bunch of dues and will shoot them in right soon. We'll get out after the others and sign up many new members."

PERSONALS

WE TAKE genuine pleasure in reporting that Charles D. (Jerry) Guthrie, "always a VWOA Director," after serving over twenty-five years in various branches of the government radio services, is again a permanent member of the government family. On August 1st, 1937, Mr. Guthrie received a permanent Civil Service appointment as Radio Supervisor in charge of the New York office of the Maritime Commission. Hearty congratulations, Jerry, and all the luck in the world to you from all your friends . . . R. H. (Bob) Frey, Radio Supervisor for the Bull Steamship Lines, again, this month, tops all for the number of new members signed up. We advise all who are eligible for membership, but not desirous of joining just now, to avoid Bob for if he catches you, you'll stay caught. Thanks, Bob—keep up the good work. A few more like you and we would get back to our pre-depression quota.

NOTES AND COMMENT

(Continued from page 27)

quirement of an amplifier for proper sawtooth amplification.

When amplifiers are to be used to amplify the output of a linear sawtooth oscillator, additional requirements must be considered. Let us again refer to the sweep circuit of Fig. 3.

In the minimum feed current position of the four-megohm rheostat, the plate load impedance of the discharge tube is five megohms. This high impedance is necessary to keep the plate current of the discharge tube at a safe value with a power supply of sufficiently high voltage to insure good linearity.

If we apply the usual ten-to-one ratio used in the previous conditions to this problem, then this plate would be required to operate into an input potentiometer of 50 megohms. In addition to physical limitations, the conditions under equation (3) render such a value impossible. For minimum return trace time, the high-frequency response should be good, and the impedance of all circuits kept at a minimum. Under the requirements of equation (3) the input potentiometer should be 10,000 ohms for a maximum sweep frequency of 30 kc. A resistance of this low value would load the plate of the discharge tube until all semblance of linearity was gone.

To obviate this difficulty, a convenient method is to use a direct-coupled stage from the plate of the discharge tube.

VERTICAL RADIATORS

*engineered and constructed
by*

■ The facilities and experience of this organization in both the engineering and construction of radio broadcasting radiators assure the efficiency of your radiator. Compare the cost of radiators on the basis of field strength—you will find IDECO offers highest efficiency per dollar invested. Write for special data information and prices.

THE INTERNATIONAL
DERRICK & EQUIPMENT CO.
DIVISION OF INTERNATIONAL STEEL CORPORATION
Columbus, Ohio

CINAUDAGRAPH

Speaker

CINAUDAGRAPH Magic Magnet Speakers

—extensively utilized by all leading radio receiver and P. A. equipment manufacturers—are available in a complete range of sizes from 5½ to 18 inches, to meet your every radio requirement.

If you demand utmost dependability and fidelity of reproduction from your equipment—insist on Cinaudagraph P. M. speakers. Carried in stock by all progressive distributors. Free descriptive literature on request.

**CINAUDAGRAPH
CORPORATION**
Speaker Division • Stamford, Conn.

Direct coupling to the grid of a vacuum tube will provide high impedance for good linearity at low frequencies and proper potential distribution for good high-frequency response. This stage may be made with a gain of approximately unity and the whole circuit may be considered as a sweep oscillator of low-impedance output. The gain control will then be located beyond the output of this stage and at a low-impedance point. The cathode of the amplifier stage must, of course, be properly biased so that the grid may have the proper potential while operating from a positive plate.

Another consideration which is not essential to amplifier design but which must be observed for sweep-circuit design is that in no case can the input capacitance of the first amplifier stage into which the discharge tube feeds be of appreciable size with respect to the smallest sweep condenser in use, since this capacity is essentially in shunt with the frequency determining capacitor.

The requirements for proper amplifier design to cover a wide frequency range may then be summed up as follows:

$$R_p \ll R_g \dots\dots\dots (1)$$

$$RC \gg \frac{10}{f_{min}} \dots\dots\dots (2)$$

$$\text{Gain } R \leq \frac{1}{10 \omega C_y} \dots\dots\dots (3)$$

It must be borne in mind that these relations hold for every stage of coupling up to and including the deflection plates of the cathode-ray tube.

If an amplifier is to be employed for general oscillograph work in addition to sawtooth amplification it is highly desirable that it have high input impedance to avoid overloading the circuit under test. For an amplifier to handle satisfactorily a 30 kc sweep signal, equation (3) requires that the gain-control resistance be less than 100,000 ohms, on the assumption of only 5 mmfd for C_y . To satisfy the requirements of equation (2), however, it is necessary that RC be equal to or greater than .66 for a minimum sweep of 15 cycles per second and therefore the coupling capacitor must be at least 6.6 microfarads, a value which is not practical in commercial amplifiers. The gain-control resistance, however, has been left at the very highest possible value.

It can be seen, therefore, that the design of oscillograph amplifiers for wide frequency ranges and for sawtooth amplification is necessarily a compromise. A sacrifice must be made either by lengthening the return trace time, by sacrificing linearity, or by using high-resistance input circuits and losing the response at the higher frequencies.

FOUR REMOTE EQUIPMENT CHAMPIONS!!



THE "DYNAMOTE"

The most compact remote amplifier in broadcasting having 3 position mixing system, 5" illuminated V.I. meter, four stage high gain amplifier which may be used with batteries or the Gates P-3 A.C. power supply. May be had with attractive felt lined carrying case which holds amplifier, power supply and as many as 3 microphones.

PRICE
\$119.00

Power supply
and carrying
case extra.

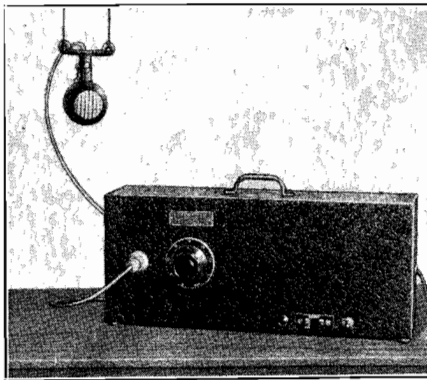

The "Dynamic Combine"

Here is a co-ordinated dynamic microphone and A.C. operated high gain remote amplifier. Hum free, excellent response, high gain and highly attractive in appearance. Microphone free of cavity resonance and ideal for voice or music transmissions. Size only 17" by 7" by 4". Finish black ripple enamel with chrome trimmings. Microphone has 25' of cable with locking type connector.

COMPLETE
PRICE

\$79.50

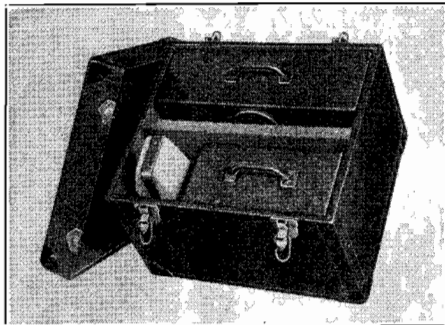

The "Remote Compact"

A complete high gain amplifier with separate power supply and felt lined carrying case with room for one microphone. Amplifier battery or A.C. operated. Input variable for 30, 200 or 500 ohm microphones. Completely hum free, wide uniform response characteristics, sufficient gain, for a plus 10 db. signal with either velocity or dynamic microphones is developed. A very popular remote equipment in leading broadcasting stations everywhere.

Price **\$79.50**

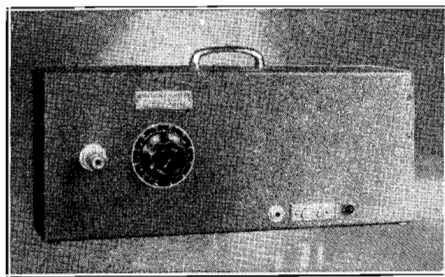

The "Remote Conditioner"

The sensation of the 1937 N.A.B. convention. A high gain amplifier, transformer type power supply, input coupling transformer all compacted in a 17" by 7" by 4" case. Completely free from hum, wide uniform response and available for 30 or 200 ohm velocity or dynamic microphones. Very attractive with combined black ripple enamel and chrome finish.

Price **\$62.50**

Your inquiries invited. Literature available.

1913
Washington Ave.
St. Louis, Mo.

GATES RADIO & SUPPLY CO.
QUINCY
Cable address
Gatesradio

5334
Hollywood Blvd.
Hollywood, Calif.

ILLINOIS

UNIVERSAL MICROPHONES

... rugged ... modern
... dependable

Crystal Hand Model

New hand-type for amateur, p.a., sport events, etc. Output — 65 db. (Desk holder \$2.50).

All crystal models under patent of Brush Development Co.

List Price \$22.50
With 10 ft. Cable



Air Velocity

Latest in scientific development and refinement. Wide range corrugated ribbon and new high flux alnico magnets. Very latest transformer with double coils. All impedances, 1 db, from 30 to 12,000 cycles.

List Price \$44.50
With 25 ft. cable and plug.

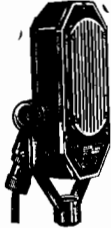

Crystal Stand Model

Especially made for stage or orchestra where mike should be mounted on floor or desk stand. Output — 65 db. (Desk mount \$3.50).

List Price \$22.50
With 10 ft. Cable



New Dynamic

100% Satisfaction or 100% Refund

Self energizing. Not affected by heat or climate. An amazing sound development. Impedances 33 or 50 or 200 or 500 ohms; also high impedance direct to grid. Frequency response 40 - 8000 C.P.S. Output—58 db.

List Price \$44.50
With 25 ft. Cable

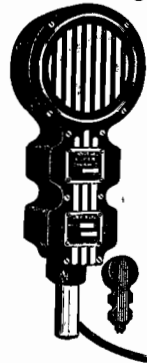

For two way communication. Inter-studios, office to office, factory, house to garage. Hundreds of other uses. Simple to install. Modern. Any number of phones on same line.

CAL-FON



List \$15.00 per Station

Handi-Mike

Single and double button. Rugged. Damped scientifically. Gold contact faces. Single button. Output level—40 db. Double button.—55 db., both incl. 6 ft. cord.

List Price \$10.00
SINGLE BUTTON
List Price \$15.00
DOUBLE BUTTON



Ribbon Microphones

Self energizing. No polarizing voltage. Plug in and use it. Semi-directional. Distant pickup. No feedback. High impedance direct to grid, also all other impedances. Can be used on amplifiers of not less than 85 db. gain. Including 10 ft. two-conductor cable.

List Price \$22.50
List Price \$24.25
With plug.



ALSO . . . Two button lapel models; several single and double button carbon models, condensers, airplane and police car models, stands and accessories. Also (Recording Division) 5 models of recording machines, discs, needles and accessories.

Microphone Division

Universal Microphone Co.
424 Warren Lane, Inglewood, Cal.

AMPLIFIER ADJUSTMENTS

(Continued from page 11)

Equation (5) may be written, using equations (2) and (6):

$$\text{Eff.} = \frac{\mu^2 E_g^2 R_L}{2S (R_L + 2R_p)^2} \dots\dots\dots (7)$$

where S is the input.

Setting the first derivative of equation (7) equal to zero we find that the efficiency and, therefore, the output is maximum when

$$R_L = 2R_p \dots\dots\dots (8)$$

The value of R_L in a transmitter is difficult to calculate, because its value depends largely on the resistance coupled in from the antenna circuit, and this is a function of the mutual inductance between the tank and the antenna coil. Mutual-inductance calculations are always rather messy, so as an alternative the circulating current in the tank may be calculated using the proper value of R_L . Then it is only necessary to tune for this value of tank current to arrive at the optimum load value. It can be shown that at the saturation point²

$$I_T = .707 \frac{E_b R_L (\mu + 1)}{X_c R_L (\mu + 1) + 2R_p X_c} \dots\dots\dots (8)$$

and if

$$R_L = 2R_p$$

then

$$I_T = .707 \frac{E_b (\mu + 1)}{X_c (\mu + 2)} \dots\dots\dots (9)$$

The above expression gives the tank current for optimum loading in terms of the known constants of the transmitter.

TUNING PROCEDURE

With these simple methods for determining the grid bias the excitation and the loading at hand, a tuning procedure may be set up. It is desirable to make the rough adjustments at the saturation point since that is a limiting factor to linearity and, therefore, a boundary point to work from. Then, too, equation (9) applies to this point. It is very difficult, however, to get enough steady-state excitation to saturate the grid of linear amplifier during normal operating conditions because twice the normal excitation is required. In view of this a better method is to reduce the grid bias and plate voltage by one half. Then, because of the linear relationships existing in the amplifier, the saturation point occurs at carrier level or at one half of the normal satura-



Manufacturers!

Save Time and Bother for Your
ENGINEERS DESIGNERS DRAFTSMEN
THIS DISPLAY CARD

Tells at a glance WHICH—Fuse, Clip, Mounting—FOR YOUR JOB! It pictures and describes **QUALITY PRODUCTS**, and **HOW**, and **WHEN**, and **WHERE**, and **WHY** to buy them. You'll find it useful daily.

MAILED FREE

A request on your letterhead brings you this helpful card, postpaid; also complete catalog of **LITTELFUSE** (quality) Products. Write today.

LITTELFUSE LABORATORIES
4242 Lincoln Avenue Chicago, Ill.

Callite Products

HAVE TESTED, PROVEN
QUALITY

TUNGSTEN

... Rod, Sheet, Wire and Special Shapes
... Hard Glass Welds

MOLYBDENUM

... Rod, Sheet, Wire and Special Shapes
... For Grids, Round or Flat
... For Grids, Supports, Heating Elements
... Hard Glass Welds

KULGRID

... For Grids, Round or Flat
... Kulgrid "C" Tungsten Welds

CONTACTS

All Sizes and Shapes For All Applications

... Tungsten - Molybdenum
... Silver and Platinum
... Special Alloys
... For High Conductivity
... Precious Metal Laminated
... Silver and Platinum on Base Metals

CAL-LUX

FLUORESCENT MATERIALS

— WITH —
Measured Characteristics

... For All Applications

Callite Products

Division of FISLER ELECTRIC CORP.
544 - 39th STREET • UNION CITY, N. J.

tion level. This half-voltage method works itself very nicely into a tuning procedure, which is shown by the following step-by-step description:

(1) Determine the operating grid bias by use of equation (3) or by adjusting the plate current to the cut-off point. Then reduce this and the operating plate voltage by one half.

(2) Apply the excitation and increase until the saturation point is reached as evidenced by non-linearity between E_g and I_T .

(3) Vary the plate loading till the value determined by equation (10) is attained. This might not be the exact optimum point so R should be varied a little on both sides of the point determined by equation (10).

(4) Check the power input to the amplifier by multiplying the current obtained at the setting of step 3 by the normal plate voltage. This will give the input at carrier level since the plate voltage will be doubled, but the efficiency will be halved. If the input thus obtained is too great the excitation may be reduced until the correct value is reached. As a matter of fact, it is advisable to reduce the excitation a little below the saturation point if at all possible, since the $E_g - I_T$ curve is non-linear in the vicinity of saturation.

(5) The plate voltage and the grid bias should now be set at their normal operating values, the excitation remaining the same. Modulation should then be applied, and the operation of the amplifier checked by means of a cathode-ray oscilloscope or a distortion-measuring set. The plate current should be the same as that obtained in step (3), or at least approximately the same, and it should not vary appreciably during modulation.

It must be remembered that the values obtained in actual tuning may vary from the calculated values by as much as 5 percent because of the approximations used in deriving them. Therefore, the final check must be made experimentally, so the value of checking instruments can not be over-emphasized. Care must be taken in the experimental tuning, however, if ambiguous results are to be avoided, for varying one constant may at the same time vary another in such a manner as to mask the real effect of the change. For this reason, if the calculated values have been departed from too greatly in the process of experimental tuning, it is well to start all over again.

In conclusion, it must be mentioned that at times distortion attributed to bad adjustment of the linear amplifier actually occurs because of the varying load the grid circuit of the linear amplifier presents to the output circuit of the preceding stage.



Unexcelled Quality!



For Recording and Reproducing

SAJA SYNCHRONOUS DUAL-SPEED MOTORS

In SAJA Dual-Speed Synchronous Motors the change is effected by simple electrical switching. There are no mechanical speed changing devices to impair quality.

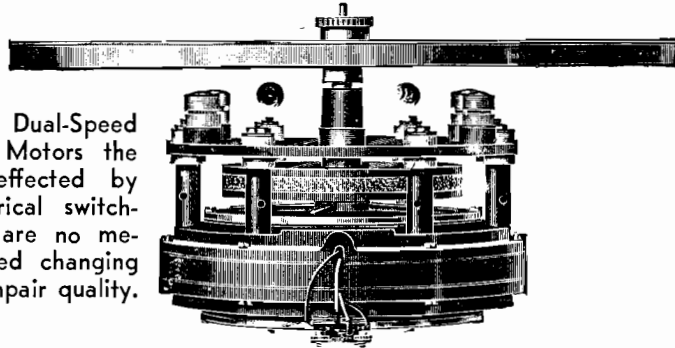

SAJA Motors incorporate basic U. S. patent-protected features on synchronous motor design including:

- Absolutely Constant Speed
- Negligible Vibration
- High Torque and Efficiency
- Gearless Construction
- Minimum Mounting Space and Servicing



NEUMANN RECORDING HEADS

These recording heads are individually tested, numbered and sealed, bearing the name of George Neumann & Co. which is a guarantee of high quality workmanship and performance.

are properly designed to have a constant velocity down to 300 cycles, and an essentially constant amplitude below this frequency. Due to their correct dampening (spring oil-damped method) they show no resonance points over the whole range. This feature simplifies the proper use of equalization which is especially necessary for slow speed direct recording to raise the higher frequencies, and to compensate the loss in materials. Their durability is warranted, as no deteriorating materials are used.

Send for technical literature and net prices.

SOUND APPARATUS CO.

150 West 46th St., New York, N. Y.

Sole Distributor of

Neumann sound recording apparatus • Duralatone records •
SAJA Synchronous Motors • Herold Recording and Reproducing
Needles.





Pluggin

THE FIRST REALLY NEW IDEA
IN CONDENSER DESIGN !!

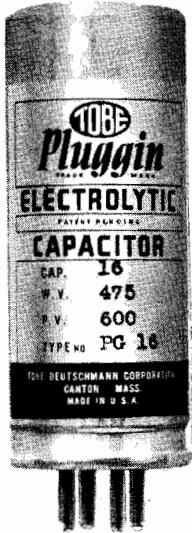

Plug
it in
just
like
a
tube!

Builders and designers of original equipment will welcome this striking new condenser . . . THE TOBE PLUGGIN! Based on a completely new construction principle . . . fully protected by patents and copyright . . . this product features a UX four-prong tube base permitting a ready interchangeability and speedy replacement. And the quality of the condenser itself is on a par with all TOBE products, the result of skillful manufacture and thorough engineering. Conservatively rated at 475 volts continuous operation, will stand 600 volts and higher. Completely sealed in non-corrosive container. Request samples on your business letterhead.

TOBE DEUTSCHMANN CORP.
CANTON, MASSACHUSETTS

RADIO-RANGE SYSTEM CONTRACT TO WESTINGHOUSE

NEW RADIO-RANGE STATIONS which transmit signals marking the lanes of the National airways have been ordered by the Department of Commerce.

A contract, amounting to \$700,000, has been awarded the Westinghouse Electric and Manufacturing Company for 44 radio-range stations of the improved simultaneous type which permit continuous transmission of "on course" signals without interruption for weather broadcasts.

Starting next March, 1938, installation of the new stations will be made at the rate of six each months.

TELEVISION ECONOMICS

(Continued from page 10)

600 hours of feature films (the 600 hours referring to running time on the screen). This is at the average rate of \$250,000 per hour or about \$4,000 per minute of screen time. Actually the approximate range of production costs, in terms of screen time, varies between about \$400 and \$30,000 per minute!

When we consider that the major networks in the United States run 17 hours a day, it is entirely clear that any parallel plan for television production would be a sure passport to financial ruin. If the television audience is to have programs resembling present-day films, unheard of economies must be introduced into film production for television purposes. It does not appear likely that any economically acceptable reduction along these lines could be carried out, particularly in present-day centers of film production where it is but natural that the personnel would view with scant sympathy a radical scaling down of production costs, perhaps fearing the repercussive effects of such a change on their own motion picture activities.

Another alternative is a great simplification of the desires of the television audience and the willing public acceptance of a type of television program far less elaborate than that of the theater. Some substitute appealing to the television lookers must be found, and it is believed that such a substitute exists. A famous painter was once asked how he produced his outstanding works of art. His answer was: "I mix my colors with brains." It is clear that television programs must use a high proportion of thought, originality, spontaneity of expression, novelty of theme, extension of scope of subject matter as compared with present day films, and must in fact cover a far wider portion of the activities of humanity than any other form of entertainment (except perhaps the printed page). The method of utilizing material and the tempo of presentation must necessarily be different in the case of television from those in the older arts. Nor is so definite a break with the past necessary exclusively on economic grounds. If television is to hold the interest of the public in the face of alternative methods of entertainment and instruction, it must develop its own technique and display unusual initiative in its selection of subject matter and the treatment of such material. It would be out of place—as well as probably impossible—to indicate here speci-

Waxes Compounds Varnishes

FOR INSULATION
OF CONDENSERS

Transformers, coils, power packs, pot heads, sockets, wiring devices, wet and dry batteries, etc. Also WAX SATURATORS for braided wire and tape. WAXES for radio parts. Compounds made to your own specifications if you prefer.

● ZOPHAR MILLS, INC.

Founded 1846
120—26th Street
Brooklyn, N. Y.

Do You Know That—

- You Can Secure Custom Built Transformers, Auto-Transformers, Chokes, Reactors, Etc. Built Exactly to Your Specifications by "Newark" for Little More or Possibly Less Than "Stock" Equipment!
- A List of the Customers of "Newark" Reads Like a Directory of the Electronics, Radio and Electrical Field!
- That "Newark" Can Give You Prompt and Dependable Service.

Send Your Specifications and Order for That Transformer to "Newark"

Specializing in custom built transformers for nearly two decades

NEWARK TRANSFORMER CO.

15 Frelinghuysen Av., Newark, N.J.
Telephone: Bigelow 3-3577-8

nc methods of interest in this connection, but enough is known of the capability of the television screen to make it certain that, within an economic framework, astonishingly attractive programs can be produced by competent producers.

It may be desirable to recapitulate the expenditures involved for the United States in the establishment of nation-wide television service. It should first be emphasized that little aid is obtainable by comparison with the data from foreign countries. For one thing, England is the size of New York State and Texas is the size of Germany. Each of them has an average population density far in excess of that of the United States. The ultra-high-frequency transmitter has a limited range as compared to that of the present-day broadcasting transmitter. These factors combine to make the task of television in the United States far more difficult than in the cited countries. It would be economically unsound and technically unwise blindly to follow what might seem to be a lead from other countries. The United States must solve its television problems in its own way and in its own good time.

Assuming the establishment of perhaps 100 television stations with interconnecting facilities of several networks, an adequate program-preparing staff, and the sale to the America public of a reasonable number of television receivers, it is found that the total capital expenditure by the public and the radio industry is of the order of a half billion dollars (and possibly much more). The effect on the industry of a radical change in the type of receivers sold and in the broadcasting service rendered, and the effect on the public psychology of a change in radio presentation methods must alike receive serious thought before television is commercially introduced. Sober consideration must be given to the twin questions: Is the public ready—and is the industry ready? It might be added—and are the engineers ready?

If we keep in mind that television is the most luxurious form of broadcasting, that its upbuilding in the United States is a major financial, artistic, and educational project, and that it must be geared to the times and the trend, we shall have a balanced economic picture of the situation. Guided by such considerations, there will undoubtedly be offered to the public in good time this latest of services. It is to be hoped and expected that the offering will be made and accepted in such fashion and at such time as will insure its enthusiastic acceptance and will thus lead to a normal and healthy growth of television broadcasting.

ASTATIC

ACORN MODEL T-3 MICROPHONE HIGHLY PRAISED



Exceptional beauty of design, flexibility of use and wide range performance of Astatic Model T-3 Microphone is a topic of much importance in Public Address, Broadcast, Recording and Amateur circles. Improved crystal assembly, skilfully suspended to prevent vibration or shock, offers greatly improved frequency response over previous single diaphragm types. By tilting the head upon its unique swivel mount, acoustic feedback may easily be controlled and the pickup made either directional or non-directional, as desired. Model T-3 comes equipped with interchangeable plug and socket connector, 8-ft. cable and spring cable protector. Polished chromium finish. Fully guaranteed..... **LIST PRICE \$25.00**

ASTATIC TRU-TAN CRYSTAL PICKUPS

Incorporate Improvements for Finer Reproduction



Astatic offset head reduces tracking error to a minimum

True-Tan Model O-7, new streamlined Crystal Pickup, is an ideal instrument for modern amplifier and phonograph combinations. Only 9" long. Designed with offset head for records to 12". Includes exclusive Axial Cushioning to reduce motor noise and prevent speaker-pickup feedback. Black finish.

LIST PRICE \$12.00



Tru-Tan Crystal Pickup Models B-10 and B-16 are both instruments of the highest type, designed for professional use and finest installations. Offset head design and substantial construction eliminate resonance periods throughout the useful recorded frequencies, provide truer reproduction and longer record life. Fully guaranteed.

Model B-10 (illustrated) LIST PRICE \$17.50
Model B-16 for LIST PRICE \$27.50
 records to 16 inches

Write for Literature Address Dept. M-2

ASTATIC MICROPHONE LABORATORY, Inc. YOUNGSTOWN, O.
Pioneer Manufacturers of Quality Crystal Products

LICENSED UNDER BRUSH DEVELOPMENT CO. PATENTS

MICROHM WIRE WOUND RESISTORS

MICROHM WIRE WOUND RESISTORS are built on the foundation of a QUALITY PRODUCT and can be used as a component with the finest of precision instruments. Manufacturers interested in maintaining the QUALITY of their apparatus recognize this merit of QUALITY, demand and use only MICROHM WIRE WOUND RESISTORS. Precision Resistor Company manufactures a complete line of all types of wire wound resistors and is equipped to meet the most rigid specifications.

Write for catalog and prices

PRECISION RESISTOR COMPANY

332 Badger Ave.

Newark, N. J.

Manufacturers of custom built PRECISION and INDUSTRIAL WIRE WOUND RESISTORS.



TYPE R 1/4 Watt (Actual Size) Res. 5 to 500000 ohms. Accuracies as close as 1/10 of 1%.

**HIGH AND ULTRA-HIGH
FREQUENCY PORTABLE
TRANSMITTER • Type HFM**

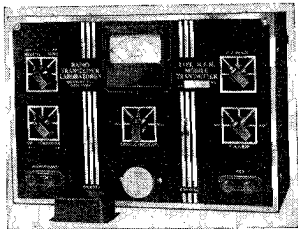

- 10 watts nominal output over entire range.
- 7000 to 60,000 Kc. with single crystal.
- Lower frequencies to order.
- Completely self-contained.
- A1, A2 and A3 emission.
- Operates from 6v. D.C. or 110 A.C. supply. Power equipment available for either.
- Anti-noise microphone for mobile operation.
- Portable receiving equipment to work with above.

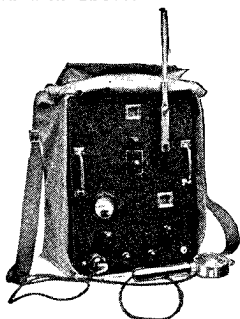

**PORTABLE PACK M.O.P.A. UNIT
TYPE PTR-19-M**

2 WATT TRANSMITTER AND A
RECEIVER MONITOR

We have helped many with their portable and mobile communication problems. Write, stating your requirements, and we will advise on available or custom built units.

Write for Bulletin C-38

Radio Transceiver Labs.

8627 - 115th Street
RICHMOND HILL, NEW YORK

**CBS TELEVISION TRANSMITTER
NEARING COMPLETION**

THE COLUMBIA BROADCASTING SYSTEM'S new television transmitter, construction of which required the work of some 50 technicians for a period of more than nine months, is being given its first power tests at Camden, N. J., and probably will be ready for delivery to New York shortly after the first of the year.

When all "bugs" have been eliminated the transmitter is to be shipped to New York for installation on the 73rd and 74th floors of the Chrysler Building. There it will provide television programs from the nearby Grand Central Station studios.

BROADCAST TRANSMITTER

(Continued from page 9)

The second is important in extending the frequency band over which the feedback is effective. Less well considered systems actually increase distortion at high frequencies—due to the fact that phase shift in intervening stages causes the energy fed back to be shifted in phase, so that at some point in the high-frequency register it becomes additive rather than canceling.

While this feedback arrangement from the circuit viewpoint is a part of the audio circuit only, it actually has an effect beyond this. Study of the circuit will indicate the reason; namely, that with a high-level modulation system it actually compensates for distortion and ripple in the Class C stage, and also tends to compensate the modulating voltage. Thus nearly the full advantages of an overall feedback system are obtained, while at the same time the usual disadvantages are avoided. Difficulties due to a varying degree of feedback, or coupling instability, are avoided, and critical adjustments are unnecessary.

FIDELITY CHARACTERISTICS

High-fidelity transmission, claimed or actual, has now become commonplace. Nevertheless, the degree of consideration given to obtaining exceptional characteristics perhaps deserves comment. The distortion characteristics, both for 5-kw operation and 1-kw operation, are shown in Fig. 5. These are from actual measurements on a typical transmitter (the manufacturer's specification says "less than 3% rms, 0-95% modulation, 50-7500 cycles"). As will be noted, the distortion level is low not only in the middle band, but also at comparatively low and high frequencies—a point to which sufficient consideration is not always given. The frequency characteristic (see Fig. 5) is similarly excellent (being substantially flat from 30 to 10,000 cycles). The carrier and hum level is specified as 60 db below 100% modulation (for measurement without a weighting filter).

Apparently in recognition of the increasing number of stations operating with 5000 watts daytime and 1000 watts night, provision has been made in this transmitter for instantaneous change-over (necessary to avoid loss of time when power is altered). A single switch on the front of the panel not only reduces the power (by changing to a lower tap on the high-voltage rectifier, and inserting resistance in the exciter plate connection), but also cut-ins a resistance in the modulation-monitor circuit, so as to automatically correct the carrier reading.

Control circuits, following the trend of recent years, are more extensive than ever before. In addition to providing the usual features of automatic or step-starting, time-sequencing, etc., an arrangement is provided so that in starting the plate voltage applied to the tubes rises smoothly from zero to full voltage

Showing an array of cathode-ray oscilloscopes used in the final testing of Aladdin Radio Industries products.



Frequency Measuring Service

Many stations find this exact measuring service of great value for routine observation of transmitter performance and for accurately calibrating their own monitors.

MEASUREMENTS WHEN YOU NEED THEM MOST
at any hour every day in the year

R.C.A. COMMUNICATIONS, Inc.

Commercial Dept.

A RADIO CORPORATION OF AMERICA SERVICE

66 BROAD STREET

NEW YORK, N. Y.



(in a time interval of approximately one second).

Protective circuits are similarly complete. New features—at least new for this power classification—include current-limiting resistors for charging the filter capacitors, and a re-setting device which, operating from any overload, interrupts the plate power rapidly and returns it again automatically, performing this function three times before power is finally removed.

The power amplifier, in addition to featuring high-efficiency operation, has another feature which is illustrative of a new trend in transmitter design. This is the use of a low kva ratio tank circuit. This trend seems to be a recognition of the necessity of avoiding side-band cutting at low frequencies. A second advantage, of course, is the reduction of circulating-current losses. The amplifier is easy to adjust, and the neutralization, which is of the fixed type, is uncritical.

In addition to the high-power rectifier (which uses six 872-A's) there are three low-voltage rectifiers—one of which supplies plate voltage for the crystal-oscillator units only—and a heavily loaded rectifier supplying bias for the modulators.

The output of the transmitter is designed to work into either a four-wire balanced open-type line or a standard concentric-type line. T-networks at both ends of the line are provided for reducing harmonics.

A feature which is not entirely new, but is interesting, is the use of a monitoring rectifier to drive a remote meter (located on the transmitter panel) indicating antenna current. This meter will not be burned out by lightning discharge, as is likely to occur with thermocouple types. It is also connected to operate the re-setting mechanism, so that in case of arc-over in the antenna circuit the arc will be broken and the transmitter returned to the air without a noticeable program break.

The construction of the transmitter is generally similar to that of recent "deluxe" designs, being of the so-called "vertical-chassis" type (also see previously published description of the exciter of this transmitter³). New features include the sealing of modulator and p-a units (mentioned above), and the location of all relays, breakers and control apparatus on a separate power control panel. This panel can be seen at the extreme right in Fig. 1. The door between this panel and the three main units is intended to furnish quick access to the rear, particularly when the units are built into a room partition, as is becoming more and more the practice.

³"The Low-Power Transmitters," by J. P. Taylor, *Communication and Broadcast Engineering*, June-July, 1937.

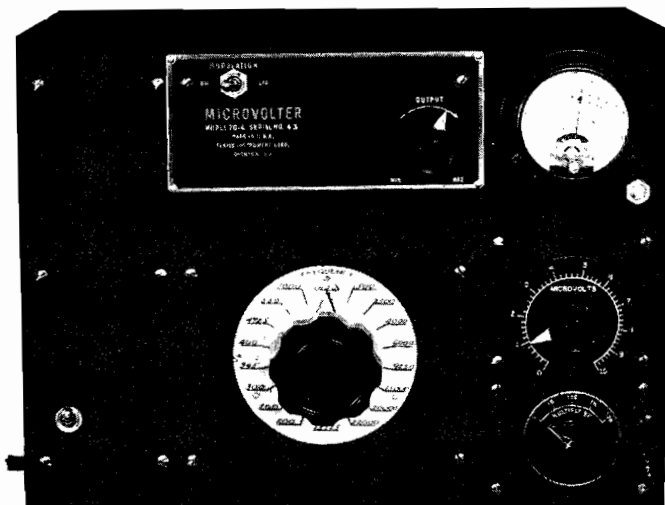

Model 20A Microvolter

A QUICK ACTION MICROVOLTER FOR THE FACTORY PRODUCTION LINE

18 Fixed frequencies, selected by a switch —(No calibration curves or tuning dial).

Any 18 frequencies between 150 and 20,000 kilocycles can be supplied, with provision for changing to new frequencies when required.

Write for illustrated circular and full details.

FERRIS INSTRUMENT CORPORATION
BOONTON, N. J.

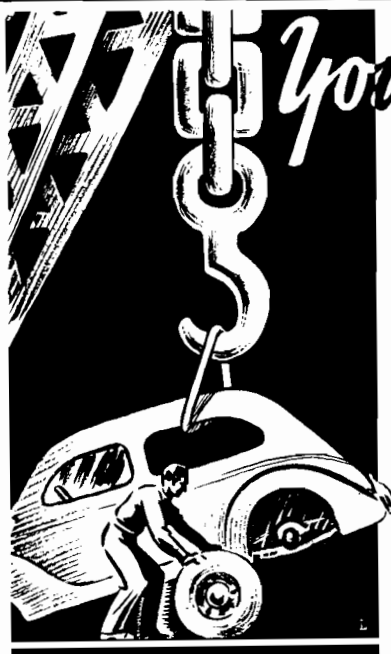

You wouldn't

USE A CRANE . . .

*When A Jack Would
Do The Job*

You could use a 20-ton crane to lift your car to change a tire. But—a 1-ton jack would do it more efficiently—more economically.

It's common sense to pick the equipment that fits the job. That's why so many electrical, mechanical, and design engineers specify Relays by Guardian—Big in contact capacity—Compact in design—Low current drain—Long Lived—These units are "tops" in efficiency and dependability. There's a size and type ideally suited to your specifications. Write today for illustrated Catalog C.

Unit shown is No. 110 AC Relay (or 115 DC).
Many other types for every application.
Also stepping switches, electric counter, solenoids, mercury switches, etc.

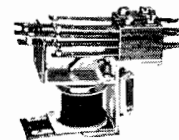

GUARDIAN ELECTRIC
1623 W. WALNUT STREET CHICAGO

OVER THE TAPE . . .

NEWS OF THE COMMUNICATIONS FIELD

GATES OPEN WEST COAST OFFICE

The Gates Radio & Supply Company, Quincy, Illinois, announce the opening of a west coast office under the personal supervision of Mr. Norman D. Neely, prominent in radio engineering circles for many years in the western states.

This new office is located at 5334 Hollywood Blvd., Hollywood, California, and offers to broadcasters in California, Arizona, Nevada and Utah not only the opportunity to see and inspect products made by the Gates Company but a source of engineering consultation regarding remote and studio equipment, design and application.

AIRCRAFT RADIO BULLETIN

A new bulletin issued by the Western Electric Company, 195 Broadway, New York City, describes and illustrates the Type 20 aircraft receivers and accessories, including modified forms of the receiver which are just being introduced to accommodate those who wish to have facilities for receiving the 500-kilocycle international distress frequency (600 meters).

This publication also announces a new unit known as the D-99018 oscillator. This addition to the Western Electric line of aircraft radio equipment is a simple and compact device which, used in conjunction with the Type 20 receiver, permits continuous wave signals to be picked up by producing a "beat note" of a frequency controlled by the operator or pilot.

Those interested in installing and using radio in aviation will find much useful material in this newly issued publication.

"CLEAR RECEPTION"

Under the title of "Clear Reception," an attractive and interesting folder is offered by Aerovox Corporation, 70 Washington St., Brooklyn, N. Y., on the subject of background noise suppression. This literature deals with the several ways in which noises reach a receiver, and how they may be stopped either at the set itself or preferably at the noise source. Also featured are the several types of noise eliminators or filters now available. A copy may be had through any Aerovox jobber or from the manufacturer direct.

MICABOND CATALOG

The Continental-Diamond Fibre Co., Newark, Delaware, have just issued a catalog. Complete descriptions, specifications, etc., of Micabond, a bonded mica insulating material, are included. The catalog may be secured by writing to the above organization.

NATIONAL UNION ANNOUNCES CONDENSER LINE

Mr. H. R. Peters, President of the National Union Radio Corporation, announced from the company's New York City headquarters this month the entry of his company in the field of condensers for radio service specialists.

AMERICAN-BOSCH BULLETINS

Bulletins describing the following equipments are available from the United American Bosch Corporation, Springfield, Massachusetts: Models 117 B1 (1500-1800 kc) and 127 B1 (2200-2500 kc) police-station radio receiver; police-car radio receivers; police-radio power supplies, Types GM-EA (250 volts) and GM-EB (190 volts); Volt-O-Matic generators.

INSTRUMENT CATALOG

Sensitive Research Instrument Corporation, 4545 Bronx Boulevard, New York, N. Y., have recently issued supplementary Catalog No. 40 on their line of electrical measuring instruments, which includes microammeters, milliammeters, ammeters, galvanometers, millivoltmeters, voltmeters, voltmeters, wattmeters, ohmmeters, volt-ohmmeters, volt-ohm-milliammeters, and irradiometers (for continuous measurement of the radiation output of X-ray equipment). This 64-page catalog may be obtained from the above organization.

P-A SHOW

A p-a show with over \$15,000 worth of equipment on display and demonstration was held on October 1st and 2nd in the Sound Auditorium of the Wholesale Radio Service Company at 100 Sixth Avenue, New York City. Large crowds of enthusiastic sound men, servicers, amateurs and others interested in sound equipment, attended on both days. Demonstrations of the complete line of Lafayette amplifiers, microphones, speakers, recorders, record-players and associate equipment were in continuous progress.

WROUGHT WASHER ANNIVERSARY

Fifty years ago in the city of Milwaukee a little plant called the Nut and Washer Mfg. Co., made an inconspicuous start in a small building measuring thirty by sixty feet. The outgrowth of that little company is the present Wrought Washer Mfg. Co., which is celebrating its fiftieth anniversary this year, and now has grown to be one of the largest producers of washers in the world.

BROADCAST ENGINEERING CONFERENCE

From February 7 to 19 a Broadcast Engineering Conference will be held at Ohio State University. This conference is intended primarily for broadcast station engineers and from all reports an excellent group of engineers will appear on the program. According to the tentative program there will be lectures on broadcast antenna design, high powered amplifiers, modulation and distortion measurements, studio acoustics, and ultra-high-frequency propagation, etc. Those interested should write to Dr. W. L. Everitt, Department of Electrical Engineering, Ohio State University, for further information.

RMA CREDIT MEETING

The Eastern RMA Credit Committee held its monthly meeting on October 20 at the Hotel New Yorker in New York City. The meeting, for the monthly exchange of credit information, will be headed by the new vice-chairman of the eastern committee, Mr. Victor Mucher, and with the usual cooperation of the National Credit Office, the official credit agency of the RMA.

RMA members are also reminded that if they desire data or are not able to have representatives attend the monthly meetings of the association's credit committees, they can apply to the National Credit Office, 2 Park Ave., New York City, and secure detailed credit data of the NCO, which is the basis for the committee meetings.

NEW PRICE SCHEDULE FOR MIRROR RECORD

Mirror Record Corporation, 58 West 25th Street, New York City, manufacturers of all types of blank discs for recording purposes, announces a new price schedule. Those desirous of obtaining this literature can do so by writing to the above organization.

DU MONT BULLETIN

A 4-page bulletin describing the new Du Mont all-purpose, 5-inch cathode-ray oscillograph, Type 168, is now available from the Allen B. Du Mont Laboratories, Inc., Upper Montclair, N. J. The Type 168 oscillograph features the sweep-expanding amplifier.

STUPAKOFF MODERNIZES PLANT

The Stupakoff Laboratories, Inc., Pittsburgh, has just completed a plant modernizing program which includes the installation of a 65-foot tunnel kiln and a complete materials preparation plant for crushing, pulverizing and screening various ceramic bodies. The die making shop and press departments have been expanded with the most modern machine tools and specially constructed ceramic presses. These additions and improvements enable the Stupakoff company to expand their activities in the manufacture of insulators in the radio, appliance and electronic tube fields.

AMERTRAN BULLETIN

The September, 1937, issue of the *Amertran Transformer News* has been devoted to the Type TH Transtat voltage regulator. A complete description, as well as standard ratings and list prices are given. Write to the American Transformer Company, 178 Emmet St., Newark, N. J.

G-E BULLETIN

The General Electric Co., Schenectady, N. Y., have recently issued an interesting 4-page bulletin covering their line of small panel instruments. Write for Bulletin GEA-2645.



Uniformity

One tube . . . a hundred tubes . . . thousands of tubes! All with precisely the same filament characteristics. That's the story of Driver exclusive "melts" earmarked for the given tube manufacturer.

FILAMENT WIRES

In keeping with the demand for longer life and improved characteristics, several filament alloys are available, such as Hilo, Modified Hilo, Cobanic, Tensite and Sylvaloy. Held to most exacting limits on size, milligram weight, resistance, elongation.

CARBONIZED NICKELS

RadioCarb A or carbonized nickel ribbon in widths up to 6" and .002 to .015" thickness. Also bare strip in widths up to 6" and as fine as .001" thick.

GRIDS AND SUPPORTS

Precisely tempered wire for grids fabricated in "Tophet A," "Tophet C," Pure Nickel, Manganese-Nickel and "Molimet." For supports, pure nickel wire specially treated for uniform elongation.

Submit your
PROBLEMS

Tell us about your tube problems. Our metallurgists and engineers will collaborate in their solution. Data sent on request.

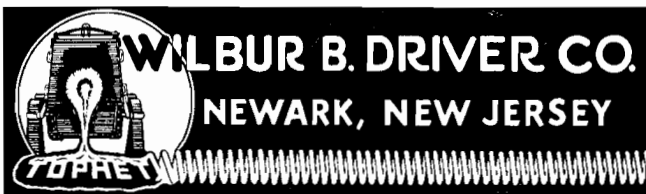

That's all we ask—your name and address on the coupon below and this big 1938 radio catalog will go in the mails. It's probably the greatest "year-book" in radio history — 180 pages, over 50,000 items. Servicer, amateur, sound engineer—anyone interested in radio, will find in this new Wholesale catalog hundreds of sensational values.



PUBLIC ADDRESS SYSTEMS

More than 25 "stopper" pages of sound equipment for modern business. You'll want to see this new Lafayette streamlined P.A. line — trim, easy to operate, with superb tone and compelling sales appeal.

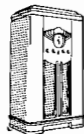

LAFAYETTE RADIOS

You have no idea what radio value is until you see this catalog. Pages of sturdy, extra powerful receiver sets in beautiful cabinets. There are 5 to 13-tube models (70 in all) with every advance feature known.



HAM RECEIVERS

The amateur, with his copy of the new Wholesale catalog is certainly "the ham what am." Every nationally known line for him to choose from, and Wholesale offers the easiest, swiftest, most economical way to order.



TEST EQUIPMENT

Servicemen will marvel at the test equipment Wholesale pictures in one catalog! Whether you need a pocket voltmeter or a Cathode-ray oscillograph, you'll find it at Wholesale.



I FEEL LIKE A KING WITH THE NEW CATALOG WHOLESALE SENT!

GOLLY, I'M SENDING IN THIS COUPON RIGHT NOW!



MAIL COUPON NOW!

WHOLESALE RADIO SERVICE CO., INC.
NEW YORK, N. Y. CHICAGO, ILL. ATLANTA, GA.
100 SIXTH AVENUE 901 W. JACKSON BLVD. 430 W. PEACHTREE ST., N. W.
BOSTON, MASS. BRONX, N. Y. NEWARK, N. J. JAMAICA, L. I.

WHOLESALE RADIO SERVICE CO., INC.
100 SIXTH AVENUE, NEW YORK, N. Y.

Rush FREE 1938 Catalog No. 69-72K7

Name

Street

City

State

PASTE COUPON ON PENNY POST CARD

"BROADCAST COMPONENTS"

"Broadcast Components" is the title of a new 46-page handbook-catalog which may be secured from United Transformer Corp., 72 Spring Street, New York, N. Y. Complete data on the UTC line of transformers, filters, chokes, equalizers, reactors, control units, and the like, are given. A number of useful engineering charts are also included, as well as a number of interesting circuits for amplifiers, preamplifier-mixer, preamplifiers, modulators, etc.

WIRE STRIPPER BULLETIN

A 4-page bulletin describing the Colonial reversible wire stripper is now available from Pyramid Products Co., 2309 South State St., Chicago. The wire stripper described will strip either clockwise or counterclockwise.

GENERAL CABLE BULLETIN

"General Cable Trenchlay (Concentric Type) and Ruralay" is the title of Bulletin UC-2 which is now available from the General Cable Corp., 420 Lexington Ave., New York, N. Y. The cables described in this bulletin are for direct earth installation.

WESTERN ELECTRIC BULLETINS

An interesting bulletin that has recently been made available by the Western Electric Co., 195 Broadway, New York City, is entitled "Police Radio-Telephone for the Small City or Town," and describes their latest police-radio equipment . . . including an ultra-high-frequency coaxial antenna for police headquarters. Also available is a 6-page bulletin describing WE's new 22A radio transmitter for police departments.

RADIO TUBE MANUAL

One of the most complete radio tube manuals to appear so far has just been published by the Philco Radio and Television Corporation under the auspices of the Radio Manufacturers Service. The 64-page volume printed on coated paper and measuring 6¼ by 9 inches is ready for distribution to the trade. Thirty-four pages are devoted to socket layouts of home sets listed numerically by models; seven pages to socket layouts of auto sets; nine pages to characteristic tables, bulb sizes and types; four pages to base views and schematics; two pages to tables of bases and types and four pages to tube complement list for all Philcos ever produced. Requests should be addressed to the above organization at 3701 N. Broad St., Philadelphia, Pa.

PACKING CATALOG

A new "miniature" packing catalog, featuring the eleven most commonly used U. S. packings, has been announced by the Mechanical Goods Division of United States Rubber Products, Inc., 1790 Broadway, New York City. The "preferred eleven" illustrated in this booklet were chosen because they meet a large percentage of normal packing requirements.

This booklet was compiled as a substitute for the larger and more comprehensive packing catalog issued by "U. S." earlier this year. It should prove valuable as a reference for engineers, plant operators, and executives.

"DURACORD TREE WIRE"

"Duracord Tree Wire," Publication C-36, is the title of a new bulletin just issued by the Anaconda Wire and Cable Co., 25 Broadway, New York City, N. Y. Complete descriptions, test data and tables of insulation thickness are included.

RMA BOARD EXPANDS SERVICES

New services for RMA Members, especially in engineering, were approved by the RMA Board of Directors at its meeting September 29 at the Hotel Roosevelt in New York City. President Leslie F. Muter, of Chicago, presided and there was a full attendance of the RMA directorate, now enlarged to twenty-five, including seven new directors elected at the convention last June in Chicago. The new directors are P. S. Billings, E. Alschuler and J. J. Kahn of Chicago, S. T. Thompson and S. I. Cole of New York, H. E. Osmun of Milwaukee, and Ray F. Sparrow of Indianapolis.

Production and merchandising problems were prominent at the meeting of the board, which was the regular fall session to outline membership services and activities for the ensuing year. There were several meetings also of committees and groups.

In expanding services for members and especially for engineering, the Association's Board authorized the committee to collect, maintain and distribute detailed data on receiving-set characteristics. To continue and expand standardization of component parts, the Board authorized an additional fund and also the engagement of a consulting engineer on special engineering problems. The Association's engineering work will continue under direction of Dr. W. R. G. Baker of Bridgeport, Connecticut, engineering committee chairman. The extensive parts standardization work will be especially valuable to parts and accessory members of the association.

The RMA Board renewed its opposition against public shows, local or national, for exhibition of receiving sets. The Board reaffirmed former resolutions against exhibits of receiving sets in trade shows or public shows, either by manufacturers or distributors, on the ground that such public shows are detrimental to the industry. The RMA recommends that its receiving set manufacturing members do not exhibit or support, directly or indirectly, any such trade or public shows, and that manufacturers urge their jobbers not to participate in such shows.

In its consideration of merchandising problems, including the new Miller-Tydings law authorizing contracts for resale price maintenance, the RMA Board received a report that action might be expected soon from the Federal Trade Commission on pending fair trade practice rules in the sale of receiving sets, including the proposed rule against "spiffs" and other sales practices.

"ADVANCED DISC RECORDING"

"Advanced Disc Recording" will be issued in a new edition November 1 by the Universal Microphone Co., Inglewood, California.

RCA BULLETINS

The RCA Manufacturing Co., Inc., Camden, N. J., have recently issued a number of interesting bulletins. These bulletins cover the following equipments: ultra-high-frequency broadcast receivers, Types MI-7802 (battery operated) and MI-7803 (a-c operated); ultra-high-frequency mobile relay transmitter, Type ET-4315 (30.1 to 42.1 mc, 15 watts); the Type 500-B police transmitter (500 watts); Type AR-5025 police station-house radio receiver; Model AR-5013 police car receiver; Terra-Wave police broadcast transmitter, Type ET-5017, and amplifier, Type AA-5018; the Type 76-A console, a self-contained, two-studio speech-input system; 68-A beat-frequency oscillator, 69-A distortion and noise meter.

RCA SOUND CATALOG

A comprehensive, 36-page catalog listing more than 100 commercial sound products has been issued by the Commercial Sound Section of the RCA Manufacturing Company, Camden, N. J.

The new catalog, which will be distributed through RCA's sound equipment wholesalers, supersedes the previous publication. It is printed on high-grade coated stock in two colors and is profusely illustrated.

C-D CATALOG

The Cornell-Dubilier Electric Corporation has made available to broadcast and radio engineers catalog No. 153A, a comprehensive folder listing in detail Cornell-Dubilier mica transmitting capacitors. This catalog can be obtained by addressing request to the Cornell-Dubilier Electric Corporation, South Plainfield, New Jersey.

THE "SHAKEPROOF ENGINEER"

The Shakeproof Engineer, a bulletin of technical information devoted to the interests of better metal fastening methods, is now being published by Shakeproof Lock Washer Co., 2507 N. Keeler Ave., Chicago, Illinois. The first issue contains some very interesting information on Shakeproof's new thread-cutting screw. Write to the above organization.

WHOLESALE NOW IN BOSTON

Wholesale Radio Service Company, Inc., of 100 Sixth Avenue, New York City, added another link to their growing chain of establishments with the opening of their display and salesroom at 110 Federal Street, Boston, Mass., with Mr. Michael Scott, well known radio merchandiser in charge.

PAUL B. KLUGH AND A. ATWATER KENT NAMED HONORARY RMA DIRECTORS

For their many years service to the radio industry and the RMA, Paul B. Klugh, formerly of Chicago, and A. Atwater Kent, of Philadelphia, have been honored by election as honorary members and also directors of the association. Their honorary election was voted unanimously at a meeting of the RMA Board of Directors in New York City on September 29. The resolution stated that the RMA desired to retain their active interest and valuable services, which will now be available formally in the future. This is the first occasion on which such honors have been bestowed on former officers of RMA.

BULLETIN ON MERCURY SWITCHES

A 12-page bulletin describing the complete line of GE Kon-nec-tor mercury switches has just been issued by the General Electric Vapor Lamp Company, Hoboken, N. J. Designated as Catalog 603, the new publication features full-size illustrations of the twelve common types of mercury-to-mercury and mercury-to-metal switches. A table shows the capacity and electrical specifications of each type. A 4-page section is devoted to desirable applications of mercury switches.

GENERAL ELECTRIC BULLETIN

The Radio Department of the General Electric Company, Schenectady, N. Y., have just released an interesting bulletin describing their 30-42 mc ultra-high-frequency police-radio receivers for station houses and police cars. Associated equipment is also described.

AMPEREX CARBON ANODE TRANSMITTING TUBES

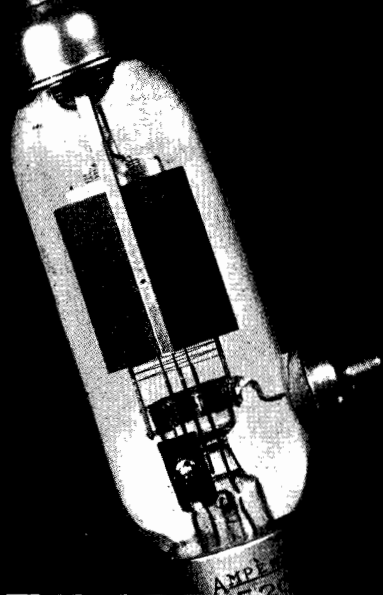

AMPEREX

ELECTRONIC PRODUCTS, Inc.

79 WASHINGTON ST., BROOKLYN, N. Y.

A MINIATURE
REVERSIBLE
Powerplant

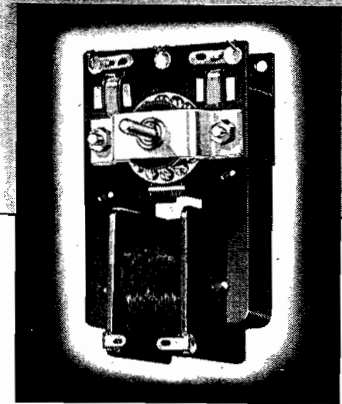

Featuring:

**COMPACT POWER
POSITIVE CONTROL
UNIVERSAL APPLICATION**

- Unusually high starting torque in both directions is now obtainable in this new midget motor.
- Dynamic braking and reversal of rotation are easily accomplished by simply switching in a low voltage circuit.
- Recent developments make it possible to announce the addition of small gear reduction assemblies, integral with the motor, enormously extending the range of applications.
- Both reversible and unidirectional models may now be mounted in any position, with or without speed reduction assemblies.

For additional information address your inquiries to

THE ALLIANCE MFG. COMPANY

SOUTH MAHONING AVENUE, ALLIANCE, OHIO

36 years experience
in **PERMANENT MAGNETS**

We make Permanent Magnets for All Purposes - Stamped, Formed and Cast Magnets - Chrome... Tungsten... Cobalt... Alnico (cast only)

**THOMAS & SKINNER
STEEL PRODUCTS CO.**

1120 E. 23rd ST. - INDIANAPOLIS

LAMINATIONS FOR RADIO TRANSFORMERS
TOOLS - DIES - STAMPINGS

WRITE FOR PRICES

ALFRED W. BARBER

Consulting Engineer

35-33 172nd Street

Flushing, N. Y.

PATENTS — TRADEMARKS — COPYRIGHTS

Correspondence Solicited

EUGENE E. STEVENS

Registered Patent Lawyer

Washington Loan and Trust Bldg. - Washington, D. C.

Approved by F. C. C.
BLILEY CRYSTALS

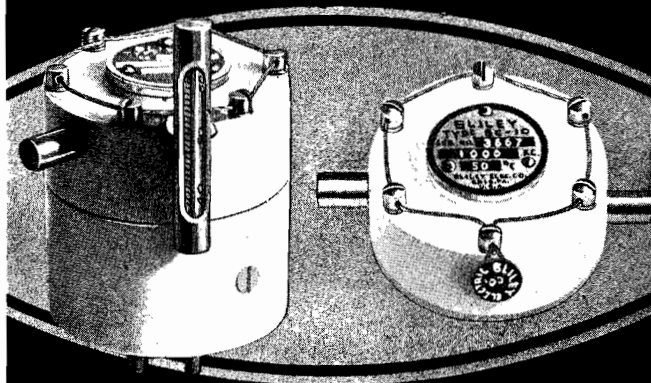

Bliley Broadcast Crystals, Holders and Ovens are specially designed for General Communication Frequencies from 20 Kc. to 25 Mc. Bliley Broadcast Crystals and Ovens are approved by F. C. C. For full information and prices, write for Bulletin G-9.

BLILEY ELECTRIC COMPANY

UNION STATION BUILDING

ERIE, PA.

AN ULTRA-SHORT-WAVE RADIO LINK

(Continued from page 22)

ticable crosstalk is a problem on its own. It is on the special design of the channel-selecting circuits, by means of which this end is achieved that the successful operation of the whole system primarily depends.

GENERAL

It is quite evident that a fault in any part of the equipment common to all

channels would be a catastrophe; a fault in one channel is serious, but the failure for any appreciable time of 9 channels is disastrous. The ultra-short-wave transmitter unit, being common to all 9 channels, is, therefore, provided in duplicate. The reserve unit is normally not under tension, but if a fault such as the failure of a tube occurs, the power supplies and the aerial are

automatically switched from the service to the reserve unit and a fault signal is given to the distant remote-control point. That portion of the receiving equipment which is common to all 9 channels is similarly duplicated. In addition, the power supply is duplicated by an emergency plant which is switched in on failure of the public supply.

DISC RECORDING

(Continued from page 19)

three terminals of the stator windings of all motors, as well as the three terminals of the distributor stator, are all connected to the three-phase a-c power supply. The three terminals of the distributor rotor winding, brought out by means of slip rings, are similarly connected to the rotor windings of all motors in the system. The distributor itself is similar in design to the motors, but of sufficient size to supply the necessary rotor current to all the motors in use. It is driven by a separate motor, the speed of which is regulated. With this arrangement, it will be seen that an electromotive force is generated, in the rotors of the distributor and motors, of a frequency equal to the difference between the excitation frequency of the stator and the frequency corresponding to the speed of rotation of the rotor. For example, if the 4-pole distributor is driven at 1200 rpm and 60-cycle excitation is used, there will be generated in the rotor an emf having a frequency of 20 cycles and a voltage of approximately 70, which is proportional to the frequency. The torque delivered by the service motors is partly transmitted from the distributor drive motor through the electrical interlock and is partly developed by the service motors themselves, functioning as induction motors whose rotor circuit resistances are reduced by means of a three-phase rheostat which is connected across the rotor buses.

REPRODUCING EQUIPMENT

The value of the precision technique used in making vertical-cut transcriptions would be entirely wasted if a similar degree of precision were not used in the design, manufacture and operation of the reproducing equipment. The first and perhaps the most fundamental item is the accuracy of speed control of the turntable. In the broadcast reproducing equipment every necessary precaution has been taken to insure absolutely uniform turntable speed. The driving force is obtained from a precisely controlled 1200 rpm motor sturdily mounted and electrically interlocked with the 60-cycle a-c power supply. The necessary reduction in speed from the motor to the turntable is accomplished by a worm-and-wheel reducing gear running in oil. In order that there will be no possibility of transmitting speed variations to the turntable which might be caused by slight gear inaccuracies or instantaneous motor-speed changes, a mechanical filter system has been built in between the last gear and the turntable. This filter system involves a flywheel and a flexible connector between the flywheel and the drive gears. The turntable disc acts as a flywheel; the flexible connector consists of a series of six springs connecting the last gear to the turntable. By properly proportioning the moment of inertia of the flywheel and the flexi-

bility of the springs, irregularities are effectively smoothed out. To suppress surges in this filter system, or a persistence of any oscillation of the turntable, frictional damping has been applied to the spring connections. All turntables are tested to be sure that they are free from oscillations that cause noticeable pitch changes. As a further precaution against transmitting gear irregularities to the turntable, separate bearings are provided for the gear and for the turntable shaft. Also, the turntable shaft is carried on a ball thrust bearing running in oil in order to keep the bearing friction low and very uniform.

Given a uniformly driven vertically-cut disc the next item of reproducing equipment is the vertical reproducer. This also must be a precision instrument in every respect. Laterally- and vertically-cut records drive the reproducer point quite differently. Lateral-cut records drive the point from both sides, but the point rarely follows the center of the groove with great exactitude. It deviates from the center in a degree chiefly dependent upon the mechanical impedance of the reproducer. On the other hand, a vertically-cut record drives in only one direction. The restoring force is due chiefly to the combination of the elasticity of the supporting structure and the weight of the stylus. The stylus point will always remain in contact with the record unless the forces set up by the undulations exceed this normal restoring force, hence, operation should always be below this limiting condition. This sets definite requirements on the mechanical impedance of the vibrating parts which must be met to insure faithful reproduction of vertical-cut records. In the vertical reproducers the stylus can follow the sudden downward motion of the record groove even to accelerations about one thousand times that due to gravity alone.

Extensive development work indicates that a highly satisfactory design of reproducer for vertical-cut records is the type of structure now familiar in loudspeaker designs, namely, that in which a coil moves in a radial magnetic field. Such a reproducer is sturdy, light and efficient, and its performance is linear over a wide amplitude range. That is to say, the energy (or sound) output is precisely proportional to the size of the undulations on the record whether they are very small or very large. The coils used have a diameter of approximately one-tenth of an inch and the total mass of the vibrating system, including the diamond stylus, is only about 25 milligrams. The total force on the record has been reduced from 150 grams in former types of reproducers to approximately 30-35 grams. This insures much longer life of the records and tests have shown that the first few thousand playings cause negligible deterioration.



Chassis Cradle

Prevents Damage—Holds Chassis in Any Position

ONLY \$4.85
at your Distributor

Holds any make or model radio chassis in desired position for testing, aligning, repairing, replacing parts, etc. Clamps hold chassis in vise-like grip. Prevents danger of accidental damage to coil assemblies, tubes, etc. Allows both hands free for work. Puts repair jobs on a production basis. Is very desirable for displaying radio chassis. Made of steel—cadmium plated. Order today through your distributor.

ACRO TOOL & DIE WORKS

1401 WILSON AVENUE

CHICAGO, ILL.

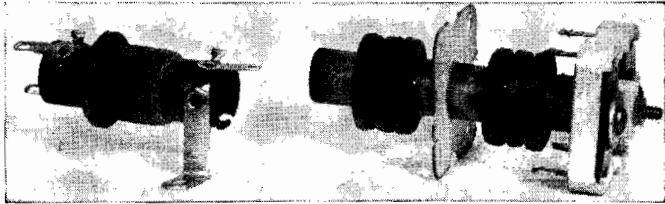

IF-RF WINDINGS—All types, your tolerance—prompt delivery any quantity—send samples or specifications for quotations—Export inquiries invited. Address Dept. C. PRECISION INDUCTANCE CORPORATION, 591 BROADWAY, NEW YORK

CHAS. EISLER EQUIPMENT PRODUCED MILLIONS

RADIO AND ELECTRON TUBES, INCANDESCENT LAMPS, PHOTO CELLS, X-RAY AND CATHODE RAY TUBES, NEON ELECTRODES AND NEON SIGNS. YOU CAN SEE CHAS. EISLER EQUIPMENT IN PRODUCTION EVERYWHERE. RELIABLE FOR OVER 20 YEARS. COMPLETE GLASS WORKING UNIT FOR SCHOOLS, COLLEGES AND GLASS PRODUCT LABORATORIES. WRITE FOR OUR LABORATORY GLASS WORKING

UNIT CATALOG, ELECTRIC WELDERS, VACUUM PUMPS, STEM SEALING, EXHAUST, ETC., ETC.

EISLER ENGINEERING CO.

750 S. 13 ST. (NEAR AVON)

NEWARK, N. J.

CLEANS BUT DOESN'T DAMAGE

IDEAL Jumbo "3-in-1" Cleaner

BLOWS—VACUUMS—SPRAYS

Powerful—but cleans most delicate electrical or other machinery and instruments without disturbing most precise adjustments. Gives high velocity of dry air at low pressure—and there's no moisture.

Cleans corners and smallest nooks, removing every particle of lint and dust.

Easy to handle—Portable—

Weights only 14 lbs.

Sent on Free Trial

IDEAL COMMUTATOR

DRESSER CO.

1062 Park Ave., Sycamore, Illinois

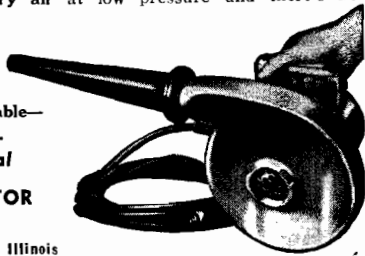

INSURE YOUR FUTURE! Start Training Now PRACTICAL RADIO ENGINEERING



Do you ever sit down and "look your job in the face"? Are you satisfied with your present position, or anxious to get ahead? Today, you can't be satisfied, because rapid new developments mean Radio wants only men who are TECHNICALLY TRAINED.

Better Men Get Better Jobs!

Right now is the time to start training—so you won't be left behind when others go ahead. CREI offers you home-training that will equip you to keep pace with Radio.

Write for FREE COPY of Booklet:
"A Tested Plan for a Future in Radio"

Capitol Radio Engineering Institute

WASHINGTON, D. C. DEPT. RE-10 NEW YORK CITY
14th and Park Rd., N.W. 29 Broadway

LOWER COSTS

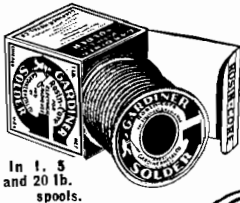

In 1.5
and 20 lb.
spools.

are made possible through the use of Gardiner Rosin-Core Solder. Its uniform high quality permits experienced workers to do faster work and inexperienced help to do better, neater work. It saves both time and material.

Made in various alloys and in gauges as fine as 1/32 of an inch. Because of modern production methods Gardiner Solder costs less than even ordinary kinds.

We also make bar and solid wire solders, and dipping and casting metals.

Eastern Sales Office and Warehouse:
DAVID M. KASSON & CO.
264 Canal St., New York



4819 S. CAMPBELL AVE., CHICAGO, ILL.

PARAMOUNT PAPER TUBE CO.

MANUFACTURERS OF SPIRAL WRAPPED TUBING FOR THE ELECTRICAL INDUSTRY

SQUARE - RECTANGULAR - ROUND

2035 WEST CHARLESTON STREET

Chicago, Illinois

"THE CRYSTAL SPECIALISTS SINCE 1925"

PIEZO-ELECTRIC CRYSTALS

GUARANTEED Accurate to BETTER than .01%

SCIENTIFIC RADIO SERVICE

Send for FREE Booklet and Price List!

UNIVERSITY PARK - - - - - HYATTSVILLE, MD.

SPEAKER GRILLE CLOTH

Complete assortment of patterns.
Special colors and patterns made to order.
Samples and prices furnished upon request.
Shipments made from stock.

A. G. HINTZE

300 WEST ADAMS STREET

CHICAGO, ILL.

RADIO IN ITS ENTIRETY!



"B-A" serves the trade with every need in radio—complete 160-page catalog of nationally known radio receivers, public address, parts, supplies and equipment. Orders shipped same day received.

BURSTEIN-APPLEBEE CO.
1012-14 MCGEE ST. - - KANSAS CITY, MO.

UP-TO-DATE CATALOG AVAILABLE

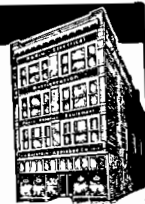

The
First Comprehensive
Treatise

TELEVISION
ENGINEERING

By J. C. Wilson
Now of Columbia Broadcasting System

While much has been written on this interesting and advancing science, most of it has been semi-popular, or else confined to the work of some one leading experimenter.

Now for the first time appears a genuine scientific textbook—a complete study of the fundamental principles and the many and impressive technical advances which have been made. The whole subject of Television is discussed from the standpoint of the advanced student and of the engineer.

Cloth. 5½" x 8¼". 504 pp. Illus. \$10.00

PITMAN

PUBLISHING CORPORATION
2 W. 45th St., New York

LYNCH
GIANT KILLER CABLE

For any and all types of radio frequency transmitting and receiving systems.

Not only endorsed by, but used by leading radio experts everywhere.

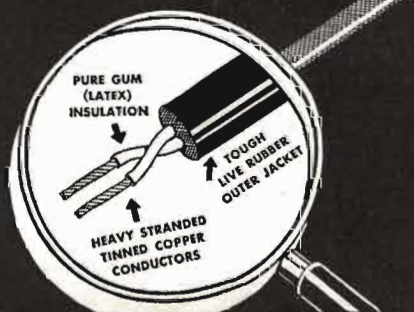

World's Largest Makers of Antenna Systems

L. S. BRACH Mfg. Corp.

Newark, N. J. BRACH Est. 1906

Advertising Index

A	
Acro Tool and Die Works.....	59
Alliance Mfg. Co., The.....	57
American Lava Corp.....	29, 30, 31, 32
American Transformer Co.....	46
Amperex Electronic Products, Inc.....	57
Anperite Corp.....	60
Astatic Microphone Laboratory, Inc.....	51
B	
Bakelite Corp.....	3
Barber, Alfred W.....	57
Bliley Electric Co.....	57
Brach Mfg. Co., L. S.....	60
Burstein-Applebee Co.....	59
C	
Callite Products.....	48
Capitol Radio Eng. Inst.....	59
Cinaudagraph Corp.....	46
Clarostat Mfg. Co.....	43
Collins Radio Co.....	42
Cornell-Dublier Corp.....	42
Crowley Co., Inc., H. L.....	Second Cover
D	
Deutschmann Corp., Tobe.....	50
Driver Co., Wilbur B.....	55
E	
Eisler Engineering Co.....	59
F	
Ferris Instrument Corp.....	53
G	
Gardiner Metal Co.....	59
Gates Radio & Supply Co.....	47
General Radio Co.....	Third Cover
Guardian Electric Co.....	53
H	
Hintze, A. G.....	59
I	
Ideal Commutator Dresser Co.....	59
International Derrick & Equip. Co.....	46
J	
Jensen Radio Mfg. Co.....	Back Cover
L	
Littelfuse Laboratories.....	48
M	
Mallory & Co., Inc., P. R.....	6
N	
National Radio Tube Co.....	59
Newark Transformer Co.....	50
P	
Paramount Paper Tube Co.....	59
Pitman Publishing Corp.....	60
Precision Inductance Corp.....	59
Precision Resistor Co.....	51
Presto Recording Corp.....	44
R	
RCA Communications, Inc.....	52
RCA Mfg. Co., Inc.....	5
Radio Transceiver Labs.....	52
S	
Scientific Radio Service.....	59
Sound Apparatus Co.....	49
Stevens, Eugene E.....	57
Superior Tube Co.....	37
Swedish Iron & Steel Corp.....	39
T	
Terminal Radio Co.....	60
Thomas & Skinner Steel Prod. Co.....	57
U	
United Transformer Corp.....	41
Universal Microphone Co., Ltd.....	48
W	
Western Electric.....	1
Wholesale Radio Service Co., Inc.....	55
Z	
Zophar Mills, Inc.....	50

the **AMPERITE VELOCITY**
with **NEW DESK STAND**



Ideal for desk, pulpit, footlights, banquets. Leaf spring suspension acts as shock absorber. **STAND ONLY** . . . LIST \$4.00 **NAME PLATE** with call letters . . . LIST \$2.00

MICROPHONES: Model RBHn (High Imped.) or RBMo (200 ohms) with cable connector & switch . . . LIST \$42.00 Models RBSn, RSHn, with switch only . . . LIST \$32.00



NEW "HAM MIKE"

No Peaks! No Splashing! Real Broadcast Quality! RF Choke Circuit included in microphone. Output—68 db. Operates directly into grid. **MODEL HAM** (High Imped.) or **MODEL HAL** (200 ohms) . . . **Gunmetal, LIST \$22.00. Chrome LIST \$23.00.** Price includes Ham Desk Stand, Call Letters, and 6 feet of cable.

MODEL RAL \$22.00 LIST

A popular Amperite Velocity of very high excellence. Used for both speech and music. No peaks. Flat response over audible range. Output—68 db. Triple shielded. Shock absorber, swivel bracket. **MODEL RAL** (200 ohms); or **MODEL RAH** (2000 ohms) high impedance . . .



FREE: Window Decal & Window Display

AMPERITE G. 561 BROADWAY, N. Y.

AMPERITE Velocity **MICROPHONE**

**HOW
TERMINAL CUSTOMERS
ARE MADE**

A few weeks ago W— Engineer R— R— was in a tight spot—he had to have a special cable connector and db. meter for a rush job—a sponsor decided at the last minute to broadcast a new price policy from his own desk. There was no time for if-ing and but-ing. It was simply up to W— to deliver.

R— tried his regular suppliers. Nowhere could he find what he wanted. It was getting late. Finally, in desperation, he called a friend— J— D—. Naturally, J— recommended Terminal Radio right off. R— dialed Barclay 7-0622, explained what he needed. In less than an hour the engineer had his equipment—exactly to specifications.

This could happen to you. Get to know Terminal today and its sleeve-rolled policy—service, speed, quality merchandise—always.

TERMINAL
RADIO CORPORATION
80 Cortlandt St., New York City



PRODUCTION COIL TESTING

WITH the new G-R Coil Comparator, an ingeniously designed measuring circuit, you can make reactance and resistance or *Q* production checks on coils and condensers over a wide range of resistance and inductance.

The comparator is extremely simple to operate, direct reading in tuning capacitance differences, shows up small variations in coil losses, and requires only inexpensive auxiliary equipment. It has sufficient accuracy to hold coils and condensers to extremely close tolerances.

The auxiliary equipment required is simple and generally already available. It consists of an oscillator, a detector (a

broadcast receiver operating at the test frequency), and the standard coil or condenser with which the test samples are to be checked.

Where precise results are not required, the comparator may be used for direct measurements of resistance and inductance by means of the approximate calibrations supplied.

The comparator is supplied in two models: Type 721-AM in cabinet (\$85.00) and Type 721-AR with metal dust cover, (\$80.00).

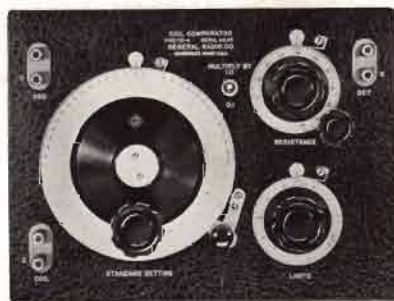

• Write for Bulletin 184 for complete description.

GENERAL RADIO COMPANY

Cambridge, Massachusetts

Branches: New York Los Angeles San Francisco

MANUFACTURERS OF PRECISION ELECTRONIC MEASURING EQUIPMENT

Another Contribution to the by Jensen The Bass Reflex Principle

☐ Briefly, this new acoustic principle involves the function of an acoustic network through which back-side radiation from the cone type of loudspeaker is made to add usefully to the acoustic output from the front-side. Thus that energy, previously a source of destructive interference and difficult to dissipate satisfactorily in open-back loudspeaker cabinets and baffles, becomes a source of useful acoustic output. And, by suitable acoustic network design this added output occurs through a range of low frequencies not heretofore possible to produce by practical method. In short, one or more octaves of low frequency response range is added to what has previously been accepted as maximum loudspeaker and baffle ability.

This accomplishment not only involves consideration of acoustic networks in simple form but also those of more comprehensive nature which are Jensen developments and which constitute new art. Application of this new *Bass Reflex* principle is practical in every known use of direct radiator loudspeakers and we predict that henceforward consideration of the principle will be mandatory if the best possible acoustic results are to be achieved in treatment of loudspeakers and associated cabinets or baffles.



☐ We offer the details of this new Engineering Service to those manufacturers who incorporate the principle in their manufacturing service may either involve consideration of simple works or of those more comprehensive in nature, the latter usually being that of finished product for a specific objective. Specifications are provided for cabinet enclosures, loudspeaker design and analysis of the receiver itself. Those interested should write and ask for a date at which the work



MODEL KM-12

range from \$12.50 up. The list price of Model KM-12, illustrated at left, is \$34.25 complete with 12-inch PM12-C speaker.

KM and KV Models are shipped in kit form with enclosure designed for easy assembly in the job. They are ideal for public address, radio and similar uses.

☐ Jensen built *Peri-Dynamic* Reproducers, incorporating *Bass Reflex*, are offered the trade for all manner of applications concerned with the Reproduction and Reinforcement of sound. Models are available with either 8, 10, 12 or 15 inch speaker equipment. List prices

Model Reproducers. Some models and variations are incorporated and are earnestly recommended. Station reference will be used when necessary for reproduction of these Reproducers. Write on all M

Write on all M

JENSEN RADIO MANUFACTURING CO
6601 SOUTH LARAMIE AVENUE

"The Name Insures the Quality"