

Western Electric

SPEECH INPUT

EQUIPMENT

INSTRUCTIONS
FOR USE

Western Electric

AMPLIFIER

No. 81A

Instructions for Use

The Western Electric No. 81A Amplifier is a two-stage, adjustable gain, resistance coupled amplifier, intended for use as a low-level line amplifier in alternating current operated speech input equipments for radio broadcasting.

The No. 81A Amplifier is designed to operate between impedance of 200 ohms and 500 ohms with a gain of 30 db, 40 db, or 50 db, as determined by the position of the flexible connector which is soldered to one of three taps on the resistance in the grid circuit of the second vacuum tube. The frequency response characteristic is uniform within approximately 1 db from 30 cycles to 10,000 cycles per second. This amplifier will deliver a zero energy level (0.006 watt) with less than 1 percent total harmonics introduced by the amplifier. Two Western Electric No. 262A Vacuum Tubes are used; these tubes have a low noise level when the filaments are operated from alternating current. The vacuum tubes are not supplied with the No. 81A Amplifier and must be ordered separately.

The schematic circuit diagram is shown in Figure 1 and the wiring diagram in Figure 2.

DESCRIPTION

The component parts of the No. 81A Amplifier are assembled on a depressed metal panel 19 inches wide and 5¼ inches high designed for mounting in a standard relay rack or equipment cabinet. The panel is equipped with a dark gray mat on the front. The mat is removable to allow access to the panel wiring and the terminal blocks which, with the smaller pieces of apparatus, are located in the depressed section of the panel behind the mat. The larger pieces of apparatus such as the vacuum tubes, coils, and condensers, are mounted on the back of the panel and are protected from dust and mechanical injury by an aluminum finished back cover. The mat and the back cover may be obtained with a black finish if this is specified in the order.

An alternating current supply of approximately 0.64 ampere at 10 ± 0.3 volts is required for the filaments of the No. 262A Vacuum Tubes, which are

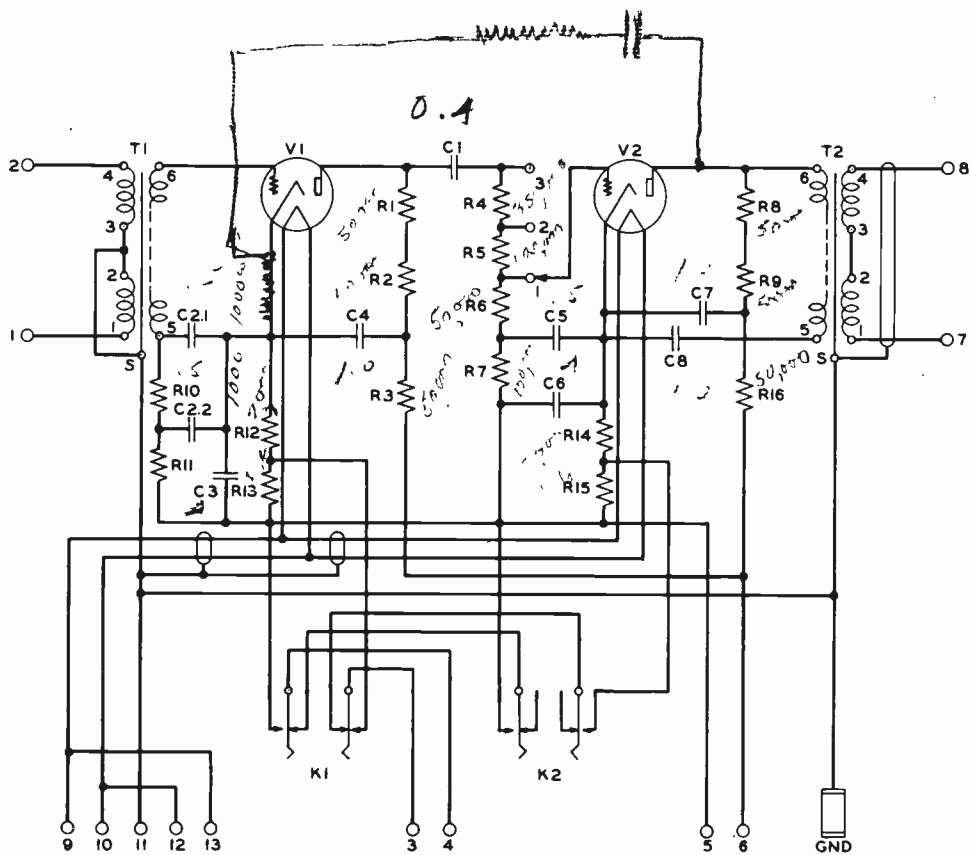

Fig. 1—Schematic Circuit

connected in parallel. The Western Electric No. 263A Voltage Regulator Panel, which supplies a constant 10-volt potential from 100-125 volt, 60-cycle power mains, is recommended for this purpose. (If the frequency of the power supply is 50 cycles, Western Electric No. 263B Voltage Regulator Panel should be used).

A plate power supply of approximately 0.005 ampere (5 milliamperes) at 375 ± 25 volts DC is required for the plate circuits of the vacuum tubes. The Western Electric No. 8A Rectifier and No. 716A Filter are recommended for this purpose.

The grid bias potentials for the vacuum tubes are obtained from voltage drops across resistances R12 and R13, and R14 and R15, located in the cathode circuits of the first and second tubes, respectively.

Keys K1 and K2 are provided at the front of the panel for measuring indirectly the plate currents of the vacuum tubes through an external meter which should be connected to terminals 3(+) and 4(-) of the amplifier. For these measurements the voltage across a part of the bias resistances in each vacuum tube circuit is measured on the external meter by depressing the proper key. An interlock circuit is provided so that the space current in only one tube can be measured at any one time even though the keys may be operated

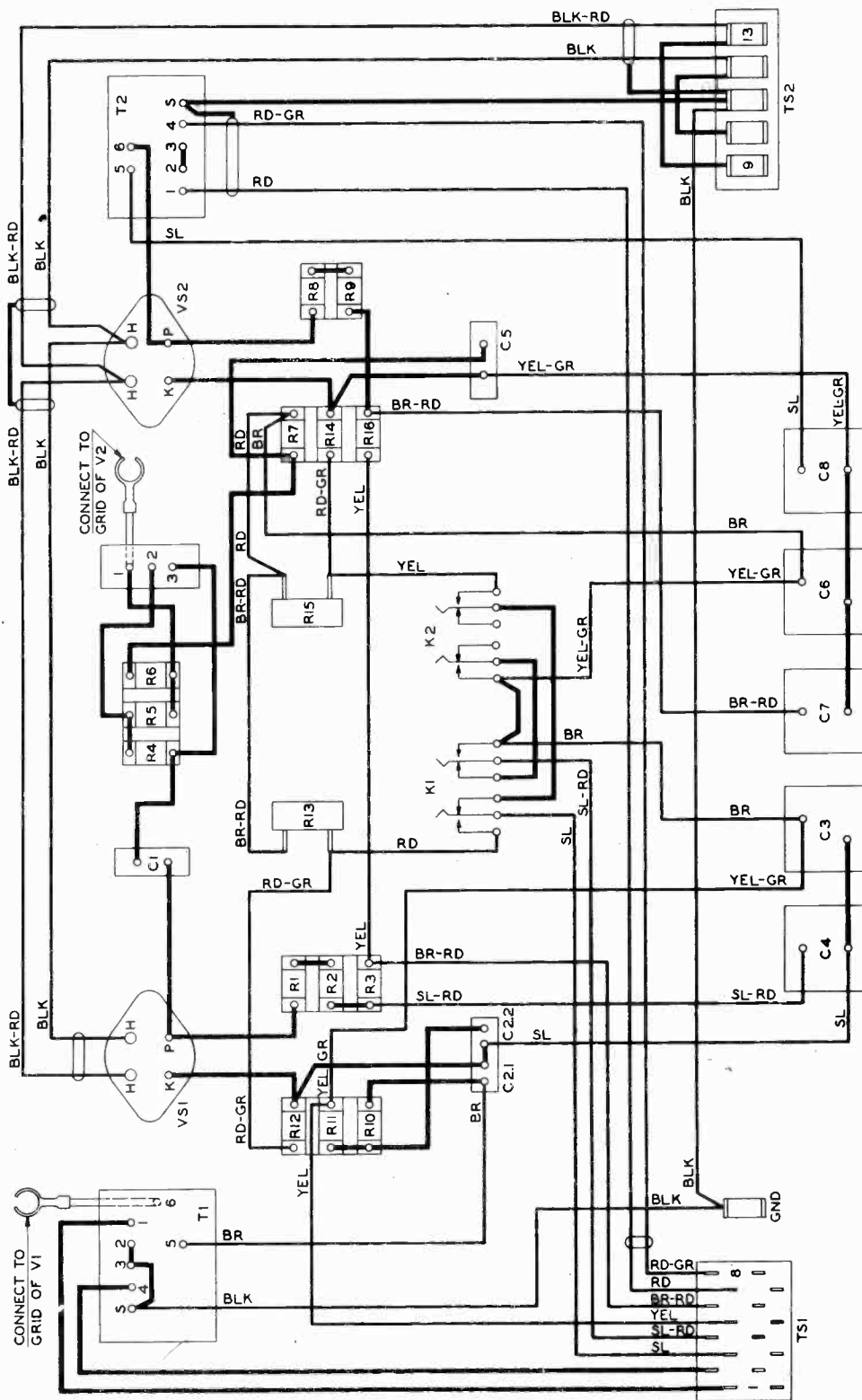

Fig. 2—Wiring Diagram

simultaneously. The circuit is designed for use with a Western Electric No. 262A Meter Panel, which is furnished as an integral part of the speech input equipments of which this amplifier forms a part. If the No. 81A Amplifier is used in assemblies other than those for which it is designed, it is recommended that a No. 262A Meter Panel be obtained for measuring the space currents. It will likewise be necessary to provide, externally, power control switches for the filament and the plate circuit power supply voltages since these controls are not included in the No. 81A Amplifier. The No. 8A Rectifier contains a power control switch with a time delay feature which permits the cathodes of the vacuum tubes in the amplifiers to reach their normal operating temperatures before the high voltage plate power is applied. This is a necessary precaution to insure long life for the vacuum tubes. The No. 8A Rectifier also contains terminals for connecting to a No. 716A Filter Panel which is designed for the plate supply circuit of the No. 81A Amplifier.

INSTALLATION

Care should be exercised in the installation of the No. 81A Amplifier to guard against unnecessary exposure to strong magnetic fields from rectifiers or other alternating current operated equipment. Since the amplifier as ordinarily employed forms a part of a larger system the gain of which may be as high as 110 db, it is obvious that any noise which is induced in the input circuit may become objectionable in the ultimate output of the system. Although special shielding precautions have been taken in the design of the amplifier, if this precaution is not observed an abnormal amount of hum due to magnetic coupling may be experienced. Two terminal strips are provided to isolate the alternating current filament leads from the input, output and plate supply wires. The terminal strip at the left side of the amplifier (viewed from the front) contains eight terminals, numbered from 1 to 8. The right side terminal strip contains five terminals, numbered from 9 to 13. The following table gives the terminal numbers and the connections to be made to each terminal.

TERMINAL NUMBERS AND CONNECTIONS FOR NO. 81A AMPLIFIER

<i>Terminal Numbers</i>	<i>External Connections</i>
1 and 2	Input
3 and 4	Meter Terminals; 3 is positive
5	-375 Volts DC
6	+375 Volts DC
7 and 8	Output
9 and 10	10 Volts AC
12 and 13	10 Volts AC (multiple)
11	Ground

All external connections to the amplifier should be made with shielded twisted pair copper wire and all joints should be securely soldered. The shields should be electrically continuous and grounded at the amplifier end by wrapping with several turns of No. 20 bare tinned copper wire, soldering, and connecting the free end to the ground lug of the amplifier.

The filament supply leads should be of such size that the voltage drop in the conductors, with the proper current flowing, does not reduce the terminal voltage at the amplifier below 10 volts.

After the connections have been made as outlined two Western Electric No. 262A Vacuum Tubes should be inserted in the tube sockets at the back of the panel, and the flexible grid leads extending from the top of the input transformer and from the coupling resistance should be attached to the metal caps at the tops of the vacuum tubes.

It is desirable to provide and install permanently a No. 262A Meter Panel for measuring the space currents. If this panel is not available a 200-scale microammeter with a 2000-ohm series resistance, or multiplier, may be used for this purpose. If this is done, the reading in milliamperes, obtained by depressing either one of the keys K1 or K2, should be multiplied by 20 to obtain the actual space current. The factor 20 is the ratio of the 2000-ohm multiplier, which is a part of the measuring circuit, to the value of resistance across which the measurement is made.

OPERATION

After the amplifier has been installed as described, it is ready for operation. The filament circuit should be closed and, after an interval of approximately 30 seconds (to allow the cathodes to reach normal operating temperatures) the 375-volt plate supply circuit should be closed. In the Western Electric Speech Input Equipments of which the No. 81A Amplifier is a part this complete operation is carried out automatically by means of the time delay circuit previously mentioned so that it is only necessary to operate a single power switch in starting.

The plate current of each vacuum tube should then be measured to determine if the tube is operating normally. With the No. 262A Meter Panel, or its equivalent, connected to the proper terminals on the amplifier the plate current measurements are made by depressing in turn each key on the front of the amplifier. The current in each tube should be 2.5 ± 0.5 milliamperes.

The gain of the amplifier should be set at the desired value by soldering the flexible connector to the proper resistance tap. The amplifier is supplied with the flexible connector soldered to tap 1 for 30 db gain. If a greater gain is required tap 2 (40 db gain) or tap 3 (50 db gain) should be used. The required gain will depend upon the use to which the amplifier is put, and upon the energy level desired at the output of the system. The input to the No. 81A Amplifier should be kept at such a level that its output does not exceed zero level as measured on a standard volume indicator.

In removing the amplifier from service the 375-volt plate supply circuit should not remain connected after the filament voltage is removed.

MAINTENANCE

The vacuum tubes used in the amplifier have a long but finite life and will require occasional replacement. The tubes should never be operated at higher filament or plate voltages than those recommended, as such operation shortens the useful life of the tubes and does not improve the operation of the amplifier.

Detailed instructions covering the maintenance of any of the apparatus incorporated in the amplifier will be found in Bulletin No. 517, "General Instructions for Maintenance of Speech Input Equipment".

When additional vacuum tubes are needed, they should be ordered as follows:

<i>Name of Part</i>	<i>How to Order</i>
Vacuum Tube	Western Electric No. 262A Vacuum Tube (for use in Western Electric No. 81A Amplifier)

Orders for other replacements should specify the apparatus designation (such as T1) shown on the schematic circuit and the wiring diagram as well as the code number which is marked on the apparatus. The order should state that the parts are intended for use in the Western Electric No. 81A Amplifier.

RECOMMENDED ACCESSORY EQUIPMENT

<i>Apparatus</i>	<i>Purpose</i>
Western Electric No. 262A Meter Panel	Amplifier Plate Current Measurement

The equipment described in this Bulletin
was designed and developed for the

Western Electric Company

by

BELL TELEPHONE LABORATORIES

DISTRIBUTOR IN THE UNITED STATES

Graybar

ELECTRIC COMPANY

Akron
Albany
Asheville
Atlanta
Baltimore
Beaumont
Birmingham
Boston
Brooklyn
Buffalo
Charlotte
Chicago
Cincinnati
Cleveland
Columbus

Dallas
Davenport
Dayton
Denver
Detroit
Duluth
Durham
Flint
Fort Worth
Grand Rapids
Hammond
Harrisburg
Hartford
Houston
Indianapolis

Jacksonville
Kansas City
Knoxville
Los Angeles
Louisville
Memphis
Miami
Milwaukee
Minneapolis
Mount Vernon
Nashville
Newark
New Haven
New Orleans
New York (2)

Norfolk
Oakland
Oklahoma City
Omaha
Philadelphia
Pittsburgh
Portland
Providence
Reading
Richmond
Roanoke
Rochester
St. Louis
St. Paul

Salt Lake City
San Antonio
San Francisco
Savannah
Seattle
Spokane
Syracuse
Tacoma
Tampa
Toledo
Washington
Wichita
Worcester
Youngstown

A NATIONAL ELECTRIC SERVICE

DISTRIBUTOR FOR CANADA AND NEWFOUNDLAND

Northern Electric Company Limited

General Sales Offices: 1620 Notre Dame Street, West, Montreal, P. Q.

Branch Houses

Halifax
Saint John, N. B.
Quebec
Montreal

Ottawa
Toronto
Hamilton
London

Windsor
New Liskeard
Sudbury
Winnipeg

Regina
Calgary
Edmonton
Vancouver

FOREIGN DISTRIBUTORS

International Standard Electric Corporation

67 Broad Street

New York, U. S. A.

Associated, Allied or Affiliated Companies

ARGENTINA

Cia Standard Electric Argentina,
Casilla de Correo 49, (Street Address,
Defensa 143), Buenos Aires

AUSTRALIA

Standard Telephones and Cables
(Australasia) Ltd., 71 York Street
(P. O. Box 525-B), Sydney, N. S. W.

AUSTRIA

United Telephone and Telegraph
Works, Ltd., Dresdner Strasse No. 75,
Vienna, XX/2

BELGIUM

Bell Telephone Manufacturing Co.,
4 Rue Boudewyns. P. O. Box 526,
Antwerp

BRAZIL

International Standard Electric
Corp., Caixa Postal 430, (Street
Address, Rua Visconde de In-
hauma, 64), Rio de Janeiro

CHINA

China Electric Co., Ltd., 230 Med-
hurst Road (P. O. Box 289),
Shanghai

CZECHOSLOVAKIA

Standard Electric Doms a Spolecnost,
Samova, U 1, 664, Prague

DENMARK

Standard Electric A/S., Gylden-
lovesgade 1, Copenhagen, V.

EGYPT

Standard Telephones and Cables,
Ltd., Cozzika Buildings, Sharia
Soliman Pasha, Cairo

FRANCE

Le Materiel Telephonique, 46-47
Quai de Boulogne,
Boulogne-Billancourt (Seine)

GERMANY

Standard Elektrizitäts Gesellschaft
A/G., Genest Strasse 5,
Berlin-Schöneberg

GREAT BRITAIN

Standard Telephones and Cables,
Ltd., Connaught House, 63 Aldwych,
London, W. C. 2

HOLLAND

Bell Telephone Manufacturing Co.,
Scheldestraat 160-162,
The Hague

HUNGARY

Standard Electric Co., Ltd.,
Ujpest 4, n. Budapest

INDIA

Standard Telephones and Cables,
Ltd., Block C2, Clive Buildings,
8 Clive Street, Calcutta

ITALY

Standard Elettrica Italiana, Via
Vittoria Colonna No. 9, Milan, 125

JAPAN

Nippon Electric Co., Ltd., 2 Mitu
Shikokumachi, Shiba-Ku, Tokyo

JAVA

Bell Telephone Manufacturing Co.,
Bureau in Nederlandsch Oost Indie
Riouwstraat, 85, Bandoeng

NEW ZEALAND

Standard Telephones & Cables
(Australasia) Ltd., 24-26 Ballance
Street, P. O. Box 638, Wellington

NORWAY

Standard Electric Aktieselskap,
Hovind, Ostre Akre, Oslo

POLAND

Standard Electric Co. W. Polsce,
Sp. Z.O.O. Wspolna 53, Warsaw

PORTUGAL

Standard Electrica, S.A. Praca Dos
Restauradores 47-1, Lisbon

RUMANIA

Standard Electric Romana, S. A.
37 Calea Victoriei, Bucharest, 1

SOUTH AFRICA

Standard Telephones and Cables,
Ltd., Locarno House, Loveday Street,
(P. O. Box 1571), Johannesburg

SPAIN

Standard Electrica, S/A., Calle
Ramirez de Prado (Post Office
Box 7040), Madrid

STRAITS SETTLEMENTS

Standard Telephones and Cables,
Ltd., 57 Robinson Road, (P. O. Box
553), Singapore

SWITZERLAND

Bell Telephone Manufacturing Co.,
10 Bubenberplatz, Berne

Western Electric

AMPLIFIER

No. 82A

Instructions for Use

General

The Western Electric No. 82A Amplifier is a two-stage, fixed-gain, transformer-coupled amplifier intended for use in alternating current operated speech input equipments for radio broadcasting. This amplifier is capable of amplifying weak audio frequency signals to a level suitable for use with a radio transmitter or a telephone line. For example, the amplifier may be used with an external gain control potentiometer, to raise the level of the incoming signals at the radio transmitting station to the required value for introduction into the radio transmitter. It may also be used for operating monitoring loud speakers.

The No. 82A Amplifier is designed to operate between impedances of 200 ohms and 500 ohms with a gain of approximately 61 db and a frequency response characteristic which is essentially uniform from 30 to 10,000 cycles per second. The output transformer is tapped so that an output impedance of 250 ohms may also be obtained. It will deliver a +24 db energy level with less than 1 per cent total harmonics introduced by the amplifier. A Western Electric No. 262A Vacuum Tube is used in the first stage and two Western Electric No. 271A Vacuum Tubes in push-pull are used in the second stage. The vacuum tubes are not supplied with the No. 82A Amplifier and must be ordered separately.

The schematic circuit diagram is shown on Figure 1 and the wiring diagram on Figure 2.

DESCRIPTION

The component parts of the No. 82A Amplifier are assembled on a depressed metal panel 19 inches wide and 7 inches high designed for mounting in a standard relay rack or equipment cabinet. This panel is equipped with a dark gray mat on the front; the mat is removable to allow access to all the panel wiring which, with the smaller pieces of the apparatus, is located in the depressed section of the panel behind the mat. The larger pieces of apparatus such as the vacuum tubes, coils, and condensers, are mounted on the back of the panel and are protected from dust and mechanical injury by an aluminum finished removable cover. The mat and the back cover for the amplifier may be obtained with a black finish if this is specified in the order.

Instruction Bulletin No. 686

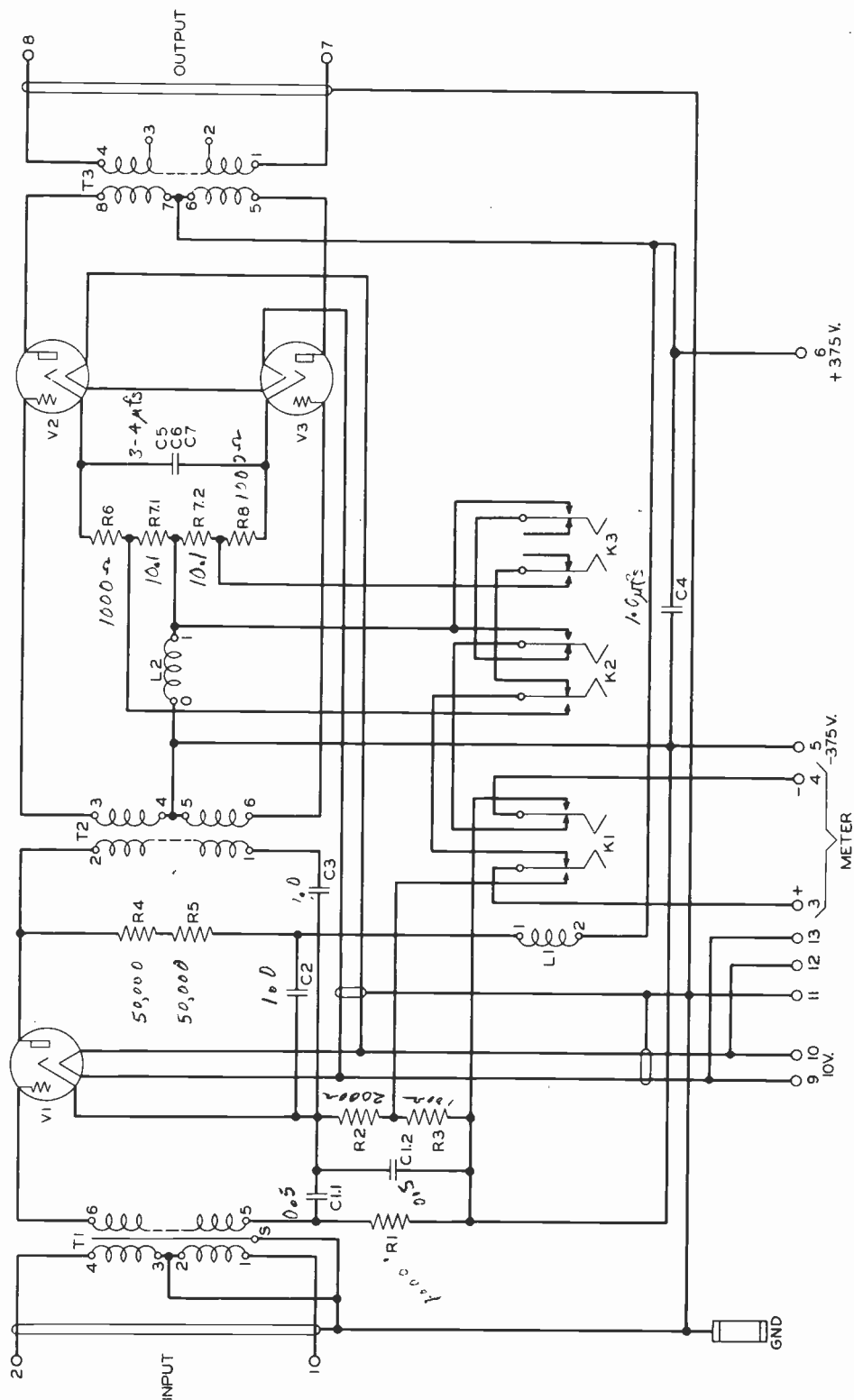

Fig. 1

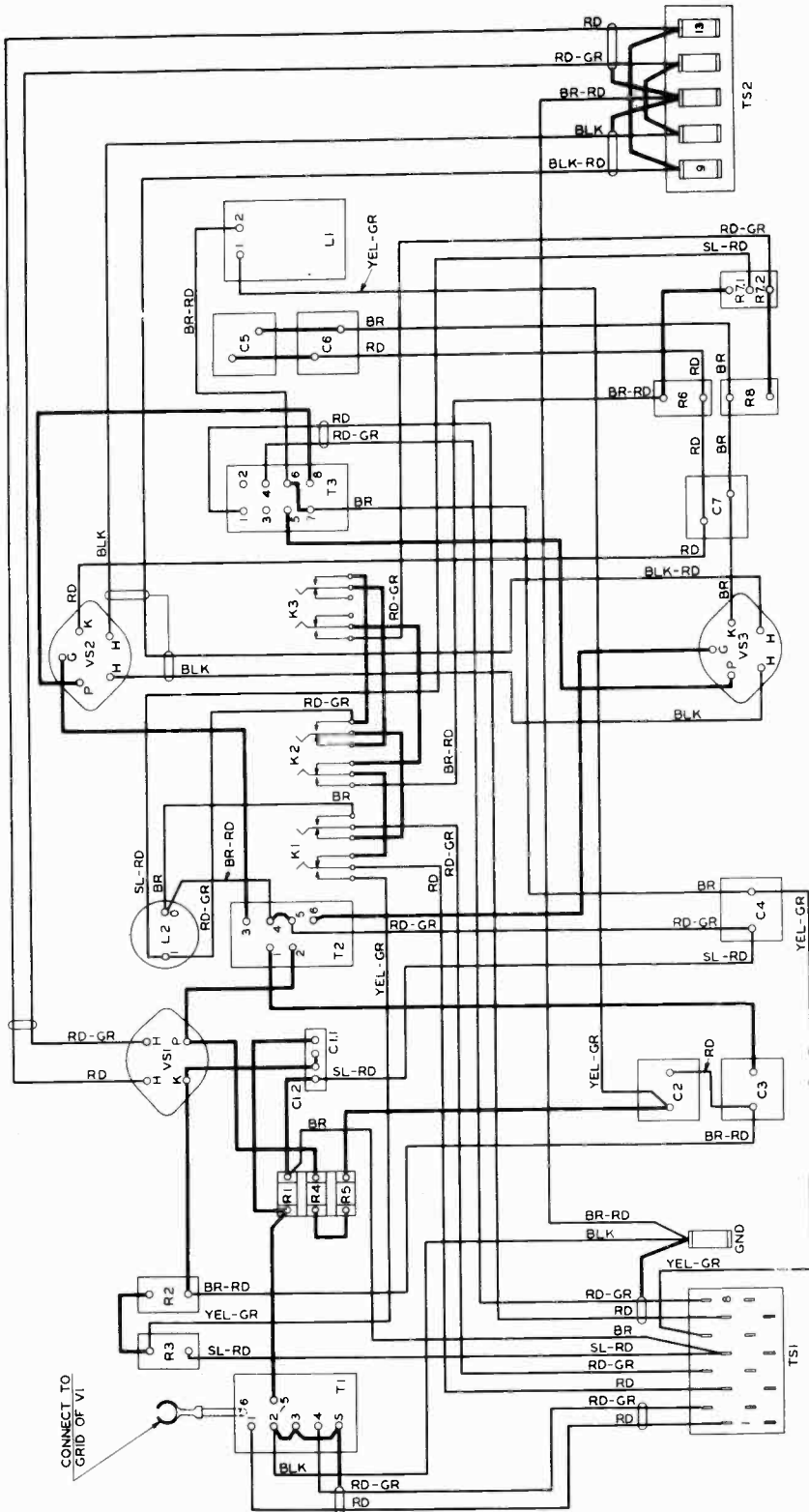

Fig. 2

An alternating current supply of approximately 2.32 amperes at 10 ± 0.3 volts is required for the filaments of the No. 262A and the No. 271A Vacuum Tubes. (The No. 262A Vacuum Tube filament is connected in parallel with the series-connected filaments of the two No. 271A Vacuum Tubes). The Western Electric No. 263A Voltage Regulator Panel, designed to supply a constant 10-volt potential from 100-125 volt 60-cycle power mains, is recommended for this purpose. (If the frequency of the power supply is 50 cycles, Western Electric No. 263B Voltage Regulator Panel should be used).

A plate supply of approximately 55 milliamperes at 375 ± 25 volts DC is required for the plate circuits of the vacuum tubes. The Western Electric No. 8A Rectifier with self-contained filter circuits is recommended for this purpose.

The grid bias for the first stage vacuum tube is obtained from the potential drop across resistances R2 and R3 located in the cathode circuit of this tube.

Grid bias for the second stage vacuum tubes is obtained in the same manner, except that separate biasing resistances are provided for each of the vacuum tubes which operate as a push-pull amplifier. The resistances R6 and R7.1 provide the bias for vacuum tube No. 2 and the resistances R8 and R7.2 for vacuum tube No. 3.

Keys are provided on the front of the panel for measuring indirectly the plate currents of each of the vacuum tubes through an external meter which should be connected to terminals 3 (+) and 4 (-) of the amplifier. The Western Electric No. 262A Meter Panel is designed for this purpose. For these measurements the voltage across a part of the bias resistances in each vacuum tube circuit is measured by depressing the proper key. This part of the circuit is so designed that the plate current in each tube should cause the same deflection of the meter on the No. 262A Meter Panel. The lower scale (0-4 milliamperes) of this meter indicates the plate current of the first stage vacuum tube and the upper scale (0-40 milliamperes) indicates the currents in the second stage vacuum tubes. For satisfactory measurements of the plate currents it is recommended that the No. 262A Meter Panel be used.

The No. 82A Amplifier does not include a control potentiometer but may be used with any external potentiometer of suitable design. The Western Electric No. 265A Control Panel contains two identical potentiometers and a repeating coil, for use with either a line amplifier or a monitoring amplifier, or both simultaneously, and is recommended for use with No. 82A Amplifiers. One potentiometer may be used as the control unit for the No. 82A (Line) Amplifier, and the repeating coil in conjunction with the second potentiometer may be employed with a No. 82A (Monitoring) Amplifier. The purpose of the repeating coil is to present a relatively high impedance to the line amplifier output circuit so that the bridging (monitoring) circuit does not cause an appreciable transmission loss on the line amplifier circuit and, therefore, may be connected or disconnected at will without affecting the load on the line amplifier circuit.

INSTALLATION

Care should be exercised in installing the No. 82A Amplifier to guard against exposure to strong magnetic fields from rectifiers or other alternating current

equipment. Although special shielding precautions have been taken in the design of the amplifier, if this precaution is not observed an objectionable hum may be experienced due to electromagnetic coupling.

Two terminal strips are provided in order to isolate the alternating current filament supply leads from the input, output, and plate supply leads. The terminal strip at the left side of the amplifier (viewed from the front) contains eight terminals, numbered from 1 to 8. The terminal strip at the right side contains five terminals numbered from 9 to 13. The following table gives the terminal numbers and the connections to be made to each terminal.

TERMINAL NUMBERS AND CONNECTIONS FOR NO. 82A AMPLIFIER

<i>Terminal Numbers</i>	<i>External Connections</i>
1 and 2	Input
3 and 4	Meter Terminals. 3 is positive
5	-375 volts DC
6	+375 volts DC
7 and 8	Output
9 and 10	10 volts AC
12 and 13	10 volts AC (multiple)
11	Ground

All external connections to the amplifier should be made with shielded twisted pair copper wire and all joints should be securely soldered. The shields should be electrically continuous and grounded at the amplifier end by wrapping with several turns of No. 20 bare tinned copper wire, soldering, and connecting the free end to the ground lug of the amplifier.

The filament supply leads should be of such size that the voltage drop in the conductors with the proper current flowing, does not reduce the terminal voltage at the amplifier below 10 volts.

After the connections have been made as outlined, a Western Electric No. 262A Vacuum Tube should be inserted in the socket at the right side of the panel (viewed from the rear). The flexible grid lead extending from the top of the input transformer should be attached to the metal cap on the top of the vacuum tube. Two Western Electric No. 271A Vacuum Tubes should then be inserted in the vacuum tube sockets at the left.

The No. 82A Amplifier is intended primarily for use in speech input assemblies in which a master power control switch is employed for the filament and the plate supply voltages. If it is used otherwise it will be necessary to provide external switches for the power supply.

As previously mentioned it is desirable to provide and install permanently the No. 262A Meter Panel for measuring the plate currents of the vacuum tubes. If this panel is not available a 200-microampere scale meter with a 2000-ohm series resistance, or multiplier, may be used for this purpose. If a meter and a multiplier are used the reading in microamperes must be multiplied by the proper factor to obtain the actual plate current. In measuring the plate

current of the first vacuum tube the indicated reading should be multiplied by 20 to obtain the actual plate current in milliamperes. In measuring the plate currents of the second and third vacuum tubes the indicated readings should be multiplied by 200.

OPERATION

After the amplifier has been installed as described in the preceding section, it is ready for operation. The filament circuit should be closed, and after an interval of approximately 30 seconds (to allow the cathodes to reach normal operating temperature) the 375-volt plate supply circuit should be closed. In the Western Electric Speech Input Equipment of which the No. 82A Amplifier is a part this complete operation is carried out automatically by means of a time delay circuit in the No. 8A Rectifier so that it is only necessary to operate a single power switch in starting.

The plate current of each vacuum tube should then be measured to determine that all tubes are operating.

With the No. 262A Meter Panel or its equivalent connected to the proper terminals on the amplifier the plate current measurements are made by depressing in turn each key on the front of the amplifier. The plate current of the No. 262A Vacuum Tube in the first stage should be 2.6 ± 0.6 milliamperes. The plate currents of the No. 271A Vacuum Tubes in the second stage should be 26 ± 6 milliamperes each, and the difference in plate currents of these tubes should not be greater than 4 milliamperes. If a greater difference is observed, other tubes should be selected until two are found whose plate currents differ by not more than this amount.

The input to the No. 82A Amplifier should be kept at such a level that the output level does not exceed +24 db (1.5 watt) as measured on a standard volume indicator such as the Western Electric No. 700A Volume Indicator. If this output level is exceeded distortion may occur due to overloading. If a potentiometer or an attenuator other than the Western Electric No. 265A Control Panel previously mentioned, is used to control the input to the amplifier, it is important that it be of such design that the impedance presented to the amplifier input terminals be maintained at 200 ohms for any setting of the potentiometer; otherwise the gain frequency characteristic of the amplifier will be affected.

In discontinuing the use of the amplifier the 375-volt plate supply circuit should not remain connected after the filament supply circuit is opened.

MAINTENANCE

The vacuum tubes used in this amplifier have a long but finite life and will require occasional replacement. The tubes should never be operated at higher filament or plate voltages than those recommended, as such operation shortens the useful life of the tubes and does not improve the operation of the amplifier.

Since the two No. 271A Vacuum Tubes in the last stage of the amplifier have their filaments connected in series an open or burned out filament in one of the tubes will render the other tube inoperative as well. For the same reason the removal of one of the vacuum tubes from its socket during operation will make the amplifier inoperative.

Detailed instructions covering the maintenance of any of the apparatus incorporated in this amplifier will be found in Bulletin No. 517, "General Instructions for Maintenance of Speech Input Equipment".

In case replacements or additional parts are required, they should be ordered from the nearest distributor. The following list gives the information necessary for ordering these parts.

EQUIPMENT LIST

<i>Name of Part</i>	<i>How to Order</i>
Vacuum Tube for first stage	Western Electric No. 262A Vacuum Tube (for use in Western Electric No. 82A Amplifier)
Vacuum Tube for second stage	Western Electric No. 271A Vacuum Tube (for use in Western Electric No. 82A Amplifier)

Orders for replacements other than those listed should specify the apparatus designation (such as T3) shown on the schematic circuit and wiring diagram, as well as the code number which is marked on the apparatus. The order should state also that the parts are intended for use in the Western Electric No. 82A Amplifier.

RECOMMENDED ACCESSORY EQUIPMENT

<i>Apparatus</i>	<i>Purpose</i>
Western Electric No. 262A Meter Panel	Amplifier Plate Current Measurement
Western Electric No. 265A Control Panel	Amplifier Gain Control
Western Electric No. 263A Voltage Regulator Panel	10-Volt Filament Supply (when power supply is 100-125-volt 60-cycle AC)
Western Electric No. 263B Voltage Regulator Panel	10-Volt Filament Supply when power supply is 100-125-volt 50-cycle AC

The equipment described in this Bulletin
was designed and developed for the

Western Electric Company

by

BELL TELEPHONE LABORATORIES

DISTRIBUTOR IN THE UNITED STATES

Graybar

ELECTRIC COMPANY

Akron
Albany
Asheville
Atlanta
Baltimore
Beaumont
Birmingham
Boston
Brooklyn
Buffalo
Charlotte
Chicago
Cincinnati
Cleveland
Columbus

Dallas
Davenport
Dayton
Denver
Detroit
Duluth
Durham
Flint
Fort Worth
Grand Rapids
Hammond
Harrisburg
Hartford
Houston
Indianapolis

Jacksonville
Kansas City
Knoxville
Los Angeles
Louisville
Memphis
Miami
Milwaukee
Minneapolis
Mount Vernon
Nashville
Newark
New Haven
New Orleans
New York (2)

Norfolk
Oakland
Oklahoma City
Omaha
Philadelphia
Pittsburgh
Portland
Providence
Reading
Richmond
Roanoke
Rochester
St. Louis
St. Paul

Salt Lake City
San Antonio
San Francisco
Savannah
Seattle
Spokane
Syracuse
Tacoma
Tampa
Toledo
Washington
Wichita
Worcester
Youngstown

A NATIONAL ELECTRIC SERVICE

DISTRIBUTOR FOR CANADA AND NEWFOUNDLAND

Northern Electric Company Limited

General Sales Offices: 1620 Notre Dame Street, West, Montreal, P. Q.

Branch Houses

Halifax
Saint John, N. B.
Quebec
Montreal

Ottawa
Toronto
Hamilton
London

Windsor
New Liskeard
Sudbury
Winnipeg

Regina
Calgary
Edmonton
Vancouver

FOREIGN DISTRIBUTORS

International Standard Electric Corporation

67 Broad Street

New York, U. S. A.

Associated, Allied or Affiliated Companies

ARGENTINA

Cia Standard Electric Argentina,
Casilla de Correo 49, (Street Ad-
dress, Defensa 143).

Buenos Aires

AUSTRALIA

Standard Telephones and Cables
(Australasia) Ltd., 71 York Street
(P. O. Box 525-B).

Sydney, N. S. W.

AUSTRIA

United Telephone and Telegraph
Works, Ltd., Dresdner Strasse
No. 75,

Vienna, XX/2

BELGIUM

Bell Telephone Manufacturing Co.,
4 Rue Boudewyns. P. O. Box 526,

Antwerp

BRAZIL

International Standard Electric
Corp., Caixa Postal 430, (Street
Address, Rua Visconde de In-
hauma, 64),

Rio de Janeiro

CHINA

China Electric Co., Ltd., 230 Med-
hurst Road (P. O. Box 289),

Shanghai

CZECHOSLOVAKIA

Standard Electric Doms a
Spolecnost, Samova, U 1, 664,

Prague

DENMARK

Standard Electric A/S., Gylden-
lovesgade 1,

Copenhagen, V.

EGYPT

Standard Telephones and Cables,
Ltd., Cozika Buildings, Sharia
Soliman Pasha,

Cairo

FRANCE

Le Materiel Telephonique, 46-47
Quai de Boulogne,
Boulogne-Billancourt (Seine)

GERMANY

Standard Elektrizitäts Gesell-
schaft A/G., Genest Strasse 5,
Berlin-Schöneberg

GREAT BRITAIN

Standard Telephones and Cables,
Ltd., Connaught House, 63 Ald-
wych,

London, W. C. 2

HOLLAND

Bell Telephone Manufacturing Co.,
Scheldestraat 160-162,

The Hague

HUNGARY

Standard Electric Co., Ltd.,
Ujpest 4, n. Budapest

INDIA

Standard Telephones and Cables,
Ltd., Block C2, Clive Buildings,
8 Clive Street,

Calcutta

ITALY

Standard Elettrica Italiana, Via
Vittoria Colonna No. 9,

Milan, 125

JAPAN

Nippon Electric Co., Ltd., 2 Mita
Shikokumachi, Shiba-Ku, Tokyo

JAVA

Bell Telephone Manufacturing Co.,
Bureau in Nederlandsch Oost In-
die Rlouwstraat, 85,

Bandoeng

NEW ZEALAND

Standard Telephones & Cables
(Australasia) Ltd., 24-26 Ballance
Street, P. O. Box 638.

Wellington

NORWAY

Standard Electric Aktieselskap,
Hovind, Ostre Akre,

Oslo

POLAND

Standard Electric Co. W. Polsee,
Sp. Z.O.O. Wspolna 53, Warsaw

PORTUGAL

Standard Electrica, S.A. Praca
Dos Restauradores 17-1,

Lisbon

RUMANIA

Standard Electric Romana, S. A.
37 Calea Victoriei, Bucharest, 1

SOUTH AFRICA

Standard Telephones and Cables,
Ltd., Locarno House, Loveday
Street, (P. O. Box 1571),

Johannesburg

SPAIN

Standard Electrica, S/A., Calle
Ramirez de Prado (Post Office
Box 7040),

Madrid

STRAITS SETTLEMENTS

Standard Telephones and Cables,
Ltd., 57 Robinson Road, (P. O.
Box 558),

Singapore

SWITZERLAND

Bell Telephone Manufacturing Co.,
10 Bubenberplatz,

Berne

ATTENUATOR PANEL

No. 269A

Instructions for Use

The Western Electric No. 269A Attenuator Panel is used with speech input equipment assemblies, to provide a maximum of 70 db attenuation in three steps of 10 db, 20 db and 40 db in each of two 600-ohm program circuits for radio broadcasting. Transducer networks are also provided for connection between the low impedance windings of program circuit repeating coils and the input to mixing potentiometers. The loss introduced by each transducer is 7 db. The repeating coils are not a part of the No. 269A Attenuator Panel and must be provided separately. An example of the use of this panel is the Western Electric No. 702A Speech Input Bay (Line Control Bay) in which the attenuator panel is connected between two program circuits and two No. 119B Repeating Coils which are mounted on the No. 993A Mounting Plate. The transducer networks are connected to the low impedance windings of the repeating coils.

If the attenuator panel is used in assemblies other than those for which it is designed, the power levels of the circuits entering the panel should not exceed 0.24 watt (+16 db).

The component parts of the No. 269A Attenuator Panel are assembled on a metal panel 19 inches wide and 3½ inches high, designed for mounting in a standard relay rack or an equipment cabinet. The panel is equipped with a mat which provides a mounting for the designation plate associated with the attenuating network keys. With the mat colored dark gray the attenuator panel is known as No. 269A-15 Attenuator Panel, the dash number after the code number designating the color finish. This is the standard color finish, and is supplied on all orders unless otherwise specified. The keys appear at the front of the assembly through openings in the mat. The mat may be obtained with a black finish if this is specified in ordering. The designation for black finish is No. 269A-3 Attenuator Panel. No back cover is furnished. The schematic circuit is shown in Figure 1 and the wiring diagram in Figure 2.

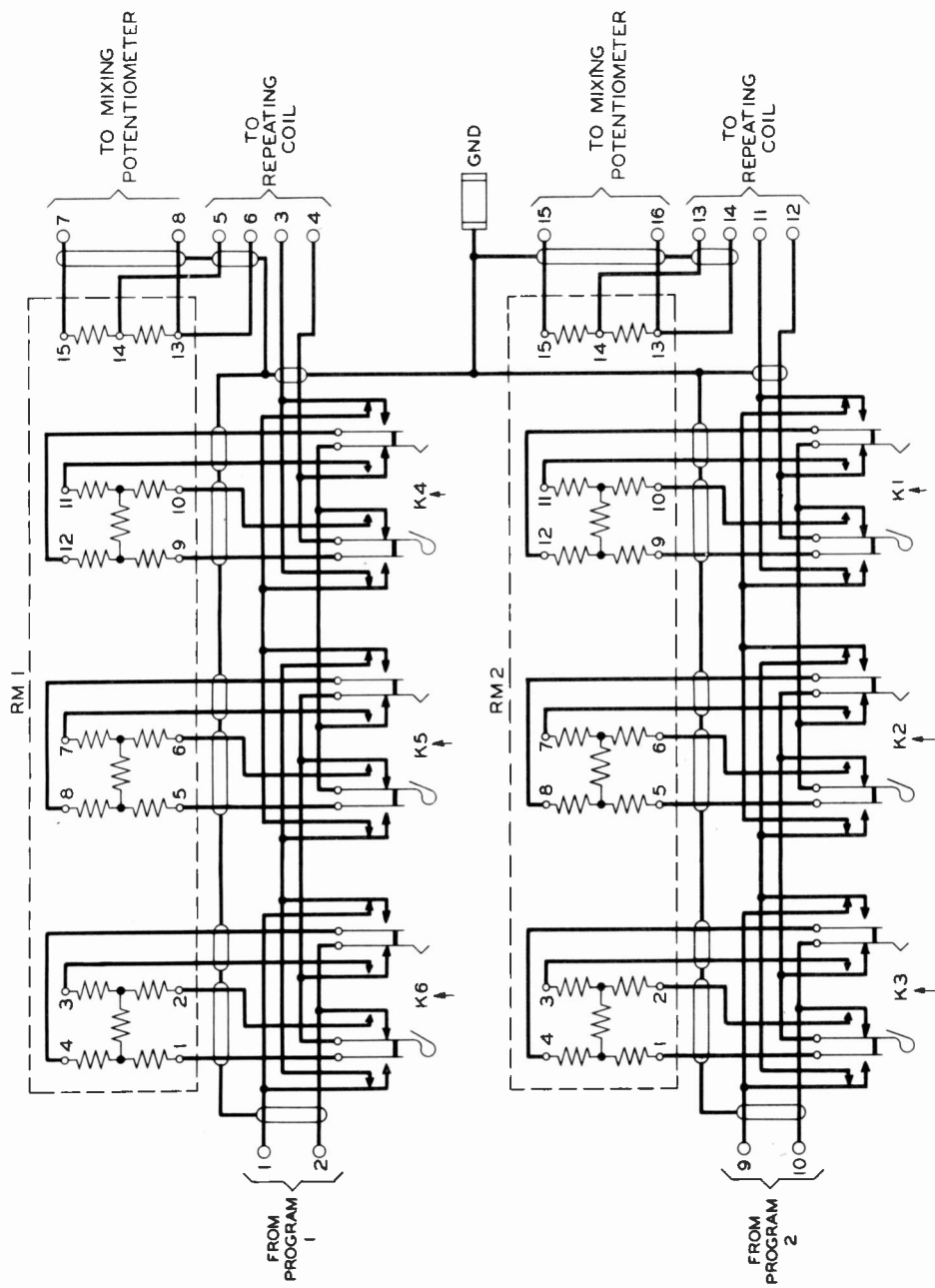

Figure 1—Schematic Circuit

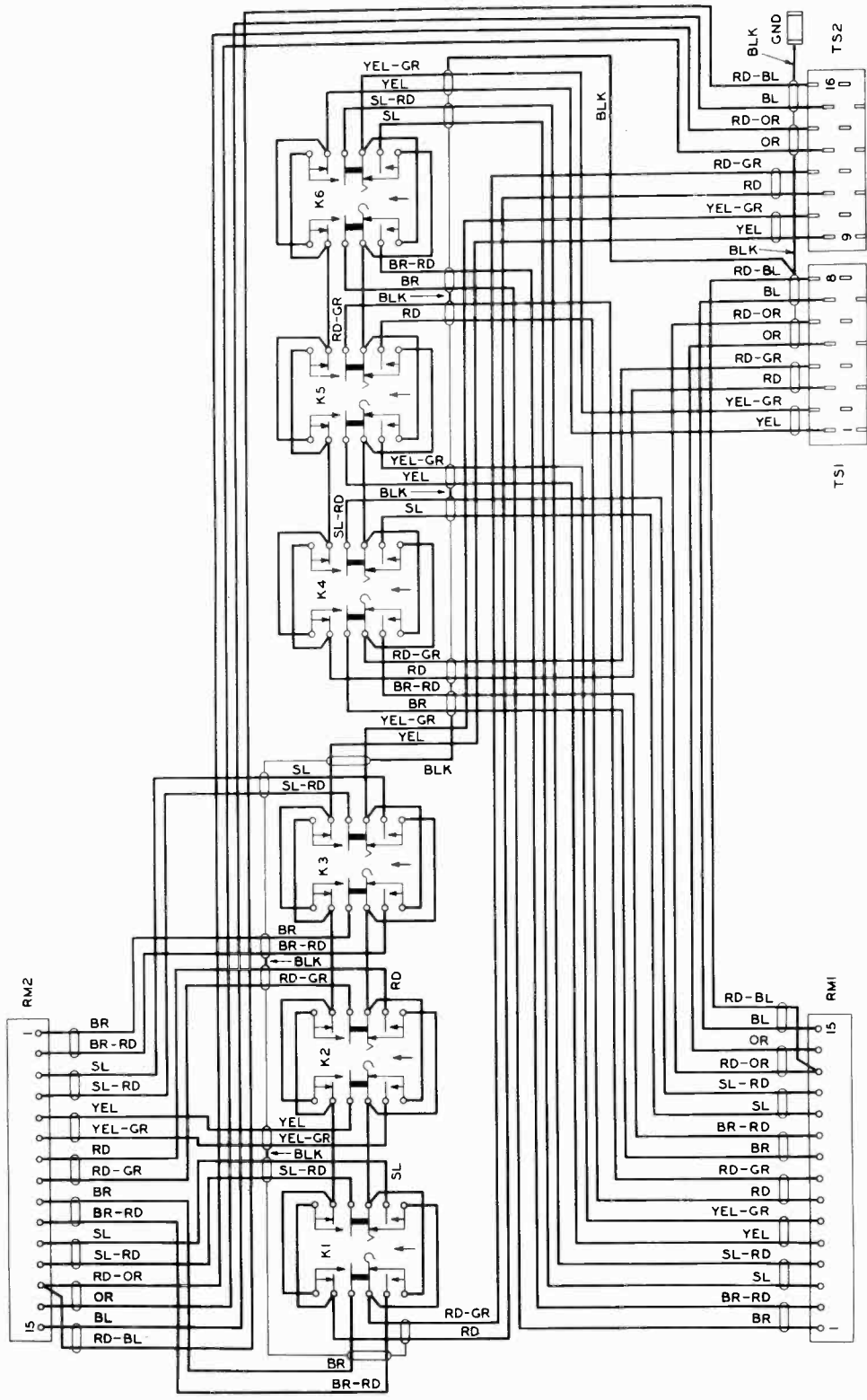

Figure 2--Wiring Diagram

Six lever-type keys, three for the attenuating networks associated with each program circuit, are mounted at the center of the panel. For reference purposes these may be considered as numbered from 1 to 6 reading from left to right viewed from the front. The first three keys control the 10 db, 20 db and 40 db networks for program line 1 and the remaining three keys control the 10 db, 20 db and 40 db networks for program line 2. (The keys are marked K1 to K6 from left to right viewed from the back.) In their normal or center positions the keys connect the program circuits through the panel to the terminal strips without attenuation. The down positions of the keys connect the attenuating networks which are of the balanced "H" type, in series with the respective circuits. The resistance units which compose the attenuating and the transducer networks are mounted at the left side of the panel viewed from the rear. Resistance mounting RM1 contains the resistances associated with program line 1, and RM2 contains the resistances for the networks of program line 2.

Two terminal strips, TS1 and TS2, for the external connections to the panel, are located at the right side of the panel viewed from the rear. TS1 provides eight terminals numbered 1—8 for program line 1 and TS2 contains a similar set of terminals numbered 9—16 for program line 2. The inputs to the panel from the program lines are connected to terminals 1 and 2 and 9 and 10 for lines 1 and 2, respectively. The 600-ohm output circuits from the panel are brought to terminals 3 and 4 (line 1) and 11 and 12 (line 2). These are ordinarily connected to the line windings of line insulating transformers (No. 119B Repeating Coils). Terminals 5 and 6, and 7 and 8, provide terminations for the transducer network associated with program line 1; terminals 5 and 6 are intended for connection to the low impedance windings of a repeating coil in program line 1. Terminals 13 and 14, and 15 and 16, are the terminations for the transducer network of program line 2; terminals 13 and 14 are for connection to the low impedance windings of a repeating coil in program line 2. Terminals 7 and 8, and 15 and 16, are the 30-ohm terminations of program lines 1 and 2, respectively when the transducer networks are employed with repeating coils as described. In this way the incoming programs may be connected to mixing potentiometers and controlled in the same manner employed with dynamic microphone (30-ohm) circuits.

The external connections to the attenuator panel should be made with shielded twisted pair copper wire and all joints should be securely soldered. The shields should be electrically continuous and grounded at the panel end by wrapping with several turns of No. 20 bare tinned copper wire, soldering, and connecting the free end to the ground lug of the panel.

Detailed instructions covering the maintenance of the apparatus incorporated in this panel will be found in Bulletin No. 517, "General Instructions for Maintenance of Speech Input Equipment".

The equipment described in this Bulletin
was designed and developed for the
Western Electric Company
by
BELL TELEPHONE LABORATORIES

DISTRIBUTOR IN THE UNITED STATES

Graybar

ELECTRIC COMPANY

Akron
Albany
Asheville
Atlanta
Baltimore
Beaumont
Birmingham
Boston
Brooklyn
Buffalo
Charlotte
Chicago
Cincinnati
Cleveland
Columbus

Dallas
Davenport
Dayton
Denver
Detroit
Duluth
Durham
Flint
Fort Worth
Grand Rapids
Hammond
Harrisburg
Hartford
Houston
Indianapolis

Jacksonville
Kansas City
Knoxville
Los Angeles
Louisville
Memphis
Miami
Milwaukee
Minneapolis
Mount Vernon
Nashville
Newark
New Haven
New Orleans
New York (2)

Norfolk
Oakland
Oklahoma City
Omaha
Philadelphia
Pittsburgh
Portland
Providence
Reading
Richmond
Roanoke
Rochester
St. Louis
St. Paul

Salt Lake City
San Antonio
San Francisco
Savannah
Seattle
Spokane
Syracuse
Tacoma
Tampa
Toledo
Washington
Wichita
Worcester
Youngstown

A NATIONAL ELECTRIC SERVICE

DISTRIBUTOR FOR CANADA AND NEWFOUNDLAND

Northern Electric Company Limited

General Sales Offices: 1261 Shearer Street, Montreal, P. Q.

Branch Houses

Hallfax
Saint John, N. B.
Quebec
Montreal

Ottawa
Toronto
Hamilton
London

Windsor
New Liskeard
Sudbury
Winnipeg

Regina
Calgary
Edmonton
Vancouver

FOREIGN DISTRIBUTORS

International Standard Electric Corporation

67 Broad Street

New York, U. S. A.

Associated, Allied or Affiliated Companies

ARGENTINA

Cia Standard Electric Argentina,
Casilla de Correo 49 (Street Ad-
dress, Defensa 148),
Buenos Aires

AUSTRALIA

Standard Telephones and Cables
(Australasia) Ltd., 71 York Street
(P. O. Box 525-B),
Sydney, N. S. W.

AUSTRIA

United Telephone and Telegraph
Works, Ltd., Dresdner Strasse
No. 75,
Vienna, XX/2

BELGIUM

Bell Telephone Manufacturing Co.,
4 Rue Boudewyns, P. O. Box 526,
Antwerp

BRAZIL

International Standard Electric
Corp., Caixa Postal 480 (Street
Address, Rua Visconde de In-
hauma, 64),
Rio de Janeiro

CHINA

China Electric Co., Ltd., 240
Klangse Road (P. O. Box 289),
Shanghai

CZECHOSLOVAKIA

Standard Electric Doms a
Spolecnost, Samova, U 1, 664,
Prague

DENMARK

Standard Electric A/S., Gylden-
lovesgade 1, Copenhagen, V.

EGYPT

Standard Telephones and Cables,
Ltd., Cozizka Buildings, Sharia
Soliman Pasha, Cairo

FRANCE

Le Materiel Telephonique, 46-47
Quai de Boulogne,
Boulogne-Billancourt (Seine)

GERMANY

Standard Elektrizitäts Gesell-
schaft A/G., Genest Strasse 5,
Berlin-Schöneberg

GREAT BRITAIN

Standard Telephones and Cables,
Ltd., Connaught House, 63 Ald-
wych,
London, W. C. 2

HOLLAND

Bell Telephone Manufacturing Co.,
Scheldestraat 160-162,
The Hague

HUNGARY

Standard Electric Co., Ltd.,
Ujpest 4, n. Budapest

INDIA

Standard Telephones and Cables,
Ltd., Block C2, Clive Buildings,
8 Clive Street,
Calcutta

ITALY

Standard Elettrica Italiana, Via
Vittoria Colonna No. 9,
Milan, 125

JAPAN

Nippon Electric Co., Ltd., 2 Mita
Shikokumachi, Shiba-Ku, Tokyo

JAVA

Bell Telephone Manufacturing Co.,
Bureau in Nederlandsch Oost In-
die Riouwstraat, 85,
Bandoeng

NEW ZEALAND

Standard Telephones and Cables
(Australasia) Lt., 24-26 Ballance
Street, P. O. Box 638,
Wellington

NORWAY

Standard Electric Aktieselskap,
Hovind, Ostre Akre,
Oslo

POLAND

Standard Electric Co. W. Polsee,
Sp. Z.O.O. Wspolna 53, Warsaw

PORTUGAL

Standard Electrica, S.A. Praca
Dos Restauradores 47-1, Lisbon

RUMANIA

Standard Electric Romana, S. A.
37 Calea Victoriei, Bucharest, 1

SOUTH AFRICA

Standard Telephones and Cables,
Ltd., Locarno House, Loveday
Street (P. O. Box 1571),
Johannesburg

SPAIN

Standard Electrica, S/A, Calle
Ramirez de Prado (Post Office
Box 7040),
Madrid

STRAITS SETTLEMENTS

Standard Telephones and Cables,
Ltd., 57 Robinson Road (P. O.
Box 553),
Singapore

SWITZERLAND

Bell Telephone Manufacturing Co.,
10 Bubenberplatz,
Berne

Western Electric

METER PANEL

No. 262A

Instructions for Use

The Western Electric No. 262A Meter Panel is designed for use with Western Electric No. 81A and No. 82A Amplifiers in speech input equipments for radio broadcasting, to measure the plate currents of the vacuum tubes. It consists of a depressed metal panel 19 inches wide and $3\frac{1}{2}$ inches high for mounting a special two scale milliammeter, a 100,000-ohm resistance, and two terminal blocks. The mat, finished in dark gray, provides a mounting for the meter which is connected to the meter terminal block TS2 through flexible conductors. A black finish for the mat may be obtained if this is specified in the order. By loosening the mat retaining screws at the back of the panel the mat and the meter may be dropped away from the panel to permit access to the wiring and the terminal strips located in the depressed section of the panel. The No. 262A Meter Panel is arranged for mounting in a standard relay rack or equipment cabinet.

Terminal block TS1 at the left of the panel contains eight terminals for connecting to the plate current meter terminals of No. 81A and No. 82A Amplifiers. The even numbered terminals are positive and the odd numbered terminals negative. A 100,000-ohm shunt to ground is provided to prevent clicks in the amplifier outputs when measuring the plate currents.

Ordinarily the No. 262A Meter Panel is furnished as a component part of a speech input equipment assembly in which the separate units are completely wired and tested before shipment from the factory. However, it is available for use with either of the above mentioned amplifiers or a combination of these amplifiers.

CAUTION: *The No. 262A Meter Panel is designed specifically for use with No. 81A and No. 82A Amplifiers in which the proper meter shunts are provided for this service. For this reason it is not suitable for use with amplifiers of other types or as a general service meter panel.*

The apparatus described in this Bulletin
was designed and developed for the

Western Electric Company

by

BELL TELEPHONE LABORATORIES

Instruction Bulletin No. 691



DISTRIBUTOR IN THE UNITED STATES

Graybar

ELECTRIC COMPANY

Akron
Albany
Asheville
Atlanta
Baltimore
Beaumont
Birmingham
Boston
Brooklyn
Buffalo
Charlotte
Chicago
Cincinnati
Cleveland
Columbus

Dallas
Davenport
Dayton
Denver
Detroit
Duluth
Durham
Flint
Fort Worth
Grand Rapids
Hammond
Harrisburg
Hartford
Houston
Indianapolis

Jacksonville
Kansas City
Knoxville
Los Angeles
Louisville
Memphis
Miami
Milwaukee
Minneapolis
Mount Vernon
Nashville
Newark
New Haven
New Orleans
New York (2)

Norfolk
Oakland
Oklahoma City
Omaha
Philadelphia
Pittsburgh
Portland
Providence
Reading
Richmond
Roanoke
Rochester
St. Louis
St. Paul

Salt Lake City
San Antonio
San Francisco
Savannah
Seattle
Spokane
Syracuse
Tacoma
Tampa
Toledo
Washington
Wichita
Worcester
Youngstown

A NATIONAL ELECTRIC SERVICE

DISTRIBUTOR FOR CANADA AND NEWFOUNDLAND

Northern Electric Company Limited

General Sales Offices: 1620 Notre Dame Street, West, Montreal, P. Q.

Branch Houses

Halifax
Saint John, N. B.
Quebec
Montreal

Ottawa
Toronto
Hamilton
London

Windsor
New Liskeard
Sudbury
Winnipeg

Regina
Calgary
Edmonton
Vancouver

FOREIGN DISTRIBUTORS

International Standard Electric Corporation

67 Broad Street

New York, U. S. A.

Associated, Allied or Affiliated Companies

ARGENTINA

Cia Standard Electric Argentina,
Casilla de Correo 49, (Street Address,
Defensa 143), **Buenos Aires**

AUSTRALIA

Standard Telephones and Cables
(Australasia) Ltd., 71 York Street
(P. O. Box 525-B),
Sydney, N. S. W.

AUSTRIA

United Telephone and Telegraph
Works, Ltd., Dresdner Strasse No. 75,
Vienna, XX/2

BELGIUM

Bell Telephone Manufacturing Co.,
4 Rue Boudewyns. P. O. Box 526,
Antwerp

BRAZIL

International Standard Electric
Corp., Caixa Postal 430, (Street
Address, Rua Visconde de In-
hauma, 64), **Rio de Janeiro**

CHINA

China Electric Co., Ltd., 230 Med-
hurst Road (P. O. Box 289),
Shanghai

CZECHOSLOVAKIA

Standard Electric Doms a Spolecnost,
Samova, U 1, 664, **Prague**

DENMARK

Standard Electric A/S., Gylden-
lovsegade 1, **Copenhagen, V.**

EGYPT

Standard Telephones and Cables,
Ltd., Cozzika Buildings, Sharia
Soliman Pasha, **Cairo**

FRANCE

Le Materiel Telephonique, 46-47
Quai de Boulogne,
Boulogne-Billancourt (Seine)

GERMANY

Standard Elektrizitäts Gesellschaft
A/G., Genest Strasse 5,
Berlin-Schöneberg

GREAT BRITAIN

Standard Telephones and Cables,
Ltd., Connaught House, 63 Aldwych,
London, W. C. 2

HOLLAND

Bell Telephone Manufacturing Co.,
Scheldestraat 160-162,
The Hague

HUNGARY

Standard Electric Co., Ltd.,
Ujpest 4, n. **Budapest**

INDIA

Standard Telephones and Cables,
Ltd., Block C2, Clive Buildings,
8 Clive Street, **Calcutta**

ITALY

Standard Elettrica Italiana, Via
Vittoria Colonna No. 9, **Milan, 125**

JAPAN

Nippon Electric Co., Ltd., 2 Mita
Shikokumachi, Shiba-Ku, **Tokyo**

JAVA

Bell Telephone Manufacturing Co.,
Bureau in Nederlandsch Oost Indie
Riouwstraat, 85, **Bandoeng**

NEW ZEALAND

Standard Telephones & Cables
(Australasia) Ltd., 24-26 Ballance
Street, P. O. Box 638, **Wellington**

NORWAY

Standard Electric Aktieselskap,
Hovind, Ostre Akre, **Oslo**

POLAND

Standard Electric Co. W. Polsce,
Sp. Z.O.O. Wspolna 53, **Warsaw**

PORTUGAL

Standard Electrica, S.A. Praca Dos
Restauradores 47-1, **Lisbon**

RUMANIA

Standard Electric Romana, S. A.
37 Calea Victoriei, **Bucharest, 1**

SOUTH AFRICA

Standard Telephones and Cables,
Ltd., Locarno House, Loveday Street,
(P. O. Box 1571); **Johannesburg**

SPAIN

Standard Electrica, S/A., Calle
Ramirez de Prado (Post Office
Box 7040), **Madrid**

STRAITS SETTLEMENTS

Standard Telephones and Cables,
Ltd., 57 Robinson Road, (P. O. Box
553), **Singapore**

SWITZERLAND

Bell Telephone Manufacturing Co.,
10 Bubenberplatz, **Berne**