



# Studer A812 MKII

*Professional  
Studio Tape Recorder*

**Operating Instructions**

Prepared and edited by  
Studer Professional Audio AG  
Technical Documentation  
Althardstrasse 30  
CH-8105 Regensdorf - Switzerland  
<http://www.studer.ch>

Copyright by Studer Professional Audio AG  
Printed in Switzerland  
Order no. 10.27.0334 (Ed. 0499)

Subject to change

---

Studer is a registered trade mark of Studer Professional Audio AG, Regensdorf



CAUTION
RISK OF ELECTRIC SHOCK DO NOT OPEN
ATTENTION
RISQUE DE CHOC ELECTRIQUE NE PAS OUVRIR
ACHTUNG
GEFAHR: ELEKTRISCHER SCHLAG NICHT ÖFFNEN

To reduce the risk of electric shock, do not remove covers (or back). No user-serviceable parts inside. Refer servicing to qualified service personnel.

Afin de prévenir un choc électrique, ne pas enlever les couvercles (où l'arrière) de l'appareil. Il ne se trouve à l'intérieur aucune pièce pouvant être réparée par l'utilisateur.

Um die Gefahr eines elektrischen Schlages zu vermeiden, entfernen Sie keine Abdeckungen (oder Rückwand). Überlassen Sie die Wartung und Reparatur qualifiziertem Fachpersonal.



This symbol is intended to alert the user to presence of uninsulated “**dangerous voltage**” within the apparatus that may be of sufficient magnitude to constitute a risk of electric shock to a person.

Ce symbole indique à l'utilisateur qu'il existe à l'intérieur de l'appareil des “**tensions dangereuses**”. Ces tensions élevées entraînent un risque de choc électrique en cas de contact.

Dieses Symbol deutet dem Anwender an, dass im Geräteinnern die Gefahr der Berührung von “**gefährlicher Spannung**” besteht. Die Grösse der Spannung kann zu einem elektrischen Schlag führen.



This symbol is intended to alert the user to the presence of **important instructions** for operating and maintenance in the enclosed documentation.

Ce symbole indique à l'utilisateur que la documentation jointe contient d'**importantes instructions** concernant le fonctionnement et la maintenance.

Dieses Symbol deutet dem Anwender an, dass die beigelegte Dokumentation **wichtige Hinweise** für Betrieb und Wartung enthält.

**CAUTION:**

Lithium battery. Danger of explosion by incorrect handling. Replace by battery of the same make and type only.

**ATTENTION:**

Pile au lithium. Danger d'explosion en cas de manipulation incorrecte. Ne remplacer que par un modèle de même type.

**ACHTUNG:**

Explosionsgefahr bei unsachgemäßem Auswechseln der Lithiumbatterie. Nur durch den selben Typ ersetzen.

**ADVARSEL:**

Lithiumbatteri. Eksplosionsfare. Udskiftning må kun foretages af en sagkyndig og som beskrevet i servicemanualen (DK).

**FIRST AID**

(in case of electric shock)

1. Separate the person as quickly as possible from the electric power source:
  - by switching off the equipment
  - or by unplugging or disconnecting the mains cable
  - pushing the person away from the power source by using dry insulating material (such as wood or plastic).
- After having sustained an electric shock, always consult a doctor.

**WARNING!**

DO NOT TOUCH THE PERSON OR HIS CLOTHING BEFORE THE POWER IS TURNED OFF, OTHERWISE YOU STAND THE RISK OF SUSTAINING AN ELECTRIC SHOCK AS WELL!

2. If the person is unconscious:
  - check the pulse,
  - reanimate the person if respiration is poor,
  - lay the body down, turn it to one side, call for a doctor immediately.

**PREMIERS SECOURS**

(en cas d'électrocution)

1. Si la personne est dans l'impossibilité de se libérer:
  - Couper l'interrupteur principal
  - Couper le courant
  - Repousser la personne de l'appareil à l'aide d'un objet en matière non conductrice (matière plastique ou bois)
  - Après une électrocution, consulter un médecin.

**ATTENTION!**

NE JAMAIS TOUCHER UNE PERSONNE QUI EST SOUS TENSION, SOUS PEINE DE SUBIR EGALLEMENT UNE ELECTROCUTION.

2. En cas de perte de connaissance de la personne électrocutée:
  - Contrôler le pouls
  - Si nécessaire, pratiquer la respiration artificielle
  - Placer l'accidenté sur le flanc et consulter un médecin.

**ERSTE HILFE**

(bei Stromunfällen)

1. Bei einem Stromunfall die betroffene Person so rasch wie möglich vom Strom trennen:
  - Durch Ausschalten des Gerätes
  - Ziehen oder Unterbrechen der Netzzuleitung
  - Betroffene Person mit isoliertem Material (Holz, Kunststoff) von der Gefahrenquelle wegstossen
  - Nach einem Stromunfall sollte immer ein Arzt aufgesucht werden.

**ACHTUNG!**

EINE UNTER SPANNUNG STEHENDE PERSON DARF NICHT BERÜHRT WERDEN. SIE KÖNNEN DABEI SELBST ELEKTRISIERT WERDEN!

2. Bei Bewusstlosigkeit des Verunfallten:
  - Puls kontrollieren,
  - bei ausgesetzter Atmung künstlich beatmen,
  - Seitenlagerung des Verunfallten vornehmen und Arzt verständigen.

**Installation, Betrieb und Entsorgung**

Vor der Installation des Gerätes müssen die hier aufgeführten und auch die weiter in dieser Anleitung mit  $\Delta$  bezeichneten Hinweise gelesen und während der Installation und des Betriebes beachtet werden.

Das Gerät und sein Zubehör ist auf allfällige Transportschäden zu untersuchen.

Ein Gerät, das mechanische Beschädigung aufweist oder in welches Flüssigkeit oder Gegenstände eingedrungen sind, darf nicht ans Netz angeschlossen oder muss sofort durch Ziehen des Netzsteckers vom Netz getrennt werden. Das Öffnen und Instandsetzen des Gerätes darf nur von Fachpersonal unter Einhaltung der geltenden Vorschriften durchgeführt werden.

Falls dem Gerät kein konfektioniertes Netzkabel beiliegt, muss dieses durch eine Fachperson unter Verwendung der mitgelieferten Kabel-Gerätedose IEC320/C13 oder IEC320/C19 und unter Berücksichtigung der einschlägigen, im jeweiligen Lande geltenden Bestimmungen angefertigt werden; siehe Bild unten.

Vor Anschluss des Netzkabels an die Netzsteckdose muss überprüft werden, ob die Stromversorgungs- und Anschlusswerte des Gerätes (Netzspannung, Netzfrequenz) innerhalb der erlaubten Toleranzen liegen. Die im Gerät eingesetzten Sicherungen müssen den am Gerät angebrachten Angaben entsprechen.

Ein Gerät mit einem dreipoligen Gerätestecker (Gerät der Schutzklasse I) muss an eine dreipolige Netzsteckdose angeschlossen und somit das Gerätegehäuse mit dem Schutzleiter der Netzinstallation verbunden werden (Für Dänemark gelten Starkstrombestimmungen, Abschnitt 107).

**Installation, Operation, Disposal**

Before you install the equipment, please read and adhere to the following recommendations and all sections of these instructions marked with  $\Delta$ .

Check the equipment for any transport damage.

A unit that is mechanically damaged or which has been penetrated by liquids or foreign objects must not be connected to the AC power outlet or must be immediately disconnected by unplugging the power cable. Repairs must only be performed by trained personnel in accordance with the applicable regulations.

Should the equipment be delivered without a matching mains cable, the latter has to be prepared by a trained person using the attached female plug (IEC320/C13 or IEC320/C19) with respect to the applicable regulations in your country - see diagram below.

Before connecting the equipment to the AC power outlet, check that the local line voltage matches the equipment rating (voltage, frequency) within the admissible tolerance. The equipment fuses must be rated in accordance with the specifications on the equipment.

Equipment supplied with a 3-pole appliance inlet (equipment conforming to protection class I) must be connected to a 3-pole AC power outlet so that the equipment cabinet is connected to the protective earth conductor of the AC supply (for Denmark the Heavy Current Regulations, Section 107, are applicable).

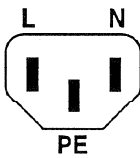
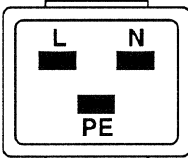
 <p><b>IEC 320 / C13</b></p>	 <p><b>IEC 320 / C19</b></p>
Female plug (IEC320), view from contact side:	National American Standard: black
L ..... live; brown	white
N ..... neutral; blue	green
PE ..... protective earth; green and yellow	
Connecteur femelle (IEC320), vue de la face aux contacts:	Standard National Américain: noir
L.....phase, brun	blanc
N.....neutre, bleu	vert
PE....terre protective; vert et jaune	
Ansicht auf Steckkontakte der Kabel-Gerätesteckdose (IEC320):	USA-Standard: schwarz
L.....Polleiter, braun	weiss
N.....Neutralleiter, hellblau	grün
PE....Schutzleiter, gelb/grün	

Bei der Installation des Gerätes muss *vermieden* werden, dass:

- das Gerät Regen, Feuchtigkeit, direkter Sonneneinstrahlung oder übermässiger Wärmestrahlung von Wärmequellen (Heizgeräte, Heizungen, Spotlampen) ausgesetzt wird
- die für den Betrieb des Gerätes benötigte Luftzirkulation beeinträchtigt und dadurch die zulässige maximale Lufttemperatur der Geräteumgebung überschritten wird (Wärmestau)
- die Belüftungsöffnungen des Gerätes blockiert oder abgedeckt werden.

Das Gerät und seine Verpackung darf nur sachgerecht entsorgt werden. Alle Teile des Gerätes, die gefährliche Stoffe (z.B. Quecksilber, Cadmium) enthalten, müssen als Sondermüll behandelt werden.

*Verbrauchte Batterien und Akkus müssen dem Hersteller zur Entsorgung zurückgegeben oder entsprechend den spezifischen Bestimmungen Ihres Landes fachgerecht entsorgt werden.*

## Wartung und Reparatur

Durch Entfernen von Gehäuseteilen, Abschirmungen etc. werden stromführende Teile freigelegt. Aus diesem Grund müssen u.a. die folgenden Grundsätze beachtet werden: Eingriffe in das Gerät dürfen nur von Fachpersonal unter Einhaltung der geltenden Vorschriften vorgenommen werden.

Vor Entfernen von Gehäuseteilen muss das Gerät ausgeschaltet und vom Netz getrennt werden.

Bei geöffnetem, vom Netz getrenntem Gerät dürfen Teile mit gefährlichen Ladungen (z. B. Kondensatoren, Bildröhren) erst nach kontrollierter Entladung, heiße Bauteile (Leistungshalbleiter, Kühlkörper etc.) erst nach deren Abkühlen berührt werden.

Bei Wartungsarbeiten am geöffneten, unter Netzspannung stehenden Gerät dürfen blanke Schaltungsteile und metallene Halbleitergehäuse weder direkt noch mit einem nicht-isolierten Werkzeug berührt werden.

Zusätzliche Gefahren bestehen bei unsachgemässer Handhabung besonderer Komponenten:

- *Explosionsgefahr* bei Lithiumzellen, Elektrolyt-Kondensatoren und Leistungshalbleitern
- *Implosionsgefahr* bei evakuierten Anzeigeeinheiten
- *Strahlungsgefahr* bei Lasereinheiten (nichtionisierend), Bildröhren (ionisierend)
- *Verätzungsgefahr* bei Anzeigeeinheiten (LCD) und Komponenten mit flüssigem Elektrolyt.

*Solche Komponenten dürfen nur von ausgebildetem Fachpersonal mit den vorgeschriebenen Schutzmitteln (u.a. Schutzbrille, Handschuhe) gehandhabt werden.*

The equipment installation *must satisfy* the following requirements:

- Protection against rain, humidity, direct solar irradiation or strong thermal radiation from heat sources (heaters, radiators, spotlights).
- Unobstructed air circulation so that the maximum air temperature in the equipment environment will not be exceeded (no heat accumulation).
- Ventilation louvers of the equipment must not be blocked or covered.

Equipment and packing materials should ultimately be disposed of according with the applicable regulations. Parts of the equipment that contain hazardous substances (e.g. mercury, cadmium) must be treated as toxic waste. *Weak batteries or exhausted rechargeable batteries must be returned to the manufacturer for competent disposal or must be disposed of in accordance with the environmental protection regulations applicable for your country.*

## Maintenance and Repair

The removal of housing parts, shields, etc. exposes energized parts. For this reason the following precautions should be observed:

Maintenance should only be performed by trained personnel in accordance with the applicable regulations.

The equipment should be switched off and disconnected from the AC power outlet before any housing parts are removed.

Even after the equipment has been disconnected from the power, parts with hazardous charges (e.g. capacitors, picture tubes) should only be touched after they have been properly discharged. Hot components (power semiconductors, heat sinks, etc.) should only be touched after they have cooled off.

If maintenance is performed on a unit that is opened and switched on, no uninsulated circuit components and metallic semiconductor housings should be touched neither with your bare hands nor with uninsulated tools.

Certain components pose additional hazards:

- *Explosion hazard* from lithium batteries, electrolytic capacitors and power semiconductors
- *Implosion hazard* from evacuated display units
- *Radiation hazard* from laser units (non-ionizing), picture tubes (ionizing)
- *Caustic effect* of display units (LCD) and such components containing liquid electrolyte.

*Such components should only be handled by trained personnel who are properly protected (e.g. safety goggles, gloves).*

*Für Wartung und Reparatur der sicherheitsrelevanten Teile des Gerätes darf nur Ersatzmaterial nach Herstellerspezifikation verwendet werden.*

Das Gerät muss ordnungsgemäss und regelmässig gewartet und somit in sicherem Zustand erhalten werden. Bei ungenügender Wartung oder bei Änderungen der sicherheitsrelevanten Teile des Gerätes erlischt die entsprechende Produkthaftung des Herstellers.

*For maintenance work and repair on components that influence the equipment safety, only replacement material conforming to the manufacturer's specifications may be used.*

The equipment should be properly serviced in regular intervals and be maintained in safe operating condition. If the equipment is not properly maintained or if any modifications are made to components that influence safety, the manufacturer's product liability gets void.

---

## Elektrostatische Entladung (ESD) bei Wartung und Reparatur

## Electrostatic Discharge (ESD) during Maintenance and Repair



**ATTENTION:** Observe precautions for handling devices sensitive to electrostatic discharge!

**ATTENTION:** Respecter les précautions d'usage concernant la manipulation de composants sensibles à l'électricité statique!

**ACHTUNG:** Vorsichtsmassnahmen bei Handhabung elektrostatisch entladungsgefährdeter Bauelemente beachten!

Viele ICs und andere Halbleiter sind empfindlich gegen elektrostatische Entladung (ESD). Unfachgerechte Behandlung von Baugruppen mit solchen Komponenten bei Wartung und Reparatur kann deren Lebensdauer drastisch vermindern.

Bei der Handhabung der ESD-empfindlichen Komponenten sind u.a. folgende Regeln zu beachten:

- ESD-empfindliche Komponenten dürfen ausschliesslich in dafür bestimmten und bezeichneten Verpackungen gelagert und transportiert werden.
- Unverpackte, ESD-empfindliche Komponenten dürfen nur in dafür eingerichteten Schutzzonen (EPA, z.B. Gebiet für Feldservice, Reparatur- oder Serviceplatz) gehandhabt und nur von Personen berührt werden, die durch ein Handgelenkband mit Seriewiderstand mit dem Massepotential des Reparatur- oder Serviceplatzes verbunden sind. Das gewartete Gerät wie auch Werkzeug, Hilfsmittel, EPA-taugliche (elektrisch leitende) Arbeits-, Ablage- und Bodenmatten müssen ebenfalls mit diesem Potential verbunden sein.
- Die Anschlüsse der ESD-empfindlichen Komponenten dürfen unkontrolliert weder mit elektrostatisch aufladbaren (Gefahr von Spannungsdurchschlag), noch mit metallischen Oberflächen (Schockentladungsgefahr) in Berührung kommen.
- Um undefinierte transiente Beanspruchung der Komponenten und deren eventuelle Beschädigung durch unerlaubte Spannung oder Ausgleichsströme zu vermeiden, dürfen elektrische Verbindungen nur am abgeschalteten Gerät und nach dem Abbau allfälliger Kondensatorladungen hergestellt oder getrennt werden.

Many ICs and semiconductors are sensitive to electrostatic discharge (ESD). The life of components containing such elements can be drastically reduced by improper handling during maintenance and repair work.

Please observe the following rules when handling ESD sensitive components:

- ESD sensitive components should only be stored and transported in the packing material specifically provided for this purpose.
- Unpacked ESD sensitive components should only be handled in ESD protected areas (EPA, e.g. area for field service, repair or service bench) and only be touched by persons who wear a wristlet that is connected to the ground potential of the repair or service bench by a series resistor. The equipment to be repaired or serviced and all tools, aids, as well as electrically semiconducting work, storage and floor mats should also be connected to this ground potential.
- The terminals of ESD sensitive components must not come in uncontrolled contact with electrostatically chargeable (voltage puncture) or metallic surfaces (discharge shock hazard).
- To prevent undefined transient stress of the components and possible damage due to inadmissible voltages or compensation currents, electrical connections should only be established or separated when the equipment is switched off and after any capacitor charges have decayed.

**SMD-Bauelemente**

Der Austausch von SMD-Bauelementen ist ausschliesslich geübten Fachleuten vorbehalten. Für verwüstete Platinen können keine Ersatzansprüche geltend gemacht werden. Beispiele für korrekte und falsche SMD-Lötverbindungen in der Abbildung weiter unten.

Bei Studer werden keine handelsüblichen SMD-Teile bewirtschaftet. Für Reparaturen sind die notwendigen Bauteile lokal zu beschaffen. Die Spezifikationen von Spezialbauteilen finden Sie in der Serviceanleitung.

**SMD Components**

SMDs should only be replaced by skilled specialists. No warranty claims will be accepted for circuit boards that have been ruined. Proper and improper SMD soldering joints are depicted below.

Studer does not keep any commercially available SMDs in stock. For repair the corresponding devices should be purchased locally. The specifications of special components can be found in the service manual.

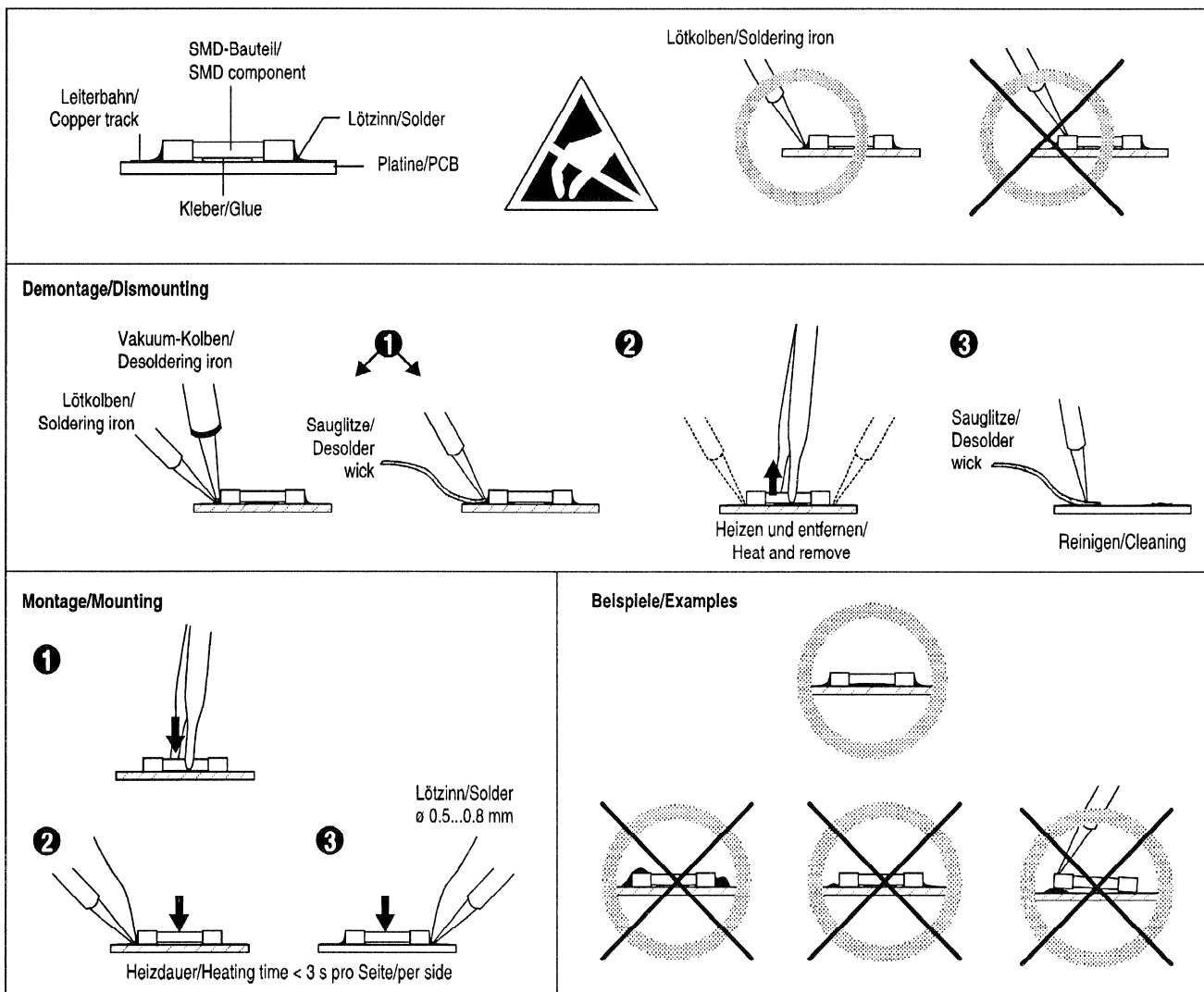

## Störstrahlung und Störfestigkeit

Das Gerät entspricht den Schutzanforderungen auf dem Gebiet der elektromagnetischen Phänomene, die u.a. in den Richtlinien 89/336/EWG und FCC, Part 15, aufgeführt sind :

1. Die vom Gerät erzeugten elektromagnetischen Aussendungen sind soweit begrenzt, dass ein bestimmungsgemässer Betrieb anderer Geräte und Systeme möglich ist.
2. Das Gerät weist eine angemessene Festigkeit gegen elektromagnetische Störungen auf, so dass sein bestimmungsgemässer Betrieb möglich ist.

Das Gerät wurde getestet und erfüllt die Bedingungen der im Kapitel „Technische Daten“ aufgeführten EMV-Standards. Die Limiten dieser Standards gewährleisten mit einer angemessenen Wahrscheinlichkeit sowohl einen Schutz der Umgebung wie auch entsprechende Störfestigkeit des Gerätes. Eine absolute Garantie, dass keine unerlaubte elektromagnetische Beeinträchtigung während des Gerätebetriebes entsteht, ist jedoch nicht gegeben.

Um die Wahrscheinlichkeit solcher Beeinträchtigung weitgehend auszuschliessen, sind u.a. folgende Massnahmen zu beachten:

- Installieren Sie das Gerät gemäss den Angaben in der Bedienungsanleitung, und verwenden Sie das mitgelieferte Zubehör.
- Verwenden Sie im System und in der Umgebung, in denen das Gerät eingesetzt ist, nur Komponenten (Anlagen, Geräte), die ihrerseits die Anforderungen der obenerwähnten Standards erfüllen.
- Sehen Sie ein Erdungskonzept des Systems vor, das sowohl die Sicherheitsanforderungen (die Erdung der Geräte gemäss Schutzklasse I mit einem Schutzleiter muss gewährleistet sein), wie auch die EMV-Belange berücksichtigt. Bei der Entscheidung zwischen stern- oder flächenförmiger bzw. kombinierter Erdung sind Vor- und Nachteile gegeneinander abzuwägen.
- Benutzen Sie abgeschirmte Kabel, wo vorgesehen. Achten Sie auf einwandfreie, grossflächige, korrosionsbeständige Verbindung der Abschirmung zum entsprechenden Steckeranschluss bzw. zum -gehäuse. Beachten Sie, dass eine nur an einem Ende angeschlossene Kabelabschirmung als Sende- bzw. Empfangsantenne wirken kann (z.B. bei wirksamer Kabellänge von 5 m oberhalb von 10 MHz), und dass die Flanken digitaler Kommunikationssignale hochfrequente Aussendungen verursachen (z.B. LS- oder HC-Logik bis 30 MHz).
- Vermeiden Sie Bildung von Masseschleifen oder vermindern Sie deren unerwünschte Auswirkung, indem Sie deren Fläche möglichst klein halten und den darin fliessenden Strom durch Einfügen einer Impedanz (z.B. Gleichtaktdrossel) reduzieren.

## Electromagnetic Compatibility

The equipment conforms to the protection requirements relevant to electromagnetic phenomena that are listed in the guidelines 89/336/EC and FCC, part 15.

1. The electromagnetic interference generated by the equipment is limited in such a way that other equipment and systems can be operated normally.
2. The equipment is adequately protected against electromagnetic interference so that it can operate correctly.

The unit has been tested and conforms to the EMC standards applicable to residential, commercial and light industry, as listed in the section „Technical Data“. The limits of these standards reasonably ensure protection of the environment and corresponding noise immunity of the equipment. However, it is not absolutely warranted that the equipment will not be adversely affected by electromagnetic interference during operation.

To minimize the probability of electromagnetic interference as far as possible, the following recommendations should be followed:

- Install the equipment in accordance with the operating instructions. Use the supplied accessories.
- In the system and in the vicinity where the equipment is installed, use only components (systems, equipment) that also fulfill the above EMC standards.
- Use a system grounding concept that satisfies the safety requirements (protection class I equipment must be connected with a protective ground conductor) that also takes into consideration the EMC requirements. When deciding between radial, surface or combined grounding, the advantages and disadvantages should be carefully evaluated in each case.
- Use shielded cables where shielding is specified. The connection of the shield to the corresponding connector terminal or housing should have a large surface and be corrosion-proof. Please note that a cable shield connected only single-ended can act as a transmitting or receiving antenna (e.g. with an effective cable length of 5 m, the frequency is above 10 MHz) and that the edges of the digital communication signals cause high-frequency radiation (e.g. LS or HC logic up to 30 MHz).
- Avoid ground loops or reduce their adverse effects by keeping the loop surface as small as possible, and reduce the noise current flowing through the loop by inserting an additional impedance (e.g. common-mode rejection choke).



### Class A Equipment - FCC Notice

This equipment has been tested and found to comply with the limits for a Class A digital device, pursuant to Part 15 of the FCC Rules. These limits are designed to provide a reasonable protection against harmful interference when the equipment is operated in a commercial environment. This equipment generates, uses, and can radiate radio frequency energy and, if not installed and used in accordance with the instruction manual, may cause harmful interference to radio com-

munications. Operation of this equipment in a residential area is likely to cause harmful interference in which case the user will be required to correct the interference at his own expense.

*Caution:*

*Any changes or modifications not expressly approved by the manufacturer could void the user's authority to operate the equipment. Also refer to relevant information in this manual.*

### CE-Konformitätserklärung

Wir,

Studer Professional Audio AG,  
CH-8105 Regensdorf,

erklären in eigener Verantwortung, dass das Produkt

**Studer A812, professionelles Tonbandgerät,  
(ab Serie-Nr. 2813),**

auf das sich diese Erklärung bezieht, entsprechend den Bestimmungen der EU-Richtlinien und deren Ergänzungen

- Elektromagnetische Verträglichkeit (EMV):  
89/336/EWG + 92/31/EWG + 93/68/EWG
- Niederspannung:  
73/23/EWG + 93/68/EWG

mit den folgenden Normen und normativen Dokumenten übereinstimmt:

- Sicherheit:  
Schutzklasse 1, EN 60065; 1993 (IEC 65; 1985)
- EMV:  
EN 50081-1; 1992, EN 50082-1; 1992

Regensdorf, 2. Mai 1997



B. Hochstrasser, Geschäftsleiter



P. Fiala, Leiter QS

### CE Declaration of Conformity

We,

Studer Professional Audio AG,  
CH-8105 Regensdorf,

declare under our sole responsibility that the product

**Studer A812, professional Tape Recorder,  
(from serial No. 2031 and up),**

to which this declaration relates, according to following regulations of EU directives and amendments

- Electromagnetic Compatibility (EMC):  
89/336/EEC + 92/31/EEC + 93/68/EEC
- Low Voltage (LVD):  
73/23/EEC + 93/68/EEC

is in conformity with the following standards or other normative documents:

- Safety:  
Class 1, EN 60065; 1993 (IEC 65; 1985)
- EMC:  
EN 50081-1; 1992, EN 50082-1; 1992

Regensdorf, May 2, 1997



B. Hochstrasser, Managing Director



P. Fiala, Manager QA

## Contents

<b>1</b>	<b>Quick reference description</b> .....	<b>1</b>
<b>2</b>	<b>Unpacking and checking</b> .....	<b>3</b>
<b>3</b>	<b>Installation site</b> .....	<b>3</b>
3.1	Setting up the tape recorder .....	3
3.2	Assembling the console.....	4
<b>4</b>	<b>Power switch</b> .....	<b>4</b>
<b>5</b>	<b>Operating Instructions</b> .....	<b>5</b>
5.1	Standard versions .....	5
5.2	Operator controls .....	6
<b>6</b>	<b>Operation</b> .....	<b>11</b>
6.1	Pilot lamps.....	11
6.2	Inserting the tape.....	12
6.3	Tape speeds.....	14
6.4	Play.....	15
6.5	Varispeed control .....	15
6.6	Record.....	15
6.7	SYNC reproduction .....	17
6.8	Spooling mode .....	17
6.9	Producing pancakes at reduced spooling speeds, LIB. WIND .....	18
6.10	Stop .....	18
6.11	Locatorfunctions.....	18
6.12	Tape timer .....	19
6.13	Auxiliary timer LAP.....	20
6.14	Remote controls .....	20
6.15	VU-Meter-Panel .....	21
6.16	Monitor .....	21
6.17	Mono-stereo switch (option) .....	22
6.18	Test generator (option) .....	22
6.19	Time code channel (TC-versions only) .....	22
6.20	Editieren, Schneiden des Bandes.....	23
6.21	Dump edit mode.....	24
6.22	Skimming (Print-through ersasure) .....	24
6.23	Spot Erase .....	24
<b>7</b>	<b>Menu tree, soft keys*</b> .....	<b>25</b>
7.1	Entering the menu tree .....	25
7.2	Display branch for the SET TIMER, SET ADDRESS and VARISPEED keys .....	26
	<b>Description of the menu windows in the:</b>	
7.3	- audio alignment branch.....	33
7.4	- tape deck alignment branch.....	34
7.5	- AUX branch.....	35
7.6	- audio keys and functions programming branch.....	36
7.7	- audio key programming branch.....	38
7.8	- tape deck keys and function programming branch .....	39
7.9	- tape deck key programming branch.....	42
7.10	- time code alignment branch.....	48
1.7.11	Tree Diagram .....	49

\* In the appendix of these operating instructions you will find an overview card of the menu tree. All valid soft settings of the A812 MKII are conveniently listed on this card.

<b>8</b>	<b>Operation with degraded performance .....</b>	<b>50</b>
8.1	Error Messages on the Service-Display .....	50
8.2	Error category breakdown via the RS232 (ASCII) interface .....	54
8.3	Procedure for DATA LOST error message.....	55
8.4	Programming the machine type (TYPE SETTING).....	56
<b>9</b>	<b>Operation with the serial interface.....</b>	<b>57</b>
9.1	SMPTE/EBU bus.....	57
9.2	RS232 interface.....	57
9.3	Serial ASCII interface of the A812 MKII 1.810.751 .....	58
<b>10</b>	<b>Installation of the Serial ASCII Interface 1.810.751 .....</b>	<b>59</b>
10.1	Command Protocol Explanations.....	59
10.2	Message Format .....	60
10.3	Communication Protocol.....	61
<b>11</b>	<b>External storage of the audio parameters.....</b>	<b>70</b>
11.1	Data (BACK-UP) on tape .....	70
11.2	VERIFYING the data stored on tape.....	72
11.3	LOADING the data from tape.....	74
11.4	SAVING the data by means of a personal computer.....	75
11.5	VERIFYING the data in the personal computer.....	76
11.6	LOADING the data from the personal computer .....	77
<b>12</b>	<b>Installation of the Serial Interface 1.820.751 (SMPTE/EBU).....</b>	<b>78</b>
<b>13</b>	<b>Technical Information.....</b>	<b>83</b>
13.1	Connectors, Fuses.....	83
13.1.1	Power connection, voltage selector, fuses.....	84
13.1.2	Line inputs and outputs for Audio or Timecode.....	85
13.1.3	Remote control socket .....	85
13.1.4	Connector for external Synchronizer System.....	88
13.1.5	RS232C interface (ASCII protocol) or RS232C interface (binary protocol) and SMPTE/EBU bus .....	89
13.1.6	Autolocator/Remote Timer .....	90
13.1.7	Connection of a NOISE REDUCTION SYSTEM.....	91
13.1.8	VU-Meter Panel .....	92
13.2	Programming the operating parameters.....	94
13.2.1	Program switch LINE AMPLIFIER 1.820.814.00 .....	94
13.2.2	Jumper REPRODUCE AMPLIFIER 1.820.710.85.....	96
13.2.3	Jumper VU-meter amplifier.....	97
13.2.4	Jumper and potentiometer M/S SWITCH .....	97
13.2.5	Jumper TC R/W UNIT 1.820.721.85/87.....	100
13.2.6	Jumper MONITOR AMPL. 1.820.860.00.....	101
13.3	Technical Data .....	102
13.4	RAM parameters for glass-metal heads .....	104
13.5	Bias adjustment parameters .....	105
<b>14</b>	<b>Tape recorder versions and options.....</b>	<b>106</b>
<b>15</b>	<b>Accessories.....</b>	<b>107</b>
<b>16</b>	<b>Daily care.....</b>	<b>111</b>
<b>17</b>	<b>Components Sensitive to Electrostatic Charges "ESE" .....</b>	<b>112</b>
<b>18</b>	<b>Index.....</b>	<b>113</b>

## 1 Quick reference description

---

With its compact and rugged design, its system flexibility, and the high operating convenience afforded by its multiple microprocessors, the STUDER A812 MKII tape recorder satisfies all requirements of a universal studio machine, be it in radio, television, or recording studios, theater or film productions, auditoriums, or scientific institutes.

### Its salient features are:

- Highly stable die-cast aluminum alloy chassis for the tape deck, the head-block, and other assemblies.
- Hall-commutated brushless DC capstan motor with capacitive tachometer for highly accurate tape speed.
- Fast tape deck with high spooling speeds and gentle tape handling through electronically controlled tape tension, 2 controlled AC spooling motors, and noncontacting tape tension sensor.
- Precision electronic tape counter with real-time indication. Photoelectric scanning of the guide roller rotation.
- Easy editing: motor-assisted hand cueing with variable spooling speed (SHUTTLE mode). For cueing in spooling mode, the high end of the frequency response can be lowered (switch selectable).
- Monitor speaker below the tape deck cover or in the meter penthouse.
- Manually operable shield above the reproduce heads; can remain closed in spooling mode.
- Dolby-HX-PRO: standard

### Due to the enormous system flexibility, a suitable A812 MKII version is available for any type of application:

- The basic version is available as a mono, 2-channel (optionally with time code center track) or stereo machine with or without external instrument panel.
- Can be operated in horizontal, inclined, or vertical position.
- Four tape speeds can be selected: 3.75 / 7.5 / 15 / 30 ips (programmable).
- The inputs and outputs are balanced and floating and can be ordered with or without input/output transformers.
- Selector switch for two tape types with different calibration data, and changeover switch for NAB/CCIR equalization.
- Zero locator and transfer locator for up to 5 addresses as standard features.
- Equipped with varispeed control (variable tape speed).
- Output selector keys on models equipped with VU meters: INPUT, REPRO and SYNC (playback via record head).
- VU-meter panel with safe/ready changeover, record level potentiometers.
- Line voltage selectable from 100 to 140 V / 200 to 240 VAC,  $\pm 10\%$ , 50...60 Hz.
- Can be remote controlled from a terminal or personal computer via an RS232 interface (option).
- Connection facilities for fader start circuit, parallel and serial remote control.

### **High operating convenience afforded by a control system comprising several microprocessors:**

- The last operating state is saved when the machine is switched off: tape counter, locator addresses, tape speed, settings of the input and output selectors. STOP mode is automatically activated when the machine is powered on again.
- Drop in by pressing only the REC key in play mode (internally programmable)
- Drop out by pressing PLAY during a recording.
- Reduced spooling speed (LIBRARY WIND):  
A lower spooling speed can be selected for producing pancakes to be saved in the library.
- TAPE DUMP (waste basket mode with disabled take-up motor).
- LAP TIME (second time level for measuring individual tape segments without influencing the main tape counter).
- Alignment of the audio parameters via the microprocessor.
- Programmable keys (softkeys): any function selected from a list of about 100 functions can be assigned to any key, for example:
- FADER: Four operating modes can be selected, for example: local keyboard blocked, only fader start possible, etc.
- REHEARSE: Simulates an electronic cut.
- AUTO MUTE: Automatically mutes the audio channels in spooling mode.
- SPOT ERASE: Activates the erase circuit without tape transport, the tape can be moved manually.
- SKIMMING: Eliminates pre-echoes from tapes that have been kept in the library for a long time.
- Internal location test system for the main functions, with error diagnosis.
- Automatic power-on self test, is partially repeated at periodic intervals.

---

## 2 Unpacking and checking

---

The A812 MKII tape recorder is shipped in a special packing that protects the machine from damage in transit. Care should be exercised when unpacking the machine so that its surfaces do not become marred.

Check that you have received all the material by comparing the packing content with the shipping list. Save the original packing material because it provides the best protection in case your tape recorder needs to be transported again.

Check all items for possible shipping damage. If you discover any damage, immediately notify the forwarding agent as well as the nearest STUDER dealer.

---

## 3 Installation site

---

The A812 MKII should be installed in a dust-free and an adequately ventilated environment. The performance data of the tape recorder are guaranteed for an ambient temperature range from 0°C to +40°C with a relative humidity of 20% to 90% (noncondensing).

Install the tape recorder in such a way that sufficient space is available all around the machine for unobstructed cooling. Particularly in recessed locations there is a possibility of heat accumulation. The air circulation zone should neither be misused as a storage area nor be obstructed with manuals etc.

The tape recorder should not be installed in the vicinity of strong electromagnetic fields. General sources of interference are: strong load fluctuations on adjacent power circuits, high-power transformers, elevator motors, electrical welding plants, as well as nearby radio and television transmitters.

The rear of the unit should remain readily accessible for service work. When the recorder is installed in a niche, sufficient space should be available for shifting the machine even when the cables are attached.

---

### 3.1 Setting up the tape recorder

---

The technical data are guaranteed for operating the tape recorder in any position between horizontal and  $\pm 15\%$  inclination.

## 3.2 Assembling the console

---

The console is shipped in disassembled condition.

- First fasten the side panels of the console with cators or gliders to the traverse (or the rack base) by means of a 5 mm hexagon-socket-screw key. Subsequently fasten the wooden side panels with 4 screws each (4 mm hexagon socket).
- The rear console panel is mounted after the tape recorder has been installed.
- In order to install the tape recorder it is necessary to remove the two long aluminum strips (3 screws each, hexagon-socket 2.5 mm, as well as 2 screws M6, screwdriver No. 6).
- Position the console horizontally (the lever for releasing the tilting mechanism is located on the left front below the console). Slide the tape recorder into the console from the back, mount the aluminum strips and fasten the screws.

### Tape recorders without VU-meter penthouse:

- Install the rear panel (6 PCS Allen screws with Allen key 2.5 mm)

### Tape recorders with VU-meter penthouse:

- Slide the cable harness and the flat cable through the panel neck (on the rear panel), connect the panel housing to the panel neck (2 screws, hexagon socket 5 mm).
- Engage the rear panel with mounted penthouse on the back of the console and fasten the screws (6 x Allen screw with 2.5 mm Allen key).

**Important:** Do not activate the tilting mechanism during tape spooling because the high centrifugal forces could damage the tape, the reels, the adapters and the tape deck cover

## 4 Power switch

---

**Important:** Before you switch on the machine for the first time, check that the setting of the line voltage selector on the back of the unit agrees with your local line voltage. If the line voltage selector is changed, also check the rating of the power fuse (see Section 11.1.1).

The power switch [1] is located at the top edge of the tape deck cover. After the machine has been connected to the mains, it can be powered on with this switch.

When the machine is switched on, the operating state before the last power off is automatically re-established.

Exceptions: The tape machine is always switched to STOP (the STOP lamp flashes if no tape is inserted or if the tape is loose). On machines with a SAFE/READY switch, SAFE is activated. After the machine has been switched on, various informations such as the release date of the master software appears on the LC display [27].

## 5 Operating Instructions

### 5.1 Standard versions

Three standard versions exist with differently programmed (and labelled) keypads.

#### Version A

Models: A812-0.75, A812-2, A812-1 A812-2F

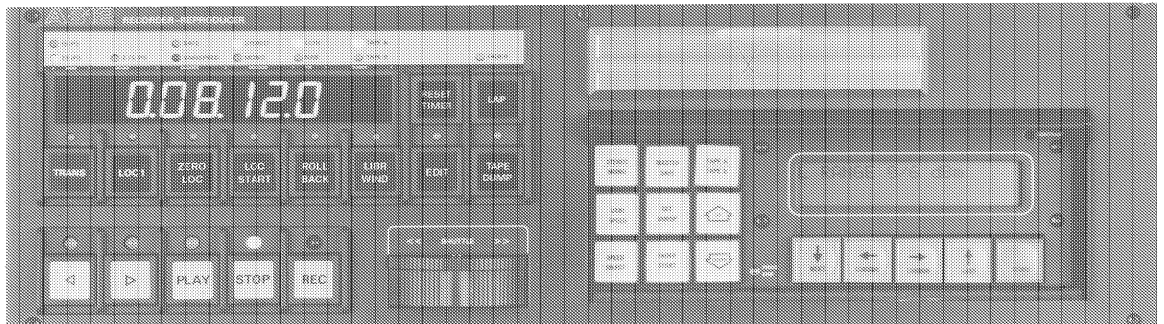

#### Version B

Models: A812-VU, A812-2/2 VU, A812-2 VU, A812-1 VU, A812-2/2

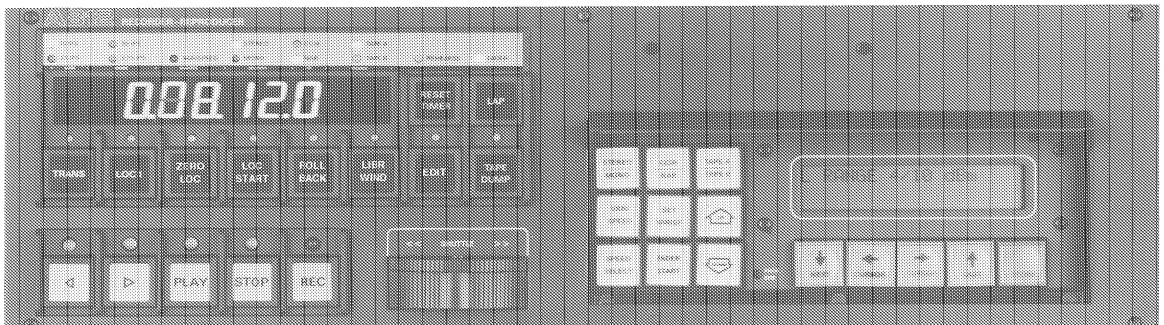

#### Version C

Models: A812-2 TC, A812-2 VU TC

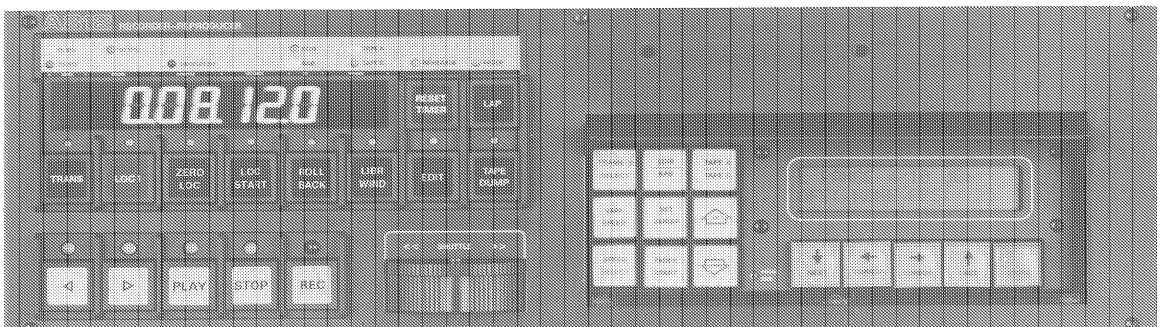



5.2 Operator controls

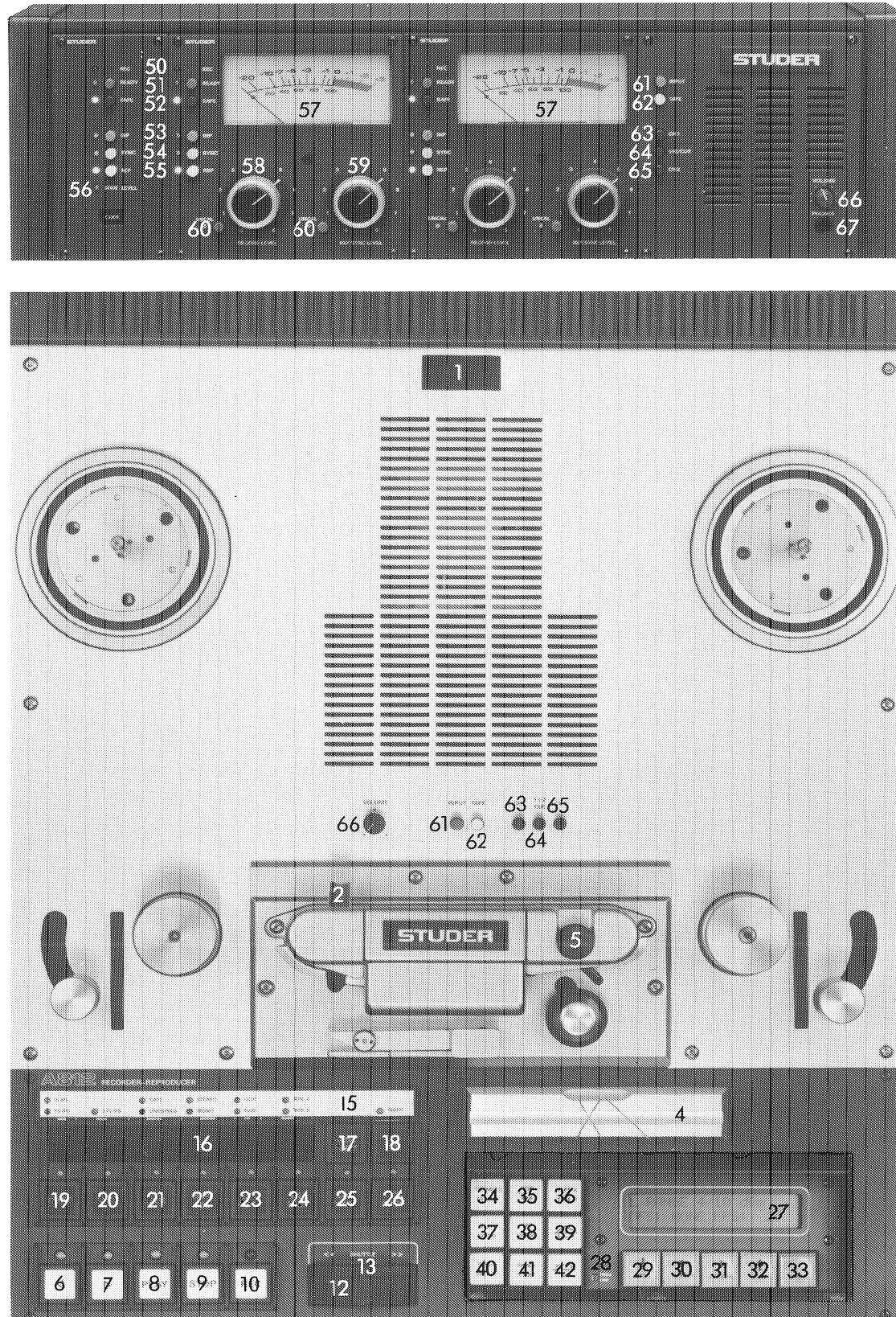

The description of the functions [6–25] apply to the default programming of the operator controls.

- [1] Power switch
- [2] Tape lift slide
- [3] Marking device (option)
- [4] Splicing rail
- [5] Scissors (option)  
Main keypad
- [6] < Rewind key
- [7] > Forward wind key
- [8] PLAY Play key
- [9] STOP Interrupts any tape deck functions.
- [10] REC<sup>1</sup> Record key. By means of F307 and F308 in the software menu this key can be programmed to perform different functions.
- [12] SHUTTLE wheel For shuttling the tape with continuously variable tape speed. Center position = STOP, left-hand limit position = max. SHUTTLE rewind speed, right-hand limit position = max. SHUTTLE forward wind speed.
- [13] SHUTTLE BAR Bar above the SHUTTLE wheel [12]. When the SHUTTLE BAR is pressed the spooling speed selected with the SHUTTLE wheel will be stored and maintained.
- [15] Status indicator field Indicator field for the keys [34] to [42].  
A self-adhesive label with complete status description is included in the supplied accessories (Part No. 1.820.012.02). It can be used if programming of the keys differs from that of the standard version.  
After the existing status indicator label has been peeled off, the empty lamp sockets can be fitted with the supplied LEDs. The new status indicator label can then be affixed and the tape recorder programmed as desired.
- [16] LED-tape timer Real-time indication for all tape speeds in hours, minutes, seconds, and tenths of seconds, switchable to a second tape timer with user-selectable reference.
- [17] RESET TIMER Reset key for the tape timer [16].
- [18] LAP Switches the (main) tape timer to a second timer with user-selectable reference. An "L" is shown as long as the reading of the second timer is displayed.

<sup>1</sup> Refer to section 7.11 for key programming explanations.

- [19] **TRANS (TRANSFER)** Preselection key for storing the current tape timer reading (functions also when the second timer has been activated with LAP). In order to store the timer reading in one of the 5 LOC memories, press one of the keys LOC1...LOC5; the tape timer continues to count. If the timer reading is not to be transferred into a LOC memory, the tape timer can be reenabled by pressing TRANS a second time.
- [20] **LOC1** Searches automatically the tape address stored with the TRANS key [19]. The LOCATE address is displayed as long as this key is pressed.
- [21] **LOC ZERO** Searches for the tape address that corresponds to the timer reading 0.00.00.0. Relates to the corresponding zero position of the tape timer in normal mode or in LAP mode.
- [22] **LOC START<sup>1</sup>** Automatic search for the tape address at which the last PLAY or REC command was entered (when tape was standing still). Depending on the programming, the machine subsequently switches to PLAY, STOP or RECORD (F319–F321).
- [23] **ROLLBACK<sup>1</sup>** Rewinds the tape by a programmable amount between 1 and 59 seconds. Default programming: 15 s. When the target address is reached, the machine switches either to STOP, PLAY, or RECORD, depending on the programming (F322–324).
- [24] **LIBRARY WIND<sup>1</sup>** Reduced spooling speed for producing library quality pancakes. Preselection key, initiates the reduced speed in conjunction with one of the spooling speeds [6] or [7]. This function can be cancelled by pressing LIBRARY WIND a second time. Speed programmable in increments of 0.1 m/s; default value 5 m/s.
- [25] **EDIT** Edit function for one-handed cueing, i.e. the tape can be positioned by turning one of the two reel flanges.
- [26] **TAPE DUMP<sup>1</sup>** Dump edit mode. For programmable possibilities:  
**TAPE DUMP-A:** Tape counter ON (F327)  
**TAPE DUMP-B:** Tape counter OFF (F328)  
**TAPE DUMP-C:** Tape counter ON, preselection key, activate with PLAY (F329)  
**TAPE DUMP-D:** Tape counter OFF, preselection key, activate with PLAY (F330).
- [27] **LC display** Alphanumeric display for indicating the software status, speed deviation in varispeed mode, error messages, programming of audio and tape deck parameters, etc.
- [28] **PROG. ENB** Enable screw (PROGRAM ENABLE) allows access to the software menu. This programming lock can only be opened by giving the hexagon-socket-head screw a few turns with a 2.5 mm key. It thus provides excellent protection against inadvertent modification of functions and parameters.
- [29] **NEXT**  
[30] **CURSOR/<**  
[31] **CURSOR/>**  
[32] **LAST** } Keys for leaf through the menu and for navigating the cursors on the service display.
- [33] **STORE** **Multifunction key:**
- For storing modified tape deck and audio parameters
  - For changing over a function that is not assigned to a key.
  - For reprogramming a key (when pressed together with the corresponding key).
  - For acknowledging an error message.

- [34] STEREO/MONO** For equipment versions A, B:  
Stereo/mono switch, changeover by simultaneously pressing the STOP and STEREO/MONO keys.
- FRAMES/S SELECT** For equipment version C:  
Selector switch for adapting the time code to the corresponding video format. Changeover by simultaneously pressing the STOP and FRAMES/SELECT keys. Selectable time code type: 24/25/29.97 frames/s.
- [35] MASTER SAFE** For equipment version A:  
Record inhibition for equipment without SAFE/READY switch.
- CCIR-NAB** For equipment version B, C:  
Selector switch for the equalization standard. Changeover by simultaneously pressing the STOP and CCIR/NAB keys.
- [36] TYPE A/TAPE B** Selector switch for two tape types (only in conjunction with STOP!).
- [37] VARISP. ON/OFF** On/off switch for variable tape speed.
- [38] SET VARISP.** VARISPEED input key. The desired tape speed can be set with the UP [39] and DOWN [42] keys.
- [39] UP,  
[42] DOWN** Multifunction keys:
  - In conjunction with keys [29–32]:  
For "leafing through" the menu.For setting the audio and tape deck parameters.
  - In conjunction with the VARISPEED function:  
For setting the desired tape speed.
  - In conjunction with the functions:  
SET ADDRESS: Input of a locator address.  
SET TIMER: Input of a tape timer address.
- [40] SPEED SELECT** "Endaround" key for selecting the speed. Each time this key is pressed the next higher or next lower speed is selected.
- |            |                    |
|------------|--------------------|
| Version A: | 3.75/7.5/15 ips    |
| Version B: | 3.75/7.5/15/30 ips |
| Version C: | 7.5/15/30 ips      |

**[41] FADER**

When opening a dedicated fader on the mixing desk, the tape recorder will start in PLAY (for wiring details see 11.1.3). For fader modes are prorammmable in the menu tree of the A812 MKII:

Characteristics of the four programmable fader modes:

Fader mode		A	*B	C	D
	FADER READY key required		■	■	■
	FADER READY key not required	■			
<b>Fader closed:</b>	Tape recorder operable	■	■		■
	Tape deck keys disabled			■	
<b>Fader open:</b>	Tape recorder operable				■
	Tape deck keys disabled	■	■	■	
	Monitor speaker muted	■	■	■	■

\*Standard programming: Fader B

**Operating Controls on the VU-meter panel (optional):**

- [50] REC** Record pilot lamp; is lit when the channel is switched to record mode.
- [51] READY** Channel is enabled for recording.
- [52] SAFE** Channel is disabled for recording.
- [53] INP** The input signal is connected to the output.
- [54] SYNC** The sync signal is connected to the output.
- [55] REP** The reproduce signal is connected to the output.
- [56] CODE LEVEL** (Provided only on code channel controls): This time code pilot light is lit when the time code is reproduced from tape or when the time code level at the input is large enough (depending on the setting of the input selector INP/SYNC/REP).
- [57] VU-Meter** Signal level meter: VU or PPM characteristic, internally switchable.
- [58] RECORD LEVEL** Level potentiometer for recording. Shows to attenuate or to boost the input signal by 10 dB when the UNCAL key is pressed.
- [59] REPRO/SYNC LEVEL** Level potentiometer for reproduction or sync reproduction. Allows to attenuate or to boost the signal level by 10 dB when the UNCAL key is pressed.
- [60] UNCAL** Activates the corresponding level potentiometer. Switched off: Calibrated line level.
- [61] INPUT** The input signal of the machine is heard via the monitor speaker.
- [62] TAPE** The output signal of the machine is heard via the monitor speaker.

- [63] CH1. Channel 1 is connected to the monitor speaker.
- [64] 1+2/CUE The sum of both channels or the CUE channel (only for TC versions) is connected to the monitor speaker. This function is programmable with jumpers.
- [65] CH2 Channel 2 is connected to the monitor speaker.
- [66] VOLUME Volume control for the monitor speaker.
- [67] PHONES Phones socket. On models with out console penthouse this socket is located at the monitor speaker, on models without console penthouse it is located above the hinged cover of the amplifier bay.

---

## 6 Operation

---

### 6.1 Pilot lamps

---

After the machine has been switched on, some of the pilot lamps may light up briefly, including READY or REC. However, the record function is electronically inhibited during this phase.

Afterwards the following LEDs will light up to indicate the actual operating state of the tape recorder:

- STOP: The stop function is active. If the LED flashes this means that both tape tension sensors are in their home position (no tape laced or tape loosely inserted slack).
- CCIR or NAB: Selected equalization standard
- STEREO or MONO (if configured).
- TAPE A or TAPE B: Selected tape type.
- Tape speed: for example 15 or 7.5 ips.

Depending on the configuration of the tape recorder the following may also be lit:

- Level meters
- On the track selector: SAFE
- On the output selector: Selected output (INP, SYNC or REC)
- UNCAL (if the key is pressed)

On the LC display, the following equipment-specific information is consecutively displayed for a few seconds (this information can be recalled at any time by pressing the LAST key):

- Software status: Release date of the machine software (calendar week/year).
- If an SMPTE/EBU interface is used, the display shows whether the SMPTE/EBU command protocol is fed out according to the RS422 or RS232 standard.
- After a software modification or the like, a warning message appears that all key functions of the machine have been assigned to the standard functions according to the original labeling and the standard audio or tape deck data have been read in.
- Any error detected by the power-on self test is shown on the LC display. Refer to Section 8, otherwise the message "No errors detected" is displayed.
- Line level (selected operating and peak recording level) and on machines with time code, the OFFSET and the time code standard (frames/sec) are displayed.

Additional signal lights on the audio remote control:

- On the track selector switch: SAFE.
- On the output selector switch, the signal available on the output is indicated (INP, SYNC or REP).

6.2 Inserting the tape

Install the adapter that matches the tape reel. Three different tape adapters are available:

- Three-prong adapter (mainly for plastic reels)
- NAB adapter (mainly for metal reels)
- Open-reel adapter

**Install the adapter**

Press against the center of the adapter [1] until the latter engages.

**Removing or exchanging the adapter**

Press down the outer ring [2] of the outer spindle until the adapter pops out.

**Three-prong reel with flange:**

(DIN 45514, 45517)

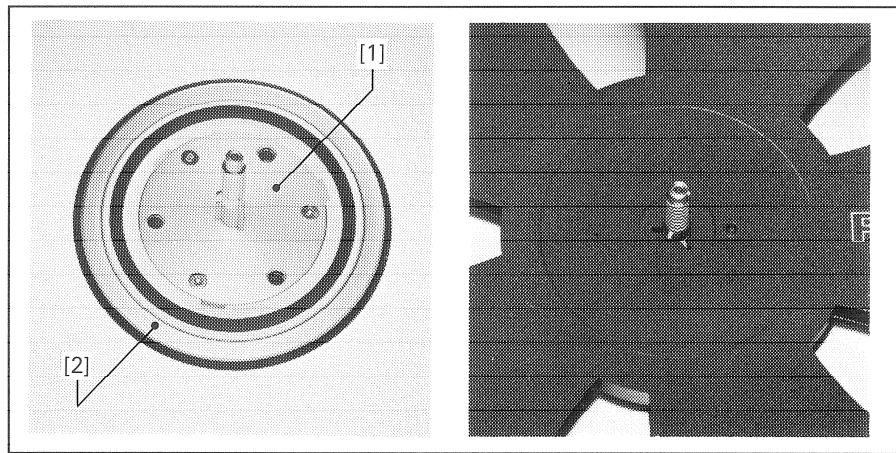
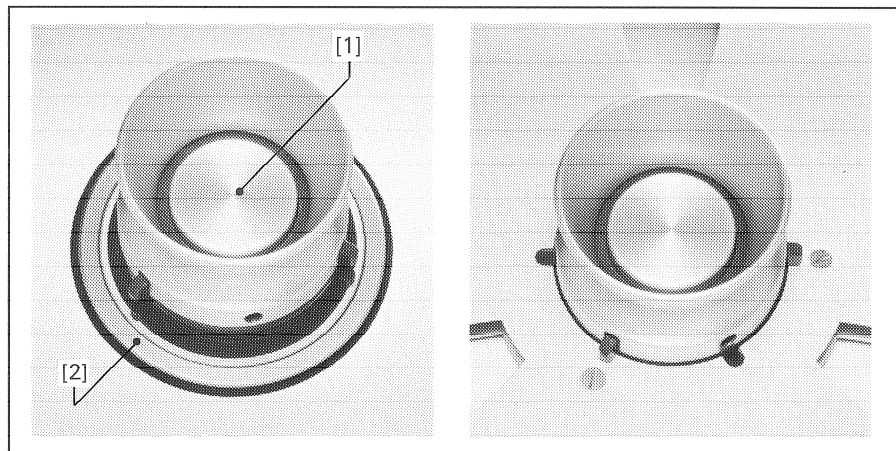

Fig. 2.5.6

Installing the adapters for 3-pronged Cine reels. Mount the full reel on the left-hand spindle, the empty reel on the right-hand spindle. Lift the three-pronged guide and lock the adapter with a 60° turn.

**NAB reel:**



**NAB adapter**

Installing the NAB adapter. Place the NAB reel or the NAB hub, if a self-supporting pancake is used, on the adapter and turn the top of the adapter clockwise until it engages.



## Self-supporting pancake

(Hub according to DIN 45515)

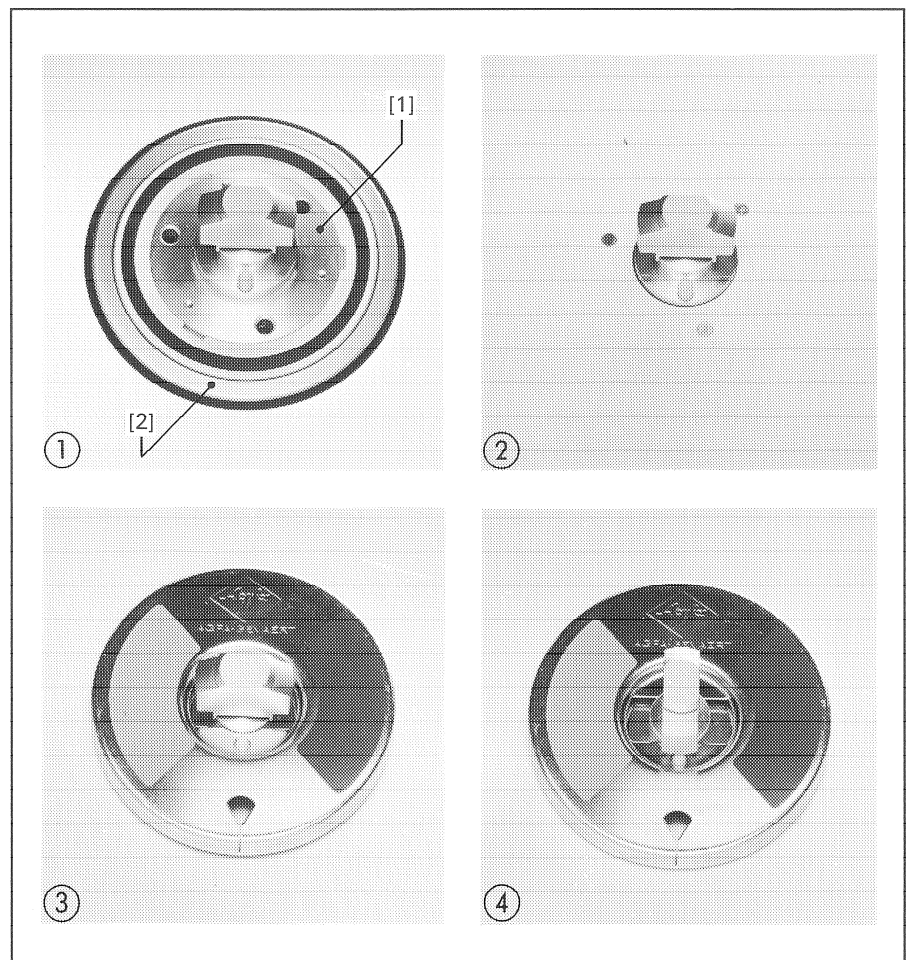

- 1 DIN AEG adapter
- 2 2 DIN AEG adapters with pancake platter
- 3 center of pancake, unlocked
- 4 center of pancake, locked.

Install the DIN adapter, mount the spindle on the adapter and engage the driving pin of the reel flange in the holes of the spindle.  
Place the full pancake on the left-hand side. Lift the clip and twist it by 90° until it rests on the guide pins. Place an empty reel flange and an empty hub on the right-hand side.



## Threading the tape

Before you thread the tape, raise the head shield in front of the soundheads.



- Insert the tape as illustrated. Wrap the leading end of the tape around the right-hand reel hub and secure the tape by giving the reel a few counterclockwise turns.
- Reset the tape timer to zero by pressing the RESET TIMER button.
- Swing the head shield over the sound heads, if necessary.

## 6.3 Tape speeds

---

Up to four tape speeds are available; various models are programmed for the three most commonly used tape speeds (e.g. in time code versions the slowest speed is not programmed because operation with time code is not advisable at 3.75 ips). When you press the SPEED SELECT key (below the hinged cover) the tape speed is increased by one step or it is changed back from the highest to the lowest speed; the corresponding pilot LED lights up

## 6.4 Play

---

If a local or an external PLAY key, a corresponding remote control key, or a fader start device is actuated, the tape recorder switches to play mode. The PLAY LED lights up.

Play mode can be cancelled by pressing the STOP key.

The PLAY key is pressed while a recording is in progress, the machine switches to play without interruption.

If the PLAY key is pressed in spooling mode, the tape is immediately decelerated and the PLAY function preselected. As soon as the magnetic tape has come to a standstill has been decelerated to nominal speed in the play direction, the machine switches to play mode, the PLAY lamp is continuously lit.

From the PLAY function you can switch directly to spooling mode or an autolocator function.

## 6.5 Varispeed control

---

The deviation relative to the nominal speed can be selected with the built-in varispeed control within the range of  $\pm 7.5$  semitones.

With the keys SET VARISP and UP or DOWN you can preselect the tape speed without changing the current nominal speed. The speed is indicated on the LC display either in semitones, in percent of the nominal speed, or as the actual tape speed in inches per second (ips).

Pressing the VARISPEED key switches from the nominal speed to the changed speed – the VARISPEED pilot lamp above the tape timer flashes. When the function VARISPEED INDICATION ENHANCED F245 is active, the two LEDs of the spooling keys < and > also flash.

If the functions SET VARISP and VARISPEED are simultaneously active, the speed change is performed directly (with the UP and DOWN keys). The result is directly audible during playback.

The delay correction for the drop-in and drop-out (see Section 6.6) is set for the nominal speed; when recordings in varispeed mode a corresponding offset will result.

## 6.6 Record

---

When the REC and the PLAY keys are pressed simultaneously, the machine switches to record mode and the PLAY and REC keys light up.

If PLAY and REC are pressed in spooling mode, the tape is decelerated, the record function preselected, and the REC and PLAY lamps flash. As soon as the tape has been decelerated to the nominal speed, the record mode is automatically initiated and the two lamps change to steady light.

From record mode it is possible to switch directly to fast wind, play or a locator function by pressing the corresponding key.

### Models with MASTER SAFE key:

The MASTER SAFE function is used for record inhibition on machines without SAFE/READY key. However, this function can also be programmed on machines equipped with a SAFE/READY key in which case the MASTER SAFE function is a higher ranking record inhibition. As long as MASTER SAFE is active, the machine cannot be prepared for recording with the READY key.

## **Models with SAFE/READY keys:**

With the SAFE key you can inhibit recording on the corresponding channel. The yellow SAFE lamp lights up; when PLAY and REC are pressed the tape deck is started; the old recording on the audio track of the channel protected with SAFE is preserved and can be monitored (REP or SYNC).

To prepare a channel for recording, the corresponding READY key must be pressed. The green READY LED lights up. If you now activate the record function by pressing PLAY and REC, the red LED lights up to signal that recording is in progress.

During a recording the channels can be inhibited directly with SAFE. To restore them to record mode, first press the READY keys; after the READY LEDs light up, the tape deck must again be switched to record mode. On 2-channel machines the two channels are either switched in parallel or individually (F051 CH CONTR PAR/INDIV), depending on the programmed option.

## **Drop-in:**

Click-free changeover from play or SYNC reproduction to record mode is possible. Depending on the jumper setting, this is achieved by either pressing REC together with PLAY (RECORD A) or only the REC key (RECORD B). Depending on the programming the erase head and the record head are activated either simultaneously, or the record head is activated with a speed-dependent delay in such a way that the erase head and the record head are switched on at exactly the same tape location (function IN-OUT DEL. Y/N).

## **Drop-out:**

Click-free changeover from record mode to play or SYNC reproduce mode is possible by pressing the PLAY key.

Depending on the programming the erase head and the record head are either switched off simultaneously or the record head is deactivated with a speed-dependent delay in such a way that the erase head and the record head are switched off at exactly the same tape location (function IN-OUT DEL. Y/N).

Drop-out with SAFE always switches off both heads simultaneously. The same applies to drop-in with STOP.

## **Crossfading an existing recording**

Mechanical (fade-in/fade-out)

If for example applause is to be crossfaded to the end of a production, the tape can be lifted off the sound head and the erase head with the tape lift slide [2]. Subsequently the machine can be started in record mode. When the tape lift slide is released slowly, the tape first contacts the record head; the applause is added to the existing modulation, e.g. to the end of a music recording.

## 6.7 SYNC reproduction

---

With the SYNC key the corresponding channel can be switched to sync reproduction. This means, the modulation is reproduced by the record head via the reproduce amplifier.

In this mode there is no speed-dependent time offset between the record and reproduce head. This makes it possible to make a synchronous recording to an existing channel (e.g. vocalizing instrumental music).

Sync reproduction is not recommended for 3,75 ips (limited frequency response). For this reason all sync audio parameters for this tape speed are defined as 00. It is possible to calibrate a tape recorder for sync reproduction at 3.75 ips, but quality loss is unavoidable.

The reproduce frequency response in sync mode is limited to approx. 12 kHz. For special mixdowns the bandwidth can be increased to approximately 20 kHz (refer to Section 13.2.2). However, strong cross talk from the record channel to the sync reproduce channel must be expected at frequencies above 12 kHz.

### SYNC preselection

SYNC reproduction can be preselected for a channel that has been readied for record mode. When the SYNC key is pressed during a recording, the corresponding channel is connected to the input (INP). This channel is automatically switched to SYNC reproduction when the drop-out occurs (PLAY, SAFE, STOP).

## 6.8 Spooling mode

---

By means of the keys < and > either rewind or fast forward can be selected and the tape will be wound at the programmed speed in the desired direction (SET MAX. WIND SPEED). The corresponding key will be lit.

Spooling is automatically cancelled by STOP, PLAY, REC+PLAY, SHUTTLE, TAPE DUMP, LOC functions, and by spooling in the opposite direction.

It is admissible to switch from fast forward directly to rewind and vice versa, or directly from play or record to rewind.

During spooling it is possible to switch directly to play or record. The LED of the preselected function flashes; the magnetic tape is decelerated, and the preselected function is activated when the tape has come to a stop or when it has reached nominal speed.

### Tape lift:

In spooling mode the tape is automatically lifted off the heads in order to minimize head wear.

When you press the LIFTER key (F332) the tape lift pin is engaged so that you can cue the recording during spooling. This key is only effective for as long as it is pressed.

### Important:

During the spooling operation the console tilting mechanism must not be actuated. The high centrifugal forces can damage the tape, reels, adapter and tape deck cover!

Depending on the programming of F201 and F202, the tape unthreads when the end is reached (no tape guard) or the speed is decelerated at approx. 30 m before the tape end (tape guard A) if the hub diameter setting is correct (set hub diameter left/right), or it stops 30 m before the end of the tape (tape guard B).

## 6.9 Producing pancakes at reduced spooling speeds, (LIBRARY WIND)

---

The reduced spooling speed selected with LIBRARY WIND is intended for producing even pancakes for tape storage. The speed can be programmed between 0.1 and 15 m/s in increments of 0.1 m/s (default 5 m/s). To activate this mode, press the LIBRARY WIND key followed by one of the spooling keys < or >. Approximately 30 m before the end of the tape, the spooling speed is automatically reduced if "Tape guard A" has been programmed.

This function can be cancelled by pressing LIBRARY WIND again. LIBRARY WIND can also be activated by simultaneously pressing TRANS and one of the spooling keys (< or >).

## 6.10 Stop

---

The STOP key has the highest priority and cancels all functions such as play, record, spooling, and autolocator. After this key is pressed the tape is decelerated and the stop lamp flashes until the tape has come to a standstill. The STOP lamp subsequently changes to continuous light.

The tape tension sensors are automatically disabled when the tape stands still so that the tape can be shuttled manually for editing.

- Any new operating mode entered during the deceleration of the tape is stored and activated as soon as the nominal speed has been attained. If STOP is pressed concurrently with one of the LOC1...LOC5 keys, the corresponding locator address is displayed on the tape timer.
- Various function keys can only be operated in conjunction with STOP (e.g. tape type selection (TAPE A/TAPE B), equalization standard (CCIR/NAB), mono/stereo changeover (STEREO/MONO), changeover of the time code standard (FRAME/S and OFFSET ON/OFF).

## 6.11 Locatorfunctions

---

The following locator functions are available:

- ZERO LOC: Zero locator. When you press this key, fast rewind (or fast forward) is performed until the tape address 0.00.00.0 is reached., regardless of whether the zero position of the main timer or the second (LAP) timer is to be searched.
- LOC START: When you press this key, fast rewind (for fast forward) is performed until the tape address is reached at which the last changeover from STOP to play or record occurred. Direct function transitions from PLAY or RECORD are not stored. Depending on the programming, the machine subsequently switches to STOP (F320 LOC START STOP), play (F319 LOC START PLAY), or record (F321 LOC START REC).
- LOC1...LOC5 (programmable): Transfer locator. Up to five tape addresses can be stored and automatically searched in spooling mode by pressing the corresponding key.

**Storing an address:**

Storing a tape time address in a locator memory:

- With the TRANS key
  - Prepare for storing a tape address by pressing the TRANS key (TRANS LED lights up).
  - Store the current tape address by pressing the corresponding locator key (LOC1...LOC5), the TRANS LED turns dark.
- With the HOLD key (F312): At the desired tape address press the HOLD key; the corresponding counter reading on the display is "frozen" (however the tape timer continues to run internally). To transfer the displayed address into the corresponding memory, press one of the LOC keys; the current counter reading reappears on the display.

Storing a known address in a locator memory:

- Programming the function F337 SET ADDRESS. When you press the SET ADDRESS key, the following information appears on the LC display:

SET ADDRESS hours. min. sec. dsec
--------------------------------------

The cursor indicates that the seconds on the LED display can be incremented or decremented with the UP and DOWN keys.

With the blue keys CURSOR LEFT, CURSOR RIGHT, you can select the appropriate display position and modify the content with the UP and DOWN keys until the display contains the desired time.

This value can be stored by pressing the TRANS (or HOLD) key, followed by the desired LOC key (LOC1...LOC5).

**Reading out an address:**

During a LOC operation: Press the corresponding LOC key again.

In STOP mode: Press the STOP key and the corresponding LOC key.

**PLAY or REC preselection:**

When the PLAY key or PLAY plus REC keys are pressed during a locate process (ZERO LOC, LOC START, LOC1...5), the tape recorder switches automatically to play or record when the corresponding tape address is reached.

All locator addresses remain stored even when the tape recorder is switched off.

**Important:**

Since the locator addresses are not related to the physical tape positions, unwanted offsets will occur if the RESET TIMER key is pressed inadvertently!

## 6.12 Tape timer

---

The electronic tape timer always displays the real tape time in hours, minutes, seconds, and tenths of seconds, relative to the selected nominal tape speed. The timer has a display range from -9 h 59 min 59.9 s to 23 h 59 min 59.9s. Numbers that are outside the display range are identified by a "u" (underflow) or a "o" (overflow) in the tens position of the hours, for example: o4.00.00.0 or u3.03.35.7 Fractional tenths of seconds are rounded. The timer can be set to 0.00.00.0 by pressing the RESET TIMER key.

When the end of the tape or a torn tape is detected, the timer stops automatically. In dump edit mode (TAPE DUMP) the timer either stops or continues to run, depending on which of the four TAPE DUMP modes has been programmed (default: TAPE DUMP A).

### 6.13 Auxiliary timer LAP

The LAP key activates a second (auxiliary) tape timer with a user-selectable reference. An "L" appears in the first position of the display.

The auxiliary timer can be set to zero (RESET TIMER key) at any tape address and can for example be used for determining the exact playing time of a selection without having to compute the difference between the start and the end time.

When the LAP key is pressed a second time, the display switches back to the main timer, and the "L" in the first display position disappears.

### 6.14 Remote controls

The following can be operated with a parallel remote control:

- PLAY
- STOP
- REC
- <
- >
- RESET TIMER
- ZERO LOC
- LOC START
- BACKSPACE (rewind for as long as this key is pressed, followed by PLAY)
- LIFTER (defeating the tape lift in spooling mode)
- FADER (FADER START Ready).

Two modes can be programmed with F345/346:

Programming	Remote A Remote control only		Remote B Remote & Local control		Neither active
	Selected	Not selected	Selected	Not selected	
Local keyboard enabled	-	■	■	■	■
Remote control parallel, serial and RS232* active	■	-	■	-	■

\* The remote control must be active for operation with the TLS4000!

- Note:**
- The REM CONTR or REMOTE key is only enabled in stop mode.
  - The REM CONTR or REMOTE key also switches the RS232 interface on and off!

## 6.15 VU-Meter-Panel

---

The level indication can be switched between PPM or VU characteristics by means of an internal jumper.

- UNCAL [60]: When you press this key the corresponding level potentiometers are activated; the corresponding pilot LED lights up. When the UNCAL key is released, the potentiometer is disabled and the input or output level is set to line level.

### Output selector

- INP [53]** Connects the input signal to the output of the tape recorder and to the level meter.
- SYN [54]** Connects the reproduce signal from the reproduce head to the output of the tape recorder and to the level meter. This mode can be preselected for the record function. (As long as the respective channel is in the record mode it is switched to input because the record head can not be switched over to perform as a reproduce head during recording. SYNC reproduction will be activated automatically again, as soon as recording becomes interrupted by pressing PLY or when switching over to SAFE).
- REP [55]** Connects the reproduce signal to the output of the tape recorder and to the level meter.  
In record mode, tape/source monitoring is possible with the INP and REP keys. INP, SYNC and REPP11 are mutually self-cancelling. On 2-channel machines, the two channels are operated in parallel or individually, depending on the programming (F051 CH CONTR PAR/INDIV).

## 6.16 Monitor

---

On machines without penthouse, the monitor speaker is installed in the tape deck cover; on machines with penthouse it is installed in the monitor panel. On machines with penthouse, the headphone socket [67] is located on the monitor panel, on machines without penthouse that socket is on the top left of the amplifier bay.

With the INPUT [61] and TAPE [62] switches (mutually cancelling) you can switch between the input and output of the tape recorder (signal is tapped before the corresponding level potentiometer).

Channel 1 (CH1) [63] or channel 2 (CH 2) [65] can be monitored. It is also possible to monitor the sum of both channels or the CUE channel (time code) (1+2/CUE) [64], depending on the jumper positions on the monitor amplifier (refer to Section 13.2.6). If the jumpers on the monitor amplifier are in the CUE position, the sum of both channels can be monitored by simultaneously pressing CH1 and CH2.

The volume can be adjusted with the VOLUME [66] knob.



## 6.17 Mono–stereo switch (option)

Stereo machines can be equipped or retrofitted with a mono/stereo switch. When the machine is switched on, the last operating state prior to switch–off is automatically re–established and displayed.

To switches from stereo to mono and vice versa, the STOP and STEREO–MONO switch must be pressed simultaneously.

If the machine is not fitted with a mono–stereo module, the two pilot lamps STEREO and MONO remain dark.

## 6.18 Test generator (option)

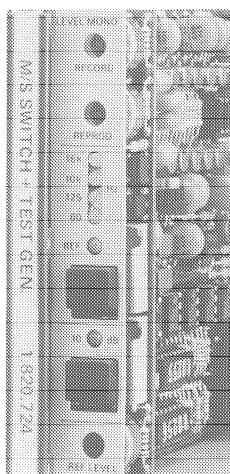

The test generator controls are located on the front edge of the test generator module. Lift the hinged cover for operating these controls!

When you press the upper key, the test generator is activated (REF pilot lamp is lit, i.e. the reference frequency, normally 1 kHz, is selected). If you continue pressing this key, the frequency is stepped through as follows: – 60 Hz – 125 Hz REF (1 kHz) – 10 – 16 kHz – OFF (REF – 60 Hz – etc.)

With the lower key you can decrease the generator level by 10 dB relative to the nominal level. If "-10 dB" is selected, the gain in the reproduce path is automatically boosted by 10 dB and the record level is decreased by 10 dB; this has the effect that for an overall measurement the VU–meter reading is the same as for nominal level.

The lower key is only enabled when the test generator has been activated with the upper key. After the test generator has been switched off and on with the upper key, nominal level is always available at the test generator output.

## 6.19 Time code channel (TC–versions only)

### Time code recording

Press the READY key on the time code channel control unit; the READY lamp lights up. Then start the machine in record mode by pressing REC + PLAY; the REC lamp is lit. Or while an audiorecording is in progress, press READY and, depending on the programming, REC + PLAY or only REC.

### Time code reproduction

Press REP or SYNC and start the machine in PLAY mode. Depending on the setting of the output selector, the green CODE LEVEL lamp is lit if a time code signal exists on the TC line input (INPUT position= or on the tape (REP or SYNC position).

### REP

The time code signal is delayed in such a way that no time offset between the audio reproduce head and the time code head occurs.

### SYN

The time code signal is delayed in such a way that no time offset occurs between the audio record head and the time code head.

## 6.20 Editieren, Schneiden des Bandes

<b>Searching a tape address in spooling mode</b>	Coarse search of a tape address (e.g. start of a recording) with the spooling keys, perhaps with library wind mode selected.
	<p><b>Note:</b> When a key programmed with the LIFTER function F332 is activated, cueing is possible in spooling mode.</p> <ul style="list-style-type: none"> <li>■ More precise searching for the desired position on tape by means of the shuttle wheel or by pressing permanently the fast forward key while occasionally touching the rewind key.</li> <li>■ Exact positioning with one-hand cueing.</li> </ul>
<b>One-hand cueing</b>	<p>One-hand editing.</p> <p>Pressing the EDIT keys activates the spooling motor, but the tape remains at stand still. The tape can now be moved forward or backward by turning the left-hand or right-hand spindle counterclockwise.</p> <p>The logic of the tape tension sensor blocking can be selected with the function F254 EDIT A/B/C.</p> <p><b>EDIT A:</b> Neither tape tension sensor is blocked.</p> <p><b>EDIT B:</b> Left-hand tape tension sensor blocked, ideal for editing with the right-hand spindle.</p> <p><b>EDIT C:</b> Right-hand tape tension sensor blocked, ideal for editing with the left-hand spindle.</p>
<b>Setting a cue point</b>	<p>In play or record mode, cue points (edit points) can be set by pressing TRANS (or HOLD) and the desired locator key (LOC1-LOC5).</p> <p>The set cue points can be searched by pressing the corresponding locator key.</p> <p>If an autolocator is used, the cue points are automatically programmed to the locator positions 0-9 when STORE CUE is pressed.</p>
<b>Editing with the built-in scissors (option)</b>	<p>Mark the cutting position (position of the reproduce head gap) with the marker (option), a grease pen or a soft pencil on the back of the tape. In edit mode, move the marker to the scissors by turning the corresponding reel. To cut the tape press the red knob on the headblock.</p> <p>By pressing the TAPE DUMP key you can play an unwanted tape section "into the waste basket" (refer to dump edit mode).</p>
<b>Cutting at the reproduce head</b>	With magnetically neutral scissors lift the tape slightly off the reproduce head and cut it exactly at the head gap (center of the head face) at an angle of 45°.
<b>Marking the tape</b>	With the marker (option), a grease pen or a soft pencil, mark the center of the reproduce head face on the back of the tape.
<b>Cutting in the splicing rail</b>	Insert the marked tape location into the splicing block and cut it with a razor blade.
<b>Splicing the tape</b>	Place the two tape ends into the splicing block, marked backside facing upward. Butt the ends together (no overlap!) and splice them with approx. 20 mm long, ¼" wide adhesive tape.

## 6.21 Dump edit mode

In dump edit mode the right-hand spooling motor is switched off. In this mode you can play unwanted tape sections "into the waste basket". Pressing the (programmable) TAPE DUMP key switches the tape machine to play; the right-hand spooling motor remains switched off. Four versions are available:

With the functions F327–F330 the following modes can be selected

Dump edit modes (F327–F330):	A F327	B F328	C F329	D F330
Direct selection with key TAPE DUMP (cancel with STOP or TAPE DUMP)	■	■		
Preselection of TAPE DUMP mode activate with PLAY (cancel with STOP)			■	■
Tape timer active	■		■	
Tape timer switched off		■		■

## 6.22 Skimming (Print-through erasure)

This function is used in conjunction with tapes that have been stored in a library for a long time. It eliminates pre-echos, caused by the print-through effect from one tape layer to another. The SKIMMING function must be programmed to a key (preferably one with a LED).

**Preparation:** Set the desired skimming value in the audio alignment block by means of the UP and DOWN keys.

**Important:** Initially you should start with a low value (e.g. 05). If the erase current is too high, this can cause strong treble and level loss.

The correct value should be ascertained by experimenting with a tape that is no longer needed, by slowly increasing the skimming current, until the unwanted copy effect disappears.

**Procedure:** After this value has been determined, load recorder with the tape to be processed. Simultaneously press the SKIMMING and PLAY keys. SKIMMING can be cancelled by pressing STOP.

## 6.23 Spot Erase

Errors in speech, switching clicks, etc. can be locally erased. SPOT ERASE is activated by consecutively pressing the following keys:

- SPOT ERASE; the pilot lamp lights up for 4 to 5 seconds; during this time
- EDIT + REC must be pressed simultaneously.

The erase heads of the channels preselected with READY are active. These tracks can be erased manually by shutting the tape by hand in front of the erase head.

The SPOT ERASE mode is indicated by a flashing LED in REC and EDIT keys.

## 7 Menu tree, soft keys

The A812 MKII MKII features a total of over 100 functions and operating modes. Less frequently used functions and operating modes can be selected in the menu tree for modification.

Except for the blue cursor keys, the red STORE key and the UP and DOWN keys, any desired menu selected function can be assigned to any of the operating keys. Operating functions can thus be arranged to ones individual liking.

- Note:**
- To make it easier to follow the explanations given below, page 1/41 should be folded out for reference purposes.
  - Words that are written in capital letters such as NEXT, UP, DOWN refer to control keys.
  - Programming is only feasible when the tape recorder is in STOP or TAPE OUT condition.

### 7.1 Entering the menu tree

**NEXT, CURSOR </>, LAST** With these four keys you can move through the menu tree to the desired setup windows.

When the machine functions correctly the following **standard information** is displayed:

```

FLUX LEVEL: NORMAL
HX: OFF    TC: NONE
  
```

It provides information on:

- Selected external line level (adjustable with F009–F012)
- On machines with time code: Time code offset between the audio and the time code signal (adjustable with F409).
- Das eingestellte Bildformat in **Frames Per Second** (Einstellbar mit der Taste FRAMES/s oder den Funktionen F401–F408).

When the LAST key is pressed, the same information appears that is also displayed for a few seconds after the machine has been powered on.

```

A812M II  SOFT VERS:
MASTER: 20/92
  
```

Release date of the software of the MKII MASTER MPU, 20/92 = calendar week/year.

**Important:** This software date should be mentioned in any contacts with your Studer dealer.

```

SERIAL IF SETTING
RS 422 SMPTE/EBU
  
```

This information appears only if the option SMPTE/EBU interface 1.820.751.xx is configured and set to the RS422 format.

```

SERIAL IF SETTING
RS 232
  
```

This information appears only if the option SMPTE/EBU interface 1.820.751.xx is configured and set to the RS232 format.

WARN: DEFAULT  
-----

Loss of data in the data memory, the data must be reloaded. Three different warnings can appear:

- DEFAULT KEYS LOADED: The keys correspond to the factory programming.
- DEFAULT PARAMETERS LOADED: The audio alignments and tape tension settings correspond to the factory programming.
- DEFAULT KEYS & PARAMETERS LOADED: The keys, audio alignments and tape tension settings correspond to the factory programming.

ERROR MESSAGE  
no errors detected

A self-test is performed whenever the A812 MKII MKII is powered on. If no fault is detected, the above information is displayed, otherwise a plain-text error message is displayed (see 8.1).

## 7.2 Display branch for the SET TIMER, SET ADDRESS and VARISPEED keys

If the functions SET TIMER (F336), SET ADDRESS (F337) and SET VARISPEED (F338) are assigned to keys, they can be selected directly and altered as desired.

When the SET TIMER, SET ADDRESS and VARISPEED keys are pressed, the current settings are displayed and they may be adjusted with the CURSOR keys </> and with the UP and DOWN keys.

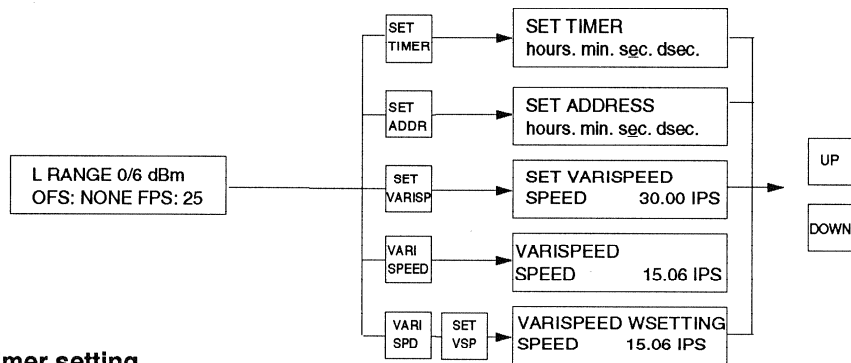

### Example: Changing the tape timer setting

#### Display shows:

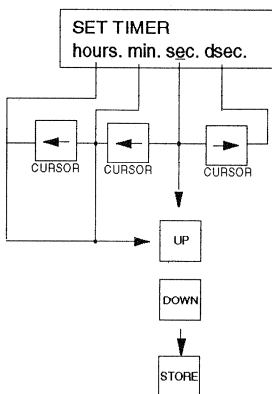

#### Operating steps:

- Switch machine to STOP
- Press the following key: SET TIMER
- The LED-display will show the time (tape position) that is to be altered; the LCD indicates which figure (hours, minutes, seconds, 1/10 seconds) can be altered by means of the UP or DOWN key.
- With the CURSOR keys </> select the minutes or hours position and enter the desired value by pressing the UP or DOWN key.
- Save the entered value by pressing the STORE key.

### Example: Programming a locator address on a LOC1...5 key

#### Display shows:

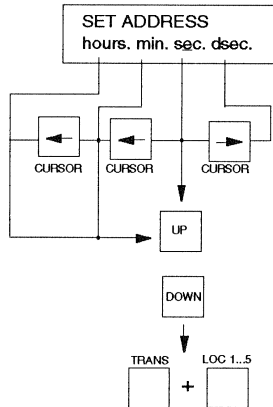

#### Operating steps:

- Switch machine to STOP
- Press the following key: SET ADDRESS
- The LED-display will show the time (tape position) that is to be altered; the LCD indicates which figure (hours, minutes, seconds, 1/10 seconds) can be altered by means of the UP or DOWN key.
- With the CURSOR keys </> select the minutes or hours position and enter the desired value by pressing the UP or DOWN key.
- Save the entered value by simultaneously pressing the SHIFT key and one of the LOC1...5 keys.

### Setup branch

Starting from the standard information shown in Section 7.1 you can access the setup branch by pressing:



The selection window for the setup branches:



- Audio alignments
- Tape deck alignments
- Auxiliary alignments

#### CURSOR </>, LAST, NEXT:

Move the cursor by means of the keys </> to the desired branch. To leaf through the various functions available within a branch, press key NEXT. In case the screw [28] for program release has not been loosened for 1/2 of a turn at least, the following will appear in the display:

#### UP, DOWN, STORE:

- These values can be entered with the UP and DOWN keys.
- To save the entered values press the STORE key.

**Example: Setting the library wind speed to 4 m/s**

**Display shows:**

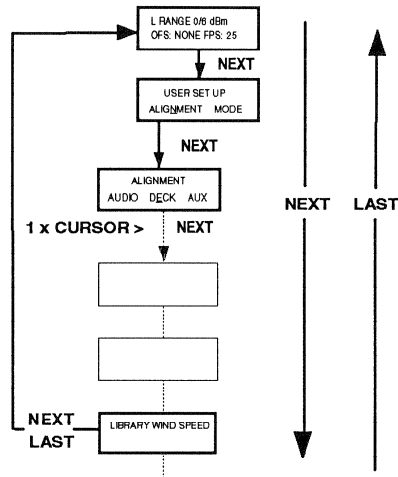

**Operating steps:**

- With a hex key No. 2.5 turn the programming enable screw (see fold-out page E/6) in order to access the programming level.
- Switch the machine to STOP.
- Press the following key sequence:  

NEXT	NEXT	CURSOR >	NEXT	NEXT	NEXT
------	------	----------	------	------	------
- With the UP or DOWN keys set the library wind speed to 4 m/s.
- Press STORE to save the setting.
- Quit the menu branch by simultaneously pressing NEXT and LAST.

**Key and function programming branch**

Starting from the standard information shown in Fig. 7.1 you can access the key and function programming branch by pressing:

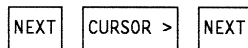

In a selection window the three keys and function programming branches are displayed:



- Audio
- Tape deck (DECK)
- Time code (TC)

**CURSOR </>**

With the two CURSOR keys move the dash segment under the desired branch.

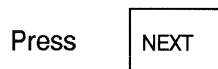

The following window appears:

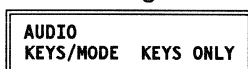

With the two CURSOR keys move the dash segment below the desired branch. By pressing the NEXT key you can now access the key or function programming branch. You can browse through the individual key or function programming windows by pressing UP. With the DOWN key you can page backward.

**KEYS/MODE**

Key and function programming, for an example see page E/31

All functions under the KEYS/MODE branches can be selected/deselected directly in the opened window or they can be program assigned to a key. i.e. the menu window is terminated after the key has been programmed and the function can be selected/deselected by pressing the programmed key.

**Direct programming:** Example: F021 Master safe  
 If F021 master safe is not assigned to any key, this is a permanent state, i.e. recording is not possible. This is useful for a setting up the machine as a play-only unit. Recording can only be re-enabled with the function F021 in the menu branch.

**Key programming:** F021 master safe can be assigned to any tape deck key and be selected or deselected at any time by pressing the programmed key.

**The two possibilities in the KEYS/MODE windows:**

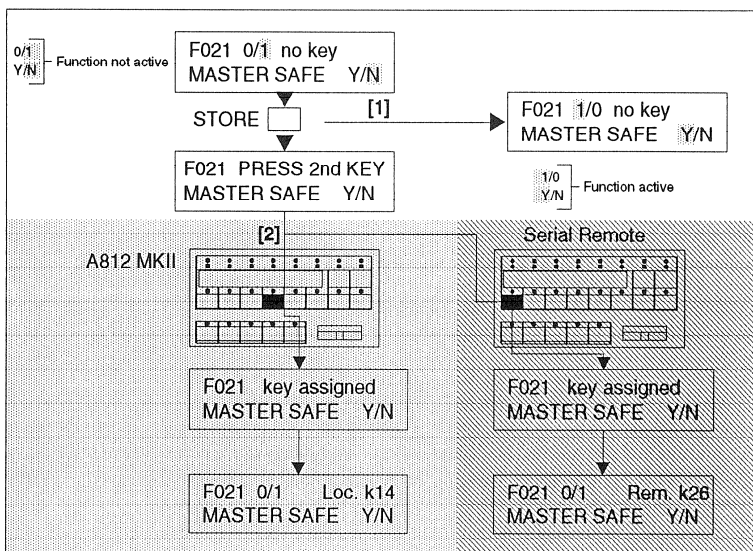

- [1] Release the STORE key
- [2] Press the STORE key plus the key on which the function is to be programmed

- Activate the function without assigning it to a key
- Assign the function to a key on the A812 MKII
- Assign the function to a key on the serial remote control

**KEYS ONLY**

Key programming, see example on page E/32

All functions of the KEYS ONLY branches must be programmed to a key. After the programming the manu window is closed. The function can be selected or deselected by pressing the programmed keys.

Press the LAST key to return to the starting menu of the selected alignment branch.

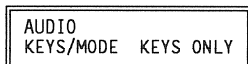



Key numbering

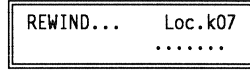

In the key mode windows the key number, e.g. loc.07, is displayed on the right-hand side of the first line.

- Loc. refers to the key number of the local keyboard on machine
- Rem. refers to the key number of the remote control

**Example:** Assuming the library wind function has been reprogrammed to the key REM IF. When the library wind window is selected in the menu tree, loc.31 is displayed on the right-hand side of the first line.

Checking the function assignment

When you are located in the key and function programming path, the function assigned to a key can be read off the LC display by pressing the corresponding key, i.e. the current key labelling can be checked against the actual function assignment.

Key numbering of the A812 MKII MKII (Loc.)

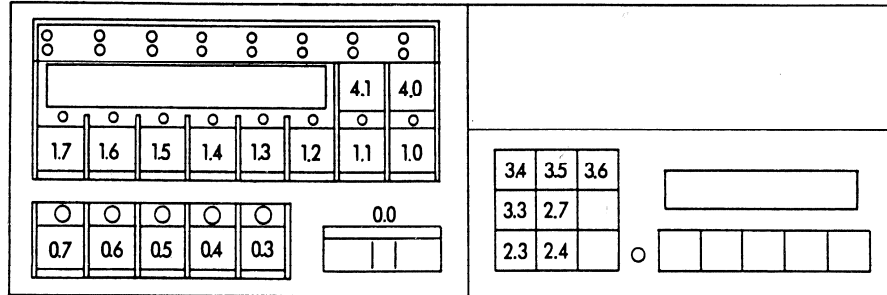

Key numbering of the serial remote control (Rem.)

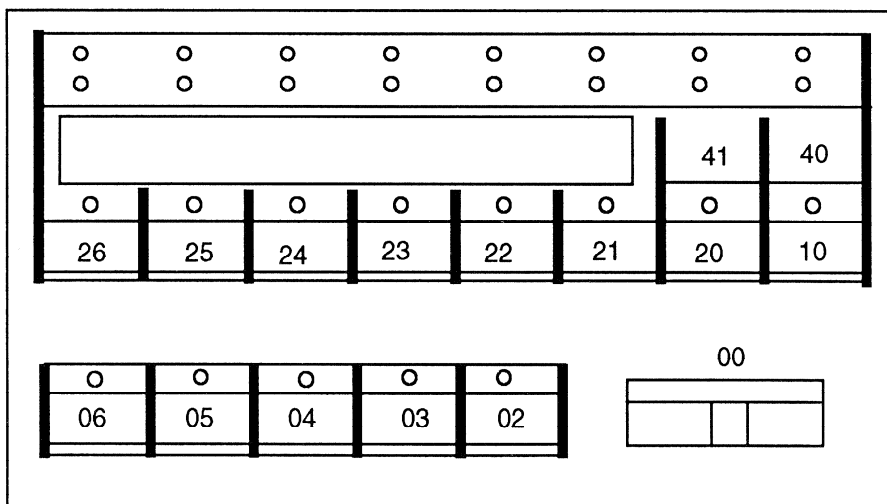

**Example 1; KEYS/MODE: activate AUTO MUTE (function 041)**

**Display shows:**

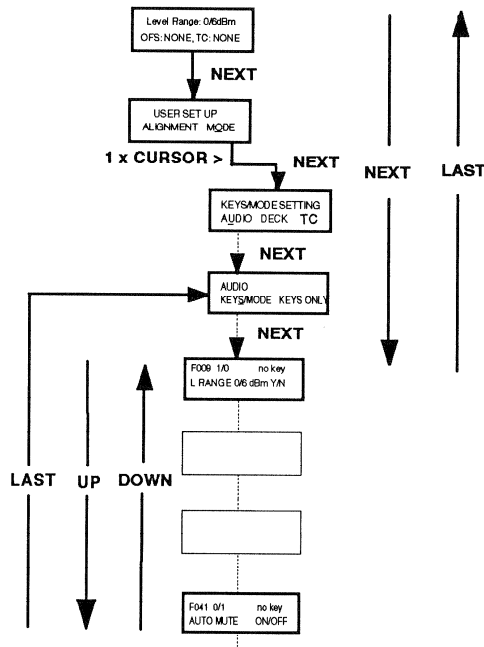

**Operating steps:**

- With a hexa key No. 2.5 turn the programming enable screw (see fold-out page E/6) in order to access the programming level.
- Switch the machine to STOP.
- Press the following key sequence:

NEXT CURSOR > NEXT NEXT NEXT

The display will show:

F 009	1/0	no key
L RANGE	0/6 dBm	Y/N

- Page to F041 by pressing the UP key.
- Press STORE.

**Note:**

0/1 means that AUTO MUTE is OFF.

1/0 means that AUTO MUTE is ON

The function can be toggled on/off by pressing the STORE key again.

- Press the UP key to page to the next function or press DOWN to page to the start of the selected menu block. To quit the menu branch, press NEXT and LAST simultaneously (starting with software version 20/92). Change the key labeling
- Turn the programming enable screw [28] to disable the programming access.

**Example 2, KEY ONLY: Reprogramming the RESET TIMER key (Loc. 10) to SET ADDRESS (F337)**

**Display shows:**

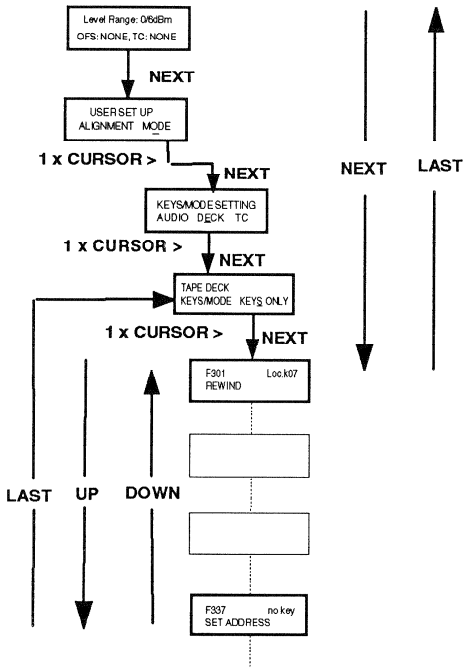

**Operating steps:**

- With a hex key No. 2.5 turn the programming enable screw (see fold-out page E/6) in order to access the programming level.

- Switch the machine to STOP.

- Press the following key sequence:

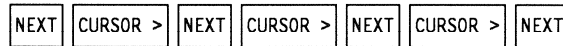

The display will show:

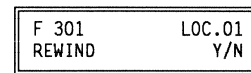

- Page to "F337 Set Address" by pressing the UP key.
- Press the STORE key and the RESET TIMER key loc. 41 (see key number E/30).
- To quit the menu branch, press NEXT and LAST simultaneously (starting with software version 20/92).
- Change the key labelling
- Turn the programming enable screw [28] clockwise to disable the programming access.

## 7.3 Description of the menu windows in the audio alignment branch

### General information:

- The audio alignment branch is only needed in conjunction with the audio alignment of the A812 MKII. For audio alignments refer to the maintenance instructions.
- The settings always relate to the tape speed displayed in the corresponding menu window. Alignments for other tape speeds are possible by first selecting the desired speed.
- All alignments can be performed for a second tape type by simultaneously pressing the STOP and TAPE B keys.
- To select the desired equalization standard simultaneously press the STOP and NAB/CCIR keys. Different parameters can be set for each equalization standard.
- The channel to be aligned can be selected with the cursor keys < and >.
- The alignment can be altered by means of the UP and DOWN keys.

### Display shows:

```
LINE OUT CALIBRATION
AUDIO CHANNELS INPUT
```

```
LVL REP 15.0 CCIR A
CH1 57 CH2 57
```

```
TRB REP 15.0 CCIR A
CH1 5A CH2 5A
```

```
BAS REP 15.00 CCIR A
CH1 A0 CH2 99
```

```
LVL REC 15.0 CCIR A
CH1 1F CH2 1F
```

```
BIA REC 15.0 CCIR A
CH1 32 CH2 32
```

```
TRB REC 15.0 CCIR A
CH1 2B5 CH2 2A
```

```
BAS REP 15.0 CCIR A
CH1 A0 CH2 99
```

```
ERASE CURRENT A
CH1 85 CH2 85
```

```
SKIMMING CURRENT A
CH1 00 CH2 00
```

### Functional description:

For machines without channel selectors (keys 63-65), you can switch to INPUT in order to perform the fine-adjustment of the internal and external level on the line amplifier board.

Selects the **reproduce** or sync level for tape type A at 15.0 ips, channel 1 or 2, for equalization standard CCIR.

Selects the **treble** alignment in reproduce or sync mode for tape type A at 15.0 ips, channel 1 or 2, for equalization standard CCIR.

Selects the **bass** alignment in reproduce or sync mode for tape type A at 15.0 ips, channel 1 or 2, for equalization standard CCIR.

Selects the **record** level alignment for tape type A at 15.0 ips, channel 1 or 2, for equalization standard CCIR.

Selects the **bias alignment** for tape type A at 15.0 ips, channel 1 or 2, for equalization standard CCIR.

Selects the **treble** alignment in record mode for tape type A at 15.0 ips, channel 1 or 2, for equalization standard CCIR.

Selects the **bass** alignment in repro or snc resp. mode for tape type A at 15.0 ips, channel 1 or 2, for equalization standard CCIR.

Selects the **erase current** alignment for tape type A, channel 1 or 2.

Selects the **skimming** current alignment for tape type A, channel 1 or 2.

COPY REP/SYNC PAR A → B  
↑↓ 7.5 15 30 IPS

To copy all the memorized Reproduce and Sync Audio Parameters from the tape sort memory A to tape sort memory B. The parameter of each speed need to be copied independent.

Procedure:

Select the requested tape speed with the cursor key (→ or ←) and press STORE key.

Please note:

A flashing cursor mark under a certain speed indicates:

The parameters of the TAPE A and TAPE B memory are not identically.

A permanent lit cursor mark under a certain speed indicates:

The parameters of the TAPE A and TAPE B memory are identically.

PARAM BACKUP RS232  
↑↓ VERIFY SAFE LOAD

Selects the function for storing the tape deck audio parameters on a personal computer in NRZ format.

VERIFY: Compares the alignment parameters stored in the microprocessor RAM of the A812 MKII with the parameters stored in the personal computer.

SAFE: Stores the A812 MKII alignment parameters in a personal computer.

LOAD: Loads the alignment parameters from the personal computer into the A812 MKII.

PARAM BACKUP ON TAPE  
↑↓ VERIFY SAFE LOAD

Selects the function for storing the tape deck audio parameters on tape in bi-phase format.

VERIFY: Compares the alignment parameters stored in the microprocessor RAM of the A812 MKII with the data stored on tape.

SAFE: Stores the A812 MKII alignment parameters on tape.

LOAD: Loads the alignment parameters from the tape into the A812 MKII.

## 7.4 Description of the menu windows in the tape deck alignment branch

### Display shows:

HUB DIAMETER LEFT A  
SET: NAB (118mm)

### Functional description:

Input of the most frequently used pancake diameters of the left-hand spindle for tape type A or B. Optimizes the dynamic behavior of the tape deck to the pancakes sizes.

HUB DIAMETER RIGHT A  
SET: NAB (118mm)

Input of the most frequently used pancake diameters of the right-hand spindle for tape type A or B. Optimizes the dynamic behavior of the tape deck to the pancakes sizes.

SET LIB WIND SPEED A  
0.50 m/s

Sets the library wind speed for tape type A or B. To achieve a more compact and smoother pancake for tapes to be stored, the spooling speed can be adjusted to the tape type being used.

SET MAX WIND SPEED A  
12.0 m/s

Sets the spooling speed for tape type A or B. For producing self-supporting pancakes from tapes with a smooth matt back coating, the spooling speed can be reduced.

SET ROLLBACK TIME  
15 SEC

Determines the length time by which the tape deck winds backward when the programmable rollback functions (F322-F324) are initiated.  
Example: 15 seconds before the current timer address.

T TENS PLAY 1/4" A
LEFT -- RIGHT --

Selects the function for the PLAY tension alignment for tape type A or B.  
For aligning the tape tension please refer to the maintenance instructions.

T TENS WIND 1/4" A
VALUE: 60

Selects the function for aligning the tape tension in high-speed spooling mode for tape type A or B.  
For aligning the tape tension please refer to the maintenance instructions.

T TENS EDIT 1/4" A
VALUE: 7C

Selects the function for aligning the tape tension in EDIT mode for tape type A or B.  
For aligning the tape tension please refer to the maintenance instructions.

SET ES BUS ADDRESS
MSB 82

Sets the SMPTE/EBU bus address.  
For addressing the A812 MKII operating in an interlinked system in conjunction with the SMPTE/EBU option 1.820.751.XX.

BIN RS232/422 FORMAT
SET: 8, ev par, 1 sb

Sets the BINARY CODE FORMAT for the optional SMPTE/EBU interface 1.820 751.XX.  
8 = 8-bit code  
ev par = even parity  
odd par = odd parity  
1 sb = 1 stop bit

ASCII RS 232 BD RATE
9600Bd 1200Bd 300Bd

Sets the baud rate for the RS232 option with ASCII protocol 1.810.751.XX.

ASCII RS 232 MODE
ECHO NO ECHO

Sets the ECHO or NO ECHO function of the RS232 option 1.810.751.XX with ASCII protocol.

TRIM NOMINAL SPEED
SET: +0.000%

FINE-ALIGNMENT OF THE NOMINAL SPEED. The nominal tape speed can be adjusted in steps of one quarter of one mill, for example in order to adjust the speed to a second machine or for aligning the tape speed with a stroboscope. Range  $\pm 0.2$  m/s.

**Warning:** There is no additional indication that a different nominal tape speed has been stored!

TYPE SETTING
TYPE: 812-2 VU TC

TYPE SETTING defines the machine type (e.g. A812-0.75, A812-2 VU, etc.). This parameter automatically selects the corresponding default programming and the correct erase current for the HF driver.  
If an incorrect TYPE SETTING has been entered, this can cause damage to the output stages of the HF DRIVERS.

## 7.5 Description of the menu windows in the AUX branch

### Display shows:

FUTURE USE
------------

### Functional description:

This branch is reserved for future applications.

7.6 Description of the menu windows in the audio keys and functions programming branch

Audio functions can be programmed directly in the menu window or be assigned to a key:

Display shows:

F009 1/0 Loc.k34  
L RANGE 0/6 dBm Y/N

F010 0/1 no key  
L RANGE 4/10 dBm Y/N

F011 0/1 no key  
L RANGE 8/14 dBm Y/N

F012 0/1 no key  
L RANGE 10/16 dBm Y/N

Functional description:

Adapts the external line level (studio level) to the internal level of the audio amplifiers.

- The values marked with red represent the operating level. **The VU meter indicates 0 VU !**
- The shaded values indicate the peak recording level. **The VU-meter indicates +6 VU !**
- In normal operation the selected line level is shown on the system display. The following rule applies:  
Peak recording level -6 dBm = operating level.
- Bei Standard - CCIR Pegel von +6dBm (=Peak Recording Pegel) muss die Funktion F009 angewählt sein.
- Bei Standard - NAB Pegel von +4dBm (=Operating Pegel) muss die Funktion F010 angewählt sein.

If the line level used in the studio is between the existing standard values (e.g. operating level +6 dB), the level 4/10 (F010) or 8/14 can be selected. In this case the internal level will be shifted by +2 dBm or -2dBm respectively.

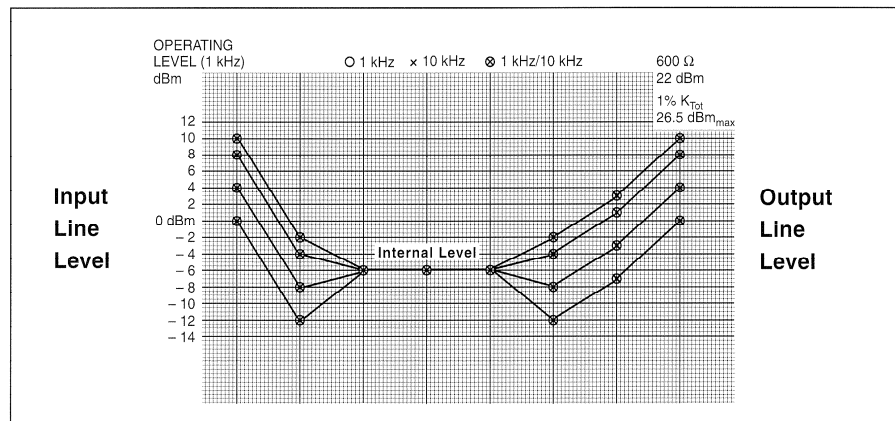

F021 0/1 no key  
MASTER SAVE Y/N

F022 1/0 no key  
TAPE A Y/N

F023 1/0 no key  
TAPE B Y/N

- Y: The higher ranking SAFE function prevents unintentional erasure of tapes.
- N: Function inactive.

- Y: If F022 is programmed to a key, the parameters for tape type A can be activated by pressing STOP and TAPE A simultaneously. Alternatively, activation in the menu window with key STORE.
- N: Parameters of tape type B selected.

- Y: If F023 is programmed to a key, the parameters for tape type A can be activated by pressing STOP and TAPE A simultaneously. Alternatively, activation in the menu window with key STORE.
- N: Parameters of tape type B not selected.

F024 0/1 TAPE A/B	Loc.k36
----------------------	---------

If F024 is programmed to a key, the parameters for tape type A can be activated by pressing STOP and TAPE A simultaneously. Alternatively, activation in the menu window with key STORE.

B: Parameters of tape type B selected.

When switching on the recorder the tape type selection used last becomes activated.

F031 0/1 MONO/STEREO	no key
-------------------------	--------

Mono–stereo changeover when the mono/stereo option exists. General mono or stereo selection or, if the function has been assigned to a key, by simultaneously pressing STOP and mono/stereo when the desired standard is active.

F032 0/1 CCIR/NAB	Loc.k35
----------------------	---------

If F032 is programmed to a key, changeover between the CCIR or NAB equalization standards is possible by pressing the STOP and CCIR/NAB keys. Alternatively, changeover in the menu window with key STORE.

When switching on the recorder, the last used equalization standard will again be activated.

F033 1/0 CCIR/NAB PAR	no key SAM/IND
--------------------------	-------------------

When calibrating for CCIR and NAB, the same audio parameters for level, high and low frequencies and for bias as they apply for reproduction and recording respectively are being written into the RAM of the microprocessor in the A812 MKII.

SAM (same): The parameters aligned to are written simultaneously into the NAB and CCIR memories when pressing the key STORE.

IND (individual): With the pressing of STORE the parameter aligned to will be stored only in that memory which has been selected with key CCIR/NAB.

**Important:**

Prior to commencing with the alignment for the other equalization characteristics, make sure that IND has been selected as otherwise these data will overwrite the values of the standard equalization!

F034 0/1 REP/SYN PAR	no key SAM/IND
-------------------------	-------------------

When calibrating the reproduce parameters, the same values are simultaneously written into the SYNC memory when the STORE key is pressed.

SAM: The reproduce parameters are automatically written into the SYNC memory when the STORE key is pressed.

IND: Individual values can be read in for reproduction and SYNC.

F041 0/1 AUTO MUTE	no key ON/OFF
-----------------------	------------------

ON: Automatic muting enabled.

- In spooling mode (except with tape–head contact)
- During the capstan acceleration phase
- While pressing the STOP key until the tape tension sensors are blocked.

OFF: Automatic muting disabled.

F042 0/1 AUTO INPUT A	no key Y/N
--------------------------	---------------

Y: All channels selected for SYNC operation will automatically be switched to INPUT during the operating modes STOP, REWIND, FORWARD, LOC– and ROLLBACK.

N: Function disabled.

F043 0/1 AUTO INPUT B	no key Y/N
--------------------------	---------------

Y: All channels for which SYNC and READY has been selected will automatically be switched to INPUT during the operating modes STOP, REWIND, FORWARD, LOC– and ROLLBACK.

N: Function disabled.

F044 1/0 IN/OUT DELAY	no key Y/N
--------------------------	---------------

Drop–in/drop–out delay.

Y: Delay compensation between the erase and record head active. Rehearse is possible only when the delay compensation is active.

N: Delay compensation disabled.

F045 0/1 DOLBY HX PRO	no key ON/OFF
--------------------------	------------------

ON: Dolby HX PRO switched on.

OFF: Dolby HX PRO switched off.



F046	1/0	no key
AUTO	LOW PASS	Y/N

Y: Automatic treble attenuation during fast wind is active. The parameters for high frequency reproduction are set to zero (00) for protection of the monitor speakers.

N: Automatic treble attenuation during fast wind is not activated.

F051	1/0	no key
CH CONTR	PAR /	INDIV

PAR: On 2-channel recorders the keys [51-55] of the channel control module are effective simultaneously on both channels.

INDIV: On 2-channel recorders the keys [51-55] of the channel control module are effective on the selected channel only.

## 7.7 Description of the menu windows in the audio key programming branch

### Audio functions that can only be used if programmed to a key:

#### Display shows:

F101	no key
REHEARSE	

#### Functional description:

With REHEARSE you can simulate punch-in/punch-out operations. When REHEARSE is active, the machine behaves the same way as in record mode, except that no recording is made. Instead the machine switches the READY and SYNC channels to input when the punch-in point is reached, and back to SYNC when the punch-out point is reached. The PLAY and REC LEDs flash.

Precondition: F044 IN-OUT DELAY must be active!

F102	no key
SPOT ERASE	

Errors in speech, switching clicks, etc. can be erased locally. To active SPOT ERASE, the following keys must be pressed consecutively:

- SPOT ERASE; the pilot LED lights up for 4-5 s, during this time
- EDIT + REC must be pressed simultaneously.

The erase heads of the channels preselected with READY are activated. These tracks can be erase manually by shuttling the tape in front of the head.

The SPOT ERASE mode is indicated by flashing REC and EDIT keys.

F103	no key
SKIMMING	

This function is used in conjunction with tapes that have been stored in a library for a long time. It eliminates the pre-echos, caused by the print through effect from one tape layer to another. The SKIMMING function must be programmed to a key (preferably one with a LED).

**Preparation:** Set the desired skimming current in the audio alignment block by means of the UP and DOWN keys.

**Important:** Initially you should start with a low value (e.g. 05). If the erase current is to high, this can cause strong treble and level loss.

The correct value should be ascertained by experimenting with a tape that is no longer needed, by slowly increasing the skimming value, until the unwanted copy effect disappears.

**Procedure:** After this value has been determined, load recorder with the tape to be processed. Simultaneously press the SKIMMING and PLAY keys. SKIMMING can be stopped by pressing STOP.

## 7.8 Description of the menu windows in the tape deck keys and function programming branch

### Tape deck functions that can be programmed directly in the menu window or be assigned to a key:

#### Display shows:

F201 0/1	no key
TAPE GUARD A	NO/RED

F202 1/0	no key
TAPE GUARD B	NO/STOP

F212 0/1	no key
7.5 IPS	Y/N

F230 0/1	no key
FADER MASTER EN.	Y/N

#### Functional description:

From the difference in the rotational speed of the two reels, the machine can determine that only a few layers of tape are left on the trailing reel.

**RED:** Reduces the spooling speed shortly before the tape unthreads. The spooling speed can be reaccelerated by pressing the corresponding spooling key. F201.

**STOP:** The spooling operation is stopped (F202)

**NO:** The spooling speed is not reduced, i.e. the spooling operation is not stopped before the tape unthreads. This requires that both functions, F201 and F202 are set to "NO"..

Speed selection.

F211–F214: One speed per key or only one single speed that can not be altered by deactivating F215–F220 from the keys.

F215–F217: Changeover between 2 speeds per key.

F218–F219: Changeover between 3 speeds per key.

F220: Changeover between 4 speeds per key.

Speed assignment:

F211: 3.75 ips

F212: 7.5 ips

F213: 15 ips

F214: 30 ips

F215: \* 3.75/7.5 ips

F216: 7.5/15 ips

F217: \* 15/30 ips

F218: \* 3.75/15/30 ips

F219: \* 7.5/15/30 ips

F220: \* 3.75/7.5/15/30 ips

\* At 3.75 ips the audio parameters and the time constants used for 7.5 ips are used for recording and playback!

Master switch for Fader Start release Fader Start is possible only when Fader Master Enable (1/0) is active. If the tape recorder is operated with a TLS 4000 synchronizing system, the TLS 4000 switches the Fader Master Enable off with the commands FEN and FEF via the serial interface (see section 10.3). This corresponds to Fader Master Enable "NO". Thus the synchronisation system has complete control of the machine. See also F231...F234.

F231 0/1	no key
FADER A	Y/N

With the FADER START circuit the tape recorder can be switched to playback by means of a mixing console fader.

- When FADER A is set, this function can be activated at any time through the connected fader start circuit.
- For the other selection possibilities, an additional key must be pressed to enable the FADER START. This function can be programmed to a local key or be wired externally on the remote control connector. In this case the yellow fader LED in the status indicator field shows that a fader start is possible.

F232 FADER B  
F233 FADER C  
F234 FADER D

### External enable key:

- If an external enable key is used for the FADER modes B, C, D, pin 6 (SR-FADRY) must be connected to pin 1 (ground) of the PARALLEL REMOTE connector by means of a switch.
- The FADER START is initiated by applying a voltage from 5 to 24 V AC or DC across pins 11 and 12 (refer to section 13.1.3).

### Faderstart operation:

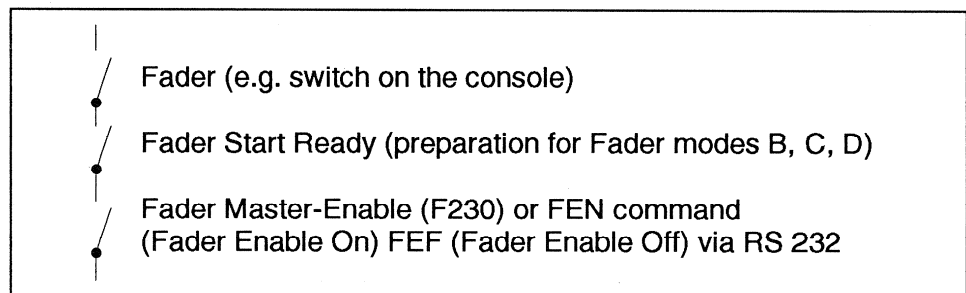

		A	*B	C	D
FADER READY key required			■	■	■
FADER READY key not required		■			
<b>Fader closed:</b>	Tape recorder operable	■	■		■
	Tape deck keys disabled			■	
<b>Fader open:</b>	Tape recorder operable				■
	Tape deck keys disabled	■	■	■	
	Monitor speaker muted	■	■	■	■

\* Standardprogrammierung: Fader B

F241 1/0 no key  
VS DISP FORM % Y/N

Y: Deviation from nominal speed is indicated in %.  
N: Indication not in %.

F242 0/1 no key  
VS DISP FORM HT Y/N

Y: The deviation of the nominal speed is indicated in semitones.  
N: Indication not in semitones.

F243 0/1 no key  
VS DISP FORM % Y/N

Y: The varispeed deviation of the nominal speed is indicated as the absolute speed in inch/s.  
N: Indication not in IPS.

F244 1/0/1 no key  
VS D. FORM IPS/HT/%

With each key depression the next of the 3 possible VARISPEED display modes is selected.  
The last selected varispeed display mode is automatically reactivated when the machine is switched on.

F245 1/0 no key  
VS IND. ENHANCED Y/N

Y: When varispeed is active, the two pilot LEDs of the spooling keys flash. This alert is particularly useful if the A812 MKII is operated only via the tape deck remote control without additional feedback lamps.  
N: Function is disabled.

F246 1/0 no key  
SAVE KEY SETTING Y/N

Y: The specific key programming is preserved.  
N: The programming of the function keys automatically defaults to the default programming, depending on the TYPE SETTING in the tape deck alignment branch, see Section 7.4.

F247 1/0 no key  
PROGRAM DISABLE A/B

A: The closed programming lock (enable screw [28] on page E/6) prevents access to the menu.  
B: The closed programming lock (enable screw [28] on page E/6) allows the following menu accesses:

- SET HUB DIAMETER LEFT
- SET HUB DIAMETER RIGHT
- SET LIBRARY WIND SPEED
- SET MAX. WIND SPEED
- SET ROLLBACK TIME

It is not possible to program a key function as long as the programming lock is closed. Any attempt will be rejected with the message "program mode not enabled" on the service display. For opening the programming lock, the enable screw [28] on page E/6 must be turned.

F250 1/0 no key  
SHUTTLE IN PLAY Y/N

Y: The SHUTTLE wheel can also be activated in play mode.  
N: The SHUTTLE wheel cannot be activated in play mode.

F252 0/1 no key  
CAPSTAN MODE A/B

A: The capstan does not turn in stop mode. PLAY or RECORD activates the capstan only when the pinch roller presses the tape against the capstan shaft (more gentle tape handling).  
B: The capstan always turns when the tape is inserted (faster acceleration behavior).

F254 1/0/0 no key  
EDIT MODE A/B/C

With function F254 EDIT A/B/C the ogic of the tape tension sensor arrest can be selected.

- EDIT A:** Both tape tension sensors free.
- EDIT B:** Left-hand tension sensor arrested (blocked). Ideal for cueing and editing by manipulating the right hand reel.
- EDIT C:** Right-hand tension sensor arrested (blocked). Ideal for cueing and editing by manipulating the left hand reel.

F255 1/0 REC INDIC MODE A/B	no key A/B
--------------------------------	---------------

- A: Record indication on the tape deck key [10] is only active if at least 1 channel is switched to record.
- B: Record indication on the tape deck key [10] is independent of the audio section status.  
Application: „Follow external record“ with TLS 4000.

F256 1/0 SYNC ENABLE	no key A/B
-------------------------	---------------

- A: Standard logic on synchronizer connector.
- B: The output on the synchronizer connector is LOW under the following conditions:
- Tape under tension, stop lamp is on but does not flash.
  - When the fader key (B, C, D) is programmed, the output is „LOW“ only if the tape is tensioned, the stop key is lit or flashing, and fader start is active.
  - If fader enable is set to „yes“ and the above condition is met.
- In all other tape deck statuses the output on the synchronizer connector is HIGH.

F259 1/0 SINGLE LOOP MODE A/B	no key A/B
----------------------------------	---------------

- For LOOP mode without numeric input of an end address.
- A: The SINGLE LOOP key **on the autolocator** functions as an instant loop.
- B: The SINGLE LOOP key **on the autolocator** functions as a single loop.

## Explanation of single loop

One individual loop as selected on the autolocator is performed.

## Explanation of instant loop

When the INSTANT LOOP key is pressed, a loop between the displayed counter address and the tape address stored in LOC 1 is performed endlessly. The lower of the two values is taken as the starting address.

F265 0/1 AUTO LOAD ENABLE Y/N	no key Y/N
----------------------------------	---------------

- AUTO LOAD is used for automatic programming the punch-in and punch-out addresses on the autolocator in AUTOREC mode. The addresses are entered by pressing REC or PLAY respectively.
- Y: The key with the TRANS/REV PLAY function **on the autolocator** determines the AUTO LOAD function.
- B: The original function TRANSFER (LED flashes) is again assigned to the TRANS/REV PLAY key function **on the autolocator**.

F270 0/1 ADR TO TAPE LINK Y/N	no key Y/N
----------------------------------	---------------

- To relate locate address to either the tape counter display or to the tape position
- N: All the memorized locate addresses will remain the same when setting the timer (SET TIMER) or when resetting the timer (RESET TIMER)
- Y: All the memorized locate addresses will be convert in such a way to keep all the memorized tape positions when setting the timer (SET TIMER) or when resetting the timer (RESET TIMER).

## 7.9 Description of the menu windows in the tape deck key programming branch

### Tape deck functions that can only be executed if assigned to a key:

#### Display shows:

F301 REWIND	L07,R06
----------------	---------

#### Functional description:

Rewind with programmed spooling speed.  
The spooling speed can be defined in the ALIGNMENT DECK block.  
Basic programming: 12 m/s.

F302 FORWARD	L06,R05
-----------------	---------

Fast forward with programmed spooling speed.  
The spooling speed can be defined in the ALIGNMENT DECK block.  
Basic programming: 12 m/s.

F303 LIBRARY WIND	no key
----------------------	--------

Library wind can be activated either with a correspondingly programmed key or by pressing TRANS and one of the spooling keys.

When this function is active, the tape is wound with the reduced, programmable spooling speed (0.1 to 12 m/s).

The library wind speed can be set in the ALIGNMENT DECK BLOCK. Default programming: 5 m/s.

F304 PLAY	L05,R04
--------------	---------

Playback at the selected tape speed.

TRANS + PLAY pressed simultaneously = REVERSE PLAY

F306 STOP	L04,R03
--------------	---------

STOP interrupts all tape transport functions.

STOP + LOC 1-5 pressed simultaneously indicates the stored tape address on the tape timer.

F307 RECORD A	L03,R02
------------------	---------

The machine is switched to record mode by pressing PLAY + REC simultaneously. Delay compensated drop-out by pressing PLAY. Recording is not possible in RECORD A mode if:

- MASTER SAFE is active.
- No channel is switched to READY.

F308 RECORD B	no key
------------------	--------

If the machine is already in play mode, the record mode can be activated by pressing only the REC key (drop-in).

Time compensated drop-out by pressing PLAY.

Recording is not possible in RECORD B mode if:

- MASTER SAFE is active.
- No channel is switched to READY.

F309 EDIT	Loc.k11
--------------	---------

Activates one-hand CUEING (tape brakes lifted, spooling motor active).

(Also refer to: Editing, tape cutting, in Section 6.20).

F311 TRANSFER	L20,R26
------------------	---------

Toggle key:

- TRANS + LOC 1-5 = Stores the current tape address in the selected LOC memory.
- TRANS + LOC1-5 during either recording or play will set a cue point.
- TRANS + </> = library wind in the selected direction.

F312 HOLD	no key
--------------	--------

Freezes the current tape timer reading (also LAP timer). The timer continues to run internally.

The frozen tape address can be stored as a locate address by pressing a LOC key.

The tape timer continues to run normally (HOLD indication off). When the same LOC key is pressed again, the stored tape position is automatically searched.

F313 LOC1	Loc.16
--------------	--------

The LOC 1-5 functions are used for automatically searching the stored addresses. These addresses refer to the normal or to the LAP Tape counter.

PLAY or PLAY + REC can be preselected during the search. The key of the preselected function flashes until the LOC address is reached.

F314 LOC2	no key
--------------	--------

F315 LOC3	no key
--------------	--------

The LOC addresses can be displayed by simultaneously pressing STOP and the corresponding LOC key, or, while the search is in progress, by continually pressing the corresponding LOC key.

F316 LOC4	no key
--------------	--------

F317 LOC5	no key
--------------	--------

All LOC addresses remain stored when the machine is switched off.

F318 LOC ZERO	Loc.15
------------------	--------

Automatically searches the address 0.00.00 (also LAP timer). While the search is in progress the PLAY or PLAY + REC function can be preselected. The key of the preselected function flashes until the LOC ZERO tape address is reached.

F319 LOC START PLAY	Loc.16
------------------------	--------

Automatic search of the address at which the last PLAY or RECORD command was entered while the tape was standing still. When this address is reached, the machine switches automatically to PLAY. STOP or REC can be preselected during the search. The key of the preselected function flashes until the LOC START tape address is reached.

F320 LOC START STOP	no key
------------------------	--------

Automatic search of the address at which the last PLAY command was entered while the tape was standing still. When this address is reached, the machine switches automatically to PLAY. PLAY or REC can be preselected during the search. The key of the preselected function flashes until the LOC START tape address is reached.

F321 LOC START REC	no key
-----------------------	--------

Automatic search of the address at which the last PLAY or RECORD command was entered while the tape was standing still. When this address is reached, the machine switches automatically to RECORD. PLAY or STOP can be preselected during the search. The key of the preselected function flashes until the LOC START tape address is reached.

F322 ROLLBACK PLAY	Loc.k13
-----------------------	---------

The tape deck automatically rewinds from the current tape address by the selected amount.

The ROLLBACK time is defined in the ALIGNMENT DECK branch under SET ROLLBACK TIME.

The PLAY command is automatically initiated when the target address is reached.

F323 ROLLBACK STOP	no key
-----------------------	--------

The tape deck automatically rewinds from the current tape address by the selected amount.

The ROLLBACK time is defined in the ALIGNMENT DECK branch under SET ROLLBACK TIME.

The STOP command is automatically initiated when the target address is reached.

F324 ROLLBACK RECORD	no key
-------------------------	--------

The tape deck automatically rewinds from the current tape address by the selected amount.

The ROLLBACK time is defined in the ALIGNMENT DECK branch under SET ROLLBACK TIME.

The RECORD command is automatically initiated when the target address is reached.

F325 BACKSPACE STOP	no key
------------------------	--------

With this spooling function the tape can be rewound at four times the PLAY speed with tape-head contact. This function remains only active for as long as this key is pressed.

F326 BACKSPACE PLAY	no key
------------------------	--------

With this spooling function the tape can be rewound at four times the PLAY speed with tape-head contact. When the BACKSPACE key is released, the machine switches to PLAY mode.

F327 Loc.k10  
TAPE DUMP A

F328 no key  
TAPE DUMP B

F329 no key  
TAPE DUMP C

F330 no key  
TAPE DUMP D

With the functions F327–F330 the following modes can be selected

Dump edit modes (F327–F330):	A F327	B F328	C F329	D F330
Direct selection key TAPE DUMP (cancel with STOP or TAPE DUMP)	■	■		
Preselection key TAPE DUMP activate with PLAY (cancel with STOP)			■	■
Tape timer active	■		■	
Tape timer switched off		■		■

F332 no key  
LIFTER

As long as this key is pressed in spooling mode, tape modulation will be audible. To protect the monitor speaker, the function that de-emphasizes the treble in spooling mode should be activated (F046: auto lowpass).

Also refer to the functions LIFTER REMOTE A/B F257 and LIFTER LOCAL A/B F258.

When the LIFTER key is pressed, the automatic muting F041 is cancelled.

Beim Drücken der Taste LIFTER wird die automatische Stummschaltung F041 aufgehoben.

F334 Loc.k40  
LAP/WATCH DISPLAY

Switches the display to a second timer (LAP). When LAP/WATCH is active, the letter "L" appears in the first position of the tape timer display. Since both timers can be updated individually, the LAP timer can be set to zero with the RESET key without influencing the main timer. In the LAP/WATCH mode all locator functions are referenced to the display of the LAP-WATCH counter.

F335 Loc.k41  
RESET TIMER

Key for resetting the main tape timer or the LAP/WATCH tape timer. Only the timer currently displayed will be reset. The timer stays at zero for as long as this key is pressed.

F336 no key  
SET TIMER

Function for changing the content of the tape or LAP timer. The hours.min.sec.dsec are shown on the service display. The cursor can be moved to the desired time unit by pressing the cursor keys < / >. To modify the value in the corresponding cursor position, press the UP/DOWN key. To store the changed counter reading press the STORE key.

F337 no key  
SET ADDRESS

Function for entering locator address. The hours.min.sec.dsec are shown on the service display. The cursor can be moved to the desired time unit by pressing the cursor keys < / >. To modify the value in the corresponding cursor position, press the UP/DOWN key. To store the changed counter reading press the STORE key.

F338 Loc.k27  
SET VARISPEED

Function for setting the desired tape speed. The deviation from the nominal tape speed is shown on the display. The displayed value can be modified with the UP and DOWN keys. To store the new value press SET VARISPEED.

The display format can be selected with the functions F241–F244.

F339 Loc.k33  
VARISPEED ON/OFF

Activates the tape speed selected with SET VARISPEED. Switches the service display to VARISPEED indication. The deviation from the nominal tape speed is displayed in the selected format. In addition the VARISPEED pilot lamp flashes in the STATUS indicator field [15].

The display format is defined with F241...F244 VARISPEED DISPLAY FORMAT.

If SET VARISPEED is selected in addition to VARISPEED, the tape speed can also be changed in play mode by means of the UP/DOWN keys.



F345 no key  
REMOTE A R. CTL ONLY

F346 no key  
REMOTE B REM+LOCAL

Enable keys for the local and/or remote control keypad. Two operating modes can be programmed with F345/346:

Programming	Remote A Remote control only		Remote B Remote & Local control		Neither active
	Selected	Not selected	Selected	Not selected	
Local keyboard enabled	–	■	■	■	■
Remote control parallel, serial and RS232* active	■	–	■	–	■

\* The remote control must be active for operation with the TLS4000!

F347 Loc.k00  
SHUTTLE BAR

Key for storing the SHUTTLE speed that has been selected with the SHUTTLE wheel.

While actuating the SHUTTLE wheel, press the SHUTTLE BAR in order to delete the stored winding speed.

Can be reset with all tape transport, LOC and ROLLBACK functions.

F351 no key  
NO FUNCTION

Function for programming a key with a dummy function (dummy key).

**Loop functions:**

F355 no key  
SINGLE LOOP

A single loop between the addresses stored in the LOC1 and LOC2 registers is performed.

Operated from the autolocator:

A single loop between any two selectable locator registers (max. 20) is performed.

Operated from the tape machine or serial remote control:

F356 no key  
AUTO LOOP

Operated from the tape machine or the serial remote control:

An endless loop between the addresses stored in the LOC1 and LOC 2 registers is performed.

Operated from the autolocator:

An endless loop between any two selectable locator registers (max. 20) is performed.

F357 no key  
INSTANT LOOP

When the INSTANT LOOP key is pressed, an endless loop between the currently indicated tape timer address and the tape address stored in LOC1 is performed. The lower of the two values is taken as the starting address.

**Examples:**

**INSTANT LOOP key determines the start of the loop**

- LOC1 register contains e.g. 0.05.00.0
- Machine parked at 0.01.00.0
- Press PLAY or INSTANT LOOP. The machine runs in PLAY mode up to the LOC1 address and then rewinds to the INSTANT LOOP address.

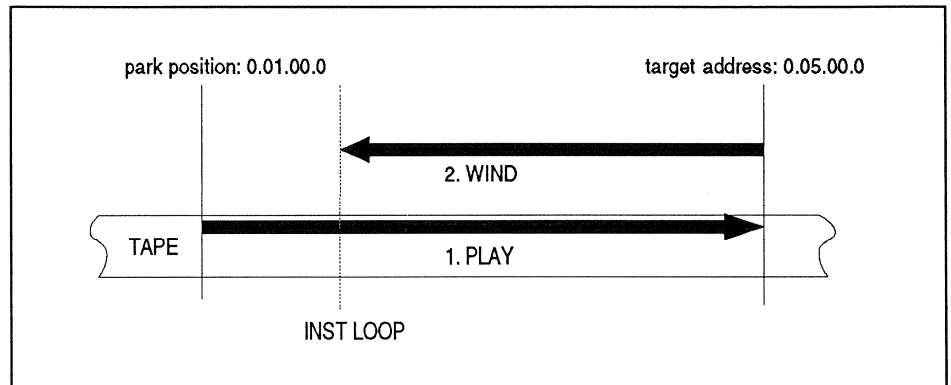

**INSTANT LOOP key determines the end of the loop**

- With the TRANS and LOC1 keys load the park position into the LOC1 register (e.g. 0.01.00.0).
- Press the PLAY key.
- At the desired tape address press INSTANT LOOP for defining the end of the loop (e.g. at 5 minutes).

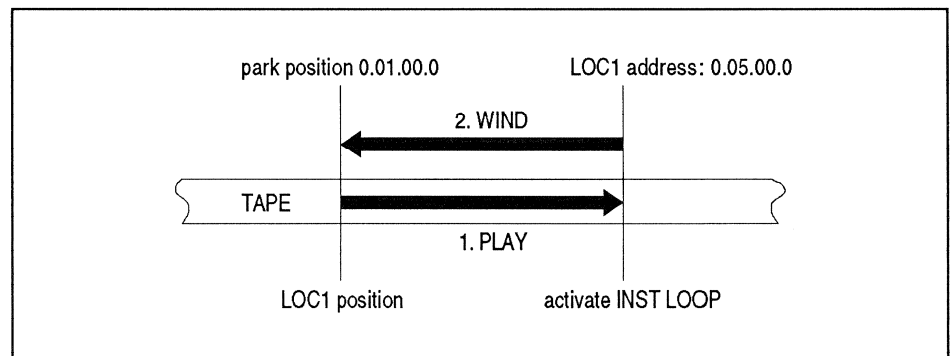

**Shortening the loop**

By pressing INSTANT LOOP again the loop can be shortened as often as desired by any amount.

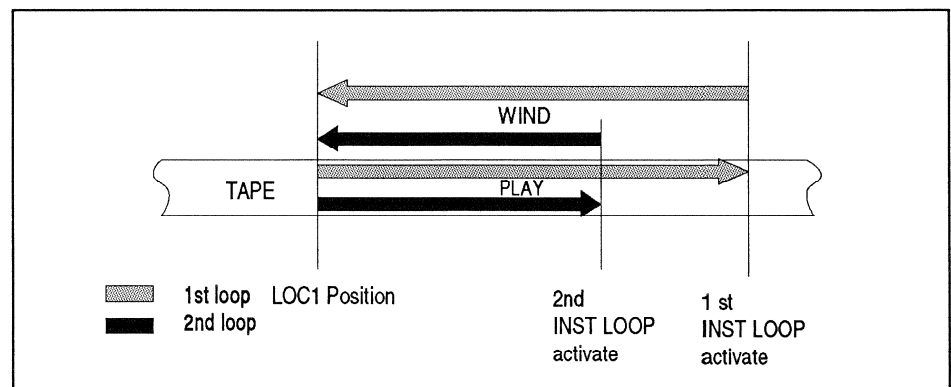

## 7.10 Description of the menu windows in the time code alignment branch

**Note:** The TC level alignments for a second tape type can be performed by pressing the TAPE B key.

### Display shows:

F401 0/1	no key
24 FPS	Y/N

F402 1/0	no key
25 FPS	Y/N

F403 0/1	no key
29.97 FPS	Y/N

F404 0/1	no key
30 FPS	Y/N

F406 1/0	no key
FPS 25/29.97	Y/N

F407 0/0	no key
FPS 29.97/30	

F409 0/1	no key
OFFSET 1.2"	Y/N

F410 1/0	no key
TC MODE	NORM/SPEC

### Functional description:

Y: Time code for 24 frames/sec.  
N: Other time code format selected.

Y: Time code for 25 frames/sec.  
N: Other time code format selected.

Y: Time code for 29.97 frames/sec.  
N: Other time code format selected.

Y: Time code for 30 frames/sec.  
N: Other time code format selected.

If programmed to a key, the time code can be changed over between 25 and 29.97 frames/sec.

If programmed to a key, the time code can be changed over between 29.97 and 30 frames/sec.

Time code delay adaptation to the older time code standard of the Telefunken M15A.

Y: Adapted to the Telefunken M15A standard. Time code offset between time code signal and audio signal 1,2".

N: Standard setting, no offset between the time code signal and the audio signal.

Activates the time code recording or reproduction at 3 3/4 ips.

NORM: No time code recording or reproduction at 3 3/4 ips.

SPEC: Enables time code recording or reproduction at 3 3/4 ips.

**Note:** At this tape speed one has to expect a higher drop-out rate. The time code record level R2 has to be used for 3 3/4 and 7 1/2 ips. It is recommended to optimize the level for the more frequently used speed.

7.11 Tree Diagram

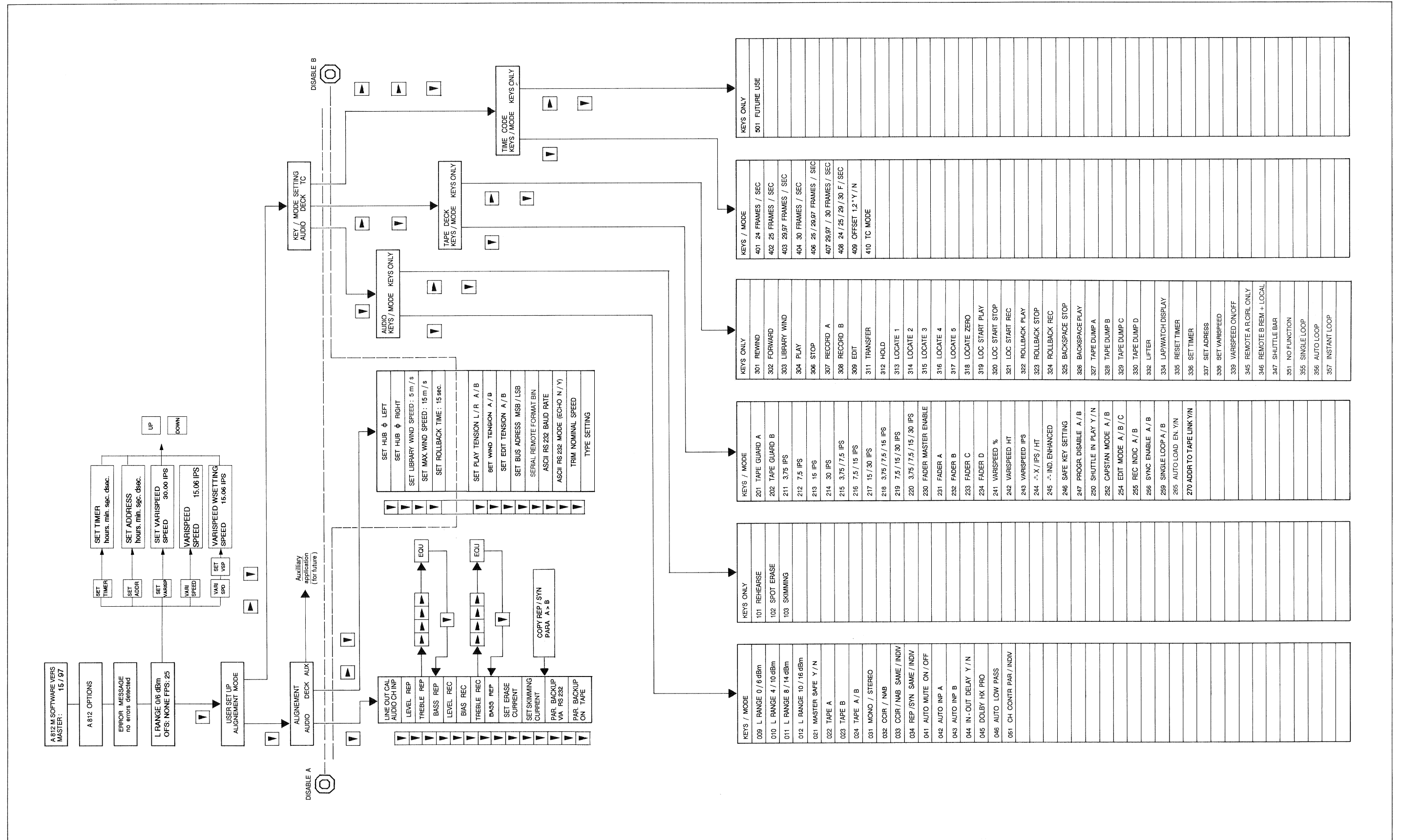

## 8 Operation with degraded performance

---

This Section describes the steps to be taken when errors occur within a specific module.

**Important:** When an error has occurred, the machine should in all cases be switched off for approx. 10 s and then be switched on again. If the same error reoccurs, proceed according to Section 8.1.

Operation on a defective unit should only be continued if this is absolutely necessary. The equipment should be repaired or be sent to the nearest STUDER service center.

The error list is not complete and may be expanded as required.

### 8.1 Error Messages on the Service-Display

---

**Display shows:**

ERR: SUPPLY  
VOLTAGE

**Tape recorder:** Switches to STOP, does not respond to command keys.

**Cause:** One (or several) supply voltages are missing.

- Remedy:**
- Switch off the tape recorder.
  - Check the secondary fuses and replace them, if necessary.
  - Repair or replace the SWITCHING STABILIZER 1.811.790.xx board.

**Display shows:**

ERR: DATA  
LOST

**Cause:** Audio- and tape tension data lost

- Remedy:**
- Switch the tape recorder off and on again. The default parameters are now loaded. The error message disappears.
  - Check the buffer battery on the MASTER MPU 1.811.786.31 and replace it, if necessary.
  - Check the supply voltages.
  - Continue to work with the default parameters (minor deviations from the optimum frequency response have to be accepted), or
  - load the parameters previously recorded on tape, or
  - Recalibrate the tape recorder.

**Display:**

ERR: SPOOLING MOTOR  
SERVO HARDWARE

**Cause:** Error in the analog spooling motor control circuit or missing or open current feedback

- Remedy:** Check the voltage and signals on the following boards:
- Move sensor board 1.811.731
  - Spooling motor drive amplifier 1.811.771
  - Tape tension sensors board (right) 1.811.771 or 1.811.703 (right)

**Display shows:**

ERR: POWER  
DROP OUT

**Tape recorder:** Switches to STOP

**Cause:** Transient line voltage interruption > 100 ms

**Remedy:** Acknowledge with STORE.

**Display shows:**

ERR: MOVE-SENSOR HARDWARE
------------------------------

**Tape recorder:**

Switches to STOP.

**Cause:**

MOVE SENSOR PCB 1.811.731 or MOTOR TACHO PCB 1.811.732 defective or too many tape move direction changes detected.

**Remedy:**

Repair, replacement, adjustment

**Display shows:**

ERR: SPOOLING MOTOR TACHO RIGHT/LEFT
---

**Cause:**

Right-hand / left-hand spooling tacho motor 1.811.732 signals too many direction changes or supplies no signal

**Remedy:**

Replace , repair or realign.

**Display shows:**

ERR: MOTOR SUPPLY VOLTAGE LOW
----------------------------------

**Cause:**

Failure of the spooling motor voltage

**Remedy:**

Wait 10 seconds. If the error persists:

- Switch off the tape recorder
- Check the fuses.
- Replace or repair Tape Deck Periphery IF, 1.811.773, Spooling Motor Controller 1.811.772 and/or Spooling Motor Drive Amplifier 1.811.771.

**Display shows:**

ERR: NO COMMUNICAT. MASTER-TAPE DECK
---

**Cause:**

- No response to the status inquiry.
- Software of the MASTER MPU 1.811.786 not compatible with the TAPE DECK CONTROLLER 1.820.786.

**Remedy:**

- Replace or repair the MASTER SERIAL INTERFACE 1.820.753 and/or the TAPE DECK CONTROLLER 1.820.786.

**Display shows:**

ERR: TACHO SENSOR
-------------------

**Tape recorder:**

Switches to STOP

**Cause:**

No output signal from one of the three tacho sensors (SPOOLING MOTORS 1.811.732, MOVE SENSOR 1.811.731), the three senses of rotation do not agree, or no tacho signal from the spooling motor.

**Remedy:**

- Check the flat cable connector to the sensors.
- Check the sensors and replace or repair them, if necessary.
- Check that the spindles and the tacho roller rotate without binding.

**Display shows:**

ERR: TAPE TENSION CONTROL
------------------------------

**Cause:**

Deviation of tape tension from the reference value too large for approx. 1 s.

**Remedy:**

- Clean the tape guide rollers.
- Check whether tape friction and friction of the spindles is too high.
- Check the tape tensions.

**Display shows:** ERR: NO COMMUNICAT.  
CAPSTAN-TAPE DECK

**Tape recorder:** Switches to STOP.

- Cause:**
- No data communication via the parallel interface of the CAPSTAN INTERFACE 1.811.775.
  - Capstan processor does not start.

- Remedy:**
- Replace or repair the CAPSTAN INTERFACE.

**Display shows:** ERR: INCORRECT  
RADIUS MEASUREMENT

**Tape recorder:** Switches to STOP.

- Cause:**
- The calculated radius of the tape pancake is outside the admissible limits.
  - Tacho sensor defective.

- Remedy:**
- Switch the tape deck (with tape) to PLAY for a few seconds. This message normally disappears as soon as a sufficient number of tacho pulses are available for calculating the pancake radius.
  - Check the tacho sensor and replace it, if necessary.
  - Refer to the ALIGNMENT DECK block in the Tree Diagram and adjust hub diameter to match the reel diameter in actual use.

**Display shows:**

ERR: LOCAL SHUTTLE  
VALUE INVALID

ERR: REMOTE SHUTTLE  
VALUE INVALID

**Cause:** Incorrect values were supplied by the respective SHUTTLE potentiometer during the initialization phase.

- Remedy:**
- During initialization the SHUTTLE-wheel must not be operated.
  - Readjust the respective SHUTTLE potentiometer.  
Local = Shuttle Potentiometer of the A812.  
Remote = Shuttle Potentiometer on the serial remote control or on the autolocator.

**Display shows:** ERR: PINCH ROLLER  
SLIPPING

**Tape recorder:** Switches to STOP.

**Cause:** The pinch roller slip is too high; the capstan speed does not agree with the tape speed.

- Remedy:**
- Clean the pinch roller and the capstan shaft; replace the pinch roller if necessary.
  - Adjust the pinching force to the correct value.

**Display shows:** ERR: NO DATA FOUND  
ON TAPE

**Cause:** The audio data settings are not readable on tape.

**Remedy:** Check the input signal (level and shape) and the tape speed.

**Display shows:** ERR: VERIFY FAILED

**Cause:** The audio data settings read from tape do not agree with the machine data.

**Remedy:** Reload the audio data from tape because an error has occurred during the previous loading operation.

**Display shows:**ERR: AUDIO  
CHANNEL 1ERR: AUDIO  
CHANNEL 2**Cause:** Fault in the record section.**Remedy:** Replace or repair HF-Driver 1.820.813.

## Warnings on the service display

---

**Display shows:**WARN: REFERENCE  
FREQUENCY WRONG**Tape recorder:** Does not attain the selected nominal tape speed in play mode.**Cause:** The frequency of the external varispeed reference signal is outside the valid range (6.4 kHz to 14.4 kHz), or the signal is missing.**Remedy:** Correct the reference signal.

After the machine has been converted (e.g. from full-track mono two two-channel) the machine type must be changed in the "TYPE SETTING" menu. With this operation the key programming is automatically adapted; the display shows:

WARN: DEFAULT  
KEYS LOADED

If the old key programming should be retained, activate function No. 246 SAVE KEY SETTING, i.e. set this function to YES.

After a loss of data (message: ERR: DATA LOST, see E/50) and after the subsequent power of/on of the machine, the following message is displayed:

WARN: DEFAULT KEYS  
& PARAMETER LOADED

The machine can either be operated with the default parameters, or it must be recalibrated, see following Section.

- After a key has been programmed, the display changes to the following message:

WARN: DEFAULT  
PARAMETER LOADED

- After an audio parameter has been reprogrammed this message disappears.



## 8.2 Error category breakdown via the RS232 (ASCII) interface

---

Errors are also output via the RS232 interface. The log is maintained in chronological order, i.e. the error that has occurred first will be listed first.

### Setup modes on the A812 MKII:

- Remote B (F346) switched to YES
- RS232 ASCII interface set to ECHO mode ON in "Alignment deck".

Under the above conditions the errors are also displayed in the data status inquiry (RS232 command: DST) and broken down by three categories:

- Master
- Audio
- Tape deck

The error messages are displayed as hexadecimal codes as shown below:

<b>Master Fehler (MCH):</b>	ERR: no communication master-tape deck	01H
	ERR: local shuttle value invalid	02H
	ERR: remote shuttle value invalid	03H
	ERR: data lost (RAM error)	01H
<b>Audio Fehler (MCH):</b>	ERR: audio channel 1	05H
	ERR: audio channel 2	06H
	ERR: no sense from audio	07H
<b>Tape Deck Fehler:</b>	ERR: power drop out	01H
	ERR: supply voltage (Sammelleitung)	02H
	ERR: motor supply voltage down/-15V	03H
	ERR: tacho sensor error	04H
	ERR: tape tension error	05H
	ERR: no communication capstan <--> tape deck	07H
	ERR: pinch roller slipping	08H
	ERR: reference frequency wrong	0AH
	ERR: spooling motor tacho left	0BH
	ERR: spooling motor tacho right	0CH
	ERR: move sensor hardware error	0DH
	ERR: spooling motor servo hardware	0FH

### Example of an error indication

On the A812 MKII LC-display:

ERR: PINCH ROLLER  
SLIPPING

On the terminal via the RS232 ASCII interface:

**TAPE DECK ERROR: 08**

### 8.3 Procedure for DATA LOST error message

- Follow the instructions according to the Section (ERR: DATA LOST) 8.1.
- Replace the battery on the MP UNIT MASTER 1.811.786.

In the event of a battery failure, the tape deck loses the audio and tape deck parameters (error message: DATA LOST) and continues to operate with the default values.

#### Exchanging the buffer battery.

- Write down the audio and tape deck parameters (including tape tensions A/B, equalization data and TYPE SETTING in the ALIGNMENT DECK block) and save them via the RS232 port on tape or in a personal computer.
- Exchange the battery and affix a label containing the next replacement date on the battery (= production date + 7 years).
- Switch on the tape recorder. After a short time the error message DATA LOST may appear on the LC display. If this is the case, press the RESET key on the MPU MASTER 1.811.786. The processor is reinitialized and the tape recorder is ready.
- Re-enter the audio and tape deck parameters or reload them. The parameter TYPE SETTING must be manually entered in all cases, i.e. this parameter is not stored on tape or in the PC, refer to Section 8.4.
- Check the programming of all keys with reference to E/30. In case of any deviations reprogram according to key designation. If the standard programming is desired, then any key has to be programmed again e.g. rewind F301 to be programmed again to the rewind key in order to avoid the display "Default Keys Loaded".

#### Packing and shipping the MPU boards

When handling ESE boards, always pack them in the black, antistatic plastic pouches.

To prevent discharge, the battery terminals should not contact the plastic foil. A piece of cardboard measuring approx. 100 x 130 mm can be inserted between the board and the plastic foil as an insulator.

#### Ordering new batteries

Please contact the nearest STUDER distributor.

#### Technical data of new batteries:

- Open-circuit voltage:  $\geq 3.66 \text{ V}$
- Nominal voltage (into 3.4 ohms, measured after 2 - 3 minutes):  $\geq 3.4 \text{ V}$ .
- The maximum current consumption of the RAM is  $13 \mu\text{A}$ , the corresponding voltage drop across diode D3 on the MPU MASTER board should be less than 300 mV.

### 8.4 Programming the machine type (TYPE SETTING)

In the ALIGNMENT DECK block, the machine type can be set with the TYPE SETTING function (e.g. A812 MKII-0.75, A812 MKII-2 VU, etc.). This selects the corresponding default programming and in the RF-driver the setting of the erase current is matched to the erase head. It is advisable to check the erase current and do adjust it if necessary. An incorrect TYPE SETTING entry can cause damage to the output stages of the RF-driver.

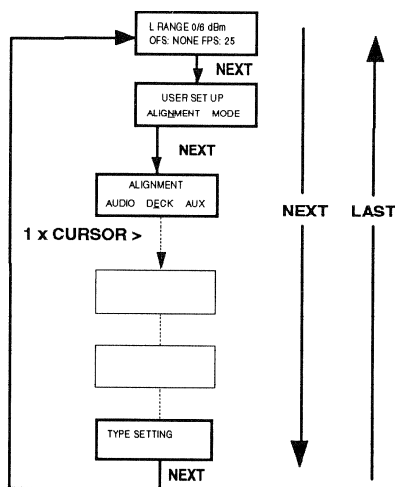

Press keys in the following sequence:

The display now shows:

- With key NEXT leaf forward to reach TYPE SETTING.
- With keys UP or DOWN select the correct machine version.

Table of TYPE SETTING parameters

Machine version	Audio erase head	Type setting
A812 - 0.75	Full track	A812 - 0.75 <b>F</b>
A812 - 0.75	Overlapping erasure	A812 - 0.75 <b>2</b>
A812 - 0.75 VU	Full track	A812 - 0.75 VU <b>F</b>
A812 - 0.75 VU	Overlapping erasure	A812 - 0.75 VU <b>2</b>
A812 - 1	Full track	A812 - 1
A812 - 1 VU	Full track	A812 - 1 VU
A812 - 2/2	Overlapping erasure	A812 - 2/2
A812 - 2/2 VU	Overlapping erasure	A812 - 2/2 VU
A812 - 2	2 - track (no TC erasure)	A812 - 2
A812 - 2 F	Full track	A812 - 2 <b>F</b>
A812 - 2 VU	2 - track (no TC erasure)	A812 - VU
A812 - 2 TC	2 - track (no TC erasure)	A812 - 2 TC
A812 - 2 TC VU	2 - track (no TC erasure)	A812 - 2 TC VU

## 9 Operation with the serial interface

Two versions of the serial interface are available:

- Version 1.820.751 supports the operation with a terminal (RS 232, ASCII protocol) and is also required for the communication with the TLS 4000 synchronizer.
- The version 1.820.751 supports the operation with a terminal (RS 422 and RS232, binary protocol). In addition this version is suited for connecting the A812 MKII to an SMPTE/EBU according to the SMPTE standard.

### 9.1 SMPTE/EBU bus

The SMPTE/EBU bus is a data transmission medium with which several individual units can be joined to a flexible and powerful system (e.g. remote control of several tape recorders).

### 9.2 RS232 interface

The term "RS 232" defines a connection between a terminal and a modem. This standard also defines the:

- Electrical characteristics (levels, lines)
- Mechanical characteristics (connectors)
- Signal shapes and
- Standard connections.

This interface supports data transmission speeds up to 19.2 kbaud (for A812 MKII: 9.6 kbaud) and cable lengths up to 15 m.

The signal levels are defined as follows:

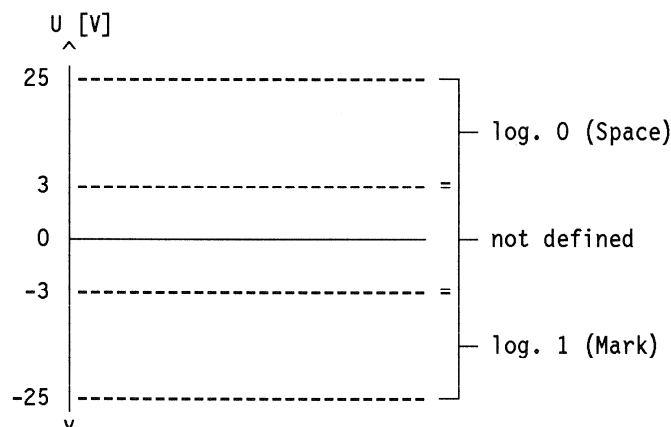

With a 25-pin connector different interface structures are feasible. In practice, however, only rarely are all 25 pins used. For establishing a terminal-terminal connection, modern systems are frequently based on the minimal structure defined in Section 9.1.

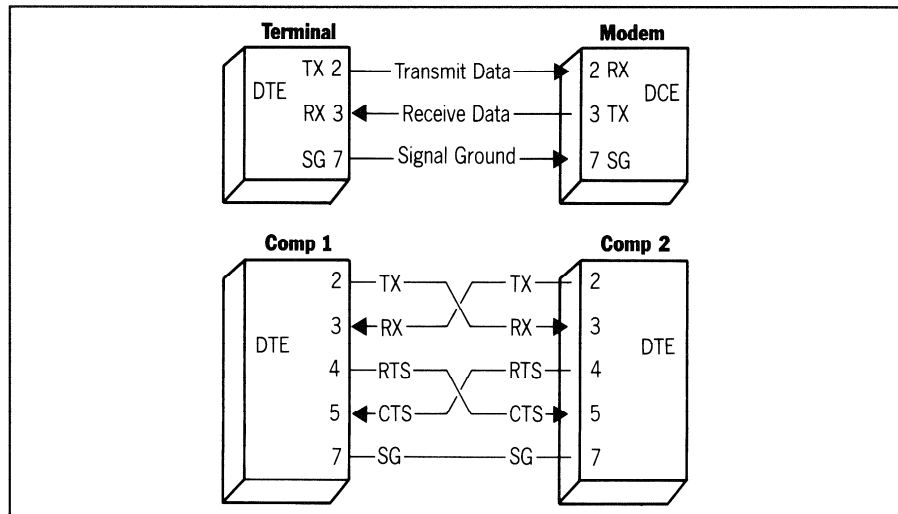

Fig. 9.1 Terminal-Terminal Connection

### 9.3 Serial ASCII interface of the A812 MKII 1.810.751

For the serial interface of the A812 MKII tape recorder a 9-pin connector conforming to the SMPTE standard is used in place of the 25-pin connector. With the aid of an adapter cable the user can define whether the connected equipment functions as a terminal or as a modem.

Tape recorder 9-pin		Terminal 25-pin		Modem 25-pin	
Signal	Pin No.	Signal	Pin No.	Signal	Pin No.
SNDATA	2	Trans.Data	2	Trans.Data	3
RCVDATA	8	Rec.Data	3	Rec.Data	2
GROUND	9	Sig.Ground	7	Sig.Ground	7

No additional handshake lines are used. A software handshake (X ON/X OFF protocol) is used for all bit rates, but is only needed for 9.6 kbaud.

X ON = 0001 0001 (ASCII DC1) continue  
 X OFF = 0001 0011 (ASCII DC3) interrupt

After the reception of an X OFF signal the tape recorder still transmits up to two characters. After it has transmitted its own X OFF it can still receive up to five characters without losing a command.

Basic setting:

- 1 start bit
- 1 stop bit
- 8 data bits
- no parity
- 9600 baud

The number of start and stop bits, even/odd parity and the following bit rates can be set in the ALIGNMENT DECK block of the software menu: 300, 1200 or 9600.

10 Installation of the Serial ASCII Interface 1.810.751

- Set up the terminal as follows: 1 start bit, 8 data bits, 1 stop bit, no parity bit, baud rate 300, 1200 or 9600. No echo mode. Handshake lines CTS and RTS to LOW.

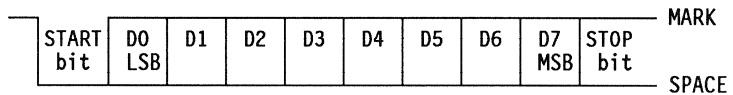

- SERIAL REMOTE CONTROLLER 1.810.751: This board contains a receiver and a driver for the RS232 interface. This universal interface can also be switched over to balanced input and output for biphase data transmission. This transmission mode is not required in the A812 MKII. For this reason the JS1 jumper on the serial interface 1.810.751.xx should be set to position H. Insert the PCB, activate the pilot LED by setting DIL switch 1 to "ON". When the A812 MKII is switched on, the TX LED lights up briefly because the A812 MKII transmits an identification code.
- Connect the computer or terminal via the adapter cable to one of the two 9-pin RS232 sockets on the rear of the A812 MKII. The two upper RX and TX LEDs on the serial interface 1.810.752.xx are light during the data flow between the A812 MKII and the terminal.
- Adjust the baud rate to the computer or terminal. After a RESET or after the A812 MKII has been switched OFF and ON, the following message appears on the terminal (only if: ECHO is ON in the alignment tape deck branch and the REMOTE key is ON):

```

A812 MKII MONITOR
ALL PROCESSES STARTED
    
```

The desired commands (see following command list) can now be entered via the terminal keyboard. The commands are executed as soon as the ENTER key (CR = Carriage Return) is pressed.

- Important:**
- Only upper case characters are accepted!
  - The REMOTE function (No. 345 or 346) has to be active!

10.1 Command Protocol Explanations

ASCII Protocol Specifications of RS232 Serial Interface for analog tape recorders STUDER A812 MKII

Connector specifications

- 9 pin connector, D type, (SMPTE/BUS / RS232 connector);
- pin out:

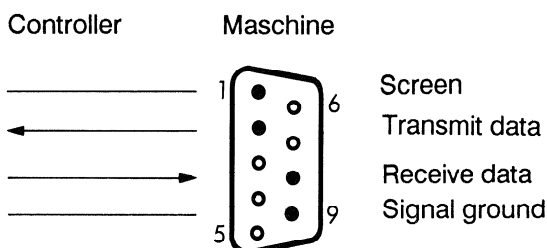

## 10.2 Message Format

---

Expressions between single quotation marks represent a non printable ASCII character, e.g. 'CR' means carriage return.  
The communication between the STUDER machine and the controller is implemented with ASCII coded strings of variable length.

A message string may contain of the following legal characters:

A...Z  
0...9  
?, \_ (SPACE)  
and the control characters:  
'CR' (0Dh)  
'LF' (0Ah)  
'CX' (18h)  
'XOFF' (13h)  
'XON' (11h)

All command mnemonics have a length of 3 characters and are usually terminated by a 'CR'.  
Only commands with parameters vary in length. The additional characters follow the command and are terminated by 'CR'. The parameters are separated by blanks or colons. There are some commands which do not have termination characters. Please refer to the individual command description for the exact syntax of each command.  
The STUDER machine uses the sequence 'CR LF' as acknowledge message or termination.

Example:

**WNF\_0400 'CR'** = controlled wind forward at 4 times nominal speed  
**WNF** = command, controlled wind forward  
**0400** = parameter, 0400h coded as ASCII string

The controller will send to the machine:

character	ASCII code sent
W	57h
N	4Eh
F	46h
_	20h
0	30h
4	34h
0	30h
0	30h
'CR'	0Dh

The machine should  
answer:

'CR'	0Dh
'LF'	0Ah

The 'CX' control character is used by the controller to reset the STUDER machine's communication port.

'XOFF' and 'XON' are used as handshake characters:

'XOFF': stop transmission

'XON': resume transmission

For terminal operation, the machine's communication port can operate in 'echo mode'. In this mode, an echo of each character is sent back to the controller and a prompt (>) is sent after the answer string.

The echo mode may be set via the machine's menu. It should not be used for computer remote control.

### 10.3 Communication Protocol

---

#### General informations

The communication between the controller and the STUDER machine is a master-slave protocol. The controller is the master and initiates the communication. The communication has to meet the following specifications:

- the machine has to acknowledge a command with a 'CR LF' within 100 msec from the moment that the command's last byte is received;
- the machine's communication port may be reset (both receiver and transmitter) by a 'CX' sent by the controller, and it has to acknowledge it with a 'CR LF' in the specified time;
- the machine can interrupt the controller anytime by sending an 'XOFF' and resume the communication sending an 'XON'. They do not have to be acknowledged by the controller;
- for the controller, there is no specification for the time between two bytes of a command;
- the controller should not output the next command before having received the machine's answer (exception: 'CX').

#### Error messages

Not defined messages are acknowledged by: ? 'CR LF'

If the machine is in echo mode, it responds with (same with some older software revisions):

**INPUT FORMAT ERROR ! 'CR LF'**



- Notes:**
- After power on, the machine may announce itself with a welcome message
  - After a power on or an error message, it is recommended to initialize the communication by sending 'CX'.  
The communication is re-established as soon as the machine answers with 'CR LF' within the specified time.
  - The machine is capable of handling at least 10 commands per second without XOFF-XON interference.
  - A locate command has a particular option. It can be followed by a command 'play' or 'record'. This preselection means that, once the locate is terminated, the machine will go in play or record. Preselection commands (play or record) can be repeated without cancelling the execution of the locate command.
  - After the reception of a DST or ST command, the machine answers with the continuously updated status.  
DST answers with the actual tape counter value, followed by the message "xx status achieved" (or "xx status not achieved").  
ST just punches out the HEX value corresponding to the status.
  - The DST-answer to a locate command is 'locate wind forward' or 'locate rewind', either 'achieved' or 'not achieved'. In addition, the machine may also answer 'play not achieved' or 'record not achieved', if play or record has been preselected.
  - A locate command is considered as completed when the machine sends a stop status.  
When the execution of 'locate' with a preselection of play or record is completed, the machine sends back the status 'play achieved' respectively 'record achieved'.

TAPE DECK COMMAND A812 MKII			Ed. 21.12.1990
Sign Set	Input	Output	Meaning
STP	STP 'CR'	'CR LF'	Stop
PLY	PLY 'CR'	'CR LF'	Play
REC	REC 'CR'	'CR LF'	Record
FWD	FWD 'CR'	'CR LF'	Forward
RWD	RWD 'CR'	'CR LF'	Rewind
WNR	WNR_xxxx	'CR LF'	Controlled wind reverse xxxx = 0000 to 5FFFF 0000 = lowest wind speed 5FFF = highest wind speed depending on the may. wind speed selected under ALIGNMENT
WNF	WNF_xxxx	'CR LF'	Controlled wind forward xxxx = 0000 to 5FFFF 0000 = lowest wind speed 5FFF = highest wind speed depending on the may. wind speed selected under ALIGNMENT
SSA	SSA 'CR'	'CR LF'	Set play speed A (3.75 IPS)
SSB	SSB 'CR'	'CR LF'	Set play speed B (7.50 IPS)
SSC	SSC 'CR'	'CR LF'	Set play speed C (15 IPS)
SSD	SSD 'CR'	'CR LF'	Set play speed D (30 IPS)
SVP	SVP_xxxxxx 'CR'	'CR LF'	Set varispeed parameter 00A5FE <= xxxxxx <= 018ACE (hex) parameter refers to nominal speed, signless, independent of tape deck status 010000 = nominal (fixed) speed
NS?	NS? 'CR'	yy IPS 'CR LF' yy = 3.75, 7.5, 15, 30	Nominal speed ?
VS?	VS? 'CR'	xxxxxx 'CR LF'	Varispeed parameter ? 00A5FE <= xxxxxx <= 018ACE (hex) parameter refers to nominal speed, signless, independent of tape deck status 010000 = nominal (fixed) speed
SVS	SVS 'CR'	'CR LF'	Varispeed on
CVS	CVS 'CR'	'CR LF'	Varispeed off
VEN	VEN 'CR'	'CR LF'	External varispeed on

TAPE DECK COMMAND A812 MKII			Ed. 21.12.1990
Sign Set	Input	Output	Meaning
VEF	VEF 'CR'	'CR LF'	External varispeed off
FEN	FEN 'CR'	'CR LF'	Fader enable on
FEF	FEF 'CR'	'CR LF'	Fader enable off
EDT	EDT 'CR'	'CR LF'	Lifter mode on (tape on heads)
LFT	LFT 'CR'	'CR LF'	Lifter mode off (tape not on heads)
LOC	LOC_hh:mm:ss:x'CR LF' or LOC_hh:mm:ss:x	'CR LF'	Locate to address < > hh = hours, -h = negative hours mm = minutes ss = seconds x = dsec
LMV	LMV_xxxxxxxx	'CR LF'	Locate move roll < > xxxxxxxx = 00000000 to FFFFFFFF
ZLO	ZLO 'CR'	'CR LF'	Locate to zero
MV?	MV? 'CR'	xx_xx_xx_xx 'CR LF'	move roll counter ?
STM	STM_hh:mm:ss:x or STM_-h:mm:ss:x	'CR LF'	Set timer on address < > -9:59:59:999<ADDR<23:59:59:999
RTI	RTI 'CR'	'CR LF'	Reset timer
TM?	TM? 'CR'	hh:mm:ss:x 'CR LF' or -h:mm:ss:x or oh:mm:ss:x or uh:mm:ss:x	timer? -9:59:59<ADDR<23:59:59 - = negative hours u=underflow o=overflow
DST	DST 'CR'	'CR LF' hh:mm:ss:x_nn_ttttt nn defined in field of 'ST?' except: rec indice B= 0AH/8AH	display machine status: actual_timer..status_code.. ..status_text [ _ ] achieved (exit by control_x)

TAPE DECK COMMAND A812 MKII		Ed. 21.12.1990	
Sign Set	Input	Output	Meaning
TP?	TP? 'CR'	aabbcdddeeff_gghhijjkkll 'CR LF' tape width 1/4": aa: tape tension play left bb: tape tension play right cc: tape tension wind dd: tape tension edit tape width 1/2": gg: tape tension play left hh: tape tension play right ii: tape tension wind jj: tape tension edit	Tape tension parameter?
ST?	ST? 'CR'	xx 'CR LF' xx: 01 = tape out 81 = tape out achieved 02 = stop 82 = stop achieved 03 = rewind 83 = rewind achieved 04 = forward 84 = forward achieved 05 = play 85 = play achieved 06 = play varispeed 86 = play vari achieved 07 = play internal ref 87 = play int ref ach 08 = play external ref 88 = play ext ref ach 09 = record or rehearse record 89 = record ach or rehearse rec ach 0B = edit 8B = edit achieved 40 = shuttle backward C0 = shuttle backw ach 41 = shuttle forward C1 = shuttle forw ach 42 = locate rewind C2 = locate rewind ach 43 = locate forward C3 = locate forward ach 46 = cueing reverse C6 = cueing reverse ach 47 = cueing forward C7 = cueing forward ach 4A = rewind controlled CA = rewind contrl ach 4B = wind forw contrl CB = wind forw ctrl ach 59 = tape dump D9 = tape dump achieved 5A = cut DA = cut achieved DD = burn in achieved	Status?

AUDIO COMMANDS A812 MKII			Ed. 21.12.1990
Sign set	Input	Output	Meaning
SMN	SMN 'CR'	'CR LF'	Set mono (only with mo-st sw.)
SST	SST 'CR'	'CR LF'	Set stereo (mo-st sw.)
SNB	SNB 'CR'	'CR LF'	Set NAB equalization
SCR	SCR 'CR'	'CR LF'	Set CCIR equalization
STA	STA 'CR'	'CR LF'	Set tape sort A
STB	STB 'CR'	'CR LF'	Set tape sort B
MSN	MSN 'CR'	'CR LF'	Master safe on
MSF	MSF 'CR'	'CR LF'	Master safe off
SRH	SRH 'CR'	'CR LF'	Rehearsal mode on only with drop in/out delay on
CRH	CRH 'CR'	'CR LF'	Rehearsal mode off
DDN	DDN 'CR'	'CR LF'	Drop in/out delay on
DDF	DDF 'CR'	'CR LF'	Drop in/out delay off
AA?	AA? 'CR'	aabbccdd 'CR LF' aa: 0 = safe 1 = ready/record bb: 0 = tape 1 = input cc: 0 = rep 1 = sync dd: 0 = demute 1 = mute	Channel 1..8 status?  MSB(xxx): chnl 8 LSB(xxx): chnl 1  xx = aa..dd
REA i	REA_i 'CR' i=1,2,3,F E=tc channel	'CR LF'	Set channel i to ready
SAF i	SAF_i 'CR' i=1,2,3,F E=tc channel	'CR LF'	Set channel i to safe
INP i	INP_i 'CR' i=1,2,3,F E=tc channel	'CR LF'	Set channel i to input
SYN i	SYN_i 'CR' i=1,2,3,F E=tc channel	'CR LF'	Set channel i to synch
REP i	REP_i 'CR' i=1,2,3,F E=tc channel	'CR LF'	Set channel i to rep
MTN i	MTN_i 'CR' i=1,2,F F=all channels	'CR LF'	Mute channel i

AUDIO COMMANDS A812 MKII			Ed. 21.12.1990
Sign set	Input	Output	Meaning
MTF i	MTF_i 'CR' i=1,2,F F=all channels	'CR LF'	Demute channel i
SAP <i,j,xx>	SAP_i,j,xx 'CR' i= channel (1,2) j= D/A converter xx=hex number 0<=xx <=FF j: 0=level repro/sync 1=treble repro/sync 2=bass repro/sync 3=equalization repro/sync 4=level record 5=treble record 6=bias record 7=equalization record 8=erase current level 9=skimming bias level 8 and 9 only in MKII	'CR LF'	Set audio parameter (write in DAC's and store)
PAP	PAP_i,j,xx 'CR' i= channel (1,2) j= D/A converter xx=hex number 0<=xx <=FF j: 0=level repro/sync 1=treble repro/sync 2=bass repro/sync 3=equalization repro/sync 4=level record 5=treble record 6=bias record 7=equalization record 8=erase current level 9=skimming bias level 8 and 9 only in MKII	'CR LF'	Preset audio parameter (write in DAC's and store)
AP? <i,j>	AP?_i,j, 'CR' i= channel (1,2) j= D/A converter j: 0=level repro/sync 1=treble repro/sync 2=bass repro/sync 3=equalization repro/sync 4=level record 5=treble record 6=bias record 7=equalization record 8=erase current level 9=skimming bias level 8 and 9 only in MKII	xx 'CR LF'	Audio parameter ?

TIME CODE COMMANDS A812 MKII		Ed. 21.12.1990	
Sign set	Input	Output	Meaning
TND	TDN 'CR'	'CR LF'	Time code delay on left & right TC heads active
TDF	TDF 'CR'	'CR LF'	Time code delay off only right TC head active
TH?	TH? 'CR'	xx 'CR LF'	Time code reading head nr ?
TC?	TC? 'CR'	[Y,M] 'CR LF'	Time code present on tape ?

MACHINE COMMANDS A812 MKII			Ed. 21.12.1990
Sign set	Input	Output	Meaning
LCD	LCD 'CR'	'CR LF'	Local keyboard disabled
LCE	LCE 'CR'	'CR LF'	Local keyboard enabled
RMD	RMD 'CR'	'CR LF'	Remote keyboard disabled
RME	RME 'CR'	'CR LF'	Remote keyboard enabled
SBA	SBA_xxxx	'CR LF'	Set bus address (8280-FFFF)
BA?	BA? 'CR'	xxxx 'CR LF'	Bus address ?
SD?	SD? 'CR'	DD.MM.YY (sw not released) OO.WW.YY (sw released)	software date ?  DD=day WW=week MM=month YY=year
MK?	MK? 'CR'	aa 'CR LF'	Mark nr of software version ? aa = mark number 00, 01, '?' = mark I , 02 = mark II
MT?	MT? 'CR'	aa 'CR LF'	Machine type? aa= machine type number 01=820,02=812,03=820MCH, 04=827MCH,05=807,06=816 07=810



## 11 External storage of the audio parameters

For copying the audio and tape tension parameters of the RAMS to an external storage medium, the tape recorder must be equipped with the serial interface 1.810.751. Two copying methods are possible: either by means of a suitable personal computer directly on to a diskette, or on to audio tape (preferably with the tape recorder whose parameters are to be stored).

With a special command the data stored in the RAM can be compared with the saved data in order to verify that they have been transmitted correctly.

The terms SAFE (data backup) for external storage of the data from the tape recorder RAM, and VERIFY for comparing the externally stored data with those in the tape recorder RAM, and LOAD for transferring the data from the external storage medium into the tape recorder RAM are used in the following description.

### 11.1 Data (BACK-UP) on tape

When the SAFE command is initiated on the tape recorder, the microprocessor serially transmits the stored audio and tape tension data to terminals 4 and 6 of the SMPTE/EBU BUS/RS232 connector.

These terminals are balanced and floating, the level is approx. 9 Vpp. In order to match the output level to the current source, a load impedance (approx. 47 ohm) must be connected between pins 4 and 6 (results in a voltage of approx. 2.5 Vpp).

For safety reasons the complete set of data is transmitted three times. The entire Data Back-up process takes approx. 65 seconds.

#### Procedure

- Connect the SMPTE/EBU BUS / RS232 with a suitable cable to the audio-input (see illustration):

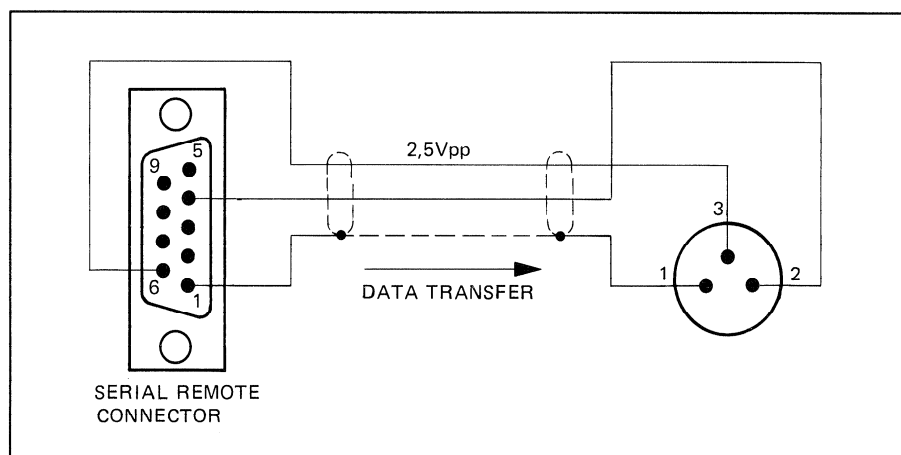

Fig. 4.8.1

- Select the tape speed (7.5 ips)
- Thread recorder with tape of suitable length (at least 65 seconds).
- Press the READY key of the desired recording channel.
- With the aid of a hex key No. 2.5, give the programming lock [28] approx. 1 – 2 counterclockwise turns

- Repetitively press V/NEXT until the LC display contains the following information:

```
PARAM BACKUP ON TAPE
↓_↑ VERIFY SAVE LOAD
```

The cursor is located between the two arrows (in a protected position).

- Press →/CURSOR twice, the cursor is now positioned below SAFE.
- Start the recorder in play mode with PLAY + REC.
- Press STORE, the LC display contains the following information:

```
DATA TRANSMISSION IN
PROGRESS - PLS WAIT
```

The data are recorded on tape.

- Measure the reproduce level with tape on the audio line output. If necessary change the impedance so that approx. 2.5 Vpp are available at the output. Or, if available, adjust the record level with the RECORD LEVEL potentiometer.
- Make the final recording.

Upon completion of the data transmission the following message is displayed:

```
DATA TRANSMISSION
COMPLETED
```

If an error has occurred during the data transmission (e.g. due to a transient line voltage failure), the following message is displayed:

```
DATA TRANSMISSION
FAILED
```

In this case press V/NEXT or ^/LAST to retrieve the following menu:

```
PARAM BACKUP ON TAPE
↑_↓ VERIFY SAVE LOAD
```

- The process can be repeated, if desired, or you can return to the starting position by pressing ^/LAST.

11.2 VERIFYING the data stored on tape

When the VERIFY command is entered on the tape recorder (verify the RAM data with the data on the external storage medium), the microprocessor serially receives all stored audio data (pins 4 and 6 of the SMPTE/EBU BUS/RS232 connector).

These terminals are balanced and floating. The level should be approx. 2.5 Vpp.

Procedure

- Connect the SMPTE/EBU Bus/RS 232 to the audio input by means of a suitable cable (see illustration):

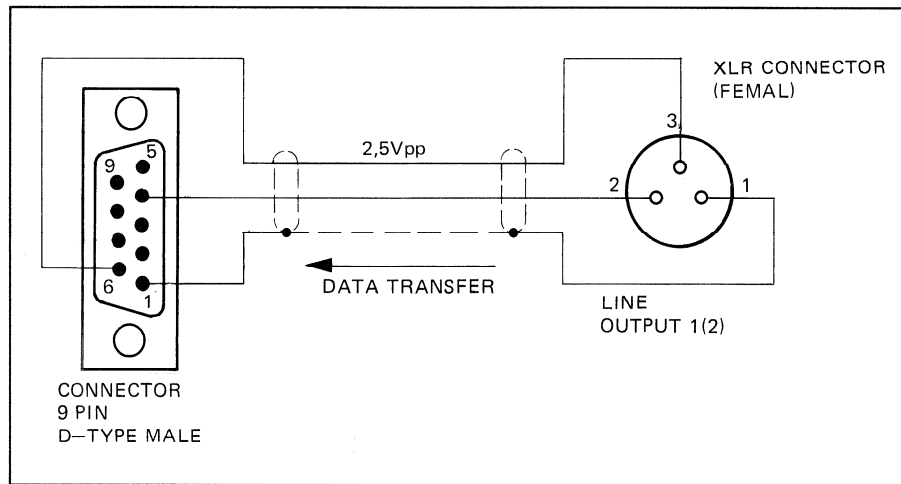

- Select the same tape speed that has been used for recording the data.
- Thread recorder with the tape containing the stored parameters.
- Adjust the reproduce level: The reproduce level should be not much less than 2 Vpp. If necessary adjust the level.
- With the aid of a hex key No. 2.5, give the programming lock [28] 1 to 2 counterclockwise turns.
- Repetitively press ↵/NEXT until the LC display shows the following menu:

```
PARAM BACKUP ON TAPE
↑ ↓ VERIFY SAVE LOAD
```

The cursor is now located between the two arrows (in a protected position).

- Press →/CURSOR once, the cursor is now positioned below VERIFY.
- Press STORE, the LC display contains the following information:

```
WAITING FOR DATA INP
PLS SEND DATA
```

- Press PLAY to start the recorder in play mode. The LC display shows the following information as soon as valid data are decoded:

```
VERIFYING DATA
PLEASE WAIT
```

After the data comparison has been successfully completed, the following message is displayed:

```
VERIFICATION SUCCES-
FULLY COMPLETED
```

If the data do not agree, the following message is displayed:

VERIFICATION FAILED  
PLEASE REPEAT

The following message is displayed if:

Play has not been started within approx. 15 seconds, and  
No valid data have been detected within approx. 30 seconds:

NO DATA FOUND

In all cases the key ↑/LAST switches back to the following menu:

PARAM BACKUP ON TAPE  
↑ ↓ VERIFY SAVE LOAD  
\_

This procedure can be repeated, if necessary, or with ↑/LAST you can leaf back to the starting position.

### 11.3 LOADING the data from tape

When the LOAD command (loading data from the external storage medium) is entered on the tape recorder, the microprocessor receives all stored audio data serially and loads them into the RAM. The same connection cable can be used as for VERIFY. Normally the first of the three identical data blocks on the external storage medium suffices for loading the data. However, if errors occur during the loading operation, the processor accesses the second or the third data block.

#### Procedure

- Same as in 11.2 until the following menu is displayed:

```
PARAM BACKUP ON TAPE
↑_↓ VERIFY SAVE LOAD
```

- Press →/CURSOR three times, the cursor is now positioned below LOAD.
- Press STORE, the LC display contains the following information:

```
WAITING FOR DATA
PLS SEND DATA
```

- Press PLAY to start the machine in play mode. The LC display contains the following information as soon as valid data are detected:

```
DATA LOADING IN
PROGRESS - PLS WAIT
```

Upon successful completion of the load operation the following message is displayed:

```
DATA LOADING
COMPLETED
```

If read errors have occurred (e.g. transient line voltage failure, contaminated soundheads) the following message is displayed:

```
DATA LOADING FAILED
DEFAULT PARAM LOADED
```

Repeat the process, or if desired, continue to work with the default parameters.

The following message is displayed if:

Play has not be started within approx. 15 seconds,  
and

No valid data have been detected within approx. 30 seconds:

```
NO DATA FOUND
```

The old audio and tape tension reference data are still available in the RAM.

In all cases the key ↑/LAST switches back to the following menu:

```
PARAM BACKUP ON TAPE
↑_↓ VERIFY SAVE LOAD
```

This procedure can be repeated, if necessary, or with ↑/LAST you can leaf back to the starting position.

## 11.4 SAVING the data by means of a personal computer

When the SAVE command is entered on the tape recorder, the microprocessor transmits the stored audio and tape tension data serially to the SMPTE/EBU BUS/RS232 connector. For safety reasons the complete set of data is transmitted three times.

### Procedure

- Connecting and operating the Personal Computer on the socket SMPTE/EBU BUS/RS232 by means of an interconnecting cable as illustrated below.
- In addition, the handshake mode (X ON/X OFF-Protocol) has to be switched on.

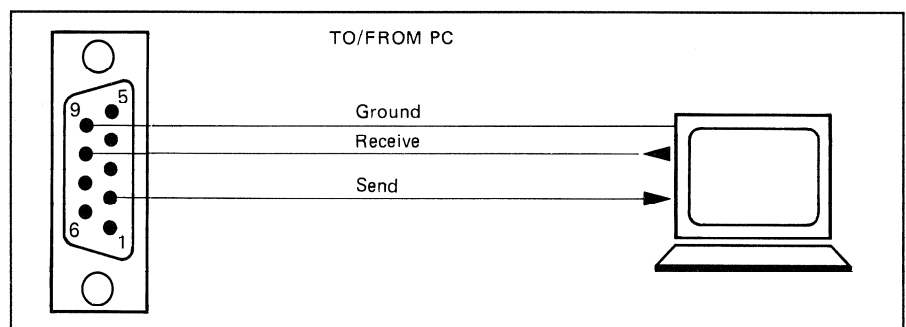

**Cab configuration for SAVE-, VERIFY-, LOAD-procedure with a PC**

- With the aid of a hex-key No. 2.5, give the programming lock [28] approx. 1 – 2 counterclockwise turns
- Repetitively press ↕/NEXT until the LC display contains the following information:

```
PARAM BACKUP RS 232
↑_↓ VERIFY SAVE LOAD
```

The cursor is located between the two arrows (in a protected position).

- Press →/CURSOR twice, the cursor is now positioned below SAFE.
- Press STORE, the LC display contains the following information:

```
DATA TRANSMISSION IN
PROGRESS - PLS WAITD
```

The data are transmitted to the personal computer.

Upon completion of the data transmission the following message is displayed:

```
DATA TRANSMISSION
COMPLETED
```

The received ASCII data can be recorded on diskette.

If an error has occurred during the data transmission (e.g. due to a transient line voltage failure), the following message is displayed:

```
DATA TRANSMISSION
FAILED
```

In either case press ↕/NEXT or ↑/LAST to retrieve the following menu:

```
PARAM BACKUP RS 232
↑_↓ VERIFY SAVE LOAD
```

The process can be repeated, if desired, or you can return to the starting position by pressing ↑/LAST.

## 11.5 VERIFYING the data in the personal computer.

When the VERIFY command is entered on the tape recorder (verifying the RAM data with the data on the external storage medium), the microprocessor serially receives all stored audio data (pins 4 and 6 of the SMPTE/EBU BUS/RS232 connector).

### Procedure

- Start up and connect the personal computer to the SMPTE/EBU BUS/RS232 connector:  
Same as described in 11. In addition the software handshake mode X ON/X OFF protocol) must be activated.
- With the aid of a hex-key No. 2.5, give the programming lock [28] 1 to 2 counterclockwise turns.
- Repetitively press ↓/NEXT until the LC display shows the following menu:

```
PARAM BACKUP RS 232
↑_↓ VERIFY SAVE LOAD
```

The cursor is now located between the two arrows (in a protected position).

- Press →/CURSOR once, the cursor is now positioned below VERIFY.
- Press STORE, the LC display contains the following information:

```
WAITING FOR DATA INP
PLS SEND DATA
```

- Activate the data transmission from the personal computer to the tape recorder. The LC display shows the following information as soon as valid data are decoded:

```
VERIFYING DATA
PLEASE WAIT
```

After the data comparison has been successfully completed, the following message is displayed:

```
VERIFICATION SUCCES-
FULLY COMPLETED
```

If the data do not agree, the following message is displayed:

```
VERIFICATION FAILED
PLEASE REPEAT
```

The following message is displayed if:

No transmission has been started within approx. 15 seconds, **and**  
No valid data have been detected within approx. 30 seconds:

```
NO DATA FOUND
```

- In all cases the key ↑/LAST switches back to the following menu:

```
PARAM BACKUP RS 232
↑_↓ VERIFY SAVE LOAD
```

This procedure can be repeated, if necessary, or with ↑/LAST you can leaf back to the starting position.

## 11.6 LOADING the data from the personal computer

When the LOAD command is entered on the tape recorder (loading data from the external storage medium), the microprocessor serially receives all stored audio data and tape tension and loads them into the RAM. Normally the first of the three identical data blocks on the external storage medium suffices for loading the data. However, if errors occur during the loading operation, the processor can access the second or the third data block.

### Procedure

- Same as in 11.5 until the following menu is displayed:

```
PARAM BACKUP RS 232
↑_↓ VERIFY SAVE LOAD
```

- Press →/CURSOR three times, the cursor is now positioned below LOAD.
- Press STORE, the LC display contains the following information:

```
WAITING FOR DATA
PLS SEND DATA
```

- Start the data transmission from the personal computer to the tape recorder. The LC display contains the following information as soon as valid data are detected:

```
DATA LOADING IN
PROGRESS - PLS WAIT
```

Upon successful completion of the load operation the following message is displayed:

```
DATA LOADING
COMPLETED
```

If read errors have occurred (e.g. transient line voltage failure, contaminated soundheads) the following message is displayed:

```
DATA LOADING FAILED
DEFAULT PARAM LOADED
```

Repeat the process, or if desired, continue to work with the default parameters. The following message is displayed if:

Transmission has not been started within approx. 15 seconds,  
and

No valid data have been detected within approx. 30 seconds:

```
NO DATA FOUND
```

The old audio and tape tension parameters are still available in the RAM.

- In all cases the key ↑/LAST switches back to the following menu:

```
PARAM BACKUP RS 232
↑_↓ VERIFY SAVE LOAD
```

- This procedure can be repeated, if necessary, or with ↑/LAST you can page back to the starting position.



## 12 Installation of the Serial Interface 1.820.751 (SMPTE/EBU)

Hardware definitions:

- Electrical standards according to RS 232C or RS422 (selectable with jumpers)
- Full-duplex
- Asynchronous transmission of the data, bit-serial and word-serial, according to the following diagram:

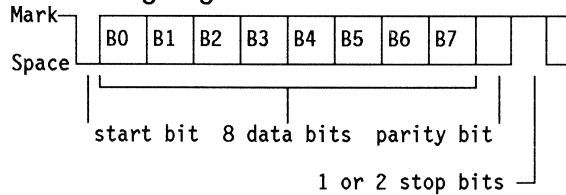

Odd or even parity and the number of stop bits (1 or 2) can be programmed.

- Baud rates for RS 232 and RS422 programmable as 9600 or 1200 baud, for operation in conjunction with an SMPTE bus it is preset to 38400 baud.
- Standard factory settings:

RS232

- 1 start bit
- 8 data bits
- even parity
- 1 stop bit
- 9600 baud.

Pin assignment:

Pin	RS232	RS422
1	SHIELD	SHIELD
2	---	TRANSMIT A
3	RX	RECEIVE B
4	0,0 V	RECEIVE COMMON
5	---	---
6	0,0 V	TRANSMIT COMMON
7	TX	TRANSMIT B
8	---	RECEIVE A
9	SHIELD	SHIELD

Jumper:

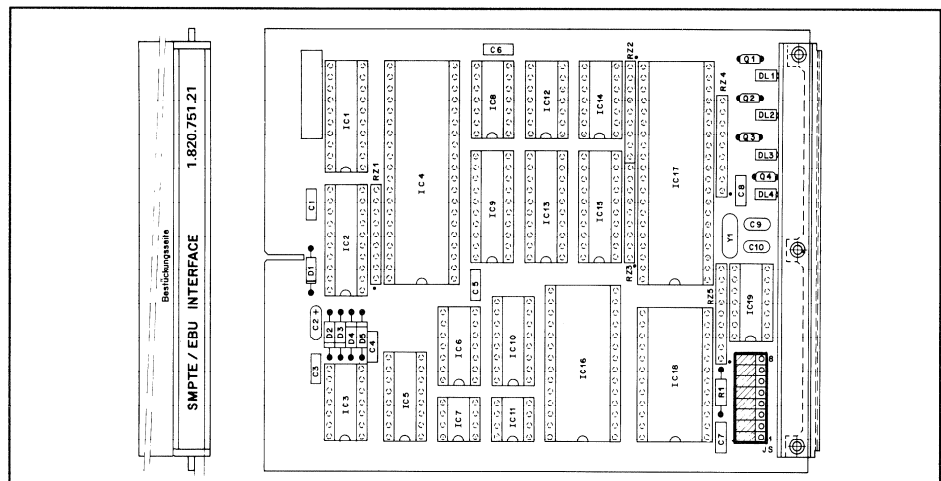

Fig. 11.1

**Changeover of the operating mode and the electrical configuration:**

	J8	J7	J6	J5	J4	J3	J2	J1
SMPTE BUS	BC	BC	BC	BC	BC		BC	BC
SERIAL RS232	AB	AB	AB	AB	AB		AB	AB
SERIAL RS422	AB	BC	BC	BC	AB		BC	BC

**Changeover of the baud rates:**

		J3
SMPTE BUS	38,4 kBd	BC
RS232/RS422	9600 Bd	BC
	1200 Bd	AB

**Standard settings:**

	J8	J7	J6	J5	J4	J3	J2	J1
SMPTE BUS	BC	BC	BC	BC	BC	BC	BC	BC
SERIAL RS232 9600 Baud	AB	AB	AB	AB	AB	BC	AB	AB

**Pilot lamps**

The four pilot LEDs on the front bracket of the module 1.820.751 are used for indicating different states, depending on whether the module is used as a serial interface (RS232/RS422) or as an SMPTE/EBU bus interface (programmable with jumpers as described above).

**SMPTE/EBU bus:**

**INTERFACE SELECTED**

Glow when the interface receives an SEL ADDR and as long as it remains in the SELECT status.

**INTERFACE POLLED**

Glow when the interface receives a POLL ADDR and as long as it remain in the POLL status.

**INTERFACE IDLE/ACTIVE**

Glow as long as the interface waits for STX (control byte).

**FIFO TX/RX ACTIVE**

Glow when the interface receives data from the FIFO or transmits data to the FIFO.

PCB

**RS232/RS422:**

**RX ACTIVE**

Glow as soon as the interface receives STX (control byte) and as long as it receives a message.

**TX ACTIVE**

Glow as long as the interface transmits a message.

**INTERFACE ACTIVE**

Glow as long as the interface waits for a BREAK signal or its own answer.

**FIFO TX/RX ACTIVE**

Glow when the interface receives data from the FIFO or transmits data to the FIFO.

**Software protocol:**

The host control system can transmit commands (function or parameter commands) or status requests to the A812 MKII.

The A812 MKII acknowledges the commands and supplies status messages on request.

- Commands from the control system to the A812 MKII:

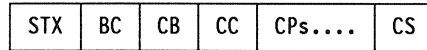

STX: is a control character and is transmitted as a start character (according to SMPTE recommendation: STX = 02H).

BC (byte count): contains the number of bytes that follow (excluding checksum).

CB (control byte):

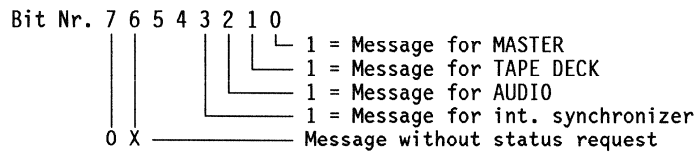

CC (command code): function or parameter command; refer to corresponding instruction set.

CP (parameter bytes): only for parameter commands; if more than one parameter byte exists, the MSB is transmitted first.

CS (checksum): 2's complement notation of the sum of all data transmitted before the checksum, excluding STX.

- Status request from the control system to the A812 MKII:

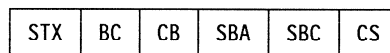

STX: is a control character and is transmitted as the start character (according to SMPTE recommendation: STX = 02H).

BC (byte count): 3 (fixed). CB (control byte):

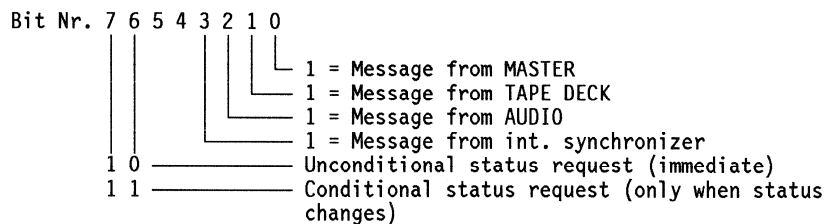

SBA, SBC (status request byte): SBA contains the base address, SBC the number of bytes of the requested status. CS (checksum): 2's complement notation of the sum of all data transmitted before the checksum, excluding STX.

- Acknowledgment and status messages of the A812 MKII to the control system:

After the control system has transmitted a command block, it must wait for an acknowledgment from the A812 MKII before a new command block may be transmitted.

This acknowledgment can consist of a control character or a status message.

If no acknowledgment arrives within the time-out period (10 ms), the control system considers the transmission as faulty.

Possible acknowledgments:

Acknowledgment after correct transmission of commands or status change request with unchanged status:

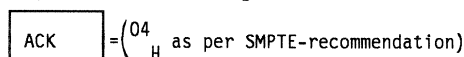

Acknowledgment after the following errors:

- Transmission error (framing, parity overrun) wrong command codes
- Time-out (2 sec) during the command transmission)

NAK | ( = 05<sub>H</sub> as per SMPTE-recommendation)

Status message as an acknowledgment to:

- Unconditional status request
- Status change request with changed status

STX	BC	CB	SBA	SBC	STATUS	CS
-----	----	----	-----	-----	--------	----

STX: is a control character and is transmitted as the start character (according

to SMPTE recommendation: STX = 02H).

BC (byte count): contains the number of bytes that follow (without checksum).

CB (control byte):

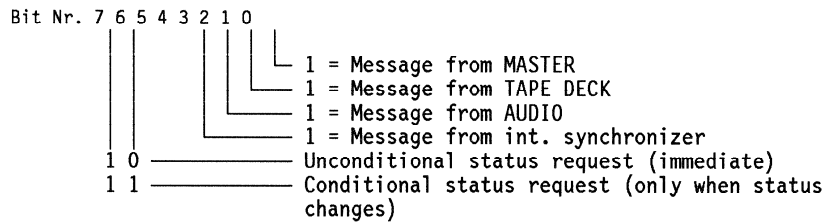

SBA, SBC (status request byte): SBA contains the base address, SBC the number of bytes of the request status.

CS (checksum): 2's complement notation of the sum of all data transmitted before the checksum, excluding STX.

Command list

On request

## 13 Technical Information

### 13.1 Connectors, Fuses

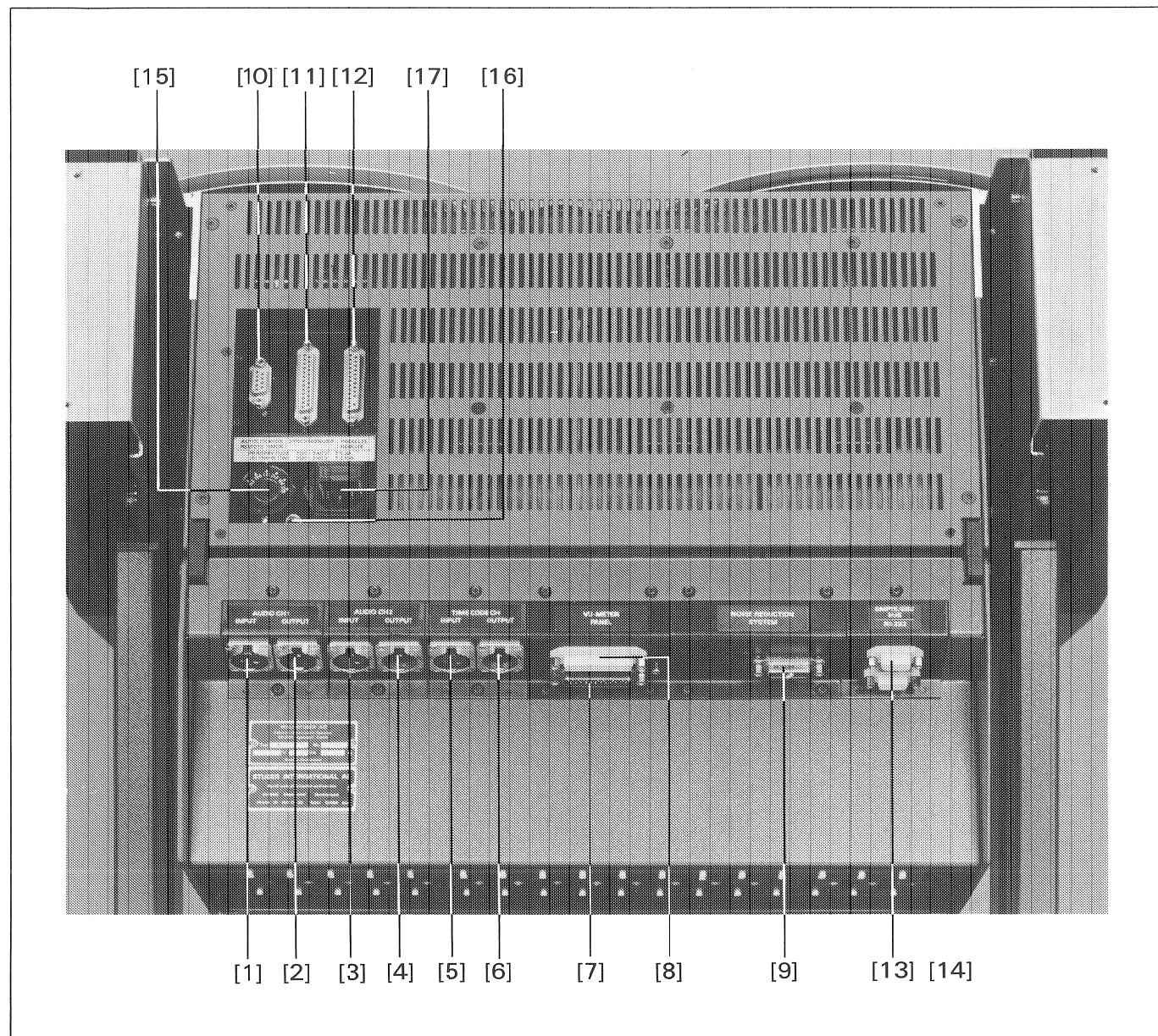

- [1] Line input CH1
- [2] Line output CH1
- [3] Line input CH2
- [4] Line output CH2
- [5] Line input time code channel (TC versions only), refer to 13.1.2
- [6] Line output time code channel (TC versions only), refer to 13.1.2
- [7] Connector for VU-meter panel (audio), see 13.1.8
- [8] Connector for VU-meter panel (control), see 13.1.8
- [9] Connector for noise reduction system (option), see 13.1.7
- [9a] Connector for the audio remote (option), see 13.1.8
- [10] Connector for serial remote control, remote counter, and autolocator (option)\*, see 13.1.5
- [11] Connector for synchronizer (only for TC versions)\*, see 13.1.4
- [12] Connector for parallel remote control\*, see 13.1.3
- [13] [14] Parallel connectors for SMPTE/EBU bus, RS232 interface or data backup to external medium (option), see 13.1.5
- [15] Line voltage selector\*, see 13.1.1
- [16] Ground socket\*
- [17] AC power inlet\* (with primary fuse, size. 5 x 20 mm), see 13.1.1
  - 100...140 V: 6.3 A slow
  - 200...240 V: 3.15 A slow

The connectors identified with "\*" are located below the hinged cover.

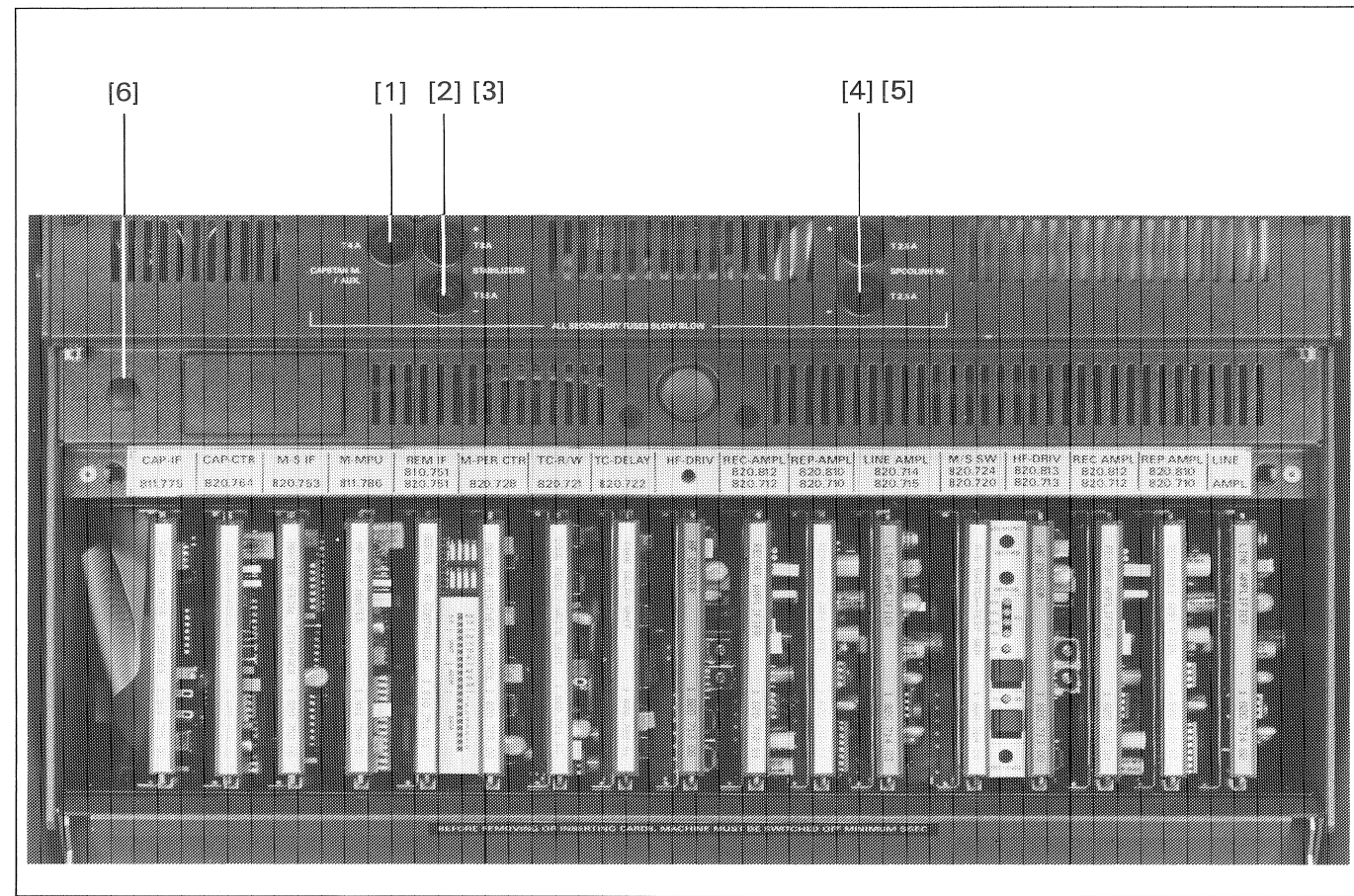

All secondary fuses: size 5 x 20 mm !

- [1] Fuse for capstan motor and auxiliary voltages 4 A SLOW
- [2] Fuse for STABILIZER 8 A SLOW
- [3] Fuse for STABILIZER 1.6 A SLOW
- [4] Fuse for positive spooling motor voltage (+) 2.5 A SLOW
- [5] Fuse for negative spooling motor voltage (-) 2.5 A SLOW
- [6] Headphones socket (on models with monitor speaker built into the tape deck cover)

### 13.1.1 Power connection, voltage selector, fuses

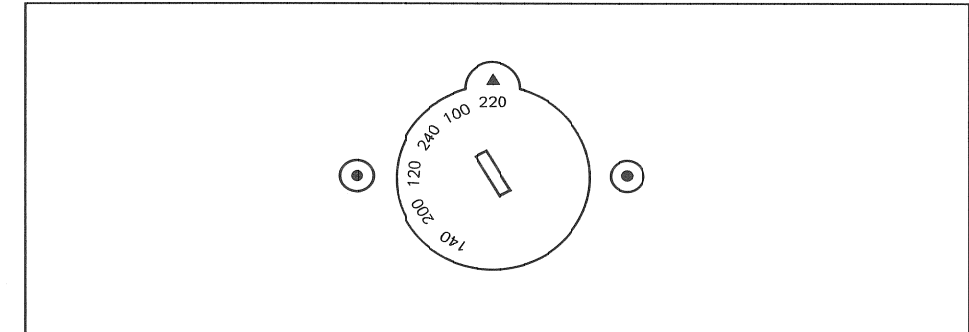

**Important:** Before you put the machine into service for the first time, make sure the setting of the line voltage selector on the back of the machine corresponds to the local line voltage. The following line voltages can be selected: 100, 120, 140, 200, 220 or 240 VAC, ±10%, 50–60 Hz, For changing the setting, the machine must be completely disconnected from the power source. After the line voltage selector setting has been changed, also the power fuse (size 5x20 mm) must be changed.

- 100 ... 140 VAC: 6.3 A (slow)
- 200 ... 240 VAC: 3.15 A (slow)

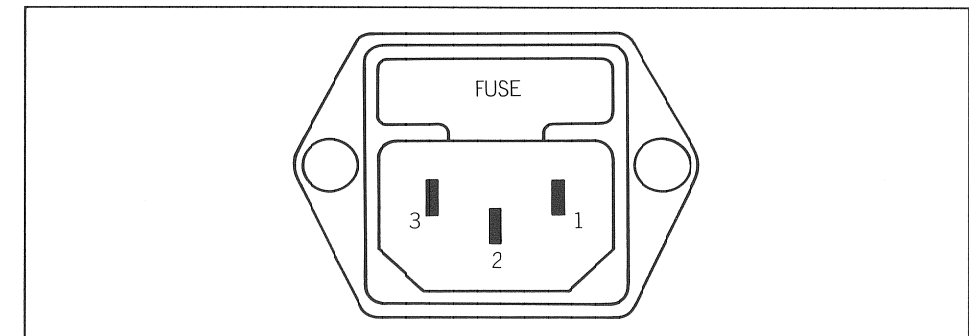

- No. 1: Phase
- No. 2: Ground
- No. 3: Neutral

### 13.1.2 Line inputs and outputs for Audio or Timecode

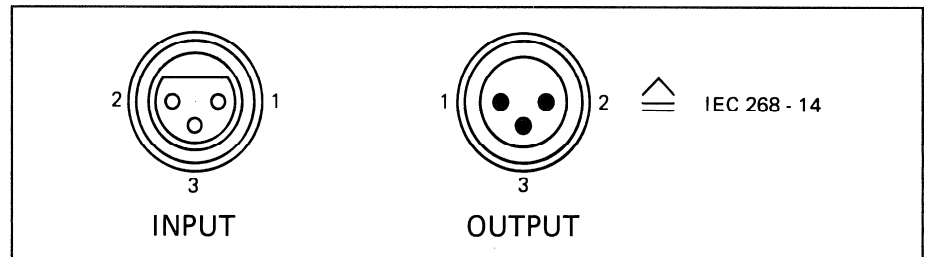

The balanced inputs and outputs are terminated on XLR sockets or connectors (pin assignment according to IEC recommendation 268-14).

- No. 1: Audio resp. Timecode Screen
- No. 2: A-line (hot) \*
- No. 3: B-line (cold)

\* Line A is "hot" with unbalanced connection of the tape recorder.

### 13.1.3 Remote control socket

#### Parallel remote control connector

A parallel remote control with the following capabilities can be connected to this 25-pin connector (female, type D):

- Remote control of the tape transport functions with status (<, >, PLAY, STOP, REC).
- RESET TIMER (resets the tape timer)
- ZERO LOC (automatically searches the tape timer address 00.00.00.0).
- LOC START (automatically searches the tape address at which the last PLAY command was entered).
- LIFTER (defeats the tape lifter in spooling mode).
- FADER (enables the fader start circuit).
- VARISPEED (variable tape speed).

Pin assignment of the  
PARALLEL REMOTE  
CONTROL:

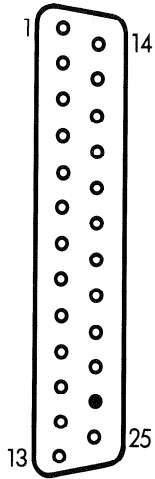

Pin	Signal name	Designation
01	+0.0	Ground (GND, 0 V)
02	BR-REW *	Status indicator lamp REWIND
03	BR-FORW *	Status indicator lamp FORWARD
04	BR-VRSPD *	Status indicator lamp VARISPEED (alternatingly LOW and HIGH, when active)
05	SR-VRSPD +	Switch for VARISPEED command
06	SR-FADRY +	Switch for FADER START READY command
07	BR-LOCST *	Status indicator lamp LOC START
08	BR-FADRY *	Status indicator lamp FADER START READY
09	BR-REC *	Status indicator lamp RECORD
10	ST-RESET +	Switch for RESET TIMER command
11	FAD1	Input FADER START command, line A
12	FAD2	Input FADER START command, line B (FADER START is active when 5 to 24 VDC or AC are available across pins 11 and 12).
13	IR-REFEX	Input for external capstan PLL reference (nominal: 9.6 kHz, TTL level recommended; max. input voltage +10 V).
14	SR-0LOC +	Switch for ZERO LOC command
15	BR-PLAY *	Status indicator lamp PLAY
16	BR-STOP *	Status indicator lamp STOP
17	SR-LIFT +	Switch for LIFTER command
18	SR-LOCST +	Switch for LOC START command
19	SR-REC +	Switch for RECORD command
20	SR-REW +	Switch for REWIND command
21	SR-FORW +	Switch for FORWARD command
22	SR-PLAY +	Switch for PLAY command
23	SR-STOP +	Switch for STOP command
24	KEY	Connector coding
25	+REMSUP	+24 V supply (max. 300 mA)

\* Open collector output, active LOW. No internal pull-up resistor. Maximum HIGH level +30 V, maximum current 200 mA (built-in current limiting resistor 22 Ω).

+ Switch input. LOW level activates the command. Internal pull-up resistor, 4.7 kΩ to +24 V. Maximum HIGH level = +30 V. Logical levels: LOW = 0 V to +4 V; HIGH = +7.5 V to +30 V.

Connector set  
Connector housing, 25-pin  
Connector, 25-pin, coded

Part No. 20.020.303.16  
Part No. 54.13.7022  
Part No. 10.217.001.06



Circuit examples

Circuit diagram for tape transport commands

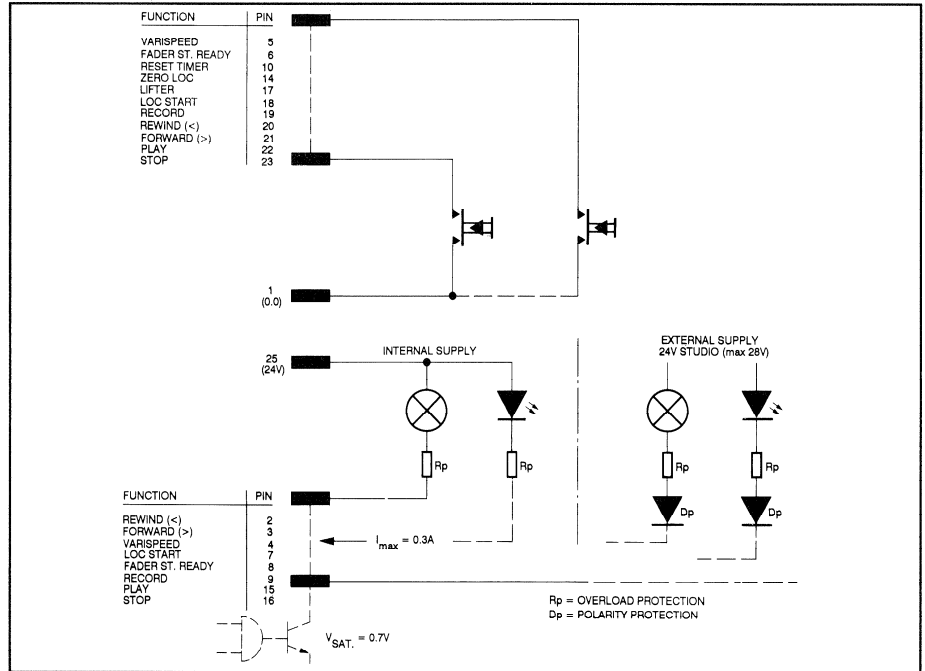

Circuit diagram for varispeed operation

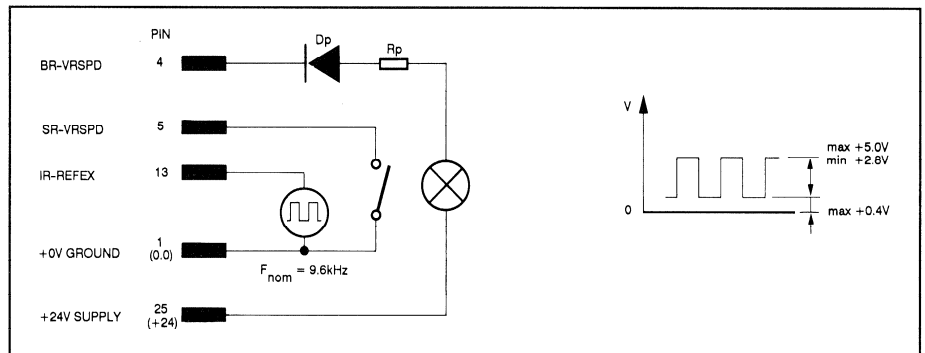

Circuit diagram for fader start with int. or ext. current supply

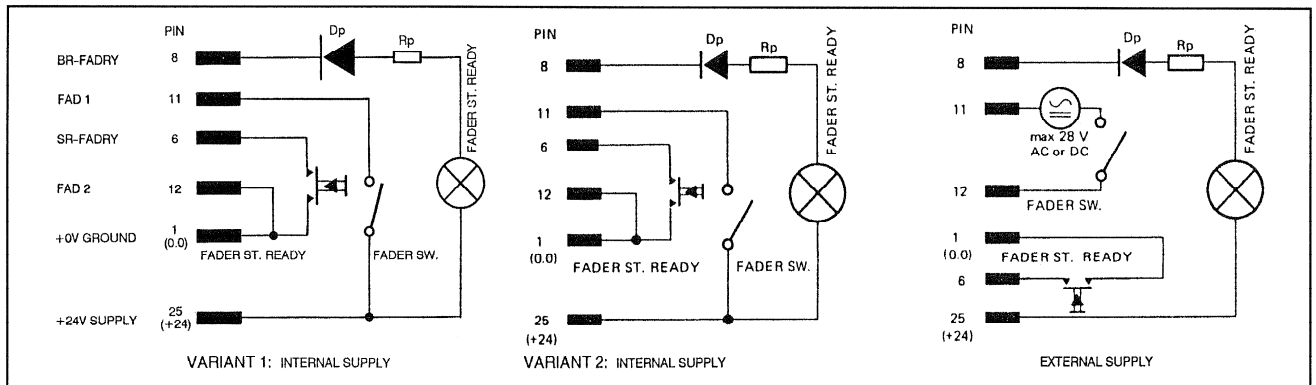

**Important:** If incandescent bulbs are used for status signalling, their inrush current must not exceed 0.3 A !

13.1.4 Connector for external Synchronizer System

A 25-pin connector (female, type D) is available for connecting an external synchronizer (time code versions only).

Pin assignment of the SYNCHRONIZER connector:

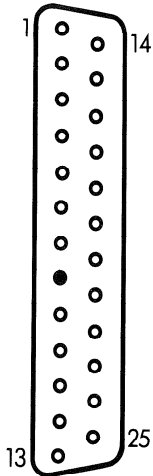

Pin	Signal name	Designation
01	+ 0.0	Ground (GND, 0 V)
02	BR-REW	* Status indicator lamp REWIND
03	BR-FORW	* Status indicator lamp FORWARD
04	BR-VRSPD	* Status indicator lamp VARISPEED (alternatingly LOW and HIGH when active)
05	SR-VRSPD	+ Switch for VARISPEED command
06	SR-REHSL	+ Switch for REHEARSAL command
07	OR-MVCLK	* Output for TAPE MOVE CLOCK signal (128 pulses/15 ips, pulse duty factor 50%).
08	KEY	* Connector coding
09	BR-REC	* Status indicator lamp RECORD
10	OR-MVDIR	* Output for TAPE MOVE DIRECTION signal (REWIND = LOW, FORWARD = HIGH).
11	OR-CMCLK	* Output for CAPSTAN MOTOR MOVE CLOCK signal (1200 pulses/s at 7.5 ips)
12	OR-SYENB	* Output for SYNCHRONIZER ENABLE signal (LOW when tape is tensioned and the recorder is operational, HIGH when the tape is not tensioned).
13	IR-REFEX	Input for external capstan PLL reference (nominal: 9.6 kHz, TTL level recommended; max. input voltage +30 V).
14	+ 0.0	Ground
15	BR-PLAY	* Status indicator lamp PLAY
16	BR-STOP	* Status indicator lamp STOP
17	SR-LIFT	+ Switch for LIFTER command
18	SR-MUTE	+ Switch for MUTE command (no influence on time code channel)
19	SR-REC	+ Switch for RECORD command
20	SR-REW	+ Switch for REWIND command
21	SR-FORW	+ Switch for FORWARD command
22	SR-PLAY	+ Switch for PLAY command
23	SR-STOP	+ Switch for STOP command
24	KEY	Connector coding
25	+REMSUP	+24V supply (max. 300 mA)

\* Open collector output, active LOW. No internal pull-up resistor. Maximum HIGH level +30 V, maximum current 200 mA (built-in current limiting resistor 22 Ω).

+ Switch input. LOW level activates the command. Internal pull-up resistor, 4.7kΩ to +24 V. Maximum HIGH level = +30 V. Logical levels: LOW = 0 V to +4V; HIGH = +7.5 V to +30 V.

Connector set  
 Connector housing, 25-pin  
 Connector 25-pin, coded

Part No. 20.020.303.15  
 Part No. 54.13.7022  
 Part No. 10.217.001.05

**13.1.5 RS232C interface (ASCII protocol) or RS232C interface (binary protocol) and SMPTE/EBU bus**

The following devices can be connected to this female 9-pin, D-type connector:

- Terminal with RS232C interface (ASCII protocol) or TLS 4000 (via the serial remote control 1.810.751 (Option 20.820.393.00)
- or
- Terminal with RS 232C interface (binary protocol) or an SMPTE/EBU bus (RS422) via the SMPTE/EBU interface 1.820.751 (option 20.820.394.00).

Connector set

Part No.20.020.303.07

**Option 1.820.751**

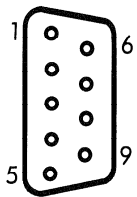

- Pin assignment of the RS232 & SMPTE/EBU bus connector (9-pin, D-type)

RS422 (SMPTE/EBU-Protocol)	
Pin	Signalname
01	FRMGND
02	TRANSA
03	RECEIVEB
04	RECEIVCM
05	---
06	TRANSCM
07	TRANSB
08	RECEIVEA
09	FRMGND

RS 232 (SMPTE/EBU Protocol)	
Pin	Signalname
01	SHIELD
02	---
03	RX Receive Data
04	0V Ground
05	---
06	0V Ground .....
07	TX Transmit Data
08	---
09	Shield

- SMPTE/EBU application with \*NRZ format

- SMPTE/EBU application with \*NRZ format.

**Option 1.810.751**

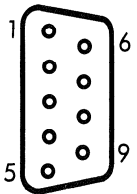

- Pin assignment of the RS232 & SMPTE/EBU connector. (9-pin, D-type)

RS232 (ASCII-Protocol)	
Pin	Signalname
01	---
02	TX Transmit Data
03	---
04	---
05	---
06	---
07	---
08	RX Receive Data
09	0V Ground

RS 232 (ASCII-Protocol)	
Pin	Signalname
01	0V Ground
02	---
03	---
04	RX Receive Data
05	---
06	TX Transmit Data
07	---
08	---
09	---

- Normal RS232 application with \*NRZ format.

- Normal RS232 application with \*biphase format.

### 13.1.6 Autolocator/Remote Timer

A serial remote control, a remote timer or an autolocator can be connected via this 9-pin connector (female, D-type). The keys of the serial remote control are freely programmable. All functions programmable on the local keyboard can also be executed from the remote control. The functions programmed on the serial remote control do not necessarily have to be the same as those on the local keyboard.

Pin assignment of the AUTOLOCATOR/TIMER connector:

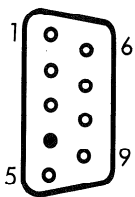

Pin	Signal name	Designation
01	SHIELD	Screen
02	SR-REC	Switch for RECORD command
03	TR-A	Serial data line A
04	KEY	Coding
05	+0.0	0 V
06	SR-PLAY	Switch for PLAY command
07	TR-B	
08	SIGN. GND	Signal ground
09	+REMSUP	supply voltage for ground

+ Connector input, LOW level activates the command. Internal pull-up resistor 4.7 kΩ connected to +24 V supply; max. HIGH input level = +30 V, logic level: LOW = 0...+4 V, HIGH = +7.5 ... +30 V.

Connector assembly:

	Part No.
Type D, 9-pin, male, solderable for connection on machine side	20.020.3030.20
Type D, 9-pin, female, solderable for connection on remote side	20.020.3030.21
Cable: screened, 10 x 0.14 mm <sup>2</sup>	10.330.007.00

### 13.1.7 Connection of a NOISE REDUCTION SYSTEM

A 2-channel noise reduction system (either DOLBY or TELCOM) can be remote controlled via this 15-pin connector.

Connector set

Part No.20.020.303.08

Pin assignment of the  
NOISE REDUCTION  
SYSTEM connector

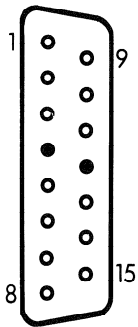

Pin	Signal name	Designation
01	B-BDY-01 *	Control signal for DOLBY system channel 1
02	B-BDY-02 *	
03	N.C.	
04	KEY	
05	N.C.	
06	N.C.	
07	N.C.	
08	N.C.	
09	N.C.	
10	N.C.	
11	B-TLC-01 +	Control signal for TELCOM system channel 1
12	KEY	
13	B-TLC-02 +	Control signal for TELCOM system channel 2
14	+REMSUP	
15	+0.0	

\* Open collector output, active LOW. No internal pull-up resistor. Max. HIGH level 30 V, max. current 200 mA.

+ Open collector output, same as above, but active HIGH.

Connector assembly:

Type D, 15-pin, male, screw-type cable fitting

Part No.  
20.020.303.08

### 13.1.8 VU-Meter Panel

#### Audio Connector

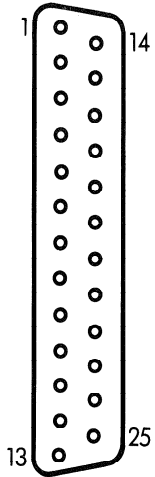

Pin	Signal name
1	TAPMS-01
2	+0.0
3	INPAD-01
4	LOUFA-01
5	+0.0
6	MONIT-01
7	T-TC/RC
8	+0.0
9	TAPMS-02
10	INPAD-02
11	+0.0
12	LOUFA-02
13	GND
14	TAPAD-01
15	+0.0
16	INPDI-01
17	LOUFB-01
18	+0.0
19	+0.0
20	MONIT-02
21	+0.0
22	TAPAD-02
23	INPDI-02
24	+0.0
25	LOUFB-02

#### Control Connector

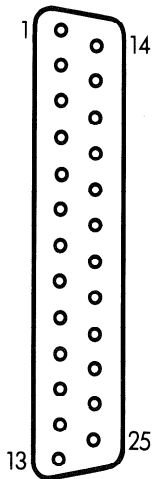

Pin	Signal name
1	+0.0
2	+5.6
3	+15.0
4	T-SADA
5	T-SADC
6	T-WRTSL
7	T-DT-CH2
8	T-DT-MP
9	---
10	---
11	T-VARSPD
12	T-REFEXT
13	+0.0
14	+0.0
15	+5.6
16	-15.0
17	T-SADB
18	T-READSL
19	T-DT-CH1
20	T-DT-CH3
21	---
22	---
23	+0.0
24	+0.0
25	+24.0

**Channel Remote Connector**

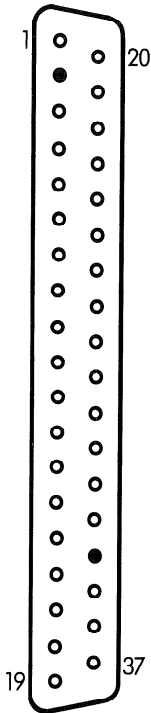

Pin	Signal name
1	+0.0
2	KEY
3	SR-INP01
4	SR-REA01
5	SR-REP02
6	SR-INPTC
7	SR-ARENB
8	BR-REA01
9	BR-SYN01
10	BR-REC02
11	BR-INP02
12	BR-REP02
13	BR-REATC
14	BR-SYNTC
15	BR-TCPRS
16	---
17	---
18	---
19	---
20	SR-REA01
21	SR-REP01
22	SR-INP02
23	SR-REATC
24	SR-REPTC
25	BR-REC01
26	BR-INP01
27	BR-REP01
28	BR-REA02
29	BR-SYN02
30	BR-RECTC
31	BR-INPTC
32	BR-REPTC
33	+24.0
34	KEY
35	---
36	---
37	---

13.2 Programming the operating parameters

13.2.1 Program switch: LINE AMPLIFIER

with transformer 1.820.814.00  
without transformer 1.820.715.83

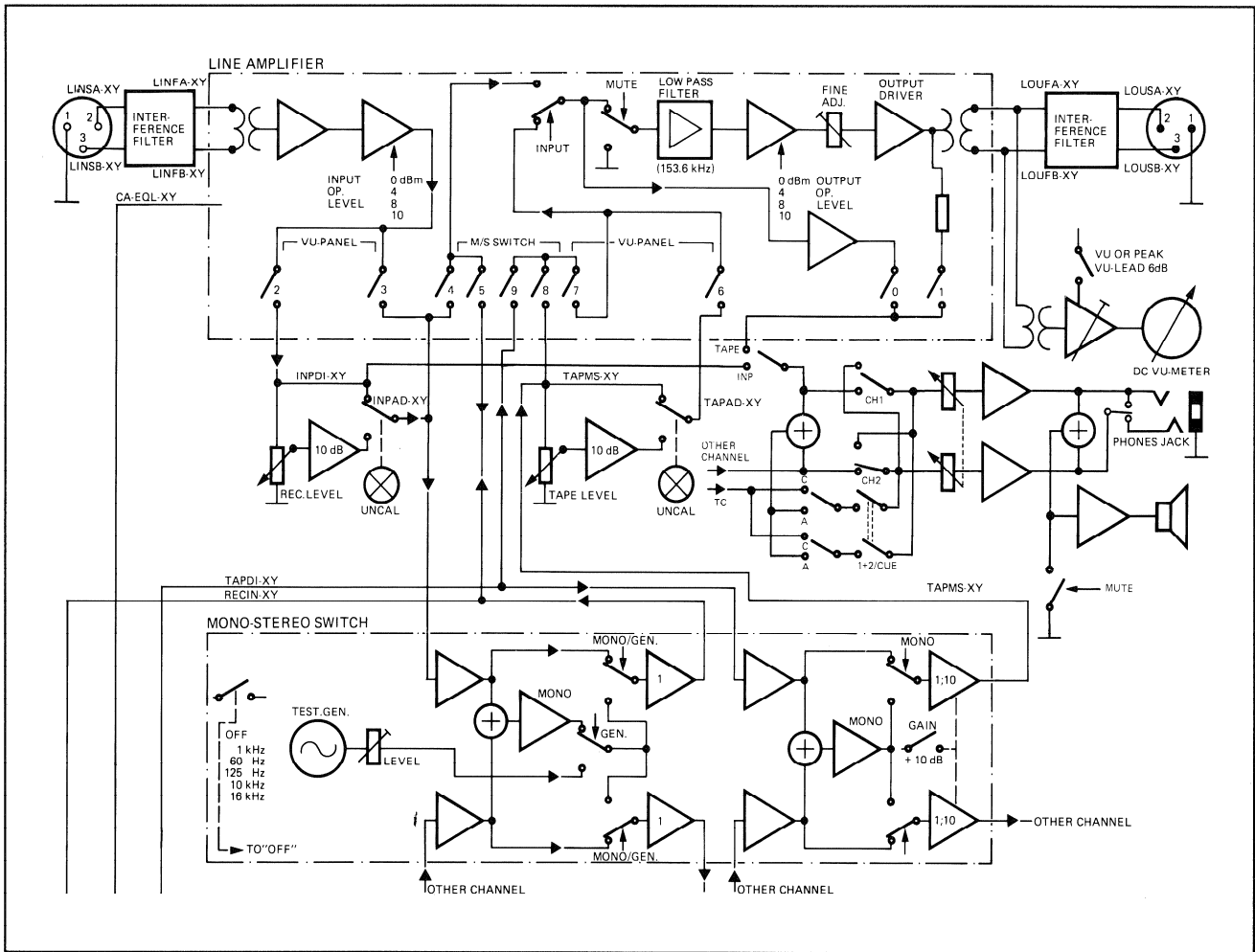

Connection of internal monitor and headphones output:

**JSX = 0: Switch open / JSX = 1: Switch closed**

- JS0 = 0 / JS1 = 1:** Tap for monitor and headphones signal directly on the line amplifier output, muting is consequently possible.
- JS0 = 1 / JS1 = 0:** Tap for monitor and headphones signal before the mute switch, muting of the monitor is consequently not possible.
- JS0 = 0 / JS1 = 0:** Monitor and headphones switched off.



JS2...JS9: VU-meter panel, mono/stereo switch:

Configuration	JS2	JS3	JS4	JS5	JS6	JS7	JS8	JS9
without VU-Panel, without M/S-Switch	1**	1	1	1	0	1	0	1
with VU-Panel, without M/S-Switch	1	0	1	1	1	0	1	1
without VU-Panel, with M/S-Switch	1**	1	0*	1*	0	1	1	0
with VU-Panel, with M/S-Switch	1	0	0*	1*	1	0	0	0

\* The indicated switch position means that the RECIN output signal of the mono/stereo switch will be heard, when the output selector is in the INP position. If the input signal is to be tapped before the mono/stereo switch, it is necessary to set JS4 to 1 and JS5 to 0.

\*\* On machines without VU-meter panel and without monitors speaker the jumper setting JS2 = 0 is required.

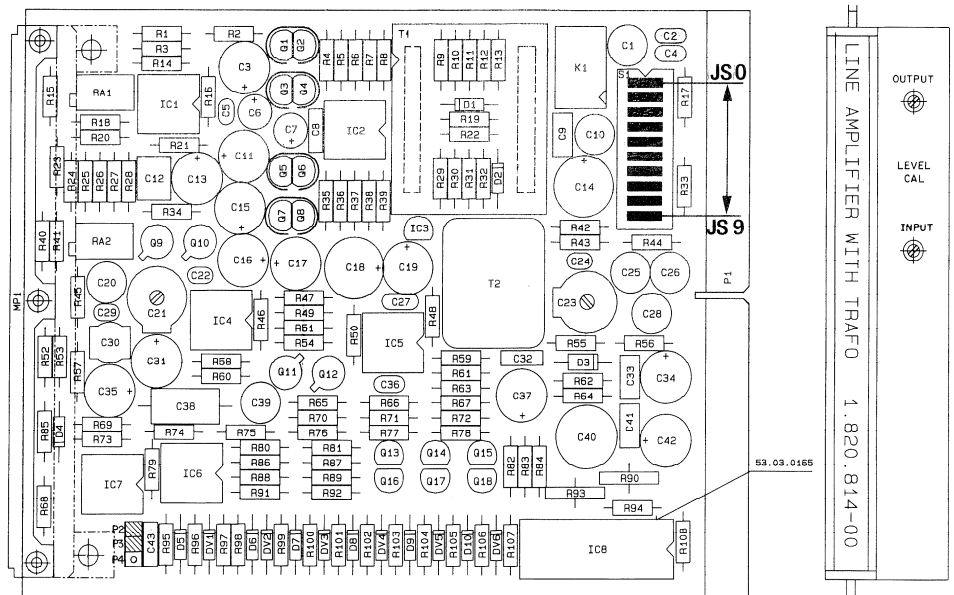

13.2.2 Jumper: REPRODUCE AMPLIFIER 1.820.710.85

The SYNC reproduce frequency response can be switched from 12 kHz ("N" = narrow) to 20 kHz ("W" = wide) by means of a jumper.

**Note:** Strong cross talk from the record to the sync reproduce channel must be expected above 12 kHz!

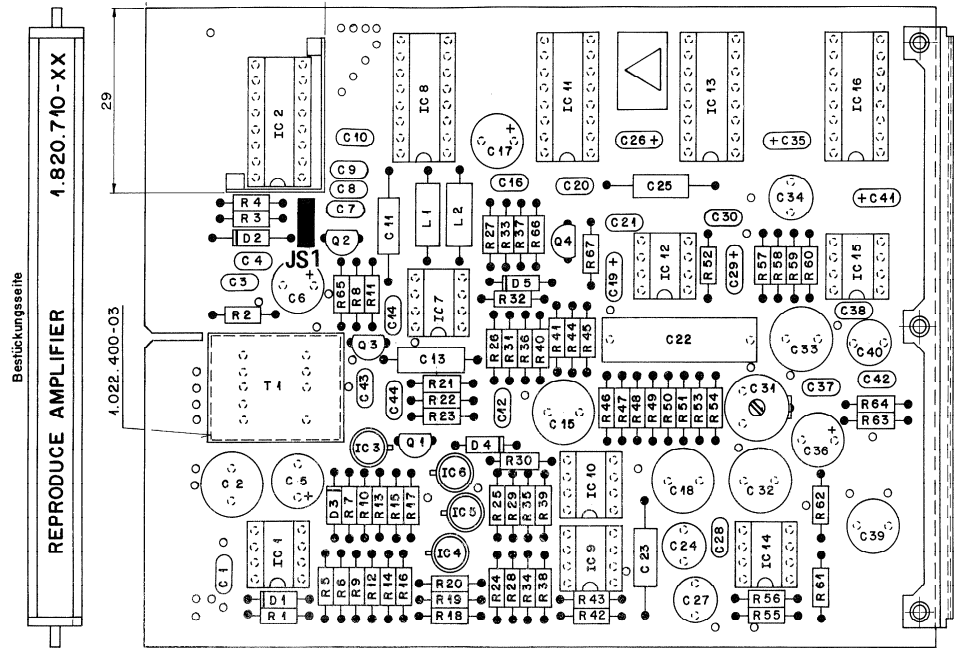

### 13.2.3 Jumper: VU-meter amplifier

Remove the VU-meter by unfastening the 4 fixing screws.

**VU characteristic:**  
**PPM characteristic:**

On the back of the VU-meter panel you can select the VU or PPM characteristic (PPM = PEAK PROGRAM METER) by means of a jumper on each instrument. According to the IEC recommendation 268, part 10, Section 4.  
According to the IEC recommendation 268, part 10, Section 3 (except 24, 1, scale division)

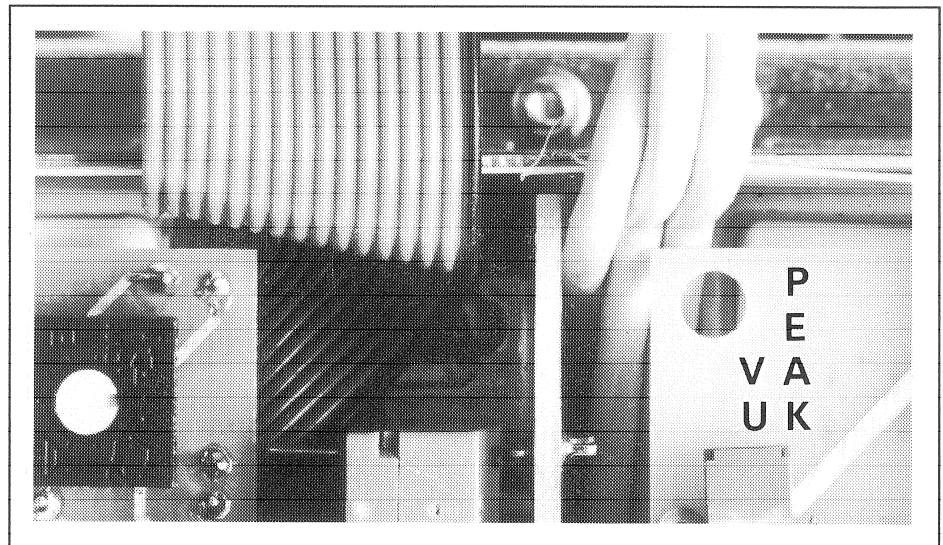

### 13.2.4 Jumper and potentiometer: MONO/STEREO SWITCH and/or test generator

**Jumper:**

If the mono/stereo selector is retrofitted, the setting of the programming switches on the LINE AMPLIFIER must be changed (see 13.2.1). In addition the following changes are necessary:

- Program F031 "STEREO/MONO" to any key (refer to the example 4 on page E/32).
- Change the labeling of the reprogrammed key, and
- Exchange the status indicator label for the one containing the complete labeling.

Labels and plug-in LEDs are included in the tape recorder accessories.

On machines for which only the test generator but no mono/stereo switch is needed (e.g. full-track version), the mono-stereo changeover logic can be disabled with jumper JS1.

With jumper JS2 you select the record mode:

- The input signal of channel 1 is recorded in mono mode on tracks 1 and 2.
- The input signal of channels 1 and 2 is summed and recorded as a mono signal on tracks 1 and 2.

With jumper JS3 you select the play mode:

- The aggregate signal of tracks 1 + 2 can be connected either to the output of channel 1,  
or
- To both channels 1 and 2.

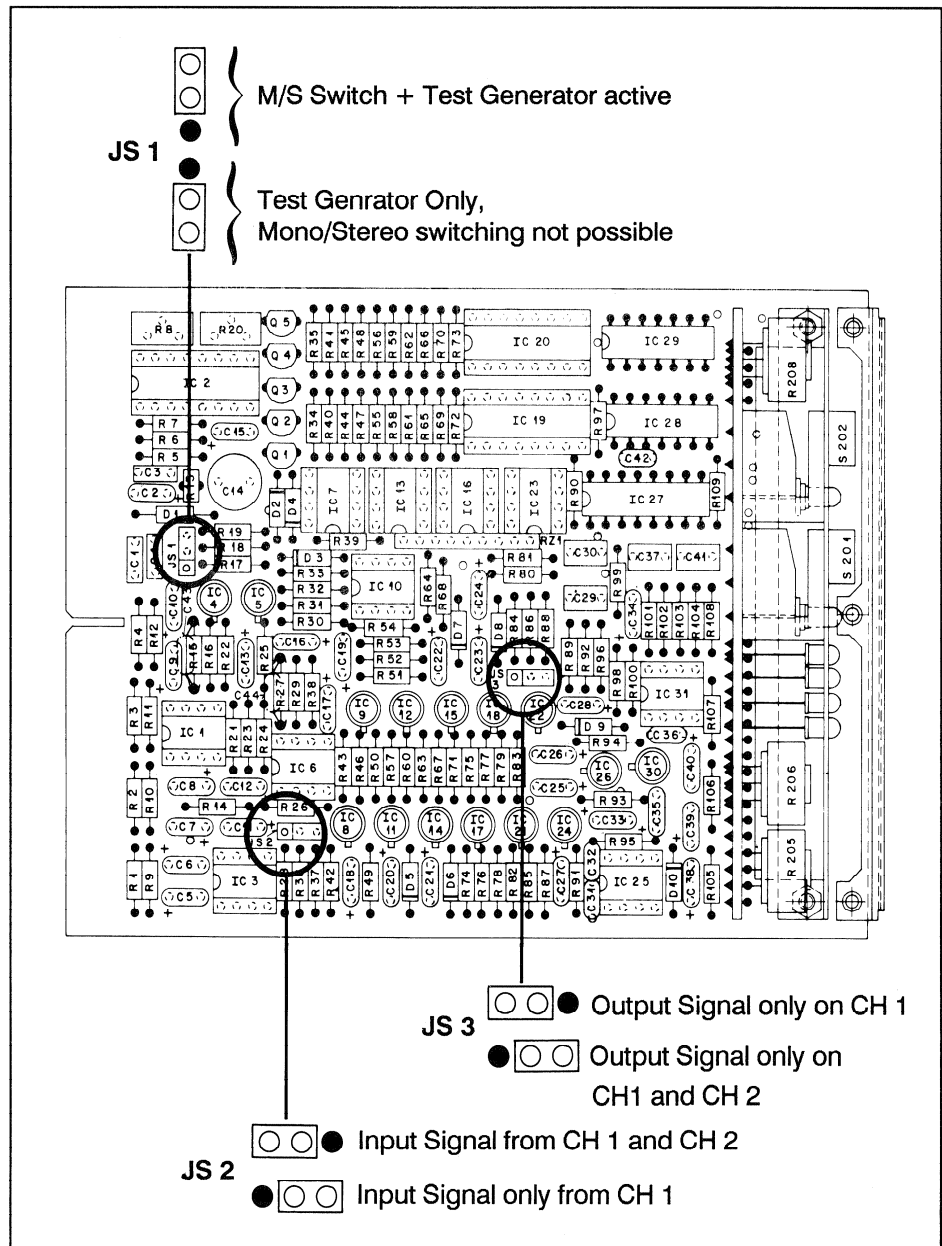

**Aligning the mono/stereo switch:****Precondition:**

Tape recorder must be calibrated according to the maintenance instructions.

**LEVEL MONO reproduce alignment:**

- Insert the test tape.
- Select MONO mode (simultaneously press STOP and STEREO-MONO).
- With the "LEVEL MONO REPROD." potentiometer align the level to the desired flux.
- Select a setting that is 1.1 dB below the MONO level in order to compensate the guard track loss (not taken into consideration in the factory setting!).

**LEVEL MONO record alignment:**

- Feed 1 kHz nominal level.
- Select MONO mode (simultaneously press STOP and STEREO-MONO).
- With the "LEVEL MONO RECORD" potentiometer align the level to the desired magnetization.

**Test generator alignment:**

- Switch the tape recorder to INPUT.
- Press "REF" on the MONO/STEREO SWITCH board, align the "REF.LEVEL" potentiometer to a reference level of 0 dB/VU.

13.2.5 Jumper: TIME CODE READ/WRITE UNIT

1.820.721.85/87

With the jumper JS1 the LED which indicates the presence of a signal on the time code track (CODE LEVEL LED) can be disabled. When the time code channel is operated without the CODE DELAY UNIT 1.820.722, the delay input and output must be interconnected. The serial interface can be used for this purpose, if available, or the jumper JS2 can be moved to the corresponding position on the CODE READ/WRITE amplifier. In the second case a CODE DELAY UNIT must not be installed!

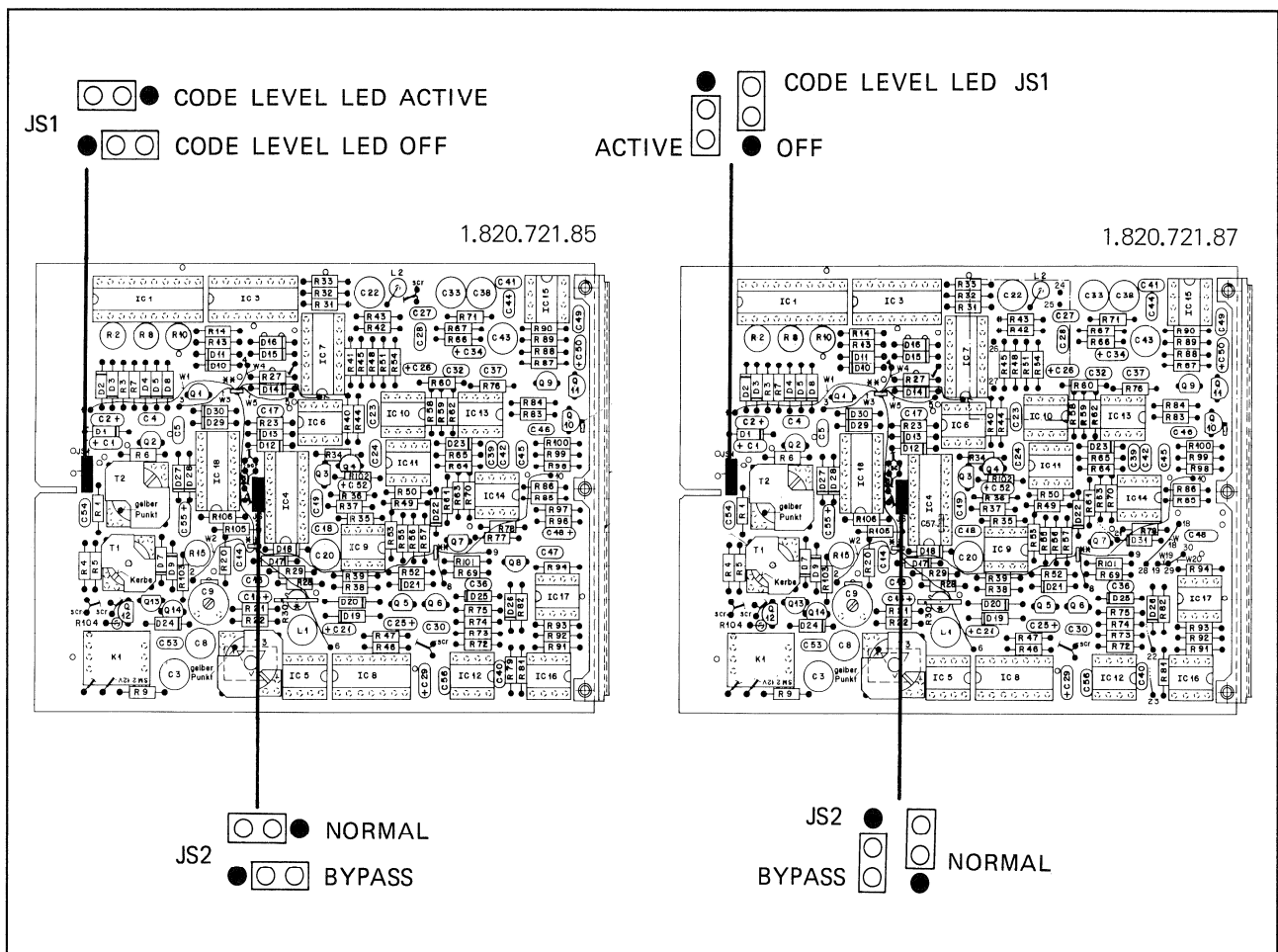

13.2.6 Jumper: MONITOR AMPLIFIER

1.820.860.00

MONITOR AMPLIFIER

(refer to Fig. 13.1):

- Jumper JS1 pos."S": both channels are connected to headphones socket.
- Jumper JS1 pos."M": only channel 1 is connected to headphones socket.

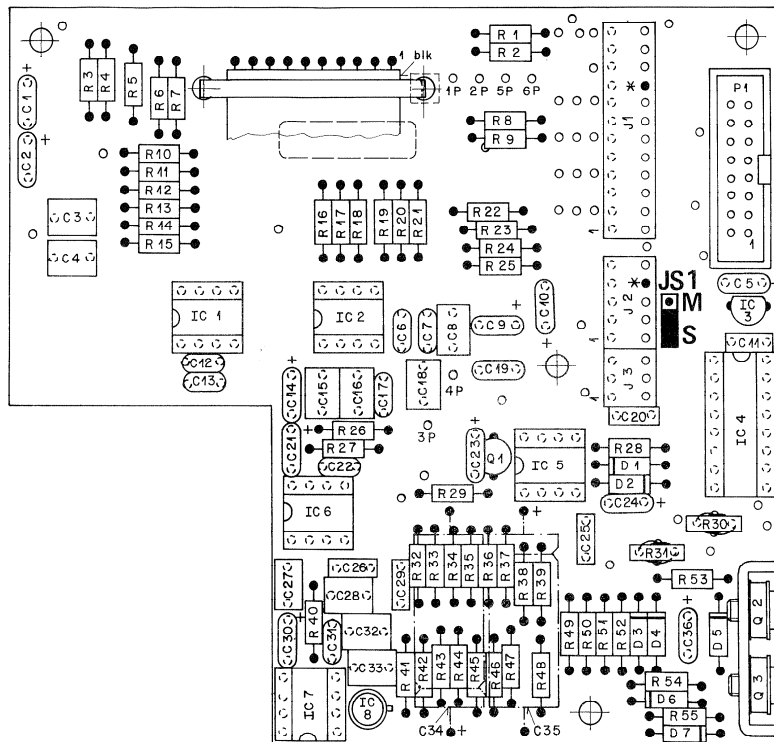

Fig. 13.1 Monitor Amplifier 1.820.860.00

SOURCE SELECTOR BOARD

JS1/JS2 in pos. A:

(see Fig. 13.2)

The jumpers JS1 and JS2 must be either in position "A" or "C"!

JS1/JS2 in pos. C:

- Jumpers JS1 and JS2 in position "A": When the switch "1+2/CUE" is pressed, the sum of both audio channels is connected to the monitor speaker or headphones socket.
- Jumpers JS1 and JS2 in position "C": When the switch "1+2/CUE" is pressed, the TC signal is connected to the monitor speaker or headphones socket. For monitoring both channels, press CH1 and CH2 simultaneously so that both remain in their locked position.

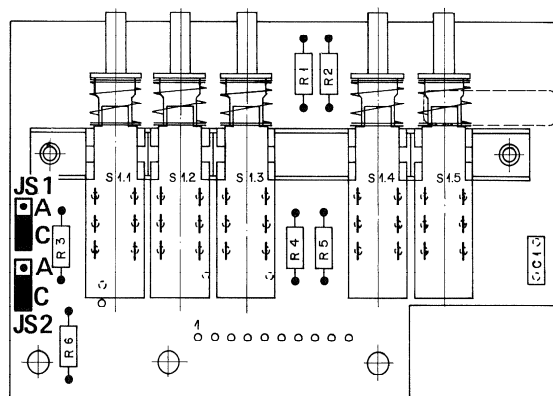

Fig. 13.2 Source Selector Board 1.820.796.00

**13.3 Technical Data**

<b>Tape speeds</b>	<b>Nominal</b>	<b>ips: 30 - 15 - 7.5 - 3.75</b> <b>cm/s: 76.2 - 38.1 - 19.05 - 9.50</b>
	Any of up to 4 nominal tape speeds can be activated via the key field.	
	Nominal speed variable by	$\pm 0.2\%$
	in steps of	<b>0.025%</b>
	<b>Variable</b>	Nominal speed $\pm 7$ semitones $\Delta + 54\%$ to $- 35\%$
	With indication of actual value, optionally in semitones, % deviation, or IPS; programmable.	
	<b>Deviation</b>	<b>max. <math>\pm 0.2\%</math></b>
<b>Tape slip</b>		<b>max. 0.1%</b>
<b>Tape reels</b>	Max. reel diameter	(318 mm) <b>12 1/2"</b>
	Min. reel hub diameter	(45 mm) <b>1.77"</b>
<b>Tape width</b>		(6.3 mm) <b>1/4"</b>
<b>Wow-and-flutter</b>	Peak weighted, measured according to DIN 45507 or IEC Publ. 386, ambient temperature 0 to 40 °C.	
	at 30 ips tape speed:	<b>max. 0.03%</b>
	15 ips:	<b>max. 0.04%</b>
	7.5 ips:	<b>max. 0.06%</b>
	3.75 ips:	<b>max. 0.10%</b>
<b>Start-up-time</b>	For attaining double the specified wow-and-flutter value. For tape speed 15 ips, DIN reel core with 1000 m tape, or NAB reel with 2500 ft tape: <b>approx. 0.4 s</b>	
<b>Tape counter</b>	6-Digit LED indication in hours, minutes, seconds and tenth of seconds at all tape speeds. Reversal past zero indicated with negative sign, incrementing. Range: <b>- 9 h 59 min 59 s to 23 h 59 min 59.9 s</b>	
<b>Tape spooling speed</b>	programmable:	(4 to 472 ips) <b>0.1 to 12 m/s</b>
<b>Winding time</b>	for 1000 m tape:	<b>approx. 90 s</b>
	for 2500 ft tape:	<b>approx. 70 s</b>
<b>Braking time from spooling</b>	With full 1000 m pancake (1/4" tape), from maximum spooling speed: <b>approx. 4 s</b>	
<b>Tape tension</b>	In reproduce and play mode:	nominal (70 p) <b>0.7 N</b>
	In fast forward/reverse mode:	nominal (80 p) <b>0.8 N</b>
<b>Inputs</b>	- with transformer,	<b>balanced and floating</b>
	Input impedance, 30 Hz to 20 kHz:	$\geq 10$ kOhm
	- without transformer,	<b>electronically balanced</b>
	Input impedance, 30 Hz to 20 kHz,	balanced: $\geq 20$ kOhm unbalanced: $\geq 10$ kOhm
<b>Input level</b>	- Relative to reference flux, internally programmable, nominal <b>+6/+10/+14/+16 dBu</b> - Relative to operating level (according to NAB), internally programmable, nominal <b>0/+4/+8/+10 dBu</b> (Internal adjustment range of the operating flux with above input levels: 100 to 1000 nWb/m). <b>Uncalibrated mode</b> , for recorder versions with VU meter panel and input/output level controls. Max. adjustable increase of input sensitivity: <b>10 dB</b> <b>Maximum input levels:</b> - With input transformer: <b>+ 24 dBu</b> - Without input transformer: <b>+ 28 dBu</b> (if nominal input level, relative to operating level, is set to 0/+6 dBu: + 26 dBu)	
<b>Outputs</b>	- With transformer,	<b>balanced and floating</b>
	Impedance, 30 Hz to 20 kHz, load $\geq 200$ Ohm:	$\leq 50$ Ohm
	- Without transformer,	<b>electronically balanced</b>
	Impedance, 30 Hz to 20 kHz, load $\geq 200$ Ohm:	$\leq 30$ Ohm
<b>Output level</b>	- Relative to reference flux, internally programmable, nominal <b>+6/+10/+14/+16 dBu</b> - Relative to operating level (according to NAB), internally programmable, nominal <b>0/+4/+8/+10 dBu</b> (Internal adjustment range of the reproduce gain for operating flux of 100 to 1000 nWb/m). <b>Uncalibrated mode</b> , for recorder versions with VU meter panel and input/output level controls. Max. adjustable increase of the reproduce gain: <b>10 dB</b>	

	<b>Maximum output levels:</b>			
	With output transformer (load $\geq 200$ Ohm): <b>+ 24 dBu</b>			
	Without output transformer (load $\geq 200$ Ohm):			
	- Balanced load $\geq 200$ Ohm:			<b>+ 26 dBu</b>
	- Unbalanced load $\geq 200$ Ohm:			<b>+ 24 dBu</b>
	- Balanced load $\geq 600$ Ohm:			<b>+ 30 dBu</b>
	(if the nominal output level, relative to operating level, is set to 0/+6 dBu: + 26 dBu)			
	- Unbalanced load $\geq 600$ Ohm:			<b>+ 24 dBu</b>
<b>Equalizations</b>	Switchable			<b>NAB/CCIR</b>
<b>Equalization time constants</b>		<b>AES</b>	<b>CCIR</b>	<b>NAB</b>
	30 ips	<b>17.5/∞μs</b>		
	15 ips		<b>35/∞μs</b>	<b>50/3180 μs</b>
	7.5 ips		<b>70/∞μs</b>	<b>50/3180 μs</b>
	3.75 ips		<b>90/3180 μs</b>	<b>90/3180 μs</b>
<b>Frequency response</b>	<b>Record/Reproduce</b>	30 ips:	40 Hz to 22 kHz $\pm 2$ dB	
			60 Hz to 20 kHz $\pm 1$ dB	
		15 ips:	30 Hz to 20 kHz $\pm 2$ dB	
			40 Hz to 18 kHz $\pm 1$ dB	
		7.5 ips:	30 Hz to 16 kHz $\pm 2$ dB	
			30 Hz to 12 kHz $\pm 1$ dB	
		3.75 ips:	30 Hz to 10 kHz $\pm 2$ dB	
			30 Hz to 8 kHz $\pm 1$ dB	
	<b>Sync track reproduction</b>			
	Amplifier programming			
	"Narrow-band"	30 ips:	60 Hz to 12 kHz $\pm 2$ dB	
		15 ips:	30 Hz to 12 kHz $\pm 2$ dB	
		7.5 ips:	30 Hz to 8 kHz $\pm 2$ dB	
	"Wide-band"	30 ips:	60 Hz to 20 kHz $\pm 2$ dB	
		15 ips:	30 Hz to 18 kHz $\pm 2$ dB	
		7.5 ips:	30 Hz to 12 kHz $\pm 2$ dB	
<b>Signal-to-noise ratio</b>	<b>measured with tape</b>		<b>(record/reproduce)</b>	
<b>CCIR</b>	Equalization according to CCIR, measured with AGFA PER 528, BASF LGR 50 or equivalent tape type.			
		ips:	3.75	7.5
	<b>Full-track</b>	6.3 mm track width nWb/m:	250	320
		unweighted, acc. to CCIR 468-II	<b>57 dB</b>	<b>61 dB</b>
		weighted, acc. to CCIR 468-II	<b>48 dB</b>	<b>51 dB</b>
		weighted, ASA-A (IEC 179)	<b>62 dB</b>	<b>64 dB</b>
	<b>Stereo</b>	2.75 mm track width nWb/m:	400	510
		unweighted, acc. to CCIR 468-II	<b>58 dB</b>	<b>62 dB</b>
		weighted, acc. to CCIR 468-II	<b>49 dB</b>	<b>52 dB</b>
		weighted, ASA-A (IEC 179)	<b>63 dB</b>	<b>65 dB</b>
	<b>2-Track</b>	2 mm track width nWb/m:	400	510
		unweighted, acc. to CCIR 468-II	<b>57 dB</b>	<b>61 dB</b>
		weighted, acc. to CCIR 468-II	<b>48 dB</b>	<b>51 dB</b>
		weighted, ASA-A (IEC 179)	<b>61 dB</b>	<b>64 dB</b>
<b>NAB</b>	Equalization according to NAB, measured with SCOTCH 3M 226 or equivalent tape type.			
		ips:	3.75	7.5
	<b>Full-track</b>	6.3 mm track width nWb/m:	510	1040
		Linear, RMS, 30 Hz to 20 kHz	<b>64 dB</b>	<b>74 dB</b>
		RMS value, ASA-A weighted, acc. to DIN45633/IEC publ.179	<b>68 dB</b>	<b>77 dB</b>
	<b>Stereo</b>	2.75 mm track width nWb/m:	510	1040
		Linear, RMS, 30 Hz to 20 kHz	<b>59 dB</b>	<b>70 dB</b>
		RMS value, ASA-A weighted, acc. to DIN45633/IEC publ.179	<b>63 dB</b>	<b>73 dB</b>
	<b>2-Track</b>	2 mm track width nWb/m:	510	1040
		Linear, RMS, 30 Hz to 20 kHz	<b>59 dB</b>	<b>69 dB</b>
		RMS value, ASA-A weighted, acc. to DIN45633/IEC publ.179	<b>63 dB</b>	<b>72 dB</b>
<b>SYNC</b>	Amplifier programming "narrow-band"			
	Equalization according to CCIR, measured with AGFA PER 528, BASF LGR 50 or equivalent tape type.			
		ips:	7.5	15
	<b>Full-track</b>	6.3 mm track width nWb/m:	320	320
		unweighted, acc. to CCIR 468-II	<b>61 dB</b>	<b>62 dB</b>
		weighted, acc. to CCIR 468-II	<b>51 dB</b>	<b>52 dB</b>
	<b>Stereo</b>	2.75 mm track width nWb/m:	510	510
		unweighted, acc. to CCIR 468-II	<b>60 dB</b>	<b>61 dB</b>
		weighted, acc. to CCIR 468-II	<b>52 dB</b>	<b>53 dB</b>
	<b>2-Track</b>	2 mm track width nWb/m:	510	510
		unweighted, acc. to CCIR 468-II	<b>59 dB</b>	<b>60 dB</b>
		weighted, acc. to CCIR 468-II	<b>51 dB</b>	<b>52 dB</b>



<b>Harmonic distortion</b>	<b>CCIR</b> Record/reproduce, measured with PER 528/LGR 50 tape	<b>Full-track</b> 3.75 ips / 1 kHz (320 nWb/m)	≤ <b>2.0 %</b>
		7.5 ips / 1 kHz (320 nWb/m)	≤ <b>1.5 %</b>
	15 ips / 1 kHz (320 nWb/m)	≤ <b>1.0 %</b>	
	30 ips / 1 kHz (320 nWb/m)	≤ <b>1.0 %</b>	
	<b>Stereo/2-Track</b> 3.75 ips / 1 kHz (510 nWb/m)	≤ <b>2.0 %</b>	
	7.5 ips / 1 kHz (510 nWb/m)	≤ <b>1.5 %</b>	
	15 ips / 1 kHz (510 nWb/m)	≤ <b>1.0 %</b>	
	30 ips / 1 kHz (510 nWb/m)	≤ <b>1.0 %</b>	
	<b>NAB</b> Record/reproduce, 1 kHz, measured with 3M 226 tape.	<b>Full-track</b> 3.75 ips / 1 kHz (400 nWb/m)	≤ <b>1.0 %</b>
			7.5 ips / 1 kHz (510 nWb/m)
15 ips / 1 kHz (510 nWb/m)		≤ <b>1.0 %</b>	
30 ips / 1 kHz (510 nWb/m)		≤ <b>1.0 %</b>	
<b>Stereo</b> 3.75 ips / 1 kHz (400 nWb/m)		≤ <b>1.0 %</b>	
<b>2-Track</b> 7.5 ips / 1 kHz (510 nWb/m)		≤ <b>1.0 %</b>	
15 ips / 1 kHz (510 nWb/m)		≤ <b>1.0 %</b>	
30 ips / 1 kHz (510 nWb/m)		≤ <b>1.0 %</b>	
<b>Channel separation</b>		according to DIN 45521, at 1 kHz (2-Track units)	≥ <b>65 dB</b>
<b>Erase efficiency</b>		at 1 kHz, 510 nWb/m, 15 ips with full-track erase head	≥ <b>80 dB</b>
	with overlapping 2-Track erase head	≥ <b>75 dB</b>	
<b>Erase and bias frequency</b>	at all tape speeds:	<b>153.6 kHz</b>	
<b>VU-meter</b>	switchable from VU characteristic (according to IEC recommendation 268, Part 10, Section 4) to PPM characteristic (according to IEC recommendation 268, Part 10, Section 2, except 24.1, concerning scale division).		
<b>Power input</b>	switchable	<b>100 V to 140 V / 200 V to 240 V / ± 10 %</b> <b>50 Hz / 60 Hz</b>	
<b>Power consumption</b>	(for nominal voltage) at standstill	<b>90 W</b>	
	Recording on 2 channels	<b>150 W</b>	
	Fast forward/rewind	<b>190 W</b>	
	Max. power consumption	<b>280 W</b>	
<b>Admissible power failure</b>	without influence on the operating state:	<b>max. 100 ms</b>	
<b>Ambient temperature range</b>	(+ 32 to 104 °F)	<b>0 to + 40 °C</b>	
<b>Relative humidity</b>	noncondensing	<b>20 % to 90 %</b>	
<b>Safety standard</b>	According to IEC recommendation, publication 65, protection category I (line filter, power switch, power fuse, power transformer, and voltage selector according to protection categories I and II).		
<b>Weights</b>	without console, depending on configuration:		
		net <b>approx. 43 kg</b> gross (air freight) <b>approx. 70 kg</b>	

<b>Technical data of time code channel</b>		
	The time code channel corresponds to the IEC publication 461, DIN 45511, part 7.	
<b>Track width/track configuration</b>	in center of tape	<b>0.38 mm</b>
<b>Code format</b>	80-bit address code (switchable 24/25/29.97/30 frames/sec)	<b>SMPTE/EBU</b>
<b>Tape speeds</b>		<b>ips: 30 – 15 – 7.5</b>
<b>Magnetic flux of time code track</b>		<b>729 nWb/m pp ± 3 dB</b>
<b>Input of time code channel</b>	via transformer, input impedance	<b>balanced, floating</b> ≥ <b>10 kOhm</b>
<b>Input level</b>		nominal: <b>2 V<sub>pp</sub></b>
		minimum: <b>0.25 V<sub>pp</sub></b>
		maximum: <b>4 V<sub>pp</sub></b>
<b>Output of time code channel</b>	via transformer, output impedance	<b>balanced, floating</b> ≤ <b>40 Ohm</b>
<b>Output level</b>	Load ≥ 200 Ohm	<b>2 V<sub>pp</sub></b>
<b>Channel separation</b>	relative to 510 nWb/m flux of the audio track, for all components of the time code signal	
<b>Code channel – audio channel</b>		≥ <b>90 dB</b>
<b>Time code delay unit</b>	switchable for:	
	– coincident time code and audio track recording or reproduction at 24/25/29.97 and 30 frames/sec.	
	– M15A-TC compatible time code and audio track recording or reproduction at 24/25/29.97 and 30 frames/sec.	
<b>Coincidence error between code track and audio track</b>	at 15 ips (if TIME CODE DELAY UNIT operates in coincidence mode).	<b>max. ± 4 ms</b>

The technical data apply for horizontal and vertical operating positions. We reserve the right to make changes as technical progress may warrant.

**Dimensions** in mm

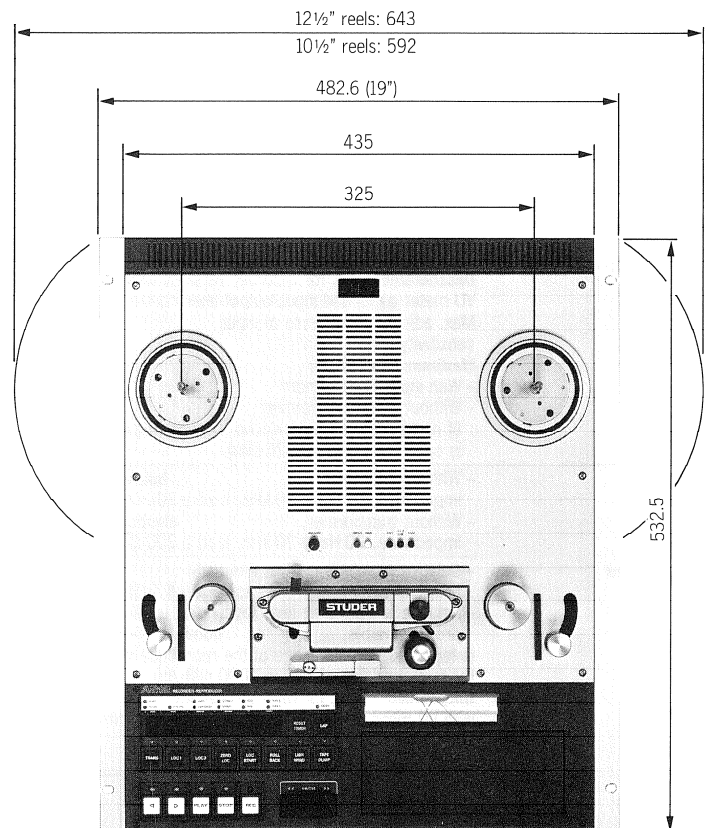
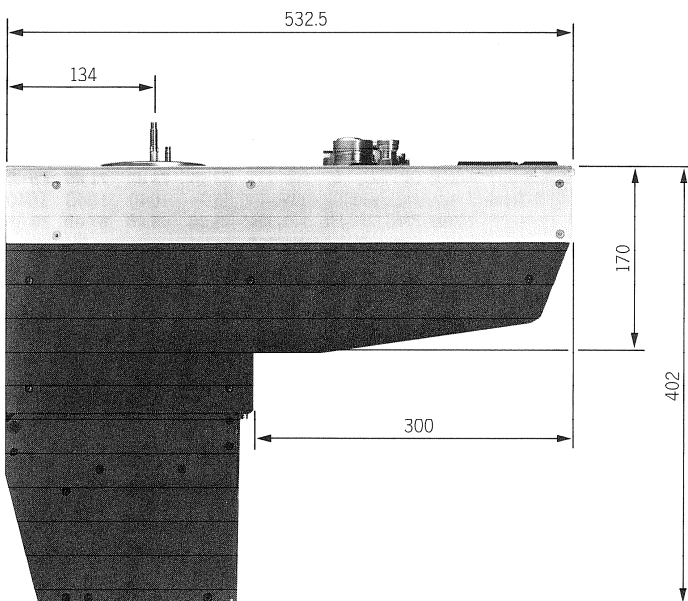

**13.4 RAM parameters for glass-metal heads**

---

**Equalization parameter**

For the equalization parameters for glass-metal heads stored in the RAM the following (hex) values apply. If the stored values should be lost they can be re-entered according to the following tables:

1/4"

	<b>9,5 cm/s</b> 3,75 ips	<b>19 cm/s</b> 7,5 ips	<b>19 cm/s</b> 7,5 ips	<b>38 cm/s</b> 15 ips	<b>38 cm/s</b> 15 ips	<b>76 cm/s</b> 30 ips
	<b>CCIR+NAB</b>	<b>CCIR</b>	<b>NAB</b>	<b>CCIR</b>	<b>NAB</b>	<b>CCIR+NAB</b>
REPRO	AE	82	68	44	68	29
REC	BB	A9	BE	C6	A5	D5
SYNC	00	85	70	44	68	29

### 13.5 Bias adjustment parameters

Tape type	▲ U values in dB			
	9,5 cm/s 3,75 ips	19 cm/s 7,5 ips	38 cm/s 15 ips	76cm/s 30 ips
Scotch 3M 226	6	6	3.5	1.5
Scotch 3M 206	5.5	5.5	3	1.5
Scotch 3M 263	6	6	3	1
Scotch 3M 250	5	6	3.5	1
Scotch 3M 256	6	6.5	3.5	1
Scotch 3M 996	6	6	3.5	1.5
AGFA PEM 526		6	3	
AGFA PEM 468	6	6	3.5	1.5
AGFA PEM 469	7	5.5	2.5	1.0
AGFA PER 525	6	6	3	1
AGFA PEM 528	6	6	3.5	1.5
BASF LGR 50	6	6	4	1.5
BASF LGR 30 P	6	6	4	1.5
BASF LGR 51	6	6	4	2.5
BASF SPR 50LH	6	5.5	3.5	1.5
BASF 910	5	6	4.5	1.5
BASF 911	6	6.5	4.5	3
AMPEX 406	6	5	3	1.5
AMPEX 456	5	6.5	3.5	1.5
AMPEX 499	6	6.5	3.5	1.5
EMI 816/815/817	6	6.5	4	1.5
PYRAL CJ 90	6	6.5	3.5	1.5

We reserve the right to make changes as technical progress may warrant.

## 14 Tape recorder versions and options

Versions	Type designation	Article No.
Mono	A812-1	60.118.12011
	A812-1 VU	60.118.12012
Stereo	A812-0.75	60.118.12021
	A812-0.75 VU	60.118.12022
	A812-2F	60.118.12030
Stereo/2-Track	A812-2/2	60.118.12031
	A812-2/2 VU	60.118.12032
	A812-2	60.118.12033
	A812-2 VU	60.118.12034
Time Code	A812-2 TC	60.118.12041
	A812-2 TC VU	60.118.12042

Features									
Track config.	Mono								
	Stereo								
	2-Track/Stereo								
	Time code track in center of tape 0.38 mm								
	Guard track 0.75 mm								
	Guard track 2.00 mm								
Erase track	Full-track overlapping								
	2-Track (TC not erasing)								
Inputs/outputs	balanced, floating								
	electronically balanced								
Tape speeds	3.75 ips/9.5 cm/s								
	7.5 ips /19 cm/s								
	15 ips /38 cm/s								
	30 ips /76 cm/s								
SYNC reproduction with overbridge									
	equipped with								
	- VU-meter								
	- Audio channel selector								
	- TC channel selector								
without overbridge									
	Broadcast version								
	Monitor speaker below tape transport cover								

### General informations

- The foregoing code numbers/type designations comprise:
- Tape recorder in chassis version, without console (see section "Accessories").
  - Instrument/channel selector panel, except broadcast version.
  - Connector for parallel remote control (D-type/25-pin).
  - One set XLR connectors for audio inputs and outputs.
  - Ciné 3-prong adapter (for other reel adapters refer to next Section, "Accessories").

### Standards

- Audio inputs and outputs correspond to US standard; inputs: XLR female outputs: XLR male
- Studer standard module (remote control option) Dimension: 1 E = 190 mm high x 40.6 mm wide.

- Standard calibration data

Equalization	Tape speed	cm/s	CCIR				NAB			
			9.5	19	38	76	9.5	19	38	76
		ips	3.75	7.5	15	30	3.75	7.5	15	30
			LGR 50/PER 528				SCOTCH 3M226			
			+ 6 dBu				+ 4 dBu			
Magnetization	Mono	nWb/m	250	320	320	320	200	250	250	250
	Stereo/2-Track	nWb/m	400	510	510	510	200	250	250	250
			= 6 VU				= 0 VU			

### Please specify on your order:

- Machine type designation and code numbers (see above table).
- Options with designation and code number.
- Accessories such as console, remote controls etc.
- Standard calibration, NAB or CCIR (see above table).

Additional Manuals		
Operating manual (English)		10.27.0333
	Operating manual (German)	10.27.3090
Service Instructions (English/German)		10.27.0343

### Retrofittable interfaces

Serial interface RS232	for synchronizer connection (Studer TLS 4000, remote counter 21.328.275.00) and audio parameter back-up	20.812.885.00
	matching cable connector* (D-type) *(included with Studer remote control)	20.020.303.07
Serial remote control interface autolocator	Interface for serial remote control, and remote counter	20.812.888.00
	matching cable connector* (D-type) *(included with Studer remote control)	20.020.303.20
Parallel interface CH control	Interface for audio channel remote control (1.328.260.00 and 1.328.267.00)	20.812.939.00
	matching cable connector* (D-type) *(included with Studer remote control)	20.020.303.19
Parallel interface NR systems	Interface for noise reduction systems	20.812.945.00
	matching cable connector* (D-type)	20.020.303.08

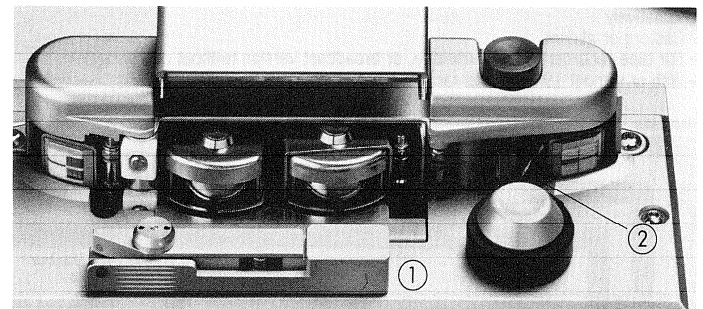

Tape scissors	2) Retrofit kit	20.812.891.00
Tape marker	1) Retrofit kit	20.812.892.00
Tape scissors and tape marker	Retrofit kit	20.812.893.00
Mono/stereo switch	Plug-in retrofit PC board for TC-Versions	20.812.902.00
	with AF test generator for TC-Versions	20.812.904.00
Mono/stereo switch with AF test generator	Plug-in retrofit PC board	20.812.903.00
Elapsed time counter		20.812.865.00
Special light barrier	Detects tape start and tape end with transparent leader and trailer	10.023.515.00

## 15 Accessories

### Standard consoles (economy version)

- Wooden side panels
  - Tilting mechanism
  - on castors, with brake
  - Operating height 840 mm
- Equipped either for
- Tape recorders with overbridge, or broadcast version (without overbridge)
  - with or without 19" pedestal rack (instead of traverse)

### Versions

	Height H (mm)	Part number
for tape recorders <b>without overbridge</b> (broadcast versions) ①	840	20.020.204.85
for tape recorders <b>with overbridge</b>	840	20.020.204.95
<b>with 19" pedestal rack</b> (instead of traverse) ③	840	20.020.204.65
	840	20.020.204.75

### Accessories for standard consoles

<b>Overbridge extension for TLS 4000-LCU (operating unit)</b>	incl. wooden side panels Fits on top of the existing overbridge. Only for overbridges with VU-meter and/or channel selector.	1.058.058.00
<b>19"/3U Pedestal rack Retrofit kit</b>	3 units high E.g. for TLS 4000 control section (1U) To be installed in place of the traverse.	1.058.057.00
Matching front filler panels:		
19"/1U, anodized finish		1.918.001.00
19"/2U, anodized finish		1.918.002.00
19"/3U, anodized finish		1.918.003.00
19"/1U, gray paint finish		1.918.011.00
19"/2U, gray paint finish		1.918.012.00
19"/3U, gray paint finish		1.918.013.00

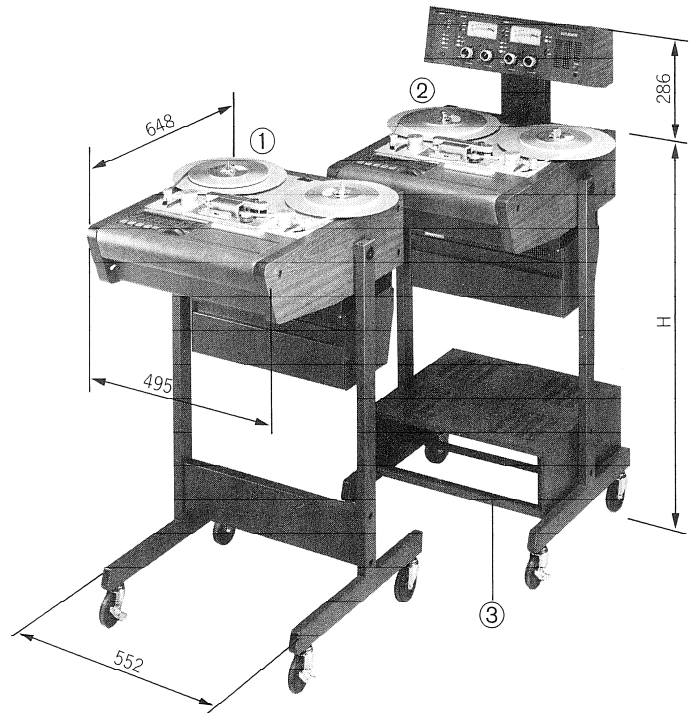

### Studio consoles

- Wooden side panels
- Tilting mechanism
- Suited for operation with 12.5" tape reels alternatively
- Castors or gliders
- For tape recorders with overbridge, or broadcast version (without overbridge)
- With or without 19" pedestal rack (in place of traverse)

### Versions

	Height H (mm)	Part number
for tape recorders <b>without overbridge</b> (broadcast version) ①	780	20.020.204.40
for tape recorders <b>with overbridge</b>	840	20.020.204.41
<b>with 19" pedestal rack</b> (in place of traverse) ③	900	20.020.204.42
<b>on gliders</b>	840	20.020.204.45
<b>on castors</b>	900	20.020.204.46
	960	20.020.204.47
	780	20.020.204.50
	840	20.020.204.51
	900	20.020.204.52
	840	20.020.204.55
	900	20.020.204.56
	960	20.020.204.57
	780	20.020.204.20
	840	20.020.204.21
	900	20.020.204.22
	840	20.020.204.25
	900	20.020.204.26
	960	20.020.204.27
	780	20.020.204.30
	840	20.020.204.31
	900	20.020.204.32
	840	20.020.204.35
	900	20.020.204.36
	960	20.020.204.37

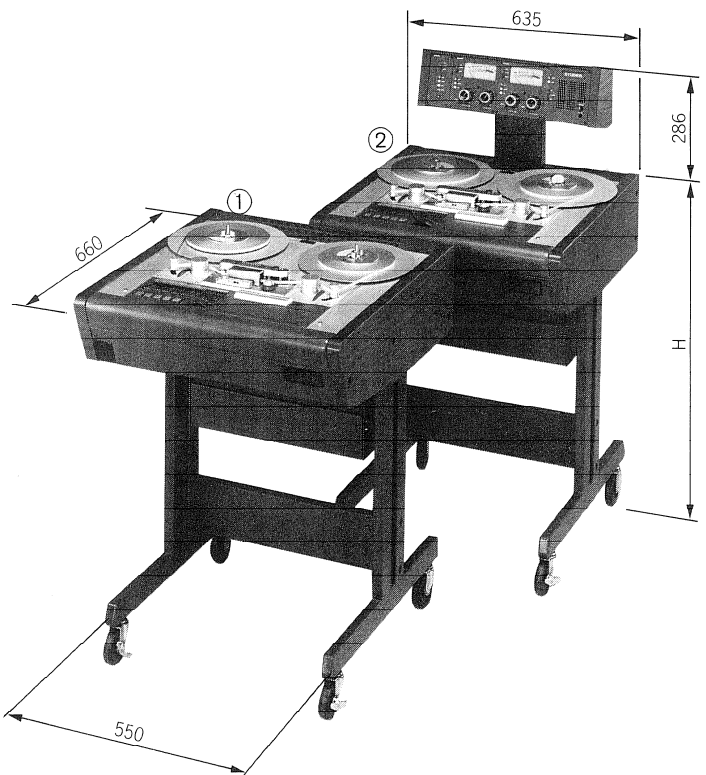

# STUDER A812 MKII

## Accessories for studio consoles

<b>Shelf</b>	instead of overbridge Suited for recorder types: A812-1 / A812-0,75 / A812-2 / A812-2F	<b>21.811.560.00</b>
--------------	--	----------------------

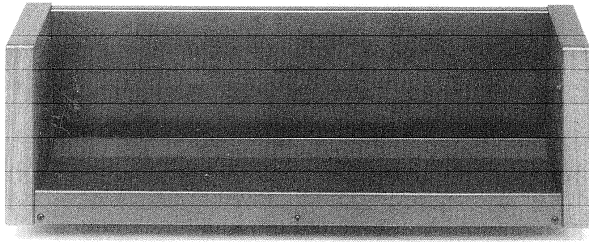

<b>Special side panel</b>	In place of the right-hand wooden panel with cutout for installing audio/TC channel remote control module 1.328.267.00	<b>1.058.021.00</b>
---------------------------	--	---------------------

<b>Dust covers</b>	for studio console without overbridge for studio console with overbridge	<b>1.058.100.31</b> <b>1.058.100.30</b>
--------------------	---	--

<b>Shelf extension with monitor speaker</b>	Retrofit kit Suited for tape recorders type: A812-1 / A812-0,75 / A812-2 / A812-2F Factory-installed	<b>21.811.563.00</b> <b>20.812.898.00</b>
---	---	--

## Tape reels, reel adapters

<b>NAB reel adapters</b>	1) Economy, (for Ciné adapter)	<b>89.01.0354</b>
<b>CINÉ-Adapter</b>	2) (supplied with tape recorder)	<b>1.013.326.00</b>
	3) Professional, with editing handle	<b>1.013.344.00</b>
<b>NAB tape reel</b>	4) for NAB adapter, without tape	<b>10.213.001.01</b>
<b>AEG core for self supporting pancakes</b>	5) 1/4", for DIN adapter	<b>10.200.003.01</b>
<b>DIN spindle for self supporting pancakes</b>	6) for DIN reel adapter 1.013.343.00	<b>1.013.328.00</b>
<b>DIN reel adapter</b>	7)	<b>1.013.343.00</b>
<b>DIN adapter/spindle</b>	∅ 299 mm for Ciné adapter	<b>1.013.047.00</b>

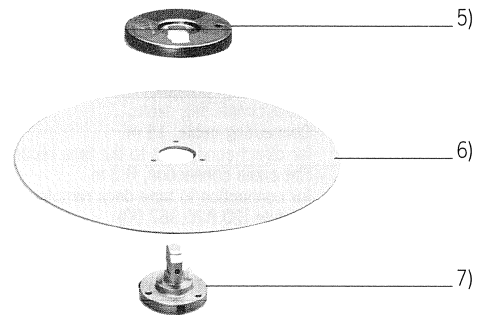
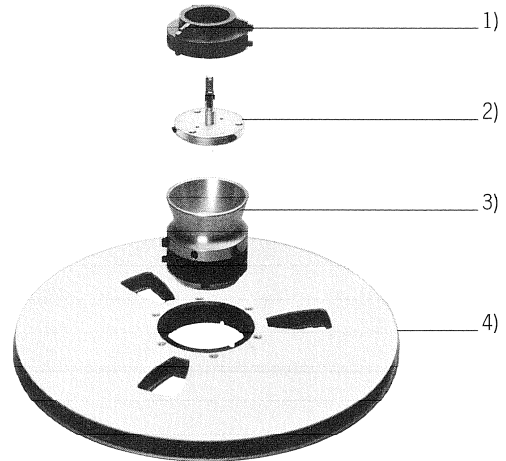

**Parallel remote controls**

**Tape deck remote control box** **1.328.250.00**

1) Parallel tape deck remote control, desktop model, slanted control panel, with wooden side panels, incl. 15 m connecting cable. With vacant space for installing the varispeed remote control module 1.328.253.00

Additional connector **1.328.254.00**  
 25-pin D-connector for additional parallel remote control facilities  
 (varispeed module, fader start input, etc.)

**Varispeed remote control module** **1.328.253.00**

2) With precision potentiometer and reference scale.  
 For installation in tape deck remote control box 1.328.250.00, including flat cable connection.

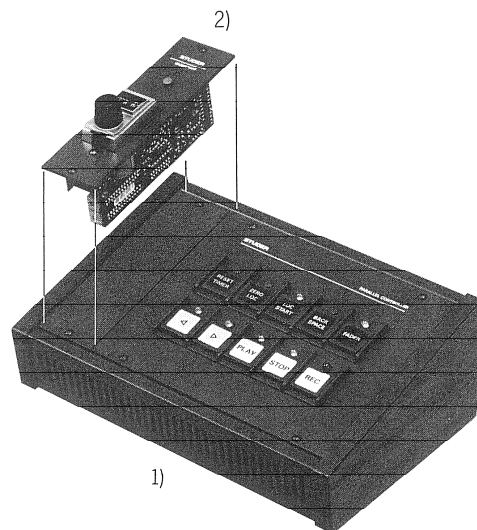

**Remote controls, chassis versions** Height 190 mm Width 40.6 mm (1E)

**Tape deck remote control** **20.820.367.00**

1) Parallel tape deck remote control, chassis version, incl. 15 m connecting cable.

**Varispeed remote control module** **1.328.290.00**

2) With precision potentiometer and reference scale, **without** connecting cable.  
 - Connecting cable, 15 m **1.328.292.00**  
 for direct connection to the tape recorder.  
 - Flat cable connection, 0.3 m **1.023.102.03**  
 for connection to tape deck remote control module (20.820.367.00)

**Varispeed remote control module** **1.328.280.00**

3) With digital input of the speed deviation and real-time indication in semitones, **without** connecting cable.  
 - Connecting cable, 15 m **1.328.292.00**  
 for direct connection to the tape recorder.  
 - Flat cable connection, 0.3 m **1.023.102.03**  
 for connection to tape deck remote control module (20.820.367.00)

**Audio/TC channel remote control module** **1.328.260.00**

4) For remote control of two audio channels and the time code channel. Includes 15 m connecting cable.  
 Required - Option "CH control interface" 20.812.939.00

**Audio/TC channel remote control module** **1.328.267.00**

For installation in special console side panel (1.058.021.00, see console accessories)  
 For remote control of two audio channels and the time code channel. Includes 1.5 m connecting cable.  
 Required - Option "CH control interface" 20.812.939.00  
 - Special console side panel 1.058.021.00

**Module box** **1.328.095.00**

Desktop model  
 Accommodates up to six modules of the standard width 1E. **1.328.095.00**

matching filler panels

- anodized finish Width 1E **1.038.341.00**
- 2E **1.038.342.00**
- 3E **1.038.343.00**
- Grey paint finish Width 1E **1.328.185.00**
- 2E **1.328.186.00**
- 3E **1.328.187.00**
- 5E **1.328.189.00**

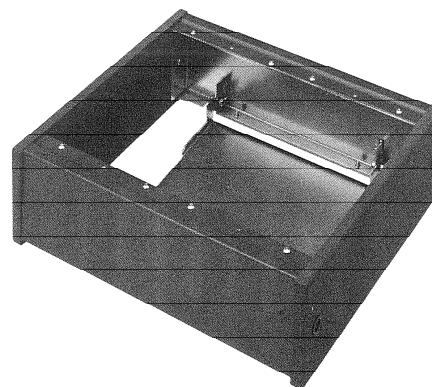
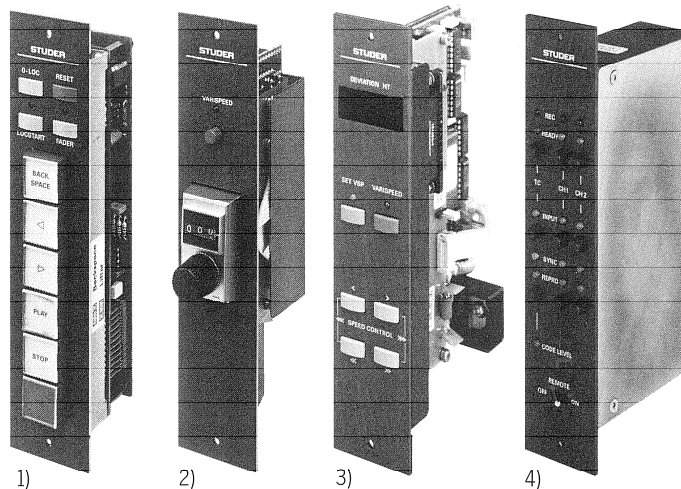



# STUDER A812 MKII

## Serial remote controls

**Remote control unit** Desktop model, slanted control panel **20.820.369.00**  
 Chassis version, width 5E **20.820.370.00**  
 Control panel for all tape deck functions,  
 incl. remote counter. Includes 15 m connecting cable.  
 Required – Option “Serial remote control interface” 20.812.888.00

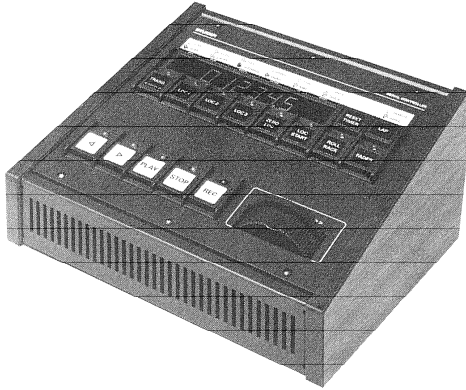

**Autolocator** Desktop model, slanted control panel **21.328.240.82**  
 Chassis version, width 6E **21.328.230.82**  
 (For machines with serial numbers from 2000 onward).  
 – 20 Memory locations  
 – Varispeed control  
 – Tape deck remote control  
 Incl. 15 m connecting cable  
 Required – Option “Serial remote control interface” 20.812.888.00

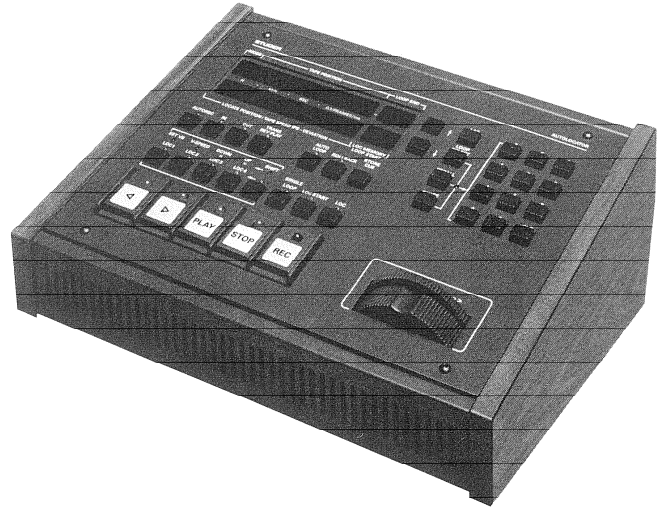

**Remote counter for RS 232** Chassis and desktop version **21.328.275.00**  
 Includes 15 m connecting cable  
 Required – Option “Serial interface RS 232” 20.812.885.00  
 Matching **filler panels** 190 mm x 202.9 mm (standard module 5E)  
 for one remote counter **1.328.275.31**  
 for two remote counters **1.328.275.32**  
 for three remote counters **1.328.275.33**

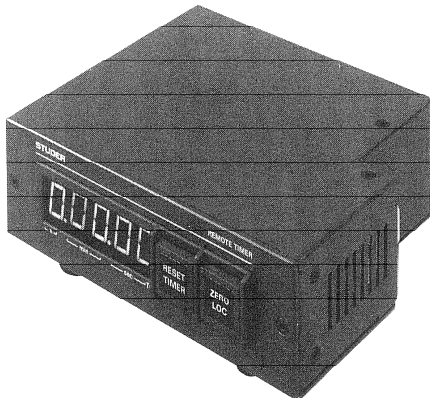

**Fernzähler** Chassis and desktop version **20.820.368.00**  
 Incl. 15 m connecting cable  
 Required – Option “Serial remote control interface” 20.812.888.00



**Remote control selector** STUDER standard chassis module 1E **21.328.248.00**  
 For selective connection of a serial remote control/remote counter unit (20.820.368.00 / 20.820.369.00 / 20.820.370.00 / 21.328.230.82 / 21.328.240.82) to up to five tape recorders (A812/A820/A827) incl. connecting cable (1 m). Remote control unit → remote control selector.  
 Required – One connecting cable (15 m) **1.328.293.81** for each additional tape recorder to be controlled (one connecting cable is supplied with the remote control unit)  
 Required – for Tape Recorder A812, Option “Serial remote control interface” 20.812.888.00

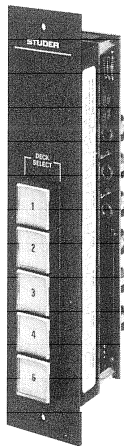

Matching **filler panels** 190 mm x 202.9 mm (standard module 5E)  
 for one remote counter **1.328.270.31**  
 for two remote counters **1.328.270.32**  
 for three remote counters **1.328.270.33**

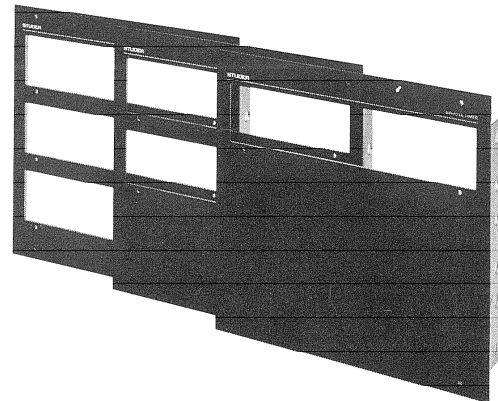



---

## 16 Daily care

---

Daily care is limited to cleaning the soundheads, the capstan shaft, and the tape guiding elements.

Dust and oxide particles of the magnetic tape coating accumulate principally on the soundheads and tape guides, and cause so-called drop-outs in the record mode.

Cleaning should be performed daily, or even more frequently if contamination is severe.

For cleaning work we recommend the STUDER cleaning set: (Part No. 10.496.010.00). It contains all utensils required for cleaning the tape recorder, a soundhead cleaning fluid, as well as aluminite cleaner.

### Procedure

Moisten the yellow piece of cloth with the soundhead cleaning fluid and clean all surfaces that come in contact with the tape. After cleaning, dry the cleaned surfaces with a dry section of the same piece of cloth.

Coarse deposits in the grooves of the right-hand time code head can be removed with a hard brush with bristles shortened to approx. 5 mm.

Normally, the capstan shaft does not rotate when the tape recorder is not operating in play mode. However, a special function (press PLAY when the tape is unthreaded) is available that puts the capstan motor in motion for cleaning purposes.

**Important:** When cleaning the capstan make sure that no cleaning fluid penetrates into the bearing! The acrylic glass cover of the VU-meters can get dulled by the cleaning fluid.



## 17 Components Sensitive to Electrostatic Charges "ESE"

### Static electricity

In our daily activities numerous materials may be a possible source of static electricity. If certain circumstances are given, a person and the various things that are being handled may build up considerable static charges. When it comes to a discharge of such a static potential, very high peak power pulses may result. Even a small portion of such energy, when finding its way into an electronic component, will result in damage or even destruction of that component.

### Handling of ESE-assemblies

It must be our aim, therefore, to protect our products from damages and fault conditions that may be the result of electrostatic discharges. Correct handling of electronic assemblies when performing service work on equipment is of utmost importance. For this the following safe handling procedures have to be observed:

1. Discharge your body by touching earth before picking up an electronic assembly.
2. Touch your partner first (handshake) before handing an assembly to him.
3. When handling complete PC-boards, make it your standard practice to hold them only at their edge or at their front panel.
4. Never touch the conductive tracks, terminal points or components on a circuit board without having first discharged yourself.
5. Switch off the electric current supply to the equipment before removing or inserting an ESE assembly.
6. Always use ESE packaging for transportation or storage of ESE assemblies.
7. Make sure to use only tools that are approved for ESE work.
8. An earthed wrist-band is to be carried whenever performing any work on or with electronic assemblies, irrespective of whether they contain ESE or not.
9. Keep Styropor, PVC foils, plastic bags, etc. far away from ESE assemblies.

**ESE-kit** This kit consists of an earthed protective base (60 × 70cm) with earthed wrist-band for any work with electronic assemblies.

**Part No.**  
**20.020.001.44**

## 18 Index

Index	Page
Accessories	107
ASCII RS 232 BD RATE	35
Assembling the console	4
AUTO LOW PASS	38
AUTO MUTE	37
BACK-UP	70
Bias adjustment	105
CAPSTAN MODE	41
Command Protocol	59
Crossfading	16
Daily care	111
DATA LOST	55
Dolby HX PRO	37
Drop-in	16
Drop-out	16
Dump edit mode	24
EDIT	7, 43
Error Messages	50
ES BUS ADDRESS	35
FADER	9, 40
FORWARD	42
FRAMES/S SELECT	8
Fuses	84
HOLD	43
HUB DIAMETER	34
Installation site	3
INSTANT LOOP	46
Jumper	97, 100, 101
Key numbering	30
LAP	6
LC display	7
LIB WIND SPEED	34
LIBRARY WIND	7, 18, 42
LIFTER	45
LOADING	74
LOADING the data	77
LOC	43
MASTER SAFE	8
Menu tree	25
Monitor	21
NAB reel	12
Operator controls	6
Play	15, 43
Power switch	4
Programming the operating parameters	94
RAM parameters	104
Record	15, 43
REHEARSE	38
Remote controls	20
REWIND	42
ROLLBACK	7, 44
ROLLBACK TIME	34

<b>Index</b>	<b>Page</b>
RS232 interface	57
RS232/422 FORMAT	35
Serial interface	57
SHUTTLE	46
SHUTTLE BAR	6
Skimming	24, 38
SPEED SELECT	8
Spooling mode	17
Spot Erase	24, 38
Standard versions	5
Status indicator field	6
Stop	18, 43
STORE	7
SYNC reproduction	17
TAPE DUMP	7
TAPE GUARD	39
Tape speeds	14
Tape timer	19
TC MODE	48
Test generator	22
Threading the tape	14
Time code recording	22
TRANS	7
TRANSFER	43
VARISP.	8
VERIFYING	72, 76
Voltage selector	84